

# Playscape

a natural playground in Sunnyside, Pretoria

by Elize Meyer

PLAYSCAPE  
A natural playground in the city.

by Elize Meyer  
27025633

Submitted in partial fulfilment of the requirements for the degree  
Master of Landscape Architecture (Professional)

in the  
Department of Architecture,  
Faculty of Engineering, Built Environment and Information  
Technology

at the

UNIVERSITY OF PRETORIA

Study leader: Ida Breed  
Studio Master: Jacques Laubscher (Dr.)

Pretoria  
2011

## Project summary

Programme: A natural playground

Site description: Vacant erven next to the Walker Spruit

Client: The City of Tshwane

Users: The children and larger community of Sunnyside

Site Location: Erven 708, R/709, R/1/709, R/2/709, R/3/709 and R/6/1201, Sunnyside

Address: c/o Bourke Street and De Rapper Street, Sunnyside, Pretoria, South Africa

GPS Coordinates: 25°45'5.28"S, 28°13'36.28"E

Architectural Theoretical Premise: Environmental psychology

Architectural Approach: Developing a natural playground (playscape) in the high-density residential area of Sunnyside

Research field: Urbanism and human settlements

In accordance with Regulation 4(e) of the General Regulations (G.57) for dissertations and theses, I declare that this thesis, which I hereby submit for the degree Master of Landscape Architecture (Professional) at the University of Pretoria, is my own work and has not previously been submitted by me for a degree at this or any other tertiary institution.

I further state that no part of my thesis has already been, or is currently being, submitted for any such degree, diploma or other qualification.

I further declare that this thesis is substantially my own work. Where reference is made to the works of others, the extent to which that work has been used is indicated and fully acknowledged in the text and list of references.

The dissertation is 24 692 words long.

Elize Meyer

*'n Hartlike dankie aan my ouers, Dirk Oosthuizen, die "Landies," Ida Breed en Dr. Vosloo vir die al die goeie en slegte tye saam, en bowenal aan God, wat my geleer het om te luister.*

## Abstract

**Keywords:** high-density residential area, natural, playscape, socio-emotional, physical and cognitive development

Quality play is fundamental to the healthy development of a child. Children living in high-density residential areas in Pretoria are deprived of necessary play experiences, due to the nature of the existing playgrounds.

This dissertation investigates why interaction with nature is beneficial to children, and how a playscape (natural playground) can be designed in such a way as to facilitate the social, emotional, cognitive and physical development of children.

The research argues that quality play is possible when children have loose parts to play with, and are able to manipulate their environment. Playing in more natural areas offers a host of physical and psychological health benefits for children.

A playscape is therefore proposed in the high-density residential area of Sunnyside in Pretoria along the Walker Spruit, to serve the play needs of the children in the area, incorporating a toy library and other economic initiatives. The design solution aims at creating a safe park which would be used by all members of the public, not only children. The proposal shows that employing natural materials in a play area could provide healthy, stimulating play opportunities for children.

## Table of Contents

Abstract .....	v
Terminology .....	x
<b>Chapter 1: Introduction</b> <b>1</b>	
1.1 The Problem in Context .....	2
1.2 What can be done about the problem? .....	4
1.3 Problem Statement .....	4
1.4 Hypothesis .....	4
1.5 Research questions .....	4
1.6 Introduction to site .....	4
1.7 Assumptions and delimitations .....	5
1.8 Client and funder .....	5
1.9 Research methodology .....	6
1.10 Overview of dissertation .....	6
<b>Chapter 2: Theoretical investigation</b> <b>7</b>	
2.1 Theoretical investigation .....	8
2.2 Why play is important .....	9
2.3 The benefits of play in natural areas for children's development .....	9
2.4 Adventure Playgrounds .....	11
2.5 Ownership .....	12
2.6 Sense of community, safety and defensible space .....	12
2.7 All ages welcome .....	13
2.8 Conclusion .....	14

### Chapter 3: Design Guidelines 15

3.1 The problem . . . . .	16
3.2 Picture study from two schools . . . . .	22
3.3 Spaces for children . . . . .	23
3.4 The natural environment as playground . . . . .	25
3.5 Conclusion . . . . .	28

### Chapter 4: Precedents 29

4.1 Interventions at Child Development Centre . . . . .	31
4.2 Water Garden . . . . .	32
4.3 Murergaarden . . . . .	33
4.3 End Street Park . . . . .	34
4.5 Sali Park . . . . .	35

### Chapter 5: Site Analysis 37

5.1 Context . . . . .	38
5.2 The Walkerspruit trail . . . . .	39
5.3 Current users . . . . .	40
5.4 Biophysical characteristics . . . . .	42
5.5 General . . . . .	44
5.6 Visual analysis . . . . .	47

## Chapter 6: Urban Framework 51

6.1 Introduction .....	52
6.2 Current condition of the Walker Spruit and Apies River .....	52
6.3 Proposed framework .....	54
6.4 Conclusion .....	56

## Chapter 7: Design Development 57

7.1 Programme .....	58
7.2 Site specific design guidelines .....	60
7.3 Nature .....	60
7.4 Play .....	60
7.5 Safety .....	60
7.6 Community .....	61
7.7 Sustainability .....	63
7.8 Main site plan revisions .....	64
7.9 Concept .....	65
7.10 Conclusion .....	69

## Chapter 8: Design Resolution 71

8.1 Masterplan .....	72
8.2 Bushveld Forest .....	77
8.3 Water features .....	78
8.4 Mountain and kick about .....	81
8.5 Age specific areas .....	84
8.6 Grassland .....	91
8.7 Shade pergolas .....	93
8.8 Tower .....	94
8.9 Tunnel .....	96

8.10 General waiting areas .....	96
8.11 Conclusion .....	98

## Chapter 9: Technical Resolution 99

9.1 Material palette .....	101
9.2 Waterwheel .....	103
9.3 Wetland .....	105
9.4 Water .....	106
9.5 Irrigation budget .....	106
9.6 Channel sizing calculations .....	112
9.7 Cut and fill volumes .....	112
9.8 Bridge .....	112
9.9 Climbing tower and kiosk .....	117
9.10 Lighting strategy .....	118
9.11 Drinking fountain .....	121
9.12 Tunnel .....	122

## Chapter 10: Conclusion 123

10.1 Conclusion .....	125
-----------------------	-----

## Chapter 11: Bibliography 128

## Chapter 12: Appendices 145

12.1 List of illustrations .....	136
12.1 List of figures .....	145

## Terminology

**Adventure playground:** a playground where children are allowed to build their own constructions without adult interference, but guidance when asked. Planks and other construction materials together with tools such as hammers and nails are available for use by the children.

**Child:** in the context of this dissertation, the word denotes any child from birth to thirteen years of age.

**Conventional playground:** a playground with standardized, catalogue play equipment such as steel climbing frames, see-saws, merry-go-rounds, and swings. The surface is usually hard (concrete, asphalt or bare soil).

**High-rise:** in the South African context, a high-rise residential block of flats includes all buildings from 4 storeys and higher.

**Junk playground:** similar to adventure playground. Discarded items such as planks, tyres, and broken pieces of furniture are freely available for the children to play with.

**Nature:** all the elements, forces and events of the biophysical world which are not controlled by man.

**Natural (area):** in the context of this dissertation this does not mean an area in a virgin state before man interfered, but rather an area consisting mostly out of natural materials and incorporating natural materials as far as possible, whilst not excluding man-made elements completely.

**Natural playground:** a playground consisting of mostly natural elements such as woodland, forest, boulders, streams or mounds, with few man-made interventions.

**Playscape:** see natural playground

**Standard playground:** see conventional playground

**Sense of community:** MacMillan and Chavis (date: 1955) assert that a sense of community is formed when residents experience “membership, influence, sharing of values and shared emotional connections”. Sarason (1974:157) defines it as “the perception of similarity to others, and acknowledged interdependence with others, a willingness to maintain this interdependence by giving to or doing to others what one expects from them, the feeling that one is part of a larger and dependable structure.” It is the opinion of the author that a sense of community is also determined by the amount of people a person “knows” (either from personal communication with other residents, or from seeing them every day, without necessarily interacting with them).

**Teenager:** in the context of this dissertation teenager implies any person from the age of thirteen to eighteen years old.

**Threshold:** thresholds are not barriers but rather transitional spaces, places of waiting, rest or anticipation, defining entrances or exits, and visually or physically linking spaces.

1



# Introduction

Illus. 1.2: Typical apartment block in Sunnyside. Note the lack of a garden area, with only the hard surface in front of the garages for outdoor play (Author, December 2010)

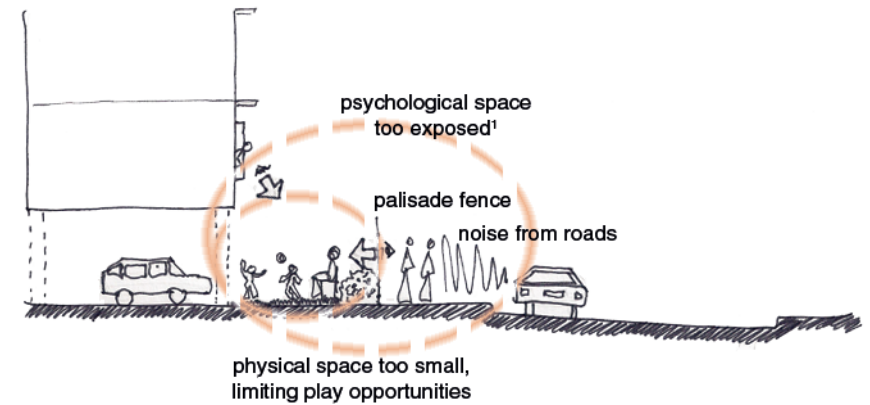

Illus. 1.3: Typical apartment block typology in Sunnyside (Author, April 2011)

*When they chopped them down  
something unravelled  
like the catcher's mitt  
of a ten year old's heart.  
Didn't they see the stone circles  
I'd built around the trees?  
Then I kept so many secrets  
with the earth, names of plants  
and African countries, clay castles  
in crawfish holes, continents  
in live oak roots.*

*By the time  
I got home they had chain-sawed  
the trees, flat-topped the yard  
with cement: "better for basketball,"  
this was the moment it  
dawned: the world outside  
exists more than I do.*

James Nolan  
(Goodenough, 2003:128)

Apart from a few fenced, fee-charging nature reserves, nature in the South African city is to a great extent disappearing. There are few public spaces left where children can still build tree-houses or dens in shrubs, play in streams and roam about safely. This has a profound effect on children, despite not always being recognised as the consequence of a lack of contact with nature. The deprivation of contact with nature during childhood has led to physical, emotional and social ills such as increasing obesity, an increase in medication used for attention deficit hyperactivity disorder (ADHD), and social incompetence in society (Freuder, 2006: 2).

## 1.1 The Problem in Context

### 1.1.1 The City

South African cities have few high-rise residential neighbourhoods. Those that do exist, such as Sunnyside in Pretoria and Hillbrow in Johannesburg, suffer from a lack of accessible, developed, green open space (see Illus. 1.4). The Tshwane Open Space

Framework (TOSF) prescribes the internationally accepted ratio of 2.4ha/1000 people open space, yet currently only 0.5ha/1000 people is provided in Tshwane (TOSF, 2006: 24)

Gauteng is the most densely populated province in South Africa with 615.7 people/km<sup>2</sup> (Stats SA, 2010: 4, 10). It is also the most urbanised province, comprising the municipal areas of Johannesburg, Ekurhuleni and Tshwane. According to the mid-year population estimates, Gauteng has 2 986 900 children under the age of 14 (Stats SA, 2010: 10), who all need space to play.

Green open spaces in urban areas (such as Pretoria) are essential for the psychological and social development of children (Freuder, 2006; Hart, 1982; Kozlovsky, 2006; Kuo & Taylor, 2004; Strife & Downey, 2009). However, existing building typologies employed in Sunnyside leave little open space for play (see Illus. 1.2 & 1.3). The space under and around the building is devoted to parking or a narrow strip garden. It is unattractive for social interaction and play due to

1. Refer to Appleton's (1975) prospect-refuge theory on page 20.

2. Refer to section 2.6, page 12 for explanation of defensible space.

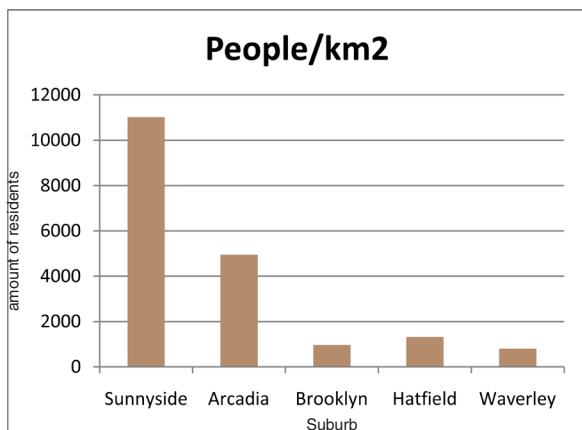

Figure 1.1: Comparative housing densities in Pretoria (Author, April 2011, compiled from personal communication, Stats SA, 19 April 2011)

limited size, feelings of exposure<sup>1</sup>, few places to sit, and proximity to the noise of streets. No appropriated defensible space<sup>2</sup> is created.

The open urban spaces that do exist are mostly vacant lots with very few amenities such as benches or litterbins. They are not used often by the public, but are rather appropriated by homeless people (see Illus. 1.5-1.7, 2.7, 3.3, 3.9, 3.10 & 5.5). These spaces are usually flat monocultures of grass, with a few scattered trees and pieces of playground equipment (see Illus. 1.5, 1.6, 3.9 & 3.10).

### 1.1.2 Playground equipment

Playgrounds in Pretoria do not cater for the needs of children, as will be discussed in Chapter 3.

Equipment typically provided in parks, such as climbing frames, merry-go-rounds, see-saws, swings and slides, are made from steel or wood and fixed to the ground. They dictate the activity by not allowing any changes to be made, and only give physical pleasure resulting

3. Refer to section 2.3.1, 2.4, 2.5-2.7 for an elaboration on why social interaction should be encouraged in children.

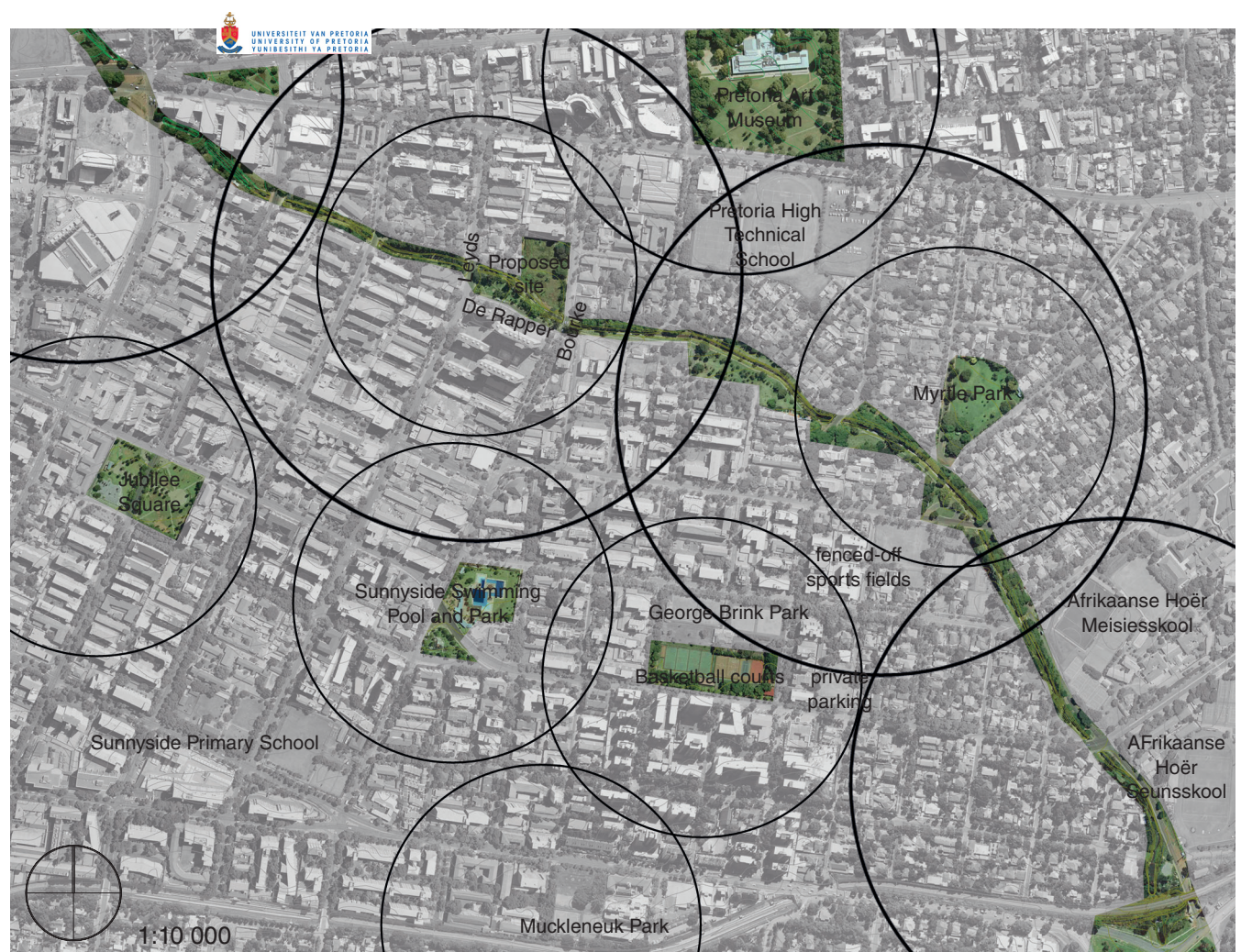

Illus. 1.4: Accessible open space and proposed site in Sunnyside. The smaller circles denote a 3 minute walking distance, which is comfortable for children. The larger circles denote a 5 minute walking distance, comfortable for adults. (Author, April 2011)

from movement. According to play researcher Eva Noren-Bjorn, children of all ages are initially interested in climbing and kinetic equipment, but quickly lose interest after the initial thrill has worn off (1982: 208-224). Isolated pieces of equipment, a lack of space definition and seats that are few and far in-between are not conducive to social interaction<sup>3</sup>.

In natural or junk playgrounds<sup>4</sup>, there are many loose parts such as tyres, planks, ropes, pebbles, pods and

flowers which can be moved, used in constructions or used to represent other objects. The child decides how each object should be used and what it should mean, giving pleasure from manipulation of the environment. Such play stimulates the child on cognitive, emotional and social level much more than play on fixed equipment. Logical, problem-solving thought processes are required, as well as interaction and teamwork with other children whilst discussing the imaginative game or building project (Frost, 2006: 5-7).

4. See Terminology on page x.

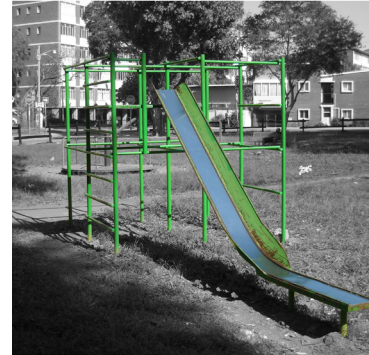

Illus. 1.5 & 1.6: Existing play equipment on proposed site (Author, March 2011)

## 1.2 What can be done about the problem?

There is a considerable body of literature on child development, as well as the beneficial effects of green landscapes on children. An application of this research in the South African context is however lacking.

As a result of this lack of proper playgrounds and limited exposure to nature, children in high-density residential areas grow up deprived of necessary experiences. Consequently, such children are more aggressive, with lower concentration spans and less motor and social skills, along with a host of other developmental problems which will be discussed in more detail in Chapter 2 (Kellert: 2005).

Adults, teenagers and the elderly also suffer from this lack of well-designed urban green space, albeit less noticeably. This dissertation will attempt to address the need for natural playgrounds in high-density residential areas, in a setting which can be used by all age groups.

## 1.3 Problem Statement

This dissertation aims to investigate how a playground in the high-density residential area of Sunnyside can be designed to create improved opportunities for the physical, emotional, social and cognitive development of children, as well as improved opportunities for social interaction.

## 1.4 Hypothesis

The hypothesis states that:

- Play in natural playgrounds<sup>1</sup> can encourage well-rounded physical, social, emotional and cognitive development of children.
- Such natural playgrounds can also encourage and foster social interaction and a sense of community.

## 1.5 Research questions

1. What is the role of nature in a child's physical, social, emotional and cognitive development?
2. How can natural elements be incorporated in

children's playgrounds in such a way as to facilitate their well-rounded development?

3. How can natural play areas increase social interaction and establish a sense of community?

## 1.6 Introduction to site

The open piece of land consisting of land-parcels 708, R/709, R/1/709, R/2/709, R/3/709 and R/6/1201, bordered by Leyds, Bourke and de Rapper streets in Sunnyside, will be used as a model to test the hypothesis (see Illus. 1.4, 1.7 & 5.6 and also refer to Illus. 5.2 - 5.5 for more information on the location of the site). Sunnyside is the most densely populated suburb in Pretoria City (Fig. 1.1). This site is ideal for constructing a playscape<sup>2</sup> as it is bordered by two pre-primary schools and high-rise apartment blocks. Two other day-care centres and the economic vein of Esselen street are also in close proximity. The streets bordering the site carry low traffic volumes which would enable easier access to the site, especially for children. The Walker Spruit runs through the site, connecting it to other green spaces along the Spruit (See Illus. 5.6 and 6.3).

4 <sup>1</sup> consisting of mostly natural elements such as woodland, forest, boulders, streams, mounds and other natural elements, without excluding man-made materials (e.g. concrete/steel/plastic) completely.

<sup>2</sup> See Terminology on page x.

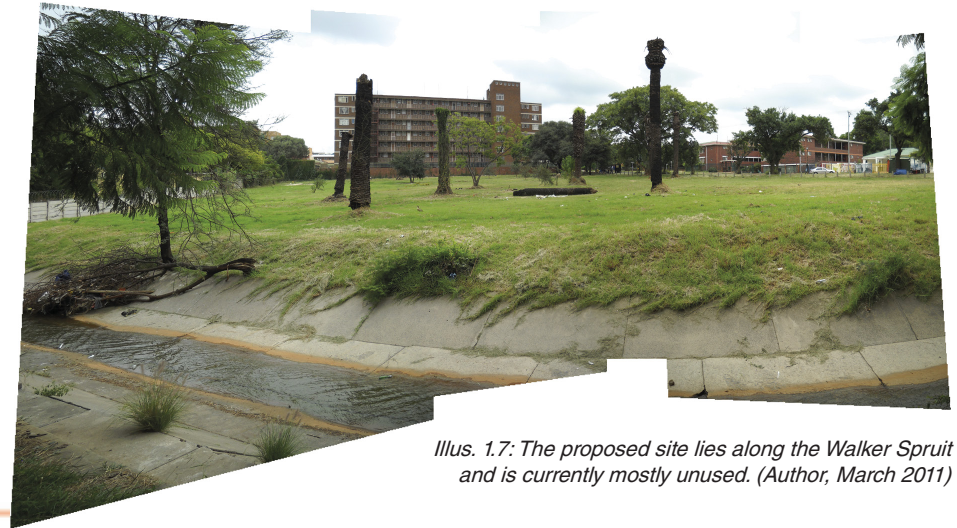

Illus. 1.7: The proposed site lies along the Walker Spruit and is currently mostly unused. (Author, March 2011)

## 1.7 Assumptions and delimitations

As a landscape architect, it is difficult to have a complete knowledge of all the factors that influence child development, the various social stages of growing up, and how different age groups interact. This is an area in itself that merits years of study to gain a complete understanding. Literature research, own observations and interviews were used to gain sufficient knowledge for design guidelines to be established.

However, the focus remains on nature and the role of design for child development as pertaining to Landscape Architecture.

The site has a severe problem with homeless people, possibly due to the undeveloped nature of the site at present. This issue will be addressed but only to an extent which would not distract from the main focus of the dissertation, namely that of designing a playground.



Figure 1.2: Relationship between client and funder. (Author, May 2011)

## 1.9 Research methodology

The following research methodologies were used to gain an understanding of how children play and develop, and how nature influences play. From this, design guidelines were established to inform the final design proposal.

- Observation of existing parks and children's play
  1. Images drawn by pupils of playspaces
  2. Analysis of existing parks
  3. Informal interviews with residents
- Investigation of precedents (real-life and in literature)
- Literature research
  1. Environmental psychology
  2. Child development literature
  3. Landscape architectural theory

## 1.10 Overview of dissertation

The following three chapters will investigate theoretical discourses and review existing parks, inferring design guidelines from the research. Chapter 4 studies successful projects as precedents. An analysis in Chapter 5 explains the context of the site, while Chapter 6 proposes an urban framework for the larger Walker Spruit area. This serves to inform the design resolution as discussed in Chapters 7 to 9. Chapter 7 discusses the design development process leading up to the design resolution in Chapter 8 and the technical resolution in Chapter 9.

2



# Theoretical Investigation





*Illus. 2.2: The architectural language of the First National Bank in Church street, Pretoria, could to be perceived as a stronghold of power, strength and safety, but can also be imposing. (Author, January 2006)*



*Illus. 2.3: The Magic Fountain in Barcelona by Jujol could inspire a feeling of power and awe. (www.flickr.com)*



*Illus. 2.4 The perception of scale and space in the landscape have the potential to unlock emotions.(Hess, March 2011)*

*Man only plays when he is human in the full sense of the word, and he is only completely human when he is playing. (Friedrich Schiller in Dattner, 1969: 7)*

(see Illus. 2.2). It follows that the landscape can also display values such as friendliness, safety, strength, happiness, order or wildness (De Botton, 2006: 98-100) (see Illus. 2.2 to 2.4).

recreational and leisure activity” (UN, 1989: 9 and OAU, 1990: 6).

## 2.1 Theoretical investigation

This chapter will investigate the importance of nature for children’s development, as well as how playgrounds can encourage a sense of community.

Keeping this and children’s psychological needs in mind, designers should help to create spaces where children can play freely and safely, in an area that displays values which would make for a pleasant environment. In a society where there has been a loss of community due to building typologies (Newman, 1996: 9-12), landscapes should encourage interaction between people, providing for intentional and unintentional meetings.

### 2.1.2 Biodiversity in the city

#### 2.1.1 The social role of landscape

Landscape architecture as a discipline constructs the outdoor experiences of the user. Having the potential to encourage relaxation, reflection, discovery and rest in an often unhealthy urban environment ( Herzog & Stevey, 2008: 749-750), urban open spaces play an important role in the physical and mental health of man.

Play and pleasure are legitimate pursuits in themselves, as play is one of the fundamental rights of a child as set out in Article 31 of the United Nations Convention on the Rights of the child, and in Article 12 of the African Charter on the Rights and Welfare of the Child. As a signatory of both documents, the South African government agrees to “encourage the provision of appropriate and equal opportunities for cultural, artistic,

In the 1950’s and 60’s, Joane Pim, a pioneer of landscape architecture in South Africa, was involved in beautifying mining towns in the Free State and the West Rand. Her usual strategy was to plant up areas with as many different plants as possible, re-establishing biodiversity and creating complexity in the landscape (Illus. 2.5). Due to her work, mines had less absenteeism, less staff turnover, and generally more content staff. Her motto, which is also the title of her book, is “Beauty is Necessary” (Pim, 1971).

It is poignant to find that very little of her approach has been manifested in parks in Pretoria today. The current standard park typology is a very sterile environment of flat lawn with a few species of trees, for example Kruger Square in Pretoria West (Illus. 2.6 & 2.7). By using a multitude of indigenous trees, shrubs, groundcovers and grasses, bio-diversity is re-established in the city, providing habitat for organisms, fulfilling ecological

The author Alain de Botton postulates that objects in the environment represent certain values, such as a fortress-like financial institution representing the appreciated qualities of safety, strength and power



*Illus. 2.5: Complexity creates interest. Jan Cilliers Park, Groenkloof (Author, September 2010)*



*Illus. 2.6: Simplicity and monoculture at Nirox, Krugersdorp (Author, May 2009)*



*Illus. 2.7: Sterile, monotonous environment in Kruger Square, Pretoria West (Author, March 2011)*

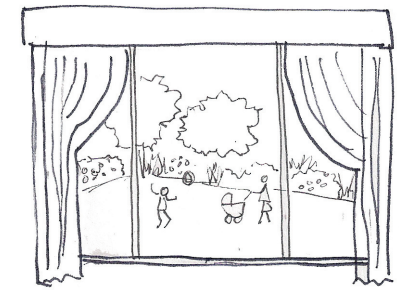

*Illus. 2.8: Having a view of greenery draws people out of their apartments (Author, May 2011)*

functions and allowing city-dwellers contact with nature.

## 2.2 Why play is important

Much research has been done about why play is important for children. However, the focus of this dissertation is rather on why play with natural elements is important and how this kind of play can be manifested in urban areas. Play is important because children learn, out of the classroom, primarily by playing (Weaver, 2000: 12) and practise for adult life in this way. Through playing, children learn what no one can teach them, exploring and orientating themselves in relation to space, people, structures, and time.

## 2.3 The benefits of play in natural areas for children's development

A large body of literature exists on the importance of play in natural areas for children's development, as well as the general positive and restorative effects of greenery on people's physical and mental health. Playgrounds consisting of standardised equipment

(such as a seesaw, climbing frame, slide and swings) on an expanse of lawn are not sufficient. "Natural" playgrounds, such as forests, woodlands, and ponds, provide much more opportunities for quality play than standard playgrounds. In the context of this dissertation, the word "natural" does not mean a state where the environment has not been touched by man. It rather denotes a design that incorporates and emphasises the use of natural elements such as plants, water, stone, sand and earth in an organic design as opposed to man-made elements such as concrete, steel and plastic in a geometric design.

### 2.3.1 Human interaction and green areas

According to the American psychologist Harry Harlows, children are likely to suffer from psychosis and neurosis in later years if they do not have sufficient contact and play with other children during their first five years of life, as proven by his studies on social deprivation in monkeys. He asserts that children need at least five friends or more during early childhood, in order to be able to function normally in later life (Harlows

in Alexander, Ishikawa & Silverstein, 1977: [68]). Educational researcher Karyn Wellhousen (2002: 114) laments the increase of solitary play (video games or watching television). Children spend more time behind screens and less time together with their peers. This poses a threat both to their health and social competence in later life.

Adding to this problem, crowding in high-density residential areas may result in social withdrawal, which can lead to social maladjustment. Views of greenery draw people out of their apartments into the outdoor areas as found by environmental psychologists Coley, Kuo and Sullivan (1997: 468), allowing more social interaction (see Illus. 2.8). Another study by Taylor, Wiley, Kuo and Sullivan (1998: 468) showed that children have more access to adults and more play opportunities in spaces with many trees. Access to adults other than one's parents is fundamental for healthy social development (Alexander et al, 1977: [26,68,86]).

Due to restricted financial resources and thus mobility,

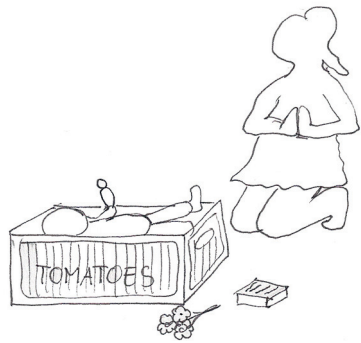

*Illus. 2.9: Play therapy: re-enacting traumatic experiences (such as a funeral) helps children to process their emotions (Author, May 2011)*



deep sand breaks falls

*Illus. 2.10: Risk-taking is necessary (Author, March 2011)*

residents (especially the children and elderly) of lower socio-economic status (SES) neighbourhoods such as Sunnyside, spend more time in and around their homes than people of a higher economic status (Coley et al, 1997: 469). Children in low SES areas also move around less in their urban environment (and rather stay at home) due to the lack of amenities and fear of harassment and other social problems such as un-removed garbage and filth (Morrow, 2000: 144-147). Children are thus restricted to their home environment, yet do not want to move about too much in the immediate vicinity of their homes. When living on higher floors, parents cannot monitor their children's outdoor play from the apartment. This increases reluctance of parents to let their children wander outside (Coley et al, 1997: 469). This makes the need for safe open spaces for these residents even more pertinent.

The factors mentioned above reduce the amount of other children and adults that children living in high-rises can come into contact with. Green spaces encourage interaction between humans, which is vital for the development of social and emotional skills in children.

### 2.3.2 Physically demanding play and motor skills

Preschool children engaged in more physically demanding play and developed better motor skills when they played in more natural areas (with large trees and rocks, an orchard, woodland and pastures) compared to with children playing in traditional playgrounds or indoors, as found by architect and psychologist Nancy Wells (2000: 781).

Rough-and-tumble play has various positive effects on children, amongst others their increased ability to correctly read emotional expressions (such as happy, sad and angry), as discussed by researchers Pellegrini and Smith (1998: 588). Playgrounds with hard or flat surfaces are not ideal for this kind of play. Natural playgrounds with grass, sand and mounds are encouraging for safe rough-and-tumble play.

### 2.3.3 Creative play

Stimulation of the imagination is important for children's cognitive, social and emotional development, as it

increases their creativity, ability to take another's perspective, to reason out alternatives, to develop resourcefulness and to reduce stress (Harvard Graduate School of Education, 2002; Wang, 2002). Children play more creatively and in more complex ways in green spaces than in built spaces (Spencer & Blades, 2005: 128). Using a large variety of natural features (shrubbery, mounds, water features, long grasses or heaps of boulders) creates a multifaceted environment which could aid in stimulating the imagination.

### 2.3.4 Attentional capabilities

Proofreading capability and attentional capacity after a time of relaxation is improved when children have spent the relaxation time in nature as opposed to having spent it indoors or in an urban area (Wells, 2000: 780,783). Nature could thus help to improve achievement at school, which is important for the children's future.

Play in natural areas also benefits children with attention deficit-hyperactivity disorder (ADHD), and

Illus. 2.11-2.14: Building and breaking in adventure playgrounds. (Hurtwood, 1969)

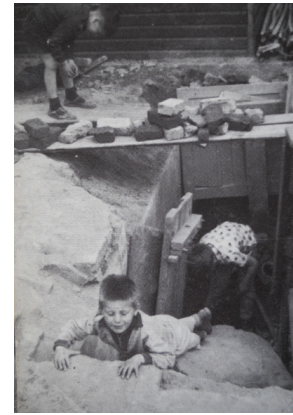

greatly reduces the symptoms. (Kuo & Taylor, 2004: 1580-1586). This is mostly due to the loose parts available (pebbles, leaves, twigs, sticks, seedpods) which allow for manipulation on the environment.

### 2.3.5 Violence, play therapy and self-esteem

Natural spaces enhance positive feelings about oneself, as well as towards and about others. Environmental researchers Strife and Downey (2009: 108-109) found that after an asphalt playground at a school in California was changed to an area with gardens, woodland, and ponds, the children's relationships with each other improved. It was also found that violence and bullying were reduced (and in some instances eliminated) when children played in more natural settings. Architect Roy Kozlovsky (2006: 6) stresses the importance of play as therapy, where a child can re-enact a traumatic experience in a situation where he is in control, for example a funeral as shown in Illustration 2.9. Play acts as catharsis. For this, moveable props might be needed. Kozlovsky also believes that allowing children to

change their environments helps to alleviate teenage delinquency (*ibid.*: 1). Children are creatively engaged and allowed to express themselves in a constructive manner, without interference from adults. This is an important factor to consider in a low income area such as Sunnyside (compared to neighbourhoods such as Waverley, Hatfield and Brooklyn), which, although it is on a downward trend, still has extremely high crime rates (SAPS: 2010).

### 2.3.6 Risk taking and playground safety

Risk-taking, especially in North America, is often designed out of playgrounds to prevent injuries and lawsuits (Frost, 2006: 12). However, the opportunity to take risks within safe limits is essential for children's development (Illus. 2.10). They gain self-esteem and competence by being able to test their abilities. Risk enables children to learn to take responsibility for themselves and for their actions (*ibid.*: 8). Playgrounds that provide challenges thus help children to develop appropriate behaviour in terms of risk.

## 2.4 Adventure Playgrounds

In 1931, the Danish landscape architect Carl Sørensen came up with the idea of adventure playgrounds, after observing that children preferred to play everywhere except in the adult-made designated playgrounds. Adventure playgrounds consisted of empty lots of land on which children could do as they please, especially build. Building materials such as planks, nail, hammers, and cement are available on site, mostly donated instead of bought (see Illus. 2.11 - 2.14). A "playleader" is appointed to run the playground. His/her job consists of helping the children realise their building ideals, and to keep a watchful eye without intervening. Sovereignty of the children is of utmost importance and the playleader is only to interfere in times of danger or extreme conflict (Lambert & Pearson, 1974).

Quality play<sup>1</sup> experiences provide opportunities for posing and solving real-world problems, and as such encourages flexible and exploratory thought processes (Staempfli, 2009: 272). Due to the variety of creative situations arising in an adventure playground, children

1. In this instance quality play refers to play as can be experienced in adventure playgrounds.

interact and converse much more than in conventional playgrounds. By being able to build their own structures, independence and self-esteem are fostered (*ibid.*: 277). Building also often requires enlisting the help of others. These relationships develop social and emotional skills such as negotiation, conflict-resolving and clear communication.

Such playgrounds are usually very noisy and an eyesore as well. In Denmark and Britain, the playgrounds often had embankments or overgrown fencing around them to reduce noise, to prevent complaints from the neighbours and to encourage safety.

In the South African context, it is almost unimaginable to give a large group of children hammers, nails and crowbars, together with large amounts of wood, to build their own structures. In the current South African city, building materials and housing are in short supply. As a result, the materials provided for the children's use would possibly be carted away soon unless security is enforced on site. Also, the current economic situation

does not encourage companies to donate building materials on a regular basis for a cause which has not yet taken root in South Africa.

Therefore it is suggested that an adventure playground in the true sense of the word might not work in South Africa, or on the proposed site. From the success of such playgrounds in Europe it is clear that the ideas driving them contain very valid principles for children's play. However, the concept will have to be adapted to fit the South African situation.

## 2.5 Ownership

In adventure playgrounds, children are allowed to express themselves constructively, to build and break as they please. The wide range of options available for play and the high degree of freedom are two of the main reasons why these playgrounds are so successful (Frost, 2007: 9). Because the children are able to influence the playground, they also take ownership of the space, resulting in a much higher quality of play experience. Also, the children are much less likely to

*The more someone is able to personally influence his surroundings, the more involved and attentive he becomes, and also the more likely he will be to give them his love and care.*

*Herman Hertzberger (Attoe & Logan, 1992: 17)*

vandalise the playground or jeopardise activities offered (Staempfli, 2009: 269, 273).

The playleader or adult presence ensures a sense of consistency and belonging to the children. Such a safe place which could become home away from home is important for children who might suffer from social ills such as poverty, domestic violence or broken families (ALL-SA, [*s.a.*]: 2-3).

## 2.6 Sense of community, safety and defensible space

McLoyd (1990: 333) has shown that having support from other family or community members increases the effectiveness of parenting, and also improves the mother-child relationship. Mothers who perceive their neighbourhoods to be safe, use less physical punishment on their children than mothers who perceive their neighbourhoods to be dangerous. It is thus important for families to have an external support system. Children should not grow up in a world where all strangers are perceived as dangerous.

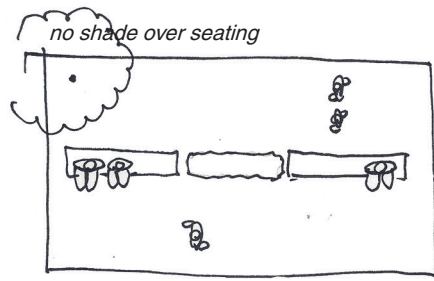

seats facing one way in an exposed area make group conversation difficult

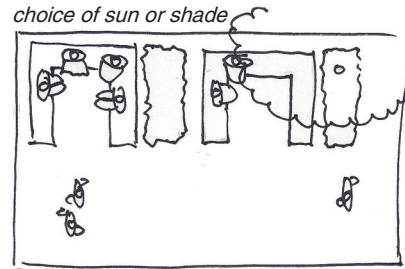

seats facing each other with the backs against a wall allows for group conversation

Illus. 2.15: According to Dee (2001) and Cooper Marcus (1998), seating arrangement can influence interaction between people. (Author, May 2011)

Various studies (Kim & Kaplan, 2004; Kuo *et al*, 1998; Bixler & Floyd, 1997) have shown that natural green open spaces play a large role in residents' sense of community<sup>1</sup> and interaction with other residents. MacMillan and Chavis (1986:9) assert that a sense of community is formed when residents experience membership, influence, sharing of values and shared emotional connections. A sense of community is important because it creates defensible space and a friendlier, more supportive and pleasant living environment (Brown, Brown & Perkins, 2004; Nasar & Julian, 1995; Unger & Wandersman, 1985). Neighbours can often form support systems for other residents, providing emotional and material help. Having good neighbouring relations give a sense of identification, and combat feelings of isolation which could easily be experienced in large blocks of flats (Unger & Wandersman, 1985:141).

Increased social interaction increases the social trust between neighbours and perceptions of community safety (Jacobs, 1961; Newman, 1996). Simply having trees and other greenery in the vicinity of housing

blocks also increases perceptions of safety (Kuo, Bacaicoa & Sullivan: 1998).

Facilitating social interaction in a pleasant environment is thus the first step towards creating a sense of community. Green open spaces that cater for the needs of the users (sitting, meeting friends, waiting) offer a platform for the creation and sharing of memories. As previously discussed (refer to section 2.3.1 on p. 9), green open spaces have the potential to attract people. A playground which children would want to visit will be visited by their parents or caretakers as well. Simple design guidelines can offer opportunities for interaction between these individuals, for example seating arrangements as shown in Illus. 2.15. Amenities such as ablutions, a kiosk, sufficient seating and shade would serve to create a pleasant outdoor experience, creating opportunities for lingering and further enhancing interaction between individuals.

When a sense of community has been established, and there are enough familiar adults and elderly people in a green space to watch over the children playing

there, parents would as a result be more willing to let their children play there, with or without their direct supervision. The space would have become defensible and appropriated.

## 2.7 All ages welcome

Public landscapes in the city are generic. Due to the scarcity of developed green spaces, parks have to cater for all age groups, and all types of users. The needs of pedestrians on their way to work, elderly or handicapped people, teenagers, families and individuals should be taken into account. The proposed park will therefore be open to the general public and not only to children.

The playscape itself should be designed in such a way as to encourage children of certain age groups to appropriate a space. Areas could be graded according to complexity and challenges afforded, as well as size. Certain areas should cater for lively group activities, others for quieter play in smaller groups (see also Chapter 7 and 8).

1. See Terminology on page xi.

## 2.8 Conclusion

Landscapes play a large role in the physical and psychological health of society, as well as ensuring the ecological health of a city. From the above the following research questions can be answered:

1. What is the role of nature in a child's physical, social, emotional and cognitive development?
2. How can play areas increase social interaction and establish a sense of community?
3. What is the role of natural play environments in social interaction and a sense of community?

### 2.8.1 Findings

- Children need to be exposed to nature (with all the textures, smells and materials it provides)
- Children of all ages need to be able to manipulate their environment.
- Loose parts in the environment serves for creative, sustained play.
- Risk-taking opportunities should be provided.

- Being exposed to nature, being able to manipulate their environment and having loose parts in playgrounds assist not only in the physical but also social, emotional and cognitive development of children.
- Stimulation of the imagination by means of natural areas is important in the cognitive, social and emotional development of children.
- Different types of spaces catering for different types of play and age groups need to be provided.
- Natural play areas can facilitate increased interaction between children, between their parents or caretakers, as well as between the children and adults, which in turn lead to an enhanced sense of community.

In the following chapter, playgrounds in Gauteng will be assessed according to the findings above, as well as other criteria necessary for pleasant environments, such as safety, seating and shade. The second research question (how natural elements can be incorporated in playgrounds to facilitate well-rounded development) will also be answered and explored further in the design resolution.

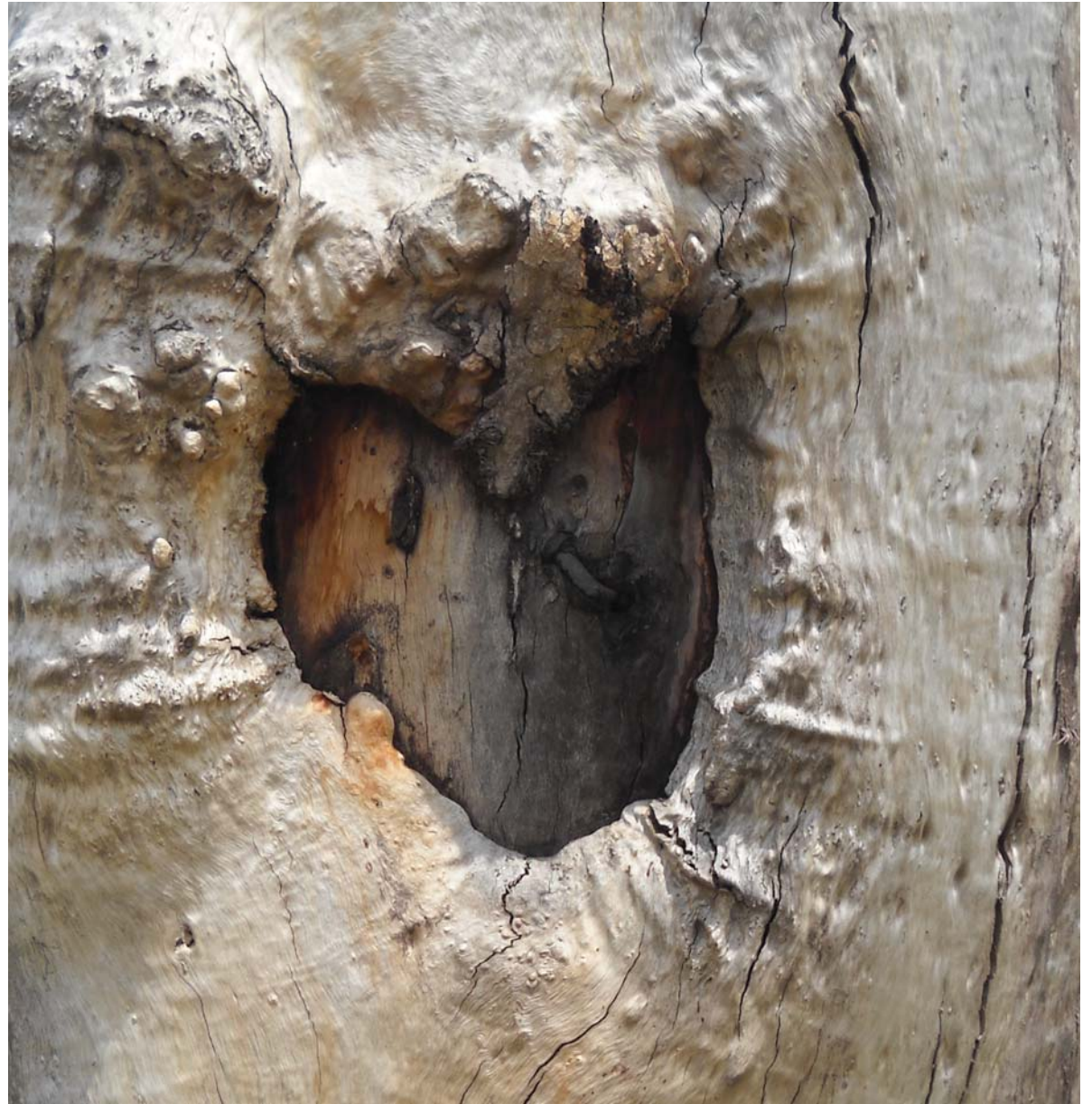

# 3

# Design Guidelines

*Illus. 3.2: When no loose parts are provided, children bring their own. Children playing with cardboard boxes in Jubilee Square, Sunnyside, Pretoria. (Author, March 2011)*



***Today we will be going on the train!*** Aunty Emma gave us cooldrink crates from the toy library. We are carrying gold ornaments (pine cones) to all the jewellers' shops in the city. Along the way, we encounter some hazards on the track. There's highway robbers! They hold us up with swords (sticks) and demand some of the products in the crates. Then there is a fallen log over the track. We have to remove it from the track. It is heavy but 5 boys can roll it out of the way. The girls bring us cooldrink from the kiosk. Lindiwe starts selling tickets (thick succulent leaves from *Crassula ovata*) to other children to join the train. Nandi takes up her idea and starts selling berries from the Jacket-plum (*Pappea capensis*) as sweets in return for leaf money. The other day we made mudpies with the soft clayey soil from the "dirty" sandpit. We decorated the cakes with leaves. The oven was an alcove in the side of the mound, and the baking tray some of the slate tiles lying around. We used light-coloured sand from the "clean" sandpit as frosting. (Author, April 2011, based on real-life play behaviour as documented by Berry, 2001 and Wellhousen, 2002)

The Swiss developmental psychologist Piaget believes that "intelligence is a special form of adaptation, which consists of a continuous creative interaction between the organism and the environment" (in Dattner 1969: 23-24). Ronald Laing, a British psychiatrist, translates this into "experience" and "control of experience" (Dattner 1969: 42). The daily living environment should therefore present a person with a wide range of experiences, and some measure of control over the environment must be available to a person. The natural environment can be especially rich in stimuli.

Design guidelines as to how natural elements can be incorporated in playgrounds (research question three) were inferred from the literature research. The following investigation into existing playgrounds, and precedent studies of well-designed playgrounds (see Chapter 4) also informed the guidelines.

### 3.1 The problem: Why existing playgrounds in Pretoria are not well-used

An arbitrary selection of 22 parks in Gauteng were

visited between March to May 2011. They are by and large representative of the typical park found in Pretoria and Johannesburg. Many of these parks consist of a general public park with a designated playground. The parks in general were assessed, not only the playground areas, as children should not be limited to a specific area. The criteria as discussed in chapter 2, as well as other general criteria necessary for a good park, such as shade and seating, were used:

1. Loose parts: Are there loose parts which could be carried around or used in play? This entails natural and man-made parts.
2. Scope for alteration or manipulation of the environment: Can the children alter the park environment?
3. Natural materials used: To what extent have natural materials such as trees, shrubs, boulders and water been used?
4. Seating: Is there sufficient seating provided for the various users, and is there a choice of seating, for example, in the sun or shade? (Seating not only denotes benches, but also walls, boulders, berms and



*Illus. 3.3: Jubilee Square, Sunnyside, Pretoria (Author, March 2011)*

mounds which could be used for seating.)

5. Shade: Are there sufficient amenities (seating/play equipment) provided in the shade for hot days?

6. Choice of spaces to gather: Are there intimate, more private spaces as well as larger public spaces? Is there a choice between sun and shade?

7. Safety: Are there escape routes? Does one feel exposed, trapped or comfortable?

8. Play equipment provided: Is the play equipment standard catalogue equipment, or has it been custom-made? Does it encourage group interaction and does it stimulate children emotionally and cognitively? (In this instance, man-made structures are meant)

9. Usage was not assessed, as many of the parks were visited in the mornings when children were at school, and others during weekends when it was very busy, although it could be quiet during the week. One visit would therefore not provide a realistic representation of the usage of the park.

It should be taken into account that this assessment was done by the author subjectively, and that feelings of safety, for example, could be experienced very differently by other users, and it would also be different

at different times of the day and week. Also, as no standard exists for the amount of shade which should be provided in public areas, the author used the size of the park and the percentages of sun and shade to decide whether the shade provided is sufficient for the amount of users and the location. The context of the park should also be taken into consideration when reading the assessment: End Street Park in Hillbrow, for example, has a neutral grading for use of natural materials, but the park has very limited space and is situated in a very built-up area with high usage which could lead to the damage of plants.

It should be noted that parks such as the Orlando West Regional Park in Soweto, the Spruitview Multi-purpose Park in Spruitview, and Sali Park in Katlehong, are all steps in the right direction, and are very good parks in their context. However, they still do not address all the developmental needs of children due to the constraints presented by the context. The parks visited were also assessed on their existing conditions, which means that although many trees may have been planted, they do not give enough shade yet or help to define spaces. In twenty years' time from now, the assessment consequently might present a very different picture.



*Illus. 3.4: Clove Park, Zakariyya Park, Pretoria (Author, March 2011)*



*Illus. 3.5: Venning Park, Arcadia, Pretoria (Author, March 2011)*



*Illus. 3.6: Orlando West Regional Park, Soweto, Johannesburg (di Monte, March 2011)*

Loose parts

very poor	no loose parts or clean, deep sand to play in
poor	some dirt/sand areas available for play, but in poor condition
moderate	clean, deep sand available
good	some natural or man-made loose parts as well/or as sand
very good	many natural or man-made loose parts as well as clean, deep sand

Scope for alteration or manipulation of the environment

very poor	all equipment fixed to ground
poor	sand only material which can be manipulated, but without water
moderate	clean, deep sand available
good	some opportunities for changing environment with water
very good	many opportunities for changing environment besides sand and water

Natural materials used

very poor	mostly hardscape
poor	very few plants used, or only a few types of plants
moderate	sterile environment with only lawn and trees
good	effort has been made to incorporate a variety of plants
very good	great biodiversity and use of different trees, shrubs and other plants

Shade

very poor	very little shade provided with hard surfaces causing glare
poor	little shade provided or play equipment not in shade
moderate	trees planted but no temporary shade structures provided in the meantime
good	some play equipment are in the shade
very good	play equipment, seating are in the shade, with a choice of seating in sun/shade

Seating

very poor	almost no seating provided
poor	very little seating provided
moderate	seating provided, but not necessarily enough or in the shade
good	enough seating provided, but not necessarily where people might want to sit
very good	a wide choice of seating provided (sun/shade, alone/in groups)

Choice of spaces

very poor	one large homogenous space
poor	different spaces perceptible, yet it is still too large to appropriate
moderate	spaces available, but not necessarily comfortable (e.g. in the shade/ providing prospect/refuge)
good	some choice of spaces (public/private/sun/shade) available to appropriate
very good	a wide choice of spaces (public/private/sun/shade) available to appropriate

Safety

very poor	feels very unsafe due to users of the park or lack of any users/ feels exposed as well
poor	feels unsafe
moderate	feels safe, yet still on guard
good	feels safe
very good	feels very safe due to visual surveillance, users and security presence

Play equipment provided

very poor	no play equipment provided
poor	only a few pieces of fixed standard catalogue play equipment provided
moderate	many different pieces of fixed standard catalogue play equipment provided
good	custom-made play equipment or contemporary catalogue play equipment <sup>1</sup>
very good	custom-made play equipment with modular units/moveable parts



*Illus. 3.7: Wilgeheuwel Park, Roodepoort, Johannesburg (Author, March 2011)*



*Illus. 3.8: Sunnyside Playground, Sunnyside, Pretoria (Author, March 2011)*

*Figure 3.1: Explanation of colour coding for each evaluation criteria (Author, May 2011)*

Assessment criteria	Loose parts	Alteration	Nature	Shade	Seating	Choice	Safety	Equipment
<b>Playpark</b>								
<b>Johannesburg and environs</b>								
End Street Park, Hillbrow								
Orlando West Regional Park, Soweto								
Thokoza Park/Moroka Dam, Soweto								
Sali Park, Katlehong								
Spruitview Multipurpose Park, Spruitview								
Wilgehuwel Park, Roodepoort								
Clove Park, Zakkariya Park								

**Pretoria**

Sunnyside Playpark, Sunnyside								
Jubilee Square, Sunnyside								
Muckleneuk Park, Sunnyside								
Myrtle Park, Sunnyside								
Venning Park playground, Arcadia								
Pretoria Art Museum playground, Arcadia								
Zita Park, Garsfontein								
Kruger Park, Pretoria West								
Princess Park, CBD								
Burger's Park, CBD								
Chris Steyn Park, Waverley								
Pieter Human Park, Waverley								
Nieuw Muckleneuk Trim Park, Muckleneuk								

**Parks without playground equipment**

Springbok Park, Hatfield								
Jan Cilliers Park, Groenkloof								

Figure 3.2: Assessment of parks in Gauteng (Author, May 2011)

### 3.1.1 Findings

There was a marked difference between the older parks (such as Kruger Park and Muckleneuk Park, and others also mostly in Pretoria) and the newer upgraded ones in Johannesburg and environs, such as Sali Park in Katlehong, Johannesburg and the Spruitview Multipurpose Park.

From the assessment it can be seen that 77% of parks rated very poor on provision of loose parts and 90% rated poor on opportunities for alteration, which are the most important factors for a park to stimulate the well-rounded development of children. Sixty-eight percent of parks had only lawn and trees with no significant shrubbery or flowers, creating a monotonous and unstimulating environment. The reason for the above three statistics could possibly be concerns for the safety of the users and the equipment provided. Feelings of safety in the parks varied. However, only 27% rated as good or very good. The parks generally had a moderate amount of seating provided, but not necessarily arranged in such as way as to encourage group interaction

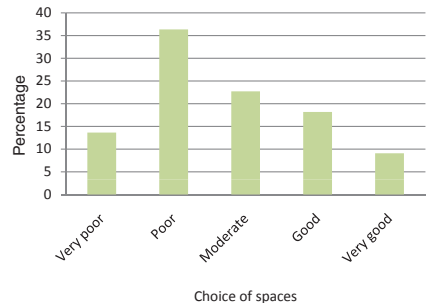
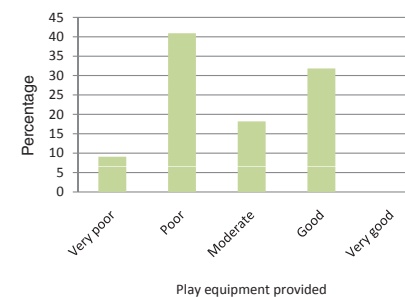
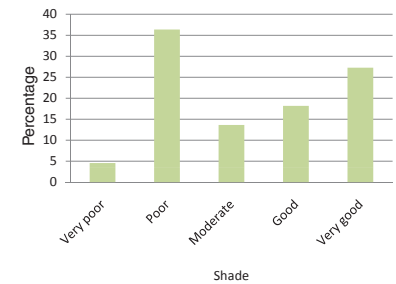
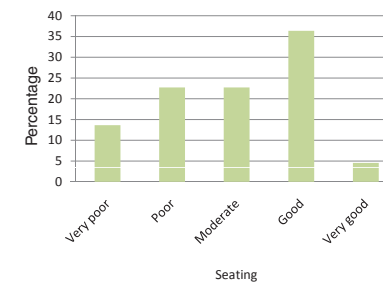
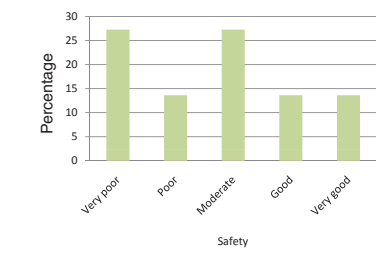
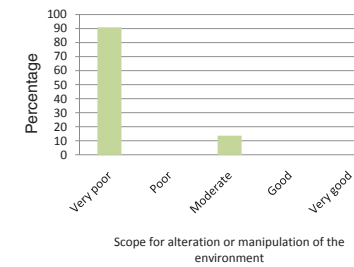
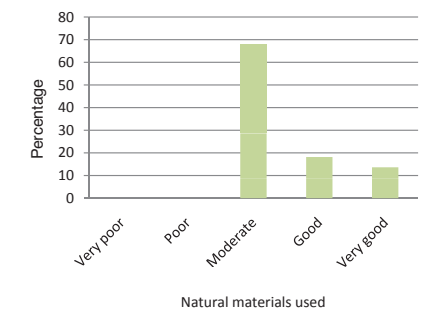
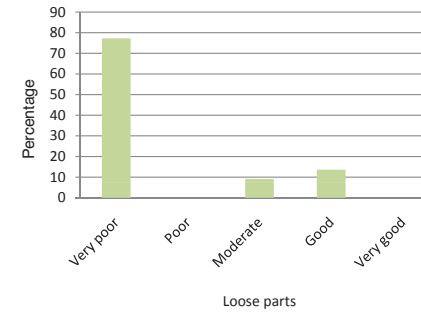

Figures 3.3 - 3.10: Graphs showing the results of the assessments (Author, July 2011)

*Illus. 3.9: Panorama of Muckleneuk Park, Sunnyside. Note the lack of seating, shade and sense of enclosure over the play equipment. (Author, May 2011)*



*I am convinced that standardised playground equipment is dangerous. When the distance between all the rungs on the climbing net or the ladder is exactly the same, the child has no need to concentrate on where he puts his feet. This lesson cannot be carried over into all the knobbly and asymmetrical forms with which one is confronted throughout life.*

*Helle Nebelong (Danish playground designer in Gill, 2005:2)*

(see page 13), or where people might want to sit (such as in the shade). The older established parks (such as the Pretoria Art Museum's park), had sufficient shade, while the newer parks (such as the Orlando West Regional Park in Soweto, Johannesburg), do not have sufficient shade to ensure that children are able to use the parks to their full potential. The play equipment provided were mostly either poor (41%, in the older parks) or good (36%, in the newer parks). Some of the custom-made equipment are, for example, in aeroplane or dinosaur shapes, stimulating the imagination. However, despite this and being visually more pleasing, the equipment still mostly caters for the physical development of the children by being climbing or kinetic equipment without any alterable parts. Only 27% of parks had a good or very good choice of spaces. Seventy-three percent of parks had a poor choice of spaces available. The above statistics give every indication that the visited parks leaves much to be desired.

### 3.1.2 Case study: Muckleneuk Park

The Muckleneuk Park playground in Sunnyside will be used as a case study to discuss playgrounds in Pretoria, as it is a good example of the typical playground found in the city (see Illus. 3.9 & 3.10).

Most playgrounds in public parks in Pretoria consist of scattered climbing frames, swings and a merry-go-round. Climbing frames do cater for the physical development of children, however, studies done by Noren-Bjorn (1982: 208-224) revealed that they are used at most for a few minutes at a time. Only when loose parts were added such as moveable boards or props for dramatic play, were they used for longer periods. According to Lillis and Jaffe (1997: 1), climbing frames are the cause of 62% of playground injuries. This causes one to question their play value and safety.

Illus. 3.10 shows the typical range of play equipment found in parks in Pretoria. Playground equipment is generally manufactured from steel, and is unshaded by vegetation or other means. In the South African climate

this results in the steel equipment being too hot to use for a large part of the day.

For understandable safety concerns, no sense of enclosure is created. On Illus. 3.10 it is evident that the park's surface is an expanse of lawn with no other plants. The tree canopies are too high to create a sense of enclosure. The playground is visible and open to all eyes from all angles. This makes one feel exposed.

The British geographer Jay Appleton's prospect-refuge theory is cardinal in understanding and creating pleasurable landscapes. Dee (2001: 19) asserts that people want to have a sense of enclosure or safety, whilst knowing what is going on in the rest of the landscape (see Illus. 3.11).

Playgrounds have no comfortable seating in the shade for mothers to watch their children play. This makes it uninviting for them to visit playgrounds, as they either have to sit on the grass, or stand around while their children play. Muckleneuk Park has no benches at all.

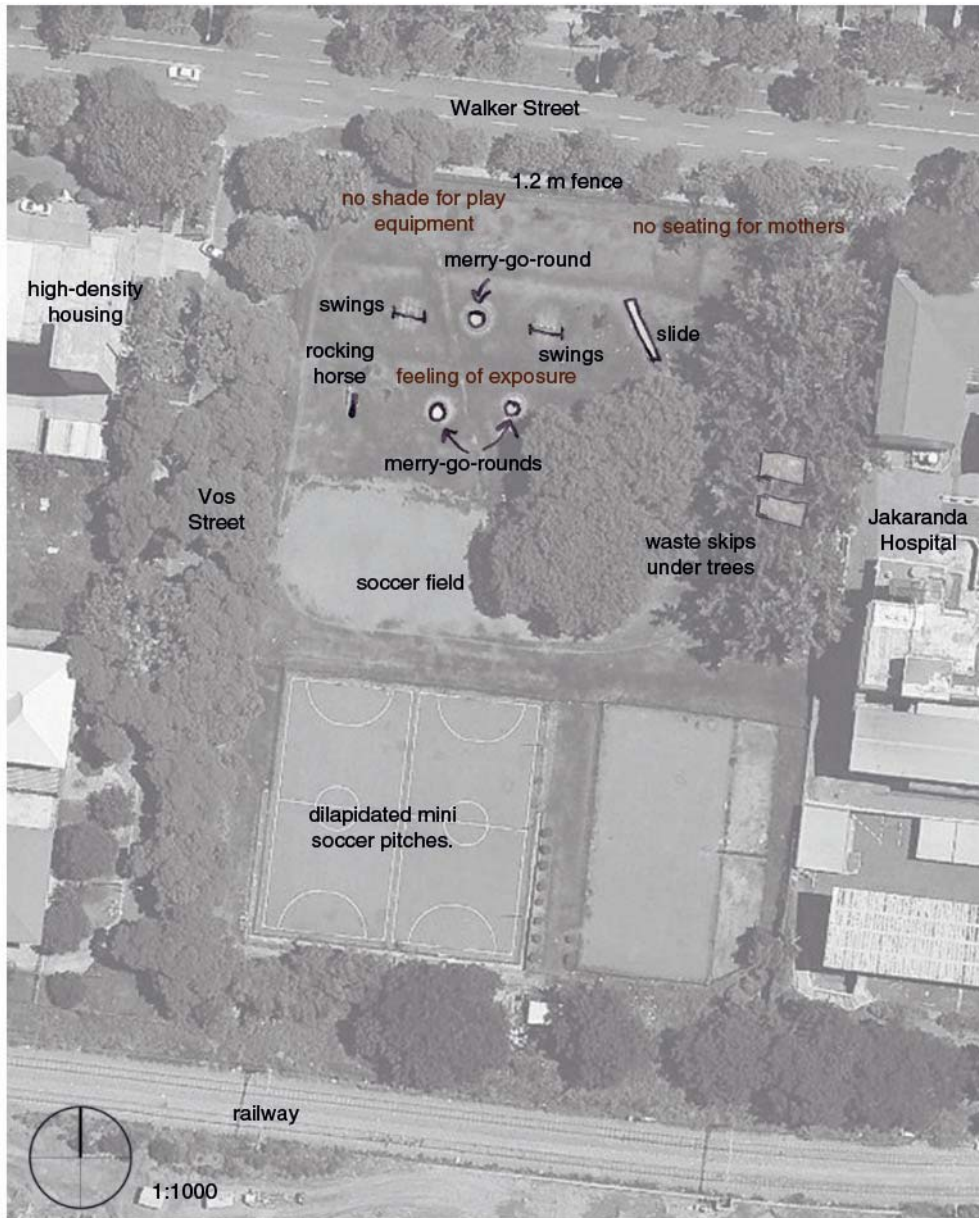

Illus. 3.10: Map of Muckleneuk Park playground, Sunnyside, indicating a typical layout of scattered pieces of play equipment on an open expanse of lawn. (Author, May 2011)

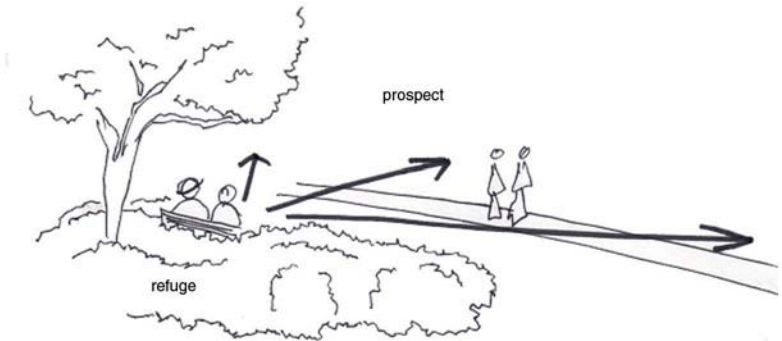

Illus. 3.11: People do not want to feel exposed (Author, March 2011)

Despite their disadvantages as discussed above, standard playground equipment is necessary, as it facilitates motor development in terms of coordination, strength and flexibility. Kinetic equipment can provide both excitement (fast speeds on a merry-go-round) and relaxation (the repetitive movement of a swing).

Lastly, research has shown that children prefer natural playgrounds over standardised ones. According to studies done by Cooper-Marcus, 86% of playspaces cited as favourite spaces are natural (Freuder, 2006: 5). Berry (2001: 21) also asserts that children will, for example, rather walk on logs, garden bed edges, rocks and tree stumps than a manufactured balance beam.

### 3.1.3 Conclusion

From the park assessment, case study and picture study, it is clear that South Africa has a pressing problem with regards to the design of open spaces for children. The design proposal will attempt to address these aspects, as listed on page 14, 16 and 17.

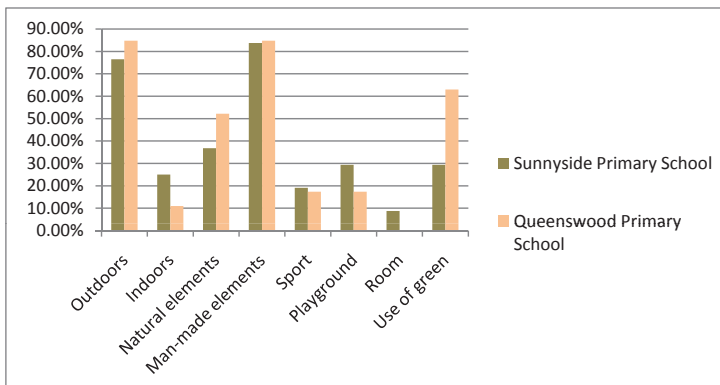

Figure 3.11: Results of picture study (Author, May 2011)

### 3.2 Picture study from two schools

A grade 3 and a grade 4 class of children from Queenswood Primary School and Sunnyside Primary School in Pretoria were asked to draw their favourite space to play. Queenswood Primary School is located in a middle-class suburb, which consists of single houses on large erven with gardens. Sunnyside Primary School is located in Sunnyside. It is mostly the low income- to middle class, living in high-rise apartment blocks. As discussed on page 2, children do not readily have access to gardens.

The different types of play-spaces contained in the drawings were counted, recorded and the results are presented in Figure 3.11.

#### 3.2.1 Conclusions drawn from analysis of the drawings

1. Children from Queenswood Primary (QP) have more access to outdoor areas due to the topography of the suburb. Children from both areas favoured outdoor areas

by far, although many children from Sunnyside Primary (SP) drew indoor areas or their rooms as their favourite playspace. It could be argued that they play indoors due to lack of sufficient outdoor space to play. None of the children from QP drew their room as their favourite playspace.

2. Children from SP seem to be less exposed to natural elements such as gardens than children from QP. Man-made elements feature more than natural elements in both groups (in many instances children drew the garden, but the swimming pool or slide were included as man-made element).

4. Children from SP drew more public playgrounds than children from QP.

5. It was noted that there is a significant difference in the use of the colour green in the drawings. This was recorded and it was found that only 29% of SP children used green, while 63% of QP children used green. This could potentially indicate a lack of green surroundings in Sunnyside.

6. Despite many children drawing natural elements such as birds, trees, and lawn, it appeared to rather be background information to help to define the setting (for example a shade tree to sit under at the swimming

*A playspace should provide spaces for discovery, relaxation, dreaming, challenges, making things, being alone, being in a group, space to stretch your legs and run, space to hide away.*

pool) than to be the favourite playspace. Only 36% of SP children and 52.2 % of QP children drew natural elements as their favourite playspace.

#### 3.2.2 Implications for the hypothesis

From the physical qualities of both suburbs and from their drawings it does not appear as if the children have access to natural playgrounds. Only one child drew a farm with a natural pool, tree house and animals as her favourite playspace. However, they do seem to favour outdoor areas.

As shown by the research in chapter 2, this lack of contact with nature has a profound impact on physical and psychological development of children. The results therefore show how dire the need is for natural playgrounds.



Illus. 3.12: *The element of mystery entices (Author, April 2011)*



Illus. 3.13: *Children have an affinity for small secret spaces (Author, April 2011)*



Illus. 3.14: *This grotto behind the waterfall became the favourite space in this playground. (Conway, 2010:5)*

### 3.3 Spaces for children

Play is process-oriented, pleasurable, exploratory, self-initiated, and constitutes activities that are pursued for their own sake (Weaver, 2000: 12). In the following section the characteristics of parks that facilitate such play will be drawn from theory.

#### 3.3.1 Child scale

When designing for children, it should always be kept in mind that they see the world from a child's perspective of scale. What may look cluttered to an adult could provide the necessary complexity and stimuli to a child. An open area might look large in an adult's eyes, but vast and intimidating to a child. A one meter hedge can be perceived as low for an adult, yet a small child might not be able to see over it.

Researcher Wendy Titman (1994: 49,59) asserts that little alcoves, hidden child-size spaces under overhanging branches or shrubs, high positions such as tree-houses, and other sheltered, intimate

nooks and crannies are all attractive to children for appropriating as their territory, such as the grotto shown in Illus. 3.14. Exploring further away from the parent is part of the process towards gaining complete independence (Slentz & Krogh, 2001).

#### 3.3.2 Developmental needs

Figure 3.12 on page 24 discusses the developmental needs of children at different ages. These needs affect, for example, open space size, the physical qualities of the space and placement of objects. Due to the factors mentioned above and for the safety of the children, a playground should preferably have different areas for different age groups.

#### 3.3.3 Continuous play opportunities

Passing from one area to another constitutes a large part of children's play (Herrington & Studmann, 1998: 202). This creates a need for interlinking play opportunities and well-defined thresholds<sup>1</sup>, to increase the children's perception of the spatiality of an area, as well as aiding their creative play.

#### 3.3.4 Archetypal landscapes

According to child psychologists Kaduson and Schaefer (2006), the stimulation of the imagination holds various benefits for a child. When children imagine things, they have control over the situation, and can create suitable outcomes to real-life situations that they may have experienced. Suggestive spaces and objects to play with "activate" the child's imagination. The application of this can be illustrated by the benefits obtained from sandplay therapy, which is used extensively in play therapy for children, with highly successful results (Pearson & Wilson, 2006).

When playing, children typically access archetypal figures such as the Bad Witch or the Fairy Godmother to act out and process their emotions, ideas and real-life situations (Linden, 2003: 246). Landscape archetypes, such as a forest, river, or mountain, offers a complex and open-ended arena for the acting out of these stories, supporting and encouraging imaginative play in a natural setting, of which the advantages have already been discussed in Chapter 2.

1. Also see Terminology. Thresholds should not act as a barrier but rather serve to reinforce

a to another.







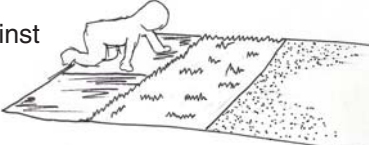

Children's development needs		
0-3 years	3-6 years	6-13 years
<p>Infants and toddlers are just beginning to experience the world around them. They are not yet very mobile, and require less space.</p>	<p>Pretend and constructive play are the most prevalent in this age group. They are becoming aware of other children's worlds.</p>	<p>Pretend play, games with rules and social interaction are prominent.</p>
<p>Physical development</p> <ul style="list-style-type: none"> <li>- different types of textures</li> <li>- safe, comfortable surfaces for crawling, sitting and falling</li> <li>- objects to pull up against</li> </ul> 	<ul style="list-style-type: none"> <li>- rule-free chasing games</li> <li>- climbing and jumping up and down</li> <li>- kicking balls</li> <li>- push/pull toys</li> <li>- balancing exercises</li> <li>- fine motoric skills developed</li> </ul> 	<p>Like:</p> <ul style="list-style-type: none"> <li>- challenges</li> <li>- a sense of adventure</li> <li>- discoveries</li> </ul> 
<p>Socio-emotional development</p> <ul style="list-style-type: none"> <li>- parallel play (alone yet close to others)</li> <li>- some interaction with other children does occur</li> </ul> 	<ul style="list-style-type: none"> <li>- props for pretend play cardinal to sustain play</li> <li>- small groups form</li> <li>- do as they see others do</li> </ul> 	<ul style="list-style-type: none"> <li>- fantasy play ( looking for fairies)</li> <li>- re-enact films or shows</li> <li>- quiet spaces where they can be alone</li> </ul> 
<p>Cognitive development</p> <ul style="list-style-type: none"> <li>- new types of materials enjoyed (dough, beads, paint)</li> <li>- pick up small objects and put in mouth</li> <li>- stimulate the senses (e.g. wind chimes, light through leaves)</li> <li>- vigilant adult care needed</li> <li>- large motor zone, dramatic play zone, messy zone</li> <li>- quiet zone prevent toddler from feeling overwhelmed</li> </ul> 	<ul style="list-style-type: none"> <li>- complexity</li> <li>- scope for alteration</li> <li>- constructions with sand/other objects</li> <li>- collecting objects</li> <li>- interested in how things work, plants and animals</li> </ul> 	<ul style="list-style-type: none"> <li>- games with rules</li> <li>- group interaction, resolving arguments, negotiating</li> <li>- new games invented</li> </ul> 

Figure 3.12: Developmental stages and needs of children (Author, March 2011, compiled from Berry, 2001; Goodenough, 2003, Hurtwood, 1966 & 1969, Lambert & Pearson, 1974, Noren-Bjorn, 1982; and Wellhausen, 2002)

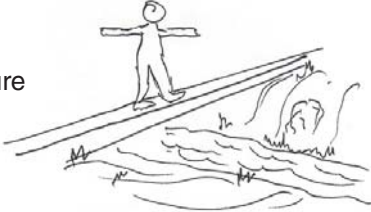

Illus. 3.15: Topography provides interest (Author, March 2011)

Archetypes lend themselves to a wide variety of play options. For example, a mountain can provide a safe castle at the top, be Mount Everest to be scaled, or provide a physically challenging route with dragons to slay in order to reach the rare flower growing at the top.

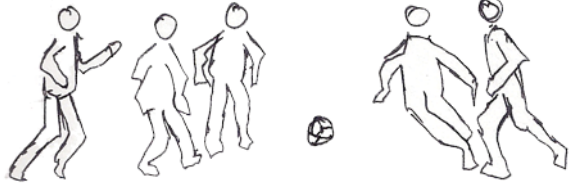
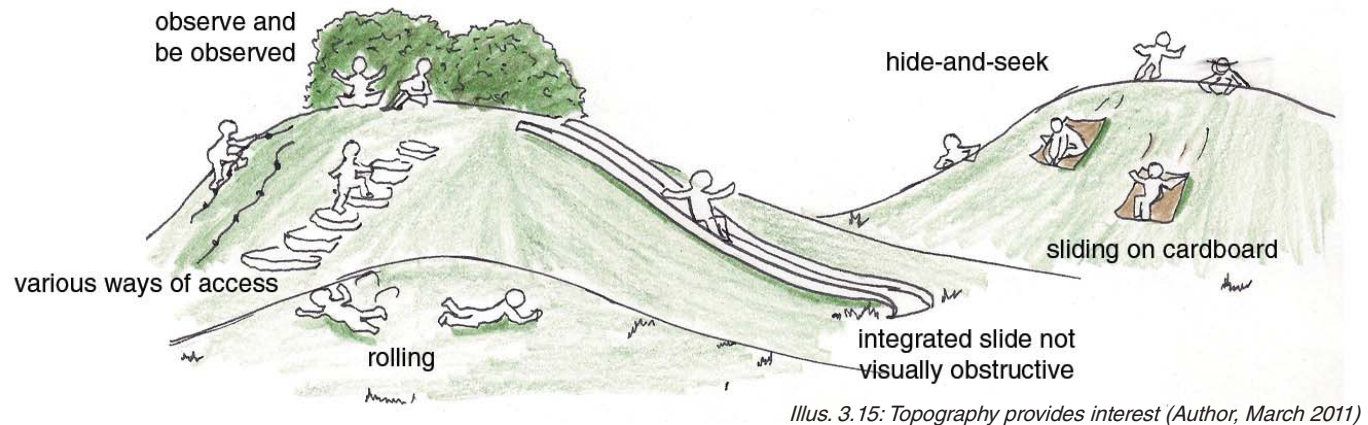
Creating archetypes also helps children to refer to their cultural heritage and makes it more tangible, since they are able to actively engage with the landscape also found in folklore.

Archetypal landscapes are a culmination of and incorporates other aspects discussed, such as child scale, the developmental needs and continuous play opportunities, as well as the need for nature. In Chapter 7 the archetypes to be used in the design proposal are discussed in more depth.

### 3.4 The natural environment as playground

Natural elements and loose parts originating from nature which could be incorporated into the design

proposal are discussed shortly below. They will form part of the construction of the archetypes.

#### 3.4.1 Ecological complexity

Plants define different spaces and create rooms in the landscape. They are a sustainable way of providing an endless supply of loose parts. Specific plants with large seeds or edible fruits, fragrant flowers, interesting leaves or textured bark should be used (refer to Chapter 8 for detailed planting palettes).

The plants used for the proposed site should be water-wise and frost-hardy. Thornless and non-toxic plants ensure safe interaction. Thorny shrubs could, however, be used to deter people from walking through an area.

#### 3.4.2 Loose parts

The loose parts used in the design should be undesirable to remove permanently from the playground, and if it is done, it should be easy to replace (e.g. pine cones are produced every year). Children might want to carry play objects away, but this

can be solved by making them sign for it to know who is in possession of a certain part, or by enclosing the space and having adult supervision.

All of the natural elements discussed below could be used to create a complex environment by defining, separating and joining spaces and thresholds.

#### 3.4.3 Hedges

Hedges could be used as vertical structuring elements in the landscape. They can be pruned or informal. Plants such as Weeping Sage (*Buddleja auriculata*) are ideal for creating small spaces where only a child can fit in (Illus. 3.13 & 3.14). They allow areas to be physically separated yet visually connected, enhancing safety.

#### 3.4.4 Mounds as landscape reference

Mounds provide a view from an elevated position. It could be a fortress, a tower, a mountain, or simply a mound. It could be accessed by a series of stone-steps, by a rope-ladder, or by a climbing wall (Illus. 3.15).



Illus. 3.16: Natural climbing equipment in Garden City Park, Canada (Broto: 2010: 527)

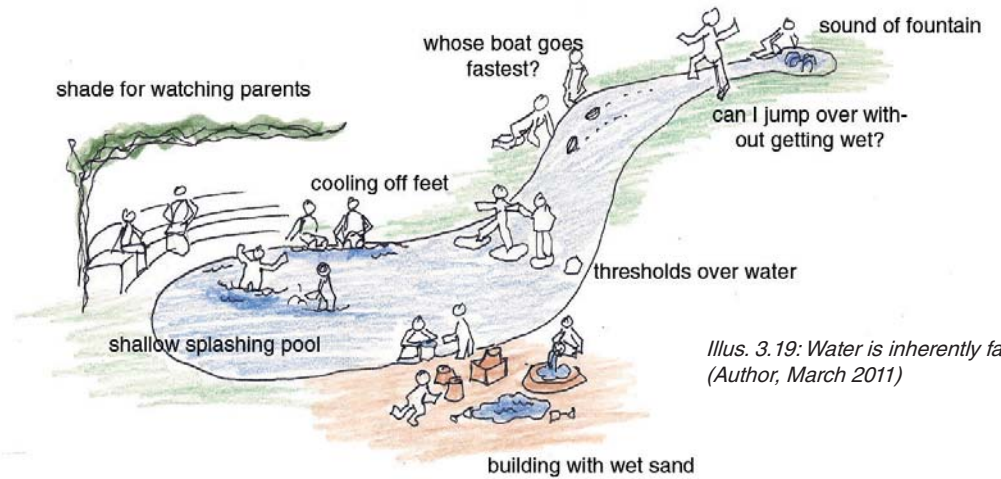

Illus. 3.19: Water is inherently fascinating (Author, March 2011)



Illus. 3.17: Water landscape at Pforzheim, Germany, by Herman Dreiseitl. (Dreiseitl & Grau, 2005: 151)



Illus. 3.18: Water and sand in Garden City Park, Canada (Broto, 2010: 526)

### 3.4.5 Logs

Logs could be used as natural posts or beams, or as climbing equipment (Illus. 3.16).

### 3.4.6 Water for interaction

Water provides endless fascination for children. It can be splashed in, dammed up, released, used for boat races, as well as being educational (Illus. 3.17 & 3.18). Wet sand is a better building material than dry sand.

### 3.4.7 Sand for manipulation

Cool wet sand is ideal for building. It should also be used as safety surface to soften falls as opposed to a synthetic safety material such as Masterfiber. Sand and water play encourages interaction between children, as well as stimulating them cognitively (for example learning about gravity, viscosity, weight, etc) (Dinwiddie, 1993).



Illus. 3.20: Stepping stones and log creating route over dry riverbed (threshold). Valbyparken, Denmark. (Broto, 2010: 121)



Illus. 3.21: *Crotalaria agatiflora* (Author, March 2011)



Illus. 3.22: *Pelargonium peltatum* has fragrant leaves (<http://www.plantzafrica.com/frames/plantsfram.htm>)



Illus. 3.23: Playing in autumn leaves (<http://tootsiegrace.blogspot.com/2009/11/raking-leaves.html>)

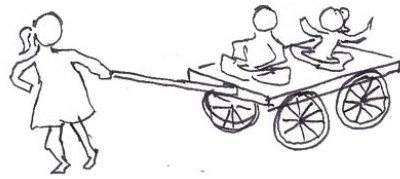

carts for pulling objects or children

Illus. 3.24: Loose parts (Author, March 2011)

### 3.4.8 Stones/boulders

Large stones or boulders can be used for building or to provide seating, while pebbles could be used imaginatively to represent board game pieces, or money, pills, food or anything else in children's play. Jumping from stone to stone develops balance and agility (White, 2008:74).

### 3.4.9 Grass

Curving pathways can be cut into long veldgrasses such as *Hyparrhenia hirta*, adding an element of discovery to the landscape.

### 3.4.10 Pine cones/pods/seeds/fruits

Several existing pine trees on and next to the site provide cones to play with. Plants with edible berries such as *Pappea capensis*, *Pittosporum viridiflorum* or *Grewia occidentalis* can provide free food and play material. Size and shape of seedpods, fruits and flowers should influence species choice.



Illus. 3.25: Sounds and smells (Author, March 2011)

Flowers should be free for the picking. Fragrant or unusual species should be used to stimulate interest, such as *Crotalaria agatiflora*, *Dais cotinifolia*, and *Lippia javanica*.

### 3.4.11 Trees

Exotic trees such as oak (*Quercus subsp.*) or plane trees (*Platanus acerifolia*), and indigenous trees such as white stinkwood (*Celtis africana*) and river bushwillow (*Combretum spp.*), provide large amounts of coloured autumn leaves to play with. The site has a few very large existing trees, such as *Jacaranda mimosifolia* and *Tipuana tipu*, which are ideal for climbing or building treehouses.

### 3.4.12 Man-made loose parts

In addition to the children's play needs, the needs of other age groups (e.g. waiting for transport or gathering in large groups) as well as security issues have to be addressed. It would therefore be inappropriate, in the urban setting, to revert the proposed site to a completely natural area for children's play. Due to this

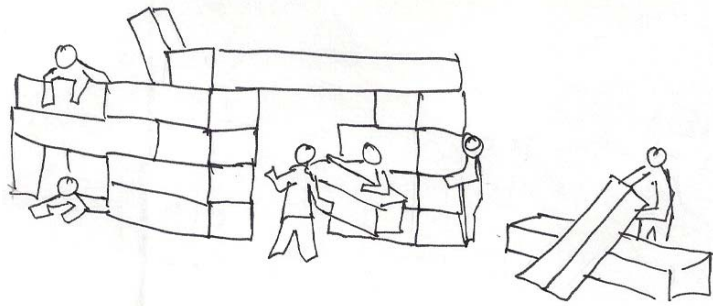

- Light-weight modular building blocks
- any number or configurations possible
  - teamwork: what and how will we build?

*Illus. 3.26: Modular units (Author, March 2011)*

limitation, other man-made loose parts should be provided as well to sustain play.

This could be buckets and shovels for playing in sand and water, small carts to pull objects or other children on, balls, building blocks, dolls, and other objects which could stimulate the imagination. For creative, non-directed play, loose parts should preferably not resemble a real-life object. It should rather be of such a nature as to be able to resemble many different objects, depending on what the child envisions. A piece of slate tile could become a baking tray, a plate, a valuable painting, a book or something to scoop sand with. Modular blocks or units enable children to build their own structures safely, are demountable and can be changed every day, as shown in Illus. 3.26.

### 3.5 Conclusion

From chapter 2 and 3 it is clear that natural areas can provide a complex environment which can facilitate high-quality play. When the aspects discussed, such as scale, developmental needs, ecological complexity and continuous and interlinking play opportunities are addressed, a park has the potential to stimulate the well-rounded physical, cognitive and socio-emotional development of children.

At the end of the design resolution chapter (chapter 8), the design matrix table will indicate how the programme addressed the play and development needs of children as discussed here.



# 4

Successful projects are investigated in terms of some of the more important design criteria as discussed in the previous two chapters. End Street Park and Sali Park, two examples from Gauteng, were included as precedents. They have had to deal with similar urban problems as are experienced on the project site, such as crime.

# Precedents

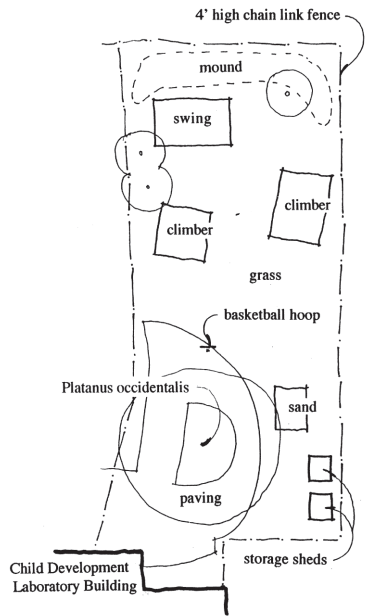

Illus. 4.2: Lab C existing conditions. Not to scale.

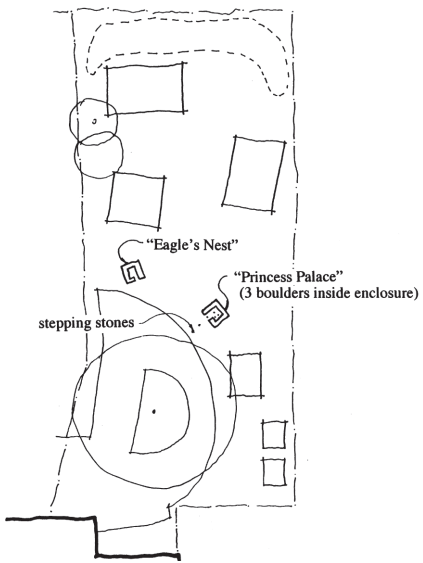

Illus. 4.3: Lab C interventions. Stepping stones, boulders and a vegetative room were added. Not to scale. Note the simplicity of the interventions in lab C, which still effected a prominent change in how children perceived and used the space. They gave the interventions names, for example, whilst the existing play equipment were never named.

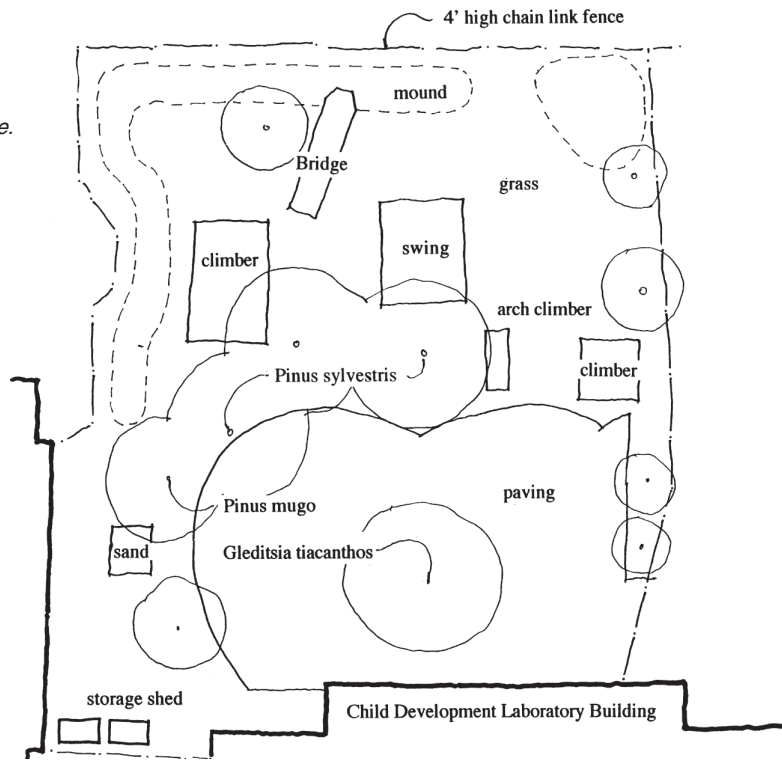

Illus. 4.4: Lab A existing conditions. Not to scale.

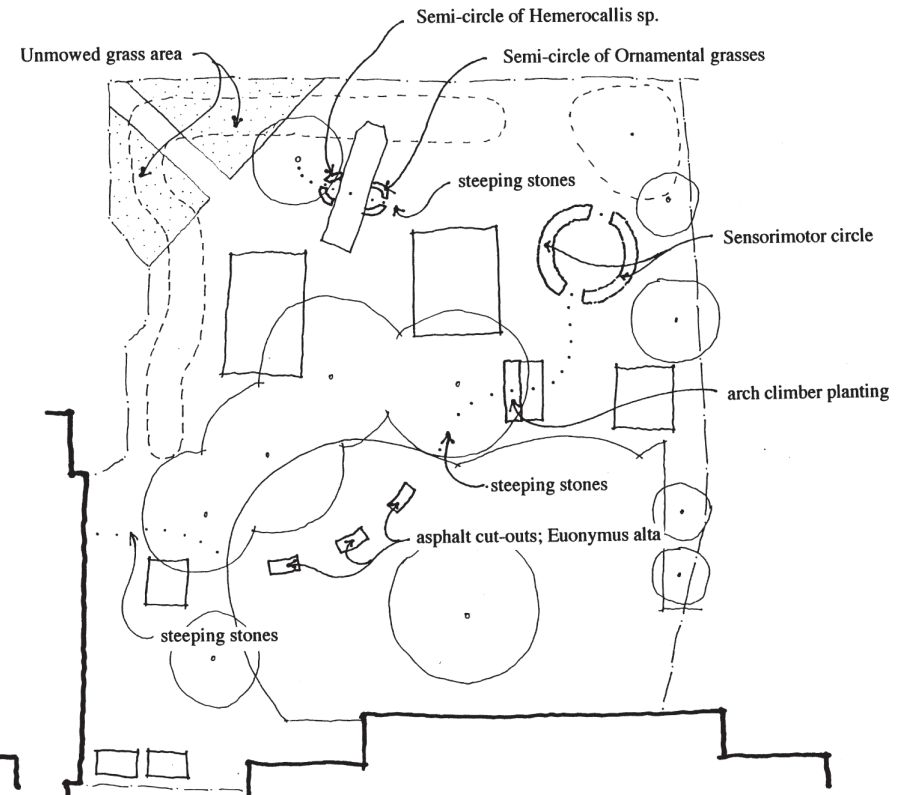

Illus. 4.5: Lab A interventions. Not to scale.

## 4.1 Interventions at Child Development Centre

Location: Iowa State University

Landscape Architect: faculty and graduate students from the Department of Landscape Architecture and the Department of Human Development and Family Studies.

Client: Child Development Centre, Iowa State University

(All images from Herrington and Studmann, 1998:193, 194, 197, 198)

**Description:** The project researched the effect of man-made and natural<sup>1</sup> interventions in the play yards at the Child Development Centre at the Iowa State University. Children involved in the study were between the ages of 2 to 6 years old. The existing play yards (see Illus. 4.2 and 4.4) were transformed to the conditions shown in Illus. 4.3 and 4.4. Man-made interventions included ice sculptures, wind chimes, a canvas canopy over a play structure, and chalk lines on asphalt. Natural interventions included stepping stones, a water feature, an arch with a climbing plant over it, boulders and vegetative rooms.

**General ideas and opportunities:** The research showed that the children responded better to the natural interventions as opposed to the man-made interventions, and interacted with it for longer periods of time. The chalk lines were barely noticed. From Illus. 4.6 it can be seen that the interventions also resulted in children using a much larger area of the playground. Children liked the smaller spaces created by, for example, the canvas canopy over the play structure, as well as the vegetative rooms. An area of grass that was not mowed was very popular to play hide-and-seek in, and to have secret meetings. Use of the vegetative rooms had an effect on the social hierarchy of the class. The children showed appropriation of the new spaces created by naming them. The stepping stones, arch and vegetative rooms increased the children's awareness of spaces and routes that lead somewhere. This project shows that very simple natural interventions (e.g. long grass or low planting in a circle), can encourage creative social play.

1. See Terminology on page x.

Illus 4.6: New movement patterns created by the natural interventions. Children use a larger part of the playground. (Herrington & Studmann, 1998:199)

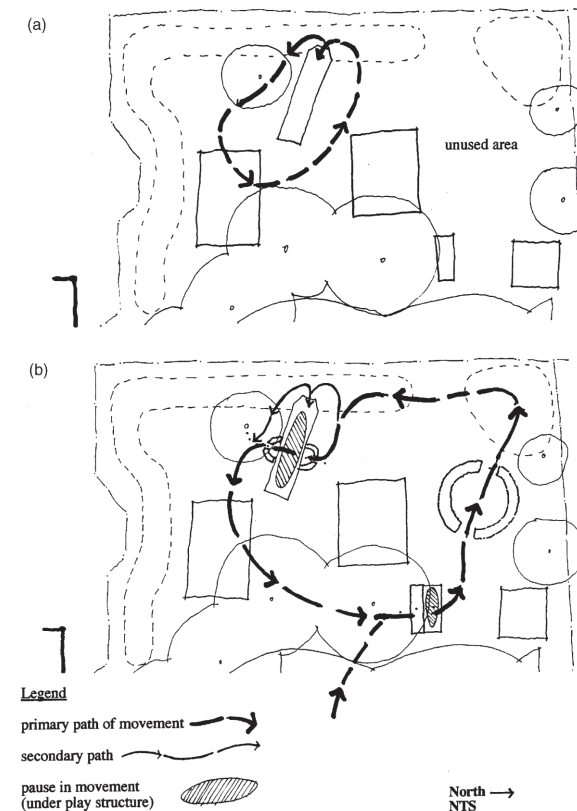

## 4.2 Water Garden

Location: Pforzheim, Germany  
Landscape Architect: Herman Dreiseitl  
Client: LGS Pforzheim 92 GmbH

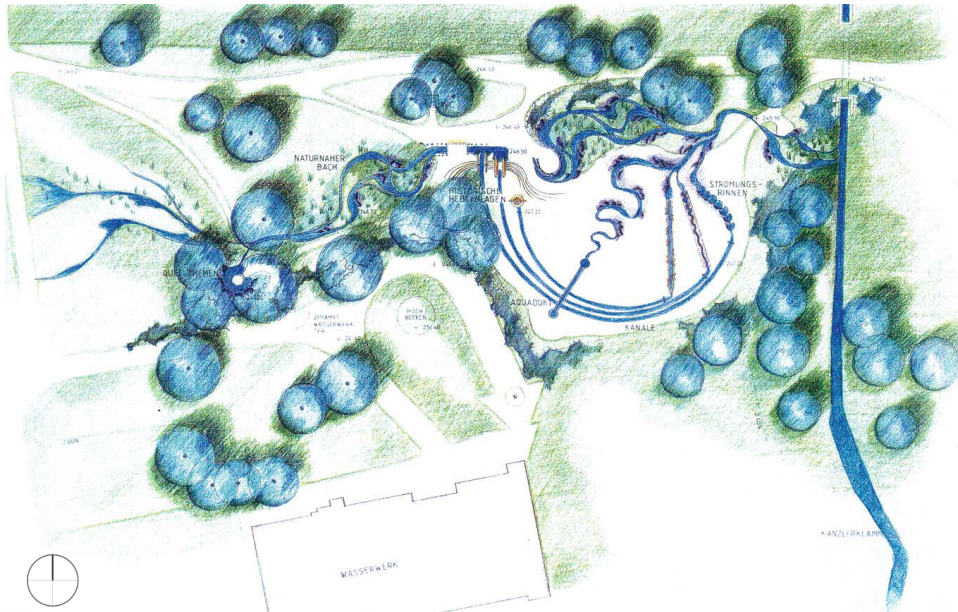

Above: Illus 4.7: Plan of Water Garden. Not to scale (Dreiseitl, 2005:150)



Illus 4.9: Fixed moveable parts to manipulate water with (Dreiseitl, 2005:151)

**Description:** Water flows from a natural area out of a natural stone basin through quiet creeks into the “civilization” section, where it flows through various elements related to water technology, such as lifting devices, channels and wells. There are Archimedean screws, a shaduf, a medieval well-shaft and a rotary pump.

**Loose parts:** There are no loose parts, but rather moveable parts which can control the flow of water.

**Complexity and choice of spaces created:** The natural area is quieter while the civilized section is busier with more activities. A wide range of spaces is created, despite the design being very simple.

**Nature:** Water is the main element in this playground, however, natural stone has been used to create the channels as opposed to bricks or concrete.

**Scope for alteration:** Children are able to manipulate the flow of the water with open-able weirs and the named devices.

**General ideas and opportunities:** There are four Archimedean screws, placed in such a way that team competitions are possible. This playground invites children to interact with the water in many different ways, individually and in groups. They learn about technology, history and the characteristics of water in general whilst playing. This park shows how it is possible to have interactive yet not loose parts.

Below: Illus 4.8: Children interacting with water (Dreiseitl, 2005:150)



### 4.3 Murergaarden

Location: Copenhagen, Denmark  
Landscape Architect: Helle Nebelong  
Client: Murergaarden Daycare Centre

(All images from Broto, 2010:343, 344 & 348)



Illus 4.10: Low shrubs provide places to explore that still have good visual surveillance.



Illus 4.11: View down spring with water channel.

**Description:** The pupils of the day-care centre were questioned about their preferences and ideas for redesigning a dilapidated playground which had standard play equipment and hard surfaces. No standard play equipment were used except for a slide. Natural materials were used as far as possible, with many sand surfaces and plantings of shrubs. A spring feeds a channel and paddling pool. Lines created by boulders and low pole fences define spaces.

**Loose parts:** Large areas of the playground have sand surfaces, and children are able to pick flowers and twigs.

**Complexity and choice of spaces created:** The playground has good visual surveillance everywhere, yet still have many spaces where children can hide and explore (for example the willow plantings around the paddling pool and along the edges of the playground).

**Nature:** Natural materials have been used almost everywhere except in some paved areas and for the lining of the water channel. Dead tree trunks replace the traditional climbing frame, and shrubs that attract butterflies are used.

**Scope for alteration:** Water from the channel and paddling pool can be used for sand constructions.

**General ideas and opportunities:** Parents were initially concerned that the playground was dangerous and to an extent boring, however, none of the children has been hurt in the park's existence of more than five years. The parents report that the children return home happier than before the playground was installed, and the staff report fewer conflicts in the playground. This shows that being able to play in a natural area has beneficial psychological effects on children.



Illus 4.12: Bridge as threshold.



Illus 4.13: Dead tree trunks as natural climbing frame.



Illus 4.14: Aerial view of park looking north (Vosloo, 2011)



Illus 4.15: Aerial view of park looking south (Vosloo, 2011)



Illus 4.16: Custom-made play equipment (Author, March 2011)

#### 4.4 End Street Park

Location: End Street, Hillbrow, Johannesburg  
 Landscape Architect: Newtown Landscape Architects  
 Client: City of Johannesburg

**Description:** End Street Park is a children's playground in the high-density residential area Hillbrow. Due to it being a busy thoroughfare, the two play areas are fenced off: one for smaller children and one for older children, with only one gated entrance each. The play equipment are fixed, yet not standard. There are mounds with Masterfiber covering, and one has Astroturf on. Low walls around the soccer pitches serve as goalposts as well as seating.

**Loose parts:** There are no loose parts in this park, except for the flowering plants under the trees. However, this is understandable in an area with extremely high crime rates and poverty.

**Complexity and choice of spaces created:** It is possible to be aware of what is going on in the park at all times, yet there are a few hiding places for children behind the mounds (one has a recess in it too). There is a good variety of sunny and shady spots available, as well as spaces for gathering in smaller and larger groups.

**Nature:** Trees (existing and new) provide shade, and there are two small patches of lawn and some low shrubbery. Due to the urban nature and high density of the area, it would have been very difficult to incorporate more natural materials.

**Scope for alteration:** none

**General ideas and opportunities:** There are no guards watching the gates, however, there are neighbourhood security staff present. The palisade fencing provide physical separation yet visual integration. For the challenges faced, the park could be called a success, even though it does not fully cater for the development of children. Custom-made play equipment provide challenging physical development opportunities. While natural playgrounds do not emphasise the use of bright colours, End Street Park provide colour in an otherwise dull urban environment. This park is a good example of how a children's playpark can be incorporated in a difficult urban area.

*Illus. 4.17: Mound with climbing frame provides views to Suikerbosrand Mountain Range. (Author, May 2011)*



## 4.5 Sali Park

Location: Sali Section, Katlehong

Landscape Architect: Outer Space Design Landscape Architects

Client: City of Ekurhuleni

**Description:** Sali Park is a small (about one hectare) park situated in an economically disadvantaged neighbourhood. Houses overlook the park, which is not fenced off in any way, creating good visual surveillance. It has a large mound with a climbing frame (which is about the highest point in the neighbourhood, affording views to the Suikerbosrand Mountain Range to the south). There are some standard playground equipment such as swings, as well as a mini-soccer pitch (fenced) and a basketball court.

**Loose parts:** The basketball court has a sand surface, and there is a large heap of sand in the park (presumably used in the construction process). Large amounts of children were observed playing in the sand (both on the heap and in the basketball court). This is the only park visited (see Assessment of Parks in Chapter 3) that had sand available, and its popularity was evident from the way children interacted with it.

**Complexity and choice of spaces created:** The park has a continuous grass surface with no good space definition, despite there being definite different areas. Singular benches and concrete tables with chairs for groups are provided. When the trees are mature, they will help to define the various areas.

**Nature:** Most of the park's surface is lawn, with many trees being planted. Some decorative planting has been incorporated. The plants used does not provide any loose parts, however, and there is very little ecological complexity.

**Scope for alteration:** None, except for the sand heap and the basketball court.

**General ideas and opportunities:** The children are afforded an opportunity to escape from their everyday environment through the views from the mound. The sand court and heap are very popular. Despite the park having only very basic amenities, it is clearly a popular park, but this could be due to the fact that it is the only park in the neighbourhood, and the high density of residents. It also shows how children use elements differently from how they were intended to be used.



*Illus. 4.18: Kinetic equipment are used more than static equipment. (Author, May 2011)*



*Illus. 4.19: Children building with sand in the basketball court. (Author, May 2011)*



*Illus. 4.20: Singular and group seating provided. Also note heavy usage of play equipment. (Author, May 2011)*



5

# Site Analysis





Illus. 5.2: Location of Gauteng in South Africa. Not to scale (manipulated by Author, May 2011)



Illus. 5.3: Tshwane Metropol in Gauteng. Not to scale (manipulated by Author, May 2011)



Illus. 5.4: Pretoria in Tshwane. Not to scale (manipulated by Author, May 2011)

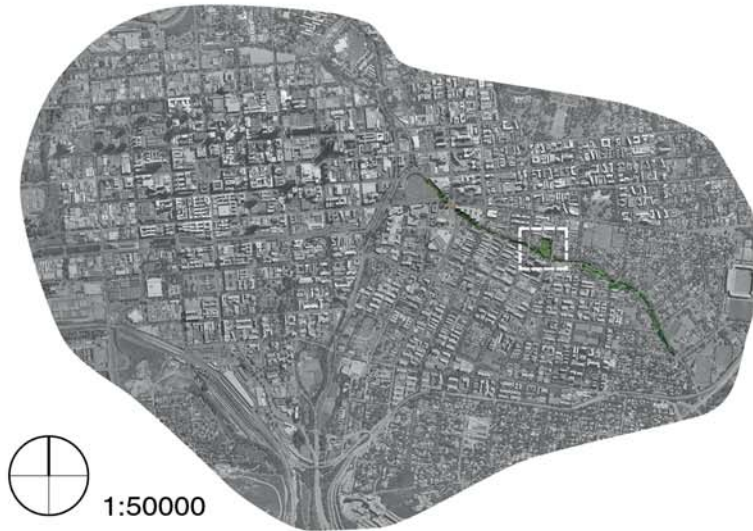

Illus. 5.5: Aerial photo showing the site within greater Pretoria. Note how the streets run perpendicular to the Walker Spruit, based on the layout of irrigation furrows. (manipulated by Author, May 2011)

## 5.1 Context

Sunnyside and Arcadia are Pretoria’s only high-density, high-rise residential areas. Other high-density areas exist on the outskirts of Tshwane, such as Mamelodi, however, they are mostly one-storey buildings. Most of the ideas explored in this dissertation would be applicable in high-density, low-rise areas as well. As the author preferred to be able to do frequent site visits, Sunnyside was chosen as it is close to where the author lives.

Mamelodi is a peri-urban area, much more dynamic and in flux than Sunnyside, which is a formal, quieter neighbourhood with an established community. Here residents are detached from the ground while in Mamelodi residents have a much more tangible connection with the ground. Being removed from the

ground has an adverse effect on the psychological health of residents and increases their need for outdoor recreation spaces (Misrachi & Whitzman, 2009; Taylor, Kuo, Sullivan & Wiley, 1998).

Sunnyside as a suburb was incorporated into Pretoria in 1890. Some old houses still exist to the eastern side, while large five- to seven-storey housing blocks dominate the western and southern part of the suburb. The direction of irrigation furrows influenced the layout of the area (note how the streets run perpendicular to the Walker Spruit on Illus. 5.5.) (South Africa, Map of Pretoria and suburbs, [s.a.] ).

As indicated on Illus. 5.6, the site is bordered to the South by Spruitsig Park, which consists of five apartment blocks with a total of 531 flats. De Rapper Street, a quiet one-way, separates the site from the



apartment blocks. To the north another housing block of six storeys overlook the site. On the east side, a crèche, a housing block and a church face the site. The Ring-Ting Pre-Primary school is on the west side of the site. The site is one block north of Esselen street, the economic vein of Sunnyside.

## 5.2 The Walkerspruit trail

The Walkerspruit trail starts in the Brooklyn suburb and was intended to become a lovely walk in the city, especially for residents in Sunnyside and Arcadia. However, most buildings turn their back on the Spruit, which is not aesthetically pleasing due to it being channelised. The channel is lined with concrete (Illus. 5.17) and base flow in June were calculated at  $0.26 \text{ m}^3/\text{s}$ .



Illus. 5.7: Homeless people appropriating park furniture. (Author, April 2011)



Illus. 5.8: Lunch goesers (Author, April 2011)



Illus. 5.9: Informal gathering space on the corner of Leyds and De Rapper Streets. (Author, July 2011)

### 5.3 Current users

There is constant pedestrian traffic along Leyds, Bourke and de Rapper streets. On the north-eastern corner of the site about seven homeless individuals live permanently. They wash themselves and their laundry in the Walkerspruit, drying their laundry along the banks. During the day, they use the existing street furniture to sleep on (Illus. 5.7).

Some children use the existing play equipment, and a few lunch goers were observed. At the western-most edge of the site, a natural gathering space has formed (Illus. 5.9). A tree in the space is used to pin up advertisements.

The southern part of the site has the most activity, while only homeless people use the northern part of the site (the Spruit acts as a barrier and prevents people from taking the shortest route right across the site). A few street vendors sometimes trade at the positions shown on Illus. 5.10. They are however not permanently

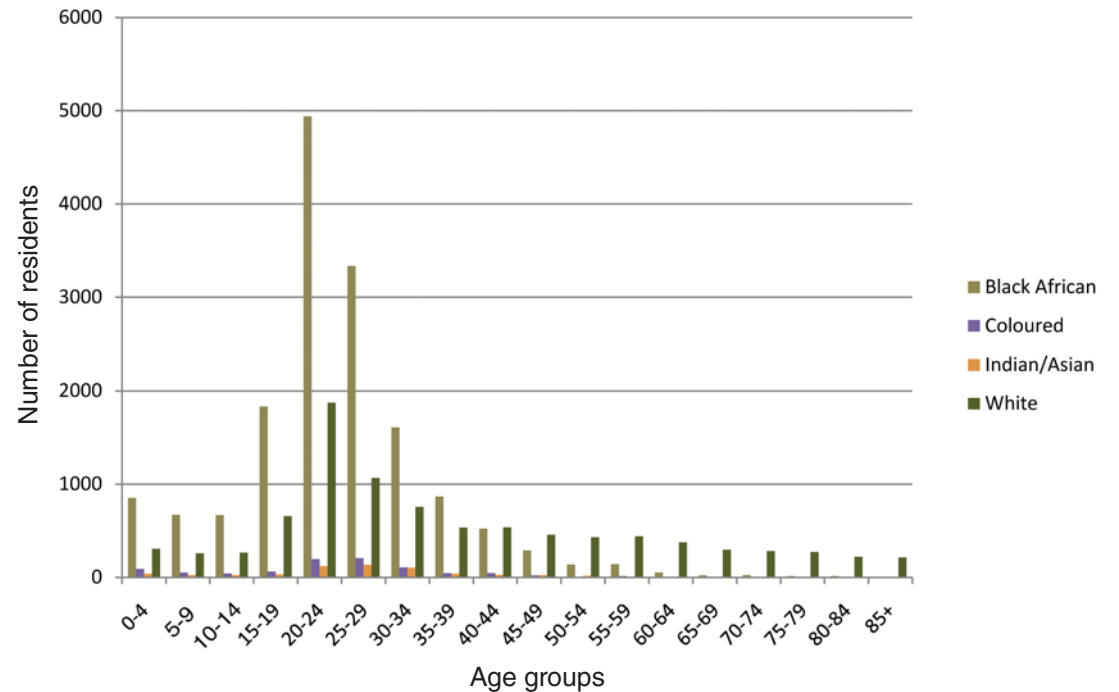

Figure 5.1: Population demographics of Sunnyside (Author, April 2011, compiled from pers. comm., Stats SA, 19 April 2011)

stationed there, but move around in Sunnyside (pers. comm., name unknown, 10 April 2011).

Sunnyside is a multicultural suburb, comprising not only South Africans but also immigrants from other countries such as Nigeria, Tanzania, Mozambique and Zimbabwe (pers. comm., Bonnie, 16 July 2011). Young people up to 30 years constitute a large part of the population (see Figure 5.1 and 5.2).

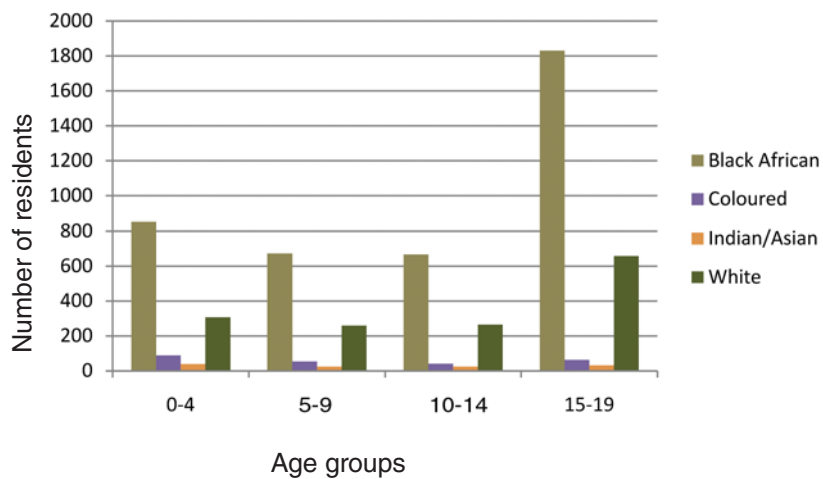





Figure 5.2: Demographics of children in Sunnyside (Author, April 2011, compiled from pers. comm., Stats SA, 19 April 2011)



Illus. 5.10: Movement and access on site (Author, April 2011)

**Legend**

-  street vendors
-  current circulation routes
-  no access

Illus. 5.11: Vegetation found on site  
(Author, May 2011)

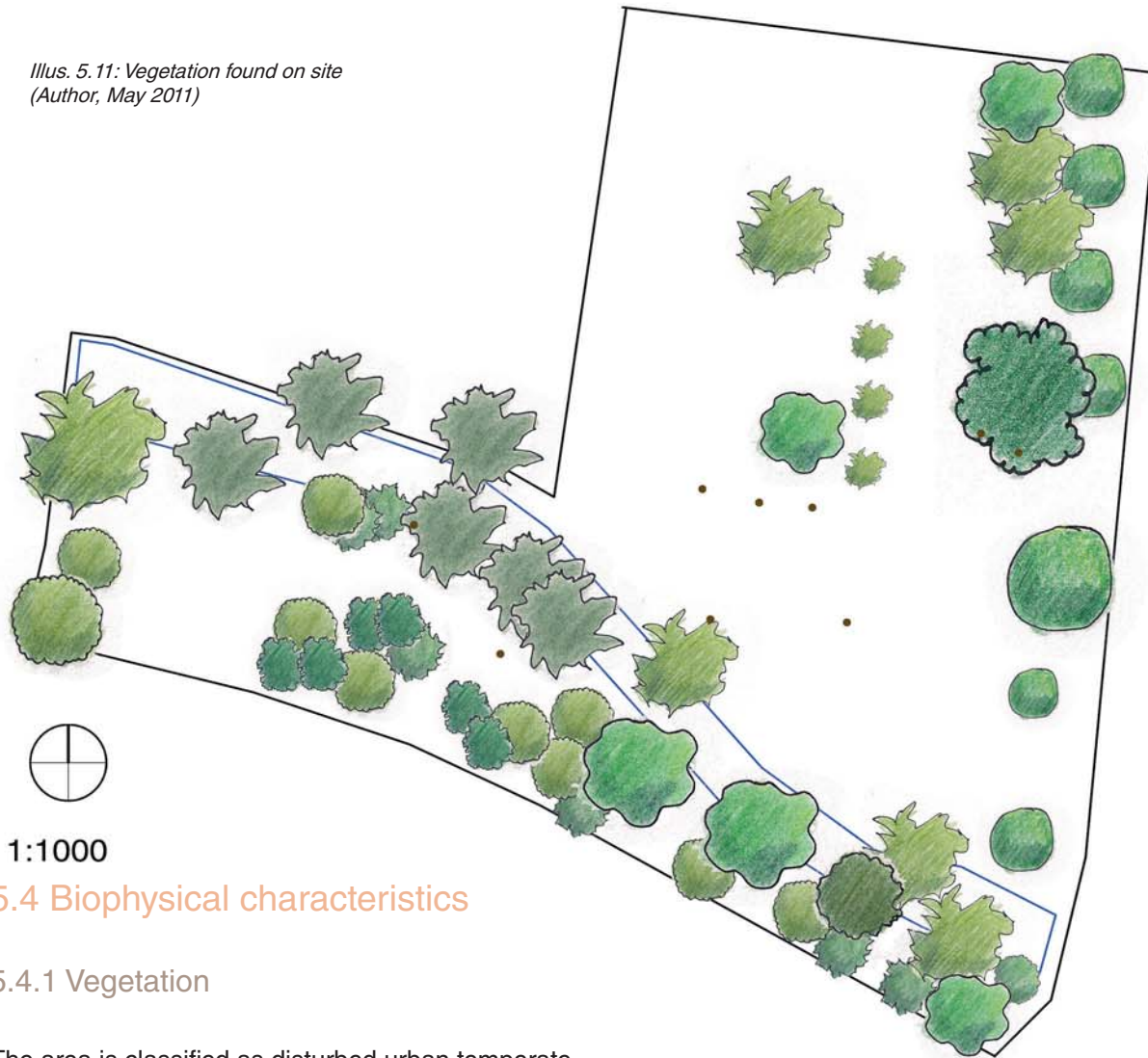

- Legend**
- Indigenous trees
- Senegalia karroo*
  - Ekebergia capensis*
  - Combretum erythrophyllum*
  - Sersea lancea*
  - Ehretia rigida*
- Exotic trees
- Pinus canariensis* (Category 2)
  - Tipuana tipu* (Category 3)
  - Jacaranda mimosifolia* (Category 3)
  - Quercus robur*
  - Phytolacca dioica* (Category 3)
- Dead trunks of *Phoenix canariensis*

1:1000

## 5.4 Biophysical characteristics

### 5.4.1 Vegetation

The area is classified as disturbed urban temperate bushveld (UP, Department of Geography, 2011), as well as Gauteng Shale Mountain Bushveld by Mucina and Rutherford (2006: 466-467). Prominent plants found in this vegetation type are for example *Senegalia caffra*, *S. karroo*, *Combretum molle*, *Dombeya rotundifolia*, *Protea caffra*, and *Vangueria infausta*.

The site has several alien plants: *Tipuana tipu*, *Jacaranda mimosifolia*, *Cestrum laevigatum* (Category 1), *Phytolacca dioica*, *Quercus robur* and *Pinus*

*canariensis* (see Illus. 5.11). According to the National Environmental Management Act (“NEMA”), Act 107 of 1998, Category 1 plants need to be removed and destroyed immediately. Category 2 plants do not need to be removed. However, a permit is needed to grow them, and then only for commercial industrial purposes. Category 3 plants also do not need to be removed, but no new plants may be propagated and reproduction of the plant must be controlled.

Besides the trees shown on Illus. 5.11 the surface of the site is covered with *Cynodon dactylon* and *Pennisetum clandestinum* (kikuyu, Category 1) lawn, with some low-growing weeds. There are several dead trunks of *Phoenix canariensis* palms. They were planted in the 1920’s at the same time as the palms planted along University Road, but have all been killed by a virus between 2005 and 2011.

**5.4.2 Geology:** Shale. Since this rock type can be very soft, other stabilizing materials may need to be added when structures are built on it.

**5.4.3 Soil:** The soil on the site consist of 34% Hutton and 22% Avalon form. These soils drain well, therefore it is good agricultural soil. They have moderate soil erosion potential.

**5.4.4 Topography:** The site has a gentle slope towards the southwest (Illus. 5.12). The banks of the Walker Spruit channel are unnaturally steep and render the water inaccessible for humans.

**Legend**

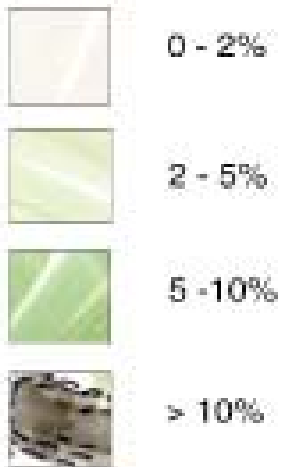

*Illus. 5.12: Slope analysis (Author, June 2011)*



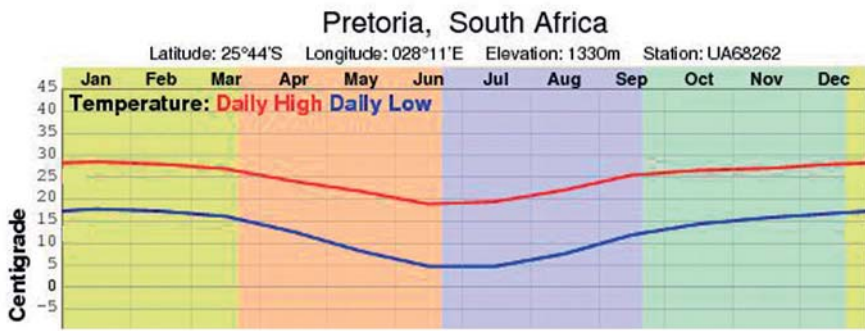

Figure 5.3: Temperature (Climate-Charts, 2010)

Statistic	Units	Jan	Feb	Mar	Apr	May	Jun	Jul	Aug	Sep	Oct	Nov	Dec	Average
Precipitation	mm	135.0	76.0	79.0	54.0	13.0	7.0	3.0	5.0	20.0	7.0	10.0	108.0	43.08
Mean Monthly Value														

Figure 5.4: Rainfall (Climate-Charts, 2010)

**5.4.5 Temperature:** Summers can be very hot with temperatures reaching the lower thirties. This implies that the provision of shade is of cardinal importance.

**5.4.6 Rainfall:** December and January are the wettest months with thunderstorms occurring frequently. Adequate provision for stormwater run-off as well as shelter from sudden rainstorms therefore need to be provided.

**5.4.7 Humidity:** Ranges from 47% in September to 69% in March. This falls within a comfortable range for humans and no compensating measures need to be taken.

**5.4.8 Wind:** The prevailing wind is from the north-east at an average speed of 4.15 m/s. The site is sheltered from strong winds by the high buildings around it, as well as by the existing trees.

**5.4.9 Sun angles:** Illus 5.13 shows the implications of sun angles on the site. In winter the apartment block on the northern side casts a shadow onto the site which could create a cold spot. In the late afternoons in summer, a part of the site south of the Spruit receives shade from the Spruitsig apartments, which would be welcome relief from the summer's heat. Apart from this, the site is mostly exposed to the sun except for the shade cast by some existing trees.

## 5.5 General

**5.5.1 Built-to lines:** 4.5 m on all boundary sides (South Africa. City Planning and Development Division, 2008:32). Permission will be requested to change the built-to lines to accommodate the proposed mixed use intervention on the groundfloor of the apartment block on the northern boundary of the site.

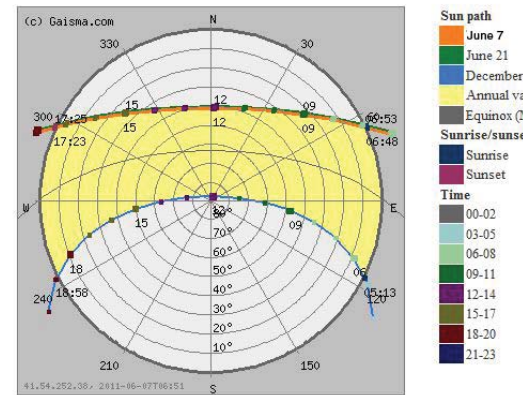
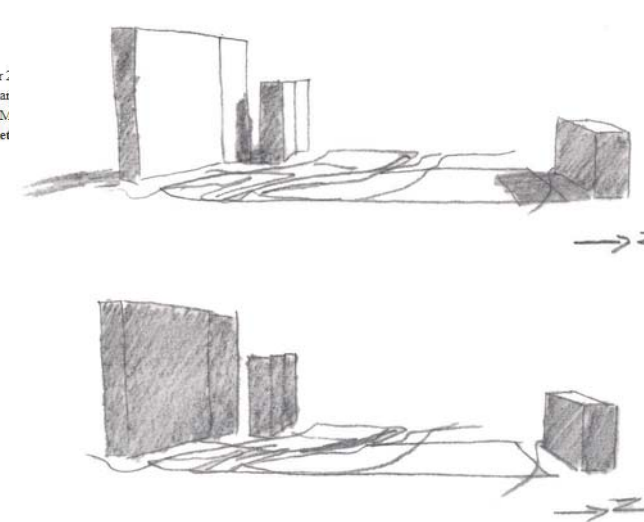

Figure 5.5: Sun angles for Pretoria (Gaisma, n.d)



Illus 5.13: Above: Solar study at 12:00 on 21 June  
Below: Solar study at 12:00 on 21 December  
(Author, June 2011)

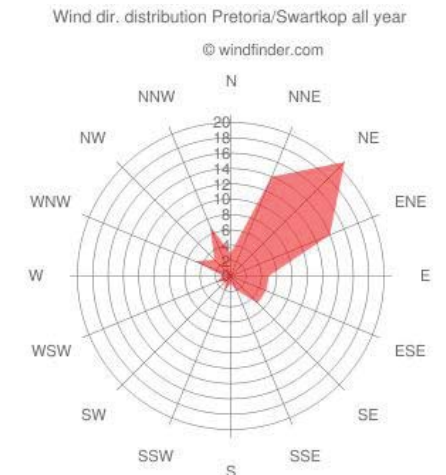
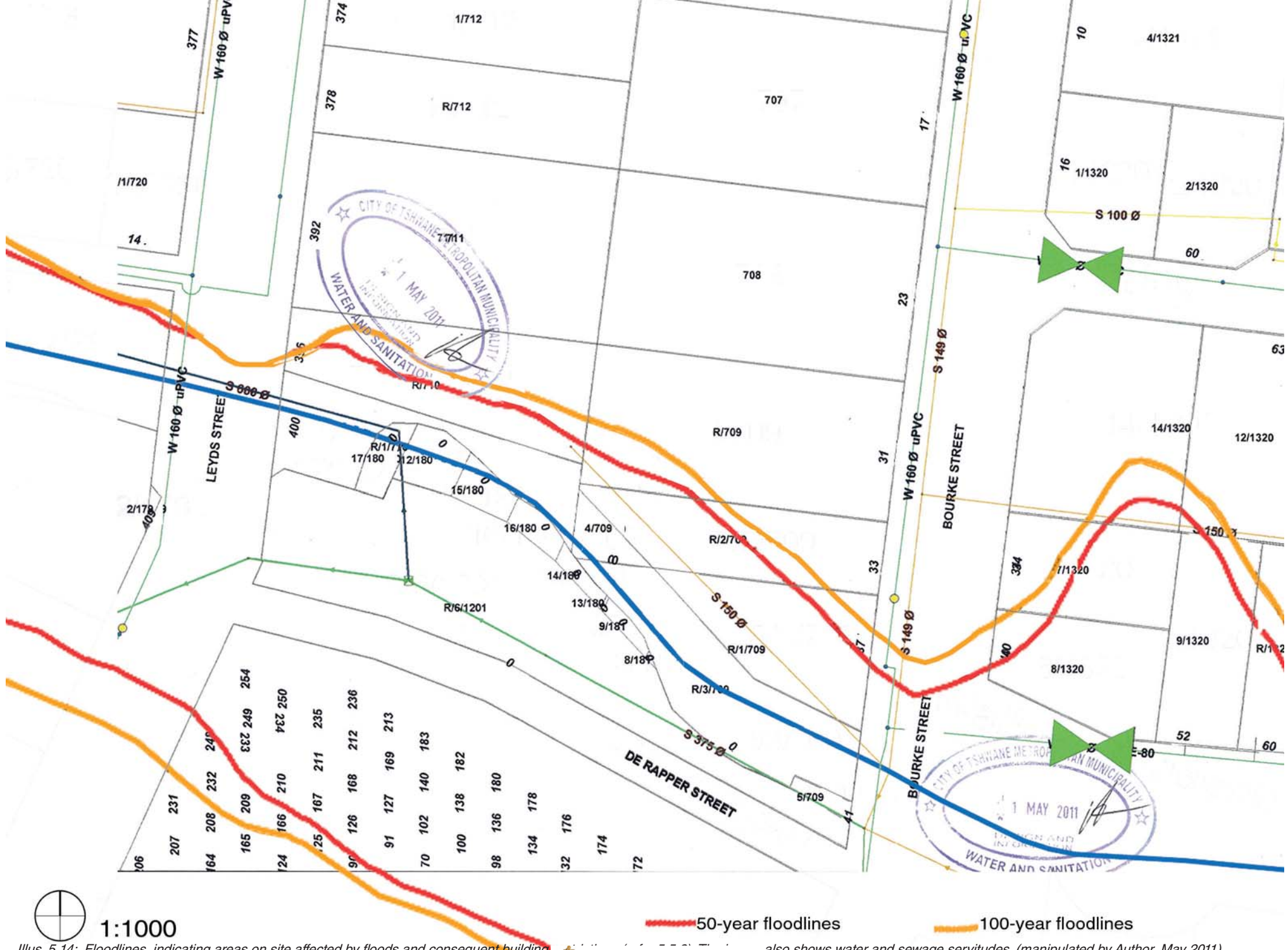

Figure 5.6: Wind direction (Windfinder.com, n.d)

**5.5.2 Services:** Illus. 5.14 shows floodlines, water and sewage servitudes on site. No structures which would alter the cross-sectional area of the flood are allowed within the 50-year floodline.



1:1000

50-year floodlines

100-year floodlines

Illus. 5.14: Floodlines, indicating areas on site affected by floods and consequent building

also shows water and sewage servitudes. (manipulated by Author, May 2011)

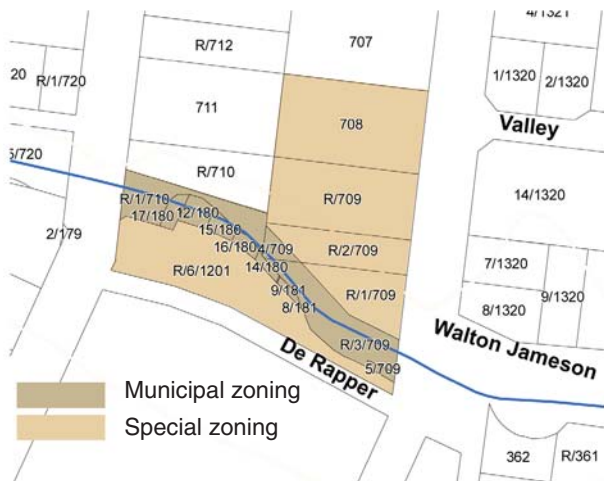

Illus. 5.15: Consolidation of erven. Not to scale (Author, May 2011)

**5.5.3 Consolidation:** For the design of the park, several erven currently belonging to the municipality will need to be consolidated (Illus. 5.15).

**5.5.4 Zoning:** The site is zoned as “special” and the erven containing the Spruit as “municipal”. The site does not need to be rezoned for the purposes of constructing a park.

**5.5.5 Legislation that affects the project:**

- National Water Act (NWA) (Act no. 36 of 1998)
- National Environmental Management Act (NEMA) (Act no. 107 of 1998)
- SANS 51176 (Playground equipment and safety standards)



Zoning legend

Special		Business		Undetermined	
Municipal		Educational		Public Open Space	
General residential		Special residential			

Illus. 5.16: Zoning (manipulated by Author, May 2011)



*Illus. 5.17: The current concrete channel has a low base flow, but could become a safety hazard during rainstorms (refer to Illus. 5.15 for floodlines). It is not feasible to rehabilitate the channel due to space constraints, but there is an opportunity to clean the water and to beautify the channel. (Author, April 2011)*



*Illus. 5.18: View from west edge of site. Note the street vendor next to the bridge, the narrow sidewalk between the road and the street, as well as the waiting area that has formed on the south-western corner of the site. The tree behind the vehicle is used for advertising. (Author, June 2011)*

## 5.6 Visual analysis

The following images will give the reader an idea of the current physical condition of the site.



*Illus. 5.19: The existing shade trees along the walkway will be kept. The site is very narrow on the south side of the Spruit. (Author, April 2011)*



*Illus. 5.20: View of existing playground on site. Note the lack of shade, seating and enclosure. There are many *Combretum sp.*, *Sercea lancea* and *Ekebergia capensis* trees which provide shade on the southern part of the site. (Author, April 2011)*



*Illus. 5.21: View of site from the east. Note the gentle slope (2 to 5%), as well as some large trees along the edges of the site and the Spruit. The Ring-Ting Pre-primary school at the western edge of the site is currently physically and visually separated from the site by a wall, and presents an opportunity for integration. (Author, April 2011)*

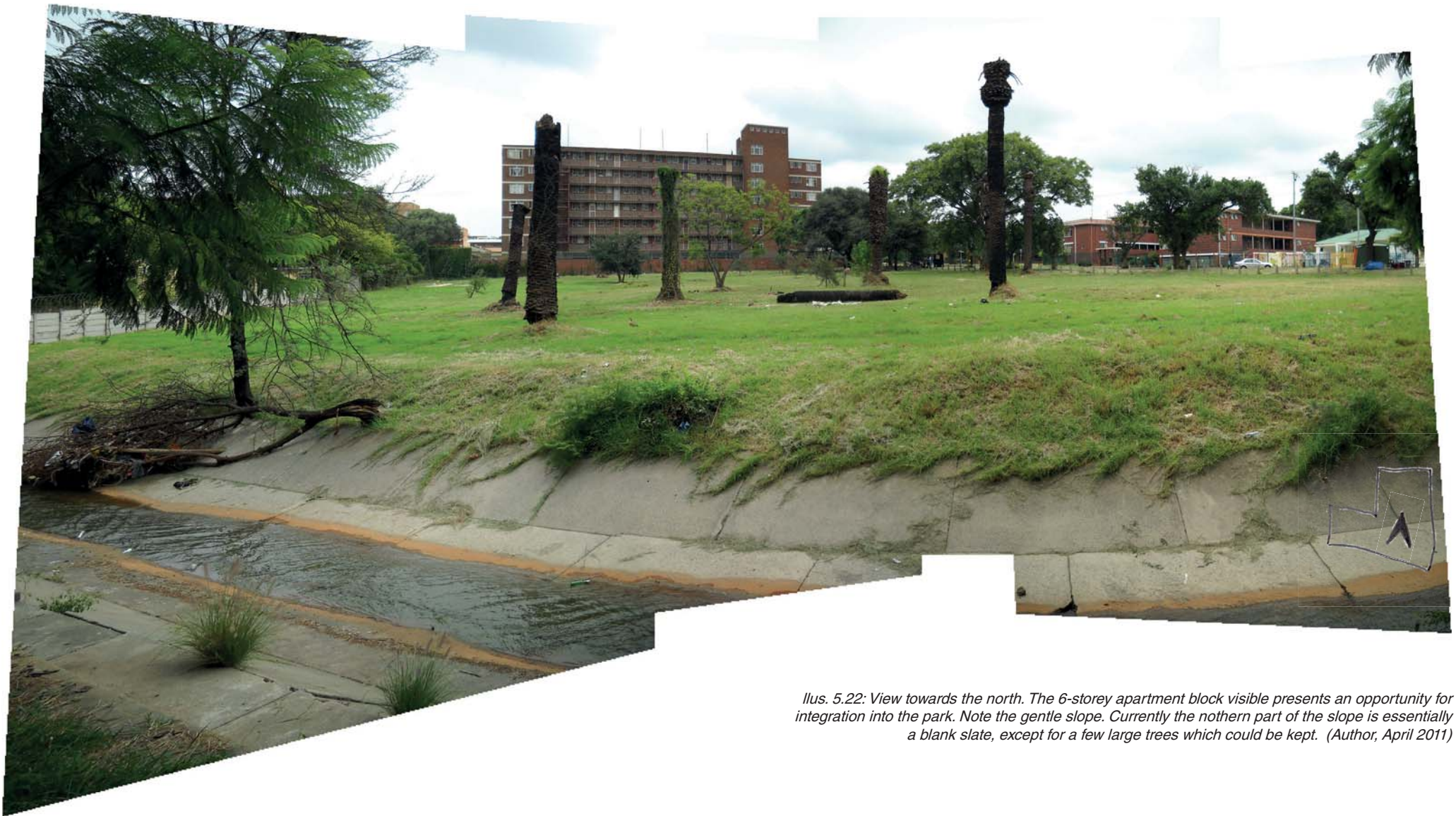

*Illus. 5.22: View towards the north. The 6-storey apartment block visible presents an opportunity for integration into the park. Note the gentle slope. Currently the northern part of the slope is essentially a blank slate, except for a few large trees which could be kept. (Author, April 2011)*



6

# Urban Framework

*Illus. 6.2: The Apies River and Walker Spruit running through the city. (Botha, April 2011)*



## 6.1 Introduction

The site analysis was done before the urban framework. This is due to the large size (and consequent large influence) of the site in relation to the rest of the open space along the Walker Spruit.

The Walker Spruit has its origin in Nieuw Muckleneuk, flowing through Bailey's Muckleneuk and Sunnyside before joining the Apies River at the Caledonian Sports Fields (Illus. 6.2 & 6.3).

## 6.2 Current condition of the Walker Spruit and Apies River

The channelization of the Apies River already started in 1910, and that of the Walker Spruit in 1925 (South Africa, town clerk, 1925). Today these two urban rivers are merely storm-water channels as opposed to the natural meandering rivers they once were. As they are not visually pleasing, buildings along the rivers turn their backs on it (Illus. 6.5 & 6.7).

In the urban framework group, it was envisioned that the Apies River and the Walker Spruit become linear urban parks running through the city, spines along which pedestrians can move. Elements from existing frameworks were used as the basis for design decisions:



*Illus. 6.3: The Walker Spruit from Walker Street to the Caledonian Sports Grounds. (Author, April 2011)*

Illus. 6.4 : Consortium Fook proposal for a Walter Battiss Memorial Park. Not to scale. (Courtesy of Joubert, 2009)

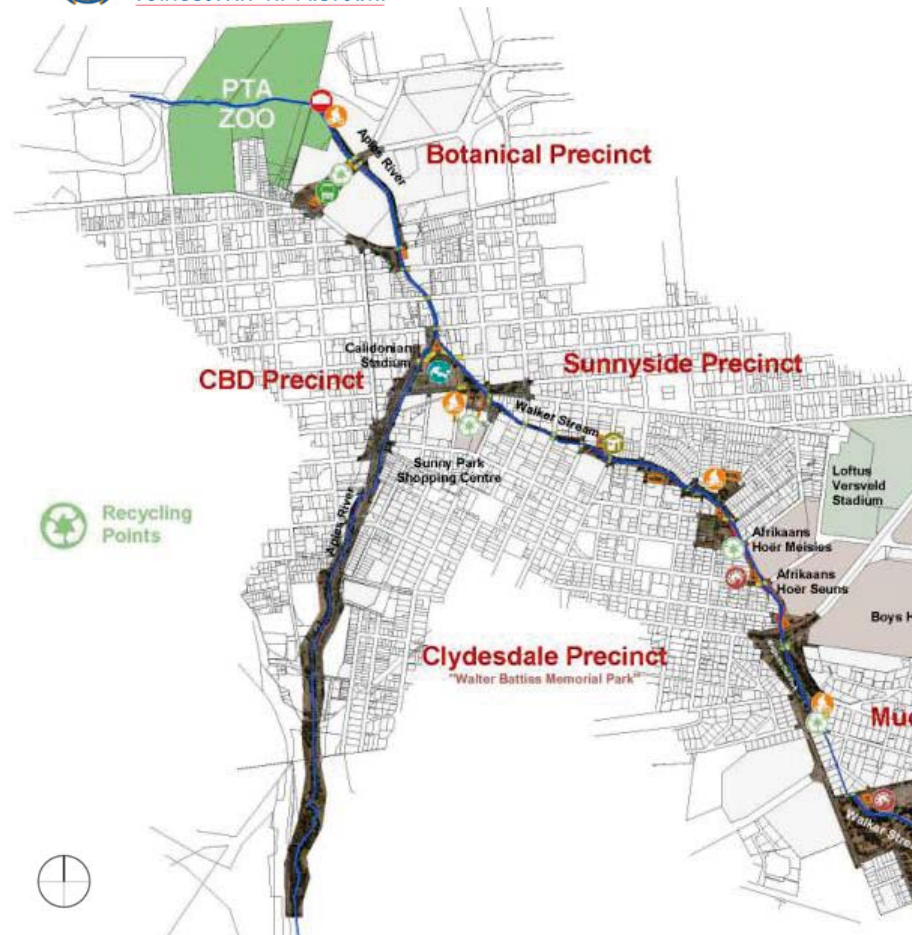

### 6.2.1 Apies River Framework

- Pedestrian and cyclist access should be established.
- Buildings should open up towards the river, with appropriate land use. Along the Apies River, mixed use is proposed. Retail and restaurants on the ground floor, with offices and housing above would ensure continuous usage of the spaces next to the river.
- Visual integration of the river with its surroundings should be established.

### 6.2.2 Tshwane Open Space Framework (TOSF)

- The TOSF has a classifying system of “ways” and “nodes.” Interconnectivity of these structuring elements would ensure continuous spaces serving as ecological corridors.
- Alternative service delivery (CID’s, partnerships with private/parastatal/NGO organizations) should be implemented.

### 6.2.3 Nelson Mandela Corridor Framework

- Both rivers should become activity spines with activity nodes along them to generate energy.

### 6.2.4 Consortium Fook Proposal

- A Walter Battiss Community Park should be established together with an eco-recycling network along the Walker Spruit (Illus. 6.4). This will promote “job creation, social sustainability and community participation” (Joubert & De Villiers, 2009). This proposal had the largest influence on the proposed framework, and its general principles were followed, such as using Battiss’s artworks as mosaics or installations along the Spruit and in underpasses, and using Norman-Eaton paving patterns.

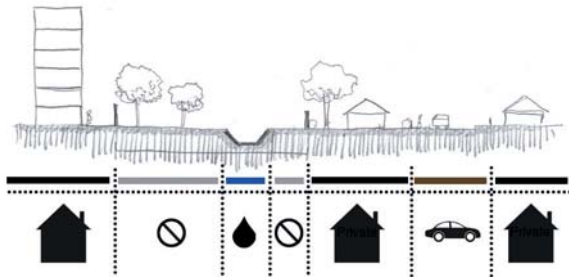

*Illus. 6.5: Currently buildings turn their backs to the Walker Spruit. There are no passive surveillance and few escape routes. The river is contained in a concrete channel. (Author, April 2011)*

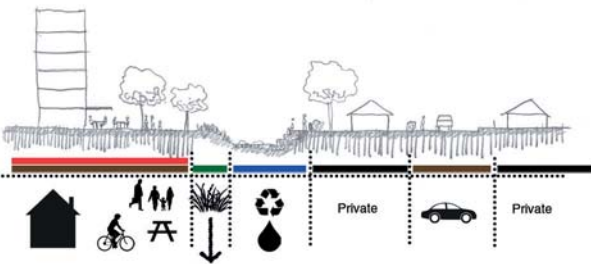

*Illus. 6.6: Design guidelines: It is proposed that buildings be converted to mixed use, opening up towards the river. The channel should be rehabilitated as far as possible and pedestrian and cyclist access enhanced. (Author, April 2011)*

## 6.3 Proposed framework

Together with T. van Deventer, D. Botha and T. Meyer, design guidelines were established to guide the detail design of sections of the Apies River and Walker Spruit. The author then chose to focus specifically on a framework for the Walker Spruit area.

On Illus. 6.6 the general guidelines for the Walker Spruit portion of the larger urban framework can be seen. Ground floor mixed use such as retail, restaurants and markets should be used to activate the space. Activity nodes as shown on Illus. 6.7 would supply energy to the spine. They would contain community amenities such as fast-food restaurants, a laundromat, post office or internet café.

An amount of water is taken out of the Spruit with a waterwheel and cleaned by means of a wetland and various filters (see Illus. 6.7, 7.6 & 7.8). It is then used in a water feature on the proposed site before being released back into the Spruit. The wetland re-establishes lost habitat and could encourage awareness of environmental issues.

Various options of dealing with the concrete channel

were investigated. Due to very high floodlines, it is impossible to rehabilitate the channel. It is therefore proposed that the *Mantis* artwork by Battiss (Illus. 6.9 & 6.10) be executed in mosaics in the channel. This work was chosen by the author as it has a natural theme with no bright colours, in keeping to the natural theme of the proposed park (see chapter 7).

The Norman-Eaton paving patterns suggested by Consortium Fook are also carried through the site in the main pedestrian pathway running along the Spruit. The mosaics and paving patterns add complexity to an otherwise dull urban environment.

### 6.3.1 Site-specific interventions

It is envisioned that the proposed project site become a natural children's playground, as it is situated close to various educational institutions. Such a playground will fulfil the needs of the community children, as discussed in Chapters 1 to 3.

De Rapper street on the south side of the site will be removed. This will open up more usable space on the south side of the Spruit, and enhancing the children's safety from vehicular traffic. Traffic calming devices

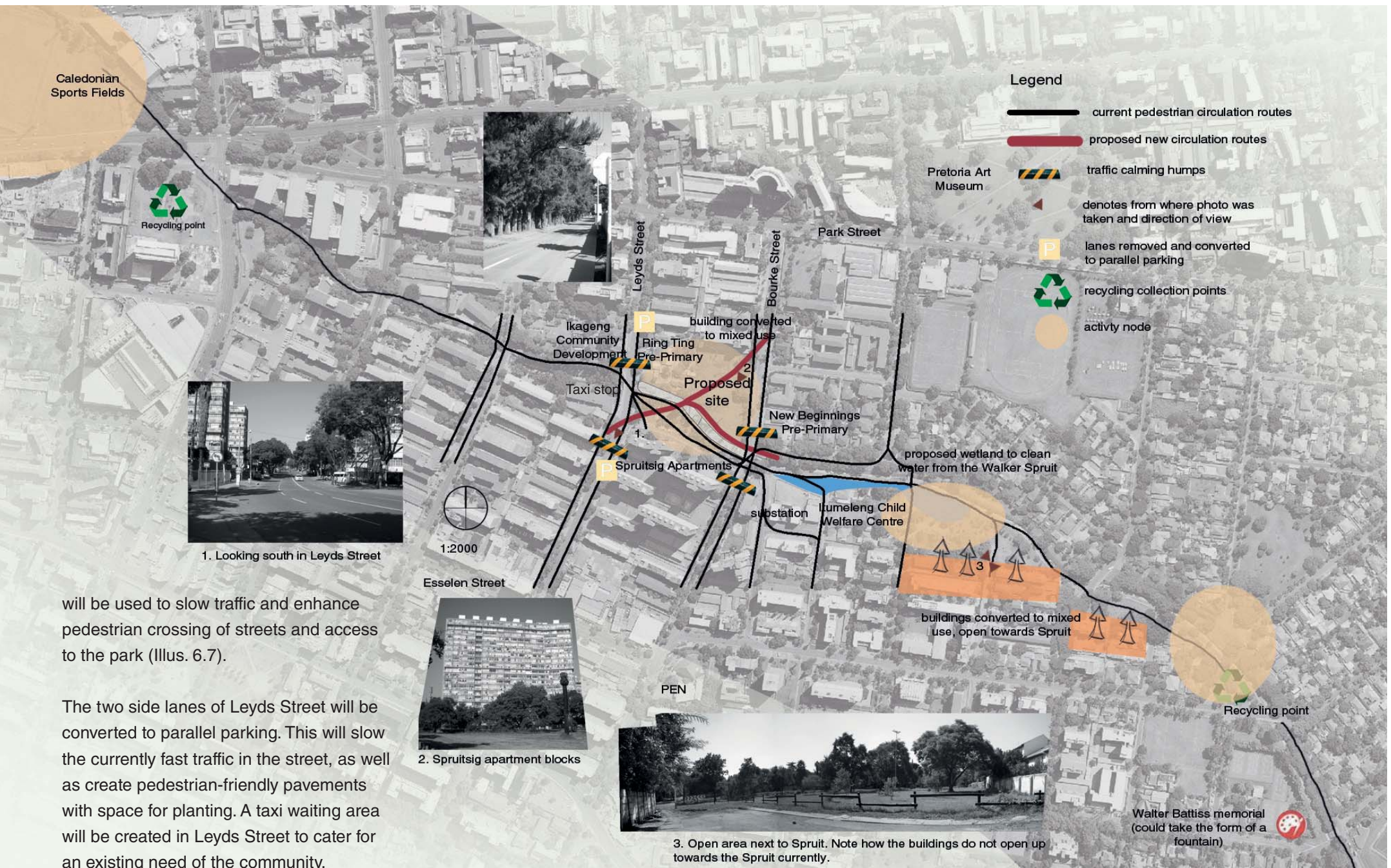

will be used to slow traffic and enhance pedestrian crossing of streets and access to the park (Illus. 6.7).

The two side lanes of Leyds Street will be converted to parallel parking. This will slow the currently fast traffic in the street, as well as create pedestrian-friendly pavements with space for planting. A taxi waiting area will be created in Leyds Street to cater for an existing need of the community.

Illus. 6.7: Proposed framework for portion of Walker Spruit (Author, May 2011).

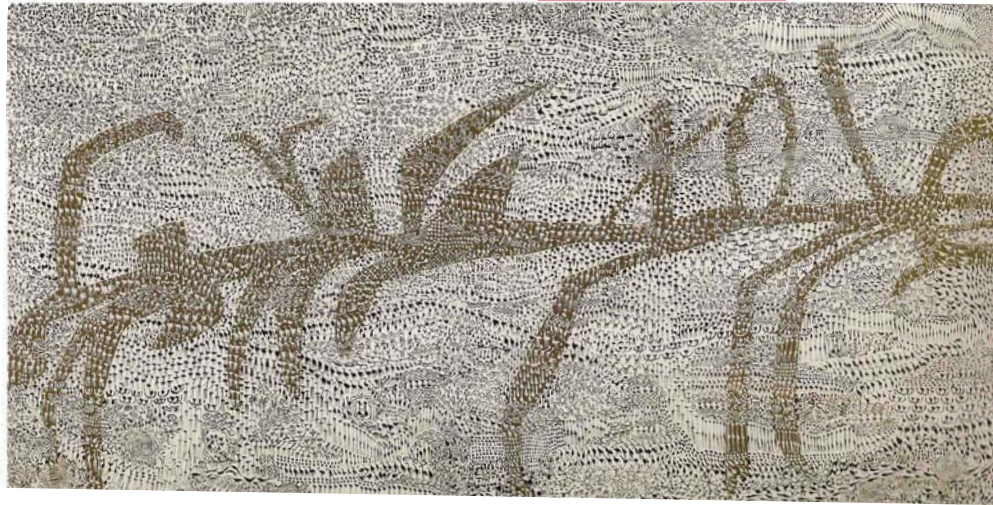
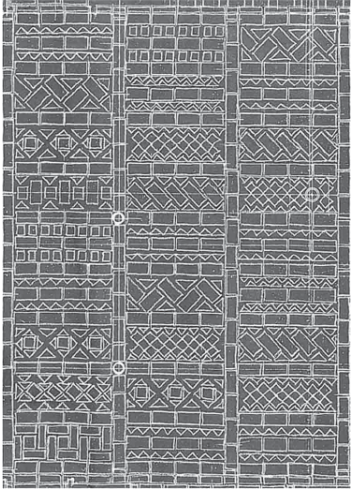

*Illus. 6.8: Norman-Eaton paving patterns (Courtesy of Joubert, 2009)*     *Illus. 6.9: Mantis. Oil on canvas, by Walter Battiss. (Skawran & Macnamara, 1985:31)*

*Illus. 6.10: Close-up of Mantis artwork showing complexity and detail. (Skawran & Macnamara, 1985:31)*

A new pedestrian route will be opened up across the site, as the northern part of the site is currently an isolated, unused space (except by homeless people).

The Costando Building on the north side of the site will be converted into mixed use on the ground floor, with a toy library, an internet café, Chicken Licken and greengrocer. The Spruitsig apartment blocks could not be converted to mixed use on the ground floor, as it is situated well within the floodline (the buildings currently stand on pilotis).

## 6.4 Conclusion

By creating activity nodes with amenities such as ATM's, cell-phone repair shops, internet cafés, and landscaped open spaces, energy will be generated along the Spruit, creating a safer and more pleasant environment.



*Illus. 6.11: Collage of vision for Spruit (Author, May 2011)*



7

Design  
development

In order for the reader to fully understand the design, this chapter starts off with the programme and an image of the final design proposal, and then proceeds to describe the process followed to produce it.

## 7.1 Programme

- A natural playground which would be divided into different areas for the three different age groups and their age-appropriate activities. This would consist of interlinking archetypal landscapes.
  - A toy library run by the Active Learning Libraries of South Africa
  - A kick about, which could double as performance space
- General park facilities such as gathering spaces, seating and drinking fountains which would cater for the needs of the public (children as well as adults, teenagers and the elderly)
  - Alteration of the Walker Spruit to beautify the current concrete channel
- A wetland for cleaning water from the Spruit before using it in an interactive water feature
  - Ablution facilities



*Illus. 7.2: Proposed design masterplan (Author, October 2011)*

Figure 7.1: The connections between man, his needs and the environment (Author, August 2011)

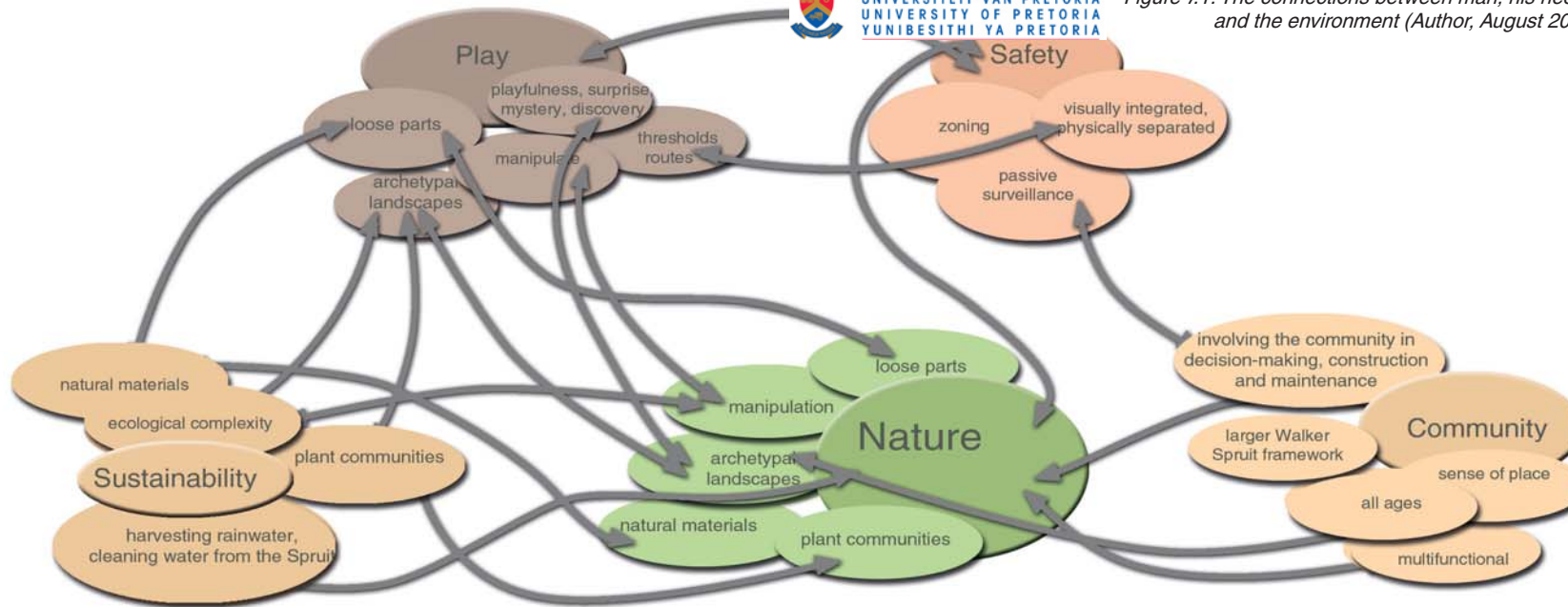

## 7.2 Site specific design guidelines

From the preceding research on children’s developmental and play needs, as well as the urban context of Sunnyside, five key appropriate design drivers were established as shown in Figure 7.1.

1. Nature is essential for children’s development and will form the core design driver of the park.
2. Children and their play needs are the main focus of the park.
3. Safety is paramount in a dense urban area such as Sunnyside.
4. Creating a sense of community will make the park safer and more popular with children and their parents.
5. Sustainability is necessary for the long-term success of the park and is an ethical prerequisite for any development today.

## 7.3 Nature

Using natural elements to create play spaces is the main focus of this dissertation. As little as possible man-made elements will therefore be used. Boulders, water, sand, lawn and plants will constitute the bulk of the playground. Plants with edible fruit, and interesting flowers or seeds will be used. They will also be chosen to provide interest throughout the year.

## 7.4 Play

To stimulate healthy cognitive and socio-emotional development of children, activities that capture the imagination should be facilitated (Pearson & Wilson, 2001; Wilson, 2008). This can be done by providing for manipulation of the environment and for loose parts (build a “house” or a sandcastle). Continuous play

opportunities, such as steps leading to a “den,” or a tunnel leading to or over a water feature, lead children from one play activity to the next, and facilitate much more complex play than when activities are disjointed. Routes leading somewhere enable surprise, mystery and discovery, important elements in an often bland urban environment. Thresholds such as crossing over a bridge or mounds serve to enhance the feeling of having passed from one area to the next and of being in a different area. Having passed a challenge, such as jumping over a wide stretch of water successfully, creates a feeling of accomplishment.

## 7.5 Safety

As safety is of paramount importance in a children’s playground, particular attention was paid to safety measures. The park will be open to all users, however,

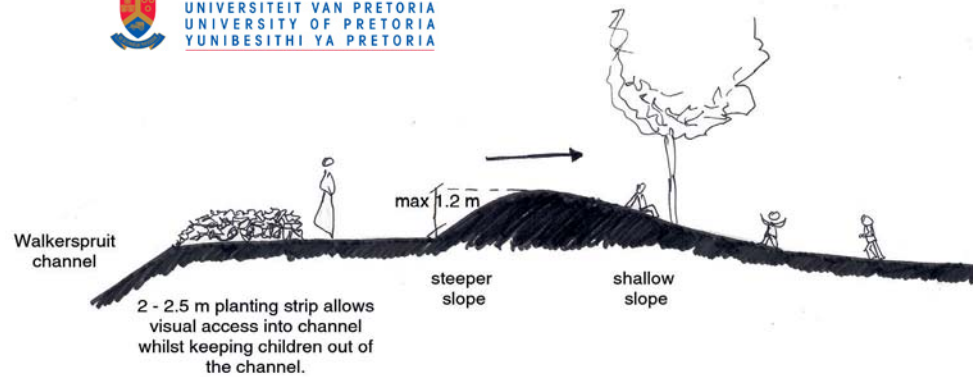

*Illus. 7.3: Berm provides psychological separation but visual integration (Author, July 2011)*

in some areas physical access will be hampered by wide planting strips (about 2-4 m wide). Berms will provide psychological separation in some areas (see Illus. 7.3), but all areas of the park will be visually integrated. Therefore no planting will be higher than 800 mm, unless the planting is sparse enough to see through (such as through the “walls” of the Tunnel area which are created by planting) (see pages 96 and 97). The park should be divided into different areas with specific design elements which would encourage specific age groups to appropriate that space (a boisterous eight year old would rather play on the rock climbing wall with a group of friends than walk on low balancing logs meant for three year olds). These measures and passive surveillance from activity nodes increases safety.

It was decided that the park should not have an excessively wild and natural look (exactly as it would look in nature) as it is inappropriate and unfavourable to recreate nature in the city (see also next paragraph). Marc Treib asserts that misinterpretations between the designer and user can arise when nature is recreated in the city: “Like the caged animal in the zoo, however,

an urban prairie is hardly a prairie at all; it is an urban garden planted with unmown grass and little else... Still, passersby wonder quietly to themselves: “When are they going to cut that lawn? I’m sure there are rats...living in it. And they should water it; it looks dead.” (Treib, 1995: 93)

The Broken Window Theory developed by social scientists George Kelling and James Wilson states that when nobody seems to care about a space (such as when weeds take over, plants are not watered and litter lies about everywhere) even more crime and unkemptness result (Kelling & Wilson, 1982). It is highly probable that more litter will appear, the space will be appropriated by homeless people, and crimes might increase in the area.

If the park thus had a completely natural look with plants dying off and looking unkempt in winter, for example, people might receive wrong impressions of the park and even start to feel unsafe. The park will therefore use indigenous plants and natural materials as far as possible, but through maintenance<sup>1</sup> it will be clear that the park is taken care of.

Passive surveillance will be gathered from the entrances of the park where people gather, the central street vendor at the tower, toy library and the shops at the northern building.

## 7.6 Community

Illus 7.7 on the next page shows an interpretation of the urban context of Sunnyside. In summary, it can be said that Sunnyside is rich in textures such as brick patterns, giving character to otherwise bland housing blocks. The layout of the neighbourhood is almost forceful in its rigidity and grid pattern, with no conspicuous natural lines or softness in the landscape. Despite having a busy street life, Sunnyside seems to be locked up behind palisades.

It is envisioned that the park will become a soft landscape in an otherwise hard environment which could be used by all age groups, such as pedestrians on their way to work, young adults, teenagers, and the elderly. It will serve as an activity node along the Walker Spruit generating energy along the linear urban

1. Refer to page 5 for a detailed explanation of who will be responsible for the park's maintenance.

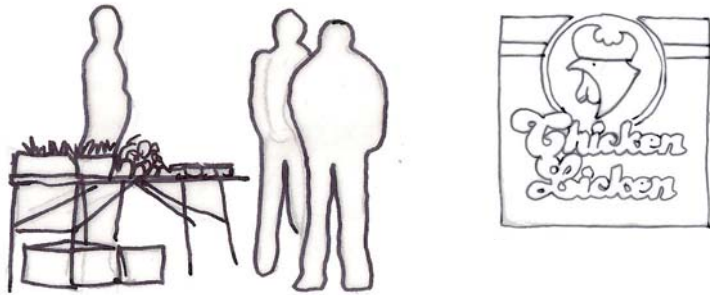

Illus. 7.4 & 7.5: Different income groups will be catered for. (Author, August 2011)

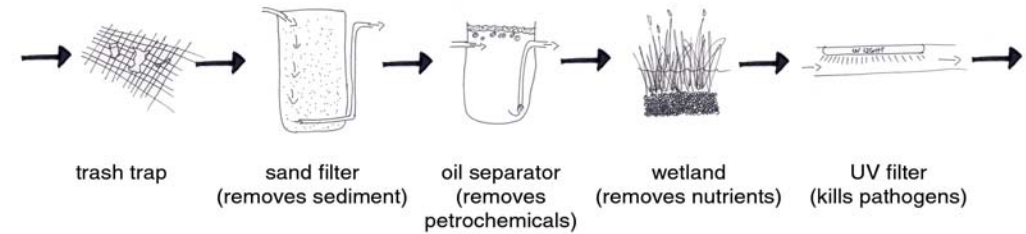

Illus. 7.6: Water purification strategy (Author, September 2011)

Below: Illus. 7.7: Moodboard collage of the urban context of Sunnyside (Author, April 2011)



park proposed in the urban framework for the Walker Spruit as discussed in the previous chapter. The park will give a sense of place and identity to this area of Sunnyside by incorporating the local community in the construction and maintenance process.

Public ablution facilities will be available at the Costando building at the northern edge of the site.

### 7.6.1 Inclusive design

The park allow wheelchair access to all areas and no slope is steeper than 1:15, with the exception of the bridge which is 1:12. Loose sand could present a difficult surface to traverse and therefore firm pathways cross the various areas. In the 0-3 year old area, sufficient space to park prams have been allowed at seating areas. Different income groups are also catered for (see Illus. 7.4 & 7.5). The street vendors will cater for low-income users, while the fast-food restaurant at the Costando building (a Chicken Licken) will cater for middle-income users. The internet café and green grocer will cater for all income groups.

Water is taken from the channel with a waterwheel, passed through the wetland for two days, and then used for irrigation in the "river" of the 6-12 year area. Excess water flows into a storage tank for irrigation and the rest flows back into the Walker Spruit. Due to space constraints, the wetland has to be placed as close as possible to the Spruit. (Author, September 2011)

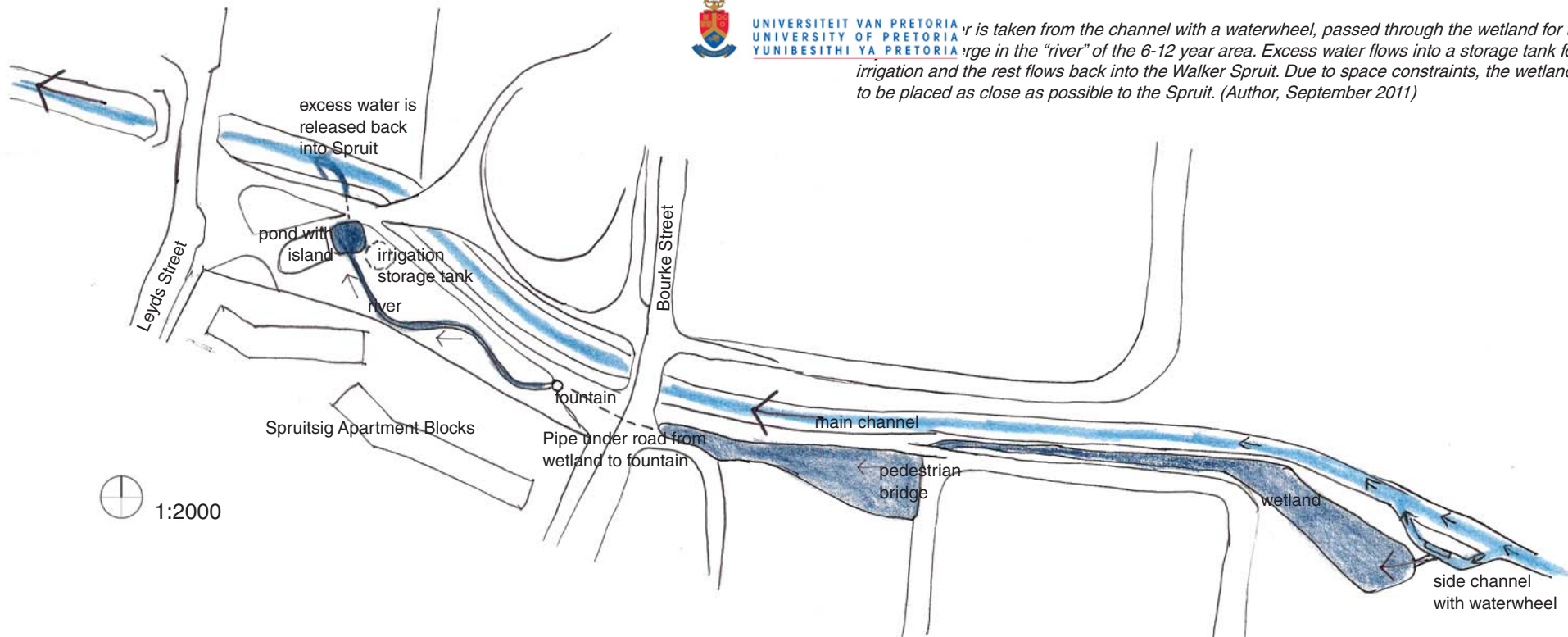

## 7.7 Sustainability

### 7.7.1 Water and stormwater

Rainwater will be harvested from the northern building's roof to supply water for a water feature in the toy library and 3-6 year old area, as well as for irrigation needs.

Stormwater will be directed into planting beds. Excess stormwater on the northern side of the Spruit will be directed into a storage tank for later use. After initial watering during the establishment phase, it is envisioned that the plants will need the minimum watering (manually controlled) because they are indigenous and receive rainwater.

Water will be taken from the Spruit with a waterwheel, cleaned by means of a wetland and other filters (see Illus. 7.6 and 7.8), and used for a shallow water feature running through the park before being released back into the Spruit. Some of the water will be stored in a tank for irrigation use on the south side of the Spruit.

Children will be discouraged to enter the channel for safety considerations by a wide planting strip which still allows visual access into the channel.

### 7.7.2 Planting strategy

It was initially decided to use only plant species found naturally in the greater Pretoria area, and to plant them in specific communities as they would occur in nature.

The site is classified as mountain bushveld (see page 42). Rocky ridges and grassland communities were however not excluded, as they are representative of the greater Pretoria area and including them would increase the complexity of the site. Plants were chosen according to Acocks in Veld Types of South Africa (Acocks, 1988:29, 112-114), Mucina and Rutherford in Vegetation of South Africa, Lesotho and Swaziland (2006:466-467), and communities found in the Faerie Glen Nature Reserve in Pretoria East, as documented by Eco Assessments (the Reserve is representative of major vegetation types found in Pretoria).

Five main communities were identified:

1. Riverine and wetland



Illus 7.9: Site plan revision 1 (Author, April 2011)



Illus 7.10: Site plan revision 2 (Author, May 2011)



Illus 7.11: Site plan revision 3 (Author, June 2011)

2. Mixed bushveld
3. Grassland
4. Forest
5. Rocky ridge

Plants that have similar habitat needs will therefore be grouped together, ensuring optimum growth opportunities. Plants were chosen for length of flowering time, conspicuous flowers and seedpods, fragrance, robustness and edibility (to provide loose parts for playing with as well as stimulate the senses). However, using plants only found in the Pretoria area proved to be too restricting, and it was subsequently decided to include plants from other parts of the country as well if they would still thrive in the Pretoria climate. This enabled the author to use a greater variety of plants with desired qualities such as fragrance or shade-tolerance.

### 7.7.3 General

Local labour will be employed in the construction of the park. This will ensure skills acquisition and create employment opportunities. The gabion seating walls, for example, will be handpacked to ensure a neat finish. The beautification of the Walker Spruit Channel will allow specific skills to be learnt, and will create a sense of ownership due to community involvement.

For material choice philosophy, refer to Chapter 9.

### 7.8 Main site plan revisions

Circulation routes, the need to activate certain areas of the park as well as safety issues influenced the functional layout of the design (refer to Illus. 7.27). On a detail scale, complexity and child-size spaces were

important.

The following site plans were drawn at various stages of the design.

#### 7.8.1 Site plan revision 1

A large undulating pergola with climbing plants that extend into the streets next to the site draws people into the site and along the proposed circulation routes. This was revisited as it makes a strong visual statement, but detracts from the actual playing areas, which should be the focus of the park. Besides providing shade and having an interesting shape it did not serve any function. A mini-soccer pitch was incorporated, but this created space constraints and awkward spaces on site.



*Illus. 7.12-7.17: Archetypal landscapes (Author, August 2011)*

### 7.8.2 Site plan revision 2

It was envisioned to have strips of natural elements running through the site, to create routes linking the various parts of the site in this way. This was further developed in revision three, as the routes alone did not provide the complexity needed to make a children's playground function as well as it possibly could. This revision still has an area for kinetic equipment such as is commonly found in playgrounds.

### 7.8.3 Site plan revision 3

In this revision, the kinetic area was removed. It was decided that the equipment detracts from the focus of the dissertation, namely a natural playground.

Only at this stage did the idea of archetypal landscapes (representing a range of landscapes typically found in children's stories, films or seen on television) surface. This was investigated and further developed into the final concept.

### 7.9 Concept (See also 3.2.4 on page 23)

Archetypal landscapes form a non-prescriptive platform for children's play, offering an environment which stimulates the imagination and which can be used for various games, or even re-enactment of stories or films that the children have seen (see Figure 3.12 on page 24). These landscapes can largely be constructed with natural materials and are found in both African and Western stories for children.

Examples of such landscapes in African stories are: ant bear holes, hollow cliffs, valleys, ditches, rivers, reeds, fountains, wells, hills, mountains, waterfalls, grasslands, kraals, and the bush.

Examples in Western stories are: woods, ponds, towers, castles, meadows, valleys, mountains, forests, caves, oceans, gorges, waterfalls, bridges, and islands.

The main archetypal landscapes (which are also suitable to reproduction on a smaller scale and do not present a safety hazard) are:

- The forest
- The grassland or open plain
- The hill or mountain
- The river
- The island
- The fountain
- The tower, castle or kraal (symbol of safety, having a view)
- The tunnel

On their own and when interlinked, archetypes are able to encourage playfulness, mystery, discovery and surprise.

### 7.9.1 Site plan revision 4

The concept of the monomyth (see Illus 7.18) was investigated to see if a universal story could be acted out in the landscape. It was consequently decided to not let the arrangements of archetypes be guided by a single children's story, but rather to allow open interpretation of the landscape and multiple routes to be followed.

From investigating the monomyth as well as reading numerous stories, it was established that most storylines started from a basecamp, went through trials and tribulations and ended again at a safe base, for example the sequence found in the African story 'How a strange creature took the place of a girl and then fell into a hole' (McCall Smith, 1989:95-100):

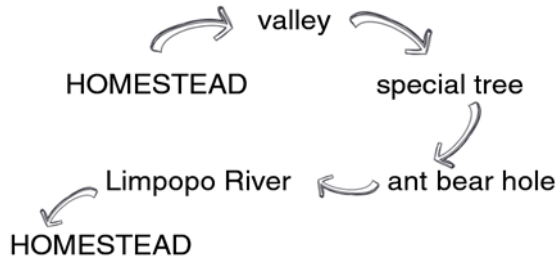

It is therefore important to create such “bases” in the landscape (see Illus. 7.30 on page 69).



*Illus. 7.20: Curving pathways entice (Author, May 2011)*



*Illus. 7.21: Small spaces to hide in (Author, June 2011)*



*Illus. 7.22: Where does the bridge lead? (Author, June 2011)*

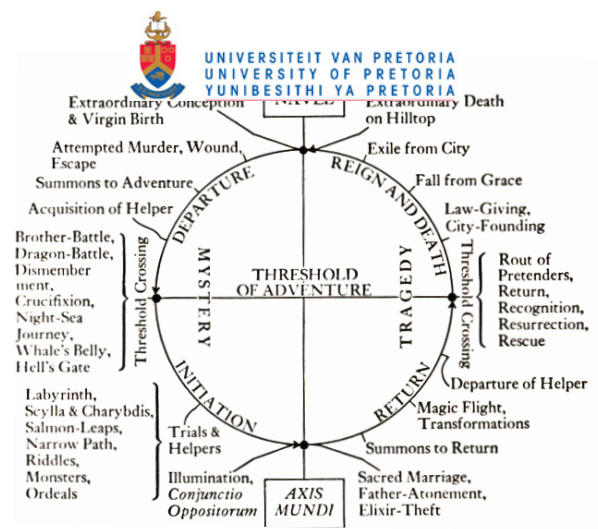

*Figure 7.2: Explanation of typical run of events in a story as summarized in the monomyth (<http://thenamingofparts.com/>)*

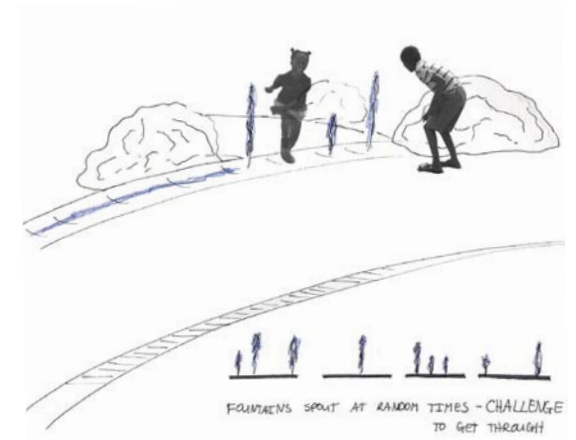

*Illus. 7.19: Interactive thresholds (Author, May 2011)*



*Illus. 7.23: Threshold investigation (Author, May 2011)*

Illustrations 7.19 to 7.27 investigate basecamps, routes, and thresholds as it was explored during the design process.

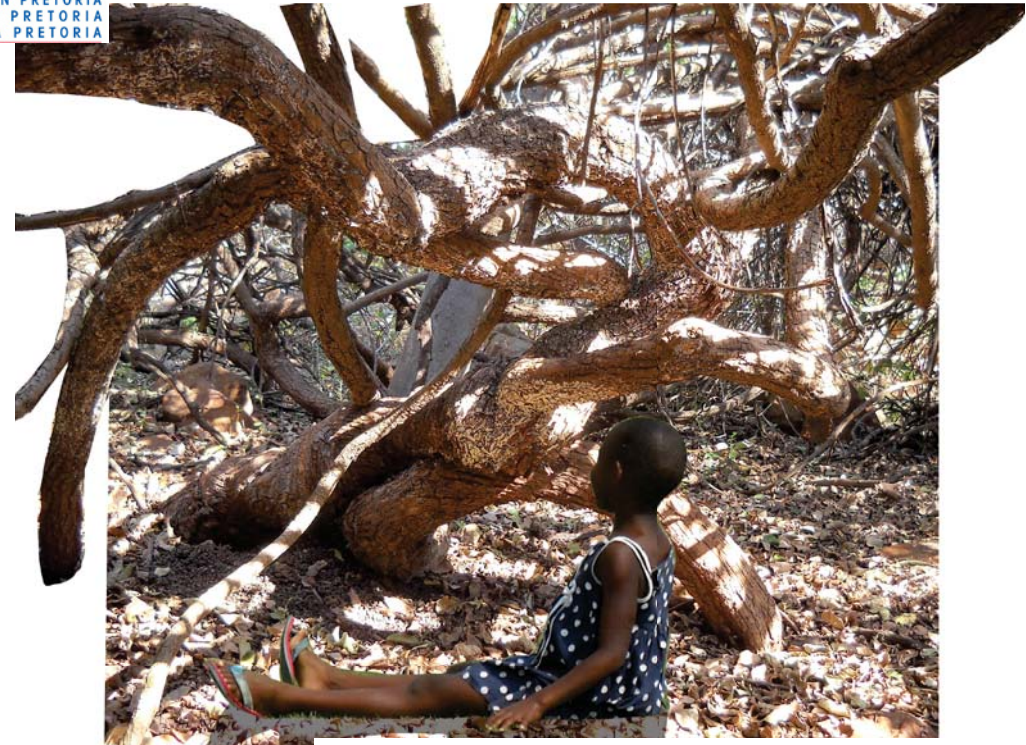

*Illus. 7.24: The twining branches of a Combretum microphyllum can create imaginative spaces. (Author, June 2011)*



*Illus. 7.25: A safe hiding place (Photo collage, Author, June 2011)*



*Illus. 7.26: Tall grasses may seem like a forest to a three year old. (Author, June 2011)*



*Illus. 7.27: Crossing water safely in Jan Cilliers Park, Pretoria (Author, June 2011)*

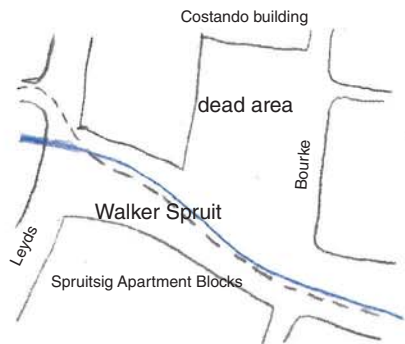

current circulation

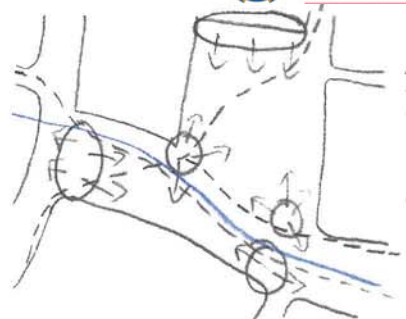

Need to activate dead areas at edges and in middle, with new circulation routes over Spruit.

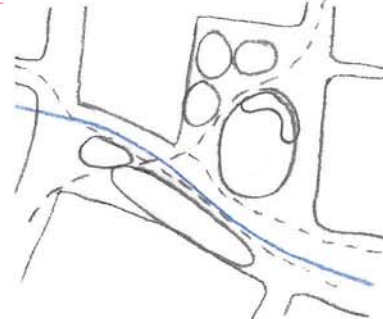

Activities and age groups are zoned

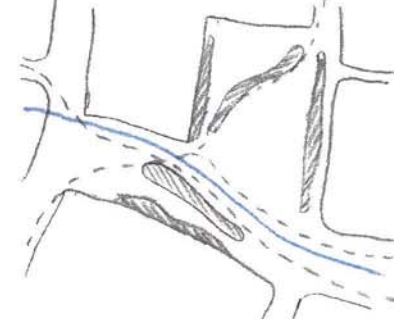

Berms and planting strips are added for psychological or physical separation.

Illus 7.28: How basic layout was generated (Author, August 2011)



Illus. 7.29: Final plan (Author, September 2011)

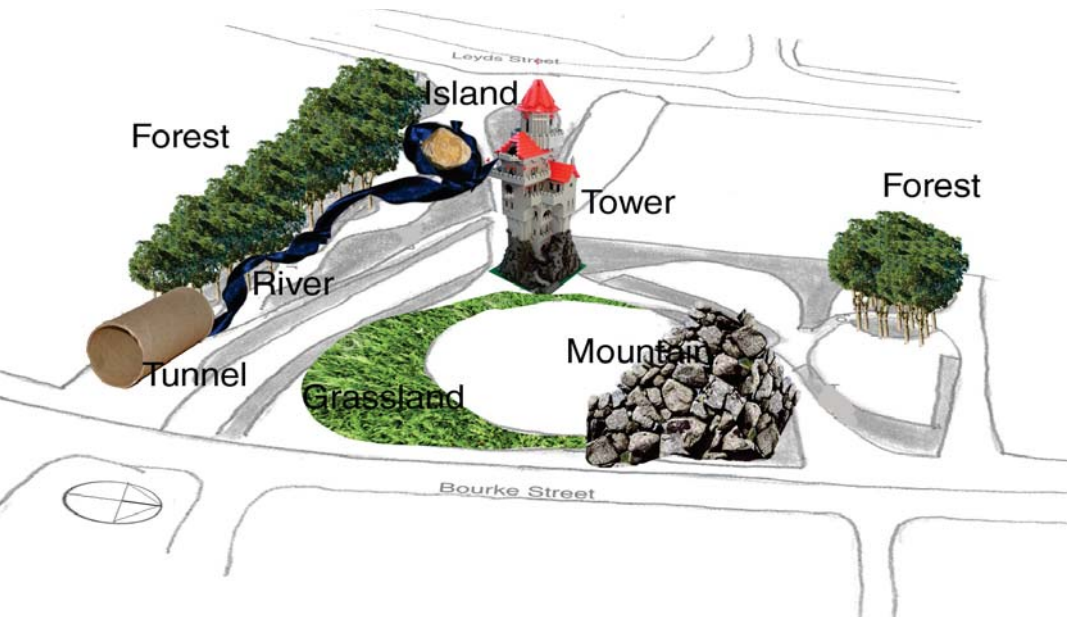

Illus. 7.30: Parti diagram showing where archetypal landscapes are located (Author, September 2011)



*Illus. 7.31: Possible basecamps and routes which could be followed through the park (Author, September 2011)*

## 7.10 Conclusion

Site plan revision 4 forms the basis of the final design resolution as discussed in chapter 8.

Illustrations 7.27 to 7.31 summarise the design in terms of the most important aspects, namely archetypal landscapes, bases and routes, and functional aspects such as safety, nodes and access.

In the next chapter the final design will be discussed in depth.

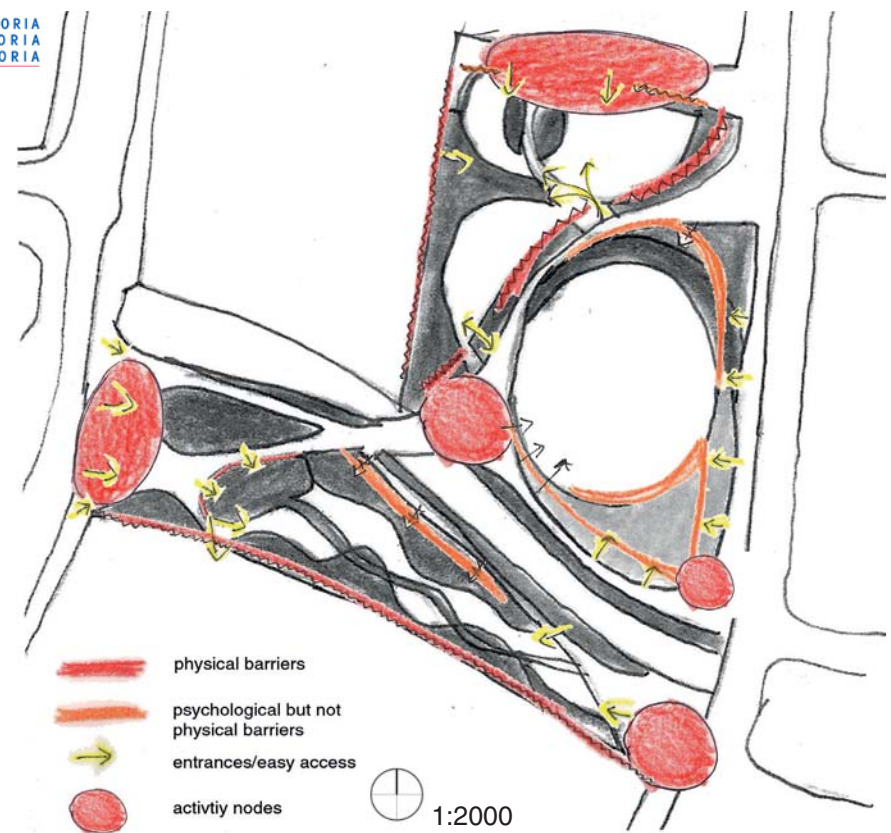

*Illus. 7.32: Activity nodes, entrances and barriers (Author, September 2011)*

Let's play!

Let's play!

Let's play!

Let's play!

Let's play!

Let's play!

Let's play!

Let's play!

Let's play!

# Design Resolution

# 8

### ***The girls are playing wedding.***

*Tuliza got a white sheet from the toy library. It is Maria's veil. Four girls are the bridesmaids. They adorn their hair with sprigs white flowers from the False Olive. It smells like perfume. What can be the church? We use the house that the boys built next to the pergola, using flattened cardboard boxes. The fallen autumn leaves are confetti. The wedding disintegrates into a leaf fight where we throw handfuls of leaves to one*

*another, falling and rolling in the leaves. Maria hurts her arm while falling. When she has finished crying we decide she is dead and bury her under the leaves. She becomes a ghost and scares us all by suddenly jumping up from the dead and chasing us. We run away and hide. The boys join us for a game of hide-and-seek. There are many spaces to hide in the playground. My favourite is in the long thatching grass. When I sit far back the other children cannot see me from the pathway (although Auntie Emma can because she's tall). Sometimes we play we hunt elephants in the grass. Tommy's favourite hiding place is in the puzzle bush under the overhanging branches. Maria usually hides in the space between the three large rocks. When it becomes dinner-time, we all start leaving the playground. Auntie Daphne at the toy library asks us to bring back the white (now slightly dirty) sheet. She's a nice lady. She never screams at us or punish us. She allows us pretty much anything. I've only seen her angry once, when a group of boys bullied a smaller one. Fortunately she could get to them before they hurt the smaller boy. (Author, April 2011, based on real-life play behaviour as documented by Berry, 2001 and Wellhausen, 2002)*

## 8.1 Masterplan

The masterplan is a culmination of all the research and design development. An explanation of each item on the master plan follows: (Refer to Figure 3.12 when reading nrs. 5-8).

1. Forest
2. Grassland
3. Water features
4. Mountain and kick about area
5. 0-3 year old area
6. Toy library and building area
7. 3-6 year old area
8. 6-12 year old area
9. Climbing tower and kiosk
10. Tunnel
11. Lawned area
12. Waiting and gathering areas
13. Channel
14. Taxi waiting area
15. Shade pergolas



Illus. 8.2: Masterplan (Author, September 2011)

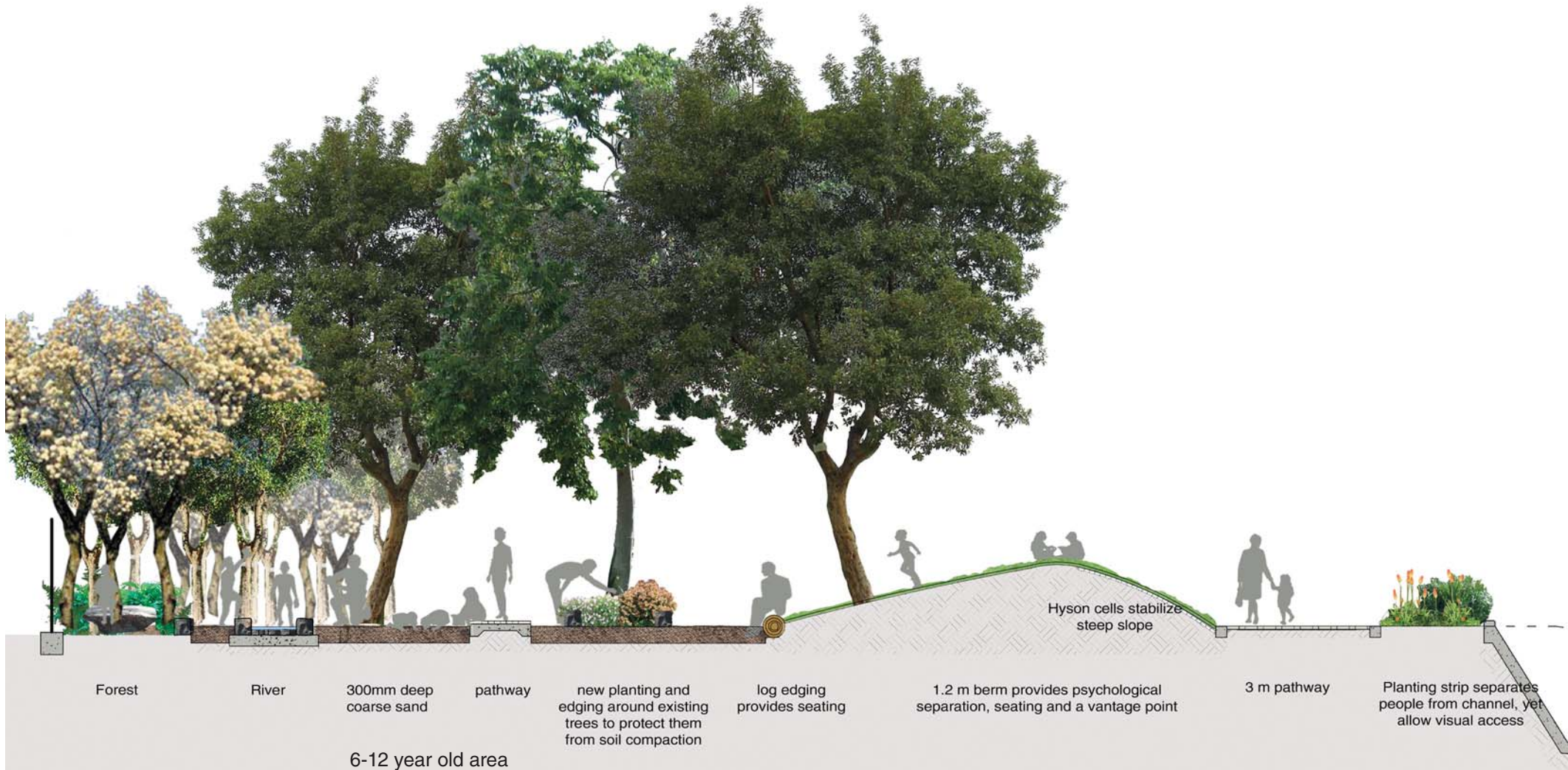

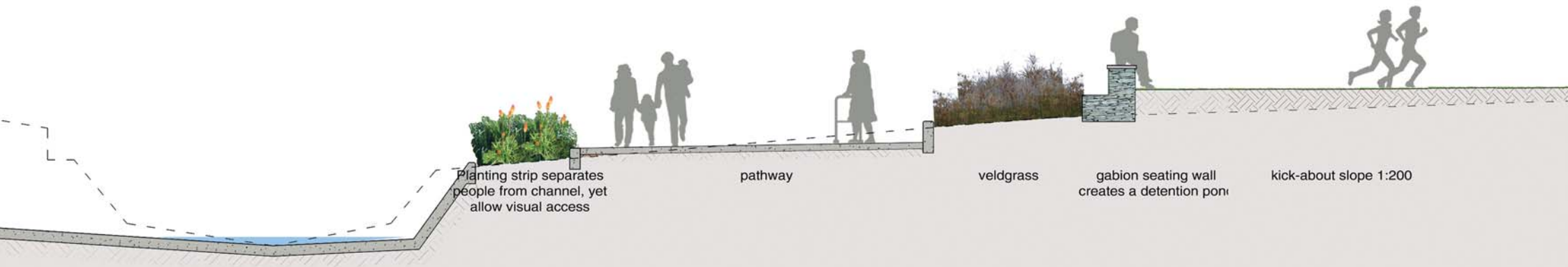

Planting strip separates people from channel, yet allow visual access

pathway

veldgrass

gabion seating wall creates a detention pond

kick-about slope 1:200



*...and presently, after ever so many days, they saw a great, high, tall forest full of tree trunks all 'sclusively speckled and spottled and spottled, dotted and splashed and slashed and hatched and cross-hatched with shadows.  
(How the leopard got its spots; Kipling, 1912: 64)*



Illus. 8.5: *Rhamnus prinoides* (Venter, 1996: 77)



Illus. 8.6: *Euclea crispa* subsp. *crispa* (Joffe, 2007: 56)



Illus. 8.7: *Dombeya rotundifolia* (<http://inheemseboome.co.za>)

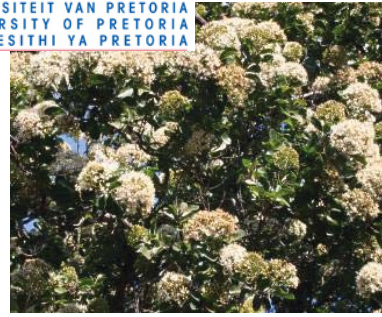

Illus. 8.8: *Nuxia congesta* ([www.plantzafrica.com](http://www.plantzafrica.com))



Illus. 8.9: *Ehretia rigida* (Venter, 1996: 173)



Right: Illus. 8.10: *Protasparagus setaceus* (Van Wyk & Malan, 1998: 71)

## 8.2 Bushveld Forest (nr. 1 on Illus. 8.2)

Trees were chosen for their upright growth and ability to grow well in dense stands, occurring naturally in the greater Pretoria area (see also page 65). The trees are closely spaced at about 1.2 m apart and the trunks are pruned clean up to a height of 1.5m. This creates an enclosed ambiance. In late winter when all else is dull the forest will be a fragrant cloud of white flowers with both *Nuxia congesta* and *Dombeya rotundifolia* in full bloom. Forests are places to hide away, to build dens in, to fight lions in or simply to pick berries.

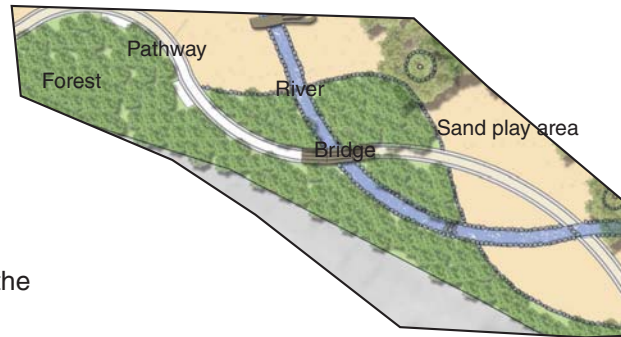

Illus. 8.11: Partial plan 1:500 of forest area (Author, September 2011)



Illus. 8.12: *Blechnum australe* (<http://sophy.u-3mrs.fr/Afriqsud/HI89.HTM>)



Illus. 8.13: *Asparagus asparagoides* (<http://luirig.altervista.org>)



Illus. 8.14: *Pteris vittata* (Joffe, 2007: 309)



Illus. 8.15: *Asplenium aethiopicum* (<http://pics.davesgarden.com>)

Two grids placed at different angles were used to determine the placement of the trees. In order to prevent compaction around the tree roots, forest plants such as *Cyrtomium falcatum* and *Protasparagus* sp. are planted around the trees. Boulders placed between the trees slow down the children and protects the groundcovers from being trampled. The river as well as a pathway runs through the forest, creating more complex play opportunities.

Forest	J	F	M	A	M	J	J	A	S	O	N	D
<i>Ehretia rigida</i>												
<i>Euclea crispa</i>												
<i>Nuxia congesta</i>												
<i>Rhamnus prinoides</i>												
<i>Dombeya rotundifolia</i>												

J	F	M	A	M	J	J	A	S	O	N	D

Left: Illus. 8.4: Vision for the bushveld forest area. (Author, July 2011)

Figure 8.1: Left: Flowering times of plants used. Right: Fruiting times of plants used (Author, August 2011, compiled from Joffe, 2007, and [www.plantzafrica.com](http://www.plantzafrica.com))

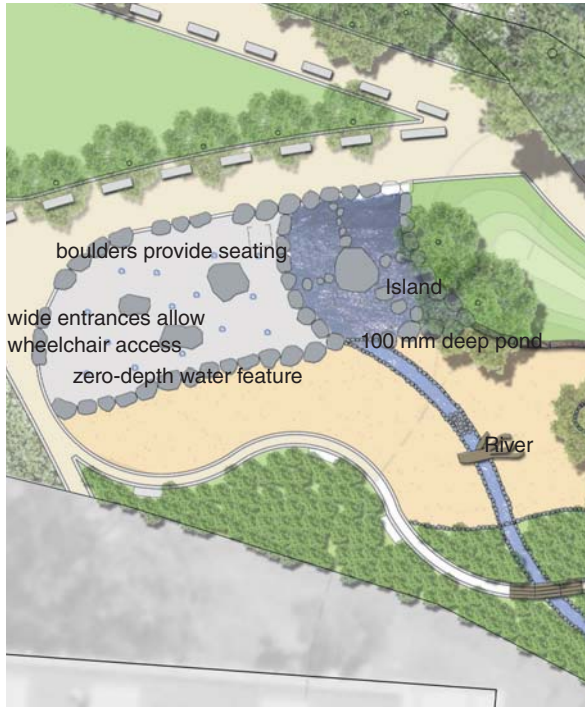

Illus. 8.16: River, pond and zero-depth water feature 1:200 (Author, October 2011)

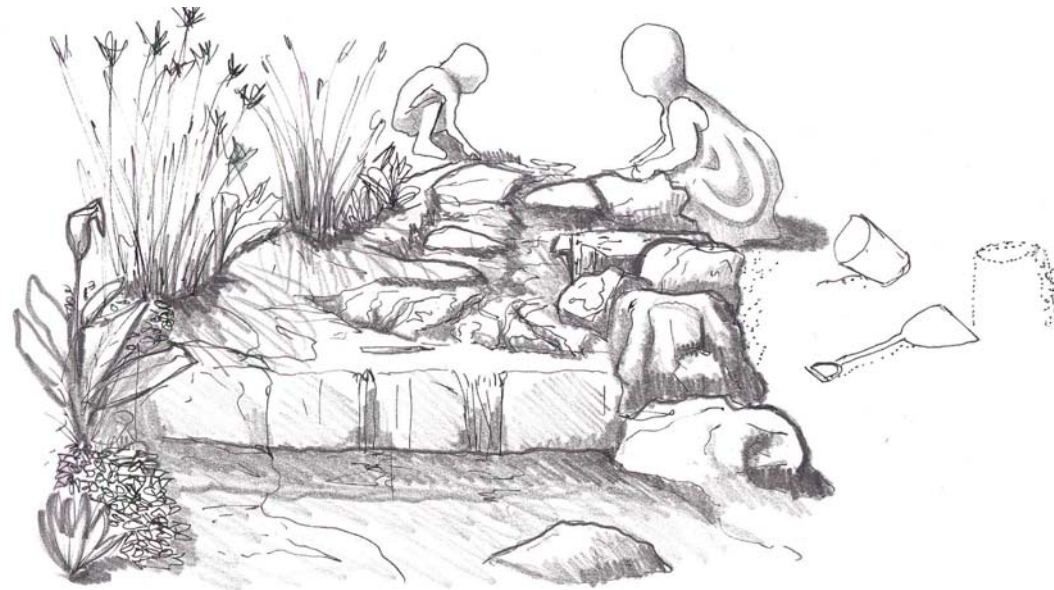

Illus. 8.17: Perspective of children playing in river (Author & Breed, July 2011)

## 8.3 Water features (3)

### 8.3.1 Wetland, River and Island

Water is a central feature of the park. After being cleaned in the process described on page 62 (Illus. 7.6), water flows from the wetland by gravity into the site. It emerges in the Fountain and flows in the River (a stone channel) through the 6-12 year area, ending in a 100 mm deep pond with a large boulder inside suggesting an island. This water feature is situated close to the western entrance for extra surveillance. The river has a maximum depth of 50 mm and falls

over five cascades.

A zero-depth water feature with spout heads ranging from 0.4 m to 1.5 m provide safe water-play opportunities for toddlers and wheelchair users. The water for this feature is chlorinated and re-used. Some of the water from the River is stored for later irrigation use, with the rest being discharged back into the Spruit.

At the Costando building, the sound of bubbling and falling water create a restful atmosphere (see Illus. 9.17). Children can play in and with the water and are allowed to scoop it out for use elsewhere.

In the planting strip along the channel, typical riverine plants discourage people from accessing the channel yet allow visual contact. Plants used are: *Kniphofia spp.*, *Gunnera perpensa*, *Asparagus suaveolens*, *Indigofera hiliaris* and *Crotalaria spp.* (see page 88). *Juncus effusus*, *Cyperus textilis* and *C. papyrus* will provide whole year round foliage interest. For a detailed discussion on the mosaics in the channel, refer to chapter 6.



Illus. 8.18: *Juncus effusus* 'Spiralis'  
([www.honeysomeaquaticnursery.co.uk](http://www.honeysomeaquaticnursery.co.uk))



Illus. 8.19: *Gomphostigma virgatum*  
([www.plantzafrica.com](http://www.plantzafrica.com))



Illus. 8.20: *Gunnera perpensa*  
(Joffe, 2007: 326)



Illus. 8.21: *Juncus effusus*  
([www.wikipedia.org](http://www.wikipedia.org))



Illus. 8.22: *Kniphofia ensifolia*  
([www.plantzafrica.com](http://www.plantzafrica.com))



Illus. 8.23: *Kniphofia porphyrantha*  
(Van Wyk & Malan, 1998: 155)



Illus. 8.24: *Zantedeschia aethiopica*  
([www.plantzafrica.com](http://www.plantzafrica.com))



Illus. 8.25: *Cyperus textilis*  
(<http://planthis.com.au>)



Illus. 8.26: *Typha capensis* (Joffe, 2007: 335)



Illus. 8.27: *Cyperus papyrus* (<http://www.ozwatergardens.com.au>)

Wetland	J	F	M	A	M	J	J	A	S	O	N	D
<i>Gomphostigma virgatum</i>												
<i>Gunnera perpensa</i>												
<i>Kniphofia ensifolia</i>												
<i>Kniphofia porphyrantha</i>												
<i>Zantedeschia aethiopica</i>												
<i>Typha capensis</i>												

Figure 8.2: Flowering times of wetland plants used. Note that *Cyperus textilis*, *Cyperus papyrus* and *Juncus effusus* were not included in this table as their flowers are inconspicuous. (Author, August 2011, compiled from Joffe, 2007 and [www.plantzafrica.com](http://www.plantzafrica.com))



*Then Kolokolo Bird said, with a mournful cry, 'Go to the banks of the great grey-green, greasy Limpopo River, all set about with fever trees, and find out!' (From the Elephant's Child; Kipling, 1912: 65)*

*Illus. 8.28: Pond (maximum 100 mm deep) at the end of the river, with large boulders that create an island with pathways leading to it. (Author, October 2011)*

## 8.4 Mountain and kick about (4)

During the course of the research in Sunnyside, it became apparent that there is a great need for children and adults for open space to play soccer. A kick about was therefore incorporated into the park. Due to the small size and irregular shape, adult players are discouraged to use the kick about for more serious matches and are in this way prevented from taking over the park. It has a grass surface and can be used for other purposes such as picnicking or performances.

The large boulders on the Mountain area on the north side of the kick about area, as well as the gabion retaining wall around the south edge provide seating for spectators. The Mountain is 3 m high and has plants typically found on rocky ridges in and around Pretoria. A rock climbing slope and a Masterfiber slope with climbing ropes provide challenging climbing options, with a vantage point over much of the park from the top.

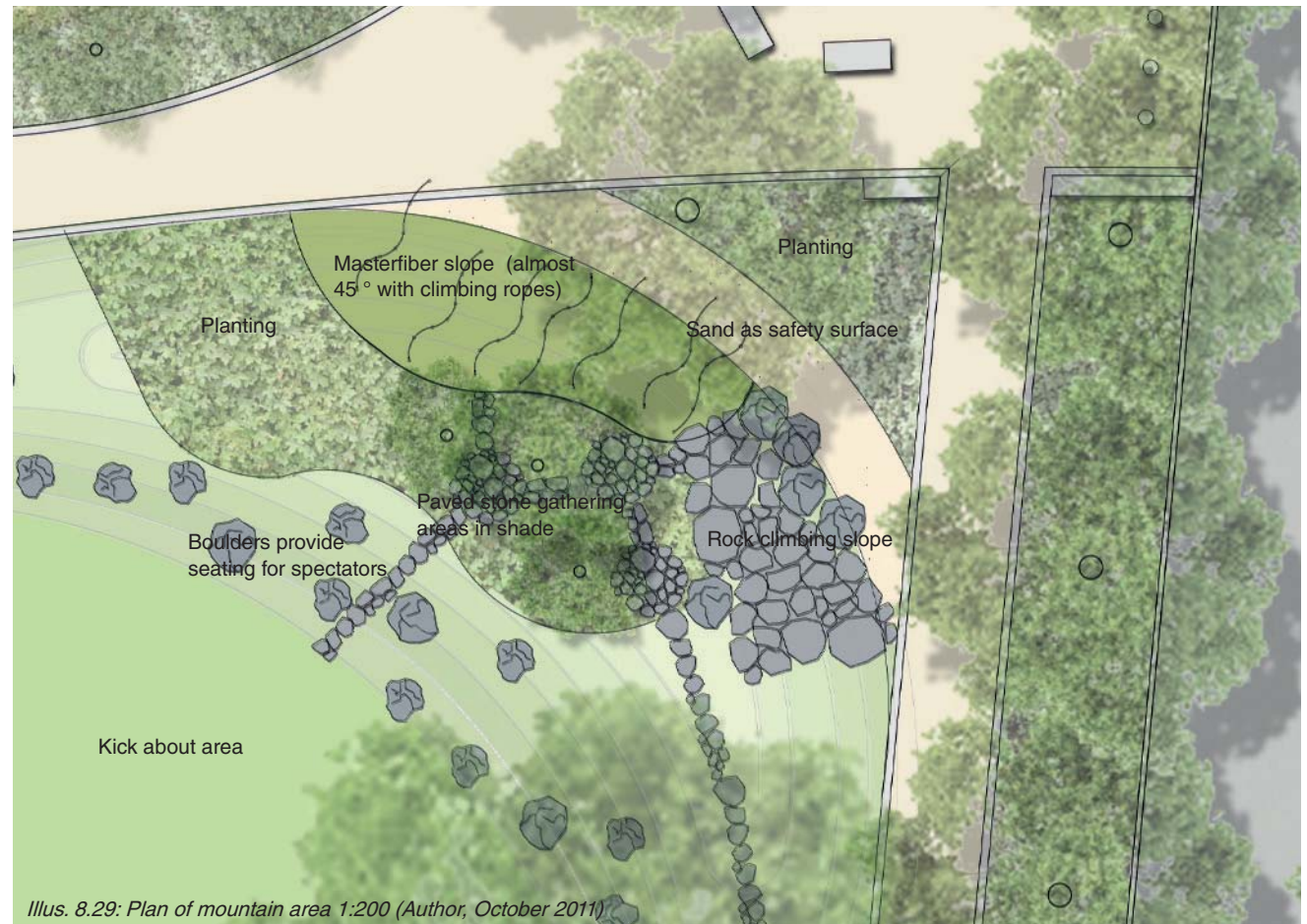



*Before crossing the river, the braves stood on the high cliffs ... and looked down on the scene of the calamity, examining the woods and rocks very closely.  
(From The Maidens of Bhakubha; Jordan, 2004:87)*



Illus. 8.31: *Burkea africana*  
(Author, August 2011)



Illus. 8.32: *Helichrysum kraussi*  
(Author, August 2011)



Illus. 8.33: *Cussonia spicata*  
(<http://www.panoramio.com>)



Illus. 8.34: *Englerophytum magalismsontanum*  
([www.fruitipedia.com](http://www.fruitipedia.com))



Illus. 8.35: *Fadogia homblei*  
([www. http://www.ais.up.ac.za](http://www.ais.up.ac.za))



Illus. 8.36: *Xerophyta retinervis*  
(Van Wyk & Malan, 1998: 91)



Illus. 8.37: *Ancylobotrys capensis*  
([www.plantzafrica.com](http://www.plantzafrica.com))



Illus. 8.38: *Digitaria eriantha*  
(Van Oudtshoorn, 2002: 226)



Illus. 8.39: *Setaria sphacelata*  
var. *sphacelata*  
(Van Oudtshoorn, 2002: 90)



Illus. 8.40: *Loudetia simplex*  
(Van Oudtshoorn, 2002:133)

Mountain	J	F	M	A	M	J	J	A	S	O	N	D	J	F	M	A	M	J	J	A	S	O	N	D
<i>Ancylobotrys capensis</i>																								
<i>Burkea africana</i>																								
<i>Englerophytum magalismsontanum</i>																								
<i>Fadogia homblei</i>																								
<i>Helichrysum kraussi</i>																								
<i>Xerophyta retinervis</i>																								

Figure 8.3: Flowering (left) and fruiting (right) periods of plants used in the mountain area. (Author, August 2011, compiled from Van Wyk & Malan, 1998, and [www.plantzafrica.com](http://www.plantzafrica.com))

Left: Illus. 9.30: Vision for the Mountain area (Author, October 2011)

## 8.5 Age specific areas (5, 6, 7, & 8)

The archetypes are reproduced on a smaller scale in the 0-3 and 3-6 year old areas. All of the following areas except the 6-12 year old area contain plants from the mixed bushveld community. It should be noted that although the park is zoned into different areas, children of any age will be able to use any area. However, due to the design, they will be more inclined to use a certain area appropriate to their age (see pages 23, 24 and 61). The staff at the toy library and the kiosk will also be able to intervene, if, for example, a group of 10 year olds play in a way that the 3-6 year olds find intimidating in their zone.

### 8.5.1 Zero-to-three year old area

This area focuses especially on using a large variety of natural textures, such as grass, stone, sand, wood, and bark textures. The area also has logs and boulders which can be used for balancing exercises, or for pulling up against. Some very small spaces are created

(e.g. about 1x1x0.5 m) to allow for quieter play. The area is subdivided into a busier and a quieter area.

Access to the 0-3 year old area is only possible from two entrances, one of which is in full visibility from the kiosk at the tower. Both have low gates to prevent children from slipping out, and it also discourages older children from entering the area.

### 8.5.2 Three-to-six year old area

This area is placed next to the toy library. This age group needs space for running, climbing, jumping and other boisterous bodily movement (see Figure 3.12 on page 24), yet it should still be in a safe area. The area is therefore separated from the main pedestrian pathway with a wide planting strip, and by a ramp on the toy library's side. In this area there is a hard compacted surface for using push-pull toys, an area for building with sand, a great complexity of plants and a large mound which could be used in a variety of pretend play situations.

### 8.5.3 Six-to-twelve year old area

Children of this age are fond of fantasy play. This area contains the forest, river, a berm, large sand play areas as well as the tunnel, creating complex interlinking play opportunities. A large variety of spaces creates different platforms for re-enactment of stories and even films the children might have seen (e.g. being stranded on an island). There are also quiet spaces where they can be alone and watch the other children play from a distance.

All three areas incorporate challenges (within safety parameters) for the children, for example jumping over the 800 mm wide River.

### 8.5.4 Toy library

The toy library is situated in the north-western corner of the site, in order to activate the currently dead area. Children can register at the toy library with an address and contact number (if available). They will be able to take out toys to play with in the rest of the park or at

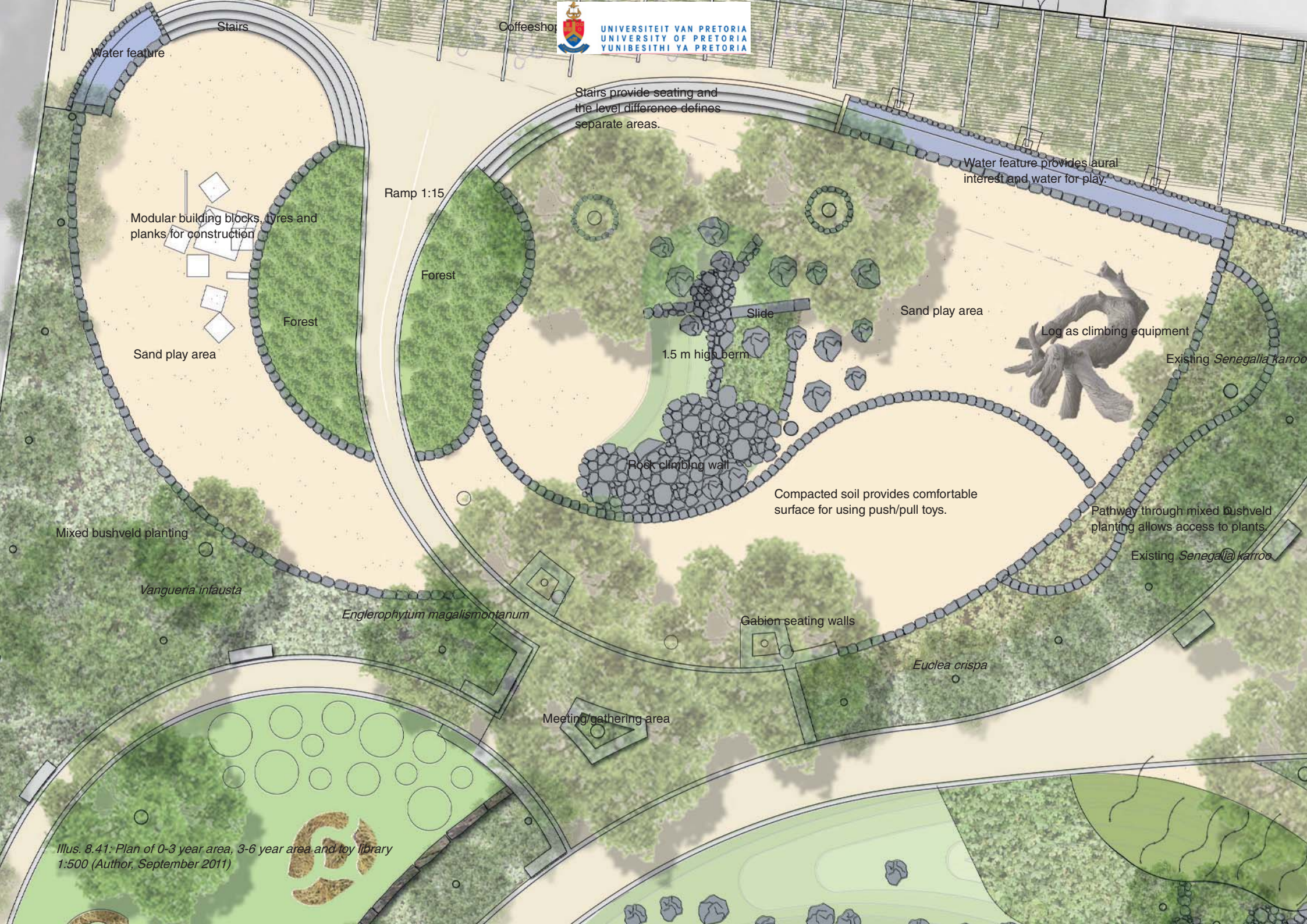

Stairs provide seating and the level difference defines separate areas.

Water feature provides aural interest and water for play.

Modular building blocks, tyres and planks for construction

Ramp 1:15

Forest

Slide

Sand play area

Log as climbing equipment

Existing *Senegalia karroo*

Sand play area

Forest

1.5 m high berm

Rock climbing wall

Compacted soil provides comfortable surface for using push/pull toys.

Pathway through mixed bushveld planting allows access to plants.

Existing *Senegalia karroo*

Mixed bushveld planting

*Vangueria infausta*

*Englerophytum magalismontanum*

Gabion seating walls

*Euclea crispa*

Meeting/gathering area

Illus. 8.41: Plan of 0-3 year area, 3-6 year area and toy library  
 1:500 (Author, September 2011)

home. This will ensure a good supply of loose parts for play, such as push-pull toys, shovels, buckets, dolls and toy cars.

In the toy library area, there are modular units, old tyres and empty crates with which the children can build their own structures. Staff members are constantly present to ensure the safety of the children.

Modular wooden units enable children to construct their own creations. This process specifically requires the development of social and cognitive skills. Children are reliant on each other's input and help to move parts and discuss their ideas.



Illus. 8.42: Section through toy library and 3-6 year area 1:200 (Author, October 2011)

Right: Illus. 8.43: Plan of 0-3 year area 1:200 (Author, October 2011)





Illus. 8.44: *Crotalaria agatiflora*  
(Van Wyk & Malan, 1998: 137)



Illus. 8.45: *Sphenostylis angustifolia*  
(Van Wyk & Malan, 1998: 213)

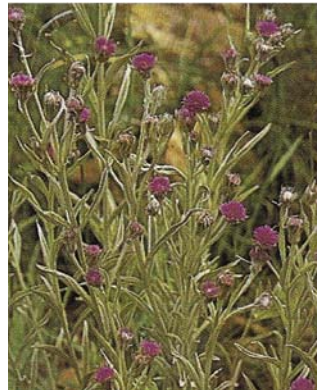

Illus. 8.46: *Vernonia natalensis*  
(Van Wyk & Malan, 1998: 247)



Illus. 8.47: *Senecio barber-tonicus*  
([www.wikipedia.org](http://www.wikipedia.org))



Illus. 8.48: *Hibiscus pusillus*  
(Van Wyk & Malan, 1998: 157)



Illus. 8.49: *Lippia javanica*  
([www.aroma-pure.com](http://www.aroma-pure.com))



Illus. 8.50: *Indigofera hiliaris*  
(Van Wyk & Malan, 1998: 211)



Illus. 8.51: *Grewia occidentalis*  
([www.seedshelf.com](http://www.seedshelf.com))



Illus. 8.52: *Hermannia lancifolia*  
(Van Wyk & Malan, 1998: 179)



Illus. 8.53: *Felicia filifolia*  
([www.plantzafrica.com](http://www.plantzafrica.com))



Illus. 8.54: *Vangueria infausta*  
(Venter, 1996: 267)



Illus. 8.55: *Halleria lucida*  
([www.earthland-scapes.blogspot.com](http://www.earthland-scapes.blogspot.com))



Illus. 8.56: *Buddleja salviifolia*  
([www.flickr.com](http://www.flickr.com))



Illus. 8.57: *Tarchonanthus camphoratus*  
([www.operationwildflower.org.za](http://www.operationwildflower.org.za))

Note that due to the complexity of a mixed bushveld community and space constraints, only some examples of plants found in this community are shown here. These images do not depict the full palette of plants which could be used.

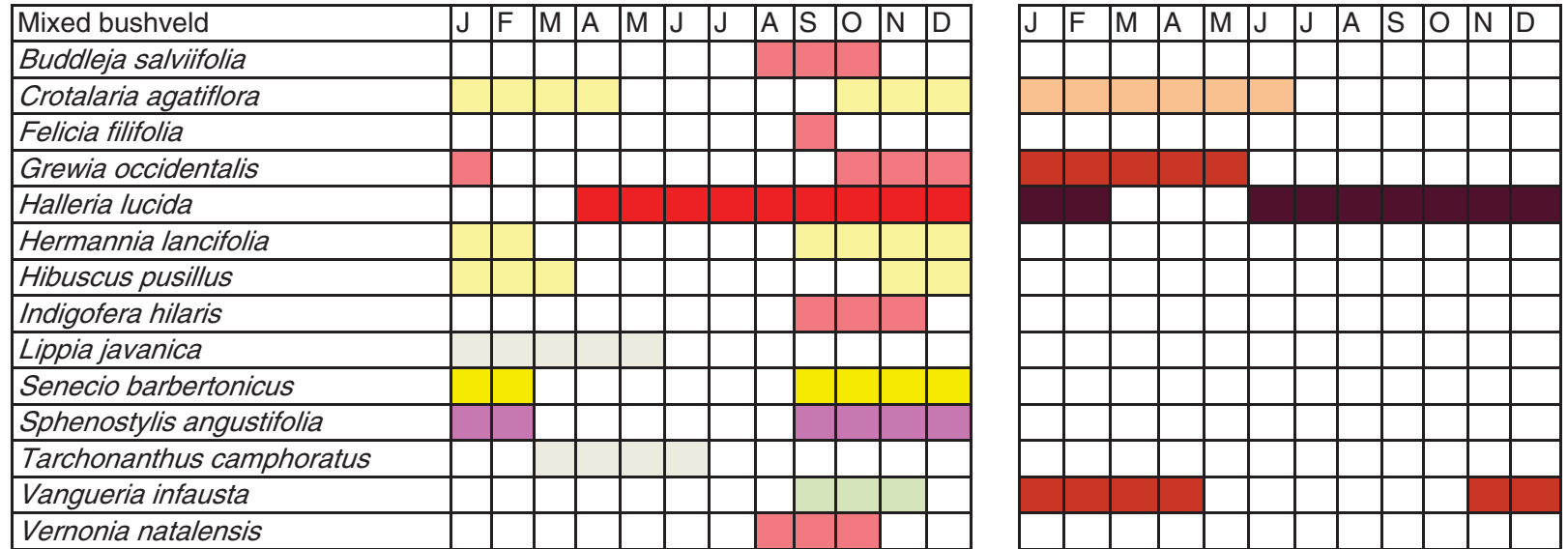

Figure 8.4: Mixed bushveld plants. Left: Flowering times. Right: Fruiting times (Author, August 2011, compiled from Joffe, 2007, Van Wyk & Malan, 1998)

“In this bottle,” he said, “there is cordial made of the juice of one of the fireflowers that grow in the mountains of the sun. If you or any of your friends are hurt, a few drops of this restore them.”(From *The Lion, The Witch, and the Wardrobe*; Lewis, 1950:47)



Illus. 8.58: Plants such as *Ehretia rigida* can create child-size spaces in the age specific areas. (Author, July 2011)



*This was very bad for the Giraffe and the Zebra and the rest of them; for [Leopard] would lie down by a 'sclusively yellowish-greyish-brownish stone or clump of grass, and when the Giraffe or the Zebra....or the Bonte-Buck came by he would surprise them out of their jumpsome lives. (Just So Stories, How Leopard Got His Spots, Kipling, 1912:44)*



Illus. 8.60: *Themeda triandra*  
(<http://www.flickr.com/photos/31031835@N08/3215313816/>)



Illus. 8.61: *Melinis repens*  
([www.fireflyforest.com](http://www.fireflyforest.com))



Illus. 8.62: *Panicum maximum*  
(Van Wyk & Malan, 1998: 335)



Illus. 8.63: *Eragrostis capensis*  
(Van Wyk & Malan, 1998: 333)



Illus. 8.64: *Urelytrum agropyroides*  
(Van Wyk & Malan, 1998: 321)



Illus. 8.65: *Elionorus muticus*  
(Van Wyk & Malan, 1998: 315)



Illus. 8.66: *Senegalia galpinii*  
(<http://www.plantzafrica.com>)



Illus. 8.67: *Cymbopogon plurinoides*  
(Van Oudtshoorn, 2002: 53)

## 8.6 Grassland (2)

This area consists of a veldgrass area with a few *Senegalia galpinii* trees. Grasses were chosen to be either lower than 600mm or to have sparse upper growth so as not to obscure the view. Some have interesting inflorescences (e.g. *Eragrostis capensis* in Illus. 8.63), are colourful, such as *Melinis repens* (Illus. 8.61), or are fragrant, such as *Cymbopogon plurinoides* (Illus. 8.67), which smells like citrus. A maze of pathways runs through the grass, passing through paved stone areas where groups of people or children can gather. Such gathering spaces with pathways linking them facilitate social interaction. After the winter the grasses will be cut down to 300mm with a brushcutter.

Left: Illus. 8.59: Vision for the grassland area (Author, August 2011)



Illus. 8.68: Plan of grassland area showing slate stone pathways and gathering areas. Scale 1:500 (Author, October 2011)

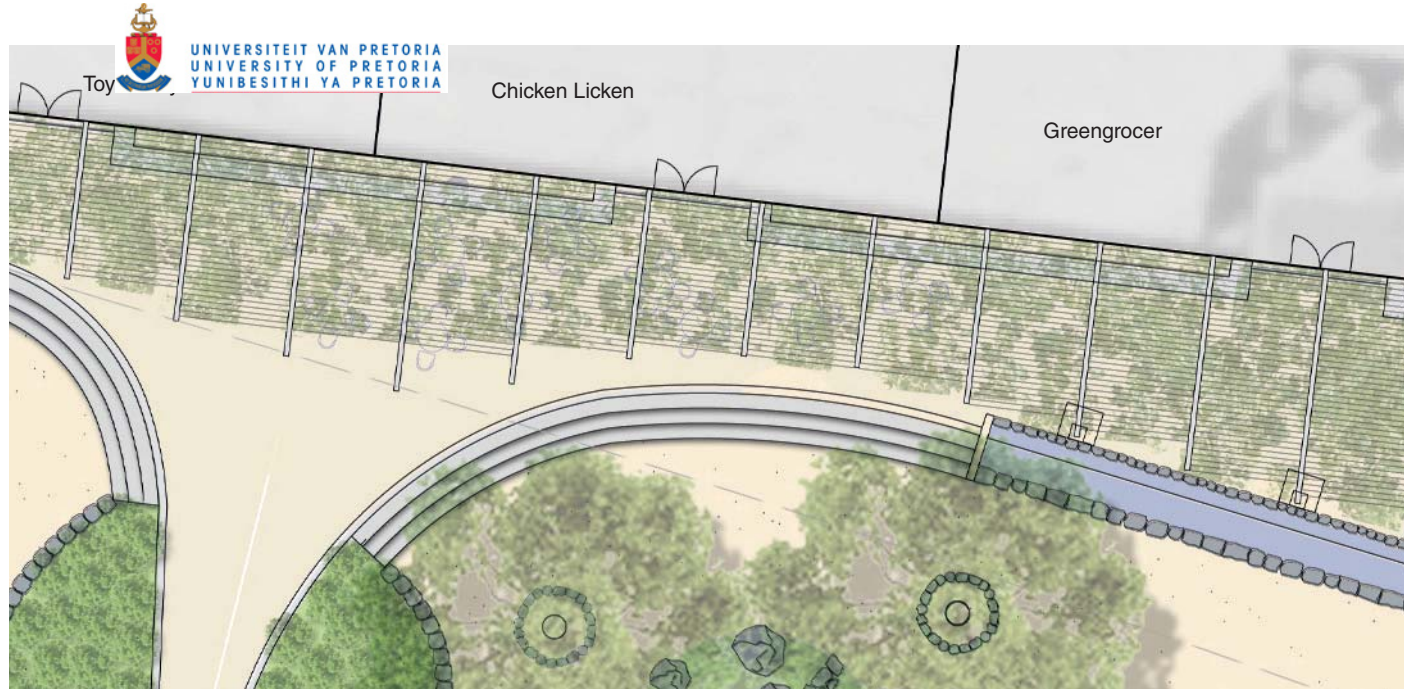

*Illus. 8.69: Plan of pergola at Costando Building 1:200 (Author, October 2011)*

*Left: Illus. 8.70: Plan of pergola at taxi waiting area 1:200 (Author, October 2011)*

*Right: Illus. 8.71: Plan of pergola at south-eastern entrance 1:200 (Author, October 2011)*





Illus. 8.72: *Senecio macroglossus* (www.plantzafrica.com)



Illus. 8.73: *Thunbergia alata* (Joffe, 2007: 361)



Illus. 8.74: *Rhynchosia caribaea* (Van Wyk & Malan, 1998: 142)



Illus. 8.75: *Tylosema esculentum* (Van Wyk & Malan, 1998: 125)



Illus. 8.76: *Rhoicissus tridentata* (www.rareplants.de)



Illus. 8.77: *Senecio pleistocephalus* (Van Wyk, 2003: 33)



Illus. 8.78: *Clematis brachiata* (Joffe, 2007: 351)



Illus. 8.79: *Pentarrhinum insipidum* (www.plantzafrica.com)

Climbers	J	F	M	A	M	J	J	A	S	O	N	D
<i>Clematis brachiata</i>												
<i>Pentarrhinum insipidum</i>												
<i>Rhoicissus tridentata</i>												
<i>Rhynchosia caribaea</i>												
<i>Senecio macroglossus</i>												
<i>Thunbergia alata</i>												
<i>Tylosema esculentum</i>												
<i>Senecio pleistocephalus</i>												

	J	F	M	A	M	J	J	A	S	O	N	D

Figure 8.5: Left: Flowering times of climbing plants used. Right: Fruiting times. (Author, August 2011, compiled from Joffe, 2007; Van Wyk & Malan, 1998; Van Wyk, 2003 and www.plantzafrica.com)

## 8.7. Shade pergolas (11, 14 & 15)

A steel pergola structure at the western entrance to the site provides shade and seating for people waiting to catch a taxi, as well as community advertising space. The seating is arranged in such a way that people can sit alone or in groups facing one another. A translucent green Perspex roof provides protection from rain. Simple geometric shapes respond to the hard edges of the urban environment found in Sunnyside, while the climbing plants covering the steel cables start the transition to the more natural areas. This transition is repeated at the Costando building north of the site, as well as at the south-eastern entrance. As one moves further into the park, more natural materials are used (for example logs and boulders as edging). The plants depicted in Illus. 8.72 to 8.79 are used at all the shade pergolas, the climbing tower, and the Tunnel.

Next to the waiting area, a spill-over lawn area with benches and shade can be used for community meetings.

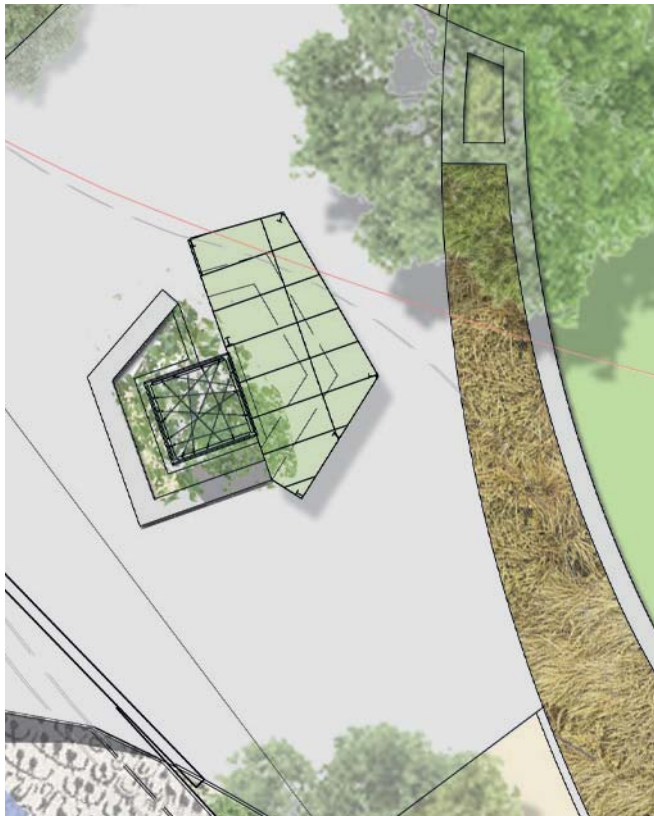

## 8.8 Tower (9)

The climbing tower provides a vantage point from which children can look across the whole park, while being behind a visually semi-permeable screen of plants (*Rhoicissus tridentata* and *Sencio pleistocephalus*). These climbers were chosen as they are able to reach the full height of the tower (9.5 m), and have different dormancy times (pers. comm., Sampson, 26 September 2011). The web of ropes inside the tower provides a challenging yet safe climbing experience. They are spaced closely enough to catch a fall if a child should slip, and also to provide resting places if one tires on the way up. At 2 m from the top of the tower, a wooden viewing platform provides resting space.

On the outside of the tower, criss-crossing steel cables reflect the web of ropes on the inside and provide sufficient hold for the climbing plants (as opposed to vertical cables).

The steel profile structure reflects the materials used in the pergolas and bridge. The kiosk attendant next to the tower is able to monitor the entry of children into the tower, and also provides visual surveillance over the park in that area.

Illus. 8.80: Plan of climbing tower 1:200 (Author, October 2011)



*Illus. 8.81: Looking up into the tower (Author, with ropes from Broto, 2010: 50, September 2011)*

## 8.9 Tunnel (10)

The tunnel is specifically child-sized at only 1.5 m high, with climbing plants covering thin steel cables between *Eucalyptus* posts. The tunnel is open between some of the posts to provide easy access without forcing children to walk it from one end to the other. A slight curve creates mystery as one cannot immediately see the other end. The climbing plants listed in Illus. 8.72 to 8.79 are used with the exception of *Rhoicissus tridentata* and *Senecio pleistocephalus*, as they are too vigorous and will crowd out the other climbers.

## 8.10 General waiting areas (12)

These areas contain gabion seating walls and ample shade.

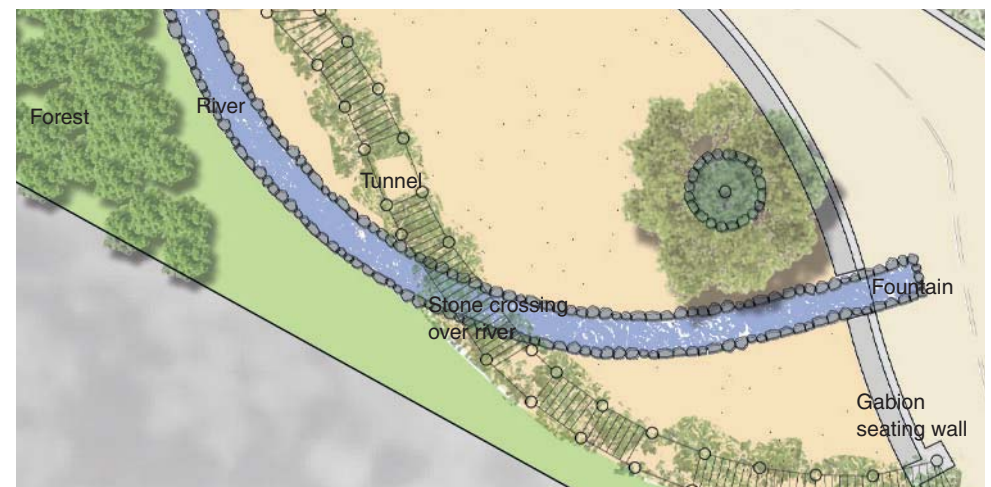

Illus. 8.82: Plan of tunnel 1:200 (Author, September 2011)



*Illus. 8.83: Perspective of tunnel (Author, September 2011)*

	Refer	Forest	Mountain	Tower	Kick-about	Grassland	Toy library	0-3 year area	3-6 year area <sup>3</sup>
Choice of spaces	3.1 & 3.3.1								
Group settings	3.3.1								
Being alone	3.3.3								
Child scale	3.3.1								
Route(s)	3.3.3								
Natural materials	3.7.1 - 3.4.11								
Complexity	3.4.1 & 3.3.1								
Loose parts	3.4.2 & 2.4								
Scope for alteration	2.4								
Scope for imagination	3.3.4								
Tactile stimulation with textures	2.3.3, 3.3.4 & 3.4								
Olfactory stimulation	2.3.3, 3.3.4 & 3.4								
Gustatory stimulation	2.3.3, 3.3.4 & 3.4								
Shade	3.1 & 3.1.2								
Safety	2.3.1								
Seating	3.1								
Physical challenges	2.3.6 & 2.3.7								

1. The column "river" should be understood as including the sand area around it.
2. The island column denotes the island and the zero-depth water feature around it.
3. The 6-12 year old area is not included in the table as it encompasses the tunnel, river, island and forest areas.

Figure 8.6: Matrix showing how each area satisfies the design criteria as determined in Chapter 2 and 3. (Author, September 2011)

## 8.11 Conclusion

Figure 8.6 shows how each area or landscape satisfies the criteria for a stimulating park as determined from the research in Chapter 2 and 3, and the evaluation criteria discussed in Chapter 3.

From the table it can be seen that only areas with water, sand or more supervision such as at the toy library have a large scope for alteration. The other areas have less scope for alteration, yet they provide a wealth of loose parts such as flowers, seeds and pebbles.

The kick about does not fulfil many of the criteria. However, it is valuable for its multi-functionality.

The loose parts such as sand, plant material and objects from the toy library increase the scope for imaginative games, and consequently the practice of social skills (such as conflict-resolution and the communication of ideas). Cognitive stimulation happens when children are able to observe and interact with the basic laws of nature (such as that water flows to a lowest point, the consistency of sand can be changed by the amount of water one adds, and by seeing the development of flowers into fruits).

Through the use of natural materials and by creating complex spaces, children are stimulated on a cognitive, physical and socio-emotional level.



9

# Technical Resolution



*Illus. 9.2: Plan indicating the location of each detail. For the wetland's position, see Illus. 7.8 (Author, October 2011)*



*Illus. 9.3: Packed gabions to be used as seating walls  
([www.gabionbaskets.co.za](http://www.gabionbaskets.co.za))*



*Illus. 9.4: Corobrik Champagne clay pavers  
([www.corobrik.co.za](http://www.corobrik.co.za))*



*Illus. 9.5: Coarse sand (Author, June 2011)*

This chapter discusses materials used, water systems, general technical details and how the design drivers were incorporated on a detail level. Illus. 9.2 indicates where each detail discussed is located.

## 9.1 Material palette

Man-made materials were restricted as much as possible, rather using plants, boulders, mounds, sand and water to construct the landscape. Materials were chosen to facilitate easy dismantling and re-use elsewhere. Labour-intensive construction methods are used, such as hand-packing the gabion seating walls. This creates employment opportunities and cuts costs. A similar hard material palette is used throughout the park, while the planting palettes differ from area to area.

### 9.1.1 Champagne clay pavers

These are readily available from Corobrik (Springs factory). They were chosen for their uniform light colour and are also recyclable.

### 9.1.2 Boulders and stone

Dolorite stone (to be used in the gabion seating walls, as edging for planted areas, and boulders for seating) can be sourced from excavation rubble from various building sites in the Pretoria area, or from the Willow and Donkerhoek Quarries, both within a radius of 20km from the site.

### 9.1.3 Sand

Coarse sand to be used in the play areas can be sourced from Donkerhoek quarries as well.

### 9.1.4 Logs

Untreated *Eucalyptus* logs to be used for the Tunnel area and as edging can be sourced from sites in Pretoria (such as the Faerie Glen Nature Reserve, from where they should be removed.)

### 9.1.5 Steel profiles

Steel profiles provide a light-weight structure for the climbing tower.

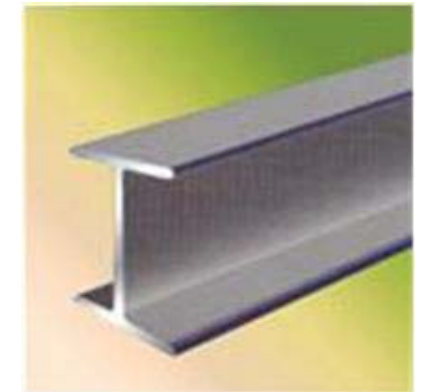

*Illus. 9.6: Galvanized steel I-profile ([www.ruiyinsteel.en.nobodybuy.com/](http://ruiyinsteel.en.nobodybuy.com/))*



*Illus. 9.7: Exposed aggregate concrete  
(Author, March 2009)*

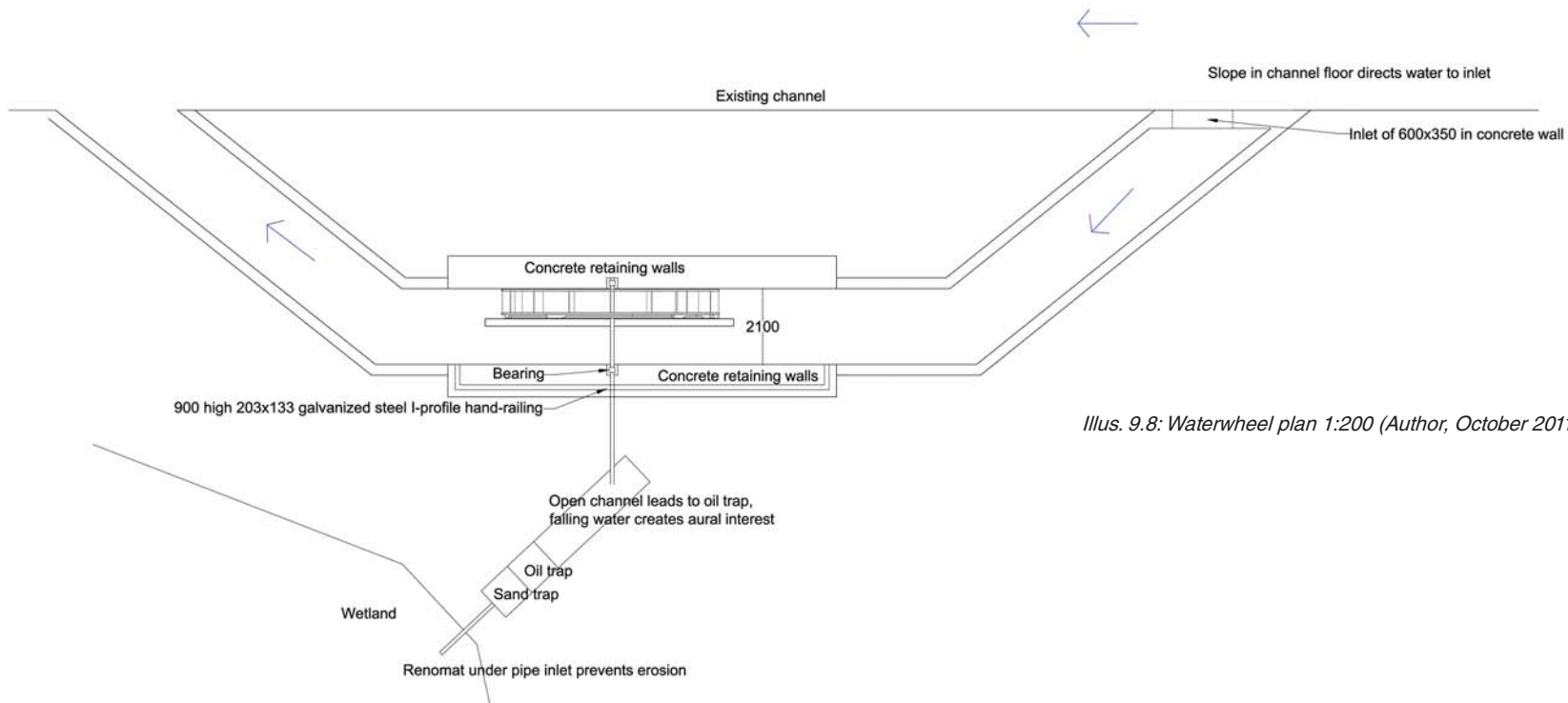

Illus. 9.8: Waterwheel plan 1:200 (Author, October 2011)

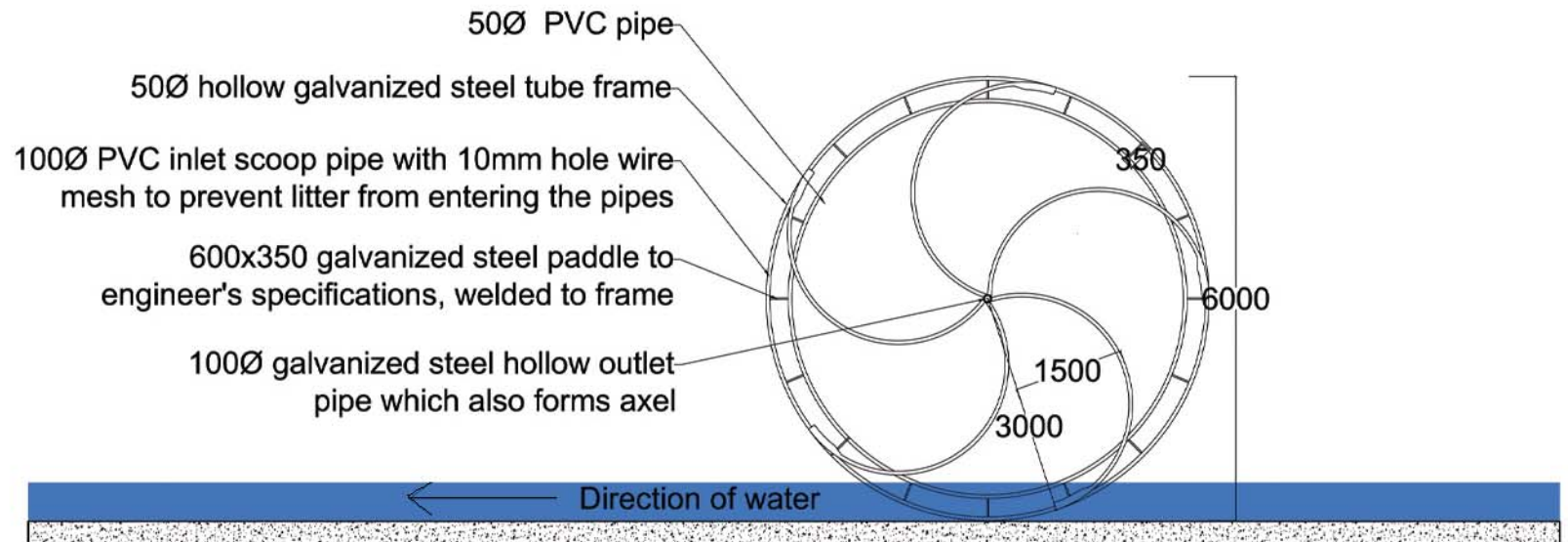

Illus. 9.9: Waterwheel elevation 1:100 (Author, October 2011)

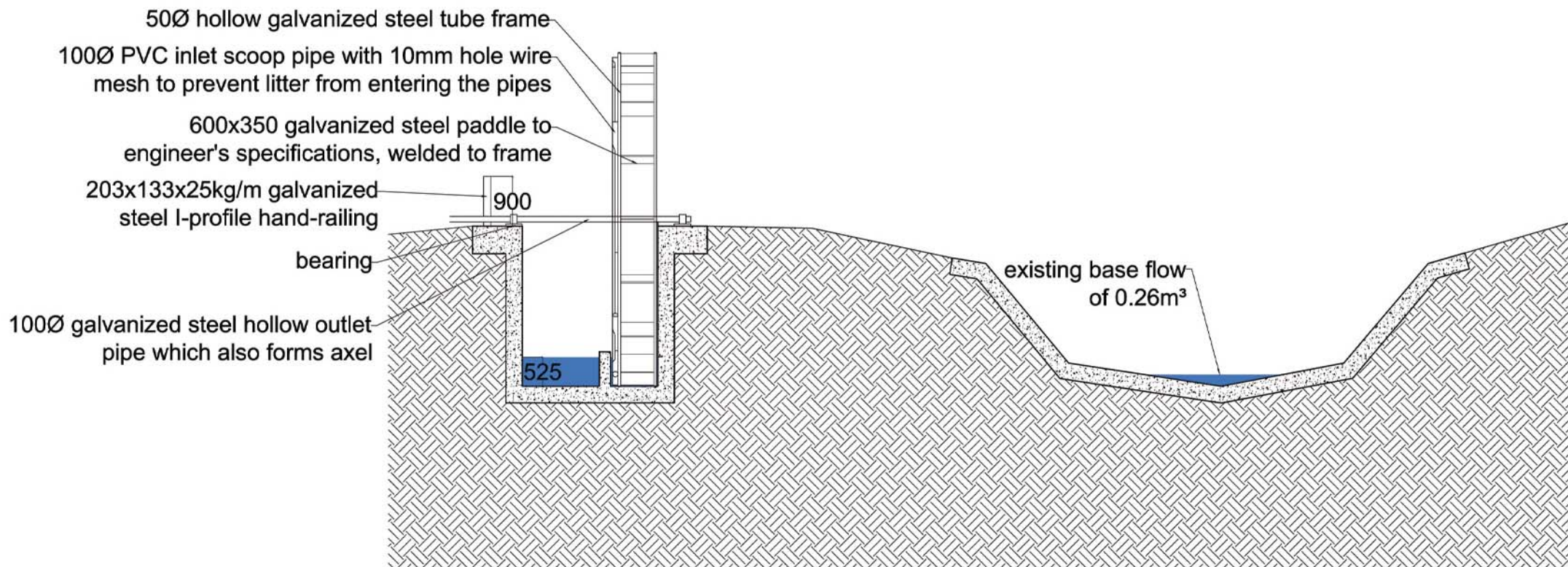

*Illus. 9.10: Waterwheel and channel section 1:100  
(Author, October 2011)*

## 9.2 Waterwheel

A coil waterwheel is used as an alternative to a waterwheel with buckets. As the water is collected within pipes it is easy to transport it to where it is needed as opposed to a bucket waterwheel which needs a collection channel into which to empty the buckets. The waterwheel is designed to deliver 4l/s.

The water from the main channel will be taken into a side channel to ensure the right speed and amount of water, and to prevent damage to the wheel during a flood event.

spiral to be made of 50mm pipe

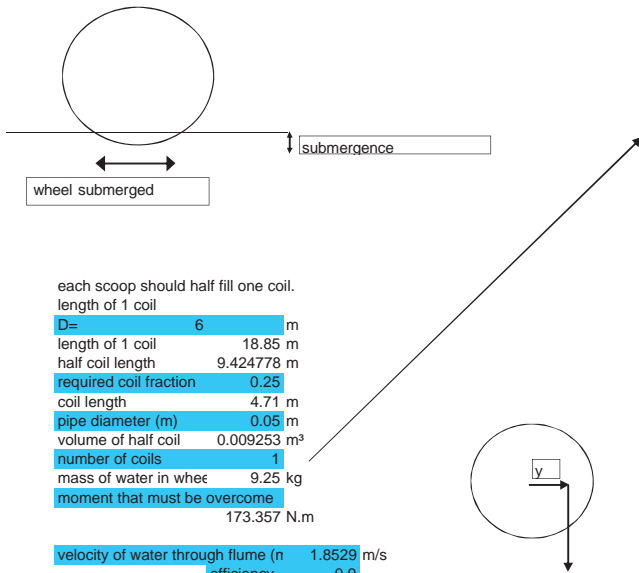

this section is only important for pumps where the head is greater than the wheel diameter  
select number of coils from head required

H = 3 delivery head  
D = 6 wheel diameter or outer coil diameter  
d = 0.05 pipe diameter  
Patm = 9.8 atmospheric pressure

hn = 7.40625  
n = 0.447552 number of coils  
add 20% = 0.537063 total number of coils

$y = 2r/\pi$

each scoop should half fill one coil.  
length of 1 coil  
D = 6 m  
length of 1 coil = 18.85 m  
half coil length = 9.424778 m  
required coil fraction = 0.25  
coil length = 4.71 m  
pipe diameter (m) = 0.05 m  
volume of half coil = 0.009253 m<sup>3</sup>  
number of coils = 1  
mass of water in wheel = 9.25 kg  
moment that must be overcome = 173.357 N.m

velocity of water through flume (n efficiency) = 1.8529 m/s / 0.9  
velocity of rim of wheel = 1.66761 m/s  
kinetic head (m) = 0.141739 m  
pressure pgh = 1390.462 Pa (N/m<sup>2</sup>) assume only one paddle submerged at a time.  
submergence (m) = 0.35 m  
width of paddle required = 0.118739 m

length of coil submerged  
angle = 0.48787 rad  
2xangle = 0.97574 rad  
submerged length = 2.93 m

length to be filled = 1.79 m  
volume that must be filled by scoop = 0.003505 / 0.003505  
diameter of scoop = 0.1 m  
length of scoop = 0.446 m

quantity to be pumped by 1 coil  
time for one revolution = 11.30 seconds  
water pumped per revolution = 0.009253

output in m<sup>3</sup>/s = 0.000819  
output l/s = 0.818586  
output l/hour = 2946.91

for multiple spirals  
number of separate spirals = 5  
paddle width = 0.593695 m  
output in m<sup>3</sup>/s = 0.004093 m<sup>3</sup>/s  
output l/s = 4.092931 l/s  
output m/s = 245.5758 l/min  
output l/hour = 14734.55 l/hour

5.31 RPM  
maxRPM = 18

Figure 9.1: Design calculations for a coil waterwheel where the water is lifted to the height of the wheel axis. (MacKellar, July 2011)

Right: Figure 9.2: Schematic design of waterwheel and channel (MacKellar, July 2011)

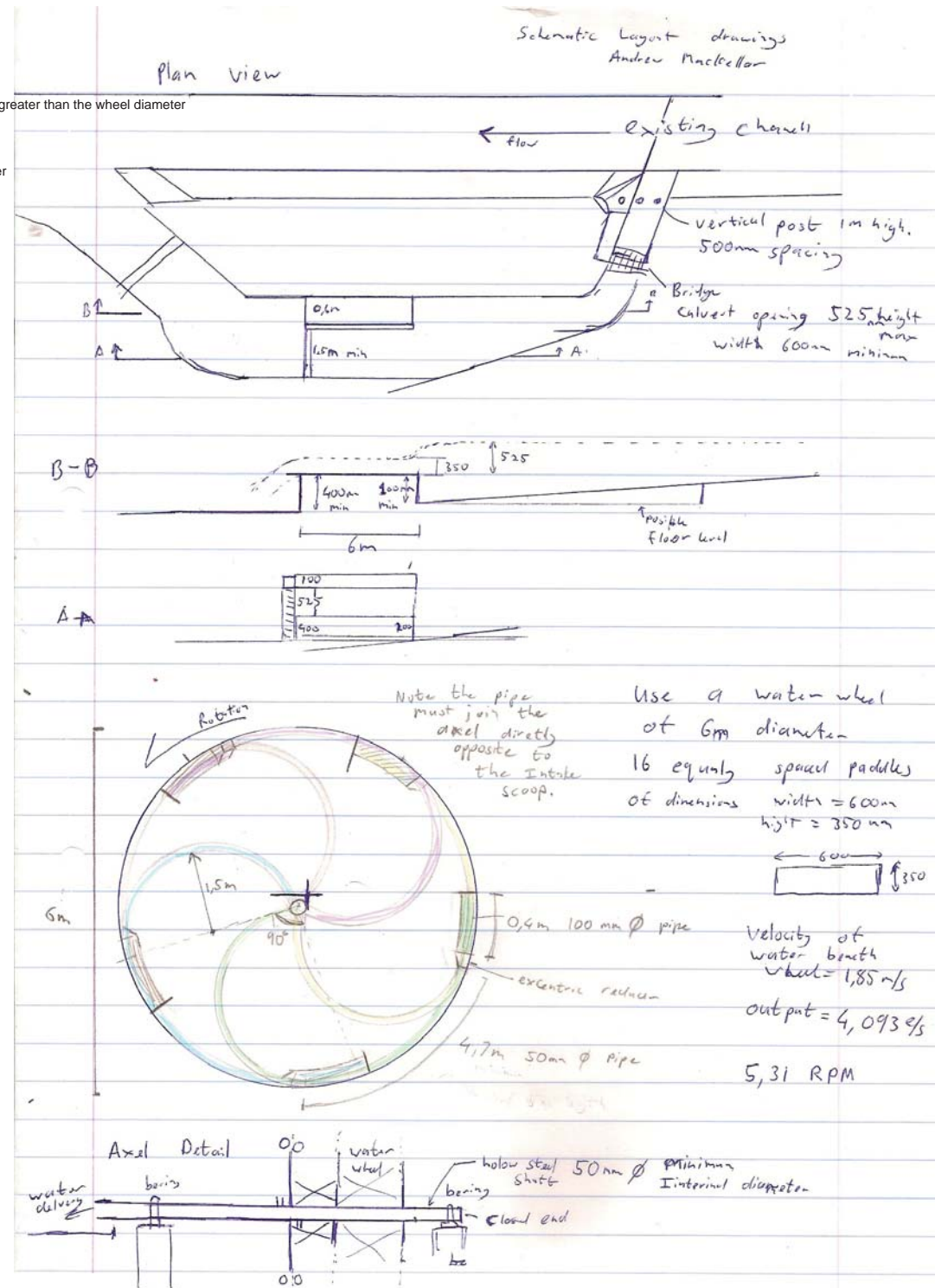

Left: Illus 9.11: Example of a coil waterwheel used in Zimbabwe. (<http://aquamor.tripod.com/Wheel.htm>)

### 9.3 Wetland

The water from the Walker Spruit is mostly polluted with petrochemicals. This will be removed by an oil trap. The wetland only needs to remove nutrients such as nitrates and phosphates, of which there are not much in an area with few gardens. To ensure the water is sufficiently cleaned, the water has to stay at least 2 days in the wetland. At a flow rate of 4l/s, 345.6m<sup>3</sup> of water is needed per day for the River to run. The wetland will thus be 2304m<sup>2</sup>, at a water depth of 300mm to ensure optimum plant growth.

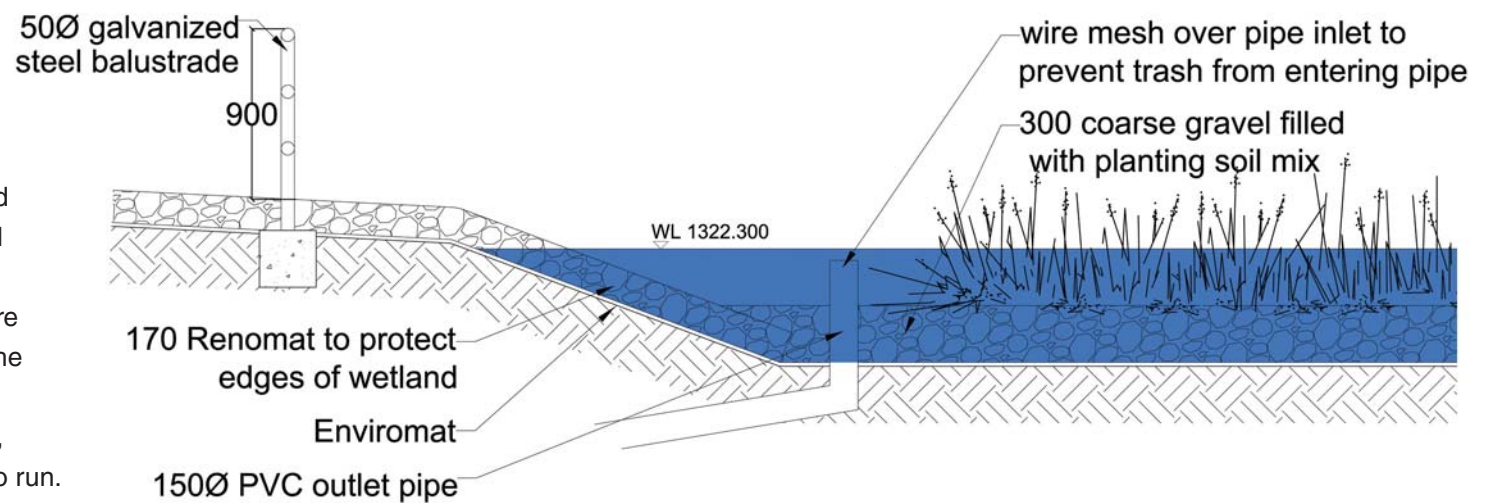

Illus. 9.12: Wetland outlet detail 1:20. People will be discourage from entering the wetland by a railing. (Author, October 2011)

## 9.4 Water

Due to the space constraints of the wetland (see Illus. 7.8), only 4l/s of water is available for use in the River. To keep the channel of average depth 50 mm and width 800 mm filled, the water has to flow at a rate of 0.1m/s. The slope of the channel has to be almost horizontal to maintain such a slow speed, and the roughness coefficient has to be large. The total length of the River is 88.5m with a drop of 1.7m over the slope of the site.

To cater for the above-mentioned aspects, a roughness coefficient (Manning's  $n$ ) of 0.15 is used, together with a series of five cascades which would enable the slope to be almost horizontal throughout the River. The cascades will range in height from 200 to 400 mm, adding aural interest and more complex play opportunities. To achieve such a high  $n$  value, the channel is constructed of rough stone, with stones jutting out of the water to further obstruct the water's flow.

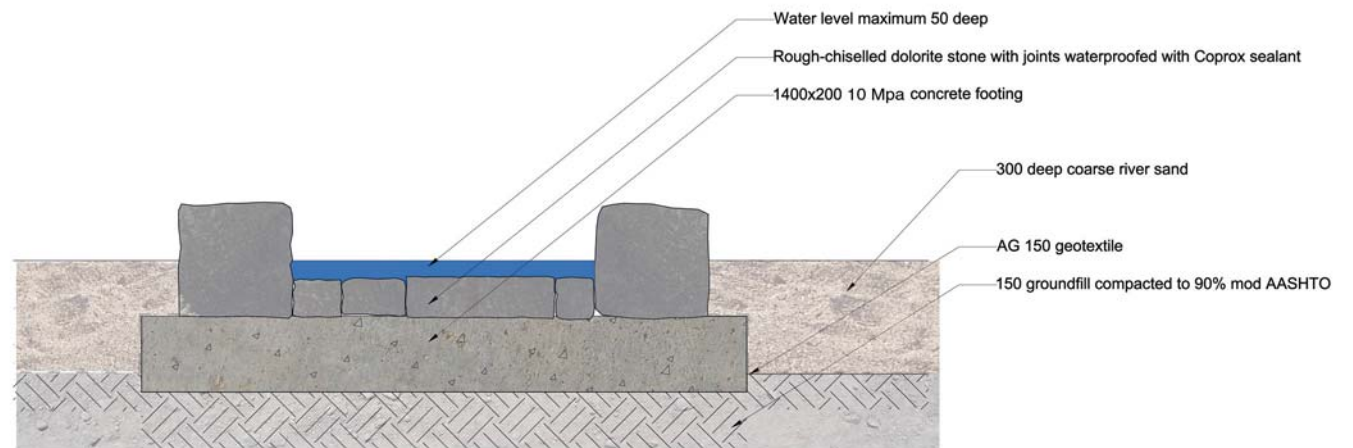

*Illus. 9.13: Detail A 1:20: River section (Author, October 2011)*

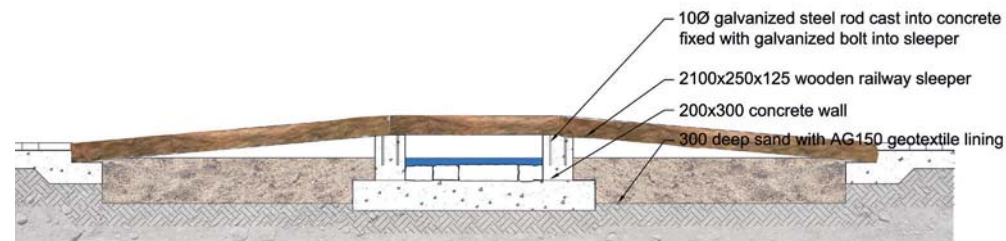

*Illus. 9.14: Detail B 1:50: River section with railway sleeper bridge (Author, October 2011)*

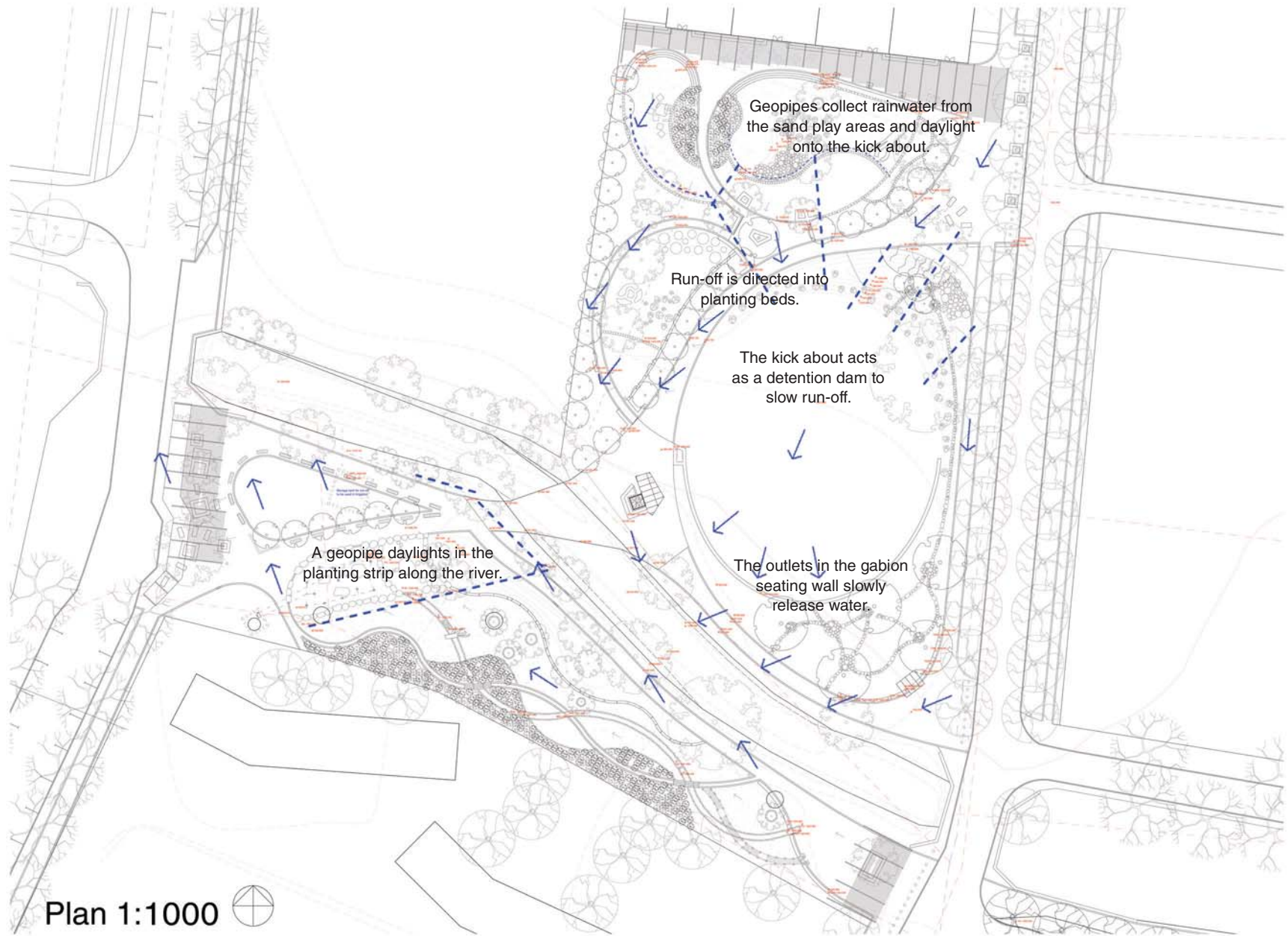

Illus. 9.15: Stormwater plan. See also 9.4. (Author, October 2011)

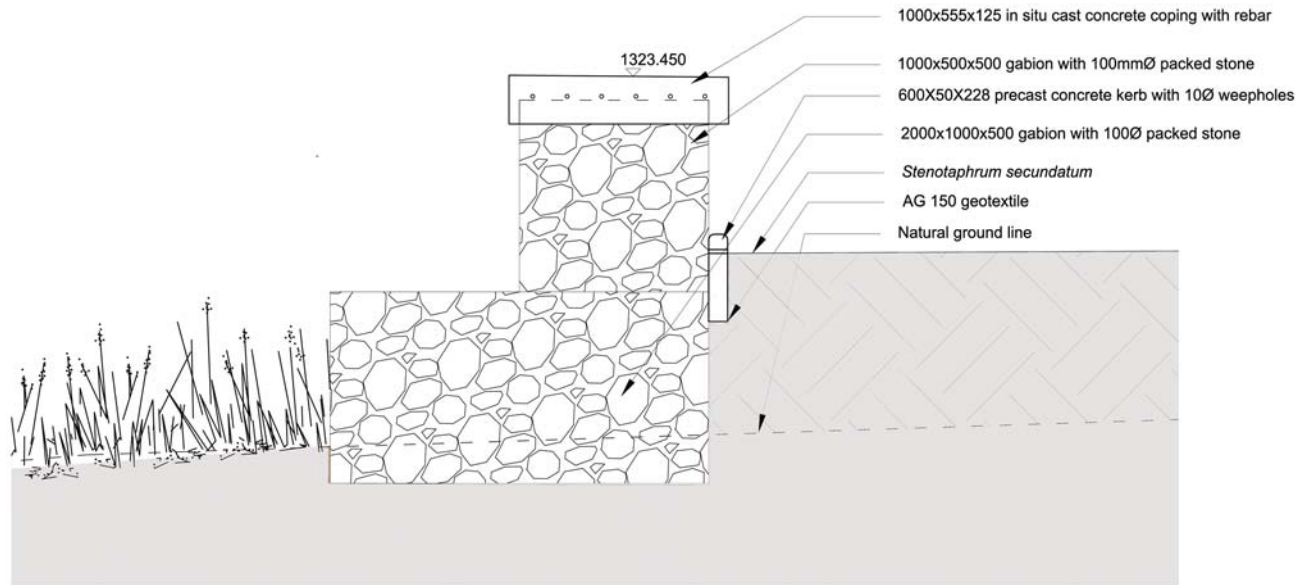

Illus. 9.16: Detail C 1:20: Gabion seating wall around edge of kick about. The precast kerbs create a detention dam. Small outlets slowly release the water from where it flows into the Spruit. (Author, October 2011)

### 9.4.1 Other water features

The water feature at the Costando Building provides a level difference between the public area next to the shops and the 3-6 year zone, enhancing safety. A rough stone wall ensures that the water creates aural interest. The water could be used by the children to play in, and for using elsewhere. Utensils to scoop it out with could be brought along from home or borrowed from the toy library. A small pump room contains a storage tank of 1500 litres and a pump.

The zero-depth water feature has an exposed aggregate concrete surface to ensure a good grip. The water is chlorinated to prevent any algae growth which could make the surface slippery. The water drains to a sump and is recirculated in the system.

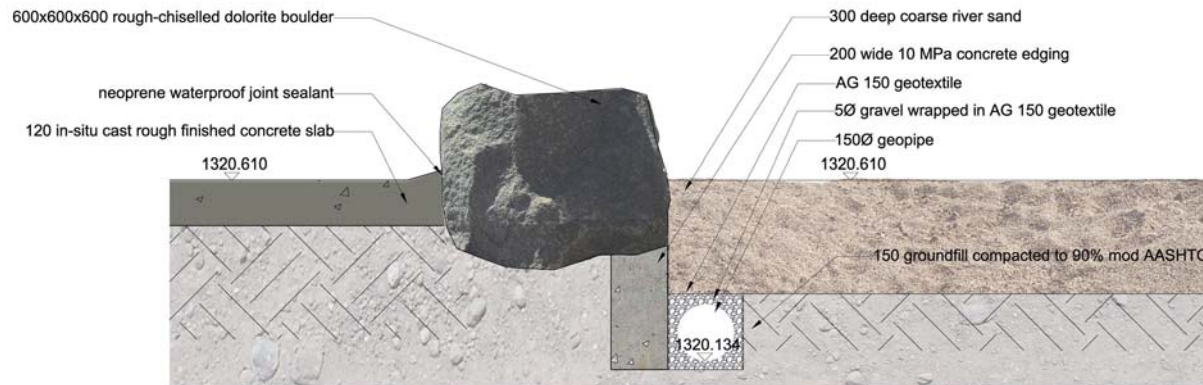

Illus. 9.17: Detail D 1:20. Edge detail of zero-depth water feature. (Author, October 2011)

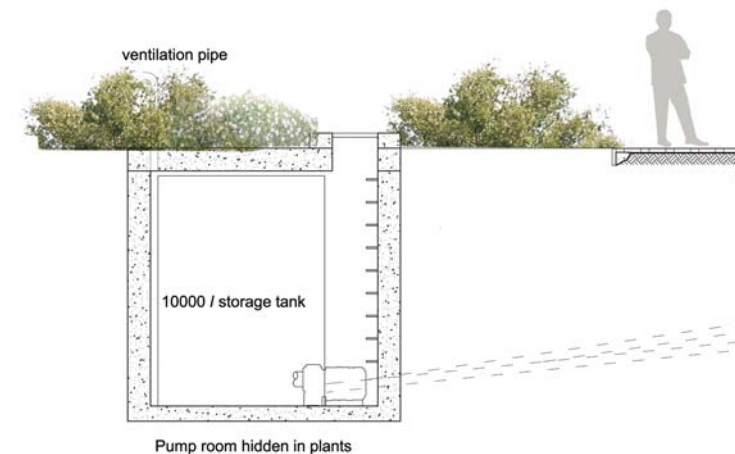

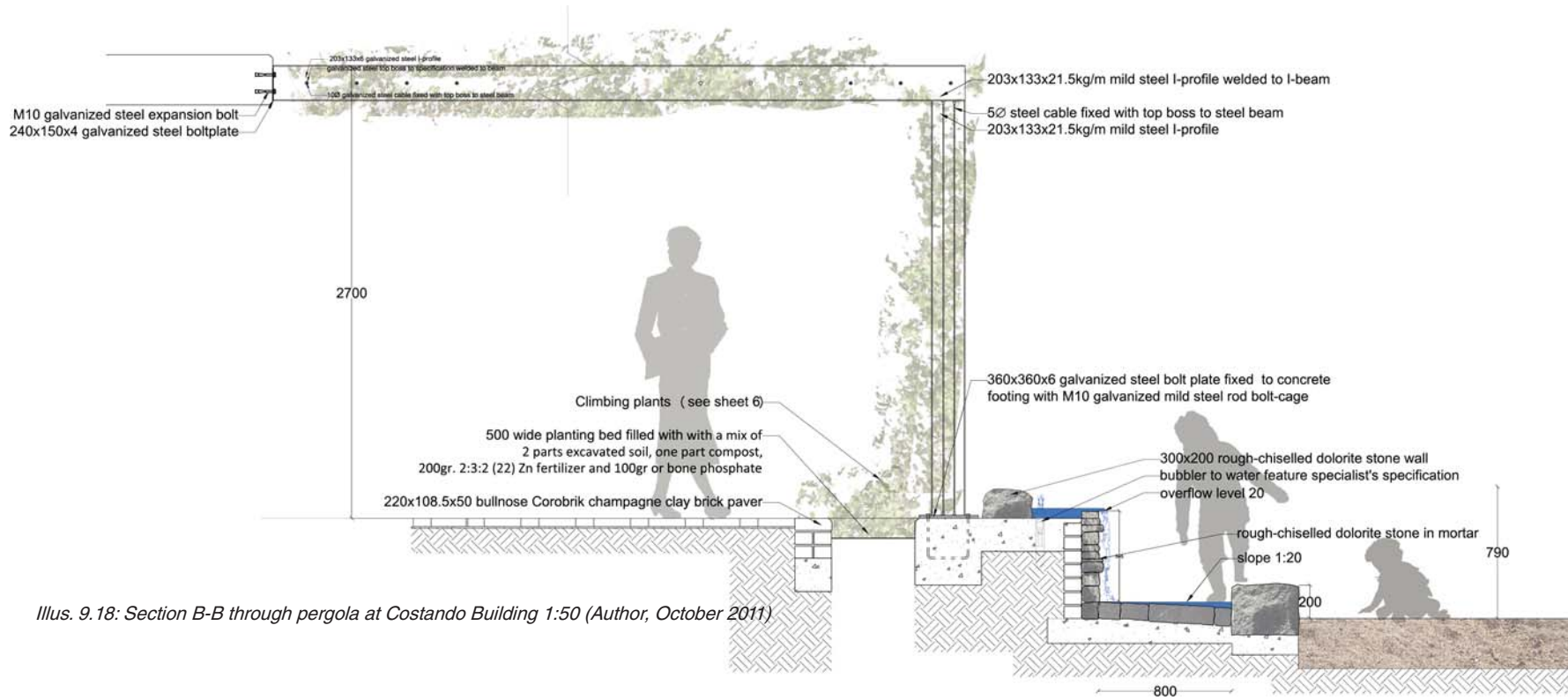

Illus. 9.18: Section B-B through pergola at Costando Building 1:50 (Author, October 2011)

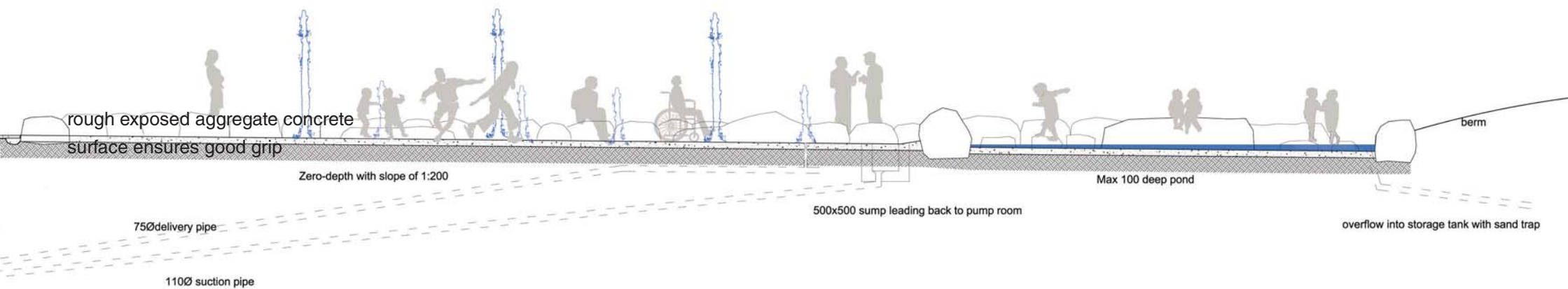

Illus. 9.19: Section C-C through zero-depth water feature and pond 1:100 (Author, October 2011)

## 9.5 Irrigation budget

The park is zoned into three areas with different irrigation requirements: the forests and riverine areas, the lawn, and all other planting areas.

The savanna area will not receive any irrigation.

The plants will not be able to survive on rainfall alone (Figure 9.4) , and therefore run-off from paving will be directed into the planted areas.

From Figure 9.4 it can be seen that the highest total water deficit per month is 136.4 m<sup>3</sup> in July. It was decided to use the water that has passed through the River and pond, as it has already been cleaned by various filters and is therefore fit for irrigation use save for some minor filtering. Therefore no water will be harvested for storage from paving areas.

A storage tank of 6x6x3 m under the lawn on the southern side of the Spruit holds 108 m<sup>3</sup> of water. Due to continuous inflow right through the year, it is unnecessary to have larger holding tanks. Irrigation will be controlled manually to ensure that plants are not irrigated unnecessarily, and in times of extreme drought, that the lawn will not receive water.

Irrigation requirements	Weeks	Lawn (m <sup>3</sup> )	Need/week	m <sup>3</sup> /month	All other planting (	Need	m <sup>3</sup> /month	River & forest (	Need	m <sup>3</sup> /month	Montly totals
January	4.43	2476	0.025	274.217	724	0.01	32.0732	1181	0.016	83.70928	<b>389.99948</b>
February	4.14	2476	0.025	256.266	724	0.01	29.9736	1181	0.016	78.22944	<b>364.46904</b>
March	4.43	2476	0.025	274.217	724	0.01	32.0732	1181	0.016	83.70928	<b>389.99948</b>
April	4.3	2476	0.00625	66.5425	724	0.005	15.566	1181	0.008	40.6264	<b>122.7349</b>
May	4.43	2476	0.00625	68.55425	724	0.005	16.0366	1181	0.008	41.85464	<b>126.44549</b>
June	4.3	2476	0.00625	66.5425	724	0.005	15.566	1181	0.008	40.6264	<b>122.7349</b>
July	4.43	2476	0.00625	68.55425	724	0.005	16.0366	1181	0.008	41.85464	<b>126.44549</b>
August	4.43	2476	0.00625	68.55425	724	0.005	16.0366	1181	0.008	41.85464	<b>126.44549</b>
September	4.3	2476	0.00625	66.5425	724	0.005	15.566	1181	0.008	40.6264	<b>122.7349</b>
October	4.43	2476	0.025	274.217	724	0.01	32.0732	1181	0.016	83.70928	<b>389.99948</b>
November	4.3	2476	0.025	266.17	724	0.01	31.132	1181	0.016	81.2528	<b>378.5548</b>
December	4.43	2476	0.025	274.217	724	0.01	32.0732	1181	0.016	83.70928	<b>389.99948</b>
				<b>2024.59</b>			<b>284.206</b>			<b>741.76248</b>	<b>3050.56293</b>

Figure 9.3: Irrigation requirements for the various planting areas (Author, October 2011)

	Lawn			Forest and river			All other planting		
	Rain	Irrigation	Balance	Rain	Irrigation	Balance	Rain	Irrigation	Balance
January	402.956	274.217	128.74	94.844	32.0732	62.7708	154.711	83.70928	71.0017
February	215.32	256.266	-40.946	50.68	29.9736	20.7064	82.67	78.22944	4.44056
March	236.852	274.217	-37.365	55.748	32.0732	23.6748	90.937	83.70928	7.22772
April	141.496	66.5425	74.954	33.304	15.566	17.738	54.326	40.6264	13.6996
May	24.608	68.55425	-43.946	5.792	16.0366	-10.2446	9.448	41.85464	-32.407
June	6.152	66.5425	-60.391	1.448	15.566	-14.118	2.362	40.6264	-38.264
July	-6.152	68.55425	-74.706	-1.448	16.0366	-17.4846	-2.362	41.85464	-44.217
August	3.076	68.55425	-65.478	0.724	16.0366	-15.3126	1.181	41.85464	-40.674
September	52.292	66.5425	-14.251	12.308	15.566	-3.258	20.077	40.6264	-20.549
October	203.016	274.217	-71.201	47.784	32.0732	15.7108	77.946	83.70928	-5.7633
November	286.068	266.17	19.898	67.332	31.132	36.2	109.833	81.2528	28.5802
December	322.98	274.217	48.763	76.02	32.0732	43.9468	124.005	83.70928	40.2957
<b>Totals</b>	<b>1888.664</b>	<b>2024.594</b>	<b>-135.93</b>	<b>444.536</b>	<b>284.2062</b>	<b>160.3298</b>	<b>725.134</b>	<b>741.76248</b>	<b>-16.628</b>

Figure 9.4: Water budget (Author, October 2011)



*Illus. 9.20: Planting legend (Author, October 2011)*

## 9.6 Channel sizing calculations

As was already discussed in the urban framework, it was found to be impossible to widen the channel or to naturalize it, due to the high flood line (See Illus. 5.14). Adding mosaic tiles was the option that had the least impact on the flood line, as some excavation was already needed to balance out infill in the kick about area, for example.

### 9.6.1 Channel design

The cross-sectional area of the channel needs to stay the same in order to not affect the 50-year floodline. The current channel of 1.5 m x 0.1 m deep discharges 0.26 m<sup>3</sup>/s with a velocity of 2.61 m/s at a slope of 1:60 (if a roughness coefficient ( $n$ ) of 0.011 for concrete is used). The new channel design with mosaic tiles will have a roughness coefficient of 0.013. To cater for the slower water (at a velocity 2.39 m/s), an area of 0.018 m<sup>2</sup> per m<sup>2</sup> of channel needs to be added to the cross-sectional area of the channel.

## 9.7 Cut and fill volumes

Illus. 9.12 shows the cut and fill needed to keep the floodline constant. Soil to create the three berms will be sourced from the cut needed to create a surface of slope 1:200 in the kick about area, as well as from the excavations needed for the sand-filled areas in the 6-12 year area. This will be more than enough soil to supply the following volumes needed:

Southern Berm volume: 118.00 m<sup>3</sup>

Northern berm volume: 190.21 m<sup>3</sup>

Berm in 3-6 year area: 61.74 m<sup>3</sup>

## 9.8 Bridge

Creating a bridge across the river was problematic, as any bridge constructed would be well within the flood line unless it is lifted with more than 1.5 m. An 11 to 12 m span was also required. The bridge therefore had to use as little material as possible, yet be able to span the distance. It has a slope of 1:12 to cater for wheelchair users. Timber decking as a light-weight option was discarded as it requires too much maintenance. Q-deck was used instead to keep the material palette simplistic and to a minimum. The balustrade railing reflects the criss-crossing cables on the outside of the tower (see 9.9).

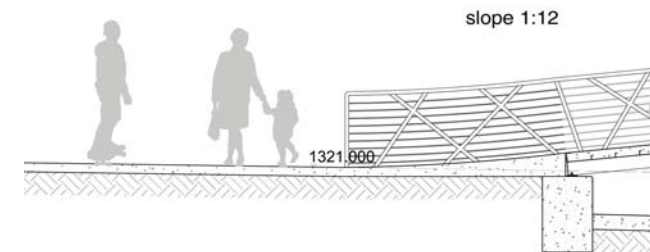

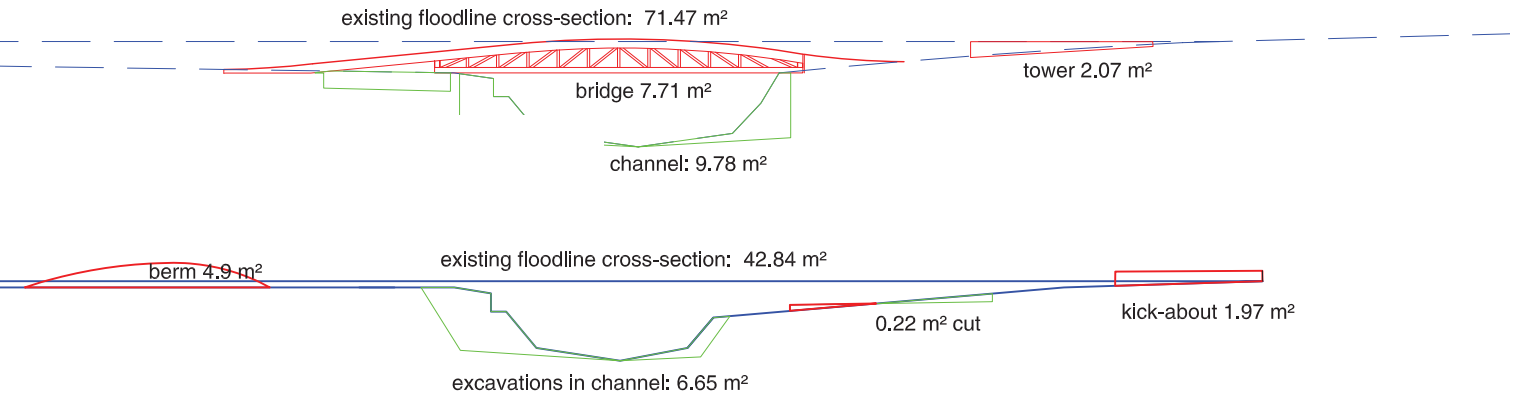

Illus. 9.21: Diagrammatic sections through channel showing existing and new cross-sections, as well as infill and excavations necessary in order to not affect the 50-year floodline. The blue line denotes the existing 50-year floodline, red shows infill and green excavations. (Author, October 2011)

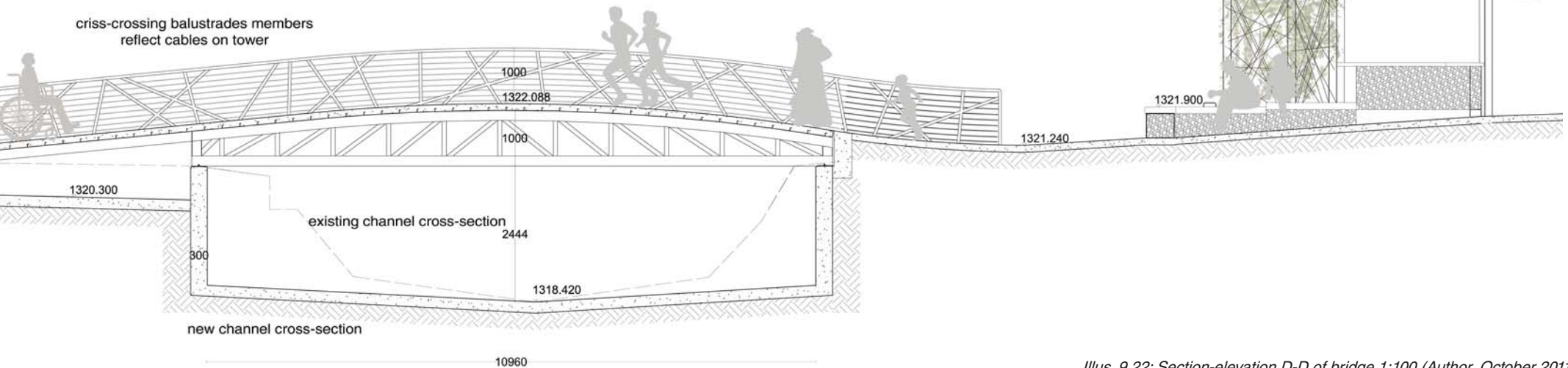

Illus. 9.22: Section-elevation D-D of bridge 1:100 (Author, October 2011)

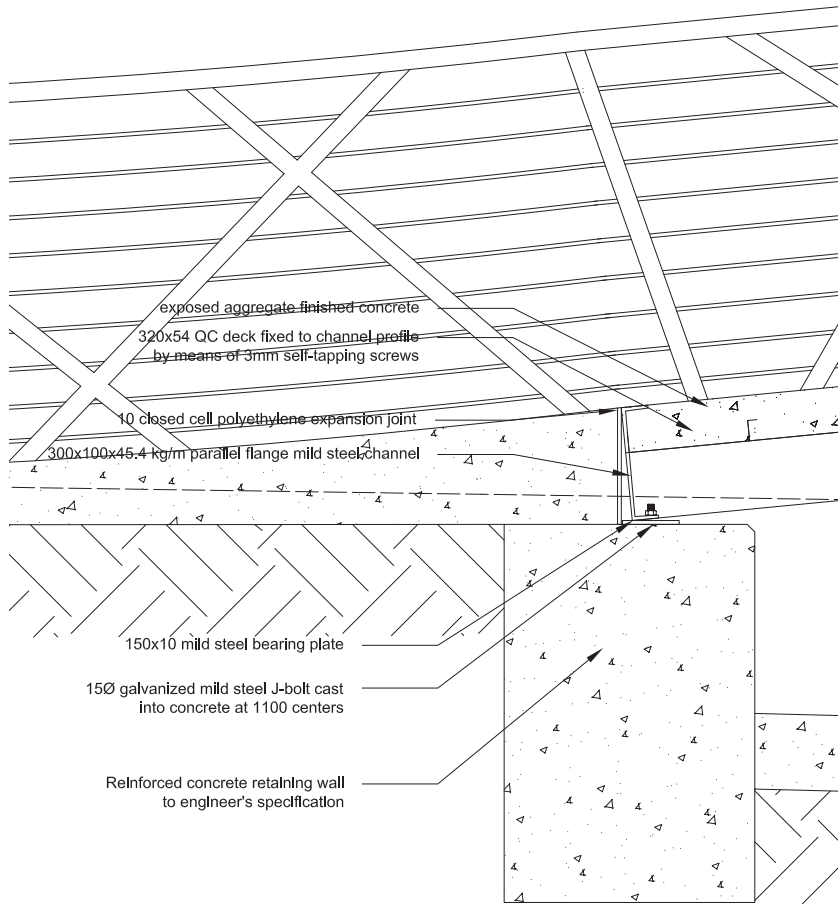

Illus. 9.23: Detail G 1:20 (Author, October 2011)

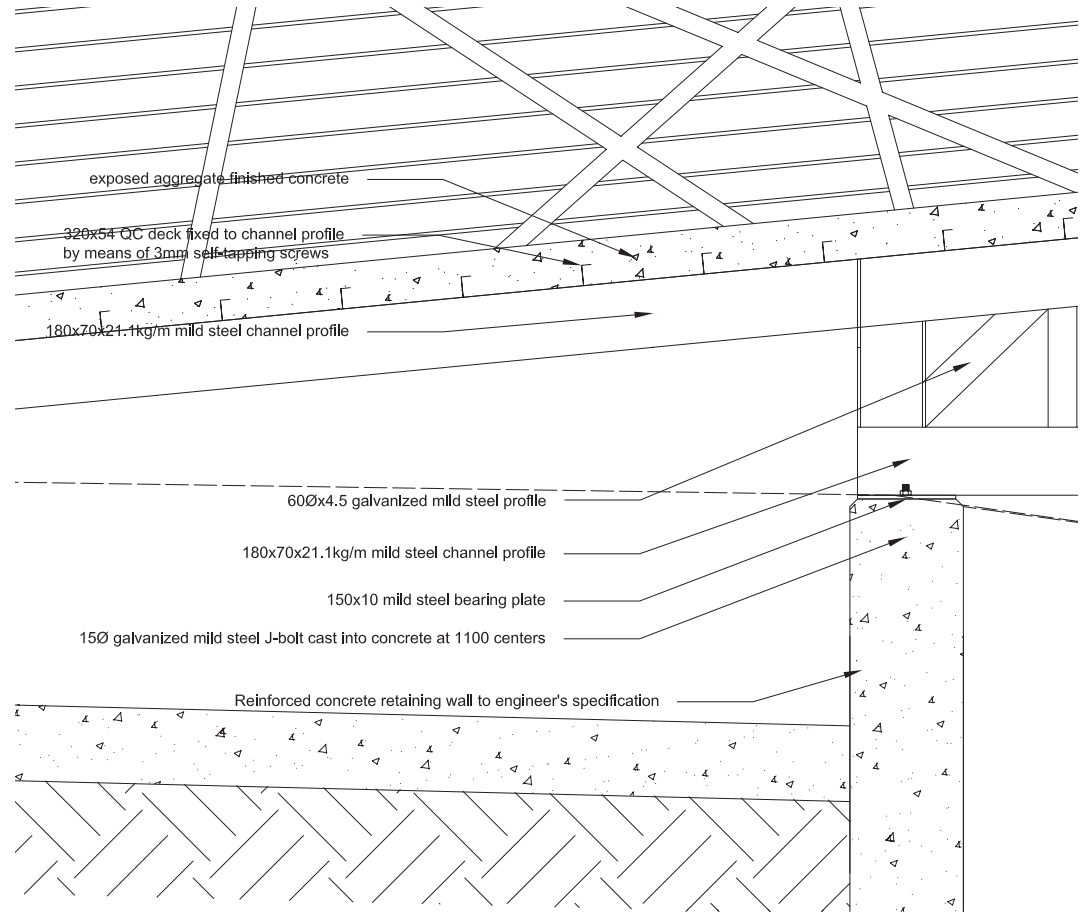

Illus. 9.24: Detail H 1:20 (Author, October 2011)

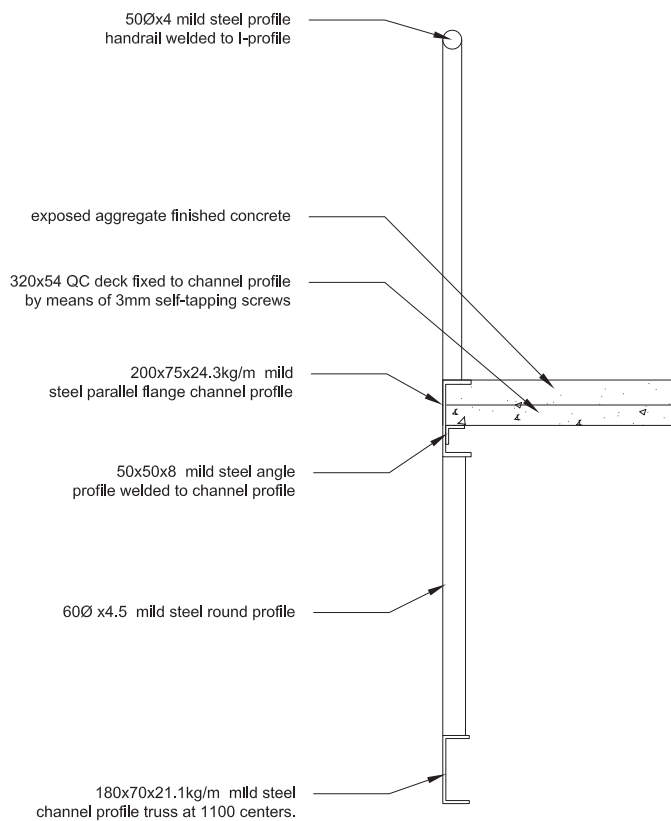

Illus. 9.25: Bridge edge and handrail section 1:20 (Author, October 2011)

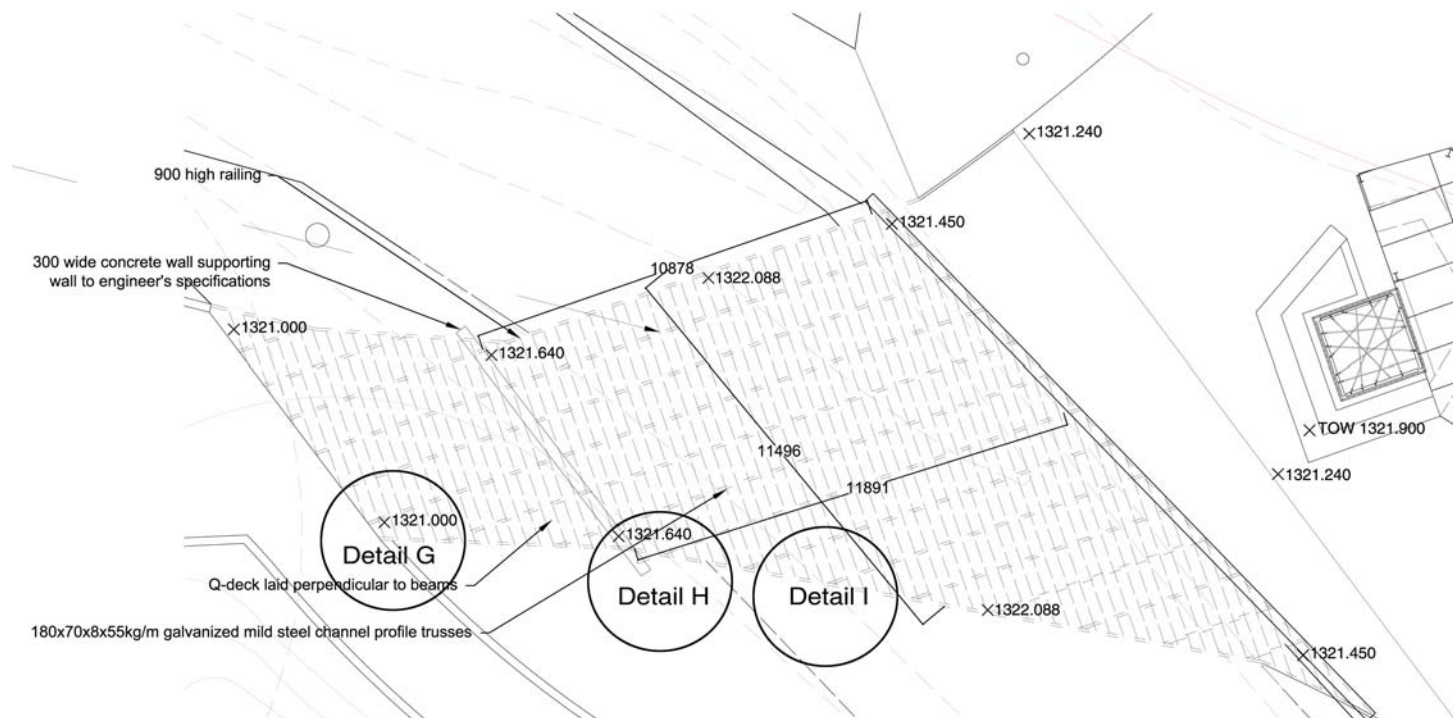

Illus. 9.26: Plan 1:200 of bridge structure showing location of structural beams and Q-deck. (Author, October 2011)

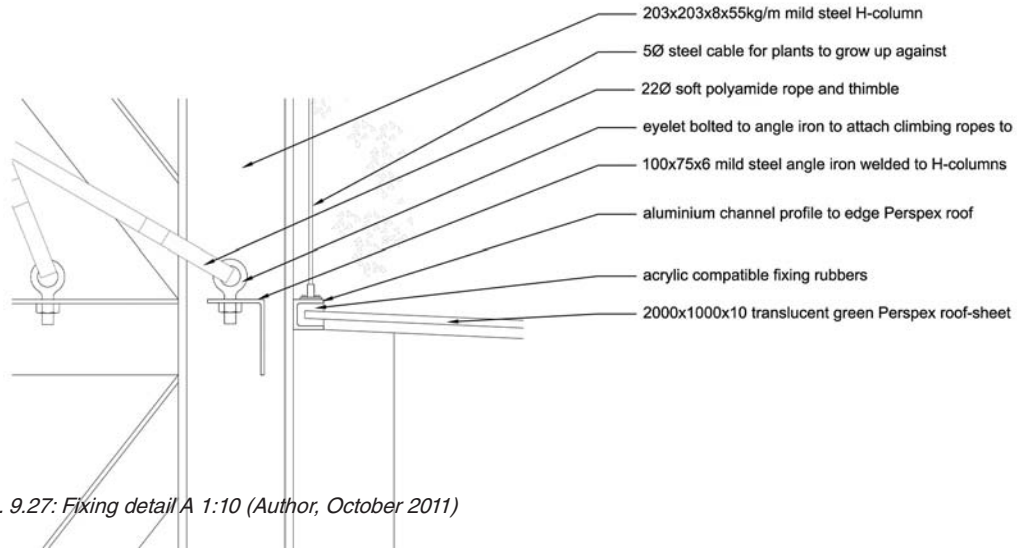

Illus. 9.27: Fixing detail A 1:10 (Author, October 2011)

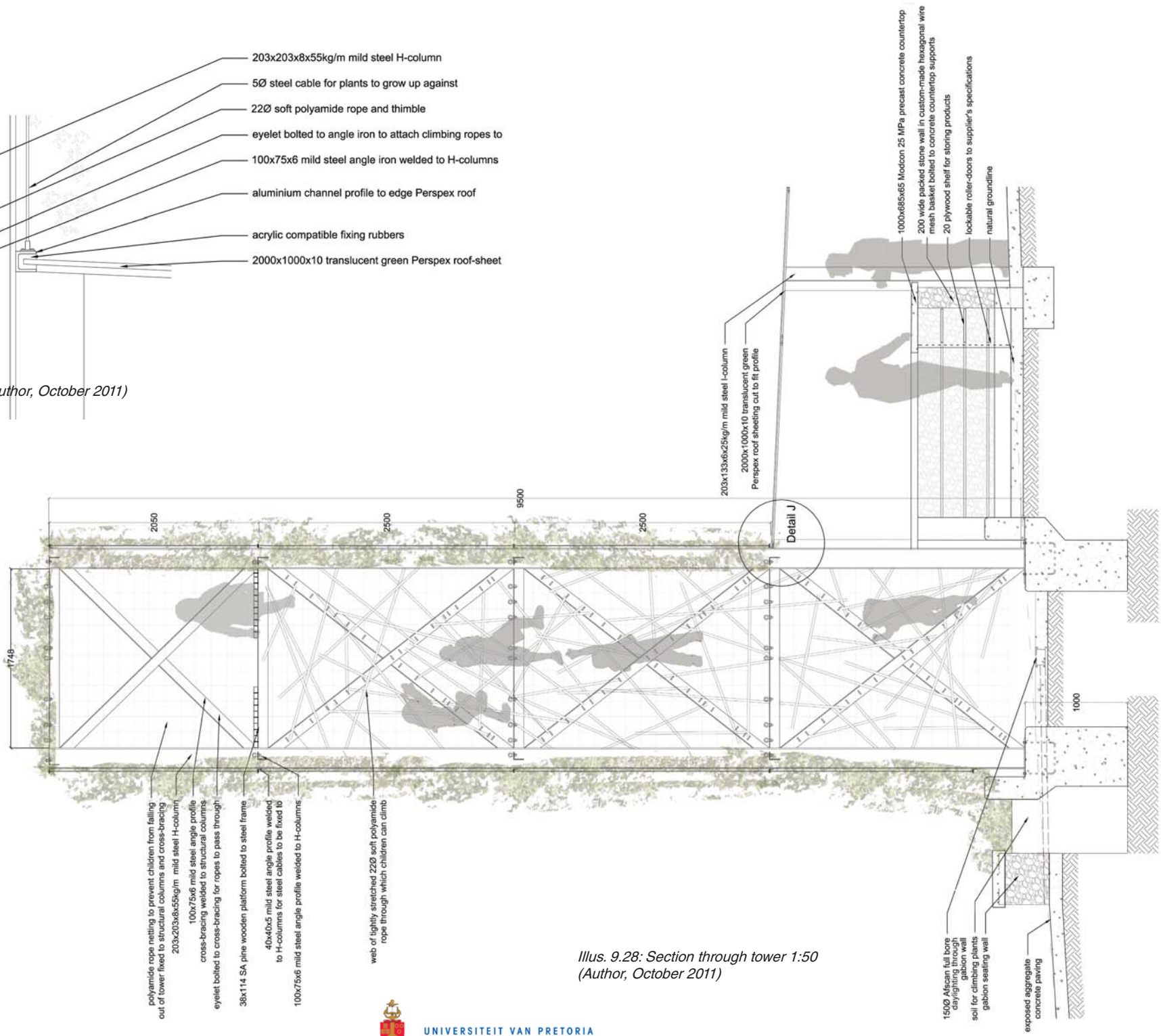

Illus. 9.28: Section through tower 1:50 (Author, October 2011)



Illus. 9.29: Example of type of rope to be used in tower, such as Corocord ([www.corocord.com](http://www.corocord.com))

## 9.9 Climbing tower and kiosk

The kiosk has lockable cupboards for the safety of the products.

The tower is oriented in such a way that the tower is on the west side of the kiosk, providing shade inside the kiosk.

Criss-crossing cables on the outside of the tower provide sufficient hold for climbing plants. A safety netting of polyamide rope between the outside cables and the inside web of ropes prevent children from falling out of the tower.

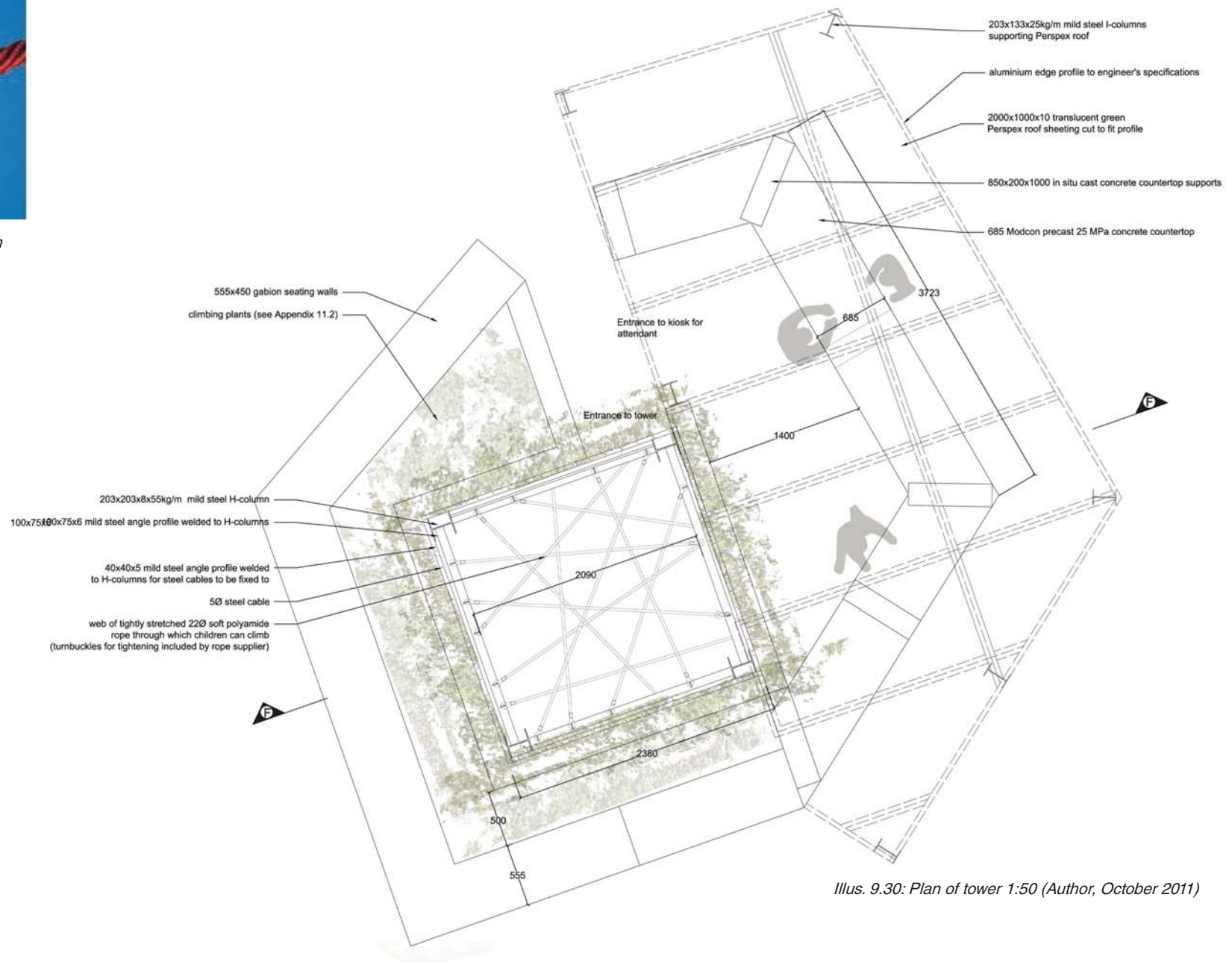

Illus. 9.30: Plan of tower 1:50 (Author, October 2011)

## 9.10 Lighting strategy

Illumination of the park is of utmost importance to ensure safety. Lights chosen are robust and vandalproof. Information from BEKA Lighting was used to determine light levels and spacings.

### 9.10.1 Five types of lights will be used:

Balmoral Solar lampposts which can provide up to 12 hour illumination are used in areas which need to be well-lit. A 9W solar panel is fixed flush into the top of the luminaire. On cloudy days mains electricity will be used. They are on average 10 m apart, depending on the amount of trees and planting. They are used along the channel to ensure that one can see into the channel at night.

BEKASPIKE LED uplighters will light the way up the ramp at the toy library.

BEKA LEDrail are used at the pergolas, attached to the underside of the I-beams or to the supporting frame of

the Perspex roofs of the taxi waiting area and the tower. They are also used within the gabion seating walls and at the bridge, creating a floating effect at night.

BEKA NEOS LED floodlights are used to light up the tower at night. From the top of the tower some also light up the kick about area.

BEKABRITE bollard lights are used in areas where tree canopies and shrubbery might obscure light from above or below. They are spaced 4 m apart.

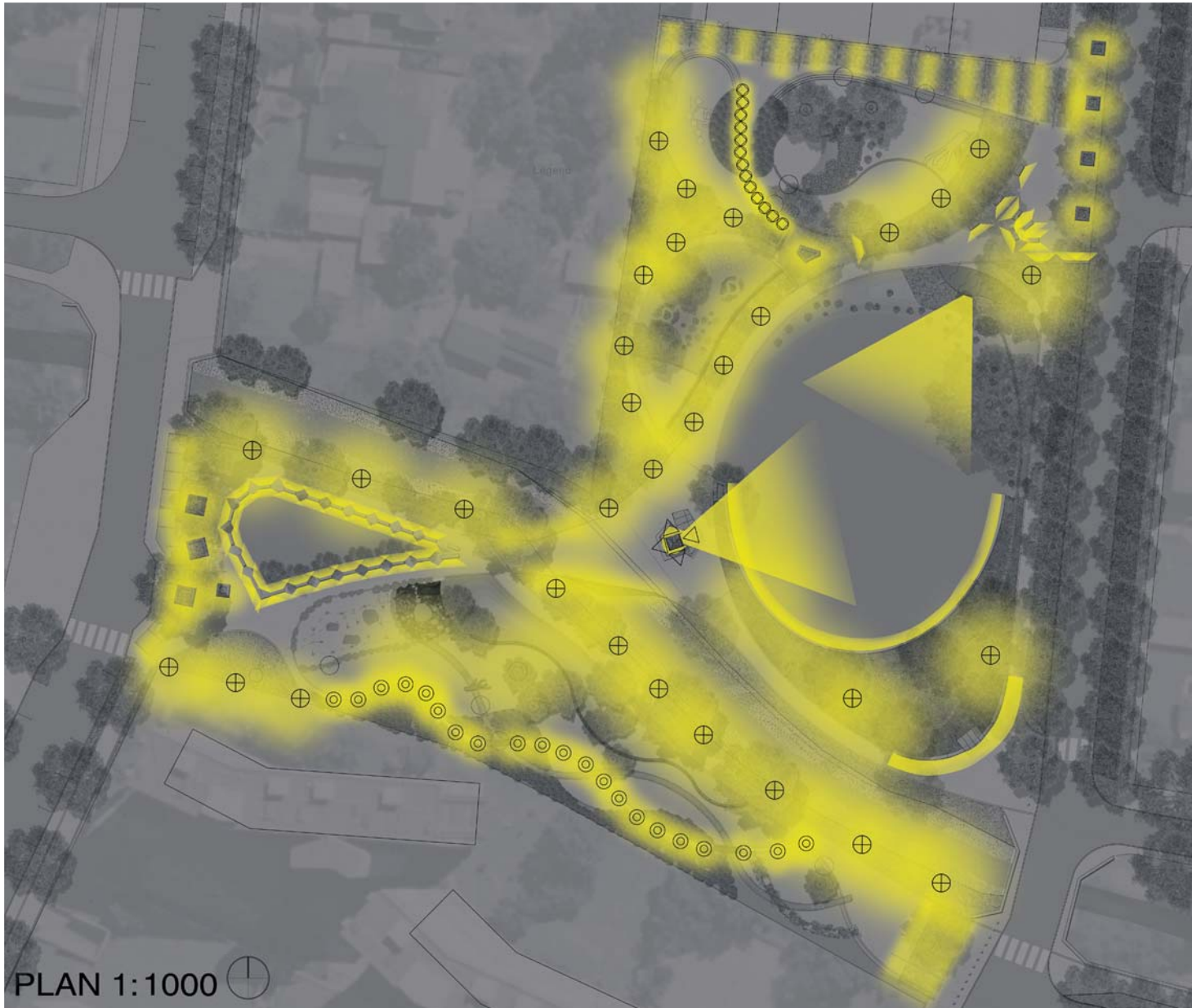

### Legend

- Balmoral Solar Lampposts 
- BEKASPIKE LED uplighters 
- BEKA LEDrail 
- BEKA NEOS LED floodlights 
- BEKABRITE bollard lights 

Illus. 9.31: Lighting plan (Author, October 2011)

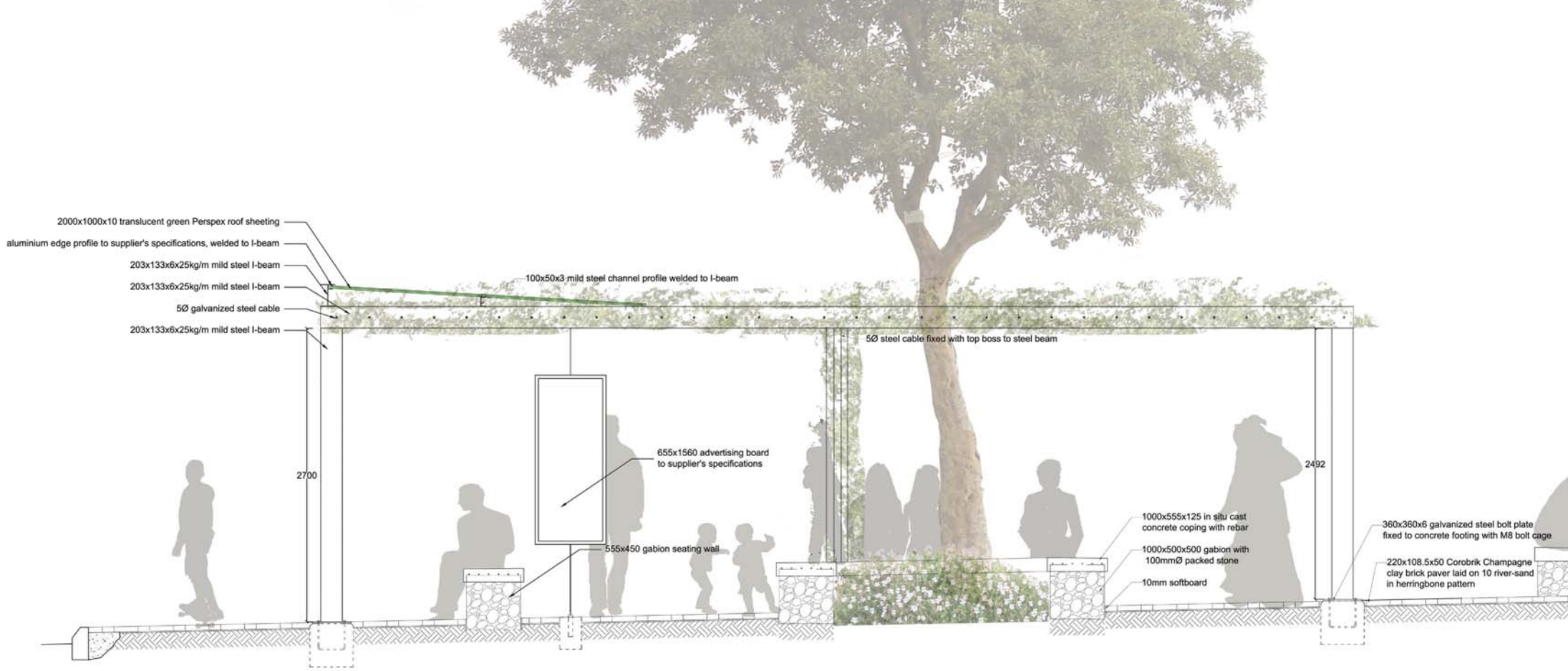

Illus. 9.32: Section E-E through taxi waiting area 1:50 (Author, October 2011)



Illus. 9.33: Detail E 1:20: Stone edgings around existing trees in 6-12 year old area (Author, October 2011)

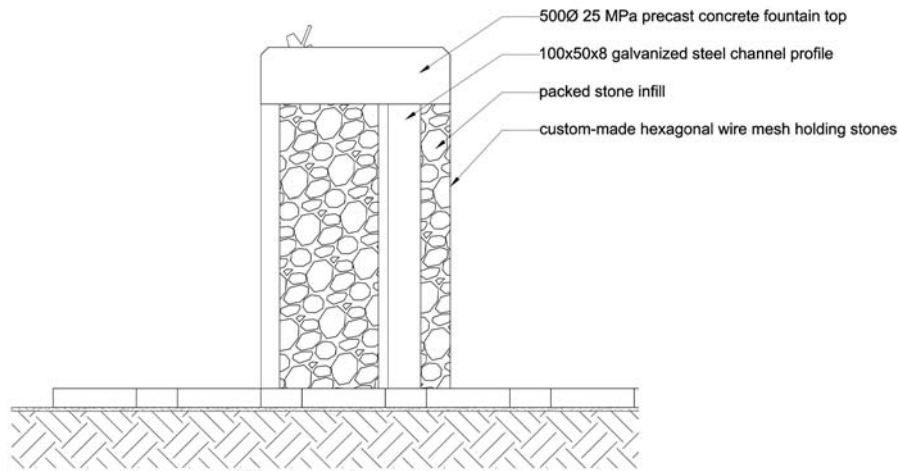

Illus. 9.34: Elevation 1:20 (Author, October 2011)

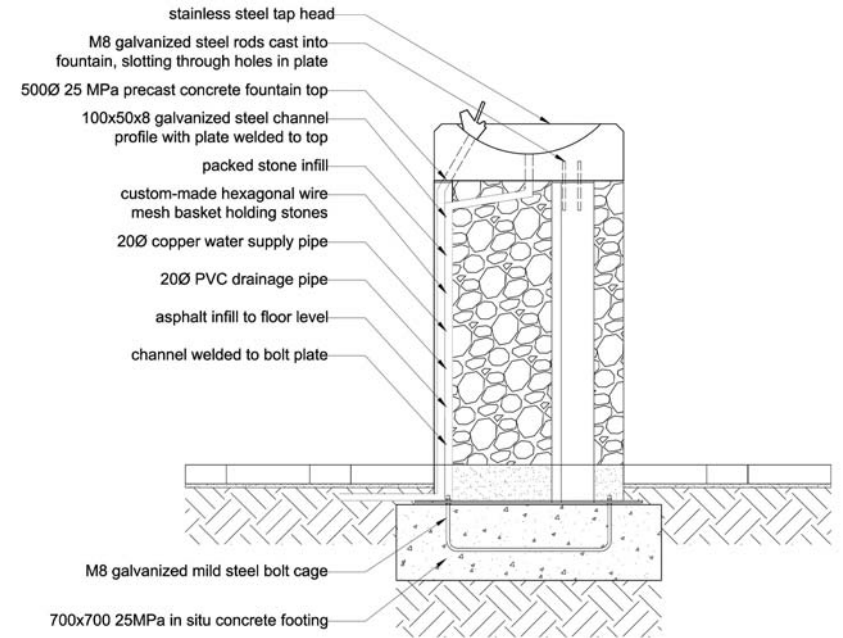

Illus. 9.35: Section 1:20 (Author, October 2011)

## 9.11 Drinking fountain (Detail F)

The drinking fountain reflects the material palette used in the rest of the park. The drainage pipe daylights into the nearest planting area.

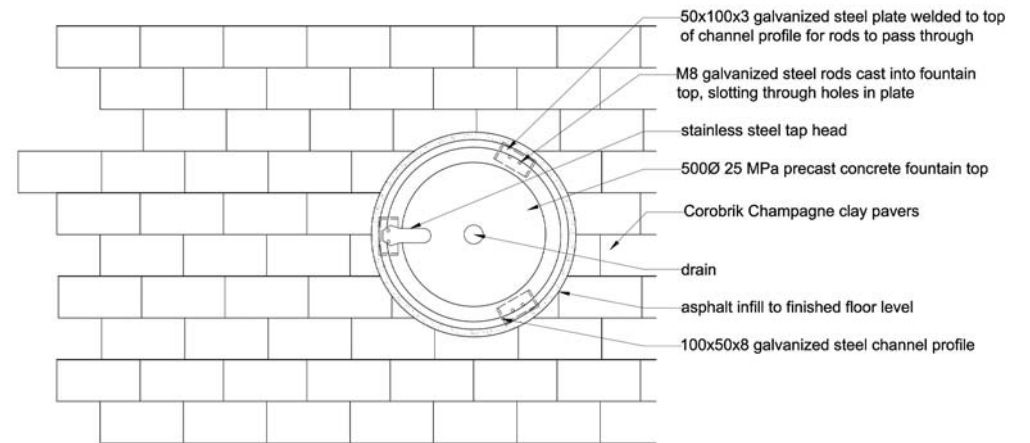

Illus. 9.36: Plan 1:20 (Author, October 2011)

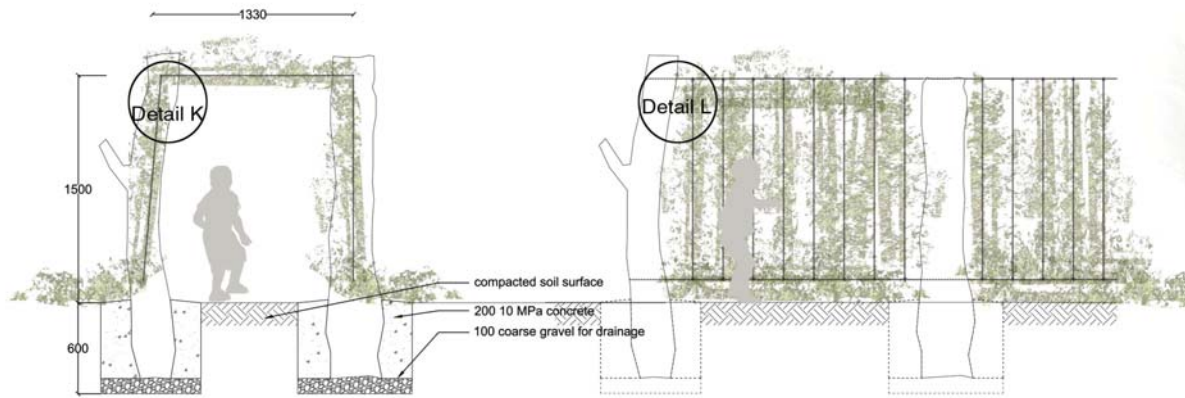

*Illus. 9.37: Section H-H 1:50 (Author, October 2011)*

*Illus. 9.38: Elevation G-G 1:50 (Author, October 2011)*

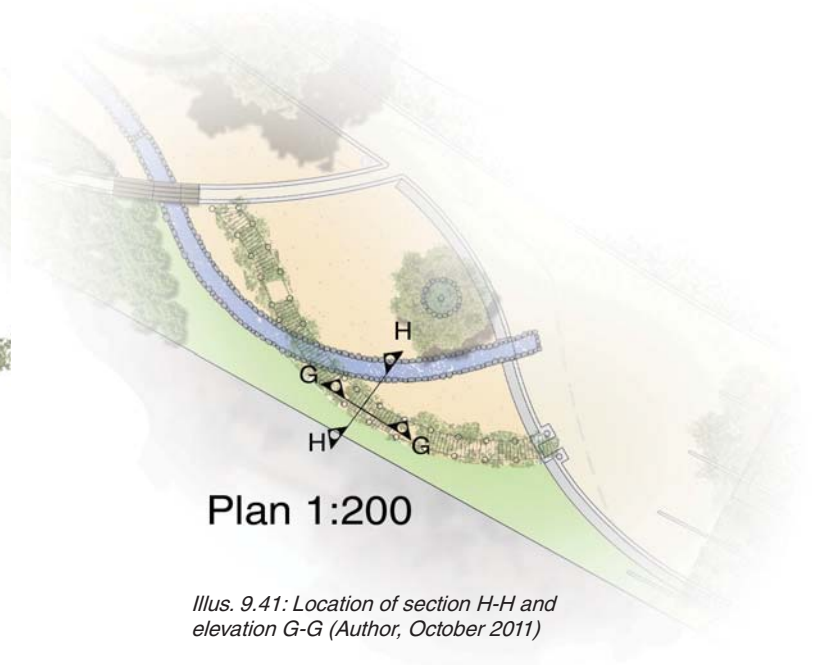

*Illus. 9.41: Location of section H-H and elevation G-G (Author, October 2011)*

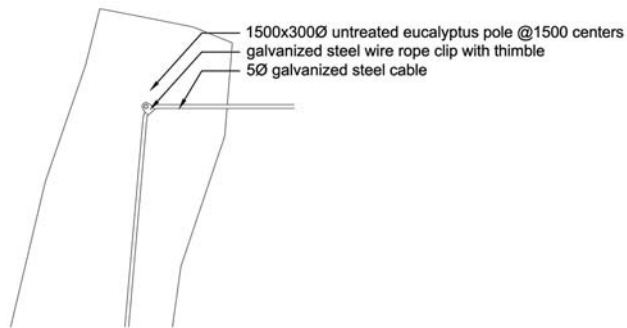

*Illus. 9.39: Detail K 1:10 (Author, October 2011)*

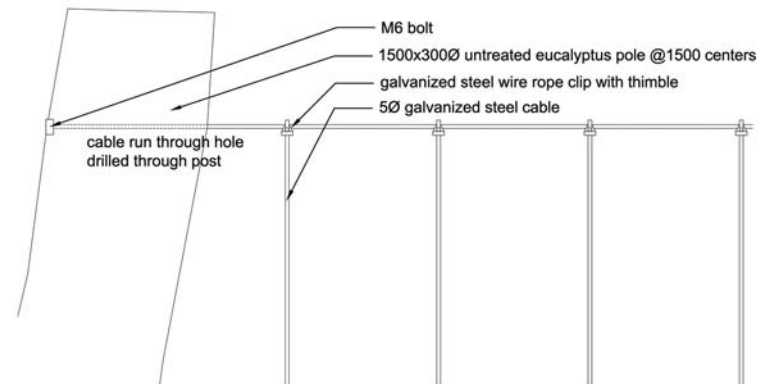

*Illus. 9.40: Detail L 1:10 (Author, October 2011)*

# 10



# Conclusion



## 10.1 Conclusion

The aim of this project was to create a natural children's playground in a high-density residential area. It is argued that nature is beneficial for the healthy cognitive, physical and socio-emotional development of children.

Through using archetypal landscapes, a complex environment offering multiple interlinking play opportunities are created. Such an environment is conducive to children's well-rounded development.

The issue of safety, maintenance and the Broken Window Theory<sup>1</sup> had a large influence on design decisions. The project shows that it is possible to create a complex natural environment that stimulates the imagination in the city without exaggerating costs or compromising safety. Children are able to take risks and stretch their own limitations within safe parameters.

The project demonstrates how a natural playground can be more sustainable through the use of recyclable materials that can easily be dismantled, as well as through natural materials, such as logs from alien invasive trees.

The park offers an opportunity for the residents in Sunnyside to become involved with their environment and take ownership of it, creating a sense of community and a place which young and old can use. It is hoped that the principles established in this dissertation will be used to create wonderful play experiences for the children of South Africa.

1. See page 61.



11

Bibliography

## 11.1 References



A Chance to Play. 2009. *A chance to play: A manual promoting play for children in South Africa*. <http://www.a-chance-to-play.org/downloads.htm> [20 March 2011].

ACTIVE LEARNING LIBRARIES SOUTH AFRICA, [s.a.] *An introduction to toy and leisure libraries*. [www.activelearninglibraries.org.za/word/IntroductiontoToyLibrariesinSouthAfrica.doc](http://www.activelearninglibraries.org.za/word/IntroductiontoToyLibrariesinSouthAfrica.doc) [7 April 2011].

ALEXANDER, C., ISHIKAWA, S. and SILVERSTEIN, M. 1977. *A pattern language*. Oxford: Oxford University Press.

ATTOE, W. and LOGAN, D. 1992. *American urban architecture: catalysts in the design of cities*. Berkeley: University of California Press.

BERRY, P. 2001. *Playgrounds that work*. New South Wales: Pademelon Press.

BIXLER, R.D., and FLOYD, M.F. 1997. Nature is scary, disgusting and uncomfortable. *Environment and Behaviour*, 29:443-467. [http://0-find.galegroup.com.innopac.up.ac.za/gtx/retrieve.do?contentSet=IAC Documents&resultListType=RESULT\\_LIST&qrySerId=Locale%28en%2C%2C%29%3AFQE%3D%28ke%2CNone%2C44%29Nature+is+scar+y+disgusting+and+uncomfortable%3AAnd%3AFQE%3D%28jn%2CNone%2C26%29%22Environment+and+Behavior%22%24&sgHitCountType=None&inPS=true&sort=Date Descend&searchType=AdvancedSearchForm&tabID=T002&prodId=AONE&searchId=R1&currentPosition=1&userGroupName=up\\_itw&docId=A19656735&docType=IAC](http://0-find.galegroup.com.innopac.up.ac.za/gtx/retrieve.do?contentSet=IAC Documents&resultListType=RESULT_LIST&qrySerId=Locale%28en%2C%2C%29%3AFQE%3D%28ke%2CNone%2C44%29Nature+is+scar+y+disgusting+and+uncomfortable%3AAnd%3AFQE%3D%28jn%2CNone%2C26%29%22Environment+and+Behavior%22%24&sgHitCountType=None&inPS=true&sort=Date Descend&searchType=AdvancedSearchForm&tabID=T002&prodId=AONE&searchId=R1&currentPosition=1&userGroupName=up_itw&docId=A19656735&docType=IAC) [24 July 2011].

BONNIE, 2011. Personal communication with resident of Sunnyside, 16 July 2011, Pretoria.

BREDENKAMP, G.J., BROWN, L.R. and MOSTERT, T. 2004. *A vegetation report on a ground truthing exercise to verify the plant communities of the Faerie Glen Nature Reserve, Pretoria*. Report prepared for Eco Assessments. Pretoria: Enviroguard Ecological Services CC.

BROWN, G., BROWN, B.B. and PERKINS, D.D. 2004. New Housing as Neighborhood Revitalization : Place Attachment and Confidence Among Residents. *Environment and Behavior*, 36(6):749-775. <http://eab.sagepub.com/content/36/6/749> [14 October 2010].

COLEY, R.L., KUO, F.E. and SULLIVAN, W.C. 1997. Where does community grow: The social context created by nature in public housing. *Environment and Behaviour*, 29(4): 468-495. <http://0-eab.sagepub.com.innopac.up.ac.za/content/29/4/468> [31 October 2010].

COOPER MARCUS, C., and FRANCIS, C. (eds). 1998. *People places: Design guidelines for urban open space*. 2nd ed. New York: John Wiley

CONWAY, M. 2010. *Adventure playgrounds built by communities*. [London]: National Children's Bureau.

DATTNER, R. 1969. *Design for play*. New York: Van Nostrand Reinhold.



DE BOTTON, A. 2006. *The architecture of happiness: The secret art of fun*. Penguin Books.

DEE, C. 2001. *Form and fabric in landscape architecture*. London: Spon Press.

DEPARTMENT OF PLANT SCIENCE, UNIVERSITY OF PRETORIA. (SAMPSON, J.) Personal communication, 26 September 2011. Appropriate climbing plants. Pretoria: [Author].

DINWIDDIE, S. A. 1993. *Playing in the gutters: enhancing children's cognitive and social play*.  
[http://ccrnj.org/acrobat\\_docs/playing\\_in\\_the\\_gutter.pdf](http://ccrnj.org/acrobat_docs/playing_in_the_gutter.pdf) [11 August 2011].

ENVIRONMENTAL PLANNING SECTION, 2006. Tshwane Open Space Framework: Executive Summary. Pretoria: Department of Housing, City Planning and Environmental Management.

EVANS, G. 2003. The built environment and mental health. *Journal of Urban Health*, 80(4):536-555. <http://0-www.springerlink.com.innopac.up.ac.za/content/332145g14675h745/fulltext.pdf> [6 May 2011].

FREUDER, T. G. 2006. Designing for the future: Promoting ecoliteracy in children's outdoor play environments. Unpublished ML. (Prof) thesis, Virginia Polytechnic Institute and State University, Alexandria VA.

FROST, J.L. [2006]. *The dissolution of children's outdoor play: causes and consequences*. [http://cgood.org/assets/attachments/Frost\\_-\\_Common\\_Good\\_-\\_FINAL.pdf](http://cgood.org/assets/attachments/Frost_-_Common_Good_-_FINAL.pdf) [25 April 2011].

GILL, T. 2005. *If you go down to the woods today*. <http://www.rethinkingchildhood.com> [19 April 2011].

GOODENOUGH, E. 2003. *Secret spaces of childhood*. Michigan: University of Michigan.

HART, R.A. 1982. Wildlands for children: Consideration for the value of natural environments in landscape planning. *Landschaft+Stadt*, 14(1):34-39.  
<http://0-web.gc.cuny.edu.innopac.up.ac.za/che/cerg/documents/wildlands%20for%20children.pdf> [1 November 2010].

HARVARD GRADUATE SCHOOL OF EDUCATION. 2002. *Who needs imagination? An interview with Professor Paul Harris*. <http://www.gse.harvard.edu/news/features/harris03012002.html> [24 July 2011].

HERRINGTON, S. and STUJTMANN, K. 1998. Landscape interventions: new directions for the design of children's outdoor play environments. *Landscape and Urban Planning*. 42:191-205, [http://0-www.sciencedirect.com.innopac.up.ac.za/science?\\_ob=ArticleURL&\\_udi=B6V91-3VGJG44-C&\\_user=59388&\\_coverDate=12%2F07%2F1998&\\_](http://0-www.sciencedirect.com.innopac.up.ac.za/science?_ob=ArticleURL&_udi=B6V91-3VGJG44-C&_user=59388&_coverDate=12%2F07%2F1998&_)



HERZOG, R.T. and STREVEY, S. J. 2008. Contact with nature, sense of humor, and psychological well-being. *Environment and behaviour*, 40(6):747-776. <http://eab.sagepub.com/content/40/6/747> [25 February 2011].

HURTWOOD, A. 1966. *New playgrounds*. London: Thames and Hudson.

HURTWOOD, A. 1969. *Planning for play*. London: Thames and Hudson.

JACOBS, J., 1961. *The life and death of great american cities*. London: Pelican Books.

JOUBERT, O., and DE VILLIERS, B. 2009. *Rejuve-a-nation proposal for the city of Tshwane/Pretoria*. Pretoria: Consortium Fook.

KADUSON, G.G. 2006. Release play therapy for children with posttraumatic stress disorder. In: Kaduson, H.G. & Schaefer, C.E. 2006. (eds) *Short-term play therapy for children*. New York: The Guilford Press.

KELLERT, S. F. 2005. Reflections on Children's Experience of Nature. *C&NN Leadership Writing Series*, 2(1):1-5. [www.childrenandnature.org/downloads/CNN\\_LWS\\_Vol1\\_02.pdf](http://www.childrenandnature.org/downloads/CNN_LWS_Vol1_02.pdf) [5 May 2011].

KELLING, G. L. & WILSON, J. Q. 1982. *Broken windows: The police and neighbourhood safety*. The Atlantic, 1982 (2). <http://www.theatlantic.com/magazine/archive/1982/03/broken-windows/4465/> [23 September 2011].

KIM, J. and KAPLAN, R. 2004. Physical and psychological factors in sense of community : New urbanist Kentlands and nearby Orchard Village. *Environment and Behavior*, 36: 313 <http://eab.sagepub.com/content/36/3/313> [1 November 2010].

KIPLING, R. 1912. *Just so stories*. New York: Doubleday Page & Company.

KOZLOVSKY, R. 2006. *The junk playground: creative destruction as antidote to delinquency*. Paper presented at the Youth and Threat Conference, New York, 1 April 2006, <http://threatnyouth.pbworks.com> [27 February 2011].

KUO, F.E. and TAYLOR, A.F. 2004. A potential natural treatment for attention-deficit/hyperactivity disorder: Evidence from a national study. *American Journal of Public Health*, 94(9):1580-1586. <http://ajph.aphapublications.org/cgi/reprint/94/9/1580> [1 August 2010].

KUO, F.E., BACAICOA, M. and SULLIVAN, W.C. 1998. Transforming inner-city landscapes : Trees, sense of safety, and preference. *Environment and Behaviour*, 30(1):28-59.

<http://eab.sagepub.com/content/30/1/28> [14 October 2010].



LAMBERT, J. and PEARSON, J. 1974. *Adventure playgrounds*. London: Penguin Books.

LEWIS, C.J. 1950. *The lion, the witch and the wardrobe*. London: Geoffrey Bles.

LINDEN, J.H. 2003. Playful metaphors. *American Journal of Clinical Hypnosis*, 45(3):245-250. <http://www.asch.net/portals/0/journallibrary/articles/ajch-45/linden.pdf> [29 September 2011].

LILLIS, K.A. and JAFFE, D.M. 1997. Playground injuries in children. *Paediatric Emerging Care*, 13(2):149-53. <http://www.ncbi.nlm.nih.gov/pubmed/9127428> [15 March 2011].

MACMILLAN, D.W. and CHAVIS, D.M. 1986. Sense of community: a definition and theory. *Journal of Community Psychology*, 14:7-23. <http://0-www.arts.manchester.ac.uk.innopac.up.ac.za/cla/projects/constantinesdream/events/hawardenmaterial/session%205%20files/fileuploadmax10mb,169310,en.pdf> [13 July 2011].

MCLOYD, V.C. 1990. The Impact of economic hardship on black families and children: psychological distress, parenting, and socio-emotional development. *Child Development*, 61(2):311-346. <http://www.jstor.org/stable/1131096> [1 November 2010].

MISRACHI, D. and WHITZMAN, C. 2009. *Vertical living kids: Creating supportive environments for children in Melbourne Central City high rises*. Report for the State of Australian Cities 2009 (SOAC 2009), Melbourne, 24-27 November 2009, <http://www.apo.org.au/node/22443> [3 November 2010].

MORROW, V. M., 2010. 'Dirty looks' and 'trampy places' in young people's accounts of community and neighbourhood: Implications for health inequalities. *Critical Public Health*, 10(2):141-152. <http://dx.doi.org/10.1080/713658244> [6 May 2011].

MUCINA, I., & RUTHERFORD, M.C. (eds). 2006. *The vegetation of South Africa, Lesotho and Swaziland*. Pretoria: South African National Biodiversity Institute

NASAR, J. L. and JULIAN, D. A. 1995. The psychological sense of community in the neighborhood. *Journal of the American Planning Association*, 61(2):178-184. <http://dx.doi.org/10.1080/01944369508975631> [7 October 2010].

NEWMAN, O. 1996. *Creating defensible space*. [Rutgers]: U.S. Department of Housing and Urban Development

NOREN-BJORN, E. 1982. *The impossible playground*. New York: Leisure Press.

ORGANIZATION OF AFRICAN UNITY. 1990. *African charter on the rights and welfare of the child*. (OAU Doc. CAB/LEG/24.9/49) [http://www.africa-union.org/official\\_documents/Treaties\\_%20Conventions\\_%20Protocols/a.%20C.%20ON%20THE%20RIGHT%20AND%20WELF%20OF%20CHILD.pdf](http://www.africa-union.org/official_documents/Treaties_%20Conventions_%20Protocols/a.%20C.%20ON%20THE%20RIGHT%20AND%20WELF%20OF%20CHILD.pdf) [16 March 2011].

PEARSON, M. and WILSON, H. 2001. *Sandplay and symbol work: Emotive*  
Council for Educational Research.



UNIVERSITEIT VAN PRETORIA  
UNIVERSITY OF PRETORIA  
YUNIBESITHI YA PRETORIA

*velopment with children, adolescents and adults.* Melbourne: Australian

PELLEGRINI, A.D. and SMITH, P.K. 1998. Physical activity play: The nature and function of a neglected aspect of play. *Child Development*, 69(3):577-598. <http://0-onlinelibrary.wiley.com/innopac.up.ac.za/doi/10.1111/j.1467-8624.1998.tb06226.x/pdf> [1 November 2010].

PERES, E. 2005. *Mindscape: a centre for creative development in Sunnyside.* Unpublished M. Arch (Prof) thesis, University of Pretoria, Pretoria.

PIM, J. 1971. *Beauty is necessary.* Cape Town: Purnell & Sons.

SABS, 2010. SANS 51176:2010 *South African National Standard: Playground equipment and surfacing.* 1st edn. Pretoria: SABS.

SARASON, S. B. 1974. *The psychological sense of community: Prospects for a community psychology.* San Francisco: Jossey-Bass.

SKAWRAN, K. and MACNAMARA, M. (eds) 1985. *Walter Battiss.* Craighall :AD Donker Publishers.

SLENTZ, K. and KROGH, S. 2001. *Early childhood development and its variations.* London: Lawrence Erlbaum Associates.

SOUTH AFRICA. City Planning and Development Division. 2008. *Tshwane Town Planning Scheme, 2008.* Pretoria: Government Printer.

SOUTH AFRICA. National Archives of South Africa. Letters from town clerk to Macintosh and Cross, 1925.

SOUTH AFRICA. National Archives of South Africa. [s.a.]. Map of Pretoria and suburbs.

SOUTH AFRICA. 1998a. *National Environmental Management Act (NEMA), Act no. 107 of 1998.* Pretoria: Government Printer.

SOUTH AFRICA. 1998b. *National Water Act, No. 36 of 1998.* Pretoria: Government Printer.

SOUTH AFRICA. South African Police Service. 2010. *Crime statistics for Sunnyside.* <http://www.saps.gov.za/statistics/reports/crimestats/2010/provinces/gauteng/pdf/sunnyside.pdf> [5 April 2011].

SPENCER, C. and BLADES, M. 2005. *Children and their environment.* Cambridge: Cambridge University Press.

STAEMPFLI, M.B. 2009. Reintroducing adventure into children's outdoor play environments. *Environment and Behaviour*, 41(2):268-280. <http://eab.sagepub.com/content/41/2/268> [8 April 2011].



STATS SA. (OLIFANT, K.) Personal communication, 19 April 2011. *Demog. a suburbs*. Pretoria: [Author].

STATS SA. 2010. *Mid-year population estimates, 2010*. Statistical release P0302. Pretoria : Statistics South Africa.

STRIFE, S. and DOWNEY, L. 2009. Childhood development and access to nature : A new direction for environmental inequality research. *Organization & Environment*, 22(1):99-122. <http://oae.sagepub.com/content/22/1/99.refs.html> [1 November 2010].

TAYLOR, A.F., KUO, F.E., SULLIVAN, W.C. and WILEY, A., 1998. Growing up in the inner city: green spaces as places to grow. *Environment & Behaviour*, 30(3):3-27. <http://eab.sagepub.com/content/30/1/3> [6 May 2011].

TITMAN, W. 1994. *Special places, special people: the hidden curriculum of school grounds*. Surrey: World Wide Fund United Kingdom.

TREIB, M. 1995. Must landscapes mean? In: Swaffield, S. 2002. (ed) *Theory in landscape architecture: A reader*. University of Pennsylvania Press: Philadelphia

UNGER, D.G. and WANDERSMAN, A. 1985. The importance of neighbors: the social, cognitive and affective components of neighbouring. *American Journal of Community Psychology*, 13(2):139-169.

UNITED NATIONS. 1989. *Convention on the Rights of the Child*. <http://www2.ohchr.org/english/law/pdf/crc.pdf> [12 April 2011].

VAN WYK, B. 2003. *A photographic guide to wild flowers of South Africa*. Pretoria: Briza Publications.

WANG, S. 2002. *The power of magical thinking : Research shows the importance of imagination in children's cognitive development*. Wall Street Journal, 22 December. <http://online.wsj.com/article/SB10001424052748703344704574610002061841322.html> [24 July 2011].

WEAVER, L. 2000. Learning Landscapes, Theoretical Issues and Design Considerations for the Development of Children's Educational Landscapes. Unpublished ML (Prof) Thesis, Virginia Polytechnic Institute, Virginia.

WELLHOUSEN, K. 2002. *Outdoor play every day*. New York: Delmar.

WELLS, N.M. 2000. At home with nature : Effects of "greenness" on children's cognitive functioning. *Environment and Behaviour*, 32(6):775-795. <http://eab.sagepub.com/content/32/6/775.refs.html> [14 October 2010].

WHITE, J. 2008. *Playing and Learning Outdoors*. Oxon: Routledge.

WILSON, R. 2008. *Nature and young children: Encouraging creative play and learning in natural environments*. New York: Routledge.

# 12

# Appendices

## 12.1 List of illustrations

Illus.1.1: <i>Crotalaria agatiflora</i> (Author, December 2010) .....	1
Illus.1.2: Typical apartment block in Sunnyside (Author, December 2010) .....	2
Illus.1.3: Typical apartment block typology in Sunnyside (Author, April 2011).....	2
Illus.1.4: Accessible open space and proposed site in Sunnyside (Author, April 2011) .....	3
Illus. 1.5 &1.6: Existing play equipment on proposed site (Author, March 2011) .....	4
Illus. 1.7: Photo collage of site (Author, March 2011) .....	5
Illus. 2.1: Piece of bark from palm tree (Author, July 2011) .....	4
Illus. 2.2: First National Bank in Church street, Pretoria (Author, January 2006) .....	8
Illus. 2.3: The Magic Fountain, Barcelona (www.flickr.com) .....	8
Illus. 2.4: Southern Namibia (Hess, March 2011) .....	8
Illus. 2.5: Jan Cilliers Park, Groenkloof (Author, September 2010).....	9
Illus. 2.6: Nirox, Krugersdorp (Author, May 2009) .....	9
Illus. 2.7: Kruger Square, Pretoria West (Author, March 2011) .....	9
Illus. 2.8: Having a view of greenery draws people out of their apartments (Author, May 2011) .....	9
Illus. 2.9: Play therapy: re-enacting traumatic experiences (such as a funeral) helps children to process their emotions (Author, May 2011) .....	10
Illus. 2.10: Risk-taking is necessary (Author, March 2011) .....	10
Illus. 2.11-2.14: Building and breaking in adventure playgrounds (Hurtwood, 1969) .....	11
Illus. 2.15: According to Dee (2001) and Cooper Marcus (1998), seating arrangement can influence interaction between people. (Author, May 2011) .....	13
Illus. 3.1: Heart shape on <i>Eucalyptus</i> wood (Author, March 2011) .....	15
Illus. 3.2: Children playing with cardboard boxes in Jubilee Square, Sunnyside, Pretoria (Author, March 2011).....	16
Illus. 3.3: Jubilee Square, Sunnyside, Pretoria (Author, March 2011) .....	17
Illus. 3.4: Clove Park, Zakariyya Park, Pretoria (Author, March 2011) .....	17
Illus. 3.5: Venning Park, Arcadia, Pretoria (Author, March 2011) .....	17
Illus. 3.6: Orlando West Regional Park, Soweto, Johannesburg (di Monte, March 2011) .....	18
Illus. 3.7: Wilgeheuwel Park, Roodepoort , Johannesburg (Author, March 2011) .....	18
Illus. 3.8: Sunnyside Playground, Sunnyside, Pretoria (Author, March 2011) .....	18

Illus. 3.9: Panorama of Muckleneuk Park, Sunnyside (Author, May 2011) .....	20
Illus. 3.10: Map of Muckleneuk Park playground, Sunnyside (Author, May 2011) .....	21
Illus. 3.11: People do not want to feel exposed (Author, March 2011) .....	21
Illus. 3.12: The element of mystery entices (Author, April 2011) .....	23
Illus. 3.13: Children have an affinity for small secret spaces (Author, April 2011) .....	23
Illus. 3.14: Grotto behind the waterfall (Conway, 2010:5).....	23
Illus. 3.15: Topography provides interest (Author, March 2011) .....	25
Illus. 3.16: Natural climbing equipment in Garden City Park, Canada (Broto: 2010: 527.....	26
Illus. 3.17: Water landscape at Pforzheim, Germany, by Herman Dreiseitl. (Dreiseitl & Grau, 2005: 151) .....	26
Illus. 3.18: Water and sand in Garden City Park, Canada (Broto, 2010: 526).....	26
Illus. 3.19: Water is inherently fascinating (Author, March 2011) .....	26
Illus. 3.20: Stepping stones and log creating route over dry riverbed (threshold). Valbyparken, Denmark. (Broto, 2010: 121).....	26
Illus. 3.21: <i>Crotalaria agatiflora</i> (Author, March 2011).....	27
Illus. 3.22: <i>Pelargonium peltatum</i> ( <a href="http://www.plantzafrica.com/frames/plantsfram.htm">http://www.plantzafrica.com/frames/plantsfram.htm</a> ) .....	27
Illus. 3.23: Playing in autumn leaves ( <a href="http://tootsiegrace.blogspot.com/2009/11/raking-leaves.html">http://tootsiegrace.blogspot.com/2009/11/raking-leaves.html</a> ) .....	27
Illus. 3.24: Loose parts (Author, March 2011).....	27
Illus. 3.25: Sounds and smells (Author, March 2011) .....	27
Illus. 3.26: Modular units (Author, March 2011).....	28
Illus. 4.1: <i>Dietes bicolor</i> (Author, 2010).....	29
Illus. 4.2: Lab C existing conditions. Not to scale (Herrington and Studmann, 1998:193).....	30
Illus. 4.3: Lab C interventions. Not to scale (Herrington and Studmann, 1998:194).....	30
Illus. 4.4: Lab A existing conditions. Not to scale (Herrington and Studmann, 1998:197) .....	30
Illus. 4.5: Lab A interventions. Not to scale (Herrington and Studmann, 1998:198) .....	30
Illus 4.6: New movement patterns created by the natural interventions (Herrington & Studmann, 1998:199) .....	31
Illus 4.7: Plan of Water Garden. Not to scale (Dreiseitl, 2005:150) .....	32
Illus 4.8: Children interacting with water (Dreiseitl, 2005:150) .....	32
Illus 4.9: Fixed moveable parts to manipulate water with (Dreiseitl, 2005:151).....	32
Illus 4.10: Low shrubs provide places to explore that still have good visual surveillance (Broto, 2010:343) .....	33
Illus 4.11: View down spring with water channel. (Broto, 2010: 344) .....	33

Illus 4.12: Bridge as threshold (Broto, 2010: 348) .....	33
Illus 4.13: Dead tree trunks as natural climbing frame (Broto, 2010: 348).....	33
Illus 4.14: Aerial view of park looking north (Vosloo, 2011) .....	34
Illus 4.15: Aerial view of park looking south (Vosloo, 2011).....	34
Illus 4.16: Custom-made play equipment (Author, March 2011).....	34
Illus. 4.17: Mound with climbing frame provides views to Suikerbosrand Mountain Range. (Author, May 2011).....	35
Illus. 4.18: Kinetic equipment are used more than static equipment. (Author, May 2011) .....	35
Illus. 4.19: Children building with sand in the basketball court. (Author, May 2011) .....	35
Illus. 4.20: Singular and group seating provided (Author, May 2011) .....	35
Illus. 5.1: Pine cone (Author, July 2011) .....	37
Illus. 5.2: Location of Gauteng in South Africa. Not to scale (manipulated by Author, May 2011).....	38
Illus. 5.3: Tshwane Metropol in Gauteng. Not to scale (manipulated by Author, May 2011) .....	38
Illus. 5.4: Pretoria in Tshwane. Not to scale (manipulated by Author, May 2011).....	38
Illus. 5.5: Aerial photo showing site within greater Pretoria. (manipulated by Author, May 2011).....	38
Illus. 5.6: Site with surrounding context (Author, May 2011) .....	39
Illus. 5.7: Homeless people appropriating park furniture. (Author, April 2011).....	40
Illus. 5.8: Lunch goers (Author, April 2011).....	40
Illus. 5.9: Informal gathering space on the corner of Leyds and De Rapper Streets. (Author, July 2011).....	40
Illus. 5.10: Movement and access on site (Author, April 2011) .....	41
Illus. 5.11: Vegetation found on site (Author, May 2011) .....	42
Illus. 5.12: Slope analysis (Author, June 2011) .....	43
Illus: 5.13: Solar study at 12:00 on 21 June and solar study at 12:00 on 21 December (Author, June 2011) .....	44
Illus. 5.14: Floodlines, water and sewage servitudes. (manipulated by Author, May 2011) .....	45
Illus. 5.15: Consolidation of erven. Not to scale (Author, May 2011).....	46
Illus. 5.16: Zoning (manipulated by Author, May 2011) .....	46
Illus. 5.17: The concrete channel (Author, April 2011) .....	47
Illus. 5.19: The existing shade trees along the walkway.(Author, April 2011) .....	47
Illus. 5.18: View from west edge of site (Author, June 2011) .....	47
Illus. 5.20: View of existing playground on site (Author, April 2011).....	48

Illus. 5.21: View of site from east (Author, April 2011).....	48
Illus. 5.22: View towards north (Author, April 2011) .....	49
Illus. 6.1: Rock formations (Author, April 2011).....	51
Illus. 6.2: The Apies River and Walker Spruit running through the city. (Botha, April 2011) .....	52
Illus. 6.3: The Walker Spruit from Walker Street to the Caledonian Sports Grounds. (Author, April 2011).....	52
Illus. 6.4 : Consortium Fook proposal for a Walter Battiss Memorial Park. Not to scale. (Courtesy of Joubert, 2009) .....	53
Illus. 6.5: Description of current condition of Walker Spruit (Author, April 2011).....	54
Illus. 6.6: Design guidelines for the Walker Spruit (Author, April 2011).....	54
Illus. 6.7: Proposed framework for portion of Walker Spruit (Author, May 2011).....	55
Illus. 6.8: Norman-Eaton paving patterns (Courtesy of Joubert, 2009) .....	56
Illus. 6.9: Mantis. Oil on canvas, by Walter Battiss. (Skawran & Macnamara, 1985:31) .....	56
Illus. 6.11: Collage of vision for Spruit (Author, May 2011) .....	56
Illus. 6.10: Close-up of Mantis artwork showing complexity and detail. (Skawran & Macnamara, 1985:31).....	56
Illus. 7.1: <i>Pterocarpus angolensis</i> seed (Author, September 2011) .....	58
Illus. 7.2: Proposed design masterplan (Author, October 2011) .....	59
Illus. 7.3: Berm provides psychological separation but visual integration (Author, July 2011).....	61
Illus. 7.4 & 7.5: Different income groups will be catered for. (Author, August 2011) .....	62
Illus. 7.7: Moodboard collage of the urban context of Sunnyside (Author, April 2011) .....	62
Illus. 7.6: Water purification strategy (Author, September 2011) .....	62
Illus. 7.8: Wetland (Author, September 2011).....	63
Illus 7.9: Site plan revision 1 (Author, April 2011).....	64
Illus 7.10: Site plan revision 2 (Author, May 2011) .....	64
Illus 7.11: Site plan revision 3 (Author, June 2011).....	64
Illus. 7.12-7.17: Archetypal landscapes (Author, August 2011) .....	65
Illus. 7.19: Interactive thresholds (Author, May 2011).....	66
Illus. 7.20: Curving pathways entice (Author, May 2011).....	66
Illus. 7.21: Small spaces to hide in (Author, June 2011).....	66
Illus. 7.22: Where does the bridge lead? (Author, June 2011).....	66
Illus. 7.23: Threshold investigation (Author, May 2011) .....	67

Illus. 7.24: The twining branches of a <i>Combretum microphyllum</i> can create imaginative spaces. (Author, June 2011).....	67
Illus. 7.25: A safe hiding place (Photo collage, Author, June 2011).....	67
Illus. 7.26: Tall grasses may seem like a forest to a three year old. (Author, June 2011).....	67
Illus. 7.27: Crossing water safely in Jan Cilliers Park, Pretoria (Author, June 2011).....	67
Illus 7.28: How basic layout was generated (Author, August 2011).....	68
Illus. 7.29: Final plan (Author, September 2011).....	68
Illus. 7.30: Parti diagram showing where archetypal landscapes are located (Author, September 2011).....	68
Illus. 7.31: Possible basecamps and routes which could be followed through the park (Author, September 2011).....	69
Illus. 7.32: Activity nodes, entrances and barriers (Author, September 2011).....	69
Illus. 8.1: <i>Banksia sp.</i> seed manipulation (Author, September 2011).....	72
Illus. 8.2: Masterplan (Author, September 2011).....	73
Illus. 8.3: Section A-A 1:100 (Author, October 2011).....	74
Illus. 8.5: <i>Rhamnus prinoides</i> (Venter, 1196:77).....	77
Illus. 8.4: Vision for the bushveld forest area. (Author, July 2011).....	77
Illus. 8.6: <i>Euclea crispa subsp. crispa</i> (Joffe, 2007:56).....	77
Illus. 8.7: <i>Dombeya rotundifolia</i> ( <a href="http://inheemsebome.co.za">http://inheemsebome.co.za</a> ).....	77
Illus. 8.8: <i>Nuxia congesta</i> ( <a href="http://www.plantzafrica.com">www.plantzafrica.com</a> ).....	77
Illus. 8.9: <i>Ehretia rigida</i> (Venter, 1996:173).....	77
Illus. 8.10: <i>Protasparagus setaceus</i> (Van Wyk & Malan, 1998:71).....	77
Illus. 8.11: Partial plan 1:500 of forest area (Author, September 2011).....	77
Illus. 8.13: <i>Asparagus asparagoides</i> ( <a href="http://luirig.altervista.org">http://luirig.altervista.org</a> ).....	77
Illus. 8.14: <i>Pteris vittata</i> (Joffe, 2007:309).....	77
Illus. 8.15: <i>Asplenium aethiopicum</i> ( <a href="http://pics.davesgarden.com">http://pics.davesgarden.com</a> ).....	77
Illus. 8.16: River, pond and zero-depth water feature 1:200 (Author, October 2011).....	78
Illus. 8.17: Perspective of children playing in river (Author & Breed, July 2011).....	78
Illus. 8.18: <i>Juncus effusus</i> 'Spiralis' ( <a href="http://www.honeysomeaquaticnursery.co.uk">www.honeysomeaquaticnursery.co.uk</a> ).....	79
Illus. 8.19: <i>Gomphostigma virgatum</i> ( <a href="http://www.plantzafrica.com">www.plantzafrica.com</a> ).....	79
Illus. 8.20: <i>Gunnera perpensa</i> (Joffe, 2007:326).....	79
Illus. 8.21: <i>Juncus effusus</i> ( <a href="http://www.wikipedia.org">www.wikipedia.org</a> ).....	79

Illus. 8.22: <i>Kniphofia ensifolia</i> (www.plantzafrica.com) .....	79
Illus. 8.23: <i>Kniphofia porphyrantha</i> (Van Wyk & Malan, 1998: 155) .....	79
Illus. 8.24: <i>Zantedeschia aethiopica</i> (www.plantzafrica.com) .....	79
Illus. 8.25: <i>Cyperus textilis</i> (http://plantthis.com.au) .....	79
Illus. 8.26: <i>Typha capensis</i> (Joffe, 2007:335) .....	79
Illus. 8.27: <i>Cyperus papyrus</i> (www. http://www.ozwatergardens.com.au/cyperus-prolifer).....	79
Illus. 8.28: Pond (maximum 100 mm deep) at the end of the river, with large boulders that create an island with pathways leading to it. (Author, October 2011) .....	80
Illus. 8.29: Plan of mountain area 1:200 (Author, October 2011).....	81
Illus. 9.30: Vision for the Mountain area (Author, October 2011) .....	83
Illus. 8.31: <i>Burkea africana</i> (Author, August 2011) .....	83
Illus. 8.32: <i>Helichrysum kraussi</i> (Author, August 2011) .....	83
Illus. 8.33: <i>Cussonia spicata</i> (http://www.panoramio.com).....	83
Illus. 8.34: <i>Englerophytum magalismontanum</i> (www.fruitipedia.com).....	83
Illus. 8.35: <i>Fadogia homblei</i> (www. http://www.ais.up.ac.za) .....	83
Illus. 8.36: <i>Xerophyta retinervis</i> (Van Wyk & Malan, 1998:91).....	83
Illus. 8.37: <i>Ancylobotrys capensis</i> (www.plantzafrica.com).....	83
Illus. 8.38: <i>Digitaria eriantha</i> (Van Oudtshoorn, 2002:226).....	83
Illus. 8.39: <i>Setaria sphacelata var. sphacelata</i> (Van Oudtshoorn, 2002:90).....	83
Illus. 8.40: <i>Loudetia simplex</i> (Van Oudtshoorn, 2002:133) .....	83
Illus. 8.41: Plan of 0-3 year area, 3-6 year area and toy library 1:500 (Author, September 2011).....	85
Illus. 8.42: Section through toy library and 3-6 year area 1:200 (Author, October 2011) .....	86
Illus. 8.43: Plan of 0-3 year area 1:200 (Author, October 2011) .....	87
Illus. 8.44: <i>Crotalaria agatiflora</i> (Van Wyk & Malan, 1998:137) .....	88
Illus. 8.45: <i>Sphenostylis angustifolia</i> (Van Wyk & Malan, 1998:213) .....	88
Illus. 8.46: <i>Vernonia natalensis</i> (Van Wyk & Malan, 1998:247) .....	88
Illus. 8.47: <i>Senecio barbertonicus</i> (www.wikipedia.org).....	88
Illus. 8.48: <i>Hibiscus pusillus</i> (Van Wyk & Malan, 1998:157).....	88
Illus. 8.49: <i>Lippia javanica</i> (www.aroma-pure.com).....	88
Illus. 8.50: <i>Indigofera hiliaris</i> (Van Wyk & Malan, 1998: 211).....	88

Illus. 8.51: <i>Grewia occidentalis</i> (www.seedshelf.com).....	88
Illus. 8.52: <i>Hermannia lancifolia</i> (Van Wyk & Malan, 1998:179).....	88
Illus. 8.53: <i>Felicia filifolia</i> (www.plantzafrica.com) .....	88
Illus. 8.54: <i>Vangueria infausta</i> (Venter, 1996:267).....	88
Illus. 8.55: <i>Halleria lucida</i> (www.earthlandscapes.blogspot.com) .....	88
Illus. 8.56: <i>Buddleja salviifolia</i> (www.flickr.com) .....	88
Illus. 8.57: <i>Tarchonanthus camphoratus</i> (www.operationwildflower.org.za) .....	88
Illus. 8.58: Plants such as <i>Ehretia rigida</i> can create child-size spaces in the age specific areas. (Author, July 2011) .....	89
Illus. 8.59: Vision for the grassland area (Author, August 2011) .....	91
Illus. 8.60: <i>Themeda triandra</i> ( <a href="http://www.flickr.com/photos/31031835@N08/3215313816/">http://www.flickr.com/photos/31031835@N08/3215313816/</a> ) .....	91
Illus. 8.61: <i>Melinis repens</i> (www.fireflyforest.com) .....	91
Illus. 8.62: <i>Panicum maximum</i> (Van Wyk & Malan, 1998:335).....	91
Illus. 8.63: <i>Eragrostis capensis</i> (Van Wyk & Malan, 1998:333) .....	91
Illus. 8.64: <i>Urelytrum agropyroides</i> (Van Wyk & Malan, 1998:321) .....	91
Illus. 8.65: <i>Elionorus muticus</i> (Van Wyk & Malan, 1998:315).....	91
Illus. 8.66: <i>Senegalia galpinii</i> ( <a href="http://www.plantzafrica.com">http://www.plantzafrica.com</a> ) .....	91
Illus. 8.67: <i>Cymbopogon plurinoides</i> (Van Oudtshoorn, 2002:53) .....	91
Illus. 8.68: Plan of grassland area showing slate stone pathways and gathering areas. Scale 1:500 (Author, October 2011).....	91
Illus. 8.69: Plan of pergola at Costando Building 1:200 (Author, October 2011).....	92
Illus. 8.70: Plan of pergola at taxi waiting area 1:200 (Author, October 2011).....	92
Illus. 8.71: Plan of pergola at south-eastern entrance 1:200 (Author, October 2011).....	92
Illus. 8.72: <i>Senecio macroglossus</i> (www.plantzafrica.com) .....	93
Illus. 8.73: <i>Thunbergia alata</i> (Joffe, 2007:361) .....	93
Illus. 8.74: <i>Rhynchosia caribaea</i> (Van Wyk & Malan, 1998:142) .....	93
Illus. 8.75: <i>Tylosema esculentum</i> (Van Wyk & Malan, 1998:125) .....	93
Illus. 8.76: <i>Rhoicissus tridentata</i> (www.rareplants.de).....	93
Illus. 8.77: <i>Senecio pleistocephalus</i> (Van Wyk, 2003:33) .....	93
Illus. 8.78: <i>Clematis brachiata</i> (Joffe, 2007:351) .....	93
Illus. 8.79: <i>Pentarrhinum insipidum</i> (www.plantzafrica.com) .....	93

Illus. 8.80: Plan of climbing tower 1:200 (Author, October 2011) .....	94
Illus. 8.81: Looking up into the tower (Author, September 2011, with ropes from Broto, 2010: 50) .....	95
Illus. 8.82: Plan of tunnel 1:200 (Author, September 2011) .....	96
Illus. 8.83: Perspective of tunnel (Author, September 2011) .....	97
Illus. 9.1: <i>Senegalia erioloba</i> wood (Author, September 2011) .....	100
Illus. 9.2: Plan indicating the location of each detail. For the wetland's position, see Illus. 7.8) (Author, October 2011) .....	100
Illus. 9.3: Packed gabions to be used as seating walls ( <a href="http://www.gabionbaskets.co.za">www.gabionbaskets.co.za</a> ) .....	101
Illus. 9.4: Corobrik Champagne clay pavers ( <a href="http://www.corobrik.co.za">www.corobrik.co.za</a> ) .....	101
Illus. 9.5: Coarse sand (Author, June 2011) .....	101
Illus. 9.6: Galvanized steel I-profile ( <a href="http://www.ruiyinsteel.en.nobodybuy.com/">www. http://ruiyinsteel.en.nobodybuy.com/</a> ) .....	101
Illus. 9.7: Exposed aggregate concrete (Author, March 2009) .....	101
Illus. 9.8: Waterwheel plan 1:100 (Author, October 2011) .....	102
Illus. 9.9: Waterwheel elevation 1:100 (Author, October 2011) .....	102
Illus. 9.10: Waterwheel and channel section 1:100 (Author, October 2011) .....	103
Illus. 9.11: Example of a coil waterwheel used in Zimbabwe. ( <a href="http://aquamor.tripod.com/Wheel.htm">http://aquamor.tripod.com/Wheel.htm</a> ) .....	104
Illus. 9.12: Wetland outlet detail 1:20. People will be discourage from entering the wetland by a railing. (Author, October 2011) .....	105
Illus. 9.13: Detail A 1:20: River section (Author, October 2011) .....	106
Illus. 9.14: Detail B 1:50: River section with railway sleeper bridge (Author, October 2011) .....	106
Illus. 9.15: Stormwater plan. Also see 9.4. (Author, October 2011) .....	107
Illus. 9.16: Detail C 1:20: Gabion seating wall around edge of kick about. (Author, October 2011) .....	108
Illus. 9.17: Detail D 1:20. Edge detail of zero-depth water feature. (Author, October 2011) .....	108
Illus. 9.18: Section B-B through pergola at Costando Building 1:50 (Author, October 2011) .....	109
Illus. 9.19: Section C-C through zero-depth water feature and pond 1:100 (Author, October 2011) .....	109
Illus. 9.20: Planting legend (Author, October 2011) .....	111
Illus. 9.21: Diagrammatic sections through channel showing existing and new cross-sections (Author, October 2011) .....	113
Illus. 9.22: Section-elevation D-D of bridge 1:100 (Author, October 2011) .....	113
Illus. 9.23: Detail G 1:20 (Author, October 2011) .....	114
Illus. 9.24: Detail H 1:20 (Author, October 2011) .....	114
Illus. 9.25: Bridge edge and handrail section 1:20 (Author, October 2011) .....	115

Illus. 9.26: Plan 1:200 of bridge structure showing location of structural beams and Q-deck. (Author, October 2011) .....	115
Illus. 9.27: Fixing detail A 1:10 (Author, October 2011) .....	116
Illus. 9.28: Section through tower 1:50 (Author, October 2011) .....	116
Illus. 9.29: Example of type of rope to be used in tower, such as Corocord ( <a href="http://www.corocord.com">www.corocord.com</a> ) .....	117
Illus. 9.30: Plan of tower 1:50 (Author, October 2011) .....	117
Illus. 9.31: Lighting plan (Author, October 2011) .....	119
Illus. 9.32: Section E-E through taxi waiting area 1:50 (Author, October 2011) .....	120
Illus. 9.33: Detail E 1:20: Stone edgings around existing trees in 6-12 year old area (Author, October 2011) .....	120
Illus. 9.34: Elevation 1:20 (Author, October 2011) .....	121
Illus. 9.35: Section 1:20 (Author, October 2011) .....	121
Illus. 9.36: Plan 1:20 (Author, October 2011) .....	121
Illus. 9.37: Section H-H 1:50 (Author, October 2011) .....	122
Illus. 9.38: Elevation G-G 1:50 (Author, October 2011) .....	122
Illus. 9.39: Detail K 1:10 (Author, October 2011) .....	122
Illus. 9.40: Detail L 1:10 (Author, October 2011) .....	122
Illus. 9.41: Location of Section H-H and Elevation G-G (Author, October 2011) .....	122
Illus. 10.1: Palm coir (Author, September 2011) .....	123
Illus. 10.2: Exploring (Author, August 2011) .....	124
Illus. 11.1 Heart-shaped flowers (Author, August 2011) .....	127

## 12.2 List of Figures

Figure 1.1: Comparative housing densities in Pretoria (Author, April 2011, compiled from personal communication, Stats SA, 19 April 2011).....	3
Figure 1.2: Relationship between client and funder. (Author, May 2011).....	5
Figure 3.1: Explanation of colour coding for each evaluation criteria (Author, May 2011).....	18
Figure 3.2: Assessment of parks in Gauteng (Author, May 2011).....	19
Figures 3.3 - 3.10: Graphs showing the results of the assessments (Author, July 2011).....	19
Figure 3.11: Results of picture study (Author, May 2011).....	22
Figure 3.12: Developmental stages and needs of children (Author, March 2011, compiled from Berry, 2001; Goodenough, 2003, Hurtwood, 1966 & 1969, Lambert & Pearson, 1974, Noren-Bjorn, 1982; and Wellhousen, 2002).....	24
Figure 5.1: Population demographics of Sunnyside (Author, April 2011, compiled from pers. comm., Stats SA, 19 April 2011).....	40
Figure 5.2: Demographics of children in Sunnyside (Author, April 2011, compiled from pers. comm., Stats SA, 19 April 2011).....	41
Figure 5.3: Temperature (Climate-Charts, 2010).....	44
Figure 5.4: Rainfall (Climate-Charts, 2010).....	44
Figure 5.5: Sun angles for Pretoria (Gaisma, n.d).....	44
Figure 5.6: Wind direction (Windfinder.com, n.d).....	44
Figure 7.1: The connections between man, his needs and the environment (Author, August 2011).....	60
Figure 7.2: Explanation of typical run of events in a story as summarized in the monomyth ( <a href="http://thenamingofparts.com/">http://thenamingofparts.com/</a> ).....	66
Figure 8.1: Left: Flowering times of plants used. Right: Fruiting times of plants used (Author, August 2011, compiled from Joffe, 2007, and <a href="http://www.plantzafrica.com">www.plantzafrica.com</a> ).....	77
Figure 8.2: Flowering times of wetland plants used. (Author, August 2011, compiled from Joffe, 2007 and <a href="http://www.plantzafrica.com">www.plantzafrica.com</a> ).....	79
Figure 8.3: Flowering (left) and fruiting (right) periods of plants used in the mountain area. (Author, August 2011, compiled from Van Wyk & Malan, 1998, and <a href="http://www.plantzafrica.com">www.plantzafrica.com</a> ).....	83
Figure 8.4: Left: Flowering times. Right: Fruiting times (Author, August 2011, compiled from Joffe, 2007, Van Wyk & Malan, 1998).....	89
Figure 8.5: Left: Flowering times of climbing plants used. Right: Fruiting times. (Author, August 2011, compiled from Joffe, 2007; Van Wyk & Malan, 1998; Van Wyk, 2003 and <a href="http://www.plantzafrica.com">www.plantzafrica.com</a> ).....	93
Figure 8.6: Matrix showing how each area satisfies the design criteria as determined in Chapter 2 and 3. (Author, September 2011).....	98
Figure 9.1: Design calculations for a coil waterwheel where the water is lifted to the height of the wheel axis. (MacKellar, July 2011).....	104
Figure 9.2: Schematic design of waterwheel and channel (MacKellar, July 2011).....	104
Figure 9.4: Water budget (Author, October 2011).....	110
Figure 9.3: Irrigation requirements for the various planting areas (Author, October 2011).....	110