

INAUGURAL ADDRESS

Towards net zero: harnessing the “hidden”
energy of latent heat

Prof Jaco Dirker

Department of Mechanical and Aeronautical Engineering

16 October 2025



UNIVERSITEIT VAN PRETORIA
UNIVERSITY OF PRETORIA
YUNIBESITHI YA PRETORIA

Faculty of Engineering,
Built Environment and
Information Technology

Fakulteit Ingenieurswese, Bou-omgewing en
Inligtingtegnologie / Lefapha la Boetšenere,
Tikologo ya Kago le Theknolotši ya Tshedimošo

Make today matter

www.up.ac.za

Towards net zero: harnessing the “hidden” energy of latent heat

A brief overview of some contributions towards understanding and implementing flow-based phase change processes, and phase change energy storage mechanisms, and a forward view of opportunities.



UNIVERSITEIT VAN PRETORIA
UNIVERSITY OF PRETORIA
YUNIBESITHI YA PRETORIA

Faculty of Engineering,
Built Environment and
Information Technology

Fakulteit Ingenieurswese, Bou-omgewing en
Inligtingtegnologie / Lefapha la Boetšenere,
Tikologo ya Kago le Theknolotši ya Tshedimošo

Make today matter

www.up.ac.za

From Hot Coffee to Hidden Power

Sensible heat



**Faculty of Engineering,
Built Environment and
Information Technology**
Fakulteit Ingenieurswese, Bou-omgewing en
Inligtingtegnologie / Lefapha la Boetšenere,
Tikologo ya Kago le Theknolotši ya Tshedimošo

From Hot Coffee to Hidden Power

Latent heat



UNIVERSITEIT VAN PRETORIA
 UNIVERSITY OF PRETORIA
 YUNIBESITHI YA PRETORIA

Faculty of Engineering,
 Built Environment and
 Information Technology

Fakulteit Ingenieurswese, Bou-omgewing en
 Inligtingtegnologie / Lefapha la Boetšenere,
 Tikologo ya Kago le Theknolotši ya Tshedimošo

The Modern Energy Challenge

Global environmental changes

Arctic sea ice minimum extent

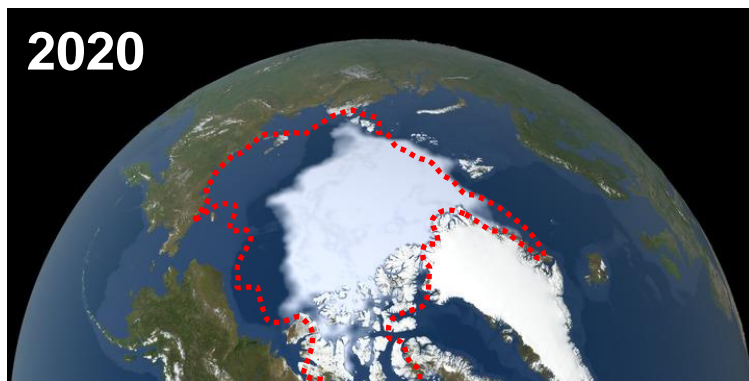
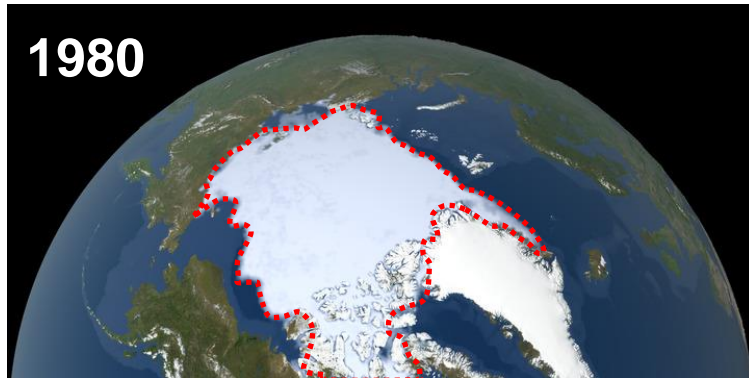

Credit: climate.nasa.gov

Global CO₂

2002



2022

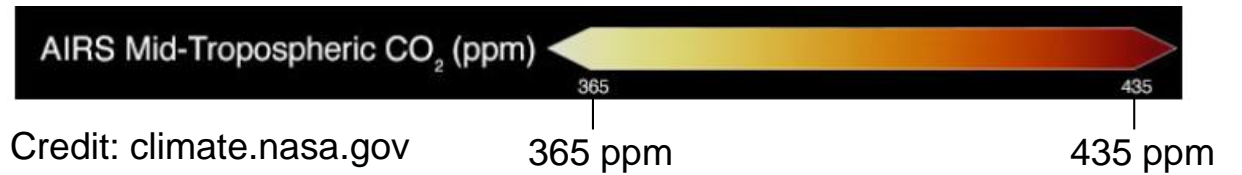

Faculty of Engineering,
Built Environment and
Information Technology

Fakulteit Ingenieurswese, Bou-omgewing en
Inligtingtegnologie / Lefapha la Boetšenere,
Tikologo ya Kago le Theknolotši ya Tshedimošo

The Modern Energy Challenge

Energy consumption shift

2025 Global electricity consumption

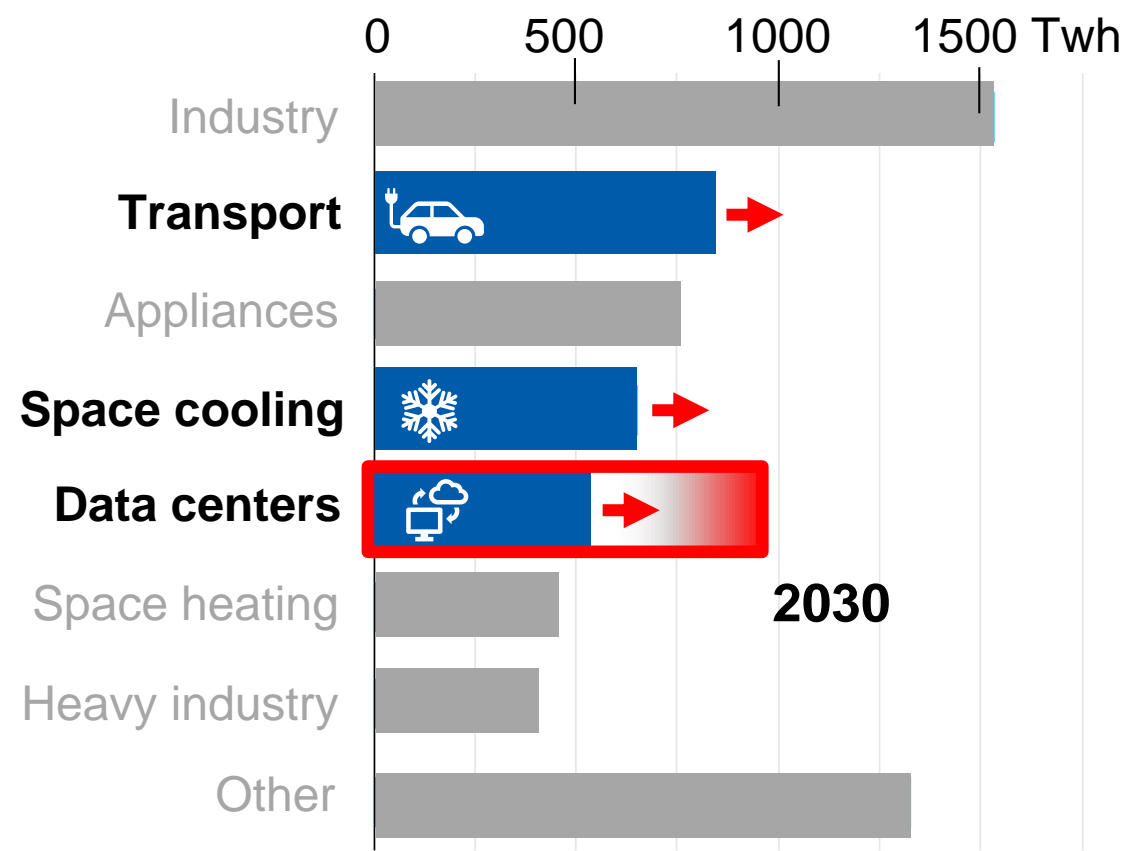

Data: iea.org

Data centers



**Faculty of Engineering,
Built Environment and
Information Technology**
Fakulteit Ingenieurswese, Bou-omgewing en
Inligtingtegnologie / Lefapha la Boetšenere,
Tikologo ya Kago le Theknolotši ya Tshedimošo

Harnessing Latent Heat: Solutions and Applications

- Passive thermal storage
- Active heat transport



UNIVERSITEIT VAN PRETORIA
UNIVERSITY OF PRETORIA
YUNIBESITHI YA PRETORIA

Faculty of Engineering,
Built Environment and
Information Technology

Fakulteit Ingenieurswese, Bou-omgewing en
Inligtingtegnologie / Lefapha la Boetšenere,
Tikologo ya Kago le Theknolotši ya Tshedimošo

Make today matter

www.up.ac.za

Harnessing Latent Heat: Solutions and Applications

Passive thermal storage

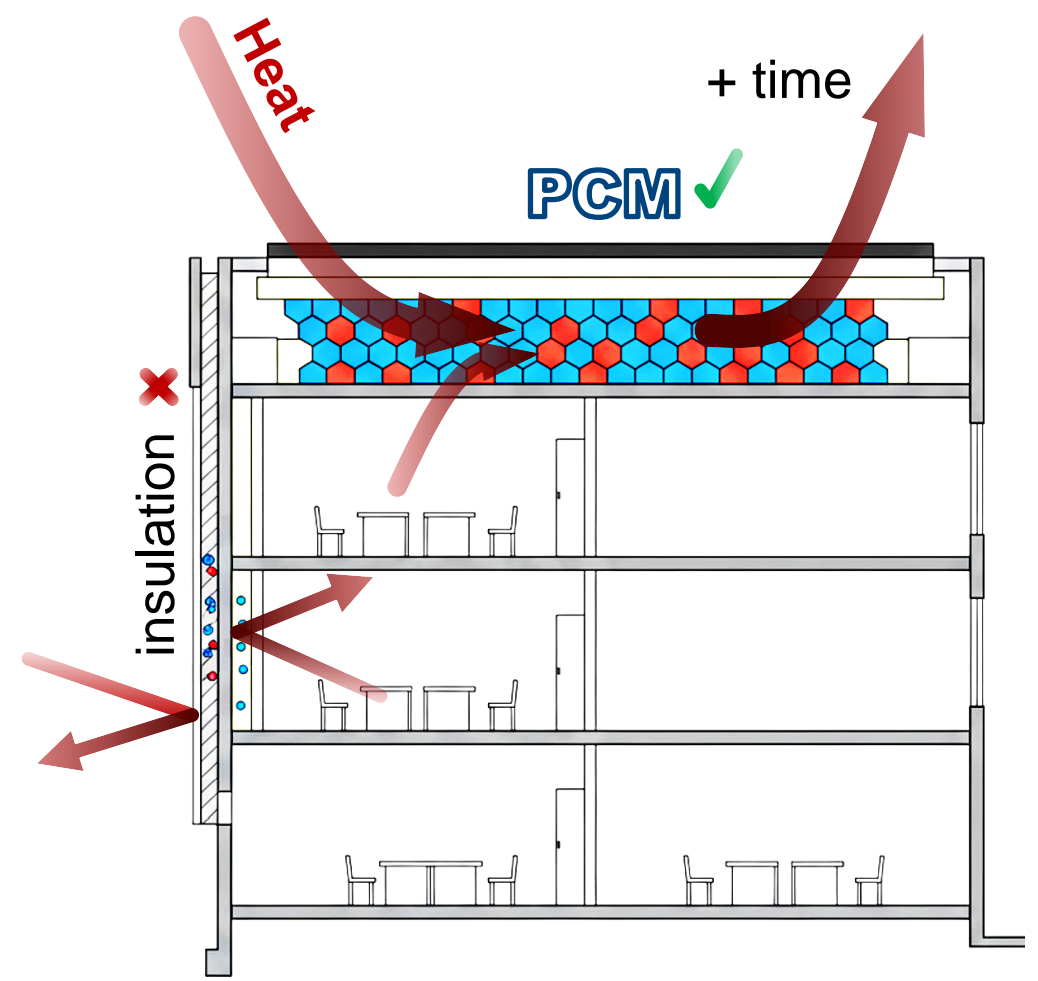
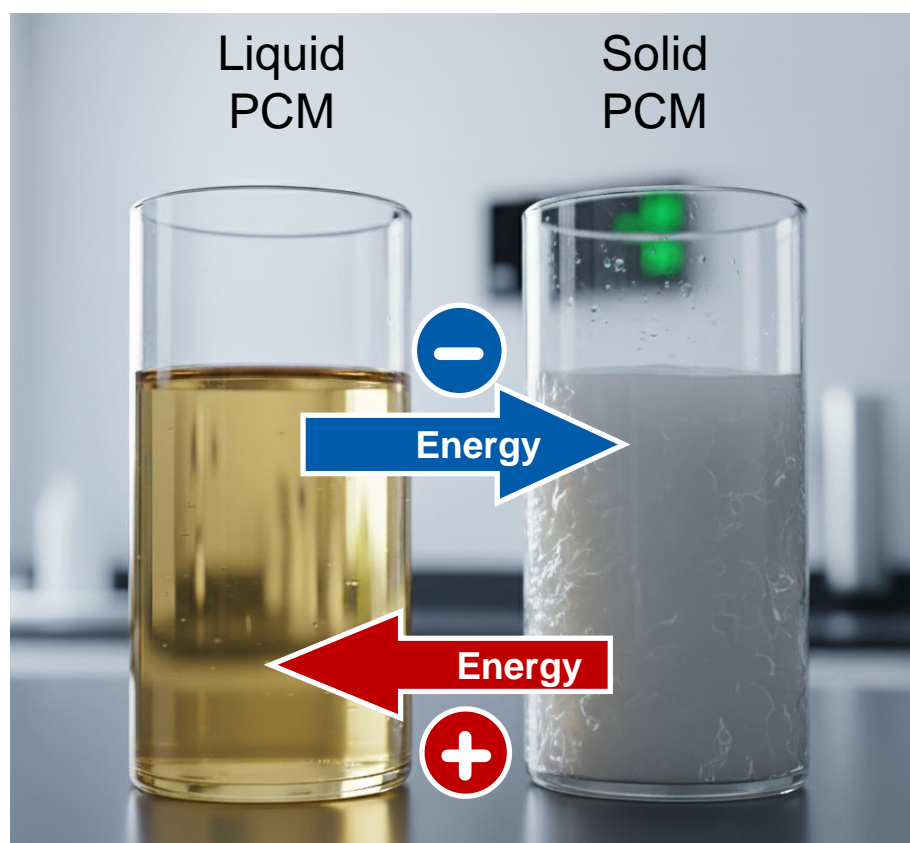

Faculty of Engineering,
Built Environment and
Information Technology
Fakulteit Ingenieurswese, Bou-omgewing en
Inligtingtegnologie / Lefapha la Boetšenere,
Tikologo ya Kago le Theknolotši ya Tshedimošo

Harnessing Latent Heat: Solutions and Applications

Active heat transport: Thermodynamic cycles
Power production

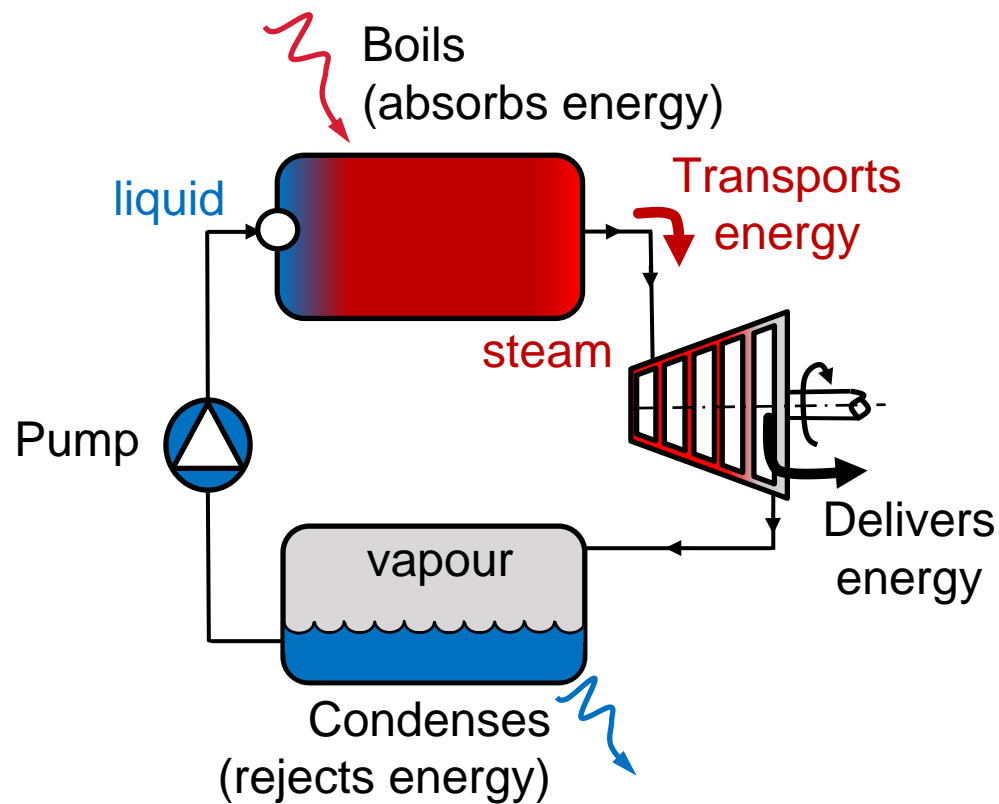

UNIVERSITEIT VAN PRETORIA
UNIVERSITY OF PRETORIA
YUNIBESITHI YA PRETORIA

Faculty of Engineering,
Built Environment and
Information Technology

Fakulteit Ingenieurswese, Bou-omgewing en
Inligtingtegnologie / Lefapha la Boetšenere,
Tikologo ya Kago le Theknolotši ya Tshedimošo

Make today matter

www.up.ac.za

Harnessing Latent Heat: Solutions and Applications

Active heat transport: Thermodynamic cycles Refrigeration and air conditioning

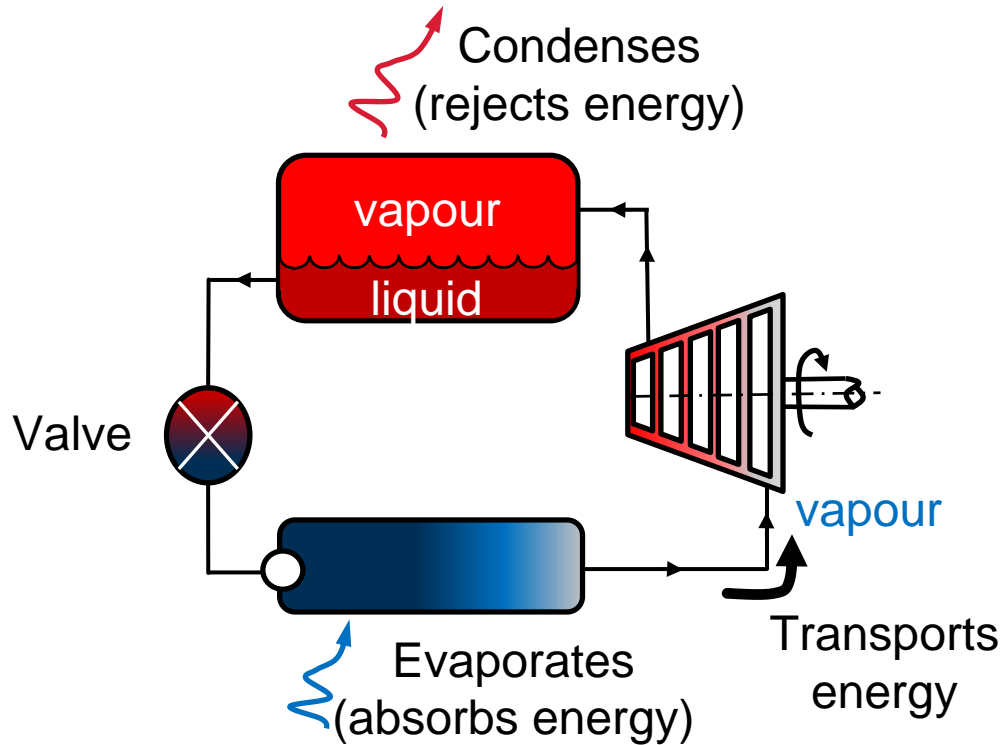

Front



Rear



UNIVERSITEIT VAN PRETORIA
UNIVERSITY OF PRETORIA
YUNIBESITHI YA PRETORIA

Faculty of Engineering,
Built Environment and
Information Technology

Fakulteit Ingenieurswese, Bou-omgewing en
Inligtingtegnologie / Lefapha la Boetšenere,
Tikologo ya Kago le Theknolotši ya Tshedimošo

Harnessing Latent Heat: Solutions and Applications

Active heat transport: Thermodynamic cycles

High density cooling

Air-cooled
Gas only

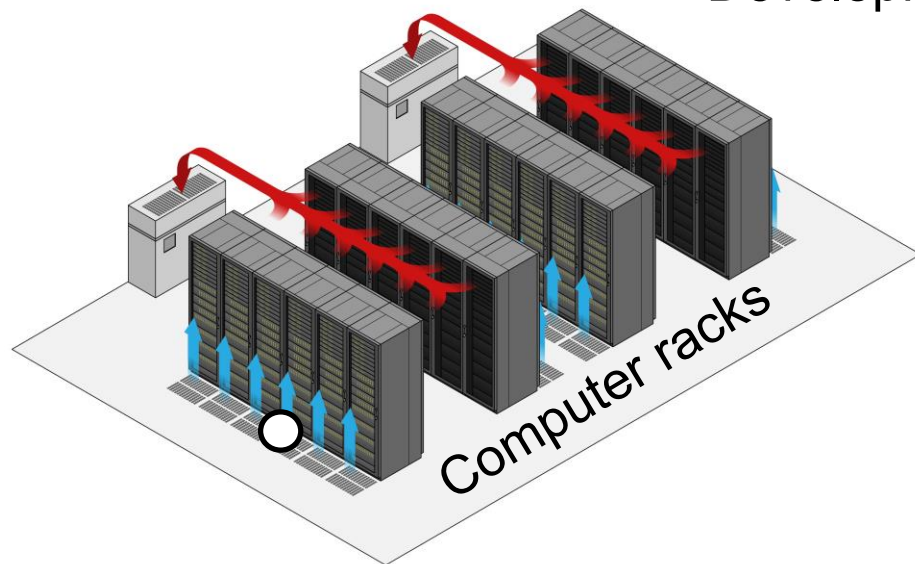

→
Development

Liquid-cooled

Boiling at the processor?

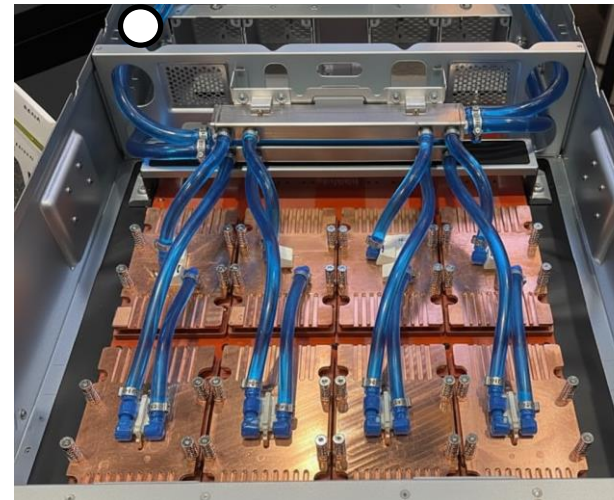

UNIVERSITEIT VAN PRETORIA
UNIVERSITY OF PRETORIA
YUNIBESITHI YA PRETORIA

Faculty of Engineering,
Built Environment and
Information Technology

Fakulteit Ingenieurswese, Bou-omgewing en
Inligtingtegnologie / Lefapha la Boetšenere,
Tikologo ya Kago le Theknolotši ya Tshedimošo

Make today matter

www.up.ac.za

The 2nd law of thermodynamics and us...

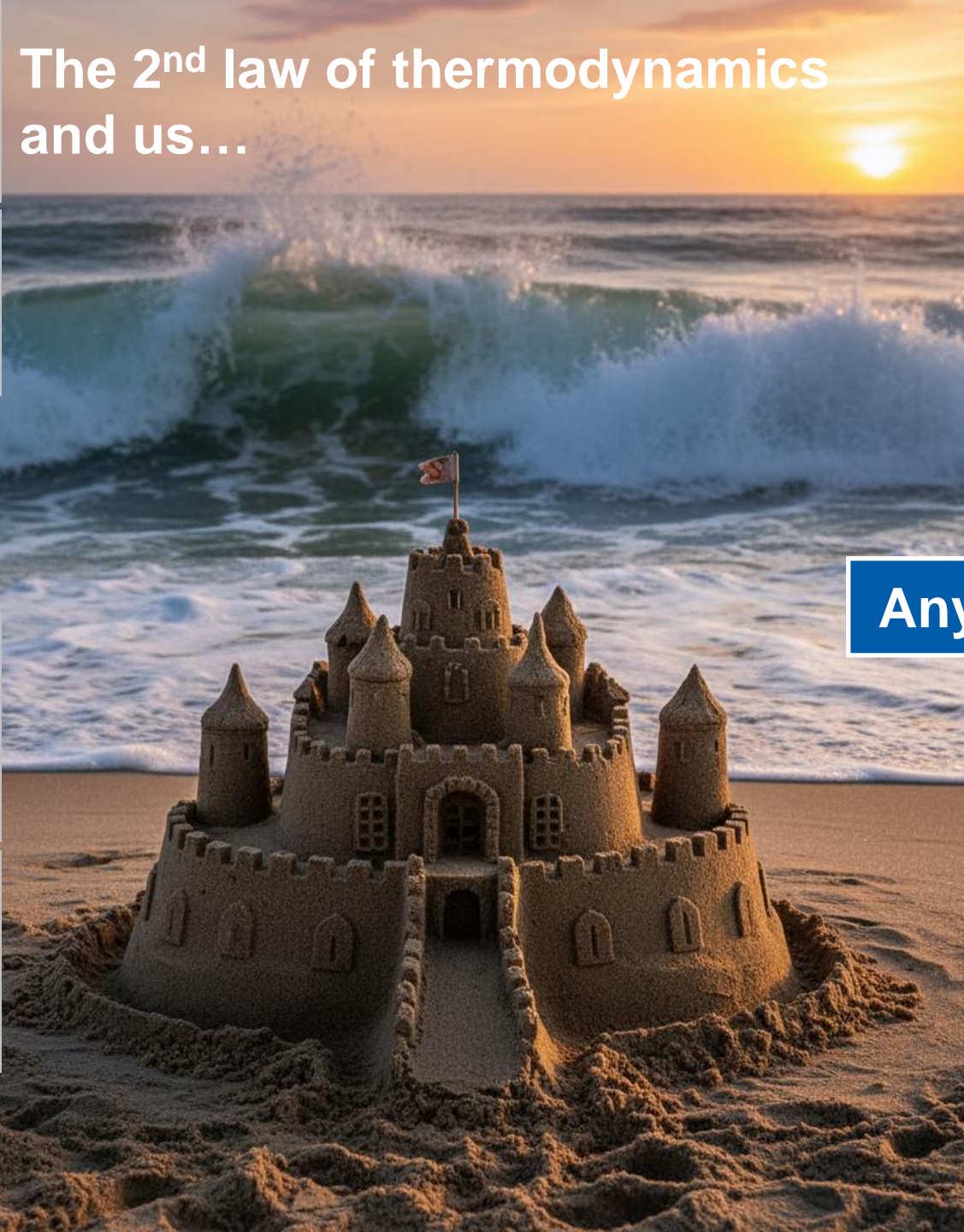

The Unseen Cost of Energy: Entropy

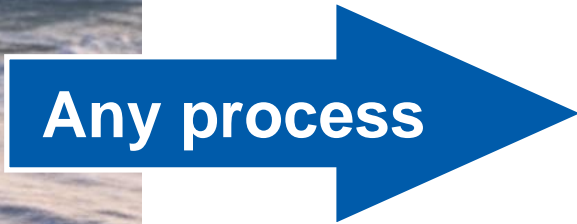

Any process

Entropy generation



UNIVERSITEIT VAN PRETORIA
UNIVERSITY OF PRETORIA
YUNIBESITHI YA PRETORIA

Faculty of Engineering,
Built Environment and
Information Technology

Fakulteit Ingenieurswese, Bou-omgewing en
Inligtingtegnologie / Lefapha la Boetšenere,
Tikologo ya Kago le Theknolotši ya Tshedimošo

Make today matter

www.up.ac.za

Latent Heat: The Efficiency Expert

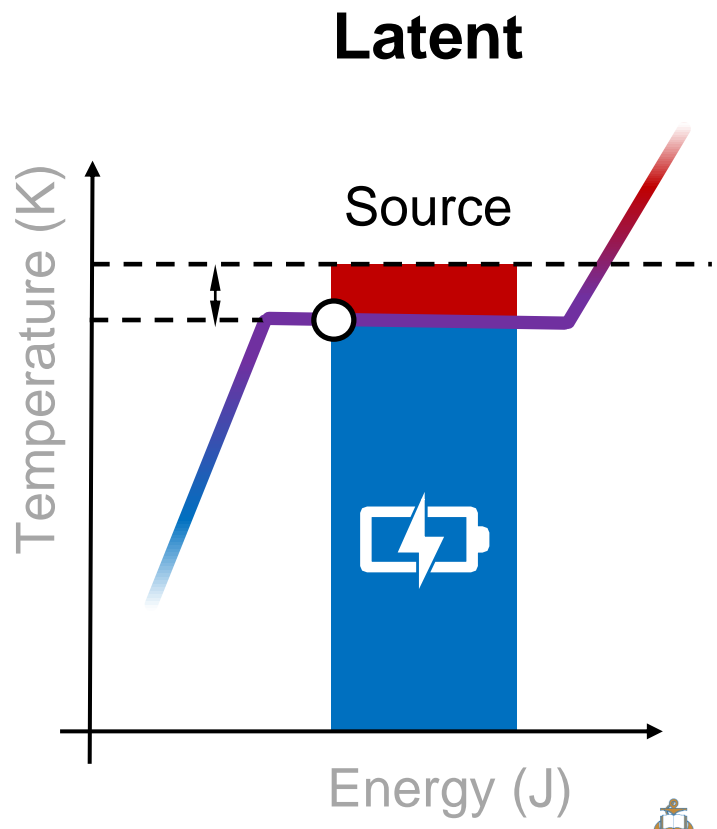
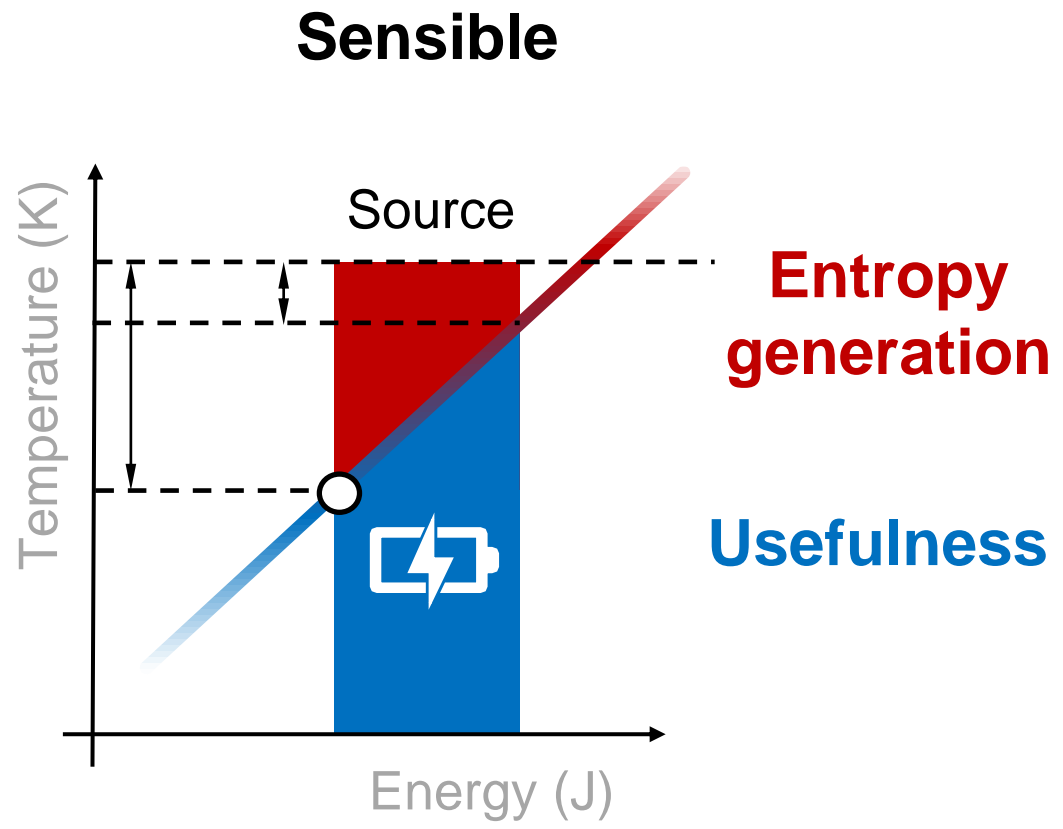
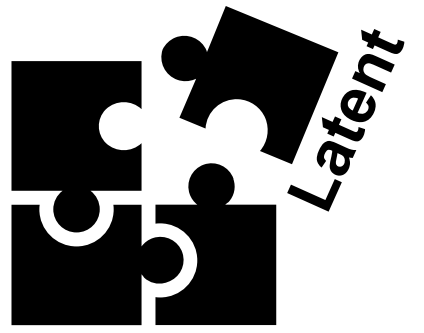

UNIVERSITEIT VAN PRETORIA
UNIVERSITY OF PRETORIA
YUNIBESITHI YA PRETORIA

Faculty of Engineering,
Built Environment and
Information Technology
Fakulteit Ingenieurswese, Bou-omgewing en
Inligtingtegnologie / Lefapha la Boetšenere,
Tikologo ya Kago le Theknolotši ya Tshedimošo

The Physics Behind the Change: A Molecular Perspective

Solid

A structured dance

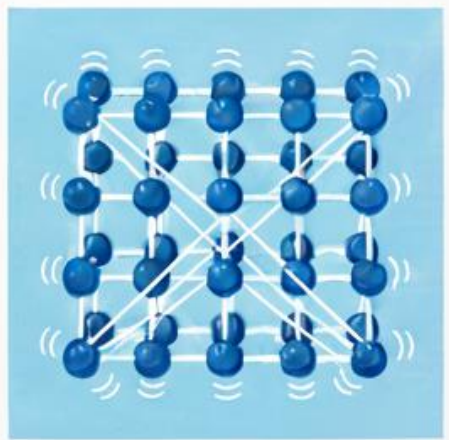

Liquid

Freedom of Movement

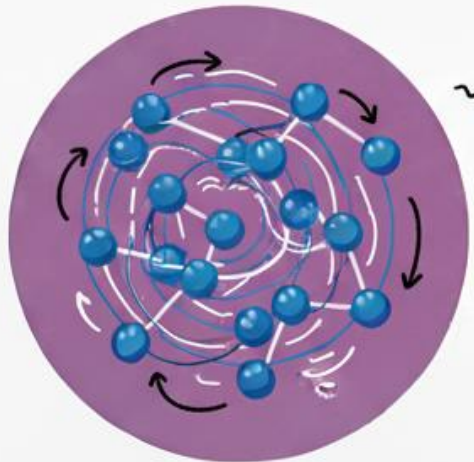

Vapour

Independence

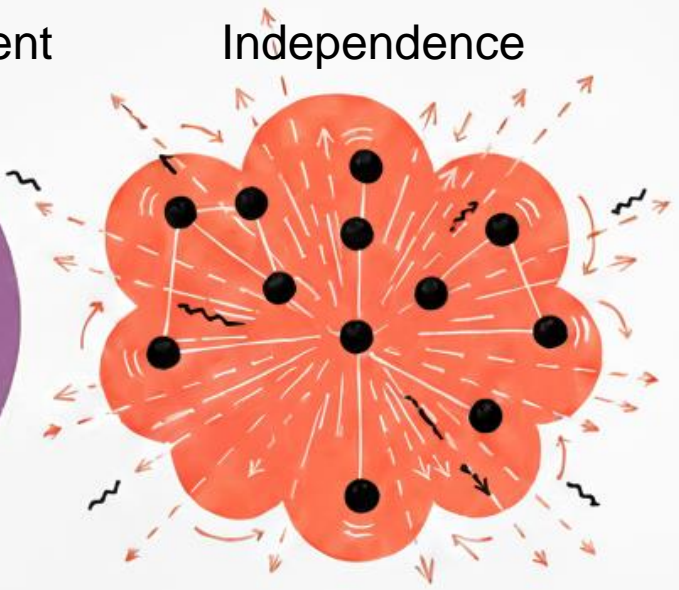

Energy content



UNIVERSITEIT VAN PRETORIA
UNIVERSITY OF PRETORIA
YUNIBESITHI YA PRETORIA

Faculty of Engineering,
Built Environment and
Information Technology
Fakulteit Ingenieurswese, Bou-omgewing en
Inligtingtegnologie / Lefapha la Boetšenere,
Tikologo ya Kago le Theknolotši ya Tshedimošo

Thermal Mechanisms: The Role of Heat

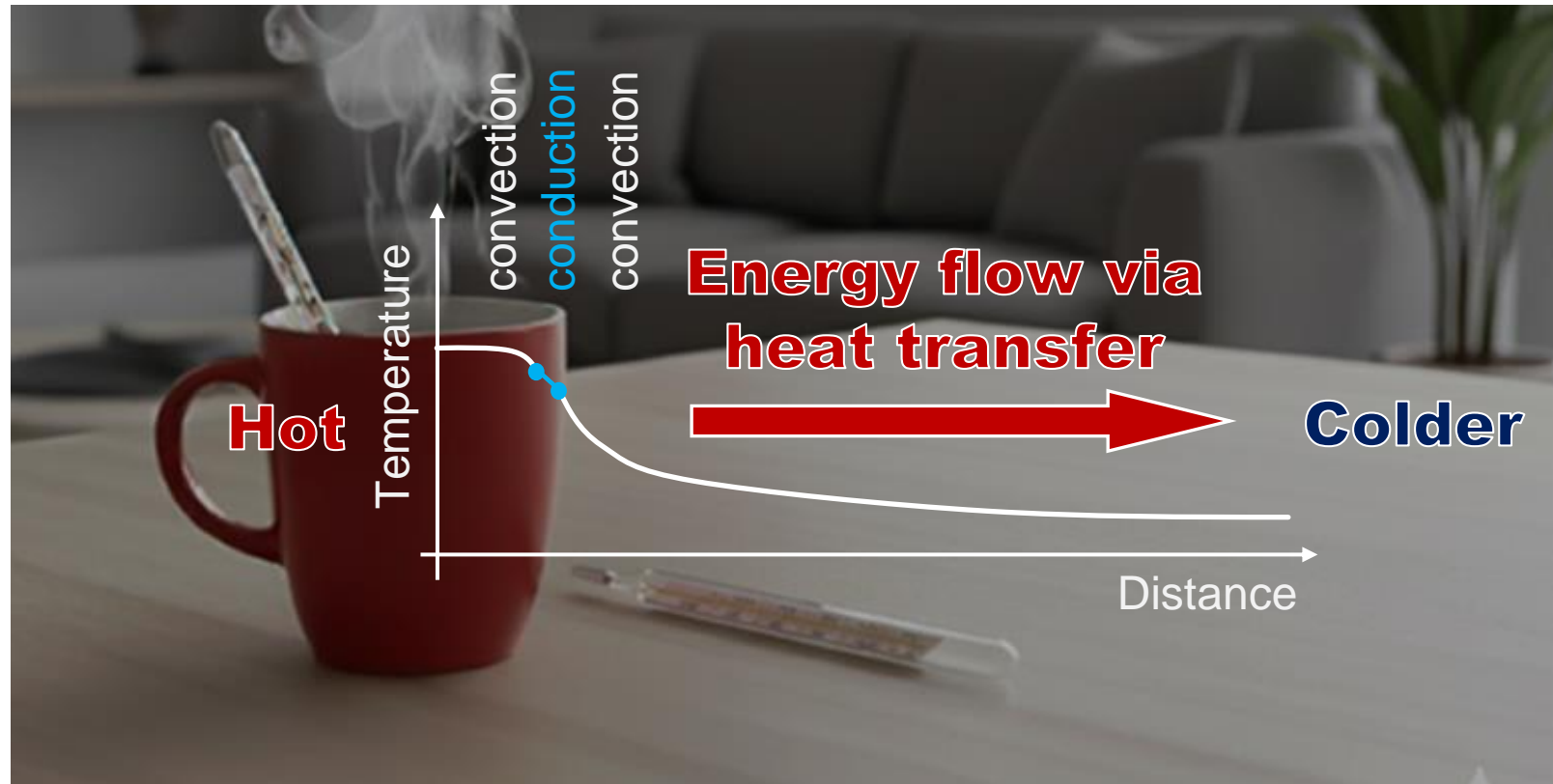

UNIVERSITEIT VAN PRETORIA
UNIVERSITY OF PRETORIA
YUNIBESITHI YA PRETORIA

Faculty of Engineering,
Built Environment and
Information Technology

Fakulteit Ingenieurswese, Bou-omgewing en
Inligtingtegnologie / Lefapha la Boetšenere,
Tikologo ya Kago le Theknolotši ya Tshedimošo

Make today matter

www.up.ac.za

Heat Transfer Mechanisms: From Weak to Powerful

Conduction



Natural convection

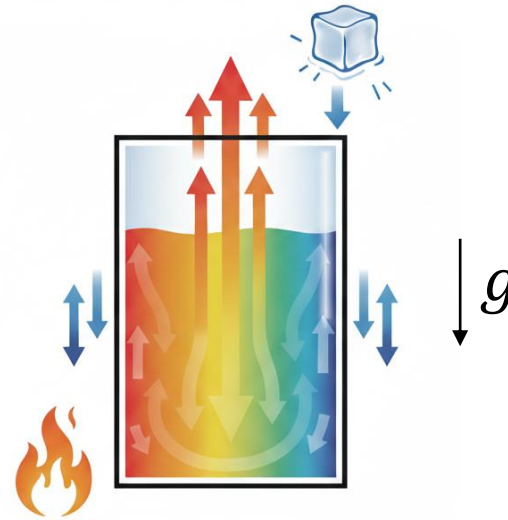

Forced convection

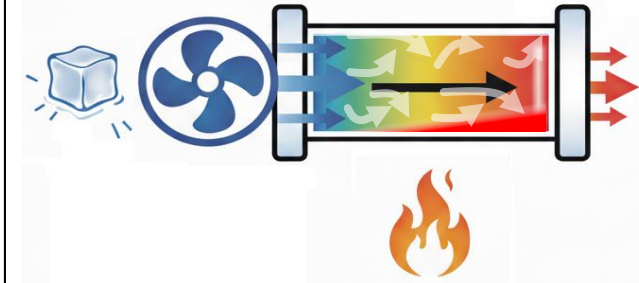

UNIVERSITEIT VAN PRETORIA
UNIVERSITY OF PRETORIA
YUNIBESITHI YA PRETORIA

Faculty of Engineering,
Built Environment and
Information Technology

Fakulteit Ingenieurswese, Bou-omgewing en
Inligtingtegnologie / Lefapha la Boetšenere,
Tikologo ya Kago le Theknolotši ya Tshedimošo

Make today matter

www.up.ac.za

Fluid Dynamics: All about Motion

Natural convection with melting & solidification

Cylindrical solid melting
simulation

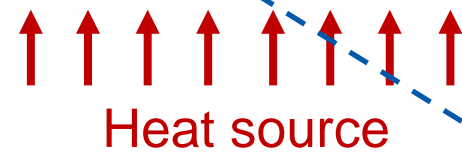
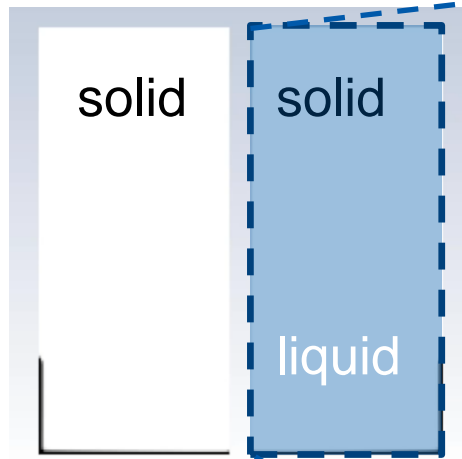

□ = solid

■ = liquid

Velocities

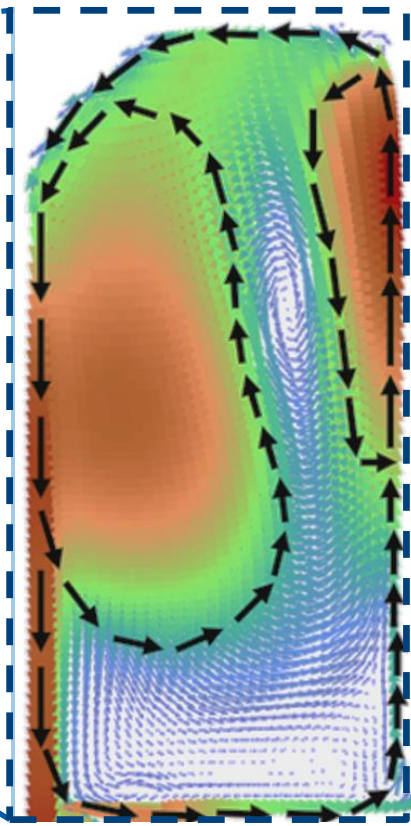

Velocity Magnitude
[m/s]

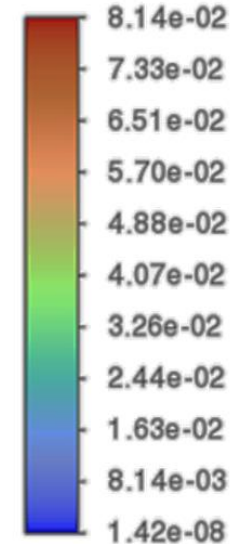

UNIVERSITEIT VAN PRETORIA
UNIVERSITY OF PRETORIA
YUNIBESITHI YA PRETORIA

Faculty of Engineering,
Built Environment and
Information Technology

Fakulteit Ingenieurswese, Bou-omgewing en
Inligtingtegnologie / Lefapha la Boetšenere,
Tikologo ya Kago le Theknolotši ya Tshedimošo

Make today matter

www.up.ac.za

Fluid Dynamics: All about Motion

Forced convective flows

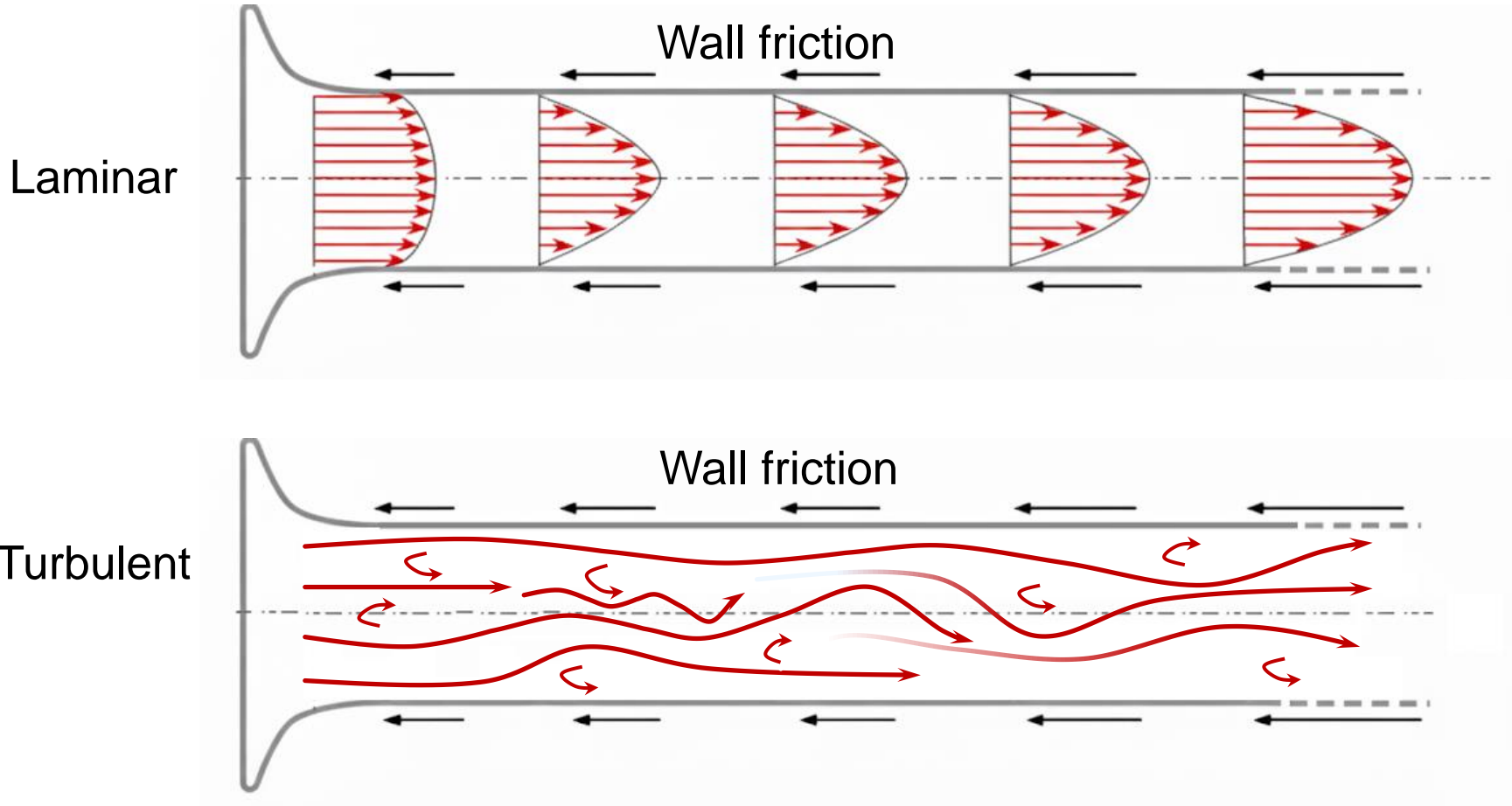

Faculty of Engineering,
Built Environment and
Information Technology
Fakulteit Ingenieurswese, Bou-omgewing en
Inligtingtegnologie / Lefapha la Boetšenere,
Tikologo ya Kago le Theknolotši ya Tshedimošo

Fluid Dynamics: All about Motion

Two-phase flows

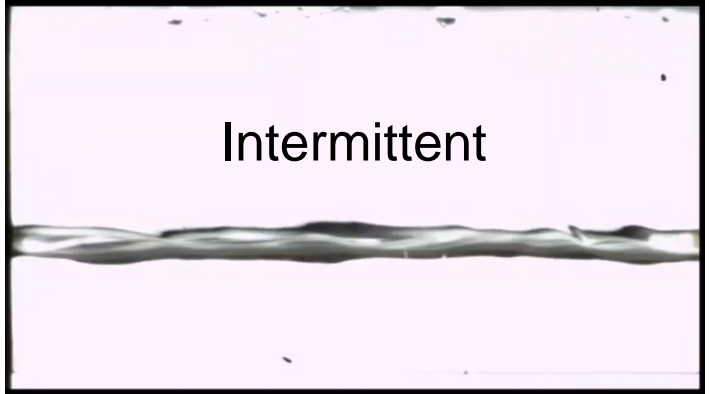
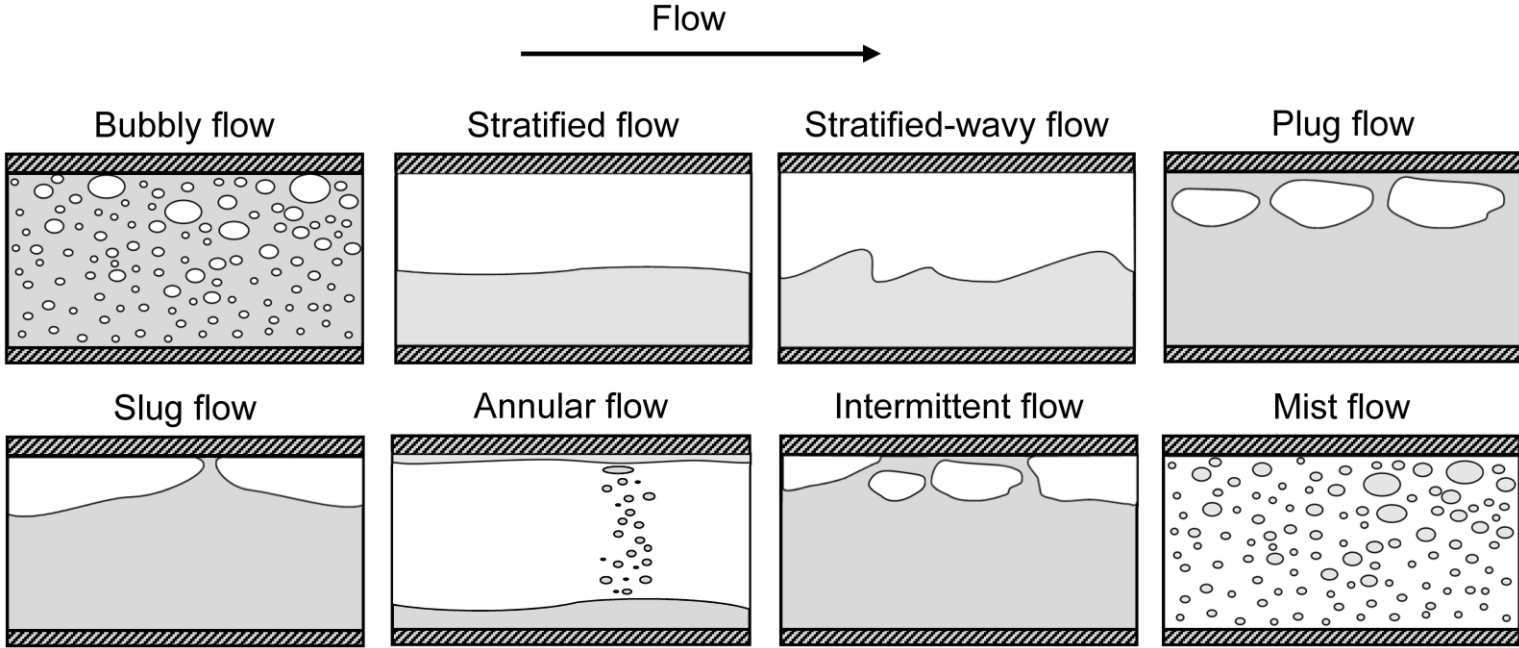

Faculty of Engineering,
 Built Environment and
 Information Technology
 Fakulteit Ingenieurswese, Bou-omgewing en
 Inligtingtegnologie / Lefapha la Boetšenere,
 Tikologo ya Kago le Theknolotši ya Tshedimošo

Some Recent and Current Focus Areas

Active heat transport

- Macro scale flow boiling
- Macro scale condensation
- Miniature scale flow boiling



Passive thermal storage

- High-temperature
- Medium-temperature



UNIVERSITEIT VAN PRETORIA
UNIVERSITY OF PRETORIA
YUNIBESITHI YA PRETORIA

Faculty of Engineering,
Built Environment and
Information Technology

Fakulteit Ingenieurswese, Bou-omgewing en
Inligtingtegnologie / Lefapha la Boetšenere,
Tikologo ya Kago le Theknolotši ya Tshedimošo

Make today matter

www.up.ac.za

Macro Scale Flow Boiling

Concentrated Solar Power: Direct Steam Generation



Stock photographs



Stock photographs



UNIVERSITEIT VAN PRETORIA
UNIVERSITY OF PRETORIA
YUNIBESITHI YA PRETORIA

Faculty of Engineering,
Built Environment and
Information Technology

Fakulteit Ingenieurswese, Bou-omgewing en
Inligtingtegnologie / Lefapha la Boetšenere,
Tikologo ya Kago le Theknolotši ya Tshedimošo

Make today matter

www.up.ac.za

Macro Scale Flow Boiling

Concentrated Solar Power: Direct Steam Generation

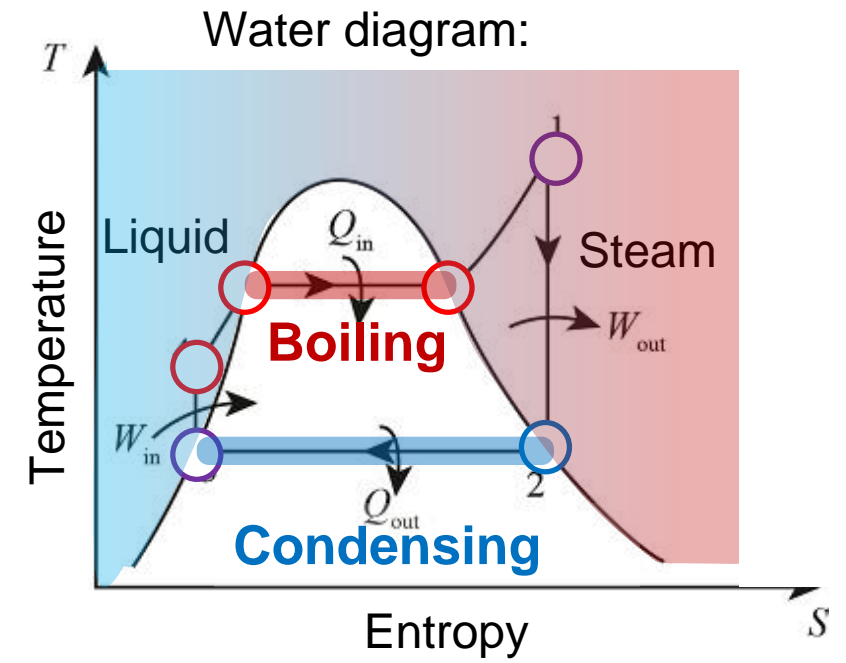
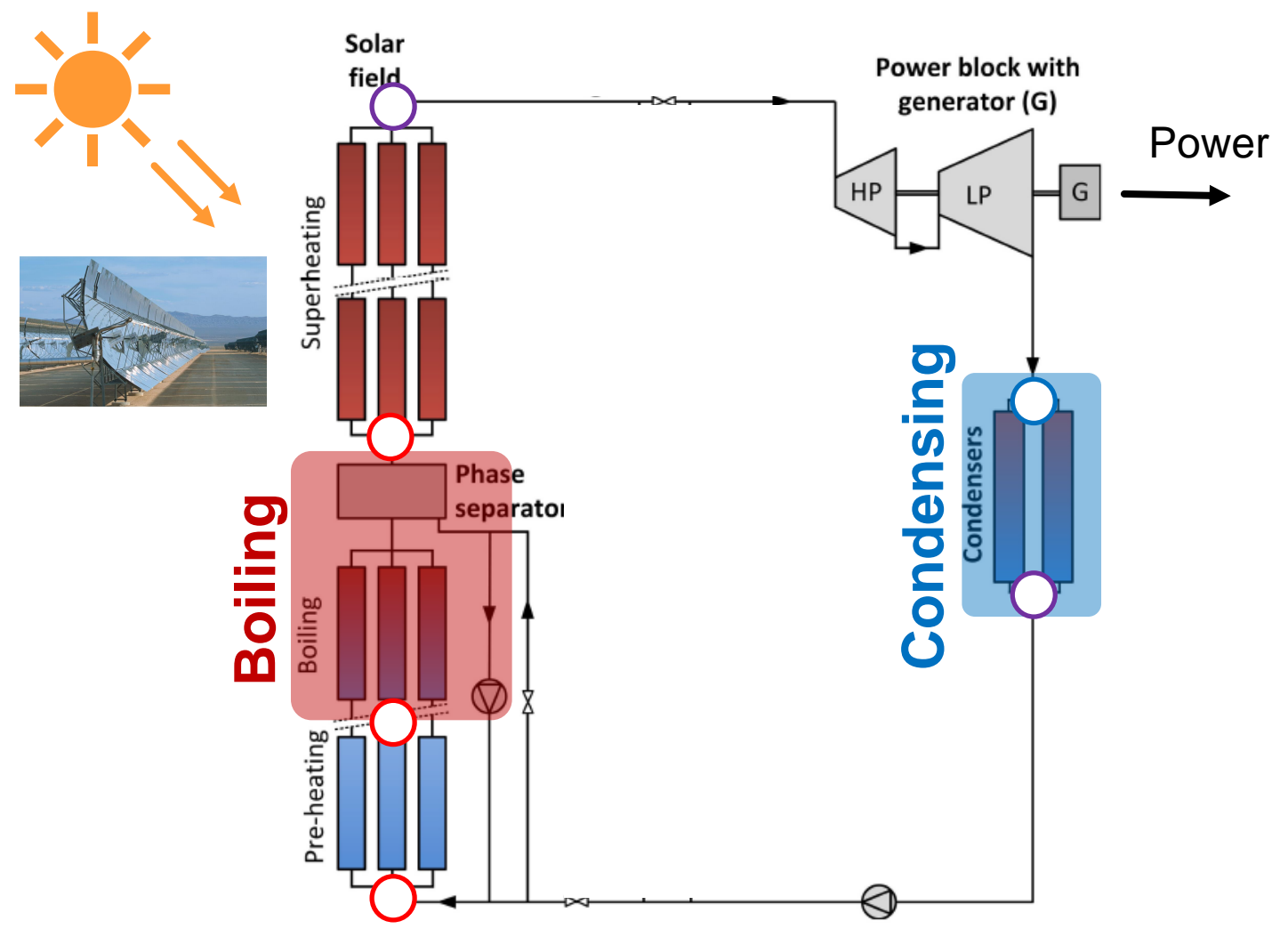

Macro Scale Flow Boiling

Concentrated Solar Power: Direct Steam Generation

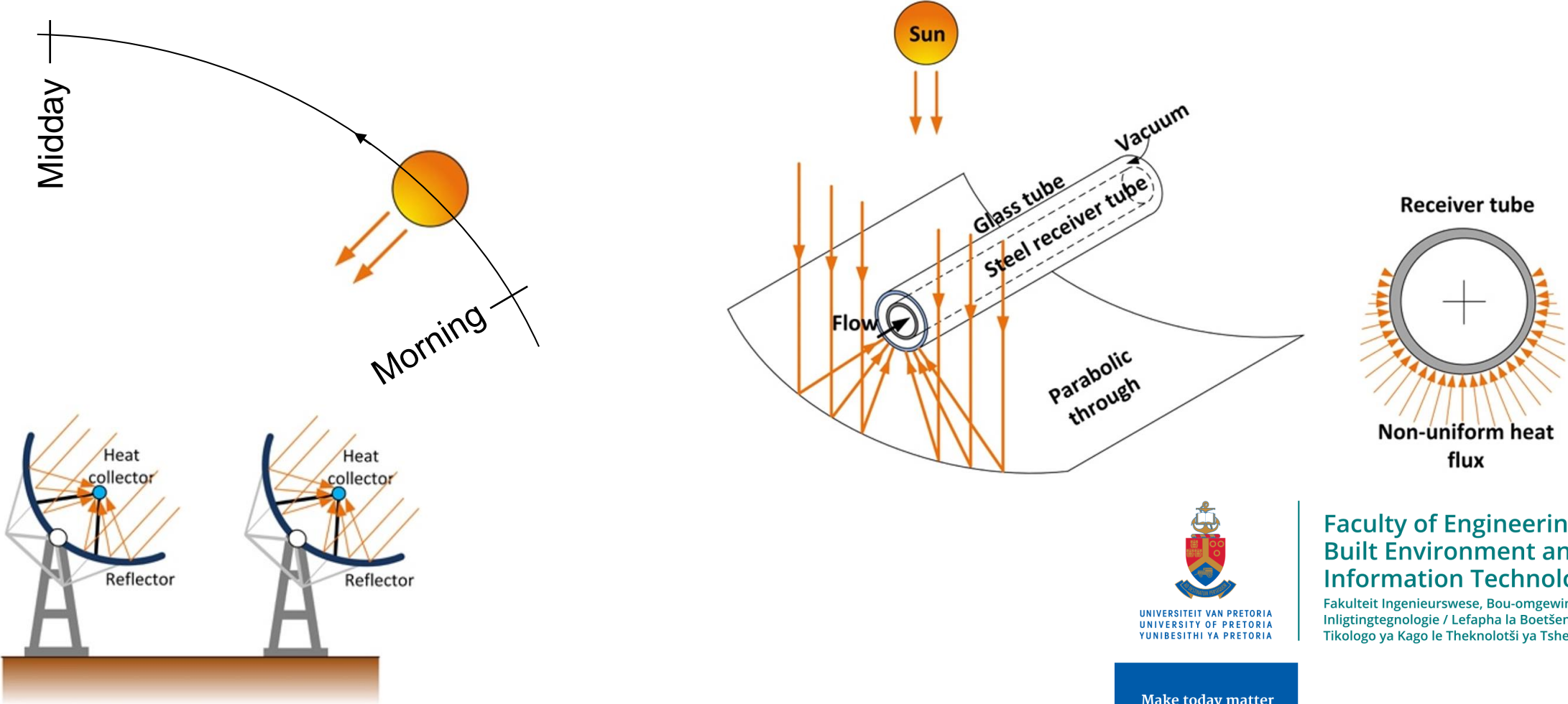

UNIVERSITEIT VAN PRETORIA
UNIVERSITY OF PRETORIA
YUNIBESITHI YA PRETORIA

Faculty of Engineering,
Built Environment and
Information Technology

Fakulteit Ingenieurswese, Bou-omgewing en
Inligtingtegnologie / Lefapha la Boetšenere,
Tikologo ya Kago le Theknolotši ya Tshedimošo

Macro Scale Flow Boiling

Direct Steam Generation: Lab reproduction

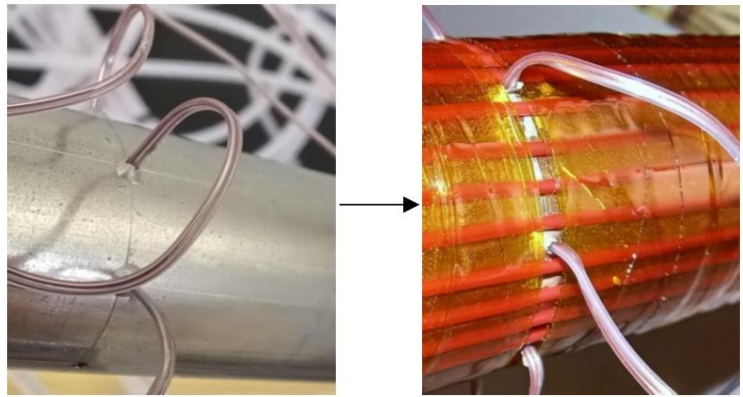

(a)

(b)

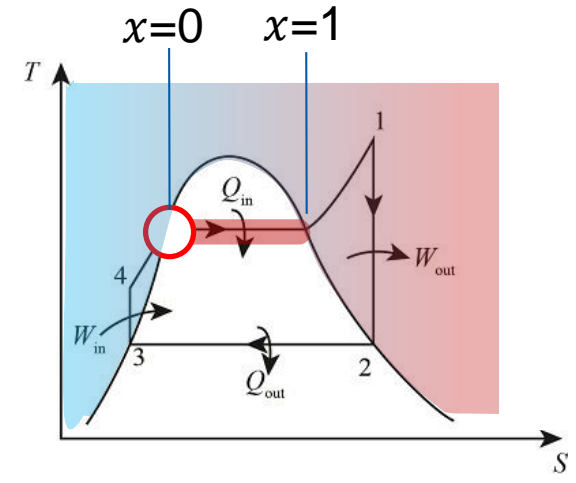
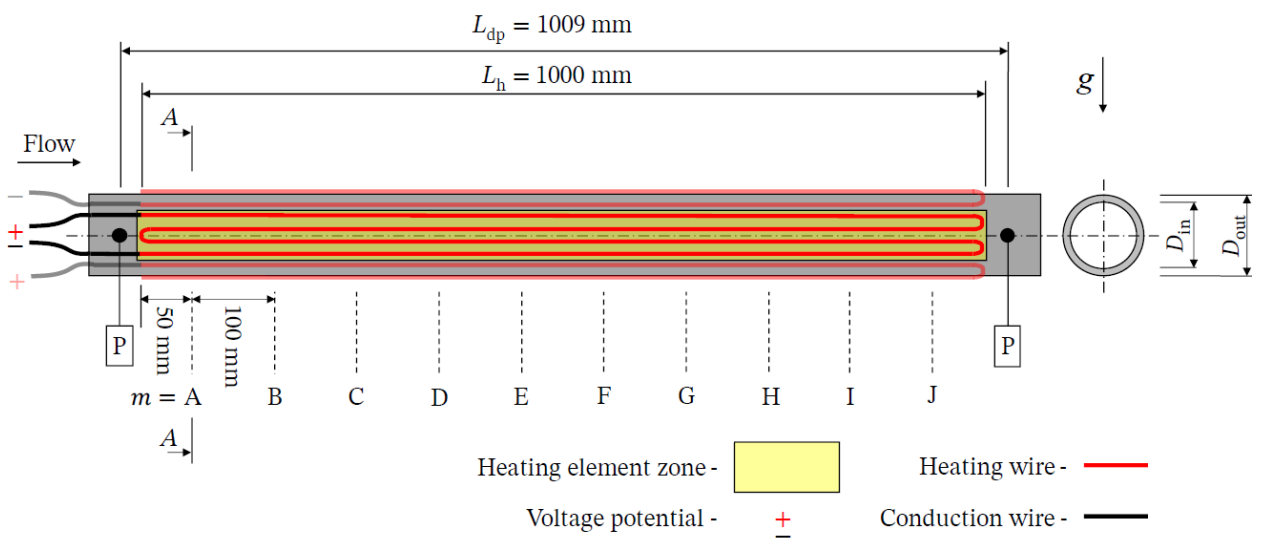

Faculty of Engineering,
Built Environment and
Information Technology

Fakulteit Ingenieurswese, Bou-omgewing en
Inligtingtegnologie / Lefapha la Boetšenere,
Tikologo ya Kago le Theknolotši ya Tshedimošo

Macro Scale Flow Boiling

Direct Steam Generation: Flow patterns

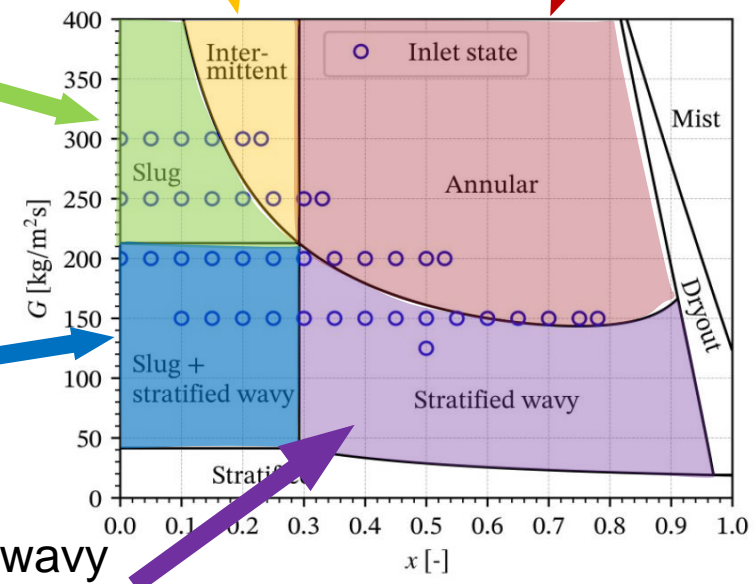
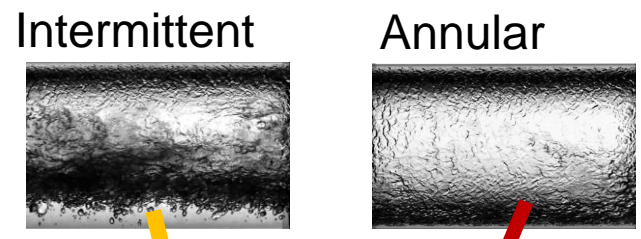

Slug + stratified wavy

Stratified wavy

More vapour

Faster flow

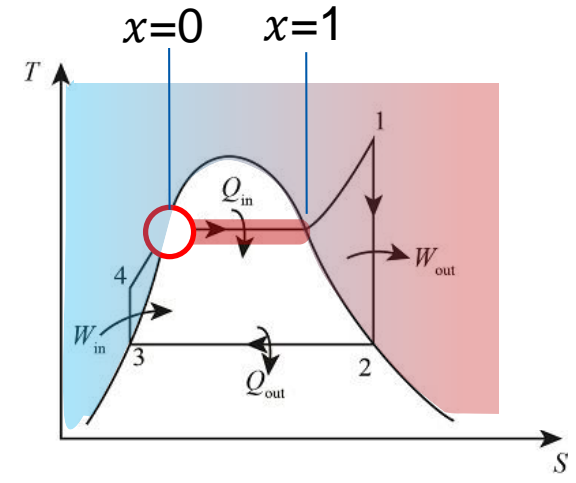

Sight-glass

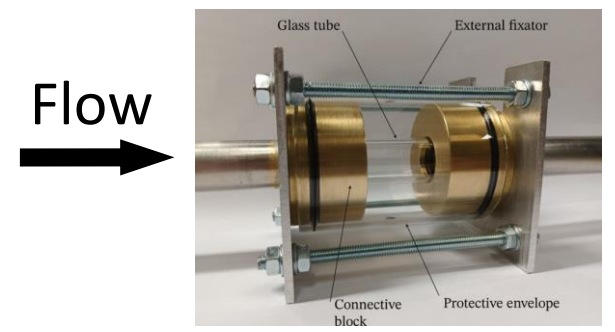

UNIVERSITEIT VAN PRETORIA
UNIVERSITY OF PRETORIA
YUNIBESITHI YA PRETORIA

Faculty of Engineering,
Built Environment and
Information Technology

Fakulteit Ingenieurswese, Bou-omgewing en
Inligtingtegnologie / Lefapha la Boetšenere,
Tikologo ya Kago le Theknolotši ya Tshedimošo

Macro Scale Flow Boiling

Direct Steam Generation: Heat flux distribution

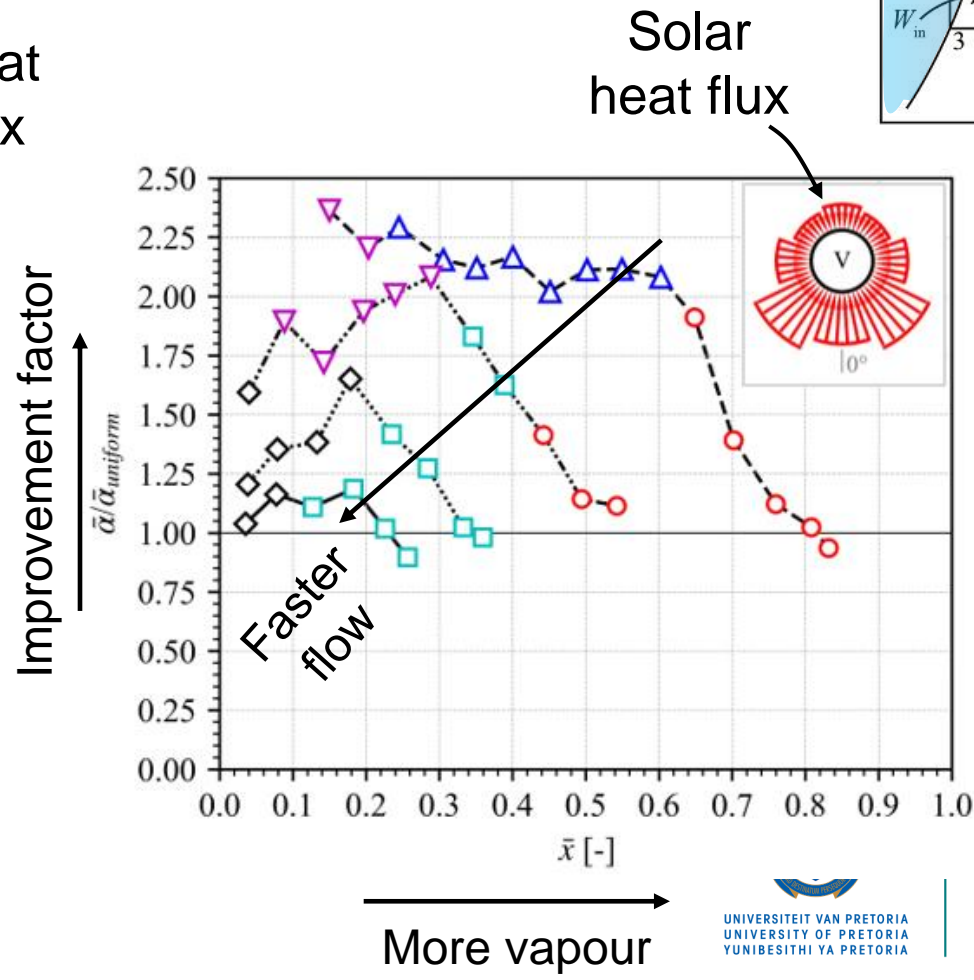
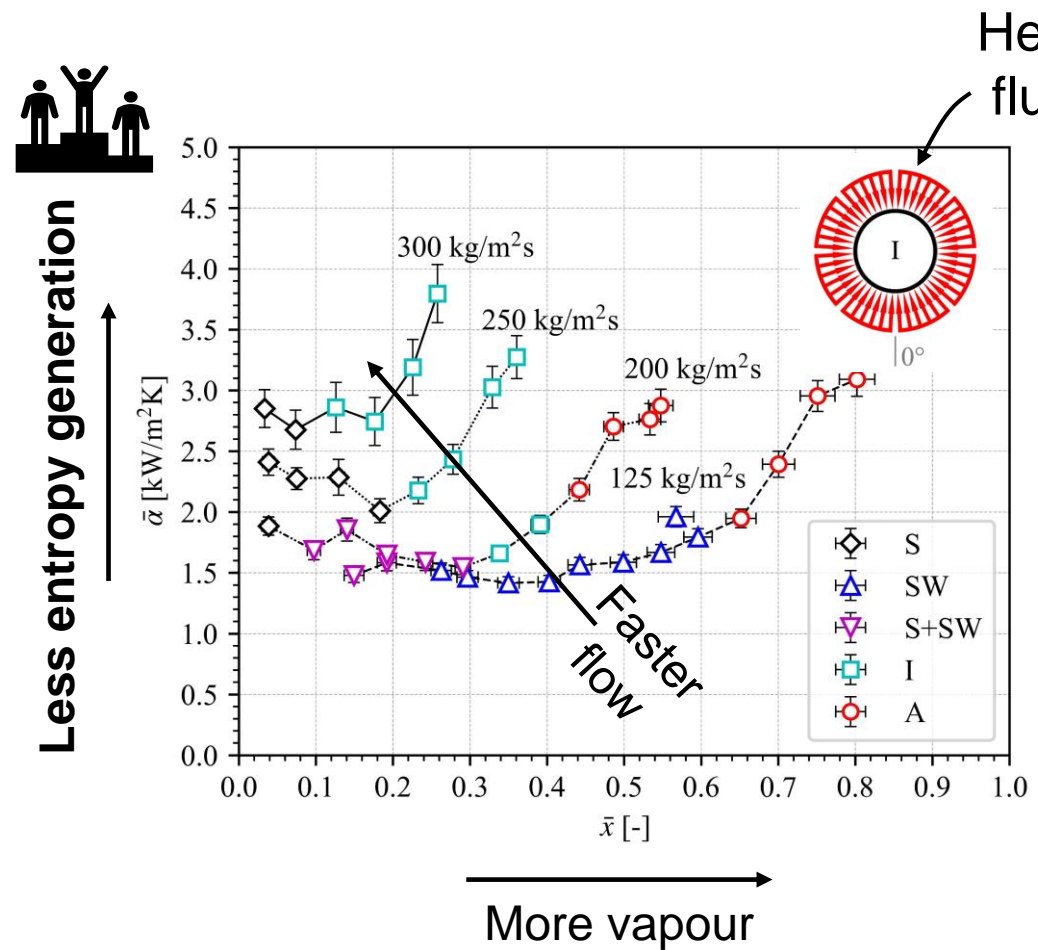
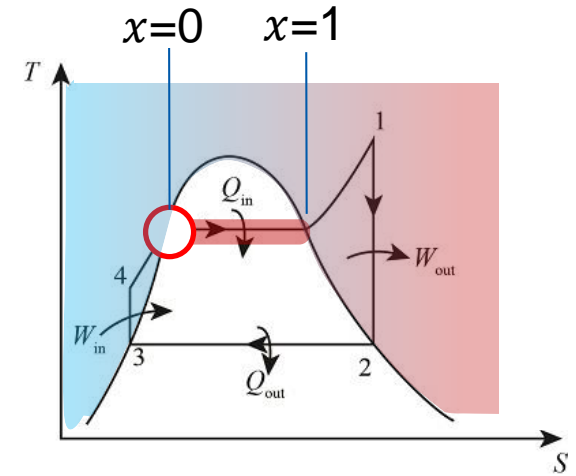

Faculty of Engineering,
Built Environment and
Information Technology
Fakulteit Ingenieurswese, Bou-omgewing en
Inligtingtegnologie / Lefapha la Boetšenere,
Tikologo ya Kago le Theknolotši ya Tshedimošo

Macro Scale Flow Boiling

Direct Steam Generation: Solar time

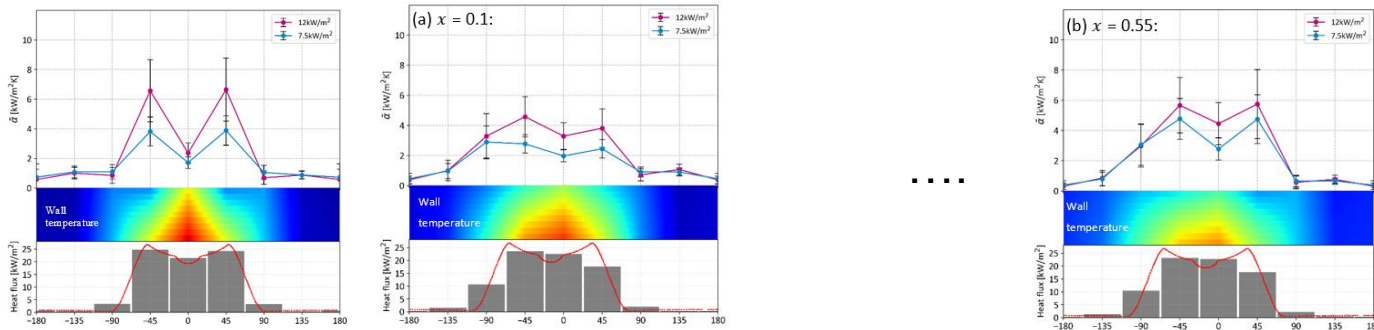

Thermal performance

2D wall temperatures

Solar radiation

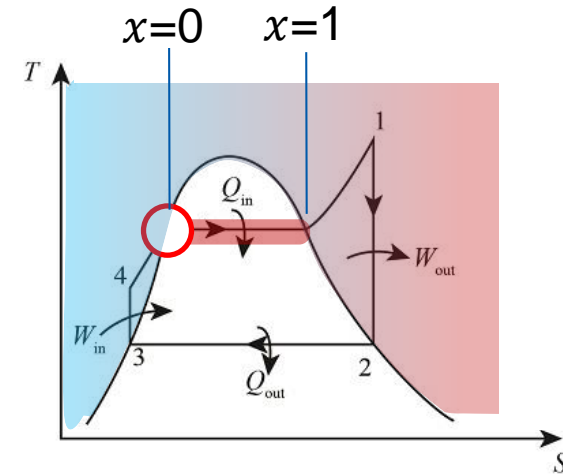

Solar time →

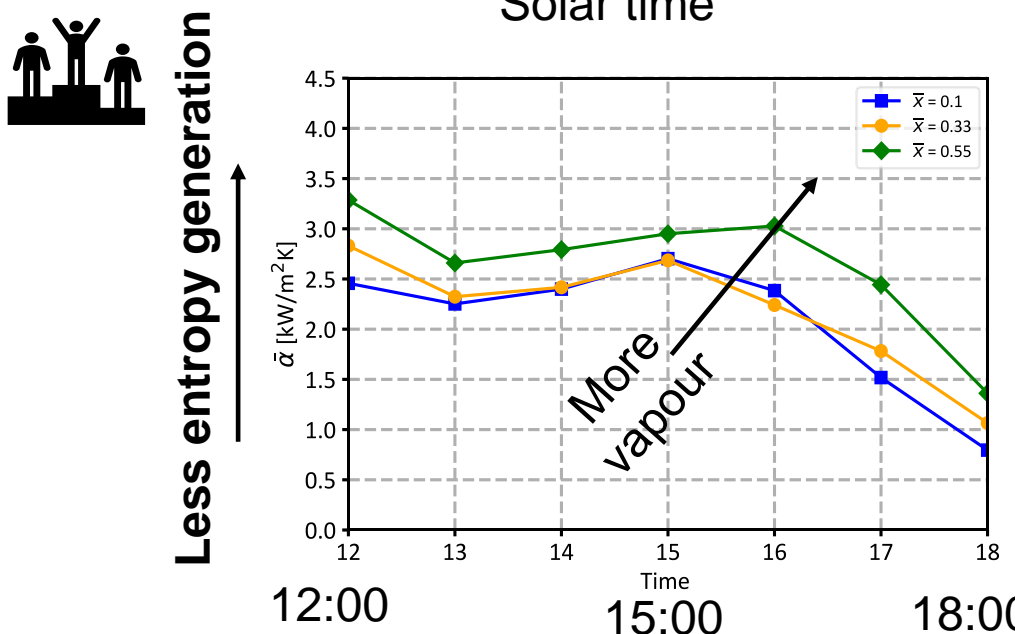

UNIVERSITEIT VAN PRETORIA
UNIVERSITY OF PRETORIA
YUNIBESITHI YA PRETORIA

Faculty of Engineering,
Built Environment and
Information Technology
Fakulteit Ingenieurswese, Bou-omgewing en
Inligtingtegnologie / Lefapha la Boetšenere,
Tikologo ya Kago le Theknolotši ya Tshedimošo

Make today matter
www.up.ac.za

Macro Scale Flow Boiling

Manipulating the flow pattern

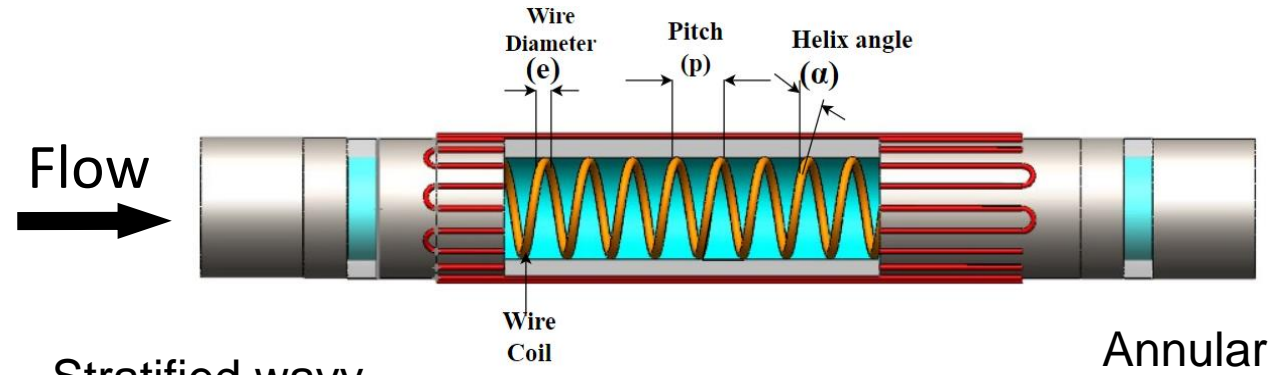

Stratified wavy



Centrifugal forces

Annular

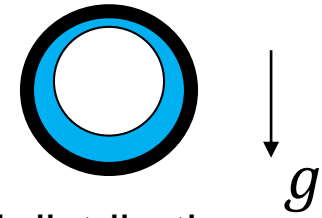
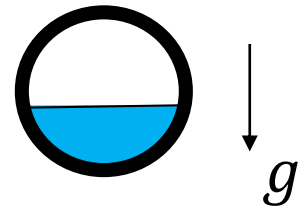

Liquid distribution around circumference

Spiral insert

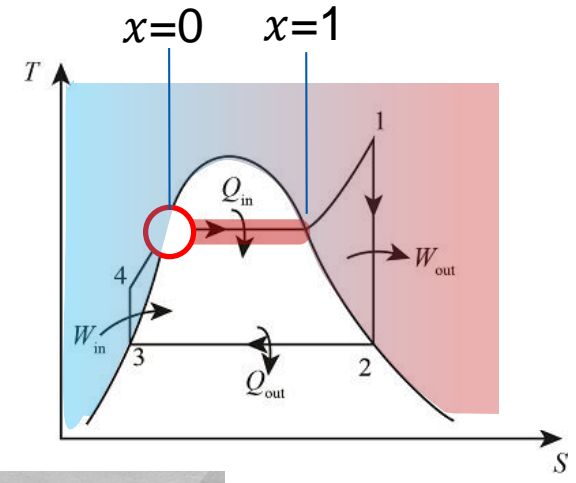
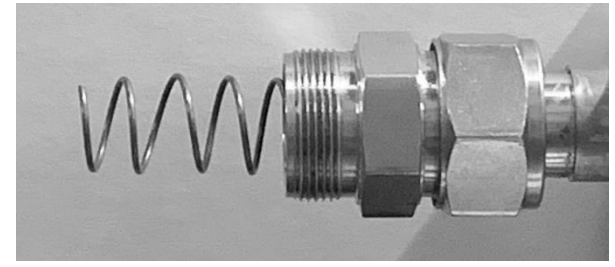

Faculty of Engineering,
Built Environment and
Information Technology
Fakulteit Ingenieurswese, Bou-omgewing en
Inligtingtegnologie / Lefapha la Boetšenere,
Tikologo ya Kago le Theknolotši ya Tshedimošo

Macro Scale Condensation

Air-cooled condensers

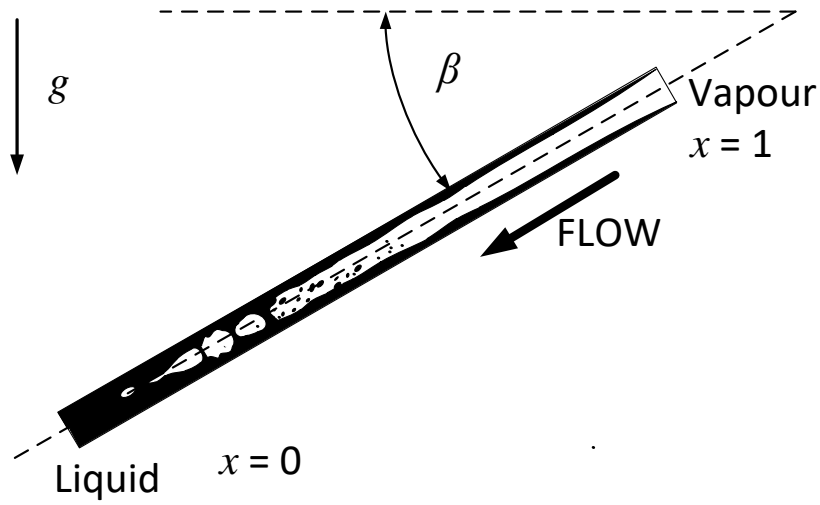
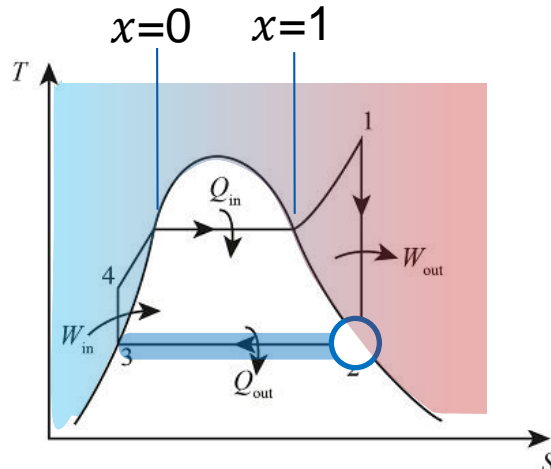
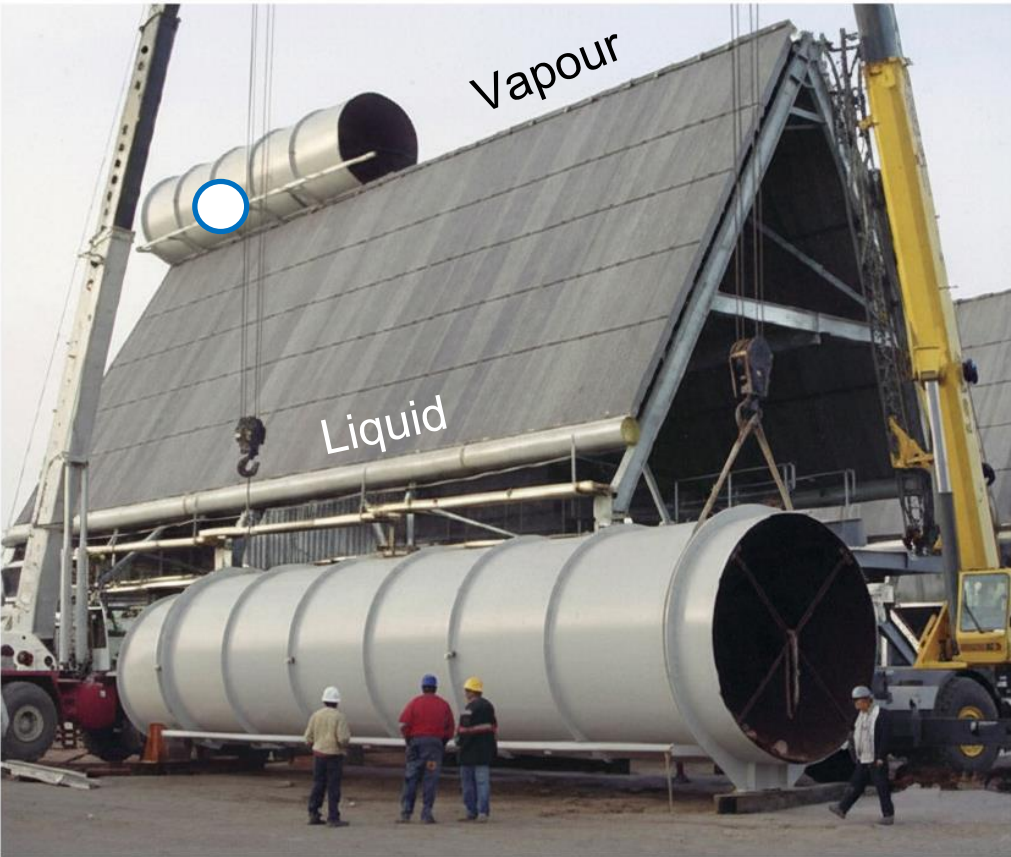

Macro Scale Condensation

Effect of angle



Less entropy generation
↑
 α [W/m²K]

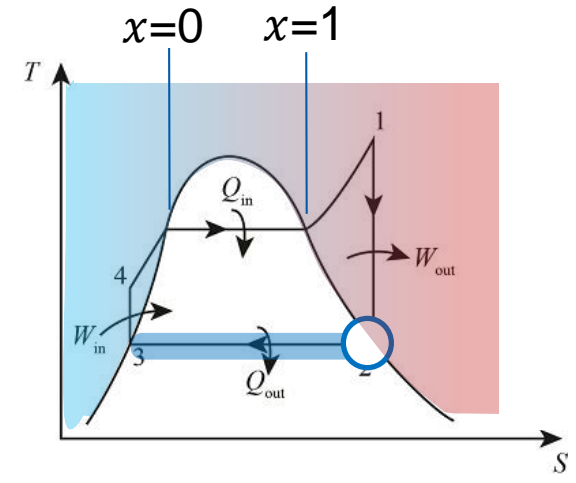
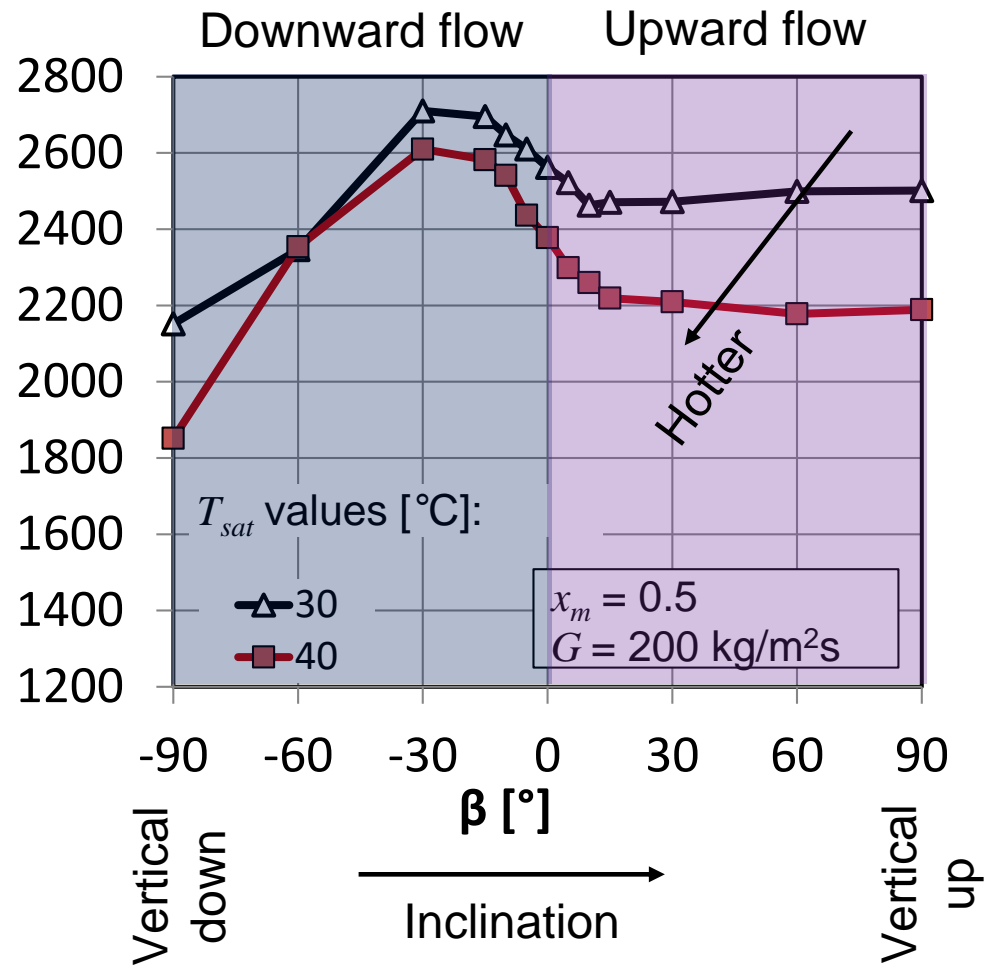

Flow friction?



Faculty of Engineering,
Built Environment and
Information Technology

Fakulteit Ingenieurswese, Bou-omgewing en
Inligtingtegnologie / Lefapha la Boetšenere,
Tikologo ya Kago le Theknolotši ya Tshedimošo

Miniature Scale Flow Boiling

Microchannel (< 500µm)

Flow pattern (playback speed= x0.1)

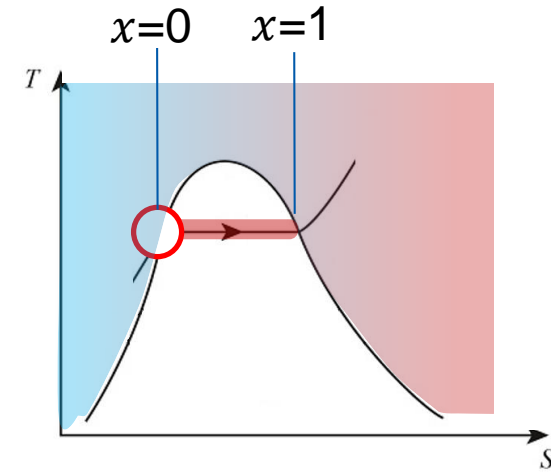

Less entropy generation ↑

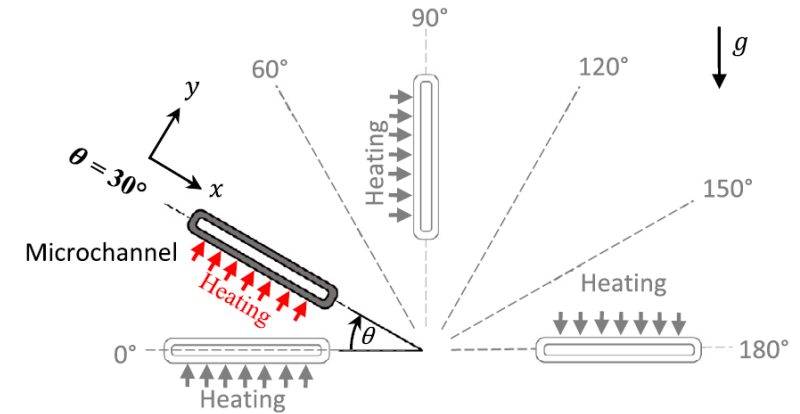
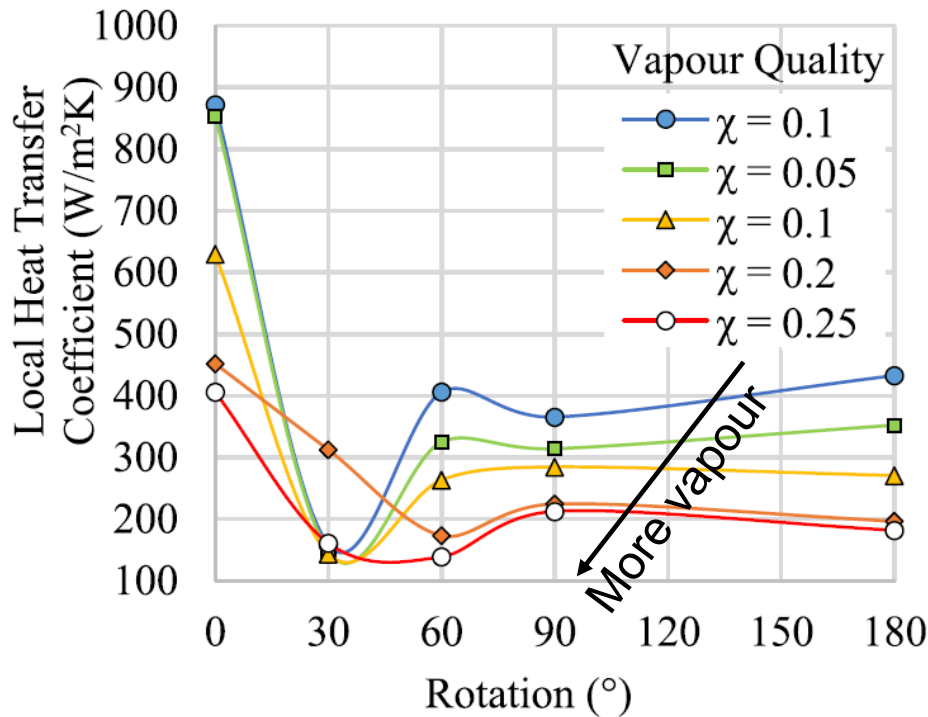

UNIVERSITEIT VAN PRETORIA
UNIVERSITY OF PRETORIA
YUNIBESITHI YA PRETORIA

Faculty of Engineering,
Built Environment and
Information Technology

Fakulteit Ingenieurswese, Bou-omgewing en
Inligtingtegnologie / Lefapha la Boetšenere,
Tikologo ya Kago le Theknolotši ya Tshedimošo

Miniature Scale Flow Boiling

Microchannels: Surface tension effects

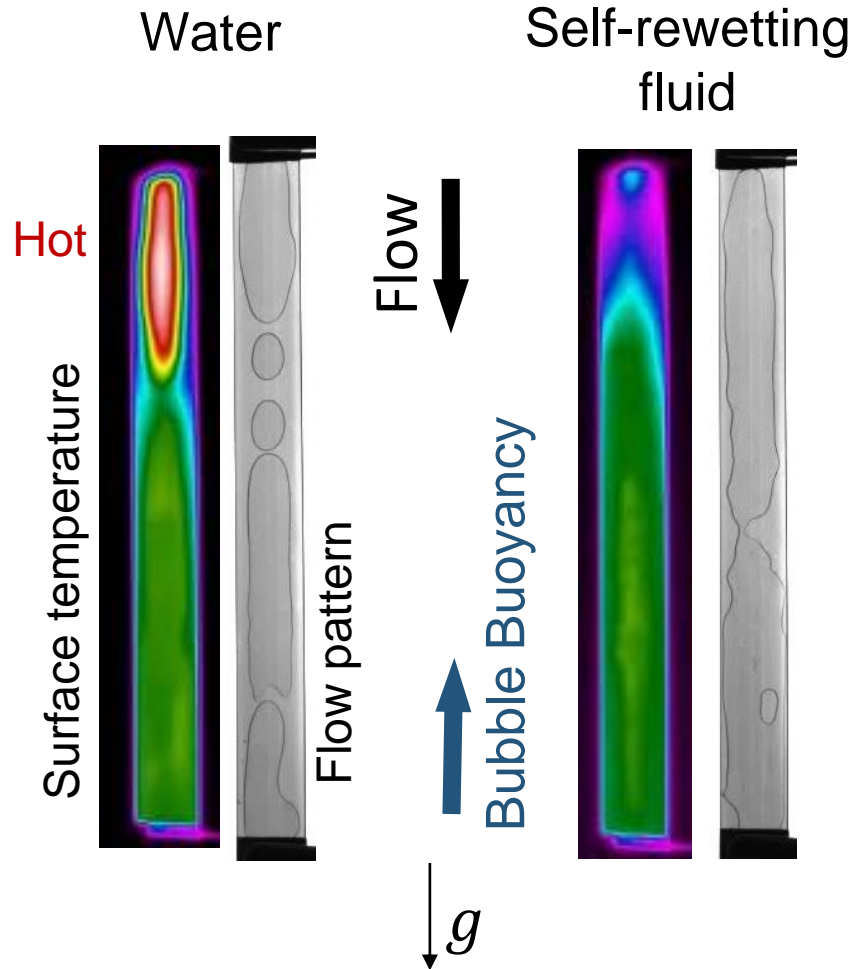

Self-wetting surface temperatures

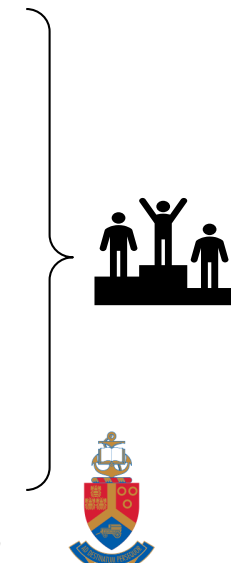
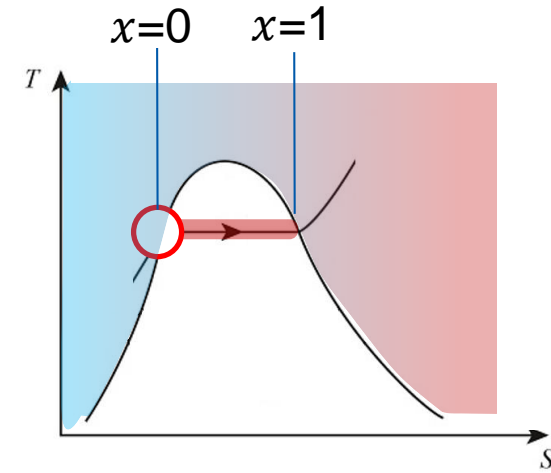
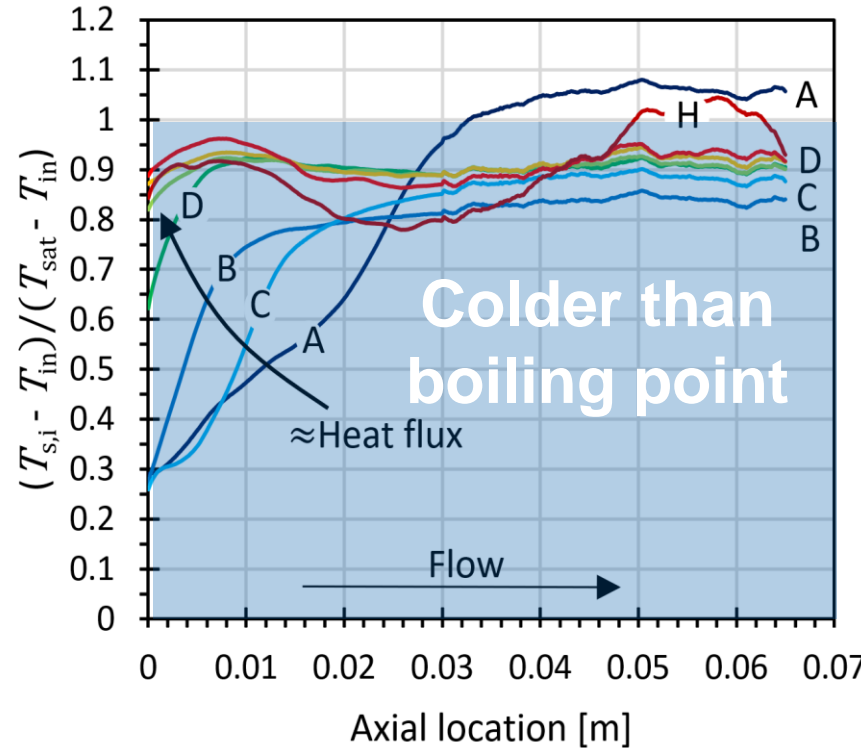

UNIVERSITEIT VAN PRETORIA
UNIVERSITY OF PRETORIA
YUNIBESITHI YA PRETORIA

Faculty of Engineering,
Built Environment and
Information Technology
Fakuleit Ingenieurswese, Bou-omgewing en
Inligtingtegnologie / Lefapha la Boetšenere,
Tikologo ya Kago le Theknolotši ya Tshedimošo

High-Temperature Thermal Storage

Direct steam generation power production Overview

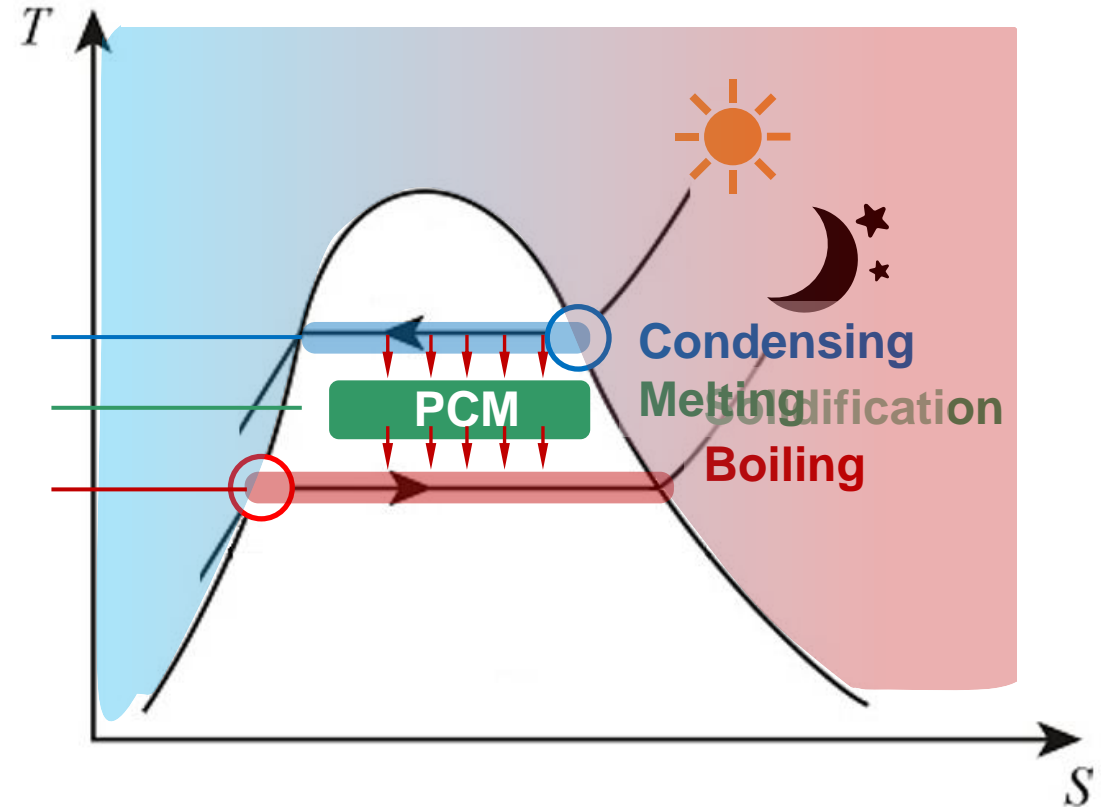
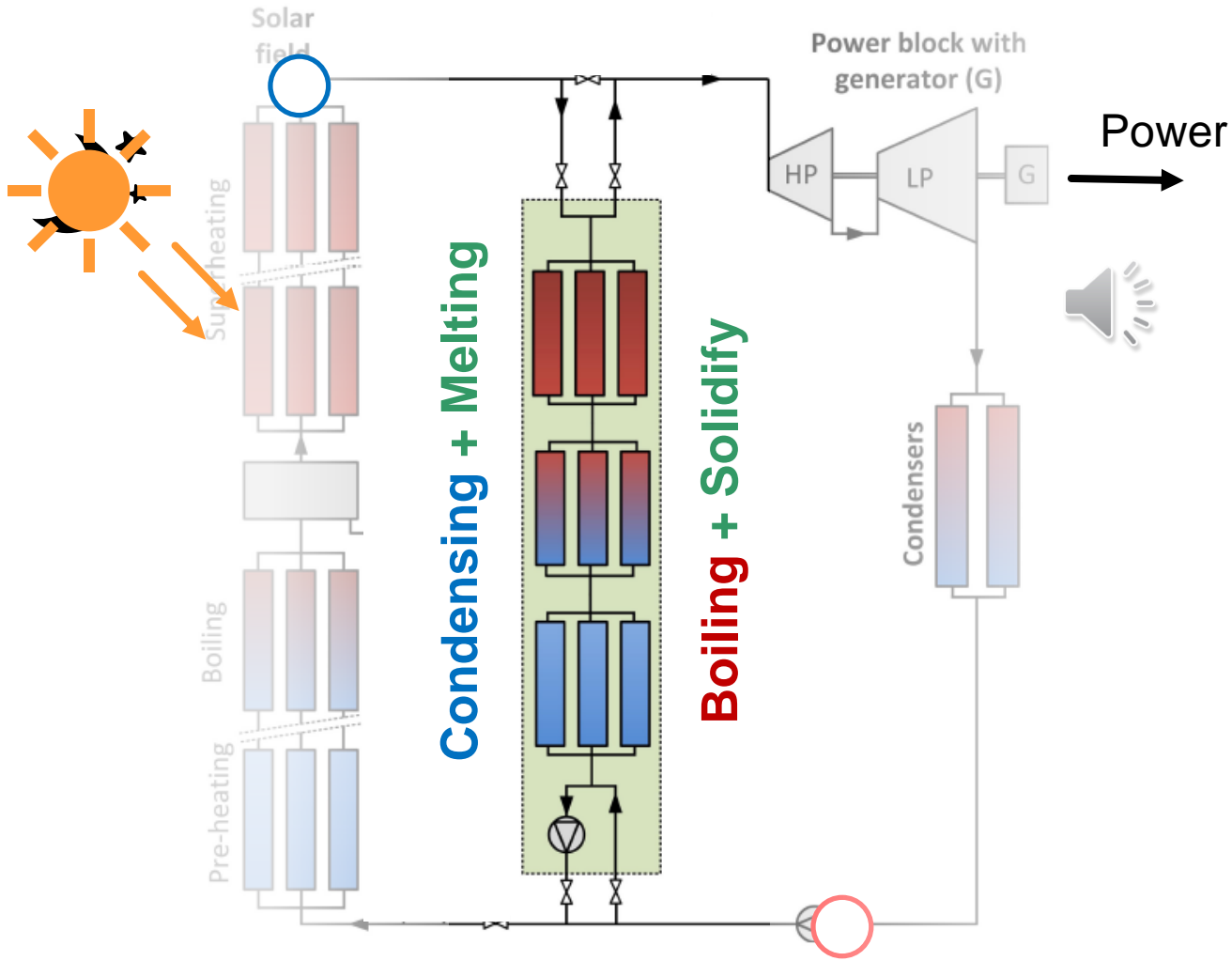

High-Temperature Thermal Storage

Direct steam generation PCM Energy storage modules

- tube wall / general
- PCM
- ▬ copper tube
- ▬ hose

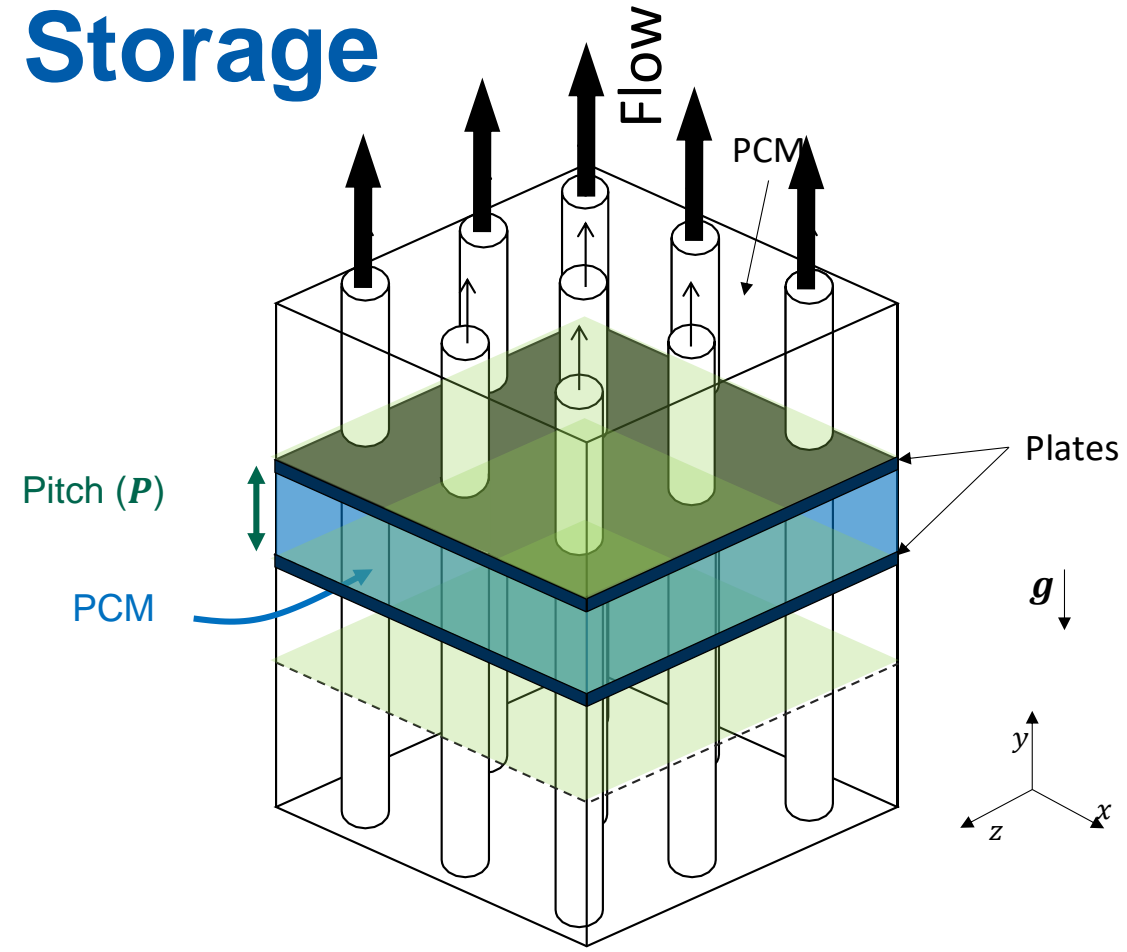
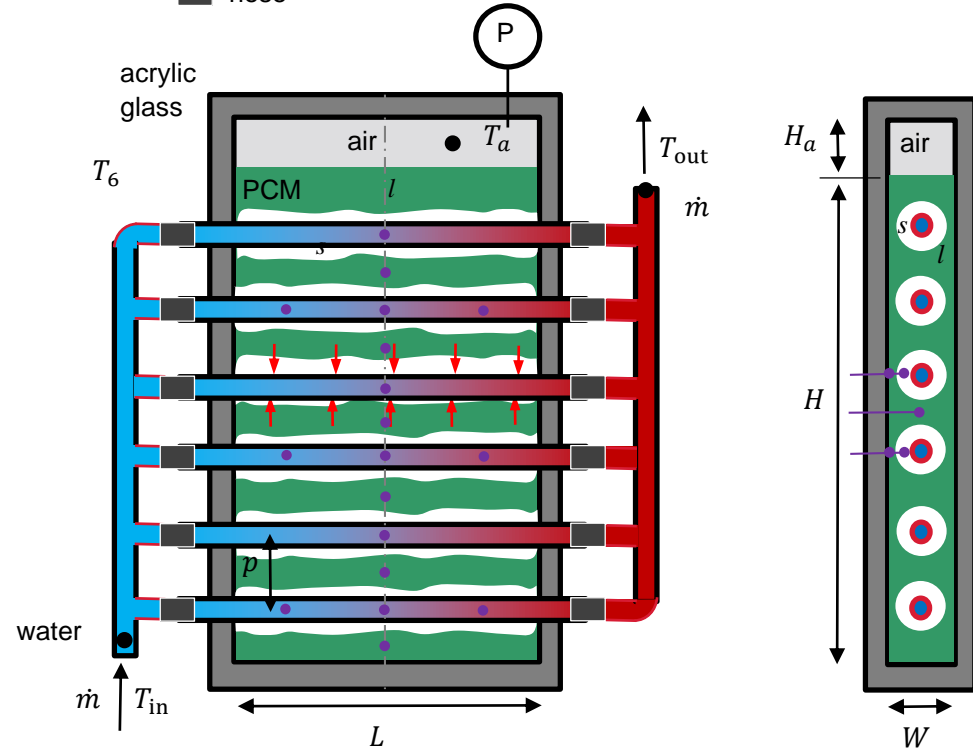

Faculty of Engineering,
Built Environment and
Information Technology

Fakulteit Ingenieurswese, Bou-omgewing en
Inligtingtegnologie / Lefapha la Boetšenere,
Tikologo ya Kago le Theknolotši ya Tshedimošo

Medium-Temperature Thermal Storage

Semi-passive → net-zero

Thermal battery cell

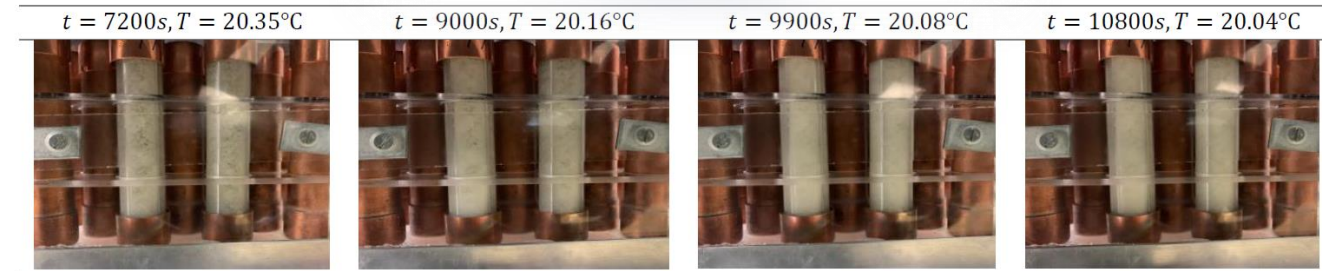

Solidification

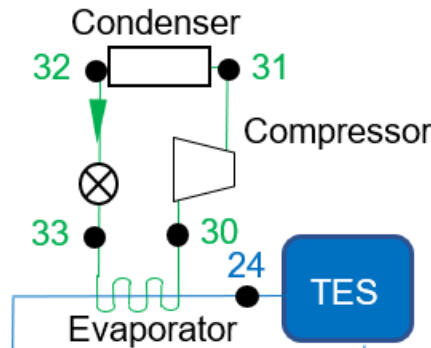

Thermal battery

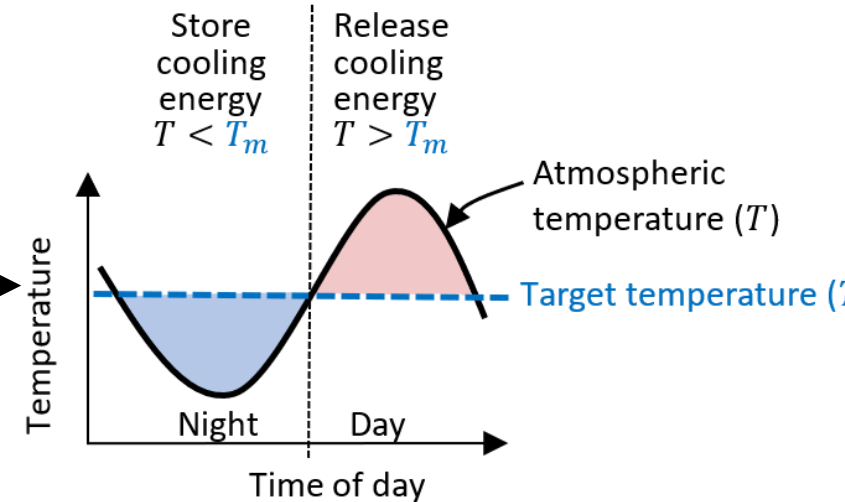
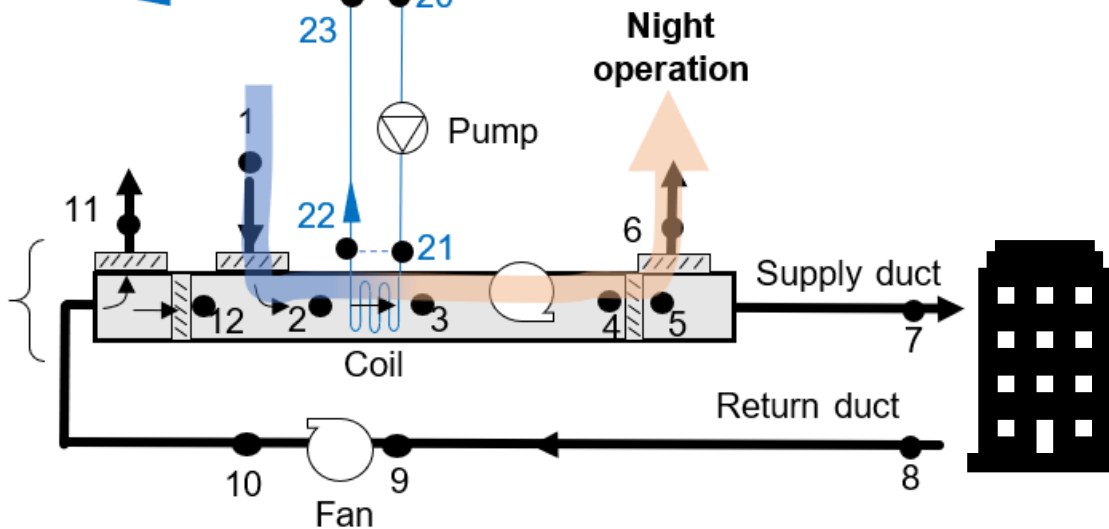

Medium-Temperature Thermal Storage

Fully-passive → net-zero

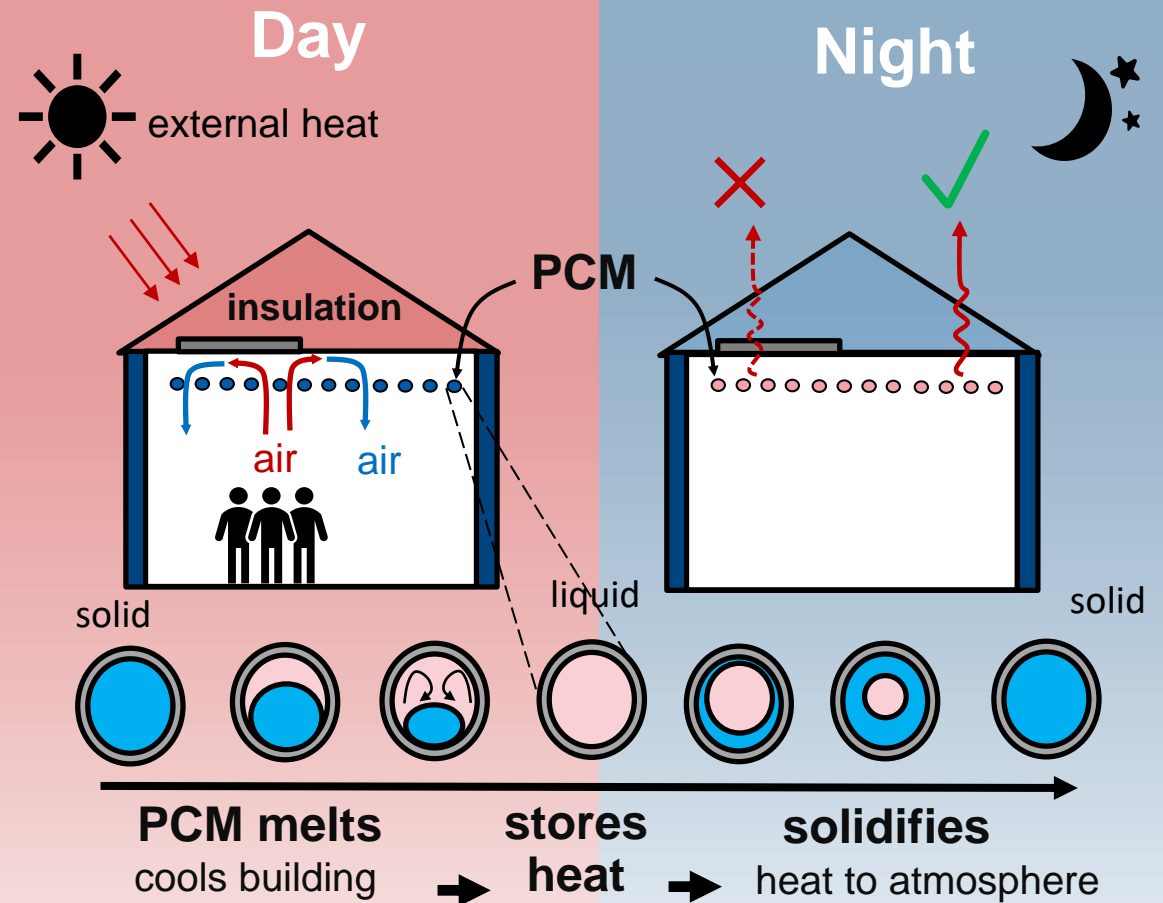
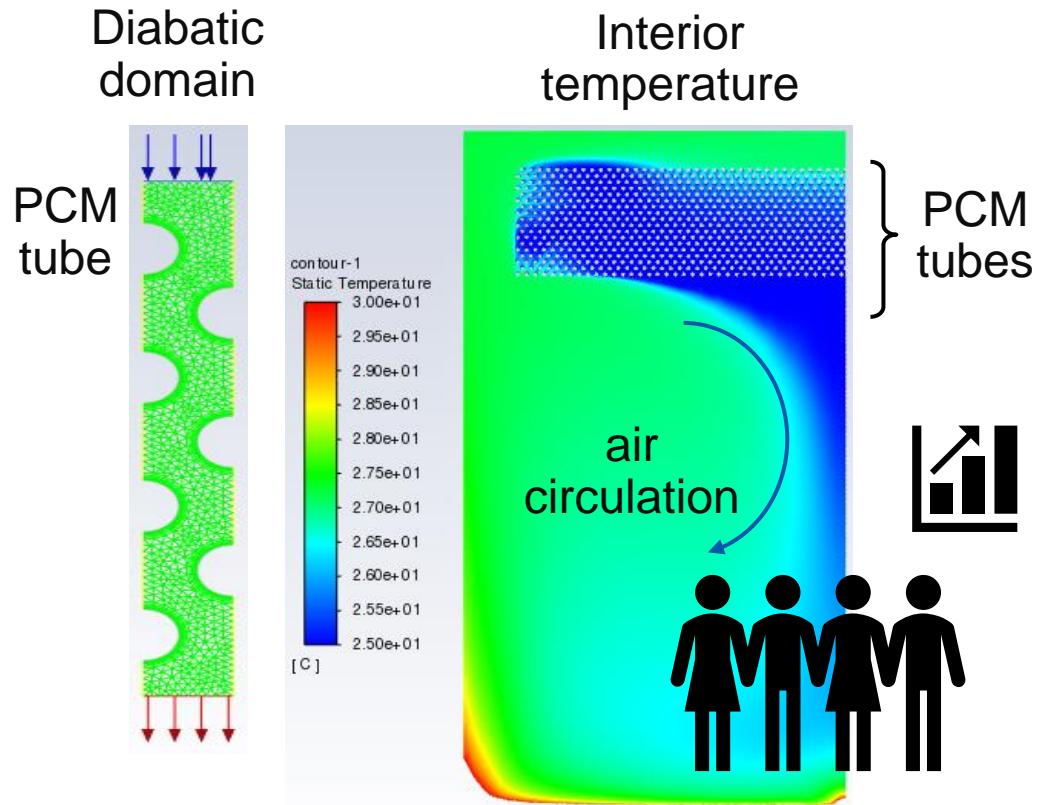

Summary

Net zero carbon and net zero energy



Active heat transport

- Direct steam generation power production
- Electronic cooling



Passive thermal storage

- High-temperature 24/7 operation
- Medium-temperature thermal regulation

Image credit: Prof Richard J. Weller
<http://atlas-for-the-end-of-the-world.com>



UNIVERSITEIT VAN PRETORIA
UNIVERSITY OF PRETORIA
YUNIBESITHI YA PRETORIA

Faculty of Engineering,
Built Environment and
Information Technology

Fakulteit Ingenieurswese, Bou-omgewing en
Inligtingtegnologie / Lefapha la Boetšenere,
Tikologo ya Kago le Theknolotši ya Tshedimošo

Closure

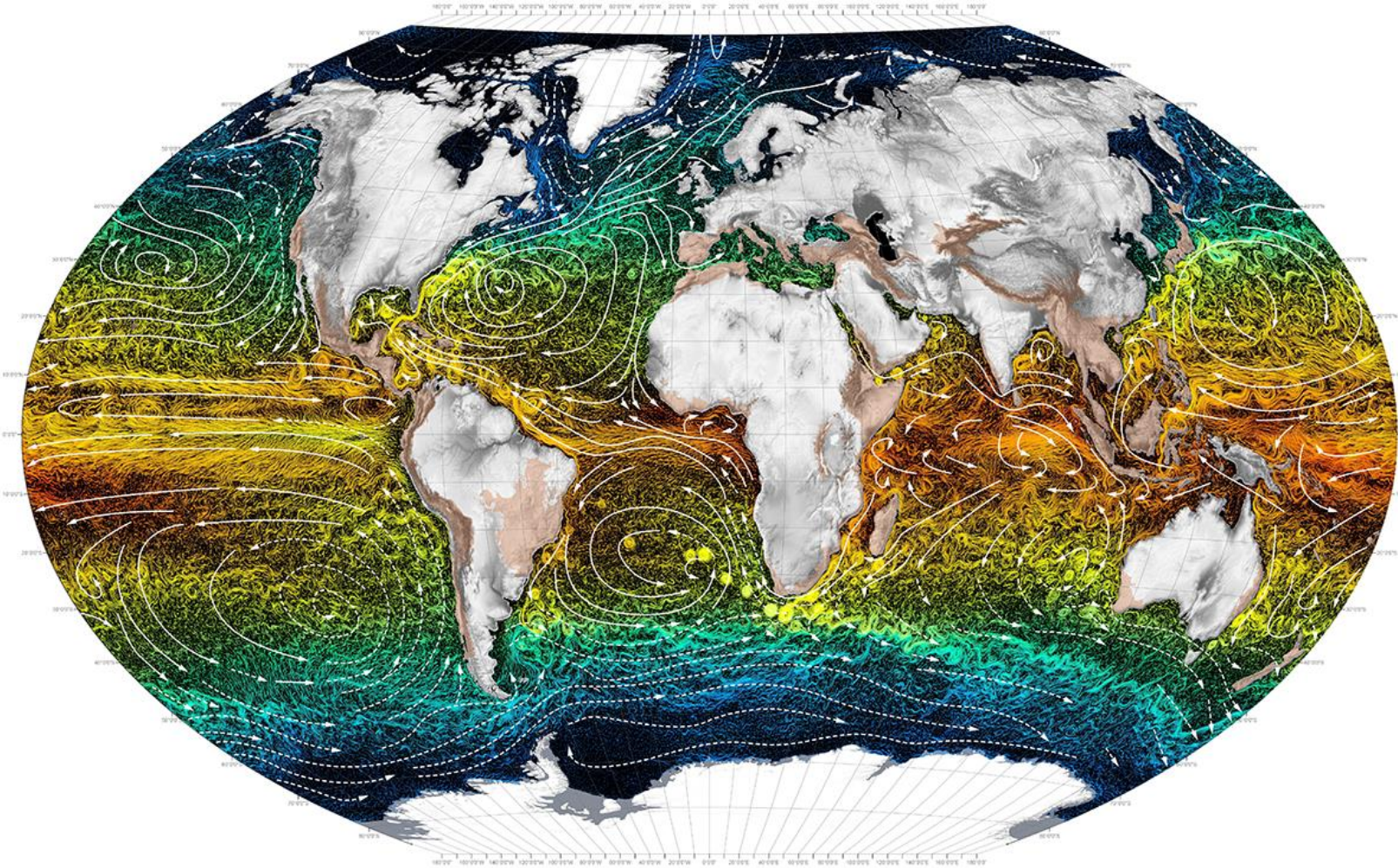

Image credit: Prof Richard J. Weller
<http://atlas-for-the-end-of-the-world.com>



UNIVERSITEIT VAN PRETORIA
 UNIVERSITY OF PRETORIA
 YUNIBESITHI YA PRETORIA

Faculty of Engineering,
 Built Environment and
 Information Technology

Fakulteit Ingenieurswese, Bou-omgewing en
 Inligtingtegnologie / Lefapha la Boetšenera,
 Tikologo ya Kago le Theknolotši ya Tshedimošo

Acknowledgement and Thanks

My loving family

Christa, Cara, Lika, and my parents

Specific collaborators and students (alphabetical)

Noori Rahim Abadi, Adekunle O. Adelaja, Ken Craig, Michael Craig, Michelle de Paepe, John Ferreira, Reinhard Ferreira, Carla Grobler, Zaid Dauhoo, Khalil Elahee, Aiden Geary, Hendrik Giesing, Diksha Juggurnath, Abdel Khoodaruth, Arje Linström, Christos Markides, Andrew Martin Josua Meyer, Karabo Mokgere, Johann Moller, Bothabo Ngwenya, Godswill Nwaji, Surajudeen O. Obayopo, Steven Okumu, Olabode T. Olakoyejo, Dani Orejon Mantecon, Emmanuel Osowade, Alec Rosema, Andre Pienaar, Jarrod Potgieter, Jana Rodrigues, Khellil Sefiane, Francois Solumu, Prashant Valluri, Johann van den Bergh, Mandi Venter, Hannalie Vergotine (nee Scheepers), Marius Vermaak, Victor Voulgaropoulos

Friends and colleagues in the Department of Mechanical and Aeronautical Engineering

Faculty and staff of EBIT

University of Pretoria



UNIVERSITEIT VAN PRETORIA
UNIVERSITY OF PRETORIA
YUNIBESITHI YA PRETORIA

Faculty of Engineering,
Built Environment and
Information Technology

Fakulteit Ingenieurswese, Bou-omgewing en
Inligtingtegnologie / Lefapha la Boetšenere,
Tikologo ya Kago le Theknolotši ya Tshedimošo

Make today matter

www.up.ac.za