



fig. 01_ Vibrant market (Mombasa, Kenya)

Introduction

4	Pretoria West
8	The City of Tshwane Spatial Development Framework
10	History of Production
13	History of Railway Stations
15	Monotonous Urban Environments
17	Aims
19	Research Questions
19	Research Methodology

This chapter will briefly state and describe the location of the study area and the approach the local authority has to rail travel followed by a brief background of production, railway stations and monotonous urban planning. The chapter will conclude with the aims of the study, research questions and research methodology.

Pretoria West

Pretoria West is a well-established neighbourhood lying directly next to the Tshwane Inner City. It is also one of the oldest residential suburbs, established in 1892. The neighbourhood has changed from residential to a more mixed-use suburb consists of restricted industry, business, retail, flats and single residential areas (Riana du Plessis Urban Planners and GWA, 2008, p.1). Although the area has a mix of uses, these uses are not integrated, thus creating a monotonous urban environment with most of the properties consisting of single use zoning.

According to the local authority's densification strategy proposal for Pretoria West the following are reasons why it is an ideal area for new development:

- *Proximity to a major employment and activity centre, namely the Tshwane Inner City;*
- *Proximity to major public transport opportunities; and*
- *The decaying character of the area which makes it ripe for urban renewal and development intervention.*

-Riana du Plessis Urban Planners and GWA (2008, p.5)

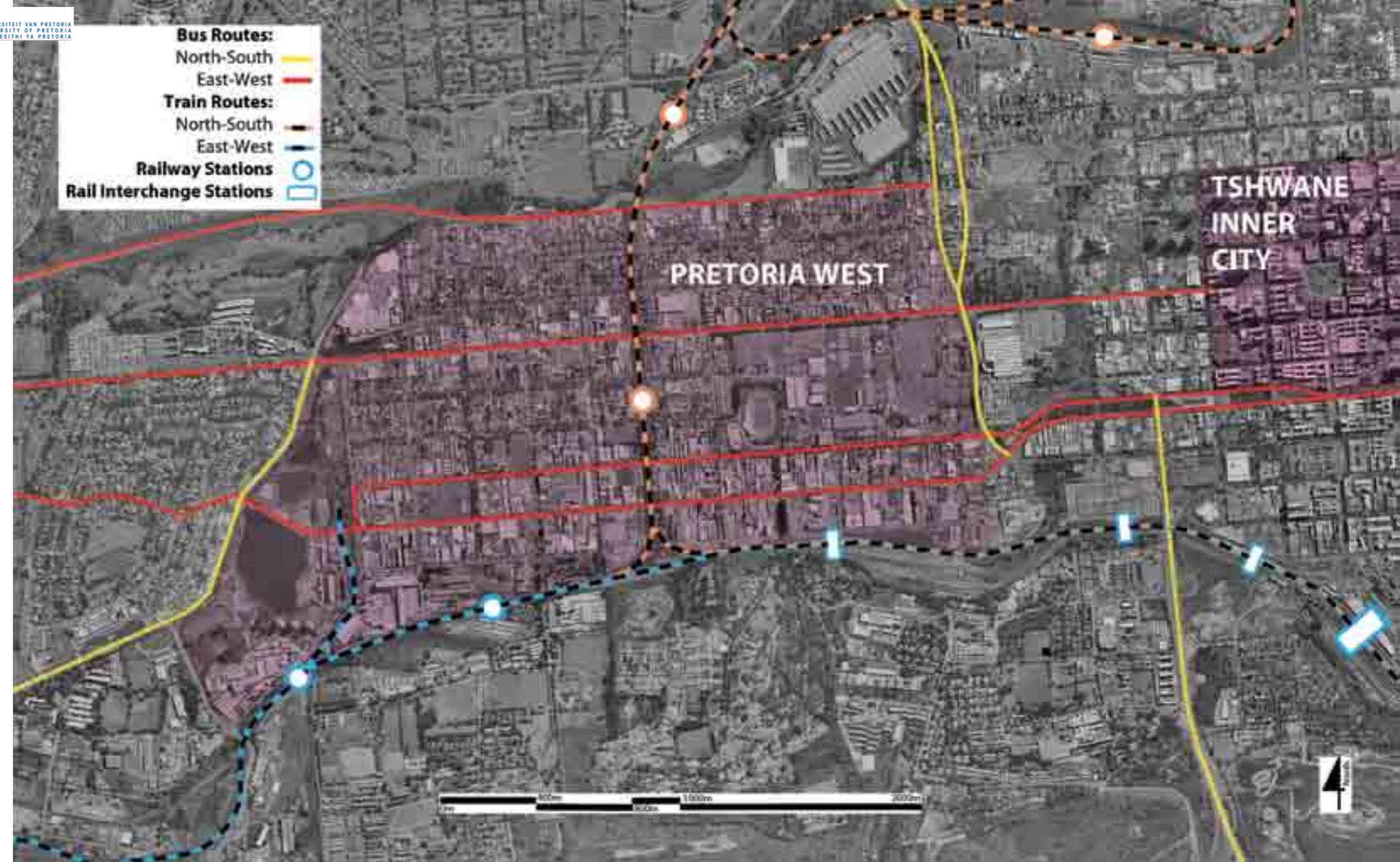

fig. 02_ Decaying urban environment, Buitenkant Street



fig. 03_ Decaying urban environment, Carl Street

fig. 04_ Pretoria [western region] aerial photograph



The focus of this densification strategy is placed on the north-south line of the railway and the east-west public transport route on Church Street, indicating that the commuter rail interchange at Schutte Street is ideally located as a future public transport hub (Riana du Plessis Urban Planners and GWA, 2008, pp.3-4).

No emphasis is placed on the east-west railway line and the public transport routes along Mitchell and Soutter Streets. The catchment area for people to walk to Schutte Street only extends in a 500m radius and therefore a large area of Pretoria West lacks commuter rail stations within walking distance. This is exacerbated by the location of stations further south of the residential area, segregated by an industrial corridor.

The possibility of a commuter station to the south-west of the area [site of the Pretoria West Power Station] situated in closer proximity to the residential zone and the opportunities for transport interchanges will be investigated.

One of the strategies of such transport interchanges according to *The City of Tshwane Spatial Development Framework: Central West Region*, is to transform current facilities into harbours of dignified provision of transport with safe and comfortable surroundings. People have to be able to change from one mode of transport to another with ease and be able to buy day-to-day goods.

Most importantly these transport interchanges should alleviate the daily stresses related to commuting for extended times of day (City of Tshwane, 2007, pp.13-14).

fig. 05_ Pretoria West Precinct aerial photograph

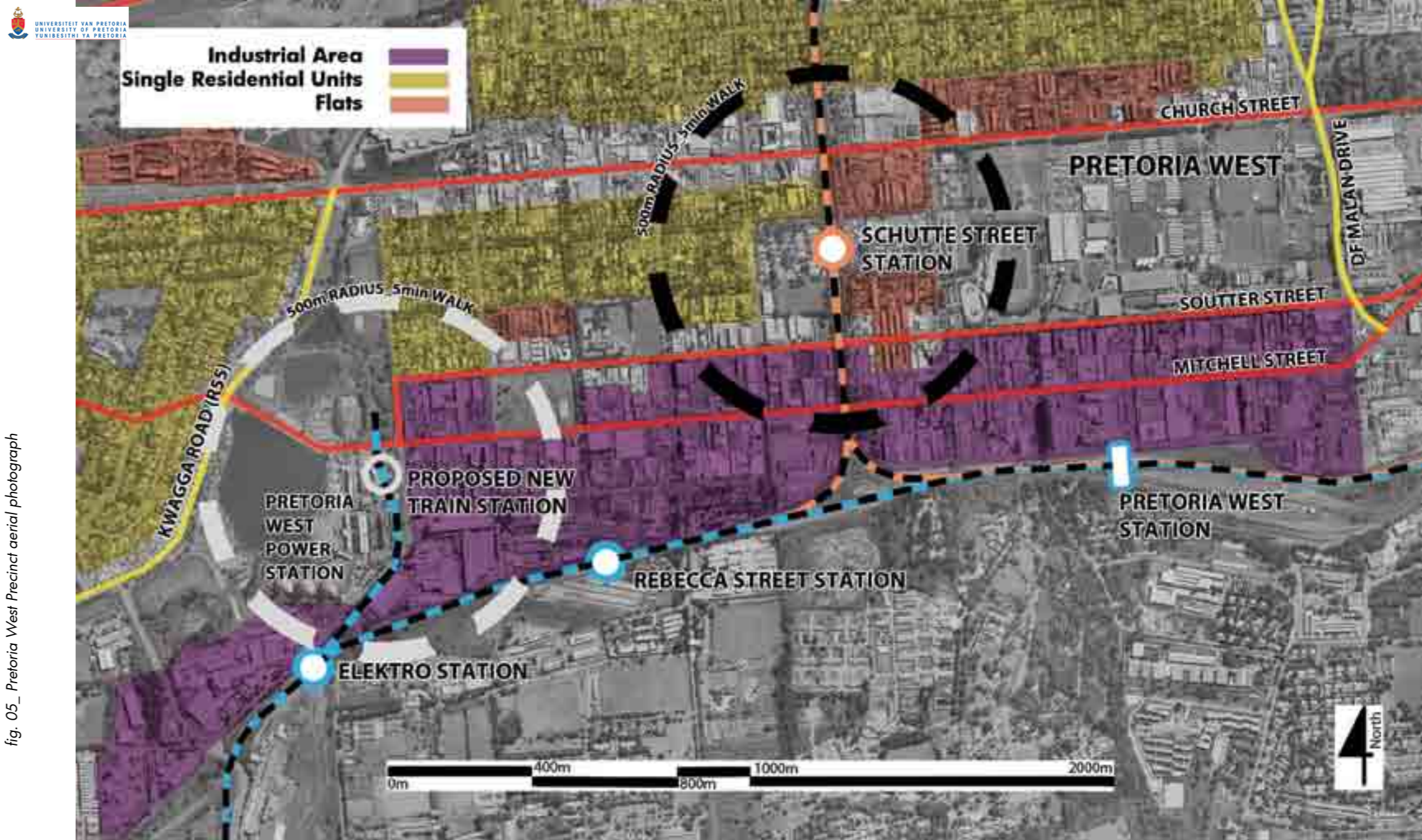

The City of Tshwane Spatial Development Framework

The framework raises the following important points. Relevant to the improvement of the cities commuter rail stations and the surrounding urban environment, thus providing first class public transport for the city and its people:

- The rail together with the first order road system should inform the city's new structure to promote transformation of the urban area.
- The metropolitan area is well served by rail infrastructure and although the integration of the different rail systems will be a major challenge, it could in future form the backbone of a public transportation system for the entire region. The new proposed Gautrain rapid rail link should also contribute a great deal towards an improved public

transport system.

- New large-scale development initiatives should be planned around public transportation facilities, with a strong pedestrian focus. The dependency on private vehicles should be minimised through the development of a first class public transportation system. The large volumes of commuters entering and leaving the CBD during the peak periods need to be addressed. Implementing a first class CBD public transport distribution system and strengthening the interfaces between the CBD and the city-wide public transport system, can be considered. The regional public transport arrival points should be linked to a dedicated feeder distribution system. The aim of this

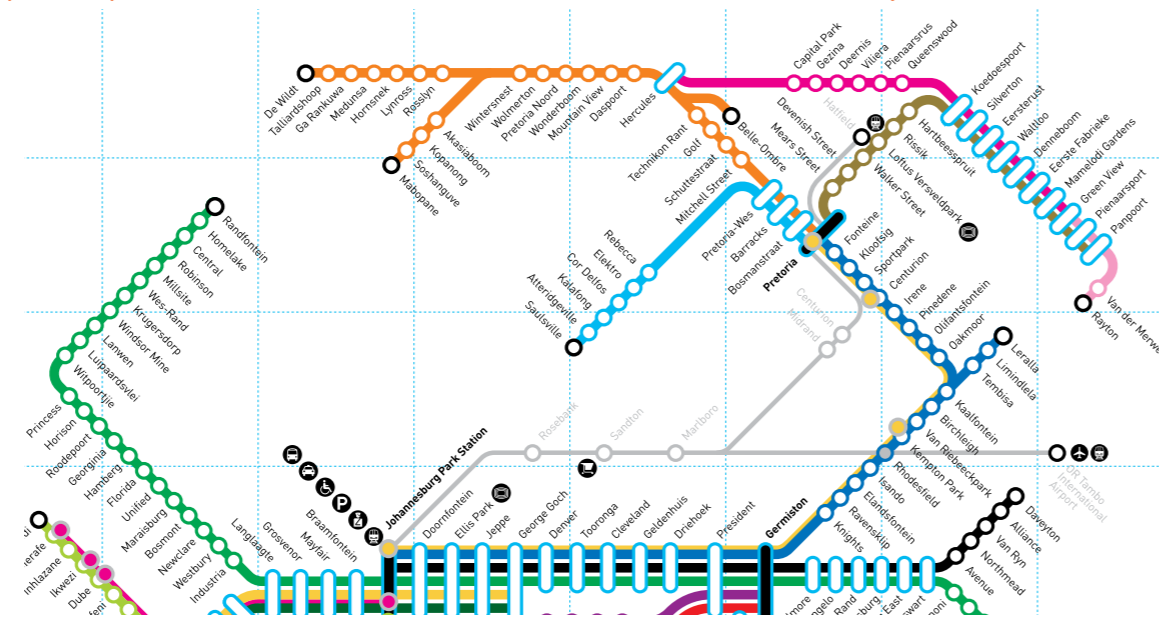

fig. 06_ Diagram of Northern Gauteng rail network



fig. 07_ People rushing out of rail station



fig. 08_ 'Train surfing' [dangerous and unsafe commuting by train]

is to move people around the inner city in a convenient, safe and comfortable manner that will reduce the need for private vehicle use in line with national policy.

- The existing rail infrastructure of the metropolitan area is well located around the core area of the city to fulfil this function in future.
- Other public transport infrastructure should be integrated with the rail system to make this ideal possible and to contribute to the sustainability of the city.
- Currently some of the railway lines do not carry passengers and service levels will have to be upgraded.

- Furthermore the negative perceptions about rail will have to be addressed to make this form of transport more acceptable.

-City of Tshwane (2007, pp.18-19)

These points emphasize the need for integrated public transport facilities which can move people in and around the city cheaper, safer and in a more dignified manner than is currently the norm. See figures below.

History of Production

Pretoria West has a well established production heritage with the first iron industry [ISCOR] founded by the Delfos brothers in 1916. Later in 1924 the Pretoria West Power Station was built to supply electricity for the increasing demand for energy. This industrial character of the Power Station and ISCOR [Arcelor Mittal] is still intact, but once decommissioned will be lost to future generations.

It is important to conserve this character of the site as it has strong ties to the history of Pretoria West. Although industrial areas have negative connotations such as pollution and noise they play an important role as part of the history of industrialised countries.

“Most products people in the industrialized nations use today are turned out swiftly by the process of mass production, by people (and sometimes, robots) working on assembly lines using power-driven machines. People of ancient and medieval times had no such products. They had to spend long, tedious hours of hand labor even on simple objects. The energy, or power, they employed in work came almost wholly from their own and animals’ muscles.”

-Hacket (1992)

| Industrial Revolution 1: The Beginning [18th century]

The Industrial Revolution changed the way people lived and their methods of manufacture [production]. The most important changes were the invention of steam powered machines and the inception of the factory.

The factory was mainly responsible for the rise of modern industrial cities, due to a large number of people migrating from rural areas to cities seeking employment in factories. Early versions of factories came about when merchants with enough capital gathered workers under one roof and supplied them with spinning wheels and looms to ‘mass produce’ cloths (Hackett, 1992). A good example of this is illustrated in the mills and related industries of



fig. 09_ Childworker in mills

Manchester in the 1800s. Chimneys and smoke characterized these cotton districts, due to the burning of coal used to power the steam engines of the cotton mills (Hackett, 1992).

“I remember my earliest view of Manchester. I saw the forest of chimneys pouring forth volumes of steam and smoke, forming an inky canopy which seemed to embrace and involve the whole place.”

-Taylor (1842)



fig. 10_ Image of the pollution created by large industries in the 1800s

| Industrial Revolution 2: | The Second Phase [mid 19th century]

The increased demand for products led to the advent of transportation networks, starting with canals to transport heavy goods such as coal. The canal boats transported more than the wagons that travelled on land. Where canals could not be used wooden or iron rails were laid for horse drawn wagons that one horse could pull more efficiently than 20 horses on ordinary roads of the time. In the early 19th century two American inventions, George Stephenson’s locomotive and Robert Fulton’s steamboat, introduced the modern transportation of goods on land and sea placing factory made products within reach of countless people at affordable prices (Hackett, 1992).

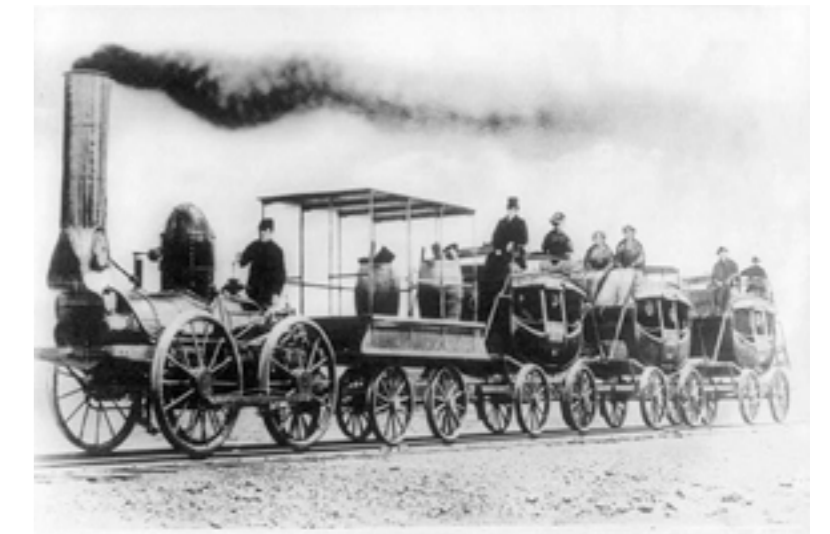

fig. 11_ Image of the first locomotives, early 1800s

History of Railway Stations

Railroads were the most important transport component as they linked every major European market between 1830 and 1860. Railroads carried large numbers of people and large amounts of material over long distances and tied countries closer together.

The first fundamental change in the second industrial revolution was the discovery of electricity in 1876, to be used as a new energy source for industry and transportation. The second was the use of gas and oil and the invention of the internal combustion engine in 1885, marking the beginning of the passenger car industry (Jewsbury, 1992).

Henry Ford introduced the assembly line in 1913 with the manufacture of the Model T Ford. By moving the assembly of the parts from one workstation to the other along the production line, the time of assembly was significantly reduced.

The production line was rapidly implemented throughout other industries (Hackett, 1992).

Today, advances made in the industrial revolution to increase production through enhanced processes continue to be repeated in the making of goods to satisfy virtually unlimited demand (Jewsbury, 1992).

Industrialization caused a massive influx of rural inhabitants to urban environments seeking employment in factories. The urban environment that resulted from the Industrial Revolution was dangerous and unhealthy. Safety regulations in the factories were non-existent and workers contracted serious diseases such as palsy and black lung disease. The early workers' families were also confronted with these dangerous and unhealthy conditions. These conditions were found in most countries undergoing the first stages of industrialization (Jewsbury, 1992).

The railway allowed passengers to travel on board trains for the first time in 1821 although the transport of goods took precedence over people.

Early passenger boarding stops were located at inns at each end of a line. There were no recognised stops and passengers had to flag down these simple horse driven coaches. As coach travel became overshadowed by train travel the inns were replaced by ticket offices, adding to the existing toll offices of goods and materials stations.

The simplest form of a station was built when the first requirement for passengers, after buying a ticket, was a waiting area [These early stations were built to accommodate both passenger and goods facilities, only later separating the two]. These stations were almost always adaptations of existing buildings put to new use with minimum alteration.

The first inter city passenger railway opened in 1830 between Manchester and Liverpool [for cheap transport of materials and finished goods between the Port of Liverpool and the mills of Manchester]. The first stations built in the modern sense of the word were constructed along this line. These structures were built simply and logically with unpretentious honesty.



fig. 12_ Thomas Edison's electric lamp, 1880

“It was a town of red brick, or of brick that would have been red if the smoke and ashes had allowed it; but as matters stood, it was a town of unnatural red and black, like the painted face of a savage. It was a town of machinery and tall chimneys, out of which interminable serpents of smoke trailed themselves for ever and ever, and never got uncoiled. It had a black canal in it, and a river that ran purple with ill-smelling dye, and vast piles of building full of windows where there was a rattling and trembling all day long, and where the piston of the steam engine worked monotonously up and down, like the head of an elephant in a state of melancholy madness. It contained several large streets all very like one another, and many small streets still more like one another, inhabited by people equally like one another, who all went in and out at the same hours, with the same sound upon the same pavement, to do the same work, and to whom every day was the same as yesterday and tomorrow, and every year the counterpart of the last and the next.”

-Charles Dickens (n.d., p.26)

fig. 13_ The Fleese Inn, at one end of the railway line, 1823



“For all building in general, if you consider it well, owes its birth to necessity, was nursed by convenience and embellished by use; pleasure was the last thing consulted in it.”

-Alberti (Cited in SAHGB Publications Ltd, 1961, p. 63)

fig. 14_ First railway ticket office in Stockton, 1830



Monotonous Urban Environments

The Crown Street station, Liverpool, opened in 1830s was designed specifically to suit the needs of railway travel. It was a long narrow building of two floors, the ground floor accommodating booking and waiting rooms for passengers and the first floor the administration offices. The first 'parade' [platform] comprised the full length of the building level with the floor of the carriages as part of the station. This platform was protected by a roof, which formed part of a larger roof, which covered the tracks of the railway. This station serves as a good precedent for railway stations (SAHGB Publications Ltd, 1961, pp.65-69).

Other stations built during this time were not so exemplary. Most had very little accommodation for passengers and focussed more on the transport of goods and materials. These stations rarely had platforms for passengers and people had to get onto trains by stepping up from the ground level (SAHGB Publications Ltd, 1961, p.71).

Modern stations follow the basic configuration of the Crown Street station but they have become the nerve centres of transportation systems, providing an interface between various modes of transit taxis, busses and cars, acting as a catalyst for surrounding development and as the central element of urban planning. Most importantly stations became a means of expressing civic and personal values of a city (Chappel, 1989, p.354).

fig. 15_ Crown Street station, Liverpool, 1830



fig. 16_ Leeds station, 1834

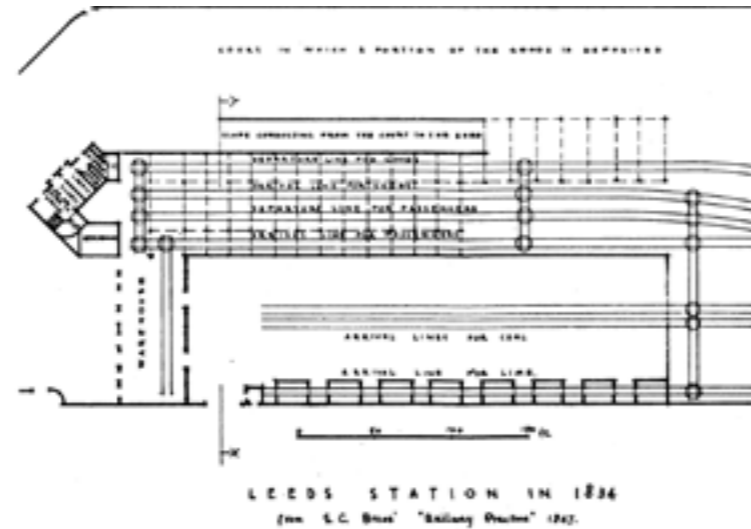

| Better Living Environments

The urban environment that resulted from the Industrial Revolution was characterised by decay and disease, but by 1914 the governments of most European cities began to provide services, such as running water, central heating, street lighting, public education, sewage systems and medical care (Jewsbury, 1992). A major paradigm shift came in the 1930's when functional planning principles were adopted to plan better cities.

| Separation of Living and Work

These principles were mainly based on the growing medical knowledge between the 1800s and 1900s stating a number of criteria for healthy living such as access to natural light, air, sun and proper ventilation as well as access to open

space. Furthermore the separation of live and work was important and was considered to be beneficial to a person's physiological wellbeing (Gehl, 2006, p.43).

"But it is also true that in the modern city industry gets treated like a disease. The areas where it exists are assumed to be dirty and derelict. They are kept to the "other side of the tracks," swept under the rug. And people forget altogether that the things which surround them in their daily lives - bread, chemicals, cars, oil, gaskets, radios, chairs - are all made in these forbidden industrial zones."
-Christopher Alexander (1977, p.228)

Christopher Alexander states in Pattern Language that in modern times all cities created specific zones for 'work' and others for 'living', enforced by law. This separation aided similar functions to be grouped together and operate more efficiently; also some places of work such as industry destroyed the safety and quiet environments of residential neighbourhoods. But this

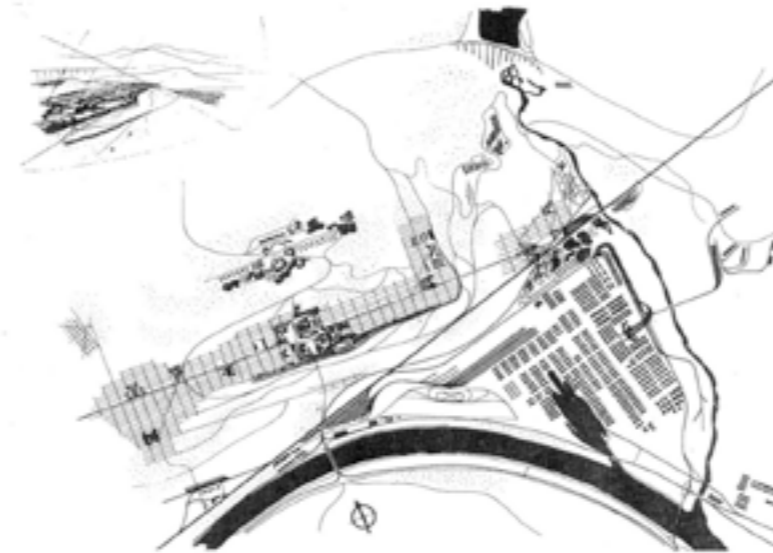

fig. 17_ Cité Industrielle: Separation of industrial from residential areas, Tony Garnier, 1917



in turn creates rifts in family life where the breadwinner (today both parents) ends up only spending time with their children on weekends thus creating dead neighbourhoods for most of the time (Alexander et al., 1977, pp.52-53).

Jan Gehl, architect and professor of Urban Design at the School of Architecture at the Royal Danish Academy of Fine Arts, Copenhagen states that since the 1930s the segregation-orientated planning of modern cities, in which the deliberate separation of unrelated functions is the aim, results in mono-functional areas. This mono-functional condition has led to urban sprawl by detaching living and work environments, as it is healthier to live away from the work [industrial] areas (Gehl, 2006, pp.101-03).

Furthermore these 'live' environments are developed as isolated dwelling units fulfilling the requirements of healthy and suitable architecture for habitation, creating north-south orientated architecture but negating the orientation toward the street. The consequence of this planning principle is that the street and square disappeared from these developments and cities (Gehl, 2006, pp.43-45).

Large continuous residential areas with identical social groups and dreary monotonous industrial areas create large "pretend" cities, built up around single functions or similar groups of people. Examples are office complexes, residential estates, suburbia and peri-urban settlements, leading to the isolation of groups of society. The advantages of this principle possibly were more rational planning and shorter distances linking related functions which rely on efficiency; but the price paid is reduced contact with the immediate society, resulting in a meagre and monotonous environment (Gehl, 2006, p.102).

"The spreading and thinning out of dwellings assured light and air but also caused excessive thinning of people and events."
-Jan Gehl (2006, p 46)

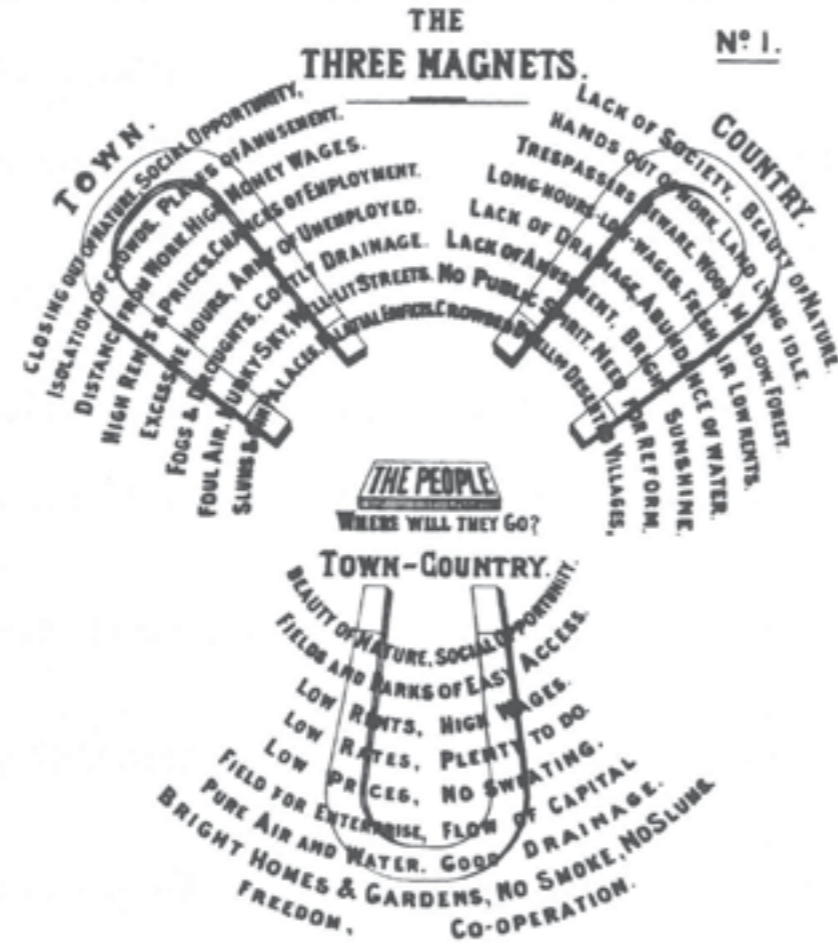

fig. 18_ The Three Magnets, Ebenezer Howard in the 'Garden Cities of Tomorrow', 1902

Aims

This investigation will focus on a transport facility - the exchange process of products and people - and the interrelationship between conflicting transportation modes, freight and passenger rail, which rely on the same infrastructure; proposing solutions contesting the current norm of transportation facilities in South Africa.

The aim of this investigation is the integration of public functions with production/ industrial functions to contest monotonous industrial environments. By developing the site as a catalyst that will renew the productive potential of Pretoria West. New products for the local and international markets can be produced.

The integration of the site will lead to an investigation on how flexible the boundaries created by such a facility are presented in order to allow public access to it and the site without isolating certain areas. Furthermore investigating what restrictions or opportunities arise when a transportation facility is integrated with the industrial/productive context and heritage of the site.

These investigations will inform the urban design and architectural design interventions proposed for this site.



fig. 19_ Diagram illustrating the integration of goods and people

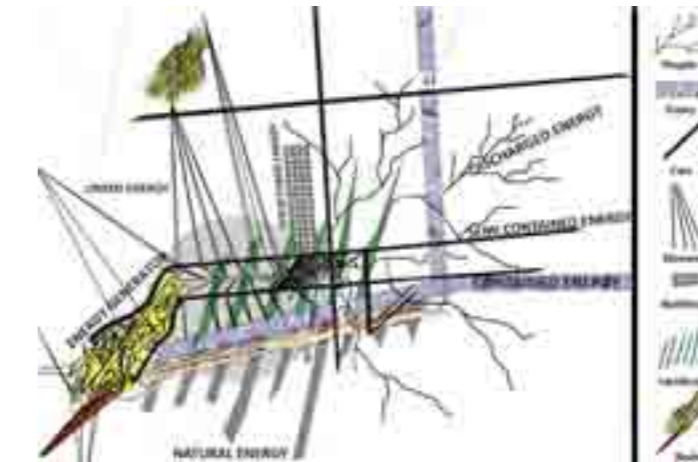

fig. 20_ Diagram illustrating the site as catalyst for the productive precinct

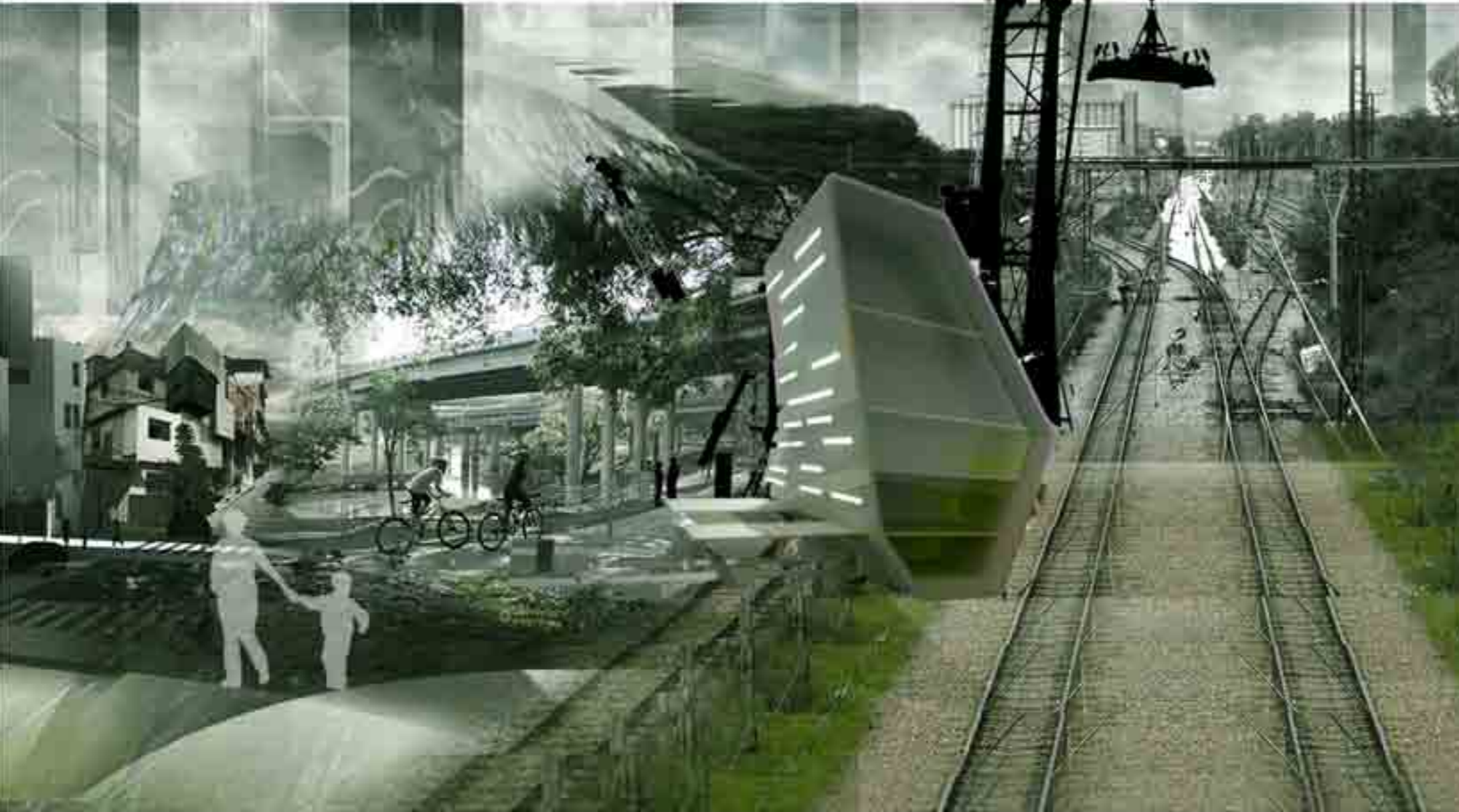

fig. 21_ Image illustrating the integration of freight and people

Research Questions

1. What can be done, urbanistically and architecturally, to facilitate the return of lost production and increase the interaction of people and process in the area?
 - What can be done to alleviate the monotony of the industrial urban environment?
 - What will attract an influx of people to the west and the site instead of merely conveying them through it?
 - What possible functions will facilitate exchanges in production on site?
 - What can be done to address the urban divides that exist?
2. What can architecturally address the decaying historical fabric of the Pretoria West Power Station?
 - What conservation strategies will acknowledge the industrial character of the site?

Research Methodology

Various qualitative research methods will be applied in this project and will inform the design solution.

- Historical method: Analysis of literature, maps, aerial photos and figure grounds, to understand the existing site and its history and through a statement of significance of the heritage aspects, to develop a future vision for the site.
- Descriptive survey method: analysis of research obtained through observation by visiting the site and interviews with relevant parties regarding function, production process and transportation of people.
- Architectural and urban theory: analysis of spatial implications of the process of production to formulate architectural and urban intentions regarding functions or programmes.
- Study Precedent: Analysis through case studies concerning context, function, material.



fig. 22_ Existing railway track on site, power station in background

Site + Context

25

Location

26

Pretoria West [Urban Character]

32

Infrastructure

34

Critique of the Urban Condition

36

Location of Site

39

Pretoria West Power Station

This chapter will locate the larger context of the study area. The urban character of the area will be investigated. The chapter will conclude with a critique of the urban environment and choice of study area, followed by a description of the site and its character.

Location

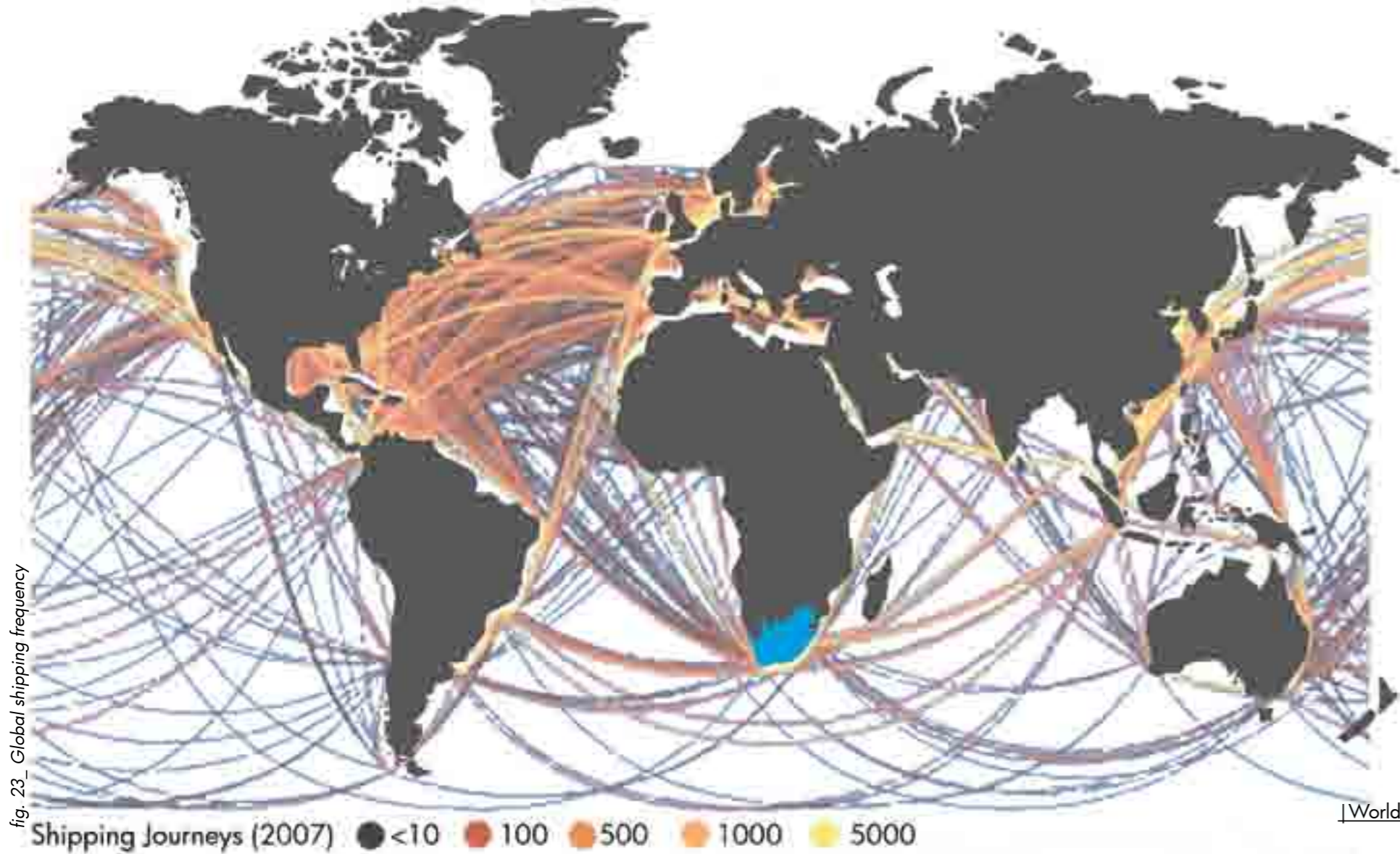

fig. 23_ Global shipping frequency

Four ports of South Africa [Cape Town, Port Elizabeth, East London and Durban] are connected with Gauteng for the transportation of products and materials. Thirty one million tonnes/year of freight is transported between these ports and Gauteng, with the largest volume of freight [66%] between Johannesburg and Durban, namely 21 million tonnes/year.

Tshwane is located north of Johannesburg and its rail freight transport routes connect to neighbouring countries towards the north [Zimbabwe] and east [Mozambique]. The largest freight volume of 9 million tonnes/year is between Tshwane and Maputo. Future predictions are made of an increase in freight volumes by 200% to and from Gauteng (Airships Africa, 2007).

The railway lines that run towards the northern and eastern neighbouring countries lies within Pretoria West and allows for opportunities for a freight interchange to be located in the area - connecting Pretoria West to inland export routes and the larger regional networks that connect Gauteng to the ports for further export.



fig. 24_ Location map

Pretoria West [Urban Character]

Within the area of Pretoria West various urban patterns can be identified, starting with the grid stretching from D.F. Malan Drive to Buitenkant Street [Urban Edge] that matches the grid of the inner city. The remnants of mass production are still evident along Mitchell and Souter Street although most have taken on a new character such as second hand car dealerships and panelbeaters. Some larger industries still continue to function such as the grain silos, bakeries, Pretoria West Power Station and Arcelor Mittal [ISCOR].



fig. 25_ Grain silos in Mitchell Street



fig. 26_ View of ISCOR from Proclamation Hill



fig. 27_ The urban grid and boundaries

The area north of Soutter Street up to the N4 consists mainly of single residential housing units, one-storey houses, with scattered low-rise apartment blocks. More single unit residential suburbs are situated towards the northwest, namely Proclamation Hill, Westpark and Danville, with the Power Station creating the divide between the more urban context to the east and the suburban areas on the west. Located further west from Westpark lies the segregated neighbourhood, Atteridgeville, that was established in 1939 to house the removed residents of areas such as Marabastad and Lady Selbourne.

fig. 28_ Diagram illustrating larger context



fig. 29_ Residential areas in context



Church Street forms a spine linking all the residential areas mentioned above to the inner city, also linking areas of cultural and historical importance such as the Show Grounds, formerly known as the old Race Course (converted in 1910/11 to its current use), The Old Cemetery, Paul Kruger House and Church Square. Government facilities such as the Pretoria Police Academy, Weskoppies Mental Hospital and military housing are located south of the railroad on Weskoppie Hill.

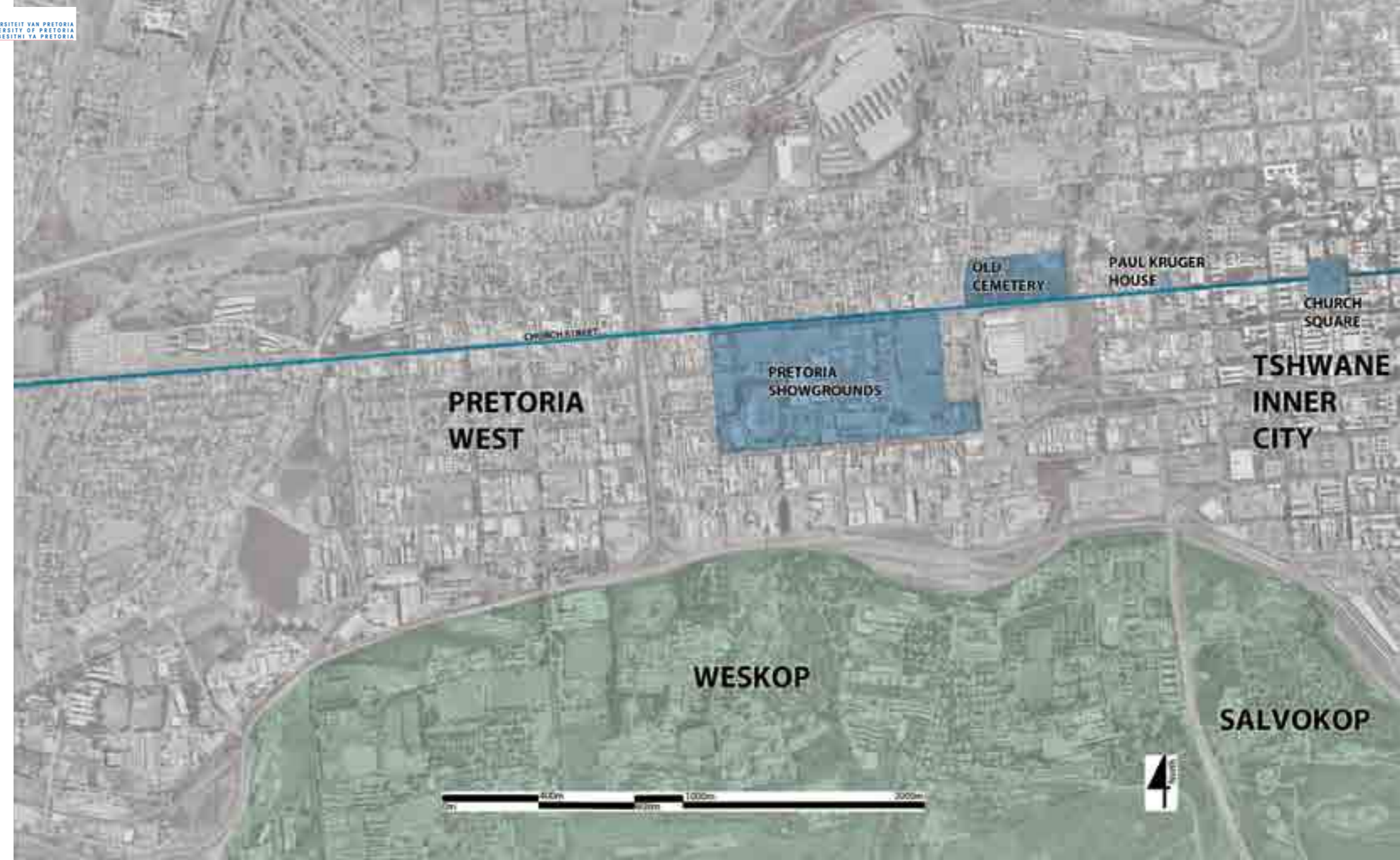

fig. 30_ Church Street connecting cultural and heritage

Infrastructure

| The Grid and Boundaries

The grid of Pretoria West is vehicle orientated. The main roads, Mitchell and Soutter Street which run in an east-west direction and connect with Skinner Street and Church Streets, also connect the grid of the inner city with that of the west; although D.F. Malan Drive, at the eastern edge, separates it from the inner city. Quagga Road (R55) connects the area to the south with Johannesburg, forming the western edge.

| Public Transport

Bus routes run in an east-west direction. The bus route to and from Atteridgeville is on Church Street and moves in both directions. Along Mitchell Street bus routes move to the Proclamation Hill and Westpark suburbs and from them to

the city along Soutter Street due to a one-way system. Future plans include an extended bus route along Church Street providing more frequent bus trips along this route.

The east-west rail infrastructure mainly serves the industrial area of Pretoria West, with private shunts into the large industrial site for freight, connecting these industries with the rest of the country's freight network.

A scattered network of platforms for passengers is spaced within walking distance from one another along the east-west line that connects Atteridgeville with the city. There is a small station on the north-south line, which connects Soshanguve/Mabopane with the city, on Schutte Street. These railway lines transport large volumes of commuters travelling from the outlying areas toward

the city, but only a small number of commuters get on or off in Pretoria West. Local public transport is thus provided and commuters can connect to the rest of the country from the larger Pretoria Station.

This railway line forms a secondary divide within Pretoria West by cutting the precinct in half and it disconnects the urban and natural environments located to the south of the railway line.



fig. 31_ Rebecca train station [platform]



fig. 32_ Rebecca train station [entrance]

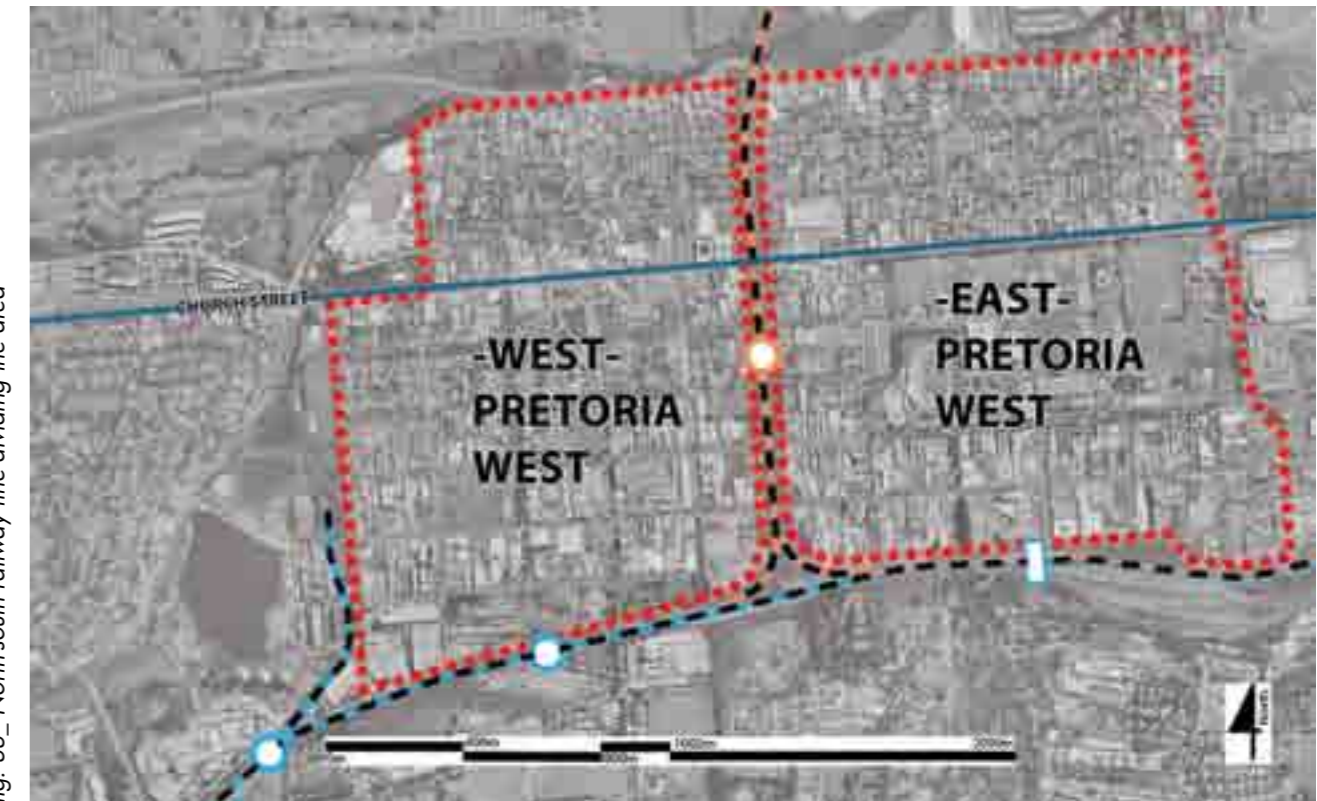

fig. 33_ North-south railway line dividing the area

Critique of the Urban Condition

Functions in the area are mono-functionally zoned, creating separate residential, industrial and commercial zones. The productive potential of the area is degraded and soon to be lost due to the focus of development within the industrial nodes further away from the inner city to areas such as Rosslyn (north of Pretoria) and Walfloo / Silverton (east of Pretoria). Housing in the area is characterized by low-income and low-density, single storey residential units, set within an urban grid. This low level housing typology does not contribute to the urbanity of the area. Recreational and cultural activity is limited to isolated areas such as the Pretoria sports and show grounds.

An urban rift exists between the West of Pretoria and the Inner City due to the physical barrier of the width of D.F. Malan drive and the division of the area by the railway line parallel to Schutte Street. Furthermore the railway line to the south of the area separates the urban environment from the natural environment. Although these two environments are in close proximity it is not easy to cross from the city to nature due to the railway line. The transportation network running through the site moves people through the site and not towards it. In Pretoria West the railway splits into two directions into the northern route towards Soshanguve and the western route to Atteridgeville. This is unlike any other neighbourhood that has only one railway line passing through.

The railway also caters for the transportation of goods with private shunts for the industries in the area, directly linked with the larger railway network. The result is that the railway lines cut off elements of the urban fabric, acting as edges or boundaries allowing people to cross over the tracks to the other side only at certain points. Further, the railway system is significantly underutilized and unsafe, contributing to the negative connotation associated with the railway lines. Apart from the negative aspects, huge potential lies in the existing railway infrastructure (rail and platforms) in the area, allowing opportunities for better access to public transport and the transportation of goods.



fig. 34_ Street panoramic of Mitchell street

Location of Site

An opportunity arises for a railway station to serve Pretoria West, combining it with the freight network to provide storage and transportation of goods and materials for future light industries in the area.

The location of this intervention is the Pretoria West Power Station, where all the existing infrastructure and public transportation routes intersect to integrate modes of transport and cargo on established routes. The site is situated on the western edge of the city where the grid ends at Buitenkant Street, positioning itself in proximity to both industrial and residential zones.

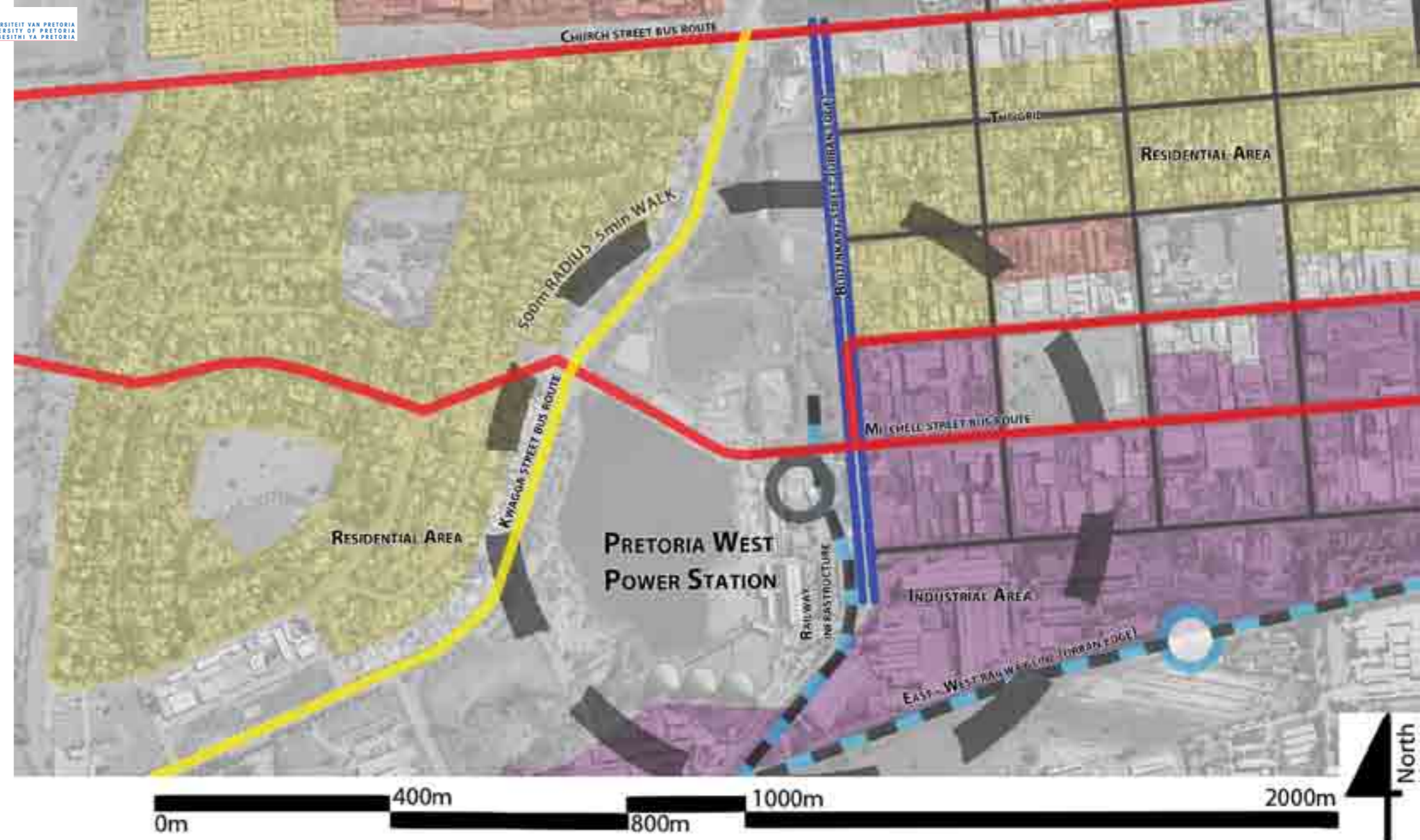

fig. 35_ Image illustrating the location of site



fig. 36_ Image illustrating the study area

| Character of Site

Pretoria West Power Station is situated on the western edge of Pretoria West with Mitchell Street dividing the site in two. The southern portion of the site is larger than the northern portion and there is a distinct difference in quality. The northern side has a more natural character with trees and grass. Most of it was man made and did not occur naturally. The landscape is also manipulated by the introduction of ash settling ponds and the large coal bunker. The southern side is a very robustly constructed industrial site, with almost all of the structures necessary for generating electricity. The structures range in age from the 1920s through to the 1950s and are all still standing. As stated earlier these buildings do not all produce electricity and only the building dating back to 1952 is still generating electricity. Of the total building stock, 60% is in use today and the other 40% is deemed unsafe.

Pretoria West Power Station

The buildings of the Pretoria West Power Station have significant industrial heritage, but are decaying and deemed to be decommissioned within 10 years when its final phase of generating electricity will end. No future plans are in place for this monolithic monument of the Industrial Revolution in South Africa. The site sparked the Industrial "Revolution" of Pretoria and till today stands as a testament of the industrial age.

To prevent further decay of the site after it has been decommissioned, new industrial programs can be introduced to conserve the historical nature of the site. By including functions such as retail, commercial and residential programmes and public open spaces such as squares, the public will be encouraged to enter the currently introverted site.



fig. 37_ Panoramic of buildings on site [earliest right - latest left]

| Infrastructure

routes that run along Mitchell and Church Street.

The site is located very close to the main railway line and has its own private shunt line that enters the site to deliver the coal to the bunker on the northern side of Mitchell Street, connecting it directly to the larger railway network and allowing it to receive coal from anywhere in the country. A railway platform is located within walking distance from the site allowing for access to public transport. The surrounding roads connect the site to the city in an east-west direction through Church Street and Mitchell Street. The R55 (Quagga Road) on the west of the site connects it to other areas in the south such as Zwartkops and Kyalami, as well as the city of Johannesburg. Public transport is easily accessible from site with the above railway platform in close proximity and the current bus

A unique part of infrastructure relating to water is in place. The large holding dam on the west of the site receives its water from Daspoort Sewerage Works. The water is treated before it is pumped 4km to the site and the term Semi Refined Effluent is used to describe the water quality. The water is presumably safe for recreational activity. The manager of the site stated that a triathlon was hosted on site earlier in 2010 and nobody was reported ill after the event. This water is used by the power plant to cool excess steam and to treat the ash that is a by-product of burning coal. The water is regularly tested by the Power plant's management to determine the quality of the water.



fig. 38_ Image illustrating built and unbuilt areas on site

fig. 39_ Railway lines on site



| Structures

The structures on site range in age and scale, they also differ above and below the surface. The older structures consist of the smallest, 'A' Station, and the newest the largest, 'B' Station and the cooling towers. There are also structures that are used to convey coal to burn in the boilers, linking the underground structures with those above the earth's surface. The buildings were designed and constructed with function in mind and the process determined configuration.



fig. 40_ Photograph of coalbunker



fig. 41_ Photograph of structures on site

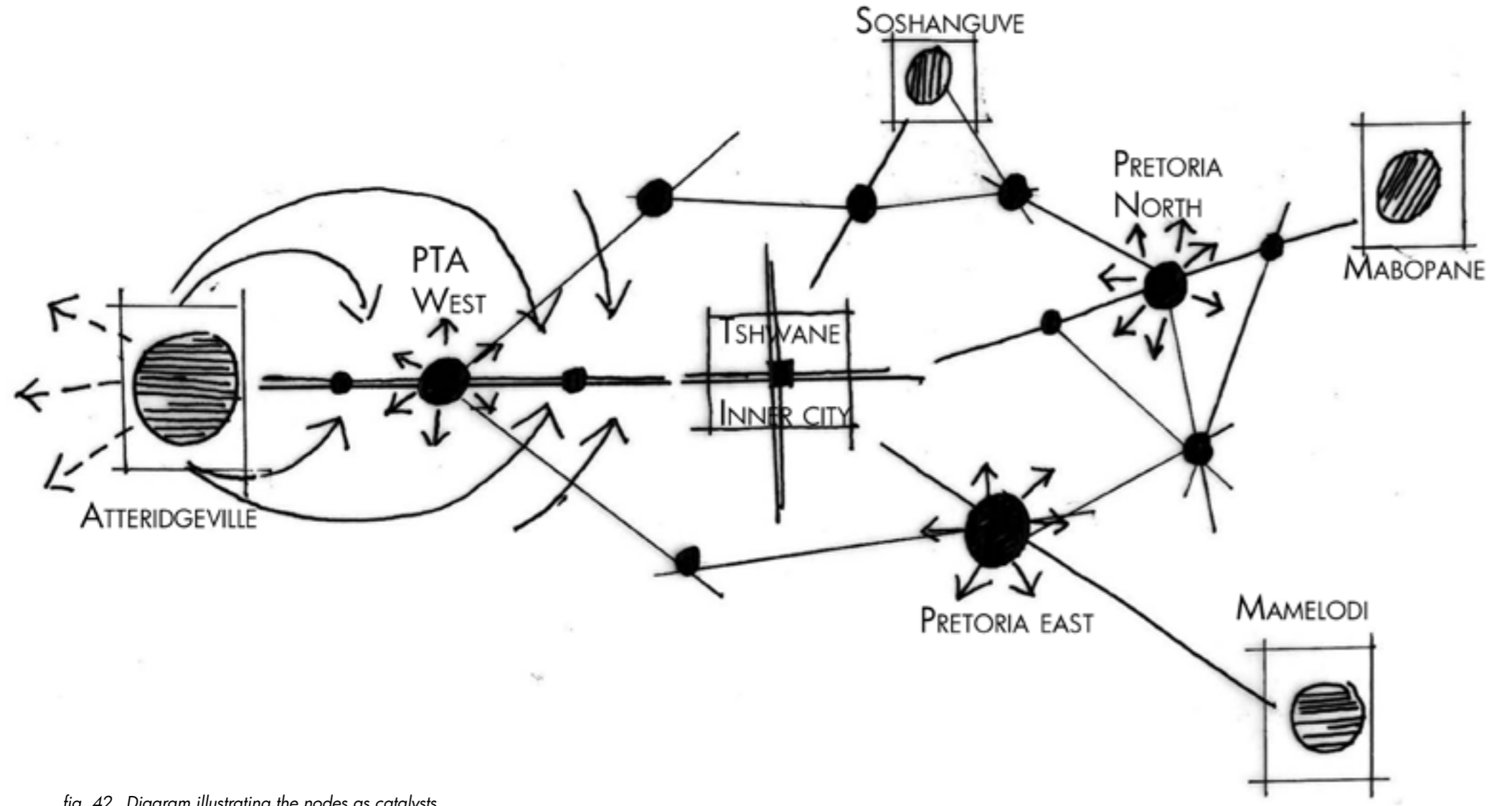

fig. 42_ Diagram illustrating the nodes as catalysts

Urban Vision

46
48
50
52
56
58
60
62
64
66
70
72

- Industracity [Vision for Pretoria West]
- Integrated Urban Environments
- Site Vision
- Higher Density
- Tshwane Rail Network
- Urban Response
- Fixed/Flexible Boundaries
- Existing Industrial Processes
- Regeneration of Industrial Heritage
- Client
- Brief
- Schedule of Accommodation

This chapter will discuss the findings and recommendations of an urban framework and vision as a prerequisite for the group framework for Pretoria West and the Pretoria West Power Station. Urban theories that inform the urban design approach will be included. The chapter concludes with a description of the client, brief and schedule of accommodation.

Industracity [Vision for Pretoria West]

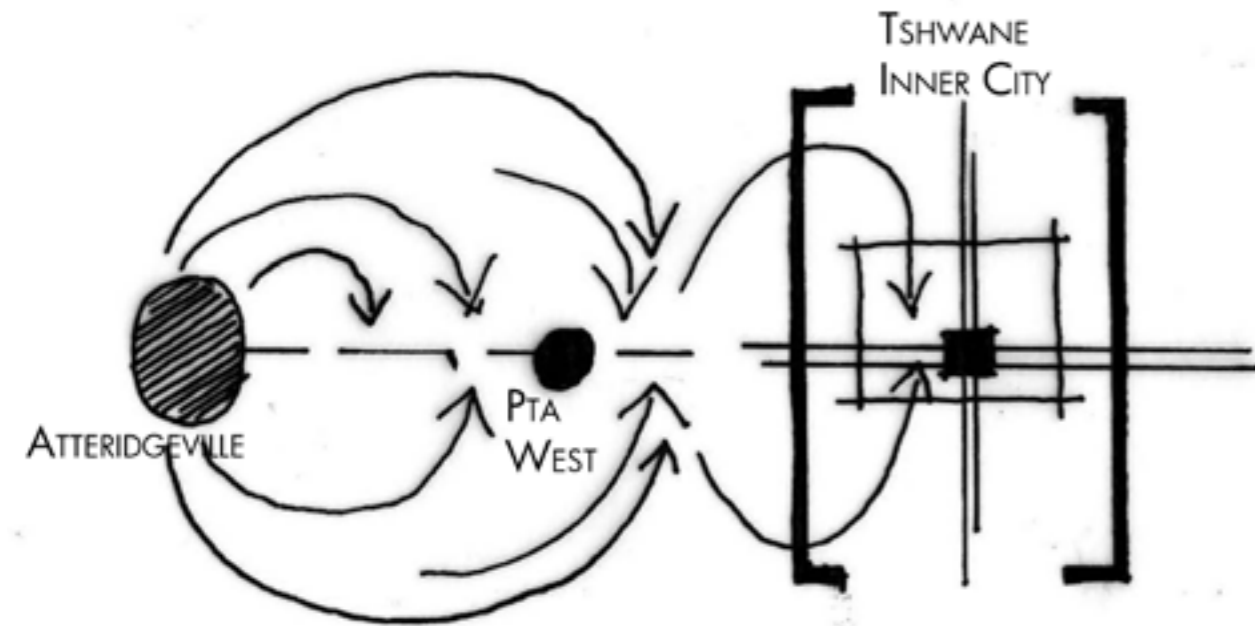

fig. 43_ Diagram illustrating Pretoria West acting as sub-support for inner city

Within the urban vision developed for Pretoria West a broad range of functions, such as housing, industrial heritage, small retail and large industry exists. The vision states that Pretoria West becomes a sub-support precinct for the city, strengthening and redeveloping the production spine along Mitchell and Souter Streets and providing containment for light or small industry to inhabit the area.

Light industry is clean and far less noisy than large industry. As a result, housing development can be situated within close proximity, albeit with the implementation of strict regulations in respect of handling of waste, noise and other hazardous by-products, as well as control measures for production in the area. In this way hybrid functions are introduced, emphasising production potential but with areas where people can live, work and play. The integration of urban functions will allow other functions such as commerce and retail to increase (Jacobs, 1961, p.145), resulting in a less monotonous urban environment and allowing an

interesting and diverse precinct to develop with an industrial character at its core.

The current housing infrastructure is very underutilised and can be exploited to create higher residential densities by developing more low-rise apartment blocks and integrating it with industry so to ease the transition between the two. The intent is to create a less stark contrast; also allowing the opportunity for shared function live/work units to be incorporated into the area, thus diversifying the housing typology for more variety and choice.

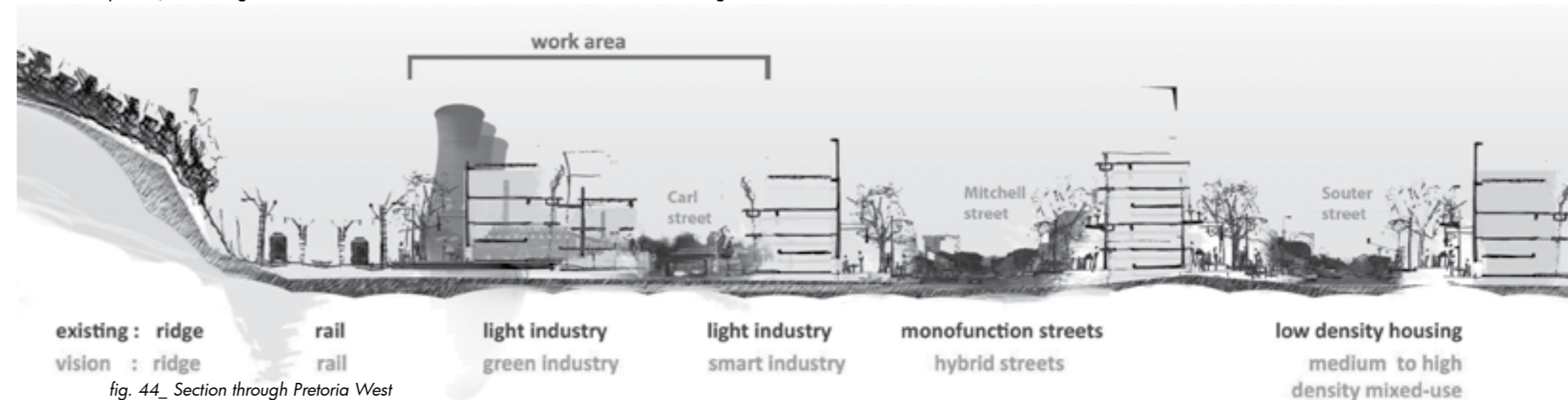

fig. 44_ Section through Pretoria West

Integrated Urban Environments

According to Jane Jacobs (1961), large industries, for example, the motor manufacturing factories, BMW and NISSAN in Rosslyn and FORD in Waltloo, that are situated on the outskirts of Pretoria, do not need to be in the city because they are self-sufficient. They can cater for all the necessary skills and equipment needs to produce a product and also provide their own storage. These facilities do not need the exchange possibilities of a city to provide them with clients or material. They can source it themselves. Smaller industries that are accommodated in smaller infrastructure have to be in the urban environment. They rely on larger networks of exchange (supplies and skills) outside their internal capacity and complementary to it. They rely on more limited markets at the place where they exist, which occur within a city (Jacobs, 1961, p.145).
 Small industry, reliant on a network of co-dependent manufacturing industries,

“The rejection of mono-functional areas is a prerequisite for the integration of various types of people and activities.”

-Jan Gehl (2006, p. 107)

within the furniture, clothing, food, computer, machinery, jewellery and ceramics sectors can provide a large amount of opportunities across the board.

The quote above states that integration of activities can alleviate the monotony of environments. Jane Jacobs lists four conditions that will generate dynamic diversity in a city (Jacobs, 1961, pp.150-51):

- A district must serve more than one primary function and preferably more than two to facilitate more outdoor activity at various times of the day.
- The blocks have to be short allowing more opportunities for street activity.
- The historical buildings have to be incorporated with new buildings or additions to utilize the energy invested in the existing structures.
- A sufficient density of people is required for whatever reason they might be there, but with a focus on residential density.

“...only a very small group of the most annoying industrial activities are unsuitable for integration with residences.”

-Jan Gehl (2006, p. 102)

Further, Jan Gehl states that the integration of various events and people on the small scale is what makes a place either monotonous or interesting. The public space linking functions such as industry, housing, commerce and retail is what is important. Thus the integration of functions allows people to connect on a daily basis (Gehl, 2006, p.101).

The quote above strengthens the argument for smaller industries to be incorporated within the urban fabric of the area, in relative proximity to housing, since they need activity, supplies and skills to survive.

Site Vision

The Pretoria West Power Station site is chosen as the starting point of the inner city production network. The site is currently functioning as a mono-functional entity [producing electricity]. It supports itself by handling all the logistics itself and not needing any outside support from a network.

The site will no longer be producing electricity within the next 10 years. Unless new interventions are proposed, the historic character of the site will be lost. The primary functions proposed on site are production related. The products will be exported to local regions as well as globally; adding a new layer and use for the site, but still keeping the well-established industrial character and heritage.

The site will act as catalyst for the urban vision of Pretoria West, by functioning

as a collaborative industrial hub that will need an exchange network of industries to assist with skills, supply, manufacturing, storage and transportation of goods.

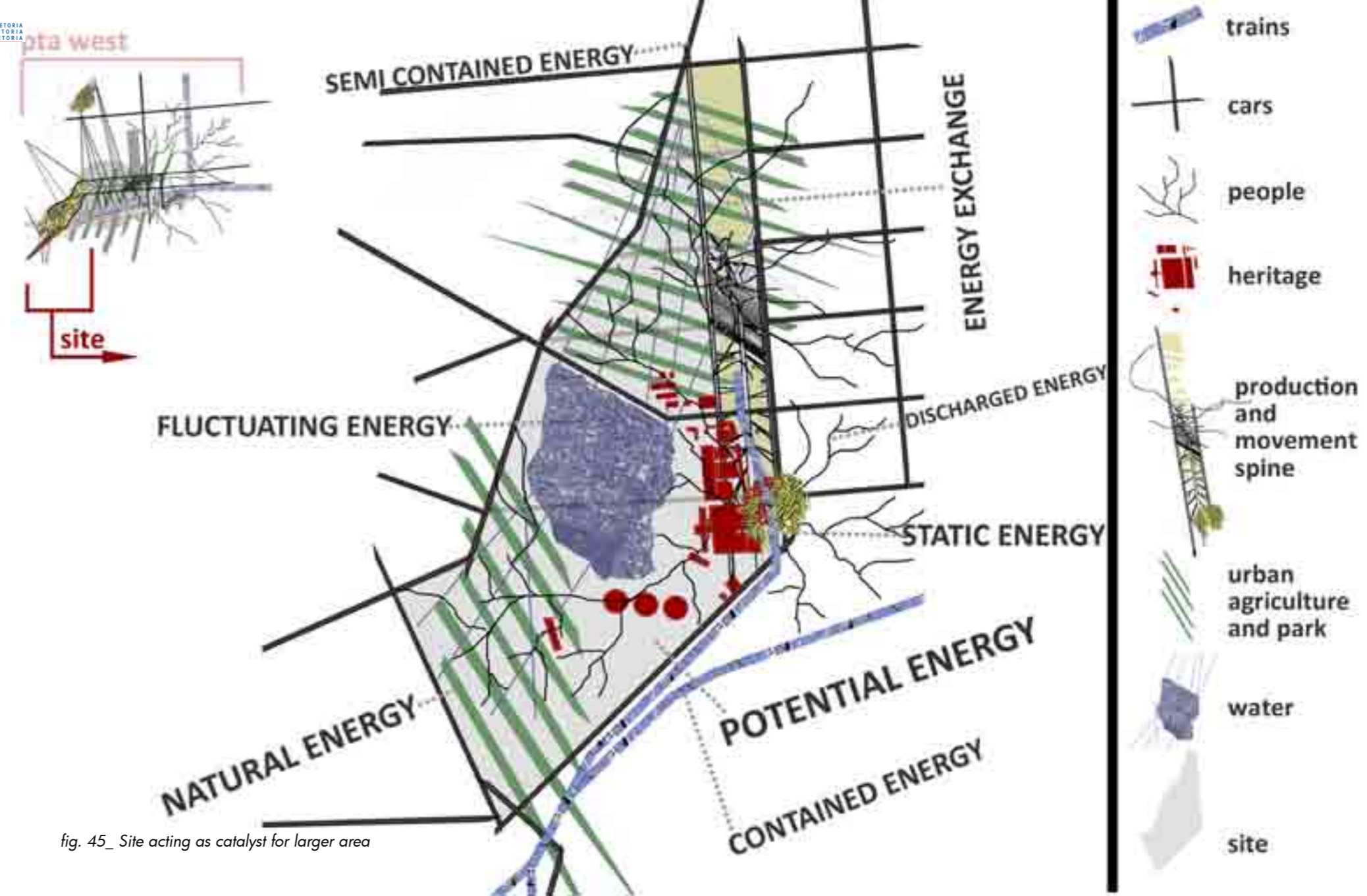

fig. 45_ Site acting as catalyst for larger area

Higher Density

If more industries are encouraged to set up shop in Pretoria West, this may in turn start to encourage people to move, seeking jobs in the area and possibly housing. Unless the housing is a good mix between mid to low cost, meeting the needs of the working class (employee) and middle class (employer) who will be working in the area, this strategy will not work. Therefore an investigation into the current distribution of people in Tshwane is necessary to determine what the possible density of the area can be and what the future densities may be. The statistics are calculated for the city of Pretoria due to the proximity between it and Pretoria West.

6%

Percentage of people who live in the city of Pretoria, 2004 [124 375 people]

The majority of people are living in peri-urban environments, such as Soshanguve, Mamelodi and Atteridgeville.

(Metropolitan Planning Urban Research & Strategic Directions, 2004, p.14).

938

Number of people/square-km [average density 2007]

The size of Tshwane is 2174 square-km, with a population 2 040 517 people, according to Stats SA 2007 Community Survey. The average annual growth is estimated at 2.17%

(South African Cities Network, 2008).



fig. 46_ Diagram illustrating current density

50%

Percentage of people who should have been living in the city of Pretoria by 2007 [2 176 258 people]

(Urban Age Project, 2008, p.9)

1001

Number of people/square-km [average density 2010]

(Urban Age Project, 2008, p.9)

75%

Percentage of people who can live in the city of Pretoria by 2050 [4 774 647 people]

(Urban Age Project, 2008, p.9)

This will be the case if people from the peri-urban areas are to be integrated into the city, in accordance with the compaction and densification strategies of the Tshwane Municipality.

(City of Tshwane, 2005, pp.8-11)

2928

People/square-km [the average density by 2050]

In 2050 the total population could be 6 366 196 people with an average density of 2928 people per square km an accumulated growth of 212%. According to the Urban Age Project, 50% of the world's population was living in urban environments in 2007 and they estimate that this figure will rise to 75% in 2050; projecting that in the future a 25% increase in the number of people living in the city.

(Urban Age Project, 2008, p.9)

The higher density of people is one aspect that will support the generation of dynamic diversity in the area, as stated by Jane Jacobs. Furthermore this will assist the sub-support framework of Pretoria West and strengthen the urban renewal frameworks of the inner city and Marabastad as well as facilitate the prevention of further urban sprawl towards the West (Atteridgeville).

People move through the area utilising many means of transport, but for the purpose of this study the rail network of Tshwane will be investigated. The transportation of goods and freight by rail will be investigated as well, due to the shared infrastructure and the focus on industry.



fig. 47_ Diagram illustrating future density

fig. 50_ Figure ground of Pretoria illustrating the densities of people

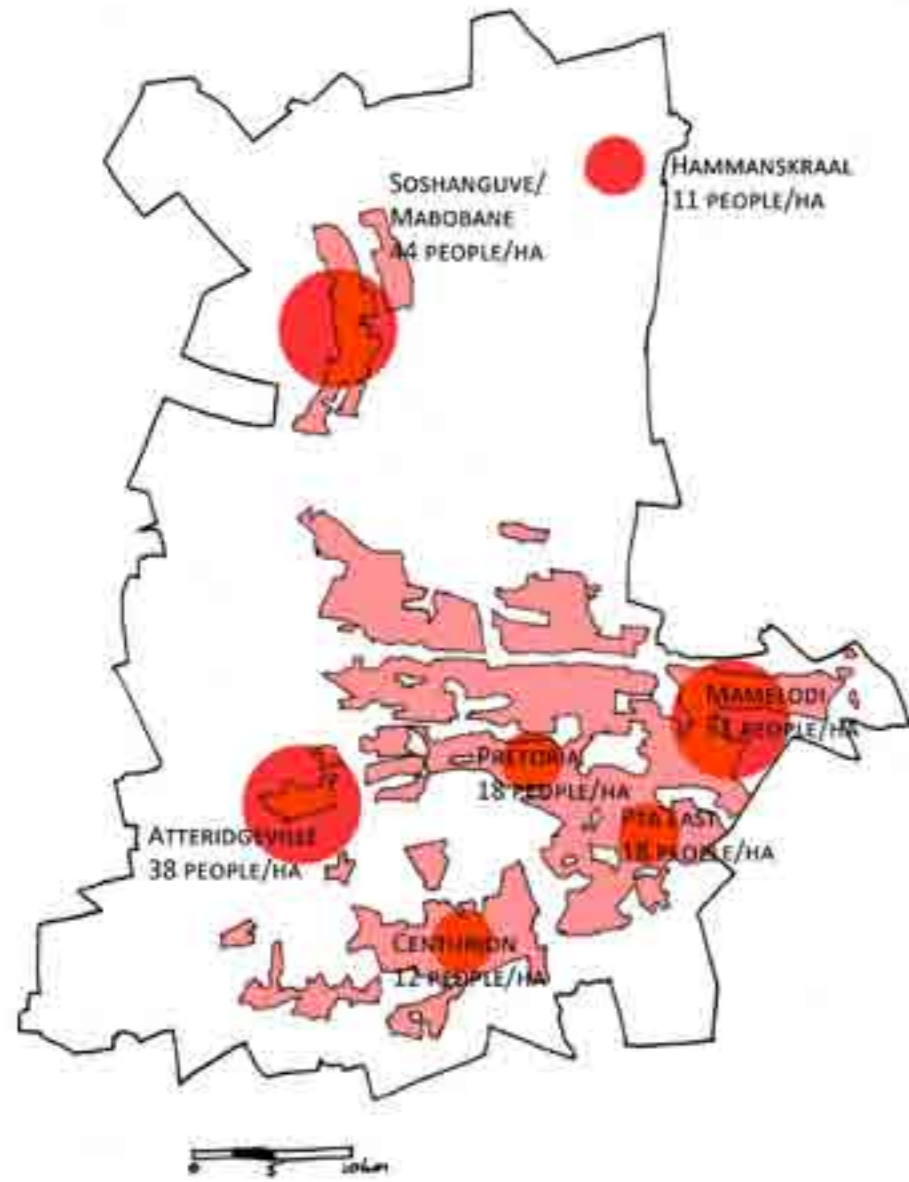

fig. 48_ Diagram illustrating the current densities of Tshwane

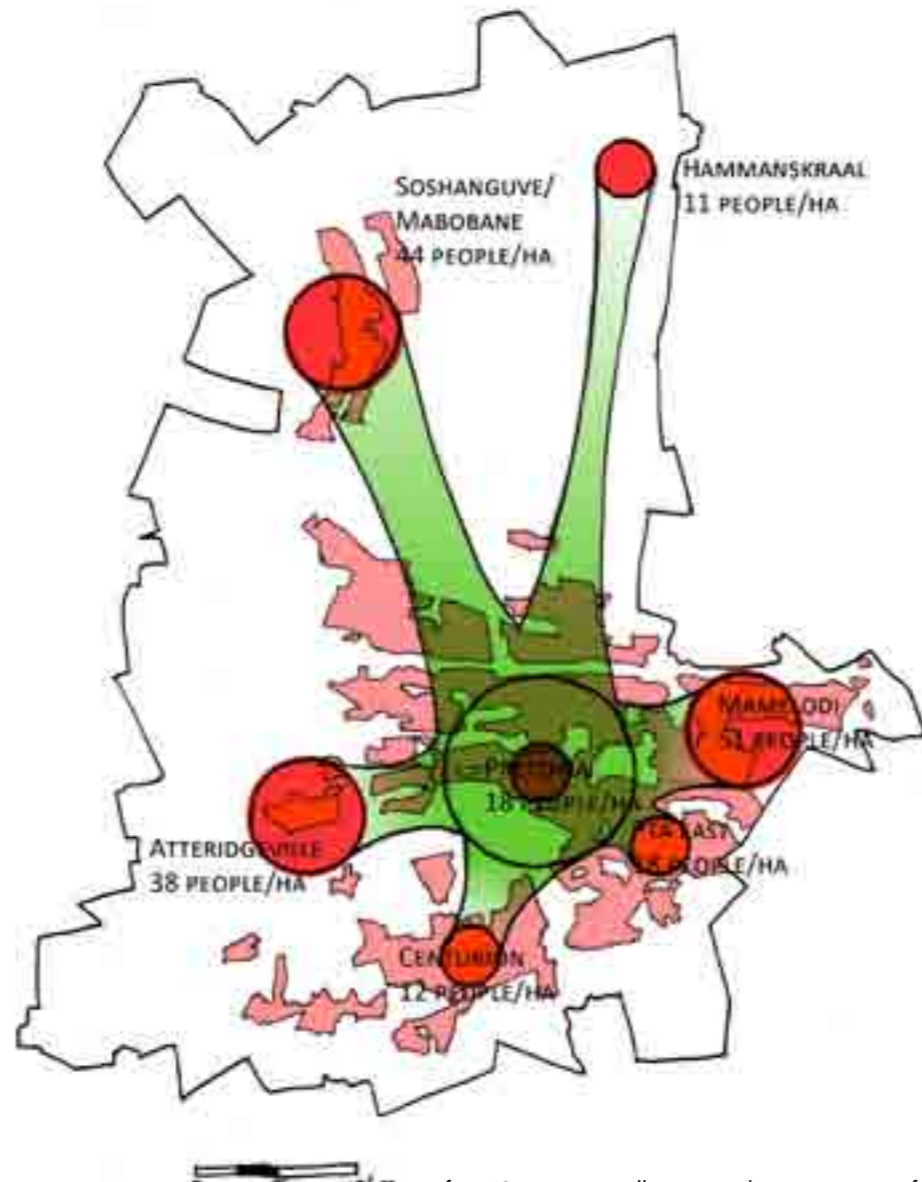

fig. 49_ Diagram illustrating the integration of peri-urban environments with the inner city



Tshwane Rail Network

The Rail system largely serves a portion of the public who are confined to public transport. Road haulers have largely captured the freight markets. Only the heavy industrial areas of Pretoria West, Walfloo and Rosslyn are served by rail freight. Long-distance passenger services run from Pretoria Station daily to Johannesburg and twice weekly to Cape Town and Durban (Cameron & Krynauw, 2001, p.16).

Most South African cities have the same transport and travel characteristics, but Tshwane is unique due to the need of long distance commuters to travel to work and back home. The lack of inter-government relationships between various agencies, such as the South African National Roads Agency Limited (SANRAL), the South African Rail Commuter Corporation (SARCC) and TRANSNET, leads to uncoordinated plans and actions. A further blow to the public transport system is decentralization and the lack of approval and implementation of Integrated Development Plans. Consequently, it does not provide the necessary densities in close proximity to the city for public transport to be more efficient and reduce travel times.

The main commuter rail, operated by PRASA, runs from Soshanguve/Mabopaan in the north, Atteridgeville in the west, Mamelodi in the east and Johannesburg, Kempton Park and Tembisa in the south. Freight is mainly transported by road on the freeway system (N1, N4, R21 and R28) toward Johannesburg and the Johannesburg International Airport (OR Tambo International) (Cameron & Krynauw, 2001, pp.1, 16).



fig. 51_ Diagram illustrating the rail and road network of Tshwane



fig. 52_ Image of accident caused by a truck

| Goods/Freight

Road freight transport is currently the norm in South Africa, due to the economic and trading flexibility to adapt to demand and door-door deliveries. A growing concern is that the heavy vehicles are responsible for the rapid deterioration of roads in Tshwane and the rest of the country. The trucks also pose a threat to other road users due to human error or equipment failures. Eighty percent [80%] of freight movement in Tshwane is by road, 35 000 heavy vehicles of 5,5tons daily (City of Tshwane, 2007, pp.45-46).

| Passenger

Tshwane has a sufficient rail network, albeit underutilised, with a ring rail surrounding the central employment area with lines running from north, south, east and west to the inner city. Major problems with the current rail system are that the Pretoria station is removed from the CBD and the infrastructure is old and poorly maintained. Very little new investment is made to the rail network and stations, although some received investment recently, namely Denneboom, Mabopane and Kopanong stations. Future investment is planned for stations in Mamelodi and Soshanguve. Furthermore, 13 of the main stations do not have road access and 15 have no parking facilities. This led to the taxi industry taking over public transport. Modal transfer stations include Mabopane, Belle Ombre, Eerste Fabrieke and Denneboom stations (City of Tshwane, 2007, p.32).

Urban Response

| Small Industry

Small industry is reliant on a network of codependent manufacturing industries forming a larger exchange network of supply and skill outside their internal ability. This complimentary network of smaller industries creates job opportunities. Consequently, low to middle income housing has to be provided to support the skills for the industries. Furthermore, integrating housing with the industrial environment provides the opportunity for diversity and also increases the density of Pretoria West. The increased density will then make it sustainable for other enterprises such as commerce and retail to be integrated into the urban fabric. This will increase diversity, relieve the monotony of the area, assist as a sub-support precinct for inner city renewal projects and encourage an influx of people rather than sprawling further away. Tshwane has the necessary density to support such a proposal, but it is reliant on a diversity in functions to be provided to sustain higher densities.

The site of the Pretoria West Power Station is proposed as the catalyst to provide the exchange for production related functions, manufacturing products that can be exported to local and global. The proposed intervention will add a new layer and use for the site, but still keep the well-established industrial character and heritage. Another layer concerned with public accessibility will be added to promote the manufacture of South African goods. By further adding retail opportunities and housing components, the monotonous nature of the site will be alleviated and flexible boundaries between public and private environments introduced. The site will act as catalyst for the urban vision of Pretoria West by functioning as a collaborative industrial hub that will need an exchange network of industries to assist with skills, supply, manufacturing, storage and transportation of goods. Reintroducing the historical productive nature of Pretoria West may spark a new production revolution in the area.

| Catalyst

| Heritage

Regeneration and conservation of the industrial heritage will be done in accordance with the Appleton Charter. It states that management of heritage environments is an imperative cultural activity (ICOMOS 1983, p.1).

The Pretoria West Power Station is a large-scale monolith rising above the skyline as a landmark. It still generates electricity and thus the existing heritage will be retained. Once the process is shut down in 10 years' time the industrial fabric can decay and become lost to future generations.

The introduction of new interventions through the removal and addition of elements will be executed sensitively to enhance the quality of the heritage resource (Appendix, p.169).

| Energy

There are sufficient contained energies [infrastructure] to support the proposed new exchanges necessary for hybridity in the study area and on site. The contained energy within the current local context is sufficient, for example roads, rail lines, bus routes, metro rail platforms and the proposed BRT along Church St, providing connections with the inner city, regionally, nationally and internationally. Furthermore the rail infrastructure runs into the site with opportunities for a transport facility on site.

| Transportation

The rail network is underutilised due to inaccessibility and lack of safety, making it a less preferred choice for commuters. The future diversity of Pretoria West involves higher densities of people, which will provide a large number of commuters requiring better transport facilities such as an intermodal transport interchange, similar to that of the Pretoria Station. Facilities for the transportation of products and material to and from the area is necessary, running concurrently to public transport. According to Tshwane's Integrated Transport Plan, Pretoria West, Pretoria Industrial and Arcelor Mittal [ISCOR] have been identified as freight transport generators (City of Tshwane, 2007, p.6). However large industries are the only ones utilizing the rail infrastructure for transportation to connect to other markets. A freight or cargo storage and management facility is necessary to support the exchange network between the proposed production facilities in the productive precinct, handling the inputs and outputs of making products - more energy efficient and cheaper rail transport for long haul freight from city-city and the more convenient and effective local door-door freight distribution by road.

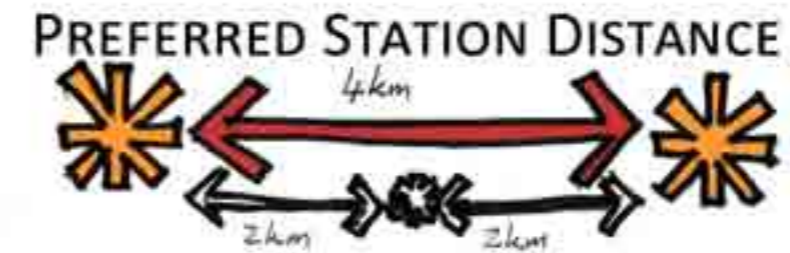

fig. 53_ Diagram illustrating distance between large train stations

Fixed/Flexible Boundaries

Kevin Lynch, in his book *Image of the City*, describes paths and edges as elements that people experience through movement. Paths are routes people use. Routes can be streets, railways, bus lines, etc. People observe the city when moving through it at varying speeds. The speed at which one travels determines what one can experience. Edges are perceived as linear elements which people perceive as boundaries, such as walls, railway lines, rivers [channels], roads, etc. They allow you to move along, but only penetrate at a predetermined point where one can cross the boundary - possibly for security, safety or privacy (Broadbent, 1990, pp.225-30).

“The enclosing properties of a boundary are determined by its ‘openings’, as was poetically intuited by Trakl when using the images of window, door, and threshold. In general the boundary, and in particular the wall, makes the spatial structure visible as continuous and/or discontinuous extension, direction and rhythm.”

-Norberg-Schulz (1996, pp. 419-20)

Boundaries denote containment of areas and definition of space, separating one thing from another, separating people from areas and certain environments, such as inside and outside of buildings or the peri-urban from the urban (Porter, 2004, pp.16-17).

Jan Gehl suggests that these boundaries become flexible and create an in-between semi-public or semi-private space.

“Flexible boundaries in the form of transitional zones that are neither completely private nor completely public, on the other hand, will often be able to function as connecting links, making it easier, both physically and physiologically, for residents and activities to move back and forth between private and public spaces,”

-Jan Gehl (2006, p. 113)

This Pretoria West Power Station site is a monotonous and isolated landmark acting as a divide between the urban fabric and the suburban areas. It needs to be reintegrated with the urban fabric by dissolving the boundaries between public and private. A broader array of production-orientated functions is proposed that rely on exchanges with the rest of the precinct and can facilitate the freedom of movement between public and private zones. The site will no longer function as a fixed edge and become more flexible to play a key role in the diversity of the area.

fig. 54_ Diagram illustrating current edge conditions [left] and the future permeability of site [right]

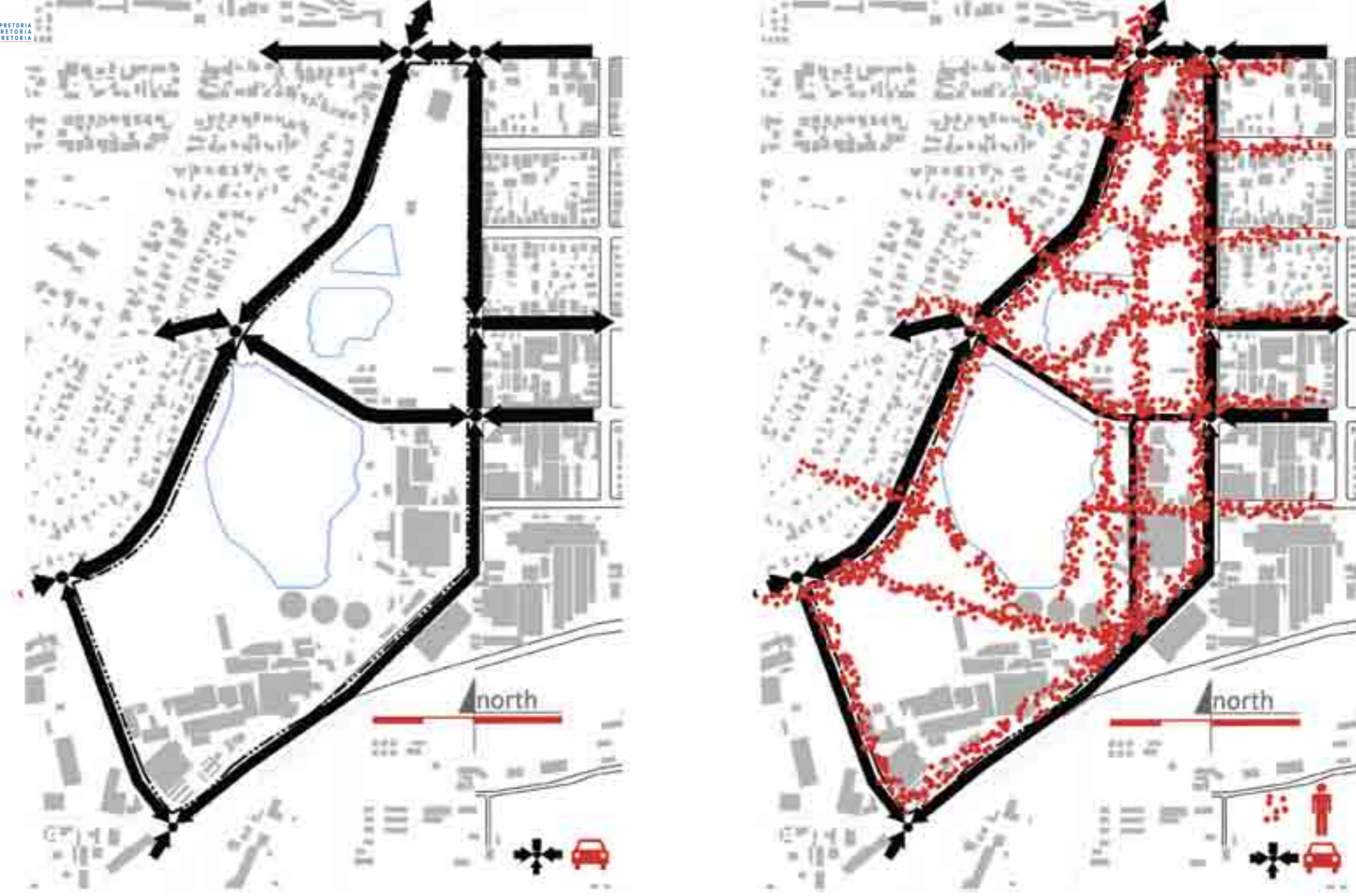

Existing Industrial Processes

Existing industrial processes on site are characterized by a series of exchanges involving inputs and outputs. Coal is transported on site by rail to the coal bunker where it is stored safely. It is then fed into boiler room via the diagonal conveyor from the coal bunker. The water used in the boilers is demineralised to prevent the build-up of minerals in the pipes that would cause the internal pipes to burst. The water is then boiled to make steam, which turns the turbines that generate electricity. The excess steam is cooled down back to water in the cooling towers, due to it being easier and safer to pump water. Water for the cooling of steam is received directly from Daspoort sewerage works, as semi refined effluent, and the excess is pumped into the holding dam. This water is also used to transport ash from the boilers to the ash treatment plant. The ash is crushed to finer aggregate and pumped to hoppers to be picked up by trucks or trains for cement and brickmakers. Finer ash is pumped to ash settling ponds where smaller contractors collect the ash by in smaller vehicles for agricultural use, cement making or brickmaking.

These processes define the site conditions. The exchanges that take place within an industrial site can be used to inform decisions for new interventions. The production exchanges that take place within an industrial site like this present conceptual and functional clues to generate new interventions while conserving the integrity of the site.

The proposed programmes on site are related to production and require a network of exchange. Exchanges with other industries in the area, exchanges of the products to different markets locally, nationally and globally, exchanges of material for the making of products to the site and exchanges between product and people. The possibility of other industries in the area to also utilise this exchange network will be incorporated, providing an integrated network of industries and forming the basis of the diverse urban environment.

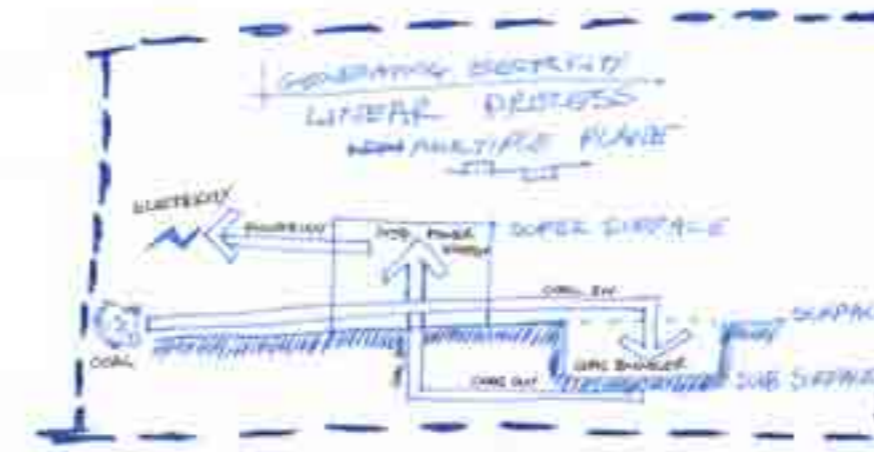

fig. 55_ Diagram illustrating the current process of producing electricity

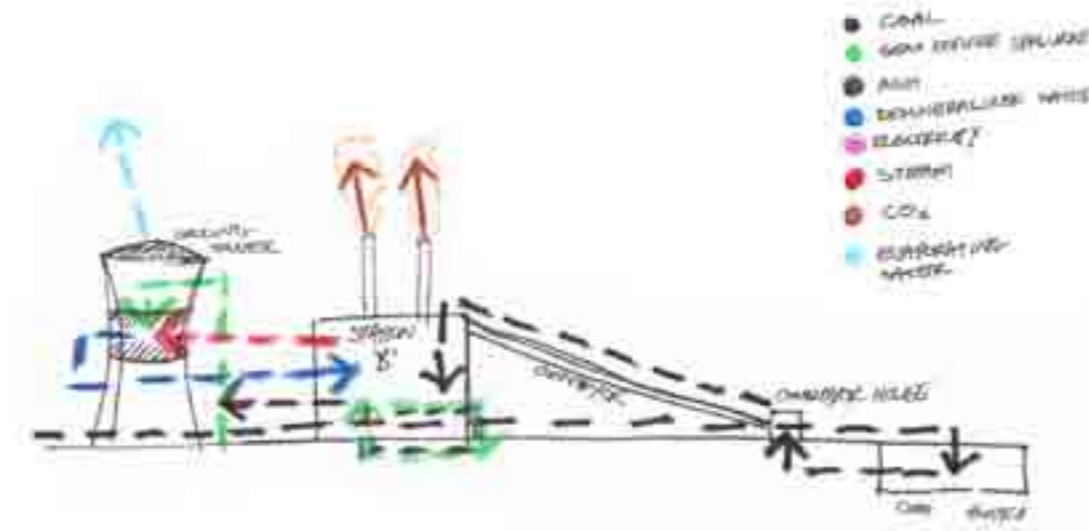
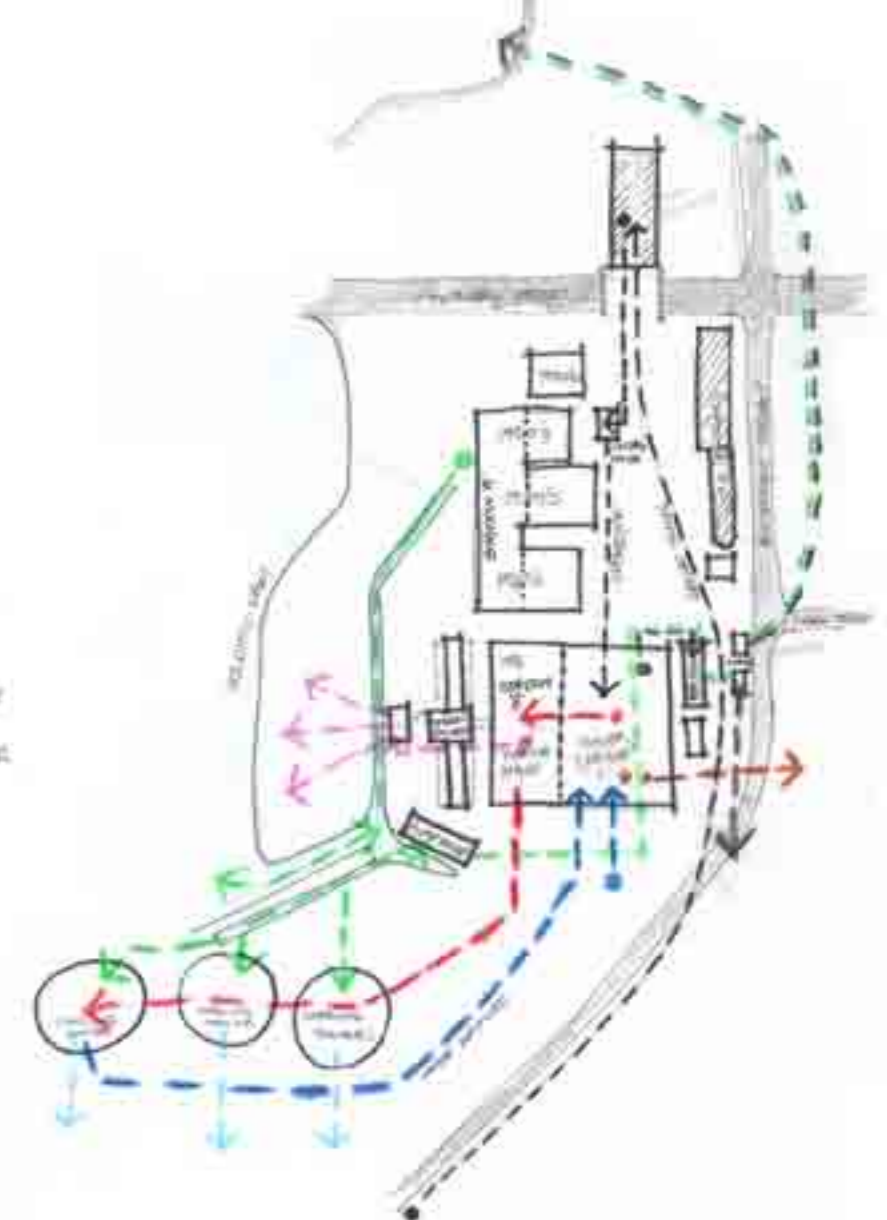

fig. 56_ Flow diagram illustrating inputs and outputs of the existing process in section and on plan



Regeneration of Industrial Heritage

Jane Jacobs states that historical buildings have to be incorporated with new buildings or additions to utilize the energy invested in the existing structures. A strategy to address this is to adapt historical buildings, thus conserving the palimpsest that tells the story of what once was.

Adaptive re-use of buildings allows one to utilise the existing invested energy and assign a new use to it, thus further extending the life of a building. Many schemes for adaptive re-use of industrial buildings are very superficially motivated, emphasising only the surface. Instead of exhibiting the history and original use of the site or buildings, a possible solution is to find a use that will enable interpretation of the industrial quality (Alfrey & Putnam, 1992, pp.16-20).

“...the reason why it was assembled are often as important or more important a resource than the artefacts themselves.”

-Alfrey & Putnam (1992, p.53)

Michael Stratton, one of the pioneers of industrial archaeology, states that the regeneration of industrial buildings can assist in the quality of urban living by integrating live, work and play environments. This is possible due to the large and vast scale of these urban giants within which a variety of functions are possible. Industrial buildings have the necessary capacity to create public space for increased contact. Sustainable approaches are realised through the conservation of industrial buildings by making the best use of resources in bringing it back to life, utilizing the embodied energy and capital investment already encapsulated within “redundant” industrial sites (Stratton, 2000, p.20).

“Renewal has given way to regeneration, at least in the rhetoric of urban planning and politics. Regeneration is now an international cause that should combine the conservation of buildings with improvement to living conditions. In some projects, it can also offer exciting new architecture, cultural provision and improved public transport.”

-Stratton (2000, p. 18)

The creation of diversity in the urban environment is possible through the conservation of the historical fabric of the site.

The site is rich in industrial heritage and already has a huge amount of capital invested into the infrastructure of making electricity. The first building was built in the 1920s with later additions following every decade up to 1950, when the current 1954 power station, currently in use, was built.

“The underlying philosophy of regeneration is that cities have rich resources and values that can be nurtured and revived, and that the benefits of an improved environment and of new jobs will filter down to bring lasting or sustainable benefits to the whole community. In contrast to the emphasis on physical renewal in the post-war period, regeneration implies that the existing urban form is a starting point, to be upgraded within social, economic, cultural and, where appropriate, natural contexts.”

-Stratton (2000, p. 18)

The site is situated on the periphery of the west of Pretoria. There are a variety of structures above ground and below. The most visible structures are the cooling towers to the south forming a landmark. The structures below ground level are bunkers used as coal storage and a train delivers the coal. Thus an existing railway line forms part of the site. The site has a large water body, which was originally constructed for cooling purposes of the older stations. Currently the water body is used as a holding dam for the semi-refined effluent pumped from Daspoort Sewerage works and is mainly used in the process of treating the fly ash generated by the burning of coal. The scale of the existing structures on site allow for a variety of new manufacturing industries to be incorporated, thus maintaining the productive character and heritage of the site.



fig. 57_ Pretoria West Power Station with the dam in the foreground

Client

| PRASA

The Passenger Agency of South Africa (PRASA) was created by Government to advance its agenda for the transformation of the public transport system into a vibrant, efficient one. PRASA's main objective is to provide a rail commuter service that envisages enhanced mobility by acting as a gateway to accessible socio-economic opportunities. The supporting principles that highlight this vision are:

- Accessibility - facilitate access to a better quality of life by enabling individuals and communities to access socio-economic opportunities.
- Mobility - connect individuals and communities through an integrated network of mobility routes.

PRASA's mission reflects four key intentions:

- Service excellence - superior performance that is safe, reliable and

affordable.

- Sustainability - a triple bottom line focus on sustainable development that considers not only financial profit, but also environmental quality and social equality.
- Mobility solutions - reframing the basis of business delivery to favour innovation, integration and partnerships.
- Integration - safe, seamless and dignified travel experiences across all modes of public transport.

PRASA is expected to play a major role in the development of social and economic infrastructure. The organisation will partner with transport and rail authorities to plan and deliver on rail and other transport infrastructure (Passenger Rail Agency of South Africa, 2009).

PRASA's primary responsibility is to effectively develop and manage rail and related transport infrastructure and to provide efficient rail

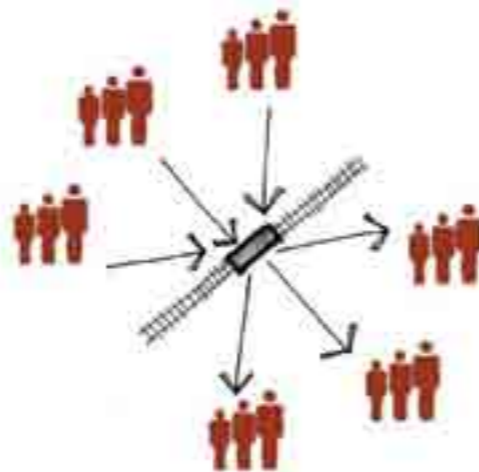

fig. 58_ Diagram illustrating the input and output of people

and road based passenger transport services. This is supported by the focused management of the property portfolio that is being developed to enhance passengers' travelling experience. This is being achieved through the transformation of key station properties into transit orientated development precincts that can generate sustainable income streams.

-Passenger Rail Agency of South Africa
(2009)

| Grindrod Limited

Grindrod Limited is a large organization with various subsidiaries that have vast experience in South Africa's freight movement and related industries, providing total logistics solutions for clients.

| Freight Services

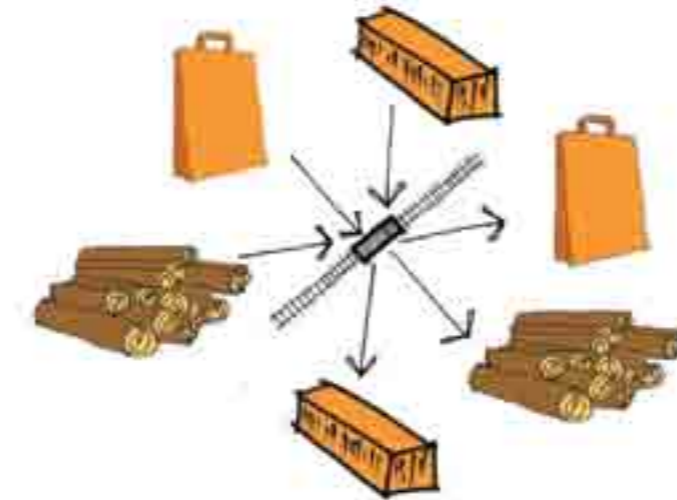

fig. 59_ Diagram illustrating the input and output of goods

Grindrod's Freight Management operation accounts for a major portion of sea freight logistics and land freight logistics.

Grindrod's Ships Agency is leader in its field offering ship operators a broad range of services in South Africa, Namibia, Mozambique, Malawi, Zimbabwe, Botswana and Swaziland.

The land based operations focus on terminals, intermodal solutions, rail, port operations and all aspects of traditional logistics, for example, international freight forwarding, contract logistics and specialized industry-solutions (automotive, projects, furniture, perishables).

| Warehousing & Distributing
[Röhlig-Grindrod]

Röhlig-Grindrod, a freight forwarding arm of Grindrod Limited, provides secure storage and warehouse facilities according to the type of cargo as well as warehousing and distribution solutions for all supply chain requirements (Röhlig-Grindrod, 2007).

| Grindrod Intermodal

Grindrod Intermodal provides a complete service to clients in the movement of containerized cargo, from receiving the cargo, to storage, packing and onward distribution by road or rail to final destination.

The cost of the supply chain contributes significantly to the final selling price of products. It is for this reason that many South African companies, in order to remain competitive, have looked long and hard at ways to improve their supply chain efficiencies.

Thus, Grindrod Intermodal supply better chain efficiencies that are offered through the large national infrastructure and resources. They provide efficient inland transport and logistical services to the freight industry in Southern Africa.

This service includes the rail transport of full and empty containers, covering all routes between port terminals and freight rail terminals within South Africa and other southern African destinations.

- The company's operating system enables the monitoring of the movement of containers between the respective delivery points and reporting progress to customers.
- Depots cater for general-purpose container handling and storage requirements by highly skilled technicians.

- Warehouse operations offer a diverse range of cargo including wine, cars and general cargo. An integral part of the groupage operations is the inter depot road and bond transport, managed by Grindrod Intermodal operations. (Grindrod Limited, 2010)

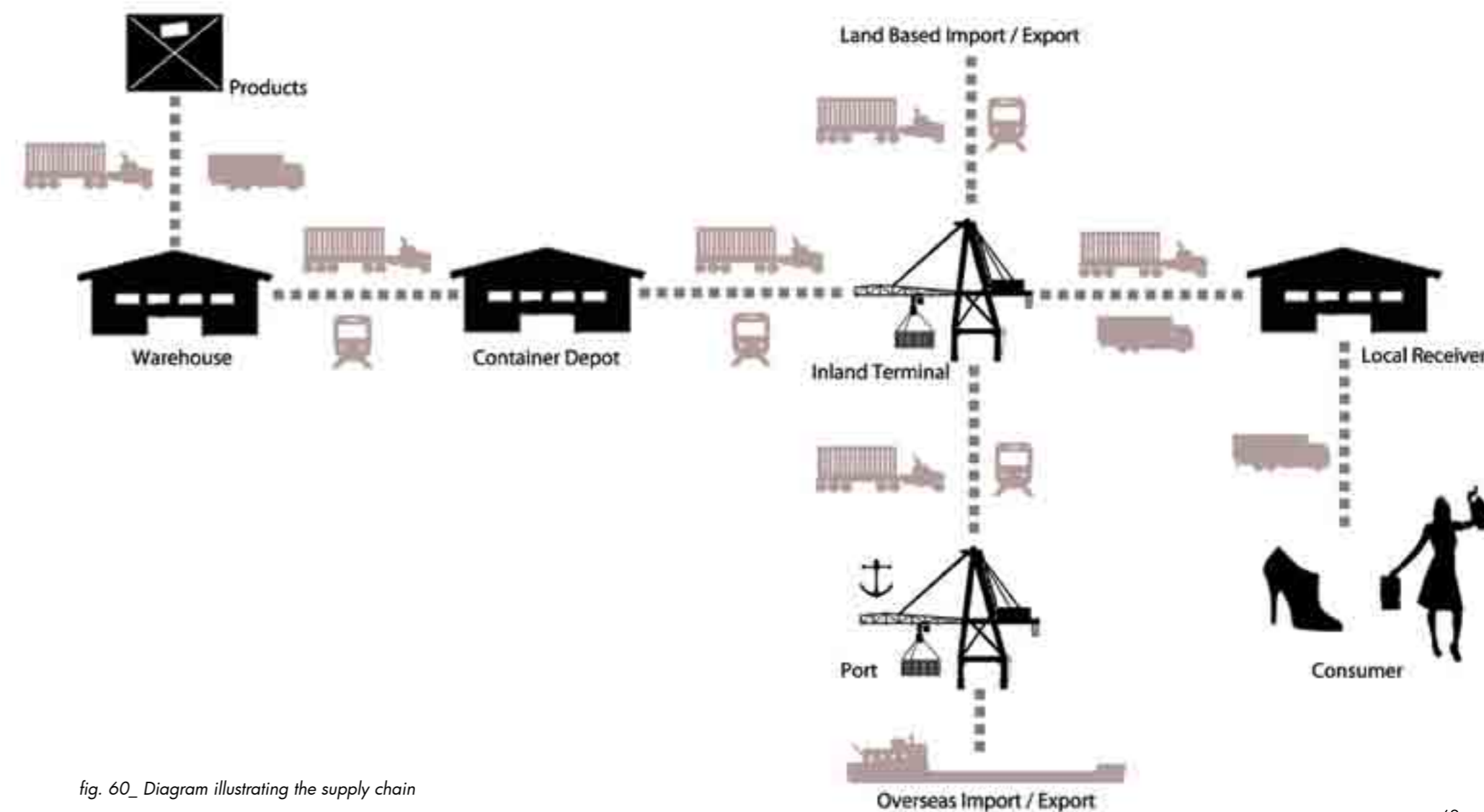

fig. 60_ Diagram illustrating the supply chain

Brief

PRASA is seeking a site where a new model for a transit orientated development precinct can be developed and provide access to socioeconomic opportunities and public transport, taking into account the two key principles of accessibility and mobility. Within this precinct a commuter rail station within close proximity to other forms of public transport and rentable retail space will add value to the client's property and provide economic opportunity on site for the people in the surrounding area.

In a public private partnership with PRASA, Grindrod Intermodal will develop a storage facility for light [clean] industries within Pretoria West, encompassing the complete service they provide to clients. Providing a storage facility for light [clean] industries within the area. The warehouse space will combine the storage of goods and containers, the packing of containers and the distribution by road or rail to international/local markets. Thus, reducing the supply chain costs due to less trips by truck or train before it meets its final destination.

The interventions will encourage an exchange between the two functions of the different client's due to the proximity of the infrastructure which will be shared.

| Programmes

- _Transit Orientated Development Precinct
- _Intermodal Freight Interchange

| Transit Orientated Development Precinct

The project will provide access to public transport networks focussing on the improvement of rail transport to enhance the commuters travel experience. It will increase the mobility of people in Pretoria West through a range of transport modes concentrating them in one area. It will create socioeconomic opportunity and added value to the clients' property portfolio by introducing other programmes on site.

| Intermodal Freight Interchange

A freight forwarding facility will provide secure storage, warehousing and distribution solutions for all supply chain requirements of the proposed light industry in the productive precinct of Pretoria West. Supply chain areas will be combined within an inland terminal, decreasing the handling and transportation of goods before they reach their final destinations. These functions include container depot, warehousing access to rail and road transport as well as a logistics office, providing a holistic solution to manufacturing and distribution clients.

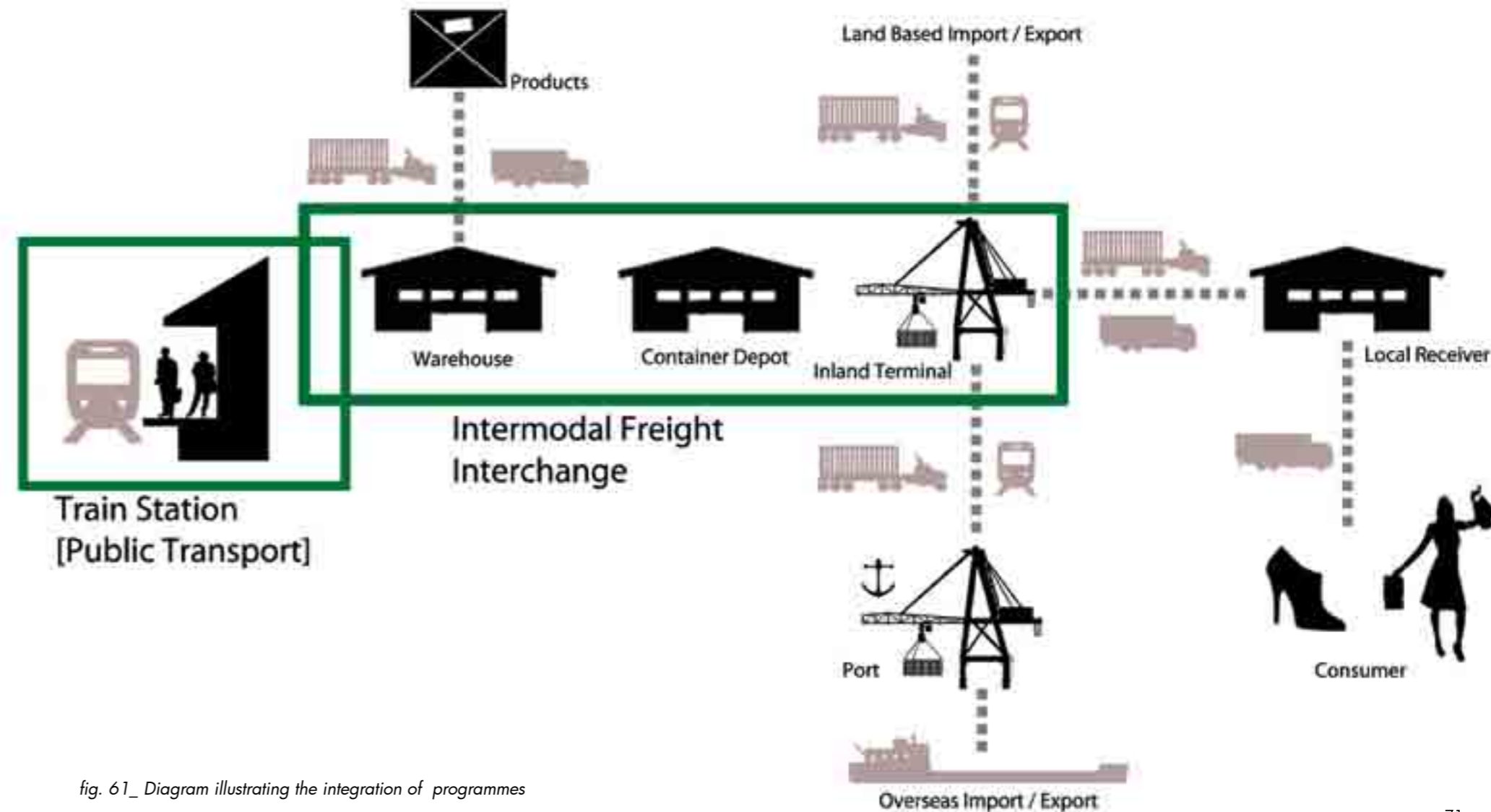

fig. 61_ Diagram illustrating the integration of programmes

Schedule of Accommodation

| Train Station

A basic provision for a station consists of:

- Customer Service Centre [CSC]
- Concourse
- Platform

| Customer Service Centre [CSC]

- Main entrance
- Ticket sales point
- Station control room
- Information point
- Administrative offices
 - Group station manager's office
 - Senior clerks office
 - Strong room
 - Store room
- Staff facilities
 - Ablution
 - Kitchenette
 - Locker room
- Public ablutions
- Medical room
- Security office
- Equipment room
- Cleaning store
- Ticket verification point
- Foyer with roof
- Waiting area
- Plant room

- Movement space
- Stairs
- Escalators
- Lift
- Entrance and exit turn styles
- Seating

| Concourse

- Unobstructed waiting/movement area
- Seating areas
- Ablutions

| Platform

| Retail

The following retail functions can be added due to the number of people who will frequently use the station:

- Kiosks
- Shops
- Restaurants
- Takeaway

| Satellite Police Station

A satellite police station can be added to the security component of the station and also serve the site.

| Freight and Logistics Facility

The freight and logistics facility consists of:

- Administration offices
- Staff facilities
- Container depot
- High bay storage area
- Receive and dispatch

| Administration Offices

- Manager's office
- Accounts office
- Open plan office
- Boardroom
- Reception
- Kitchenette
- Ablutions

| Staff Facilities

- Ablutions
- Locker room
- Security check
- Canteen

| Container Depot

- Dispatch and receive storage
- Packing and unpacking area
- Loading and off loading area

| High Bay Storage Area

- Local distribution storage
- Export storage
- Import storage
- Clerk's office
- Ablutions

| Receive/Dispatch

- Clerk's office
- Receiving area
- Dispatch area
- Loading area

| Truck Driver Refreshment Stop

Combined with the bio-diesel plant adjacent to the freight warehouse a large amount of trucks will be on site daily, thus facilities will be provided for the truck drivers.

- Ablutions
- Take aways
- Seating inside and outside

| Site Support Programmes

Due to the length of the rail it interacts with all the other proposed functions on site and can provide services to the other programmes on site.

- Rain water storage, filter and pump room
- Data distribution room
- Electricity transformer room

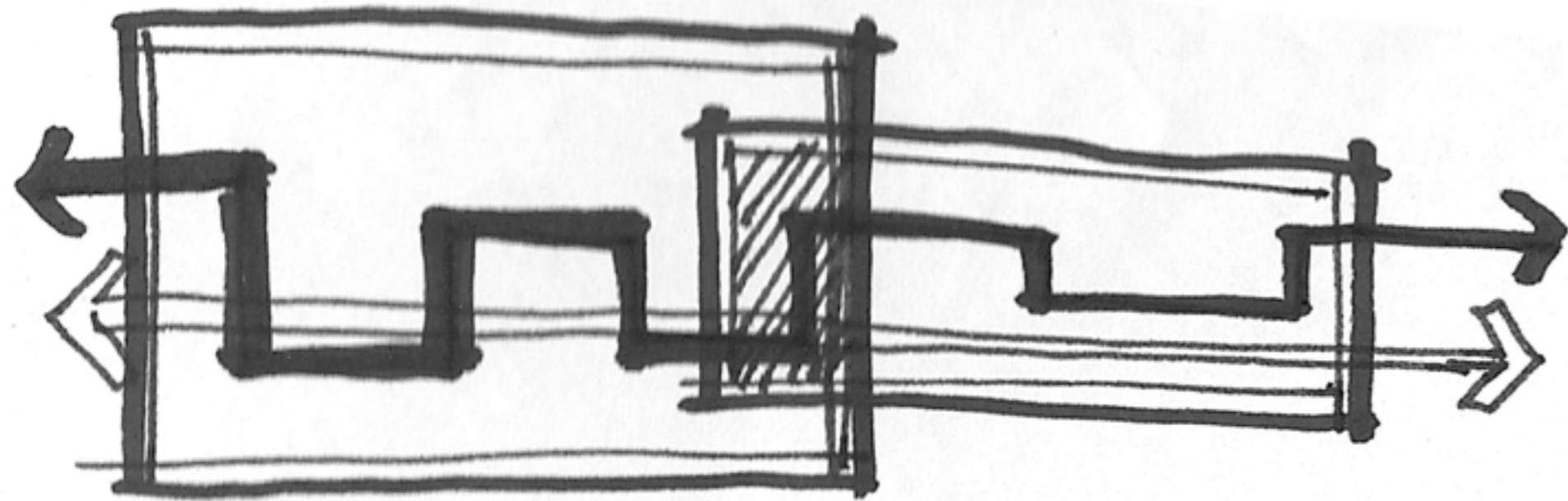

fig. 62_ Diagram illustrating the exchanges of new and old, industrial process and people

Design Development

78

Design Objective

80

Design Concept

86

People [Ex] Change

88

Precedent Study of Function - Context

90

Product [Ex] Change

92

Precedent Study of Form - Function - Context

94

Precedent Study of Context - Heritage

96

Movement [Ex] Change

98

Precedent Study of Function

100

Concept Development

114

Design Development

This chapter will illustrate the design development through investigation of the aims set out in this thesis. It will describe the objective and how the concept is developed and translated into a building, and will conclude with concept sketches and the design development.

Design Objective

The aim of the design is twofold. Firstly, the extension of the existing rail line as a suspended platform to provide access for both freight and passengers and secondly, the provision of support facilities to the storage and station precincts.

Departing from the introverted nature of industrial buildings the general public will be encouraged to interact with the process of making consumer goods. In turn this will inform people about the manufacturing process through visual interaction.

The function the elevated rail will consist of freight delivery and dispatch where it enters into the existing building. The centre of the rail will become the passenger

station to entrain and detrain people to and from the site. At the end of the rail it will terminate into a food factory programme where containers will be loaded with fresh produce. The large elevated structure necessary for the trains allows for support services to be provided within the structure to the other buildings on site. These services consist of electricity, water and data/telecoms.

The industrial component of this intervention deals with the storage and distribution of materials and final products necessary for the manufacturing process. Such facilities have very pragmatic functional requirements and the uninterrupted flow of materials and goods to and from storage, via moving equipment, are of great importance. Focus is placed upon providing functional

and efficient spaces. For a storage facility to perform economically it requires that goods/materials be processed with the shortest turnaround time.

The challenges are how to allow public interaction with the industrial component without interrupting the process of flows. Further these facilities control the entry of people for safety and security purposes. Thus the general public will not be allowed to move freely between containers, cranes and forklifts.

Adding a passenger component to the railway line that is intended for freight transport on site will allow the public to interact visually with the storage process without being inside this restricted space.

The passenger train/platform acts as a stage from which the whole production process on site can be viewed from receiving and dispatch to manufacturing and to the final product sold as they exit the station.

People are exposed to the manufacturing processes on site while in motion inside the train. The slowing down of the train before it stops also encourages people to start looking outside the train.

Injecting a new set of parameters, this programme also has its own set of uninterrupted flows along with controlled access, but it is a more public programme.

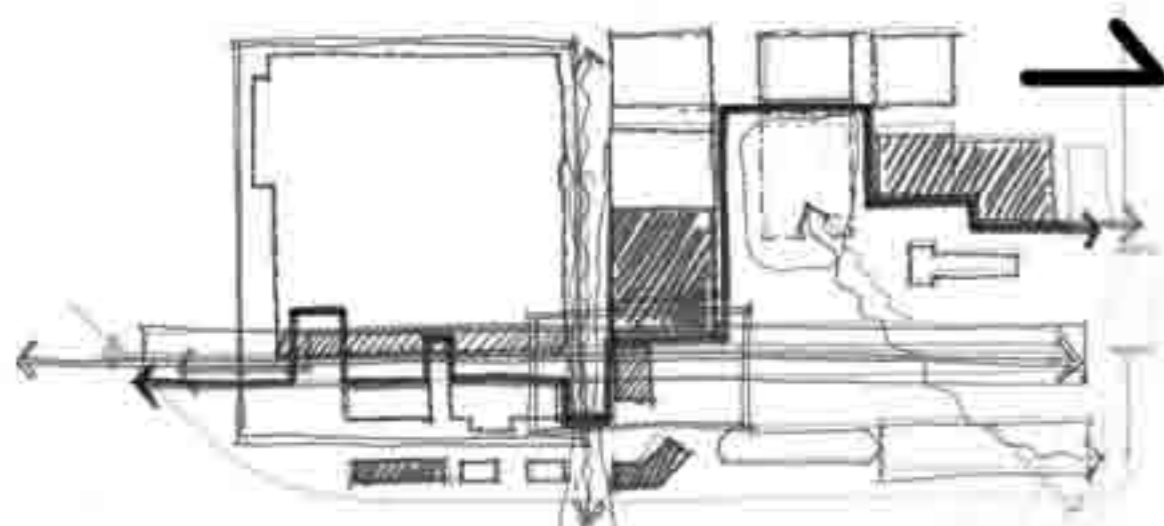

fig. 63_ Diagram illustrating the exchanges on site

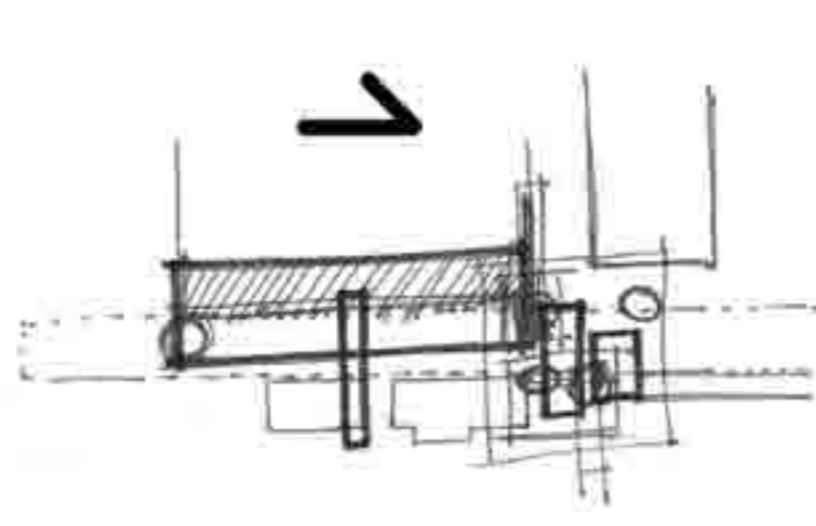

fig. 64_ Diagram illustrating points of possible integration between the process and people

“I’m fascinated by container ships. They’re my favourite metaphor for a connected world. When I visit port cities, I often try to drag friends with me to watch cranes load and unload stacks of interchangeable red, blue and grey boxes.”

-Zuckerman (2008)

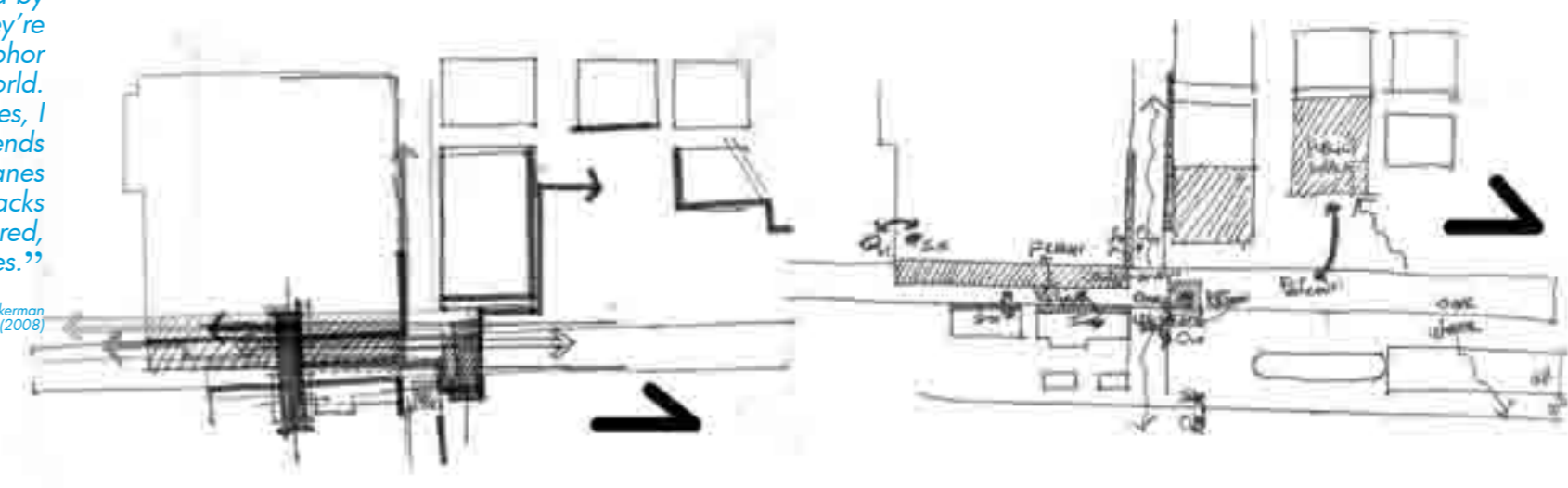

fig. 65_ Diagram illustrating integrated exchanges

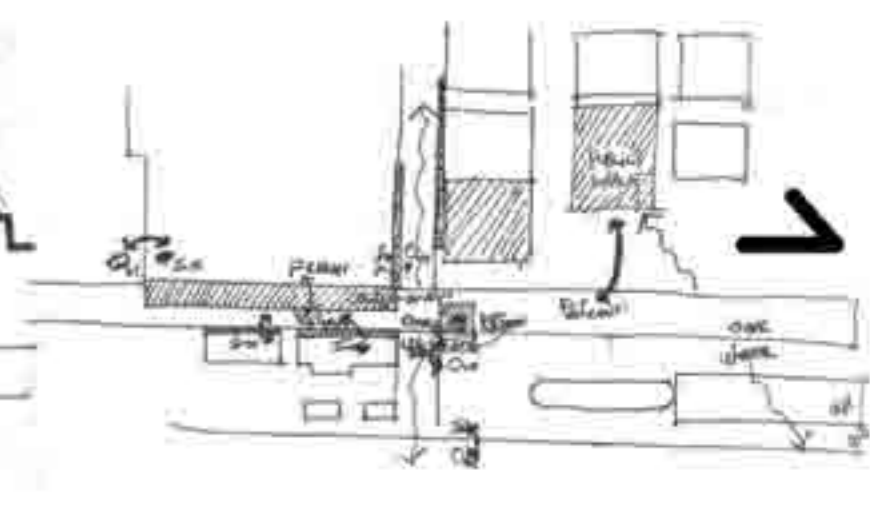

fig. 66_ Diagram illustrating the input and output between process and/or people

Design Concept

| Exchange

Ex_Change

Energy

[Intensity + Movement]

Physical

[Heritage + People/Products]

Visual

[Heritage + People/Products]

Services

[Intervention + Site]

Functions

[Freight + People]

Context

[Heritage + Production]

Transitions + Time

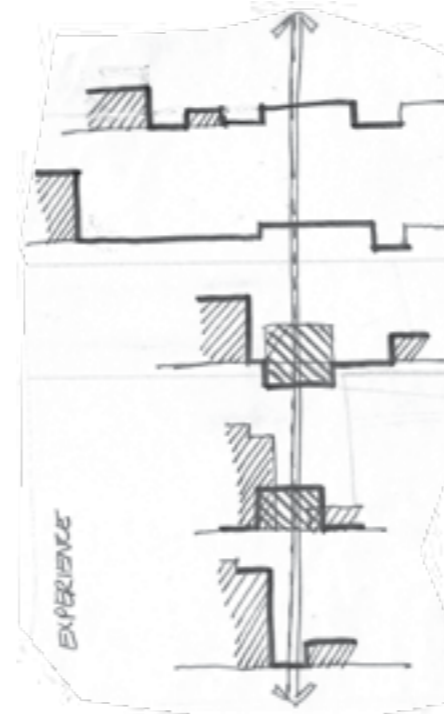

fig. 67_ Diagrams illustrating exchanges in section

The design concept is generated from the idea of electrical input and output exchanges of a power station, such as the one on site. When the power station is decommissioned a new set of inputs and outputs will have to be introduced to continue the industrial character and heritage of the site. The integration of the site with the rest of the urban fabric is essential to dissolve the barrier that exists between monotonous and introverted industrial facilities.

The new exchanges deal with the ins/outs of the production process of the new programs introduced on site. The inputs/outputs include raw materials, tools, people, products, byproducts and waste.

The first exchange is the in/out of products to and from the various factories on site and off site at various times of the day. This exchange provides storage and logistics for the export and import of various elements needed for the production process. The second exchange, in/out of people via a commuter station, is added to integrate people-centred public activities with the process of making goods.

§

| Energy

The intensity and movement of people introduces tremendous energy into the site consisting of people who travel predominantly to and from home and work. This commuting pattern introduces two peaks of movement intensity in the morning [disembarking] and afternoon [arriving] on trains.

The energy of freight contrasts that of people, with a more steady continuous input and output of products daily, weekly and monthly.

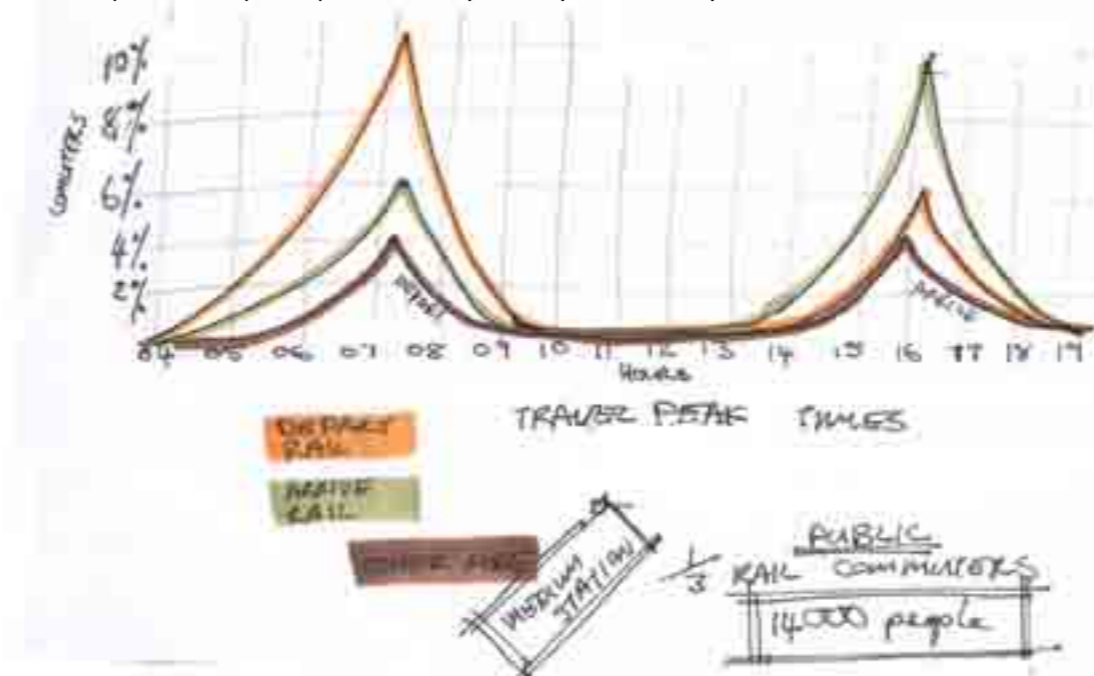

fig. 68_ Diagram illustrating the peak travel times of people arriving and departing by train

| Intensity

Commuting patterns are tied to various intensities of activities throughout the day. These activities are also related to modern human behaviour. The activities can be grouped under home, work, industry, commerce and leisure. These activities can be tied to physical and visual exchanges and generate spatial organisations of functions along the platform length.

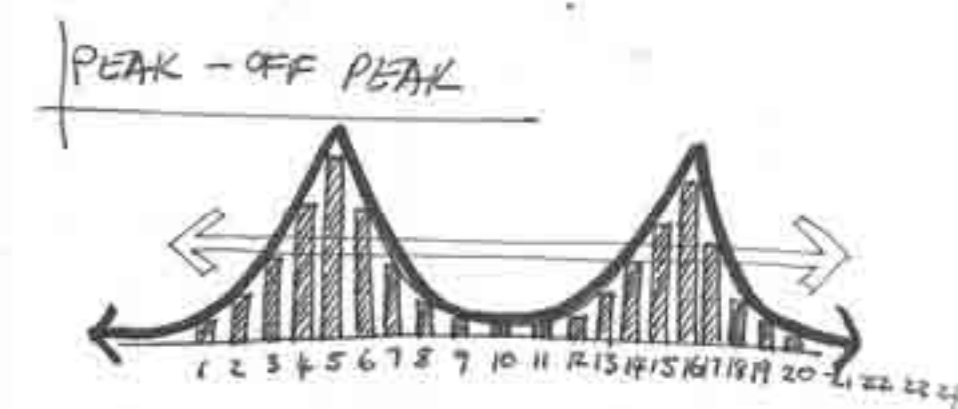

fig. 69_ Diagram illustrating the exchanges between the peak travel times and the arriving and departing of trains

| Physical

Physical exchanges between people/products happen on grade as people enter or exit the concourse where they can buy food, newspapers and goods produced on site and from the surrounding productive precinct.

By integrating the platform within the existing power station, commuters are physically connecting with the old as they pass through on trains or wait for incoming trains.

| Visual

The intensity and volume of people encourages a visual exchange between people and the production process. Commuters interact while in motion as the train arrives and departs. Stationary interaction happens as commuters wait for trains on the platform. Further exchange between the commuter and heritage of the Pretoria West Power Station is introduced by integrating the commuter station within the site.

The structure necessary for an elevated rail is large and will be more costly than constructing it on grade. The elevated rail way line allows for more functions to be placed under the structure making more efficient use of the site as resource.

The extra cost can be justified by the possible opportunities, arising from the elevated rail, such as integrating services necessary for other site functions within the structure. For example the current day services provided for a building are water, electricity, telecoms and data.

| Serve

| Contain

If these services are provided on site they need larger intermediary zones where they are collected from the external providers and then distributed to the buildings on site.

| Assemble/Disperse

The exchanges that occur between production [storage] and public transport functions are assembly and dispersing. The storage function will include programmes necessary for the assembly of goods and services on site and the study area.

The elevated rail facilitates the dispersing of these goods and services. Simultaneously the commuter station deals with programs related to the assembly and dispersal of people.

| Introvert

The existing Power Station building is enveloped by a skin of bricks, the structure and function is hidden from the viewer when looking from the outside, acting as a introverted container. The new storage functions will be placed inside this structure, providing a new use for the soon to be decommissioned building.

The commuter platform will reveal the introverted structure of the building by exposing the structure of the building where the two intersect.

| Extrovert

The commuter terminal/station in turn will be designed to expose the user to the viewer and the user to the production process. This way the structure can expose itself where the facade retracts, focusing the attention of the viewer on the production processes and spaces of the site.

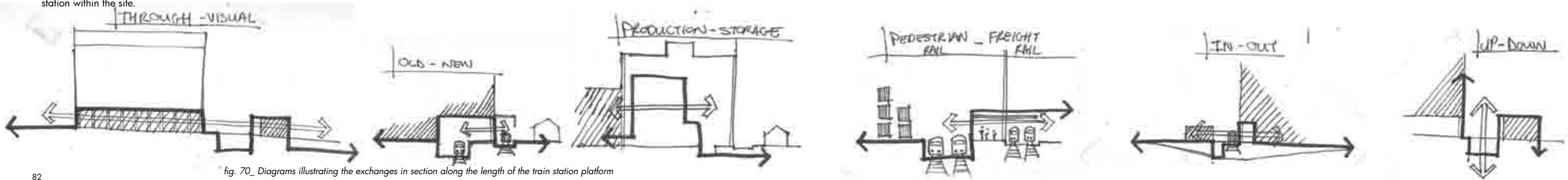

fig. 70_ Diagrams illustrating the exchanges in section along the length of the train station platform

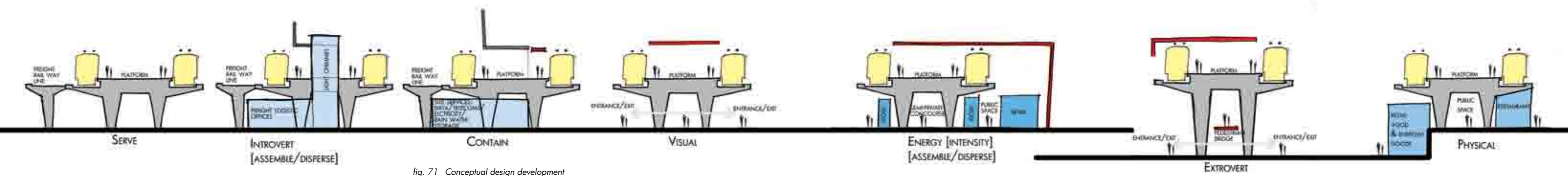
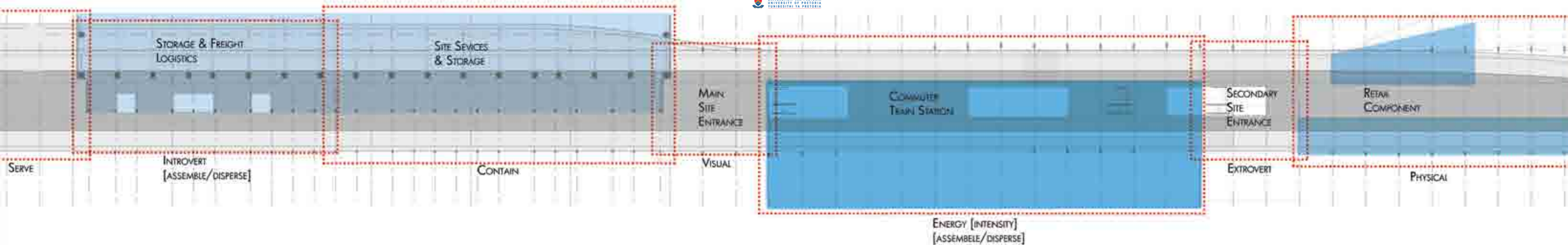

fig. 71_ Conceptual design development

People [Ex] Change

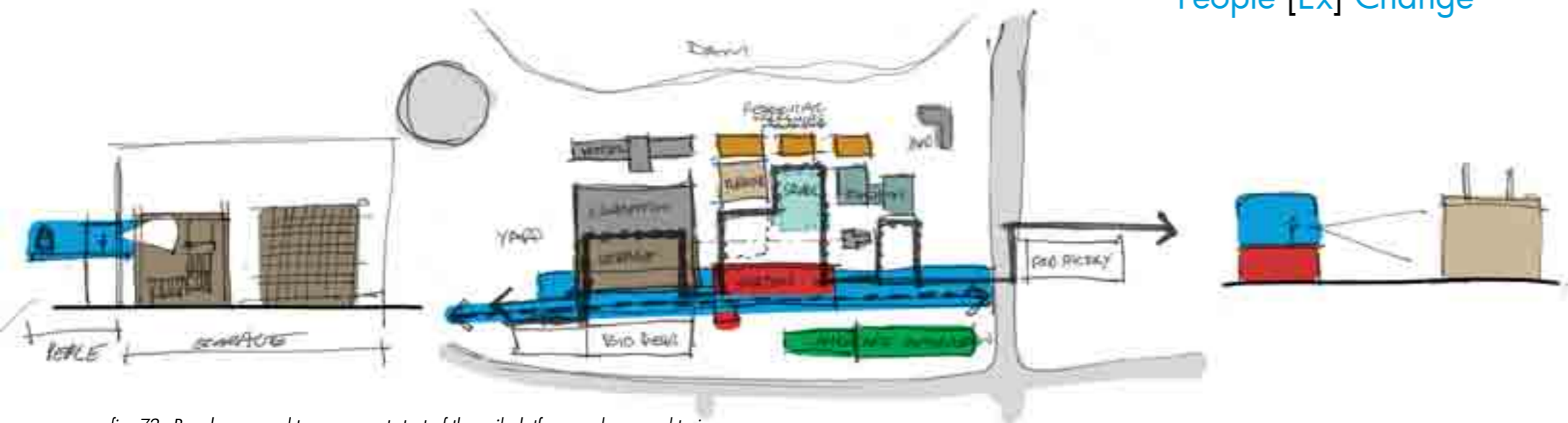

fig. 72_ People exposed to process at start of the rail platform and exposed to industrial character of the site from the centre to the end of the platform as illustrated on previous page.

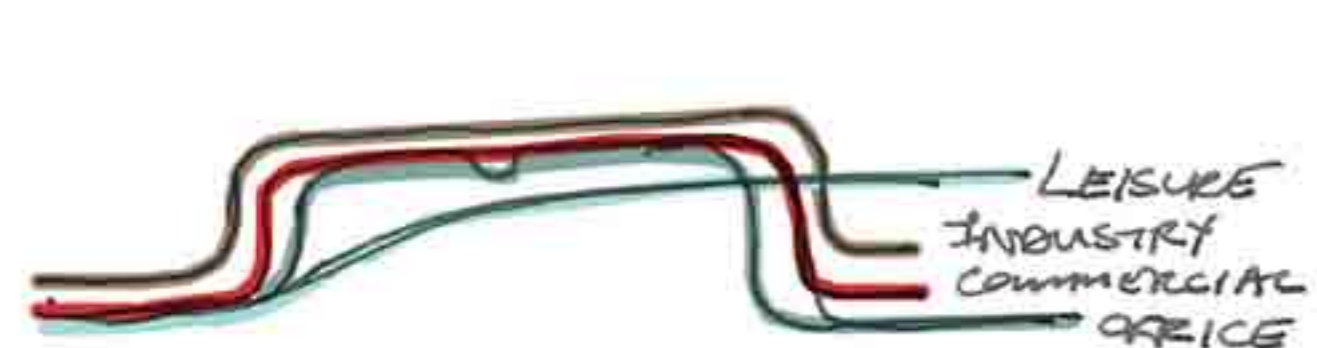

fig. 73_ Intensity of activities [energy exchange], one day



fig. 74_ Intensity of activities [energy exchange], one week

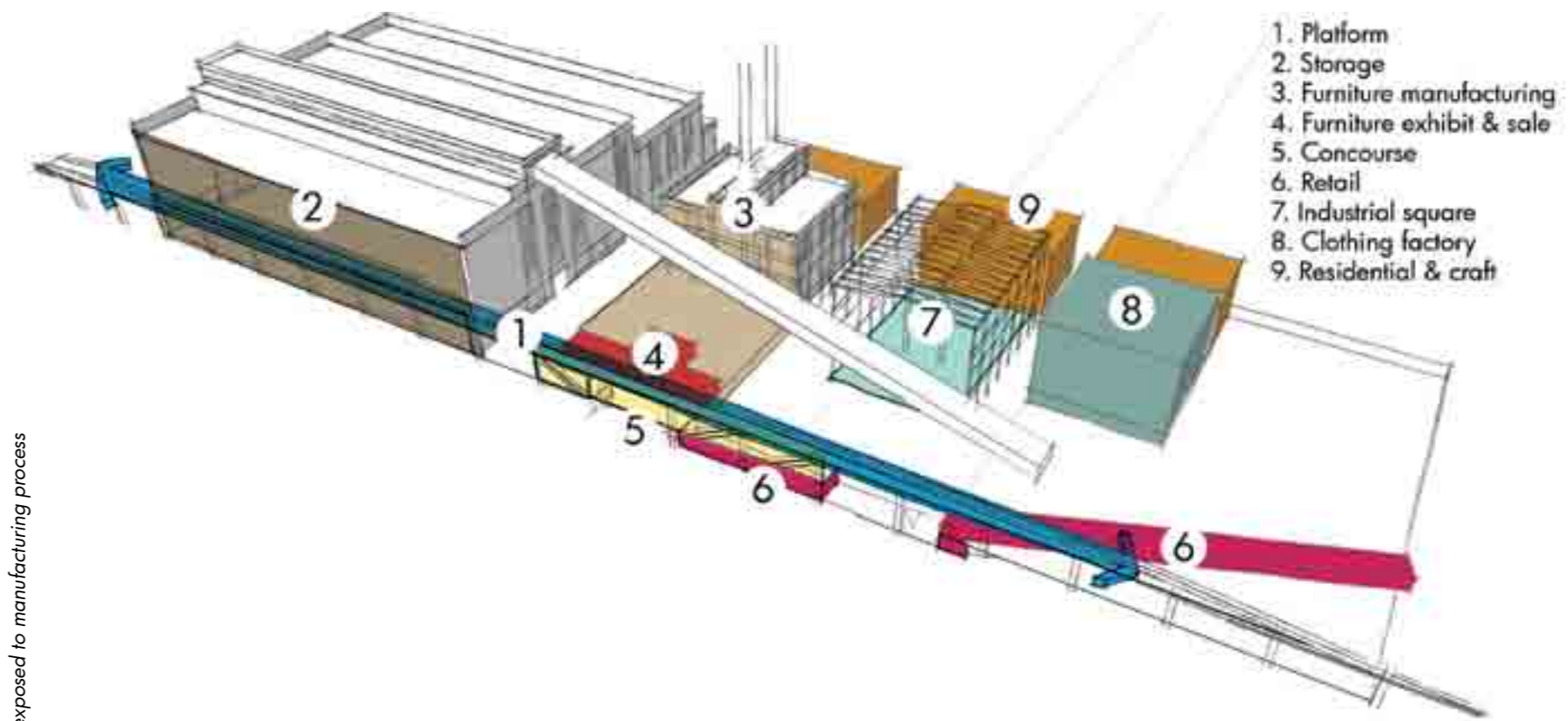

fig. 75_ Variety of people exposed to manufacturing process



Precedent Study of Function - Context

- Movement
- Visual
- Interaction
- Threshold
- Public versus Private

| Function Follows Flow

This design illustrates how a element, in this case the central set of stairs, encourages visual interaction of the users with various functions of the building as they move along.

The proposal invites people to freely gather and move through the building. The large atrium serves as orientation space as well as visual connection with the other functions on different levels. The central stairway allows users to move past other functions, thus changing the users visual perspective.

| Encourage Interaction

The atrium opens up onto the city square, attracting public to interact with the inside through the large atrium.

The public is encouraged to enter the building from the square into the atrium where various public functions are placed. Creating a threshold between the square and the functions inside the building (Sebastian, 2009).



fig. 76_ Artists impression of internal space

| Beirut's House of Arts and Culture

NRJA
Beirut, Lebanon
Multifunctional arts and culture centre
2009
Competition entry



fig. 77_ Spatial diagram indicating relationship of main stair and atrium to other functions



fig. 78_ Beirut's House of Arts and Culture_ Beirut, Lebanon_NRJA 2009

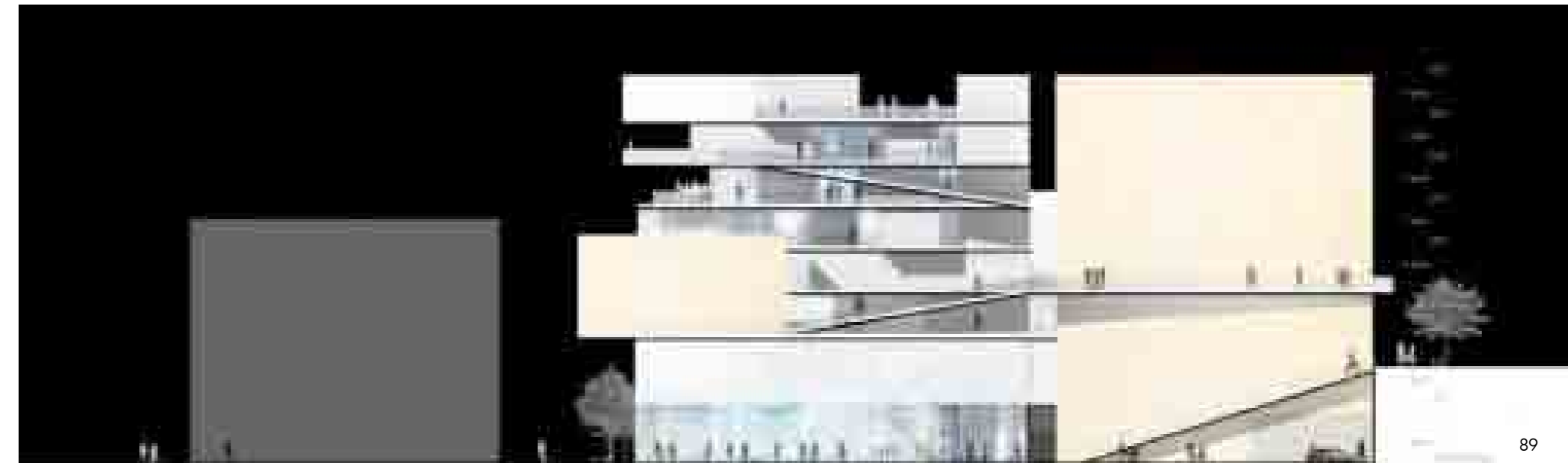

fig. 79_ Section indicating relationship of atrium to public square

Product [Ex] Change

The new programme for station 'B' is storage and logistics of freight and products for local and global distribution. This new process deals with the input and output of materials, goods and large freight containers from and for Pretoria West, as well as abroad. The assembling and moving of people [passenger rail component] is combined with the process. It will run alongside the freight rail. This introduces a new process into the building and site, thus keeping the productive nature of the site intact and allowing the general public to interact with the heritage and the memory of the current process.

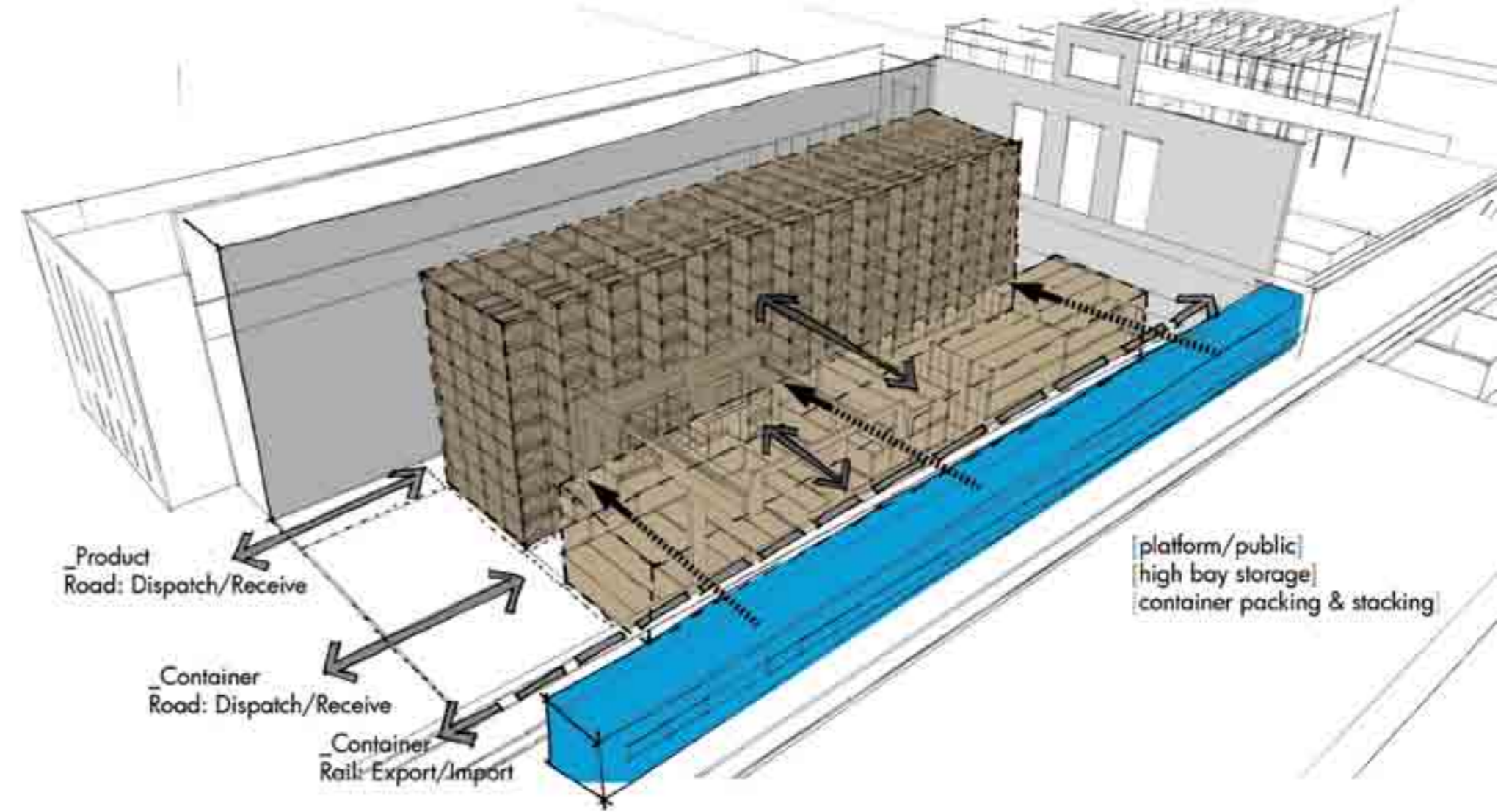

fig. 83_ Storage process illustrating flow and visual connection

EXISTING PROCESS:

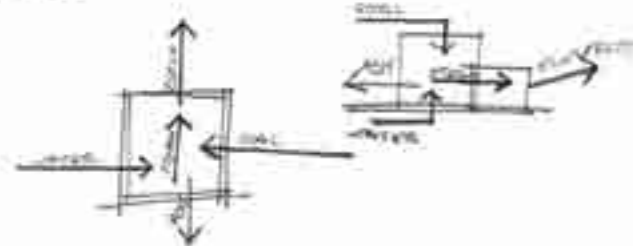

fig. 80_ Diagrams illustrating the existing process

ONCE SHUT DOWN PROCESS STOPPED THE FIBER WILL DECAY.



fig. 81_ Diagrams illustrating the imminent demise of the process

RESPECT OLD PROCESS WITH NEW



fig. 82_ Diagrams illustrating the proposed new process respecting the memory of the existing process

Precedent Study of Form - Function - Context

| ERCO P3 Automated Warehouse

schneider + schumacher architects
Luedenscheid, Germany
function_Automated warehouse
2001
3,365 sqm

- Form
- Visual
- Transparent
- Express
- Process
- Flow
- Private
- Landmark

| Form Follows Function

The form is dictated by the high bay storage structure, which acts as support for the building, performing a dual purpose. Three parts of building follows the logic of the production line: Storage - Packaging - Dispatch/Receive.

| Function Follows Exhibition

The high bay storage structures and its workings are seen through the large transparent facade. People interact visually, experiencing the process from outside without interrupting the inner workings of the industrial building.

| Context and Identity

The building is slightly sunk in at the one end to integrate it with the landscape. The formidable form and illumination has become a signature for client (Schneider + Schumacher, 2003).

fig. 84_ Photograph of building exterior

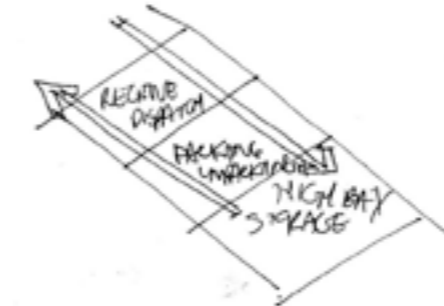

fig. 85_ Diagram of product flow

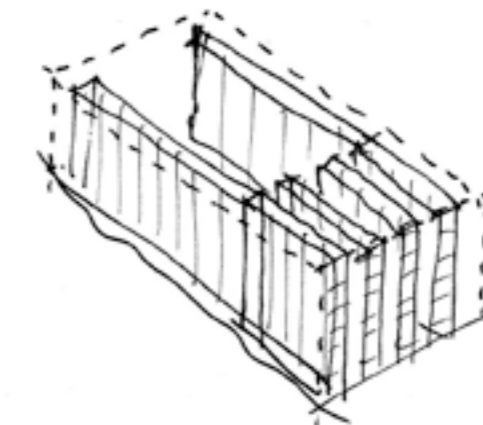

fig. 86_ Diagram of high bay storage structure

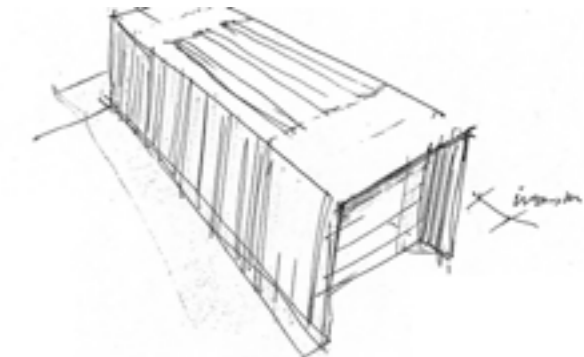

fig. 87_ Sketch of translucent shell (schneider+schumacher, 2003)



fig. 88_ ERCO P3 Warehouse_ Luedenscheid, Germany_ schneider + schumacher 2001



fig. 89_ Photograph of illuminated translucent shell

Precedent Study of Context - Heritage

| The Horse on the Ceiling

Zauberscho[e]n
Münster, Germany
Library addition
2010
400 sqm

- Addition
- Subtract
- Visual
- Contrast
- New and Old

| Juxtapose

Contrasting of the new with the old heightens the visual integrity of the old. The gap in the roof between the new and the old illuminates the old brickwork and strengthens the link between the two.

| Visual Education

The glass envelope of the new extension allows passersby to see into the building thus introducing them to the educational function of the structure.

| Aggressive Addition + Sensitive Subtraction

New openings are cut where old openings existed, illustrating that the integrity of the heritage is kept. Where new elements are inserted they are in contrast with the existing forming a distinction between new and old.

fig. 90_ Photograph of the old and new



fig. 91_ Illustration indicating how the new touches the old and expresses the connection



fig. 93_ Photograph indicating contrast between new and old



fig. 92_ Illustration of public interaction



fig. 94_ The Horse on the Ceiling_ Münster, Germany_ Zauberscho[e]n_2010

Movement [Ex] Change

| Fixed/Flexible Boundaries

The intended platform will be elevated to allow the public to move freely into and out of the site. If the rail is positioned on grade, it imposes a negative edge condition [barrier], forcing people to cross over at fixed points. People will only interact with the railway lines [platform] when entering through the control area of the train station to board a train.

The elevated rail allows boundaries to be flexible and create points of entry to the site where necessary. It creates the opportunity for additional exchanges between people and programmes such as retail, restaurants or parks and squares.

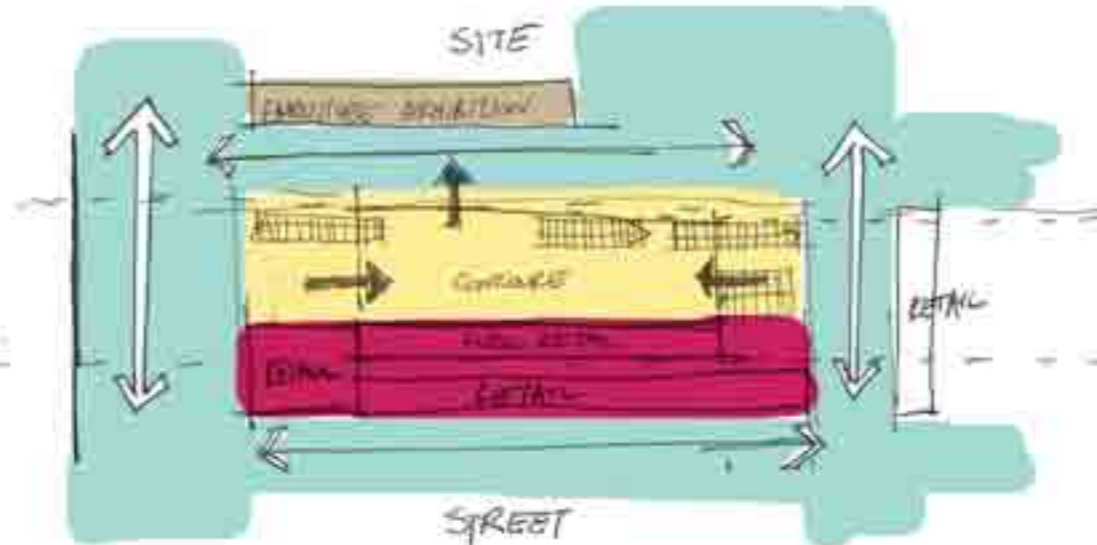

fig. 95_ Diagram illustrating access to site and station entry points



fig. 96_ Diagram illustrating access to platform and site



fig. 97_ Diagram illustrating fixed boundary, no access to site.



fig. 98_ Diagram illustrating flexible boundary, access to site at certain points

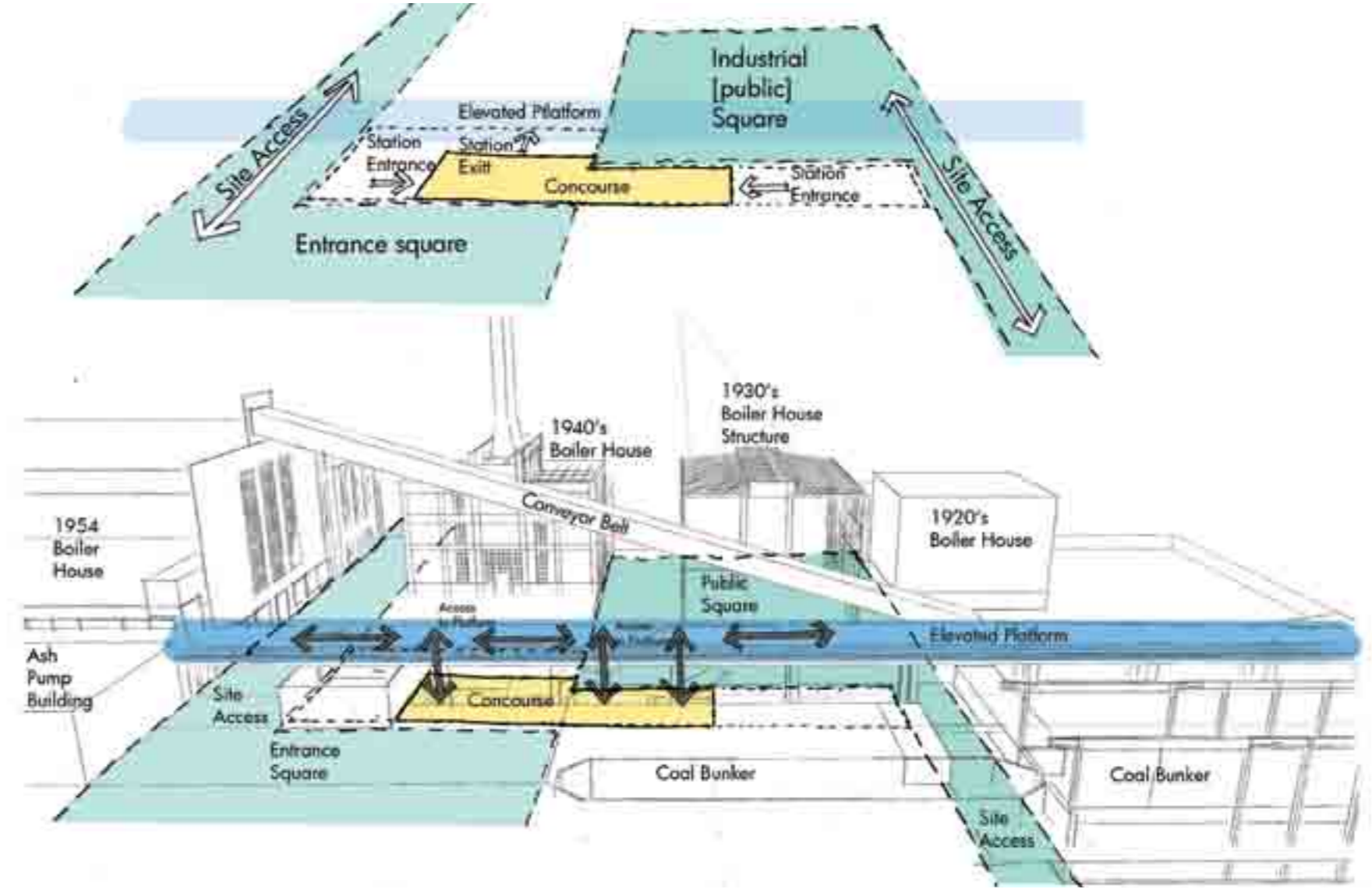

fig. 99_ Station access close proximity to public access of site

Precedent Study of Function

| Shanghai METRO

function_subway stations
Shanghai, China
Physical observation
2010

- Circulation
- Boundaries
- Movement
- Security
- Branding

| Circulation

A very simple circulation pattern is evident, with passengers entering through two entry points and exiting via one point. Once in the control area staircases lead to and from the platform below.

| Security + Access

Ticketing is done electronically similar to the way one would pay for parking in a mall. Security is enforced by the x-ray scanning of any bags on your person before entering the control area that leads to the platform

| Branding

Concourses are branded by colour of the line one is travelling on.

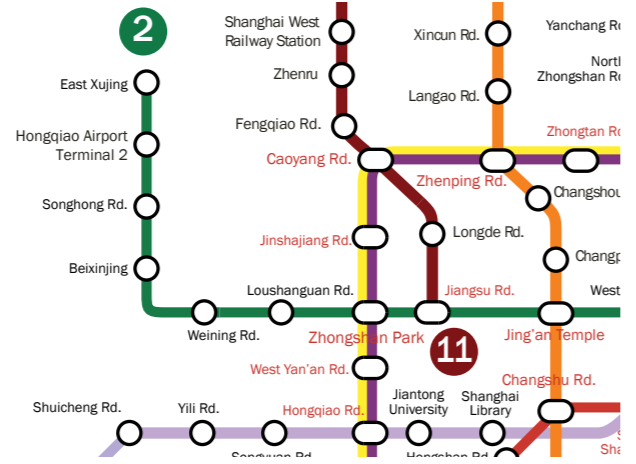

fig. 100_ Shanghai Metro Map_Shanghai, China_explore shanghai_2010



fig. 101_ Shanghai Metro logo

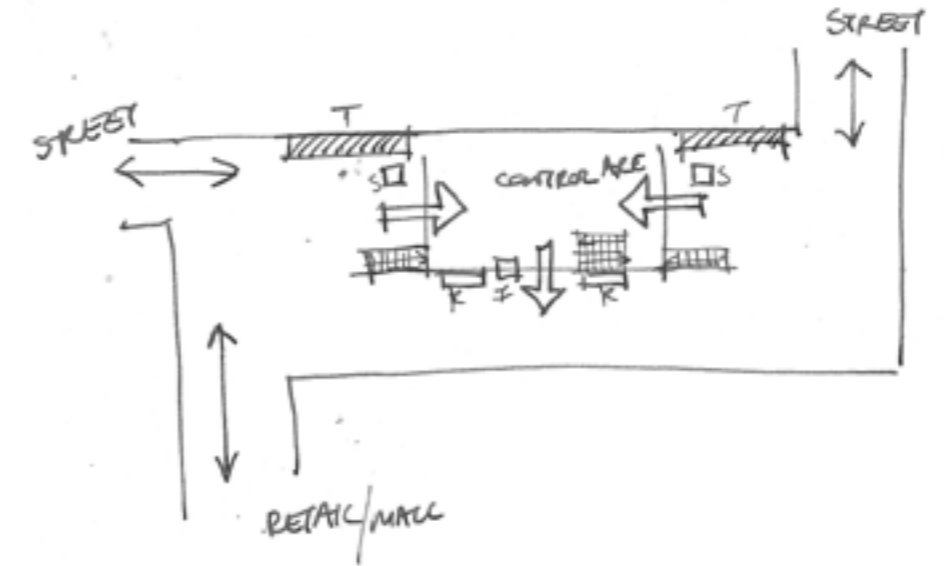

fig. 102_ Diagram illustrating concourse and public areas on plan

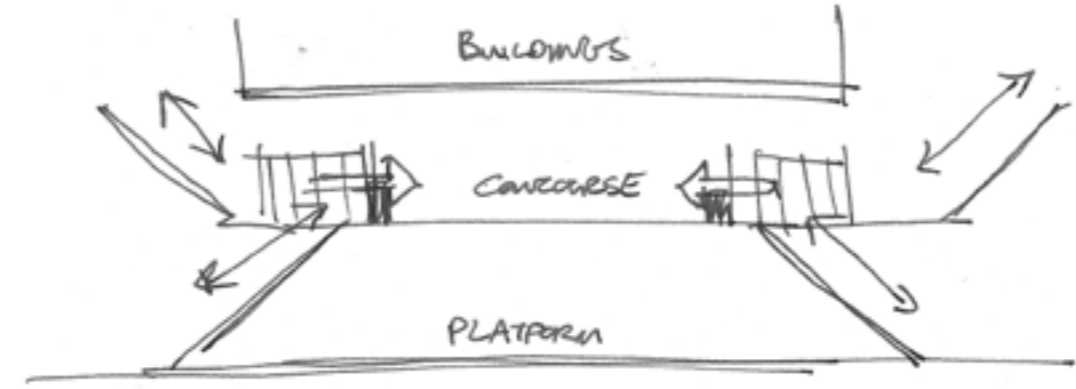

fig. 103_ Diagram illustrating concourse and platform areas in section

Concept Development

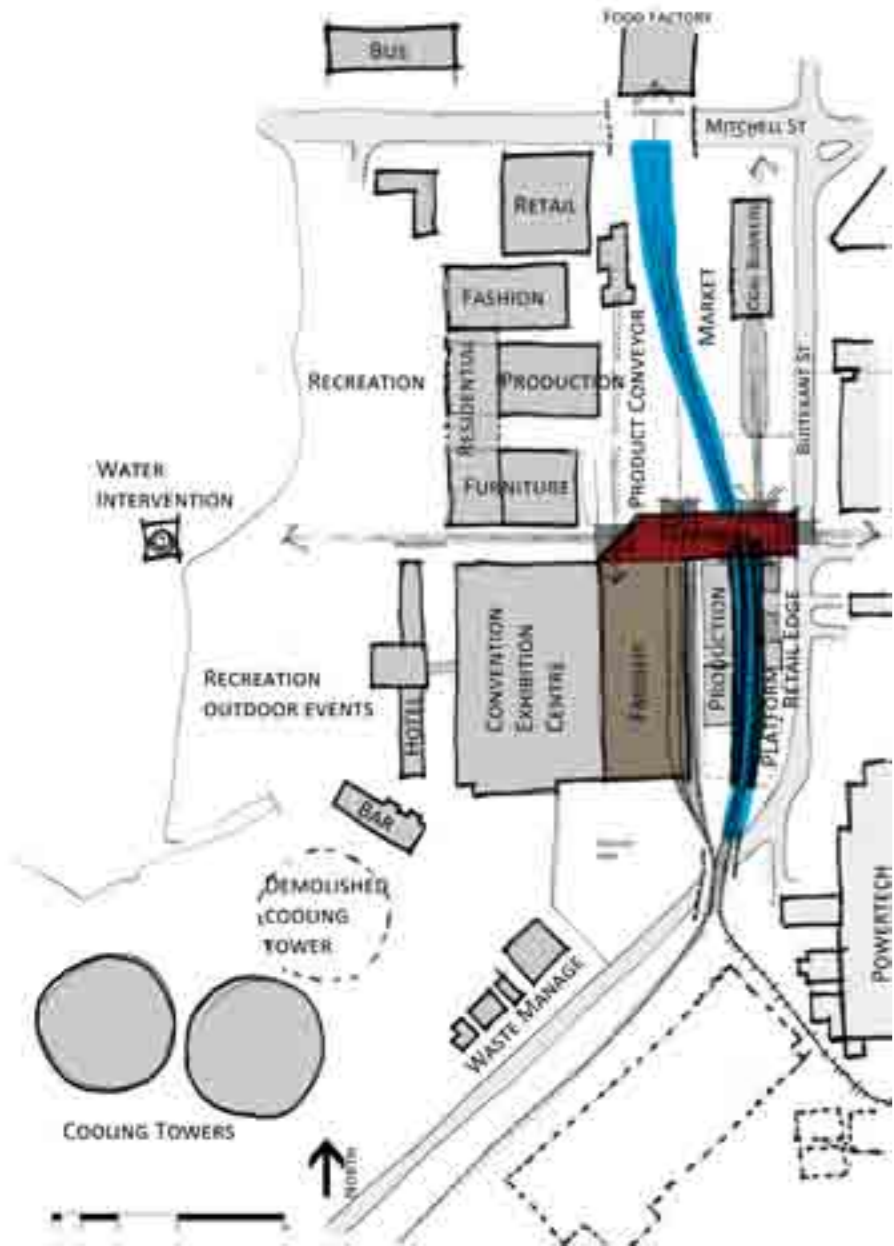

fig. 104_ Concept sketch of site plan illustrating the possible location of intervention. Platform follows the existing railway tracks

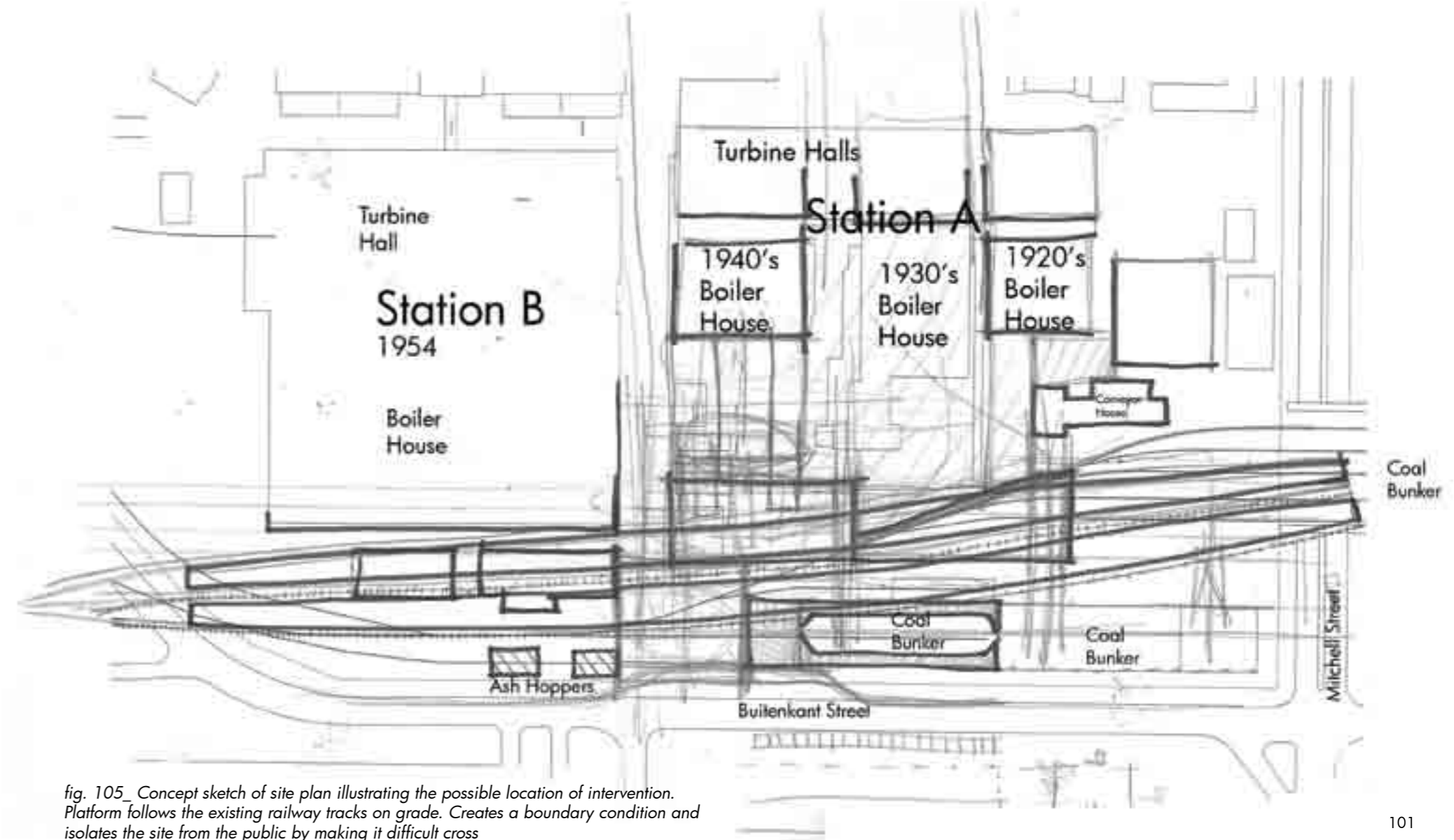

fig. 105_ Concept sketch of site plan illustrating the possible location of intervention. Platform follows the existing railway tracks on grade. Creates a boundary condition and isolates the site from the public by making it difficult cross

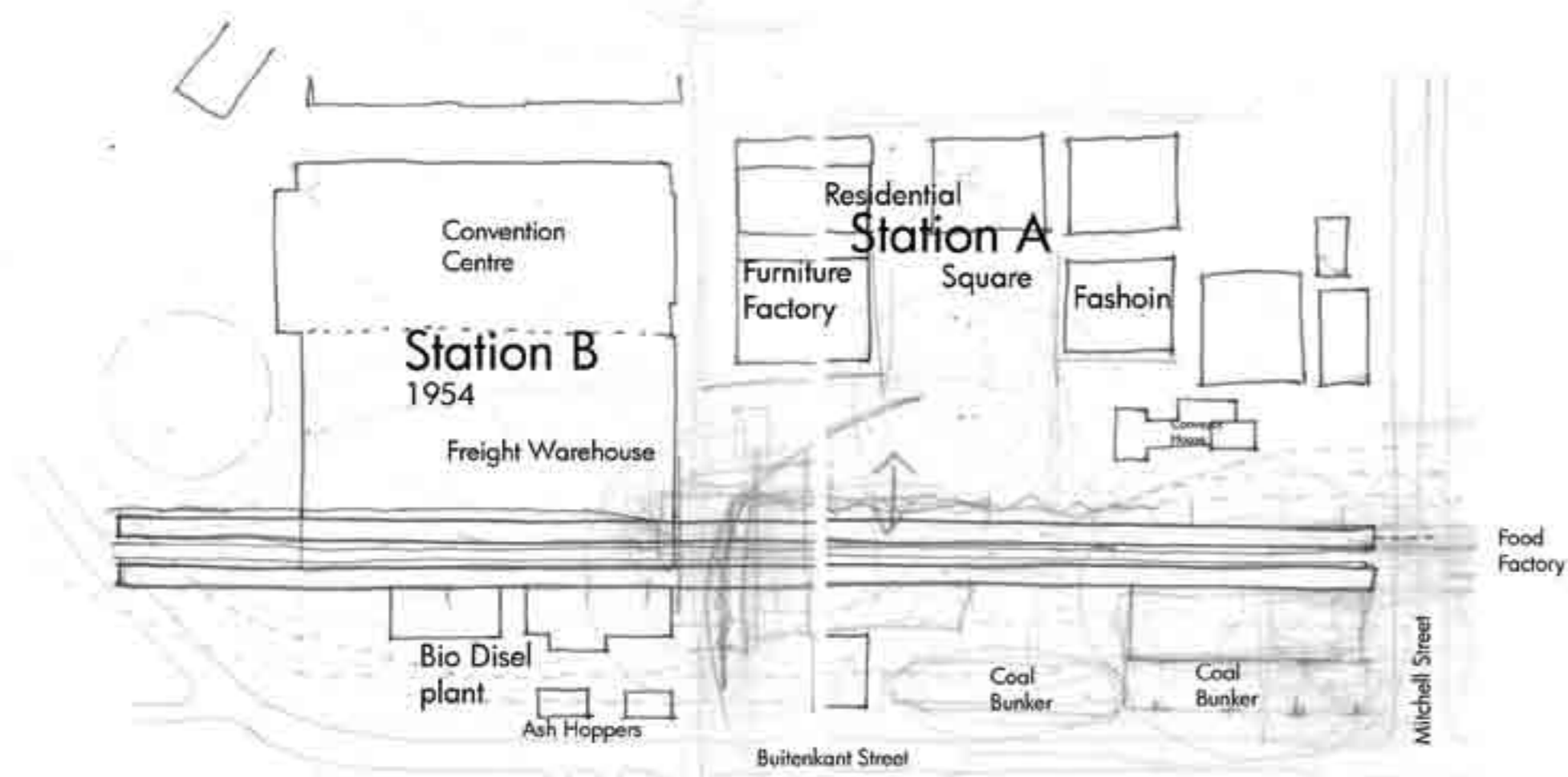

fig. 106_ Concept sketch of site plan illustrating the location of intervention. Platform no longer follows the existing tracks complying to railway station norms. The passenger rail platform is integrated with the proposed freight and storage warehouse allowing for containers to be loaded directly out of freight intervention.

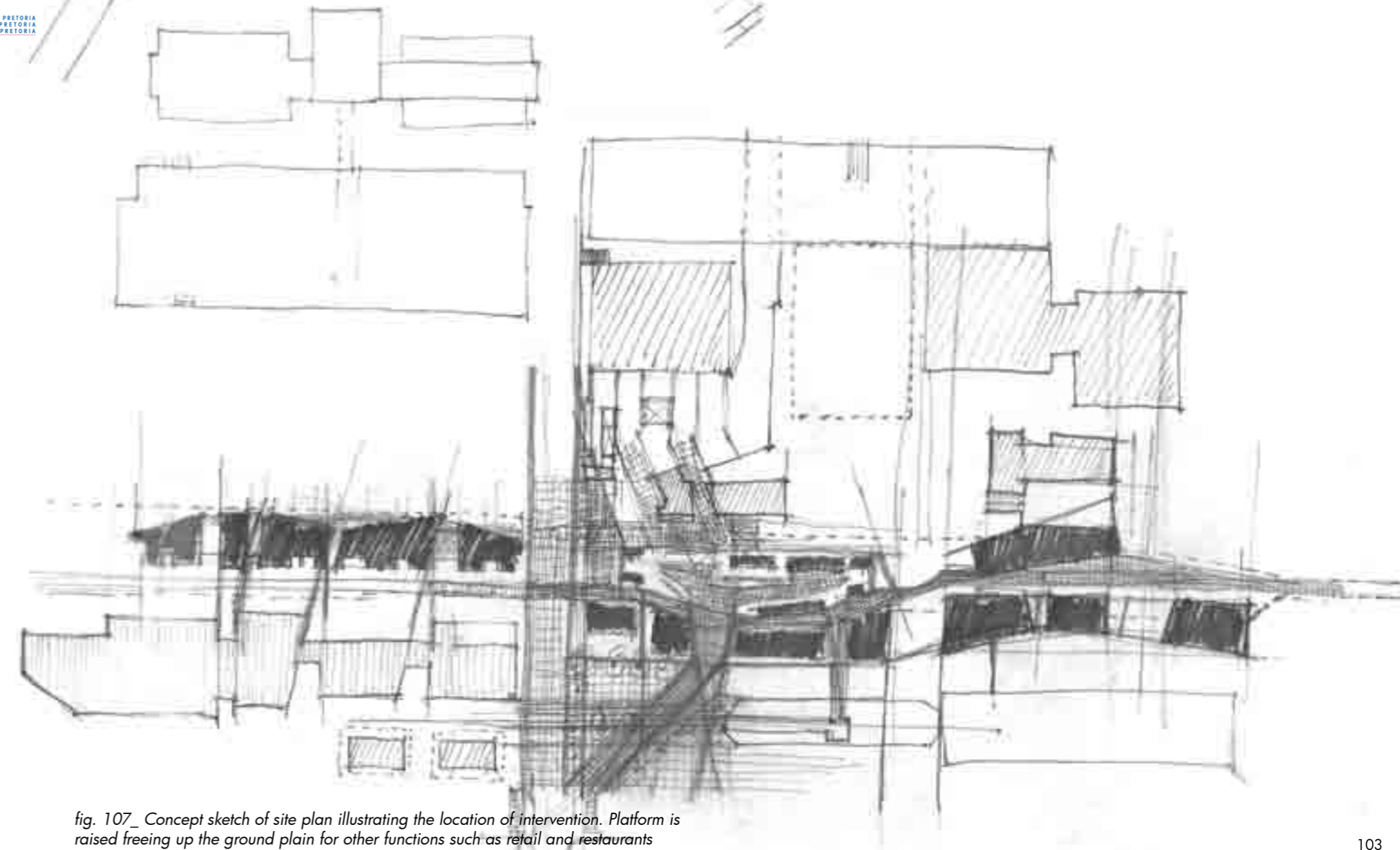

fig. 107_ Concept sketch of site plan illustrating the location of intervention. Platform is raised freeing up the ground plain for other functions such as retail and restaurants

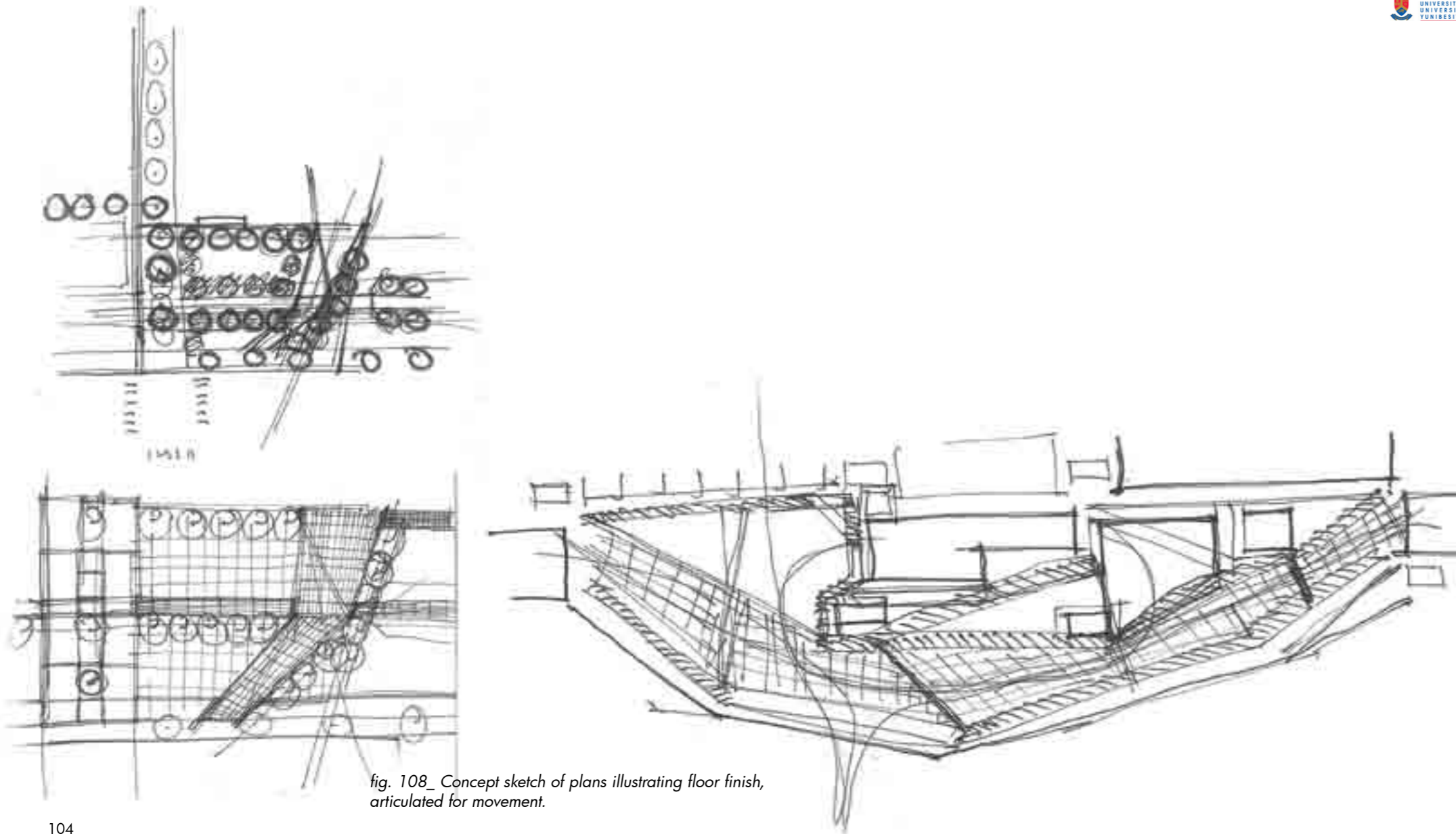

fig. 108_ Concept sketch of plans illustrating floor finish, articulated for movement.

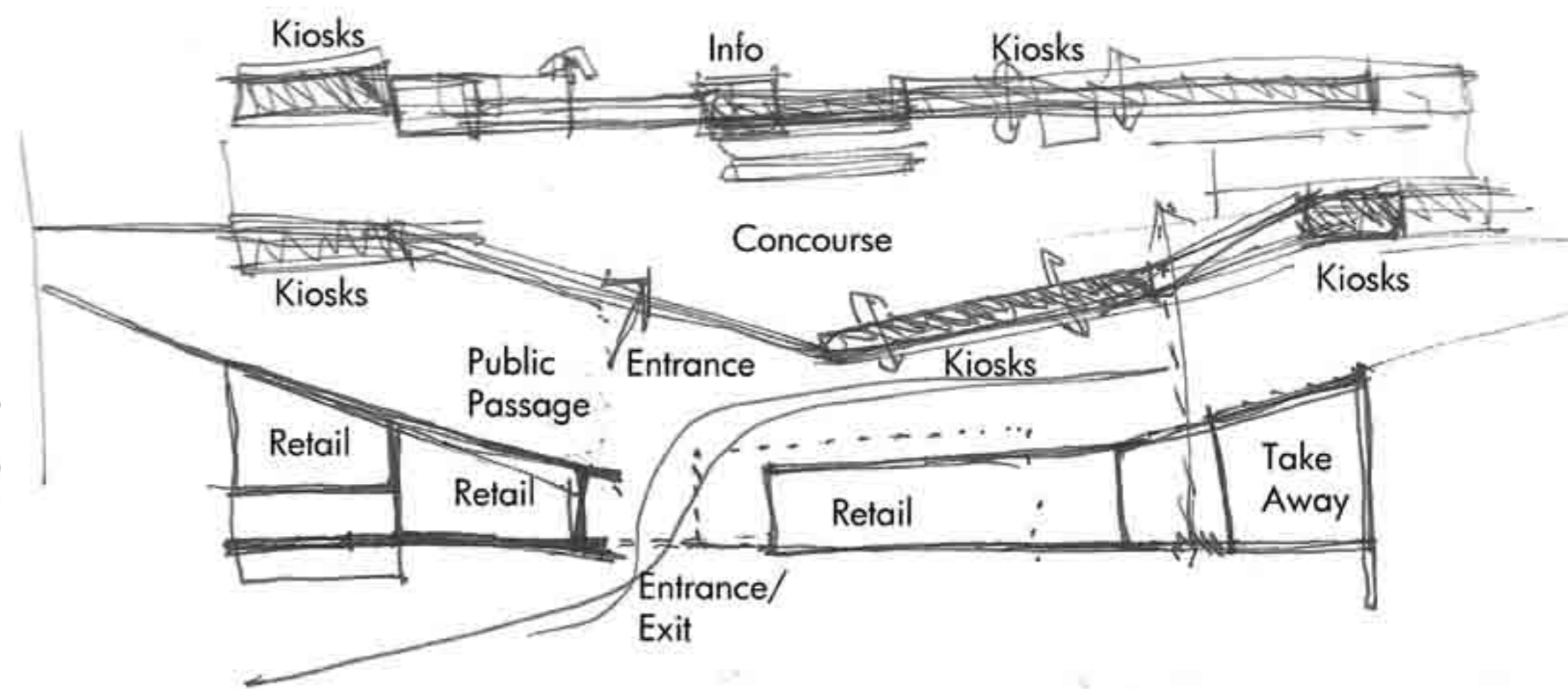

fig. 109_ Concept sketch plan illustrating the public passage, entry and exit points of concourse and location of retail programmes.

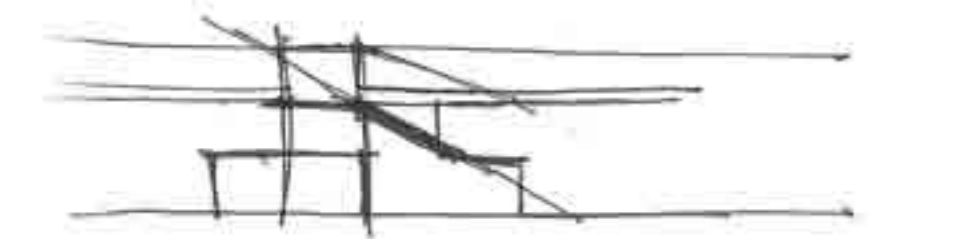
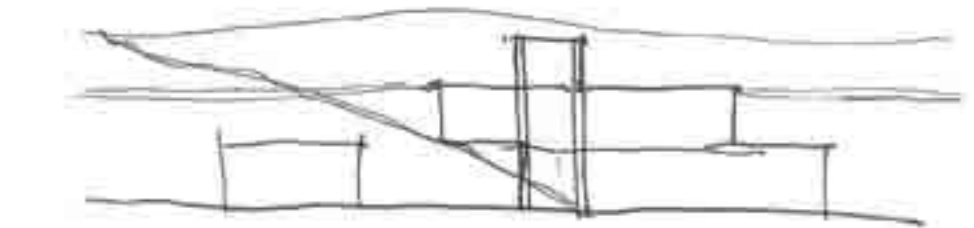
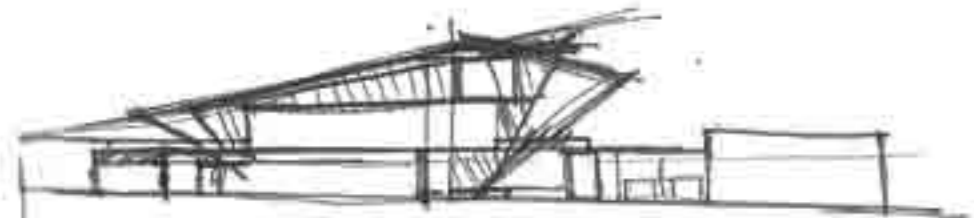

fig. 110_ Exploration sketches of roof becoming facade

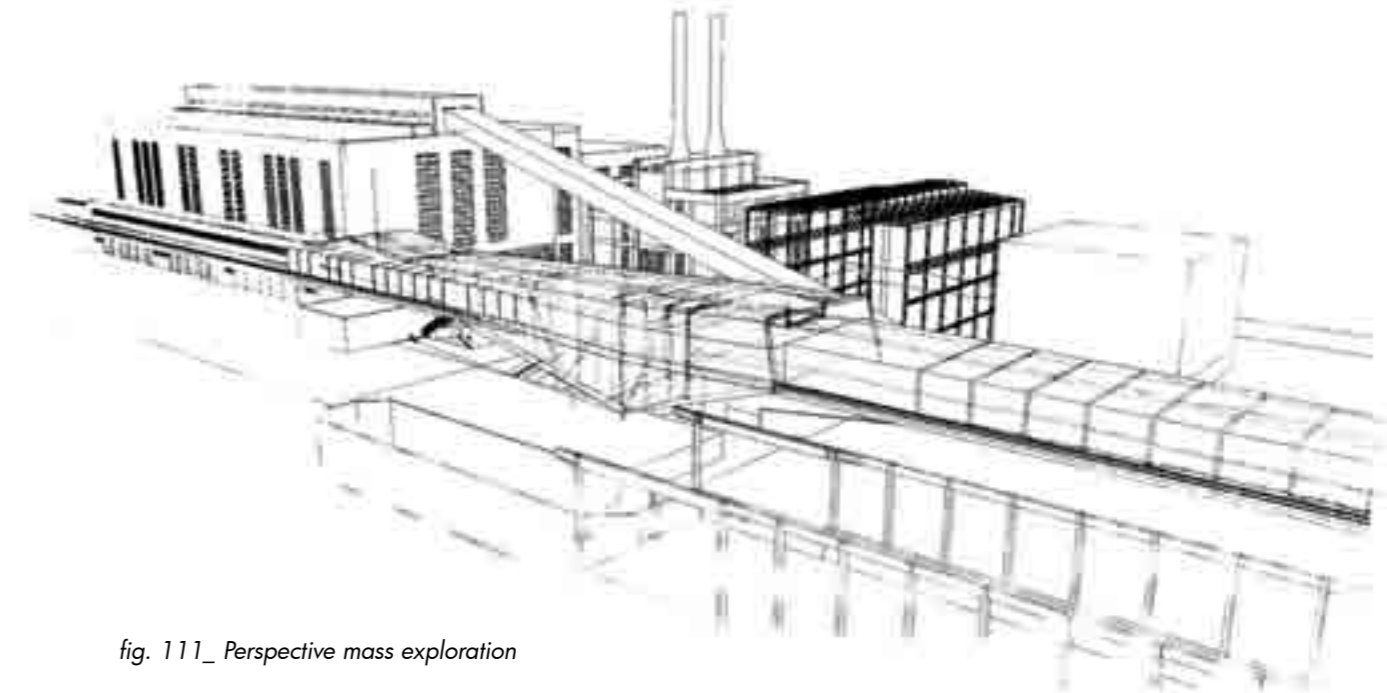

fig. 111_ Perspective mass exploration

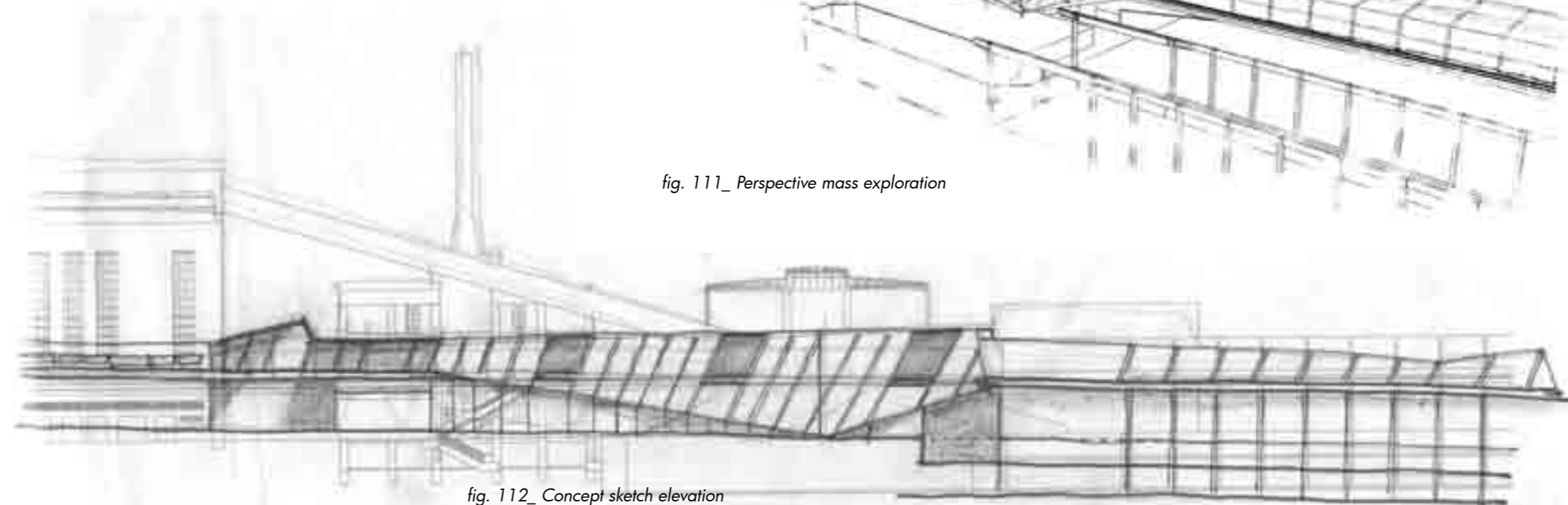

fig. 112_ Concept sketch elevation

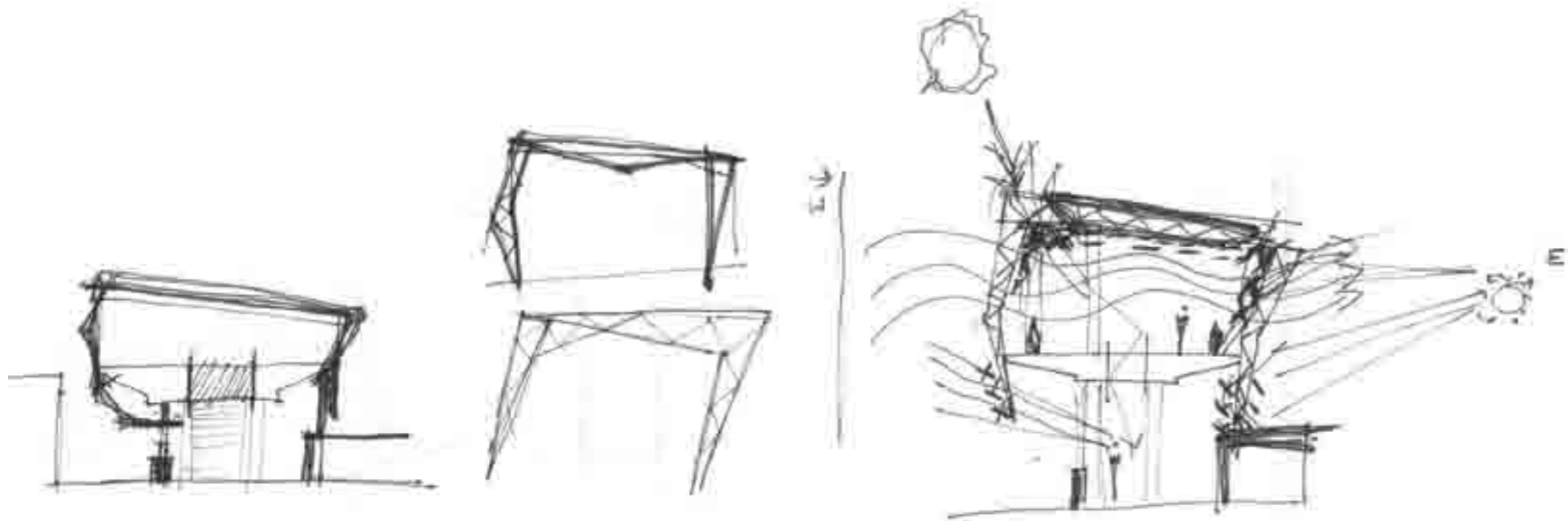

fig. 113_ Sections illustrating development of structure

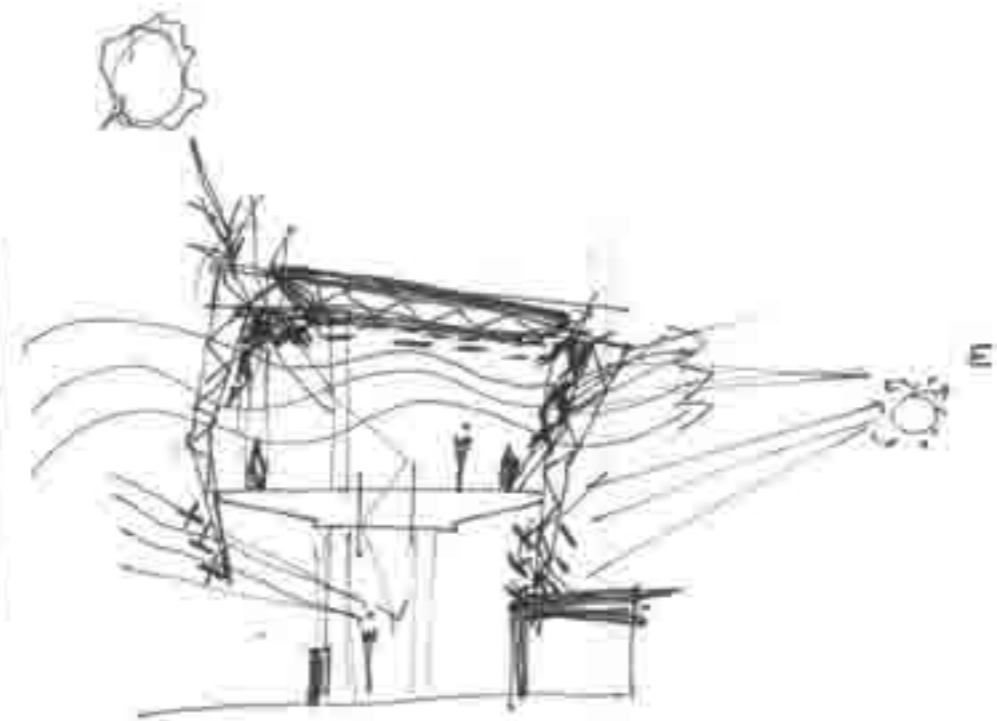

fig. 114_ Sections illustrating shading from east and west sunlight as well as permeable structure for natural ventilation

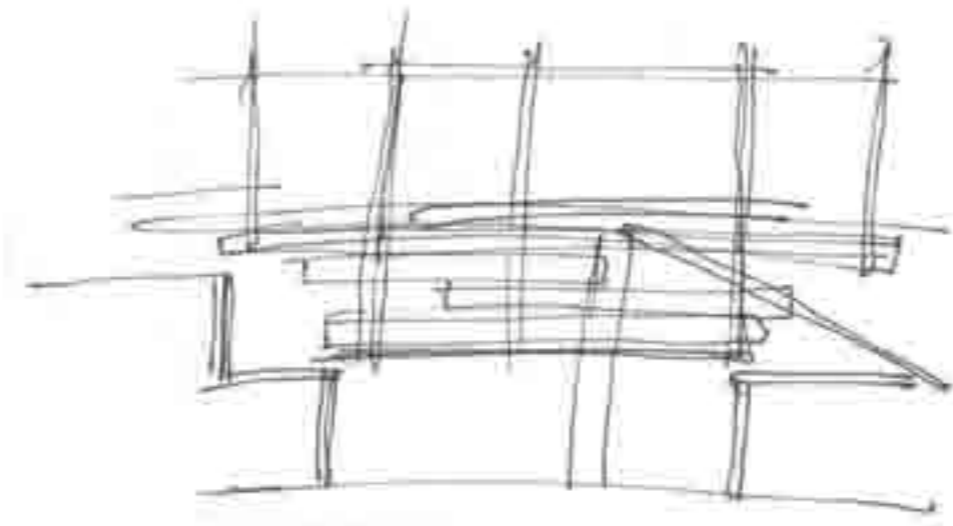

fig. 115_ Section illustrating permeable facade treatment [fragmented elements]

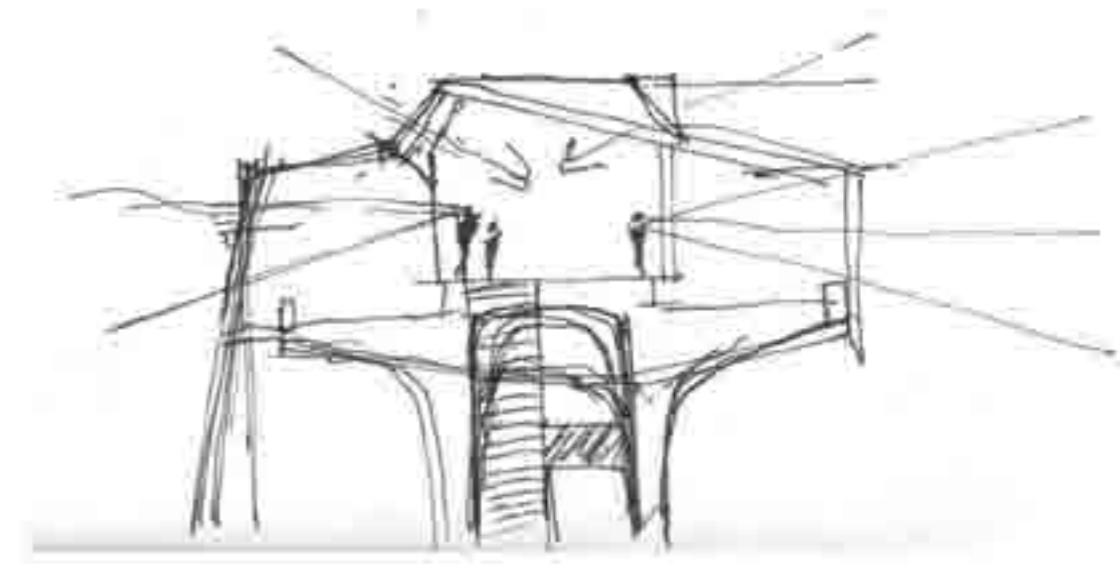

fig. 116_ Section illustrating views necessary from platform.

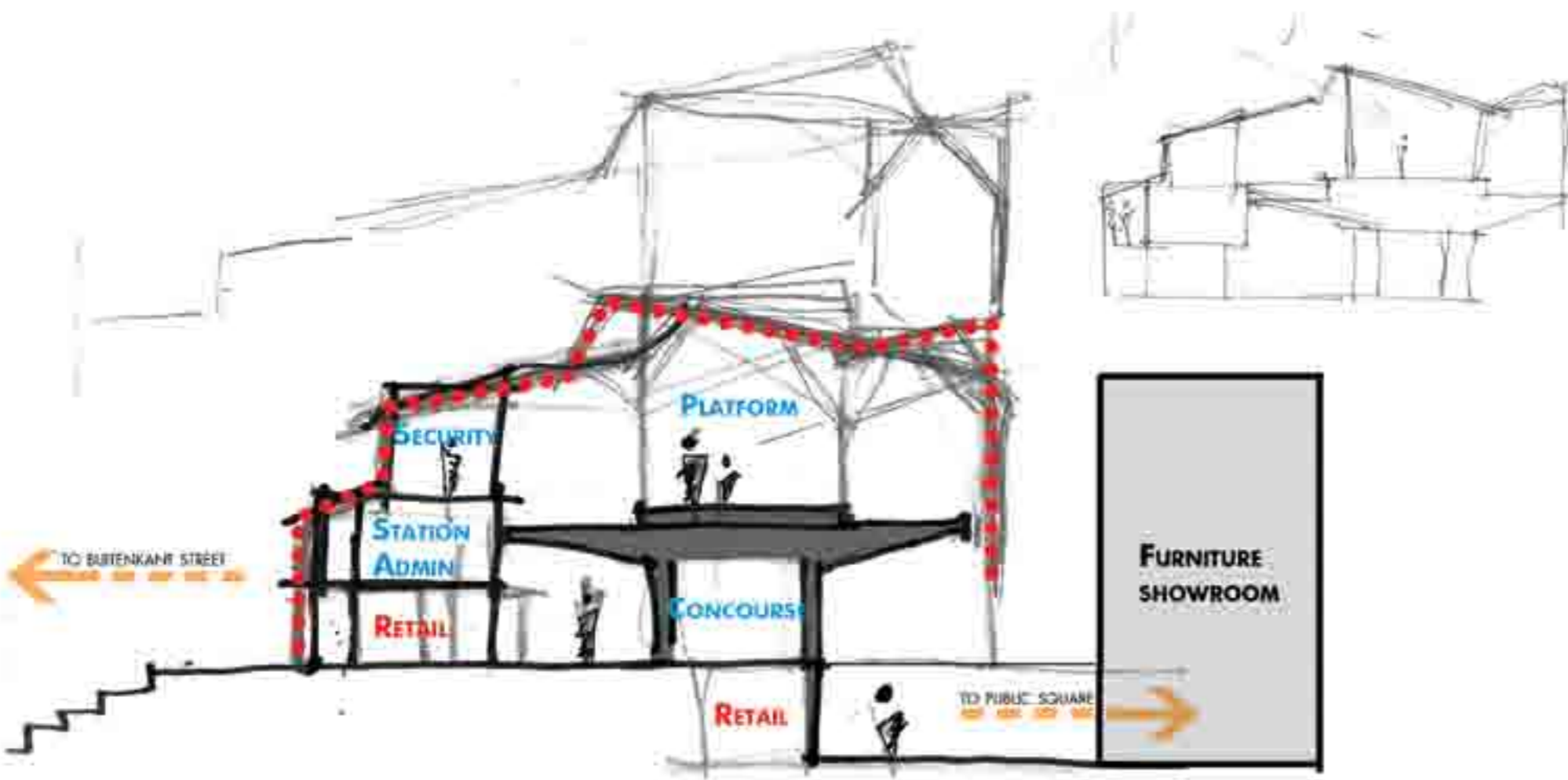

fig. 117_ Conceptual section

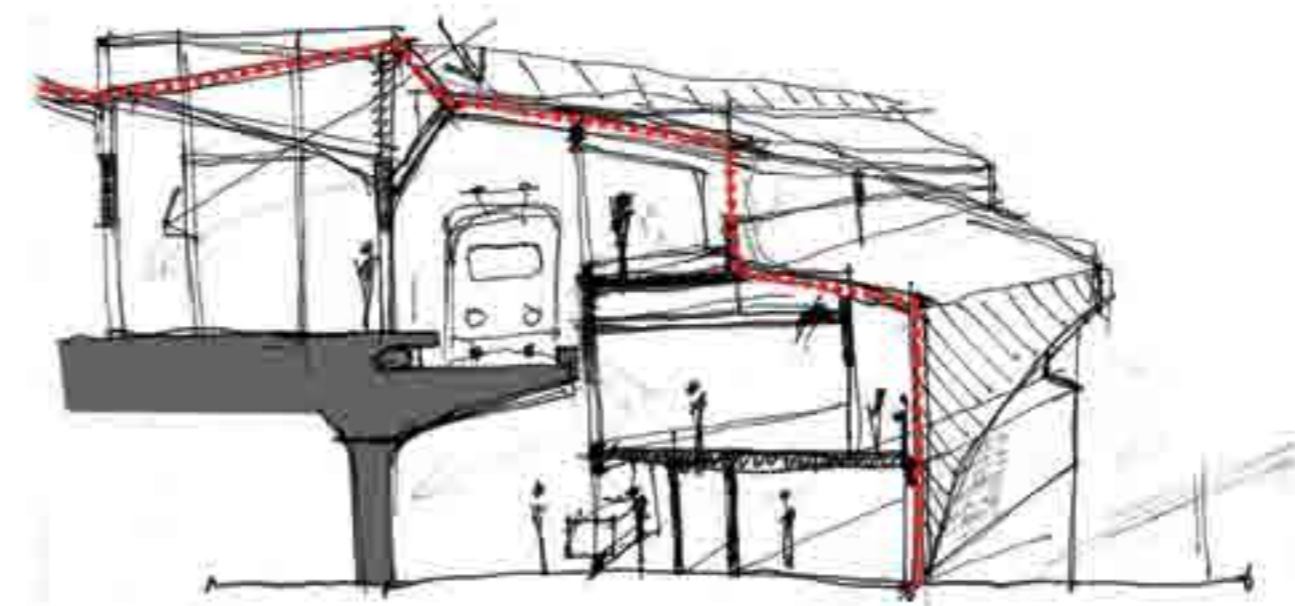

fig. 118_ Conceptual perspective in section

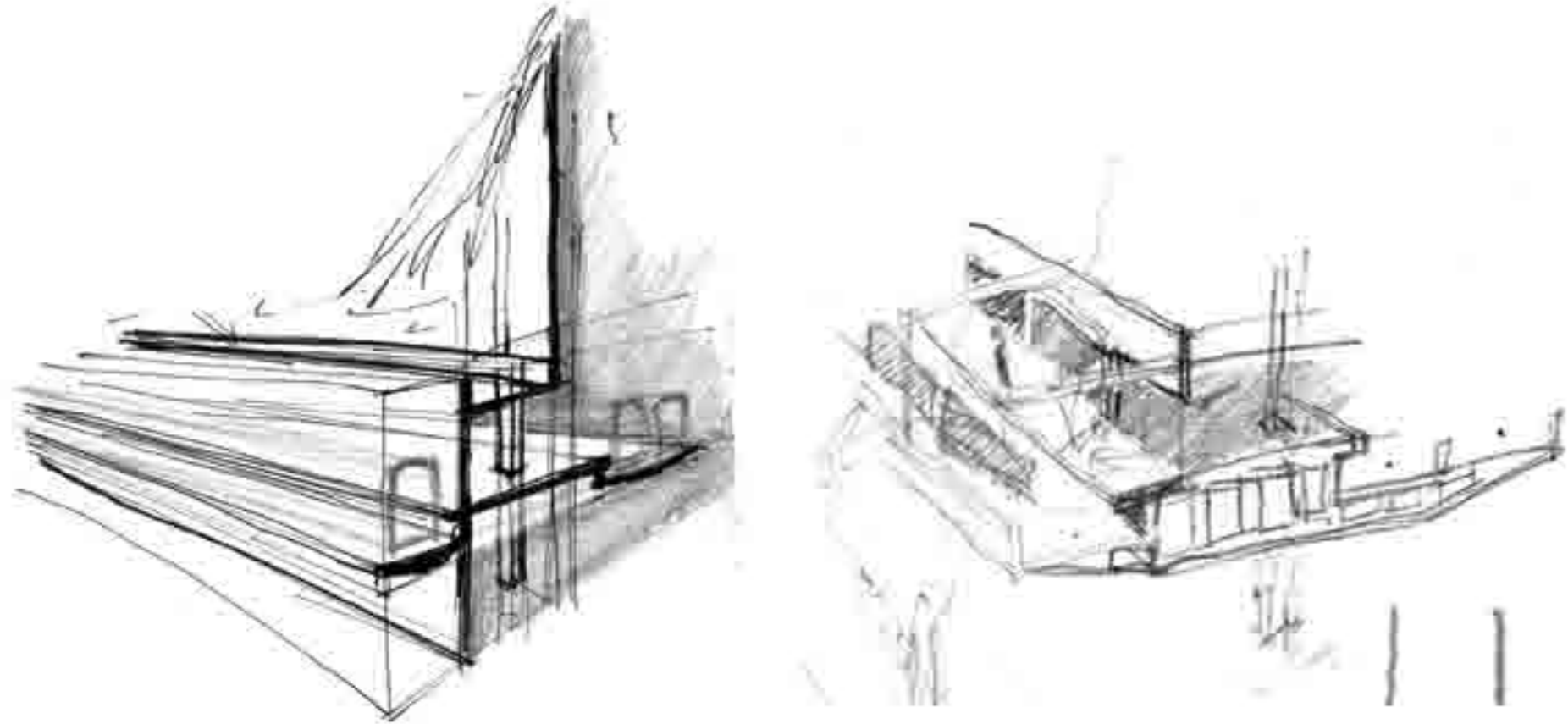

fig. 119_ Conceptual section of the freight and logistics [introvert/contain]

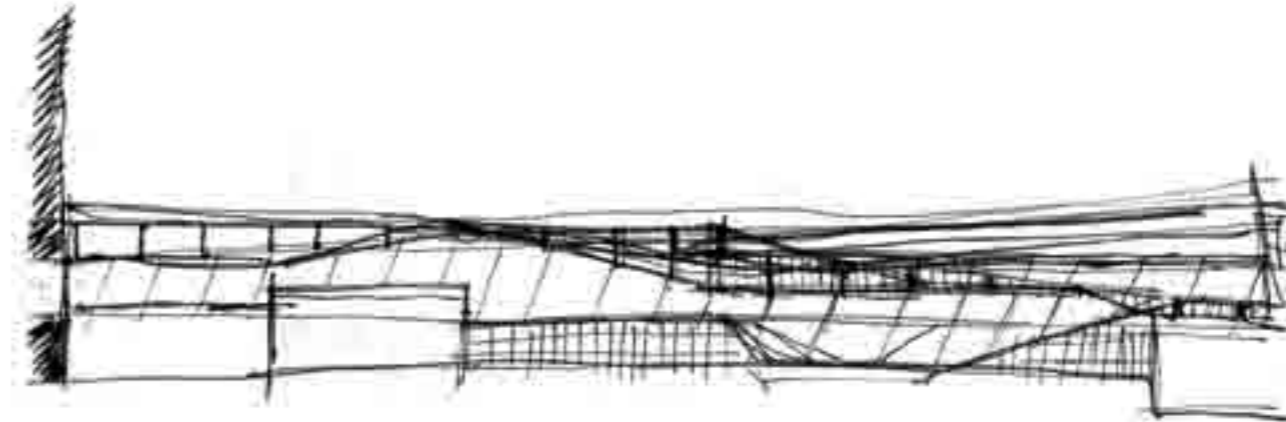

fig. 120_ Conceptual design development of platform roof and facade acting as containing element

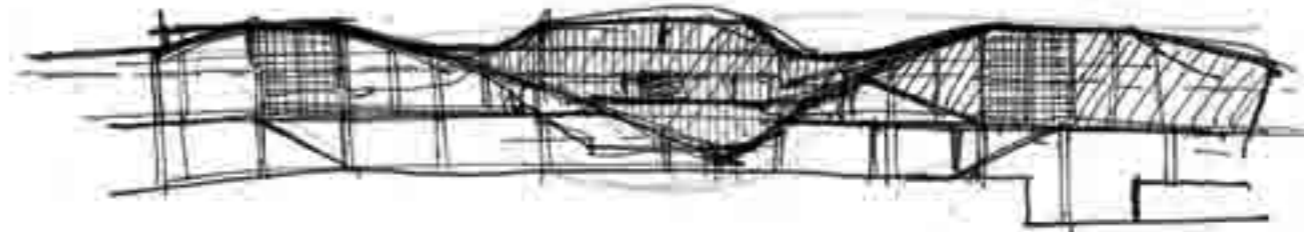

fig. 121_ Conceptual design development of platform roof and facade becoming more open to reveal the platform, allow for views and break the monotonous facade.

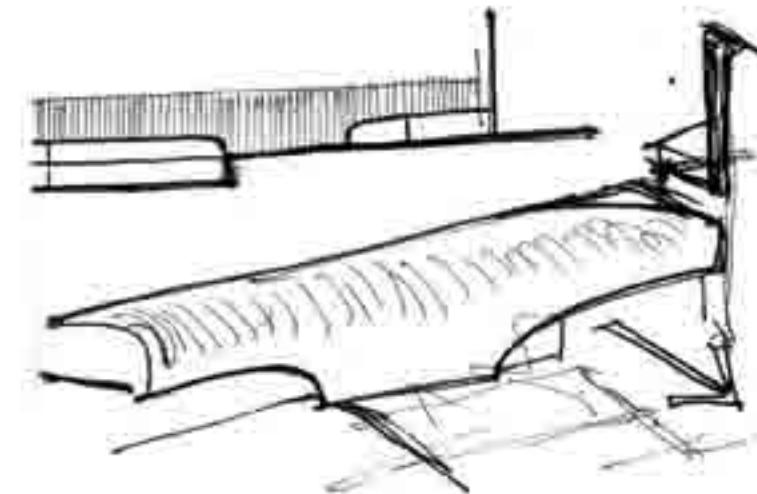

fig. 122_ Conceptual design development of platform roof wrapping over to become the facade, opening up at access points

Design Development

The plans, section and elevations that follow are the result of the research in this dissertation and the concept development (see previous section). It aims to illustrate the exchanges of movement, access, visual/physical interaction, heritage and services, reacting to context and the functional requirements of the programmes.

For instance the facade cuts open to reveal views of the site and in doing so allows the structure to be open. It brings opportunities for ventilation and natural light to enter the envelope.

The design development is illustrated in the following drawings.

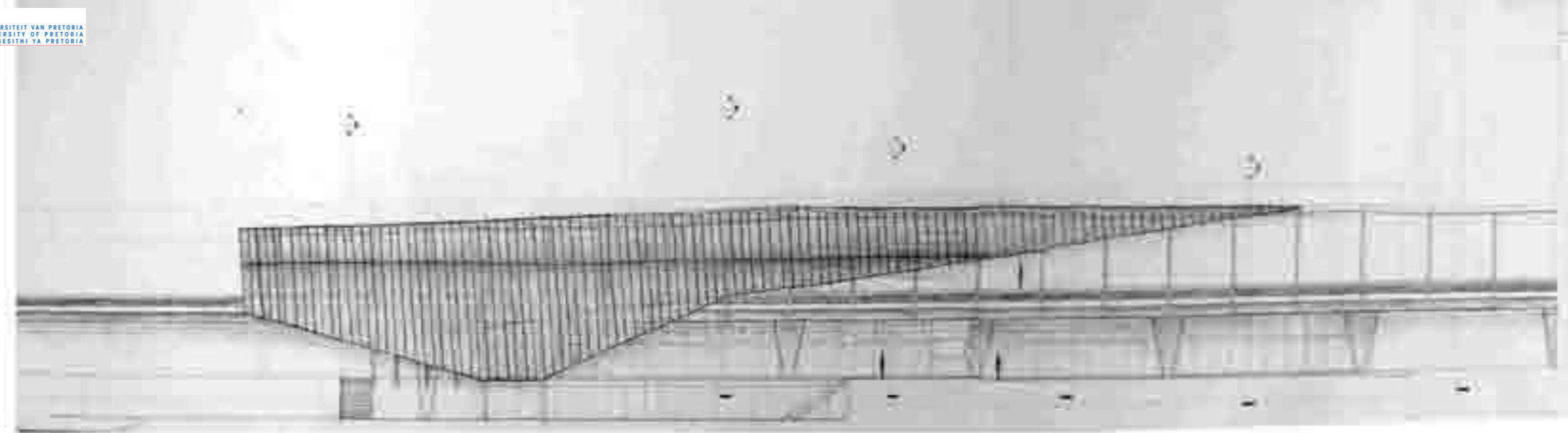

fig. 123_ West elevation

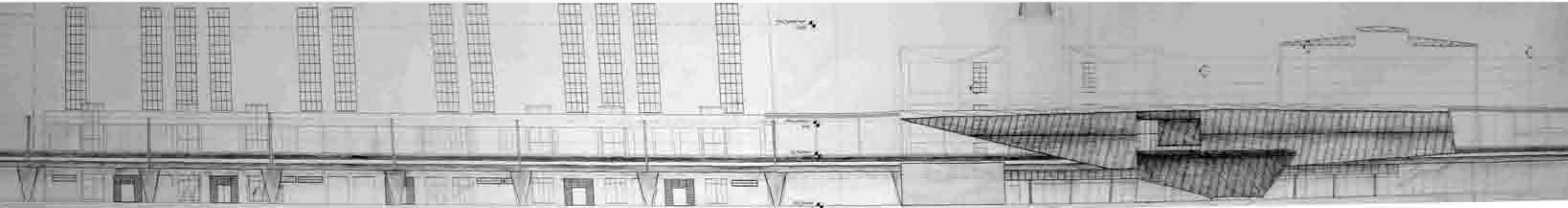

fig. 124_ East elevation

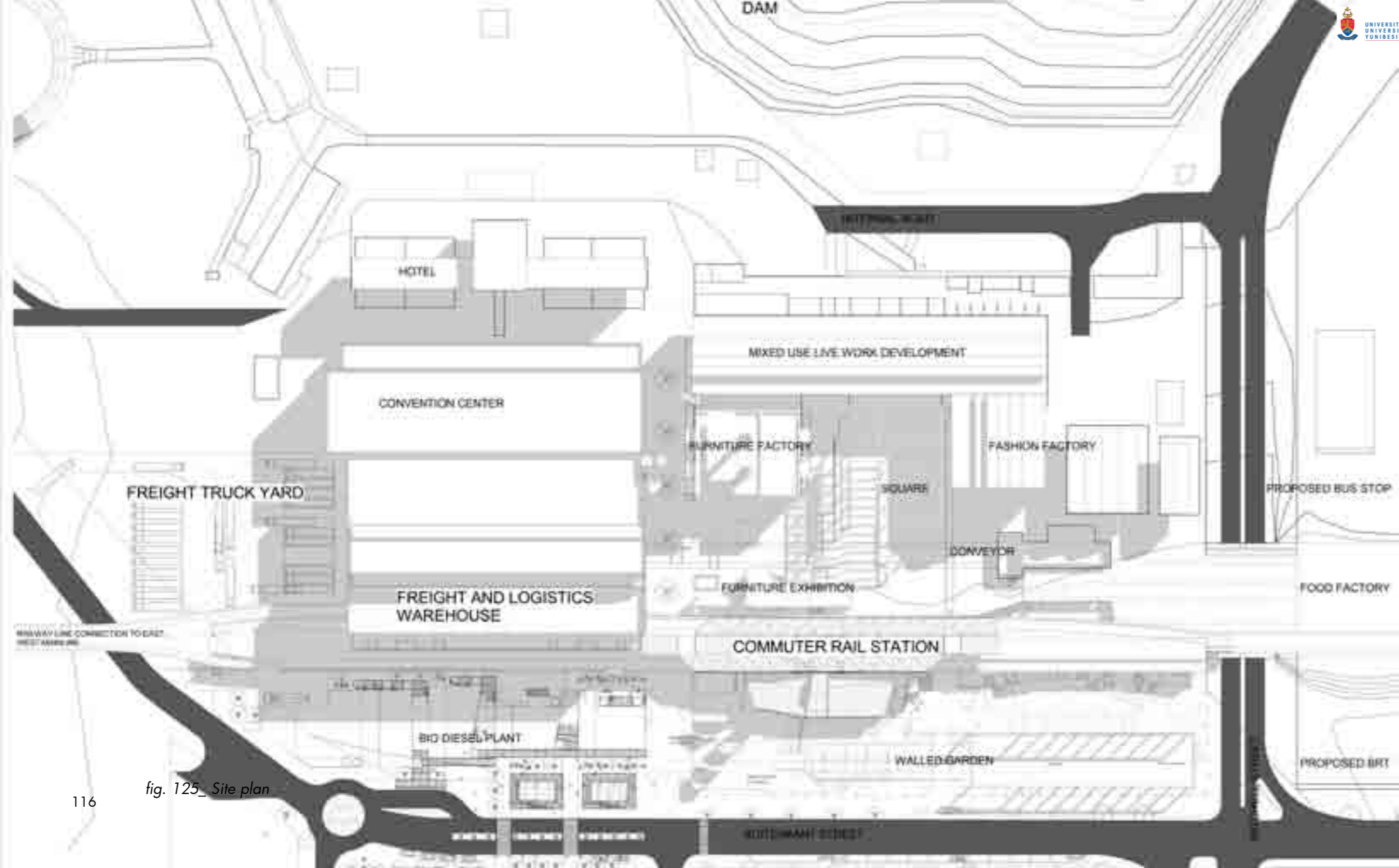

fig. 125_ Site plan

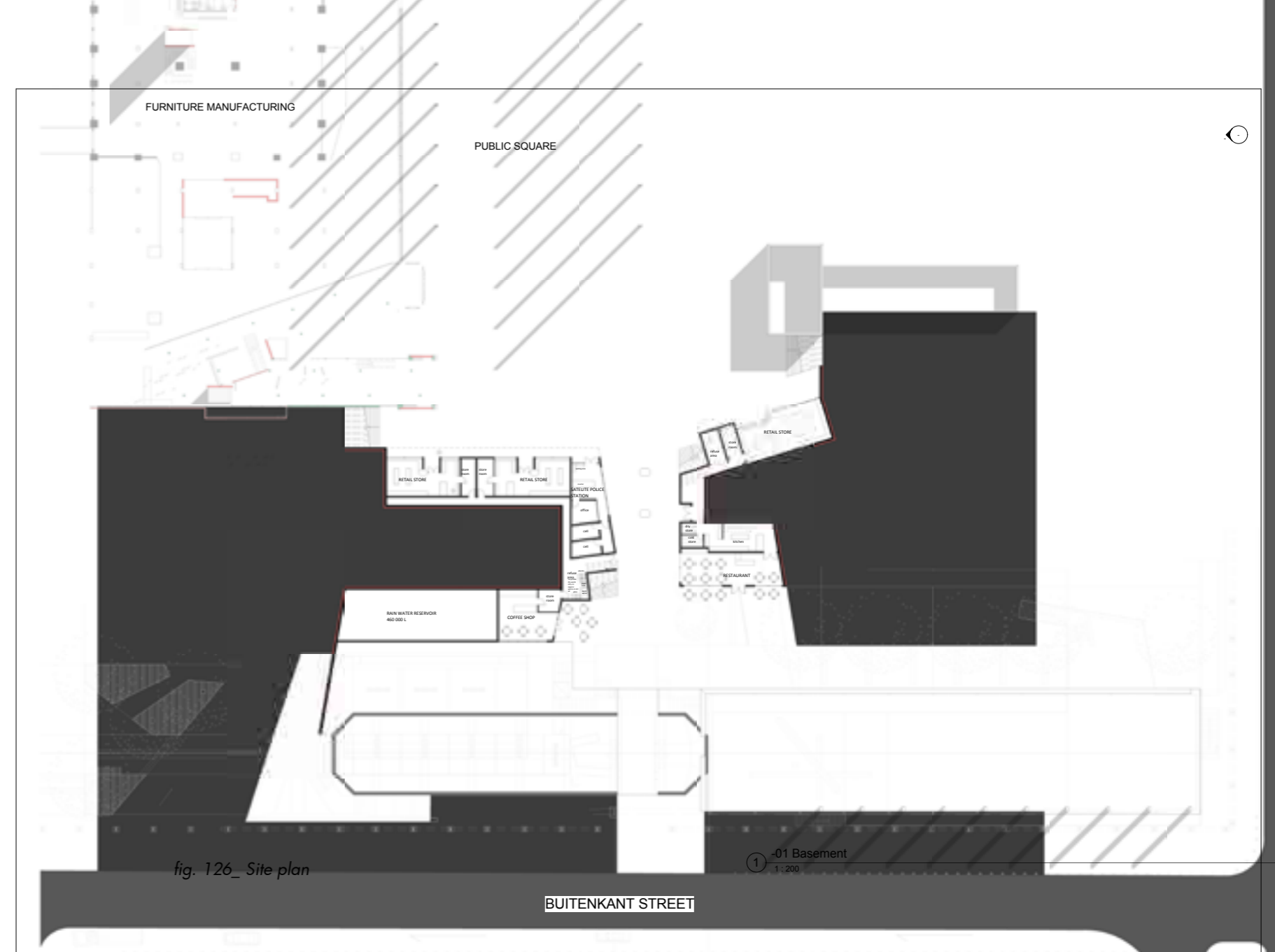
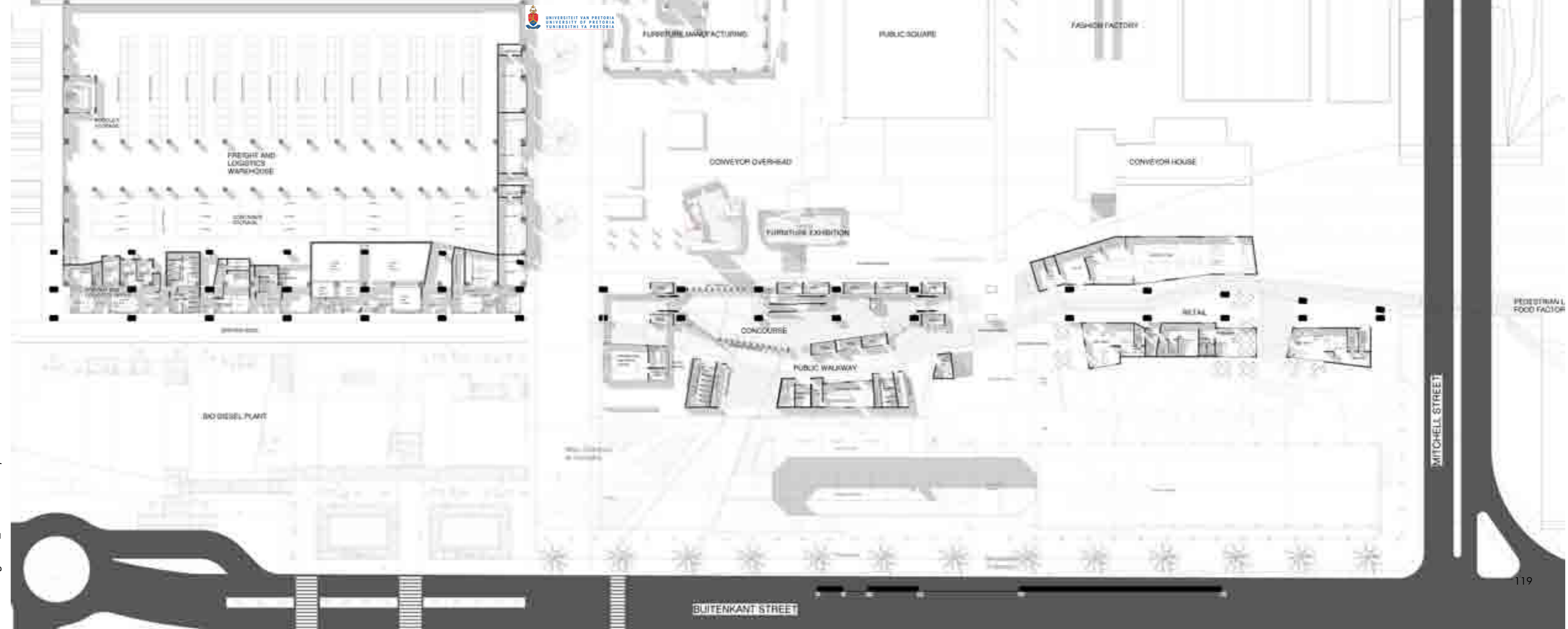

fig. 126_ Site plan

BUI TENKANT STREET

1:200
-01 Basement

fig. 127_ Ground floor plan



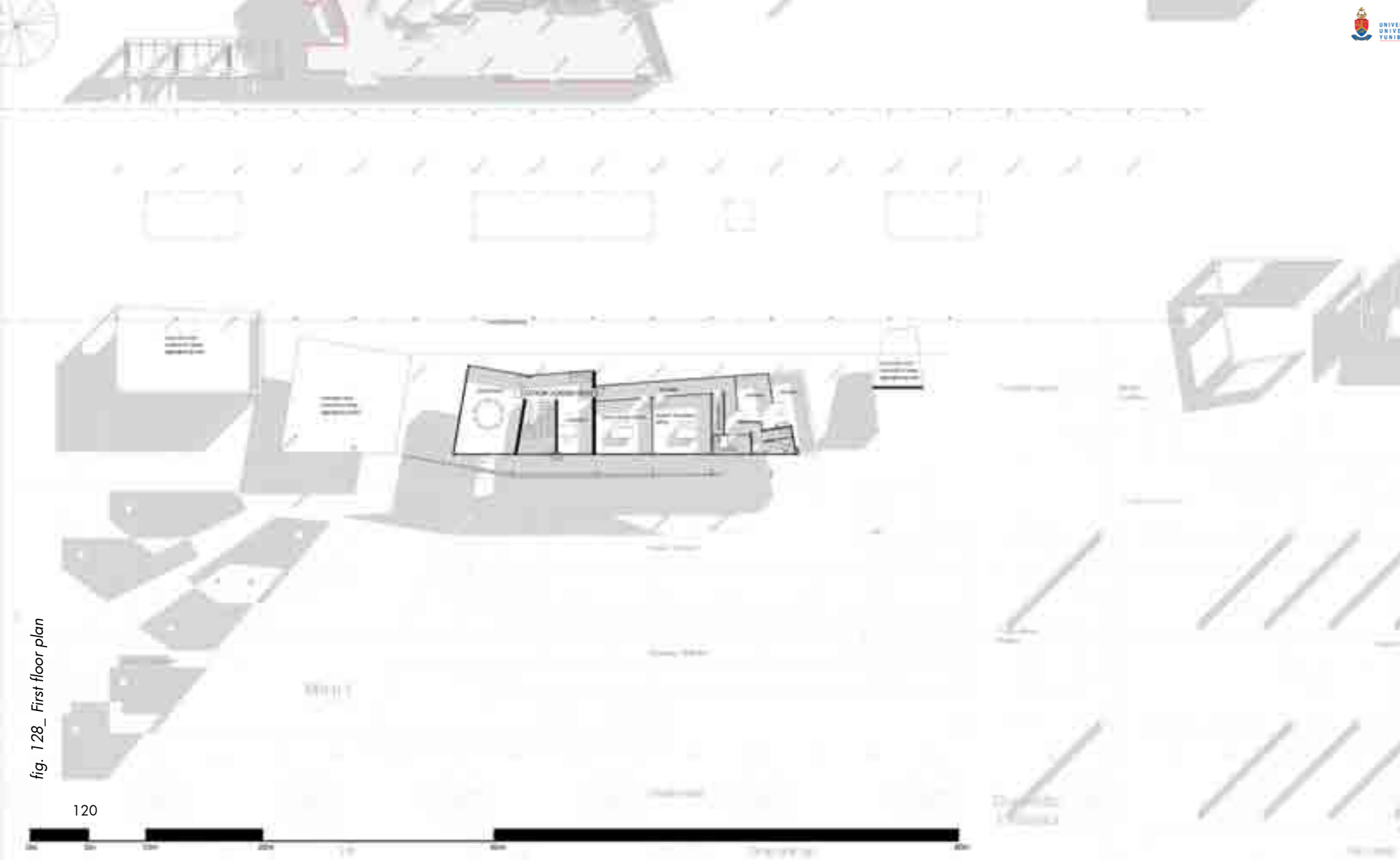

fig. 128_ First floor plan

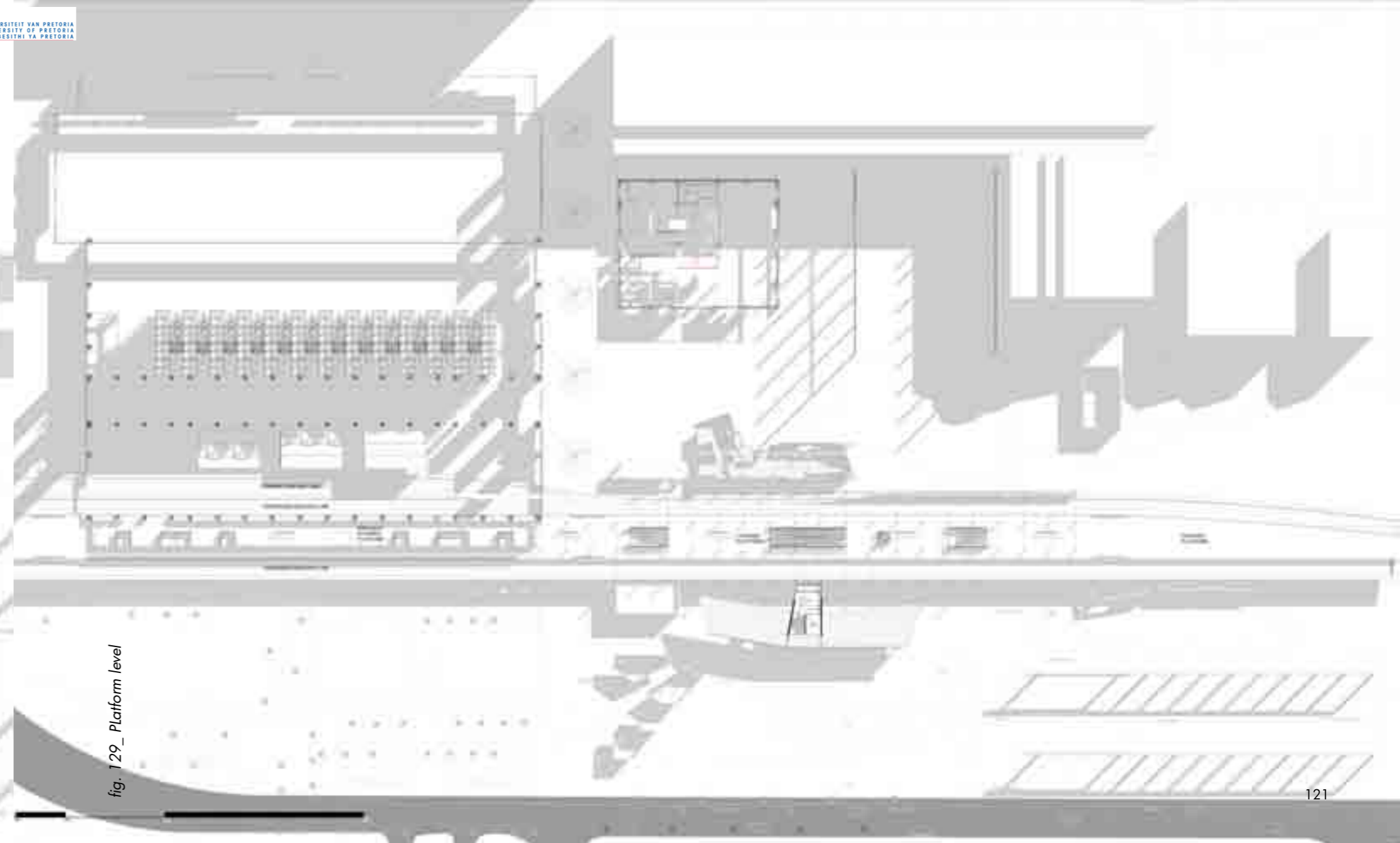

fig. 129_ Platform level

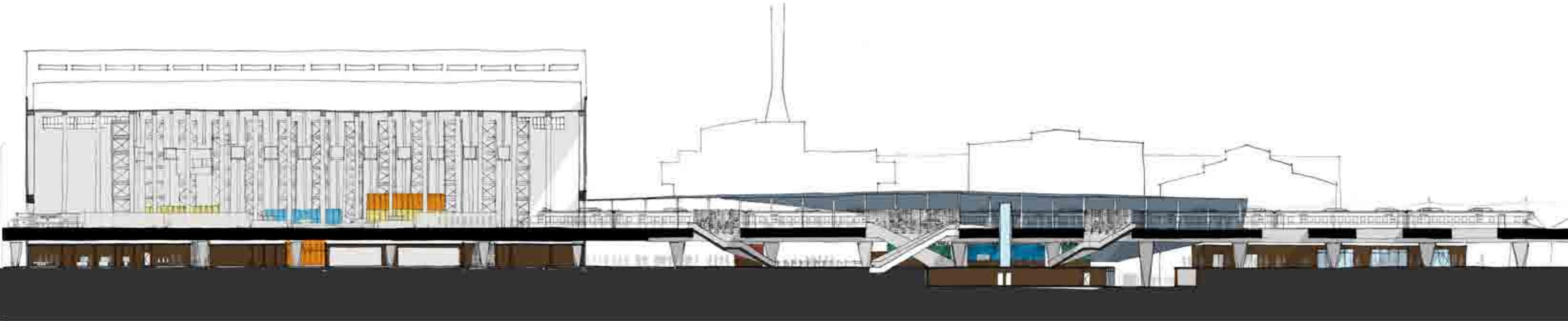

fig. 130_ Section through length of platform

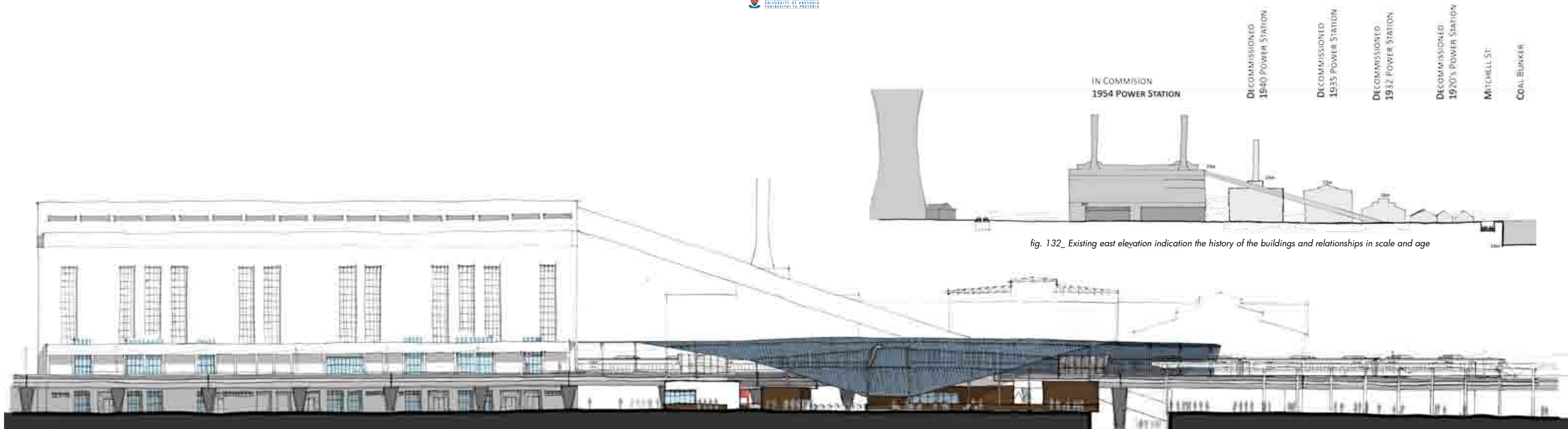

fig. 132_ Existing east elevation indication the history of the buildings and relationships in scale and age

fig. 131_ New east elevation



fig. 133_ New west elevation

fig. 134_ Perspective section



fig. 135_ Entrance perspective

fig. 136_ Perspective of public walkway



fig. 137_ Perspective of concourse



Technical Investigation

136

Technical concept

138

Structure

142

Material choice

150

Technology, Services and Sustainable Systems

158

SBAT Rating

This chapter will illustrate the technical concept and how the structure and materials relate to the concept. Services provided to the building and passive and active sustainable systems will be investigated. The chapter concludes with the SBAT rating for the intervention.

Technical concept

The technical design concept is generated out of the concept of exchanges. The exchanges between different stereotomic and tectonic structural systems and materials will be investigated.

Stereotomic:

The existing structures on site are built of brick and concrete.

New structures that touch the ground plane will be consist of similar materials and structures. The structures are:

- Platform
- Columns
- Ground floor structures

Tectonic

All new additions that do not touch the ground plane will have a lighter structural response, including the infill or cladding that will be lightweight materials.

- Steel structure of platform roof
- Second floor structures
- Kiosk infill

Exchanges occur where different elements meet, with transitional elements connecting the different materials. This emphasizes the contrast and difference between elements and illustrates which elements belong to each other.

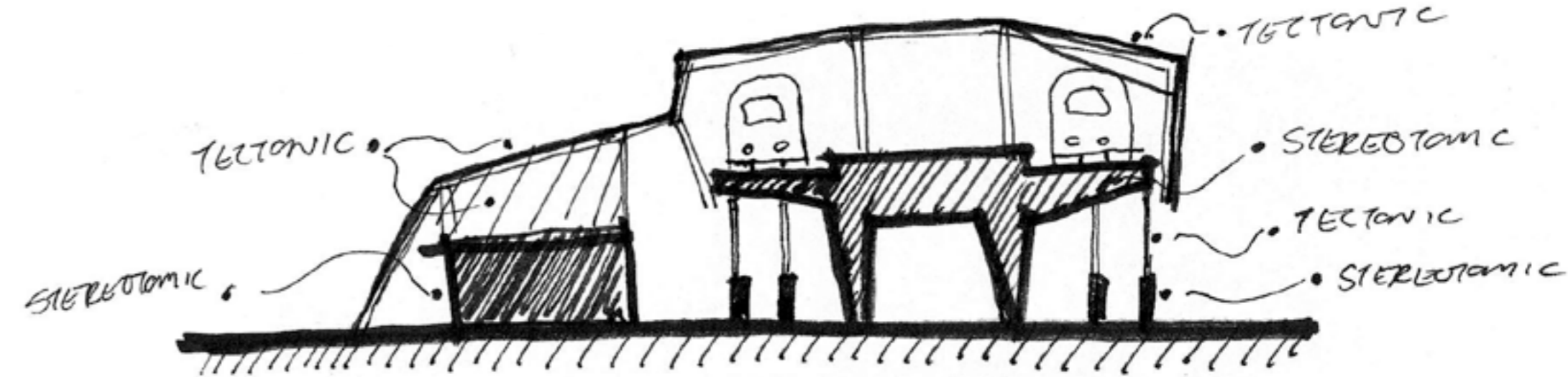

fig. 138_ Diagram illustrating technical concept

Structure

Stereotomic:

The existing structures on site are constructed of concrete beams and columns, with brick infill or cladding.

The new elevated railway platform is a large structure adding to the stereotomic nature of the existing structure. The structures constructed on ground level are of brick and mortar, mimicking the existing structures and, thus becoming part of the existing.

Tectonic:

The structures added on the levels above the platform and the ground floor structures are more tectonic in nature and light-weight, contrasting with the existing structures on site and distinguishing between new and old

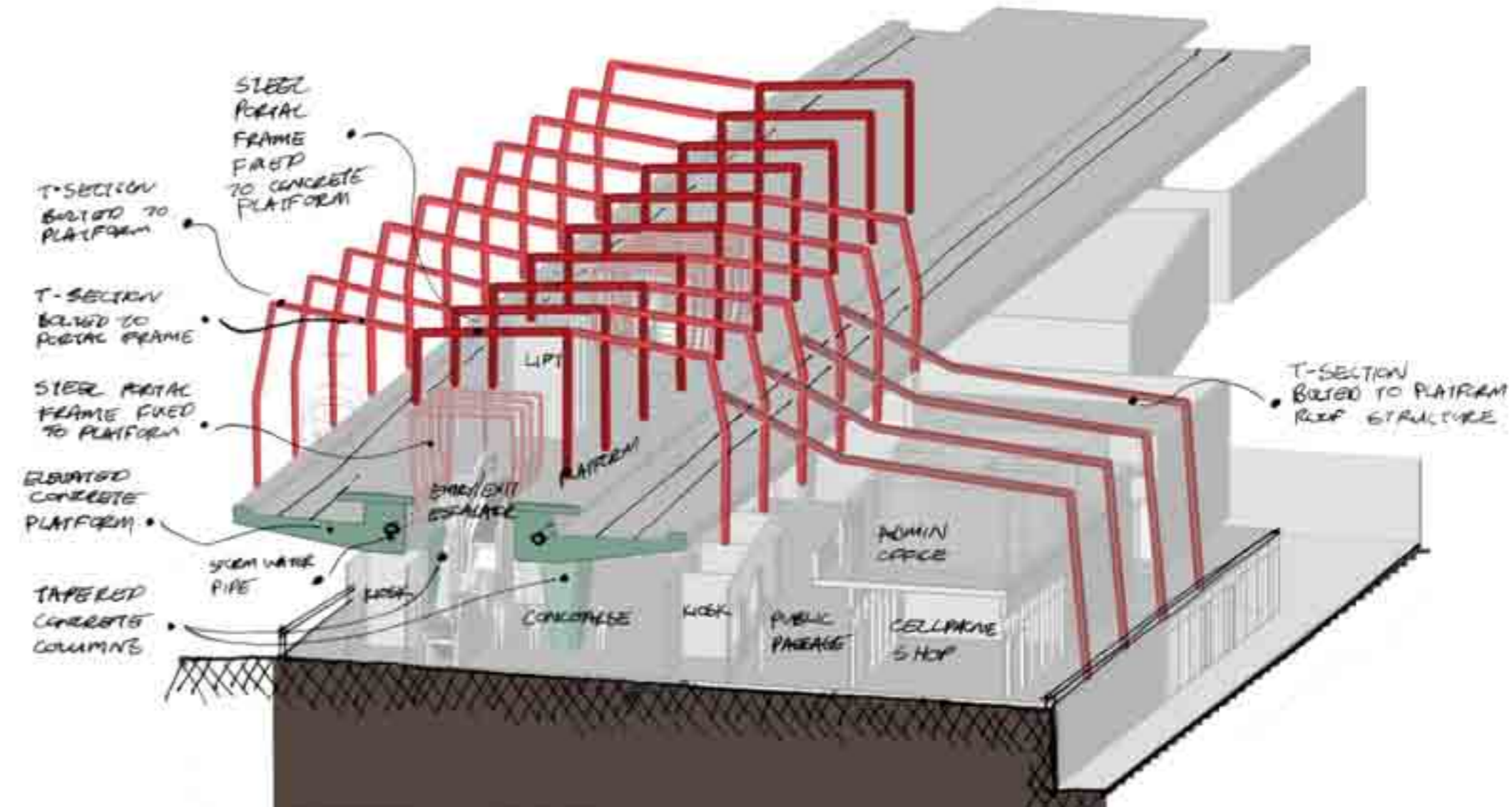

fig. 139_ Axonometric section illustrating structural elements

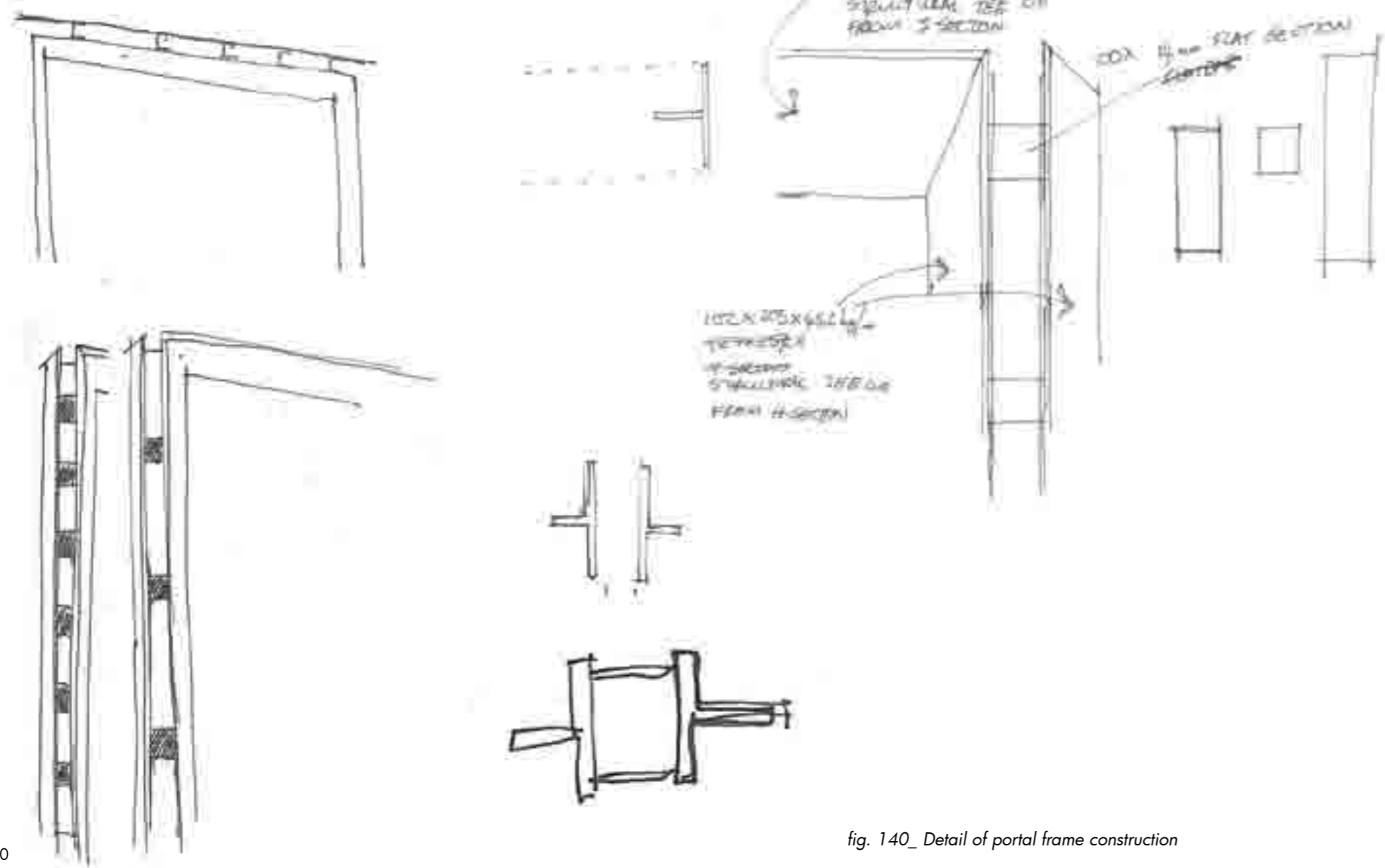

fig. 140_ Detail of portal frame construction

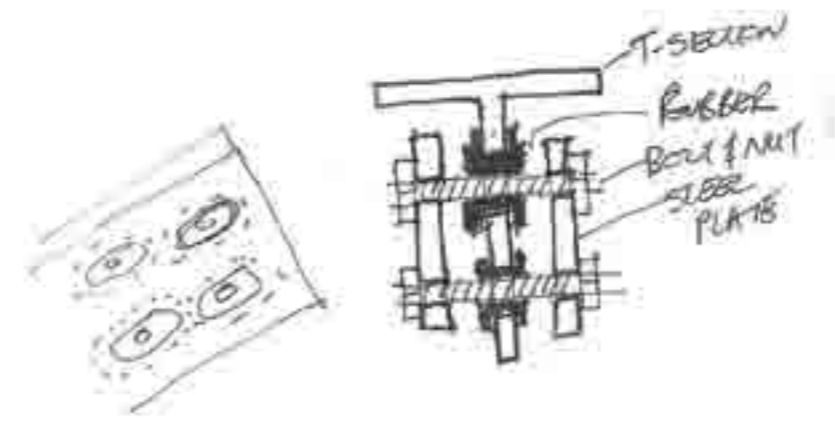

fig. 141_ Detail of steel frame connection where movement will occur to prevent vibration

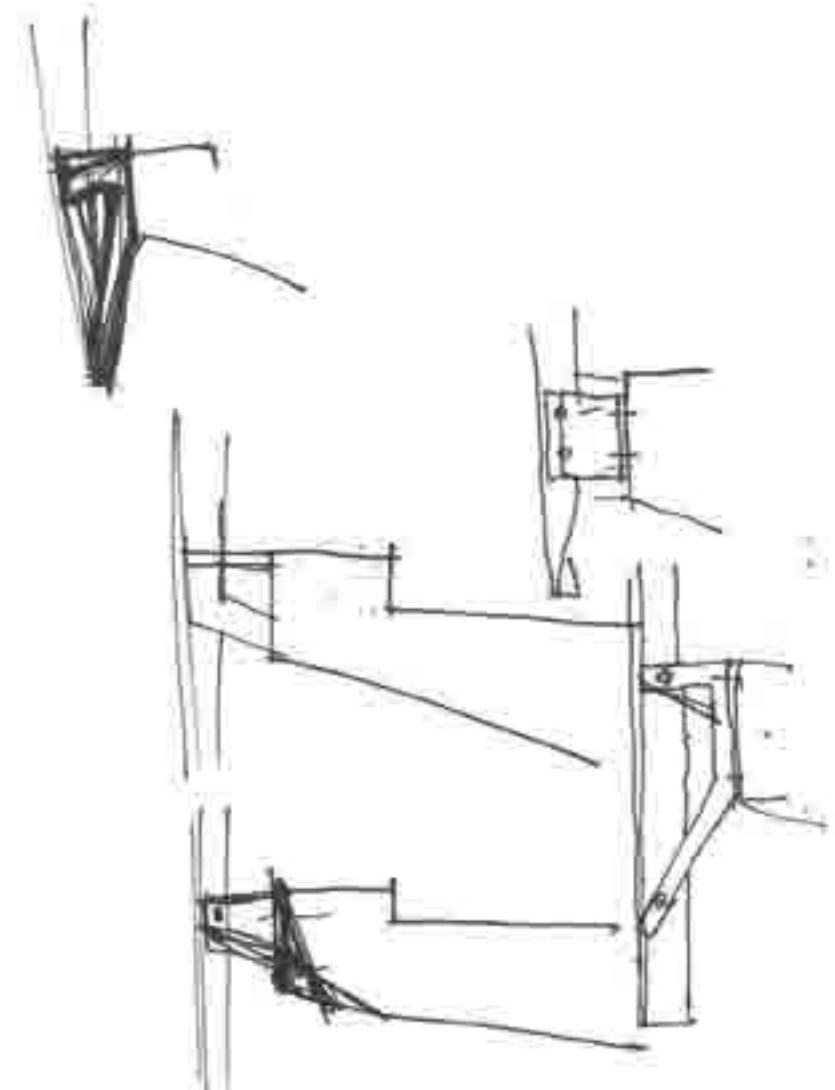

fig. 142_ Exploration of facade structure connection to platform

Material choice

The materials chosen are durable and easy to construct to suit the industrial character of the site.

The roof and facade material is of profiled zinc sheets, which is very common and a well known material in the construction industry.

The ground floor structures are constructed out of brick and mortar, also a very common material.

The kiosk facades will be constructed of translucent polycarbonate sheets, to allow visual connection between the public space and the concourse. Polycarbonate will be used rather than polyethylene sheets, due to its strength and durability.

A welded mesh is added to the facade of the building where more transparency is required for visual connections. It covers the exits from the platform to the concourse and forms the connection between the kiosks and the platform, becoming a transitional material. 'Steeledale specimesh' will be used due to following specifications by the manufacturer. It is:

- Available in a wide variety of aperture and wire diameters
- Flush-cut all round (no sharp edges)
- Ease of installation when welding and framing
- Easy to profile.

Concrete is used for the stairs and also encloses the escalators, acting as a part of the platform extending to the ground.

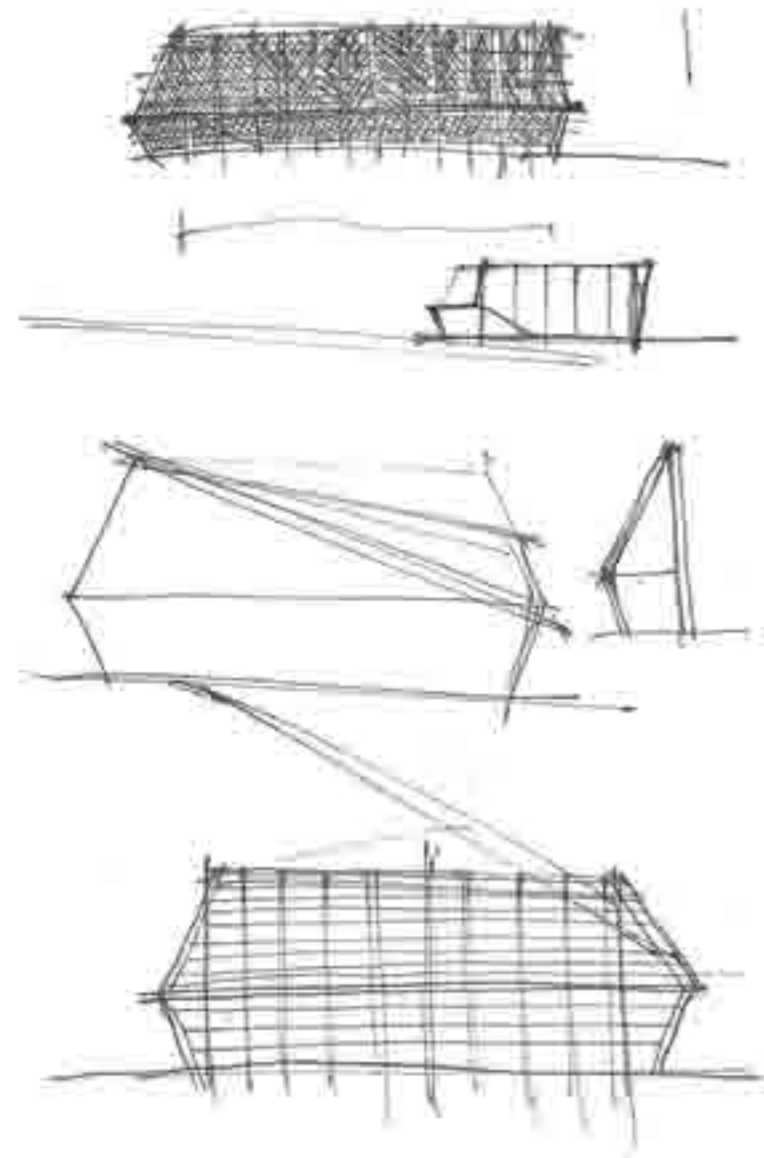

fig. 143_ Exploration of shape and permeability of platform entry and exit enclosure

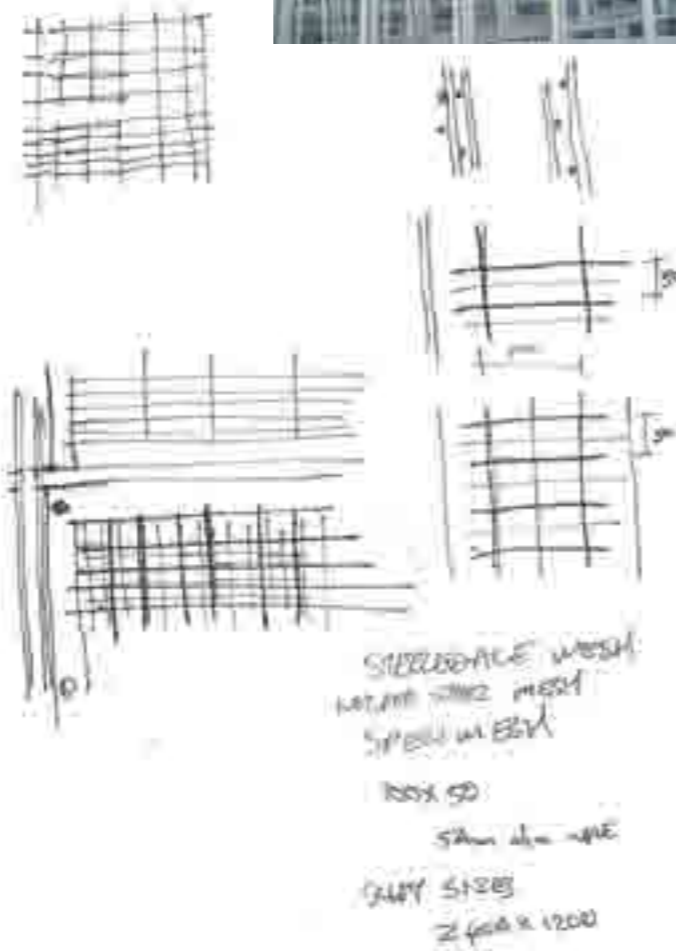

fig. 144_ Wire mesh specification and weaving detail

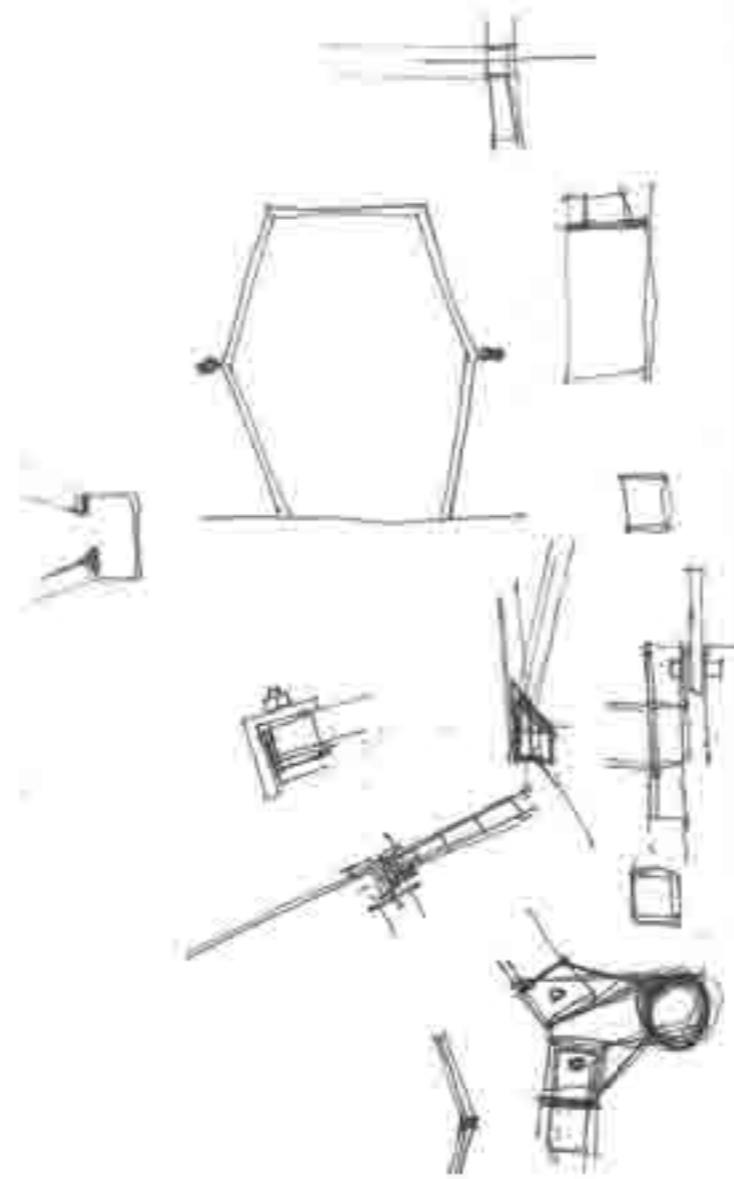

fig. 145_ Platform entry and exit enclosure connections

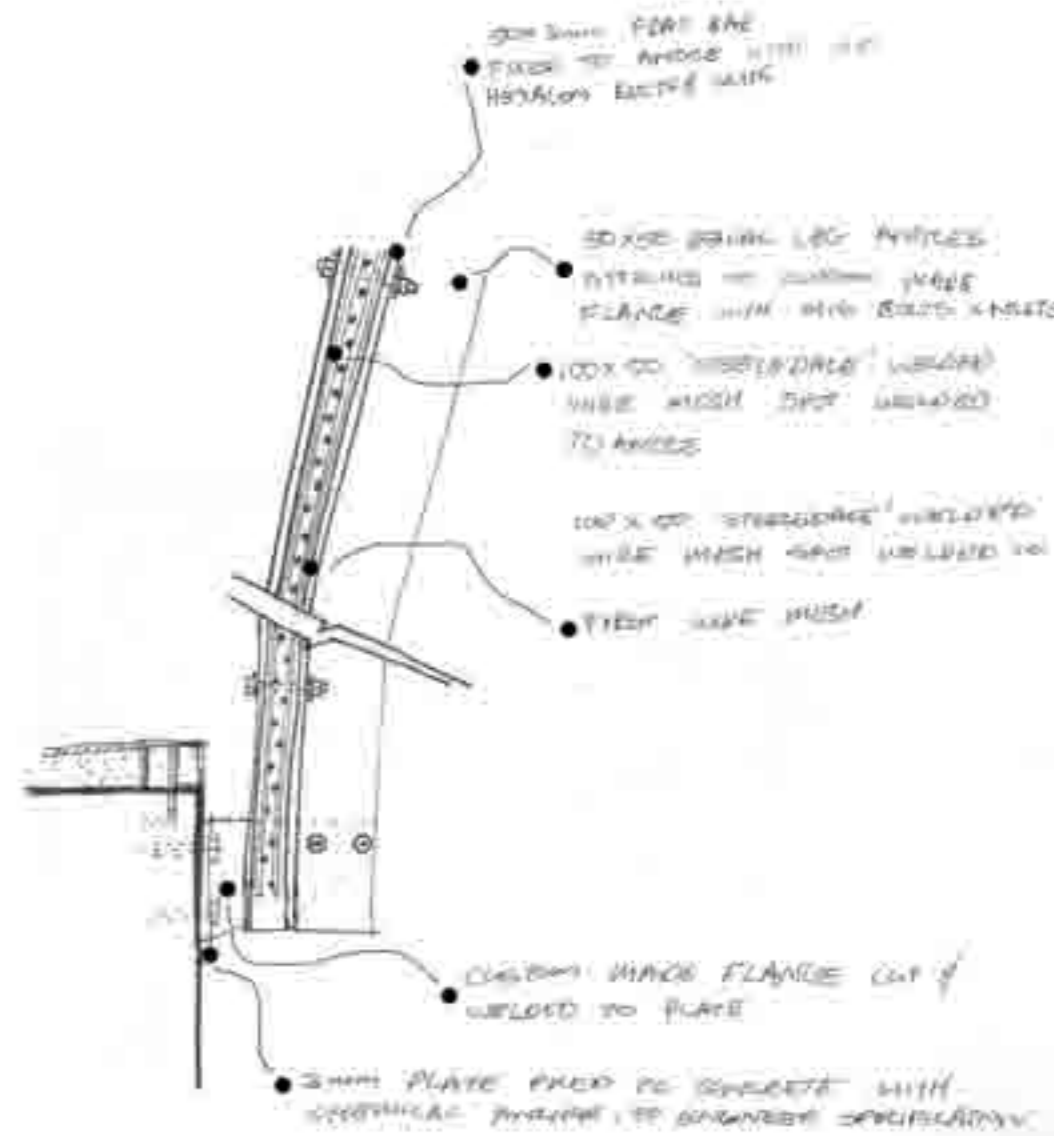

fig. 146_ Detail of platform enclosure, not to scale



fig. 148_ Image of translucent polycarbonate sheets

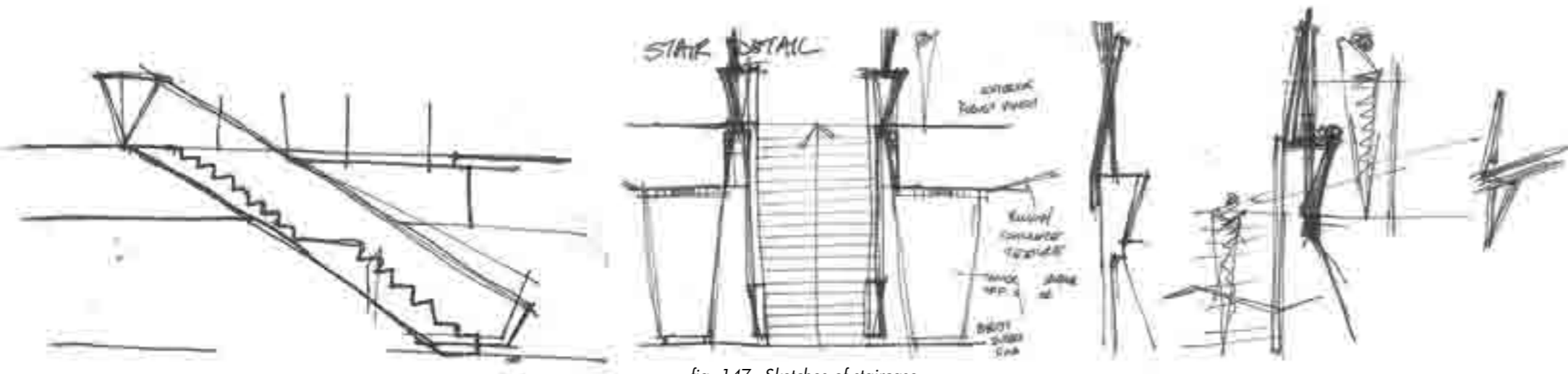

fig. 147_ Sketches of staircase

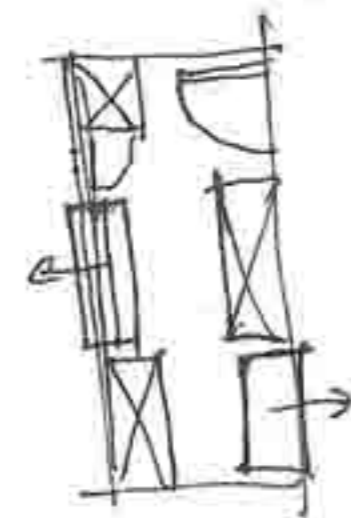
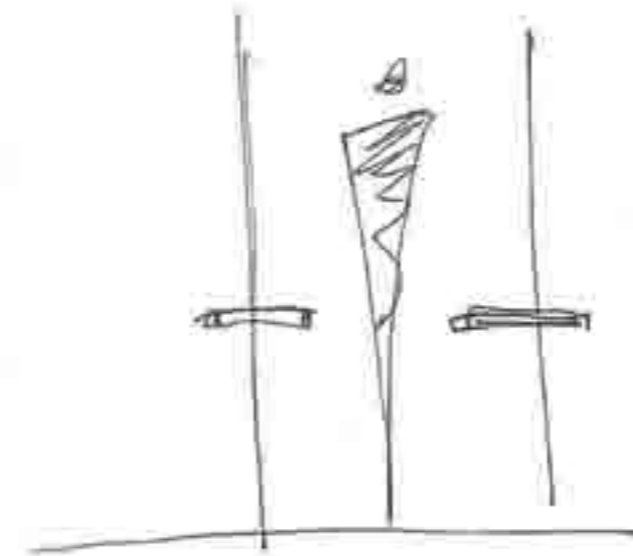

fig. 149_ Sketches of kiosks illustrating materiality

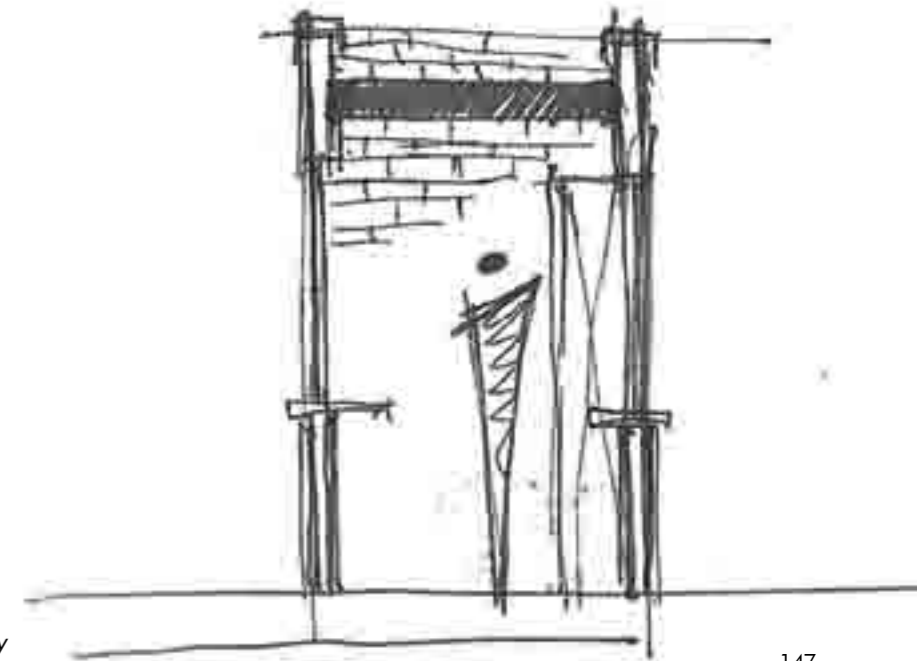



fig. 150_ Section, not to scale

Technology, Services and Sustainable Systems

| Rain Water Harvesting

Water will be collected from the roof and the railway tracks and piped in a stormwater pipe [cast into concrete of platform] to a leaf and large particle filter followed by a grease trap with a series of baffles to remove oil and smaller particles collected from the tracks, finally stored in the water reservoirs. (Appendix, p. 170)

This water will be used to flush toilets and will reduce the water consumption drastically.

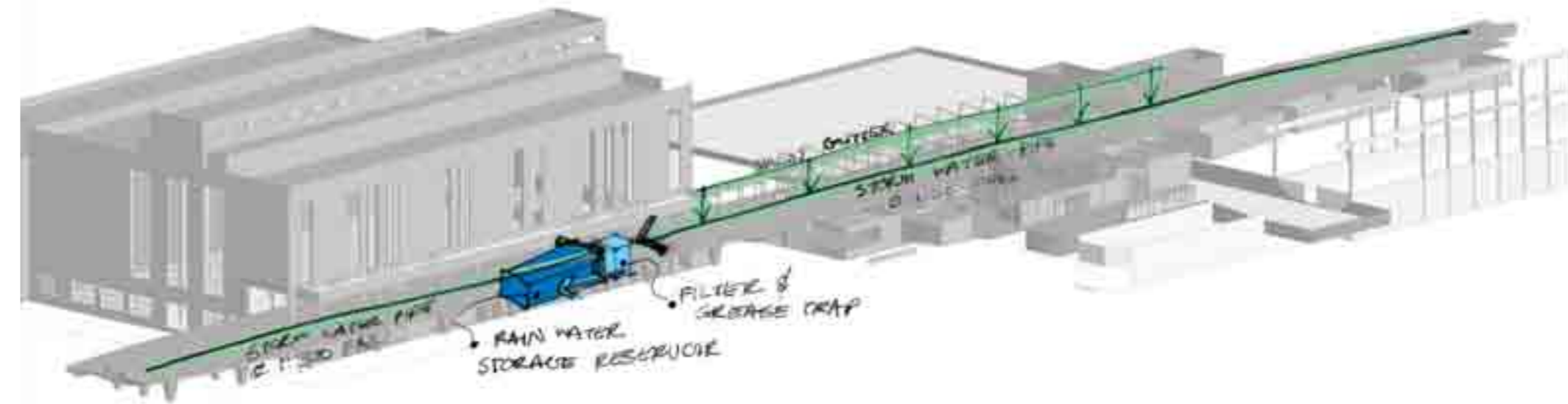

fig. 151_ Diagram illustrating rainwater harvesting system

| Heating and Cooling System

The offices and retail programmes will be heated and cooled by a underfloor piped system. Polyethylene pipes are cast into the screed of the floor and connected to an air cooled chiller which cools the floor in summer, in winter solar heating modules are used to heat the floors. The system works with water that gets continually circulated through the floors and a chiller or solar heating elements to heat or cool the spaces.



fig. 152_ Diagram illustrating the heating and cooling pipes

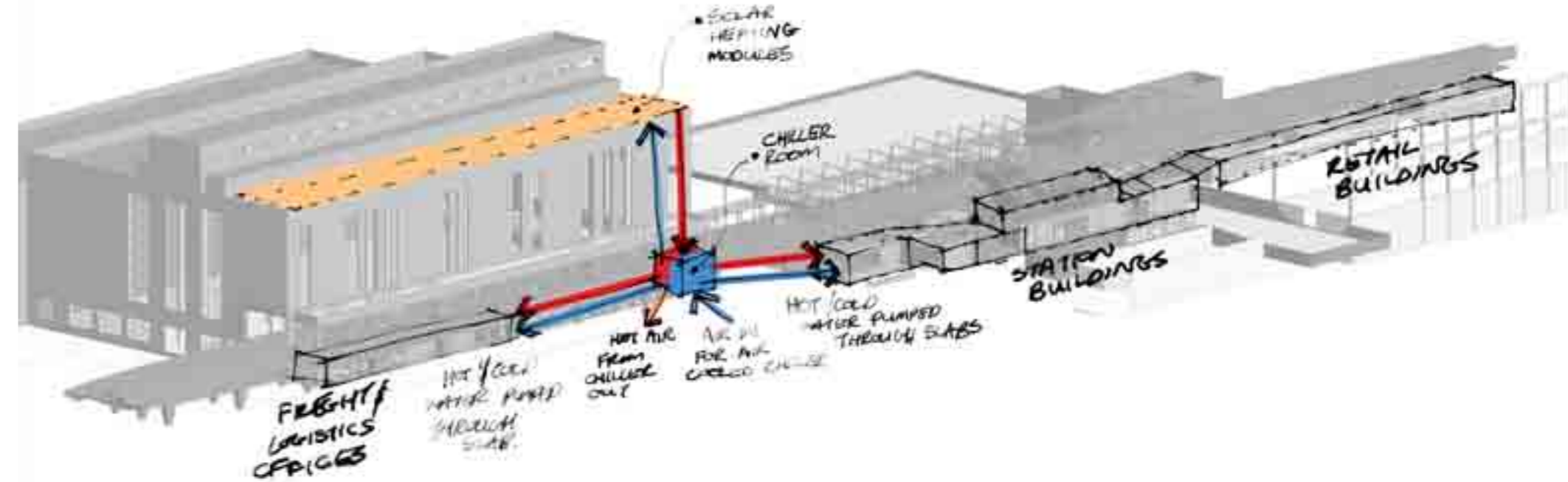

fig. 153_ Diagram illustrating the heating and cooling system

| Services

Electrical services are distributed from a transformer along with four backup generators through the elevated railway platform to the train station buildings and retail programmes. The distribution network includes the other industrial programmes proposed on site.

Rainwater is pumped from the reservoirs along the elevated railway platform to the ablution facilities of the train station.

Data and telecommunications is also distributed through the railway platform to the station, retail and other industrial programmes on site.

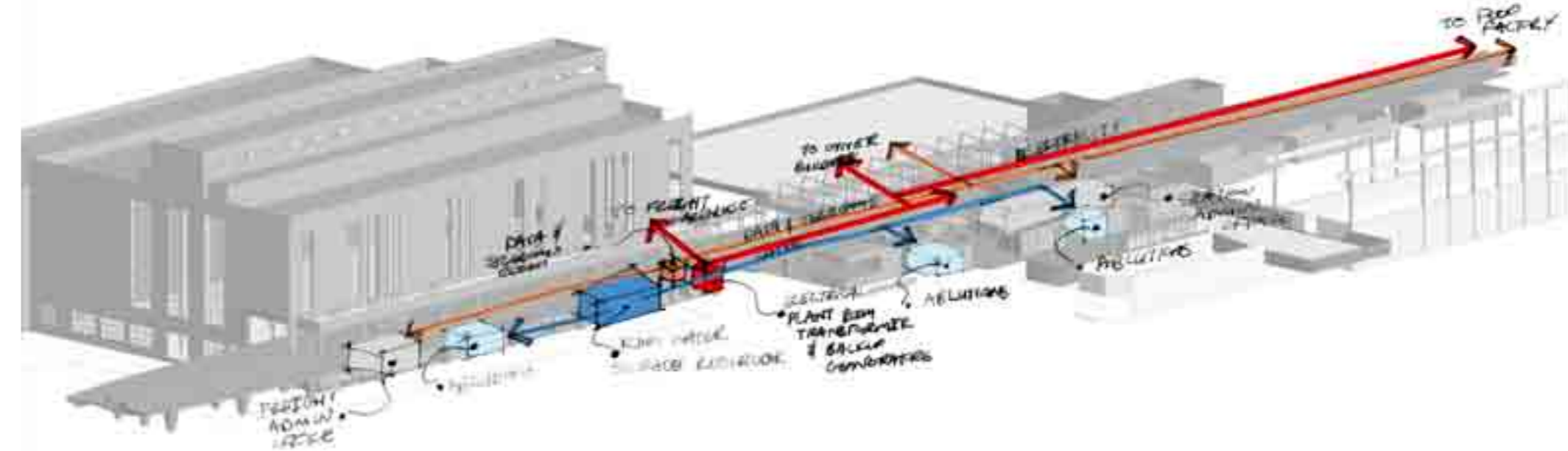

fig. 154_ Diagram illustrating the distribution of services through the elevated railway platform

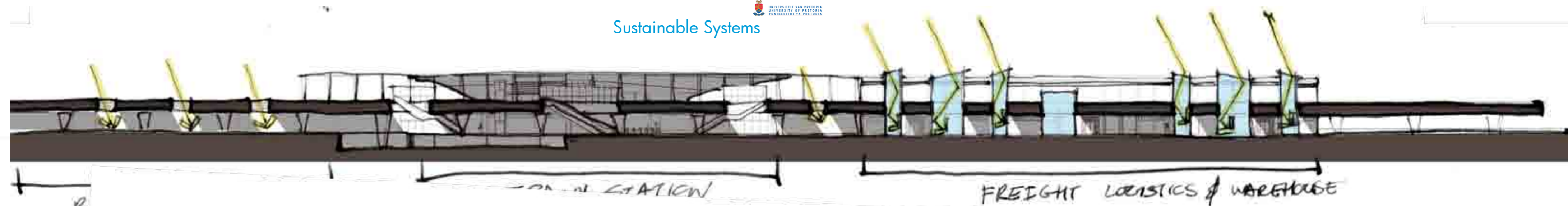

fig. 155_ Section illustrating the natural light provided to the ground plane by punching openings into the elevated railway platform.

fig. 157_ Section illustrating the natural light provided to the inside of the freight and logistics warehouse through light and ventilation chimneys

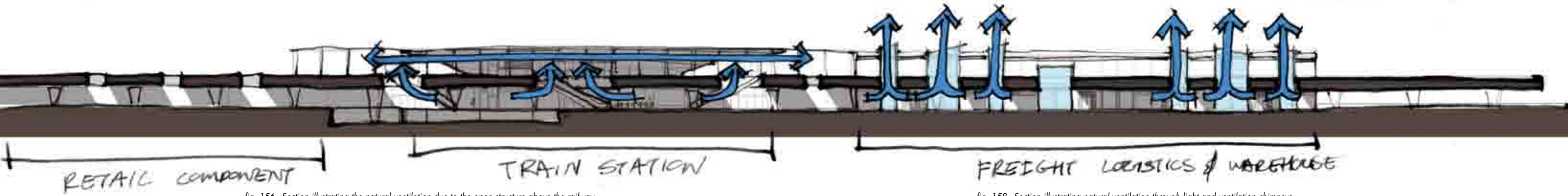

fig. 156_ Section illustrating the natural ventilation due to the open structure above the railway platform

fig. 158_ Section illustrating natural ventilation through light and ventilation chimneys

SBAT Rating

According to the SBAT results (see next page), the buildings overall classification is good between 3 and 4 (highest value awarded is 5 = very good). The buildings performance on social and environmental level relates to the overall classification. The economic sustainability is very good.

SUSTAINABLE BUILDING ASSESSMENT TOOL (SBAT- P) V1

PROJECT	ASSESSMENT
Project title:	Date:
Location:	Undertaken by:
Building type:	Company / organisation:
Internal area (m2):	Telephone: Fax:
Number of users:	Email:

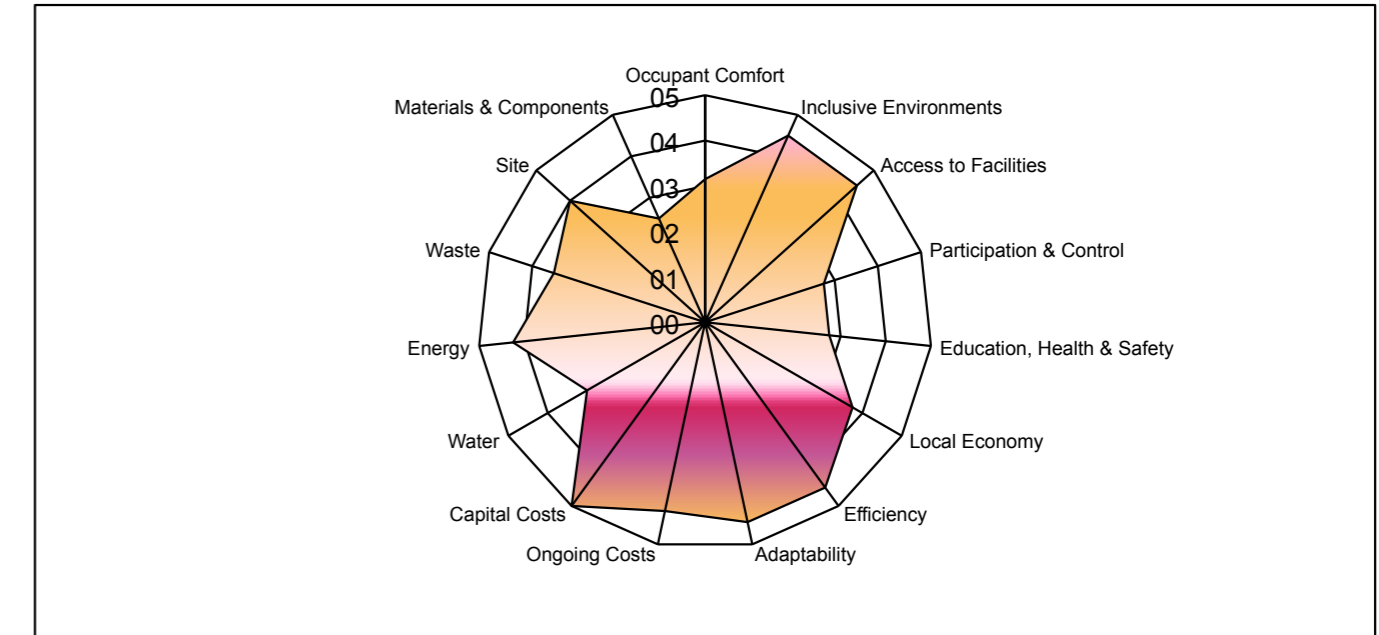

Social	3,5	Economic	4,4	Environmental	3,5
Overall	3,8	Classification			

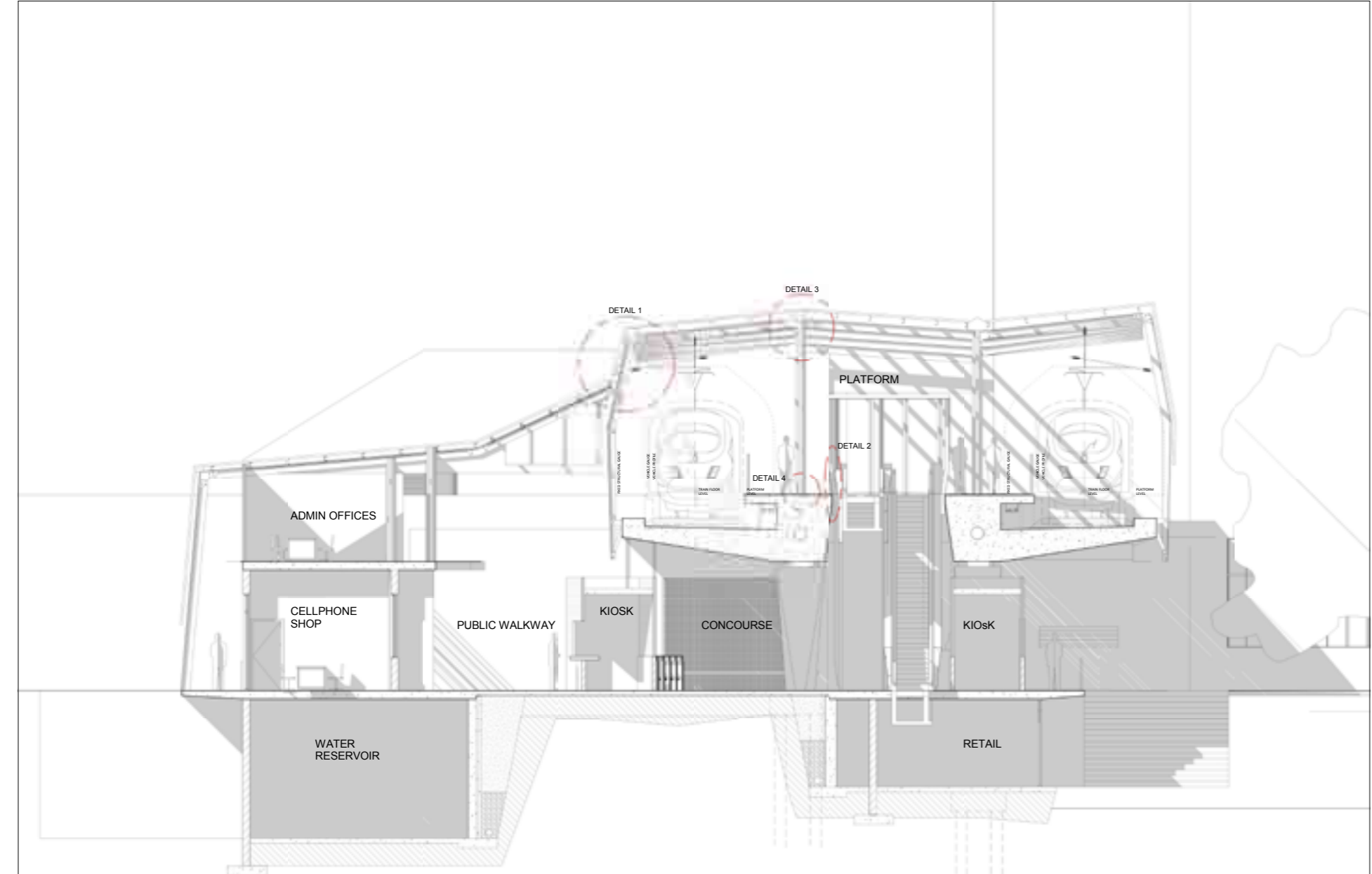
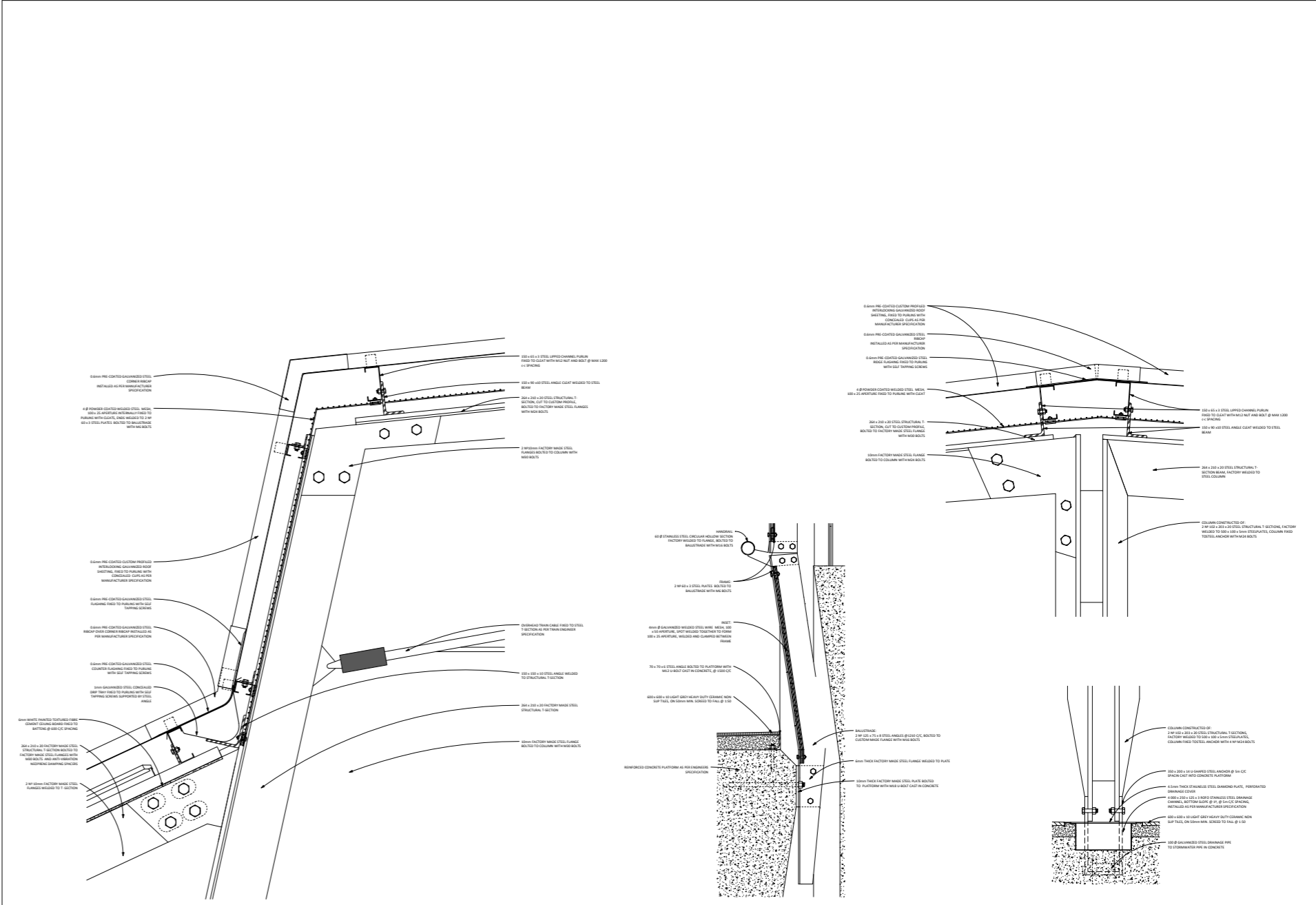
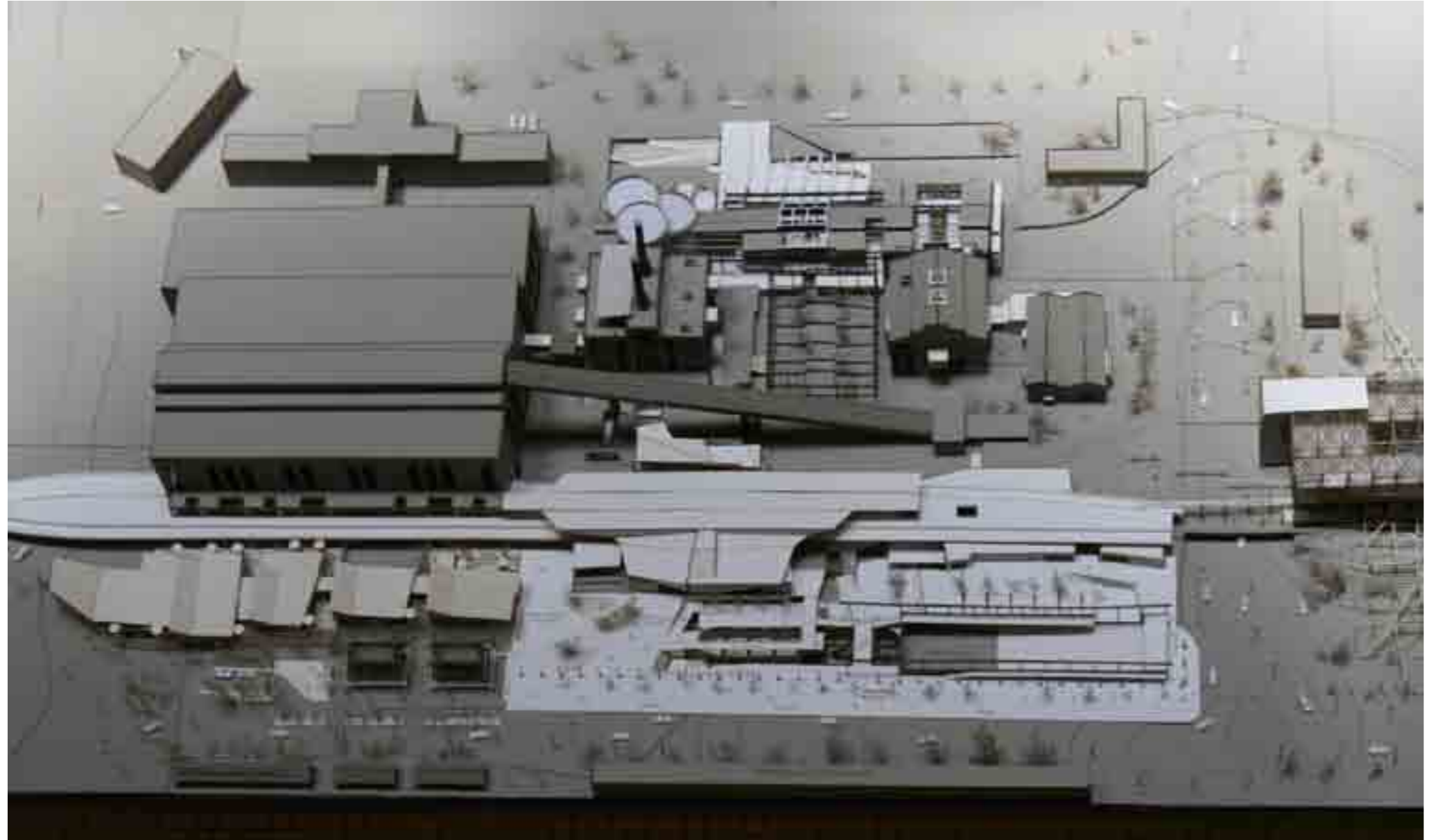

fig. 160_ Cross section

fig. 161_ Details



Model Photos









The dissertation has investigated the integration of a train station with an industrial site and heritage building. The proposal allows for opportunities to integrate and combine production processes with the public nature of a train station. Value is added by introducing first class public transport to a neglected area in the city and providing a hub which can act as catalyst to future development in the area. This forms the intrinsic part of the proposal.

The study focused on the site of the Pretoria West Power Station and an existing 1954 Boiler House. The industrial heritage of this landmark in Pretoria West is important to conserve as testament to the history of the place.

The idea of exchanges, derived from the input/output of a power station formed the concept and guideline for the design development.

Conclusion

The author used the Appleton charter as guideline for the conservation of the existing structure. An investigation into the urban integration and fixed and flexible boundaries was conducted on both urban and architectural scale.

The train station platform is raised to facilitate ease of access to the site and also frees up the ground plane for more public functions such as retail and restaurants. The existing building is converted into a freight management and logistics warehouse.

The integration of these two functions with the existing building and site allows for public interaction with production processes and alleviates the monotony of industrial buildings and sites.