

2012

Optimization of manufacturing workflow, stock and inventory control

Final Year Project (BPJ 420)
Final Report



Executive Summary

Aveng Manufacturing Duraset Company, a division of the Aveng Group is located in Alberton, South Africa. **Aveng Manufacturing Duraset** specializes in the manufacturing of support (reinforcement) and suspension products mainly used within the mining industry, worldwide. Some of these products include: Rock Studs, Rock Bolts, Rope Eye Bolts and Pigtails each with their sub section of components. Safety is a major factor in the success of Aveng Manufacturing Duraset.

This project will aim to smooth the general workflow of raw materials and products throughout the manufacturing process and also the general control and allocation of stock and inventory with, if time allows it, a simulation model for a recommendation of a new and improved manufacturing system would be included.

This will be achieved by using the various relevant Industrial Engineering methods, tools and problem solving techniques gathered and learned in the BEng Industrial Degree thus far. This report will show the author's recommendation to the current problems at Duraset Manufacturing.

System improvements, whether it is the decrease of idle times, increase in productivity and output of finished products, by eliminating bottlenecks and implementing new technology, simple, basic designs and equipment, even the control of finished products, good housekeeping and accurate stock data in whichever way possible, that should provide Aveng Manufacturing Duraset with one of many solutions.

Table of Contents

Executive Summary	i
Table of Contents	ii
List of Figures	iv
List of Tables	v
1. Introduction and Background	1
1.1. Company Background.....	1
1.1.1. Aveng (Africa) Group	1
1.1.2. Duraset Manufacturing	3
1.1.3. Export	3
1.1.4. Products and Safety	3
1.2. Products Discussion (Alrode Manufacturing Factory)	5
2. Problem Statement	6
3. Problem Statement Defined	7
4. Project Aim.....	7
4. Project Scope	7
5. Deliverables	8
6. Literature Review	9
6.1. Overview.....	9
6.2. Facilities Planning.....	10
6.2.1. Introduction	10
6.2.2. Design and Technology.....	10
6.2.3. Facility Layout	11
6.3. Material Handling Equipment and Methods	16
6.3.1. Introduction	16
6.3.2. Material Handling Principles.....	17
6.3.3. Investigation: Material Handling Equipment Used at Aveng Manufacturing Duraset	18
6.3.3.1. Management and Personal Concerns.....	18
6.4. Literature Review Conclusion	24
7. Data Gathering and Analysis.....	25
7.1. Optimizing Workflow and Layout (Between Peeling and Threading Machines)	25
7.1.1. Defining the processes and stakeholders involved	25
7.1.2. Inspection and Analysis of the Present Manufacturing System.....	26

7.1.3. Time Studies and Measurements.....	32
7.1.4. Simio Simulation Model Discussion	42
7.1.5. New Proposed Systems (Alternatives) Discussion.....	48
9. Recommendations	54
Big Changes	54
Small Changes	54
10. Conclusion	55
Scope Incompleteness Explanation	56
Bibliography	57
Images:	59
Appendix A: Current Facility Layout	62
Appendix B: Time Study Sheet.....	64
Appendix C: Simio Model, Results and Report.....	66
Appendix D: Design Alternatives	67
Appendix E: Aveng Manufacturing Duraset Products.....	73

List of Figures

Figure 1: Mother Company Aveng Group with its different divisions	1
Figure 2: Three Core Values of the Aveng Group	4
Figure 3: Safety is High Priority at the Aveng Group	4
Figure 4: Roof Bolt Explosion	5
Figure 5: Drum-Buffer-Rope System	15
Figure 6: Gravity Conveyor	19
Figure 7: Forklifts and Warning Sign	20
Figure 8: Overhead Crane.....	20
Figure 9: Safety Risks of an Overhead Crane	21
Figure 10: Explanatory Overhead Crane.....	21
Figure 11: Wire Drawing and Cropping Machines a) Karl Fuhr b) Bull Block	21
Figure 12: Barcoding Methods and Scanners	22
Figure 13: Carousel Wheel.....	22
Figure 14: Shunting Rail with Container	23
Figure 15: 2-Bin-System Application	23
Figure 16: Focus Area - Peeling and Threading.....	27
Figure 17: Two Areas Under Discussion - Peeling Left - Threading Right	28
Figure 18: Time Study Key	32
Figure 19: Peeling Measurements (Averages) Summary	33
Figure 20: Peeling Average Work vs Average Idle	33
Figure 21: Peeling Average Work Measurements	34
Figure 22: Peeling Average Idle Measurements	34
Figure 23: Threading Measurement (Averages) Summary	35
Figure 24: Threading Average Work vs Average Idle	35
Figure 25: Threading Average Work Measurements	36
Figure 26: Threading Average Idle Measurements	36
Figure 27: Overhead Crane Measurements (Averages) Summary	37
Figure 28: Crane 2 Usage Average Work vs Average Idle	37
Figure 29: Crane 2 Usage Idle Measurement	38
Figure 30: Average Movements Made By Overhead Crane.....	38
Figure 31: Crane 2 Usage A1 vs A2 vs A3.....	39
Figure 32: Average Crane 2 Movement Times.....	40
Figure 33: Crane 2 Usage Average Work Measurements	40
Figure 34: Simio Brand Logo.....	42
Figure 35: Top View Simulation Run of Focus Area.....	43
Figure 36: Clean Top View Of Focus Area	44
Figure 37: Views of Work Stations	44
Figure 38: Top View of Run Pallets Number Monitors.....	45
Figure 39: View of Point Tally Monitors	46
Figure 40: Weighing Station (Sink).....	46

List of Tables

Table 1: Aveng Group's Construction and Engineering Capacity	2
Table 2: Tactical Level Criteria for Layout	11
Table 3: Types of Layouts	12
Table 4: Process Positioning Strategies	13
Table 5: Material Handling Principles	17

1. Introduction and Background

1.1. Company Background

1.1.1. Aveng (Africa) Group

Aveng (Africa) Limited is based in South Africa and is a multi-disciplined engineering and construction group which focuses on the infrastructure, energy and mining opportunities in Africa.

The group is registered in South Africa and listed in the Heavy Construction (Construction and Materials) Sector of the JSE Limited. Aveng Limited owns seventy-five percent of all issued share capital and the remaining twenty five percent is owned by a TisoGroup led BEE (Black Economic Empowerment) consortium.

The Aveng Group was established as the mother company that consists of the following group of operating companies:

- GRINAKE-LTA
- McCONNELL DOWELL
- E+PC (ENGINEERING & PROJECTS COMPANY)
- DURASET
- INFRASET
- LRS (LENNINGS RAIL SERVICES)
- STEELEDAL
- TRIDENT STEEL
- MOOLMANS



Figure 1: Mother Company Aveng Group with its different divisions

The Aveng Group is a world renowned manufacturing company (within and for key countries worldwide) as well as the largest infrastructure development company currently in South Africa with the satisfied client base as proof.

The Aveng Group has capabilities across a broad range of multi-disciplinary projects in engineering, construction, mining, rail, steel, water and manufacturing.

		Client industry						Manu- factured products	
		Transport	Power	Mining	Water and environ- ment	Infra- structure	Commer- cial	Industrial	– Steel – Concrete
The Aveng Group segments	Building	✓	✓	✓	✓	✓	✓	✓	✓
	Civil engineering	✓	✓	✓	✓	✓	✓	✓	✓
	Concessions	✓	✓		✓	✓	✓	✓	
	Concrete and steel manufacturing and processing	✓	✓	✓	✓	✓	✓	✓	✓
	Detailed multi- disciplinary engineering		✓	✓	✓	✓		✓	
	Roads and earth works	✓	✓	✓	✓	✓	✓	✓	
	Marine infrastructure			✓		✓		✓	
	Mechanical and electrical/ fabrication	✓	✓	✓	✓	✓	✓	✓	✓
	Opencast and underground mining			✓					
	Deep shaft mining			✓					
	Plant operations		✓	✓	✓	✓		✓	
	Pipelines		✓	✓	✓	✓		✓	
	Process engineering		✓	✓	✓		✓		
	Project and construction management	✓	✓	✓	✓	✓	✓	✓	✓
	Rail construction and maintenance services	✓	✓	✓		✓		✓	✓
Tunnelling	✓	✓	✓	✓	✓			✓	

Table 1: Aveng Group's Construction and Engineering Capacity

1.1.2. Duraset Manufacturing

Aveng Manufacturing Duraset is a broadly talented supplier in the mining and geotechnical industries of engineered support solutions with leading production and supply numbers established, earned and kept over the years. Aveng Manufacturing Duraset has its own well established research and development facilities, manufacturing plants and commercial services to meet the needs of a diverse, competitive and modern technology driven world market.

In the year 2000, Duraset Manufacturing was formed out of the merging of two construction company giants, Grinaker (established 1935) and LTA (established 1965). In May 2007, Aveng Manufacturing Duraset reached a new business level and identity in Aveng (Africa) Limited and got its own branded logo that will very soon be world renowned and respected.

Aveng Manufacturing Duraset serves all major mines operating in South Africa, with the likes of AngloGold Ashanti, Impala Platinum, Goldfields, Anglo Platinum, Anglo Coal, Harmony, Sasol and BHP Billiton and geotechnical contractors like Esor, BombelaFranki Africa, Grinaker-LTA and CMC di Ravenna.

1.1.3. Export

Export is not Aveng Manufacturing Duraset's biggest market or source of income, but the relationships that are built with the business deals can be worth more for future use or plans.

This ten percent includes countries from Africa, Europe and other destinations. Some of them, but not all of them include Ghana, Zimbabwe, Zambia, Germany, Sweden, Estonia, Russia (more recently), Canada, USA, Indian Ocean Islands and Australasia.

1.1.4. Products and Safety

The safety aspect of both their products and work force is a huge issue inside and outside the gates of Aveng Manufacturing Duraset and always at the top of every management meeting's discussion list and something to be proud of.

In-house manufacturing and design is done with the tightly knit bond and research teams of both Aveng Manufacturing Duraset and the mines to target root problems that occur in everyday practice. Having such a wide variety of balanced cultures and values makes Aveng Manufacturing Duraset a highly competitive force in the manufacturing market with a stable and diverse workforce (strong labour unions) built for future growth. All of this is done to keep the total cost of ownership down and very importantly, improving mine safety.

Alrode is one of three Aveng Manufacturing Duraset factories where roof bolts and other steel related products are manufactured, Germiston the geotechnical products and Westonaria cementitious products (concrete sleepers and pack support).

“Our values of safety, honesty and accountability underpin the way we expect employees to conduct business and interact with our stakeholders”
(About the Aveng Group)



Figure 2: Three Core Values of the Aveng Group

“Safety is paramount, never to be compromised in the pursuit of any objective”

(About the Aveng Group)



Figure 3: Safety is High Priority at the Aveng Group

1.2. Products Discussion (Alrode Manufacturing Factory)

The Alrode Factory (the manufacturing factory considered for this project) produces a wide variety of steel support and suspension products, which falls under the heading of “Roof Bolts”, that is split into the two groups mentioned above (support and suspension) and consists of the following sub-products:

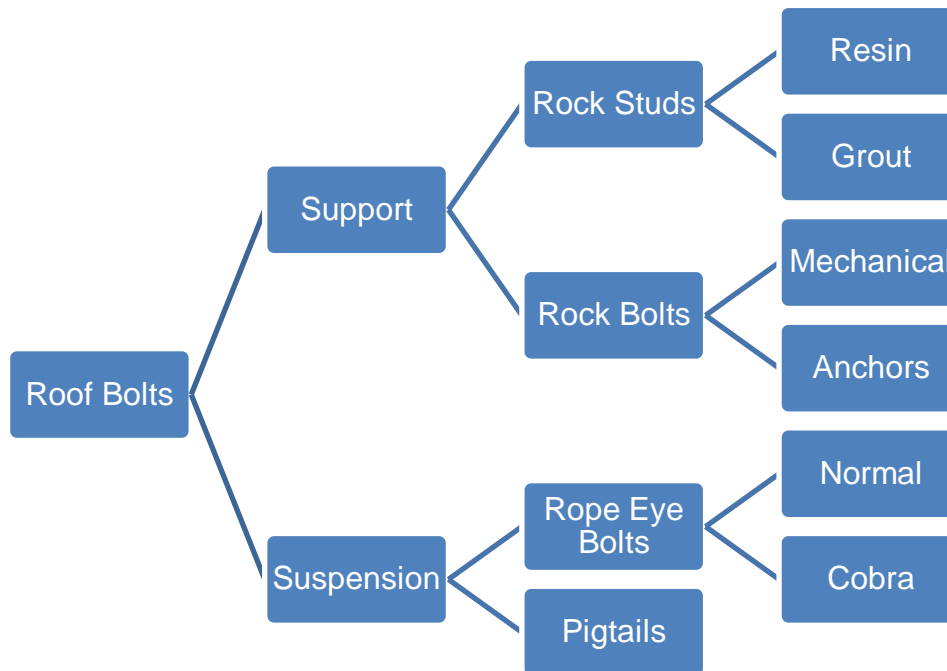

Figure 4: Roof Bolt Explosion

2. Problem Statement

Aveng Manufacturing Duraset wants to increase productivity within their production line and have better control over inventory and stock levels at the Alrode factory.

Productivity is massively influenced by the restricting use of the single overhead crane per section in the factory. This is crippling the smooth flow of materials and production throughout the manufacturing process. Because of the nature of the raw steel materials used, being really heavy and that it is handled in bulk all the time, everyone “has to” wait for the use of the overhead crane. This increases idle time considerably and thus creates more non-productive time, lost by this problem called: “I’m waiting for the crane...”.

Most of the machines and material handling equipment are old and out of date. The down time on these equipment pieces can be time consuming and keep the rest of the production line waiting or even without any work to continue on for cumbersome time periods. Oil and metal shavings are spilled everywhere from machines or work in progress and can become a health and safety hazard.

Work in progress or already assembled products are either moved to an unknown and unspecified location by forklift drivers because there is no more space at its allocated area even trying to keep track of all manufactured and assembled amounts per day is hard to control or even put on paper. There is also a permanent shortage in pallets for loading and moving materials or finished products. The reason for this is because no record is kept of either the storing of the stock or movements thereof.

The current “stockyard” is actually not one and not covered like the rest of the factory. Thus the finished products are stored in inventory, whether it’s written up or not and in any space found, for months on end. Thus these products are exposed to the natural elements like rain, sun and cold. This causes rust to take over these final products because they are not pulled when needed by demand (lost or not captured) or unprotected. This leads to a loss in inventory and thus income, because those products have to be scrapped or sold at a much cheaper rate than originally budgeted for to the recycling company contracted with.

Safety is a major issue in the factory because of all the moving parts, machines, overhead cranes (lifting and carrying materials) and forklifts driving around with pallets. Care must be taken when either using the overhead crane, walking in the factory or moving material.

3. Problem Statement Defined

Aveng Manufacturing Duraset management have established that the current trend of production and modus operandi are unacceptable. It is starting to affect the company negatively, being it financially, with the labour unions or client base.

The management of both the mother group, Aveng (Africa) Limited and her sub-company, Aveng Manufacturing Duraset would like to increase productivity and stock control whilst keeping their safety standards and levels at their highest possible up at all times.

4. Project Aim

The aim of this project is:

- Smooth flow between stations in manufacturing line
- Introduce new machines, new material handling equipment to process (like two bin)
- Do new layout of the facility and stockyard for smooth flow and storage (moveable barriers)
- Implement new technology (like barcoding and security boom) and job cards
- Create new or revisit safety factors in the factory
- If time allows it, build a simulation model of manufacturing process
- Have a definite and positive financial impact on manufacturing and storage

4. Project Scope

The purpose of this project is to smooth the work flow of a manufacturing company and control the inventory and stockyard. This should be accomplished by altering the current facility layout and operating procedures, introducing alternative material handling equipment and new technology.

All of this must be done for the final positive outcome of Aveng Manufacturing Duraset. If time allows it, build a simulation model representing the current manufacturing system for identifying areas of improvement.

5. Deliverables

This project's deliverables are used to help optimize the modus operandi at the Aveng Manufacturing Duraset Factory in Alrode. This is with regard to facility planning, inventory control, material handling systems and simulation modelling. The deliverables are as follows:

- ▣ Operational Analysis: What, Why, How, Who, Where, When?
- ▣ Analyse current facility layout
- ▣ Analyse current material handling equipment
- ▣ Study and implement new dummy systems
- ▣ Perform time studies and determine material flow rate, old and new
- ▣ Analyse barcoding methods, job card variety and introduction thereof
- ▣ Determine alternatives and compare
- ▣ Determine a final recommendation that would satisfy/solve the optimization of the workflow and inventory control problem stated by Aveng Manufacturing Duraset

6. Literature Review

6.1. Overview

The literature review will be essential for the gathering of important information about the engineering methods, tools and techniques that will be relevant and useful for this project. These methods, tools and techniques would help to find solutions to the problems Aveng Manufacturing Duraset are currently facing and in the development and implementation thereof. The goal currently is to develop a solution for each problem area with the use of various industrial engineering techniques that would finalize the facility layout and improve the current material handling system, flow of products in the production line/system and the control of inventory and stock.

Resources from Aveng Manufacturing Duraset are convinced that production numbers can be increased, idle time almost completely eliminated and lost stock can be controlled accurately at all times. However it has been determined that with the current facility layout, material handling system and stock controlling features' numbers, the expected throughput will not be achieved. With the definite promise of an increase in production units in a smaller amount of time and better housekeeping at the same time, Aveng Manufacturing Duraset would support all efforts in this project.

Information gathered and support received from previously defined sources:

- Joe Visagie (Technical advisor)
- Alwyn van Loggerenberg (Industrial Engineer)
- Internet
- Standard Bank
- UP Library
- Mr. Eric Brett (UP Tuks)
- Ben Konyane (Project Manager)
- Aveng Manufacturing Duraset
- Jabulani and Kevin (Industrial Engineers)
- Gerald Munaih

6.2. Facilities Planning

6.2.1. Introduction

Facilities Planning can be broken up into the two words, Facility and Planning.

1. **Facility:** *noun (plural facilities)* “a place, amenity, or piece of equipment provided for a particular purpose”
(Oxford Online Dictionary)
2. **Planning:** *noun [mass noun]* : “the process of making plans for something”
(Oxford Online Dictionary)

So according to the Oxford dictionary, Facilities Planning can be defined as:

“The **process** of making **plans** for a **place** or piece of **equipment** for a particular **purpose**.”

The subject Facilities Planning is very broad and can include anything from designing and building the building itself (drawing plans), changing material handling equipment used, the optimal location for the building, redesigning a current layout and many, many more.

6.2.2. Design and Technology

Design and technology are some of the core fundamentals to a successful facility and how it functions.

Design might be seen by most people as purely a single part of the process before the building of the facility itself, but actually it is a continuous and on-going process that could be implemented at any point in time deemed necessary. On the other hand, a facility must be designed as close to perfect as possible, to keep redesigning and additions to a minimum. Even though a facility is designed and built big enough, all available space WILL be filled at some time in the future. Thus, all facilities must be designed with expansion options in mind for the near future.

The less design changes made/required will ultimately require fewer changes in the plant layout and handling material and equipment. By keeping design as standard and simple as possible, equal less maintenance, machine changeovers, inventory floor space and material handling as a whole.

The ever evolving world of technology can make life and business that much easier and simpler. But this usually comes at a price. Sometimes that capital invested now, will eventually pay itself back in the long-run and have some of its own advantages too, but it must be thought through in detail and all options and alternatives have to be considered.

If the appropriate technology is installed or bought, it should boost key competitive factors such as:

- Delivery
- Quality
- Cost
- Speed
- Flexibility

More on this subject and conclusion later on in this literature review.

6.2.3. Facility Layout

6.2.3.1. Overview

Facility layout does not only include the drawing and building of the facility. It is about more than that. Critical factors that influence the layout design can be, the flow of products through the system (smooth or stochastic), ergonomics (ease the job and increase safety for the worker), emergency exits and access (law), storage space and expansions (extra space and future possibilities), material handling equipment movements and storage (keep movements to a minimum and regular maintenance schedules), how inviting it looks to visitors and workers (ergonomics and mental psychology), user – and environment friendly (health and green footprint impact) to name but a few.

On a calculated (tactical) level, the following criteria are satisfied by layout:

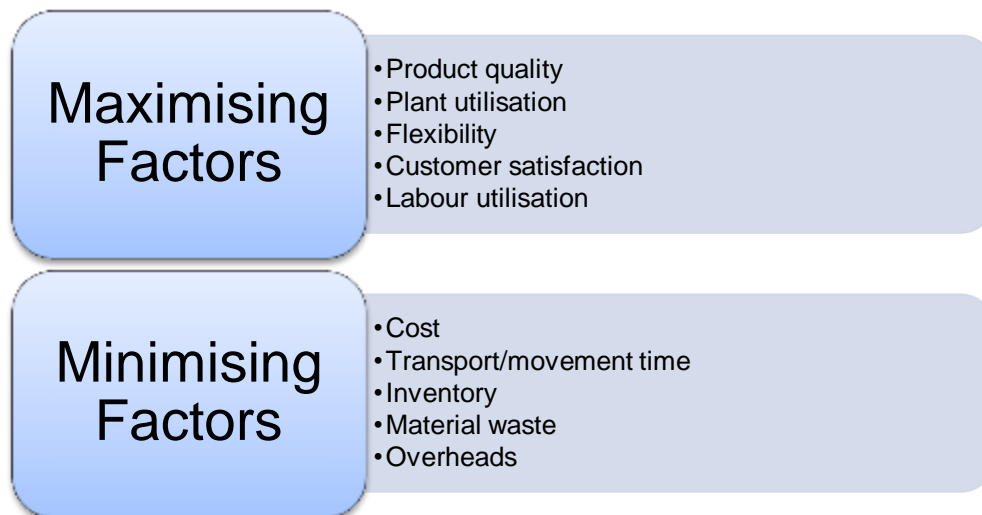

Table 2: Tactical Level Criteria for Layout

With the criteria in mind, appreciation of a plants' or process' capability as a considered (strategic) weapon in the industry today, is a must.

6.2.3.2. Basic Layout Types

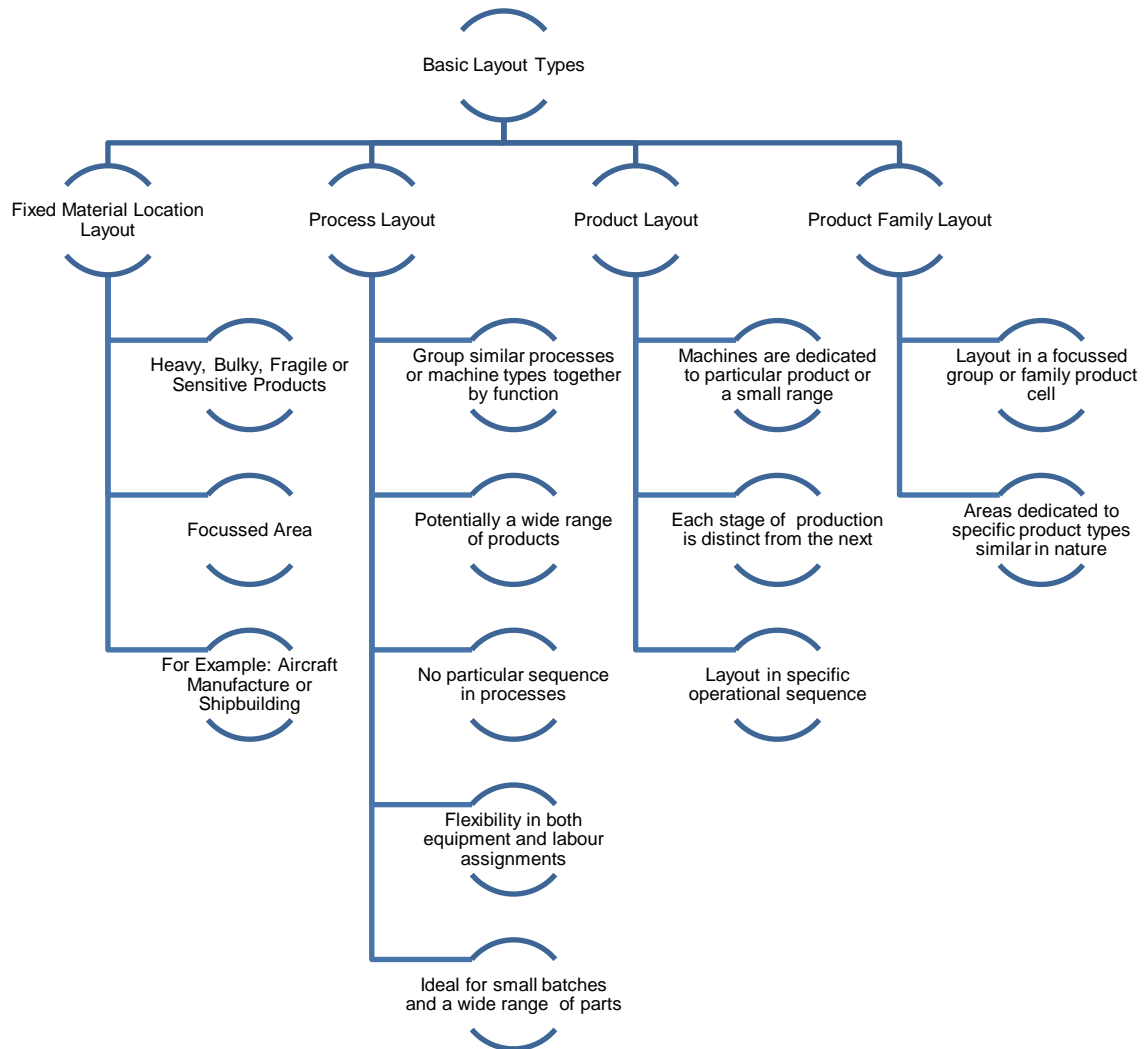

Table 3: Types of Layouts

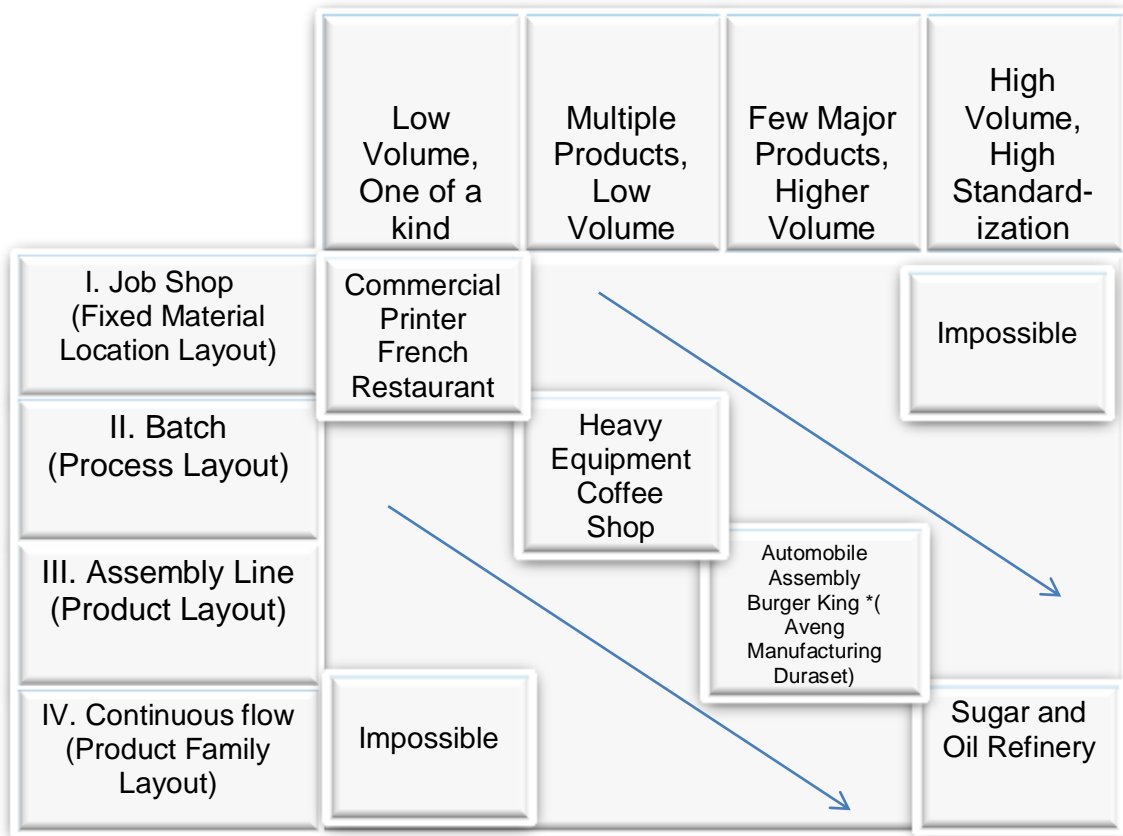

Table 4: Process Positioning Strategies

* Current Aveng Manufacturing Duraset process policy

6.2.3.3. Facility Layout Conclusion

The layout at Aveng Manufacturing Duraset currently is a Process Layout. This is because the same machines are grouped together and the product must move great distances within the facility when it is WIP (Work In Progress). With the single overhead crane that everybody has to use to move the WIP around, creates a lot of idle time for workers and thus even less productivity and effective output.

The ideal would be, with the help of alternative material handling equipment (discuss in the following section) for Aveng Manufacturing Duraset to switch to a Product Layout. This should increase production unit numbers, by decreasing product travel time, material handling, number of change overs of jigs and tool bits and idle time to wait for the overhead crane. Added to this, Aveng Manufacturing Duraset has a Make-to-Stock policy that triggers a process that chases expected or forecasted demand and customer orders are met from target stocking levels.

Ideal systems to fit in Aveng Manufacturing Duraset, once suggested improvements are tested and implemented, is Drum-buffer-rope scheduling and Kanban. Both these schedules encourage a Pull system rather than the current Push system for as small amount of inventory possible to balance the system capacity.

The Kanban system is activated when the following/next worker or workstation is out of materials or products to work on. The worker then notifies the previous station or worker by means of a flashing light or color-coded card that they should send more materials. The idea behind it is to decrease idle time and up the production time and amount of units.

Drum-buffer-rope scheduling is mainly used to identify 1) bottlenecks (drum) within a system. The “drum” gives the “beat” to the systems’ production output rate and acts as a control point for time studies and quality control. Being an excellent characteristic of Aveng Manufacturing Duraset, quality is of utmost importance and critical. If the quality of the products before the bottleneck (control point) is not in order, then the bottleneck is going to produce non-conforming (tolerances, strength, functionality) products. This could thus lead to loss in clients and customers who rely on good quality products, like the mines, where quality equals safety and safety equals lives. The next step is achieved by putting a 2) “buffer” for stock accumulation before the bottleneck, so that the system should never perform slower than it already is and could even have a smoother flow in the line as a result. 3) The communication line (rope) between the bottleneck and the “upstream” stations must be sufficient and in working condition for this to work and keep the buffer from overflowing.

It goes hand in hand with the make-to-stock policy, because products are “pulled” by customer/market demand and involves a leaner and cleaner inventory system opposed to the clustering, heaping and sometimes disappearance of products within the Aveng Manufacturing Duraset stockyard.

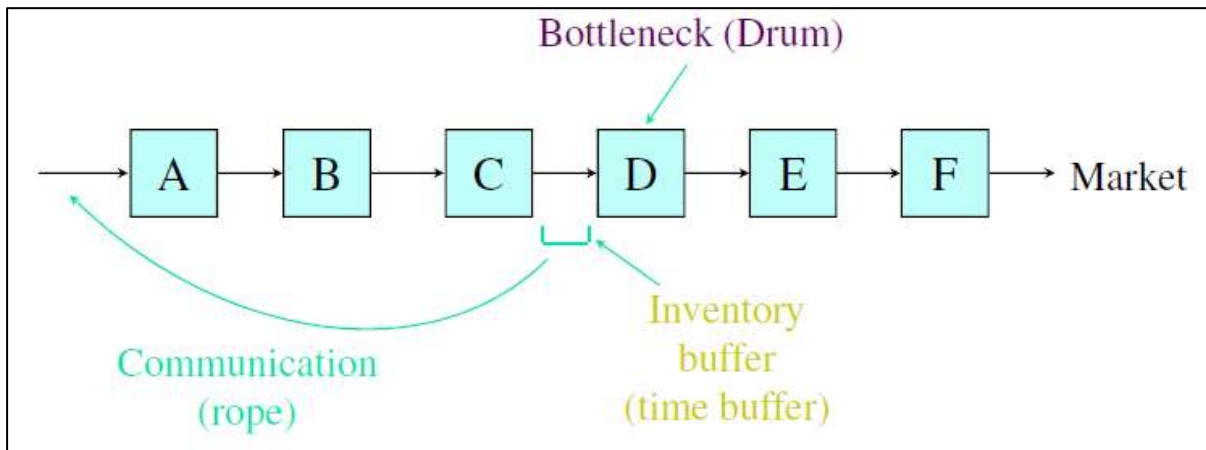

Figure 5: Drum-Buffer-Rope System

6.3. Material Handling Equipment and Methods

6.3.1. Introduction

“Layout design and the material handling system design are inseparable.”

(Tompkins, White, Bozer, & Tanchoco)

“1. Material Handling is the art and science associated with the movement, storage, control and protection of goods and materials throughout the process of their manufacture, distribution and disposal.

2. Material handling means providing the right amount of the right material, in the right condition, at the right place, in the right position, in the right sequence, for the right costs and by the right methods.”

(Tompkins, White, Bozer, & Tanchoco)

Some interesting facts about material handling: Material handling cost accounts for twenty to fifty percent of total operating costs and it can even add up to be fifteen to seventy percent of the total cost of a product. Although only between three and five percent of material handled gets damaged, it still is responsible for most industrial accidents. If executed and sustained effectively, a material handling system can reduce operating costs by up to thirty percent.

The scope of material handling is so broad and diverse, because it includes people, commodities and information, not only the usual materials and products we generally know of. Some terminology used for movements in material handling consists of the horizontal Movement = Transfer, Vertical Movement = Lift, as well as the Loading and Unloading of either 1) the materials into the workstations, or 2) the semi-manufactured products between the designated stations or finally, 3) the movement of assembled products to the storage area.

There is no shortage in the help and integration of different systems that exists with material handling in the industry today. An integrated system perspective can easily be kept with some of the following systems that exist: materials management, manufacturing planning, management information systems (IS) and distribution.

A few material handling objectives that should be implemented at every company to:

- ⊗ INCREASE: Throughput, Material Control, Utilization of Facilities, Space and Personnel
- ⊗ IMPROVE: Effective flow of material through the system by making sure of their availability, Safety and Working Conditions
- ⊗ REDUCE: Inventories, Damage, Inventory - and Operating Costs with the effective material handling required, Cost of Material Handling
- ⊗ Simplify the involved Manufacturing Processes

6.3.2. Material Handling Principles

The following factors are important material handling principles in practice:

• The method (how and who) of a material handling plan is defined by the material (what) and the moves (when and where).	1. Planning Principle
• Keeping variety and customization in methods and equipment to a minimum.	2. Standardization Principle
• Work is measured by multiplying material flow with distance moved.	3. Work Principle
• Making adaptations to best suit the abilities of the worker	4. Ergonomic Principle
• Is a single load like a pallet that can be moved as one entity at any given point in time	5. Unit Load Principle
• Space must be used in all three dimensions (cubic space)	6. Space Utilization Principle
• Interacting or independant collection of entities that creates a unity as one.	7. System Principle
• The collaboration of electro mechanics and computer programming into a system to handle, control and manufacture products.	8. Automation Principle
• To be as enviromentally friendly as possible in everyday actions and not create unnecessary waste.	9. Environmental Principle
• The entire cashflow that would collect over the product lifespan or replacing equipment/methods.	10. Life-Cycle Cost Principle

Table 5: Material Handling Principles

There are ten more principles that are not as important as the first ten, but should still be considered none the less:

11. Flexibility – Making use of equipment and/or methods that are capable of performing a variety of tasks under a variety of operating conditions.
12. Simplification – Reduce or combine the use of equipment and movements.
13. Gravity – Use gravity for material handling and movement where possible.
14. Safety – Provide safety equipment and methods.
15. Computerisation – Implement the use of computers to improve inventory and handling control.
16. System Flow – Integration of data and physical flow.
17. Layout – Select the best alternative solution out of the possible options
18. Cost – Compare the price per unit handled between alternative equipment and methods.
19. Maintenance – Prepare a routine check-up and maintenance schedule for equipment.
20. Obsolescence – Prepare a long term replacement policy for obsolete equipment.

For the use in this project principles Planning, Work, Ergonomic, Unit Load, Space Utilization, Flexibility, Simplification, Gravity, Safety (a MUST), System Flow and Layout will be considered and investigated.

6.3.3. Investigation: Material Handling Equipment Used at Aveng Manufacturing Duraset

6.3.3.1. Management and Personal Concerns

Material handling equipment and methods are the means and machinery used to move products within a factory or warehouse.

Management has major concerns about the material handling equipment and methods used within Aveng Manufacturing Duraset at this current stage. The problem areas that were identified are:

- Safety and health issues – Oil and off-cut materials, overhead crane usage above workers, heavy lifting by workers
- Idle time between working stations – Wait for new or WIP material, wait for availability of the overhead crane (one per section), lost products from stock yard
- Flow of products between stations – Maintenance on machines, jig and tool bit changeovers, wait for WIP material, no available pallets, machine grouping
- Technology and machines are old and out-dated – some parts have to be specially made or imported to fit machine and then production is halted for that time
- Stockyard – Control is lacking and is visibly weak to the eye, misplacement of assembled products yields rusted heaps of metal (no cover for stockyard, open-air floor) or waste of time looking for products that are on the system, but nowhere to be found in stockyard
- No enforcement of rules on the misplacement or unidentified products placed anywhere on the grounds without valid reason or paperwork, which results in either loss of stock or very old stock that once recovered, are already rusted or damaged

6.3.3.2. Summary of Material Handling Equipment Types that can be Implemented

The types of equipment that can be used and implemented in Aveng Manufacturing Duraset (and anywhere else) are influenced by the characteristics and properties of the material, volume, physical environment and nature of the processes.

The equipment can be classified according to:

- Reach:
 - Unlimited (Industrial vehicles like forklifts)
 - Area limited (Overhead cranes)
 - Line limited (Conveyors)
 - Position limited (Stacker cranes, Industrial Robot)
- Type of equipment:
 - Conveyors (Frequent movement)
 - Monorails, cranes, hoists (Interrupted transferring)
 - Industrial vehicles (Internal transport)
- Also have a trade-off between Standard and Purpose made equipment

Conveyors: Are world renowned and used in almost every factory or at most construction sites. Once the electrical or petrol driven engine is started it is a continuous flow of material from one point to the next. Material can be loaded or removed from the conveyor if material allows it and large amounts as well. Material or products can be transported in unit loads, containers, singles or heaps while the conveyors' position is fixed in space.

A very good solution to be implemented at Aveng Manufacturing Duraset is the Chute or Gravity Conveyor. These conveyors use the earths' gravity and a good shunt by the worker to move materials over distances on installed roller wheels. The straight paths are usually short of nature so that the material cannot pick up too much speed and damages something or injures someone.



Figure 6: Gravity Conveyor

Industrial vehicles: Usually ruled by the forklifts and pallet jacks in industry and unlike the conveyors have the freedom of variable paths inside or outside a factory. They are used when large or heavy products on pallets and in drums have to be moved over long distances or have intermittent movements. Flexibility is a big factor here.

Forklifts are already in use at Aveng Manufacturing Duraset, but pallet jacks can also be brought into the work flow strategy. It is a cheaper alternative to the forklift and always available when needed, in comparison. The only downside to the implementation of the pallet jack is that the heavy WIP that have to be moved would prove difficult on the rough and cracked surface and the messed oil will clog the wheels.



Figure 7: Forklifts and Warning Sign

Cranes: Used to lift even heavier products and raw materials than the forklifts and also over some distance. If there is a need to lift products a certain height to be able to move them, as at Aveng Manufacturing Duraset, the overhead crane is the best bet. But this comes at an expensive capital investment and must be absolutely necessary. Other bad characteristics of cranes are the load bearing structures required in the buildings with limited mobility other than the area underneath.

Seeing that there are already overhead cranes at Aveng Manufacturing Duraset, the plan is to get rid of them by means of clever facility planning rearrangements and moving the same production line machines closer together to rid the unsafe and unnecessary use of the overhead crane.



Figure 8: Overhead Crane

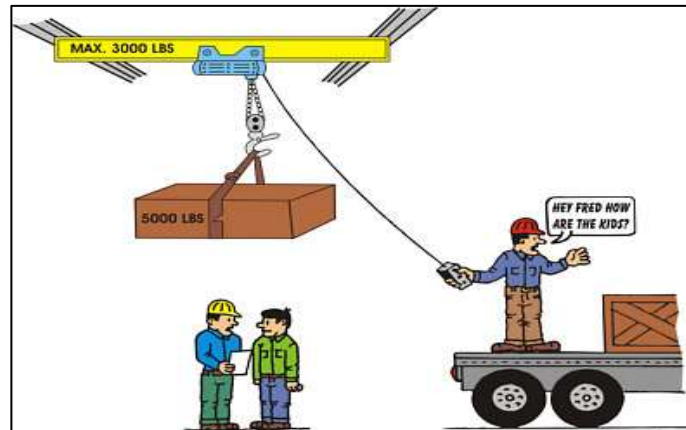

Figure 9: Safety Risks of an Overhead Crane

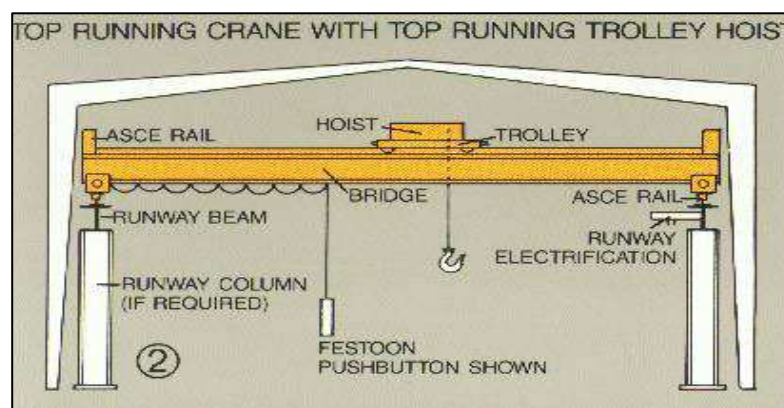

Figure 10: Explanatory Overhead Crane

Just on an explanatory note: The initial idea for use of the overhead crane at Aveng Manufacturing Duraset is because of the Monorail, that is directly in the way of the ground movements of the cropped raw materials brought in by truck, that transports the rolled coils to the Bulk Block (very old Drawing Machine) and Karl Fuhr (Cropping Machine) for the drawing and cropping operations to get the production processes started.



Figure 11: Wire Drawing and Cropping Machines a) Karl Fuhr b) Bull Block

Barcoding: The new and modern technology that has taken the world by storm and seen almost everywhere nowadays. It does not escape the clutches of supermarkets, offices, warehouses and factories. By using appropriate scanners, a printed barcode on a paper/sticker can instantaneously provide and insert data or information about the certain product or pallet that would usually have taken much longer by hand. Human error is automatically eliminated and can be available on soft copy immediately. Radio Frequency Identification (RFID) tags is another cost effective way to track and control products flowing through a production system. Same as the barcoding, scanners receive data or information about the contents, the only difference is the method of data exchange. Some advantages to the use of these products are: 1) You get your money's worth and are inexpensive, 2) The ease at which it can be installed and 3) The speed and accuracy at which it collects the data.

The implementation of barcoding has already started at Aveng Manufacturing Duraset, but the admin and follow through is not done on a regular basis. Thus with the implementation of the security boom, hand-in-hand with the scanners and barcodes, could solve the current stock and inventory control problem of misplacing and loss of finished goods in the stockyard.



Figure 12: Barcoding Methods and Scanners

Carousel and 2-Bin-System: These are equipment used to, according to us that would help increase the smoother flow of WIP through the system, at the same time decrease worker idle time at each station and rids of the problem of pallet shortage.

The Carousel system works like follows: it mainly consists of a turn-able wheel (horizontally flat) that has two or four containers on top. Once the one bin is full and the following workstation has no more material, the wheel can just be turned by ninety or hundred and eighty degrees (depends on how many containers are fixed on the wheel) to reveal an empty container to the previous or feeding workstation and another full container to the receiving workstation.

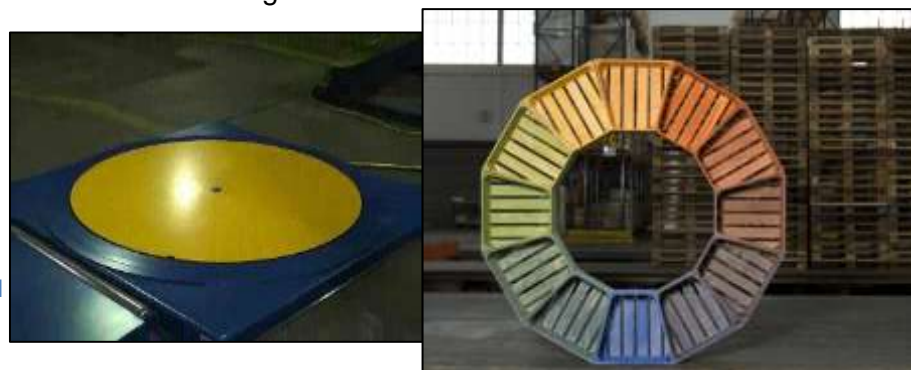

Figure 13: Carousel Wheel

The same idea goes for the 2-Bin-System as well. The only difference is the wheel is exchanged for either a shunting rail or two pallets. The shunting rail includes a small piece of rail track that stretched from the one workstation to the next (proceeding or following) and two “cocopans” or containers with wheels on, to be moved independently or together with contents. The two pallets are basically two pallets placed before and after each workstation to indicate whether finished material is available for collection by the next worker.



Figure 14: Shunting Rail with Container

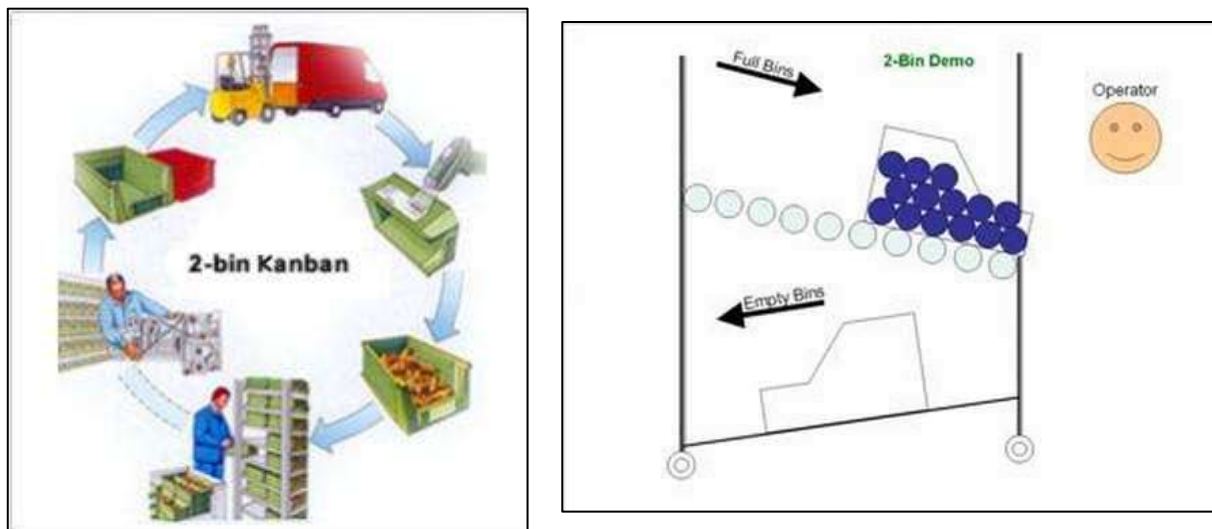

Figure 15: 2-Bin-System Application

6.4. Literature Review Conclusion

In order to decrease cost of production, smooth out the flow of WIP and introduce sufficient control on stock, solutions must be found to automate processes where necessary, improve on material handling equipment and methods, implement new technology where possible, improve the facility-, stockyard- and production line layout where needed, introduce job cards and two bin system.

Changes from a Facilities Planning perspective:

- ✓ Switch to a Product Layout
- ✓ Make-to-Stock Policy
- ✓ Drum-buffer-rope Scheduling and Kanban
- ✓ Pull System rather than the current Push System
- ✓ More Quality Control Checkpoints
- ✓ Leaner and Cleaner Inventory System (better control and accuracy)

Changes from a Material Handling perspective:

- ✓ Chute or Gravity Conveyor
- ✓ Forklifts
- ✓ Get rid of Overhead Cranes
- ✓ Security Boom with Scanners and Barcodes (correct and accurate paperwork)
- ✓ Visible Stockyard Marked-off Sections (clothes-line concept)
- ✓ Carousel or 2-Bin-System

These suggested changes should be able to provide possible solutions to Aveng Manufacturing Duraset's current problems as discussed and show some financial improvement once implemented and kept by in the long-term, even maybe short-term as well.

CLAUSE: (Due to the sensitivity of some figures, amounts and numbers towards the market and competitors, Aveng Manufacturing Duraset requested that “placebo” figures be used for the remainder of this investigation/report)

7. Data Gathering and Analysis

7.1. Optimizing Workflow and Layout (Between Peeling and Threading Machines)

7.1.1. Defining the processes and stakeholders involved

The study done to improve and “smooth” the flow of WIP throughout the process has a main point of focus, namely the relationship between the Peeling- and Threading machines. This is a simple relationship of give and take but with some major, negative impacts like being very time consuming and that the productivity down the manufacturing line is suffering greatly.

The stakeholders (people, machines/equipment and departments from Aveng Manufacturing Duraset) required for this optimization operation and study are:

- Production Department
- Technical Department
- Maintenance Department
- General Labourers and Team Leaders
- Peeling - and Threading Machine
- Overhead Crane
- Newly Designed Bogey and Construction
- New Gravity Chute Design and Construction
- Measuring Tools
- General Operating Equipment

With these in place and meetings held, the experimenting on the proposed new “linking/marrying” systems could commence and continue to deliver data and results to be interpreted and compared to the present manufacturing system.

The present system will be discussed and analysed in the following section.

7.1.2. Inspection and Analysis of the Present Manufacturing System

7.1.2.1. General Information

- A working day consists out of two shifts, each nine hours in duration, two fifteen minute tea breaks and one thirty minute lunch break, which adds up to four hundred and eighty minutes (eight hours) of available manufacturing time per shift. Most productive time goes to waste by not keeping track of the workers, their actions, walking routes, overhead crane or their manufacturing progress, as long as they meet the target set for the end of each shift they are happy and so their unions.
- Some of the manufacturing equipment and especially the machines run all day, all week, almost the entire year. This can be quite tiring for both the worker and “machine”, be it hard manual labour, big movements and some stressful jobs. Repairs, upgrades or maintenance cripple the work stations and do not allow for productive time, so the idle worker is moved to another work station.
- An excellent safety record and striving to keep a clean sheet
- Ergonomics are applied or improved where possible or needed after thorough investigation
- That it is important that the factory cleanliness is kept up to scratch every day, of their stations, their tools and WIP.
- Quality is extremely important for the name of the company, reputation of the brand, design and products, the successful application in the environment it was designed for and the safety of the lives working underneath and with these products.
- Unnecessary storing of WIP and finished products everywhere, whether it is correctly placed or not. Not always using vertical space clever when available, but sometimes just too heavy to store one more level higher.
- Maintenance is always busy with repairs, new fittings and adjusting old measures on new versions of machines or equipment. They are equipped with their own overhead crane and diverse variety of tools and machines for every job.

7.1.2.2. Current layout

Please refer to the Appendix A for the entire current facility layout plans.

The facility consists of a box shape design with two separate buildings next to each other. One building is for the receiving and storing of most of the raw materials as well as manufacturing processes, where the other is for final assemblies of products, packing, palletisation and storage of WIP. For this study, the Peeling and Threading areas are considered and brought under the light.

The current layout area of focus:

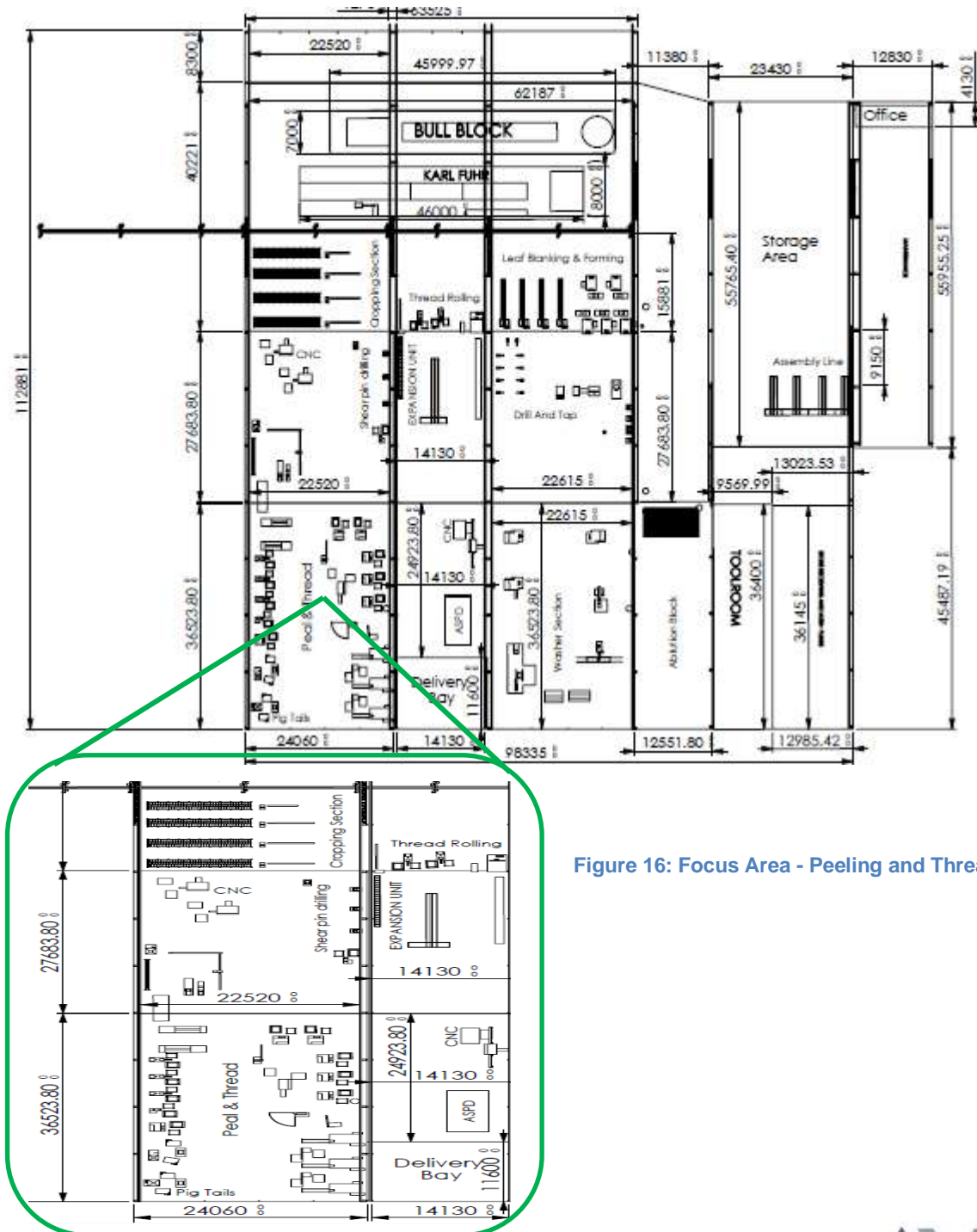

Figure 16: Focus Area - Peeling and Threading

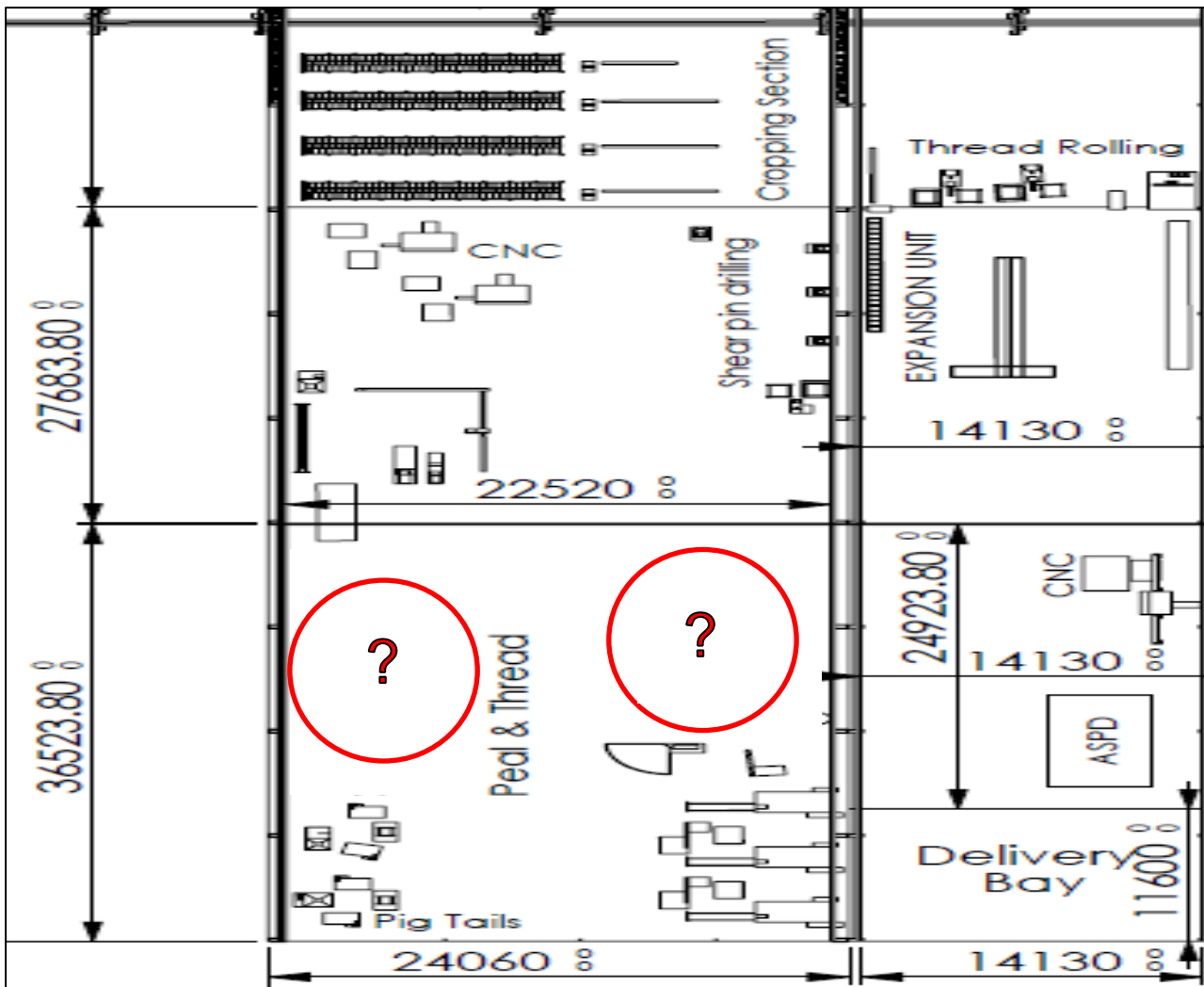

Figure 17: Two Areas Under Discussion - Peeling Left - Threading Right

Peeling and Threading machines have their own demarcated/situated areas for the manufacturing process. Divided by a clearly marked walk way, occupying the overhead crane is a must to link the twenty meter distance between the two stations to complete the production line, because the weight of the WIP and pallets are too much for human movement without additional help. This constraint resource is a noticeable problem for the general flow of the WIP through the process, thus by taking up no space, which is not the problem in this case, rather the time it takes to complete all its tasks during the shifts. Each shift consists of different types of actions for the overhead crane which includes: general moving/transporting (lifting and lowering movements included), sling, unslung, being idle and waiting. Thus every pallet or bunch of products that's moved is done overhead and has a definite safety risk connected.

At present every station, including those of other manufacturing lines, are place very spacious and thus they are not fully utilizing the total space available in the building. The rest of the open spaces on the floor are used for temporary waiting or storage bays for palletized WIP or out of order equipment and machine parts. Another problem, as is in numerous other warehouses and factories, is the underutilized vertical space throughout the entire building, which there is a lot of.

7.1.2.3. Process Description

The pre-, main and post actions of the process taken into account for the study functions as follows:

Raw material is delivered by the truck loads. The twenty meter long bars arrive strapped in either bundles or coils. The long bars are hoisted by use of an overhead crane to the cropping section and the coils, with a monorail out of storage (outside the building), to the Bull Block drawing machine. The smooth coiled steel is first drawn to a smaller diameter and straightened before it's cropped into the shorter required lengths for the pigtails (product). The longer Z-bar bars are cropped at the cropping station into their predetermined and required lengths and stored in pallets used to move them throughout the facility.

The full pallets (about five hundred bars) are also moved be means of the overhead crane to the next available peeling station, if both the worker and the machine have not been waiting for more than ten minutes already for a delivering refill of its feeding material. Once the procedure has started at peeling, a certain length would be "peeled" clean on one or both ends of each bar, depending on what the customer or product specifications are, and dropped into a waiting empty pallet. The fully peeled pallet has to wait for the overhead crane again to be slinged, thus resulting in both the worker and the machine becoming idle before the pallet is moved to an available threading station and unslinged, if all the threading stations are not already yet occupied. This releases the crane as a resource, which only then becomes available again for other tasks. The worker at the threading station can begin or continue with the empty already threaded bars pallet at his/her station. When this pallet is completed, the seized overhead crane is moved to the station before it picks the pallet up and moves it to the weighing area. Once here a weight tag is issued in unison with the pallet, which a forklift is summoned to fetch it to be transported to another station, namely either assemblies or a waiting area (if all else are busy or other products having a higher priority than the current pallet in possession).

All manufacturing stations have a target to reach per shift and a shift list is filled in to give reasons for not reaching targets, when and why the station/worker is idle and when a certain pallet and pallet number is finished. Each pallet has an identification tag that travels with it at all times when the overhead crane moves it.

Please refer to the simulation model of the current layout for a more descriptive picture of what is going on where and when.

7.1.2.4. Utilization and Productivity Numbers

There is lots of room for improvement at Aveng Manufacturing Duraset when it comes to their production numbers, utilization of machines and other types of outputs. For a successful company and especially in manufacturing, the cheaper and more you can produce at the same expense, the greater the profit at the end of the sale.

Problems and potential areas for improvement that is prominent in the current studied processes:

- According to the speed settings on the machines, threading is supposed to produce more than twice that it is now per productive eight hour shift. Current utilization is around forty percent, nothing near the preferred number of seventy to seventy five percent.
- Calculations show that the peeling machines are supposed to be almost twice as productive as they are at the moment. Utilization is more than that of threading, although having the same target per day. Because of more actions required to peel one bar in comparison to that of threading the same, fatigue setting in from the manual labour, increases the times too. It comes down to sixty percent per shift of about seven productive hours, which is more acceptable, but still not good enough to live up to expectations and standards set in the industry.
- The overhead crane is a big thorn in the flesh for the production lines at Aveng Manufacturing Duraset according to the time studies done. It has an idle action time of approximately twenty minutes per shift. This adds up to forty minutes a day, which is almost one month a year that stations have to wait for the overhead crane and do not get served. Human (operator) error and idle time also hugely influences the times of the overhead crane. This could prolong the non-working time of their fellow workers and thus prohibit them from achieving their daily targets and keeping up with the weekly production plan.
- Quality is a very important selling and branding factor for Aveng Manufacturing Duraset, but an even more important and lifesaving factor in the mines for which their products are designed and used for mostly. There is a permanent deployment of quality officers throughout the entire facility with the sole responsibility to test and verify the work being done at each station. This is to maintain and keep the level of quality at the predetermined standard and rid of most variance between the products.

- Vertical space and gravity are some of the most unused “free” elements in facilities today. Same goes for at Aveng Manufacturing Duraset. Even though they are implemented and integrated in some areas, like storage behind the assembly area (vertical) and between the leaf press and nut drilling areas for instance, they still pull on the shortest end of continuous improvement. A restricting problem arises when the pallets are stacked to use vertical storage space. Because the pallets with their contents are so extremely heavy, anything between two to four tons, not too many of them can be stacked according to safety rules and procedures within the industry and to what Aveng Manufacturing Duraset has to answer to.
- Area utilization is extremely poor and could be improved considerably. This should improve general safety, mobility space and visibility within the factory as well.
- With each stock count Aveng Manufacturing Duraset, there are numerous amounts of stock either missing, stolen or misplaced. This should be sorted out fast, because it is a very expensive mistake and there is no cure for plain laziness. Implementing a standard system of capturing the stock as they enter the stockyard or various storage areas to keep track of them and indirect saving the company millions in lost, missing or rusted stock and paying less often for expensive stock counts.
- Bad habits, laziness, attitude and being inconsiderate are some of the main reasons the company, in fact any company, loses small amounts of money everywhere and often. Accumulating to enormous sums of money being thrown down the drain, or in this case in the scrap bins, which original or even sales value are never retrieved. This has to be changed, by either bringing in incentives, bonus payments or performance status in their area with a certain acknowledgement.

7.1.3. Time Studies and Measurements

7.1.3.1. Time Study Infiltration

Newly designed time study sheets were used to complete the studies on all three areas. These areas include: Peeling, Threading and the Overhead Crane.

The sheet is designed to accommodate all three areas of studies. The date and area information are filled in on the top of the sheet. Study start and ending times must be included to be able to form opinions later on, on the time of day or something related. Symbols and columns make for easier and quicker identifiable allocation of certain actions performed, followed by a time measured column.

Capital letters describe what kind of idle action group is under inspection, while both a letter and number gives a finer description to the idle action.

Idle Code:	A - Material Handling	A1 - General worker handling	C1 - Absent
	B - Set-up and tooling	A2 - Crane usage	C2 - Not present
	C - Labour related	A3 - Positioning of WIP	C3 - Standing/talking
	D - Material	B1 - General set-up and starting procedures	D1 - No material available
		B2 - Tooling change	D2 - No feeding material
		B3 - Machine breakdown	D3 - Other reason

Figure 18: Time Study Key

These studies were performed over a stretch of three days and the analysis of the data a further two days, in order to identify where the problem areas are and connect a measured “time” to that problem. Different times of the day were randomly selected to make it possible to collect a wider variety and more realistic set of data which includes all types of attention span problems, challenges and distractions for the worker. Different workers, machines, stations and bar lengths were also considered to bring in some form of variation in the set of times.

Analysing the data brought forth confirmation of the suspicion/opinion formed out of experience and what can be seen with the naked eye.

7.1.3.2. Analyse

The collected data is interpreted in terms of the averages in summary for the three main areas (namely Peeling, Threading and the Overhead Crane) of the time study and descriptive graphs were drawn as follows:

Peeling

Peeling Summary					
Date	Time	Average Working Times Recorded (in seconds)	Average Idle Times Recorded (in seconds)	Worker	Machine no.
26/06/2012	07:40	10.6	302.5	Alfred	90024
	08:20	15.6	60.3	Abram	THD015
	08:35	14.8	15.9	Joseph	Fette 728
	11:10	12.1	16	Joseph	Fette 728
	13:10	9.4	233.9	Alfred	90024
	14:00	14.6	238.6	Steven	THD016
	14:45	12	16.5	Joseph	Fette 728
28/06/2012	10:20	12.3	179.6	Maria	90024
02/07/2012	11:10	14.1	347.2	Abram	THD015
Average		12.8	156.7		

Figure 19: Peeling Measurements (Averages) Summary

On average the Peeling stations had a cycle time of 12.8 seconds. This was captured and calculated between five different workers, across the three days, working on four different machines and varying lengths of bars. The idle time had an average value of 156.7 seconds and was caused by a diverse amount of reasons.

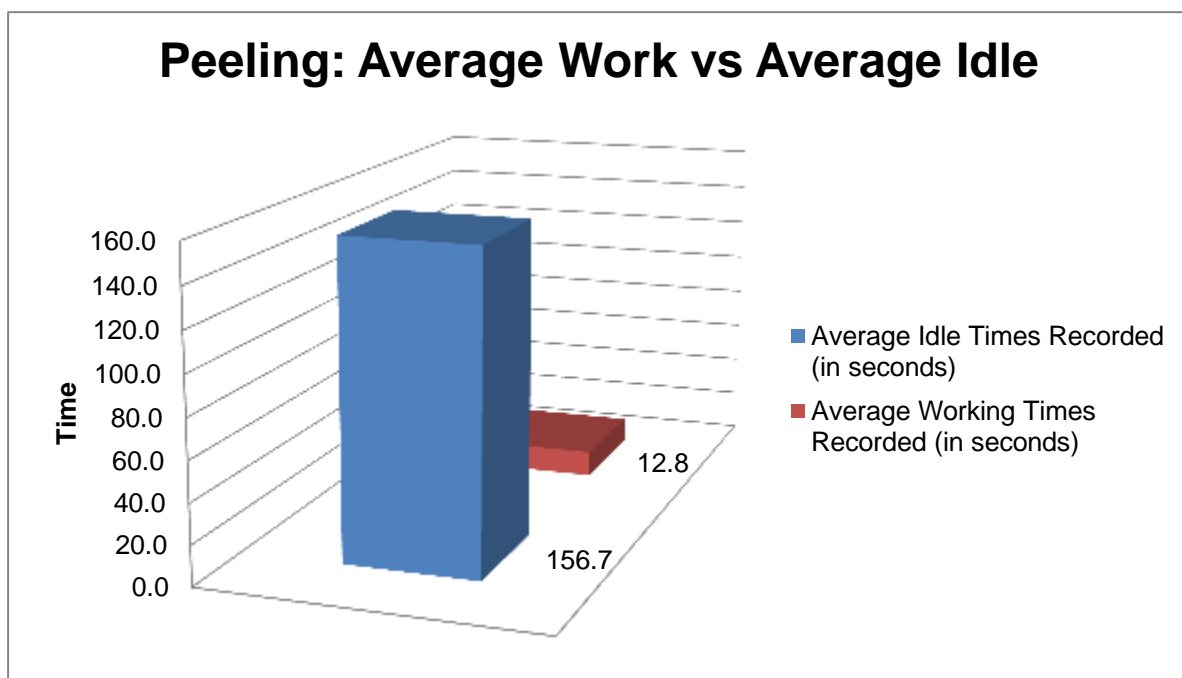

Figure 20: Peeling Average Work vs Average Idle

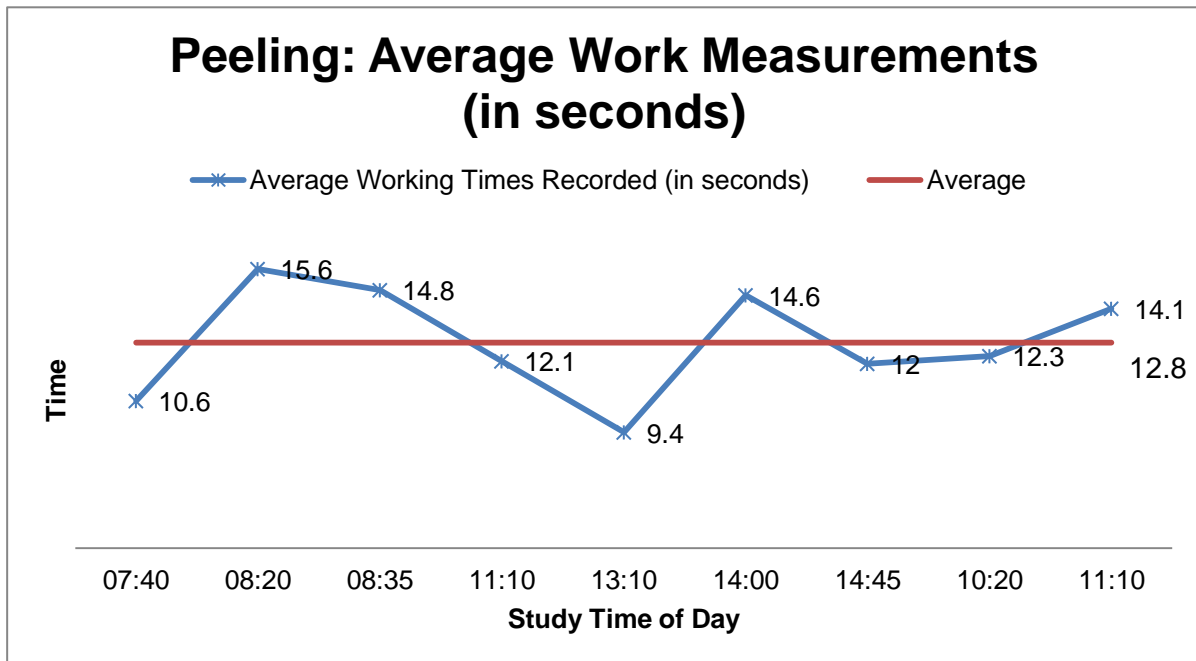

Figure 21: Peeling Average Work Measurements

Variance and inconsistency in time values are due to an array of different factors, like worker capacity and fatigue, bar diameter, length, weight and peel length and ease of working on and of the peel machine itself. The above graph displays the variance in average Peeling times (in seconds) at different times of the day to have an idea how the productivity numbers and levels differ and coincide throughout the day.

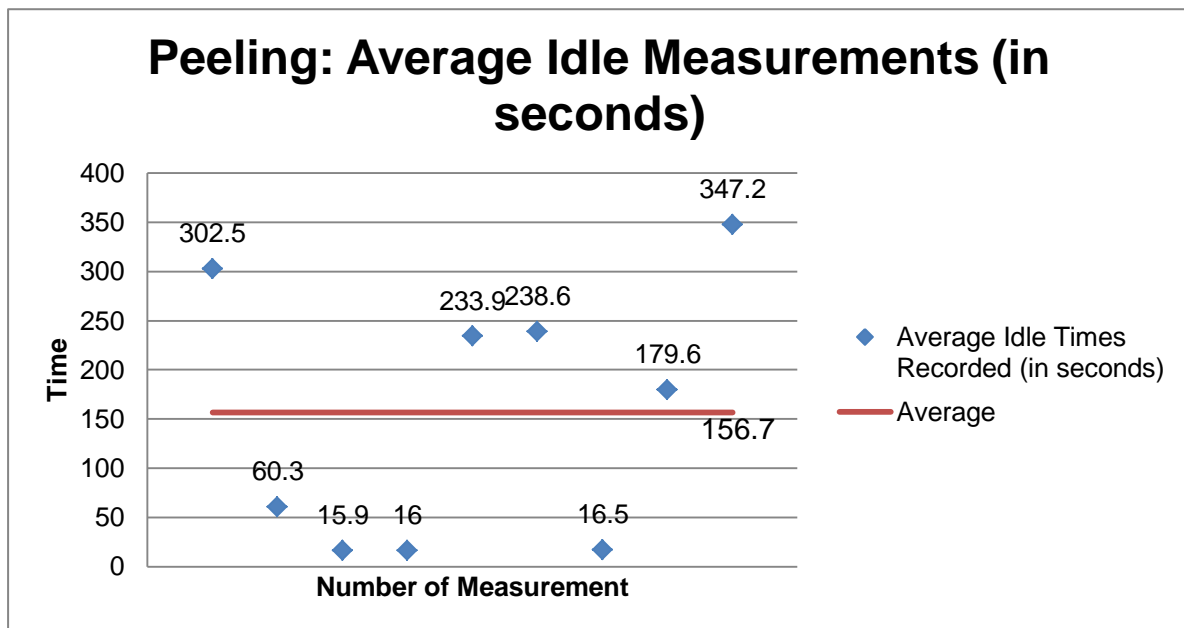

Figure 22: Peeling Average Idle Measurements

Threading

Threading Summary					
Date	Time	Average Working Times Recorded (in seconds)	Average Idle Times Recorded (in seconds)	Worker	Machine no.
26/06/2012	07:30	8	9.5	Talita	THD008
	07:45	10	-	Elias	THD006
	11:40	8	-	Talita	THD008
	11:53	12	5.6	Elias	THD006
	13:32	8.8	-	Elias	THD006
28/06/2012	-	-	-	-	-
02/07/2012	15:19	7.6	31.8	Elias	THD010
	15:35	9.2	112.7	Sam	THD009
	15:45	14.6	-	Talita	THD008
Average		9.8	39.9		

Figure 23: Threading Measurement (Averages) Summary

On average the Threading stations had a cycle time of 9.8 seconds. On average three seconds faster than the Peeling machines. Thus this gave rise to the problem of how to “marry” the Peeling and Threading areas or stations with such a “big” time difference. This was captured and calculated between three different workers, over two days, working on four different machines and varying lengths of bars. The idle time had an average value of 39.9 seconds. A lot lower than the Peeling, but some idle actions were not caught on paper due to the workers working when timed, sometimes idle when not.

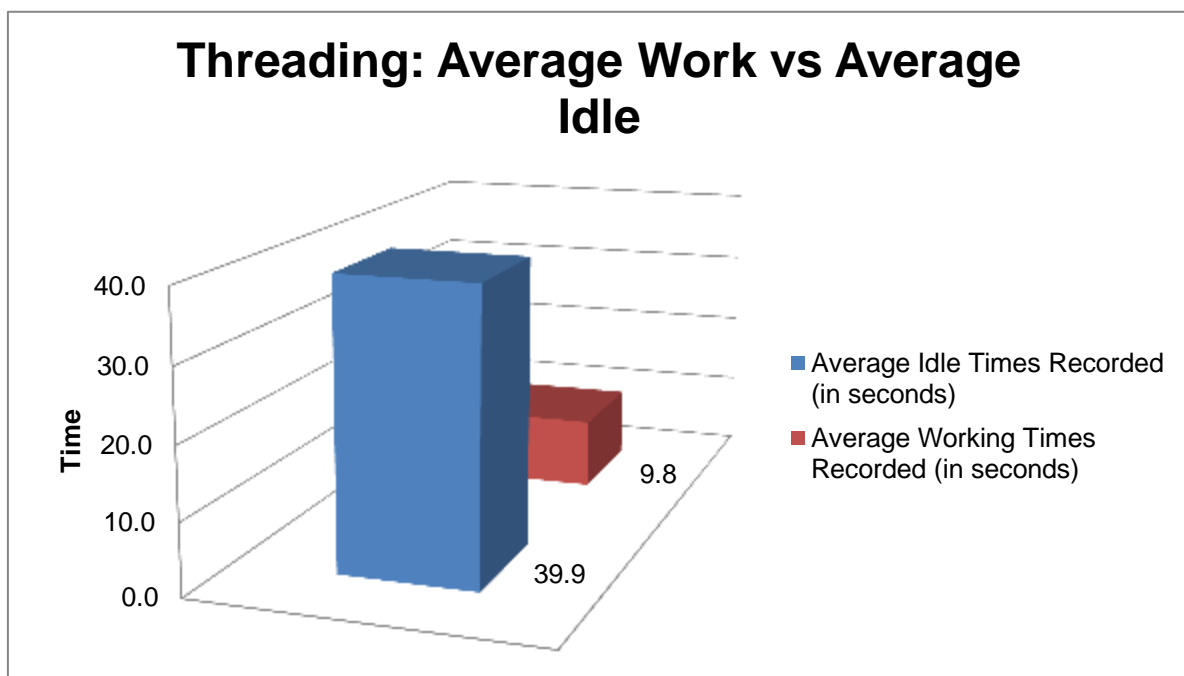

Figure 24: Threading Average Work vs Average Idle

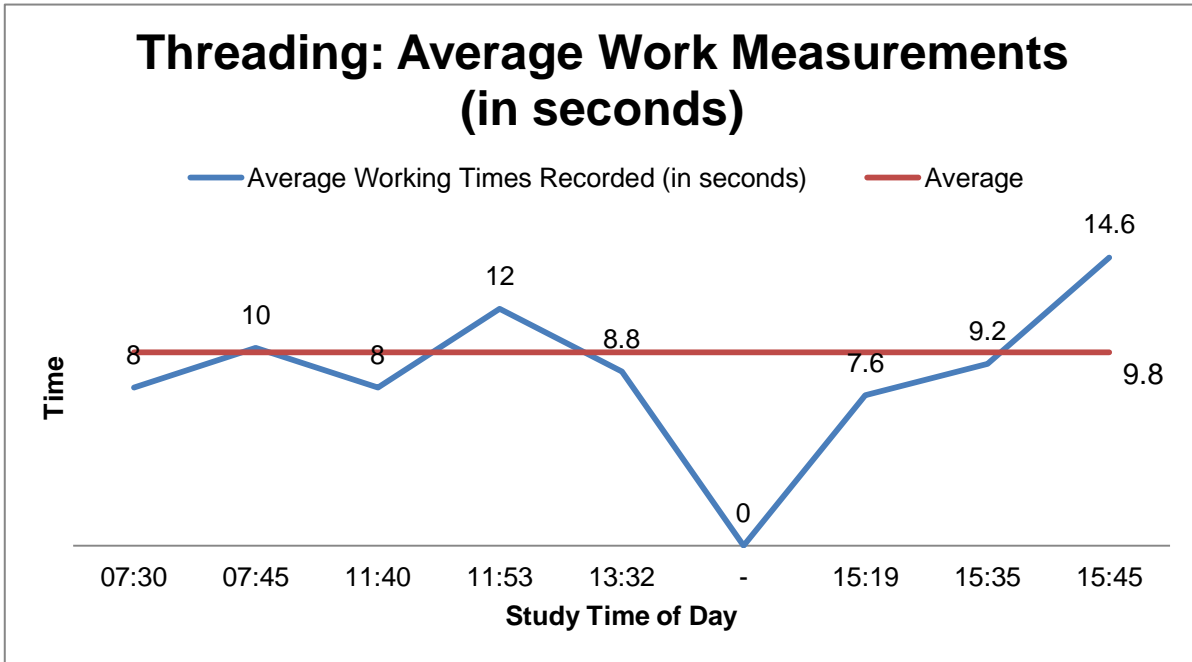

Figure 25: Threading Average Work Measurements

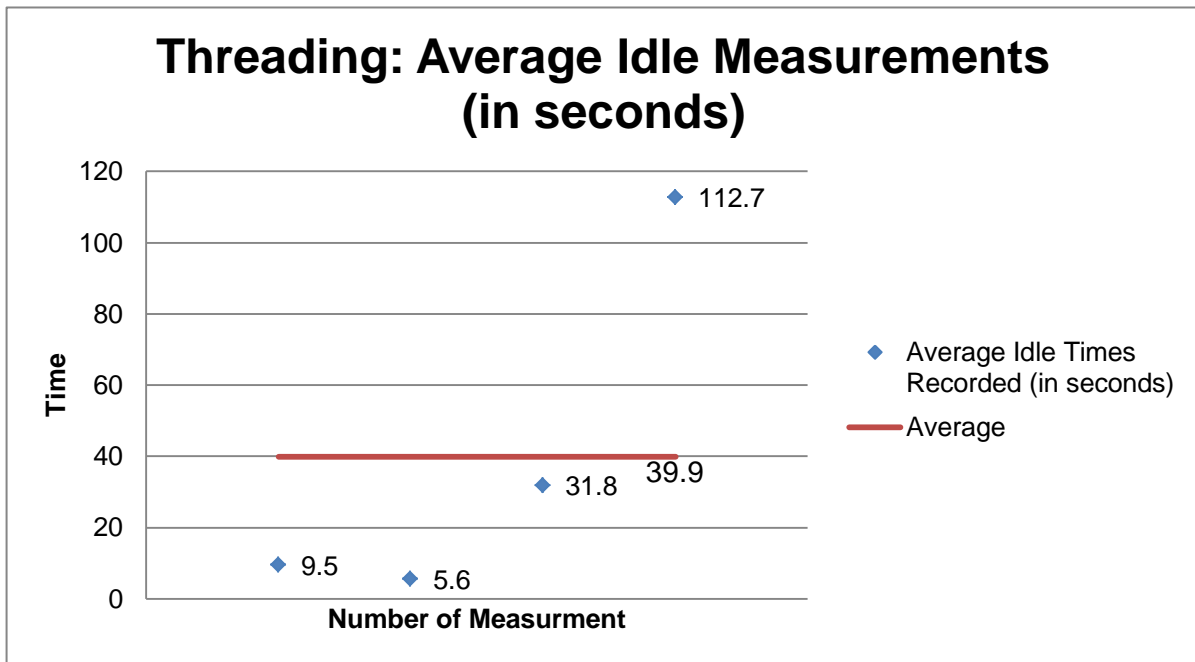

Figure 26: Threading Average Idle Measurements

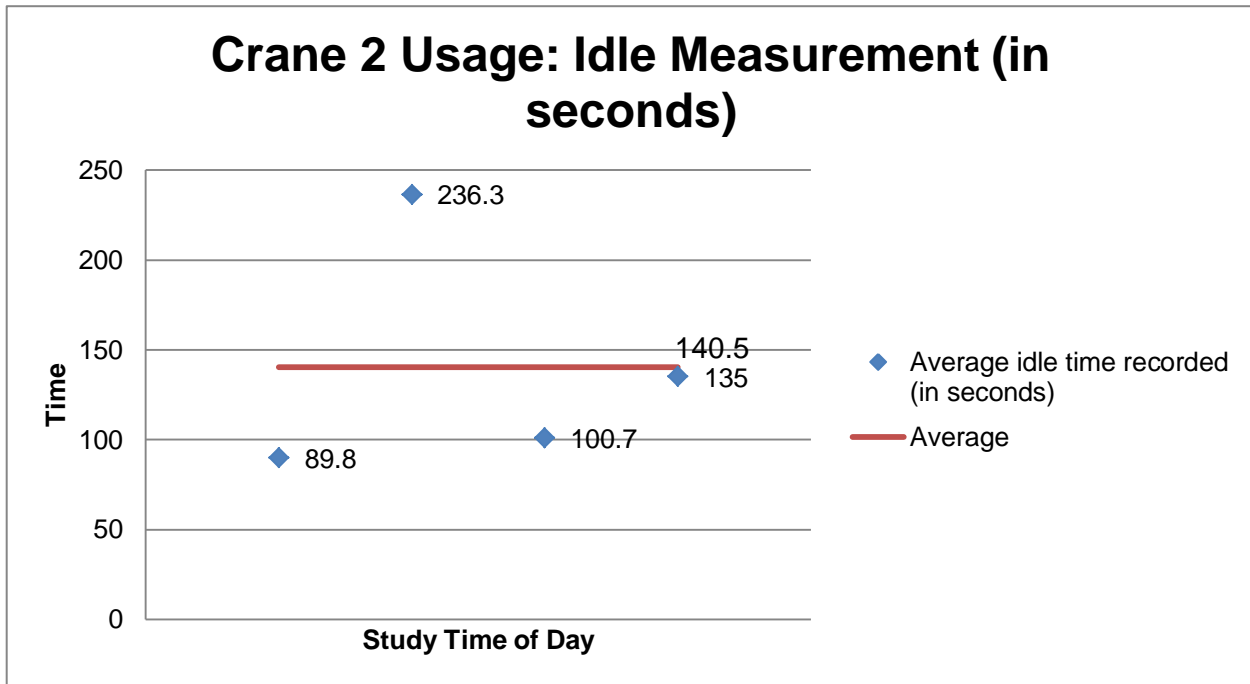

Figure 29: Crane 2 Usage Idle Measurement

The average number of each movement made was also captured and interpreted as follows:

Date	Time	Average Number of Slings (A1) Recorded	Average Number of Movements (A2) Recorded	Average Number of Unslings (A3) Recorded
26/06/2012	13:40	8	11	4
28/06/2012	10:20	6	12	4
	15:25	8	17	7
02/07/2012	10:20	11	23	11
Average		8.3	15.8	6.5

Figure 30: Average Movements Made By Overhead Crane

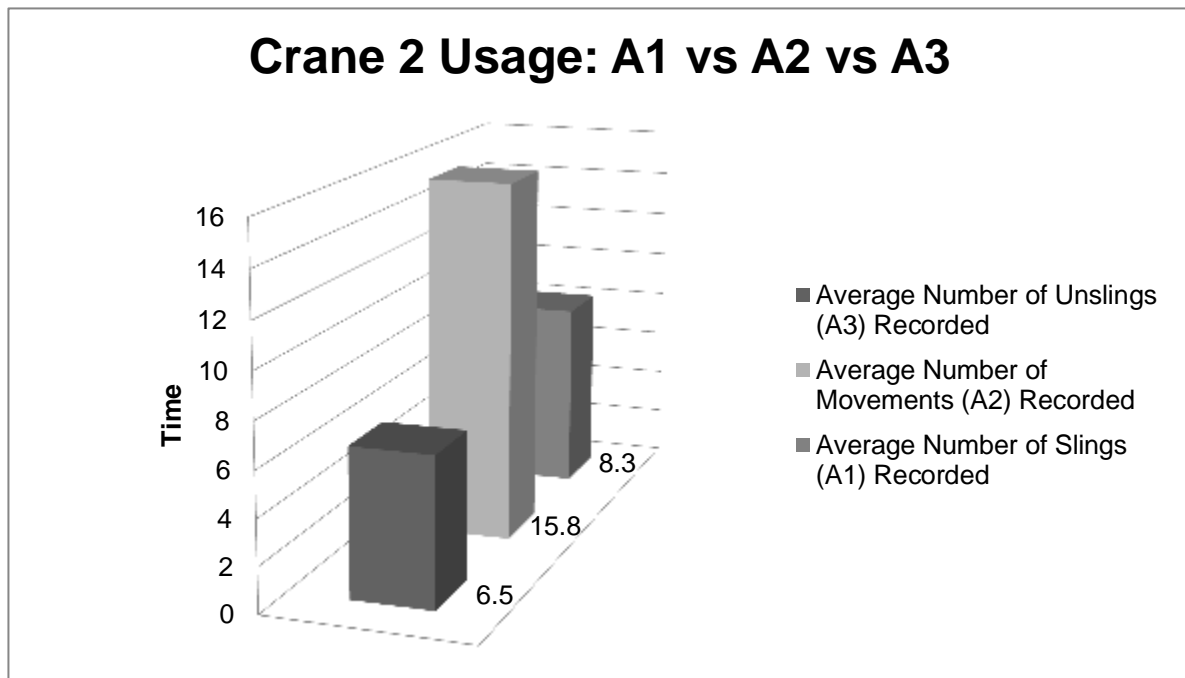

Figure 31: Crane 2 Usage A1 vs A2 vs A3

On average there are more movement actions made by the crane than loading and unloading (Sling and Unslung) actions. The difference between the Sling and Unslung amounts are due to the re-arranging of the pallets or bundles that are not placed correctly at their destination the first time. This still counts as an “Unslunging action” according to these studies.

The time studies for Crane 2 were also longer in general than that for the peeling and threading studies and added more value to what had to be achieved. This is because of the true, real life productive time recordings that were done and no “falsifying” of work rate or productivity as in some of the cases with the Peeling and Threading workers.

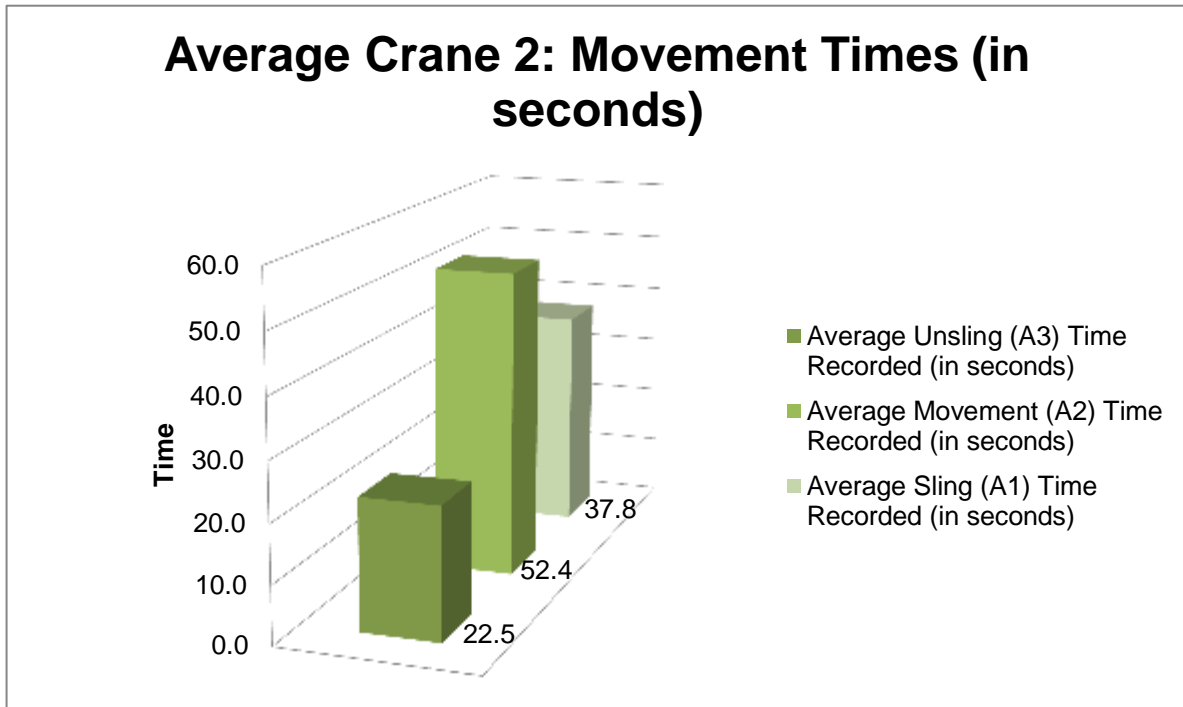

Figure 32: Average Crane 2 Movement Times

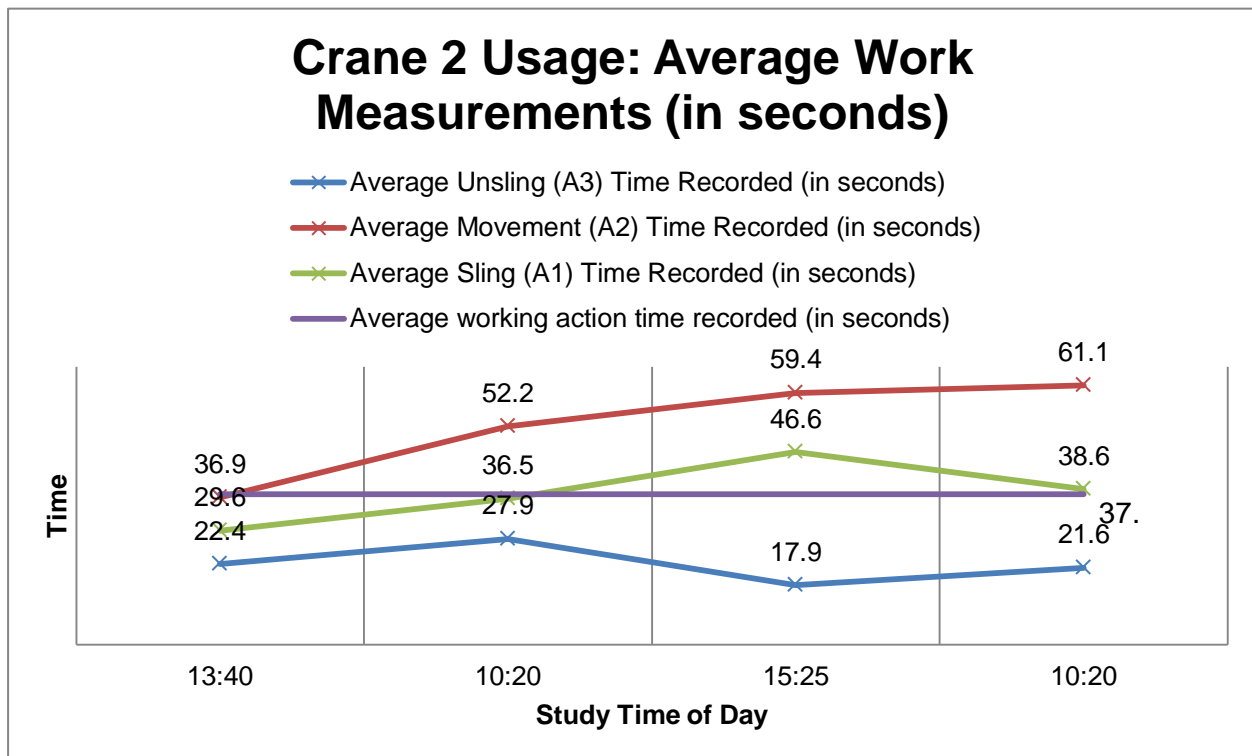

Figure 33: Crane 2 Usage Average Work Measurements

7.1.3.3. Conclusion

As originally suspected, the overhead crane is the constrained resource that takes up a lot of time to try transport pallets to every station, leaving some of the other stations idle in waiting for new feeding material. This is exactly the reason why this investigation was launched in the search for a better and faster material feeding solution, especially between the Peeling and Threading stations.

Thus this is where another problem arises, as previously stated, the cycle time difference between Peeling and Threading. This difference in cycle time of three seconds on average (Peeling = 12.8 seconds, Threading = 9.8 seconds) can be problematic in future when the Peeling and Threading machines are “married”, when it becomes the only way that Threading could receive feeding material. This would create situations that maybe Peeling targets be met, but the often then idle Threading station’s not. So as soon as the Peeling worker is idle, it is going to keep the Threading even longer from being productive and overall production too. But this could be evaded by either having other Peeling machines manufacturing stock or a proposed new air clamping system (already on one Peeling machine) on all the Peeling machines and even slowing the Threading machines down to close the three second gap till it is basically eliminated.

Newly proposed designs for the “marrying” of these two machines will be discussed later on.

7.1.4. Simio Simulation Model Discussion

7.1.4.1. Simio Program Background

The founder and CEO of the company Simio LLC, Dr. C. Dennis Pegden, has over thirty years' experience in simulation and scheduling and is seen as a leader in the industry.

Himself, with a team of highly experienced members found this incredibly powerful tool used worldwide today in every area of our daily existence for example;

- Healthcare
- Military
- Airports
- Manufacturing
- Supply chain
- Ports
- Mining
- Lean-six-sigma and many other disciplines

Simio is an exclusive multi-paradigm modelling program that gives the user/programmer the opportunity to create two and three dimensional, object based simulations of real life situations or a proposed production system and processes or the flow and function of a newly designed and built warehouse or car assembly plant. This is a very powerful tool to use in facility and production line designs and many more applications.



Figure 34: Simio Brand Logo

7.1.4.2. Simio Modelling Application at Aveng Manufacturing Duraset

To achieve a simulated “real world” scenario of the production system as is and under study at Aveng Manufacturing Duraset, the simulation program Simio is approached.

A layout copy of the current facility layout is created to simulate similar walking and traveling distances of workers and WIP throughout the floor space and designated paths whether it is in the air or on the floor.

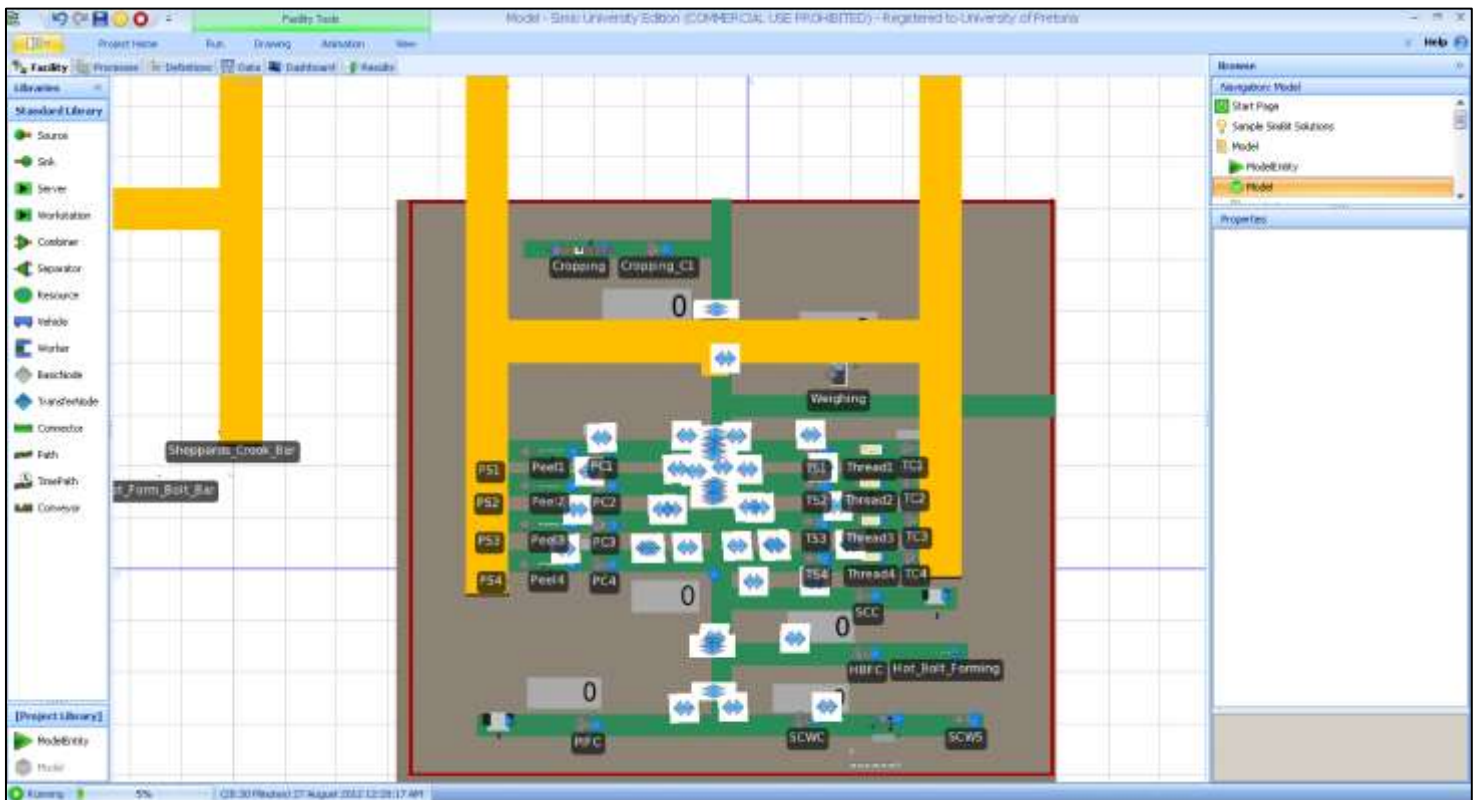

Figure 35: Top View Simulation Run of Focus Area

With this handy tool, possible scenarios can be simulated with alternative proposed, new manufacturing systems or machines.

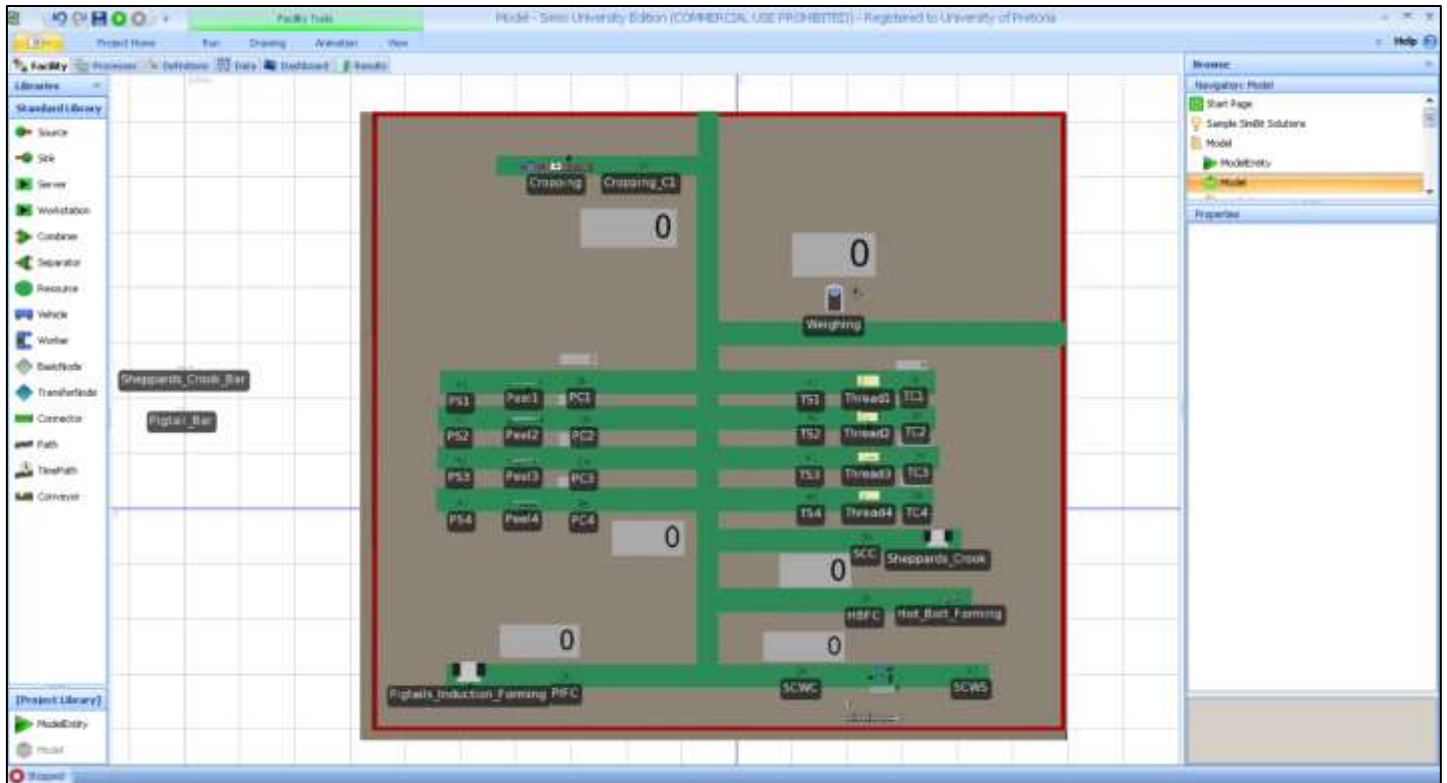

Figure 36: Clean Top View Of Focus Area

Within this simulation model there are modelled working stations which include those of Peeling, Threading, Pigtails, Sheppards Crook and Hot Bolt Forming.



Figure 37: Views of Work Stations

They use data gathered from the time studies and previous experiments at Aveng Manufacturing Duraset to function and know when to start or continue manufacturing a product

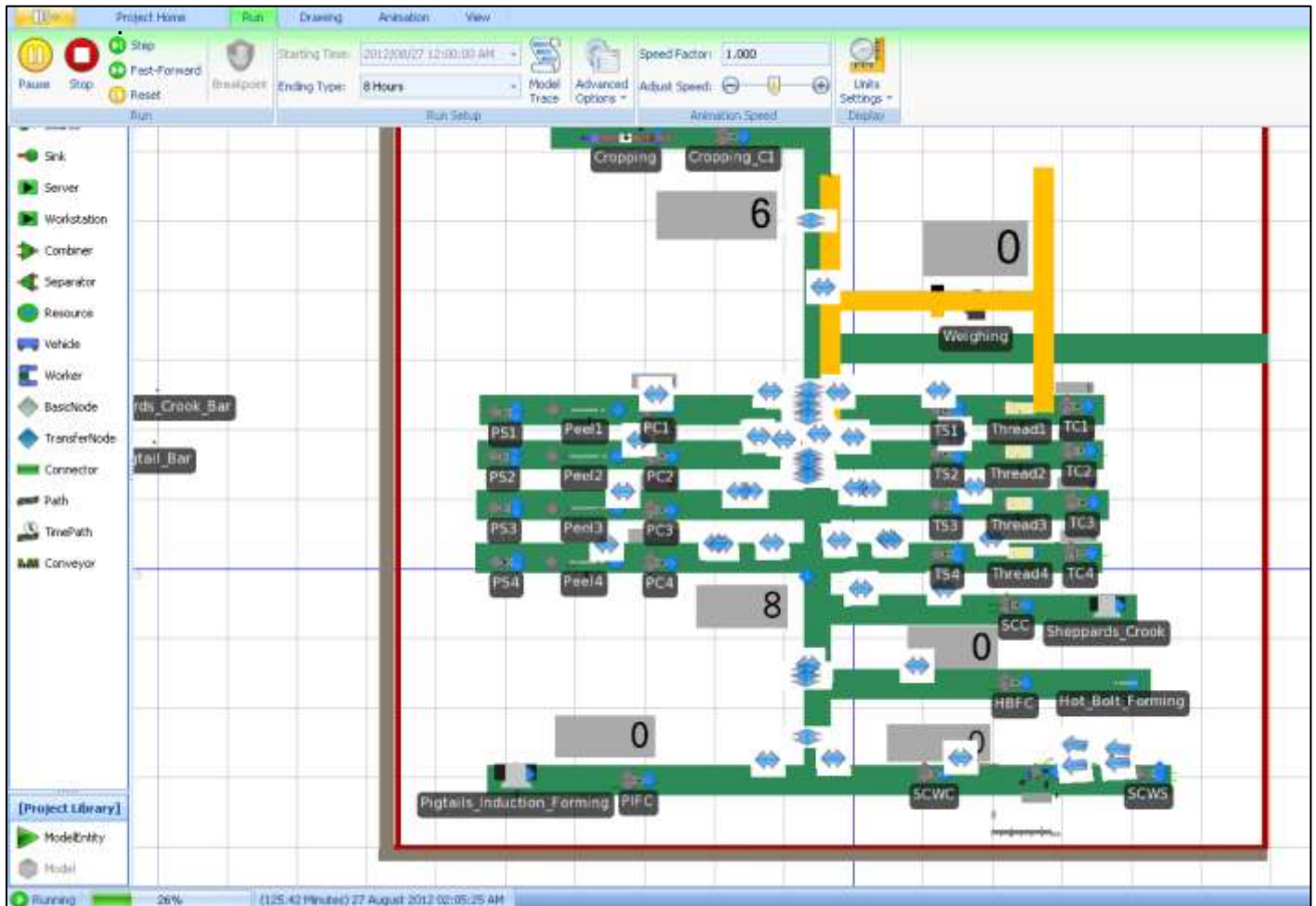

Figure 38: Top View of Run Pallets Number Monitors

Figures in the results might not be what expected because the model is run from the beginning, as if Aveng Manufacturing Duraset was started just now when the run button is pressed.

A small piece of programming logic is still missing though, to tell the overhead crane to ONLY move a full pallet from Cropping to a Peeling station as soon as that very same Peeling station's input pallet capacity is null and that Peeling machine and worker become idle (as in real life in the factory).

Thus the overhead crane is just feeding the Peeling machines as soon as a pallet arrives from Cropping. The idle and utilization figures for the Peeling and Threading won't be that accurate.

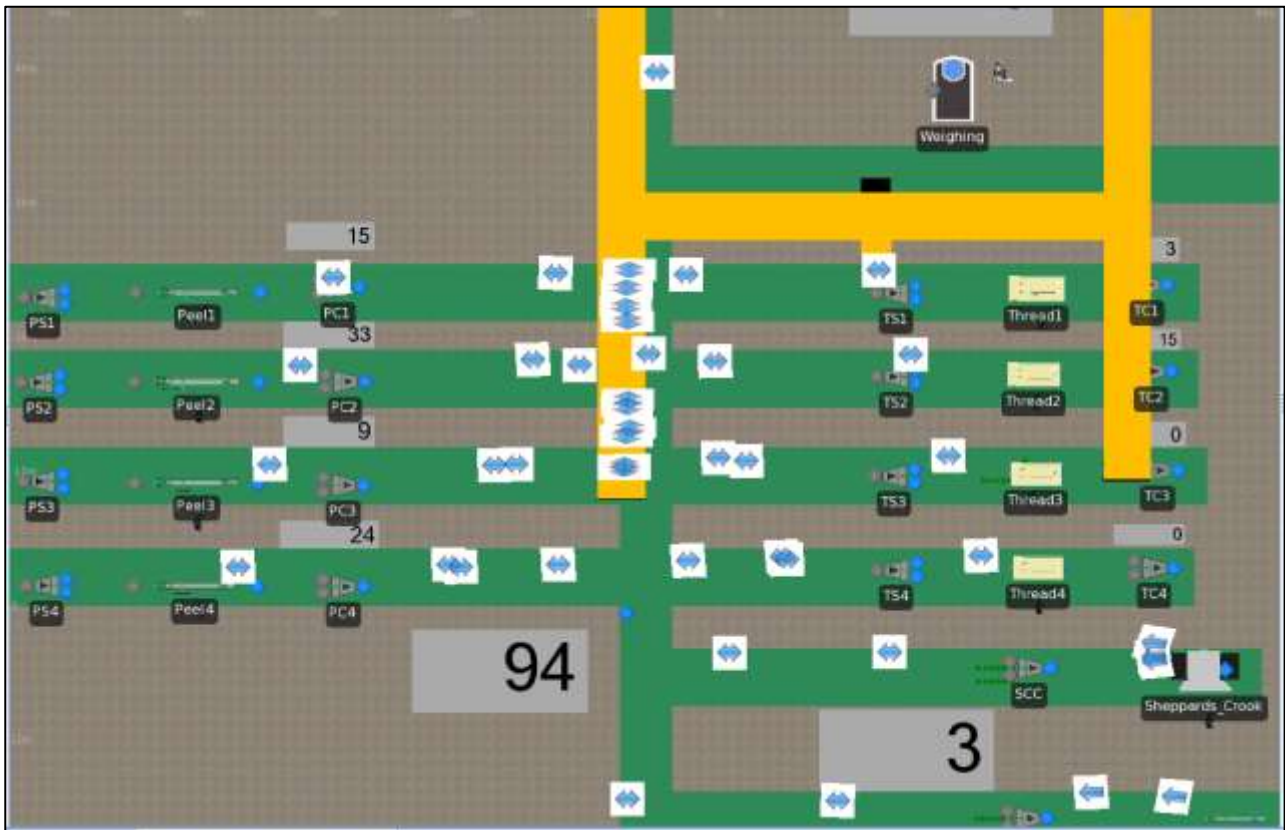

Figure 39: View of Point Tally Monitors

Tally monitors are placed all over floor to keep track of amounts of pallets moving through certain points in the system: from (Sources or starting/creating points) Cropping, Sheppards Crook, Pigtails and Hot Bolt Forming, to Peeling, to Threading, then finally to Weighing before it is moved to another process (destroyed in sink of model)



Figure 40: Weighing Station (Sink)

7.1.4.3. Simio Results

Since these are not the real times and data collected, the model's results might not be very accurate, except for the program logic gap, thus a definite and final conclusion would not be recommended from what can be seen or collected from this model.

But according to what can be seen and analysing the data captured it is easily clear to see that the Overhead Crane is the bottleneck and constraint resource in this manufacturing line.

The following results were exported to a Microsoft Excel file to make it available for processing, analysing and discussion.

Please Refer to Appendix C for the model run results and Simio report.

7.1.5. New Proposed Systems (Alternatives) Discussion

The idea of “marrying” these two necessary starting procedures (after cropping) in this particular manufacturing process, of the numerous processes for the manufacturing of their support and suspension products, Aveng Manufacturing Duraset has an opportunity to improve their productivity and try ridding the use of the overhead crane completely (between the two stations), as well.

In achieving the inoccupation of the Overhead Crane, it could decrease the total time used and utilization would come down. This is both advantageous, because it should promote a longer life span for the Overhead Crane and automatically open up its availability towards other stations and pallets, thus resulting in less waiting and idle time of the workers each day and less breakdowns and services. Another result of the implementation of this new system could be that the current “Gridlock” can be unravelled, opening up more transporting opportunities and increased area productivity. With this bottleneck sorted out, others can be identified and worked on if necessary (if any), other than that the system should be free of any hold-ups or problems. The flow of products would be smooth and fast, as physically and productive possible.

7.1.5.1. Safety, Quality, Ergonomics

Safety precautions have to be taken and are extremely critical for the lives of the workers and the excellent safety reputation that Aveng Manufacturing Duraset currently has.

Some safety problems that may arise during the implementation of the new system:

- Threading worker’ general safety
- Bogey stability, cleanliness, maintenance and life span
- Possibility of finger or hand getting caught between bars
- Throw trajectory and run (skew) on chute of peeled bar
- Life span of gravity chute, other structures and designs and possible breaking dangers
- Divider fitted between feeding and taking ends (keep the threading worker’s hand or fingers from getting caught or them getting hurt)
- Poor cleanliness in factory posing possible health risk

Quality should be more easily controllable in future and not only be the responsibility of the quality officers and group leaders, because they cannot be at every station at all times. Implementing and keeping to the following factors should increase quality of the product and work being done by and between each station:

- Double check between Threading and Peeling station
- Quality testing done by Threading worker and be able to stop Peeling from creating more scrap if it is the case

A lot of ergonomics were considered for this new system. Some of them are the use of the bogey with wheels for easier movability on the drip tray, not much higher than the average shoulder height, the use of gravity to “transport” the bars between the two stations with “zero energy wasted”, with the ideal gradient of the chute and pivot point for placing the next bar when waiting for the previous one to finish threading. All these points were looked at for the utmost user friendliness in the replacing of the current Overhead Crane driven system.

7.1.5.2. Possible Measures for New System

When drawing up a new and custom comparison sheet, the following could be considered as possible headings:

- ↯ Idea behind “marrying” and value adding property to system
- ↯ Amount of space saved compared to previously wasted
- ↯ Measurements
- ↯ Testing
- ↯ Designs complexity and applicability
- ↯ Observation and time study ease
- ↯ Idle observations and productivity gestures
- ↯ Trends
- ↯ Forecasting
- ↯ Safety
- ↯ Quality product output
- ↯ Ergonomics
- ↯ Initial investment
- ↯ Lead times
- ↯ Add-ons or extra equipment to be made, bought or installed
- ↯ Repairs, parts and maintenance availability and time
- ↯ Ease of use and understanding
- ↯ Energy consumption (electricity and human)

7.1.5.3. Design Alternatives

Through many meetings and discussions with workers and management from all levels, many design alternatives were listed. They include the following:

- a. Bogey and Gravity Chute
- b. Bundle Loading Magazine (Tensioning Belt)
- c. Drum-Wheel Grabs
- d. Carousel/Four-Arm Pallet Design
- e. Two-Bin Carousel Combined Shunting Rail
- f. Straight Line Placing
- g. Pneumatic Foot Pedal Feeder

Through further research, discussion, drawings, measurements and equations, a better understanding could be formed about the various new options that revealed themselves in the search for a successful “marrying link”.

All possible pros and cons had to be considered for each option and weighed up against each other to consider the “best of the bunch”. These consist of the most obvious and logical criteria like cost/investment, weight, space consumption, energy consumption (manual/electrical), functionality, output, capacity, labour intensity, storage and movement space around the linking machine and lastly, tooling and adjustment changes. This should give a preliminary classification from one to seven on a list, one being the better option to choose from the lot, but not necessarily the best choice there is for the current situation or in industry.

The information collected, discussions had follows next.

7.1.5.4. Design Alternative Discussion

Please refer to Appendix D for sketches and images.

a. Bogey and Gravity Chute

This design involves the use of the “free earthly” energy which is gravity, a designed chute from the peeling to the threading machine and design change on the bogies used in another area of the plant.

The gravity chute would consist of a steel, preferably lightweight, sloped structure that would feed peeled bars from the Peeling machine to the Threading machine into the awaiting bogey.

The mobile bogey has a divider in the centre, be it upright bars or a piece of sheet metal, which is higher than the corner pillars on the bogey to keep the incoming bars from falling out or onto the threading worker's hands. The idea is to create a 2-bin carousel system, having one side (half) bars fed into and clear of the thread worker for safety sake, because the machines are facing different directions, would help in turning the bars around automatically so that the peeled side of the bar is facing the correct way for the thread worker to just pick them up and continue with her/his actions. The wheels on the bogey make it turn-able and a new, bigger drip tray will be designed too.

Some drawbacks with this system are whether it is completely safe and fool proof for either worker, especially the receiving thread worker, the design for the gravity chute, the distance between the two machines and the turning radius of the bogey (with the longest bars included), could prove troublesome and create more effort plus time wasted when trying to switch the "two bins" around.

b. Bundle Loading Magazine (Belt)

From the overseas manufacturers, Rattunde & Co. comes this bar bundle loading magazine which is ideal for the automation of any bar feeding operation in manufacturing.

A description of its functions: a bundle of bars are loaded, within the maximum weight restrictions of the machine, onto the tensioning belt. The belt then tensions as soon as the machine is activated to drop a single bar through an eye sensor, to indicate that a single bar passed through, onto the transporting system of the machine. The belt then has to be relaxed to keep the rest of the bars on the belt until the next one can be dropped.

Apart from being an expensive investment and the unions that should be reasonably unhappy about its purchase and installation, this is an ideal piece of equipment to use as bar feeder for the Threading machine.

This piece of equipment comes with an entire CNC machining unit that is fully automated that can be programmed to treat each bar with peeling and threading qualities and pushes out a finished bar at the end of its own manufacturing line with a decrease in cycle times, no human error or laziness, just full out working machine that will increase output numbers and overall productivity if treated correctly.

c. Drum-Wheel Grabs

This idea functions the same as a water wheel.

Mechanically driven by either a motor, chain or by hand, the peeled bars are collected in a hand shaped bucket, one of many strategically placed others for the calculated grabbing of falling bars, attached all around a wheel or circle like structure (can be an old, used oil drum) to keep a continuous feed going. Until finally turning around and the bucket is upside down and the contents drop into an awaiting bogey or pallet.

d. Carousel/Four-Arm Pallet Design

This design consists of four steel arms joined together, a pivotal pole in the centre and smaller versions of pallets at the ends of each arm.

Placed in between the Peeling and Threading machines, this steel structure has the concept of having at least one pallet full (the pallet that just left the Peeling station), one being fed by the Peeling station, an empty one coming from Threading and the fourth being emptied by Threading. This can be rotated using either a motor or manually by a worker.

The set back of this design is that it takes up a lot of space, having to take into account the turning circle radius, the heavy structural requirements and maintenance of the arms and pivot system and how dirty the floor or surrounding area is going to be if not a big enough drip tray is designed or used.

e. Two-Bin Carousel Combined Shunting Rail

This system has a “merry-go-round” concept.

It has two pallets with wheels on a shunting rail that ends at each of the two working stations. Once the one is filled and the other emptied, they are moved to the centre of the shunting rail on a spinning platform, in order to be swopped around, each new pallet is moved to the end of their respective rails and the work can continue like before.

Cons of this system is the maintenance and initial investment made, the fixed placing of the rails on the ground, fixed routes of the pallets on the ground and the waste of space that it would incur.

f. Straight Line Placing

This is a very basic and simple design.

Placing all stations, output into the next station's input. From the first pallet at Peeling, the system is fed and dependant on smooth flowing WIP, with no bottlenecks or interruptions which this line is not, yet.

Making room for the entire line and others adjacent to the first could also prove to be a problem as well as the flow of threaded bars and the general walking flow of people through the area and between the stations.

g. Pneumatic Foot Pedal Feeder

This sophisticated piece of machinery which is easy to use can be installed for the thread worker who can control the feeding speed of the peeled bars from a separate storage container with feeding claws or a chain feeder.

Whether it is manufactured by the maintenance crew at Aveng Manufacturing Duraset or it is ordered and bought through professional suppliers it may still be expensive to get, maintain and adapt it to the current machines. This could even include the extra machines or bar storage structures needed for it to function.

Even though each alternative is a viable option for the new proposed system, they have varying levels of disadvantages, very expensive initial investments and time, space and energy consumption.

9. Recommendations

In eliminating the overhead crane completely out of the linking system of the Peeling and Threading stations, an alternative has to be chosen in its functioning place.

The designs discussed earlier have a variety of pros and cons that can include anything from cycle times, throughput rate, maintenance, initial investment and a lot more and it will differ from company to company.

For a cheaper and faster applicable solution, the Bogey and Gravity Chute, Drum-Wheel Grabs and Straight Line Placing are viable options. The Pneumatic Foot Pedal Feeder is also a cheap application, but the accompanying feeding structure might not be. After enough experiments and fine tuning, one of these options could be an acceptable quick and fast fix to the problem, but not necessarily on the long run or for the best possible linking mechanism to boost productivity to the highest level.

The more expensive solutions are the remaining. Some being easy to install, some easy to order, but once installed, takes up a fixed space, cannot be made smaller or moved. The rail and pivot pole for the Four-Arm Pallet Carousel and Two-Bin Shunting Rail are fixed in or on the ground and you lose that floor space for good.

If money and space is not a problem and the unions not as powerful as in Aveng Manufacturing Duraset, then the linking process can be fully automated with the Bundle Loading Magazine CNC machine. A very big initial investment, expensive parts and maintenance and taking up a lot of floor space, the output numbers will be the only deciding and measurement factors.

All these alternatives shorten traveling times and distances between the Peeling and Threading work stations and even rid most material handling as well.

Big Changes

- Elimination of Overhead Crane
- Change in layout of machines
- Feature different/same linking design(s)

Small Changes

- Full worker participation
- Different working and moving routine
- Different feeding position/structure/height/method
- More often quality controls between two stations

10. Conclusion

Facility Planning has many sub dividers. This includes Facility Layout, Material Handling and Material flow to name but a few, but they are all critical to be considered in making a success of a manufacturing line like this one at Aveng Manufacturing Duraset. This project will focus on smoothing the flow of Work-in-Progress through the system and improving productivity between the Peeling and Threading working stations.

The current system is brought under study and a couple of problems were identified, being either new ones or old re-occurring problems that do not go away. Old ones that include the overhead crane, tool changes, lazy and idle workers and products that are not of the quality level expected.

After the implementation of any of the proposed systems, whether they are in this report or contained in a future version, there should be a definite increase in either productivity, output production numbers, employee morale and the smoother flow of products throughout the system. The financial decision rests with the company.

Better housekeeping and control of numbers going in and out of each system will keep and help Aveng Manufacturing Duraset from spending thousands of Rands on a regular occurring stock count and having staff come in, over weekends for overtime rates.

Saving thousands in decreasing the number of stock counts per year, loss in stock be it by means of theft, rust or misplacement and resulting in an increase in products produced and sold. This will give Aveng Manufacturing Duraset a bigger profit margin in decreasing their expenses and upping their sales/income. This will improve the quality brand leaving the gates and to the client worldwide, keeping Aveng Manufacturing Duraset in the leading position.

In consideration of all data and information collected, whether it is from a worker, co-worker or machine, and portraying it in this report, this concludes the report:

Optimization of Manufacturing Workflow, Stock and Inventory Control

Scope Incompleteness Explanation

Due to time constraints and a lack of visit opportunities to Aveng Manufacturing Duraset, the entire scope did not enjoy equal and enough attention, thus the final parts containing facility layout and the stock and inventory control are not complete.

Parts include Facility Layout, Stock and Inventory Control and all the contents of each.

If the company would consider this report and the author as a possible employee for the year 2013, a further and more detailed study of all the topics would be partaken in with more time and resources available for use.

Bibliography

- (n.d.). Retrieved May 6, 2012, from Oxford Online Dictionary:
<http://oxforddictionaries.com/definition/facility?q=facility>
- (n.d.). Retrieved May 6, 2012, from Oxford Online Dictionary:
<http://oxforddictionaries.com/definition/planning?q=Planning>
- (n.d.). Retrieved March 19, 2012, from Chandoo:
www.chandoo.org/wp/2009/06/16/gantt-charts-project-management/
- (n.d.). Retrieved March 19, 2012, from Sportsman:
http://www.sportsman.co.za/client/53/image_lib/Tuks_Logo.gif
- (n.d.). Retrieved March 19, 2012, from Aveng:
http://www.aveng.co.za/reports/Aveng_AR_2011/about-aveng-group
- (n.d.). Retrieved March 19, 2012, from Aveng:
http://www.aveng.co.za/reports/Aveng_AR_2011/capability-matrix
- About the Aveng Group.* (n.d.). Retrieved March 19, 2012, from Aveng Group:
http://www.aveng.co.za/reports/Aveng_AR_2011/about-aveng-group
- An Introduction to Simio for Arena Users.* (n.d.). Retrieved October 16, 2012, from Simio: <http://www.simio.com/resources/white-papers/For-Arena-Users/An-Introduction-to-Simio-For-Arena-Users.htm>
- Aveng Africa.* (n.d.). Retrieved March 19, 2012, from Aveng:
<http://www.aveng.co.za/aveng-africa>
- cone-bolts-yielding-roof-bolt.* (n.d.). Retrieved March 19, 2012, from Duraset:
<http://www.duraset.com/product/cone-bolts-yielding-roof-bolt>
- durabar-yielding-roof-bolt.* (n.d.). Retrieved March 19, 2012, from Duraset:
<http://www.duraset.com/product/durabar-yielding-roof-bolt>
- Duraset.* (n.d.). Retrieved March 19, 2012, from Avengman:
<http://avengman.ltc.co.za/duraset>
- durastud-mechanical-anchor-bolt.* (n.d.). Retrieved March 19, 2012, from Duraset:
<http://www.duraset.com/product/durastud-mechanical-anchor-bolt>
- expansion-shells.* (n.d.). Retrieved March 19, 2012, from Duraset:
<http://www.duraset.com/product/expansion-shells>
- flexibolt-anchor.* (n.d.). Retrieved March 19, 2012, from Duraset:
<http://www.duraset.com/product/flexibolt-anchor>
- flexibolt-anchor.* (n.d.). Retrieved March 19, 2012, from Duraset:
<http://www.duraset.com/product/flexibolt-anchor>
- gemini-bar.* (n.d.). Retrieved March 19, 2012, from Duraset:
<http://www.duraset.com/product/gemini-bar>
- pigtail-eyebolt-suspension-bolt.* (n.d.). Retrieved March 19, 2012, from Duraset:
<http://www.duraset.com/product/pigtail-eyebolt-suspension-bolt>
- Planning Plan Format.* (n.d.). Retrieved March 19, 2012, from Cioarchives:
www.cioarchives.ca.gov/.../pdf/PM3.11_Planning_Plan_Format.pdf
- (n.d.). BFB Facilities Planning Notes. In C. Prof. van Schoor.
- rope-eyebolts-wedges.* (n.d.). Retrieved March 19, 2012, from Duraset:
<http://www.duraset.com/product/rope-eyebolts-wedges>
- shepherds-crook.* (n.d.). Retrieved March 19, 2012, from Duraset:
<http://www.duraset.com/product/shepherds-crook>

Simio LLC Company Background. (n.d.). Retrieved October 16, 2012, from Simio:
<http://www.simio.com/forums/viewtopic.php?f=15&t=912>

Simio Simulation Software. (n.d.). Retrieved October 16, 2012, from Ceenex:
<http://www.ceenex.com/services/technology/simio-simulation-software/thread-bar-600-dyno-bar>.

thread-bar-600-dyno-bar. (n.d.). Retrieved March 19, 2012, from Duraset:
<http://www.duraset.com/product/thread-bar-600-dyno-bar>

(n.d.). In J. A. Tompkins, J. A. White, Y. A. Bozer, & J. M. Tanchoco, *Facilities Planning*. John Wiley & Sons, inc.

unibar-mechanical-anchor-bolt. (n.d.). Retrieved March 19, 2012, from Duraset:
<http://www.duraset.com/product/unibar-mechanical-anchor-bolt>

z-bar. (n.d.). Retrieved March 19, 2012, from Duraset:
<http://www.duraset.com/product/z-bar>

Images:

<http://www.highveld.co.za/pages/events/events/94dayssoccercity2010/images/logos.png>

<http://makingcsimatter.co.za/images/AVENG-logo.jpg>

<http://www.webin10.com/cida/images/stories/logos/aveng%20group.jpg>

http://www.engnetglobal.com/images/companies/S/STE001_355.gif

http://www.engnetglobal.com/_imagecache/190x-1w-STE001_logo_150311060023logo.gif

<http://www.infomine-africa.com/manager/clientfiles/advertimages/small/Duraset1.BMP>

<http://www.ileadmining.co.za/wp-content/uploads/2010/02/Duraset-logo.bmp>

http://www.engnet.co.za/images/companies/S/STE001_main.gif

<http://www.southafricanbusinessinfo.co.za/sites/default/files/aveng%20logo.jpg>

www.nissanforklift.com

www.toyotaforklift.com

www.yale.com

<http://www.forkliftaction.com>

<http://www.crown.com>

www.materialhandlingproducts.com

<http://www.titanconveyors.com/products/roller-conveyors/gravity/model-425-gravity-roller-conveyor.htm>

<http://www.gi3.ca/product/7.aspx>

<http://www.mysafetysign.com/Safety-Signs/Look-Out-For-Forklifts-Sign/SAF-SKU-S-1969.aspx>

<http://maiscoisamenoscoisa.blogspot.com/>

<http://www.forklift-manufacturers.com/diesel-forklifts/>

<http://www.overhead-crane.org/overhead-crane-safety-4/>

<http://www.asia.ru/en/ProductInfo/420398.html>

http://www.dearborncrane.com/crane_buyers_guide/bridge_cranes.htm

<http://www.leguellec-tubes.com/en/modern-process-bull-block-2-15.html>

http://immm.com/zbxe/?document_srl=2103

http://www.umformtechnikmagazin.de/1-2006-maerz/artikel_-karl-fuhr-gmbh-and-038;-co.-kg-maschinenfabrik-_10777_2_336_de.html

<http://howishow.eu/search/how-barcode-scanners-work.html>

<http://warehousebuildings.blogspot.com/2012/04/choosing-barcode-scanner-and-software.html>

<http://www.gfxcasa.com/2010/11/advantages-of-barcoding-and-barcode.html>

<http://estore.sjf.com/sjf.nsf/vwAllDocs/D482B6C58CA2FB2086256B920066E869?OpenDocument&Count=5&EndVars>

<http://inhabitat.com/wood-pallets-repurposed-into-modular-furniture/>

<http://www.allianceindia.co.in/newsite/eseminar.aspx>

http://wn.com/Kanban_and_JIT_2_Bin_system

http://fr.wikipedia.org/wiki/Fichier:Water_Wheel.PNG

<http://chestofbooks.com/crafts/mechanics/Engineer-Mechanic-Encyclopedia-Vol2/Water-Wheel-Part-2.html>

http://etc.usf.edu/clipart/27900/27939/water-wheel_27939.htm

<http://www.soco.com.tw/products-p1.php?code=NEW00002&t1=NEW00019&t2=Extreme+Speed+Tube+Cutting+In-line+System&m=NEW00079>

<http://www.rattunde-corp.com/products/acs-cfmcurve-bdm/photo/9.htm>

<http://bernardandcompany.wordpress.com/>

<http://www.rattunde-corp.com/products/acs-cfmcurve-bdm/photo/8.htm>

http://www.siouxsteel.com/images/uploads/product-images/Sioux_Steel_1380.jpg

http://outdoorzgallery.com/storage/alex/alex_m_det_big.jpg

<http://www.1st-product.com/uploads/12/4802/new-axles-scale-with-ramps-350.jpg>

<http://www.bhindust.com/images/endura-veyor/stainless-steel-low-profile-belt-conveyor.jpg>

http://rattunde.com/img/products/p_blm_0001.jpg

http://www.rattunde.com/img/products/p_cfc_0002.jpg

http://www.knauf-interfer.de/deutsch/aktuell/archiv_2006/05_rattunde_2006_003.jpg

http://www.ehrg.de/agentur/ref_logos/rattunde.jpg

<http://chestofbooks.com/home-improvement/woodworking/Beginners/images/Water-Wheels-169.jpg>

http://www.sullivanwaterwheels.com/images/600px-Undershot_water_wheel_schematic_svg.JPG

<http://chestofbooks.com/home-improvement/woodworking/Beginners/images/Water-Wheels-172.jpg>

<http://www.tribuneindia.com/2009/20090804/bth2.jpg>

<http://www.interchangeablecomponents.com/North-Carolina-/Production-/Food-Processing-/New-pres-air-trol-foot-switch-pneumatic-pedal-displaypic.jpg>

<http://aerotechlab.com/shop/images/ATL-FP.JPG>

<http://www.edx.co.za/ClientData/www.lubreqipvaal.edx.co.za/images/prod1.jpg>

Appendix A: Current Facility Layout

Current Facility Layout

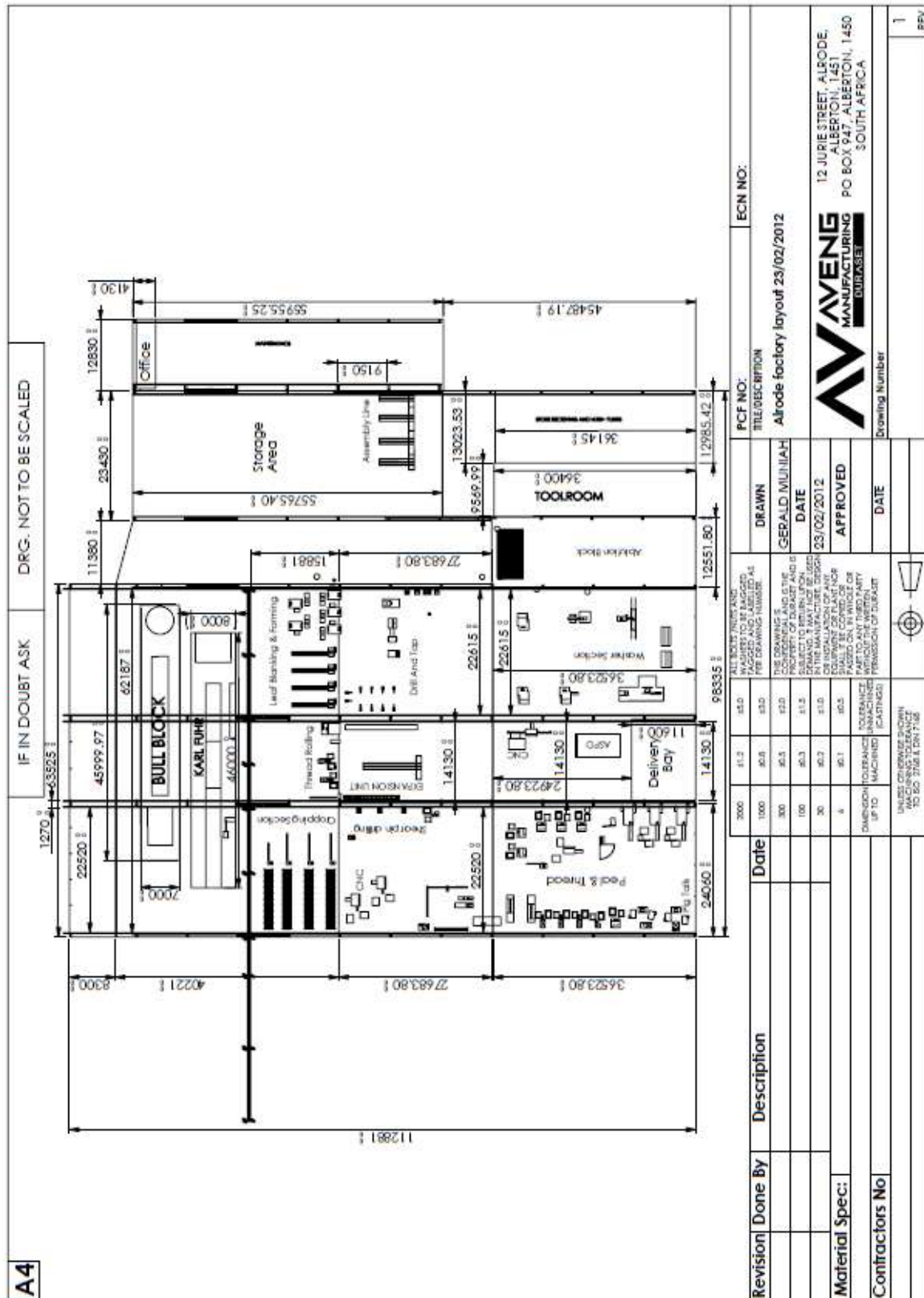

Appendix B: Time Study Sheet

Appendix C: Simio Model, Results and Report

Appendix D: Design Alternatives

Gravity Chute and Bogey Design

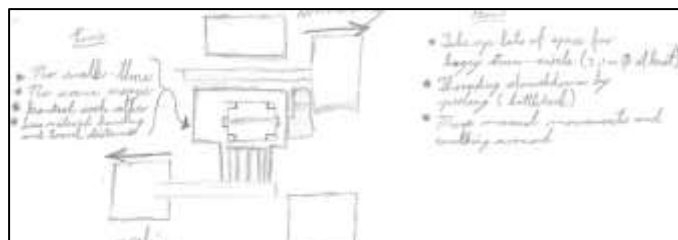

$85,5 + 2) - 20 - 2,25 = 02$

$v^2 = u^2 + 2as$
 $v = u + 2as$

100 horizontal pipes @ 12,5% flow pool: 1200 s/14,53 m
 x 2 + 100
 @ 9,0% / bar thread: 900 s/14,53 m

Bar	Volume	Flow
Bar 1	1033,4 cm ³ /bar	12,5%
Bar 2	2678,9 cm ³ /bar	12,5%
Bar 3	2,46 x 10 ⁵ cm ³ /bar	12,5%

Volume lost:
 Bar 1: 1033,4 cm³ / 2 = 516,7 cm³
 Bar 2: 2678,9 cm³ / 2 = 1339,45 cm³
 Bar 3: 2,46 x 10⁵ cm³ / 2 = 1,23 x 10⁵ cm³

Total Volume Lost: 1,29 x 10⁵ cm³ (12,5%)

Total Volume: 200000 cm³ - 1,29 x 10⁵ cm³ = 71000 cm³
 Loss: 1,92 x 10⁵ cm³ (0,5%)

100 horizontal pipes @ 12,5% flow pool: 1200 s/14,53 m
 x 2 + 100
 @ 9,0% / bar thread: 900 s/14,53 m

100 horizontal pipes @ 12,5% flow pool: 1200 s/14,53 m
 x 2 + 100
 @ 9,0% / bar thread: 900 s/14,53 m

100 horizontal pipes @ 12,5% flow pool: 1200 s/14,53 m
 x 2 + 100
 @ 9,0% / bar thread: 900 s/14,53 m

Bundle Loading Magazine



Drum-Wheel Grabs

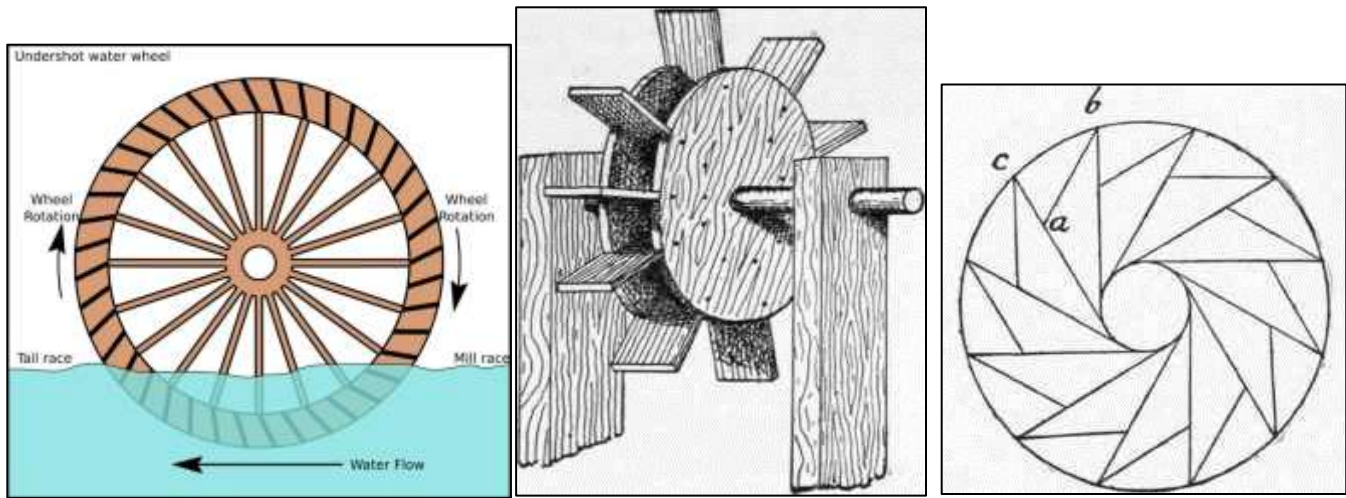

Four-Arm Carousel Pallet

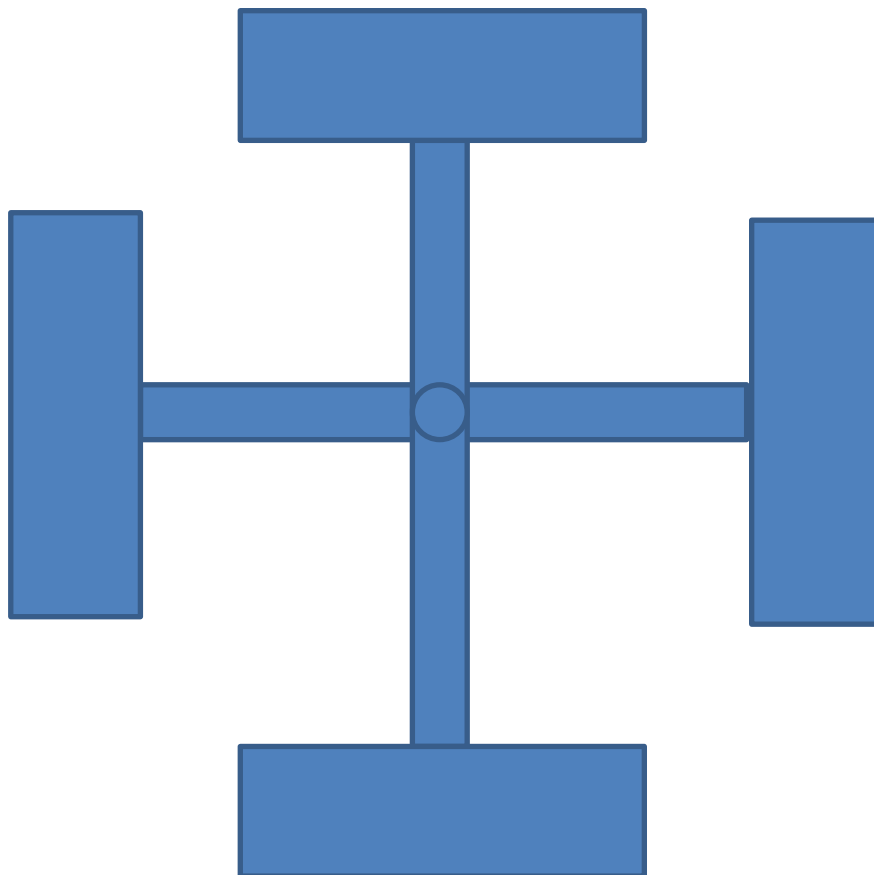

Two-Bin Shunting Rail



Pneumatic Foot Pedal Feeder



Appendix E: Aveng Manufacturing Duraset Products

Support

Rock Studs

Resin

Z-Bar → Hot rolled for purpose built performance when used in combination with the latest resin bolting technology. The design of the Z-Bar allows for maximum thread strength.



Unibar™ → With improved load retention capability, the Unibar™ which is hot rolled, gives a smaller tolerance between the thread and nut, plus better tensile strength.



Grout

Shepherds Crook → Manufactured to client specification and needs that includes a variety of arm lengths and steel. All Shepherds Crooks conform to the requirements of SABS 920 and in accordance with Duraset's ISO 9001.

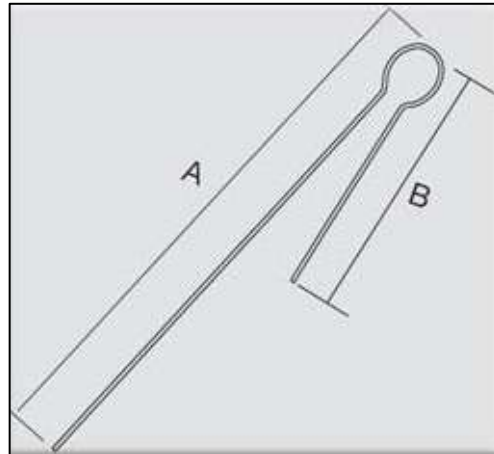

Durabar® (Yielding Roof Bolt) → An engineered yieldable tendon capable of effectively carry loads in areas prone to seismic activity and ground to swelling.



Cone Bolts → Another yielding tendon that provides effective load carrying capability in areas prone to seismic activity and high stress changes. Rock bursts etc. that damages tunnels are in return decreased.



Rock Bolts

Mechanical

Durastud™ → The expansion shell on the Durastud™ (mechanically anchored friction bolt) provides the user with end anchorage and the “expandable C-section” guarantees the integrity of the pre-stressing should any scaling occur around the collar of the hole.



Gemini Bar® → This easy solution consists of a cold rolled bar that’s fully threaded and made up of twin halves to result in a breathing hole down the centre. With an expansion shell fitted to the one end and to the other end a free running nut, seat, load indicator and bearing plate are all attached. Completing the assembly is a short grouting tube with a gasket.



Thread Bars → Made from different strengths of steel, thickness and threads. Each intended for their ideal work forces and aim of use.



Expansion Shells → The design includes a unique “3-leaf expansion unit” that ensures to provide anchorage in difficult conditions and more even distribution, of the weight, between the anchor and rock at anchor point.



Suspension

Rope Eye Bolts

Normal and Cobra

Rope Eyebolts and Wedges → A wedge secures the ferrule swaged end of the rope in the hole. The other end has another ferrule swaged to it and an eye welded to it.



Flexibolt Anchor → A flexible anchor system with pre tension loads of two to five tonnes that can be achieved.



Pigtails

Pigtails → Hot worked on the one side to form a "pigtail"-like eyebolt for suspension purposes and threading on the other for attaching an expansion unit.

