

The Plant Project

An Urban Agricultural Intervention in Marabastad.
Timothy Latim

STUDY LEADER: **EMMANUEL NKAMBULE**
STUDIO COORDINATOR: **ARTHUR BARKER**



Dedicated to my
Mum, without whom I would not have made it this far.

With special thanks to my family, for all your support,
Emmanuel - for your mentoring and direction
Arthur - for your words of wisdom
To all my friends - you gave me help when needed.
Thank you all.

The dissertation investigates the notion of resilience in the urban environment. The potential for architecture to adapt to changing contexts. Focusing on regenerating decayed urban environments using a relationship between architecture and landscape.

Table of Contents

Project Summary:	9
INTRODUCTION	
1.1 Abstract	11
1.2 Problem statement	12
1.3 Hypotheses	13
1.4 Research questions	13
1.5 Methodology	14
HISTORY AND BACKGROUND	
2.1 Establishment	18
2.2 Demolitions and relocations.	20
THEORETICAL INVESTIGATION	
3.1 Systems Theory	24
3.2 Resilient systems	29
URBAN AND SITE INVESTIGATION	
4.1 Introduction: Living network dead fabric	39
4.2 Meso context: Architecture and Urban Character	40
4.3 Nodes and networks	45
4.4 Site	51
URBAN FRAMEWORK	
5.1 ARUP Framework	66
5.2 Introduction.	70
5.3 The liquid network.	71
5.4 Social and Produce Network	72
5.5 Green and Grey Network.	75
PRECEDENT STUDIES	
6.1 Construction precedents.	80
6.2 Programme	87
DESIGN INVESTIGATION	
7.1 Background	94
7.1 Building programme	97
7.2 The site	125
7.5 Services	131
7.6 Stuff.	133
7.7 Space	134
TECHNOLOGICAL INVESTIGATION	
8.1 Site to structure	154
8.2 Structure to skin connection	156
8.3 Services	162
9.0 CONCLUSION	
9.1 Summary	168

Partial submission for the fulfilment of the requirements for MArch (Professional) in the Faculty of Engineering, Built Environment and Information Technology at the University of Pretoria.

Project Summary:

Urban agricultural intervention that utilises existing systems (landscape and urban) to create a resilient strategy for growth and development.

Site:

Bloed and Steenhovenspruit.
35-41 Stand street
Pretoria, GP
0002
South Africa
2544'31.0"S 2810'43.8"E

Research field:

Environmental Potential, Human settlements and urbanism

Theoretical Premise:

Regenerative design, Resilience, Landscape urbanism, Systems theory.

Main research question:

How can one provide the necessary infrastructure social and physical in Marabastad, for it to thrive and adapt with a growth in the social fabric?

Architectural Issue:

Architecture as a regenerative tool for the decayed ecology and urban spaces.

Architecture as a facilitator for regeneration of ecological, urban, social and economic systems.

Key words:

Resilience, Regenerative architecture, Productive landscapes.

The natural cycle.
Death feeding life,
life enduring to sustain itself,
only to die to give birth...
No loss
Harmony from one state to the
next.
From birth to death.

Landscapes grow, landscapes live,
landscapes die...
People are born, people thrive,
people die...
Are Cities are born,
do cities grow,
Are cities going to die...



Figure 1.0 From birth to decay
(Author, 2014).

_INTRODUCTION

The following chapter introduces the site, the problem statement, subquestions and the methodology. To place into context the research and proposed framework and design intentions.

1.0 INTRODUCTION

- 1.1 Abstract
- 1.2 Problem Statement
- 1.3 Hypotheses
- 1.4 Research questions
- 1.5 Methodology

1.1 Abstract

The dissertation investigates the notion of resilience in the urban environment. The potential for architecture to adapt to the changing contexts. The study focuses on regenerating decayed urban environments using a relationship between architecture and the landscape.

The dissertation is inspired by Japanese *shinto* shrines in Ise. The *Ise Jingū* shrines officially known as *Jingū*. The Shinto shrine complex in the city of Ise in southern Honshu, is important to Japanese culture. (Anon, 1975:142)

The site of Jingū Shrine has long been sacred, due to its forests of sacred Japanese cypress trees. The basis of Shinto faith is the consciousness that nature and human beings are united firmly through the *kami* (Japanese deities) (Jingū, 2014). Located on two main sites Naikū and Gekū. The Inner Shrine, Naikū (also officially known as *Kotai Jingū*) is dedicated to the worship of Amaterasu-ōmikami (deity of the sun and universe). The Outer Shrine, Gekū (also officially known as *Toyouke Daijingu*) is dedicated to *Toyouke no ōmikami* (the deity of agriculture and industry). (CNN Travel, 2014).

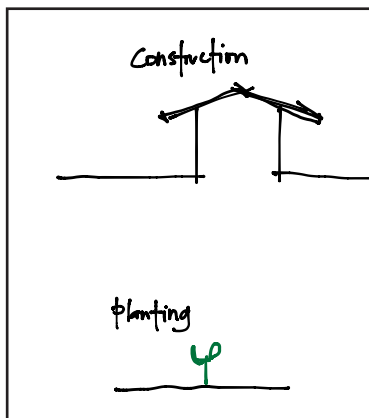

Figure 1.1 Planting the tree, building the house (Author, 2014).

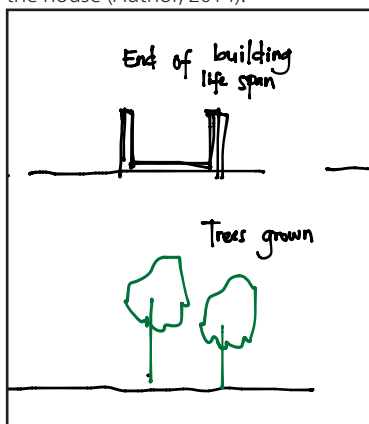

Figure 1.2 Rebuilding the house, harvesting the forest (Author, 2014).

The temples are rebuilt every 20 years, illustrated in figures 1.1 and 1.2. A process known as *Sengu*. (Jingū, 2014). As a part of the Shinto belief of: the coexistence of man and nature through *kami*, the death and renewal of nature and the impermanence of all things.

A symbiotic relationship between man and his natural environment.

The ceremony is a way of passing building techniques from one generation to the next. The 20 years before provides enough time for the forest to recover the trees lost to the temple.

1.2 Problem statement

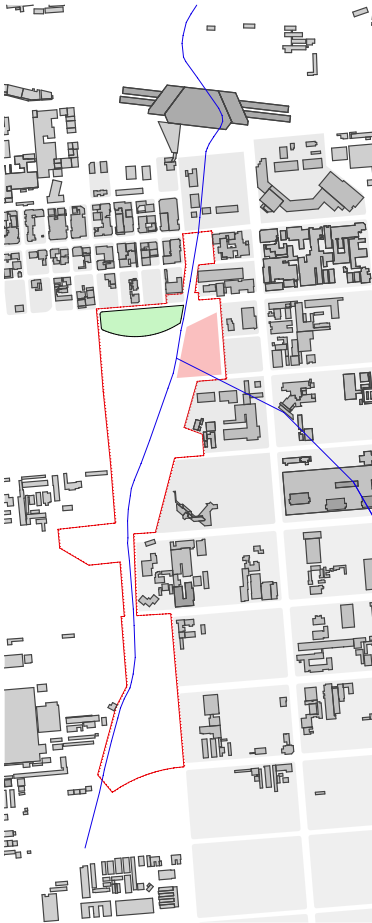

Fig 1.3 Urban focus and site (Author, 2014).

1.2.1 Architectural issue.

The site exists at a border between nature, the fine fabric and the inner city. Steenhoven spruit and Marabastad Jazz park (the natural), Marabastad to the North (the fine fabric), Pretoria to the East (the inner city) and the edge of demolished fabric to the west and south. This border condition presents the opportunity for an architectural intervention that creates a relationship between the nature, the city and man.

The site is inhabited by homeless people and rubbish dumps that are decaying both the urban environment and the natural systems.

How can architecture act as a catalyst for the regeneration of decayed natural and urban fabric?

1.2.2 Urban Issue.

The existing fabric of Marabastad was subject to demolition and evictions during Apartheid. Echoes of Apartheid on Marabastad can be seen throughout the precinct affecting the current community. The community have adapted to the situation, one of neglect, decay, crime and insecurity. This has created a sterile environment for economic growth and development.

How can the design of the urban precinct create a relationship between the ecological systems and the urban ecosystems to create a strong urban identity?

The public white washes the original identity that celebrated a mixed liberal society and has overlaid a negative image of poverty and insecurity.



Fig 1.4 Photo of empty lots in Marabastad (Author, 2014)

1.2.3 General issue.

Over time all systems are subject to stresses and strains. These affect the system or object, the extent to which the system is affected determine the degree of resilience of the system. The native community of Marabastad is resilient but doesn't have enough capital to thrive.

How can the existing resources be used by residents to develop the area economically, socially and ecologically?

1.3 Hypotheses

In studying the ecology and built environment, a synthesis between the two will be investigated.

The synthesis will look into creating a closed loop production system in an urban context.

1.4 Research questions

The research questions guide the three different relationships established by the architectural intervention.

Architecture and urban form.

How can an architectural intervention be contextually relevant and adapt to the changing demands of the precinct over time?

Urban form and urban agriculture.

How can urban agriculture be used as a catalyst for regeneration of decayed urban environment?

Urban agriculture and architecture.

How can architecture inform and be informed by urban agriculture?

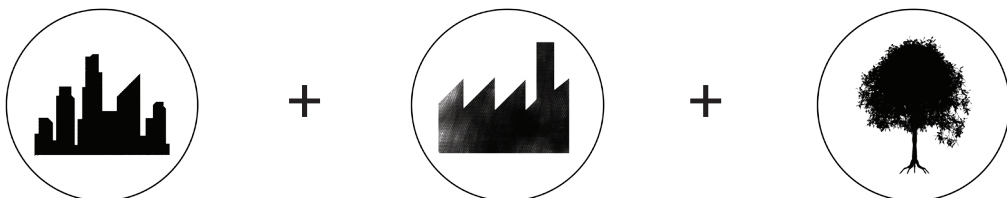

Fig 1.5 Dialogue between the different interventions (Author, 2014)

1.4.1 Sub-questions:

The design intervention acts as a catalyst for regeneration. To fully understand Marabastad precinct the investigation will be guided by the following sub-questions:

- How do the existing social, economic and ecological systems function?
- How can architecture facilitate the cradle to cradle production process?
- How can architecture respond to the existing fabric to create a more resilient building?
- What role does will intervention play in the social and economical systems of Marabastad?

1.5 Methodology

Aims and objectives

The investigation aims to define a relationship between architecture and urban agriculture in a derelict environment. The relationship is driven by the notions of resilience, systems and productive landscapes.

The objective is to create a spatial design strategy where:

- The landscape plays a productive role for urban agriculture, the architectural intervention and the urban environment.
- The architectural technological expression is neo-technic making use of the resources on site and promoting the development of new technologies.
- The existing social, ecological, cultural and natural systems are linked to the architectural intervention.

1.5.1 Delimitations and assumptions.

The basis of the vision for Marabastad is a response to the framework proposed by ARUP Metropolitan Framework.

Site visits and observations have been used to gather information about the existing state of Marabastad.

Old newspapers, magazines and other publications have been used to gather information about the heritage of Marabastad.

The purpose of this dissertation is to provide a design solution. The time constraint therefore does not allow for an in depth study of all the systems existing and assumptions made from observations and from interviews residents are regarded as accurate.

1.5.2 Quantitative and qualitative field research

Research is conducted through site visits and observations. Interpretation of the historical events, historical artefacts and the current status quo on site.

These investigations are the basis of the existing site conditions with Marabastad.

1.5.3 Literature study

The following fields are studied to substantiate the design approach:

Theory that focuses on the way objects relate other than on the objects themselves.

Resilience theory:

The purpose of this study is to create a framework for interpreting the urban environment as a system to:

- Gain an understanding of what are the causes of degeneration to places (what places should be resilient to).
- Identify what attributes makes places more resilient.
- Be able to factor the attributes into the design.

Regenerative architecture

- How architecture can be used as an instrument in regenerating urban space through programme and form.

Utilising urban landscapes for the production of crops for food and cash needs.

Productive Landscapes

- To gain an understanding of urban and peri-urban agriculture.
- How production and leisure can be integrated into an urban environment
- How buildings design can be integrated with the natural systems.

1.5.4 Case studies.

Precedent studies are divided into three categories.

Context:

Architectural interventions that are located in contemporary decayed urban environments that act as a catalyst for urban regeneration.

Programme:

Small to medium scale closed loop industrial processes with exchanges between the landscape and the built fabric.

Materials:

A study on materials that have can be used appropriately in the local context.

2.0 HISTORY AND BACKGROUND

- 2.1 Establishment
- 2.2 Demolitions and relocations.

2.1 Establishment

Pretoria was established in 1855 and proclaimed the Capital for the Boer Republic in 1860. Under the Boer Republic, the movement and settlement of all racial groups was controlled centrally. Residents and labourers from townships were levied 'head taxes' and 'hut taxes' from the conventions of Pretoria (1881) and London (1884). The conventions gave more rights to Indian and Coloured communities in the Transvaal. The first 'location' (also referred to as townships) for resettlement of Blacks in Pretoria was called Schoolplaats. It was established north-west of the city around 1867. The informal settlement pattern was influenced by the presence of the local Ndebele chief Maraba in the area and soon the 'location' began to surround the kraal. The new 'location' or township was declared Marabastad in 1888. Its boundaries were the Apies River in the north, Skinner spruit in the west, Steenhovenspruit in the east and De Korte street in the south.

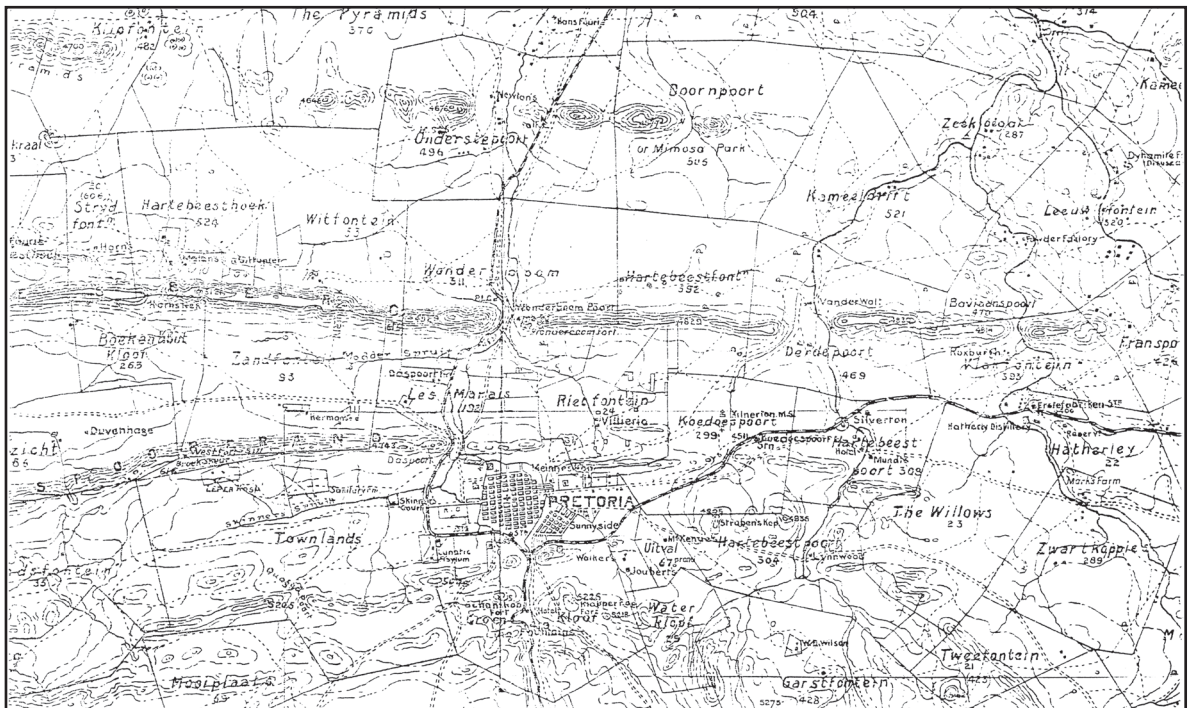

Fig 2.1 Plan of Pretoria in 1902 (Unknown).

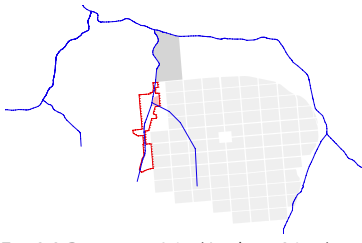

Fig 2.2 Pretoria 1867 (Author, 2014).

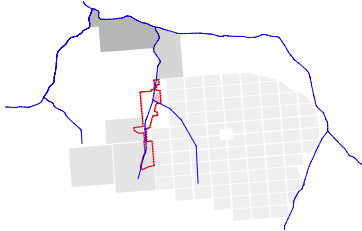

Fig 2.2 Pretoria 1888 (Author, 2014).

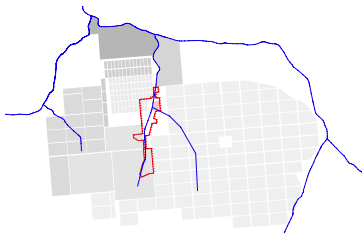

Fig 2.2 Pretoria 1892 (Author, 2014).

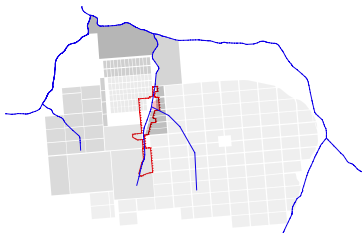

Fig 2.2 Pretoria 1910 (Author, 2014).

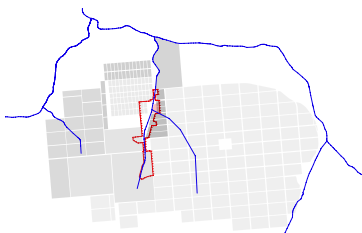

Fig 2.2 Pretoria 1912 (Author, 2014).

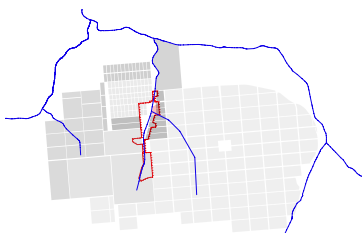

Fig 2.2 Pretoria 1925 (Author, 2014).

The name Marabastad either referred to headman Maraba, or to Jeremia Maraba, a contemporary chief constable and interpreter (Van der Waal 1998:5).

Originally it had 67 stands ranging between 1400 and 2500 square meters. Residents could not own the land but had to rent it from government for 4 £ per year.

The conventions (Group Areas Act, Land Act and Population Registration Act) facilitated migration of the Indian and other Asians into Pretoria. As the Asian groups began to resettle, the settlement areas became known as wards or 'bazaars'. If a township was referred to as a bazaar it implied that it had acquired a more elevated status than a 'location' and in bazaars Indians were allowed to trade, own immovable property and build religious buildings.

Between 1892 and 1893 an Indian township, known as 'Coolie Location' for people with Asian descent, was proclaimed south of Marabastad. Its boundaries were Bazaar Street in the North, Steenhoven Spruit in the West, Struben Street in the South and Von Weilligh Street (today D.F. Malan) in the East. The area had 380 stands that were much smaller than those in Marabastad (Van der Waal 1998:6).

Marabastad could not accommodate the influx of Black emigrants and the land between Marabastad and this coolie location gradually filled up, this area became known as 'The New Marabastad' although intended to be temporary, New Marabastad soon acquired a permanent character (Friedman 1994:42).

Several Coloured people from the Cape Colony and elsewhere started settling in Pretoria. A separate township for coloured people was demarcated. This township was known as Cape Location or Cape Boys Location. This area was between Bloed Street and Struben Streets and all Coloureds who were not living on their white employers properties were ordered to move to this location (Van der Waal 1998:6).

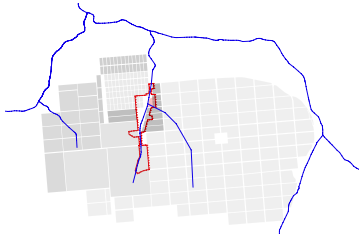

Fig 2.2 Pretoria 1934 (Author 2014).

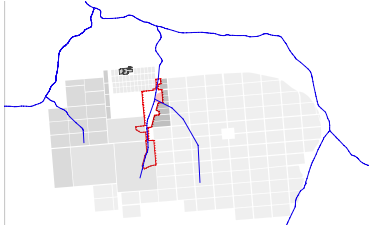

Fig 2.2 Pretoria 1976 (Author, 2014).

2.2 Demolitions and relocations.



Fig 2.2 Pretoria 1981 (Author, 2014)

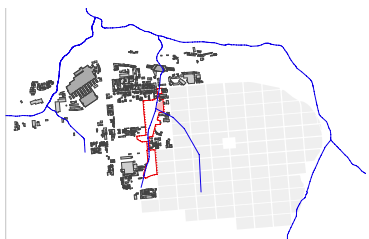

Fig 2.2 Pretoria 2014 (Author, 2014)

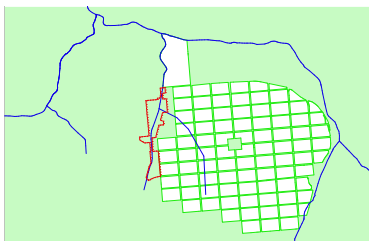

Fig 2.3 Conceptual Inverse mapping 1867 (Author, 2014)

In 1903 the area then known as ‘Coolie Location’ was resurveyed and renamed the Asiatic Bazaar. In 1904 the management of both the old and new Marabastad, the Asiatic Bazaar and the Cape Location were transferred to the Pretoria City Council. Pretoria City Council started resurveying properties for the purpose of implementing rates and regulations.

As a result of the survey done, Old Marabastad and New Marabastad had effectively become one township by 1906. This became known as Marabastad. 1166 small stands were created. The new stands were 665 in Old Marabastad, where 67 large stands had existed and 501 stands in New Marabastad where 412 had existed (Van der Waal 1998:8). The division of these stands is what determined the now fine fabric of Marabastad.

Because land ownership was prohibited for Blacks, it left them at the mercy of the Pretoria City Council, then controlled by the Boer Republic. And in 1907 Pretoria City council decided to establish a sewage farm on the land occupied by the Old Marabastad. The first evictions took place between 1912 and 1918. The Daspoot Sewage Works can be found in that area today. The residents were resettled north-west of the town centre in an area known as Bantule (Van der Waal 1998:8).

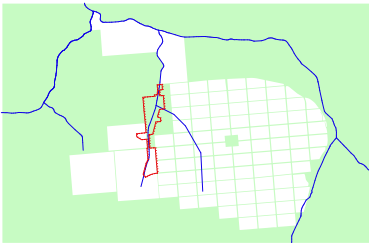

Fig 2.3 Conceptual Inverse mapping
1888 (Author, 2014)

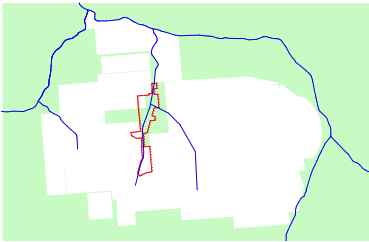

Fig 2.3 Conceptual Inverse mapping
1892 (Author, 2014)

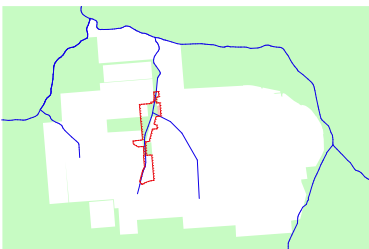

Fig 2.3 Conceptual Inverse mapping
1893 (Author, 2014)

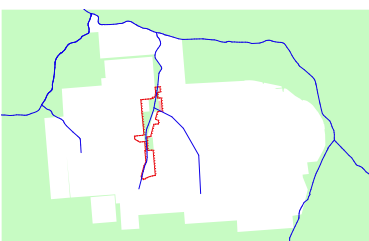

Fig 2.3 Conceptual Inverse mapping
1925 (Author, 2014)

The Schoolplaats 'location' was declared a slum and in 1934 under the Slums Clearance Act of the same year, was set for demolitions. The Population Registration Act of 1950 classified people according to their skin colour, descent and language. These acts were a means through which the apartheid policies were implemented.

The Group Areas Act of 1950 proclaimed separate Group Areas for people classified as White, Coloured or Indian, although separate areas for Black people already existed in terms of the 1923 and 1945 Natives Acts (Urban Areas Act). The Group Areas Act of 1950 determined that all residents of Marabastad had to be relocated to newly established townships on the periphery of the city. From 1940 to 1950 Black people from Marabastad were relocated to Atteridgeville, south west of the city centre. In 1950 the larger portion of the former township was evicted and more evictions were realised by 1958.

By 1959 the township Claudius had been proclaimed a Group Area for Indians and in 1960 Laudium was established. All Indian residents of the Asiatic Bazaar had to move to these two townships. In 1967, a proposal was made for a large freeway interchange that would result in the demolition of most of what was left over of Marabastad. Although the scheme was never implemented in full, it resulted in the clearance of the area south of Bloed street.

In 1976 the Asiatic Bazaar was finally abolished as a residential area. From 1962 to 1965 the Coloured population of the Cape Location was moved to the township of Eersterus and most of the buildings were demolished. This tract of land between Bloed and Struben Street is currently occupied by a bus depot (Van der Waal 1998:13).

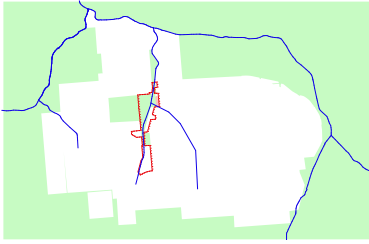

Fig 2.3 Conceptual Inverse mapping
1976 (Author, 2014)

The remaining part of Marabastad was declared an Indian business district and a shopping centre. The Asiatic Bazaar, was built in the open pieces of land. This area quickly became over populated.

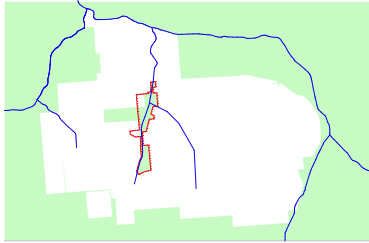

Fig 2.3 Conceptual Inverse mapping
1981 (Author, 2014)

In 1981, a railway line and Belle Ombre station were laid over the leftover pieces of land of the former Old Marabastad 'location'. The line and station, were to connect labourers from out of town with the inner-city. This turned Marabastad into one of the busiest commuter nodes of Pretoria.

While the building had a negative effect on the landscape the demolitions had the opposite effect. While this is the norm a systematic approach to the development of the urban precinct as well as the landscape would benefit both in the long run.

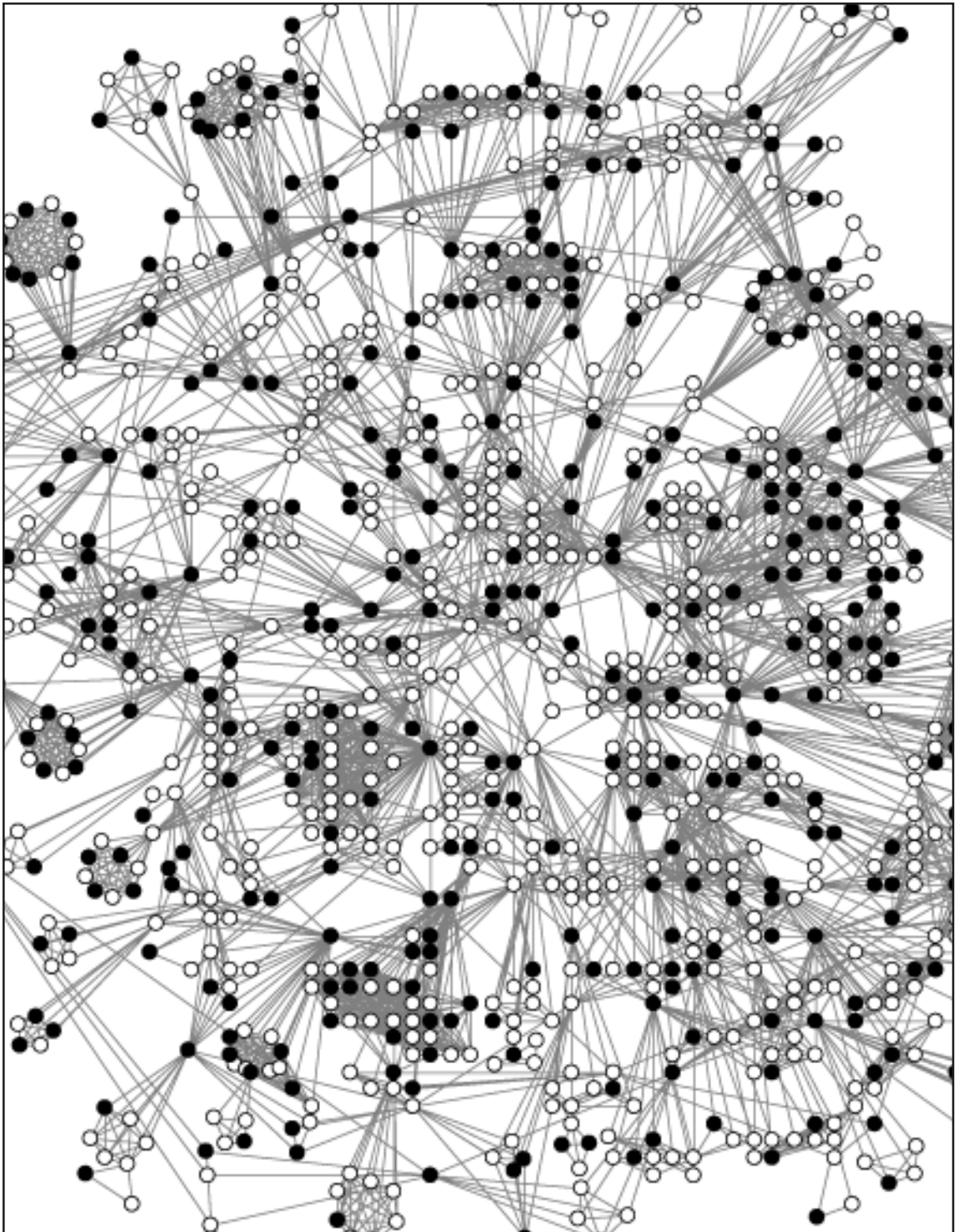

Fig 3.0 Interconnected (Unknown,2011)

THEORETICAL DISCOURSE

This chapter focuses on the theoretical premise which forms a base for the mapping and the urban and architectural interventions.

3.0 THEORETICAL INVESTIGATION

- 3.1 Systems Theory
- 3.2 Resilient systems

3.1 Systems Theory

Systems theory is the study of how complex entities interact openly with their environments and evolve continually by acquiring new, “emergent” properties. (Fiksel, 2003).

Explanation of the System behaviour

(i) System A is typical of a highly controlled systems. It operates within a narrow band of possible states and is designed to resist perturbations from its equilibrium state. It recovers rapidly from small perturbations, but it may not survive a large perturbation. This is called a resistant system.

(ii) System B is typical of social and ecological systems. It can function across a broad spectrum of possible states and gradually tends to return to its equilibrium state. Through adaptation and evolution, it is capable of surviving large perturbations. This is referred to as a resilient system.

(iii) System C is even more resilient than System B in that it can tolerate larger perturbations. Under certain conditions it may shift to a different equilibrium state, representing a fundamental change in its structure and/or function. (Fiksel, 2003).

Rather than reducing an entity to its parts or elements systems theory focuses on the relationships between the parts that connect them into a whole. It turns out that many system properties are independent of the concrete substance of their elements (e.g. particles, cells, transistors). Complex systems are generally dynamic, non-linear, and capable of self-organization to sustain their existence. Closed systems will gradually decay from order into chaos, tending toward maximum entropy. Living systems are open, in the sense that they continually draw upon external sources of energy and maintain a stable state of low entropy. Perhaps the essence of sustainability is resilience which is the ability to resist disorder. (Fiksel, 2003).

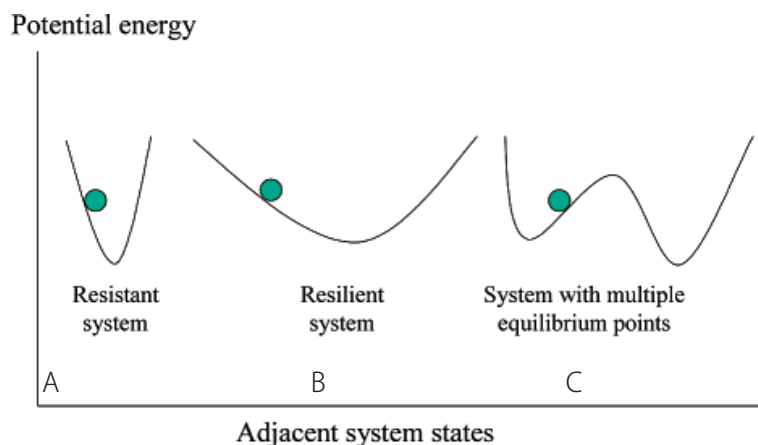

Fig 3.1 Examples of system behavior (Fiksel, 2003)

The figure 3.1 by Fiksel (2003), provides a simplified illustration of changes that characterize different types of systems. Each system has a stable state representing the lowest potential energy at which it maintains order, and each is subject to perturbations that shift it.

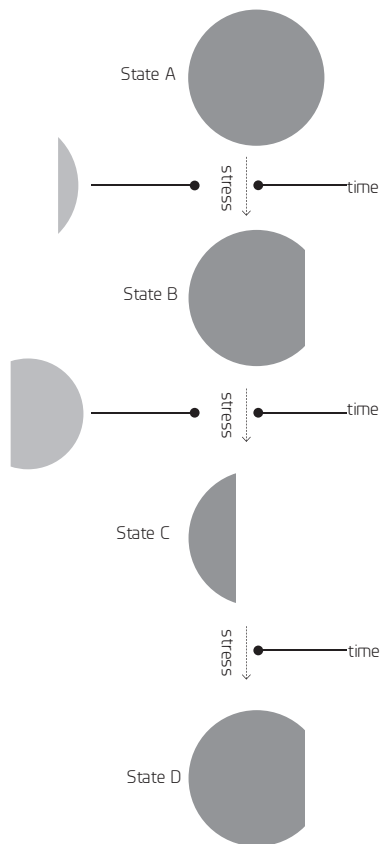

Fig 3.2 Stress and strain on objects
(Author, 2014)

A general theory of adaptive cycles developed by L. Gunderson and C. S. Holling, argues that all systems exhibit similar patterns of slow accumulation of resources, increasing connectedness, and decreasing resilience, punctuated by periods of crisis, transformation and renewal, illustrated in figure 3.2. Based on an understanding of these patterns, it may be able to intervene in appropriate ways that take advantage of the system dynamics rather than merely resisting change.

Resilience is the capacity of a system to absorb disturbance and reorganize while undergoing change so as to still retain essentially the same function, structure, identity, and feedbacks. The focus is on the dynamics of the system when it is disturbed far from its equilibrium state. (Fiksel, 2003).

Because of the possibility of multiple stable states, when considering the extent to which a system can be changed, return time doesn't measure all of the ways in which a system may fail to retain essential functions (permanently or temporarily). It is also important to bear in mind that "systems" consist "sub-systems," as it were, of households to villages to nations, trees to patches to landscapes, to cities. (Fiksel, 2003).

3.1.1 City as a system

Asset based analysis of cities tends to focus on physical assets rather than considering intangible assets that influence human behaviour such as social networks, culture and knowledge (da Silva & Morera, 2014). And in turn these intangible networks influence the usage and maintenance of the physical assets.

The city as a complex system of systems that is constantly adapting to changing circumstances. Over time systems are subject stresses and strains and these may cause the system to lose its core function. Traditional design of cities places emphasis on the assets and infrastructure of the city while a more resilient system would place emphasis on the networks and connections. Systems that are not able to recover from the disruptions soon become derelict and are discarded.

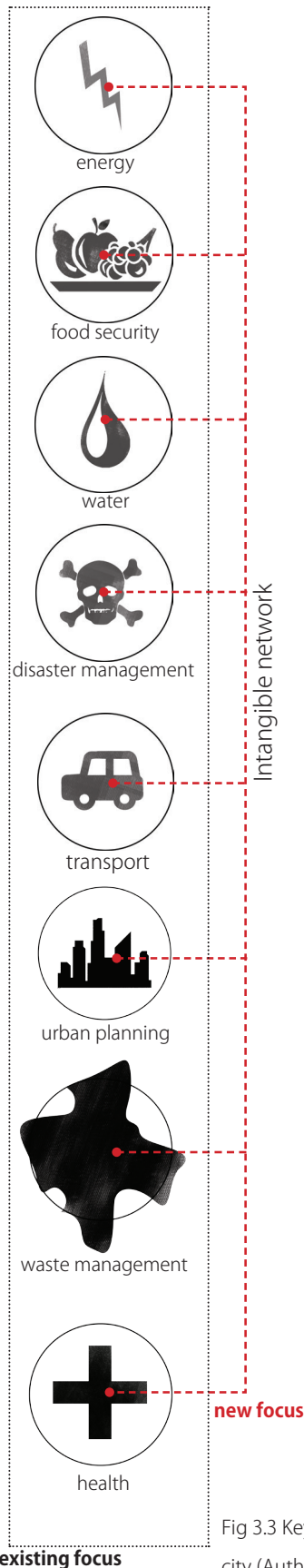

Fig 3.3 Key infrastructural points of a city (Author, 2014)

The function of the city to its citizens is to:

- deliver basic needs
- safeguard human life
- protect, maintain and enhance assets
- facilitate and maintain human relationships and identity
- promote knowledge
- defend rule of law, justice and equity
- support livelihoods
- stimulate economic prosperity.

The structure of the city.

The City Resilience Framework provides a lens through which the complexity of cities and other factors that contribute to a city's resilience can be understood. It comprises 4 categories and 12 main indicators. The four categories are: health and well being of individuals (people); urban systems and services (place); economy and society (organisation); and leadership and strategy (knowledge). The overall structure of the city is illustrated in fig below (da Silva & Morera, 2014).

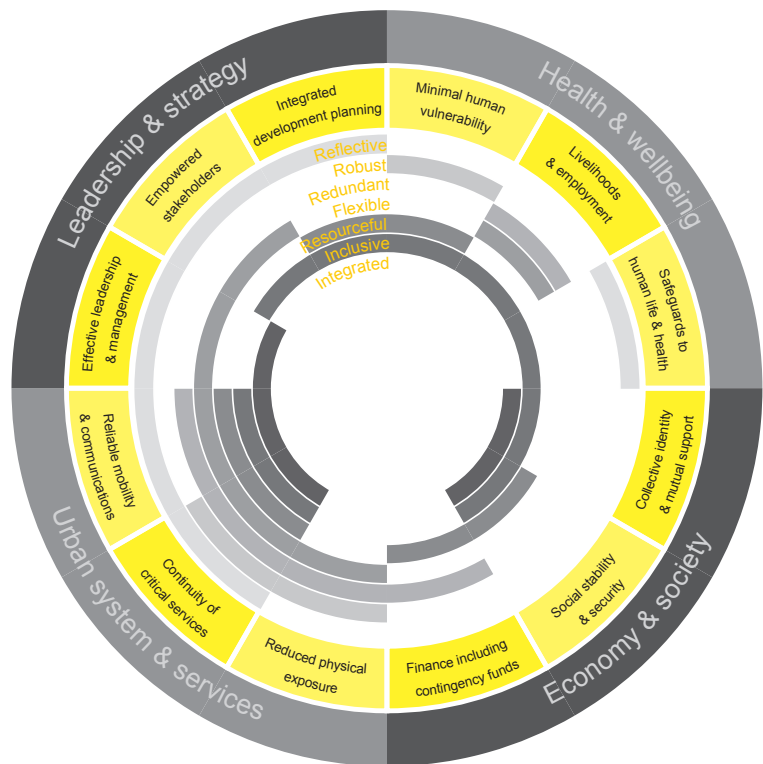

Fig 3.4 (City Resilience Framework, 2014)

Brand's shearing layers of change create a system to analyse the physical aspects of building as series of overlaid layers.

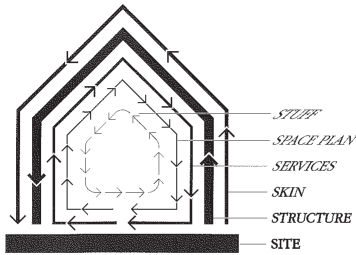

Fig 3.5 Shearing Layers of Change (Brand, 2010).

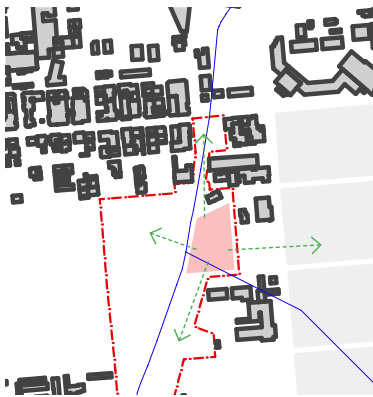

Fig 3.6 Site Connections (Author, 2014).

Positioning and detailing of the structure however can allow for more flexible space.

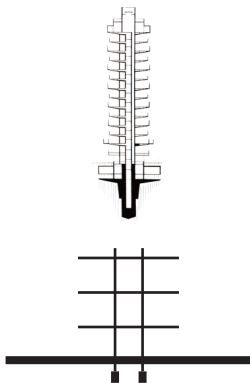

Fig 3.7 Section through Johnson Wax Research centre (Unknown, 2013).

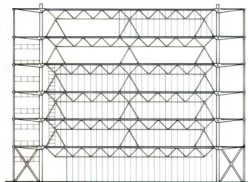

Fig 3.8 Section through Pompidou Centre (McMahon, 2013).

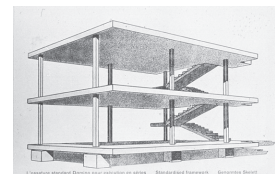

Fig 3.9 Le Corbusier's Dom-ino (Wilson, 2009).

3.1.2 Building as a system

Buildings comprise of different overlaid physical and experiential layers. Each layer is analysed considering its life span and its relation to the users and in relation to other layers.

Site

Although Brand considers the site as permanent, in a geographical setting and location i.e. all that is below and above an demarcated area.

It is not always the case to have a permanent site, and with the development of technology, there exists mobile buildings whose site can either be considered to be the structure of the vehicle or to be the temporary rest points. And in some circumstances a site may be subject to various forms of disaster e.g. sink holes, volcanoes or earth quakes, rendering it technologically unfeasible to construct on.

The site is the first level at which the building interacts with the urban environment and the users.

Structure

The structure refers to all elements that are directly responsible for holding up a building. These are the foundations and load bearing elements of a building. The life span of these members is typically between 30 - 300 years (Brand 2010). The second level at which the building interacts with the community and the city is on the structure. The position of structure, the and the footprint are restricted by the community and city. (Brand 2010).

The structure also conforms to the laws of physics and is the primary element that is responsible for the safety of the users.

Skin

The skin is the envelope of the building. This refers to the surface that separates outside from inside within building. The skin creates a habitable space for the occupants.

The skin lasts typically between 2 - 20 years. The skin is changed according to fashion, technology and repair. (Brand, 2010).

The skin is the level at which the building interacts with the users. As illustrated below, the skin may be used to define the relationship between outside and inside.

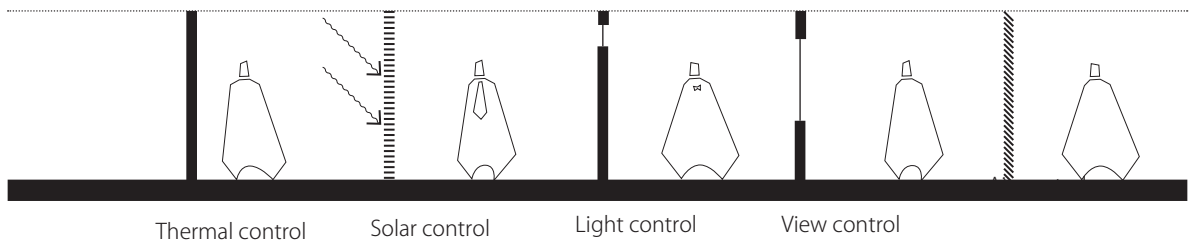

Fig 3.10 Functions of the skin (Author, 2014).

Services

'Services are the working guts of the building; communications, electrical wiring, heating, ventilation and air conditioning, elevators etc. They last between 7 to 15 years. However if fixed rigidly and embedded too deeply, they may cause a building to be demolished. (Brand, 2010). The services facilitate the needs of the occupants.

The building interacts with the main agent (owners, landlords) and council at the level of services. The placement of the services affects the flexibility of the space and its adaptability for future uses. The figures below illustrate the relationship between services and structure.



Fig 3.11 Service distribution (Author, 2014).

Space plan.

This is the interior layout; ceilings, floors, doors etc. The space plan is defined by both the structural and non structural elements which together compose the experience through the building.

The space plan is the level at which the building interacts with the occupants and the public.

The interior layout is affected by the services, skin and structure and is typically changed between 3 and 30 years.

Stuff

These are the move-able objects which the occupants use for their day to day activities. The stuff may be changed at any time by the occupants.

3.2 Resilient systems

Resilient systems are an ongoing process involving a multitude of actions at different scales. Most systems however different have the same underlying qualities.



Fig 3.12 Resilience qualities (Author, 2014).

3.2.1 Qualities of a resilient system

The seven qualities of a resilient city as defined by da Silva & Morera (2014) are.

Reflective

Reflective systems have mechanisms to evolve rather than seek permanent solutions based on status quo. They are accepting of inherent and ever and ever increasing uncertainty and change in today and tomorrow's world. They systematically learn from the past and leverage this learning to inform future decisions.

Robust

Robust systems are well-conceived, constructed and managed physical assets. So that they can withstand impacts and hazards without significant damage or loss of function. Robust design anticipates potential failures in systems, making provision to ensure failure is predictable, safe and not disproportionate to cause.

There are four aspects of resilience identified by Fiksel (2003) that are crucial to a resilient system. The first three can apply both to a whole system or the sub-systems that make it up.

- **latitude: the maximum amount a system can be changed before losing its ability to recover (before crossing a threshold which, if breached, makes recovery difficult or impossible).**
- **resistance: the ease or difficulty of changing the system; how “resistant” it is to being changed.**
- **precariousness: how close the current state of the system is to a limit or “threshold.”**
- **panarchy: because of cross-scale interactions, the resilience of a system at a particular focal scale will depend on the influences from states and dynamics at scales above and below. For example, external oppressive politics, invasions, market shifts, or global climate change can trigger local surprises and regime shifts.**

Redundant

Redundancy refers to the spare capacity purposely created within systems so that they can accommodate disruption, extreme pressures or surges in demand. It includes creating multiple ways to create achieve a given goal or fulfil a particular function. Creating diversity in a system. Redundancies should intentional, cost-effective, prioritised and not externalities of inefficient design.

Flexible

Systems can change, evolve and adapt in response to changing circumstances. This may be achieved through introduction of new knowledge and technologies or indigenous and traditional knowledge as needed. In infrastructural development it may favour decentralised and modular approaches.

Resourceful and networked

Resourceful systems find different ways to achieve goals and meet demands. To achieve these systems involves investing in the capacity of people and institutions to anticipate future conditions, set priorities and respond.

Inclusive

Inclusion involves consulting and engaging of all communities, including the most vulnerable. An inclusive approach contributes to a sense of shared ownership or joint vision. Addressing the shocks and stresses faced by one sector, location or community to be absorbed by another sector experiencing profit.

Integrated

Connecting systems across different scales promotes consistency and ensures that all investments are mutually supportive to a common outcome. Exchange of information between systems enables them to function collectively and respond rapidly through shorter feedback loops throughout the system.

Cycle of a resilient system.

A resilient system undergoes a closed loop cycle. From generation (birth), to growth/decay to evolution and adaptation back into the system.

The system is generated (or regenerated in the circumstance that it previously existed and has collapsed) with the purpose of healing the constituent systems and objects passively or actively related to it, illustrated in the figure 3.13.

The system grows or decays over time. Growth beyond the current capacity will eventually lead to breaking of the system into smaller systems or to adapting of system to accommodate higher output. Decay of the system to less than the self sufficient value will lead to its absorption into a bigger system or its evolution into a smaller more self sufficient system.

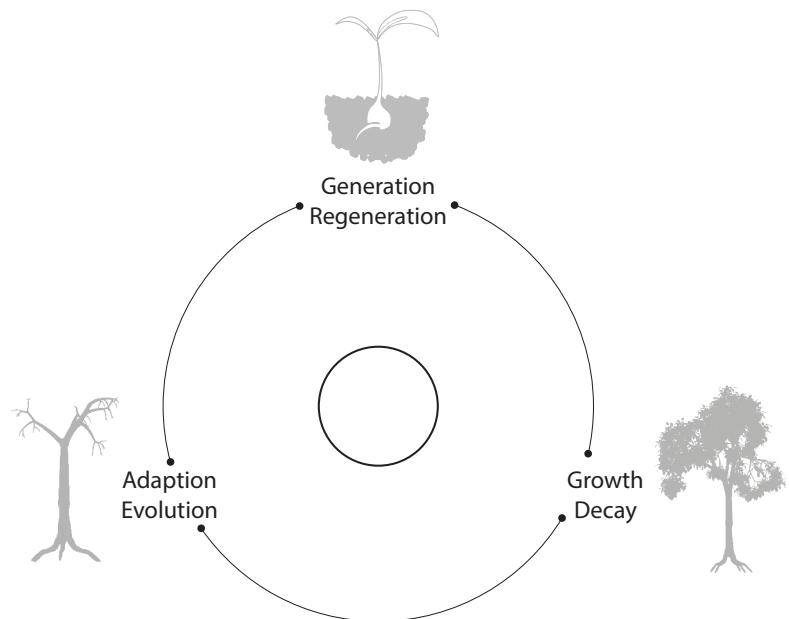

Fig 3.13 Resilience cycle (Author, 2014).

3.2.2 Resilience in cities

City resilience describes the capacity of cities to function, so that the people living and working in cities – particularly the poor and vulnerable – survive and thrive no matter what stresses or shocks they encounter.

Resilience is applicable to cities because they are complex systems that are constantly adapting to changing circumstances. As a term, resilience emerged front the field of ecology in the 1970's, to describe the capacity of a system to maintain and recover in the event of disruption or disturbance (da Silva & Morera, 2014).

The notion of a resilient city becomes conceptually relevant when chronic stresses or sudden shocks threaten widespread disruption or the collapse of physical and social systems. The conceptual limitation of resilience is that it does not necessarily account for the power dynamics that are inherent in the way cities function and cope with disruptions (da Silva & Morera, 2014).

In the context of cities, resilience has helped to bridge the gap between disaster risk reduction and climate change adaptation. It moves away from traditional disaster risk management, which is founded on risk assessments that relate to specific hazards. Instead, it accepts the possibility that a wide range of disruptive events – both stresses and shocks – may occur but are not necessarily predictable. Resilience focuses on enhancing the performance of a system in the face of multiple hazards, rather than preventing or mitigating the loss of assets. (da Silva & Morera, 2014).

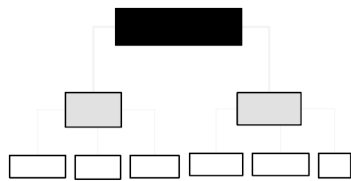

Fig 3.14 Hierarchical organisation (Author, 2014).

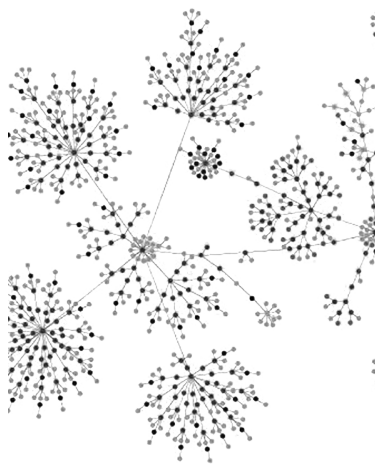

Fig 3.15 Interconnected (Unknown,2011)

The design of systems, has been approached traditionally as a process of hierarchical organisation (i.e., the overall system function is developed first and then the systems and subsystems are designed accordingly). Complex, hierarchically organized systems (e.g., aircraft, nuclear plants) tend to have rigid operating parameters, are resistant to stress only within narrow boundaries, and may be vulnerable to small, unforeseen perturbations. Alternatively, distributed systems composed of independent yet interactive elements may deliver equivalent or better functionality with greater resilience. (Fiksel, 2003). Non-hierarchical systems where every subsystems plays just as important a role distribute the possibility of failure throughout the system.

Stresses and strains

There exists two types of stresses that can alter the state of a city.

1. Natural: The most common natural threats are weather related hazards

- earth quakes
- flooding,
- hurricanes,
- cyclones
- changing rainfall patterns - which cause drought and water scarcity.
- landslides and erosion
- volcanoes
- asteroids

2. Artificial: These are mostly induced by man which include

- changing socio-economic cycles
- energy constraints.
- war and terrorism
- pollution
- fire

3.2.3 State of Marabastad

Marabastad underwent the generation, and the urban fabric is currently under a state of decay forcing the tenants to adopt to low state system.

After the forced evictions and demolitions in Marabastad, the city council ignored the area. Services were not provided for the residents. The city council either utilised the open tracts of land for activities that discourage trade and development in that area or condoned it off, encouraging homeless people to hijack. The open tracts were used for bus parking and service areas.

Pretoria developed towards the East, taking the finance and capital away from the area. Some people migrated with it. Of the ones who stayed, some resorted to crime and others tried to maintain their livelihood. The main source of revenue of the residents comes from the trade of products by vendors and shop owners. The traders come in during the day, sell their products and leave in the evening. The products are brought in and traded. Few products are manufactured in the area. There is a high rate of unemployment among the residents of the area and as a result some have resorted to crime or begging.

Marabastad is a main transport hub that connects Pretoria CBD to other areas. High volumes of commuters connect travel daily through Marabastad. Despite this, the traders haven't been able to expand their trading so they maintain the same size or collapse.

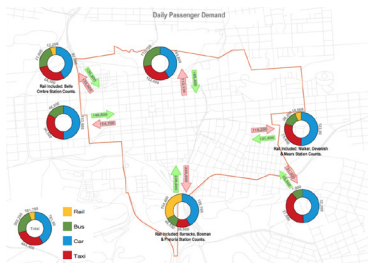

Fig 3.16 Daily Passenger Demand (ARUP,2012)



Fig 3.17 Daily Public Transport Use (ARUP,2012)



Fig 3.18 Daily Transport Demand (ARUP,2012)

While most of the products and foods being traded in Marabastad are being transported in, the waste from them is left in the area. The growing and manufacturing is done far and then finished products transported to the precinct. This pattern of 'food miles' is not sustainable (Viljeon, 2005). This pattern also affects the traders ability to expand. While larger retail chains enjoy economies of scale, smaller businesses operating on the same model have smaller margins for profit and in this circumstance make enough only to sustain themselves but not to grow leaving the area stuck in a state of decay.

How do buildings adapt to their new uses over time?

3.2.4 Resilience in buildings

Form follows function fallacy

"Architecture, we imagine, is permanent. And so our buildings thwart us. Because they discount time. They misuse time. Almost no buildings adapt well. They're designed not to adapt; also budgeted and financed not to, constructed not to, maintained not to, regulated not to and taxed not to, even remodelled not to. But all buildings (except monuments) adapt anyway, however poorly, because the usages in and around them are changing constantly." (Brand, 2010)

The problem with the doctrine that ‘form follows function’ is that as function changes buildings that were designed specifically to accommodate that function become obsolete. They become difficult to adapt to any other future spatial needs. We design our built environment, and over time are influenced by different trends which lead us to redesign our built environment to reflect these changes. (Brand, 2010)

We shape our buildings, then our buildings shape us, continually. The change of buildings is related to the economic and cultural conditions of the society.

So why then are some buildings still designed not to change?

Use.

Commercial: These adapt quickly and radically. Form follows financing in this case. Because businesses grow and fail, buildings follow the same trend. “Commercial buildings are forever Metamorphic.” Brand

Domestic: Dwelling residences respond to the families/individuals needs. The house and its occupants mould each other. Unlike commercial properties, the period when they may be changed is uncertain and also depends on ownership or rental.

Institutional: These are designed specifically to reflect a constant organisational structure. They convey timeless reliability to everyone outside.

Religious: Like institutional buildings, these are designed to reflect timelessness. These are rarely subject to change.

Sports and recreation: The size, scale and functional requirements of sporting facilities have been designed solely for hosting large events, requiring change of more than structure for the building to be adapted to suit another purpose.

Transit: These are buildings where travellers access transport facilities. Although these buildings reflect the temporal nature, they are designed for permanence.

Form follows function is not a complete fallacy when the function of a building allows for adaptation.

Manufacturing: These are probably the most adaptable To different uses. From “factory to artists, studios, to offices’ Brand

A possible solution is to use materials in by process, as suggested by McDonough & Braungart, 2002, using two operational cycles, a techno-sphere and a bio-sphere. Where materials that operate in the techno-sphere can be recycled with minimal waste, and those in the bio-sphere can be safely degraded to the environment. The initial cost of upgrading the construction industry will over time will cost less than the current trend of buildings once the industry advances technologically advances.

Technology

The economies of scale associated with use of the existing infrastructure. This forces users to utilise the same materials and techniques of construction to attain a predictable outcome.

The challenge with the current technology is the manufacturing industry did not design adaptable materials. The focus was on firmness, economy and delight, environment was never in the equation. Take an example of the use of embodied energy to evaluate the carbon footprint of a building material. At the current level of technology, this measure takes into consideration extraction and manufacturing and transportation. This is the industry standard in a particular country. However at this same level of technology, it is not possible to use the same amount of energy to return the material back to its original state, its not physically possible for some materials, or it costs more energy. Thus embodied energy at this point acts as a one way currency of measurement. Measuring the amount of energy manufacture a material and not the amount of energy required to get the material back into the earth. The materials usually get ‘downcylced’, leaving them less valuable than they were earlier in the building process. (McDonough & Braungart, 2002).

Heritage and culture.

One of the pillars of a culture is its built environment. One way that society relays continuity is through the permanent structures that the next generation experience. Considering all different levels of a society, from the family, to the suburb, district, province and state. All of which have a memory they would like to pass on. If the memory is passed on through a buildings, then across the different scales, there would be different corresponding building sizes.

Identity.

Despite peoples knowledge about the existing technological trends. The choice between fitting into a particular urban setting or advancing with technology, some people chose to fit in. Although it is not always a choice, in some circumstances there already exists a framework with guidelines e.g. heritage guidelines, council regulations or estate guidelines, for the type of building that can be built in a particular area. This framework is sometimes biased to a historic precedent which limit the form and technology that can be used for the building.

This dissertation does not seek to make future assumptions on the level of technology. The main question that arises is how can buildings be designed to reflect a unique identity of an area and yet be adaptable to change in an environmentally and economically sensitive way?

4.0 URBAN AND SITE INVESTIGATION

- 4.1 Introduction: living network dead fabric
- 4.2 Meso context: Architecture and urban character
- 4.3 Nodes and networks
- 4.4 Site

4.1 Introduction: Living network dead fabric

The urban area is in the Northwest precinct of the inner city of Tswane (Pretoria). It is located along the Steenhovenspruit and starts where the channel first appears above ground at Nana Sita Street in the south, and ends on Boom street in the north. The eastern and western edges are determined by vacant plots.

Pretoria’s memories of apartheid urban structuring create dichotomies of formal and informal, tangible and intangible, present and past coexisting in the city. While the commercial part of the city moved to the East, leaving the West to decay. The dilapidated and empty buildings were used by people in need of shelter. These shelters created a temporal use of space. This temporal use of building and site provides a platform for developing a new urban identity and architecture.



Fig 4.1 Location (Author, 2014)

4.2 Meso context: Architecture and Urban Character

4.2.1 Ethos

The buzz and the blank

Marabastad is buzzing by the day,
blank by the night,

Buzzing with smiles and welcoming
faces by sunlight
blank with criminals and hobos by
moonlight

Buzzing with commerce and trade,
blank with spoils and waste

Buzzing with sounds and tones of taxis
and hooligans,
blank with ruffle of papers in dark
buildings and in recessed streets

Buzzing with scents and smells of
various culinary delicacies,
blank with nose defying odours, grays
and blacks to the nose,

Buzzing with fragrant colours and
textures,
blank with dirt and dilapidation

Buzzing with different peoples from
different walks of life
blank with similar crime and insecurities

Buzzing with the beat of life,
blank with the stillness of death.

Poem by author (Author, 2014)



Fig 4.2 Street corner (Author, 2014)



Fig 4.3 Street corner (Author, 2014)



Fig 4.5 Photo of Marabastad (Author, 2014)



Fig 4.6 Don't Go (Author, 2014)



Fig 4.7 Kruger Park (Author, 2014)



Fig 4.8 Struben Street (Author, 2014)



Fig 4.9 Jazz Park (Author, 2014)



Fig 4.10 Marabastad open lots (Author, 2014)

4.2.2 Heritage and Architectural Value

The value of Marabastad heritage precinct is in the original fabric. It is now mixed use (Aziz Tayob framework). The buildings are pedestrian scale, between one and two storeys, have simple pitched roofs, chamfered corners and covered sidewalks on the street façades. This represents a part of the historical architecture of the township that existed in Pretoria.

Buildings with heritage value ●



Fig 4.11 No. 1 Barber Street (Volkwyn, 2012)



Fig 4.12 Untitled (Volkwyn, 2012)



Fig 4.13 Untitled (Author, 2014)

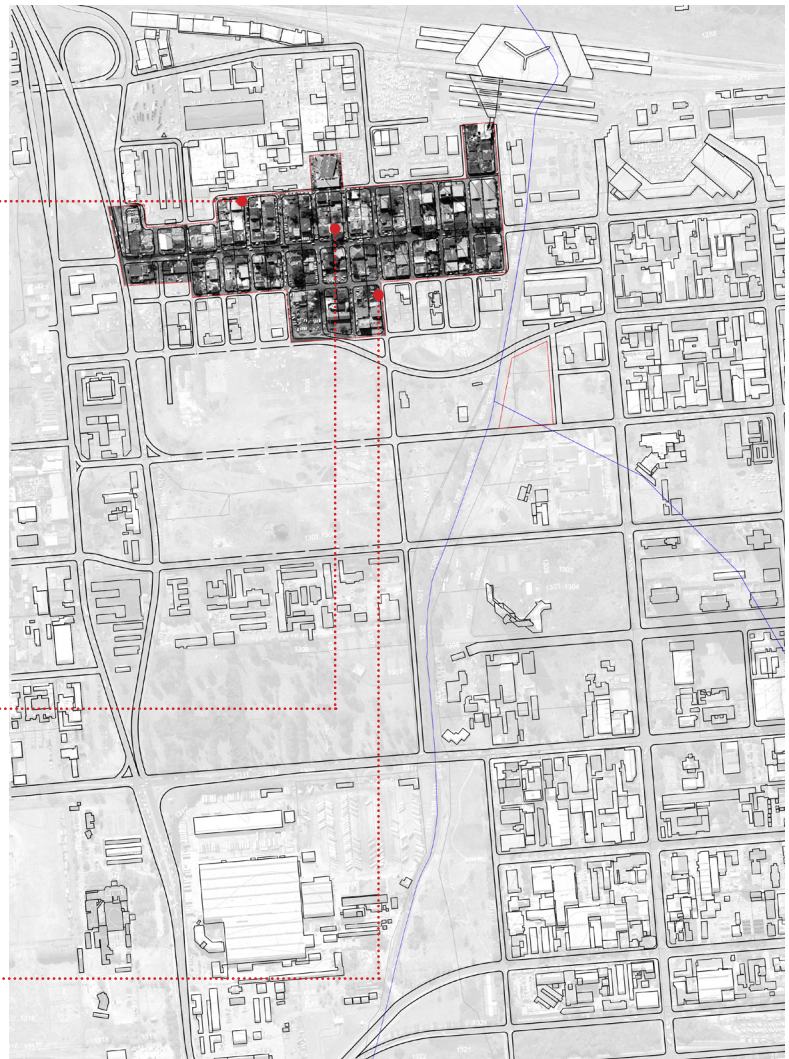

Fig 4.14 Heritage Potential (Author, 2014)

4.2.3 Fragments in the Urban Structure

The scale of the city and Marabastad meets at Steenhoven spruit channel. The change in urban character from the bigger city blocks to the small scale buildings. Map

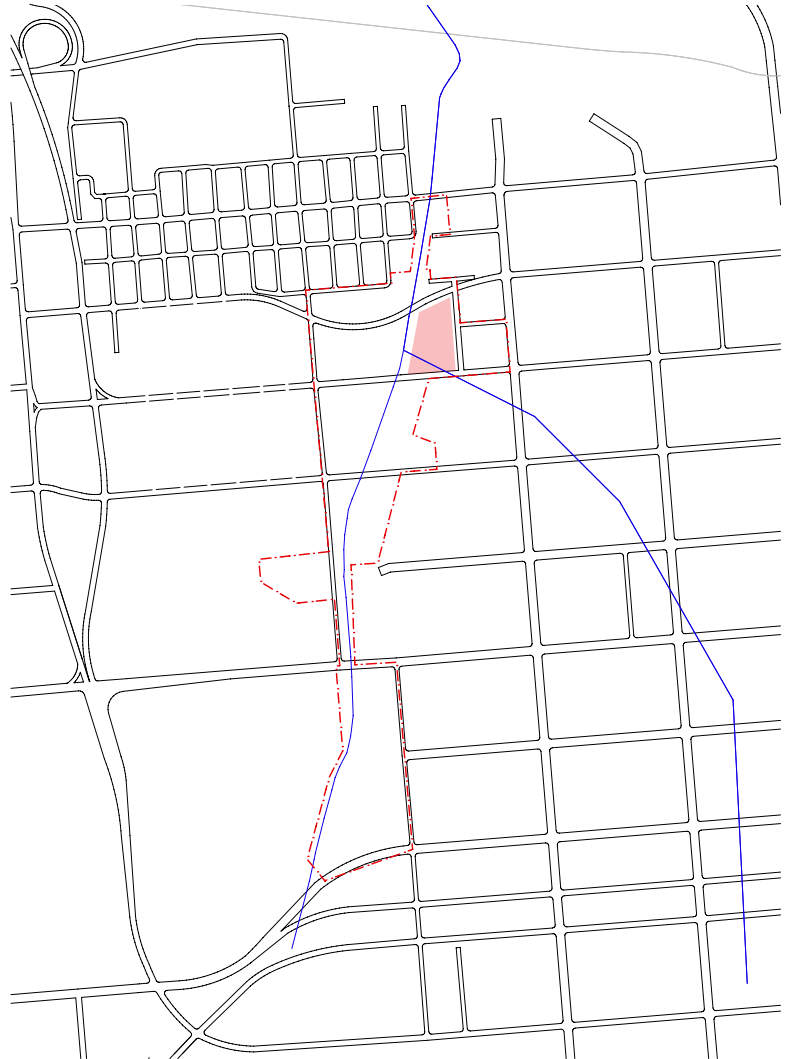

Fig 4.15 Existing road network (Author, 2014)



Fig 4.16 Hard edges (Author, 2014)



Fig 4.17 Urban voids (Author, 2014).



Fig 4.18 Urban decay (Author, 2014).

4.3 Nodes and networks

4.3.1 Trade and industry

While the informal trade network responds to the pedestrian movement. There is an opportunity to create a link to the main trade nodes. The waste from the fresh produce markets can be composed for agricultural use or for energy generation.



Fig 4.4 Photo of Marabastad (Kekena, 2013)

There are three main market structures in Marabastad, the Indian Bazaar, and two fresh produce markets. Another string of revenue comes from small to medium scale traders owning and operating their retail businesses. The formal and informal sectors co-existing alongside each other. The products traded are mainly electronics, fashion accessories, and fresh produce.

The formal sector nested in the buildings while the informal sector grows and adapts to the street.

The main trading nodes are the markets, while the trade networks is woven in the streets. The trade networks are comprised of temporary structures like tents and people trading from the back of their vehicles.

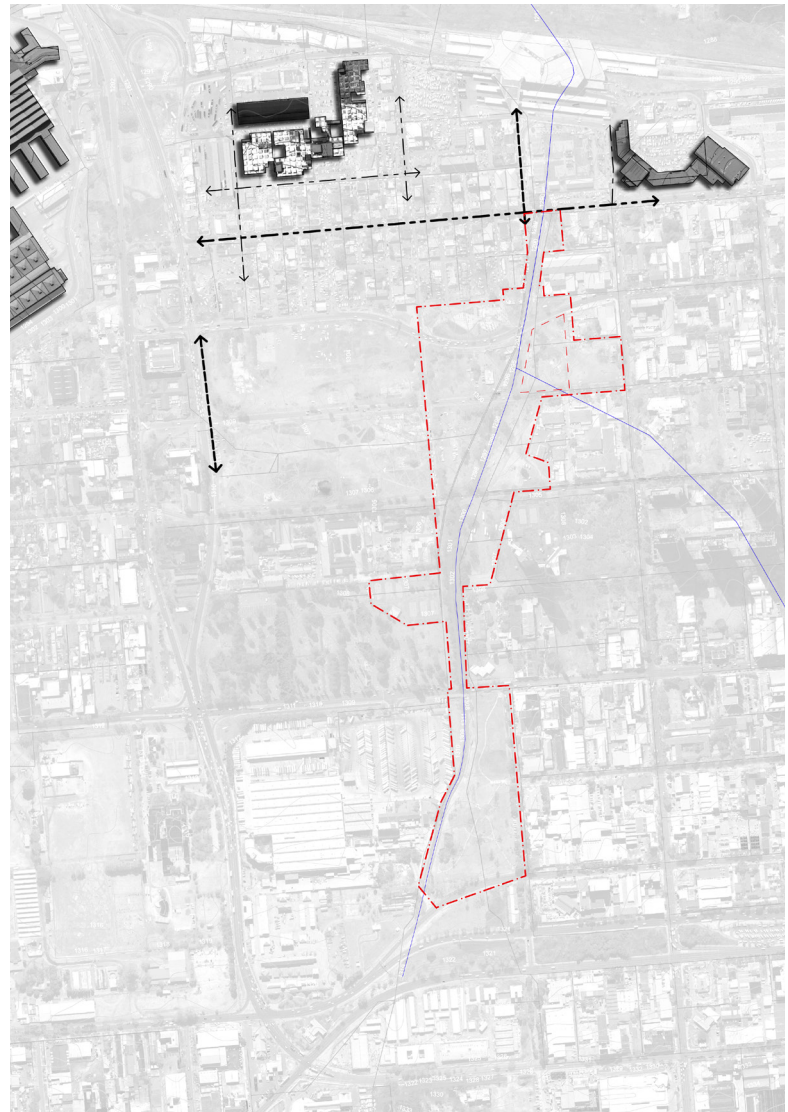

Fig 4.19 Trade nodes and networks (Author, 2014)

Key

----- Informal network

Formal nodes

4.3.2 Transport and movement

The transport network is also limited to rail, vehicular and pedestrian in some parts. There is opportunity to utilise more transport alternatives for pedestrian oriented development.

There are four main transport hubs around Marabastad through which majority of the commuters use. Belle Ombre station, and two taxi ranks and the Putco bus stop. The main volumes of commuters move through these transport hubs

Because the links to the other hubs are not defined, after arriving into the precinct, there's no orientation and people move out of the precinct as fast as they move in. The mini-bus taxis don't operate on a schedule and utilise any available space as a drop or pick off point. The undefined destination points into the precinct coupled with the random behaviour of the transport network makes Marabastad a transit hub with no destination points in it. As a result its development is stagnant because all the energy that moves through it never stays there.

Key

- Vehicular network
- Pedestrian network
- Formal nodes

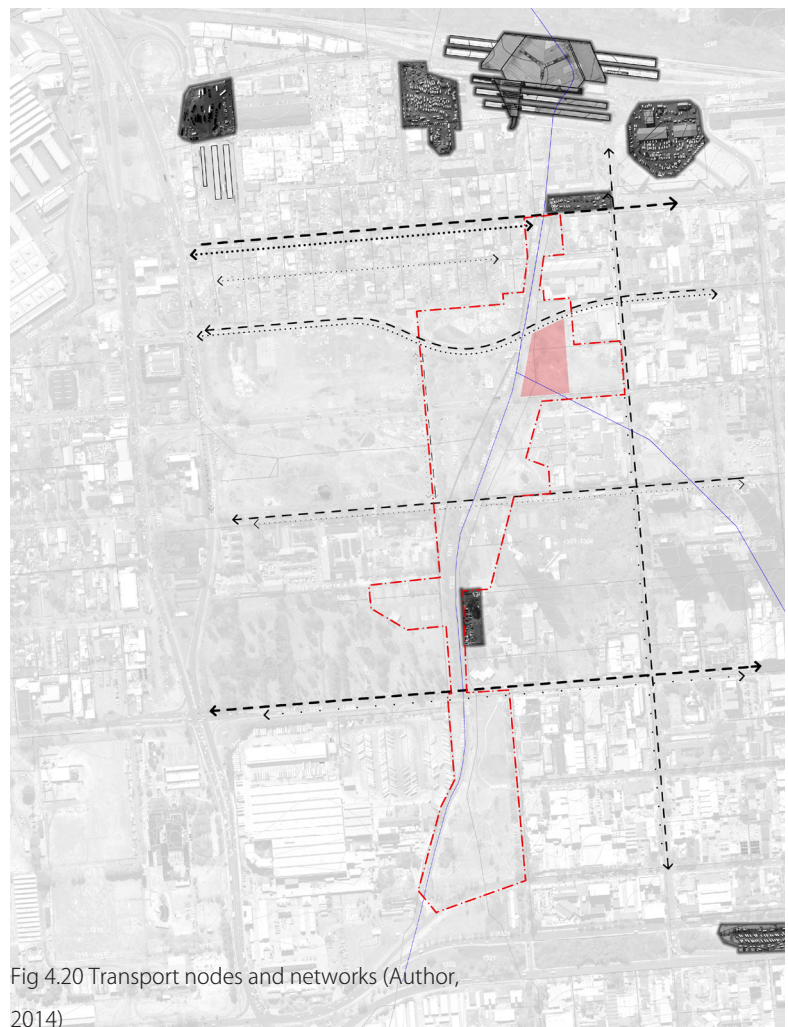

Fig 4.20 Transport nodes and networks (Author, 2014)

4.3.3 Municipal and other institutions.

There is an opportunity to develop the other programmes e.g. educational (building number) and skills development, which will attract users into the precinct creating a mixed use zone.

The activity around Marabastad Home affairs creates a micro-economy. While the Municipal and other institutional buildings create borders for the vacant tract of land. These activities diversify the development around Marabastad.

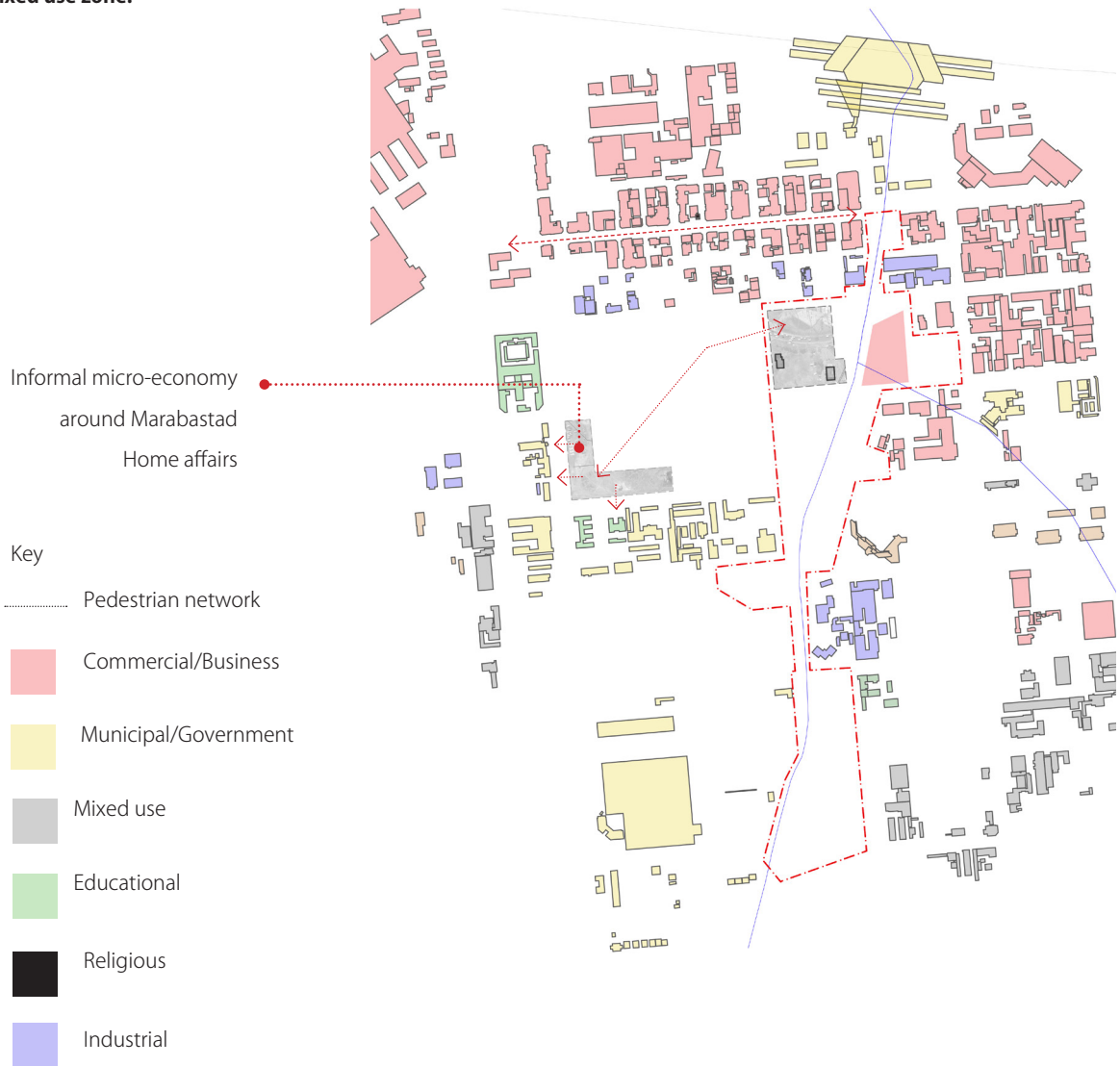

Fig 4.21 Existing Zoning and programming (Author, 2014)

4.3.4 Green and brown

By optimising the green the green belt, a spine from Belle Ombre station in the north to Nana Sita Street in the South can be created. This pedestrian spine can connect Madiba Street (Church Street) and W.F Nkomo street that connects to the proposed bus routes.

The water from the river can be used for irrigation in urban agriculture. Sites can be placed along the river for filtration of the water and collection.

The Steenhovenspruit channel flows year round and provides a green belt from the south to the north. The water is a resource for the homeless people who can be seen taking a bath in the channel.

The storm water drains into the channels from varying points and during the rainy season it floods because of the excess water from the storm water drains.

While it is also polluted by waste from the storm water drains, human excrete and dumping from the nearby buildings illustrated in Fig 4.3.2..



Fig 4.22 Existing Green and brown network (Author, 2014)



Fig 4.32 Degradation along the green belt (Author, 2014)



Fig 4.23 Photo-Mapping around urban framework (Author, 2014)



Fig 4.26 Dumping at the end of river (Author, 2014)



Fig 4.27 Dumping by the street (Author, 2014)



Fig 4.28 Underutilised Marabastad Jazz Park (Author, 2014)



Fig 4.29 Bridge over Bloed Street (Author, 2014)



Fig 4.24 Bamboo growing along river



Fig 4.30 Site (Author, 2014)

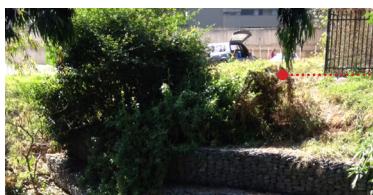

Fig 4.25 Bamboo growing along river



Fig 4.31 Panorama from urban void (Author, 2014)

4.4 Site

Over time the site has been occupied mainly as residential units before they were eventually demolished.

4.4.1. Site History

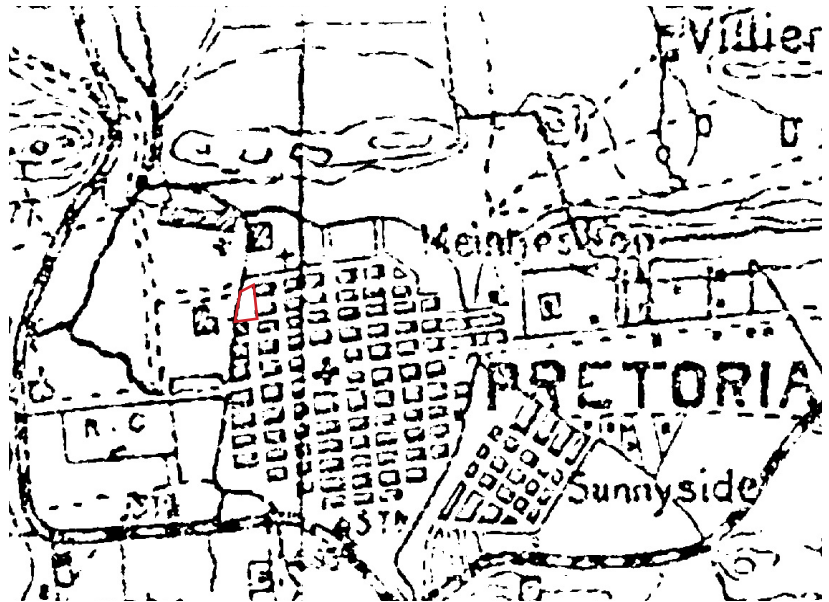

Fig 4.33 Pretoria 1902 (Unknown)



Fig 4.44 Pretoria 1934 (Unknown)

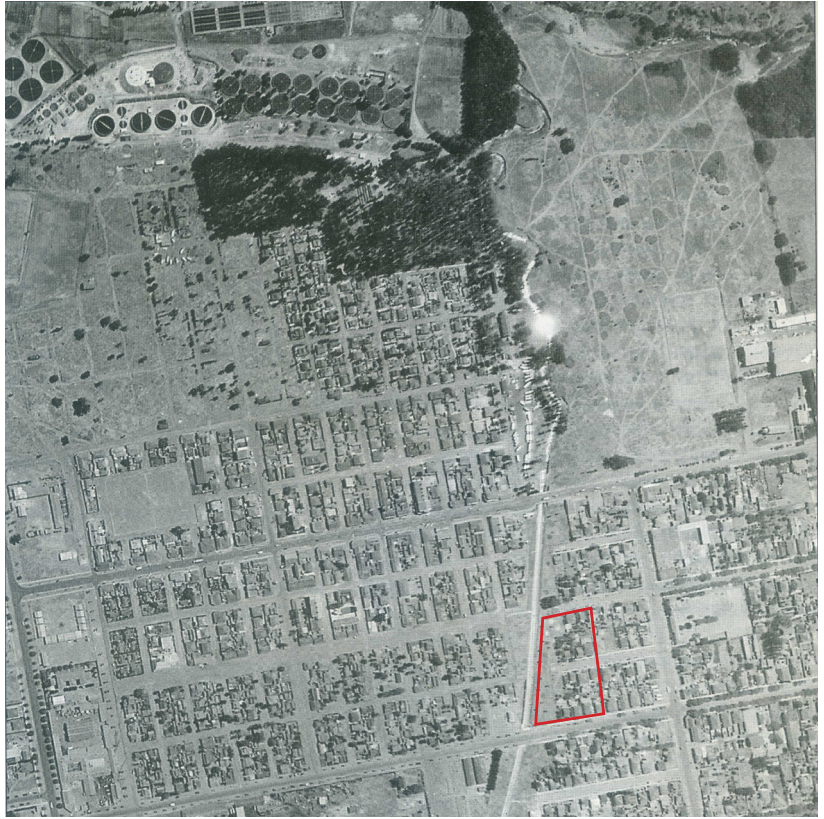

Fig 4.45 Pretoria 1947 (Unknown)



Fig 4.46 1996 Pretoria
(Unknown)

4.4.2 Ethos (photos)

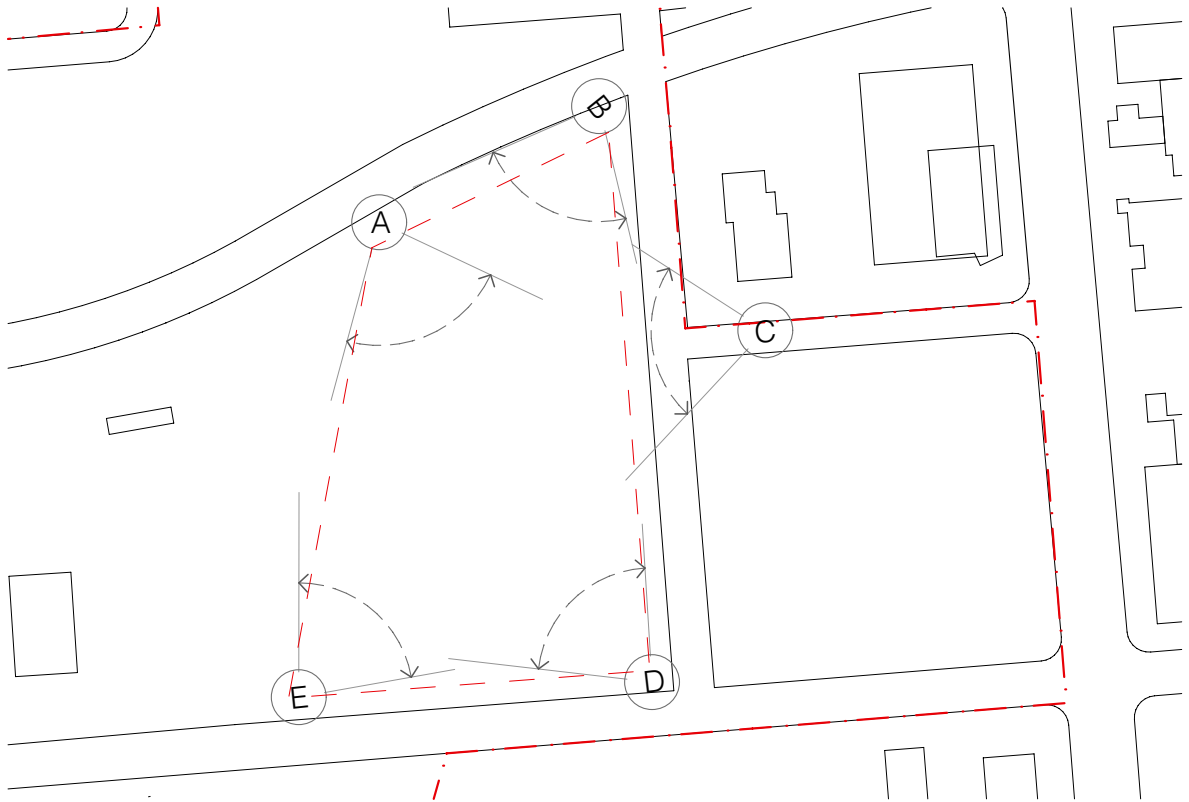

Fig 4.47 View from A showing the site, the street edge and the current site use (Goggle Earth, 2014). Photo edited by Author.



Fig 4.48 View from B showing the site, the street edge and the current site use (Goggle Earth, 2014). Photo edited by Author.



Fig 4.49 View from C showing the site, the blocked access and nearby dumping sites (Goggle Earth, 2014). Photo edited by Author).



Fig 4.50 View from D showing the site, the street edge and the current site use (Goggle Earth, 2014). Photo edited by Author.



Fig 4.51 View from E showing the site, the street edge and the current site use(Goggle Earth, 2014). Photo edited by Author.



Fig 4.52 Activities around site (Author 2014)



Fig 4.53 Green and brown (Author 2014)

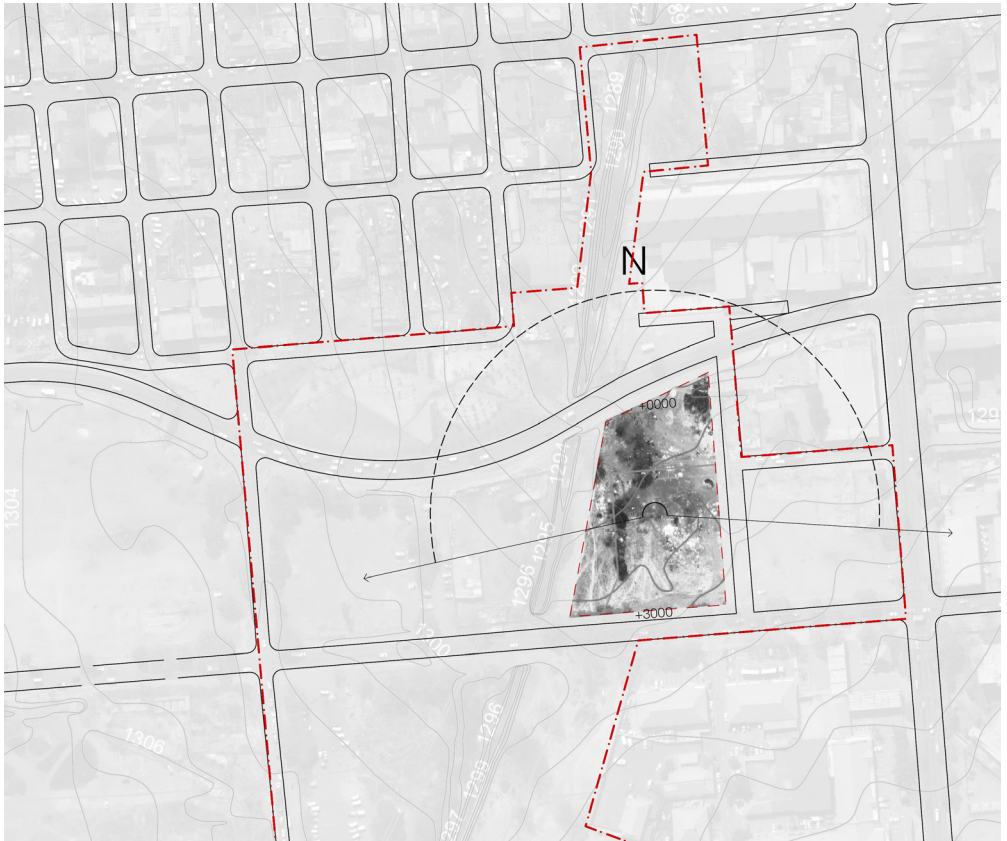

Fig 4.56 Site terrain and orientation (Author 2014)



Fig 4.57 Movement and rest through site (Author, 2014).

4.4.3 Existing Features

Climate data for Pretoria													[hide]
Month	Jan	Feb	Mar	Apr	May	Jun	Jul	Aug	Sep	Oct	Nov	Dec	Year
Record high °C (°F)	42 (108)	37 (99)	35 (95)	33 (91)	29 (84)	25 (77)	26 (79)	31 (88)	37 (99)	36 (97)	39 (102)	37 (99)	42 (108)
Average high °C (°F)	29 (84)	28 (82)	27 (81)	24 (75)	22 (72)	19 (66)	20 (68)	22 (72)	26 (79)	27 (81)	27 (81)	28 (82)	25 (77)
Daily mean °C (°F)	23.5 (74.3)	22.5 (72.5)	21.5 (70.7)	18 (64)	15 (59)	12 (54)	12.5 (54.5)	15 (59)	19 (66)	20.5 (68.9)	21.5 (70.7)	22.5 (72.5)	18.6 (65.5)
Average low °C (°F)	18 (64)	17 (63)	16 (61)	12 (54)	8 (46)	5 (41)	5 (41)	8 (46)	12 (54)	14 (57)	16 (61)	17 (63)	12 (54)
Record low °C (°F)	8 (46)	11 (52)	6 (43)	3 (37)	-1 (30)	-6 (21)	-4 (25)	-1 (30)	2 (36)	4 (39)	7 (45)	7 (45)	-6 (21)
Precipitation mm (inches)	154 (6.06)	75 (2.95)	82 (3.23)	51 (2.01)	13 (0.51)	7 (0.28)	3 (0.12)	6 (0.24)	22 (0.87)	71 (2.8)	98 (3.86)	120 (4.72)	703 (27.68)
Avg. precipitation days	14	11	10	7	3	1	1	2	3	9	12	15	87
Mean monthly sunshine hours	261	235	254	246	283	271	289	296	284	275	254	272	3,220

Source #1: South African Weather Service^[12]
Source #2: The Weather Network (sun only)^[13]

Fig4.75 Average temperature and rainfall distribution throughout the year. (Wikipedia, 2014).

Climatic conditions.

The climate of Marabastad is characterised by relatively low humidity combined with high afternoon temperatures during the summer.

The annual rainfall is on average 700 mm. With peak rainfalls during summer.

The prevailing winds are calm, blowing from North-East in the morning and from North-West in the afternoons during summer. However thunderstorms are occasional with turbulent wind patterns in summer. During winter cold fronts bring winds from the south. (Whitcomb, 2011:32).

Marabastad falls in a gentle slope from South West to North East.

The underlying geology is composed of localised Andestic lava with shale and turf. Soil conditions vary from solid rock to andesite soils. (Whitcomb, 2011:32)

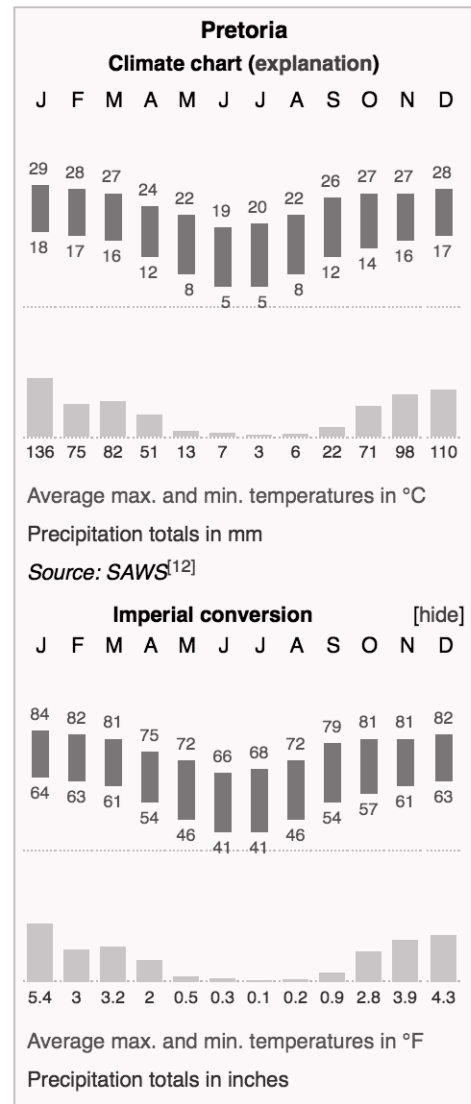

Fig4.76 Rainfall distribution throughout the year. (Wikipedia, 2014)

Solar radiation and sun movement

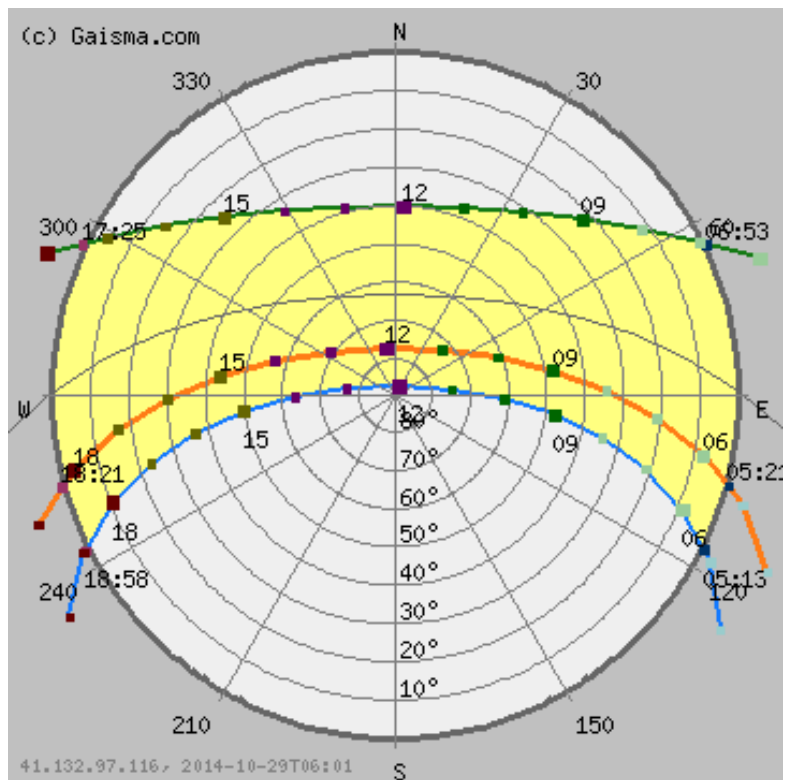

Fig 4.77 Sun path diagram for Pretoria (GAISMA, 2014).

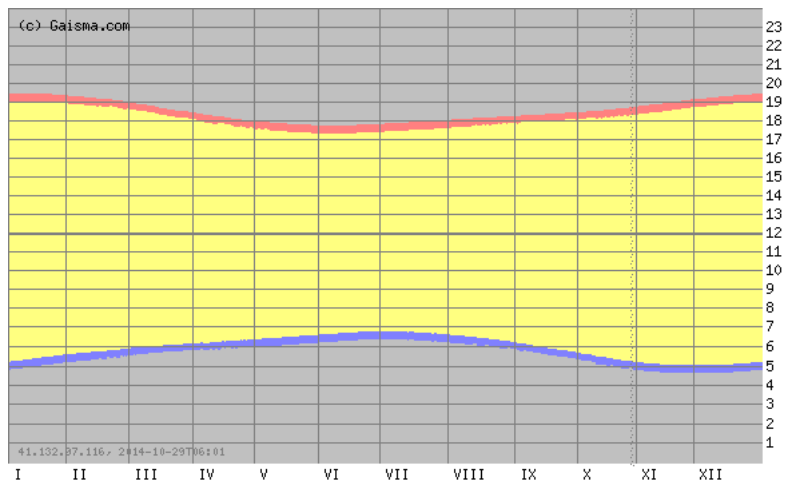

Fig4.78 Sunrise, sunset, dawn and dusk times graph (GAISMA, 2014).

Variable	I	II	III	IV	V	VI	VII	VIII	IX	X	XI	XII
Insolation, kWh/m ² /day	6.70	6.10	5.46	4.77	4.21	3.80	4.08	4.78	5.69	5.98	6.29	6.62
Clearness, 0 - 1	0.57	0.55	0.56	0.59	0.64	0.65	0.66	0.65	0.64	0.58	0.55	0.56
Temperature, °C	22.23	22.11	21.07	18.66	15.25	11.61	11.46	14.61	18.50	20.20	20.85	21.36
Wind speed, m/s	3.62	3.50	3.37	3.54	3.74	4.04	4.18	4.74	4.95	4.73	4.31	3.77
Precipitation, mm	134	75	79	56	12	8	3	6	20	75	103	114
Wet days, d	13.3	9.9	10.4	7.0	2.4	1.5	0.9	1.9	2.9	8.5	12.2	13.9

Fig4.79 Solar energy and surface meteorology (GAISMA, 2014).

Existing Features on site

_river

_access

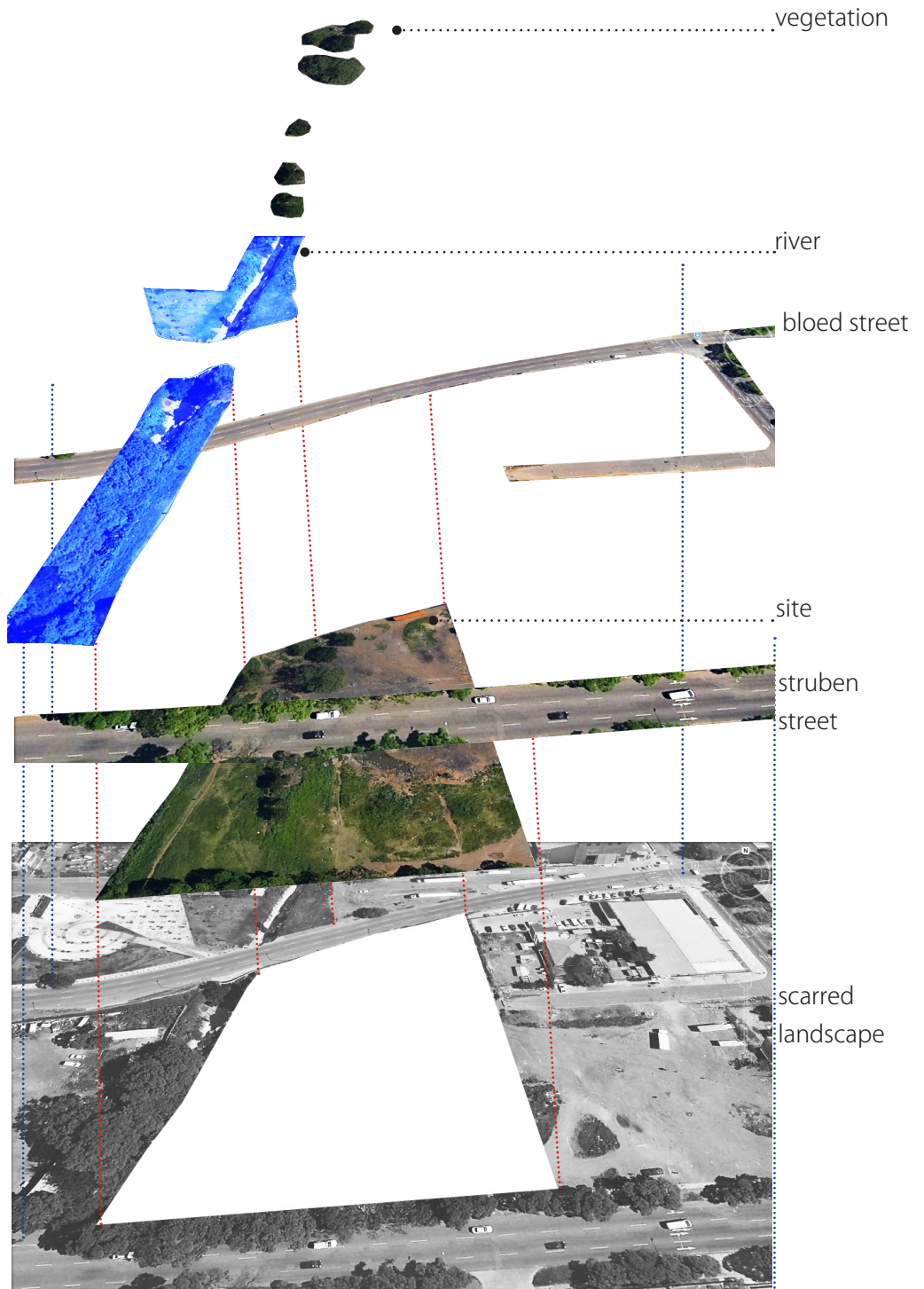

Fig 4.59 Analysis parti (Author, 2014)

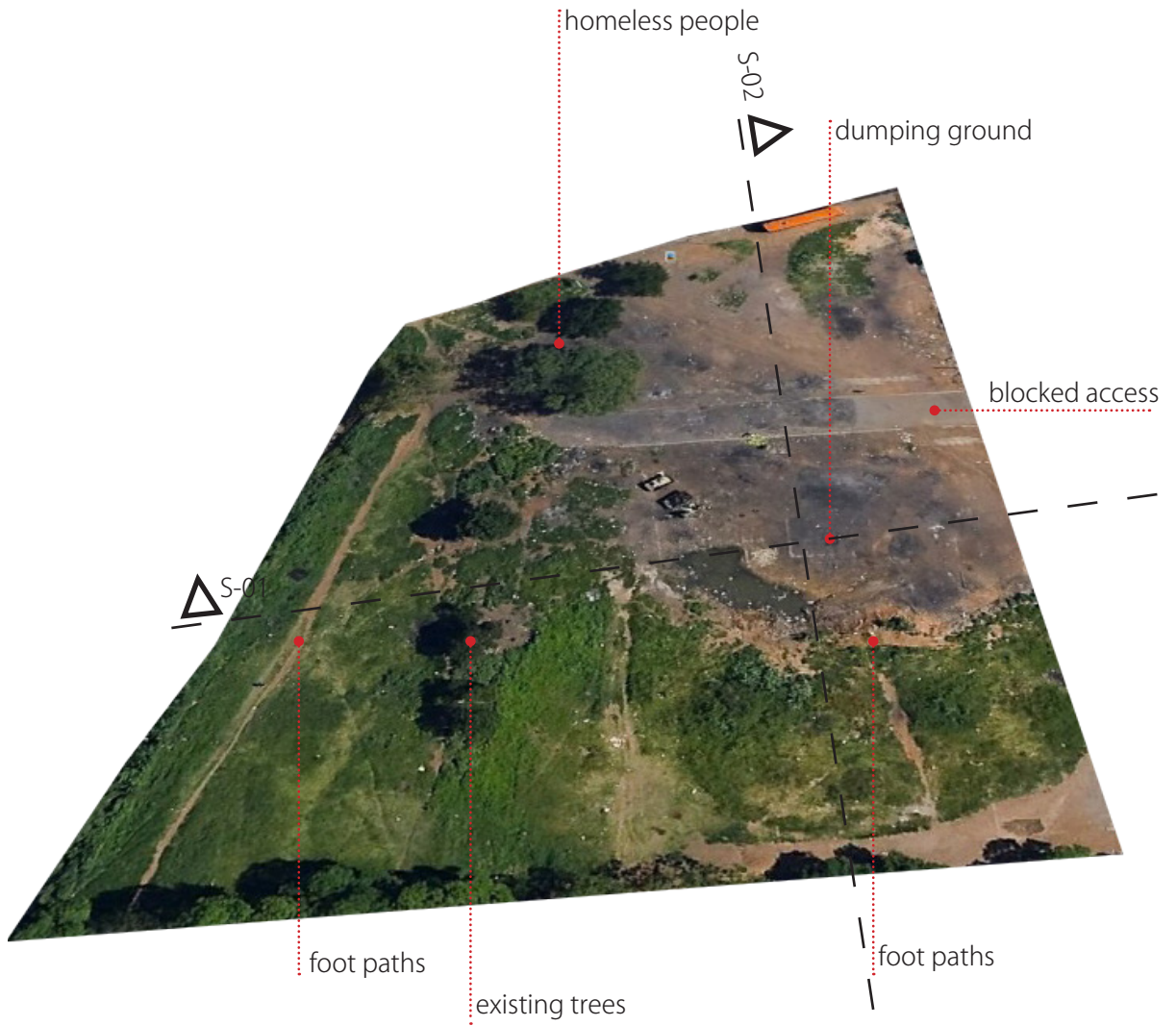

Fig 4.60 Site Diagram (Author, 2014)

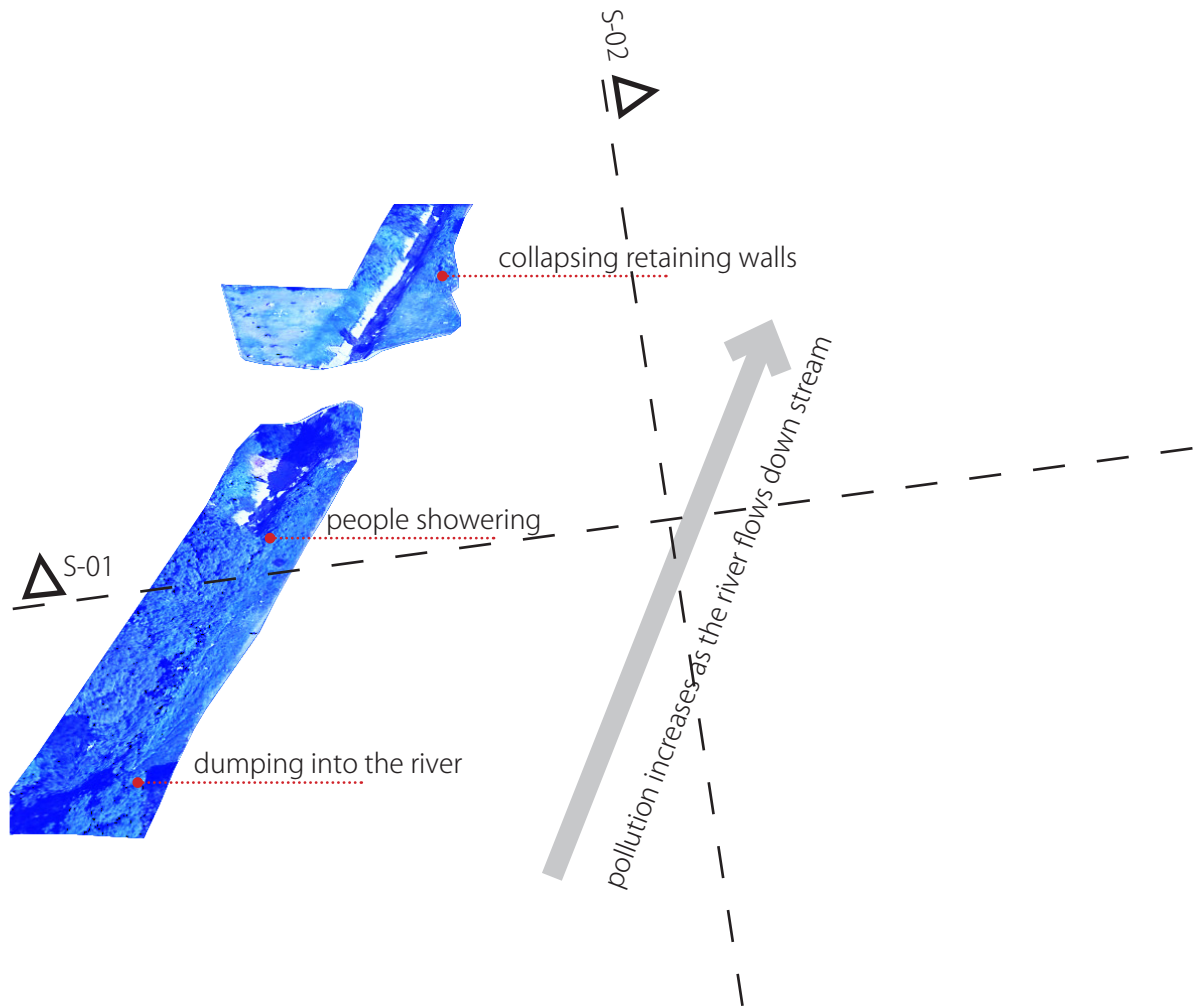

Fig 4.70 Steenhovenspruit (Author, 2014)

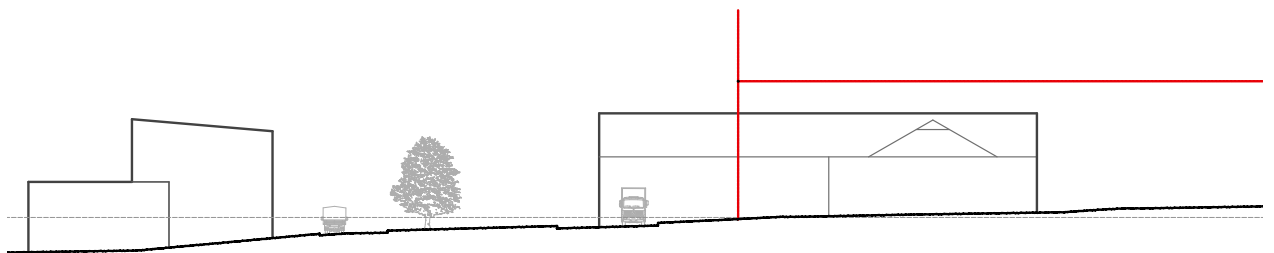

Fig 4.72 Site Section 02 (Author, 2014)

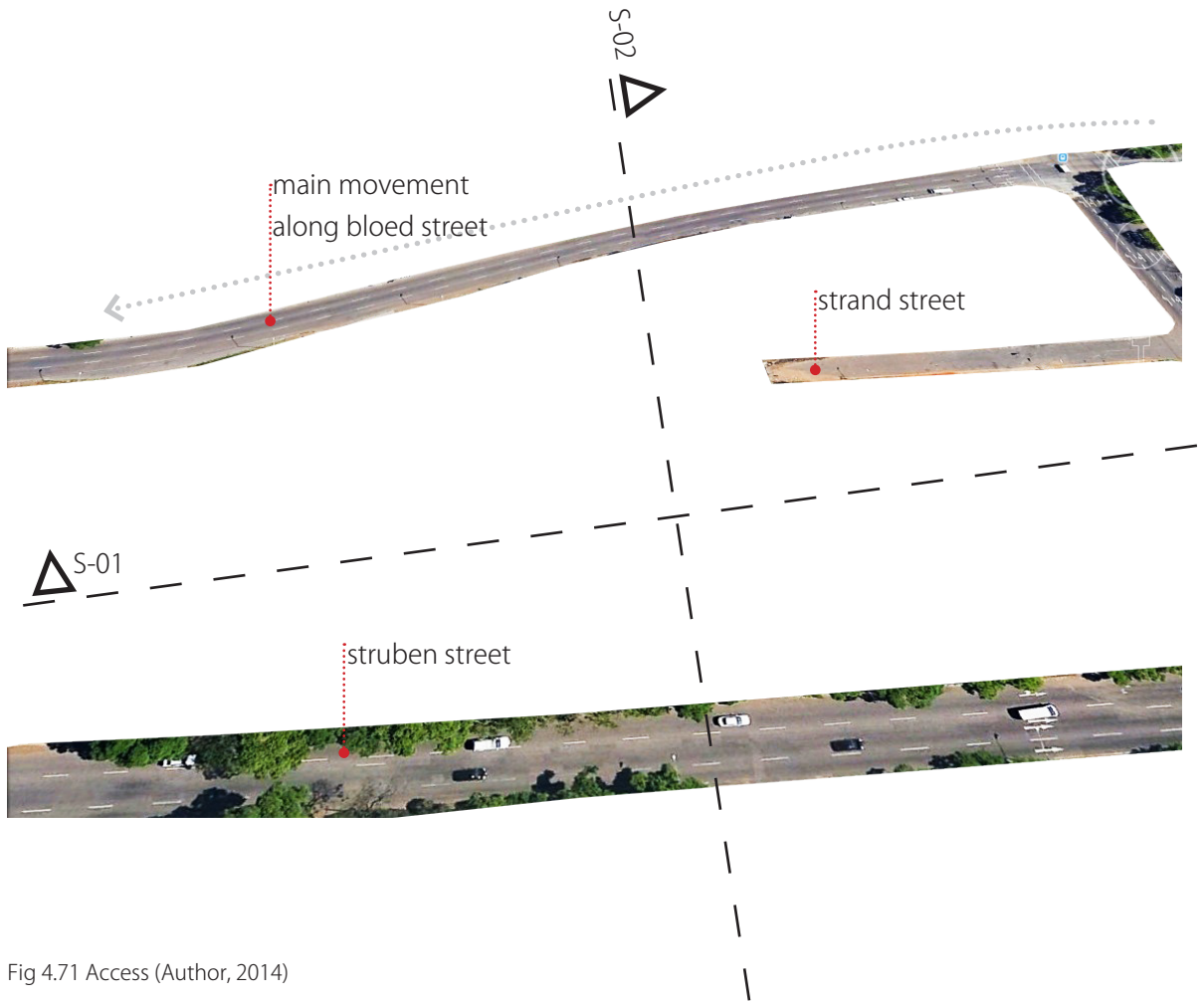
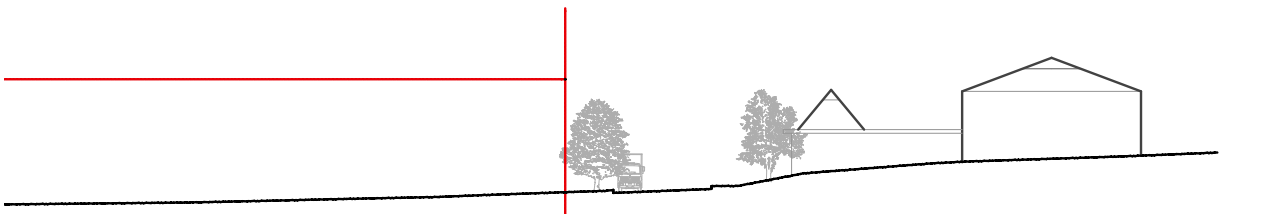

Fig 4.71 Access (Author, 2014)



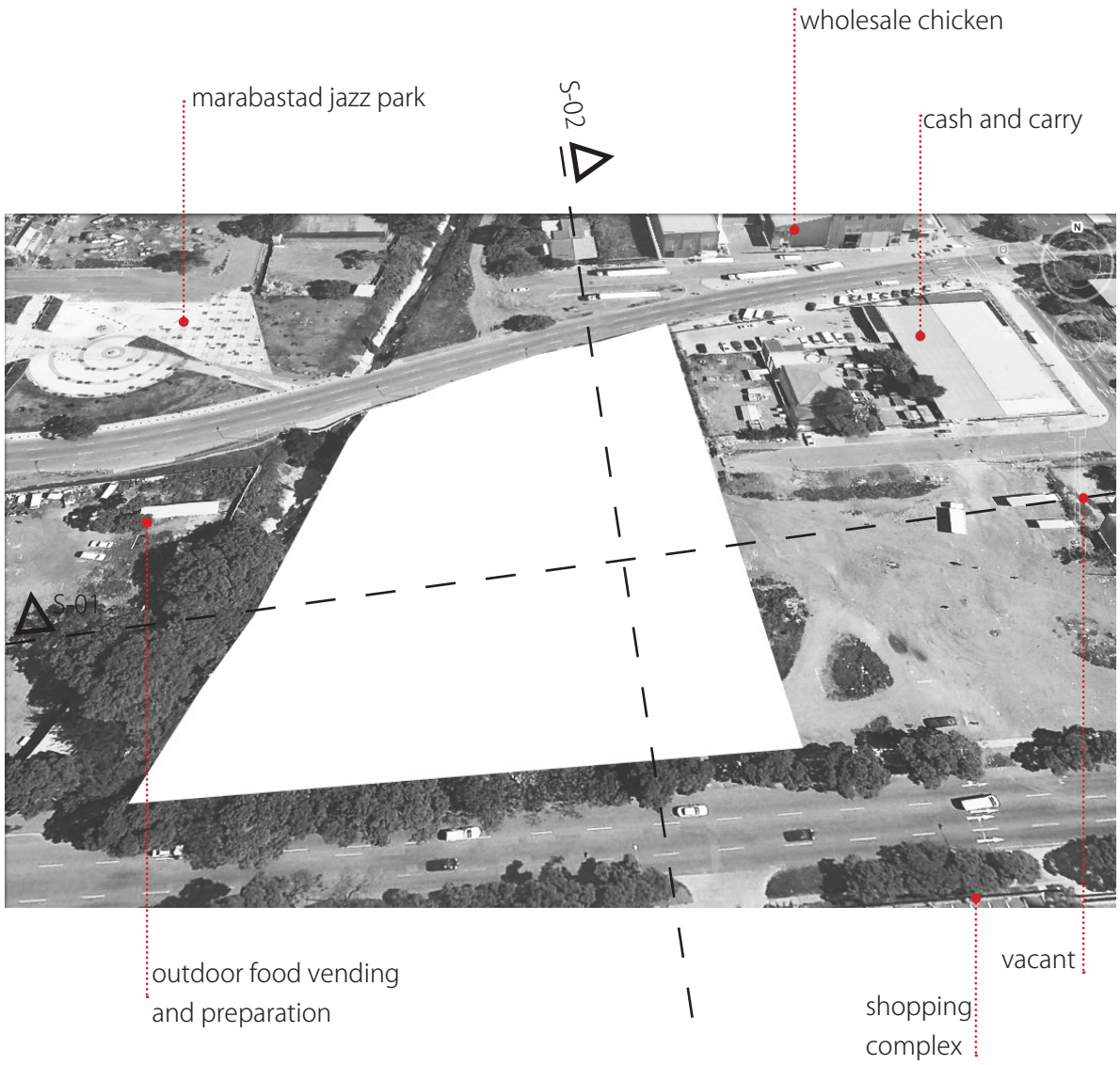

Fig 4.73 Surrounds (Author, 2014).

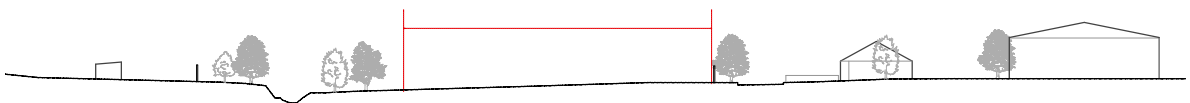

Fig 4.74 Site Section 01 (Author, 2014).

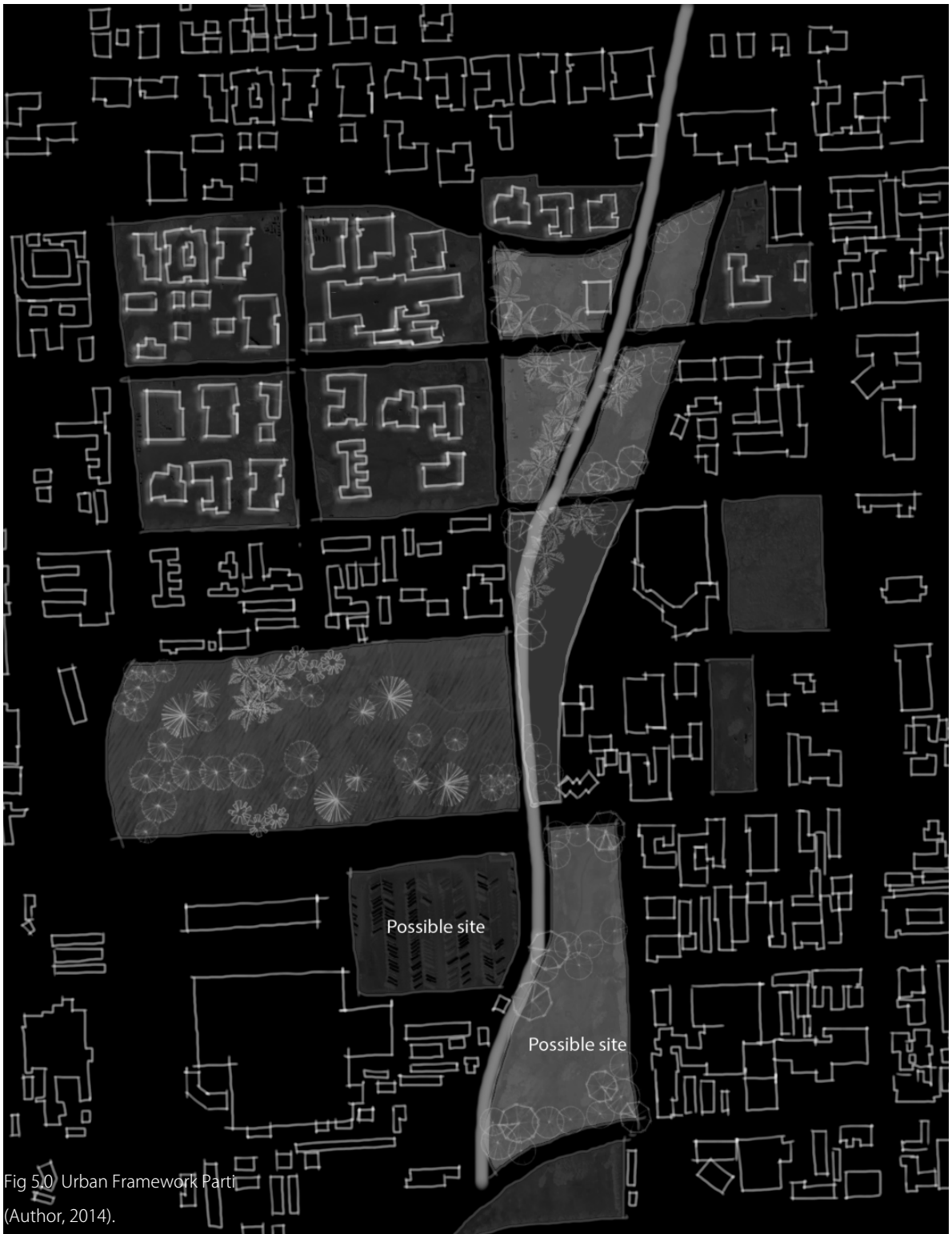

Fig 5.0 Urban Framework Part I
(Author, 2014).

URBAN FRAMEWORK

The urban framework looks at the Steenhovenspruit Channel from Princess Park in the South, where it commences its journey above ground to Boom Street in the North where the river terminates the journey above ground. Moving through the decayed urban landscapes on either of its banks.

5.0 URBAN FRAME- WORK

- 5.1 Existing Framework
- 5.2 Meso context: Architecture and urban character
- 5.3 Nodes and networks
- 5.4 Site
- 5.5 Green and Grey Network

5.1 ARUP Framework

The ARUP Framework, proposes development of four seed areas in Pretoria Central, one of the seeds is Marabastad/Belle Ombre. The redevelopment interventions in Marabastad are aimed at:

- Expanding and creating attractive market stalls
- Creating space for micro and small businesses, and attracting micro-finance organisations and small business support services
- Revamping transport access, pedestrian corridors and providing proper ranks and facilities for taxis
- Providing community facilities and amenities, including waste receptacles, public toilets, parks and green space
- Safety and policing (ARUP Framework, 2011)

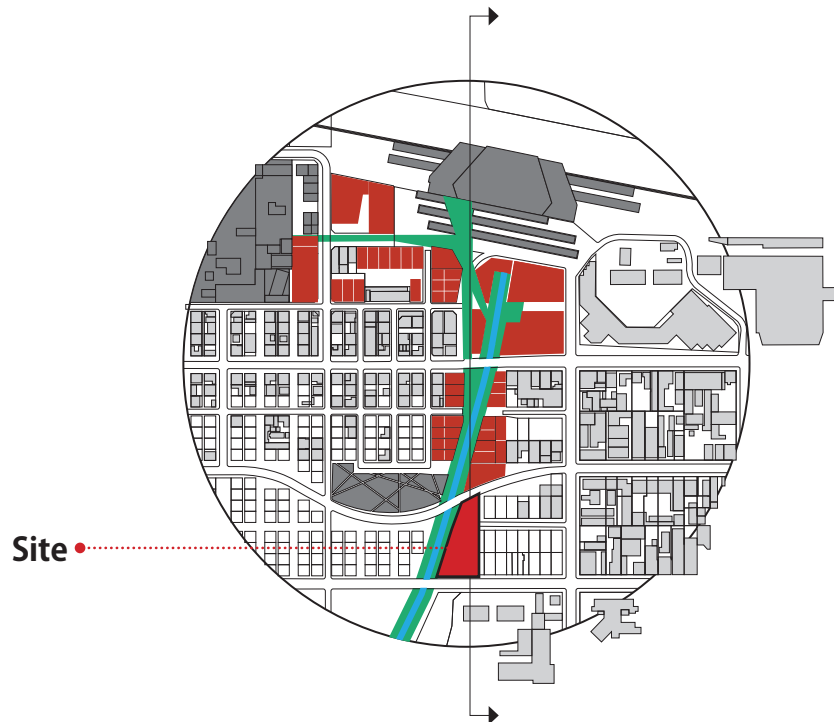

Fig 5.1 Focus Area Marabastad (ARUP Framework, 2011)

Shortcomings.

The framework assumes that provision of the urban amenities (fig 3.3) will automatically result into urban prosperity. This approach as described in the chapter 03 is a more asset based approach to design and financially it is more favourable to those already in possession of some material wealth and will therefore cut out a majority of the current inhabitants of Marabastad.

The framework also does not take into consideration the impact of increasing the urban population in the area and relies on the existing module of transportation of required agricultural produce to the area. A practice which as mentioned earlier is energy intensive and expensive to the environment.

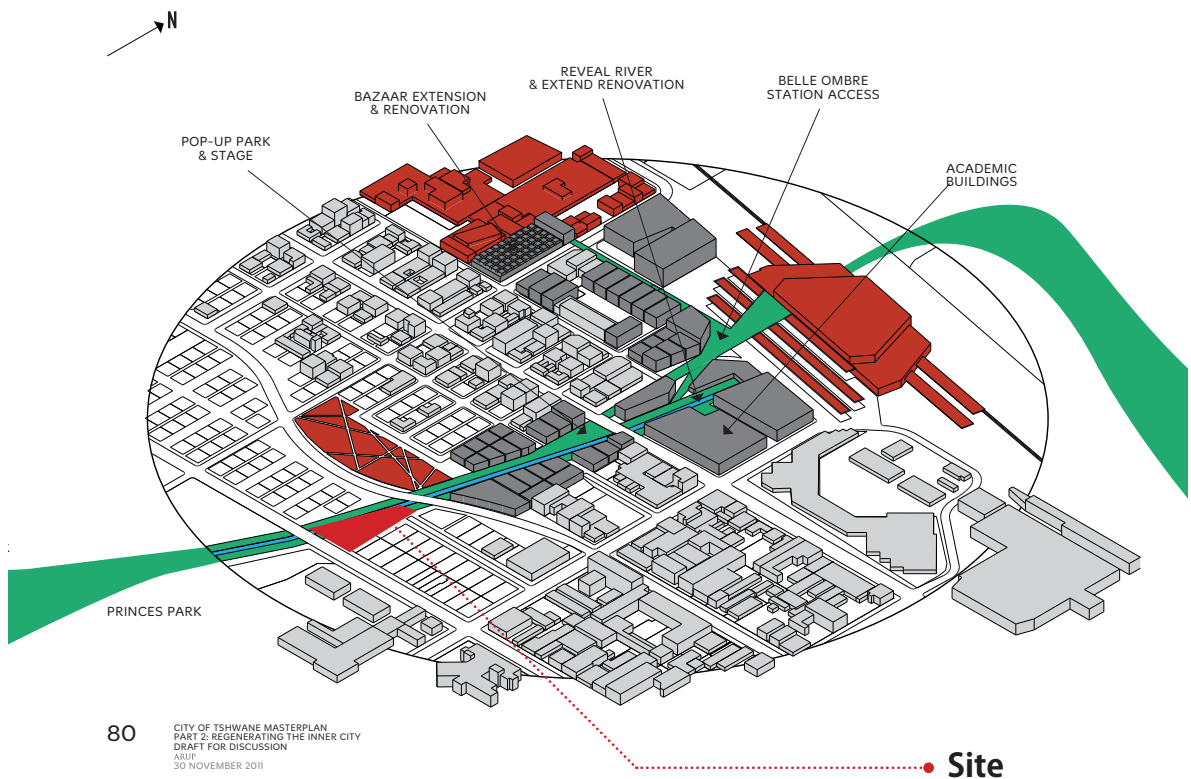

Fig 5.2 Interventions in Marabastad (ARUP Framework, 2011)

The following issues from the ARUP proposal shall be built on in the proposed urban framework.

- Pedestrian access and mobility (particularly from Belle Ombre Station)
- Physical state and condition of markets
- Connectivity to Church Square and other districts (ARUP Framework, 2011).

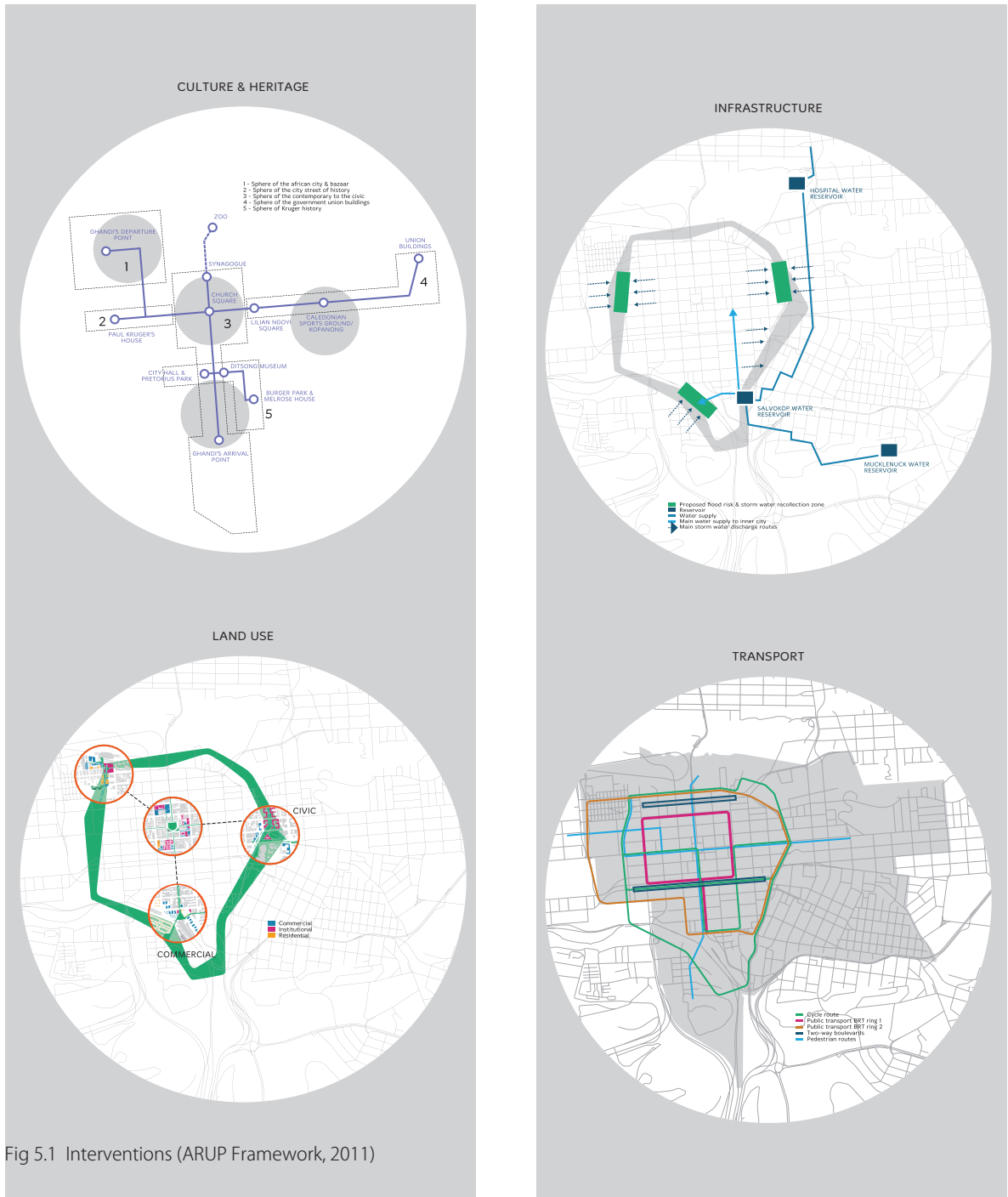

Fig 5.1 Interventions (ARUP Framework, 2011)

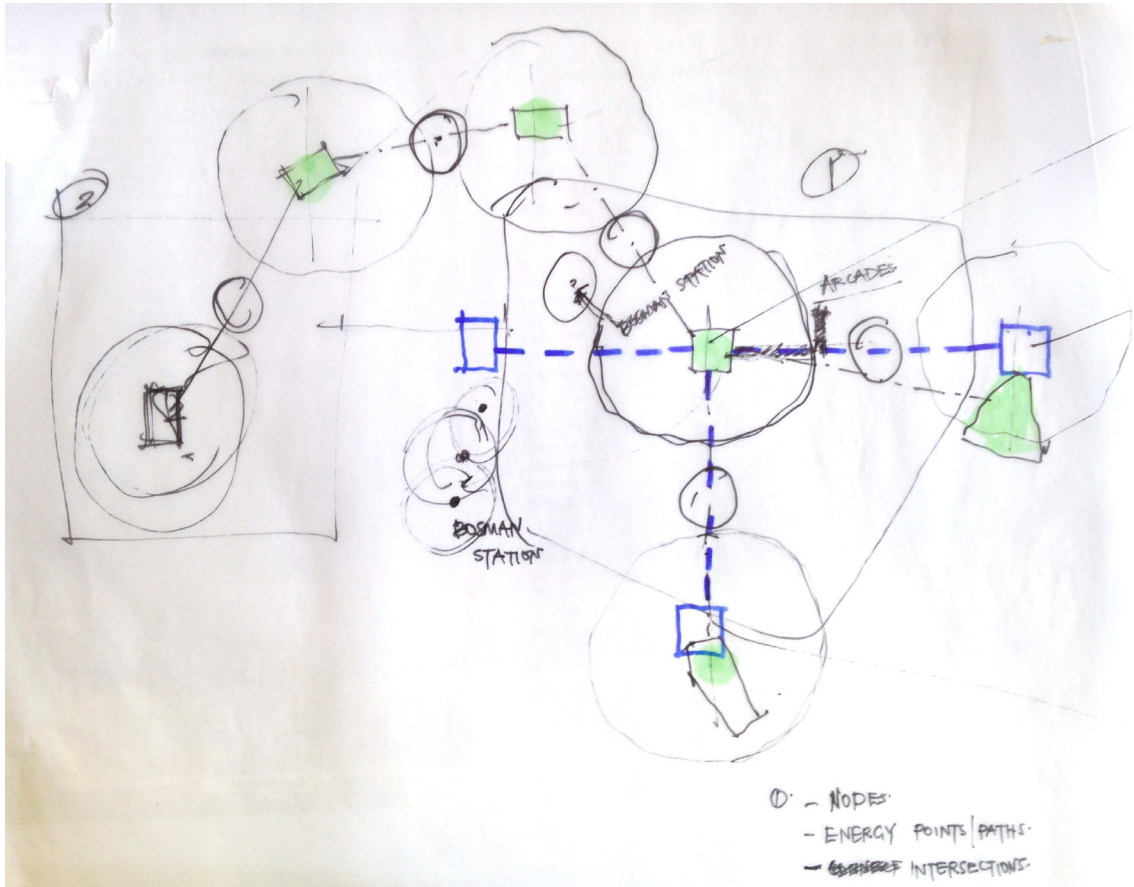

Fig 5.12 Interventions (Author, 2014)

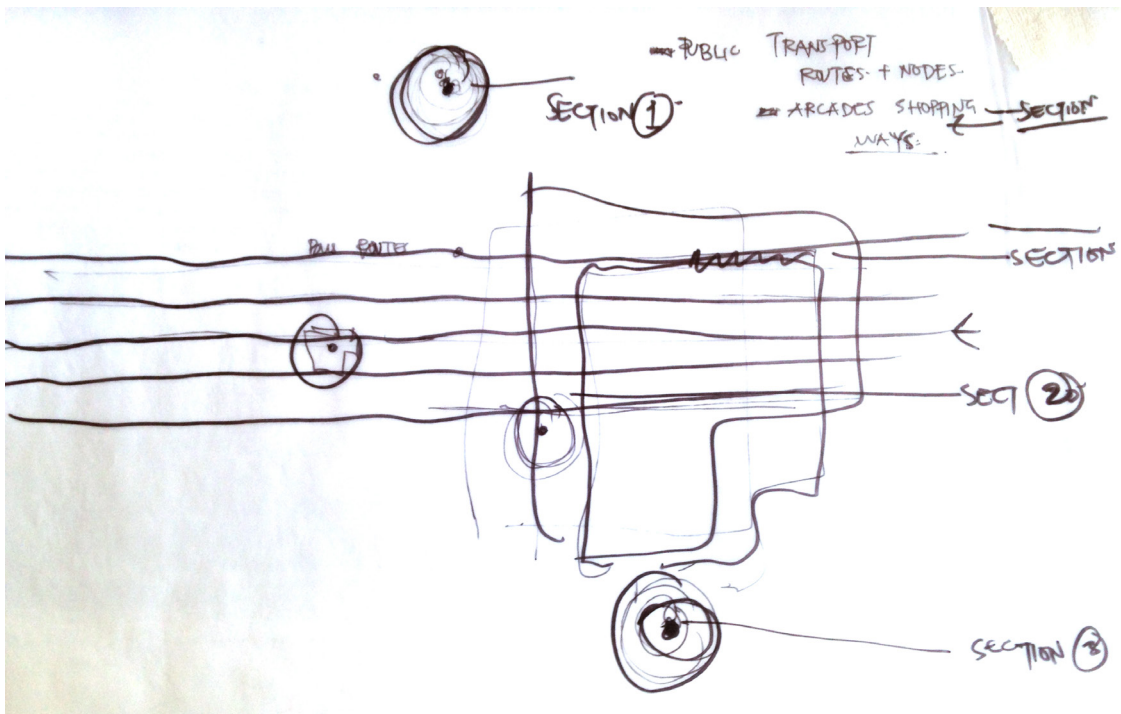

Fig 5.13 Transport links Interventions (Author, 2014)

5.2 Introduction.

The framework investigates the possibility of using the river as a spine along which productive landscapes are connect to the natural ecology and from which productive landscapes are infused into the urban fabric.

5.2.1 A case for productive urban landscapes.

Open urban space planted and managed in such a way as to be environmentally and economically productive, for example, providing food from urban agriculture, pollution absorption, the cooling effect of trees benefit the city dwellers. The three main benefits that can be realised from urban agriculture are; preserving biodiversity, tackling waste and reducing the amount of energy used to produce and distribute food. (Viljeon, 2005).

Urban agriculture will not however supply all the food or forestry needs. A degree of imported or staple products will be needed to top up the production. (Viljeon, 2005). The goal is not to eliminate industrial plantation but to reduce it to a minimum. Supporting local self-sufficiency could provide a sound base from which a region could develop its economy. This could help by alleviating the unnecessary intermediate traders, reducing the transport costs and reducing the unsustainable use of land.

By providing the residents with the opportunity to practice productive urban landscaping, it can facilitate economic development which will aid in poverty alleviation and provide urban food security which will improve nutrition. The system can also be extended to reabsorb organic waste from the city, which will reduce the load on the municipal facilities.

Introducing the productive landscapes will not only connect the public back to production cycles but will also start curb the agricultural and forestry needs of the city. The productive landscapes can also filter the water from the city's pollutants. The urban framework proposes a step by step strategy to regenerate Marabastad into a Productive Urban Landscape.

5.3 The liquid network.

The channel is a potential source of life in the area. The pollution increases as you move further downstream consisting of human excrete, heavy metals and oxidants from the city.

The channel is a storm water drain for 40 km² of the area around and as such faces flood risks when it rains. The framework proposes a series of water filtration systems at various points to clean out the water and to store it. The reserves are the first part of the future development of the area, they become the first mediation point between the natural landscape the urban. The reserves serve as markers where the public spaces meets with the productive landscapes.

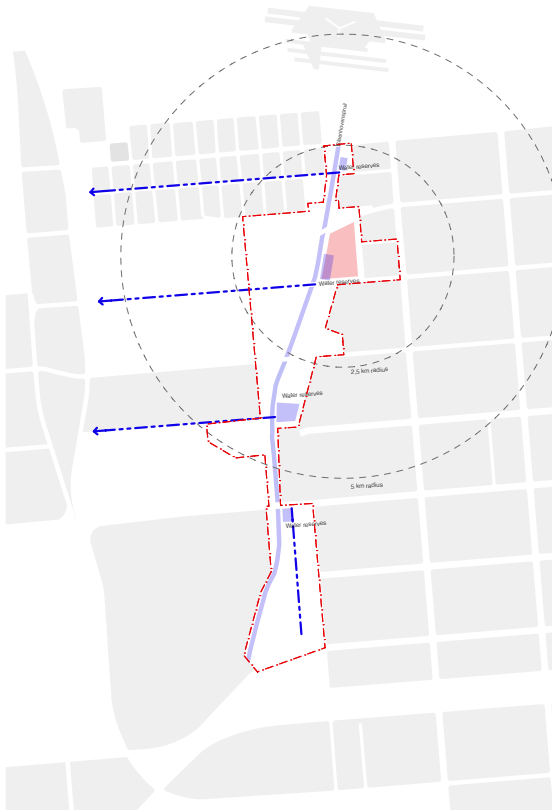

Fig 5.2 Water Network Intervention 1 with a 2,5 and 5km radius (Author, 2014)

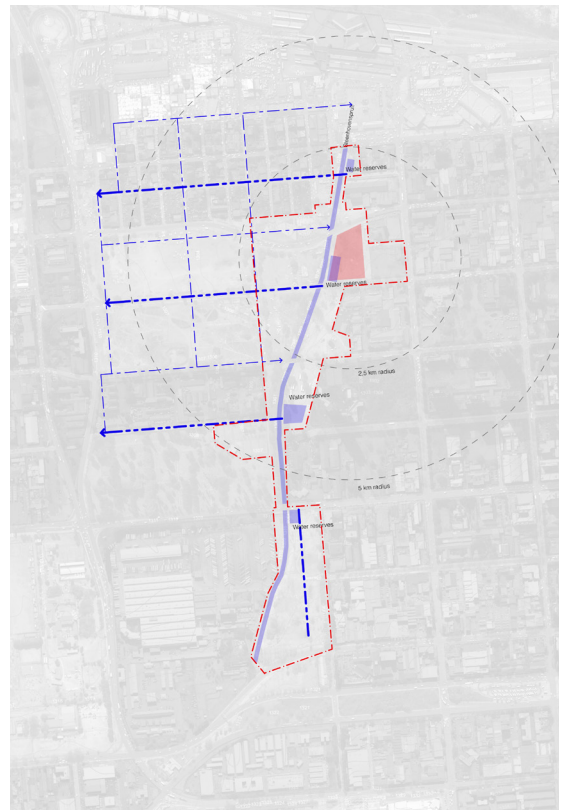
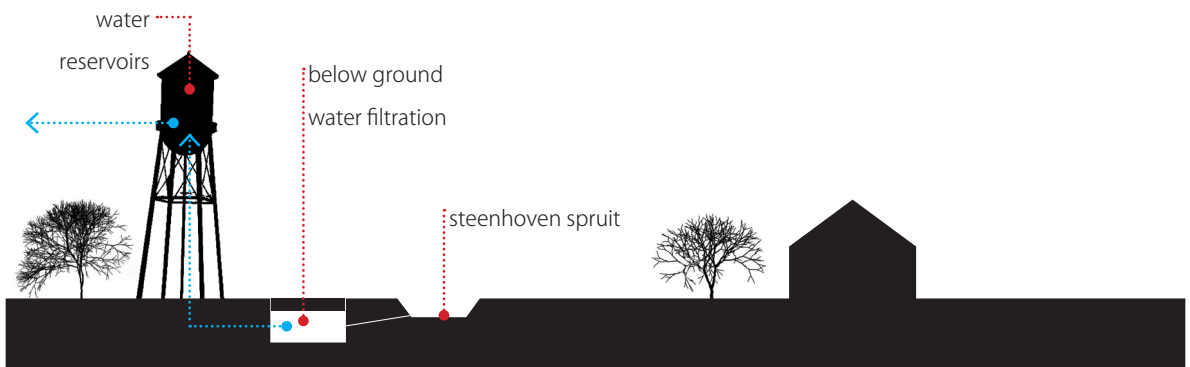

Fig 5.3 Water Network Intervention 2 with a 2,5 and 5km radius (Author, 2014)



5.4 Social and Produce Network

The main arterial routes for the public and for the produce are established perpendicular to the river.

The social network refers to a series of pedestrian and vehicular roads which connect the different nodes. The public links are focused on connecting the public to the existing informal and formal routes where trade occurs.

The produce network refers to main routes along which production occurs, the movement of produce and services. The produce network connects different stages of production to research and services.

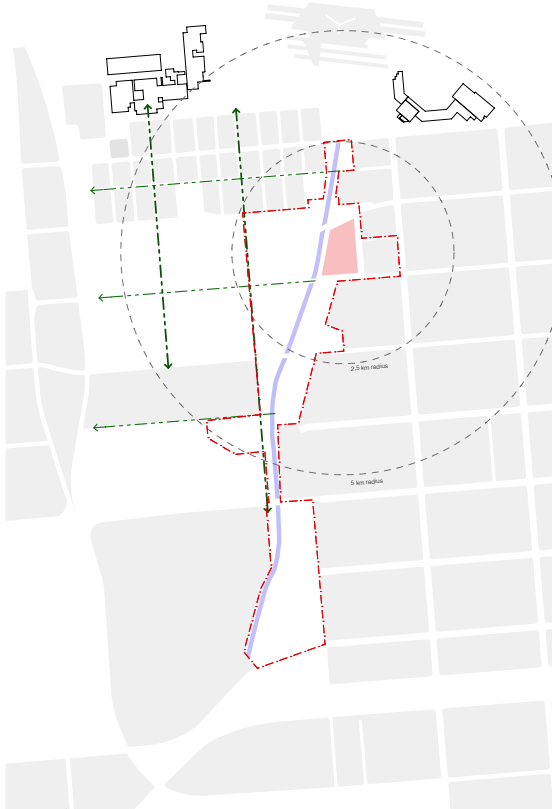

Fig 5.4 Produce Network Intervention 1 (Author, 2014)

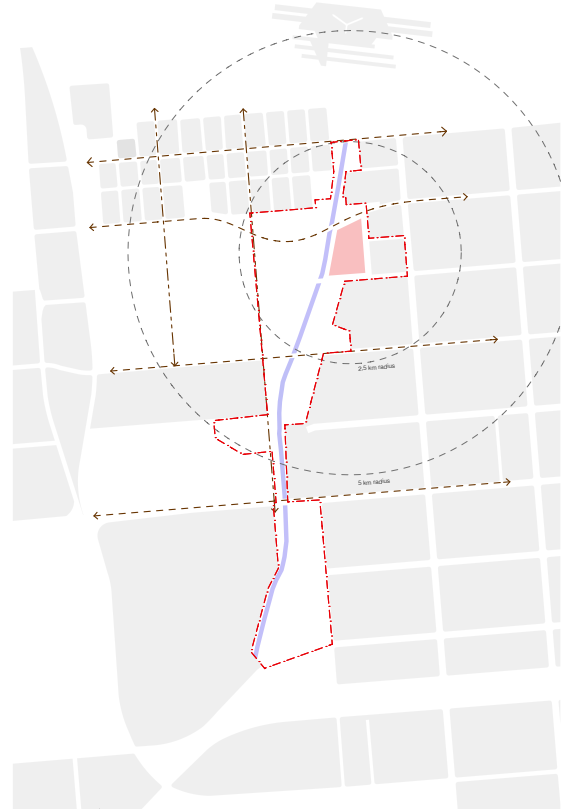

Fig 5.5 Social Network Intervention 1 (Author, 2014)

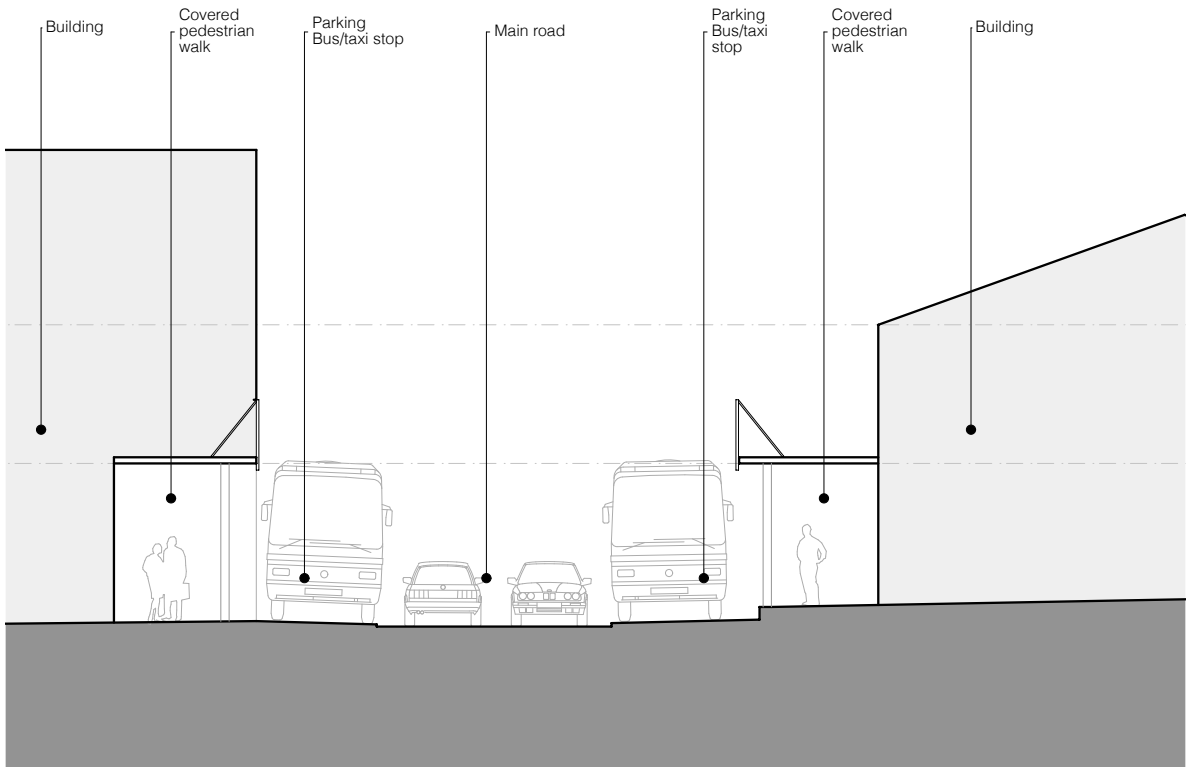

Fig 5.6 Section to illustrate Public access section through Heritage District. (Author, 2014)

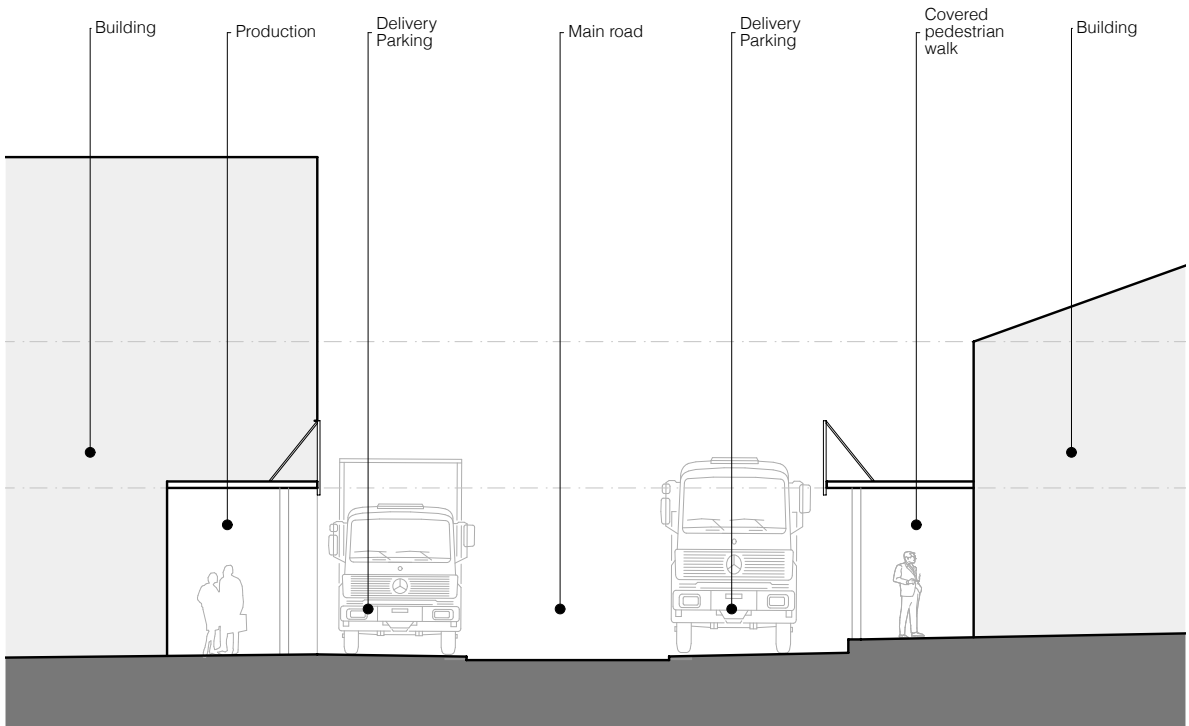

Fig 5.7 Section to illustrate Production section through Heritage District. (Author, 2014)

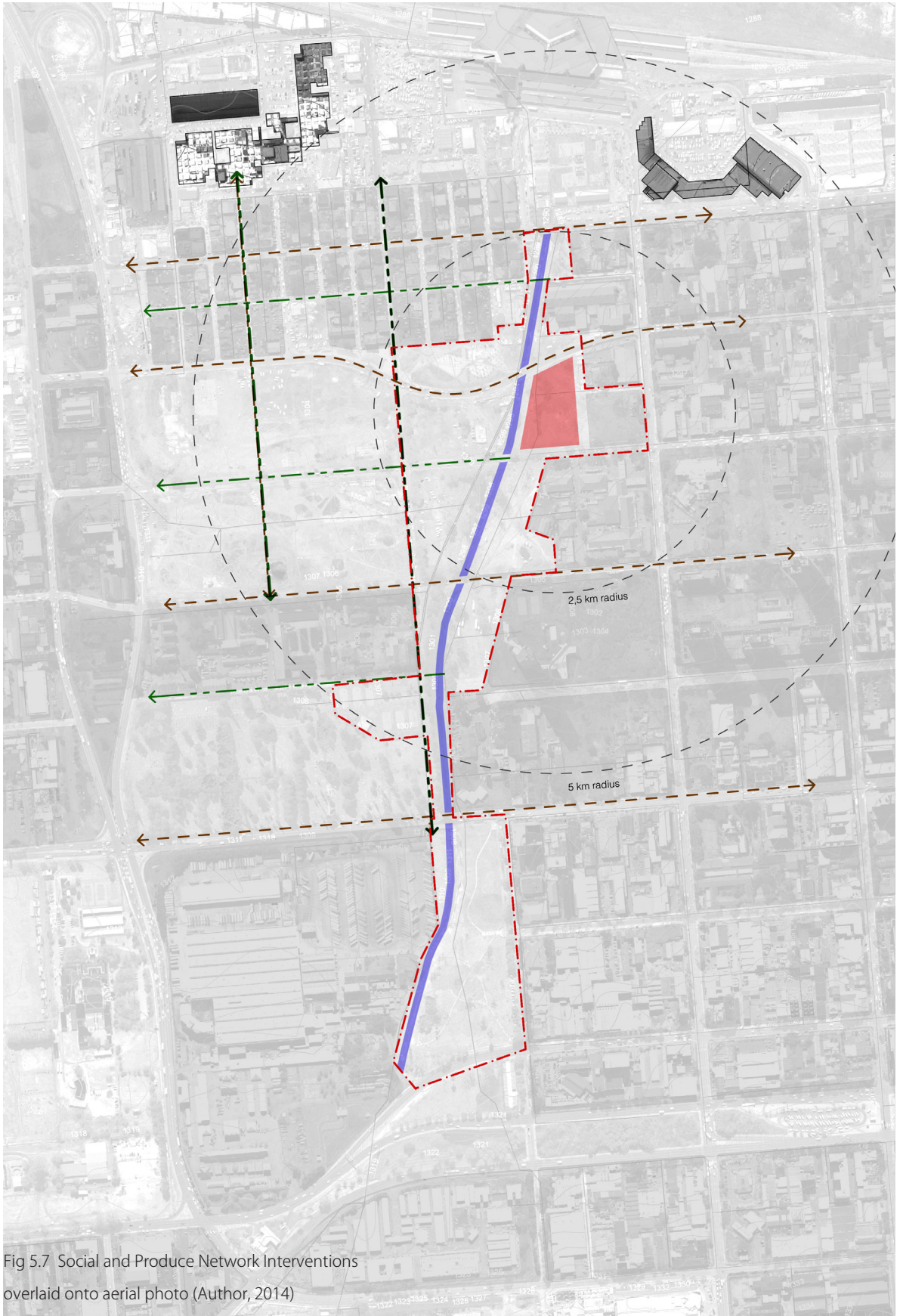

Fig 5.7 Social and Produce Network Interventions overlaid onto aerial photo (Author, 2014)

5.5 Green and Grey Network.

The green network represents the productive urban landscapes.

The grey network refers to the urban fabric.

Upon linking the services to the open urban areas, biodiversity will be introduced. Through vertical and horizontal methods of agriculture the forest and agriculture needs of the needs of the precinct will be subsidised. Introducing seasonal plants into the system will ensure a diversified continuous productive landscape.

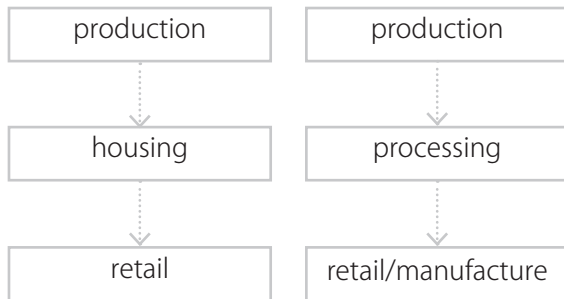

Fig 5.8 Sectional Diagram (Author 2014)

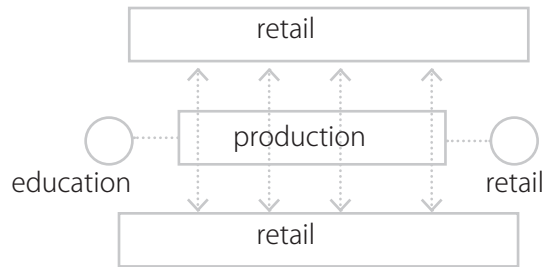

Fig 5.9 Plan Diagram (Author 2014)

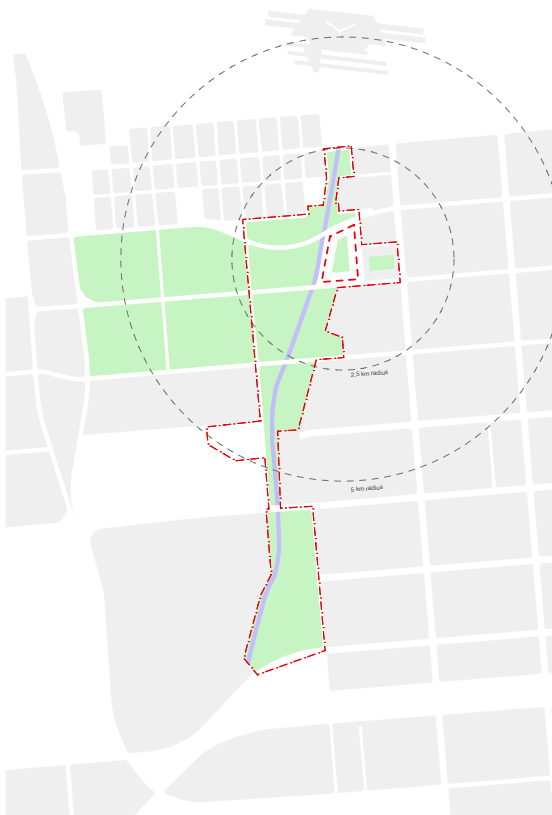

Fig 5.10 Green Network Intervention (Author, 2014)

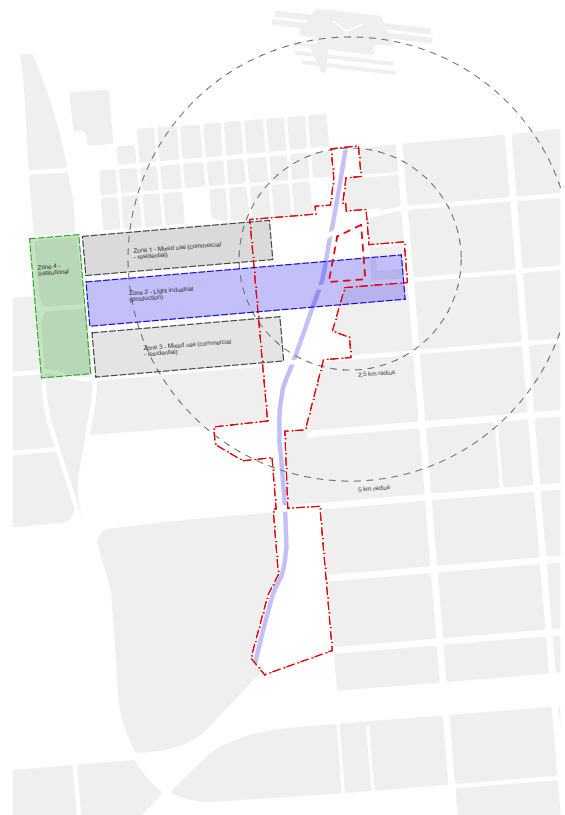

Fig 5.11 Building zoning Intervention (Author, 2014)

Using a mixed use typology to facilitate research, education, manufacturing, production, retail and consumption. The grey network is a densification strategy that synthesis the urban fabric with the productive landscapes. The main anchors are the education to the West, production and housing in the centre, and the retail and production to the East of the precinct.

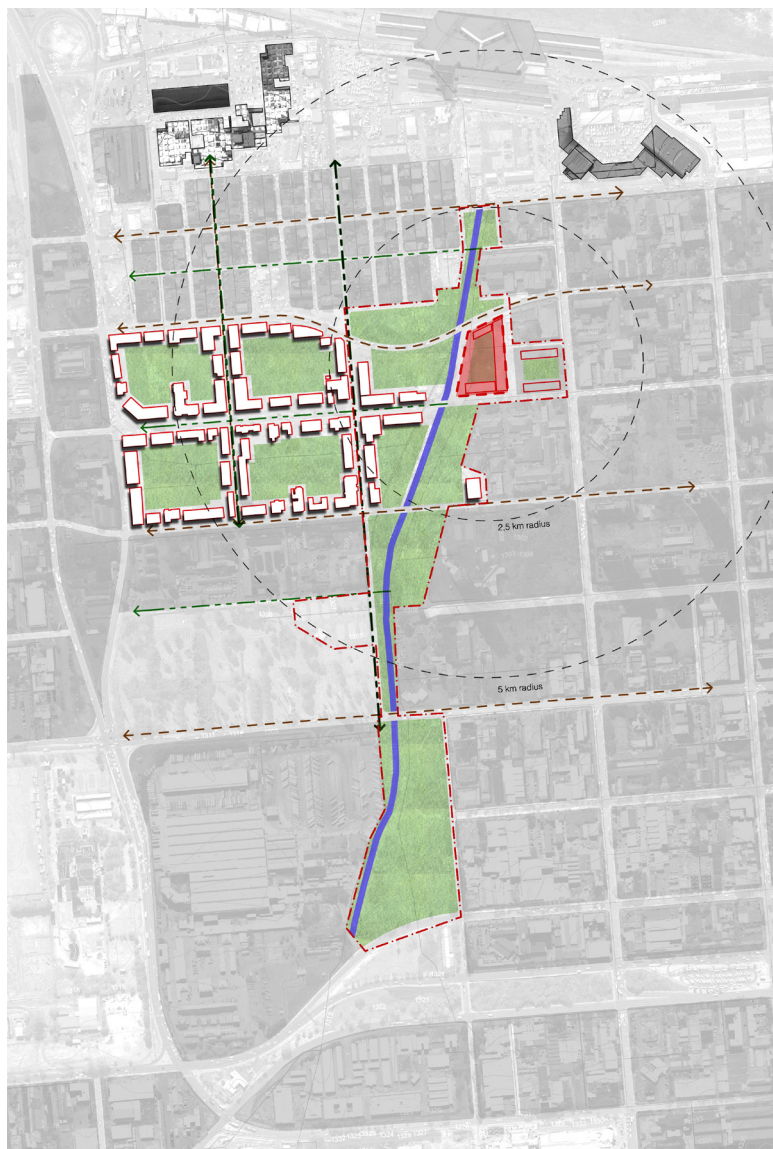

Fig 5.12 Urban Framework Parti

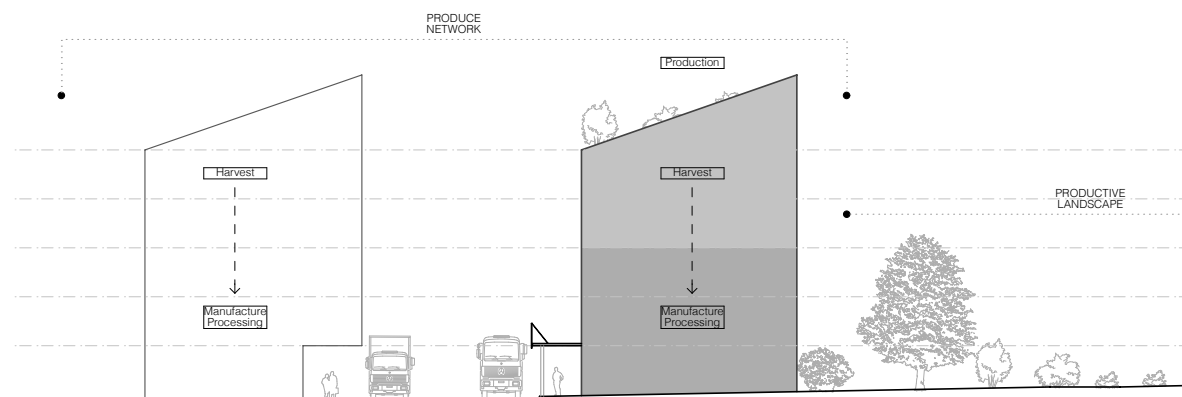

Fig 5.13 Proposed intervention in section (Author, 2014)



Fig 5.14 Proposed intervention in Rendering (Author, 2014)

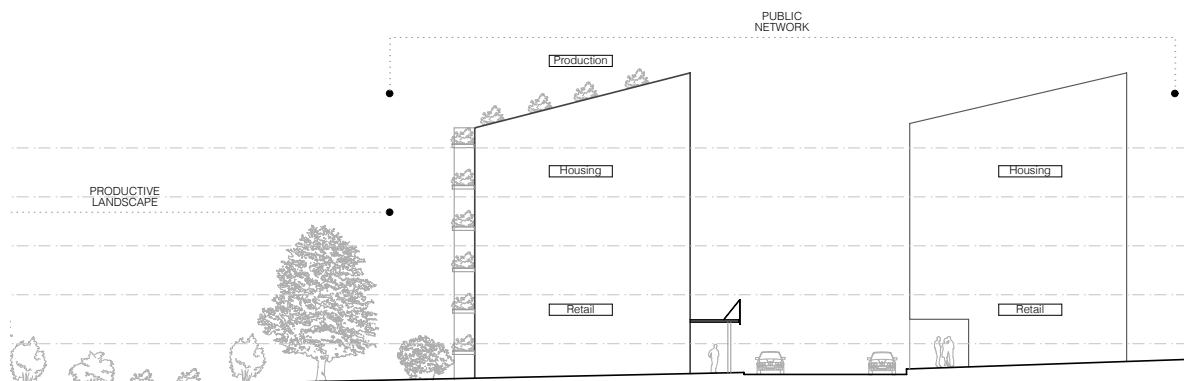



Fig 5.15 Proposed intervention Aerial View
from the North (Author, 2014)

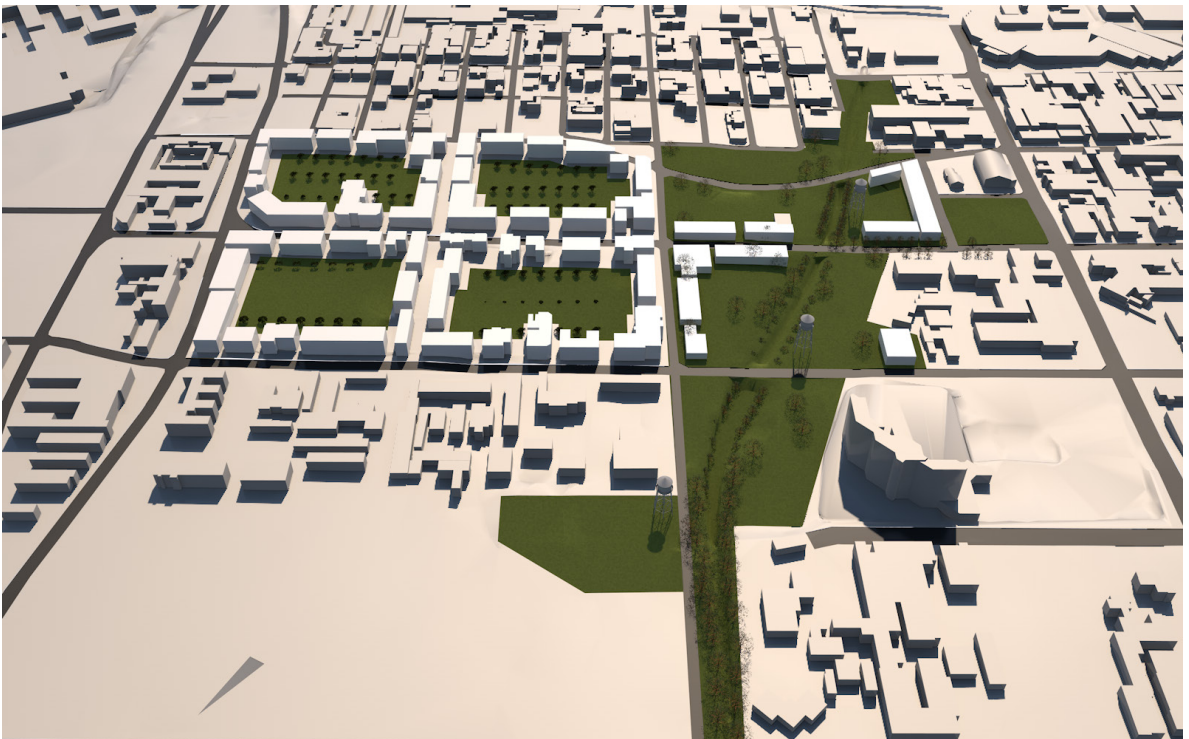

Fig 5.15 Proposed intervention Aerial View
from the South (Author, 2014)

6.0 PRECEDENT STUDIES

6.1 Construction precedents.

6.2 Programme related precedents

6.1 Construction precedents.

Both projects celebrate the making of architecture as a process of time. Celebrating the deterioration of materials in the construction process. In the Plant project the market structure is designed to provide awareness for the use of bamboo as a construction material and to create a dialogue between the productive landscapes and the building. The market building is designed to sit lightly in the environment.

6.1.1 Canopy for MoMA P.S.1. by NArchitects

The Canopy was envisioned as a temporary structure built in the courtyard of P.S.1 a contemporary art and music venue. The pavilion was built with freshly cut green bamboo which over time turned tan. This process gave people who visited the pavilion an experience of weathering and decay of the pavilion. To build the pavilion, the bamboo was spliced and bound together using stainless steel wire. The bamboo is inserted into the ground using steel ring beams with welded pipes.

The canopy was dipped to define open rooms to the sky. To create different degrees of shading, the number of bamboos were increased in specific areas.

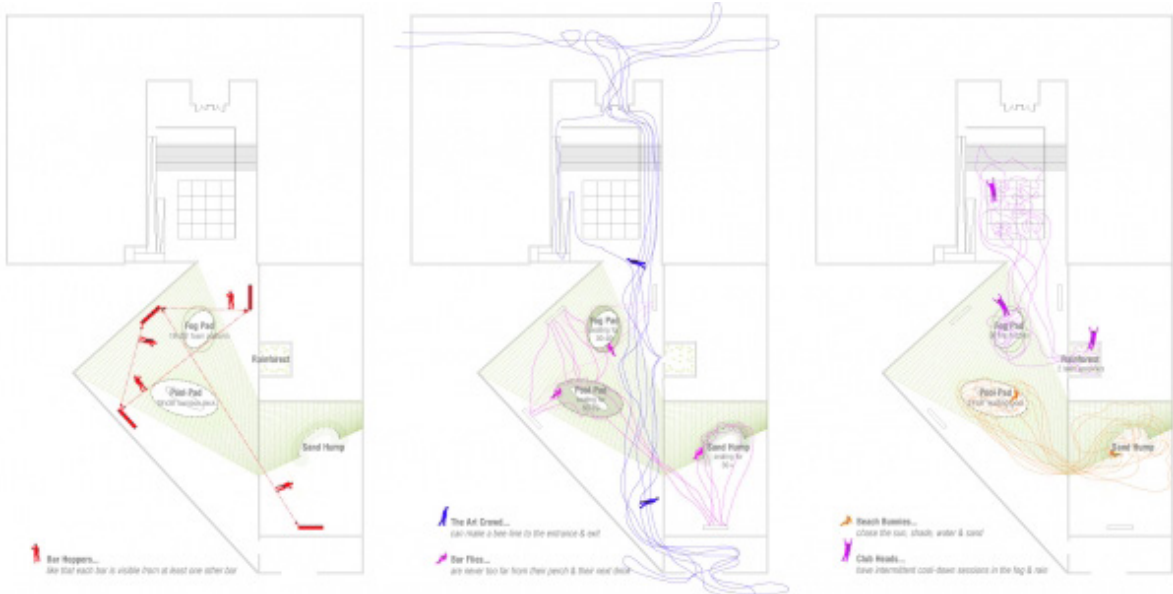

Fig 6.10 Site Analysis (Archdaily: Canopy for MoMA, 2012).

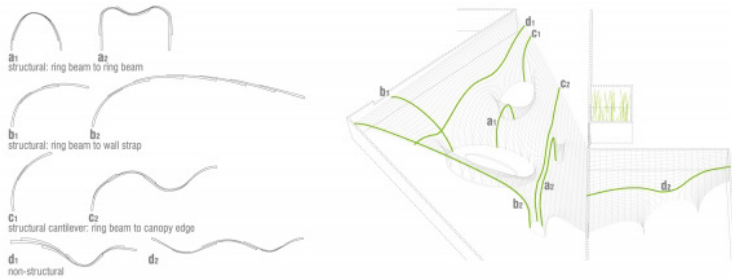

Fig 6.11 Bamboo Sections Archdaily: Canopy for MoMA, 2012).

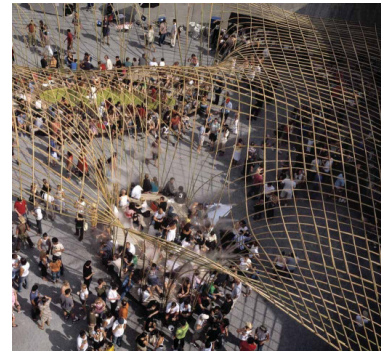

Fig 6.12 Aerial view 1 (Archdaily: Canopy for MoMA, 2012).



Fig 6.13 Experience through view 2 (Archdaily: Canopy for MoMA, 2012).

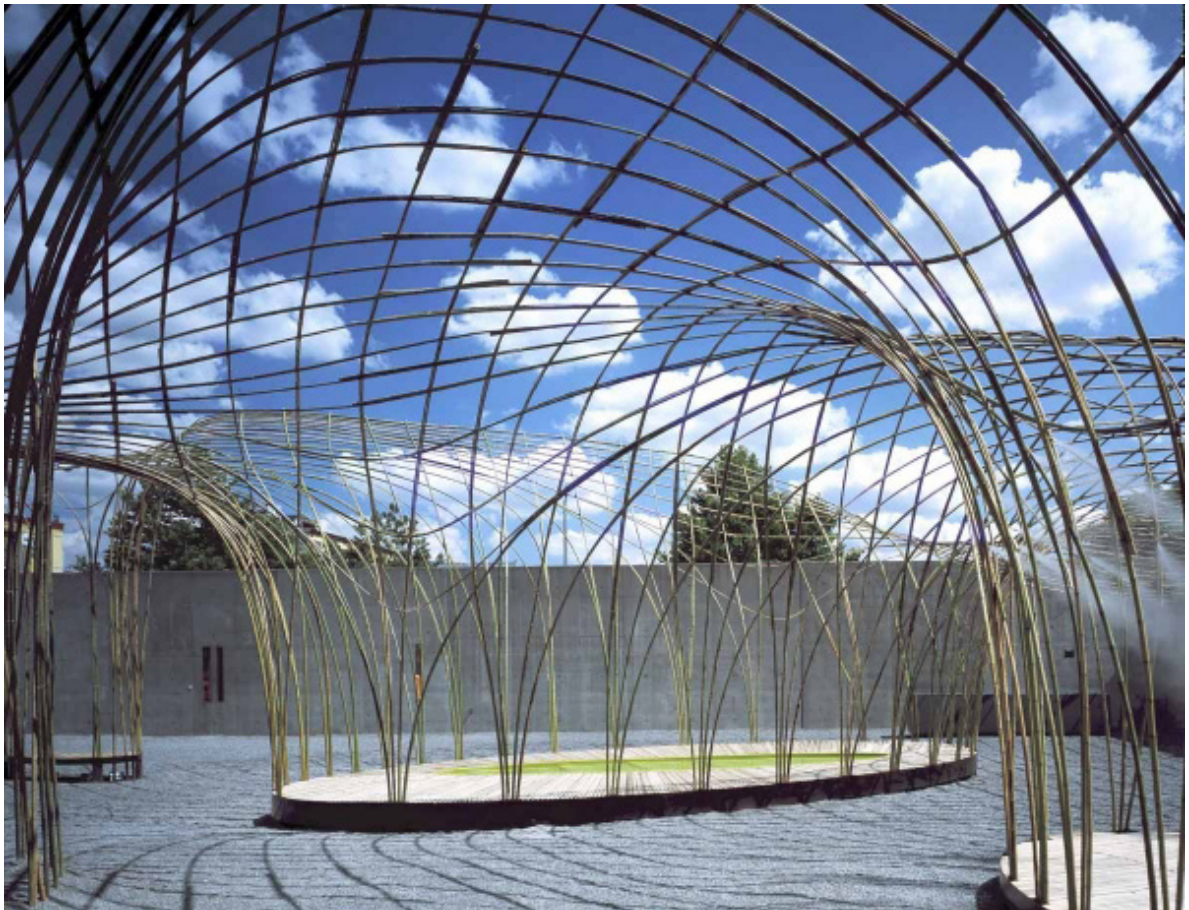

Fig 6.5 Canopy Pavilion view 3 (Archdaily: Canopy for MoMA, 2012).

6.1.2 Forest Pavilion

The pavilion is designed as an outdoor theatre. A circular deck, with 11 vaults around it. The mission was to design a landmark installation suited for the scenic site while providing a sense of enclosure shade and sense for the public. The pavilion sits lightly in its environment with minimal disruption.

The Forest Pavilion serves as a shaded meeting and performance space for visitors to the Da Nong Da Fu Forest Park and Eco Park in Taiwan. It was curated with the objective to create awareness of a new growth forest that is being threatened by development. Like the Canopy for MoMA, the project is constructed of freshly cut green bamboo. The wet bamboo is still pliable and allows for tolerances when bent, and finally dries into the form.

The bamboos are arranged in vaults around a circular pavilion, 11 vaults in all. The vaults are a single a parabolic arch.

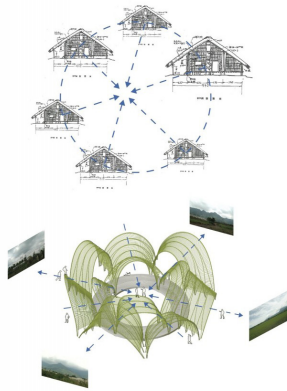

Fig 6.14 Parti (Archdaily: Forestry Pavilion, 2012).



Fig 6.15 Photo (Archdaily: Forestry Pavilion, 2012).



Fig 6.16 Photo (Archdaily: Forestry Pavilion, 2012).



Site is cleared and graded with steel pipes and concrete foundations laid out



Bamboo is freshly cut from nearby forests and transported to site in small increments



Primary arcs and main spanning are erected, with scaffolding for support as needed.

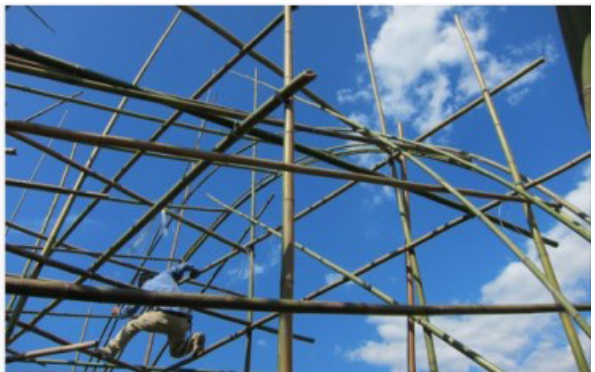

Bracing arcs are erected, weaving in between scaffolding and vault.

Fig 6.17 Construction Methodology (Archdaily: Forestry Pavilion, 2012).



Primary structure of vaults are erected, with scaffolding as needed.



Bamboo sheathing is installed for vaults with primary structure rigid and complete steel rings for woodwork decking is welded to steel pipes.



Scaffolding is removed from each completed vault and wood decking installed.



Minor repair work for completed vaults is conducted and the Amis bamboo construction team in front of the completed pavilion

Fig 6.18 Construction Methodology (Archdaily: Forestry Pavilion, 2012).

6.1.3 The Great Bamboo Wall

The project was developed along the Great Wall of China. The solidity of the great wall as a division to insulate and isolate territory and culture of China front outsiders.

The Bamboo wall house while a dividing space contrasts the solid wall. Bamboo material being of significant cultural value in the area begins to act as a unifying element.

Through altering the density and diameters of the bamboo, thresholds through the house are created. Controlling the privacy and light through the building.

The house becomes an environmental filter, containing human activities.

Transparency is controlled in the building by using bamboo.

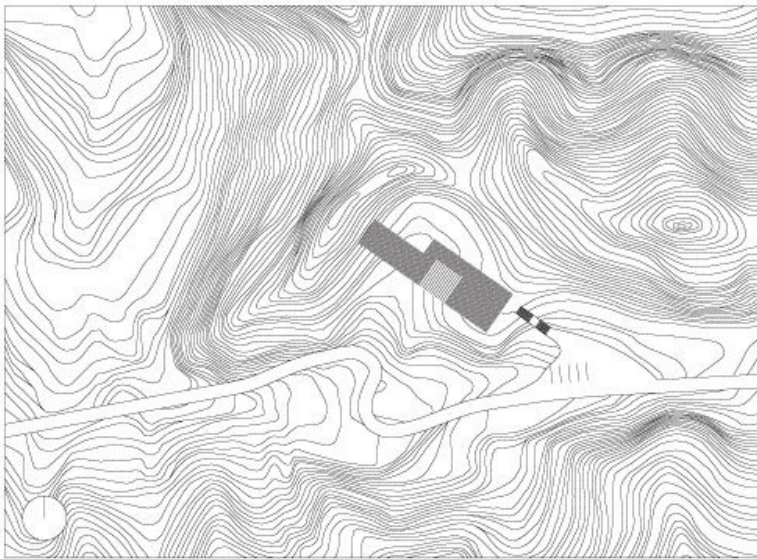

Site plan/1500

Fig 6.19 Site Plan (The Architectural Apprenticeship, 2014)

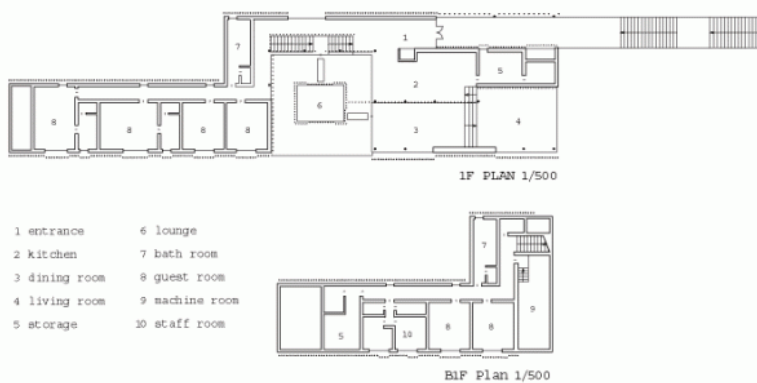

Fig 6.121 Floor Plans (The Architectural Apprenticeship, 2014)

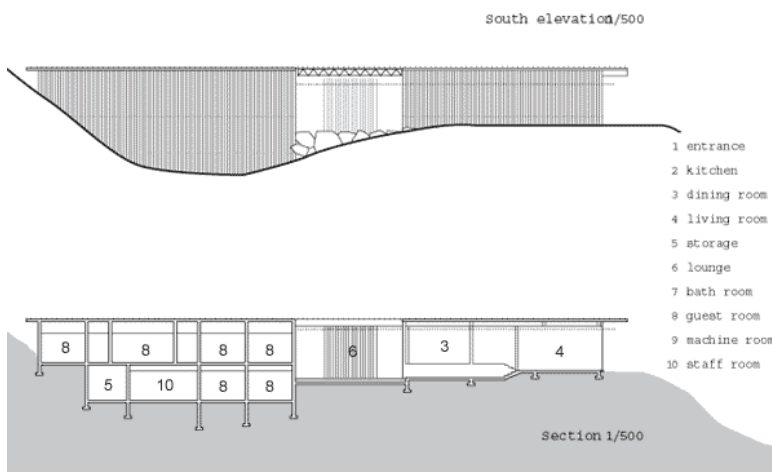

Fig 6.122 Section and elevation (The Architectural Apprenticeship, 2014)



Fig 6.123 Entrance photo (The Architectural Apprenticeship, 2014)



Fig 6.16 Interior (The Architectural Apprenticeship, 2014)



Fig 6.127 Entrance view (The Architectural Apprenticeship, 2014)



Fig 6.124 Staircase (The Architectural Apprenticeship, 2014)

Summary:

The project demonstrates the use of bamboo to define spaces through the building. The solid is created by overlaying various panels of bamboo. Creating various layers of transparency through the building. By using varying thickness's of the bamboo Kuma was able to obtain structural as well as experiential elements using bamboo.



Fig 6.125 Photo (The Architectural Apprenticeship, 2014)

6.2 Programme

The project demonstrates how agricultural landscape can become part of the urbanised environment and how cultural identity can be created through productive landscapes. By mixing social spaces with the productive landscapes.

6.2.1. Shenyang Architectural University Campus by Kongjian YU (Principal Designer), Shihong LIN (Overseeing Landscape Planting)

The arable land is being encroached for urbanisation in China. With a high population and limited tillable land, food production and sustainable land use is one of the issues architects must face. (Architecture, Landscape Architecture, Urbanism, 2003).

To solve this challenge, the designers decided to use rice, native plants and crops to keep production in the landscape while fulfilling its role as an environment for learning. It is designed to raise awareness of farming amongst the college students.



Fig 6.21 Rice Fields (Architecture. Landscape Architecture. Urbanism, 2003).

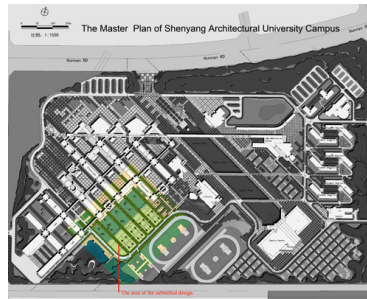

Fig 6.22 Master Plan (Architecture. Landscape Architecture. Urbanism, 2003).



Fig 6.23 Master Plan (Architecture. Landscape Architecture. Urbanism, 2003).

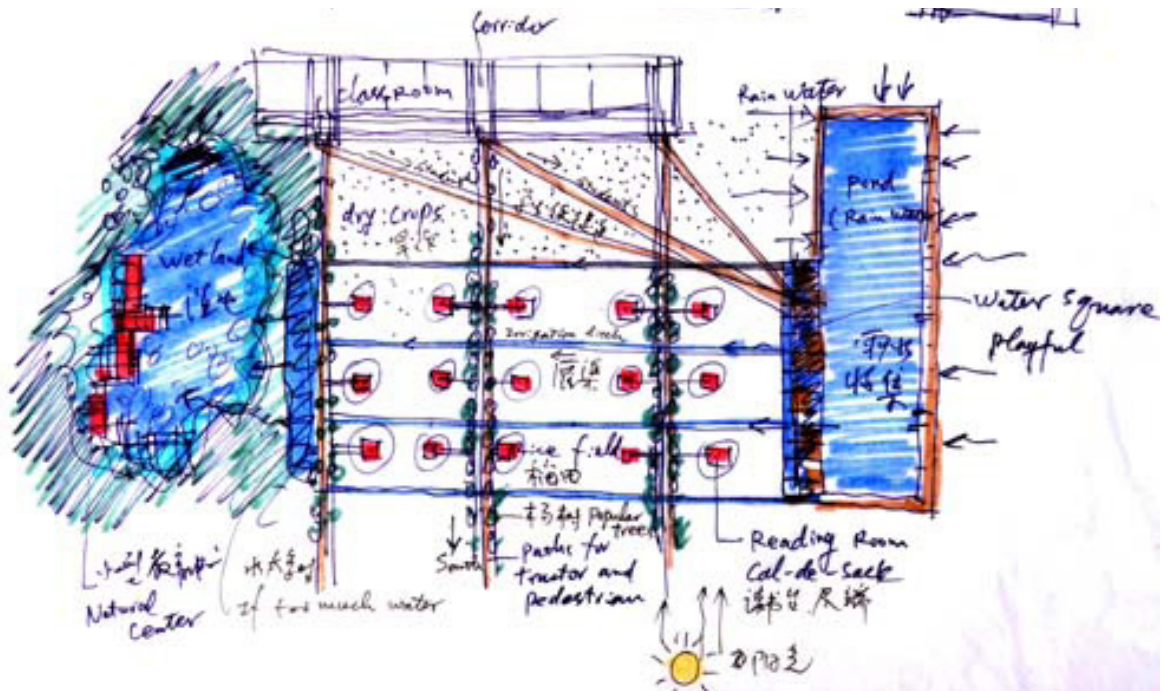

Fig 6.20 Concept Sketch (Architecture. Landscape Architecture. Urbanism, 2003).



It demonstrates how inexpensive and productive agricultural landscapes can become useable space. The project engages students and faculty in a dialogue of sustainable development.

The project allows the process of agriculture to become transparent and accessible to all on campus. The staff and students alike become a part of the productive landscape. The rice harvested from the campus became an icon serving as a source of identity and awareness for the university.

Fig 6.24 Walkways (Architecture. Landscape Architecture.Urbanism, 2003).



Fig 6.25 Aerial Photo showing the landscapes and the student walkways through. (Architecture. Landscape Architecture.Urbanism, 2003).

6.2.2. Briter-Water Project

The project looked at developing and demonstrating an innovative wastewater treatment system using bamboo. The system is a vegetation filter; in this kind of treatment, the wastewater is sent through the soil of a plantation. Wastewater passes through the soil or the filtration media, where naturally occurring micro-organisms degrade the organic matter.

The system is designed to treat grey water. Water that does not contain sewage or toxic chemicals. The main pollutants in the water is organic matter, soaps and disinfectants, which when discharged into aquatic media can lead to production of bad odours from proliferation of anoxic micro-organisms and in extreme cases death of the aquatic life. (Cordis, 2012)



Fig 6.26 Bamboo being planted
(Phytorem, 2014)



Fig 6.27 Harvested bamboo water treatment system (Phytorem, 2014)

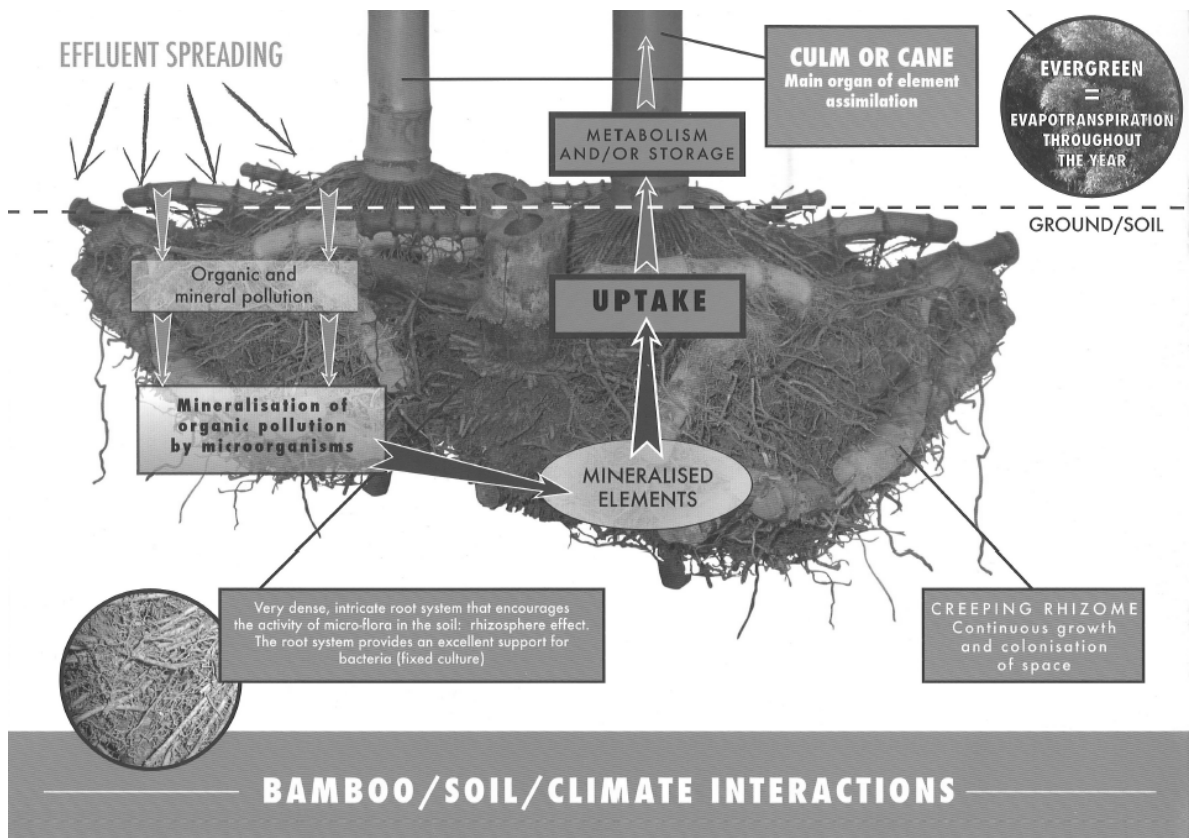

Fig 6.25 Bamboo root system (Phytorem, 2014)



Fig 6.26 Bamboo harvested for biomass (Phytorem, 2014)

The pilot waste water treatment plant uses bamboo to degrade the environmental contaminants like nitrogen, coliform and phosphorous. Bamboo was chosen because of its dense root system. The fast growing plant is among the most productive in the world. It can resist many environmental stresses including too little and too much water or extremely low temperatures. The biomass produced during the waste water treatment can be used for other functions. (Cordis, 2012).

6.3.1. Z-Gallery by O-Office Architects

The factory building was designed with large openings on a grid. This allowed the intervention to be serviced easily.

The ID Town project originates from the abandoned Honghu Dyeing Factory. The 8 hectar factory is surrounded by the mountain near the coast of Chinese sea.

The factory was topographically divided into two quarters. The living quarter and the production quarter. The study looks at the elements in the factory that allowed the old building to accommodate the new programme. The main building is a single level building with a double sloping roof. The building has a concrete structural frame with a 6 metre grid. The grid modulated the openings. All windows and doors were inset into the facade



Fig 6.27 Old Factory (Archdaily: Z Gallery 2014).



Fig 6.28 Intervention (Archdaily: Z Gallery 2014).



Fig 6.29 Intervention at night (Archdaily: Z Gallery 2014).

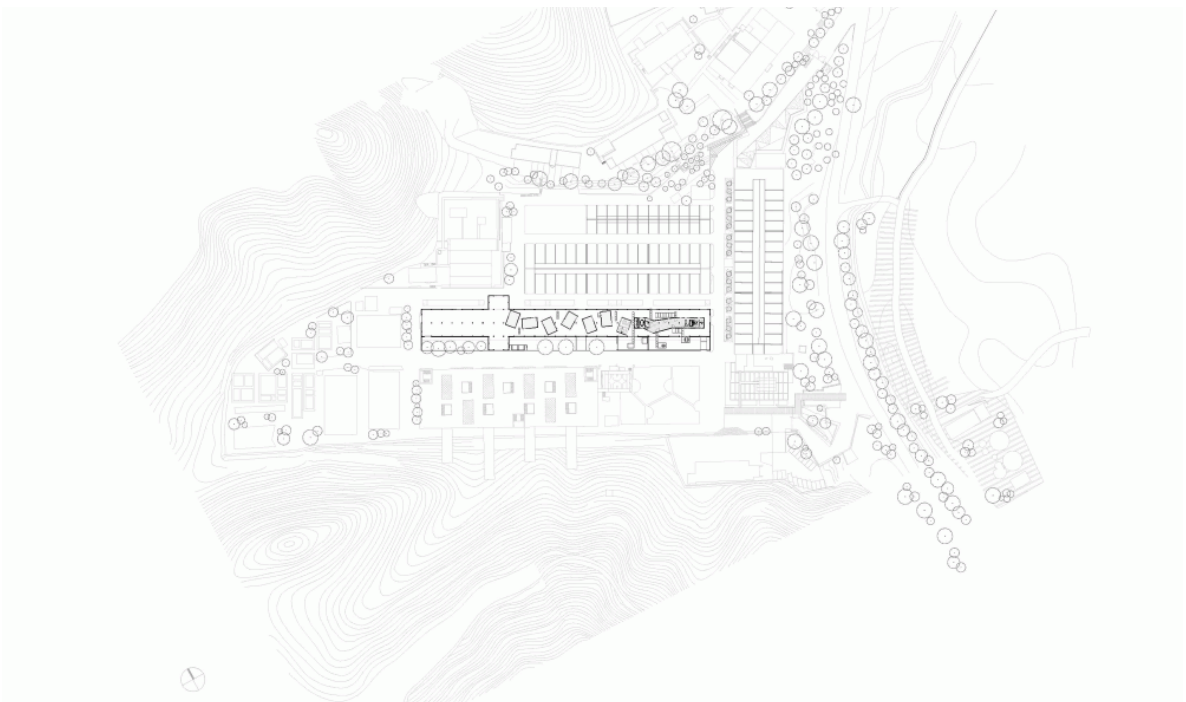

Fig 6.30 Site Plan (Archdaily: Z Gallery 2014).

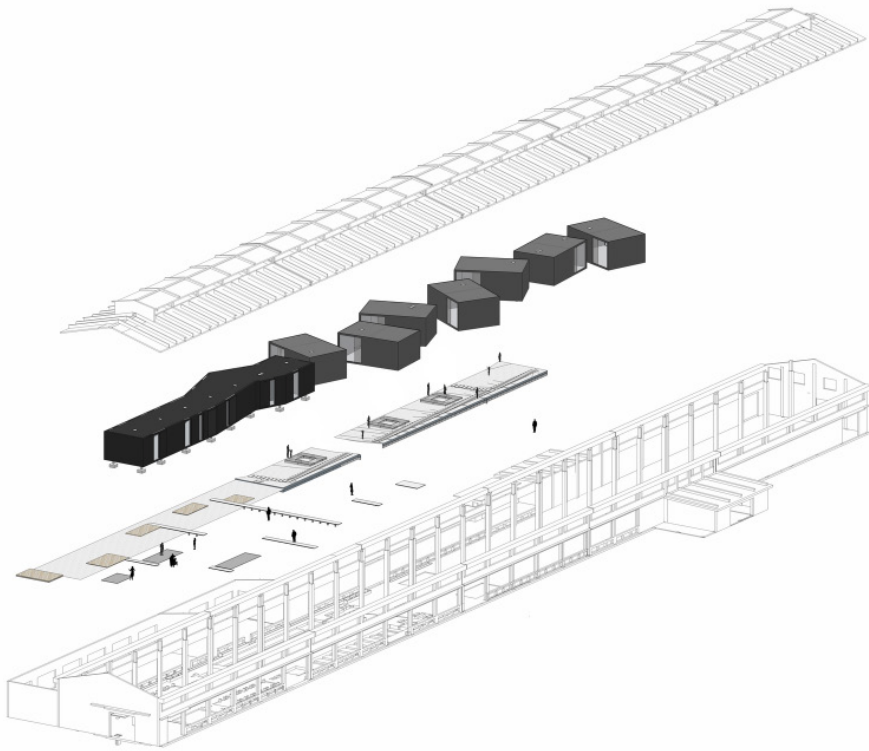

Fig 6.31 Design Parti (Archdaily: Z Gallery 2014).

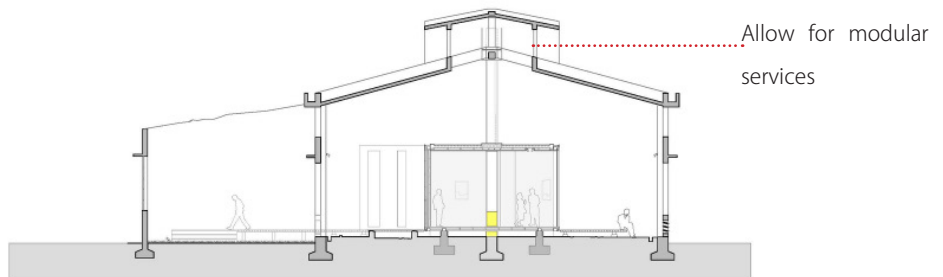

Fig 6.32 Cross Section (Archdaily: Z Gallery 2014).



Fig 6.33 Longitudinal Section (Archdaily: Z Gallery 2014).

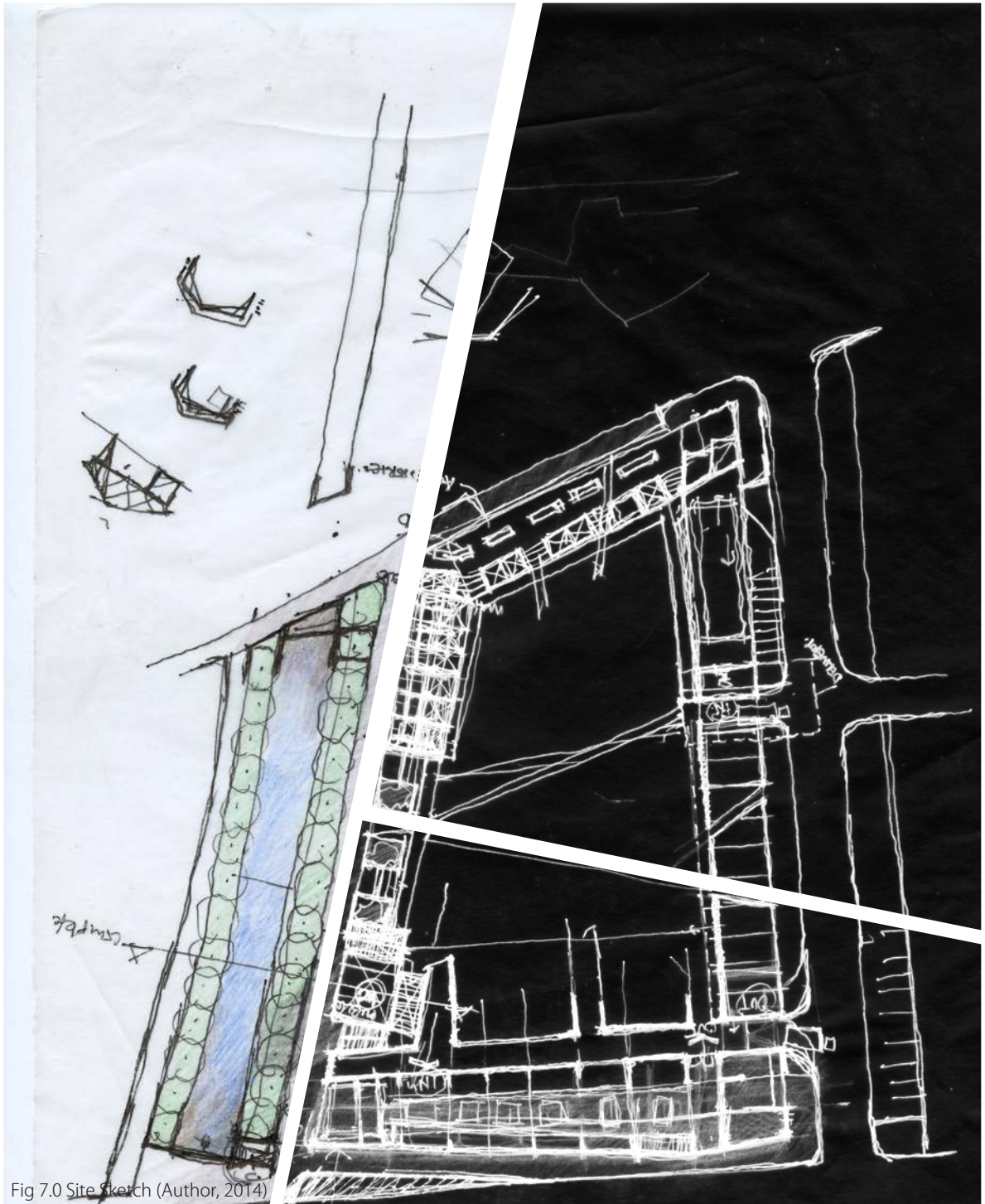

Fig 7.0 Site Sketch (Author, 2014)

DESIGN INVESTIGATION

Ordinary Edge
— Janu

This chapter focuses on the main design generators. The project is explained within the parameters of the 6 layers of a building from Brands analysis of a building. The layers of the building are overlaid with the programme. The 7 layers are developed as a series of systems connected to each other.

7.0 DESIGN INVESTIGATION

- 7.1 Background
- 7.2 Building Programme + conceptual investigations
- 7.3 Site
- 7.4 Structure
- 7.5 Skin
- 7.8 Services
- 7.9 Space plan
- 7.10 Stuff
- 7.11 Sketch plans

7.1 Background

How can architecture act as a catalyst for the regeneration of decayed natural and urban fabric?



The building programme is situated as a pilot project for the development of the precinct. Growing bamboo, utilising it in its various forms and in so doing creating awareness and promoting the use of bamboo. This project will plant the idea for a systematic integration of more productive plants into the urban fabric.

Understanding the programme.

Marabastad is comprised of majority trading areas with most of the trade products brought into the area. The urban framework proposes to create a productive district to create a new identity for the precinct. Creating a positive identity as a productive place. This will in turn create a compact self sustaining precinct.

This implies that the area will have to develop its forestry and food supplies. Marabastad already hosts 2 fresh produce markets (excluding the sheds and informal vendors). Thus there exists a steady food supply met by external farmers. To develop the infrastructure to begin producing food, there is a need for forestry products in the area.

7.1.2 Why Bamboo?

Growth and production of forests typically takes between 10 -25 years prior to harvest. This may be environmentally beneficial, however it is not economically viable. Considering the life cycle, the productive capacity of the trees and the output per tree. Bamboo however provides the solution to the above mentioned problems. With an average time of maturity being between 3 - 4 years and yield of 6 - 8 culms per 25m². It provides a more economically sound option with environmental and ecological benefits.

Species

There are over 1500 species of bamboo world wide. Most of which are native to Asia. While Africa hosts about 40 species, majority of them are located in Madagascar. Only one species, *Thamnocalamus tessellatus*, is indigenous to South Africa (it grows in the high Drakensberg) although the Venda people grow *Oxytenanthera abyssinica* for ceremonial purposes, this species is appropriately named the Holy Venda bamboo and is thought to have been introduced by the ancestors of the Venda from further north in Africa. (University of Pretoria, 2012)

There are two species that have been naturalised to South Africa, the *bambusa balcooa* typical of height between 12 - 25 metres and thickness 150 mm diameter and the *bambusa vulgaris* species whose culms grow 10–20 metres high and 40 –100 mm thick. (Food and Trees for Africa, 2014).



Fig 7.10 *Thamnocalamus tessellatus*,
(Gaudua Bamboo, 2014)



Fig 7.11 *Oxytenanthera abyssinica*
(Horti News, 2014)



Fig 7.12 *Bambusa balcooa* (Bamboo
Web Info, 2012)



Fig 7.13 *Bambusa vulgaris* (Gercens K,
2014)

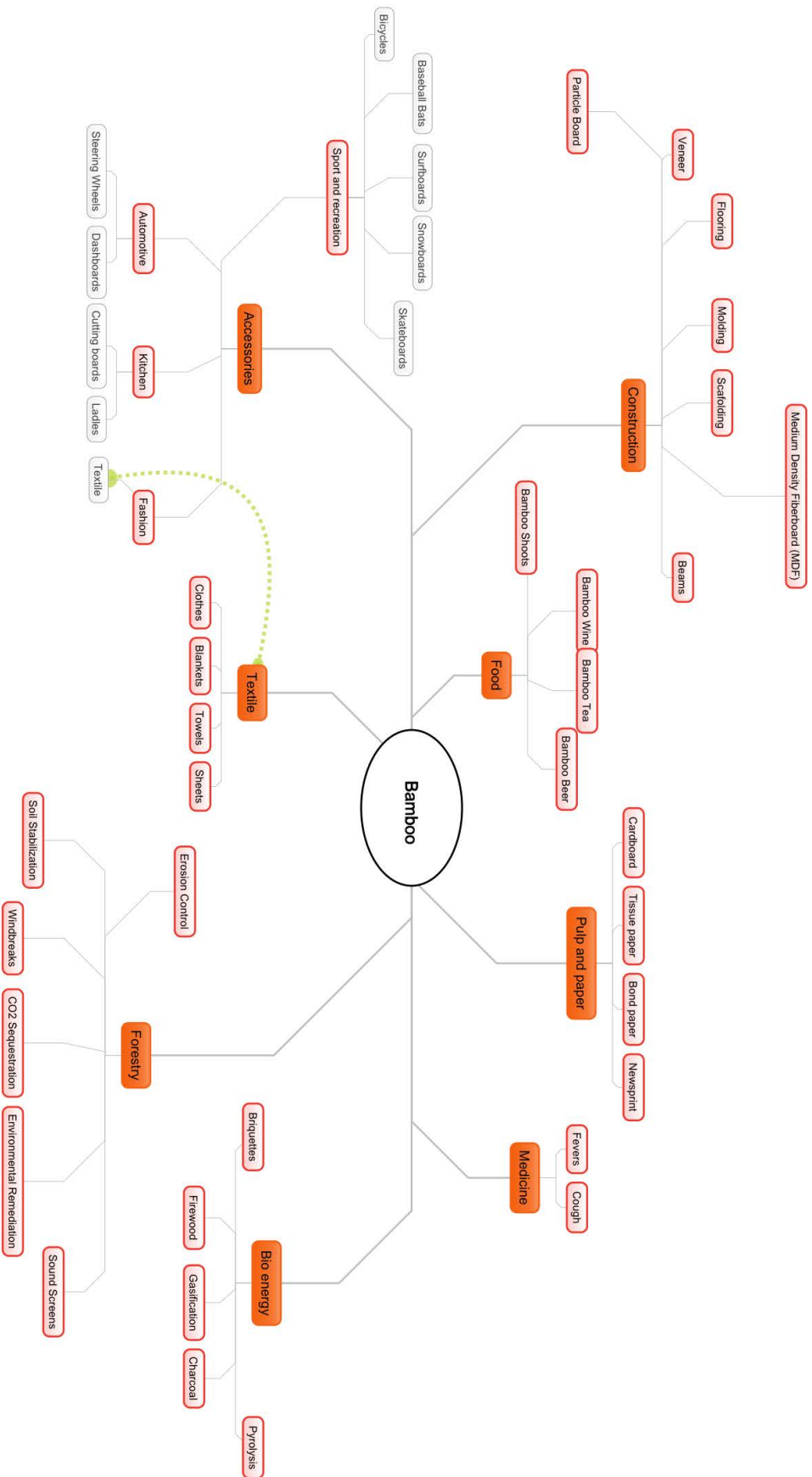

Fig 7.15 How Bamboo can be used to manufacture forestry products. (Author, 2014).

7.1 Building programme

In introducing the pilot programme into the precinct the project aims to:

- manufacture products from bamboo (workshop and factory)
- sell the products to the public (market)
- inform the public through the project about sustainable development (synthesis between architecture and landscape).



7.1.1 Programme influences: Operation (landscape)

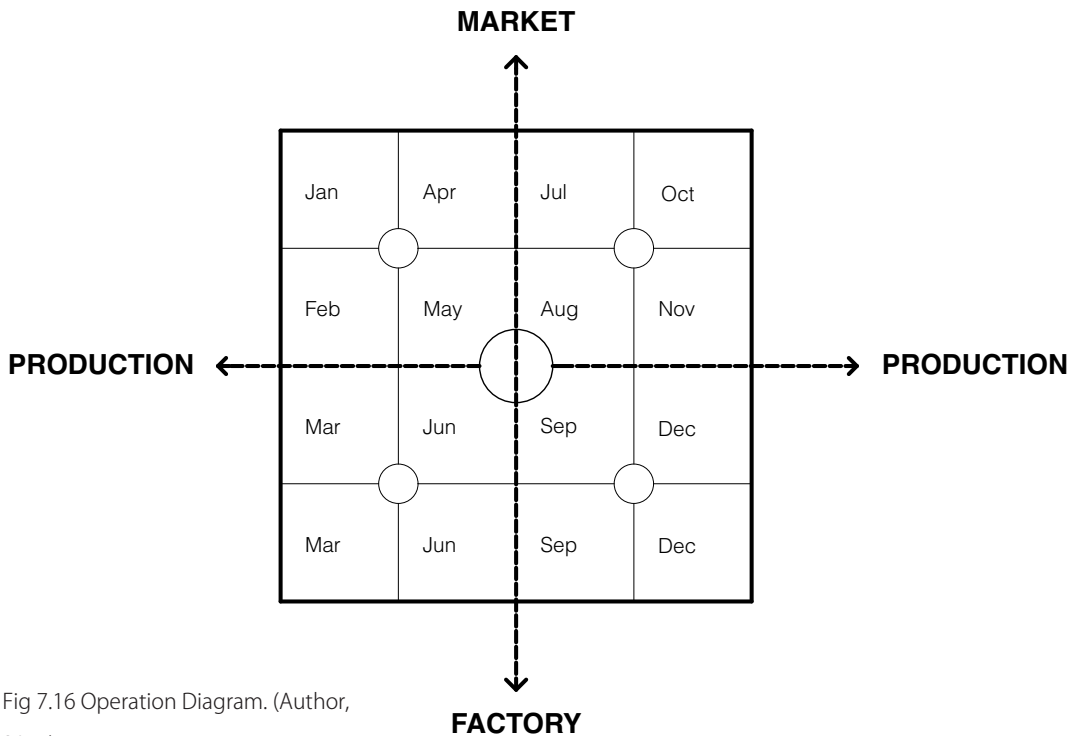

Fig 7.16 Operation Diagram. (Author, 2014).

Occasional views to other buildings



Fig 7.17 Section Operation Diagram, creating a relationship between landscape and architecture. (Author, 2014).

STEP 1 - IN THE GARDEN

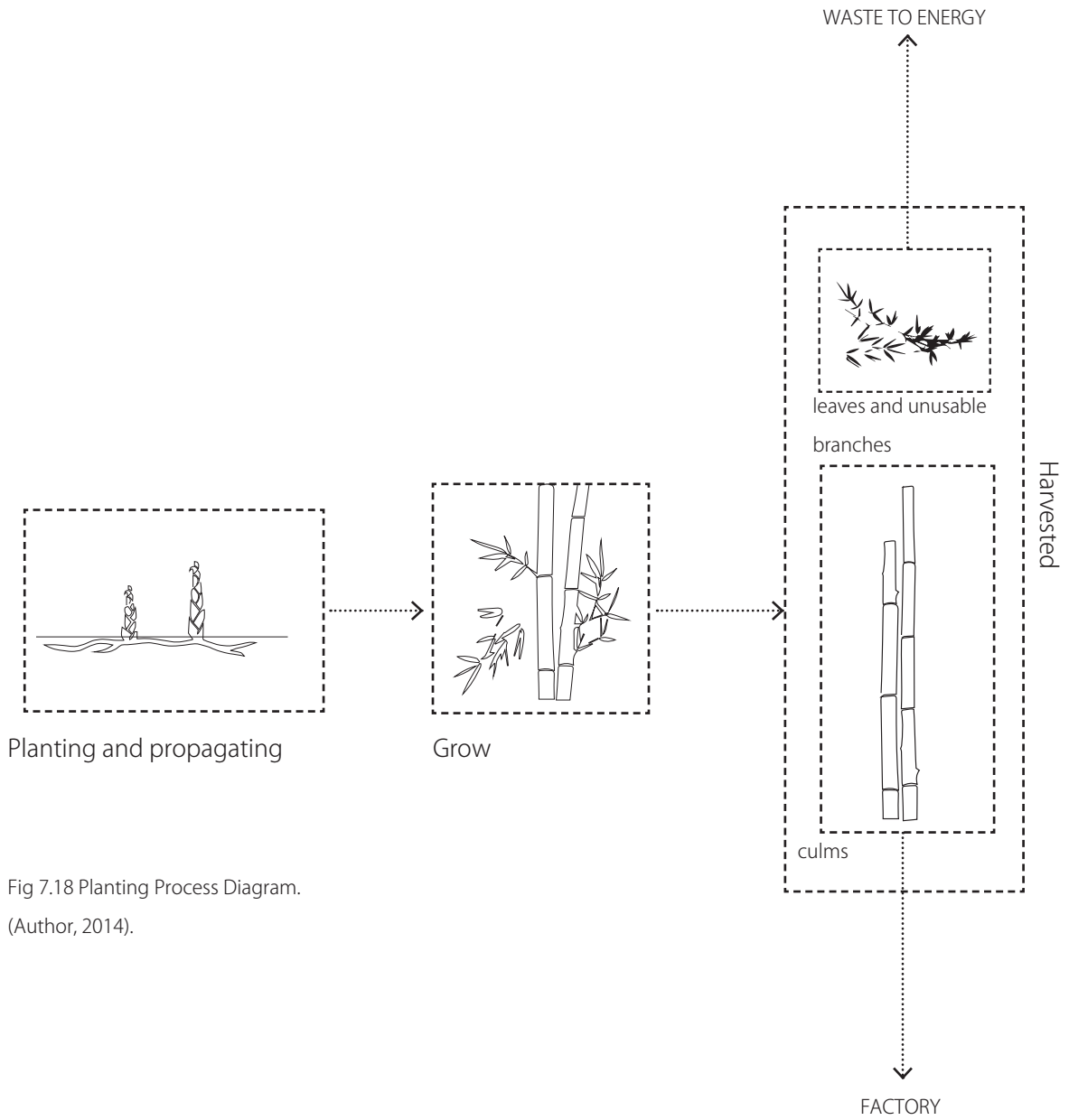

Fig 7.18 Planting Process Diagram.
(Author, 2014).

STEP 2 - IN THE FACTORY

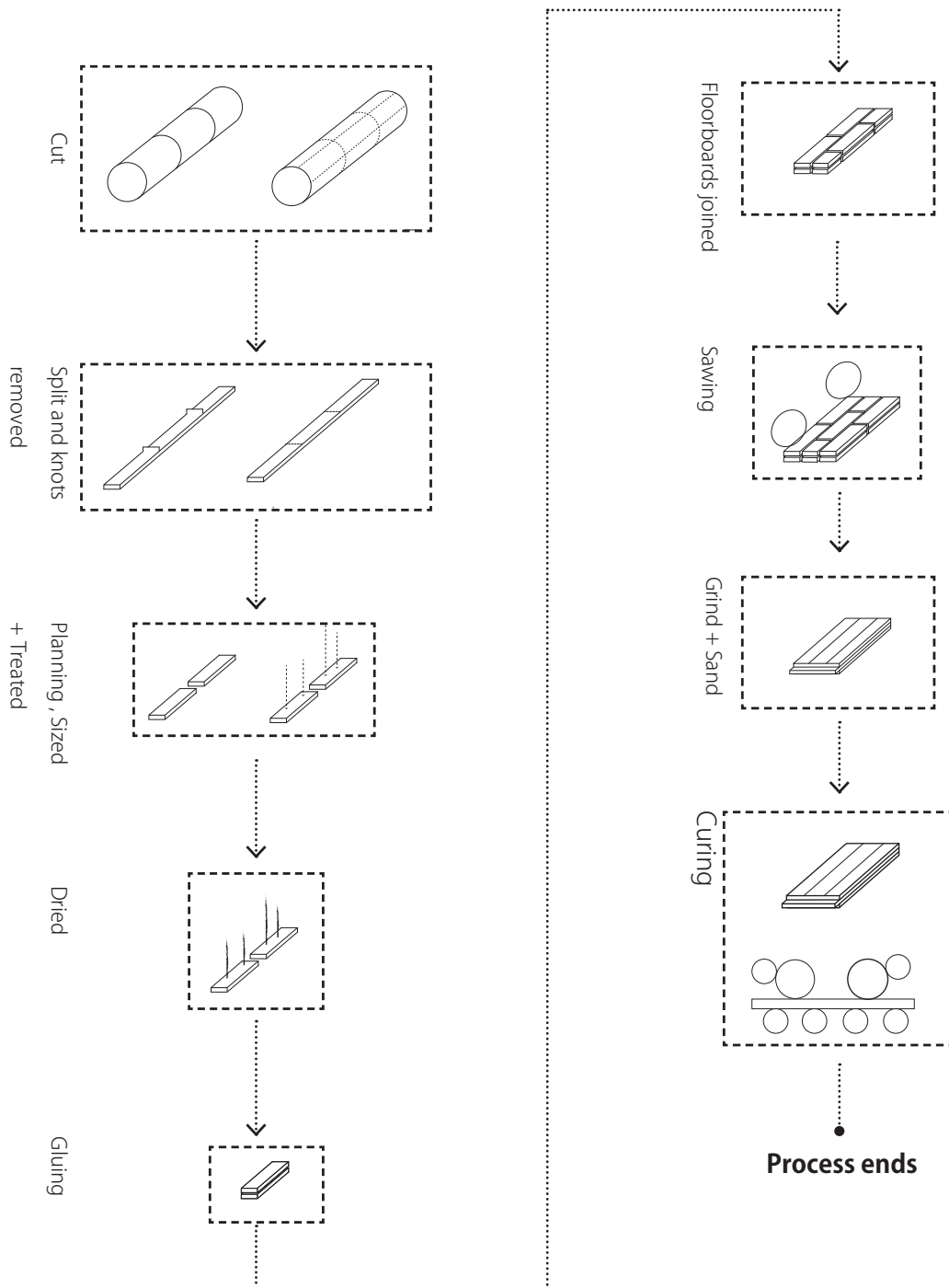

Fig 7.19 Manufacturing Process Diagram. (Author, 2014).

STEP 3 - IN THE WORKSHOP

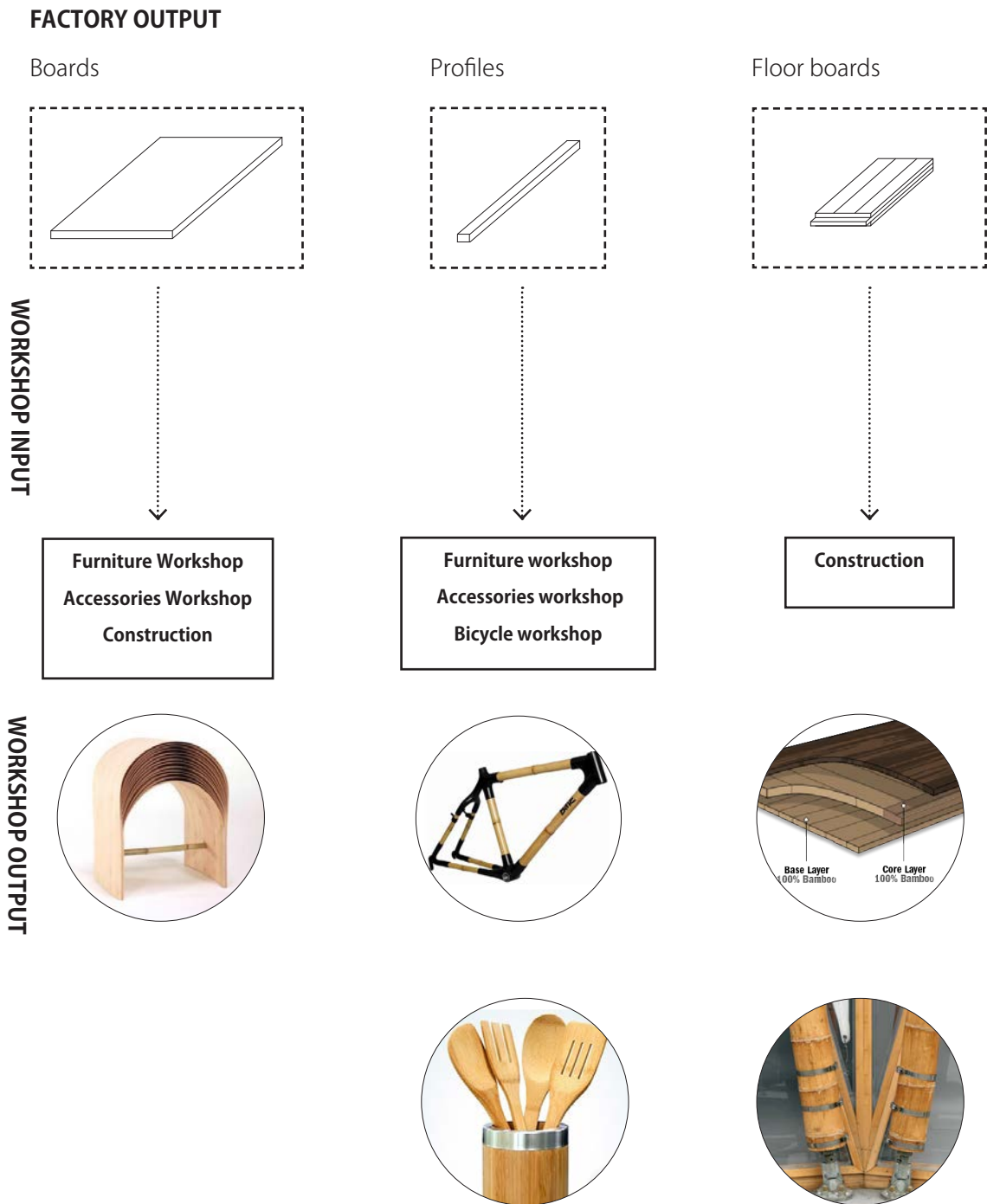
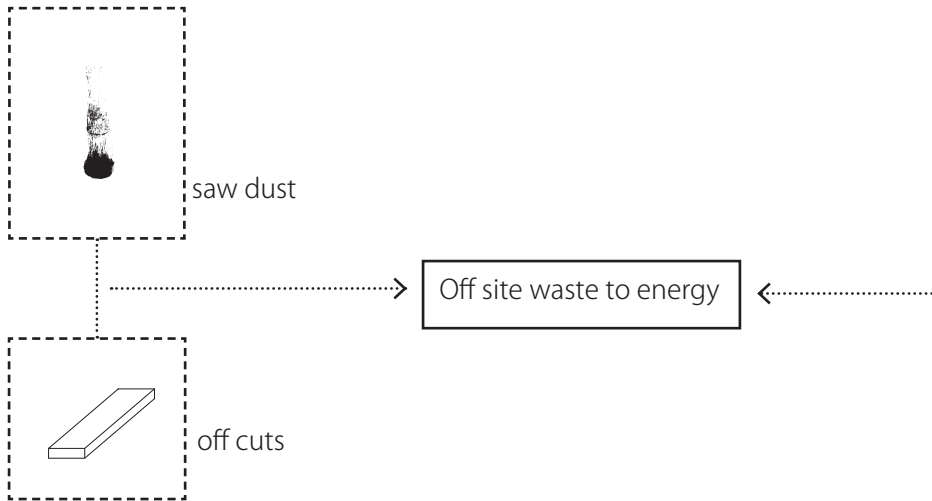

Fig 7.110 Workshop Process Diagram.
(Author, 2014).

STEP 4 - AFTER THE FACTORY, WORKSHOP (EXCHANGE NETWORK)

Factory/ Workshop waste



Market waste

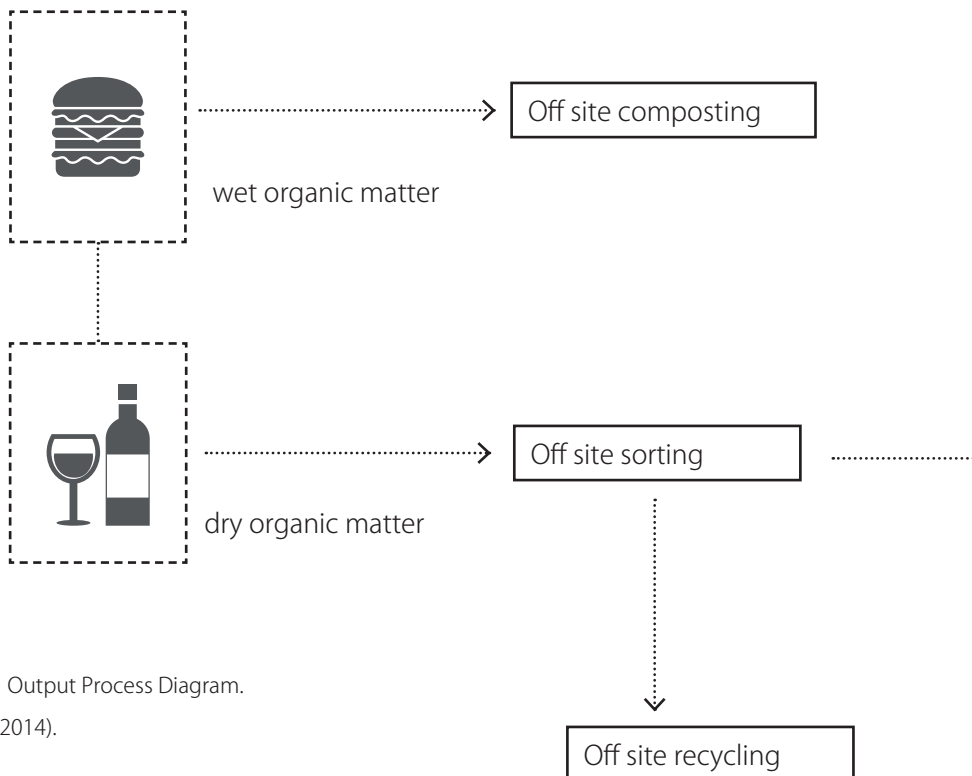

Fig 7.111 Output Process Diagram.
(Author, 2014).

Organic network

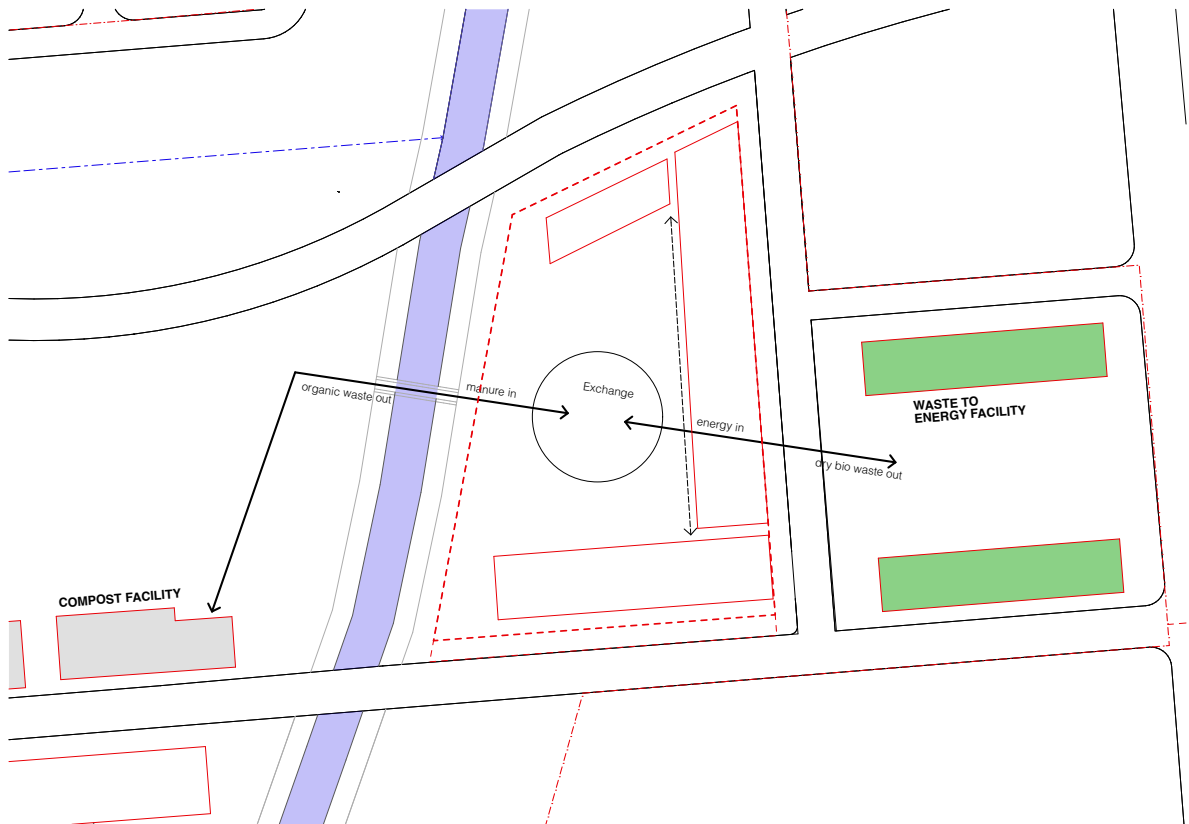

Fig 7.112 Organic network Diagram. (Author, 2014).

Building influence 1:

The programme resulted into two building typologies that respond to the conditions of the site.

The temporal structure

The industrial shed

The main issue with creating a building that is resilient and adaptable to any programme is the building follows a generic form and that form may not respond to the context. To counter this the contextual typologies that related to the different building programs are analysed and interpreted. This creates a new identity that is suitable to the context.



Fig 7.113 Photo of industrial building (Author, 2014).

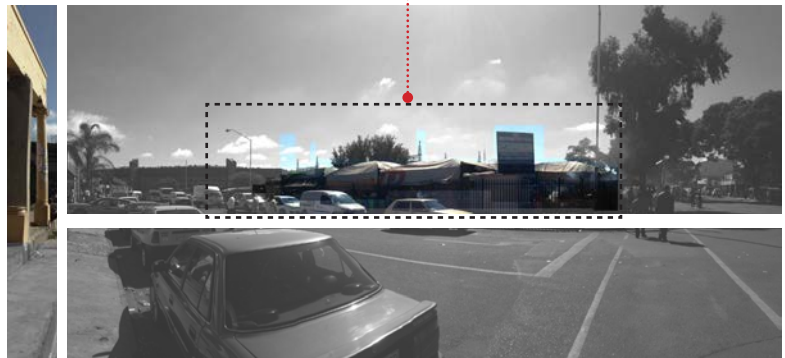
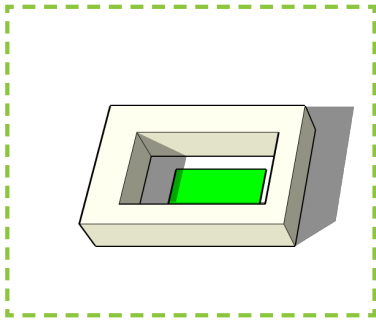
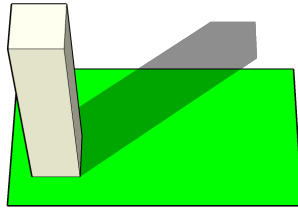

Fig 7.114 Photo of tents in Marabastad (Author, 2014).



Courtyard typology

- Sensitive to the existing qualities of the precinct.
- Maximise surface contact of garden with earth.



Object in the landscape

- Sensitive to the existing qualities of the precinct
- Maximise surface contact with garden

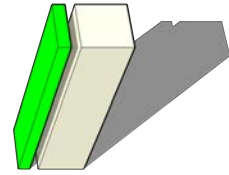

Vertical agriculture

- Sensitive to the existing qualities of the precinct
- Space saving

Social network

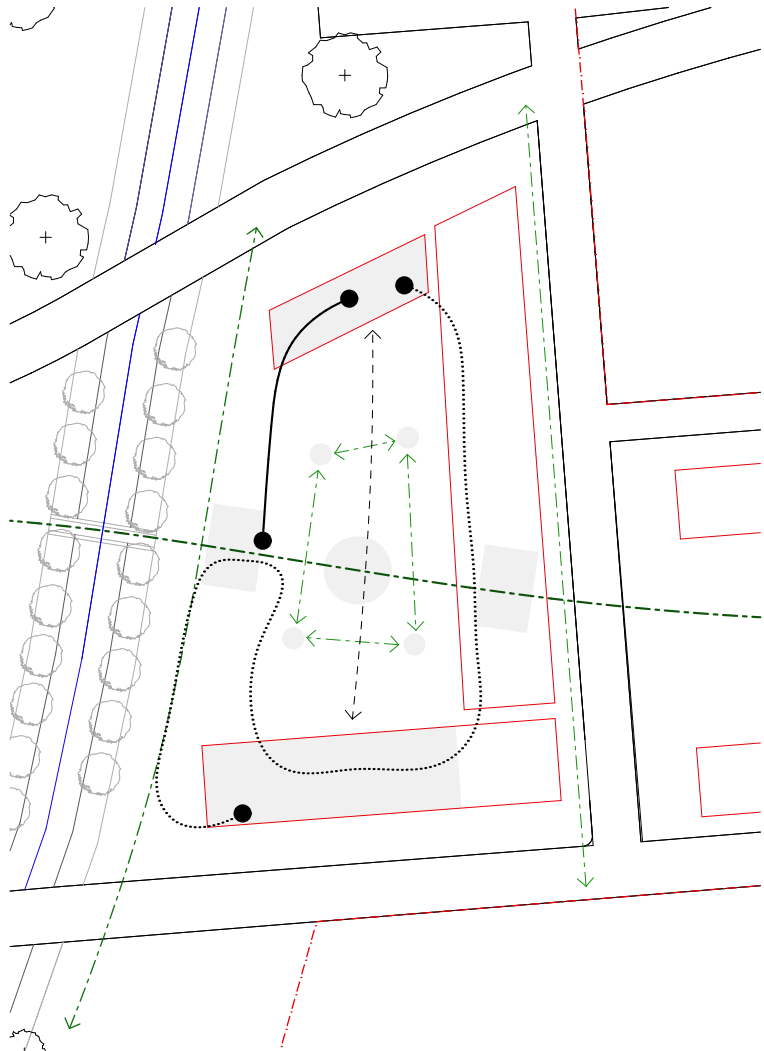

- Key**
-● Information/education route
 - ←- - - -> Market users
 - ←- - - -> General public
 - Rest points

Fig 7.115 Social Network (Author, 2014).

Liquid network

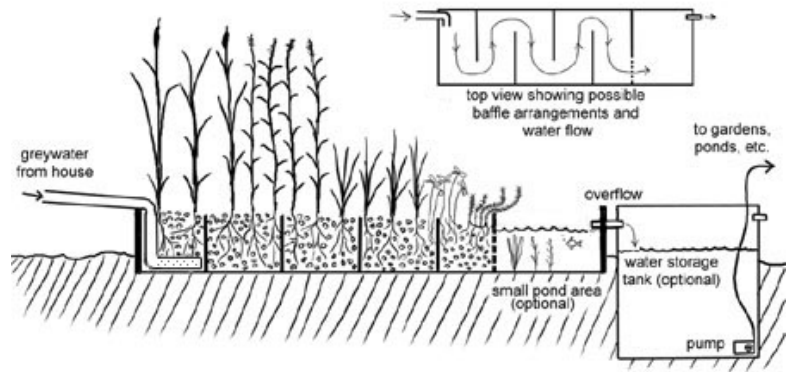

Fig 7.116 Phytoremediation by plants (Frog Watch, 2012).

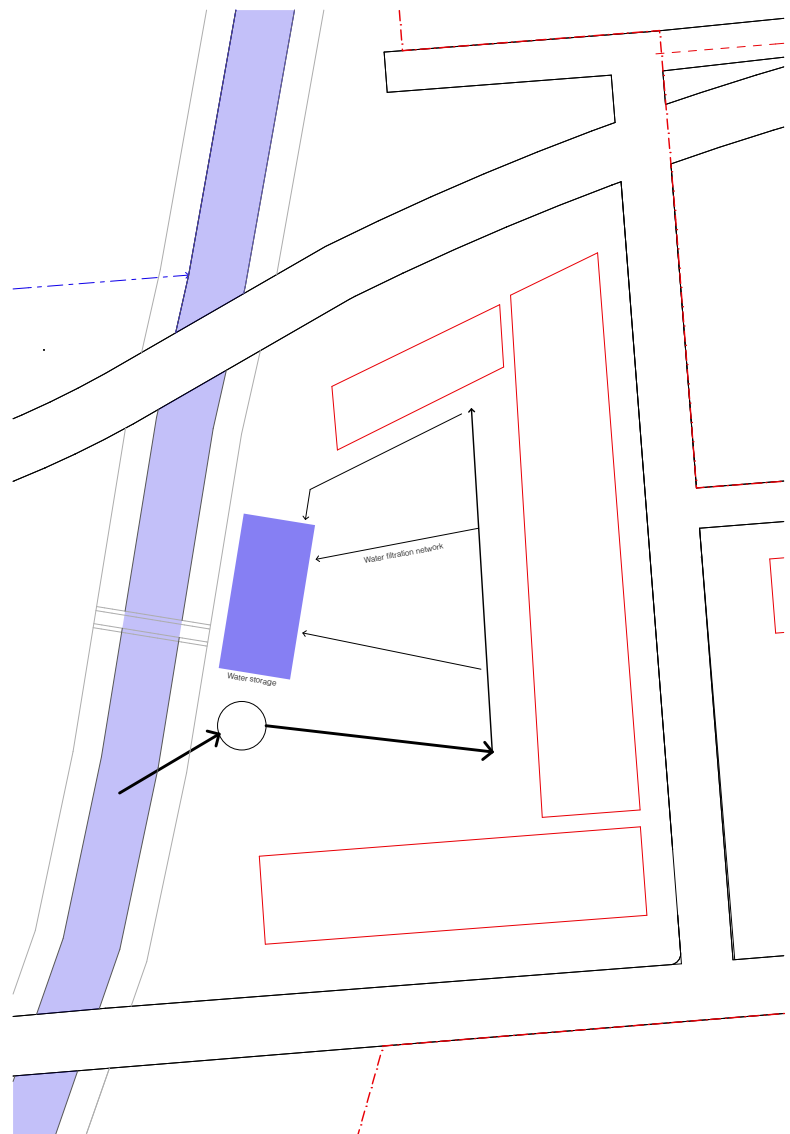

Fig 7.118 Phytoremediation by plants (Frog Watch, 2012).

Explorations 01
Models



Fig 7.120 Edited Photo of model illustrating building use and landscape (Author, 2014)

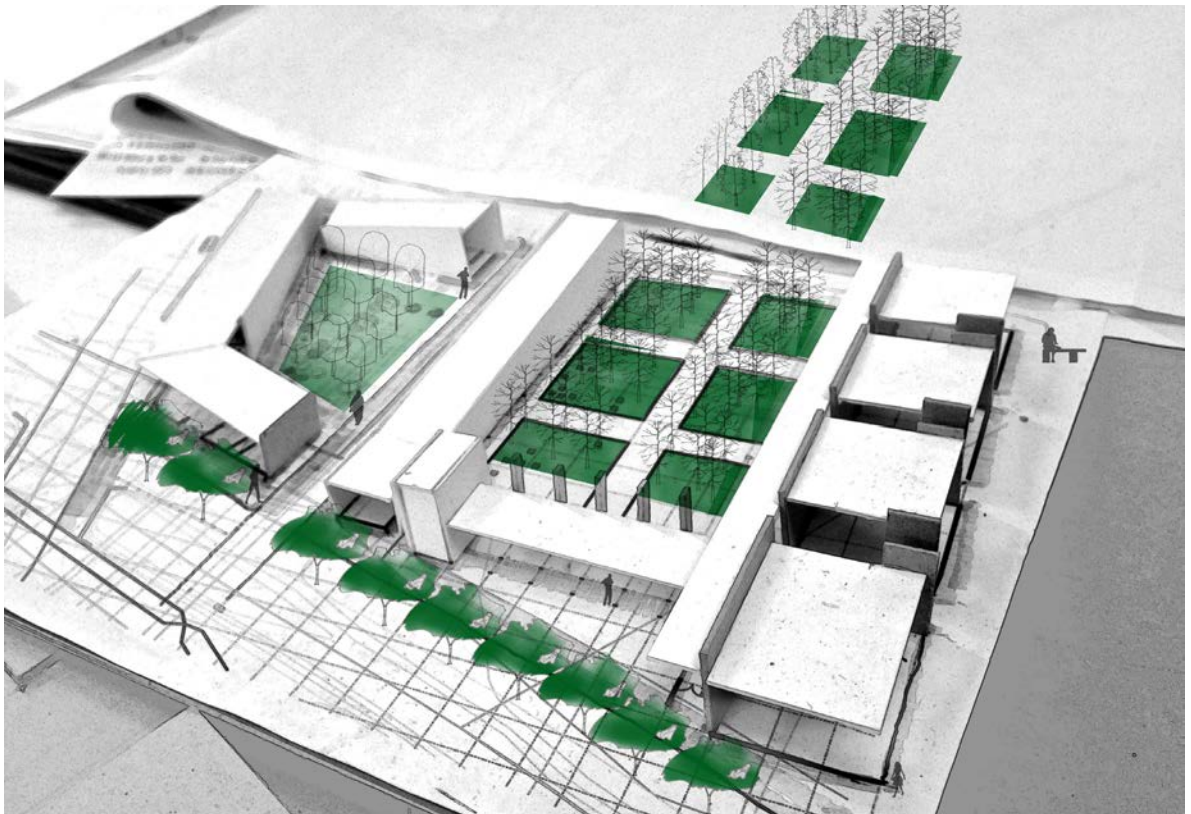

Fig 7.120 Edited Photo of model illustrating continuous landscapes (Author, 2014)

Model Investigation 02

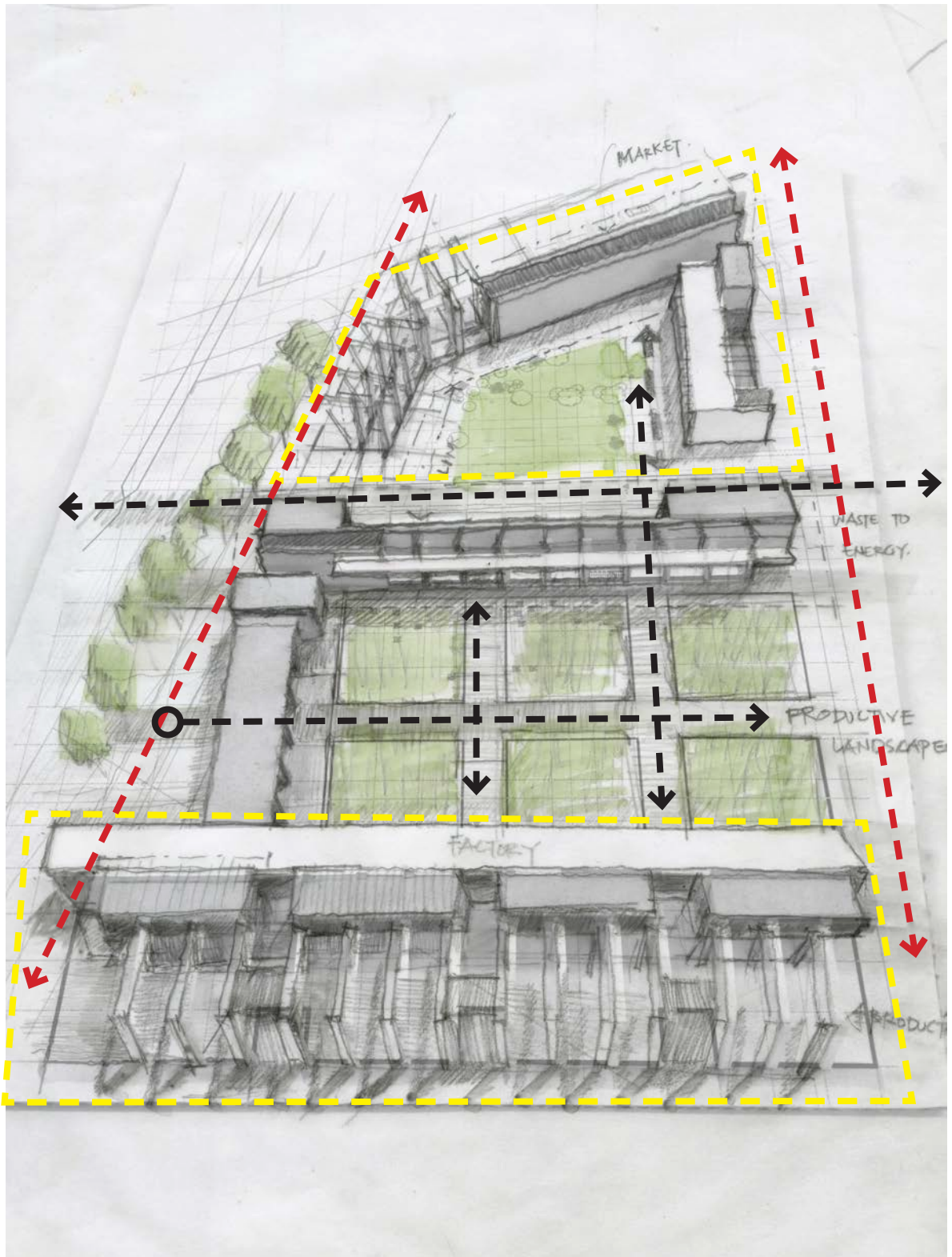

Fig 7.121 Edited Photo of model illustrating links (Author, 2014)

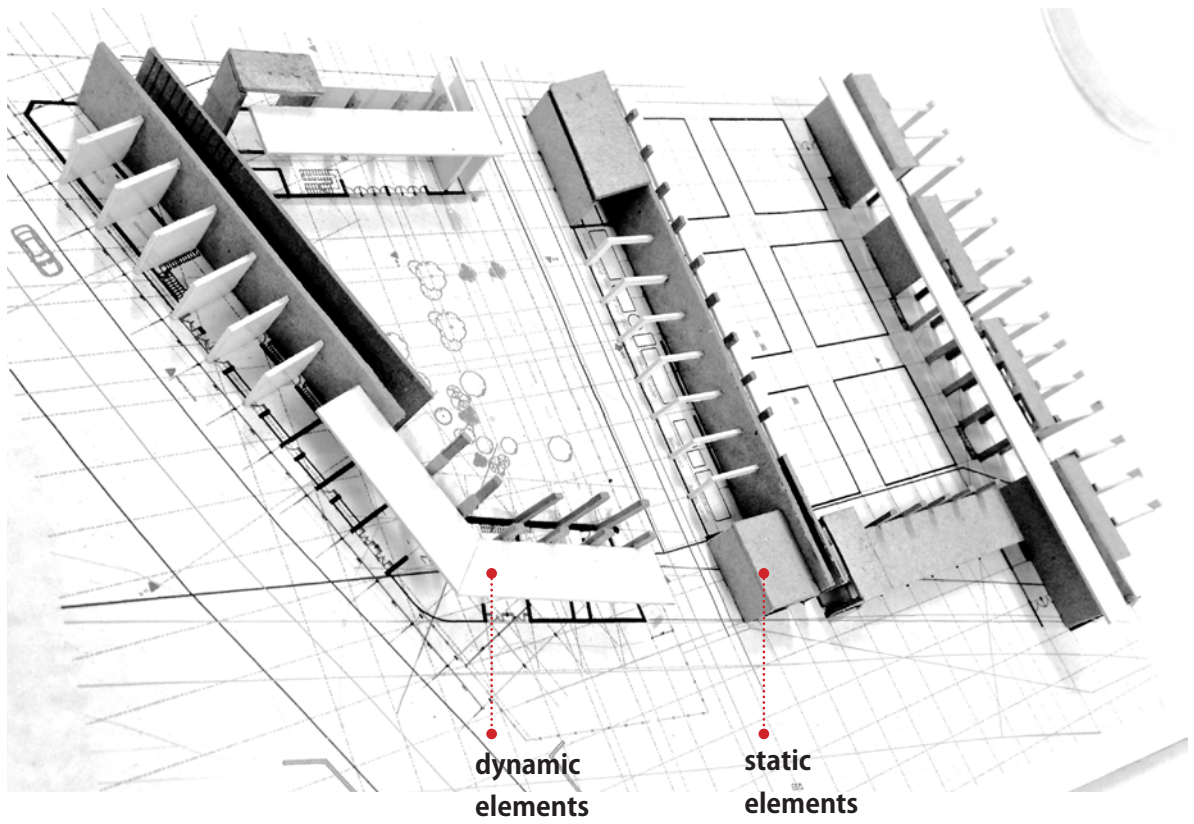

Fig 7.122 Edited Photo of model dynamic and static elements (Author, 2014)

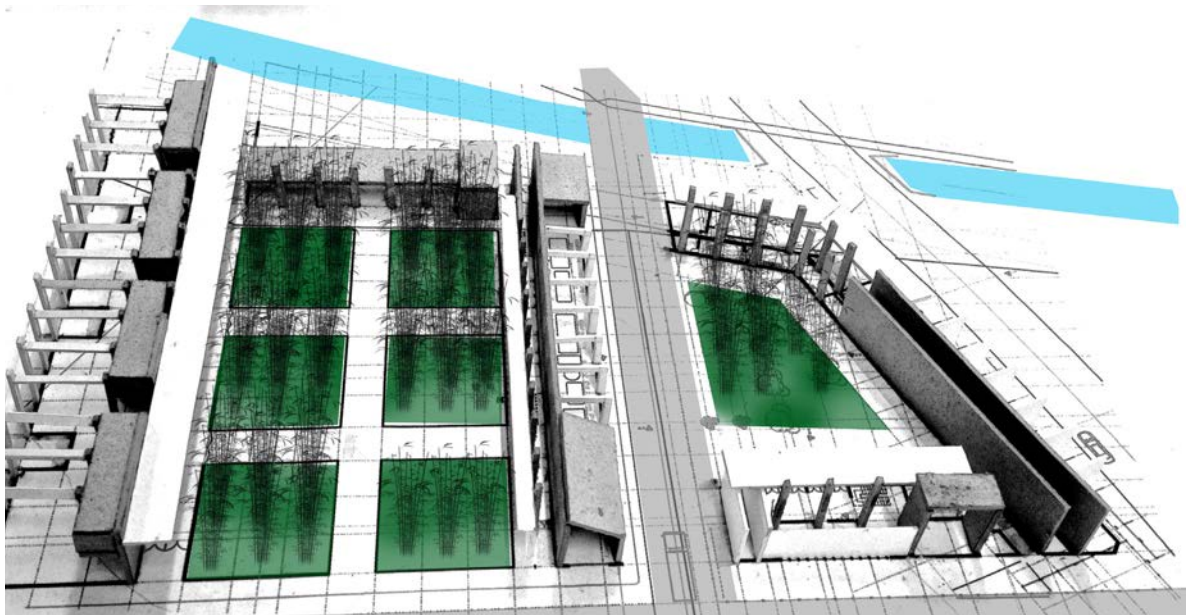

Fig 7.123 Edited Photo of model dynamic and static elements with landscape (Author, 2014)

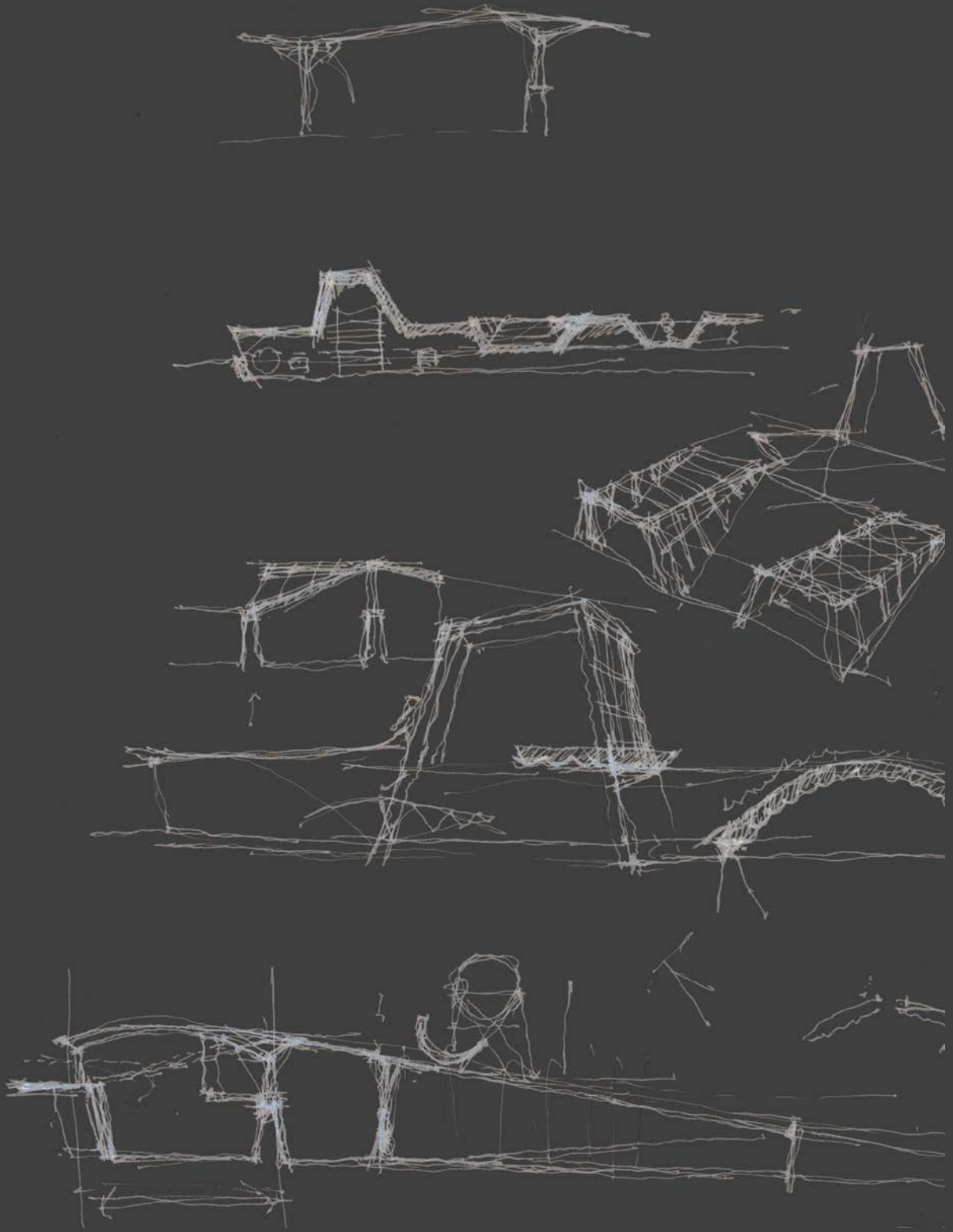

Fig 7.121 Compilation of concept sketches (Author, 2014)

Explorations 02

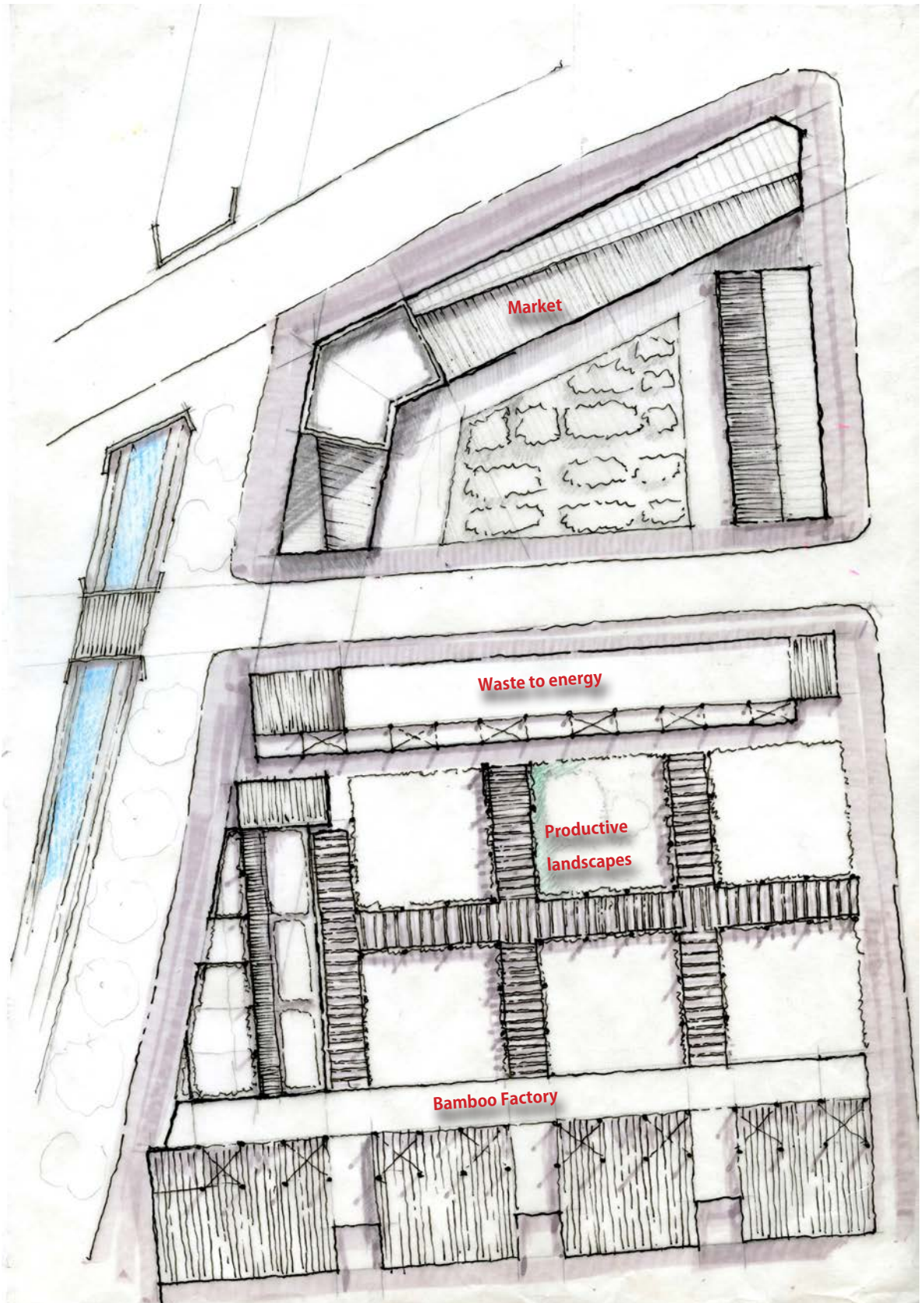

Fig 7.122 Sketch Plan (Author, 2014)

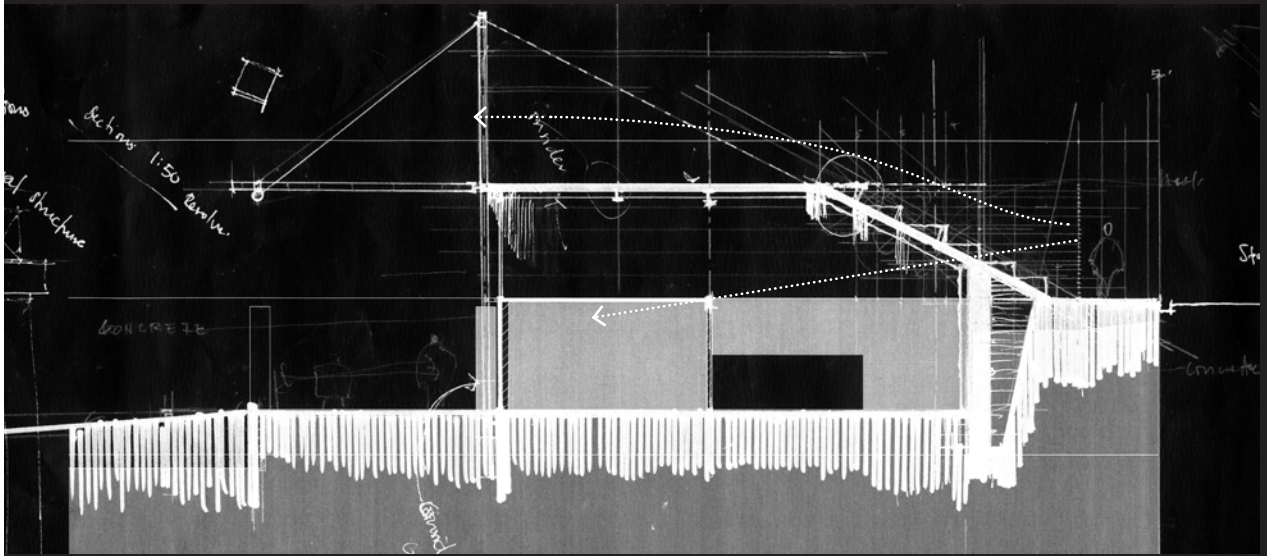

Fig 7.123 Conceptual Section expressing relationship between street, factory and landscape (Author, 2014)

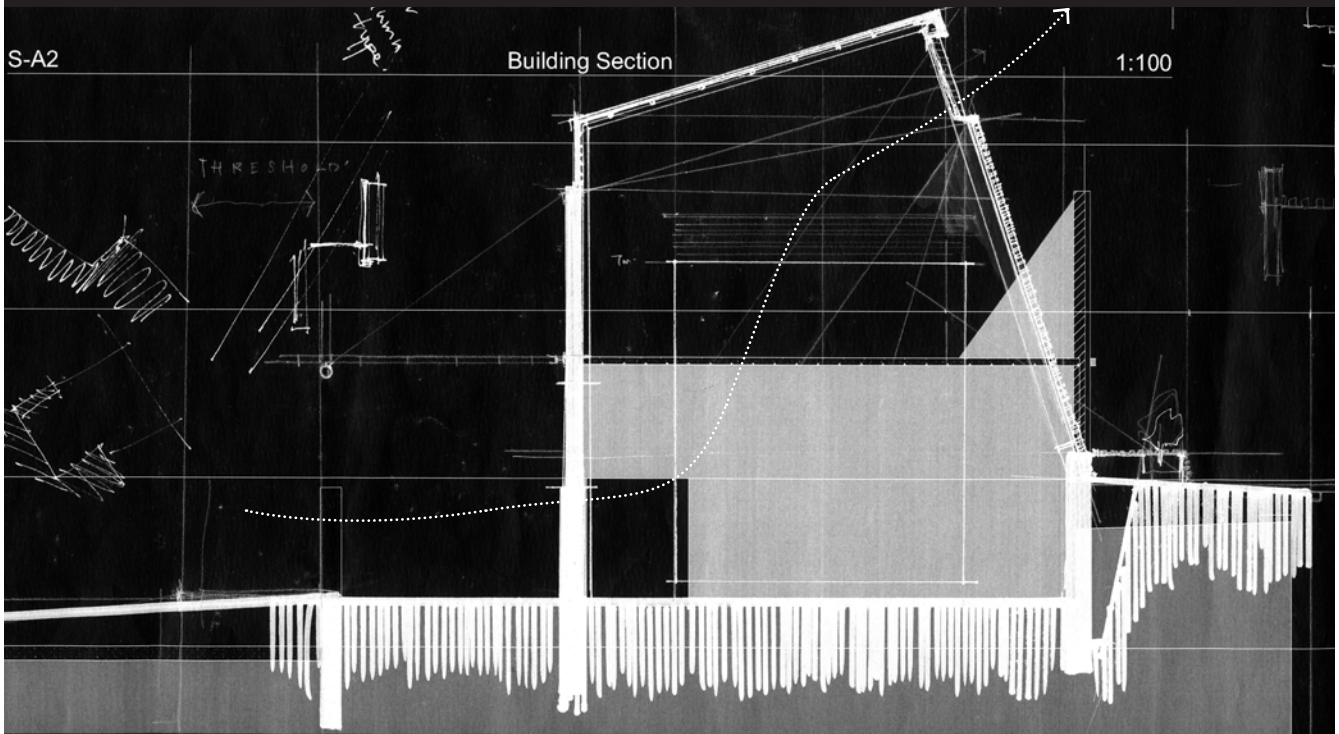

Fig 7.124 Conceptual Section explaining air flow (Author, 2014)



Fig 7.125 Ground floor Plan (Author, 2014)

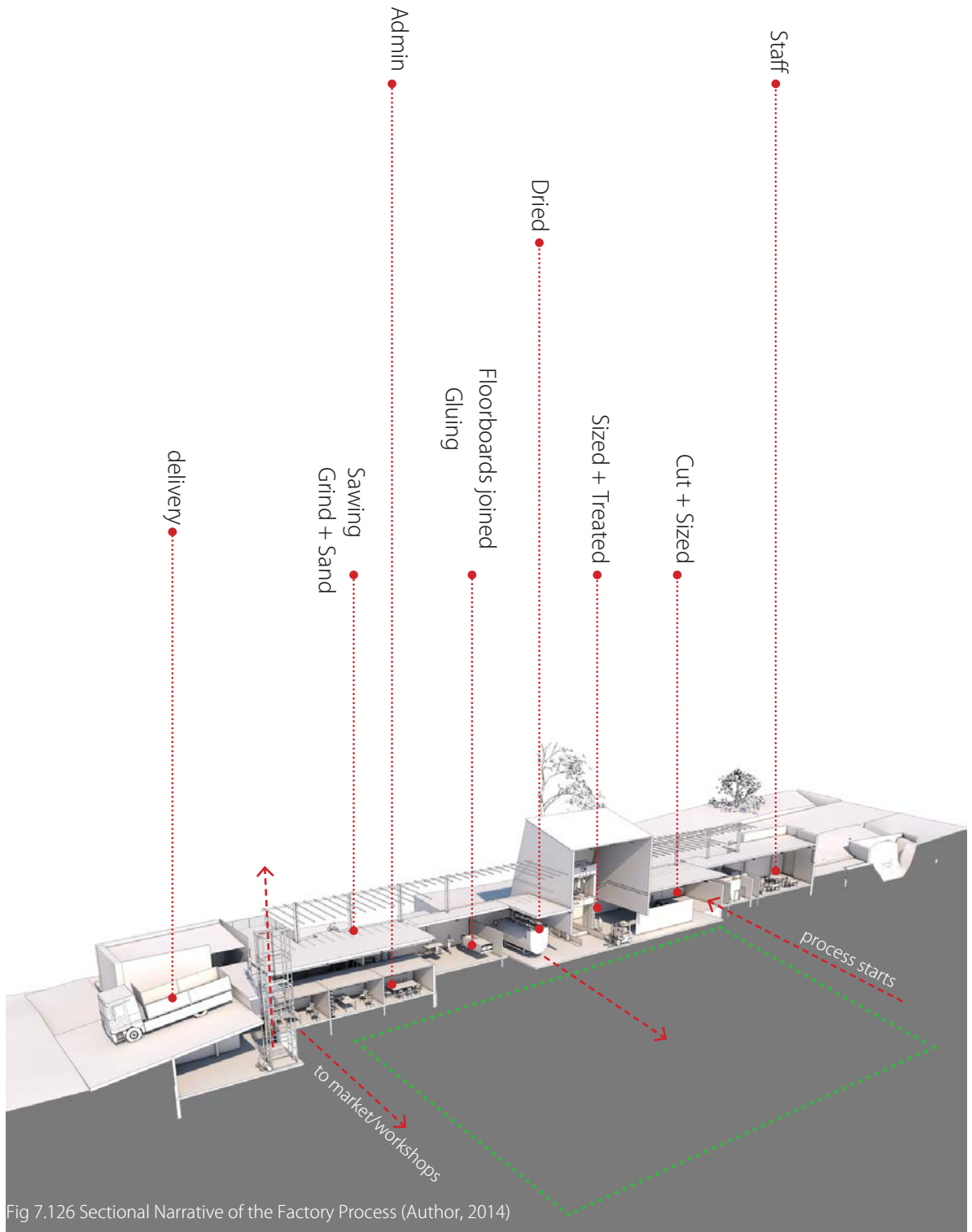

Fig 7.126 Sectional Narrative of the Factory Process (Author, 2014)



Fig 7.127 First floor Plan (Author, 2014)

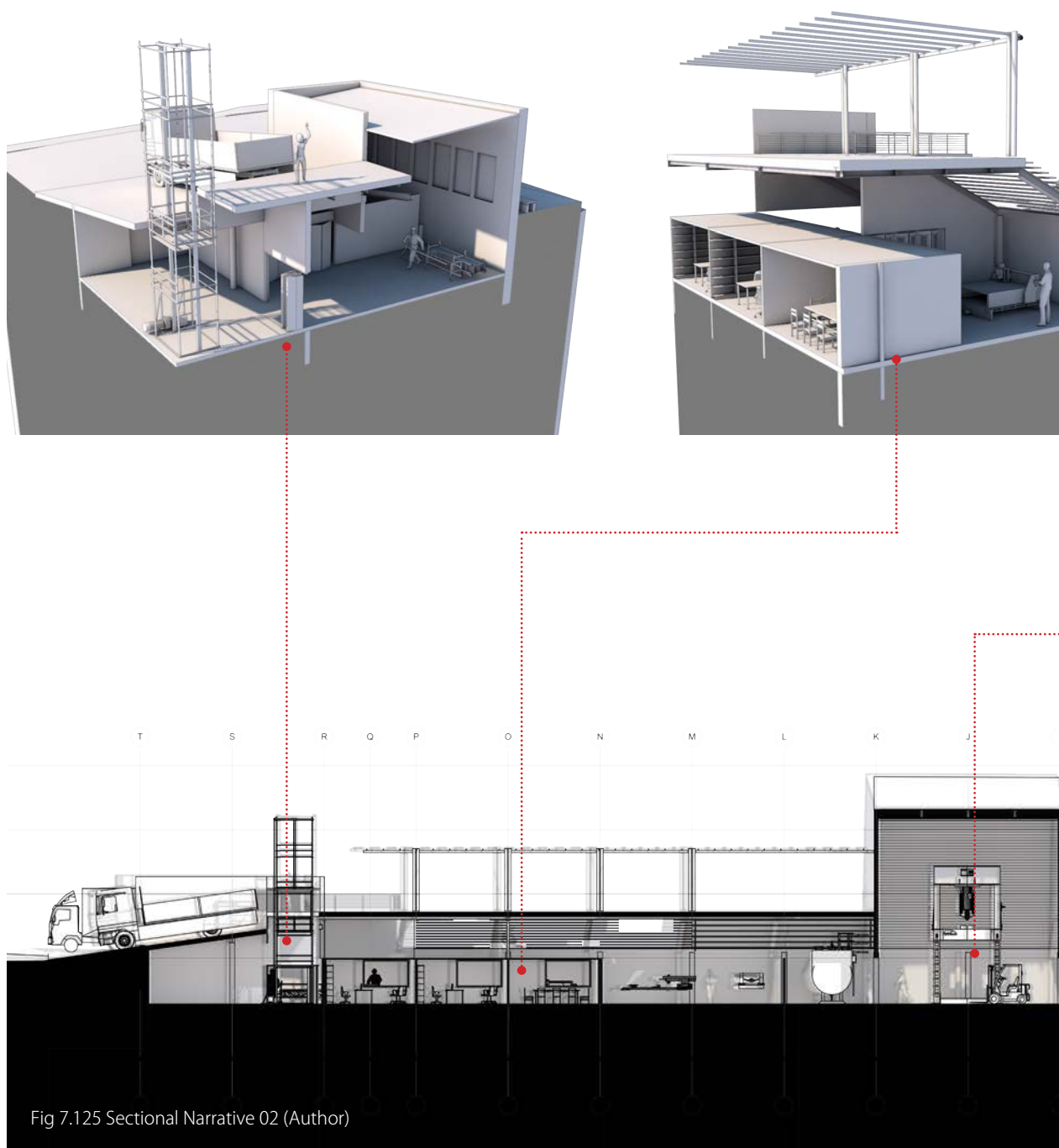
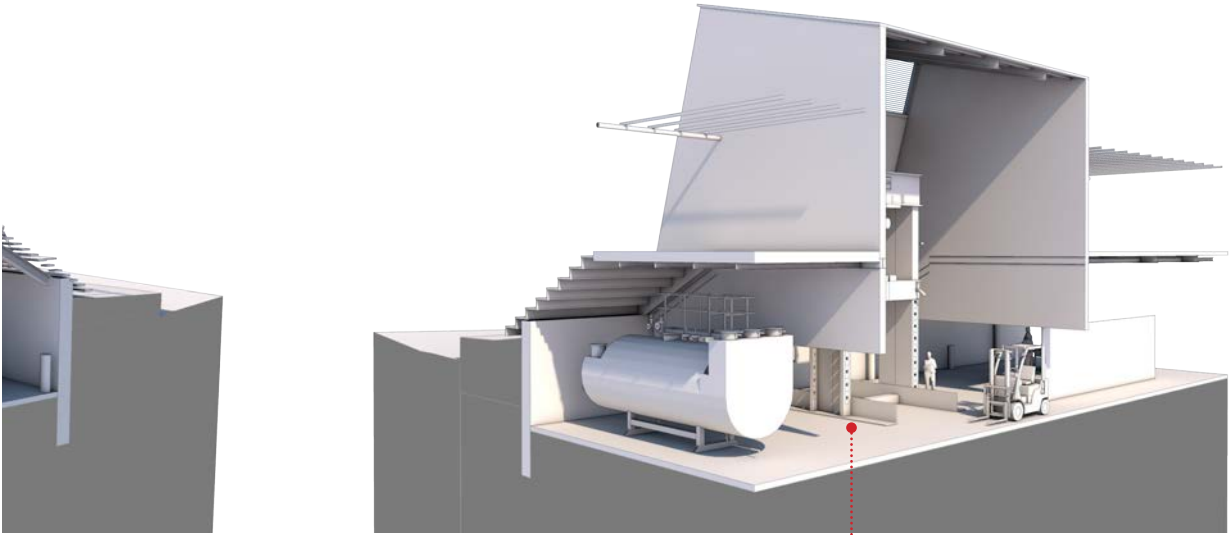

Fig 7.125 Sectional Narrative 02 (Author)



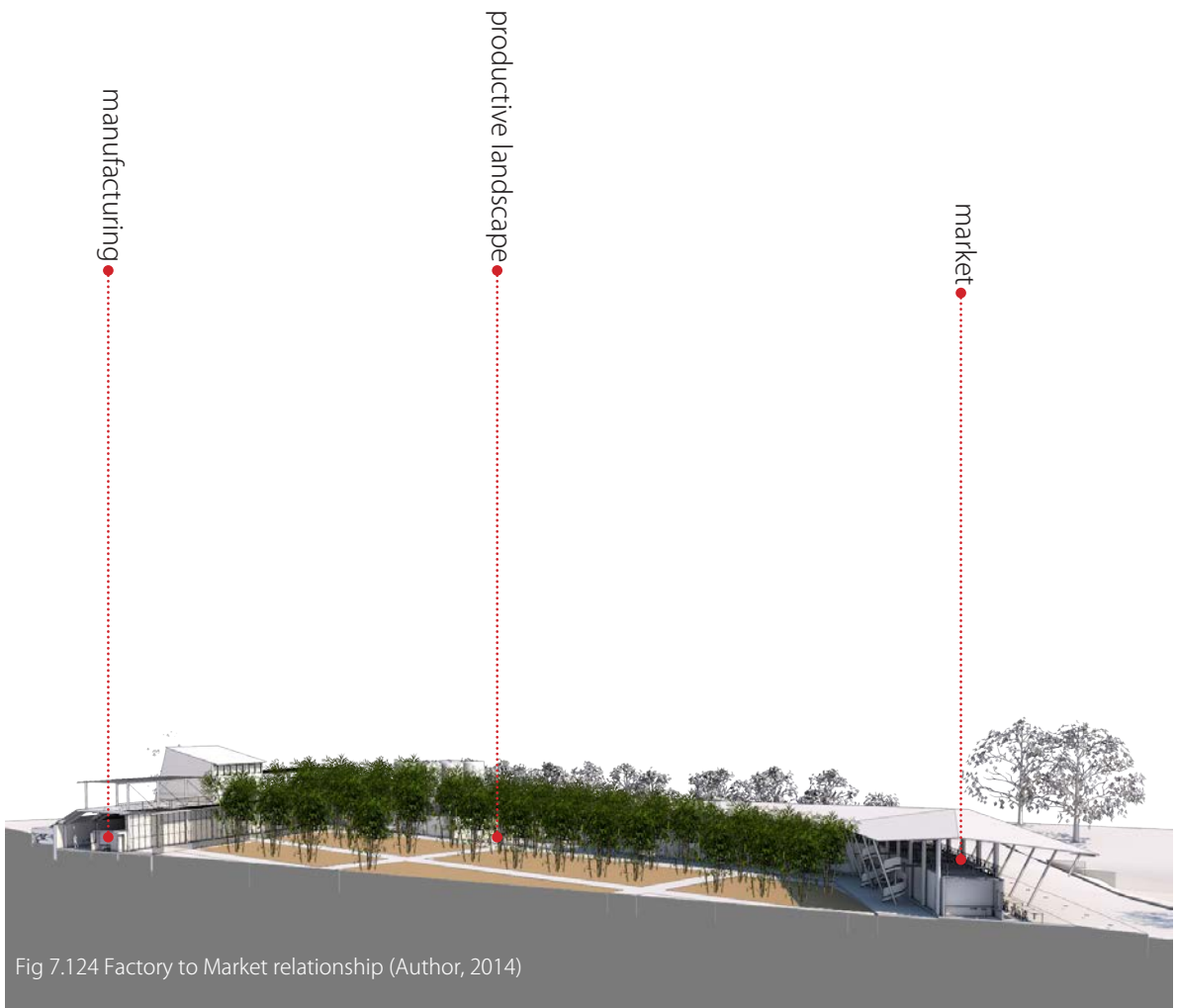
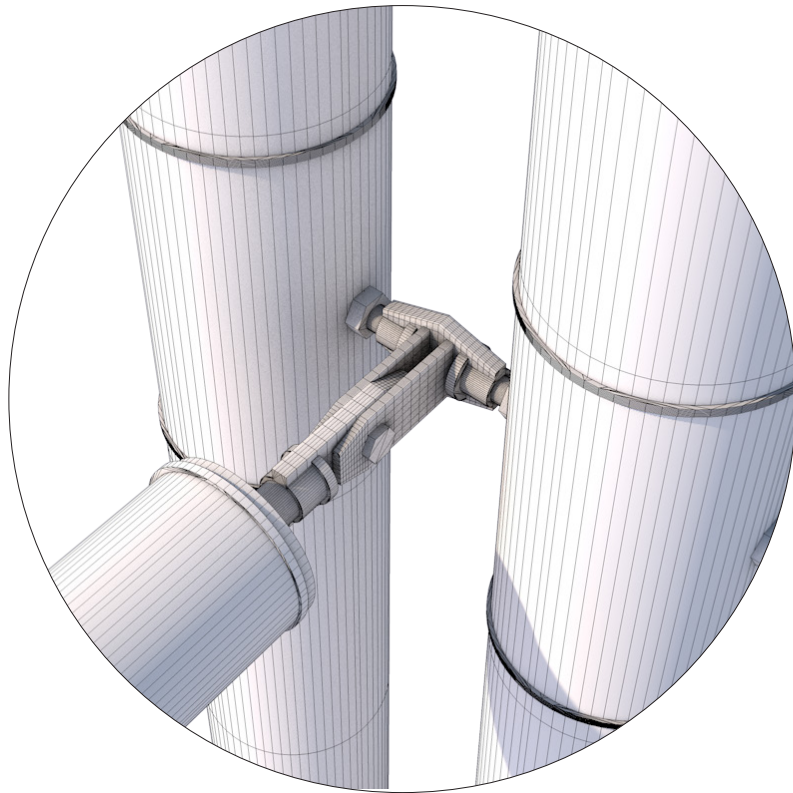

Fig 7.124 Factory to Market relationship (Author, 2014)



BAMBOO CONNECTIONS



STEEL CONNECTIONS: drilled into bamboo

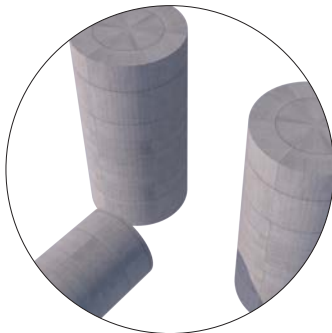

CONCRETE: poured into bamboo culm



CONNECTION

Fig 7.125 Detail Exploration (Author, 2014)

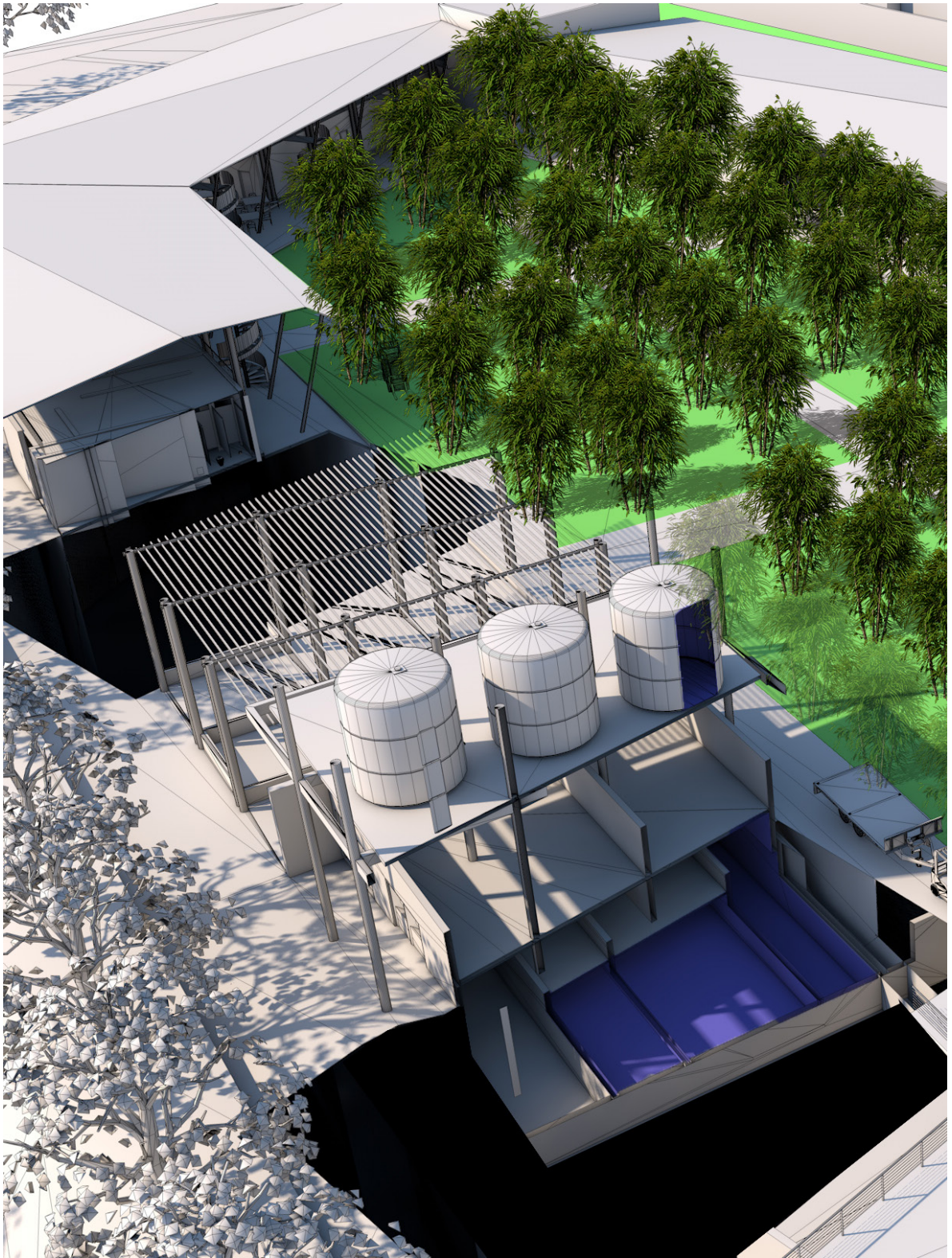
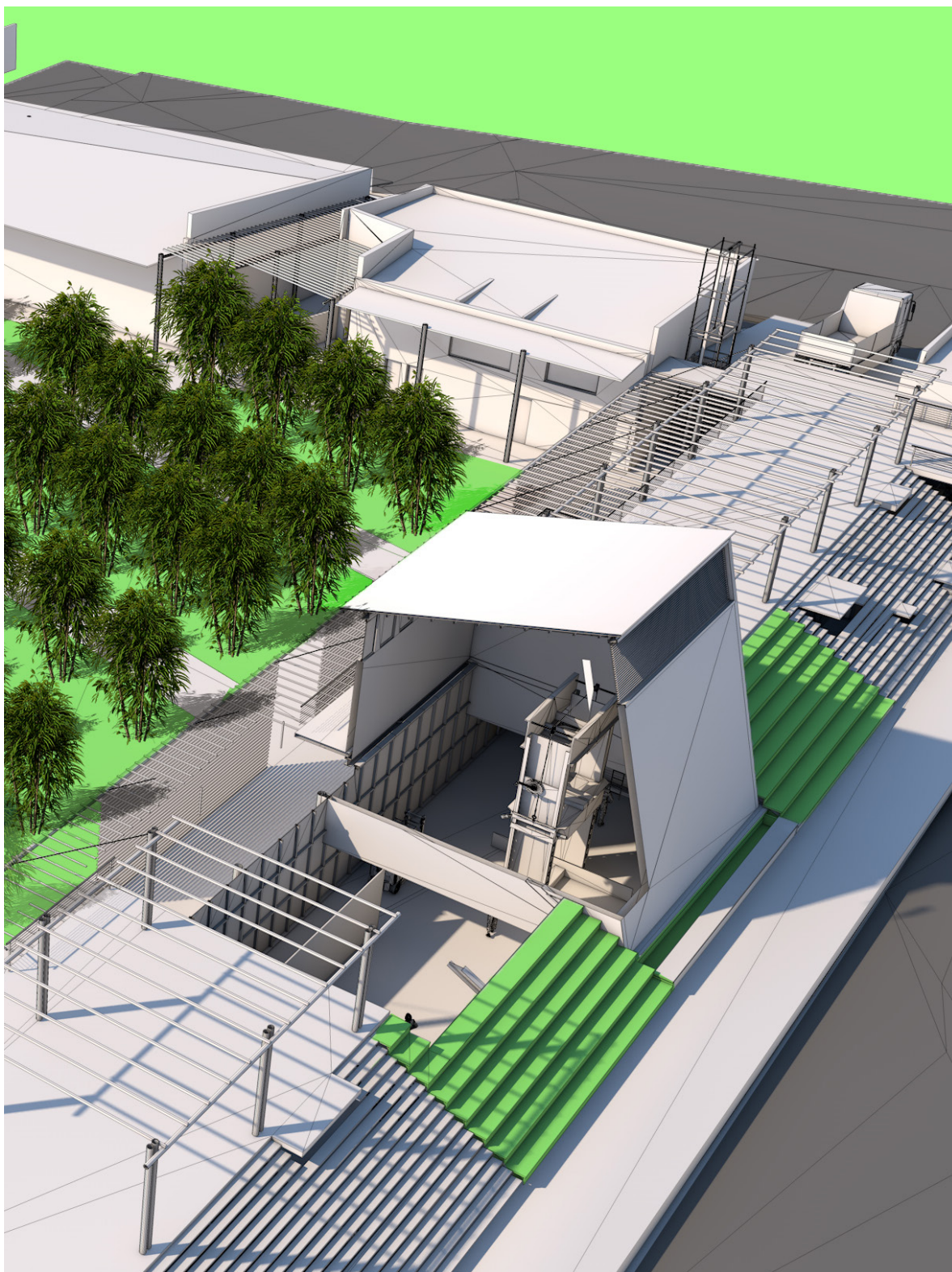

Fig 7.126 Context Render showing relationship between buildings and landscape (Author, 2014)



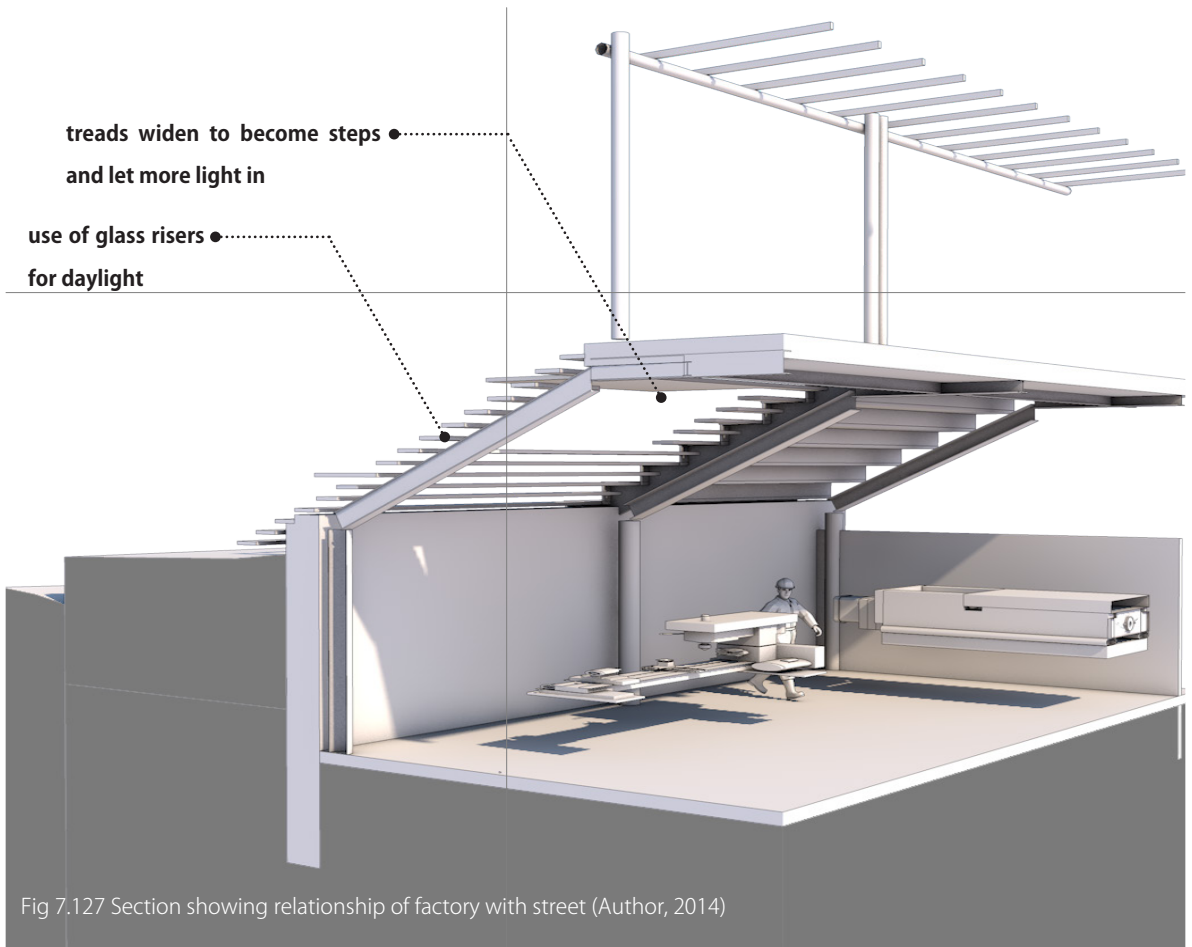
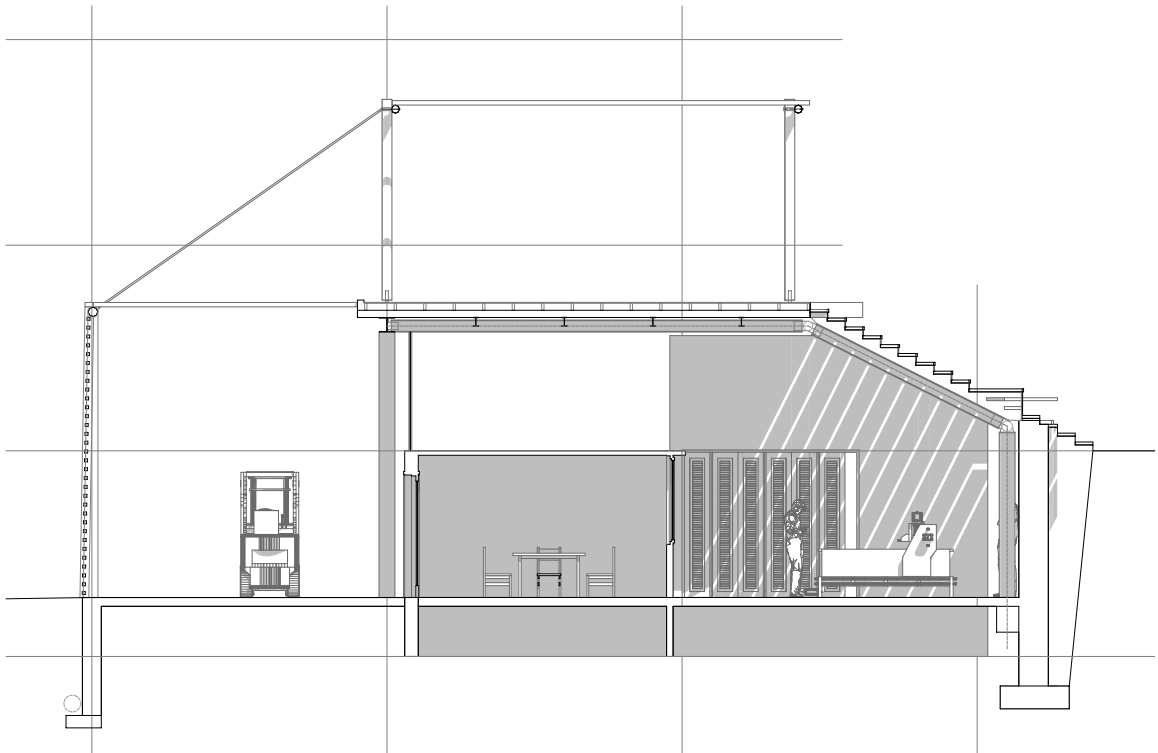

Fig 7.127 Section showing relationship of factory with street (Author, 2014)

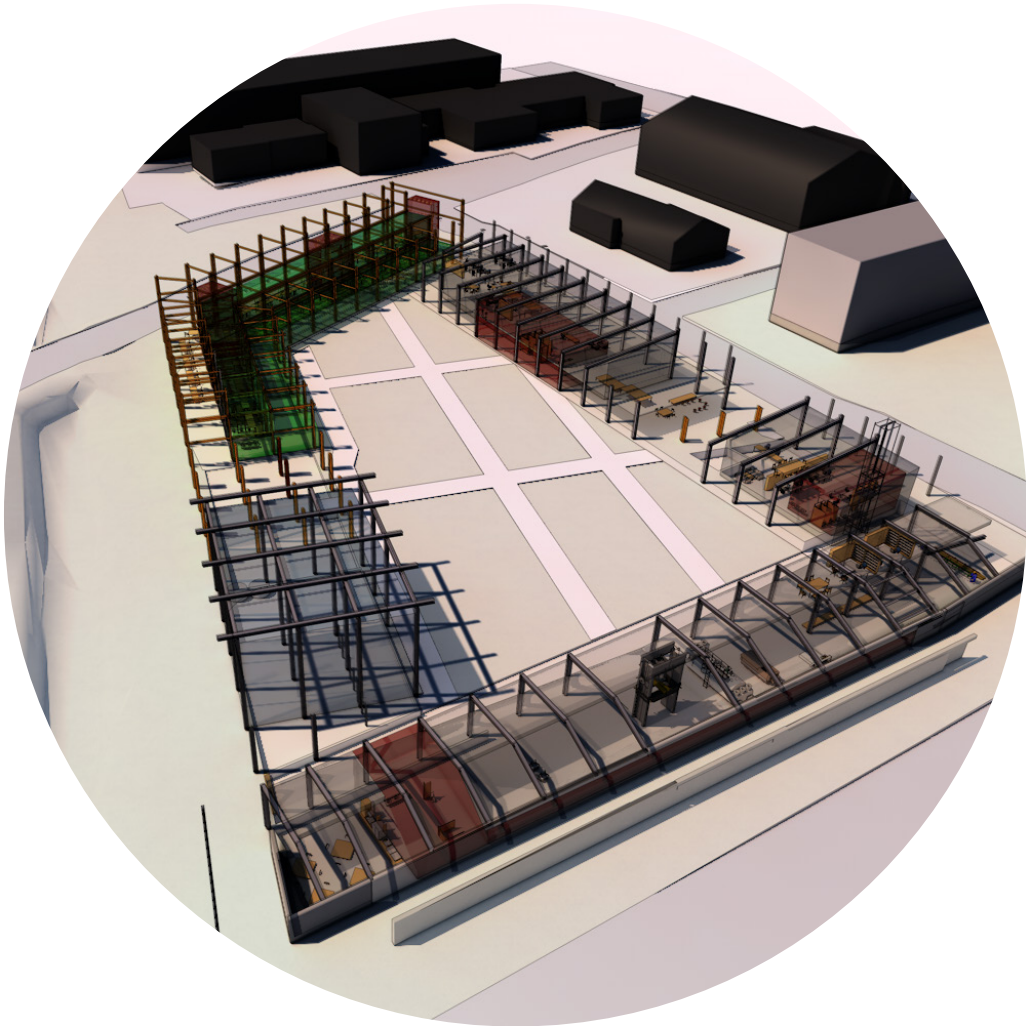

Fig 7.128 Image overlay of all the layers of the building (Author, 2014)

Design development

Dynamic shed - The tent

This is represented by the tents and other structures that the informal vendors put up to protect themselves from the elements for the duration of the day and take down in the evening.

The tent is a cheap versatile response to the urban condition currently existing. These trading spaces are characteristic in the main streets in the area. Unlike the markets, the tents are more dynamic.

The tent structure is the basis of the market structure. The intention is to create a building that will change and adapt over time.

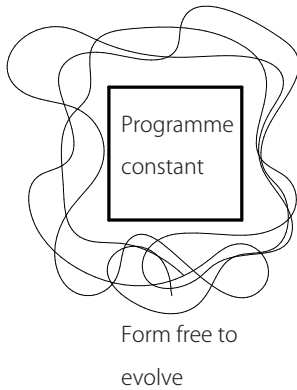

Fig 7.129 Form programme relationship (Author, 2014)

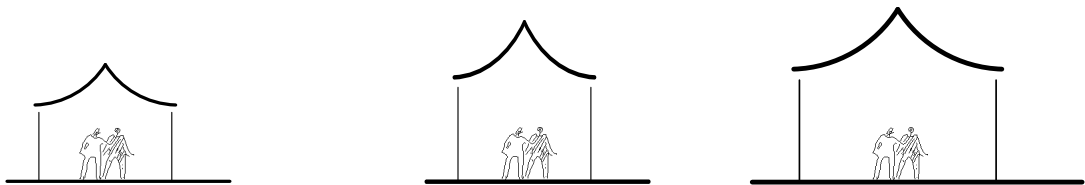

Fig 7.130 Changing form constant programme (Author, 2014)

The static shed - The industrial shed

The industrial shade, like the tent is versatile building typology designed for mechanised processes to inhabit. While there are several industrial typologies, the ones available in the context follow two main forms. The mono pitch and the dual pitch roof.

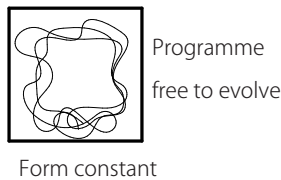

Fig 7.131 Form programme relationship 2 (Author, 2014)

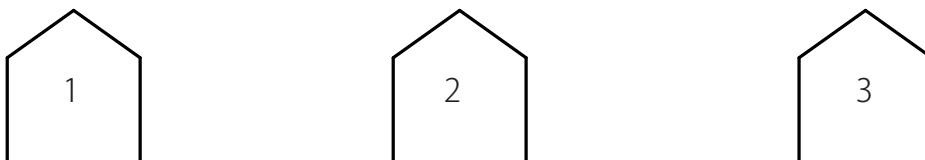

Fig 7.132 Constant form changing programme relationship 2 (Author, 2014)

7.2 The site

The site is influenced by three main aspects. The produce network, the liquid network and the social network.

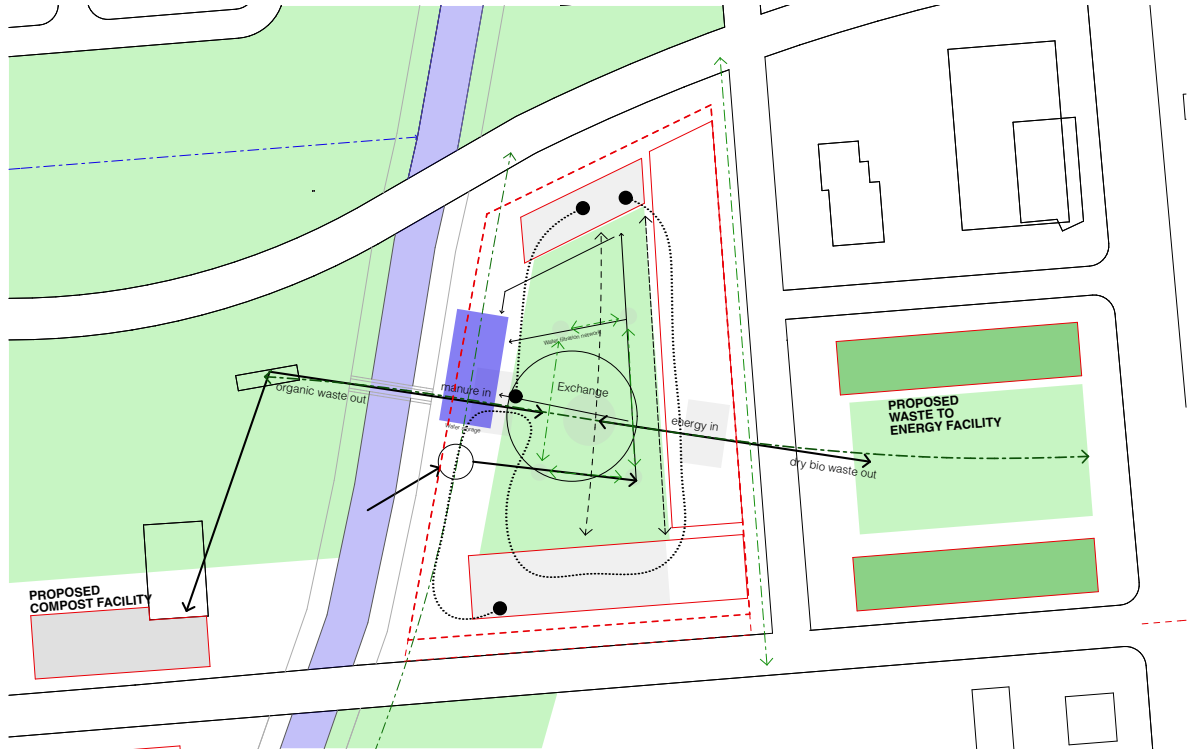

Fig 7.20 Site influences (Author, 2014)

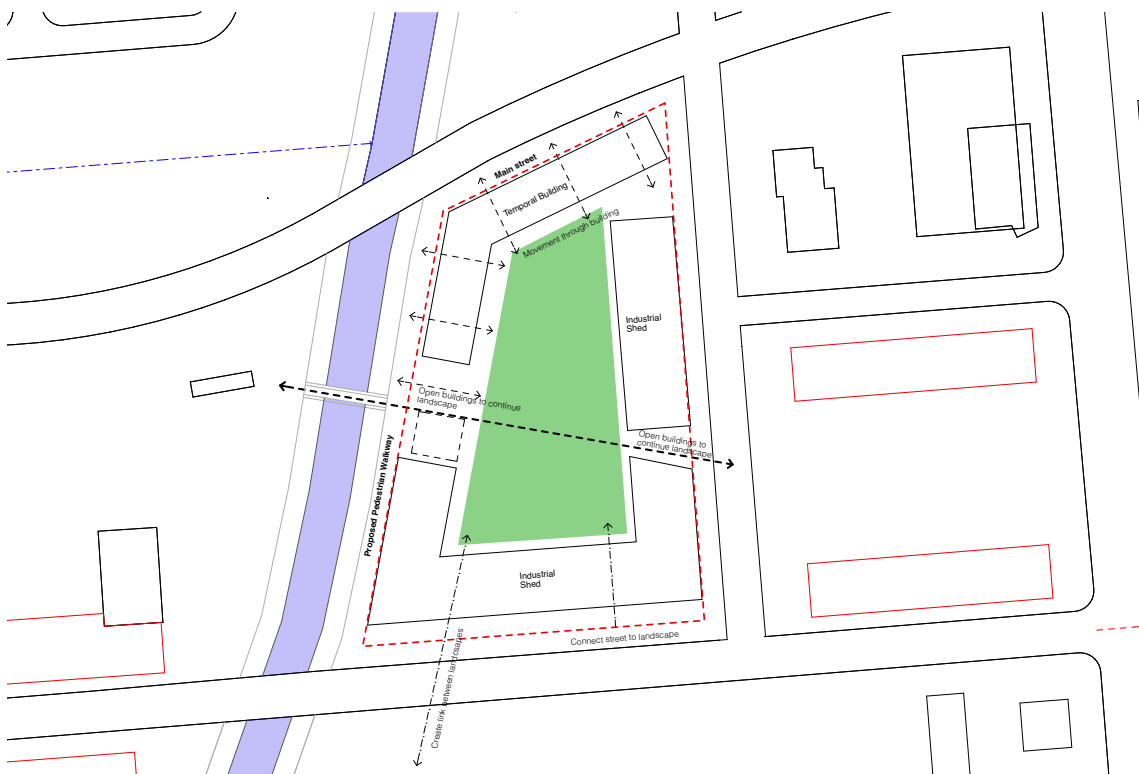

Fig 7.21 Site response (Author, 2014)

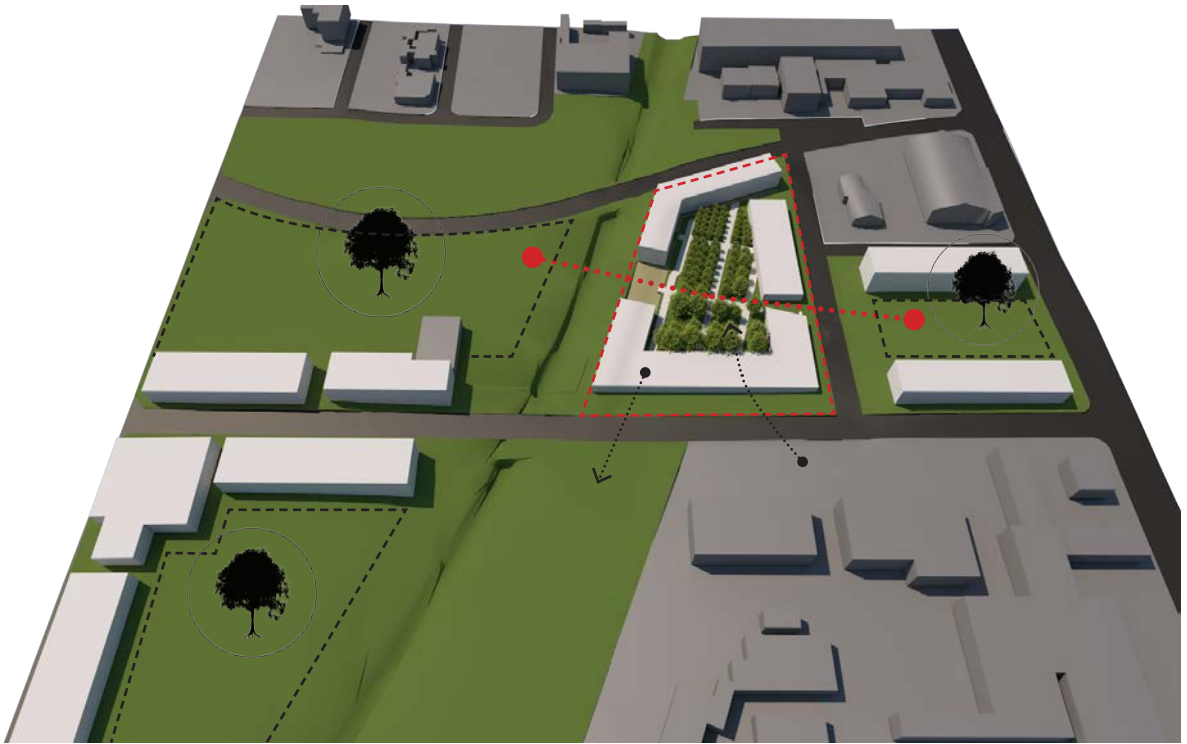

Fig 7.22 Site in context (Author, 2014)



Fig 7.24 Section diagrams illustrating site influences from site (Author, 2014)

7.3 Structure

Main intentions.

- Celebrating the passage of time in the precinct
- Connecting the building back to the productive landscape
- Create a cohesive form of all three structures

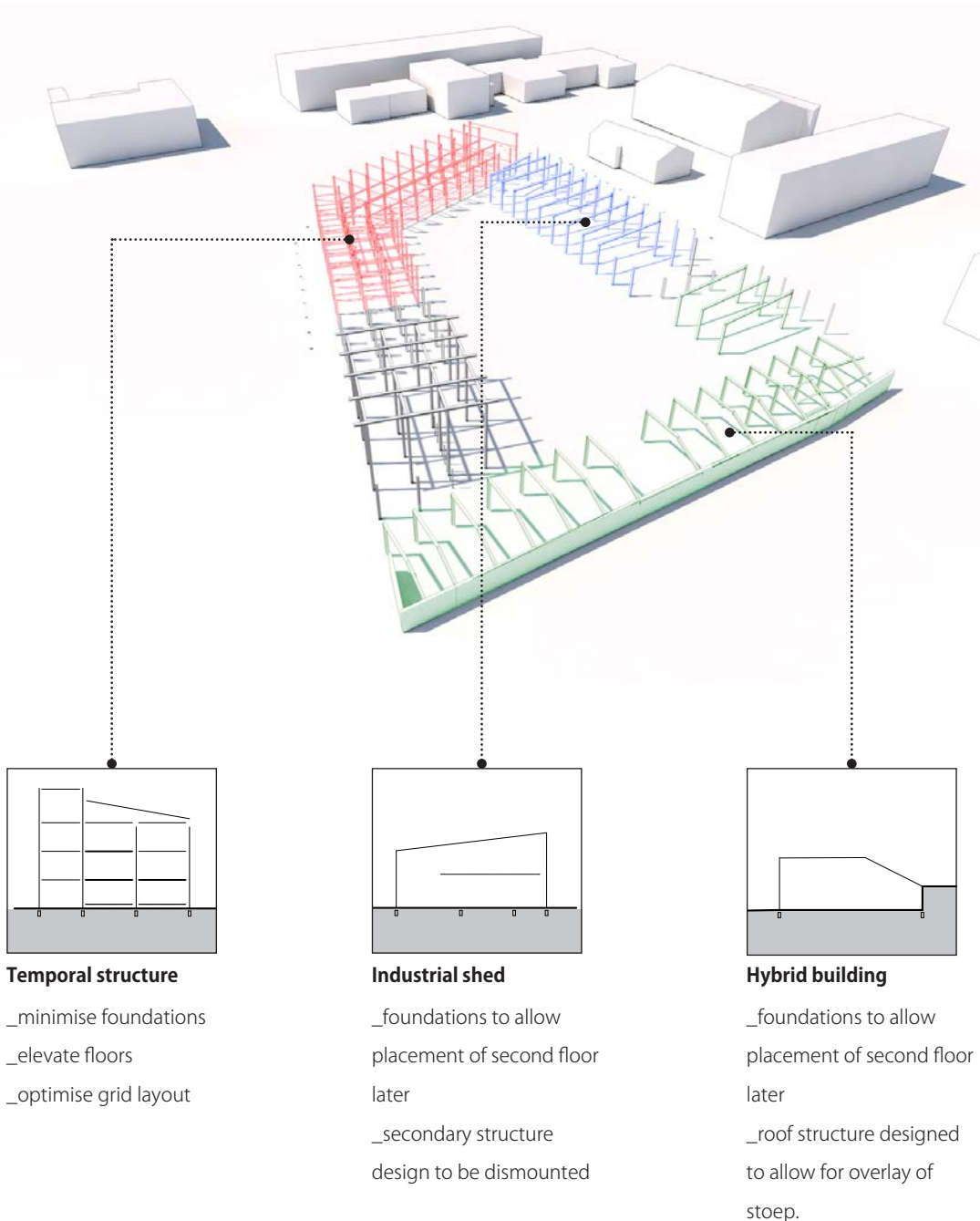
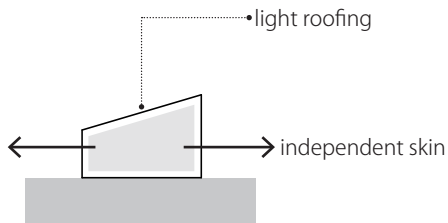
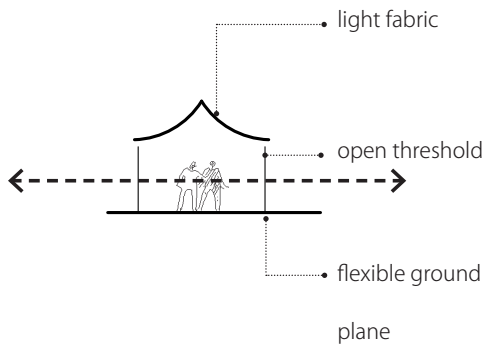

Fig 7.30 Diagram illustrating structure response and influences (Author, 2014).

7.4 Skin

The skin is a medium through which sound, light, people air and water are filtered into the building. The skin of the building combined with the structure creates a series of thresholds from the street to the productive landscape. Promoting interaction with the building spaces, and movement through the site. The project utilizes bamboo as cohesive language through the building.

Influences



Response

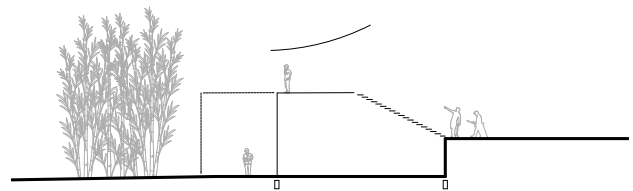
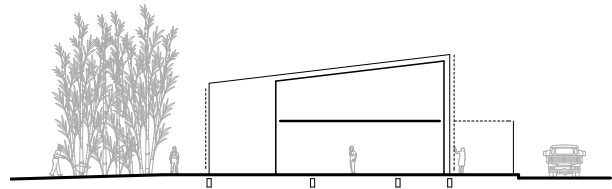
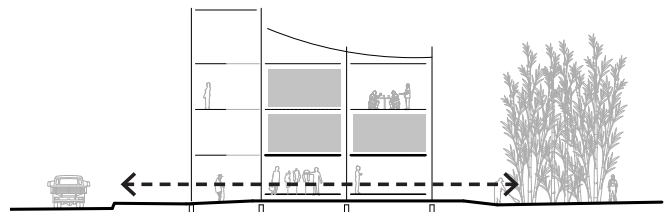

Fig 7.40 Diagram illustrating skin response and influences (Author, 2014).

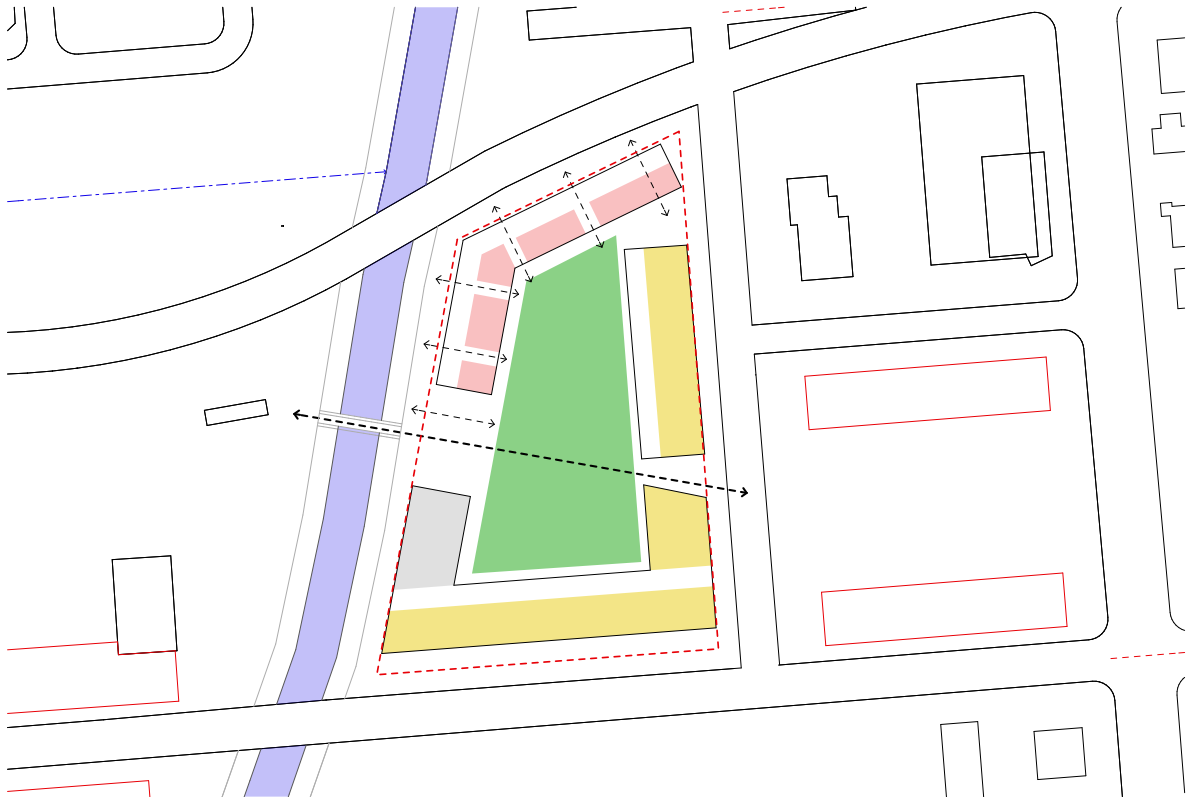

Fig 7.41 Plan Diagram illustrating skin response and influences (Author, 2014).

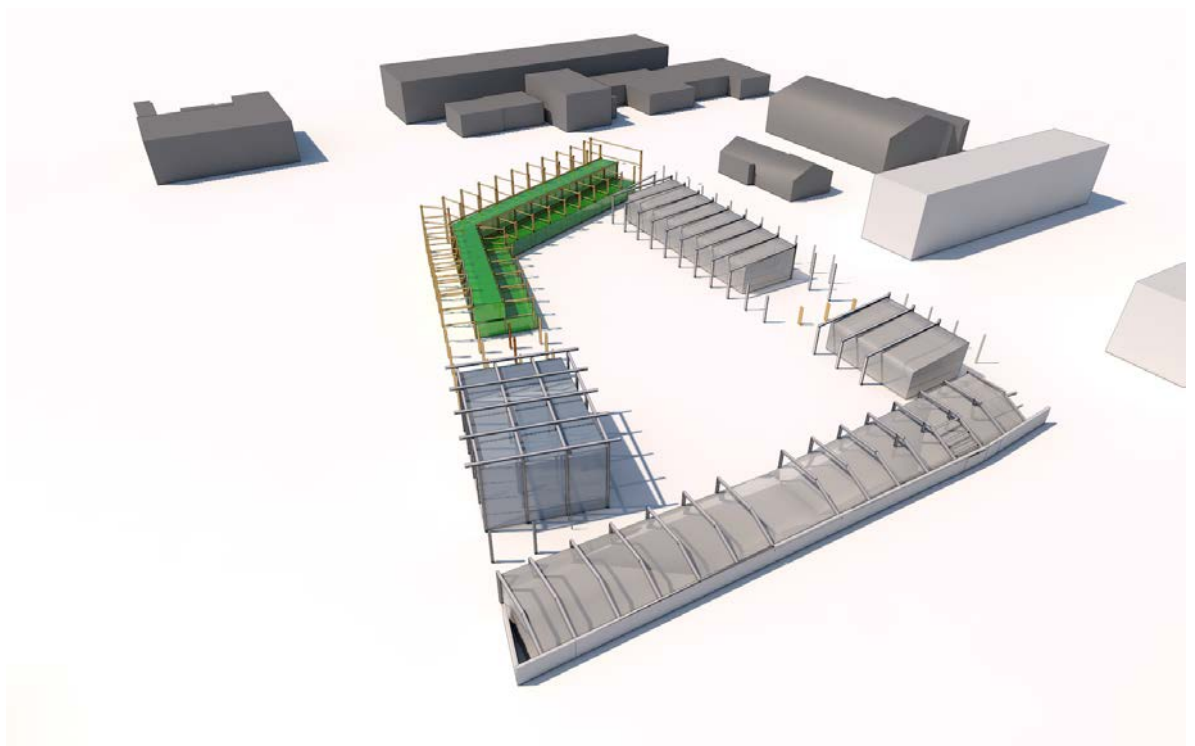

Fig 7.42 Diagram illustrating skin of the building in context(Author, 2014).

Horizontal

Vertical

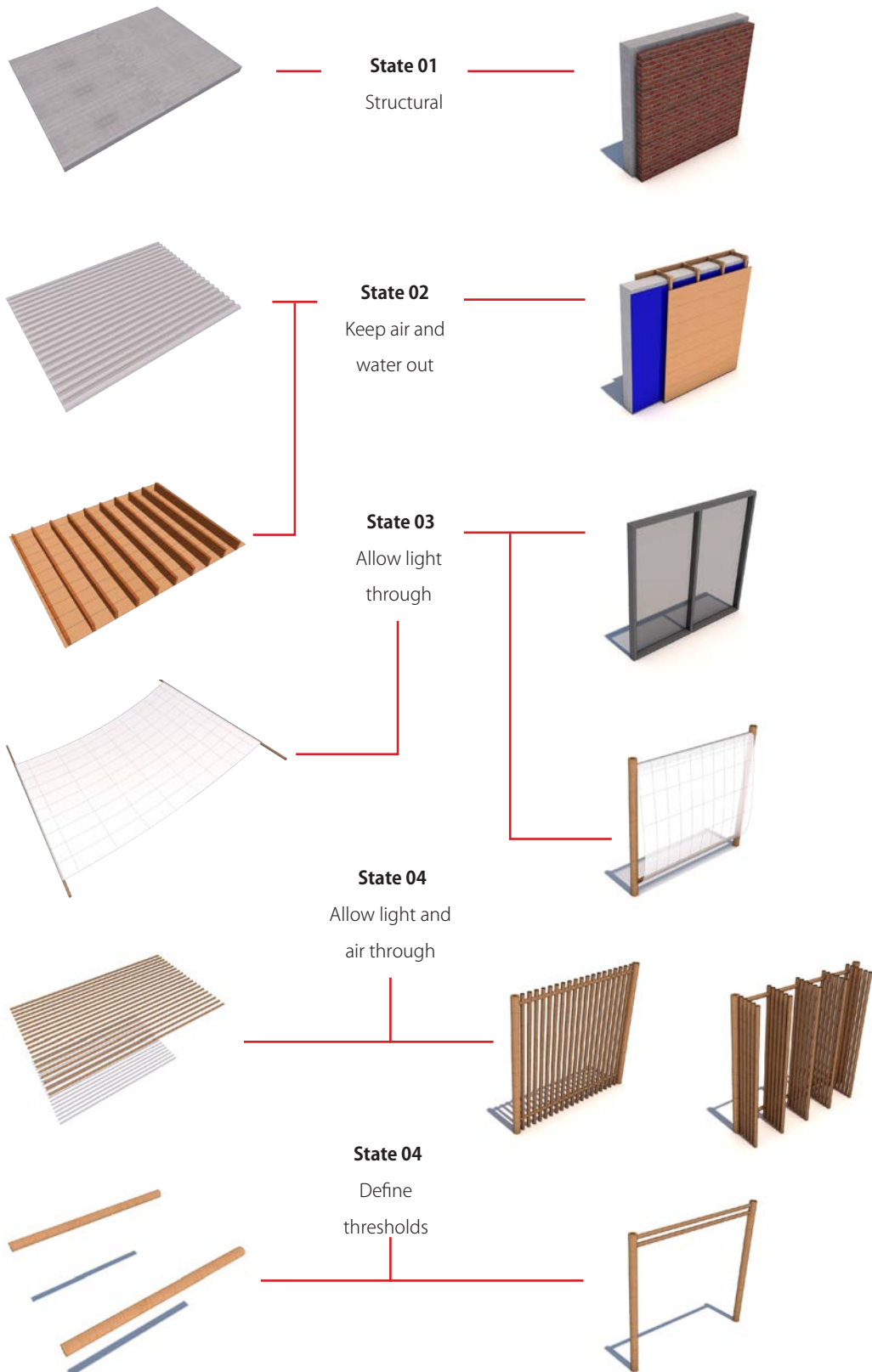

Fig 7.42 Diagram illustrating skin thresholds (Author, 2014).

7.5 Services

The services are run through the building unobtrusively to the building functions.

Influences

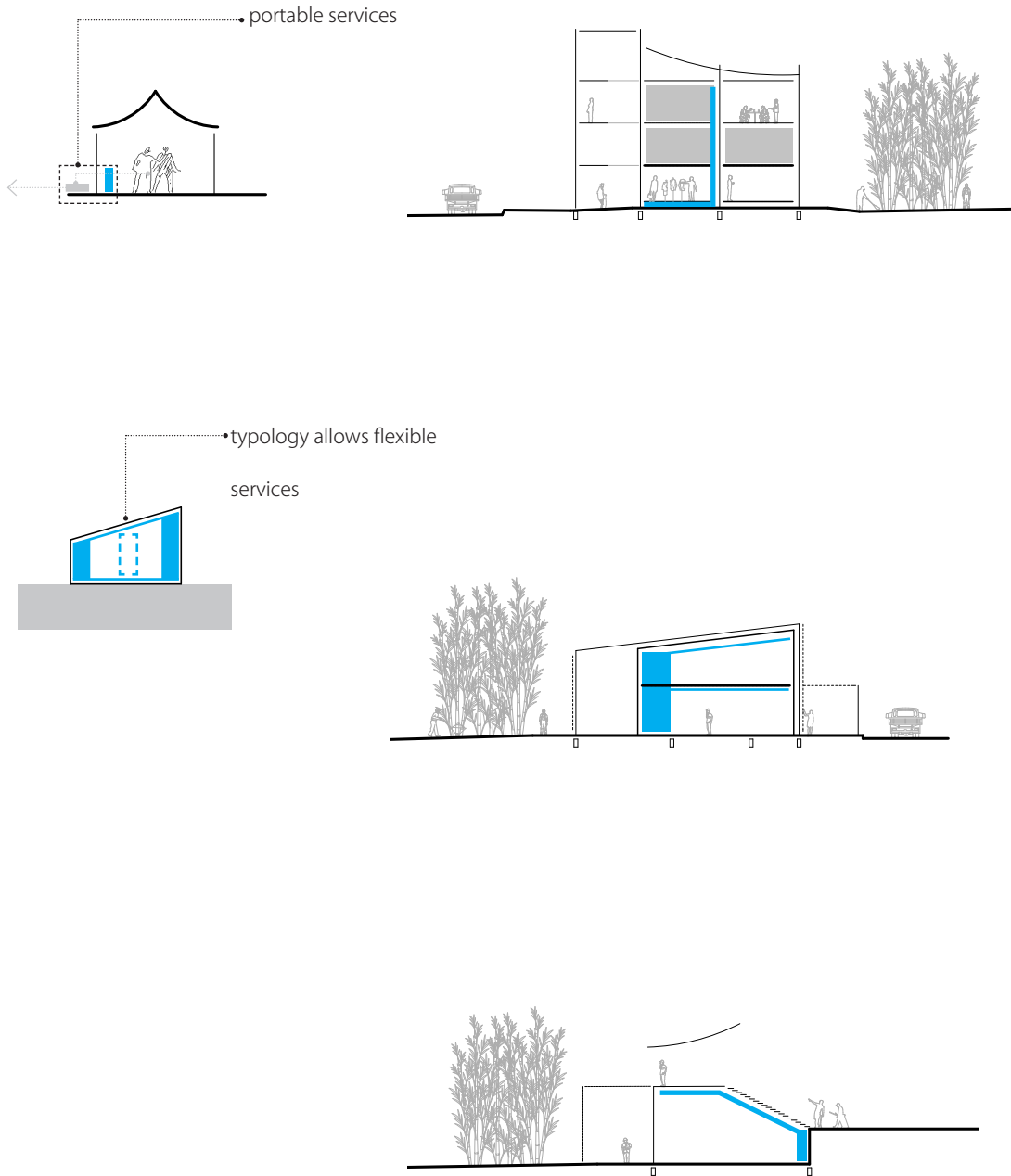

Fig 7.50 Diagram illustrating how the building will be services (Author, 2014).



Fig 7.51 Plan Diagram illustrating service points in the building (Author, 2014).

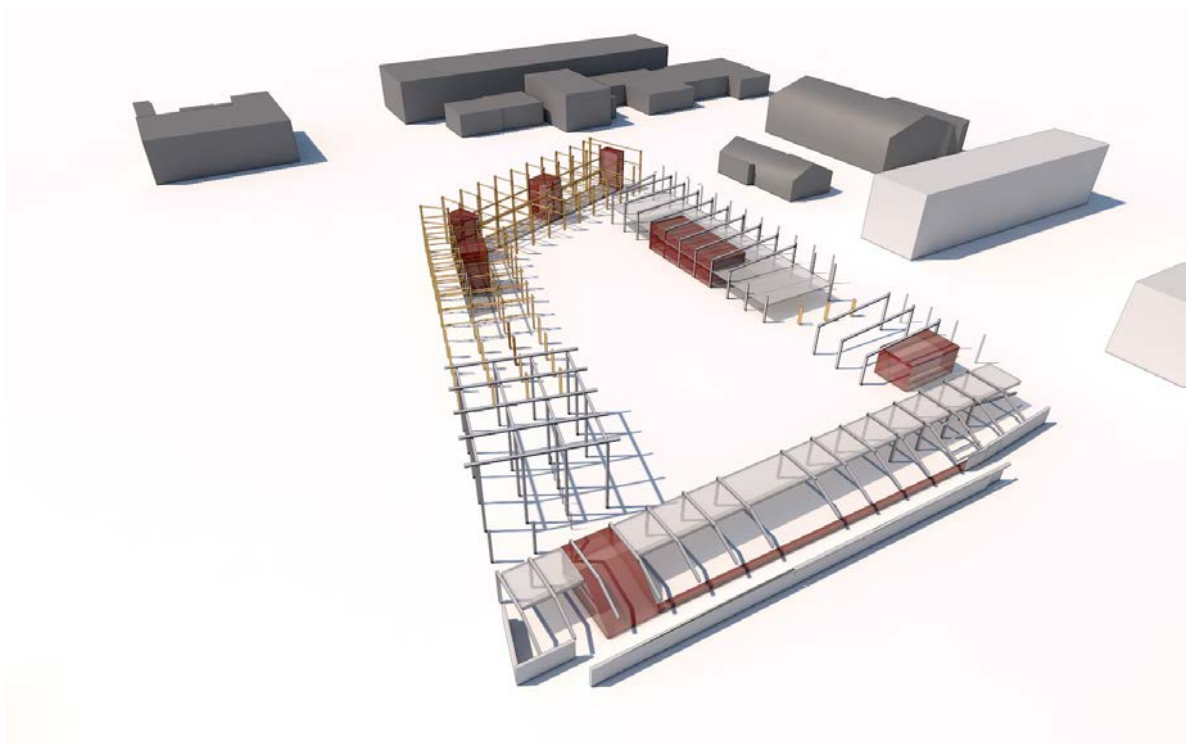

Fig 7.52 Diagram illustrating service points in the building (Author, 2014).

7.6 Stuff.

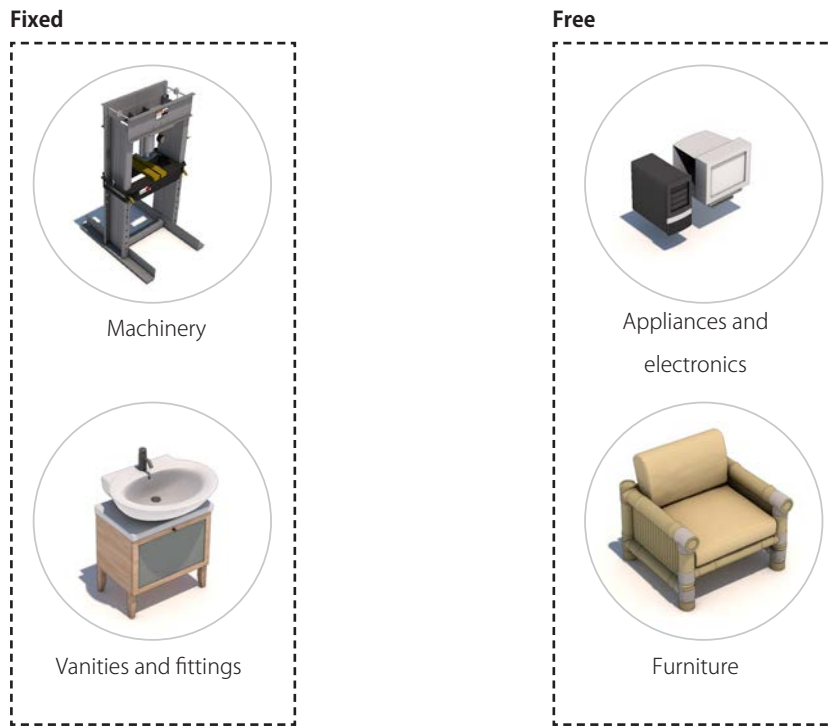

Fig 7.60 Types of stuff in the building (Author, 2014)

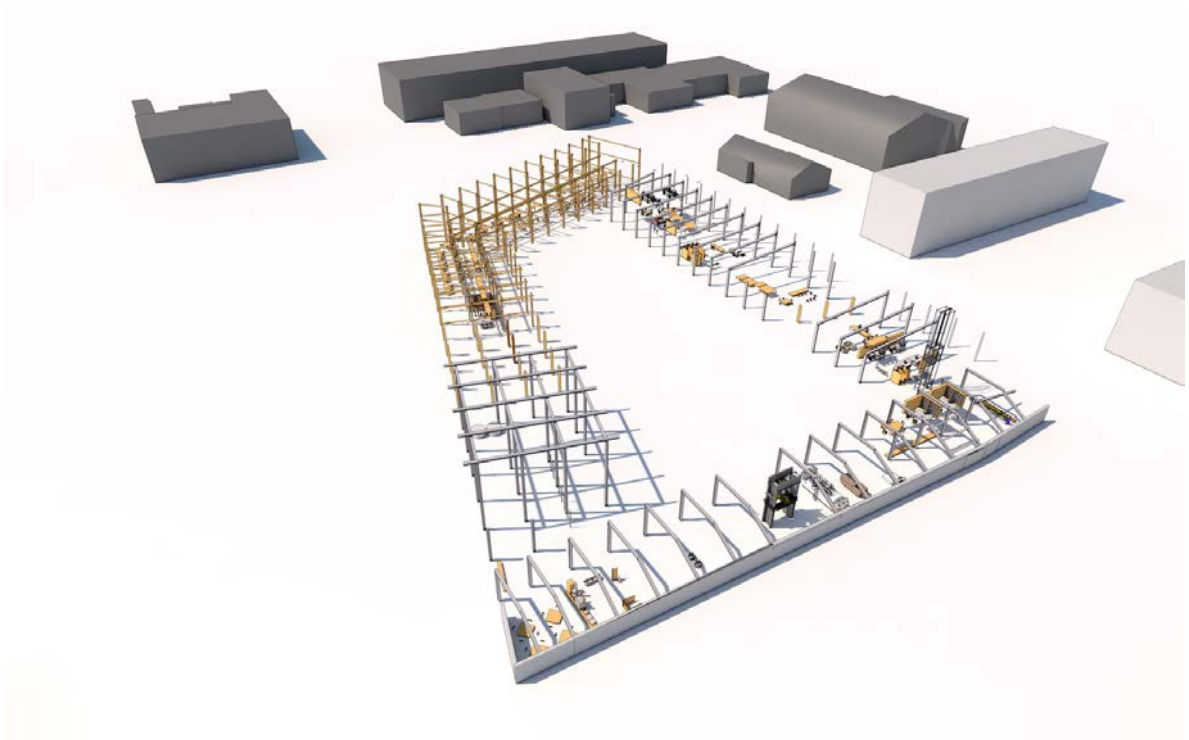
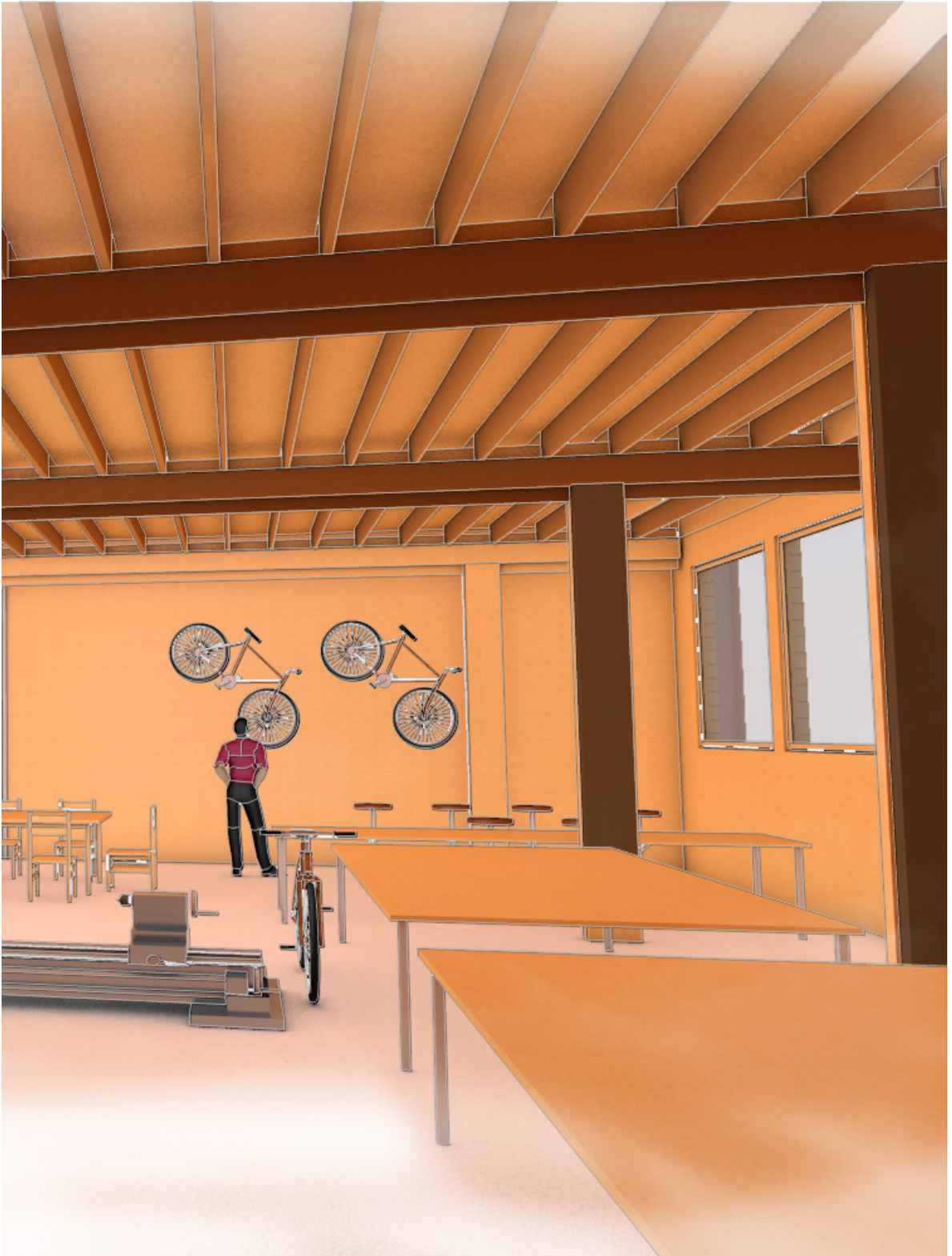

Fig 7.61 Stuff in the building (Author, 2014)

7.7 Space



Fig 7.60 Interior view of workshop spaces (Author, 2014)



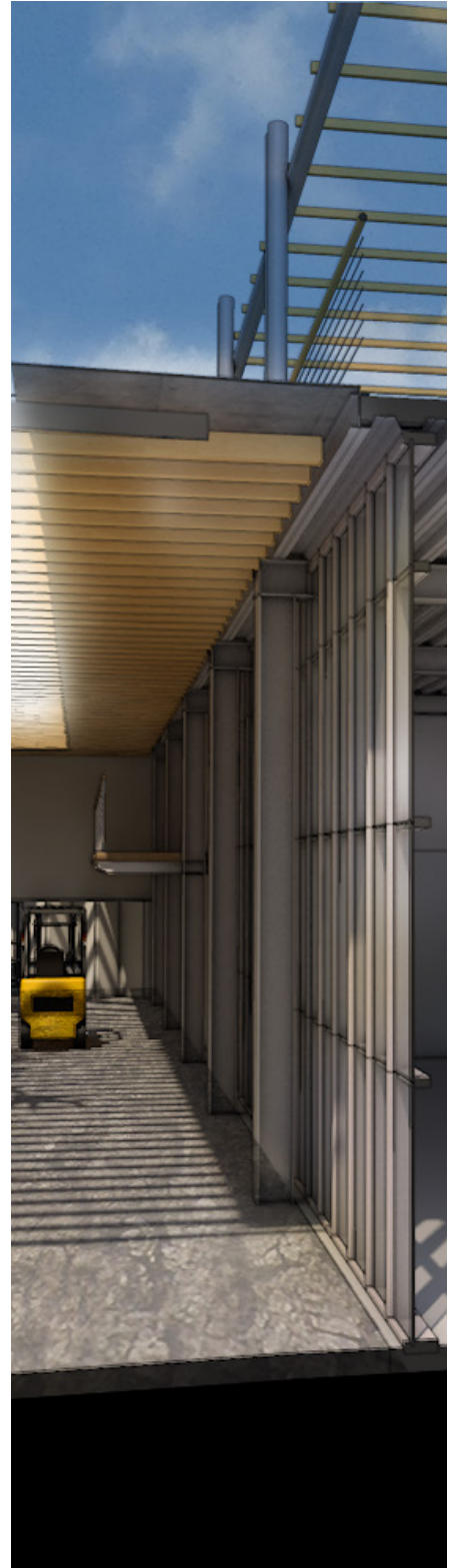

Fig 7.612 Sectional cut view of workshop illustrating the thresholds through the space (Author, 2014)



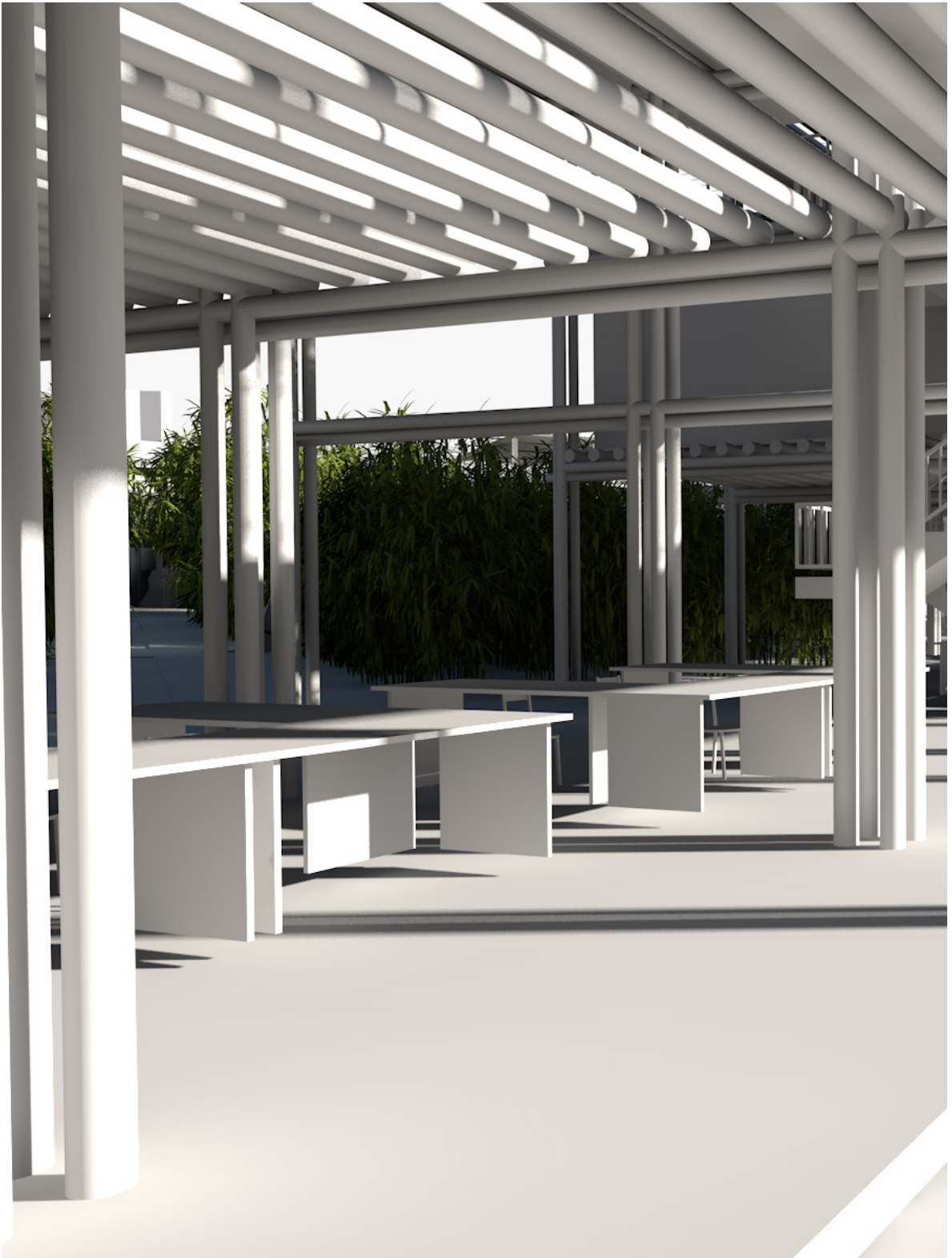
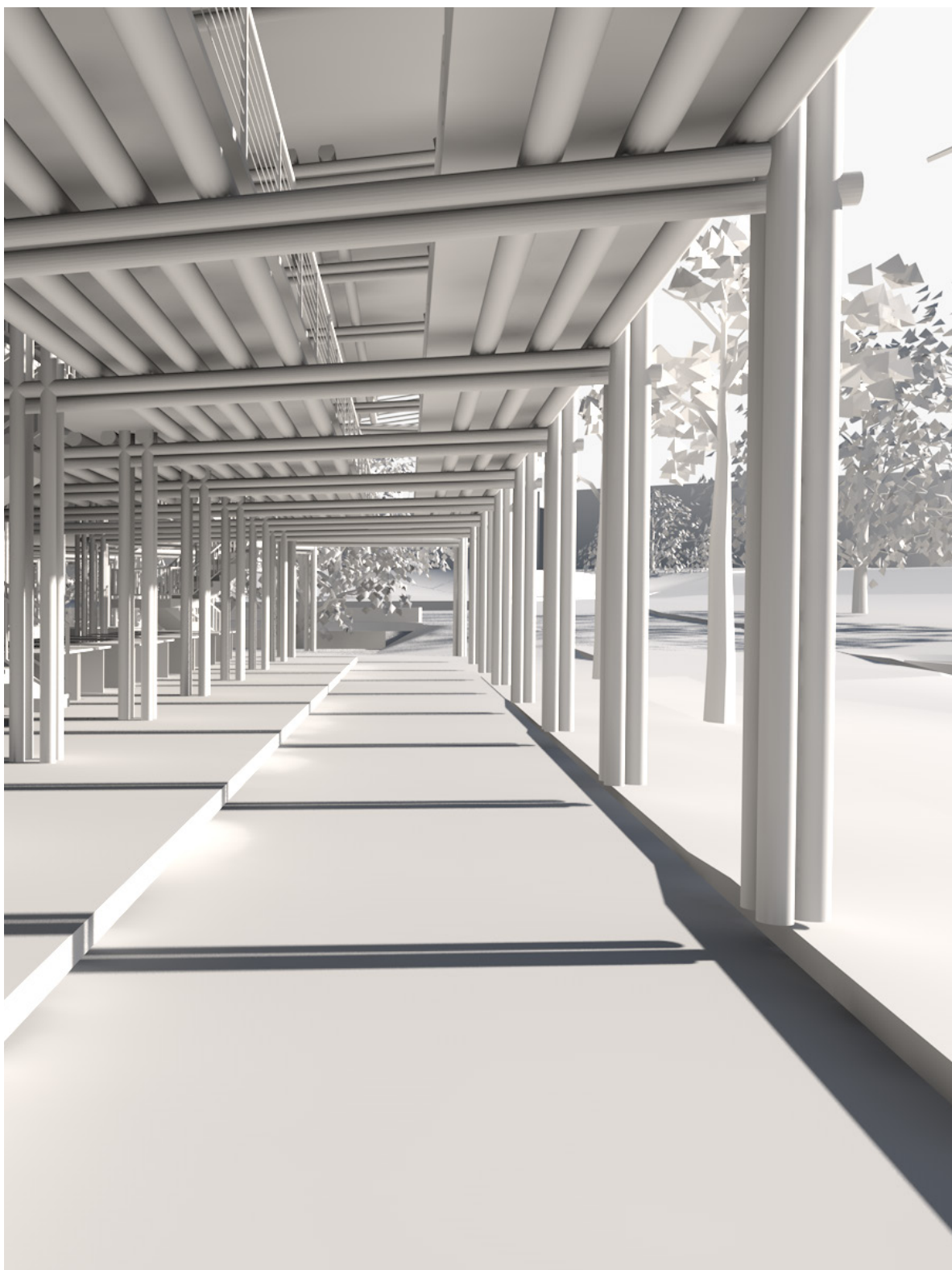

Fig 7.613 Render from inside the market (Author, 2014)-



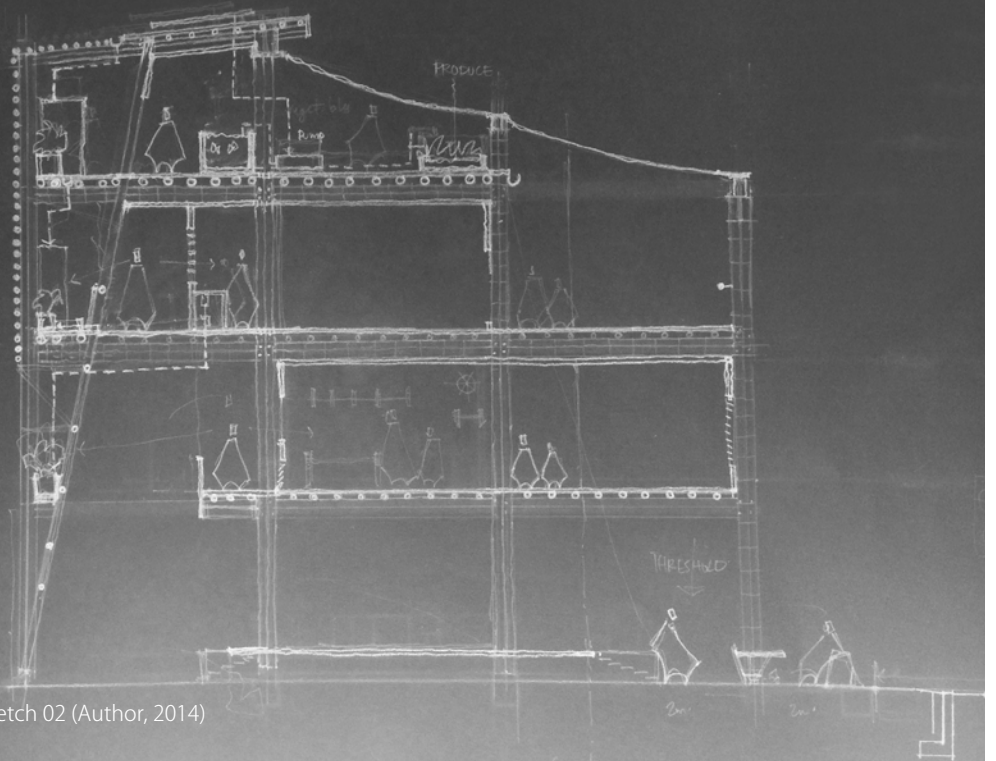

Fig 7.615 Market Concept sketch 02 (Author, 2014)

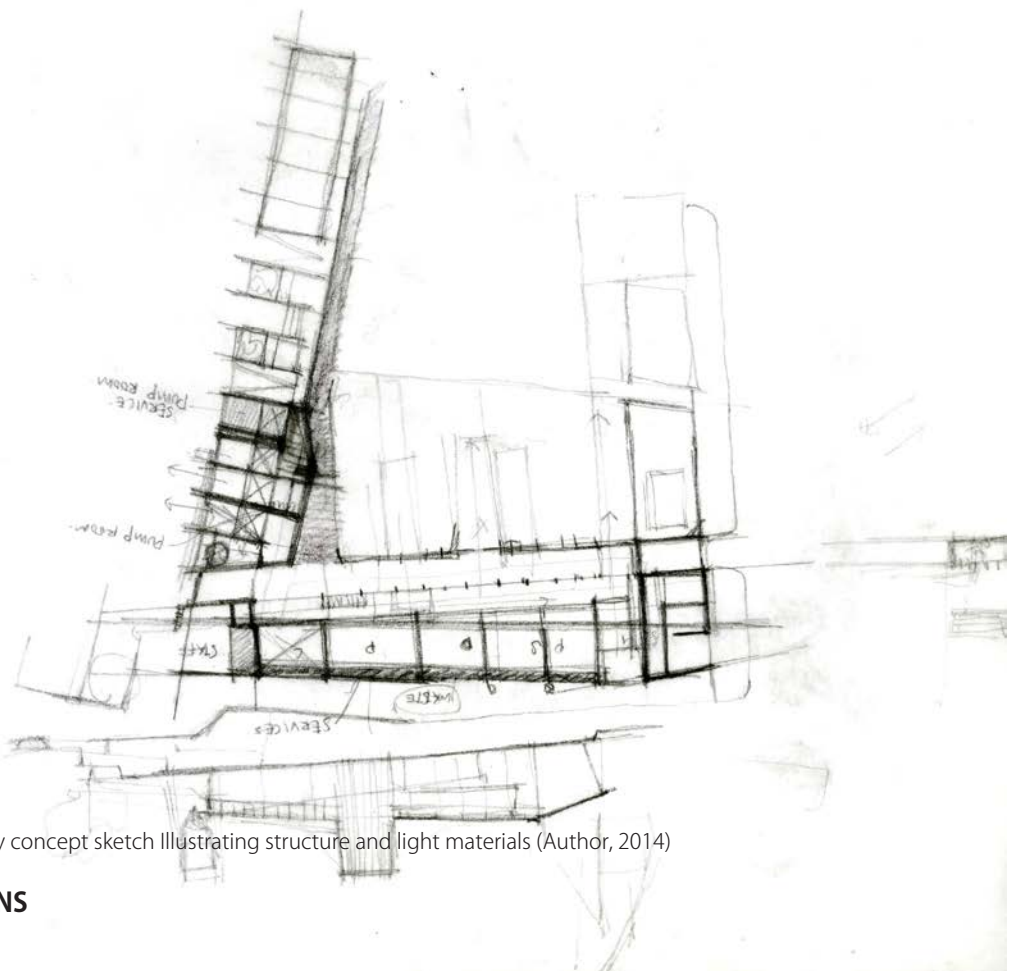

Fig 7.616 Factory concept sketch illustrating structure and light materials (Author, 2014)

SKETCH PLANS



Fig 7.617 Location Plan (Author, 2014)

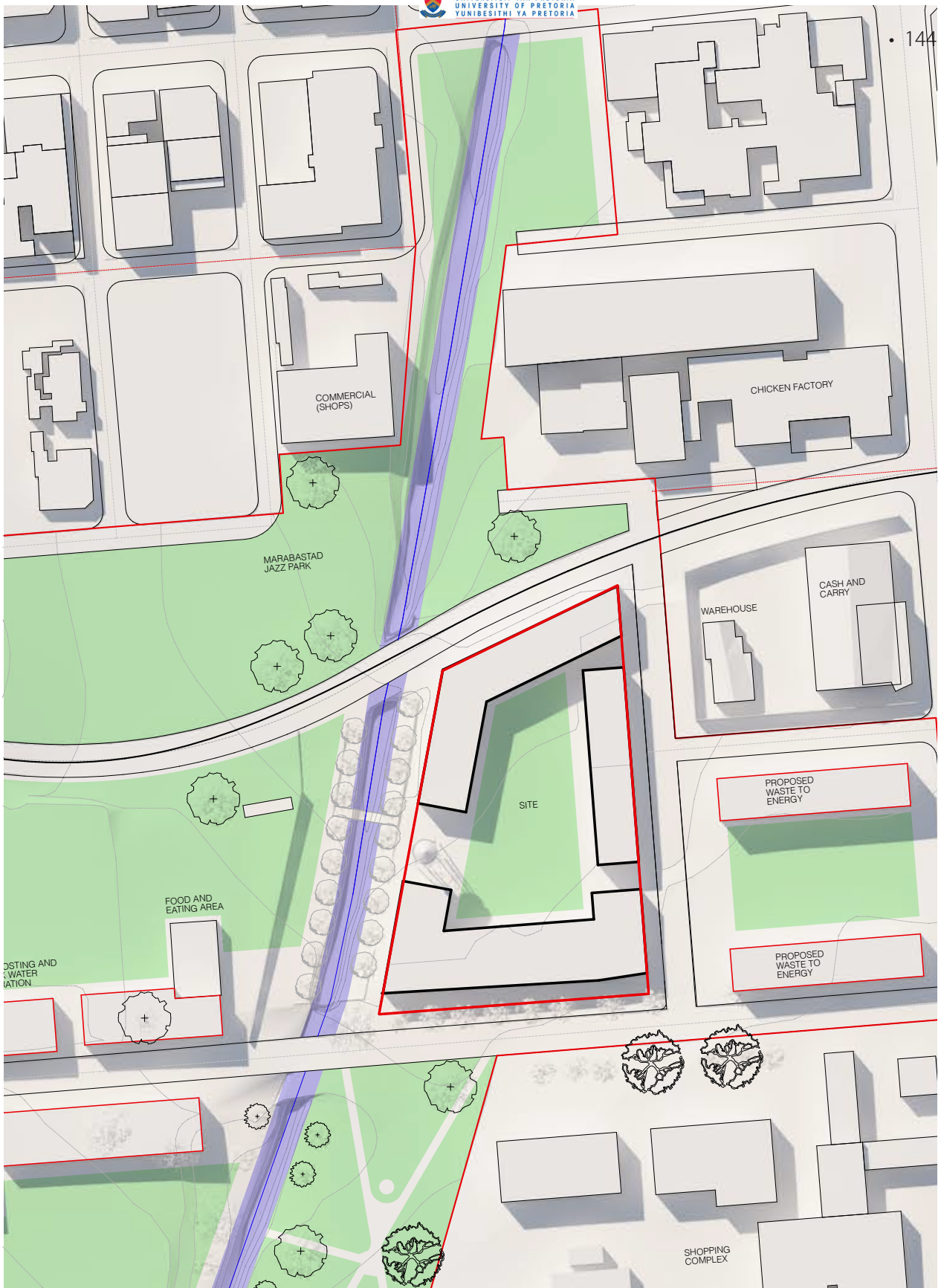

Fig 7.618 Site Plan (Author, 2014)

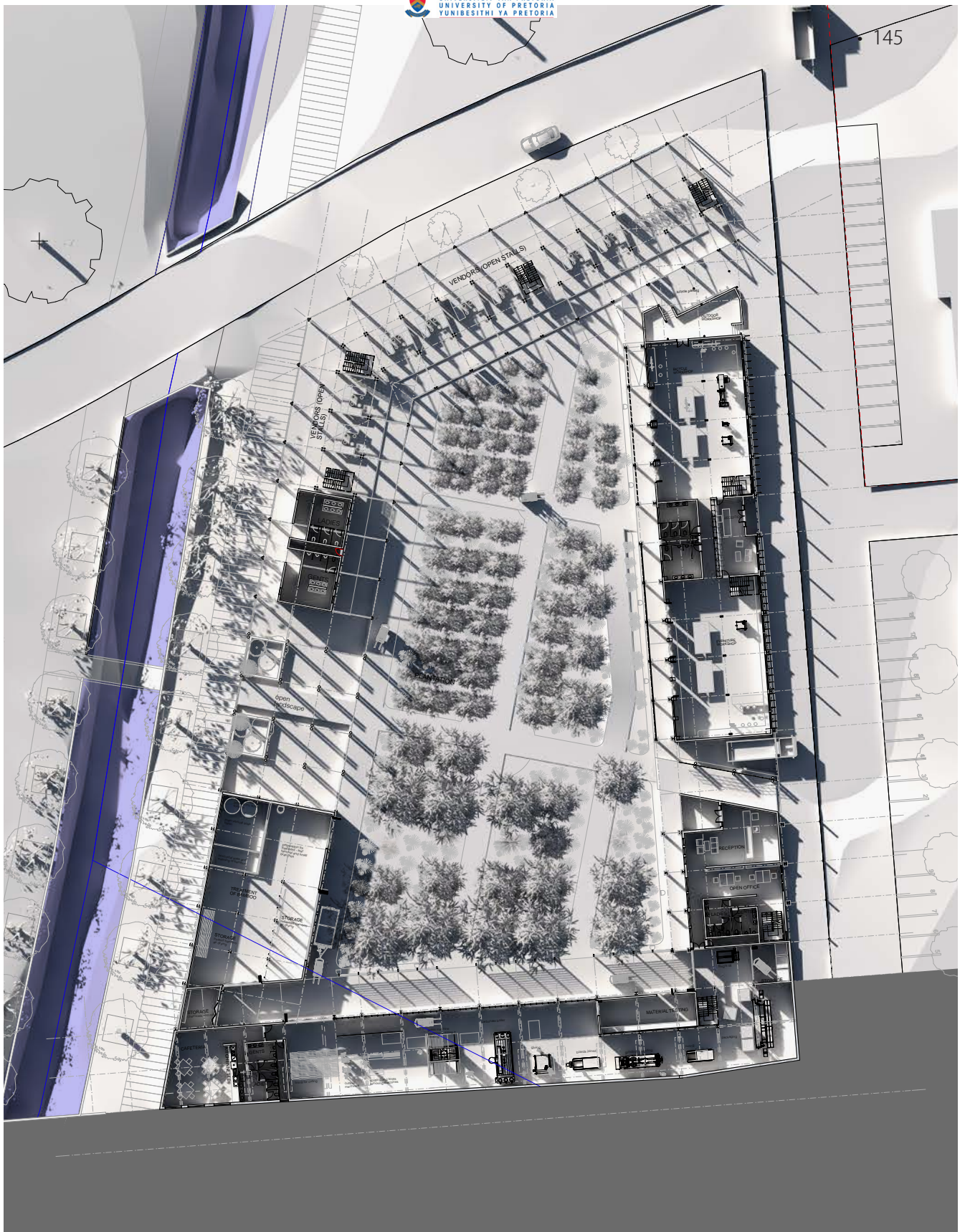

Fig 7.619 Ground Floor Plan (Author, 2014)

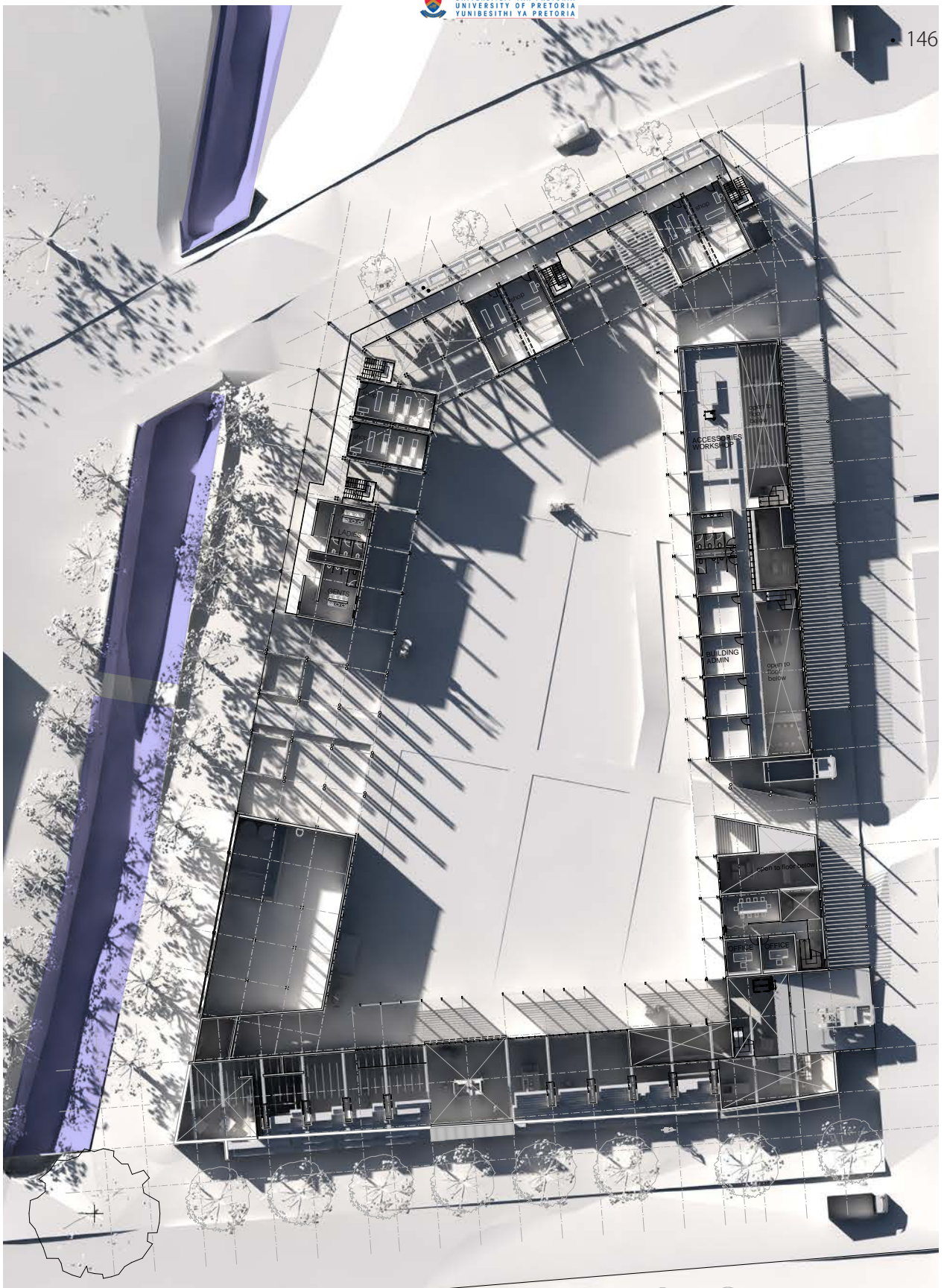

Fig 7.620 First Floor Plan (Author, 2014)

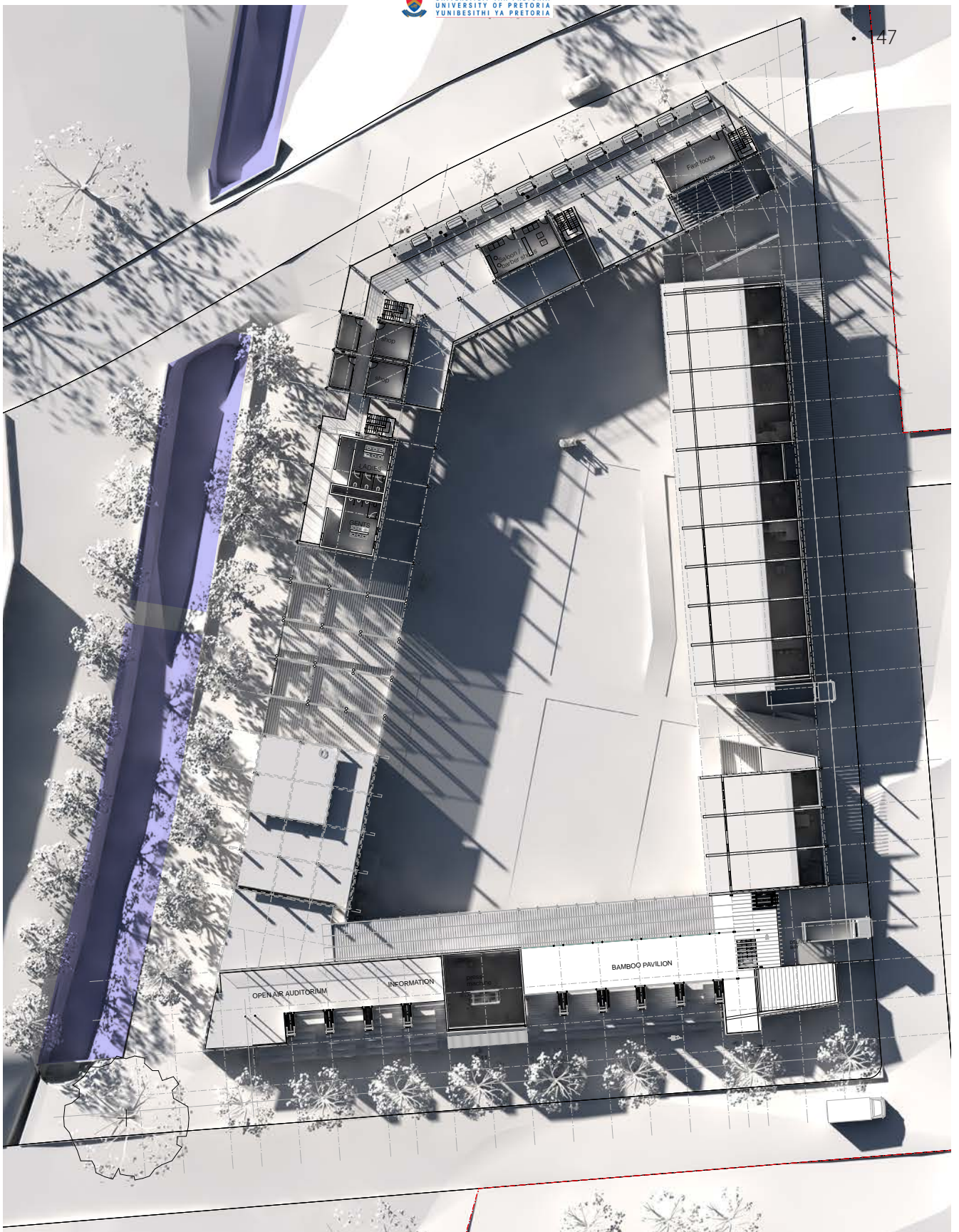

Fig 7.621 Second Floor Plan (Author, 2014)

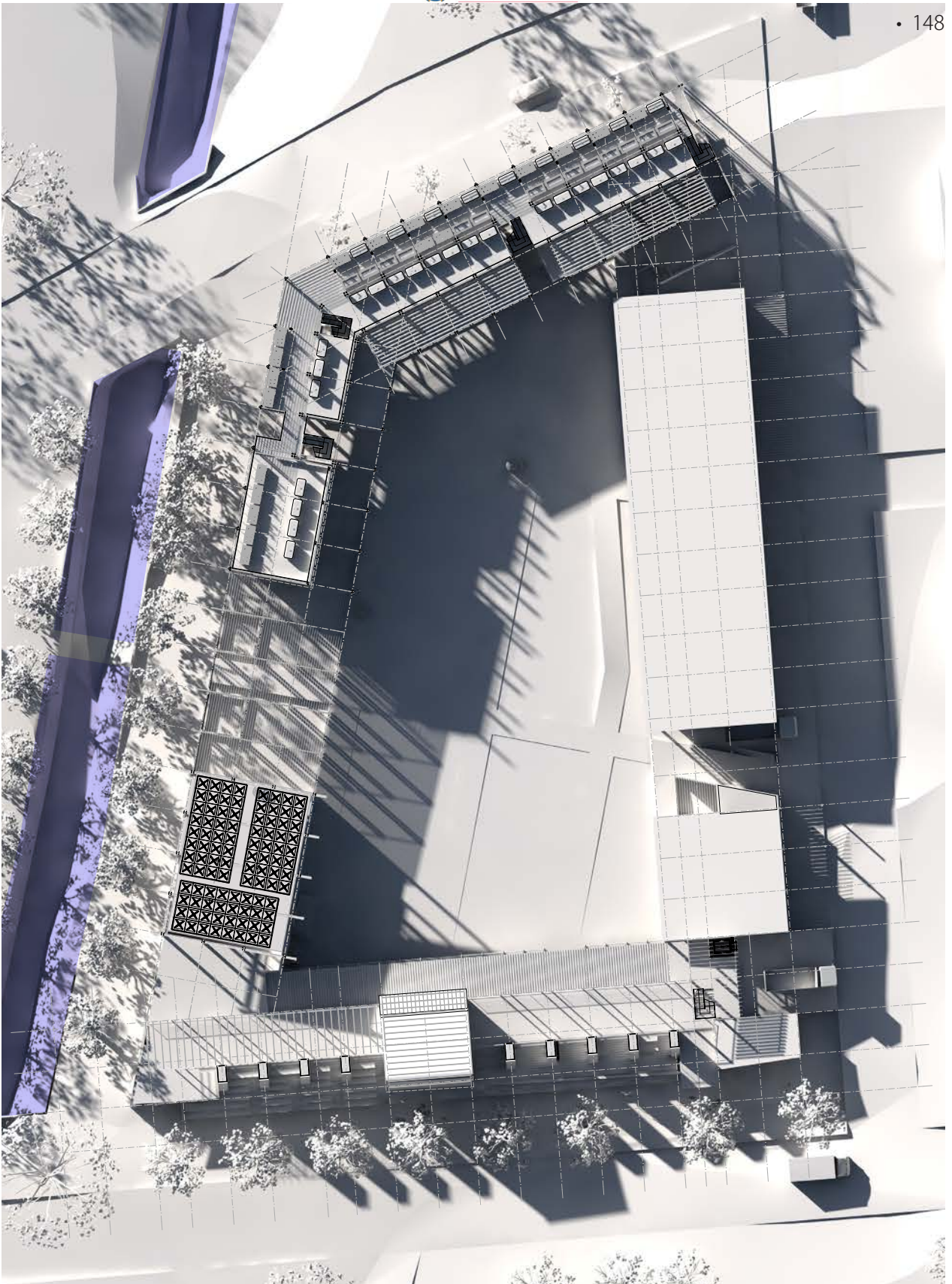

Fig 7.622 Second Floor Plan (Author, 2014)

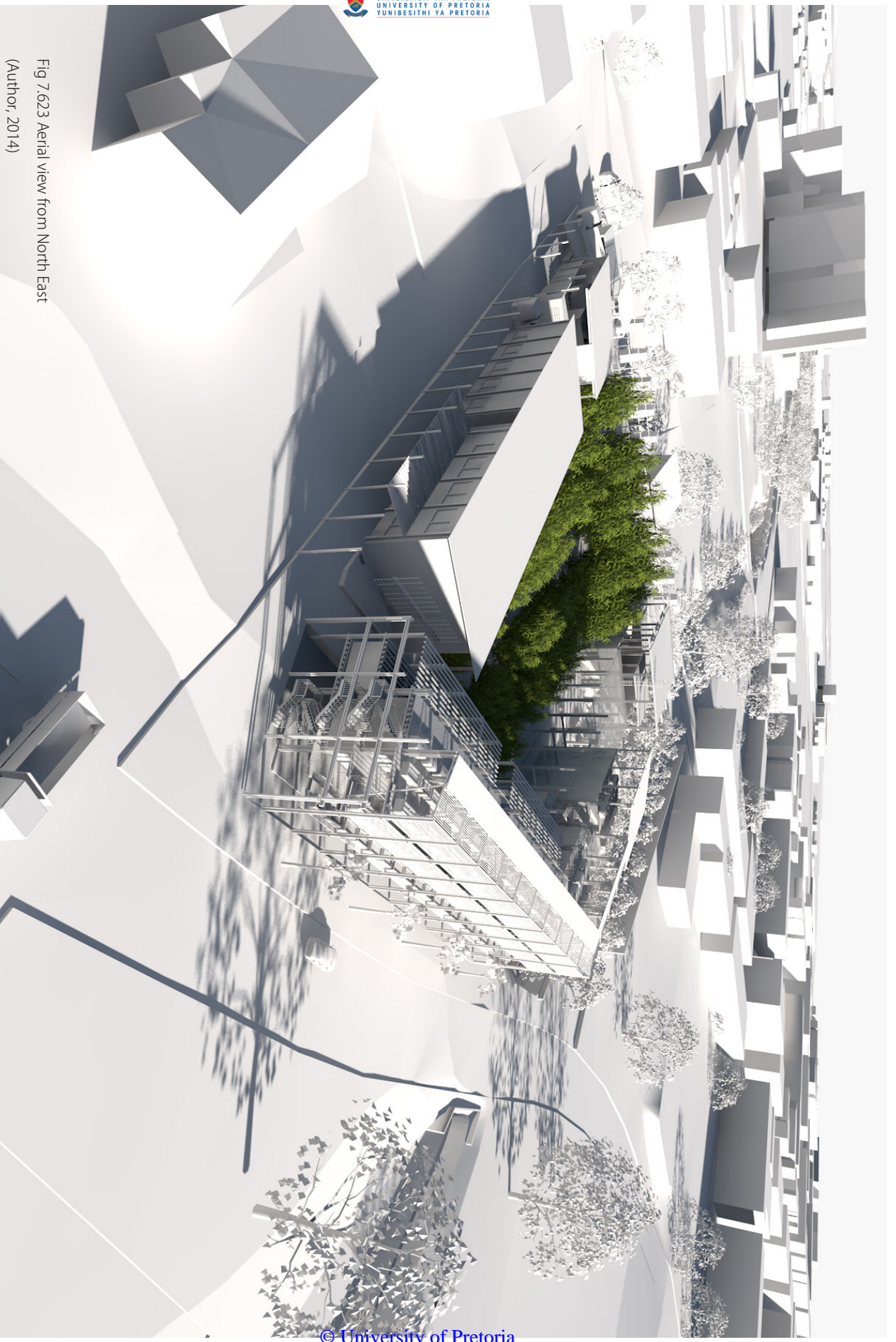

Fig 7.623 Aerial view from North East
(Author, 2014)

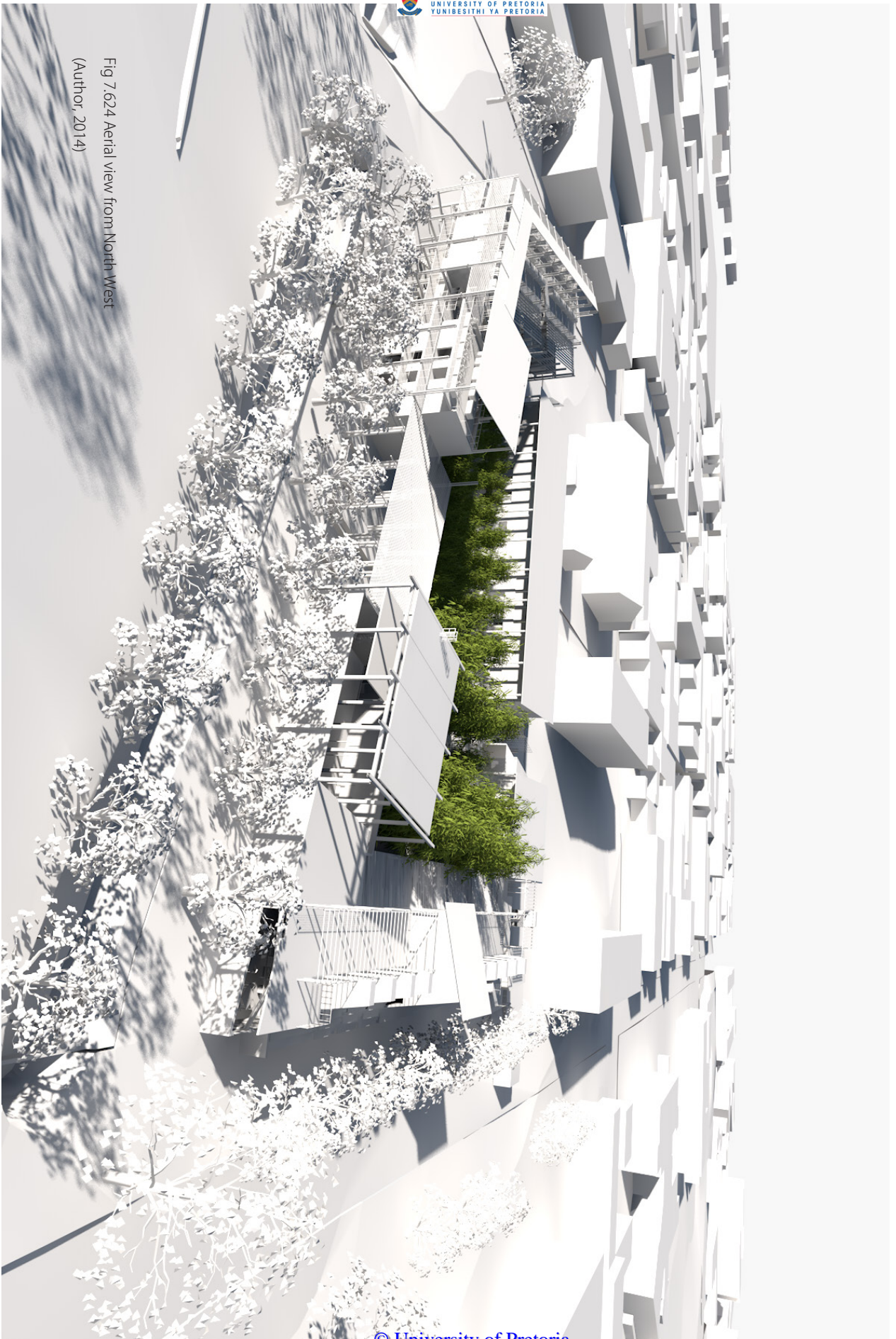

Fig 7.624 Aerial view from North West
(Author, 2014)



Fig 7.625 Section Through Market (Author,
2014)



Fig 8 Section Through Factory (Author, 2014)

TECHNOLOGICAL INVESTIGATION

This chapter focuses on the resolution of the theoretical and pragmatic parameters within the proposed framework.

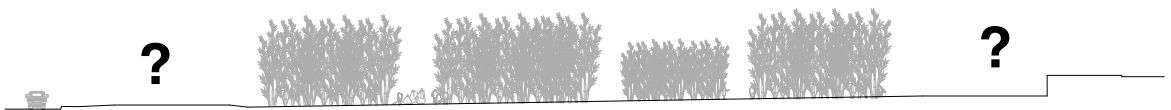
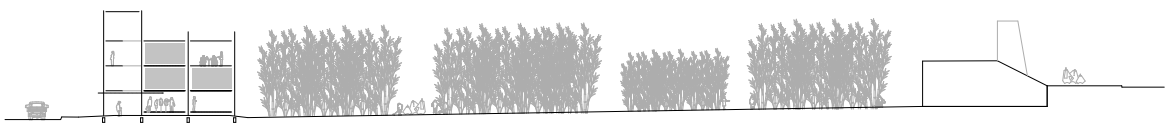
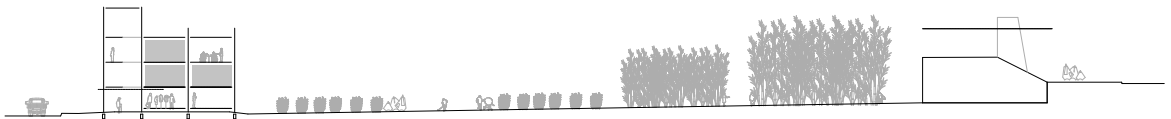
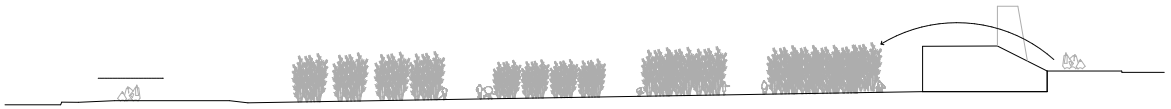
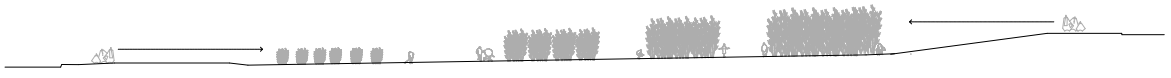

TECHNOLOGICAL CONCEPT

8.1 TECHNOLOGICAL INVESTIGATION

- 8.1 Site to Structure
- 8.2 Structure to Skin
- 8.3 Services

The technological investigation focuses on the resolution between the connections of the two main elements in the scheme. The static and the dynamic. The statics that evolves at the same with the site, and the dynamic which may change overnight. Using both elements to link the project to the productive landscape, this introduces people to materials and their origins. The elements are investigated through the different layers of the building.

8.1 Site to structure

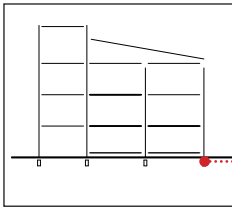

The structural resolution was governed by the design and programmatic intentions. The dynamic relationship between the site and the structure users is reflected in the connection between the site and structure. Creating a light connection between the main structure and site liberates the building from the ground, creating a smaller permanent footprint and elevating the building.

8.1.1 Site to structure connection

The structural investigation focuses on two material compositions from the theoretical premise discussed in chapter 7. The static and the dynamic structural connections. The static comprising all structural elements that connect the building to the site, these alternate between stereotomic and tectonic.

The static resolution serves as the platform for the inherent function and all future possible uses. This celebrates an architecture that allows for the change of programme.

The dynamic structure celebrates the mortality of materials through the process of weathering and ageing. The replacing and maintenance of the materials creates a dialogue between the project and the landscape.

Market

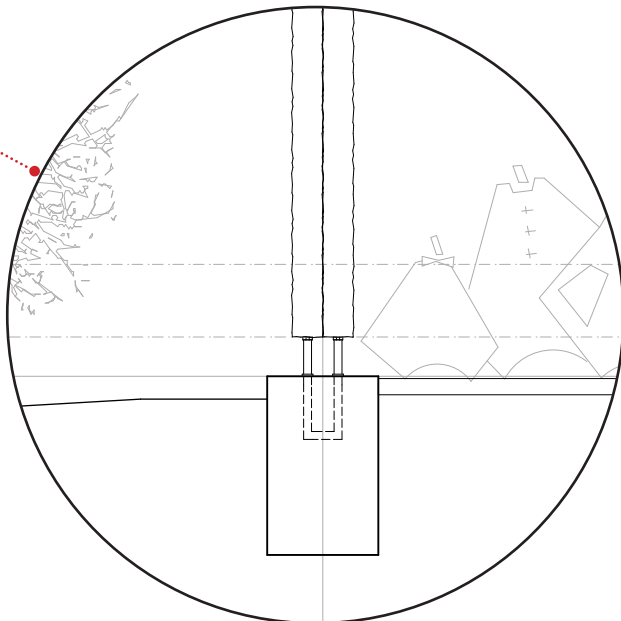
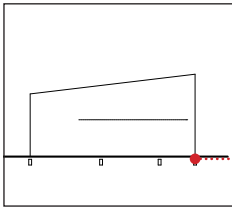

Fig 8.21 Detail of Bamboo (Author, 2014)

Workshops



The possibility of changing programmes in the workshops dictated a building that would be easily accessible at street level. This is to facilitate the movement of mechanical equipment.

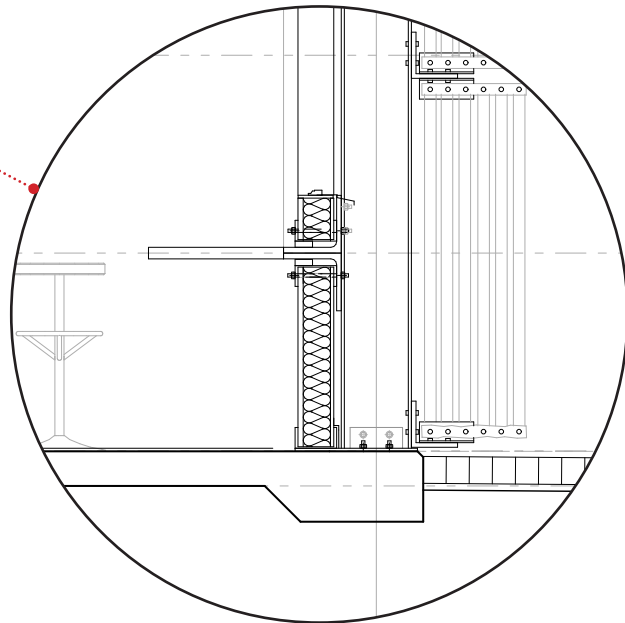
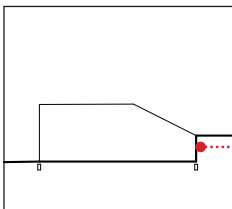

Fig 8.22 Detail of Workshop connection Concrete footing (Author, 2014)

Factory



While the programme is more constant the building is more the interaction with the site reflects that condition. The Factory is a more stereotomic building.

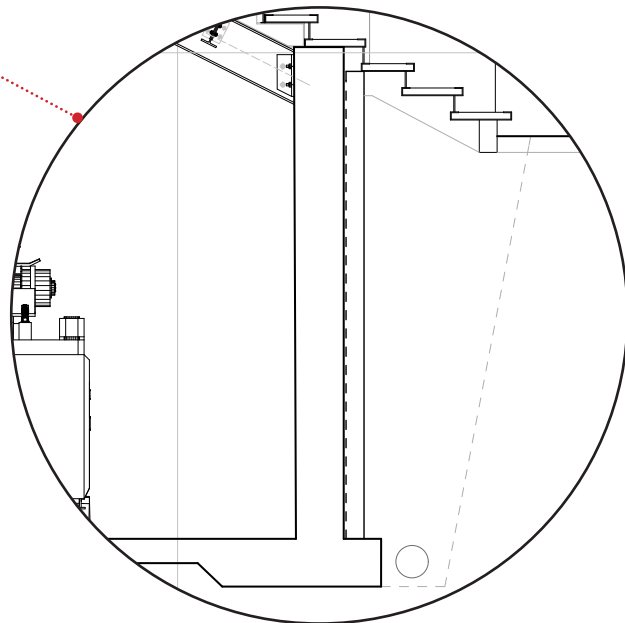

Fig 8.23 Detail of Factory connection footing (Author, 2014)

8.2 Structure to skin connection

The skin is connected to the urban framework from the choice of the materials and the cyclic process the materials undergo parallel to the environment. The static element of the skin responds to the needs of the users. Creating a habitable indoor environment. The dynamic element of the skin evolves, weather and engages the building with the elements. The dynamic elements of the skin links the project to the productive landscape.

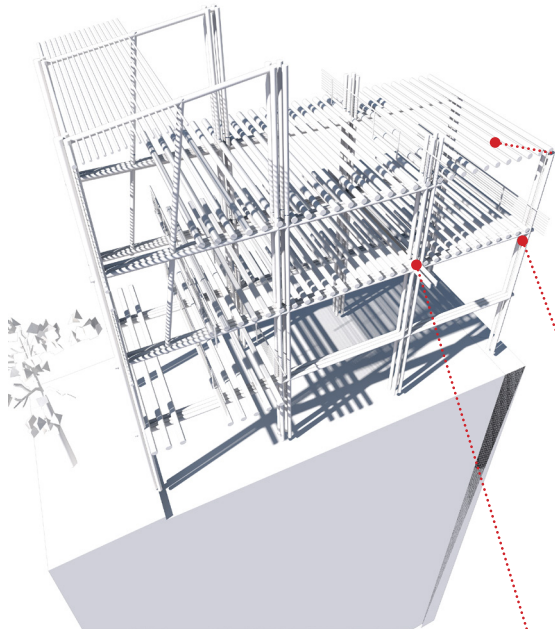

Fig 8.41 Strip Sectional perspective through market
(Author, 2014)

Market

Primary columns consist of 4 bamboo culms 150 - 200 mm diameter. Two bolted together, two separate 150 mm apart. Columns are at 5000 mm intervals.

Primary beams consist of two 150 mm bamboo culms aligned vertically. These are bolted to the columns.



Fig 8.43
Exploratory details
(Author, 2014)

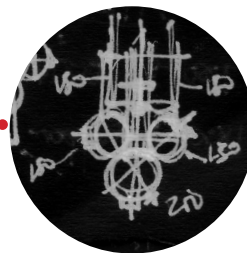

The secondary beams are 200mm diameter bamboo culms spaced at 450 mm intervals onto which a 50mm bamboo floor board is nailed.

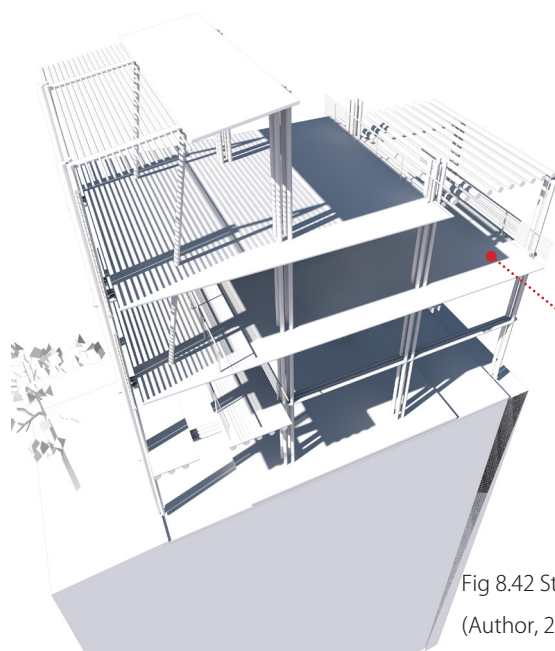
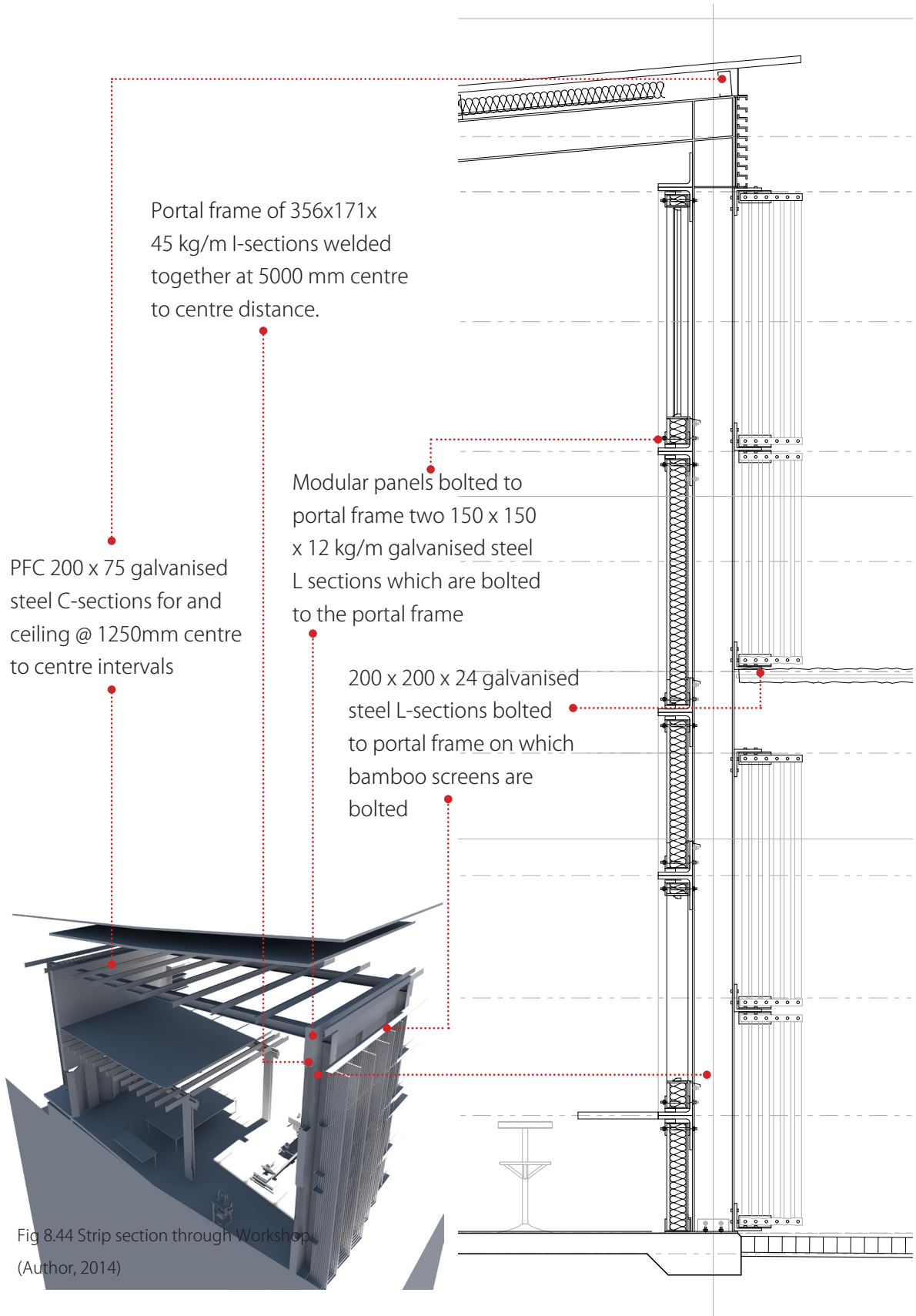

Fig 8.42 Strip Sectional perspective through market
(Author, 2014)

Workshop



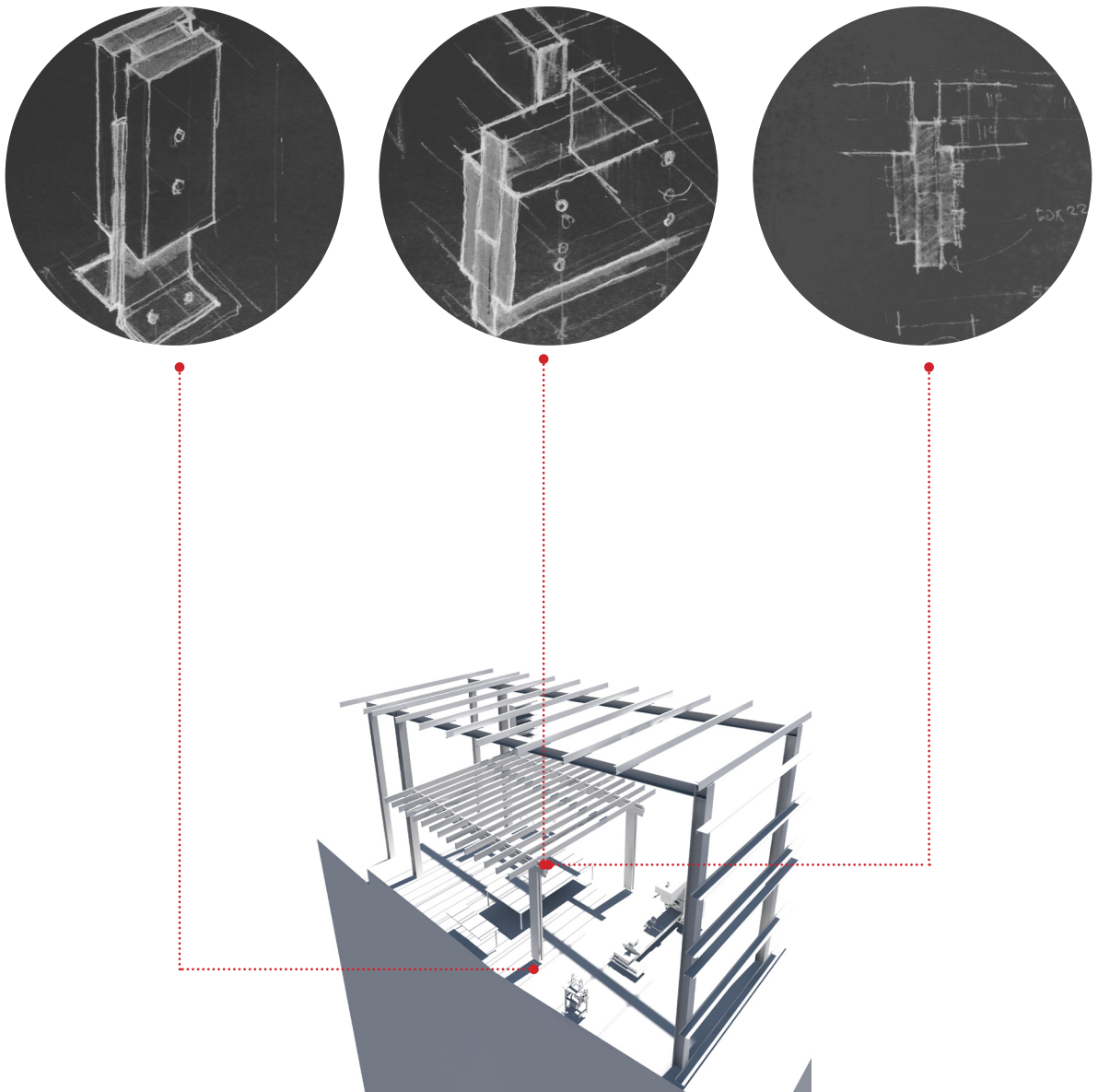
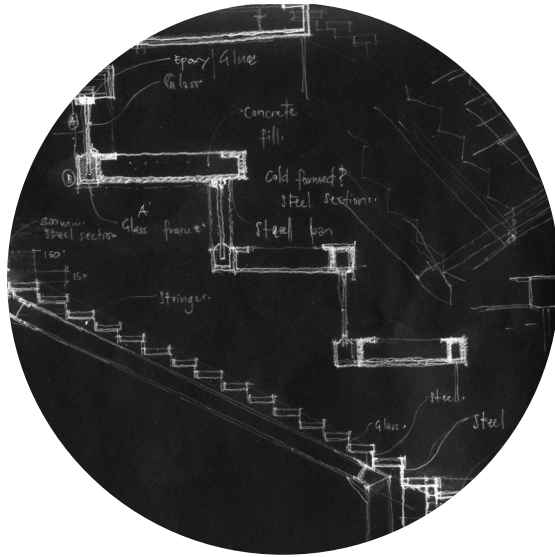

Fig 8.45 Strip section through Workshop with column and connection details (Author, 2014)

Factory



Steel tray

Glass glued to two sections

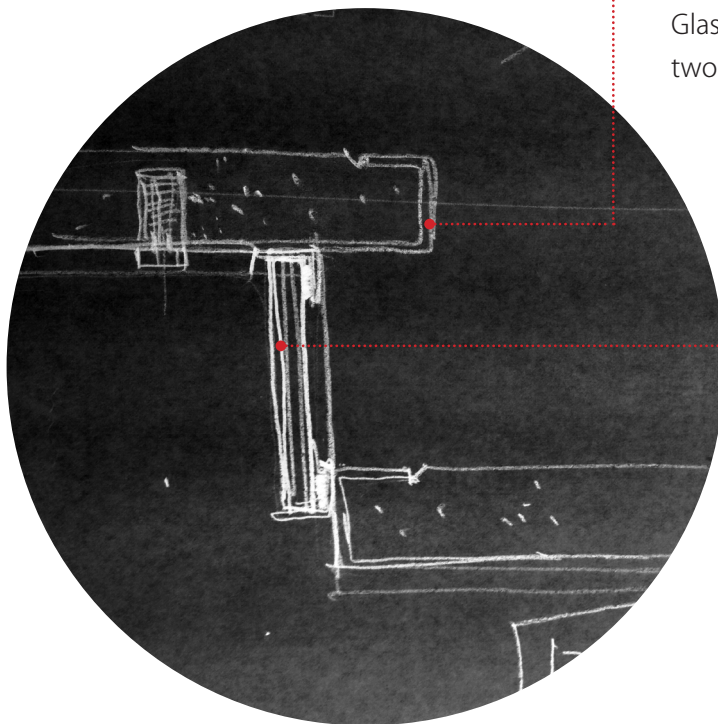

Fig 8.46 Details of floating stairs (Author, 2014)

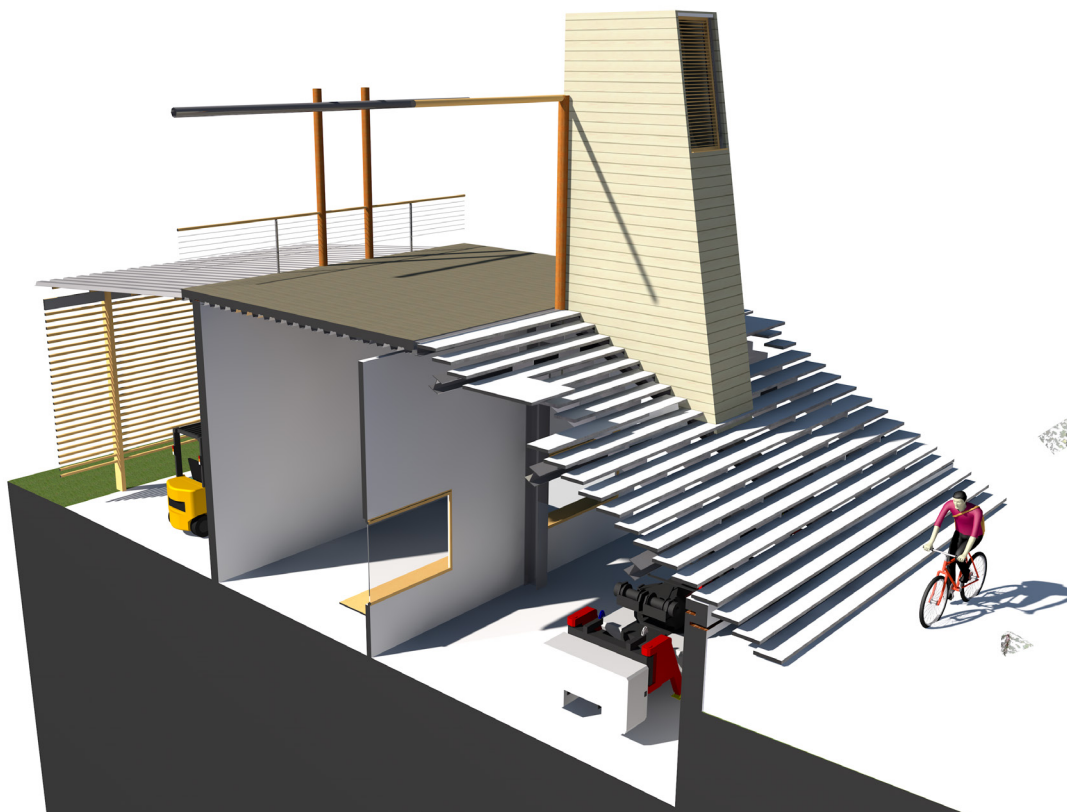

Fig 8.47 Strip perspective section through Factory (Author, 2014)

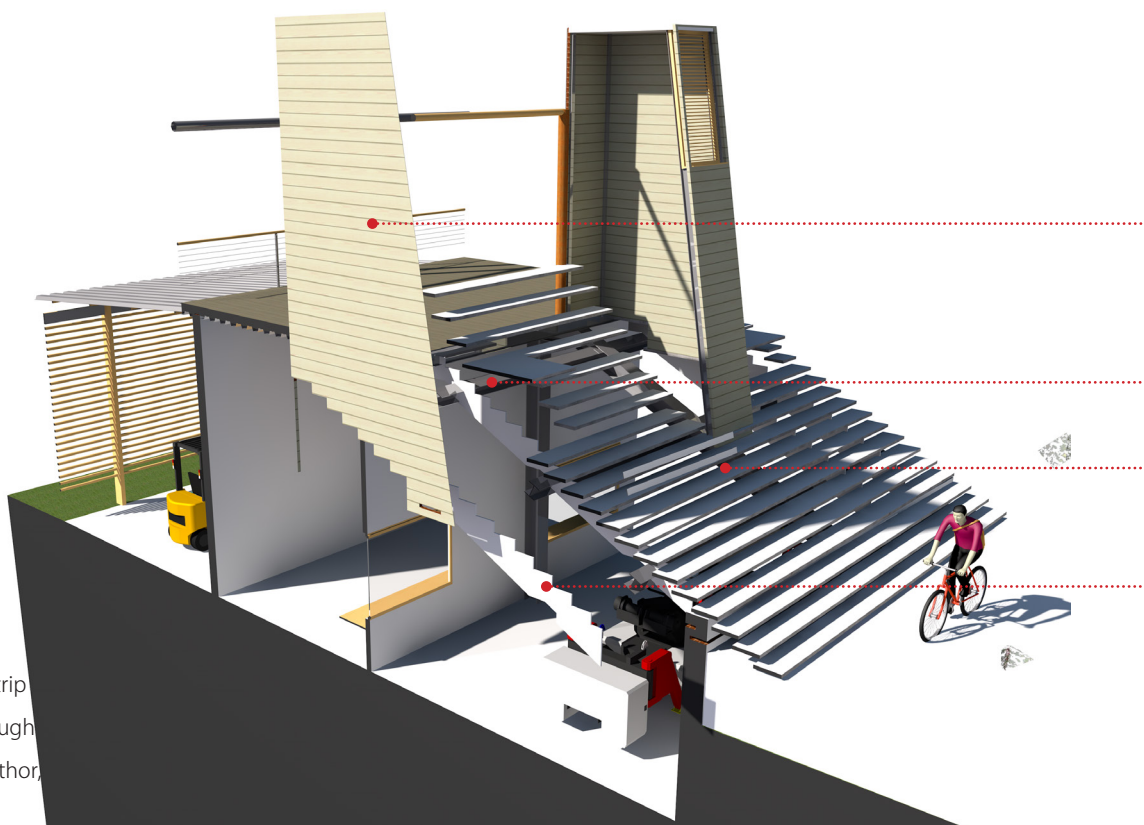

Fig 8.48
Exploded strip
section through
Factory (Author,
2014)

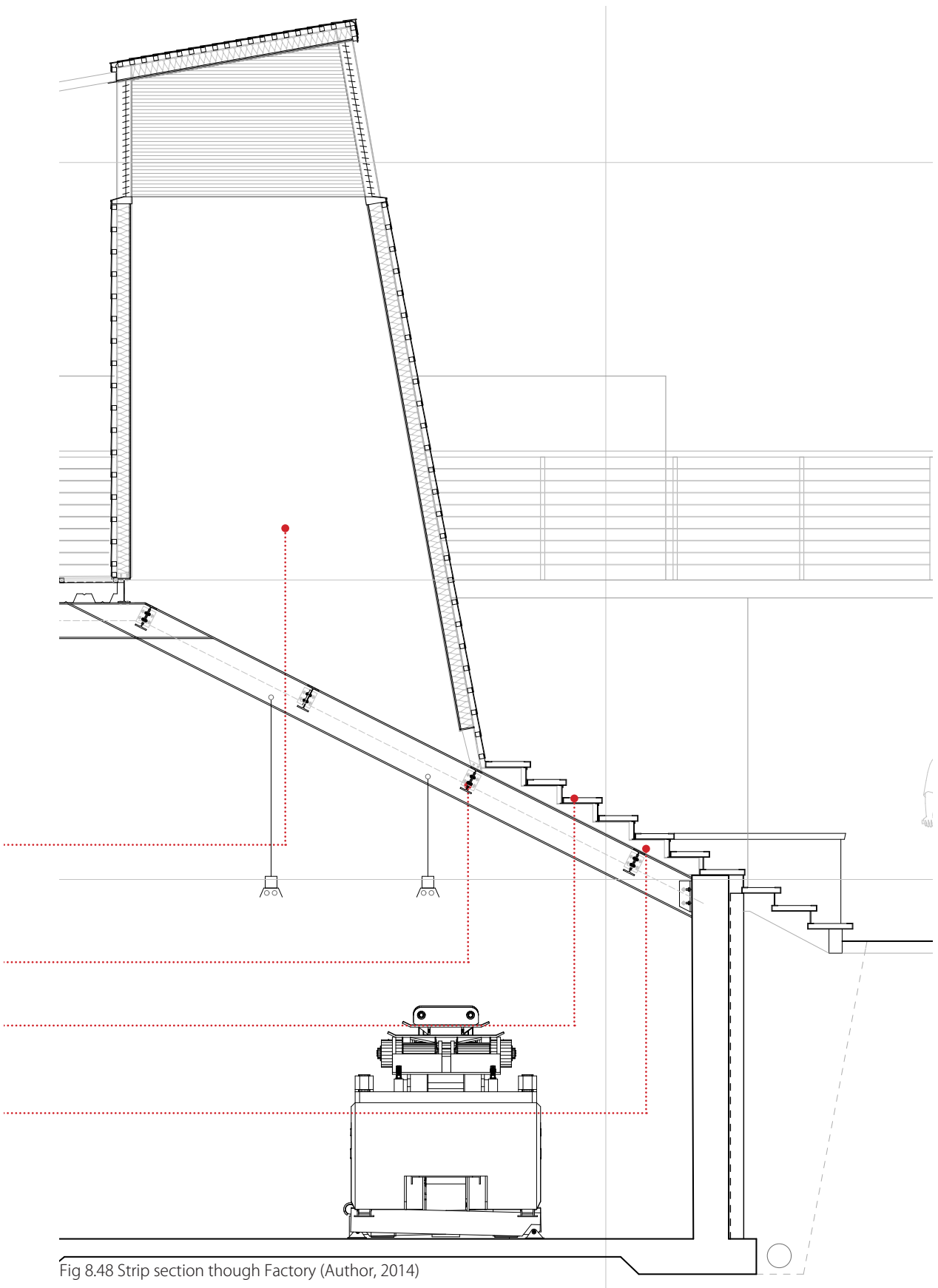

Fig 8.48 Strip section through Factory (Author, 2014)

8.3 Services

8.3.1 Water portable and grey water

The services in the building are networked to other programmes in the urban framework in a system of exchanges. The project focuses on the provision filtration of grey water services and supply of water for industrial and agricultural purposes in exchange for the black water disposal and energy supply.

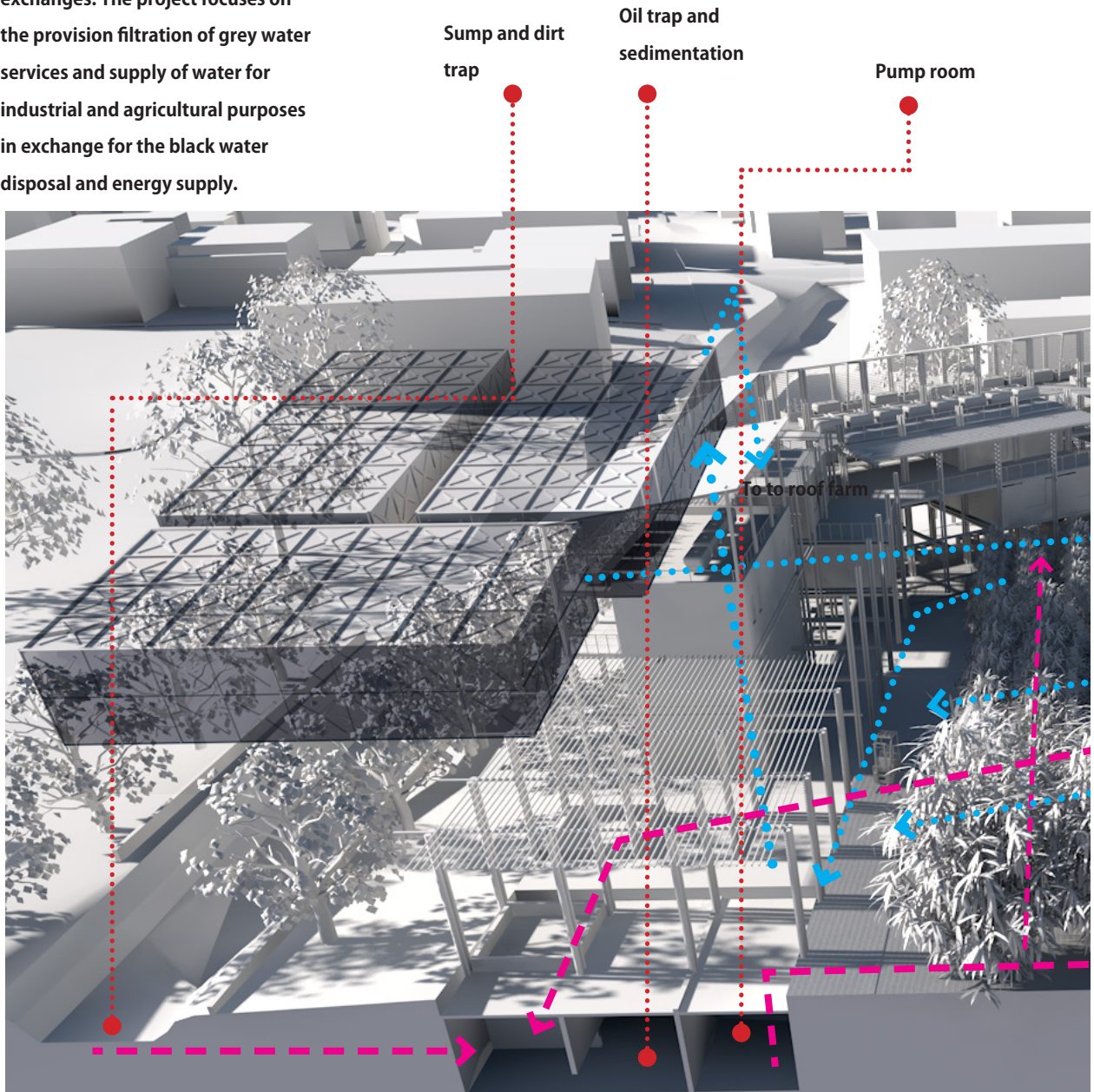
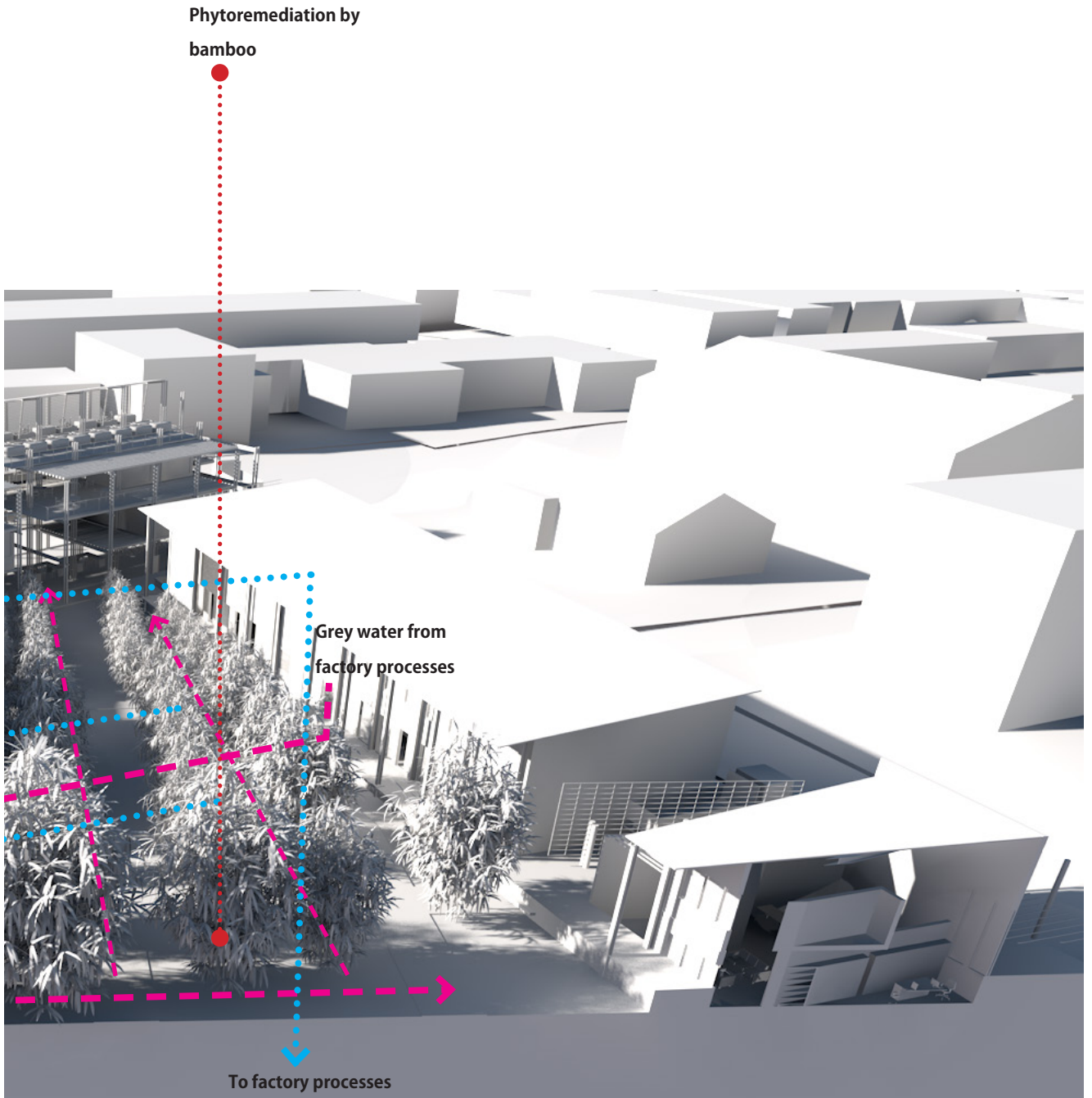

Fig 8.49 Strip section illustrating water filtration (Author, 2014)



8.3.2 Ventilation

Market

Open building will allow for cross ventilation

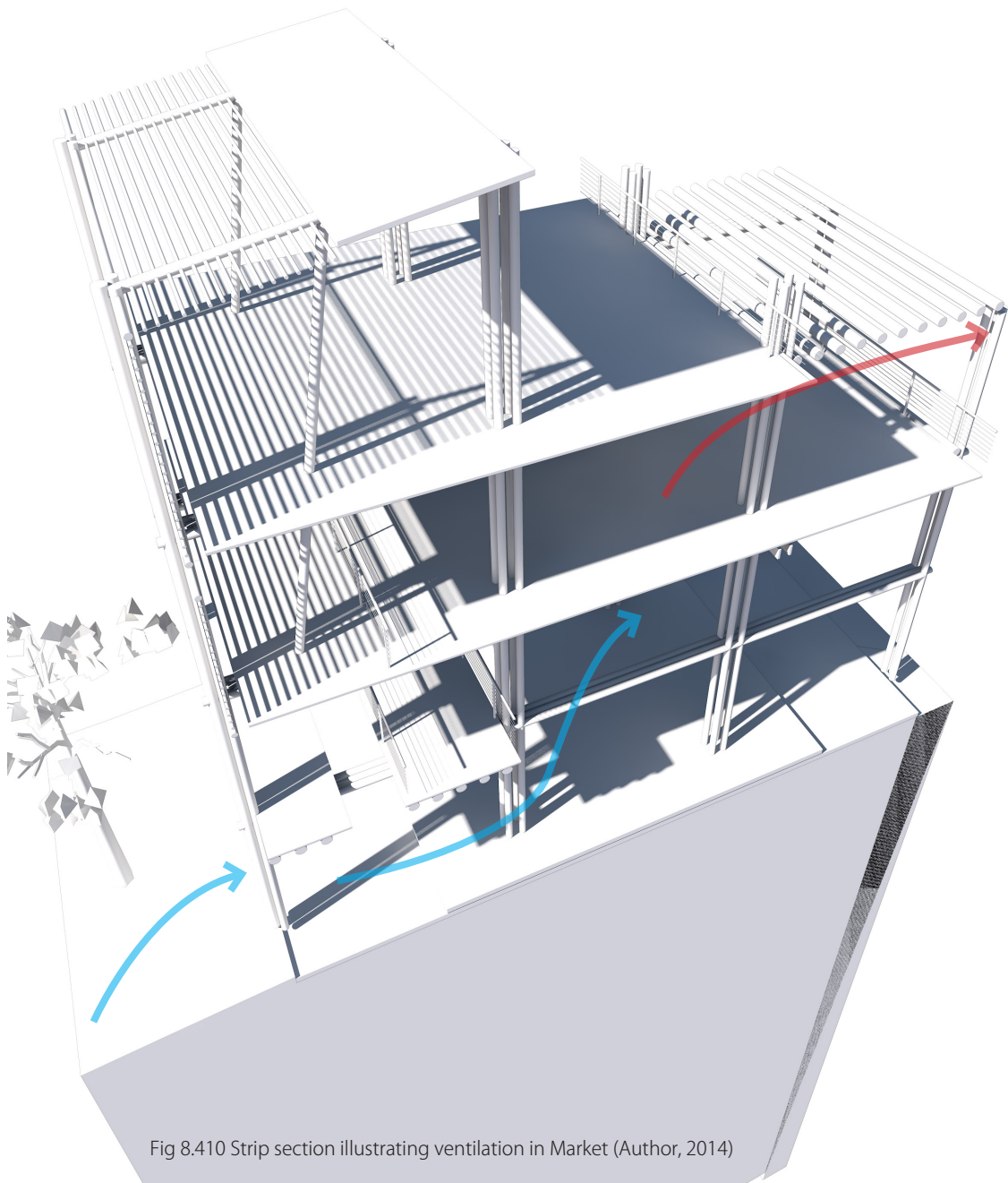

Fig 8.410 Strip section illustrating ventilation in Market (Author, 2014)

Workshop

The building receives cool air through earth tubes from the coolest side of the building (on the west, after the plantation). The use of machinery gradually heats up the air which rises and escapes from the vents on the east side of the building.

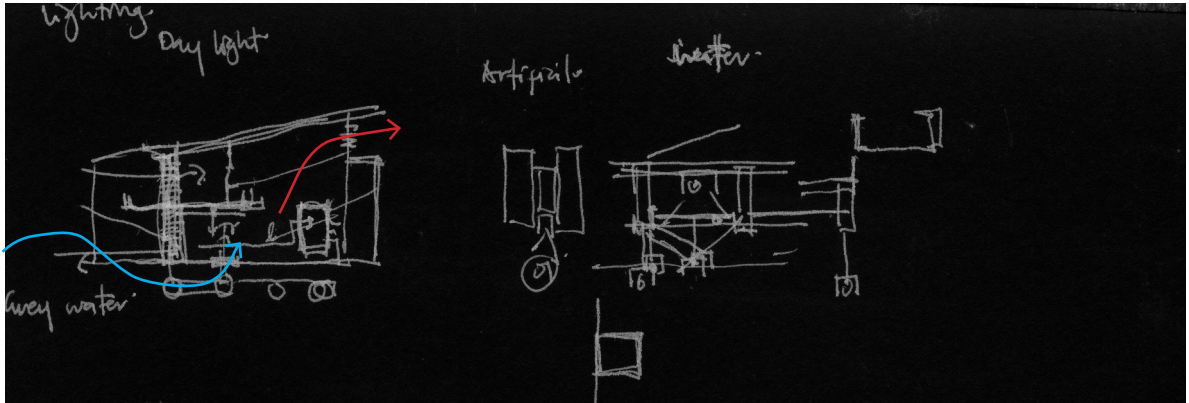

Fig 8.411 Sectional diagram illustrating ventilation of workshop spaces

(Author, 2014)

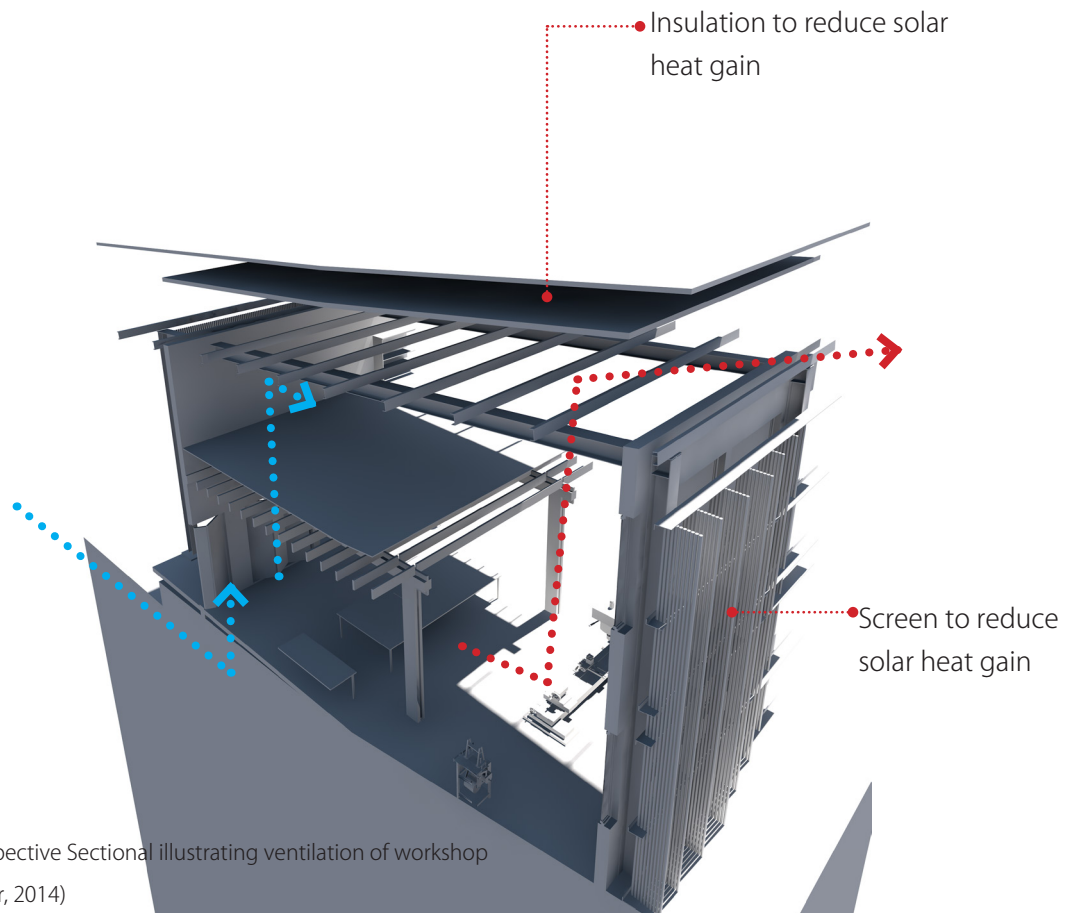

Fig 8.412 Perspective Sectional illustrating ventilation of workshop spaces (Author, 2014)

Factory

Using a similar principle to the Workshop, the building receives cool air through earth tubes from the coolest side of the building (on the north). The use of machinery gradually heats up the air which rises and escapes from the vents on the east side of the building.

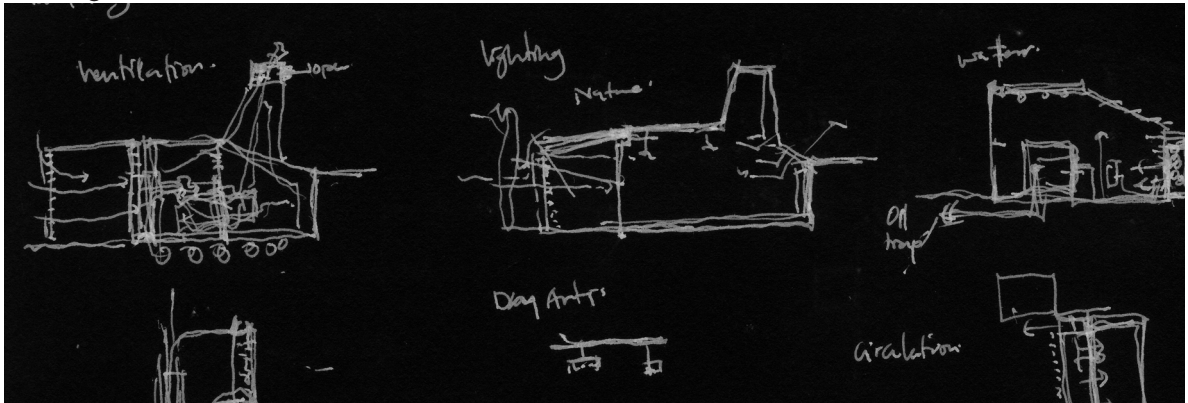

Fig 8.413 Conceptual Sectional diagram illustrating services in the Factory (Author, 2014)

Fig 8.414 Perspective Sectional diagram showing ventilation in the Factory (Author, 2014)

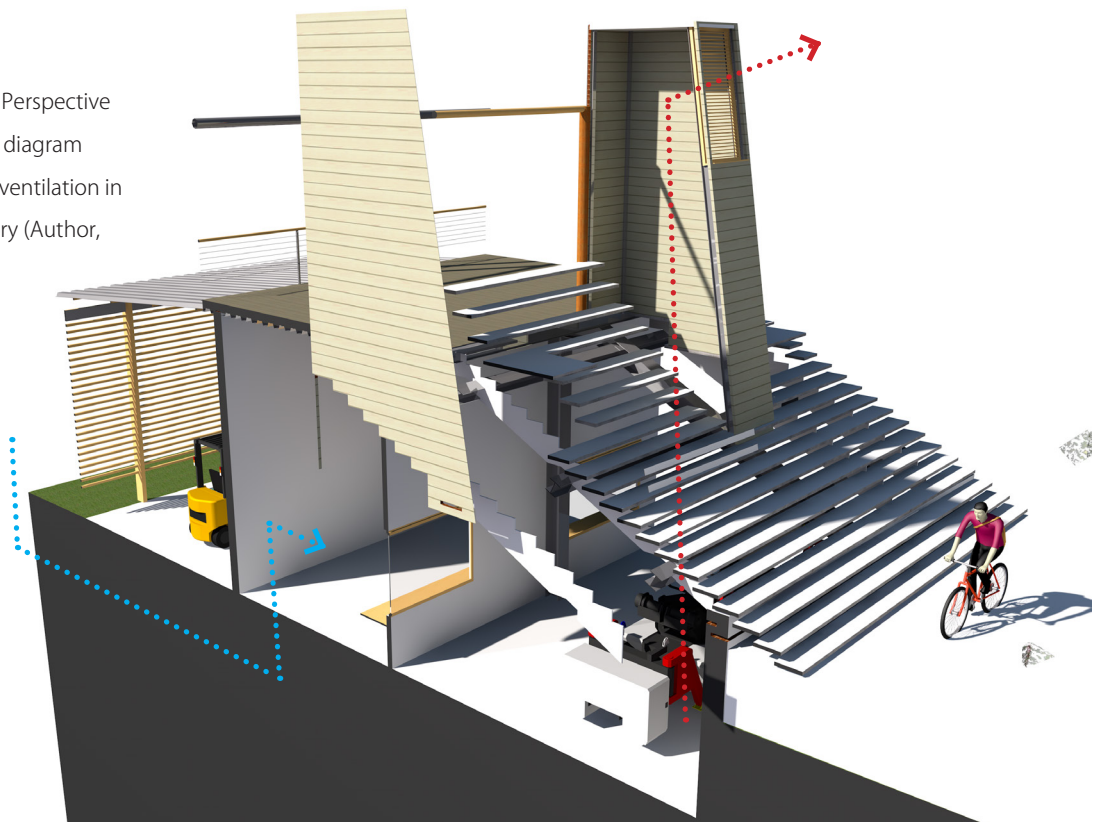



Fig 9 Conditions for germination (Unkown, 2014)

CONCLUSION

This chapter focuses on the research summary of the dissertation.



Fig 8 Section Through Factory (Author, 2014)

TECHNOLOGICAL INVESTIGATION

This chapter focuses on the resolution of the theoretical and pragmatic parameters within the proposed framework.

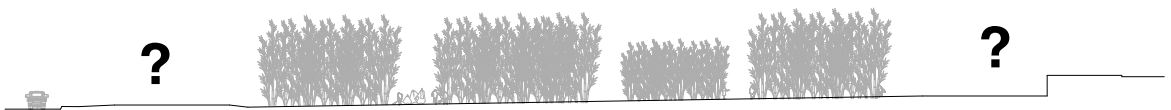
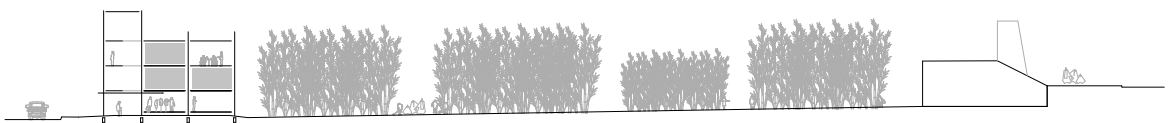
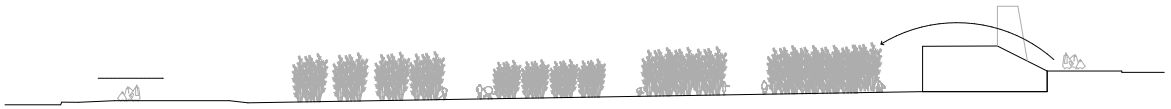
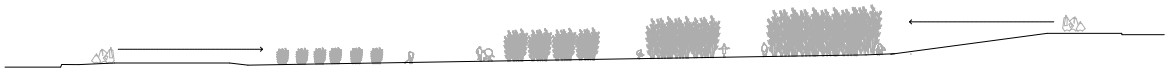

TECHNOLOGICAL CONCEPT

8.1 TECHNOLOGICAL INVESTIGATION

- 8.1 Site to Structure
- 8.2 Structure to Skin
- 8.3 Services

The technological investigation focuses on the resolution between the connections of the two main elements in the scheme. The static and the dynamic. The statics that evolves at the same with the site, and the dynamic which may change overnight. Using both elements to link the project to the productive landscape, this introduces people to materials and their origins. The elements are investigated through the different layers of the building.

8.1 Site to structure

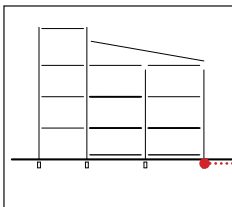

The structural resolution was governed by the design and programmatic intentions. The dynamic relationship between the site and the structure users is reflected in the connection between the site and structure. Creating a light connection between the main structure and site liberates the building from the ground, creating a smaller permanent footprint and elevating the building.

8.1.1 Site to structure connection

The structural investigation focuses on two material compositions from the theoretical premise discussed in chapter 7. The static and the dynamic structural connections. The static comprising all structural elements that connect the building to the site, these alternate between stereotomic and tectonic.

The static resolution serves as the platform for the inherent function and all future possible uses. This celebrates an architecture that allows for the change of programme.

The dynamic structure celebrates the mortality of materials through the process of weathering and ageing. The replacing and maintenance of the materials creates a dialogue between the project and the landscape.

Market

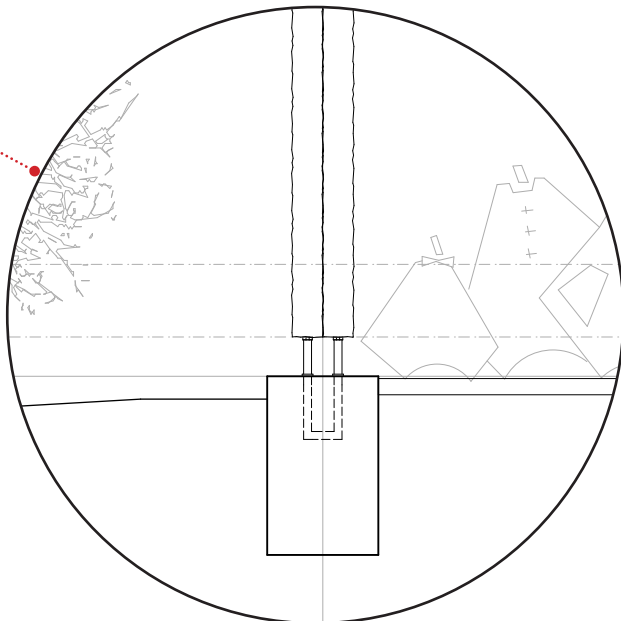
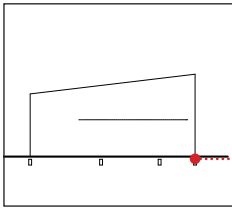

Fig 8.21 Detail of Bamboo (Author, 2014)

Workshops



The possibility of changing programmes in the workshops dictated a building that would be easily accessible at street level. This is to facilitate the movement of mechanical equipment.

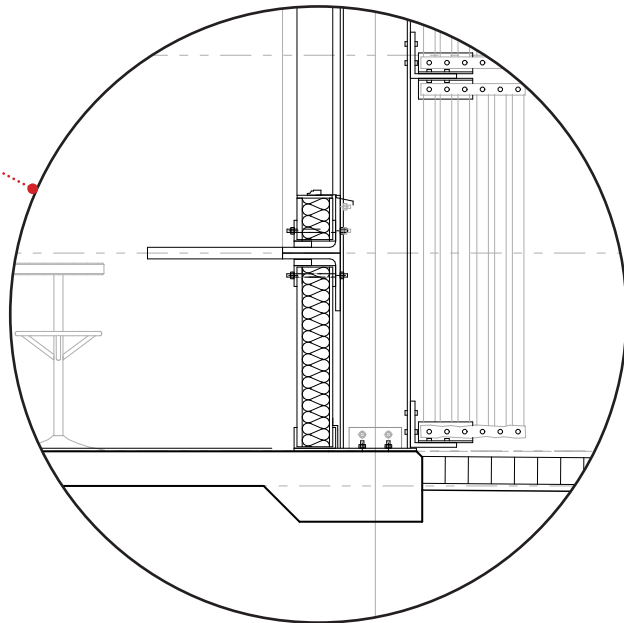
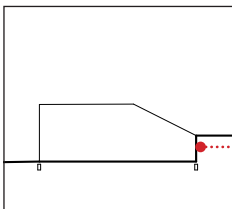

Fig 8.22 Detail of Workshop connection Concrete footing
(Author, 2014)

Factory



While the programme is more constant the building is more the interaction with the site reflects that condition. The Factory is a more stereotomic building.

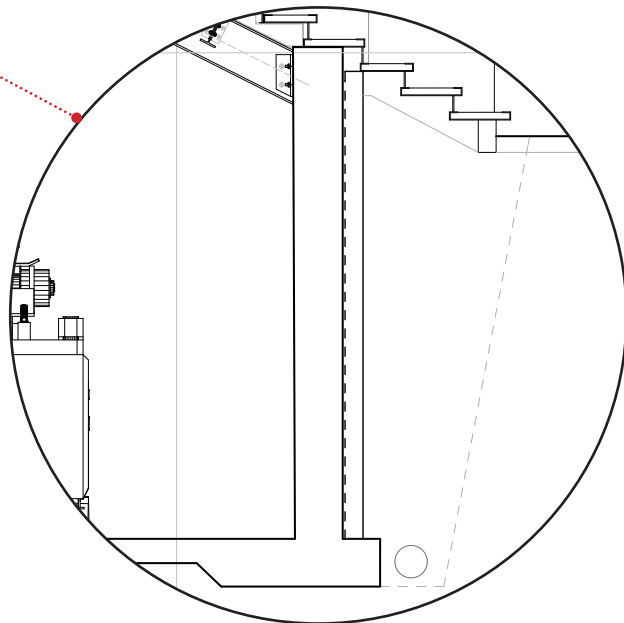

Fig 8.23 Detail of Factory connection footing (Author, 2014)

8.2 Structure to skin connection

The skin is connected to the urban framework from the choice of the materials and the cyclic process the materials undergo parallel to the environment. The static element of the skin responds to the needs of the users. Creating a habitable indoor environment. The dynamic element of the skin evolves, weather and engages the building with the elements. The dynamic elements of the skin links the project to the productive landscape.

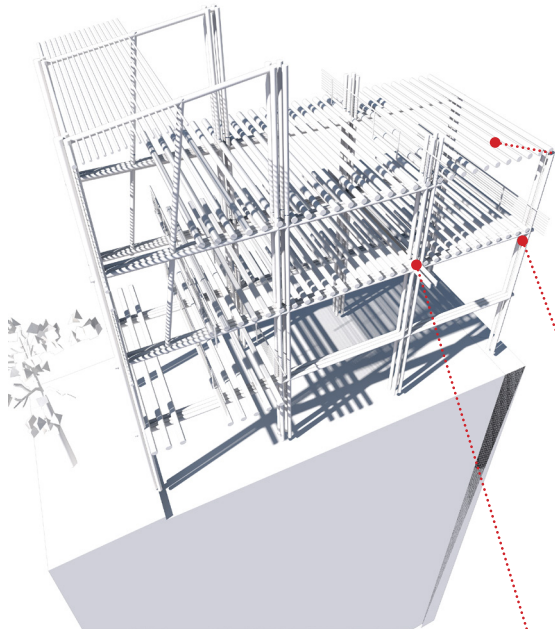

Fig 8.41 Strip Sectional perspective through market
(Author, 2014)

Market

Primary columns consist of 4 bamboo culms 150 - 200 mm diameter. Two bolted together, two separate 150 mm apart. Columns are at 5000 mm intervals.

Primary beams consist of two 150 mm bamboo culms aligned vertically. These are bolted to the columns.



Fig 8.43
Exploratory details
(Author, 2014)

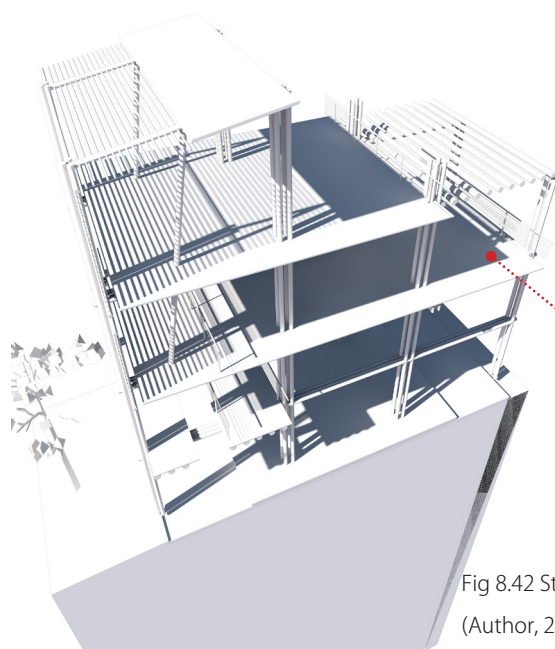
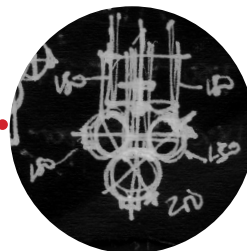
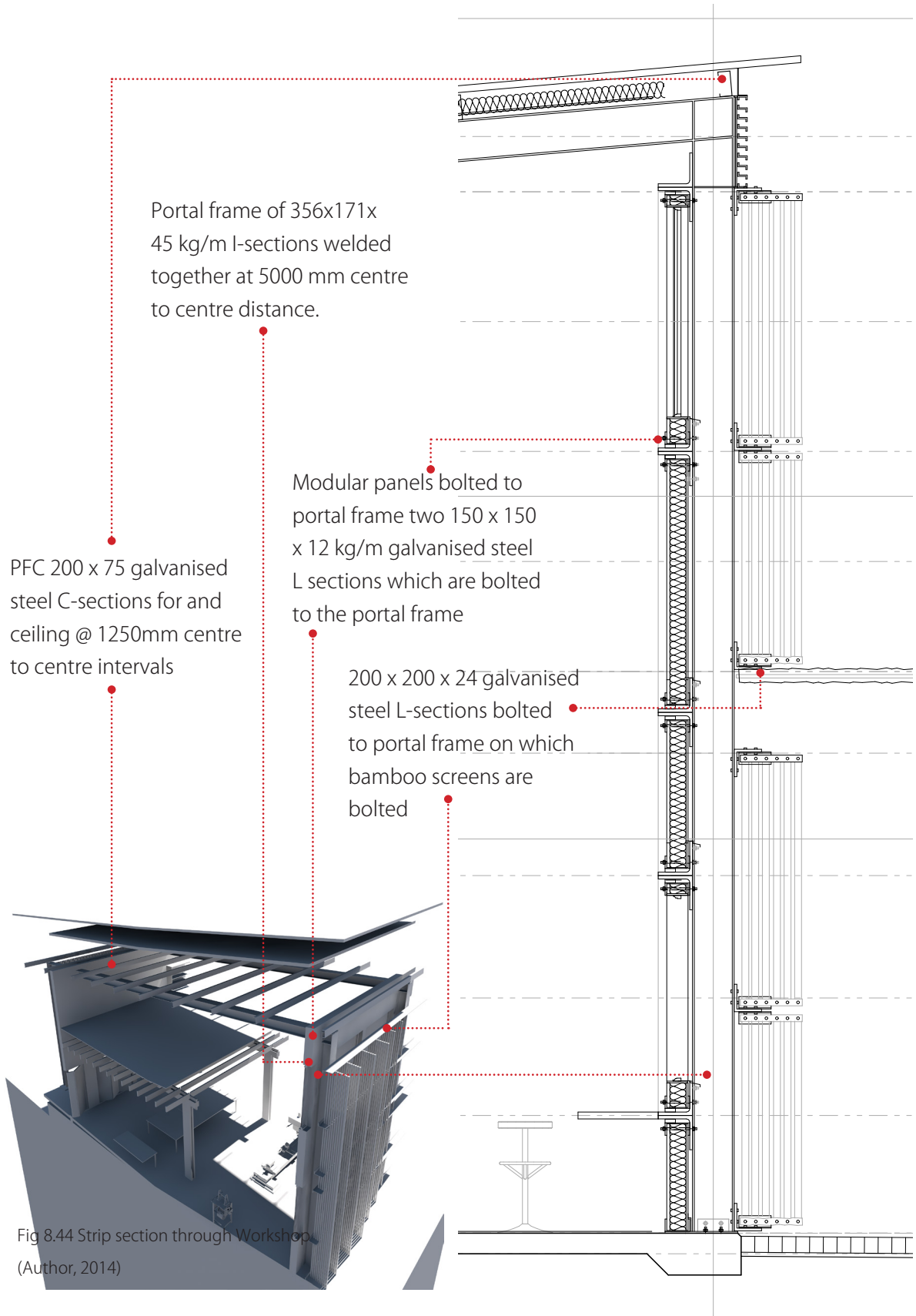

Fig 8.42 Strip Sectional perspective through market
(Author, 2014)

The secondary beams are 200mm diameter bamboo culms spaced at 450 mm intervals onto which a 50mm bamboo floor board is nailed.



Workshop



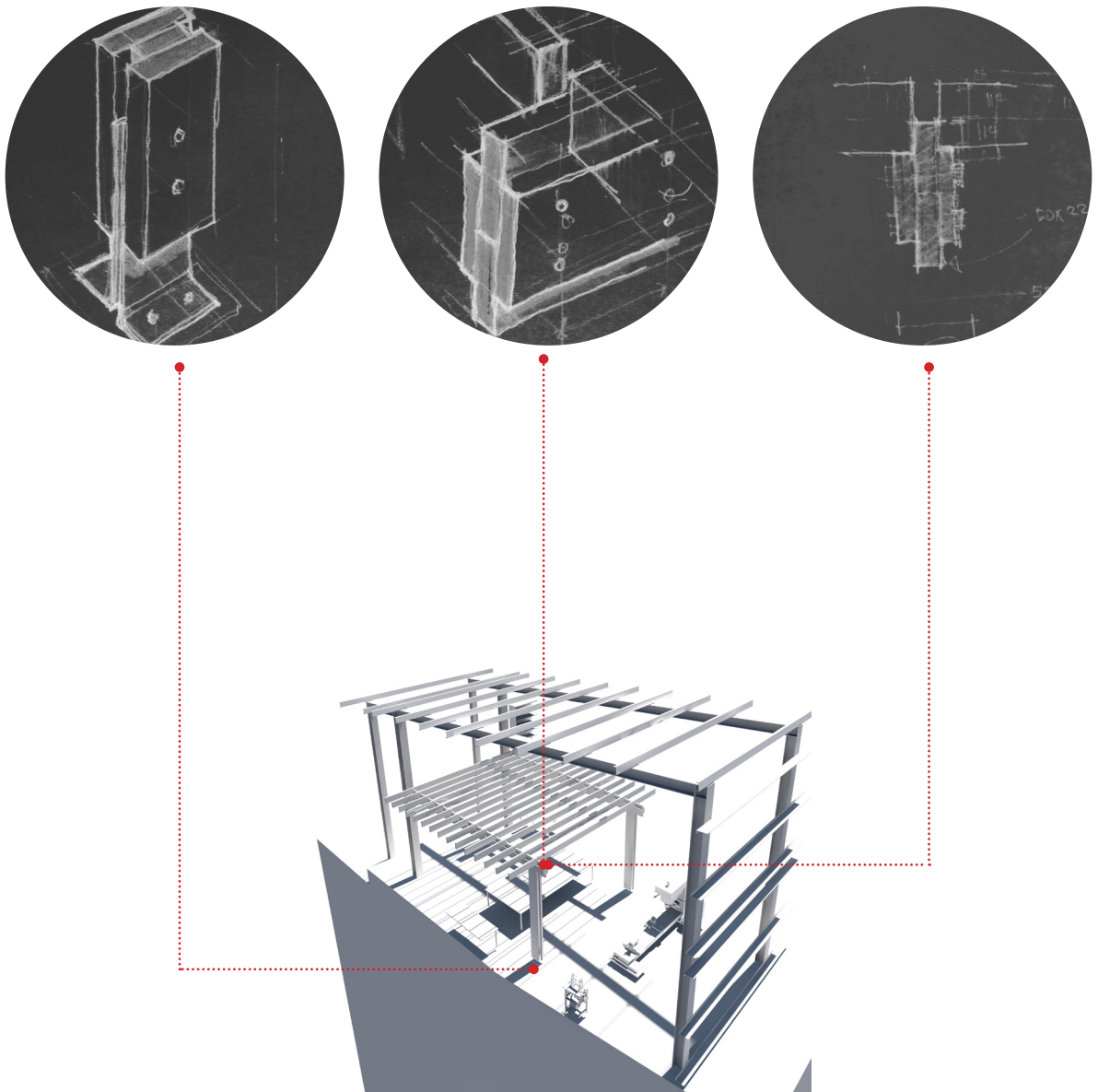
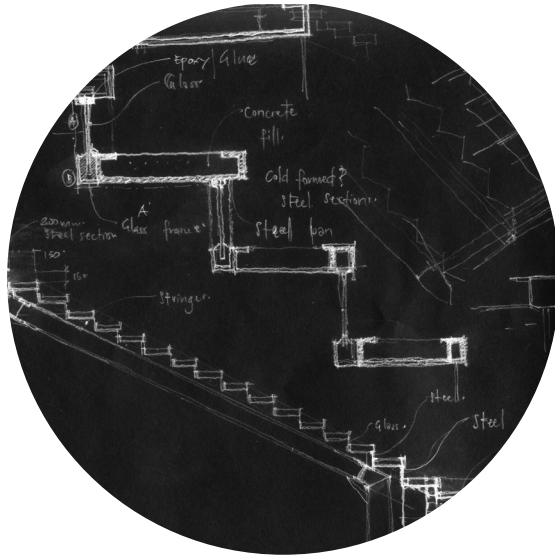

Fig 8.45 Strip section through Workshop with column and connection details (Author, 2014)

Factory



Steel tray

Glass glued to two sections

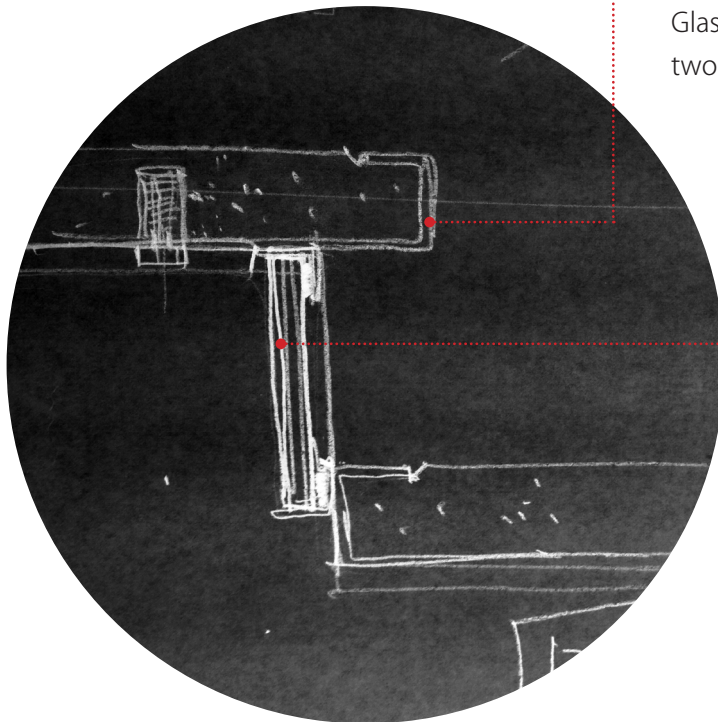

Fig 8.46 Details of floating stairs (Author, 2014)

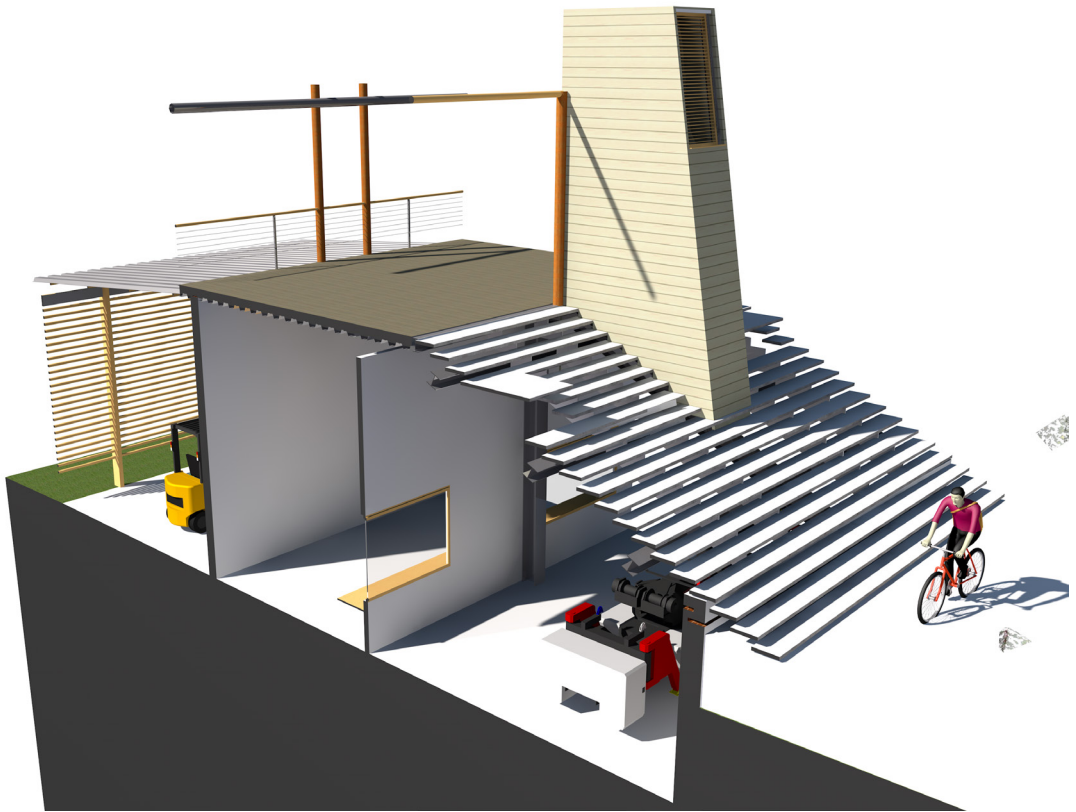

Fig 8.47 Strip perspective section through Factory (Author, 2014)

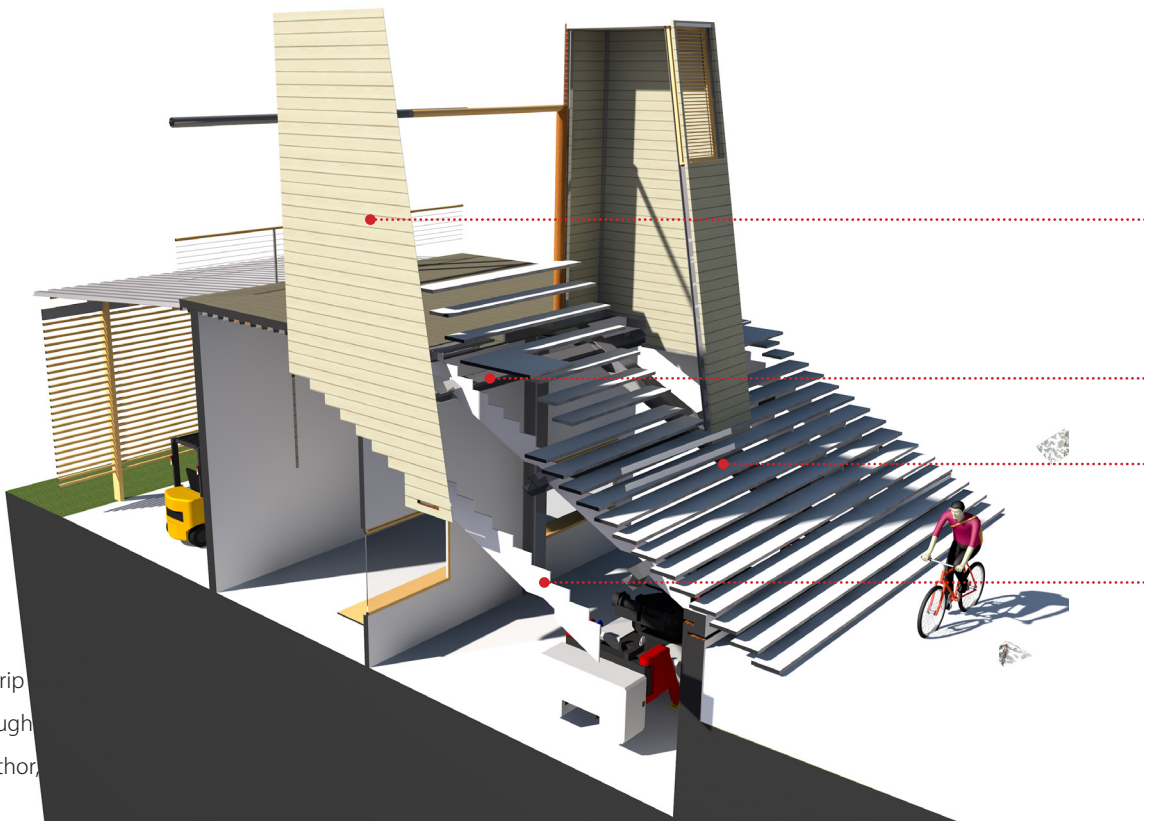

Fig 8.48
Exploded strip
section through
Factory (Author,
2014)

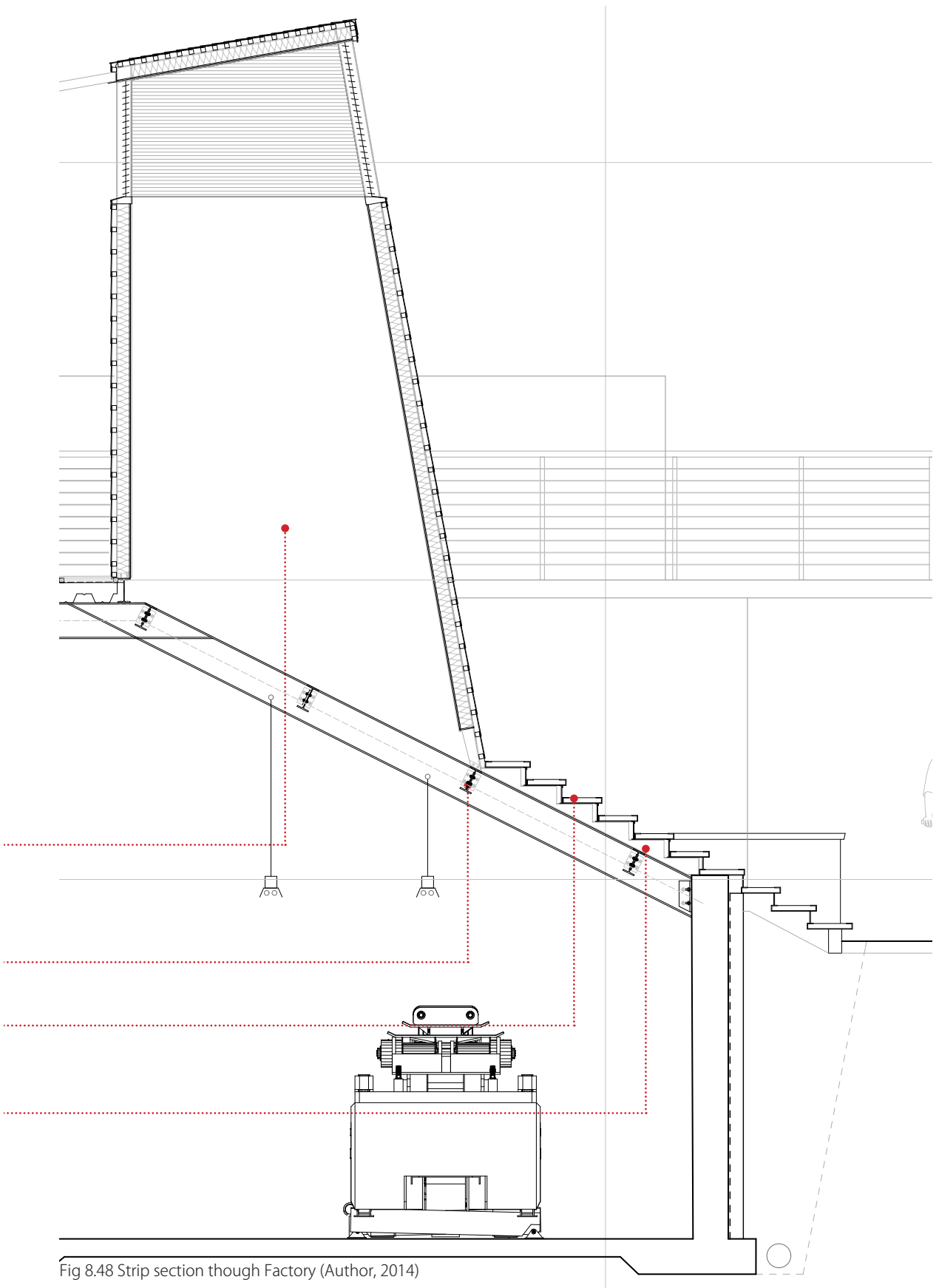

Fig 8.48 Strip section through Factory (Author, 2014)

8.3 Services

8.3.1 Water portable and grey water

The services in the building are networked to other programmes in the urban framework in a system of exchanges. The project focuses on the provision filtration of grey water services and supply of water for industrial and agricultural purposes in exchange for the black water disposal and energy supply.

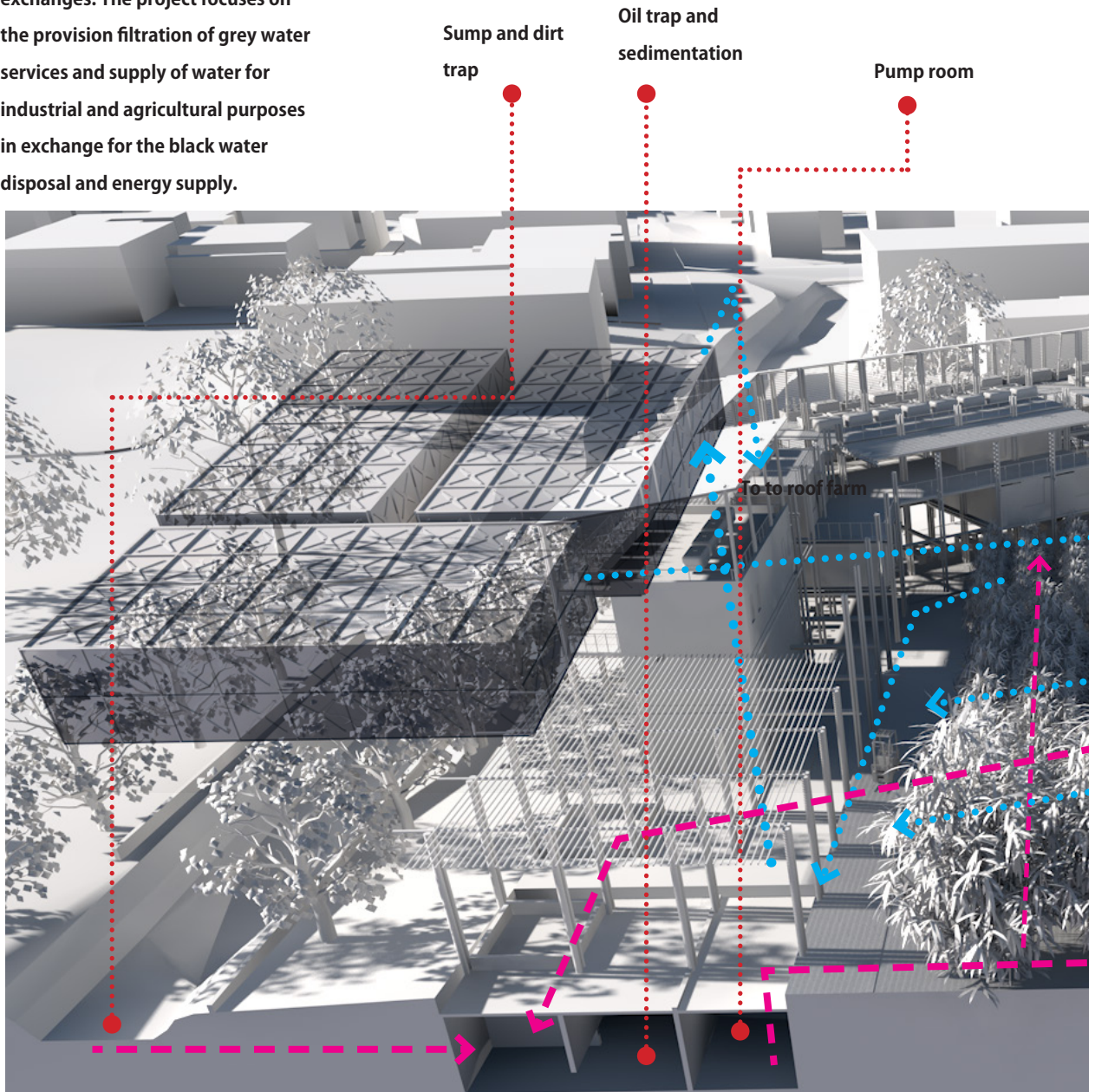
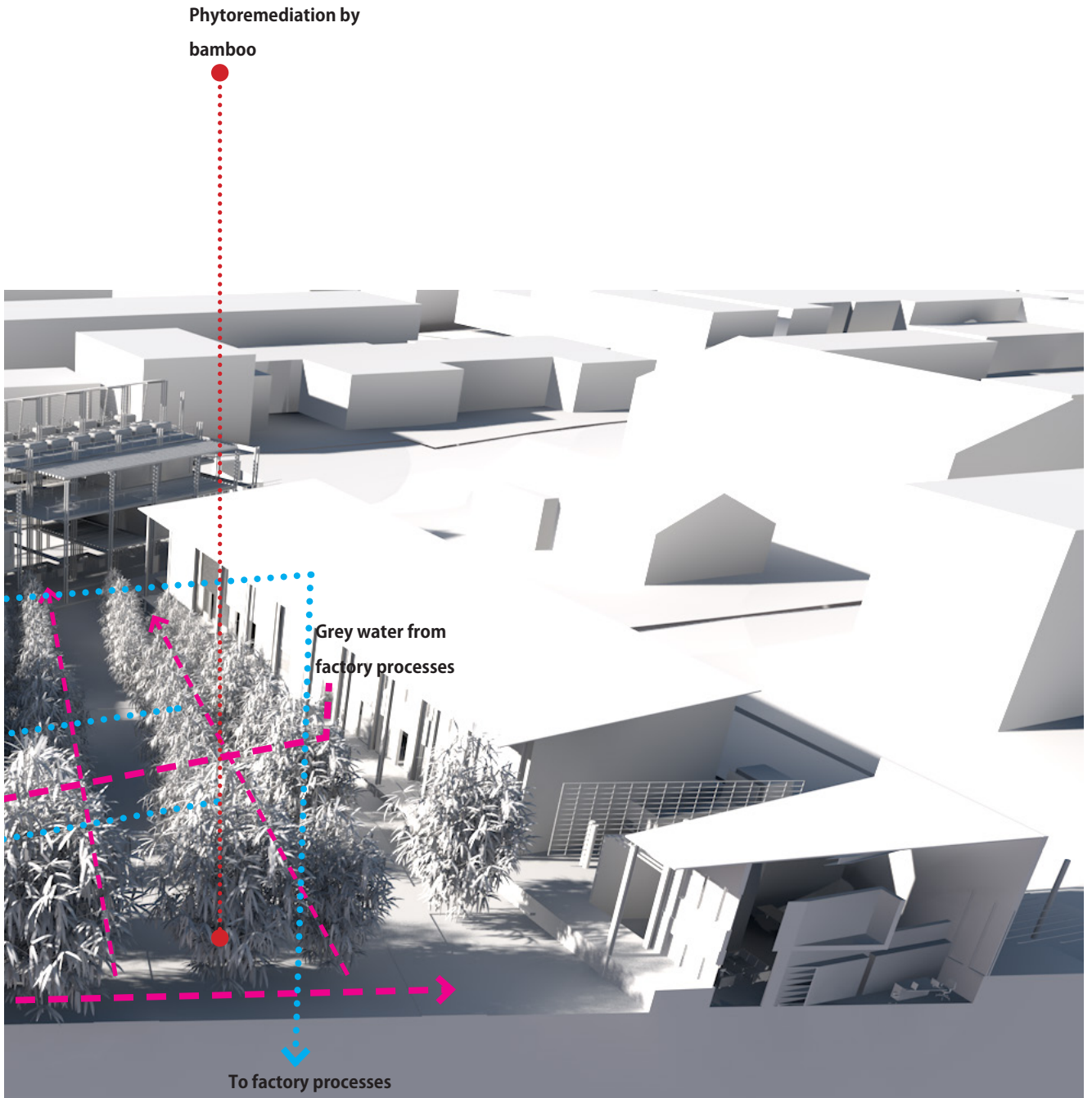

Fig 8.49 Strip section illustrating water filtration (Author, 2014)



8.3.2 Ventilation

Market

Open building will allow for cross ventilation

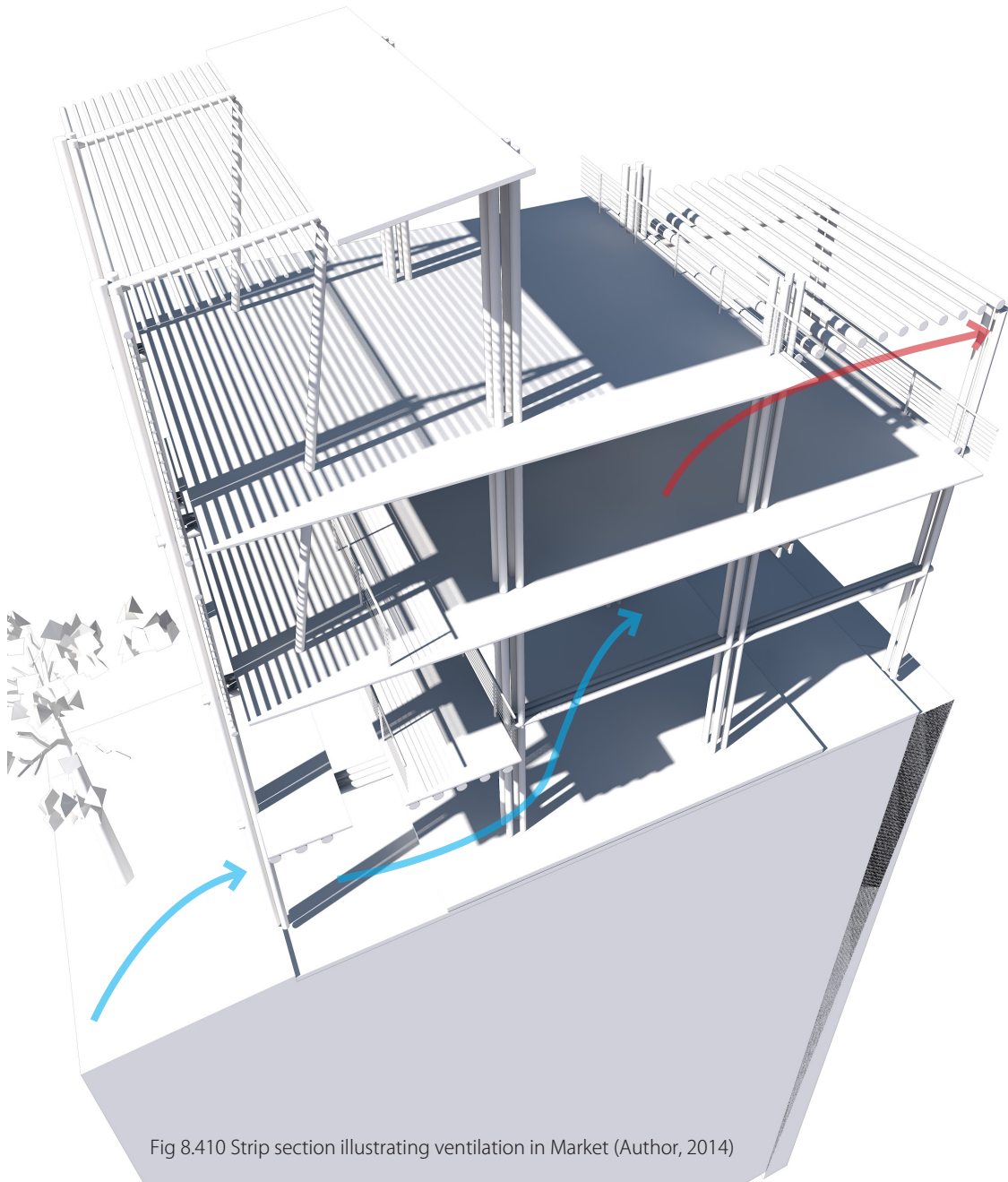

Fig 8.410 Strip section illustrating ventilation in Market (Author, 2014)

Workshop

The building receives cool air through earth tubes from the coolest side of the building (on the west, after the plantation). The use of machinery gradually heats up the air which rises and escapes from the vents on the east side of the building.

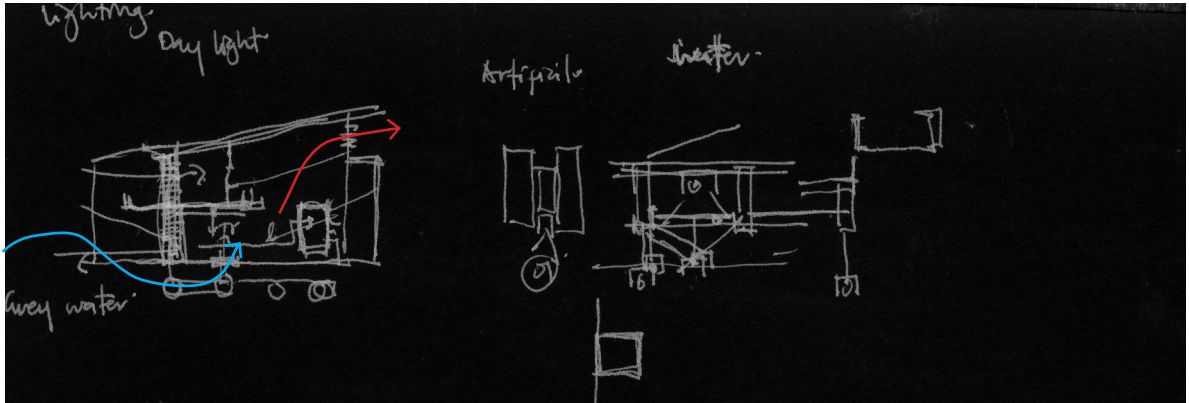

Fig 8.411 Sectional diagram illustrating ventilation of workshop spaces

(Author, 2014)

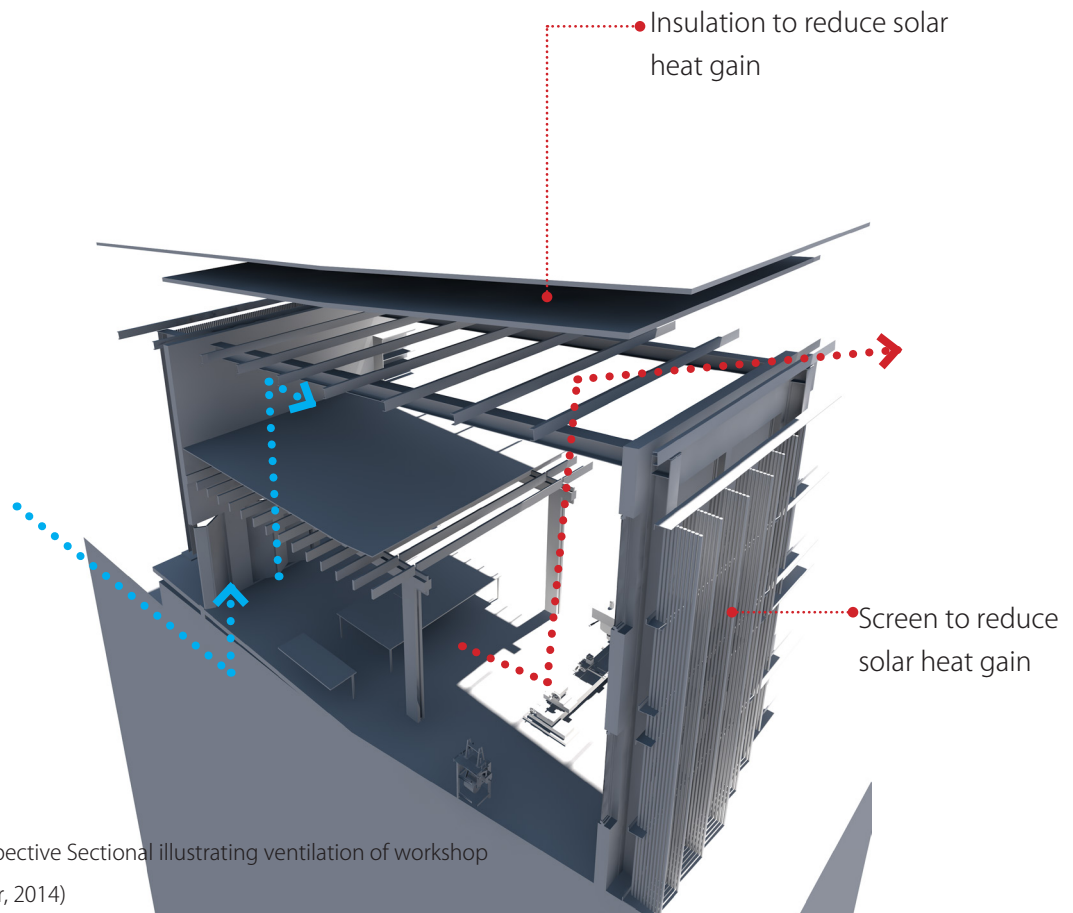

Fig 8.412 Perspective Sectional illustrating ventilation of workshop spaces (Author, 2014)

Factory

Using a similar principle to the Workshop, the building receives cool air through earth tubes from the coolest side of the building (on the north). The use of machinery gradually heats up the air which rises and escapes from the vents on the east side of the building.

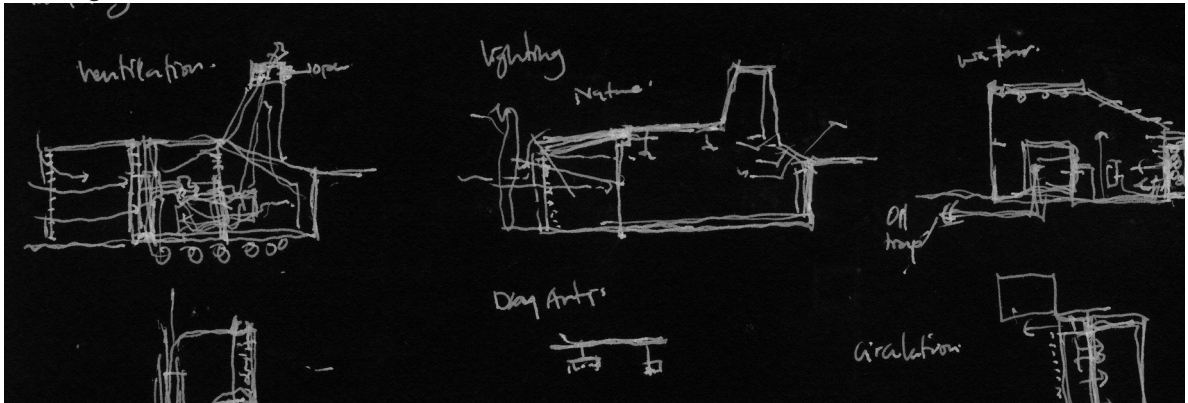

Fig 8.413 Conceptual Sectional diagram illustrating services in the Factory (Author, 2014)

Fig 8.414 Perspective Sectional diagram showing ventilation in the Factory (Author, 2014)

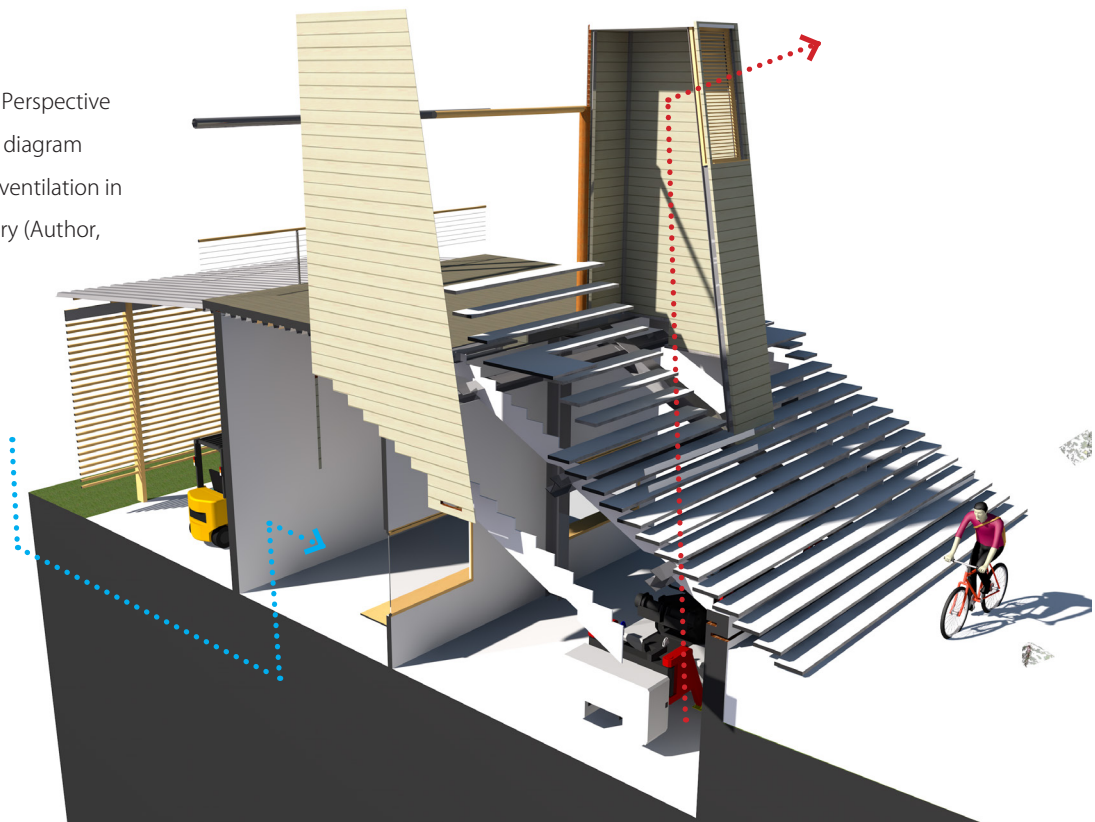



Fig 9 Conditions for germination (Unkown, 2014)

CONCLUSION

This chapter focuses on the research summary of the dissertation.