

**The Optimisation of Truckload Utilisation
within the Automotive Sector of the PFG
Network**

by

**C Fourie
26262623**

**Submitted in partial fulfilment of the requirements for the
degree of**

BACHELORS OF INDUSTRIAL ENGINEERING

in the

**FACULTY OF ENGINEERING, BUILT ENVIRONMENT AND
INFORMATION TECHNOLOGY**

**UNIVERSITY OF
PRETORIA**

SEPTEMBER 2011

Executive Summary

Each distribution network has a few common problems, but truckload utilisation has proven to be one area, that deserves more consideration that it is currently receiving. Truckload utilisation can have a considerable impact on the productivity and cost efficiency of a distribution network. This project will be focussed on truckload utilisation and is monitored by IMPERIAL Logistics and Volition Consulting Services.

There are a few engineering tools that can be applied in order to improve the truckload utilisation, such as facilities planning, ergonomics, process management, simulation modelling and in some cases simple logic. In this project, information gathering will be done including a literature review on these tools and methods in order to create a framework for optimising truckload utilisation and finally a model. This will explain what truckload utilisation is, what it consists of and how it fits into the distribution network. The scope will include the study of the distribution network as well as application of engineering techniques and methods to improve truckload utilisation. If these improvements can be implemented successfully, productivity will increase and costs will be considerably reduced.

Table of Contents

Executive Summary	i
List of illustrations.....	iv
1. Introduction and Background	1
1.1 Introduction.....	1
1.2 Background to the problem.....	2
1.3 Problem Statement	3
1.4 Project Aim	3
1.5 Project Scope.....	4
1.6 Project Deliverables	5
2. Information Gathering.....	6
2.1 Introduction.....	6
2.1.1 Background to the distribution network.....	7
2.1.2 Background to truckload utilisation.....	9
2.2 Literature Review	11
2.2.1 Management	11
2.2.2 Facilities Planning	13
2.2.2.1 Arrangement of area.....	15
2.2.2.2 Space Planning.....	16
2.2.3 Simulation as a tool.....	19
2.2.3.1 Introduction.....	19
2.2.3.2 Arena as a simulation tool.....	22
2.2.4 Information Gathering Summary.....	23
3. Model input gathering and analysis.....	24
3.1 Data analysis	24
3.1.1 The process.....	24

3.1.2	Flowchart	25
4.	Solution design and implementation	28
4.1	Design of solution model.....	28
4.1.1	Current simulation model	28
4.1.1.1	Analysis of current model.....	29
4.1.2	Solution model simulation.....	31
4.2	Evaluation and Testing.....	35
5.	Conclusion.....	39
6.	References	40
7.	Addendum	42
7.1	Appendix A: Section of current layout.....	42
7.2	Appendix A: Solution layout 1	43
7.3	Appendix A: Solution layout 2	44

List of illustrations

List of Figures

Figure 1: The IMPERIAL Logistics divisional structure	1
Figure 2: Truck turnaround times at SX Sites	2
Figure 3: Major cost factors of a distribution network.....	7
Figure 4: Map of the transportation routes.....	8
Figure 5: Graphical representation of the PFG Network	9
Figure 6: Major factors of truck turnaround time	10
Figure 7: Representation of the Process of Management.....	12
Figure 8: Facility requirements for receiving and shipping activities	13
Figure 9: Illustration of a multi-echelon logistics channel.....	14
Figure 10: Representation of Receiving and Shipping Area Arrangement.....	15
Figure 11: Receiving and shipping analysis chart.....	16
Figure 12: (a) Recessed truck entrance to property. (b) “Y” truck entrance to property.	18
Figure 13: Representation of area requirements example	19
Figure 14: Key for using process flowchart.....	25
Figure 15: Flowchart of generic process for receiving and shipping	26
Figure 16: Shapes indicating the start of the process	26
Figure 17: Shape indicating the truck driver opening the trailer	26
Figure 18: Shape indicating load acceptance/rejection.....	26
Figure 19: Shape indicating the process of loading and offloading	27
Figure 20: Shape indicating the truck driver closing the trailer.....	27
Figure 21: Shapes indicating the end of the process	27
Figure 22: Current process simulation model in Arena.....	28
Figure 23: Current model utilisation of resources	29
Figure 24: KPI's of current model	30
Figure 25: Solution process simulation model in Arena	32
Figure 26: Solution model utilisation of resources	33
Figure 27: KPI's of solution model.....	34
Figure 28: Old utilisation vs. New utilisation	35
Figure 29: Solution waiting time vs. Current waiting time	36
Figure 30: Current queue length vs. Solution queue length.....	36

List of Tables

Table 1: Raw data as input for simulation model	24
Table 2: Utilisation of resources current model.....	29
Table 3: Illustration of current model waiting time.....	30
Table 4: Illustration of current model queue length.....	30
Table 5: Utilisation of resources in solution model.....	33
Table 6: Illustration of solution model waiting time	33
Table 7: Illustration of solution model queue lengths.....	34

1. Introduction and Background

1. Introduction and Background

1.1 Introduction

IMPERIAL Logistics, established in 1975, is a totally owned subsidiary of IMPERIAL Holdings (Pty) (Logistics, Imperial, 2011), as shown in Figure 1. IMPERIAL Logistics is a global logistics company and a clear leader in the supply chain industry in Southern Africa. As shown in Figure 1, IMPERIAL Logistics consists out of four divisions such as Transport and Warehousing, Consumer Products, Specialised Freight, Integration Services and Africa, each playing a key role within IMPERIAL Logistics. Recently two divisions have been added, namely Africa and Support Services. These divisions have operations that are spread over 14 countries in Africa and internationally it spans from Europe to the USA, also in India and the Far East. This specific project will focus on the transport of raw glass material and automobile windscreens within the PFG network that consists out of PFG, Shatterprufe, GSA and Widney.

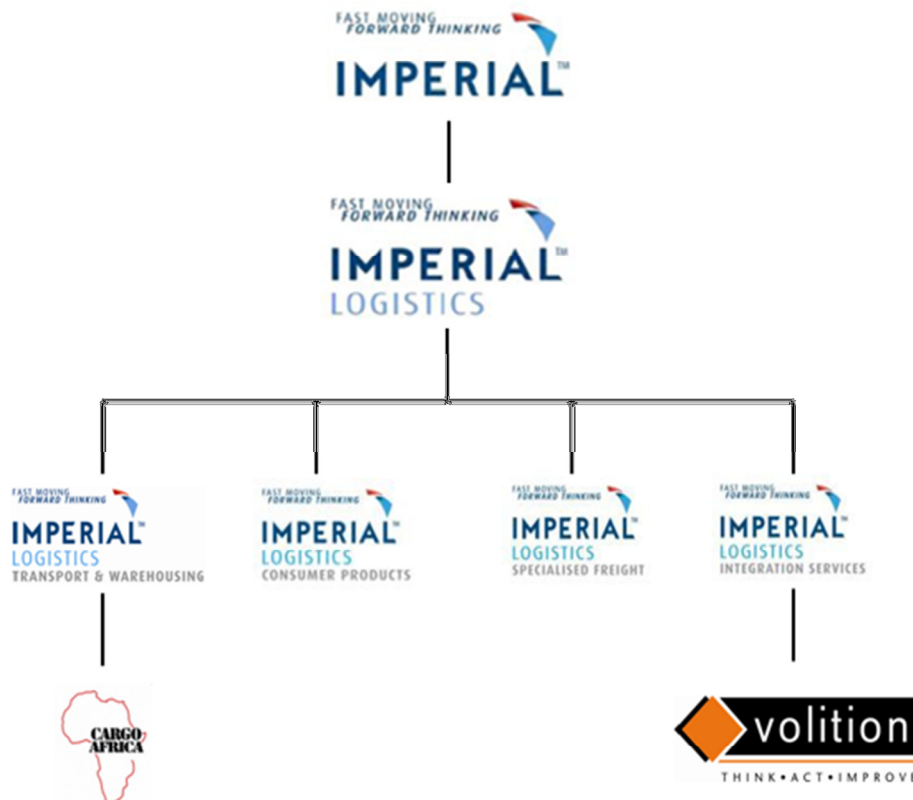

Figure 1: The IMPERIAL Logistics divisional structure

1. Introduction and Background

IMPERIAL Logistics is in charge of managing the logistics of Shatterprufe. Cargo Africa is the third-party logistics provider (3PL) and manages all the trucks used to transport these windscreens and raw glass.

1.2 Background to the problem

The problem has been identified to be the truckload utilisation. Truckload utilisation consists out of many factors such as loading of the truck, routes that the truck follow, truck turnaround time, impact of the site's facility on the truck, etc. According to current analysis, before information gathering, it has been noticed that truck turnaround times can be a possible cause of insufficient truckload utilisation. The reasons for high truck turnaround times are very broad, especially in problems where man, machine and money have to be balanced. These truck turnaround times should be improved to a certain average maximum allowable time as shown in Figure 2.

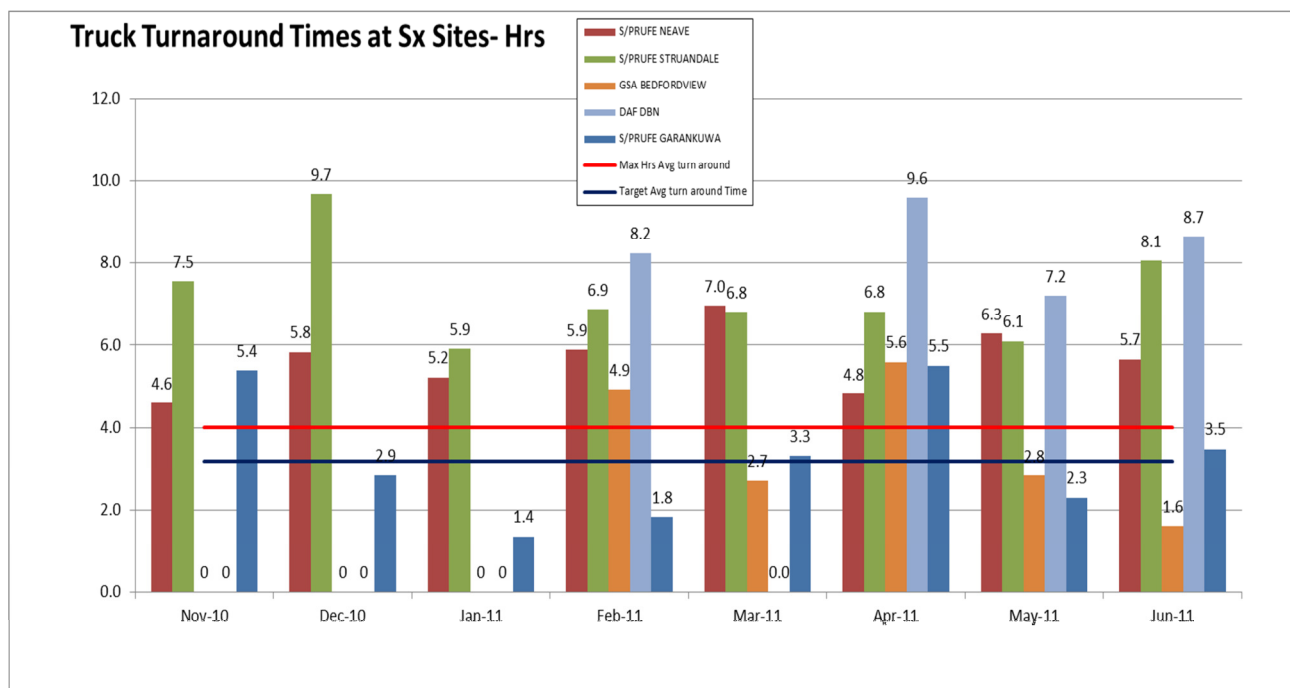

Figure 2: Truck turnaround times at SX Sites

In order to obtain success, the company must have tactical and strategic initiatives at all levels (Tompkins, White, Bozer, & Tanchoco, Defining Requirements, 2010) resulting in better communication for example. Truck turnaround times which is one of many factors contributing to truckload utilisation, add unnecessary costs to a distribution network. These unnecessary costs include additional truck driver costs and also opportunity costs.

1. Introduction and Background

After the information gathering, the truck turnaround times at the SX site in Neave has been identified as the key contributing factor to truckload utilisation. Currently the facility and management is having a negative impact on truck turnaround time. Looking at the PFG network which consists of PFG in Springs, SX sites in Port Elizabeth and GSA in Bedfordview, the real problems and additional costs happen between SX Neave and GSA in Bedfordview. GSA only has one area used for receiving and shipping and there for tries to schedule all incoming goods between 7:00 AM and 12:00 PM and their outgoing goods between 12:00 PM and 5:00 PM. It takes on average 21 hours to drive from Port Elizabeth to Bedfordview.

1.3 Problem Statement

IMPERIAL Logistics has identified that truckload utilisation is not optimal in the PFG Network which has a negative impact on cost efficiency.

1.4 Project Aim

The aim of this project is to improve truck turnaround times to a certain average maximum allowable time at SX Neave in order to improve truckload utilisation and reduce costs.

Objectives to achieve this aim:

- Understanding the distribution network in order to understand individual requirements of the site
- Develop a framework that can be applied in general to the different sites

By achieving the aim of this project, IMPERIAL logistics will be able to reduce the time it takes a truck to unload raw glass material or load laminated windscreens, empty pallets, cullets or broken glass at the SX site in Neave, resulting in the improvement of time delays and reducing the cost.

1.5 Project Scope

The project scope can be divided into two sections. The first section consists of what is included in the scope with an approach based on the following list of activities:

- The current distribution network needs to be analysed, with regards to inputs and outputs. The inputs refer to the number of workers (Forklift and incoming and outgoing truck operators) as well as the number of trucks in the network and the routes travelled. The outputs are referring to the capacity of each truck.
- The communication channels used at the site should be analysed.
- Establish work schedules of workers, length of shifts, number of workers per shifts and number of trained workers to operate a forklift.
- Determine the constraints and bottlenecks at the site.
- Convey a literature study on optimising truckload utilisation by the following methods:
 - Management
 - Facilities planning
 - Simulation modelling

The activities listed above are a good framework to include the factors and unforeseen variables that play a part in this project. The second section of the project scope consists of what is not included in this project.

- The manufacturing cost or selling cost of the windscreens
- Buying or selling price of a truck
- Toll cost
- Maintenance cost on a truck
- The quality of the roads on which the trucks travel and the impact it has
- Types of pallets used for stacking the windscreens on the truck

1.6 Project Deliverables

The deliverables that will be listed are the different requirements of IMPERIAL Logistics.

- An in depth analysis of the loading and unloading area at the SX site
- Identification of possible areas for problems and bottlenecks
- Three project status reports (Status reports on three specific dates indicating whether the project is on track or not)
- Framework on how to optimise truckload utilisation
- Literature review (Information gathering)
- Proposed solution with simulation model

2. Information Gathering

The information gathering will be divided into two parts. The first part will be an information study and introduction elaborating on the distribution network and truckload utilisation. This will explain how it fits into the distribution network and also elaborating on the factors that may cause inefficient truckload utilisation.

The second part will consist of a literature review on methods to improve truckload utilisation.

2.1 Introduction

The sale of vehicles within South Africa's automotive industry has increased in the last decade and there is still decent demand for windscreens, even though the sales have been decreasing again. This directly impacts the distribution network in several ways. The distribution network of a supply chain is an essential driver in the overall profit of a company since it has a direct impact on the supply chain cost and customer experience (Chopra, 2003). Distribution cost can be seen as all the costs incurred when a company moves goods from the point of manufacturing to the point of sale. A large number of factors can impact the distribution cost for example when looking at the number of facilities and transportation cost. As the number of facilities increase, the transportation cost decreases, but only to a certain point where total cost increases again.

Most companies outsource their logistics functions and in a single distribution network, there can be different companies used to transport the goods. This project will focus on the third-party logistics service provider, Cargo Africa and their distribution network for PFG.

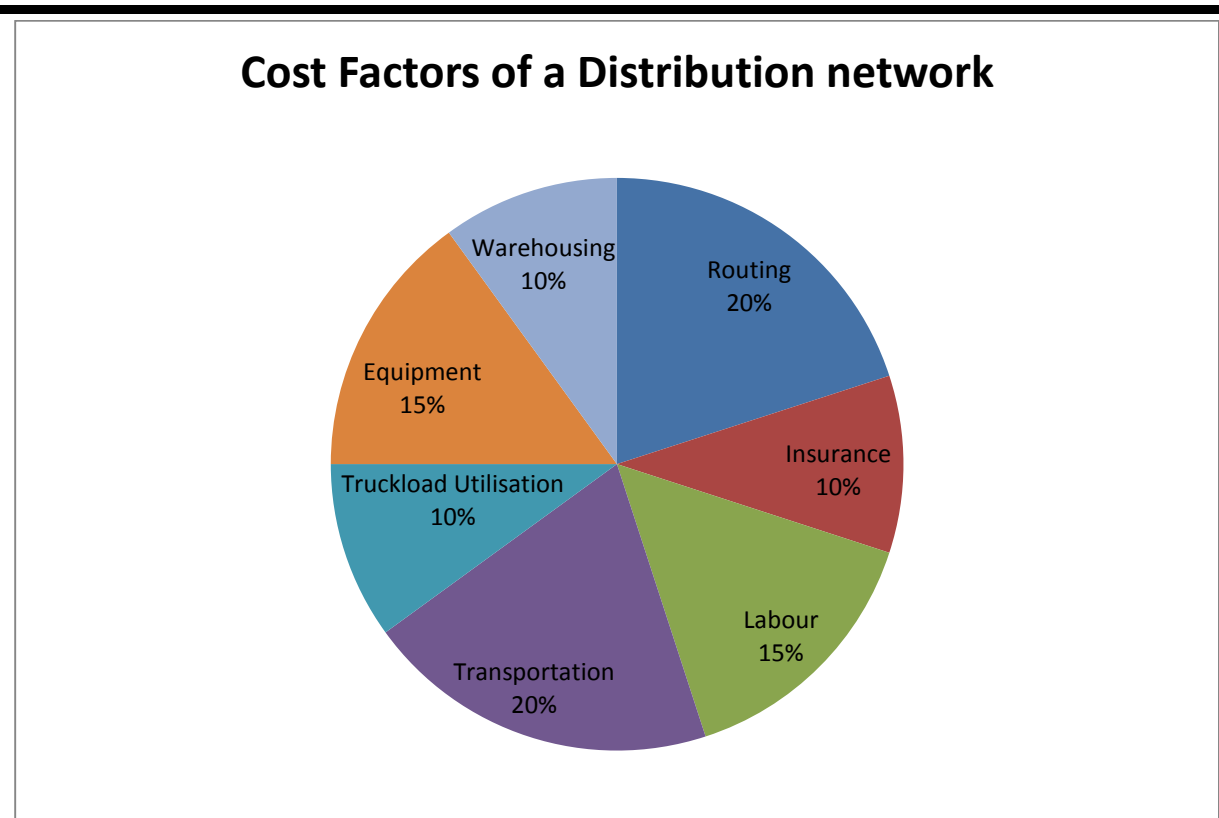

Figure 3: Major cost factors of a distribution network

As seen from Figure 3, a few factors including truckload utilisation contribute to the cost of a distribution network (IMPERIAL Logistics, 2011). Referring to page 2, the problem has been identified to be truckload utilisation and even though every factor has an impact on cost, this project will focus specifically on this.

2.1.1 Background to the distribution network

Raw glass sheets are manufactured at PFG in Springs, Gauteng. These glass sheets are referred to as raw glass since they're not cut according to specification for windscreens yet. These raw glass sheets are then transported to either the SX site in Neave or Struandale, which are both situated in Port Elizabeth, depending on the specifications of the windscreens. The raw glass sent to Neave will be cut into windscreens and laminated where the SX site in Struandale produces OE toughened rear lights and door glasses. From these sites in Port Elizabeth the windscreens are sent to GSA in Bedfordview, the wholesale supplier of Shatterprufe windscreens from where it is distributed nationally and

2. Information Gathering

internationally (PFG, 2011). Figure 4 displays the map of South Africa containing the material flow (The University of Texas, 2011).



Figure 4: Map of the transportation routes

- ▶ Transportation of raw glass material
- ▶ Transportation of windscreens (Raw glass cut into windscreen specification)

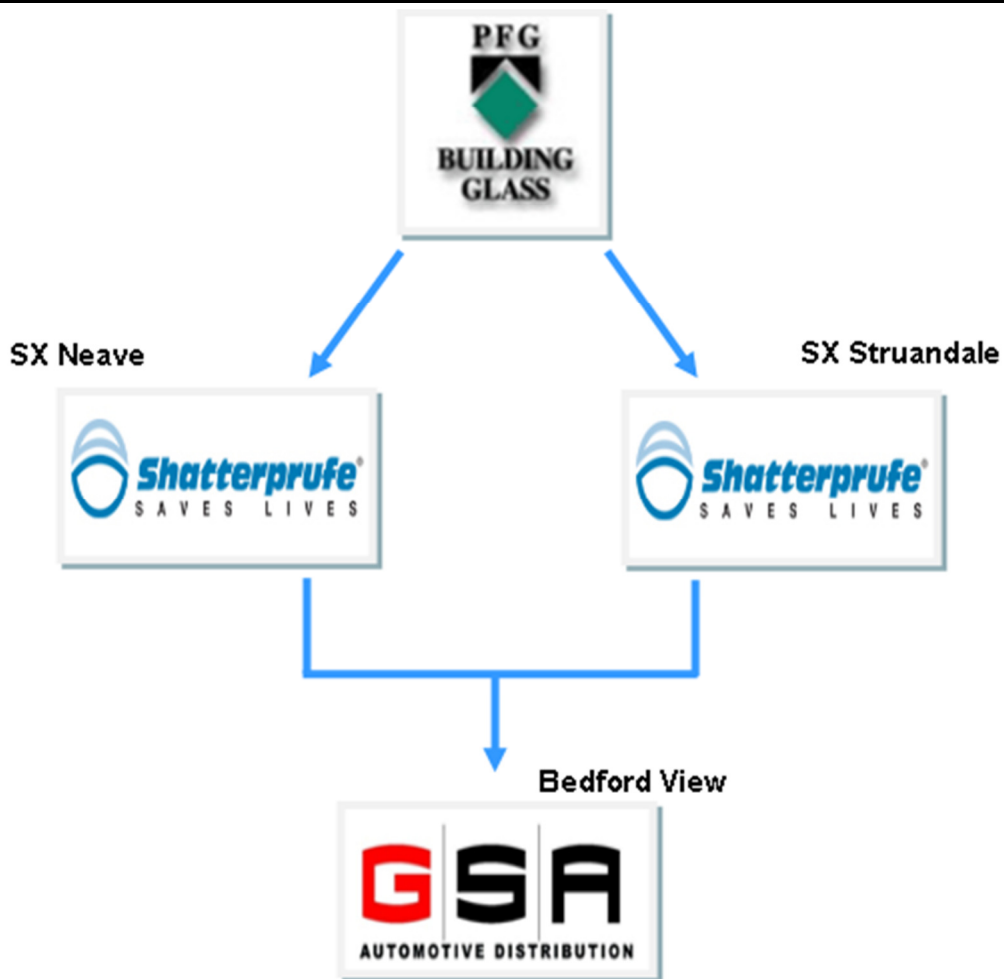

Figure 5: Graphical representation of the PFG Network

2.1.2 Background to truckload utilisation

Elaborating on Figure 5, truckload utilisation can be further divided into a number of contributing factors. These factors can be seen as major observations such as the load service and routing to the little observations such as truck turnaround times and a facilities layout. The problem has been identified to be truckload utilisation and after research done at the SX site in Neave, the problem has been identified to be the truck turnaround times that if improved can greatly impact truckload utilisation lower costs.

2. Information Gathering

In Figure 6 below, a Pie-chart is used to illustrate the factors contributing to truck turnaround time (IMPERIAL Logistics, 2011).

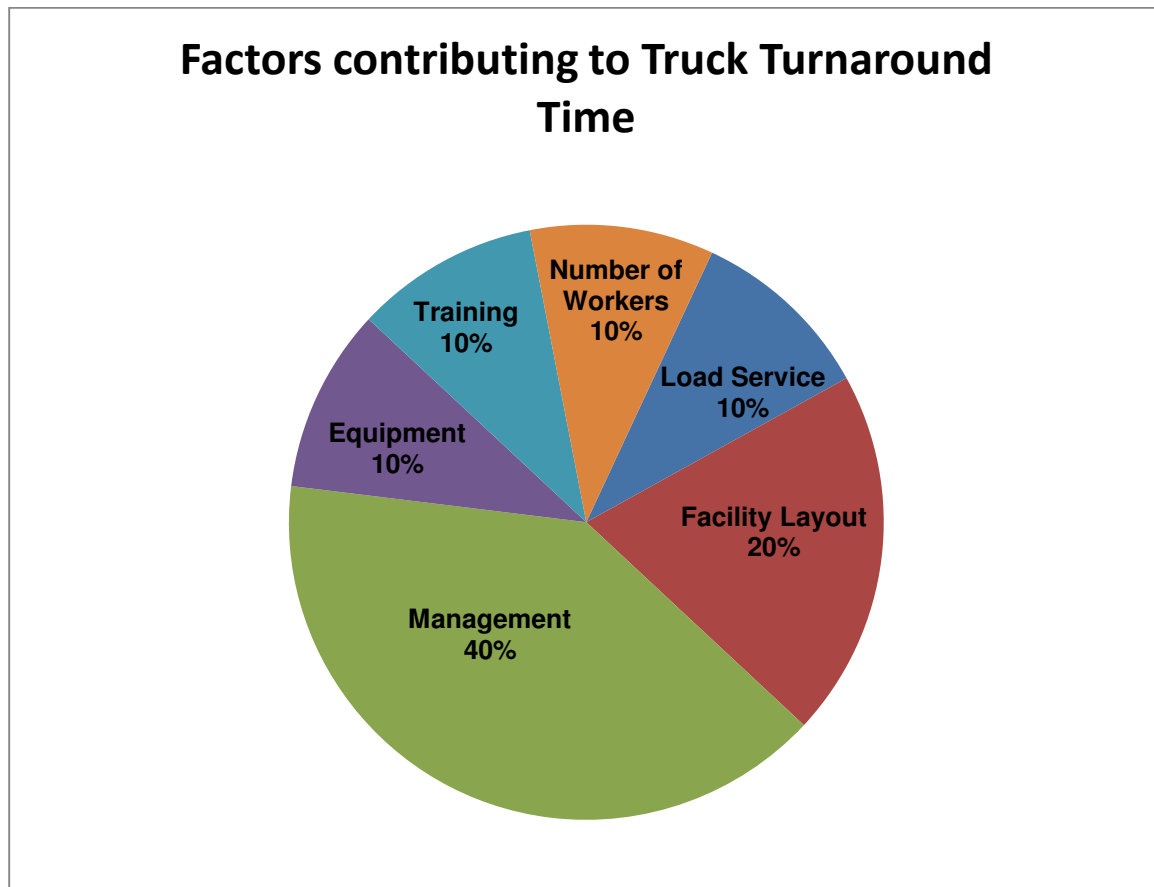

Figure 6: Major factors of truck turnaround time

Looking at Figure 6, Load Service refers to whether the truck is delivering a full truckload or less-than-truckload. The bigger the load that the truck is delivering obviously adds to the turnaround time, but mostly it is more cost efficient to have a full-truckload. A full-truckload aids in decreasing the cost per unit.

The facility layout can add or subtract a substantial amount of time, when looking at space availability for trucks with trailers to move in or to be loaded or unloaded. Even the entrance to the facility can impact truck turnaround time.

2. Information Gathering

Management has the biggest impact on truck turnaround time. Focussing on the PFG network, when a truck is ready to leave with a load from PFG Springs a message is sent to SX Neave or SX Struandale (depending on the determined destination for the raw glass material) via a software tool called SAP. Currently there is no pro-active plan set in place for the workers to follow when such a message is received to start planning the load. So when the truck arrives, only then is planning done by the workers. Typical criteria for a pro-active plan will be actions, namely familiarising tools, familiarising paths to use, organising the loading and shipping area for a clean and safe environment, etc. Please see page 12 for more details.

The equipment (referring to forklifts), training and number of workers go hand in hand. For every forklift there has to be a trained operator to operate the forklift. Logically when increasing the forklifts and workers may reduce the truck turnaround time but this may involve hiring and training new workers and even if there are forklifts and workers available, space requirements and surface quality may not always allow the addition.

2.2 Literature Review

The problem in this project can be divided onto three areas of engineering tools that has been acquired in the degree of Industrial Engineering at the University of Pretoria. These areas will be analysed and discussed in the following sections.

2.2.1 Management

Management has a great influence in the success of a company and can positively impact truck turnaround time which in turn will reflect improved efficiency of the receiving and shipping processes.

Focussing on the PFG network, management becomes part of the picture when the truck leaves the PFG site in Springs and the notifying message is sent to the SX site which will receive the raw glass material.



Figure 7: Representation of the Process of Management

According to (Lewis, Goodman, & Fandt), management focuses on organisational goals as shown in Figure 7. Organisational goals can be categorised in four areas such as planning, organising, leading and controlling and these four areas can be applied to the SX site in Neave.

Planning can be interpreted as planning ahead of time for arrival of trucks, resulting in a sense of “pre-programmed” actions for the workers and the more familiar they are with a job, the faster they will be able to do it. Leading can be seen as bringing the staff together to form a team in order to make them feel important and also giving them the feeling of really making a contribution to the company. They can feel proud of their work which keeps them motivated and other initiatives can be implemented such employee of the month within different sectors of the company and also giving incentives for their efforts.

In this context, organising can form part of planning. Organising refers to predetermining the tasks and who will be managing those tasks. Controlling can form part of leading in the sense of motivating staff with prizes for the worker with the least deviations between results but also giving penalties when necessary.

2.2.2 Facilities Planning

When the carriers that interact with the receiving and shipping activities are not properly considered, problems might occur in planning a receiving and shipping facility (Tompkins, White, Bozer, & Tanchoco, Warehouse Operations, 2010). These considerations include factors such as positioning of the carriers and also to consider the receiving and shipping function to start when the carrier crosses the property line. In order for the facility to perform receiving and shipping activities, it has a few standard requirements shown in Figure 8 (Tompkins, White, Bozer, & Tanchoco, Warehouse Operations, 2010).

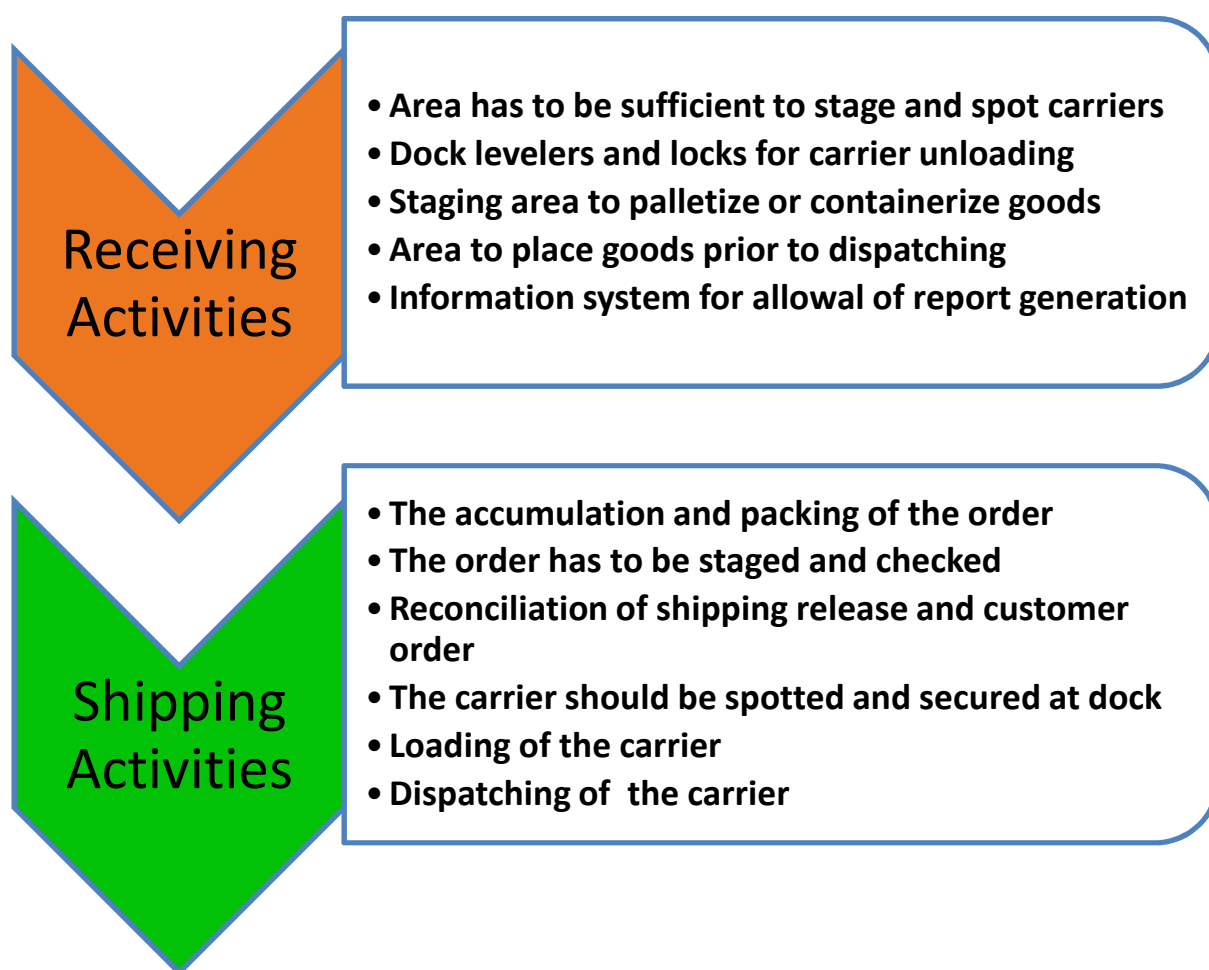

Figure 8: Facility requirements for receiving and shipping activities

A multi-echelon logistics channel is illustrated in Figure 9 (Langley Jr., Coyle, Gibson, Novack, & Bardi, 2008). When considering the warehouse design for the “Warehouse” in a logistics channel like in Figure 9, it is logical to design a facility with separate areas for

2. Information Gathering

receiving and shipping to avoid “traffic jams” with incoming and outgoing trucks. In these logistics channels, goods are received and stored in a warehouse until a customer order is received or for future shipment. By having separate receiving and shipping areas, it becomes easier to facilitate cross-docking without first having to wait for the inbound truck to finish offloading and get loaded. According to (Langley Jr., Coyle, Gibson, Novack, & Bardi, Warehousing Decisions, 2008), cross-docking is defined as an operation that supports the product-mixing function. How it works is that when a carrier arrives with goods from different suppliers, instead of taking everything to the warehouse for picking later, the goods are immediately moved to waiting trucks in the shipping area to be loaded for specific customers.



Figure 9: Illustration of a multi-echelon logistics channel

It is the logical choice to still have separate areas for receiving and shipping but the reason is primarily to avoid the time wasted when incoming trucks are waiting for other trucks to load their shipment. It is unnecessary to design the receiving and shipping area for a manufacturing plant to enable cross-docking because very seldom will there be a scenario where the raw material received is immediately shipped again.

At any manufacturing plant, it's usually the same process that is followed. The raw material is received after which it is taken to a basic storage area. From there it is taken to a basic storage area. The manufacturing plant then requests raw material as it is needed, the product is manufactured and then a finished product is packed and shipped.

2.2.2.1 Arrangement of area

Facilities planning combined with receiving and shipping space requirements can acquire quite a lot of information in the sense of balancing space, equipment and people (Tamcam, 2011). Looking at the receiving area, it is necessary to look at the requirements of the space used such as to stage and spot the carrier, dockboards, receiving area, staging area and office area.

Due to space constraints, some sites have the receiving and shipping area in one area but where it is separate, the shipping area also has some requirements such as staging area, office area, area to stage and spot carriers and sufficient space for dockboards. The receiving and shipment area can be arranged in a few ways as shown in Figure 10 below.

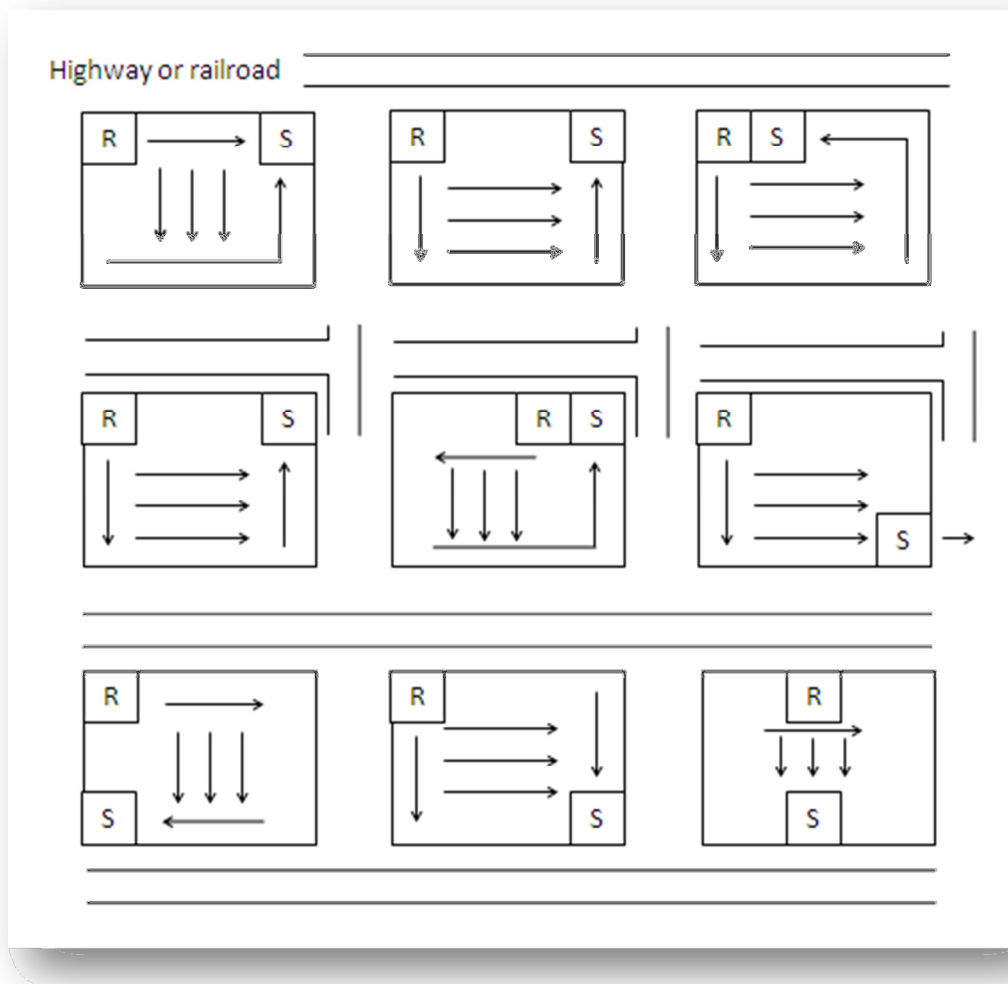

Figure 10: Representation of Receiving and Shipping Area Arrangement

2.2.2.2 Space Planning

According to (Tompkins, White, Bozer, & Tanchoco, Warehouse Operations, 2010), with regards to the planning of the space, it is imperative to look at the three steps required to determine the requirements of the space for receiving and shipping such as:

- What is to be received and shipped
- The number and type of docks needed
- The physical space requirement for receiving and shipping

Looking at what will be shipped and received will tell you what type of vehicle you can expect to enter and leave the site. It also tells you what size weight the goods are that you will be receiving and shipping and whether the site's equipment is sufficient or not. A receiving and shipping analysis chart (Tompkins, White, Bozer, & Tanchoco, Defining Requirements, 2010) is shown in Figure 11 below and can be used to thoroughly execute the first step.

Company _____		Date _____		Raw Materials _____		Finished Goods _____				
Prepared by _____		Sheet _____ of _____		Plant Supplies _____						
1	2	3	4	5	6	7	8	9	10	11
Description	UNITLOADS				Size of Shipment (unit loads)	Frequency of Shipment	TRANSPORTATION		MATERIAL HANDLING	
	Type	Capacity	Size	Weight			Mode	Specifications	Method	Time

Figure 11: Receiving and shipping analysis chart

2. Information Gathering

With the receiving and shipping analysis chart, information can be gathered on what, when and how much will be received or shipped. If there is an existing receiving and shipping operation or the current operation has similar objectives than a previous operation, this data can of course be obtained from previous reports or shipping releases. When this information is obtained, column 1 to 7 can be completed. With regards to columns 8 and 9, the type of carrier used will be identified here. This specifies the length, height and width of the carrier which is critical information when planning the entrance to a site for example.

The Material handling column concerns the loading and offloading of the goods onto the carrier. If there is an existing area for receiving and shipping, then the current methods need to be analysed and recorded on the chart. If the chart is being compiled for a new operation, the method and the time it takes to load and offload material should be analysed and charted. This data can be obtained from historical data or time studies.

In determining the number of docks needed, the waiting line analysis can be applied to determine the required number of docks if the arrivals are Poisson distributed and not random. When the arrival of trucks and data vary with the time of day, simulation can be used. After all the information is gathered and the number of docks required is determined, the configuration of the docks has to be designed. In designing the proper dock configuration, the first step is to look at the flow of the carriers in, around and out of the facility. In the case of trucks, the access to the facility should be planned in such a manner that the trucks don't need to back onto the facility upon entry. If trucks enter the facility from a narrow street, a recessed or "Y" approach need to be implemented and is illustrated in Figure 12 (Tompkins, White, Bozer, & Tanchoco, Warehouse Operations, 2010).

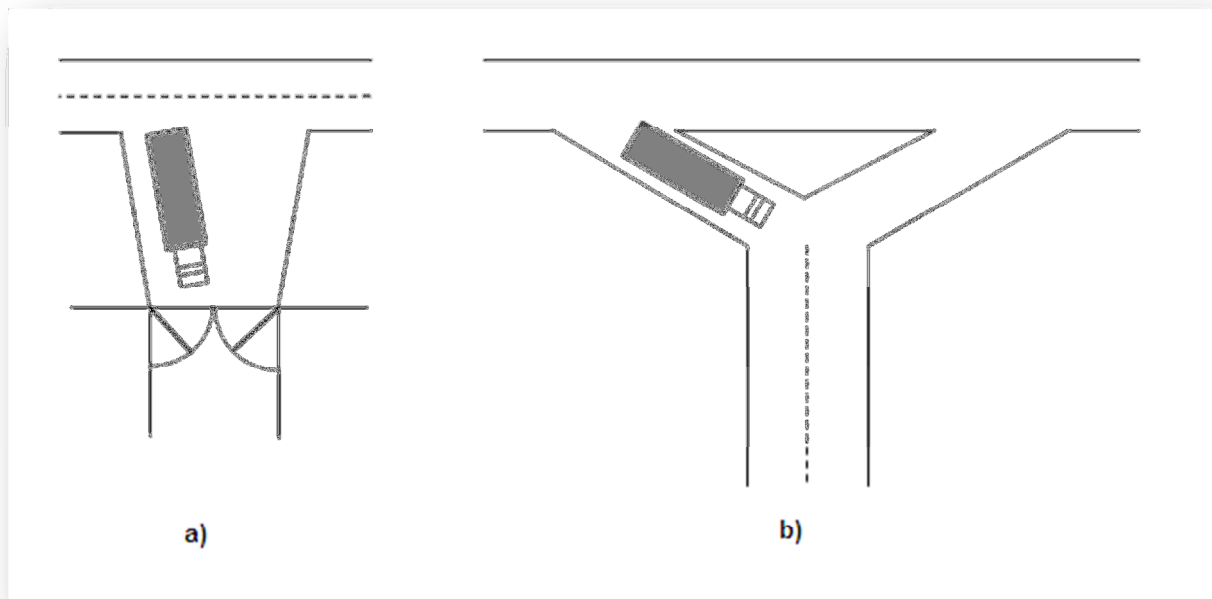

Figure 12: (a) Recessed truck entrance to property. (b) “Y” truck entrance to property.

When new sites are planned and developed, the minority of managers will actually look at all their customers and communicate with their third-party logistics provider to see what vehicles will have to be facilitated (Cargo Africa, 2011). The facility does not only add to truck turnaround time but can also damage the truck and trailer.

A simple example of area requirements is illustrated in Figure 13 below (Tamcam, 2011). Different types of vehicles need different amount of space in order to enter the site, turn around, manoeuvre and exit the site.

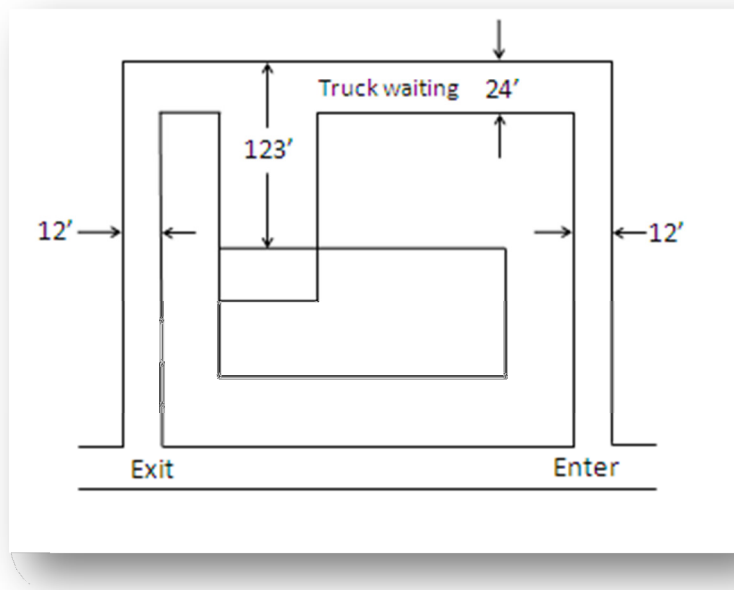

Figure 13: Representation of area requirements example

The classic u-shape is commonly used but due to the difficulties in scheduling of truck arrivals due unforeseen circumstances such as truck breakdowns and traffic, there are cases where two or more trucks arrive at the same time and thus resulting in the need for more space to reduce waiting time by not only loading one trailer at a time (Cargo Africa, 2011).

2.2.3 Simulation as a tool

2.2.3.1 Introduction

In the past decade, many considerable improvements occurred in material flow problems due to the development of simulation packages (Tompkins, White, Bozer, & Tanchoco, Quantitative facilities planning models, 2010). Simulation modelling has evolved to such extent, that facility planners will use simulation modelling at least once in developing new facilities. It involves modelling a system being analysed and changing properties and inputs to see what effect it will have on the system. Simulation can be described as a mechanism to understand and possibly predict behaviour of a system.

2. Information Gathering

Simulation can be used for a vast amount of reasons, but some of the major reasons are:

- When a mathematical model is too difficult to create or even impossible
- Helps in selling a facilities plan to management
- Demonstrating how a proposed system will function to operating personnel
- Testing and experimenting how feasible a proposed system is
- The validation of mathematical models
- Possible to predict the impact of change in the entire system
- Able to analyse and demonstrate a system at a level of far more detail than any mathematical model can

According to (Jacobs, Chase, & Aquilano, 2009), the term simulation can be defined as the process of using a computer to execute experiments on a model of a system in practice. The primary function of a simulation is to aid in the design of a system and also how it might react to changes before the system is operational. In cases where the size or complexity of the problem becomes too large for optimising techniques to solve, simulation can prove to be quite useful. Simulation can also be very useful when it comes to training staff and showing management how the real system operates in real-time control.

According to (Jacobs, Chase, & Aquilano, 2009), simulation can be divided into major phases, namely:

- **Define the problem**

When defining the problem for a simulation, it is a bit different than defining the problem for another tool of analysis. With simulation it is necessary to specify the objectives as well as the uncontrollable and controllable variables of the system.

- **Construct simulation model**

Constructing the simulation model is custom uniquely built for every problem and there are a few simulation languages that can be used for modelling. This is what distinguishes it from other techniques, namely linear programming and queuing theory. With regards to specifying the variables and parameters, this is the first step in constructing a simulation model. The parameters refer to the properties which are fixed in the model and the variables refer to the properties which may change during the

simulation. The second step will be to specify the decision or operating rules which are conditions under which the simulation is observed. These rules are usually priority rules for job sequencing, namely FIFO, LIFO, SOT, etc. The last two steps will be to specify the probability distributions (Empirical frequency distributions and standard mathematical distributions) and the time-incrementing procedure (Fixed-time increments or variable-time increments).

- **Specify values of variables and parameters**

In specifying the values of variables and parameters, you have to determine the starting conditions and run length. To determine the starting conditions is a tactical decision, because the model is biased to the starting values that are entered until the model has reached a steady state. The run length primarily depends on the purpose of the simulation. A good practice may be to run the simulation until it has reached equilibrium.

- **Run the simulation**

Run the simulation to obtain results.

- **Evaluate the results**

The results obtained depend on how close the model was simulated to the real system. After the results are obtained, it can be compared to past data from the real system or can be seen as the results for hypothesis testing.

- **Validation**

Validation refers to testing the program to ensure that the data obtained from the simulation is correct. Errors may result in coding or from simple logic in the simulation. When errors are suspected, the analyst has three alternatives to deal with the problem. The first alternative is to print out all the calculations and verify it with separate computation.

The second alternative is to run the simulation and compare the results with the existing system. The last alternative is to pick a certain point in the simulation, obtain the results and compare the output with the result obtained in solving a relevant mathematical model of that same point in the simulation

- **Propose new experiment**

Based on the results of the simulation, a new simulation may be required. Many factors, namely parameters, variables, decision rules, starting conditions and run length may change in the new simulation.

2.2.3.2 Arena as a simulation tool

Arena is a modelling system that was designed by Systems Modelling Corporation in 1993 (Andradóttir, Healy, Withers, & Nelson, 1997). Arena is released to give an object-oriented design for graphical model development. The analyst places graphical objects (modules) as part of a layout in order to specify system components, namely machines, operators and devices for material handling. There are many simulation languages available, namely SLAM II, SIMSCRIPT II.5, SIMAN, GPSS/H, GPSS/PC, PC-MODEL, RESQ, etc. (Jacobs, Chase, & Aquilano, 2009). The simulation language used for Arena is SIMAN. The SIMAN simulation language is the basis and chore of Arena. Within the Arena template there are modules that were created using the SIMAN's modelling blocks to act as their components.

The Arena template, which is the core collection of many modules, was designed to enable analysts to use a general-purpose collection of over 60 modules and modelling features to simulate all types of applications. These core features include recourses, queuing, inspection, system logic and external file interface. Arena also provides modules that are specifically designed to focus on specific factors of manufacturing and material handling. When considering manufacturing, Arena includes modules to support features, namely machine downtime and maintenance schedules. On the other hand, modules for conveyors and transportation devices also exist for material handling applications. The Arena template exists of three panels, namely common, support and transfer. The common panel contains modules for the fundamental simulation processes. The support panel contains the supplemental modules, primarily for actions and decisions. The Transfer panel contains the modules used to model the transfer or flow of entities through the system.

When building a simulation model for any operation, the first step will be to construct a flow chart indicating the process. This flowchart will follow an IF/THEN/ELSE-type branching and queue selection rules which the user connects with the modules by placing the appropriate graphical models on the layout. Arena is a simulation tool that was designed to create a

2. Information Gathering

simulation model in a completely graphical process. When building a simulation model for operations receiving and shipping, a simple model can obtain important information on utilisation of resources and waiting time. These can be seen as part of the output, but before the output can be obtained, inputs are required. These inputs can be classified as the following:

- Number of trucks and truck arrival times
- Number of workers on site
- Working hours of workers
- How many working hours in one day
- Number of material handling equipment such as forklifts
- Time it takes for loading and unloading carriers
- Time it takes for doing checks

2.2.4 Information Gathering Summary

In the information gathering, sufficient research has been done on methods to improve truckload utilisation the conclusion was reached to focus specifically truck turnaround times within truckload utilisation. It is of critical importance to understand the entire problem in order to solve what is necessary to solve as best possible. In the literature review, three topics were covered, giving a better understanding of how receiving and shipping operations work, how it is planned and how it can be improved. After research done within the literature review, it indicates that the best method to improve truck turnaround times will be to combine management, facilities planning and simulation modelling, but to focus primarily on simulation modelling with Arena.

The research done in the information gathering indicates that applying these methods correctly may result in improvements. These improvements include decrease of resource utilisation, the improvement productivity and a positive impact on cost efficiency.

3. Model input gathering and analysis

In this chapter, the process flow chart of a receiving and shipping operation will be modelled, as well as all the inputs required for successfully modelling the problem. After obtaining information from the research done, Arena has been identified as the most sufficient tool for simulating the receiving and shipping operation.

There are a few major advantages in using simulation to solve a problem and can be listed as the following (Miller & Bapat, Accessed in 2011):

- The evaluation of performance is performed in a controlled environment
- Once the model is created, changes can be easily made and evaluated
- The analyst has the ability to simulate a variety of incoming volumes per day
- The model can easily control influencing factors when conducting a sensitivity analysis

3.1 Data analysis

3.1.1 The process

As previously discussed, the inputs for the process are:

Average number of trucks per day	2
Number of workers at receiving and shipping	1
Working hours per worker	9 hrs
Length of one day	9 hrs
Number of material handling equipment: Forklift	1
Average time to load a truck	3 hrs
Average time to unload a truck	1 hr
Average time to couple a horse and trailer and do checks	20 min
Average time to manoeuvre horse to align with other trailer	10 min
Average time to open or close trailer	30 min

Table 1: Raw data as input for simulation model

These are inputs required to build a simulation model for the current system at the SX site in Neave.

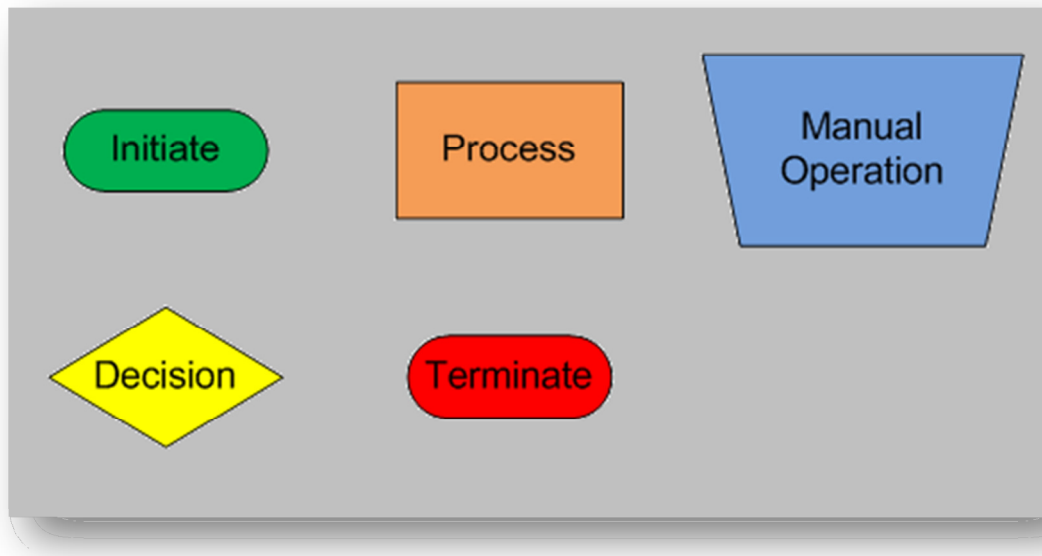

Figure 14: Key for using process flowchart

3.1.2 Flowchart

The flowchart illustrates the generic flow of shipping and receiving operations. Even though the process is quite simple, vital information can be obtained.

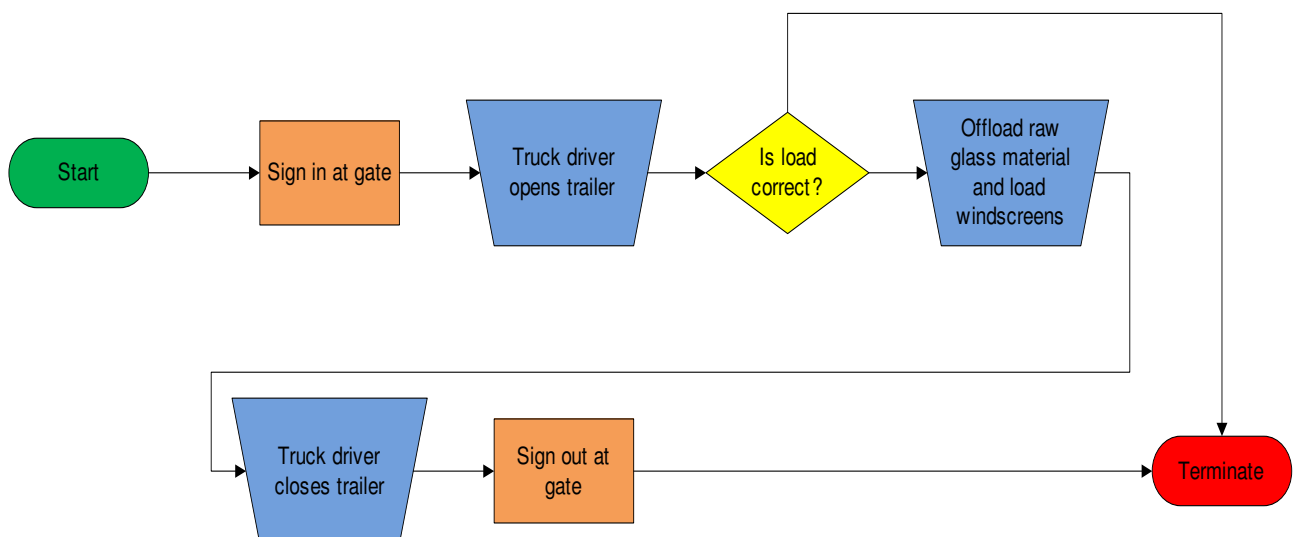

Figure 15: Flowchart of generic process for receiving and shipping



Figure 16: Shapes indicating the start of the process

The process starts where the truck or carrier enters the premises of the site. Truck turnaround time is measured from the moment the truck crosses the line of the premises till the time that same truck crosses the line of the premises to exit again. From there the truck driver needs to sign in at the site due to security reasons.

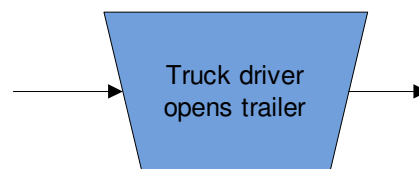

Figure 17: Shape indicating the truck driver opening the trailer

After the truck driver has signed in at the gate, the truck then nears the receiving and shipping area. This is currently where the first problem might occur since the SX site in Neave can only accommodate one truck at a time. So if the truck is first then it can immediately enter the receiving and shipping area, where the truck driver opens the trailer for unloading.

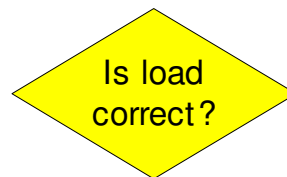

Figure 18: Shape indicating load acceptance/rejection

After the truck driver has opened the trailer, checks are done to see whether the load is correct or incorrect. If the load is correct, then the trailer can be offloaded, but if the load is incorrect, the process is terminated and the truck is sent back. This step is included in the flowchart, but at the SX site in Neave, the possibility of a load being incorrect is so small that it can be left out for future reference.

4. Solution design and implementation

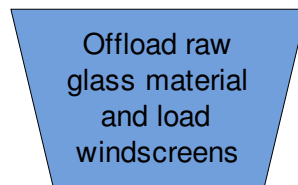

Figure 19: Shape indicating the process of loading and offloading

At this stage, the incoming truck will be offloaded and the pallets will be taken into storage. The truck is then loaded with windscreens or if there wasn't an order or a small order for windscreens, the truck will be also loaded with empty pallets, broken windscreens and cullet. Cullet refers to the broken raw glass sheets that can immediately be melted and used again.

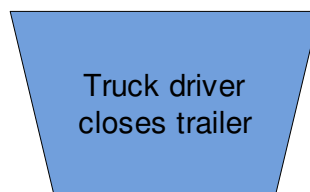

Figure 20: Shape indicating the truck driver closing the trailer

After the truck has been offloaded and loaded again, the truck driver has to close the trailer and do all the safety checks before the truck can leave the premises.



Figure 21: Shapes indicating the end of the process

When the truck driver has closed the trailer and did all the checks, the truck proceeds to the gate to sign out. After the truck has signed out, the process is terminated.

4. Solution design and implementation

This chapter illustrates the application of the solution to the problem described earlier in this dissertation. It consists of two parts, namely the design of the solution model and the evaluation and testing of the model.

4.1 Design of solution model

The solution model is based on the problem concerning truck turnaround times that are too high at the SX site in Neave.

Before the solution model will be discussed, the model as it currently is will be analysed. The model is run according to a 9 hour working day. The truck arrival is 2 for the 9 hour day and for modelling purposes, the trucks are scheduled to arrive close to directly after each other.

4.1.1 Current simulation model

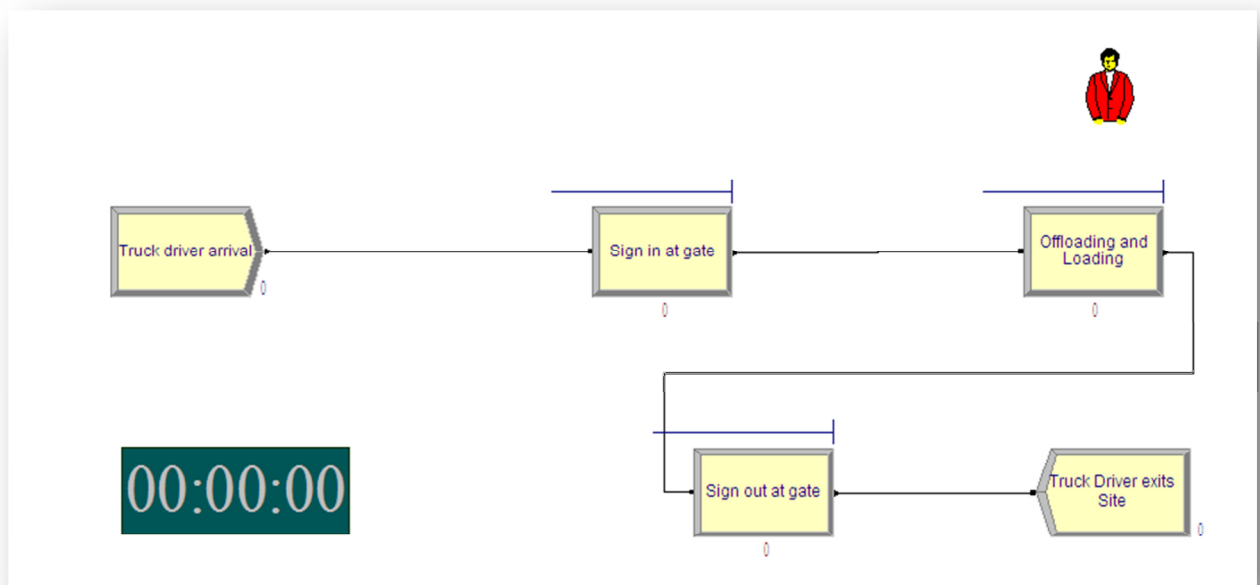
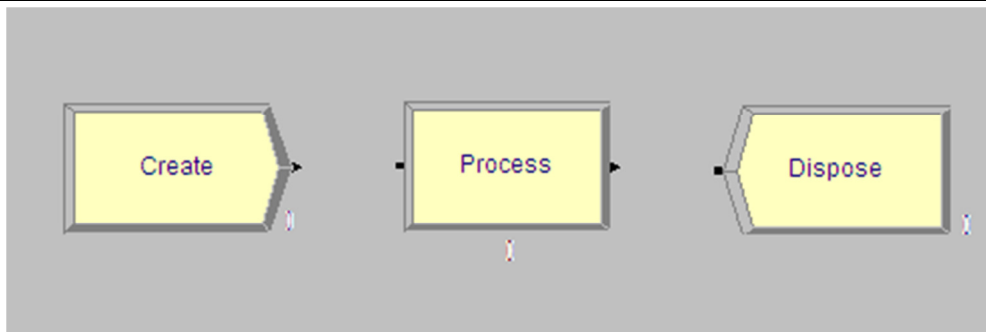

Figure 22: Current process simulation model in Arena

4. Solution design and implementation



4.1.1.1 Analysis of current model

The results obtained from running the current simulation model are displayed in the tables and figures below.

Resource	Utilisation
Loading Area	0.9773
Security Booth	0.01783

Table 2: Utilisation of resources current model

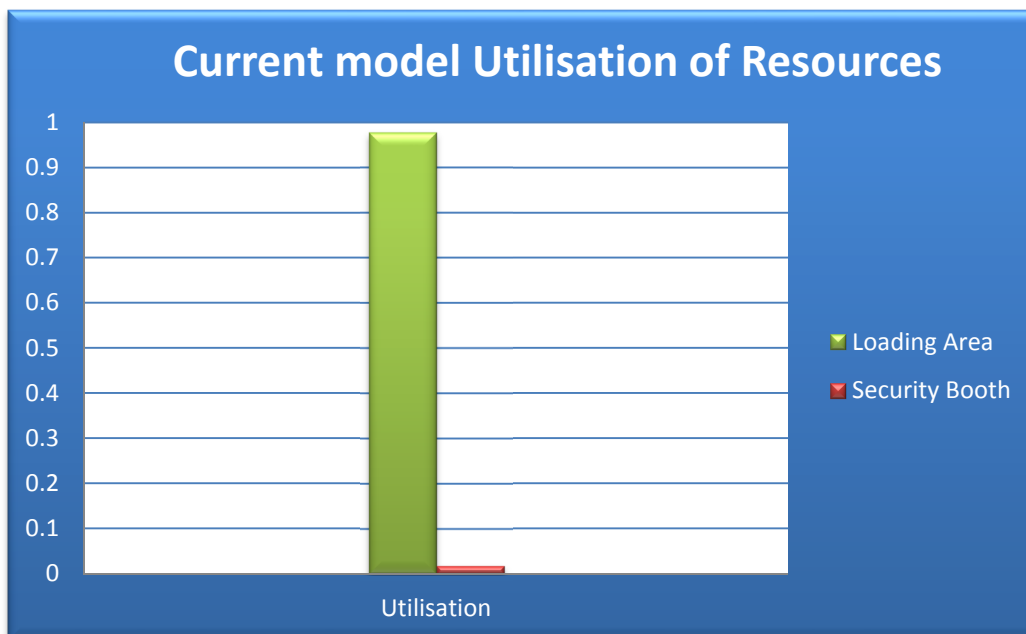

Figure 23: Current model utilisation of resources

4. Solution design and implementation

In the current model, the focus was on the resources, specifically the loading area. If the utilisation can improve at the loading area, then waiting time will improve before the resource and queue length can shorten.

Resource	Waiting Time (min)	
	Ave	Max
Loading Area	212.08	448.99
Sign in gate	0	0
Sign out gate	0	0

Table 3: Illustration of current model waiting time

As shown in Table 3, the current model has an average waiting time in front of the loading area of about 212 minutes and a maximum waiting time of 449 minutes.

Resource	Number Waiting	
	Ave	Max
Loading Area	1.1782	2
Sign in gate	0	0
Sign out gate	0	0

Table 4: Illustration of current model queue length

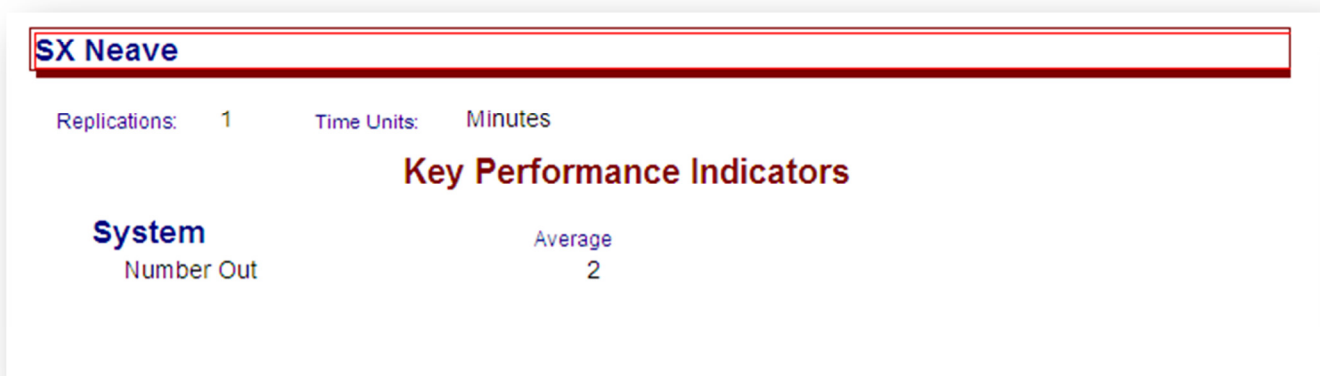

Figure 24: KPI's of current model

The KPI's for the current model is measured by the number of trucks leaving the site. The current model indicates only two trucks leaving the site. This all together adds up to truck turnaround time with an average of 5.6 hours in the last 5 months. A max average of 4 hours is required.

4.1.2 Solution model simulation

After the analysis of the results of the current model, a few changes have to be made. Not only the process, but also minimal changes to the layout have to be made. Changes to the facility layout include the widening of the entrance to the receiving and shipping area. This makes it possible for more than one truck to pass through the entrance simultaneously. Please see Appendix A for an illustration of the changed layout.

The changes in the process are to try and eliminate the excessive waiting time and then finally try to improve utilisation at the loading area. This can be achieved by using a “drop trailer” method. With the proposed solution, instead of having one truck arriving and having another truck wait for it to offload and load, the loading area will have two designated areas for a trailer to be coupled and uncoupled. What this means is that a trailer can be loaded and offloaded while the horse and truck driver isn't there. The truck alone without a trailer is referred to as a horse. When the horse arrives, it can simply couple the trailer do its checks and leave. If the horse arrives with a trailer, it uncouples the trailer, manoeuvre to the other trailer, couple the trailer and horse and leave the premises.

The inputs for the solution model are very similar to the current model. It only differs by breaking the loading and offloading into smaller segments and by adding inputs, namely time to couple, manoeuvre and uncouple a trailer.

Space can become an issue and it will require some skill of the truck driver and training to enable the driver to manoeuvre around in confined spaces, whether the horse is coupled with a trailer or not. Further research can be done on the facility layout and whether other areas can be used to drop the trailers.

4. Solution design and implementation

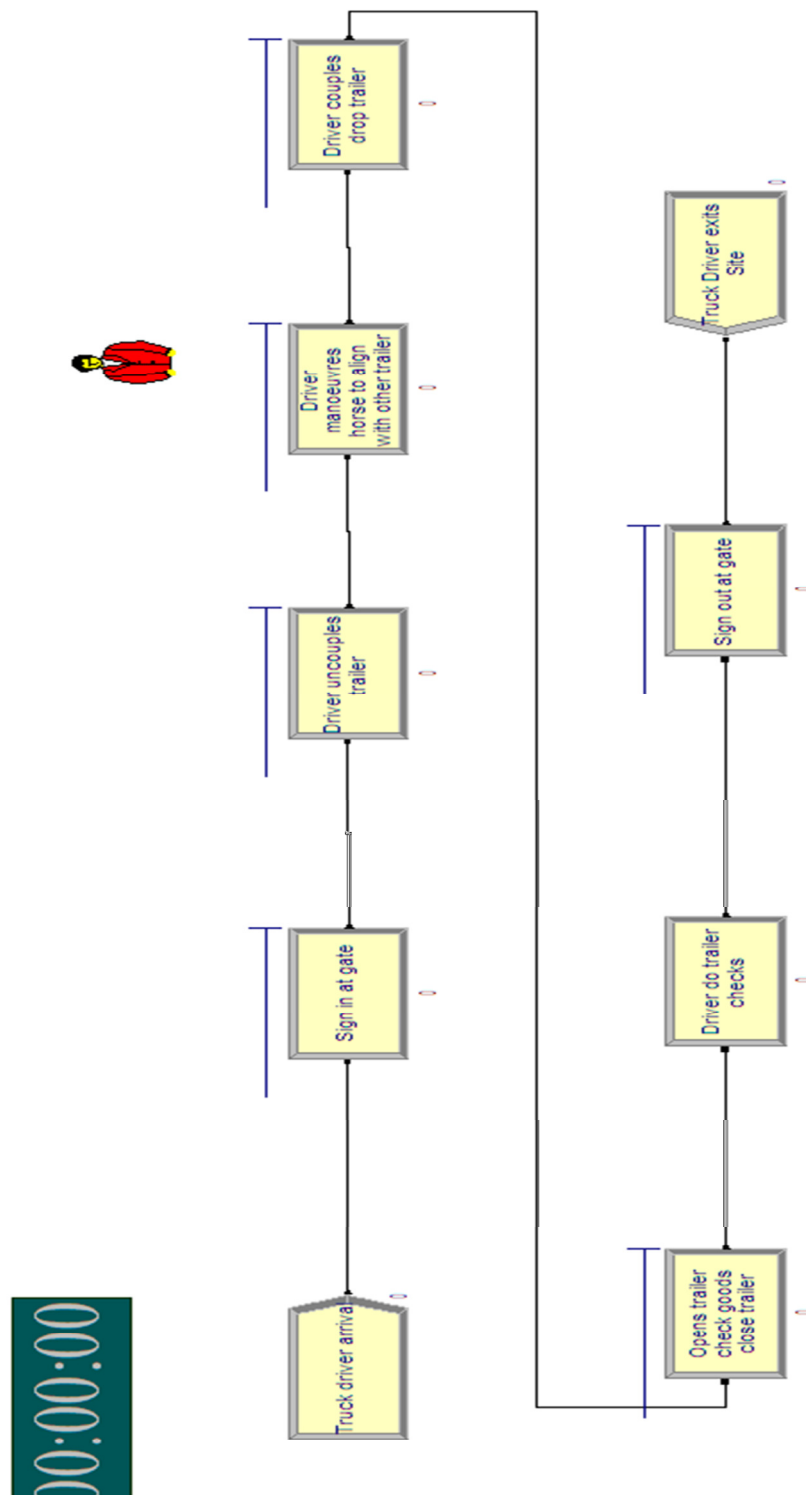

Figure 25: Solution process simulation model in Arena

4. Solution design and implementation

Resource	Utilisation
Loading Area	0.7282
Security Booth	0.03

Table 5: Utilisation of resources in solution model

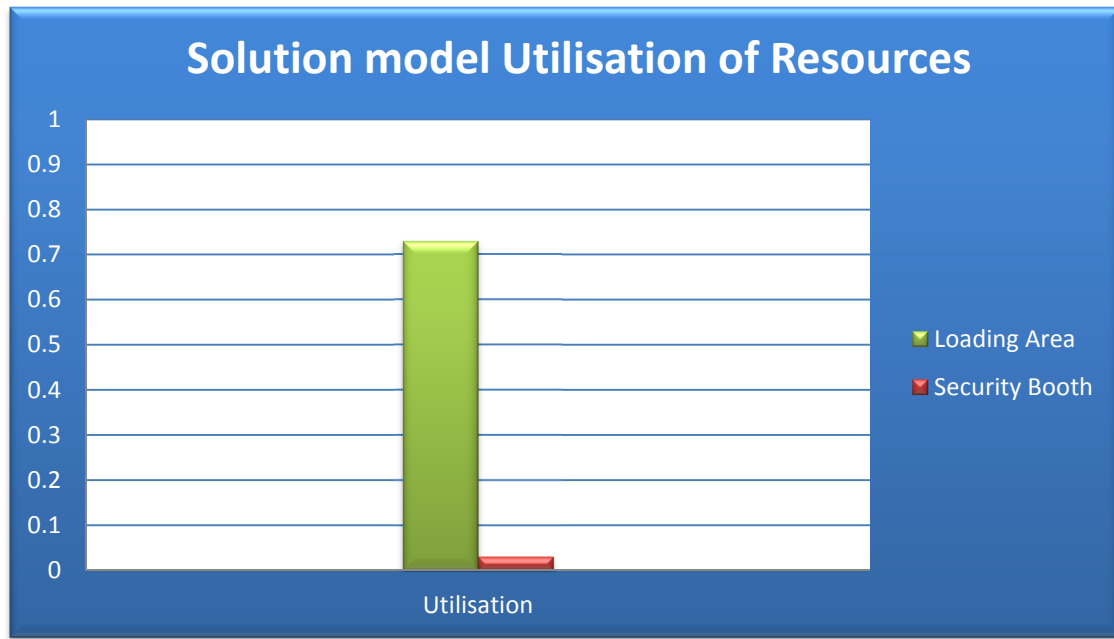

Figure 26: Solution model utilisation of resources

Resource	Waiting time (min)	
	Ave	Max
Driver couples drop trailer	51.3477	84.0777
Driver manoeuvres horse to align with other trailer	47.4927	87.9508
Driver uncouples drop trailer	11.8998	26.1203
Open trailer, check goods, close trailer	50.8019	83.8429
Sign in at gate	0	0
Sign out at gate	0	0

Table 6: Illustration of solution model waiting time

4. Solution design and implementation

The waiting time in Table 5 adds up to an average total of 161.5421 and a maximum waiting time of 281.9917.

Resource	Number Waiting	
	Ave	Max
Driver couples drop trailer	0.3804	1
Driver manoeuvres horse to align with other trailer	0.3518	2
Driver uncouples drop trailer	0.08815	2
Open trailer, check goods, close trailer	0.3763	1
Sign in at gate	0	0
Sign out at gate	0	0

Table 7: Illustration of solution model queue lengths

The average and maximum queue lengths shown in Table 6 indicate that the system is handling more trucks than usual.

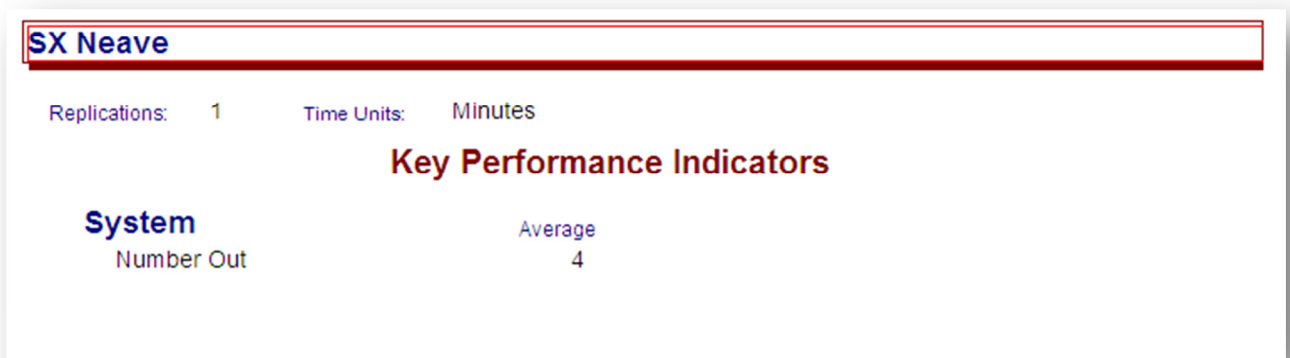

Figure 27: KPI's of solution model

The solution model indicates and output of four trucks. The target for average number of outgoing trucks at the SX site in Neave is three.

4.2 Evaluation and Testing

In this section, the results of the current model and solution model will be compared. These results include waiting times, queue lengths and lastly resource utilisation. The best method to compare these results is with graphs and interpretation and then finally the cost framework will be discussed. The resource utilisation will be analysed and discussed first.

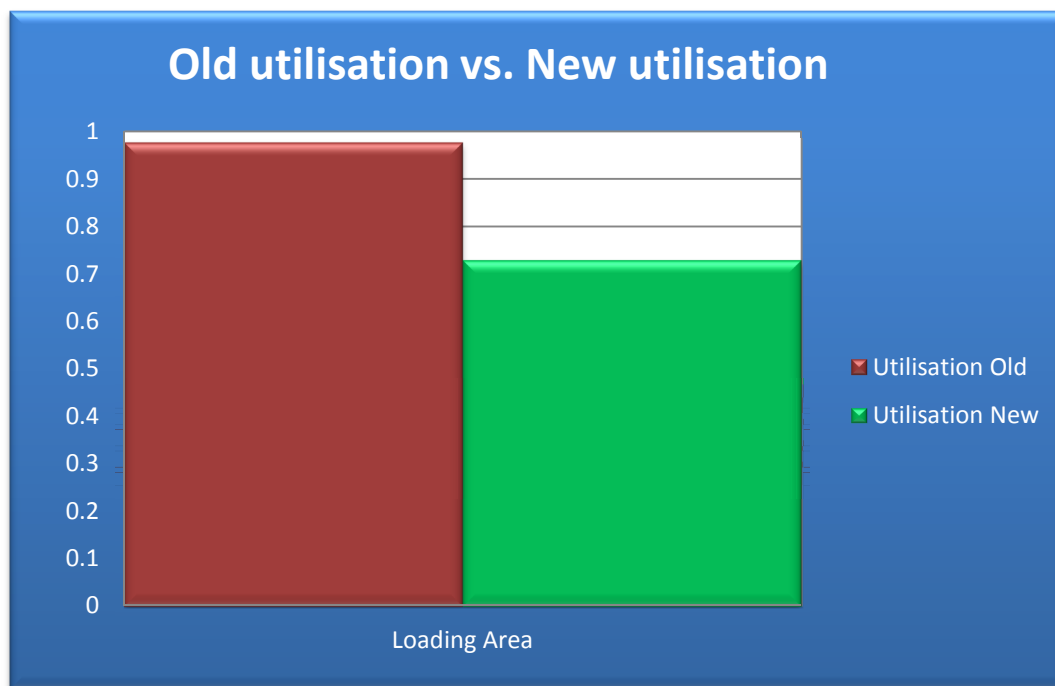

Figure 28: Old utilisation vs. New utilisation

Comparing the current model (old utilisation) with the solution model (new utilisation) indicates a clear improvement in utilisation. This means that the resource, loading area, is not as busy as it used to be in the current model and has more capacity. The utilisation has improved from 0.9773 to 0.7282.

Considering the waiting time, the current model and the solution model has 0 minutes waiting time at the gate and thus can it be left out in the graphs. The solution model does have other inputs for the loading and unloading area than the current model, but adding all these different inputs together and referring to it as waiting time in the loading area will be sufficient. Looking at Figure 29, a considerable improvement in waiting time is noticed.

4. Solution design and implementation

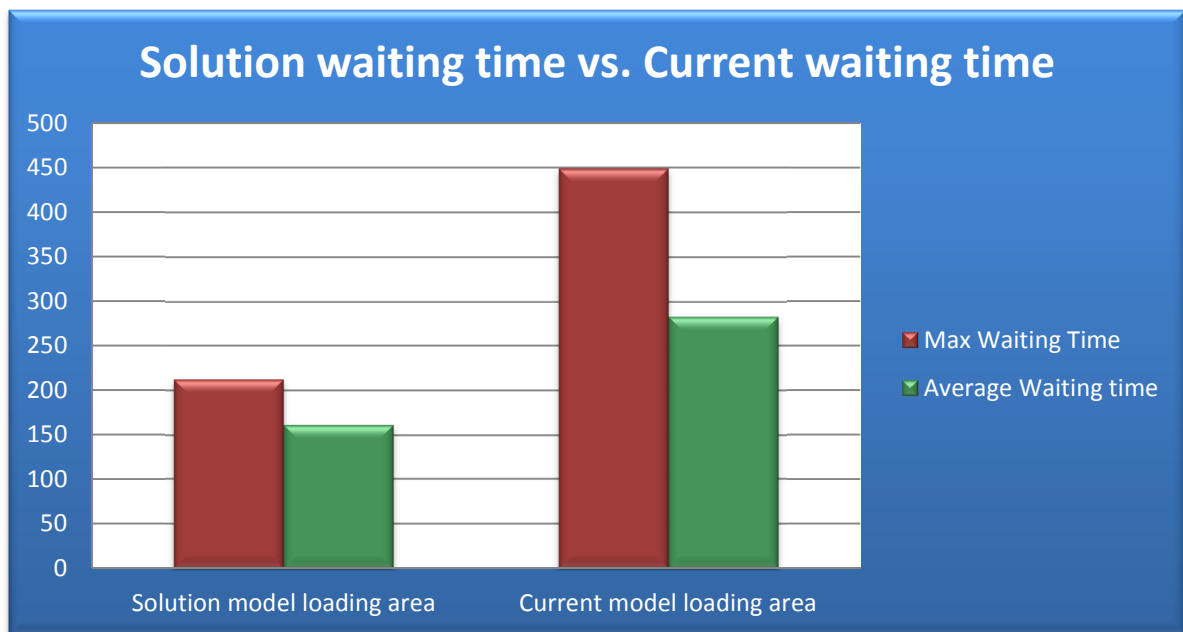

Figure 29: Solution waiting time vs. Current waiting time

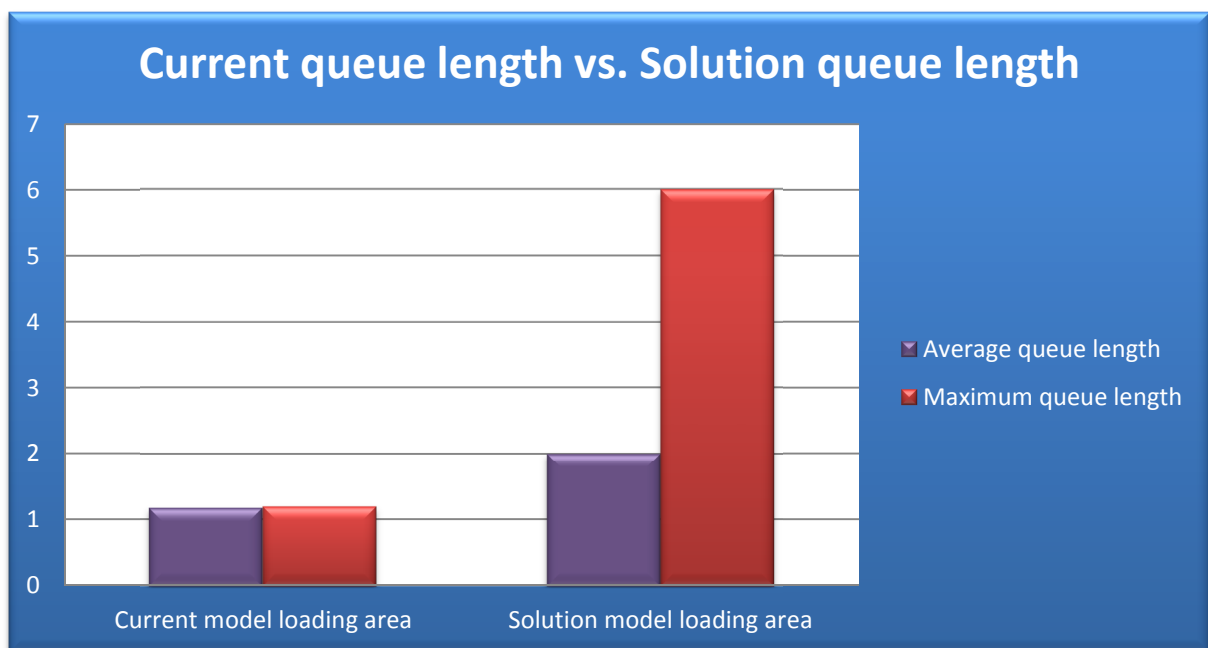

Figure 30: Current queue length vs. Solution queue length

The queue length of the solution model is considerably more than the current model, but since utilisation has improved and the number of trucks leaving the facility in a day has increased, this indicates a positive impact. This simply indicates that the process has a

4. Solution design and implementation

bigger capacity for truck arrivals. The output has increased from two trucks per day to four trucks per day. According to PFG Springs, an increase from two trucks per day to three trucks per day will result in a profit of about R60 000 per month.

The improvement that the proposed solution can give is far more than just the outgoing trucks per day. The number of trucks entering the SX site in Neave and leaving per day also impacts the rest of the distribution network and the cost. Within the PFG Network, there are PFG Springs, SX Neave and SX Struandale and GSA Bedfordview. When a truck is sent from PFG to SX Neave and the truck turnaround time is too high, firstly not enough trucks are sent to GSA and secondly, GSA Bedfordview only receives incoming trucks between certain times during the day. So when a truck is sent down to Port Elizabeth from PFG Springs with a certain time in mind to arrive at GSA Bedfordview, but the truck turnaround time is too high, the truck driver loses an entire day in order to arrive at GSA at the correct time.

Not only does it impact opportunity cost, but when a truck is late, Cargo Africa has to hire additional trucks in order to deliver the next load. For every hour that a truck is late, Cargo Africa pays an additional R230 per hour with regards to fixed cost. A day that is lost will cost Cargo Africa an average total of R9000 per truck consisting of variable and fixed cost. The variable cost is calculated by the following equation.

$$\text{Variable Cost} = \text{Kilometres travelled} \times 7,40$$

After some calculations, there is a fixed amount that Cargo Africa has to pay per day, for example an amount of R21000 per day per truck for variable cost. When the variable cost is calculated and it is less than R21000, the difference is paid by Cargo Africa. So if a truck is late and cannot complete its deliveries, those kilometres that was supposed to be travelled in that day cannot be taken into account and thus result in Cargo Africa paying an additional amount to compensate for the payment of the truck driver. In the circumstance where a truck is late, that specific truck's trailer is now no longer available for other loads. This is then an additional cost that Cargo Africa has, because they have to take trailers from another fleet or hire additional trailers in order to successfully satisfy Shatterprufe's demand.

As mentioned earlier, by increasing the outgoing trucks from two per day to three per day, PFG Springs can increase their profit with about R720 000 annually (R60 000 per month).

4. Solution design and implementation

Costs that can be saved by Cargo Africa can be illustrated with the following example. In this example, the assumption is made that one truck per week arrives late at GSA Bedfordview. This means that the truck has to spend the night and 35 km can't be travelled. In addition to this, it also means that a day is lost because the truck will arrive too late at PFG Springs the following day.

$$\text{Kilometres per day (Target)} = 2167$$

$$\text{Kilometres per day (Actual)} = 2132$$

$$\text{Variable and Fixed Cost for losing one day} = R9000$$

TC_{Weekly} = Total cost lost for one week

$$TC_{\text{Weekly}} = [\text{Kilometres per day (Target)} - \text{Kilometres per day (Actual)}] \times 7,40 + 9000$$

$$TC_{\text{Weekly}} = 35 \times 7,40 + 9000$$

$$TC_{\text{Weekly}} = R 9259, 00$$

Annually this adds up to a cost of R 444432 that Cargo Africa can save. This is an indication that Shatterprufe, PFG Springs and GSA Bedfordview will benefit from this solution.

5. Conclusion

Truckload utilisation and specifically truck turnaround time has a great impact on a distribution network, as seen in this report. Management plays a vital role and combined with facilities planning and simulation, the process can be improved and maintained.

There is room for further research regarding the facility layout of SX Neave and the management there of in order to improve truck turnaround time. This cost of implementing this project will also have to be weighed against the profit, cost improvement and increase in productivity that will be achieved.

There are many stakeholders in this project it is difficult to estimate a total cost improvement, but if implemented successfully, PFG Springs can increase profit by up to R720 000 annually, SX Neave can improve productivity and Cargo Africa can minimise unnecessary additional costs.

To conclude, in order to implement this project, Cargo Africa has sufficient trailers and no additional trailers are necessary. However, a night shift should be established at SX Neave to have the trailers ready in the morning. The cost of adding a night shift compared to the costs saved with this project renders this project economically viable and further investigation is recommended. According to the results obtained by the simulation of the proposed solution, it can be concluded that if implemented successfully, this model can prove to be of great value to PFG Springs, Cargo Africa and Shatterprufe.

6. References

Andradóttir, S., Healy, K. J., Withers, D. H., & Nelson, B. L. (1997). Arena Software Tutorial. *Winter Simulation Conference* (pp. 541-544). Pennsylvania: Systems Modeling Corporation.

Cargo Africa. (2011). Project Meeting. *Peter Cheetam, Noel Zedi*. Cargo Africa, Alrode.

Chopra, S. (2003). Designing the distribution network in a supply chain. *Transportation Research Part E* 39 , 123-140.

IMPERIAL Logistics. (2011). Project Meeting. *Leigh Weimer, Sean Engelbrecht*. IMPERIAL Logistics, Germiston.

Jacobs, F. R., Chase, R. B., & Aquilano, N. J. (2009). Simulation. In *Operations and Supply Management, Twelfth Edition* (pp. 652-667). McGraw-Hill/Irwin, China.

Langley Jr., C. J., Coyle, J. J., Gibson, B. J., Novack, R. A., & Bardi, E. J. (2008). Warehousing Decisions. In *Managing Supply Chains: A Logistics Approach, Eighth Edition* (pp. 66-67). Cengage Learning, Canada.

Langley Jr., C. J., Coyle, J. J., Gibson, B. J., Novack, R. A., & Bardi, E. J. (2008). Warehousing Decisions. In *Managing Supply Chains A Logistics Approach, Eighth Edition* (pp. 413-414). Cengage Learning, Canada.

Lewis, P. S., Goodman, S. H., & Fandt, P. M. Management, Challenges in the 21st Century, Third Edition 2001. In *Management, Challenges in the 21st Century* (pp. 5-7). Southwestern College Publication.

Logistics, Imperial. (2011). www.imperiallogistics.co.za. Retrieved from www.imperiallogistics.co.za [Accessed 12 April 2011]

Miller, K., & Bapat, V. (Accessed in 2011). Simulation of the call centre environment for comparing competing call routing technologies for business case ROI projection. 1999

6. References

Winter Simulation Conference Proceedings, 'Simulation - A Bridge to the Future', (pp. 1694 - 1700). Phoenix, USA.

PFG. (2011). Project Meeting. *Mpho Mulaudzi, George Moses*. PFG, Springs.

Tamcam. (2011). Retrieved August 23, 2011, from <http://tamcam.tamu.edu/courses/inen416/Handouts/STORAGE.pdf>

The University of Texas. (2011, August 10). Retrieved August 19, 2011, from The University of Texas: http://www.lib.utexas.edu/maps/south_africa.html

Tompkins, J. A., White, J. A., Bozer, Y. A., & Tanchoco, J. M. (2010). Defining Requirements. In *Facilities Planning, Fourth Edition* (pp. 4-5). John Wiley & Sons, Inc., Hoboken.

Tompkins, J. A., White, J. A., Bozer, Y. A., & Tanchoco, J. M. (2010). Quantitative facilities planning models. In *Facilities Planning, Fourth Edition* (pp. 701-703). John Wiley & Sons, Inc., Hoboken.

Tompkins, J. A., White, J. A., Bozer, Y. A., & Tanchoco, J. M. (2010). Warehouse Operations. In *Facilities Plainng, Fourth Edition* (pp. 399-400). John Wiley & Sons, Inc., Hoboken.

Tompkins, J. A., White, J. A., Bozer, Y. A., & Tanchoco, J. M. (2010). Warehouse Operations. In *Facilities Planning, Fourth Edition* (pp. 391-394). John Wiley & Sons, Inc., Hoboken.

7. Addendum

7.1 Appendix A: Section of current layout

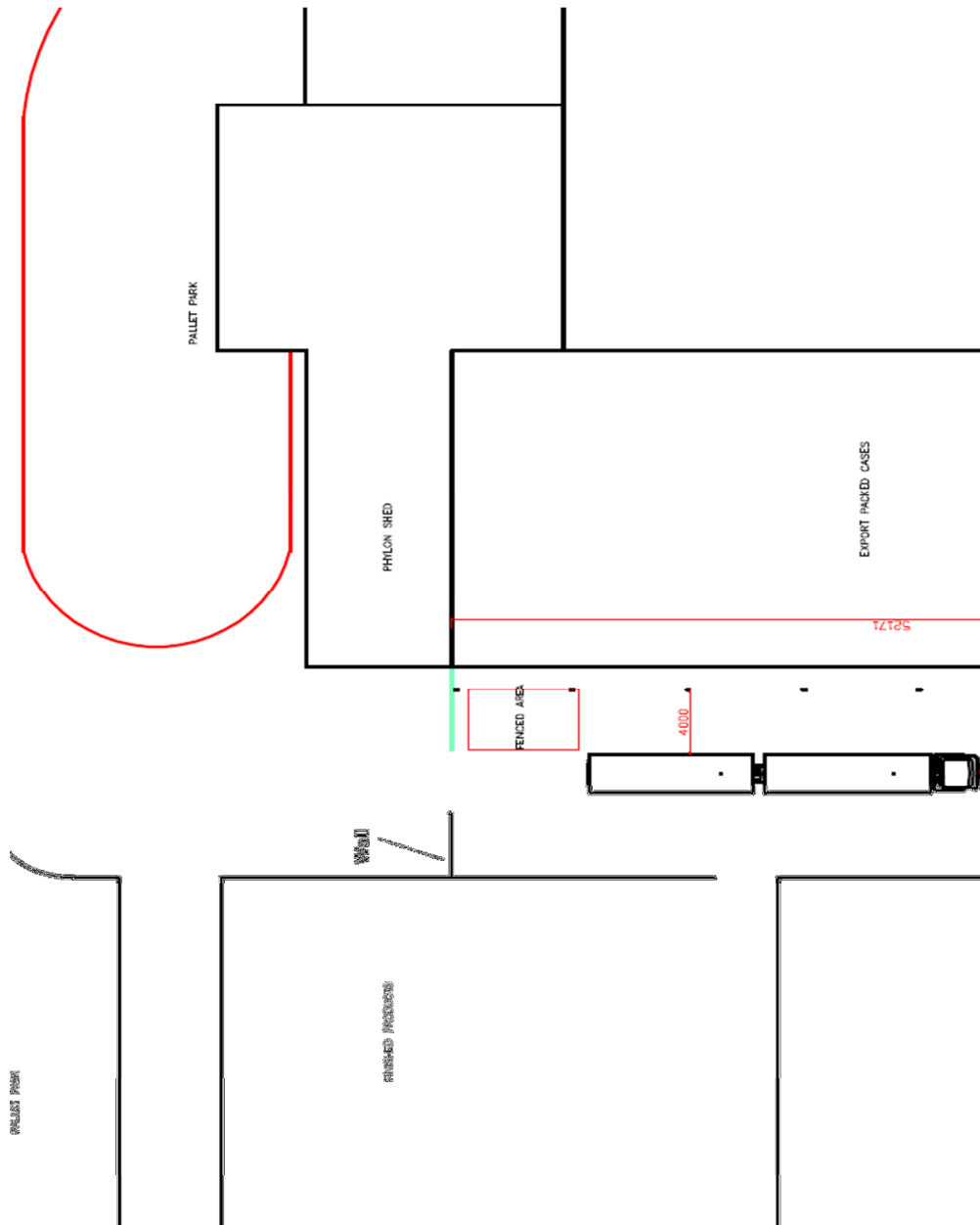

The current entrance to the receiving and shipping area has a wall that prohibits two trucks from entering simultaneously.

7.2 Appendix A: Solution layout 1

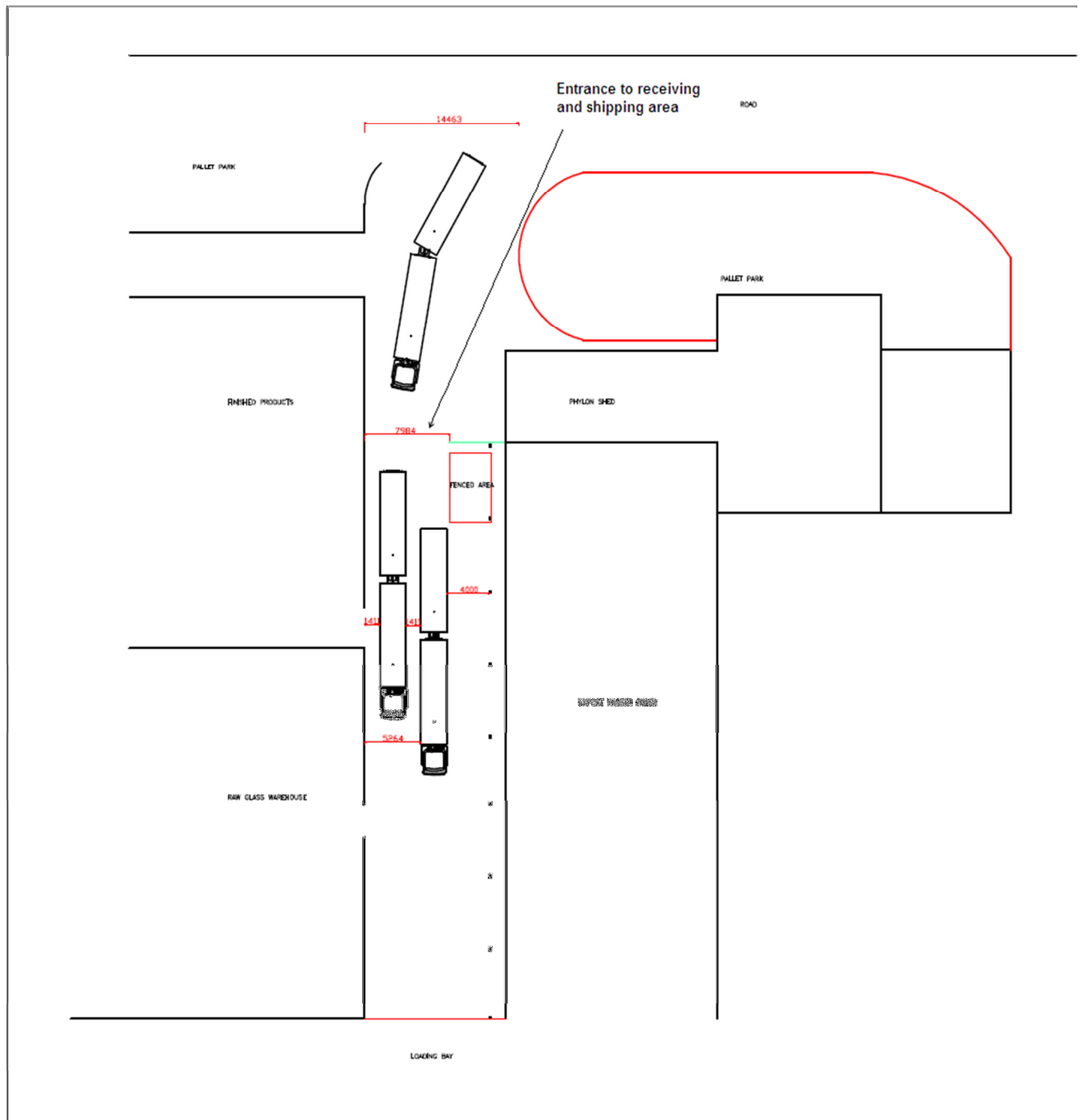

As indicated in Solution layout 1, the wall has been removed at the entrance to the receiving and shipping area.

7.3 Appendix A: Solution layout 2

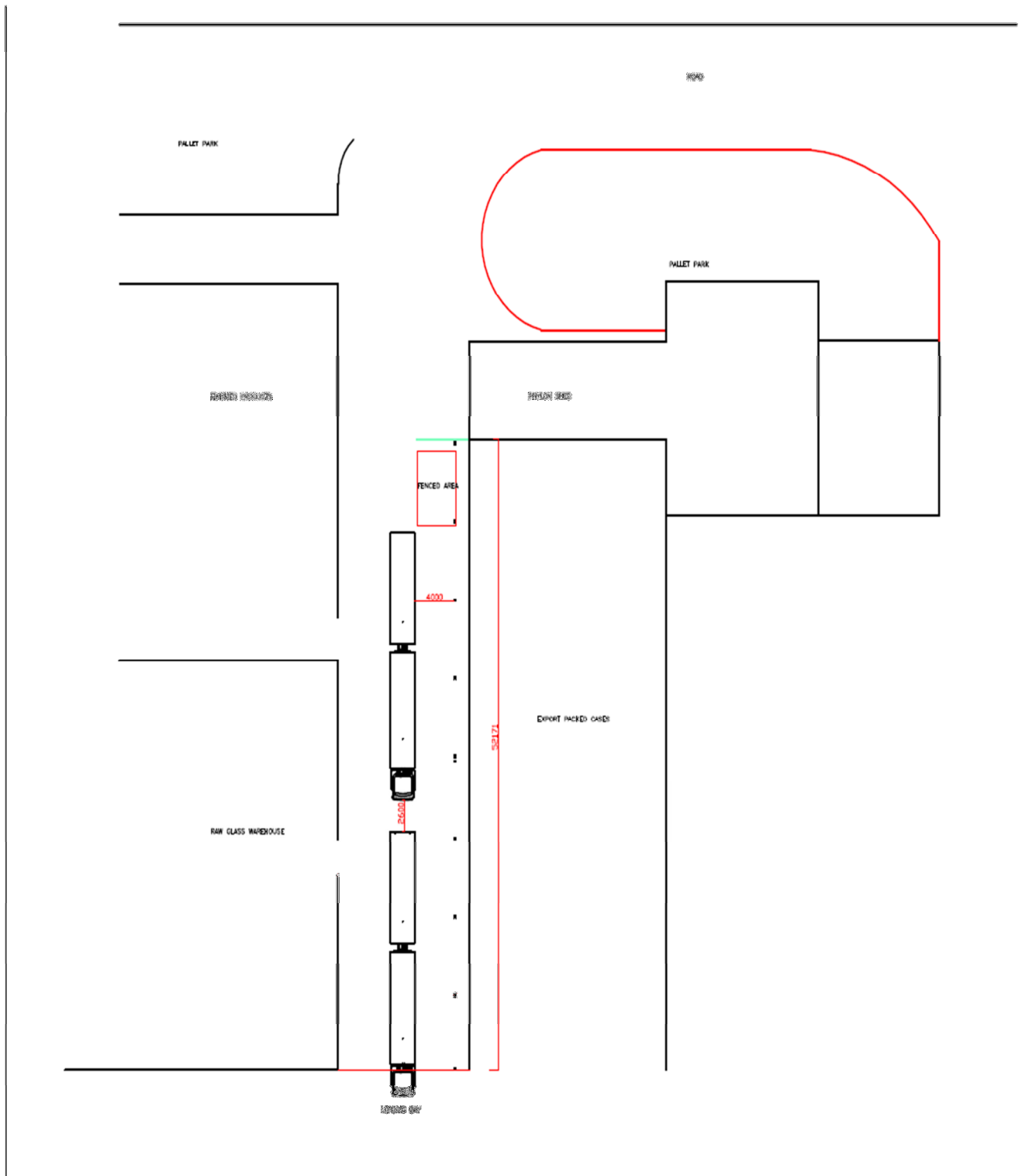

Shown in Solution layout 2, it is now possible for two trucks to be coupled and manoeuvred in comparison to the one truck of the current layout.