

The Monster

Liminality, Threshold and Spatial Experience

by

Izak Coetzee

Submitted in fulfillment of part of the requirements for the degree Magister in Architecture [Professional] in the faculty of Engineering, Built Environment and Information Technology.

University of Pretoria

Department of Architecture.

Study Leader: Catherine Karusseit

Mentor: Gary White

November 2008

Thank You:

My Lord and saviour Jesus Christ.

My Parents, study leader Catherine and mentor Gary.

Piet van Heerden, Rudolf Roos.

Jean-Pierre de la Porte.

My fellow students and friends.

Summary

Victor Turner (in Dodds, 1992: 82) suggests to take every day elements and rearrange them in ways not experienced every day is to create a “monster”, which will achieve liminality in architecture. The title of this dissertation is a result of this phenomenon. In this design investigation ways to transform liminality into a building are explored. Smith (2000) states, “liminality or the liminal refers to transitional space; neither one place nor another; neither one discipline nor another; rather a thirdspace in-between”. Various devices were examined to facilitate the transition from abstract concept into architectural possibility. The following devices: typology, technology, spatial experience, interlocking volumes, superimposition, programmatic bands and atmospheric effects have been examined. The final product is a fusion of theoretical notions and technology expressed as a hybridized typology, all these qualities are arranged in ways not experienced every day, resulting in a building called the Monster.

“God created paper for the purpose of drawing architecture on it. Everything else is at least for me an abuse of paper.” Alvar Aalto, Sketches, 1978, 104.

This dissertation is structured in such a way that it portrays the process followed in designing the Monster. This process has subsequently been divided into 5 stages. Each stage explores a different element of the design, and is indicated with a specific colour text box. The concepts explored are realized in the final design.

CONTENTS: STAGES

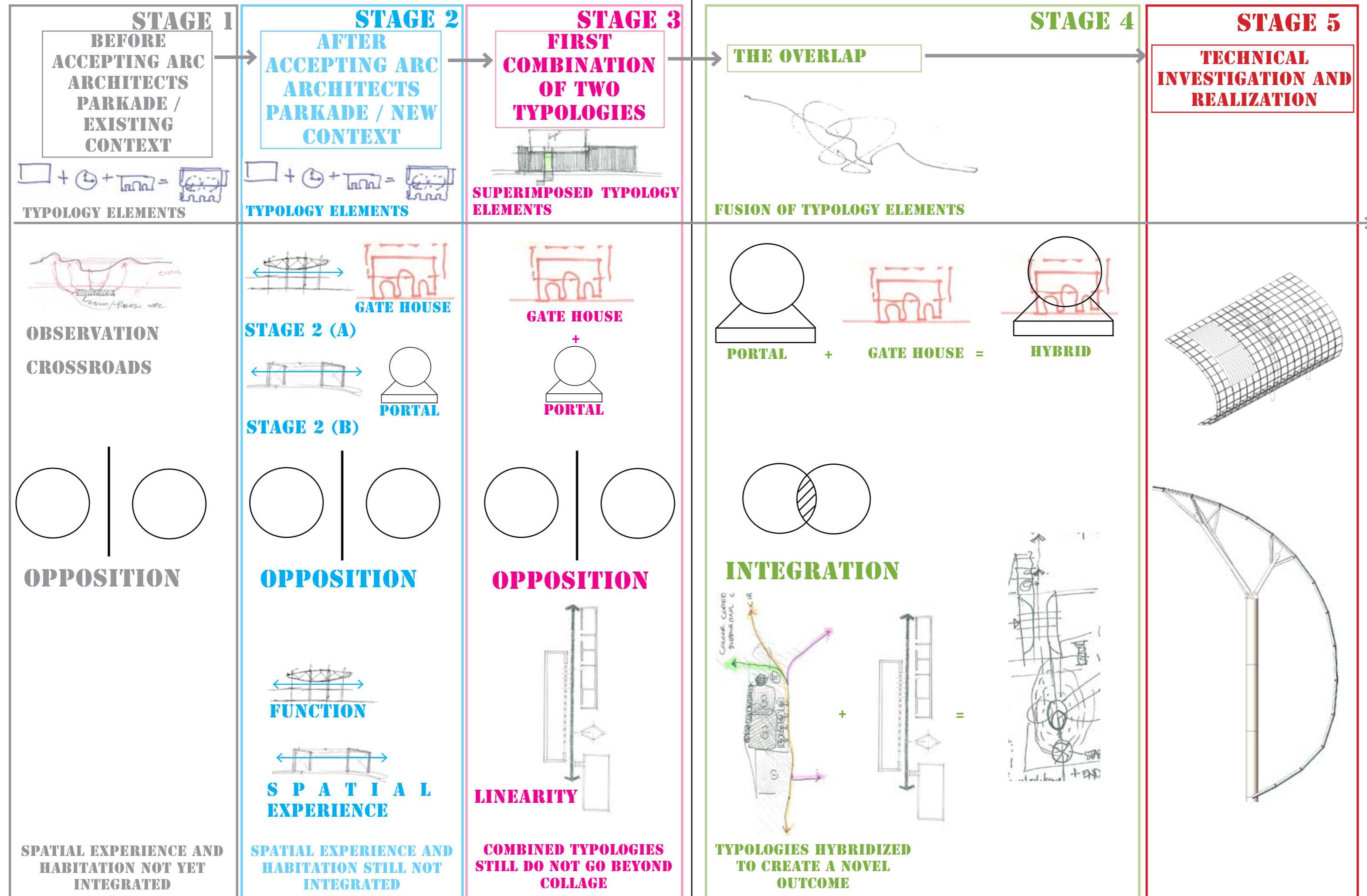

THE OBSERVATION

Students are only seen on campus when they are between classes. The “student life” on campus is a conducted during this in between time. Van Gennep (in Smith, 2000) refers to a rite of passage as “the precarious threshold between a person’s previous role in society and their new, evolved existence.” Personally there are similarities between studying and a rite of passage, during the liminal stage the student’s status becomes ambiguous. Students are referred to as students. The student are in a crossroads in their life. Definition of crossroads: (wikipedia: Crossroads) “a location ‘between the worlds’. Symbolically it can mean a locality where two realms touch and therefore represents liminality, a place literally ‘neither here nor there’”. Students are “betwixt and between all fixed points of classification, and thus the form and rules of both their earlier state and state-to-come are suspended” (Palmer, R E. 2001).

THEORY TEXT BOX

The theoretical premise relates to liminality in architecture. Dodds (1992: 82) stated that “limen signifies threshold”. Aldo Van Eyck (in Smith, 2000) suggested that threshold spaces rely on the “interrelationship between two phenomena rather than their opposition”. These two phenomena in the Monster are the ‘male’ and ‘female’ views of space. According to Luce Irigaray (in Smith, 2000), male space is solid and inflexible, where female space is defined by “open conceptual possibilities.” This in turn is supported by a definition of crossroads. The Monster was specifically designed with the intent to create a hybrid which falls between classifications. Elements like collage, superimposition and fusion were explored to achieve the desired outcome. The outcome not only has a function but also conveys an experience. Based Norberg-Schultz’s definition of path.

CONTEXT TEXT BOX

This year (2008) is the centenary celebration of the University of Pretoria. The Masters class were assigned projects with the University as the context. My study is located on the Main Campus, in Hatfield. This project is delimited to the main entrance. All entrances into University grounds can be designed in the way suggested by this project to enhance the thresholds. The University held a competition for the design of parkades to be built on campus property. Arc Architects won the competition for the parkade at the main entrance. An assumption of this project is that this parkade will be built and so becomes the context for the Monster. The Monster is situated on the threshold between the outside, the parkade and the inside of campus grounds.

PRECEDENT TEXT BOX

Precedents were looked at for specific qualities which would contribute to the Monster, such as technology, theoretical elements, spatial experience, organization, planning, design language, contextual response and structure. These precedents were applied as techniques to convert the premise of liminality into a physical reality.

DESIGN TEXT BOX

The design process was conducted in stages according to the aforementioned. Each stage of the design was approached from a different point of view, yet the overriding focus was to create a building which is a Monster. Only at the end did it become clear how to achieve this. The final design is a fusion of elements distilled from each stage.

TECHNICAL TEXT BOX

The technical investigation was done to deliberately to imbue the theoretical premise into every element of the building and to support the design and theory rather than to detract from them. Further investigation of the technical stage was done into the building process and possible ways to manufacture spacial parts of the building locally.

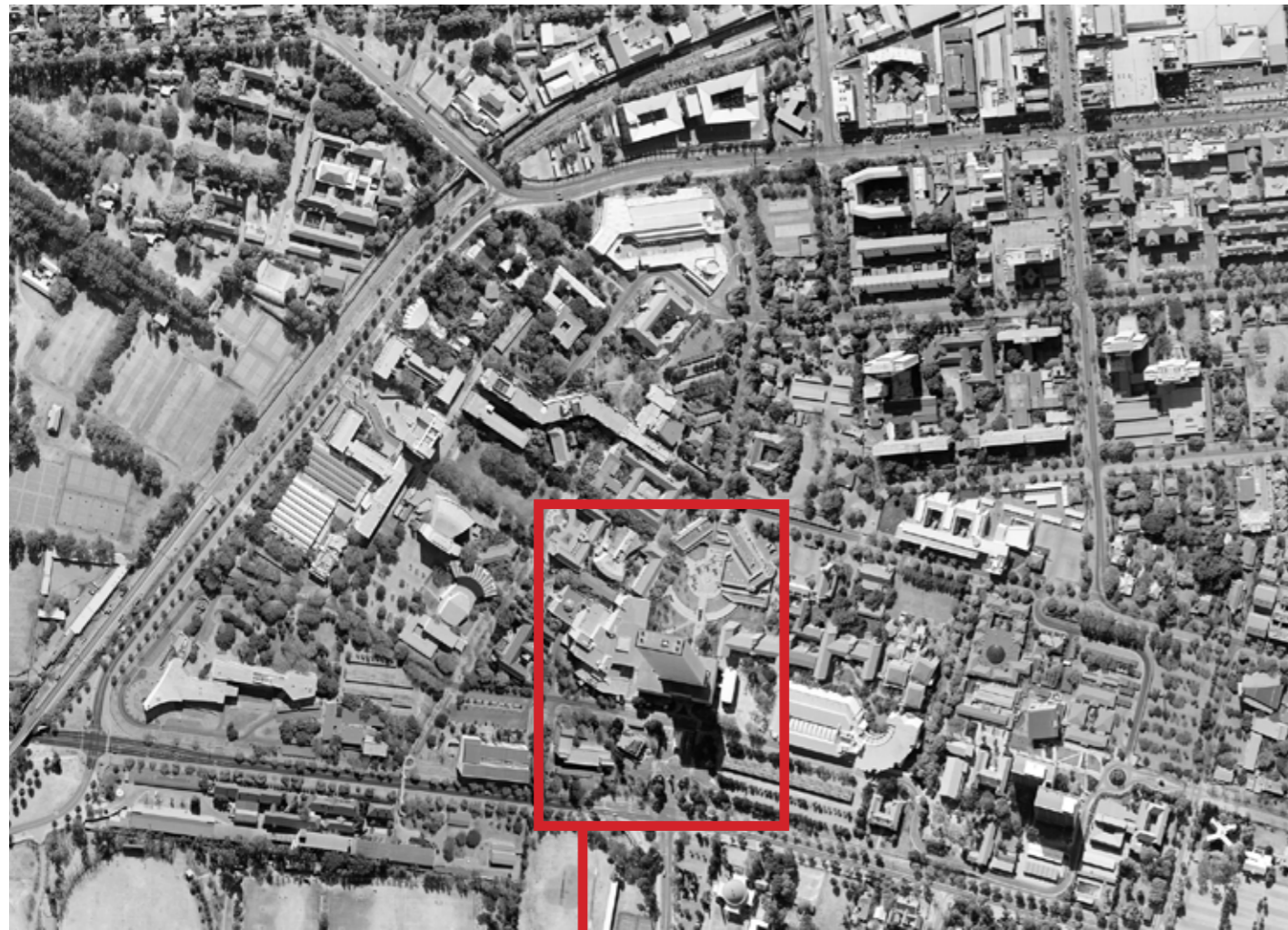

SITE LOCATION

1

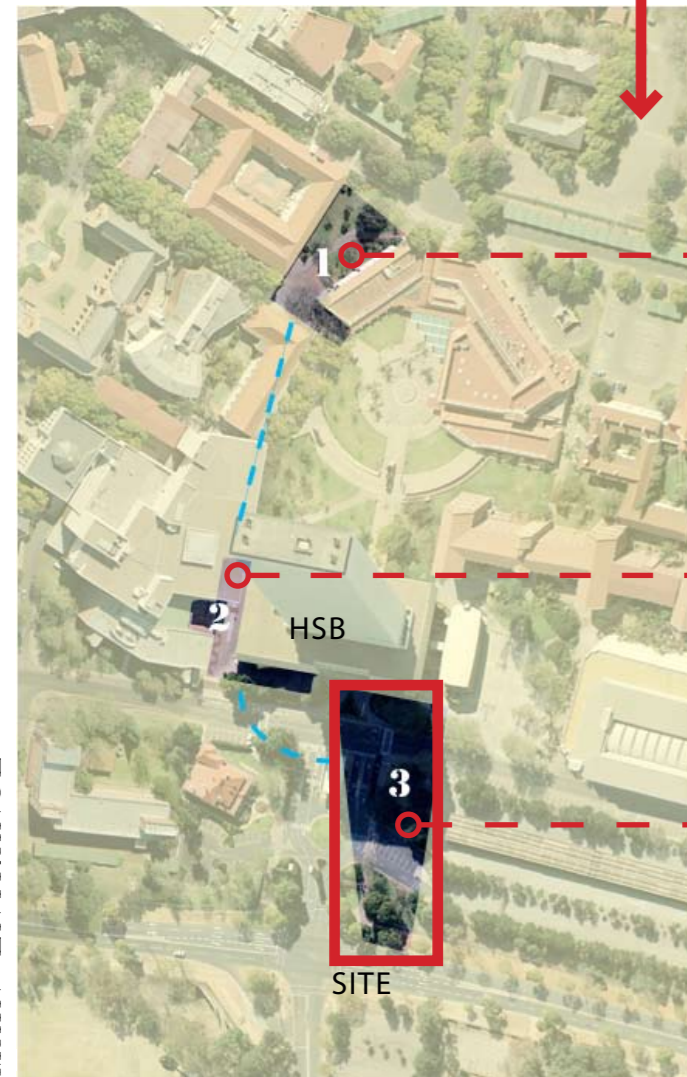

1 First choice: between the student centre and the Zoology buildings. Some students use this area between classes to study, eat or socialize.

2 Second choice: between the Academic Information Centre and the Human Sciences building. More students use the space between the AIC and the HSB.

3 Third Choice: between the outside and inside of the university grounds. All students use the entrances to get on and off campus.

2

SITE ANALYSIS FRAMEWORK

The 2008 thesis students' urban framework vision is to re-introduce the University of Pretoria into the surrounding environment. This will be done in phases. The first phase will be to address the Roper Street connection through to Hatfield, making public access through this area more convenient. The entrances to this path will need to be addressed, which is a major intervention. The rest of the phases will consist of compartmentalizing campus in ever diminishing compartment sizes. This will be done until the campus is fully re-introduced into the surrounding context.

This thesis forms part of the first phase. It is concerned with the main entrance to campus. "Gateway" and "front door" were terms assigned to this particular part of the framework. The terminology determines a mind set.

Path: Lynch, K (1960) 'are the channels along which the observer customarily, occasionally or potentially moves. They may be streets, walkways, transit lines, canals, railroads, highways, etc. For many people, these are the predominant elements in their image. People observe the city while moving through it, and along those paths the other environmental elements are arranged and related.'

Gateway: (gateway wiktictionary.org) 'Any entrance capable of being blocked by use of a gate; Any point that represents the beginning of a transition from one place to another.'

Node: Lynch, K (1960) 'are points, the strategic spots in a city into which an observer can enter, and which are the intensive foci to and from which he is travelling. They may be primarily junctions, places of break in transportation, a crossing or convergence of paths, moments of shift from one structure to another. Or the nodes may be simply concentrations, which gain their importance from being the condensation of some use or physical character, as a street-corner hangout or an enclosed square. Some of these concentration nodes are the focus and epitome of a district over which their influence radiates (cores).'

Edges: Lynch, K (1960) 'are the linear elements not used or considered as paths by the observer. They are the boundaries between two phases, linear breaks in continuity: shores, railroad cuts, edges of development, walls. Such edges may be barriers more or less penetrable, which close one region of from another.'

Precinct: Lynch, K (1960) 'are the medium to large sections of the city, conceived of as having two-dimensional extent, which the observer mentally enters 'inside of' and which are recognizable as having some common, identifiable character.'

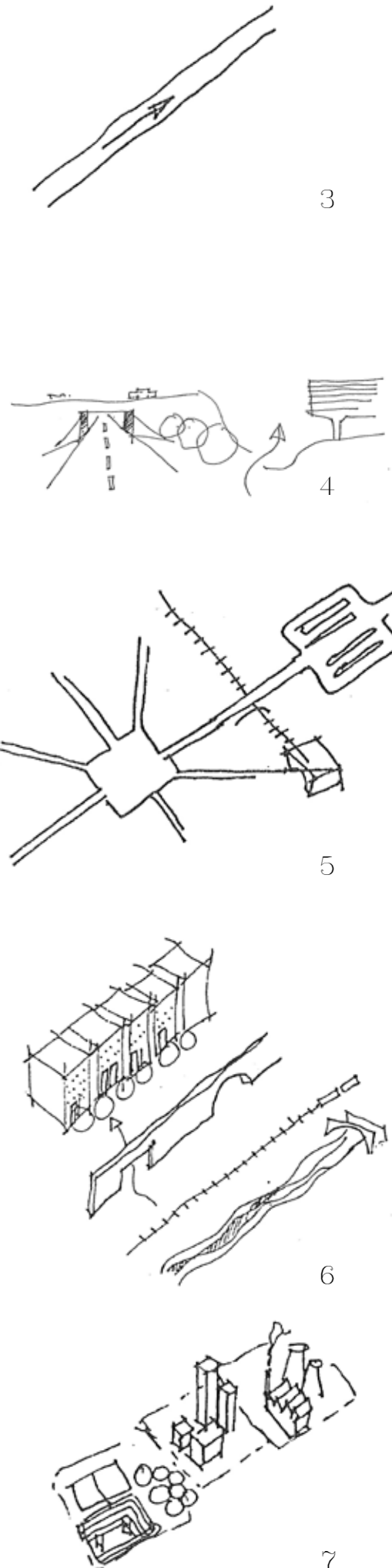

3

4

5

6

7

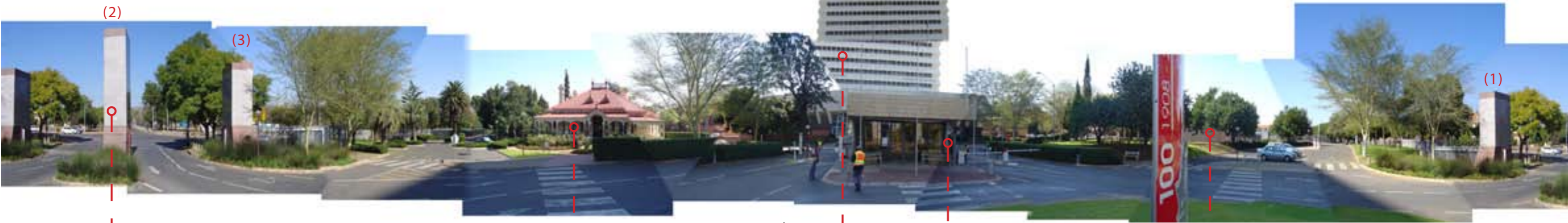

(2)

(3)

(1)

— EXISTING ENTRANCE: MARBLE COLUMNS — KAYA ROSA

— HUMAN SCIENCES BUILDING — CURRENT GUARD HOUSE — MY SITE

The traffic congestion during rush hour is a major problem at the main entrance. The congestion at the entrance is mainly caused by vehicles which need to sign in to be allowed into campus grounds. In addition students needs to be dropped and collected during peak times thus causing even more delays.



(2)

(3)

(1)

(2)

— MY SITE



VIEW NORTH TO THE SITE FROM ACROSS THE STREET



VIEW SOUTH AWAY FROM THE SITE, ACROSS THE STREET



TYPICAL APPROACH FROM THE EAST



SURFACE PARKING LOT SOUTH OF SITE



PRIMARY SCHOOL FENCE AND FIELD SOUTH OF SITE

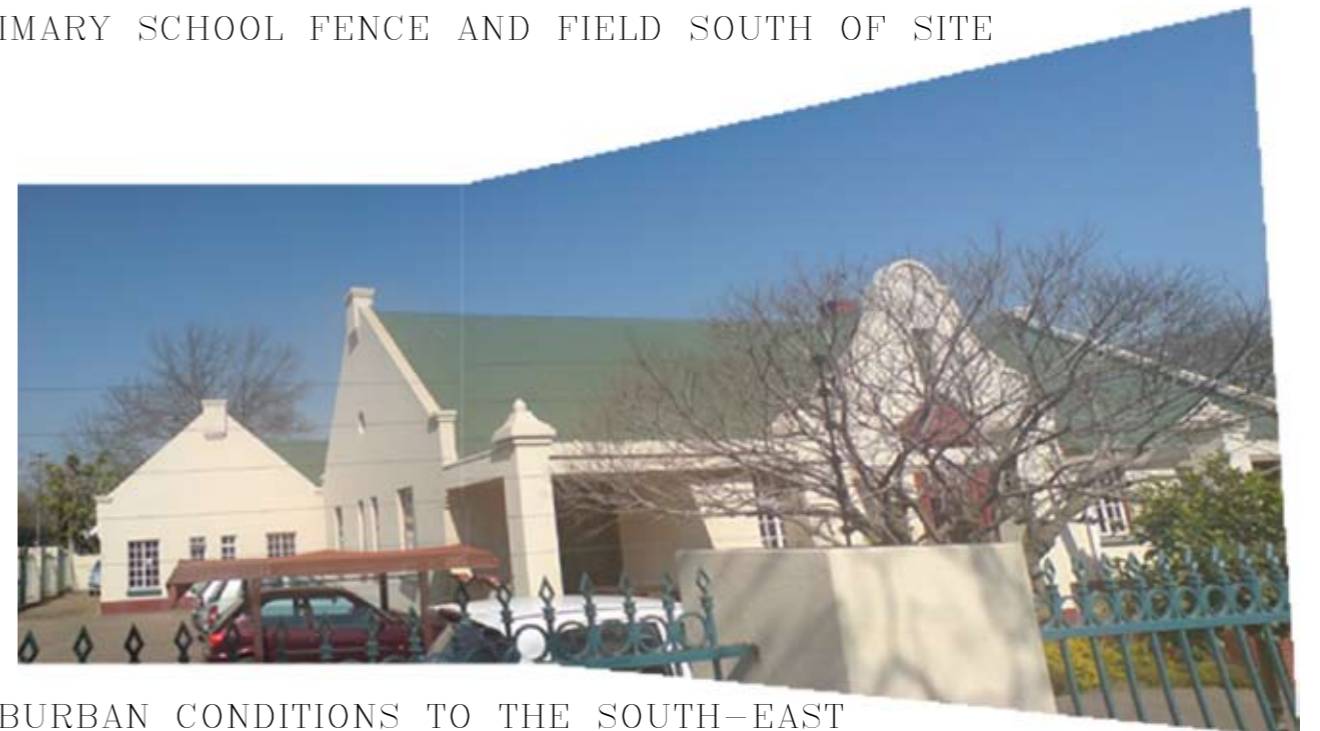

SUBURBAN CONDITIONS TO THE SOUTH-EAST

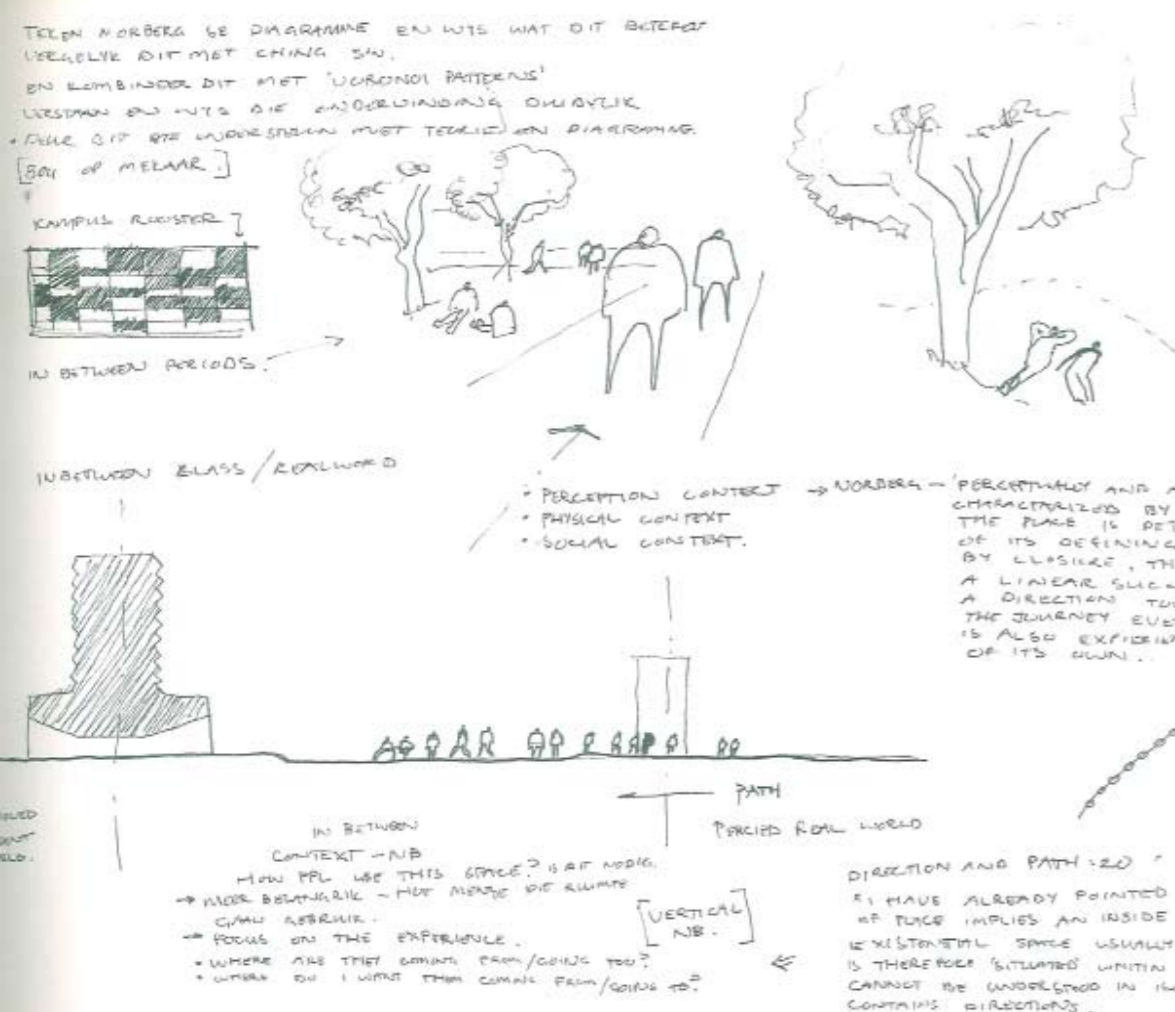

THE PREMISE

Students are only seen on campus when they are between classes. The “student life” on campus is a conducted during this in between time.

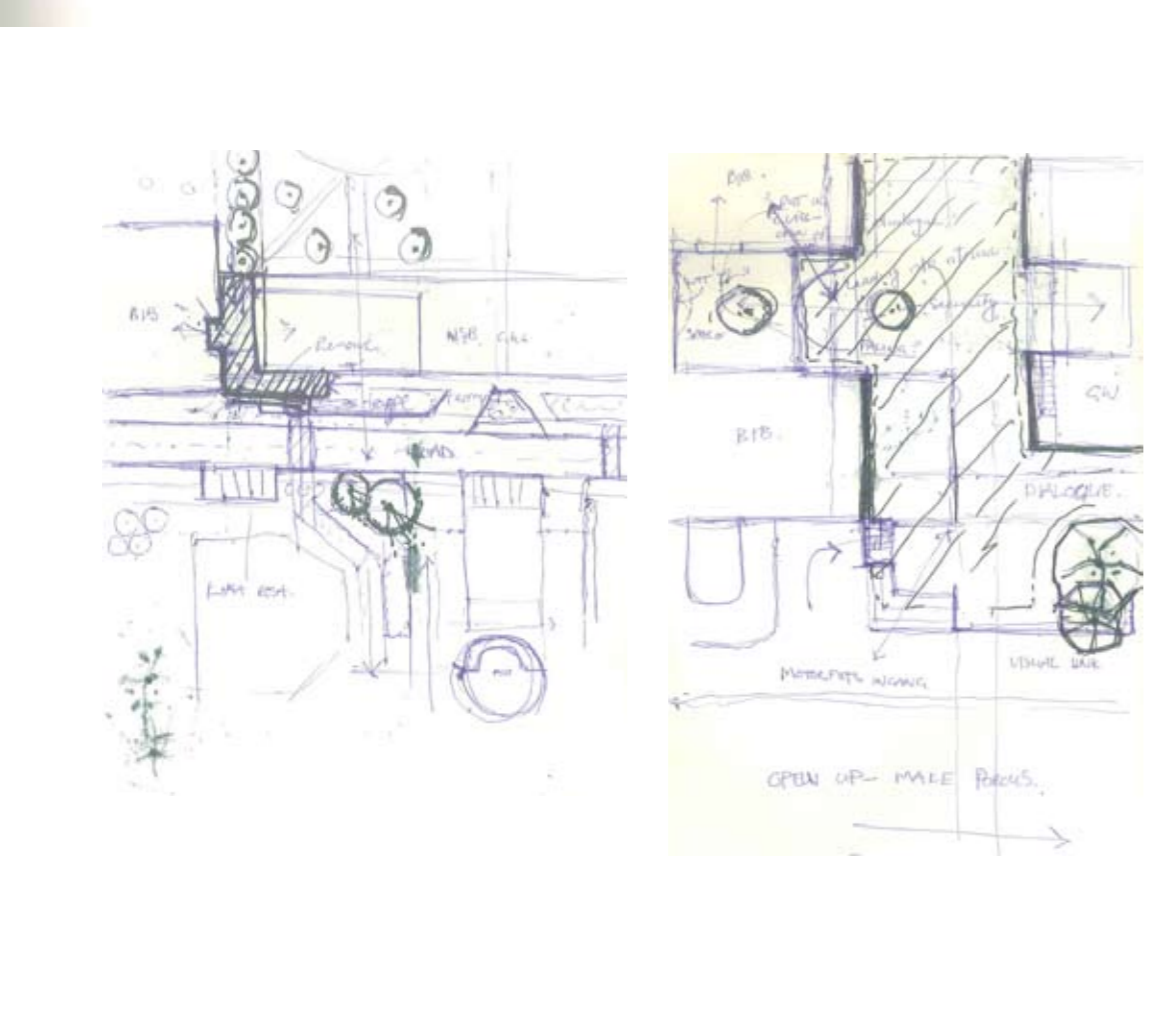
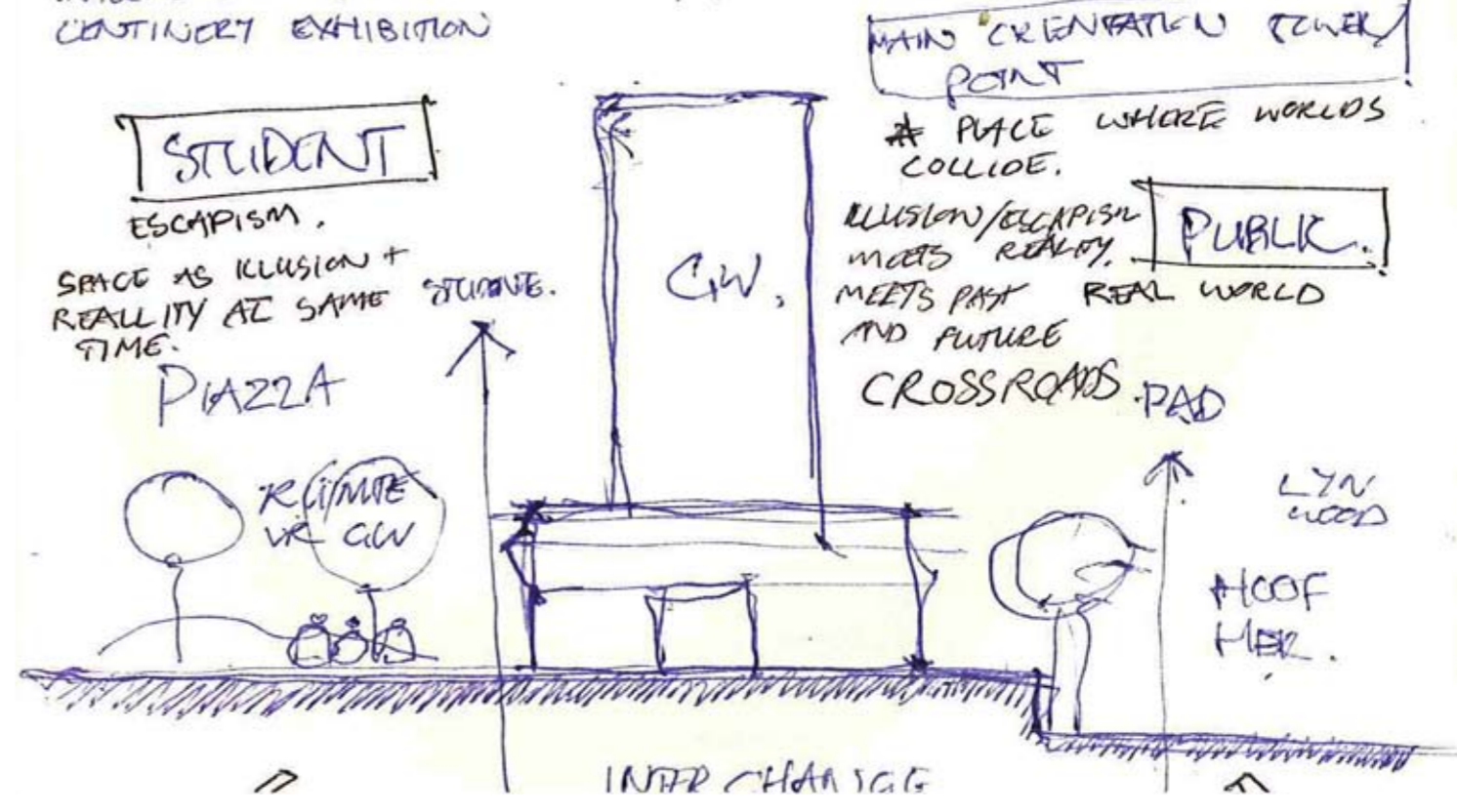

CAMPUS STUDENT LIFE

The main areas where students hang out during this time is around the Student Centre, and also on the grass north of the Human Science Building. North of the Aula there is also a stretch of lawn where students gather. The students sit on the lawn and socialise, study or eat.

GENIUS LOCI

The campus creates an impression of being removed from the “real” world outside. It seems more relaxed. It provides a relaxed academic environment, conducive to study.

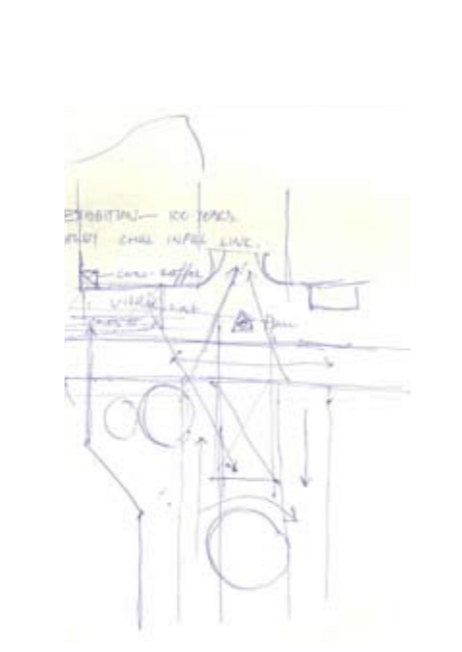

CROSSROADS

(wikipedia: Crossroads) a location ‘between the worlds’. Symbolically it can mean a locality where two realms touch and therefore represents liminality, a place literally ‘neither here nor there’.

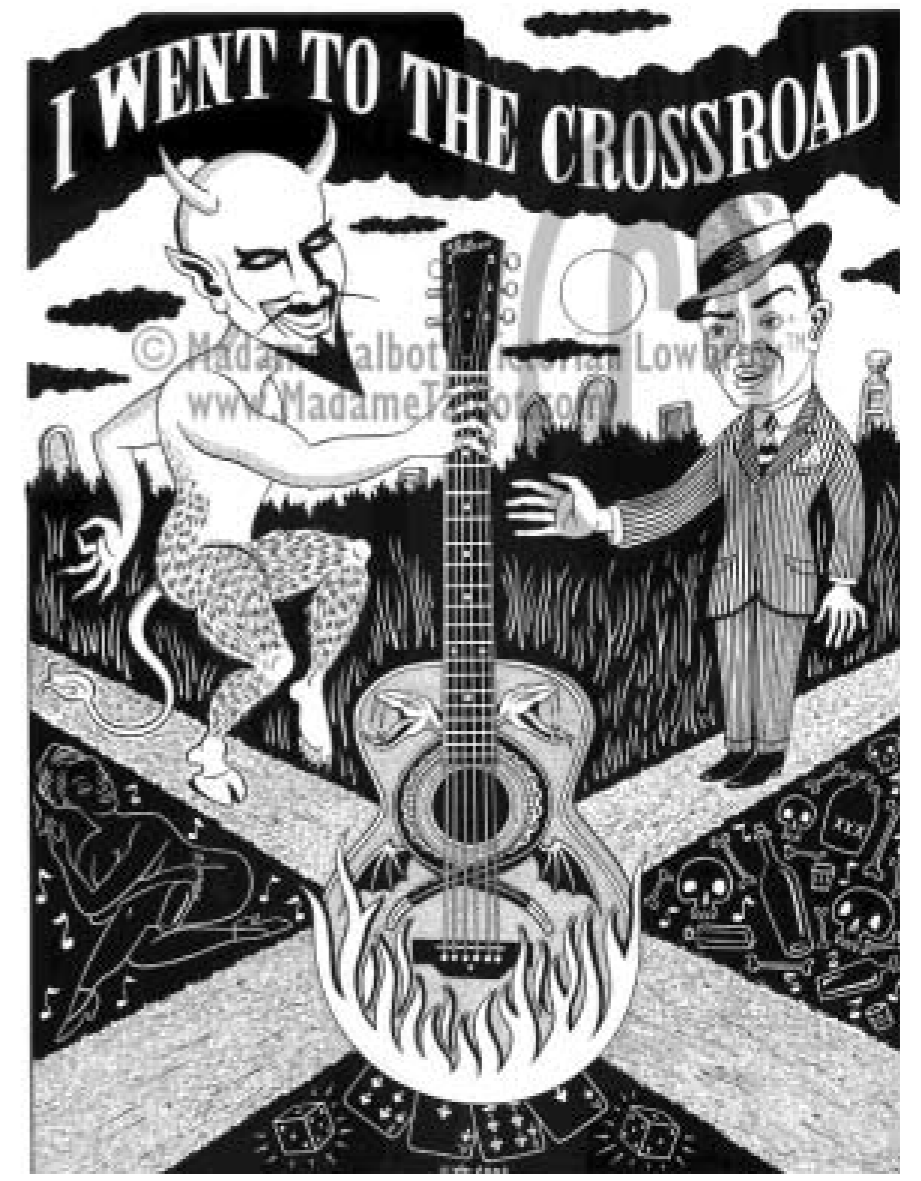

theory

There are 7 (a - f) distinct aspects of the total theory explained graphically on these 2 pages. The 4 stage process will show an investigation into all these aspects, culminating in a design adhering to all these criteria. This has also become the brief for the building.

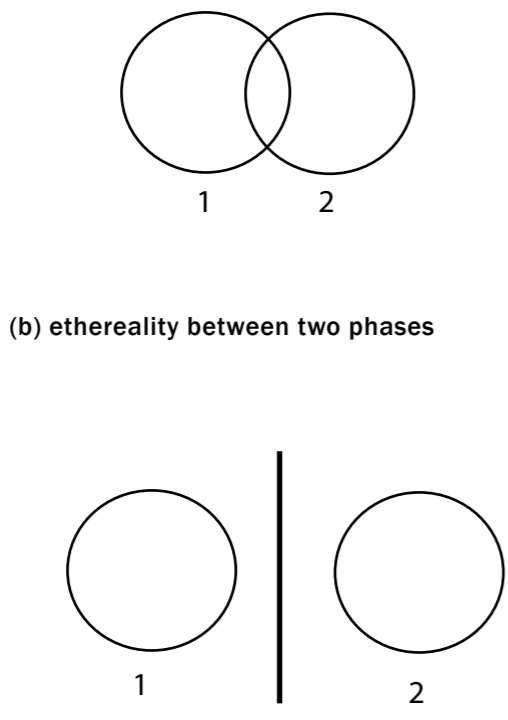

Theory

Smith, C (2000) (a) Interrelationship of two phenomena

rather than

opposition

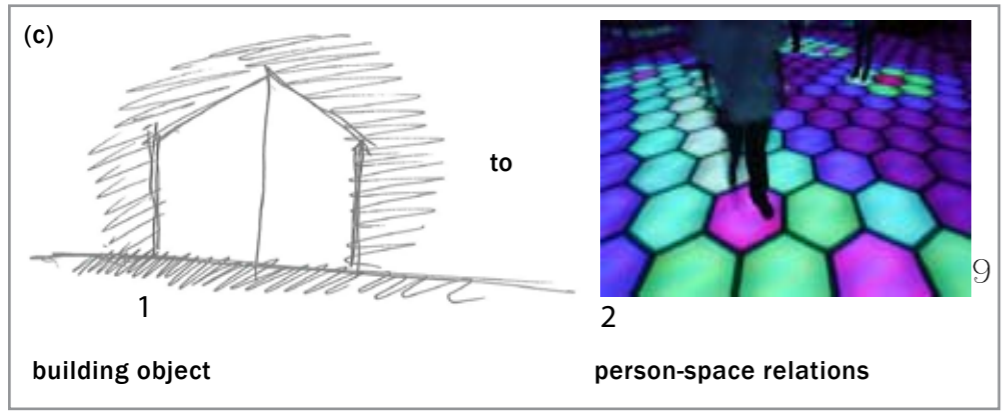

theory

Smith, C (2000) (c) re-conceptualization of architecture from building-object to person-space environment.

(d) Smith, C (2000) 'male' solid + inflexible stereotomic

[Interrelationship of two phenomena]

of two 'female' open-conceptual possibilities tectonic

ARCHITECTURE

• SOMETHING WHAT IT IS BUT ALSO WHAT ITS NOT

STEREO TONICS
+
TECTONICS
||
BUILDING.

NECESSARY TO BE UNNECESSARY.

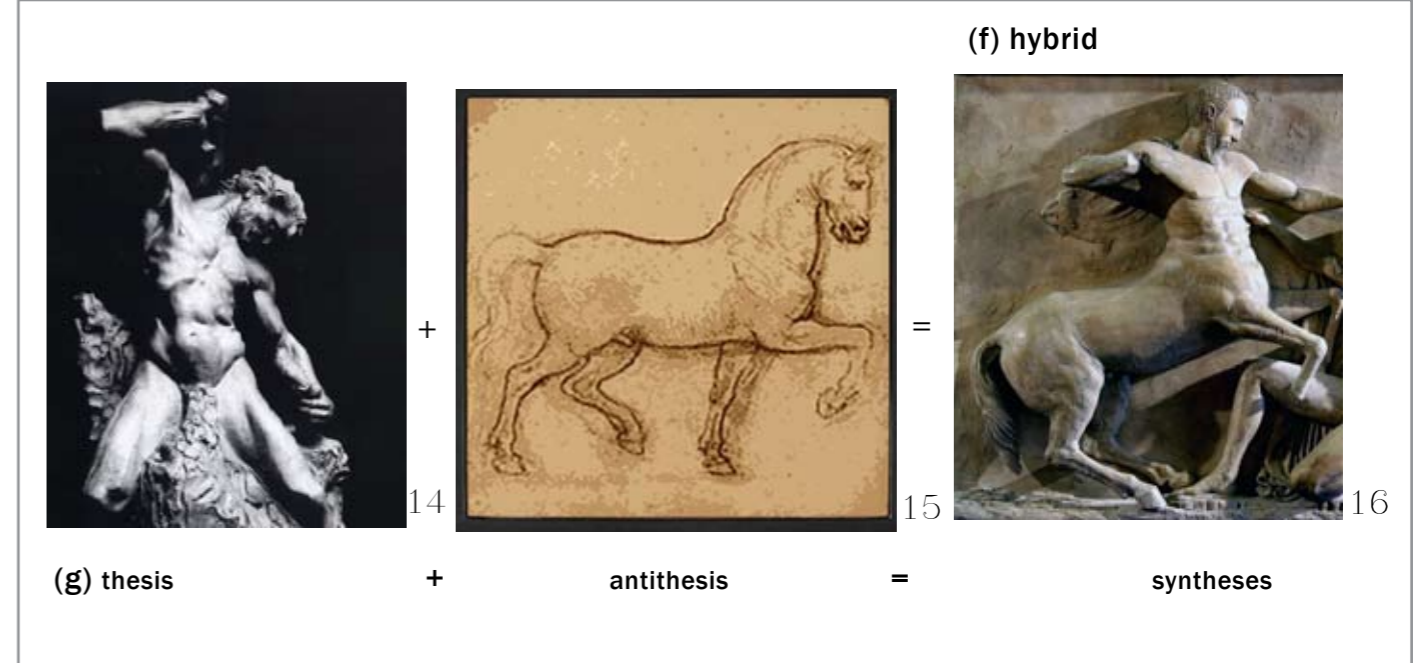
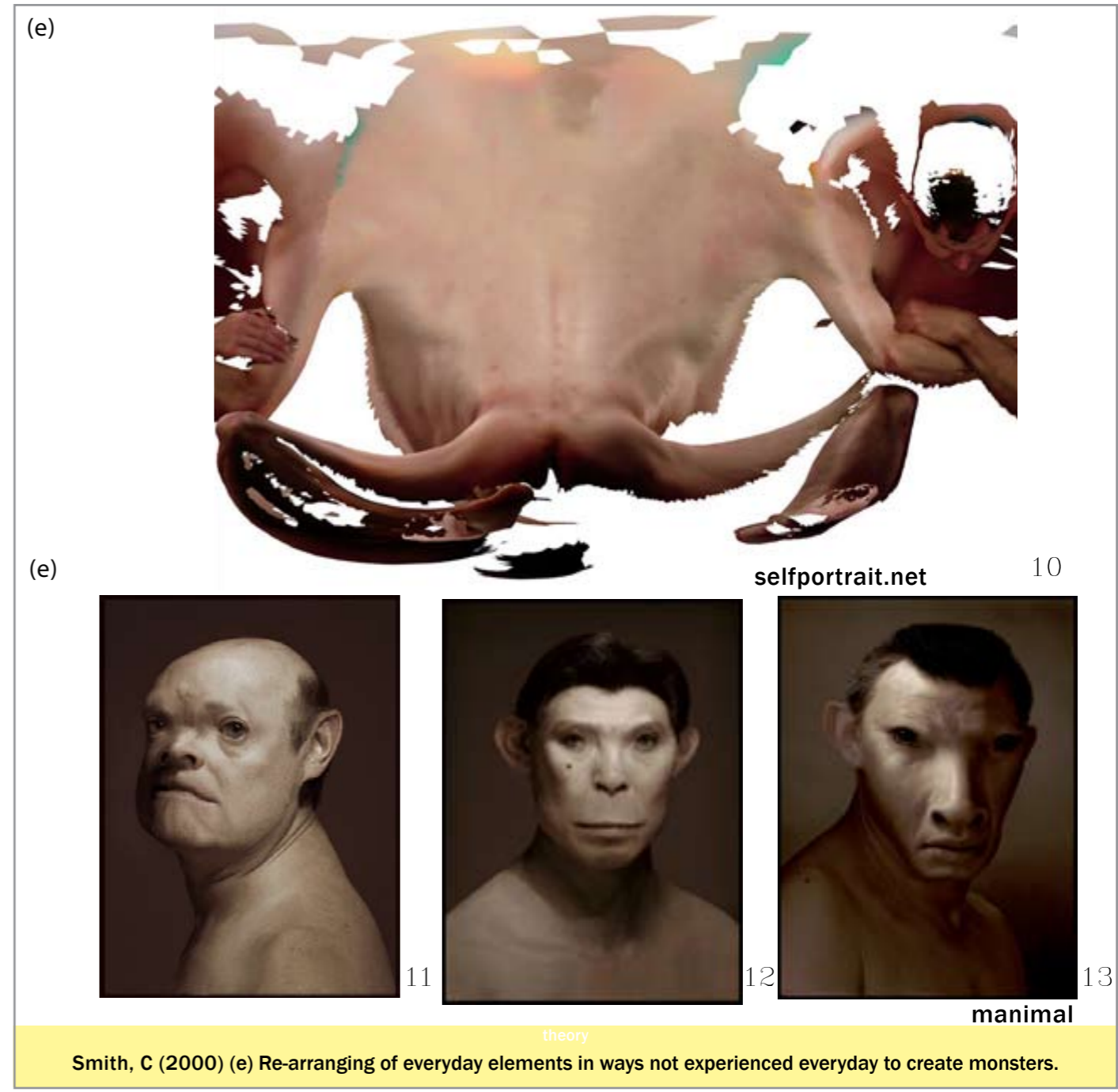

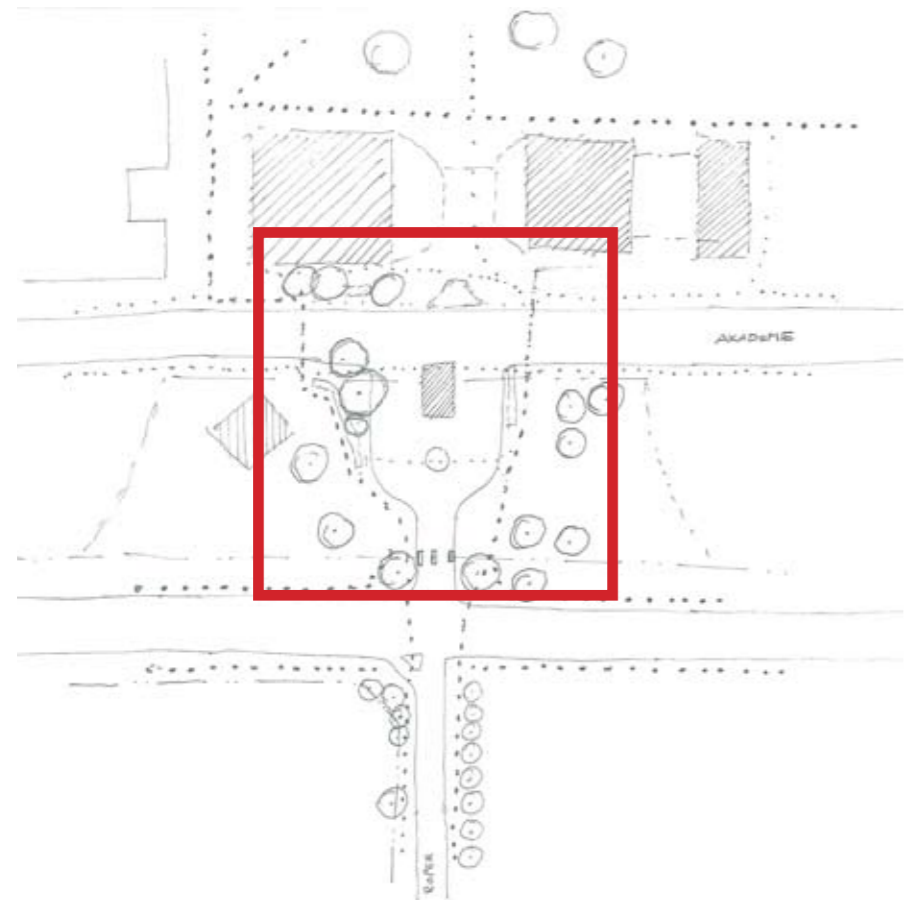

context

From personal experience, after 5 years of entering and exiting through this space as a student, I have realized that there is a repressed spatial experience at the main gate.

When you are approaching the university you know you are going to enter campus. That is your intent, however, there is no progression facilitating the manifestation of what could be an experience, which could make you aware of the university's genius loci.

TYPICAL MOVEMENT PATTERNS OF PEOPLE OVER THE SITE

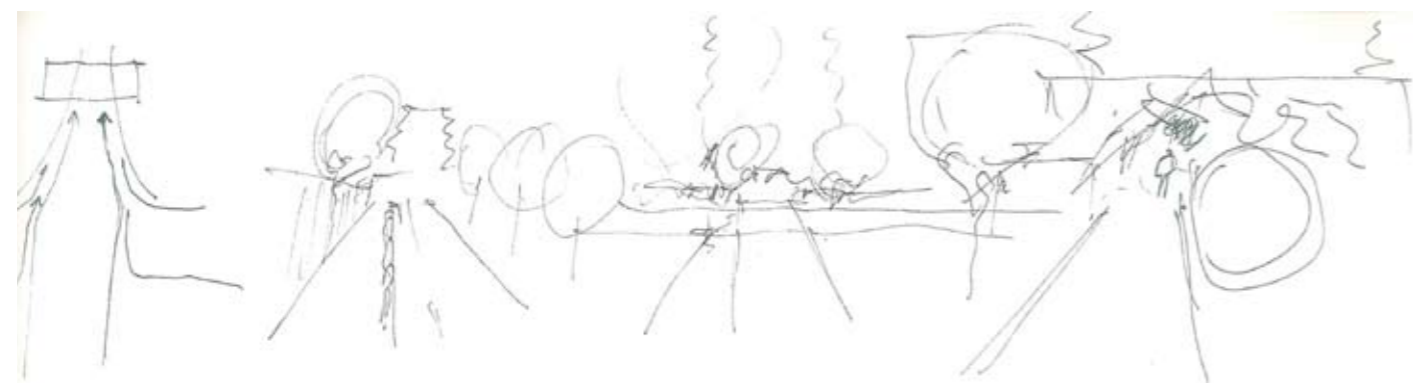
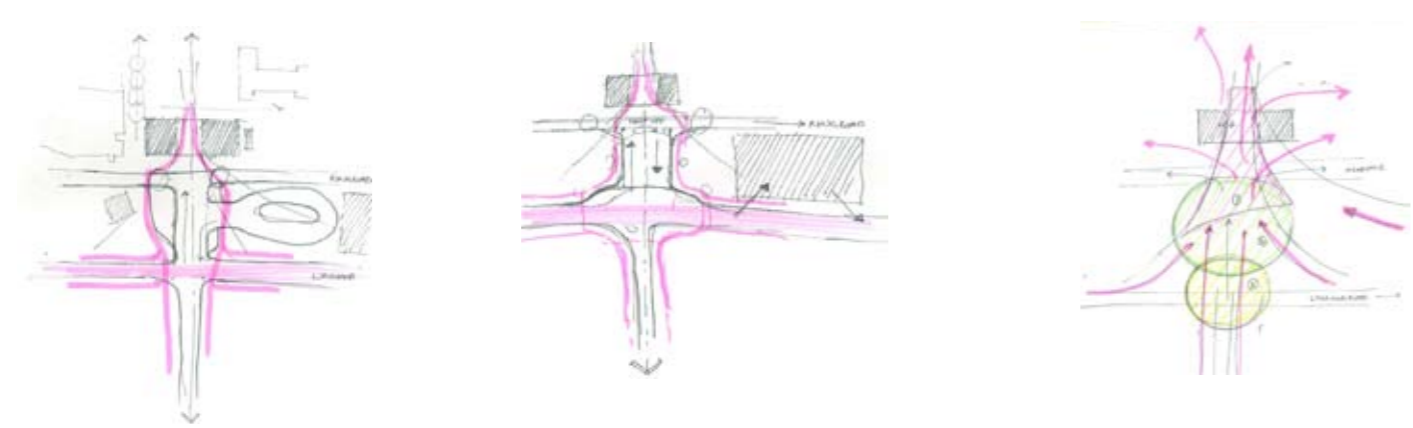

APPROACH TO UNIVERSITY MAIN GATE

context

The drawings [fig. 17] show the current parking areas around campus. Current surface parking at the main entrance amount to a hundred parking bays.

The ARC proposed parkade will have over a 1000 parking spots. Arc Architects is the firm who won a competition for the building of a new parkade at the main entrance.

There are currently +- 400 cars parked along Lynwood Road.

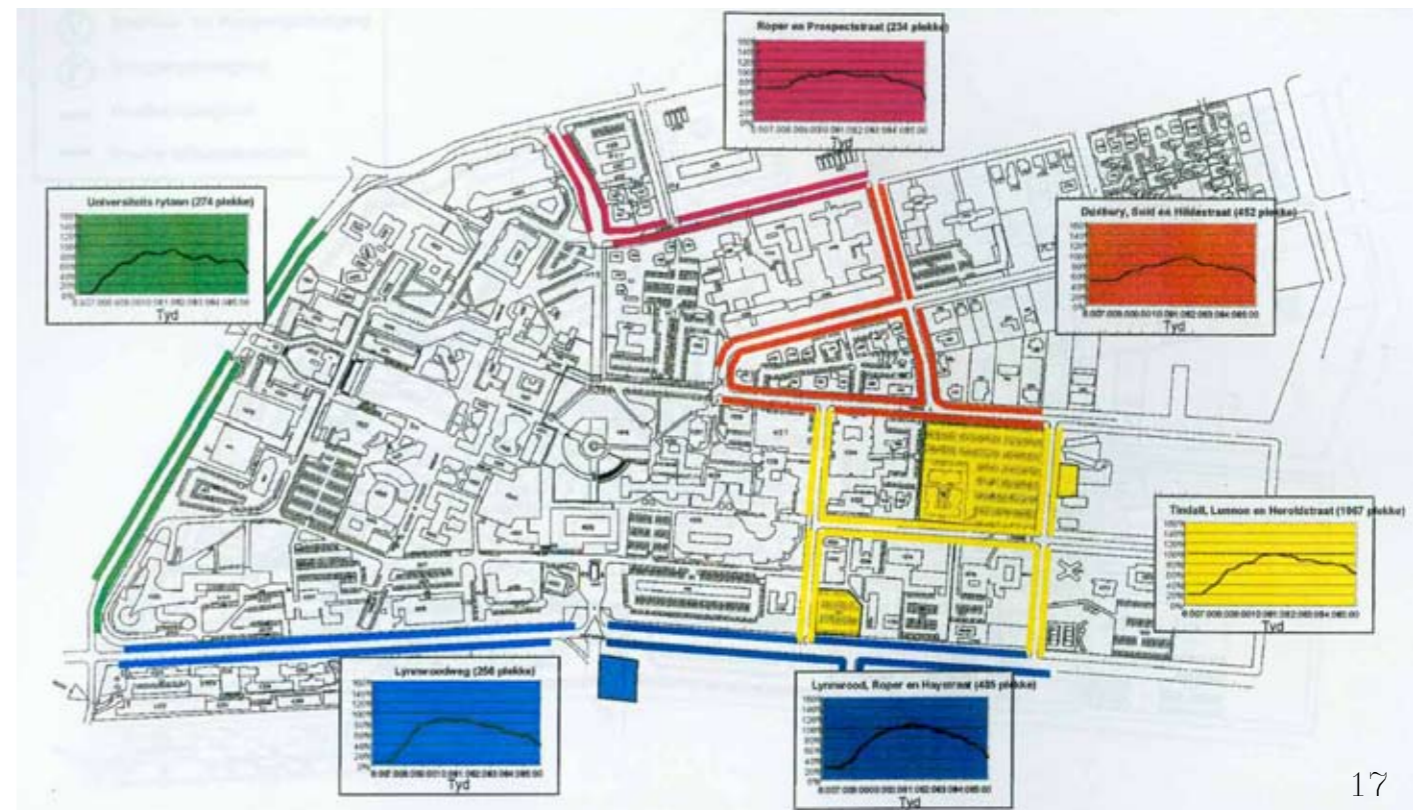
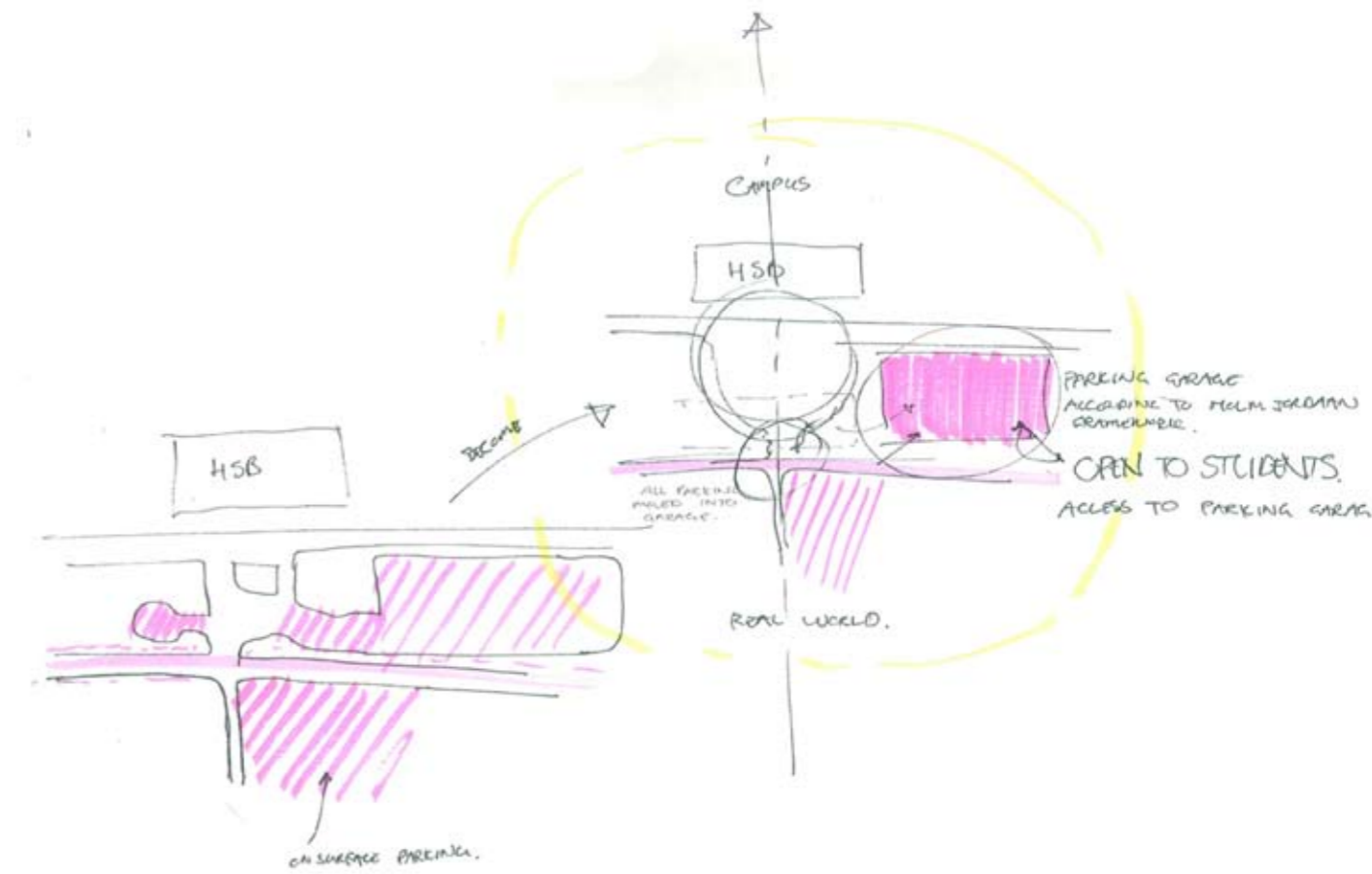

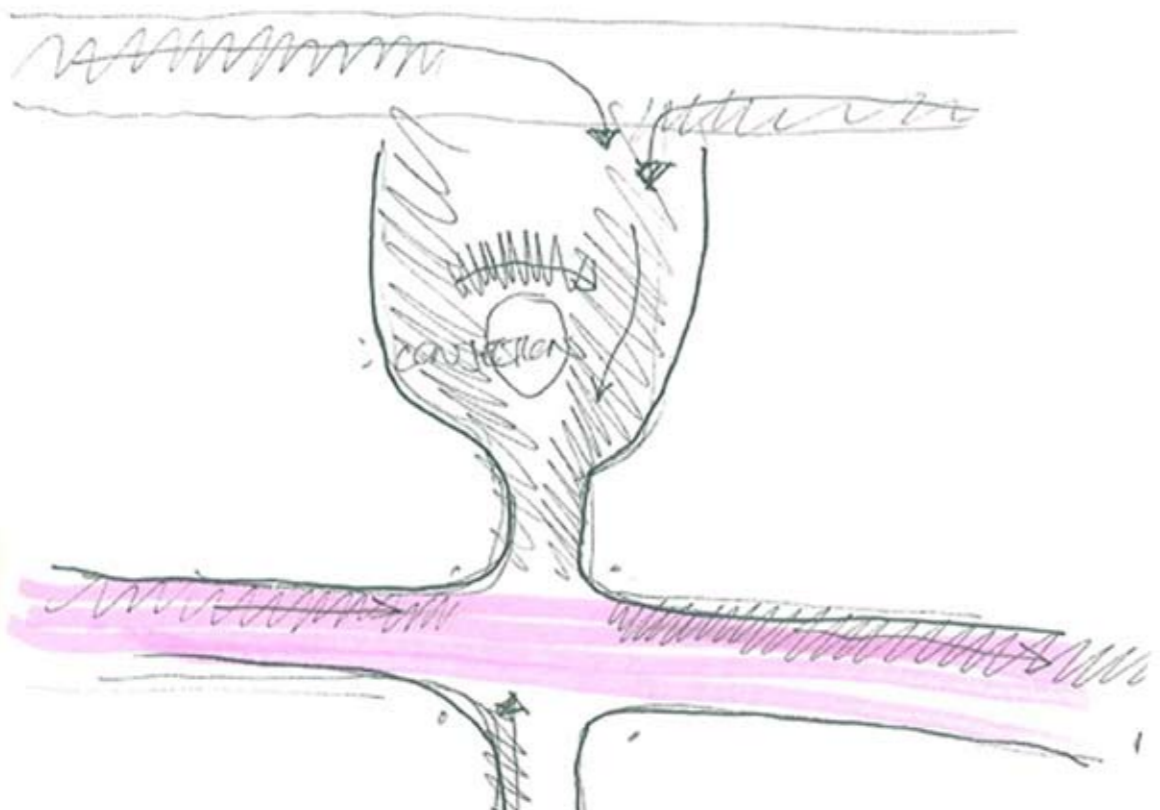

CURRENT TRAFFIC CONGESTION AT FRONT ENTRANCE

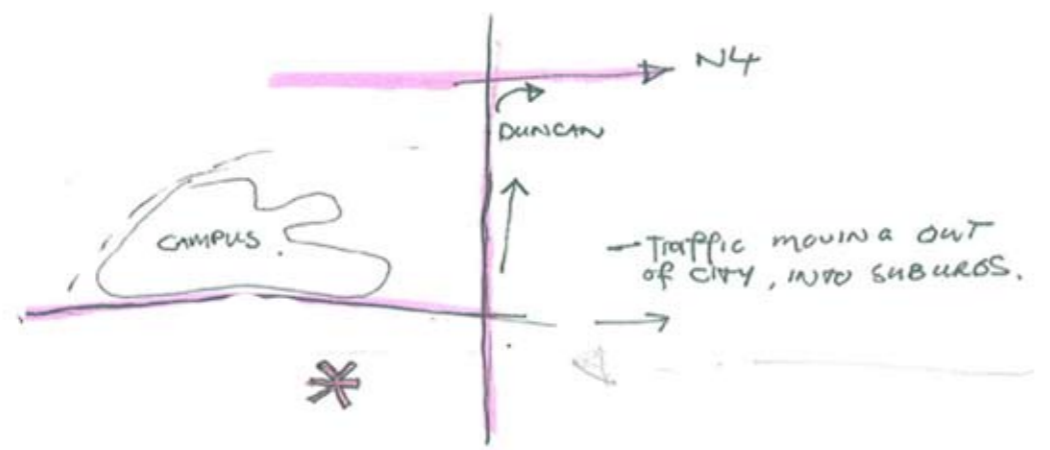
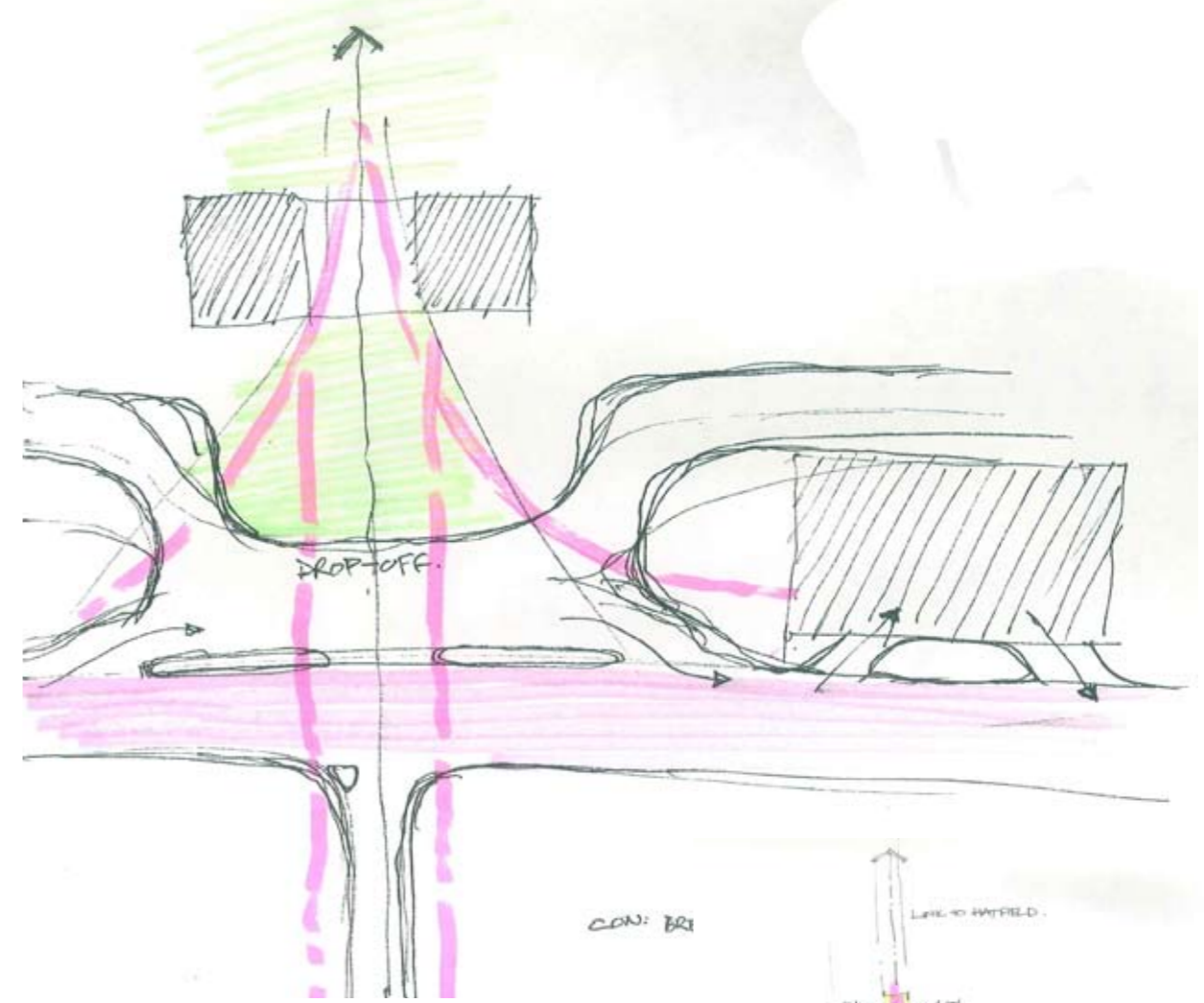

MAJOR ROADS

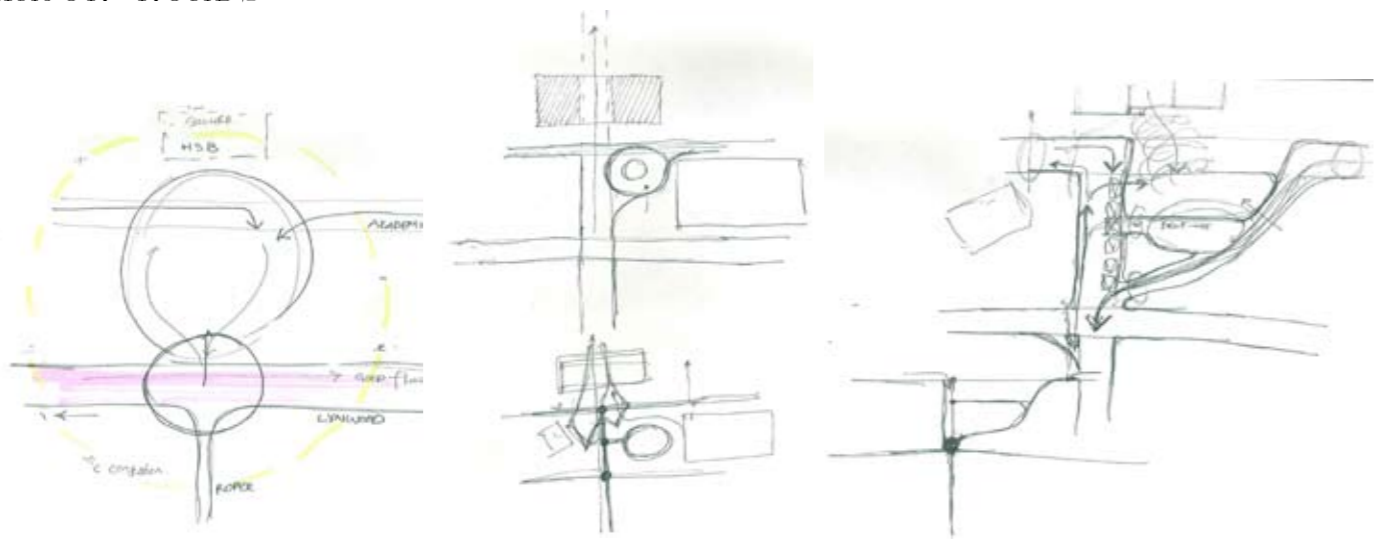

THESE DRAWINGS INVESTIGATE THE CURRENT TRAFFIC CONGESTION PROBLEMS.

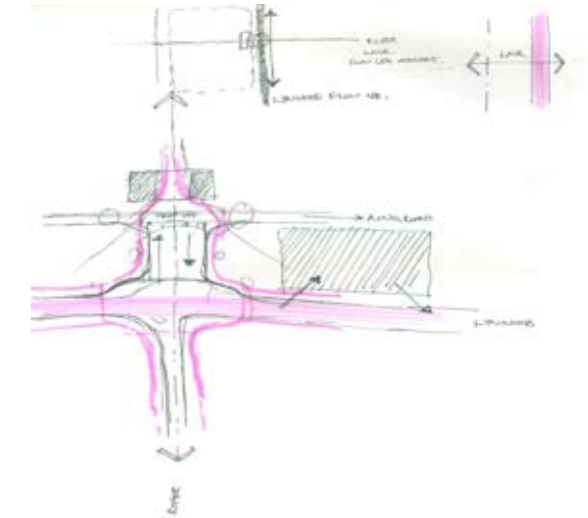
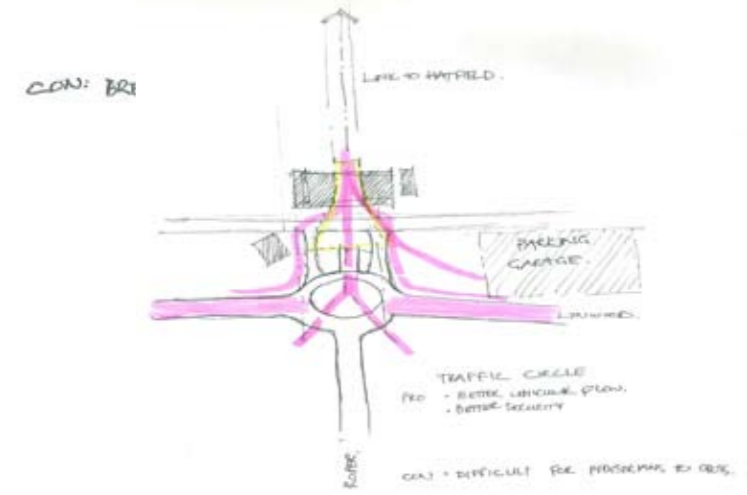
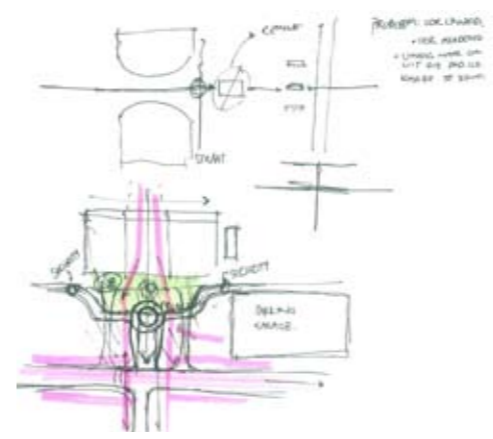

context
The drawing top left shows the current traffic congestion, which is a result of heavy traffic , during rush hour, on major roads leading to the East and North of Pretoria.

Lynwood Road leads out of the CBD.
Duncan Road leads North to the suburbs.
Schoeman Street leads East to the N1.

VARIOUS ATTEMPTS AT SOLUTIONS



18

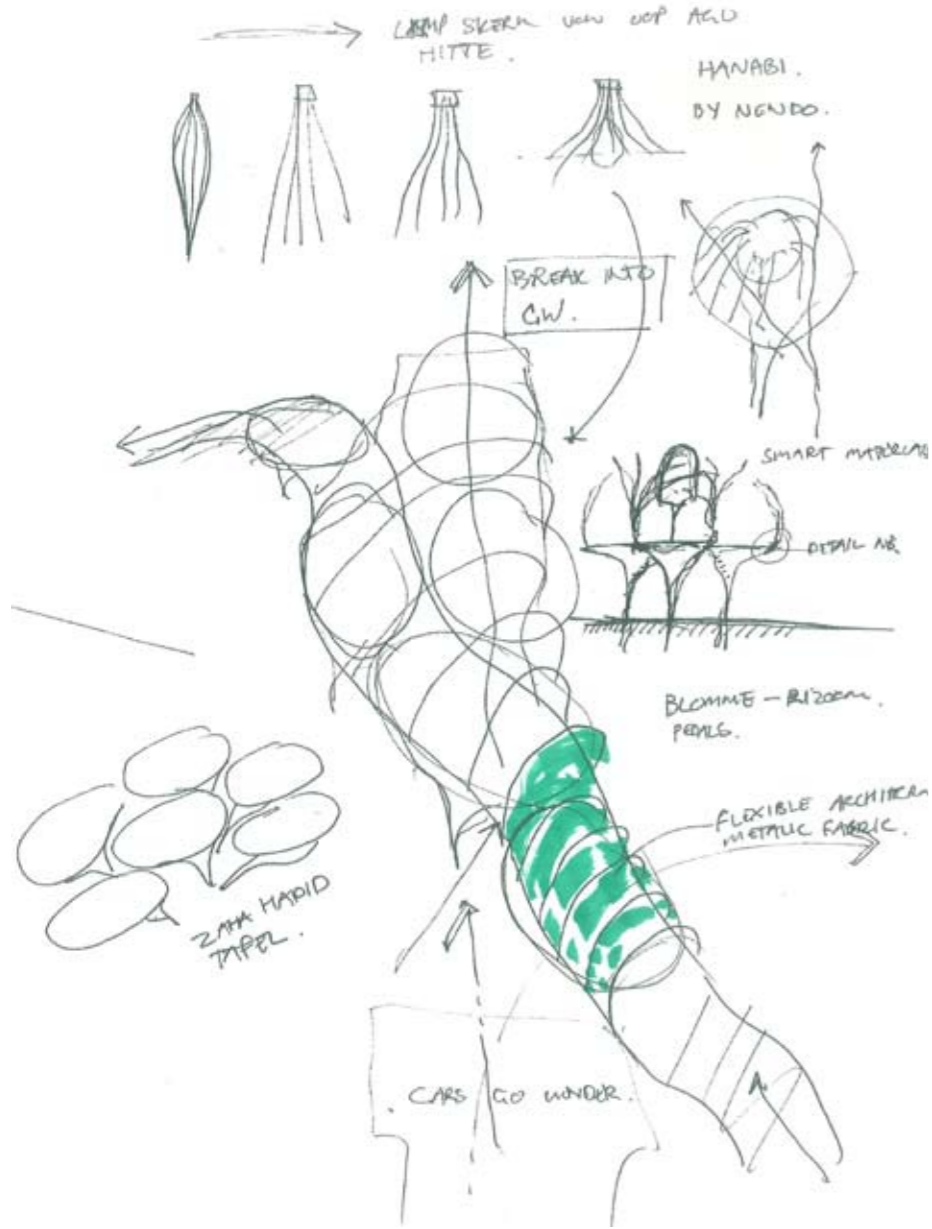

design
Working with the existing context, the main drive was to create a building which physically captures student life as a dynamic monument.

It is located between two phases, always moving and changing. In relation to the changing students and information on campus. To explore the possibilities of 'ethereality between two phases' (Smith, C. 2000).

The aim of this exploration was to discover typology which would be relevant to the focus of the design.

The building typologies which were chosen were that of gate house and billboard. The gate house because it's at the main entrance. The billboard, to communicate information and university identity.

The building should communicate information about student life on campus. The students will have a direct influence on what information the building projects.

precedents
Technology which will allow for physical change and movement of the building was investigated. The lamp shade (fig. 18) was found, which is made of memory metals. As the lamp heats up, the heat causes the lamp to shape shift and open up.

This idea could be transposed into becoming a building, in which physical movement and change would occur. This would be driven by student life on campus or activity such as studying or research.

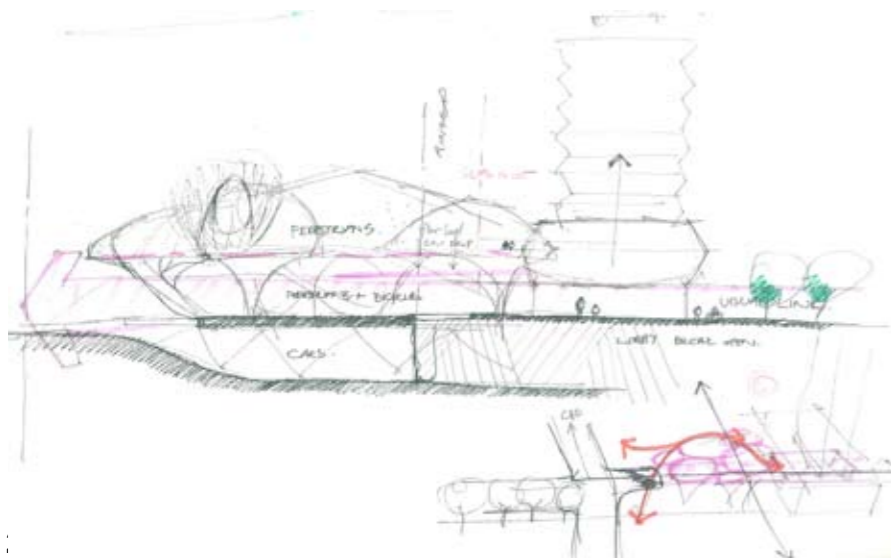

precedent
The Zaha Hadid projects below were influential in terms of form. The Serpentine pavilion [fig. 19] could be the how the gate house will look. The table [fig.20] and its supports could be the way the spacial experiences can be created.



SERPENTINE PAVILION



TABLE

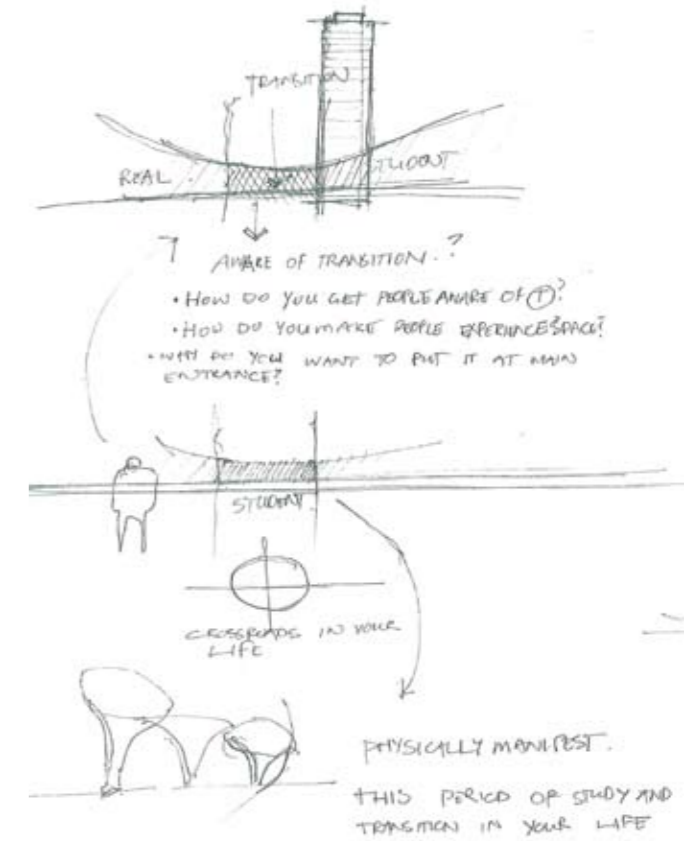

19

20

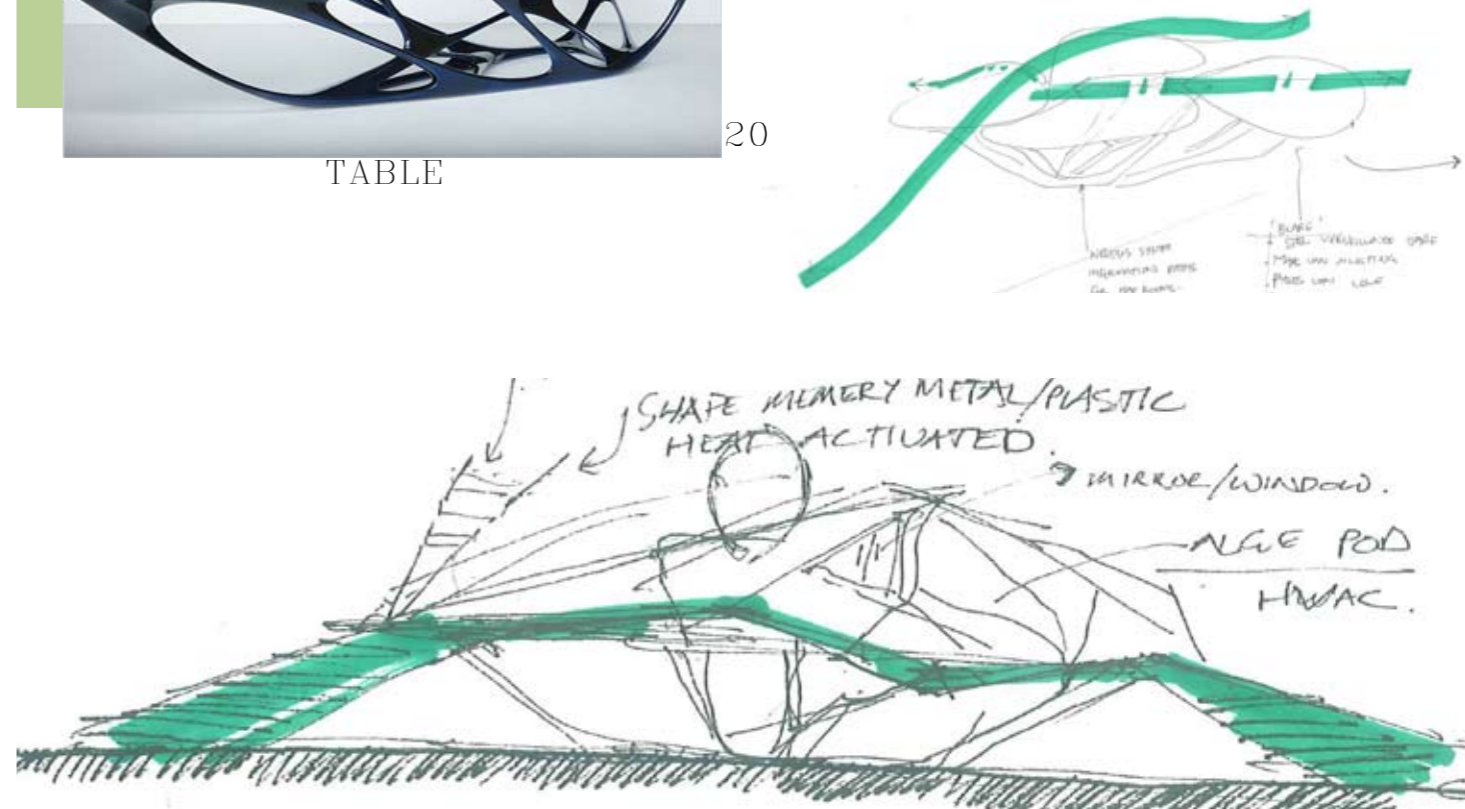

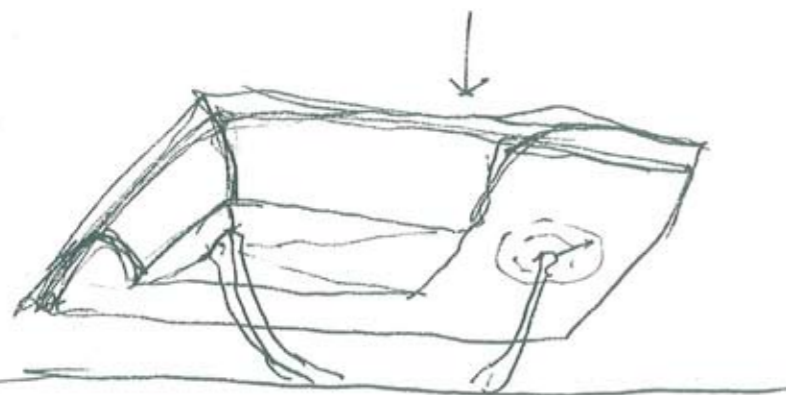
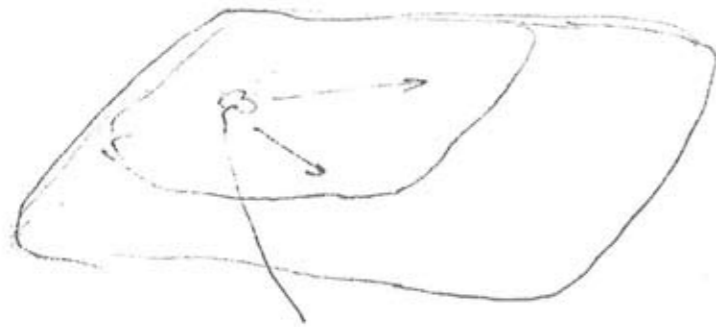
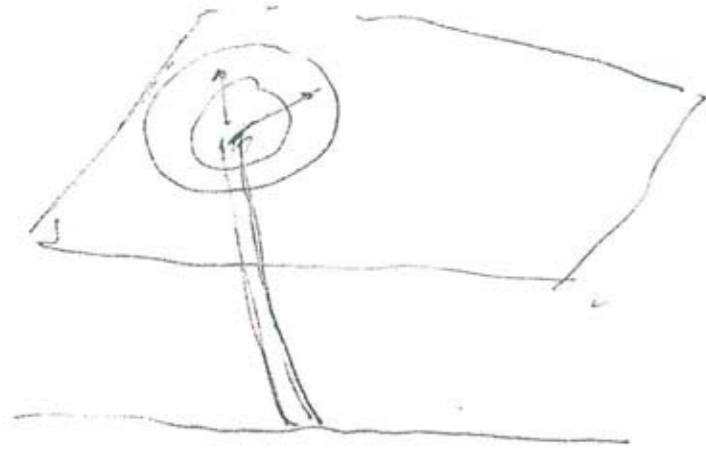
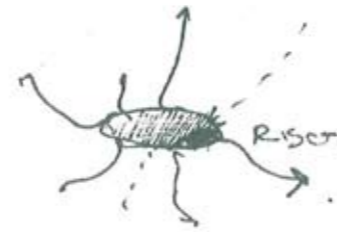
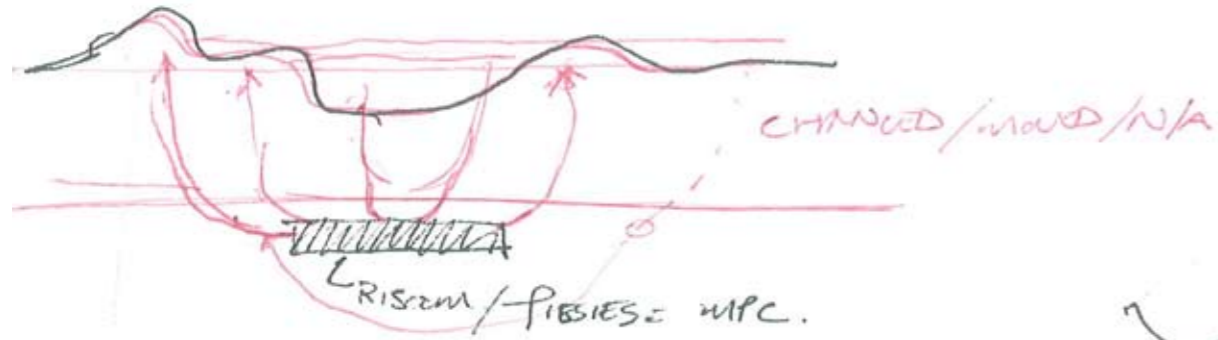
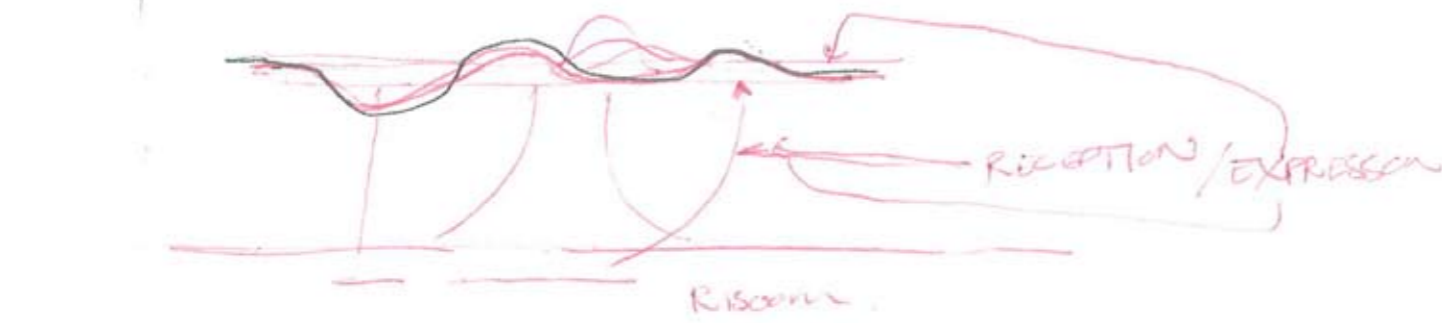

theory
Here the concept creates an interrelationship between the two typologies, a type of hybrid. However, the technical improbability was the deciding factor.

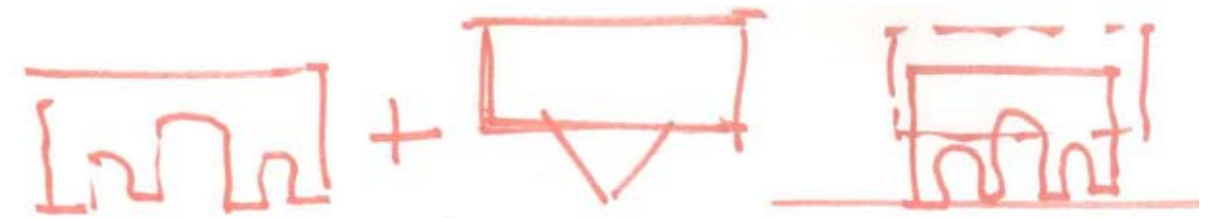
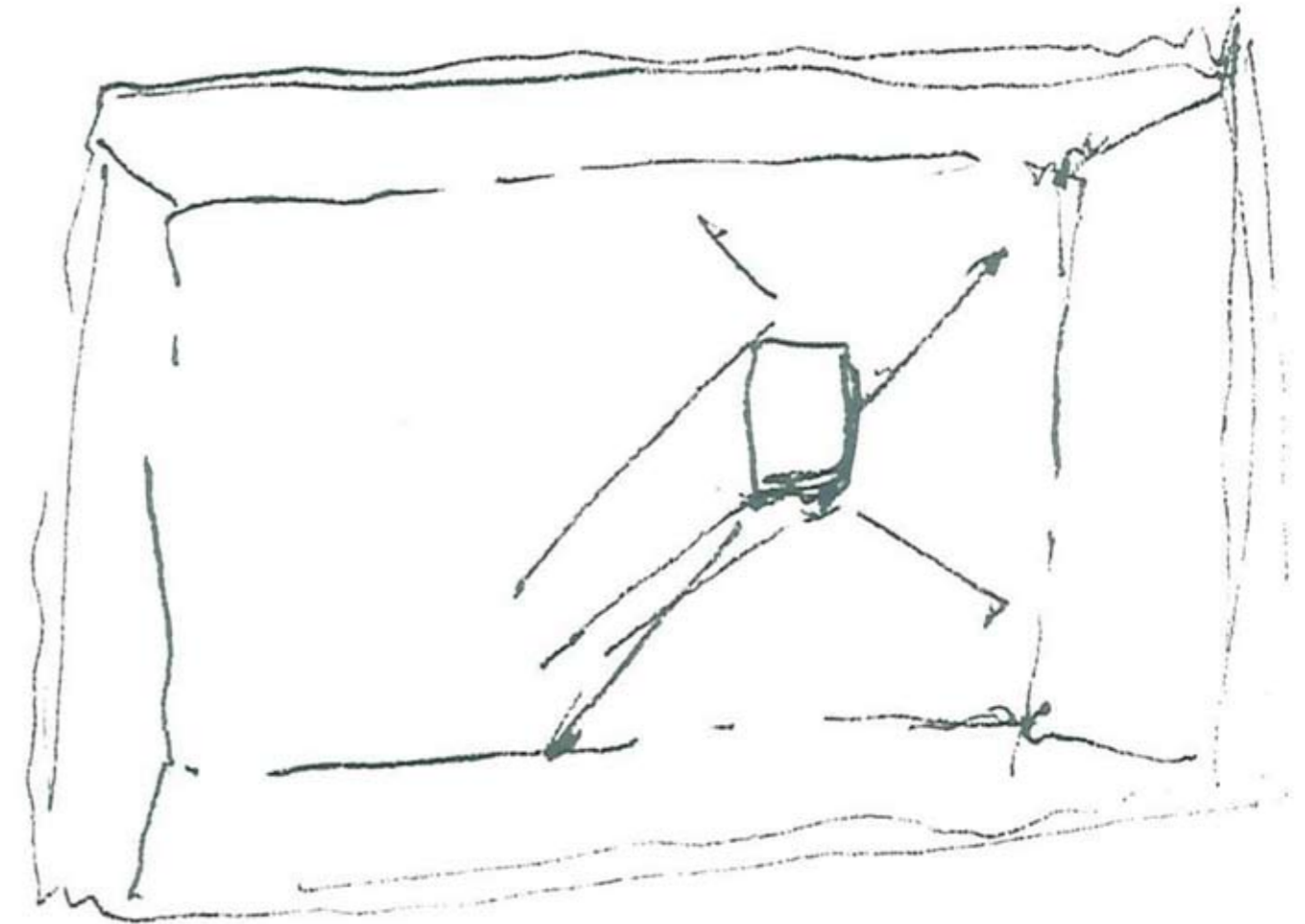
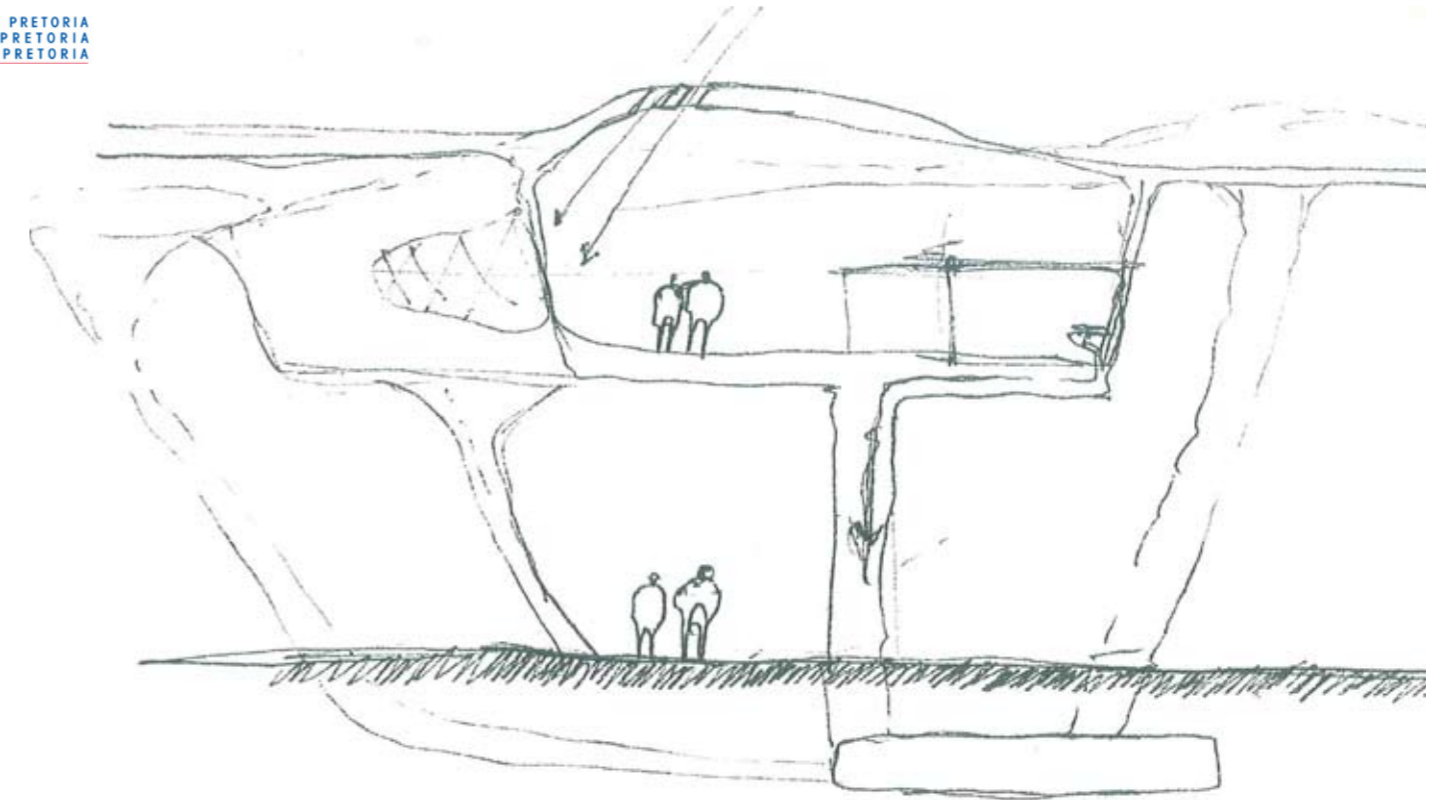
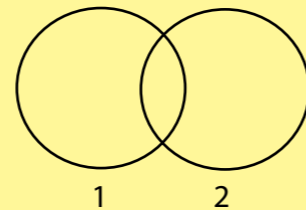

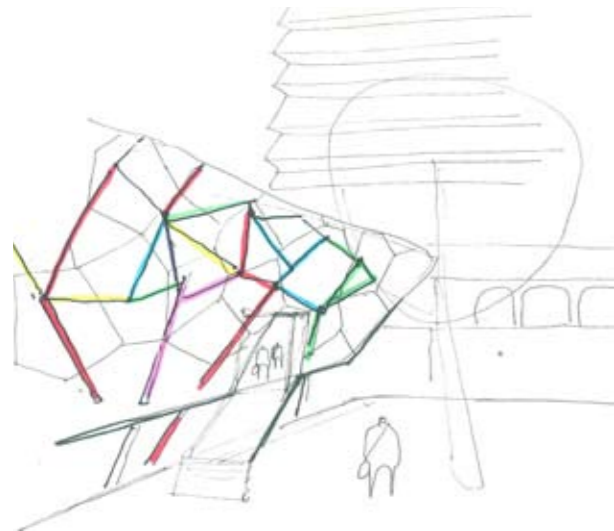
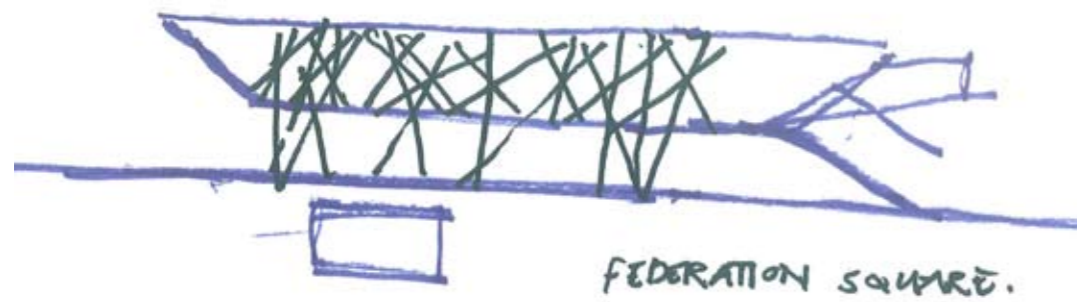

WATCH TYPOLOGY WHICH IS A MACHINE WHICH FOCUSES TIME UPON ITSELF

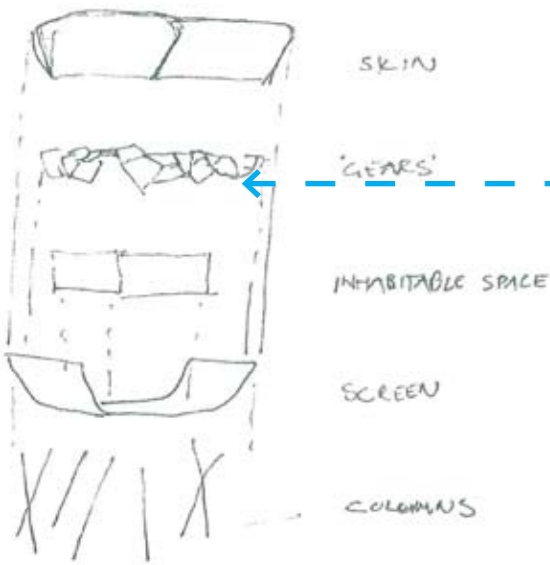

precedents
Federation Square, Melbourne

design
The building has become a type of machine, which focuses time upon itself. As the gears move you see how the machine works. This building would then become a machine that exposes the inner workings of the university.

The working of the university includes the amount of research the university is producing and the flow of information and graduates. Thus it exposes the "gears" of the university. The way it would be translated into a building is similar to Federation Square. The triangulated superimposed structure would change colour to represent the different faculties and how they are performing.

context
The drawing to the right shows the placement of the building in context. A diagram describes the contextual influences as well as the circulation concerns.

The vignette shows the spatial implication of the above diagram.

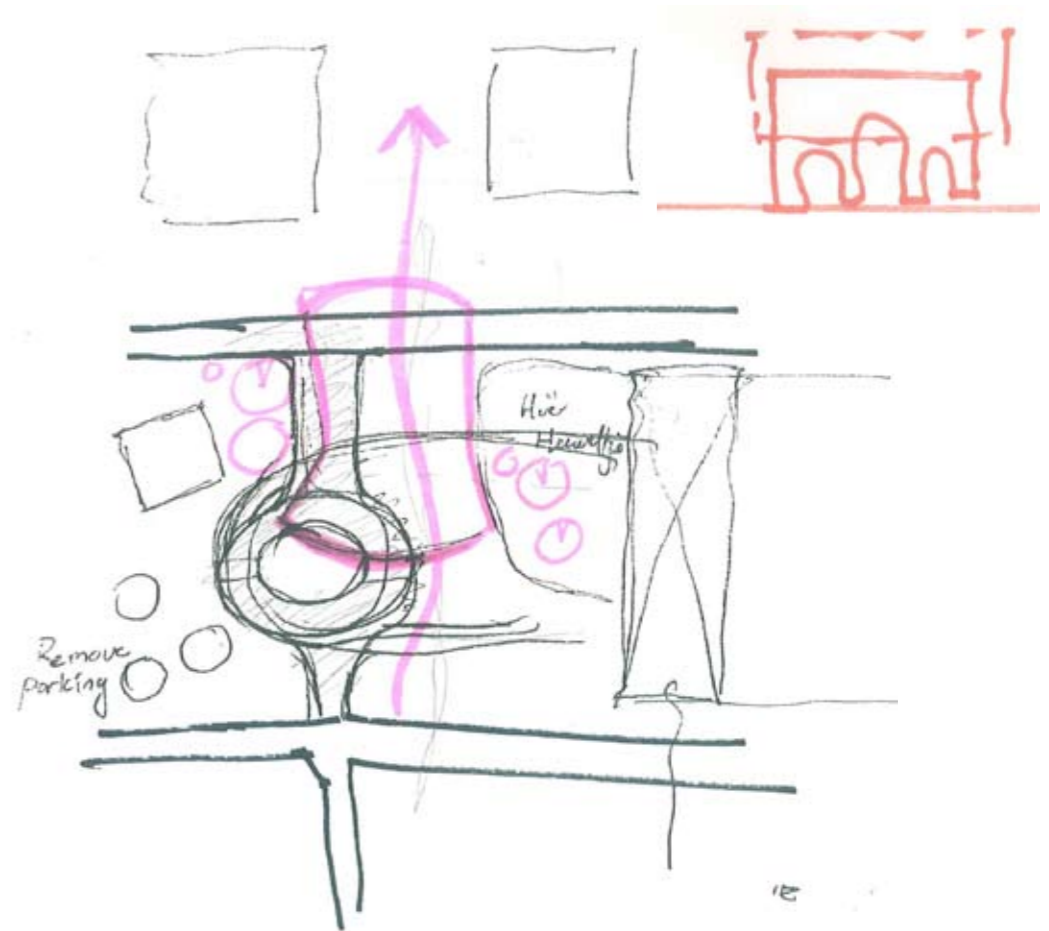

PLACEMENT IN CONTEXT

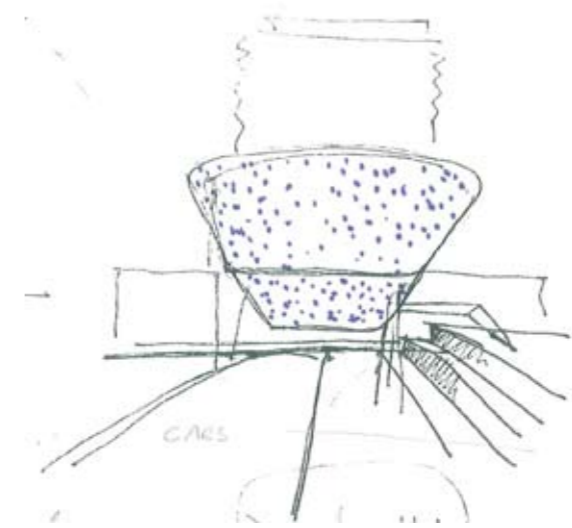

FIRST CONCEPT MAY 2008

CONCLUSION

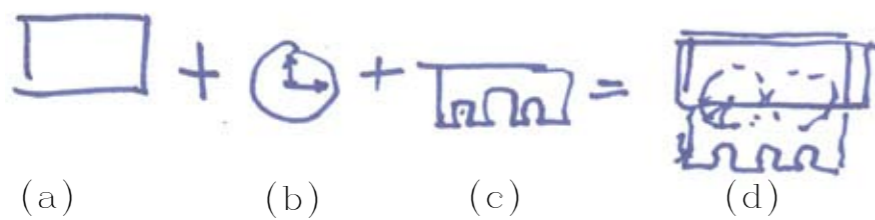

- (a) INFORMATION
- (b) EXPOSED WORKING OF UNIVERSITY
- (c) ARCHITECTURAL WEIGHT, INHABITABLE 1ST FLOOR
- (d) SYNTHESIS

theory
However, it was concluded that the attempt to create a hybrid by combining even more typologies still fails because of their inherent opposition.

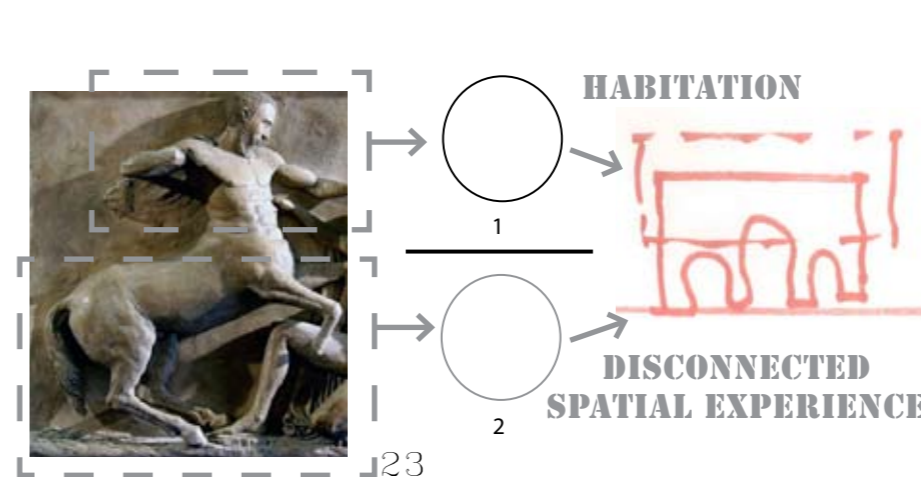

[Fig. 24] ARC ARCHITECTS competition winning proposal for the parking garage and traffic congestion solution. For the purposes of this study it is assumed that it will be constructed. The parking garage is located to the east of the entrance. The vehicular traffic is dealt with on the lowest level. Pedestrians and bicycles are ramped over that level. That ramp is covered by a roof and colonnade system.



24



26



27

DESIGN CONTEXT
 [Fig. 25] the lower ground floor plan by ARC ARCHITECTS. This is the plan which suggest the sinking of the current road level with 1,5m. Resolution of the traffic will happen in this lowered system.
 The red block indicates the design context of this thesis on the upper ground floor [fig. 28]. The green block indicates the Human Science Building. Kaya Rosa is indicated with a tag.
DESIGN CONTEXT
 The ARC proposal provides design context for the Monster.

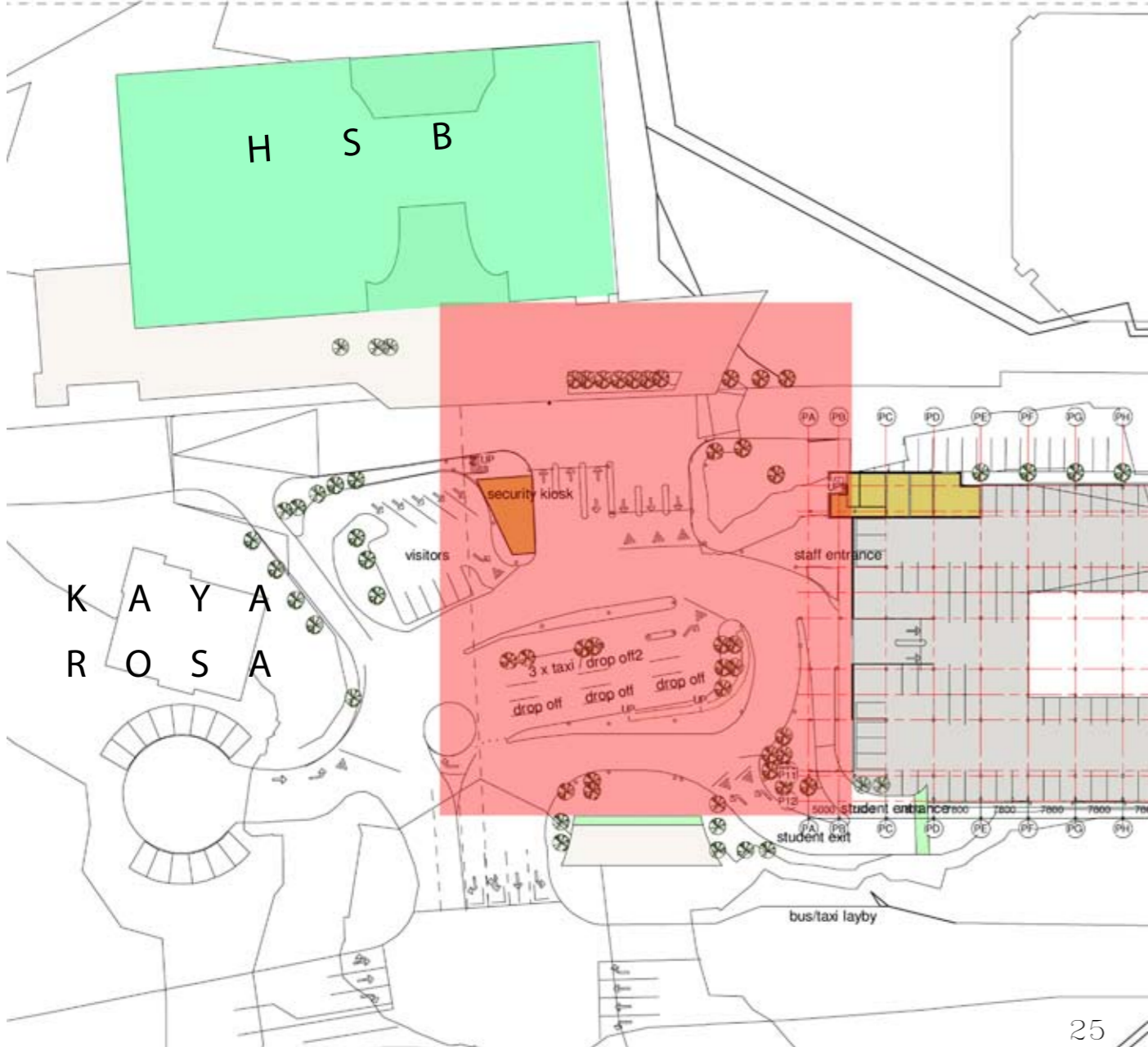

ARC LOWER GROUND

25

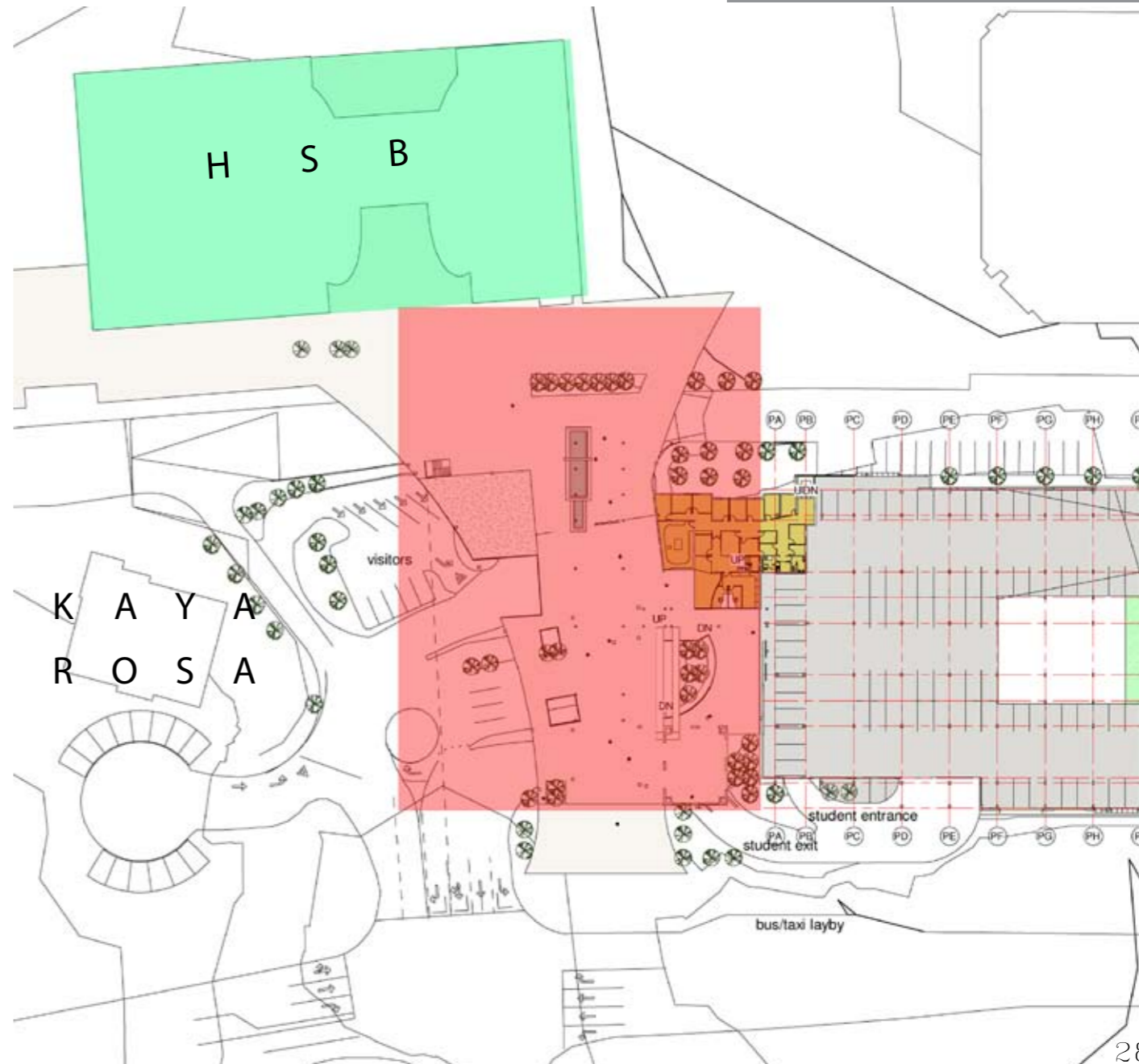

ARC UPPER GROUND

28

POSSIBLE PROGRAMS - DIGITAL MOULDS

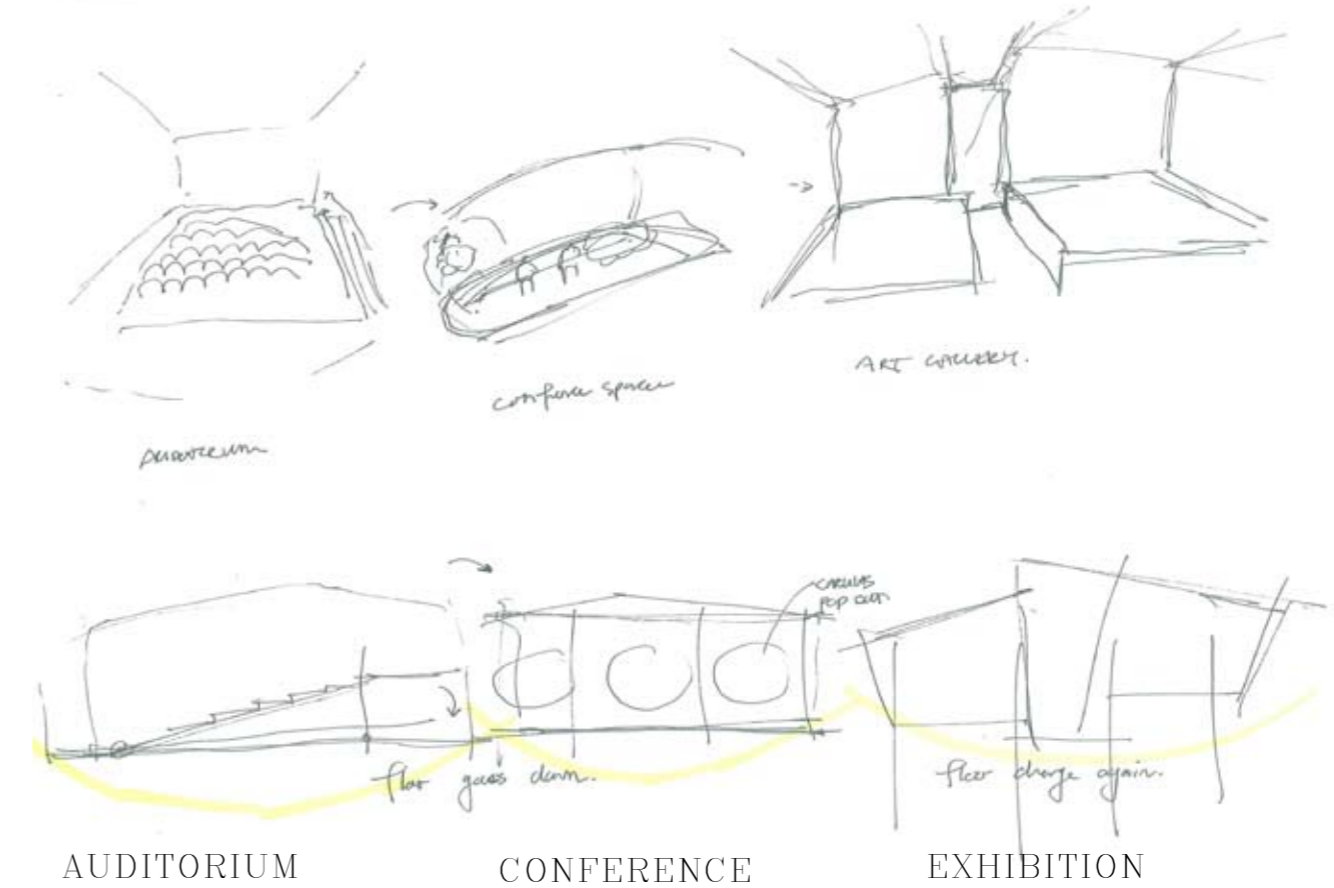

design

My interest in the moving building technology was renewed, because the inherent flaw of the typology has not been grasped yet. By researching studies on hyperbodies, the technology was found which will make a changing building a reality. This concept is driven by the notion that as student grow and change so should the building.

The Monster is stuck between two phases: moving and changing like the people and workings of campus, being literally unresolved. The answer to a building which will be the physical manifestation of liminality, neither here nor there, is a hybrid.

Model predictive control

The way the shape and content change would work is by a controlled process. Electronic engineers have developed Model Predictive Control Systems. The diagram shows how it works. As the information comes into the model, it predicts what the university needs and pulls these digital moulds from a database.

The idea for the digital moulds comes from vacuum plastic extrusion, which is done with moulds. These digital moulds would be the different functional programs and would be inhabitable, giving the building an element of evolution. Evolution here alludes to the building physically changing its shape and content to fulfill the programmatic needs of the university as determined by the model predictive control system. This building physically embodies and symbolically suggests how students grow and become more like their study field.

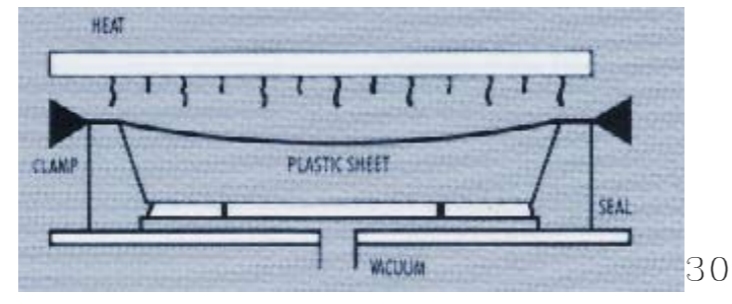

30

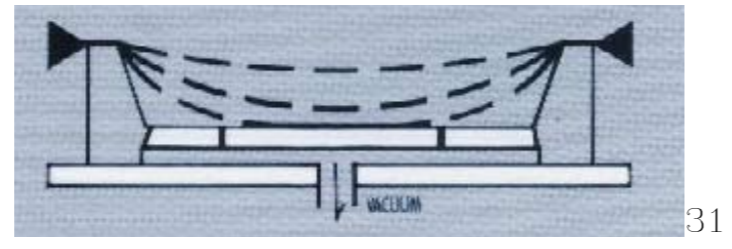

31

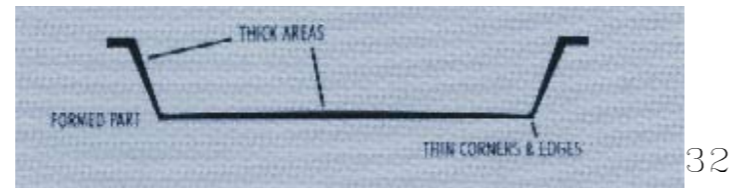

32

PLASTIC VACUUM EXTRUSION

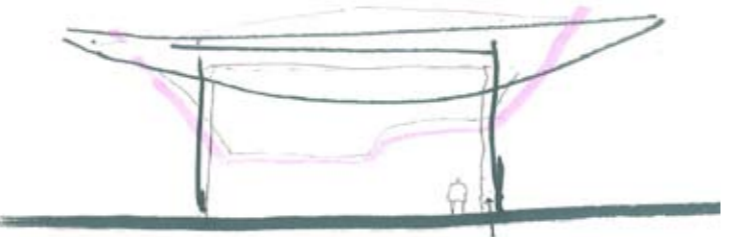

SHAPE SHIFTING GATE HOUSE

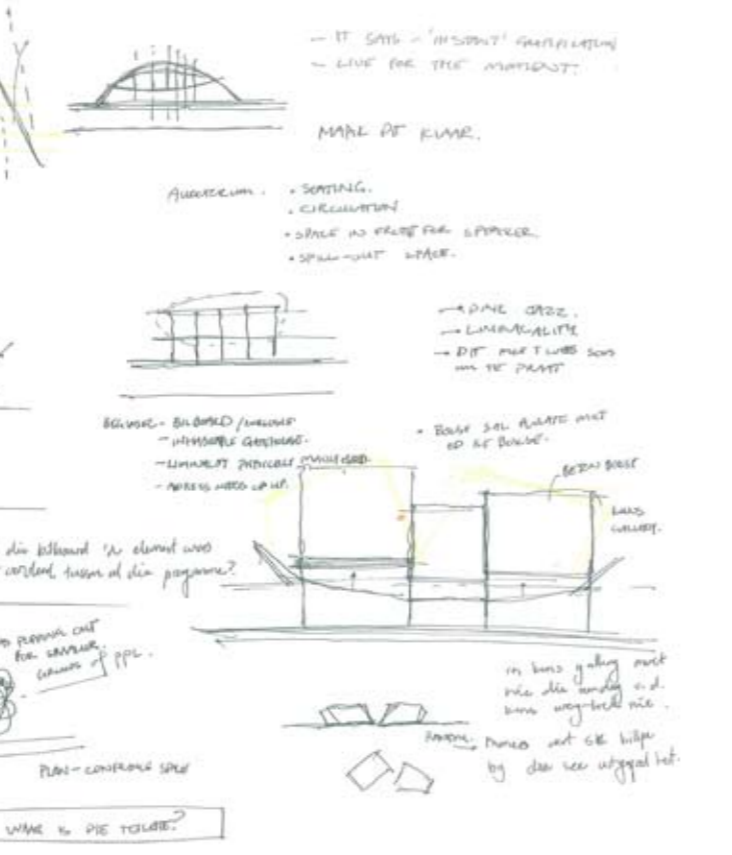

29

precedent

Hyperbody precedent study, suggesting current technology for movement of buildings, changing its shape and content in real time.

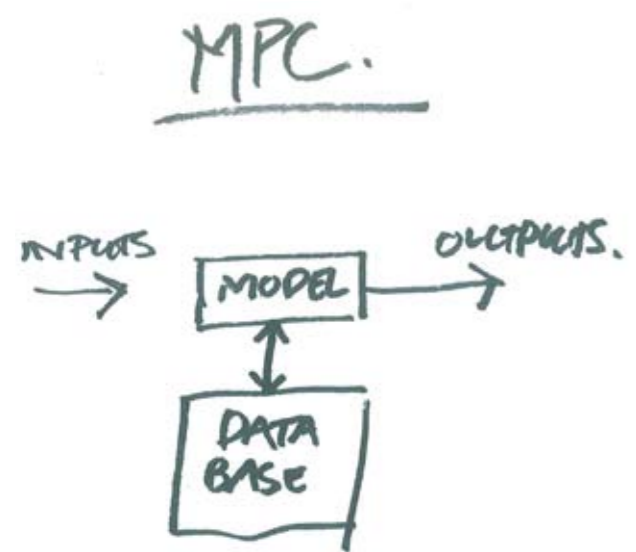

ENGINEERING SYSTEM

- 3 PROGRAMS WITH 20-30% CHANGE
- AUDITORIUM - VIA M.A.G. (WALL 3-3)
- KINDS GALLERY - VIA SHEDDING (CLOSED)
- CONFERENCE SPACE (17 1000)

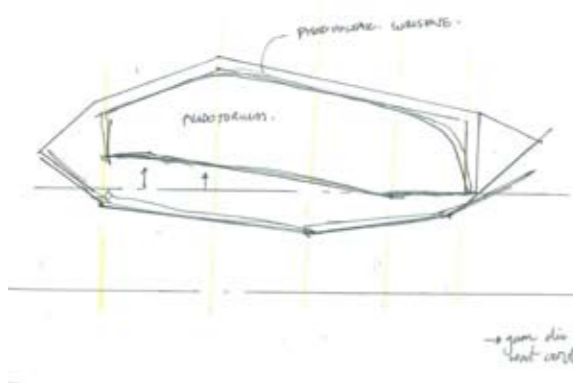

AUDITORIUM AND CHANGING CONTENT

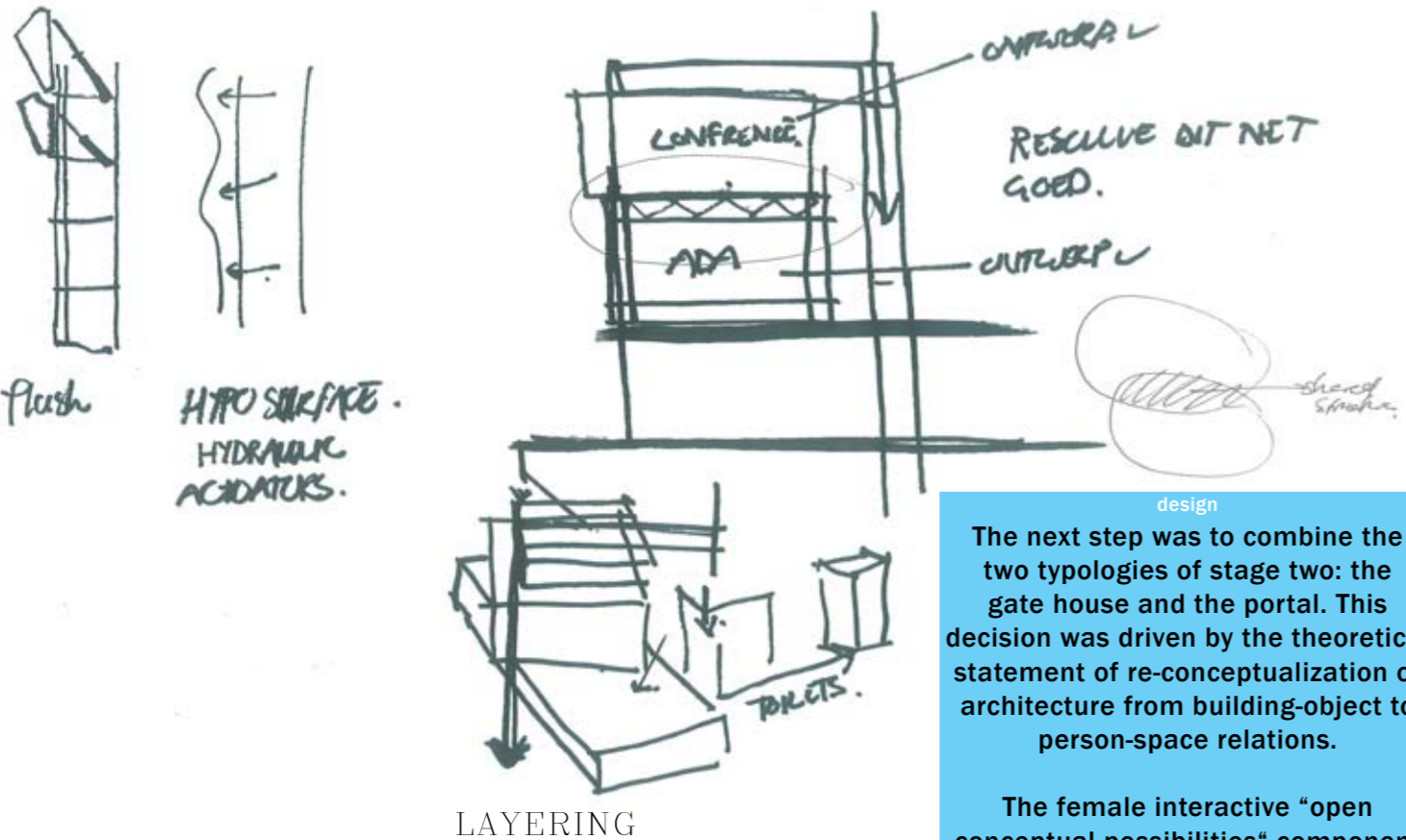

design
The next step was to combine the two typologies of stage two: the gate house and the portal. This decision was driven by the theoretical statement of re-conceptualization of architecture from building-object to person-space relations.

The female interactive "open conceptual possibilities" component would be the ground floor. It connects to the portal typology and hyper body technology.

theory
Physical places of liminality:
Doors, windows, springs, caves, shores, rivers, volcanic calderas, fords, passes, crossroads, bridges and marshes.

design
The male static, inflexible and solid component would be the first floor level. It is derived from the gate house typology. The theoretical reason for doing this was to locate the building in a physical place of liminality, between earth and sky.

An aspect of liminality is that it is sometimes experienced as a chance encounter.

The ground floor plan was also driven by the idea of the labyrinth. There is a specific path to follow, but sometimes a hybrid mythological creature is located in the middle.

There would be a central platform which represents this hybrid. This platform would be the apex of sensorial immersion into the interactive and intelligent space.

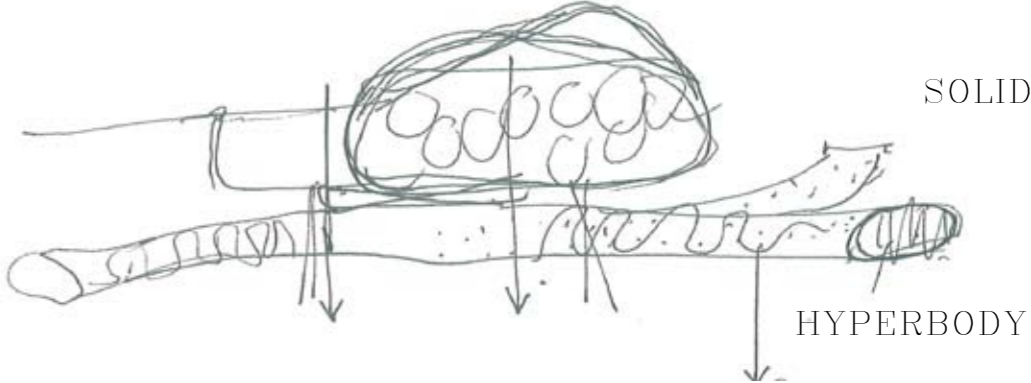

precedent
A "hyperbody" is a building that can "change its shape and content in real time". (Oosterhuis, K . 2003: 91)

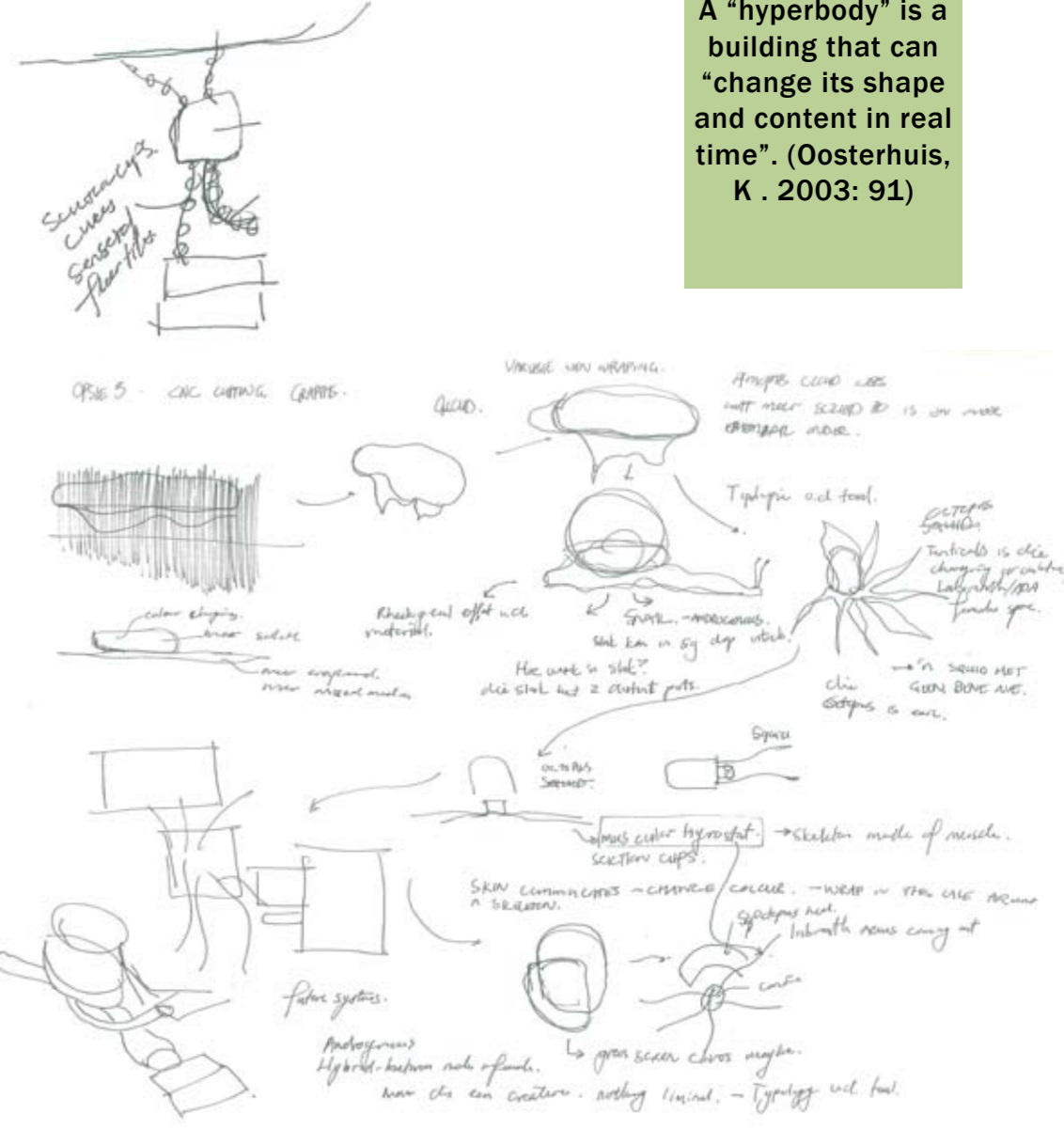
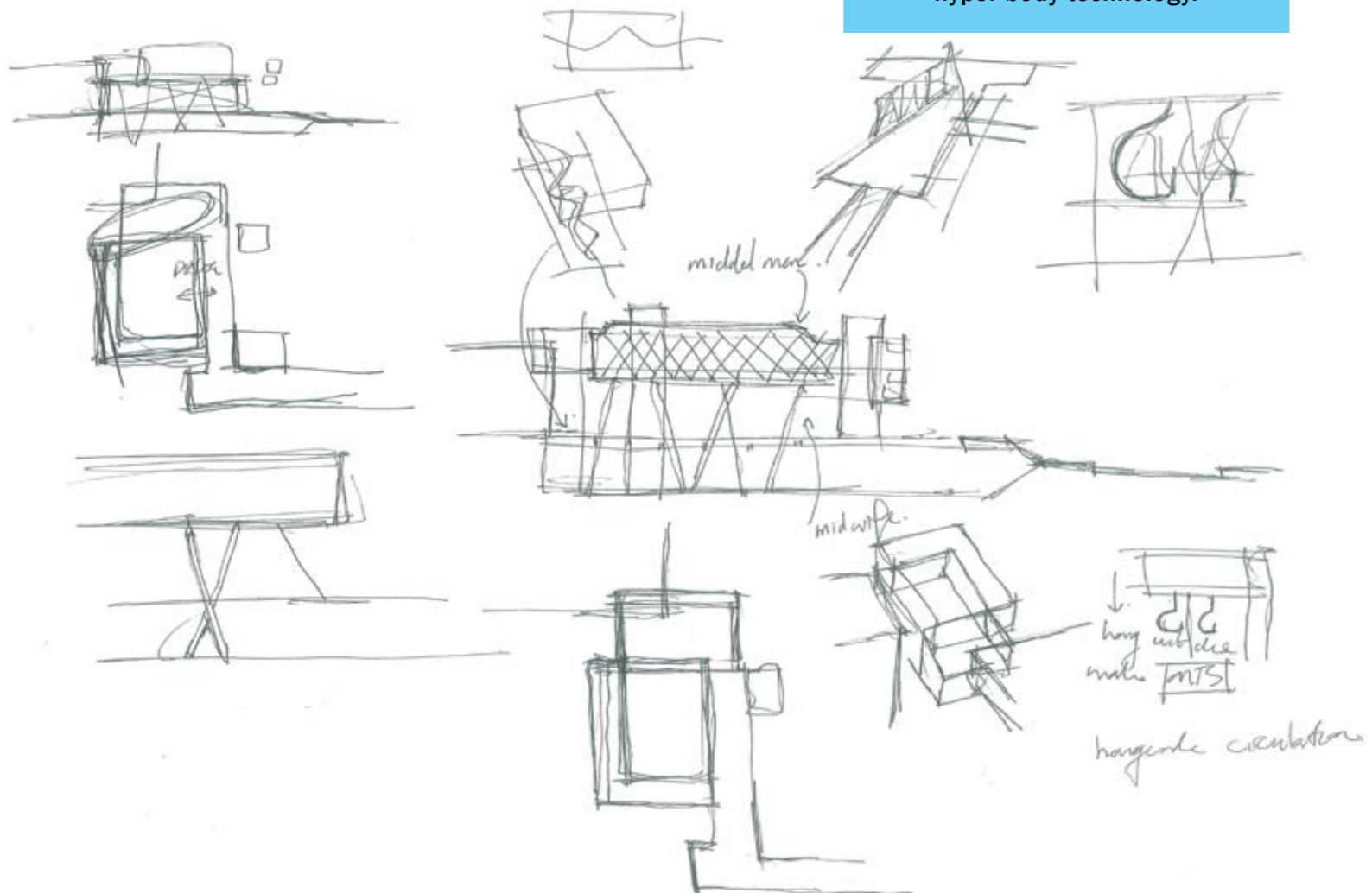

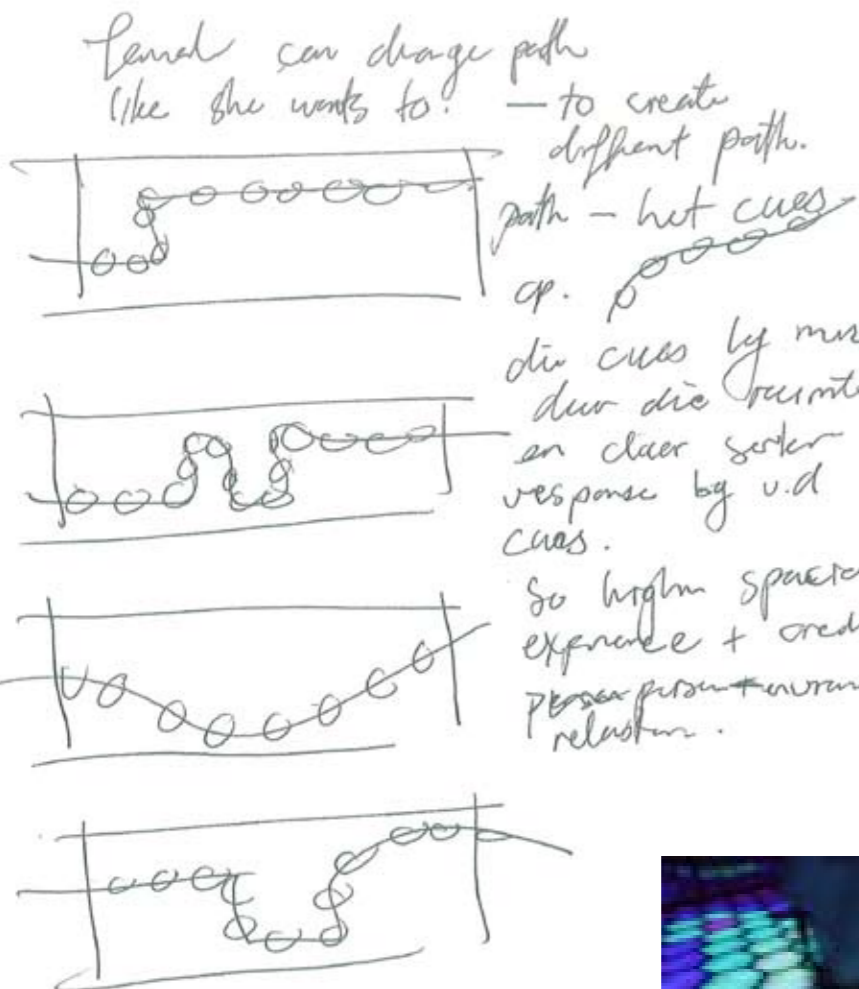

CHANGING PATHS

design
Changing Paths

Changing paths were an exploration to convert the concept of "open conceptual possibilities" through the female space into architecture.

Every day the path you would walk along would be physically changed, allowing for a different spacial experience every day.

precedent
ADA SPACE

The main concern of this project is ARTIFICIAL INTELLIGENCE and PERSON TRACING developments, which materialise in the VISUAL TRACKING and SENSORIAL FLOOR TILES.

By assigning UNIQUE ID NUMBERS to the visitors.

'ADA [fig. 35] gives CUES to the visitors to LURE them into certain POSITIONS IN THE SPACE.' (Oosterhuis, K 2003:32)

It is noteworthy how SPACE AND PEOPLE PLAY GAMES and how people and space have an interactive and interpersonal connection, experience and exchange.

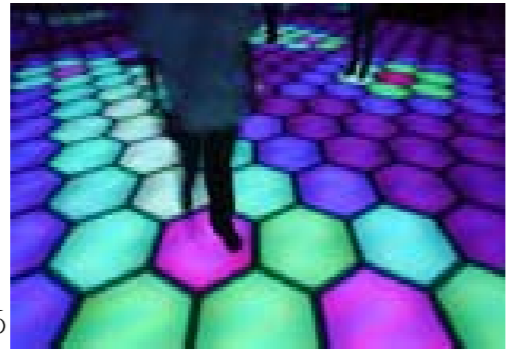

35

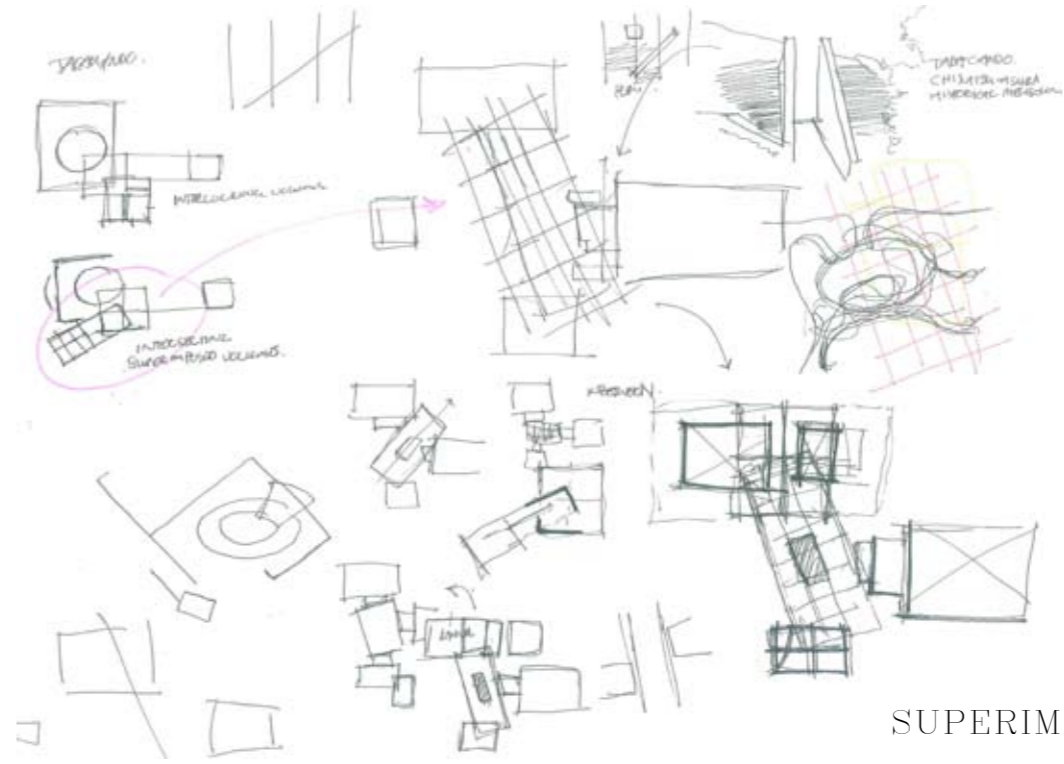

SUPERIMPOSED PLANNING

precedent
Tadao Ando

Tadao Ando's work was particularly influential at this point, especially in the planning of the ground floor.

The use of super-imposition was of critical importance.

Ando's architecture happens where the collisions occur.

At these points, the spaces are neither here nor there, thus creating new spaces.

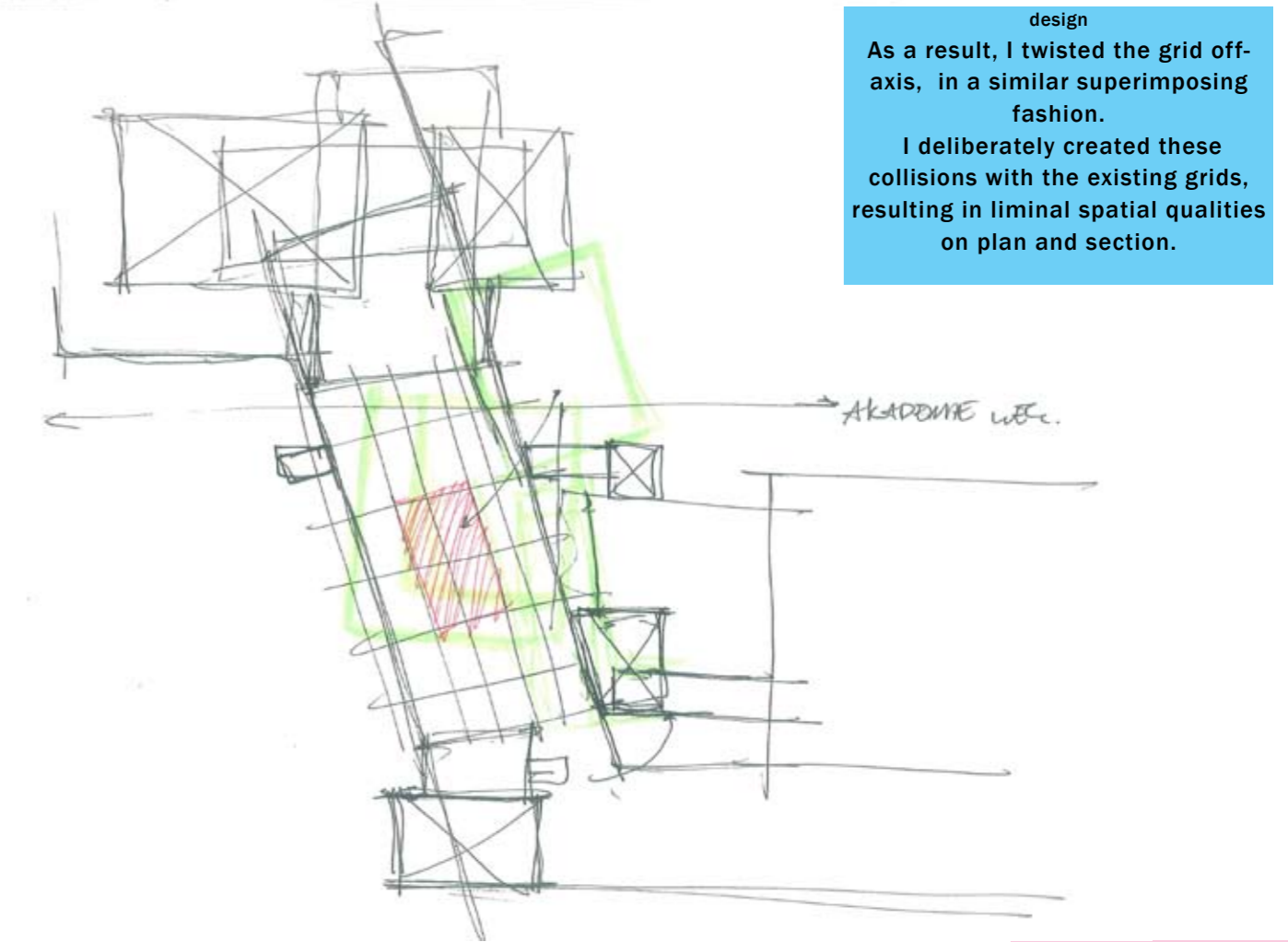
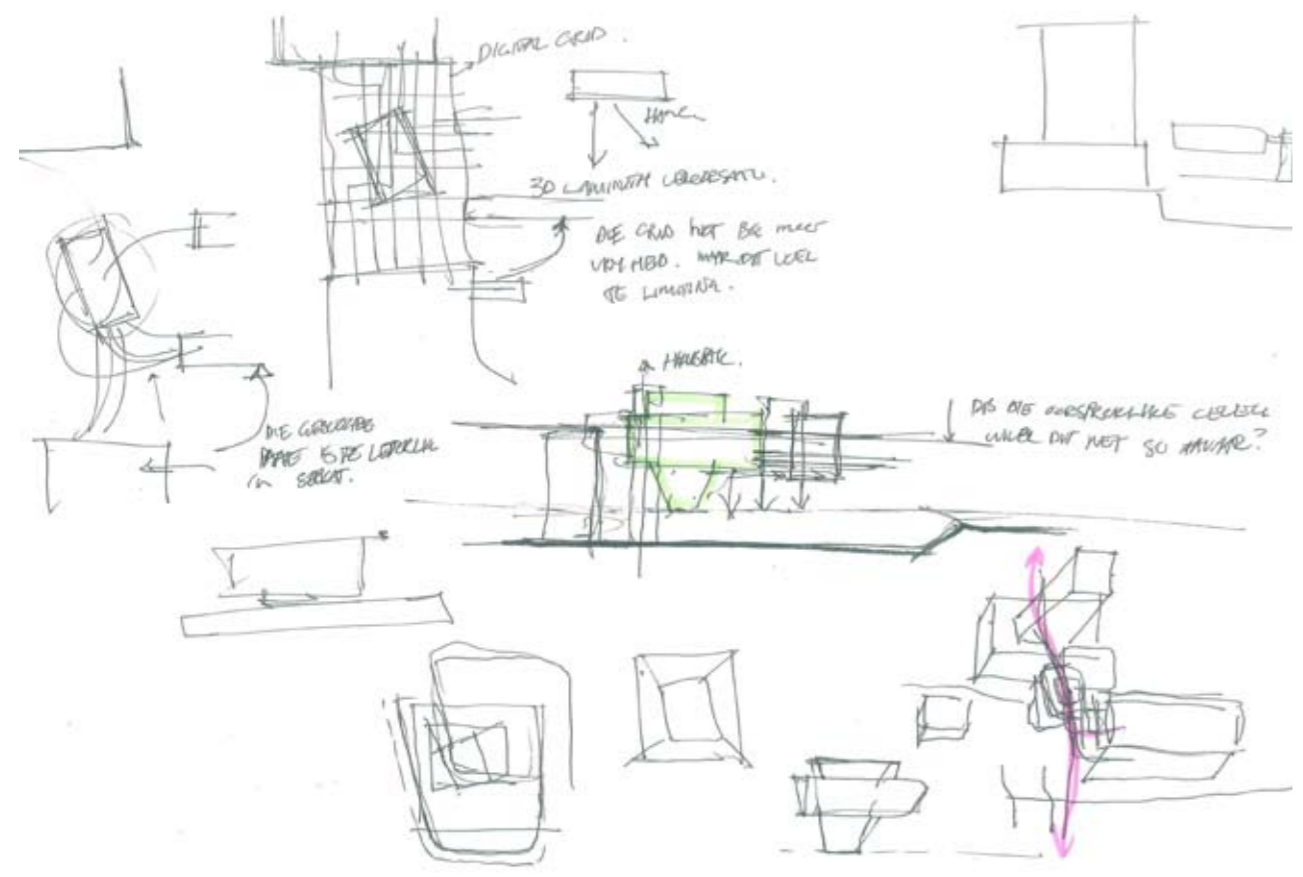

design

As a result, I twisted the grid off-axis, in a similar superimposing fashion.

I deliberately created these collisions with the existing grids, resulting in liminal spatial qualities on plan and section.

CONNECTIONS WITH CONTEXT

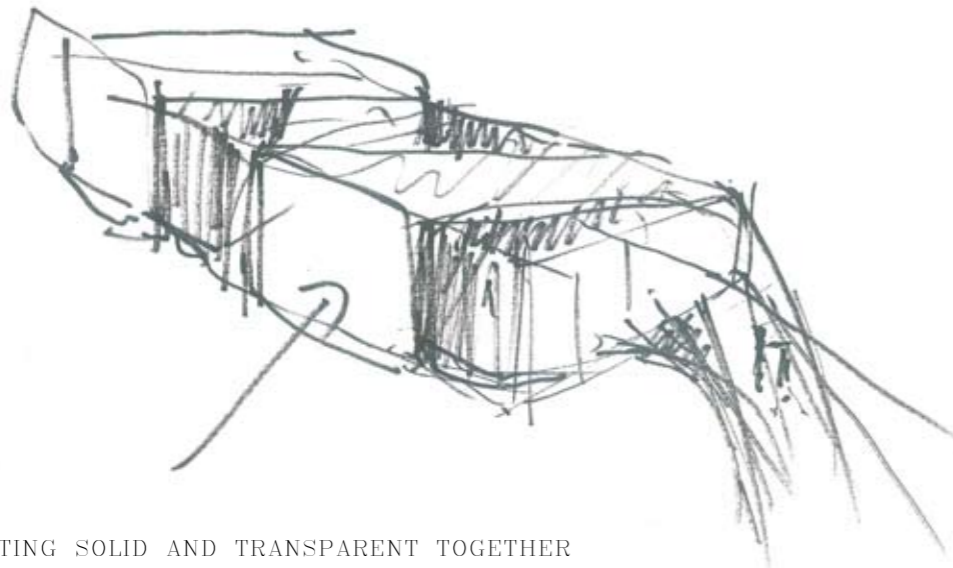

TWISTING SOLID AND TRANSPARENT TOGETHER

design
These drawings were attempts to better integrate the two parts of the building. The idea was to twist the building into one either horizontally or vertically.

precedent
This idea was stimulated by the art work of Patricia Piccinini. Seen in the example of the scooters. [fig. 39] The scooters features are rearranged in a way not experienced everyday, to create a type of monster. In this way the scooter communicates emotion.

precedent
H&dm
De Yong museum [fig. 40], the tower, twists from the grid on which the museum is situated, to align with the grid on which the rest of the city is built.

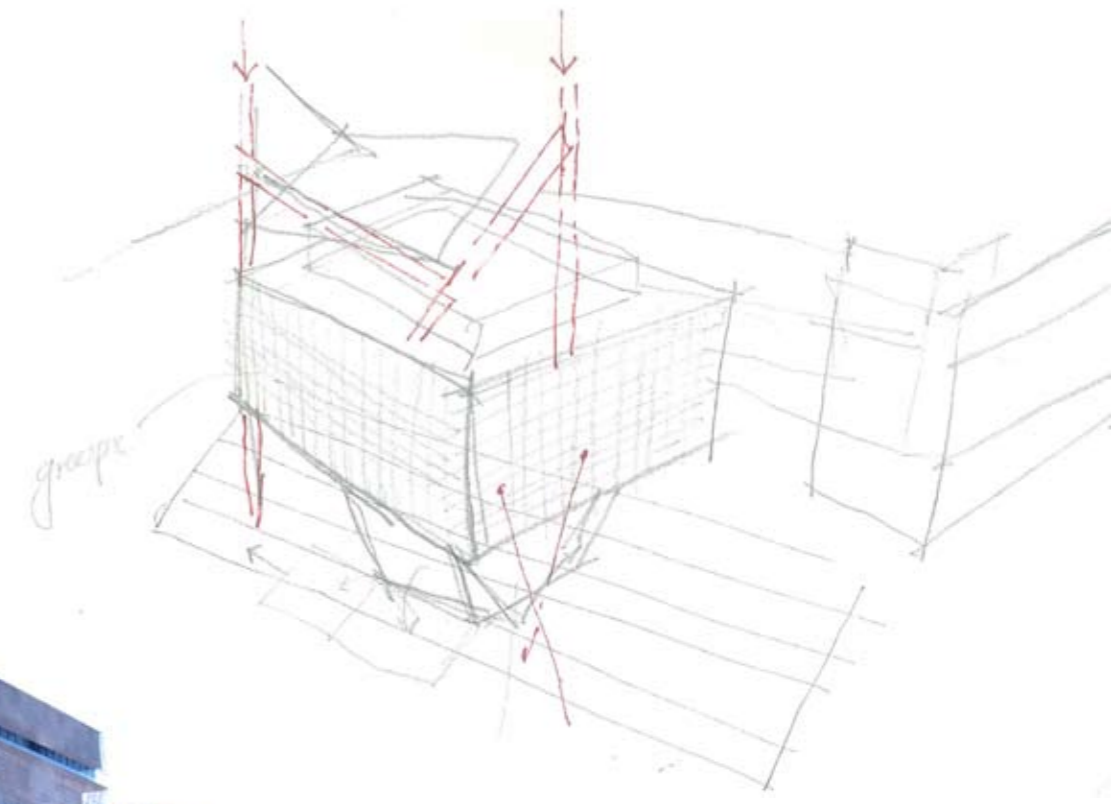

TWISTING FEMALE SPACE

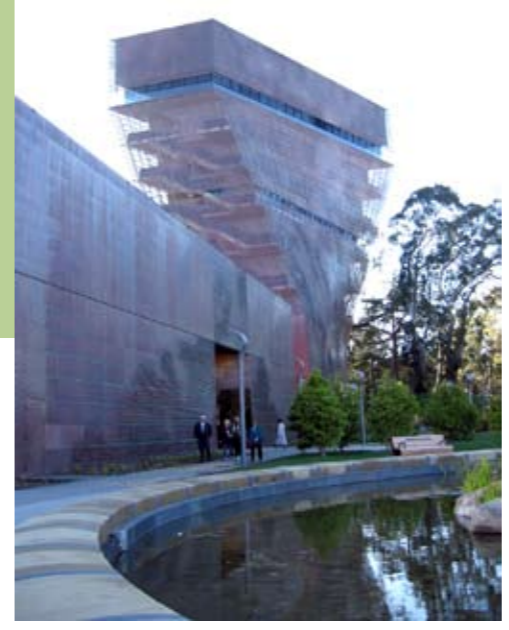

40



41



38



39

SYSTEMS EXPLORATION

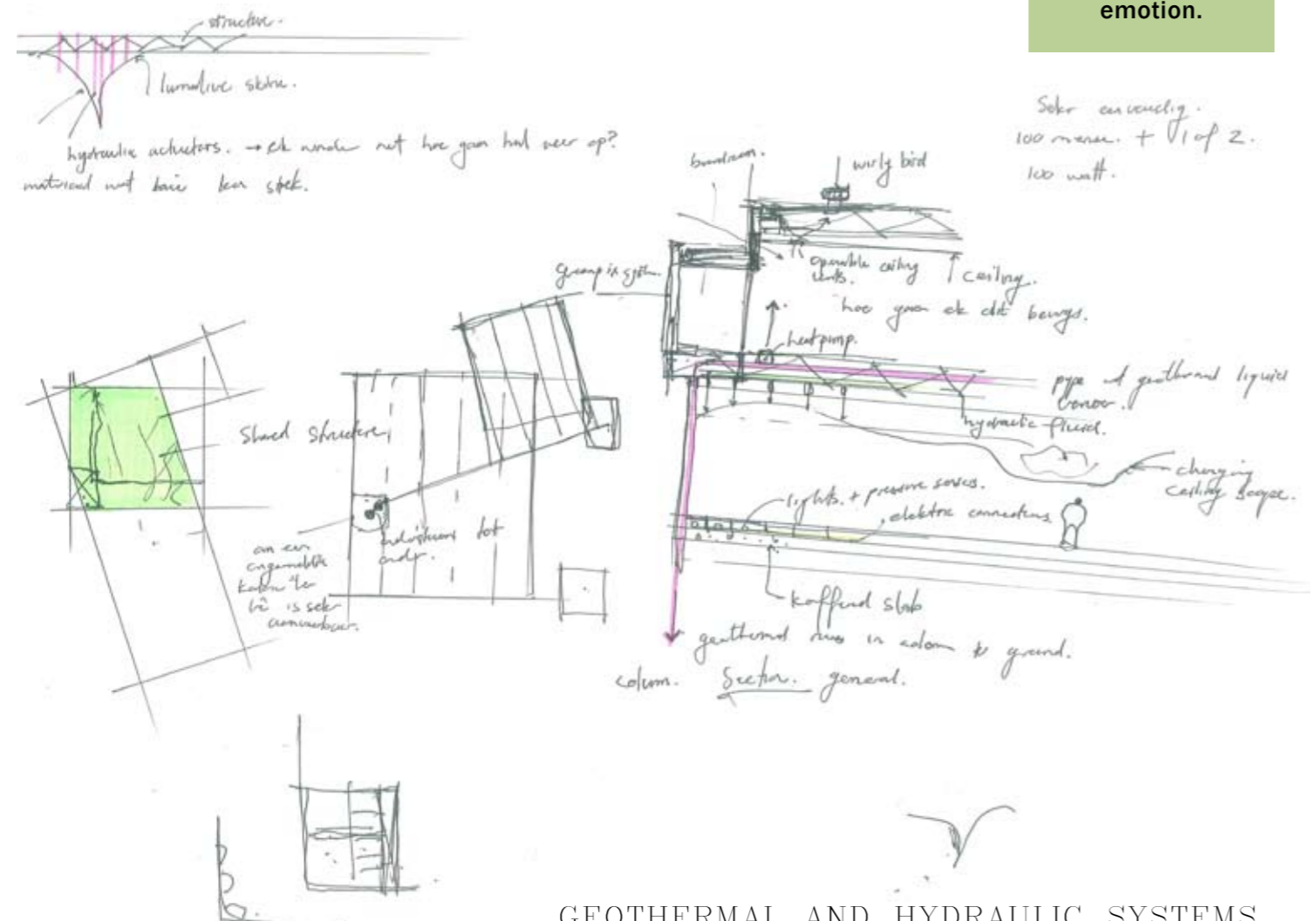

GEO THERMAL AND HYDRAULIC SYSTEMS

design
The twist in the vertical direction was further investigated. The twist is quite similar to H&dm's de Yong museum. The ground floor level is off-axis and the first floor level is on the existing grid of the HSB. The twisted part was envisaged to contain all the Hyperbody technology to create the changing paths.

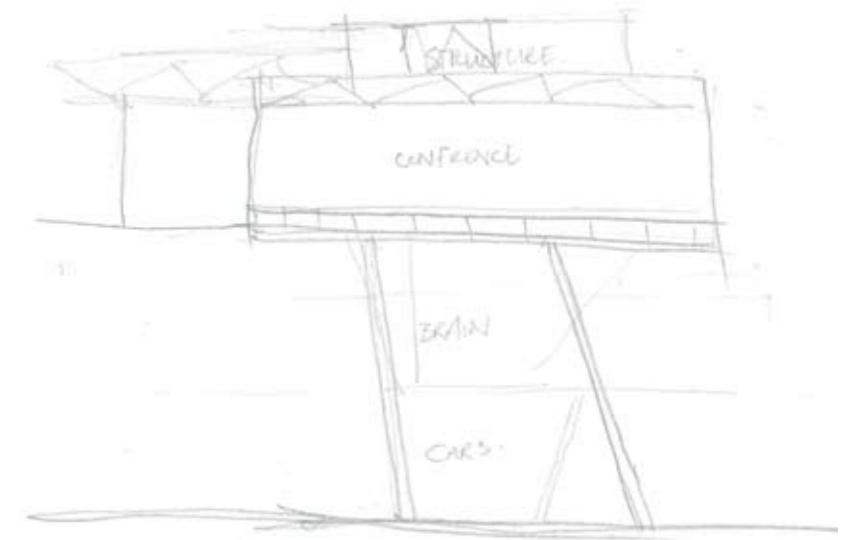

STRUCTURAL DIAGRAM

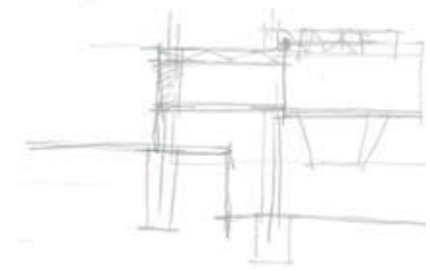

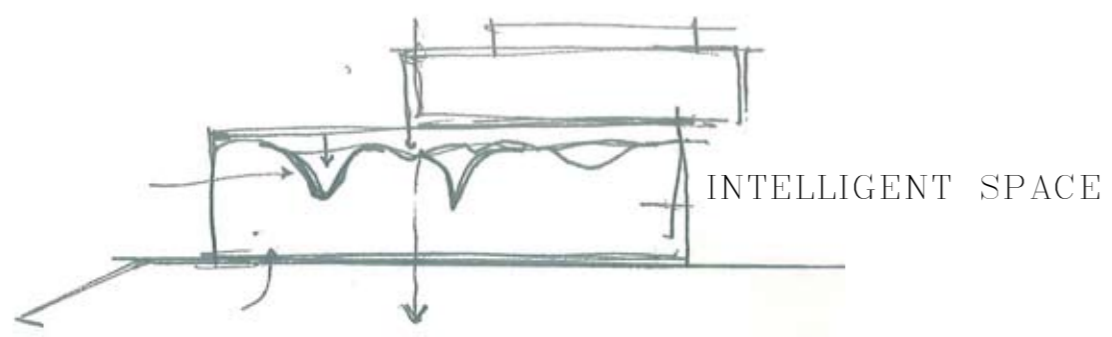

INTELLIGENT SPACE

SECTION

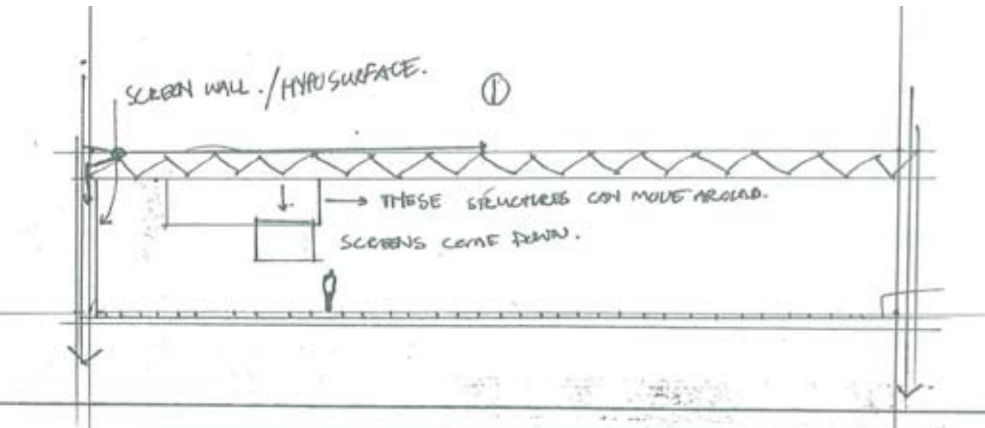

SECTION



SECTION



HYPOSURFACE AS CEILING

CONCEPT JULY '08



42

design

From here on the idea to create a building which physically moves has been discarded. Instead there will be technology inside or certain parts which move.

Therefore the female space would get a moving ceiling, creating spaces in an interactive real time manner.

The technology which can be applied here is that of Hyposurface [fig.42].

The Hyposurface reacts to human presence, causing physical and spatial changes. It was envisaged to cover the entire ground floor ceiling space.

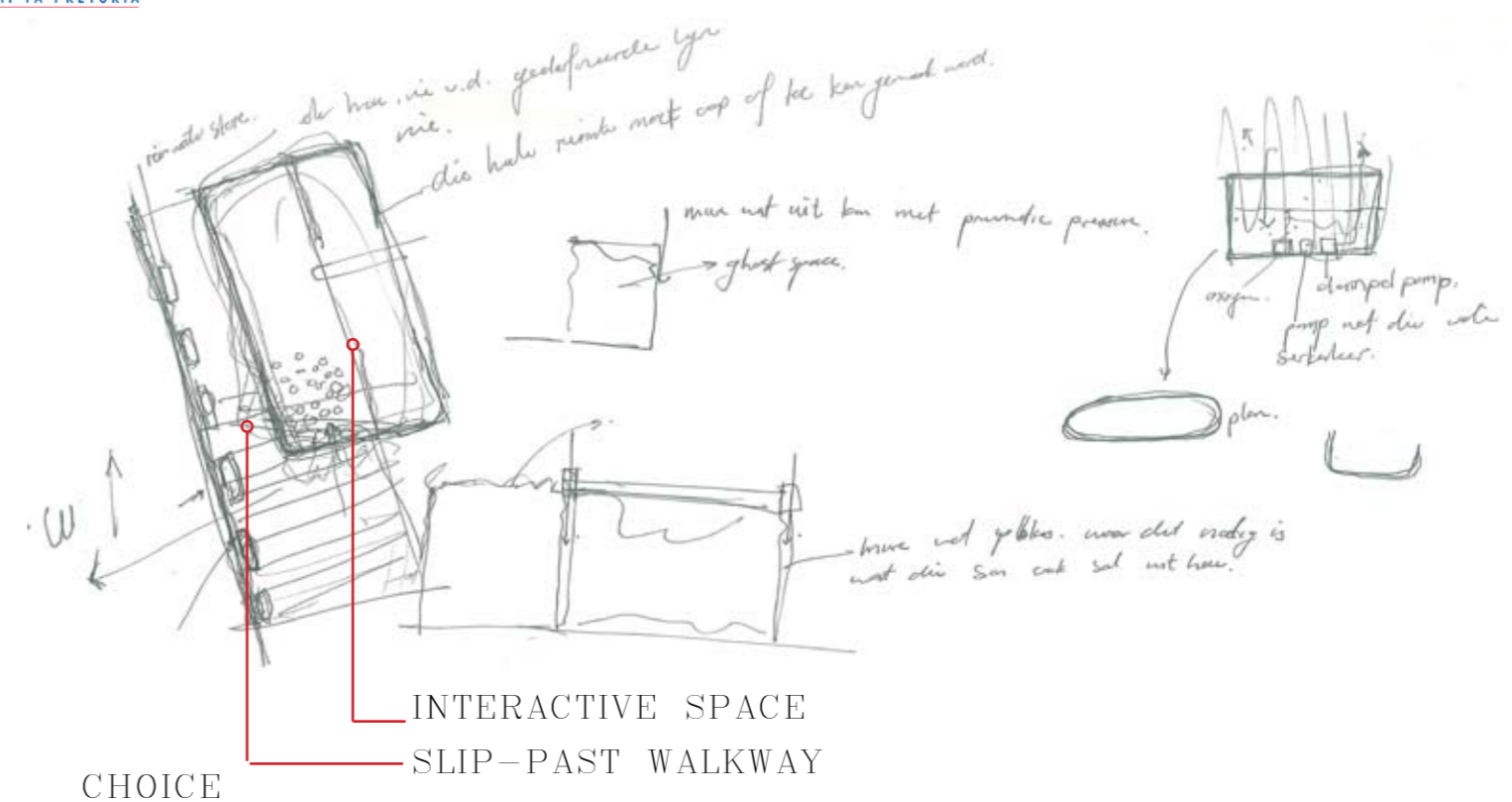

INTERACTIVE SPACE

SLIP-PAST WALKWAY

CHOICE

design

Choice

Here the concept of choice was introduced. Choice allows for exploration to find where the interactive parts are. It also alleviates the mandatory spatial experience. Creating the opportunity for more spatial experiences. The hyposurface ceiling was changed to be located only over the interactive parts.

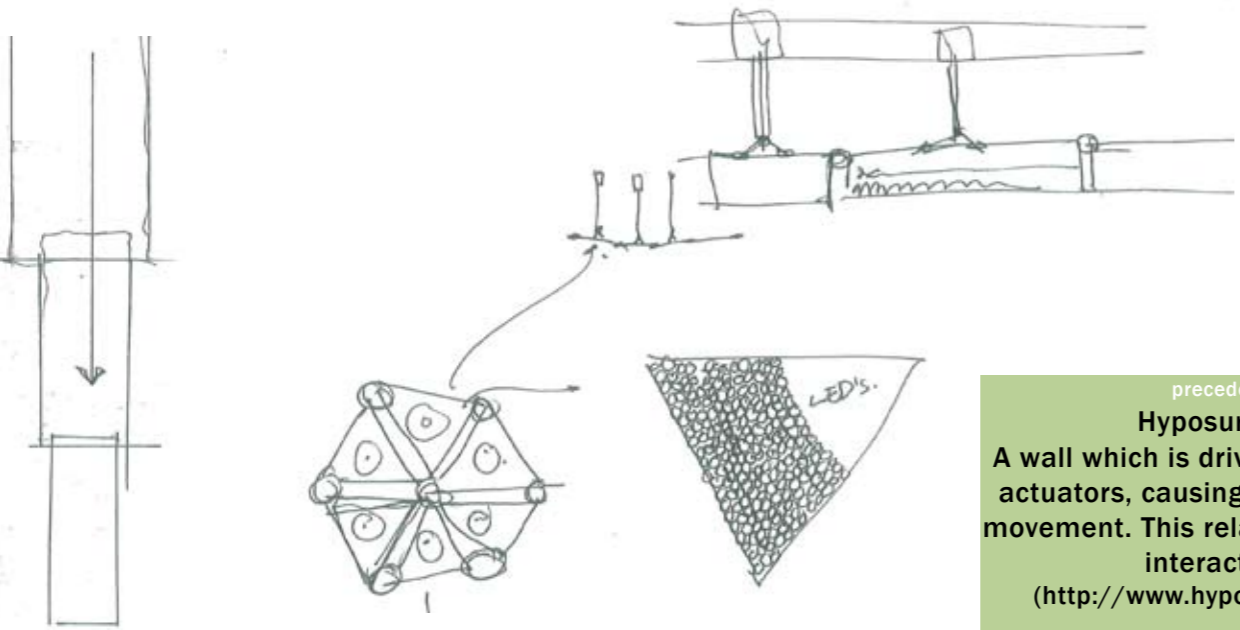

precedent

Hyposurface

A wall which is driven by hydraulic actuators, causing instantaneous movement. This relates to real time interaction.

(<http://www.hyposurface.org/>)

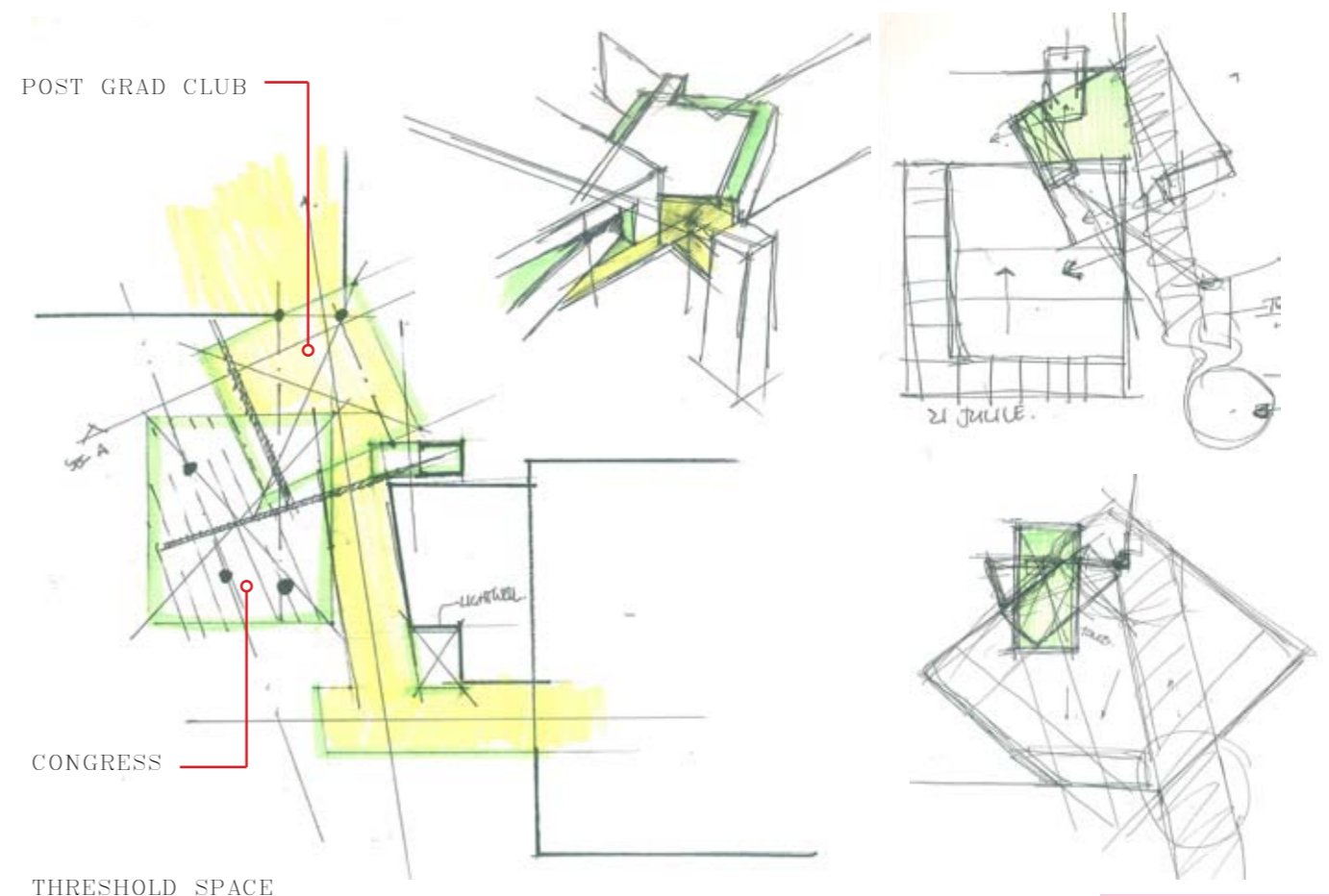

POST GRAD CLUB

CONGRESS

THRESHOLD SPACE

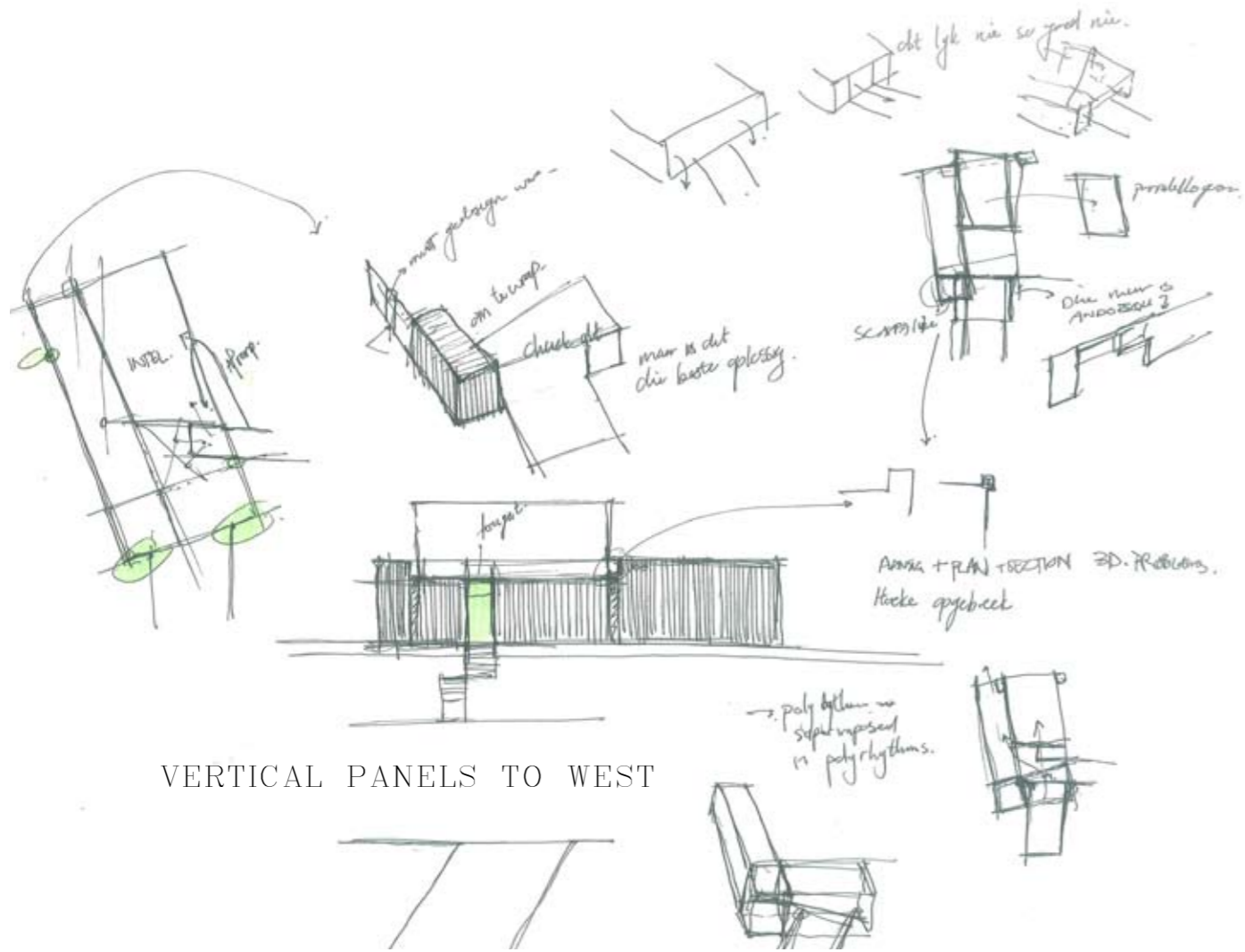

VERTICAL PANELS TO WEST

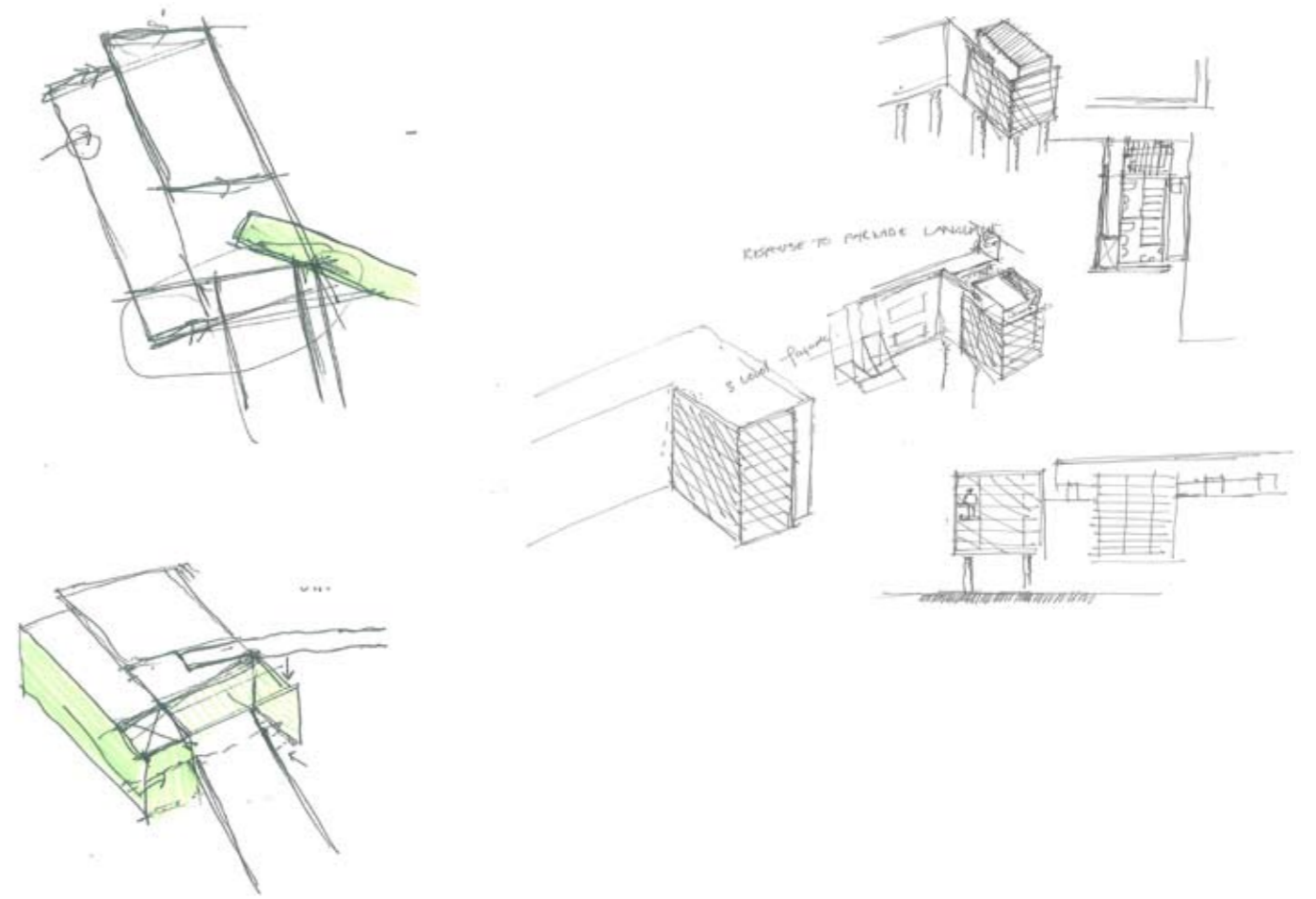

TADAO ANDO SUPERIMPOSED PLANNING

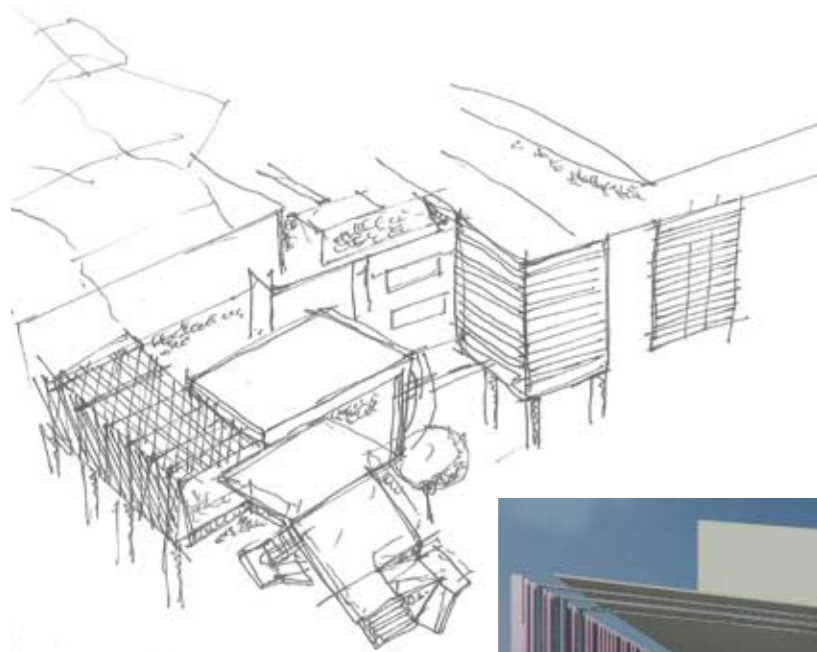

ENTRANCE IN CONTEXT



CONCEPT JULY '08

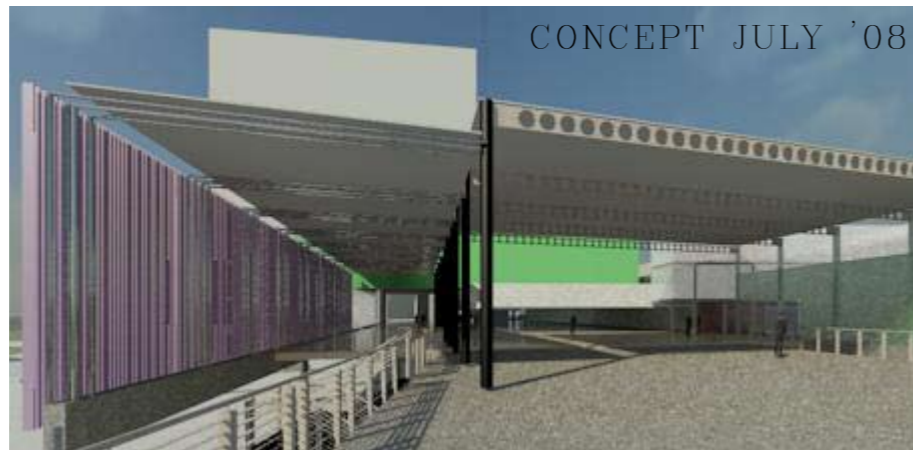

CONCEPT JULY '08

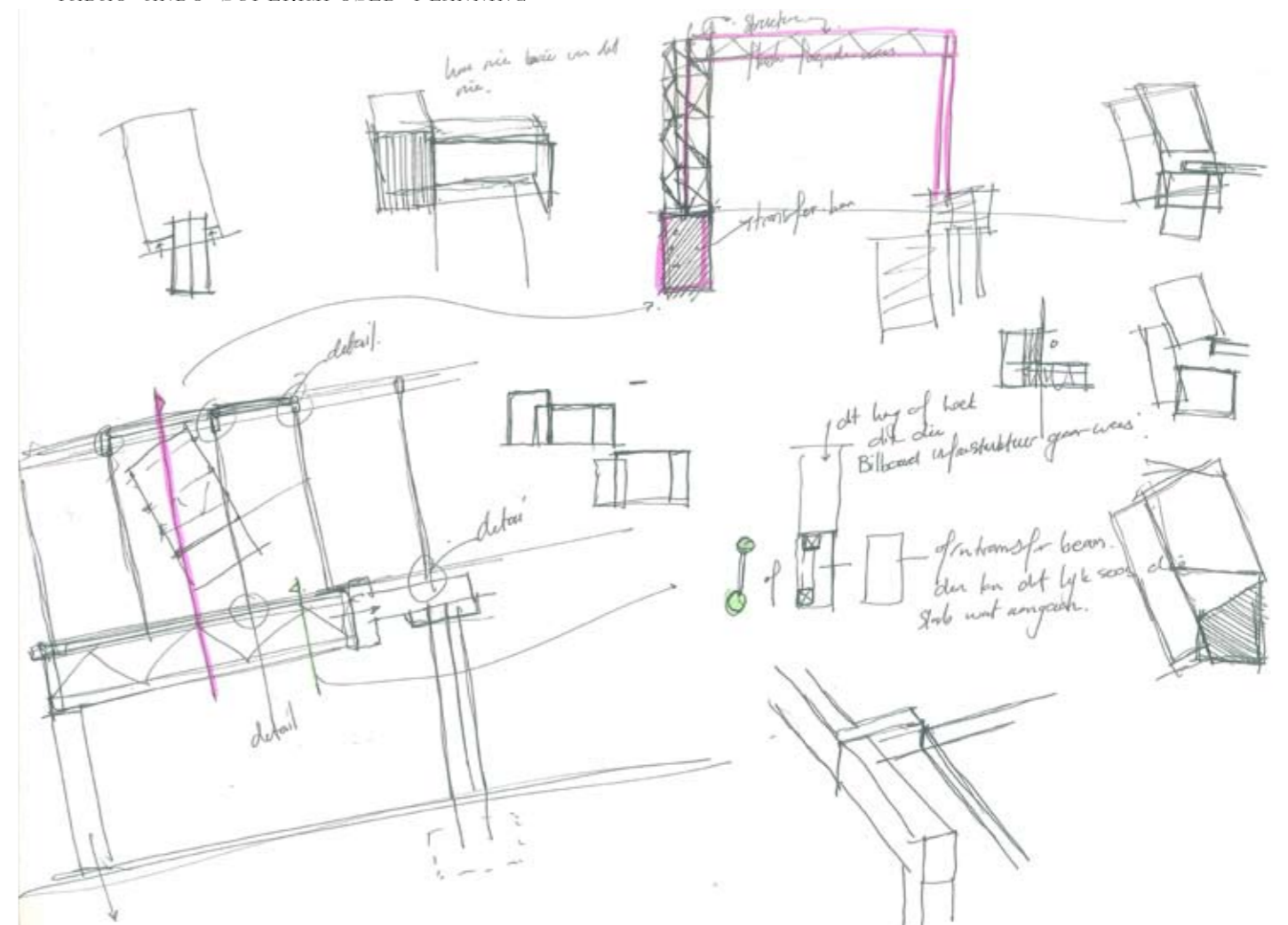

STRUCTURAL EXPLORATION

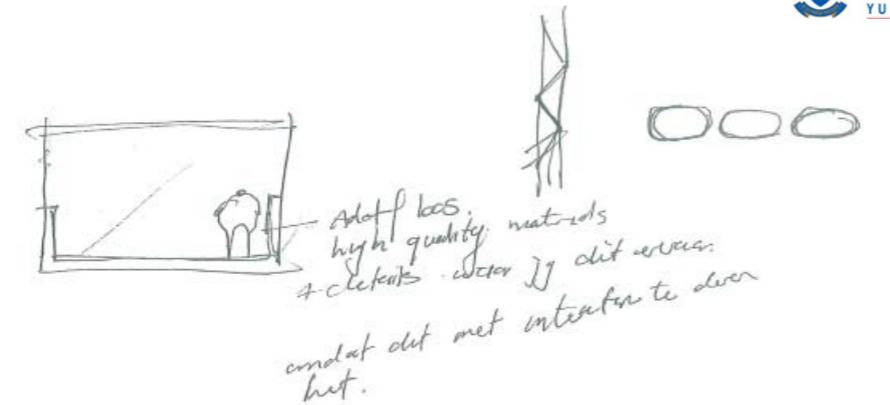
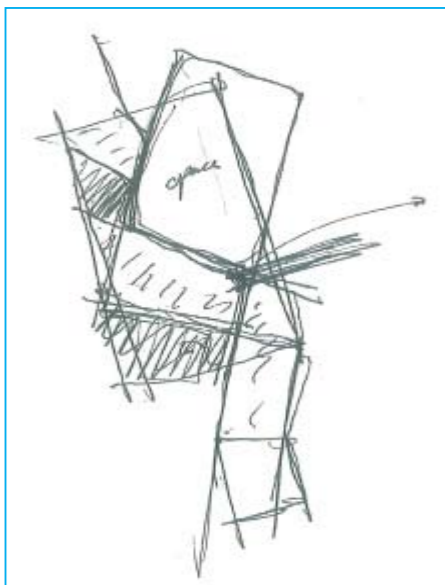

TRIANGULAR GRILL BLOCKS

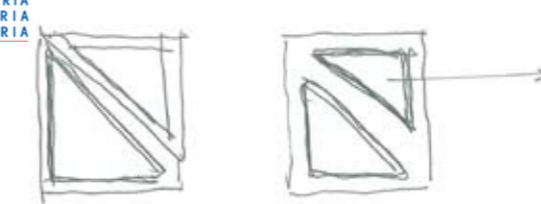

- Fill die driehoek in met:
- 1 nits.
 - 2 clear glass.
 - 3 Decore glass.
 - 4 etched glass.
 - 5 Perforated metal.
 - 6 Glass bricks.
 - 7 concrete.
 - 8 opaque panels. → painted / marmer
 - 9 ↓ → clad with terracotta.

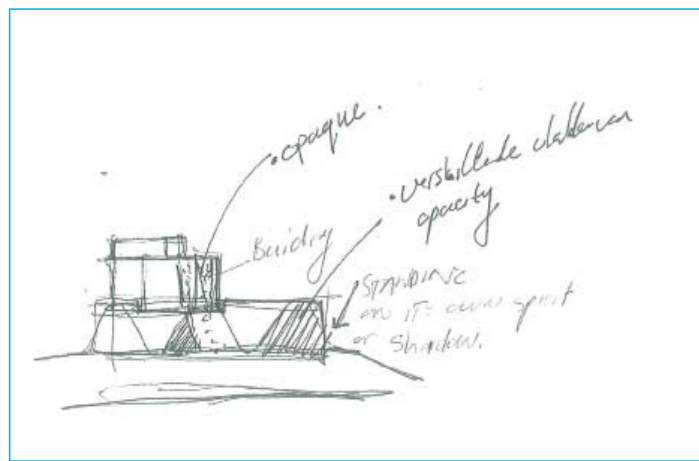
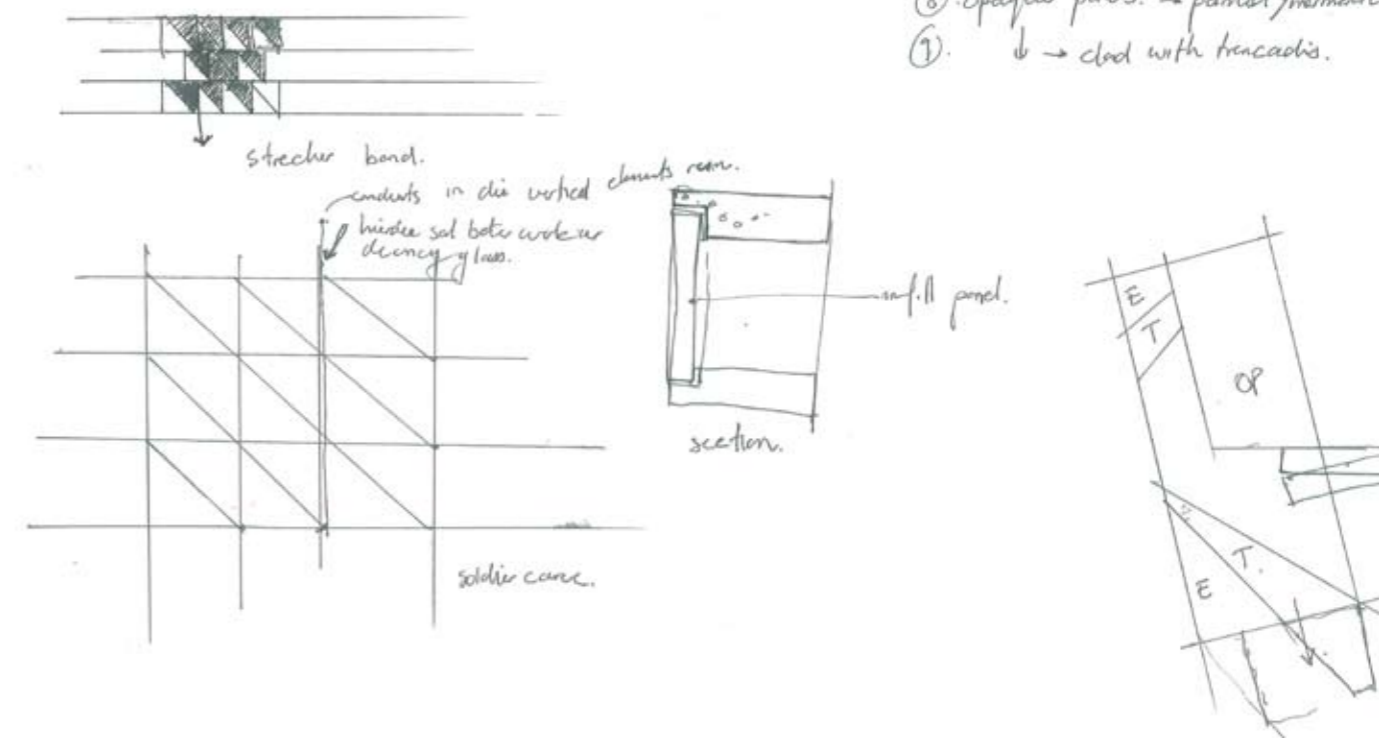

ELEVATION AND PLAN SHOWING TRANSPARENT PARTS OF THE BUILDING

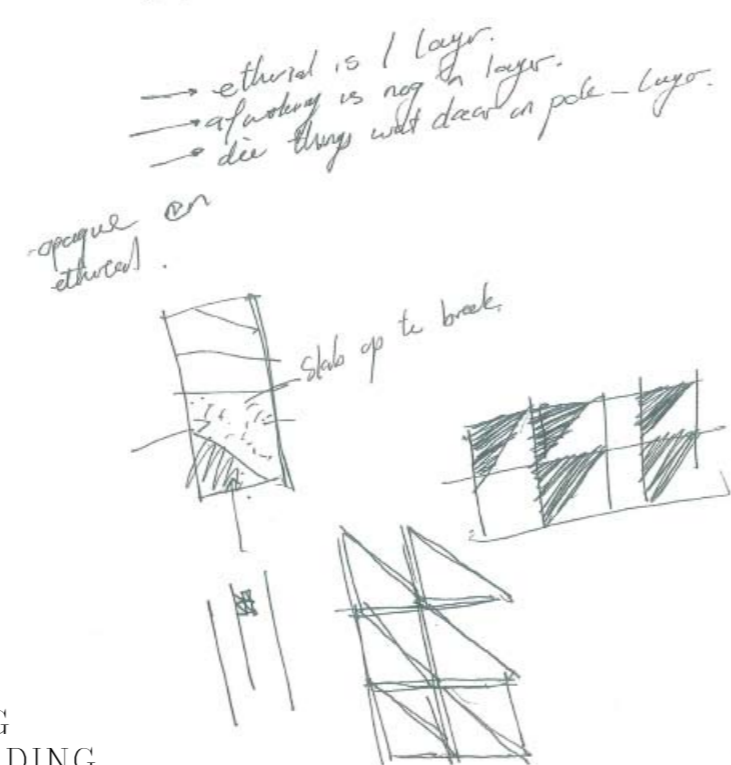

TRIANGULAR SHAPE SKIN - EXTENDED INTO THE FLOOR MATERIAL, TO MAKE THE BUILDING TRANSPARENT FROM THE BOTTOM

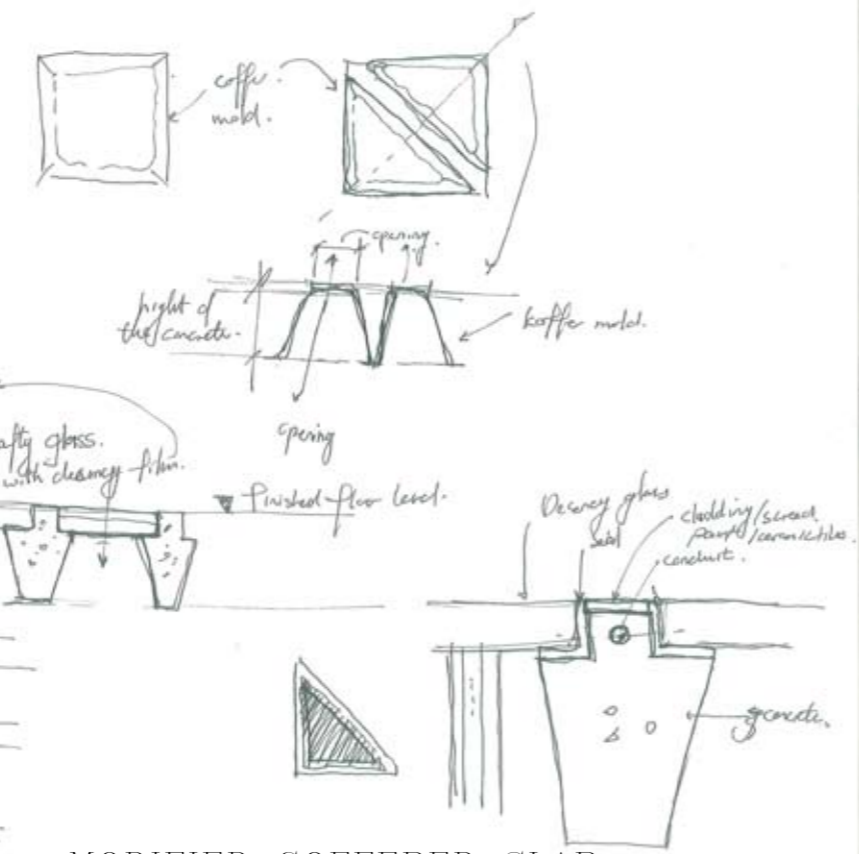

MODIFIED COFFERED SLAB

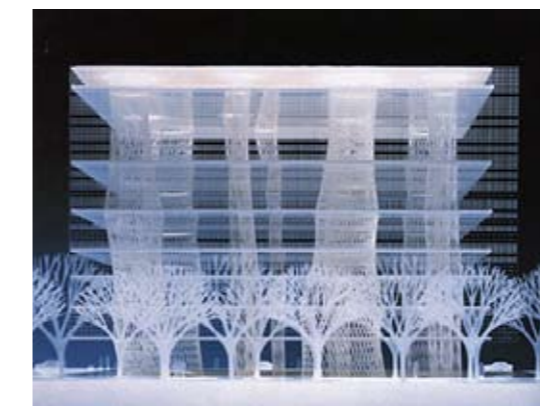

43
TRANSPARENT BUILDING

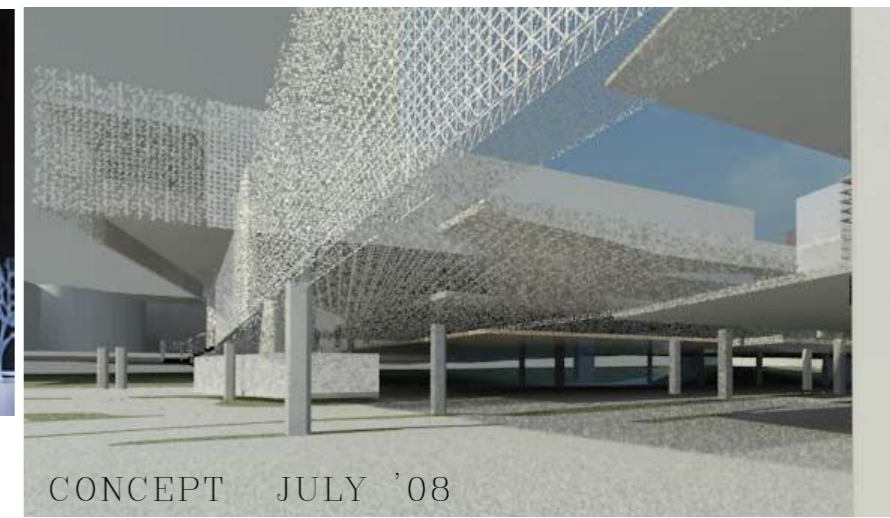

CONCEPT JULY '08

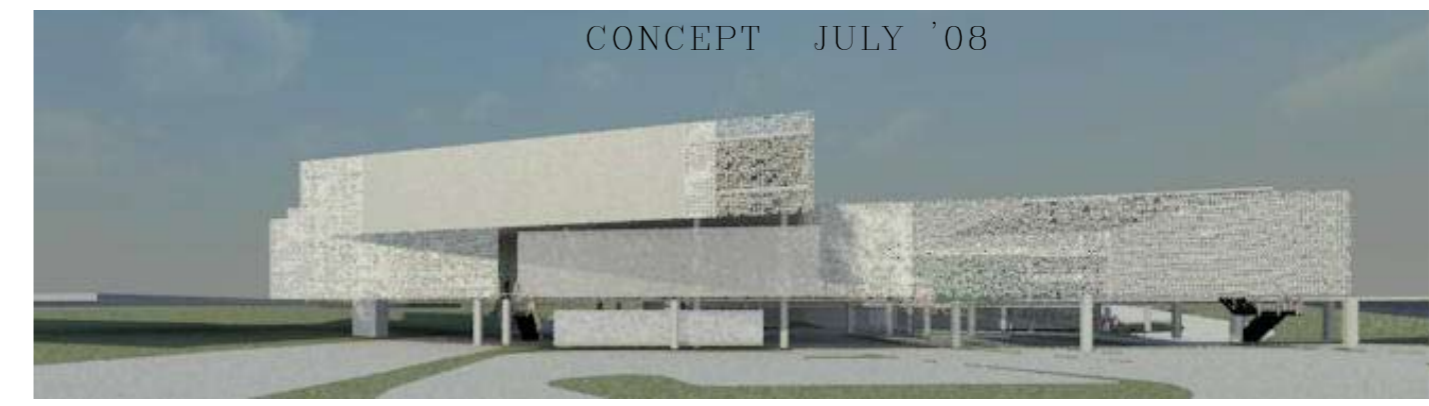

CONCEPT JULY '08

30 JULY 2008

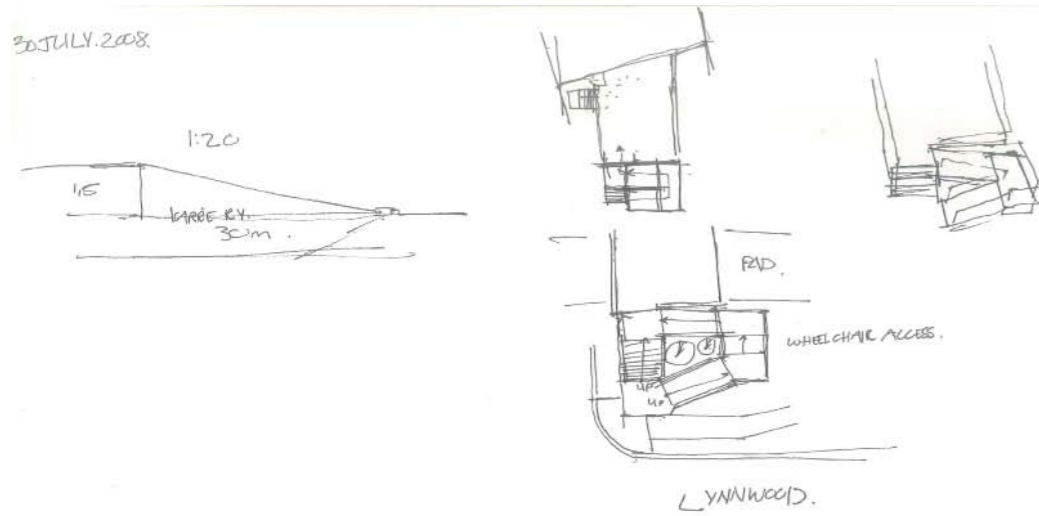

UPPER GROUND

DESIGN FOR RAMP AND STAIRCASE FROM LYNNWOOD ROAD TO GROUND FLOOR LEVEL.

STAIRCASE

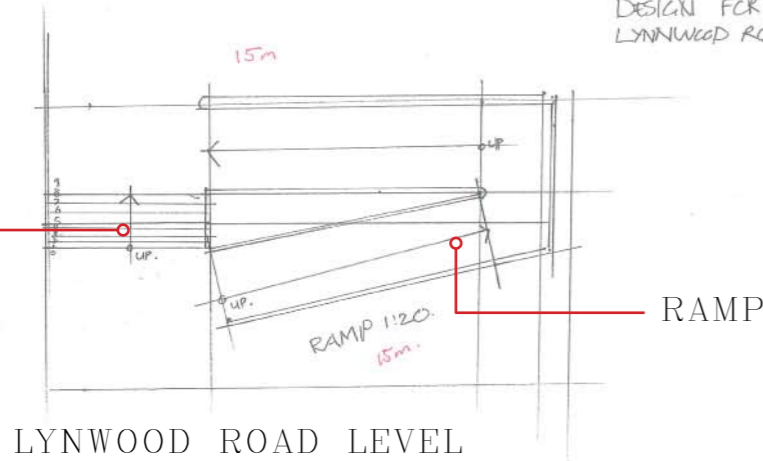

1500 x 30 9 TRAPPE
9 x 300 x 2700

RAMP

LYNNWOOD ROAD LEVEL

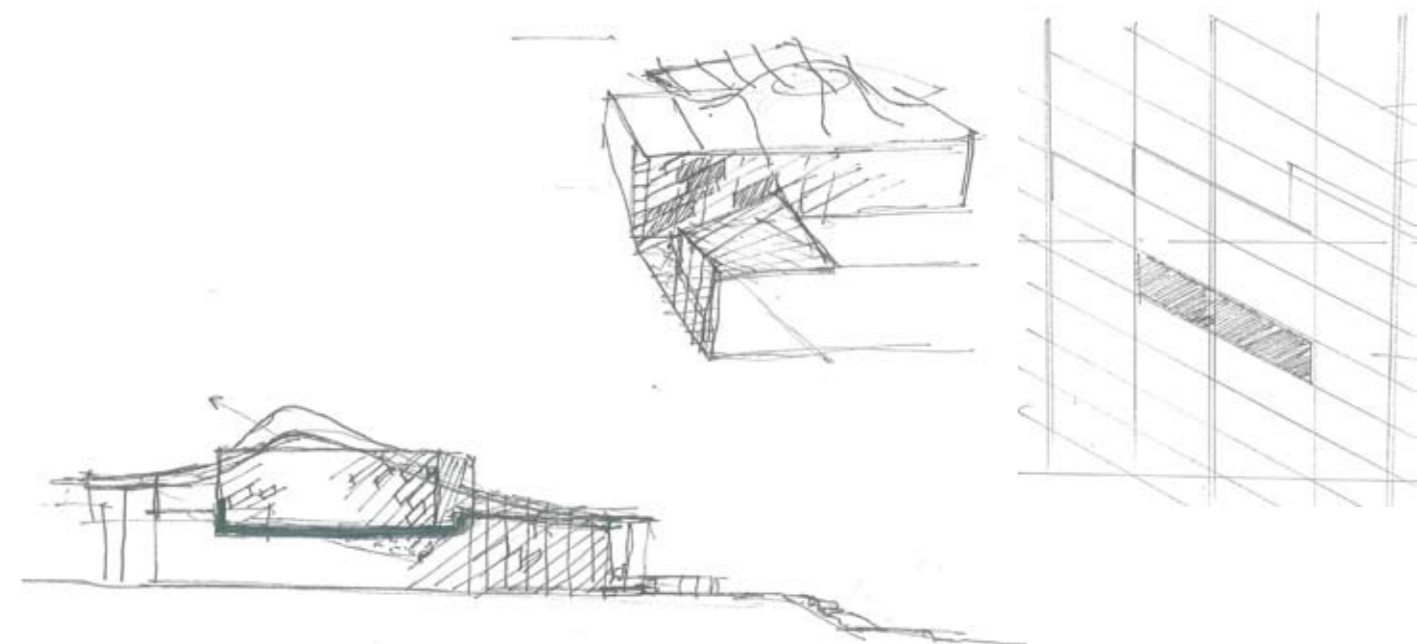

INVESTIGATION INTO FORM TO ENHANCE SPACES

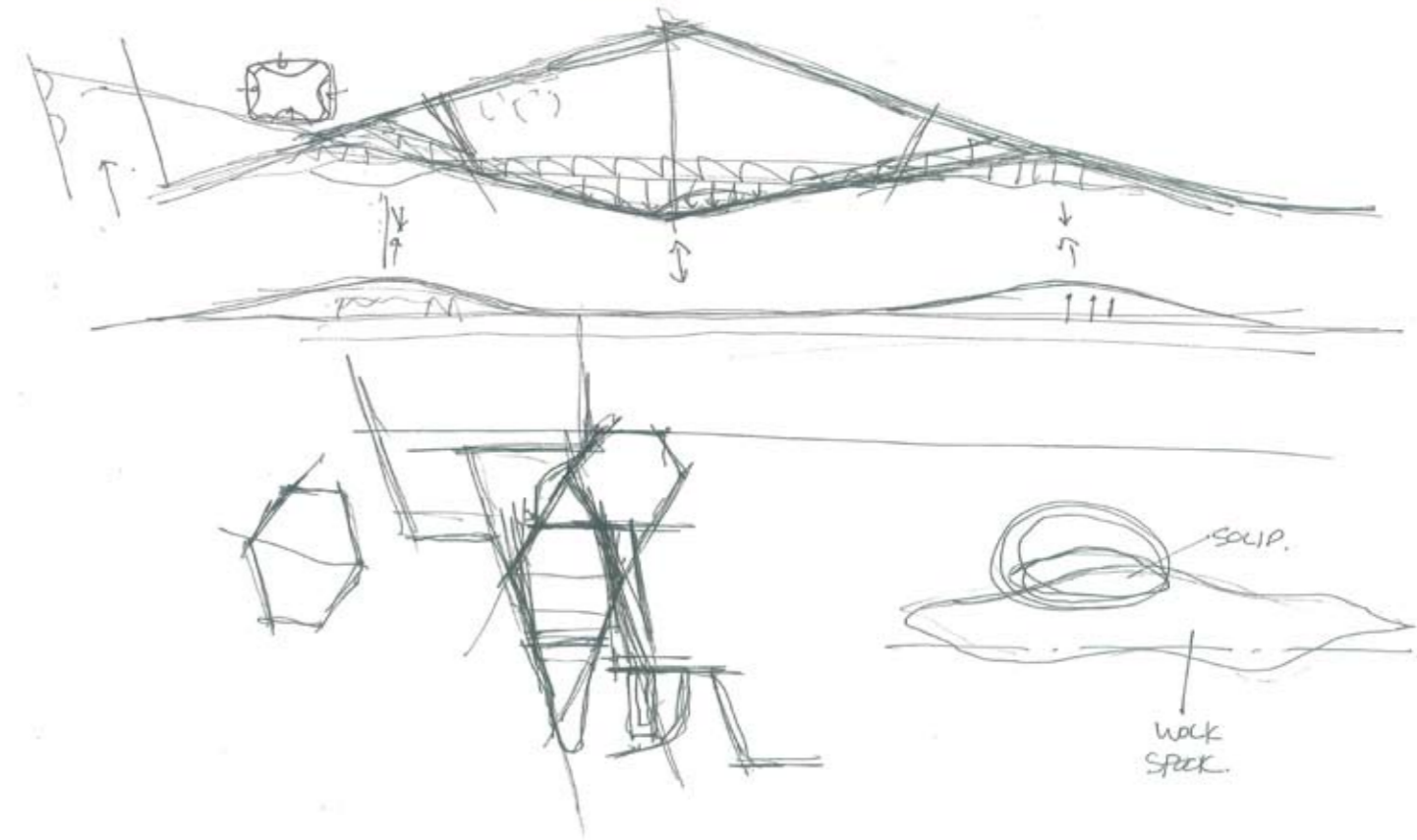
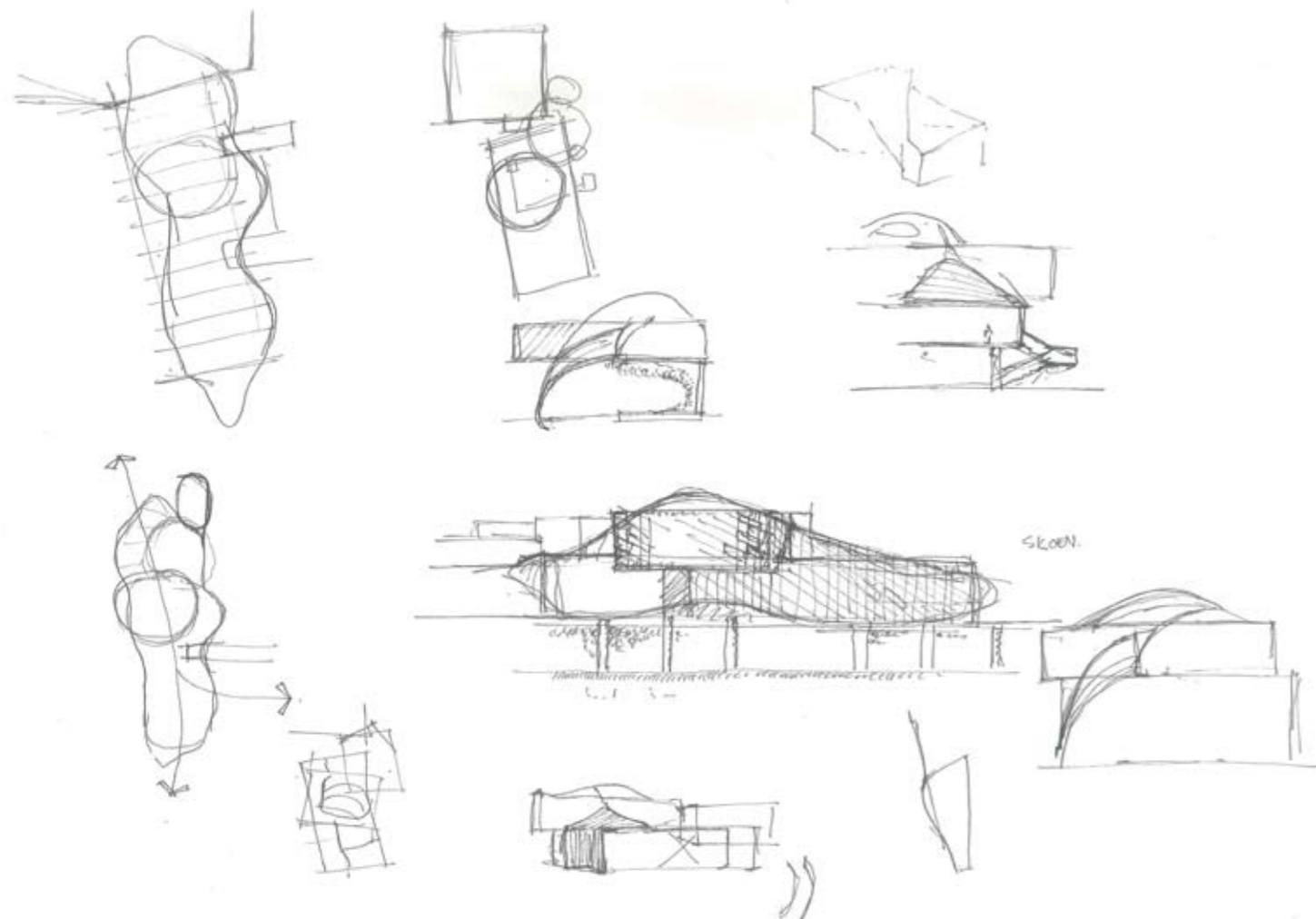

FREE FORMS TO ENHANCE SPACES

EXPLORATION FROM BOX TO FREE FORM



44



GATE HOUSE

+

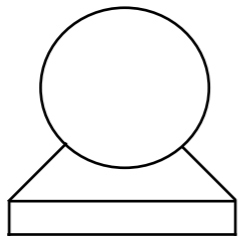

PORTAL

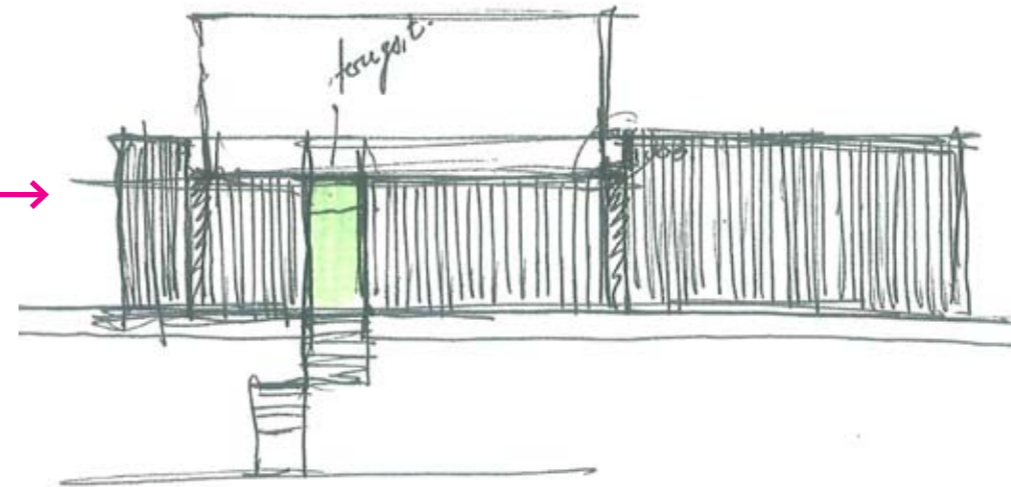

HYBRID

CONCLUSION

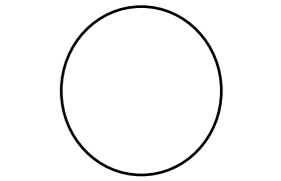

1

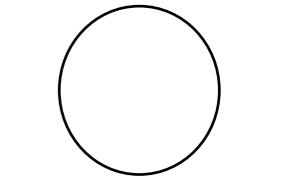

2

OPPOSITION

- (1) FUNCTION
- (2) SPATIAL EXPERIENCE

COMBINED TYPOLOGIES
STILL DO NOT GO
BEYOND COLLAGE

design

A hybrid between the two typologies was created by adding them together one on top of the other, containing the qualities of male and female, wrapped in one skin, communicating the quality of the space behind. The theoretical notion of ethereality between two phases was achieved, but the interrelationship between two phenomena was not.

STAGE 4 CONTEXTUAL INFLUENCE



KAYA ROSA

context

Important Buildings On Site

The two main buildings of greatest importance on the site are Kaya Rosa and the Human Sciences Building. Kaya Rosa was the original class building in 1908. The very first classes were conducted in this building. Originally Kaya Rosa was located in the city. Later the university moved it to this site. By the 70th year of existence of UP the university wanted to build a replica of Kaya Rosa at the main entrance to serve as an information kiosk and to house the Alumni. Symbolically Kaya Rosa is very important on the site. It symbolizes the origins of the university. The alumni are also housed in it. Thus it suggests the beginning and end of study at the university, while the Monster implies the in-between period of studying and growing.

The other iconic building is the Human Science Building. Construction on this building started in 1976. Its main function is that of office building. Lecture rooms and labs are also housed in the building. It was used as a bridge linking West and East campus when Roper Street was still separating the two halves. In 1994 Roper Street through campus was closed, thus negating its bridging function. The Monster will take over that function by linking over the outside of campus to the inside, suggesting a transition from childhood to adulthood, through the study period. Below are some of the major rules which govern both worlds. The liminal is the space between the worlds, literally neither here nor there. Thus it should negate those rules. The major difference between the worlds is the intent of each world. The university is a place for learning. It also has a reasonability aspect. Students are somewhere between childhood and becoming professional adult. The real world is a place of responsibility and work.

RULES OF 'REAL' AND 'STUDENT' WORLDS

Student World

Built Environment
Sky
Horizon
Wind
Sun
Rain
Trees

Liminal

Negate Built Environment
Negate Sky
Negate Horizon
Negate Wind
Negate Sun
Negate Rain
Negate Trees

Real World

Built Environment
Sky
Horizon
Wind
Sun
Rain
Trees



This map in green indicates the 'real' world. Yellow is the 'student' world. All the major gateways into campus are shown in blue. These gateways should all be treated as part of this project, as this project suggests the theoretical and design guidelines. This particular study is delimited to the main entrance of the university.

Context map

GROWTH OF SITE Historic Figure ground development of the university.

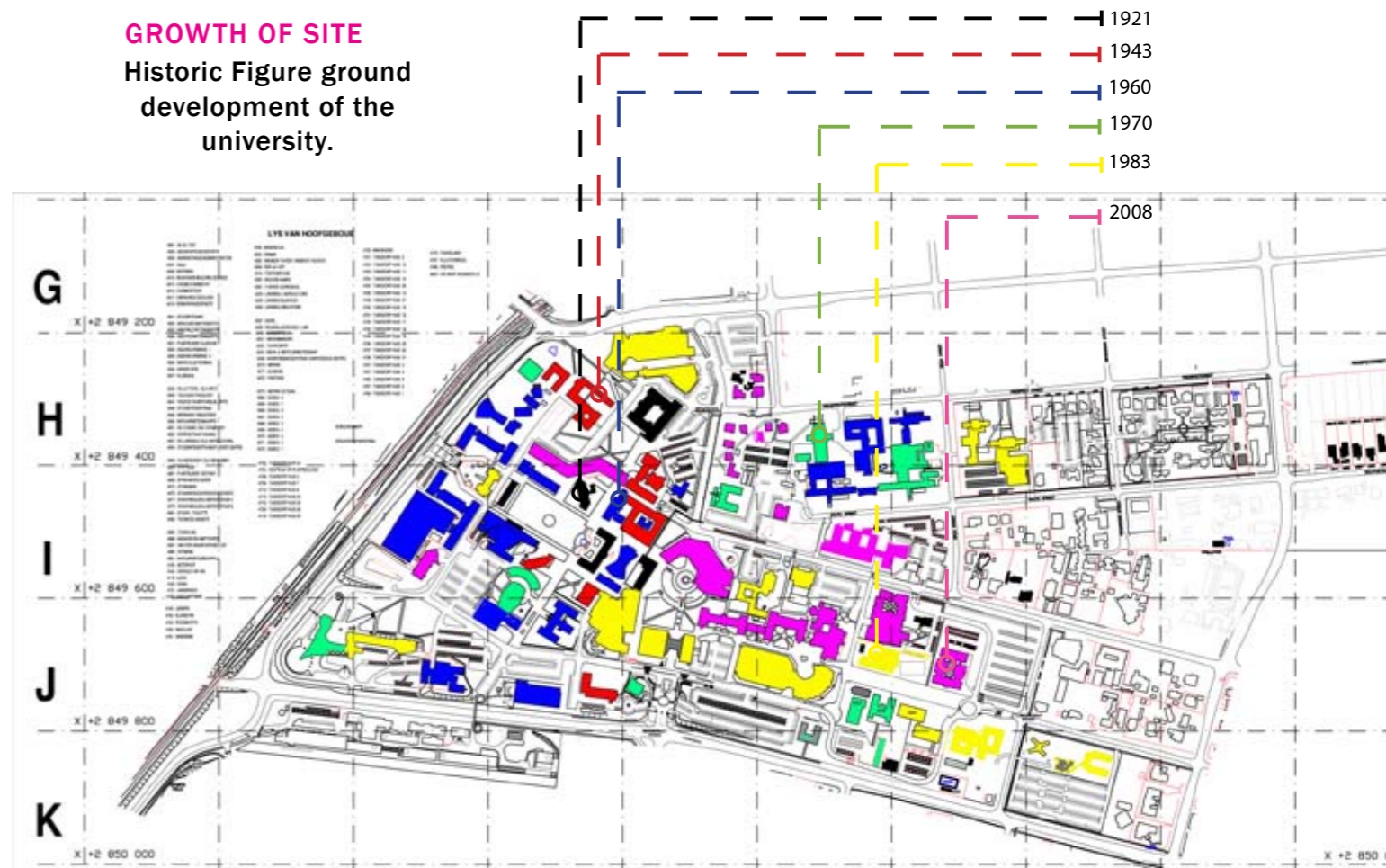

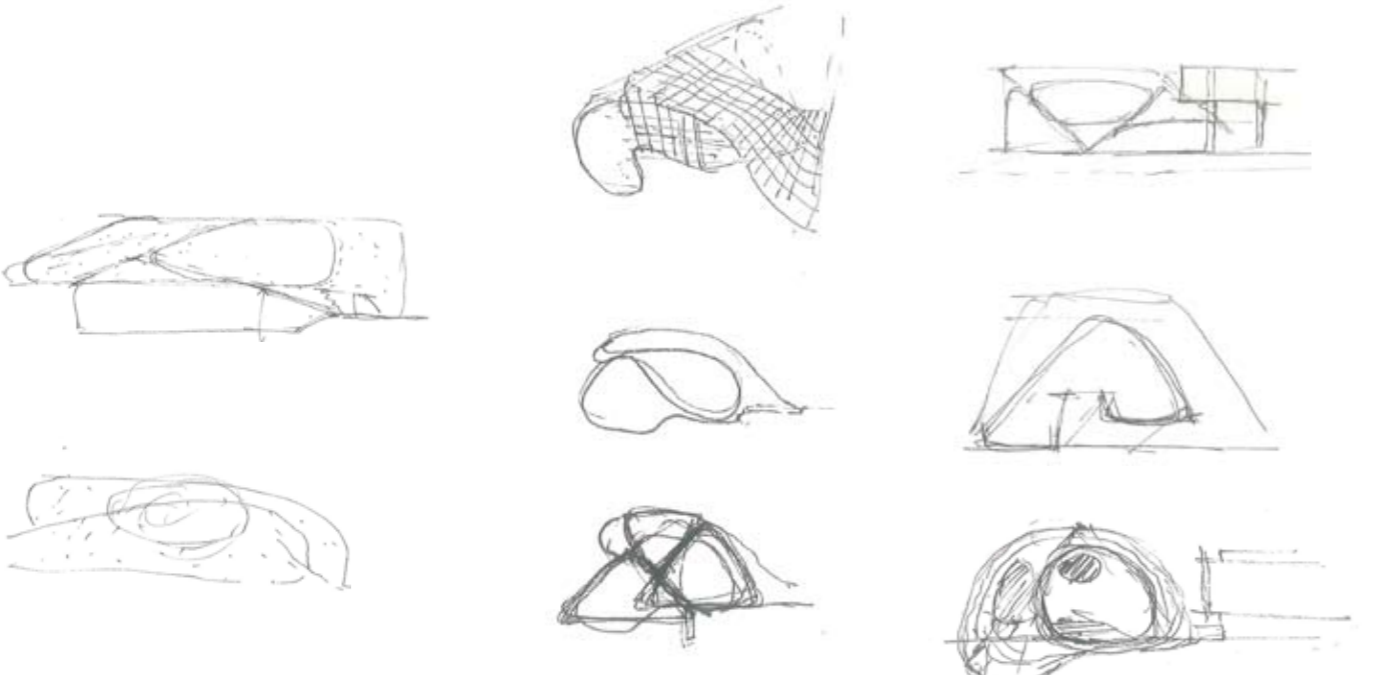
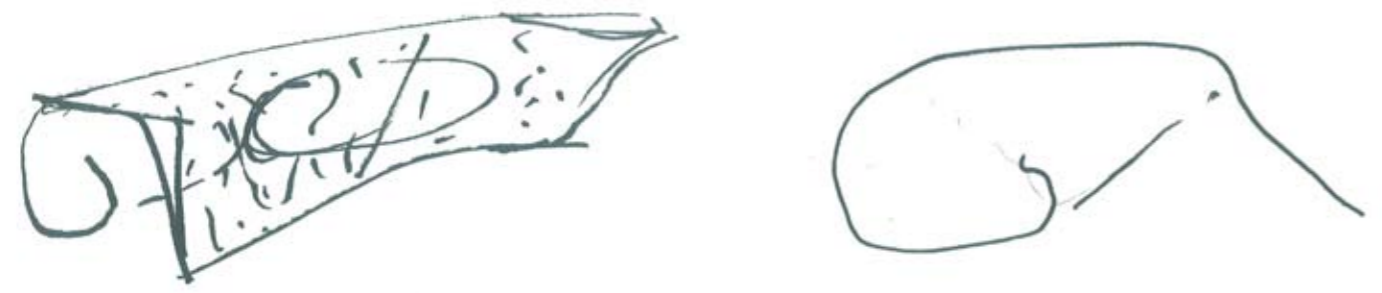

SECTIONS

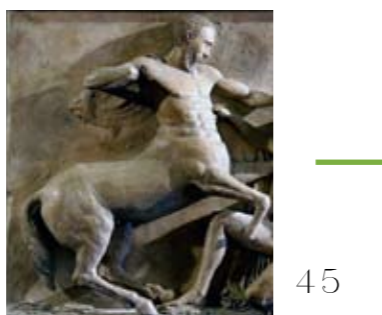
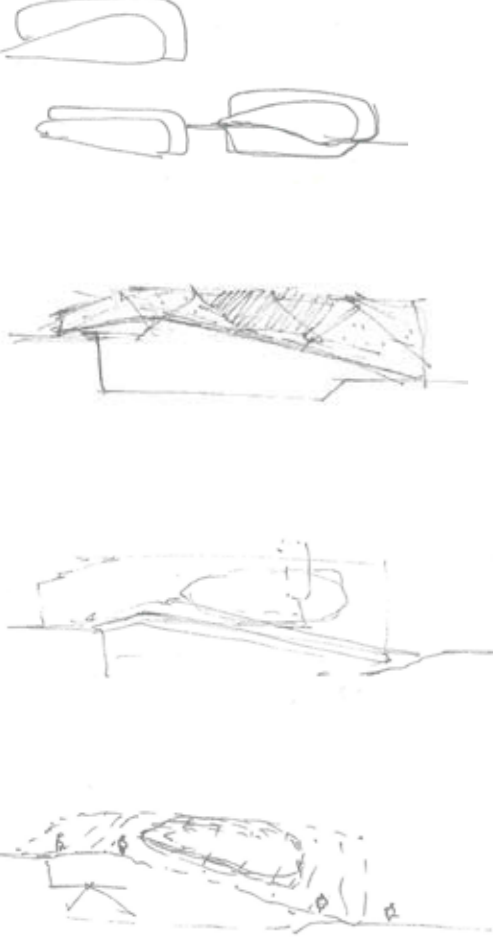

The hybrid was fully achieved by making the two typologies exist simultaneously in the same place, an overlapping. The monster was also achieved by rearranging the typologies in a way not experienced every day.

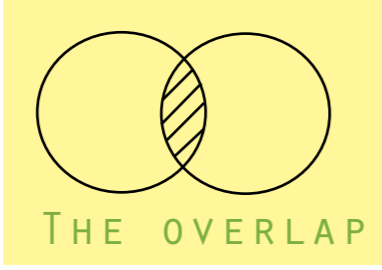

The nox son-o-house, has the theoretical notion of ethereality between 2 phases which moves between opaque and transparent. As the skin of Son-o-House [fig. 47] shows.

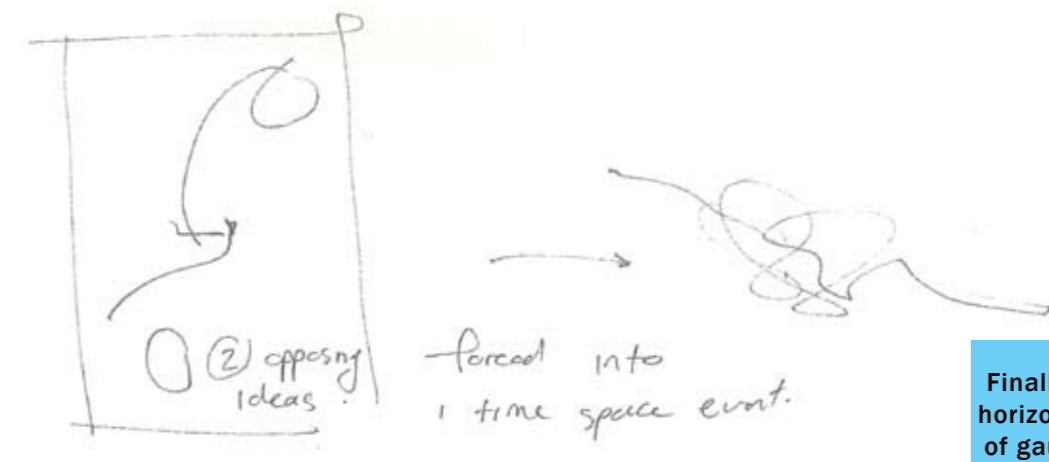

CONCEPT

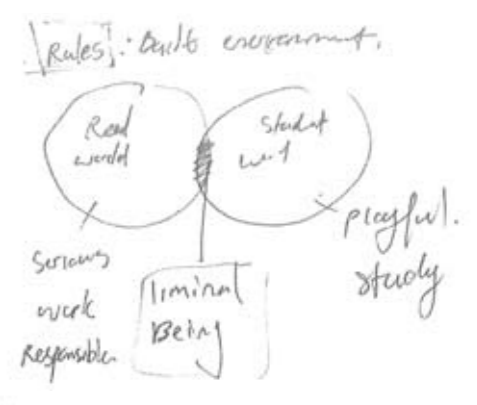

design
Finally, twisting of the building in the horizontal plane was explored. A piece of gauze was used as the touchstone. This strip was twisted over itself. The places where more of the gauze twisted over itself became more opaque.

A seamless transition from ethereal to opaque was achieved. Achieving this built upon all the exploration done up to this point. The twisting made the building into one unit, rather than two distinct opposing typologically driven pieces of a building. Thus this building was neither of the two combined typologies but synthesized the qualities into a relevant hybrid.

Twisting the building horizontally forced the two opposing ideas to coexist in the same place simultaneously, thus creating the interaction sought.

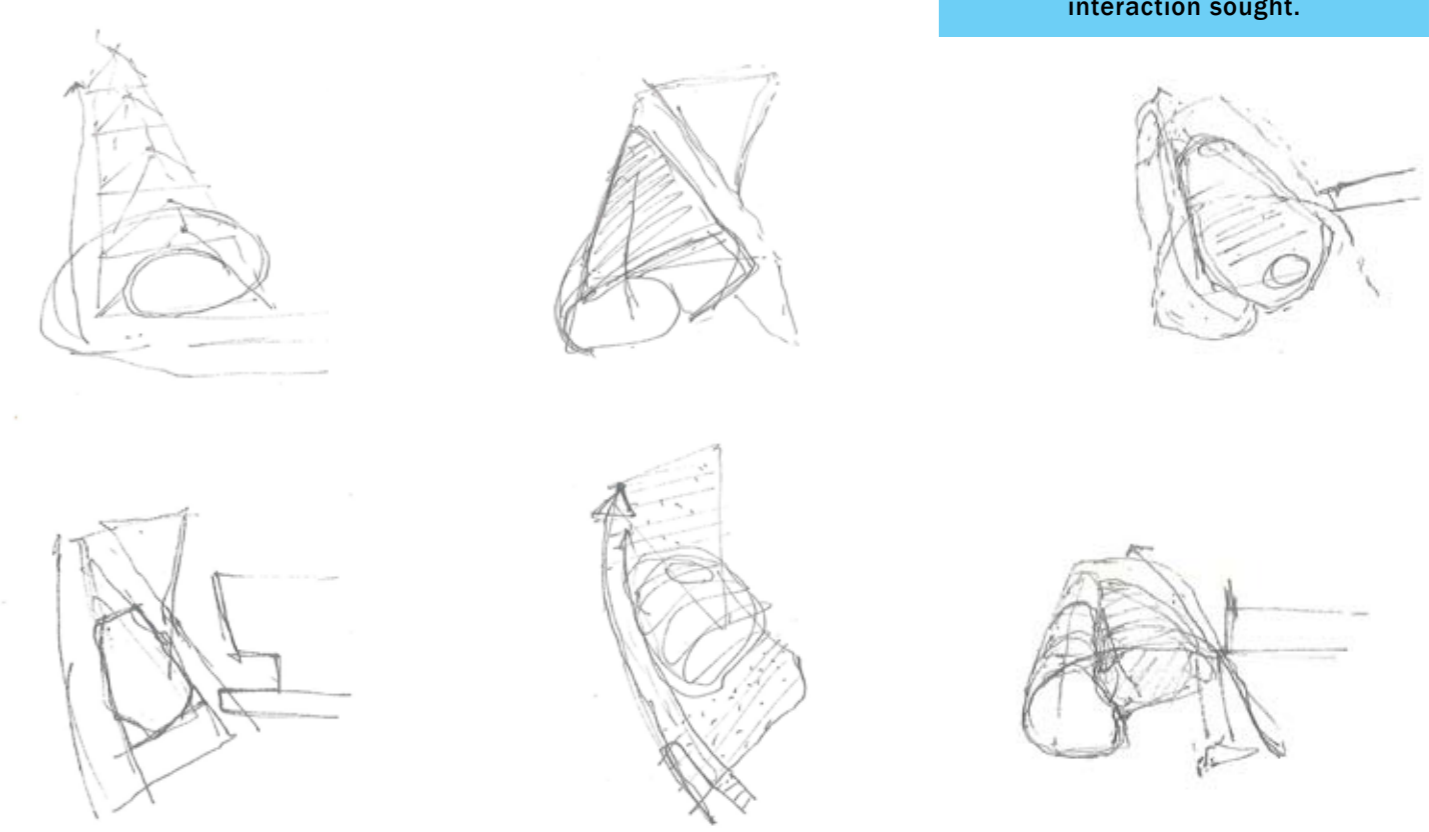

PLANS

¹ Roget's Thesaurus suggest a Touchstone to be a testing agent, yardstick, gauge, litmus paper, proving ground and so on.

precedent

Cloud like form giving

The ethereality of clouds, as well as the difficulty to remember their form served as stimulus for the design.

This relates to the context, so as to remove it from the aesthetics and forms common to the context. This is done to negate the rules of the context as discussed earlier.

The design evolved: viewing the building as a cloud, which has a form very difficult to remember. Moreover, it should provide a fitting spacial experience which is removed from the two worlds.

This idea is supported by the NOX H2O Expo [fig. 50]. The interior looks like what a cloud is expected to look like inside, removing the horizon, and changes the experience from walking to the feeling of falling.



50



48

MASSIMILIANO FUKSAS: CONGRESS CENTRE, MILAN



49

ATELIER HAPSITUS - THE CLOUD, DUBAI

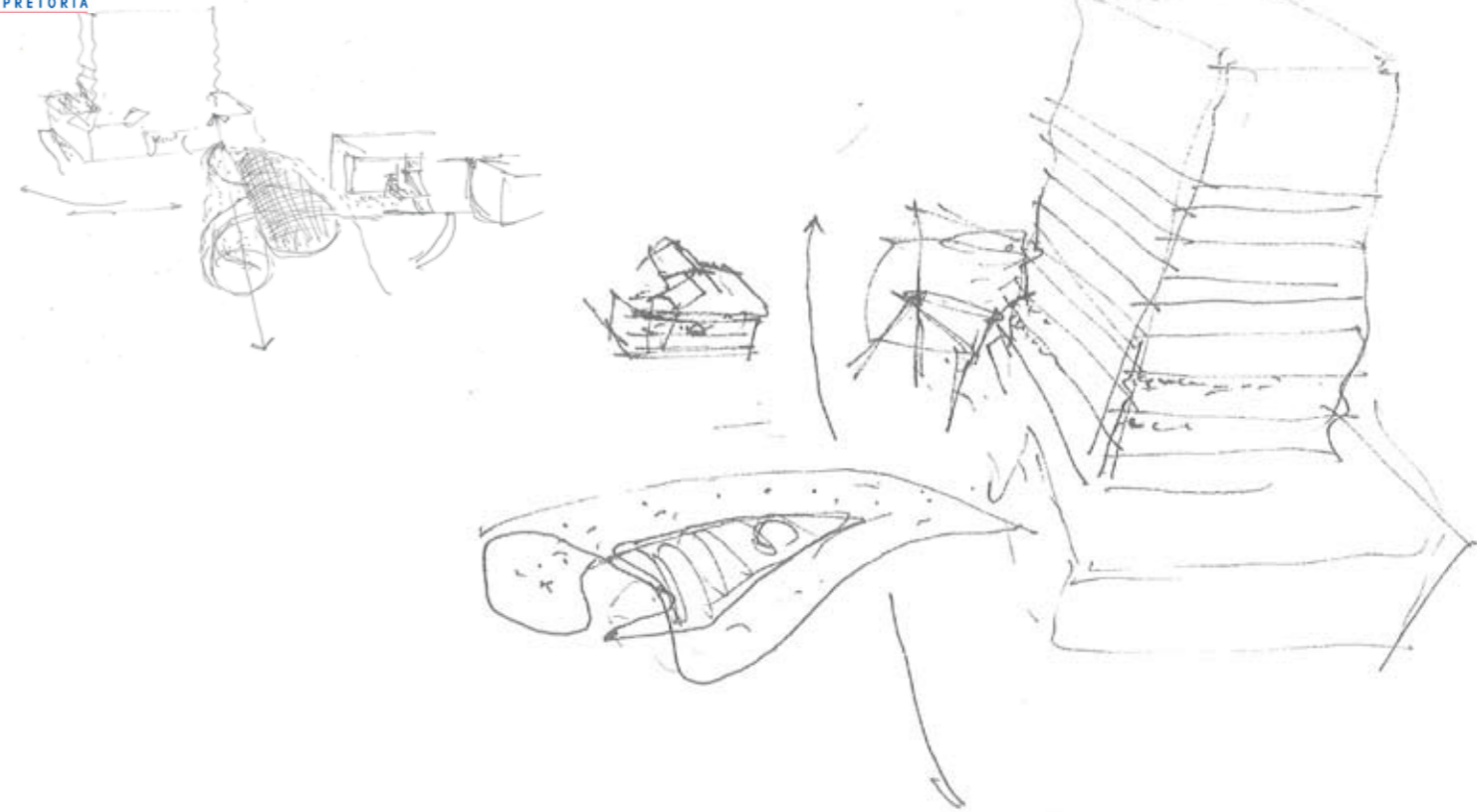

THE MONSTER



design

Monster

The design has clearly been influenced by Fukas and Gehry. The form is intended not to be similar to any formal geometry in the context of the university.

The form is determined by the spaces inside. These are intended to be something which is not experienced every day.



MASSIMILIANO FUKSAS

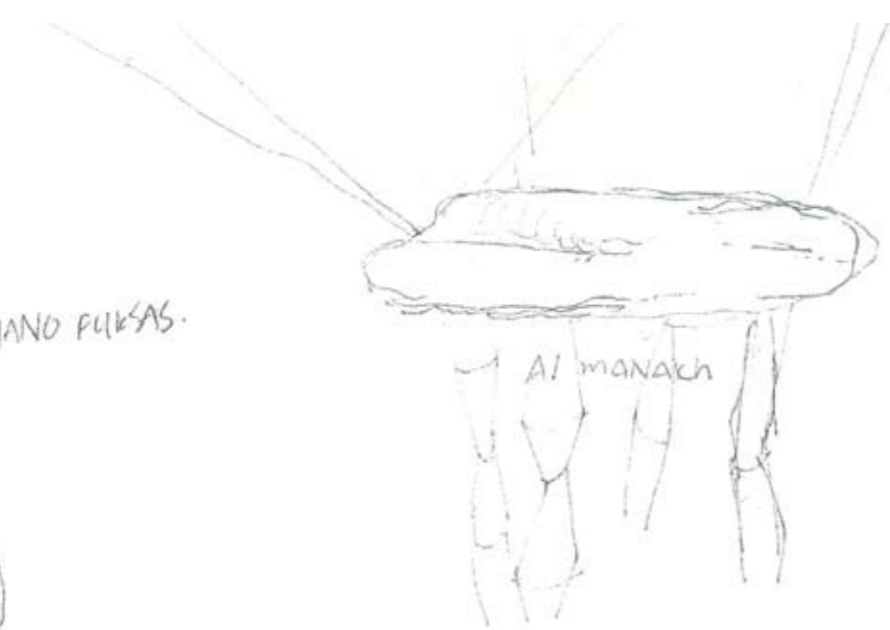

THE CLOUD

formal precedents.



FRANK GEHRY

51



MASSIMILIANO FUKSAS

52

precedent

Frank Gehry

Uses Catia for the modelling and file-to-factory fabrication of the curves in his buildings.

My interest in his work is how the fabrication works: from computer model to factory.

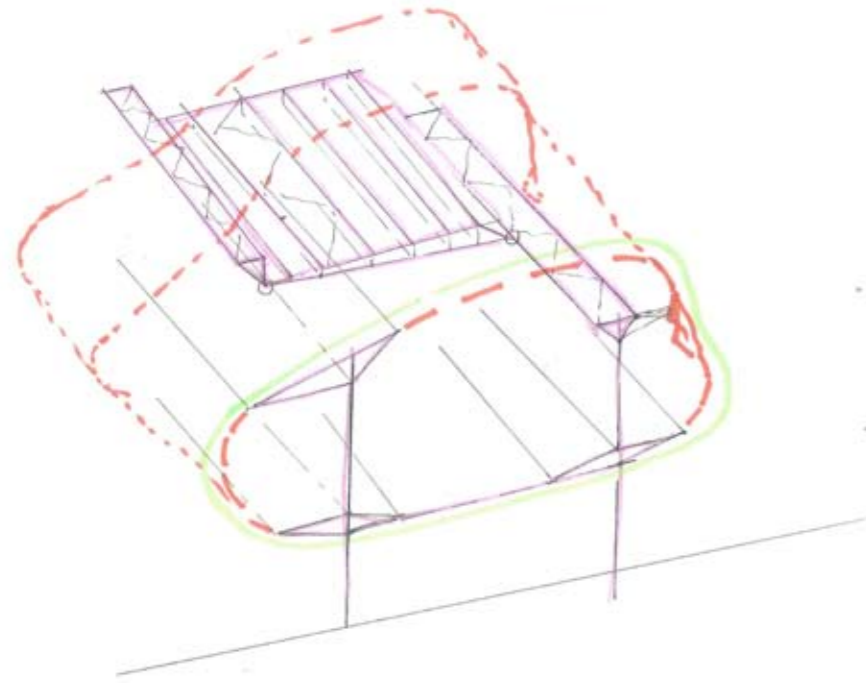

AXO OF STRUCTURE



PLAN

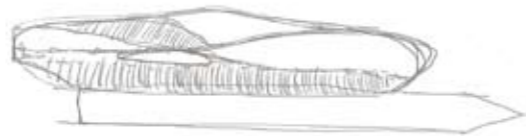

design
From the start it was quite apparent that the structure of the building should be simple. The structure should support the free form shape, thereby contributing to making it possible and not restrict it in any way. The structure is limited by how it can touch the ground. Columns are the only option, between lower ground and upper ground floor.

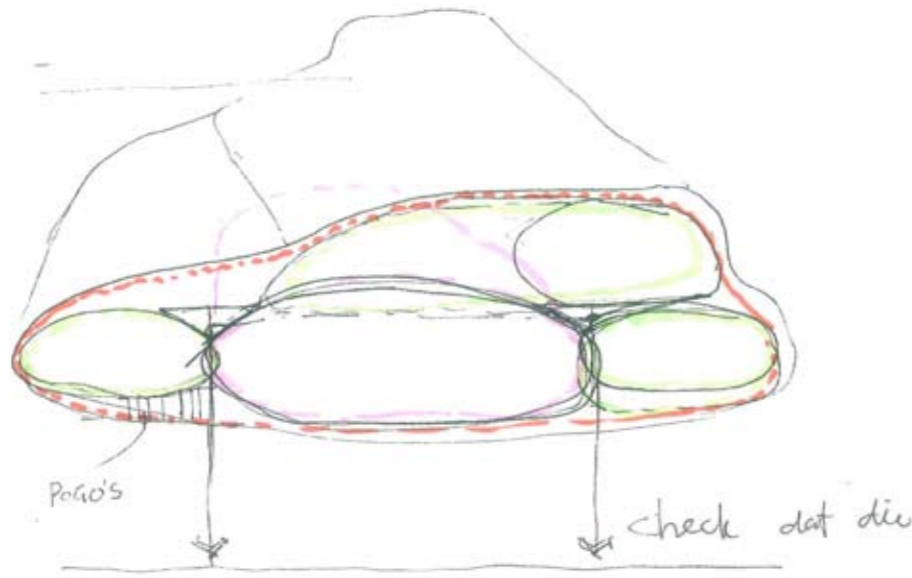

CROSS SECTION WITH STRUCTURE

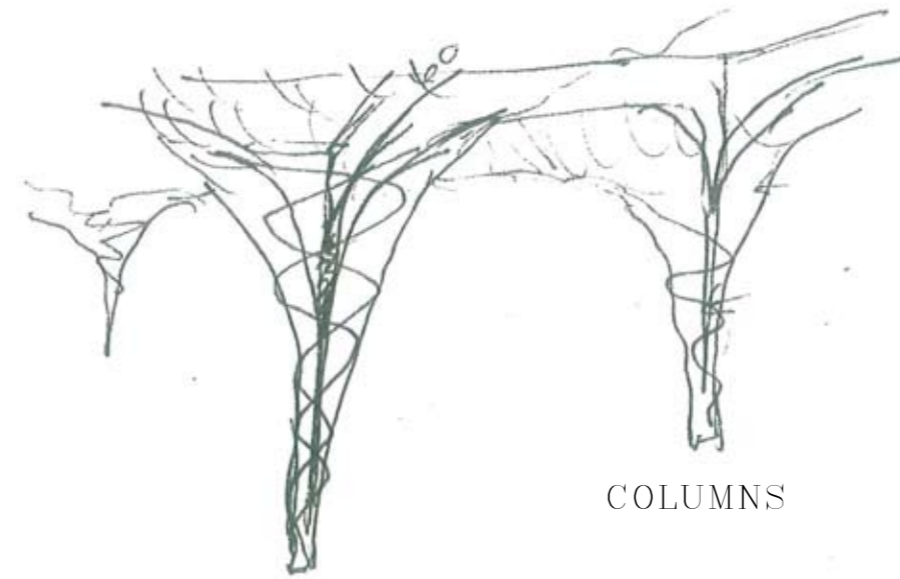
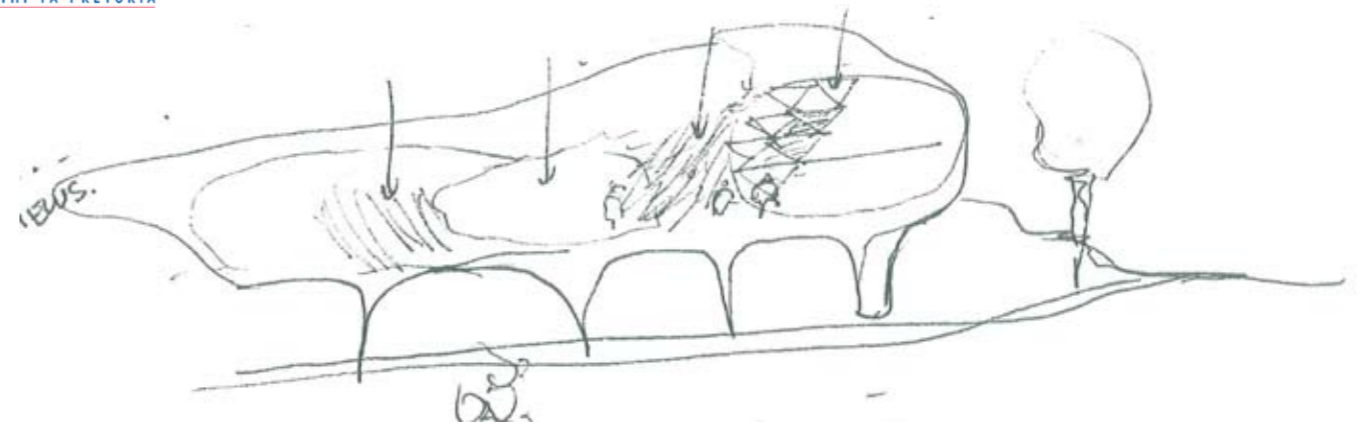
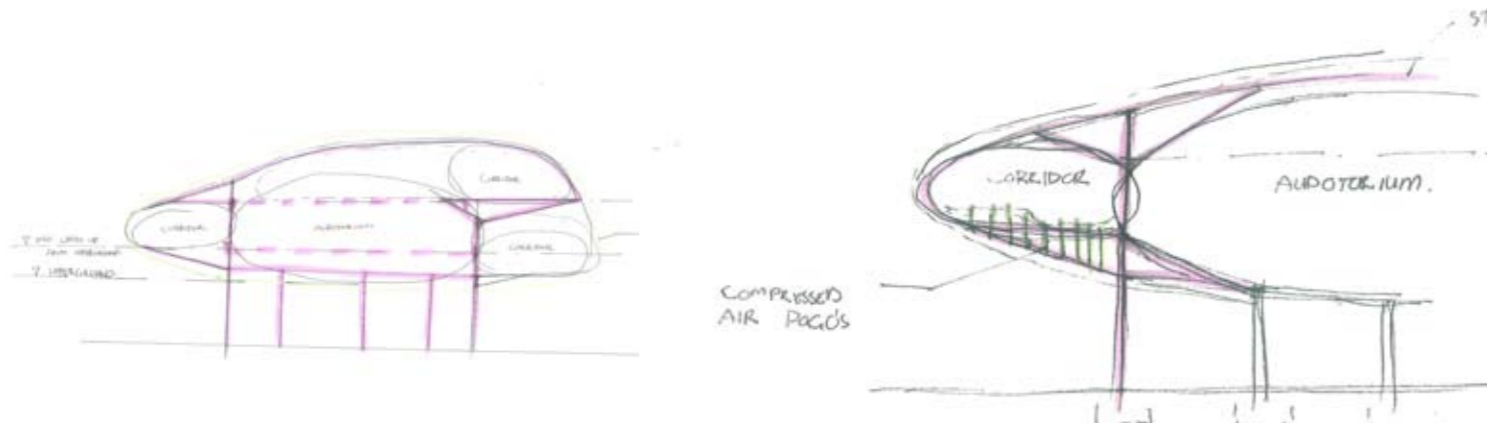

COLUMNS

design
The reason why the building has to stand on columns is a result of accepting ARC Architects proposal. The existing ground level is dropped by 1,5m. There is a bridging platform envisaged 3m above the new ground level, where the Monster is situated.

The design language of the building must be carried through to the columns, as well as how they touch the ground.



TRANSPARENT STRUCTURE

Toyo Ito Library

53

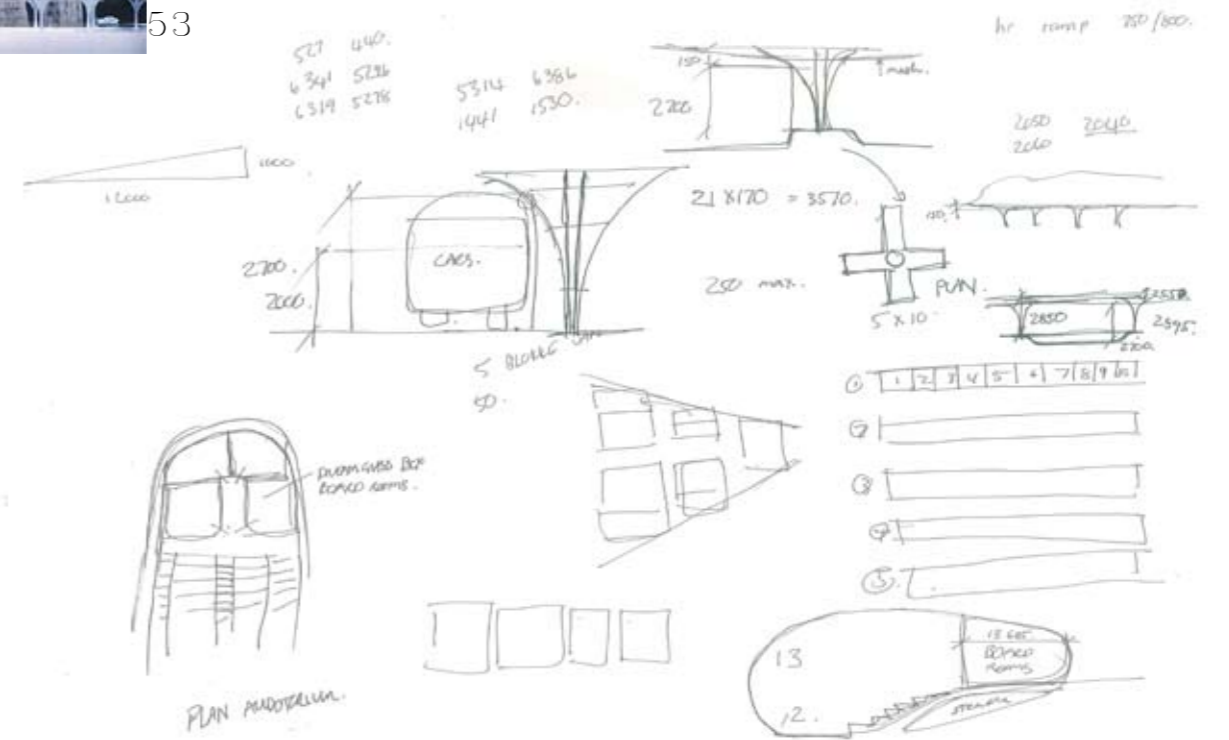

SIZING OF COLUMN

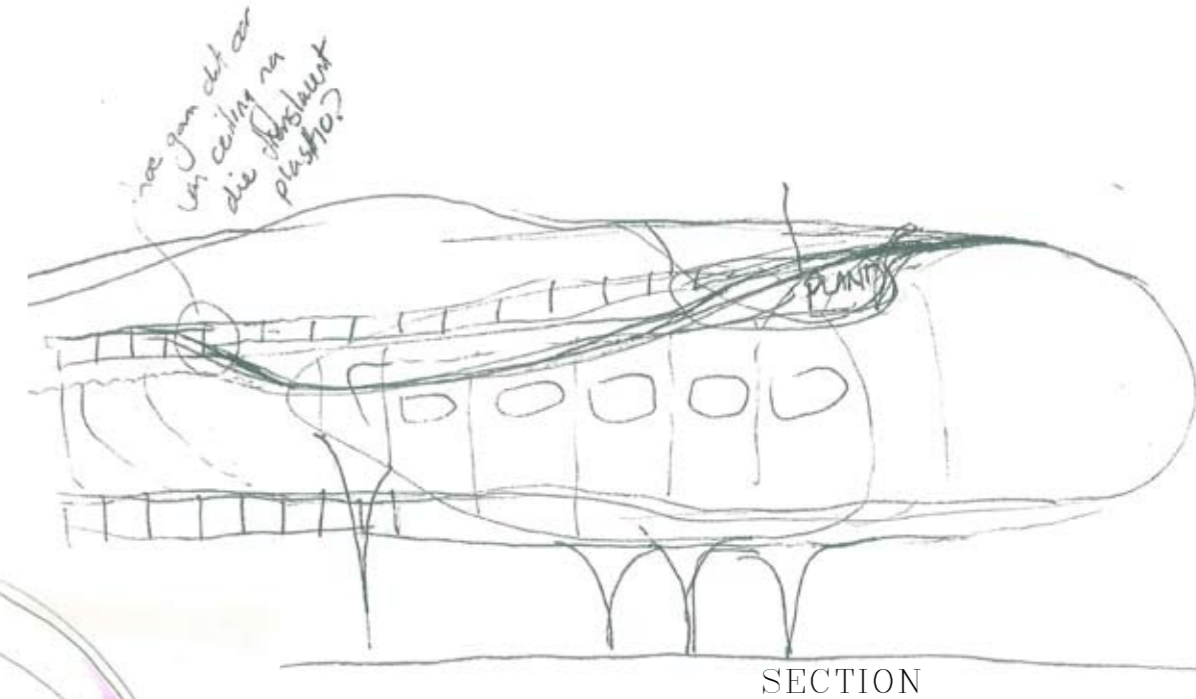
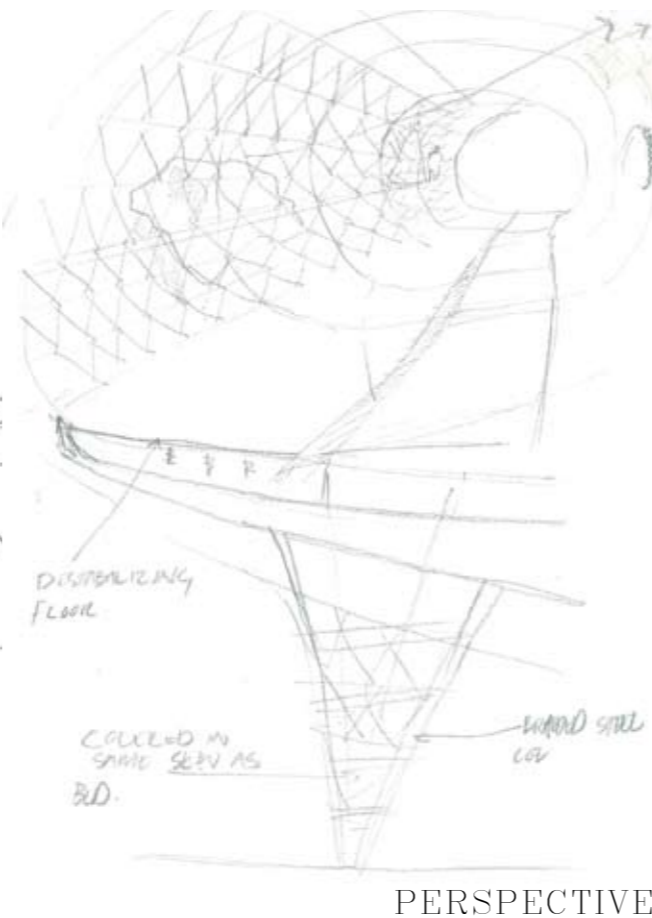
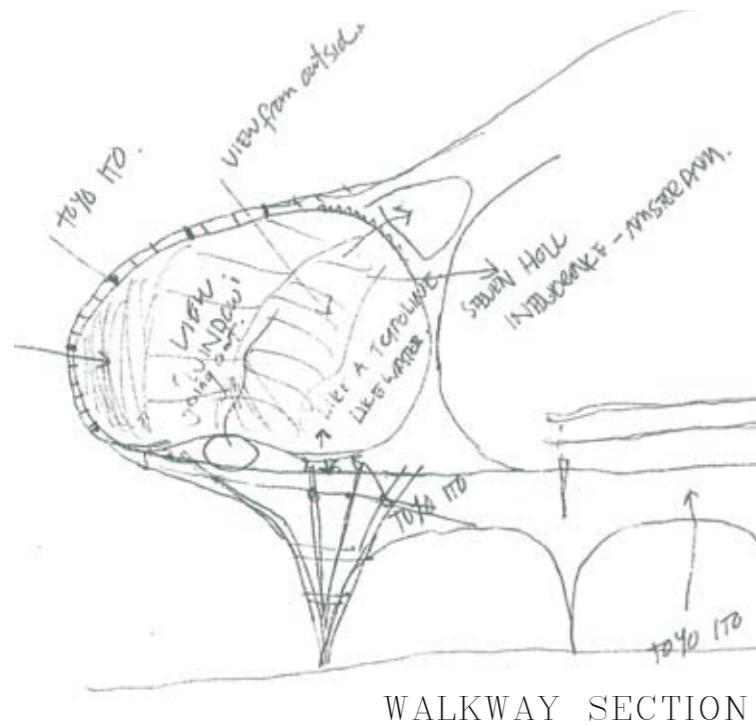

54

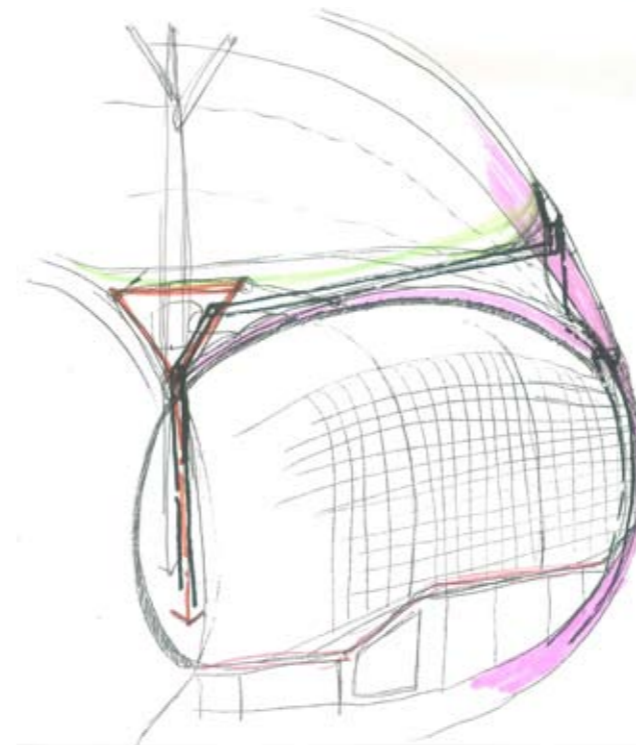

design

The NOX H2O Expo was very influential in the design. The expo negates the horizon. Walking becomes an experience in itself, which relates to the way you experience the space. Experiencing the building like this is dislocated from the context. Therefore it would heighten your awareness of the context once you have exited.

This walkway becomes the embodiment of the procession which communicates the intent of the "world" you are entering. It reintroduces an idea explored earlier: through linear movement and projection media this exhibition of intent can be manifested.

Nox Water expo
[fig. 54, 55]

The precedent has influenced the design in the way you walk through the space. The building conveys people from the outside to the inside. The rules of the two worlds should be negated, to be neither here nor there. The spatial experience should not be an everyday one, raising the level of sensorial stimulation and then communicating information about both sides.

Student World
Built Environment
Sky
Horizon
Wind
Sun
Rain
Trees

Liminal
Negate Built Environment
Negate Sky
Negate Horizon
Negate Wind
Negate Sun
Negate Rain
Negate Trees

Real World
Built Environment
Sky
Horizon
Wind
Sun
Rain
Trees



55

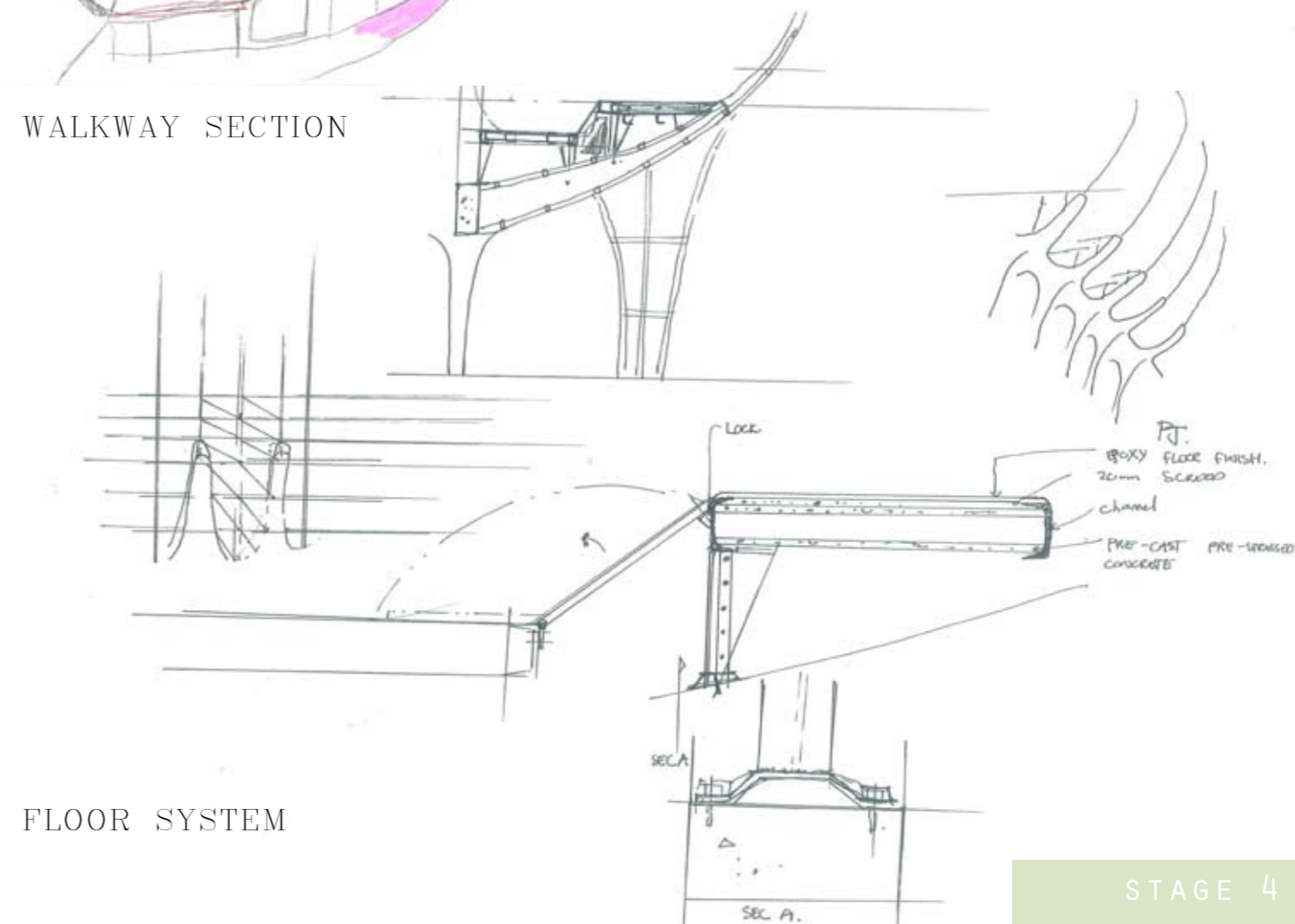

FLOOR SYSTEM

ELEVATION

design
First floor. The post graduate club gradually evolved into a cafe. The cafe is situated next to the walkway connecting the parkade to HSB. This introduces a new circulation connection.

From the HSB there are ramps and staircases down to ground floor campus level, allowing disabled people access to campus through this route.

CAFE

FIRST FLOOR

SECTION

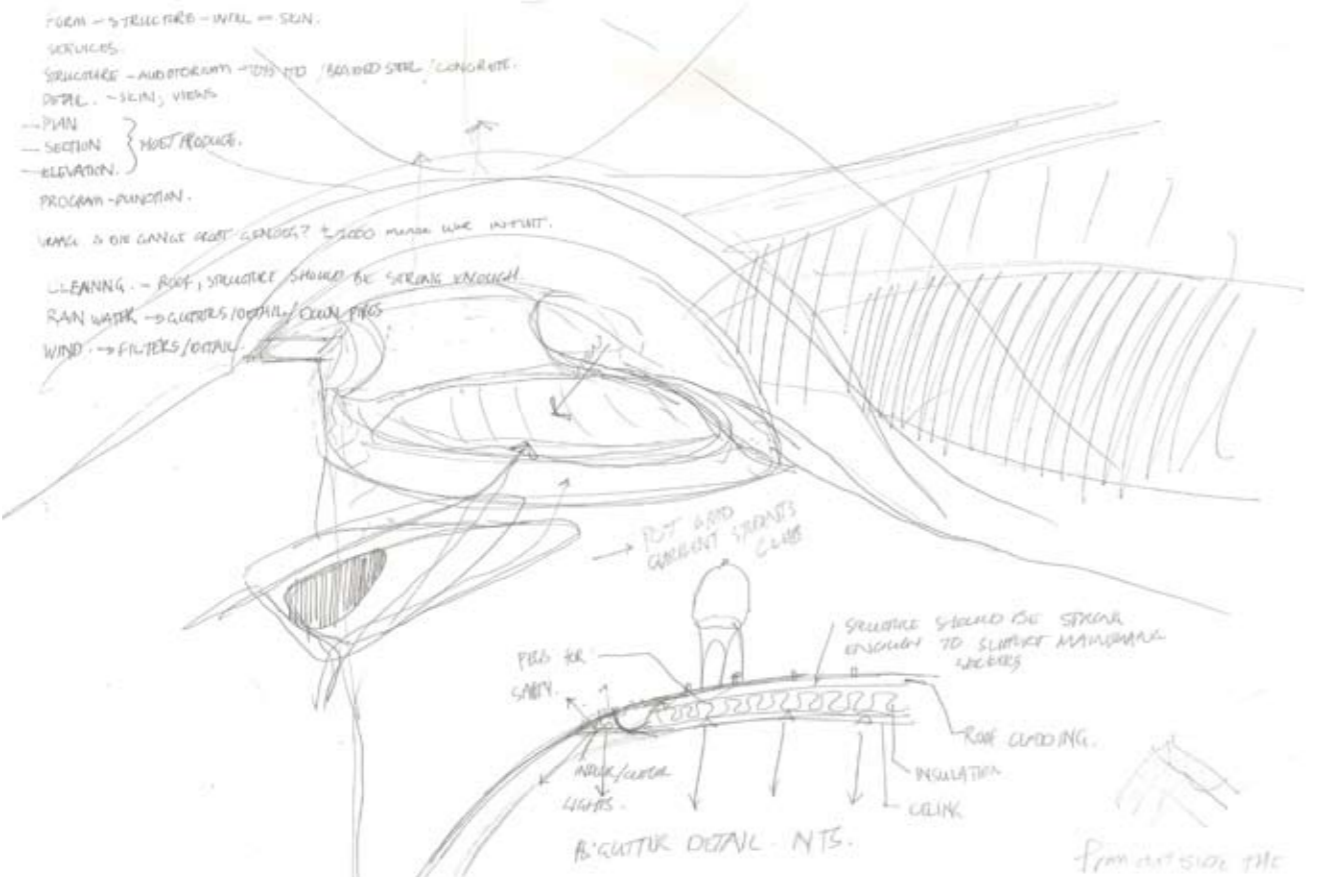
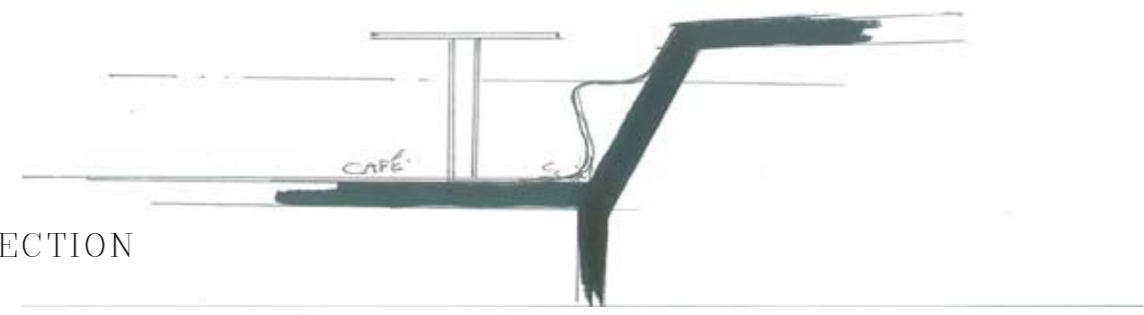
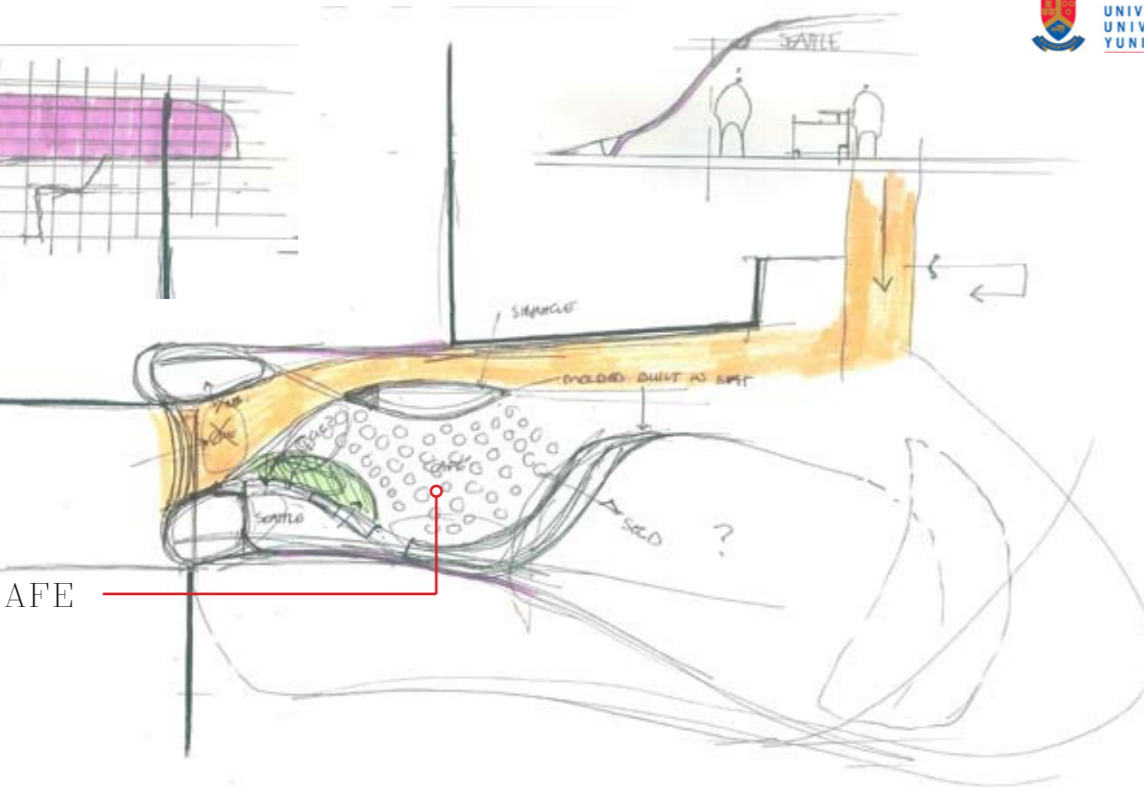

SECTION SHOWING INSULATION IN ROOF AND MAINTENANCE WORKERS ON THE OUTSIDE

PLAN

PASSAGE CHANGE

TOILET

design
Planning to integrate the public toilets into the existing HSB, to create threshold spaces interlocking the toilet into the interactive space.

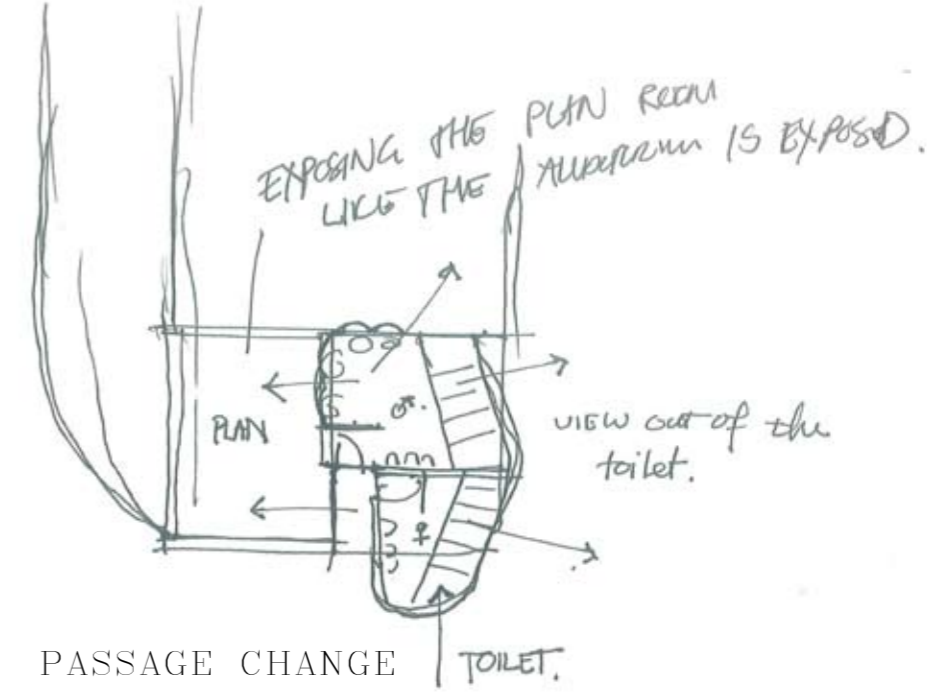
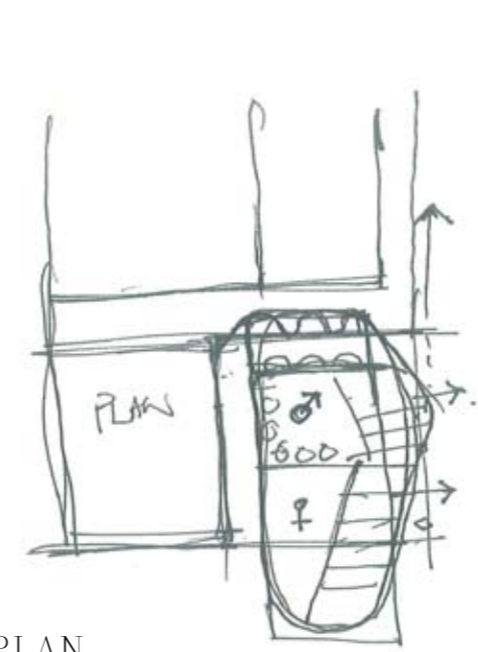

CONTEXTUAL PERSPECTIVE

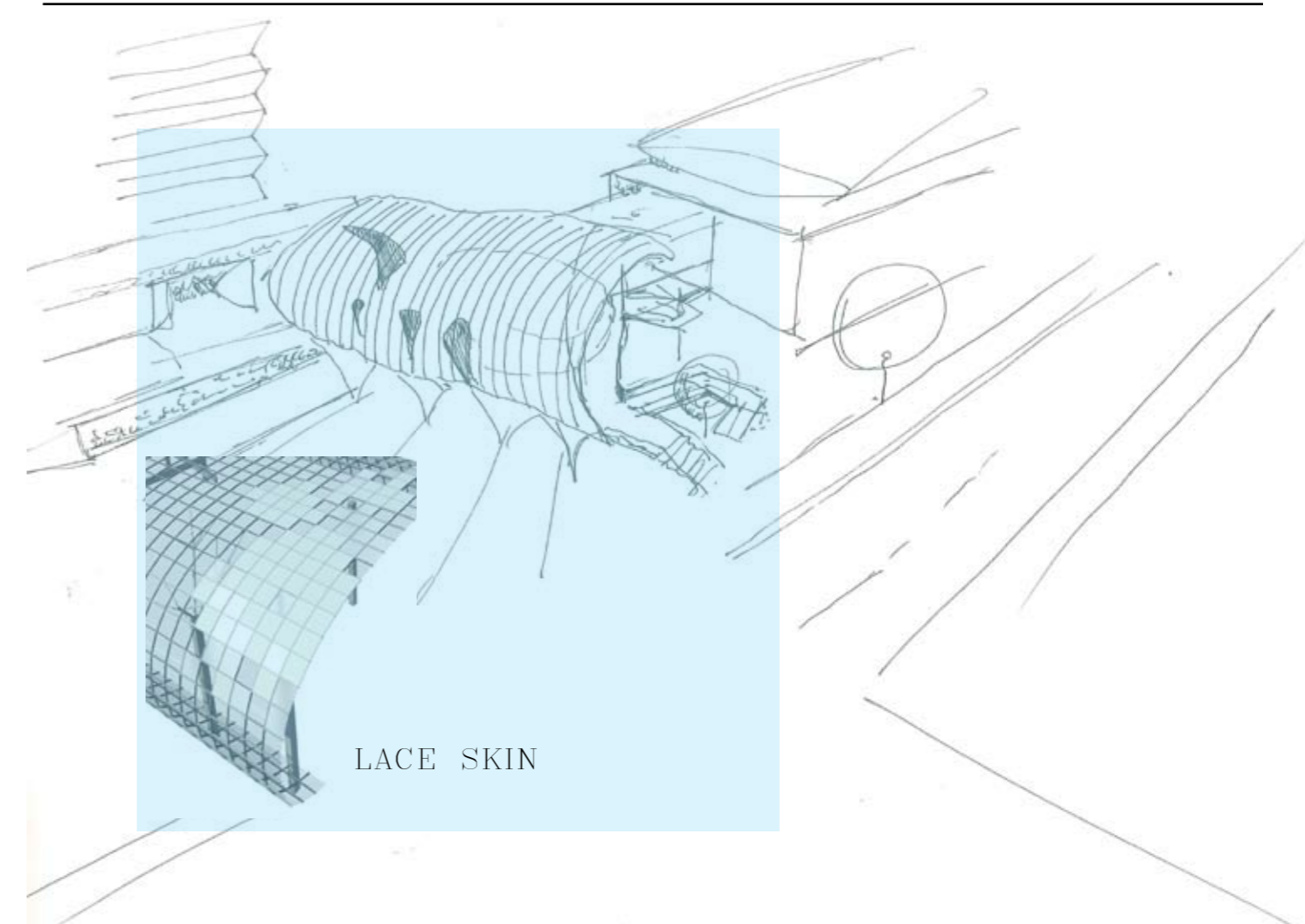

LACE SKIN

design

The design of the skin was further refined so as to achieve a gradual transition from opaque to transparent. This opposes the Son-o-House way of randomly placing opaque elements in the ethereal skin.

The skin serves not only to clad the structure but it also articulates spatial qualities of the interior. Opacity represents inhabitable space, while transparency alludes to open-conceptual possibilities.

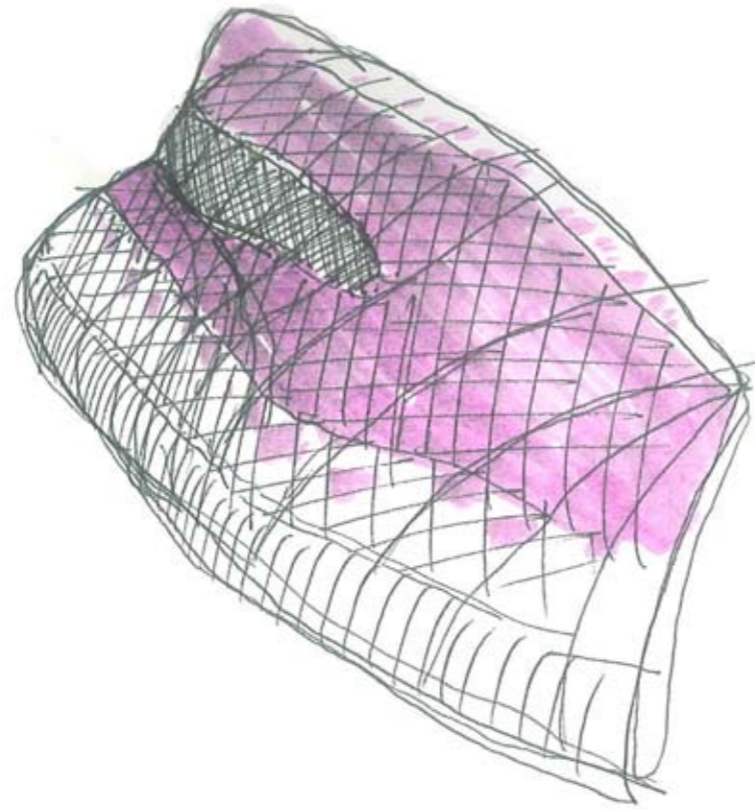

PERSPECTIVE OF THE MONSTER

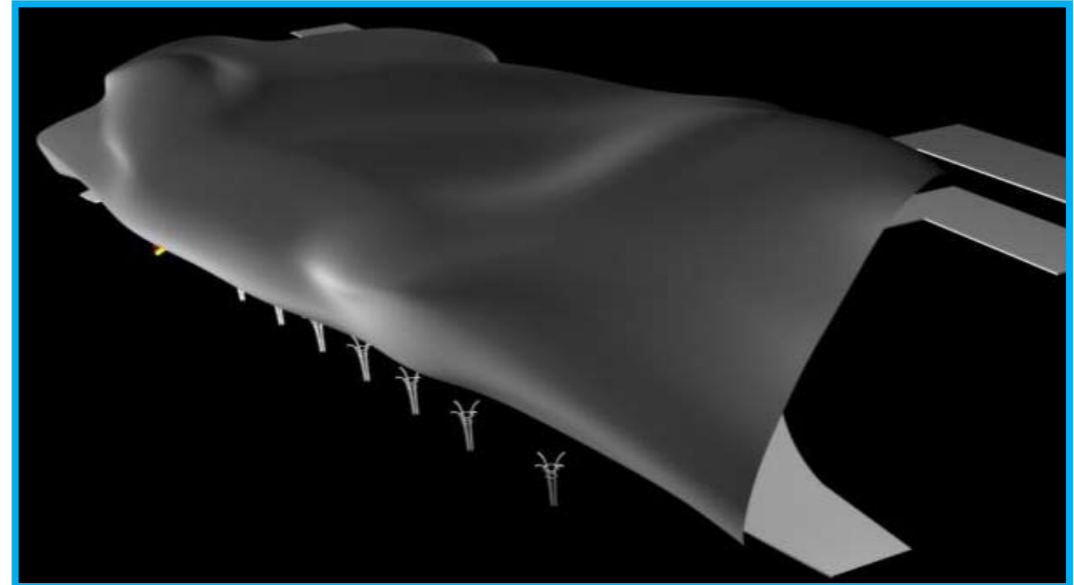
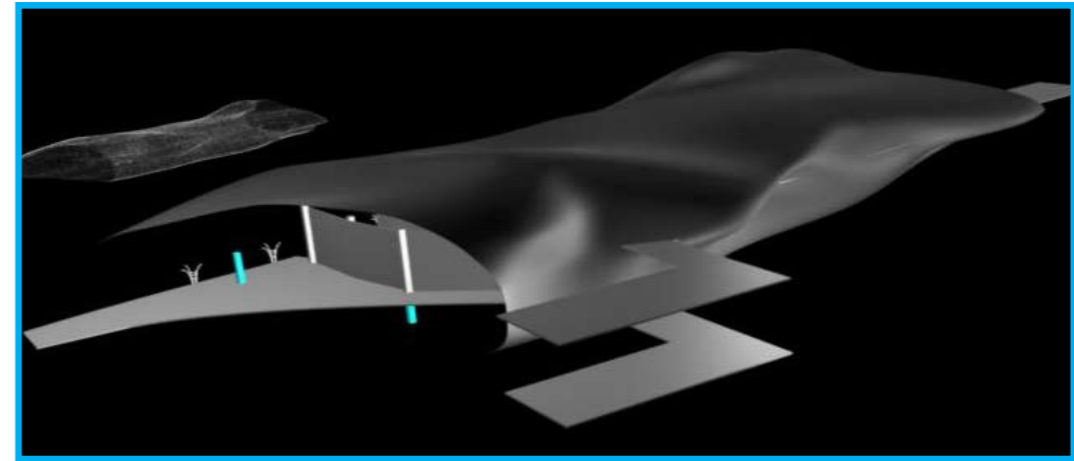

EARLIER VERSIONS OF THE SKIN EXPLORING THE FREE FORM QUALITIES

precedent



NOX
SON-O-HOUSE

56



LACE

57

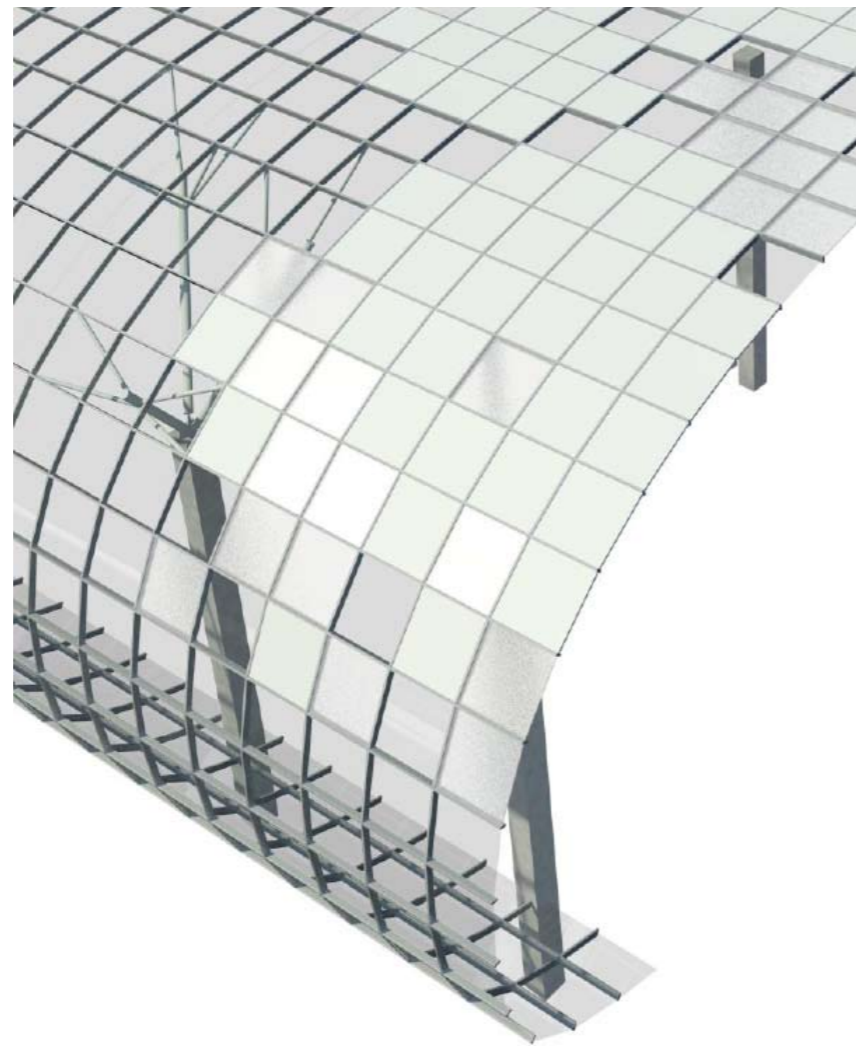

SKIN OF THE MONSTER

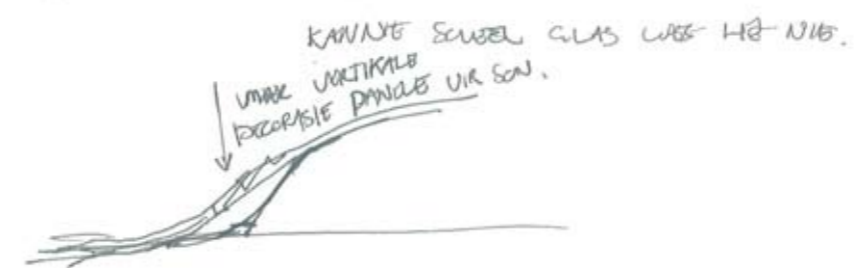

WESTERN SUN BREAKS

Die heutige d.h. Brems schil. production idea.

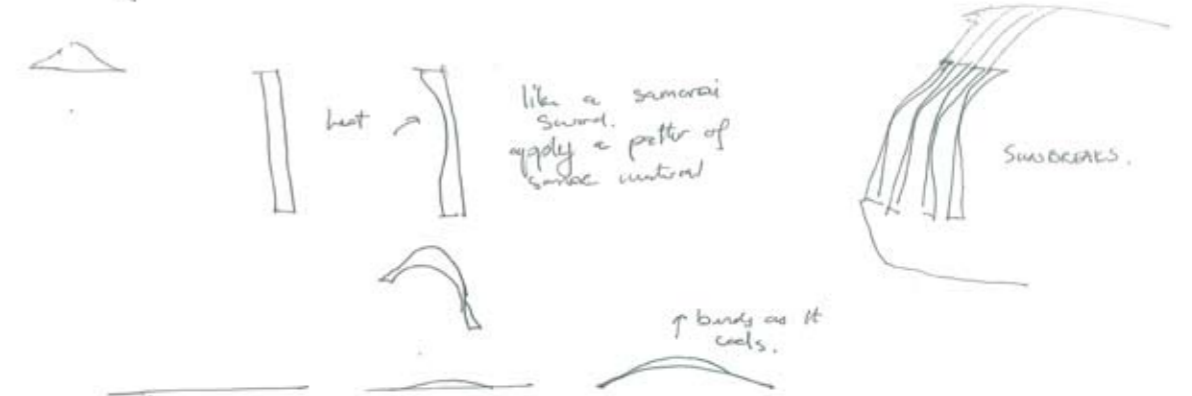

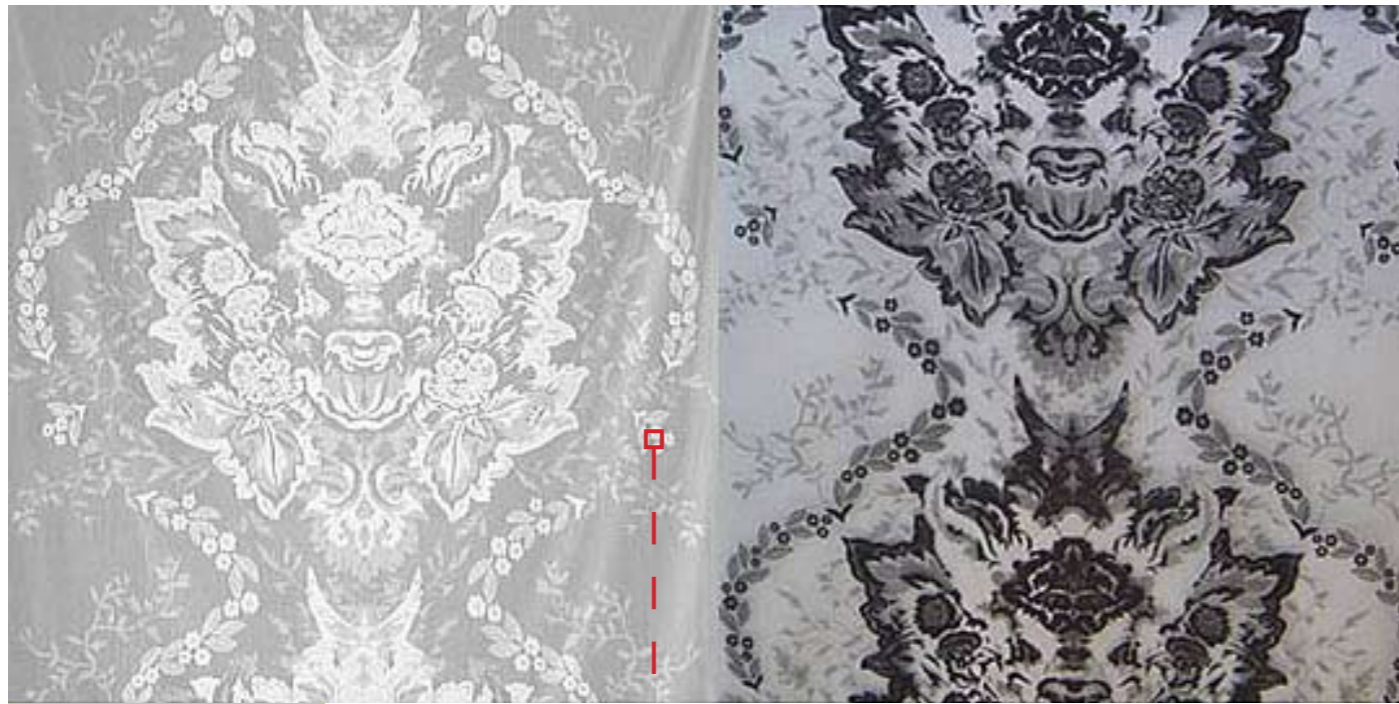

58

precedent

Lace

Lace [fig. 58] is a material which contains all the qualities of the skin that will clad the Monster. Lace consists of patterns resulting in opaque and translucent areas. Usually it is one colour. Lace is the most relevant concept to base the system of the skin on and it is ethereal and delicate.

The image below shows light qualities as a result of the skin design. It is similar to Jean Nouvel [fig. 59].

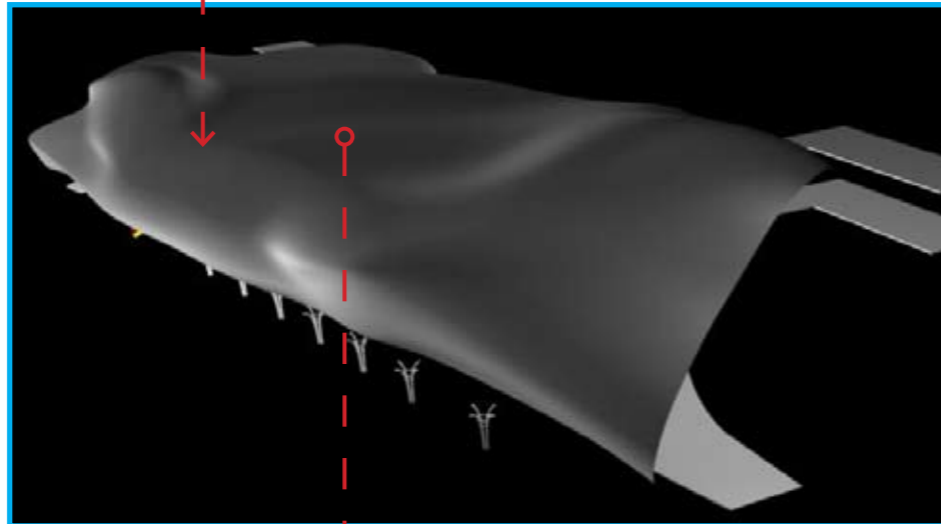

Lace applied to skin

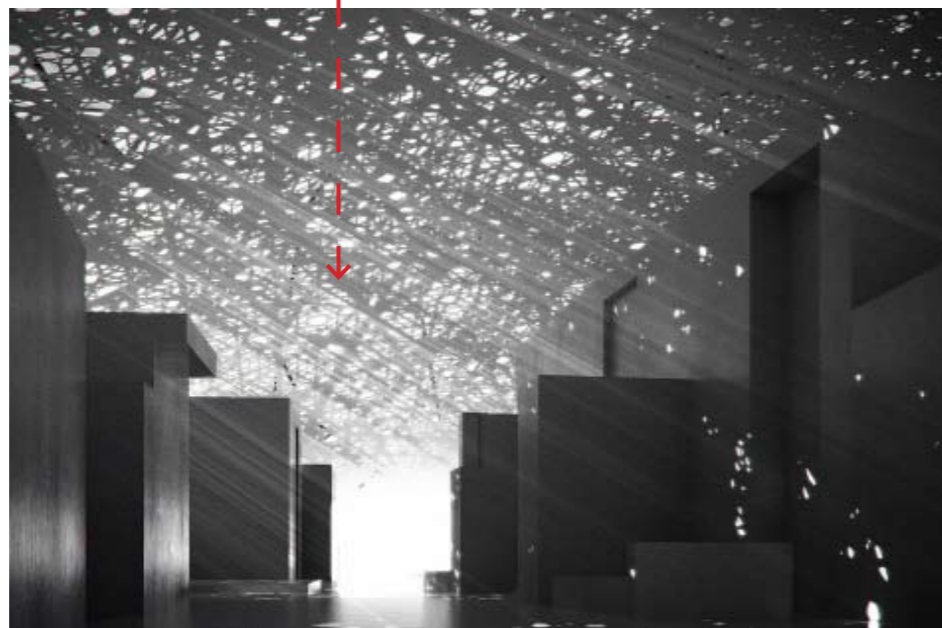

59

Possible light quality due to lace skin

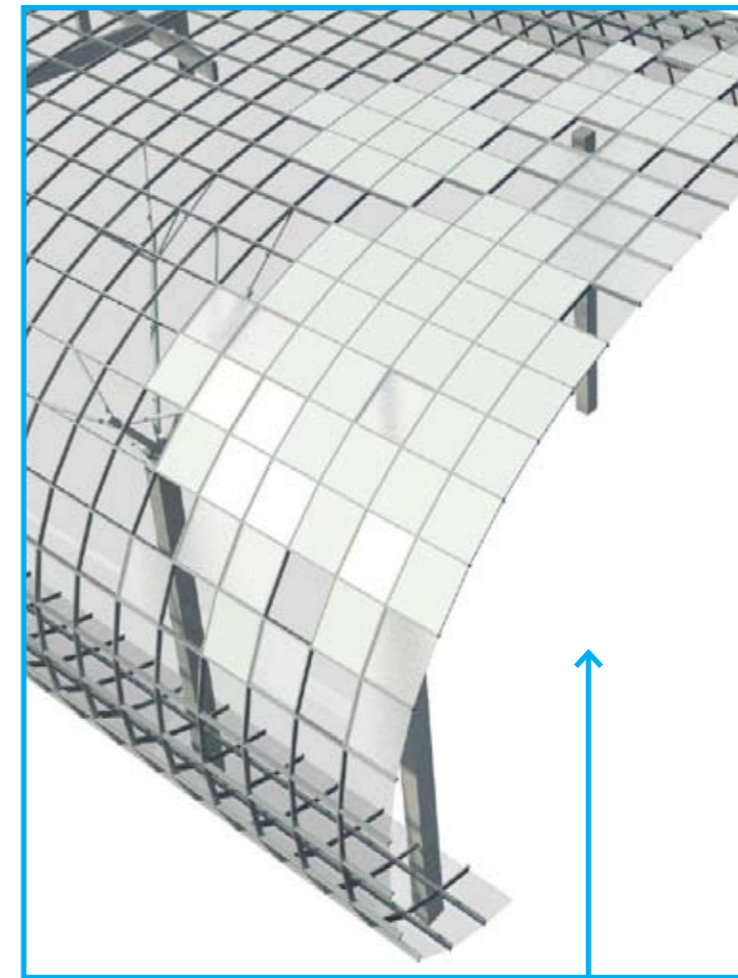

RESULTANT LACE SKIN

Lace
4 panels in-fill system:
(a) Lattice
(b) Glass
(c) Translucent Glass
(d) Opaque



(a)
lattice

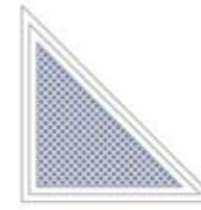

(b)
double glazing
with lattice print

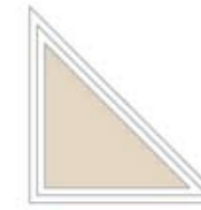

(c)
translucent glass



(b)
solid panel



INTERIOR VIEW OF LACE SKIN

design

A thin skin (1) was envisioned to encapsulate the entire building. (1) With a uniform mesh of regular sized members. It is based on the process followed during the design of Zlote Tarasy. Arup engineers attempted to solve a similar problem which "proved extraordinarily difficult, and was achieved only through Arup fine-tuning the mesh design and its supports". (Arup Journal, 2008: 42) The mesh for my design will be clad with a variety of panels. Ranging from solid to transparent, expressing the building as a unique entity. The arrangement of the panels could deliberately create differentiating climatic conditions inside for specific needs like passive ventilation.

Colour is very important: the building skin will be clad with 4 distinct triangular panels. The structural elements will be powder coated white, and aluminium anodizing will also be white - 15 microns thick. Conceptually this system will communicate the spatial qualities, from opaque to clear panels.

technical

The end result is a continuous triangulated grid of steel rectangular hollow section, (RHS) of constant size, 150 mm deep by 100 mm wide, with wall thicknesses probably in the range of 5mm-15mm depending on the forces in the members. This will be stressed with a finite element grid analysis.

experiences based on number and geometry. → spatial experience.
Rhythm in Time NB p 19

Harmonic Order p 89

- INTENT of university -
- INSTRUMENTALIZING RESPONSIBILITY.
- Learning Jargon.
- specific field.

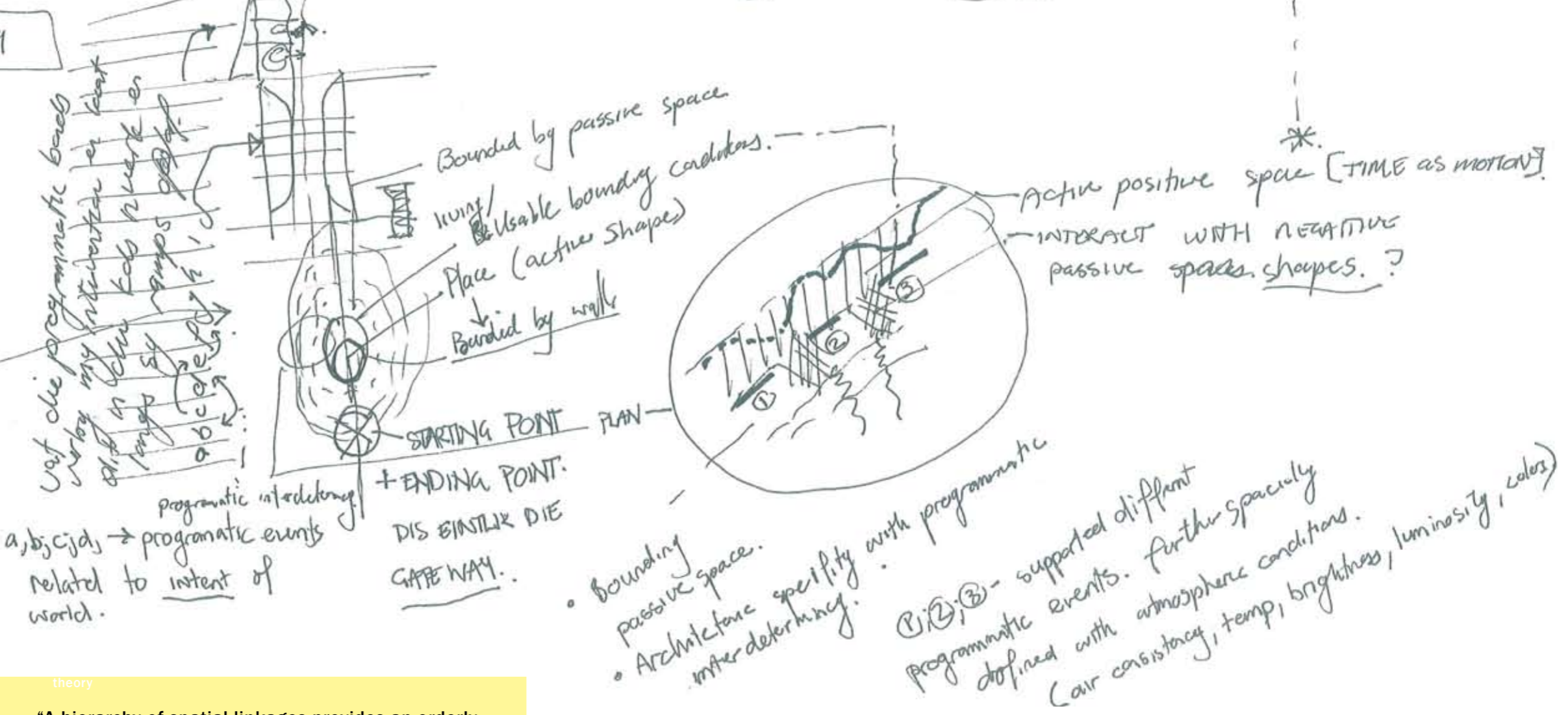

“Decosterd and Rahm use atmospheric conditions as building materials. Air consistency, temperature, brightness, luminosity, colour. These are the physical variables that define the spatial and functional organization of their controlled environments.” (Verb. 2005: 128) These atmospheric conditions will further enhance the linear succession and contribute to the definition of the programmatic bands, which is expressed as a ramp with folly like pods arranged in a sequential manner.

The pods “combines architectural specificity with programmatic inter-determinacy.” (Koolhaas, R. 1997: 921) These programmatic bands specific to this design will communicate the intent of the world you are moving to.

“A hierarchy of spatial linkages provides an orderly system that allows for both consistency and change”. “In conception of ‘place’ a central space is created by enveloping it in walls. These boundary conditions may in time become ‘usable’ or ‘living’ wall... The city, as previously mentioned, is viewed as an active shape bounded by passive space. Moving within the three dimensional mass of the city, active, positive spaces interact with negative passive shapes.” (Ardalan, N. 1973: 17) The auditorium is the central space bound by circulation. From the beginning these boundary conditions are usable as spatial experiences.

Time / Form simultaneity
“Space contains both active and passive possibilities. It is in relation to the active aspects of space that the idea of time as motion occurs. Concurrently, the passive possibilities are manifested in matter of form which is directly a product of this movement. Thus the locus of time and form is space, which simultaneously manifests its active and passive aspects through motion.” (Ardalan, N. 1973: 19) Movement is also an important aspect to experience the building.

“The project marries the desire for initial effect with the functionalist notion of the exterior as a reflection of the interior program, deepening the skin to allow program itself to become ornament”. (Verb. 2005: 64) This notion is applied in the Monster to the border conditions surrounding the auditorium.

A path is continuous, linear succession. Norberg-Shultz (1974: 22) states “Primarily it is a direction to be followed towards a goal, but during the journey events happen and the path is also experienced as having a character of its own.”

This diagram shows all these elements just in terms of spatial experience, as a result liminality is experienced spatially.

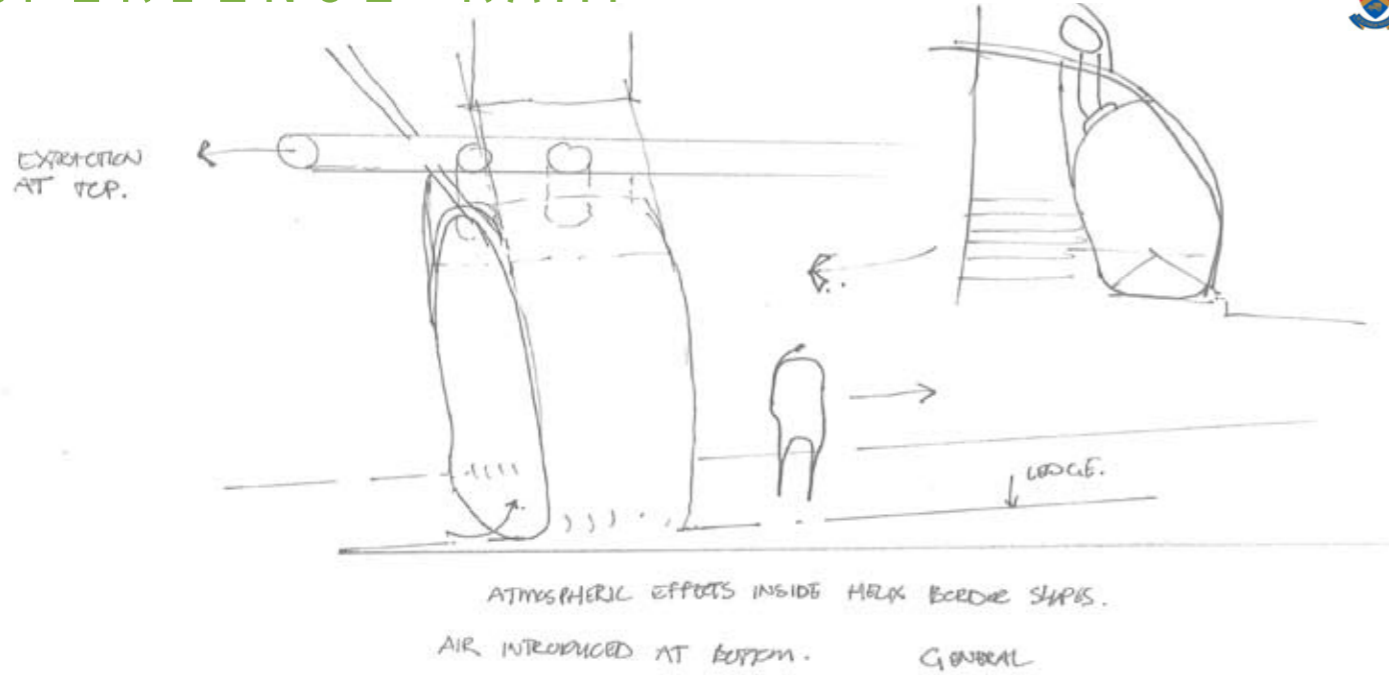

EXPERIENCE POD

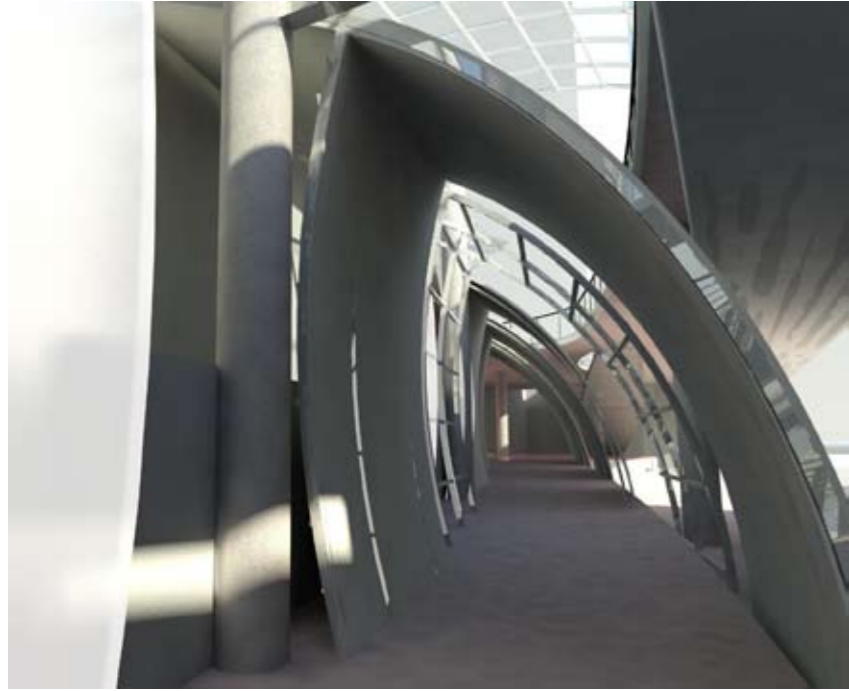

RENDERING OF EXPERIENCE RAMP

design

The experience pods are derived from the NOX H2O Expo. These pods are the border conditions around the Auditorium. They are situated on a ramp.

These pods are equipped with projectors and screens which communicate the intent of the world you are going into.

A further element which is used to define these spaces is atmospheric effects, in the same way Decosted and Rahm suggested using atmospheric effects as building materials.

Each pod would get a specific atmospheric effect to define it as a space. The experience ramp creates a sequential contextual based path similar to Norberg-Schultz's notion of path. All the pods would be designed specifically but with flexibility to change its content, similar to a folly. This relates to Tschumi's Parc de la Villette and its programmatic bands. These programmatic bands are essential in determining the pod sizes.

They are superimposed perpendicular to the linear movement. This in turn is related to positive space systems in which "a hierarchy of spatial linkages provides an orderly system that allows for both consistency and change". (Ardalan, N. 1973: 17) This ramp forms a procession, the procession leads up to the most female part of the space: the interactive intelligent ADA influenced space. This space is where the person-environment relation is realized to its fullest. From this space there is the greatest variety of choice to the user in terms of paths into university grounds.

technical

Acoustic absorbing materials dealing with the noise of Lynwood Road.

design

Floor finish

The floor finish further contributes to the spacial experience. The planning was influenced by the progression from outside to inside.

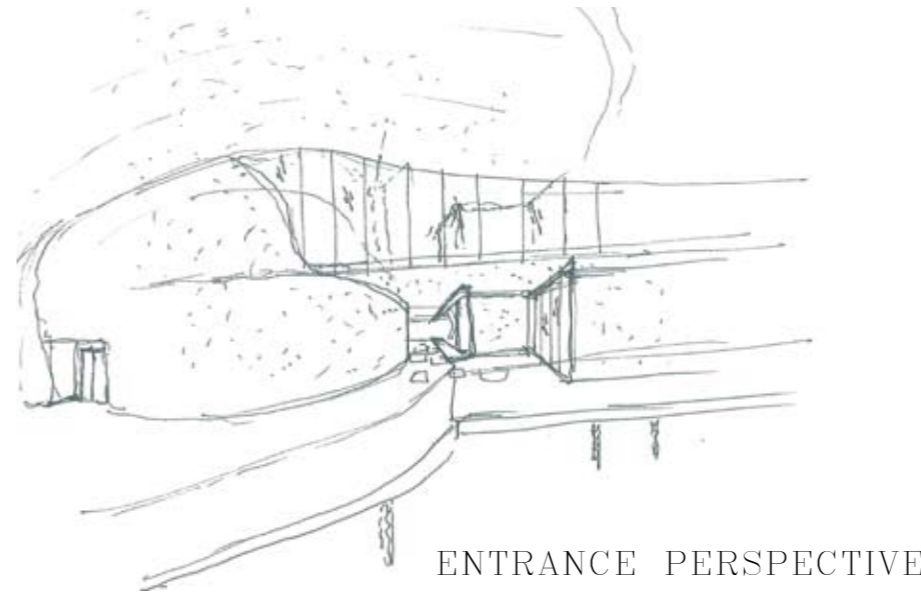

ENTRANCE PERSPECTIVE

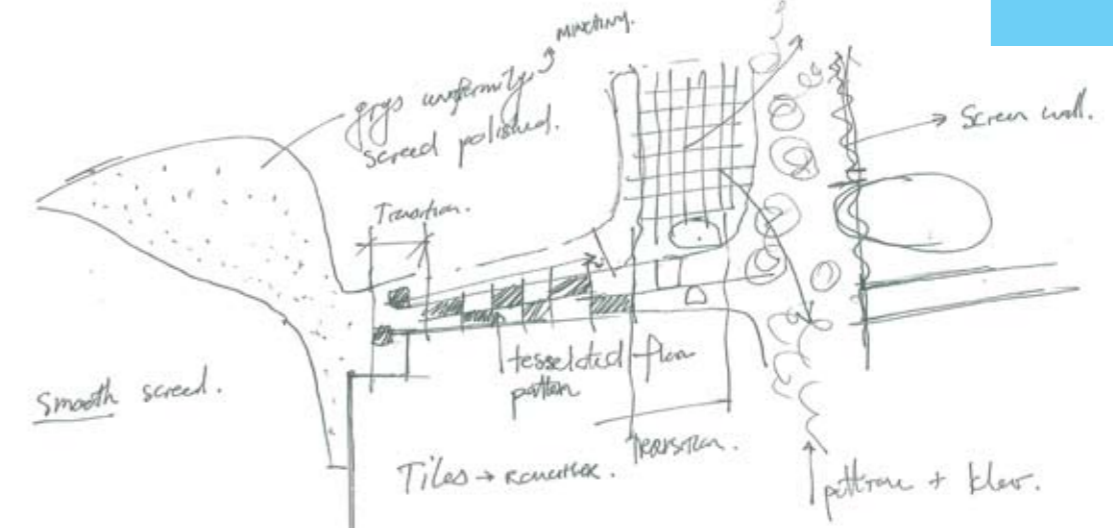

FLOOR FINISH DIAGRAM

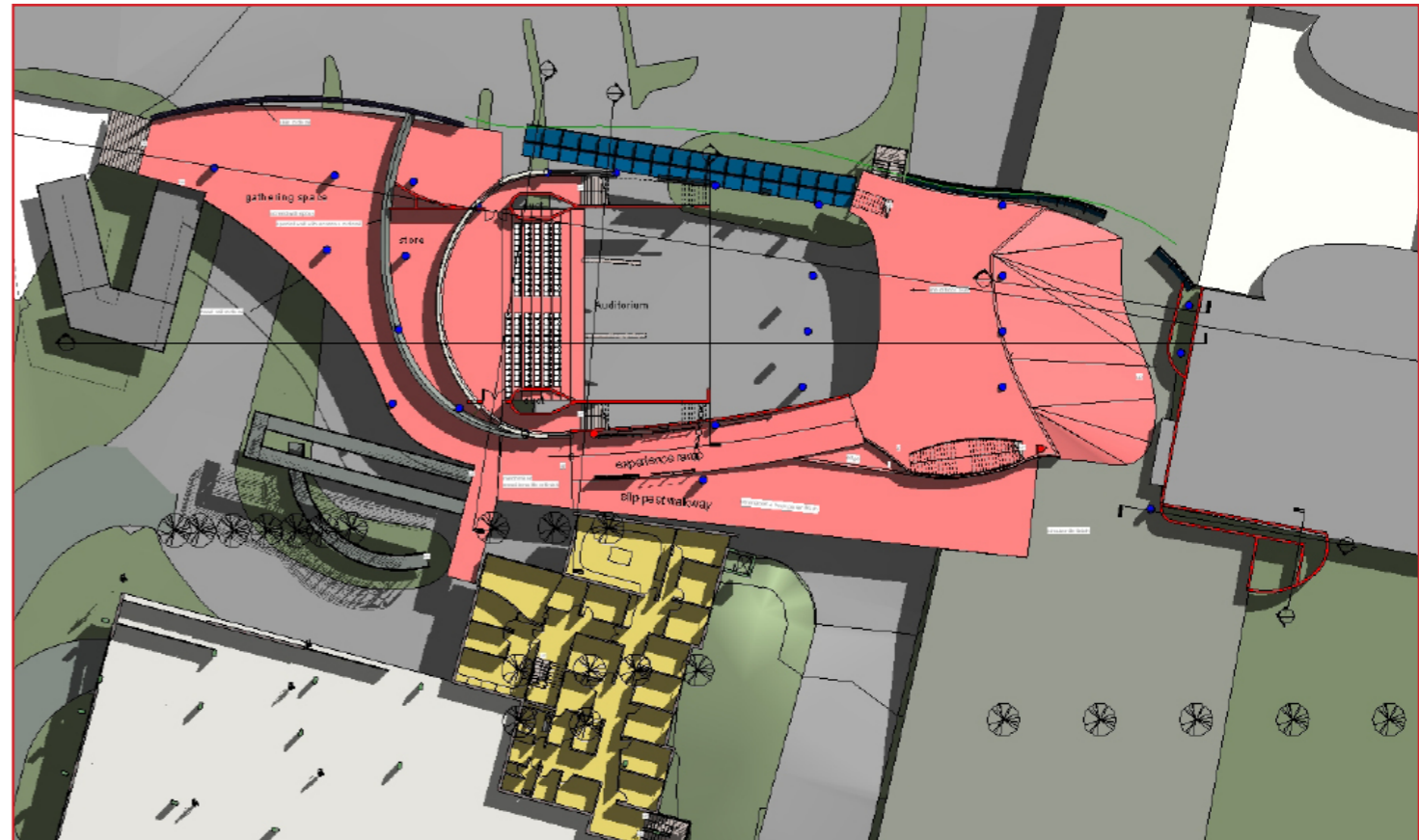

UPPER GROUND FLOOR

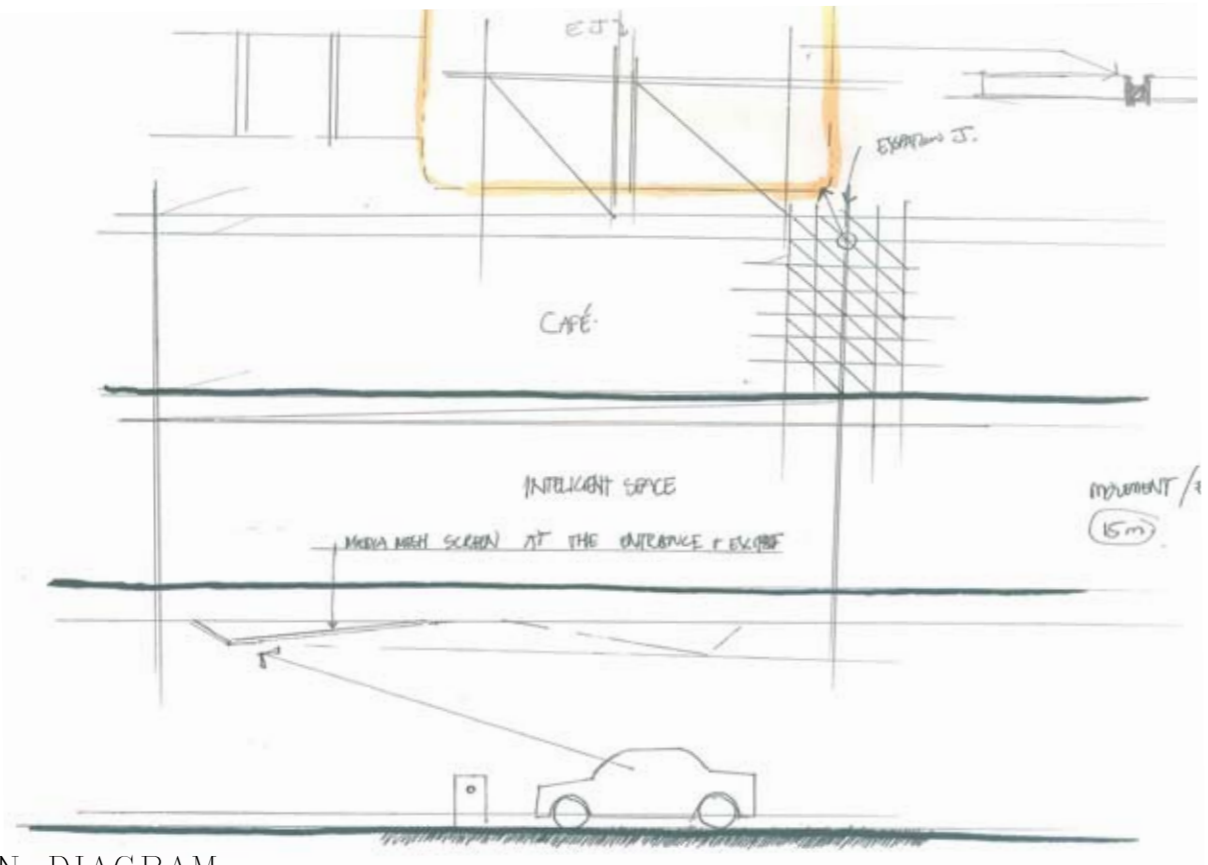

PLAN DIAGRAM

design

The notion explored earlier of making the building transparent from underneath as well, is reiterated, by suggesting overhead LED screens where the cars enter and exit into the university grounds.

Similar to the experience ramp which communicates the intent of the realm you are travelling to, these screens will also communicate the intent to the people in the vehicles.

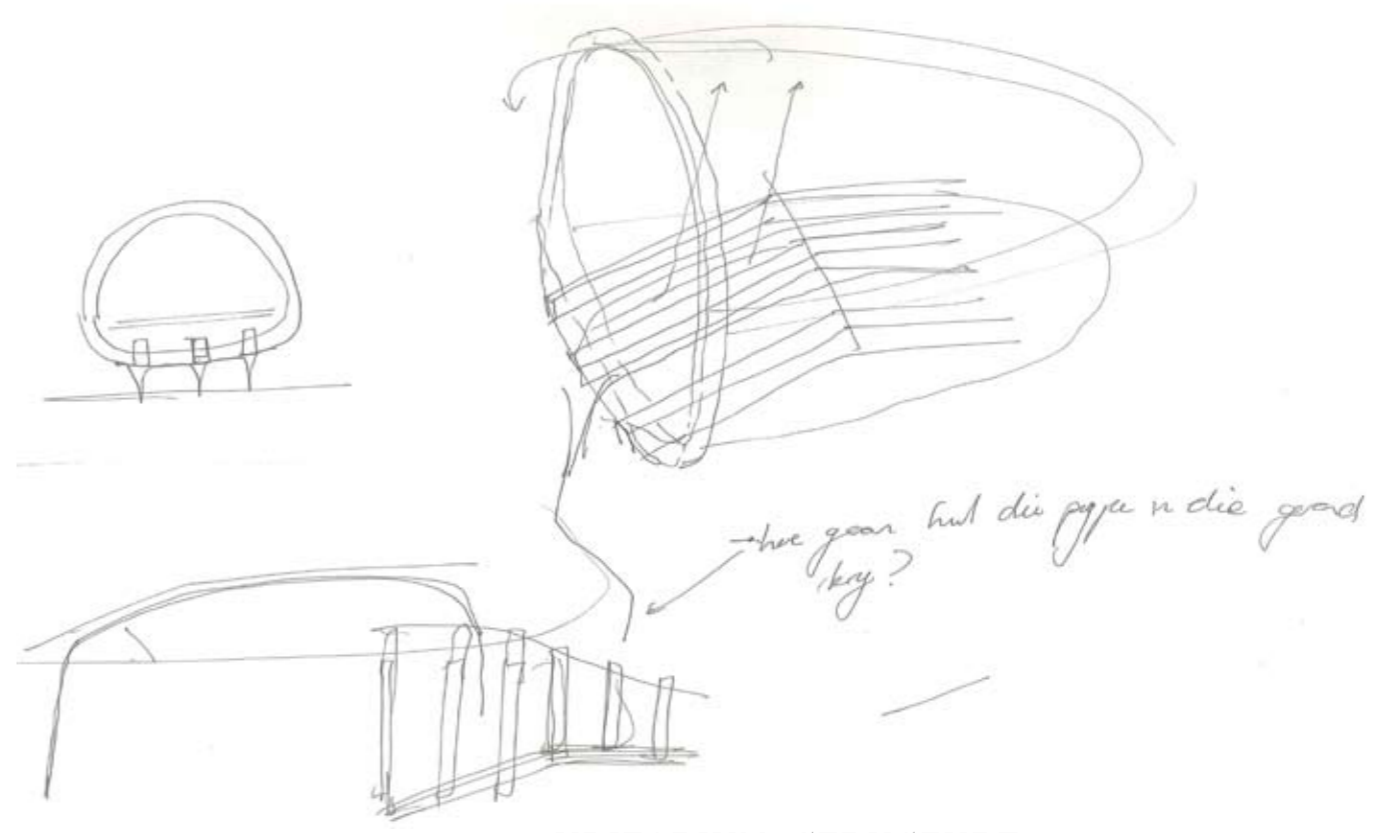

AUDITORIUM STRUCTURE

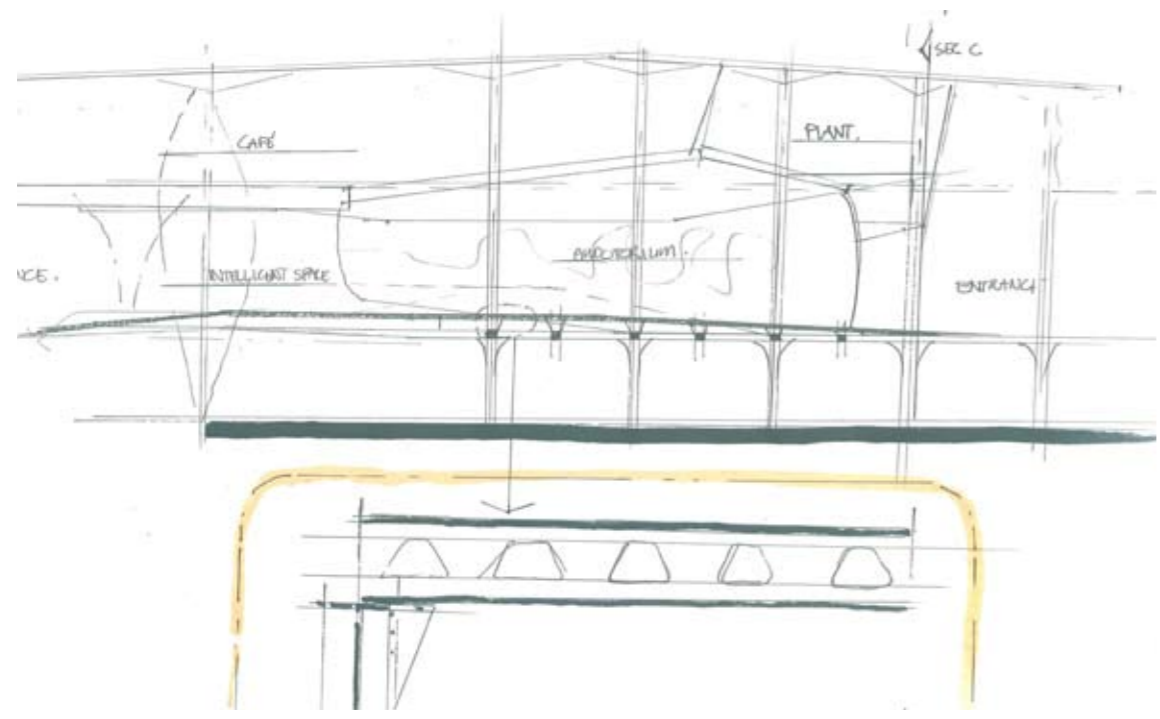

AUDITORIUM WITH SURROUNDING SPACES

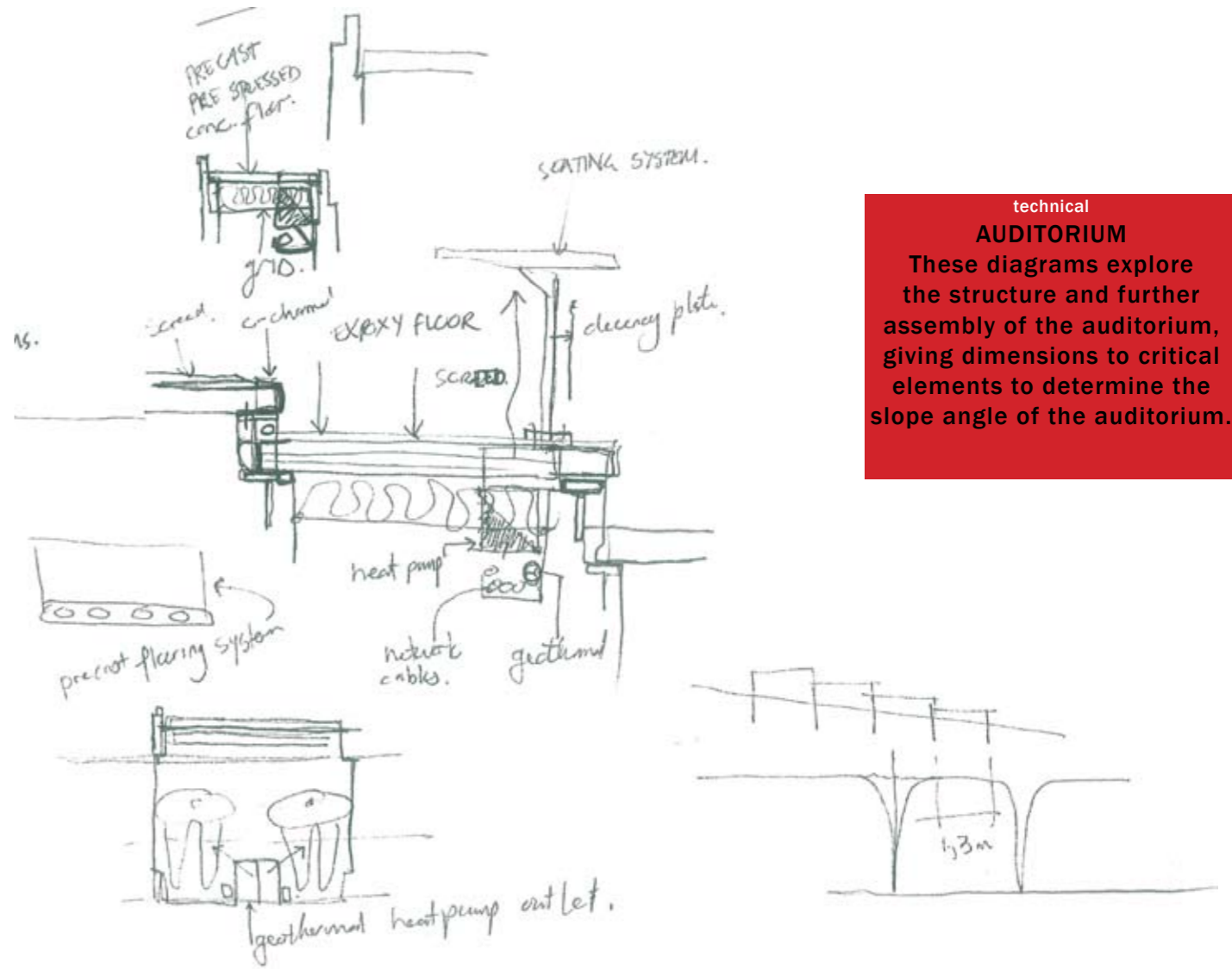

technical

AUDITORIUM

These diagrams explore the structure and further assembly of the auditorium, giving dimensions to critical elements to determine the slope angle of the auditorium.

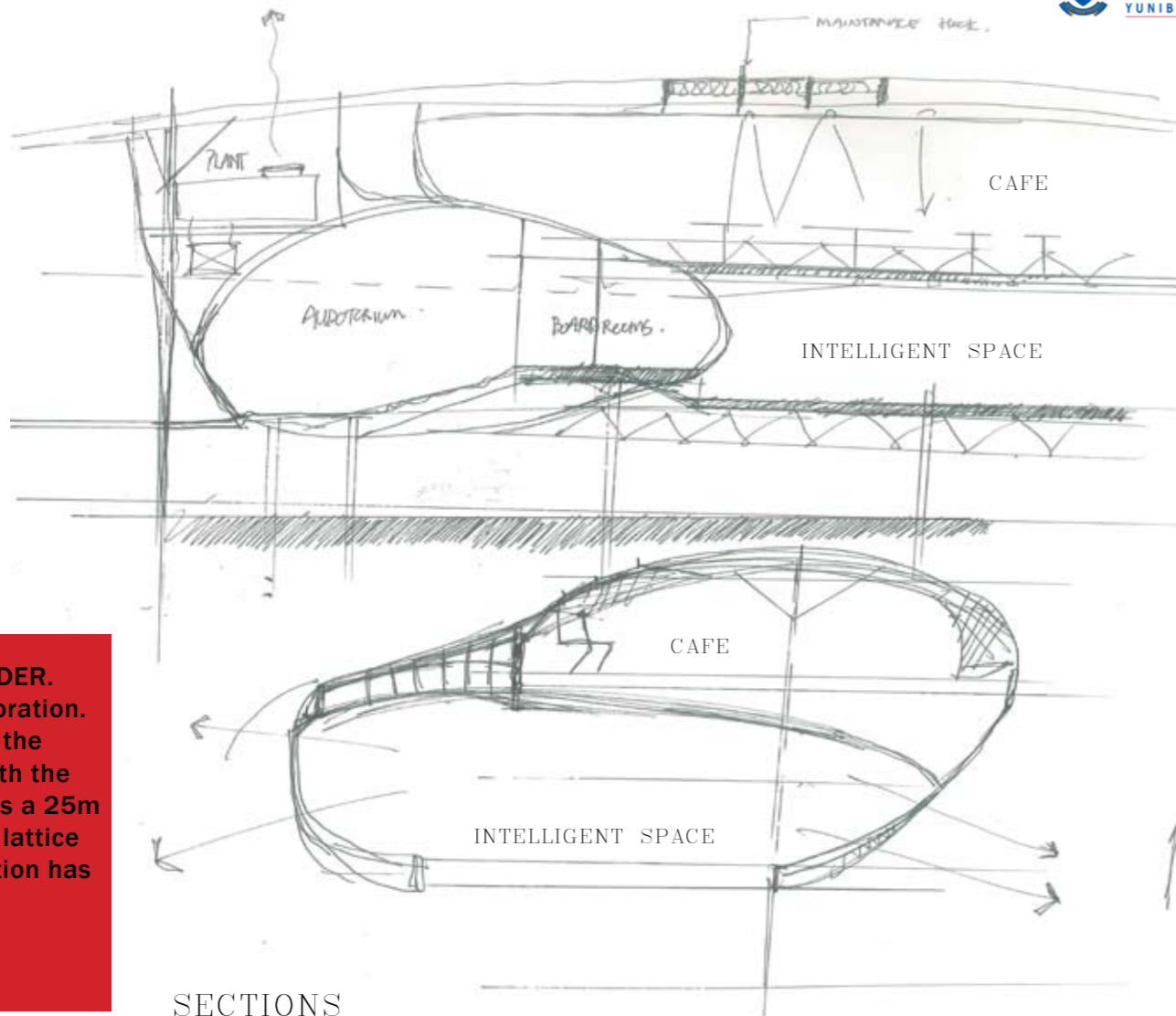

technical
LATTICE GIRDER.
Structural exploration. Connecting the auditorium with the existing HSB. It is a 25m span, thus the lattice girder construction has chosen.

SECTIONS

CAFE SUPPORTS

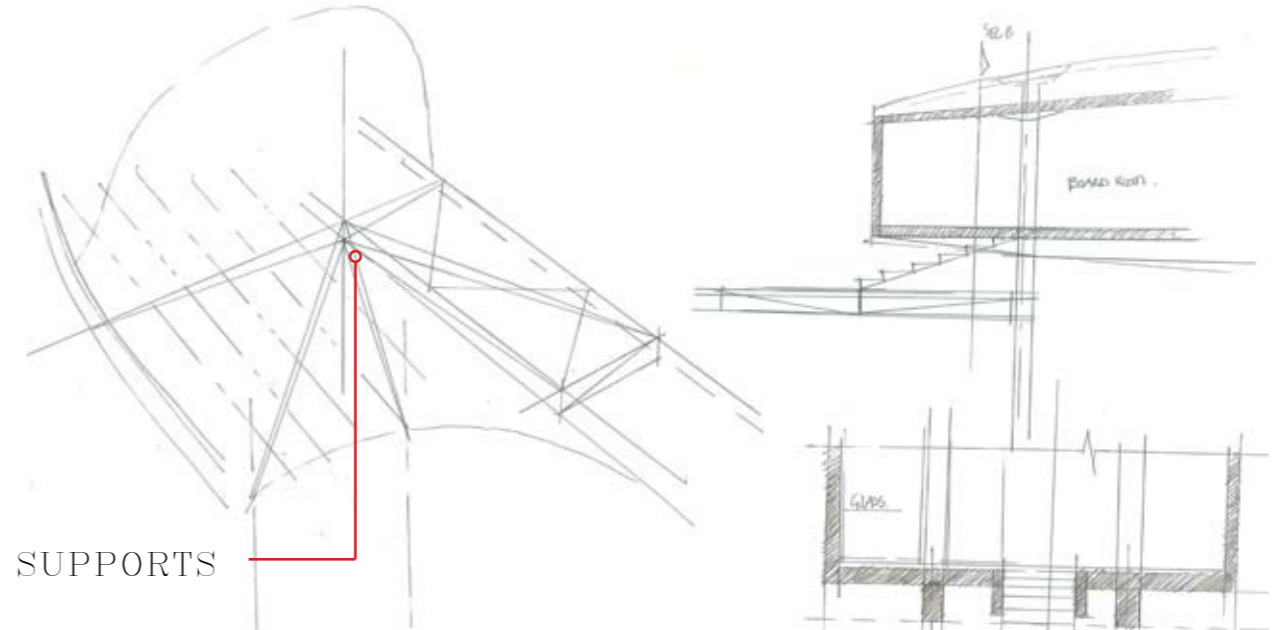

technical
Radial structural concept.
The first floor is still touching the skin. Later the section will also interlock the spaces between the ground and first floors like the Villa at Carthage by Le Corbusier.

SECTIONS THROUGH BOARDROOMS

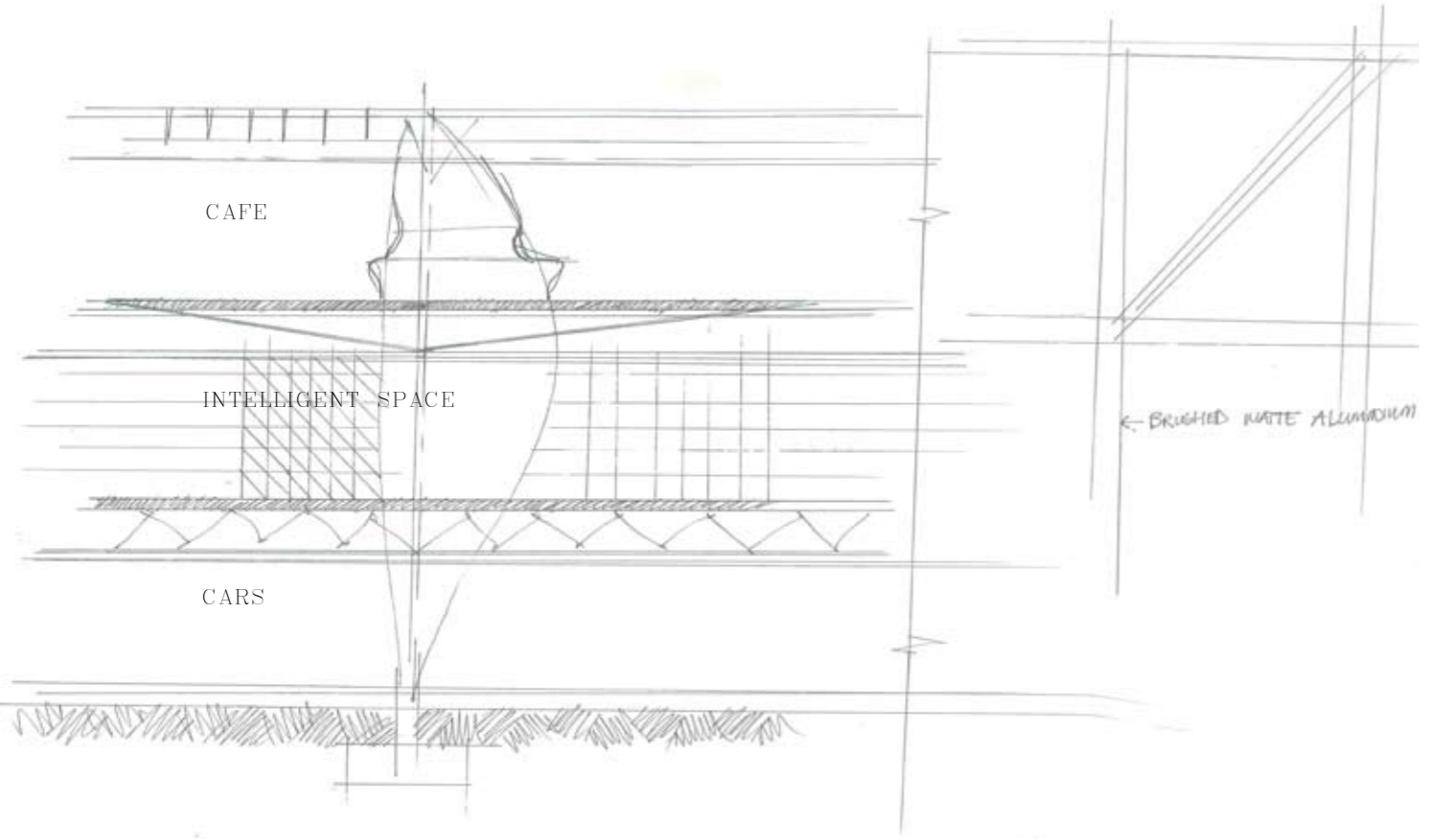

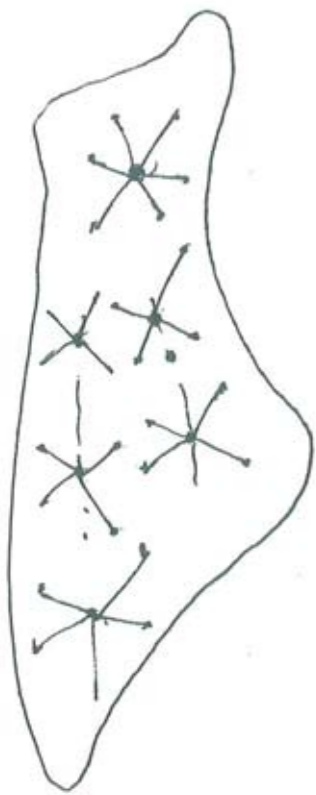

ROOF DIAGRAM



BASIC COLUMN GRID

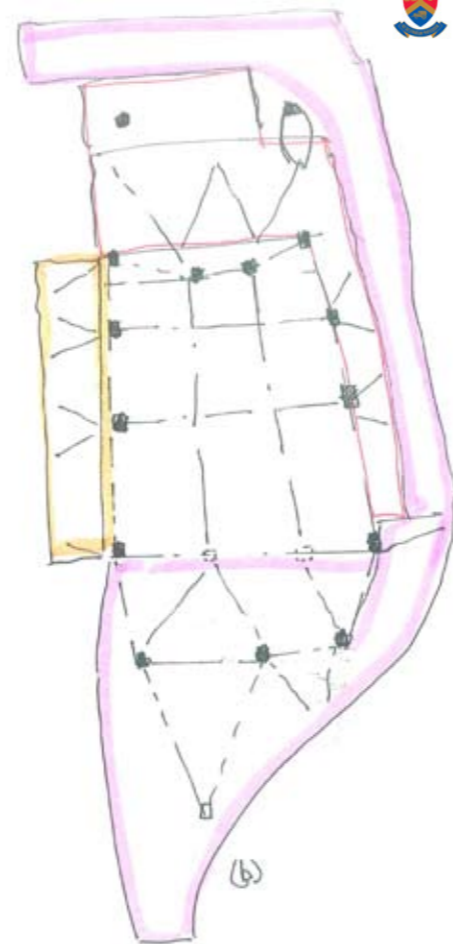

COLUMN GRID WITH FLOORS

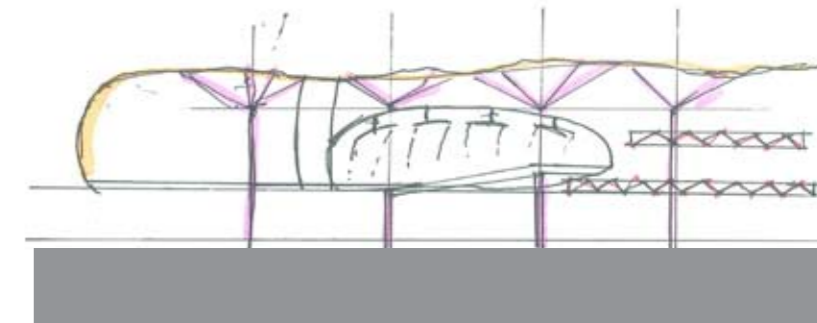
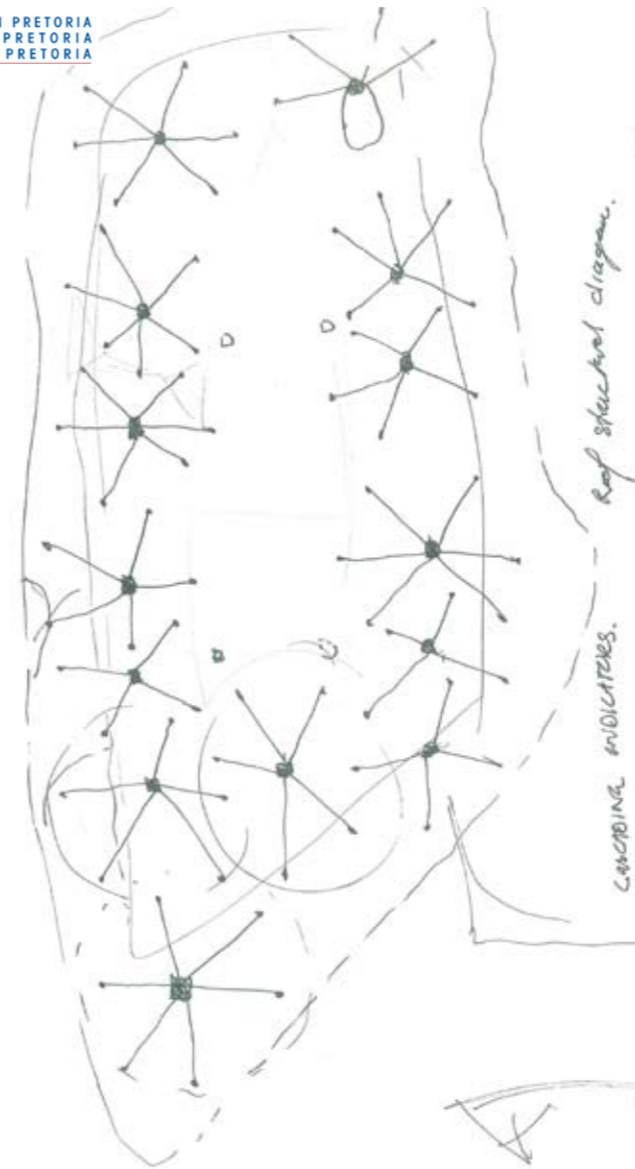

COLUMN GRID WITH TREE SUPPORTS

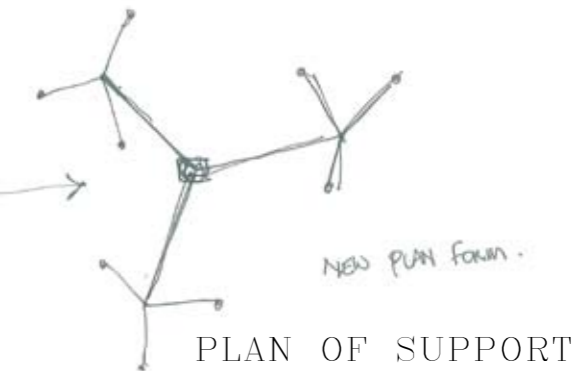

PLAN OF SUPPORT

technical
STRUCTURAL DIAGRAMS SHOWING THE DIFFERENT LAYERS OF THE STRUCTURAL ARRANGEMENT ON PLAN.



60

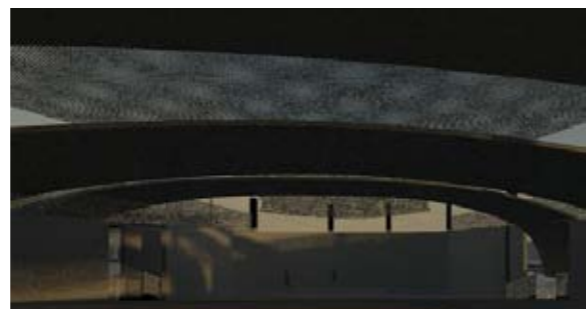

AN EARLIER RENDERING EXPLORING ACHIEVABLE LIGHT QUALITIES IN THE AUDITORIUM.

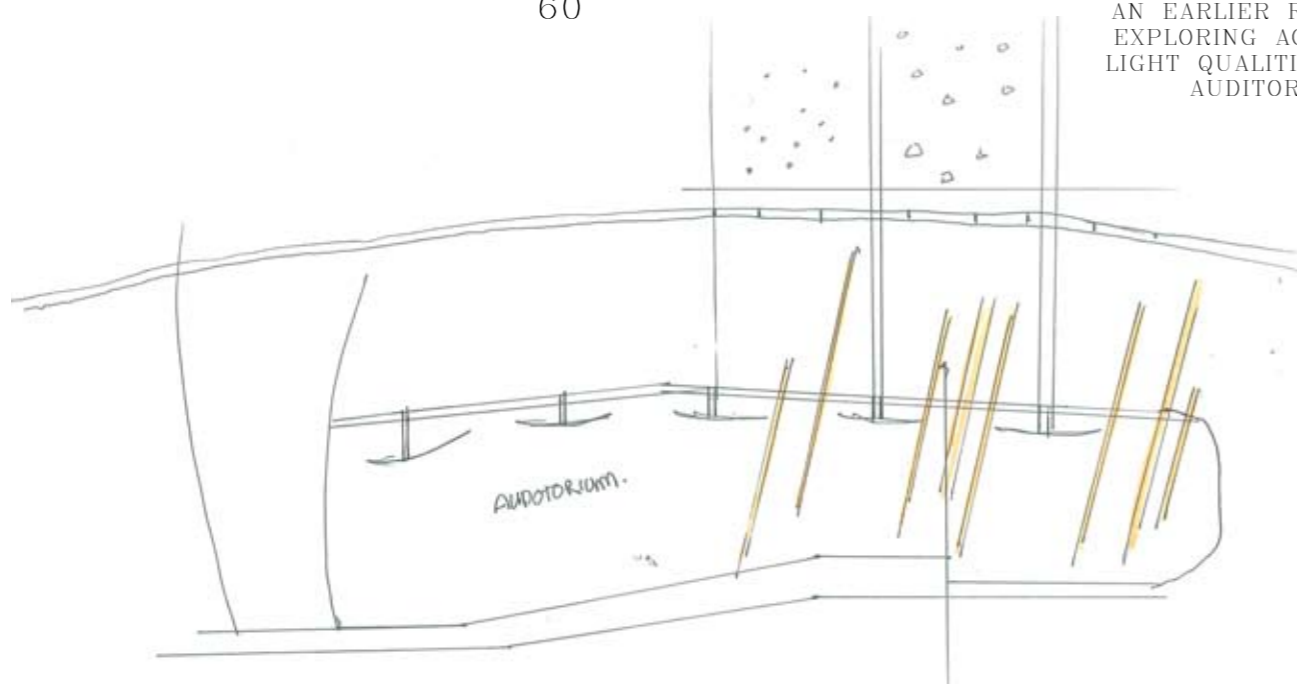

COLUMN GRID WITH TREE SUPPORTS

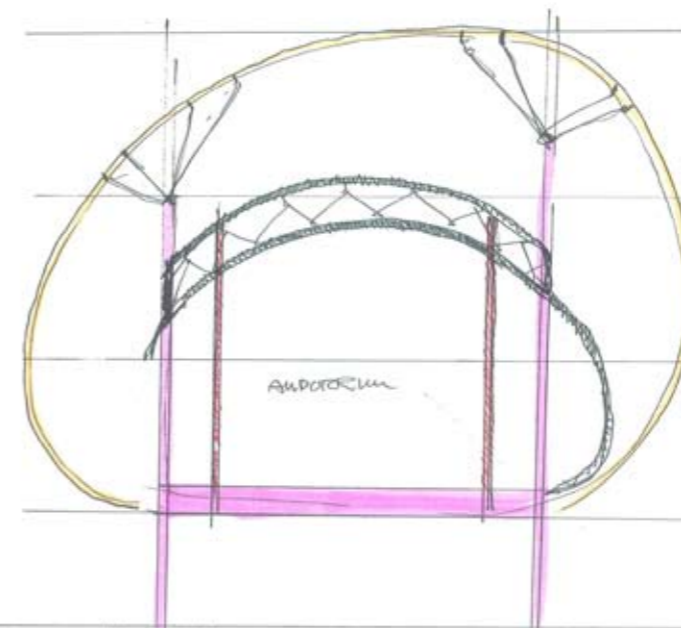

COLUMN GRID WITH TREE SUPPORTS



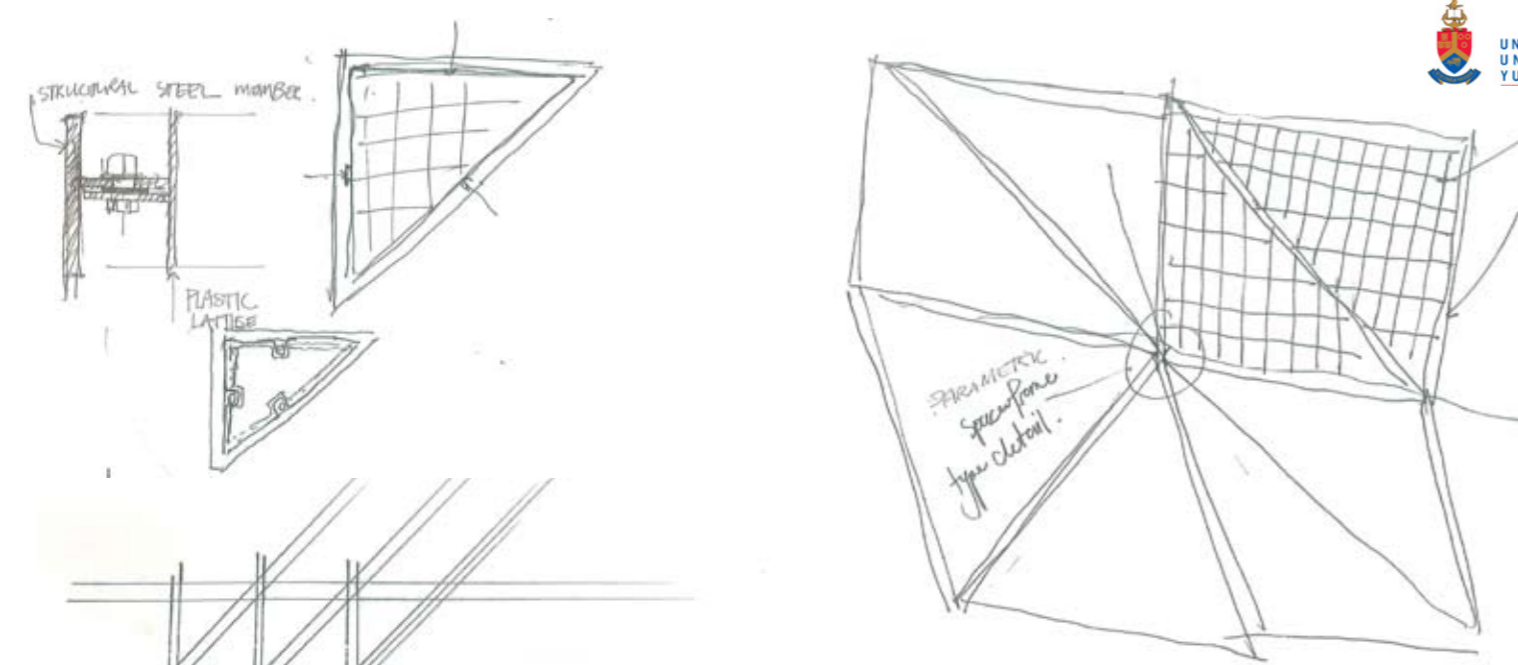

THE SIX PLANES INTERSECT AT ONE POINT.

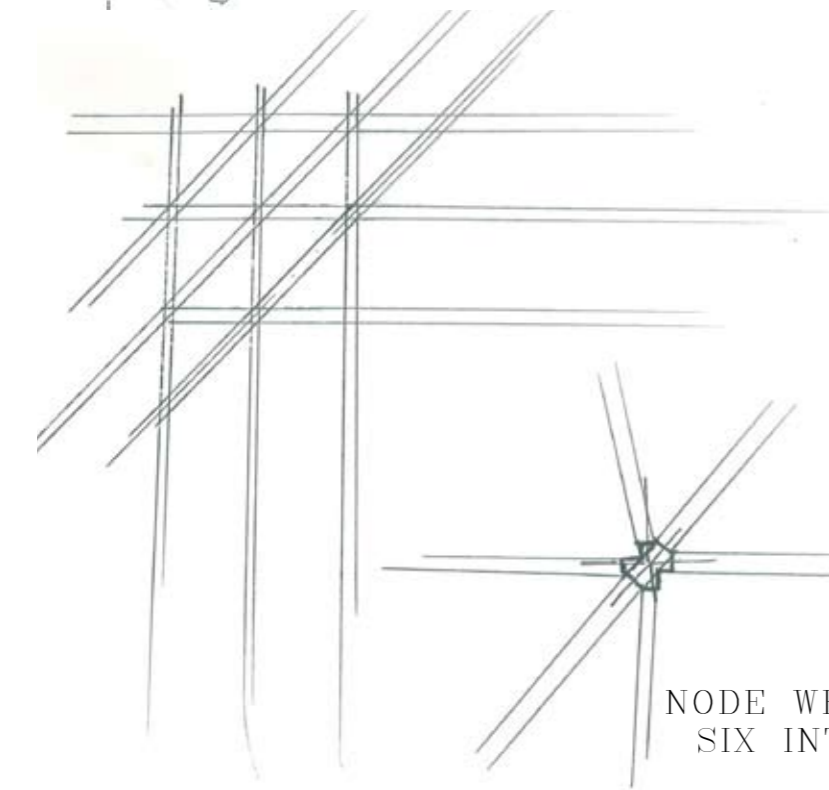

NODE WHERE THE SIX INTERSECT

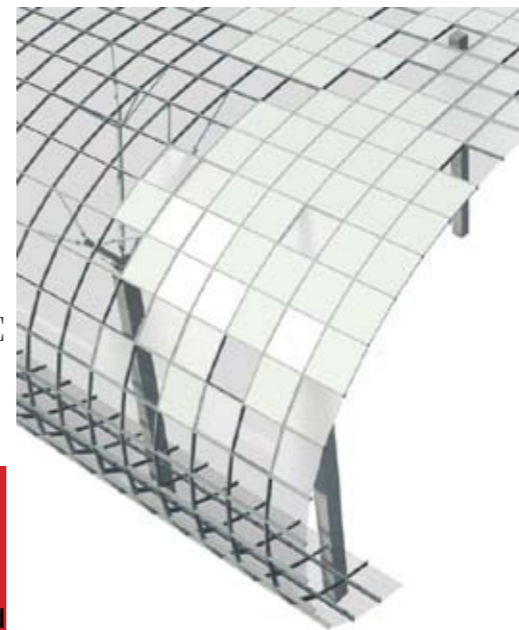

WATERPROOFING DETAIL

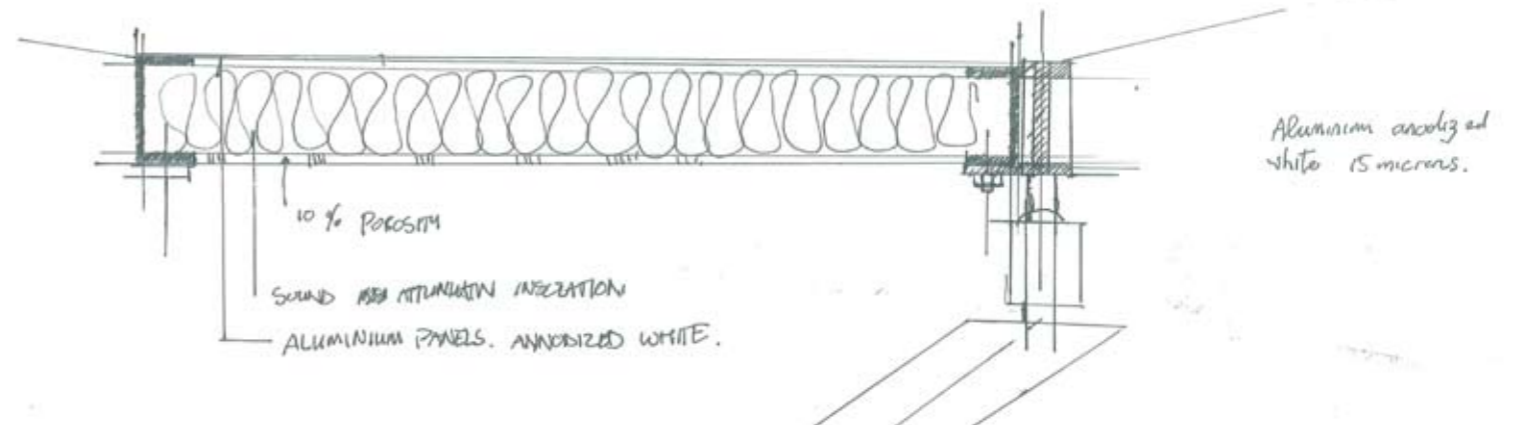
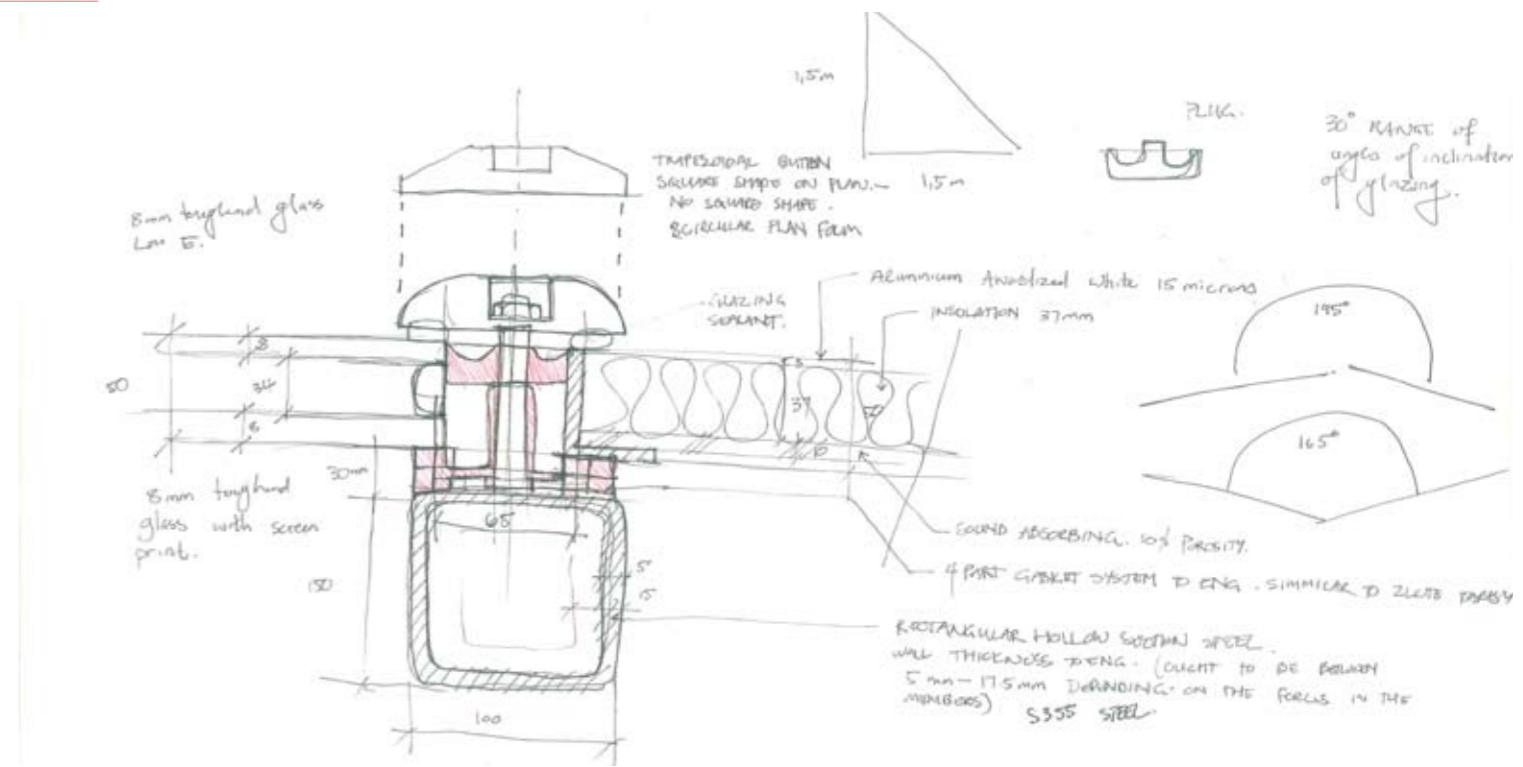

SOLID PANEL WITH INSULATION AND SOUND ABSORBING MATERIAL

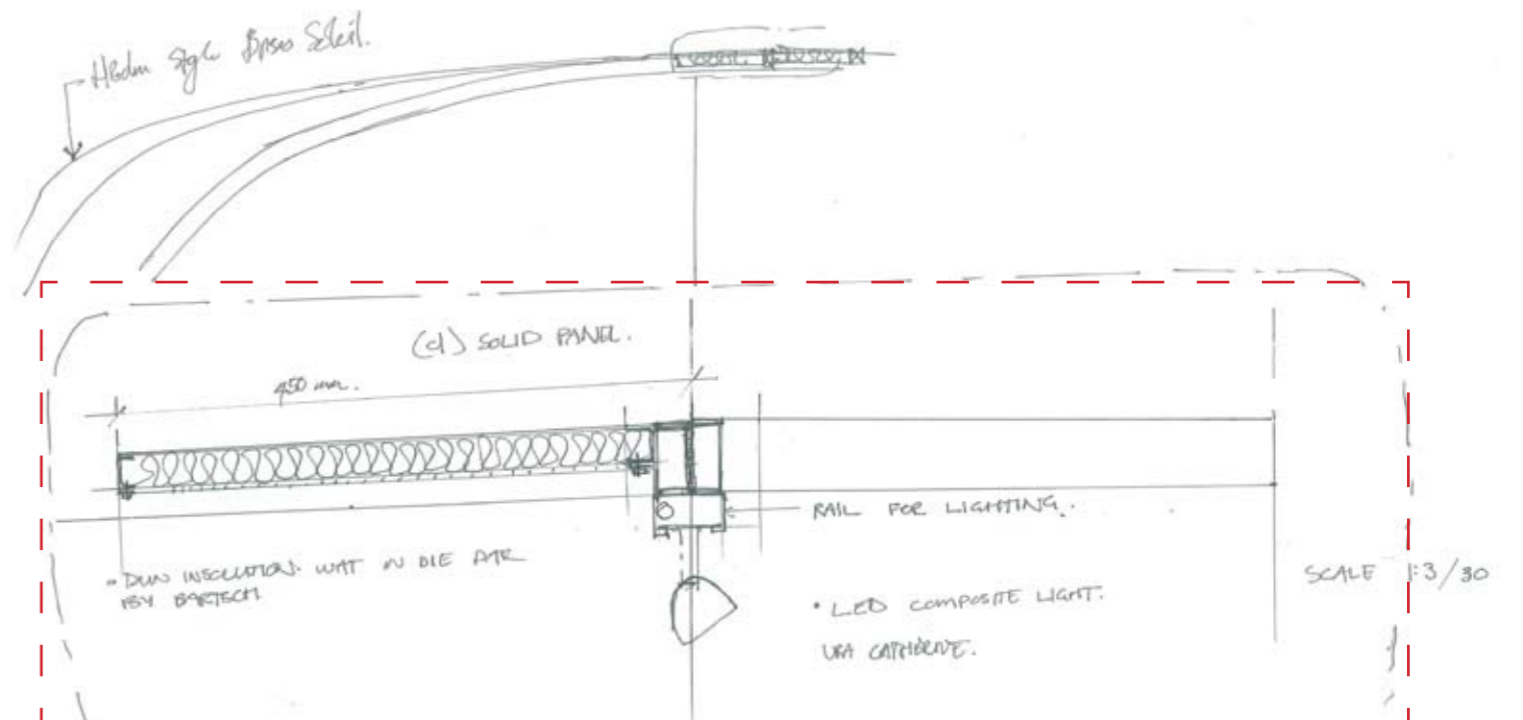

ARTIFICIAL LIGHTING, CONNECTED TO SKIN

technical
The exploration of the skin featuring 4 panels to facilitate the ethereality of the building. "The geometry was subtly shifted so that at each node, the six planes of the underside of the glazing coincided at a single point." (Arup journal. 2008: 43) This is done to eliminate the problem of unwanted steps between the members and panels at the nodes, caused by making a soft free-form with hard materials.

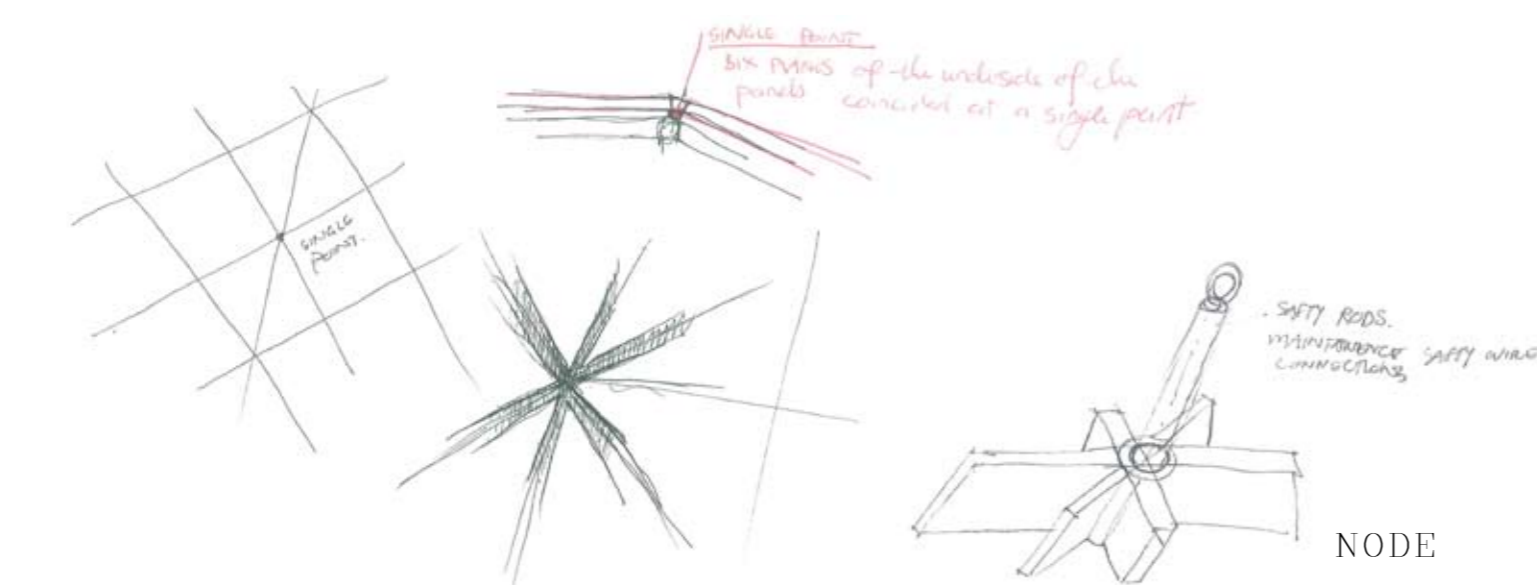

NODE

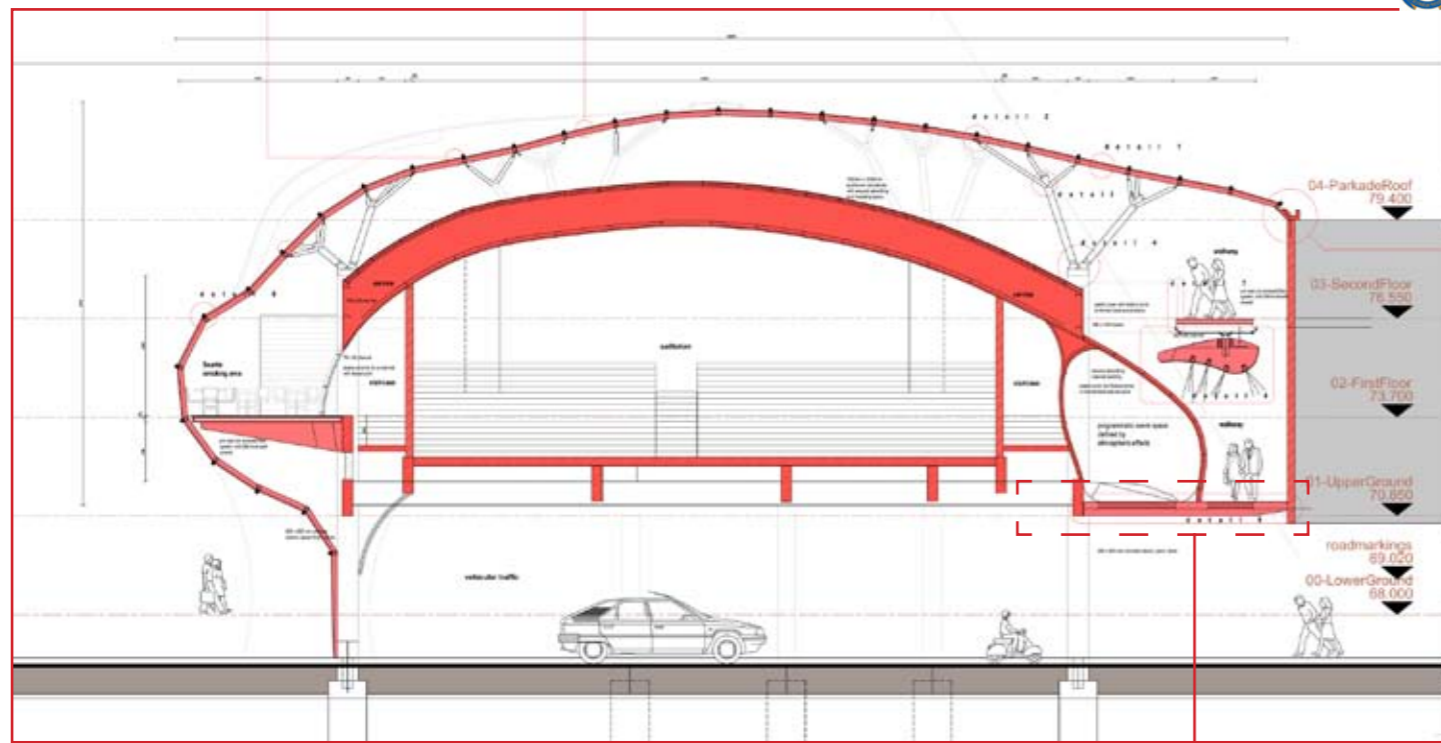

SECTION A-A

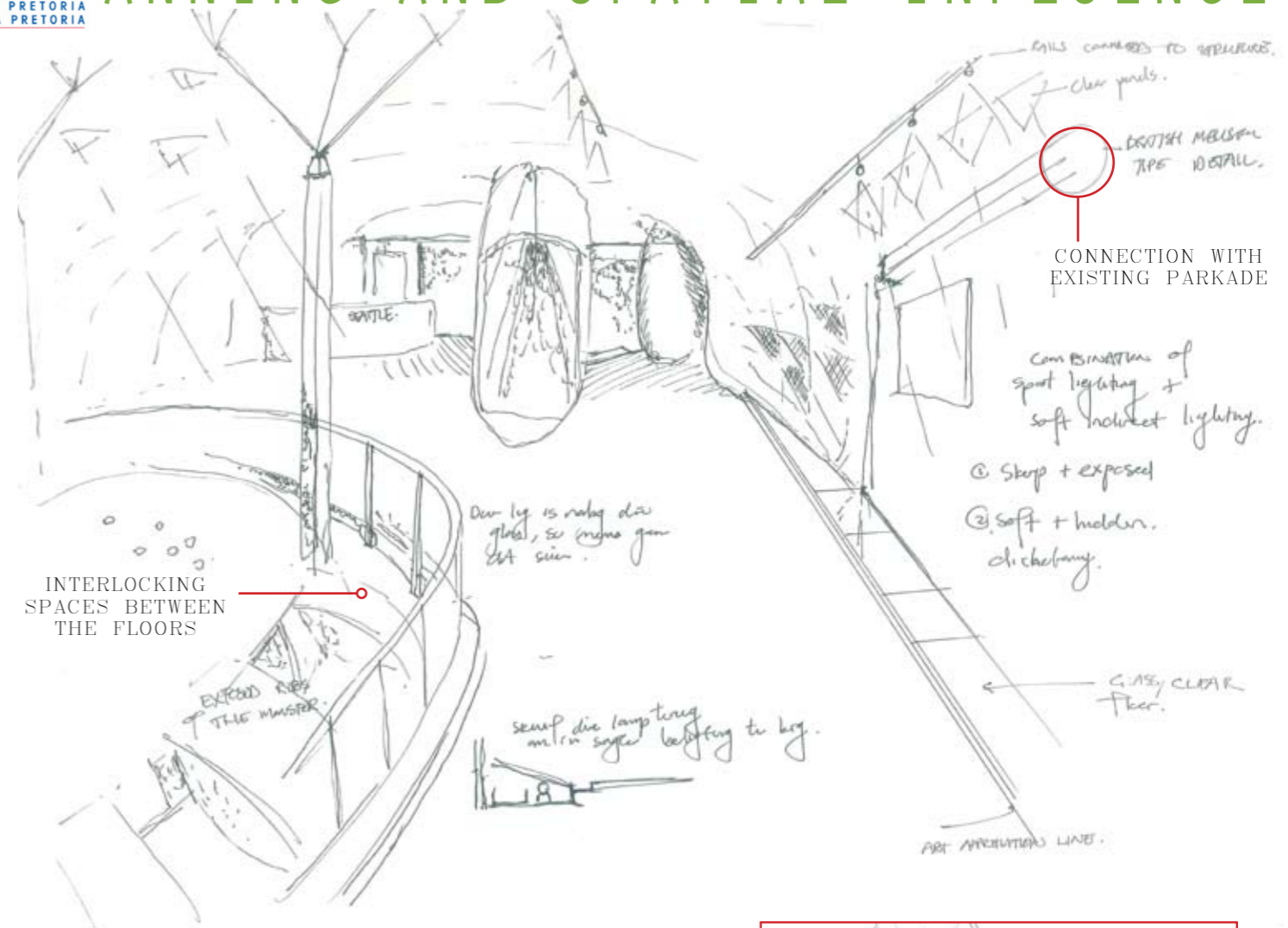
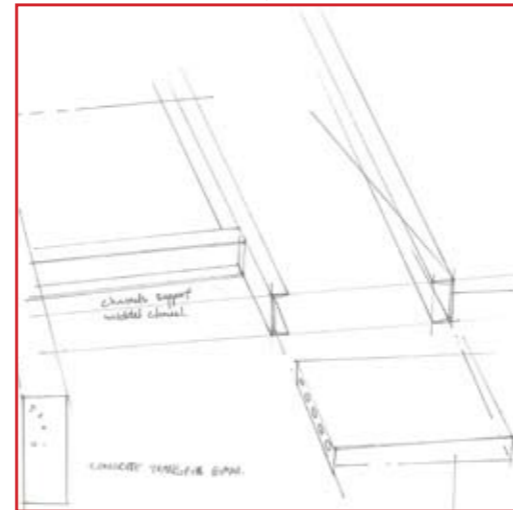

technical
SKIN CONNECTING TO PARKADE BUILDING.

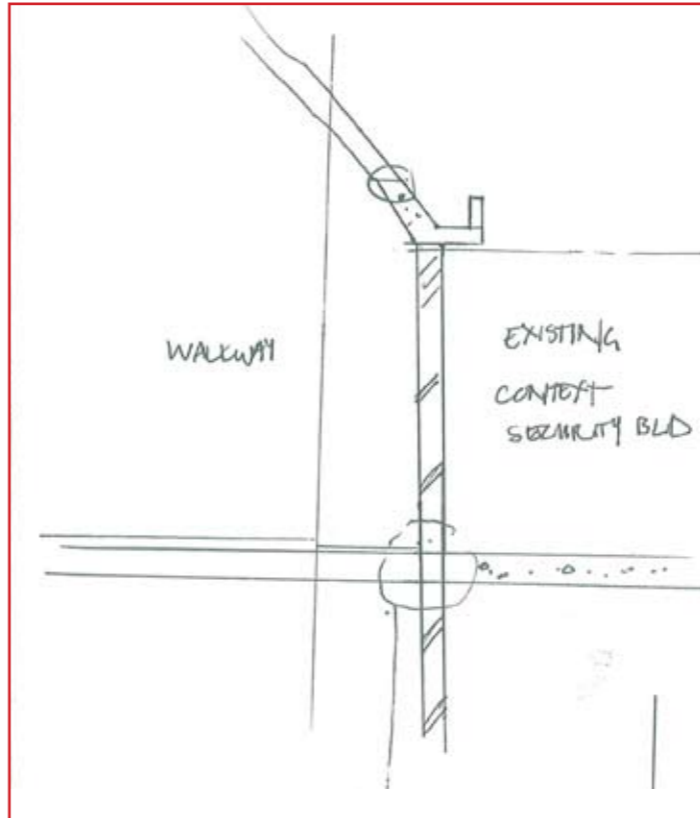

SKIN DETAIL

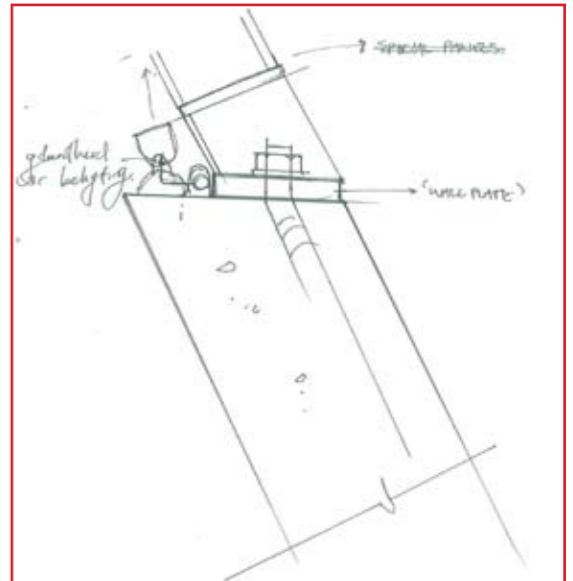
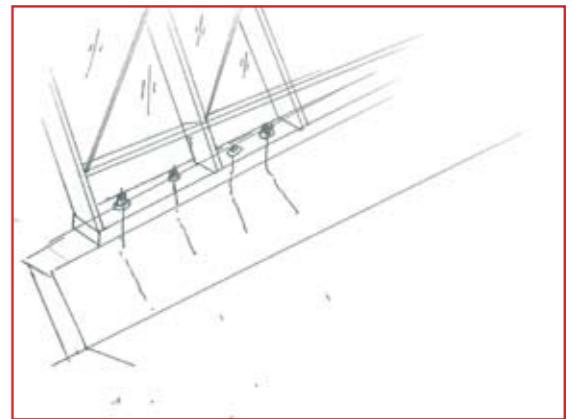

technical

From the touchstone which suggests a seamless transition from opaque to ethereal, from inhabitation to open-conceptual possibilities, comes the need to assign programs to these spaces. The auditorium is a program taken from earlier exploration at Stage 2 where I investigated spaces that transform to accommodate different programs. One of the other programs also considered was a conference space. The final design includes both, albeit that they do not shape shift. Boardrooms are connected to the auditorium making it usable as a conference space as well.

The auditorium is the ultimate expression of the 'male' view of space, in the monster. It is built from solid heavy materials. It is functionally specific and adheres to the notion of building object. Further parts relating to this view of space is expressed by inserting solid panels into the skin.

Usually buildings built according to the 'male' view of space would grow out of the earth, and have architectural mass. In the case of the Monster that part is removed from the earth and located in a liminal place, between earth and sky.

Due to the constraints imposed by the lower ground vehicular circulation, a randomised column support system was accepted to anchor the building to the ground. It is this system which allows the auditorium to be lifted off the ground. These columns are substantial concrete columns with a diameter of 600 mm. Further, the auditorium is wrapped in 'female' space, which has an impact on the structural supports.

The heavy columns first support the auditorium, thereafter, break through into the female space to support the skin. Techniques were employed to make this part of the structure transparent. Influenced by the way Toyo Ito designs transparent structures, treelike steel supports are used in an ever decreasing section to connect to the skin above. As a result, the treelike supports seem to be aesthetic rather than structural, thereby contributing to the aesthetic quality and complexity of the space.

technical Handrail.
The handrail is twisted off-axis. Made of a composite material which suggests the interrelationship or fusion between the two materials. The composite material will be an alloy of Aluminium and silicon. It is corrosion resistant and useful in humid environments (wikipedia: Silumin). Thus ideal for a hand rail. This alloy is called Silumin and will give a fresh matt aluminium tactile feel to the hand rail. Thus taking the theory down to the materiality of the building.

technical Handrail.
The in fill panels of the handrail is also a place where the theory is translated into the technical part of the design. These panels range from obscure to clear glass. Therefore relating to the ethereality between two phases.

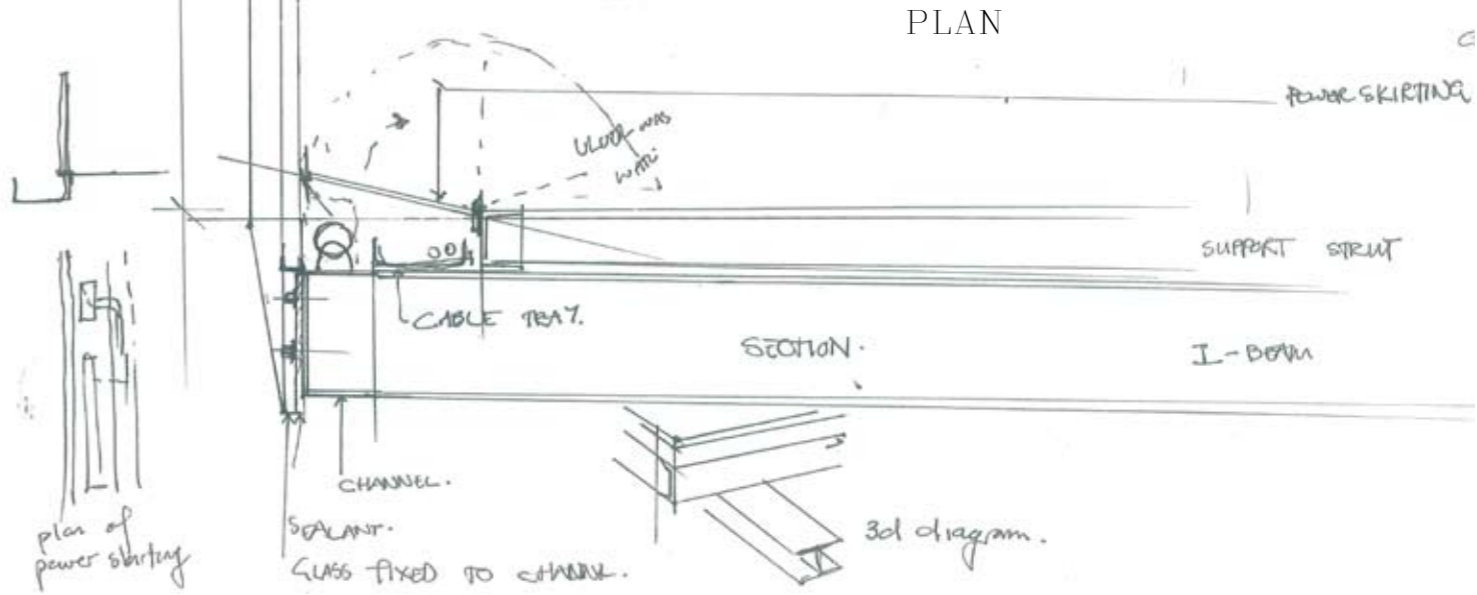
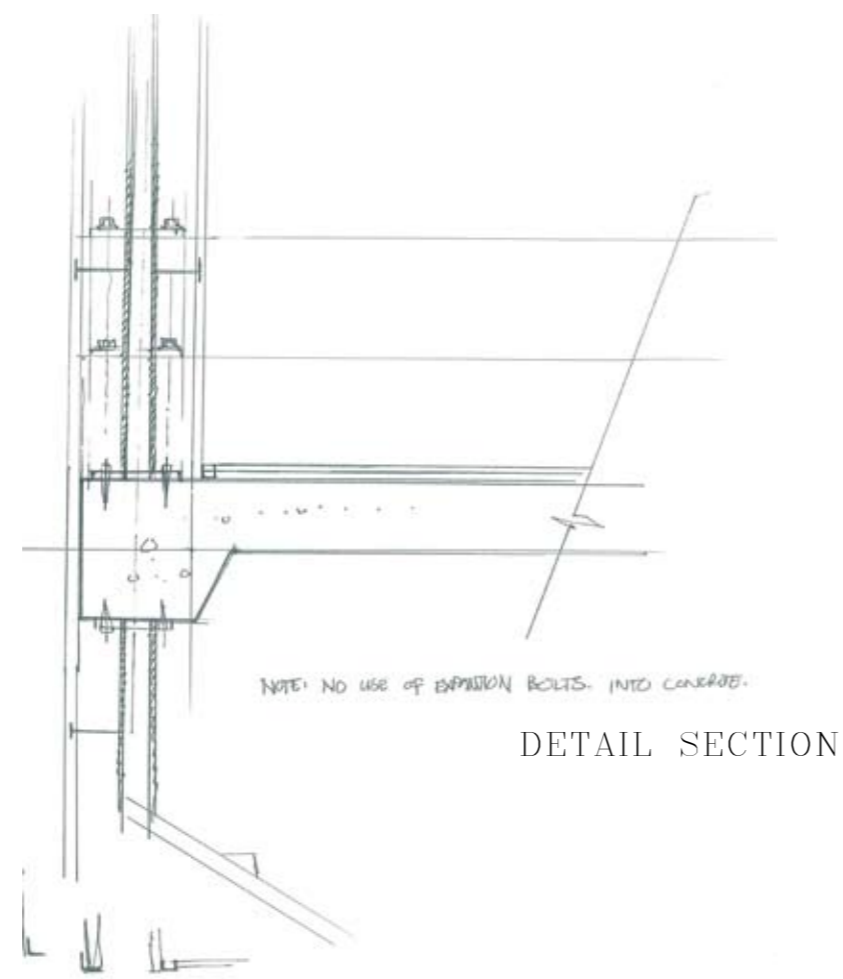
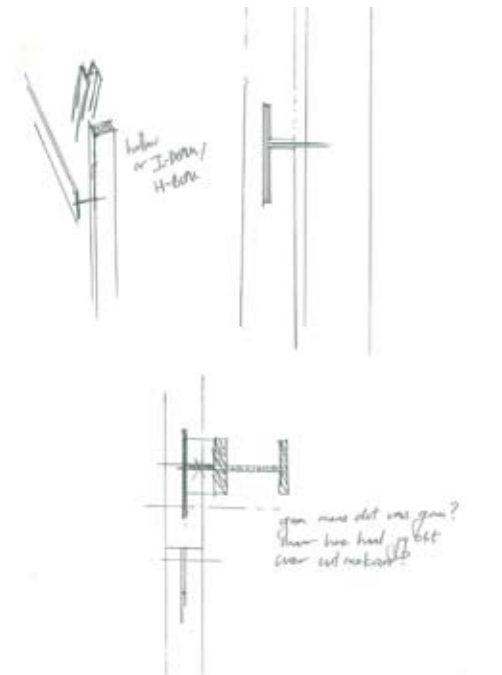
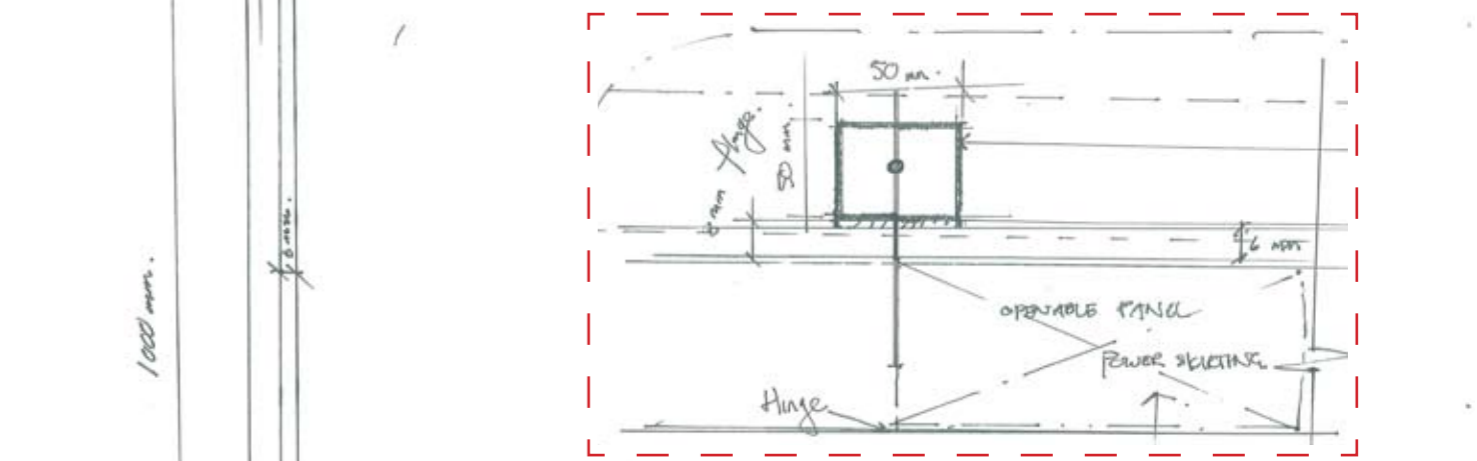
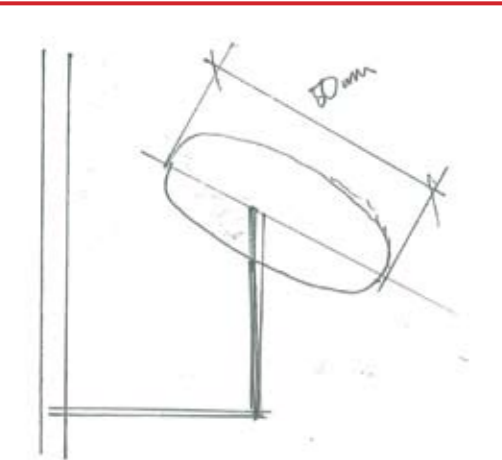
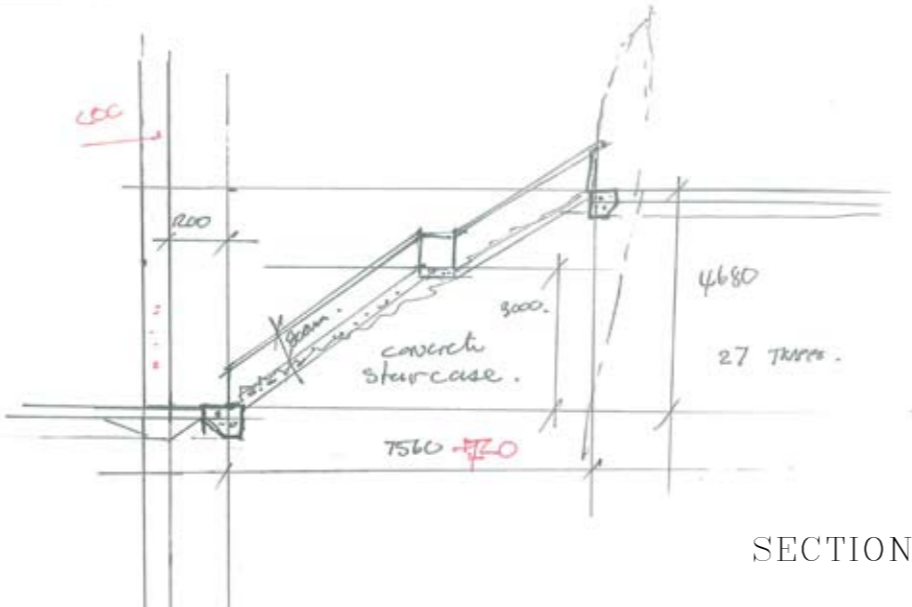
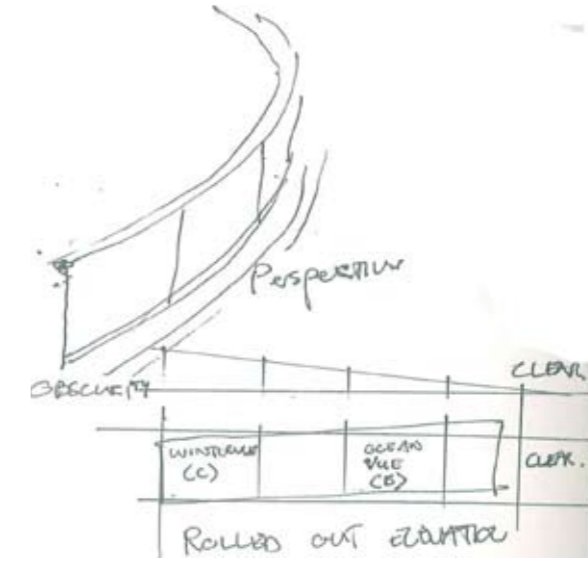
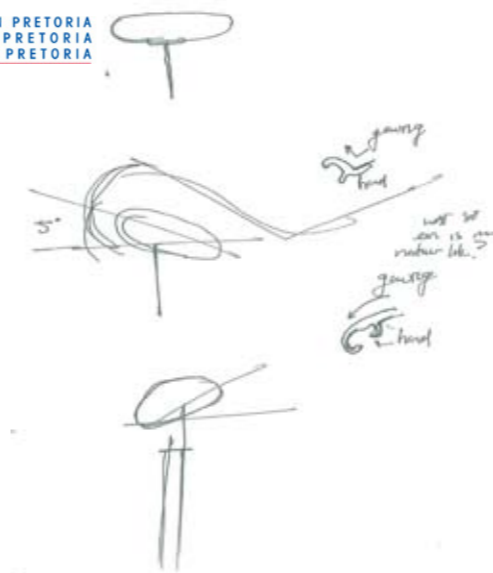
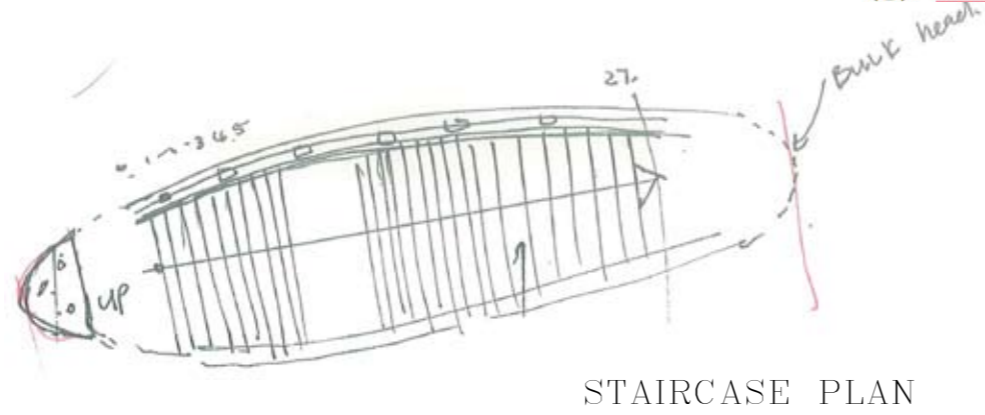

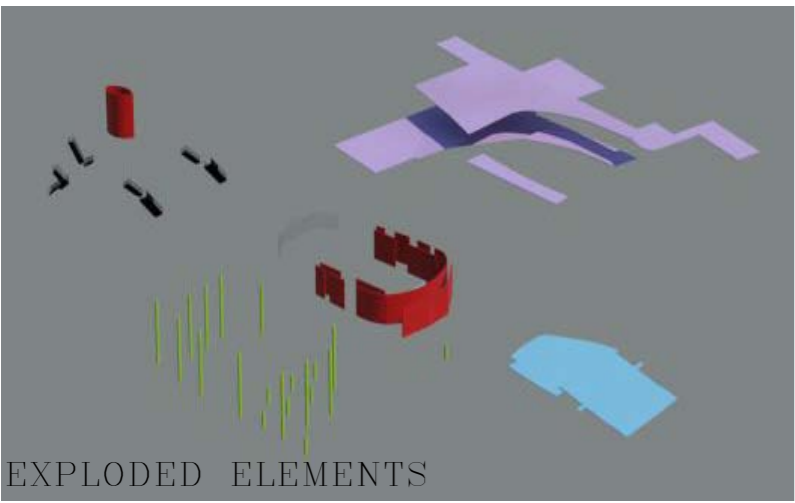

EXPLODED ELEMENTS

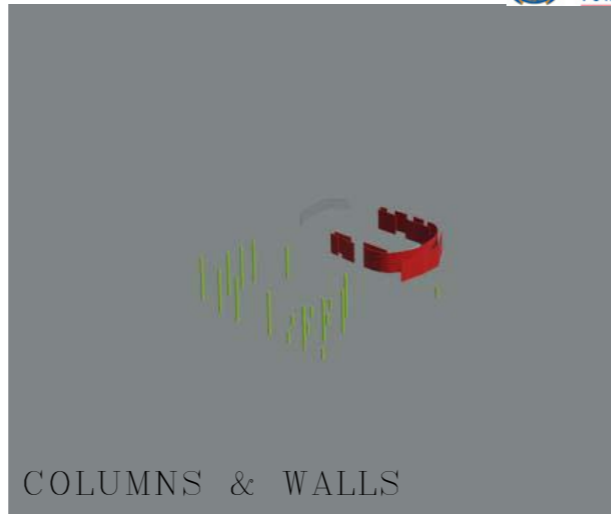

COLUMNS & WALLS

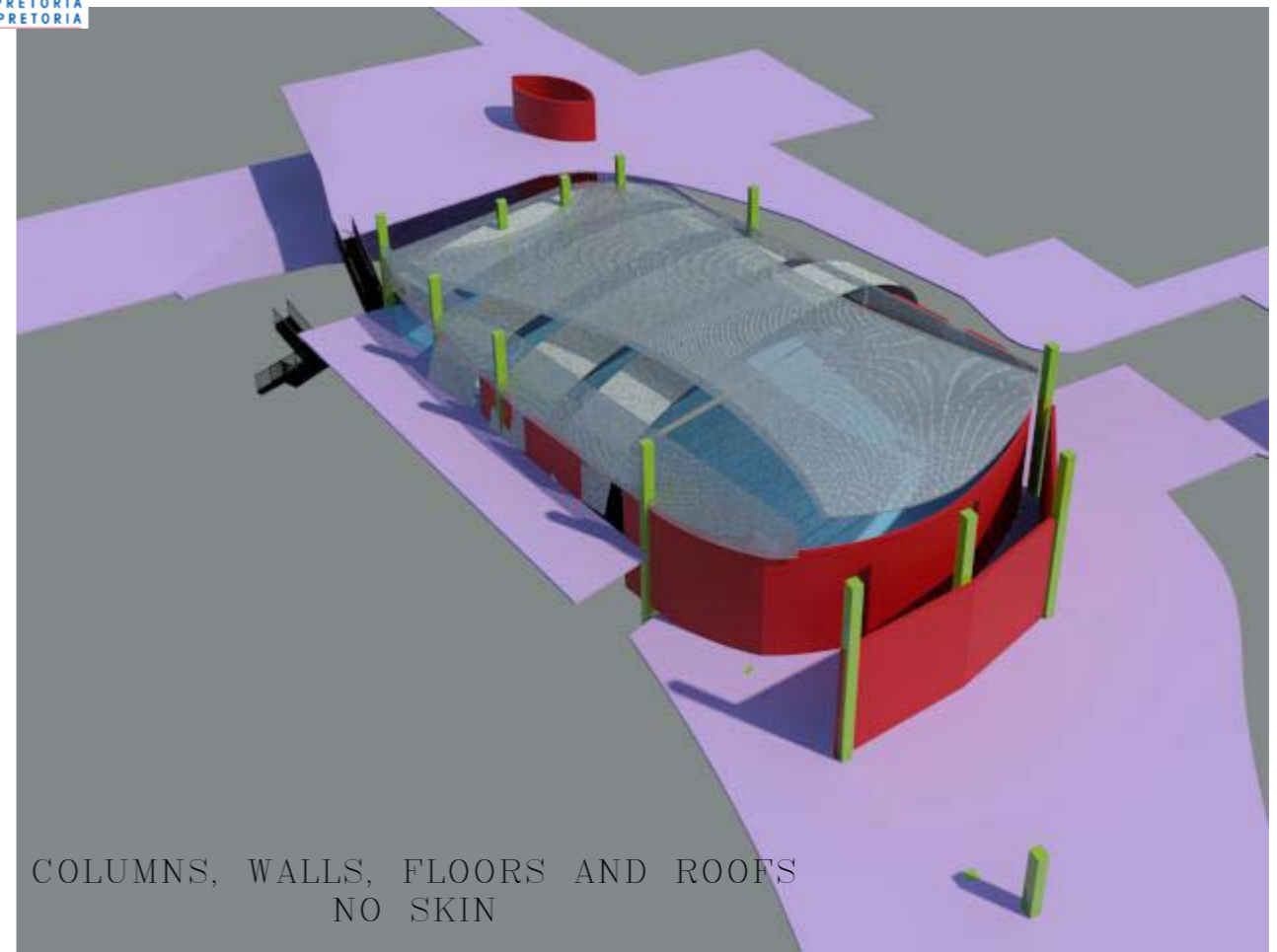

COLUMNS, WALLS, FLOORS AND ROOFS
NO SKIN

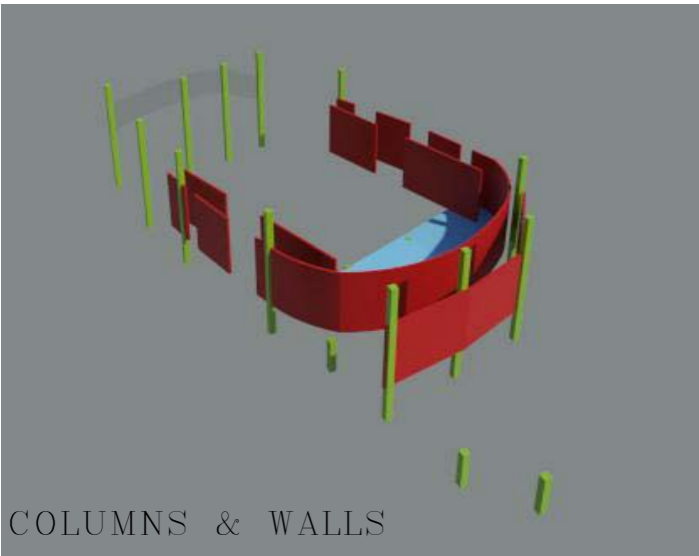

COLUMNS & WALLS

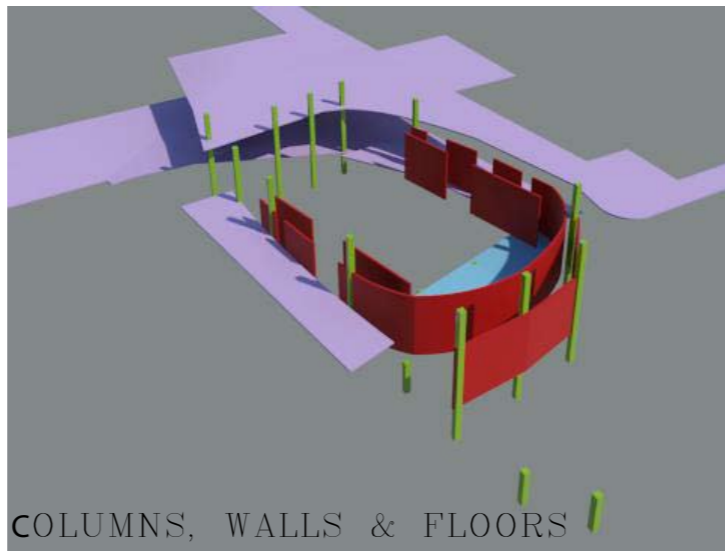

COLUMNS, WALLS & FLOORS

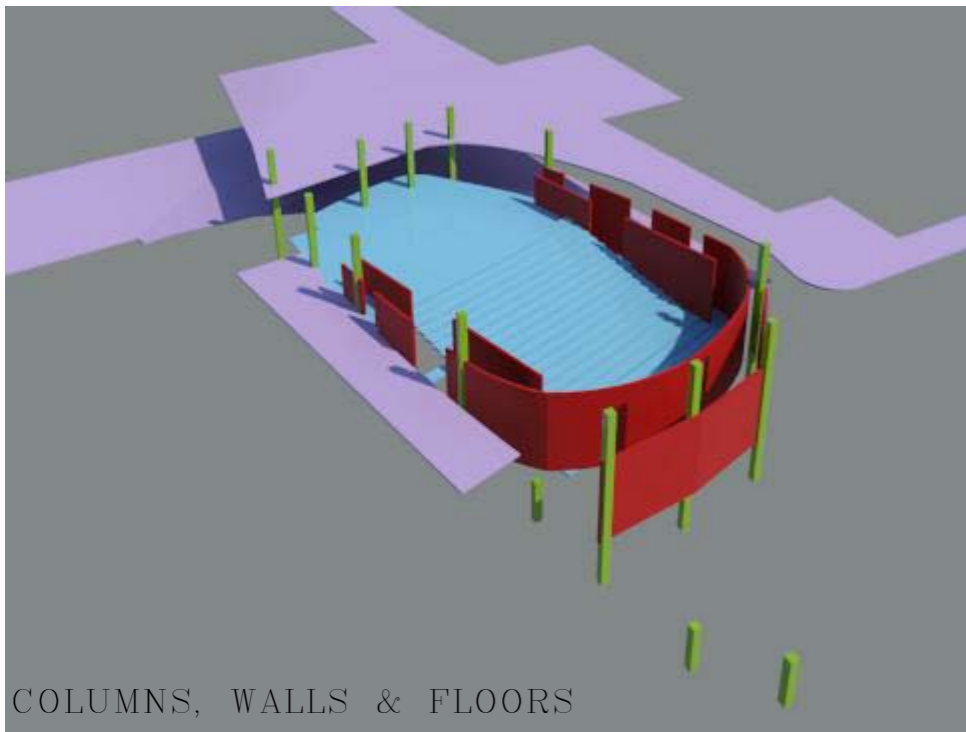

COLUMNS, WALLS & FLOORS

Basic parts
The basic elements of the Monster are shown here in a series indicating the assembly of the various parts.

The drawing to the right illustrates a refined model of the internal pieces assembled.

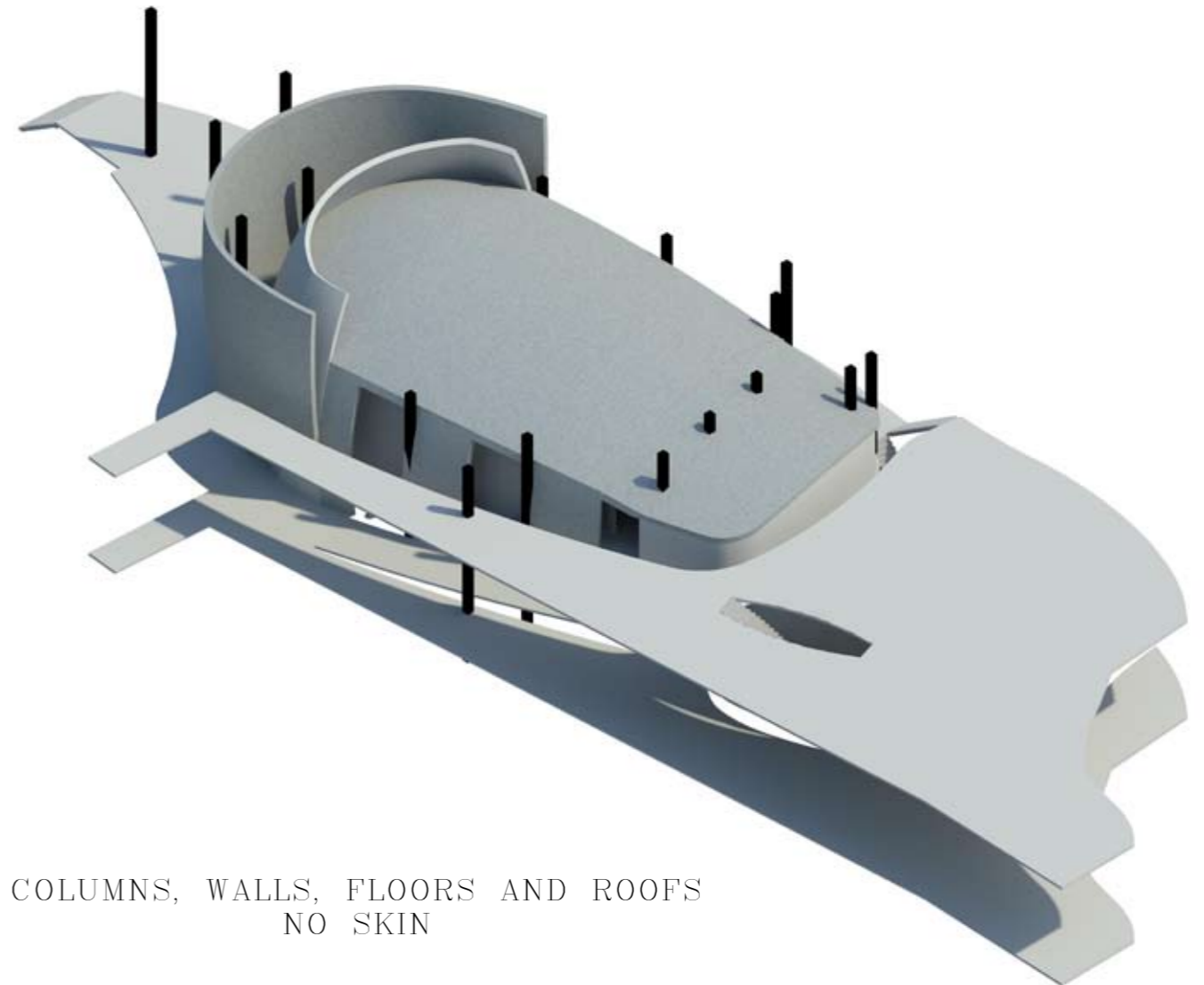

COLUMNS, WALLS, FLOORS AND ROOFS
NO SKIN

THE MONSTER MODELED IN 3D STUDIO MAX WILL BE FURTHER DEVELOPED IN CATIA

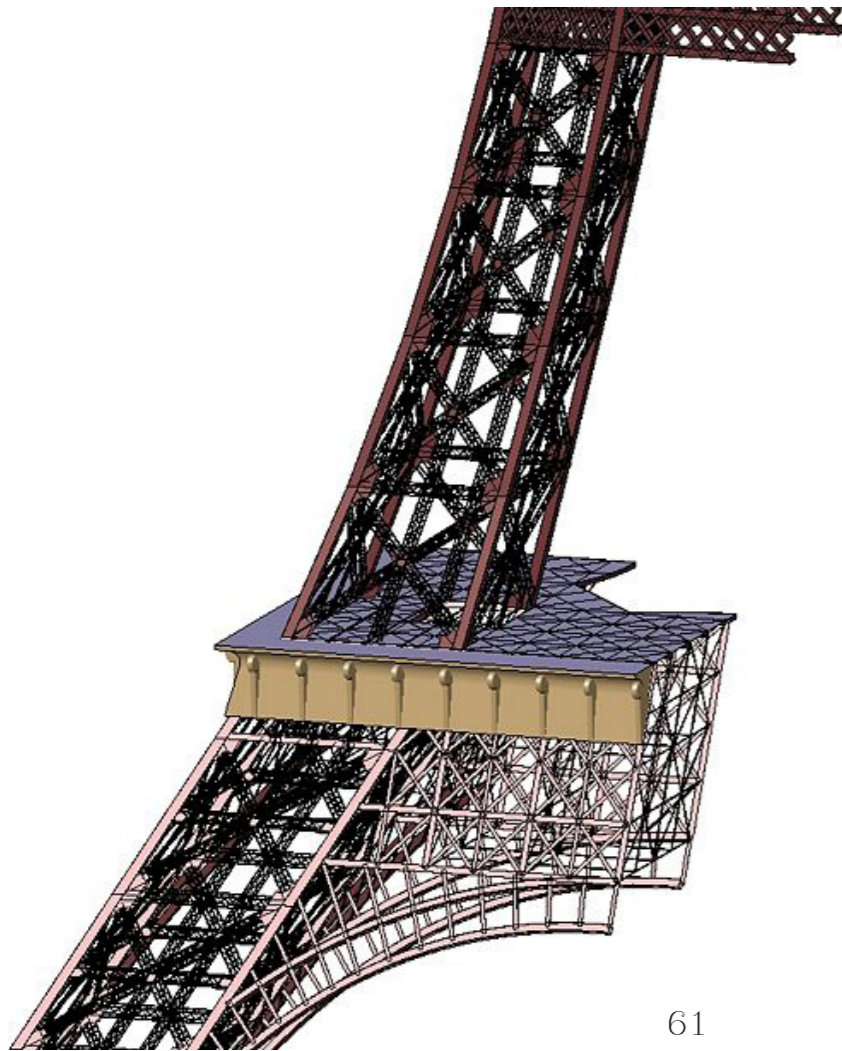

61
 EIFFEL TOWER MODELED ON CATIA

Catia
 The building can be modelled in three dimensions in Catia. A finite element grid can be placed over the structure. The structural engineers use this tool to load stress the structure. The result is a colour coded image to indicate the areas of most load (red) and optimally loaded (green).

[fig. 62]

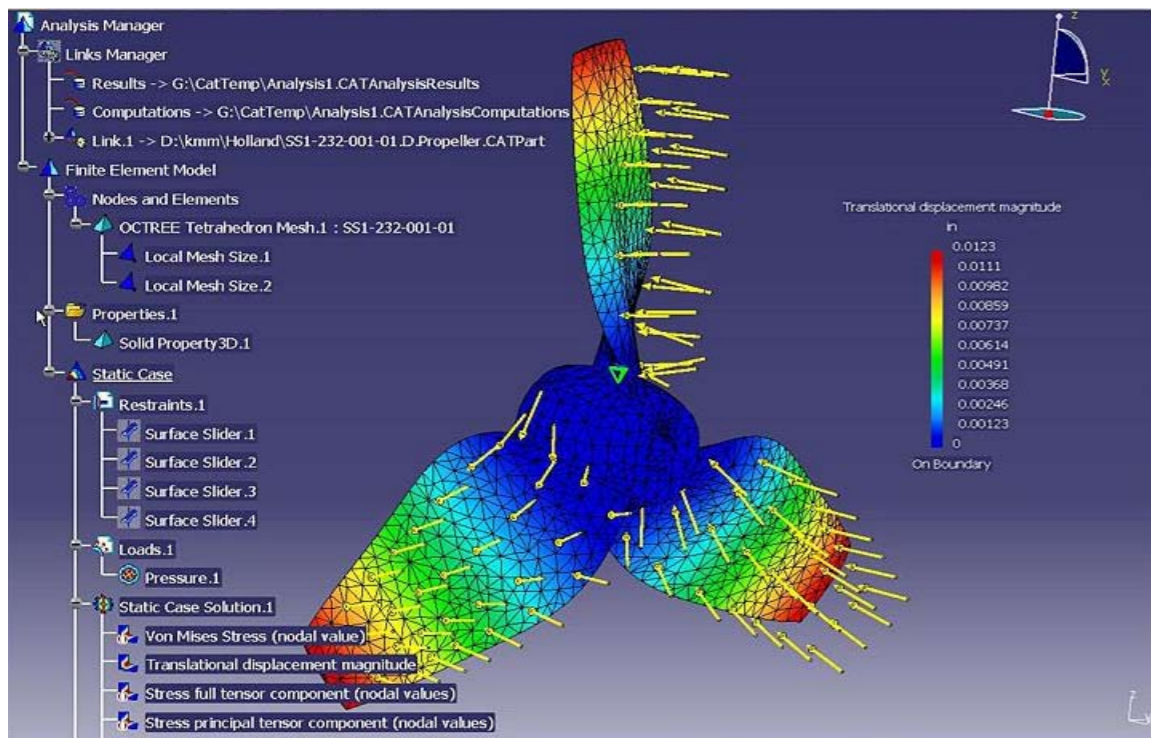

62

The Monster
 The skin can be created in any modelling program. Thereafter it can be converted to files accepted by Catia. From Catia these files can be loaded into other more specialized programs like Nastran and Pastran.
 These programs are structural engineering programs. The load stressing in terms of individual members are done here. These programs also does the wind loading, earth quake, snow loads and rain loads prediction and stressing. The engineers will suggest the following steps.

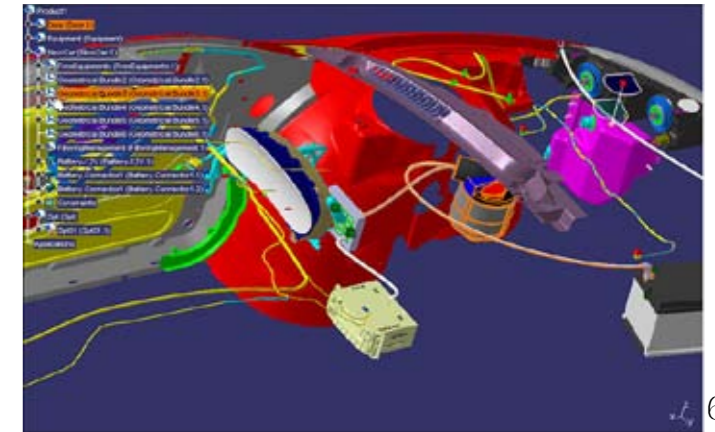
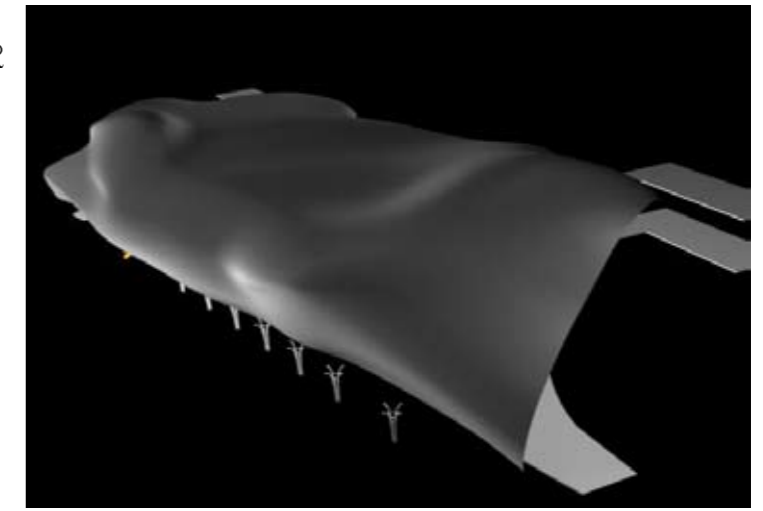

63

Catia
 The entire building can be built as a digital mock-up on a central file, with all the systems, services and structures in place. This is an efficient means of information management. After the entire building has been built on computer, it can be laser-cut in steel to scale.



64

Figures [61-65] illustrate some applications which Catia has been used for.

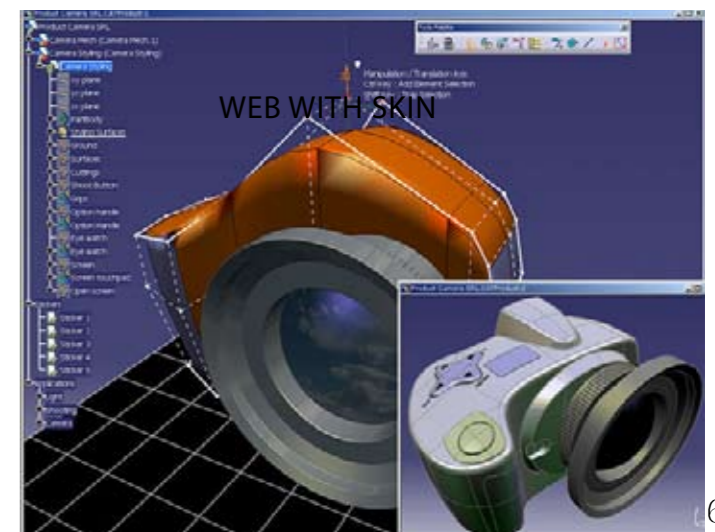

65

Technical Investigation

Building process _ Precedents Kas Oosterhuis: Web

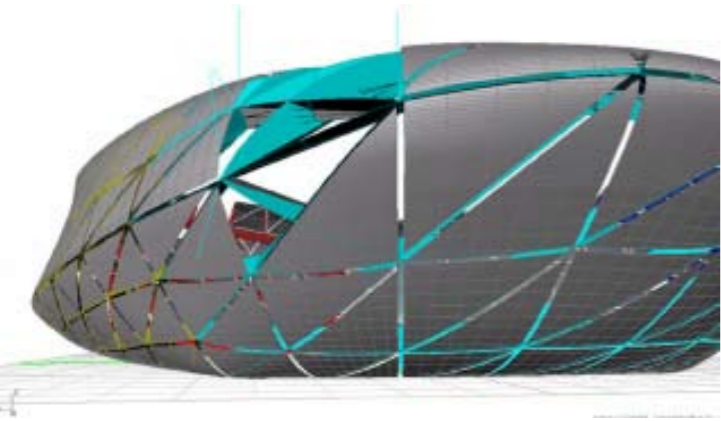

66

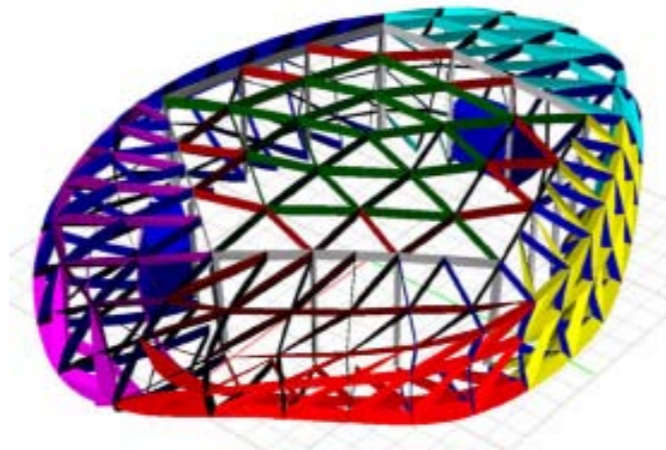

67

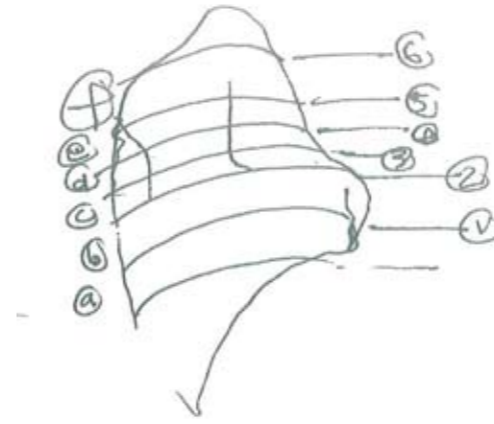

As shown in the precedent and as advised by a structural engineer, a complex curving element like the skin would be divided into sectors[fig.67-69]. Here the drawings show the division into sectors of the Monster's skin. Each sector individually gets load stressed and colour coded. After all the stressing is done, the elements are flattened [fig. 70-72] to create working documents for each element. These flattened drawings are laser cut to steel [fig.73, 75]. The steel elements are assembled in a workshop off site [fig 74, 76]. From the workshop it will be transported to site via truck. On site the contractor can assemble these larger pieces to the plans and sections [fig.77-79].

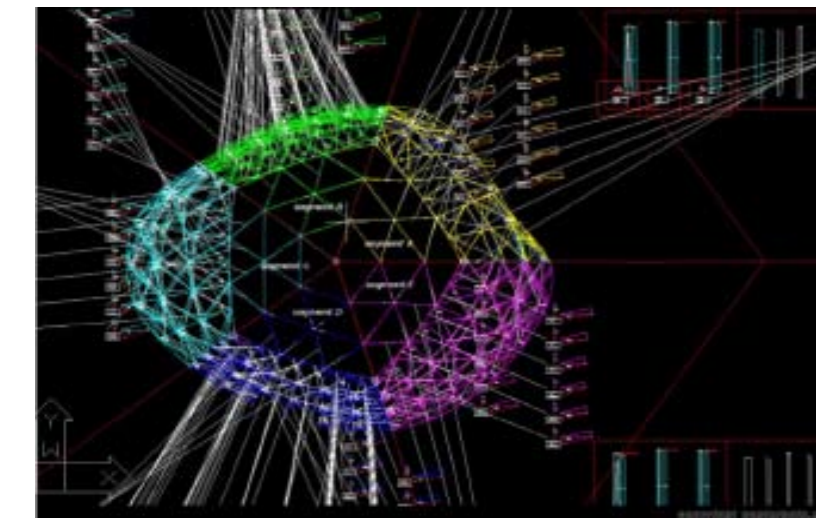

68

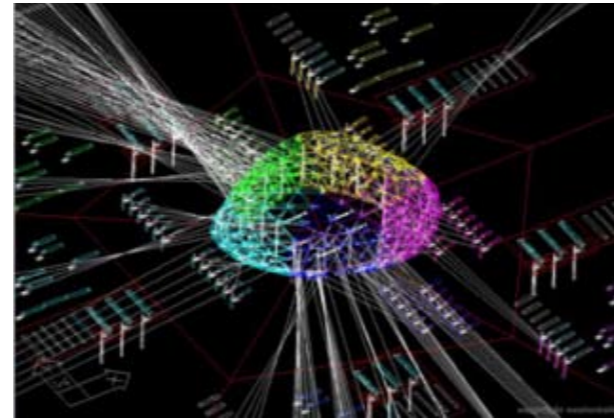

69

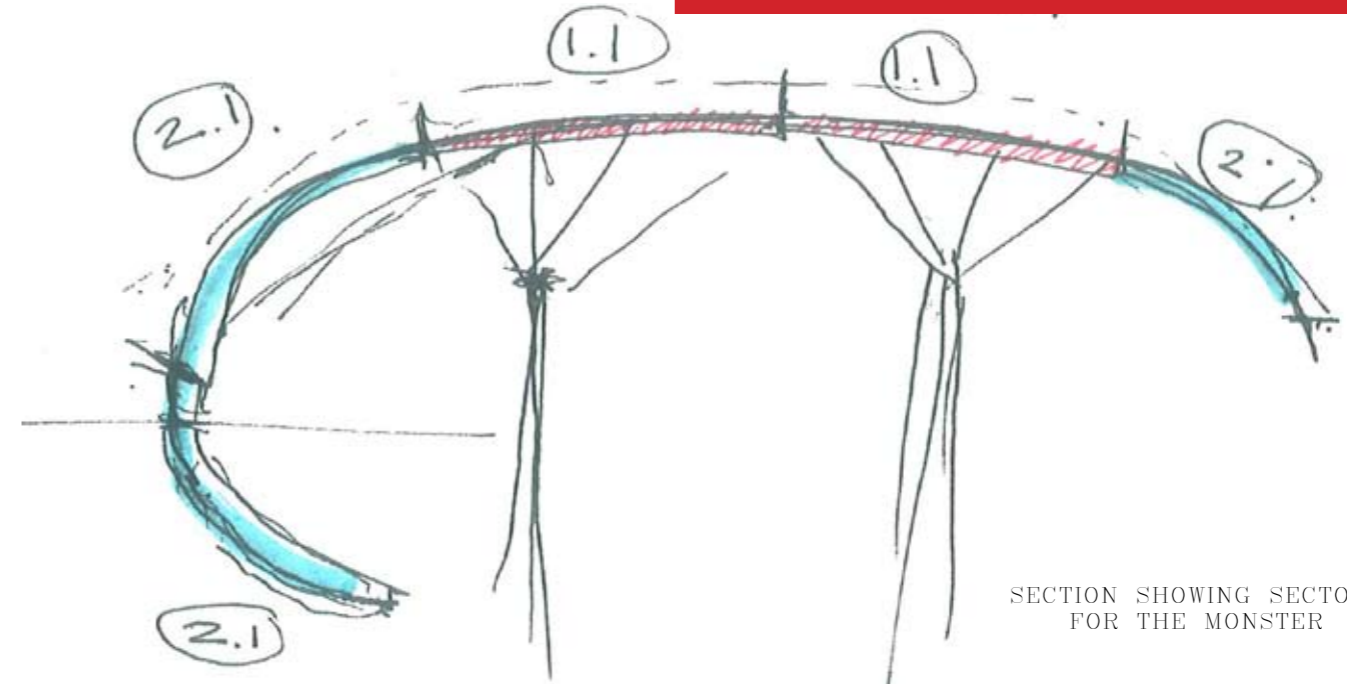

SECTION SHOWING SECTORS FOR THE MONSTER

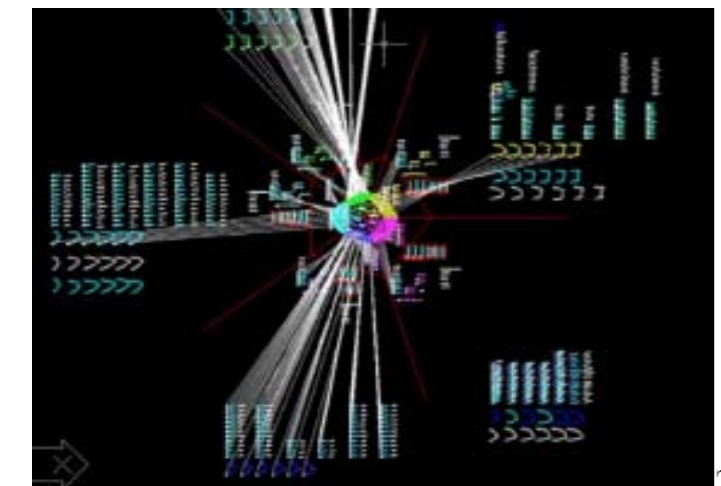

70

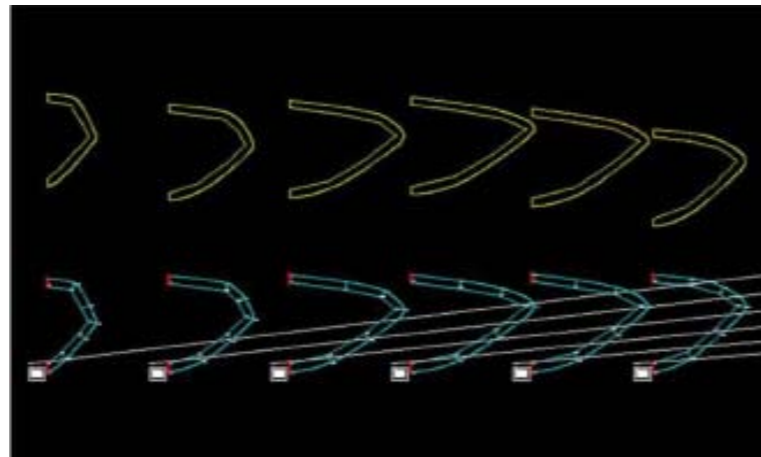

71



PLAN SHOWING SECTORS FOR THE MONSTER

The building process for this dissertation will follow a similar process to this precedent.

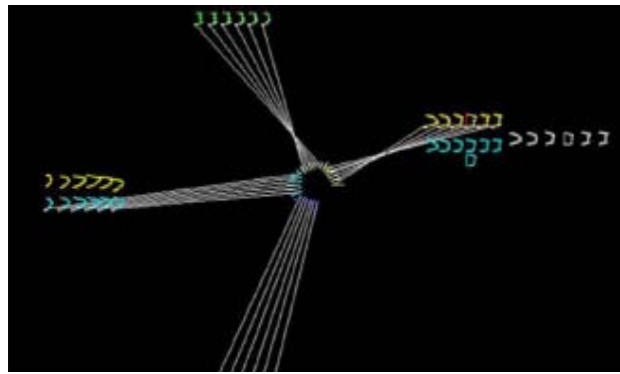

72



73



74



75



76



77



78



79

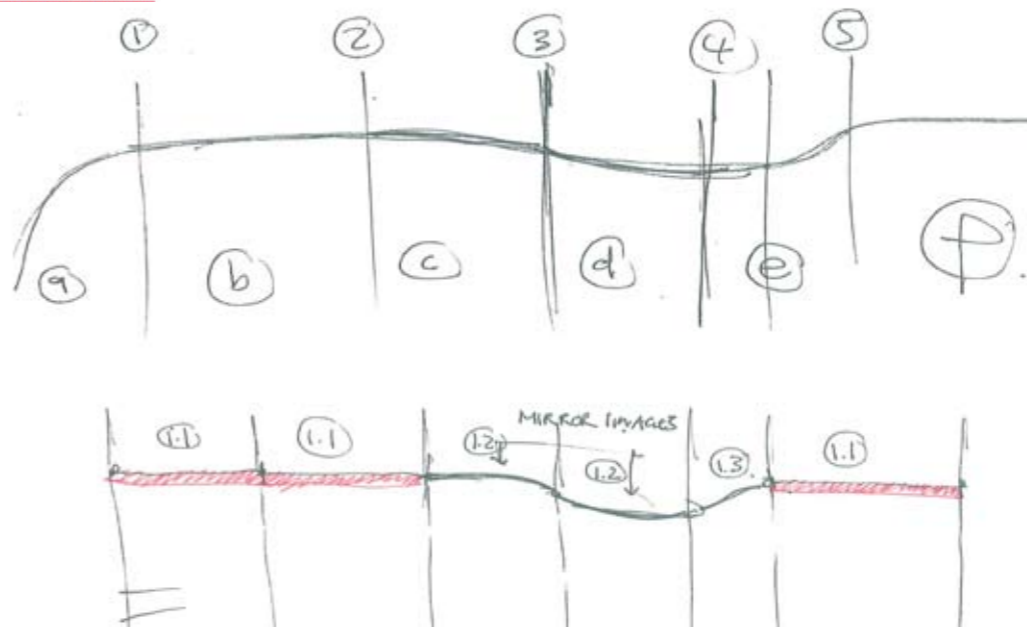

Basic sections divide the skin of the Monster into sectors as the example shows. These sectors are similar in dimension. This is in order for construction and structural analysis.

The sectors of the skin will be expressed using coordinates. The nodes where the six RHS come together will be assigned these coordinates. The entire skin will be communicated as X, Y and Z points.

SECTIONS SHOWING SECTORS FOR THE MONSTER

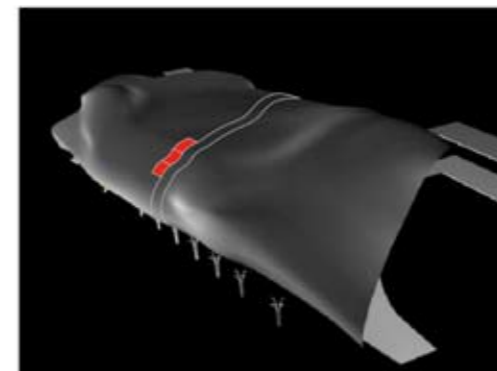
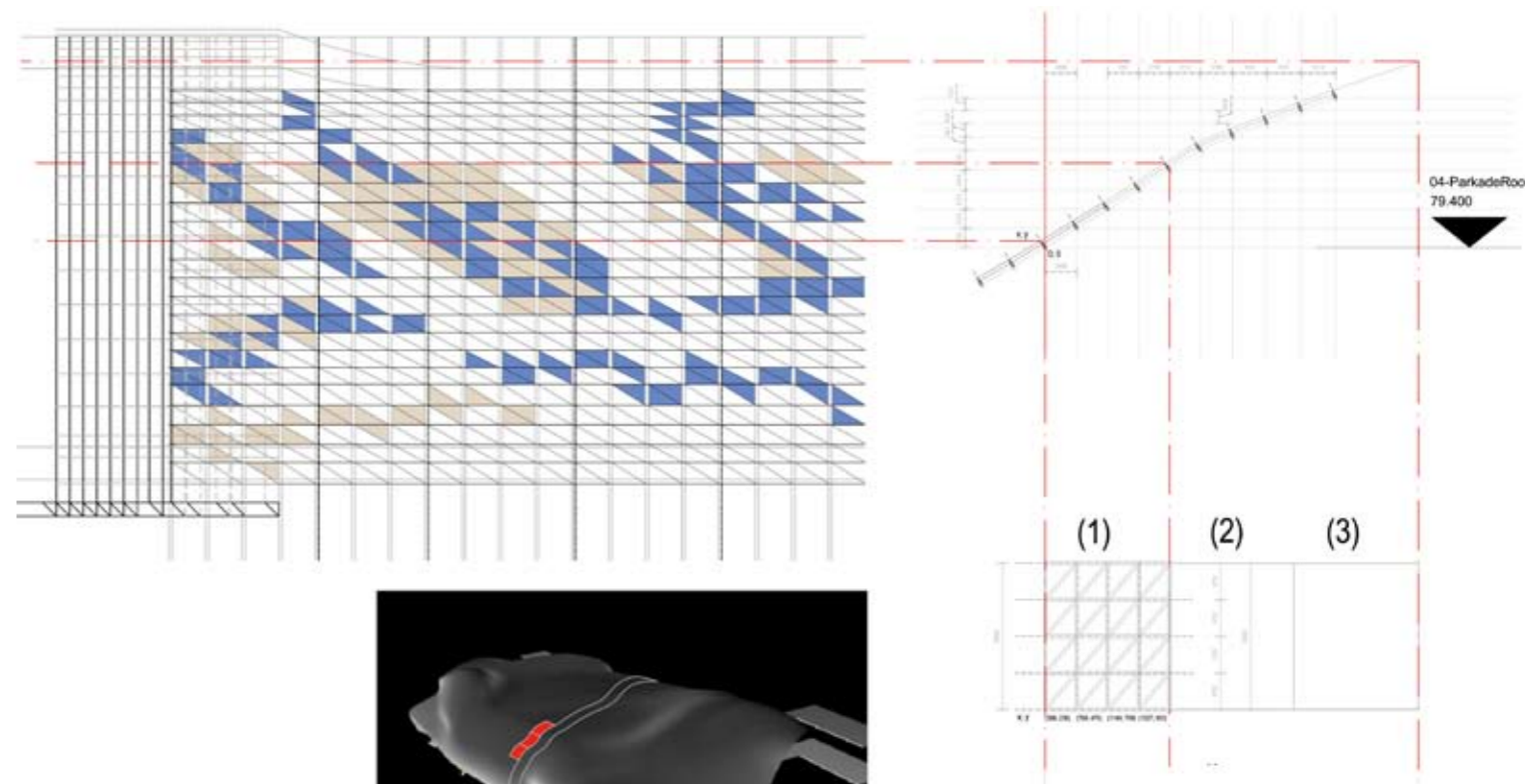

SKIN, MAP WITH COORDINATES FOR ASSEMBLY

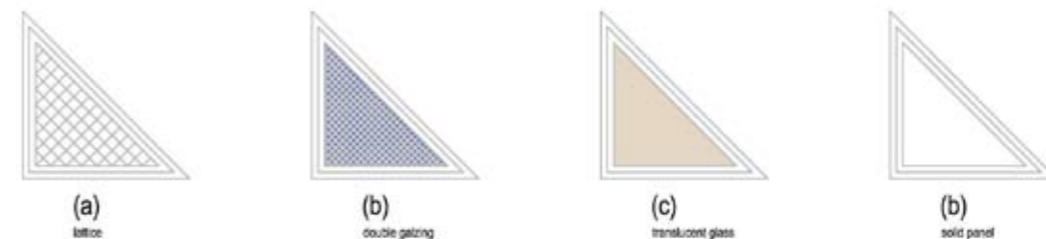

4 INFILL PANELS FOR THE SKIN OF THE MONSTER

Sectors assembled in a workshop (fig. 74, 76).
These sectors can be transported to site and assembled by the contractor on site. (fig. 77)
Adding of in-fill panels. (fig. 78)
Completed project. (fig. 79)

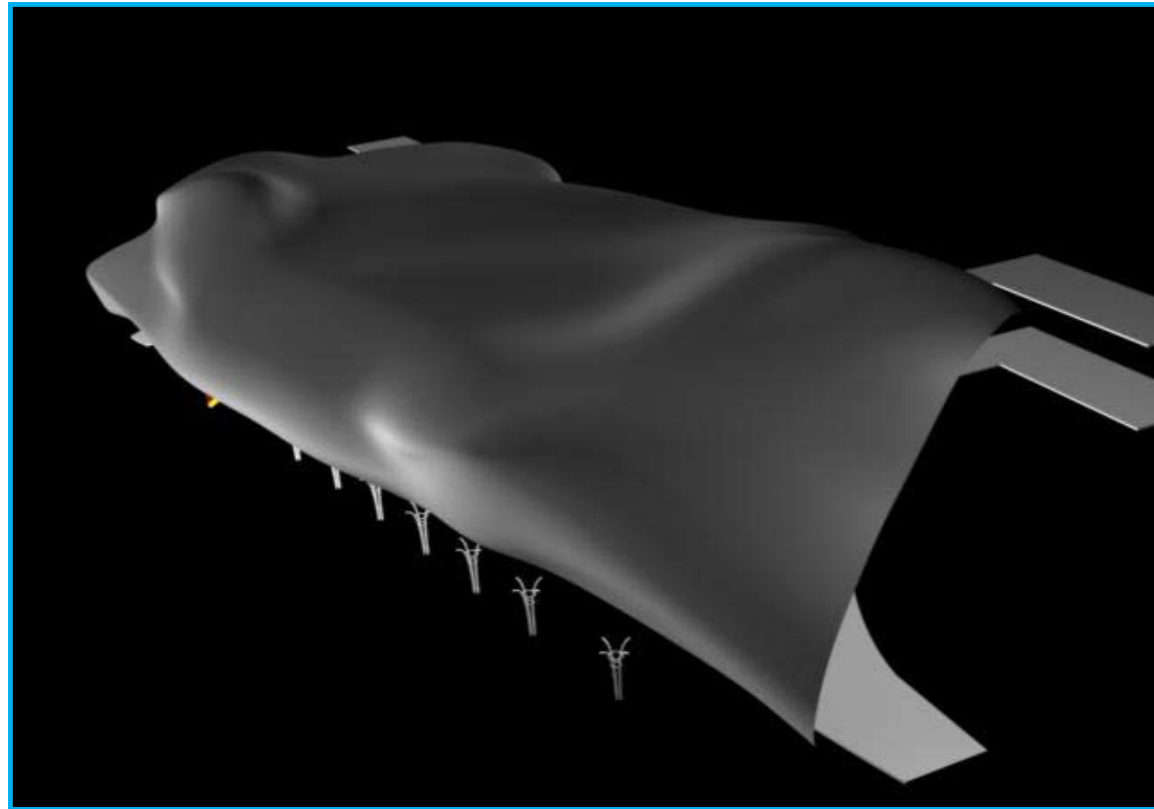

MONSTER WITH SKIN

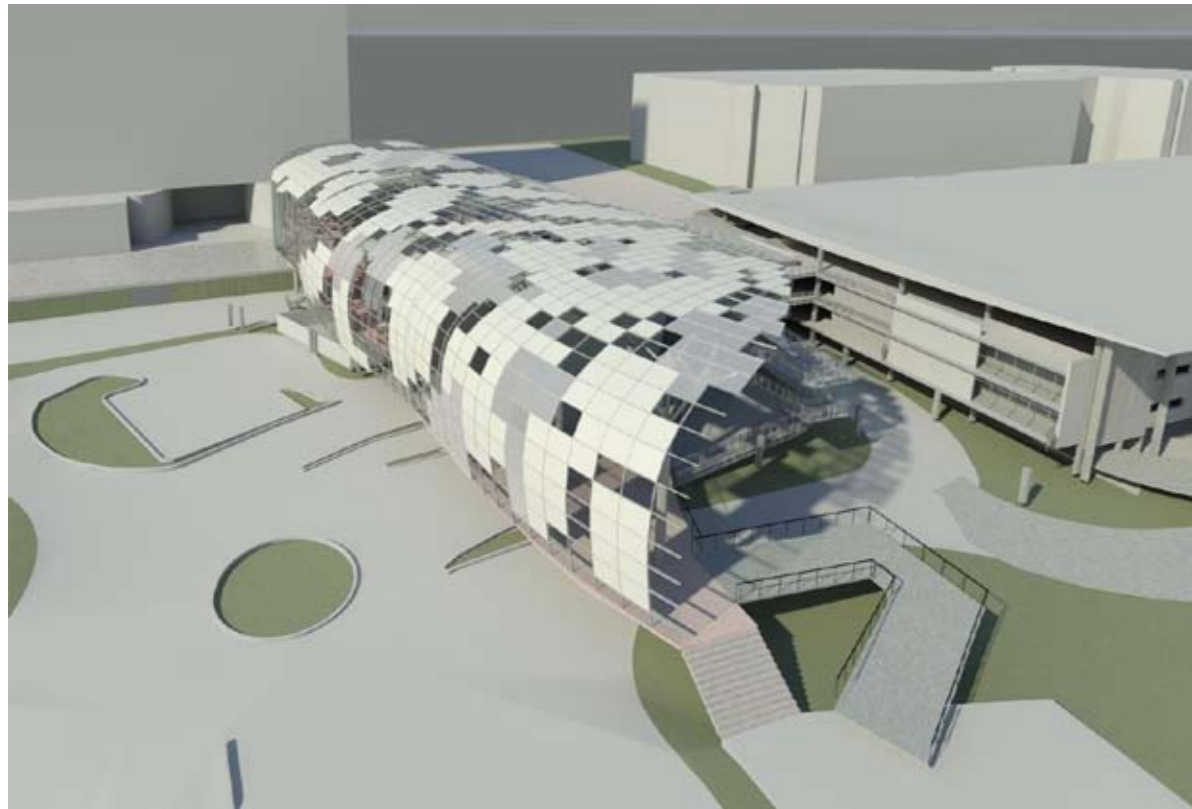

MONSTER WITH SKIN

Developmental renderings of 3d model of the Monster

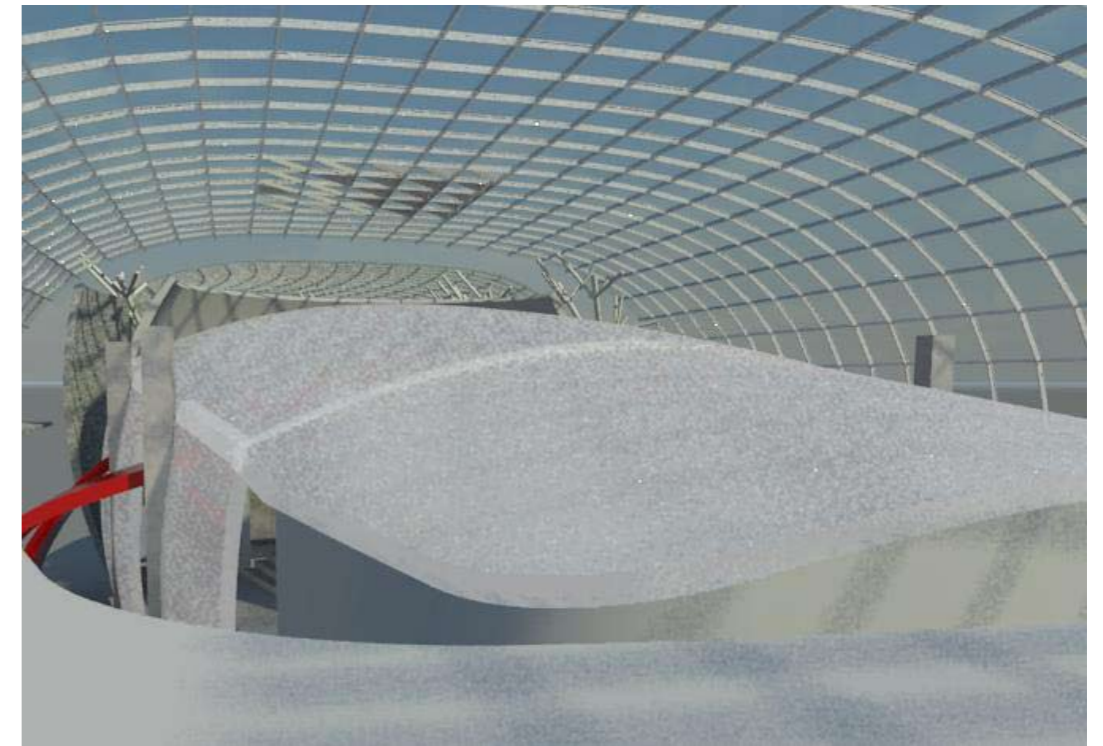

INTERNAL VIEW FROM CAFE OVER AUDITORIUM



INTERNAL VIEW FROM SMOKING AREA

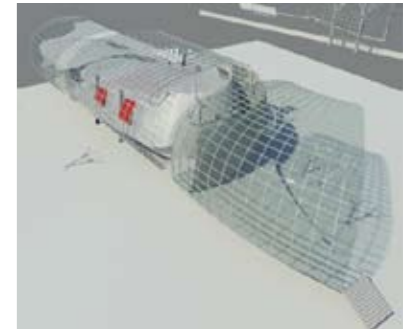
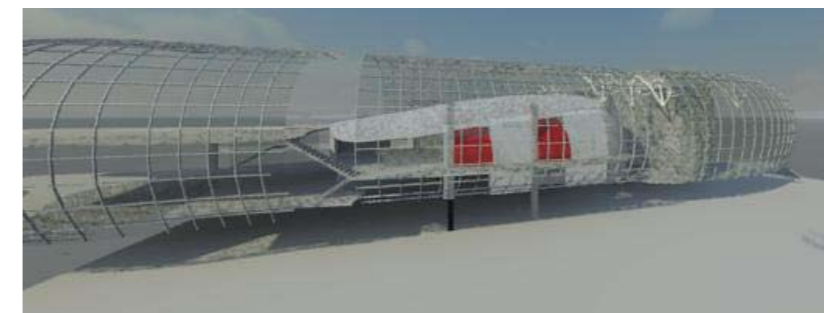

MONSTER WITH SKIN

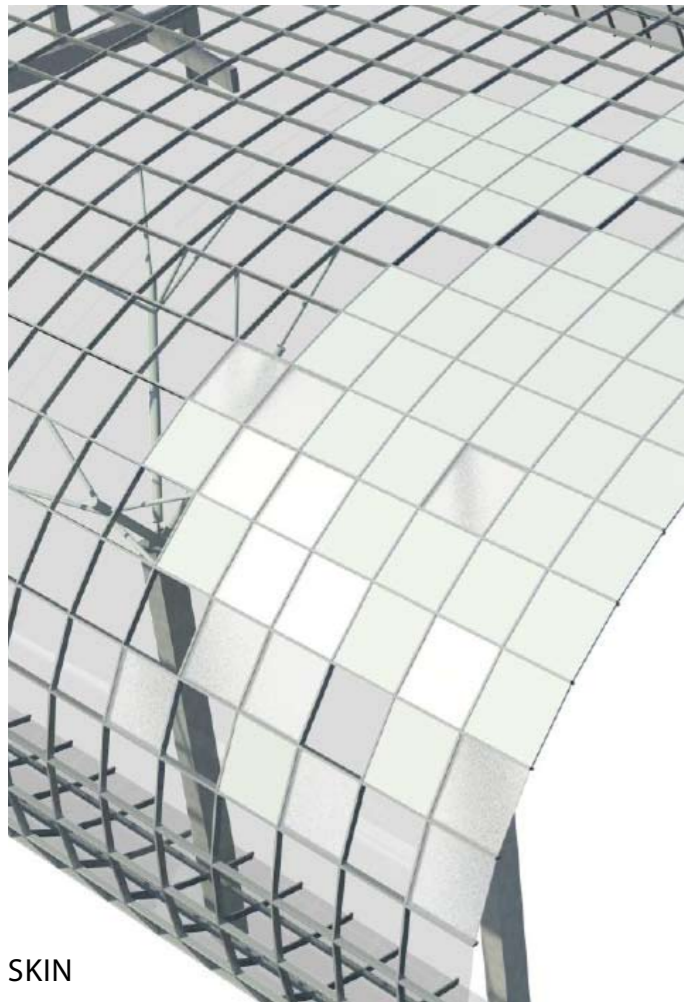

Thermal movement
The skin could have movement joints, but like Zlote Tarasy no movement joints were chosen. The reason was to create a flush waterproof finish (fig. 82). Therefore thermal movement would have to be considered especially because there are "steel members directly below glazing". (Arup Journal. 2008: 43) The entire skin is not glazed (as seen left) therefore the temperature difference between members would be significant due to the "angle of incidence to the sun." (Arup Journal. 2008: 43) The thermal load cases investigated for Zlote Tarasy determined that the members running East-West would have higher temperatures compared to North-South members.

SKIN

- 150mm Ø steel glazing button
- glazing sealant
- 8mm toughend low-e glass
- 8mm toughend screen printed glass
- 4 part rubber gasket system to engineer
- 150mm x 100mm RHS thickness of members between 5mm to 15mm according to the loads by engineer

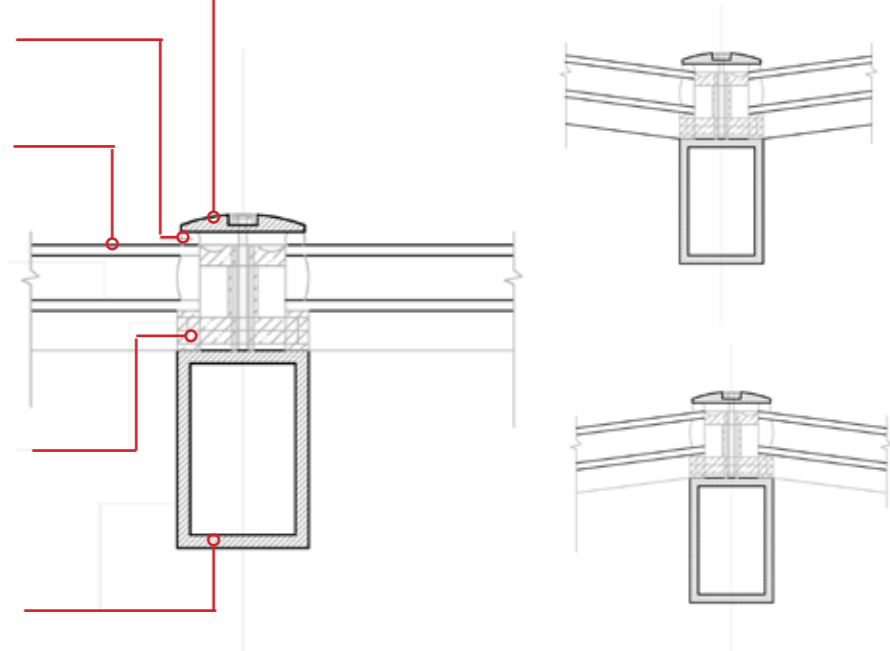

(DETAIL 1) WATERPROOFING DETAIL GLAZING SYSTEM WITH GLAZING BUTTONS



Massimiliano Fuksas - Milan Trade Fair

80

This precedent [fig. 80] shows how it is possible to make a skin which is free-form. It is faceted to render it able buildable. The facets consists of a square grid. This grid is given depth through stressing programs.

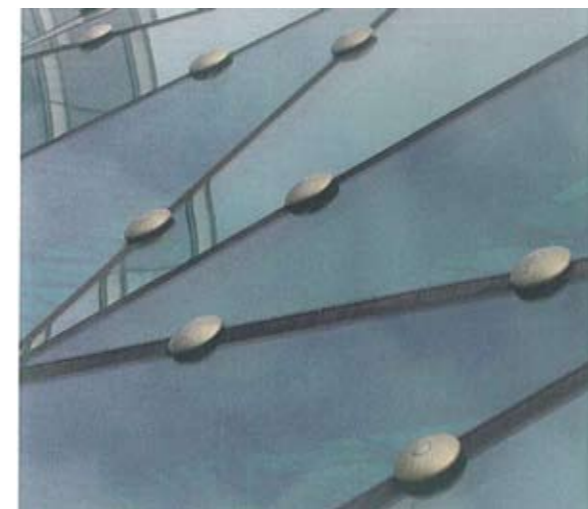

82



INSTALLATION OF GASKET SYSTEM

83

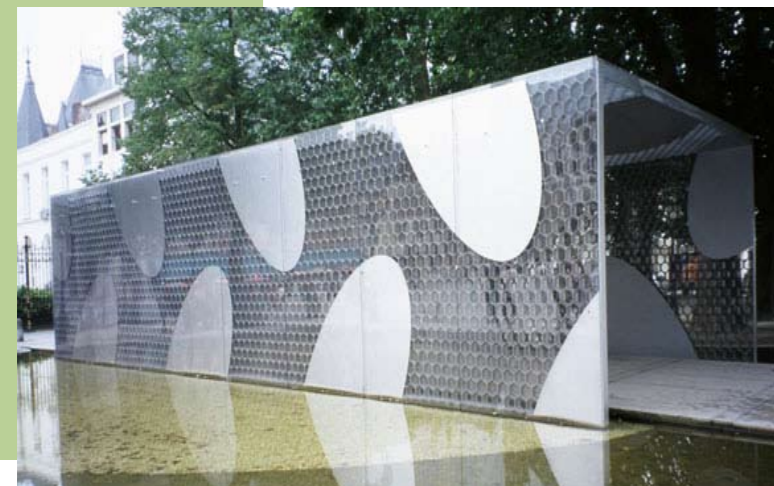

81

Toyo Ito - Pavilion in Brugge [fig. 81]
Steel Lattice construction creates a transparent structure (left), which is one of the qualities derived from my theory and relevant for my design.
(a) Lattice in-fill panels

Waterproofing
The structural engineers for Zlote Tarasy also developed a unique four-part silicone gasket system, which will be duplicated for this design (detail 1). This supports the glass planes and accommodates the wide variety of glass angles, "while also providing a second line of drainage [fig. 83]." (Arup Journal. 2008: 45) To create a flush finish [fig.82] at each node the underside of "the glazing panels coincided at a single point." (Arup Journal, 2008: 45)



INSTALLATION OF GLAZING SEALANT

84

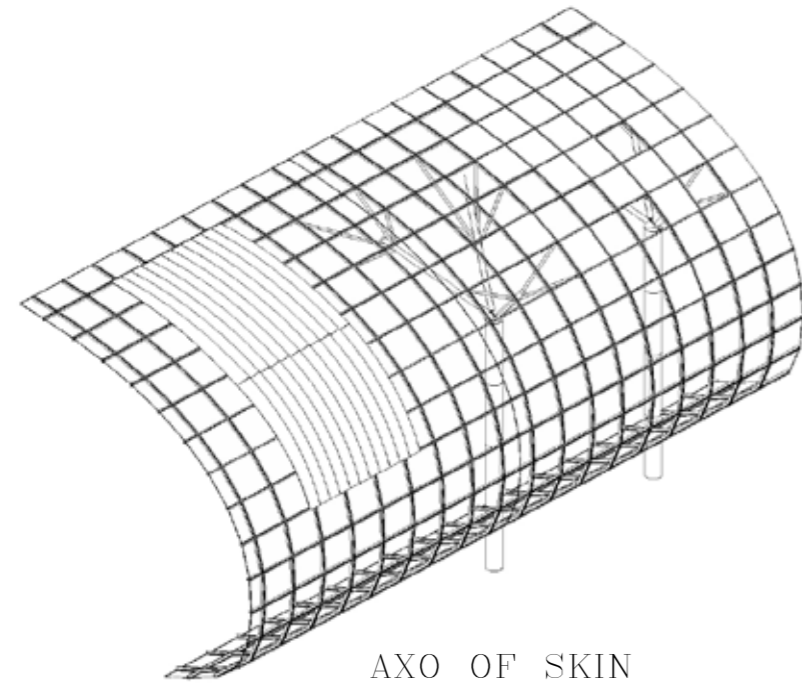

AXO OF SKIN



SECTION THROUGH SKIN

The supports
The skin would need to span 30m wide by 85m long, therefore internal columns would be needed. The main considerations for the support can be taken from the Zlote Tarasy project by Arup:

- provide stability for the roof mesh
- avoid excessive deflections
- minimize local stress concentrations to achieve the required uniform mesh
- allow thermal expansion of the mesh without building up excessive stresses
- be structurally efficient
- be elegant and visually interesting
- minimize obstructions at the floor, allowing clear walkways
- allow ease of cleaning and maintenance of the glazing underside.” (ARUP journal, 2008: 40)

These structural trees (left) are divided into 3 parts. A circular reinforced column, which would “transfer some large out-of-balance bending moments” (ARUP journal, 2008: 41) “Splayed out from the top of each trunk at different angles are three tubular steel branches, each of which in turn splits into a “quad” of four tubular members [right] that connect to the roof mesh [far right].” (Arup Journal, 2008: 41)

The end result is a continuous triangulated grid of steel rectangular hollow section, (RHS) of constant size, 150 mm deep by 100 mm wide, with wall thicknesses probably in the range of 5mm-15mm depending on the forces in the members. This will be stressed with a finite element grid analyses.

“The most complex part of the roof mesh design was the node connections [fig. 86]”. “Six RHS members intersect at every node, a star with six arms, each arm intersecting the angle between two adjacent members.” (ARUP Journal, 2008: 40)



NODE STRESS TEST

85



PRECEDENT NODE

86

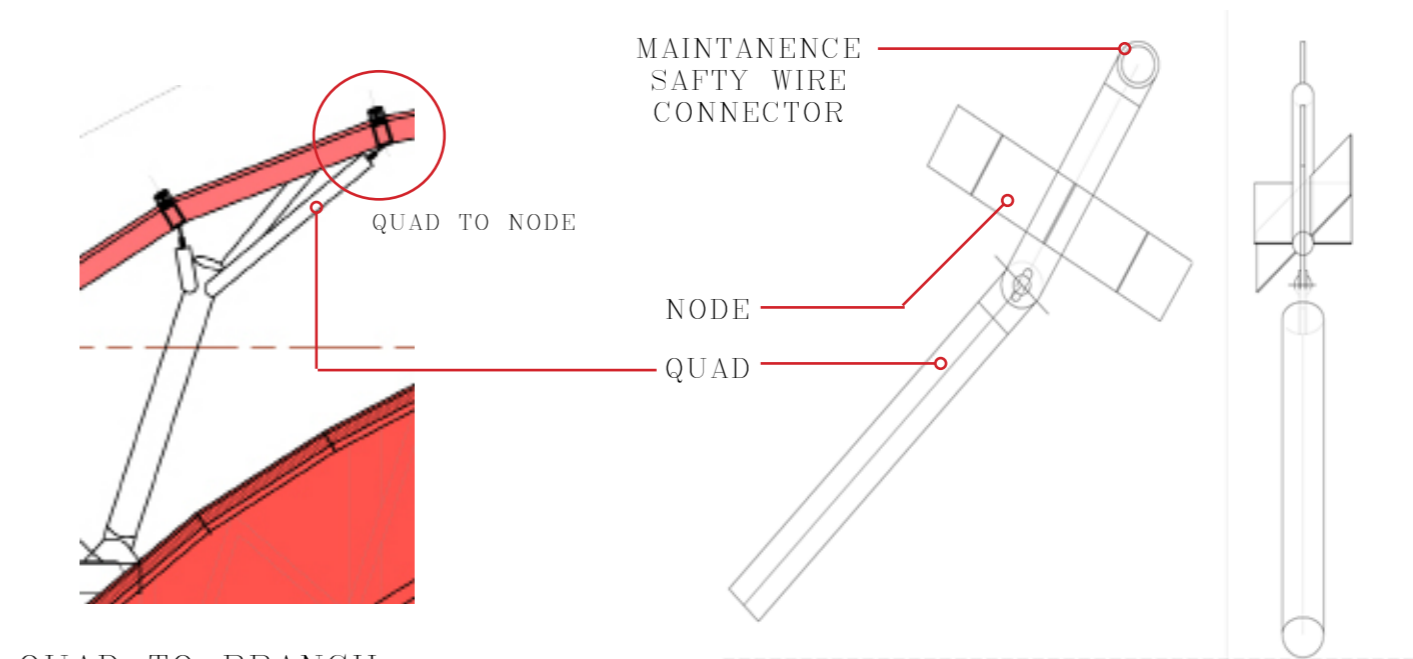

QUAD TO BRANCH

QUAD TO NODE

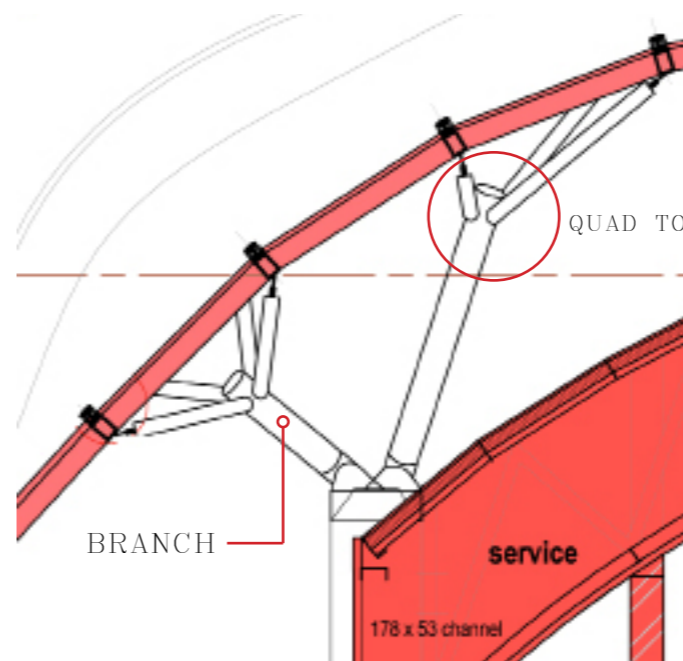

COLUMN TO BRANCHES

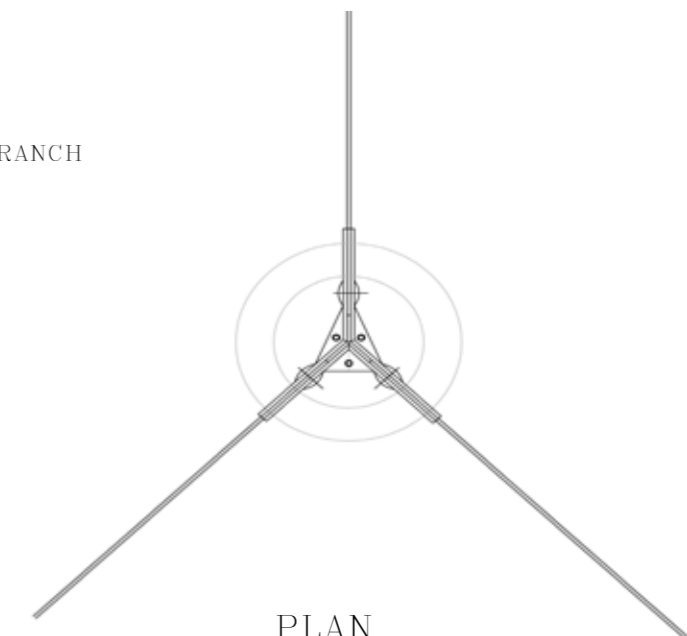

PLAN

SKIN OF THE MONSTER
WITH SUN BREAKS

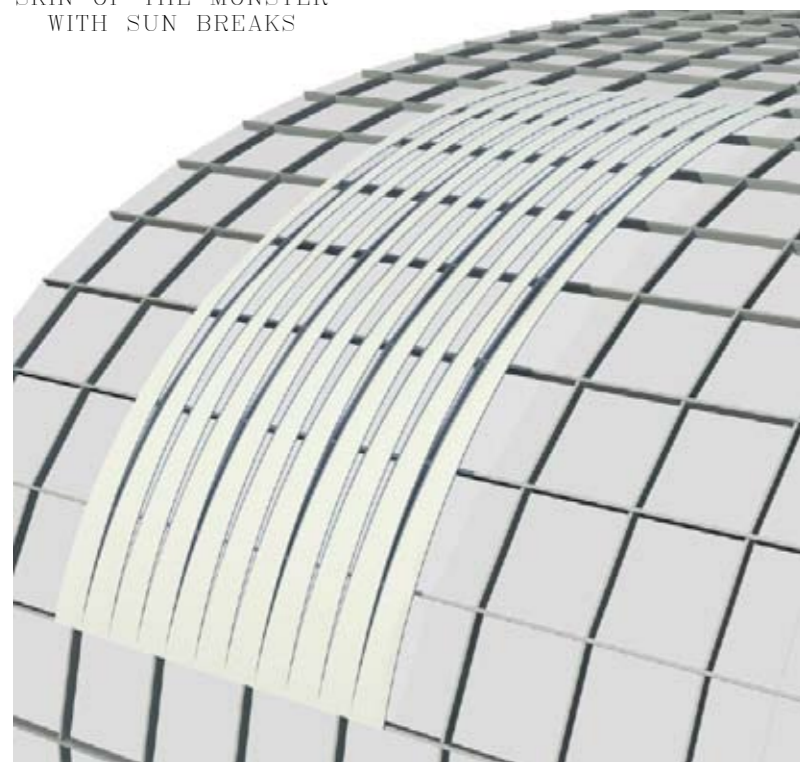

EXTERNAL VIEW



INTERNAL VIEW

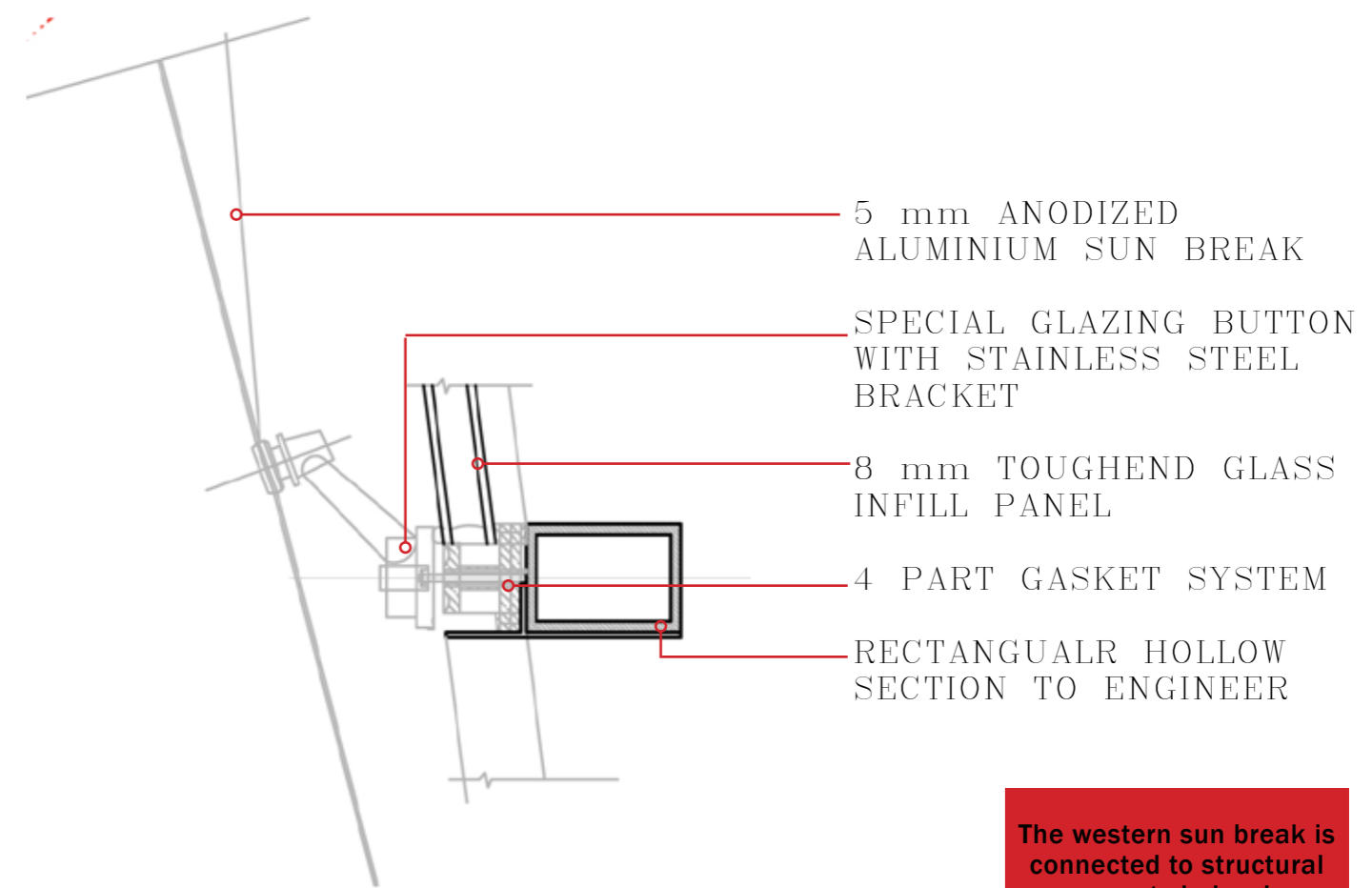

DETAIL 6
CONNECTION OF SUN
BREAKS TO SKIN

The western sun break is connected to structural supports below by replacing the normal glazing button with a stainless steel bracket influenced by Grimshaw's work.

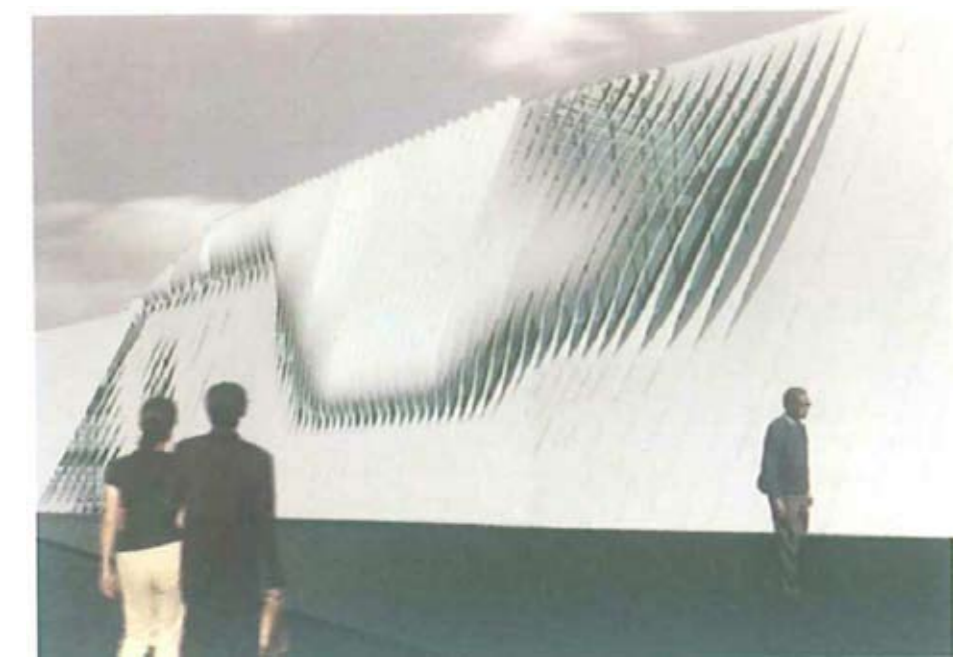

87

The western sun breaks consist of vertical twisted steel. The vertical panels are the most effective to the west. Further they are twisted upwards to the South. These control the sun to the west of the cafe to enhance the internal climatic performance. The western sun breaks were inspired by the skin for a department store by Chad Burke [fig. 87].

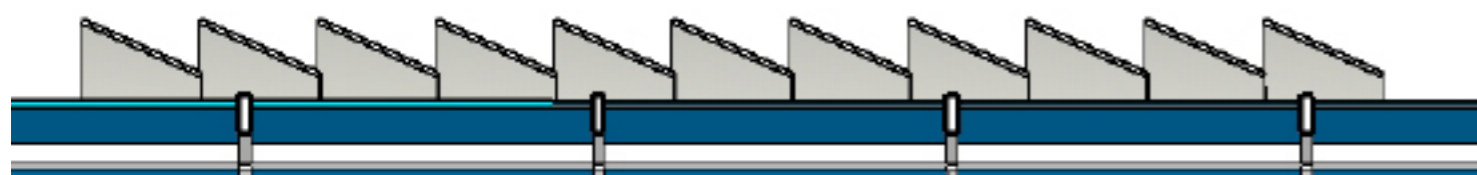

PLAN OF THE SKIN WITH THE SUN BREAKS

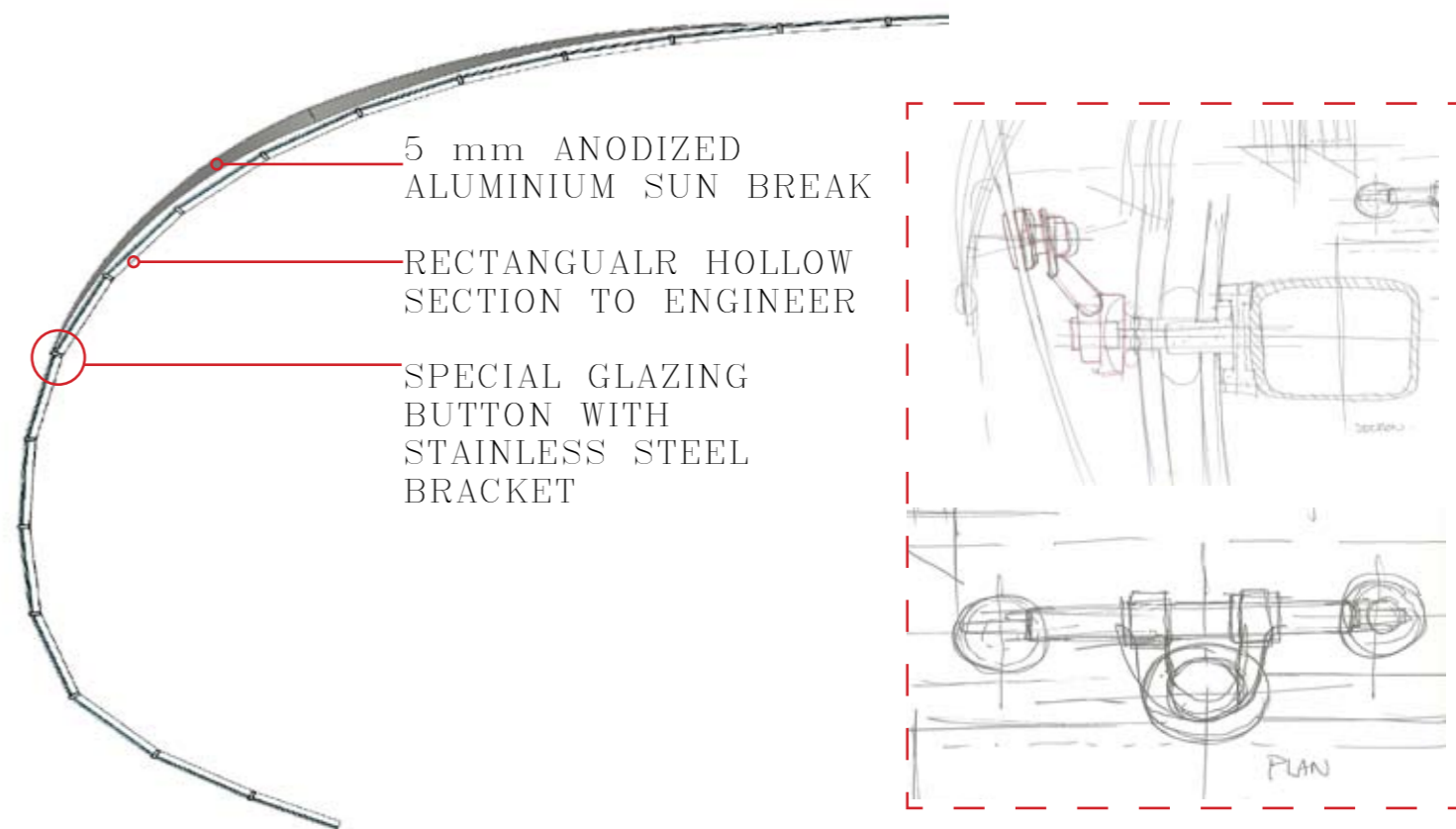

SECTION OF THE SKIN WITH THE SUN BREAKS

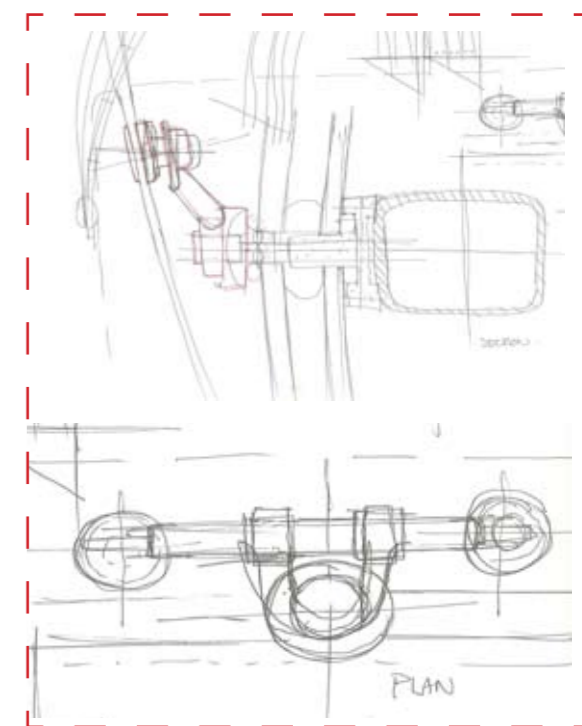

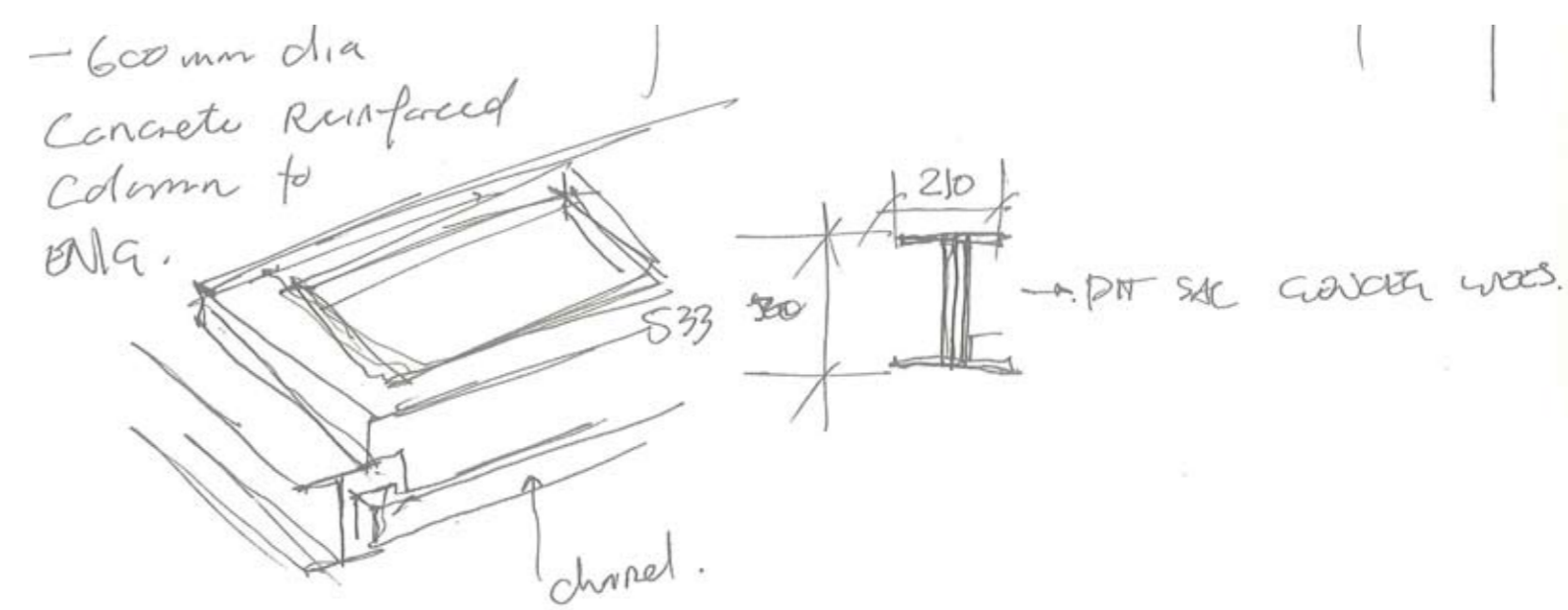
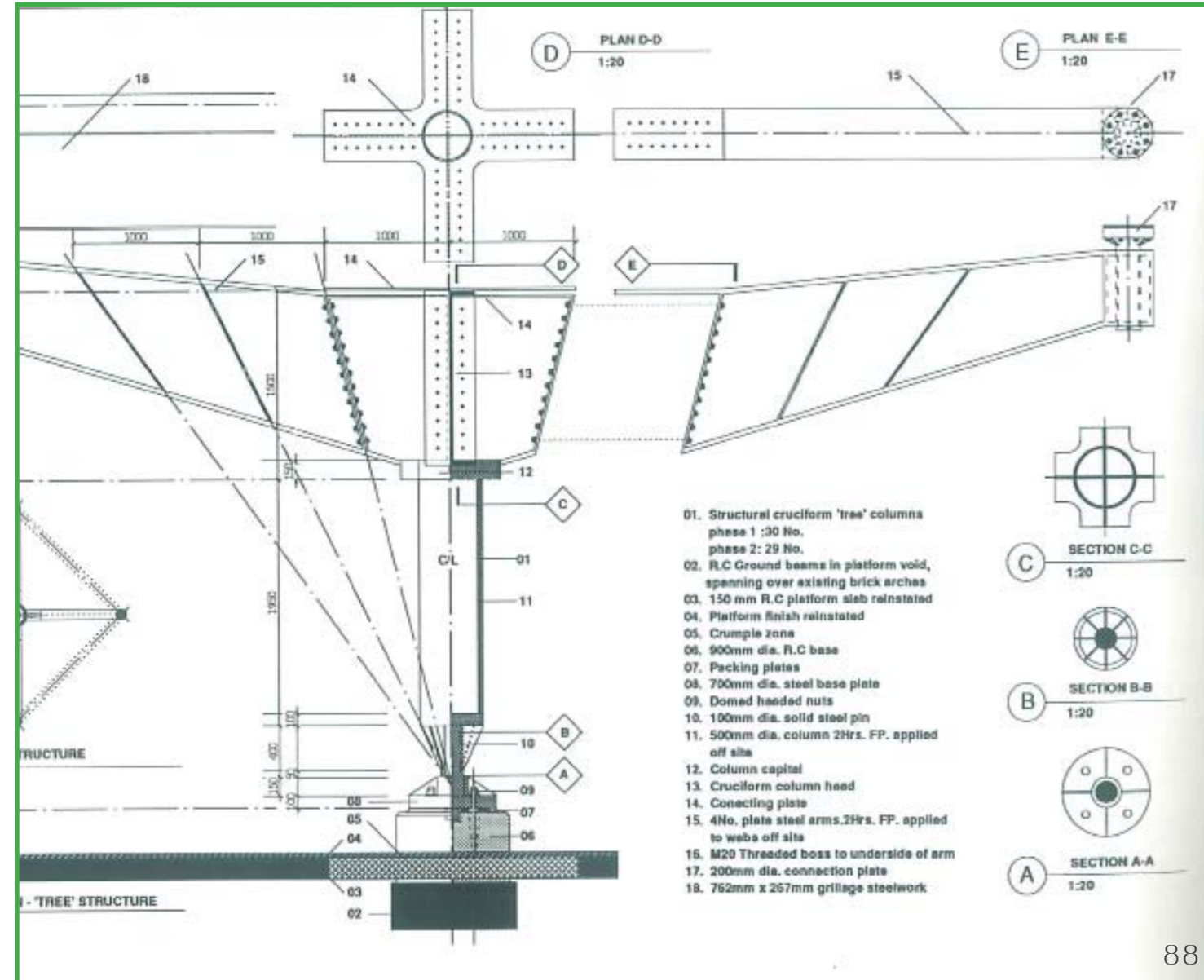
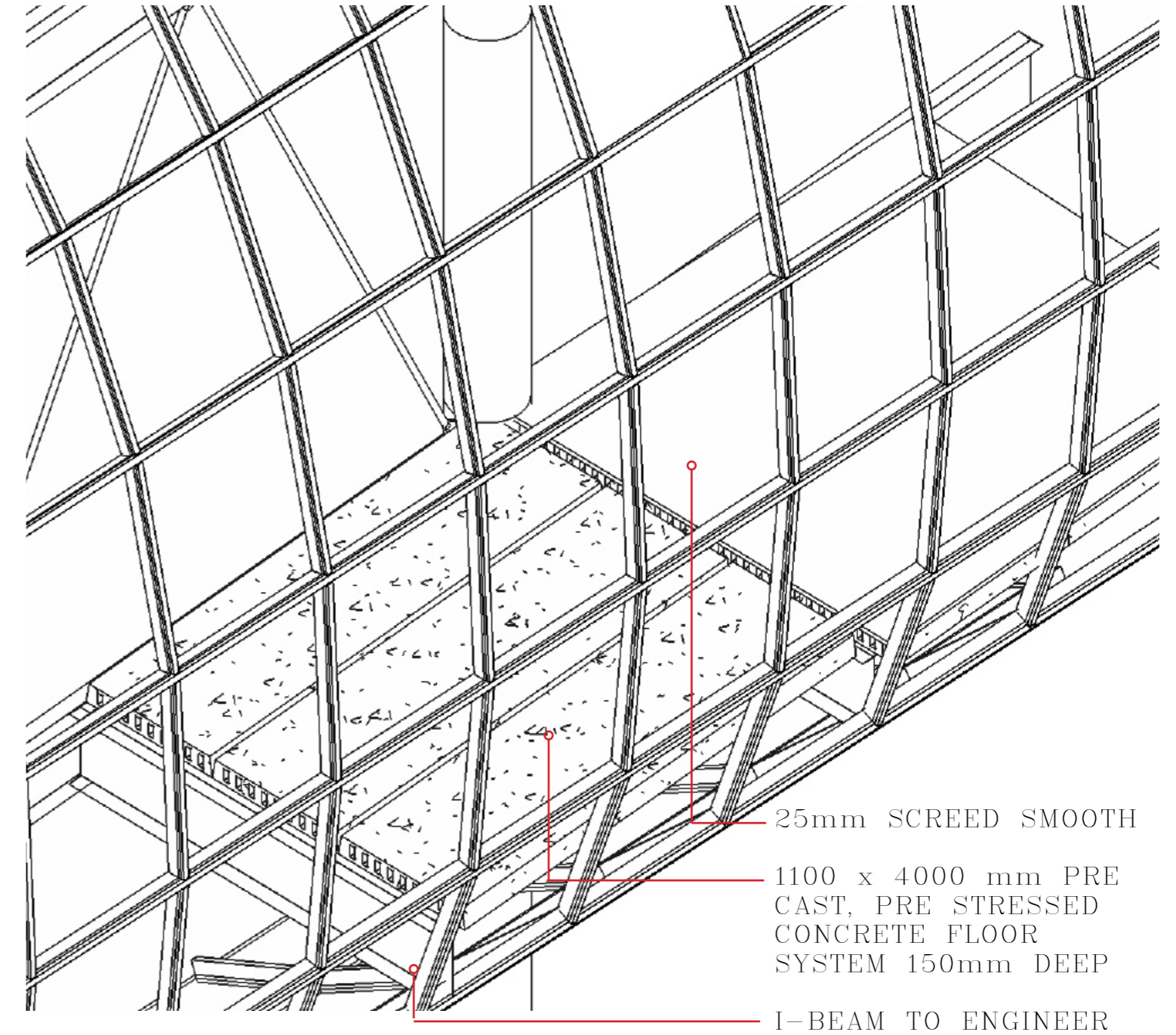
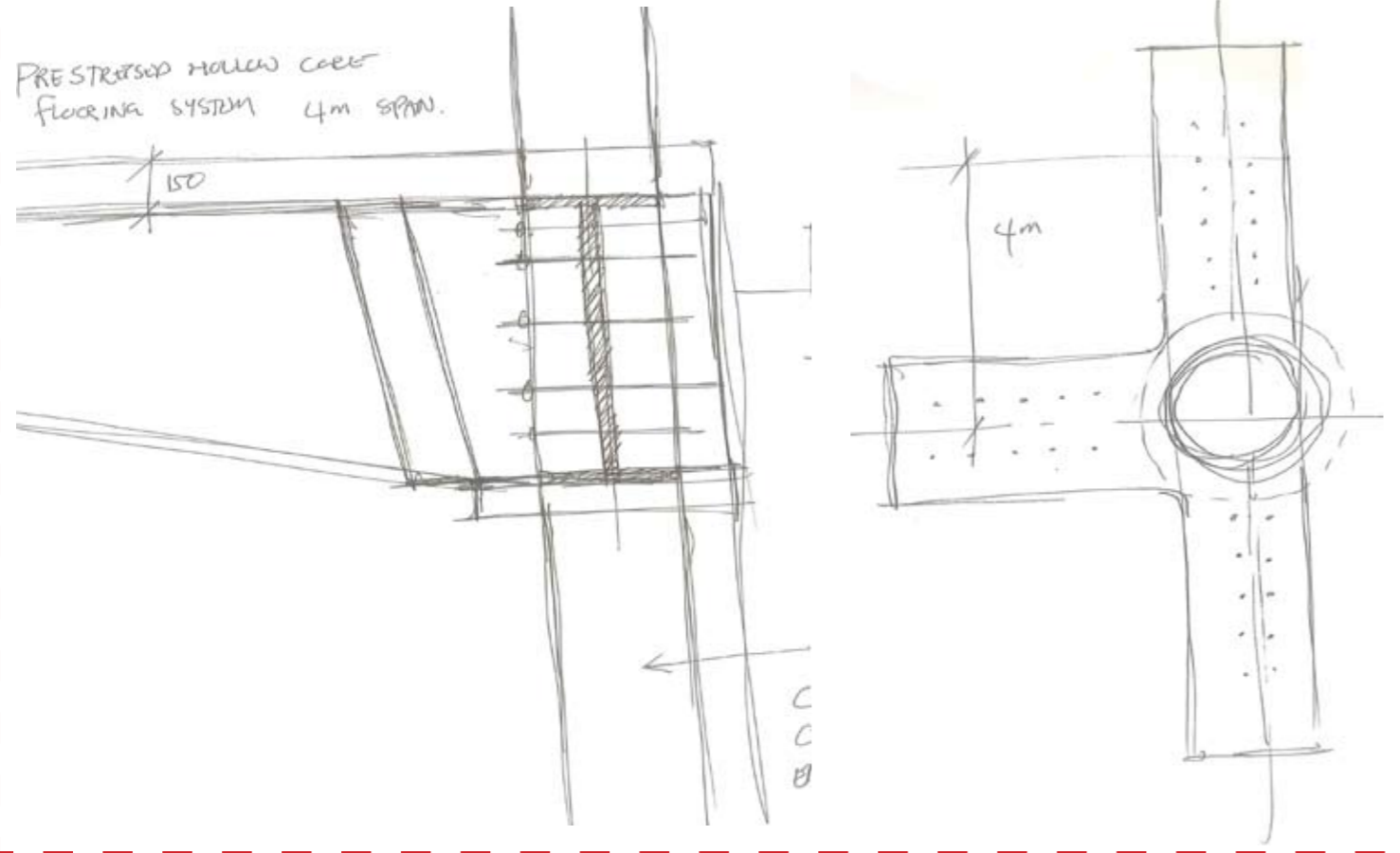

Climatic Performance

The climatic performance of the building is a result of the skin, therefore strategies involving sun breaks, passive ventilation and air conditioning systems are employed. The 4 panel system which is suggested for the skin allows parts of the space inside to be heated or cooled. Heating of the space will occur through the glass panels allowing sunlight through. Through reradiating sunlight and convection passive ventilation will occur. Solid panels will be inserted into the skin where less sunlight and heat is wanted. The auditorium needs air conditioning, with air being introduced through the ceiling, circulating through the entire space and being returned from the back of the auditorium. The plant room is situated below the auditorium, and has a chimney that sucks in clean air from above the Monster.

Texture

The textures of the materials like the handrail are deliberate so as to physically manifest the theory. The in-fill panels of the handrail follow a gradual transition from obscure glass to clear glass. Textures of the floor finish materials also contribute to the progression of the spaces. From a smooth Epoxy monotonous floor finish, to grainier ceramic tiles and finally brick paver units laid out in circular patterns. Various textures are employed from smooth to rough, these textures follow and express the different parts of the building. This is also done to further define the male and female parts of the space. As the skin portrays these qualities to the outside the textures will to the inside.

The resultant light qualities from the textures and material choices materialize the theory visibly. Light would reflect from the different materials and textures in unique ways. Thus subtly further enhancing the definition of those spaces. The handrail panels are a transitory progression from obscure to transparent glass. The handrail has a fluorescent light concealed in the power skin. The obscure glass would absorb and emit this light at night. The light being emitted would clearly communicate the progression from ethereality to clarity. Where the Monster and the new parking garage touch a wall cladding is suggested which will reflect natural light into the walkways, which is predicted to be the darkest areas of the building. During the day natural light will filter through the skin lighting up the spaces behind. This is done to minimize the use of artificial lighting during the day.

Acoustics and noise

The planning of the building was modified in such a manner as to dampen and lessen the effect of the noise produced by Lynwood Road. The acoustic absorbing materials were placed to enhance their effectiveness. Acoustic absorbing and isolating bands were employed to mainly to the South where all the traffic noise occurs. The acoustic qualities of the auditorium can be dealt with by a specialist.

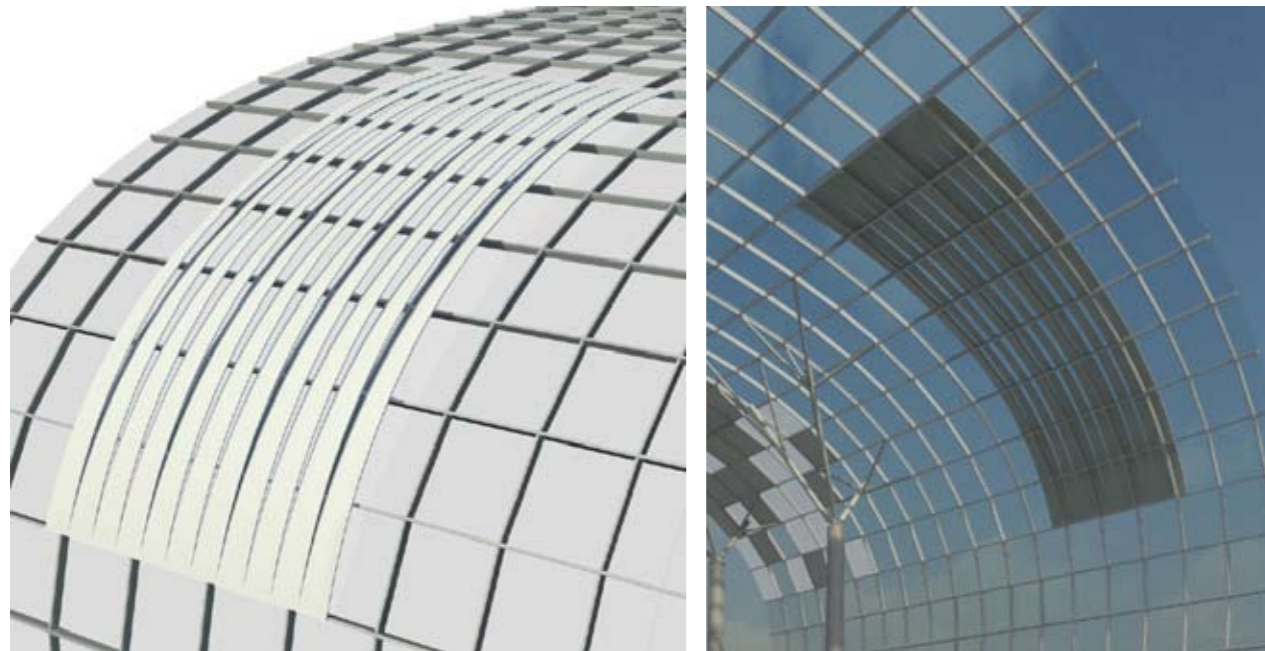

What I have done.

I explored ways to transform liminality into a building. Various devices were investigated to facilitate the transition from abstract concept into architectural possibility. The final product is a fusion of theoretical notions and technology expressed as a hybridized typology, all these qualities are arranged in ways not experienced every day, resulting in the Monster.

What are its limitations?

The Monster is functionally specific and does not allow for further flexibility.

What is its Future?

The Monster as is will be built as is. Further extensions of the building are possible. Currently no further additions are envisaged due to the functional limitation.

What will its impact on the University be?

The Monster acts as the threshold to the University grounds. All the students and visitors who pass through it would see the University in a different light. The University can gain financially as well from the Monster through its rentable conference centre.

What is its iconic significance to context of Tshwane?

The faceted skin fuses the new with the reflections of the existing. The skin is imbued with a unique sense of iconic imagery through the technique of integration. By reinvigorating these icons of the past legacy with contemporary conditions a symbolic unity is created.

How will it transform the self-perception of the students and staff?

As the awareness of the intent of the University by the students and staff becomes greater, the possibilities open up to pushing the boundaries of the system. The students and staff will perceive themselves within this system. The students will become aware of their liminal state as students. The transformation into this self-perception would result in greater understanding of circumstances and opportunities.



REFERENCES

- Ardalan, N and Bakhtiar, L. (1973) A sense of Unity. Chicago and London: The university of Chicago Press
- Brown, D. (2008). Zlote Tarasy. Arup Journal 43(1), 31-54
- Ching, F D.K. (1996) Architecture - Form, Space and Order. USA: John Wiley & Sons, Inc.
- Dodds, G. (1992) On the Place of Architectural Speculation. Journal of Architectural Education, Vol. 46, No. 2. (November): 76-86.
- Ferre, A; Hwang, I; Kubo, M; Prat, R; Sakamoto, T and Tetas, A. (2005) Verb Conditioning. European Union: Ingoprint
- Koolhaas, R. (1997). S M L XL. Monacelli Press.
- Lynch, K. (1960) The Image of the City. Cambridge, Mass: MIT Press.
- Norberg-Schulz, C. (1971). Existence, Space & Architecture. London: Studio Vista Limited.
- Oosterhuis, K. (2003) Hyperbodies - Towards as E-motive Architecture. Switzerland: Birkhauser - Publishers for Architecture.
- Repenning, S S. (2003). An Architecture Of Liminality. M.Arch. thesis, University of Cincinnati, Ohio.
- INTERNET**
 Crossroads. Wikipedia. INTERNET.
http://en.wikipedia.org/wiki/Crossroads_%28culture%29
 Cited 24 February 2008.
- Gateway, INTERNET
www.wiktionary.org/wiki/gateway.html
 Cited October 2008.
- Hyposurface. INTERNET.
<http://www.hyposurface.org/>
 Cited 15 July 2008
- Liminality. Wikipedia. INTERNET.
<http://en.wikipedia.org/wiki/Liminality>
 Cited 24 February 2008.
- Liminal Beings. Wikipedia. INTERNET.
http://en.wikipedia.org/wiki/Liminal_beings
 Cited 15 June 2008.
- Nest. INTERNET.
<http://www.patriciapiccinini.net>
 Cited 8 July 2008
- Palmer, R E (2001) The Liminality of Hermes and the Meaning of Hermeneutics. INTERNET
<http://www.mac.edu/faculty/richardpalmer/liminality.html>
 Cited 2 March 2008
- Silumin. INTERNET.
<http://en.wikipedia.org/wiki/Silumin>
 Cited November 2008
- Smith, C (2000). Looking for liminality in architectural space. INTERNET.
http://limen.mi2.hr/limen1-2001/catherine_smith.html
 Cited 2 March 2008.

IMAGE LIST

1. Aerial photo of University of Pretoria Hatfield Campus. (sourced from: Departement Geografie. UP)
2. Edited Aerial photo zoom in on main entrance. (sourced from: Departement Geografie. UP)
3. Lynch diagram: Path (Lynch, K (1960) The Image of the City. Cambridge, Mass: MIT Press)
4. Lynch diagram: Gateway (Lynch, K (1960) The Image of the City. Cambridge, Mass: MIT Press)
5. Lynch diagram: Node (Lynch, K (1960) The Image of the City. Cambridge, Mass: MIT Press)
6. Lynch diagram: Edge (Lynch, K (1960) The Image of the City. Cambridge, Mass: MIT Press)
7. Lynch diagram: Precinct (Lynch, K (1960) The Image of the City. Cambridge, Mass: MIT Press)
8. Crossroads (www.madamtalbot.com) Cited 2 March 2008
9. ADA space (www.Oosterhuis.nl)
10. A human self portret - rearranged to create a monster (www.selfportret.net)
11. Manimal (http://inventorspot.com/articles/manimals_13736) Cited 9 July 2008
12. Manimal (http://inventorspot.com/articles/manimals_13736) Cited 9 July 2008
13. Manimal (http://inventorspot.com/articles/manimals_13736) Cited 9 July 2008
14. Man carving his own destiny (<http://www.orlandofloridaguide.com/museums/albin.htm>) Cited 4 October
15. Horse (<http://gifts.cafepress.com/item/leonardo-da-vinci-horse-keepsake-box/185432565>) Cited 4 October
16. Centaur (<http://www.timelessmyths.com/classical/centaurs.html>) Cited 4 October
17. Parking Study - 2000 UP framework
18. Shapeshifting Lampshade (<http://www.nendo.jp/en/works/detail.php?g=furniture&t=71>) Cited 27 February
19. Zaha Hadid - Serpentine Pavilion
(http://www.serpentinegallery.org/2007/03/serpentine_gallery_commissionz.html) Cited 3 March 2008
20. Zaha Hadid - Table [Cited 3 March 2008]
(<http://www.ultrafeel.tv/wp-content/uploads/image/design/zaha-hadid/zaha-hadid-mesa-design-table-1.jpg>)
21. Watch (<http://www.ofrei.com/images/eta6497gpeb.jpg>) Cited 24 June 2008
22. Federation Square - Melbourne (http://www.gaa.com.au/case_studies/case_fsm.html)
23. Centaur (<http://www.timelessmyths.com/classical/centaurs.html>) Cited 4 October
24. Arc Architects (2007) - Rendering of new parking garage
25. Arc Architects (2007) - Lower Ground (unpublished working drawings)
26. Arc Architects (2007) - Rendering of new parking garage
27. Arc Architects (2007) - Rendering of new parking garage
28. Arc Architects (2007) - Upper Ground (unpublished working drawings)
29. Hyperbody [Cited April 2008]
(<http://iaac-digitalarchitecture.blogspot.com/2007/10/performative-architecture-as-complex.html>)
30. Vacuum Molding [Cited 10 March 2008]
(<http://www.conceptplastics.ca/default.asp?mn=1.4&id=190&pagesize=1&sfid=MenuId&search=4>)
31. Vacuum Molding [Cited 10 March 2008]
(<http://www.conceptplastics.ca/default.asp?mn=1.4&id=190&pagesize=1&sfid=MenuId&search=4>)
32. Vacuum Molding [Cited 10 March 2008]
(<http://www.conceptplastics.ca/default.asp?mn=1.4&id=190&pagesize=1&sfid=MenuId&search=4>)
33. ADA space (www.Oosterhuis.nl) Cited April 2008
34. ADA space (www.Oosterhuis.nl) Cited April 2008
35. ADA space (www.Oosterhuis.nl) Cited April 2008
36. Will Alsop - Sharp Design Centre
(http://canada.archiseek.com/ontario/toronto/ocad/images/10_lge.jpg) Cited 14 August 2008
37. Will Alsop - Sharp Design Centre [Cited 14 August 2008]
(http://lh6.ggpht.com/chauandrew/R0UbVae_s3l/AAAAAAAAA28/FNd5x6Uv-NM/Will+Alsop+Toronto+OCAD.jpg)
38. A human self portret - rearranged to create a monster (selfportret.net)
39. Patricia Pecinni - Nest (<http://www.patriciapiccinini.net>) Cited 8 July 2008
40. Hertzog & de Mournon - De Yong Art Centre (http://www.tropolism.com/IMG_6996.JPG)
41. Will Alsop - Sharp Design Centre [Cited 14 August 2008]
(http://lh6.ggpht.com/chauandrew/R0UbVae_s3l/AAAAAAAAA28/FNd5x6Uv-NM/Will+Alsop+Toronto+OCAD.jpg)
42. Hyposurface (http://www.erratica.us/wp-content/uploads/2007/05/aegis_hyposurface_image_003.jpg)
43. Toyo Ito - Library
(http://archive-www.smt.city.sendai.jp/ja/data/mediatheque/competition/images/competition1_l.gif)
44. Centaur (<http://www.timelessmyths.com/classical/centaurs.html>) Cited 4 October

- 47 Nox - Son-o-house (<http://www.evdh.net/sonohouse/index.html>) Cited 3 September 2008
- 48 MASSIMILIANO FUKSAS: CONGRESS CENTRE, MILAN
(http://www.arcspace.com/architects/Fuksas/congress_index.htm)
- 49 ATELIER HAPSITUS - THE CLOUD, DUBAI
(<http://travel.anlattube.com/dubai-10-the-cloud.htm>) Cited 10 August 2008
- 50 NOX H2O EXPO (<http://www.classic.archined.nl/news/9701/nox-in1.JPG>)
- 51 Frank Gehry - Experience Music Centre [Cited 10 July 2008]
(http://kevinkovaleski.com/gallery/AcrossTheNation/Frank_Gehry_s_Experience_Music_Project_1_Seattle)
- 52 MASSIMILIANO FUKSAS: CONGRESS CENTRE, MILAN
(http://www.arcspace.com/architects/Fuksas/congress_index.htm)
- 53 Toyo Ito - Library
(http://archive-www.smt.city.sendai.jp/ja/data/mediatheque/competition/images/competition1_l.gif)
- 54 NOX H2O EXPO (<http://www.classic.archined.nl/news/9701/nox-in1.JPG>)
- 55 NOX H2O EXPO (<http://www.classic.archined.nl/news/9701/nox-uit1.JPG>)
- 56 Nox - Son-o-house (<http://www.evdh.net/sonohouse/index.html>) Cited 3 September 2008
- 57 Lace (http://images.teamsugar.com/files/upl1/6/61259/17_2008/timorous-beasties.preview.jpg)
- 58 Lace (http://images.teamsugar.com/files/upl1/6/61259/17_2008/timorous-beasties.preview.jpg)
- 59 Jean Nouvel - Abu Dabi Dome [Cited 3 September]
(<http://www.changemymanbags.com/2007/09/jean-nouvel-leaves-louvre-museum-in-abu.html>)
- 60 Jean Nouvel - Abu Dabi Dome [Cited 3 September]
(<http://www.changemymanbags.com/2007/09/jean-nouvel-leaves-louvre-museum-in-abu.html>)
- 61 Catia - Eiffel Tower (<http://en.wikipedia.org/wiki/Image:EiffelCATIALeg.jpg>) Cited 3 September 2008
- 62 Catia - Generic Images (www.wikipedia.com/Catia) Cited 3 September 2008
- 63 Catia - Generic Images (www.wikipedia.com/Catia) Cited 3 September 2008
- 64 Catia - Generic Images (www.wikipedia.com/Catia) Cited 3 September 2008
- 65 Catia - Generic Images (www.wikipedia.com/Catia) Cited 3 September 2008
- 66 Kas Oosterhuis - Web [Building Process] computer design
(<http://www.oosterhuis.nl/quickstart/index.php?id=43>) Cited 3 September 2008
- 67 Kas Oosterhuis - Web [Building Process] structural analysis
(<http://www.oosterhuis.nl/quickstart/index.php?id=43>) Cited 3 September 2008
- 68 Kas Oosterhuis - Web [Building Process] structural analysis
(<http://www.oosterhuis.nl/quickstart/index.php?id=43>) Cited 3 September 2008
- 69 Kas Oosterhuis - Web [Building Process] structural analysis
(<http://www.oosterhuis.nl/quickstart/index.php?id=43>) Cited 3 September 2008
- 70 Kas Oosterhuis - Web [Building Process] structural analysis
(<http://www.oosterhuis.nl/quickstart/index.php?id=43>) Cited 3 September 2008
- 71 Kas Oosterhuis - Web [Building Process] flattened structural pieces
(<http://www.oosterhuis.nl/quickstart/index.php?id=43>) Cited 3 September 2008
- 72 Kas Oosterhuis - Web [Building Process] flattened structural pieces
(<http://www.oosterhuis.nl/quickstart/index.php?id=43>) Cited 3 September 2008
- 73 Kas Oosterhuis - Web [Building Process] lazer cut from steel
(<http://www.oosterhuis.nl/quickstart/index.php?id=43>) Cited 3 September 2008
- 74 Kas Oosterhuis - Web [Building Process] assembled in workshop
(<http://www.oosterhuis.nl/quickstart/index.php?id=43>) Cited 3 September 2008
- 75 Kas Oosterhuis - Web [Building Process] lazer cut from steel
(<http://www.oosterhuis.nl/quickstart/index.php?id=43>) Cited 3 September 2008
- 76 Kas Oosterhuis - Web [Building Process] assembled in workshop
(<http://www.oosterhuis.nl/quickstart/index.php?id=43>) Cited 3 September 2008
- 77 Kas Oosterhuis - Web [Building Process] assembled on site
(<http://www.oosterhuis.nl/quickstart/index.php?id=43>) Cited 3 September 2008
- 78 Kas Oosterhuis - Web [Building Process] assembled on site
(<http://www.oosterhuis.nl/quickstart/index.php?id=43>) Cited 3 September 2008
- 79 Kas Oosterhuis - Web [Building Process] assembled on site
(<http://www.oosterhuis.nl/quickstart/index.php?id=43>) Cited 3 September 2008
- 80 Massimiliano Fuksas - Milan Fair
(http://designbeans.com/images/specials/salone%202006/06_newfair_fuksas-04.jpg)
- 81 Toyo Ito - Pavilion in Brugge (http://rWSC2.inforce.dk/graphics/Current_Architecture/Articles/wickerwork/1.jpg)
- 82 Zlote Tarasy - Glasing System (Arup Journal 01/2008)
- 83 Zlote Tarasy - Glasing System [Gasket Installation] (Arup Journal 01/2008)
- 84 Zlote Tarasy - Glasing System [Glasing Sealant] (Arup Journal 01/2008)
- 85 Zlote Tarasy - Node [Stress Test] (Arup Journal 01/2008)
- 86 Zlote Tarasy - Node [Computer Model] (Arup Journal 01/2008)
- 87 Skin - Department Store (Ferre, A; Hwang, I; Kubo, M; Prat, R; Sakamoto, T and Tetas, A. (2005) Verb Conditioning. European Union: Ingoprint)
- 88 Nicolas Grimshaw - Train Station [p 90] (Grimshaw, N and Powell, K. (1993) Structure, Space and Skin: The Work of Nicholas Grimshaw & Partners. London: Phaidon Press)
- 89 Social Demographics (<http://www.sacities.net/2004/Chapter3.pdf>) cited 15 june 2008
- 90 Social Demographics (<http://www.sacities.net/2004/Chapter3.pdf>) cited 15 june 2008
- 91 Social Demographics (<http://www.sacities.net/2004/Chapter3.pdf>) cited 15 june 2008
- 92 Daylight (<http://www.gaisma.com/en/location/pretoria.html>) [Cited 13 August 2008]
- 93 Sunangles (<http://www.gaisma.com/en/location/pretoria.html>) [Cited 13 August 2008]
- 94 Sunlight (Sculze, B, R. (1982). Climate of south Africa. Part 8, General Survey. Department of Transport, Weather Bureau. Pretoria)
- 95 Wind Roses - Summer (Sculze, B, R. (1982). Climate of south Africa. Part 8, General Survey. Department of Transport, Weather Bureau. Pretoria)
- 96 Wind Roses - Winter (Sculze, B, R. (1982). Climate of south Africa. Part 8, General Survey. Department of Transport, Weather Bureau. Pretoria)
- 97 Renzo Piano Details
(Buchanan, P. (2000) Renzo Piano Building Workshop - Volume 4. London: Phaidon Press)
- 98 Renzo Piano Details
(Buchanan, P. (2000) Renzo Piano Building Workshop - Volume 4. London: Phaidon Press)
- 99 Nano Structure Programmable matter [Cited 19 October 2008]
(<http://www.cs.utk.edu/~mclennan/UPIM/index.html>)
- 100 Utility Fog (<http://www.nanotech-now.com/images/foglet1-large.jpg>) [Cited 19 October 2008]
- 101 Utility Fog (<http://www.nanotech-now.com/images/foglet2-large.jpg>) [Cited 19 October 2008]

Note: All drawings not listed by I. Coetzee 2008.

APPENDIX 1: TECHNICAL DRAWINGS

APPENDIX 2: CONTEXTUAL DATA

SOCIAL DEMOGRAPHICS

SOCIAL DEMOGRAPHICS

Social demographic studies support the perception that there are students in the 'student' world. People from different age groups are situated outside in the 'real' world.

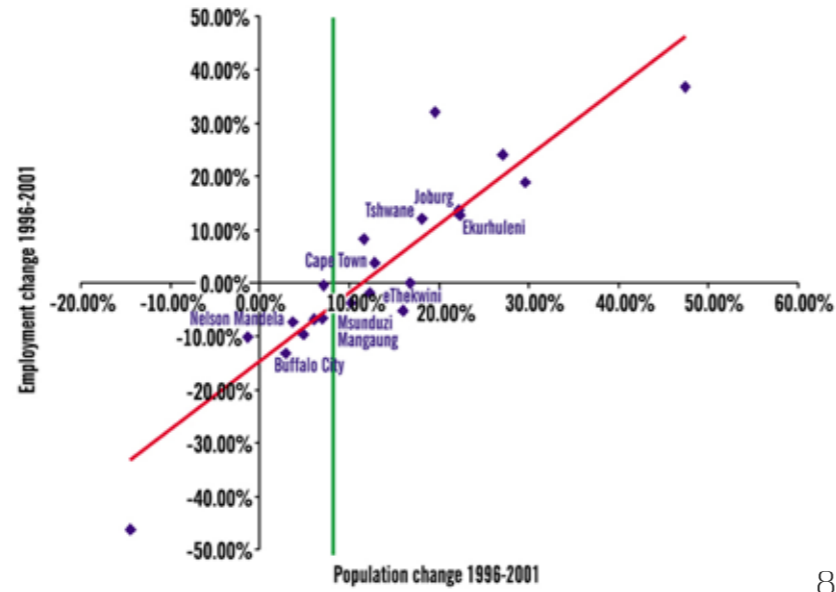

89

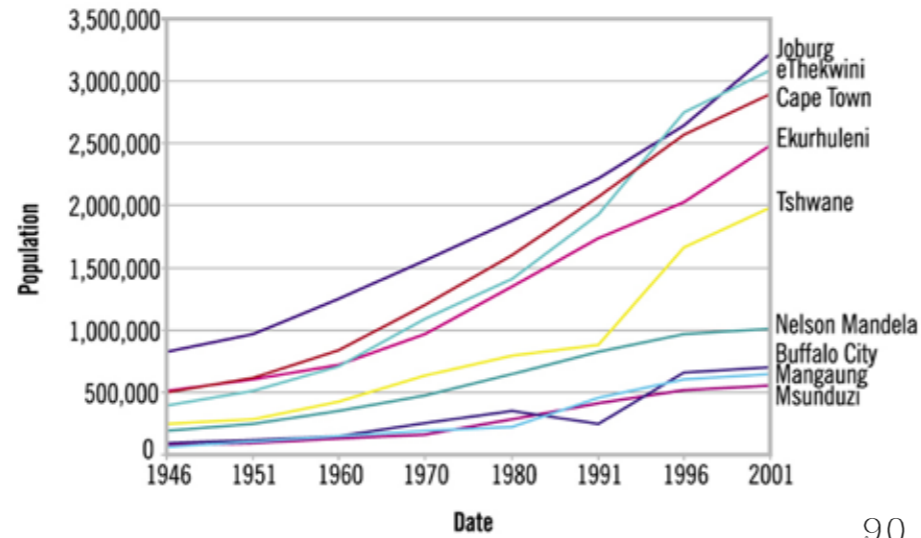

90

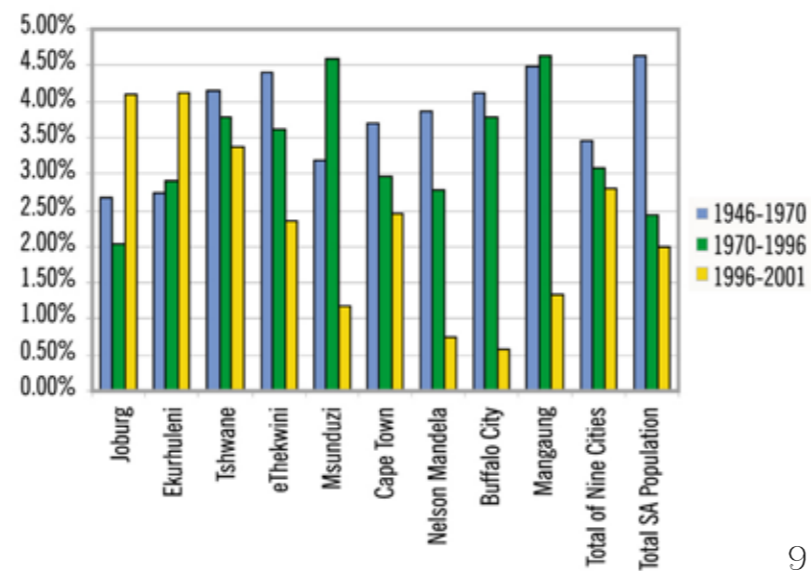

91

UNIVERSITY OF PRETORIA
NUMBER OF STUDENTS AS ON THE FIRST TUESDAY OF JUNE 2007 (Cancellations deducted)*

1. RACE GROUP : TOTAL

FACULTY	UNDERGRADUATES									POST GRADUATES			TOTAL			% Increase/Decrease wrt 2006
	FIRST TIME ENTRANTS			OTHER			TOTAL			MALE	FEMALE	TOTAL	MALE	FEMALE	TOTAL	
	MALE	FEMALE	TOTAL	MALE	FEMALE	TOTAL	MALE	FEMALE	TOTAL							
FULL-TIME																
01 HUMANITIES	462	817	1279	847	1824	2671	1300	2641	3950	378	776	1154	1687	3417	5104	5.96%
02 NATURAL AND AGRICULTURAL SCIENCES	527	615	1142	1136	1459	2595	1963	2074	3737	693	676	1369	2356	2750	5106	0.37%
04 LAW	124	208	332	571	866	1437	696	1074	1769	30	29	59	725	1103	1828	-1.19%
05 THEOLOGY	39	20	59	124	61	185	163	81	244	319	73	392	482	154	636	3.75%
07 ECONOMIC AND MANAGEMENT SCIENCES	810	1045	1855	2390	2726	5116	3200	3771	6971	876	873	1749	4076	4644	8720	-0.63%
08 VETERINARY SCIENCE	8	28	36	180	338	498	168	366	534	61	62	123	229	428	657	4.95%
09 EDUCATION	225	455	680	431	1272	1703	656	1727	2383	162	340	502	818	2067	2885	18.09%
10 HEALTH SCIENCES	88	251	339	644	1632	2276	732	1883	2615	259	260	519	991	2143	3134	0.64%
12 ENGINEERING, BUILT ENVIRONMENT AND INFORMATION TECHNOLOGY	924	347	1271	2983	1108	4091	3907	1456	5362	739	274	1013	4646	1729	6375	0.77%
TOTAL	3207	3786	6993	9286	11286	20572	12493	15672	27565	3517	3363	6880	16010	18435	34445	2.36%
PART-TIME																
01 HUMANITIES	0	0	0	1	1	2	1	1	2	58	120	178	59	121	180	-32.33%
02 NATURAL AND AGRICULTURAL SCIENCES	0	0	0	3	12	15	3	12	15	54	54	108	57	60	123	-30.90%
04 LAW	0	0	0	0	1	1	0	1	1	112	94	206	112	95	207	-18.50%
05 THEOLOGY	0	0	0	0	0	0	0	0	0	65	7	72	65	7	72	-30.77%
07 ECONOMIC AND MANAGEMENT SCIENCES	0	0	0	2	0	2	2	0	2	194	102	296	196	102	298	+16.29%
08 VETERINARY SCIENCE	0	0	0	0	1	1	0	1	1	49	60	109	49	61	110	44.74%
09 EDUCATION	0	0	0	1	5	6	1	5	6	130	235	365	131	240	371	-50.86%
10 HEALTH SCIENCES	21	57	78	35	577	612	56	634	690	268	340	608	324	974	1298	1.80%
12 ENGINEERING, BUILT ENVIRONMENT AND INFORMATION TECHNOLOGY	0	0	0	0	0	0	0	0	0	1146	383	1531	1146	383	1531	3.87%
TOTAL	21	57	78	42	597	639	63	654	717	2878	1385	3473	2141	2049	4190	-11.57%
GRAND TOTAL (FULL-TIME + PART-TIME)																
01 HUMANITIES	462	817	1279	848	1825	2673	1310	2642	3952	436	896	1332	1746	3538	5284	3.95%
02 NATURAL AND AGRICULTURAL SCIENCES	527	615	1142	1139	1471	2610	1966	2086	3752	747	730	1477	2413	2816	5229	-0.68%
04 LAW	124	208	332	571	867	1438	696	1075	1770	142	123	265	837	1198	2035	-3.28%
05 THEOLOGY	39	20	59	124	61	185	163	81	244	384	80	464	547	161	708	-1.26%
07 ECONOMIC AND MANAGEMENT SCIENCES	810	1045	1855	2392	2726	5118	3202	3771	6973	1070	975	2045	4272	4746	9018	-1.24%
08 VETERINARY SCIENCE	8	28	36	180	339	498	168	367	535	110	122	232	278	489	767	9.26%
09 EDUCATION	225	455	680	432	1277	1709	657	1732	2389	292	575	867	949	2307	3256	1.81%
10 HEALTH SCIENCES	109	308	417	679	2209	2888	788	2517	3305	527	600	1127	1315	3117	4432	0.98%
12 ENGINEERING, BUILT ENVIRONMENT AND INFORMATION TECHNOLOGY	924	347	1271	2983	1108	4091	3907	1456	5362	1887	657	2544	5794	2112	7906	1.36%
TOTAL	3228	3843	7071	9328	11883	21211	12556	15726	28282	5595	4758	10353	18151	20484	38635	0.64%

*These numbers represent:
1. Net enrolment numbers, viz cancellations deducted
2. A headcount, viz should a student be enrolled for more than one course of study, the student is counted only once.

% Increase/Decrease wrt 2006: 0.72% -2.11% -0.84% 0.36% 0.87% 0.65% 0.45% 0.13% 0.27% 1.86% 1.45% 1.67% 0.88% 0.43% 0.64%

Student numbers

Pretoria, South Africa

Latitude: 25°44'S Longitude: 028°11'E Elevation: 1330m Station: UA68262

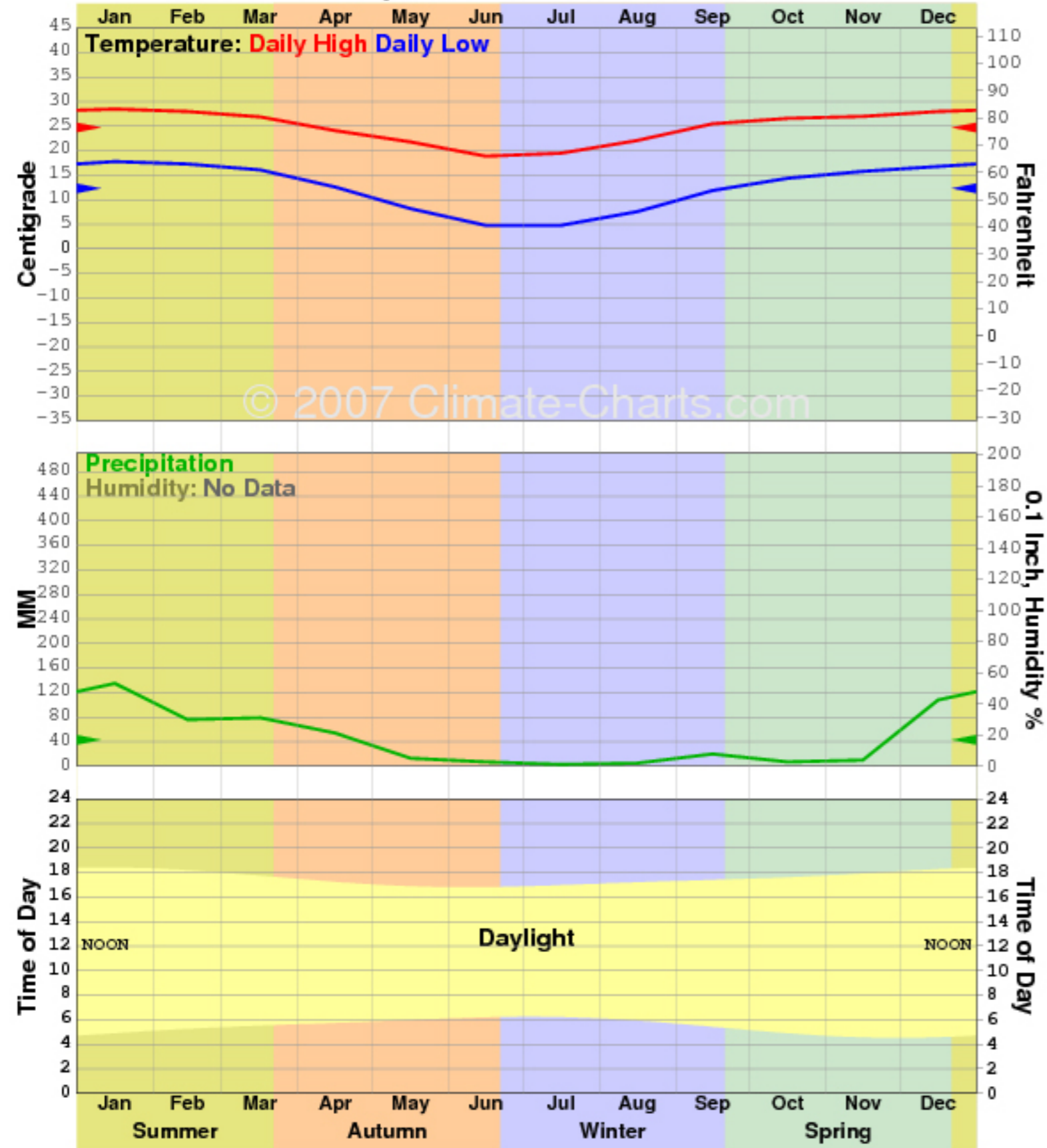

Date	Sunrise	Sunset	Length	Change	Dawn	Dusk	Length	Change
Today	06:37	17:47	11:10		06:13	18:11	11:58	
+1 day	06:36	17:48	11:12	00:02 longer	06:12	18:11	11:59	00:01 longer
+1 week	06:31	17:50	11:19	00:09 longer	06:07	18:14	12:07	00:09 longer
+2 weeks	06:24	17:53	11:29	00:19 longer	06:01	18:16	12:15	00:17 longer
+1 month	06:08	17:59	11:51	00:41 longer	05:45	18:22	12:37	00:39 longer
+2 months	05:35	18:12	12:37	01:27 longer	05:12	18:35	13:23	01:25 longer
+3 months	05:12	18:30	13:18	02:08 longer	04:48	18:55	14:07	02:09 longer
+6 months	05:50	18:52	13:02	01:52 longer	05:26	19:16	13:50	01:52 longer

SOLAR ENERGY AND SURFACE METEOROLOGY

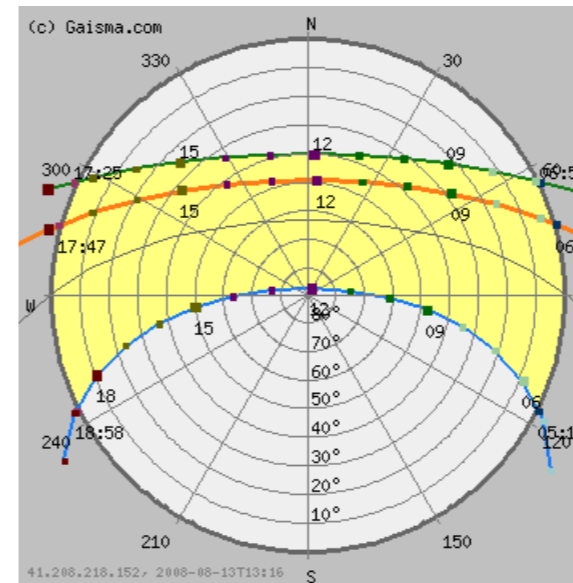

Variable	I	II	III	IV	V	VI	VII	VIII	IX	X	XI	XII
Insolation, kWh/m ² /day	6.70	6.10	5.46	4.77	4.21	3.80	4.08	4.78	5.69	5.98	6.29	6.62
Clearness, 0 - 1	0.57	0.55	0.56	0.59	0.64	0.65	0.66	0.65	0.64	0.58	0.55	0.56
Temperature, °C	22.23	22.11	21.07	18.66	15.25	11.61	11.46	14.61	18.50	20.20	20.85	21.36
Wind speed, m/s	3.62	3.50	3.37	3.54	3.74	4.04	4.18	4.74	4.95	4.73	4.31	3.77
Precipitation, mm	134	75	79	56	12	8	3	6	20	75	103	114
Wet days, d	13.3	9.9	10.4	7.0	2.4	1.5	0.9	1.9	2.9	8.5	12.2	13.9

Sun path	
Today	
June 21	
December 21	
Annual variation	
Equinox (March and September)	

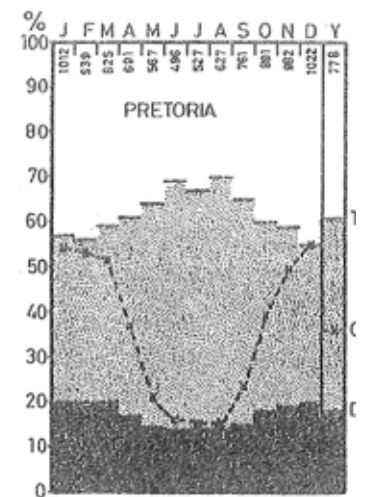

WIND ROSES

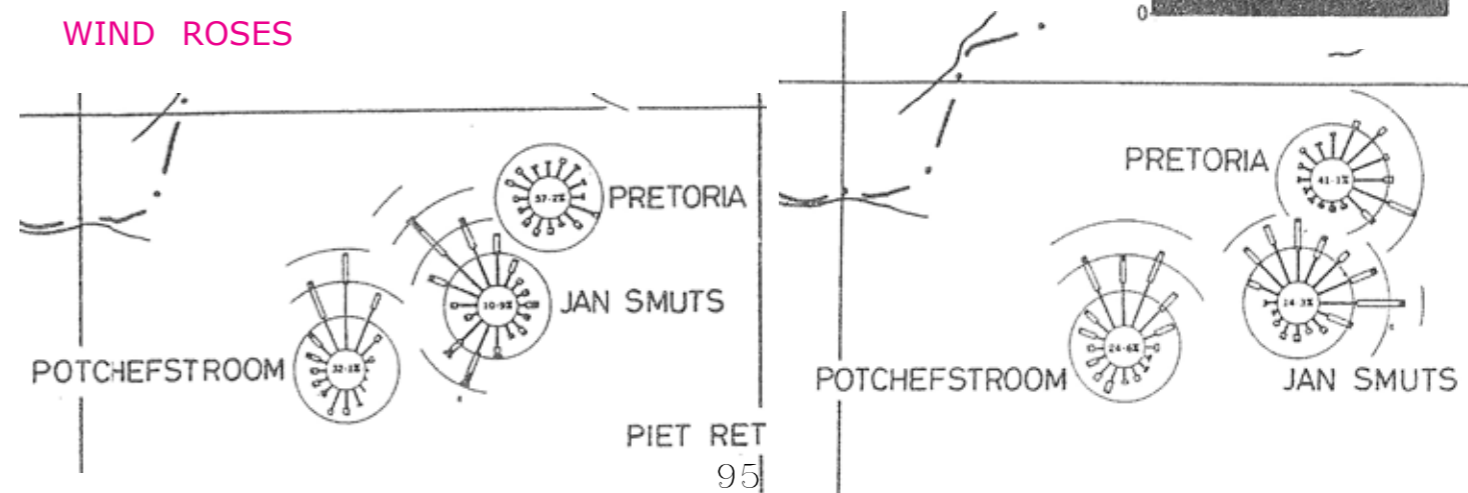

92

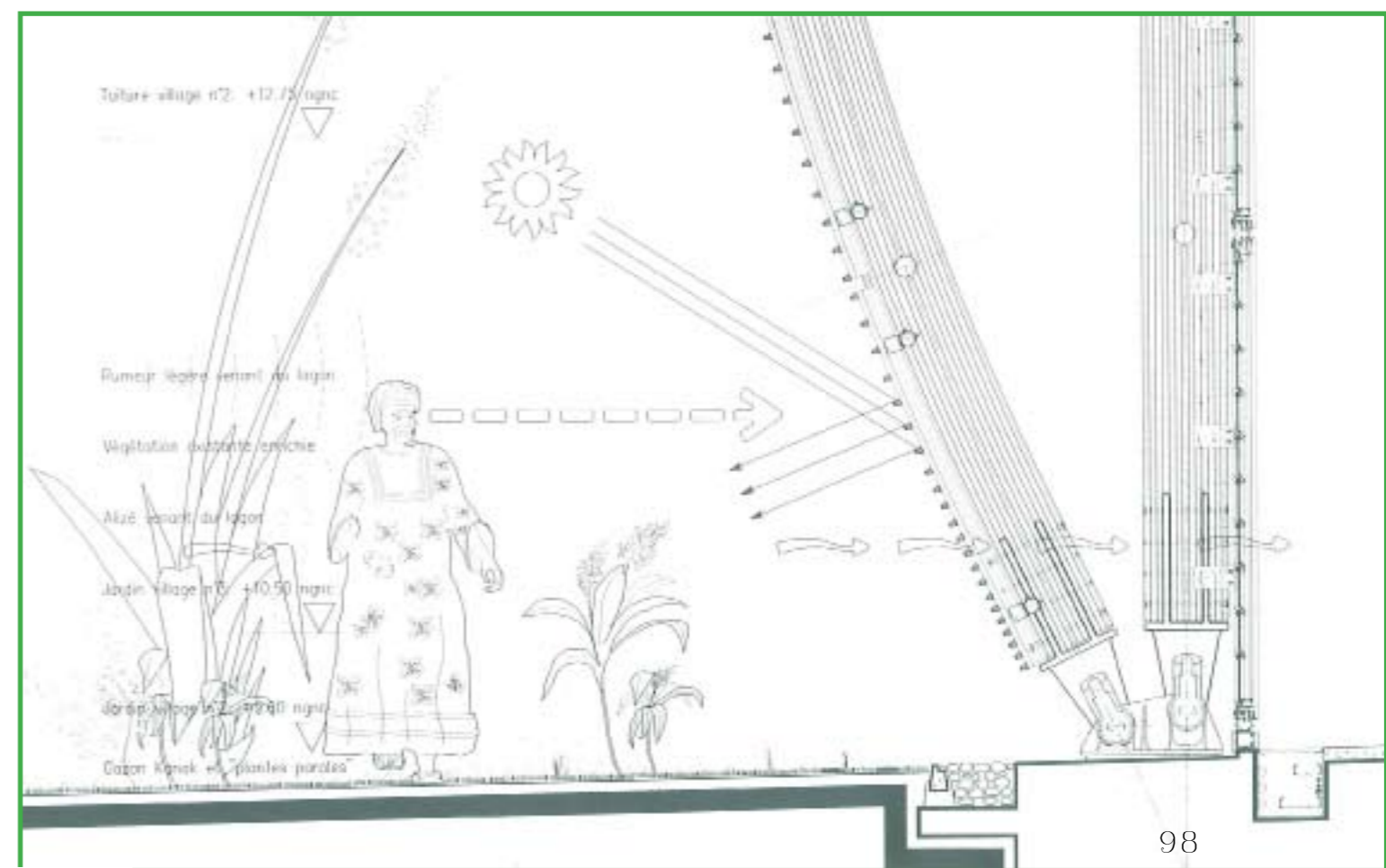
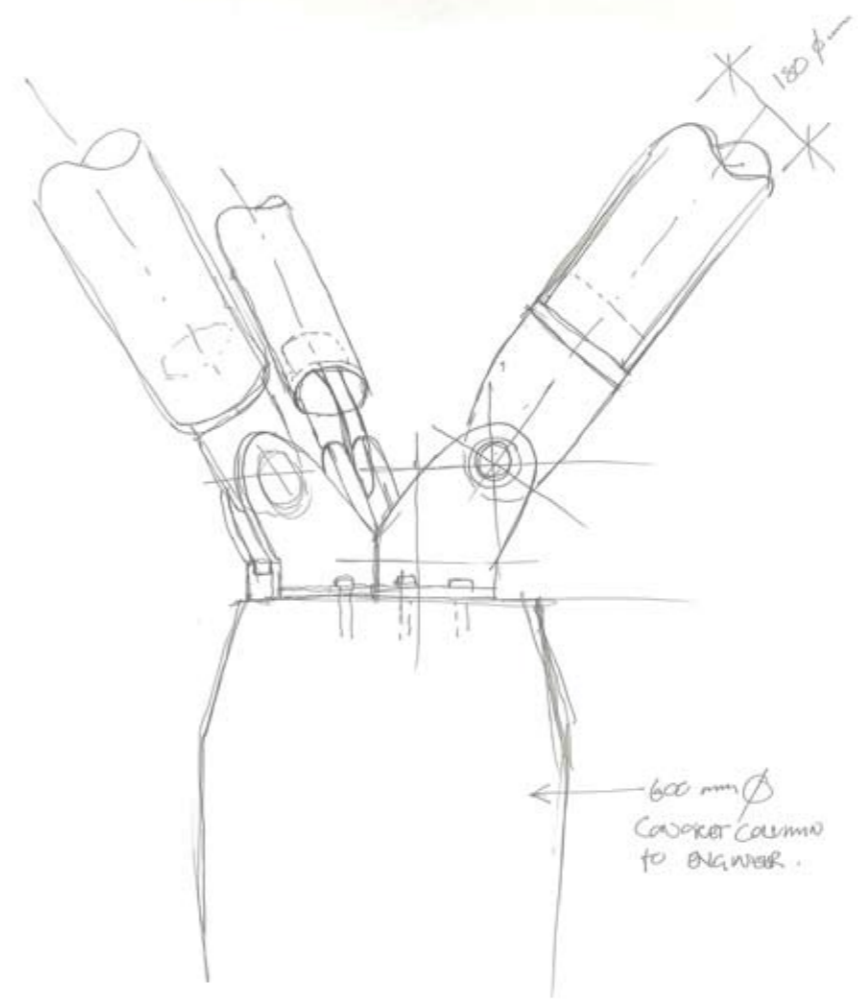
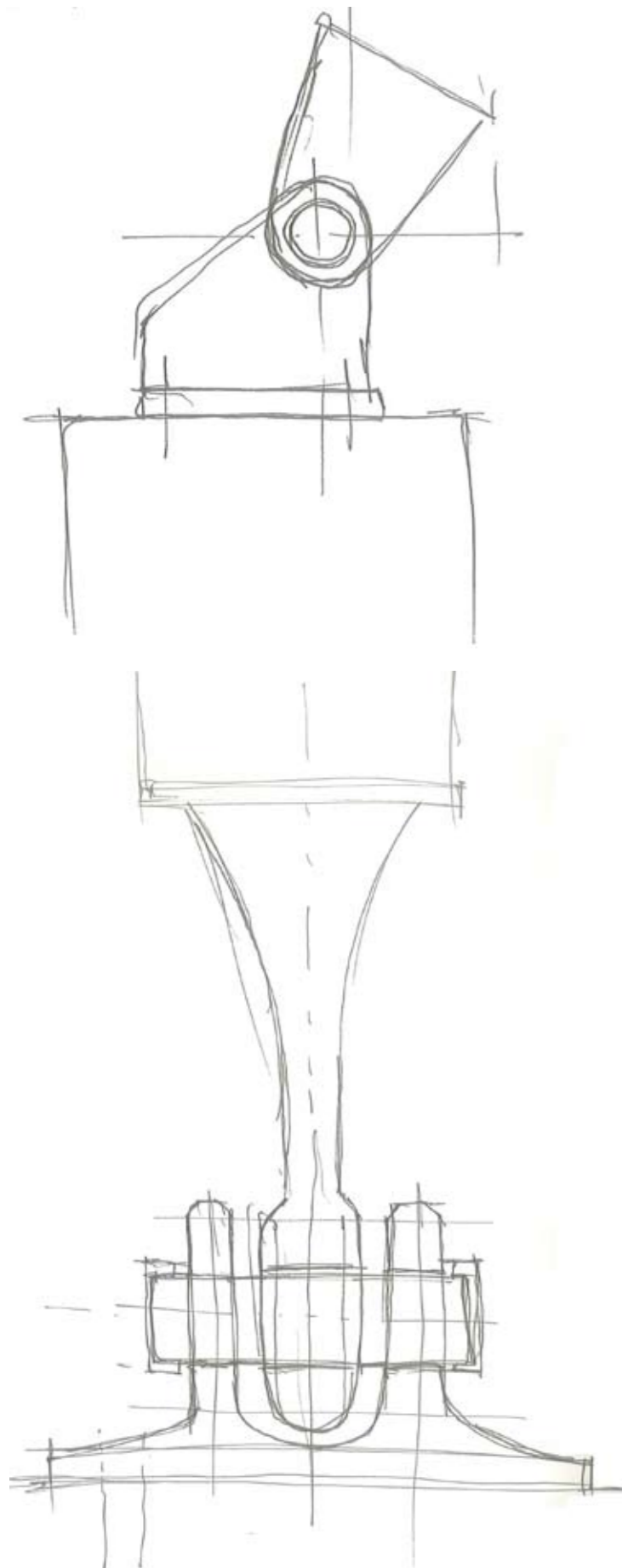

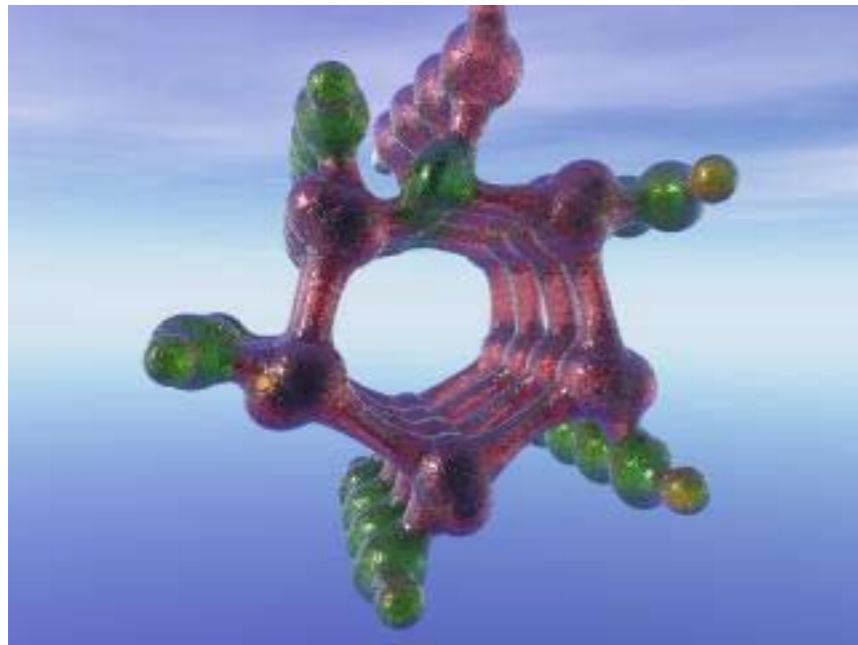

99

Technology was found which will materialise the concept. It is called programmable matter, a very advanced form of computer technology. Programmable matter is a very evolved form of the semiconductor.

Programmable matter is located in the meso scale, is a smaller factor than Nano.

Artificial atoms or quantum dots are very important in this technology. Artificial atoms are used in every computer today. It is a store which houses electrons. Like a kraal, it allows electrons out as needed. These artificial atoms don't have a normal atom centre and the electrons move in a 2d field around the kraal.

Programmable matter is these artificial atoms arranged in a 3d nano structure (fig. 99). Thus it would be nano scale strands. These strands would be weaved into a fabric like material or bulk material.

The material can then be programmed to assume the appearance of any matter.

Programmable matter look like any material imaginable and can be formed into any form with the aid of utility fog.

Therefore in the portal, it can create any world - real or fantasy. This created world would be real, essentially to the nano scale.



100

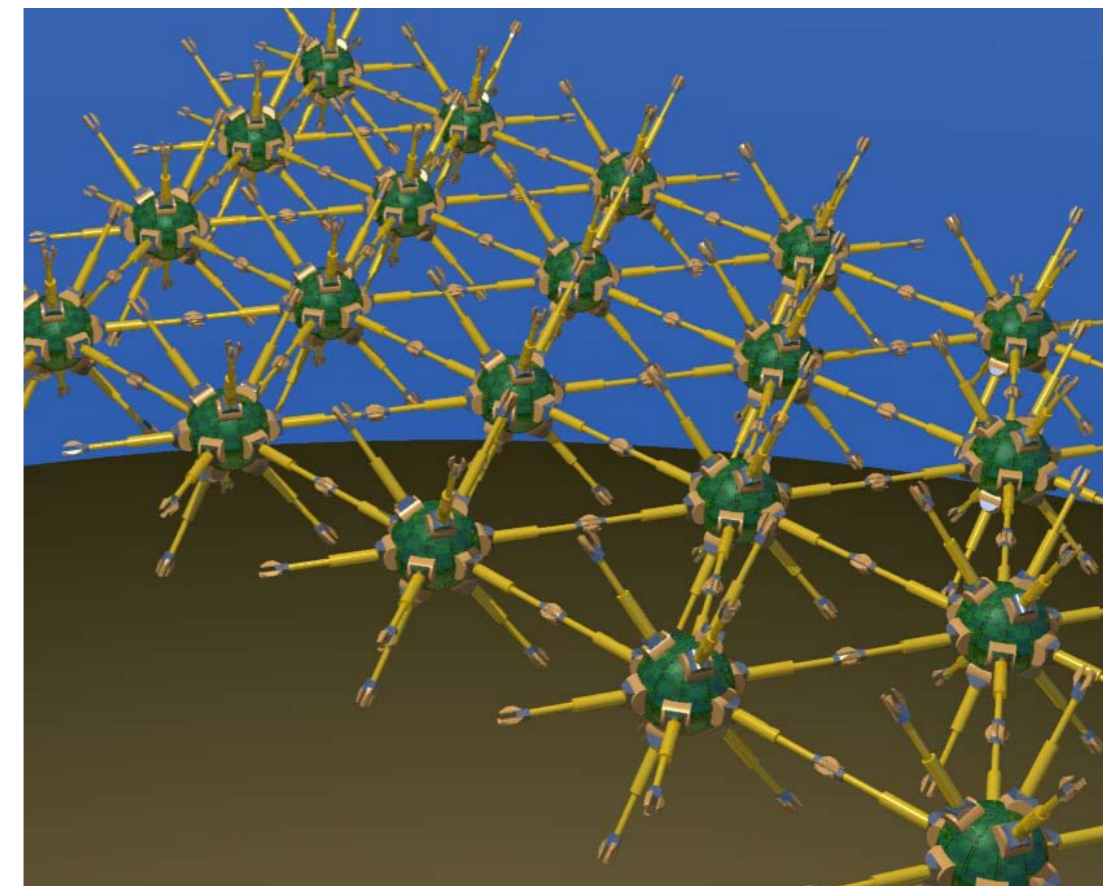

Utility fog is a nano technology where a foglet looks like (fig, 100)

These foglets have 12 arms telescoping out from the central core. Each arm has a 3 fingered claw. The foglets attach to one another at these claws.

They build up any form through a complex swarm based mathematics control system (Fig. 101).

101

MOVEMENT EXPLORATION - STRUCTURE

MOVEMENT EXPLORATION - TECHNOLOGY

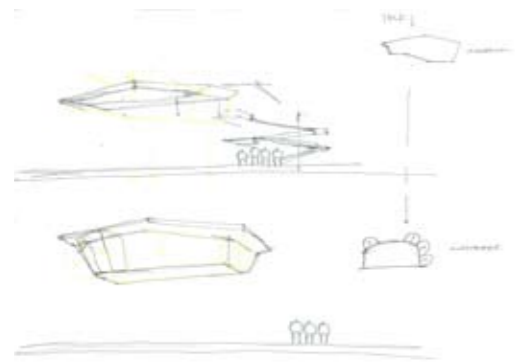

SUPPORTS ON EAST

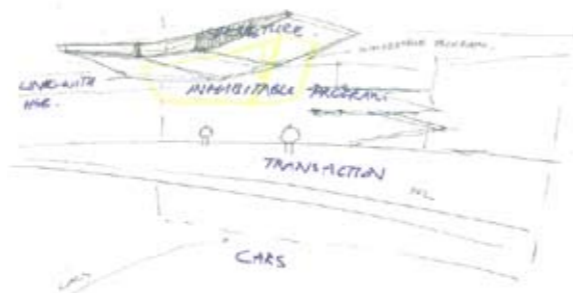

POSSIBLE FORM CHANGES



design

The shapeshifting moulds need a structure to support them. The structure will be the top layer with the shapeshifting mould literally suspended from it. A thick lattice girder structure with a formidable overhang was envisaged.

The definition of transaction space: it is a combination of transition and interaction space. It is a hyperbody term. The transaction space indicated on the drawing is the circulation from the 'real' world to student world, transacting through the threshold. Spatial experience is focused on interaction and real time feedback.

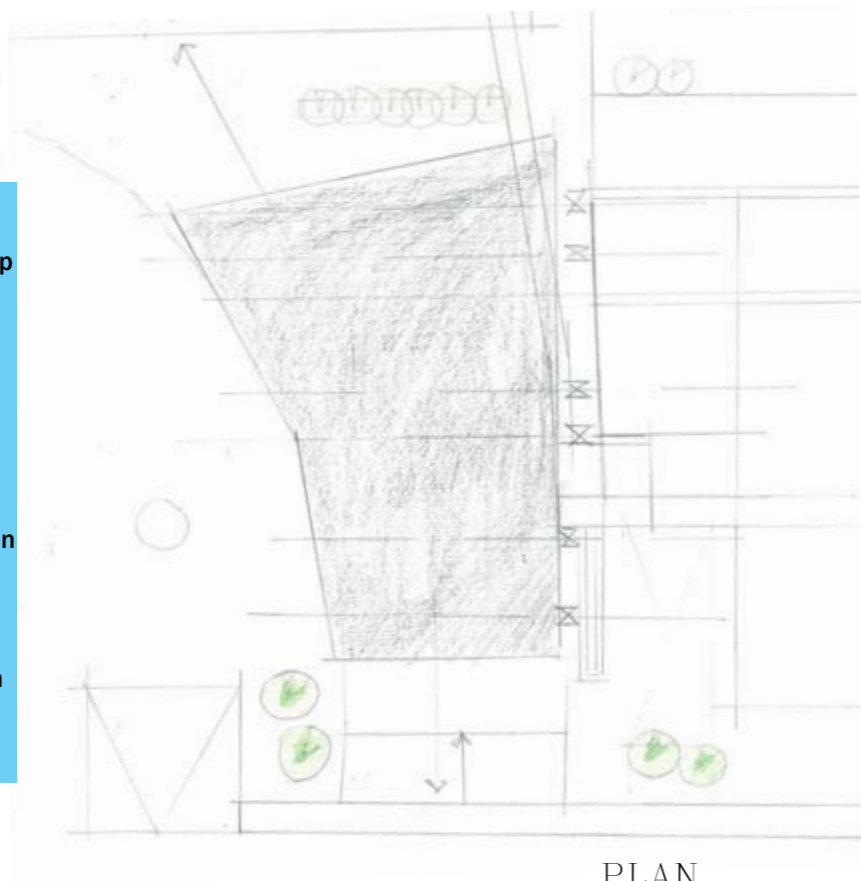

PLAN

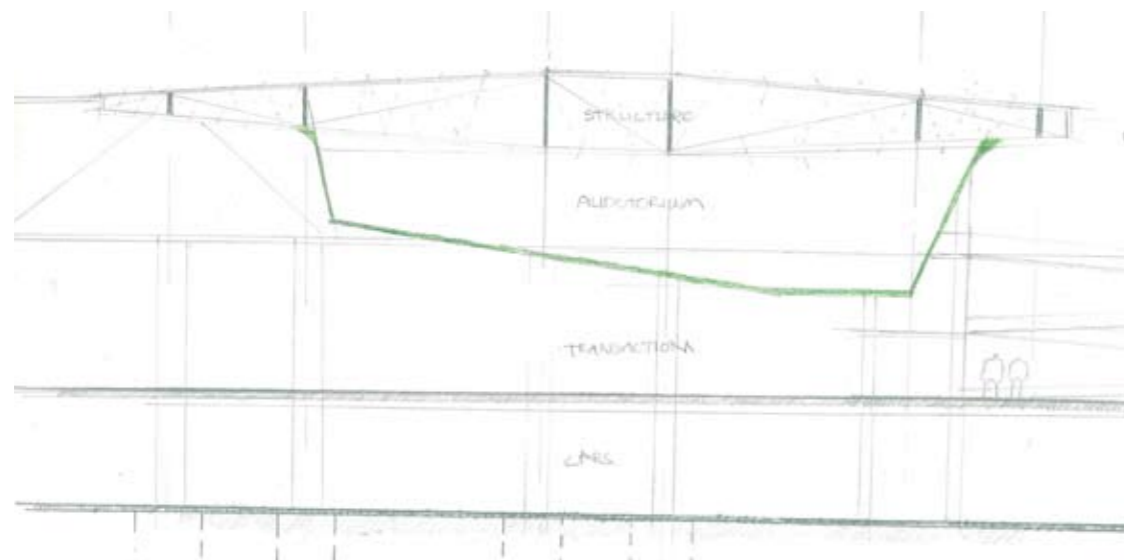

SECTION

STRUCTURE

EVOLUTION

TRANSACTION

CARS

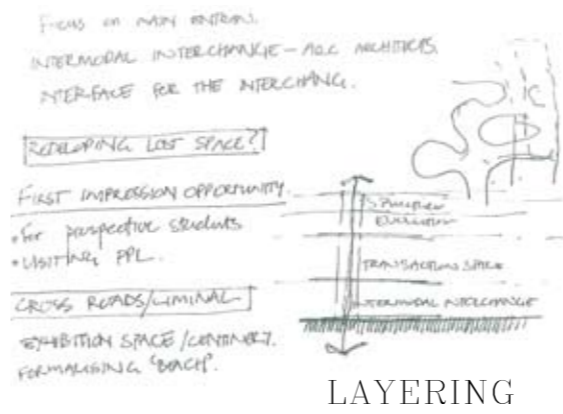

LAYERING

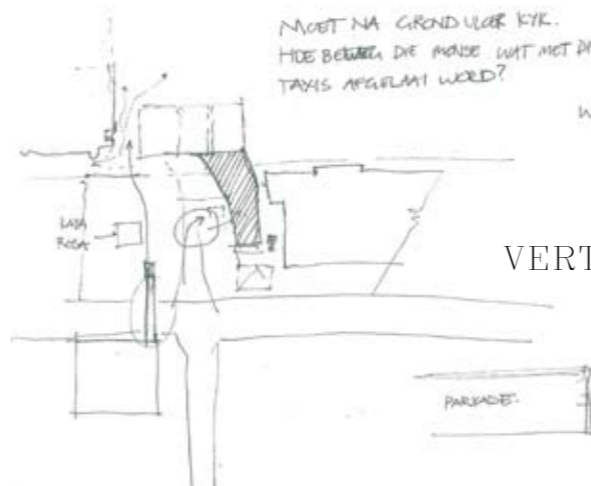

PLAN

VERTICAL CIRCULATION

Vertical circulation
The new parkade provides levels of circulation. The new ground level is sunk by 1,5m. This level is for vehicular traffic. The pedestrian ramp is 3m above the new ground level.

There is a need for vertical circulation, between these new levels. The vertical circulation is mostly ramp based to accommodate disabled people.

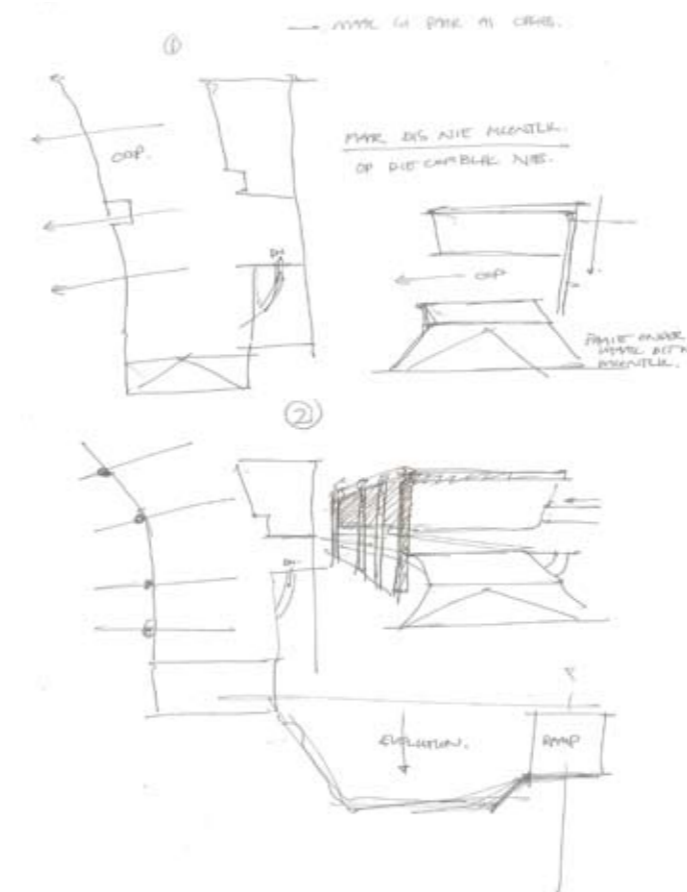

SUPPORTS ON WEST

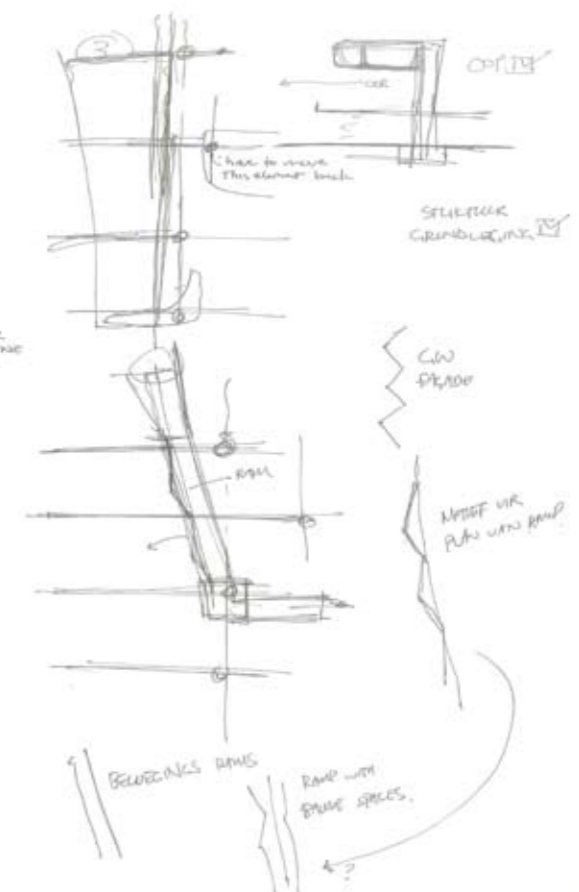

CANTILEVER STRUCTURE

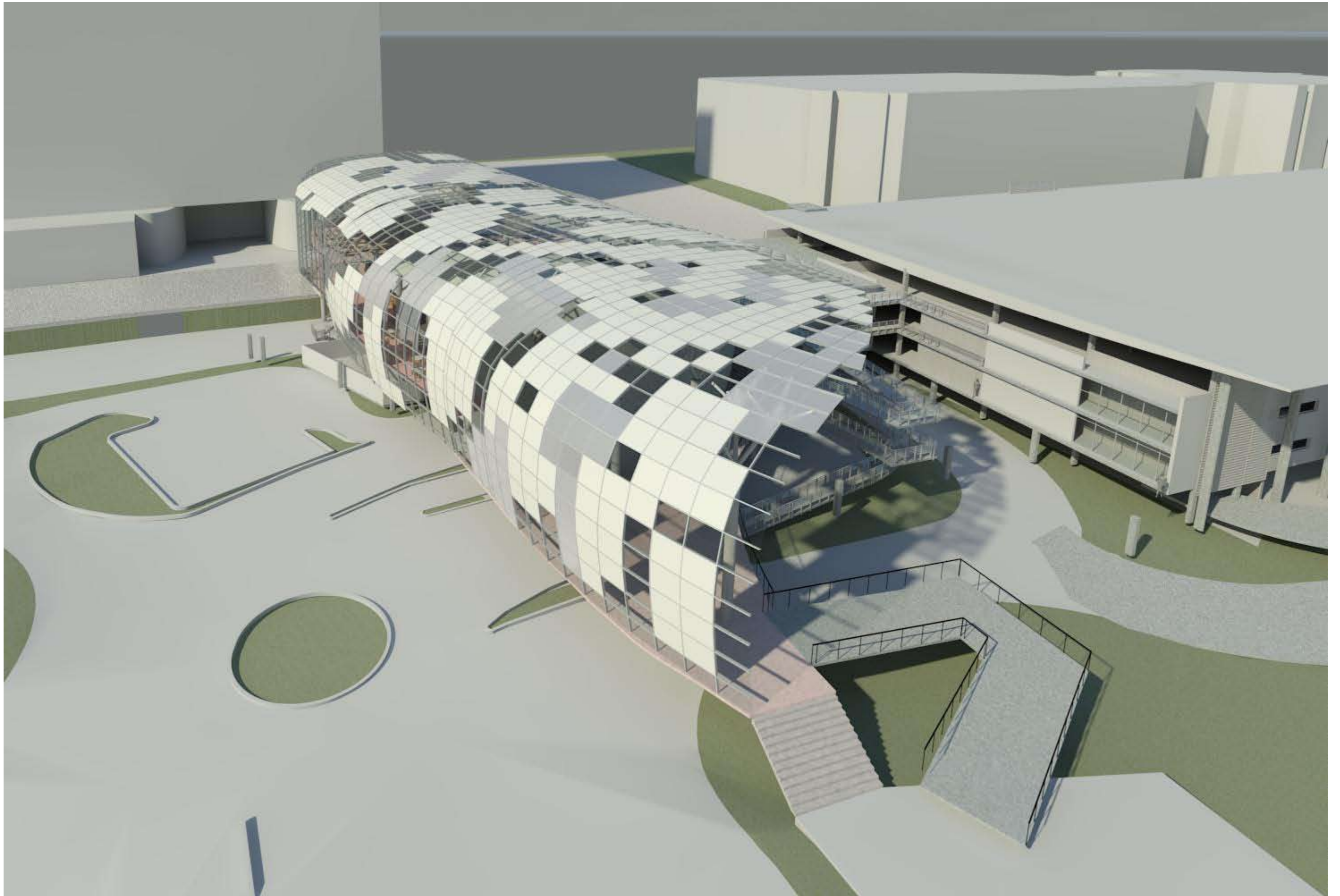

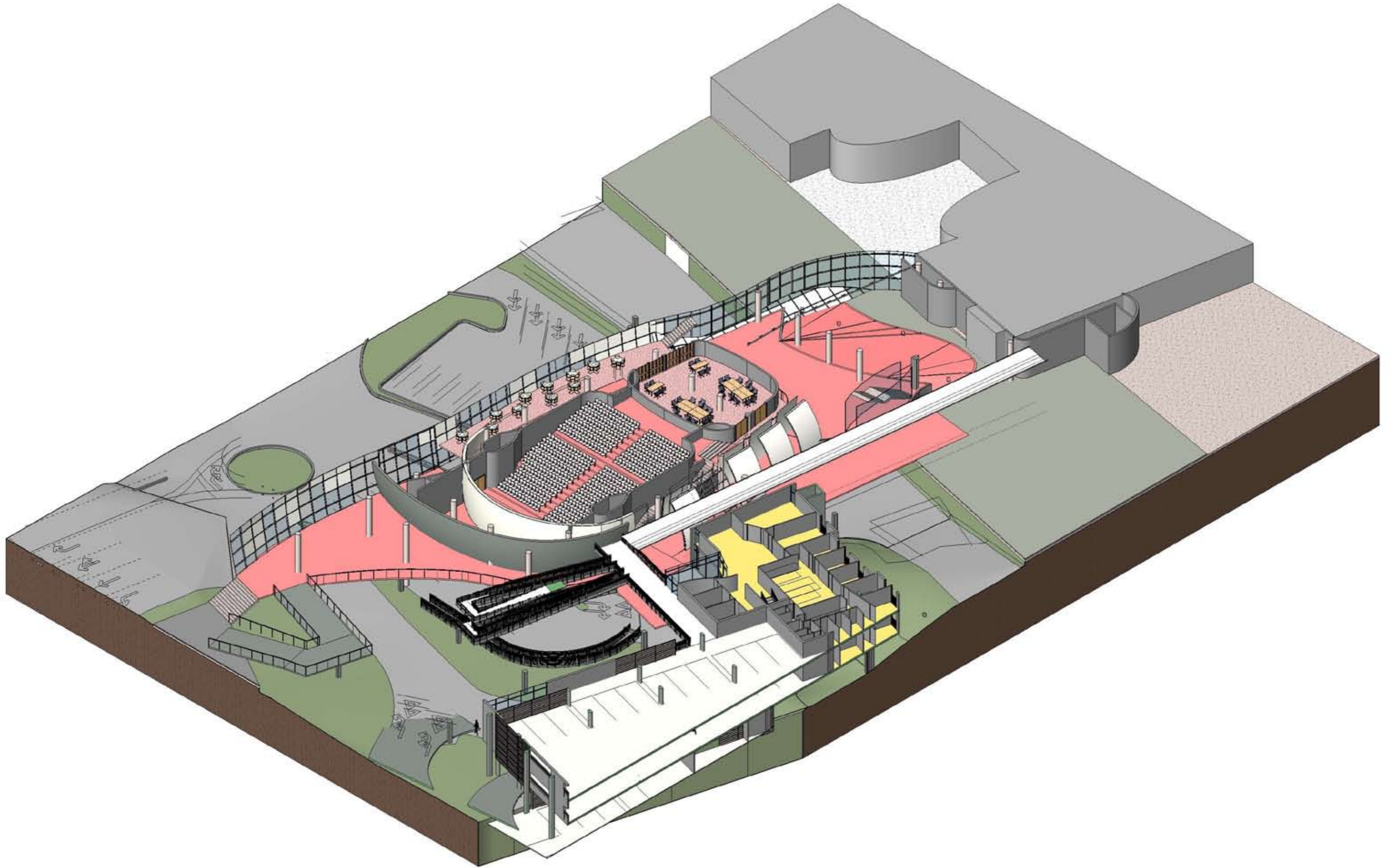

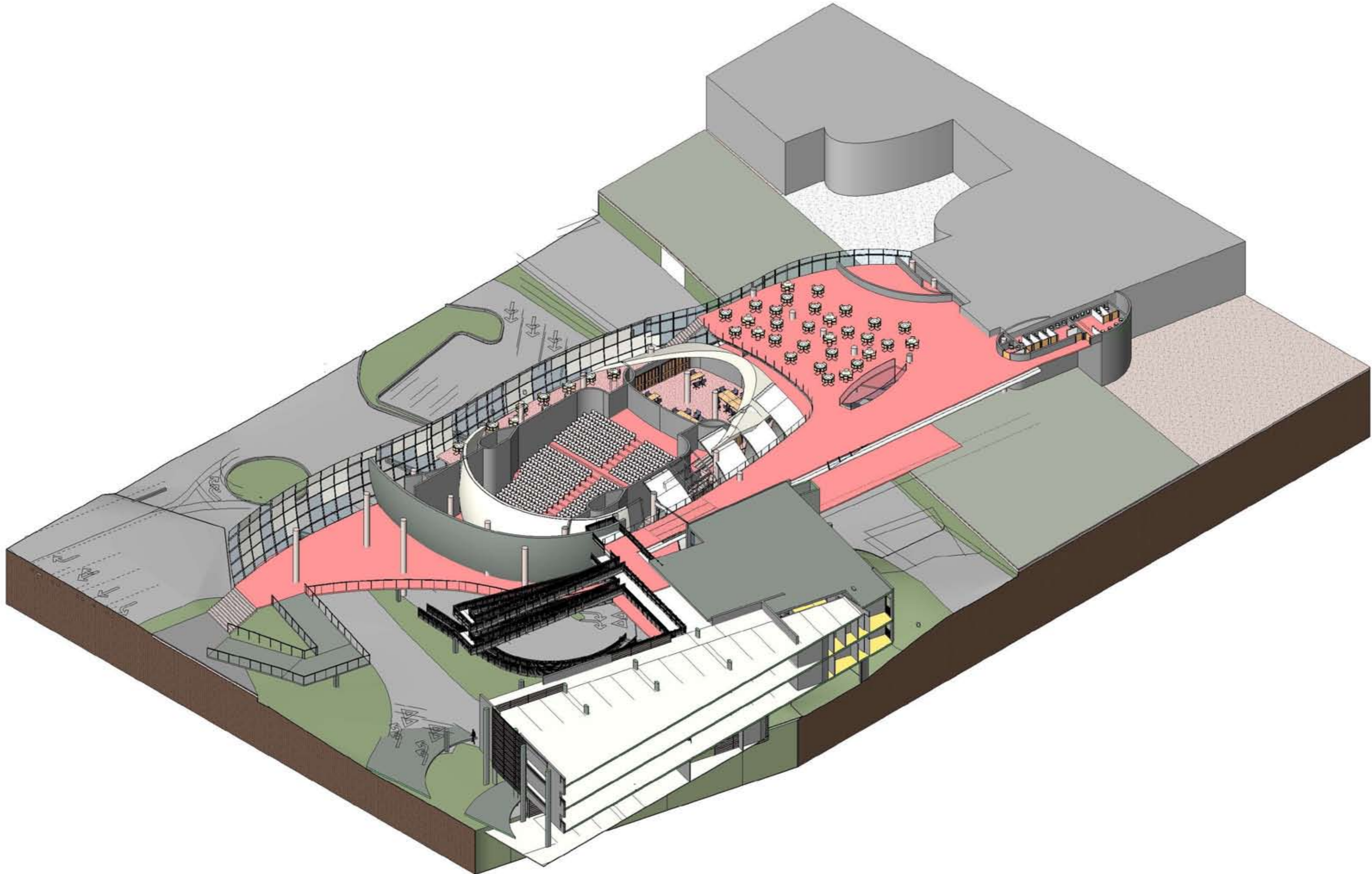

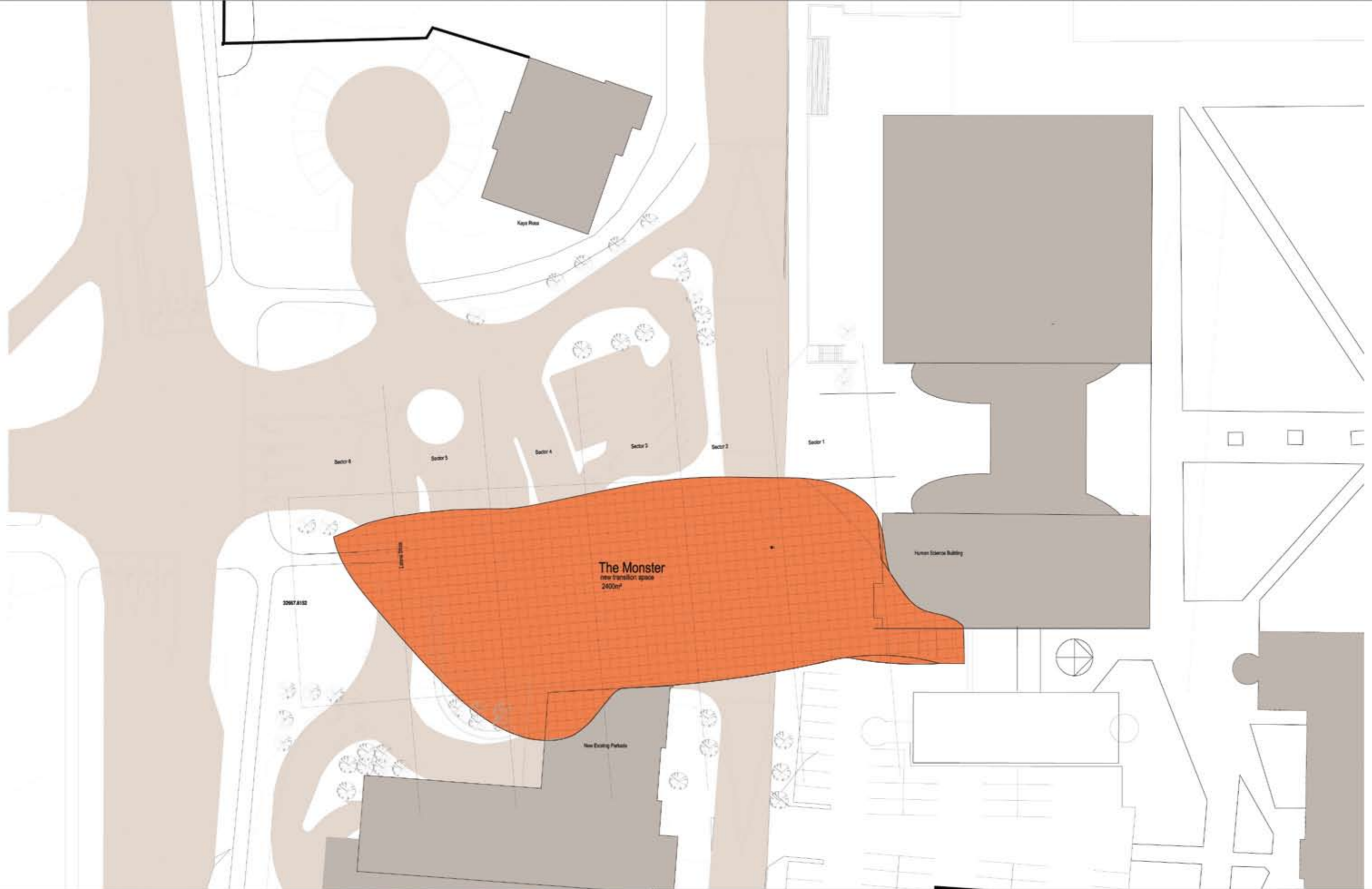

siteplan

izak coetzee m.prof(arch)

thesis 2008

the monster

university of pretoria

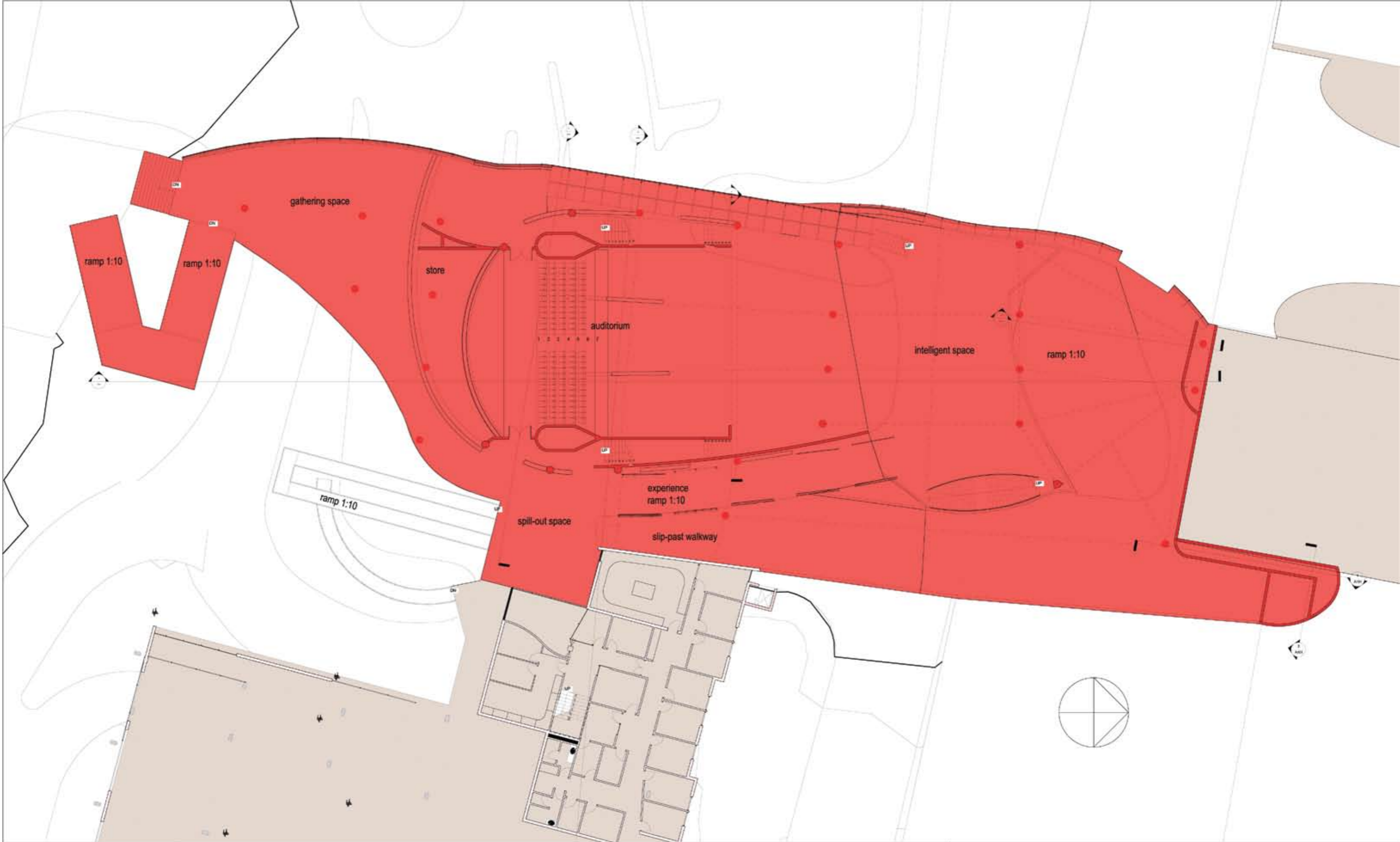

upperground

izak coetzee m.prof(arch)

thesis 2008

the monster

university of pretoria

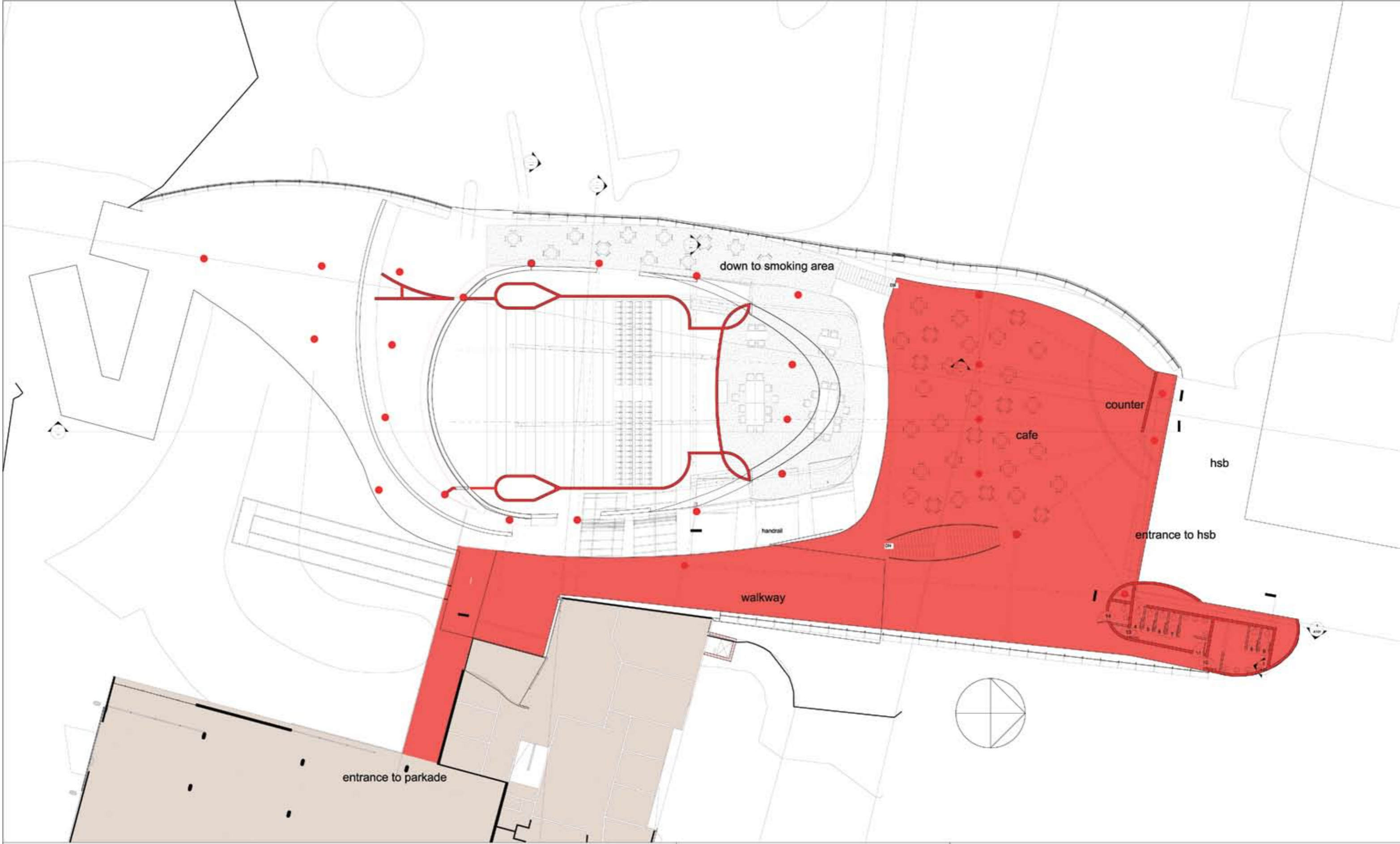

first floor
 izak coetsee m.prof(arch)
 thesis 2008
 the monster
 university of pretoria

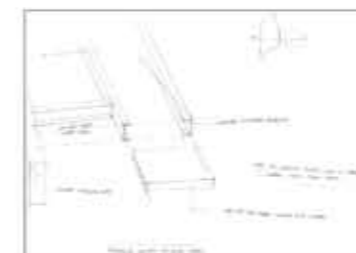
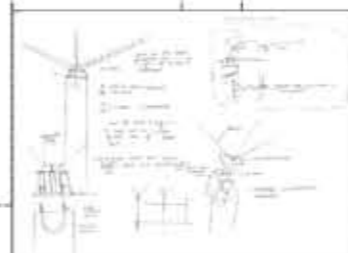
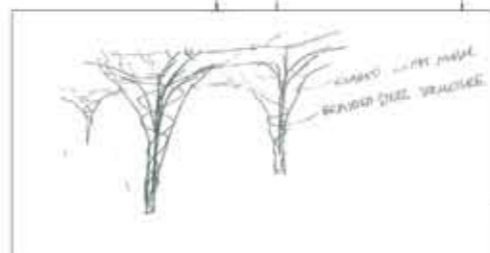
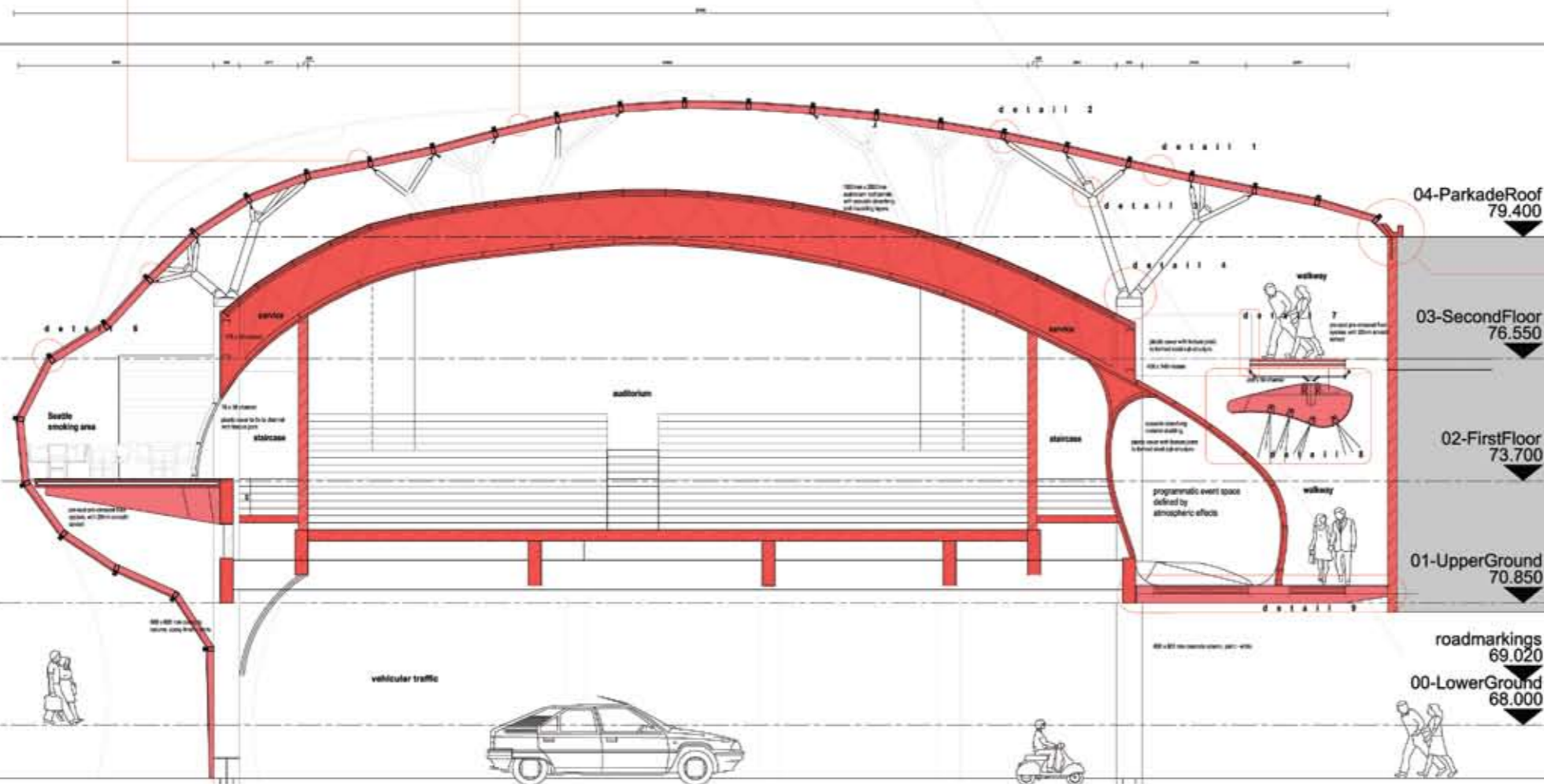
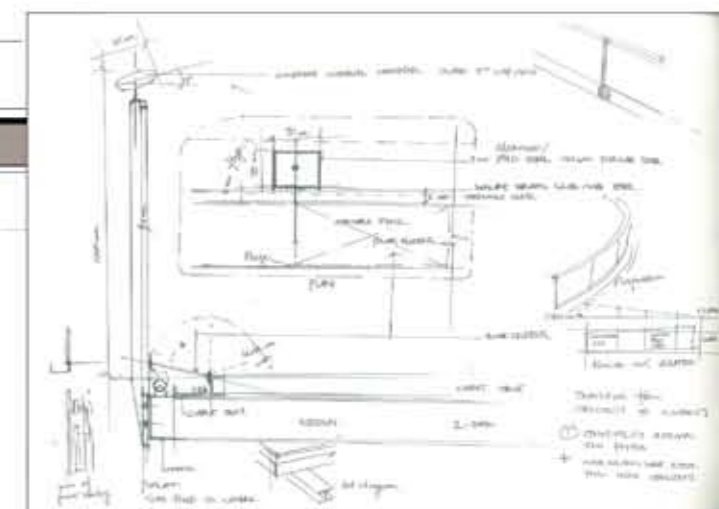
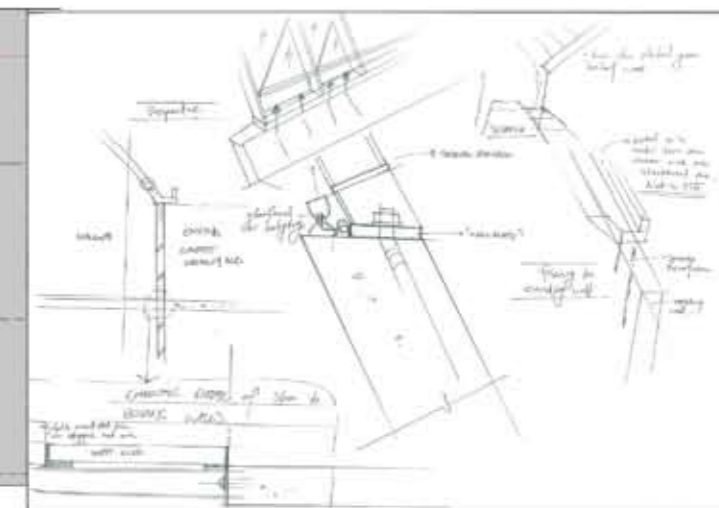
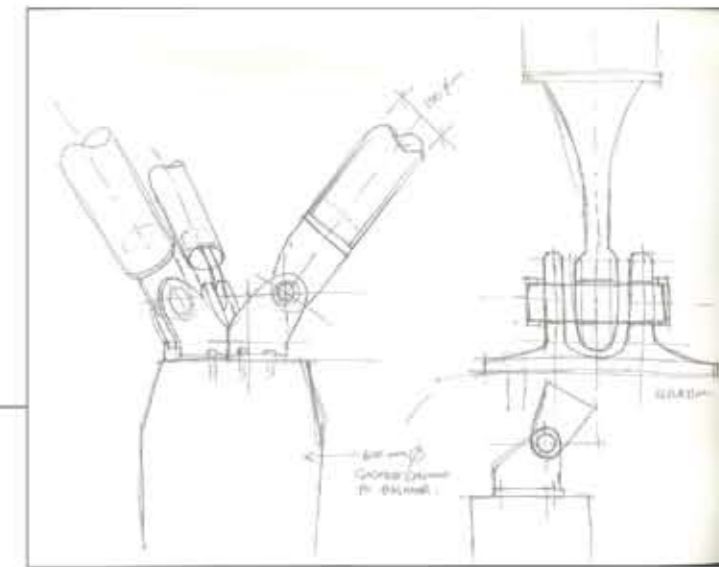
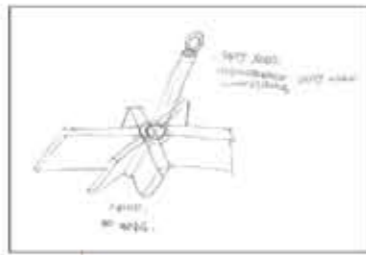
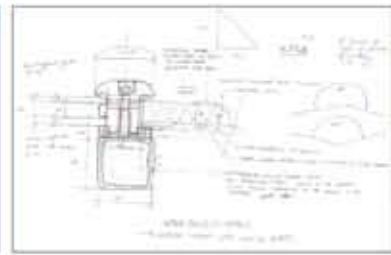

section a-a

structure - fixings

izak coetzee m.prof(arch)

thes i s 2008

monster

university of pretoria



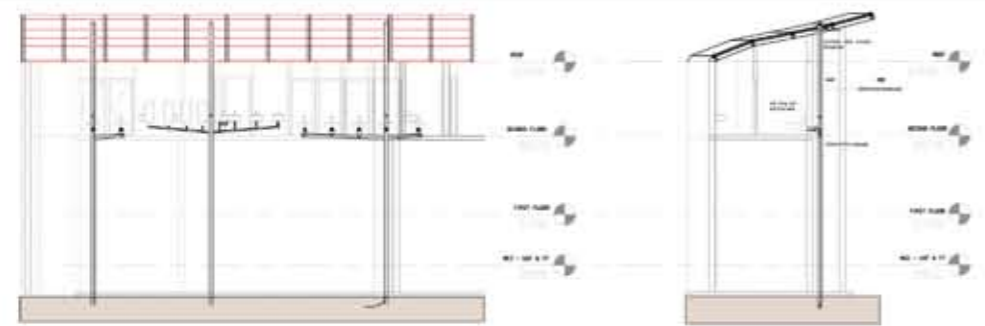
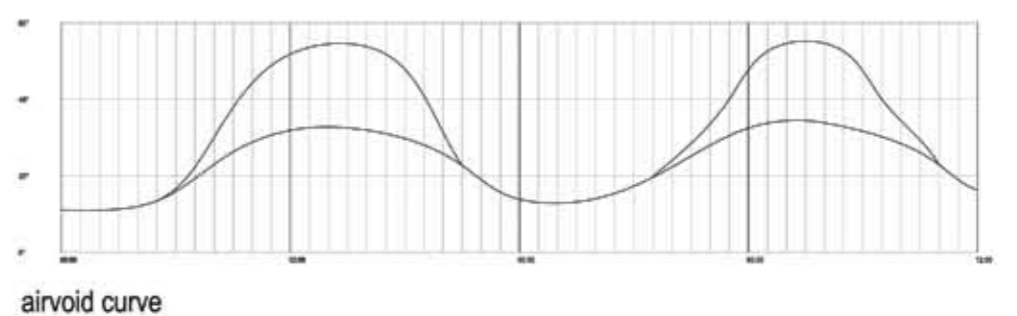
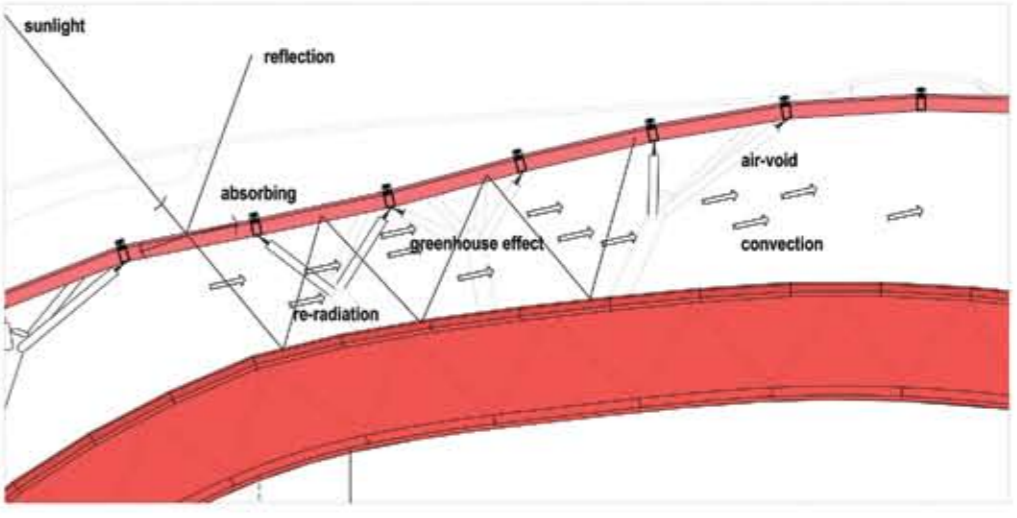
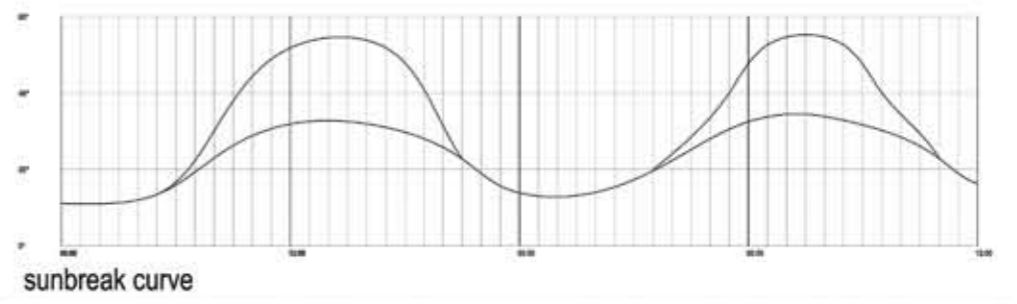
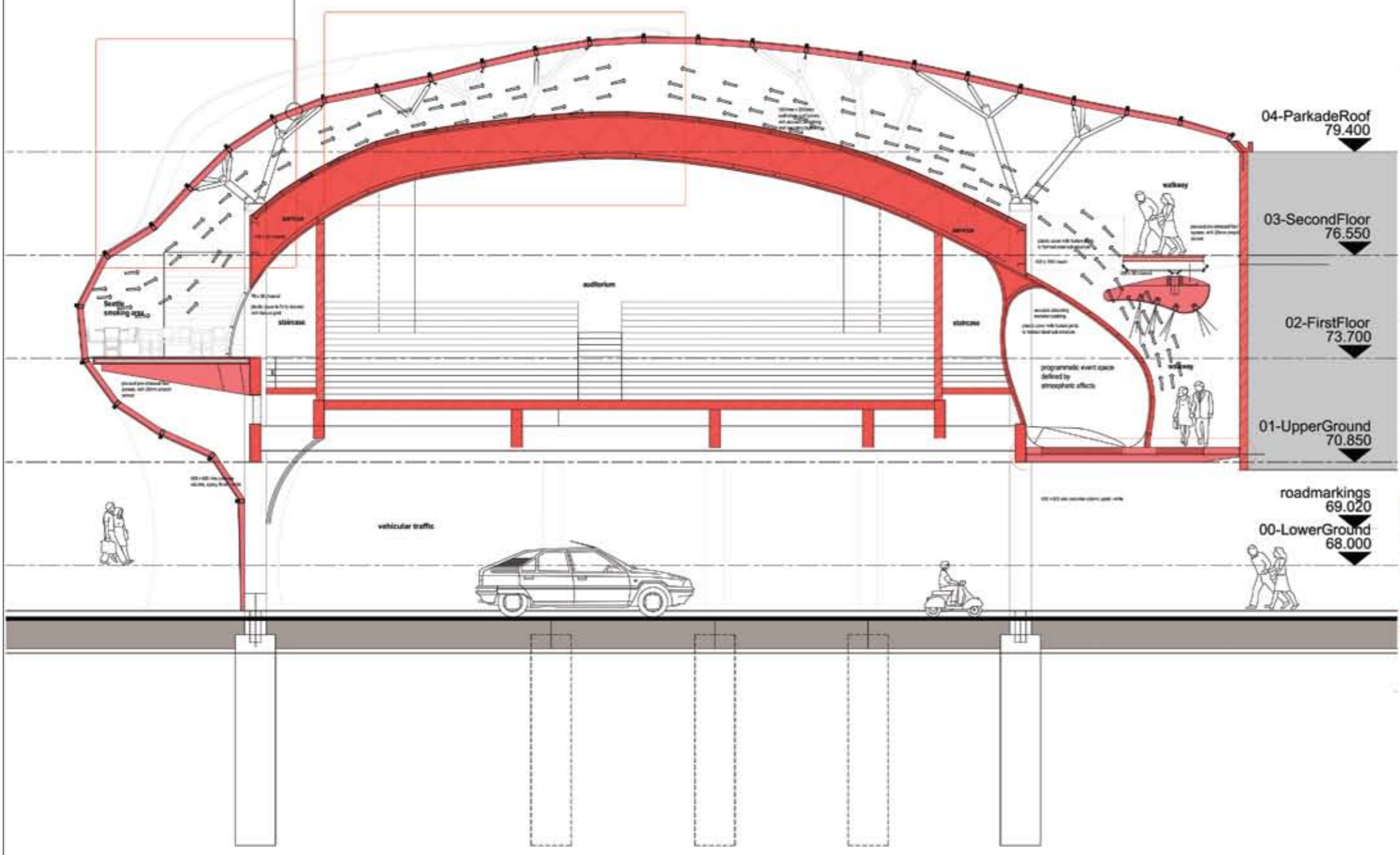
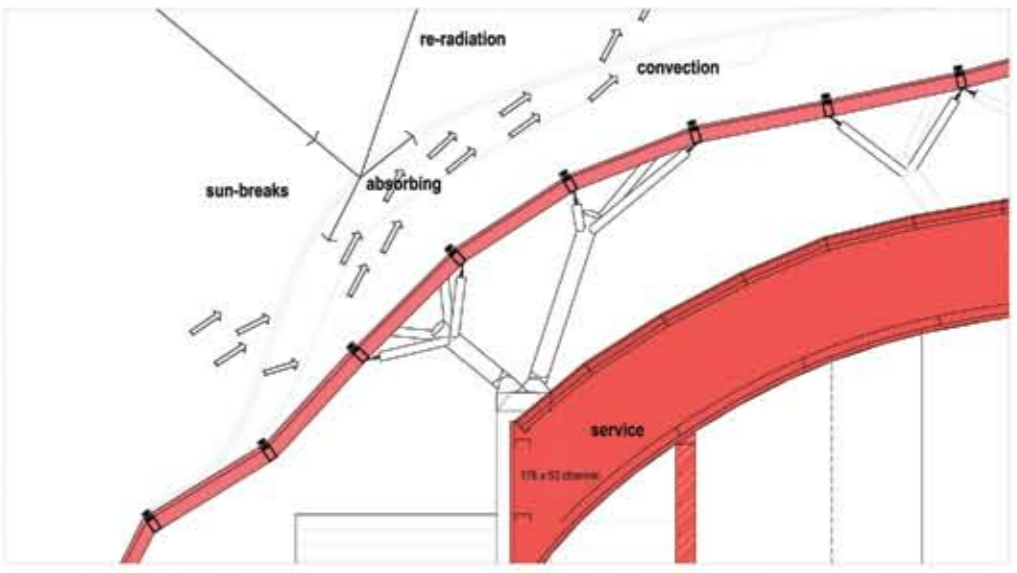
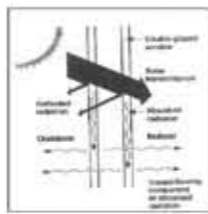
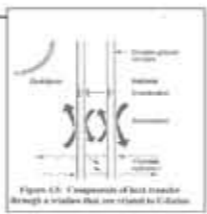
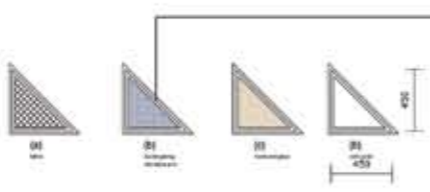
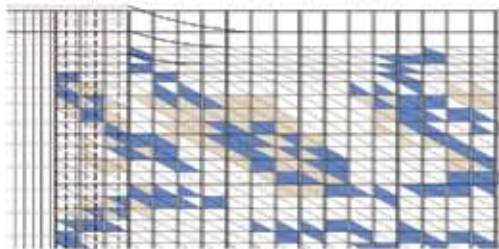

section
service duct

section a-a

izak coetzee m.prof(arch)

this is 2008

monster

university of pretoria

climatic performance - material properties



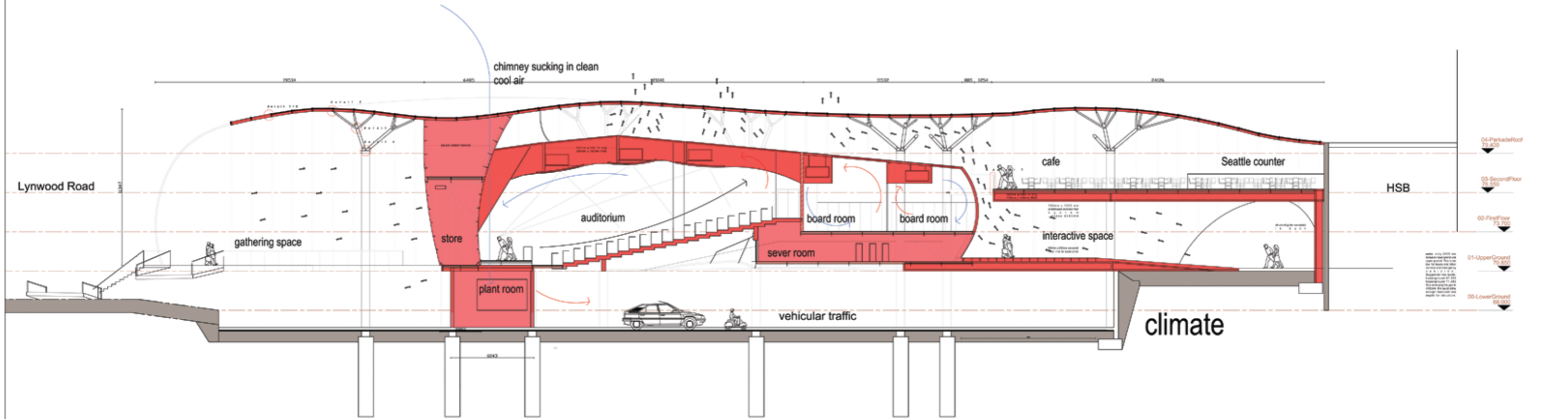
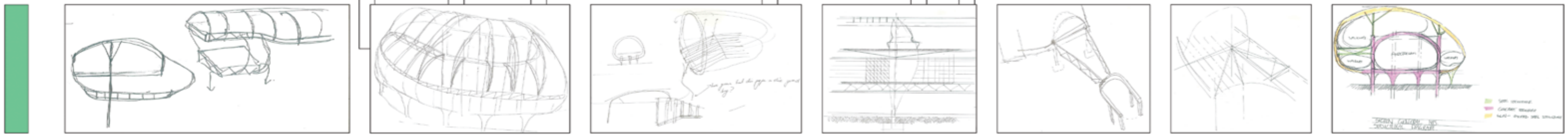
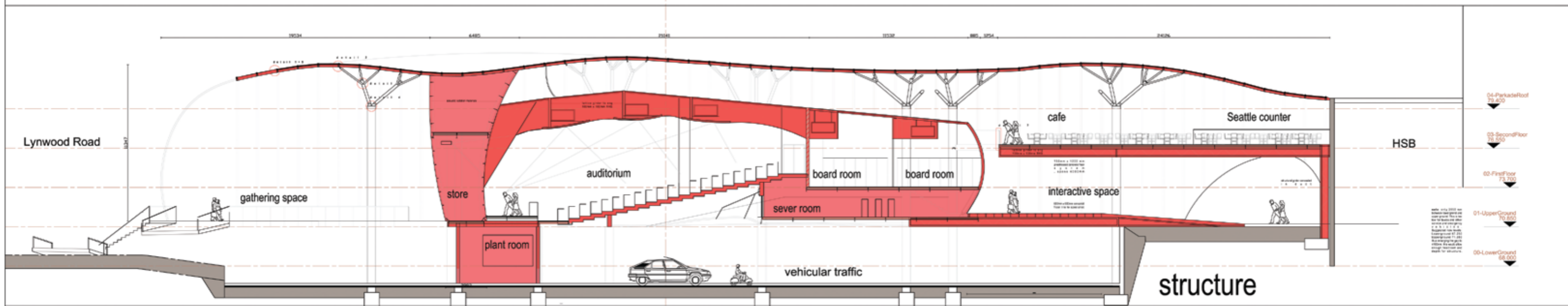

<p>section b-b</p> <p>izak coetzee m.prof(arch)</p> <p>thesis 2008</p> <p>monster</p> <p>university of pretoria</p>	<p>structure + climate</p>
---	----------------------------

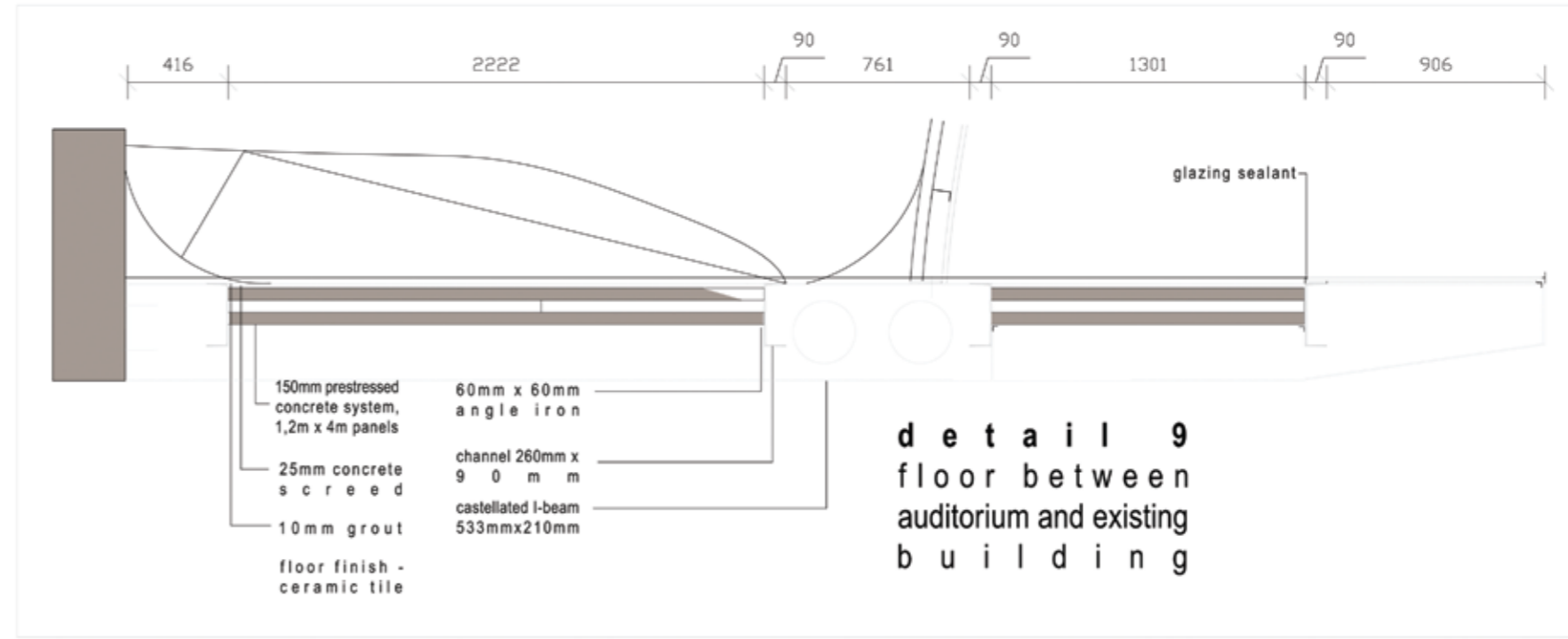
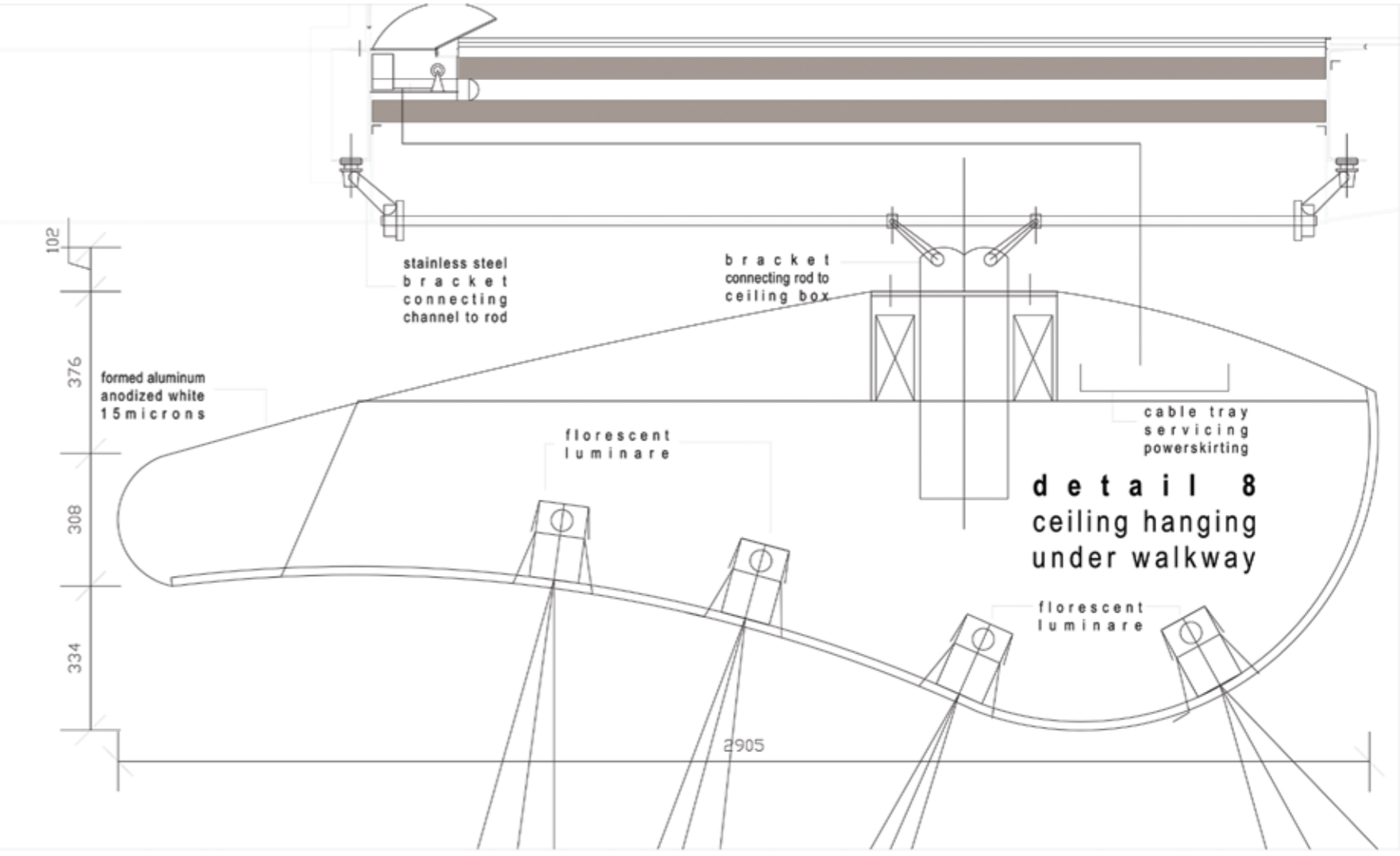
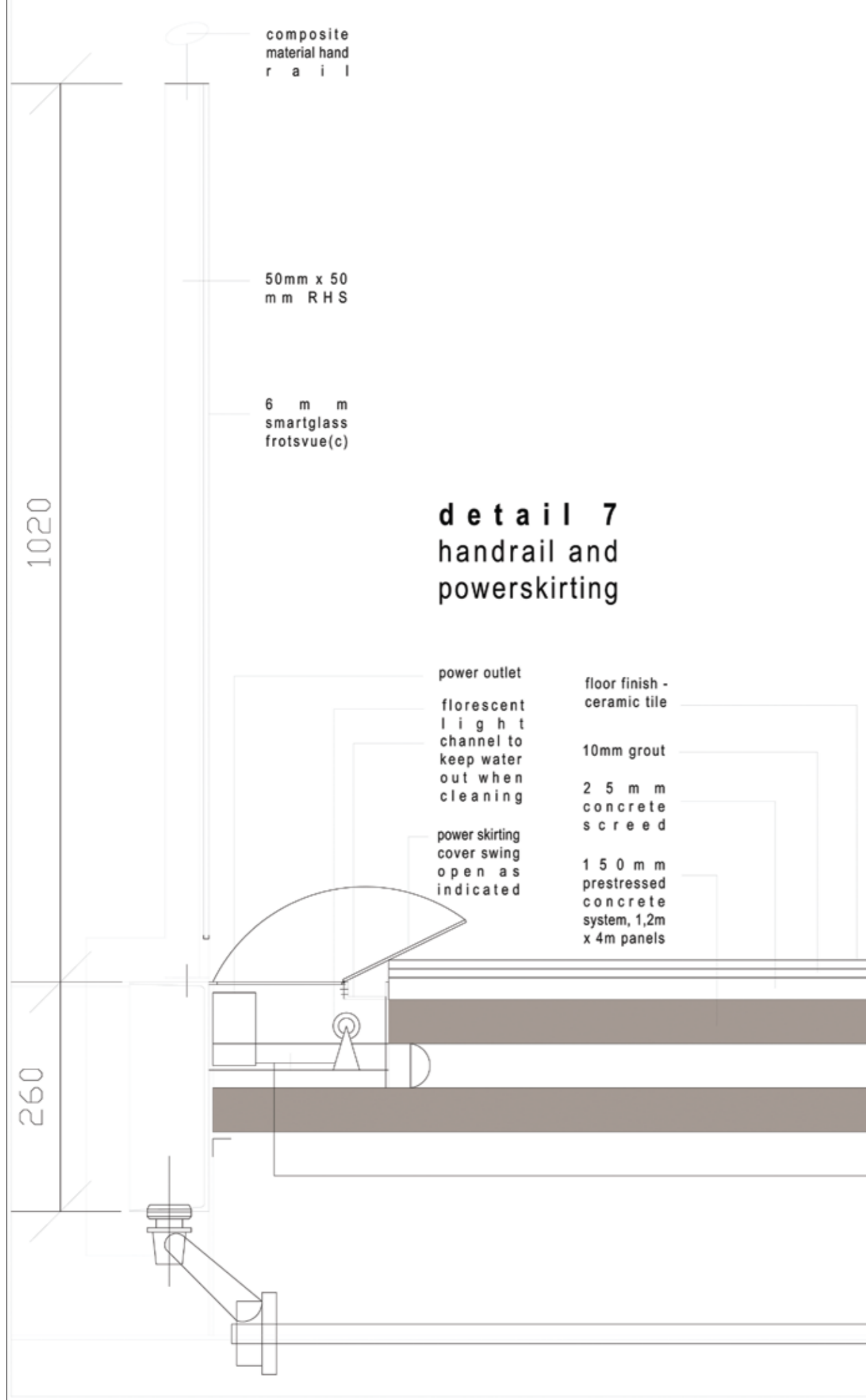

details

izak coetzee m.prof(arch)
thesis 2008
the monster
university of pretoria

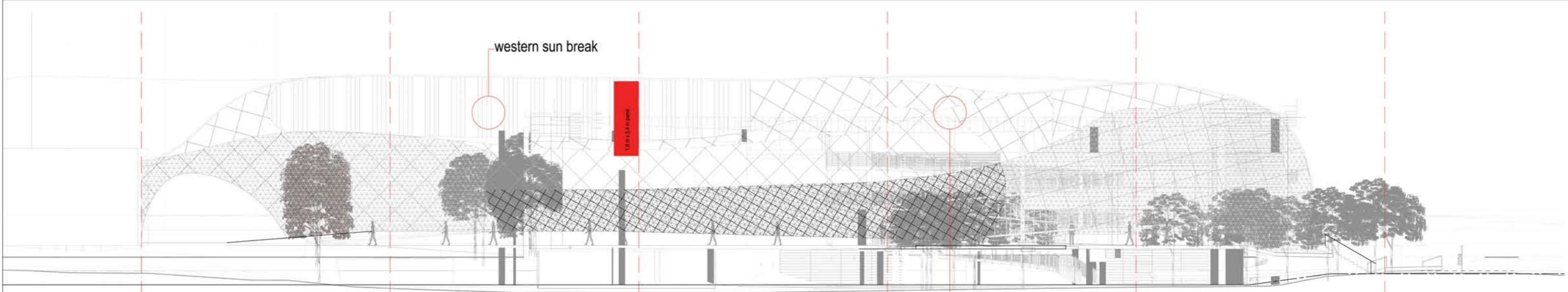

sector 1 sector 2 sector 3 sector 4 sector 5

west 1:100

* solid, translucent and glazed panel arrangement

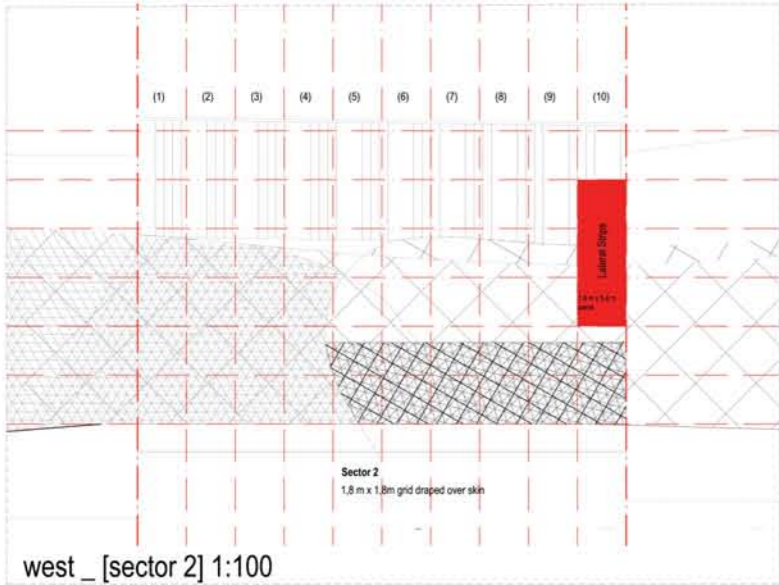

west _ [sector 2] 1:100

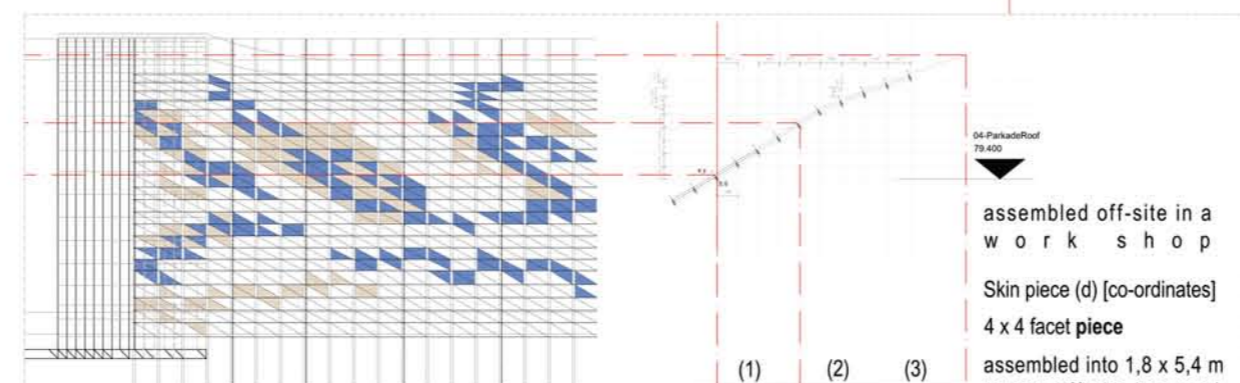

west elevation 1:100

Zlote Tarasy ladder strip assembly on site (ARUP journal)

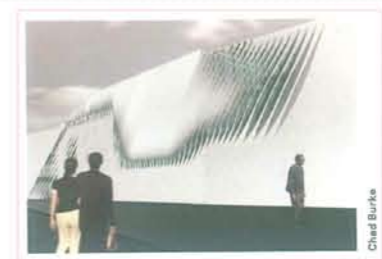
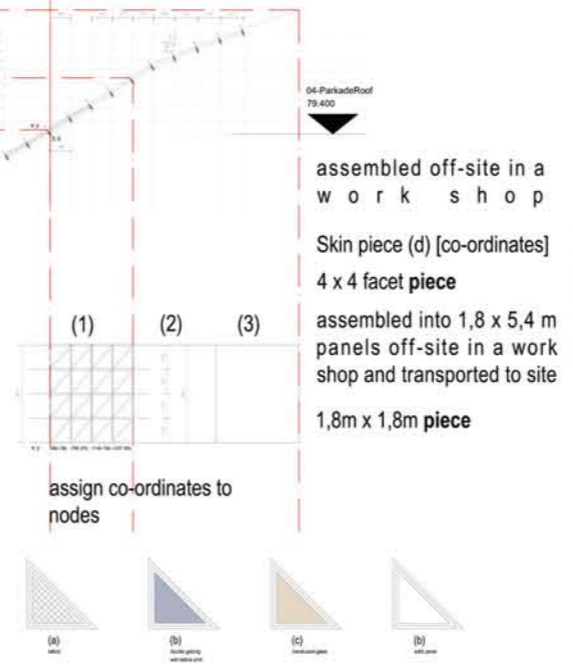
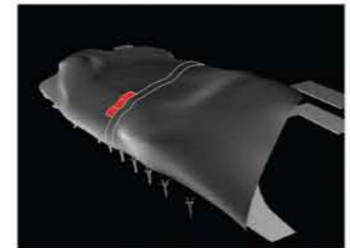

detail 6
glazing button with stainless steel bracket securing sun breaks

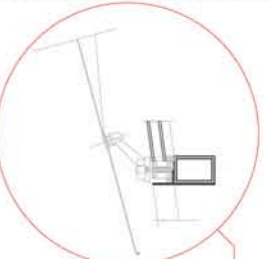

western sun breaks precedent (verb, boogazine, p 66)

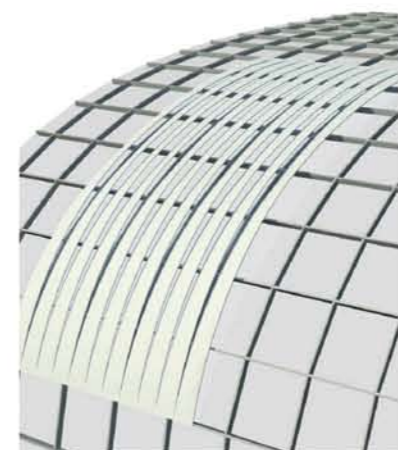

western sun breaks

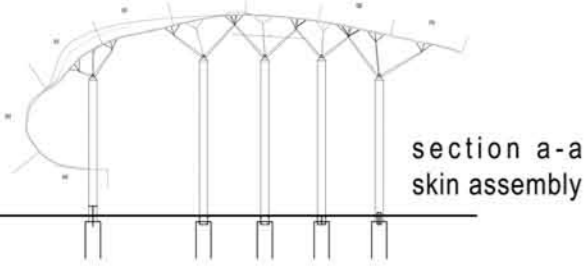
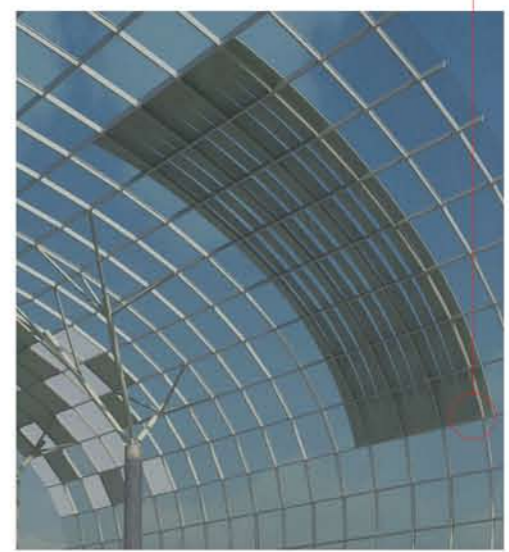

section a-a skin assembly

building process precedent from www.oosterhuis.nl



computer model divided into sectors

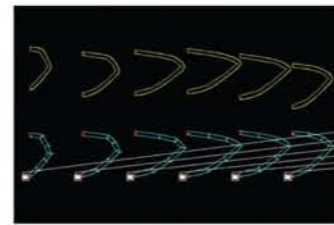
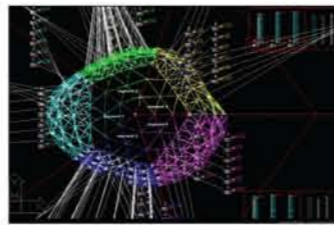
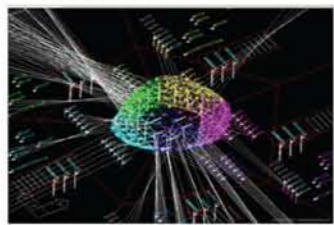

pieces flattened and laser-cut from steel



assembled in a workshop off-site



transported to site and completed

Elevation

izak coetsee m.prof(arch)
thesis 2008
monster at the gate
university of pretoria

Structural - Production



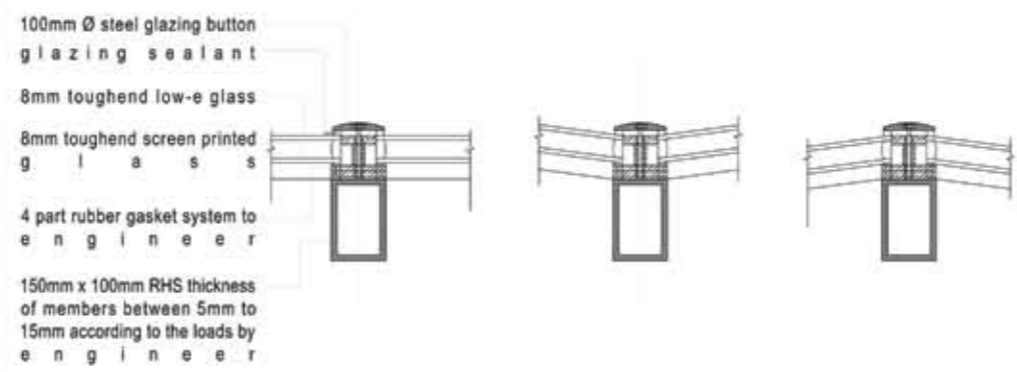
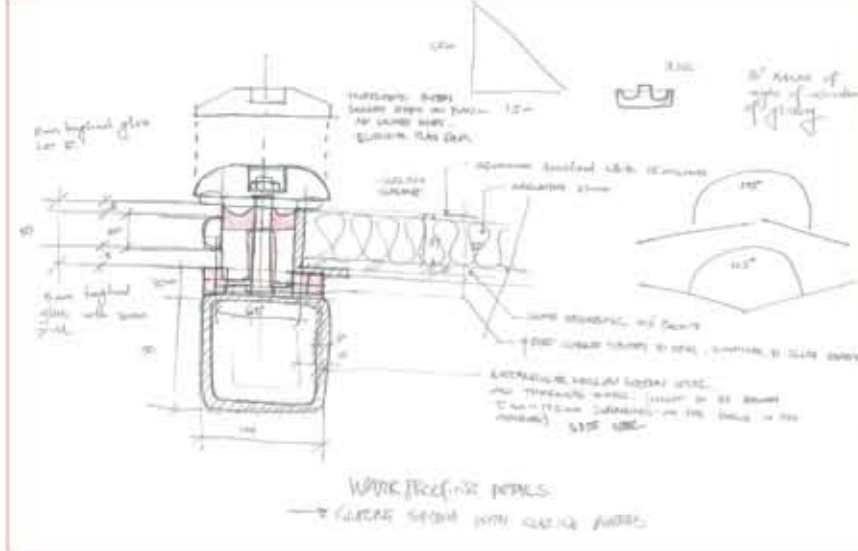

waterproofing detail glazing system with glazing buttons detail 1

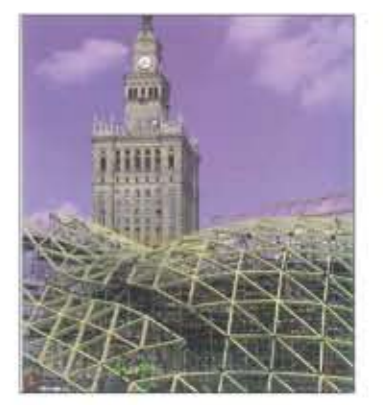
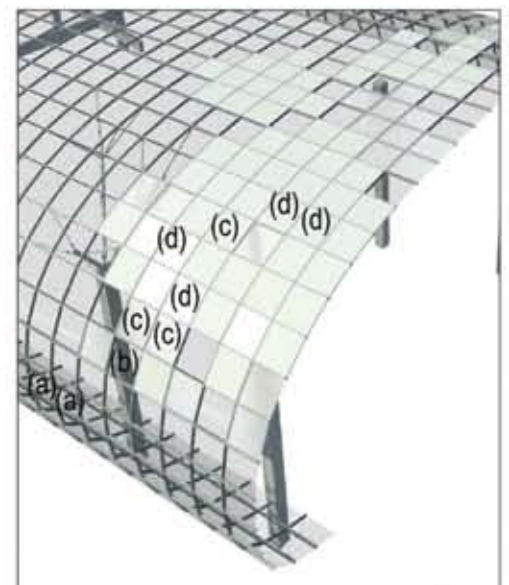
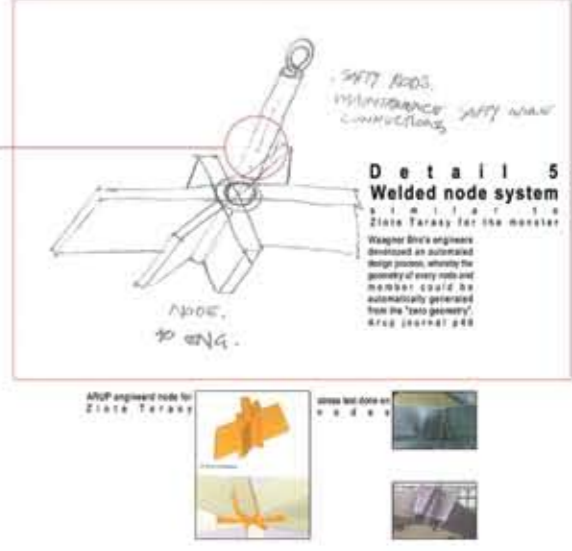

precedent

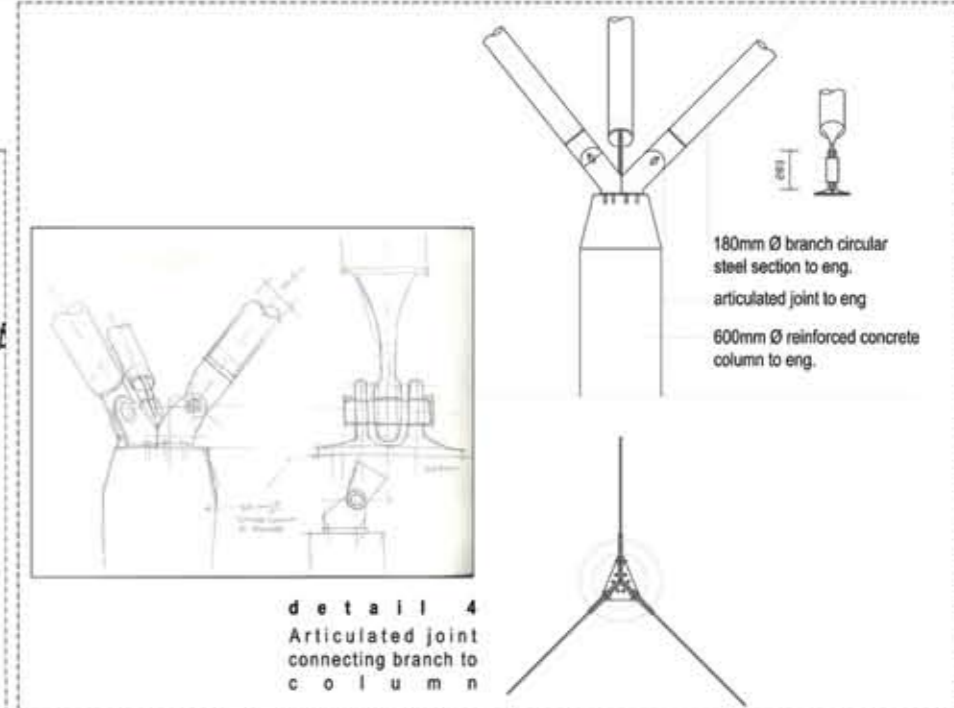
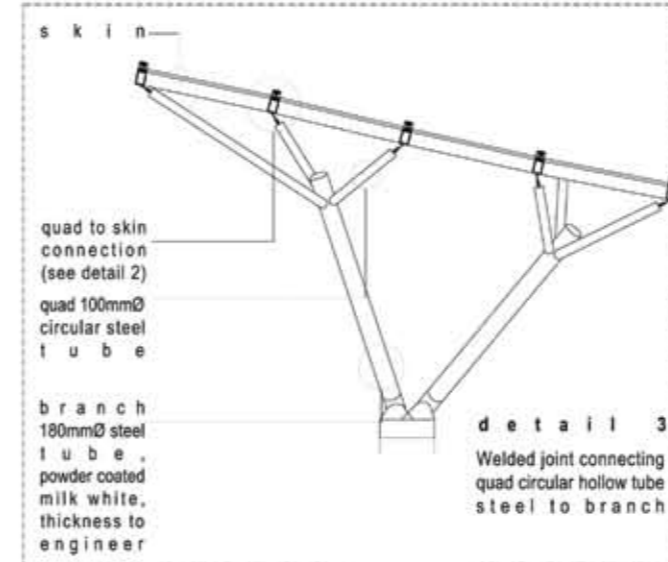
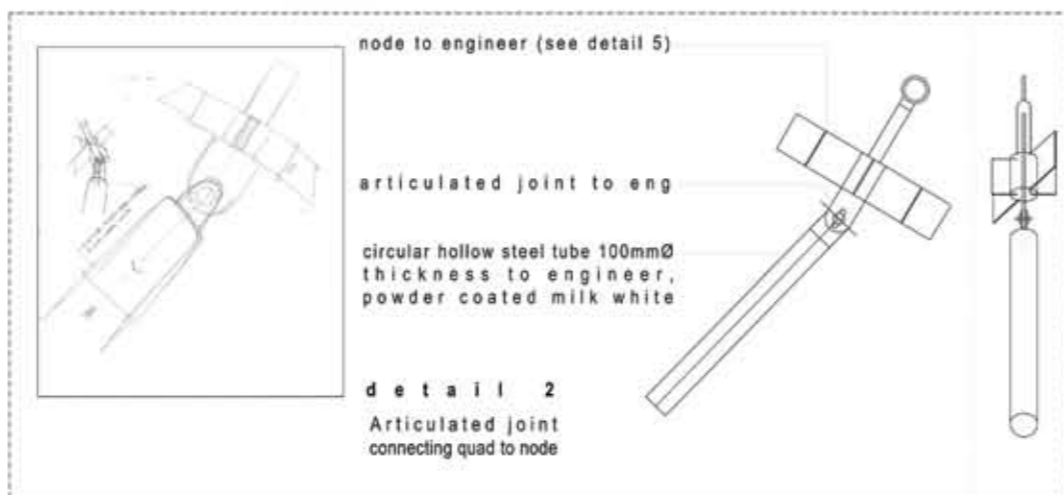

Elevation
izak coetzee m.prof(arch)
thesis 2008
monster at the gate
university of pretoria

Skin - waterproofing and support
UNIVERSITEIT VAN PRETORIA
UNIVERSITY OF PRETORIA
YUNIBESITHI YA PRETORIA