

THE HEALING OF A LOST PAST

THE REVITALIZATION AND ADAPTION OF CULLINAN MINING COMPOUND

PAIGE DU TOIT

2014

≡ INTRODUCTION

Dedicated to:

Professor Karel Bakker

I am so grateful to have had a study leader as inspirational as you.

Submitted in partial fulfillment of the requirements for the degree
Magister in Architecture (Professional),
Department of Architecture.

Faculty of Engineering, the Built Environment and Information
Technology, University of Pretoria, 2014

Course coordinator: Arthur Barker
Study leaders: Karel Bakker and Johan Swart

Special Thanks to:

Prof Karel Bakker, Dr Arthur Barker and Johan Swart for their guidance and knowledge.

John Lincoln for your generosity and knowledge of Cullinan.

Thank you to my Family, Jeffrey Moodie, and friends for your constant support, assistance and tea.

ABSTRACT

This dissertation will focus on revitalizing and adapting an abandoned mining Compound on the outskirts of Cullinan. Through this journey of uncovering and understanding this lost, abandoned and deteriorating site, one starts to fall in love with the beauty of these ruins within an unrestricted landscape, where the natural has started infiltrating into all areas of this site. It starts to evoke emotions of a romantic lost time although this is not the case. This environment has lost its identity of a harsh working lifestyle where many of the workers died in extremely uncomfortable and inhuman conditions. Uncovering this intangible narrative of the past has led to the idea of contrasting these two very different conditions, the harsh past environment with the vision of a new productive landscape where there is an opportunity for healing. Healing through exposing and appreciating the past; healing the people of Cullinan by providing new skill and opportunities during this decommissioning transition and healing this abandoned and neglected land.

Hierdie skripsie is gefokus op die vernuwing van 'n verlate mynkampong in Cullinan. Tydens die soeke na die verstaan en ontginning van hierdie vervalle en verlate terrein, word mens oorrompel deur die nostalgiese skoonheid van die ruines, waar die natuur reeds alle areas van die terrein geïnfiltreer het. Emosies van verlange na 'n romantiese, vervloe verlede word opgeroep, alhoewel hierdie beelde ver verwyder is van die realiteit van wat hier gebeur het. Die kompleks het sy identiteit as 'n harde werksomgewing verloor, waar menige werkers in ongemaklike en onmenslike toestande oorlede is. In die strewe daarna om hierdie verlore storielyn te ontgin en ontbloot, ontstaan die idee van kontras tussen die ongenaakbare landskap van die verlede en die visie van 'n vrugbare en produktiewe landskap in die toekoms, waarin die moontlikheid vir genesing opgesluit is. Genesing deur die erkenning van die verlede, genesing vir die mense van Cullinan deur die ontwikkeling van nuwe vaardighede en geleenthede tydens die sluiting van die myn, en genesing van hierdie verlate en verwaarloosde landskap.

TABLE OF CONTENT

1 INTRODUCTION

1	Background	1
1.1	Site	5
1.2	Problem Statement	7
1.3	Research Questions	7
1.4	Issues	8
1.5	Aims	11
1.6	Research Methodology	12
1.7	Dissertation Overview	13

2 CONTEXT

2.1	Macro Context : <i>Cullinan</i>	14
2.2	Macro Mapping	22
2.3	Macro Vision	30
2.4	Meso Context : <i>No2 Shaft Compound</i>	34
2.5	Meso Mapping	36
2.6	Meso Vision	46

3 SITE

3.1	History and Cultural Significance	51
3.2	Statement of Significance	60
3.3	Proposed Site	63

4 PROGRAMME

4.1	What the Site requires?	66
4.2	Programme requirements	68
4.3	Textile process	70
4.4	The history of Hemp	72
4.5	The benefits of Hemp	73
4.6	The history of Silk	79
4.7	Sustainability	82
4.8	Pigments	84

5 THEORY

5.1	Memory	88
5.2	Adaptive Reuse	90
5.3	Historic Landscapes vs Productive Landscapes	94
5.4	Guidelines for Design	96

6 DESIGN STRATEGY

6.1	Understanding the Significance	99
6.2	Space Drivers	100
6.3	Working with the existing	102
6.4	Retaining the Memory	104
6.5	Altering the existing	106
6.6	Design Influences	107

7 DESIGN DEVELOPMENT

7.1	Design Concept	109
7.2	Iteration 1	112
7.3	Iteration 2	115
7.4	Iteration 3	116
7.5	Iteration 4	118
7.6	Iteration 5	126
7.7	Model development	134
7.8	Design explained	136

8 TECHNICAL DEVELOPMENT

8.1	Technical concept	139	
8.2	Materiality	140	
8.3	Water Management	142	
8.4	Services	142	
8.5	Rainwater calculations	144	
8.6	Thermal comfort and Natural ventilation	145	
8.7	Structure	147	
8.8	Plans	150	
8.9	Sections	Building 1	156
8.10	Details	Building 1	158
8.11	Sections	Building 2	164
8.12	Details	Building 2	167
8.13	Sections	Building 3	170
8.14	Details	Building 3	174

9 CONCLUSION

	Reflection	179
	List of Sources	186
	List of Figures	188

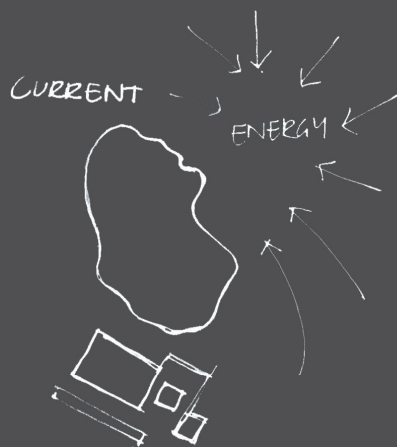

INTERVENTION.

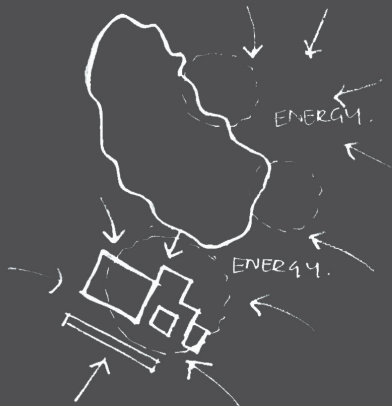

01

INTRODUCTION





“What we need is continuity . . . historic preservation is not sentimentality but a psychological necessity. We must learn to cherish history and to preserve worthy old buildings. . . We must learn how to preserve them, not as pathetic museum pieces, but by giving them new uses.”

(Cantell 2005)

01. INTRODUCTION



Figure 1.2 The Premier Diamond Mine in Cullinan during the initial mining years

This dissertation is set in Cullinan, a small mining town east of Pretoria. This industrial town was developed around the discovery of diamonds in 1902 and thereafter de Beers Diamond Mine.

On the outskirts of the town lies an abandoned complex, known as a compound or hostel. This compound was one of many in and around Cullinan; which housed black mine workers from about 1905 to the early 1950's.

The word compound means

"1. A building or buildings, especially a residence or group of residences, set off and enclosed by a barrier.

2. An enclosed area used for confining prisoners of war." (*The Free Dictionary, 2014*)

The focus for this dissertation is centred around the lives of industrial workers and their accommodation. For one to fully understand the history of the compounds it is essential that they are understood in the context of the apartheid era as well as the predominant European authorities within these industrial companies. The conditions within these compounds were brutal and inhuman but when viewed within the context of South Africa's society during this time, their conditions were not part of an isolated situation.

This dissertation does not attempt to pass judgment or give comment on the social ills of this era but rather to explore the architectural potential in order to provide healing to the people of Cullinan and the scarred landscape.

The following quote taken from the Journal; *Exceptional Space: Concentration Camps and Labor Compounds in Late Nineteenth-Century South Africa*; provides an insight into the lifestyle of typical mineworkers living in compounds throughout South Africa.

"The blacks are lodged in barracks, which are built in the form of a square, the outer wall being much higher than the inner wall; the roof slopes inside. The entrance to the place is by a large gate, over which at night hangs a

powerful lamp . . . Men and women answer to the call of their names while passing out at the gate in the morning and in the evening when entering. They retire to rest early, and an overseer locks up the premises each night." (*Kitto 1882 cited in Turrell 1987:97*)

A specific compound typology was developed throughout South Africa. These enclosed hostel spaces housed the accommodation for black mine workers. The compounds were designed with a courtyard space in the centre, where the open wash and cooking facilities were situated. The hostel rooms then surrounded the courtyard. Each room was approximately 160m² and housed up to 40 workers. The compound complex was made up of smaller compound buildings each containing a courtyard and outdoor facilities. Around the entire complex was a boundary wall with a single entrance into the mine, here the workers would be monitored entering and leaving the mine. Guard stations were situated throughout these smaller compounds for further supervision. Different ethnic groups were separated into smaller compounds to prevent fights from occurring.

The following quote indicates what the labour laws for miners were during apartheid.

"The worker compounds of the early mining companies of the Diamond Fields not only segregated and incarcerated laborers for the duration of their contract, but they also relied upon strategic suspensions of the law—invoking a state of exception, even if only for the purpose of commodity security. The relationship between the 1880's labour compounds of diamond mining companies such as De Beers and the subsequent network of industrial labour systems under apartheid later raised concerns among company directors about comparisons to the infamous relationship between the I.G. Farben corporation and the Nazi regime" (*Ibharwoh 2008:281*).

From the information about the history of the compounds in South Africa, one can start to piece together an idea of the compounds living conditions, but this information only provides a small insight into the lives of these mineworkers. Only when entering the compound site will there be a deeper understanding of these conditions through connecting with the ruins that exist today. Thus one cannot fully understand the intangible history without being immersed in the tangible.



Figure 1.3 Aerial photograph of Cullinan as it exists today edited by author (photographer unknown)

1.1 SITE

The identified site sits in isolation; an abandoned ruin on the southern entrance of Cullinan. These structures were used as hostel for the mine workers during the start of De Beers Diamond mine and are some of the oldest structures within Cullinan.

Although left to deteriorate, these buildings contain an enormous amount of significance for the mine and the mine workers, as well as the political history within south africa. This layered site relates to the industrial heritage of the mine and the Italian prisoners of war. These abandoned structures encompass the fragile and often controversial intangible history of the early mining life. These buildings are a direct result of the industrial mine and the production of diamonds; although they concentrate more on the lifestyle and routine of the mineworkers.

Therefore it is imperative that these buildings are preserved to portray the intangible history and the life of mine workers embodied in the compound ruins.



Figure 1.4 Photographs depicting areas of Compound 5 (author 2014)

“Around the World a great diversity of sites, structures, complexes, cities and settlements, areas, landscapes and routes bear witness to human activities of industrial extraction and production. In many places, this heritage is still in use and industrialization is still an active process with a sense of historical continuity, while in other places it offers archaeological evidence of past activities and technologies. Besides the tangible heritage associated with industrial technology and processes, engineering, architecture and town planning, it includes many intangible dimensions embodied in the skills, memories and social life of workers and their communities.” (ICOMOS 2011)



Figure 1.5 Photograph indicating the remains of the No2 Shaft Compound (photo by Jeffrey Moodie)

1.2 PROBLEM STATEMENT

Cullinan developed due to the discovery of diamonds. The town has grown as a direct result of the mine, therefore with the inevitable decommissioning of the mine it is important to develop a plan which generates a new form of income in order to keep Cullinan alive.

The abandoned buildings within the Mining Compound have the potential to be reused in order to generate revenue but due to the controversial history and meaning of the site it is important to approach the design in a sympathetic manner in order to preserve the sense of place and portray the history of the site while creating a new layer of opportunity and production.

1.3 RESEARCH QUESTIONS:

- 1 With the decommissioning of the mine could there be an opportunity for agriculture as a new form of industry to develop in order to replace the core income within Cullinan?
- 2 How can the revitalisation of the Compound become a catalyst for community upliftment by providing job opportunities after the removal of Cullinans core income?
- 3 How can the architecture become a way of mediating between what has been lost, what exists today and what can exist?
- 4 How can architecture revitalize the energy that once existed within this building, where the user becomes an integral part of the building, while still understanding the history of the site?
- 5 How can the compound be regenerated while still working within physical isolation to the town?

Issues were identified during the initial site analysis, these issues were then separated into different scales (General, Urban and Architectural) to be addressed on different levels throughout the design processes.

1.4a GENERAL ISSUES

>The Loss of tangible Heritage

The neglected and disintegrating compound buildings



Compound During its Use

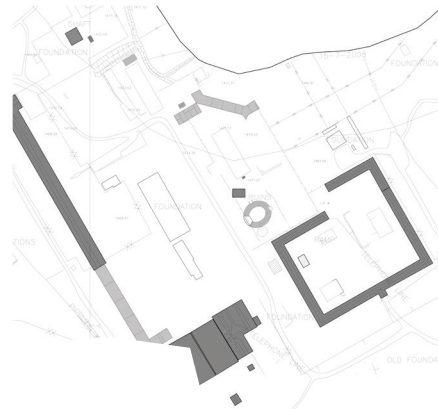

Existing structures (what is left of the compound)

>The Loss of Intangible Heritage

The lives of the mineworkers



Figure 1.6 Mineworkers in the Premier Diamond mine (photographer unknown)

1.4b URBAN ISSUE:

> *Site sits in Isolation*

The Compound sits in isolation and detached from Cullinan. How do we create the energy needed for this area to be regenerated and revitalized if the energy is centred within the town?

> *New Production:*

With the inevitable decommissioning of the Premier Diamond Mine, how can we evolve a Mining town into an agricultural town in order to generate a new form of income.

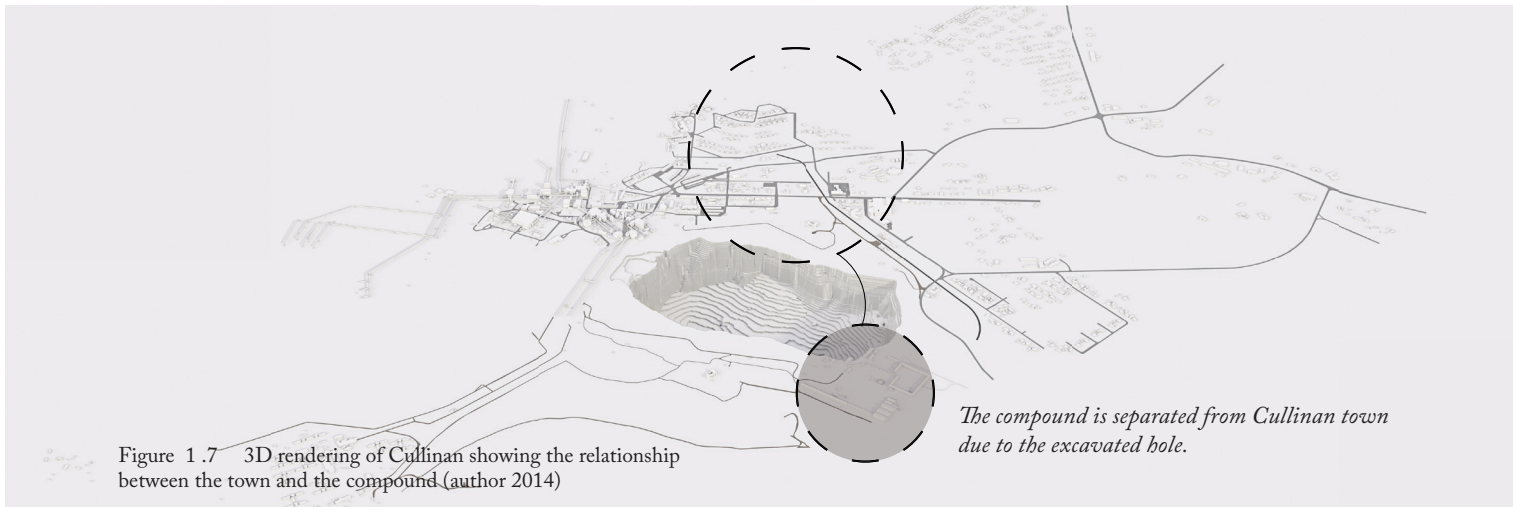

1.4c ARCHITECTURAL ISSUE:

- > Understanding the Sense of Place
- > Moving From Past to present to future while still understanding what happened there before
- > How can this architecture become a vessel for understanding the past, healing the past and moving into the future.
- > How does one keep the integrity and identity of the isolated site while still creating an informative intervention, which revitalizes the intangible and tangible history of the site, and yet still relates to the issues and potential that exists within Cullinan?

1.5 AIMS:

- 1 To maintain the character or the sense of place within the compound while reusing the site for a new function.
- 2 Revitalize the old existing fabric through a new form of production. The relationship between old and new will help revive these timeworn structures. It is important for the visitor to still understand what the significance of this compound was for the mineworkers.
- 3 This dissertation will focus on the stories and routine of the mineworkers and how this very controversial history can be translated through the building and the landscapes.
- 4 On a larger scale, this architecture needs to facilitate in the rejuvenation of the revenue, skills development and education needed within the post decommissioned mining town of Cullinan.
- 5 To look at the relationship between historical architecture and new contemporary architecture, and how they can work harmoniously in order to facilitate new functions.
- 6 The idea of memory in architecture can be used to understand the history of the site by evoking emotions which relate to the harsh conditions which existed within the Compound.

1.6 RESEARCH METHODOLOGY:

- 1 Collect literature reviews to understand the importance of the compound in order to recognize how to revitalize the compound through new functions and new architecture, while still being respectful and sympathetic to the heritage that exists there.
- 2 Analyze the place, the history, the potential and the intangible history of the site through drawings and diagrams, this can then be translated into a statement of significance to refer to in the design process.
- 3 Once there is enough information about the site, and a thorough site analysis obtained, further sketches can be developed which start to understand where new structures can be appropriately placed within a historic site. These sketches will then help ensure that the most appropriate solution is taken forward into the design process.



Figure 1.8 Artifacts evident within the Compound (photo by Jeffrey Moodie)

1.7 DISSERTATION OVERVIEW:

The macro vision looks at creating an agricultural and educational town. This will provide a new source of income for the people of Cullinan after the decommissioning of the mine as well as re-energise the town with new educational facilities such as a possible satellite station for the Agricultural Department for the University of Pretoria.

The micro vision revitalises the abandoned mining compound, through an agricultural intervention that portrays the narrative of the site and the past mineworkers as well as create new architecture that houses the facilities for a new form of agricultural production. The project aims to create a symbiotic relationship between the existing historic buildings and a new layer of productive landscape.



02

CONTEXT

02.

CONTEXT

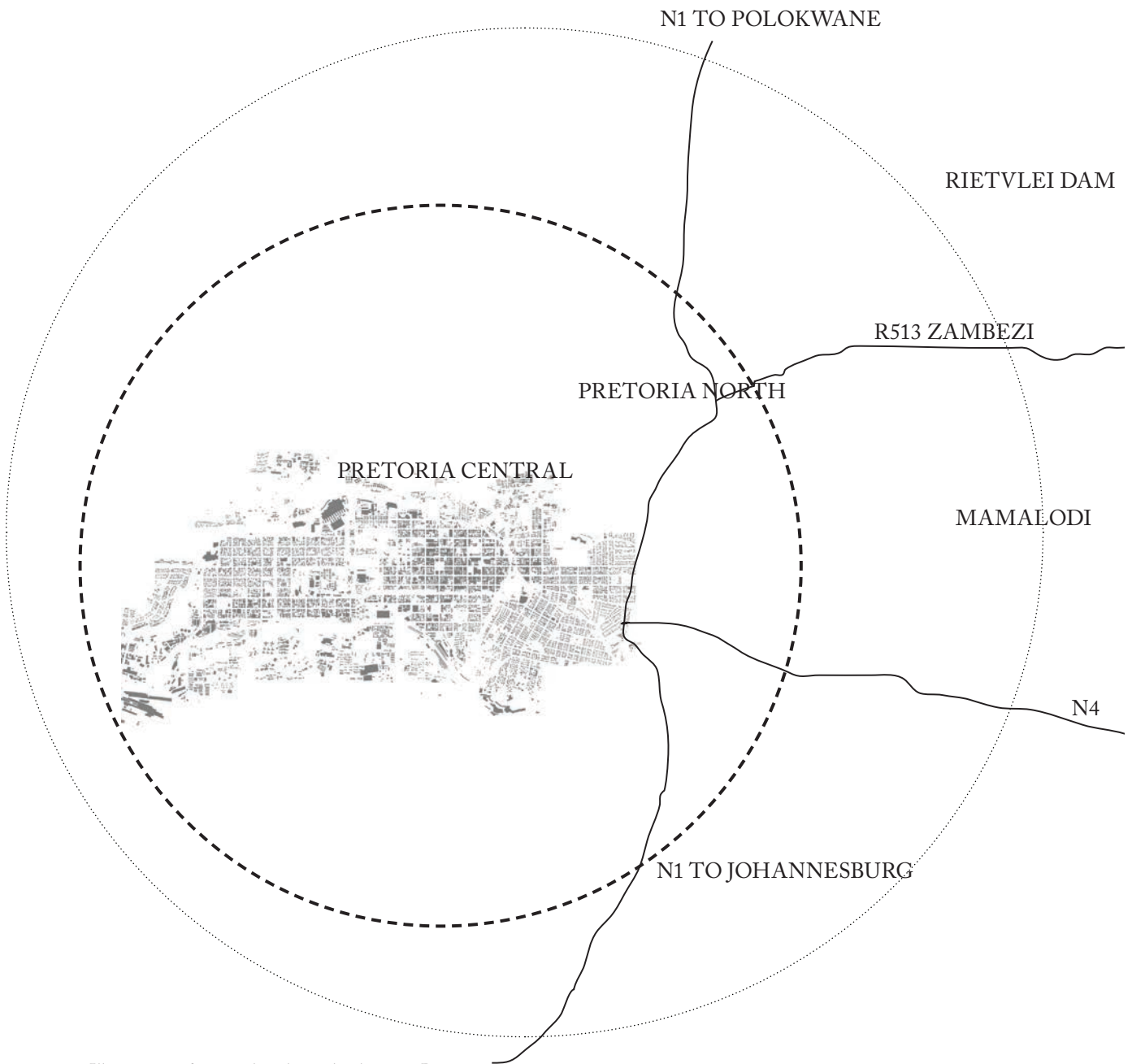
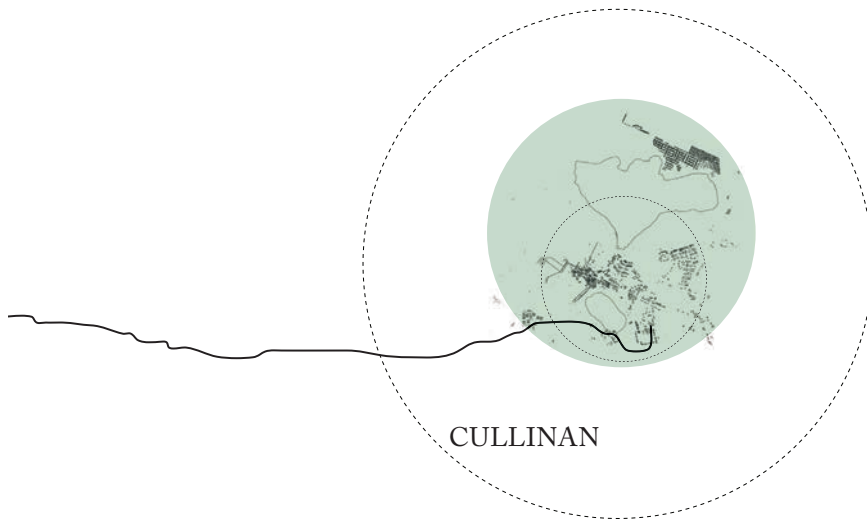

Figure 2.1 Illustration indicating the relationship between Pretoria and Cullinan (Natasha Laurent 2014)



MACRO CONTEXT

This chapter focuses on the site analysis and framework obtained as the Cullinan Group:

Marcel Mattheus
Natasha Laurent
Nikita Edwards
Walter Raubenheimer
Hugo van Niekerk
Paige du Toit

MESO CONTEXT

A thorough site analysis and vision for the No2 Shaft Mining Compound was collected as a smaller group which includes:

Hugo van Niekerk
Natasha Laurent
Paige du Toit



Silt Dam

Petra Diamond Mine

Mining Excavation

Cullinan Town

Abandoned Mining Compound

Figure 2.2 Aerial map of Cullinan indicating the town, mine and compound (photographer unknown)

2.1 MACRO CONTEXT

CULLINAN

Cullinan is situated 30 kilometers east of Pretoria. Thomas Cullinan started this quaint town, after the discovery of a diamond pipe in the early 1900's. The town is most famous for the discovery of the Cullinan Diamond (The Star of Africa). This diamond was given to King Edward VII where it was cut into 9 gems, 6 of which were placed into the British Crown Jewels. (Lincoln 2011)

The Cullinan Village grew as a direct result of the mine, first tents, then corrugated houses (which are still evident today) then stone houses, like the ones in Oak Avenue. Oak Avenue was the first street in Cullinan and followed the English Linear city plan, where the Edwardian houses are situated close to the street with long plots to the rear. These houses have been beautifully preserved and are currently used as restaurants and tourist attractions.

The Cullinan Mining Hole is a result of the Open Pit mining technique. This hole is approximately 1000m long, 500 m wide and 450 m deep.

After 112 years from the genesis of the Mine, it is now in its final section of excavation. Petra Mining Company estimates a further 20 years of mining before the decommissioning. The question that then arises is, what happens to the town of Cullinan once the primary source of income has been decommissioned? In the Dinokeng Urban Vision for Cullinan it speaks about the idea of boosting tourism due to Cullinan being in close proximity to Pretoria and Johannesburg. It is the intention to make Cullinan a tourist destination while still involving the people within the nearby township in new craftsmanship.

We as the Cullinan Group believe that this town will not survive solely on the revenue of tourism. The new vision of Cullinan thus looks at a need for a new core

source of income as well as a tourism interface. When Mapping Cullinan, it became evident that there were three major elements, which are in tension with one another. These elements are the mine, the town, and landscape. With the neutralizing of the mine, there is an opportunity for the town and landscape to thrive, this then brought about the idea of reconnecting the town and the landscape to their original functions, which was agriculture.

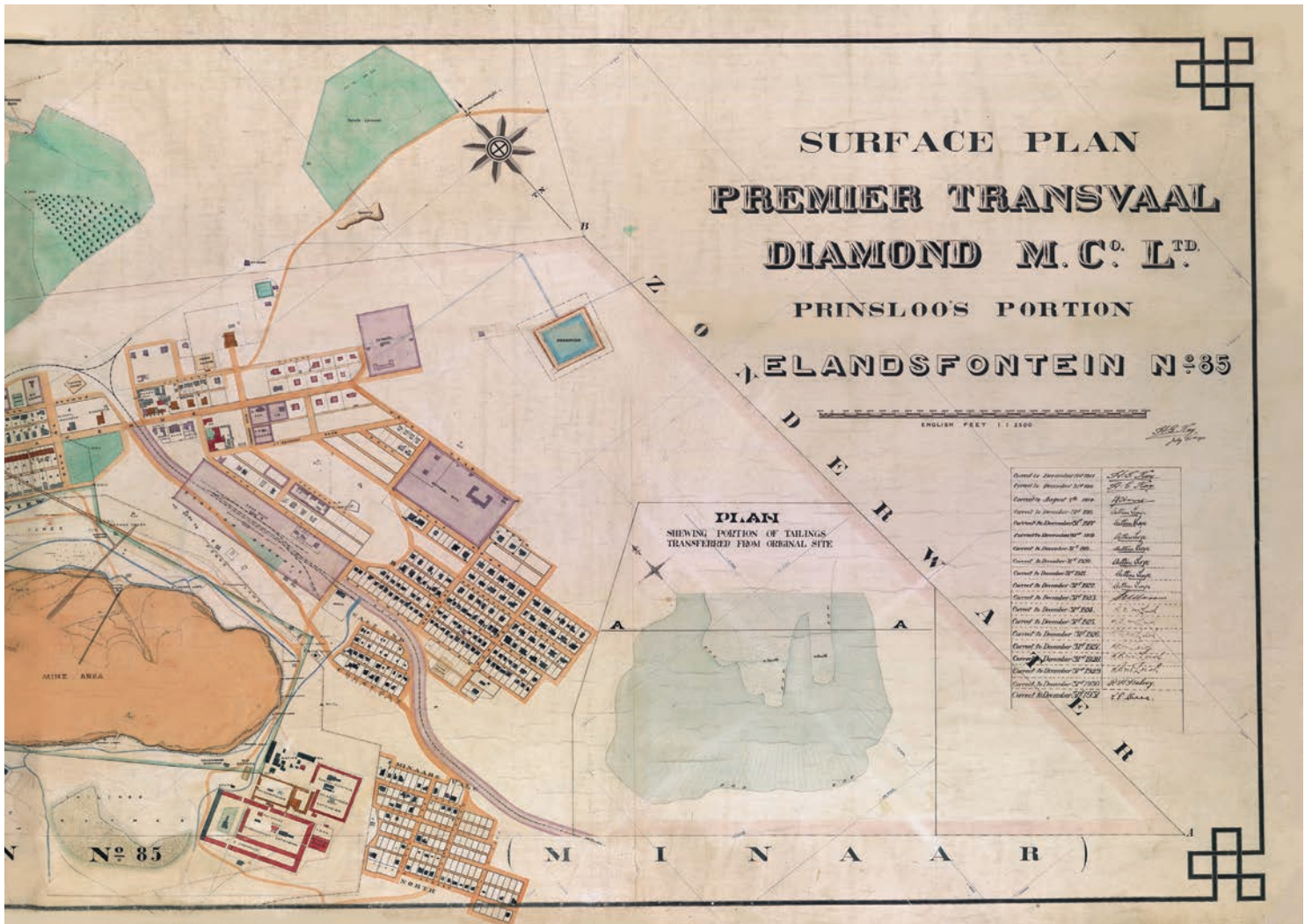

Horse ride 1hr

1895

Horse ride 1hr

Minnaar' Farm
Elandsfontein No.
85



1861

Portion of land was
laid out for orchards,
vegetables and herb
gardens

1902

Treaty of
Vereniging
signed

1903

Farm was
sold to
Premier Mine
for 20 000
pounds



1905

Cullinan
Diamond
was found
(the biggest
diamond in
the world)

The compound
for the mine
workers was
built
15 000 workers
in compound

3rd Gear was
constructed
and gear 1
and 2 were
closed for
several
years due to
shortage of
water

1907

The Hotel
Was Built



1909

Blue Heart
Diamond Found

Post Office,
Catholic Church
and Masonic
Lodge Built

1911
New
School

1896

Second
house
built



1896

People fled during
Anglo Boer war.

These people
were captured
and sent to Irenes
concentration
camp

1904
2nd Gear
installed

1906

Completion of
the Pretoria to
Premier Mine
Railway

Nedbank
building
Constructed

1908

The St George's
Anglican Church
designed by sir
Herbert Baker
was built

Railway station
was built

1912

Recreation
Club was
built

1903

No. 1 Gear
was put into
Commission
with 3 rotary
pans

First House in
Oak street
including
'House Mcardy'

1914

Start of
WORLD WAR 1

Mine Closes
after hostilities
broke out in
Europe.

Workers join
the army

1918

End of 1st
world war

Spanish
Flu

1930

World Wide
Depression

1939

Start of
WORLD
WAR 2

South African
army use
Cullinan as army
barracks

Italian Prisoners
of war are held
at zonderwater

1945

End of 2nd
world War

Mine is
reopened

1973

Compound
Closes
New Hostels
open for mine
workers

2008

De Beers
sells mine to
Petra Mining
Company

1916

Mine
reopens

1920

Thomas
Cullinan
Resigns.
De Beers
Takes
over mine

1942

Murals painted
in the recreation
club by the
Italian prisoners
of war

1932

Mine Closes
due to
depression.
The hole fills
with water
during this
time

1957

Compound is
renovated

1995

Mine De-proclaimed
village and houses
are sold to residents

2.2 MACRO MAPPING

TOWN DEVELOPMENT

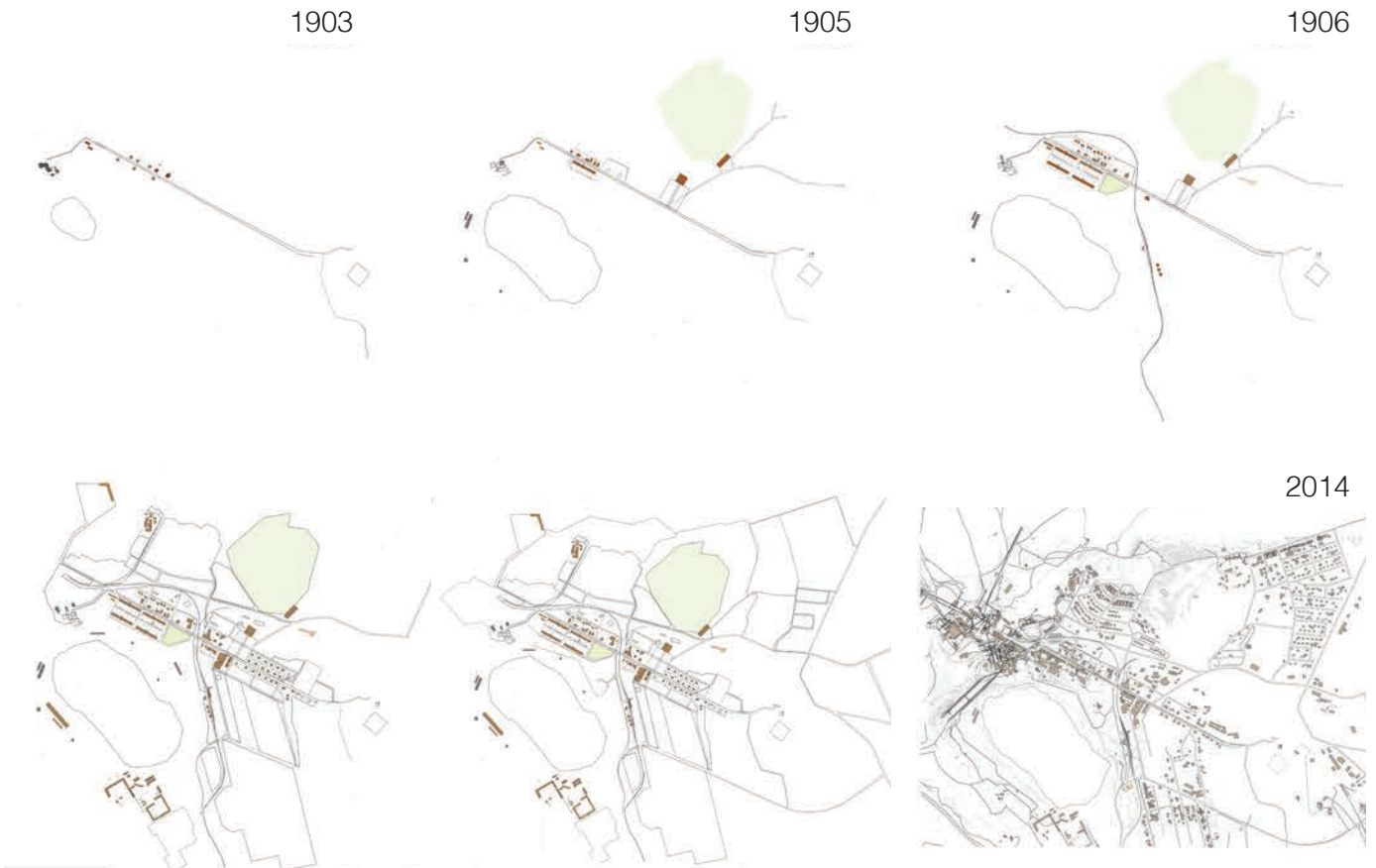

Figure 2.4 Maps indicating the development of Cullinan over time (Nikita Edwards 2014)

Oak street was the first street in Cullinan. The town later grew out towards the north- east but mainly centred around the diamond mine and excavation pit.





The town developed due to the success of the mine, but during the war in 1932 Cullinan was converted into a military camp. The town was most likely selected due to abandoned mining houses which could be utilized as accommodation for the military; its open fields which could be used for training and its close proximity to the railway. (Military History Journal 2007)

The Italian Prisoner of War camp was constructed in Zonderwater which is on the outskirts of Cullinan. (Lincoln 2011) Remains of these different events are still evident today. Italian Prisoner of war paintings from 1942 can be seen in the old Recreation building as well as an old fountain built by the Italians, which has been left to deteriorate in the veld, south of the town.

Today the town has become a tourist attraction where many people from Pretoria and Johannesburg take day trips to visit the museums, shops and restaurants. People often attend the organised tours through the mine but know very little about the town and its history.

As is evident through the site mapping (figure 2.7) there are many historic buildings along the main street (Oak street) and a rich history within Cullinan. A large portion of the towns money is generated through its tourism and it is important to keep the attraction of this quaint town alive when looking at the future development and vision for this area.

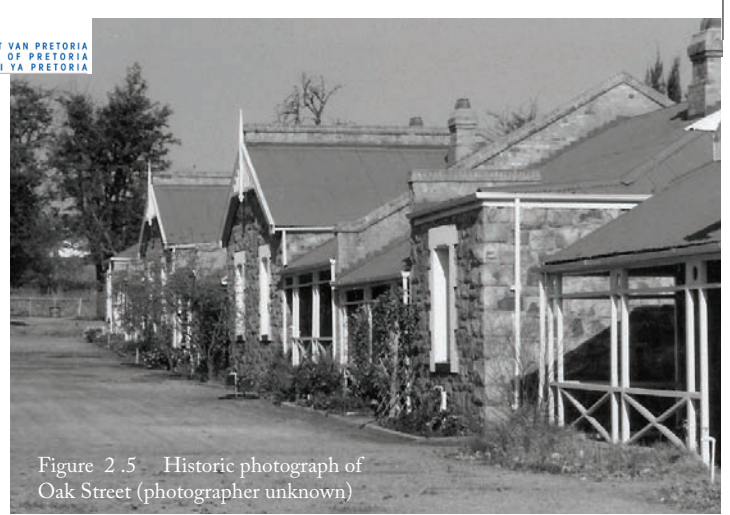

Figure 2.5 Historic photograph of Oak Street (photographer unknown)



Figure 2.6 Cullinan town as it exists today (Photos by Natasha Laurent)

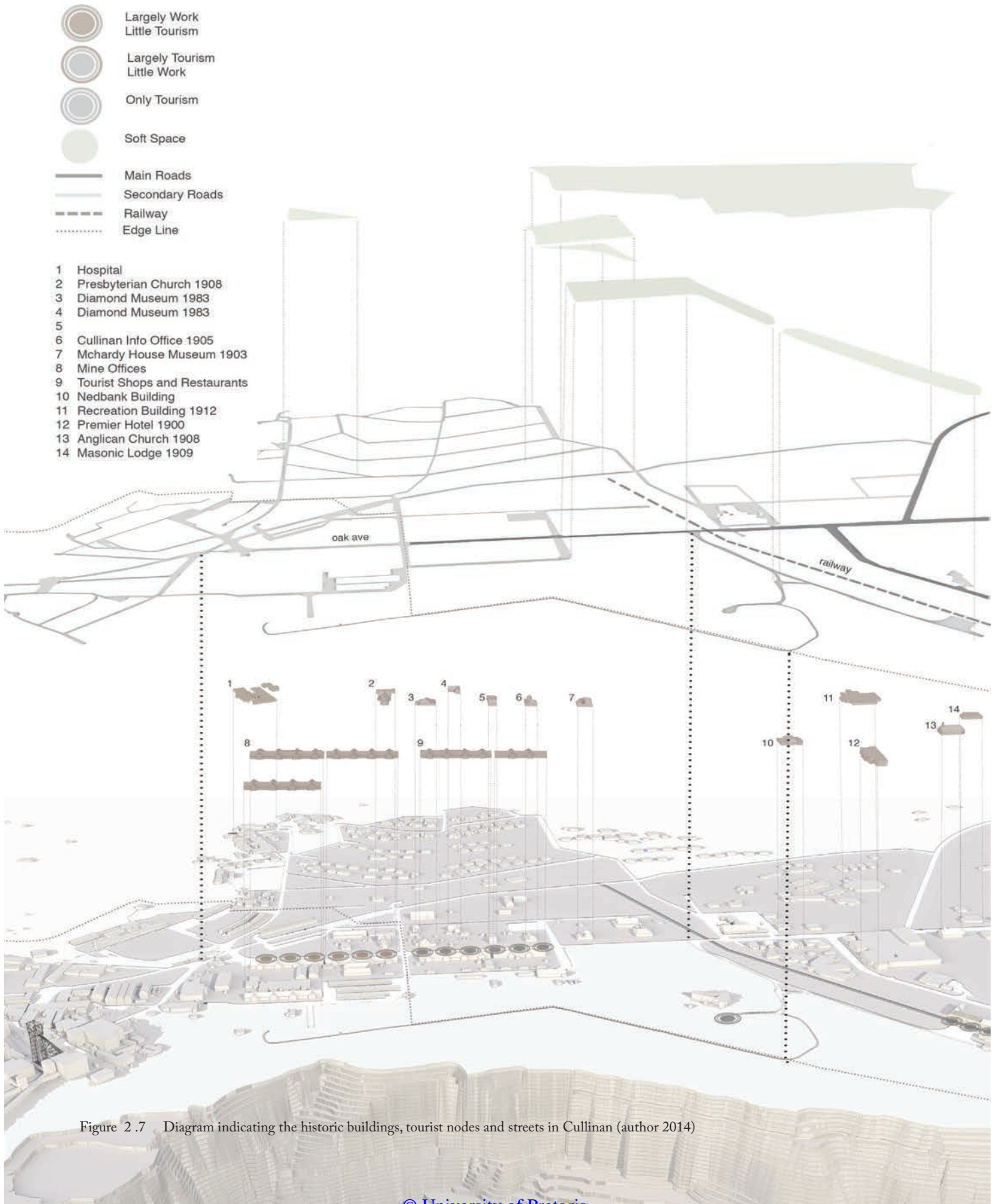

Figure 2.7 Diagram indicating the historic buildings, tourist nodes and streets in Cullinan (author 2014)



Mine

The Genesis of the Premier Diamond Mine was in 1903 (Lincoln 2011). The mine sits above one of the largest Kimberlite pipes in the world and has produced the most spectacular diamonds such the world famous Cullinan Diamond and the Star of Josephine. (A blue diamond)

The Premier Diamond Mine was previously owned by De Beers and is now currently owned by Petra (Lincoln 2011). The mine started with open pit excavating (which has left a huge hole or excavated scar in the landscape four times the size of Kimberley's hole). Due to a layer of rock below the excavated pit, shafts were constructed in order to get to the layers of kimberlite beneath the rock layer.

It is estimated that within the next 12- 20 years the Kimberlite Pipe will have been completely excavated and although there is a process to re-mining the already excavated kimberlite hills there is a possibility the mine will be decommissioned leaving a large portion of Cullinans community without jobs.

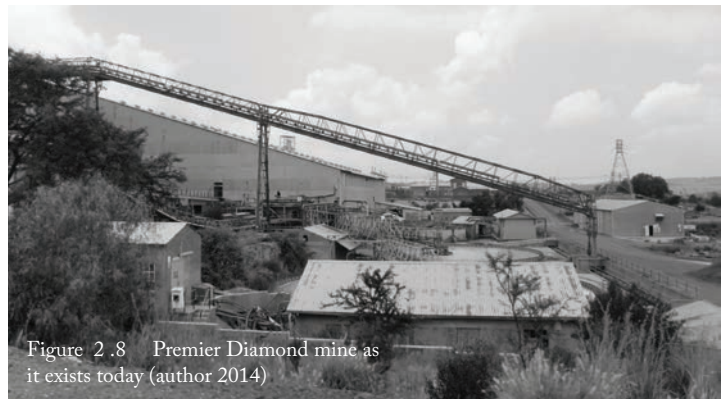

Figure 2.8 Premier Diamond mine as it exists today (author 2014)



Figure 2.9 Historic Image of mineworkers in Premier Diamond Mine

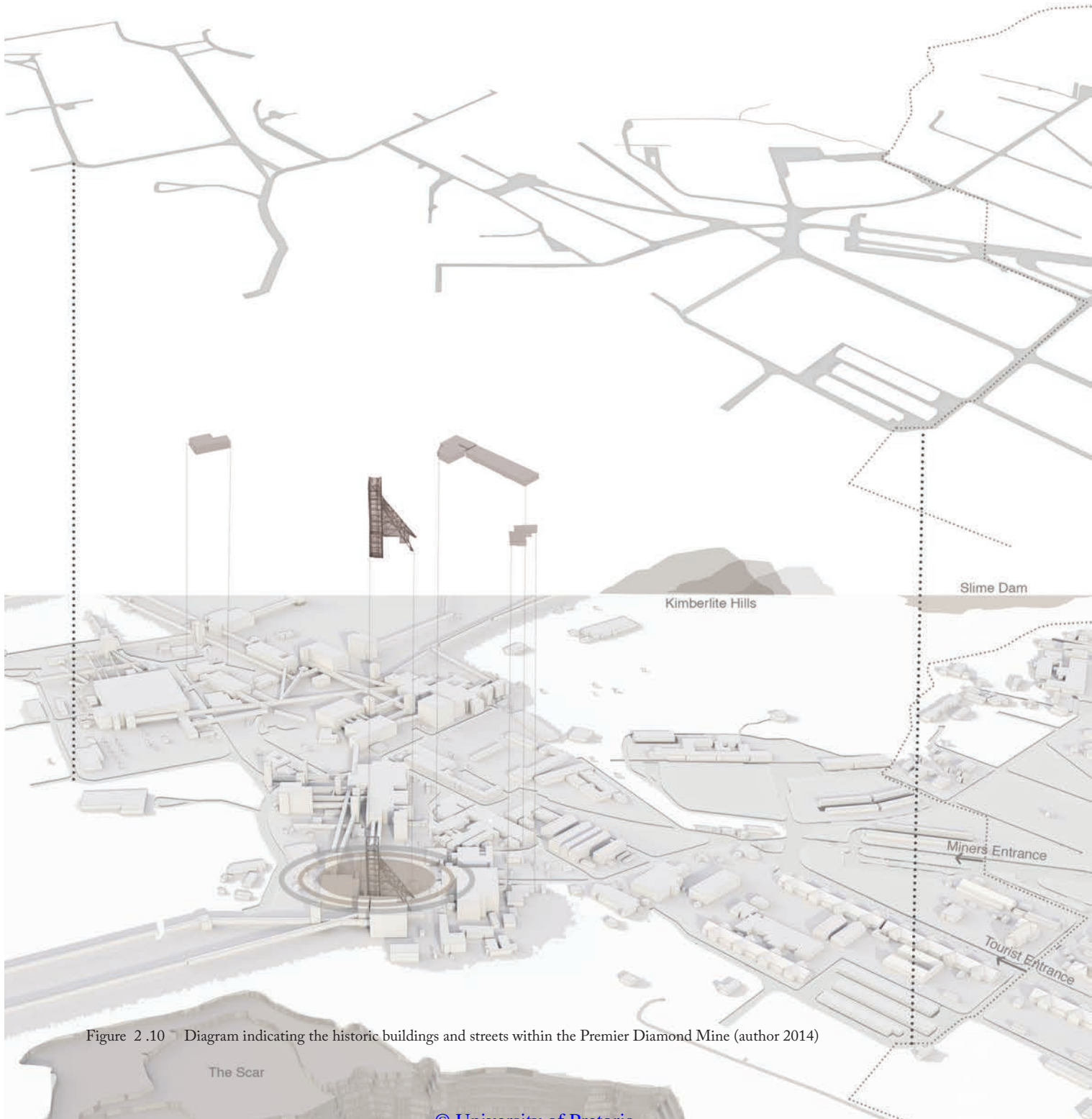

Figure 2.10 Diagram indicating the historic buildings and streets within the Premier Diamond Mine (author 2014)



Landscape

The landscape once used for pastoral land is now scattered with evidence of the mine. In the horizon one can see the ventilation shaft, No1 mining shaft and the excavated pit. This landscape has become controlled by this machine and its by-products. To the north, the Slime dam extends as far as the eye can see, covering the land in a gray silt.

This land needs to be revitalized, once the mine has been decommissioned and brought back to its original use. To be in harmony with the town and the new sources of production.



Figure 2.11 The Landscape in Cullinan as it exists today (photos by Natasha Laurent 2014)

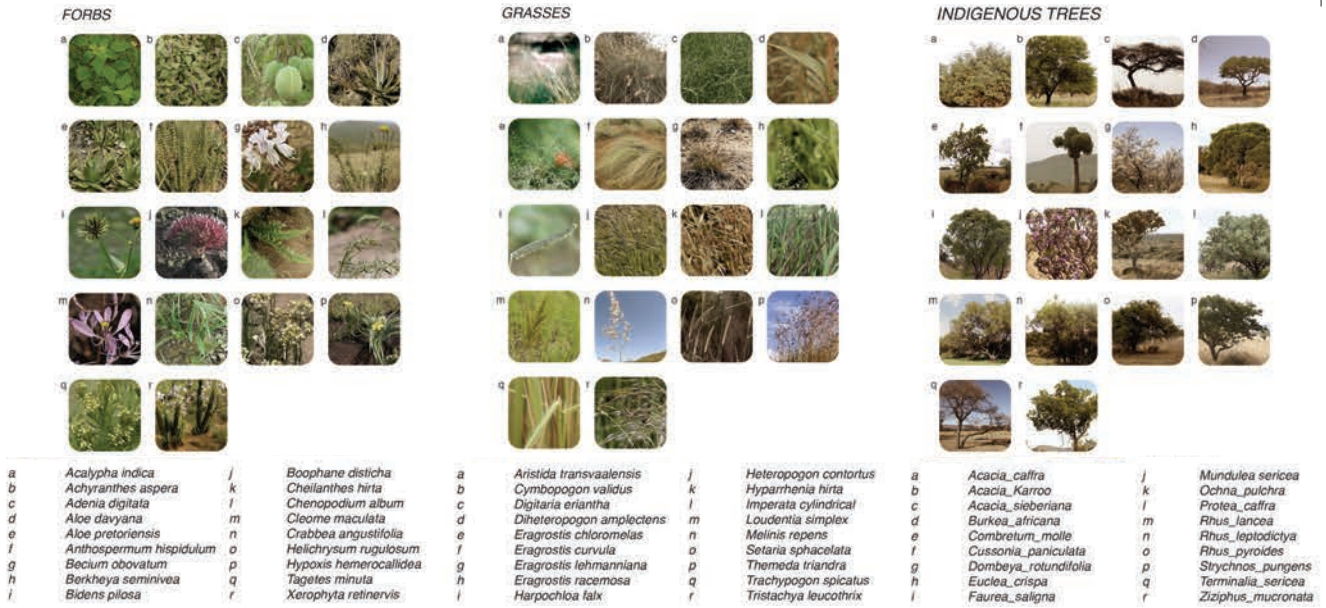

STREET NAMES



- 1 Oak Street- (*Quercus suber*)
- 2 Kameeldoring Street- (*Acacia erioloba*)
- 3 Suikerbos Street- (*Protea cynaroides*)
- 4 Seringa Street- (*Melia azedarach*)
- 5 Oliehout Street- (*Olea eurpaea Africana*)
- 6 Protea Street- (*Protea*)
- 7 Mimosa Street - (*Acacia dealbata*)
- 8 Jasmine Street- (*Jasmine*)
- 9 Paperbark Street- (*Acacia sieberiana*)
- 10 Jacaranda Street- (*Jacaranda mimosifolia*)
- 11 Bluegum Street- (*Eucalyptus globulus*)
- 12 Willow Street- (*Salix babylonica*)
- 13 Baobab Street- (*Adansonia digitata*)
- 14 Pine Street- (*Pinus Patula*)
- 15 Poplar Street- (*Populus canescens*)

Figure 2.12 Fauna and Flora found in and around Cullinan (Marcel Mattheus 2014)

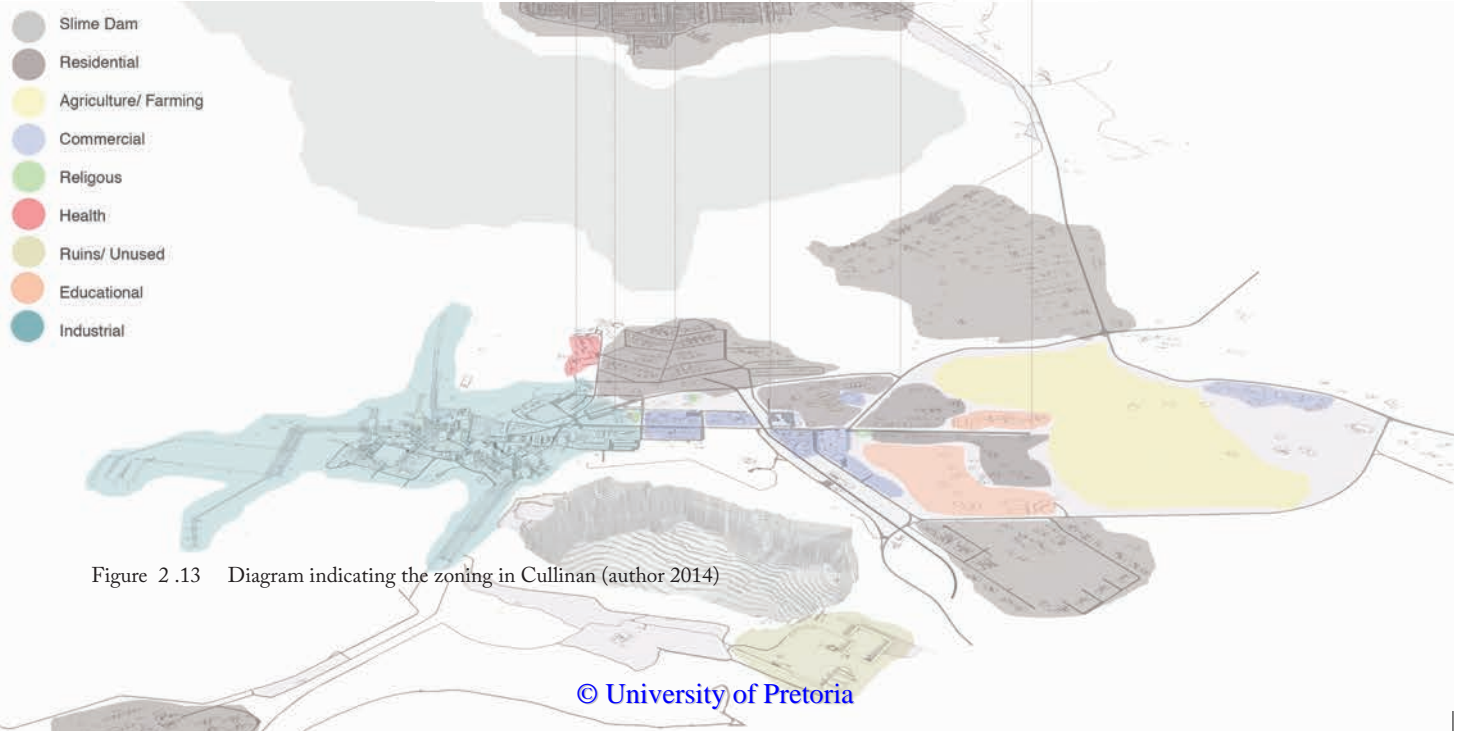

Figure 2.13 Diagram indicating the zoning in Cullinan (author 2014)

2.3 MACRO VISION

CULLINAN



PRIMARY AND SECONDARY ROUTES

- Primary Route
- Secondary Route

Description:

The Primary route focuses on connecting the decommissioned mine; the existing town and the old mining compounds. The route continues around the excavated hole allowing people to view the scar in the landscape from all angles. Along the primary route new public squares have been designed to define certain areas of the town and to create more of a pedestrian friendly route where shops and restaurants can spill out onto these spaces.

The Secondary Routes are then allocated closer to the hole. These routes are designed for pedestrians and bicycles. It allow people to meander around the hole to the different interventions and viewing points.



GREEN SPACES

- Natural Bushveld
- Productive land
- Recreation space

Description:

The existing landscape has been developed into a productive landscape where all the new interventions plug into. On the eastern side of the hole the natural bushveld has been retained with smaller sections of production closer to the town. The main belt of productive landscape is allocated on the western side of the hole. This agriculture contains orchards, hemp, and vegetable farming. Along Oak Avenue (the main street in town) new recreational green spaces have been designed for the new accommodation as well as a space for festivals and events.

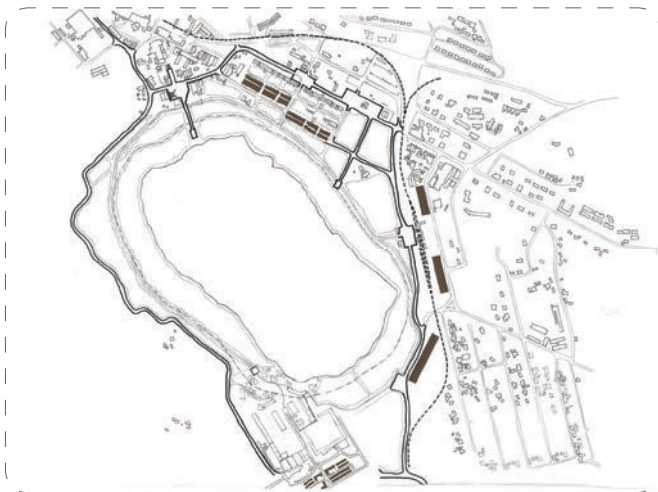

NEW DEVELOPMENT

■ New Development

Description:

The new development throughout the town will mainly contain accommodation and facilities for agricultural based education. This development is again centred around the scar in the landscape and provides a further connection between the town and mining compound

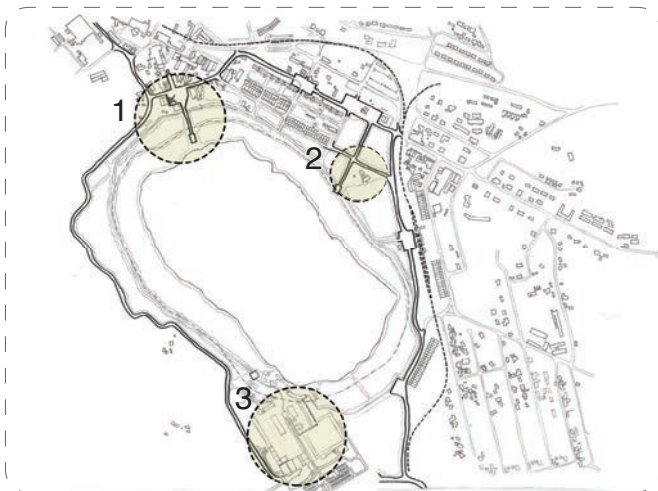

SITE ALLOCATIONS

- 1 MINE: Walter Raubenheimer
Marcel Mattheus
- 2 TOWN: Nikita Edwards
- 3 COMPOUND: Natasha Laurent
Paige Du Toit
Hugo van Niekerk (landscape Architect)

Figure 2 .14 Diagrams indicating the vision for Cullinan after the decommissioning of the mine (author 2014)



STUDY AREA: MINE
Walter Raubenheimer
Marcel Mattheus

STUDY AREA: CULLINAN TOWN
& VENT SHAFT
Nikita Edwards

STUDY AREA: COMPOUND
Paige du Toit
Natasha Laurent
Hugo van Niekerk (Landscape Architecture)

Figure 2.15 Map illustrating the framework for Cullinan once the mine has been decommissioned. (Natasha Laurent 2014)



VISION FOR CULLINAN:

The Cullinan Group then developed a macro framework for the development of Cullinan after the decommissioning of the mine. All the new interventions plug into the agricultural, educational and tourism vision in order to reconnect the town, the mine and the landscape harmoniously.

The agricultural area forms a belt along the western side of the hole creating a link between the mine, town and compound. New accommodation is proposed near the entrance to the town and public squares have been designed around the existing mining shaft, as well as in Oak Street and at the train station. These public squares create a tourism interface to the new interventions.

There is a new primary route where cars are able to loop round the hole and through the mine and in doing so reconnecting the mine and the town. Secondary pedestrian and bicycle routes are proposed closer to the hole where people can walk to the 3 look out points as well as walk to all the interventions.

Parking areas are proposed near the mine as well as the compound to promote pedestrian movement through the town. All the interventions help to portray the intangible and tangible history of Cullinan.

Meso Context

No2 Shaft Mining Compound

This dissertation will focus on, the No2 Shaft Mining Compound to the south of Cullinan. Currently this site is abandoned and has been left to deteriorate since the 1950s. Nature has infiltrated into all aspects of this beautiful site, but the public knows little about the lives of the mineworkers that once lived inside these vast stonewalls.





Figure 2.16 Illustration of how Compound 5 could have looked during the initial mining years (author 2014)

2.4 MESO CONTEXT

NO2 SHAFT MINING COMPOUND

2.5 MESO MAPPING

NO2 SHAFT MINING COMPOUND

Figure 2.17 Panoramic of the courtyard space within Compound 5 (photo by Jeffrey Moodie)

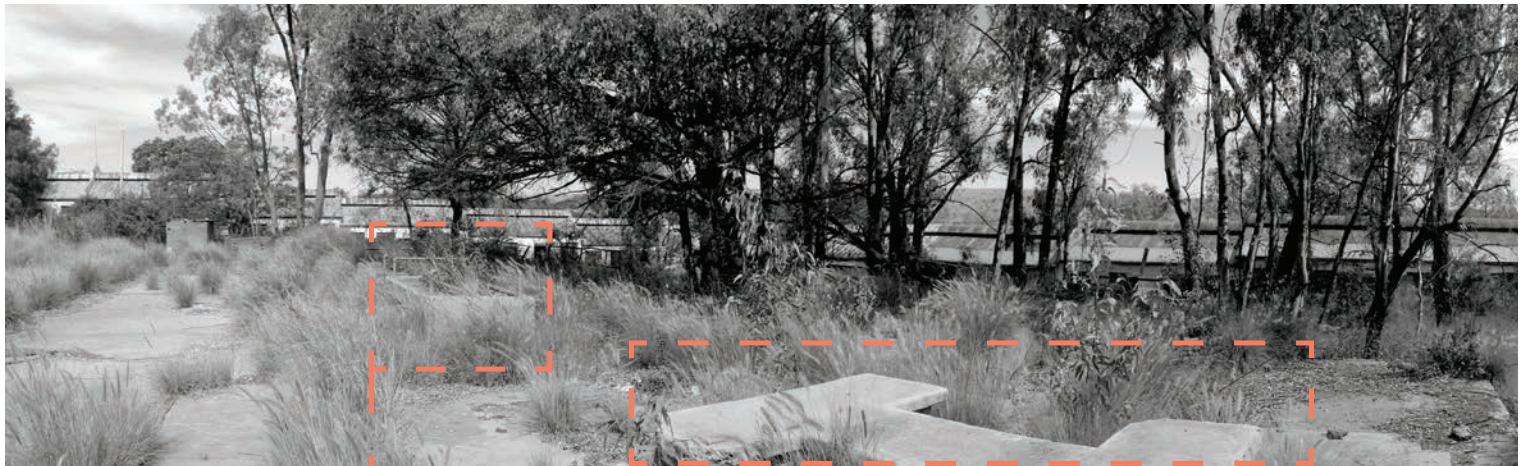

WASHING AREA
Preparing Food
Washing Clothes

REMAINS OF AN OLD TABLE
Possibly for ironing

Figure 2.18 Panoramic of amphitheatre within No2 Shaft Compound (photo by Walter Raubenheimer 2014)



COMPOUND 5
Behind Buttress wall, entry to
compound 5 is situated in top left
hand corner

TICKET HOUSE
Built during the 1950's
To Facilitate the Amphitheatre
Still in very good condition



ACCOMMODATION COMPOUND 5
Sleeping Quarters, One room would
House 40 Workers



AMPHITHEATRE
Built during the 1950's
Where the mineworkers would watch movies
projected from the small projector house
Perform Tribal Dances

PHOTOGRAPHIC STUDY



Figure 2.20 Aerial map indicating where the photographs were taken in the photographic study (Edited map from the Geographic Department)



Figure 2.21 Photo of Compound 5 rooms (author 2014)



Figure 2.22 The abandoned Compound 5(author 2014)



Figure 2.23 Memories of the past (author 2014)



Figure 2.24 Gable wall with block symbol (author 2014)



Figure 2.25 Compound 5 accommodation(author 2014)



6

Figure 2.26 Remains of the past (Jeffrey Moodie 2014)



8

Figure 2.28 Corrugated roof (author 2014)



7

Figure 2.27 Abandoned corridor (author 2014)



9



10

Figure 2.29 Comound 5 (author 2014)



Figure 2 .30 Entrance to the Mine (author 2014)

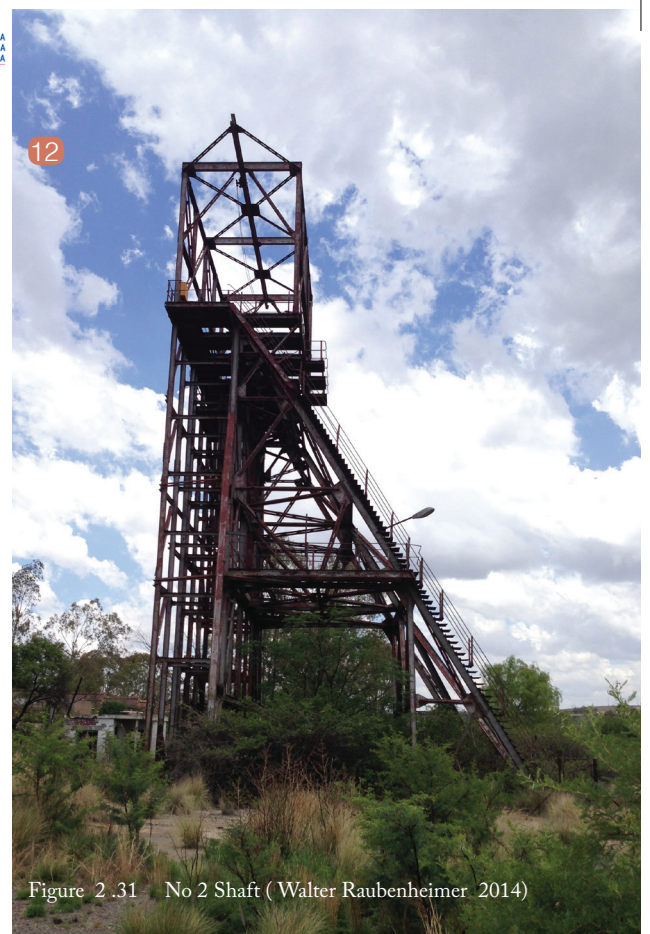

Figure 2 .31 No 2 Shaft (Walter Raubenheimer 2014)



Figure 2 .32 A lost past (author 2014)



Figure 2 .33 Hidden Amphitheatre (Walter Raubenheimer 2014)



13
Figure 2.34 Remains of Washing facilities (author 2014)



14
Figure 2.35 Unused warehouse space (author 2014)



15
Figure 2.36 Compound Ruins (author 2014)



16
Figure 2.37 Memories (author 2014)



17
Figure 2.38 Stone arch, a memory of a lost compound (author 2014)



2.6 MESO VISION

NO2 SHAFT MINING COMPOUND

The essence of this new vision is to allow the tourists to understand the story of the mineworkers and what they endured in this site, as well as to understand the tangible history through the old ruins which are in desperate need of preservation or adaption. This new approach will link to the larger framework of an agricultural and educational area, where the land will become a productive landscape that benefits the community of Refilwe (the township outside of Cullinan) as well as rehabilitating the land. The vision allows for the incorporation of both a productive intervention as well as a tourism interface where the tourists can move through the site, and start understanding the past as well as a new productive vision for the future. There will be market spaces and Restaurants where people can buy the produce produced in the area.

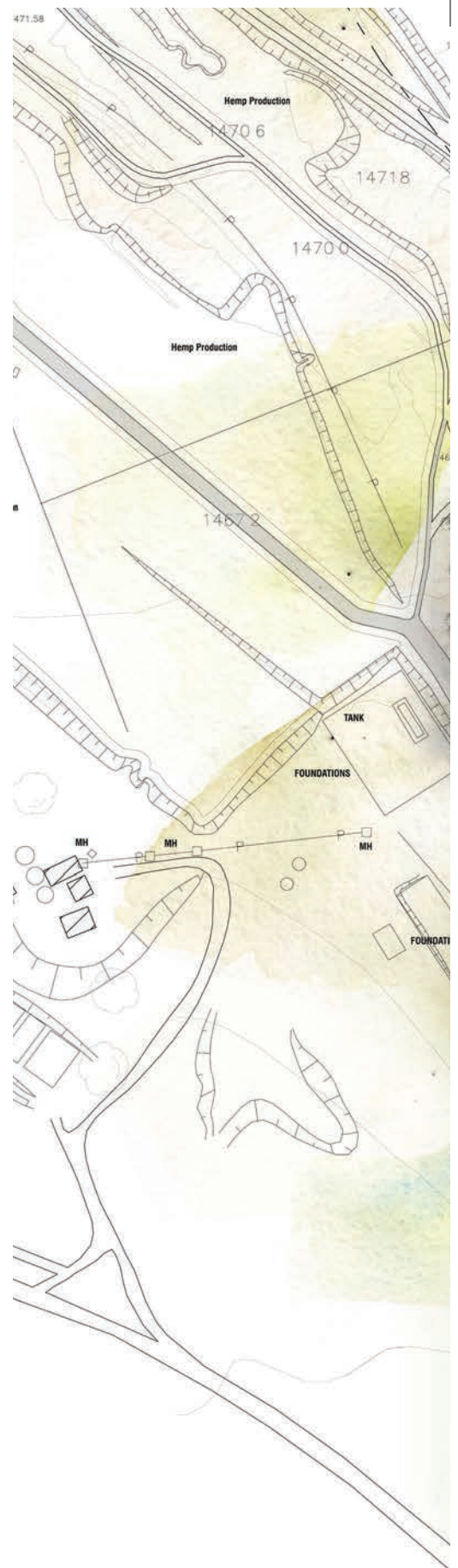

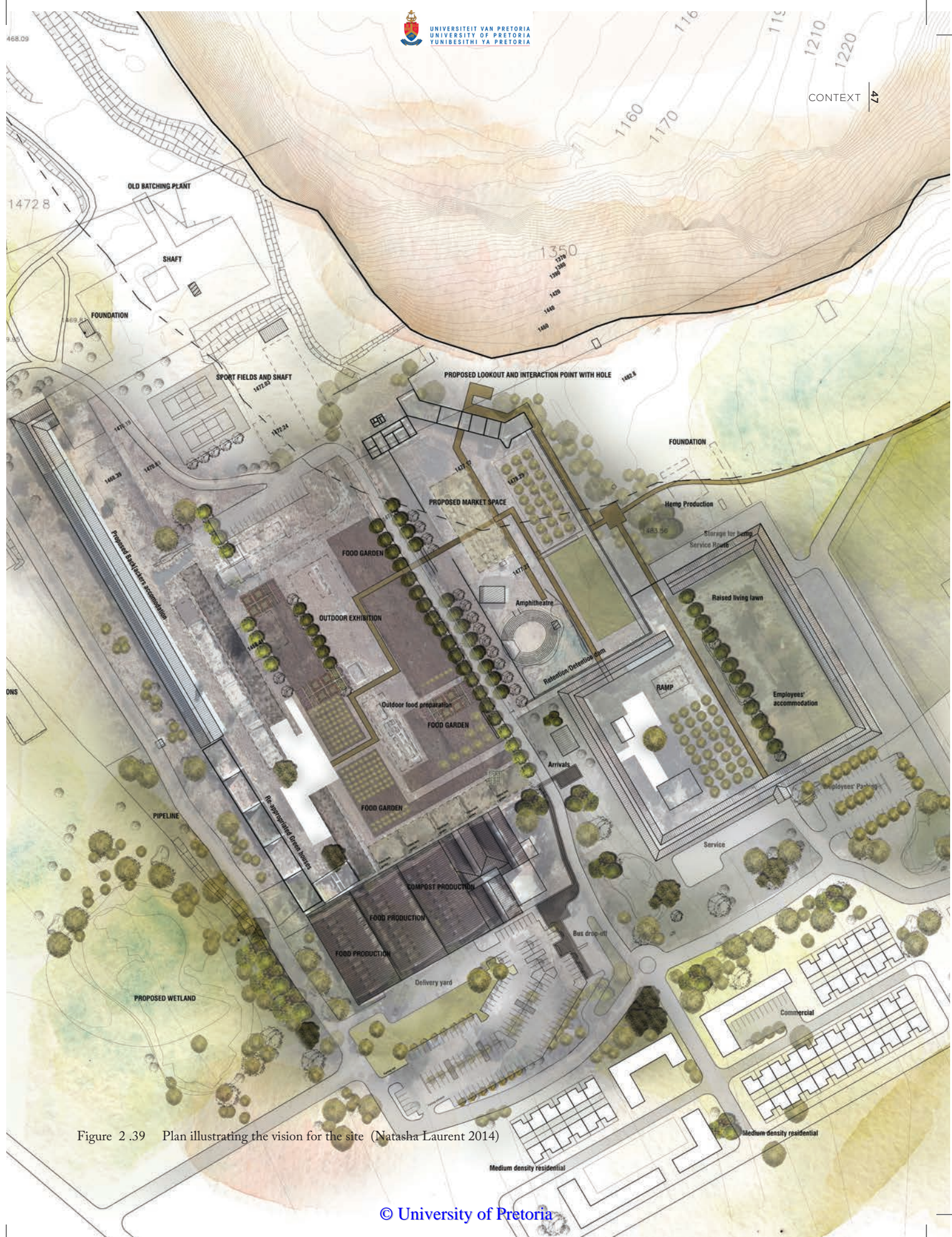

Figure 2 .39 Plan illustrating the vision for the site (Natasha Laurent 2014)

RECREATION:
Soccer fields for the mineworkers are reused as recreational spaces for the backpackers

ACCOMMODATION:
The old accommodation for the mineworkers are reused as a backpackers facility

MINING ENTRANCE:
The entrance into the mine where the workers would line up for work is reintroduced as a second entrance to the site

COMMUNITY SPACES:
The areas within the courtyards where the mineworkers would gather to eat, wash or do laundry are designed as gathering spaces to connect with the past

ACCOMMODATION:
The old accommodation quarters for the mineworkers are reused as accommodation for the workers on site.

LATRINE:
Reused as Public toilet facilities for the site.

PROPOSED SITE:
Textile Production

OLD COOKING FACILITIES
The New food production is situated where remains of the old cooking facilities can still be seen

OLD BUTCHER
The abandoned warehouses are now proposed as refrigerators and packaging areas which relate to the history of the site

ADMINISTRATION:
The existing entrance to the compound is kept in the new vision to allow people to understand the historic story of the site

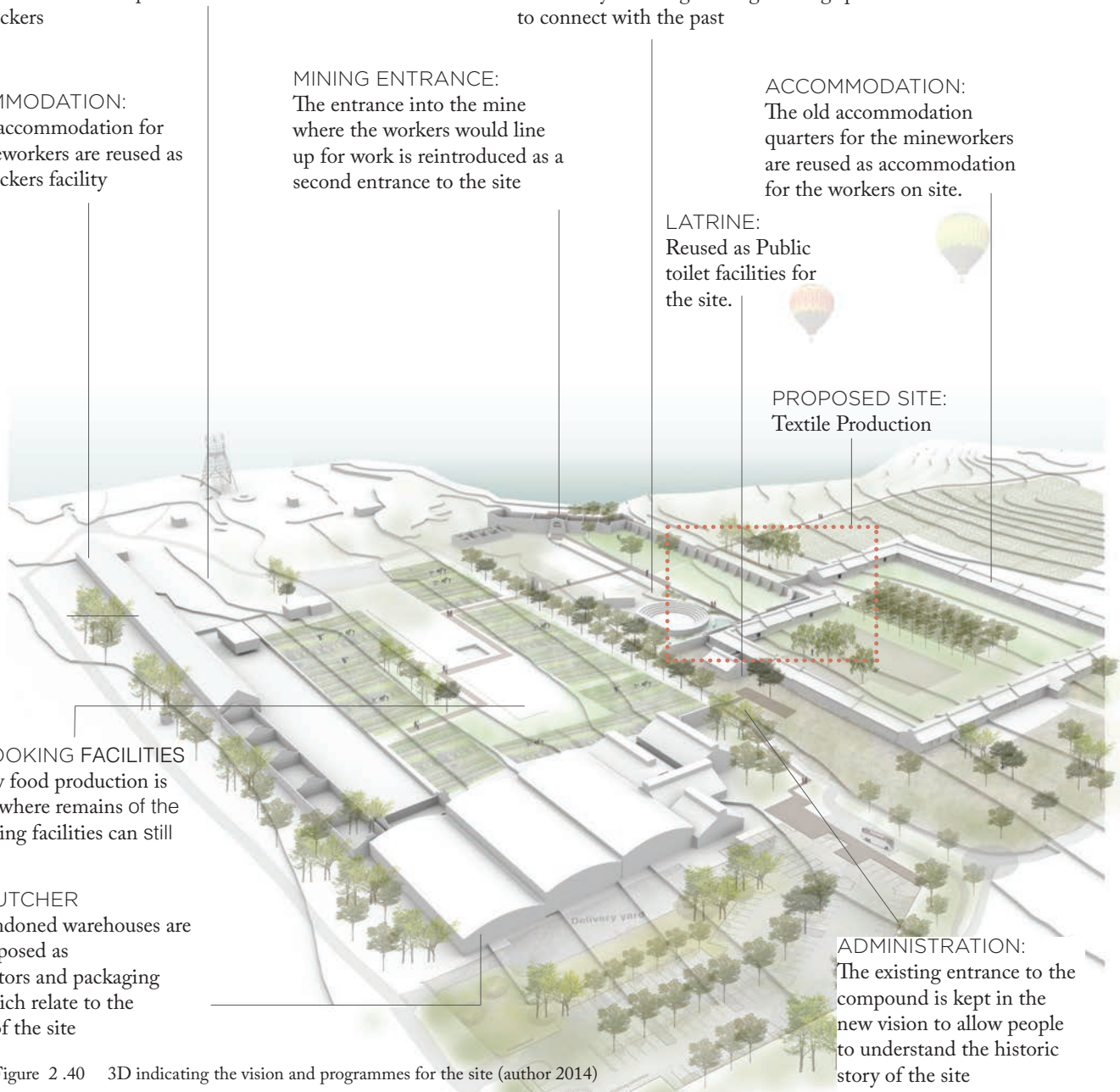

Figure 2 .40 3D indicating the vision and programmes for the site (author 2014)

03

SITE

03.

SITE

This chapter looks at the history of the meso context, No2 Shaft Compound, as well as an allocated portion of the context known at Compound 5 as a proposed site for this dissertations intervention.



Figure 3.1 Map indicating Compound 5 within No2 shaft Compound

3.1 HISTORY AND CULTURAL SIGNIFICANCE

NO2 SHAFT COMPOUND

The Compound was built during 1902 to 1905 and later altered during the 1950's (Site Solutions 2002). It housed accommodation for 15000 workers, washing and cooking facilities, a small hospital, outdoor theatre, detention house, offices and shops. The mine workers once signing a contract were required to stay in these compounds until their contract was complete, this would often be up to year at a time. Due to these restrictions and safety regulations the compound resembles a detention facility, isolated from the mine and town with high walls, strict security and only 2 entrances.

The accommodation within the compound was separated into ethnic groups to help prevent fighting amongst one another. During the early mining years, the compound living conditions were very poor. There were no bunks available to the 'boys' (as the mineworkers were called during that time) which meant they would have to sleep on the cold concrete floor with as many as 40 people per room (approx. 160m² rooms) (Site Solutions 2002)

The People living in the compound suffered from pneumonia, enteric fever, chronic recurrent malaria and scurvy. (Site Solutions 2002). Lime juice bottles were found throughout the compound, which indicates the treatment of scurvy. Due to these sickness the hospitals were overcrowded, and as many as 28 people per ward instead of a required 15 were documented. The workers would drink up to a bottle of brandy a day to reduce mortality rates. They would mix brandy with quinine, a medicine that helps fight malaria and fever, in order to disguise the bitter taste of the medicine. The recorded mortality rate for mineworkers in the compound was an average of 40 people per year. This was due to the diseases that spread through these living quarters as well as the malnourishment of the mineworkers. They would survive on a bag of meel; tinned food, which was discarded from the military stores and often rusted, and the content bubbled when opened; as well as small amounts of meat and coffee. Very little fresh food was available to these workers.



Figure 3.2 Historic photographs indicating the life of a mineworker working in Premier Diamond Mine (photographer unknown)

Outdoor washing facilities such as public baths and communal showers are still evident in the ruins of the Compound today. (Site Solutions 2002). These facilities only contained cold water and were often used to wash linen. The compound water was said to be contaminated and could be the source of some of the diseases. There were cooking facilities (which are still evident today) where the workers would buy food from the shops located inside the compound and would cook as a group of individuals. The compound had their own currency, which would ensure that a portion of the mineworker's wages would be kept within the company. Up to 42 percent of a mineworker's salary would return to the Mine through the stores. During the initial years the cooking facilities were outdoors, which meant that when wet weather occurred the cooking facilities could not be used. They later built a steel structure over the cooking facilities.

What exists of the compound today is a mere glimpse into the life that once existed there. Although unforgiving and inhuman conditions were the daily lifestyle within the compound it is important to be able to understand and not neglect the history that once filled these walls.

Due to the development of Refilwe (an informal settlement north of Cullinan) and a new mining compound to the west of the mine, the mine closed this compound where it stood abandoned until the war. Cullinan became an army barracks and the compound buildings were utilized as work shops for the military vehicles (Lincoln 2011).



Figure 3.3 A forgotten past (photo by Jeffrey Moodie 2014)

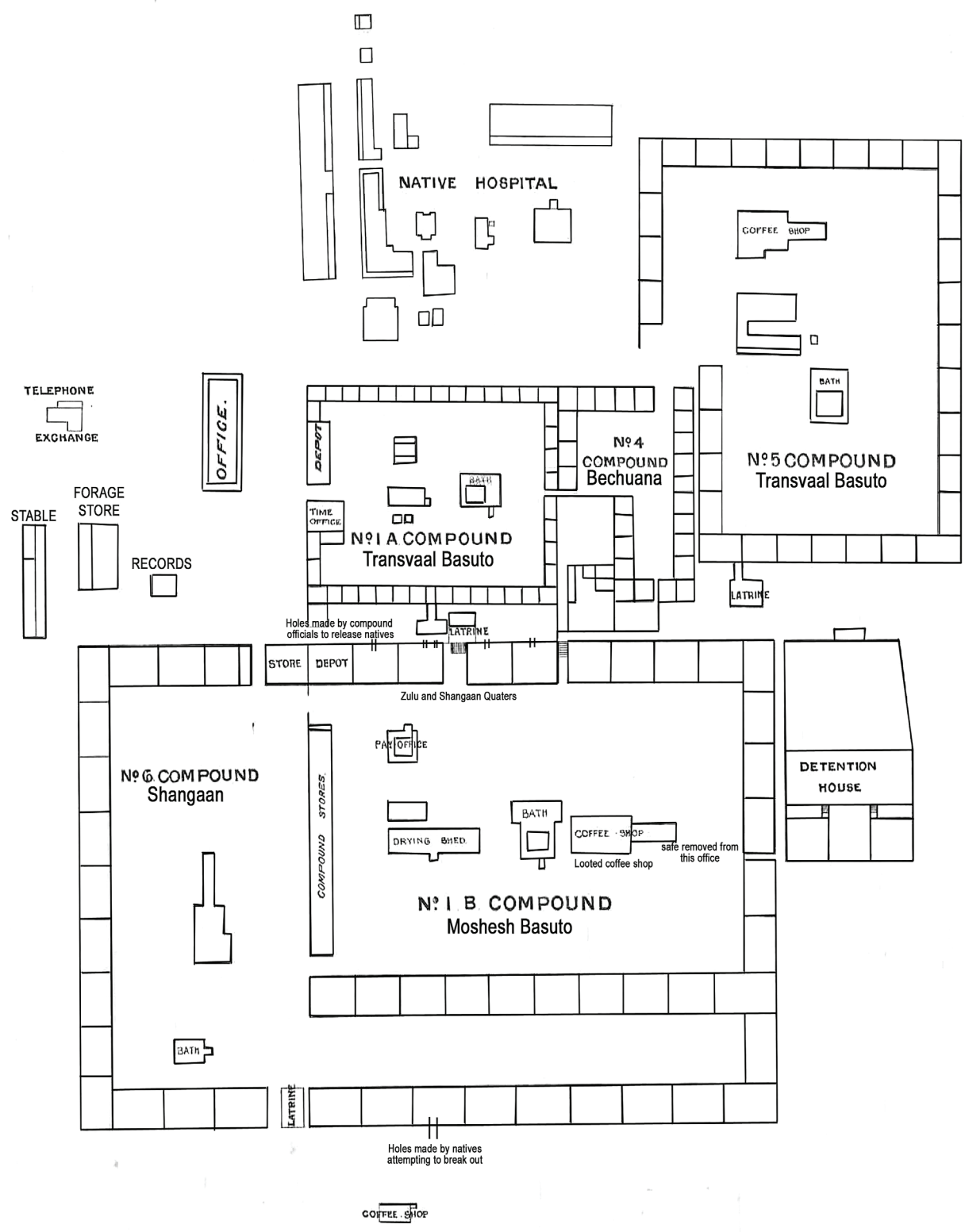

Figure 3 .4 Block Plan of No2 Shaft Compound indicating the ethnic group separation

- 1 This photo indicates the type of work the mineworkers were expected to do during the initial stages of excavation.
- 2 An image indicating the Entrance to the mine, from within the compound. This arch is still evident today although the office rooms along the side have slowly deteriorated.
- 3 The mineworkers were educated within the compound.
- 4 A soccer field was set up on the northern side of the compound where the workers were able to play during their time off.
- 5 This image depicts the hospital building within the compound, which was often overcrowded.
- 6 The cooking facilities were located in the courtyard spaces. One worker from a room would take his day's wage and buy the necessary ingredients for a meal, which would feed the rest of the workers living in that room. The cooking facilities were originally exposed to the elements but were later roofed.
- 7 This image depicts workers dancing within the compound. A rare social occasion.
- 8 This is one of the only photos, which illustrates what the compound looked like, before the deterioration and demolition of certain compound buildings.
- 9 The beautiful stone entrance to the mine.

Figure 3.5 Historic Photographs of the compound and the mineworkers during the initial mining years. (Photographer unknown)



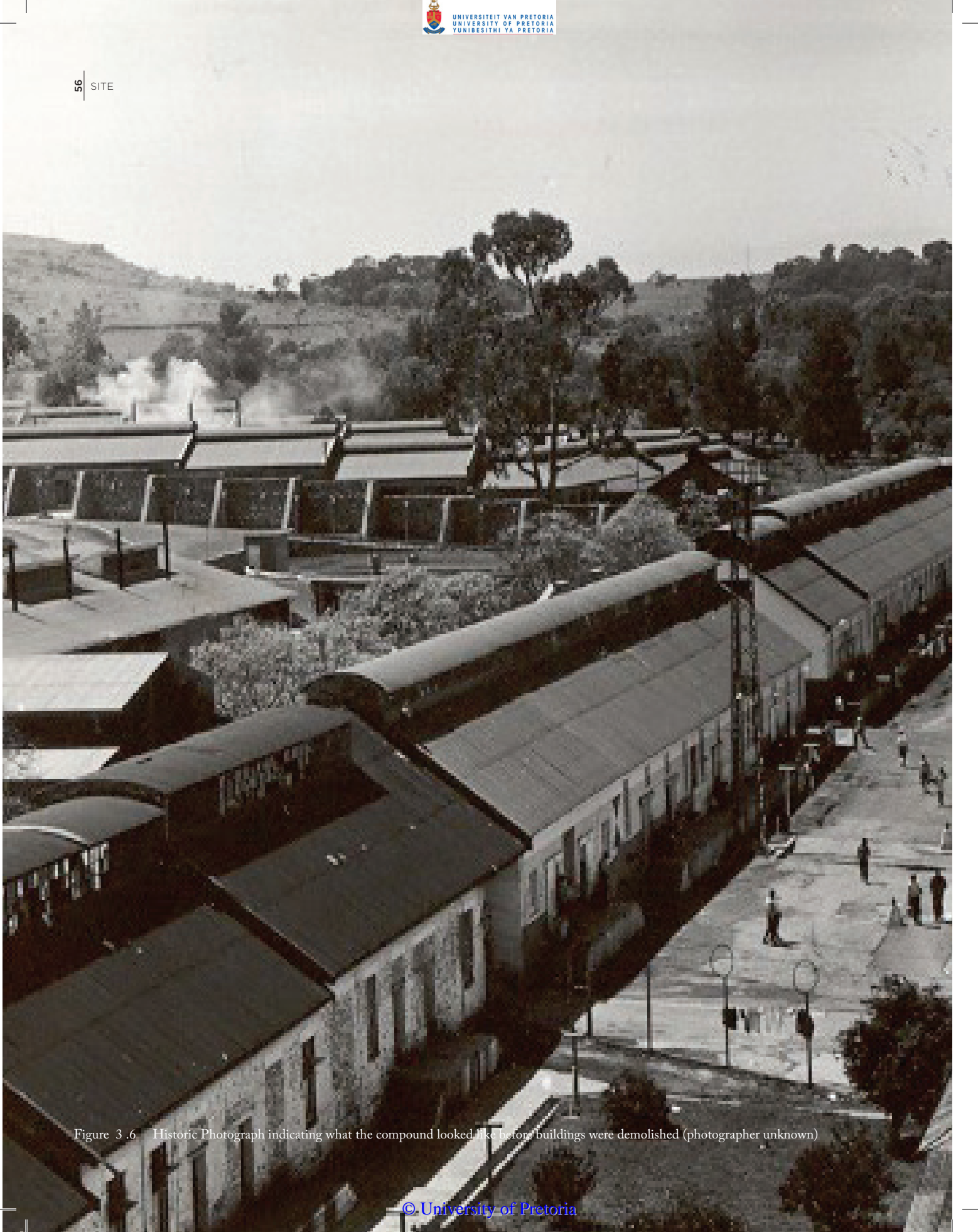

Figure 3.6 Historic Photograph indicating what the compound looked like before buildings were demolished (photographer unknown)

THE LIFE OF A MINERWORKER



The Cullinan No2 Shaft Compound Held 15 000 black mineworkers
Due to the outbreak of violence on more than one occasion the compound accommodation was split into Ethnic Groups (Site Solutions 2002).



The Workers in the compound suffered from Pneumonia, Enteric Fever, chronic recurrent Malaria and Scurvy. (A Large amount of Lime Juice bottles were excavated from the mine dump site which is known for the treatment of scurvy)



There was overcrowding in the hospitals. Regulation stated that the hospital accommodation should have beds for 350 patients, the compound was already overcrowded with 416 inmates.
Wire Gauze was installed in the windows to keep out flies.
Workers were drinking up to a bottle of brandy a day to reduce the mortality rates.
Quinine was mixed into the brandy to make it more stomachable.
The death rate was extremely high- 40 per 1000 per annum.



Workers were malnourished as they often only survived on a bag of meel.
Tinned food had rust and was damaged, and often exuded gas bubbles when opened. Most of the tinned meat was from the military army stores which had been discarded.
The shops within the compound where the mineworkers would buy their food were- a meel shop, General goods store, a butcher and a coffee shop.
The coal for the cooking facilities was provided by the mine but with outdoor cooking facilities in wet weather there was no cooking.
42 percent of the mineworkers wage would go back to the mine through the food stores.



There was outdoor bath facilities with public showers and dip baths.
No hot water
The showers were often used for washing food tins and linen
Compound rooms held 40 men
In 1910 there were no bunks available so ' the boys' would sleep on the concrete floor.
The compound water was contaminated
Rooms needed more light and air- new roofs were then added with ventilation to improve this and help with the spread of diseases.

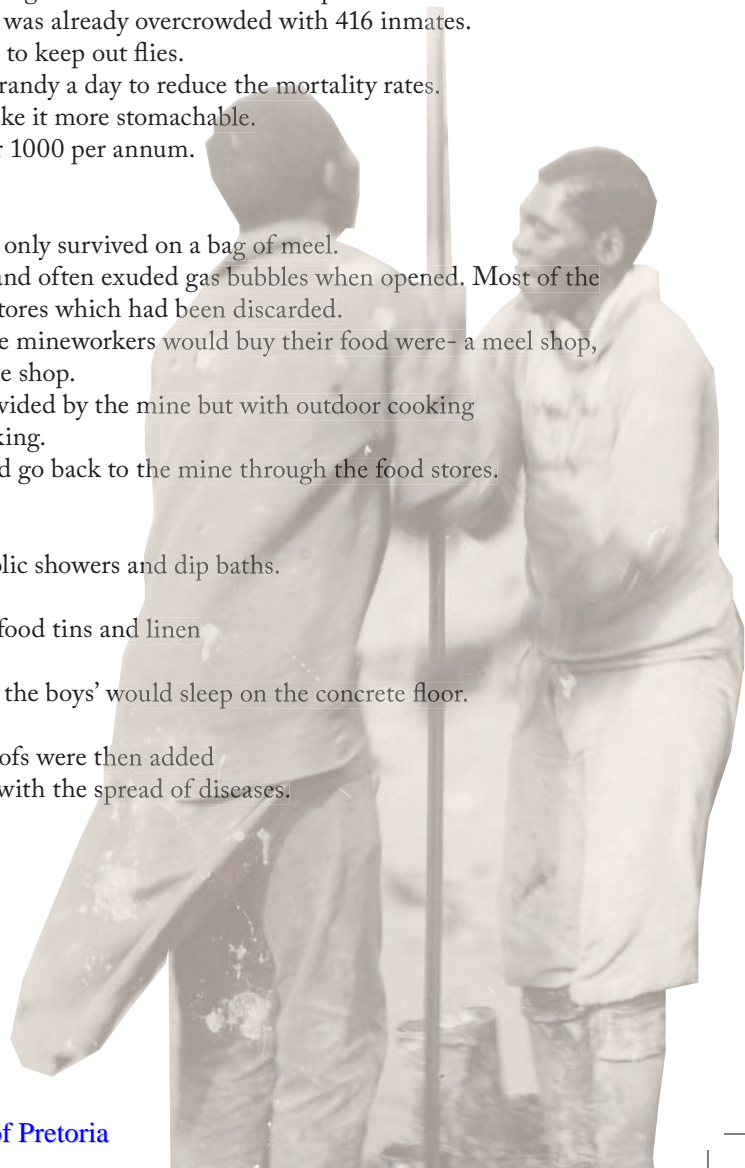

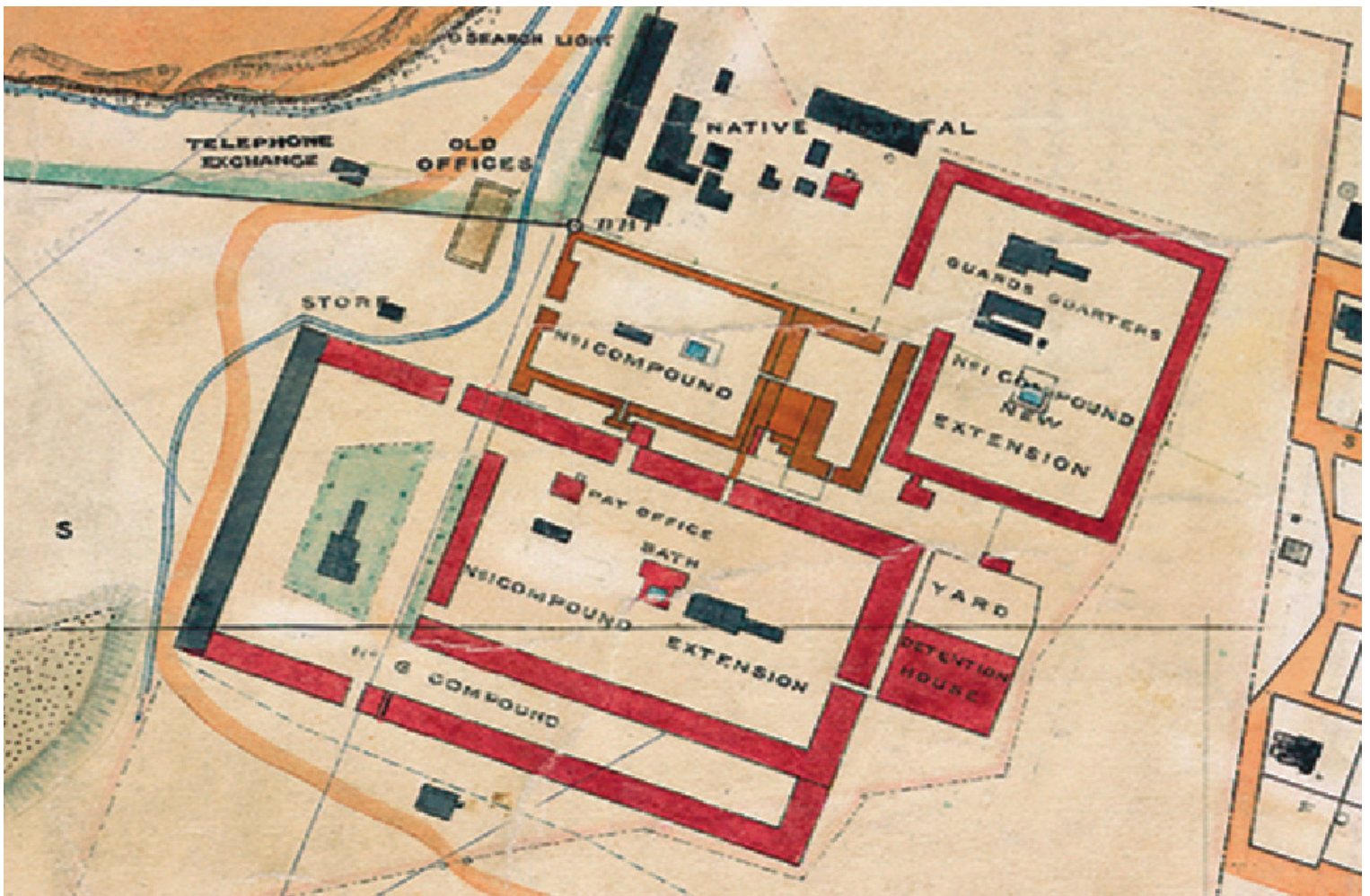

Figure 3.7 Historic Map of Cullinans Mining Compound 1911

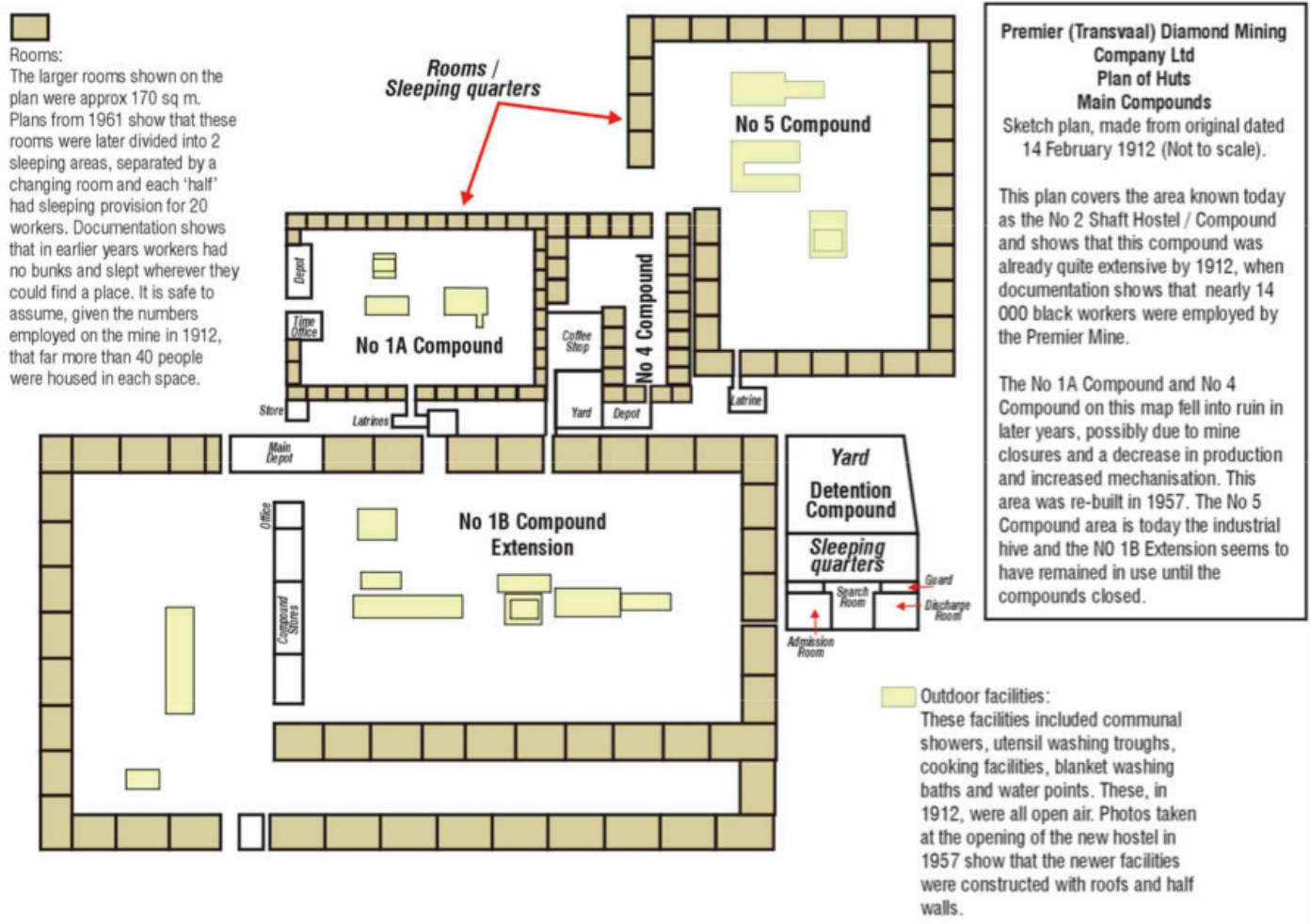

Figure 3.8 Map indicating the specific areas of the compound

3.2 STATEMENT OF SIGNIFICANCE

NO2 SHAFT COMPOUND

No2 Shaft Mining Compound is situated on the Southern side of Cullinan below the mining excavations. This Compound was built during 1904 and later altered during the 1950's. It housed approximately 15000 black mine workers. The harsh conditions within the compound resulted in many deaths during the years while the compound was in use. The history of the compound needs to be seen within the context of South Africa during this time, where mineworkers throughout South Africa lived in very bad conditions. Although the compound has been left to deteriorate over the years, it is important to remember the lives lost which aided in the great success in the Diamond Industry.

The site forms part of the industrial and social heritage of Cullinan. It provides a visual link into the lives of the mineworkers. The compound still displays evidence of shower and wash facilities, sleeping quarters and recreational spaces. These structures help us understand the social and political history of that time.

These tangible elements become the vessel for the intangible to be portrayed. It is important that the public has access to this history, as the Diamond industry is the core industry within Cullinan as well as the reason for the towns formation.

Approach based on the Statement of Significance

The site has the potential to house new forms of production and housing facilities in order to boost Cullinans economy after the decommissioning of the mine. This new production industry will work in synergy with a tourism interface. The compound will be open to the public and the design will facilitate in telling the story of the mineworkers. The new design will be sympathetic to the existing ruins as well as provide all the necessary equipment for a Textile Industry as well as new accommodation for the textile workers. The ruins will be preserved in their natural environment and restored where necessary.

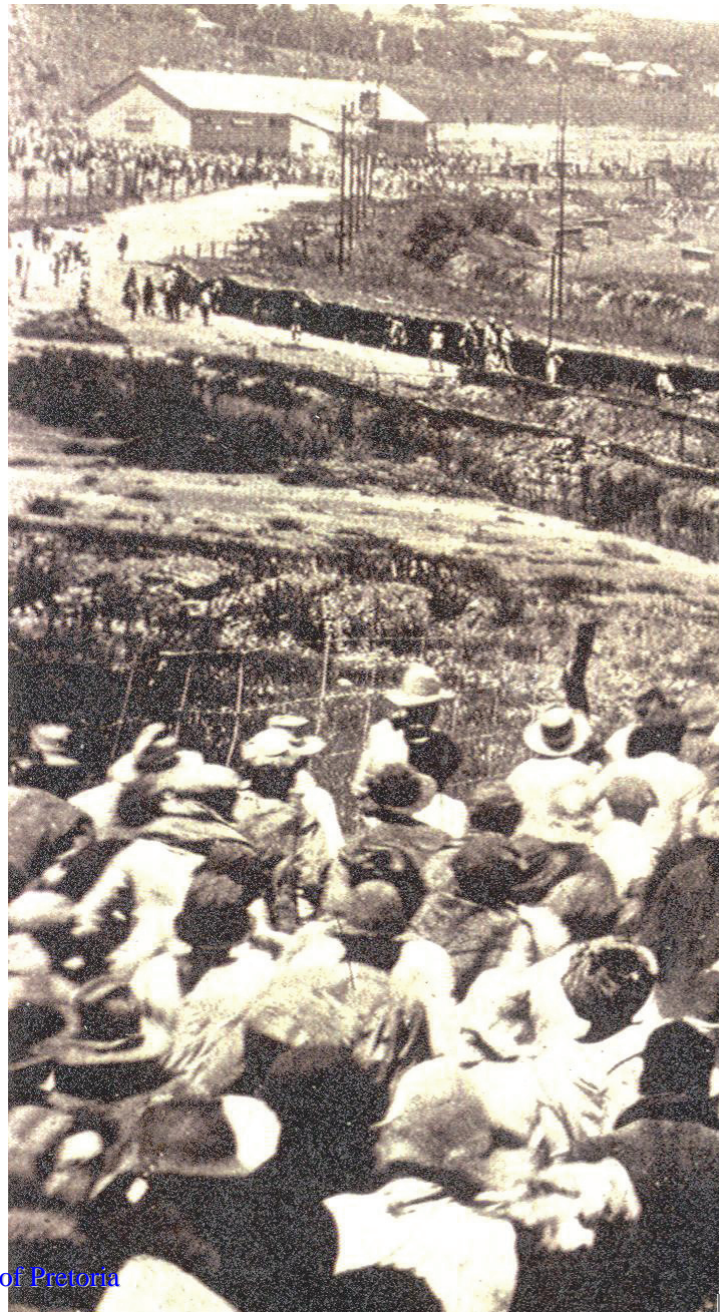



Figure 3.9 Mineworkers starting their shift (photographer unknown)



Figure 3.10 Map indicating the selected site for the intervention

3.3 PROPOSED SITE

COMPOUND 5

Compound 5 sits within the No2 Shaft Compound (Figure 3.10) which forms the site for the intervention. It is the only remaining compound in its entirety within the larger compound. The only way to enter the site is through a hole in the entrance door on the southern side of the compound. The entrance between the larger compound and the courtyard has been closed with fencing and razor wire, this leaves the site isolated and abandoned. When entering the site you start to picture the lifestyle of these mineworkers and what their daily routine would have been. The buildings are dilapidated with roofs and gutters falling in, and the vegetation has taken over throughout the site almost to the point where one needs to search for evidence of the past.

But these compounds provide an important window into the lives of the mineworkers as well as the difficult conditions they lived in, in order to make the Premier Diamond Mine a success.

Remains of washing and cooking facilities are scattered around the courtyard and the beautiful gable walls still display painted symbols (which I am told are the numbers to the compounds, as the workers could not read or write)

These buildings and ruins are the connection to this era, it is important that we preserve what is there and make it available to the public, as it forms part of the history of Cullinan and the Mining Industry



Figure 3.11 Possible vision for Compound 5 (author 2014)



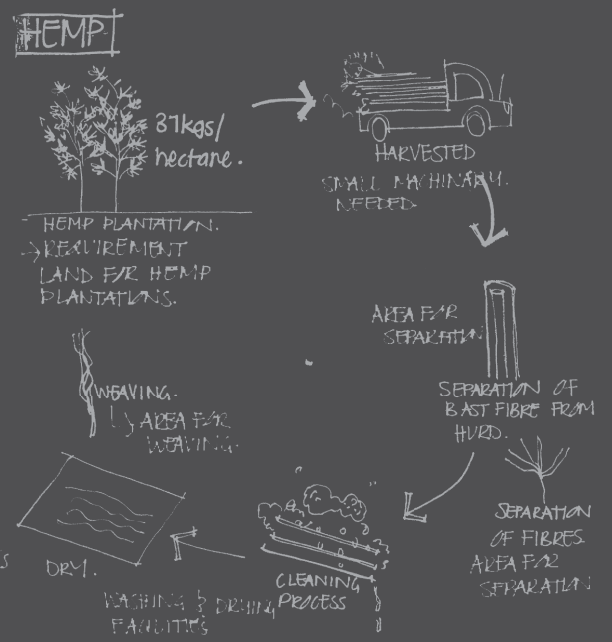
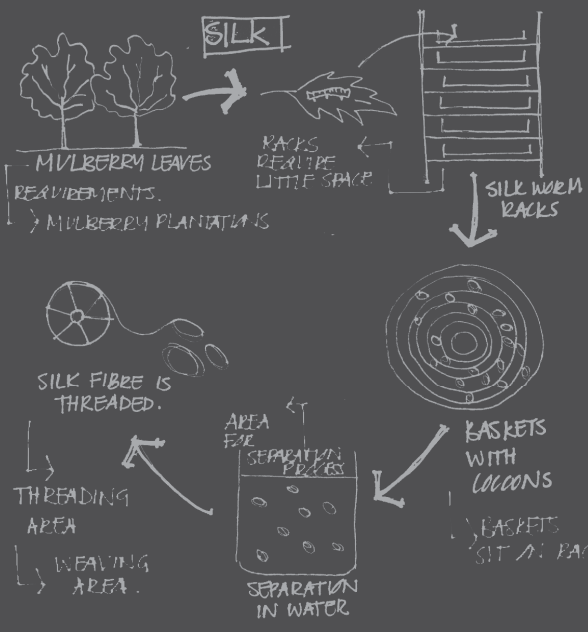

04

PROGRAMME

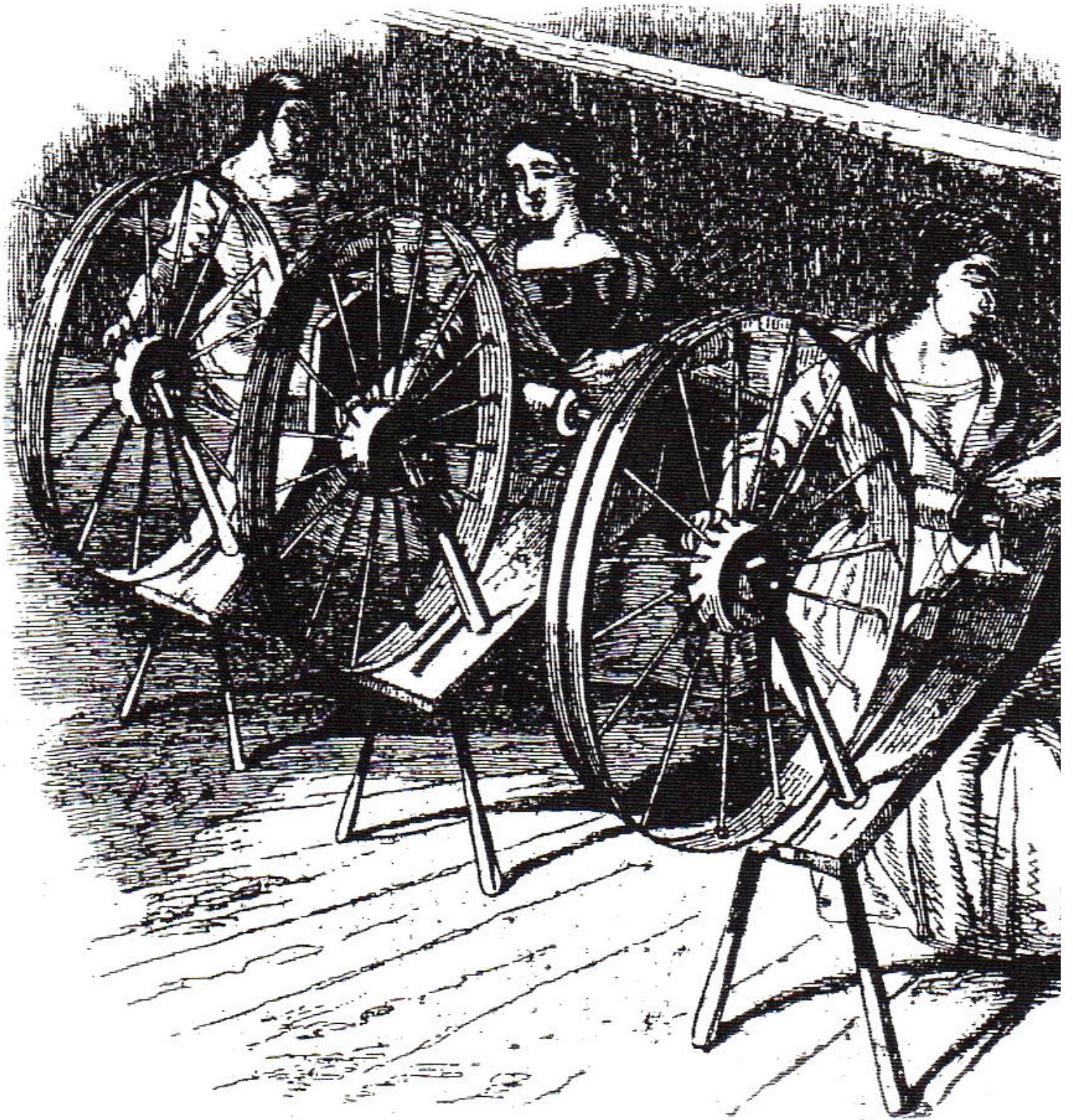
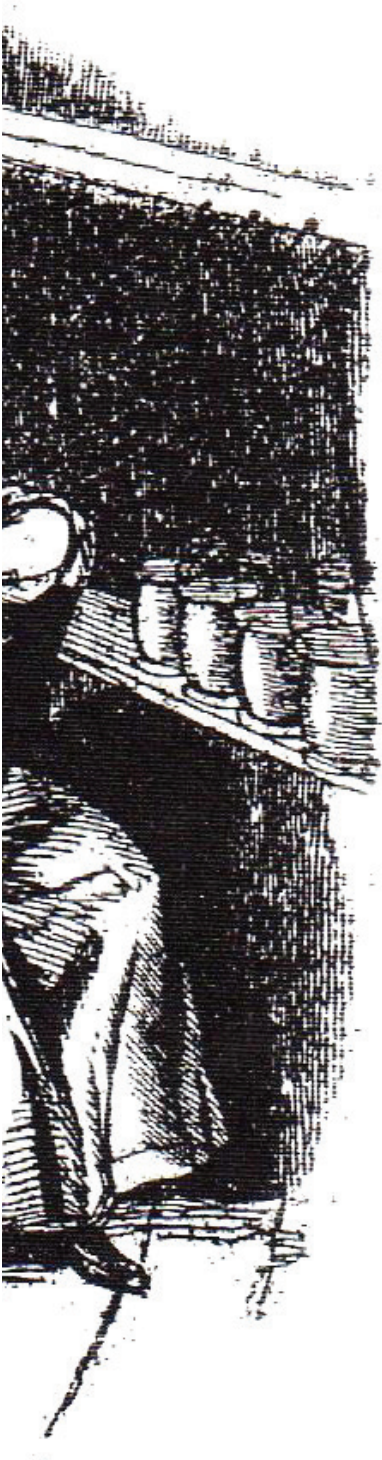

Figure 4.1 Silk spinning process



The proposed programme for this dissertation is the production of textiles. This textile mill will mainly focus on the manufacturing of hemp and silk. In addition to the production, there will be facilities for Research, to further investigate the natural fibres for new products and technologies. This intervention falls within the larger urban vision of an agricultural and educational area with a tourism interface.

04.

PROGRAMME

4.1 WHAT THE SITE REQUIRES?

This programme starts to address the issues mentioned in chapter 3 by providing the opportunity for the abandoned Mining compound to be reused and revitalized. The site has immense potential for a new type of production to be introduced. There is an abundance of rich, uniform land available for agriculture. With the decommissioning of the mine, there is a need for a new primary income to keep the people of Cullinan and the surrounding areas employed. The site shows evidence of a scarred mining landscape with excavations; neglected mining shafts; foundations and abandoned buildings. The site is in desperate need for renewal. These ruins scattered throughout the landscape form a layer of history that needs to be preserved and displayed in an amongst the new production facilities where the public has an opportunity to understand the history that once filled those walls.

The site was formally used as pastoral land before the genesis of the mine. It is in close proximity to Pretoria with an existing train link between them. This mining town has the potential to become an Agricultural town with the prospect of a new University campus for the Agricultural department. This new vision will reconnect with the history of the landscape while still celebrating the story of the mine through the revitalization of the abandoned buildings as well as the preservation of some of the industrial structures that retain this mining heritage.

Through the concept of an agricultural town where new production can help with the renewal of this misplaced town, the idea of an industrial textile mill was developed. This intervention will focus on 3 elements, namely the rehabilitation of the land; the revitalization of the people and reconnecting with the past industrial and mining heritage.

To rehabilitate the land, it is important to look at what impact different plants have on the landscape. Hemp is a plant that naturally enhances the soil through returning nutrients; it also requires very little pesticides and water in order to produce the fibres required and it grows extremely quickly. (nemeton)

Silk requires mulberry trees to feed the silkworms, which can grow in any soil types. These trees need full sun, which is available on site, due to the site having very little existing trees. There are two known silk producing industries in South Africa which are located in Graskop and Hoedspruit, this then provides an opportunity for locally produced textiles in the Gauteng region. The textiles that have been selected use old techniques, which will employ a large amount of people who will be left without jobs due to the decommissioning of the mine. Due to the use of historic processes and natural dyeing techniques the concept of craftsmanship is reiterated.

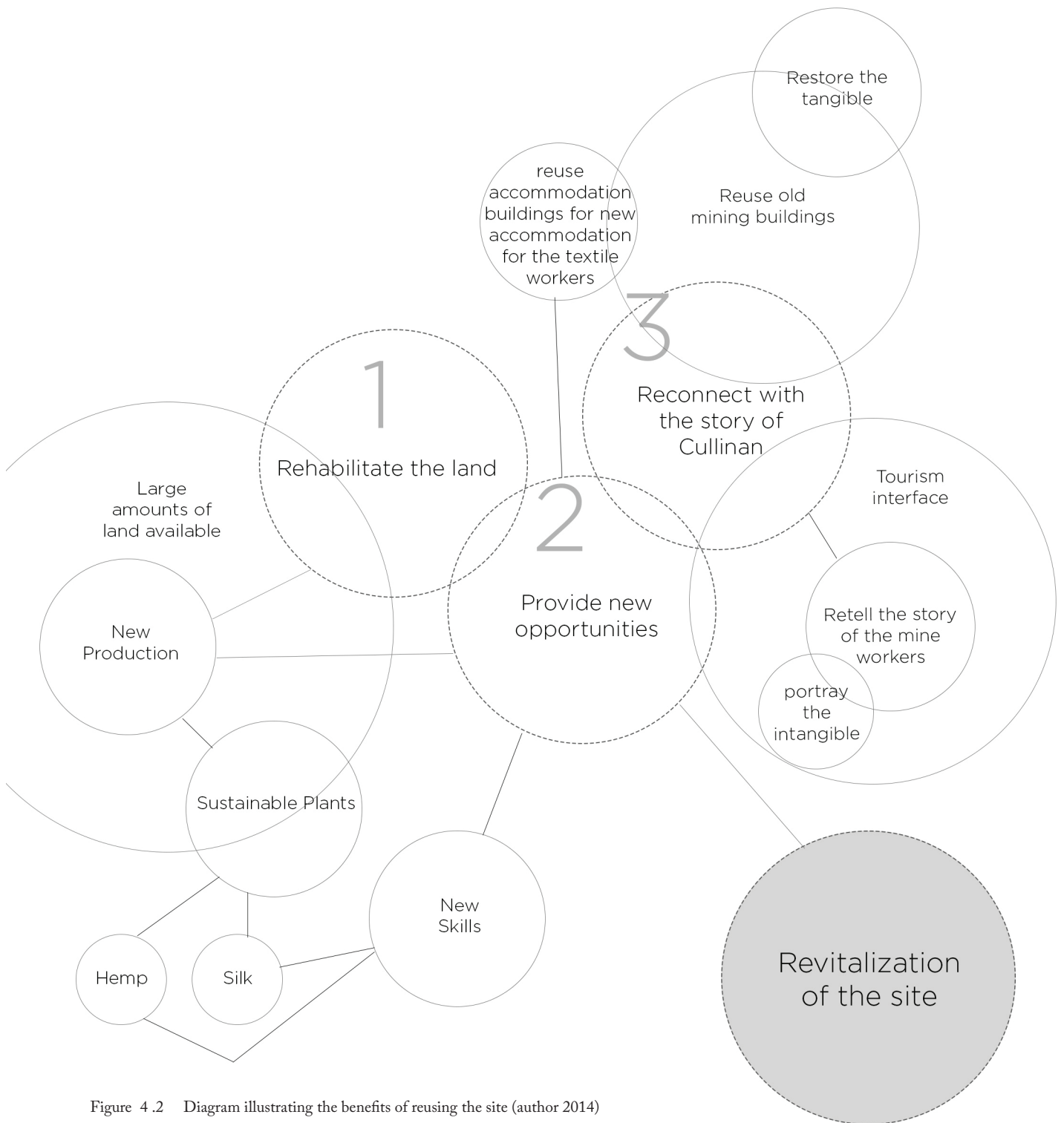

Figure 4.2 Diagram illustrating the benefits of reusing the site (author 2014)

4.2 PROGRAMME REQUIREMENTS

	Production Process	Description	Requirements
Hemp	Plantations	Up to 100 plants per m ² and an average of 5-7 tons/ ha	Irrigation Few Pesticides
		The amount of land available for hemp production is 7,9ha	Harvesting
	Retting /Baling	Hemp stalks are cut and rolled into bales	Storage of bales
	Fibre Separation	Hemp bales are then put through decorticator machine to separate the hurd from the outer fibre	Decorticator is approximately 3mx 5m and requires space around the machine for hemp to be fed through.
		The hemp over fibre is used for textiles while the hurd is then used for building materials	Noisy machine
			Hemp produces fine dust
	Spinning	The fibres are spun together to form threads	Pleasant environment for workers spinning the fibres
		blends of different fibres such as silk and hemp will occur during this stage	Enough space for simple spinning wheels 2mx1m
	Weaving	Weaving of Hemp into different textiles such as rope and material. This is where patterns can be generated	The traditional weaving machines are approximately 5mx 5m
	Dyeing	materials are then dyed in vats which natural pigments found in the surrounding areas	outdoor vats with different pigments in each vat. 2mx 2m vats
	Drying	materials then dry in indoor or outdoor drying facilities	A structure is required where materials can dry
			Floor needs to be easily cleaned
			water supply
			drainage

	Production Process	Description	Requirements
Silk	Mulberry Plantations	10m distance between trees	Irrigation
		20 trees in available space in courtyard	Harvesting
	Eggs	a portion of the moths are kept from the previous process in order to lay eggs	Room needs to be sealed from other insects entering.
			Shelving units where the eggs are kept
			No direct sunlight, natural ventilation
	Silkworms	The Silkworms once hatched are given fresh mulberry leaves until they have matured enough to form cocoons	Room needs to be sealed from other insects entering.
			Shelving units where the silkworms are kept
			No direct sunlight, natural ventilation
	Cocoons	When the silkworms are mature they are placed in flat woven baskets where they form cocoons	Room needs to be sealed from other insects entering.
			Shelving units where the cocoons are kept
			No direct sunlight, natural ventilation
	Boiling area	a portion of the cocoons are sent to the moth area to lay eggs where the rest are boiled	Good ventilation due to boiler
		During this process the silk thread is unravelled into single threads	Water supply; Drainage
	Dyeing	The threads are then dyed in vats before they are spun using natural pigments from the surrounding areas	
	Drying	materials then dry in indoor or outdoor drying facilities	A structure is required where materials can dry
			Floor needs to be easily cleaned
			Water supply; Drainage
	Spinning	The fibres are spun together to form threads	Pleasant environment for workers spinning the fibres
		Blends of different fibres such as silk and hemp will occur during this stage	Enough space for simple spinning wheels 2mx1m
	Weaving	Weaving of Hemp into different textiles such as rope and material. This is where patterns can be generated	The traditional weaving machines are approximately 5mx 5m

4.3a HEMP

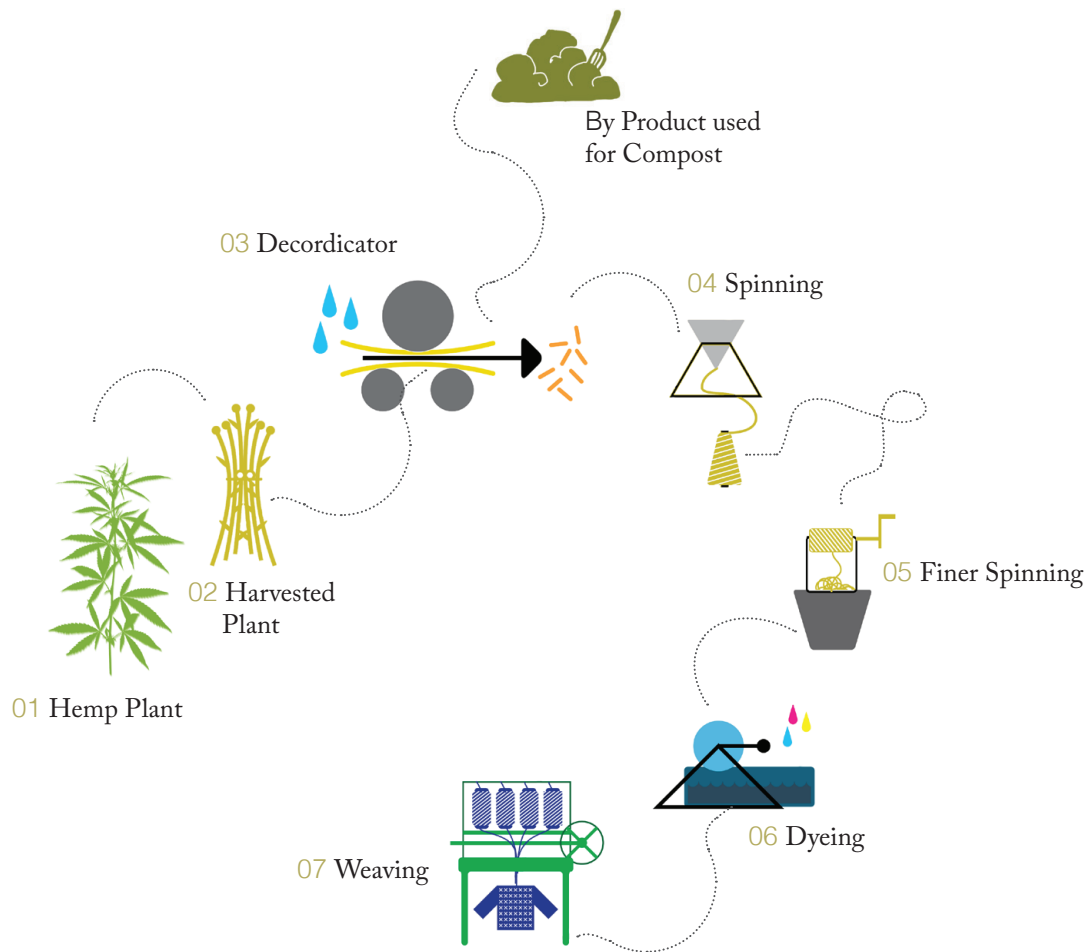

- 01 The hemp plant is grown in plantations of up to 100 plants per m2.
- 02 The plants are harvested, the outer woody stem is used for the textiles while the hurd or centre fibres is used for the composite materials
- 03 The Decordicator is a machine developed to separate the hurd from the outer fibre

- 04 The spinning is where the rough fibres are pressed through a roller where thick bands of hemp fibres are then produced
- 05 The finer threads are then spun from these thick bands
- 06 The Threads are then dyed
- 07 These threads are then woven into fabrics using a weaving machine. These machines can allow for the 2 types of materials to be interwoven

Figure 4.3 Illustration indicating the Hemp process (author 2014)

4.3b SILK

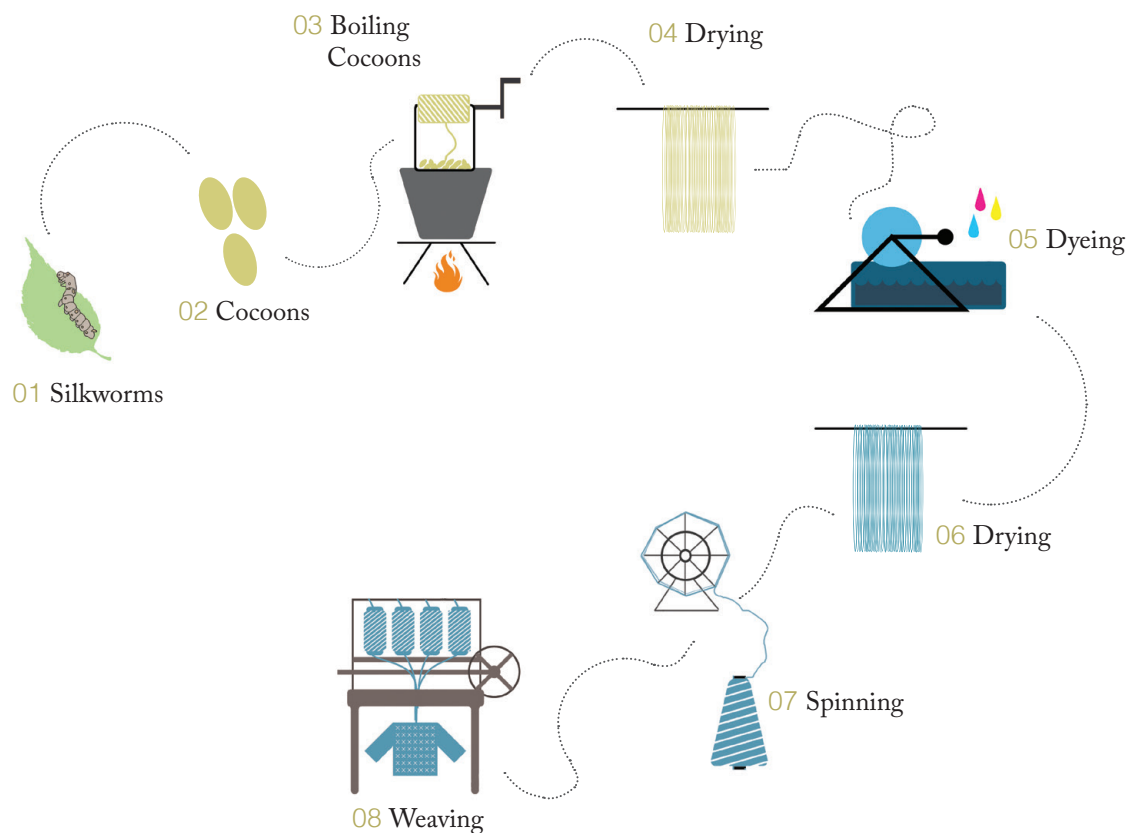

- 01 The Silkworms are bred for the cocoon they produced.
- 02 Each Silkworm produces one cocoon when they are ready to transform into a moth
- 03 The cocoons are then collected and placed into boiling water to unravel one single thread from each cocoon approximately 1,6 km long
- 04 These threads are then rinsed and dried
- 05 These threads can then be dyed using organic dyeing materials
- 06 The threads are then left to dry in order to seal the dye.
- 07 These threads are then spun to produce finer threads for weaving
- 08 These threads are then woven into fabrics using a weaving machine. These machines can allow for the 2 types of materials to be interwoven

Figure 4.4 Illustration indicating the silk process (author 2014)

4.4 HISTORY

HEMP

Hemp and Silk have both been used for centuries in different countries throughout the world.

Hemp is known as ‘cannabis sativa’ and although it is from the same family as marijuana it has extremely small amounts of THC (tetrahydrocannabinol), which is the chemical that creates the psychoactive drug. Wild Hemp has been discovered to date back as late as 8000 B.C. The weaving of hemp began more than 10 000 years ago for the British Navy’s equipment, such as sails, ropes and even paper for maps.

During the 17th Century farmers in Connecticut and Virginia were ordered to grow hemp and were even sentenced to jail if they did not comply with the regulations (hemp.com). This plant became such an important commodity in America during this times that it could even be used to pay your taxes. A U.S. census during the 1850’s documented that there was approximately 8400 Hemp Plantations. During the 1920’s a new machine was designed to change the way hemp was cultivated forever. This machine could break the retted stalks and produce clean fibres for textiles or other materials. This reduced the labour needed for hemp farming and decreased the time needed for the harvesting of crops.

4.5 BENEFITS

FARMING HEMP:

- > The paper manufactured by hemp would produce 4 times as much paper than from trees. Any paper can be produced; it ranges from stationary paper to newspaper to toilet paper, which ultimately leads to natural forests being preserved (hemp.com).
- > Hemp is extremely fast growing; it required 4 months before it is ready to be harvested.
- > Hemp has little soil requirements and needs very little water and pesticides.
- > It naturally repels weeds.
- > It needs very little fertilizer and helps rehabilitate the soil
- > Hemp fibre is approximately 10 times stronger than cotton.
- > Hemp seed oil is high in protein, and can be used in a variety of foods.
- > Hemp fibres can be used in building materials like insulation and fiberboard.

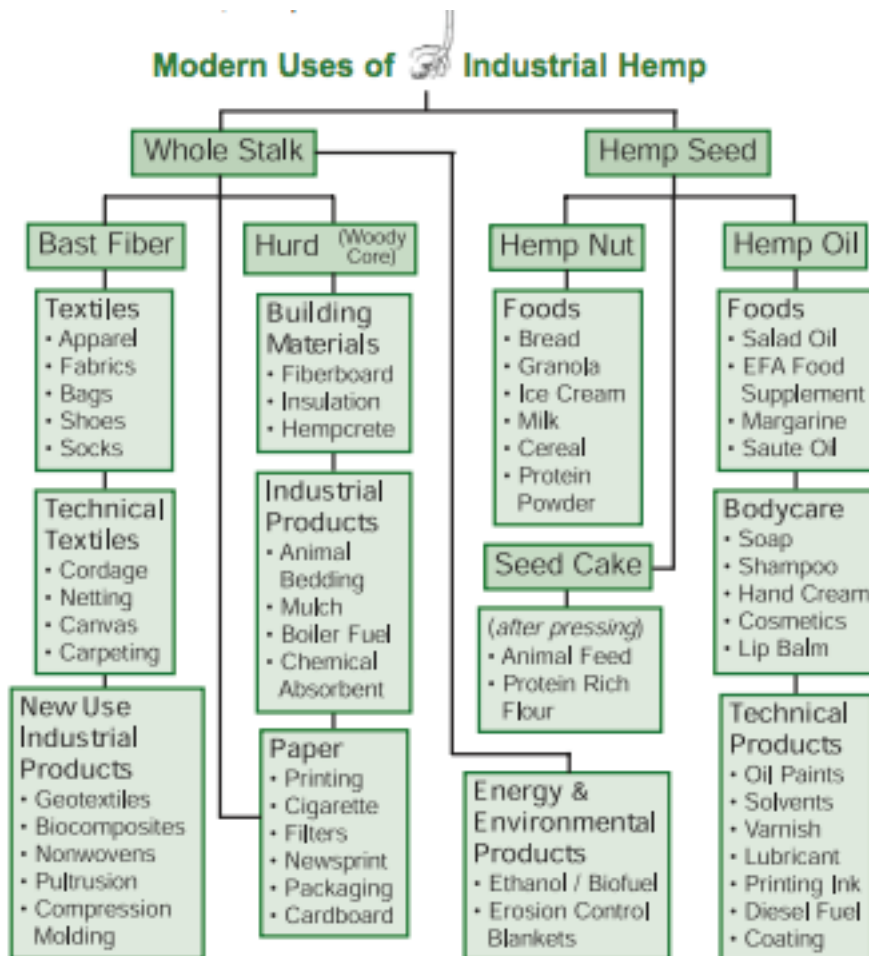

Figure 4.5 Benefits of industrial hemp



Figure 4.6 Harvesting Hemp



Figure 4.8 Hemp retting



Figure 4.9 Separation of hemp fibres



Figure 4.7 Dense hemp plantations



Figure 4.10 Natural Hemp Fibres



Figure 4.11 Natural Hemp before spinning and weaving

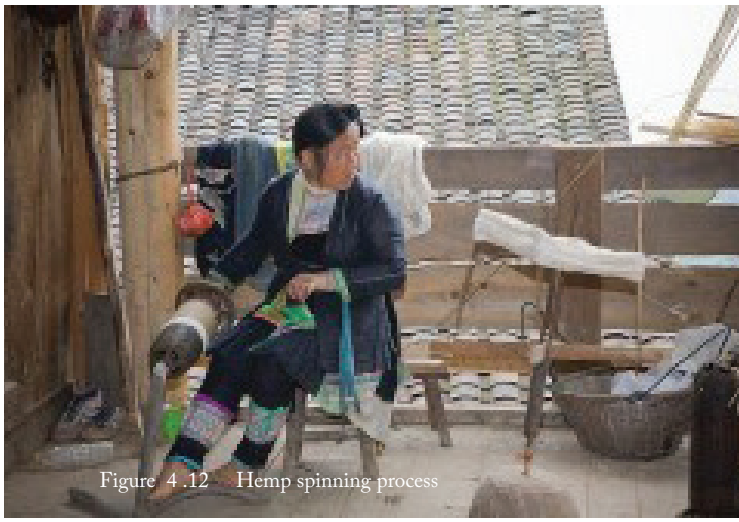

Figure 4.12 Hemp spinning process



Figure 4.13 Final product



Figure 4.14 Final product

So with all these benefits why are people only recently starting to change their minds about hemp? What made farmers stop producing hemp?

There have been many viewpoints as to why Hemp was banned. The one theory is that after the 1937 Marijuana Tax Act was passed, it became increasingly difficult to farm hemp under these new regulations, and hemp was seen as a harmful drug.

The Second theory is that Hemp was banned due to its competitiveness with the wood and synthetic fibre industry. These industries then started a campaign to make people believe hemp or marijuana is a harmful drug that can make people violent and in doing so it forced the hemp industry to close.

With the revitalization of hemp throughout the world there is now an opportunity for South Africa to follow suit and benefit from this unbelievably plant.

“Fact: No tree or plant species on earth has the commercial, economic and environmental potential of hemp. Over 30 000 known products can be produced for hemp.”(nemeton)

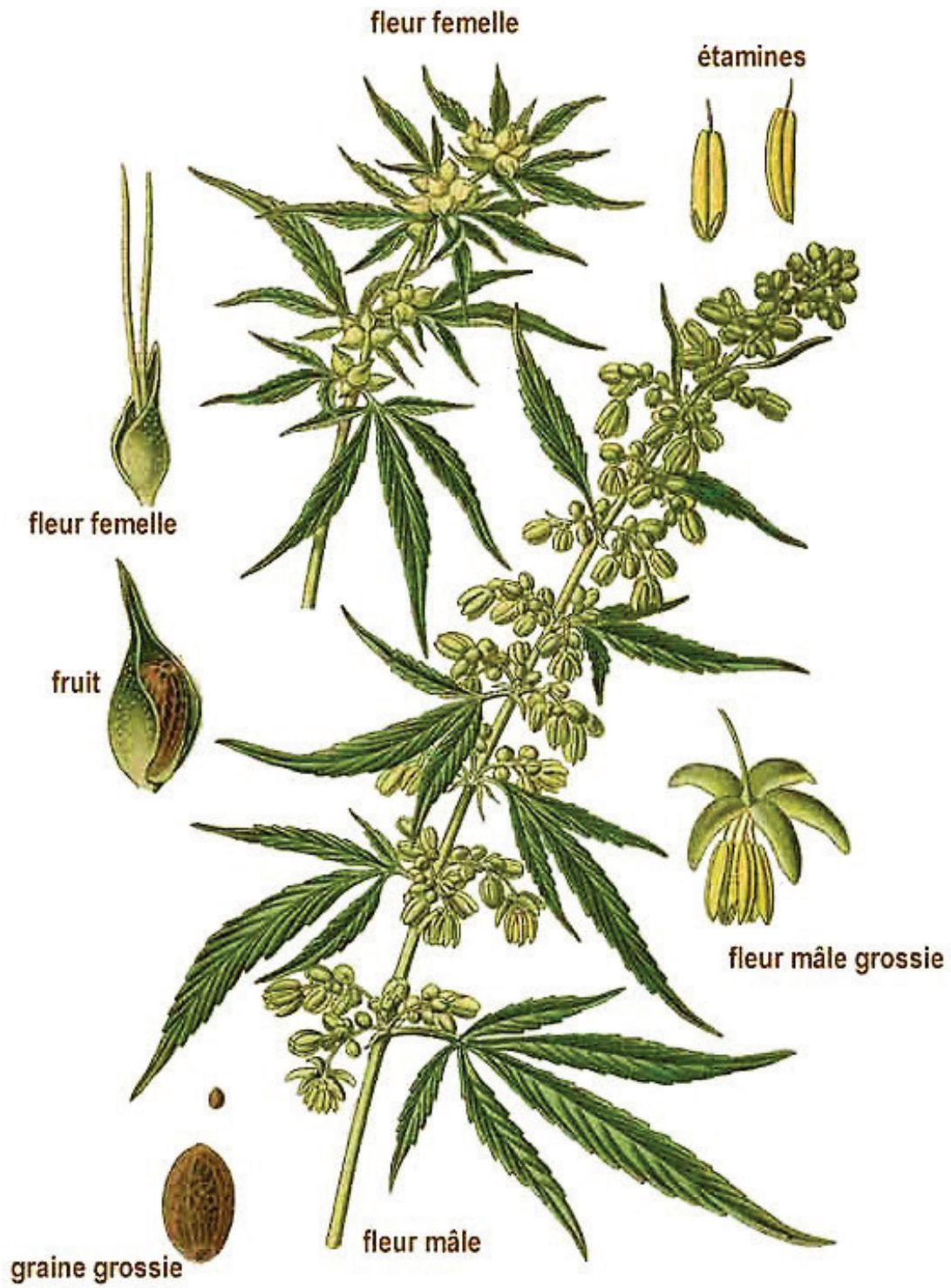

Figure 4 .15 Hemp plant comes from the same family as marijuana



Figure 4.16 Illustration depicting historic silk weaving

4.6 HISTORY

SILK

Silk originated in China and was a guarded secret in the Chinese culture for centuries. The first known threads and woven remains date back to 3000 B.C in Zhejiang province (Foundation 2000). During the genesis of silk or sericulture, this textile was only worn by the emperor and his close relations but as time went on silk was worn throughout society. Silk was not only used for textiles but was furthermore utilized for industrial uses. This included fishing line, string instruments, and even luxury paper.

Sericulture has doubled in the last 30 years although there is a variety of synthetic fibres, which can replace silk in many industries. Silk production has been kept a secret within china for many years, although there are now places throughout the world that produces this beautiful material. In South Africa there are two silk farms, which are located in Graskop in Mpumalanga Province and in Hoedspruit in the Limpopo province, these industries not only produce silk for local textile industries but also provide employment for women in these areas.

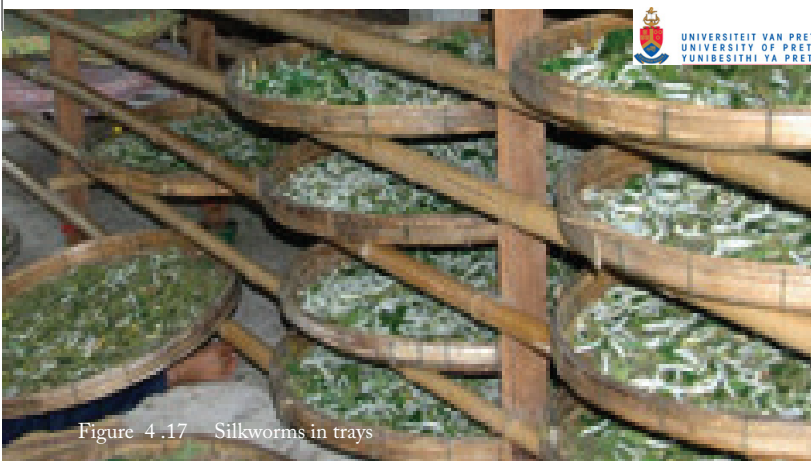

Figure 4.17 Silkworms in trays



Figure 4.18 Sericulture

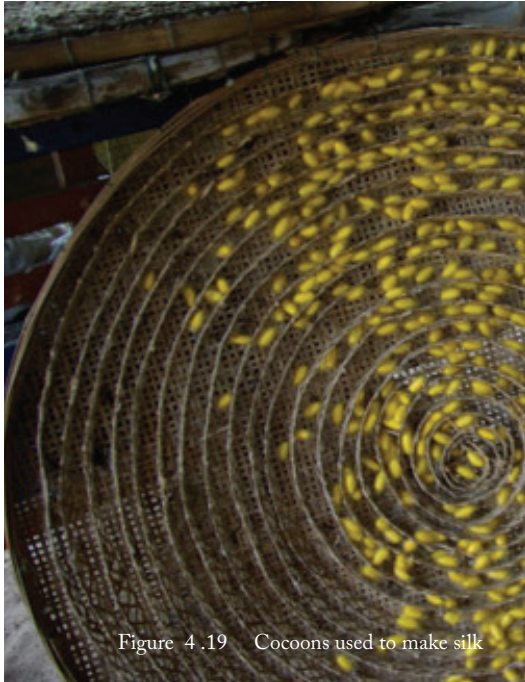

Figure 4.19 Cocoon used to make silk



Figure 4.20 Huge amounts of silk are needed to produce one item.

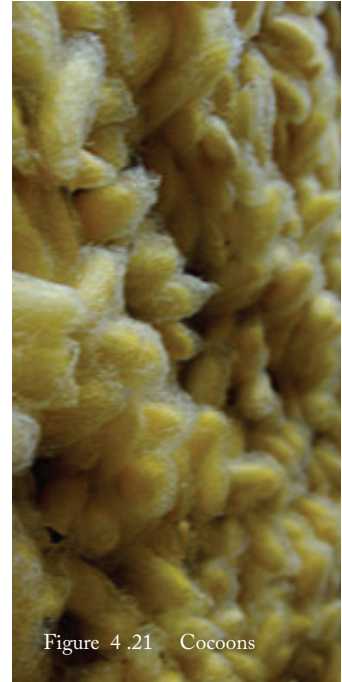

Figure 4.21 Cocoon



Figure 4.22 Cocoon is then boiled and a single thread is unwound, this is known as fine silk



Figure 4.23 Silk is then stretched and washed, before dyeing.



Figure 4.24 Natural dyeing techniques



Figure 4.25 Fibres left to dry after dyeing process



Figure 4.26 Silk thread is then spun



Figure 4.27 Part of spinning process



Figure 4.28 Ladies spin thread to create thicker strands of silk before weaving process



Figure 4.29 Natural Silk



Figure 4.30 Weaving process

4.7 SUSTAINABILITY

Hemp is naturally a sustainable plant in comparison to other textiles such as cotton. Not only is it due to hemp needing very little water, and pesticides but it also grows extremely fast, and grows close together which means less space is required. Every portion of the hemp plant can be used for textiles, building materials, food and even paints.

To create a further sustainable environment it is important to look at the 'cradle to cradle' approach when processing these textiles.

"In cradle to cradle production all material inputs and outputs are seen either as technical or biological nutrients. Technical nutrients can be recycled or reused with no loss of quality and biological nutrients composted or consumed" (The Dictionary of Sustainable Management 2014)

During the harvesting process the plantations require irrigation. This water can be pumped from the water collected within the excavated pit or the effluent from the sewage treatment plant on the eastern side of the site. Rainwater will be collected from roof areas for grey water use. The natural dyes will be collected from in and around the site as well as over ripe fruit and vegetables from the 'Bionic Evolution' and 'Land of Scattered Seeds' interventions. Mulberry plantations will be planted on site to prevent importing food for the silkworms. The mulberries can be used for dyes and in the 'Bionic Evolution' intervention for jams.

Compost is created on site with excess food materials, hemp remains, sericulture remains and kimberlite collected from the mining hills.

Existing buildings are reused for the production of silk where as new buildings using hempcrete and reused steel from the abandoned mining buildings house further production processes. The hemp plantations will help regenerate the soil by stabilizing and providing nutrients back into the soils.

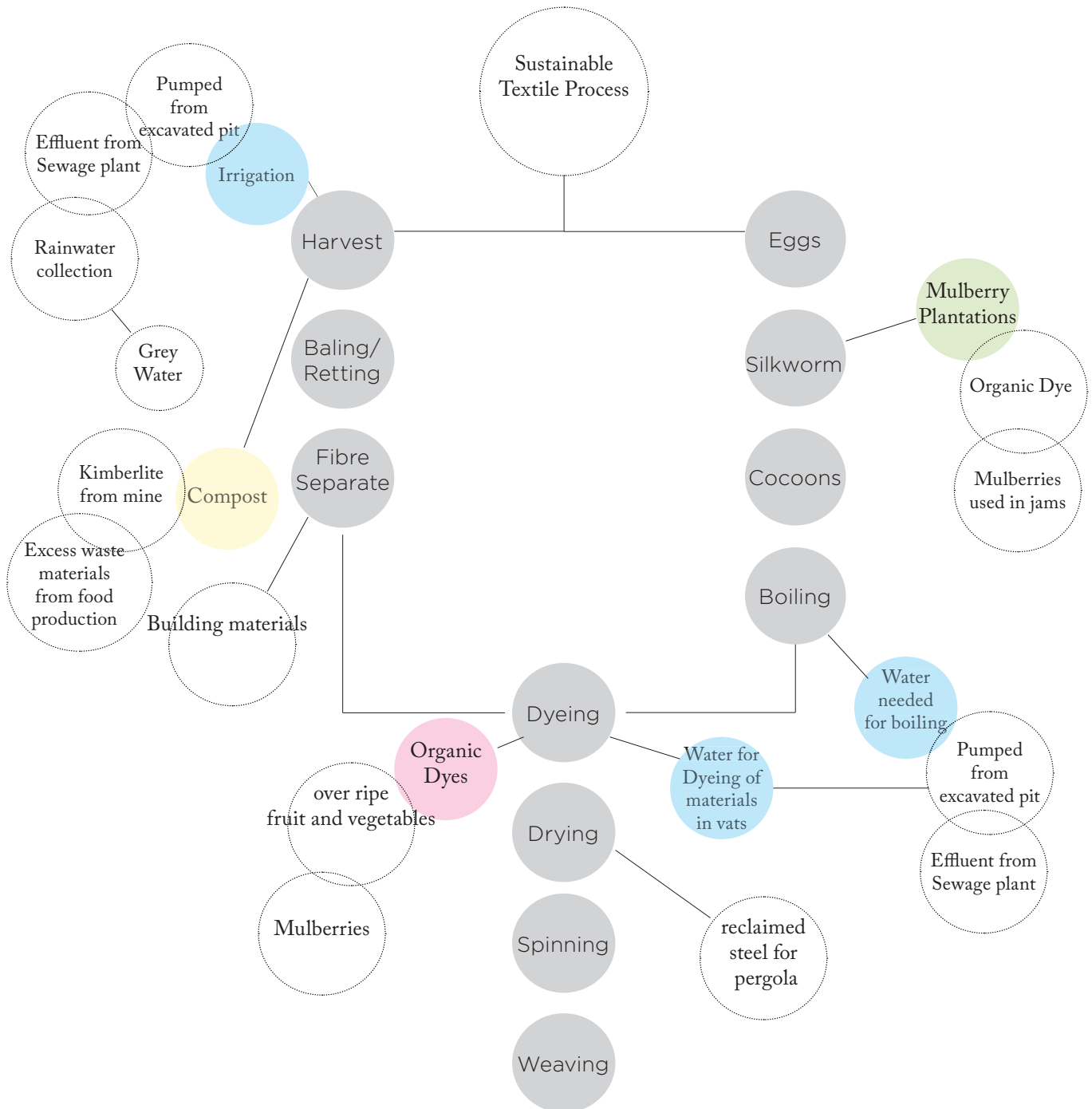

Figure 4 .31 Diagram indicating sustainability process

4.8 PIGMENTS

Natural Pigments are traditionally used for both silk and hemp in the dyeing process. These pigments provide beautiful earthly colours to the textiles. Although synthetic dyeing techniques are more commonly used today, they are extremely harmful to the environment and the workers; therefore many people are returning to the art of natural dyeing techniques.

This technique of fabric dyeing has been around for centuries (Donatelli 2013). Natural pigments are mainly derived from plants and insects. The most common colour for pigments is yellow. The pigments were often found in the surrounding natural environments; due to these different geographical locations where the different colours are produced, we are able to identify their origin and in that way each material has a story.



Figure 4.32 Natural Dyeing techniques in open vats

NATURAL PIGMENTS:

Plants found in and around the site that can be used as Organic Pigments

These natural dyes can be produced through waste products from other interventions in Cullinan such as the Preservary and Food production dissertations.

	Yellow	Pomegranate rinds, onion skins, saffron and turmeric, Bay leaves
	Green	Treated with yellow dyes and iron mordants are added, lichen, Spinach Leaves, red onion peels
	Yellow/ Green	Fennel
	Brown	Walnut
	Gray/Purple	Sunflower seeds
	Red	Mulberries
	Orange	Carrot
	Tan	Eucalyptus tree bark
	Dark Brown	Beetroot
	Pink	Strawberries, Cherries, Avocado
	Purple	Whole Pomegranates
	Grey	Butternut Hulls
		

From the information gathered, it is evident that the production of silk and hemp will address the issues of unemployment and the renewal of the abandoned compound which will follow through into the design process.

vessel for the intangible to be portrayed as well as the relationship between the new structures and existing buildings will therefore form a main part of the design concept.

Design elements which have been touched on is the idea of integrating the public into the site in order to expose the history of the site while still creating a productive environment, in order to generate revenue. The Design will aim to preserve the existing fabric within the site to create a



Figure 4.33 Map indicating where natural dyeing products are located

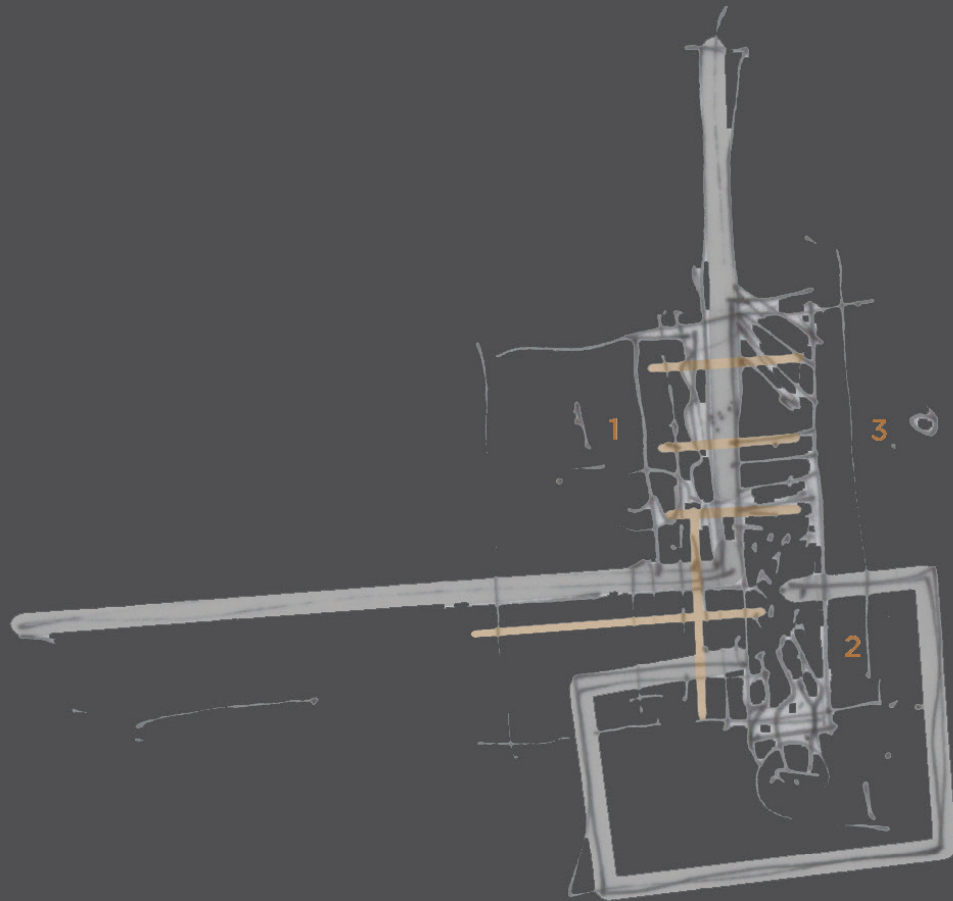

05

THEORY

THEORY

5.

5.1 MEMORY

This intervention is supported by the idea of Memory in architecture, where one can understand the past that is represented within the building while still revitalized by a new function, in order to create healing. By rehabilitating the compound buildings and adapting it for a new function we are creating resilient architecture. The idea is to heal the people that have suffered at the hands of the machine while rehabilitating or healing the land of this scar and destruction.

How to Achieve this:

In the Book Spatial Recall, Marc Treib speak of Cultural Amnesia, where there is:

“A Secret bond between slowness and memory and between speed and forgetting. The degree of slowness is directly proportional to the intensity of memory and the degree of speed is directly proportional to the intensity of forgetting.” (Treib 2009)

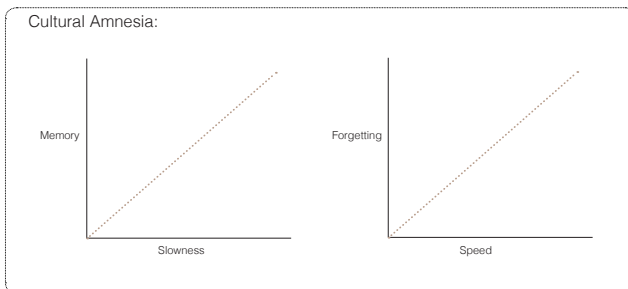

In today's society we move at such a speed. Our consuming lifestyle has led to this idea of mass production and mass consumption. It is inevitable that we forget the past. In Cullinan there is a focus on mass production. It is after all an internationally recognized Diamond mine, but after the decommission of the mine there is an opportunity to slow down, to remember the lives that made this mine so successful, and to create an opportunity for the land and the people to thrive through slow craftsmanship and quality in production. This slowing down could help to contribute to the prolonging of memory.

The quote that follows, provides the starting point for this design, where ones emotions are strengthened by the architecture and the spaces that are created.

“Architecture cannot create feelings but through their authority and aura they evoke and strengthen our own emotions and project them back to us as if these feelings of ours had an external source.” (Treib 2009)

RELEVANCE TO THE DESIGN

What aspects of “Memory in Architecture” can be incorporated into the design strategy.

For one to fully understand a journey of healing, it is important to understand the conditions that caused pain and suffering within the compound during its utilization. This understanding can then help form a relationship between the past and the revitalizing future of production in order to facilitate in the healing process.

In the book ‘Spacial Recall’ the author states a building cannot recreate feelings it can only evoke emotions. This is an important idea to be used in the design strategy for the Mining Compound. One cannot recreate the feeling of isolation, separation and weakness but instead one can start looking at what types of spaces can evoke emotions of isolation and separation even though they may not be a true representation of the feeling and situations endured by the workers, these spaces will still help connect the visitor with the past events.

HOLOCAUST MUSEUM

Belzberg Architects
Los Angeles



Figure 5.1 Descending into Holocaust Museum

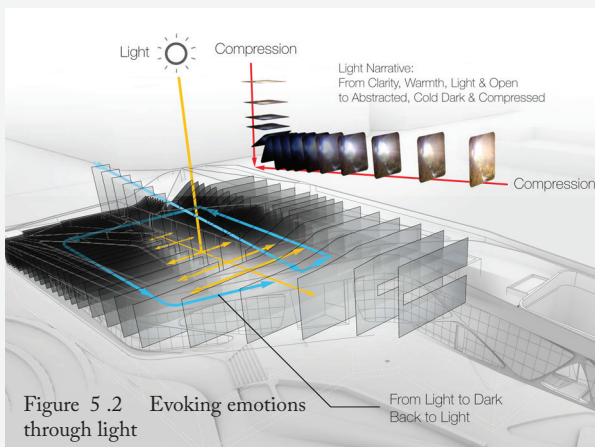

Figure 5.2 Evoking emotions through light



Figure 5.3 Holocaust Museum blends into park surroundings

“The building is partially submerged beneath the grassy, park landscape, entry to the building entails a gradual deterioration of this visual and auditory connection to the park while descending a long ramp. Upon entering, visitors experience the culmination of their transition from a playful and unrestrained, public park atmosphere to a series of isolated spaces saturated with photographic archival imagery.”

(archidaily 2014)

Hagy Belzberg uses the manipulation of light and connection with the outside world in order to evoke emotions of isolation and detachment. As the building is submerged under the ground, one slowly descends into the building and becomes detached from the park. Natural light fades as you move further into the building. As you descend and the light fades you are introduced to the concentration camp.

One moves through these isolated spaces without any orientation of where you are in the building until you arrive at the end of the journey where natural light filters in and you leave the building with a feeling of relief.

“Museum visitors explore the Holocaust’s historic world of despair, and then emerge from it into the world of joy, delight, and re-creation flourishing in Pan Pacific Park”
(belzberg architects 2010)

There is a beautiful connection and integration with the site as well as an understanding of how light qualities and spaces can evoke emotions in the visitor in order to connect with the past.

5.2 ADAPTIVE REUSE

Not only is it important to look at how to revitalize the existing Compound buildings in order to portray the narrative of this site but to further look at the sustainability of these buildings through adaptive reuse.

“The reuse of existing buildings to suit the needs of the present and future generations, while avoiding demolition and reconstruction is one of the most sustainable form of urban development.” (Yung & Chan 2012)

“We live in a disposable society where people have been taught to consume without consequences and that can be said about the way we view our infrastructure. It has become the norm to demolish the old and create enormous new buildings, which embody huge amounts of energy in the making of these new materials and the depletion of non-renewable resources. Why can we not use the resources we have available by reusing and revitalizing old buildings for new functions? This idea can prolong the life of a building and reduce carbon emissions and that way, add to sustainability.”(Yung & Chan 2012).

Sustainable architecture is about being innovative with the solutions to reusing neglected and abandoned spaces in order to reduce the embodied energy of new buildings. Adaptive reuse is broadly defined as *“Any building work and intervention to change its capacity, function or performance to adjust, reuse or upgrade a building to suit new conditions or requirements.”(Douglas, 2006).*

“When adapting a building with historic significance it becomes more complex. It is important to make sure that any additional architecture that is added to the historic fabric has value and have minimal impact on the heritage or cultural significance of the site. The new function for these heritage buildings must be appropriate within the site.” (Yung & Chan 2012).

Reusing heritage buildings connect people with their past while saving their future. The new function will bring new opportunities for these buildings, which are often stale, abandoned or used as museums. These buildings provide very little use to the growing society. By using industrial buildings for new industries we allow people to still experience the architecture of the past and the intangible history that can only be portrayed through the tangible, while creating new uses for the existing structure.

The most successful built heritage adaptive reuse projects are those that best respect and retain the building’s heritage significance and add a contemporary layer that provides value for the future (Department of Environment and Heritage, 2004)

TURBINE HOTEL

CMAI Architects

Knysna



Figure 5.4 The turbine hotel



Figure 5.5 Distinct contrast between the old industrial building and the new architecture



Figure 5.6 Machinery connects the visitor with the past production

The Turbine Hotel is the revitalization and reuse of the old power station which previously provided electricity to Knysna. It has been abandoned for approximately 10 years.

This building is a great example of how existing structures can be reused for new functions while still acknowledging the past history. There is an integration between portraying the history of the site and a new function. Instead of isolating the building as a museum, it incorporates the museum and hotel functions allowing the guests to experience the building in a different way.

This reused of an old structure provides new energy for an otherwise abandoned and deteriorating site.

CASTELVECCHIO MUSEUM

Carlo Scarpa
Verona



Figure 5.7 Beautiful contrast between old and new materials



Figure 5.8 Contrasting lines



Figure 5.9 Relationship of different materials

Carlo Scarpa's work beautifully displays how one can adapt and reuse old buildings effectively. He contrasts materials to easily distinguish between the existing fabric and the new elements. There is a synergy between the new and the old where the new fits seamlessly into the existing without competition in hierarchy.

Castelvecchio is a Museum within an existing castle where the new insertions bring out the beauty of the existing fabric. Carlo Scarpa focuses on the details such as doors, staircases and even the stands for the artwork. These intricate elements often made from steel and timber do not overpower the stereotonic environment of the castle but rather facilitate the new function through beautiful details and design.

RELEVANCE TO THE DESIGN

What aspects of “Adaptive Reuse” can be incorporated into the design strategy.

This specific site deals with existing structures which are of value. These structures have been left abandoned, to decay while their memory fades. There is an opportunity for these buildings to be reused for a new form of production, while retaining the memory.

From the research obtained it is important to focus on how the buildings are reused and to make sure the significance of the building is retained. Therefore in the design strategy it is important to analyze what is significant in certain areas of the site, such as the structure, the intangible heritage or rituals and allow these different values to help inform and mold the design.

5.3 HISTORIC LANDSCAPE VS PRODUCTIVE LANDSCAPE

The compound can be seen as an historic landscape with many artifacts scattered throughout the courtyard spaces. These artifacts help one connect to the narrative of the site and are important in distinguishing the functions that occurred there. These artifacts include clay tiles, old basins, a concrete bath, tables with slate tops used for cooking and washing and even remnants of the currency that existed there.

From UNESCO's Historic Urban Landscape approach it states

“The HUL approach moves beyond the preservation of the physical environment and focuses on the entire human environment with all of its tangible and intangible qualities. It seeks to increase the sustainability of planning and design interventions by taking into account the existing built environment, intangible heritage, cultural diversity, socio-economic and environmental factors along with local community values.” (UNESCO 2011)

RELEVANCE TO THE DESIGN

What aspects of “Historic and productive landscapes” can be incorporated into the design strategy.

This then becomes difficult when introducing a productive landscape into this site, as a large portion of the compound has sensitive historic value. On the other hand the scale of this site, and the amount of unused land that is available, requires a form of productive landscape in order to benefit the community of Cullinan, as well as rehabilitate the soil while still being respectful and sensitive to the historic value of the site.

Therefore the design will respond to the historic value of the site by retaining the ruins or artifact within their natural environment and allowing the productive landscape to weave between these areas.

The hemp plantations will be beyond the boundary of the compound where the land has no historic value and will not negatively impact the area due to tractors and trucks moving through.

The mulberry trees will be contained within the courtyard space to provide shade for visitors as well as a necessary requirement for sericulture. This orchard will take into consideration the historic artifacts and only be placed in areas of least sensitivity.

The artifacts relating to the compound history will be displayed in their natural environment. The design will react accordingly, depending on how fragile or sensitive these artifacts are.

DUISBURG-NORD INDUSTRIAL LANDSCAPE PARK

Latz + Partners
Germany



Figure 5.10 New landscapes intergrated into an industrial wasteland



Figure 5.11 Revitalisation of this industrial wasteland



Figure 5.12 Relationship between old and new

Duisburg-Nord is an industrial landscape park which displays the perfect integration of a new function in amongst existing industrial buildings, allowing one to understand the history of the site while still utilising the site for cultural or corporate functions and public park spaces.

This design shows the symbiotic relationship between old and new, where the new structures are easily distinguishable in and amongst the existing ironworks machinery. They do not compete with existing but instead expose and complement these beautiful industrial structures.

This project not only makes this industrial wasteland accessible and relevant for today's society but also uses the idea of bioremediation in order to neutralise the ecological damage that this industry has produced.

5.4 GUIDELINES FOR DESIGN

BURRA CHARTER

The Compound is a window into the life of an industrial mineworker. It allows people to understand and connect with the hard laborious lifestyle within these ruins where many people lost their lives. It draws together the industrial tangible heritage with the social intangible heritage. The remaining ruins then become important vessels in portraying the past, therefore it is essential that these ruins are preserved and adapted in order for people to appreciate and have access to this history.

In doing so we need to refer to different Charters which will guide the design in how to go about adapting and altering these ruins in order to not lose the sense of Place.

The Burra Charter, although an Australian Charter, it is relevant in the conservation of Cultural Heritage. The Burra Charter states

“Places of cultural significance enrich people’s lives, often providing a deep and inspirational sense of connection to community and landscape, to the past and to lived experiences. They are historical records that are important as tangible expressions of Australian identity and experience. Places of cultural significance reflect the diversity of our communities, telling us about who we are and the past that has formed us and the Australian landscape. They are irreplaceable and precious.” (Burra Charter 1999)

With the Abandoned Mining Compounds, it is important to look at the cultural significance of the site and what it meant for the mineworkers as well as the Mining industry in Cullinan at that time, therefore the Burra Charter becomes an important tool in making sure the significance of the place is not altered through the design process.

Article 22.1 of the the Burra Charter refers to new work within a culturally significant area.

“New work such as additions to the place may be acceptable where it does not distort or obscure the cultural significance of the place or detract from the interpretation and appreciation. (Burra Charter 1999)

The design follows the Burra Charter guidelines where the new architecture not only contrasts with the existing buildings, but is also situated in the area of least significance. Where the new design encroaches on the existing ruins the architecture does not compete with the heritage of the site.

TICCIH CHARTER

The TICCIH charter looks at the Conservation of Industrial Heritage sites. In the TICCIH Charter it states

“Appropriate original or alternative and adaptive use is the most frequent way and often the most sustainable way of ensuring the conservation of industrial heritage sites or structures. New uses should respect significant material, components and patterns of circulation and activity.”
(TICCIH Charter 2011)

*“Programmes and facilities such as visits of active industrial heritage sites and the presentation of their operations as well as the stories and intangible heritage associated with their history, machinery and industrial processes, industrial or city museums and interpretation centres, exhibitions, publications, websites, regional or trans-boundary itineraries should be developed and sustained as means to raise awareness and appreciation for the industrial heritage in the full richness of its meaning for contemporary societies. These should ideally be located at the heritage sites itself where the process of industrialisation has **taken** place and can be best communicated. Wherever possible, national and international institutions in the field of research and conservation of heritage should be empowered to use them as educational facilities for the general public and the professional communities.”* (TICCIH Charter 2011)

The concept of creating public awareness is incorporated into the vision for the Compound where the public can interact and appreciate the heritage of the site and be exposed to the history of Cullinans mining compound, even though the site has been adapted for new productive uses.

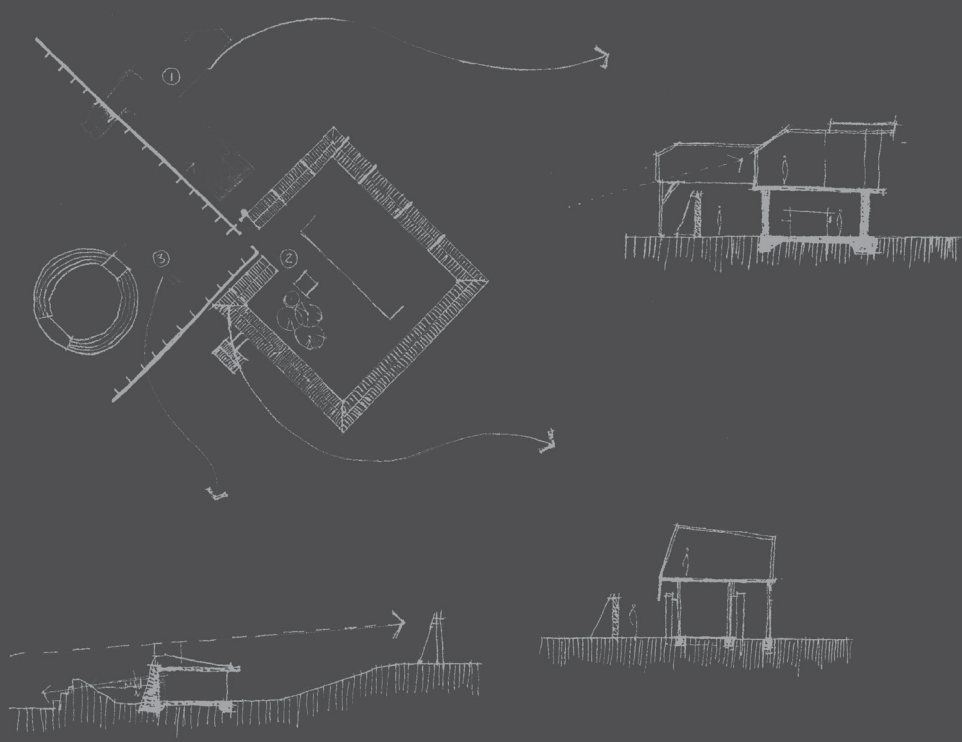

06

DESIGN STRATEGY

06. DESIGN STRATEGY

The design strategy provides a framework which guides the design process. This strategy is developed through the understanding of the site, its significance, as well as the understanding of the history and how this new architecture can help portray this.

This understanding is then developed into design drivers (Figure 6.2-6.5) which mainly looks at evoking different emotions in different spaces in order to connect the visitor with the past. In Figure 6.8 these diagrams look at the physical spaces and rituals which could be re-created in the design through the programme.

In the diagram 6.1, a heritage assessment was completed where the buildings were rated on their condition, intention and significance. This assessment helps guides the design process to know how to react to different areas of significance.

6.1 UNDERSTANDING THE SIGNIFICANCE

- Good
- Moderate
- Bad
- Ruin

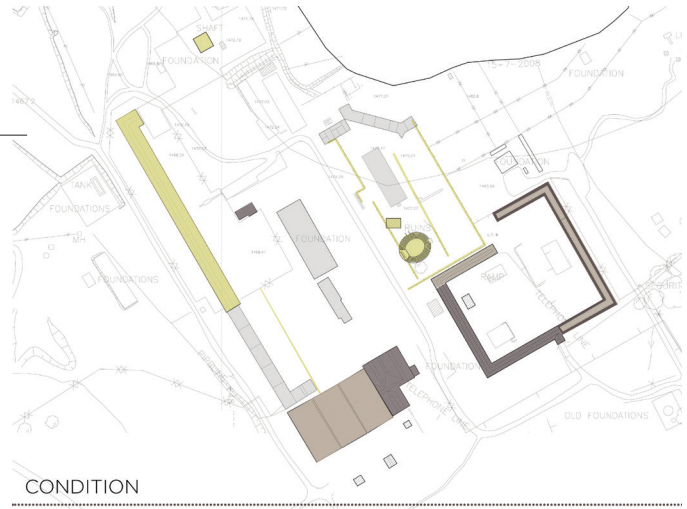

- High
- Medium
- Low

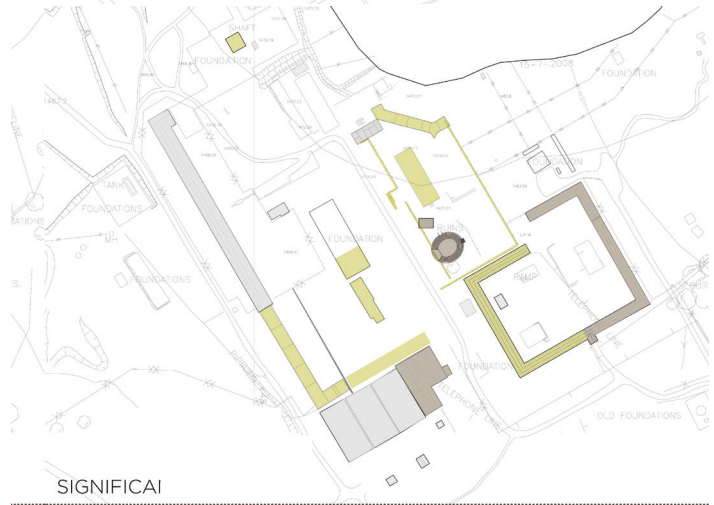

- As Built
- Addition
- Restored/Retrofit
- Preserved
- Demolished

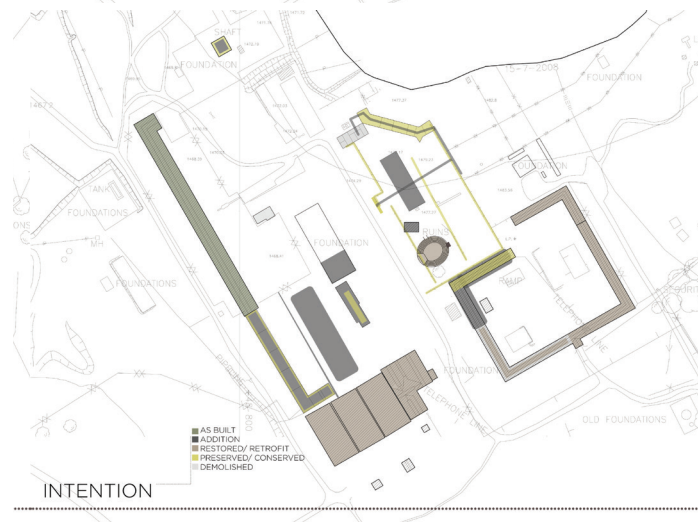

Figure 6.1 Diagrams adapted from the Rapid Heritage Assessment (author 2014)

6.2 SPACE DRIVERS

It is important to understand the conditions that caused pain and suffering within the compound during its utilization. This understanding can then help form a relationship between the past and the future in order to facilitate in the healing process.

These elements can then be seen as:

Isolation and segregation:

The mineworkers were separated from their families during their contract with the mine. They were kept isolated from their communities as well as the Cullinan community.

Within the compound many fights broke out amongst different ethnic groups due to this the ethnic groups were then separated into smaller groups within the larger compound, this then created further segregation.

Linear Movement:

Due to the strict control within the compound, an association is created between the linear movement of people and the conditions within the compound. People would line up to enter the mine; they would have communal showers and cooking areas where the men would queue. These restricted movement patterns reflect on the control within the compound.

Understanding the Compound:

The compound was originally designed along a classical grid formation. Where every building was perpendicular and proportional, over the years as the buildings have been removed or have crumbled the relationship to this grid has been lost. The grid is a way of understanding the lost fabric, which once added to the lifestyle of the mineworkers, as well as reinforced the ideas of isolation and linear movement.

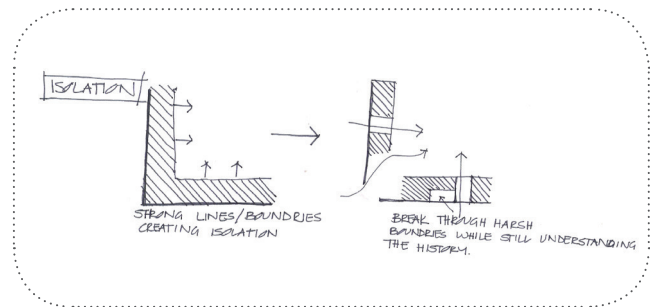

Figure 6.2 Diagrams indicating isolation (author 2014)

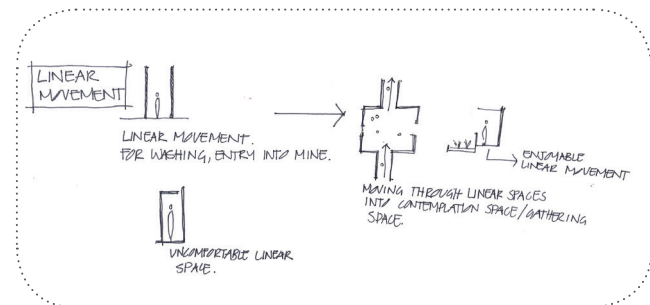

Figure 6.3 Diagrams illustrating linear movement (author 2014)

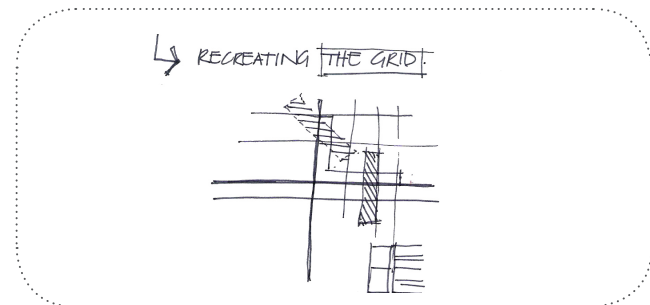

Figure 6.4 Diagrams illustrating how one can recreate the lost classical grid (author 2014)

To turn the idea of a typical museum on its head where the traditional museum is isolated from its society and only serves one purpose, to preserve and portray the past. This intervention looks at combining the museum and a productive industry where the tourist can then walk through a space that evokes emotions, tells a story of the past and displays a new story of liberation, education and production. The other user is then the worker within the textile mill. The textile mill provides new job opportunities for these people as well as new skills. This intervention then creates a relationship between these two users as well as a transition from understanding the past and a sense of relief for the future.

These elements of isolation, linear movement, the classical grid and the relationship of users become the initial drivers for the intervention. These space drivers are then layered with retaining the memory in different spaces (Figure 6.8) and start to form the initial design concept as a process of movement and programme.

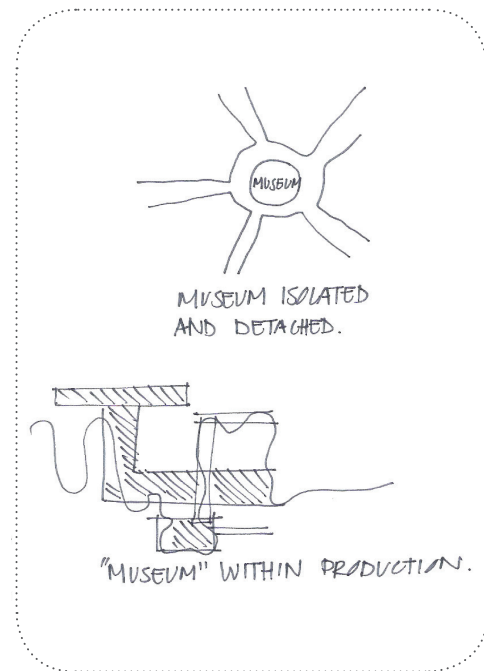

Figure 6.5 The amalgamation of the museum within a productive landscape (author 2014)

6.3 WORKING WITH THE EXISTING

With the site comprised of significant tangible and intangible history, it is important to look at how to approach the design, in order to help portray the lost narrative as well as the lost fabric without losing the integrity of the site.

Firstly it was important to understand the rituals that occurred in and around compound 5 in order for the design to reflect this.

From the information given about the history of the compound, it is evident that the courtyard spaces became areas of relief where the mineworkers could socialize (Figure 6.7) There are remains of board games, cooking areas and laundry spaces where the workers could relax, and move away from the strict environments of the compound rooms. These internal spaces then became the communal areas where people could overcome the segregation.

Therefore the design then starts to look at the relationship between the formalized spaces where the production facilities are held and the communal spaces where the tourists can interact with the site as well as understand the past conditions (Figure 6.7) and the new production. These spaces then reflect the spaces of the past, where the production is held within the compound rooms and the public spaces are recreated within the courtyard spaces.

The underlying driver for the design is not only to revitalise the lost spaces but also create a sense of healing through breaking the boundaries of segregation and in doing so the design needs to pull together the isolated courtyard of compound 5 with the larger compound as well breaking through the compound walls and out.

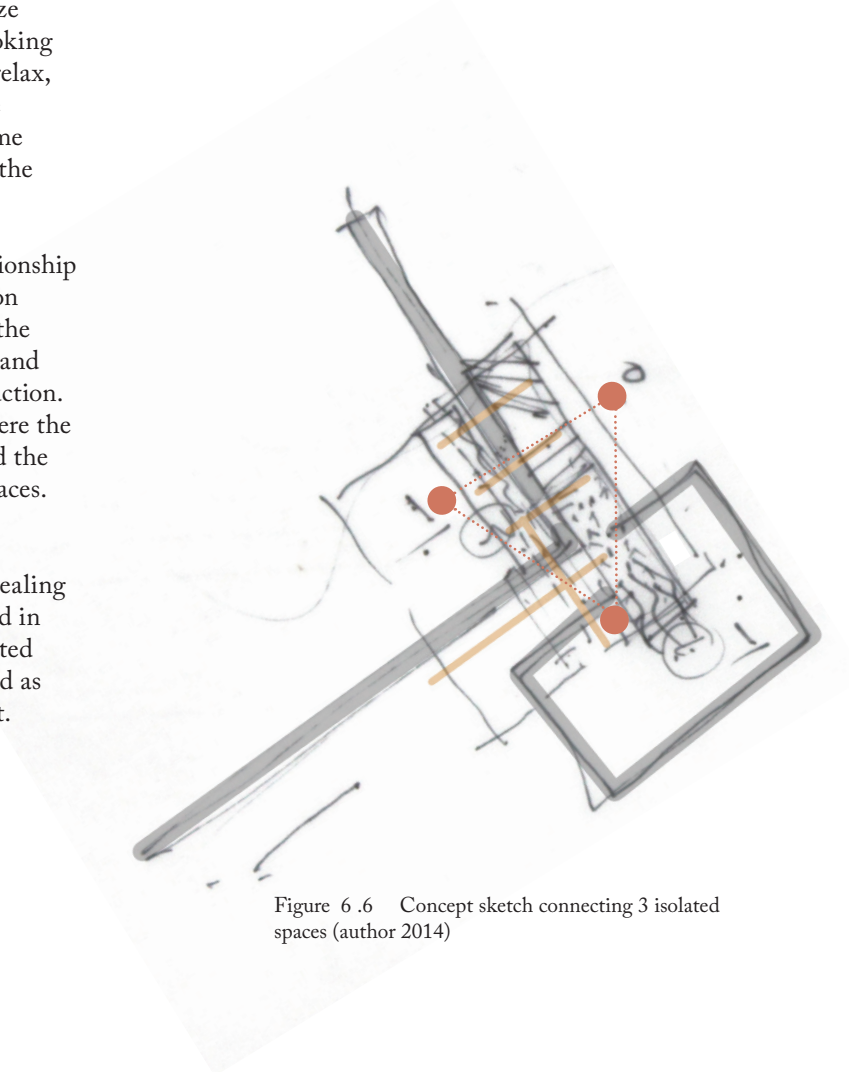

Figure 6.6 Concept sketch connecting 3 isolated spaces (author 2014)

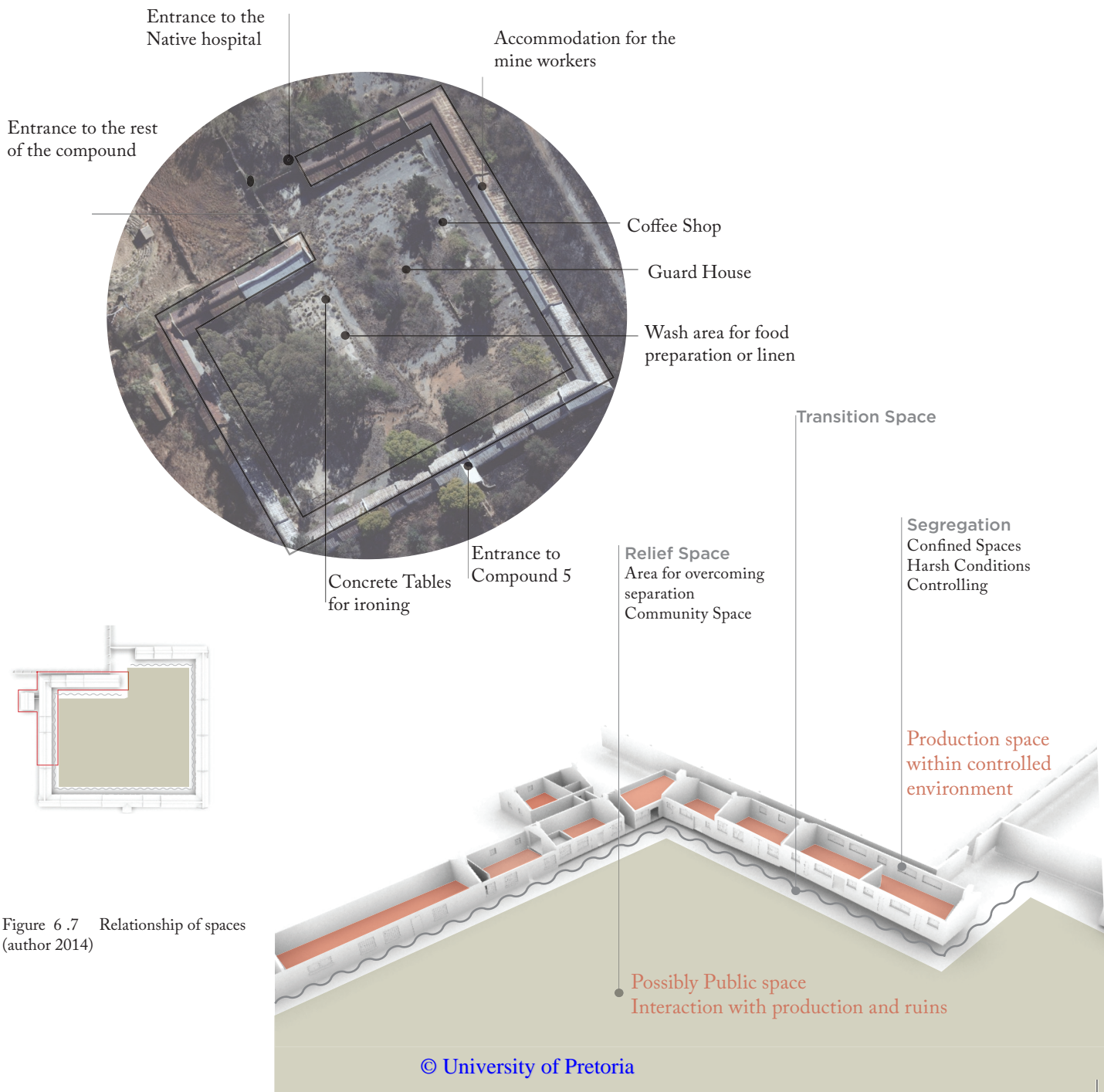
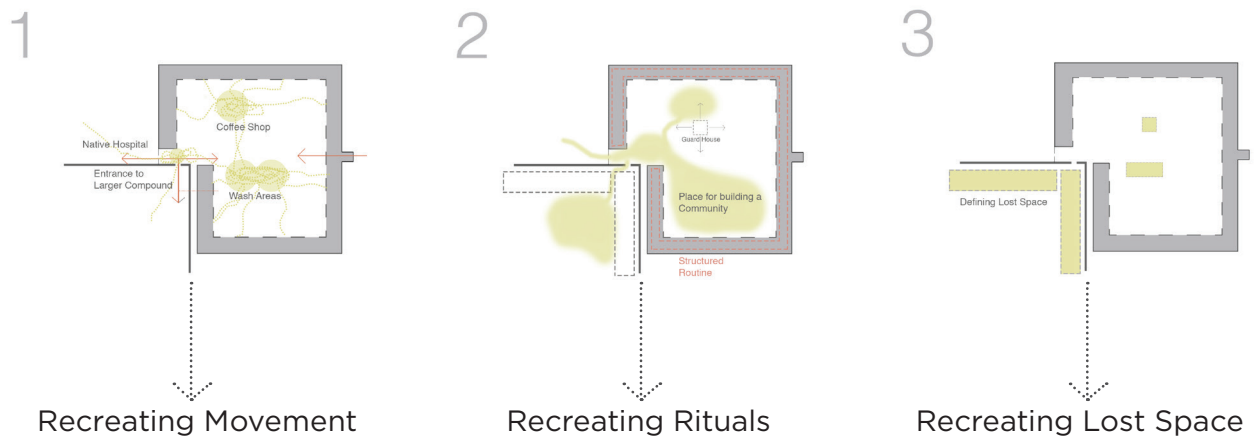

Figure 6.7 Relationship of spaces (author 2014)

6.4 RETAINING MEMORY

SPACES AND RITUALS

These diagrams below indicate the rituals of the compound (figure 6.8) and how these spaces can be reused in a way that relates to the historic nature of that space.



The linear movement of people from one compound to the other is recreated in the design. The movement of people from structured production spaces to communal or public space is further recreated in the design.

The rituals that existed in the compound are brought out through the design of the new textile industry. The facilities are ordered in such a way that they start to mimic the past.

Buildings that have been lost over time are linked to the new design through the foundation of the new building as well as movement patterns in order for people to understand and remember the past.

Figure 6.8 Memory of spaces (author 2014)

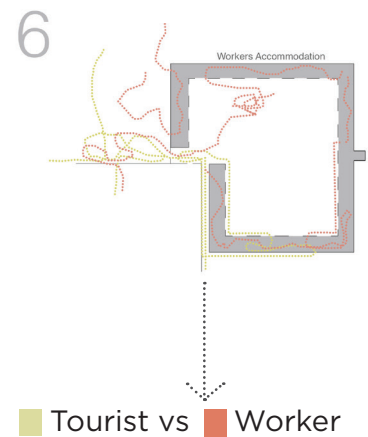
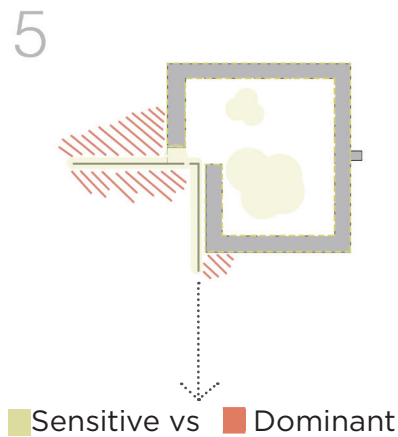
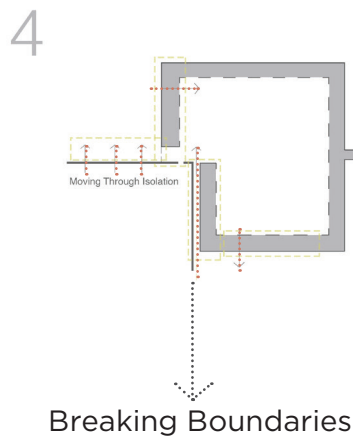

The compounds were isolated from one another as well as the town. They facilitated in the segregation of ethnic groups and separation of families. By creating a building that starts to stitch together these lost connections it will aid in the healing of the past.

To create the stitching of these isolated sectors it is important to break through from compound 5 to the larger compound as well as breaking out and drawing the energy from the town into this abandoned area while still retaining the integrity of the compound.

The areas of most significance have been identified. This is then where the new architecture is simplistic in order to not compete with the beauty of the existing fabric. Where there is little or no significance on the site, it provides an opportunity for the new architecture to become more dominant.

There is a relationship between the worker and tourist throughout the site. The worker is healed through new job opportunities, and skills where as the tourist starts to understand the past as well as the future production for this site.

In some places in the design the tourist is forced into isolation as well as into linear movement patterns, this then allows the tourist a glims into the life of the mineworker inside these compounds where as the worker within the textile industry is free to move through the site with little or no restrictions.

6.5 ALTERING THE EXISTING

When adapting the existing compound buildings to facilitate the new functions, it was important to see how these additions will affect the integrity of the site.

The new additions are simplistic, in order to not detract from the existing structure as well as designed to be more stereotonic where the existing structures are tectonic. This contrasting use of materials provides a clear distinction between old and new.

Figure 6.9 illustrates three possible buildings that start to reflect the design strategy, by reconnecting and activating these three separate areas. The architecture for each building will then relate to the history, sentivity and ruins depicted in that space.

In Figure 6.11 the design starts to investigate how to adapt the existing compound structures without losing their sense of identity. In option 1 and 2 the angle of the original roof is obtained where as in option 3 the first floor reacts to the angle of the buttress wall.

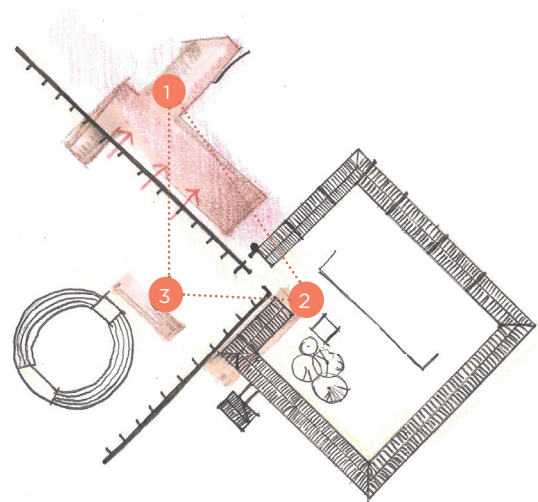

Figure 6.9 Activating 3 spaces (author 2014)

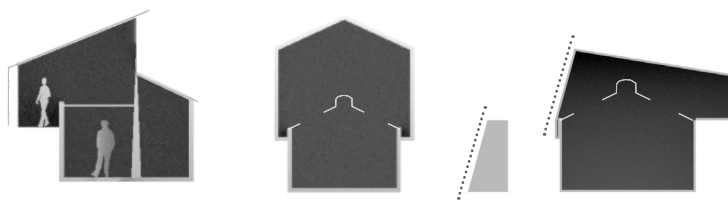

Figure 6.11 How to alter the existing compound buildings (author 2014)



Figure 6.10 Abandoned Compound 5 (photo by author 2014)

6.6 DESIGN INFLUENCES:

The in depth value both in tangible and intangible elements then means the design has to work within certain guidelines in order to insure that these values are portrayed and preserved. These design influences are layered over one another to create the guidelines for the design in order for the architecture to help expose the rituals, memories and tangible elements within the site.

6.2

SPACE DRIVERS

Isolation, Linear Movement, the classical grid and the relationship of Users

6.3

FUNCTION DRIVERS

Courtyard spaces-
Relief Spaces
Compound rooms-
Controlled environments

6.4

RITUALS

Recreating Rituals vs
breaking Traditions

6.5

RECONNECTING LOST SPACES

Reconnecting the larger compound, compound 5 and the space beyond the compound walls

Figure 6 .12 Diagram provides the framework for the design (author 2014)

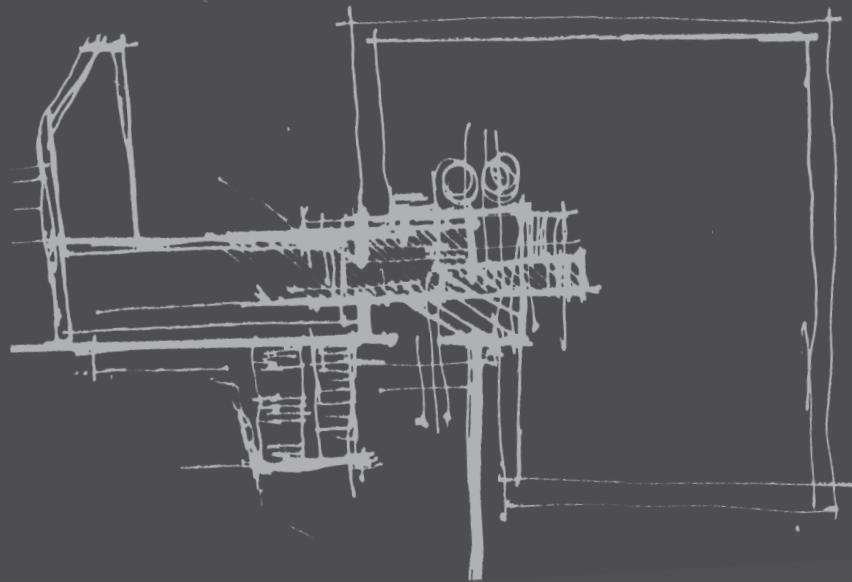

07

DESIGN

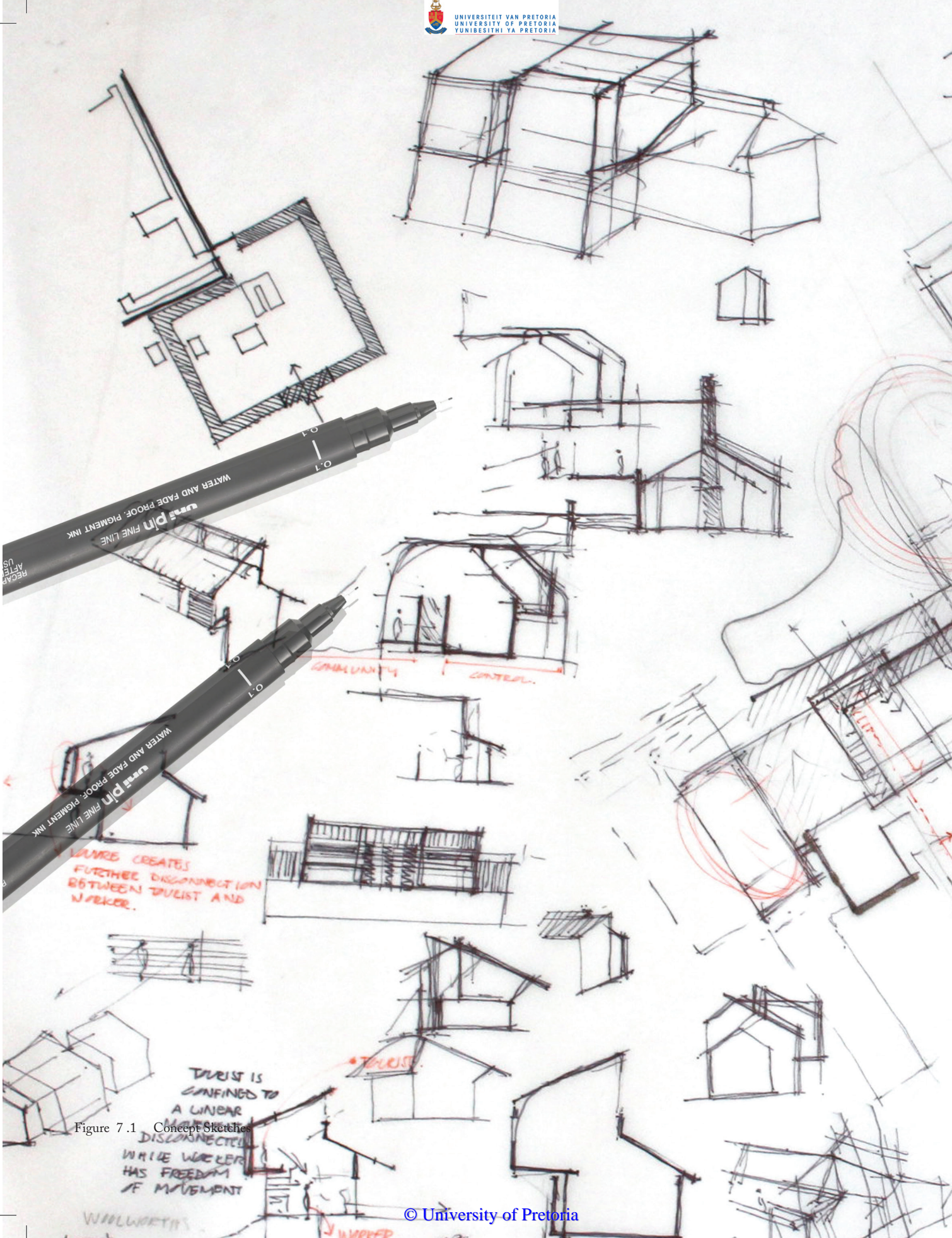
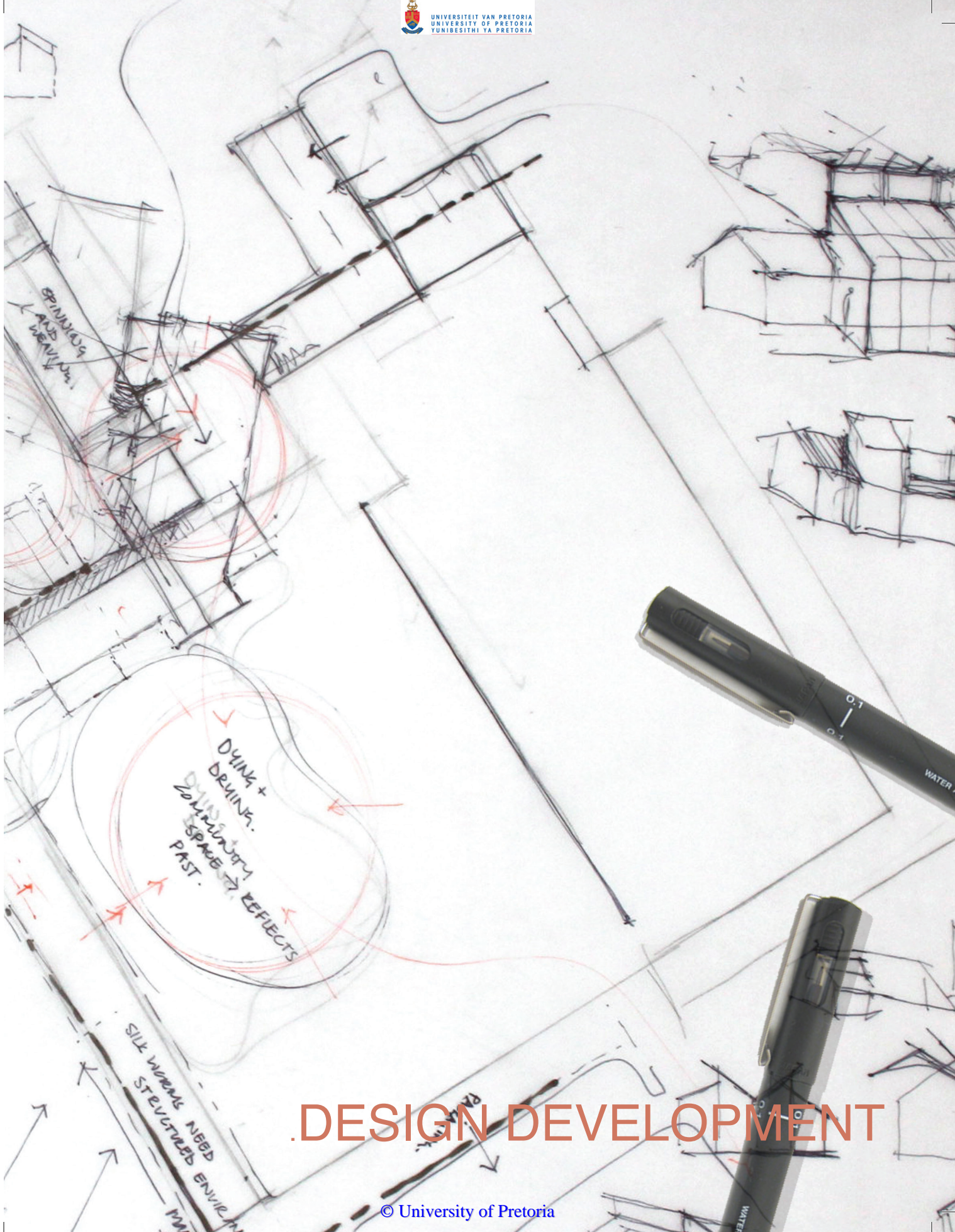

Figure 7.1 Concept Sketches



DESIGN DEVELOPMENT

7.

DESIGN

The design aims at creating a relationship between a new form of production and the existing abandoned mining compound. This relationship will help reuse the site as well as the existing buildings. These buildings help tell a story of the mine workers, and the design aims to portray the history of the site .

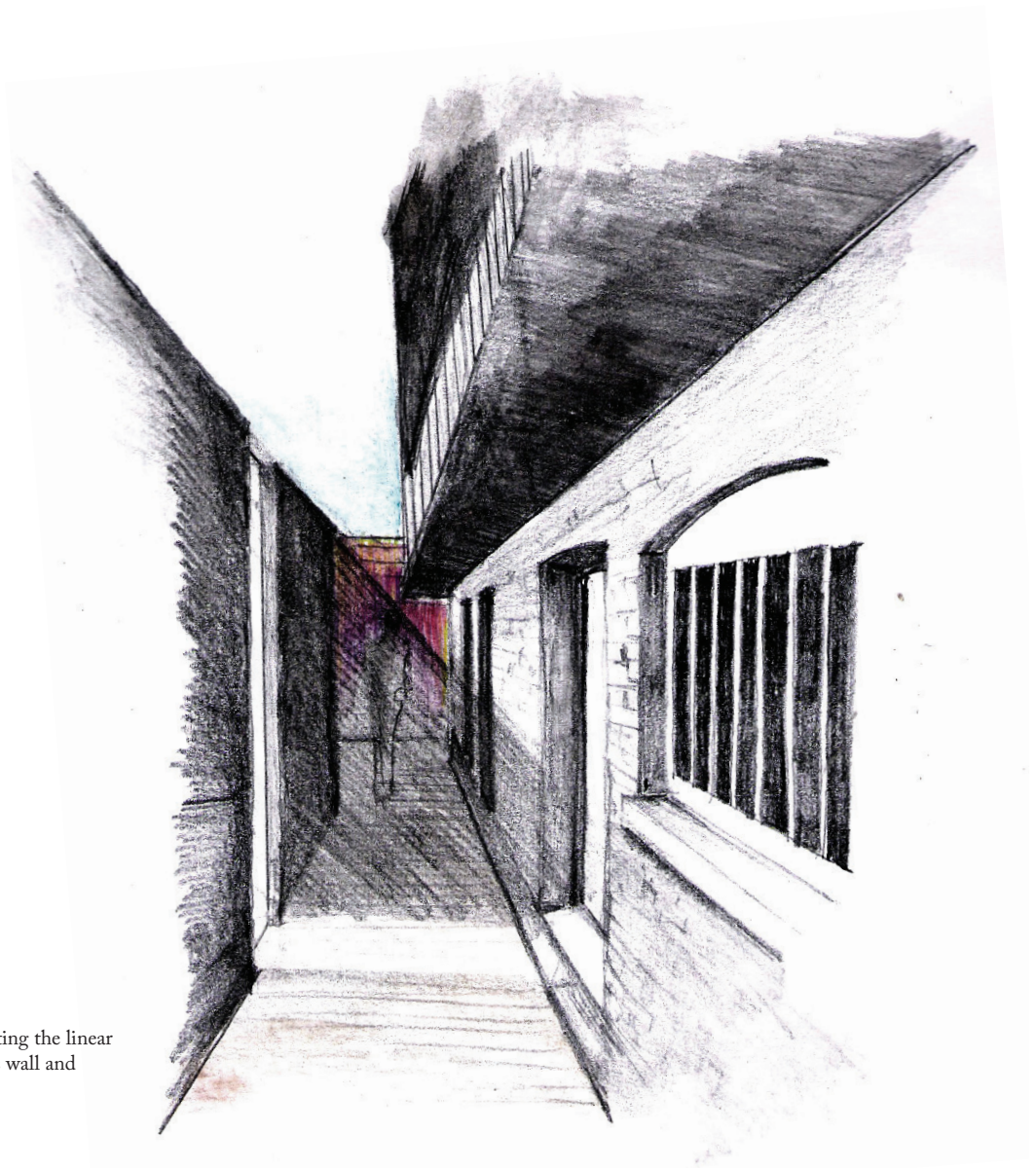
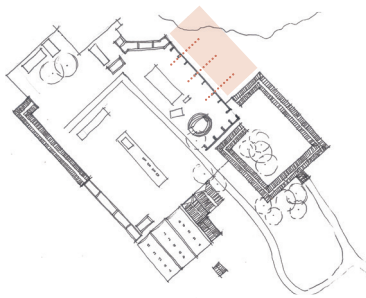

Figure 7.2 Concept Sketches indicating the linear movement between the existing buttress wall and compound rooms (author 2014)

7.1 DESIGN CONCEPT

From the analysis leading up to the design development, 4 main concepts form the core of the design process and start to address the issues of isolation, segregation and healing within the compound.



Breaking Boundaries

Moving out of the confines of the compound to reconnect with Cullinan and the surrounding landscapes. This will address the issue of isolation, and segregation.

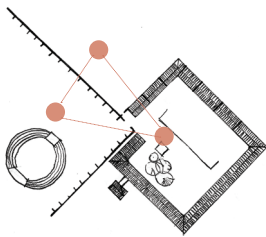

Reconnecting

Compound 5, the larger compound and the surrounding environment are completely separated by the existing buttress wall. This architecture will try to reconnect these areas and activate them.



Historic Landscape vs Productive Landscape

The No2 shaft compound can be seen as a historic industrial landscape with artifacts and ruins relating to the history of the mineworkers. By creating a new productive landscape that filters into the site and in between some of the existing ruins it will help revitalise this abandoned compound.

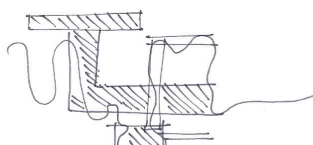

"MUSEUM" WITHIN PRODUCTION.

Visitor vs Worker

There is a relationship that forms between the visitor and the worker. The visitor will move through the site experiencing the history of the site as well as the new production. This challenges the idea of a museum space which is often isolated, but here one can understand both history and production when moving through the space

Figure 7.3 Sketches indicating design concept (author 2014)



Figure 7.4 A living barn

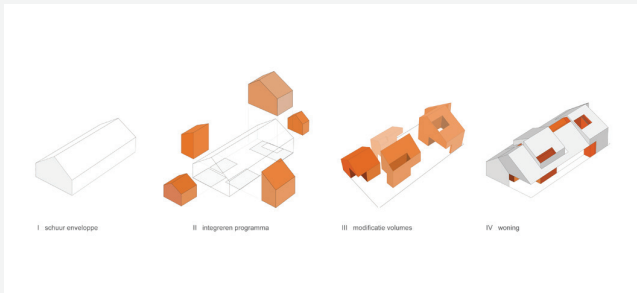

Figure 7.5 Diagrams showing how these individual elements can still be read as a barn like structure



Figure 7.6 Model of Villa HD

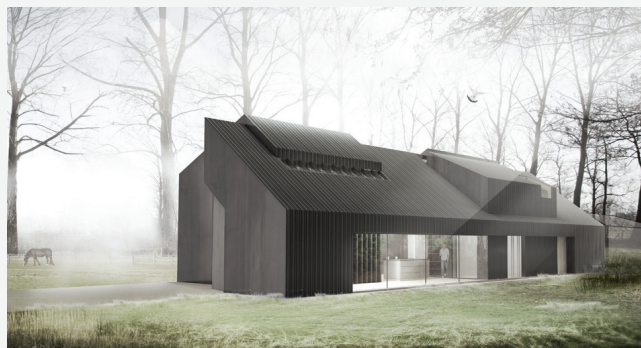

Figure 7.7 Beautiful example of how to adapt a basic shape without losing its identity.

VILLA HD

Design Prototype Amsterdam

The architecture focuses on creating a living barn for a family, using a grid that relates to a typical Dutch home.

“The required program of the client is translated to a clear programmatic grid, which is also used as a starting-point to arrange the spatial concept. The grid is modified compared to the former grid and spatially translated into several opened and functional objects based on the outline of the typical Dutch home. Depending on the different functions the objects are designed in a more open or closed manner and also the outline of the house adapts to the specific functions within the dwelling.” (Design Prototype)

What interested me about this design is the idea of deconstructing a simple barn shape and modifying it to suit different functions but still understanding it in its entirety as a barn.

This design illustrates how one can approach the additions to the existing building, where new elements are added onto the existing compound rooms to facilitate the functions but when read in its entirety the existing is understood as a separate unit to the additions.

GLENEAGLES COMMUNITY CENTRE

Patkau Architects
Vancouver



Figure 7.8 Beautiful integration of materials



Figure 7.9 Quality of spaces



Figure 7.10 Details and Connections with different materials

‘The building utilizes a highly innovative system of structural, mechanical and electrical systems integration to foster environmental sustainability while minimizing operating costs. Heating and cooling is provided by a thermo-active slab system, consisting of water piping embedded within the concrete structure. Heated and cooled water passes through the piping, allowing the walls and floors to act as radiant surfaces. Ventilation is accomplished using a displacement system. 100% fresh air is tempered and supplied at low velocity at low levels. This air rises, flushing contaminants upward where it is then captured and exhausted. As air is not being used for heating or cooling, operable doors and windows may be used at any time without affecting the performance of the system. Heating and cooling for the mechanical systems is provided by heat pumps in combination with a ground source heat exchanger, a clean energy source.’ (Patkau Architects 2003)

This building was beautifully designed to integrate the sustainable systems mentioned above, as well as incorporate the programmatic requirements throughout the building. The design reinvents the idea of a typical sports centre through the use of timber and concrete which is detailed to perfection.

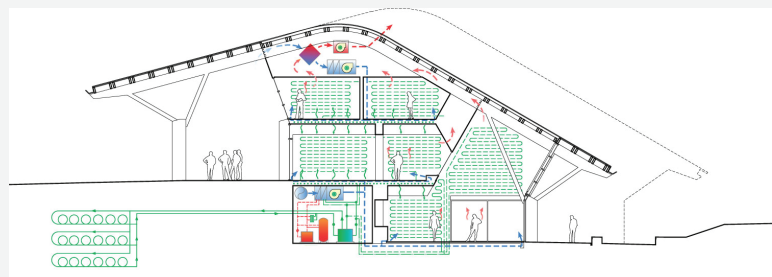

Figure 7.11 Influenced by the roof design

7.2 ITERATION 1

The start of this design development looks at linking the new buildings to the past in various ways. The first was to recreate parts of the lost classical grid which formed the structure to the compound. This would then help the visitor understand where buildings have been demolished or disintegrated.

The second design informant was the idea of isolation, the square courtyard is isolated from the larger compound, so when opening up this space to the larger compound one must still understand and feel the isolation that existed there.

Thirdly the design was influenced by the idea of linear movement. When the compound was in use the workers would queue to enter the mine or to use any facilities, so control became an important element of the design.

↳ RECREATING THE GRID.

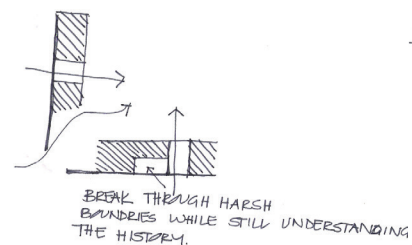
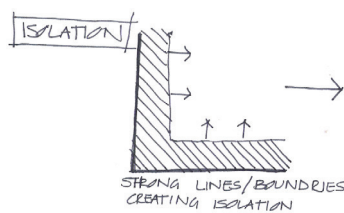
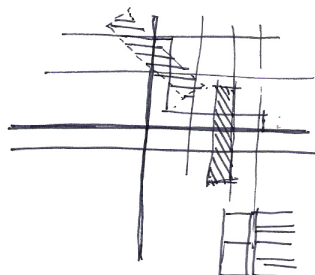
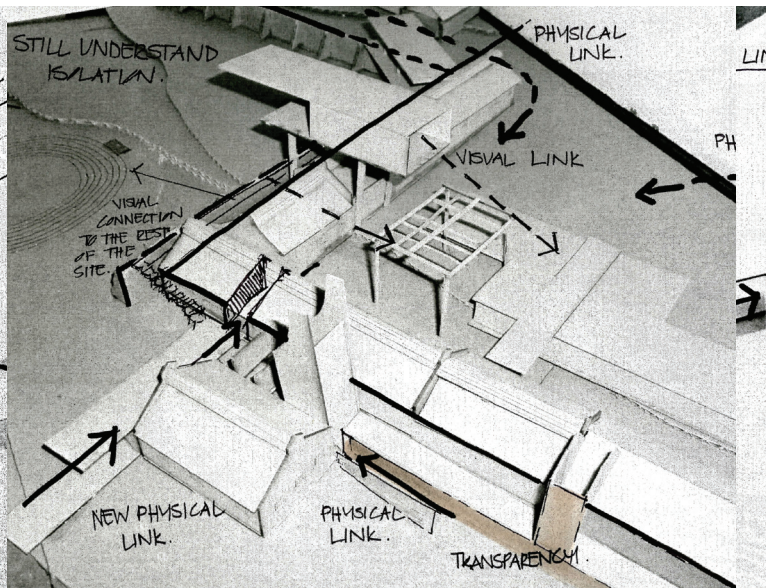
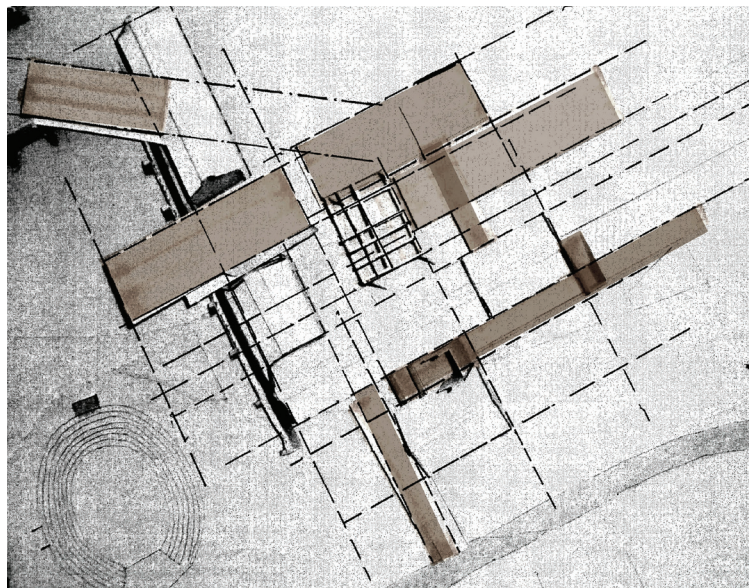

Figure 7.12 Concept Sketches (author March 2014)



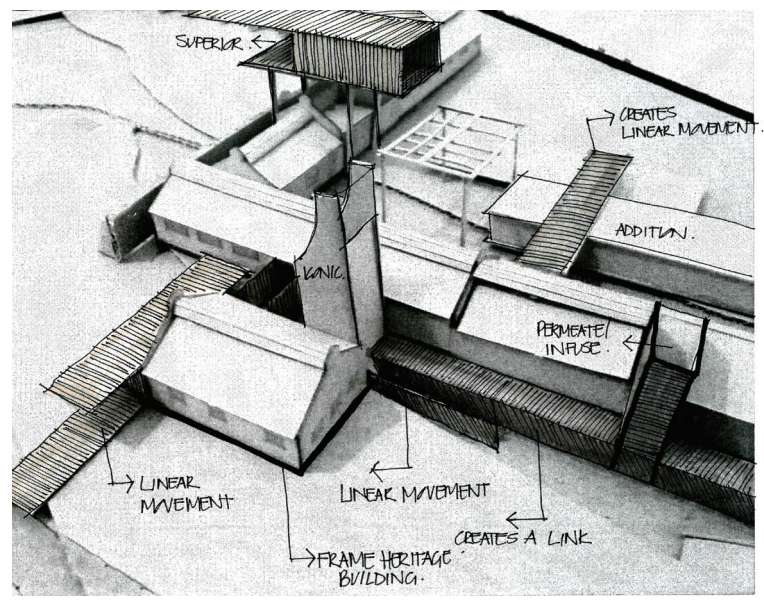
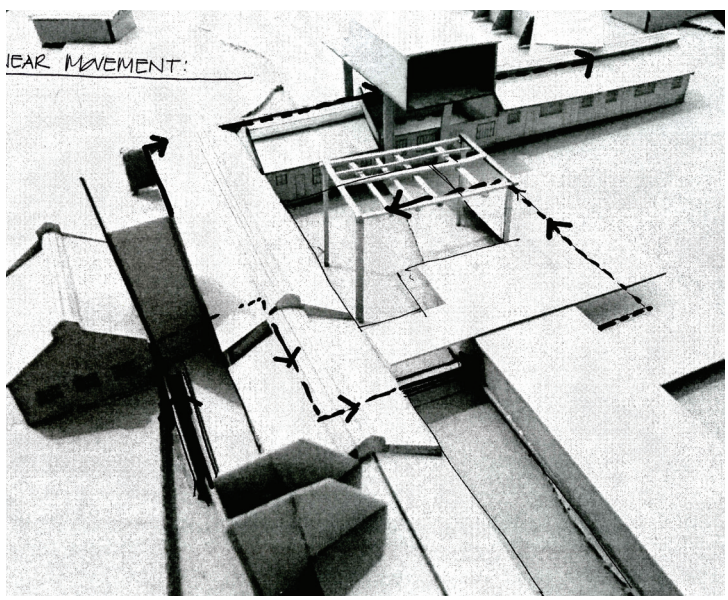
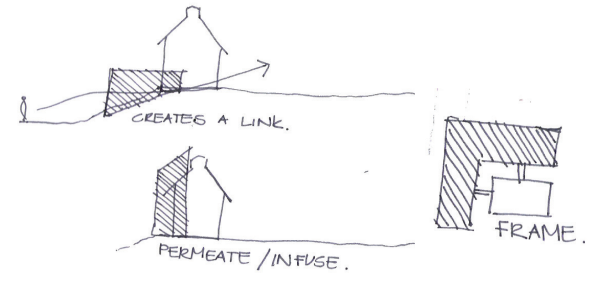
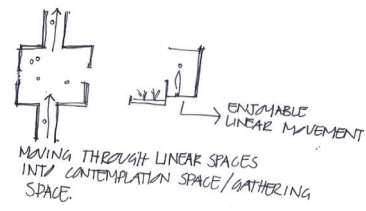
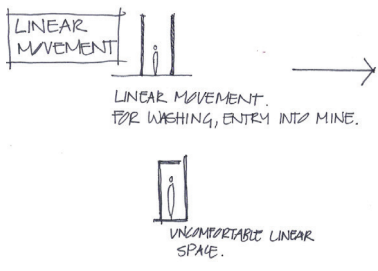



Figure 7.13 Concept Sketchplan (author March 2014)

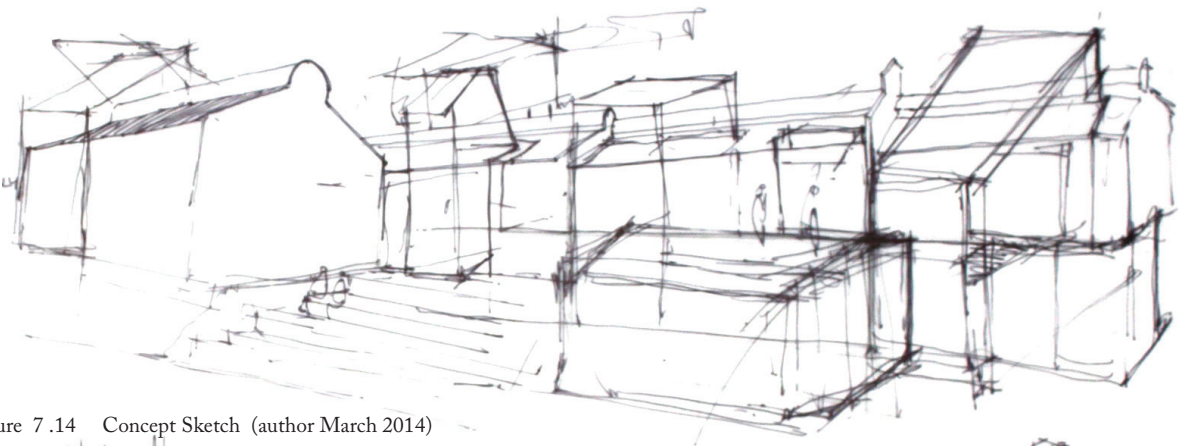

Figure 7.14 Concept Sketch (author March 2014)

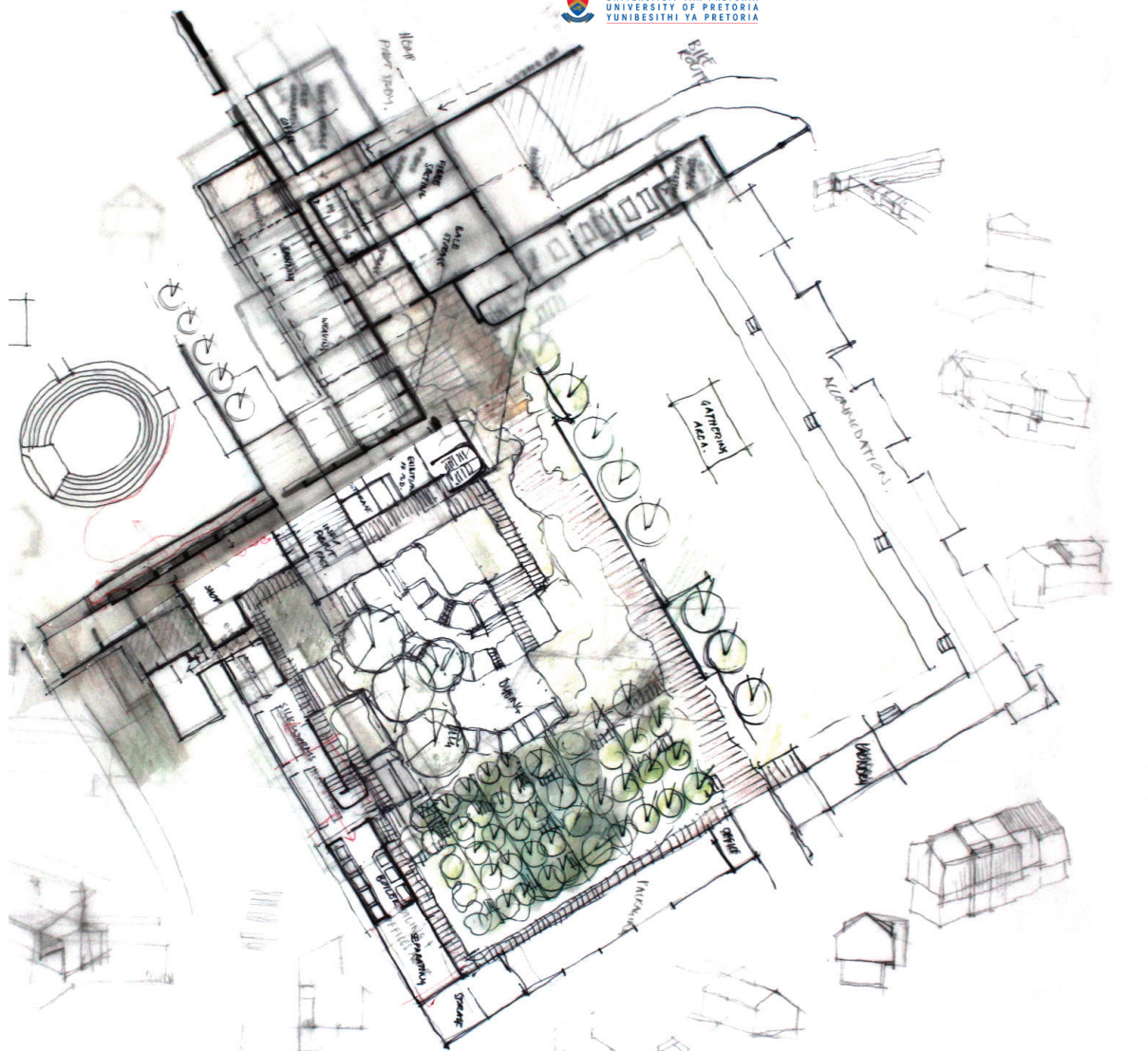

Figure 7.15 Concept Sketchplan (author April 2014)

7.3 ITERATION 2

By creating new buildings in the courtyard space, one starts to lose the scale of this enclosed area and the rituals that occurred there.

Therefore this iteration starts to opened up these spaces, where the courtyard space is used for landscaping and small elements such as the dyeing vats. The new structures then focuses on reconnecting the isolated compound 5 with the larger compound and beyond the buttress wall by moving underneath it.

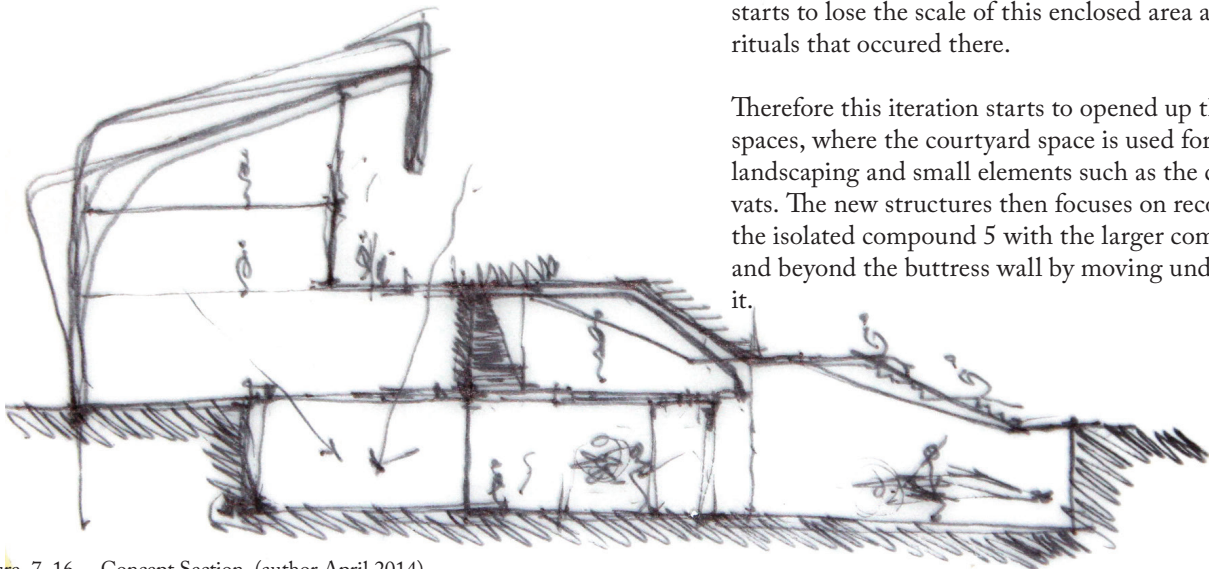

Figure 7.16 Concept Section (author April 2014)

New Building to house the hemp production process.
This building sits outside the compound where there is little or no evidence that relates to the compound

7.4 ITERATION 3

This design is a continuation of iteration 2, but starts to look at the production process of hemp and silk and the spacial requirements; as well as a contrast of existing fabric and new materials.

The new design links compound 5 with the larger compound and the area outside of the buttress walls.

In this area a new building sits above the existing compound rooms to house offices and the silk production process.

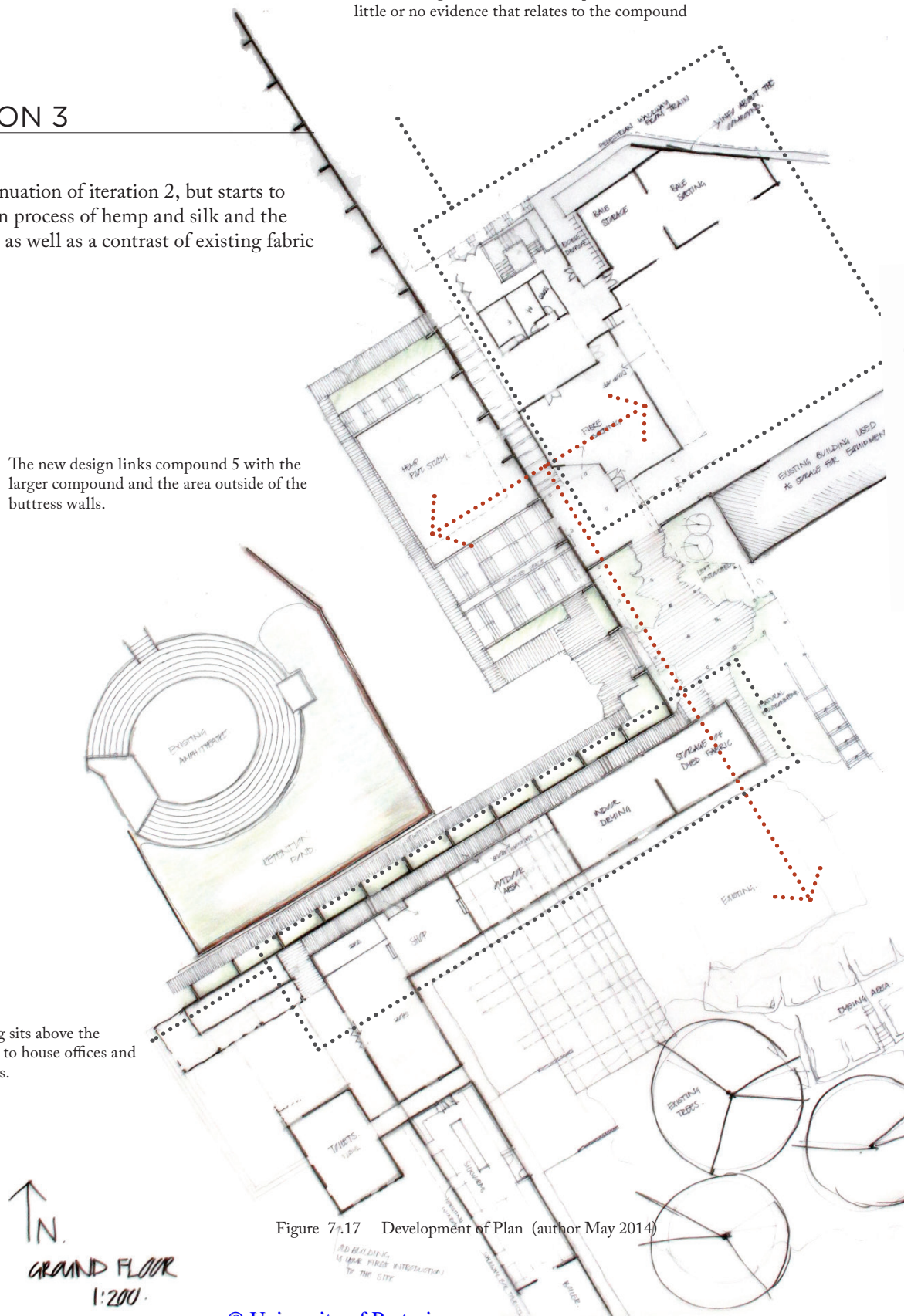

Figure 7.17 Development of Plan (author May 2014)

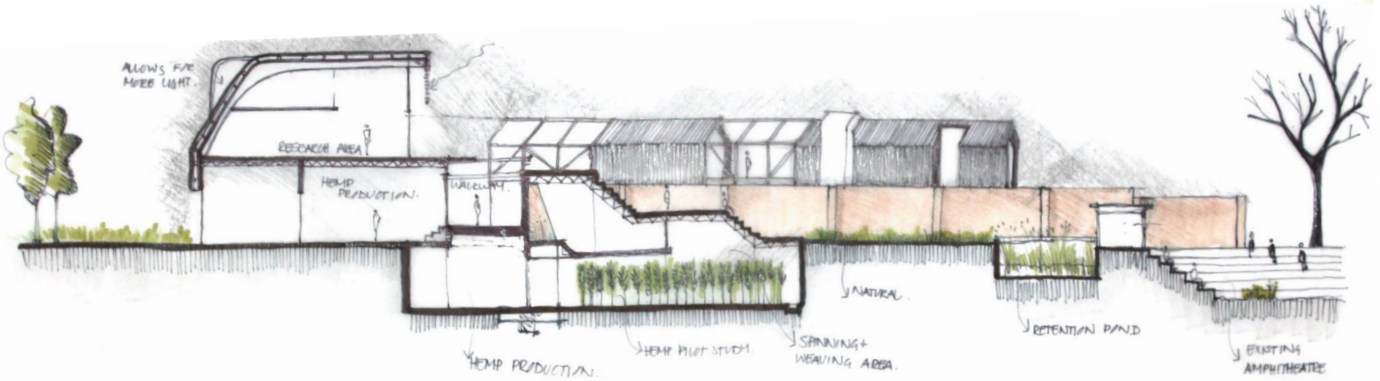
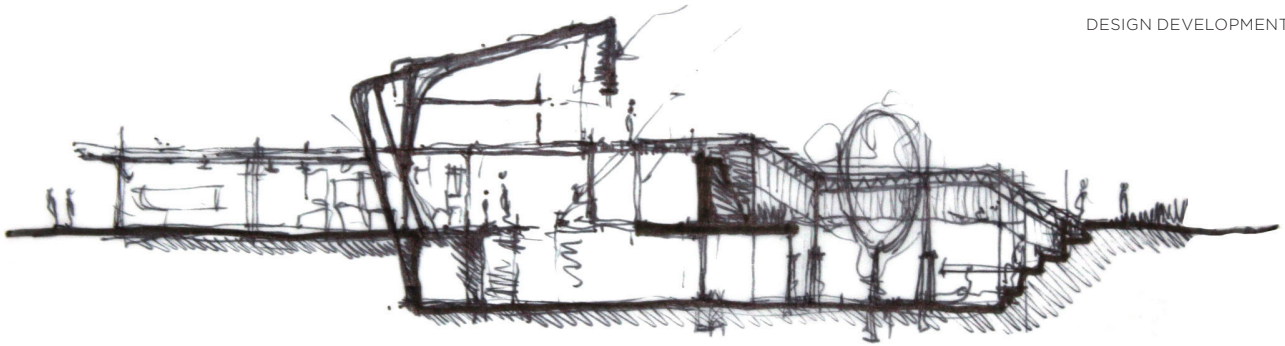

Figure 7.18 Section moving under buttress wall (author May 2014)

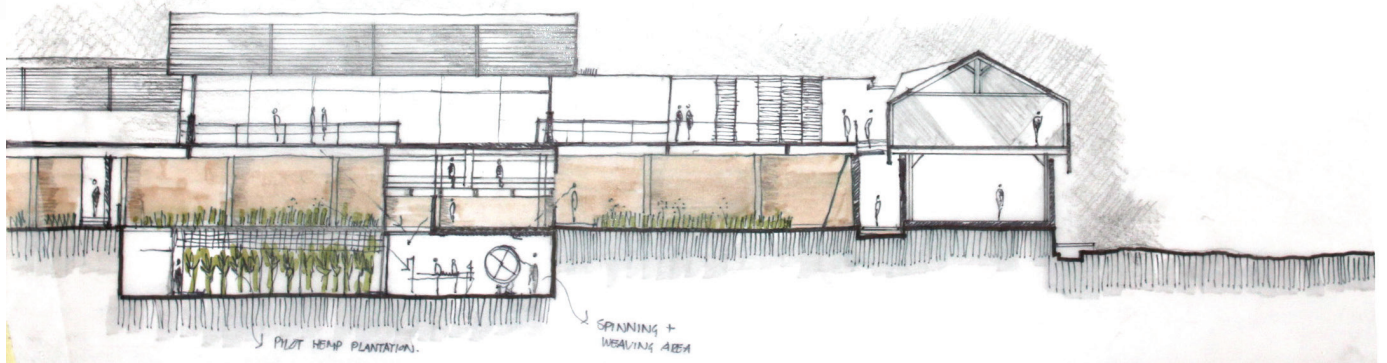

Figure 7.19 Section through Silk production and weavery (author May 2014)

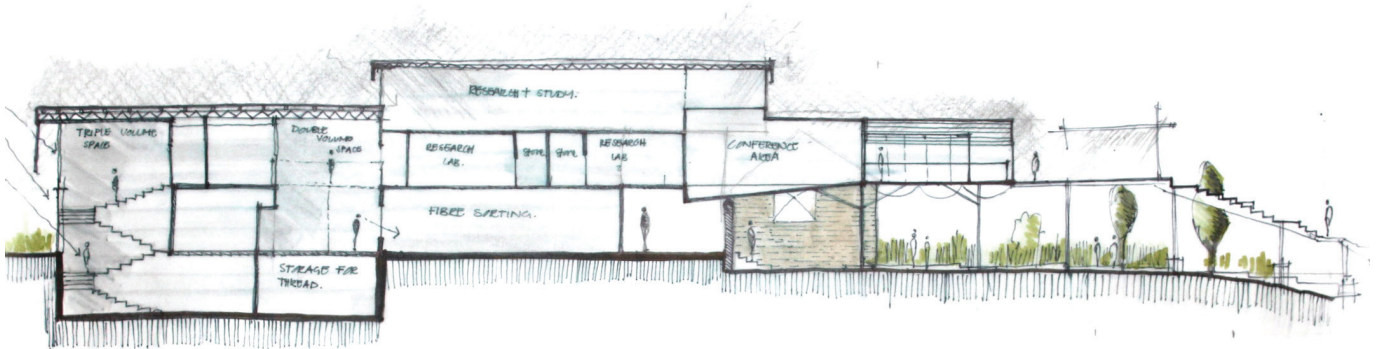

Figure 7.20 Section through Hemp production and Research space (author May 2014)

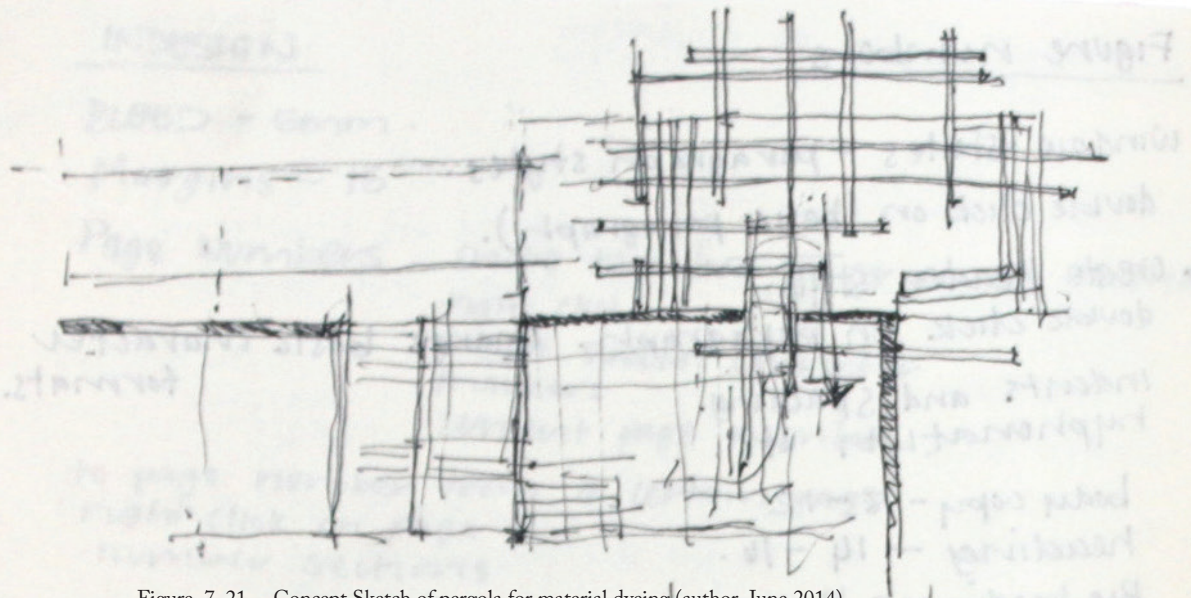
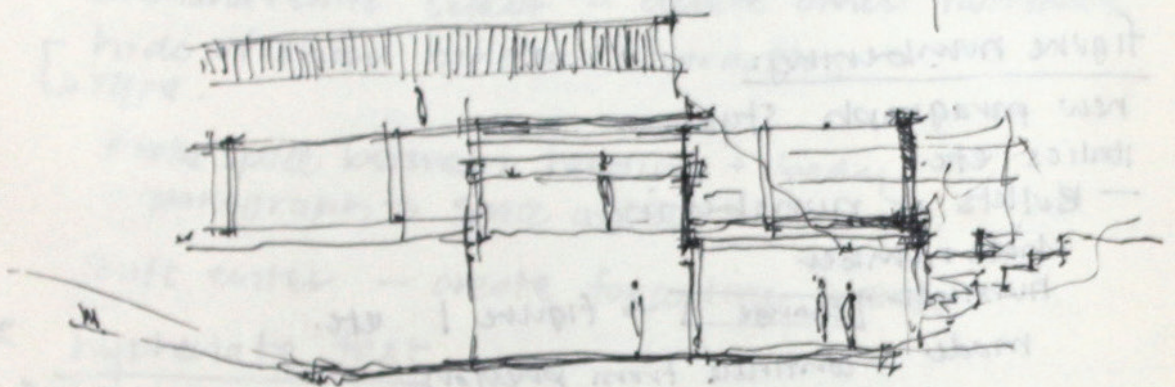

Figure 7.21 Concept Sketch of pergola for material dyeing (author June 2014)



7.5 ITERATION 4

This is a continuation of Iteration 3 but it starts to look at the outdoor spaces forming part of the production process which exposes the production of silk and hemp to the visitor.

The Pergola structures are then used to dry the fibres once they are dyed. These structures can be created using reclaimed steel from the decommissioned mine and therefore have varying lengths.

These steel structures help to define the public spaces below them as well as link the existing and new.

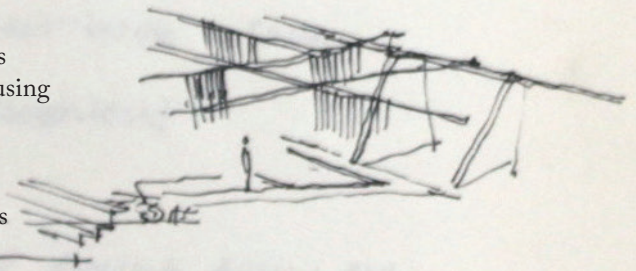

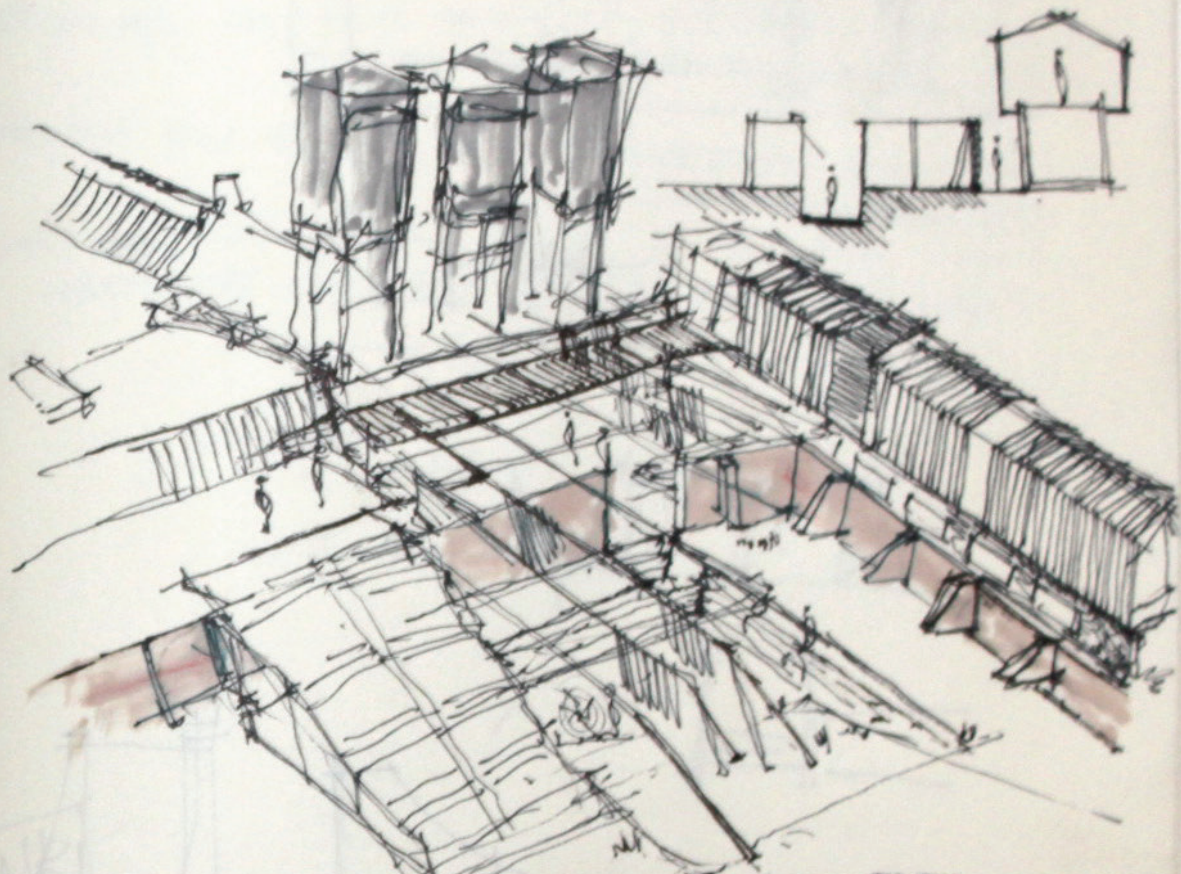

Figure 7.22 Perspective of Textile production (author June 2014)

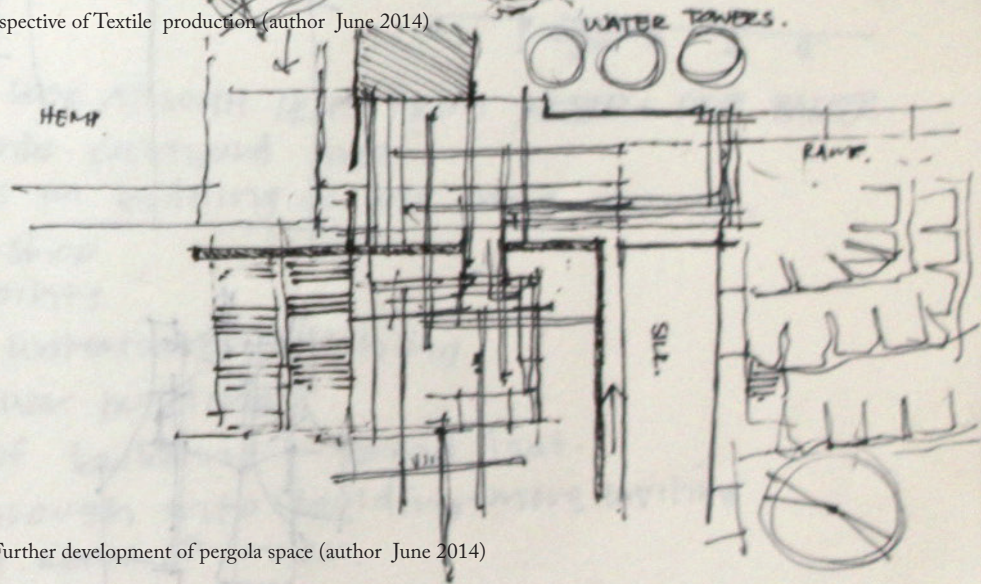

Figure 7.23 Further development of pergola space (author June 2014)

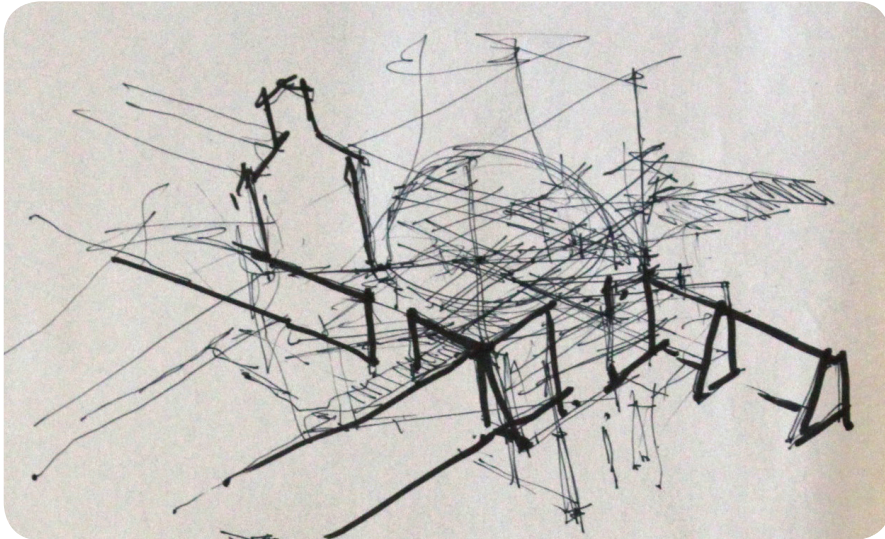

Figure 7.24 An exploration of the pergola creating a public space and connect the different buildings

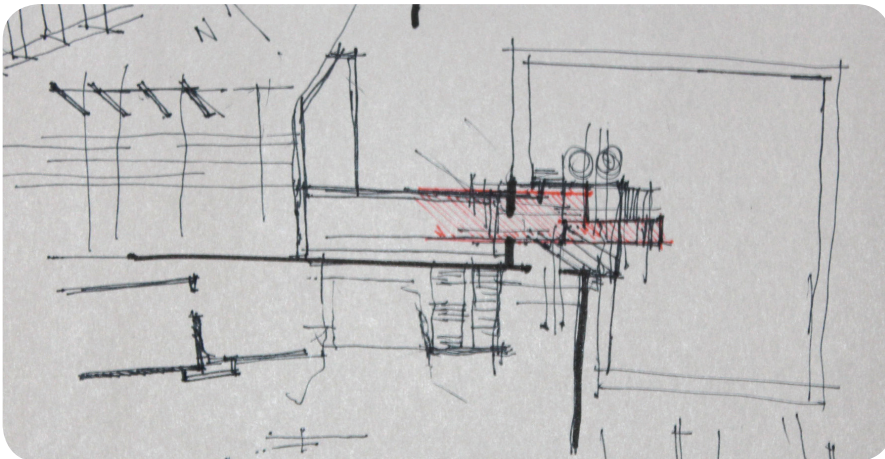

Figure 7.25 A conceptual diagram looking at how this building can connect the courtyard space with the landscape beyond the compound's perimeter.

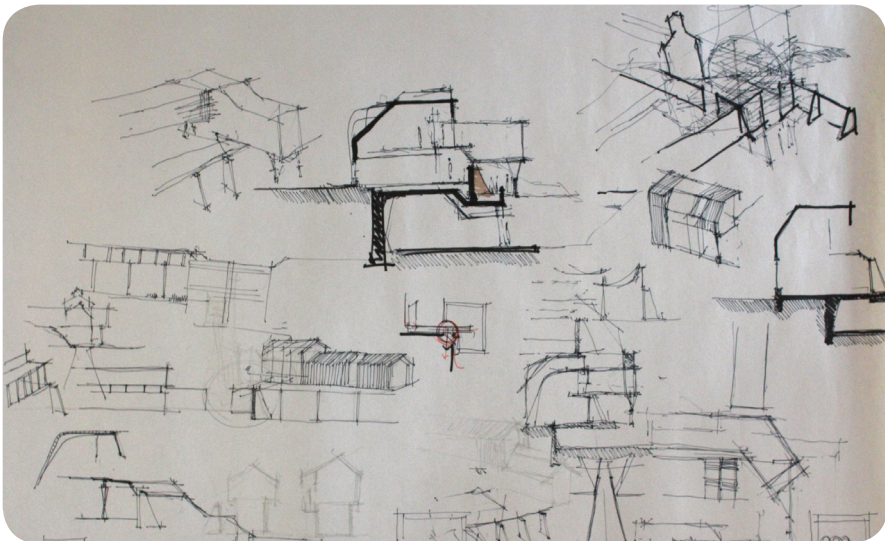

Figure 7.26 An exploration of roofs in reaction to the existing elements

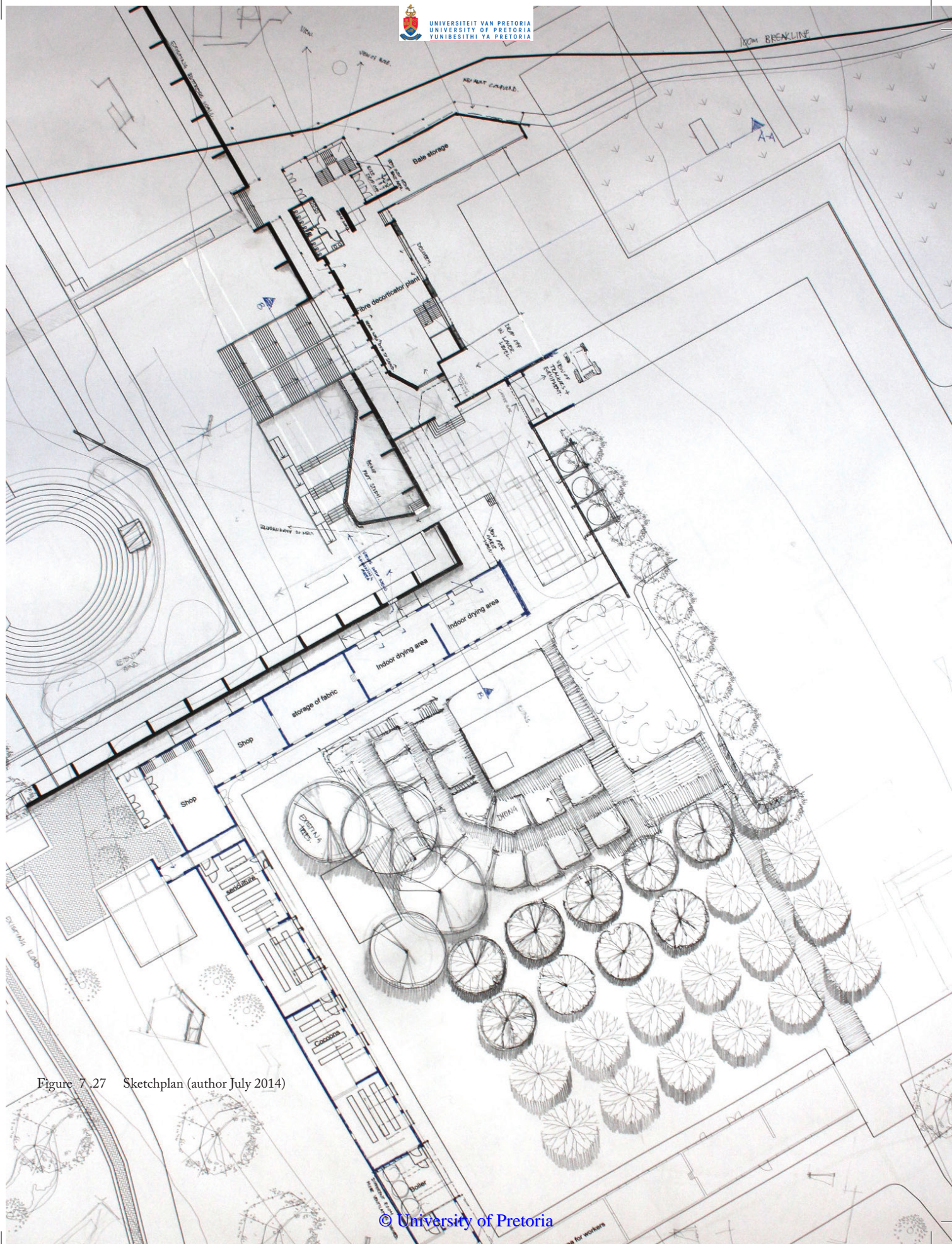
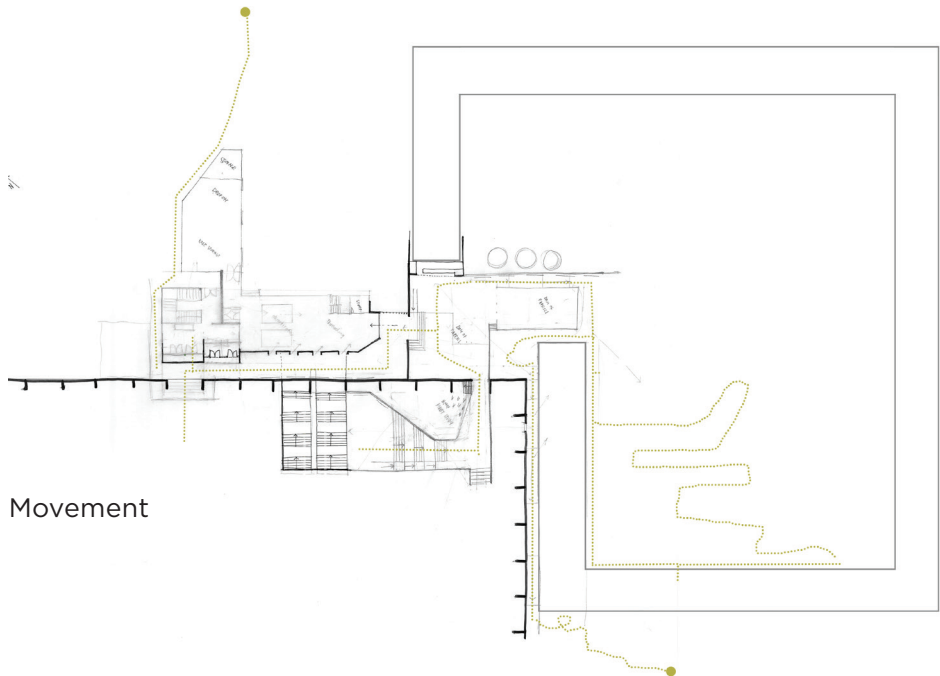
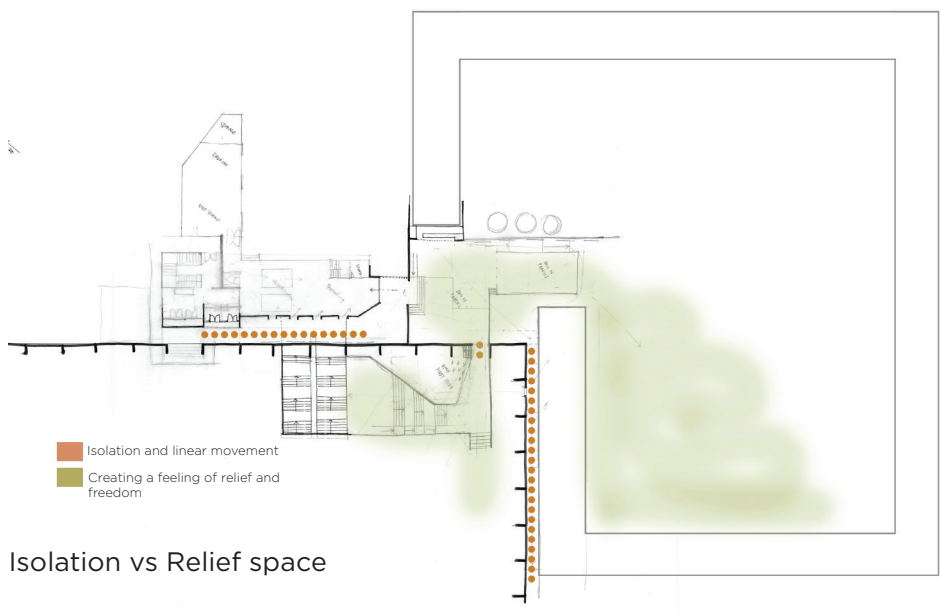

Figure 7.27 Sketchplan (author July 2014)



Movement

Figure 7.28 Diagram indicating movement throughout the site (author 2014)



Isolation vs Relief space

Figure 7.29 Diagram indicating the relationship of isolation and spaces of relief (author 2014)

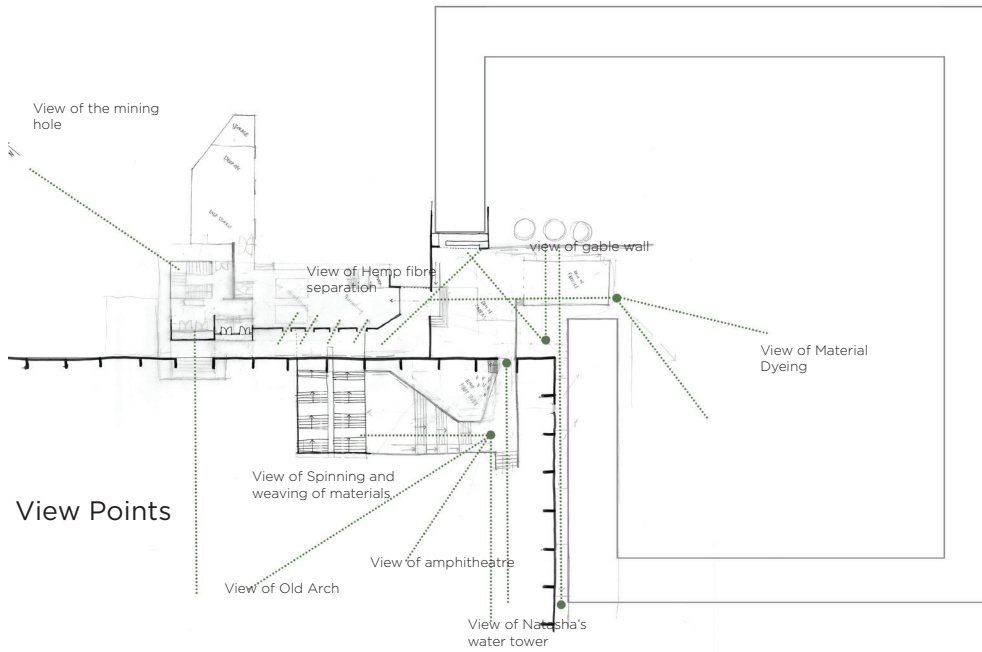

Figure 7.30 Diagram of viewpoints in different areas of the site (author 2014)

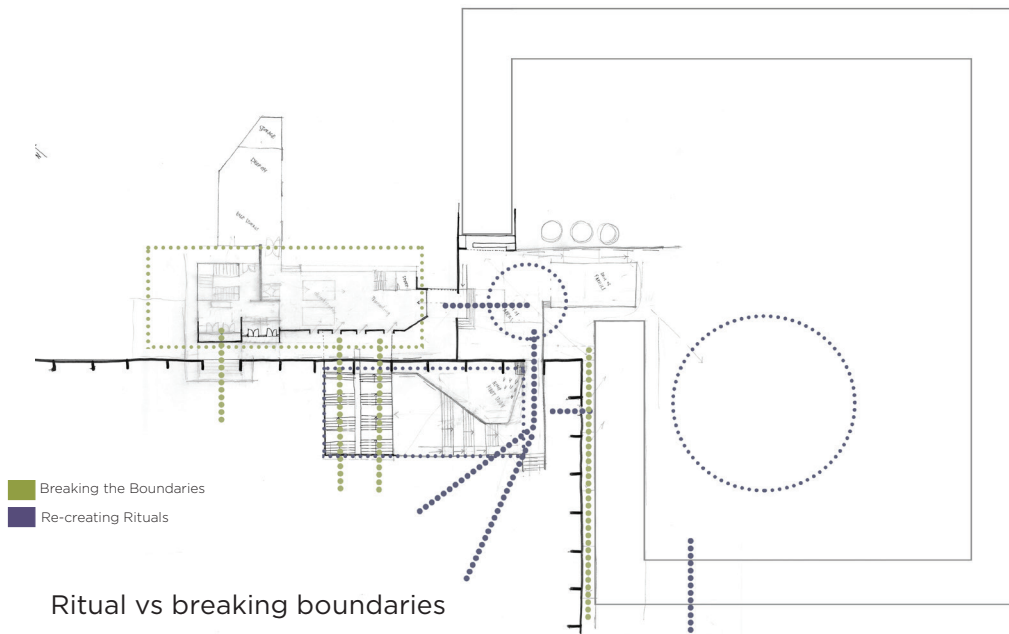

Figure 7.31 Diagram indicating where the building follows historic rituals or breaks from the past (author 2014)

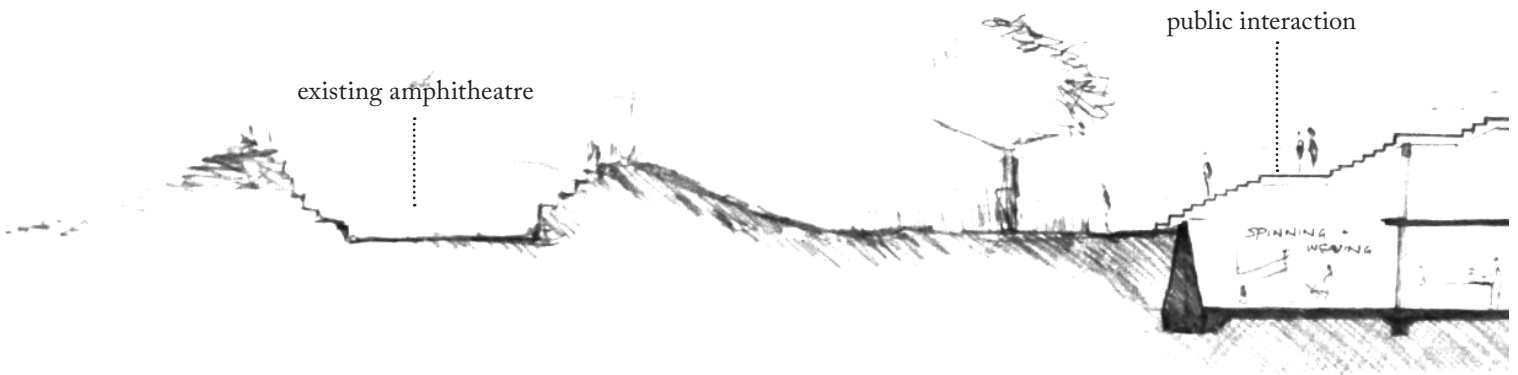

Figure 7.32 A section from west to east displaying how the building cuts into the earth and moves out of the compound into the untouched landscape beyond.

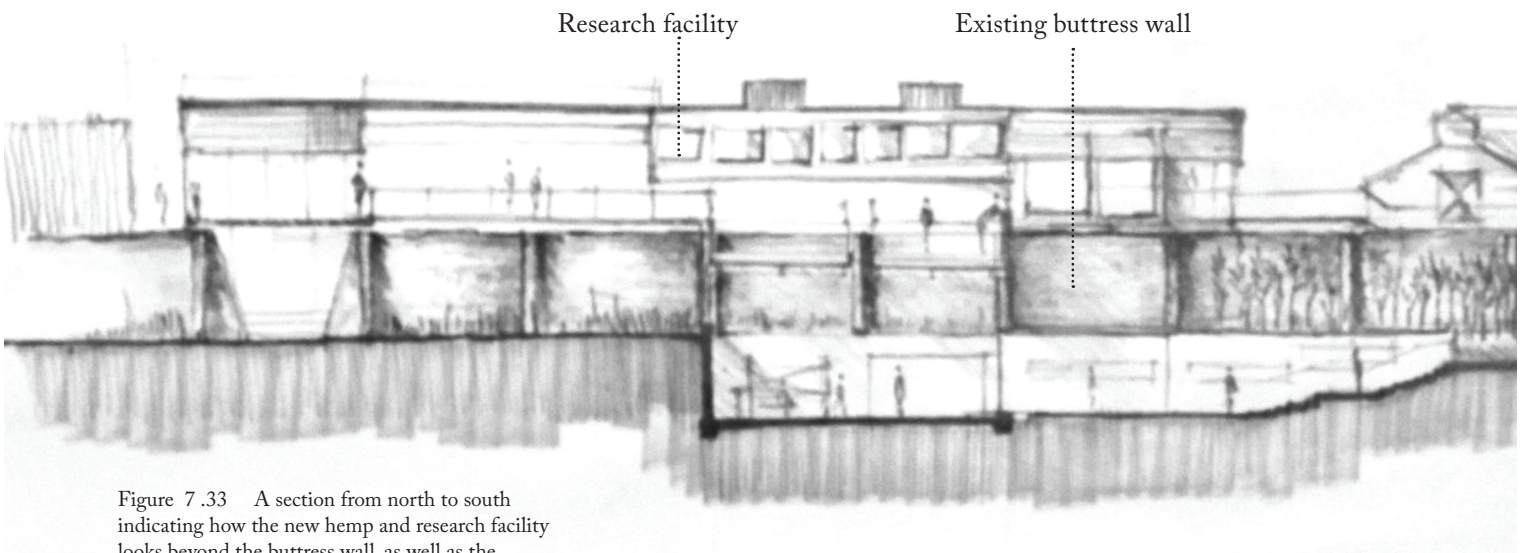
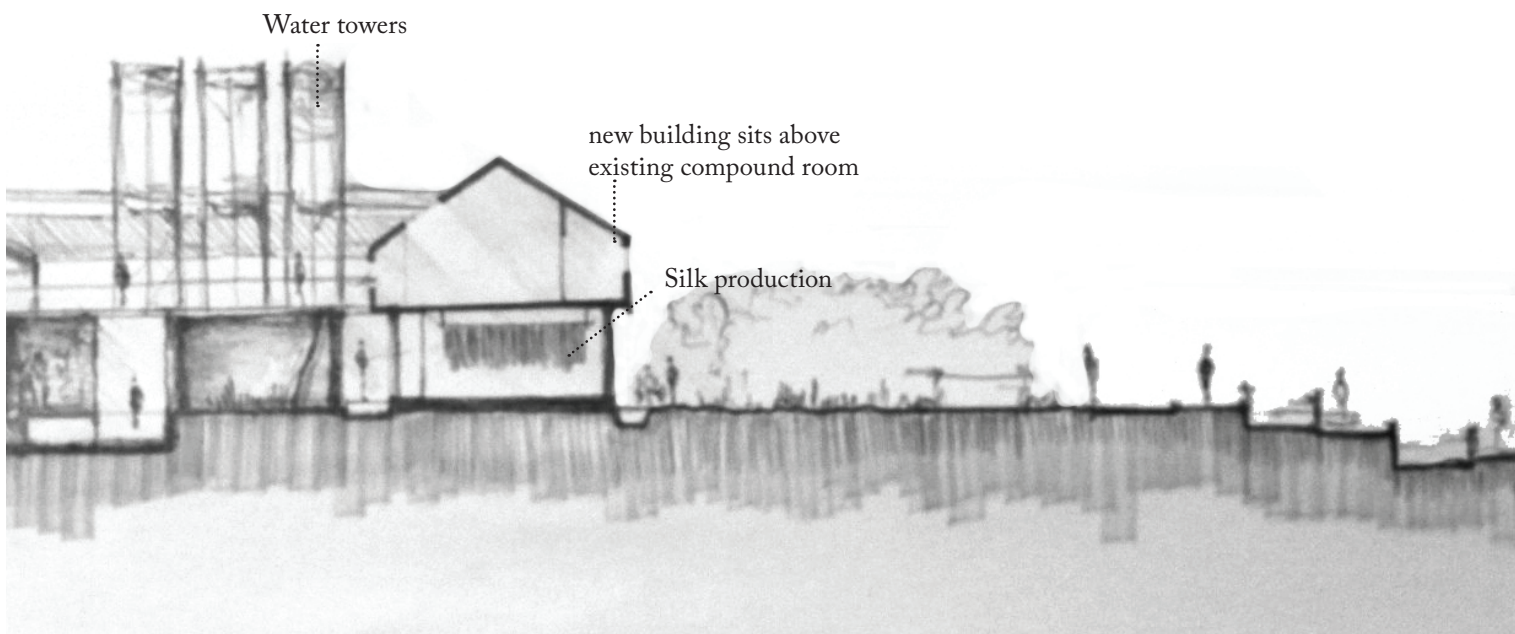
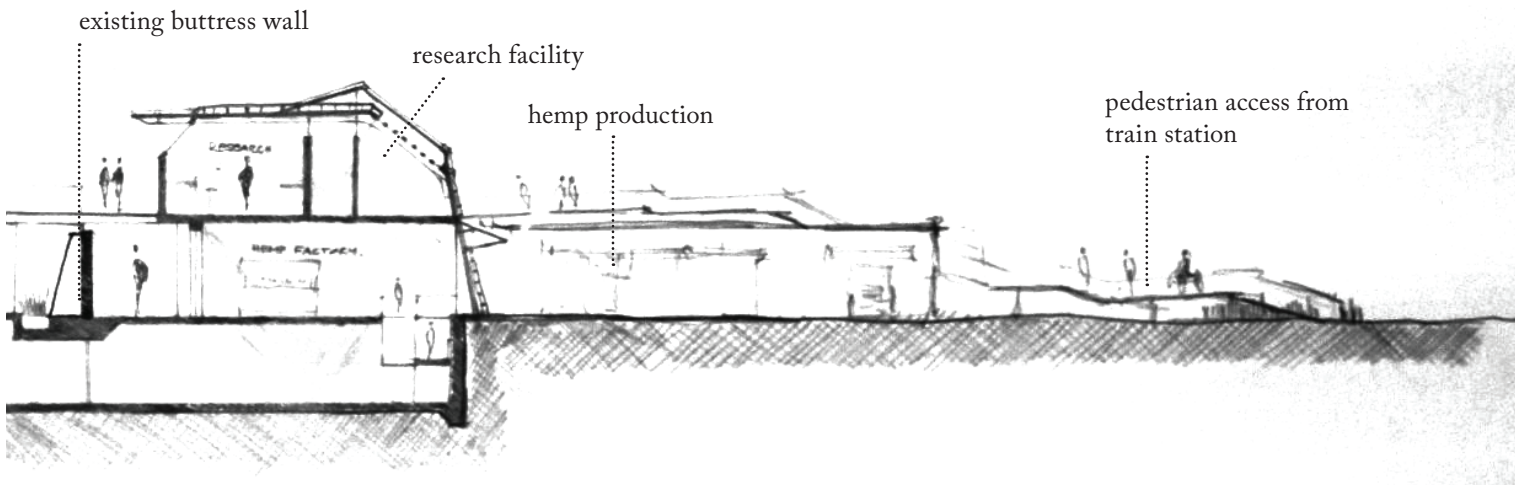

Figure 7.33 A section from north to south indicating how the new hemp and research facility looks beyond the buttress wall, as well as the relationship between the existing architecture and the new production



7.6 ITERATION 5

Iteration 5 starts to finalize the design and the relationship between the existing buttress wall and the new buildings which are situated along the wall. The roof design reflects the line of the buttress and steps back allowing the existing to be emphasized.

At this point in the design, three different buildings have evolved which relate to the conditions in which they are situated. These buildings are then referred to throughout the rest of the book with the symbols 1, 2 and 3. Building 1 houses the Hemp and research facilities; building 2 houses the Silk production and offices and building 3 is where the spinning and weaving of the different materials occurs.

Design changes from Iteration 4 to Iteration 5



Figure 7.34 Diagram indicating the three buildings (author 2014)

1

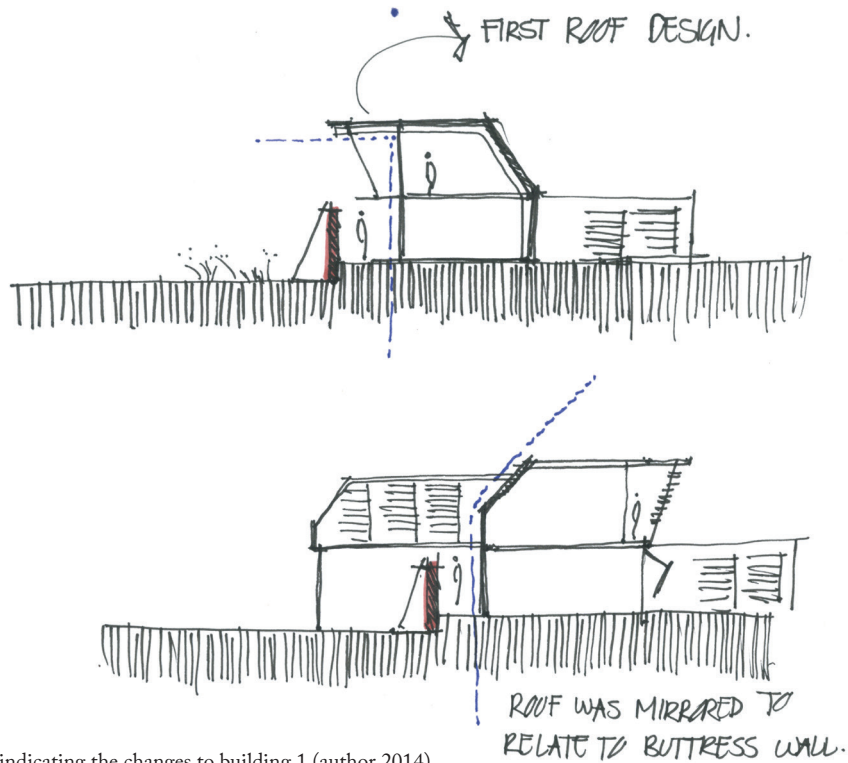

Figure 7.36 Diagrams indicating the changes to building 1 (author 2014)



Figure 7.35 3D image of design in iteration 5 (author 2014)

2

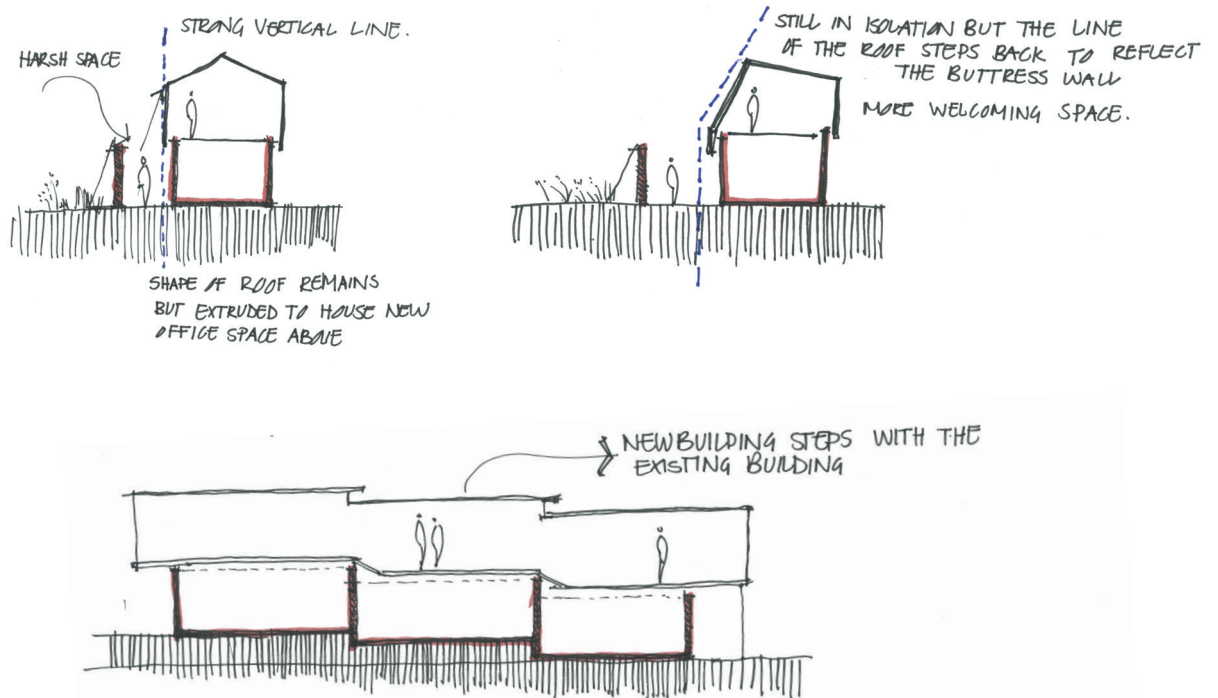
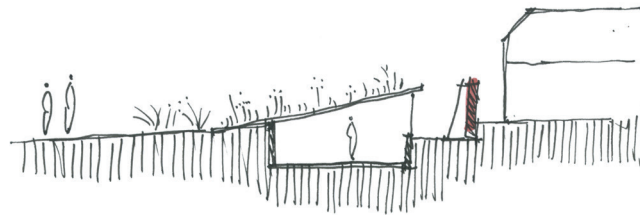

Figure 7.37 Diagrams indicating the changes to building 2 (author 2014)



3



SPINNING & WEAVING ROOM
IS RECESSED INTO THE EARTH TO
KEEP THE CONTINUOUS VISUAL
CONNECTION WITH THE BUTTRESS
WALL.

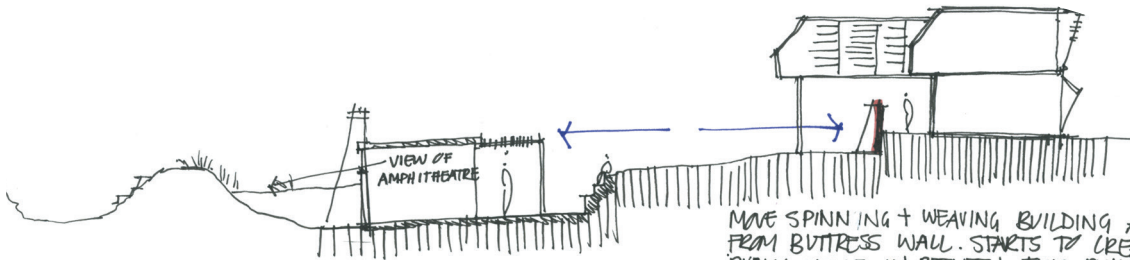

MOVE SPINNING + WEAVING BUILDING AWAY
FROM BUTTRESS WALL. STARTS TO CREATE A
PUBLIC SPACE IN BETWEEN TWO BUILDINGS.
SUNK INTO EARTH TO NOT DETRACT FROM OTHER BUILDINGS.

Figure 7.39 Diagrams indicating the changes to building 3 (author 2014)



Figure 7.40 Weaving area in Iteration 5 (author 2014)



Figure 7.41 Section through weaving room and hemp processing plant (author 2014)

Research Facilities

Hemp Bale Storage

Hemp Plantations



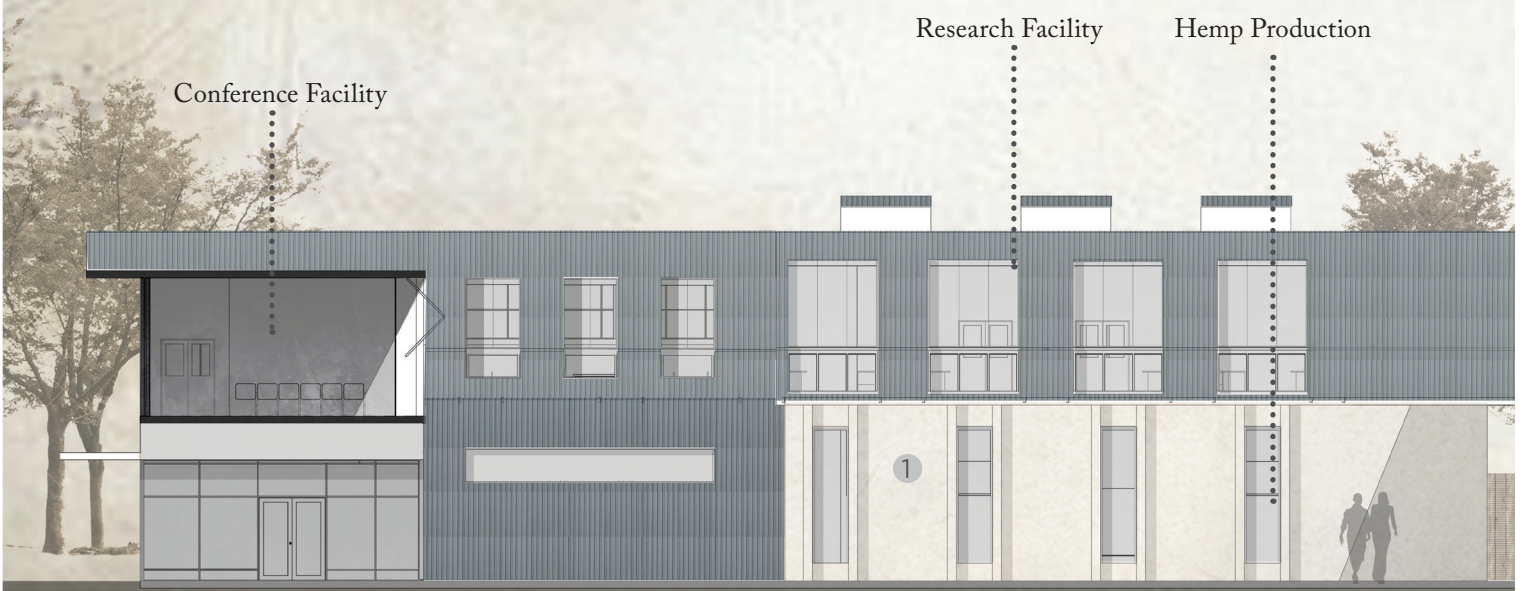
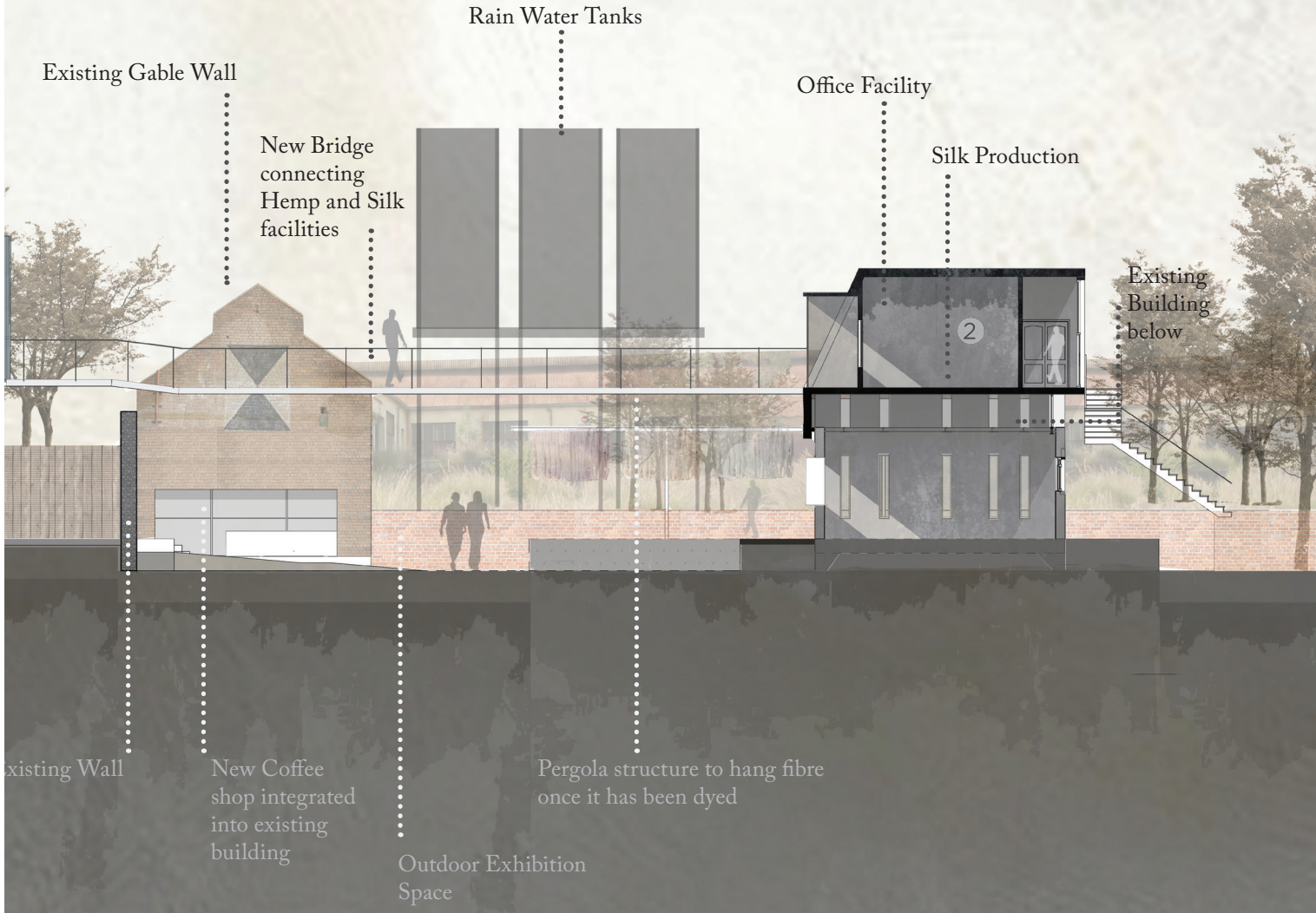

Figure 7.42 Elevation of Hemp and Research building in relation to the existing structures (author 2014)



7.7 MODEL DEVELOPMENT

Models were used throughout the design process as a way to visualize the design and the relationship to the existing buildings.

These models refer to Iteration 3, 4 and 5 of the design process. As evident in the model process the design centres itself around the public space where the existing amphitheatre is situated, and the courtyard space becomes a space for production this idea remains throughout the design.

The new silk production sits within and attaches itself to a portion of the existing compound, where as the hemp facilities are situated on the outskirts of the compound moving out into the landscape as well as connecting itself with the buttress wall which forms the perimeter of the mining compound.

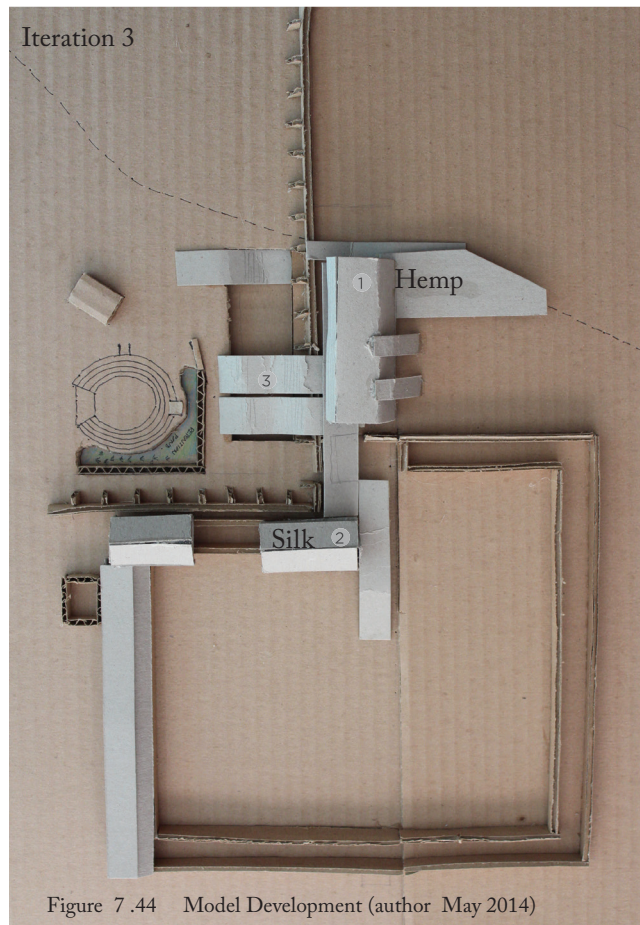

Figure 7.44 Model Development (author May 2014)

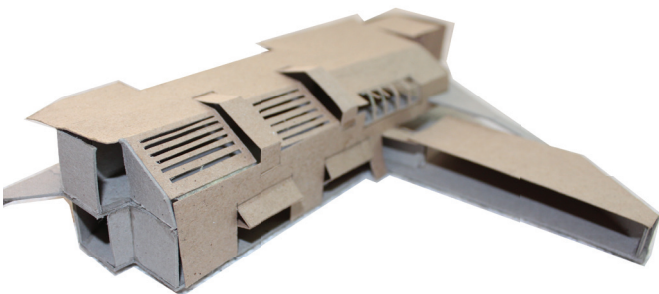
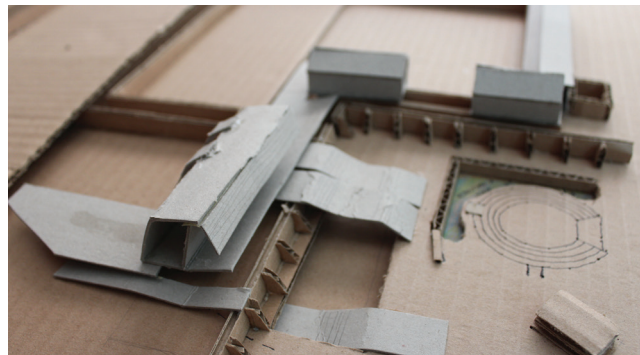

Figure 7.43 Model Development (author 2014)



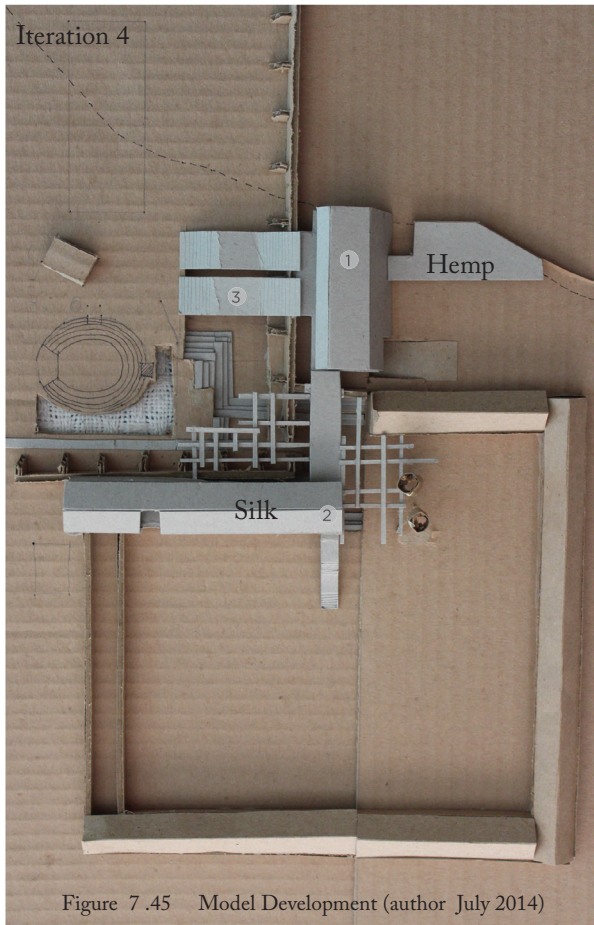

Figure 7.45 Model Development (author July 2014)

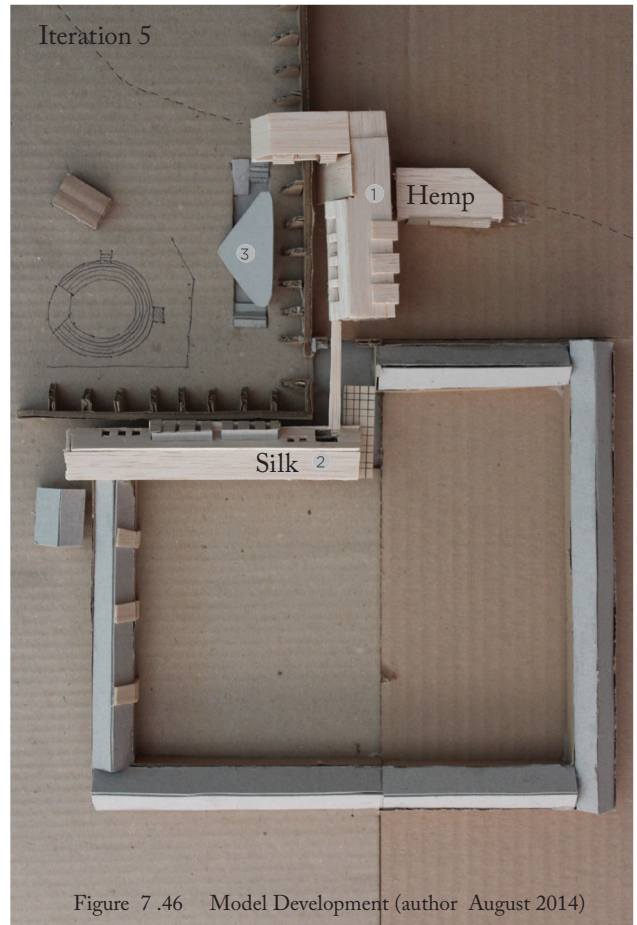
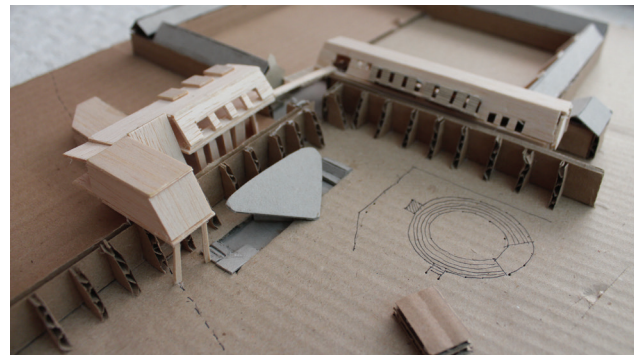
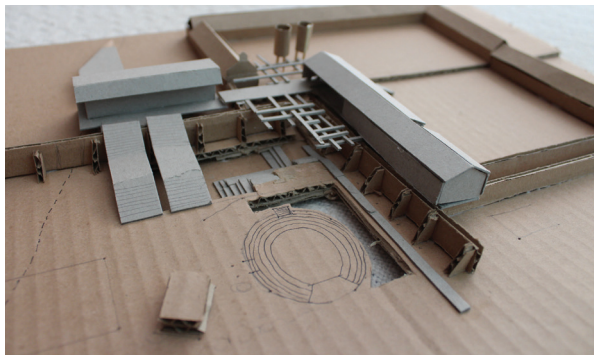

Figure 7.46 Model Development (author August 2014)



7.8 DESIGN EXPLAINED

The design is broken up into 3 buildings, which all have a different relationship with the site.

When entering the site, a visitor is brought through a long narrow corridor between the existing buttress wall and the compound. This corridor is there to create isolation, and linear movement which is a reaction to the historic conditions of the site. Towards the end of the corridor visual links into the new production spaces are introduced until the corridor opens up into a public space, creating a sense of relief. This public space houses the drying fibre once it has been dyed, displaying beautiful colours produced by natural dyes. This is a space where both textile processes come together. It is also an important space historically as it was a control area for the mineworkers before entering the larger compound or the native hospital. This area is then emphasized by recessing it into the ground. The pergola above this area helps to further define this space. Information about the site is displayed in this outdoor exhibition space, and connects to a small indoor museum space within one of the existing compound rooms.

- The new silk facilities are situated within a part of the existing compound with a new simple structure floating above the existing building, creating an additional floor. This design looks at the relationship with the existing building below and how to respect the memory of the building while still creating a new form of architecture. The roofs of the existing compound are in poor condition, and therefore need to be replaced. The compound will be restored to house new facilities such as accommodation for the workers. Only a small segment where the silk production occurs, will the roof be completely altered to house the new offices above. This therefore allows the history of the site to still remain.

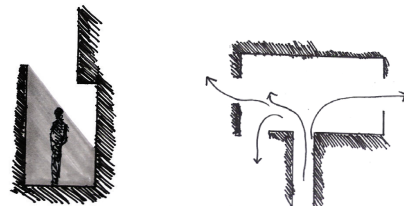

Figure 7.47 Isolation to Relief space

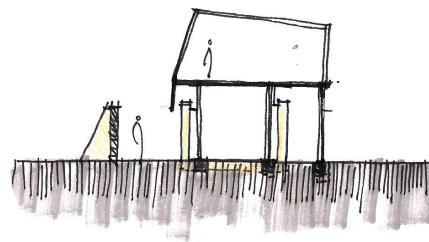
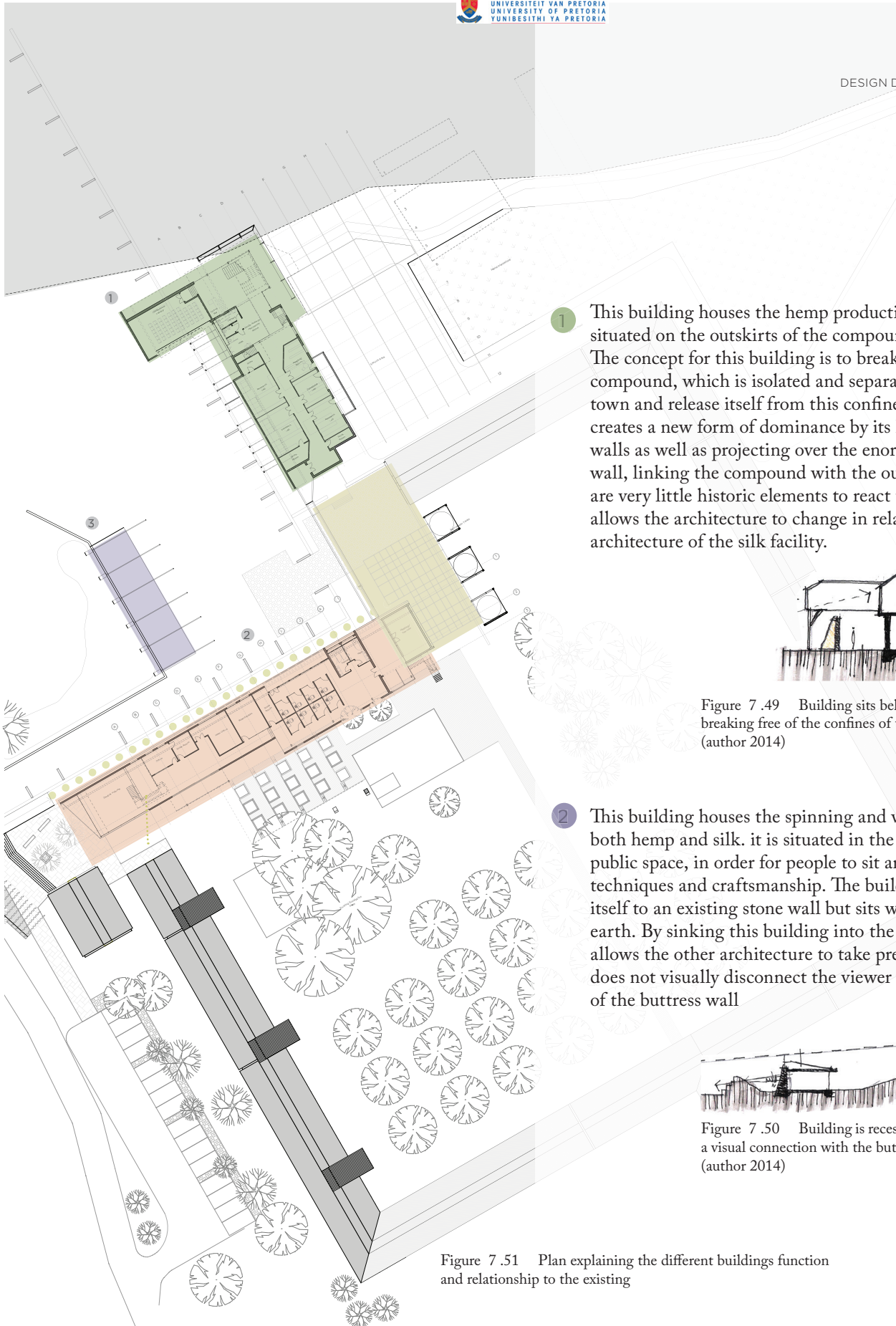

Figure 7.48 New building in relation to existing structure



1 This building houses the hemp production and is situated on the outskirts of the compounds perimeter. The concept for this building is to break out of the compound, which is isolated and separated from the town and release itself from this confined space. It creates a new form of dominance by its heavy hemp walls as well as projecting over the enormous buttress wall, linking the compound with the outside. There are very little historic elements to react to which allows the architecture to change in relation to the architecture of the silk facility.

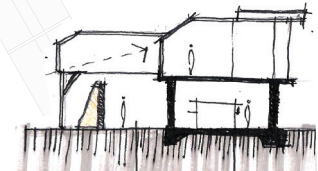

Figure 7.49 Building sits behind buttress wall, breaking free of the confines of the compound (author 2014)

2 This building houses the spinning and weaving for both hemp and silk. it is situated in the heart of the public space, in order for people to sit and enjoy the techniques and craftsmanship. The building attaches itself to an existing stone wall but sits within the earth. By sinking this building into the ground it allows the other architecture to take preference and does not visually disconnect the viewer with the line of the buttress wall



Figure 7.50 Building is recessed to provide a visual connection with the buttress wall (author 2014)

Figure 7.51 Plan explaining the different buildings function and relationship to the existing

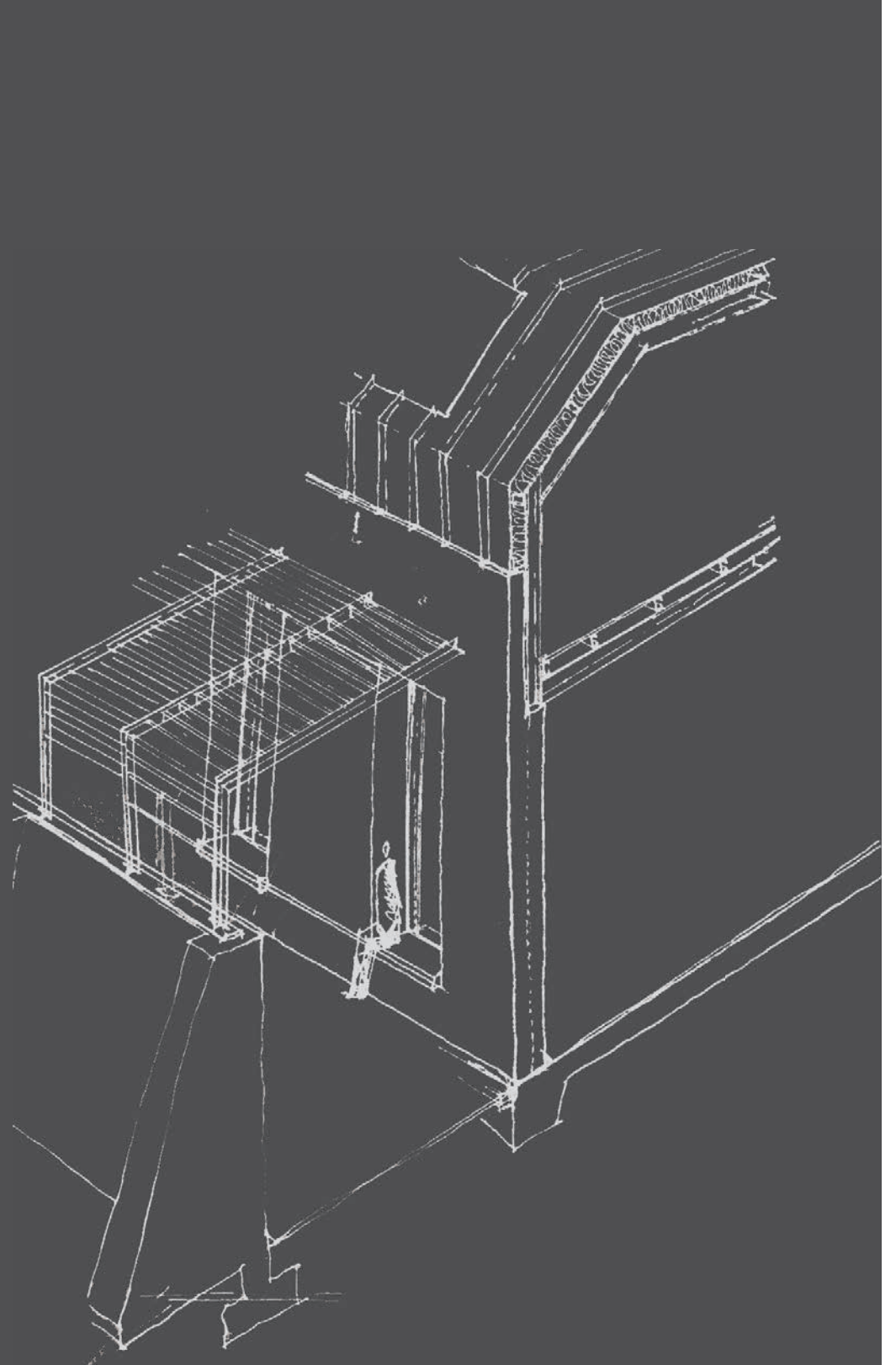

08

TECHNICAL

8. TECHNICAL

This chapter will focus on all the technical aspects of the design as well as materiality and building systems. It is a continuation of the design concept but key technical drivers are highlighted (Figure 8.1) which form the guidelines for how the technical aspects should relate to the existing environment.

8.1 TECHNICAL CONCEPT

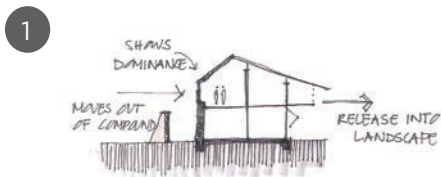
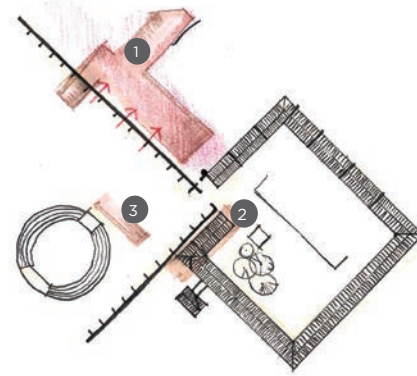

To Release

This building sits on the outskirts of the compound and releases itself from this contained area. The tectonic concept reflects this idea, where the facade closest to the existing buttress wall creates a sense of dominance, that a new form of production has infiltrated these walls in order to revitalize this forgotten site. The building then releases itself towards the uninhabited landscape beyond the compound and in this way its reconnecting the compound with what lies beyond the buttress wall, and towards the town.



To Protect

This building floats over the existing compound rooms, as its protector. It cantilevers over the existing walls to protect it from the elements. The external facade of the existing building shows the true beauty of the site and its architectural significance, therefore the structure sits within the building, in order to not detract from this facade.

The new structure touches the earth lightly as to not overwhelm the areas where reconnecting with the history of the site is most important.

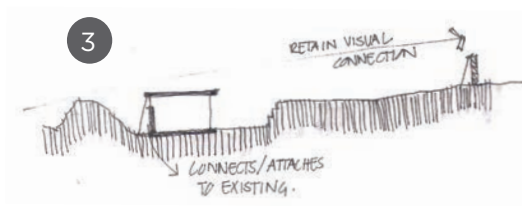

To Attach

The 3rd building attaches itself to an existing stone wall which is recessed into the ground, by having this building at a lower level, we retain a constant view of the existing buttress wall, which wraps around this part of the site.

The materials are much heavy, to create the feeling of the building becoming one with the earth. It disappears into its surrounding.

Figure 8.1 Diagrams explaining technical concept (author 2014)

8.2 MATERIALITY

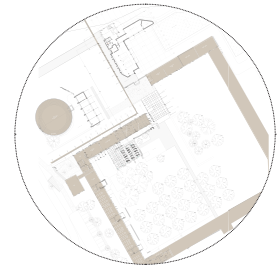

Existing Fabric

The existing fabric consists of natural stone, brick, concrete and remains of old steel structures. This fabric displays a stereotomic type of architecture which dominates in the landscape. These materials are in contrast to the existing mining fabric which mainly consists of steel elements.



New Fabric

The New Fabric contrasts with the existing materials, using steel construction where the areas have a high cultural significance. Hempcrete and Hemp insulation are used throughout the new design, this hemp is grown on site which reduces transportation of materials and is extremely sustainable. Reclaimed steel from the Premier mine is used for the pergolas where little structural strength is required.

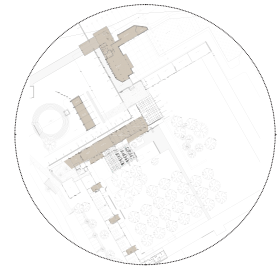
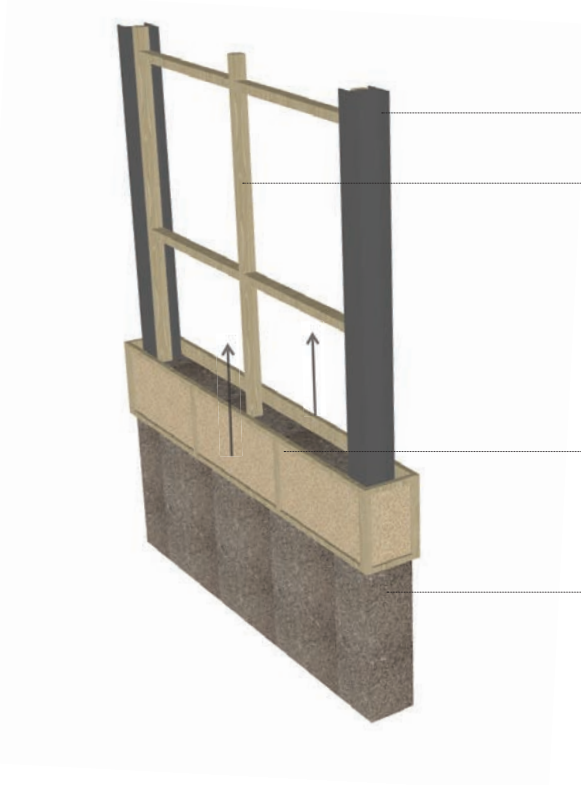

Figure 8.2 Material Palette

HEMP CONSTRUCTION METHOD



254x254mm hot rolled steel column to engineers specifications

38x75mm untreated timber frame to support hemp construction.

Timber sliding shuttering

400mm insitu hemp wall, finished with 2 layers of lime plaster after 2 months of construction



8.3 WATER MANAGEMENT

Wet Core system to service toilets and urinals
Rainwater used for these services

Roof Run off towards Northern facade
Water is collected for irrigation and grey water usage

Rainwater is collected and stored before being pumped into rainwater tanks

3 Rainwater tanks
Water to be used for irrigation and grey water

Roof Run off towards Southern facade
Water is collected for irrigation and grey water usage

Rainwater is collected and stored before being pumped into rainwater tanks

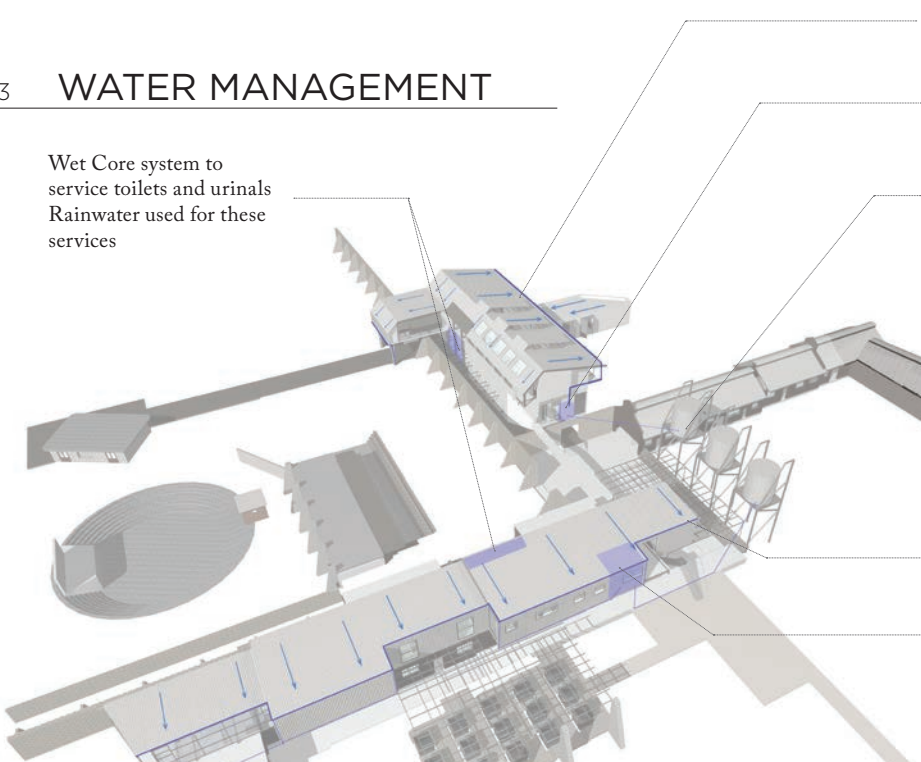

Figure 8.3 Diagram indicating water runoff and rainwater collection (author 2014)

8.4 SERVICES

Wet Service Duct

Electrical service duct

Duct for extraction fan in Hemp processing room

Suspended ceiling services the ground and first floor with electricity connections and data, as well as provides space for ducts connected to extraction fan.

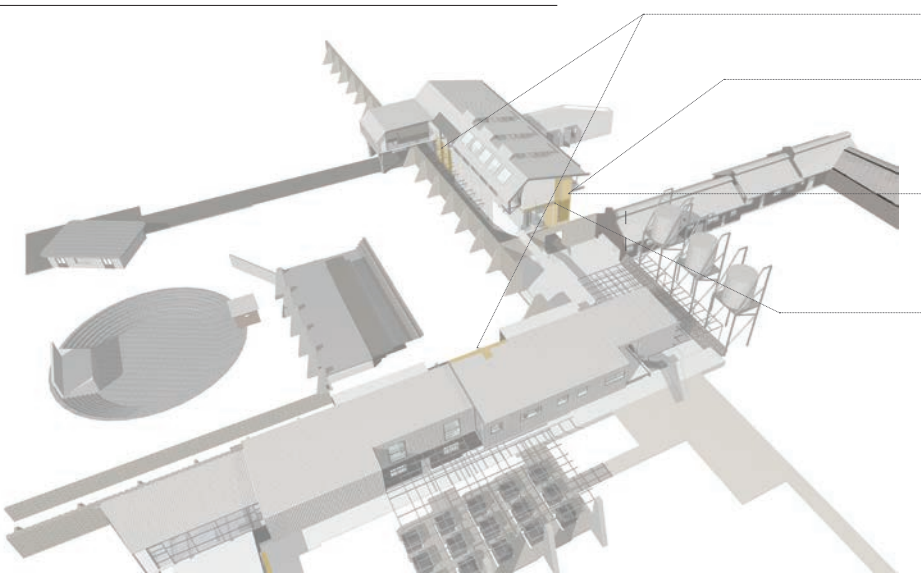

Figure 8.4 Diagram indicating where the service areas are located in the building (author 2014)

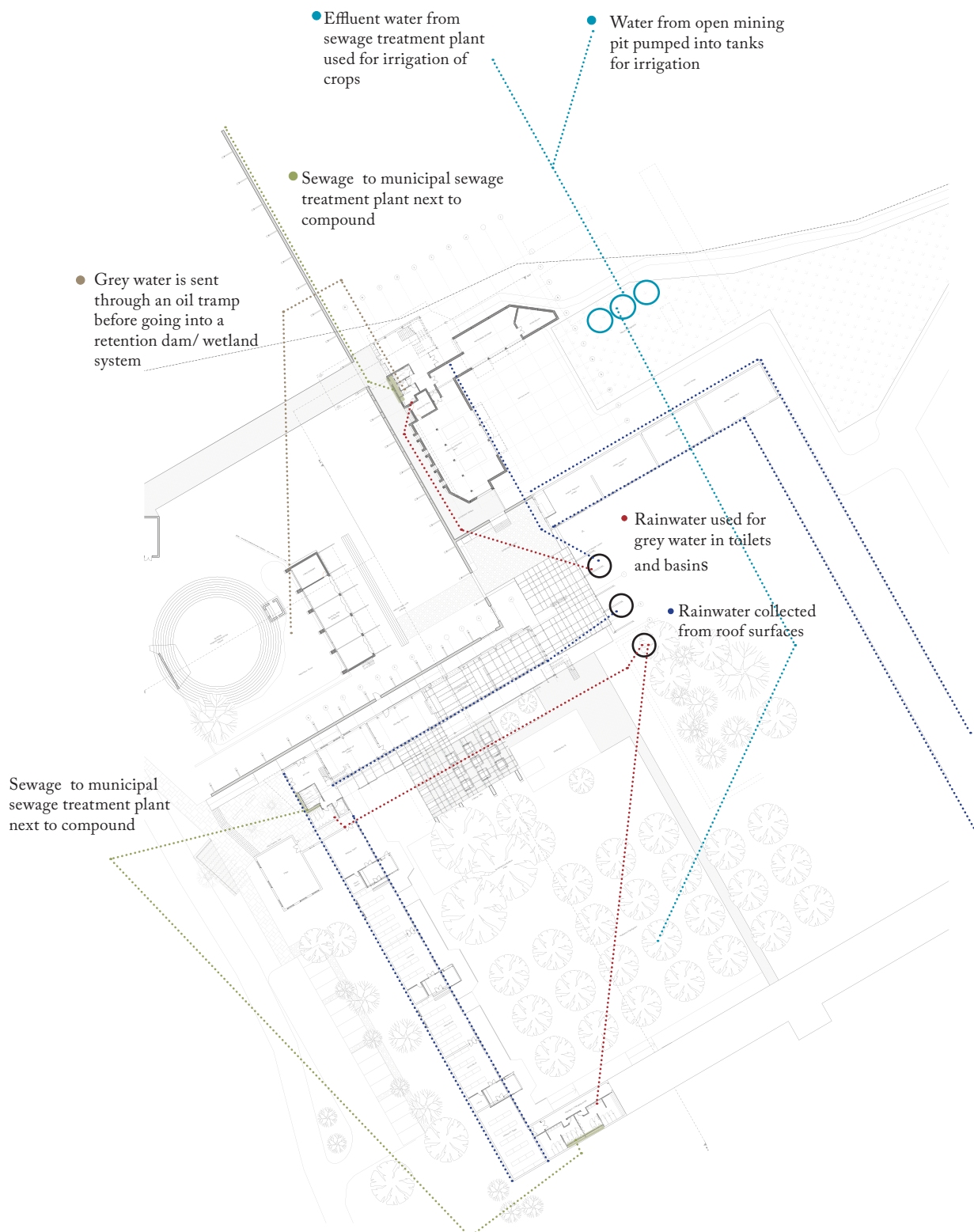
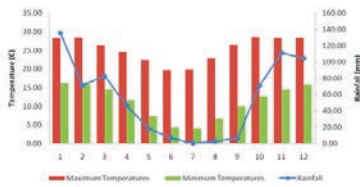

Figure 8.5 Plan of service connections and water management (author 2014)

8.5 RAINWATER CALCULATIONS

Average rainfall per month in Cullinan

Month	(mm)	(m)
January	136	0,136
February	72	0,072
March	80	0,08
April	50	0,05
May	20	0,02
June	10	0,01
July	0	0
August	2	0,002
September	5	0,005
October	70	0,07
November	110	0,11
December	105	0,105



Monthly rainwater yield from roof catchment

Months	Average Monthly Precipitation (P)	Area of Catchment (A)	Co-Efficient (C)	Yield (m3) PxAxC
January	0,136	1113	0,9	136,2
February	0,072	1113	0,9	72,1
March	0,08	1113	0,9	80,1
April	0,05	1113	0,9	50,1
May	0,02	1113	0,9	20,0
June	0,01	1113	0,9	10,0
July	0	1113	0,9	0,0
August	0,002	1113	0,9	2,0
September	0,005	1113	0,9	5,0
October	0,07	1113	0,9	70,1
November	0,11	1113	0,9	110,2
December	0,105	1113	0,9	105,2
Total Annual	0,66			661,1
Average Month	0,055			55,1

Calculated water demand for site

Sanitary	Quantity	Approximate Water usage per application (l)
Water Closet	26	4
Wash Hand Basin	34	1
Urinals	16	1
Shower	6	20

Application	Water Usage per Application (l)	Amount of Usage per month	Description	Total water usage (l)
Visitor's on Site 40 ppl per day	Water Closet	4	Working on an average of 1 usage per person per day	3520
	Wash Hand basin	1	Working on an average of 1 usage per person per day	880
Sub-Total				4400

Application	Water Usage per Application (l)	Amount of Usage per month	Description	Total water usage (l)
Researchers 50 ppl	Water Closet	4	Working on an average of 2 usage per person per day	5280
	Wash Hand basin	1	Working on an average of 2 usage per person per day	1320
Sub-Total				6600

Application	Water Usage per Application (l)	Amount of Usage per month	Description	Total water usage (l)
Workers 60 ppl	Water Closet	4	Working on an average of 2 usage per person per day	10560
	Wash Hand basin	1	Working on an average of 2 usage per person per day	2640
	Shower	20	Working on an average of 1 usage per person per day	26400
Sub-Total				39600

Total Indoor Demand (l) per month				50600
Average Water usage per day			Working on a average month of 30 days	1686,7

Irrigation demand for agricultural area of 8ha

This demand will be met by using the effluent from sewage treatment plant or from water pumped out of the mining hole.

Irrigation Demand for agricultural area of 8ha

Months	Planting Area (m2)	Irr Depth/ week (m)	Irr Depth/ Month (m)	Irrigation Demand (m3)
January	80000	0,04	0,16	12800
February	80000	0,04	0,16	12800
March	80000	0,04	0,16	12800
April	80000	0,03	0,12	9600
May	80000	0,02	0,08	6400
June	80000	0,02	0,08	6400
July	80000	0,02	0,08	6400
August	80000	0,02	0,08	6400
September	80000	0,03	0,12	9600
October	80000	0,04	0,16	12800
November	80000	0,04	0,16	12800
December	80000	0,04	0,16	12800
Total Annual				121600
Average Month				10133,3333

Volume of water in reservoir monthly

Month	Yield (m3) Yield= PxAxC	Total water demand (m3)	Monthly Balance	Volume of water in Reservoir (m3)
January	136,2	50,6	85,6	171,2
February	72,1	50,6	21,5	192,7
March	80,1	50,6	29,5	222,2
April	50,1	50,6	-0,5	221,7
May	20,0	50,6	-30,6	191,1
June	10,0	50,6	-40,6	150,5
July	0,0	50,6	-50,6	99,9
August	2,0	50,6	-48,6	51,3
September	5,0	50,6	-45,6	5,7
October	70,1	50,6	19,5	25,2
November	110,2	50,6	59,6	84,8
December	105,2	50,6	54,6	139,4
Annual Average	55,1	50,6		

From Table we can see that the Greatest water volume in the Reservoir is during the March month with 222,2kl

Safety Capacity 222,2 x2,5= 555,5KL

555,5m3

8.6 THERMAL COMFORT AND NATURAL VENTILATION

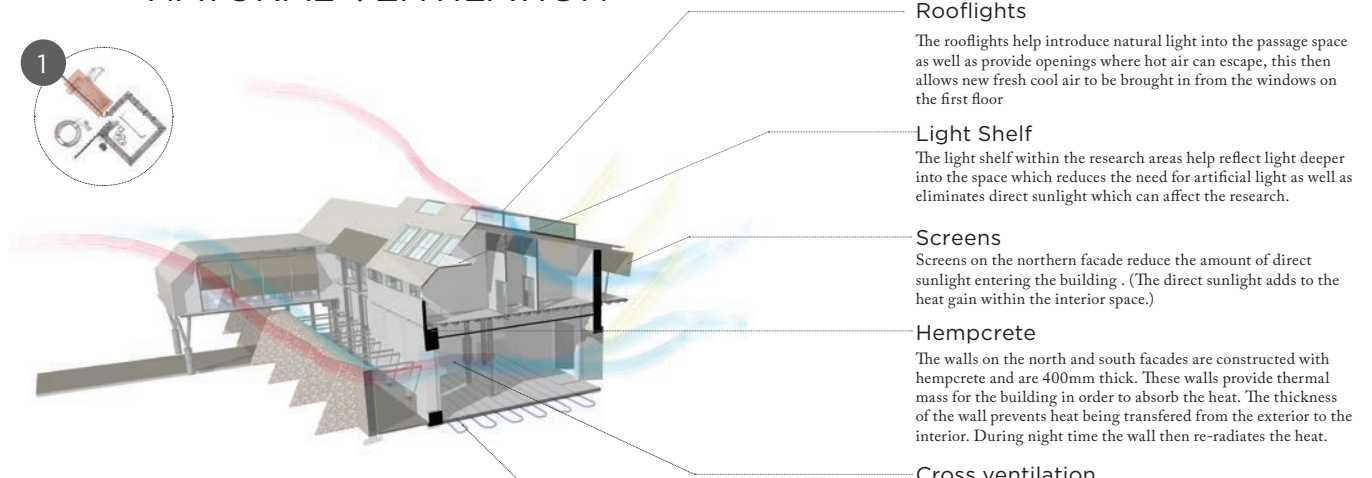
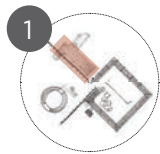

Figure 8.6 Thermal comfort for building 1 in summer (author 2014) (North-Easterly wind)

Rooflights

The rooflights help introduce natural light into the passage space as well as provide openings where hot air can escape, this then allows new fresh cool air to be brought in from the windows on the first floor

Light Shelf

The light shelf within the research areas help reflect light deeper into the space which reduces the need for artificial light as well as eliminates direct sunlight which can affect the research.

Screens

Screens on the northern facade reduce the amount of direct sunlight entering the building. (The direct sunlight adds to the heat gain within the interior space.)

Hempcrete

The walls on the north and south facades are constructed with hempcrete and are 400mm thick. These walls provide thermal mass for the building in order to absorb the heat. The thickness of the wall prevents heat being transferred from the exterior to the interior. During night time the wall then re-radiates the heat.

Cross ventilation

On the ground floor, where the Hemp processing plant is situated, a combination of natural ventilation and mechanical ventilation is required. Large doors on the northern side allow for fresh air to move through the space, where openings on the southern facade allow for hot air to be removed. Ducts are placed directly above hemp machines to extract hot air that often contains tiny hemp fibres.

Geothermal Pipes

Geothermal pipes are laid 1m underneath the concrete surface bed. These pipes provide passive heating and cooling within the building. The temperature within the soil bed is kept at a moderate temperature. The air that passes through these pipes heats or cools to match the temperature of the soil before entering the building. This air entering the building will be at a temperature that is comfortable for the interior environment.

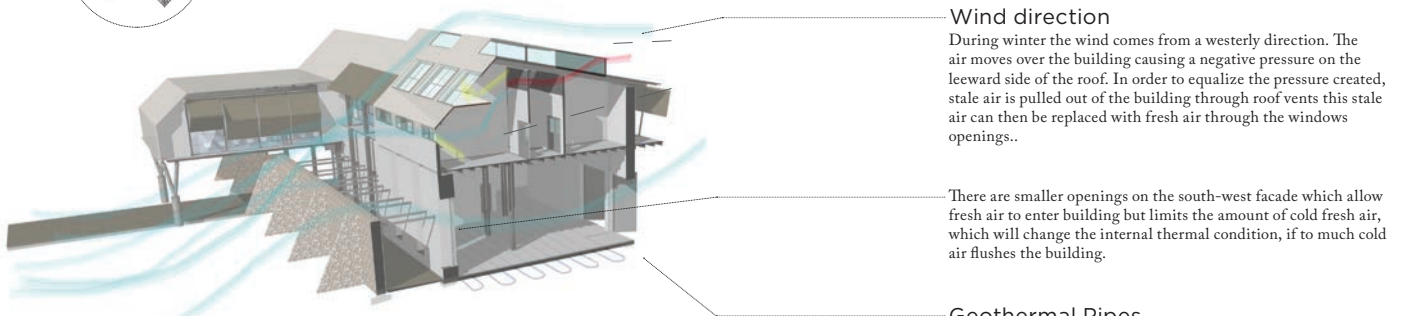
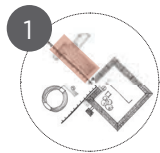

Figure 8.7 Thermal comfort for building 1 in Winter (author 2014) (Westerly wind)

Wind direction

During winter the wind comes from a westerly direction. The air moves over the building causing a negative pressure on the leeward side of the roof. In order to equalize the pressure created, stale air is pulled out of the building through roof vents this stale air can then be replaced with fresh air through the windows openings..

There are smaller openings on the south-west facade which allow fresh air to enter building but limits the amount of cold fresh air, which will change the internal thermal condition, if to much cold air flushes the building.

Geothermal Pipes

Geothermal pipes are used to regulate the internal temperature through passive cooling and heating. In winter the temperature within the soil is higher than the temperature in the air, this then means by moving air through these pipes under the concrete slab the air can heat to a comfortable temperature before entering the building.

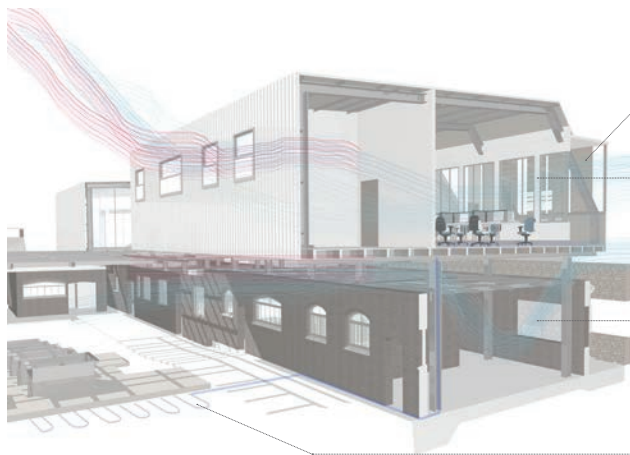
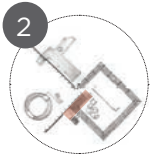

Screens

Screens on the northern facade reduce the amount of direct sunlight entering the building. (The direct sunlight adds to the heat gain within the interior space.)

Cross ventilation

Fresh air moves through large windows on the northern facade this air then heats as it moves through the space and then exits through windows on the southern facade.

By creating a building that is long and narrow, it allows for easy movement of air from the north to the south facade.

Air movement

The new building floats above the existing structure, where there is no glass enclosing the existing rooms below, this then means air can move freely into that space which facilitates in the drying of the fibres hung in those spaces.

Geothermal Pipes

The new building is inserted above an existing structure, therefore the geothermal pipes are then laid next to the build, as to not disturb the existing foundations.

These pipes provide passive heating and cooling within the building. The temperature within the soil bed is kept at a moderate temperature. The air that passes through these pipes heats or cools to match the temperature of the soil before entering the building. This air entering the building will be at a temperature that is comfortable for the interior environment.

Figure 8.8 Thermal comfort for building 2 in Summer (author 2014) (North-Easterly wind)



Figure 8.9 Exploration diagrams of wind movement and thermal comfort (author 2014)

8.7 STRUCTURE

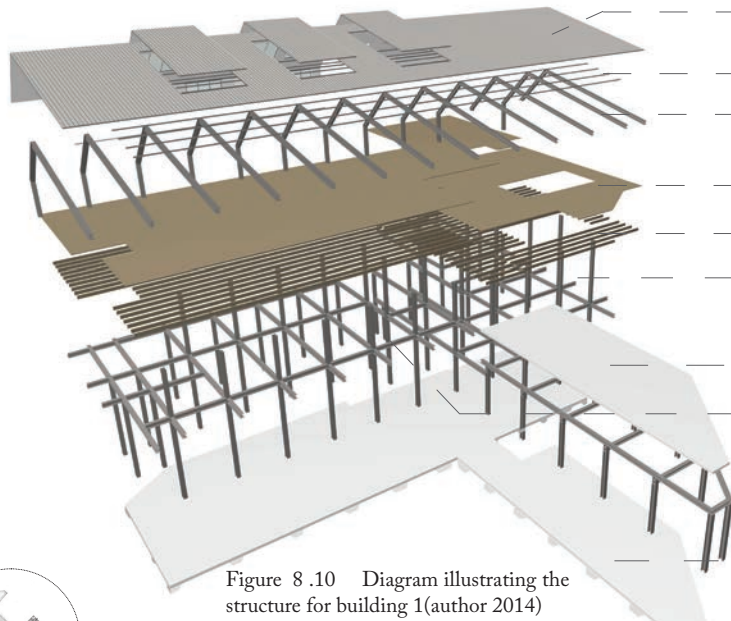
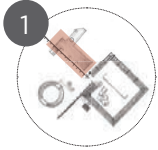

Figure 8.10 Diagram illustrating the structure for building 1(author 2014)

Kliplok sheeting

Galvanized steel sheeting with a dove grey chromodek finish.
Manufacturer: Corr-line Steel and Roof
Ribs 200mm centres

Tertiary Steel structure

75x 50mm Steel purlins fixed to I beam to hold Roof sheeting
Hemp insulation 75mm will be laid between purlins

Secondary Steel structure

254x 254mm Steel I-beams to engineers specifications

Reclaimed wood flooring

22x140mm hardwood flooring

Timber floor joists

75x225mm hardwood timber floor joists
Timber joists sit within I-beam

Primary steel structure

254x254 Steel Columns placed on a 3500mmx 4000mm grid

Infill

Hemperete is used as infill between structural columns with timber framework.
400mm thick walls with lime screed finish
The hemperete walls add to the thermal mass of the building

Concrete roof

Concrete roof with screed laid to fall, waterproofing and 60mm gravel
Concealed downpipes

Secondary Steel structure

305x 165mm I-beams fixed to steel columns

Raft foundation

Concrete Raft foundation used due to unstable soil conditions near the existing mine.
Fly Ash used within concrete to reduce cement mixture.

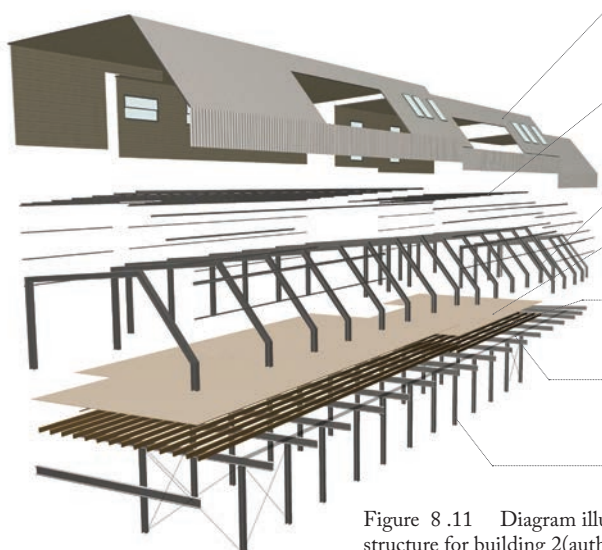
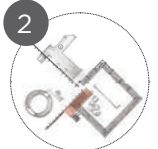

Figure 8.11 Diagram illustrating the structure for building 2(author 2014)

Kliplok sheeting

Galvanized steel sheeting with a dove grey chromodek finish.
Manufacturer: Corr-line Steel and Roof
Ribs 200mm centres

Tertiary Steel structure

75x 50mm Steel purlins fixed to I beam to hold Roof sheeting
Hemp insulation 75mm will be laid between purlins

Secondary Steel structure

254x 254mm Steel I-beams to engineers specifications

Reclaimed wood flooring

22x140mm hardwood flooring

Timber floor joists

75x225mm hardwood timber floor joists
Timber joists sit within I-beam

Secondary Steel structure

406x178mm steel I-beam to engineers specifications
(Size of beam due to cantilever on both sides of steel columns)

Primary steel structure

254x254 Steel Columns placed on a 3500mmx 6000mm grid on new concrete pad, cutting through existing foundations and floor.

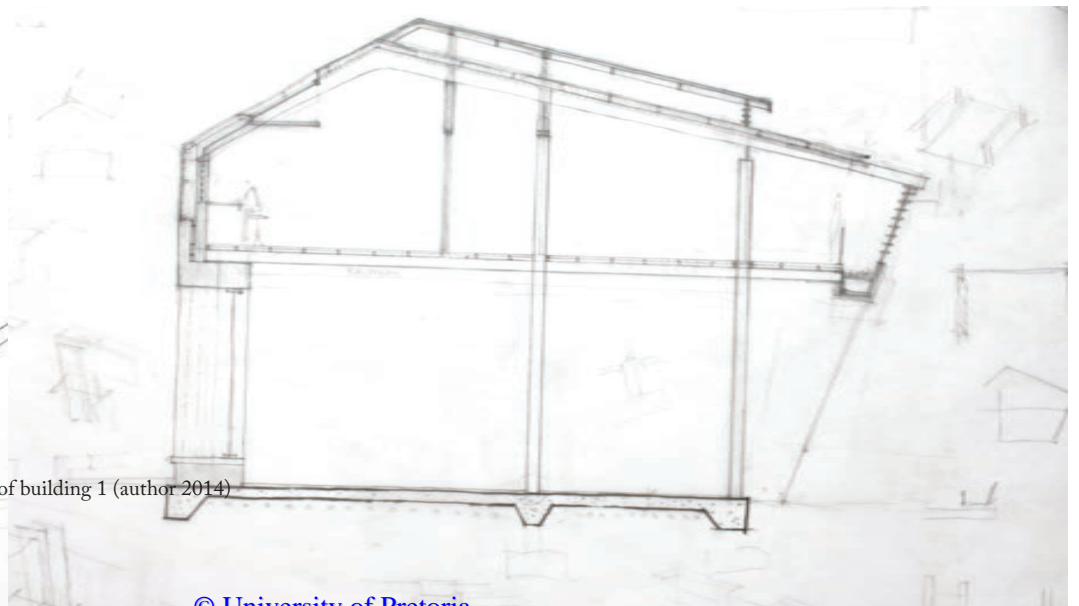
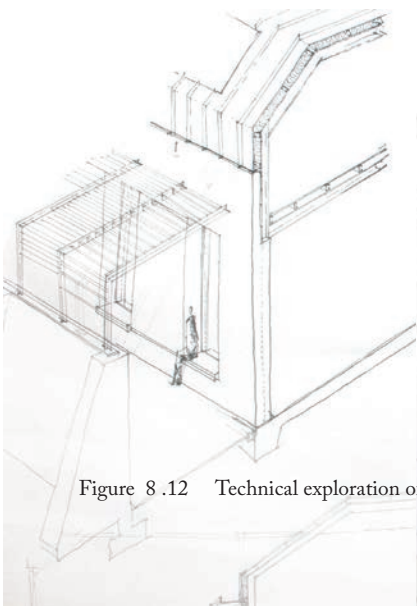
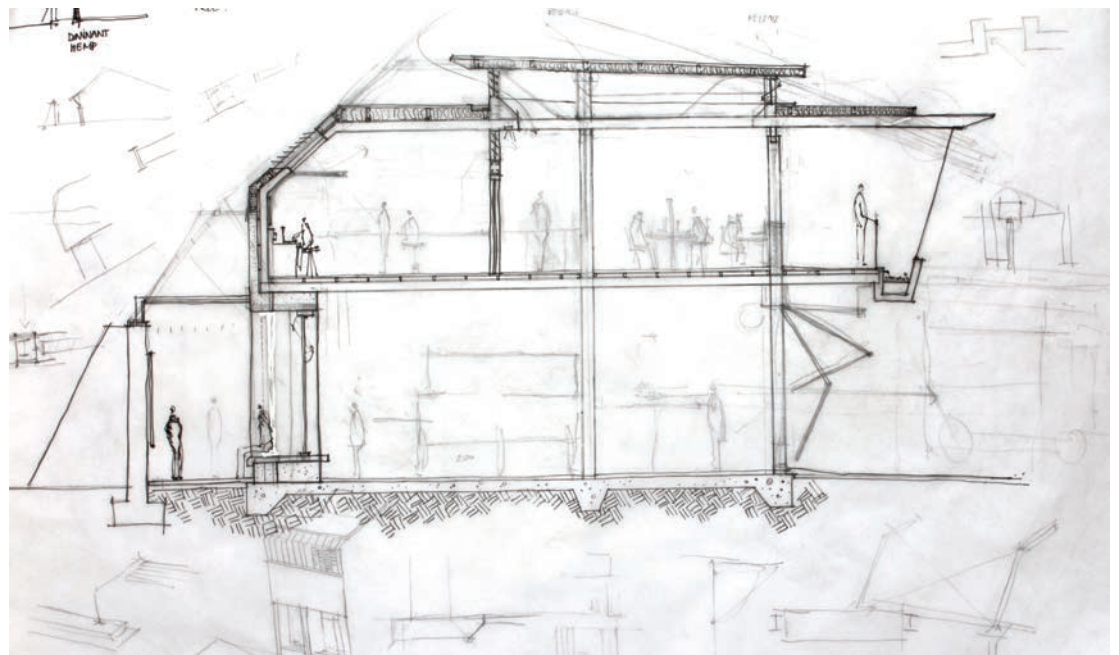
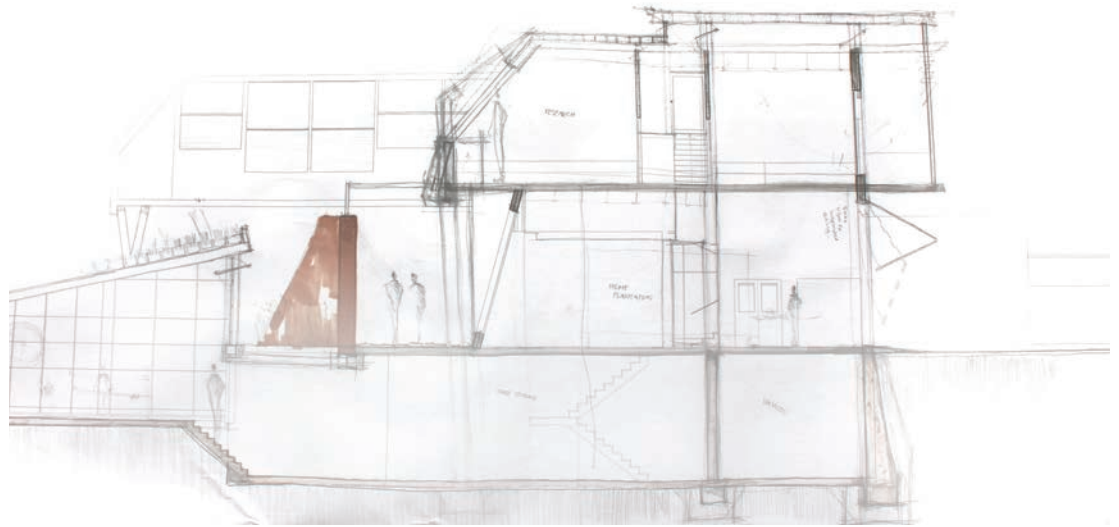
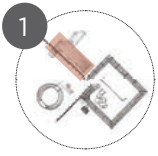

Figure 8.12 Technical exploration of building 1 (author 2014)

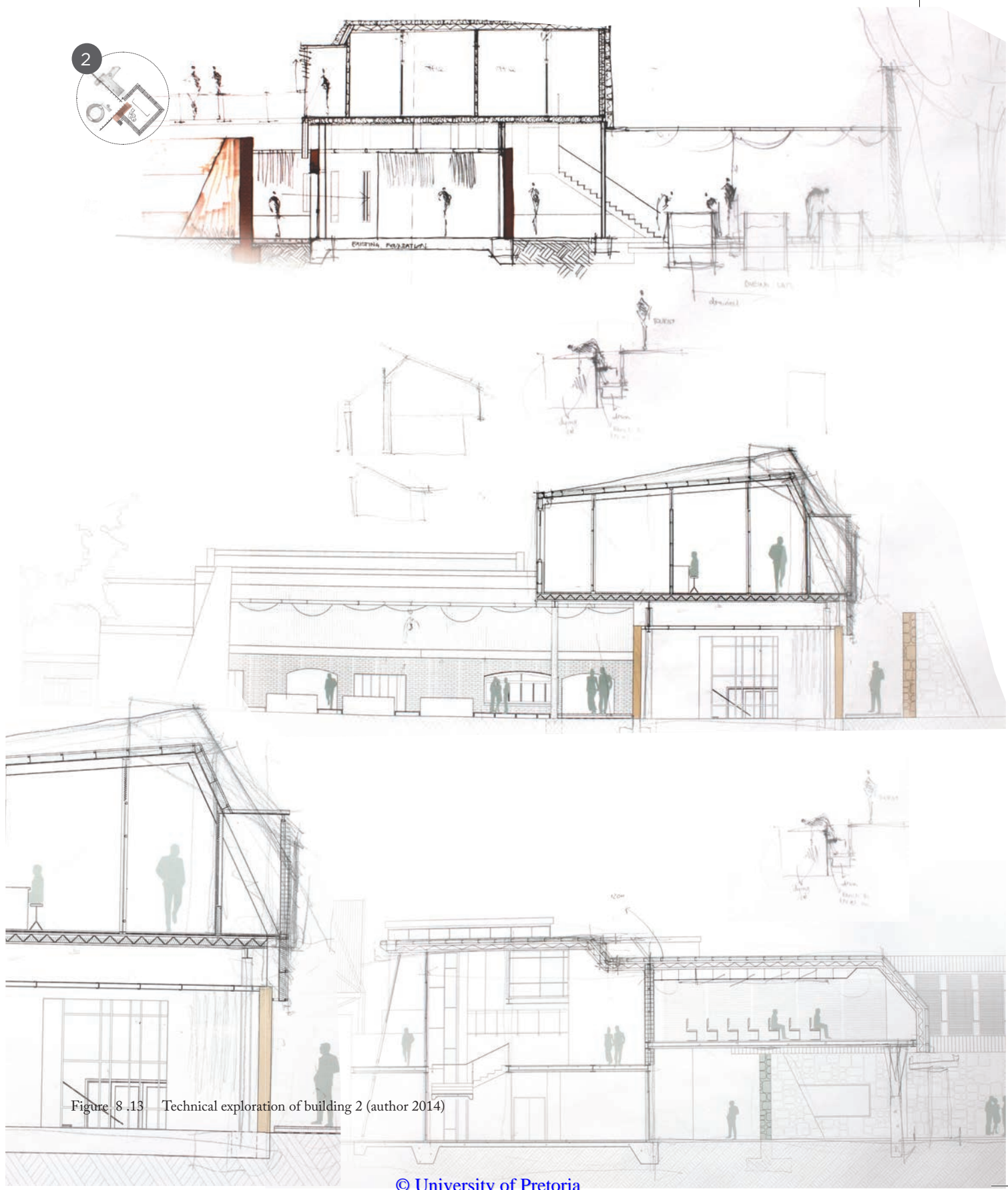
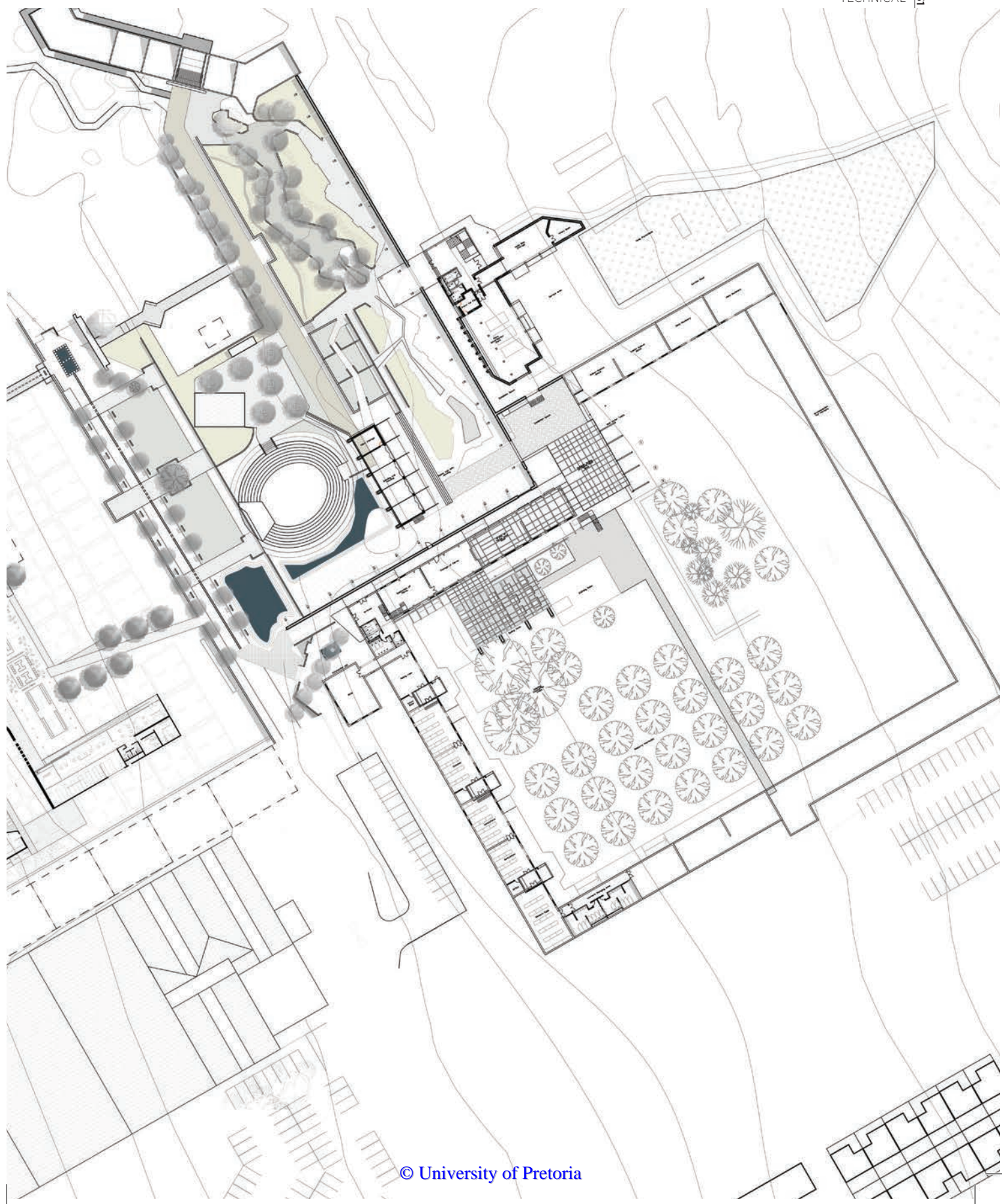

Figure 8.13 Technical exploration of building 2 (author 2014)

8.8 PLANS



Figure 8.14 Site Plan indicating the landscaping within No2 Shaft Compound (Hugo van Niekerk)





Ground Floor Plan
1:200

Figure 8.15 Site plan indicating entire courtyard (Author 2014)

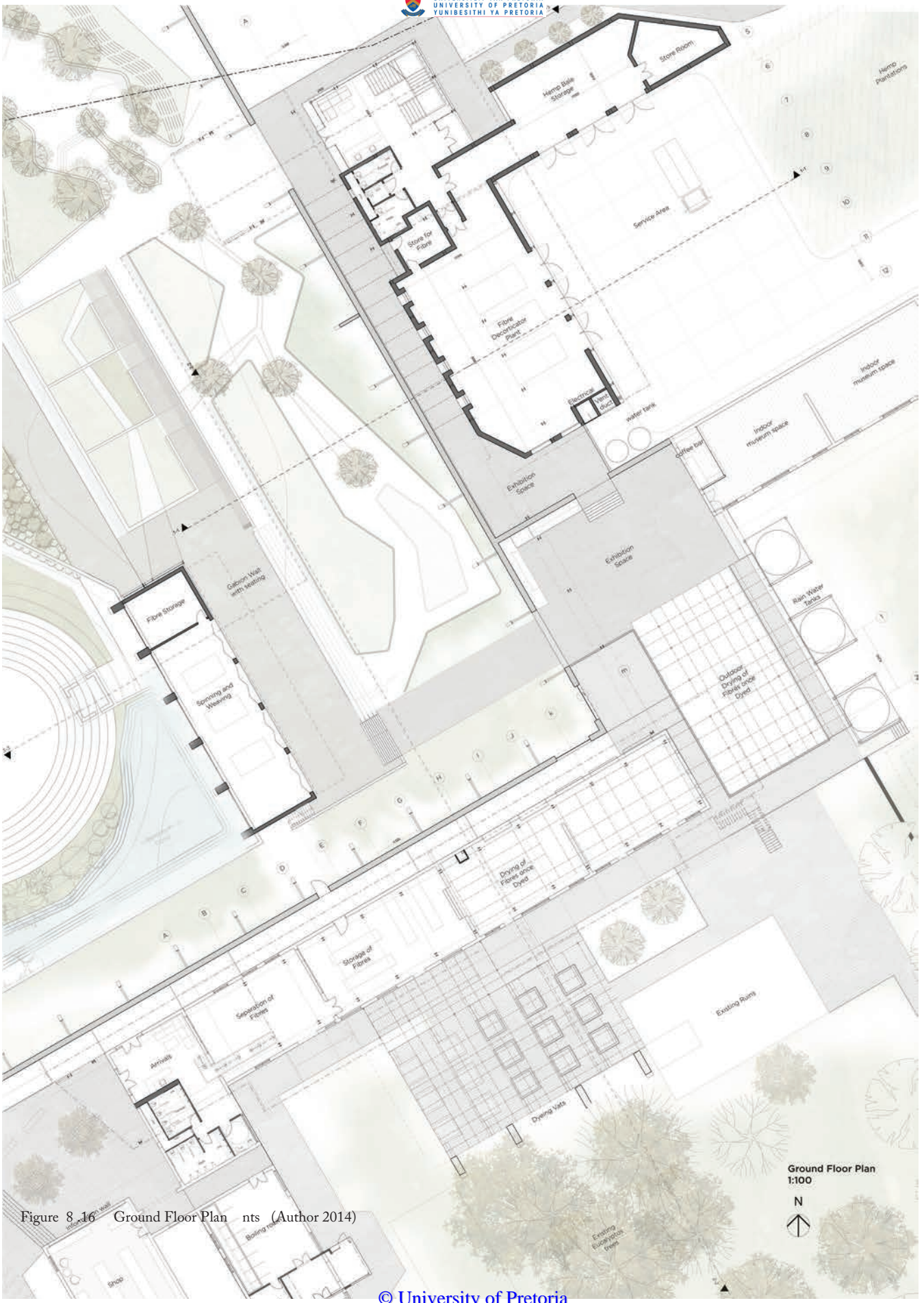

Ground Floor Plan
1:100
N

Figure 8.16 Ground Floor Plan (Author 2014)

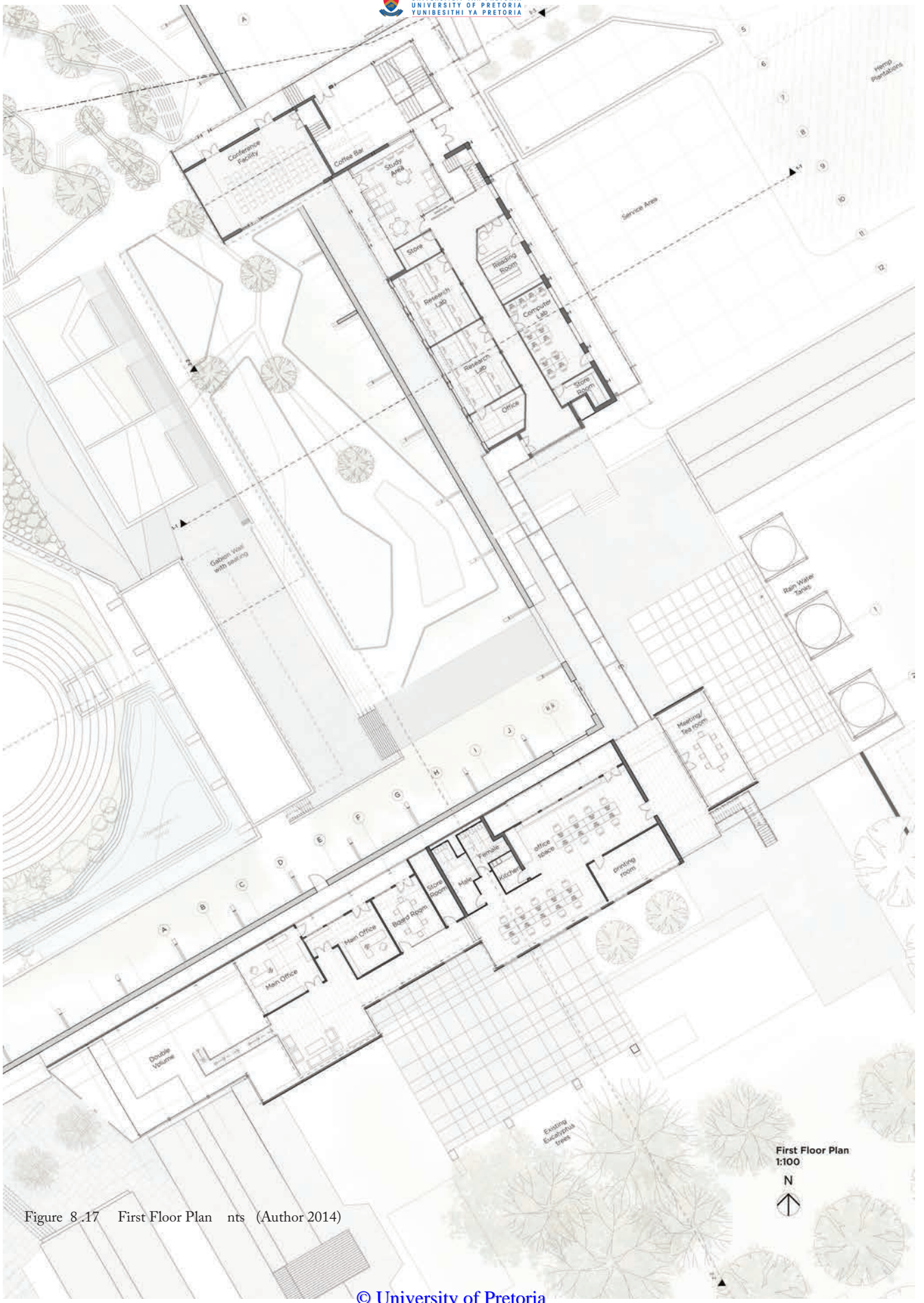
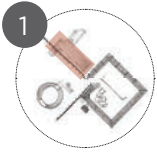

Figure 8.17 First Floor Plans (Author 2014)



8.9 SECTIONS: BUILDING 1

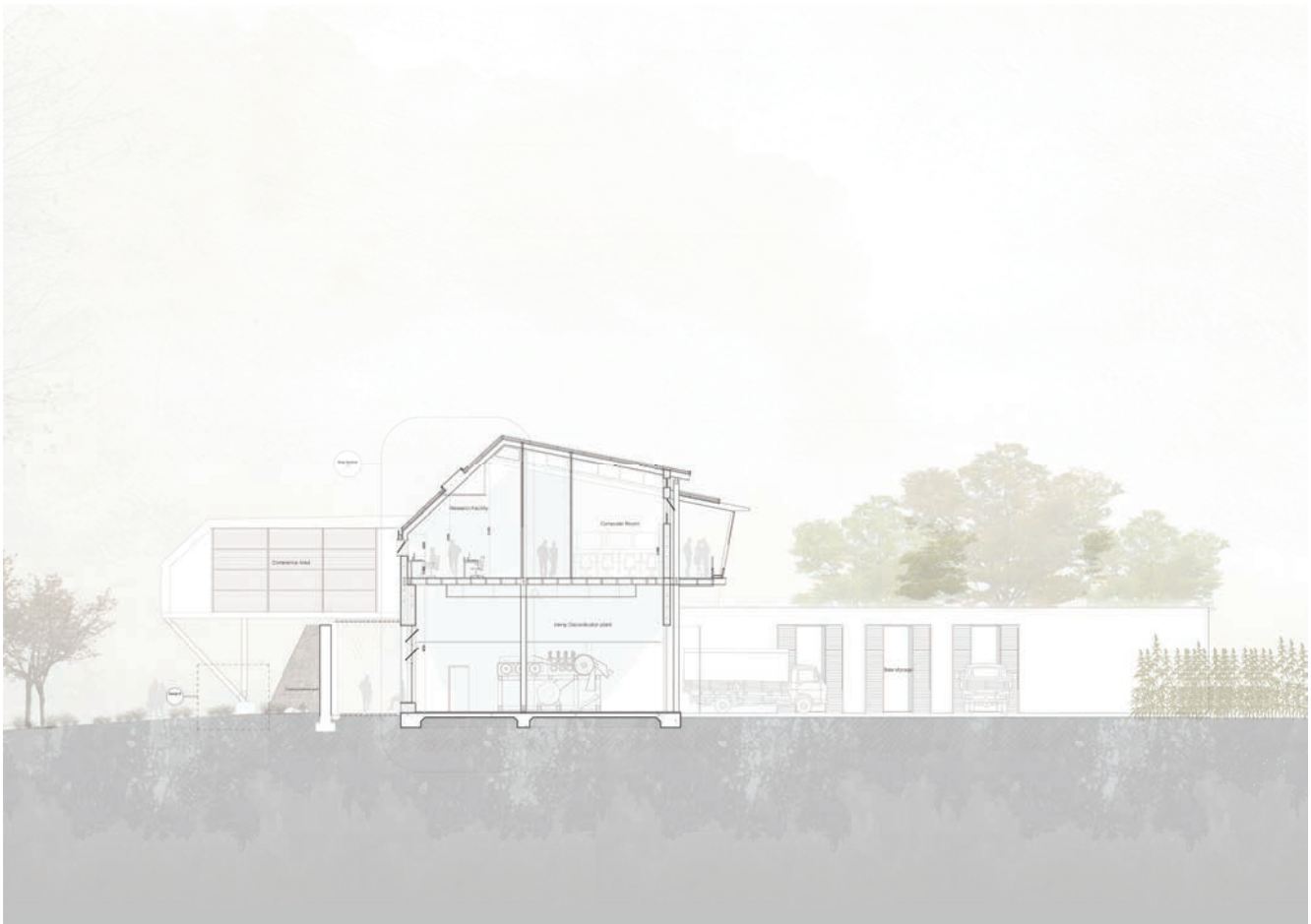

Figure 8.18 Section through hemp building (Author 2014)

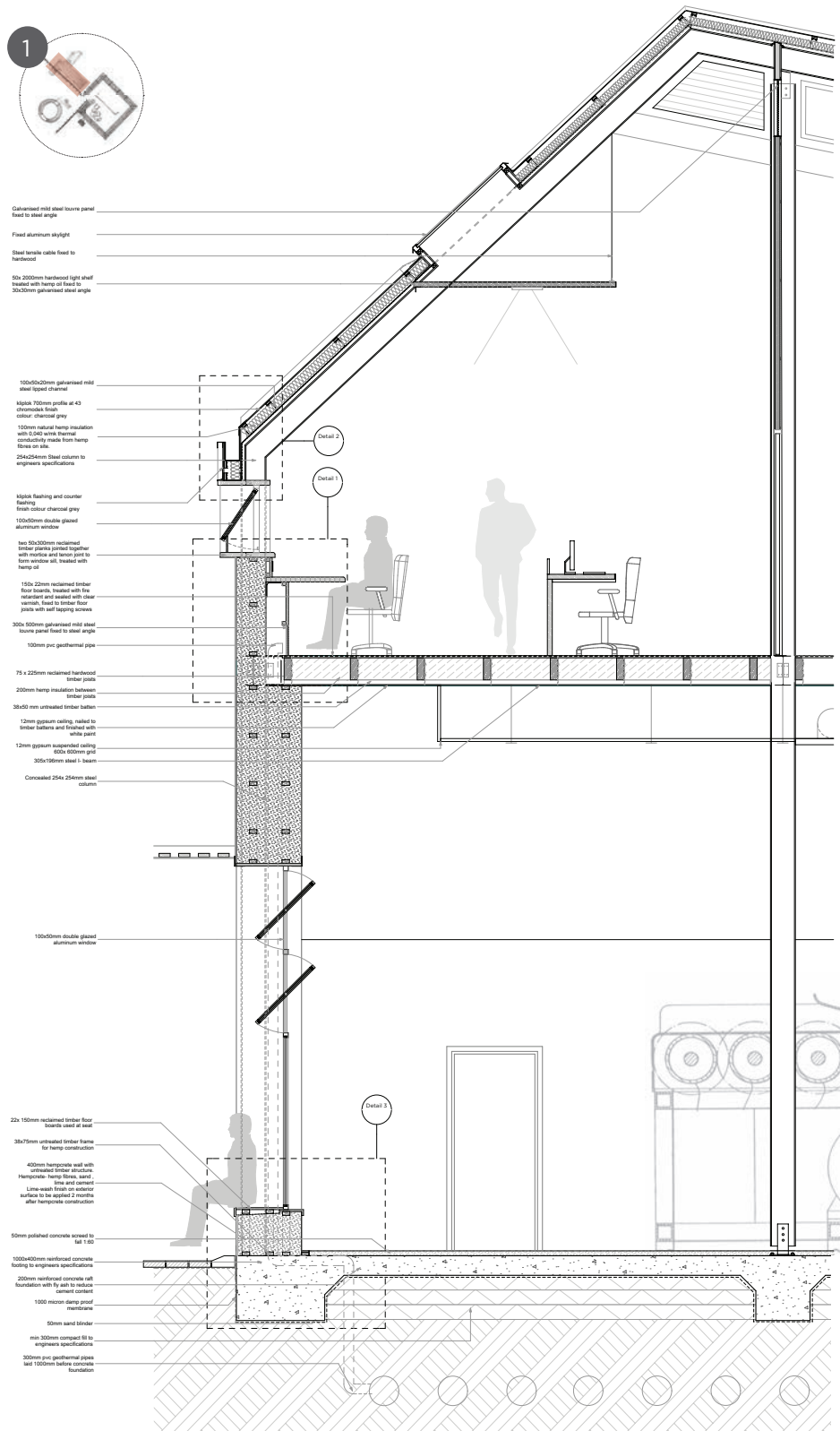

Figure 8.19 Strip Section 1 nts

8.10 DETAILS: BUILDING 1

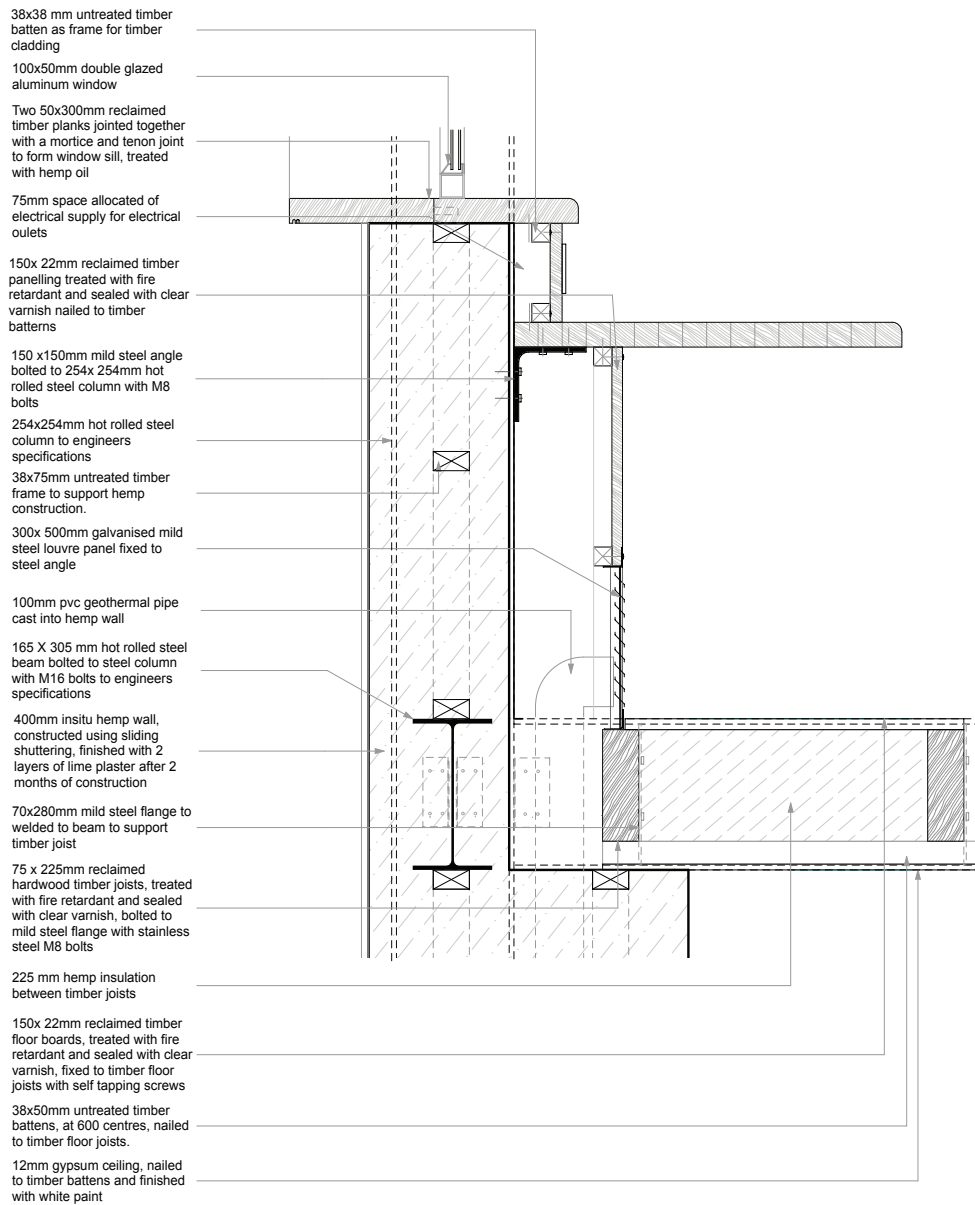

Figure 8.20 Detail 1- Window and Desk Details

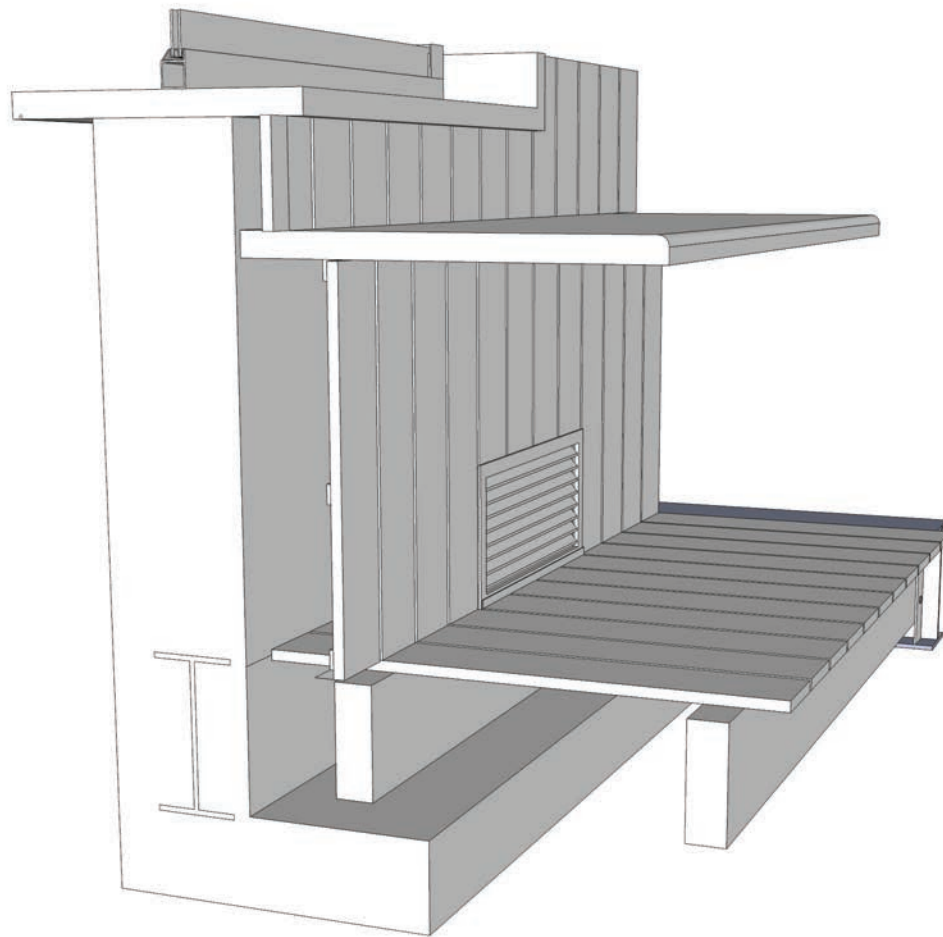

Figure 8.21 3D representation of Detail 1 nts

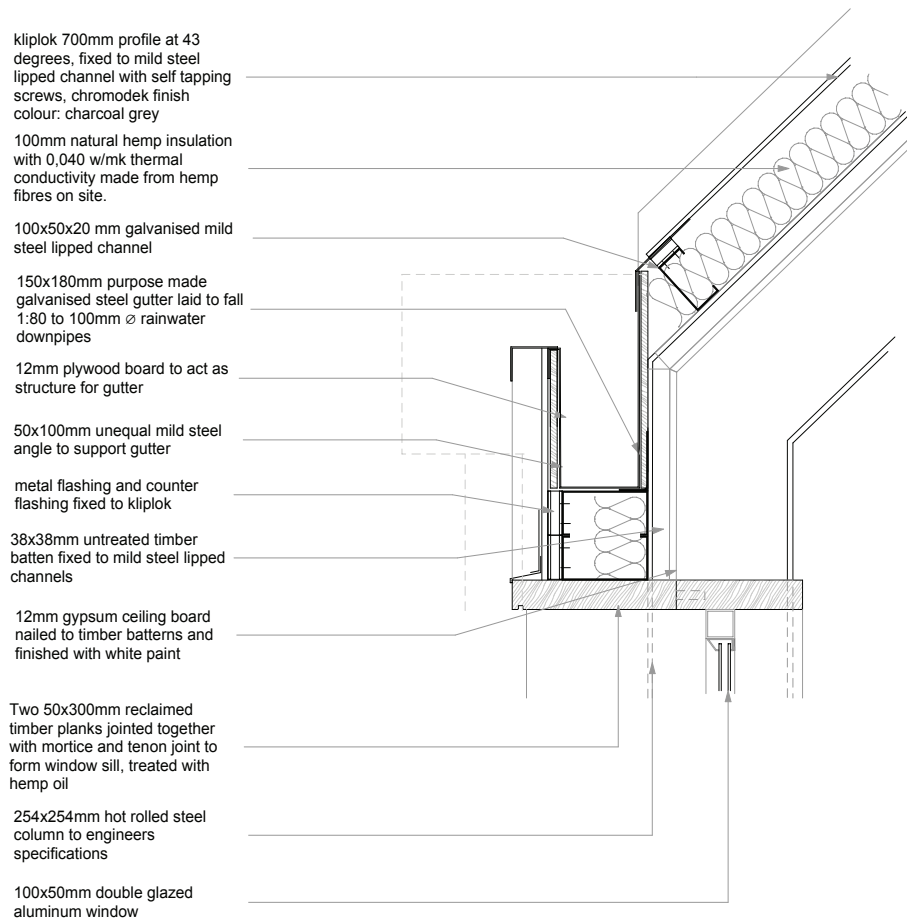

Figure 8.22 Detail 2- Gutter Detail nts

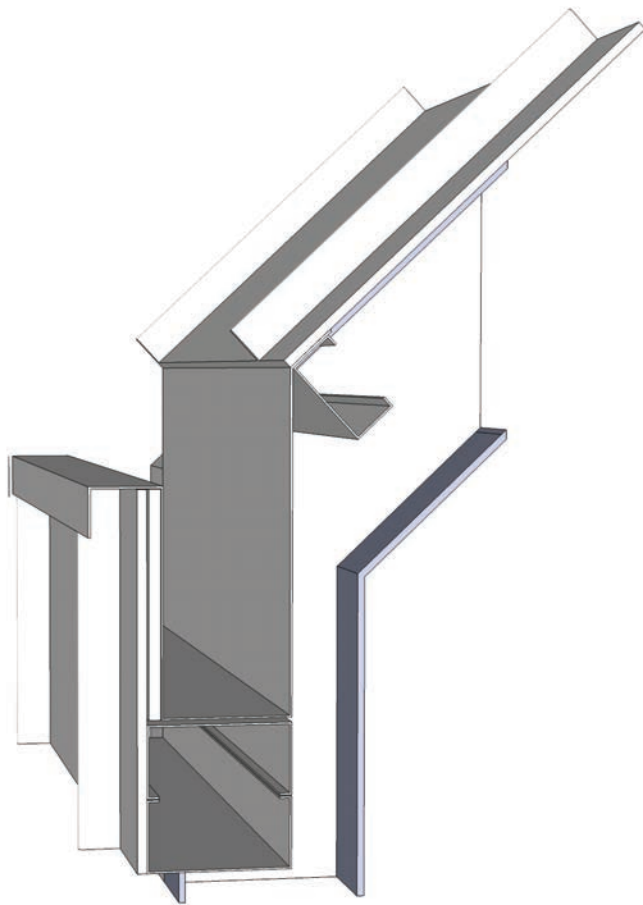

Figure 8.23 3D representation of Detail 2 nts

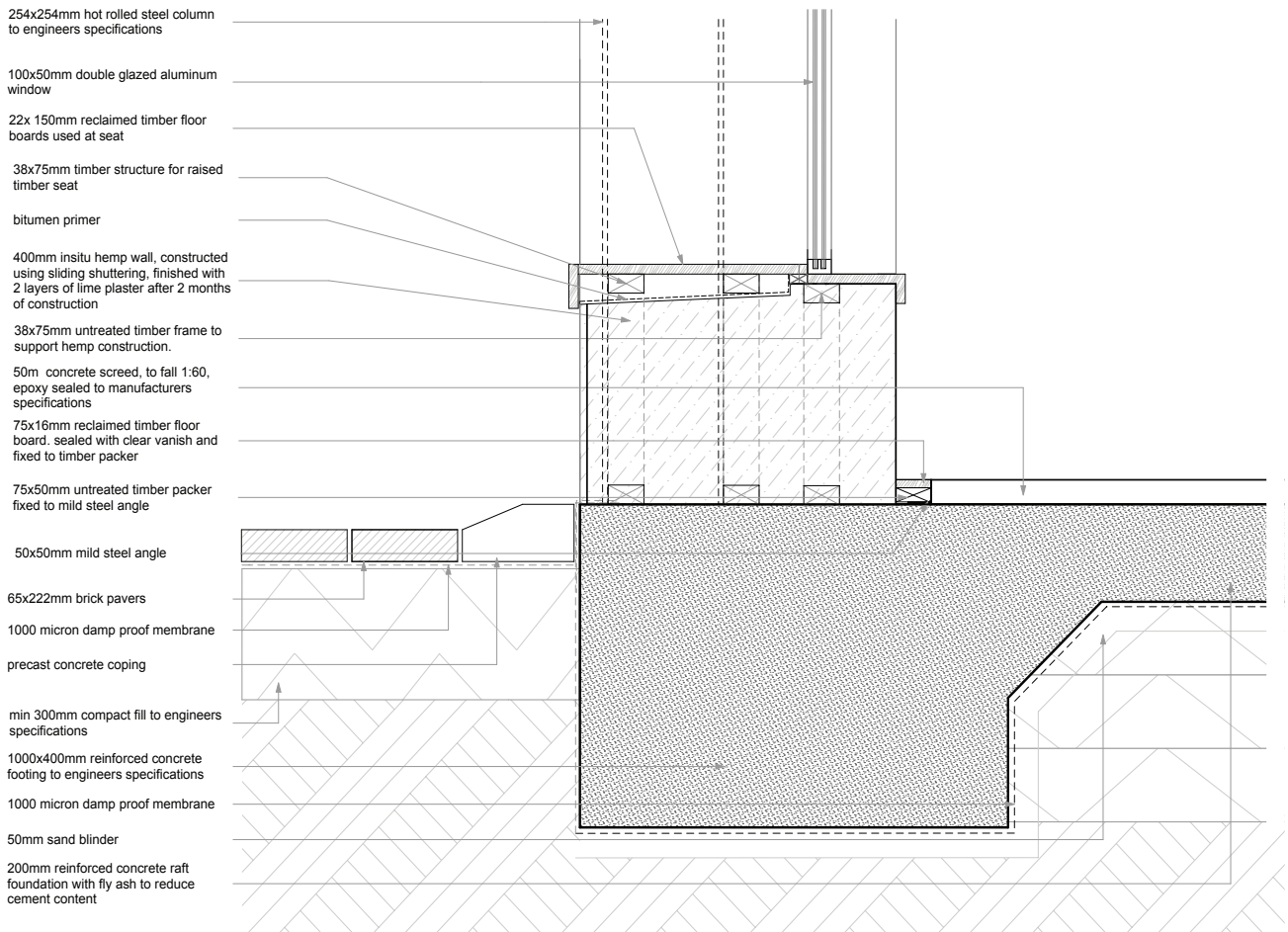

Figure 8.24 Detail 3- Indicating the Foundations for the Hemp Building nts

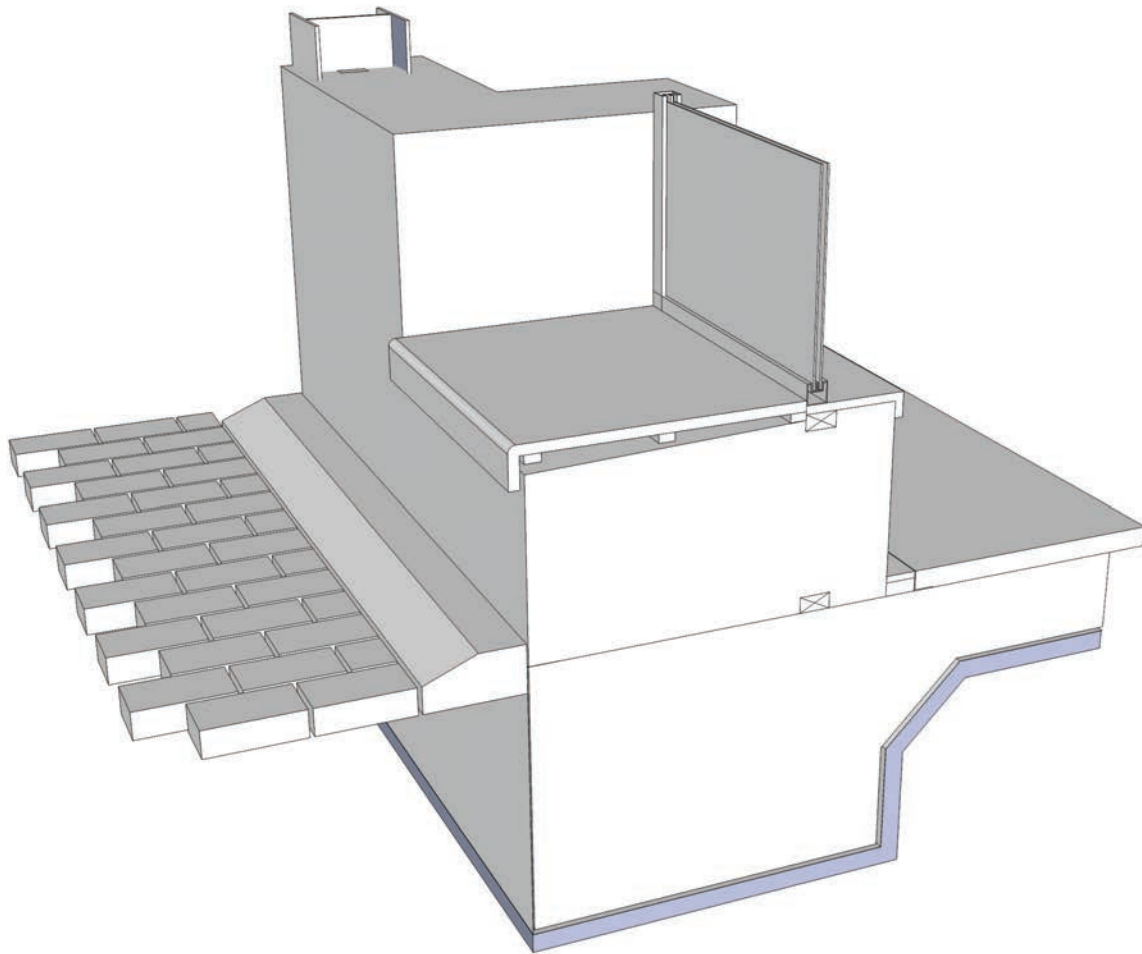
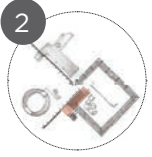

Figure 8.25 3D representation of Detail 3 nts



8.11 SECTIONS: BUILDING 2

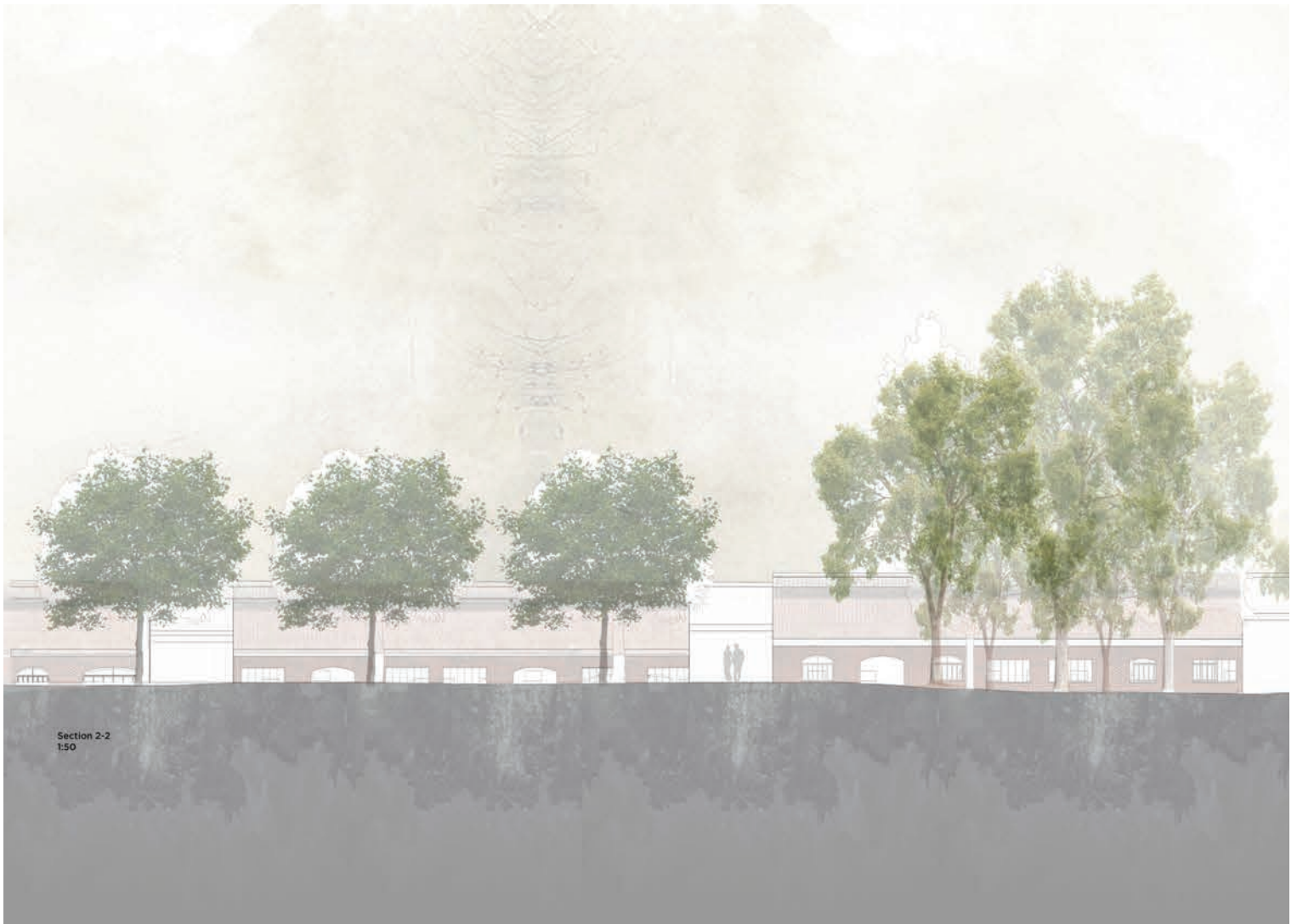
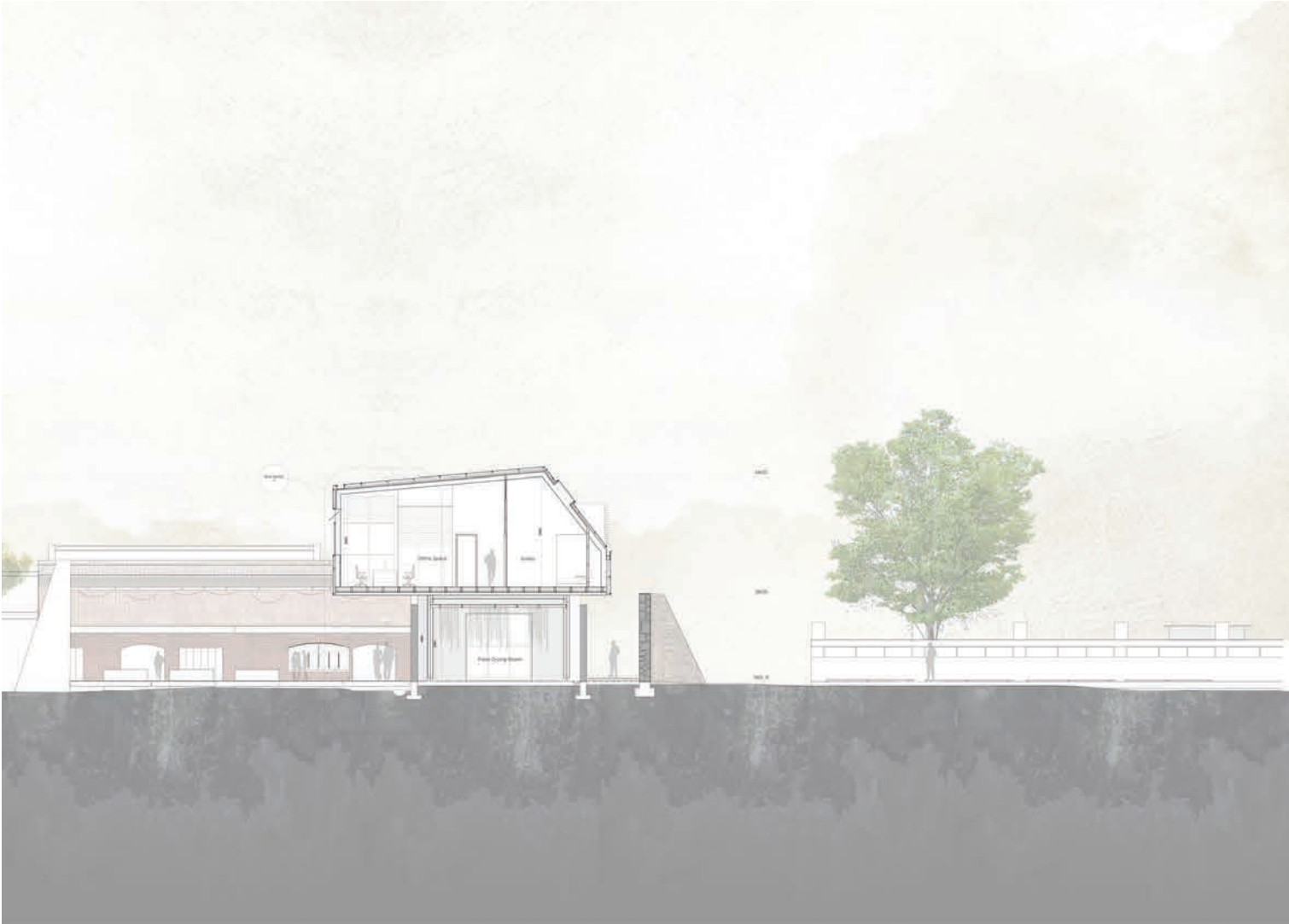

Figure 8.26 Section through Building 2 and courtyard space. nts



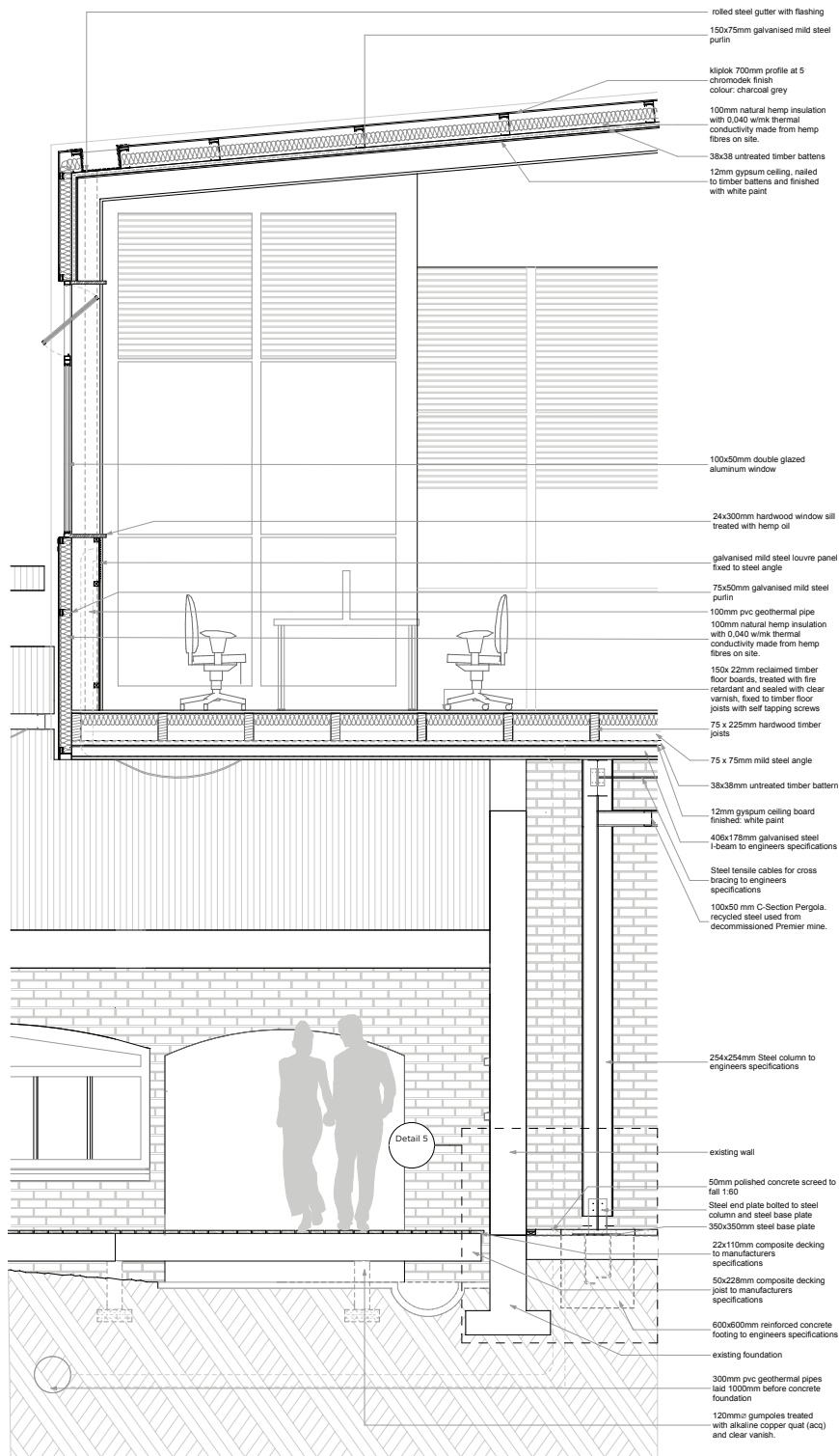
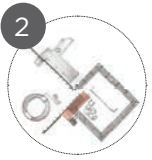

Figure 8.27 Strip section of Building 2

8.12 DETAILS: BUILDING 2

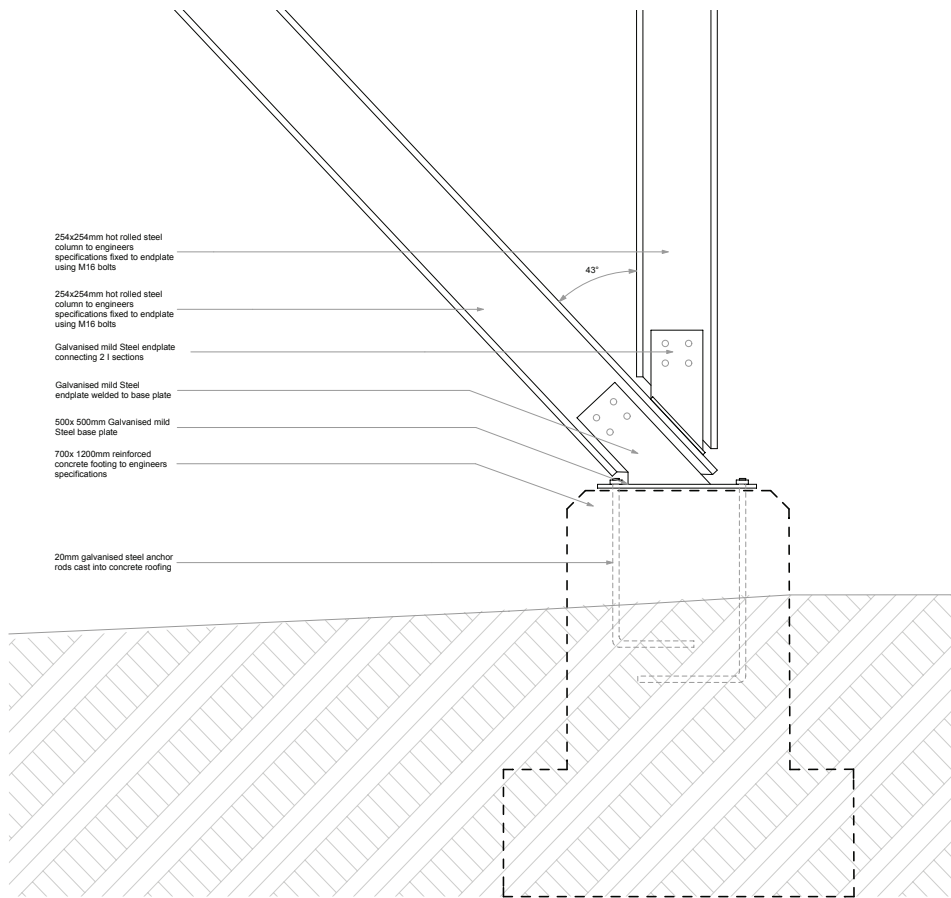

Figure 8 .28 Detail 4- Foundation detail for steel columns

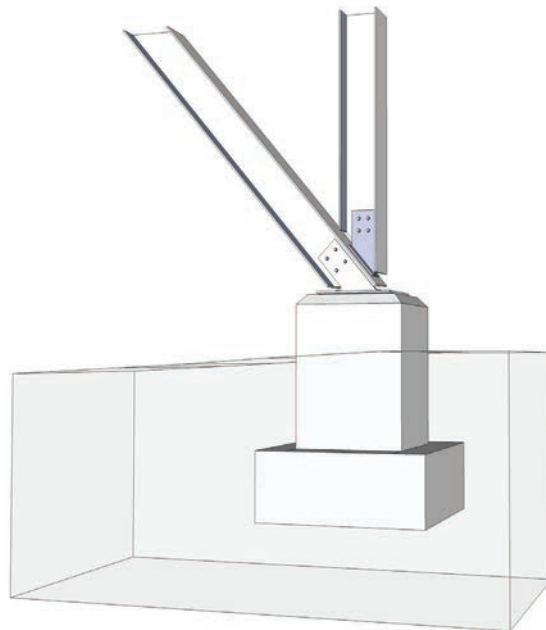

Figure 8 .29 3D Representation of Detail 4

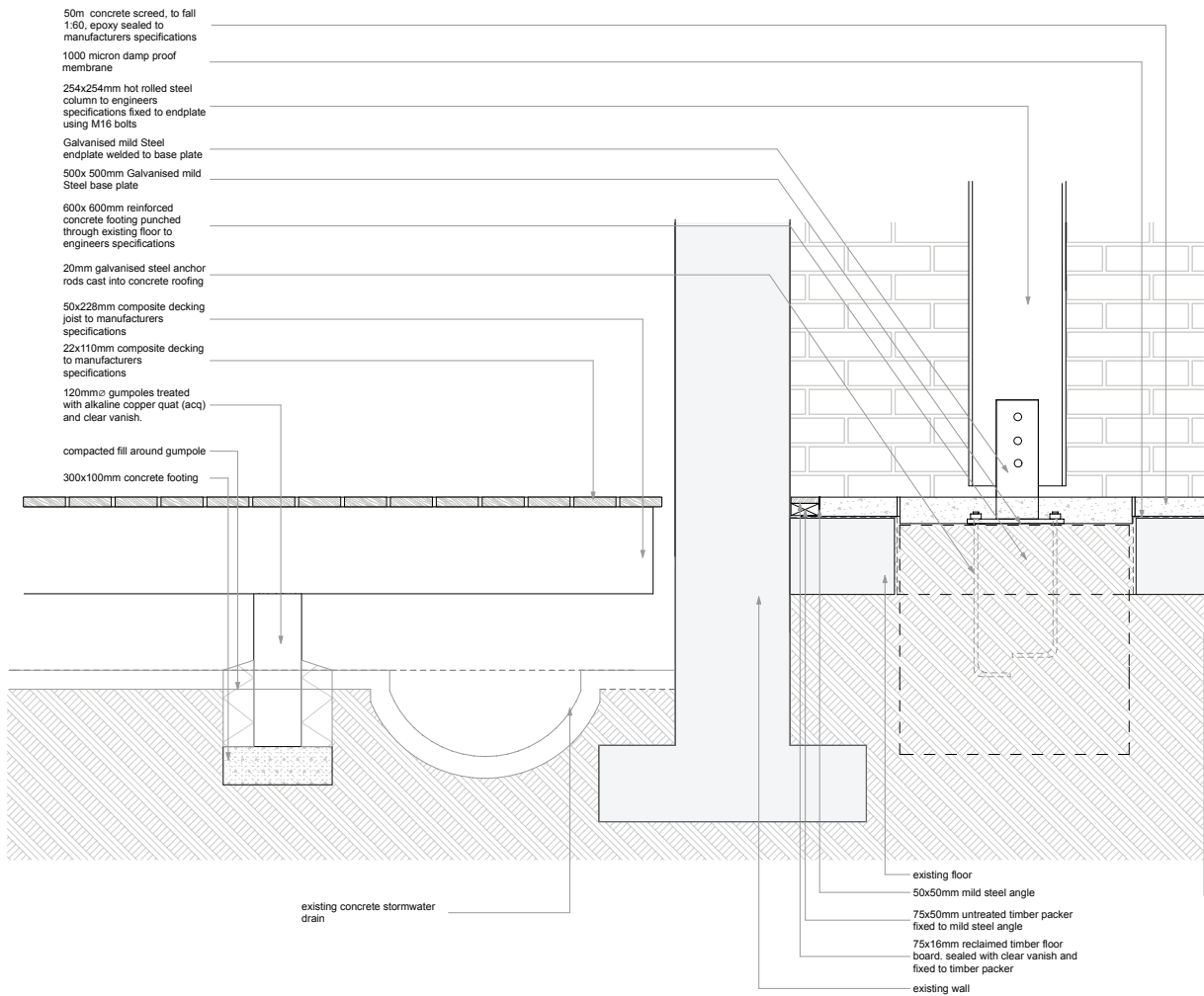

Figure 8.30 Detail 5- Foundation detail for Building 2 , within the existing compound building nts

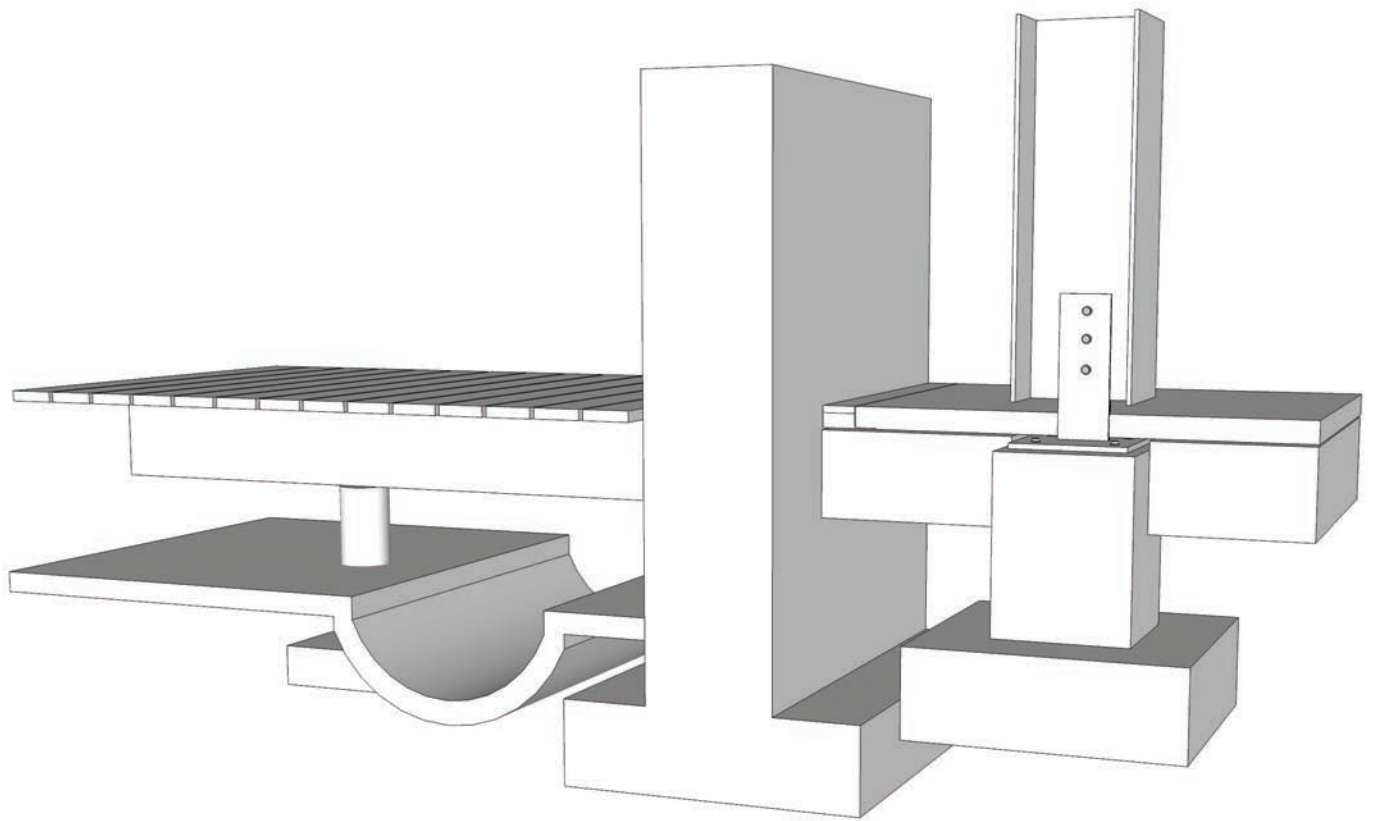
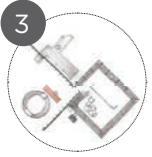

Figure 8 .31 3D Representation of Detail 5



8.13 SECTIONS: BUILDING 3

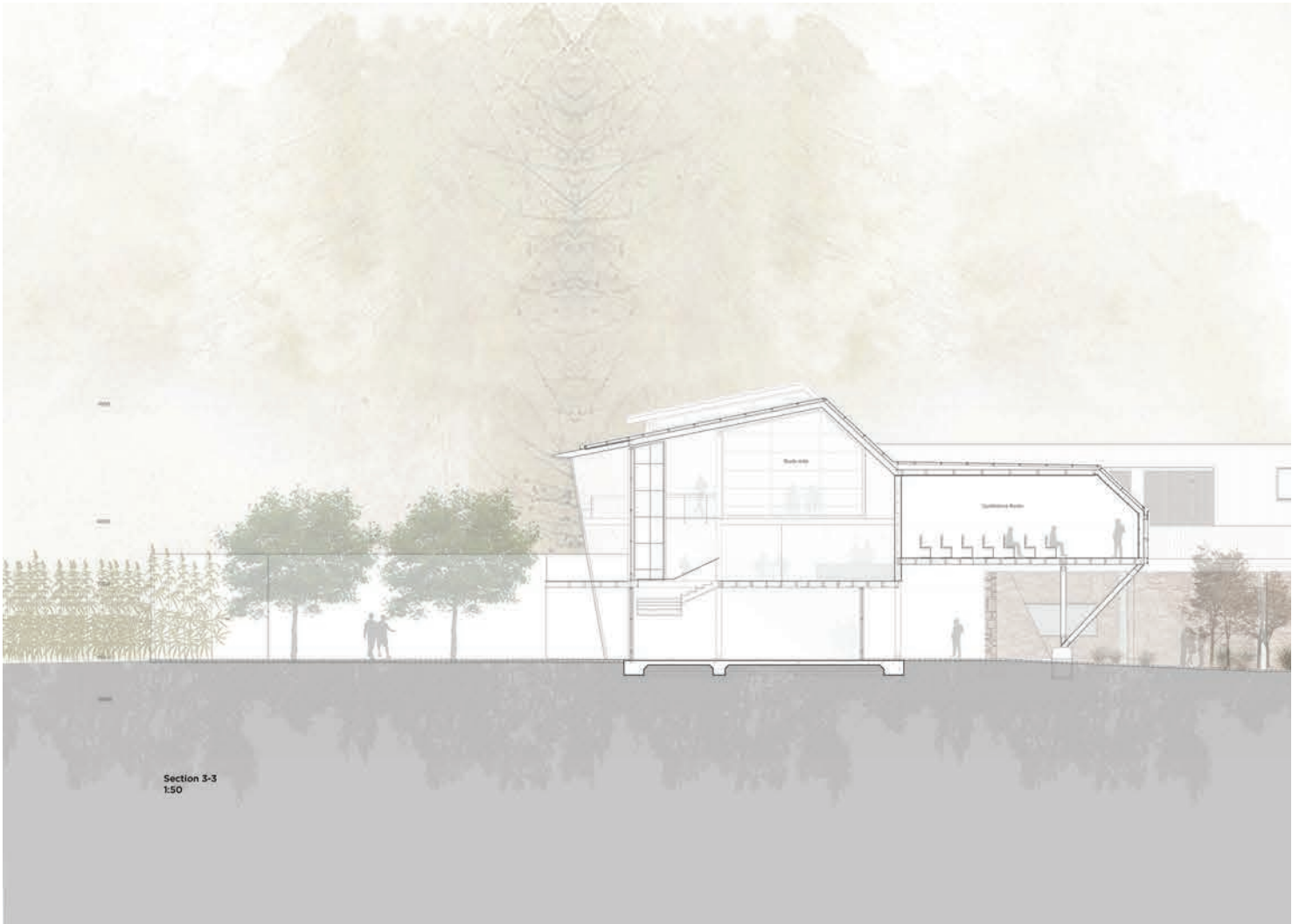

Figure 8.32 Section indicating building 1 and building 3



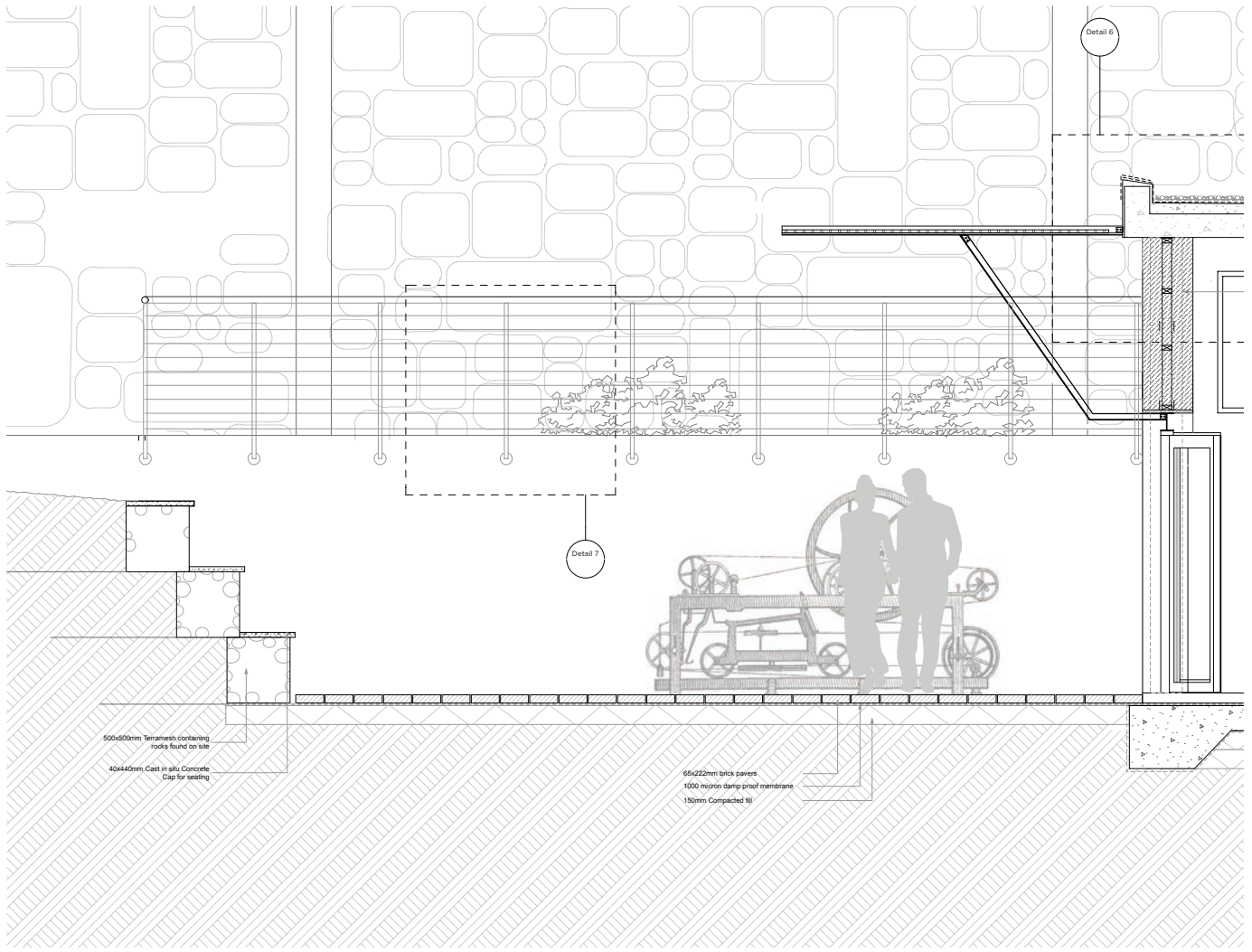
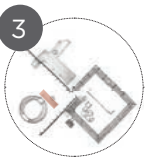
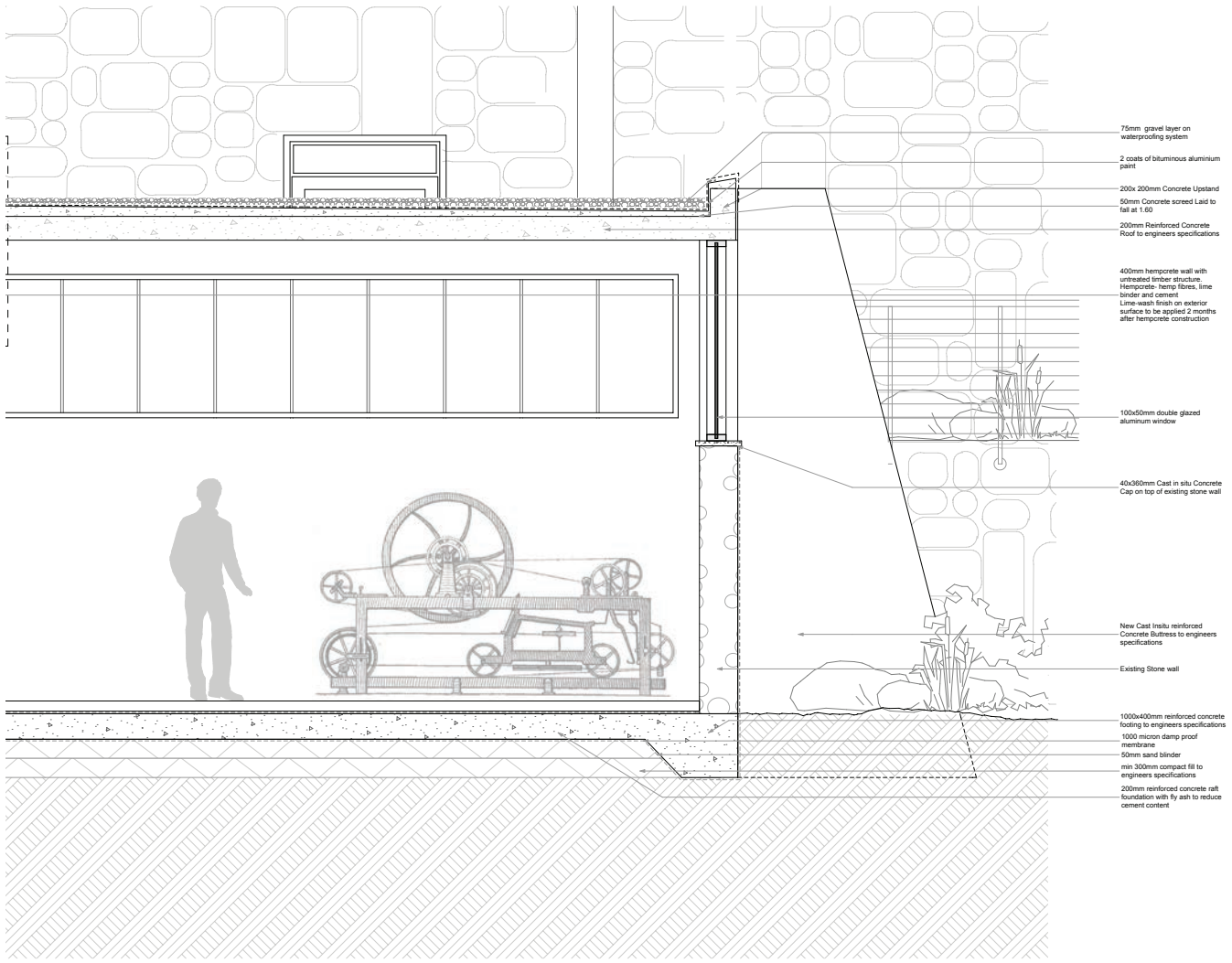

Figure 8.33 Detailed section of Building 3



8.14 DETAILS: BUILDING 3

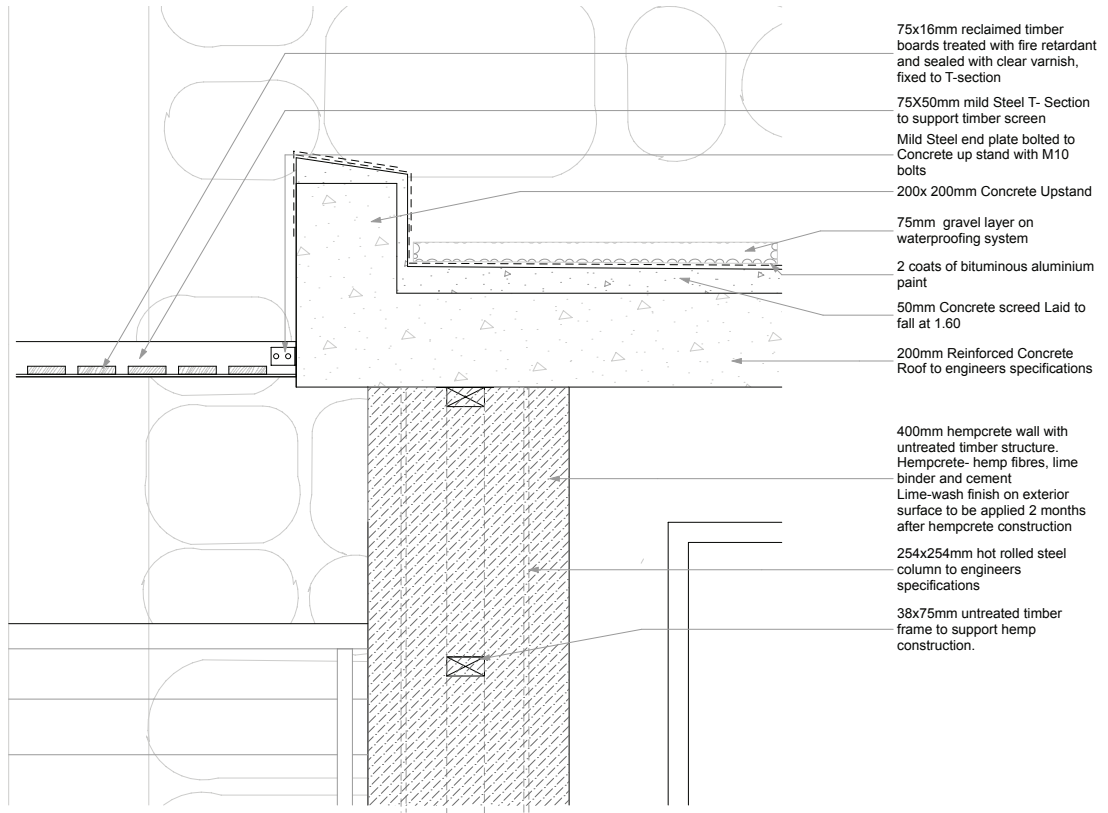

Figure 8.34 Detail 6- Roof Detail of Building 3 nts

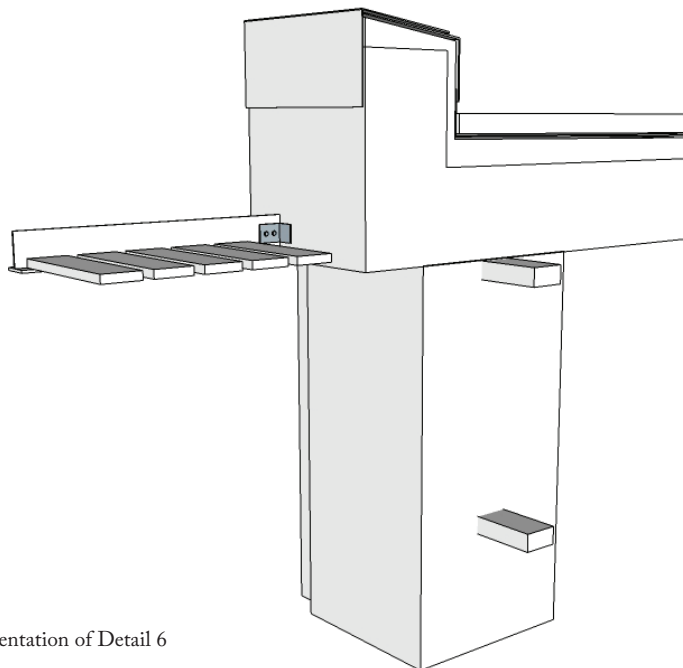

Figure 8.35 3D representation of Detail 6

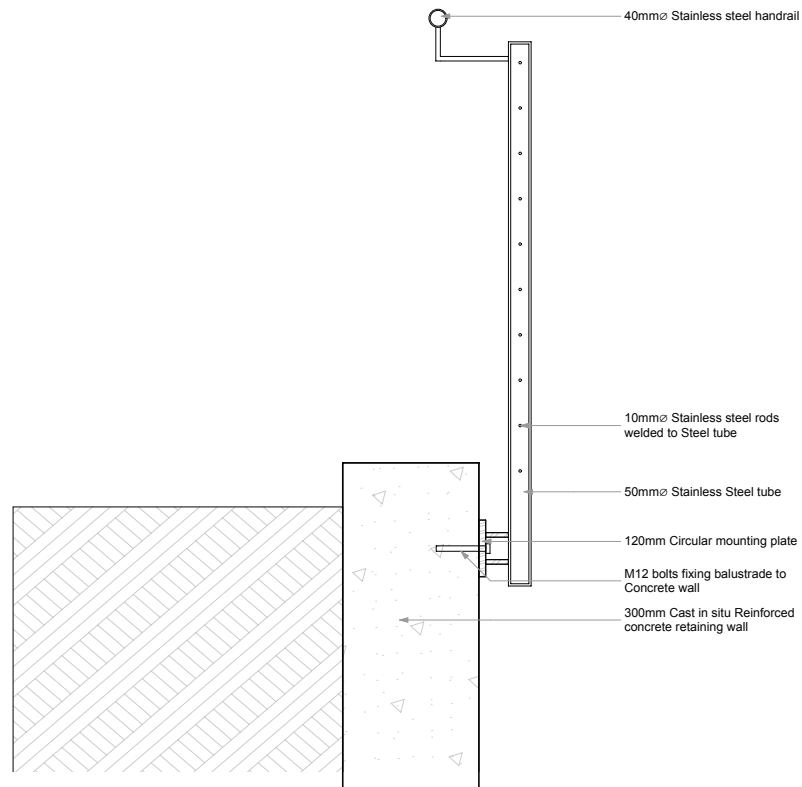

Figure 8.36 Detail 7- Balustrade Details

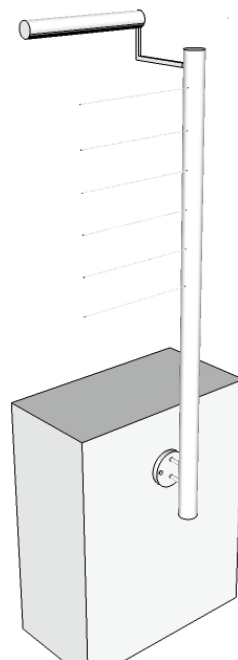

Figure 8.37 3D representation of Detail 7

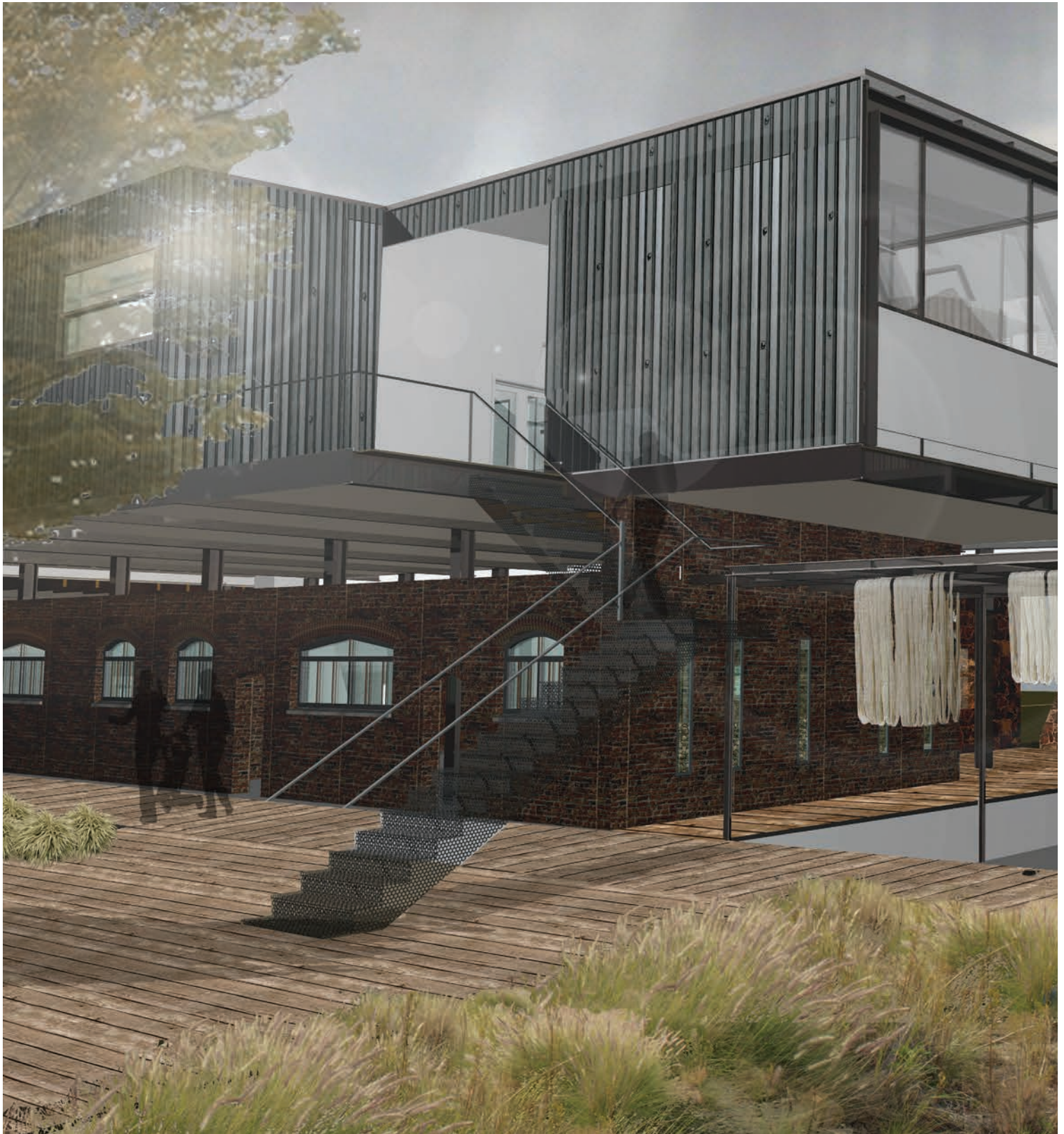

Figure 8 .38 3D image of courtyard space



9. CONCLUSION

REFLECTION

This dissertation set out to create resilient architecture that reused and revitalises the abandoned N02 Shaft Compound. The intentions on an urban scale for this project were to reconnect the compound with the town; start to understand the life of the mineworkers and provide new job opportunities after the decommissioning of the mine.

In this intervention a symbiotic relationship was created between the history of the compound and new layer of production. This relationship between the old and the new was brought through into the design and technical development where the new architecture responded to its surrounding conditions. This was achieved in either a protective and sympathetic manner towards the existing buildings, or a more dominant manner where the new architecture becomes the catalyst for change through breaking the boundaries of segregation.

This new architecture helps facilitate in the healing process. This was achieved by revitalizing the compound; reusing the abandoned buildings; creating new job opportunities and uncovering the history of these mineworkers who played an important role in the growth of Cullinan.

By creating a pilot study for textile production this industry will create over 100 jobs and has the potential to expand in future. This project remains a work in progress where these first structures can become a catalyst for the reuse of industrial buildings in and around Cullinan to provide more job opportunities after the removal of the mine as its core income.

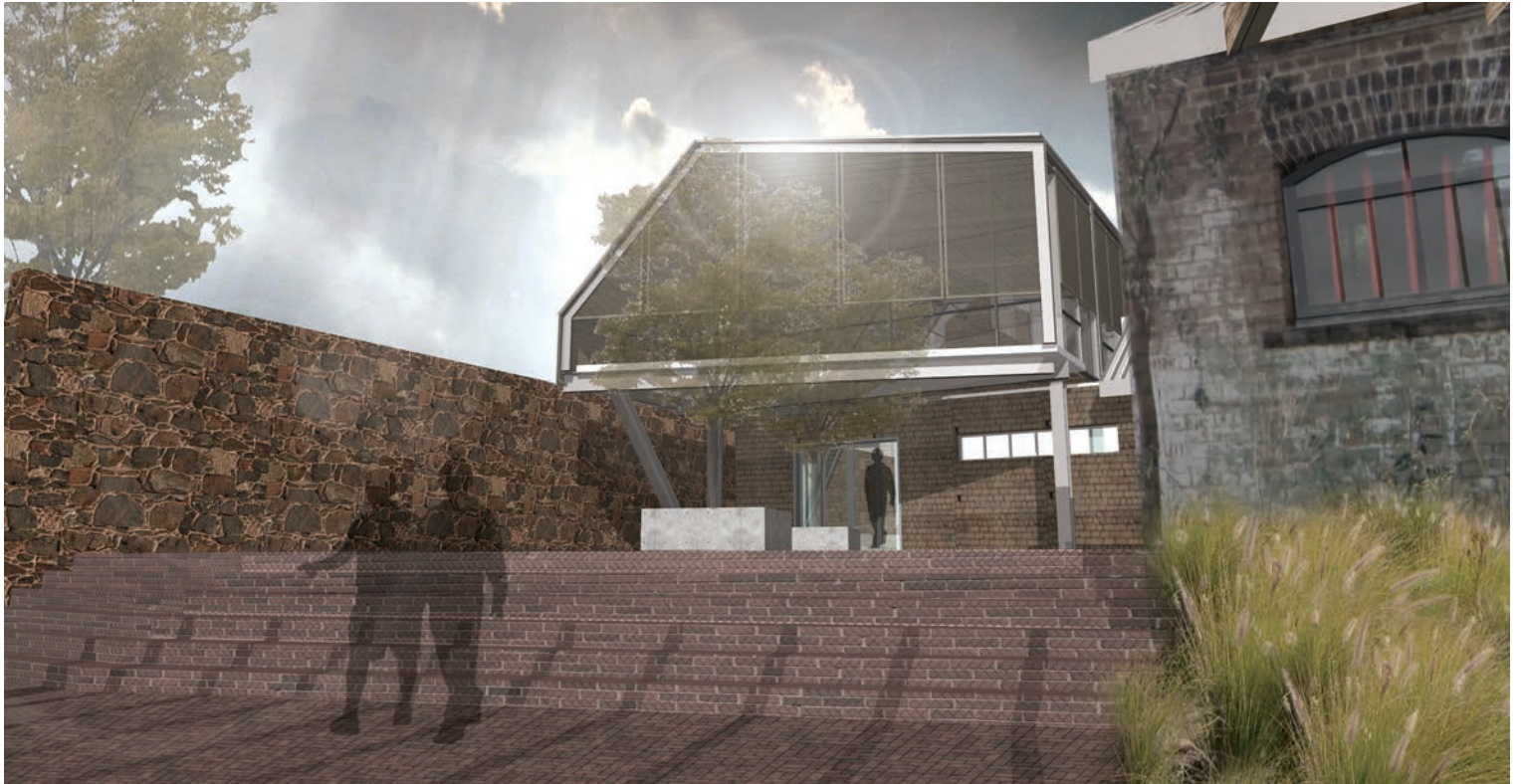

Figure 8 .39 Entrance to the Textile mill



Figure 8 .40 Dyeing Vats

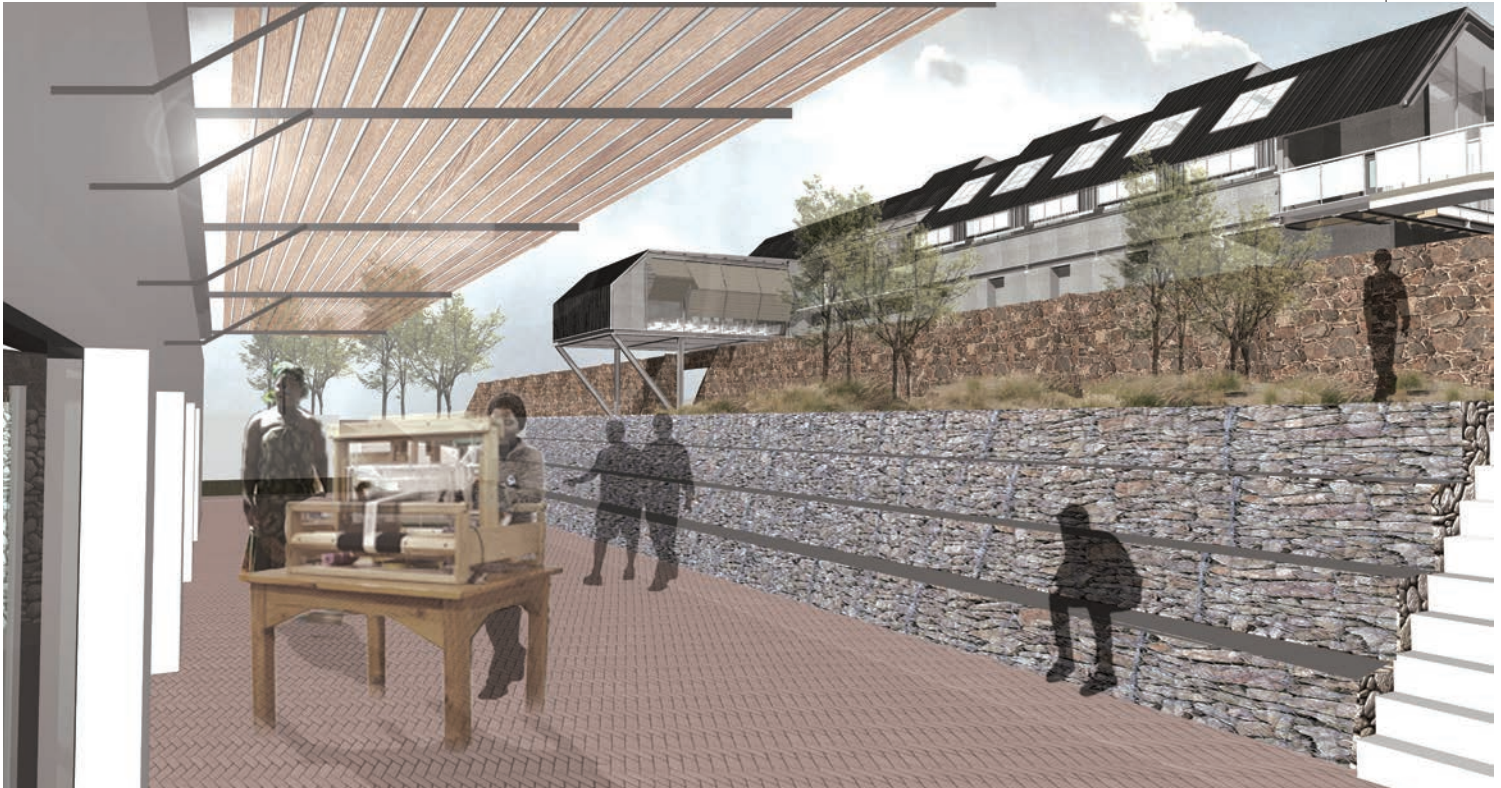

Figure 8.41 Spinning and Weaving Area



Figure 8.42 Arrivals Area



Figure 8.43 3D image of Final Design





Figure 8.44 3D image of Final Design



LIST OF SOURCES

- Cantell, S. 2005. The Adaptive Reuse of Historic Industrial Buildings. Regulation Barriers, Best Practices and Case Studies , 40.
- Site Solutions. 2002. Development Plan Proposal. No 2 Shaft Compound Interpretive Centre Premier Mine , 1-27.
- Lincoln, J. 2011. Stories of a Diamond Mine. Pretoria: TCM.
- Postekkis, A. 2010. Incremental Revitalization. Abandoned Industrial Buildings , 33.
- Treib, M. 2009. Spatial Recall: Memory in Architecture and Landscape. New York: Routledge.
- The Australian National Committee for ICOMOS. (1999). The BURRA Charter. The Australian ICOMOS Charter for Places of Significance , 1-10.
- ICOMOS. 2011. TICCIH Principles for the Conservation of Industrial Heritage Sites, Structures, Areas and Landscapes. 1-7.
- Nemeton. Nemeton: Environmental and Economic benefits of Hemp. Retrieved May 11, 2014, from Nemeton: <http://www.nemeton.com/static/nemeton/axis-mutatis/hemp.html>
- Hemp.com. The History of Hemp. Retrieved May 11, 2014, from Hemp.com: Renewable Food, Fuel and Fibre: <http://www.hemp.com/history-of-hemp/>
- Foundation, S. 2000. History of Silk. Retrieved June 15, 2014, from Silk Road: <http://www.silk-road.com/artl/silkhistory.shtml>
- Donatelli, J. 2013. The History of Fabric Dye. Retrieved June 15, 2014, from Zady: <https://zady.com/features/37>
- Weiss, L. 2011. Exceptional Space. Concentration Camps and Labor Compounds in Late Nineteenth-Century South Africa , 21-31.
- The Free Dictionary. 2014. Retrieved October 08, 2014, from The Free Dictionary: <http://www.thefreedictionary.com/compound>
- UNESCO. 2011. New life for historic cities. The historic urban landscape approach explained , 5.
- Archdaily. 18, January 2014. Los Angeles Museum of the Holocaust / Belzberg Architects. Retrieved September 11, 2014, from Archdaily: <http://www.archdaily.com/467894/los-angeles-museum-of-the-holocaust-belzberg-architects/>
- Belzberg Architects Group. 2010. Los Angeles Museum of the Holocaust. Retrieved September 11, 2014, from Belzberg Architects Group: <http://belzbergarchitects.com/project/los-angeles-museum-of-the-holocaust/>

Yung, E. H., & Chan, E. H. 2012. Habitat International. Implementation challenges to the adaptive reuse of heritage buildings: Towards the goals of sustainable, low carbon cities , 352-361 .

Prototype, Design. 2014. Prototype. Retrieved September 26, 2014, from Villa HD: http://www.studioprototype.nl/scale/villa_hd/#

Patkau Architects. 2003. Gleneagles Community Centre. Retrieved September 20, 2014, from Patkau Architects: <http://www.patkau.ca/project/gleneagles.htm#>

McDonough , W., & Braungart , M. 2003. Sustainable building and construction . Towards a sustaining architecture for the 21st century: the promise of cradle-to-cradle design , 14.

LIST OF FIGURES

Figure 1.1	Textile as a new form of Production (Author 2014)	X
Figure 1.2	The Premier Diamond Mine in Cullinan during the initial mining years (Historic photographs details contact John Lincoln)	2
Figure 1.3	Aerial photograph of Cullinan as it exists today edited by author (Aerial photograph details contact John Lincoln)	4
Figure 1.4	Photographs depicting areas of Compound 5 (author 2014)	5
Figure 1.5	Photograph indicating the remains of the No2 Shaft Compound (photo by Jeffrey Moodie)	6
Figure 1.6	Mineworkers in the Premier Diamond mine. (Historic photographs details contact John Lincoln)	8
Figure 1.7	3D rendering of Cullinan showing the relationship between the town and the compound (author 2014)	9
Figure 1.8	Artifacts evident within the Compound (photo by Jeffrey Moodie)	
		12
Figure 2.1	Illustration indicating the relationship between Pretoria and Cullinan (Natasha Laurent 2014)	14
Figure 2.2	Aerial map of Cullinan indicating the town, mine and compound (photograph details contact John Lincoln)	16
Figure 2.3	Map from 1911 indicating the Premier Transvaal Diamond Mine (Historic map details contact John Lincoln)	18
Figure 2.4	Maps indicating the development of Cullinan over time (Nikita Edwards 2014)	22
Figure 2.6	Cullinan town as it exists today (Photos by Natasha Laurent)	24
Figure 2.5	Historic photograph of Oak Street (photographer unknown)	24
Figure 2.7	Diagram indicating the historic buildings, tourist nodes and streets in Cullinan (author 2014)	25
Figure 2.9	Historic Image of mineworkers in Premier Diamond Mine (Historic photographs details contact John Lincoln)	26
Figure 2.8	Premier Diamond mine as it exists today (author 2014)	26
Figure 2.10	Diagram indicating the historic buildings and streets within the Premier Diamond Mine (author 2014)	27
Figure 2.11	The Landscape in Cullinan as it exists today (photos by Natasha Laurent 2014)	28
Figure 2.12	Fauna and Flora found in and around Cullinan (Marcel Mattheus 2014)	29
Figure 2.13	Diagram indicating the zoning in Cullinan (author 2014)	29
Figure 2.14	Diagrams indicating the vision for Cullinan after the decommissioning of the mine (author 2014)	31
Figure 2.15	Map illustrating the framework for Cullinan once the mine has been decommissioned. (Natasha Laurent 2014)	32
Figure 2.16	Illustration of how Compound 5 could have looked during the initial mining years (author 2014)	35
Figure 2.17	Panoramic of the courtyard space within Compound 5 (photo by Jeffrey Moodie)	36
Figure 2.18	Panoramic of amphitheatre within No2 Shaft Compound (photo by Walter Raubenheimer 2014)	36
Figure 2.19	Diagrams indicating how the compound has changed over time (author 2014)	39
Figure 2.20	Aerial map indicating where the photos were taken in the photographic study (Adapted from the Geographic Department map)	40
Figure 2.21	Photo of Compound 5 rooms (author 2014)	41
Figure 2.22	The abandoned Compound 5(author 2014)	42
Figure 2.23	Memories of the past (author 2014)	42
Figure 2.24	Gable wall with block symbol (author 2014)	42
Figure 2.25	Compound 5 accommodation(author 2014)	42
Figure 2.27	Abandoned corridor (author 2014)	43
Figure 2.29	Compound 5 (author 2014)	43
Figure 2.26	Remains of the past (Jeffrey Moodie 2014)	43
Figure 2.28	Corrugated roof (author 2014)	43
Figure 2.30	Entrance to the Mine (author 2014)	44
Figure 2.31	No 2 Shaft (Walter Raubenheimer 2014)	44
Figure 2.32	A lost past (author 2014)	44
Figure 2.33	Hidden Amphitheatre (Walter Raubenheimer 2014)	44
Figure 2.34	Remains of Washing facilities (author 2014)	45
Figure 2.36	Compound Ruins (author 2014)	45
Figure 2.37	Memories (author 2014)	45
Figure 2.35	Unused warehouse space (author 2014)	45
Figure 2.38	Stone arch, a memory of a lost compound(author 2014)	45
Figure 2.39	Plan illustrating the vision for the site (Natasha Laurent 2014)	47
Figure 2.40	3D indicating the vision and programmes for the site (author 2014)	

Figure 3.1	Map indicating Compound 5 within No2 shaft Compound (Adapted from the Geographic Department map)	50
Figure 3.2	Historic photographs indicating the life of a mineworker working in Premier Diamond Mine (Historic photographs details contact John Lincoln)	51
Figure 3.3	A forgotten past (photo by Jeffrey Moodie 2014)	52
Figure 3.4	Block Plan of No2 Shaft Compound indicating the ethnic group separation (Historic map details contact John Lincoln)	53
Figure 3.5	Historic Photographs of the compound and the mineworkers during the initial mining years. (Historic photographs details contact John Lincoln)	54
Figure 3.6	Historic Photograph indicating what the compound looked like before buildings were demolished (Historic photographs details contact John Lincoln)	56
Figure 3.7	Historic Map of Cullinans Mining Compound 1911 (Lincoln 2011)	58
Figure 3.8	Map indicating the specific areas of the compound (Site Solutions 2002)	59
Figure 3.9	Mineworkers starting their shift (Historic photographs details contact John Lincoln)	61
Figure 3.10	Map indicating the selected site for the intervention (Adapted from the Geographic Department map)	62
Figure 3.11	Possible vision for Compound 5 (author 2014)	64
Figure 4.1	Silk spinning process [online] Available at < http://en.wikipedia.org/wiki/Silk_throwing#mediaviewer/File:Silk_doublers_at_work.jpg [Accessed: 8 September 2014]	68
Figure 4.2	Diagram illustrating the benefits of reusing the site (author 2014)	67
Figure 4.3	Illustration indicating the Hemp process (author 2014)	70
Figure 4.4	Illustration indicating the silk process (author 2014)	71
Figure 4.5	Benefits of industrial hemp [online] Available at < http://b-i.forbesimg.com/ashoka/files/2013/05/Hemp-1.png > [Accessed: 10 September 2014]	73
Figure 4.6	Harvesting Hemp [online] Available at < http://buymarijuanaseeds.com/community/attachments/hempbundled-jpg.359328/ > [Accessed: 10 September 2014]	74
Figure 4.7	Dense hemp plantations [online] Available at < http://cdn1.buydutchseeds.com/media/wysiwyg/nevashhh/Difference_Between_Industrial_Hemp_and_Cannabis.PNG > [Accessed: 10 September 2014]	74
Figure 4.8	Hemp retting [online] Available at < http://cdn1.buydutchseeds.com/media/wysiwyg/nevashhh/Difference_Between_Industrial_Hemp_and_Cannabis.PNG > [Accessed: 3 September 2014]	74
Figure 4.9	Separation of hemp fibres [online] Available at < http://en.wikipedia.org/wiki/Hemp#mediaviewer/File:Hanfstengel.jpg > [Accessed: 20 August 2014]	74
Figure 4.10	Natural Hemp Fibres [online] Available at < http://sensiseeds.com/en/blog/hemp-textiles-produced/ > [Accessed: 20 August 2014]	74
Figure 4.11	Natural Hemp before spinning and weaving [online] Available at < http://cmsimg.courier-journal.com/apps/pbcsi.dll/bilde?Site=B2&Date=20140104&Category=NEWS0101&ArtNo=301040025&Ref=AR > [Accessed: 20 August 2014]	75
Figure 4.12	Hemp spinning process [online] Available at < http://sensiseeds.com/en/blog/hemp-textiles-produced/ > [Accessed: 20 August 2014]	75
Figure 4.14	Final product [online] Available at < http://sensiseeds.com/en/blog/hemp-textiles-produced/ > [Accessed: 20 August 2014]	75
Figure 4.13	Final product [online] Available at < http://nutiva.com/hemp-oil-and-more-why-this-ancient-crop-is-great-for-more-than-just-smoothies/ > [Accessed: 20 August 2014]	75
Figure 4.15	Hemp plant comes from the same family as marijuana [online] Available at < http://www.summagallicana.it/lessico/c/Cannabis%20sativa%20tavola.jpg > [Accessed: 20 August 2014]	77
Figure 4.16	Illustration depicting historic silk weaving [online] Available at < http://www.naturallsilk.com.au/historyofsilk.html > [Accessed: 21 August 2014]	78
Figure 4.17	Silkworms in trays [online] Available at < http://www.designboom.com/history/silk1.html > [Accessed: 10 June 2014]	80
Figure 4.19	Cocoons used to make silk [online] Available at < http://www.designboom.com/history/silk1.html > [Accessed: 10 June 2014]	80
Figure 4.22	Cocoons are then boiled and a single thread is unwound, this is known as fine silk [online] Available at < http://www.designboom.com/history/silk1.html > [Accessed: 10 June 2014]	80
Figure 4.20	Huge amounts of silk are needed to produce one item. [online] Available at < http://www.designboom.com/history/silk1.html > [Accessed: 10 June 2014]	80

Figure 4 .23	Silk is then stretched and washed, before dyeing. [online] Available at < http://www.designboom.com/history/silk1.html > [Accessed: 10 June 2014]	80
Figure 4 .18	Sericulture [online] Available at < http://www.designboom.com/history/silk1.html > [Accessed: 10 June 2014]	80
Figure 4 .21	Cocoons [online] Available at < http://www.designboom.com/history/silk1.html > [Accessed: 10 June 2014]	80
Figure 4 .26	Silk thread is then spun [online] Available at < http://www.designboom.com/history/silk1.html > [Accessed: 10 June 2014]	81
Figure 4 .28	Ladies spin thread to create thicker strands of silk before weaving process [online] Available at < http://www.designboom.com/history/silk1.html > [Accessed: 10 June 2014]	81
Figure 4 .24	Natural dyeing techniques [online] Available at < http://www.designboom.com/history/silk1.html > [Accessed: 15 September 2014]	81
Figure 4 .25	Fibres left to dry after dyeing process [online] Available at < http://www.designboom.com/history/silk1.html > [Accessed: 15 September 2014]	81
Figure 4 .29	Natural Silk [online] Available at < http://www.designboom.com/history/silk1.html > [Accessed: 10 September 2014]	81
Figure 4 .27	Part of spinning process [online] Available at < http://www.designboom.com/history/silk1.html > [Accessed: 10 June 2014]	81
Figure 4 .30	Weaving process [online] Available at < http://www.designboom.com/history/silk1.html > [Accessed: 10 June 2014]	81
Figure 4 .31	Diagram indicating sustainability process (author 2014)	83
Figure 4 .32	Natural Dyeing techniques in open vats [online] Available at < http://www.godsmurf.com/pictures/2009-05-Morocco/2 > [Accessed: 15 Septmeber 2014]	85
Figure 4 .33	Map indicating where natural dyeing products are located (author 2014)	87
Figure 5 .1	Decending into Holocaust Museum [online] Available at < http://belzbergarchitects.com/project/los-angeles-museum-of-the-holocaust/ > [Accessed: 10 September 2014]	89
Figure 5 .2	Evoking emotions through light [online] Available at < http://belzbergarchitects.com/project/los-angeles-museum-of-the-holocaust/ > [Accessed: 10 September 2014]	89
Figure 5 .3	Holocaust Museum blends into park surroundings [online] Available at < http://belzbergarchitects.com/project/los-angeles-museum-of-the-holocaust/ > [Accessed: 6 September 2014]	89
Figure 5 .4	The turbine hotel [online] Available at < http://www.nightjartravel.com/accommodation/turbine-boutique-hotel-spa > [Accessed: 6 September 2014]	91
Figure 5 .5	Distinct contrast between the old industrial building and the new architecture [online] Available at < http://www.nightjartravel.com/accommodation/turbine-boutique-hotel-spa > [Accessed: 6 September 2014]	91
Figure 5 .6	Machinery connects the visitor with the past production [online] Available at < http://www.thesenharbourtown.co.za/wp-content/uploads/2012/07/IMG_3640-Turbine-Hotel-1.jpg > [Accessed: 14 August 2014]	91
Figure 5 .7	Beautiful contrast between old and new materials [online] Available at < http://www.archdaily.mx/mx/02-371108/clasicos-de-arquitectura-restauracion-del-museo-de-castelvecchio-en-verona-carlo-scarpa > [Accessed: 14 August 2014]	92
Figure 5 .8	Contrasting lines [online] Available at < http://www.archdaily.mx/mx/02-371108/clasicos-de-arquitectura-restauracion-del-museo-de-castelvecchio-en-verona-carlo-scarpa > [Accessed: 14 August 2014]	92
Figure 5 .9	Relationship of different materials [online] Available at < http://archistyle.blogspot.com/2009/01/humble-abode-of-day.html > [Accessed: 14 August 2014]	92
Figure 5 .10	New landscapes intergrated into an industrial wasteland [online] Available at < http://scienceabroad2013.blogspot.com/2013/06/dusseldorf-and-beginning-of-hamburg.html > [Accessed: 14 August 2014]	95
Figure 5 .11	Revitalisation of this industrial wasteland [online] Available at < http://omsaiproperties.tradeindia.com/real-estate-projects-1140827.html > [Accessed: 14 August 2014]	95
Figure 5 .12	Relationship between old and new [online] Available at < http://www.abrief.info/wp-content/uploads/2013/12/1312-176.jpg > [Accessed: 10 September 2014]	95
Figure 6 .1	Diagrams adapted from the Rapid Heritage Assessment (author 2014)	99
Figure 6 .2	Diagrams indicating isolation (author 2014)	100

Figure 6 .3	Diagrams illustrating linear movement (author 2014)	100
Figure 6 .4	Diagrams illustrating how one can recreate the lost classical grid (author 2014)	100
Figure 6 .5	The amalgamation of the museum within a productive landscape (author 2014)	101
Figure 6 .6	Concept sketch connecting 3 isolated spaces (author 2014)	102
Figure 6 .7	Relationship of spaces (author 2014)	103
Figure 6 .8	Memory of spaces (author 2014)	104
Figure 6 .9	Abandoned Compound 5 (photo by author 2014)	106
Figure 6 .10	Activating 3 spaces (author 2014)	106
Figure 6 .11	How to alter the existing compound buildings (author 2014)	
Figure 6.12	Diagram provides the framework for the design (author 2014)	107
Figure 7 .1	Concept Sketches (author 2014)	110
Figure 7 .2	Concept Sketches indicating the linear movement between the existing buttress wall and compound rooms (author 2014)	108
Figure 7 .3	Sketches indicating design concept (author 2014)	109
Figure 7 .4	A living barn [online] Available at < http://www.studioprototype.nl/projects/villa_hd/ >[Accessed: 10 September 2014]	110
Figure 7 .5	Diagrams showing how these individual elements can still be read as a barn like structure [online] Available at < http://www.studioprototype.nl/projects/villa_hd/ >[Accessed: 15 July 2014]	110
Figure 7 .6	Model of Villa HD [online] Available at < http://www.studioprototype.nl/projects/villa_hd/ >[Accessed: 15 July 2014]	110
Figure 7 .7	Beautiful example of how to adapt a basic shape without losing its identity. [online] Available at < http://www.studioprototype.nl/projects/villa_hd/ >[Accessed: 15 July 2014]	110
Figure 7 .8	Beautiful integration of materials [online] Available at < http://www.patkau.ca/images/gleneagles_00.jpg > [Accessed: 15 July 2014]	111
Figure 7 .9	Quality of spaces [online] Available at < http://ad009cdnb.archdaily.net/wp-content/uploads/2011/01/1293967256-gcc-in-01.jpg > [Accessed: 15 July 2014]	111
Figure 7 .10	Details and Connections with different materials [online] Available at < http://image.architonic.com/imgArc/project-1/4/5205319/Patkau-Gleneagles-11.jpg > [Accessed: 10 September 2014]	111
Figure 7 .11	Influenced by the roof design [online] Available at < http://www.archdaily.com/100591/gleneagles-community-center-patkau-architects/ > [Accessed: 15 July 2014]	111
Figure 7 .12	Concept Sketches (author March 2014)	112
Figure 7 .13	Concept Sketchplan (author March 2014)	114
Figure 7 .14	Concept Sketch (author March 2014)	114
Figure 7 .15	Concept Sketchplan (author April 2014)	115
Figure 7 .16	Concept Section (author April 2014)	115
Figure 7 .17	Development of Plan (author May 2014)	116
Figure 7 .18	Section moving under buttress wall (author May 2014)	117
Figure 7 .19	Section through Silk production and weavery (author May 2014)	117
Figure 7 .20	Section through Hemp production and Research space (author May 2014)	117
Figure 7 .21	Concept Sketch of pergola for material dyeing (author June 2014)	118
Figure 7 .22	Perspective of Textile production (author June 2014)	119
Figure 7 .23	Further development of pergola space (author June 2014)	119
Figure 7 .24	An exploration of the pergola creating a public space and connect the different buildings (author 2014)	120
Figure 7 .25	A conceptual diagram looking at how this building can connect the courtyard space with the landscape beyond the compounds perimeter. (author 2014)	120
Figure 7 .26	An exploration of roofs in reaction to the existing elements(author 2014)	120
Figure 7 .27	Sketchplan (author July 2014)	121
Figure 7 .28	Diagram indicating movement throughout the site (author 2014)	122
Figure 7 .29	Diagram indicating the relationship of isolation and spaces of relief (author 2014)	122
Figure 7 .30	Diagram of viewpoints in different areas of the site (author 2014)	123

Figure 7.31	Diagram indicating where the building follows historic rituals or breaks from the past (author 2014)	123
Figure 7.32	A section from west to east displaying how the building cuts into the earth and moves out of the compound into the untouched landscape beyond. (author 2014)	124
Figure 7.33	A section from north to south indicating how the new hemp and research facility looks beyond the buttress wall, as well as the relationship between the existing architecture and the new production (author 2014)	124
Figure 7.34	Diagram indicating the three buildings (author 2014)	126
Figure 7.36	Diagrams indicating the changes to building 1 (author 2014)	127
Figure 7.35	3D image of design in iteration 5 (author 2014)	127
Figure 7.37	Diagrams indicating the changes to building 2 (author 2014)	128
Figure 7.38	Public square where material is hung to dry after dyeing process (author 2014)	128
Figure 7.39	Diagrams indicating the changes to building 3 (author 2014)	129
Figure 7.40	Weaving area in Iteration 5 (author 2014)	129
Figure 7.41	Section through weaving room and hemp processing plant (author 2014)	130
Figure 7.42	Elevation of Hemp and Research building in relation to the existing structures (author 2014)	132
Figure 7.43	Model Development (author 2014)	134
Figure 7.44	Model Development (author May 2014)	134
Figure 7.45	Model Development (author July 2014)	135
Figure 7.46	Model Development (author August 2014)	135
Figure 7.48	New building in relation to existing structure (author 2014)	136
Figure 7.47	Isolation to Relief space (author 2014)	136
Figure 7.51	Plan explaining the different buildings function and relationship to the existing (author 2014)	137
Figure 7.49	Building sits behind buttress wall, breaking free of the confines of the compound (author 2014)	137
Figure 7.50	Building is recessed to provide a visual connection with the buttress wall (author 2014)	137
Figure 8.1	Diagrams explaining technical concept (author 2014)	139
Figure 8.2	Material Palette	140
Figure 8.3	Diagram indicating water runoff and rainwater collection (author 2014)	142
Figure 8.4	Diagram indicating where the service areas are located in the building (author 2014)	142
Figure 8.5	Plan of service connections and water management (author 2014)	143
Figure 8.6	Thermal comfort for building 1 in summer (author 2014)	145
Figure 8.7	Thermal comfort for building 1 in Winter (author 2014)	145
Figure 8.8	Thermal comfort for building 2 in Summer (author 2014)	146
Figure 8.9	Exploration diagrams of wind movement and thermal comfort (author 2014)	146
Figure 8.10	Diagram illustrating the structure for building 1 (author 2014)	147
Figure 8.11	Diagram illustrating the structure for building 2 (author 2014)	147
Figure 8.12	Technical exploration of building 1 (author 2014)	148
Figure 8.13	Technical exploration of building 2 (author 2014)	148
Figure 8.14	Site Plan indicating the landscaping within N02 Shaft Compound (Hugo van Niekerk)	150
Figure 8.15	Site plan indicating entire courtyard (Author 2014)	153
Figure 8.16	Ground Floor Plan (Author 2014)	154
Figure 8.17	First Floor Plan (Author 2014)	155
Figure 8.18	Section through hemp building (Author 2014)	156
Figure 8.19	Strip section 1 (Author 2014)	157
Figure 8.20	Detail 1- Window and Desk Detail	158
Figure 8.21	3D representation of Detail 1	159
Figure 8.22	Detail 2- Gutter Detail	160
Figure 8.23	3D representation of Detail 2	161
Figure 8.24	Detail 3- Indicating the Foundations for the Hemp Building	162
Figure 8.25	3D representation of Detail 3	163
Figure 8.26	Section through Building 2 and courtyard space.	164

Figure 8 .27	Strip section of Building 2	nts	166
Figure 8 .28	Detail 4- Foundation detail for steel column	nts	167
Figure 8 .29	3D representation of Detail 4	nts	167
Figure 8 .30	Detail 5- Foundation detail for Building 2 , within the existing compound building	nts	168
Figure 8 .31	3D representation of Detail 5	nts	169
Figure 8 .32	Section indicating building 1 and building 3	nts	170
Figure 8 .33	Detailed section of Building 3	nts	172
Figure 8 .34	Detail 6- Roof Detail of Building 3	nts	174
Figure 8 .35	3D representation of Detail 6	nts	174
Figure 8 .36	Detail 7- Balustrade Detail	nts	175
Figure 8 .37	3D representation of Detail 7	nts	175
Figure 8 .38	3D image of courtyard space		176
Figure 8 .39	Entrance to the Textile mill		180
Figure 8 .40	Dyeing Vats		180
Figure 8 .41	Spinning and Weaving Area		181
Figure 8 .42	Arrivals Area		181
Figure 8 .43	3D image of Final Design		182
Figure 8 .44	3D image of Final Design		184

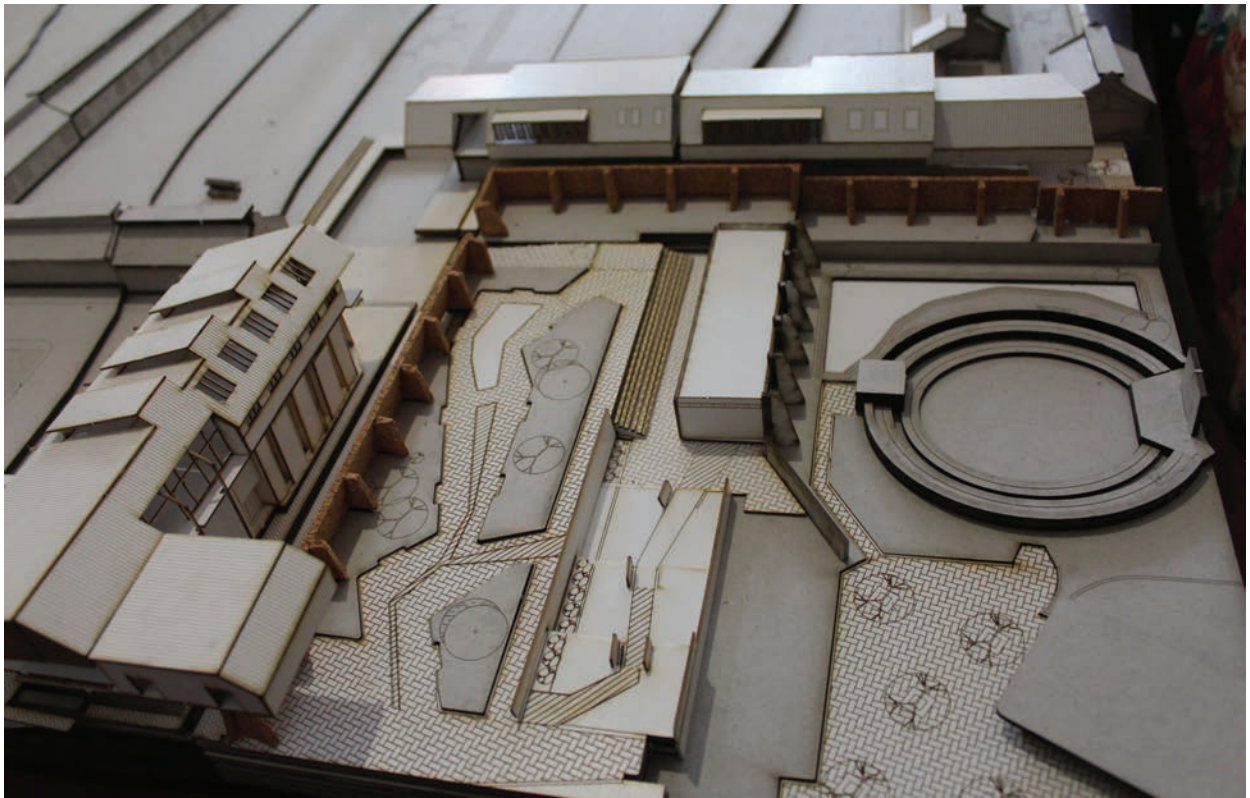



In Accordance with Regulation 4(e) of General Regulations (G.57) for dissertations and theses, i declare that this thesis, which i hereby submit for the degree Master of Architecture (Professional) at the University of Pretoria, is my own work and has not previously been submitted by me for a degree at this or any other tertiary institution.

I further declare that no part of my thesis has already been, or is currently being, submitted for any such degree, diploma or other qualification.

I further declare that this thesis is substantially my own work. Where reference is made to the work of others, the extent to which that work has been used is indicated and fully acknowledged in the text and list of references.

Paige Du Toit
October 2014