



CYBRID AESTHETICS:

Exploring the expressive potential of paper as a material for spatial application to define the new cybrid archive character.

Dissertation by Gerda Scheepers

Submitted in partial fulfilment of the requirements for the degree Master of Interior Architecture (Professional) to the faculty of Engineering, Built Environment and Information Technology.
Department of Architecture
University of Pretoria

November 2016

Study leader: Anika Grobler
Co-Study leader: Prof Raymund Königk
Studio Master: Prof Barbara Jekot

PROJECT SUMMARY

Dissertation title: *Cybrid* Aesthetics: Exploring the expressive potential of paper as a material for spatial application to define the new *cybrid* archive character.

Submitted by: Gerda Scheepers

Study Leader: Anika Grobler

Co Study Leader: Prof. Raymund König

Studio Master: Prof. Barbara Jekot

Degree: Master of Interior Architecture (Professional)

Department: Department of Architecture

Faculty: Faculty of Engineering, Built Environment and Information Technology

University: University of Pretoria

Proposed Programme: Architectural Archive

Site: Eastern wing of the Building Science building a.k.a Boukunde

Address: University of Pretoria, corner of Lynwood Road and Roper Street, Hatfield, Pretoria, South Africa

Research Field: Heritage and Cultural Landscapes

KEYWORDS

Archive

Paper

Research through making

Aesthetics

Cybrid

Artefact

Dematerialization

Digital realm

Physical realm

ABSTRACT

In recent years the concept of dematerialization has had an effect on design professions that rely on materiality for its manifestation. This process has diminished the unique characteristics of design, but through the investigation of making as integral part of the design process, the creative identity and status of design can be strengthened again. This dissertation proposes a parallel process which integrates the act of making into the conventional design process, to address both the material and immaterial qualities of a space.

The focus of the study is to investigate and determine a new spatial language as the digital and physical realms are merging together to create the concept of a *cybrid* space. The Boukunde archive holds opportunity for this investigation to express the new character of a *cybrid* space. Characteristics of both the paper archive and a digital archive are extracted to inform and define the re-representation of the archive in its contemporary context.

Paper at present does not yet have a clearly defined spatial language in the built environment therefore through the exploration of this unconventional material in an innovative way, creates the opportunity for a new interaction and experience. Paper becomes a symbol of the old paper archive that has been re-interpreted in the *cybrid* archive where this new space embodies qualities of both the physical realm and the digital realm that are experienced in novel ways. The paper installation becomes the visual link in the space which captures the essence of the architectural drawing archive.

UITTREKSEL

In onlangse jare het die konsep van dematerialisering 'n invloed op die ontwerp beroepe gehad. Hierdie proses het die unieke eienskappe van ontwerp onderdruk, maar deur die ondersoek van die Research Through Making metodiek as integrale deel van die ontwerpproses, kan die kreatiewe identiteit en status van ontwerp weer versterk word.

Die doel van die verhandeling is om weg te beweeg van konvensionele ontwerp prosesse, deur die proses van maak te versterk sodat die materiële en nie-materiële eienskappe meer geïntegreer kan word in die ruimtelike uitkoms.

Die fokus van die studie is om ondersoek in te stel en te bepaal wat die nuwe ruimtelike taal is wanneer die digitale en fisiese ruimtes geïntegreer word in een nuwe ruimte, as deel van die *cybrid* konsep. Die Boukunde argief hou geleentheid vir hierdie ondersoek om die nuwe karakter van 'n *cybrid* ruimte te ondersoek en uit te beeld.

Papier tans het nie 'n duidelike ruimtelike taal in die bou omgewing nie en dus deur die verkenning van hierdie onkonvensionele materiaal op 'n innoverende manier, skep dit geleentheid vir 'n nuwe ruimtelike toepassing en ervaring. Papier word 'n simbool van die ou papier argief asook die estetiese en funksionele voorstelling van die *cybrid* argief. Die nuwe ruimte vergestalt eienskappe van beide die fisiese and digitale ryke en die papier installasie word die visuele verbinding in die ruimte wat die essensie vna die argitektoniese tekening argief vas vang.



JT Pienaar

Thank you for all your love, patience and support through this year. Thank you for sharing my excitement in the good times, and giving words of motivation in the bad.

Jy is my rots

...en die beste model bouer.

Eloise Thompson

Thank you for being my *kla maatjie* through this year, I would not have been able to do this without you.

In accordance with Regulation 4(e) of the General Regulations (G.57) for dissertation and theses, I declare that this dissertation, which I hereby submit for the degree Master of Interior Architecture (Professional) at the University of Pretoria, is my own work and has not previously been submitted by me for a degree at this or any other tertiary institution. I further state that no part of my dissertation has already been, or is currently being, submitted for any such degree, diploma or other qualification.

I further declare that this thesis is substantially my own work. Where reference is made to the works of others, the extent to which that work has been used is indicated and fully acknowledged in the text and list of references.

Gerda Scheepers



TABLE OF CONTENTS

<i>Cybrid</i> Aesthetics:	i
Project Summary	ii
Keywords	ii
Abstract	iii
Uittreksel	iii

CHAPTER 1: INTRODUCTION 1

1.1	
Dematerialization	2
1.2	
Effects of dematerialization	3
1.2.1	
Fractured space	3
1.2.2	
Need for interaction	4
1.2.3	
Design process	4
1.3	
Research Through Making	5
1.4	
Context	5
1.5	
Paper	5
1.6	
Research questions	6
1.7	
Objectives	6
1.8	
Delimitations	6
1.8	
Defining terms	6
1.9	
Chapter overview	7

CHAPTER 2: METHODOLOGY

2.1	
Dematerialization in design	10
2.2	
Research Through Making	11
2.2.1	
Fabrikaat	11
2.3	
Precedents	12
2.3.1	
Reflections	14
2.3.2	
Synthesised design process	14
2.5	
Conclusion	17



CHAPTER 3: CONTEXT	19
3.1	
Archive	20
3.1.1	
Importance of archives	20
3.2.1	
Site analysis	22
3.2.2	
Operational purpose	24
3.3	
Convergence - <i>Cybrid</i> space	26
3.3.1	
Comparative analysis	27
3.3.1.1	
Beinecke archive	27
3.3.1.2	
Carlo Scarpa archive	28
3.3.2	
Thick Description	29
3.4	
Precedent study	30
3.4.1	
Kanazawa Umimirai Library	30
3.4.2	
James b. Hunt jr. Library	30
3.4.3	
Unnumbered Sparks	31
3.5	
Guidelines	32
3.6	
Conclusion	33
CHAPTER 4: MAKING	35
4.1	
New Materiality	36
4.2	
Paper	37
4.2.1	
Paper in architecture	37
4.3	
Visual study	38
4.3.1	
Shigeru Ban	38
4.4	
Paper objective	40
4.5	
Material exploration	41
4.5.1	
Folds	42
4.5.2	
Paper Maché	43
4.5.3	
Cut and Layer	44
4.5.4	
Conclusion	45
4.6	
Material Analysis	46



4.7		
Aesthetic	47
4.7.1		
Methods of making	48
4.7.2		
Texture	49
4.7.3		
<i>Cybrid</i> characteristics	50
4.8		
Making image	52
4.8.1		
Model 1	53
4.8.2		
Model 2	54
4.8.3		
Model 3	55
4.8.4		
Model 4	56
4.8.5		
Reflection	57
4.9		
Conclusion	59
CHAPTER 5:TECHNIFICATION		61
5.1		
Intervention	62
5.2		
Spatial requirements	64
5.2.1		
Space defining element	64
5.2.2		
Light control	64
5.2.3		
Perceived privacy	64
5.3		
Technification: Reflections	66
5.3.1		
Suspended grid model	66
5.3.2		
Kinetic mechanism	67
5.3.3		
Flexible grid	67
5.3.4		
Glide reflection fold	68
5.3.5		
Multiple V-Fold	69
5.4		
Spatial intervention	70
5.5		
Suspended paper installation	72
5.6		
Grid and kinetic mechanism	74
5.6.1		
Management system	74
5.7		
Grid installation	76
5.8		
Material selection	78
5.8.1		
Durability fold test	78
5.8.2		
Light quality	78
5.8.3		
Conclusion	79
5.8.4		
Tyvek Paper	79



5.9		
Finishing and maintenance	80
5.9.1		
Fire retardant finish	80
5.10		
Fabrication and assembly	81
5.11		
Archive	86
5.11.1		
Archive requirements	86
5.12		
Digital Screens	88
5.13		
Conclusion	92
CHAPTER 6: FINAL REFLECTIONS		95
6.1		
Personal Reflections	96
6.2		
Contributions	97
6.3		
Recommendations	97
6.4		
Conclusion	98
LIST OF REFERENCES		101
7.1		
List of references	102

LIST OF FIGURES

INTRODUCTION

Figure 1.1 Effects of Dematerialization (Author. 2016)	2
--	---

METHODOLOGY

Figure 2.2.1 Material Experimentation (Dezeen. 2012)	11
Figure 2.2.2 Fabrikaat Material Exploration (Dezeen. 2012)	11
Figure 2.2.3 Texture Tectonics Making (Taubman College. 2016)	11
Figure 2.2.4 Texture Tectonics (Taubman College. 2016)	11
Figure 2.2.5 Hybrid Research Strategy (Wherry. 2015:8)	11
Figure 2.3.1 Grace under pressure (O'Neil. 2009)	13
Figure 2.3.2 Knowing through making (Wherry. 2015)	13
Figure 2.3.3 Grace under pressure interpreted process (Author. 2016)	14
Figure 2.3.4 Knowing Through Making design interpreted process (Author. 2016)	15
Figure 2.3.5 Proposed design process (Author. 2016)	15
Figure 2.3.6 Synthesised design process (Author. 2016)	16

CONTEXT

Figure 3.1.2 Boukunde 3rd Floor Plan (Author. 2016)	21
Figure 3.1.3 Photographs of existing archive (Author.2016)	21
Figure 3.1.4 Vision sketch of redefined archive (Author.2016)	21
Figure 3.1.1 Building location on University of Pretoria Main Campus (Author.2016)	21
Figure 3.2.1 Existing reading room	22
Figure 3.2.2 Existing Honours studio	22
Figure 3.2.3 Double volume crit space	22
Figure 3.2.4 Existing floor plan and function	23
Figure 3.2.6 Section(not to scale): Natural light entering the space	23
Figure 3.2.5 Photo board of existing materiality and space.	23
Figure 3.2.8 Conversation and debate (Author. 2016)	25
Figure 3.2.9 Research and learning (Author. 2016)	25
Figure 3.2.7 Operational purpose (Author. 2016)	25
Figure 3.2.10 Presentation space (Author. 2016)	25
Figure 3.3.1 Beinecke Archive (Perez. 2010)	27
Figure 3.3.2 Beinecke archive office (Yale University Library. 2013)	27
Figure 3.3.3 Reading room (Yale University Library. 2013)	27
Figure 3.3.5 Plan and Sections of Beinecke Archive (Stoller. 2010)	27
Figure 3.3.4 Book tower (Perez. 2010)	27
Figure 3.3.6 Screen view of Carlo Scarpa online archive (Author.2016)	28
Figure 3.3.7 Convergence (Author.2016)	28
Figure 3.4.1 Kanazawa Library (Archdaily. 2011)	30

Figure 3.4.2 James B Hunt Jr (Dezeen. 2013)30
Figure 3.4.3 Unnumbered Sparks (Unnumbered Sparks.2016).31

MAKING

Figure 4.3.1 Japanese Pavilion (Anderson. 2014)38
Figure 4.3.2 Close up of Pavilion (Designboom. 2013)38
Figure 4.3.3 Pavilion Detail (Richter. n/a)38
Figure 4.3.4 Detail joinery (Richter. n/a)38
Figure 4.3.5 JR Onogawa station (Hirai. 2015)38
Figure 4.3.6 Hermes pavilion (Designboom. 2011)38
Figure 4.3.7 Cardboard cathedral (Anderson. 2014)38
Figure 4.3.8 Paper Tower (Designboom.2009)38
Figure 4.3.9 Collage of paper products and interior application (Various Sources)39
Figure 4.4.1 Convergence of paper characteristics (Author. 2016)40
Figure 4.5.1 Techniques for making with paper.41
Figure 4.5.3 Sketch development: adaptable plane (Author. 2016)42
Figure 4.5.2 Folds: Material Exploration42
Figure 4.5.4 Associations of folding (Author. 2016)42
Figure 4.5.5 Paper Maché: Material Exploration43
Figure 4.5.6 Associations of paper maché (Author. 2016)43
Figure 4.5.7 Sketch development: Potential application (Author. 2016).43
Figure 4.5.9 Sketch development: layered paper planes (Author. 2016).44
Figure 4.5.8 Layered: Material Exploration (Author. 2016)44
Figure 4.5.10 Associations of cutting and layering (Author. 2016).44
Figure 4.5.11 Qualities of paper(Author. 2016)45
Figure 4.6.1 Material Associations (Author. 2016)46
Figure 4.6.2 Material palette (Author. 2016)46
Figure 4.7.1 Methods of Making (Author. 2016)48
Figure 4.7.2 Spatial Character (Author. 2016)52
Figure 4.8.3 Spatial development sketch: Reflection to model 1 (Author. 2016)54
Figure 4.8.1 Collection of photographs: Test 25 (Author. 2016).54
Figure 4.8.2 Sectional Model 1 (Author. 2016)54
Figure 4.8.4 Collection of photographs: Test 28 (Author. 2016).55
Figure 4.8.6 Spatial development sketch: Reflection to model 2 (Author. 2016)55
Figure 4.8.5 Sectional Model 2 (Author. 2016)55
Figure 4.8.7 Sectional Model 3 (Author. 2016)56
Figure 4.8.8 Collection of photographs: Test 26 (Author. 2016).56
Figure 4.8.9 Collection of photographs: Test 23 and 26 (Author. 2016).57
Figure 4.8.11 Spatial development sketch: Reflection to model 4(Author. 2016)57
Figure 4.8.10 Sectional Model 4 (Author. 2016).57
Figure 4.8.12 Integration of codes and <i>cybrid</i> characteristics (Author. 2016).58

TECHNIFICATION

Figure 5.1.1 Levels of intervention (Author. 2016)	.62
Figure 5.1.2 Demolition section (Author. 2016)	.63
Figure 5.1.3 Demolition plan (Author. 2016)	.63
Figure 5.2.1 Flat ceiling plane (Author. 2016)	.64
Figure 5.2.2 Convex ceiling plane (Author. 2016)	.64
Figure 5.2.3 Concave ceiling plane (Author. 2016)	.64
Figure 5.2.5 Scenario 2: Conversation and debate (Author. 2016)	.65
Figure 5.2.4 Scenario 1: Presentation (Author. 2016)	.65
Figure 5.3.2 Representation of paper artefact (Author. 2016)	.66
Figure 5.3.1 Suspended grid model (Author. 2016)	.66
Figure 5.3.3 Movement of suspended artefact (Author. 2016)	.66
Figure 5.3.4 Kinetic mechanism with staggered cam and arm (Author. 2016)	.67
Figure 5.3.5 Kinetic mechanism (Author. 2016)	.67
Figure 5.3.6 Flexible grid (Author. 2016)	.67
Figure 5.3.7 Dowel and eye hook (Author. 2016)	.67
Figure 5.3.8 Stretched glide reflection fold (Author. 2016)	.68
Figure 5.3.9 Glide reflection fold texture (Author. 2016)	.68
Figure 5.3.10 Fluidity of glide reflection fold (Author. 2016)	.68
Figure 5.3.11 Fluidity of multiple v-fold (Author. 2016)	.69
Figure 5.3.12 Collapsed multiple v-fold (Author. 2016)	.69
Figure 5.3.13 Multiple v-fold texture (Author. 2016)	.69
Figure 5.4.1 Section 1-1 (Author. 2016)	.71
Figure 5.5.1 Suspended installation diagram (Author. 2016)	.72
Figure 5.5.2 Double volume space (Author. 2016)	.73
Figure 5.6.2 Spatial scenarios (Author. 2016)	.74
Figure 5.6.1 Plan view of kinetic mechanism (Author. 2016)	.74
Figure 5.6.3 Section 3-3 (Author. 2016)	.75
Figure 5.6.4 Call out detail: Mechanism (Author. 2016)	.75
Figure 5.7.1 View of conversation and debate spaces (Author. 2016)	.76
Figure 5.7.3 Kinetic armature layout (Author. 2016)	.77
Figure 5.7.2 Static armature layout (Author. 2016)	.77
Figure 5.7.4 Plan indicating grid for installation (Author. 2016)	.78
Figure 5.7.5 Suspended installation (Author. 2016)	.78
Figure 5.7.6 Detail: Kinetic armature and adjustable detail (Author. 2016)	.79
Figure 5.7.7 3D: Timber dowel grid (Author. 2016)	.79
Figure 5.8.1 Fold test (Author. 2016)	.80
Figure 5.8.2 White paper 80g/m2 light quality (Author. 2016)	.81
Figure 5.8.3 Tracing paper light quality (Author. 2016)	.81
Figure 5.8.6 Dupont Tyvek (Author. 2016)	.81
Figure 5.8.4 Kraft paper light quality (Author. 2016)	.81
Figure 5.8.5 Dupont Tyvek light quality (Author. 2016)	.81
Figure 5.10.1 Fold instructions (Author. 2016)	.83
Figure 5.10.2 Fold and perforation pattern (Author. 2016)	.84
Figure 5.10.3 Folded sheet assembly (Author. 2016)	.85

Figure 5.10.4 Layout plan (Author. 2016)86
Figure 5.10.5 Furniture legend (Author. 2016)87
Figure 5.10.6 Section 2-2 (Not to scale) (Author. 2016)87
Figure 5.10.7 Floor finishes plan (Author. 2016)88
Figure 5.10.8 Acoustic ceiling (Author. 2016)89
Figure 5.11.2 View of archive storage space (Author. 2016)91
Figure 5.11.1 3D: Archive (Author. 2016)91
Figure 5.11.4 Ventilation section diagram (Author. 2016)92
Figure 5.11.3 Electrical layout (Author. 2016)92
Figure 5.12.1 View of digital interaction spaces (Author. 2016)93
Figure 5.12.2 3D: Spatial layout (Author. 2016)94
Figure 5.12.3 Digital interfaces (Author. 2016)94
Figure 5.12.4 3D: Shelf details and configuration (Author. 2016)95

LIST OF TABLES

CHAPTER 1: INTRODUCTION

Table 1.1 Contrasting Character of the digital and physical realm (Author. 2016).3
---	----

CHAPTER 3: CONTEXT

Table 3.3.1 Comparative Analysis (Author.2016)28
--	-----

CHAPTER 4: MAKING

Table 4.6.1 Material Analysis (Author. 2016)46
Table 4.7.1 <i>Cybrid</i> Characteristics (Author. 2016)50

CHAPTER 5: TECHNIFICATION

Table 5.7.1 Kinetic grid installation specifications (Author. 2016)76
Table 5.8.1 Fold test observations (Author. 2016)78
Table 5.9.1 Technical specifications of Tyvek (Author. 2016)80



UNIVERSITEIT VAN PRETORIA
UNIVERSITY OF PRETORIA
YUNIBESITHI YA PRETORIA



chapter one Introduction

This dissertation investigates the connection between material and immaterial qualities of both the digital and physical realm to establish the re-representation of the architectural paper archive. This dissertation will place emphasis on the act of making in the design process to achieve an imaginative spatial application of a paper artefact as a creative outcome. The paper as medium for exploration becomes the visual link within the spatial aesthetic of the *cybrid* archive.

Chapter one provides a discussion for the process of dematerialization and the effects on the interior environment as background to the study, from where a series of research questions arise. This is followed by the effect of dematerialization on the design process where after research through making as the methodology to the study is introduced and placed into a larger research context. The effects will be placed in context through the elaboration of the paper archive as the programme for this study. Paper as material choice is introduced as is the nature of the research through making method.

1.1 DEMATERIALIZATION

Over the past few years there has been a shift towards an immaterial culture due to the manifestation of a digital era, and because of this society has become reliant on technologies which influence how we socialize, communicate and work. The increasing application of technologies such as the internet and wireless networks in the physical environments is in the process of changing the perception of our physical environments and the materiality thereof. Van Campenhout (2013:3) defines dematerialization as a field of on-going evolutions which include miniaturization of products, reducing material use by recycling and the shift from matter to information.

For the purpose of this study a deeper investigation will be placed on dematerialization as the shift from matter to information. A simple example given by Roscoe (2005:14) is the dematerialization of photographs, which due to the advances of cameras allows photos to be stored digitally. The traditional paperback photographs are being replaced by digital images that are transmitted through networks and stored in files on computers. The artefact no longer requires a physical container or a place and now not only does the traditional paperback photo disappear but also its supporting structures such as the film camera, the processing labs and photo albums. The tangible paper photograph has shifted to a digital screen as part of the digital realm. The result is that support structure, building typologies and interior environments become immaterial. Interior design is defined by the physical boundaries of architecture and Roscoe (2005:4) states that is therefore indebted to material culture for its manifestation. Artefacts will lose its characteristics in the physical environments and adopt those of the digital world as an

effect of this emerging immaterial culture, which becomes a concern to those who deal with the design of physical environments. The digital era creates great limitations on interior design because it requires more abstract and complex manifestations in contemporary interiors. Roscoe (2005:20) explains that it is not to argue that everything material will completely disappear but rather to highlight the effect it will have on the spaces, and although certain things will disappear, it creates massive opportunity for innovative spatial manifestations.

Roscoe (2007:99) raises important questions such as: What does an immaterial culture imply for the properties and characteristics of physical environments? How will the expanding immaterial culture affect the future identity and status of interior spaces? What are we actually losing and what gets left behind in the place of the digitized artefact? Through this process of dematerialization interior design should establish a firm understanding of how this will affect the tangible spatial experience and how spaces will be perceived. The physical fabric that remains should be redefined to adapt to this changing paradigm.

What does an immaterial culture imply for the properties and characteristics of physical environments? How will the expanding immaterial culture affect the future identity and status of interior spaces?

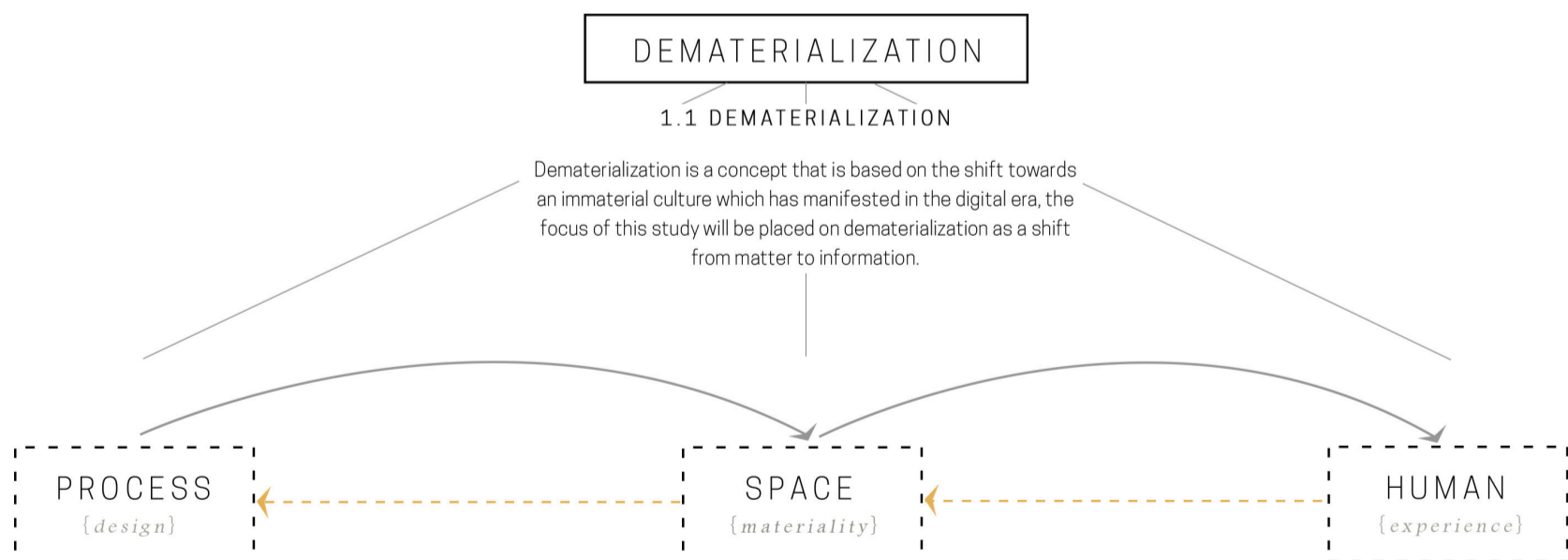

1.2.3 DEMATERIALIZATION OF PROCESS

In recent years the design discipline has become less focused on the production of material things and as more design activities become computer based, it diminishes the significance of material exploration. Resulting in a lack of insight, unimaginative outcomes and a disjointed design process.

1.2.1 FRACTURED SPACE

Roscoe (2005:42) stresses the problem that the digital and physical realm are often considered two separate domains because they are approached and created in isolation to each other and result in disconnected spaces.

1.2.2 NEED FOR INTERACTION

The focus has shifted away from the physical spatial experience toward an immaterial interaction driven by technological devices. This interaction stimulates mostly cognitive skills and dilutes the rich sensory experience of physical spatial interaction.

Figure 1.1 Effects of Dematerialization (Author. 2016)

1.2 EFFECTS OF DEMATERIALIZATION

The effects of dematerialization on interior environments are elaborated in the sections to follow. There are three main aspects that need to be addressed within the context of interior design, which will either diminish the characteristics of our interior environments if left unattended or if seen as a design opportunity, could allow for novel design exploration and solutions. Refer to figure 1.1 for clarity and the relationship between the effects of dematerialization.

1.2.1 FRACTURED SPACE

The differences in characteristics of the digital and physical realm, see figure 1.2.1, is highlighted by Van Campenhout (2013:3). He explains that a physical object is static and cannot suddenly change into something else; the object is dedicated to one task, whereas information is dynamic and can constantly change giving it the sense of temporality. Information can disappear without leaving anything behind whereas a physical object cannot. These differences show that the two realms are disjointed and fractured.

Roscoe (2005:42) stresses the problem that the digital and physical realm are often considered two separate domains because they are approached and created in isolation to each other and result in disconnected spaces. Ishii and Ulmer (1997:1) point out that we live between these two realms, that although they are disconnected they are still parallel because we interact with them simultaneously. We can only interact with the digital through physical but the relationship is disjointed because of their opposite characteristics. The relationship between the two realms becomes a complex area for investigation and how these complexities manifest in interior spaces become an area for intricate design exploration. Refer to Chapter 3 section 3.3 convergence of *cybrid* space for further clarification.

Technologies in the digital era support anytime anywhere activities which alters functional spatial typologies and therefore Roscoe (2005:93) explains that this manifestation of new space requires an intricate investigation into interior design as a study of desire. And she goes on to say that spaces will need to remain flexible

for re-appropriation, but this could have an effect on design aesthetics of spaces as it will become uniform and undefined resulting in a mundane character within spaces. If a space takes on all of the characteristics of cyberspace in order to remain relevant and allowing for constant change, there is a risk of designing spaces that are too flexible and adaptable and not leaving space for any meaningful artefacts.

The presence of the digital realm is altering how space will be used. Where these activities will take place in physical space, is an emerging question that requires a new complex level of investigation from the designer. The change in perception of interior environments should be seen as an opportunity for rethinking and innovative outcomes for the social interaction in a digital era. Chapter 3: Context, offers an in depth elaboration which addresses the re-appropriation of the archive typology to accommodate the characteristics of the *cybrid* space.

The relationship between the two realms becomes a complex area for investigation and how these complexities manifest in interior spaces become an area for intricate design exploration

DIGITAL REALM	PHYSICAL REALM
Intangible	Tangible
Dynamic	Static
Transient	Persistent

Table 1.1 Contrasting Character of the digital and physical realm (Author. 2016)



1.2.2 NEED FOR INTERACTION

Roscoe (2013:42) raises an important question in the following quote which highlights the disappearance of valuable qualities:

What of the tangible, the sensual in the process of increasing immaterial culture? As nostalgic as it may sound, it is imperative that designers embrace a deep investigation of dematerialization to ascertain what is leaving, what is remaining, what is redefined and what is changing in the world. It is imperative for designers to gain a critical analysis on dangers and opportunities offered through dematerialization, and develop a deeper understanding of how it will continue to evolve and expand into the future.

Once an artefact is incorporated into the digital realm, it loses its physical characteristics and adopts those of the digital realm. Because it allows artefacts to break loose from its physical limitations, it becomes dynamic and transient. Although dematerialization creates limitless opportunities it also has many downsides for the human interaction. Van Campenhout (2013:3) highlights that humans are not merely cognitive but action driven beings.

An artefact in the physical realm is tangible and can be touched and understood through its form, texture and materials, all of which gives it meaning. In contrast the information in the digital realm as described by Van Campenhout (2013:2) is intangible and has no shape therefore it is not suitable for human perception. It can only be perceived through mediation of a device and currently these devices appeal mainly to the user's cognitive skills. Anders (2004:135) states that the materiality of spaces is important for creating meaningful spatial conditions where information is interpreted and turned to knowledge. The spaces should offer a context for the appreciation of this information.

The growing immaterial culture raises the question of what is lost in this process. Roscoe (2005:42) highlights that not only does dematerialization translate into the shift from matter to information and the resulting space but she also raises the issues it may have for humans as tactile beings. This places emphasis on the abstract nature of the digital realm and the lack of rich physical interaction which raises the question of how interior environments can be redefined to create opportunity for a richer sensory engagement that integrates the *limitless* characteristics of the digital realm.

1.2.3 DESIGN PROCESS

In recent years the interior design discipline has become less focused on the production of material things and as more design activities become computer based, it diminishes the significance of material exploration. It has resulted in a hands-off design process which could be threatening the creativity of design disciplines. Refer to Chapter 2, section 2.1 Dematerialization in design for further clarification.

1.3 RESEARCH THROUGH MAKING

Due to a growing immaterial culture, the characteristics of the digital have replaced the messy studio based design.

As a counter action to this concept, this dissertation is a response to two preceding projects that dealt with making as a method of research. This study will critically reflect on the projects and contribute to the discipline of interior design by employing the act of making within the design process to achieve more insightful and creative outcomes.

The application of a parallel design process is elaborated in Chapter 2: Methodology, along with a hybrid research strategy developed by Wherry (2015:8) to support the act of making throughout.

1.4 CONTEXT

As a response to the fractured space as an effect of dematerialization, emphasis will be placed on the connection between the digital and physical realm, with the aim to create a seamless integration for the new spatial language. Anders (2004:393) defines a new space where the digital and physical realm is merged into one composition; he denotes this space as the *cybrid*. To place this concept of *cybridity* into the context of this study, the Boukunde archive becomes an ideal specimen for the exploration of the integration of the digital and physical. The *cybrid* concept will inform the character of the re-representation of the Boukunde archive, as it will fuse together the most valuable qualities of both the paper archive and the digital archive.

The site chosen for intervention is located on the Hatfield main campus of the University of Pretoria, in the Building Science building better known as Boukunde which houses the Department of Architecture. The existing architectural archive of Boukunde will be relocated and redefined to create access to valuable information in a contemporary context. The archive will house significant architectural drawing collections which will be stored for proper preservation whilst allowing visual access to actual artefacts. The intention is to expose the archiving process to students as well as creating access to the drawings and artefacts.

1.5 PAPER

In the nature of research through making, paper is chosen to support the act of making throughout the design process.

Paper is a material present in our everyday lives that is perceived as a fragile and unsophisticated product, but for the purpose of this study, paper will be investigated as an expressive medium for interior spatial intervention. The intention is to redefine the spatial language and perception of this very versatile and dynamic material by expressing its unique characteristics through novel application within the architectural *cybrid* archive. The paper will become the visual link between the digital and physical realm through the application of a spatial intervention. Refer to Chapter 4 section 4.2 and 4.3, for further elaboration on paper as a medium for design exploration.

1.6 RESEARCH QUESTIONS

1. What does an immaterial culture imply for the properties and characteristics of physical environments and how will we redefine the things that stay material?
2. What is the new aesthetic character of the *cybrid* space?
3. What are the possibilities and limitations of paper as a material for intervention in interior environments?
4. How can a material driven design process influence the expression of a material in the final spatial outcome?
5. How does the act of making manifest within the interior design discipline?

1.7 OBJECTIVES

1. To explore and express the unique characteristics of paper through a three dimensional spatial intervention.
2. To explore paper as the aesthetic link between the physical and digital realm.
3. To further develop and contribute the proposed process and methods of research through making within the interior design discipline.
4. To define the characteristics and aesthetic language of the *cybrid* space by creating a seamless integration between the digital and physical realm.
5. To create access to significant cultural and historical archived information and determining the re-representation of the archive in a contemporary context.

1.8 DELIMITATIONS

- + This study is driven by material and therefore the conventional method of defining space through spatial layout as initial design phase will not be followed.
- + This study will not investigate paper as a sustainable or recyclable material for building application.
- + This study will not focus on the interface design of the technological device. The design will serve as support to the device.

1.8 DEFINING TERMS

The following is composed from various sources and sources are indicated where necessary. The Oxford Dictionary online was used for the general definition of terms.

DEMATERIALIZE: v. 1. Become free of physical substance. Dematerialization is the process where matter shifts to information and becomes part of the digital realm.

DIGITAL REALM: Van Campenhout (2013:2) defines the digital realm as information and data in the form of bits and bytes that is not perceivable to the human senses, it only manifests through an object, see *device*.

PHYSICAL REALM: The physical environment contains substances like animals, humans, objects which are made up of tangible 'things' but for the purpose of this project the physical environment will refer to all artefacts and interior spaces habitable for humans.

CYBRID: *Cybrid* space is the convergence of spatial domains where the physical and cyberspace is merged into one space. It is a space that is defined not by only one or the other, but by both as explained by Anders (2004:133).

ARCHIVE: n. 1. A collection of historical documents or records providing information about a place, institution, or group of people. 2. The place where historical documents or records are kept.

Archive is not limited to historical documents and includes all artefacts that hold significant cultural and historical value which usually only one of its kind exists.

PAPER: n. 1. Material manufactured in thin sheets from the pulp of wood or other fibrous substances, used for writing, drawing, or printing on, or as wrapping material. 2. A sheet of paper with something written or printed on it.

Paper is a thin flexible sheet of material which can be used as a flat mechanical object or be manipulated into three dimensional artefact.

ARTEFACT: Königk (2015:44) defines artefact as all cultural residue.

DEVICE: n. 1. A thing made or adapted for a particular purpose, especially a piece of mechanical or electronic equipment.

The mediating object through which information of the digital realm manifests in order to make it perceivable to the human senses.



1.9 CHAPTER OVERVIEW

Chapter 1: The chapter introduces the context in which the study will take place. The chapter gives a clear outline of the objectives of the study.

Chapter 2: Methodology of study is placed in a larger research field where this dissertation becomes an iteration on two preceding projects that dealt with the act of making. The aim of this study is to contribute new knowledge to the concept of research through making. A general synthesised design process is elaborated that essentially guides the process followed for the study.

Chapter 3: The chapter is introduced as a response to the background theory given in Chapter 1, where the concept of *cybrid* space will be elaborated. A comparative analysis of a digital and physical archive becomes the core of the investigation and is supported by precedent studies, from which a set of guidelines are established. The Boukunde architectural archive is introduced as the programme for the intervention and the re-representation of the archive is investigated.

Chapter 4: The process of making is introduced along with paper as the material for interior application, where after a visual study and a series of intuitive material explorations follow. The chapter concludes with the documentation, observation and reflection of sectional models as part of the second phase of making. The chapter defines the aesthetic character and requirements for the technification of the space.

Chapter 5: This chapter deals with the design application and technification of the paper artefact as the third phase of the making process, where the detail and fabrication of the paper artefact is investigated, documented and reflected. This chapter includes a series of technical drawings, details and perspectives to express the final spatial outcomes of the design and making process.

Chapter 6: This chapter is a final reflection on the work and research done through the act of making. This chapter includes contributions made by the study as well as recommendations for further study.



UNIVERSITEIT VAN PRETORIA
UNIVERSITY OF PRETORIA
YUNIBESITHI YA PRETORIA



chapter two Methodology

In the post digital age, an increasing proportion of design practices are adopting hybrid modes of experimentation, and even rejuvenating techniques such as hand drawing, model making, craft or the testing of ideas in actual rather than virtual environments. Techniques that were once consigned to the distant past are being renewed as tools that offer results in a way that digital counterparts cannot Sheil (2008:8).

Dematerialization has an effect on the design process which creates limitations to the design outcome, therefore an alternative process is chosen for this study which responds to two preceding projects done through the act of making. Making as a method of research is implemented to support and contribute to the larger body of knowledge of the interior design discipline.

This chapter elaborates on the effect of dematerialization and the value of making and interacting with material where after the study is placed in context with two preceding projects. These projects are analysed and critically reflected on to determine the goals for this study. A design process is also generated to serve as guide for the tasks to be performed throughout the course of the design and making exploration.



2.1 DEMATERIALIZATION IN DESIGN

Over the last two decades the design disciplines have become less focused on the production of material things as well as a decline in material learning in art and design education, and more concerned with immaterial interactions. Computer aided design has become the main tool for spatial modelling and design and has replaced the messy studio based workshops. It has resulted in a hands-off design process which could be threatening the creativity of design disciplines. Ward (2015:228) highlights the concerns of the decline in workshops in design education, that it destroys the *playful exploration and sensitive understanding of the material domain*.

As more design activities become computer based it diminishes the significance of material exploration, however there has in recent years been a growing interest toward the handmade. Ward (2015:229) speculates that this could be nostalgia for simpler times. Design academics have tried to give design a serious, thoughtful status which has intellectual opportunity by moving away from material exploration as a tool for design. This process has diminished the unique characteristics of design and through the investigation of making as integral part of the design process we are strengthening the identity and status of design again. Ward (2015:229) state that designers make things to achieve a deeper understanding and it allows them to push the boundaries of knowledge.

Roscoe (2005:32) illuminates the cultural shift towards immateriality, which will continuously challenge its material counterpart and for this reason designers will have to adapt to this new paradigm and challenge their own processes. It is imperative to define what is of most value and relevance in current and future environments to have a clear understanding in moving forward in what they do and how they will do it. Through the act of making in the design process it allows the designer to reconnect with the materiality and an intimate understanding of the artefact will result in better spatial applications.

As technology increasingly becomes part of our everyday experiences it is creating a new awareness of our physical surroundings and the significance of materiality. The qualities of the material realm has always been a great source of inspiration to designers and the bodily interaction through the act of making with these materials becomes a source of stimulation to the imagination, and according to Treadaway (2009:231) it illuminates how it feels to be physically, emotionally and intellectually involved in the creative process. The process of making stimulates and inspires innovative ideas through new insight to the material or artefact.

Making by hand is a slow process which allows the designer to think, develop ideas and make decisions during this interaction and should be an encouraged process as it creates opportunity for imaginative thought. The spirit of that artefact lies in the process of making it.

Piet Zwart Institute
Angelique Etman and Marie
Gade-Lundlie
Fabrikaat



Figure 2.2.1 Material Experimentation (Dezeen, 2012)



Figure 2.2.2 Fabrikaat Material Exploration (Dezeen, 2012)

Taubman College
Ellie Abrons & Adam Fure
Research through making
2015



Figure 2.2.3 Texture Tectonics Making (Taubman College, 2016)

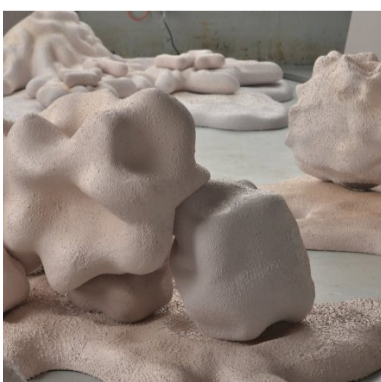

Figure 2.2.4 Texture Tectonics (Taubman College, 2016)

2.2 RESEARCH THROUGH MAKING

This dissertation moves away from conventional methods of design and aims to address both the material and immaterial qualities of spaces as explained above, through the act of making. The research method implemented is defined through the act of making otherwise defined by Candy (2006:1) as an investigation undertaken to gain new knowledge through means of practice and the creative outcome of that practice, this is defined as a Practice Based Research Method.

This dissertation is an iterative response to two preceding projects that dealt with the act of making as a method of research within the design process. Both the projects were done by students in the Masters Interior Architecture programme at the University of Pretoria.

1. O'NEIL, E. 2009. Grace under pressure: investigating a design response in the event of a disaster. Unpublished MInt Dissertation. Pretoria: University of Pretoria.
2. WHERRY, L. 2015. Knowing through making: an investigation into the construction of hand knotted textiles and their collective application as textile space defining elements within the interior. Unpublished MInt Dissertation. Pretoria: University of Pretoria.

Wherry (2015:8) states that the success of this research method relies on rigorous documentation of the process as well as the artefact's role in the creative process and therefore proposes a hybrid strategy where the practice based research is supported by an Action Research Method which could support the act of making through rigorous observation, documentation and reflection, refer to figure 2.2.1. Zuber-Skerrit, 2001 as found in Wherry (2015:16) defines action research as being a cyclical iterative process where reflections are made on actions preformed. The actions research includes planning, action, observation and reflection on this process.

Knowing through making therefore signifies a definite shift away from the more established research methods that operate from the 'known to the unknown' towards Practice-based Research that operates from the 'unknown to the known' (Wherry, 2015:8).

Wherry (2015:17) states the creative artefact contributes significant knowledge to the study obtained through the making process that is described in words as a outcome of the hybrid research strategy, refer to figure 2.2.5. Wherry further elaborates the importance of the creative artefact as playing the key role to collect data essential to the study.

2.2.1 FABRIKAAT

To place this methodology within a larger context, Fabrikaat and Research Through Making at the Taubman College are used as precedents where research through making is implemented at educational facilities in an international context where research is conducted through the creative act of making which results in a creative tangible outcome refer to the precedents to the left of the page.

Fabrikaat is an exhibition which took place at Ventura Lambrate which investigated the role of the garden with research through making as method for design exploration and celebrates the idea of making by hand. The projects were done during a three month design studio by students of the Master of Interior Architecture and Retail Design programme at the Piet Zwart Institute in the Netherlands. Craft was the inspiration to the design projects and the approach to craft raised questions such as what can be learned through making by hand in a digital age? Can new material behaviours and applications emerge from the research through making approach?

Students worked in teams and became experts in specific techniques such as cutting/folding, knitting/weaving, moulding, and cutting/scoring. They spent extensive periods of time in rigorous, unadulterated experimentation mode - exploring materials, their behaviour, techniques and applications. This process informed the design parameters for the development of the investigations and full-scale projects (Dezeen, 2012).

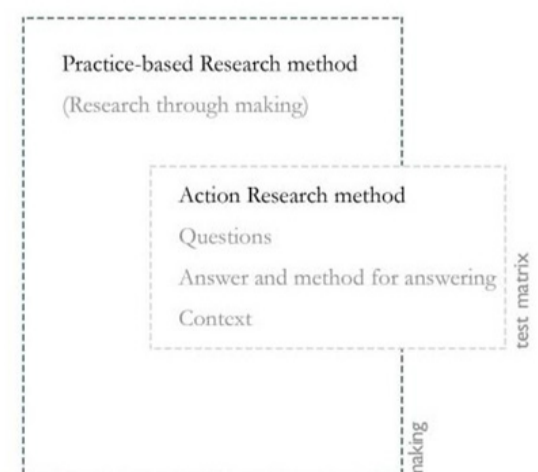

Figure 2.2.5 Hybrid Research Strategy (Wherry, 2015:8)

2.3 PRECEDENTS

The projects were used as precedent and therefore a critical analysis of the documents is required to establish the shortcomings and contributions of both:

1. O'NEIL, E. 2009.

2. WHERRY, L. 2015.

Using these dissertation documents as starting point supported by verbal communication allowed for clear understanding of where contributions were made and how this dissertation could respond to that.

1. Grace under pressure: Investigating a design response in the event of a disaster:

Project was not formally defined as 'research through making', but the making with cardboard as material was a response to a pragmatic requirement and therefore lacked the exploration of the material in all its manifestations. The project resulted in an unfinished design due to the lack of a clear research methodology. Raw data was not formally documented and although iterations would have been done, the process is unclear.

The following contributions were made by the study:

+ The study contributed to the body of knowledge of interior design by exposing the possibilities of interior design within the larger context of the built environments.

+ The study contributed to defining the importance of interior space not as an addition to, but rather a critical completion of architecture.

+ The act of making as a method to test and develop the design outcome contributes to the discipline of interior design as a method of research.

2. Knowing through making: an investigation into the construction of hand knotted textiles and their collective application as textile space defining elements within the interior:

This project employed the *research through making* as design and research strategy where focus was placed on making data instead of collecting. There was little knowledge of the implementation of this process within the interior design discipline, and great amount of effort was placed on this unconventional research methodology. The hybrid research strategy created obstacles when alternating between act of making and conventional design techniques, where long periods of time was focused on only one or the other.

The implementation of an unconventional research process proved to be time consuming and took attention away from a site specific and programmatic design response. The material was explored and developed, separately from the site, as a textile unit and the possible spatial applications were there after investigated. The hand knotted textile unit lacked dimension and remained two dimensional through the exploration. The space was treated as a testing site for the textile unit where the creative outcome was applied to rather than being influenced by.

Wherry (2015:102) listed the following contributions of the study:

+ *The study makes a contribution to the discipline of interior design at the University of Pretoria by applying a hybrid research strategy that includes the Practice-based Research method.*

+ *The study makes a contribution to the discipline of interior design as it employs the act of making as a way to do research. The discipline of interior design is concerned with interaction between the user and its environment, yet the current design process is far removed from this tactility.*

+ *The study contributes to the present discussions regarding the definition of the boundaries of the interior design discipline in relation to the architectural discipline and the architectural profession.*

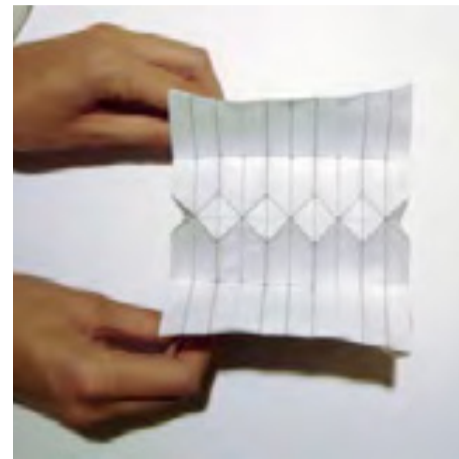
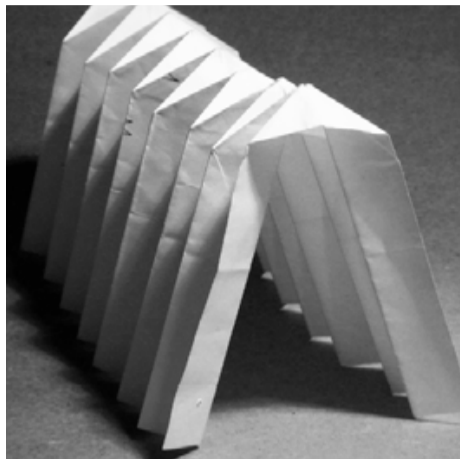

Figure 2.3.1 Grace under pressure (O'Neil, 2009)

1. O'NEIL, E. 2009. Grace under pressure: investigating a design response in the event of a disaster. Unpublished MInt Dissertation. Pretoria: University of Pretoria.

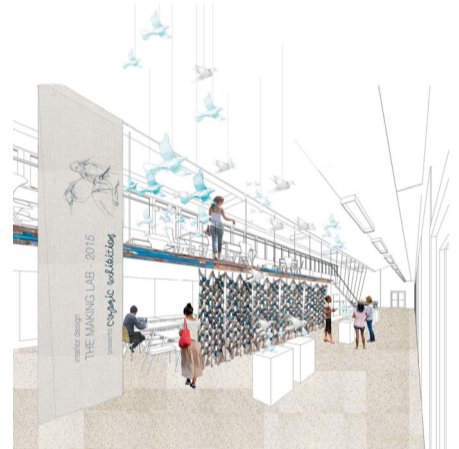

Figure 2.3.2 Knowing through making (Wherry, 2015)

2. WHERRY, L. 2015. Knowing through making: an investigation into the construction of hand knotted textiles and their collective application as textile space defining elements within the interior. Unpublished MInt Dissertation. Pretoria: University of Pretoria.

3.

CYBRID AESTHETICS

Exploring the expressive potential of paper as a material for spatial application to define the new *cybrid* archive character.

2.3.1 REFLECTIONS

From the shortcomings identified through the analysis of the preceding projects, the following reflections are made in order to respond and contribute to the field of study.

A clear methodology is of utmost importance for contributing new knowledge through the making process. The hybrid research strategy will be applied as precedent for the making and investigation process of this project which consists of rigorous documentation, observation and reflection that is crucial for the design development.

A parallel process will be followed for this study which places focus on both the act of making along with conventional design development of the site and programme. The aim is for one process to influence the other constantly throughout to achieve a well-integrated spatial outcome. This dissertation aims to achieve a better resolved spatial resolution as a whole where artefact is not perceived as a product but should contribute to the spatial aesthetic and become seamlessly integrated into the intervention.

The site and material development should be integrated from the initial phases of the design process and should not be approached as two separate methods. Refer to figure 2.3.5 Proposed design process, where the development of the spatial intervention is approached as a parallel process. It is important to reach a clear understanding of the possibilities and limitations of the material in the context of the site.

2.3.2 SYNTHESISED DESIGN PROCESS

Critically looking at the preceding projects a preliminary design process is developed to gain more clarity of the steps that should be followed to achieve the required outcomes of the project brief. These steps are listed as a parallel process that should be followed where the one informs the other. Refer to figure 2.3.6 on page 16. This process serves as guideline for the project in order to achieve a resolved spatial and creative outcome.

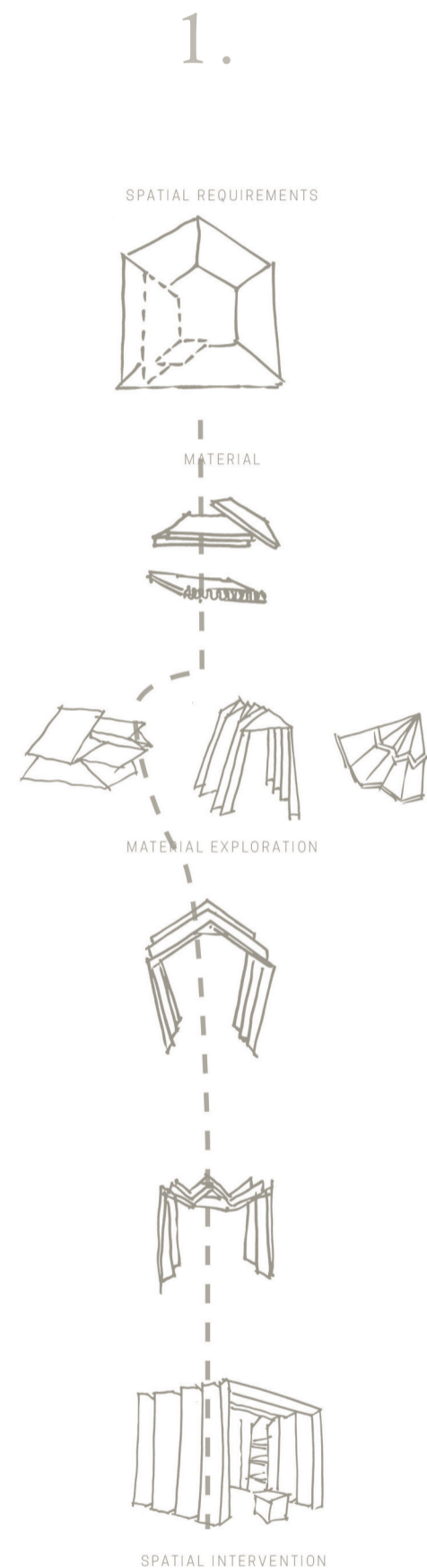

Figure 2.3.3 Grace under pressure interpreted process (Author. 2016)

2.



Figure 2.3.4 Knowing Through Making design interpreted process (Author. 2016)

3.

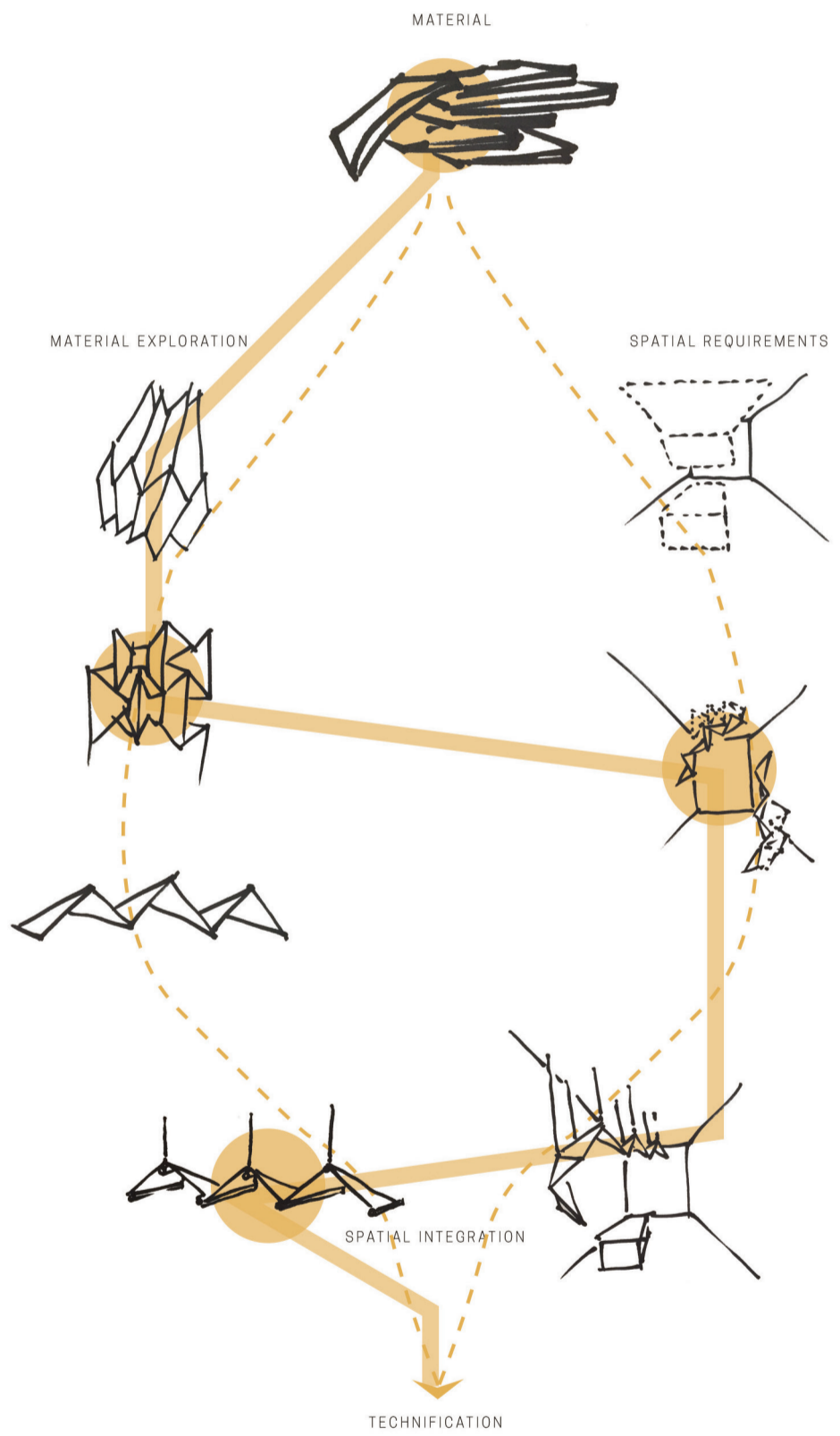

Figure 2.3.5 Proposed design process (Author. 2016)



Context should also be given in order to theoretically position the issue. Literature review is conducted in order to identify the sources to support the argument and define the issue.

METHODOLOGY

The methodology for the study need to be identified and clearly defined to place the study within a specific context.

MATERIAL

Verghese (2007:204) states that we should stop seeing material as just the outcome but rather give character to and start making material an essential part of the design process. Material should be identified that offers opportunities for development and investigation. The material should support the theoretical issue through the process of making and design application. It is not necessarily the use of new technologies but rather new approaches to old technologies, innovative ways to apply and rethink what materials can become or would be able to do.

SITE AND TYPOLOGY

The theory researched will inform the typologies considered for the project. The choice of typology should be able to support the theory and the application and testing of the material choice. Material, site and programme should be integrated as one unit for research and design development.

VISUAL STUDY

Images will be collected to aid as a visual study for determining the current use and design of the material; to position it and come to a conclusion of the current status of paper as building material. The collection of visual data will be used to create a visual board that will serve as a visual study to identify unique characteristics and craft methods of paper, which will support the material exploration.

SPATIAL ANALYSIS

A conventional site analysis will be done to achieve clarity of the opportunities as well as limitations of the site. The requirements for the functional use identified in earlier steps will be determined within the parameters of the site. Scenarios for the use of the space will be investigated to support the support the spatial requirements.

1st Phase of Making

MATERIAL EXPLORATION

The samples made will be rigorously documented, for limitations and opportunities to be identified. Material type, format and method need to be specified throughout the documenting process.

THEORETICAL APPLICATION

The theory research will be applied to the specific requirements of the site and typology. Design intentions, opportunities and limitation need to be determined based on conclusions made through the relationship between the space and theoretical approach.

2nd Phase of Making

MAKING IMAGE

The samples made in a preceding step will be explored through further making of 3 dimensional spatial image with the support of photographs, samples, models and sketches.

CHARACTER

Methods for achieving this character of the space need to be identified.

INTERIOR ARTEFACT

Through the exploration of image and character of space more clarity should be reached on what the creative outcome of the material study would be. Specific requirements need to be identified for further development of the craft method. Constraints and parameters need to be set in place for the development of the interior artefact and the spatial development.

3rd Phase of Making

TECHNIFICATION

The material artefact will be developed in further detail where technical development and construction techniques will be investigated through the act of making. Instructions for the fabrication of the artefact will be developed.

Figure 2.3.6 Synthesised design process (Author. 2016)



2.5 CONCLUSION

Through the critical analysis of the two projects a clear understanding was achieved which serve as guide to the process of making as well as the objectives that need to be achieved for the final spatial outcome. The parallel process proposed in this chapter will be tested and used to achieve the goals set out in Chapter 1 and 2.

The following chapter places the study in context, where the site and programme for investigation is elaborated. The investigation in Chapter 3 sets out a basic guide for the design and making explorations to follow. The material chosen to strengthen the proposed programme and support the act of making will be investigated in Chapter 4: Making, where the act of making and documentation of the parallel process is clearly expressed.



UNIVERSITEIT VAN PRETORIA
UNIVERSITY OF PRETORIA
YUNIBESITHI YA PRETORIA

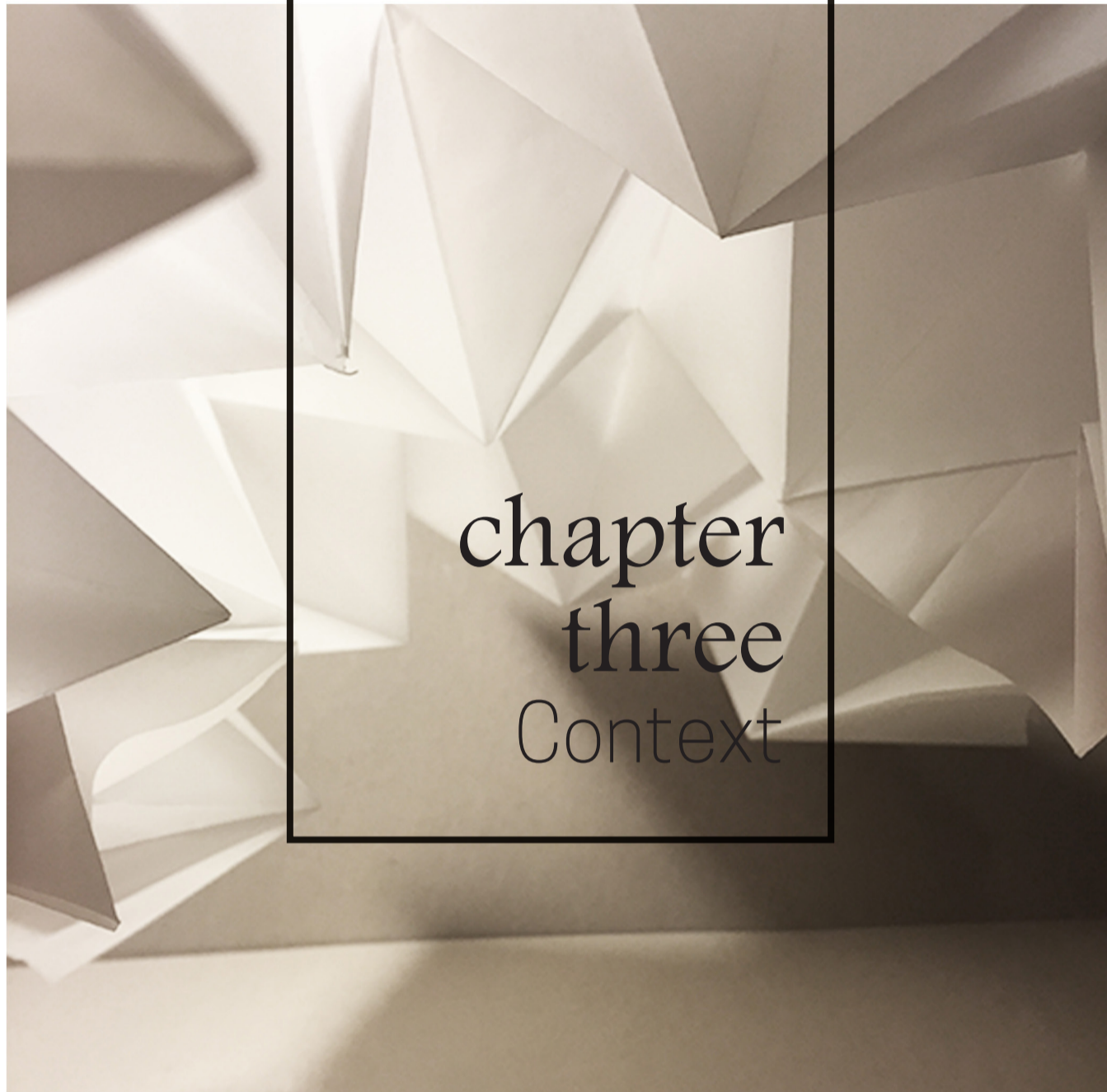

chapter three Context

The archive is currently going through a process of dematerialization, where artefacts are losing their tangible qualities and becoming part of the digital realm, resulting in a space that has become redundant and perceived to be insignificant in the digital age.

The architectural archive of Boukunde holds valuable and significant cultural information but is currently inaccessible and has become an insignificant fractured space, as the result of its digital counterpart.

The objective of this investigation is focussed on the analysis of the character of both the physical and digital archive in order to determine a new character for the concept of a *cybrid* archive.

This chapter focuses on establishing the connection between the paper archive and the digital archive, to define the re-representation of a new vibrant space, accessible to users, in a contemporary context. The chapter introduces the site and location for the application of the *cybrid* concept while emphasising the importance of the physical sensory spatial experience of the interior space through the use of a comparative analysis.

3.1 ARCHIVE

Archives are defined by The National Archives (2016) as an accumulation of documents or records selected for their long term cultural and historical value and these records are created by the activities of individuals or organizations over a period of time. Archive is also the physical place where these documents are kept and preserved. The International Council on Archives (2016) defines a characteristic of archives as being authentic, where usually only a single copy of a document exists, making it unique and therefore important to be properly stored, managed and preserved for current and future use. Archive is not only defined by paper documents and can take form in various digital or analogue media.

3.1.1 IMPORTANCE OF ARCHIVES

An archive is a reminder of the past, but more importantly, it is a source of knowledge, caution or inspiration for the future Barker (2016:6).

Barker (2016:6) states that international and locally legislated institutions manage and coordinate the preservation of artefacts for future use and the University of Pretoria is amongst many other universities in South Africa which houses architectural archives that contributes to the continuum of architectural work in South Africa.

The site and typology selected for the investigation of the connection between the digital and physical realm is the architectural archive of the University of Pretoria which was established in 1966. The archive is housed by Boukunde which acts as home to the Department of Architecture; the department accommodates three fields of study namely Architecture, Interior Architecture and Landscape Architecture.

The archive started with only a few drawings and has grown into a valuable collection of documents of almost 80 significant physical and digital archival collections which has been collected by staff members over the years. The archive committee of the department continues to actively engage in this endeavour to collect, index and digitize the archival material which holds significance to South African architecture.

The collections of the UP architectural archive are unique in that they are representative of a continuum of architectural production and thinking since the turn of the 20th century, and focus on regional thinking Barker (2016:9).

The archival material consists of original drawings and portfolios from architectural practices which represent the legends of their time. At present the archive houses physical collections from architects like Norman Eaton, Gordon McIntosh, Herbert Prins, Philip Nel amongst many others. The archive also houses other physical artefacts such as an extensive slide collection, maps, photographs, documents about Pretoria as well as works of art. The physical archival collections are housed in Boukunde while the digitization of the material gives anytime anywhere access to the digital collections housed on the UP Space online platform. The architectural archive has a significant contribution to the education and research activities of the architectural department and the value of this information should be made more contemporary and accessible.

Barker (2016:9) explains that the aim of the departmental committee is to express the value of these architectural artefacts through continuous process of collecting, sorting, indexing and digitizing. The mission is to collect curate and disseminate information that are or could be of value to interested parties and to focus on how to make material more accessible.

The Boukunde archive in its current state is unorganized and inaccessible, due to spatial limitations. The archive has become seemingly redundant in the contemporary context, refer to section 3.2.1 site analysis and comparative analysis, where the process of dematerialization has allowed for documents to be made more accessible through digital platforms. The result is the perception of a space filled with old dusty shelves and a lack of understanding and insight to the value of the archive. This is the residual effect of a fractured space, refer to Chapter 1 section 1.2.1, where the digital realm and physical realm have not been integrated and is deprived of its opportunity due to the lack of an innovative spatial resolution.

Although the paper artefacts are leaving the physical realm and forming part of the digital realm, the need to interact with and access the information remains and the vision of this design intervention is focused on re representation of what the archive could be in a contemporary context.

There are a few limitations that arise from the character of the digital archive which is the main driver of this study. With the scale of architectural drawings, there is a need to view the digital version in full scale and not be limited by the dimensions of a small computer screen. Investigation originated from the question of how can digital architectural drawings be perceived in context and full scale?





Figure 3.1.1 Building location on University of Pretoria Main Campus (Author.2016)

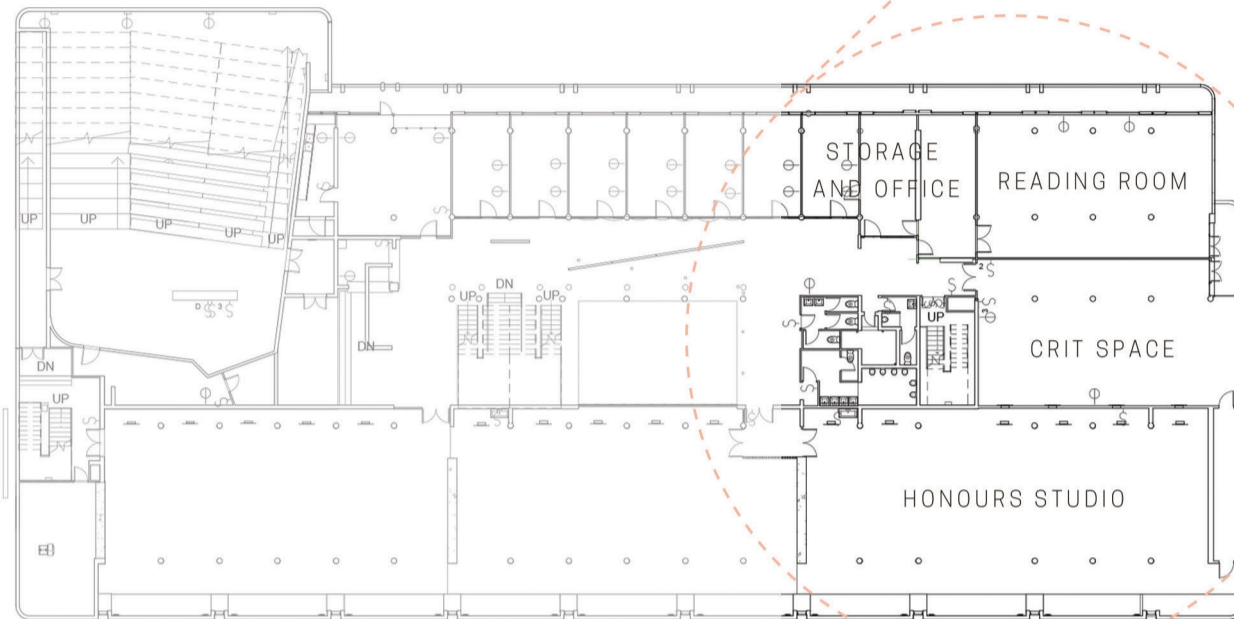

Figure 3.1.2 Boukunde 3rd Floor Plan (Author. 2016)



WHAT IT IS...



Figure 3.1.3 Photographs of existing archive (Author.2016)

WHAT IT COULD BE...

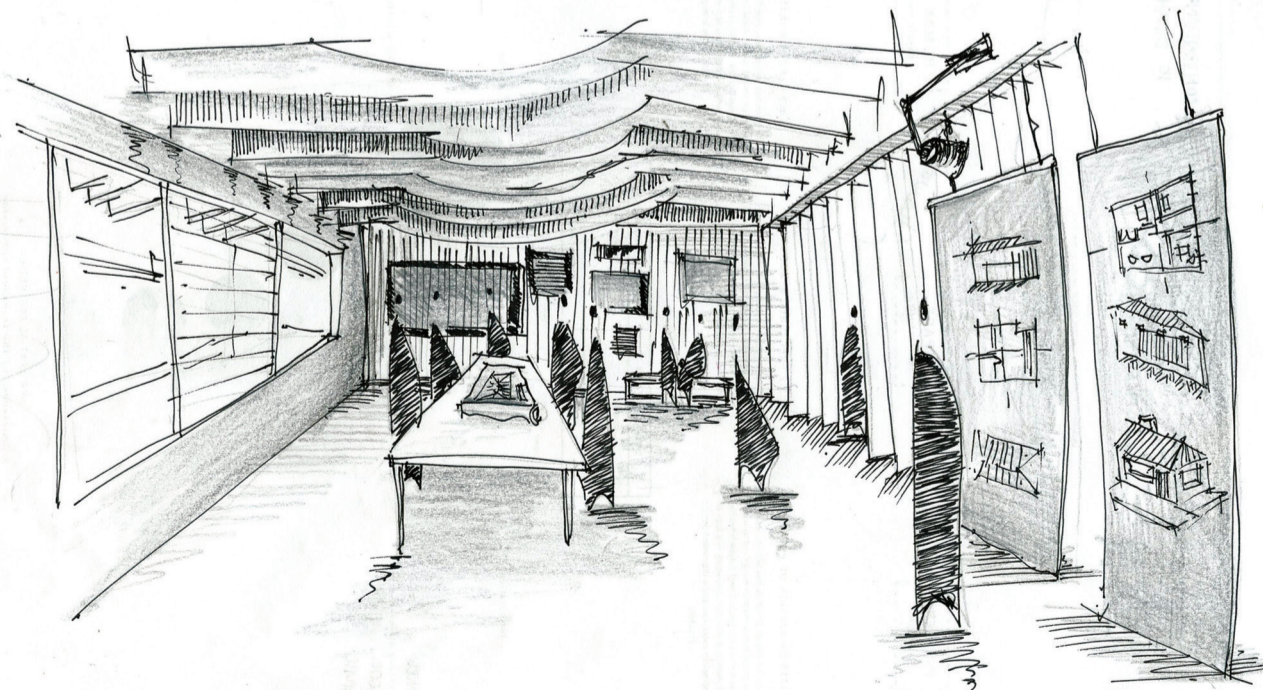

Figure 3.1.4 Vision sketch of redefined archive (Author.2016)



3.2.1 SITE ANALYSIS

The site for intervention is located in the Building Science building also known as Boukunde, which is located on the main campus of the University of Pretoria. Boukunde is home to the Department of Architecture, which accommodates three fields of study namely Architecture, Interior Architecture and Landscape Architecture. The focus of this study is placed on a operational purpose already found in the building as an extension of the educational typology.

Site parameters: The spaces dedicated to the preservation of the archive artefacts are currently located on the 1st floor of the building. These two rooms were not intended for this purpose and therefore the confined spaces create limitations to the use and access of the architectural archive. Due to these limitations the archive artefacts are scattered into other spaces within the building such as the reading room. The artefacts stored in the reading room are not well preserved as the store room does not fulfil the requirements of an archive such as the control of temperature, light, humidity and security.

This dissertation investigates the relocation of the archive to the proposed site where requirements will be addressed accordingly. See figure 3.1.2 for the proposed location of the Boukunde archive. The reading room, the adjacent double volume crit space and the honours studio will be used as the site for the re-representation of the Boukunde archive. The current functions of the site will be adapted or moved to appropriate locations within the building.

Existing materiality: The existing material palette of the building consists of various rigid, hard and mismatched materials and colours. A unique feature of the building lies in the vertical, linear and repetitive forms and surface treatments, see the collection of photographs in figure 3.2.5 on page to the right, these are elements which should be taken into consideration for the interior intervention as response to the existing.

Volume: The double volume contributes to the unique character of the building, as it is a design element that manifests throughout the building see figure 3.2.5. The volume of the space holds potential for a novel design intervention and should enhance this characteristic of the building.

Light: Both the existing reading room and crit space are flooded with natural light entering from the skylights in the double volume as well as the north facing glass façade/window as expressed in figures 3.2.10 and 3.2.19. During winter months direct sunlight enters the space which is undesirable as it creates glare on the floor surfaces. During summer the harsh sunlight is blocked out but the space remains extremely bright. The treatment of the northern

window façade should be investigated to create a more desirable interior environment. The specific requirement for the lighting in the space will be discussed in Chapter 5 section 5.11.

Ventilation: Currently the existing office space and reading room do not have artificial ventilation and no effective natural ventilation although there are windows in the north facing facade there is no opportunity for cross ventilation. The existing honours studio is mechanically ventilated with south facing windows which do not have effective natural ventilation.

The current ventilation and climate of the space is not sufficient for the new use of the space, therefore opportunities and limitations identified in this section will be explored. The requirements for indoor environmental quality for an archive will be discussed in Chapter 5 section 5.11.



Figure 3.2.1 Existing reading room



Figure 3.2.2 Existing Honours studio



Figure 3.2.3 Double volume crit space

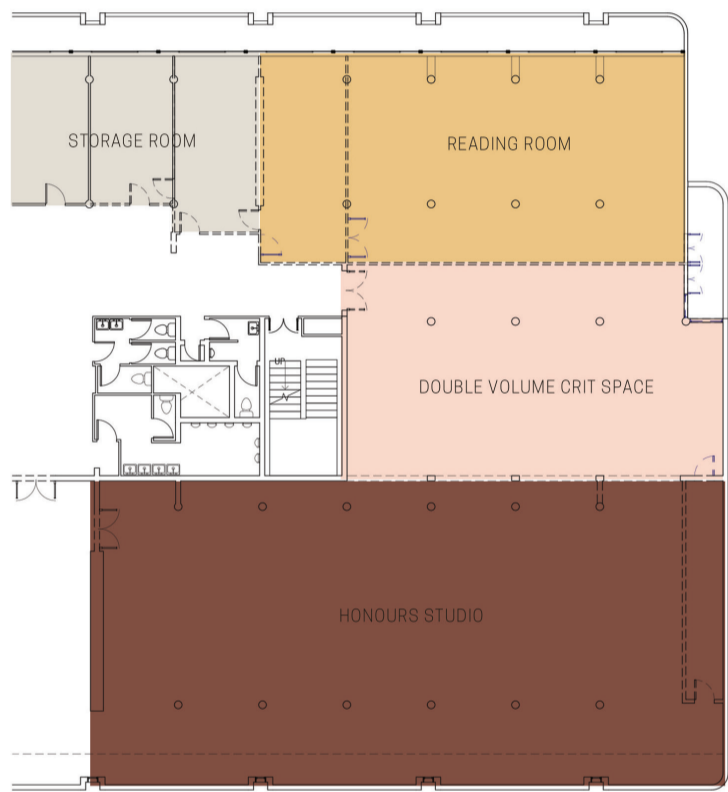

Figure 3.2.4 Existing floor plan and function

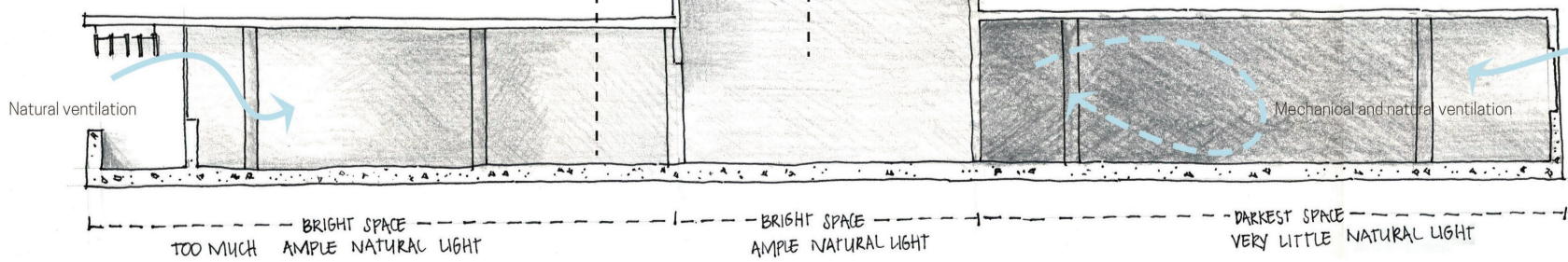
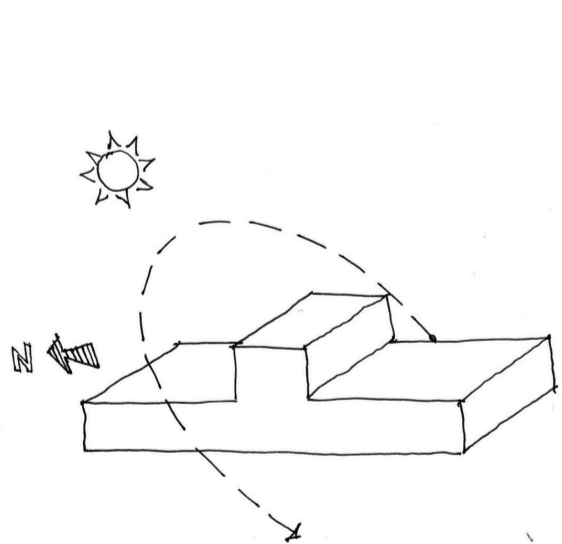

Figure 3.2.6 Section(not to scale): Natural light entering the space

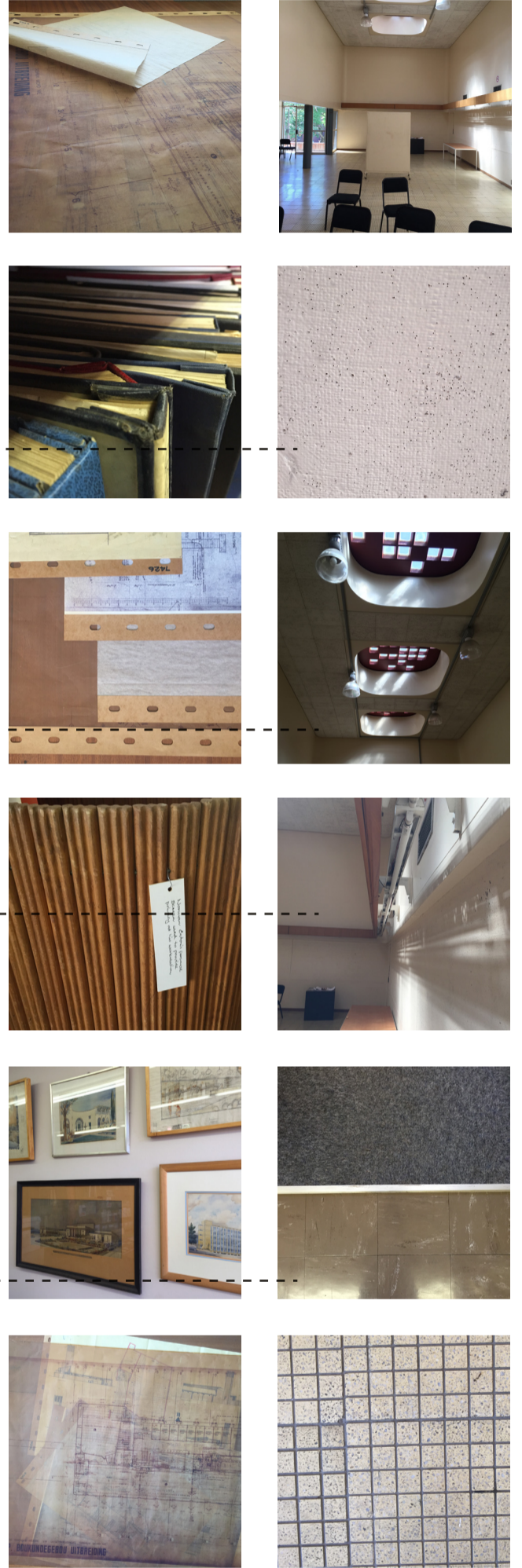

Figure 3.2.5 Photo board of existing materiality and space



3.2.2

OPERATIONAL PURPOSE

The new Boukunde archive would house architectural drawings, documents, slides and photographs significant to the context of Pretoria which are currently found in the existing archive. The intention of the new archive is to accommodate the growth of the architectural collections and therefore larger spaces are required. Along with the architectural drawings, master dissertations and thesis documents will be kept in this archive as well as presentations of the master exam presentations that would will be digitally uploaded and made accessible for educational purposes.

The archive is divided into two spaces; back of house which consists of the storage, preservation and processing of the archive artefacts, allowing access only to archive staff members and limited access to students and the front of house which will incorporate screens to access the digital archive material and presentations.

The intention of the re-representation of the Boukunde archive is to create a place for people, to access cultural information through a vibrant experience. The space should encourage meaningful conversation, debate, research, learning and interaction in a digital era.

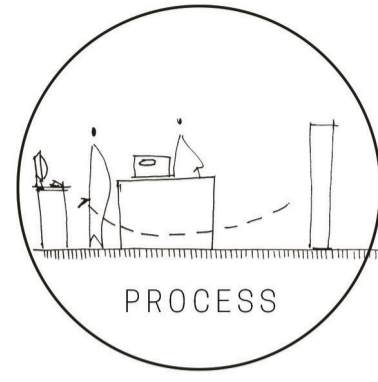
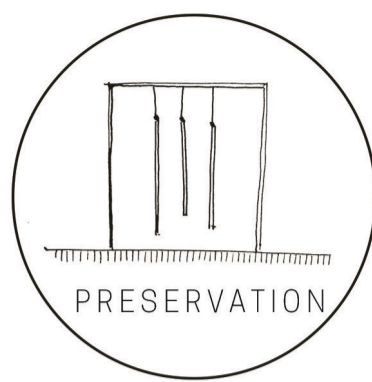
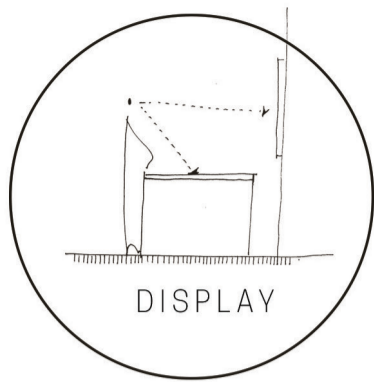

Figure 3.2.7 Operational purpose (Author. 2016)

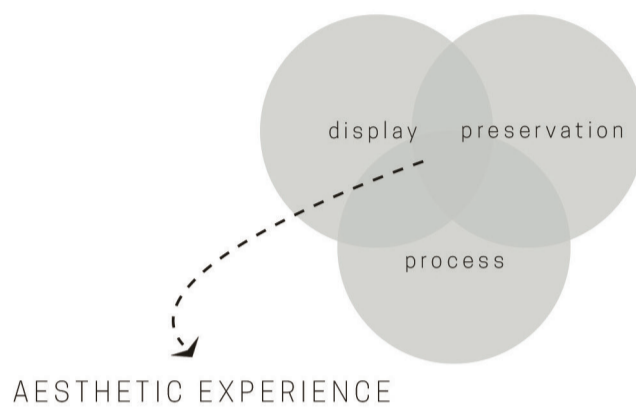
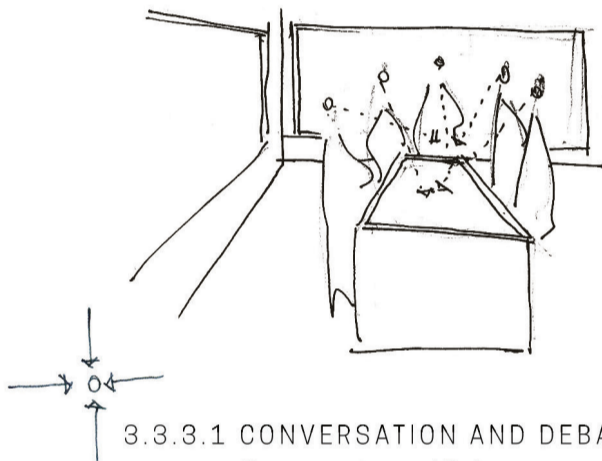

Figure 3.2.8 Conversation and debate (Author. 2016)



3.3.3.1 CONVERSATION AND DEBATE

Conversation and Debate
This space could accommodate a variety of scenarios where group discussions and informal presentations can take place

Users: Students, lecturers and other interested parties. Max 10 people

Furniture:
Interactive screen table
Vertical display screen
Chairs

Spatial requirements:
Lighting control
Adaptable spatial element

3.2.2.4 ARCHIVING

The archive processing space should allow for bulk sorting, inspection, indexing and digitizing.

Users: Limited to staff and interested parties on request

Furniture:
Large tables
Seating
Scanner, printer, computer
Digital display screen

Spatial requirement:
Access control
Sufficient lighting

Figure 3.2.9 Research and learning (Author. 2016)

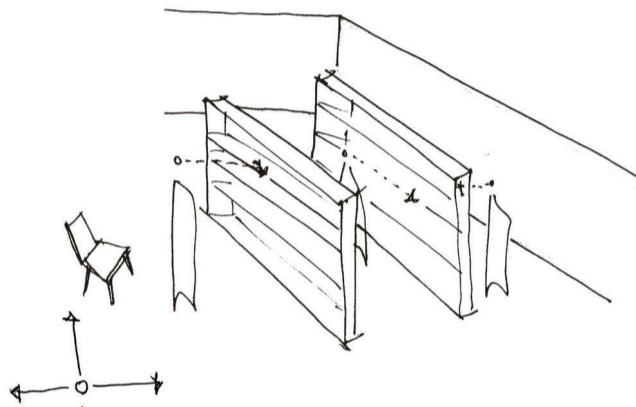

3.2.2.2 RESEARCH AND LEARNING

The research spaces should be able to access information through informal researching and browsing of collections.

Users: individual students, staff and other interested parties

Furniture:
Seating
Work surfaces

Spatial requirements:
Visual access to processes and information

3.2.2.5 STORAGE

The storage space should be adequate for the proper preservation of significant architectural drawings and documents.

Users: Limited to staff and interested parties on request

Furniture:
Shelves
Lay flat and hanging storage units
Tables + Chairs

Spatial requirements:
Controlled climate, humidity and light
Access control

Figure 3.2.10 Presentation space (Author. 2016)

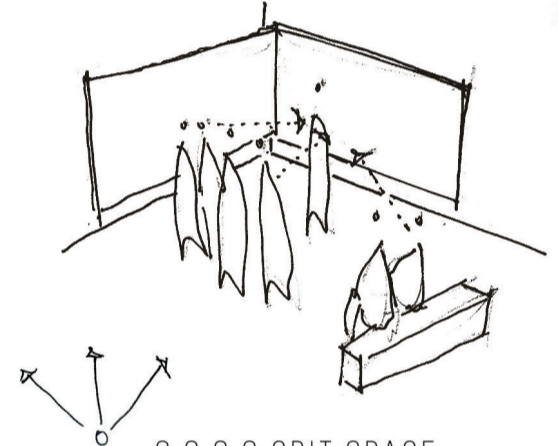

3.2.2.3 CRIT SPACE

The crit space should accommodate a formal presentation and discussion of master students work.

Users: Master students and examination panel. Max 20 people

Furniture:
Vertical display screen
Adjustable lighting
Display stand for models
Seating

Spatial requirements:
Attention should be focussed on work presented

3.2.2.6 EXHIBITION

The exhibition space will create visual access to archive material as well as student work and design installation.

Users: Students, staff and interested parties

Furniture:
Display cases
Modular fittings

Spatial Requirements:
Open space
Adjustable lighting

3.3 CONVERGENCE - CYBRID SPACE

With the emergence of digital technologies it was perceived as parallel worlds whereby Thackara (2001:40) explains that the physical and digital are coexisting in a hybrid space. The hybrid as defined by Thackara in Roscoe (2005:46) becomes the edge where the digital and physical realm come into contact with one another, but remain in conflict and unsettle the spatial character. The two realms, each with its own defined character is now present in one space, which requires both to actively engage with another in order to move toward a new spatial language. The manifestation of both the realms in a single space holds opportunity for innovative design application through the exploration of the potential connection. The fractured space as the effect of the distinct characteristics of each realm reveals this potential for the digital and physical to morph into something unfamiliar yet exciting as elaborated in the following quote by Roscoe (2007:102)

Similar to the crafting or joinery of a material-to-material connection in the physical realm, the design of the threshold requires a different yet equally important level of attention to detail. The threshold between cyberspace and physical space becomes an area for careful study and complex joinery; it is an emerging area of design craft and detailing.

Emphasis is placed on the connection between the two realms, with the aim to create a seamless joinery for the new spatial language. Anders (2004:393) defines a new space where the digital and physical realm are merged into one composition, he denotes this space as the *cybrid*. The *cybrid* concept moves away from the edge condition of hybridization where the two realms have up to this point come into contact through the insertion of the one into the other, toward a new environment that integrates both. How the two realms come together to form this new spatial language becomes the threshold for design to create a seamless spatial experience. The most valuable characteristics are extracted from each realm and merged together to form a new character which would determine the identity of the *cybrid* space.

To place this concept of *cybrid* into the context of this study, the Boukunde archive becomes an ideal specimen for the exploration of the integration of the digital and physical. The *cybrid* concept will inform the character of the re-representation of the Boukunde archive, as it will fuse together the most valuable qualities of both the paper archive and the digital archive. The intention of the *cybrid* is to converge the Boukunde paper archive and its digital counterpart into a space where the one informs the other so they will no longer be perceived as two separate realms. It is important to consider the contribution of the interior designer in the process of creating the spatial language of the *cybrid*. The interior designer is amongst many

other professionals who contribute to the process of constructing the threshold connection between the physical space and digital space. As these two realms move into a state of convergence it becomes important to consider how they visually collide and how the aesthetics of the spatial design can either support or diminish the spatial integration.

Anders in Roscoe (2005:64) argues that merely creating a representation of the physical within digital space defeats the idea of an integrated environment and the opportunities given to define a new spatial language, and also merely creating a physical space with insertion of devices returns to the fractured nature of design in its current state. Designing for a seamless spatial outcome relies on the exploration of both the aesthetic as well as the functional qualities present in both realms. Defining the overlapping and valuable characteristics as elaborated in section 3.3.1 Comparative Analysis, allows for a creative interpretation.

The functional requirements need to be supported for both realms but also a deeper understanding of what the spatial conversation is between the physical and digital. The interior designer's responsibility therefore lies in manipulating the physical spatial aesthetics in order to create a cohesive outcome. It now becomes important for the designer to create a clear understanding of what the opportunities are for designing this threshold which merges together the paper archive and the digital archive into an appropriate contemporary environment.

Paper as the medium for exploration is used as the aesthetic link to the integration of the digital and physical realm holds opportunity to create an intriguing conversation which defines the *cybrid archive*. Refer to Chapter 4 section 4.2 for further elaboration.



3.3.1 COMPARATIVE ANALYSIS

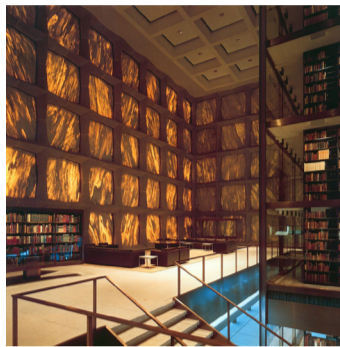

Figure 3.3.1 Beinecke Archive (Perez. 2010)



Figure 3.3.2 Beinecke archive office (Yale University Library. 2013)

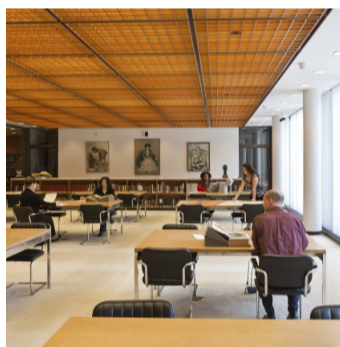

Figure 3.3.3 Reading room (Yale University Library. 2013)



Figure 3.3.4 Book tower (Perez. 2010)

- 1 Book Tower
 - 2 Entrance Lobby
 - 3 Reading Room
 - 4 Office
 - 5 Control Desk
 - 6 Work Area
 - 7 Book Storage
 - 8 Cataloging Room
 - 9 Lounge
- Work Spaces
 - Lounge / Pause Spaces
 - Archive Material

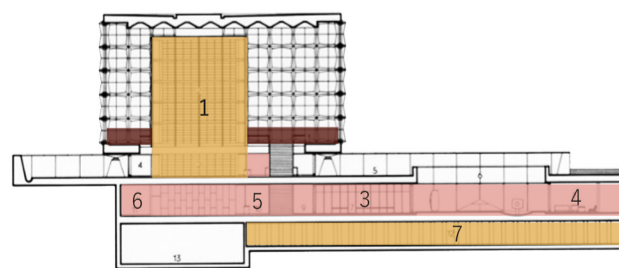
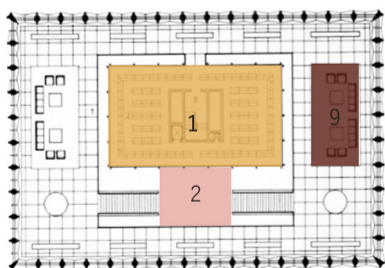

Figure 3.3.5 Plan and Sections of Beinecke Archive (Stoller. 2010)

The *cybrid* is no longer at the edge where the two realms encounter but a new environment that incorporates both. The comparative analysis is the first step in the process of determining the character of the *cybrid* and is used as a method to extract the most valuable qualities of each realm and integrate them into the new spatial language. Within the context of this study the Boukunde Archive and the Beinecke Rare Book archive are used to analyse the character of the physical realm; along with the Carlo Scarpa online archive as precedent for the digital character.

The intention of this analysis is to investigate the overlapping characteristics as well as the gaps which would become the areas for further investigation. With logic reasoning the most valuable characteristics from both the physical and the digital realm are extracted to be interpreted and integrated into the new *cybrid* realm.

3.3.1.1 BEINECKE ARCHIVE

According to Skidmore, Owings & Merrill (2016) the Beinecke Library is the largest building that is purely devoted to hold rare books and literary manuscripts which serves as a research centre for student, faculty and scholars of the Yale University. Perez (2010) describes the space when upon entering the space the six storey glass enclosed structure emphasizes the main purpose of the building. A mezzanine level allows people to move around the glass encased core which gives visual access to the archived books. The glass structure with the surrounding mezzanine creates visual access of the archive documents to the user of the space and therefore how the space is articulated becomes an important design consideration.

The purpose of the space is to store and preserve books and literary documents that are authentic and rare therefore by definition, see Chapter 1 section 1.9 Defining terms, can be defined as an archive rather than a library.

The intention of this precedent is not to extract spatial qualities but rather to define possibilities of how the space is programmed. This precedent serves as a good example of the activities that could be incorporated into the new architectural archive of Boukunde. The space incorporates a variety of functions, Skidmore, Owings & Merrill (2016) explains that the levels below the plaza contain a catalogue and reference room, a reading room, staff offices and a sunken court. All of which are designed to throughout the building create an integration and accessibility to the archive.

3.3.1.2 CARLO SCARPA ARCHIVE

The Carlo Scarpa Archive is used as support to the characteristics extracted through the comparative analysis. The Carlo Scarpa Archive (2016) was formed with the help of a joint committee with the goal of increasing the awareness and conservation of Carlo Scarpa, Veneto architect's work. The drawings, photograph, interactive models and documents are accessible to the public which allows for greater insight into the architect's design process. Documents of high quality can be accessed directly on the website and sketches and drawings are photographed along a ruler to give the user a perception of the scale, but is limited to a screen of a device, refer to figure 3.3.6.

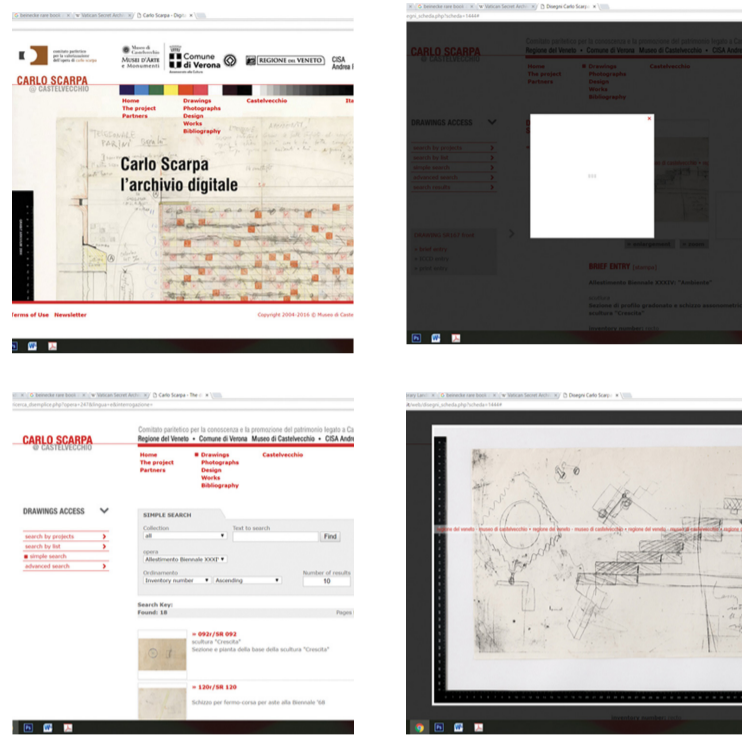

Figure 3.3.6 Screen view of Carlo Scarpa online archive (Author.2016)

BOUKUNDE ARCHIVE	SCARPA ONLINE ARCHIVE
Presence of Paper	Object
Complex Spatial Configuration	Cognitive interaction
Sensory Experience	Anytime anywhere access
Tactile interaction	Lone activity
Nostalgic experience	Dynamic
Limited access	Transient
Co-presence	Context
Static	Scale
Permanence	Preservation

Table 3.3.1 Comparative Analysis (Author.2016)

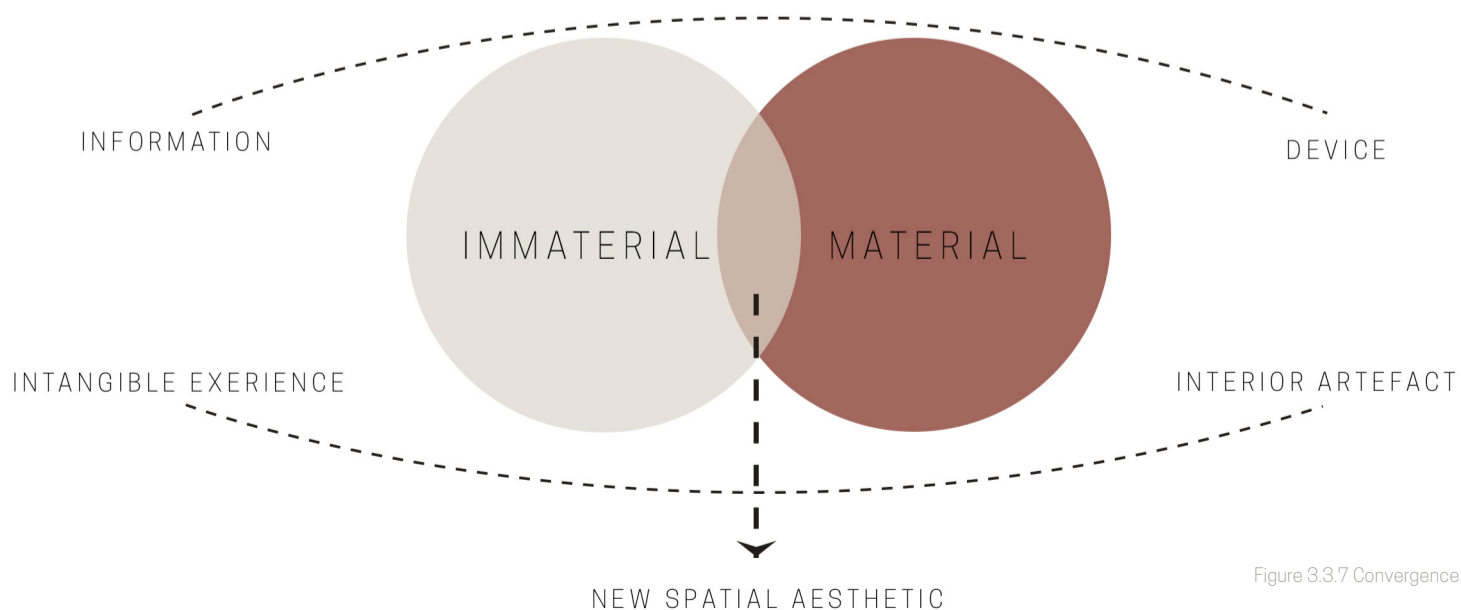

Figure 3.3.7 Convergence (Author.2016)

3.3.2 THICK DESCRIPTION

The characteristics analysed in section 3.3.1, table 3.3.1 comparative analysis, will be elaborated to place within the context of the study.

Presence of Paper: The content of the architectural archive of Boukunde as well as the Beinecke archive manifests through paper. It is not the only medium present but it is the most significant one.

Complex Spatial Configuration: Sailer (2012) defines one characteristic of the physical realm as having a complex spatial configuration. The spatial configuration of the Beinecke archive carries narrative as it controls the perception of the space. Upon entering the space the visitor is met by two large staircases which ascend up to the mezzanine level where the glass encased book tower becomes the emphasis of the space, allowing visual access from any point. The operation, movement, articulation and lighting are amongst many complex elements required in such a space.

Object: Information in the digital realm is intangible, Van Campenhout (2013:2) states that although information is a physical thing it can only be perceived by a human by displaying it on a screen or device. The digital realm manifests through an object which gives opportunity for human perception.

Sensory Experience: Space is experienced as a whole through physical activities. Lighting qualities and vast volume created in the Beinecke Library contributes to the calm and still atmosphere of the space.

Tactile interaction: Interaction with the actual archive material contributes to the tactile experience of paper. Both the Boukunde archive and Beinecke archive create opportunity for these encounters where material can be physically accessed for research and learning. This interaction with the material stimulates the senses through the sound of paging through a book, rolling or unfolding a drawing as well as the smell of the collective paper artefacts.

Cognitive interaction: Information in the digital realm as described by Van Campenhout (2013:2) is intangible and has no shape therefore it is not suitable for human perception. It can only be perceived through mediation of a device and currently these devices appeal mainly to the user's cognitive skills.

Nostalgic experience: An intangible characteristic of both the Boukunde archive and the Beinecke archive which allows the user to experience a sense of wonder and curiosity in the presence of the archive material. Individual pieces carry knowledge and narrative.

Limited Access: The Boukunde Archive is inaccessible to users; anytime access to material is limited to staff and students need to request material. Unorganized material as a result of the lack of proper spatial requirements and additional resources create limitations to the access of information. The size of the architectural drawings of the Boukunde Archive along with the spatial limitations create obstacles for the access of information.

Anytime Anywhere Access: The dynamic nature of the digital realm allows for anytime anywhere access. The Carlo Scarpa online archive gives access to the public through the convenience of personal computers, information/artefacts which could not have been accessed by an individual of another country if it has not been digitized.

Co-Presence : The presence of users in the space creates clarity and understanding for the operational purpose of the space. Sailer (2012) explains that the physical realm allows for a co-presence of people where interactions might occur.

Lone Activity: Although the digital realm allows society to interact and form networks, it remains an intangible activity. The action of accessing information of a device remains an activity done by the individual in her/his own space.

Static: Van Campenhout (2013:3) explains that objects and artefacts of the physical realm are static; they do not have the ability to suddenly change into something different. The Boukunde archive can be seen as a static space where the content and the spatial configuration do not have the ability to adapt to different requirements. The space as a unit of storage alone has become outdated in the digital era.

Dynamic: In contrast to the static nature of the Boukunde archive Van Campenhout (2013:3) states that information and data in the digital realm is dynamic, where information can be presented in different ways. The display of information can rapidly change its identity.

The Carlo Scarpa online archive allows for drawings, photos and renderings to appear with the click of a button, and creates opportunity to access information open in multiple windows on a computer screen instantly.

Preservation: The main purpose of the both Boukunde archive and the Beinecke archive is to preserve valuable documents and artefacts. The success of the Beinecke Library lies in its ability to preserve whilst at the same time providing access to material, whereas the Boukunde archive preserves artefacts by placing them in a storeroom of dusty shelves with limited access. Although artefacts are preserved, the damage that occurs through interaction with the material is certain. The process of digitizing physical artefacts allows information to be accessed and interacted with through a digital interface, therefore minimizing the damage to actual artefacts.

Context: Being able to view the surrounding artefacts and operational purpose of the space allows the user to form an understanding of the space and its context. Entering the Boukunde archive one has an understanding of the archive for architectural drawings as it is located within a building which is home to the architecture department. The Beinecke archive places the book tower at its core, allowing it to reveal the building's main purpose as a place that holds unique and rare literary artefacts.

Scale : With specific reference to the architectural drawings of the Boukunde Archive, the physical artefact not only allows a tactile interaction but also gives the true scale of the original artefact, where in contrast the digital archive, artefacts are limited to the size of the screens they are viewed on.

Transient: The transient nature of the digital realm gives it the ability to disappear and reappear out of the blue as described by Van Campenhout (2013:3), and he explains that computers have a very distinct on/off nature which creates a discontinuous effect whereas an object of the physical realm has a continuous presence.

3.4 PRECEDENT STUDY

Three precedent studies were done to investigate the integration of the digital realm into a contemporary library space, which houses similar functions as the proposed archive space, to store and access information. The third precedent is chosen not for similar operational purpose but rather for the integration of both the physical and digital realm into a single experience.

3.4.1 KANAZAWA UMIMIRAI LIBRARY

Kanazawa, Japan
2011
Coelacanth K&H Architects

Archdaily (2011) states that the architect's intention was to create a space that is defined by a strong physical presence of books, which connects to the experience that comes from reading, something that can not necessarily be given by electronic or digital books. The idea was focussed on creating that specific physical atmosphere where these artefacts and activities can manifest in order to strengthen the relationship between humans and books in a digital age.

The presence of the actual artefact translates into a nostalgic feeling and atmosphere in the space, the books become spatial elements which define more intimate space within the large volume of the building. It becomes clear that the natural light, the volume and the presence of the artefacts enhance the spatial atmosphere. However emphasis is only placed on the physical realm and does not show any integration of the digital realm.

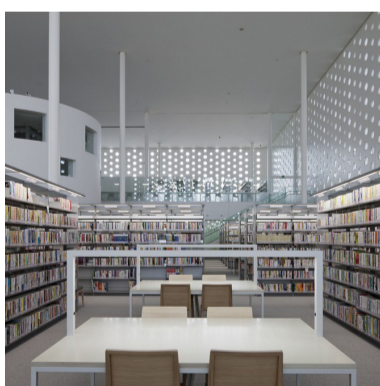

Figure 3.4.1 Kanazawa Library (Archdaily, 2011)

3.4.2 JAMES B. HUNT JR. LIBRARY

North Carolina, America
2013
Snohetta

The library is designed to integrate the technologies of our digital era into how the space works and features a robotic book retrieval system amongst other technologies as explained by Frearson (2013). This system allows the storage of books to fit into a much smaller space than the traditional library shelving.

The aesthetic of the space reads as two separate entities, where there is a bias of either the conventional library space or of the new technology. Integration of virtual software was the only attempt to retain relationship a between physical experience and technology. The focus on technology seems to be overpowering and the presence of the library artefacts disappear, resulting in a generic spatial aesthetic.

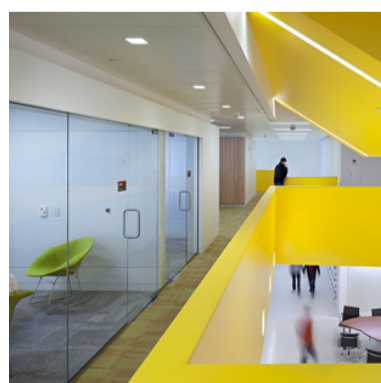
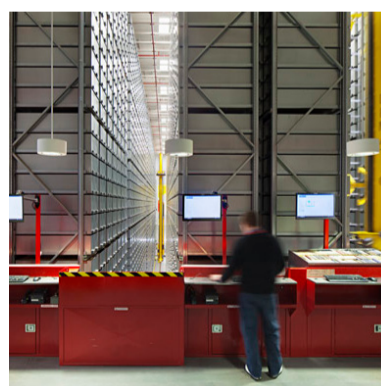

Figure 3.4.2 James B Hunt Jr (Dezeen, 2013)

3.4.3 UNNUMBERED SPARKS

Vancouver, Canada

2014

Janet Echelman + Aaron Koblin

Unnumbered sparks is an interactive rope sculpture suspended in the sky and created through collaboration by artist Janet Echelman and Aaron Koblin for TED's 30th anniversary. Janet Echelman (2013) states that the artist wanted to explore how people could experience the sculpture in a new way and with the help of technology created a giant visual artwork that could be choreographed by the visitors in real time. At night the sculpture was illuminated and visitors were able to 'paint' beams of light across it with the use of their smartphones and tablets.

This installation brings together both the power of technology and the physical experience of the user. It takes away the focus from the digital object by bringing the experience into the world that surrounds us. The digital interface is no longer the focus and the experience of the artefact is supported through the application of technology (digital realm) which allow for a captivating experience.

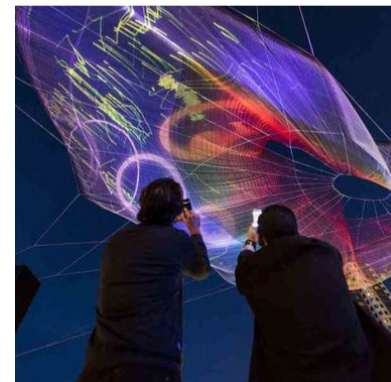
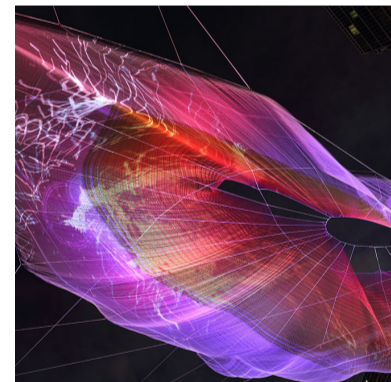

Figure 3.4.3 Unnumbered Sparks (Unnumbered Sparks.2016)



3.5 GUIDELINES

Guidelines were set up to serve as a reminder to support the decision-making process of the design; the intention is not to apply these as a list of requirements, but rather valuable aspects to take into consideration for the design. The guidelines are informed by theory, comparative analysis as well as precedent studies done.

Creating context: The operational purpose of the space should be clearly expressed through spatial configurations and artefacts.

Presence of the artefact: The artefacts contribute to the intangible qualities of the space and also help to formulate a better understanding of the surroundings and should be incorporated as spatial elements.

Dynamic space: The space should be dynamic in its use and character and should be able to adapt to specific requirements.

New character: The new spatial character requires the integration of both realms' characteristics into one. It requires a careful exploration of how the one could influence and inform the other.

Seamless physical aesthetic: The integration of the two realms requires an intricate investigation of how they visually collide into a cohesive space.

Intangible experience: Intervention should be explored on an immaterial level, where the space expresses a unique atmosphere.

Balance: Placing emphasis on the design of lost qualities to restore balance in the new spatial language. Selective design to enhance the valuable qualities that have been lost through this process of dematerialization.

Interaction: The intervention should encourage physical interaction and stimulate the senses of the user. We are still material beings/ surrounded by materials.

Accessibility: Where physical accessibility is not possible, the intervention should create opportunity for visual access in space. The space should incorporate various levels of transparency.

Volume: Open volume should be investigated as it contributes to the intangible qualities and atmosphere of the space.

It becomes clear that the process of dematerialization is affecting our interior environments, immaterial characteristics of the digital realm influencing how we perceive space and therefore it becomes imperative to grasp the importance of materiality as it adds nuances to the experience of the place.

Refer to Chapter 4 section 4.6.2, for an additional list of characteristics which are defined to support the spatial development of their representation of the architectural drawing archive.



3.6 CONCLUSION

The investigation done in this chapter becomes the base of all the design exploration to follow. The chapter concludes with a list of guidelines that would support the decisions to be made for the spatial intervention.

Through the comparative analysis the essence of the archive was obtained and the significant qualities that need to be re-introduced and integrated into the new *cybrid* archive where defined. Chapter 4: Making will be an investigation of paper as the material to support the act of making as specified in Chapter 2: Methodology, with the aim to strengthen and create a link between the digital and physical archive.



UNIVERSITEIT VAN PRETORIA
UNIVERSITY OF PRETORIA
YUNIBESITHI YA PRETORIA

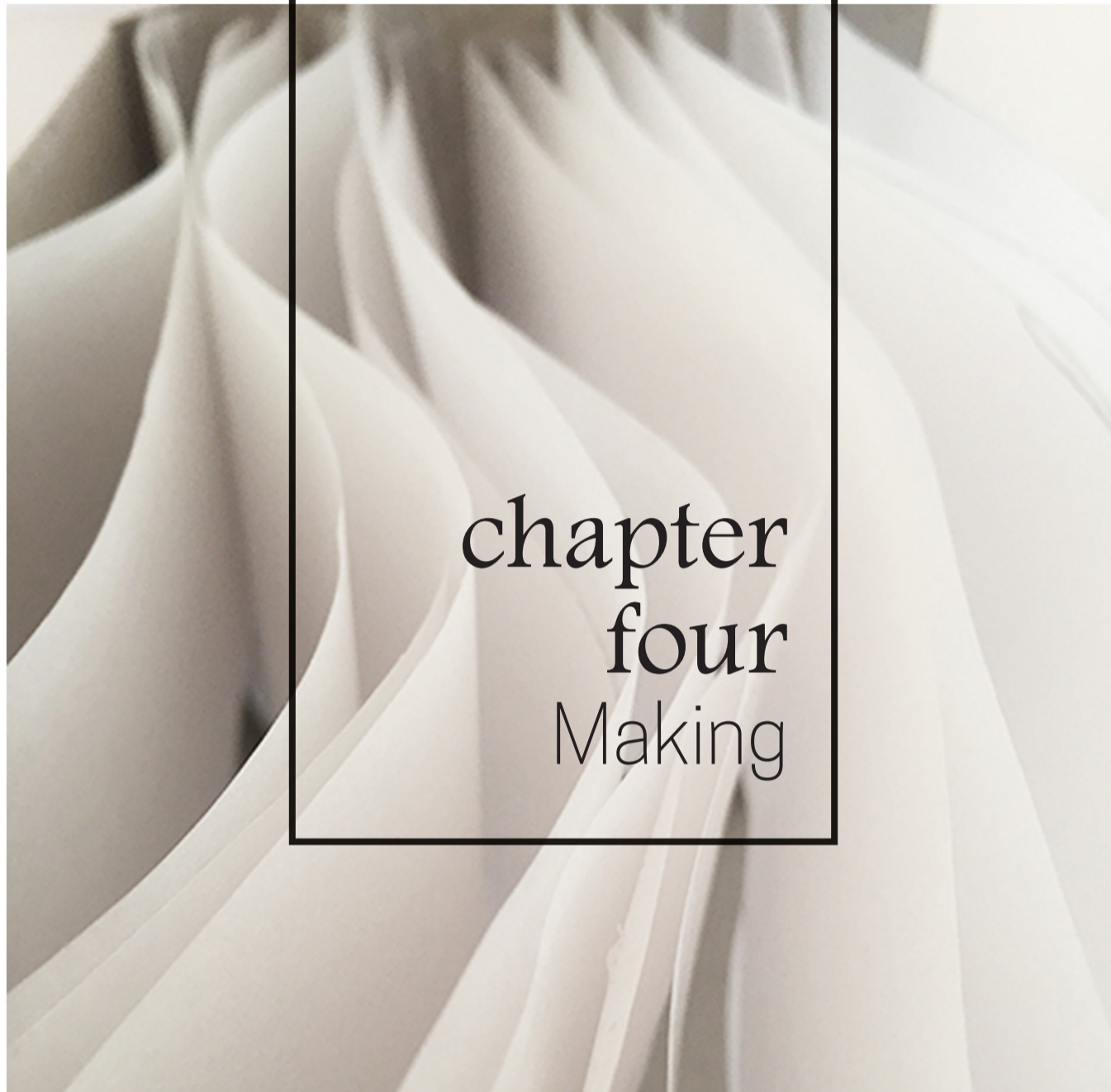

In the nature of this study which employs making as the methodology, paper is chosen as the material that will be investigated as the artefact for the spatial intervention.

Currently the use of paper within the discipline of interior design is limited by the perception of its technical limitations. Paper as a material in the built environment holds opportunity for a unique character and identity to be expressed and therefore this project explores the unique and latent characteristics of paper as a material for innovative three dimensional spatial applications.

This chapter introduces the concept of new materiality followed by the elaboration of paper, where the objectives of the material study is established. A visual study is the initial step in the making and design process and an intuitive material exploration follows as the first phase of making. The chapter investigates the aesthetic character of the *cybrid* archive and integrates the paper as the visual link between the physical and digital realms.

4.1 NEW MATERIALITY

Interior space is constructed of boundaries and these boundaries only become real once we fill them with materials, and these in return give certain sensual qualities that we can perceive through our senses and understanding. We understand the materials of our surroundings by touching contours and textures, seeing the contrasts of light and shadows cast on surfaces, feeling hot or cold and hearing sounds that come from echoes or voices in the space. Materiality allows the designer to create a sense of place and through materials a space becomes something that has its own character, atmosphere and identity.

Vergheze (2005:3) highlights the idea of abstraction in the design process, and argues that the development of abstraction lies in materiality. Abstraction defines design as both a process of producing an outcome as well as the outcome itself, and can be described as reducing something to its essence. Abstraction holds a lot of potential for developing new ideas yet there is a misplaced perception that the professional world belongs to reality, and it is creating a lack of abstraction in the approach taken by interior designers. Vergheze (2005:8) stresses the fact that interior designers are designing with an outdated process where materials are selected as an outcome to the design and they are falling short to the abstract ideas that new materiality has to offer. Addressing materiality in the early stages of the design process helps to generate a clear understanding of the qualities that a material could contribute to a design. Materiality takes the space further than mere spatial organization but adds value through the abstract qualities that creates emotional responses in a place. A new methodology such as research through the act of making is needed to address the issues that are currently found in the design process as explained earlier in this chapter.

If a sense of place is established through a material enclosure, Vergheze (2007:197) then explains that new materiality could address a sense of place in a new manner. Then use of innovative materials creates opportunities for these environments to evolve and to meet the needs of the user. Vergheze (2007:199) make the relevant statement that *new materials by themselves do not constitute change, or design innovation. It is the application of these materials within a context that issues forth a new era in design, and that new era must coincide with the implementation of new materiality into the process of design and not solely as an aspect of the outcome.*

Paper at present does not yet have a clearly defined spatial language in the building environment therefore through the exploration of this unconventional material in an innovative way creates the opportunity for a new interaction and experience. Paper becomes a symbol of the old paper archive that has been re-interpreted in the *cybrid* archive where this new space embodies qualities of both the physical realm and the digital realm that are experienced in novel ways. Refer to chapter 3 section 3.3 Comparative Analysis.

Materiality should form part of the whole design process and not just be the outcome. It is not necessarily the use of new technologies but rather new approaches to old technologies, innovative ways to apply and rethink what materials can become or would be able to do that could enable the manifestation of novel experience in a space such as the *cybrid* archive.

4.2 PAPER

Williams (2005:7) expresses the potential of paper in the following quote.

Paper is amazing. You can write, draw, paint and print on it, you can cut and fold it, you can mould it, and that's not all – the list of things you can do with it is boundless.

Paper is a thin material made through the process of pressing together fibrous pulp derived from wood and other natural fibrous substances to create thin flexible sheet which could be used for drawing, writing, printing and packaging amongst many other uses. The name paper is derived from the word papyrus which Williams (2005:169) describes as a material made of sliced sections of the flower stem of the papyrus plant which was found in Egypt, laid in two layers, pressed together and dried and was used by the Egyptians, Greeks and Romans as a paper-like material for writing, but the type of paper used today was originally created in China around the end of the first century and was the most important carrier of information in the past.

Schmidt(2009:9) begins to explain that our relationship with paper is most of the time a troubled one, as it reminds us of homework books and report cards and the notebook that was nothing more than a record of our achievements. However there was always the opportunity given to us by a blank untouched page, that allowed us to dream and forget about all the errors and bad grades, allowing us to feel unchallenged and without fault. Yet a blank piece of paper can also become challenging, and this could possibly be a fear of commitment.

Schmidt (2009:9) explains that on paper our abilities manifest. Scant facts, garrulousness, or perhaps even talent: here it all becomes visible. For on paper it is not easy to hide inadequacies. Those who write, record something, sometimes for eternity, sometimes just for a moment.

Paper is present in our everyday lives, we interact with it throughout the day from the most mundane toilet roll of tissue to office stationary or a book we read at the end of the day, it also becomes a bearer of cultural heritage and a means of mass communication. It is one of the most accessible and widely distributed materials across the world with a seemingly endless stream of applications.

Williams (2005:8) explains that there has been an anticipated disappearance of paper due to the growth of the digital era, but the complete opposite has appeared to happen and paper production is growing every year. Now the well-known material that has previously been taken for granted is being re-looked and an exponential growth in the use of the material amongst product designers, fashion designers as well as architects who are experimenting with the properties of paper.

For the purpose of this study the material will be investigated as a medium for 3 dimensional design manifestations. Paper has a high value due to the easy production and the wide range of possibilities for use and many ways which it can be shaped. Although this material has so many opportunities and variety of applications it is still viewed as a fragile, temporary and unsophisticated material which we dispose of after use.

4.2.1 PAPER IN ARCHITECTURE

Paper has been an extremely important part of the design process for many architects and designers. It is one of the first steps in the design process and models built express sculptural qualities that inform many designs. A paper model can easily be altered to explore and understand scale or we can experiment with shapes and spaces, and these qualities add to the significance of the use of paper in the design process. Apart from the design process, paper has not been a material for building application until recently, only as an exception as the surface based application of wallpaper and Japanese shoji screens. Architect Shigeru Ban pushes the boundaries of this unsophisticated and fragile material. Refer to section 4.3.1 for further elaboration on the work of architect Shigeru Ban.

Many creative artistic expressions have emerged from developing paper as an artistic medium as well as product based material exploration but there still remains very little exploration of paper as a material for spatial intervention, which goes beyond the technical limitations and surface based application. Refer to the visual study done in section 4.3.

4.3 VISUAL STUDY

The visual study, figure 4.3.8 on the opposite page, is used to place paper in a larger context of design applications to be able to identify the current status, character and identity of the material. The visual study supports the initial insight to the material as a medium for making from which making techniques are identified for the material exploration see section 4.5 for clarification.

4.3.1 SHIGERU BAN

To place paper in the context of the built environment, a section of the visual study is focussed on Japanese architect Shigeru Ban who is known for his innovative application of cardboard and other paper based materials. Hill (2014) states that Ban has been applying paper and cardboard tubes as material in his building constructions since 1986. He focusses on design for disaster relief and is attracted to paper because of the low cost, recyclability and availability which allows for efficient building construction.

The first application of paper as construction material was for the Alvar Aalto Exhibition in 1986 where Ban experimented with paper tubes to construct the building, the kind of paper tubes found in textile factories. According to Hill (2014) the constraints of the budget as well as the recyclability of the installation was the main justification for the use of cardboard tubes and this became Ban's main argument for the use of this material.

Ban enables cardboard to go beyond the technical limitations through the investigation of meticulous and innovative joinery and techniques. By designing intricate fittings for the cardboard tubes to be fixed to additional materials and surfaces, a vast amount of opportunities are presented for light weight, sustainable and efficient construction. However the predominant use of cardboard tubes as substitute to conventional materials such as timber poles results in a lack of paper application in all its possible manifestations. Ban's structures do not express the unique qualities of the paper-like material to its full potential.

The Japanese pavilion at the expo in Hanover expressed sustainable design which was the central theme of the expo. The pavilion was designed to be dismantled after the expo to be used again. The pavilion was constructed of recycled materials, which consisted of the timber frame, cardboard tubes plastic as well as waterproof paper.

The use of innovative joining solutions enabled the lightweight construction with the use of cardboard and contributed to the overall aesthetic character of the pavilion. Detail (2000) describes the structure as having a lattice grid shell made of cardboard tubes which spans over the main hall, while the walls are cable-tensioned honeycomb cardboard construction. The skin that covers the entire structure consists of a layered fire and waterproof paper membrane, see figure 4.3.1.

For the purpose of this study, paper will be investigated as an artefact in an interior environment which expresses the unique latent character. The exploration becomes focussed on enabling paper to do which it ordinarily cannot, due to the limitations inherent in its technical characteristics, through meticulous joinery which allows for a novel expression of an unsophisticated material. The exploration of paper will therefore be supported by additional materials that would act as armature to the paper artefact.

Figure 4.3.1 Japanese Pavilion (Anderson. 2014)

Figure 4.3.2 Close up of Pavilion (Designboom. 2013)

Figure 4.3.3 Pavilion Detail (Ricther. n/a)

Figure 4.3.4 Detail joinery (Ricther. n/a)

Figure 4.3.5 JR Onogawa station (Hirai. 2015)

Figure 4.3.6 Hermes pavilion (Designboom. 2011)

Figure 4.3.7 Cardboard cathedral (Anderson. 2014)

Figure 4.3.8 Paper Tower (Designboom.2009)

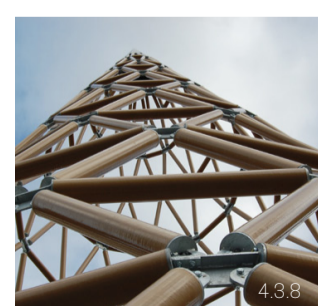
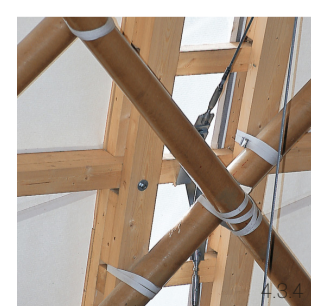
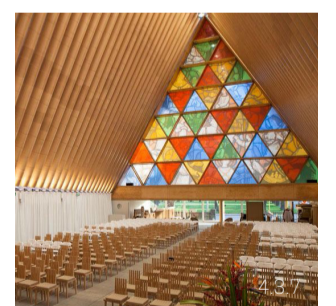
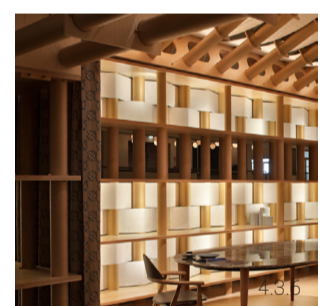
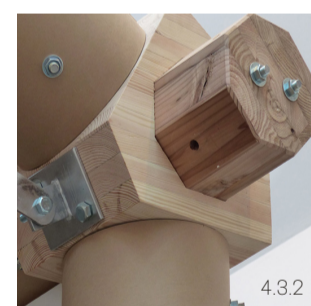
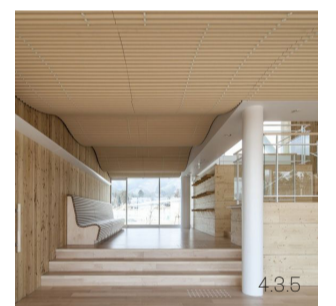



The exploration becomes focussed on enabling paper to do which it ordinarily cannot, due to the limitations inherent in its technical characteristics, through meticulous joinery which allows for a novel expression of an unsophisticated material.

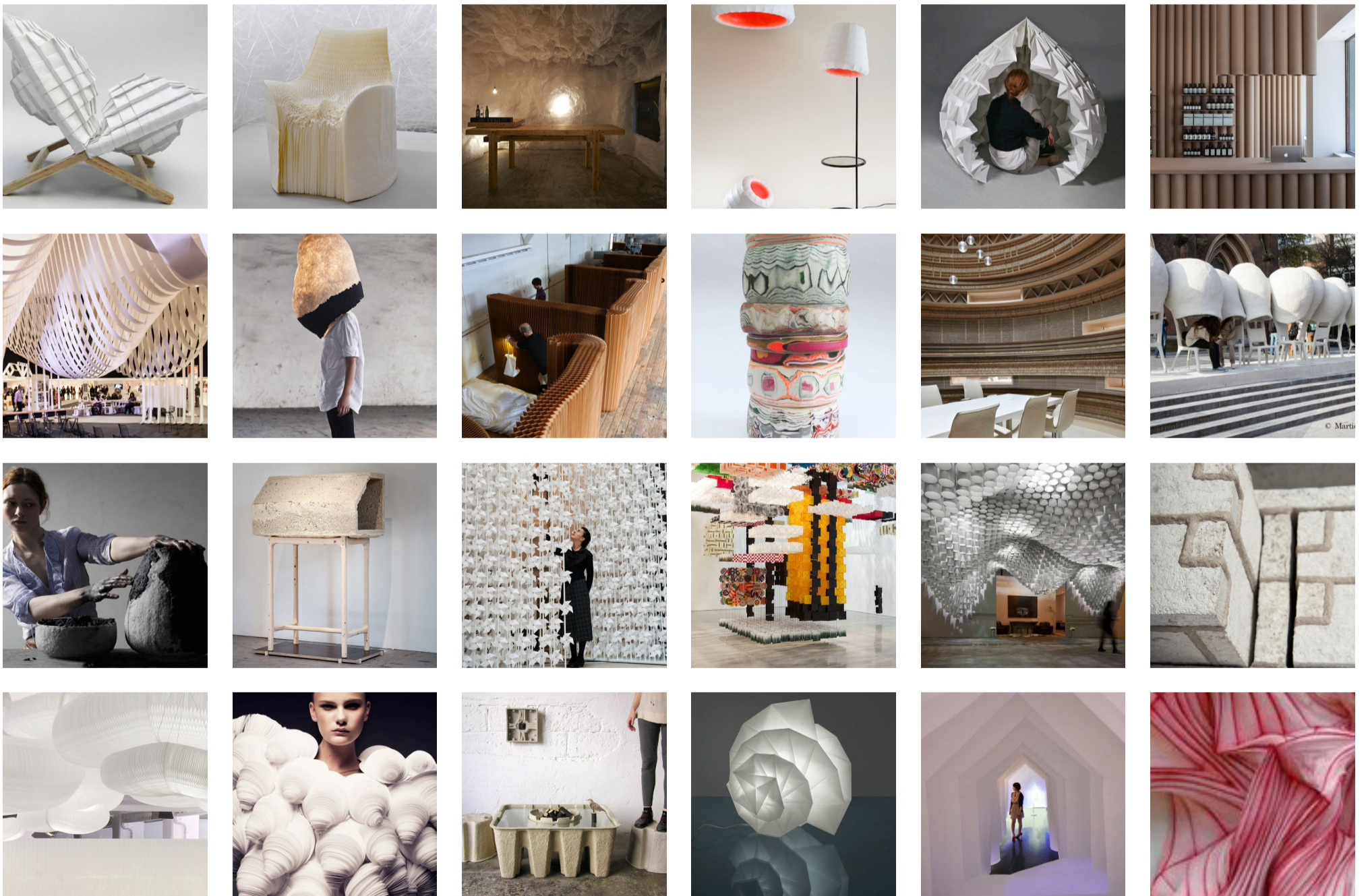

Figure 4.3.9 Collage of paper products and interior application (Various Sources)

4.4 PAPER OBJECTIVE

The focus is not to create an individual creative object, but to explore what the relationship is of paper to the materiality of an interior environment. The question is focussed to what the materiality of paper can contribute to the aesthetic of interior space as the mediator in the convergence of the physical and digital realm, as elaborated in Chapter 3 section 3.3.

The intention is to investigate paper as a medium to create a visual link in the convergence of the digital and physical realm, to express a novel character of the *cybrid* archive. Within the context of this study, the aesthetic material qualities should root us to the ground as material beings through the application of a rich sensory experience. The material and immaterial qualities of paper therefore becomes the rare and exotic material and tactile experience in a sea of technology. Refer to figure 4.4.1 as well as section 4.5.4 where through the act of making, unique qualities have been extracted which will serve as guide to the intended spatial aesthetic and character.

Paper will be explored as the artefact that becomes the aesthetic joinery on a larger spatial scale as well as the application of intricate material to material joinery.

The unique expressive characteristics of paper are celebrated through novel application within the architectural *cybrid* archive where designing architecture on paper takes a shift towards paper becoming the architecture.

The exploration of paper for spatial intervention will be driven by both the artistic expression as well as the technical limitations, see figure 4.4.1, as preliminary associated characteristics attained through theoretical and visual studies.

PAPER	
OPERATION	Record and document
	Carrier of information (communication)
	Blank canvas
	Lasting
IMMATERIAL	Dynamic
	Ephemeral
	Unsophisticated
MATERIAL	Thin
	Fragile
	Flexible
	Lightweight

NEW SPATIAL AESTHETIC

Exploration not only of one or the other but the integration of both, to define a new spatial aesthetic, as the material and immaterial joinery between the digital and physical realm to support the *cybrid* character.

What is the aesthetic language in an interior environment that captures the artistic and goes beyond the technical limitations?

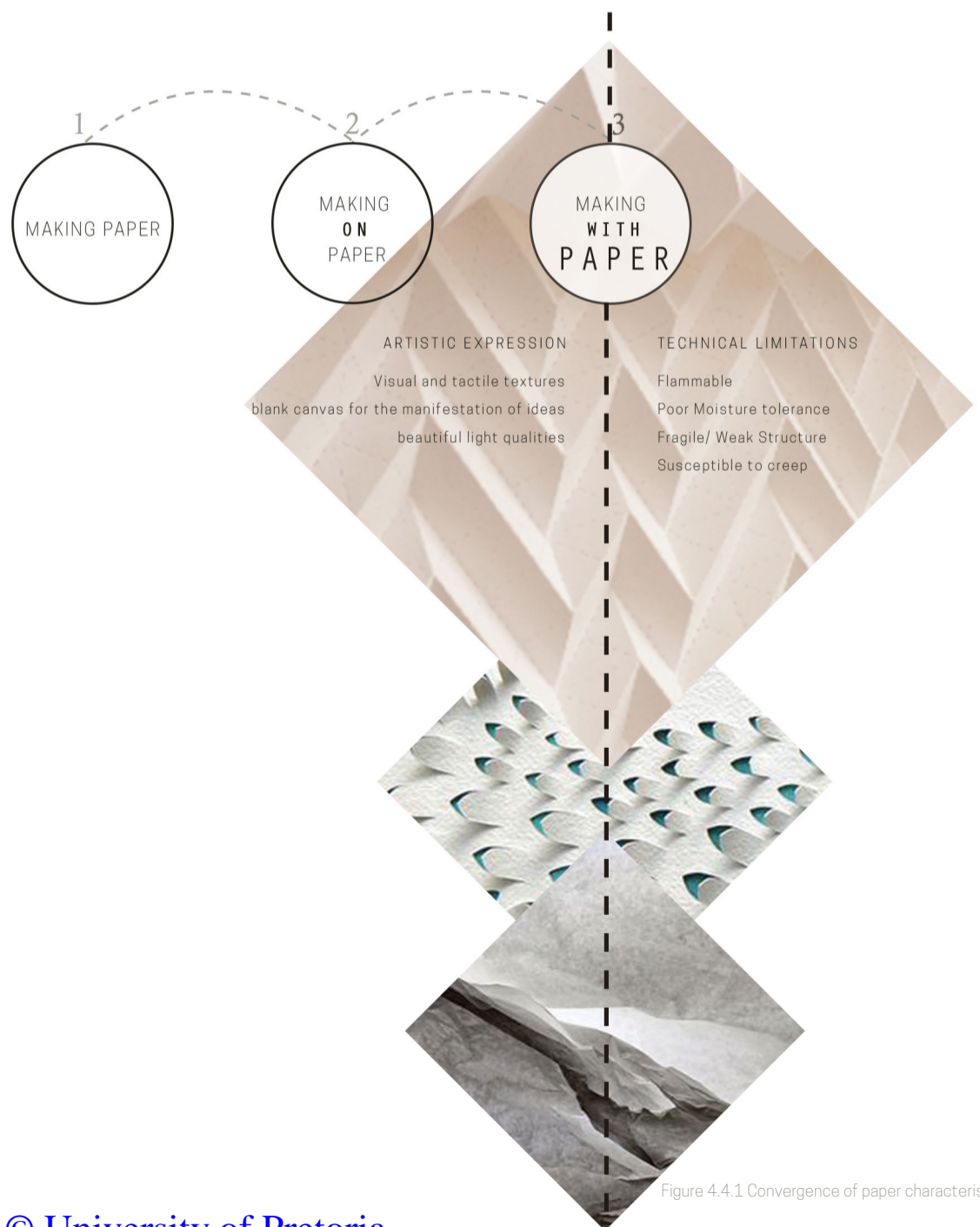

Figure 4.4.1 Convergence of paper characteristics (Author. 2016)

4.5 MATERIAL EXPLORATION

TWIST



ROLL



WEAVE



FOLD



CUT



LAYER



MACHE



My experience of making my own design ideas convinced me that understanding materials, and gaining practical experience of using them, was essential to developing ideas and finding ways of making them happen. (Heatherwick. 2013:10)

Nimkulrat (2012:1) explains that the act of making by hand can be seen as a way of thinking through the senses. Through the making process a deeper understanding and insight of the paper is achieved. An intuitive exploration was conducted to gain the insight and to further extract the unique qualities inherent in paper, through the use of the hybrid process which is supported by a rigorous documentation of the observations made and reflection to the samples as proposed by Wherry (2015).

The visual study served as inspiration point for further exploration to be done, from which crafting techniques are identified to move into material exploration. There is an endless range of crafting techniques that could be used for the exploration of paper which was identified through the process of doing the visual study. They could be categorised into industrial processes which require machinery and technologies for the material exploration, and hand craft processes which requires only the skills of the maker for the material exploration. Within the boundaries of this project techniques are identified which do not need a sophisticated workshops and technologies. The following crafting techniques were selected for exploration through acquiring a better understanding from the visual study as well as prior knowledge attained of paper.

The intention of the first phase, see figure 2.3.6 Synthesised design process in Chapter 2 section 2.3.3, of making as an intuitive exploration is to define the unique characteristics of paper which would inform the design of the spatial intervention.

Figure 4.5.1 Techniques for making with paper

4.5.1 FOLDS

Technique:

Folds

Description:

Process of folding paper allows the flat sheet to become 3 dimensional through specific folded patterns. Samples include 2-4, 9, 15-19, 22-26 refer to Appendix A for clarification of individual samples.

Observation:

Creating intricate folds is a timely process and therefore time becomes a limitation when making by hand. The fold samples made are small scale and simple patterns and it would be beneficial to explore more complex folds that could manifest into more organic forms.

Aesthetic Quality:

Intricate three dimensional forms are created through different folding techniques which allows for various textures to be explored. The textures from samples 17,18 and 22 are visually stimulating as they have a complex yet organized pattern. The folded samples add a new dimension to the paper creating defined planes with shadows. The folded paper has a rigid and geometric pattern as well as defined sharp edges and has organic movement.

Potential:

The folded samples create intriguing visual textures and could be employed to give a flat surface new dimension. The fold patterns have strong defined sculptural character which could become a focal point within the whole intervention which would contribute to the aesthetic value of the space. Textures can be explored further to create irregular patterns to avoid a monotonous texture in a larger scale. Sample 3, 4, 17 and 18 holds potential for kinetic application in the interior environment, creating opportunity for adaptable spaces. Selected folds have structural potential to carry itself and not additional weight. Sample 4, the symmetrical repeat fold, inspired movement in the space.

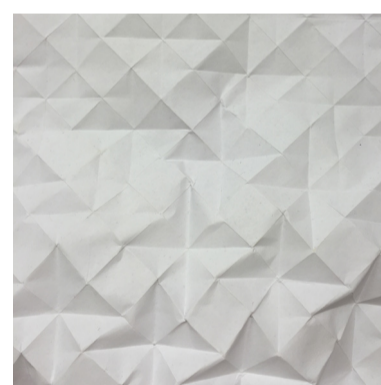
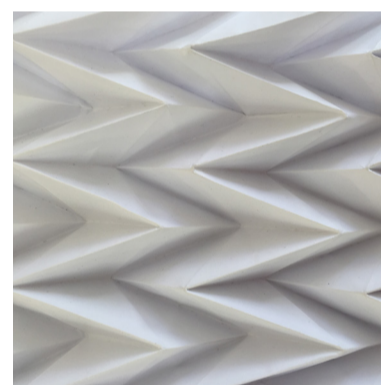
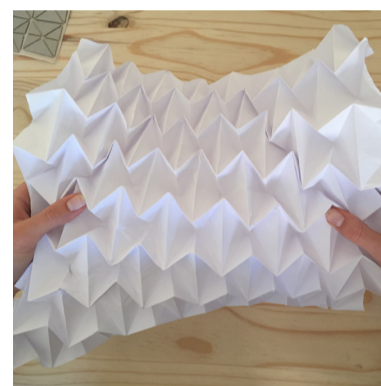
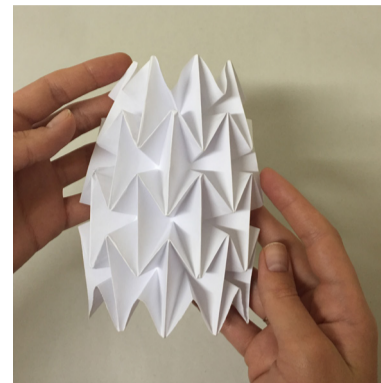

Figure 4.5.2 Folds: Material Exploration

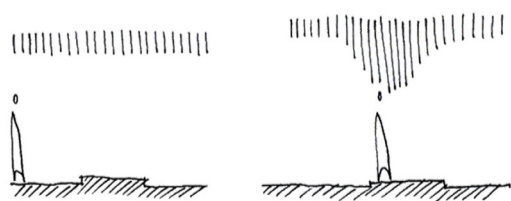

Figure 4.5.3 Sketch development: adaptable plane (Author. 2016)

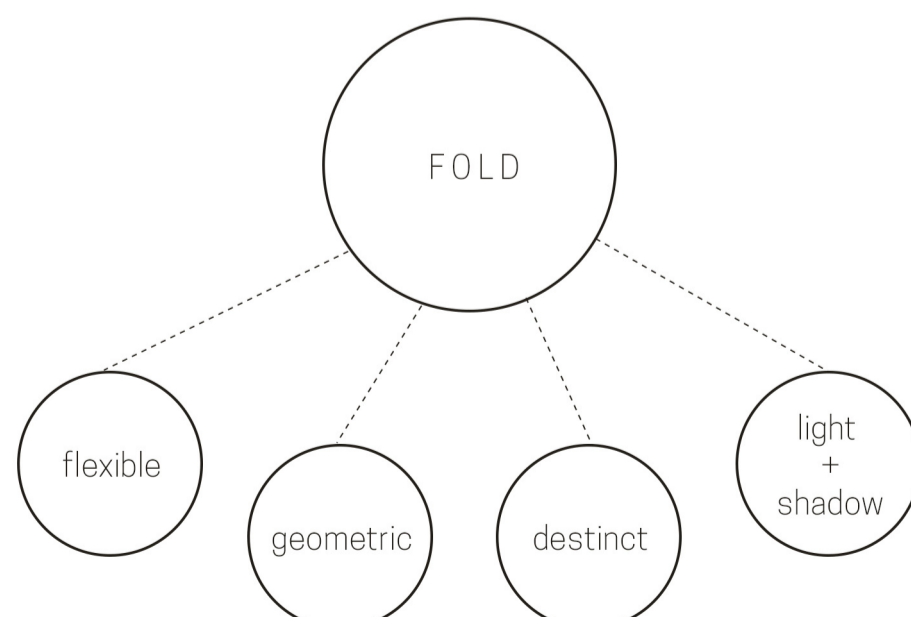

Figure 4.5.4 Associations of folding (Author. 2016)

4.5.2 PAPER MACHE

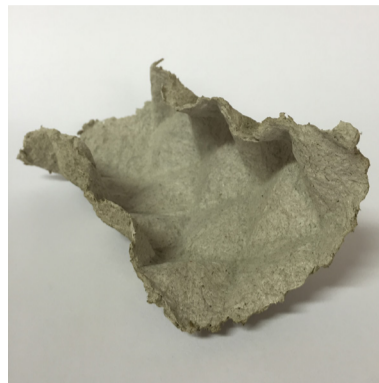

Figure 4.5.5 Paper Maché: Material Exploration

Technique:
Maché

Description:
Mixture of paper pulp and glue or of layers of paper glued and pressed together, which can be moulded when wet, becoming hard and stronger when dry. Samples include 8, 11-13 Refer to Appendix A.

Observation:
Processing material creates new material that is extremely malleable and could take almost any form. Although the pulp consists mainly of paper, after processing it obtains new characteristics and loses its flexibility and malleability after it has dried. No longer allows light through. Paper pulp could be dyed to explore a colour palette. Could be explored with additional materials such as cement.

Aesthetic Quality:
The paper maché samples have a rough and irregular surface texture creating a rough and crafted look and feel. A hand crafted quality is clearly expressed through the samples and could contribute to a deeper association of hand craft, making and process to the aesthetic of the archive.

Potential:
The pulp has a lot of structural potential to carry weight and could be treated to achieve moderate level of durability. The paper pulp can be moulded into a variety of three dimensional shapes that requires low tech processes. Material is extremely lightweight and strong, can be employed as space defining or furniture element.

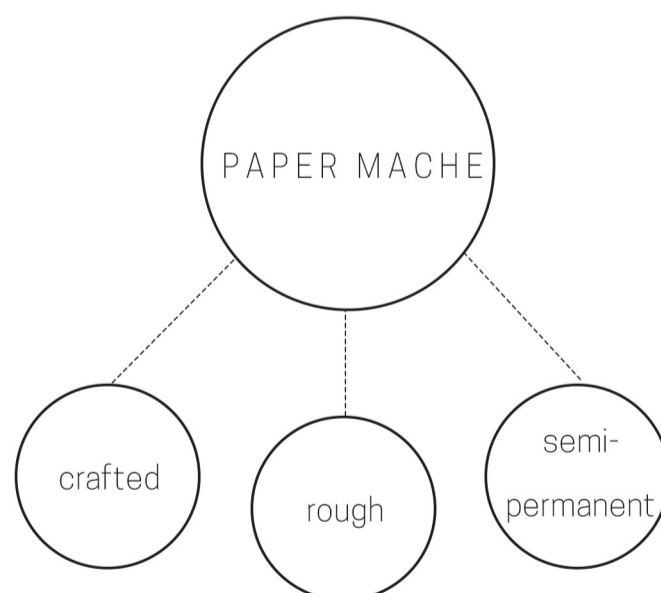

Figure 4.5.6 Associations of paper maché (Author. 2016)

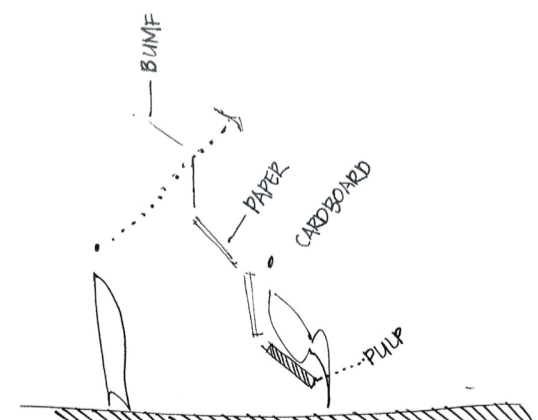

Figure 4.5.7 Sketch development: Potential application (Author. 2016)

4.5.3 CUT AND LAYER

Technique:
Cut and Layer

Description:
Cutting and Layering samples include 6, 7, 14 and 27 refer to Appendix A.

Observation:
Cutting and layering with paper is one of the simplest methods of making with paper, however the configurations could have extremely intricate outcomes by shaping the planes in successive sequences.

Aesthetic:
Layering paper, as per figure 4.5.8, creates a pleasing visual texture whilst allowing light to create a dappled effect. The use of tracing paper contributes an ephemeral feeling due to the thin fragile quality of the paper. The way the light reacts with the layered paper emphasises the sculptural qualities and potential of the sample.

Potential:
Layering the paper vertically holds potential for adding a new layer of depth to the space and volume. The paper can be cut in endless configurations that could define the space in multiple artistic expressions.

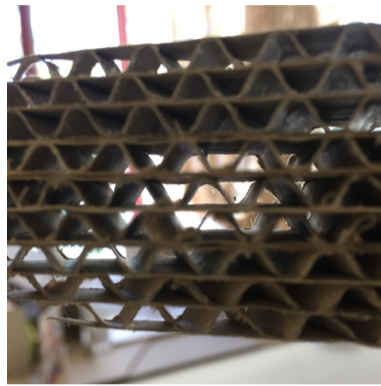

Figure 4.5.8 Layered: Material Exploration (Author. 2016)

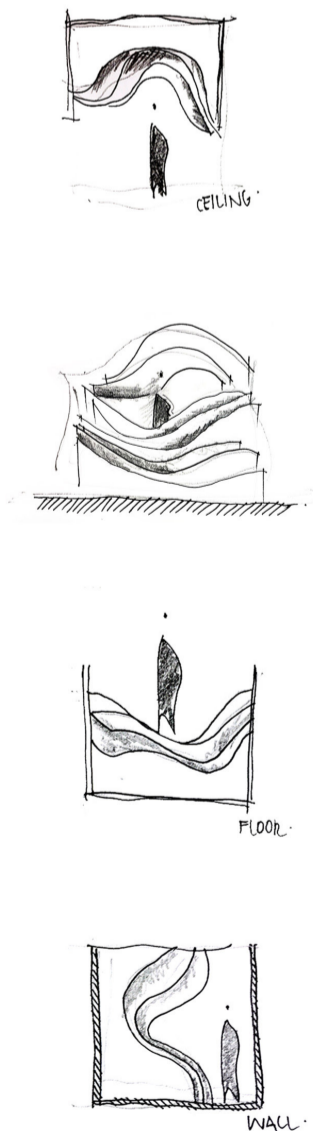

Figure 4.5.9 Sketch development: layered paper planes (Author. 2016)

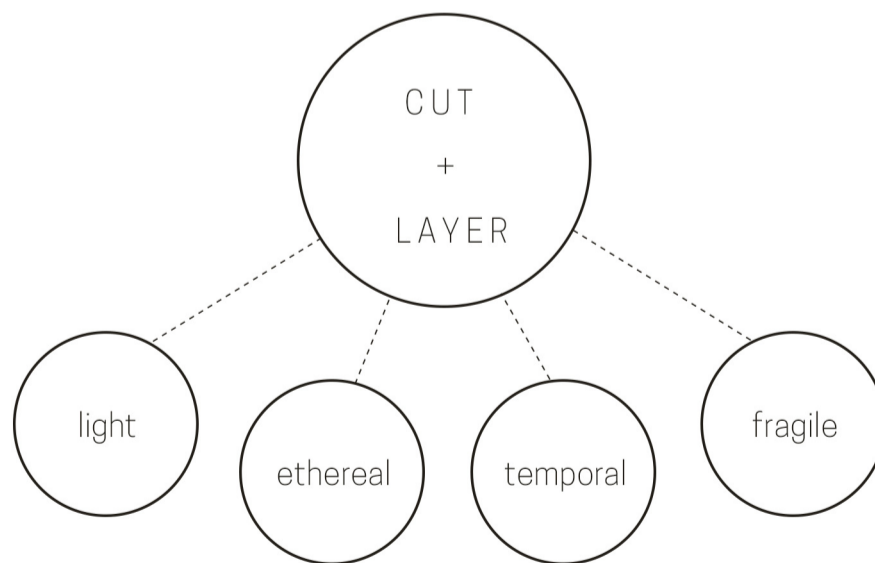

Figure 4.5.10 Associations of cutting and layering (Author. 2016)

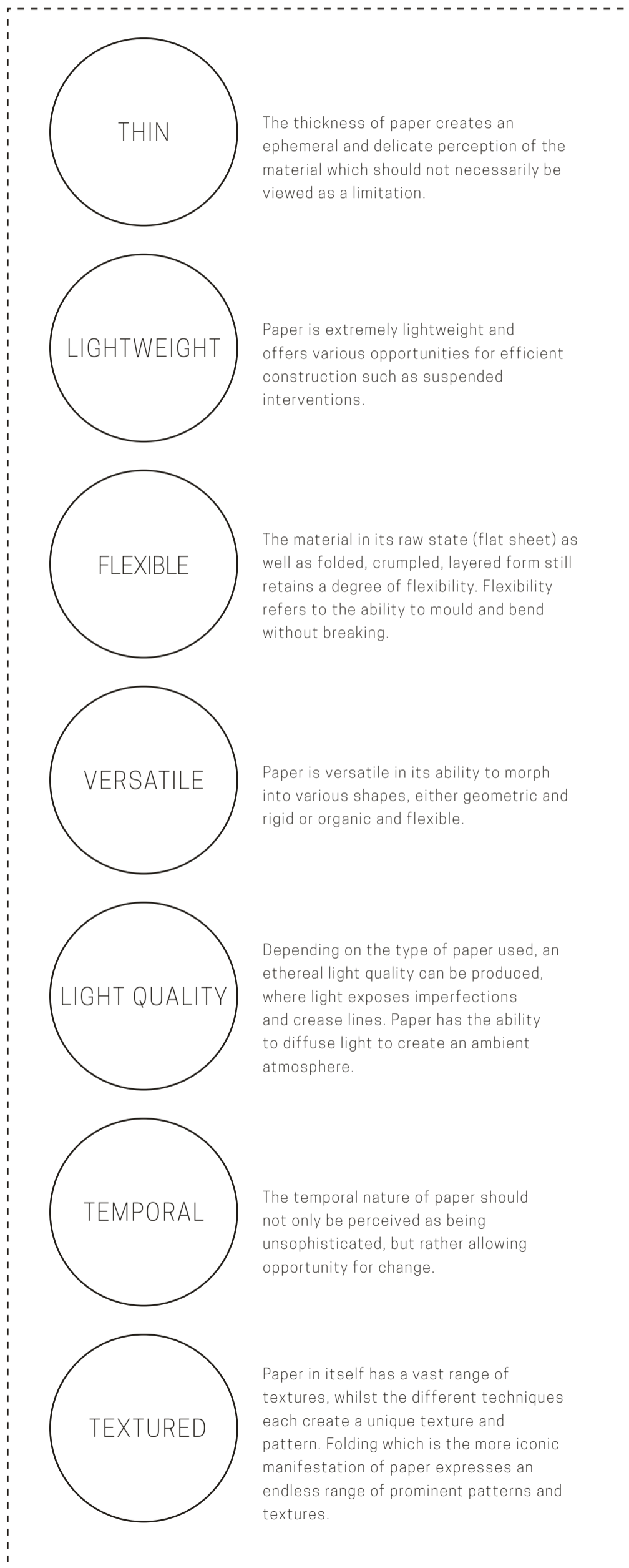

Figure 4.5.11 Qualities of paper(Author. 2016)

4.5.4 CONCLUSION

Through the process of exploring the potential and character of paper, a clear understanding was achieved of the material's potential and limitations. The act of making allowed ideas to develop for possible spatial application whilst designing in a conventional manner (two dimensional spatial planning and design sketches) alongside the making process. Refer to Chapter 2 section 2.3.1 and 2.3.2 for further elaboration on the proposed parallel design process.

All of the samples could be explored as hybrid methods to enhance and redefine the qualities of paper. For further exploration of paper this study takes a tectonic approach to the making with paper. In the following phases of making an armature will be considered to enable paper to go beyond the perceived technical limitations.

The material exploration was conducted by manipulating different types of paper and photographing the outcomes to extricate the character of paper to inform the spatial design development. Figure 4.5.11 elaborates the characteristics and qualities extracted from both the visual study and the material exploration done.

4.6 MATERIAL ANALYSIS

This study places emphasis on the exploration of material as an initial step in the design process, where the expression of paper becomes the crux of the design investigation. It becomes clear that the selection of supporting materials for the intervention is vital for the development of the spatial character and artefact. The additional materials, as indicated in figure 4.6.1 and 4.6.2, are chosen according to the similarities in attributes as listed in table 4.6.1.

Figure 4.6.1 Material Associations (Author. 2016)

Figure 4.6.2 Material palette (Author. 2016)

Table 4.6.1 Material Analysis (Author. 2016)

PHYSICAL	DIGITAL
Paper presentation is determined by the student's own taste and the fibre board wall allows for a variety of arrangements	The digital screen presentation is defined by the screen size and format. Less space is required as technology allows pin up to be controlled by user.
Form of the space and artefact expresses its content and function	Form expresses its general function but does not express the specific content.
Aesthetic attributes: Textured Warm	Aesthetic attributes: Smooth Cold Glossy Reflective Hard
Perceived attributes: Organic Vibrant Nostalgic Lasting	Perceived attributes: Monotonous Futuristic Fleeting
Spatial Manifestation	Manifestation through object
Dimmed lighting, only illuminated when in use	Screen is illuminated to reveal content

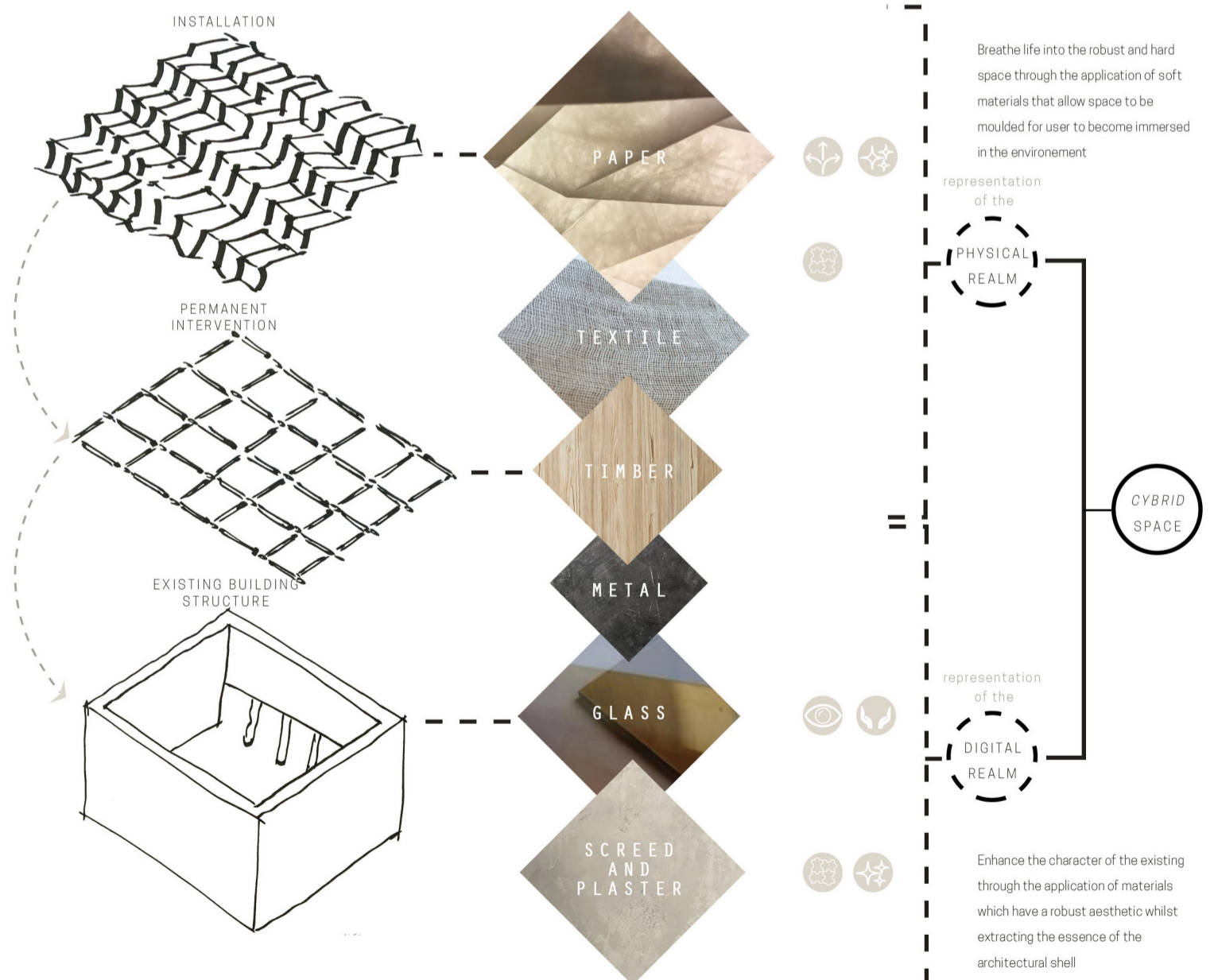

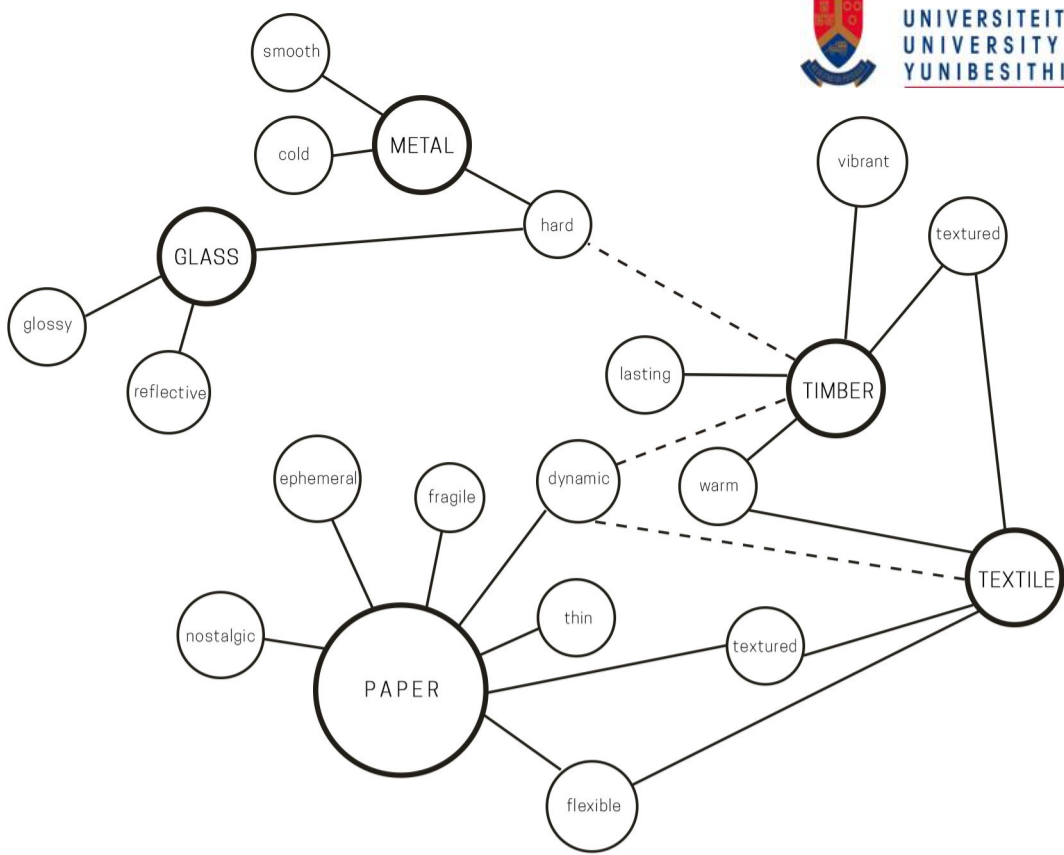

MATERIAL PALETTE

FLOOR



CEILING

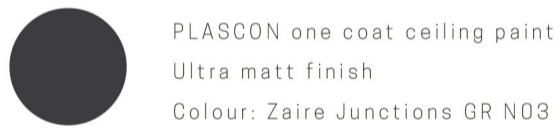
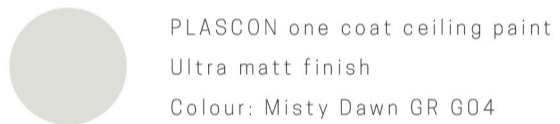

PAPER



WALL

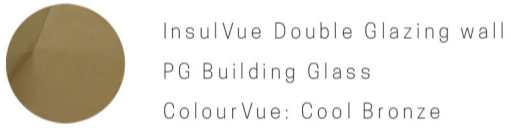
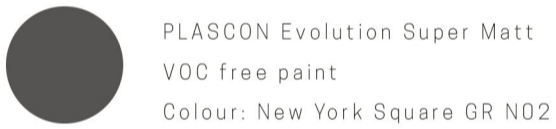

ARMATURE

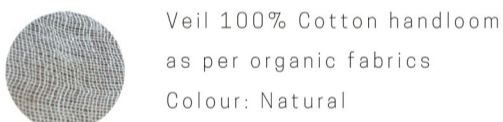

4.7 AESTHETIC

The role of the interior designer becomes focused on creating a seamless spatial aesthetic for the cybrid space refer to Chapter 3 section 3.3 Convergence of *cybrid* space. With reference to the comparative analysis, see Chapter 3 section 3.3.1, it becomes clear that we are losing valuable tangible qualities that create rich aesthetic and sensory experiences in the interior environments, therefore the materialization of the unique qualities of paper and of the *cybrid* archive becomes a key element to the design of a vibrant/elegant spatial aesthetic. Goldblatt (2007:11) uses the term aesthetic *as the perception of qualities generating feeling and emotion*. Within the context of this study the aesthetic quality of the space denotes the atmospheric and immaterial qualities experienced through physical and non-physical interaction of the space. Thackara in Roscoe (2007:105) brings to light that, *in response to our overexposure to digital objects and environments delivered through immaterial culture, that which remains tangible, tactile and material has the power to potentially root us to the ground as human beings*.

Mitchell (2002:428) illuminates the effect of technology on our perception to environments and explains that because technology makes it possible to locate oneself anywhere, *you will locate to where it's particularly attractive in some way* which he refers to as the revenge of place. Roscoe (2007:105) states that *as more experiences become immaterial, that which remains material may actually attain a new status as the exotic, the rare, and perhaps, the more meaningful*.

It becomes evident that the spatial aesthetic plays a significant role in the making of an integrated interior environment. The **exploration** of a new concept of *cybrid* space allows for opportunity to reintroduce a vibrant atmosphere and sublime beauty into the architectural archive.

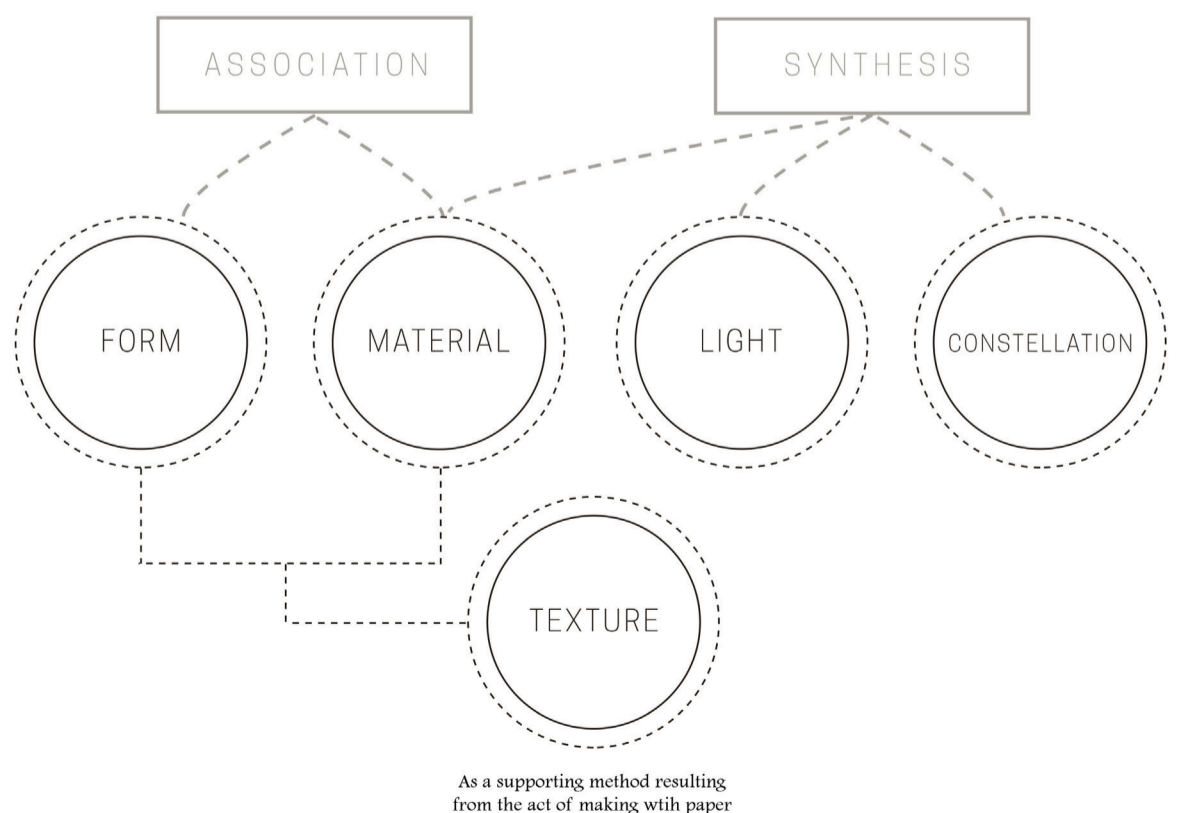

The exploration of a new concept of *cybrid* space allows for opportunity to reintroduce a vibrant atmosphere and sublime beauty into the architectural archive.

Figure 4.7.1 Methods of Making (Author. 2016)

4.7.1 METHODS OF MAKING

With the investigation of the new concept of a *cybrid* archive, the use of theoretical guidelines to serve as tools for defining the requirements (conceptual + functional) for the re-representation of the architectural archive. The two methods with their specified codes as discussed below are chosen as the most relevant tools to support the design development of the interior spatial intervention. The investigation of these two methods as primary focus does not disregard the additional three methods listed, as it becomes part of the intuitive design process.

König (2015) lists five methods of constructing meaning in an interior. The five main categories for the production of culture and meaning in interior design are synthesis, proximity, associations, timeliness and technification. Under each of these categories König (2015) identifies different codes used to construct the interior and he explains that these codes represent interior design actions in their use.

Focus is placed on association and synthesis to support the process of creating the new aesthetic character. The five most relevant codes namely: form, material, light and colour are identified to support the process of defining the *cybrid* character, but are not limited to only these codes. The design and making is an intuitive process which makes use of guidelines, refer to Chapter 3 Section 3.5 and Chapter 4 Section 4.7.3, to guide the decision making process throughout in order to achieve a cohesive aesthetic and spatial outcome.

The first method is *synthesis* and is defined by König (2015:151) as the selection of meaningful components and bringing them together as a cohesive whole. These components make up a complex interior space in a meaningful way to create a cohesive space. To counter the effect of fractured space refer to Chapter 1 section 1.2.1, synthesis is the appropriate method to be used for the design of the new *cybrid* space that would allow for both the physical and digital realm to be merged.

Synthesis comprises of twelve codes which are colour, constellation, curation, ensemble, light, material, object, style, symbolic motif, synthesis, taste good and techneme as determined by König (2015:169). The predominant codes selected for synthesis for the investigation of this study are light, constellation and material.

The second method is *association* which König (2015:205) defines as components of the interior space that creates connections in the mind that infer meaning, therefore without the association between the artefact and its referent the user would not be able to interpret its meaning. König (2015:225) denotes eleven codes for the concept of association which include analogy, boundary object, form, image, intertextuality, iteration, material, narrative, performance, tradition and wit. The predominant codes selected for association are material and form.

König (2015:208) explains the importance of the relationship between synthesis and association in the following quote:

Various elements with their own associations communicate a sense of diversity. The interactions between meaningful elements generate depth and diversity in the message which makes it more subtle than if single elements were employed. This indicates the reliance on synthetic methods to generate associations in the interior.

The influence and application of these methods and their codes are clarified through reflection and observations documented as an outcome of the act of making in section 4.8.



4.7.2 TEXTURE

Garcia (2009:9) highlights that pattern (texture) has always been a significant element of style, and elaborates pattern as being style, decoration, adornment, structure and detail. He further states that spatial pattern includes order, complexity, hierarchy, joint, expression, imagination, scale, function, unity, organization, balance, symmetry, symbol and creativity. Schumacher (2009:39) highlights the significance of pattern (texture) in the following quote:

What things look like matters. Architectural patterns are a potent device for architectural articulation. Pattern emphasized function.

As the result of the act of making with paper, particularly folding, it has become evident that tactile and visual texture manifest. The flat object (paper sheet) is manipulated into a three dimensional object and texture is no longer surface based, but the paper object becomes the texture, it attains a new dimension.

Djonov (2011:342) uses the study of visual surface textures to determine the meaning making potential of texture, as it is also a means for expression and communication for artists and designers. There lies potential in the act of making with paper from this study, to define spaces through the application of textures derived from the paper samples. The intention is to explore how the complexity of texture could articulate function within the larger archive space.

Schumacher (2009:39) clearly states that the concepts of expression and aesthetic character were traditionally used to show that decoration, particularly texture, was related to the space's purpose. He continues to explain that:

Planning, structure and decoration are together involved in expressing the character of the building. Ornamental pattern convey atmospheric values which translates into the atmosphere of the spaces which conveys the character and expression Schumacher (2009:40).

4.7.3 CYBRID CHARACTERISTICS

The characteristics which define the aesthetic of the *cybrid* archive will be defined through the interpretation of associations extracted from both the digital and physical realms as identified in Chapter 3 table 3.3.1: Comparative analysis and section 4.6: material analysis, as well as throughout the theory and precedent analysis done. The most significant characteristics are taken from each realm and are translated into a *cybrid* column which denotes the *cybrid* space, refer to table 4.7.1 for further elaboration.

The characteristics listed in the table below, are key elements which drive the decisions made for the spatial aesthetic and function of the intervention, and will further be elaborated in the application of each design element, see Chapter 5: Technification. The aesthetic palette on the opposite page serves as inspiration for the application of the characteristics listed in the *cybrid* column of table 4.7.1, to create a space which captures an ethereal quality through material, form, and light.

CYBRID CHARACTERISTICS

	PHYSICAL REALM	DIGITAL REALM	CYBRID SPACE
OPERATION	Preservation Collect, Document and Record Process	Preservation Efficiency Accessibility	PROCESS: exposure of how space and systems work PRESERVATION: preservation of valuable qualities threatened by dematerialization VISUAL ACCESSIBILITY: creating access to information in all its manifestations
IMMATERIAL	Permanence Nostalgic Tangible	Transient Futuristic Intangible	MORPH: how the interior environment accommodates various scenarios through a space that changes over time. ETHEREAL: an exquisite atmosphere that captures both the nostalgic and futuristic qualities.
MATERIAL	Vibrant Textured	Reflective Smooth	METICULOUS JOINERY: elaborating the material to material joinery to deliberately emphasize the contrasting characteristics.

MORPH

VISUAL ACCESS

ETHEREAL

PRESERVATION

PROCESS

METICULOUS JOINERY

Table 4.7.1 *Cybrid* Characteristics (Author. 2016)

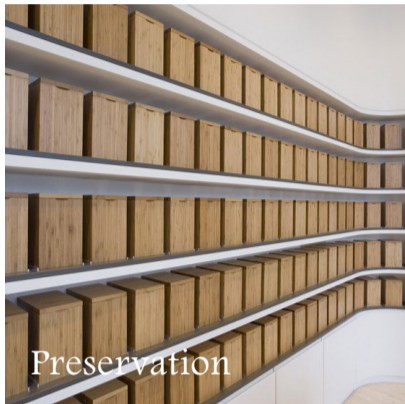
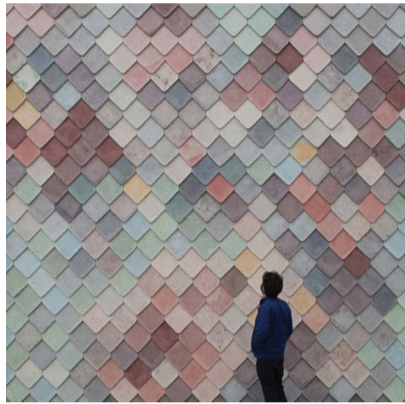

Preservation



Morph

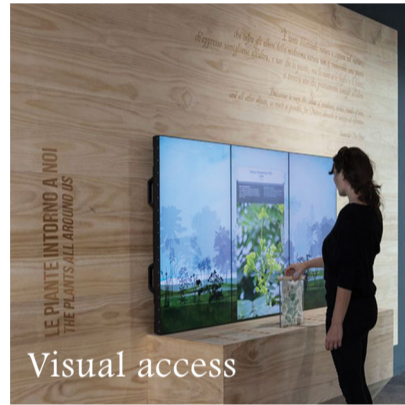

Visual access



Nostalgic



Ethereal light quality

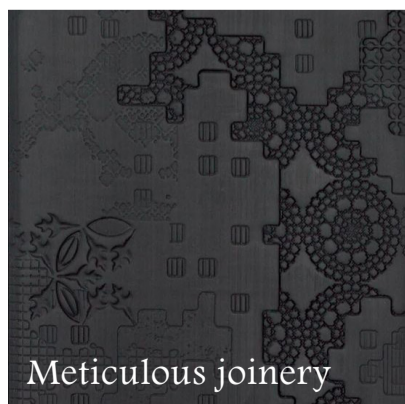
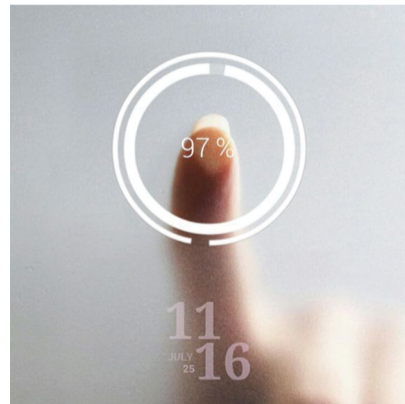

Meticulous joinery

Figure 4.7.2 Spatial Character (Author, 2016)



4.8 MAKING IMAGE

Moving from material exploration to spatial planning and layout design proved to be a struggle and resulted in a very two dimensional understanding of the space, making it extremely hard to imagine and design for the intangible spatial experience. The design process shifted away from conventional two dimensional drawings and planning back to making to further explore the spatial expression of the paper.

Nimkulrat (2012:10) explains that in order to understand the experience of the users of the space, the designer must embody the attitude of the user while making the artefact, which will give the designer maker more insight into the qualities expressed through the material to encourage the user to interpret and experience the artefact in a specific way. Through making we stimulate our own senses as designers.

The study has taken a shift away from the material exploration (material as product) as is the nature of the research through making methods, towards a spatial exploration through the expression of materiality. The making process now shifted focus to how one can make space by using the material (paper) not only as a creative outcome but as an expressive process which is intertwined in the spatial intervention. The aim is to investigate a method that allows one to develop an imagined image (space) through the exploration of a 3 dimensional physical image (model). The model should capture qualities of the space that cannot be easily explored on a conventional plan or section. The making process now starts to look at how a designer can make space through exploring a material spatially and volumetrically rather than developing a material artefact that could be applied to the space.

Heatherwick (2013:12) makes an interesting statement regarding the act of making as a powerful tool for imagination:

Adopting a spirit of purposeful aimlessness, I was trying to avoid needing an outcome. Although giving myself permission to experiment, I remained open and receptive to the possibilities that the material in my hands were offering, ready to convert them into something useful.

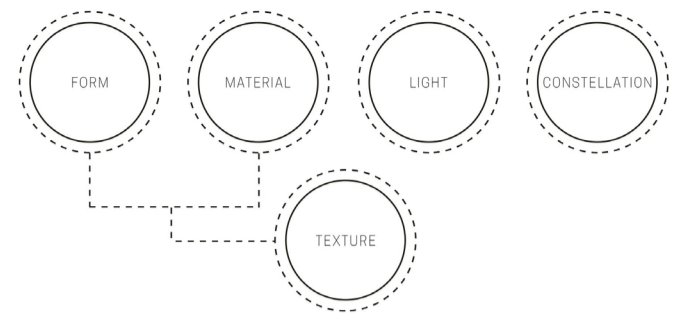

4.8.1 MODEL 1

Description: Model 1 was the initial step in the process of making the image to spatially express, within the specific context of the proposed interior space, the paper samples made. A section extrusion through all the significant spaces is used to explore the integration between different volumes.

Observation: The model clearly expresses the possibilities of what the paper artefact could be in this interior environment. Making the models takes definite shift away from material exploration toward more spatial exploration where a sample is translated into a volumetric application.

The scale of the paper installation in the space is over exaggerated, but it creates opportunity for the paper to be explored as a material that could be moulded into the space as it is an extremely malleable and flexible artefact once folded. The geometry of the fold patterns create interesting spatial forms, refer to figure 4.8.2, whilst creating a beautiful light quality on the folded planes.

Reflection: Documenting all the models in an informal manner during the making process allows for thoughts and observations to be recorded without breaking the creativity which connects to the informal nature of making.

The scale and ratio of fold to the space folded artefact could be explored further, to investigate the aesthetic effect as well as the spatial articulation of activities. Investigate the lighting effect as a result of the manipulated paper.

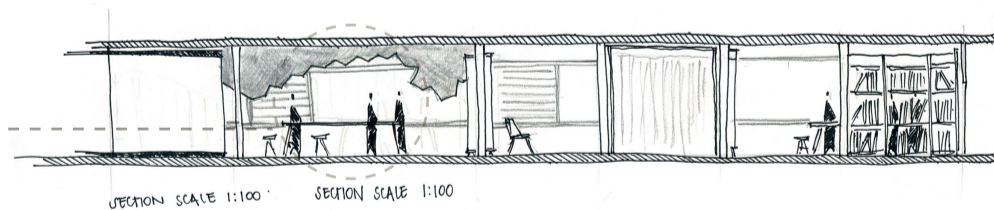

Figure 4.8.1 Collection of photographs: Test 25 (Author. 2016)



Figure 4.8.2 Sectional Model 1 (Author. 2016)

Moulding the artefact to articulate spaces.



Overhead plane is exaggerated in spaces where significant activities take place.

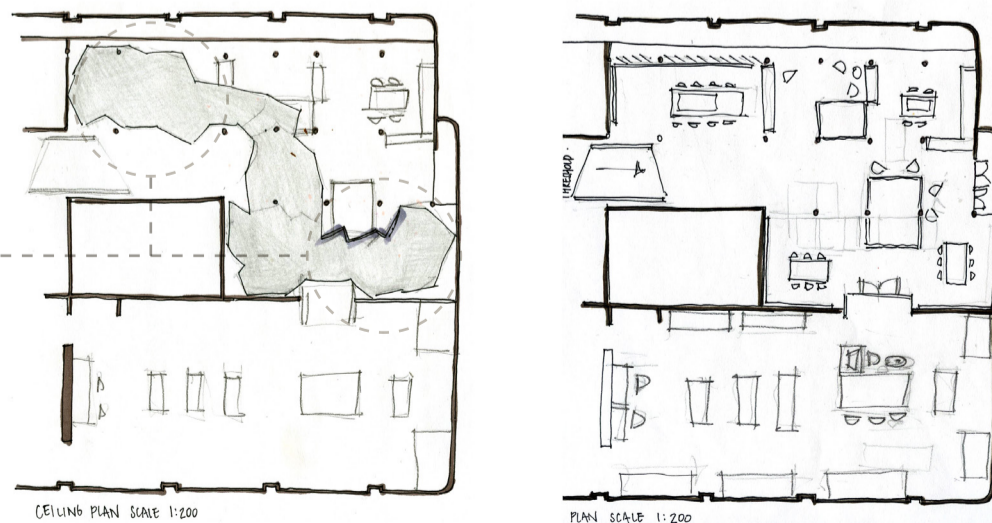
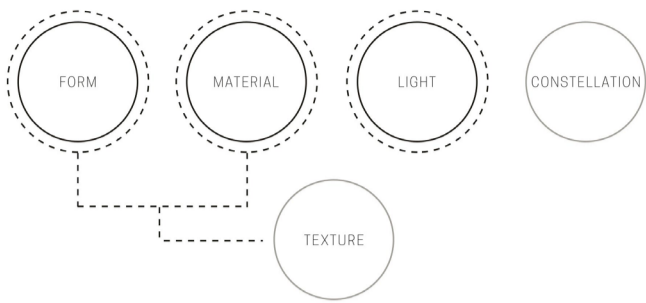

Figure 4.8.3 Spatial development sketch: Reflection to model 1 (Author. 2016)



4.8.2 MODEL 2

Description: Model was built roughly scale 1:100 and from sample 27 sketches where explored, refer to Appendix A sample 27, for possible spatial applications where after an intuitive exploration was done to express the material and its intangible qualities throughout the whole space. The sample, as per figure 4.8.4, was developed to investigate the effect of light with the translucent paper as well as the fluid planes.

Observation: Section extrusion model becomes inspiration for the whole interior space. Exploring the application of layered paper in one section allows the image created to be applied in the rest of the interior intervention. Caution should be taken as the design easily becomes focused on one cut plane in the same direction.

With support of objects in the space, the paper articulates spaces through unconventional form and texture, see figure 4.8.4 and double volume in figure 4.8.5. The fluidity of the paper planes as well as the translucent material creates unique shadows and allows light quality to change if the source of light is adjusted.

Reflection: Conventional plan and section drawings should be investigated for the application of the artefact as a whole for a well-integrated design outcome. Layering as technique in the space gives unique ethereal spatial effect which could be taken further in investigation of associations. Layers can be explored as individual elements with alternative techniques such as paper maché to strengthen individual layers. Explore possibility kinetic design.

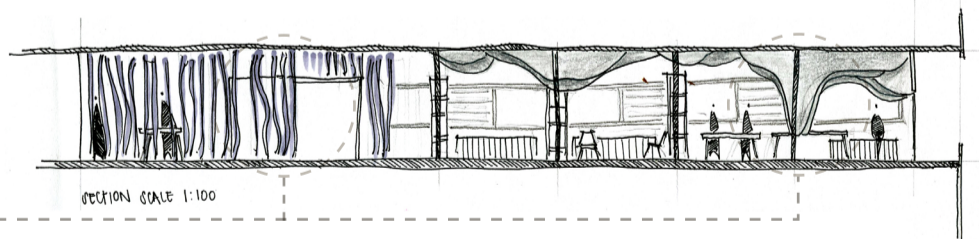

Figure 4.8.4 Collection of photographs: Test 28 (Author. 2016)



Figure 4.8.5 Sectional Model 2 (Author. 2016)

Layering with the paper allows for the views and transparency of spaces to be challenged.



Layering creates opportunity for privacy to be controlled to support the activities in the space.

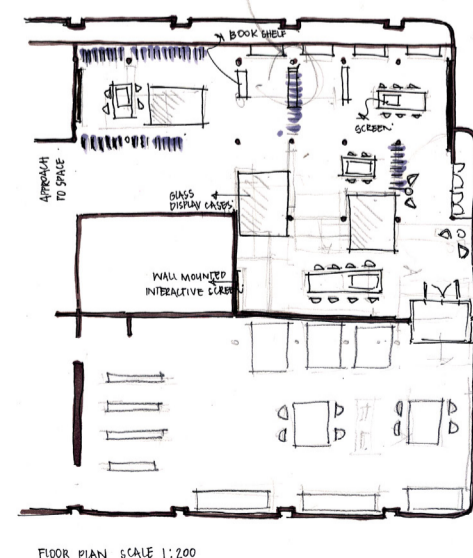
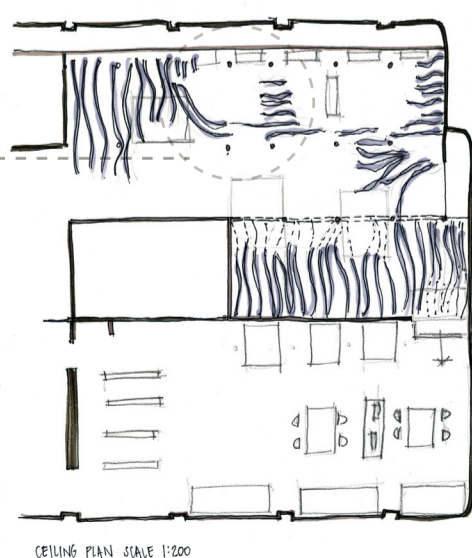
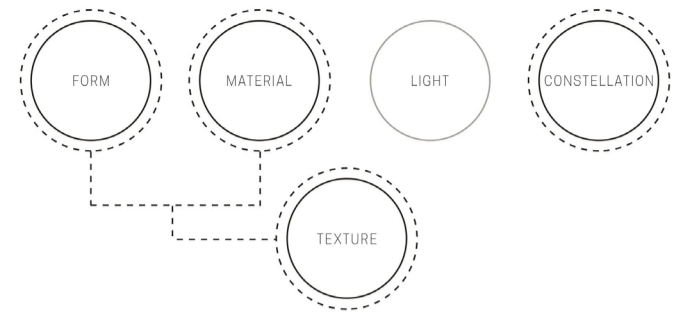

Figure 4.8.6 Spatial development sketch: Reflection to model 2 (Author. 2016)



4.8.3 MODEL 3

Description: : Model 3 is a reflection on model 1 which investigates a similar folded quality but through the use of an additional loose woven textile layer that serves as armature to the paper. The paper expression in the model is a response to test 8, see Appendix A. The model is built to explore the application of the hybrid paper sample in a different spatial configuration.

Observation: Section is cut only through one space therefore limits the spatial exploration as a whole. Adjacent spaces are separated from the model exploration and results in a fragmented outcome for the application of the paper artefact.

The series of photographs in figure 4.8.8 are used to investigate the flexibility and potential of movement of the artefact.

Reflection: Kinetic potential of folded paper should be explored as a method to create constellations within the space, to define spaces for activity.

The application of an armature to the paper artefact should be investigated to enable and manipulate artefact.

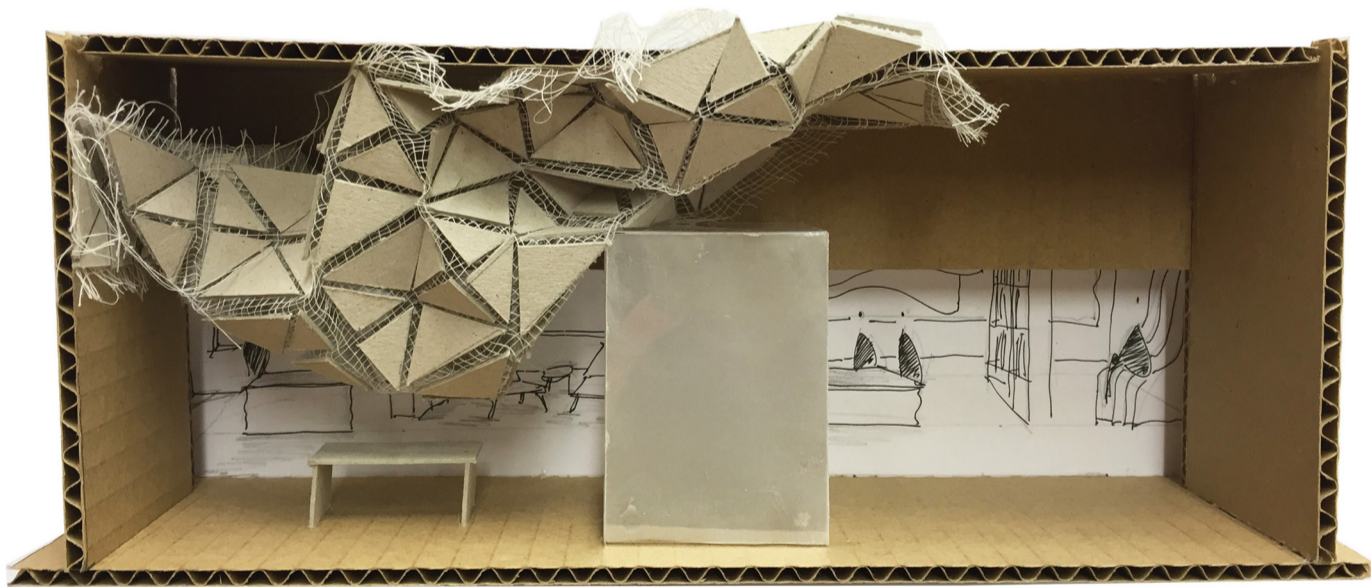

Figure 4.8.7 Sectional Model 3 (Author. 2016)

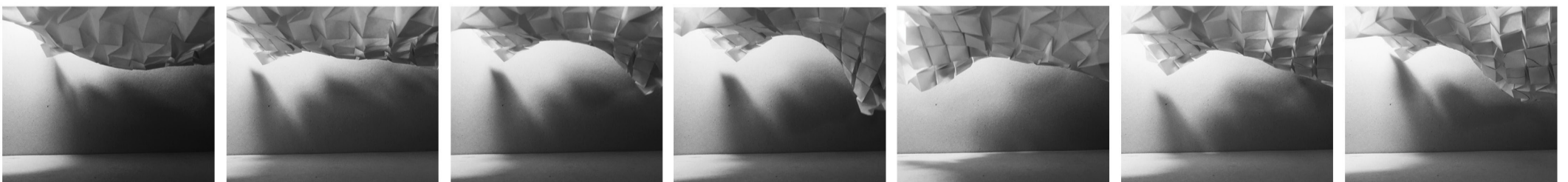
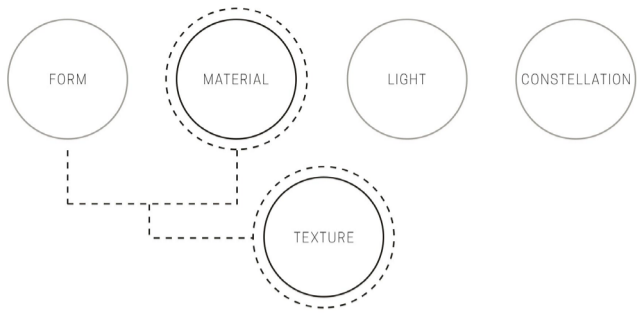

Figure 4.8.8 Collection of photographs: Test 26 (Author. 2016)



4.8.4 MODEL 4

Description: : Model 4 aims to explore alternative applications for the paper artefacts apart from ceiling based interventions.

Observation: The artefact loses its dimension when applied as a vertical surface treatment and does not have enough spatial impact because spaces are not defined enough through this intervention. This application does not contribute to the spatial experience of the space.

Reflection: Vertical application of paper as space dividing element will not be investigated further as it shows the least potential to achieving a intriguing spatial and aesthetic impact and is perceived as a surface based application. Textures show diversity, refer to figure 4.8.9, and should be explored as elements to articulate space.

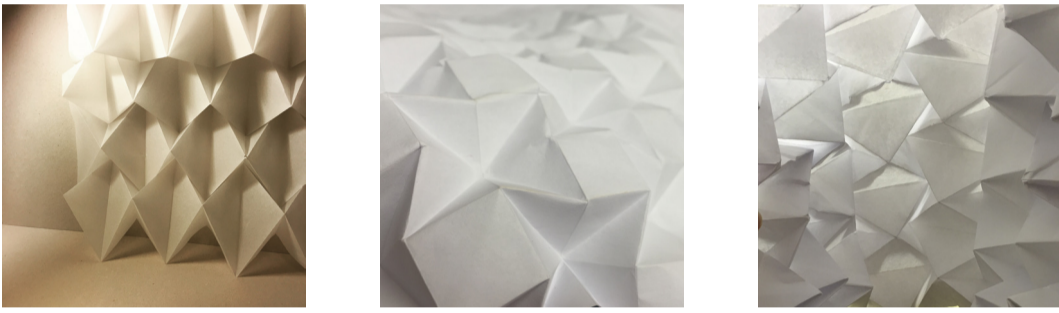

Figure 4.8.9 Collection of photographs: Test 23 and 26 (Author. 2016)

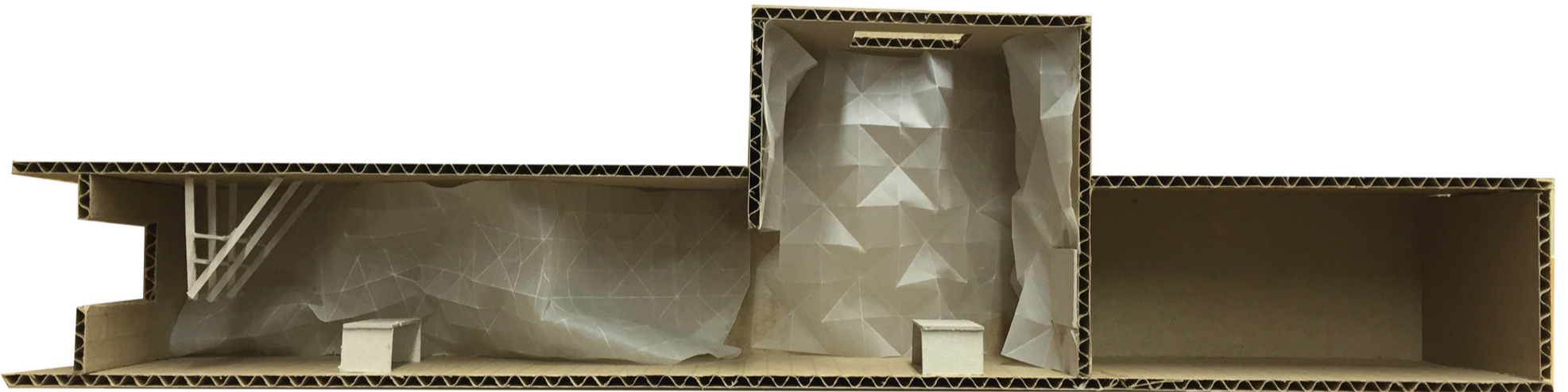

Figure 4.8.10 Sectional Model 4 (Author. 2016)

Vertical planes obstruct view in the space and creates too many smaller spaces, resulting in a disjointed environment.

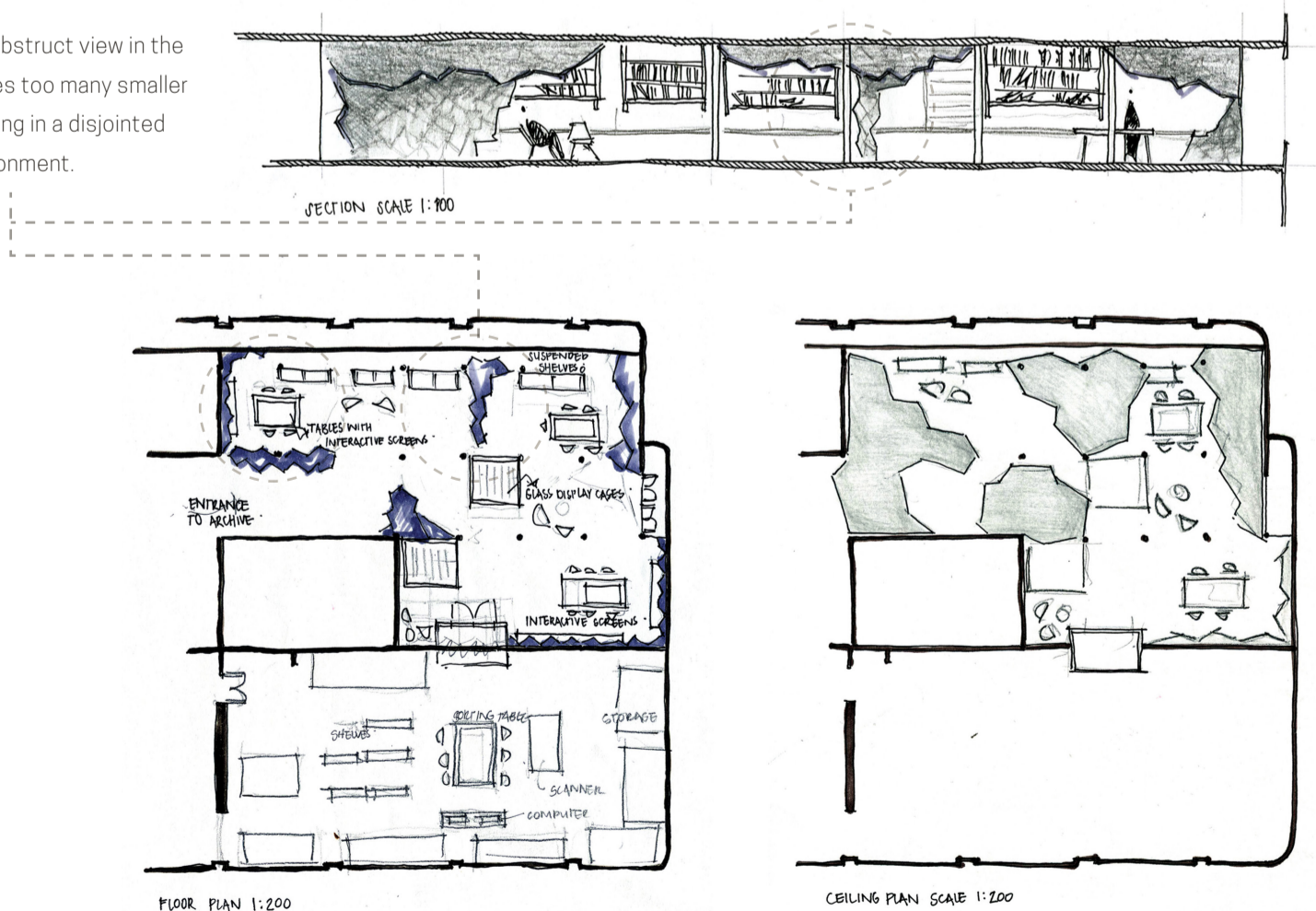

Figure 4.8.11 Spatial development sketch: Reflection to model 4(Author. 2016)

4.8.5 REFLECTION

The process of exploring the potential of paper within a spatial application through the use of a three-dimensional model contributes valuable and imaginative thought to the design development process. With the freedom to express the material in an intuitive manner without the pragmatic restrictions of two-dimensional plans and sections, creative insight to the overall spatial aesthetic experience is reached.

Observation:

The application of paper as a floor element was eliminated as it did not align with the qualities extricated in section 4.4.4, see figure 4.4. The investigation of a vertical wall application was terminated, due to the anticipated lack of spatial impact in order to achieve the ethereal quality and ability to morph as specified in table 4.7.1 at section 4.7.3.

Reflection:

The most successful explorations were models 1, 2 and 3. Through the manipulation of the form, material, light and texture, the immaterial qualities as specified in table 4.7.1 of *cybrid* characteristics was achieved. The quality of movement captured in figure 4.8.8 of model 3, inspired the manipulation of the space through the possible application of a kinetic suspended paper installation. This concept of movement could be investigated in more depth as an element to create constellations in the space.

The application of paper for further investigation and technification, will be focused on the development of a suspended overhead installation as a space-defining element. The lightweight quality of paper allows for an installation of a temporary nature as infill to the existing structure with the support of an armature.

The development of form, texture and constellation will be elaborated in Chapter 5: Technification.

The quality of movement captured in figure 4.8.8 of model 3, inspired the manipulation of the space through the possible application of a **kinetic suspended paper installation**.

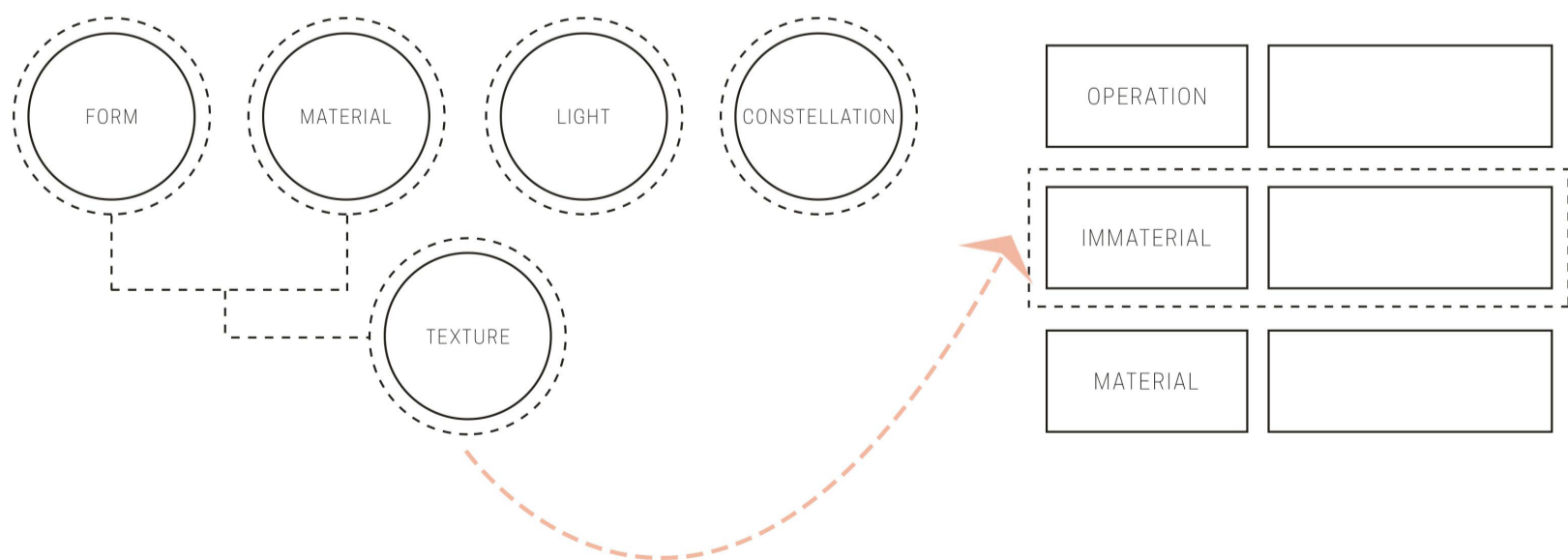

Through the manipulation of the five codes, the immaterial *cybrid* characteristics are met

Figure 4.8.12 Integration of codes and *cybrid* characteristics (Author, 2016)



4.9 CONCLUSION

The process of exploring the potential of paper within a spatial application through the use of three-dimensional models, contributes valuable and imaginative thought to the process. With the freedom to express the material in an insightful manner without the pragmatic restrictions of two-dimensional plans and sections, insight into the overall spatial aesthetic experience is developed.

The intention of Chapter 4 was to capture the essence and intangible character of the paper within the context of an interior spatial intervention. The chapter concludes with the conceptual approach which would inform the design decisions to follow.

The following chapter will focus on the physical, tangible aspects of the design development, where the technification of the paper artefact and the spatial will be investigated. Chapter 5: Technification will also address the technical requirements for the archive, such as lighting and climatic control.



UNIVERSITEIT VAN PRETORIA
UNIVERSITY OF PRETORIA
YUNIBESITHI YA PRETORIA

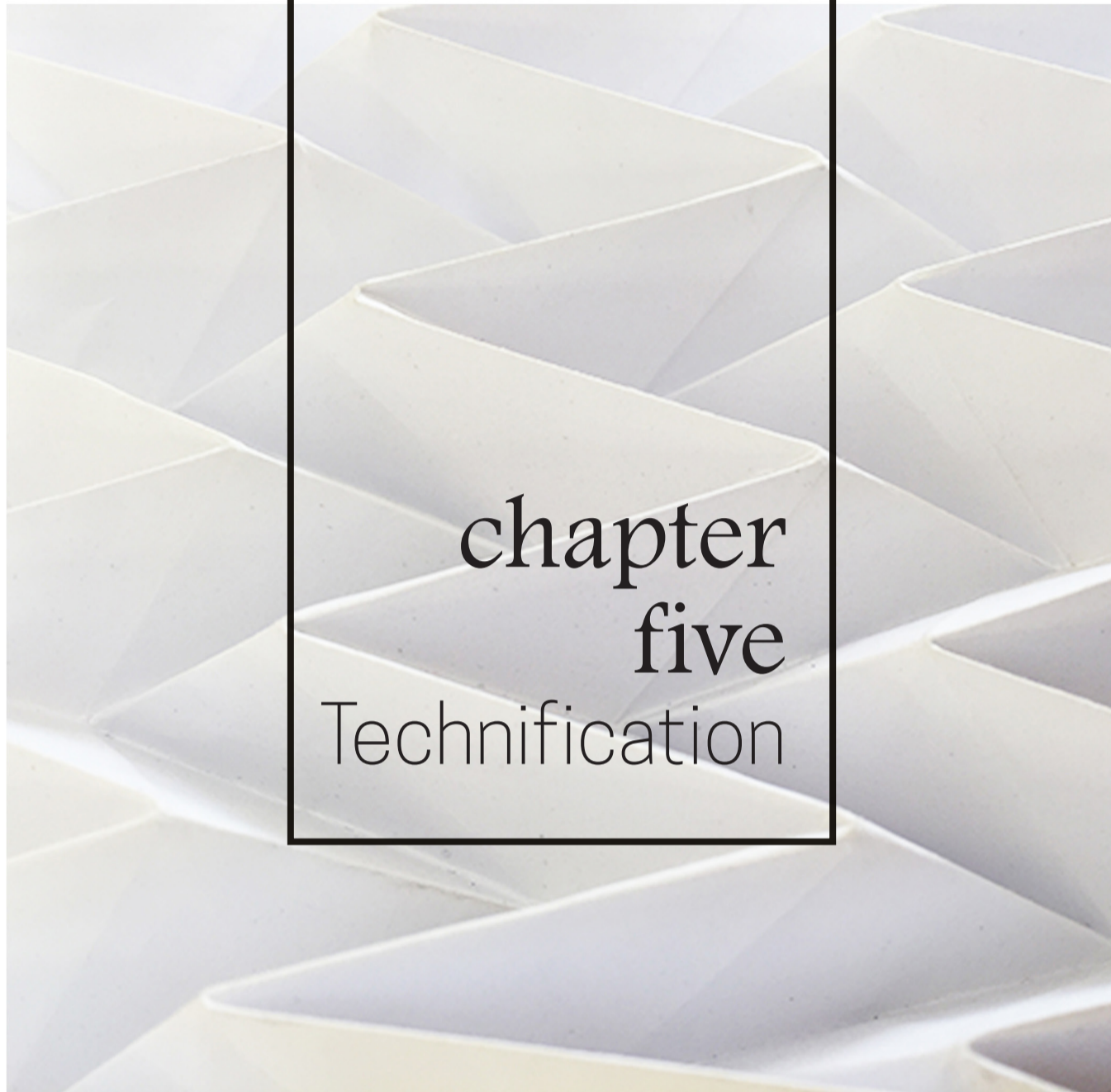

chapter five Technification

This chapter follows on the conclusions made in chapter 4, the third phase of the making process is introduced through a series of photographs and design development sketches supported with written observations and reflections. The third phase of making focusses on the technification of the paper artefact and the fabrication and installation thereof. The guidelines and *cybrid* characteristics identified in earlier chapters are elaborated through the application of design elements.

Chapter 5 introduces the intervention approach for the space, where after the technical requirements for the artefact are defined. The documentation, reflection and conclusions of the third phase of making is followed by a section drawing through the whole space, to place the paper artefact installation in context. A series of drawings express the detail, construction and installation process of the paper artefact, further followed by a series of technical drawings, perspectives and details which visually expresses the final spatial outcome of the design and making process. The specific environmental requirements for the archive will also be elaborated in this chapter.

5.1 INTERVENTION

The general design intent for the space is developed at different levels of intervention as indicated in figure 5.1.1. To allow for the installation of new work the following procedures will be followed as specified by Scott (2008:108):

Stripping back: this entails the stripping out of damaged and unwanted fabric. Refer to figure 5.1.2 and 5.1.3.

Enabling works: this involves the demolition and removal of fabric which would prevent the application of new work if it were to remain.

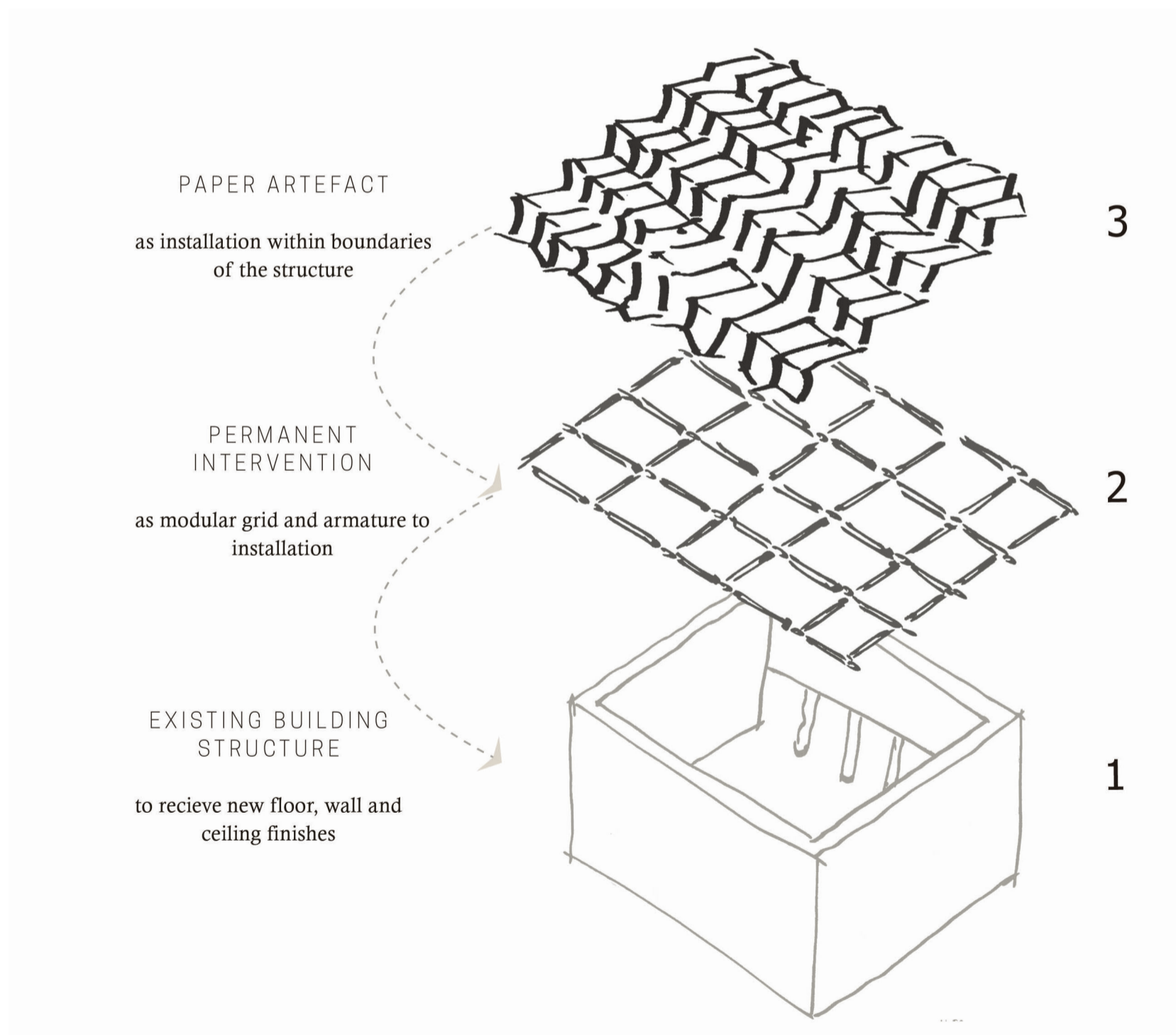

Figure 5.1.1 Levels of intervention (Author: 2016)

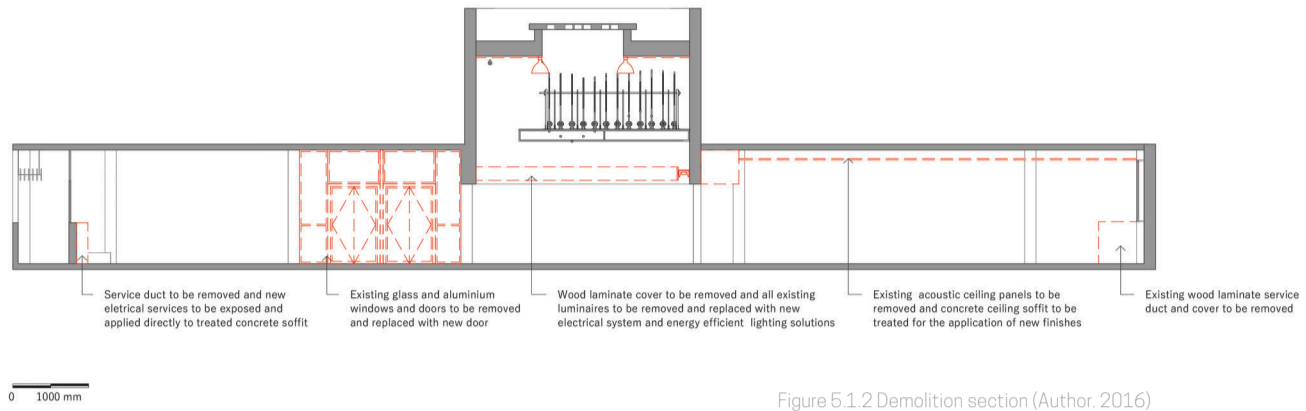

Figure 5.1.2 Demolition section (Author. 2016)

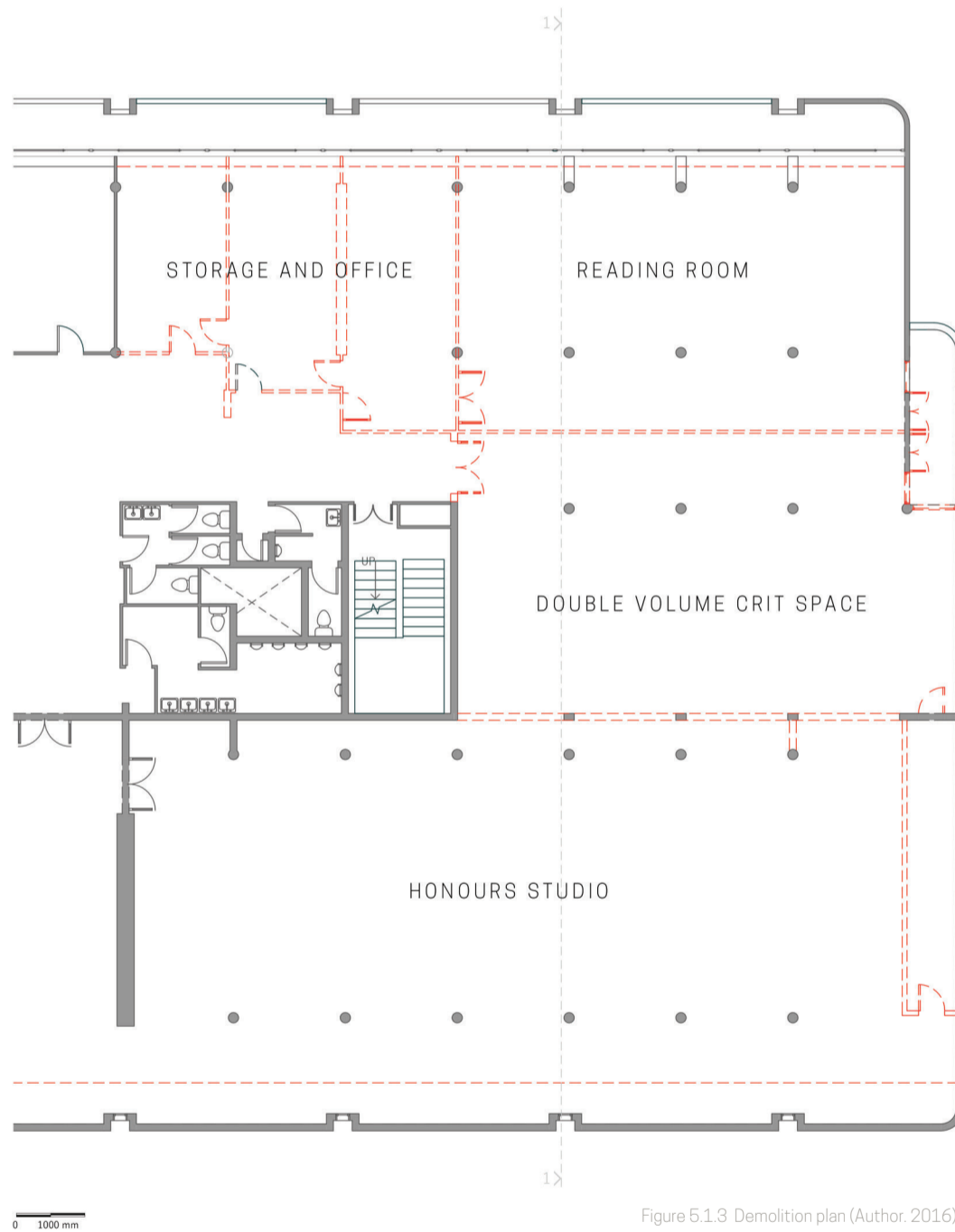

Figure 5.1.3 Demolition plan (Author. 2016)

LINE LEGEND

- - - - - To be demolished
- Existing structure

5.2 SPATIAL REQUIREMENTS

The requirements listed below is a continuation of the conclusions made in Chapter 4, where the possibilities and limitations of the application of the paper artefact where explained. This section addresses what the requirements are for the paper intervention.

5.2.1 SPACE DEFINING ELEMENT

Any three dimensional form naturally articulates the volume of space surrounding it and generates a field of influence or territory which it claims as its own (Ching, 2007:102).

Ching (2007:122) explains that a ceiling plane can be manipulated to articulate zones within a space and as the edges of the overhead plane could define the boundaries of the space, the texture, form, height, colour could support and define the formal qualities of the space. Refer to figure 5.2.1 through 5.2.3 where the form of the ceiling plane is explored diagrammatically. The artefact should be able to:

Articulate zones in the space where information can be accessed whilst creating a stimulating environment.

5.2.2 LIGHT CONTROL

With the presence of reflective surfaces of the digital screens in the space, it becomes important to consider the lighting conditions for the different functions that will take place. The overall light quality of the space should be manipulated to create the ethereal quality to breathe new life into the space, which would encourage interaction and stimulate a vibrant sensory experience. The paper artefact should be able to:

Minimize the glare on the individual digital screens.

Create a ethereal light quality that would enhance the aesthetic of the space as per the *cybrid* characteristics.

5.2.3 PERCEIVED PRIVACY

The space should allow for multiple users in the space whilst separate activities are taking place in designated areas. The intention is to create visual delineation where focus is needed for a scenario such as a formal presentation as elaborated in figure 5.2.4, whilst allowing for interaction between users to encourage conversation as shown in figure 5.2.5. The artefact should be able to:

Create perceived acoustic privacy.

Create visual delineation and privacy to focus attention to specific activity.

The development of the artefact to accommodate these requirements will be elaborated in the sections to follow.

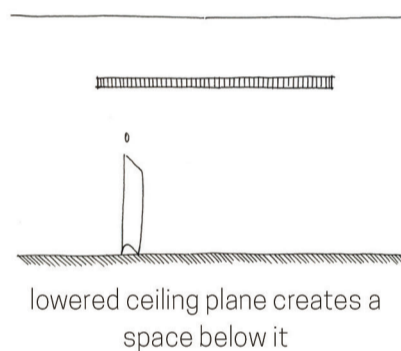

Figure 5.2.1 Flat ceiling plane (Author, 2016)

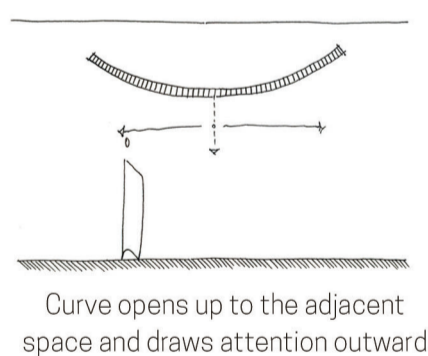

Figure 5.2.2 Convex ceiling plane (Author, 2016)

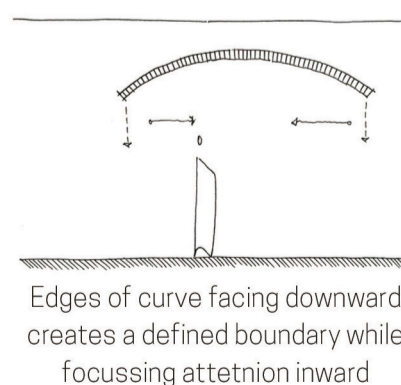
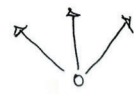
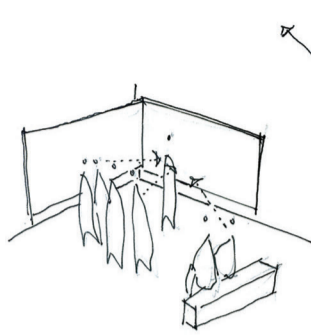

Figure 5.2.3 Concave ceiling plane (Author, 2016)



PRESENTATION SPACE

Formal presentation requires visual focus toward the vertical plane on which the work is presented, as well as a visual delineation to create perceived visual privacy.

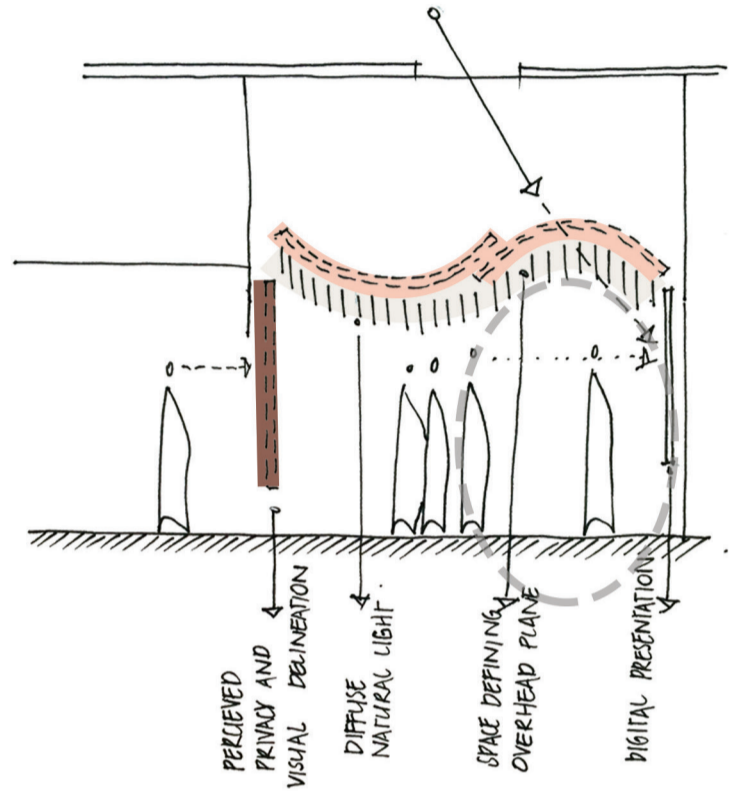
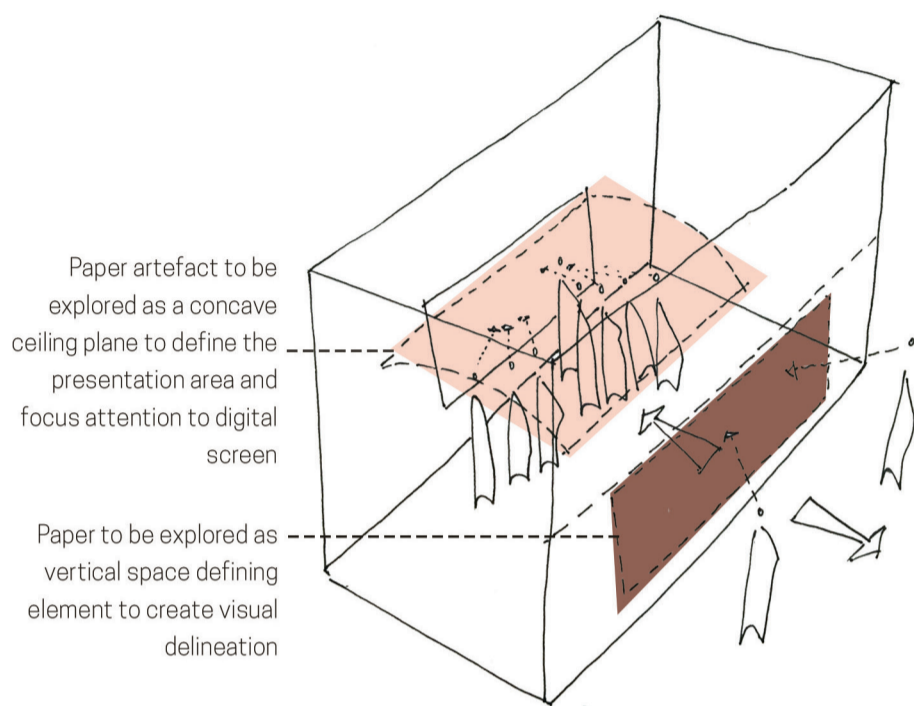
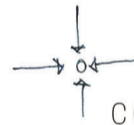
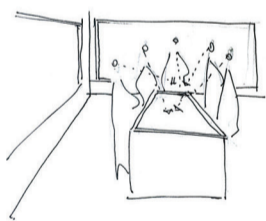

Figure 5.2.4 Scenario 1: Presentation (Author, 2016)



CONVERSATION SPACE

The conversation space should allow for visual access to adjacent spaces to encourage interaction from other users

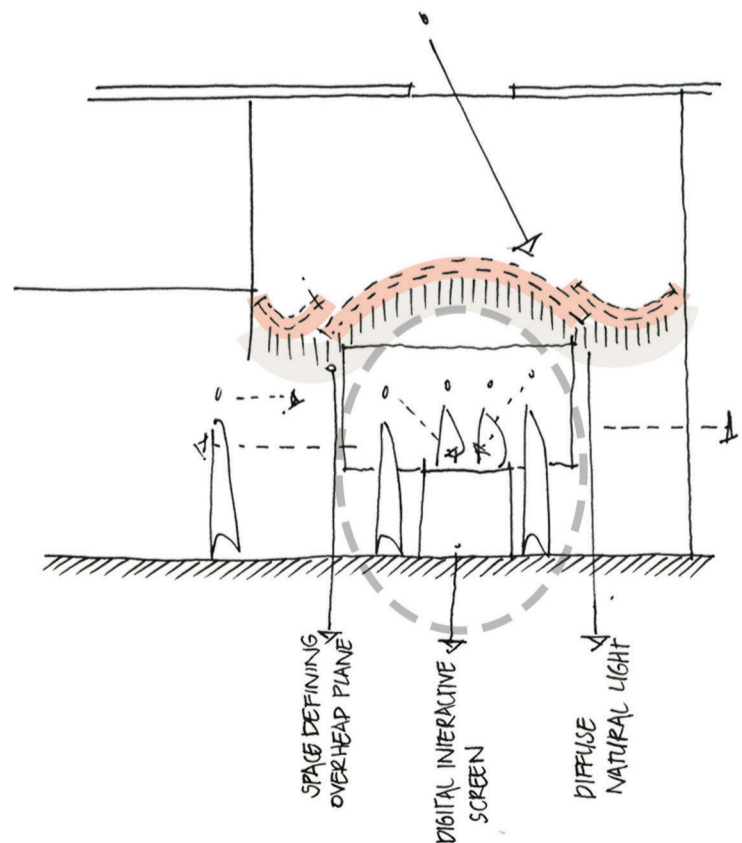
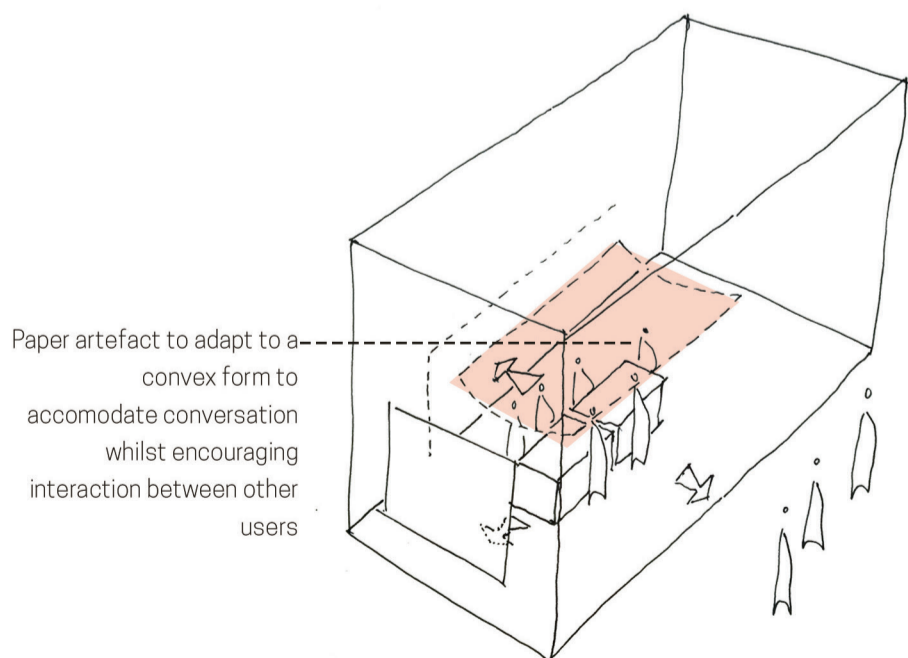

Figure 5.2.5 Scenario 2: Conversation and debate (Author, 2016)

5.3 TECHNIFICATION: REFLECTIONS

From the second phase of making the image with the support of the sectional spatial models, the focus of the investigation shifted toward the form of the space and the movement of the paper artefact as part of the kinetic mechanical system.

With a clear understanding of the spatial qualities that could be achieved with the paper, further spatial development was explored through sketches, spatial planning and computer generated models. Conventional two dimensional plan and section drawings were generated for the space as a whole.

The potential and requirements discussed in section 5.2, is developed further through the 3rd phase of making where the technification of the paper artefact becomes the focus. With the support of various drawing explorations on section and plan, the overall form of the space was developed to define the perceived acoustic and visual privacy through the application of a kinetic mechanism. The form and movement is determined by two dominant scenarios of the space, refer to section 5.2 figure 5.2.4 and 5.2.5, which creates opportunity for the application of adaptable elements manipulated by the kinetic system. Refer to Appendix B for the sketch development of the technical details.

5.3.1 SUSPENDED GRID MODEL

Description: Sample was built as a representation of the paper artefact, using cardboard triangle cut outs fixed to a textile to allow for flexibility, see figure 5.3.1 and 5.3.2. The model was not built to scale. The sample is suspended from a cardboard structure and attached to a grid with rope to be able to manipulate investigate movement of the sample.

Observation: Because the sample is one single element, the movement is limited, once a string is pulled the entire sample pulls slightly towards that point, as illustrated in the photograph series in figure 5.3.3. The model gives a good understanding of what the limitations and possibilities are for the suspended paper artefact.

The pattern of the sample creates interesting shapes when pulled at single points, but when pulled in a similar motion as a kinetic wave, the form stays flat.

Reflection: Build a suspended model that can illustrate a continuous kinetic movement for the paper sample. Explore the depth of movement and pattern of the paper artefact, to move beyond a flat surface.



Figure 5.3.1 Suspended grid model (Author. 2016)



Figure 5.3.2 Representation of paper artefact (Author. 2016)



Figure 5.3.3 Movement of suspended artefact (Author. 2016)

5.3.2 KINETIC MECHANISM



Figure 5.3.4 Kinetic mechanism with staggered cam and arm (Author. 2016)



Figure 5.3.5 Kinetic mechanism (Author. 2016)



Figure 5.3.6 Flexible grid (Author. 2016)



Figure 5.3.7 Dowel and eye hook (Author. 2016)

Description: In order to achieve the required motion for the manipulation of the paper in the space, a mechanical system was investigated, from which the model was developed and technified. The model is a lasercut cardboard model with multiple parts, some exaggerated to represent the actual detail. It was built in order to determine the placement of the cams and the result it would have on the movement of the paper. See figure 5.3.4 and 5.3.5 for clarity.

Observation: The depth of movement is limited to the radius of the cam and placement of the shaft on the mechanism, within the limitations of the space a depth of 400 mm could be achieved. The intention of creating movement in two directions, allowing spatial manipulation in four planes is eliminated as it is an extremely complex system to construct.

Reflection: The rotating mechanism enables the motion of the paper therefore further exploration to a grid system as armature to the paper should be investigated.

5.3.3 FLEXIBLE GRID

Description: Grid model was constructed on a scale 1:2 with the use of 6 mm timber dowels and eye hooks. The dowels are attached to one another in a 150 x 150 mm square grid and fixed to a cardboard sheet with rope to manipulate the height of the suspended grid.

Observation: Simple construction with eye hooks allows for an extremely flexible grid that could accommodate a fluid motion of the kinetic mechanism. The smaller the grid (the more moveable parts) the more flexibility it has.

Reflection: The joining of rope to the eye hook, refer to figure 5.3.7, should be investigated further to achieve a more sophisticated yet simple detail. Thickness of timber dowels should be explored as well as the potential fixing points for the paper artefact.

5.3.4 GLIDE REFLECTION FOLD

Description: White cartridge paper 420 x 420 mm sheet.

Observation: Folded product size is limited to the flat sheet size because the folding technique results in more than 50% shrinkage in size after folding.

Small folded pieces are flexible but not as organic as would be required to achieve specific aesthetic quality. The artefact should be extremely malleable to manipulate the suspended paper to achieve the fluid spatial form. The form of the folded paper creates an intricate texture as a result of the shaping process, and the texture is no longer just surface based but three dimensional. Paper as an object in itself has a vibrant texture.

Once the paper is applied to the space the texture could be perceived as being surface based and an organic textile like form is a result of the folded texture, creating a new dimension for paper to move in.

Reflection: Investigate the folded product on a larger scale with a larger sheet of paper. Investigate similar folds that could potentially be more relaxed and even more organic and malleable. The artefact should have the ability to be draped from the ceiling to achieve morph and ethereal quality as specified in Chapter 4 table 4.7.1, while being extremely delicate and intricate.

Investigate the texture of the fold to create more diversity in its spatial application, to create spaces where texture becomes a supportive space defining element.



Figure 5.3.8 Stretched glide reflection fold (Author, 2016)

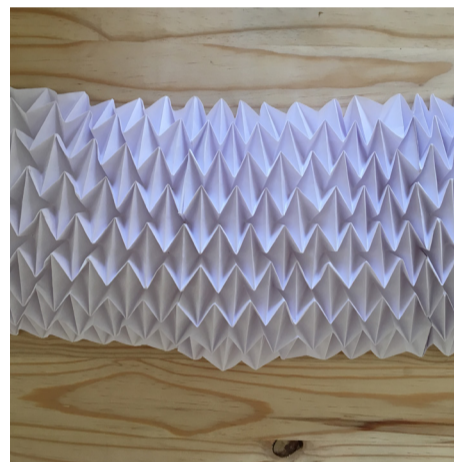

Figure 5.3.9 Glide reflection fold texture (Author, 2016)



Figure 5.3.10 Fluidity of glide reflection fold (Author, 2016)

5.3.5 MULTIPLE V-FOLD



Figure 5.3.11 Fluidity of multiple v-fold (Author. 2016)



Figure 5.3.12 Collapsed multiple v-fold (Author. 2016)



Figure 5.3.13 Multiple v-fold texture (Author. 2016)

Description: The intention of this fold pattern is to explore the scale of the folds for the paper artefact as well as to test its flexibility in two directions, to allow for kinetic motion in one direction and form manipulation in the other.

Observation: Small scale folds are harder to collapse into the three dimensional shape and if the pattern is not folded extremely accurately, the folds crumple on the edges.

The V-fold is extremely malleable in one direction but does not flex enough in the other direction.

Individual panels (+- 500 x 500 mm) do not have the same dramatic aesthetic quality as one large element. The smaller individual folded panels move one another and not as one structure. Joining the individual panels with glue is not an optimal solution (aesthetically and practically).

Reflection: Investigate more intricate fold patterns to achieve variation in texture. Explore the joinery between individual panels to contribute to the aesthetic quality as well as to make installation and maintenance more efficient.

Extend size of fold sheet in direction two to test if the size could add flexibility. Test perforated paper to see if it makes folding process easier.

5.4 SPATIAL INTERVENTION

Understanding and appreciating the fundamentals of detail design in regard to architecture and interior architecture is without a doubt important: it is not until the architectural elements are brought together through sensitive detailing that a space becomes wholly believable and creditable Hay (2007:36).

The development of the spatial design response is informed by all the data generated through the phases of making with paper, as well as the analysis and interpretation of collected data.

The intention of this study is focused on the aesthetic and atmospheric quality achieved through the re-representation of the architectural drawing archive. The design was developed to achieve an ethereal spatial quality with the application of a suspended paper intervention as the visual link between the material and immaterial. Through the act of making the sublime beauty and potential of paper within the context of the paper archive was realized. The movement, textures and light qualities of the paper is intended to stimulate the user's senses and breathe new life into the perceived redundant archive.

Throughout the space, subtle design elements are developed to define the new *cybrid* space. The space is designed to be perceived as a robust space which captures the very basic character of the architectural shell, to which the addition of the paper installation contributes all of the intricate aesthetic, intangible and functional qualities.

The intention is to ultimately create a space which celebrates the significance of the architectural drawing archive, through the integration of both the physical and digital realm. The unique qualities which will be showcased in the following diagrams, three dimensional models, plans and section, will each highlight specific qualities that are introduced back into the space as per the discussion in Chapter 3 section 3.3.1 the comparative analysis.





Figure 5.4.1 Section 1-1 (Author, 2016)

5.5 SUSPENDED PAPER INSTALLATION

The development of the paper artefact is informed by the following *cybrid* characteristics: Ethereal, morph and meticulous detail.

The paper artefact is developed as the infill to the modular grid intervention which serves as armature to enhance the spatial impact of the installation. The paper installation creates an intriguing spatial experience which aims to capture the essence of both realms whilst supporting and enhancing the operation and activities that takes place in the *cybrid* archive by:

- + Defining space as both an overhead plane and vertical plane
- + Controlling natural and artificial light within the space to minimize glare on smooth surfaces
- + Creating an ambient and ethereal light quality to stimulate the senses

- + Introducing textures as supportive space defining elements
- + Introducing texture and pattern to encourage interaction of the senses
- + Reintroducing sound of paper through the kinetic sculpture
- + Extricating the qualities of the physical paper archive whilst representing the new *cybrid* character in the ability to morph, create ethereal spatial quality and through meticulous joinery.

Section 5.7 through 5.8 will elaborate the material selection, fabrication and installation of the paper artefact within the space.

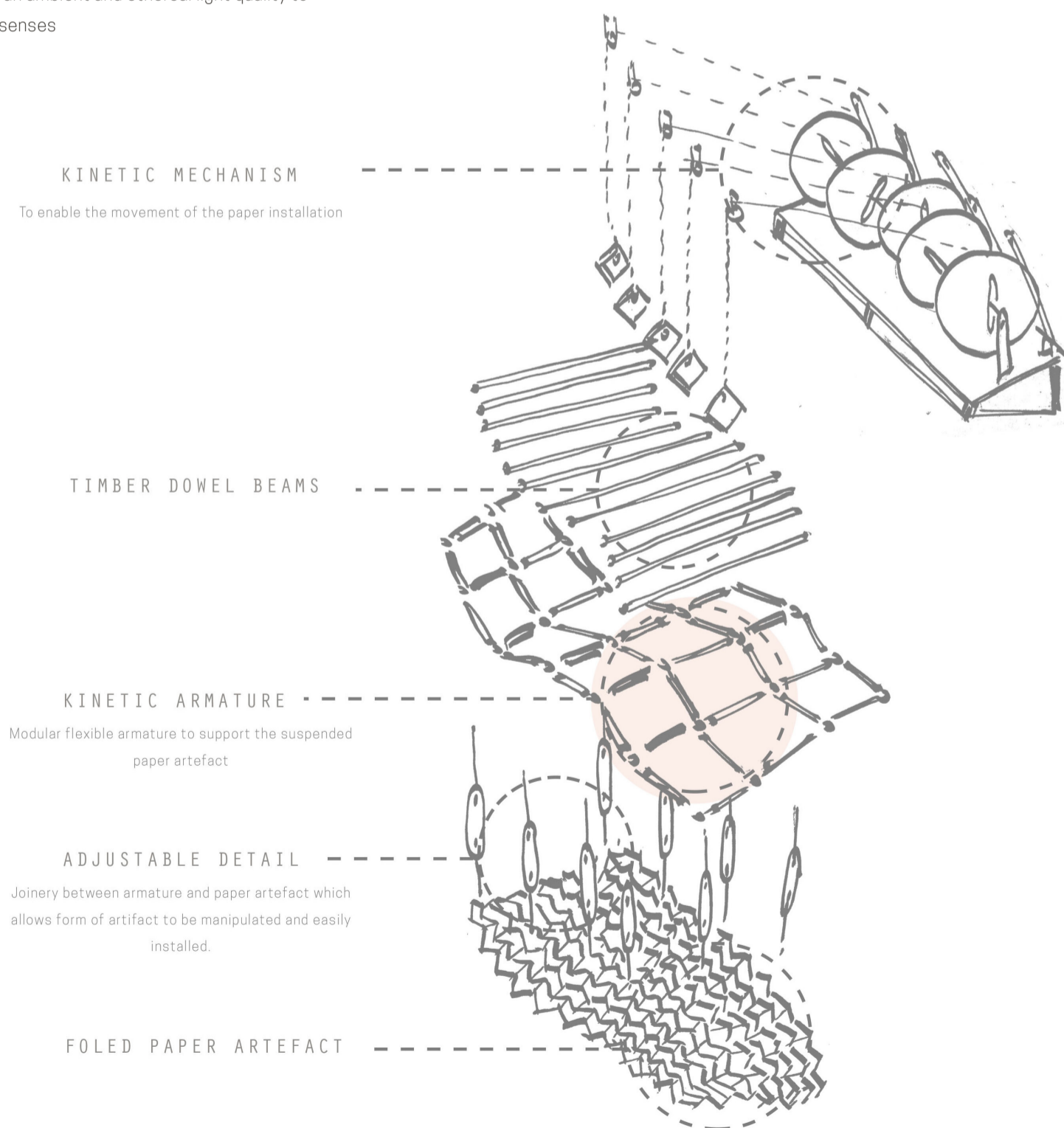

Figure 5.5.1 Suspended installation diagram (Author. 2016)

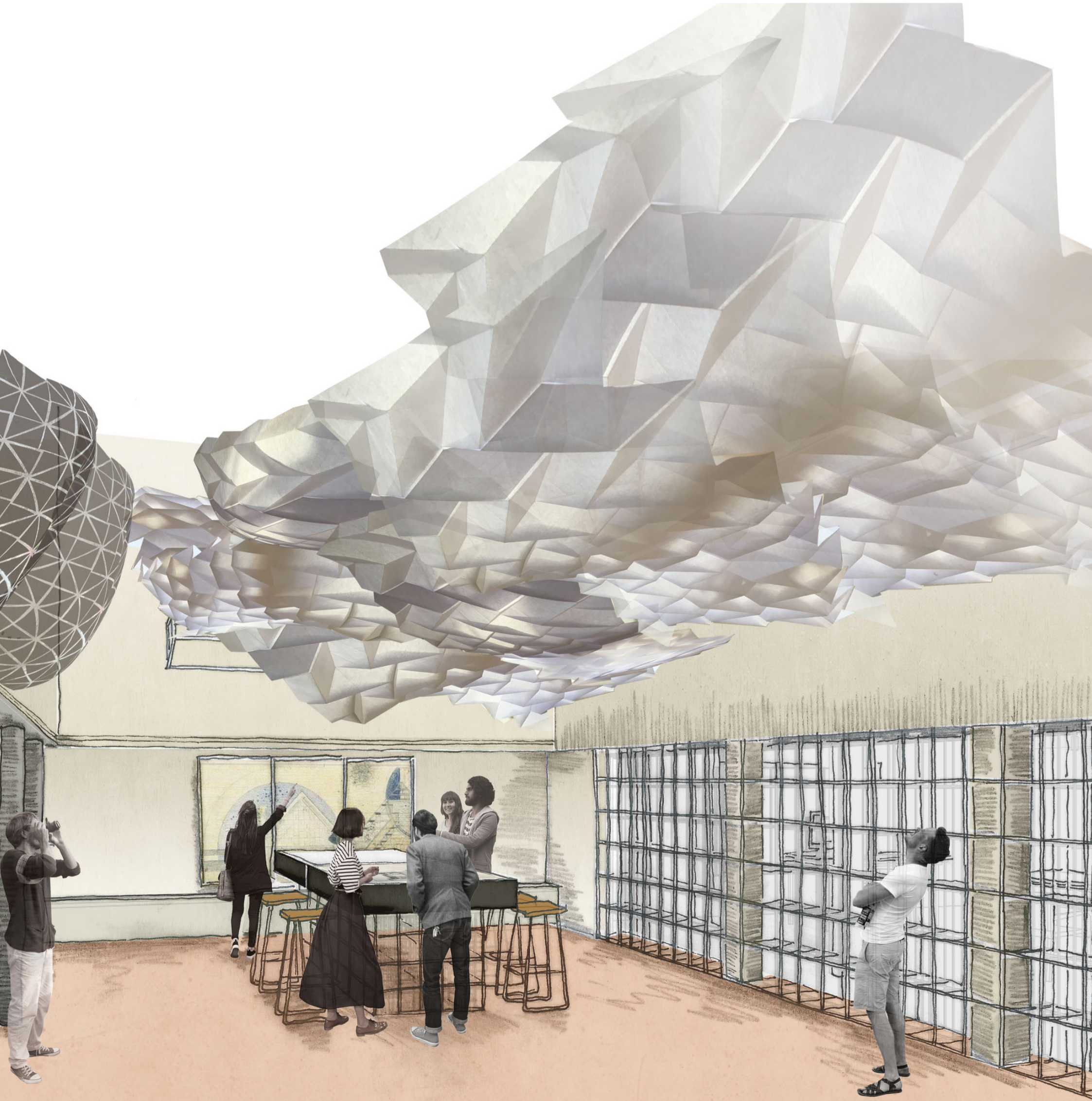

Figure 5.5.2 Double volume space (Author. 2016)

5.6 GRID AND KINETIC MECHANISM

The spatial development is informed by the following *cybrid* characteristics: morph, ethereal, visual access and meticulous joinery.

The intention of both the fixed and kinetic modular grid structure throughout the space is to allow for multiple smaller spatial interventions to take place. The grid system is designed as an armature to enable the paper installation to achieve the specific aesthetic and functional requirements of the *cybrid* archive.

The mechanical system is developed as a permanent intervention within the boundaries of the existing structure. The bespoke timber constructed mechanism, refer to figure 5.6.1 through 5.6.4, enables a wave motion to be translated to the suspended grid system, see drawing for further detail, which ultimately allows the manipulation of the space through the paper installation.

5.6.1 MANAGEMENT SYSTEM

The kinetic wave motion will be enabled by an electrical motor which would be programmed to move in a continuous wave motion for one minute from when the digital interactive screens, refer to section 5.12 Digital screens, are turned on and off. The kinetic mechanical system will be manipulated through the activation of settings installed to the digital interactive screens, for which the system will have two static positions, refer to figure 5.2.4 and 5.2.5, which will support the individual spatial scenarios.

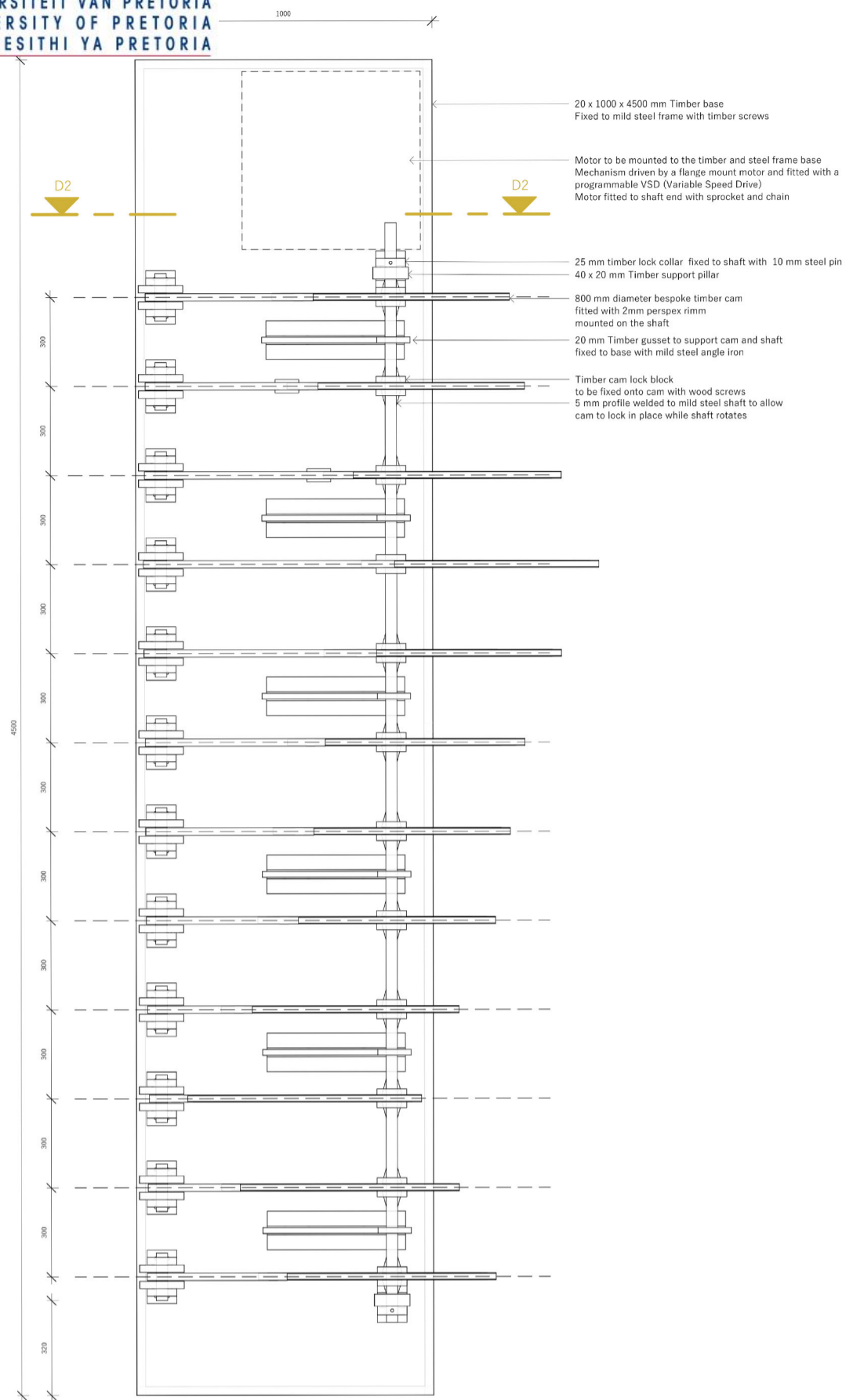

D1 KINETIC MECHANISM SCALE 1:10

Figure 5.6.1 Plan view of kinetic mechanism (Author, 2016)

SCENARIO 1: CONVERSATION AND DEBATE

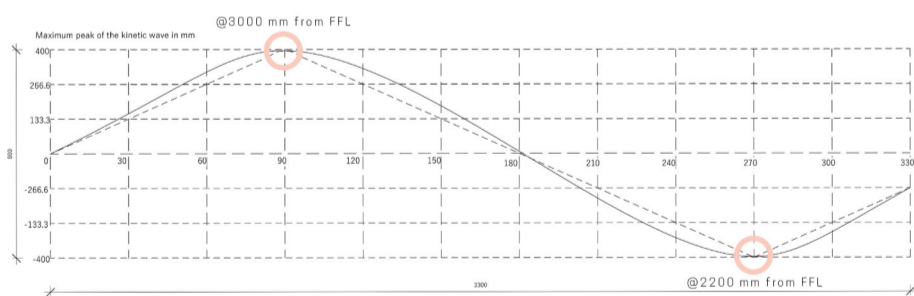

SCENARIO 2: FORMAL PRESENTATION

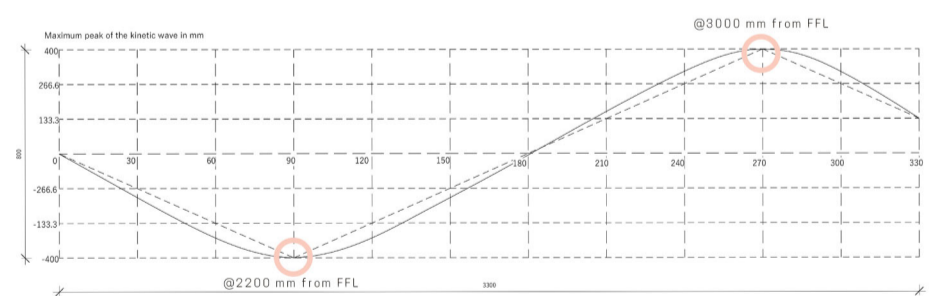

FORM OF KINETIC WAVE IN POSITION 2 SCALE 1:10

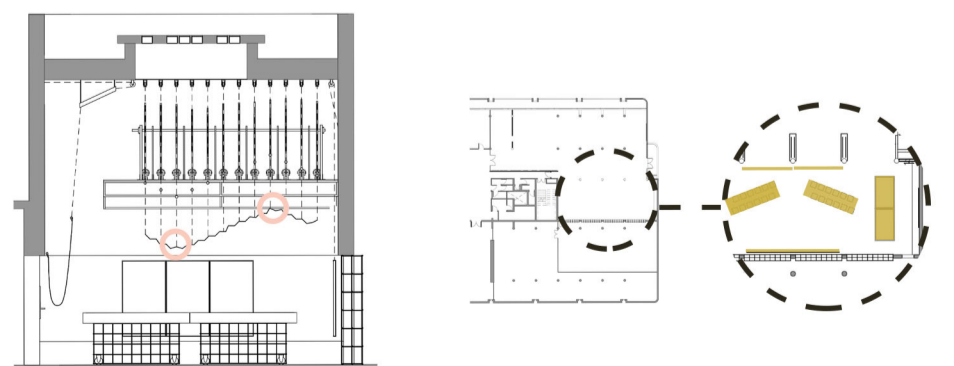
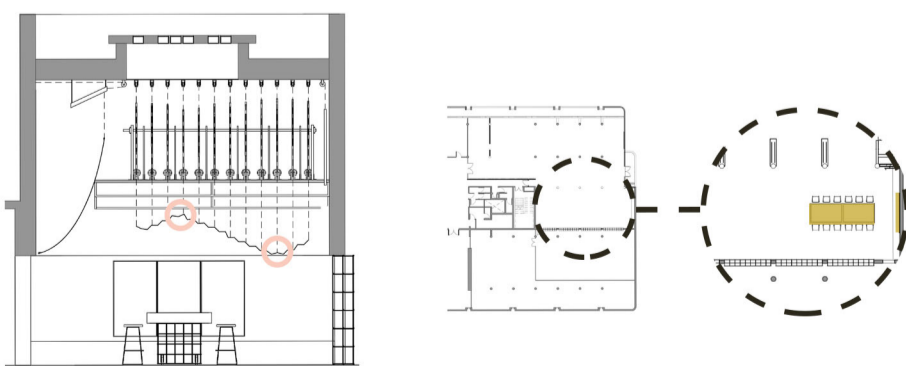

Figure 5.6.2 Spatial scenarios (Author, 2016)

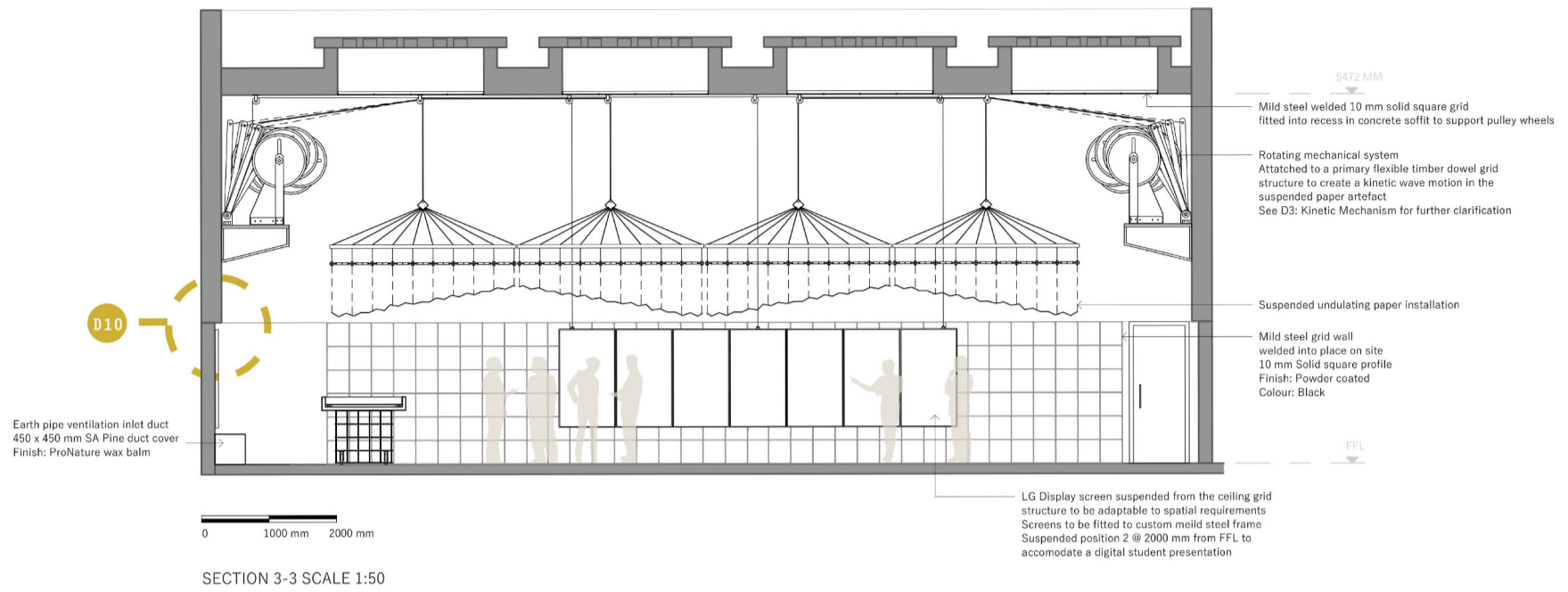

Figure 5.6.3 Section 3-3 (Author. 2016)

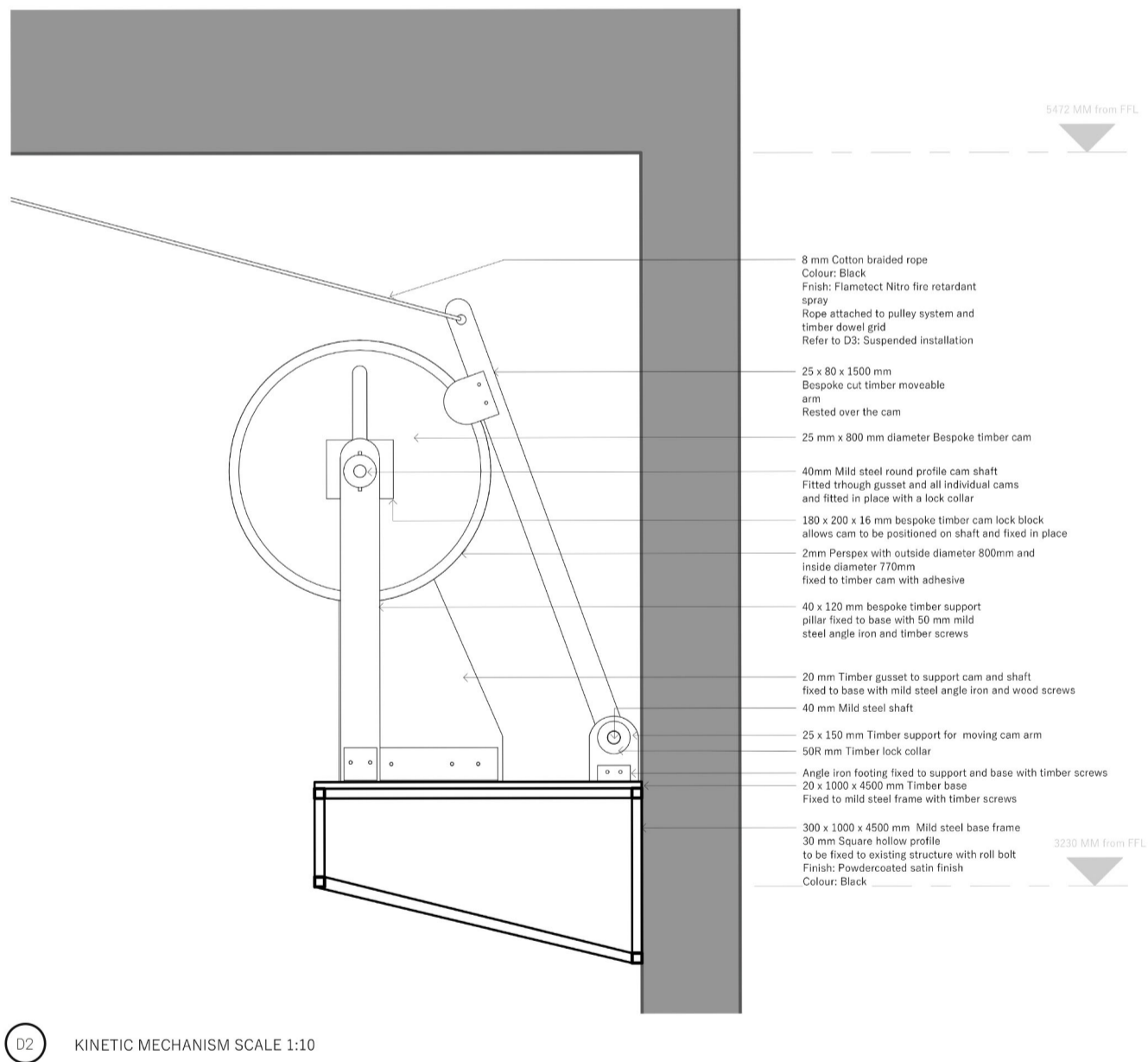
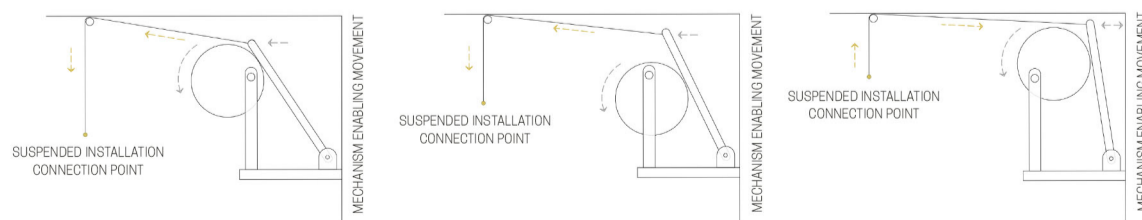

Figure 5.6.4 Call out detail: Mechanism (Author. 2016)



5.7 GRID INSTALLATION

The grid number column in table 5.7.1, indicates the point on the kinetic grid system as per figure 5.7.1, where the adjustable detail will be placed and attached to the folded paper artefact. The detail setting column in table 5.7.1 indicates the setting on the adjustable detail to achieve required heights for the paper installation.

Distance is measured from the hook to the joinery of rope knot to paper artefact.

ROPE 1:	ROPE 2:	ROPE 3:
A1 = 500 mm	A1= 300 mm	A1= 900 mm
A2 = 550 mm	A2= 400 mm	A2= 1000 mm
A3 = 600 mm	A3= 500 mm	A3= 1100 mm
A4 = 650 mm	A4= 600 mm	A4= 1200 mm
A5 = 700 mm	A5= 700 mm	A5= 1300 mm
A6 = 750 mm		
A7 = 800 mm		
A8 = 850 mm		
A9 = 900 mm		

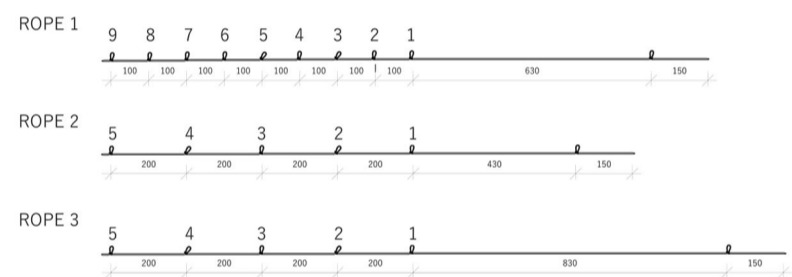
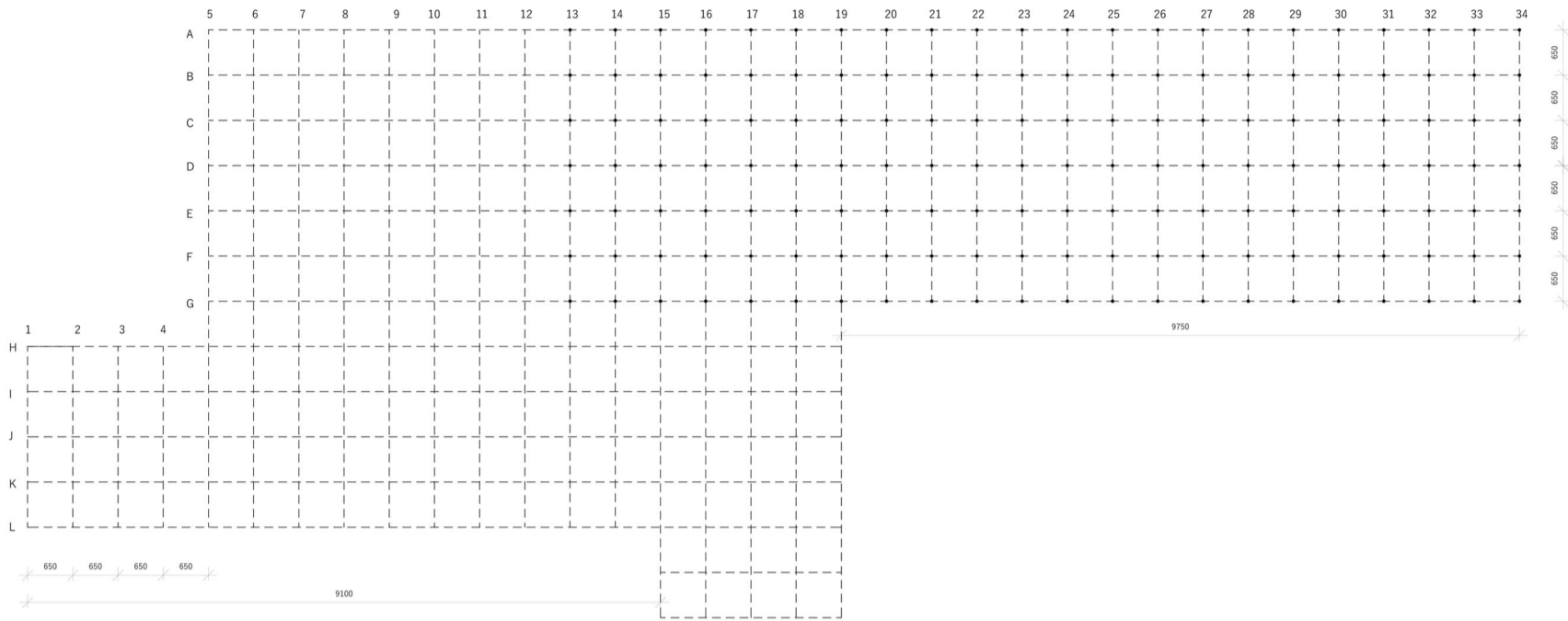
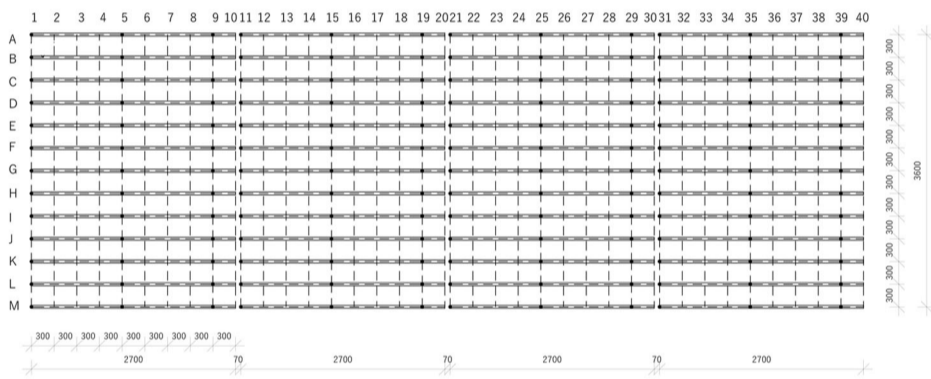

Figure 5.7.1 View of conversation and debate spaces (Author. 2016)



G1 STATIC ARMATURE LAYOUT SCALE 1:50

Figure 5.7.2 Static armature layout (Author. 2016)



G2 KINETIC ARMATURE LAYOUT SCALE 1:50

- Timber dowel beam
- Adjustable detail
- +-+ Kinetic armature (grid)

Figure 5.7.3 Kinetic armature layout (Author. 2016)

GRID NUMBER	DETAIL HEIGHT SETTING
A1 - M1	A9
A5 - M5	A5
A9 - M9	A1
A11 - M11	A1
A15 - M15	A5
A19 - M19	A9
A21 - M21	A9
A25 - M25	A5
A29 - M29	A1
A31 - M31	A1
A35 - M35	A5
A39 - M39	A9

Table 5.7.1 Kinetic grid installation specifications (Author. 2016)

GRID NUMBER	DETAIL HEIGHT SETTING
A13 - G13	R2: A1
A14 - G14	R2: A4
A15 - G15	R3: A5
A16 - G16	R3: A2
A17 - G17	R2: A5
A18 - G18	R2: A4
A19 - G19	R2: A3
A20 - G20	R2: A2
A21 - G21	R2: A2
A22 - G22	R2: A4
A23 - G23	R2: A5
A24 - G24	R3: A2
A25 - G25	R3: A5
A26 - G26	R3: A2
A27 - G27	R2: A5
A28 - G28	R2: A4
A29 - G29	R2: A3
A30 - G30	R2: A2
A31 - G31	R2: A2
A32 - G32	R2: A2
A34 - G34	R2: A2
A35 - G35	R2: A1

Table 5.7.2 Static grid installation specifications (Author. 2016)

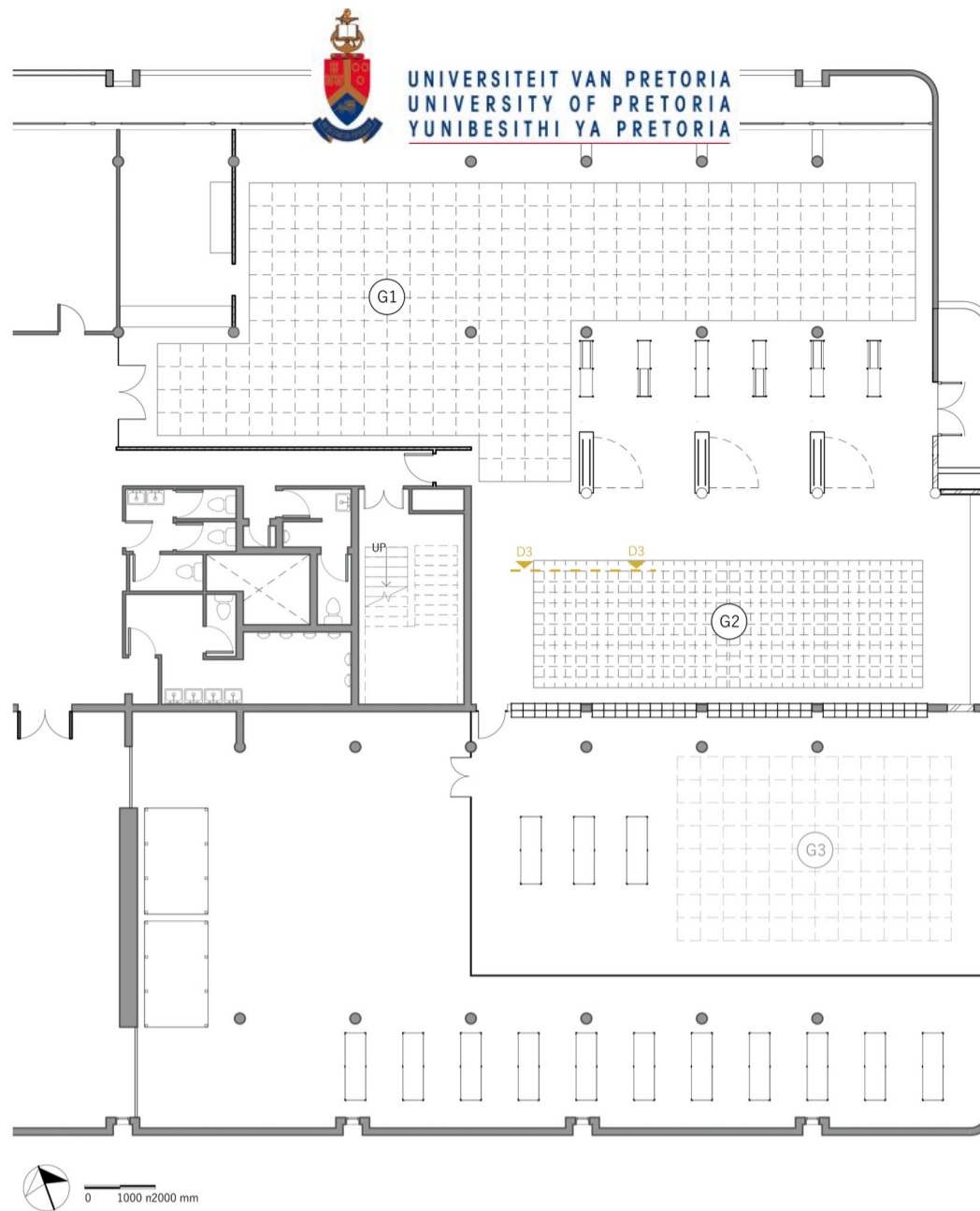

- GRID LEGEND:**
- G1** **STATIC ARMATURE:**
7750 x 5200 mm Static 10 mm solid square profile mild steel grid fixed directly to existing concrete soffit base at 650 x 650 mm spacing @ 2800 mm from FFL
Finish: Powdercoated black
 - G2** **KINETIC ARMATURE:**
Kinetic undulating grid suspended from concrete soffit base and movement enabled through electrical motor driven mechanism
Material: Perforated timber dowels and bespoke moulded Perspex profiles
 - G3** **STATIC GRID:**
Static 10 mm solid square profile mild steel grid fixed directly to existing concrete soffit base at 650 x 650 mm grid spacing @ 2800 mm from FFL
Finish: Powdercoated black



ARMATURE (GRID) LAYOUT SCALE 1:100

Figure 5.7.4 Plan indicating grid for installation (Author. 2016)

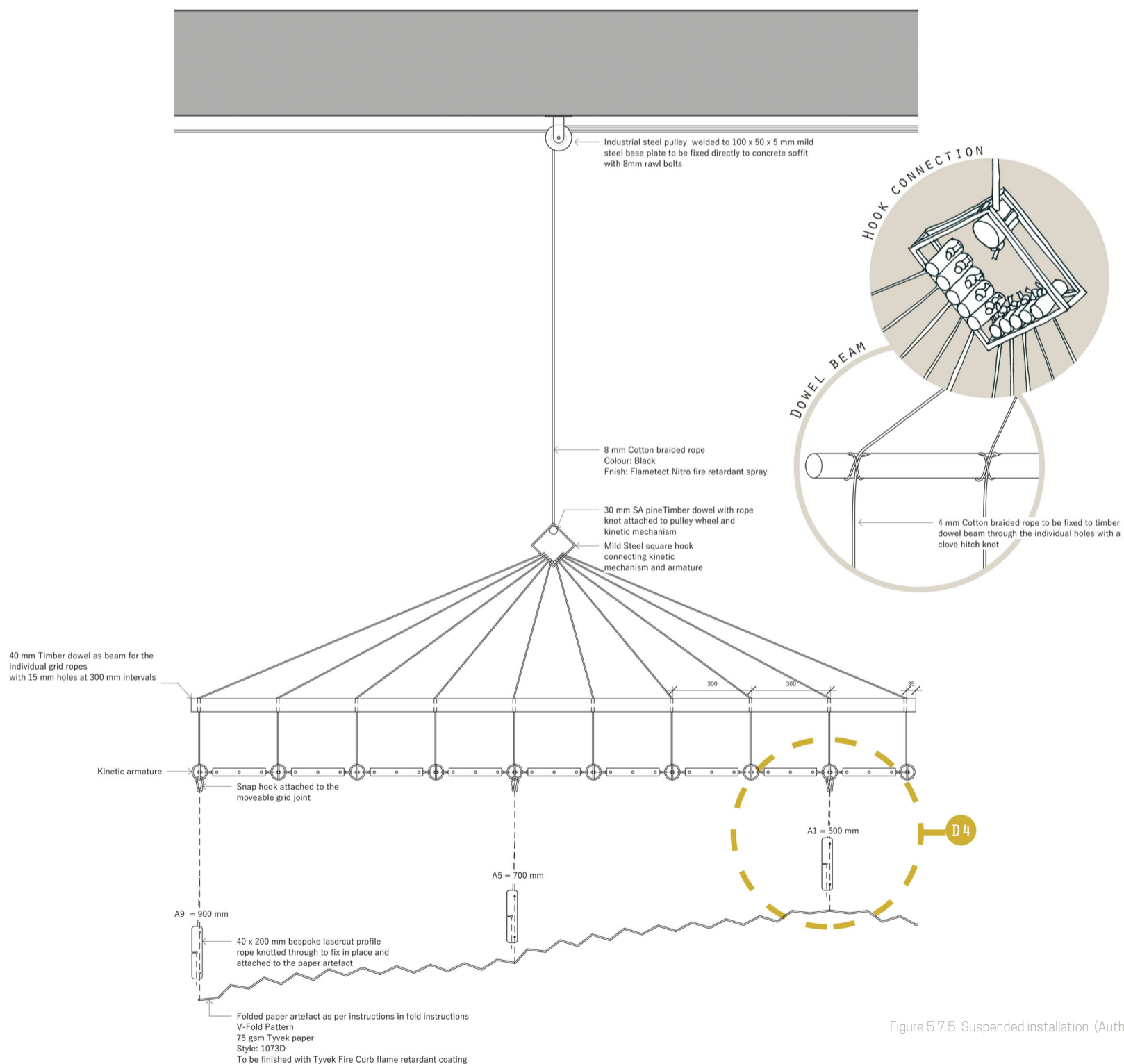

D3 SUSPENDED INSTALLATION SCALE 1:10

Figure 5.7.5 Suspended installation (Author. 2016)

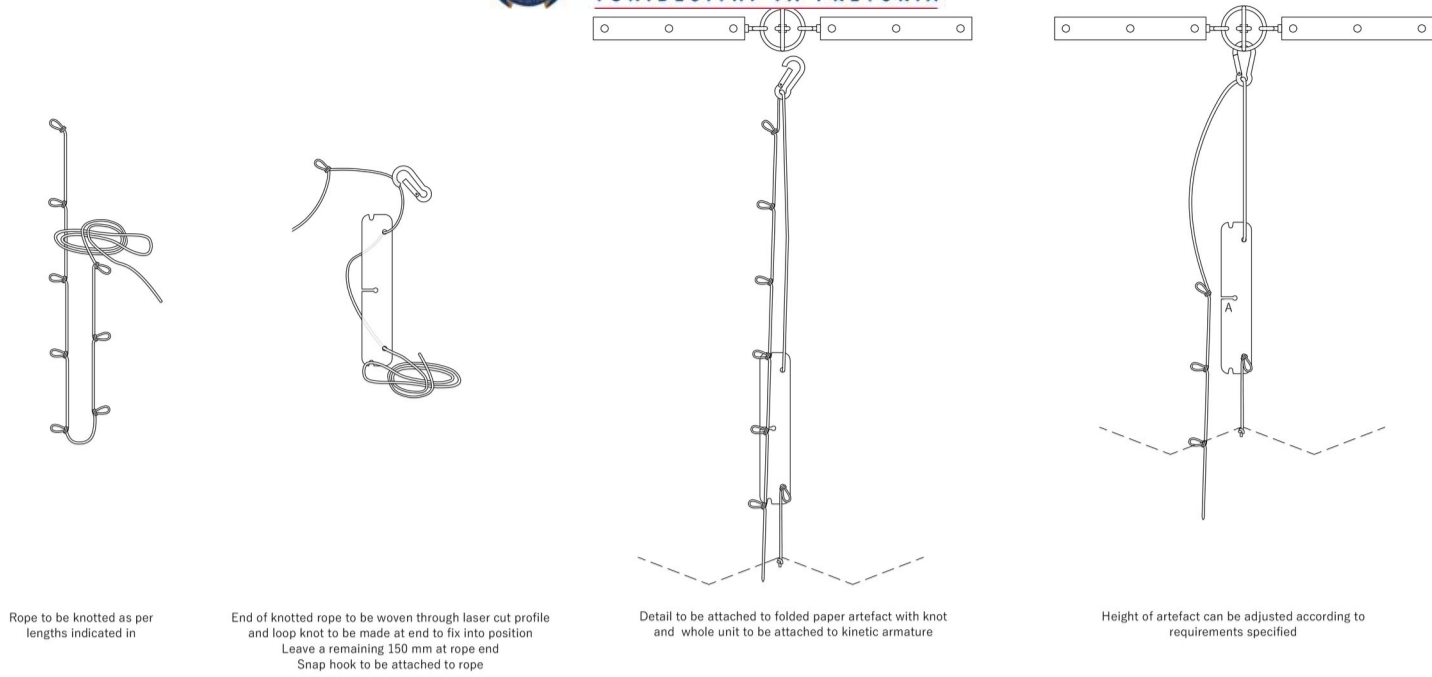

D4 KINETIC ARMATURE AND ADJUSTABLE DETAIL SCALE 1:5

Figure 5.7.6 Detail: Kinetic armature and adjustable detail (Author, 2016)

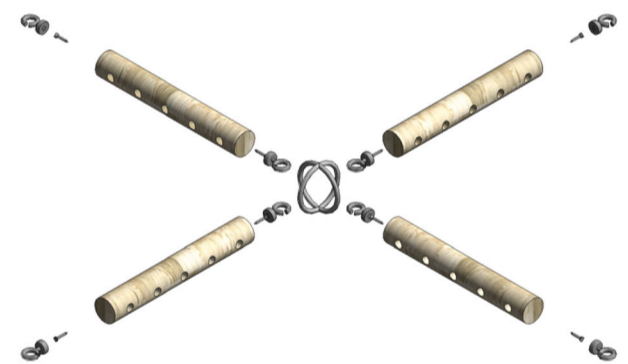

D4 EXPLODED 3D: KINETIC ARMATURE

Figure 5.7.7 3D: Timber dowel grid (Author, 2016)

HARDWARE LEGEND

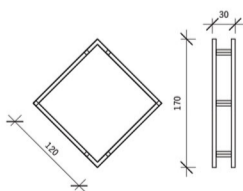

Bespoke welded hook profile
Material: 5 mm Mild steel solid square profile
Finish: Powdercoated satin black



Bespoke moulded connection ring
Material: Perspex Cast Acrylic Vario
Colour: Grey

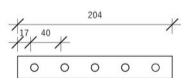

Perforated grid dowel
Material: 30 mm Pine timber dowel with 10 mm holes
Finish: ProNature clear wax balm

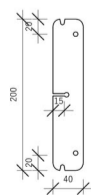

Bespoke lasercut profile
Material: 2 mm Perspex Cast Acrylic Vario
Colour: Grey



Bespoke moulded eye hook
Material: Perspex Cast Acrylic Vario
Colour: Grey



60 mm Stainless steel snap hook



4 mm Cotton braided rope
Colour: Black
Finish: Flametect Nitro fire retardant spray

5.8 MATERIAL SELECTION

The material selection process is guided by all the characteristics listed in Chapter 4 section 4.4. The primary requirements for the paper or paper like material are the following:

- + Material should fold easily and retain its shape
- + Material should be available in large format sheet sizes
- + Material should be flexible enough to create malleable folded element
- + Material should be able to diffuse light to create an ambient atmosphere to achieve an ethereal spatial quality

Two additional tests are done which include the light quality as well as the durability of the material, to assist with the material selection for the specific spatial application.

5.8.1 DURABILITY FOLD TEST

The intention of the experiment was to establish an estimated wear and tear on the fold lines of the paper. No specific data was captured and only observation used to draw conclusions from. Each 150 x 150mm paper has one fold down the middle and was folded in both directions, 300 times. Two samples were used for each type of paper, one folded with no tools and one perforated beforehand and then folded one the perforated line.

The fold motion for this test was elaborated in comparison to the motion of the kinetic paper installation, therefore the wear and tear documented in table 5.8.1, can be assumed to much less in the case of the actual paper installation.

5.8.2 LIGHT QUALITY

The light quality achieved in the material exploration, see Chapter 4 section 4.5.4, as well as the *cybrid* characteristics identified serve as the guideline for the light quality required for the spatial application.

The lighter paper types achieve a better aesthetic and lighting quality that is more suitable for the specific application. The kraft paper, refer to figure 5.8.3 is too dense and allow minimal light through therefore the Kraft paper is not suitable for this installation. The tracing paper and white paper, refer to figure 5.8.1 and 5.8.2, has a beautiful light effect and allows more light through which could create an ethereal atmosphere in the space. The Tyvek, see figure 5.8.4, has a unique light effect as all the fibres can be seen if illuminated from behind and also allows enough light through to create an ambient light effect.



Figure 5.8.1 Fold test (Author. 2016)

MATERIAL	FOLD (NO TOOLS)	FOLD (PERFORATED)
Kraft paper	Because paper is more stiff it does not fold as easily and starts to crack on the fold line, but still remains intact	After 200 folds the paper starts to tear on the edges
Tracing paper	Paper does not fold evenly and becomes stiff on the fold line, making it harder to fold in the opposite direction	The perforation makes it easy to fold but weakens the paper making it easy to tear
White 80 g/m ² paper	The fold line remains consistent and no noticeable damage occurs during the fold test	Perforation allows for easy folding but weakens the paper, but the fold line remains consistent without any noticeable damage.
White 200 g/m ² paper	The fold line remains consistent and very little damage occurs during the fold test	After 200 folds the paper cracks along the fold line and tear on the outer edges
Tyvek 55g/m ²	The fold line remains consistent and no damage occurs during the fold test	Perforation allows for Tyvek to be folded easily along fold line whilst the fold edge remains consistent and no damage occurs

Table 5.8.1 Fold test observations (Author. 2016)

Paper: n. 1. Material manufactured in thin sheets from the pulp of wood or other fibrous substances, used for writing, drawing, or printing on, or as wrapping material. 2. A sheet of paper with something written or printed on it. Paper is a thin flexible sheet of material which can be used as a flat mechanical object or be manipulated into three dimensional artefact.

5.8.3 CONCLUSION

Tyvek as a paper-like material was considered for this investigation as it clearly fulfils the definition of paper, as elaborated in Chapter 1 section 1.8. As per the definition above as well as other similar characteristics elaborated throughout the study, Tyvek can be defined as a paper product for the purpose of this study. Dupont Tyvek is the most suitable choice for this specific spatial application and the product description and technical features will be elaborated in section 5.8 and 5.9. The material is chosen for its novel character as it fulfils all the qualities of the paper products whilst having advanced technical characteristics. The Tyvek creates opportunity for intricate material to material investigation without the limitations and fragility of the paper products.

* Following this investigation the product brand Dupont Tyvek will be referred to as Tyvek paper.

5.8.4 TYVEK PAPER

Dupont Tyvek (2015:3) states that Tyvek is manufactured from 100% high density polyethylene (HDPE) bonded by heat and pressure in a sheet form. Marshall Hinds (2013) elaborates that Tyvek is a non-woven structure which bonds very fine polyethylene fibres to create a durable and flexible paper like sheet material which is 100% recyclable.

Tyvek® combines the best properties of paper, film and fabric and thus makes it ideal for a wide range of applications, in which strong resistance is needed Dupont Tyvek (2015:3).

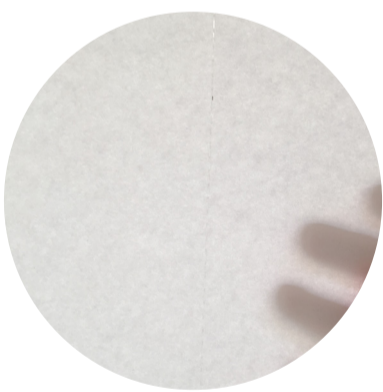

Figure 5.8.2 White paper 80g/m2 light quality (Author. 2016)

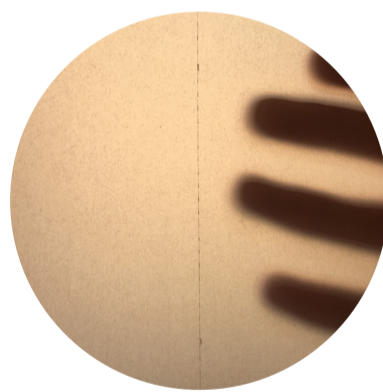

Figure 5.8.3 Tracing paper light quality (Author. 2016)

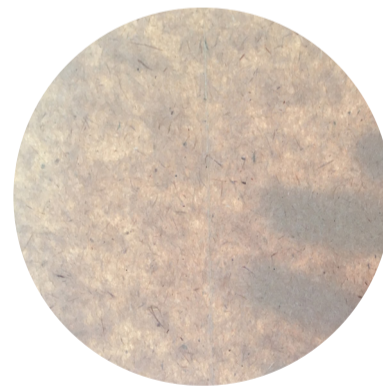

Figure 5.8.4 Kraft paper light quality (Author. 2016)

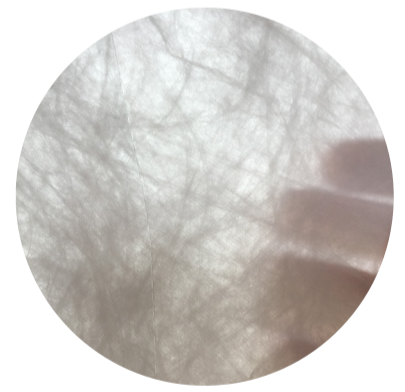

Figure 5.8.5 Dupont Tyvek light quality (Author. 2016)

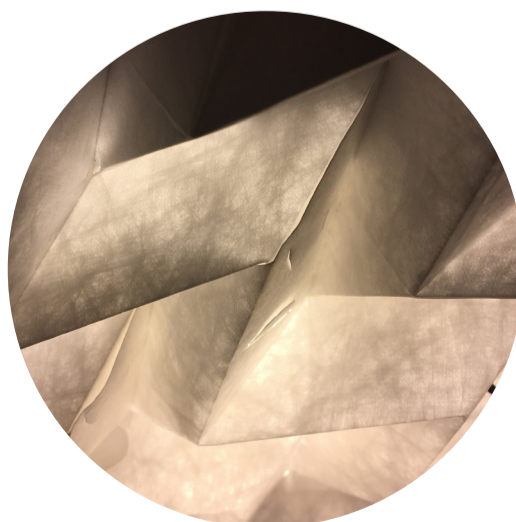

Figure 5.8.6 Dupont Tyvek (Author. 2016)

5.9 FINISHING AND MAINTENANCE

Although the material is extremely durable, the installation and nature of the artefact remains temporary. The application, installation and lightness of the artefact communicates the temporal character as specified in Chapter 4, section 4.4

The modular system, as elaborated in section x, serves as an armature to support the folded paper artefact and it also creates a system for efficient installation. Because the paper is installed as separate folded panels, this means that individual panels can easily be removed and replaced if necessary.

The Tyvek paper artefact can be removed for scheduled cleaning by staff on site. The material's resistance to water allows for dirt to be washed off without damaging the artefact. Care should be taken for the application of heat to the product.

The fabrication and installation of the paper artefact within the actual space would become an extension of the three phases of making addressed in this study, as the fourth and final phase of making. The space becomes a test site to determine how the paper will react in full scale and to investigate the lifespan of the kinetic paper artefact. This process will be a continuation of the Research Through Making methodology followed in this study, and therefore would require rigorous documentation for further development of the material in this context.

The life span of the installation is to be determined by the Department of Architecture.

5.9.1 FIRE RETARDANT FINISH

The fire treatment discussed below is based on the application for future use of paper within the space and does not apply to the Tyvek paper.

O'Neil (2009:65) investigated finishes for cardboard which would make it fire retardant and amongst a list of options the Boric acid is the most sustainable option that would be best suited for this specific application.

Because paper is a flammable material, it will be treated with boric acid powder which is both an insecticide and a fire retardant. O'Neil (2009:65) states that the boric acid is an organic compound that can either be used as a coating or be added during the pulping process of the paper.

The Tyvek paper will not receive any alternative finishes as the material in itself complies with the technical requirements as listed in table 5.9.1 below. The paper-like qualities of the Tyvek will be tested in its application as a prototype installation to determine its durability and lifespan within this specific spatial application. The intention is to further explore what the visual impact will be if and when the Tyvek paper starts to wear and tear, as it connects well to the concept of processes found in archiving of the architectural drawings.

PRODUCT FEATURES	DESCRIPTION
Flammability	<i>A strip of clean untreated Tyvek® when first exposed to an open flame, shrinks away from it. If the flame follows the strip, it will catch fire, burn slowly and drip melted polymer (Dupont.2015:5).</i>
Toxicity	<i>Tyvek® is classified as non-toxic. Testing on skin resulted in no irritation, swelling or allergic reaction (Dupont.2015:5).</i>
Strength	<i>Tyvek® is tear resistant whether wet or dry. Due to its unique structure it remains strong even when nicked and folded (Dupont.2015:4).</i>
High flex strength	<i>Tyvek® can be creased and bent almost indefinitely without losing its strength (Dupont.2015:5).</i>
Water resistant	<i>Physical properties of Tyvek® are not affected by water (Dupont.2015:5).</i>
Rot and mildew resistant	<i>Tyvek® does not degrade after being buried in soil for an extended period. Clean Tyvek® will not promote the formation of mildew or other micro-organisms (Dupont.2015:5).</i>
Chemical resistance	<i>Tyvek® is unaffected by most acids, bases and salts. Prolonged exposure to oxidising agents such as concentrated nitric acid or sodium persulphate may cause some loss of strength (Dupont.2015:4).</i>

Table 5.9.1 Technical specifications of Tyvek (Author. 2016)

5.10 FABRICATION AND ASSEMBLY

This description for the folding process is based on the description found in Jackson (2011: 124-127), which will be slightly adapted to this study.

The 1020 x 4000mm Tyvek paper sheets will be perforated and cut off site, to the specific pattern which will assist with a more accurate and easy folding process. The sheets will be printed with the graphics before folding.



1. Pleat along the vertical black lines as indicated in the fold pattern of figure x to create universal folds, refer to figure x



2. Pleat along the diagonal lines facing down, to create alternating mountain and valley folds

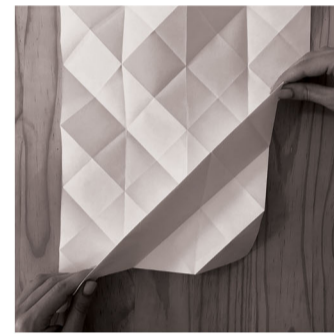

3. Repeat the process described in step 2 with the diagonal lines facing up



4. Crease the vertical universal pleat lines again to create alternating mountain and valley folds.



5. From the base of the pleated paper, start to collapse the first row of zigzags. The first row should form a mountain zigzag and the second a valley zigzag. Work across the paper from edge to edge.



6. Gently continue pressing the zigzag rows to pop them into place. The pleats are already there so no new folds should be made.



7. Continue until all the rows are collapsed



8. Collapse the folded paper into a narrow stick and press it on a flat surface to sharpen all the folds



9. Pull open to reveal the three dimensional folded paper



Valley fold



Mountain fold



Universal fold

Figure 5.10.1 Fold instructions (Author. 2016)



PERFORATION AND CUT LINES

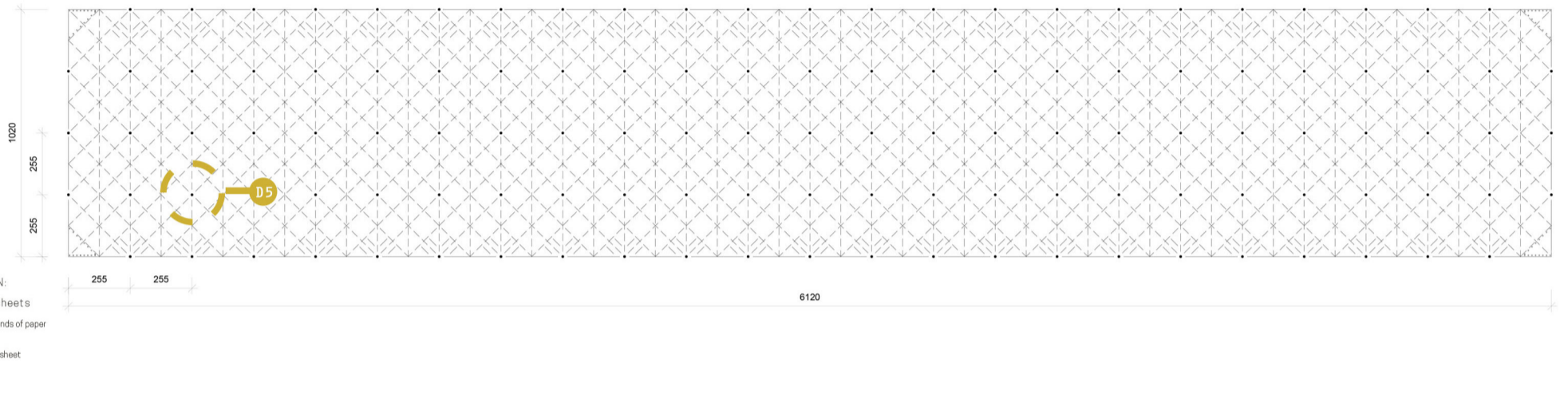

FOLD PATTERN

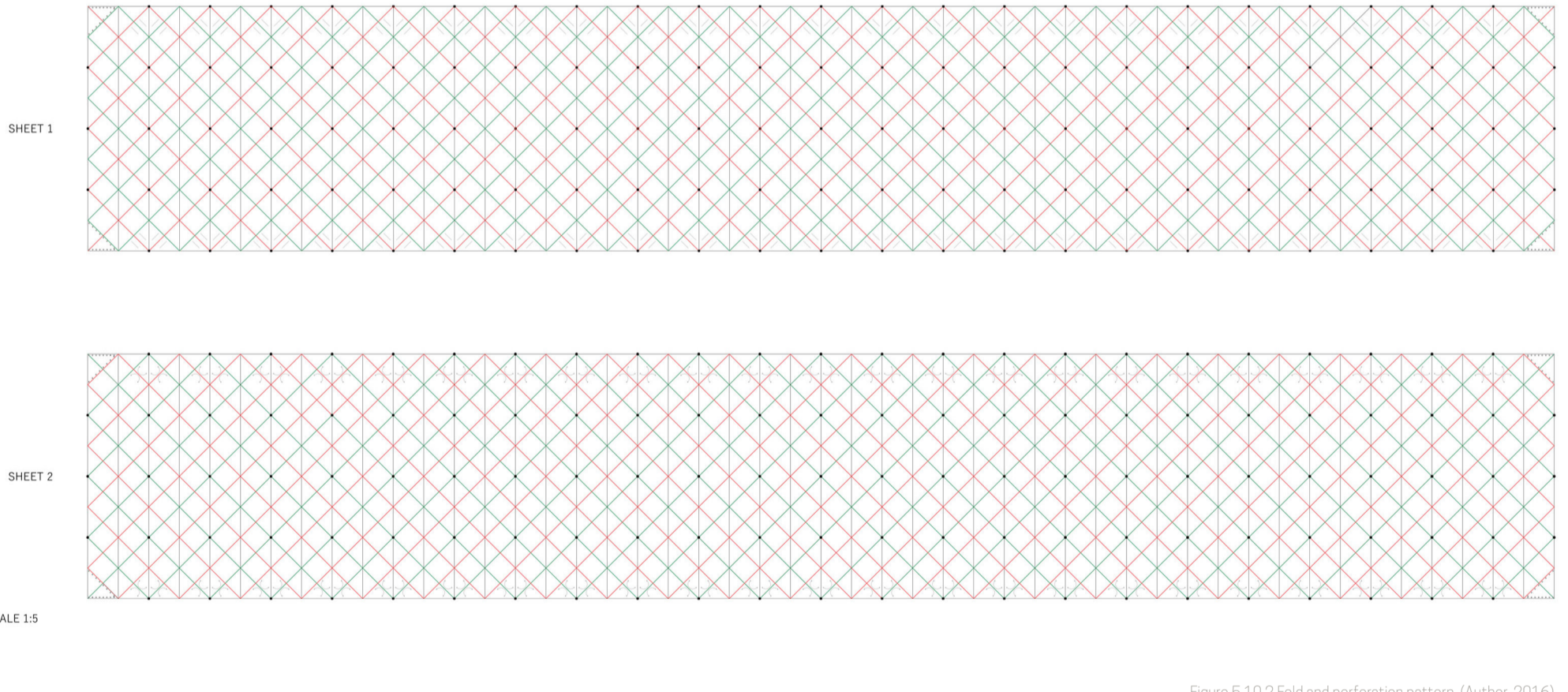
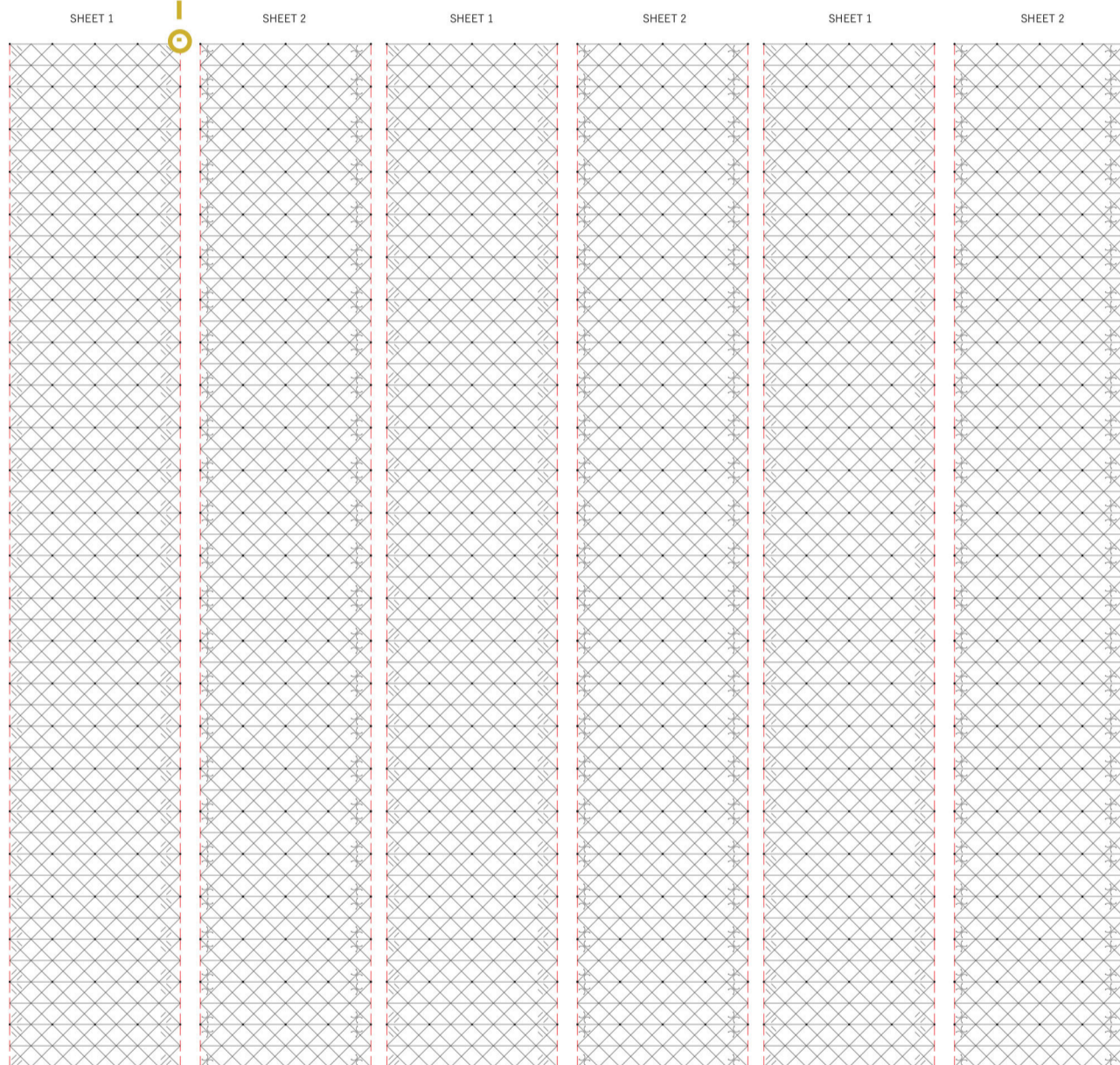
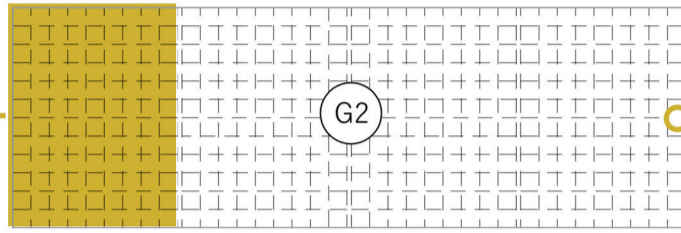
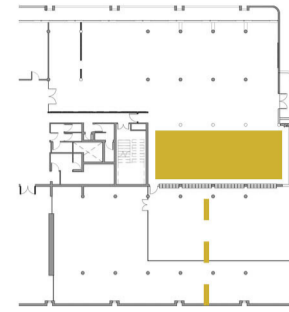

Figure 5.10.2 Fold and perforation pattern (Author: 2016)



FOLDED SHEET ASSEMBLY SCALE 1:20

--- Joinery Line
Edge of folded sheet to overlap with adjacent sheet edge

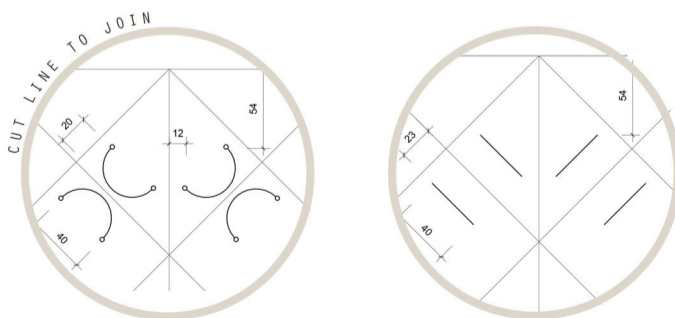
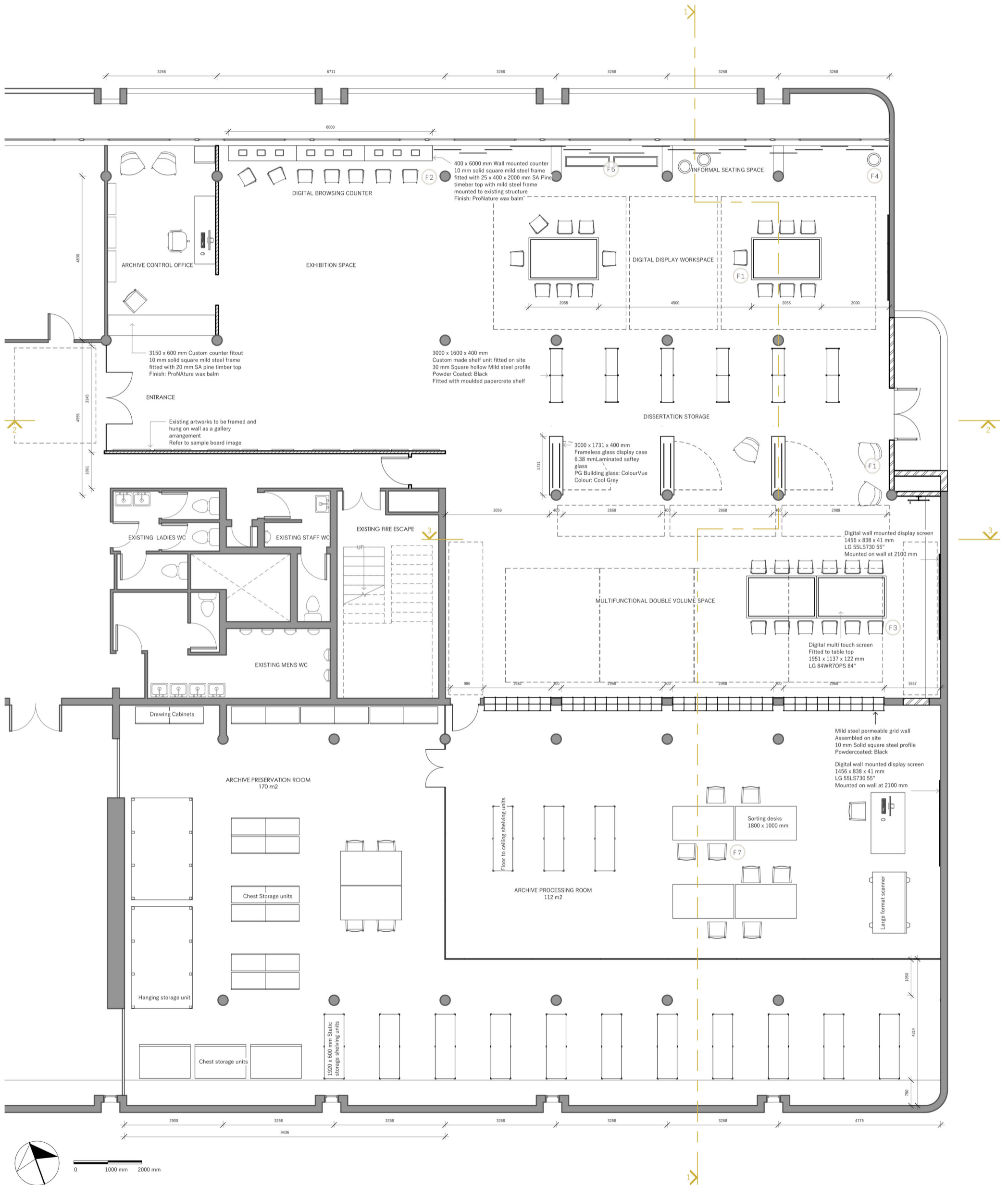

Figure 5.10.3 Folded sheet assembly (Author. 2016)



LAYOUT PLAN SCALE 1:50

Figure 5.10.4 Layout plan (Author. 2016)

SPATIAL USE:

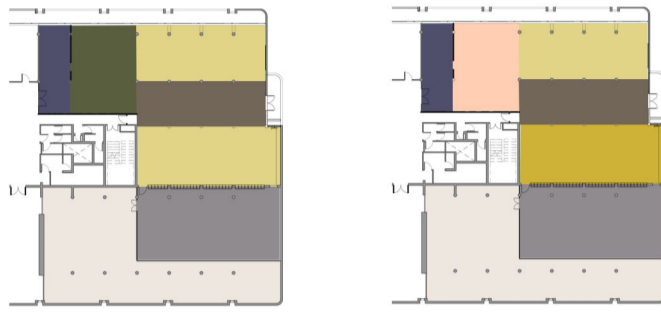

- Conversation and debate space
- Formal presentation space
- Exhibition space
- Dissertation storage
- Archive preservation room
- Archive processing room
- Open single volume space
- Control desk and entrance

FURNITURE LEGEND:







-  F1 Ava Chair
Casarredo
Colour: Pink and
-  F2 650mm 440 x 430 x 650 mm
Industrial Stool
Weylandts
Colour: Saddlewood Grey, Water Based
Natural
Finish: Powder Coated, Water Based
-  F3 460 x 530 x 850 mm
Leila Bar Stool
Weylandts
Colour: Grey
Finish: Natural, Powder Coated
Code: CONTIMP0003
-  F4 450 x 300 x 1300 mm
Cork Low Stool
Wiid Design
Finish: Cork
-  F5 450 x 300 x 1300 mm
Cork and steel bench
Wiid Design
Colour: Black
Finish: Powder Coated, 50mm Cork
-  F6 Existing lounge chair to be
-  F7 Existing black

Figure 5.10.5 Furniture legend (Author, 2016)

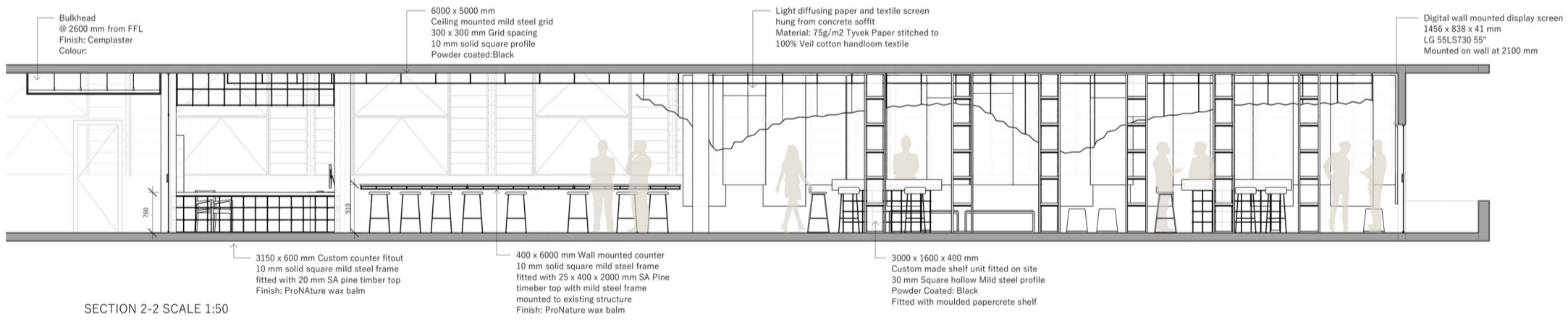
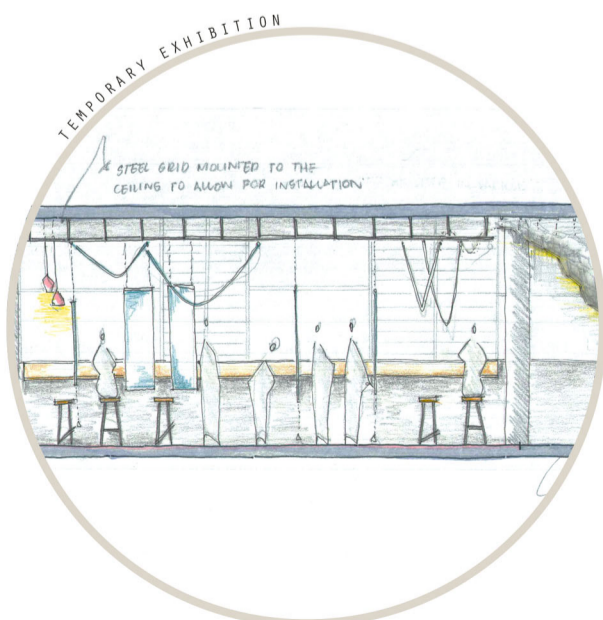
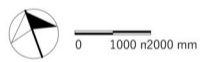

Figure 5.10.6 Section 2-2 (Not to scale) (Author, 2016)





FLOOR FINISH PLAN SCALE 1:100

FLOOR FINISH LEGEND:





-  200 x 200 mm Existing Mosaic floor tiles
-  2 mm Self leveling screed applied over woodfloated concrete screed
Finish: Matt
Colour: Dusky Rose
-  2 mm Self Leveling Screed applied over woodfloated concrete screed
Finish: Polished
Colour: Dusky Rose
-  Brass strip floor detail

Figure 5.10.7 Floor finishes plan (Author, 2016)



ACOUSTIC CEILING LAYOUT SCALE 1:100

CEILING PANEL LEGEND:

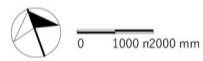
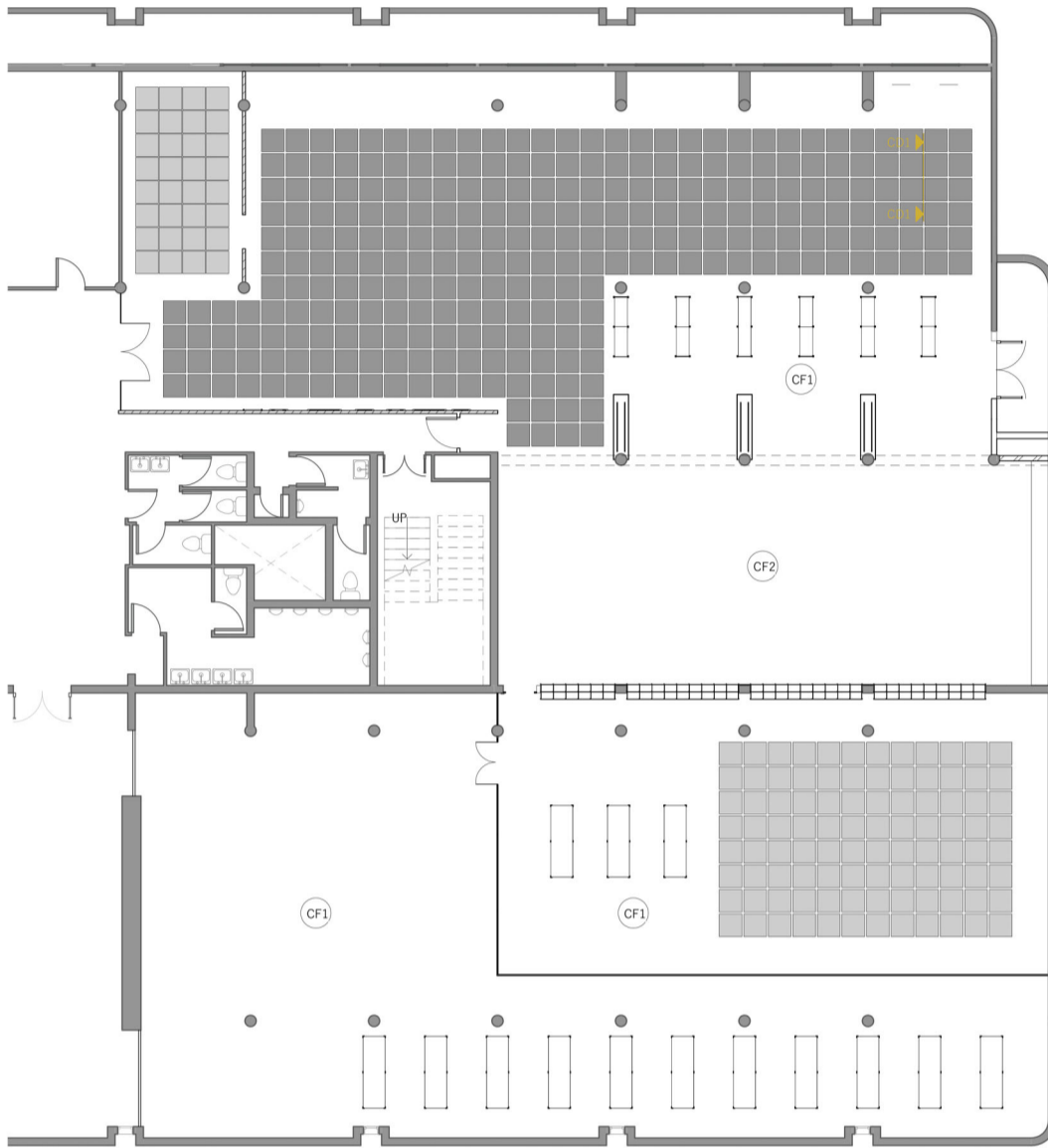
NOTE: Existing suspended ceiling to be removed
Base of concrete soffit, uneven surface to be filled and sanded
Surface to be skimmed and prepared for new finish

- | | |
|--|--|
| <p>Ecophon Focus SQ
600 x 600 x 20 mm 8 mm spacing
Direct application to concrete soffit
Finish: Akutex FT
Colour: Soft Slate</p> | <p>CF1 Soffit to be painted with
PLASCON one coat ceiling paint
ultra matt finish
Colour: Zaire Junctions GR N03</p> |
| <p>Ecophon Focus SQ
600 x 600 x 20 mm 50 mm spacing
Direct application to concrete soffit
Finish: Akutex FT
Colour: Soft Slate</p> | <p>CF2 Soffit to be painted with
PLASCON one coat ceiling paint
ultra matt finish
Colour: Misty Dawn GR G04</p> |

WALL FINISHES

- Walls to be stripped and uneven surfaces to be filled and sanded
Surface to be skimmed and primed
Walls to be painted with PLASCON Evolution Super Matt VOC free paint
Colour: New York Square GR N02
- Walls to be stripped and plaster surface to be prepared as per product specifications
Cemplaster to be applied onto wall with trowel
Colour: Milano Milk
- Walls to be stripped and plaster surface to be prepared as per product specifications
Cemplaster to be applied onto wall with trowel
Colour: Pavilion Grey

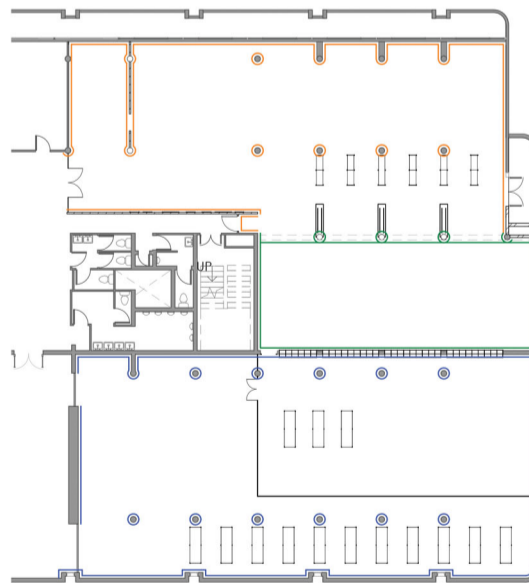

WALL FINISH DIAGRAM SCALE 1:100

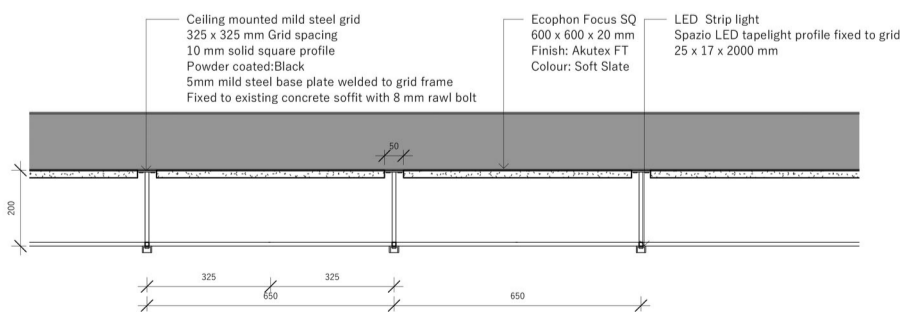

CD1 STATIC ARMATURE (GRID) SCALE 1:10

Figure 5.10.8 Acoustic ceiling (Author, 2016)

5.11 ARCHIVE

The spatial development is informed by the following *cybrid* characteristic: process, preservation and visual access.

Visual access is achieved through the design development of the permeable mild steel grid wall which creates a physical barrier for the purpose of access control between the double volume space and the archive processing room whilst allowing visual access into the archive processing room and the archive preservation room.

The archive processing room is designed to allow for the sorting, indexing and digitizing process of large format architectural drawings and documentation. The room is equipped with large format scanner, printer and wall mounted digital screens to allow for archive material to be digitized. Within the space a floor to ceiling colour tinted double glazing wall separates the archive processing room from the archive preservation and storage room. The intention of the glass wall is to allow a glimpse into the space when it is illuminated.

5.11.1 ARCHIVE REQUIREMENTS

Ogden (n/d) explains that the control of the environmental conditions which include the light, temperature and relative humidity is critical for the preservation of archival material which could increase the life expectancy of the artefacts. Ogden (n/d) further states that with installation of adequate operation systems which could control the environmental quality to specific requirements will retard the deterioration significantly.

Temperature and Humidity:

Ogden (n/d) states that a constant environmental quality is very important, and a climate control system should be on throughout the year.

Canadian Counsel of Archives (2003:12) explains that low humidity can make archive material brittle and susceptible to cracking when handled, and high humidity can increase the chemical deterioration of the artefacts. According to Wilson (1995:1) and Canadian Counsel of Archives (2003:12) the optimal humidity for the preservation of paper would be minimum of 30% and maximum of 50%. The optimal conditions are not always easy to achieve for both temperature and humidity, but a critical point of departure would be to keep the humidity constant throughout the year.

According to Canadian Counsel of Archives (2003:23) The optimal temperature for the preservation of paper drawings is a maximum of 15.5°C and 18.3°C with a 2°C fluctuation, for storage, whereas occupied space can go up to a maximum of 23.8°C.

Light:

According to Canadian Counsel of Archives (2003:19) all light damages the archive material by fading and yellowing of the paper artefacts, while light with shorter wavelengths like UV light is more damaging to the material. Canadian Counsel of Archives (2003:20) lists the following requirements for lighting in an archive:

- + Eliminate sunlight where possible or reduce the UV light with the application of a UV filter film to windows.
- + Lights should be turned off when archive is not in use.
- + Reduce overall lux and UV levels
- + Reduce heat gain from the light source, and do not locate lights close to archive material.

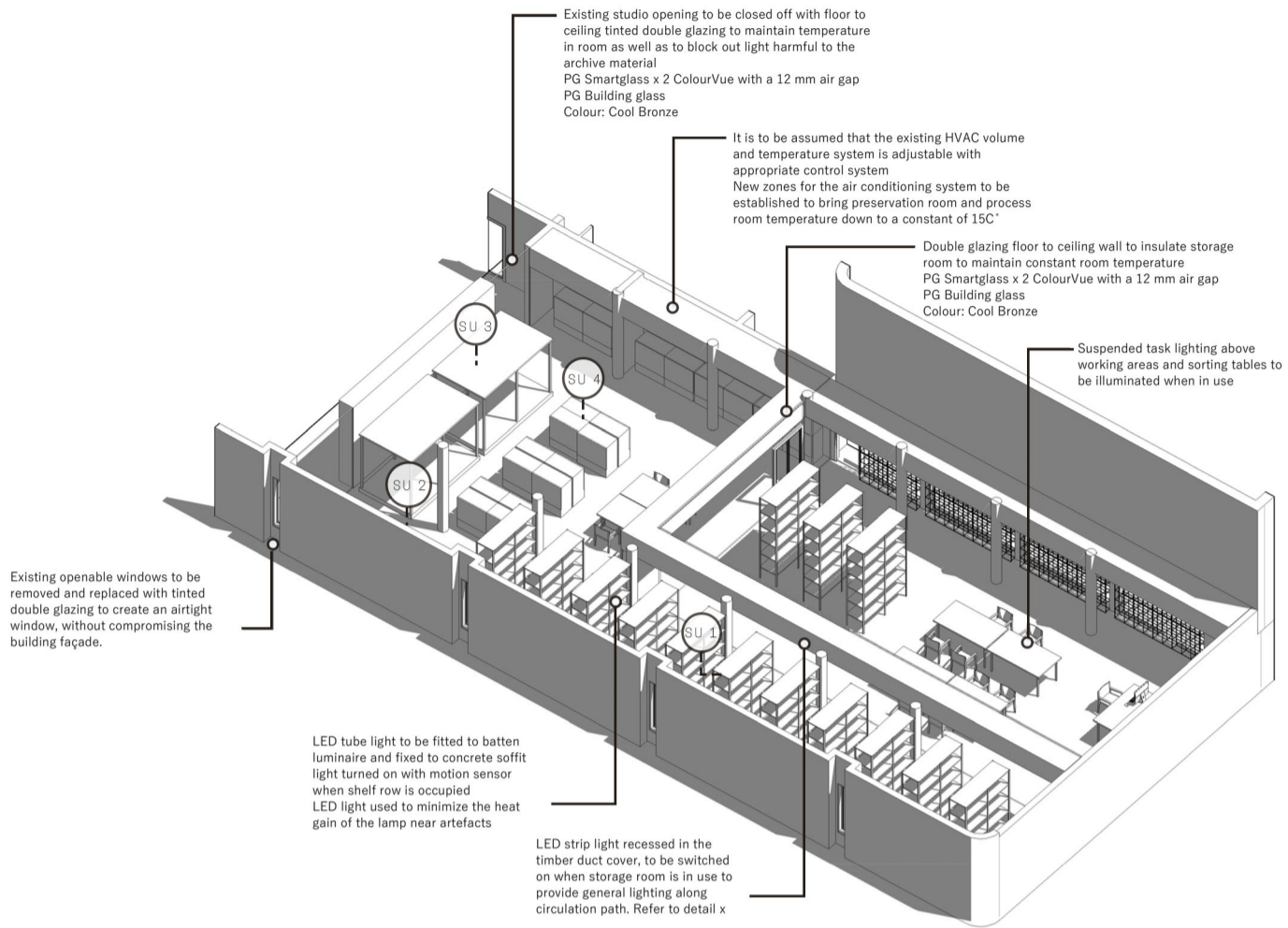

Figure 5.11.1 3D: Archive (Author. 2016)



SPECIALISED STORAGE UNITS

All storage units for the preservation archive room as per Rackline
Bespoke units are fitted to spatial requirements and dimensions
Material: Aluminium
Colour: White

Figure 5.11.2 View of archive storage space (Author. 2016)

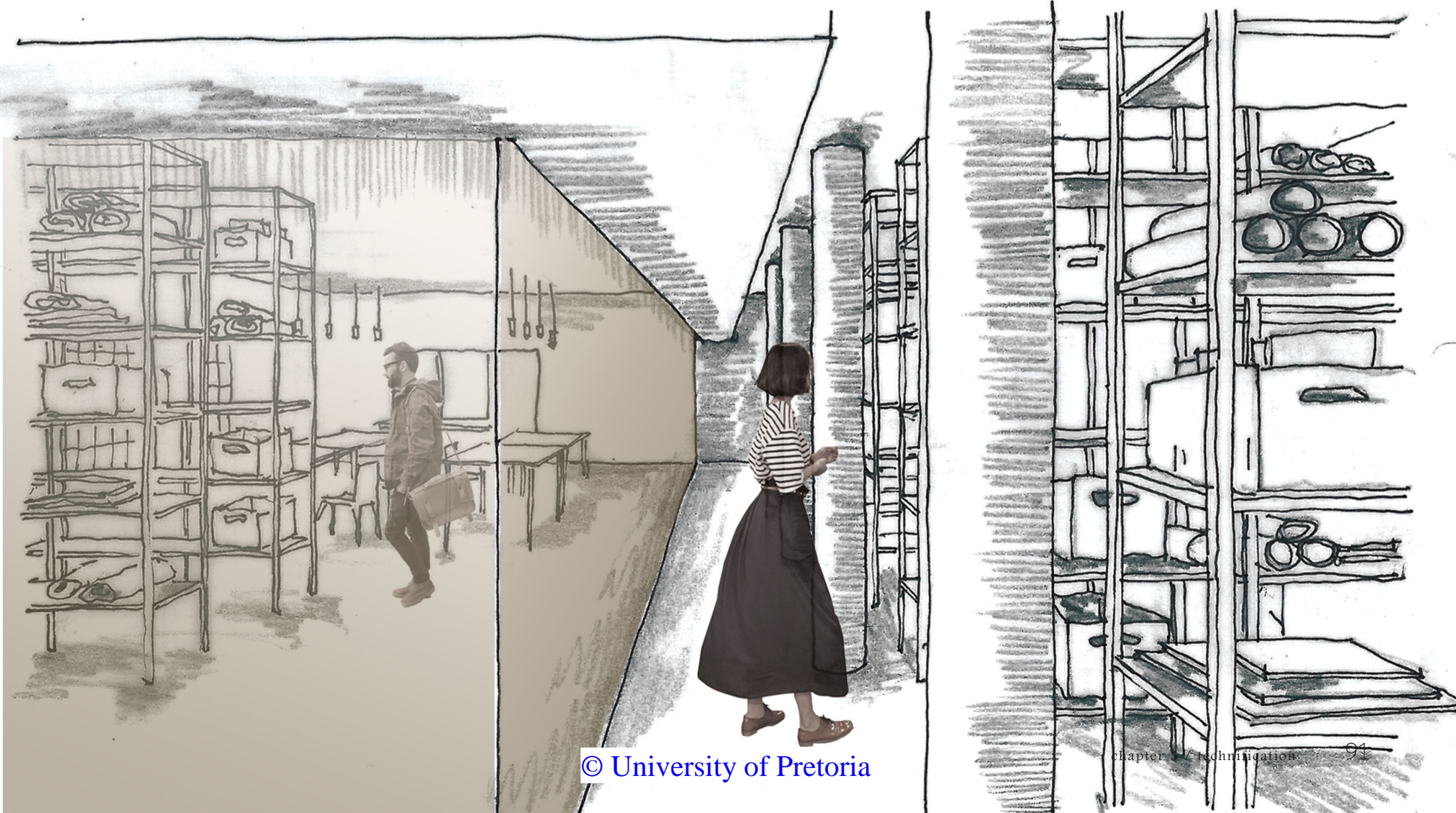

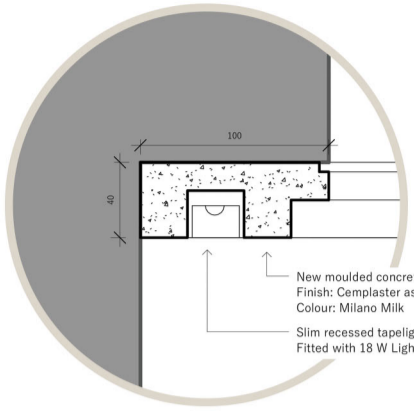

010 LIGHT STRIP DETAIL SCALE 1:5

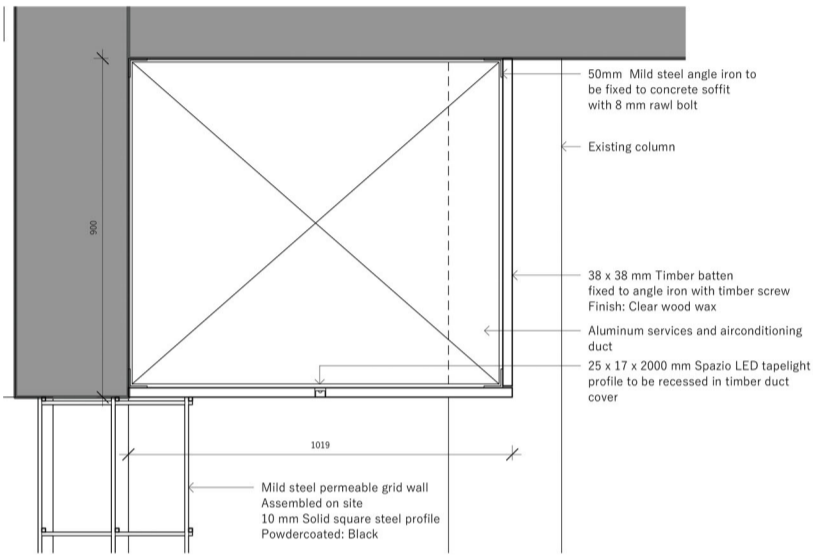

DUCT DETAIL SCALE 1:10

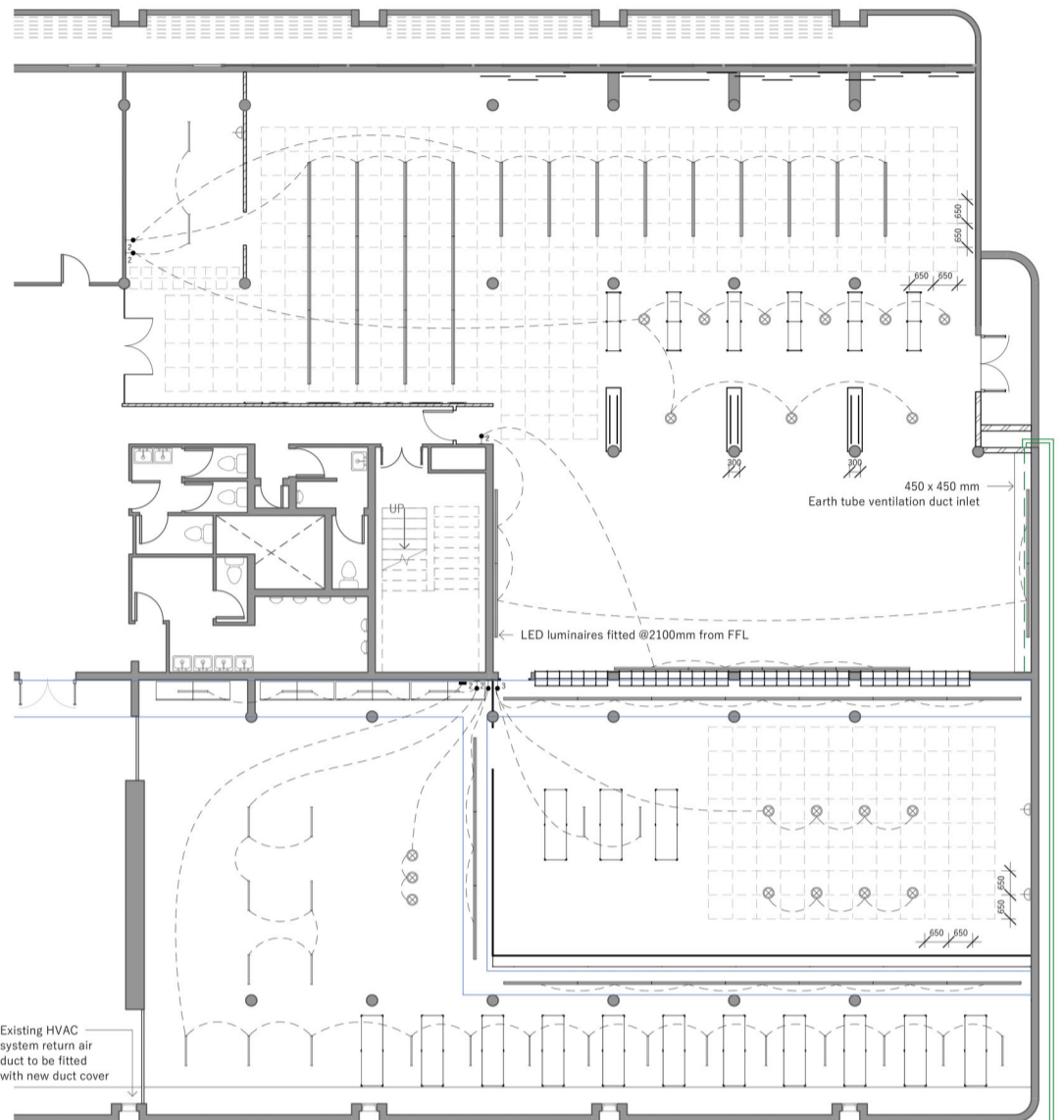
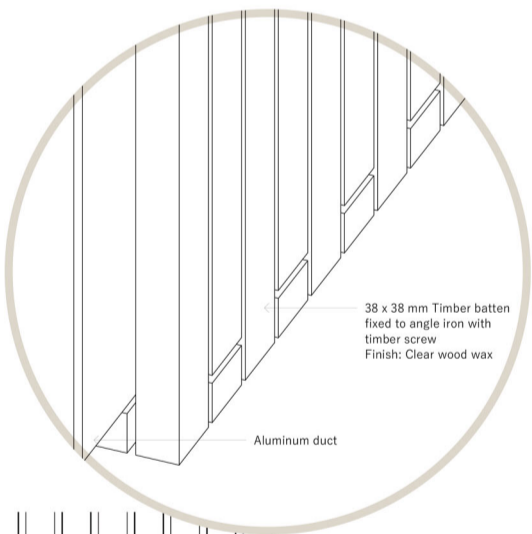

GRID AND LIGHTING LAYOUT SCALE 1:100

- LIGHTING LEGEND:**
- Surface mounted slim tapelight profile luminaire as per Spazio to be fixed to mild steel grid with adhesive
Code: 1039.1.05
Colour: Powdercoated Black
Fitted with 18 W Lightify flex RGBW lamp as per OSRAM
 - ⊗ Solo round pendant luminaire as per Spazio mounted to mild steel ceiling grid
Colour: Black and gold
Fitted with 40W Parathom advanced CLASSIC A lamp as per Osram
 - Surface mounted 50 x 32 mm profile as per Spazio
Code: 1044.1.05
Colour: Powdercoated Black
Fitted with 8.9 W SubstiTUBE Advanced HF lamp as per Osram
- LINE LEGEND:**
- Existing HVAC to be fitted with new duct cover
New zones for the air conditioning system to be established to bring preservation room and process room temperature down to a constant of 15C°
 - - - Mild steel grid fixed to concrete soffit
 - Earth tube to run along eastern side of building into new service duct from the ground floor up
 - == Existing shading device to block direct northern sun

Figure 5.11.3 Electrical layout (Author. 2016)

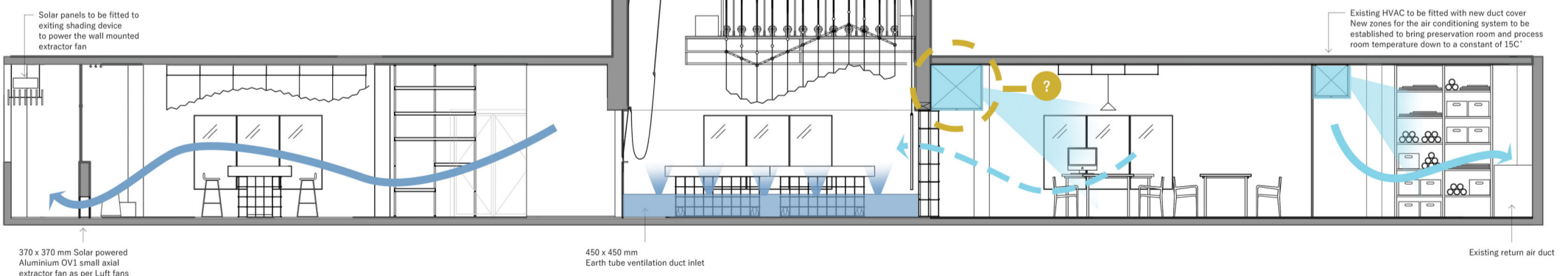

VENTILATION DIAGRAM SCALE 1:50

Figure 5.11.4 Ventilation section diagram (Author. 2016)

5.12 DIGITAL SCREENS

The addition of large format digital screens as interactive tables as well as wall mounted screens, allows for a vibrant experience and access to the information. The significant drawing collections can be displayed in full scale on the digital screens, allowing the users to interact and form conversations without the potential of damaging the physical architectural archive drawings.

Suspended display screens are able to be hoisted into position, to allow a digital presentation to take place. This addition of a digital pin up creates opportunity for new and innovative ways in which students can present to and interact with an examination panel.

The intention of the digital screens is to encourage conversation and debate regarding valuable archive material as well as previous master student dissertation work.

Figure 5.12.1 View of digital interaction spaces (Author. 2016)



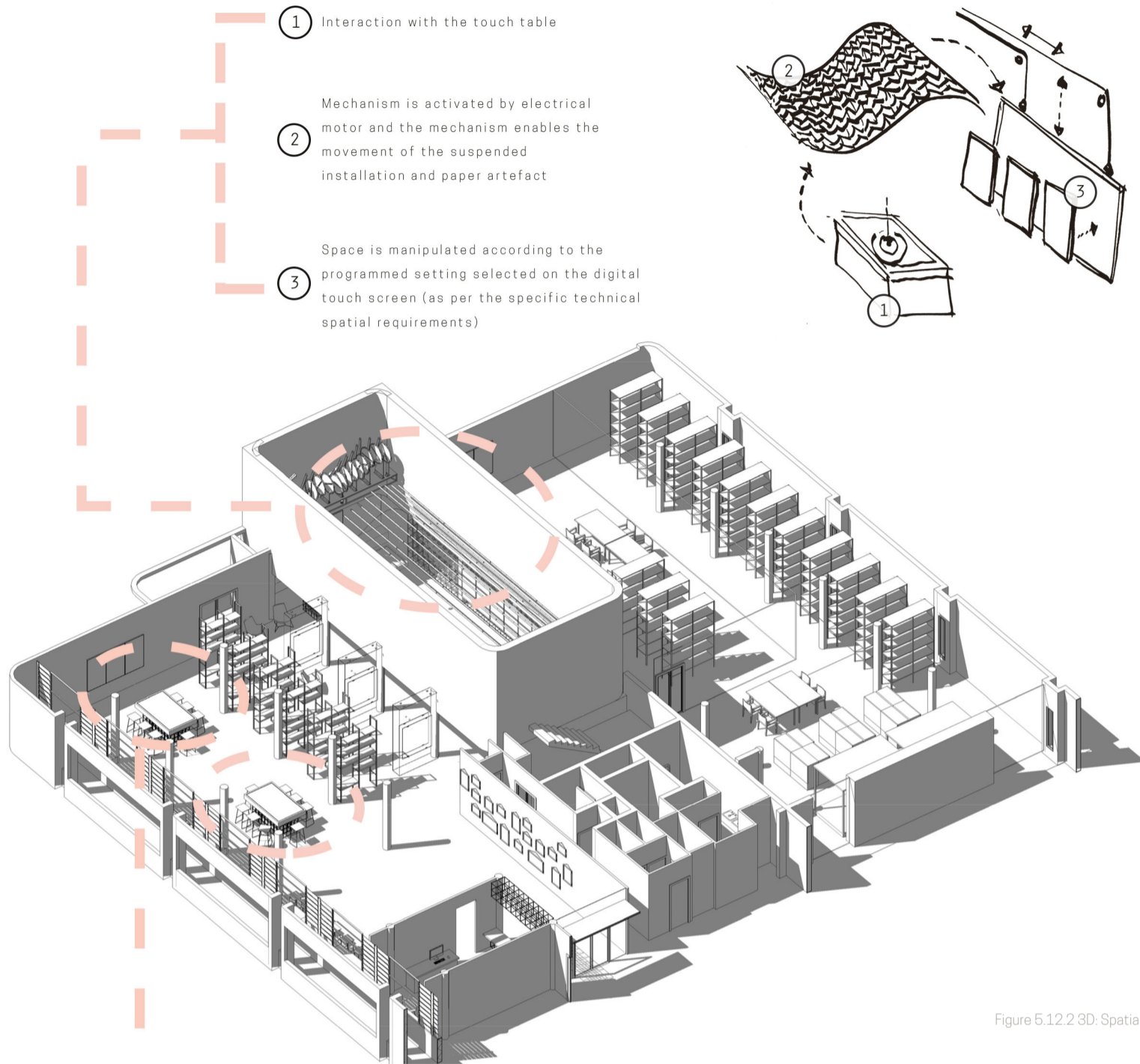
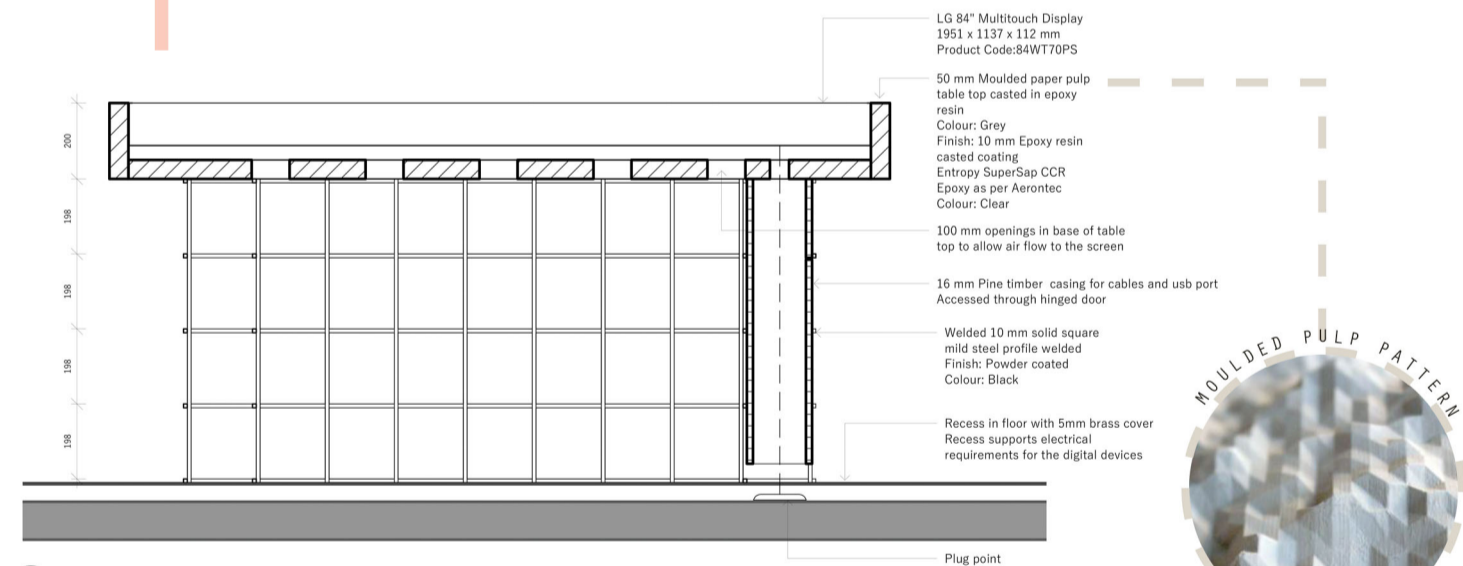

Figure 5.12.2 3D: Spatial layout (Author. 2016)



DB INTERACTIVE TABLE SCALE 1:10



Figure 5.12.3 Digital interfaces (Author. 2016)

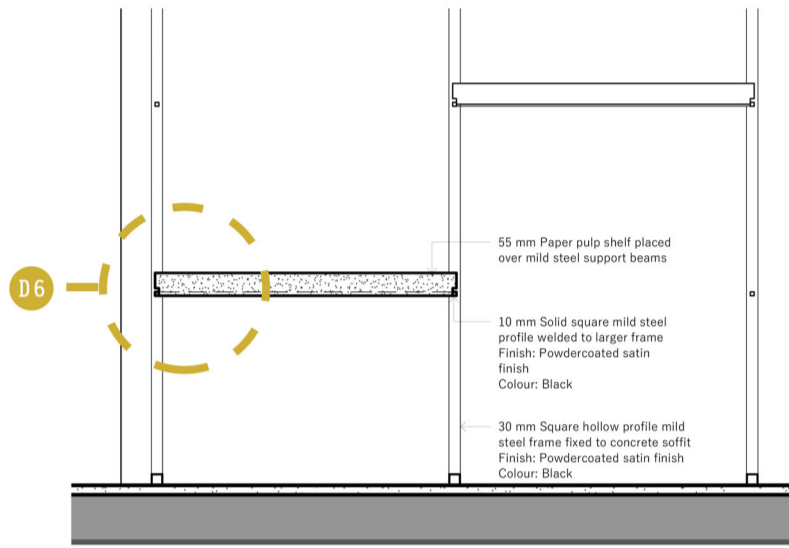

SHELF DETAIL SCALE 1:10

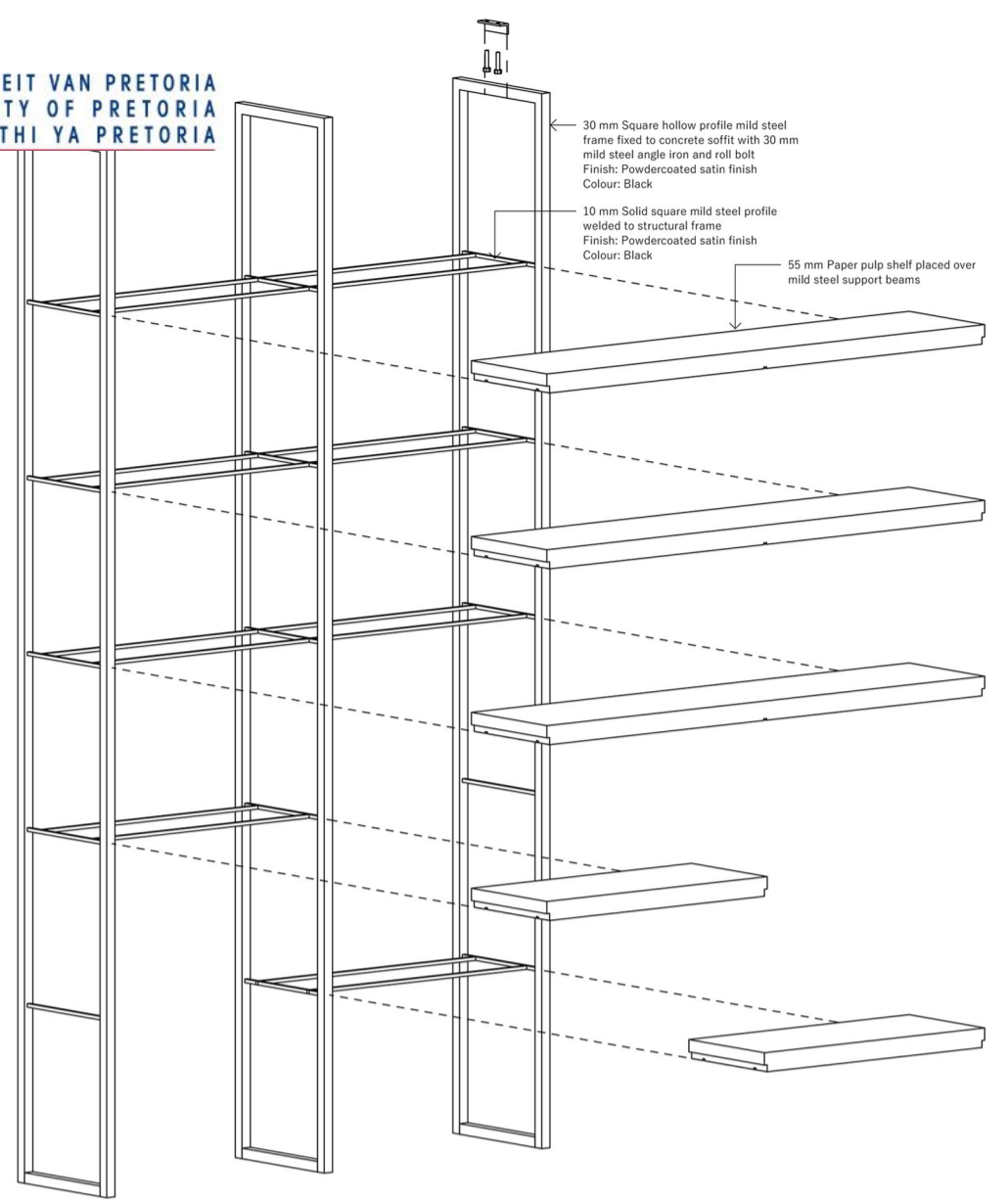

CUSTOM FLOOR TO CEILING SHELF UNIT SCALE 1:10

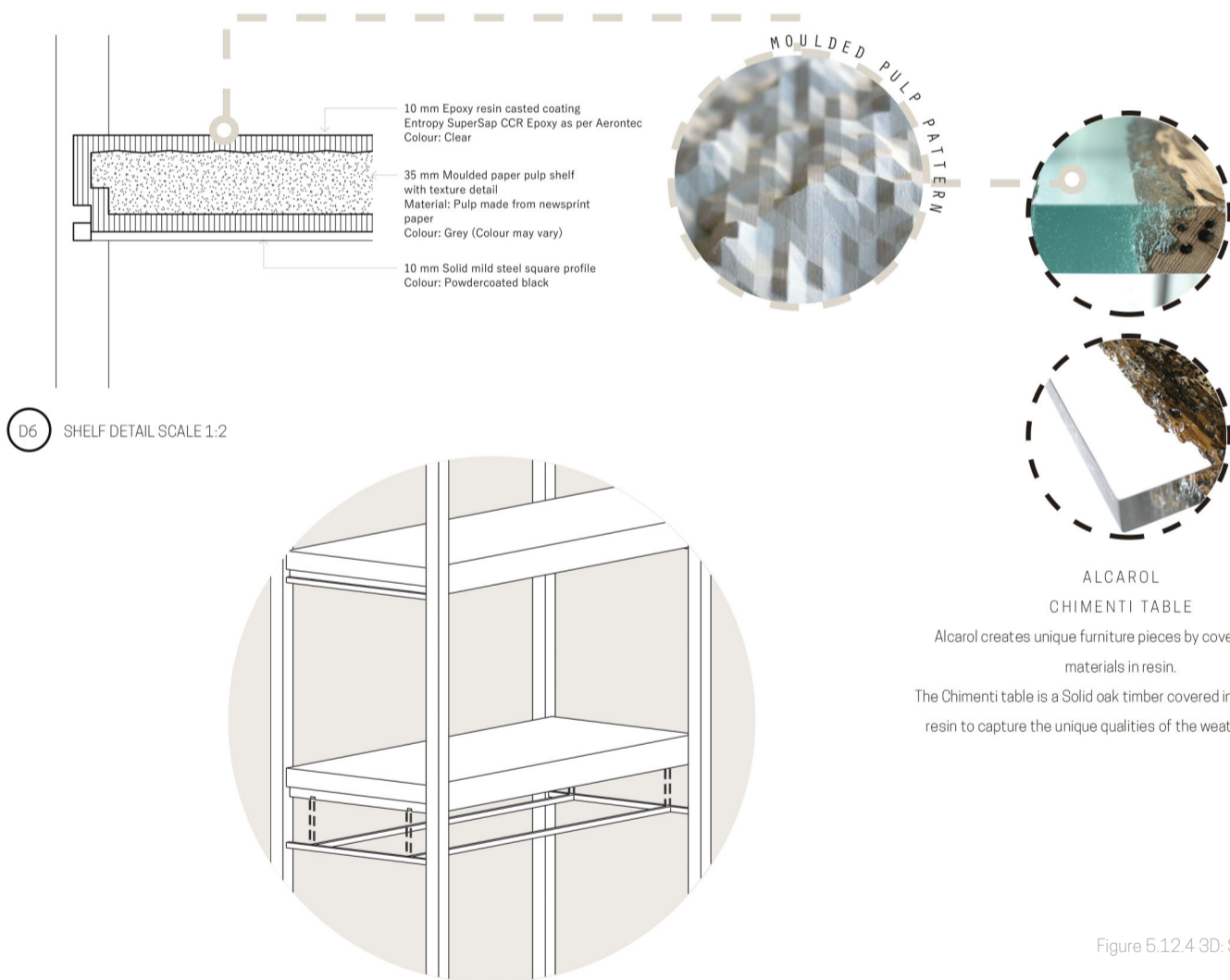
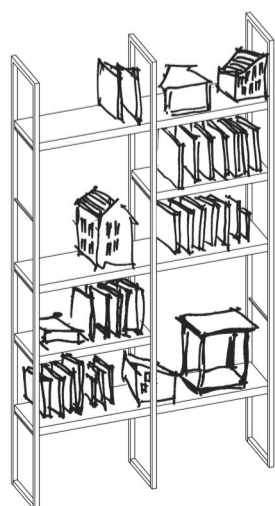
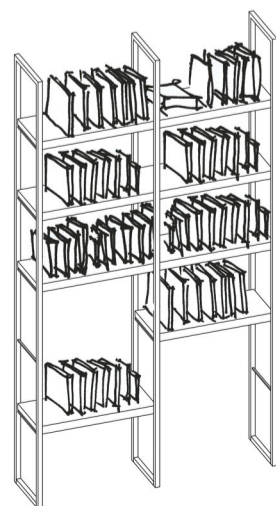

Figure 5.12.4 3D: Shelf details and configuration (Author. 2016)



CONFIGURATION 1



CONFIGURATION 2

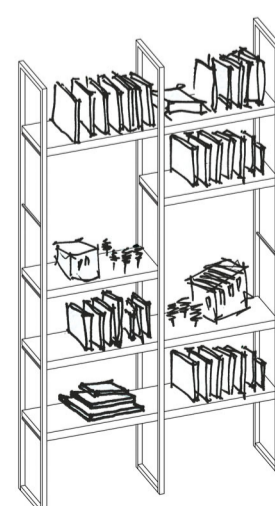

CONFIGURATION 3



5.13 CONCLUSION

This chapter was a continuation of the making process introduced in Chapter 4: Making and focussed on the technical aspects of the spatial outcome of the space as a whole. The technical drawings conveyed the spatial integration of the paper installation as an element that supports the activities in the space by defining zones, controlling light qualities and creating a unique spatial aesthetic which supports the characteristics of the *cybrid* archive. The chapter clearly defined the character of the new space and created clear links between the theoretical approach and the design development and application.

Further reflections of the design and making process of the study will be discussed in Chapter 6: Final reflections.





UNIVERSITEIT VAN PRETORIA
UNIVERSITY OF PRETORIA
YUNIBESITHI YA PRETORIA

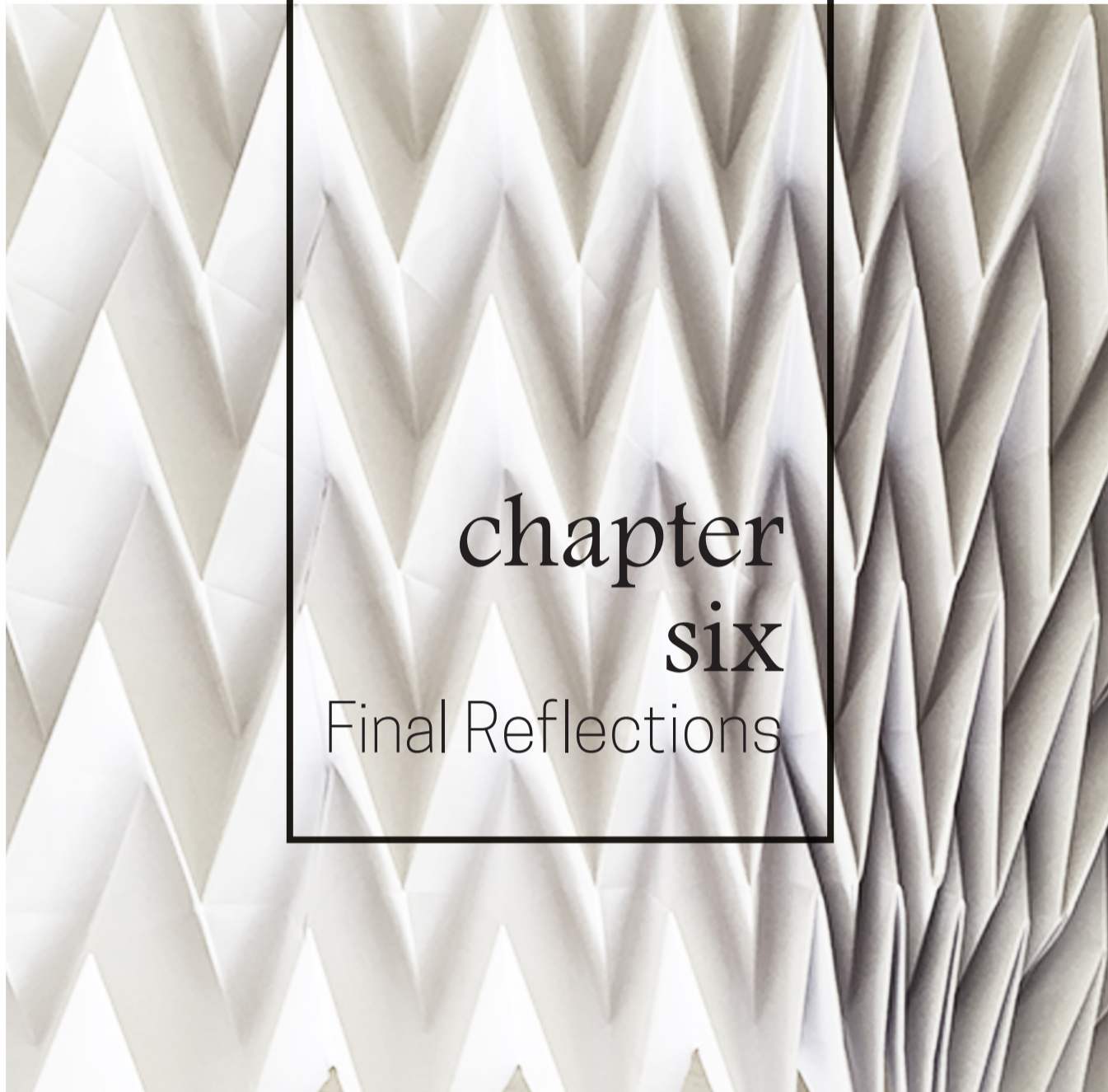

The investigation of the concept of dematerialization as a shift from matter to information is what initiated the theoretical development of this study. This process has a significant impact on the process of spatial design as interior design relies on materiality and the physical realm to manifest. Through the shift of matter to information, valuable spatial qualities are lost and the unique characteristics of the process of the design is diminished, refer to Chapter 1 section 1.2.

Therefore the act of making is reintroduced into the design process to strengthen the unique character of the interior design discipline. The dissertation implements the Research Through Making methodology with the support of proposals made by a preceding project done by Wherry (2015), where a Hybrid Research Strategy was developed, along with new proposals made in this study to develop a parallel making and design process.

This section includes an overview of the work done throughout the study to bring together all the themes discussed in the individual chapters. The final chapter will be a reflection on the observations and reflections of the work done and the objectives that were achieved, and will be written with the support of a diary which was kept throughout the year. The chapter concludes with contributions made by this study as

well as recommendations for further study.

6.1 PERSONAL REFLECTIONS

The structure of Chapter 6 is similar to the final reflections written by Wherry (2015:100) where she brought together and reflected on the whole study of all the themes throughout the separate chapters of the document. The chapter is written as a personal reflection to the entire study.

The style of the writing in the form of a personal reflection allows the reader to gain insight into the theoretical, design and making process, as it is not a linear process as conveyed in the form of the document. Therefore this chapter will follow a similar style to conclude and reflect on the experience and development of the final outcome of the dissertation.

Throughout the course of the study an informal diary was kept to help me document general thoughts as well as the time that was spent on specific activities done. Notes were made at the end of each day and sometimes at the end of a week, where meetings, milestones and activities were noted as well as significant observations or reflections. The thoughts documented, supported reflections that were written for the making process in the document on various occasions, to recall observations made on the day, if they were not documented elsewhere. The diary was used to recall thoughts and the development of the design process which greatly informed the final reflections for this chapter.

At an early stage I reflected on the preceding projects to determine a clear methodology for this project to support the process. Throughout this study I constantly used *Knowing through making* (Wherry, 2015) as a touchstone to be able to determine if the parallel process proposed in this study met the objectives set out in Chapter 1: Introduction, as a reflection on the preceding projects. Because this study is a reflection on previous work done, the outcome had to contribute new knowledge to the Research Through Making process and reflect on the criticism given on the projects, as elaborated in Chapter 2 section 2.3.1.

The structure of *Knowing through making* (Wherry, 2015) also assisted greatly with the structure of the document and allowed me time to focus on the actual application of the methods proposed and tested by Wherry (2015) rather than to spend time developing the methodology.

The approach to material as the initial step in the design process and not as an application to the final outcome, led to an intricate and imaginative spatial understanding of the space in all its manifestations, giving me the insight needed to understand what the user experience would be like and therefore creating opportunity to observe and reflect on the process.

From the start, a good theoretical approach formed the basis for the study to develop from. A clear idea of the material that would be used for this study was also achieved from the beginning of the study. With the clarity of the theory and material, it took a while to find a way to integrate everything into one theme. As I started investigating the concept of dematerialization a clear concept started to develop, allowing opportunity for the methodology, material and space to become interdependent throughout the dissertation. The strong link between the three themes (methodology, material and space) strengthened the proposed parallel process. The intertwined nature allowed for the conventional process and making process to constantly inform one another and develop as one process, refer to Chapter 2 figure 2.3.5 parallel design process and 2.3.6 synthesised design process.

The material chosen in the nature of the Research Through Making methodology, was initially an arbitrary choice, but after the development of the theoretical approach along with the choice of a site and typology, the material choice was strengthened and a significant layer was added to the concept.

Whilst the development of the site and programme and the analysis of the theory, I started intuitively exploring the material to allow myself to gain insight to the possibilities of the paper as early in the study as possible. This process informed the decisions made for the site and programme, which would support the act of making with paper.

If a student chooses to implement the Research Through Making methodology along with the proposed synthesized process, the order of the material and theory, refer to Chapter 2 Section 2.4, could be changed, but ideally the choice of the one should be informed by the other from the beginning to allow for the development of a clear concept. Another extremely important aspect would be to start the making process at the earliest stage of the study, as the nature of this proposed process is based on the significance of the material and the influence it has on the spatial outcome if implemented as a core to the design exploration and spatial development.

From the early stages of the study the material was selected and new knowledge was largely made whereas collected knowledge was used to support the arguments. Because the act of making allows for data to be generated, the integration of the theoretical aspect and the design application of the study is more naturally and successfully integrated, and the final outcome does not seem removed from the theoretical and design explorations.

6.2 CONTRIBUTIONS

This study makes the following contributions:

- + This study contributes new knowledge to the Research Through Making methodology, as it builds on a prior proposal for a hybrid research strategy implemented by Wherry (2015) as part of the MInt (Prof) programme at the University of Pretoria.
- + This study contributes a creative spatial outcome by implementing and improving on the proposed hybrid research strategy.
- + This study contributes to the discipline of interior design as it implements a parallel process which integrates the act of making as well as more conventional spatial design processes, to achieve a creative and integrated spatial outcome.
- + This study contributes to the interior design programme of the Department of Architecture at the University of Pretoria as it creates opportunity for a new parallel design and making process to be implemented which could lead to more creative spatial outcomes.
- + This study contributes to the development of the *cybrid* concept, and the implementation of *cybridity* in a specific typology.
- + This study contributes significant and creative concepts to the proposed future development of the Boukunde architectural archive.
- + This study contributes to the present discussions regarding the impact of dematerialization on the interior design discipline and environments.
- + This study contributes new knowledge regarding the approach to materiality as an initial step in the design development to guide and inform the creative spatial outcome.

6.3 RECOMMENDATIONS

This study makes the following recommendations for further study:

- + The implementation of paper as interior artefact be further investigated to develop the durability of the material as a spatial application.
- + Investigate the spatial impact of pattern and texture as a space defining element.
- + Further explore the spatial possibilities for paper as a material for sustainable interior design solutions.
 - Further develop and strengthen the spatial language of paper as both a temporary and or structural material in the built environment.
- + Explore and develop the generic character for the *cybrid* aesthetic which could accommodate various typologies beyond the archive.
- + Investigate the crafted essence of making, with the support of technology as it has a unique aesthetic language.



6.4 CONCLUSION

The diary contributed significant value to the time management and documentation of thoughts, therefore the use of a diary would be beneficial to any future studies undertaken, and students should as far as possible document thoughts and reflections on a daily basis. The personal reflections of this chapter allows for the reader to gain a better understanding of the actual non-linear process of the study, and the structure of this chapter has the potential to inform and encourage the archiving of student work and the nature of the design processes followed.

This dissertation is concluded with personal reflections of the process. The chapters to follow include the appendix and a list of references where further information can be gathered.



chapter seven

List of References

7.1 LIST OF REFERENCES

A

ACNE STUDIOS. 2016. Paris stores. [Image found online at:](#)

<http://www.acnestudios.com/cn/en/stores?city=Paris> [Accessed 19 October 2016]

ANDERS, P. 2004. Cybrid principles: guidelines for merging physical and cyber spaces. *International Journal of Architectural Computing*, 3(3), 391-406. [Available online at:](#)

<http://cumincad.architecturez.net/system/files/pdf/ijac20053308.pdf> [Accessed 9 May 2016]

ANDERSON, B. 2014. *Shigeru Ban's cardboard cathedral in New Zealand*. [Image found online at:](#)

<http://design-milk.com/shigeru-bans-cardboard-cathedral-new-zealand/> [Accessed 31 March 2016]

ARCHDAILY. 2011. *Kanazawa Umimirai Library / Coelacanth K&H Architects*. [Available online at:](#)

<http://www.archdaily.com/145757/kanazawa-umimirai-library-coelacanth-kh-architects>. [Accessed 2 May 2016]

ASHBY, M, JOHNSON, K. 2002. *Materials and design: the art and science of material selection in product design*. Burlington:

Butterworth-Heinemann.

B

BARKER, A., VAN NIEKERK, K., SWART, J. 2016. The importance of architectural archives. *ArchSA: Journal of the South African institute of architects*. issue 79, 6-9.

C

CANADIAN COUNCIL OF ARCHIVES. 2003. Basic Conservation of Archival Materials : Revised Edition, 2003 Chapter 3 – Environment. [Available online at:](#)

http://www.cdncouncilarchives.ca/public_free.html [Accessed 23 September 2016]

CANDY, L. 2006. *Practice based research: a guide, CCS Report 2006-V1.0 November*. University of Technology Sydney. [Available online at:](#)

<http://www.creativityandcognition.com/resources/PBR%20Guide-1.1-2006.pdf>. [Accessed 2 February 2016]

CARLO SCARPA ARCHIVE. 2016. *The Carlo Scarpa Project*. [Available online at:](#)

<http://www.archiviocarloscarpa.it/web/progetto.php?lingua=e>. [Accessed 12 July 2016].

CHING, F.D.K., 2007. *Architecture: form, space and order*. 3rd ed. New Jersey: John Wiley and Sons.

D

DESIGNBOOM. 2009. *Shigeru Ban: Paper tower*. [Image found online at:](#)

<http://www.designboom.com/architecture/shigeru-ban-paper-tower/> [Accessed 27 July 2016]

DESIGNBOOM. 2011. *Shigeru Ban's paper house pavilion for Hermès*. [Image found online at:](#)

<http://www.designboom.com/design/shigeru-ban-hermes/> [Accessed 31 March 2016]

DESIGNBOOM. 2013. Shigeru Ban: Architecture and humanitarian activities. [Image found online at:](#)

http://www.designboom.com/architecture/shigeru-ban-architecture-and-humanitarian-activities/?utm_campaign=Saturday&utm_medium=e-mail&utm_source=subscribers [Accessed 5 September 2016]

DETAIL. 2000. *Japanese Pavilion at the EXPO in Hanover*. [Available online at:](#)

<http://www.detail-online.com/inspiration/japanese-pavilion-at-the-expo-in-hanover-106867.html>. [Accessed 27 July 2016].

DEZEEN. 2012. *FABRIKAAT exhibition at Ventura Lambrate*. [Image found online at:](#)

<http://www.dezeen.com/2012/04/04/fabrikaat-exhibition-at-ventura-lambrate/> [Accessed 20 April 2016]

DEZEEN. 2013. *James B. Hunt Jr. Library*. Image found online at:
<http://www.dezeen.com/2013/04/03/james-b-hunt-jr-library-by-snohetta/> [Accessed 4 May 2016]

DJONOV, E. & VAN LEEUWEN, T. 2011. The semiotics of texture from tactile to visual. *Visual Communication*, Vol 10, 541-564.
Available online at:
<http://vcj.sagepub.com/content/10/4/541.abstract> [Accessed 16 February 2016].

DUPONT TYVEK. 2015. *Dupont Tyvek graphics: technical handbook*. Available online at:
http://images.protectiontechnologies.dupont.com/Web/DuPontInternationalOperationsSarl/%7Bb0958626-64e8-4f3cb9fe705fb8e0ea46%7D_Tyvek_Graphics_TH_UK_2015_web.pdf?elqaid=362&elqat=2&elqTrackId=ff751a1fd65e4b31bdf1f9bb2911f43b [Accessed 19 October 2016]

E

ECHELMAN, J. 2013. *Skies painted with Unnumbered Sparks, Vancouver, Canada*. 2014. Available online at:
<http://www.echelman.com/project/skies-painted-with-unnumbered-sparks/> [Accessed 24 September 2016]

F

FOESSEL, D. 2014. *Cafe Coutume Aoyama/CUT Architectures*. Image found online at:
<http://www.archdaily.com/514524/cafe-coutume-aoyama-cut-architectures> [Accessed 16 October 2016]

FREARSON, A. 2013. *James B. Hunt Jr. Library by Snohetta*. Available online at:
<http://www.dezeen.com/2013/04/03/james-b-hunt-jr-library-by-snohetta/>. [Accessed 2 May 2016].

G

GOLDBLATT, D. 2007. Lightness and Fluidity: Remarks Concerning the Aesthetics of Elegance. *Architectural Design: Elegance*, 77(1), 10-17.

GRIFFITHS, A. 2016. *Delicate brass framework divides spaces inside Neri&Hu's Sulwhasoo flagship store*. Image found online at:
<http://www.dezeen.com/2016/05/24/neri-hu-sulwhasoo-flagship-store-seoul-south-korea-brass-framework-lattice/> [Accessed 19 October 2016]

GROSZ, E.A. 2001. *Architecture from the outside: essays on virtual and real space*. London: MIT Press Cambridge.

H

HAY, F. 2007. Interior Architecture. In J. Gigli, F. Hay, E. Hollis, A. Milligan, A. Milton, & D. Plunkett (eds). *Thinking inside the box: a reader in interiors for the 21st century*. London: Middlesex University Press.

HEATHERWICK, T. 2013. *Thomas Heatherwick: Making*. London: Thames and Hudson.

HEKKERT, P. 2006. Design aesthetics: principles of pleasure in design. *Psychology Science*, vol. 48, 157-172. Available online at:
<http://www.csuchico.edu/~nschwartz/Hekkert,%20P.%20Design%20aesthetics%20principles%20of%20pleasure%20in%20design.pdf> [Accessed 24 July 2016]

HILL, J. 2014. *The Materials of Shigeru Ban*. Available online at:
<http://www.world-architects.com/pages/insight/materials-shigeru-ban>. [Accessed 3 March 2016].

HIRAI, H. 2015. *JR Onagawa Station / Shigeru Ban Architects*. Image found online at:
<http://www.archdaily.com/631067/jr-onagawa-station-shigeru-ban-architects> [Accessed 7 June 2016]

I

INTERNATIONAL COUNCIL ON ARCHIVES. 2016. *Discover archives and our profession*. Available online at:
<http://www.ica.org/en/discover-archives-and-our-profession>. [Accessed 12 July 2016].

ISHII, H. & ULMER, B. 1997. *Tangible Bits: Towards seamless interfaces between people bits and atoms*. In Proceedings of the SIGCHI Conference on Human Factors in Computing Systems (pp 234-241). New York, NY: ACM Press. Available online at: <http://web.media.mit.edu/~anjchang/ti01/ishii-chi97-tangbits.pdf> [Accessed 10 May 2016]

J

JACKSON, P. 2011. *Folding techniques for designers: from sheet to form*. London: Laurence King Publishing.

K

KÖNIGK, R. 2015. *An Imaginal Interpretation of Interior Design's Methods of Cultural Production: Towards a Strategy for Constructing Meaning*. PhD Thesis. Pretoria: University of Pretoria.

M

MARSHALL HINDS. 2013. *Tyvek packaging*. Available online at: <http://marshallhinds.co.za/tyvek-graphics/> [Accessed 19 October 2016]

MITHELL, W.J. 2002. E-Bodies, E-Buildings, E-Cities. In Leach, N (ed). *Designing for a digital world*. London: John Wiley and Sons.

O

OGDEN, S. 2009. THE ENVIRONMENT 2.1 Temperature, Relative Humidity, Light, and Air Quality: Basic Guidelines for Preservation. Available online at: <https://www.nedcc.org/free-resources/preservation-leaflets/2.-the-environment/2.1-temperature,-relative-humidity,-light,-and-air-quality-basic-guidelines-for-preservation>. [Accessed 23 September 2016].

P

PEREZ, A. 2010. *AD Classics: Beinecke Rare Book and Manuscript Library / Gordon Bunshaft of Skidmore, Owings, & Merrill*. Available online at: <http://www.archdaily.com/65987/ad-classics-beinecke-rare-book-and-manuscript-library-skidmore-owings-merrill> [Accessed 24 September 2016]

R

RICTHER, C. n/d. *Japanese Pavilion at the EXPO in Hanover*. Image found online at: <http://www.detail-online.com/inspiration/japanese-pavilion-at-the-expo-in-hanover-106867.html> [Accessed 27 July 2016]

ROSCOE, T. 2005. *Immaterial culture: Beyond disappearance Consequences of advanced technologies on interior design*. MInt Dissertation. Canada: University of Manitoba. Available online at: <http://mspace.lib.umanitoba.ca/xmlui/handle/1993/20274> [Accessed 22 March 2016]

ROSCOE, T. 2007. *Immaterial Culture: the interior environment repositioned*. In J. Gigli, F. Hay, E. Hollis, A. Milligan, A. Milton, and D. Plunkett (eds). *Thinking inside the box: a reader in interiors for the 21st century*. London: Middlesex University Press.

S

SCHMIDT, P & STATTMANN, N. 2009. *Unfolded: Paper in design, art, architecture and industry*. Basel: Birkhauser

SCOTT, F. 2008. *On altering architecture*. New York: Routledge.

SHEIL, B. 2005. Design through making: An introduction. *Architectural Design: design through making*. 75(4), 5-12.

SHEIL, B. 2008. Protoarchitecture: Between the analogue and the digital. *Architectural Design*. 78(4), 6-12.
SKIDMORE, OWINGS & MERRILL. 2016. *Yale University – Beinecke Rare Book And Manuscript Library*. Available online at: http://www.som.com/projects/yale_university_beinecke_rare_book_and_manuscript_library. [Accessed 7 July 2016]

STOLLER, E. 2010. *AD Classics: Beinecke Rare Book and Manuscript Library / Gordon Bunshaft of Skidmore, Owings, & Merrill*.

Image found online at:

<http://www.archdaily.com/65987/ad-classics-beinecke-rare-book-and-manuscript-library-skidmore-owings-merrill> [Accessed 8 July 2016]

T

TAUBMAN COLLEGE. 2015. *Texture tectonic*. Image found online at:

<https://taubmancollege.umich.edu/research/research-through-making/2015/texture-tectonics> [2 March 2016]

THACKARA, J. 2001. Designing the space that flows. In Antonelli, P (ed). *Workspheres: Design and contemporary work*. New York: The Museum of Modern Art.

THE NATIONAL ARCHIVES. 2016. *Archive principles and practice: an introduction to archives for non-archivists*. Available online at:

<http://www.nationalarchives.gov.uk/documents/information-management/archive-principles-and-practice-an-introduction-to-archives-for-non-archivists.pdf>. [Accessed 12 July 2016].

TREADAWAY, C. 2009. *Materiality, Memory and Imagination: Using Empathy to Research Creativity*. *Leonardo*.42(3), 231-237.

Available online at:

<http://0-eds.a.ebscohost.com.innopac.up.ac.za/ehost/pdfviewer/pdfviewer?sid=29d48395-36ba-45c8-9a5a-460e880386c1%40sessionmgr4001&vid=6&hid=4210> [Accessed 14 March 2016]

U

UNNUMBERED SPARKS. 2016. Unnumbered sparks. Available online at:

<http://www.unnumberedsparks.com/> [Accessed 5 May 2016]

V

VAN CAMPENHOUT, L., FRENS, J., OVERBEEKE, K., STANDAERT, A. & PEREMANS, H. 2013. Physical interaction in a dematerialized world. *International Journal of Design*. vol 7, 1-18. Available online at:

<http://www.ijdesign.org/ojs/index.php/IJDesign/article/view/1124> [Accessed September 2015]

VERGHESE, G. 2005. *Material matters in modern interior*. DX conference: BY DESIGN: An Interdisciplinary Conference on Issues of Design Education, Business and Material Culture. Available online at:

https://www.academia.edu/4987501/Material_Matters_in_a_Modern_Interior [Accessed 20 May 2016]

VERGHESE, G. 2007. Sensual Spaces through material abstraction. In J. Gigli, F. Hay, E. Hollis, A. Milligan, A. Milton, and D. Plunkett (eds). *Thinking inside the box: a reader in interiors for the 21st century*. London: Middlesex University Press.

VIMEO. 2016. Rigid origami with kangaroo. Video found online at:

<http://www.harvardgenerator.com/references/online-video>. [Accessed: 23 October 2016].

W

WARD, M.A. 2015. Rapid Prototyping Politics: Design and the De-material Turn. In: W Jonas; S Zerwas and K von Anshelm, (eds). *Transformation Design: Perspectives on a New Design Attitude*. Basel: Birkhäuser. 227-245.

WHERRY, L. 2015. Knowing through making: An investigation into the construction of hand knotted textiles and their collective application as textile space defining elements within the interior. Mnt Dissertation. Pretoria: University of Pretoria.

WILLIAMS, N. 2005. *More paperwork: exploring the potential of paper in design and architecture*. New York: Phaidon Press.

WILSON, W.K. 1995. *Environmental Guidelines for the Storage of Paper Records*. Maryland: NISO Press.

Y

YALE UNIVERSITY LIBRARY. 2013. *Beinecke Rare Book and Manuscript Library*. Image found online at:

<http://beinecke.library.yale.edu/research> [Accessed 8 July 2016]



APPENDIX A
SAMPLE AND MODEL DOCUMENTATION



TEST	DATE	TIME	METHOD	MATERIAL	FORMAT	DESCRIPTION	VISUAL DATA	OBSERVATION	REFLECTION
1	2015	2 hours	Weave	Coated/glossy print	Old newspaper	Roll individual sheets diagonally to create tube and fix end with adhesive Press tubes flat Weave pieces and fix in place with adhesive		Sample is strong and quite durable but becomes rigid and results in 2D surface. Does not express the qualities of paper and resembles other material	Test woven sample as structural infill for other methods.
2	30/03	15 minutes	16 Linear division folding	80gsm white cartridge paper	210x297mm Sheet	Fold instructions as per Jackson (2011:16)		This is a basic concept for dividing paper and sample was made in order to learn basic folding techniques	
3	30/03	20 minutes	Symmetrical Repeat Fold: Translation	80gsm white cartridge paper	210x297mm Sheet	Fold instructions as per Jackson (2011:31)		Sample can fold into compact form and unfold and manipulated into various 3D forms. Sample is very flexible	Identify a few 'new' forms that develop from the original and test and develop each individually
4	30/03	45 minutes	Symmetrical Repeat Fold: Glide Reflection	80gsm white cartridge paper	210x297mm Sheet	Square paper Fold 8 linear divisions (valley) Turn sheet 90 degrees and fold 4 linear divisions (valley) Turn sheet over and fold motif (shown in image) in straight line 'slide' next row of folds		Intricate 3D surface texture created through fold. Due to flexibility sample show potential for cladding. Grid folds create potential for sample to be structural. Extraordinary flexible surface created	Test structural possibilities of sample. Test cladding potential of sample
5	01/04	30 minutes	Twist	Newsprint paper	420x594mm Sheet	Cut into strips of 50mm Slightly crumple Roll two pieces between hands		Paper tears easily and has very irregular outcome Process for preparing pieces is timely Does not express unique qualities of paper All of the above mentioned shows lack of potential for further development	This method does not show potential for further investigation

TEST	DATE	TIME	METHOD	MATERIAL	FORMAT	DESCRIPTION	VISUAL DATA	OBSERVATION	REFLECTION
6	01/04	20 minutes cutting 1 hour drying	Cut + Wet Folding	180gsm textured paper	148 x 210 mm Sheet	Cut strips into paper Wet paper with damp sponge Mould into shape and let dry in that position		Versatile form can be achieved. Cutting into paper allows for intricate surface manipulation. The sample outcome lacks structural potential.	This method does not show potential for further investigation
7	01/04	30 minutes	Cutting	Cardboard Tracing paper	N/A 210x297mm Sheet	Draw out cut pattern Cut cardboard into required shapes (triangles) Fix with adhesive to tracing paper in grid pattern		Aim: to test the potential of 'folded qualities' with the possibility of a more structural outcome, by using hybrid method (cut, fold and additional material for support) Tracing paper is too rigid and does not allow for intricate manipulation of shapes.	Further exploration of hybrid method can be done with alternative materials and patterns.
8	02/04	20 minutes mache 30 minutes drying	Maché	80gsm white cartridge paper Textile : Cotton	Torn strips of paper 300x200mm	Tear sheet of paper into strips Place strips into bowl of water Apply individual strips to textile with adhesive and water mixture Leave to dry		Aim: To strengthen paper with additional material and to investigate the flexibility of sample after method has been applied. Sample remains flexible to an extent but does not cling to textile.	Use of textile as structural yet flexible can be further investigated with integration of other methods Investigate alternative adhesive which will allow material to remain flexible and cling better to textile
9	03/04	30 minutes	X-form Span fold	80gsm white cartridge paper	210x297mm Sheet			Sample has structural potential but is only flexible in one direction. Only as strong as weakest fold	Investigate any other possible manipulation of form and shape
10	03/04	1 hour	Roll	Newsprint paper	Old newspaper	Cut into strips of 50mm Fold in half through length of strip Roll individual strips and fix with adhesive		Aesthetic is too crafty When individual pieces are fixed together sample has structural potential Inefficient use of material	Test the structural potential through various fixing methods

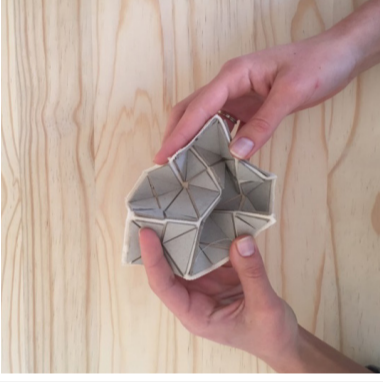
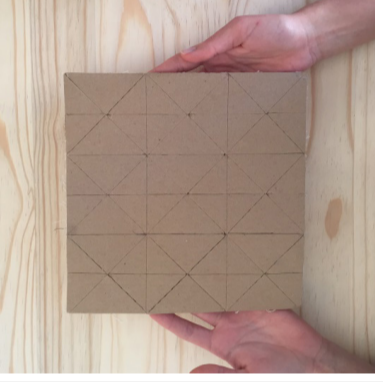
TEST	DATE	TIME	METHOD	MATERIAL	FORMAT	DESCRIPTION	VISUAL DATA	OBSERVATION	REFLECTION
11	04/04	40 minutes	Maché	80gsm white cartridge paper	Torn strips of paper	Tear sheet of paper into strips Place strips into bowl of water Apply individual strips over mould (balloon) with adhesive and water mixture Leave to dry		Material has unlimited moulding potential and a variety of organic shapes can be achieved through this method. Preparation for this method is time consuming and aesthetic outcome is dependent on individual 'maker' Sample does not stick and therefore material is not suited for method	Layering paper to make thicker material should be further investigated Alternative material should be used to achieve more successful outcome.
12	04/04	2 hours material preparation 30 minutes moulding Estimate 4 hours drying	Maché (Pulp)	Newsprint Paper Plastic Mesh (Fine + Coarse)	Pulp	Tear sheets into small pieces Place in water for paper to soften Place paper in blender to create pulp Drain excess water Mix adhesive with pulp Mould over mesh Leave to dry		Aim: to strengthen material by adding mesh as substructure and to see if pulp would adhere to the mesh Sample warped through the drying process	Drying of the moulded pulp will need to be controlled by avoiding direct sunlight. This will lengthen the drying time but have a more predictable outcome
13	04/04	2 hour material preparation 30 minutes moulding Estimate 7 hours drying	Maché (Pulp)	Newsprint paper	N/A	Tear sheets into small pieces Place in water for paper to soften Place paper in blender to create pulp Drain excess water Mix adhesive with pulp Mould over object Leave to dry		Method leads to new material with different qualities than paper before process, it is a more rigid and structural material Any variety of shapes can be achieved	Test by combining with other materials to see reaction. How does it adhere to other materials (raw) or how can it be fixed Test colour potential and texture Test alternative pulp mixtures (papercrete etc)
14	05/04	40 minutes	Layering	Cardboard	594x420mm sheet	Cut cardboard with flutes angled in 4 directions along cut line Glue layers together		Layers create intriguing textures Light can be controlled through angled flutes of layers Excessive use of material More durable than paper Structural potential	How can material use be reduced but still achieve similar characteristics.

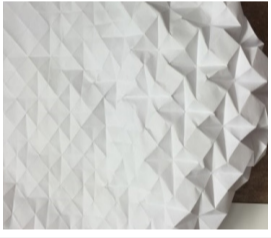
TEST	DATE	TIME	METHOD	MATERIAL	FORMAT	DESCRIPTION	VISUAL DATA	OBSERVATION	REFLECTION
15	05/04	1 hour	Basic Parabola fold	80gsm white cartridge paper	210x297mm Sheet	Fold instructions as per Jackson (2011:146)		Interesting outcome through type of folds but it is a very timely process Multiple units can be connected to form more complex unit	Investigate a grouping of parabolas to create more complex unit which could possibly become flexible or structural.
16	05/04	40 minutes	Cylindrical V Pleat	80gsm white cartridge paper	420x297	Fold instructions as per Jackson (2011:130)		Extremely flexible and fold type allows for various angles and forms Structural potential Expresses unique characteristic of paper	Explore with application of multiple V folds to create more intricate shapes Test for structural application
17	18/05	2 hours	Symmetrical repeat fold: Glide reflection	80gsm white cartridge paper	594x594	Reflection on sample 4 to explore the flexibility of sample if size is increased.		Larger sheet allows for more flexible model/sample Model becomes very organic in movement although made with rigid folds.	
18	18/05	45 minutes	Rigid origami Fold	80gsm white cartridge paper	420x297	Fold pattern as per Vimeo (2016)		Relatively easy fold pattern but to collapse is time consuming	Larger sheet will make for an interesting sample which could become extremely flexible.

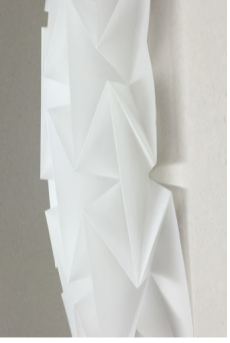
TEST	DATE	TIME	METHOD	MATERIAL	FORMAT	DESCRIPTION	VISUAL DATA	OBSERVATION	REFLECTION
19	18/05	30 minutes	Fold Pattern	80gsm white cartridge paper	420x297	Create fold pattern without collapsing sample to explore 3D patterns that occur when pressed together.		If paper is lightly pressed interesting 3D shapes emerge. Paper moves in its own way	The patterns could be explored with other materials and possibly hybrid material combinations
20	18/05	30 minutes	Cutting	Hybrid: Cardboard + canvas textile	N/A	Test the flexibility of hybrid material. Fixing cardboard cut outs onto canvas textile.		Sample can be moulded into many shapes but does not retain its shape.	Spacing between cardboard pieces can be made larger to achieve more intricate 'folds'
21	18/05	40 minutes	Cutting	Hybrid: Cardboard + canvas textile	N/A	First fix cardboard to textile and then cut 'fold' pattern		Aim: explore the process of making the hybrid sample to speed up time it takes to make as well as to achieve more precision.	Explore alternative textiles(stretch) that could allow for more flexibility
22	18/05	30 minutes	V-fold	80gsm white cartridge paper	420x297	Fold instructions as per Jackson (2011:124)		Collapses fairly easy Does not have enough flexibility for more organic shapes	
23	4/06	1.5hours	Rigid Origami	80gsm white cartridge paper	594x594	Fold pattern as per Vimeo (2016)		Paper is too thin and buckles/ crumples around folded lines therefor making it extremely hard to collapse the pattern.	

TEST	DATE	TIME	METHOD	MATERIAL	FORMAT	DESCRIPTION	VISUAL DATA	OBSERVATION	REFLECTION
24	2/06	30 minutes	Symmetrical repeat fold: Glide reflection	Tracing paper	594x594	This sample is a response to sample 17. The intention was to change the scale of the fold as well as the paper type to test the effect light will have with the model		Tracing paper tears where folds are made. Material is very brittle. Textures become muted with the use of tracing paper; shadows are less prominent due to opacity of the material.	Test the light potential, opacity of material has potential to create defined lighting qualities.
25	2/06	N/A	N/A	N/A	Photograph	Sample 24 was used to photograph possible spatial applications. The intention of the photograph was to capture spatial qualities which could not be depicted on conventional drawings.		Scale of fold is not accurate according to the ratio of the perspective. Ambient Light quality.	
26	4/06	N/A	N/A	N/A	Photograph	Malleability and motion of the sample was photographed as a series to create various forms and fluid movement.			
27	5/06	45 minutes	Paper Layering	Tracing Paper + Cardboard	N/A	An abstract spatial application of the layering of paper.		Intuitive cutting a layering had effective outcome. Creating the sample as a partial spatial representation helps give insight to all the possible applications of the sample.	Photograph the qualities such as texture and lighting that is created with sample.
28	5/06	N/A	N/A	N/A	Photograph	Photographs taken from sample 27 to explore the qualities of the layered paper		Playful investigation of model allowed for imaginative photographed qualities. Layered sample has intriguing textures from different perspectives. Dapple light effect. Ambient light created.	Apply to a spatial model to test effects in a different scale.

MODEL	DATE	TYPE	DESCRIPTION	VISUAL DATA	OBSERVATION	REFLECTION
1	30/05	Section Extrusion	The intention of this model was to test the making of an image and to spatially express the paper sample. The model was extruded from a hand sketched section. Investigation of model to see what effect it has on the spatial outcome in addition to designing on 2D plan.		The model creates better understanding of the possibilities of what the paper artefact could be. Model takes definite shift away from material exploration toward more spatial exploration. Space and paper artefact show better potential for integrated intervention rather than purely installation.	Explore more models of similar nature to express variety of spatial applications. Documenting all the models in an informal manner during the making process allows for thoughts and observations to be recorded without breaking the creativity which connects to the informal nature of making.
2	8/06	Section Extrusion	Model was built roughly scale 1:100 and from the sample 28 sketches where explored of possible spatial applications where after a very playful exploration was done to express the material throughout the whole space.		Extrusion of section further allows for better spatial investigation. Lack of plan and section as starting point for model allows for a more playful exploration of unknown application of paper artefact. Layering as technique in the space gives unique spatial effect which could be taken further in investigation of associations.	Layers can be explored as individual elements with alternative techniques such as paper maché to strengthen individual layers. Explore possibility (if any) of movement/ kinetic design.
3	11/06	Section Extrusion	This model is a reflection on model 1 which investigates a similar folded quality but through the use of additional material. The model was also created in a different section of the space to determine the spatial effects.		Section is cut only through one space therefore limits the spatial exploration as a whole. Sketched image as background creates a lack of depth in the model. Hybrid technique of textile and cardboard has potential for further investigation.	Model 1-3 is only ceiling based interventions and need to explore other applications. Explore the integration of techniques in model 2 and 3.
4	12/06	Section Extrusion	The intention was explore other possible applications of paper artefacts		Potential to create smaller spaces through movement /kinetic walls. Space seems empty due to artefact applied as wall finish and therefor becomes installation rather than intervention. Use of tracing paper creates opportunity to explore transparency throughout space.	Folds of sample used can be explored with other technique (glide reflection fold) to achieve more flexibility. Avoid application of artefact onto existing structure as it minimizes the impact on the space as translates into surface based installation.

APPENDIX B
RAW DATA - SKETCH DEVELOPMENT

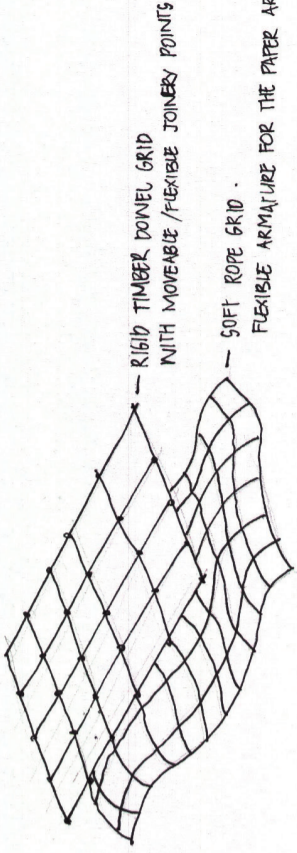
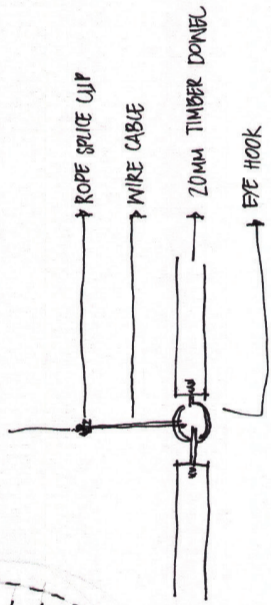
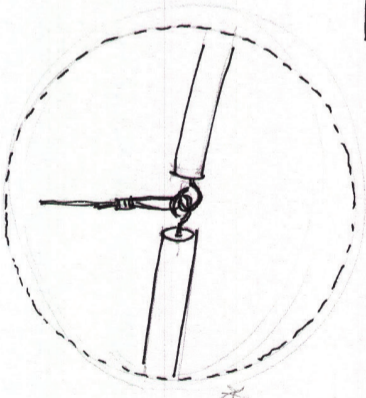
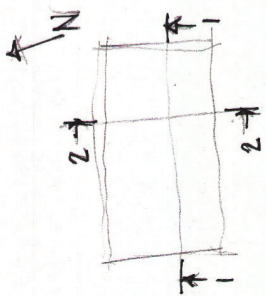

* TO ACHIEVE AN UNDOING FORM, A SYSTEM (FOR INSTALLATION) HAS TO BE CONSIDERED TO MAKE PROCESS OF MANIPULATING THE OVERALL FORM EASIER.

SECTION 1-1

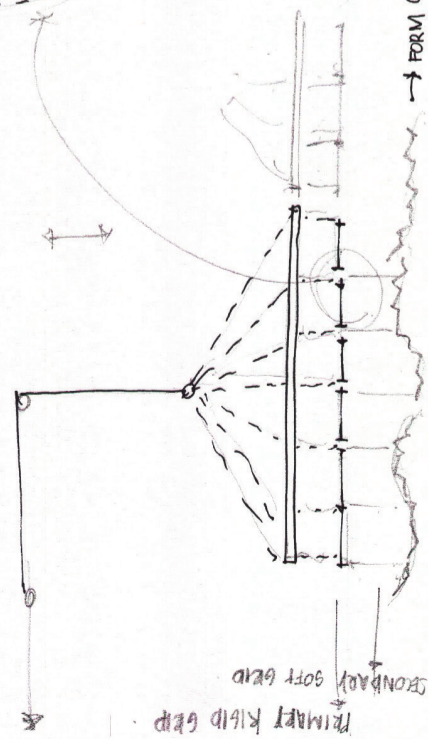

FORM OF PAPER IS MANIPULATED IN THIS ELEVATION TO ADD THE ILLUSION OF MOVEMENT IN THIS DIRECTION. PAPER ARTIFACT WILL NOT MOVE IN THIS DIRECTION BUT THE FORM WILL SUPPORT AND FURTHER DEFINE THE SPACE.

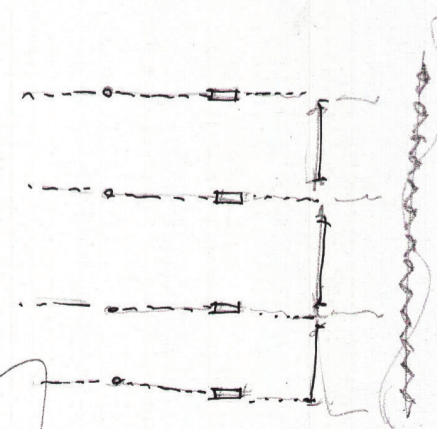

NON 2-2

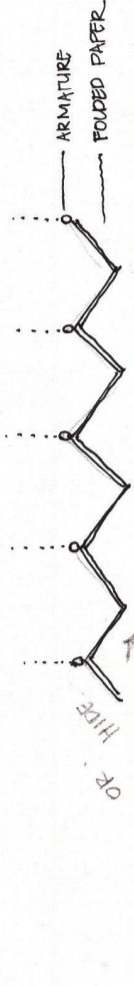

* ARMATURE IS REQUIRED TO PREVENT FOLDED PAPER FROM SAGGING OUT.

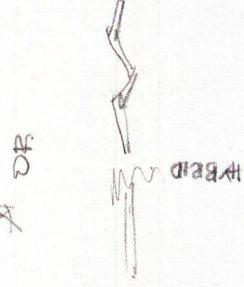

TIMBER DOWEL (HARD) ARMATURE

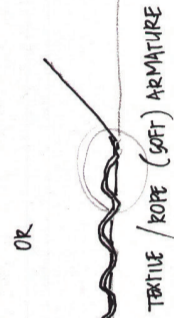

STITCHED / NOVEN IN D PAPER.

SOFT GRID WILL ALLOW MORE FLEXIBILITY AND COULD BE OPPORTUNITY FOR UNPREDICTABLE AND INTERESTING FORMS.

BOTH PATTERNS CAN EASILY BE ATTACHED TO A GRID SYSTEM AT FOLD LINES.

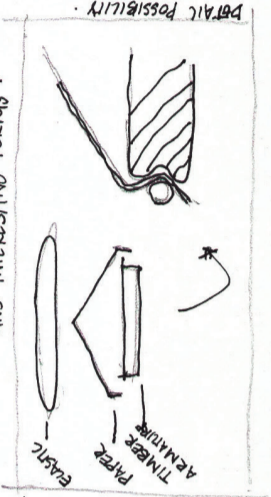

SOFTLAB INSTRUMENTATION

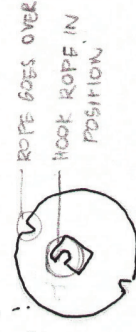
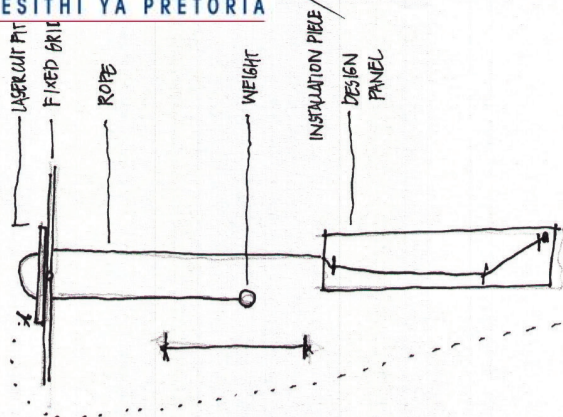

ALONGS KEY PIECE TO BE SUSPENDED FROM GRID WHILE BEING ABLE TO EASILY ADJUST HEIGHT

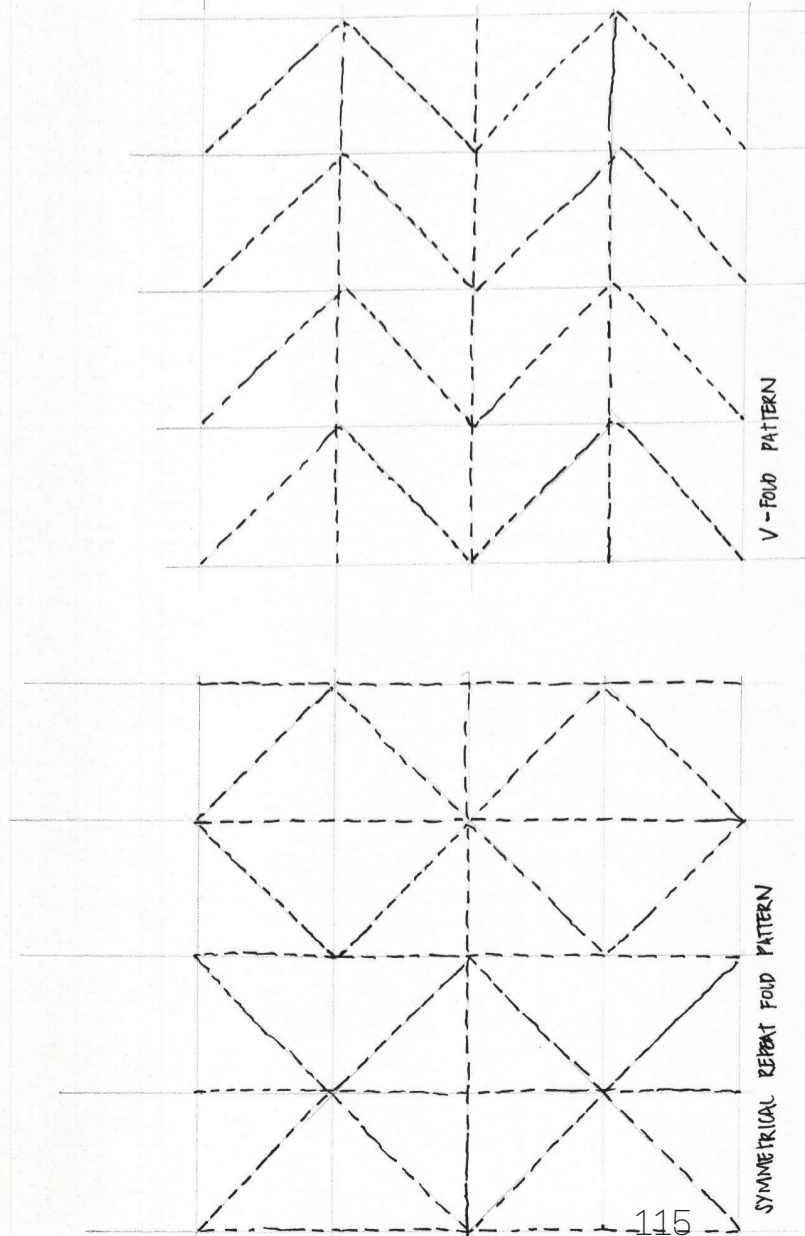



3600

12

MOVIEBLE POINTS WHICH CONNECT TO THE MECHANICAL SYSTEM.

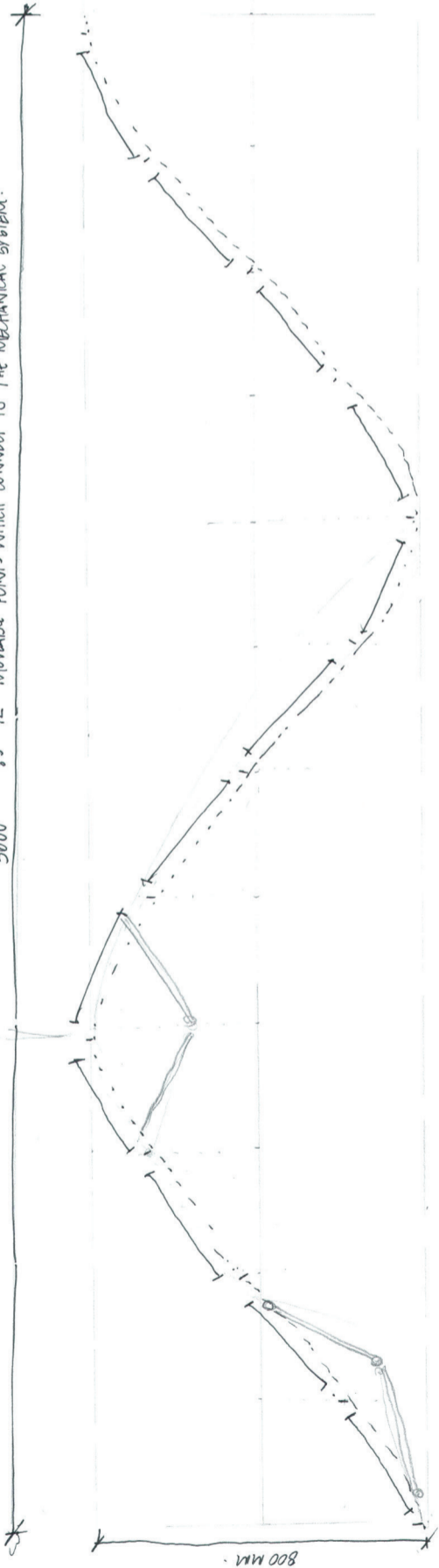

BECAUSE GRID AND TILE IS RIGID THE MOVEMENT WILL BE COMPROMISED

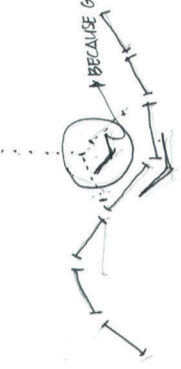

NEED 4 MORE FLUID JOINTS BETWEEN GRID AND PAPER TILES TO ALLOW FOR MORE MOVEMENT.

INDIVIDUAL TILES CANNOT EXCEED 300 X 300 MM. GRID SIZE
∴ WILL LIMIT MOVEMENT. CAN ONLY GO SMALLER IN 300 X 300 SQUARE

GRID : SCALE 1:5

300

FOR PRACTICAL REASONS THE GRID SHOULD ALLOW FOR EASY INSTALLATION AND REMOVAL OF THE PAPER TILES.

↓
COULD BE EXPLORED AS A MODULAR SYSTEM.

EXPLORE THE APPLICATION OF A HEXAGON GRID.

EXPLORE THE POTENTIAL OF INDIVIDUAL TILES IN A SHIMAZU PATTERN AS

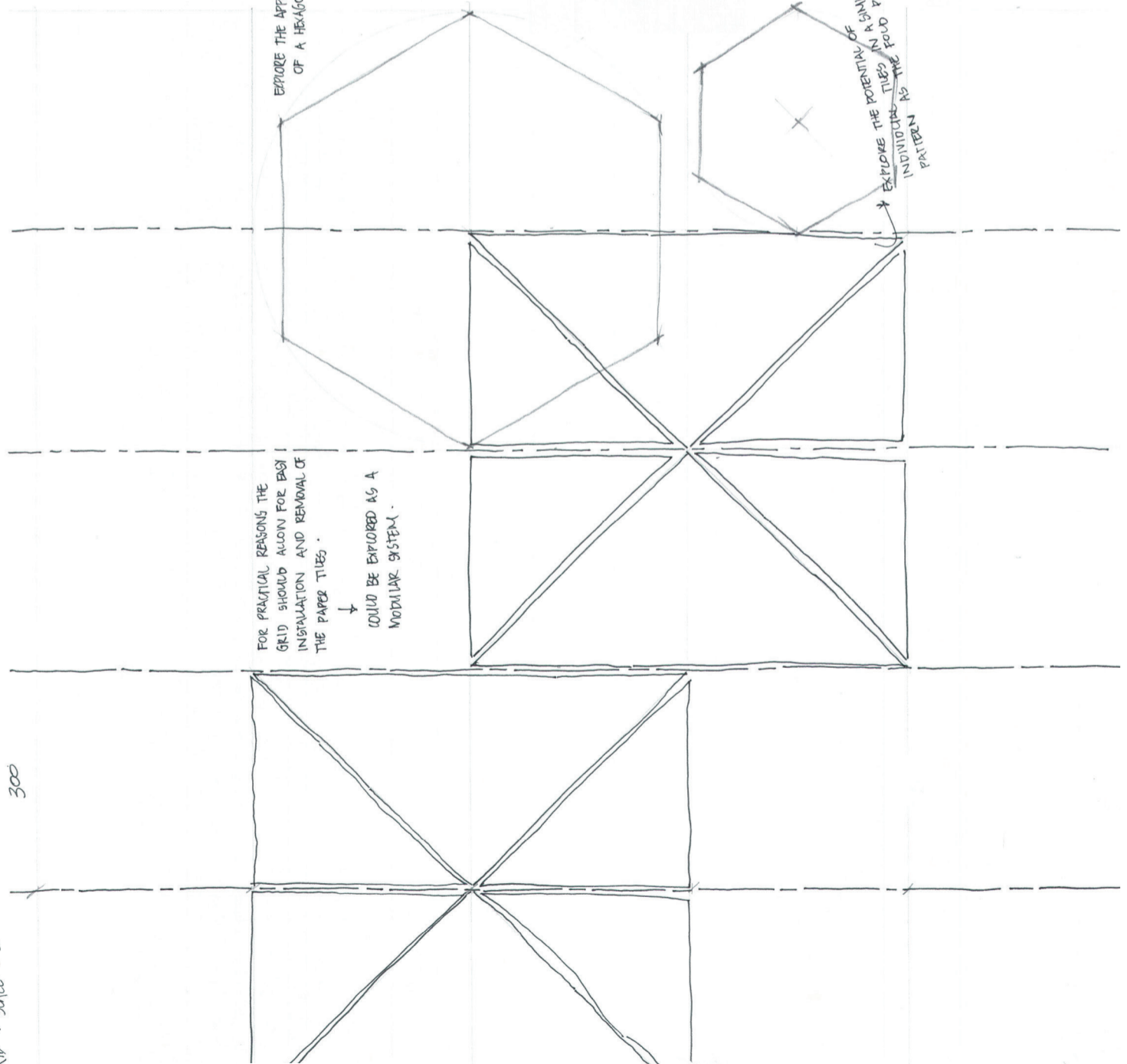

WIRE CABLE ATTACH TO HOOK.

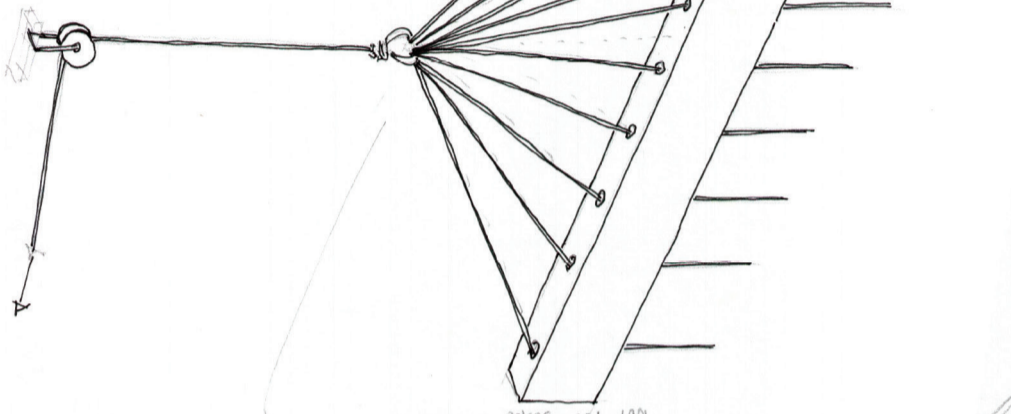

NOT TOO SCALE

WIRE ROPE
TIMBER BEAM

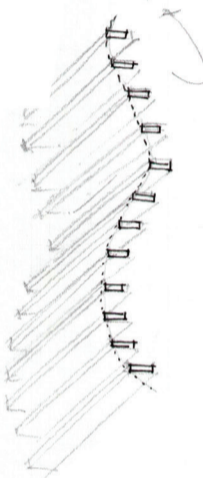

KINETIC WAVE (MOVEMENT IN ONE DIRECTION)

