

Technical Report

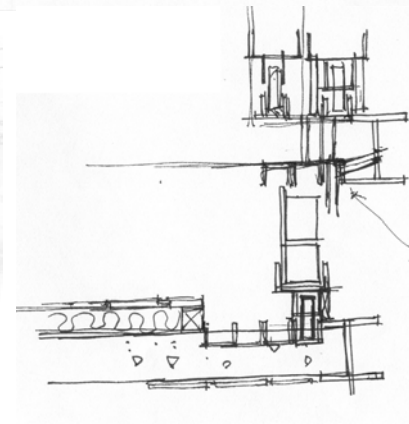

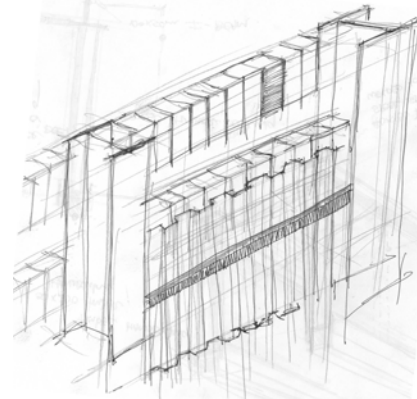
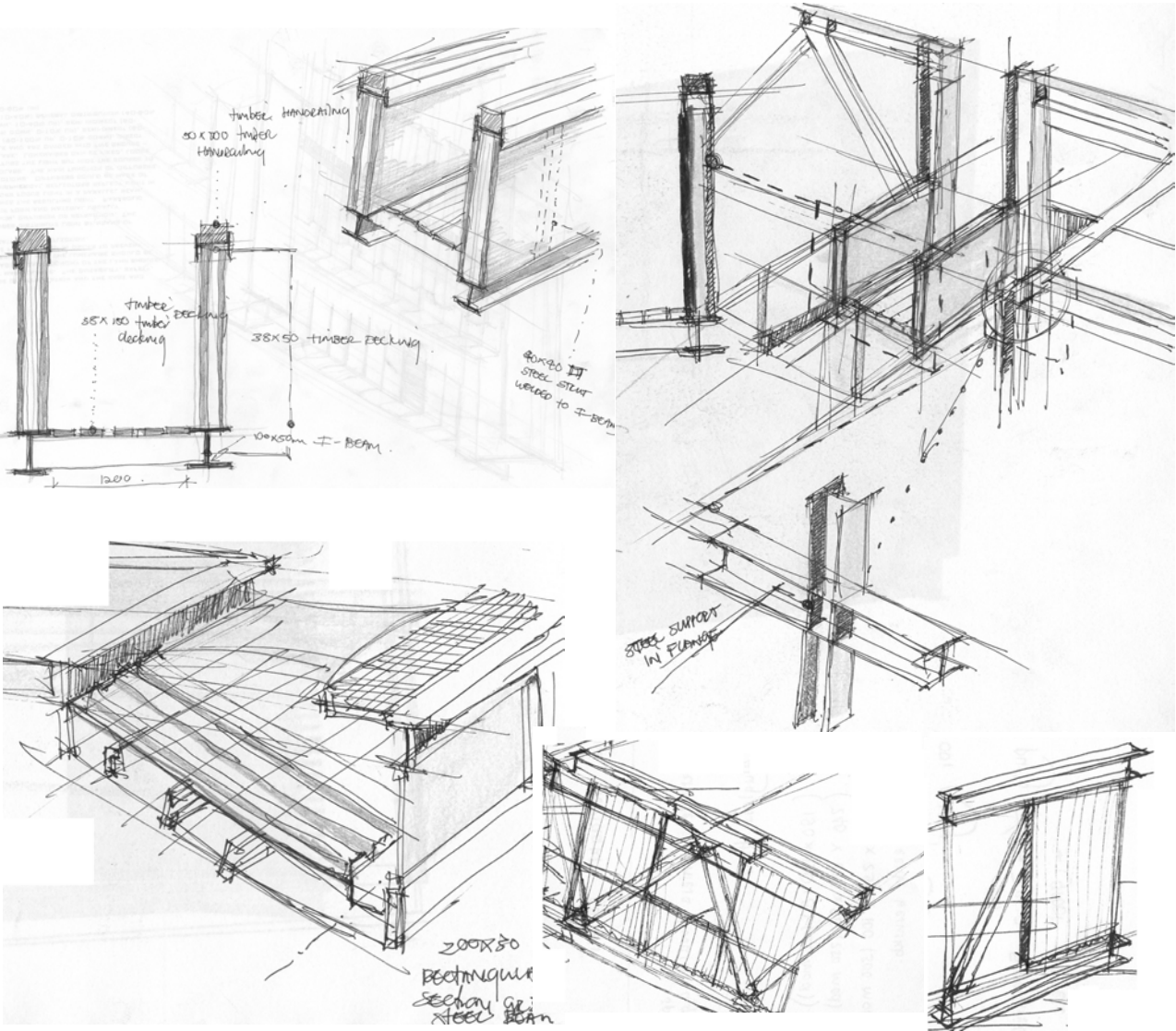

8.1 **STRUCTURE**

The structure of the complex comprises two superimposed three-dimensional structural grids. The first grid comprises an in-situ cast concrete grid, supporting the offices, vertical transportation and bus terminal infrastructure. The second is a steel grid, carrying the overhead accommodation units. As a result of this layering, it also contributes to the concrete grid, and *visa versa*.

The location of the overhead accommodation units, with respect to the development below, is problematic in terms of normal construction procedures such as in-situ cast concrete, making it relatively inaccessible. Other feasible construction techniques consequently had to be adopted. For the floor and roof slabs of the accommodation units the Econoslab™ suspended concrete system will be used. This system is cost effective and relatively easy to implement, being a suspended flooring system consisting of lattice lintels and concrete hollow blocks, which together form a permanent shutter for ribbed type concrete floors.

The lattice lintels, which contain positive reinforcement in their concrete part, form the bottom shutter for floor ribs. This system minimizes the amount of "in-situ" concrete work, which basically comprises of a screed to finish the slab.

The vertical structure, supporting the overnight accommodation units, will be based on GR. 300W 305x305x283 steel H-profile columns, with the horizontal structure being GR. 300W 305x305x137 bottom beams and 178x108x22 I-profile top beams supported by a 203x102x10 rectangular hollow section truss.

51

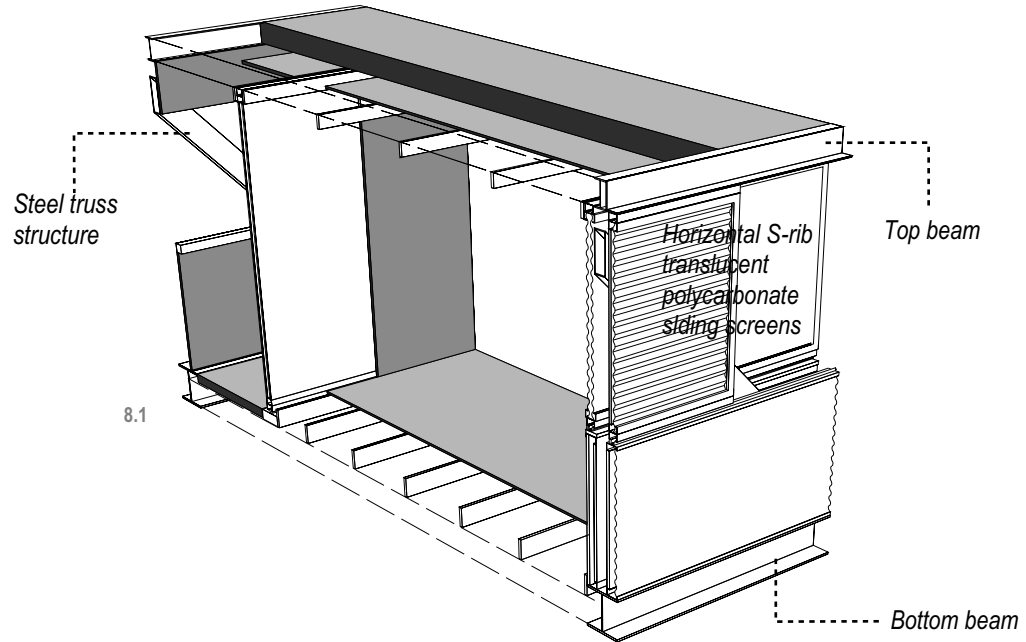

8.1

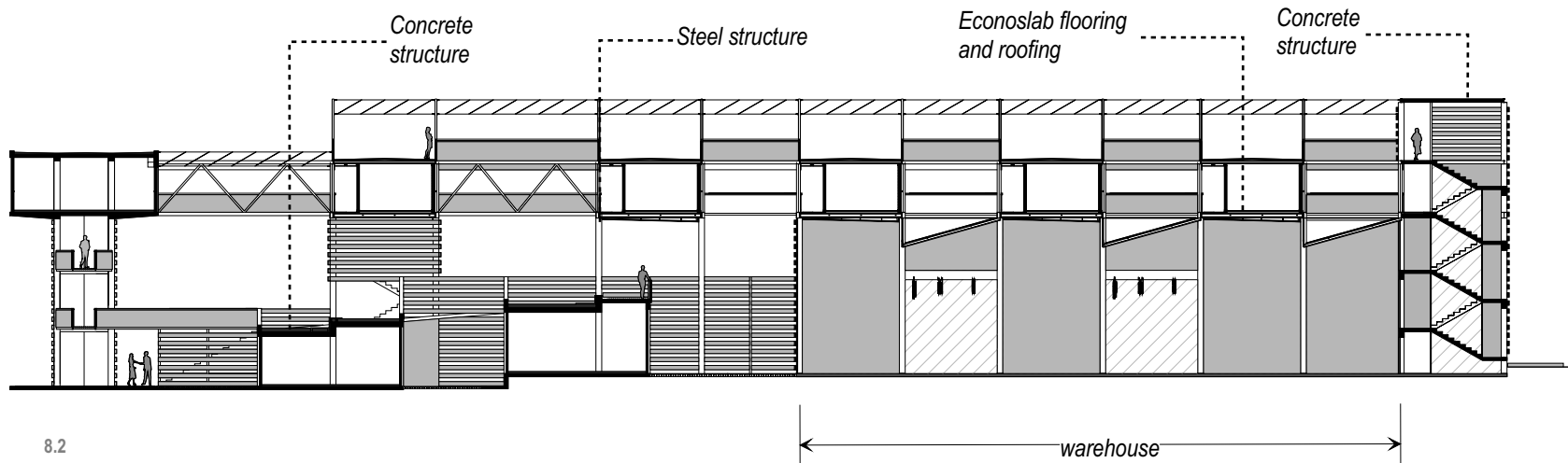

8.2

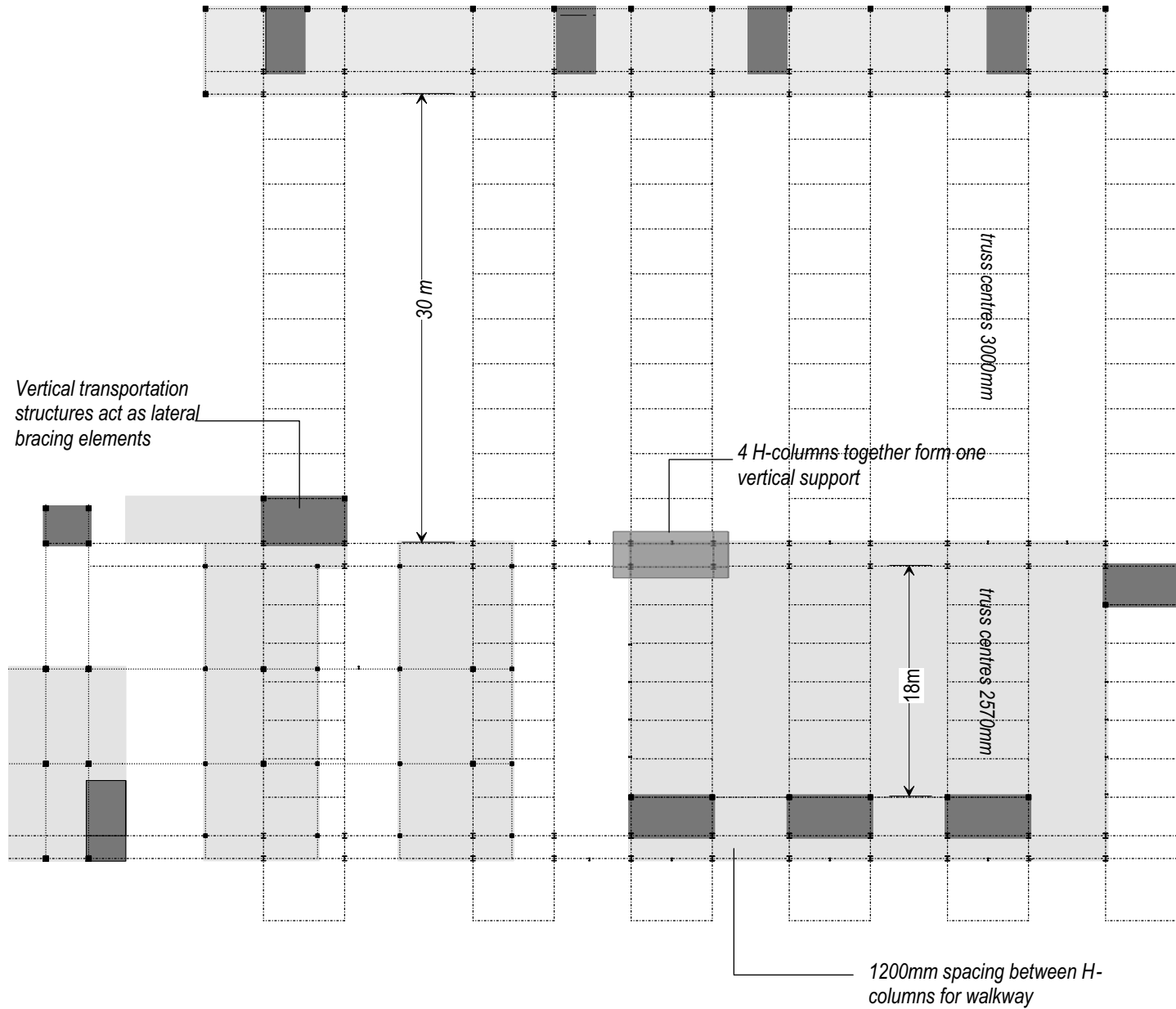

8.1 Structure of overhead unit in conceptual stage. In the final proposal the sliding screens were shifted to the interior to expose the structure.
 8.2 Section indicating structure.
 8.3 Plan of structural grid.

53

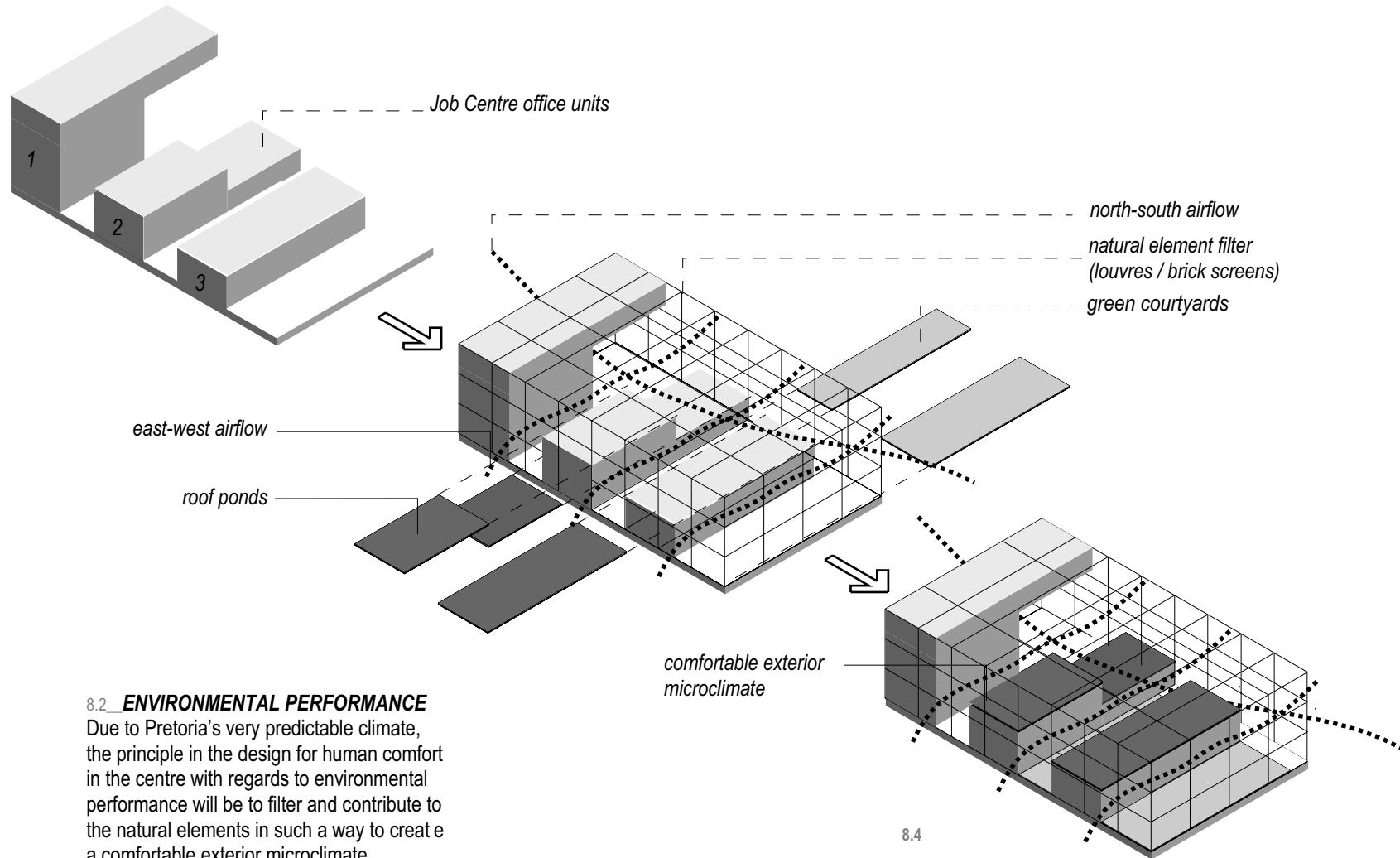

8.2 ENVIRONMENTAL PERFORMANCE

Due to Pretoria's very predictable climate, the principle in the design for human comfort in the centre with regards to environmental performance will be to filter and contribute to the natural elements in such a way to create a comfortable exterior microclimate, minimizing the need for further controls on the interior. The main microclimate under investigation will be the area surrounding the three office blocks of the *Job Centre*.

To promote mental activity, cooler than optimum thermal comfort will be aimed for in the office units, while optimum conditions will be targeted in the accommodation units to promote sleep and relaxation.

8.4 Diagram depicting environmental filter to obtain a comfortable exterior microclimate.

8.5 Section through unit indicating external insulation and internal exposure of mass elements.

8.3 **THERMAL INERTIA**

Through the damping effect referred to as thermal inertia, high -mass structures absorb heat during the day, and radiate excess heat at night. This stabilizes the interior temperature around the mean ambient temperature, resulting in a larger temperature lag. In the three office buildings concrete has been used extensively in the floors, columns and roofs to enhance thermal mass in the building.

Due to water's high thermal mass, five times the heat storing capacity of concrete, the roof ponds contribute to this aspect. Heat storage in the water will be more desirable during winter than in summer. During summer circulation will be quickened to limit the heating effect, with less exposure to direct sunlight due to the louvre system. The pebbles, forming the base of the water ponds are also of a dark colour to promote heat absorption.

In the accommodation units the floors and roofs consist of high -mass concrete to promote thermal inertia, playing a significant role in thermal damping, being used as a solar heat store.

8.4 **INSULATION**

In a climate with large daily temperature fluctuations, such as Pretoria's, insulation should optimally be applied on the outside of a high -mass structure. By exposing the high-mass structure on the inside, thermal performance will be maximized due to the effect of radiative heat. In the case of the accommodation units, a layer of insulation is applied on the roof in the form of an elastic tile. The tiles also function as flooring, and have low thermal radiation and build-up.

The bottom of the floor slabs will be exposed and finished with a screed, covered with gloss enamel paint. This specification will result in the maximum usage of the radiative heat caused by the

presence of high -mass materials such as concrete. The use of suspended ceilings would have limited this effect. Internally the floor slab will be finished with slate tiling (again a high -mass material) to enhance the thermal performance due to heat absorption in winter as a result of direct sunlight, as well as the effect of radiative heat. The floor slab will be externally insulated by means of a layer of insulation on top of the acoustic ceiling panel, which also contributes to the U -value of the external ceiling system. All dry walling will include insulation material.

The external walkways and accessible roofs of the accommodation units will be tiled with Regupol Elastic Interlocking paving tiles to enhance the acoustic and thermal performance. The tiles are manufactured of recycled synthetic rubber, having a shock absorption rate of 70%. The 500x500x43 tiles also act as an insulation layer, while preventing heat storage and build -up due to its porous structure. The porous surface also absorbs sound, and the impact of footsteps. The tiles are red -brown in colour and are laid on a clean concrete surface with a special adhesive provided by the manufacturer. The sub-base needs to have a slight slope for drainage, as the tiles are permeable.

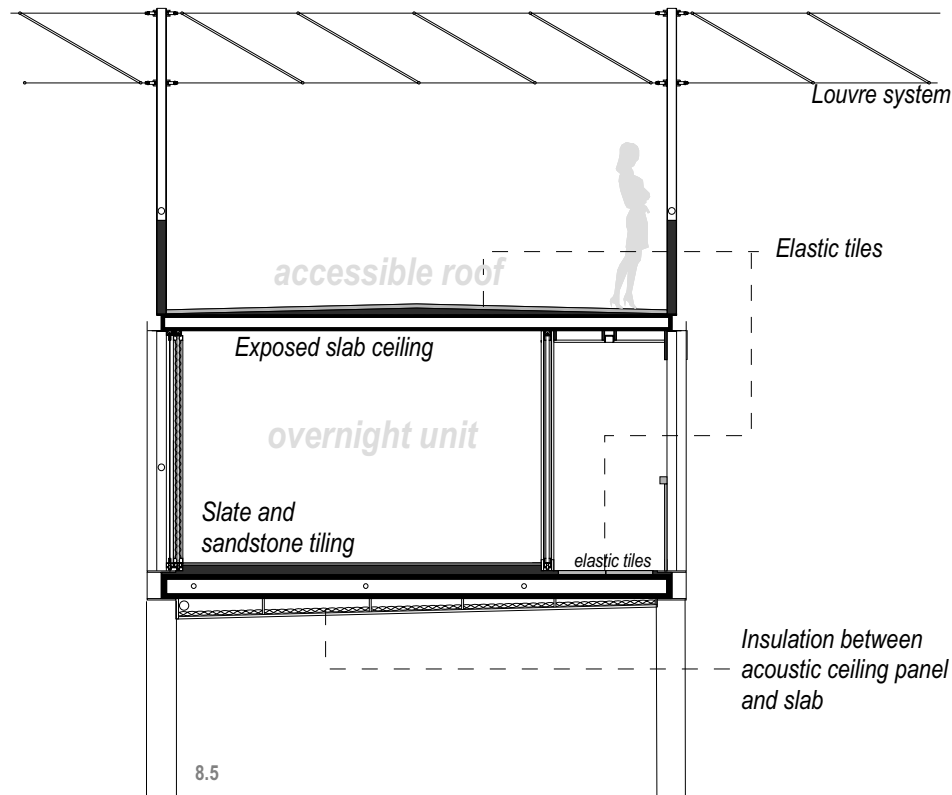

8.5 **NATURAL VENTILATION**

The structure of the building allows for external openings into courtyards which promote air movement and natural ventilation. The brick screens form openings into the courtyards allowing turbulence caused by the passing shuttles to promote air movement changes in the courtyards and on the surface of the building's outer skin. The subsequent air movement helps to keep the building's outer skin cool in the summer while turbulence causes pressure changes with subsequent air movement.

55

The natural air velocity will also be enhanced by the Venturi effect as a result of the air being compressed and expanded due to the presence of the overhead structure. Natural ventilation can also be combined with direct evaporative cooling where air can be drawn over the roof ponds.

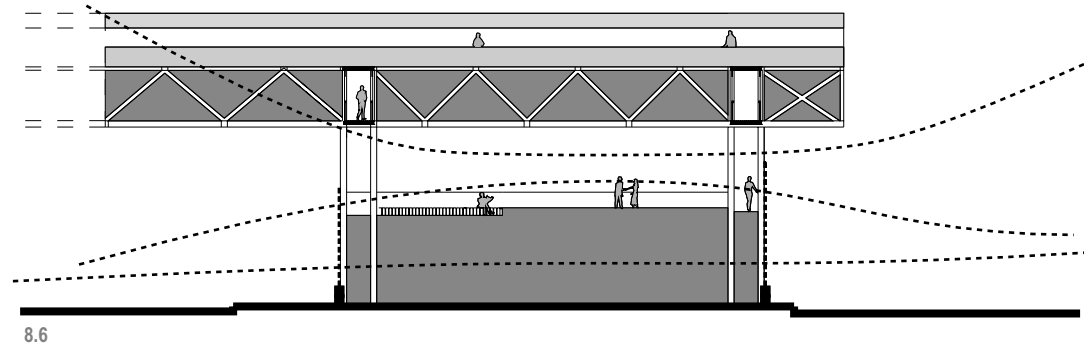

8.6

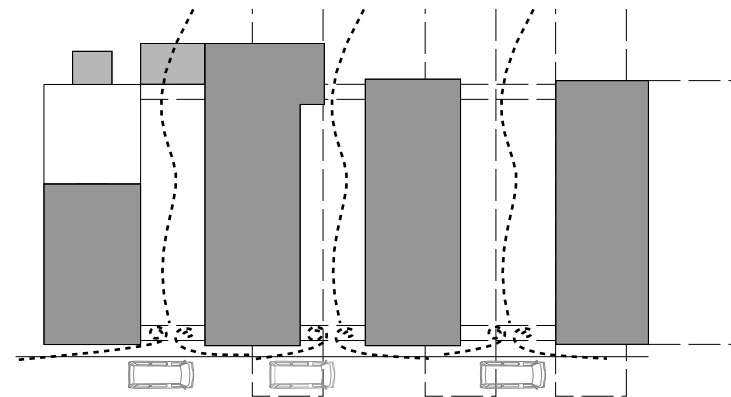

8.7

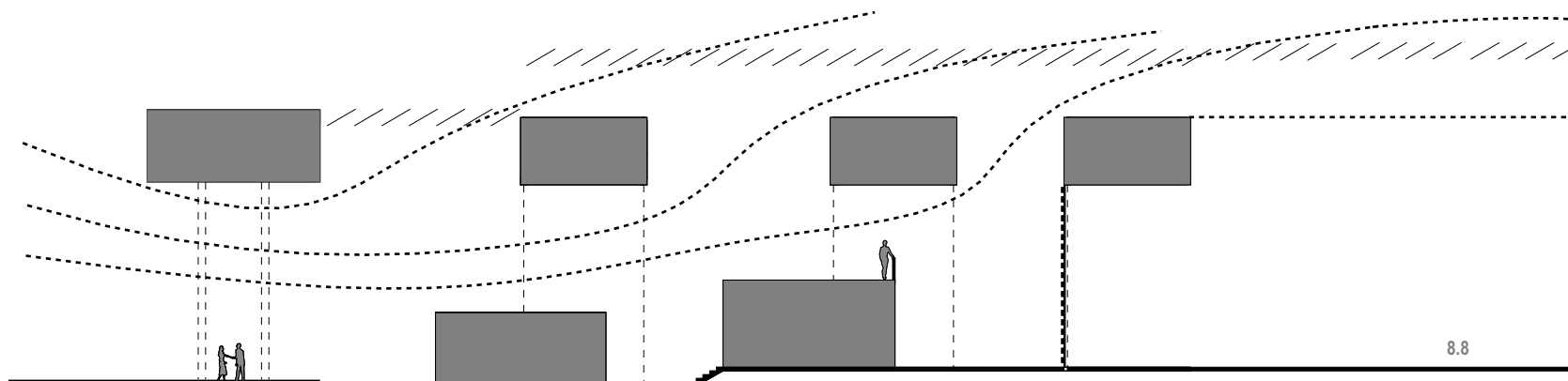

8.8

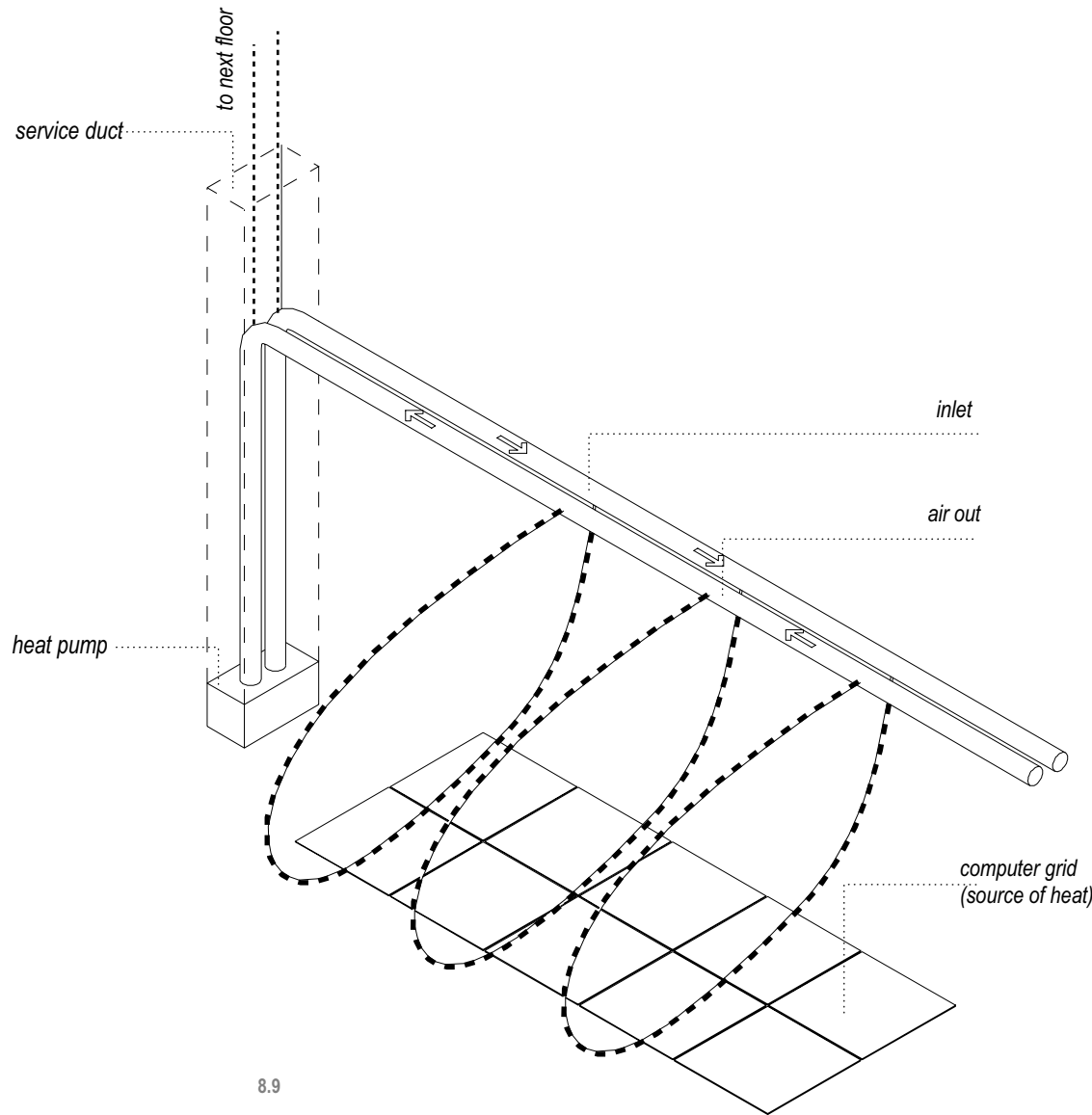

8.6 **MECHANICAL VENTILATION**

The computer rooms will need to be mechanically ventilated due to restrictive specifications for dust and noise levels (call centre), limiting the possibility for use of natural ventilation. The effect of the external filter system will however minimize the load on the system.

A closed-system cooling heat pump is specified. The heat generated by the computer and occupants will function as a heat cycle, requiring the need for ventilation only during winter.

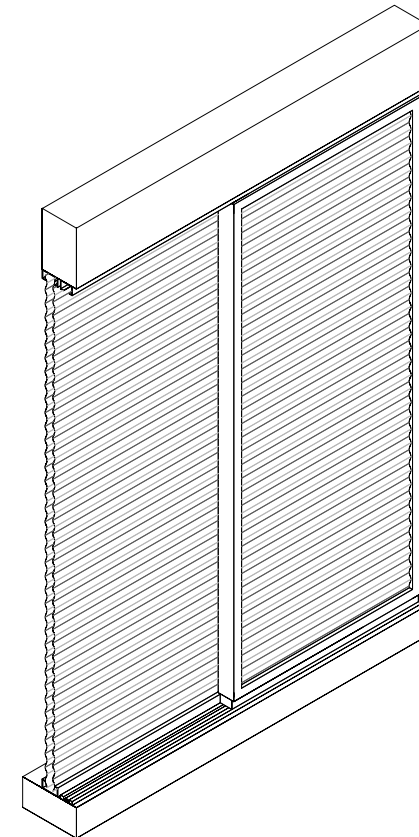

- 8.6 East-west wind propagation due to Venturi effect.
- 8.7 Turbulence due to passing shuttles.
- 8.8 North-south wind propagation due to Venturi effect.
- 8.9 Mechanical ventilation system.
- Following page**
- 8.10a Polycarbonate sheeting sliding windows.

8.10a

8.7 SKIN SYSTEM

Lighting. Light can provide visual comfort or cause discomfort. Glare and high contrasts in lighting levels promote discomfort and cause a blinding effect, especially undesirable when dealing with computer workstations. This can be alleviated by more even distribution of light (diffused light). For a building to limit its dependence on natural resources, natural daylight levels need to be utilized as much as possible. The use of shade net louvres and translucent polycarbonate sheeting curtain walls (rather than glass), diffuses the light partially. Soft diffused light is attained without the normal heat loss or gain, and glare due to direct sunlight.

The accommodation unit's daylight level will be designed for 100 lux, while the offices will be expected to operate under 200 lux lighting.

To limit heat gain as well as glare during the mornings and afternoons, the building's east and west facades does not accommodate any openings into rooms

Walls and Screens. Due to the large spans (18m and 30m), the walls of the accommodation units need to be lightweight to minimize the load on the steel structure. Two skins of translucent sheeting will be used on the northern façade, to reduce solar radiation, while gaining as much sunlight as possible. The outer skin, in the form of a sliding solar screen, consists of Lexan Thermoclear™ , a multi-wall, ribbed polycarbonate sheet. A 6mm clear screen will be specified, with 82% light transmission to acquire adequate thermal performance without loss in lighting levels.

The sliding windows, forming the second skin, will consist of two layers Modek™ Polycarbonate S -Rib Sheeting, with a 25mm cavity, allowing even better thermal performance at a more affordable price than double-glazing.

A 1mm nominal thickness is specified, with an extruded layer of UV protection on the weathering side of the panels. The clear panels have 90% light transmission with 13% reflectance. Solar energy transmission through one sheet will be 88%. The presence of a cavity between the two skins will however improve this specification considerably. The effect of a cavity halves the U -value of a material. The shading coefficient of these panels is 1.00, the same as glass, without the transmission of harmful UV rays.

The three skins, with effectively two cavities, ensure the presence of 5 surface coefficients, minimizing the impact of heat convection between the interior and exterior of the building.

The same system will be specified

for the office units to maximize sunlight. This system is much more affordable than a glass curtain wall, yet will be more efficient in its prevention of loss or gain of heat.

User Participation. As part of the building management, user participation will be needed for ventilation openings to be opened or closed as necessary. In case of a power failure, or emergency, all curtain walls are provided with sliding windows to ensure adequate ventilation. During normal operation these openings should rather be kept closed for the mechanical system to operate optimally.

The building users should close the shading screens over windows at night to prevent heat loss, especially in winter. The external screens should be closed during the day in summer to prevent solar gain should the rooms be unoccupied.

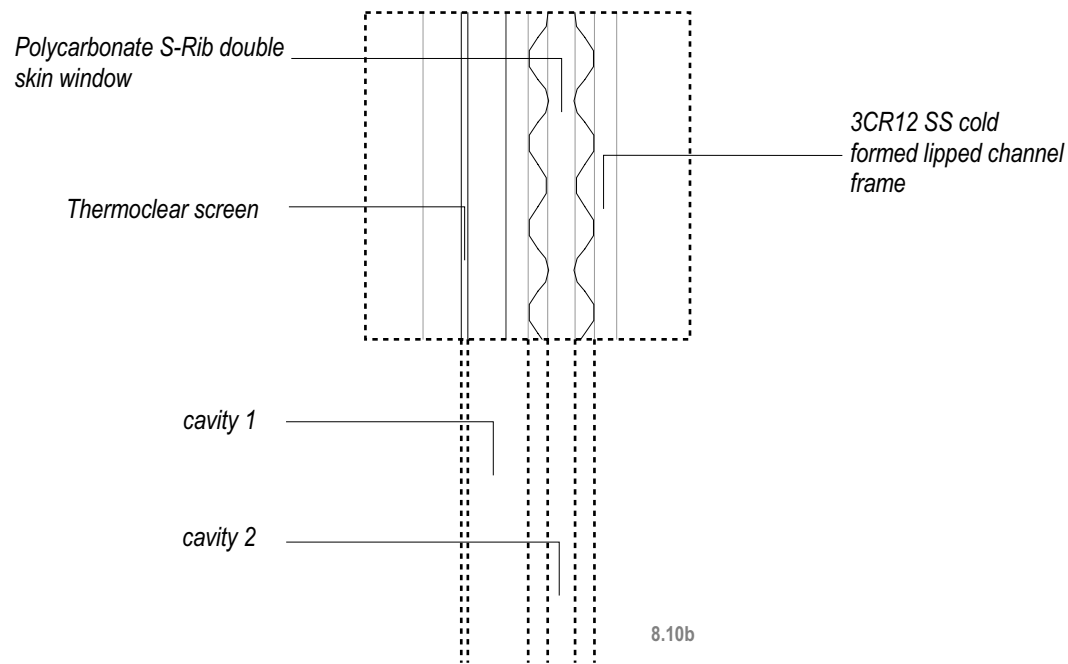

8.10b

8.8 **LOUVRE SYSTEM**

To minimize solar radiation during summer, but still allowing direct sunlight during winter, a shading net louvre system will be specified to form a translucent roof for the centre. The louvers have been arranged at such intervals and angles to allow maximum protection against direct sunlight during summer, with maximum exposure during winter. The structure consists of 30mm dia chromed aluminium tubing shade net frames, suspended from 6mm dia stainless steel tension cables, and strung between 0600 screwed STA-LOK eye ends, connected to 100x55x8 I-profile columns. Shading nets with 60% light transmission are tensioned into the rectangular shade net frames and threaded at the ends.

The louvre system operates in conjunction with the overnight accommodation units to form a solar filter.

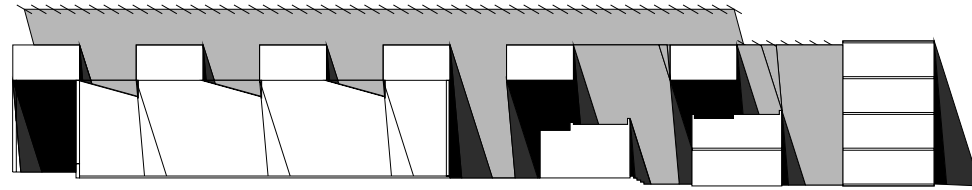

summer sun angles

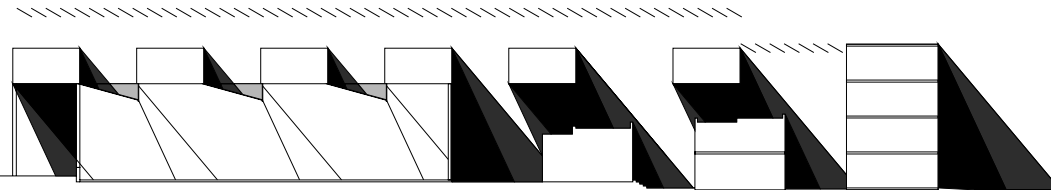

winter sun angles

58

8.11

100x55x8 I-profile column
welded to 178 x 102 I-profile
top beam
30 dia tubing rectangular
shade net frames

shading net

6 dia stainless steel
tension cables

6 dia stainless steel
tension cables as
bracing for columns

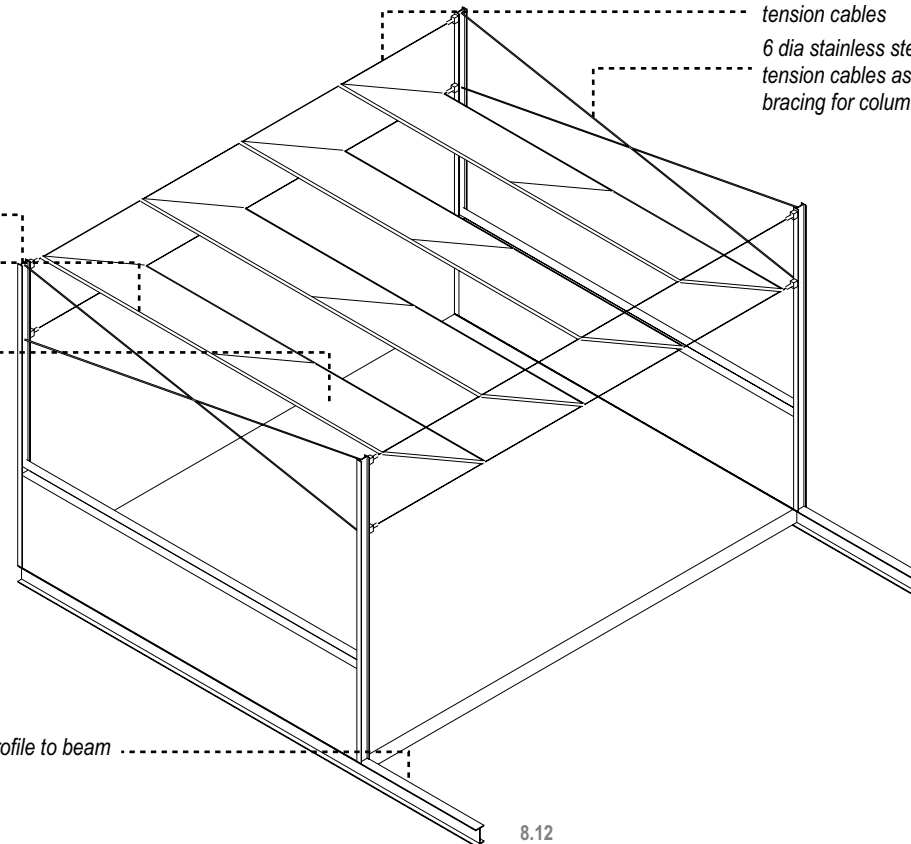

178 x 102 I-profile to beam

8.12

8.10b Skin system consisting of translucent screens and cavities.

8.11 Summer and winter sun and shadow lines indicating influence of louvre system.

8.12 Louvre system structure.

8.9 **BRICK SCREEN SYSTEM**

As part of the filter system used to attain an artificial exterior microclimate for the development, brick beams are used as screens. Normal screens such as timber and aluminium does not have any thermal mass. Bricks do have significant thermal mass. This system will therefore also contribute to thermal inertia while filtering the elements.

The brick screens consist of brick lintels formed by compressing a row of bricks on edge, using 20mm dia steel stiffening rods tension bolted to 120x220x10 mild steel ends, welded to the columns.

59



Blouberg
Travertine
Face Brick Aesthetic



Huguenot Blue
Satin
Face Brick Aesthetic



Silvergrey
Satin
Face Brick Extra

8.13

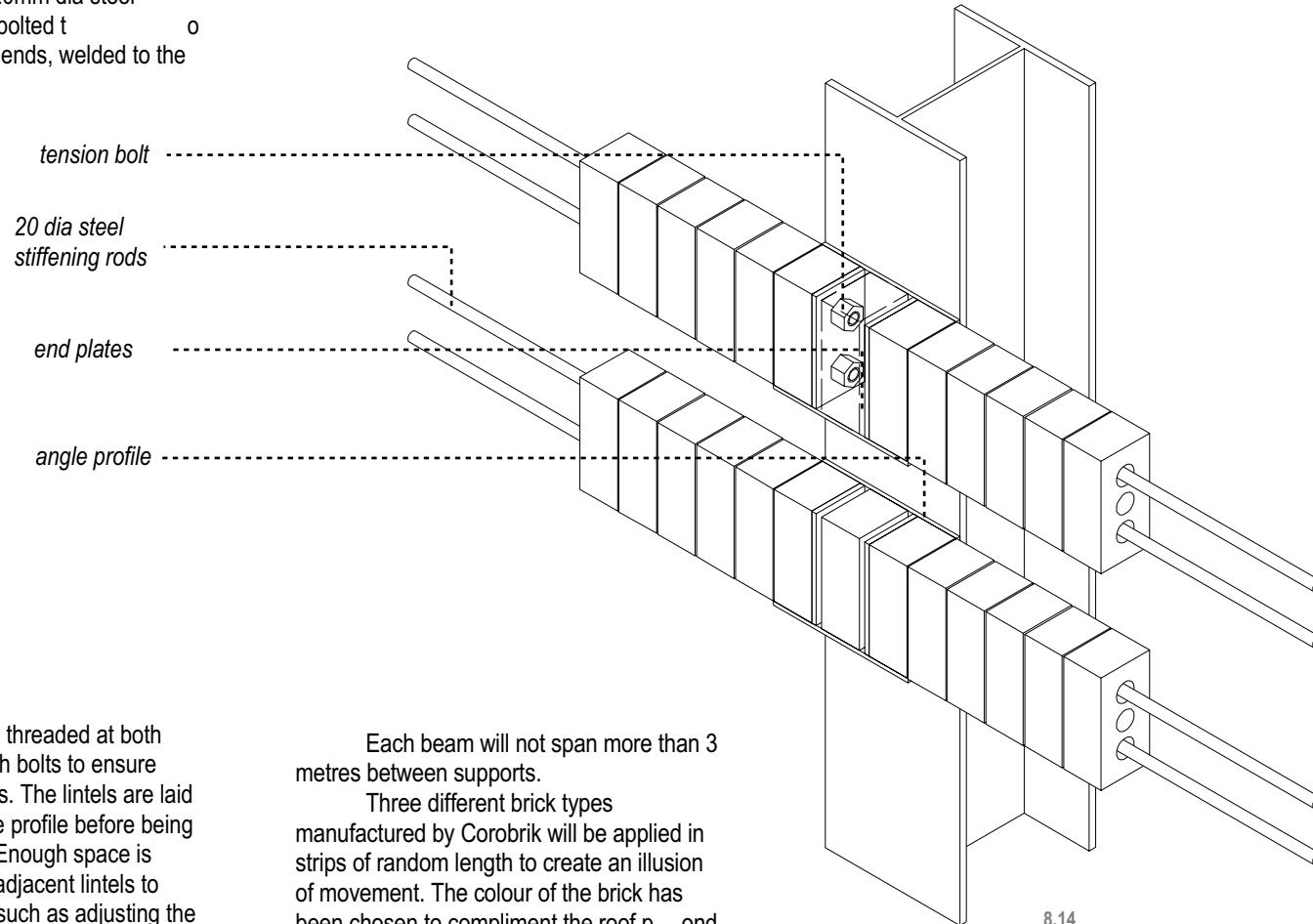

8.14

The rods will be threaded at both ends and tensioned with bolts to ensure sufficient beam stiffness. The lintels are laid on a welded steel angle profile before being clipped to the column. Enough space is provided between two adjacent lintels to allow for maintenance such as adjusting the tension in the rods, as well as for the space to be covered with a half brick on edge for a smooth finish.

Each beam will not span more than 3 metres between supports.

Three different brick types manufactured by Corobrik will be applied in strips of random length to create an illusion of movement. The colour of the brick has been chosen to compliment the roof pond system in creating a cool, tranquil atmosphere.

8.10 **BUILDING SERVICES**

The building services for the overnight accommodation units will be channeled between the flanges of the H-profile columns supporting these units. Fibre cement hinged covers will hide the unsightly service piping, adding to fire protection. Horizontal channels for services will be chased into screed covering the hollow core concrete slabs. The 110 dia soil water pipes will horizontally be guided @ 1:40 slope beneath the slab to terminate in a down pipe guided along one of the columns.

Energy (80 -95% energy efficiency) and space efficient LP-gas geyszers will be installed in all the ablution facilities.

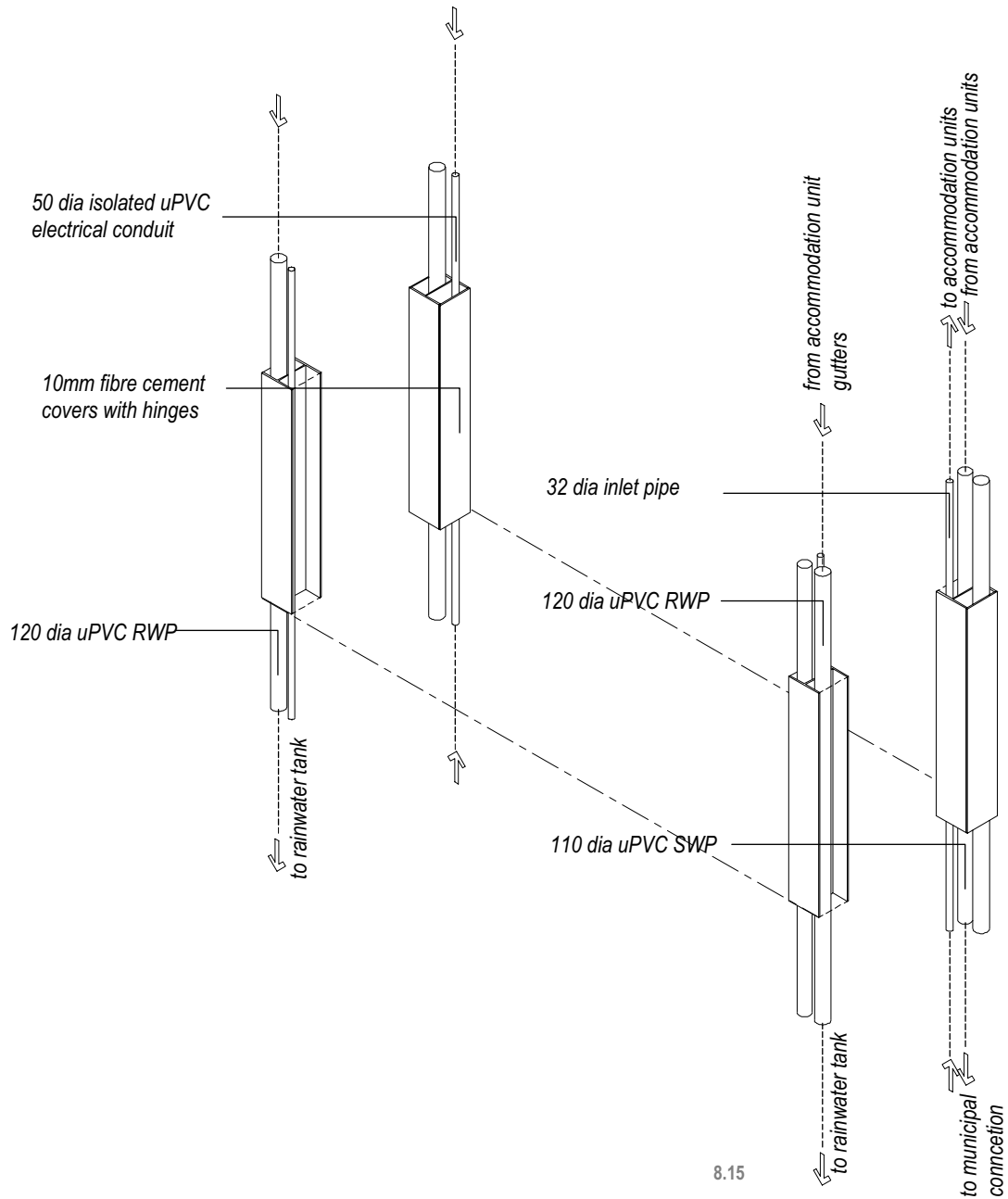

- 8.13 Brick types used in brick screen system.
- 8.14 Component detail of brick screen system.
- 8.15 Overnight accommodation unit building service channels in steel columns.

8.15

8.11 **ACOUSTIC TREATMENT**

The main acoustic problem expected in the development will be noise emanating from the shuttle road on the east of the site and noise from below as a result of the bus terminal and loading/offloading bay.

The shuttle road's main source of noise will be the sound of the 18 or 30 seater Mercedes-Benz sprinter buses' tires on the surface due to an expected speed of +/- 40 km/h. To keep the source of noise down, a very smooth surface need to be aimed for, such as a bitumen road. The smoothness of the road surface for the bus terminal will not influence noise factors since low speeds will be maintained. The main source of noise in this area will be engine noise of the vehicles themselves. This area needs to be "friendly" in terms of appearance. A light coloured cobblestone paving surface will be implemented to achieve a durable, yet attractive surface.

Some external noise in usable spaces can however not be decreased to acceptable levels. The design solution was to override this noise with water sounds caused by the roof ponds. Falling water or the sound of splashing water can infuse a sense of calm, which contributes to productivity in a working environment. Each level difference between the six different ponds act as a weir, with the associated sounds expected from such a feature.

In external applications such as the underside of the overnight units forming a ceiling for the activities below, Sonit™ D30 sound-absorbing tiles will be used to achieve a low maintenance natural stone finish combined with sound absorbing qualities. This acoustic layer is applied at an angle to prevent the reverberation of noise caused by passing vehicles below, as well as forming a cover for the 110 dia SWP. The tiles, manufactured from sorted silica sand and bonded with special adhesives, were chosen since

it can be used externally, and has a sound absorption coefficient of 13dB.

The D30 tile's dimensions are 300x300x30mm. A light grey finish is specified to aid lighting levels. The sound absorbing lining is designed for installation on a supplied steel support structure with a rust resistant finish. The clearance between the lining and the underside of the slab will be used for extra thermal insulation in the form of Sol-Thermo™ insulation, a composite element consisting of two layers of foil enveloping a layer of insulation.

Further sound attenuation will be achieved through the use of the Regupol™ Elastic Interlocking paving tiles. The tiles were chosen for its porous surface which also absorbs sound. Its shock-absorbing properties minimize the impact of footsteps on the building structure.

The double layer polycarbonate sheeting windows used on the northern side of the accommodation units further improves sound attenuation. The timber cladding on the southern side will similarly improve sound. Both these outer insulation skins have cavities, contributing to acoustic performance.

The brick screen system used on the exterior of the building also contribute to sound attenuation by diffusing sound as a result of irregular exposed surface areas.

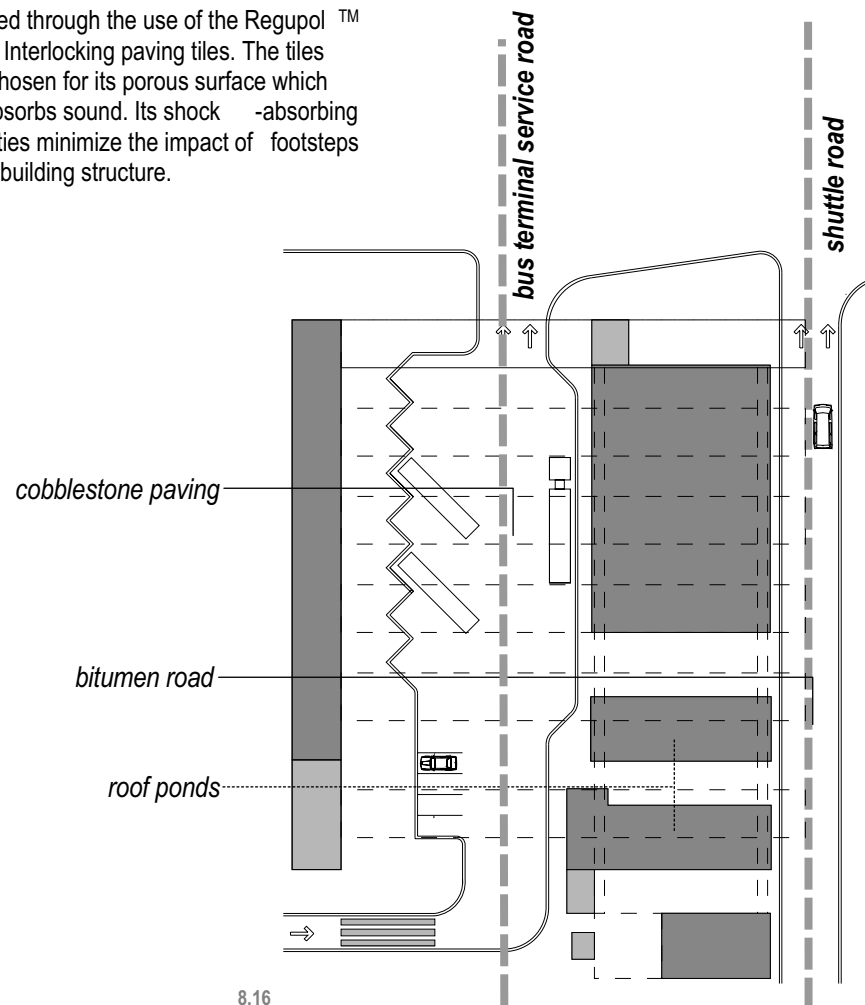

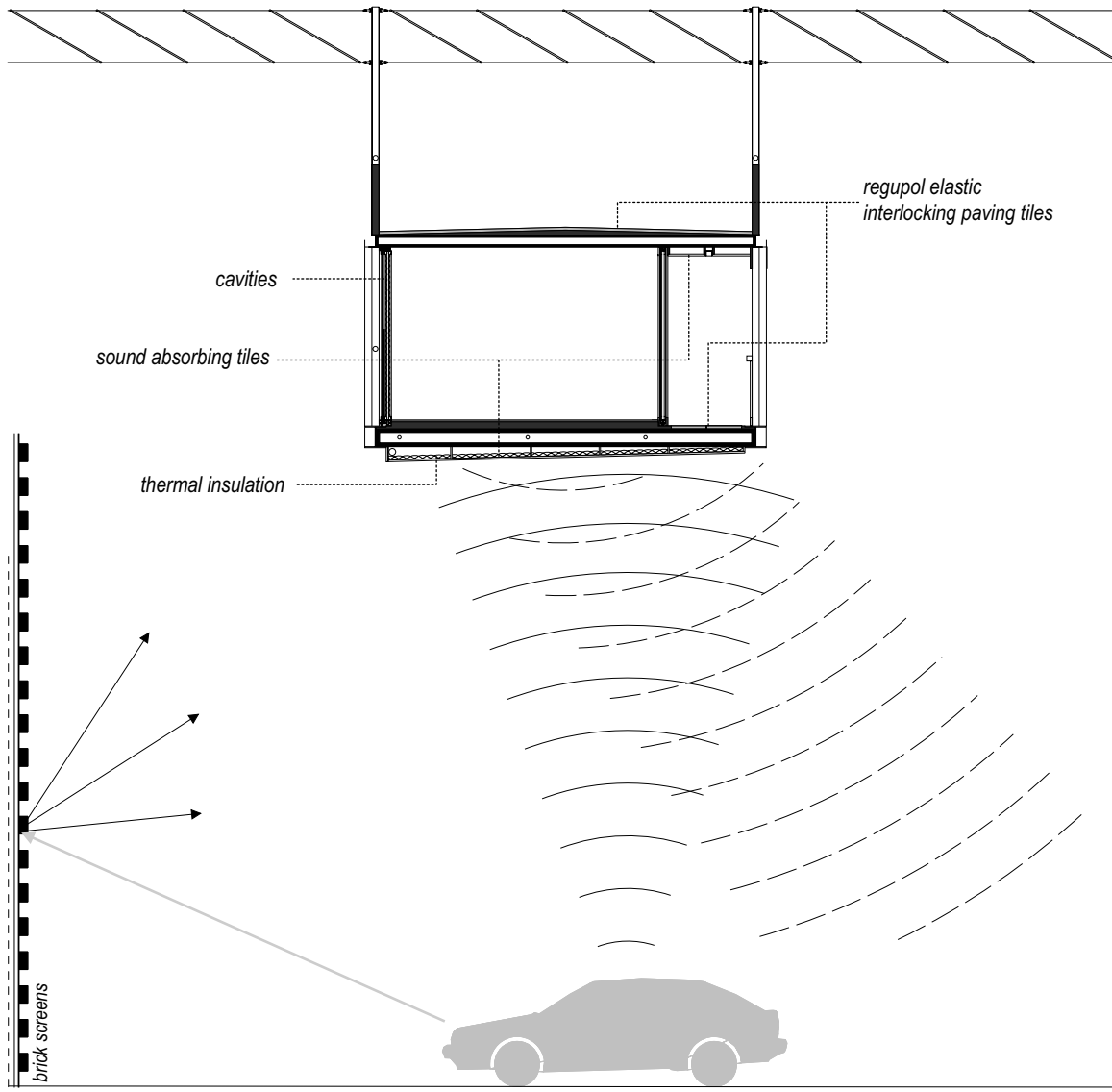

8.17

8.16 Sources of noise and large-scale acoustic treatment.
8.17 Acoustic treatment diagram.

8.12 ROOF POND SYSTEM

Water stimulates the senses of sight, touch, and hearing and is, in fact, synonymous with the basic existence of life. This effect of water was also one of the key considerations in the design of the roofscape for office units two and three. These roofs were made accessible to follow a pedestrian ramp linking the first and second storeys, providing a usable exterior space for the centre's occupants. The level changes as a result of the pedestrian ramp are followed by the 6 roof ponds, which itself are accessible by means of timber decked seating and walkways.

Other added benefits of the use of roof ponds are that it can be used as temporary stormwater catchments to retain stormwater. The relevant two accommodation unit strips covering the roof ponds will drain into the roof ponds.

Structure. The roof pond structure is based on 255mm reinforced concrete slabs waterproofed with a layer Sikaplan PVC 14.6 Tunnel 2mm topped by a 30mm layer medium grade black pebble stone. Each water pond is 170mm deep and the water is transferred from one roof to the other by means of 110mm uPVC overflow pipes cast into the slab edges with inlets, equipped with filters. Some of the pond edges are finished with external grade timber decked seating and walkway strips for accessibility. The overflow between the two pond levels are hidden by these strips

Pump System. The lowest roof pond (1) is overflows through a 150 dia uPVC overflow pipe which is connected to a 150 dia uPVC vertical pipe. The latter contains a borehole pump which continuously provides the highest roof pond (6) of water via a 50 dia inlet pipe.

A dual media filter system will be incorporated into the design for the removal of suspended solids. The flow design speed will be adequate to ensure that the body of water will be recycled every hour for the system to work efficiently. Chlorine gas treatment will be used to kill fresh water algae as well as sterilize the ponds. This necessitates a larger capital outlay to ensure lower maintenance costs.

To prevent possible overflows from blockage/stormwater and for maintenance reasons, each pond will be equipped with a drainage pipe, and a water level switch to stop the pump.

The speed of the circulation process can be regulated to allow faster circulation in summer and slower circulation in winter, allowing water to heat.

Evaporative Cooling. Indirect evaporative cooling is achieved by lowering the temperature of the structure elements of the building through water evaporation from the roof ponds. Warm dry air has the ability to absorb moisture. To absorb moisture, however, water must evaporate, with a resultant cooling effect. By increasing the humidity ratio of the air-water vapor mixture, a psychometric chart can be used to estimate the change in temperature possible. Due to the low relative humidity in Pretoria, fresh air can be cooled through evaporation quite successfully. For a large enough water surface to be exposed to air, fluctuating flow would be encouraged, in conjunction with the evapotranspirative effects of plants as found in the courtyards.

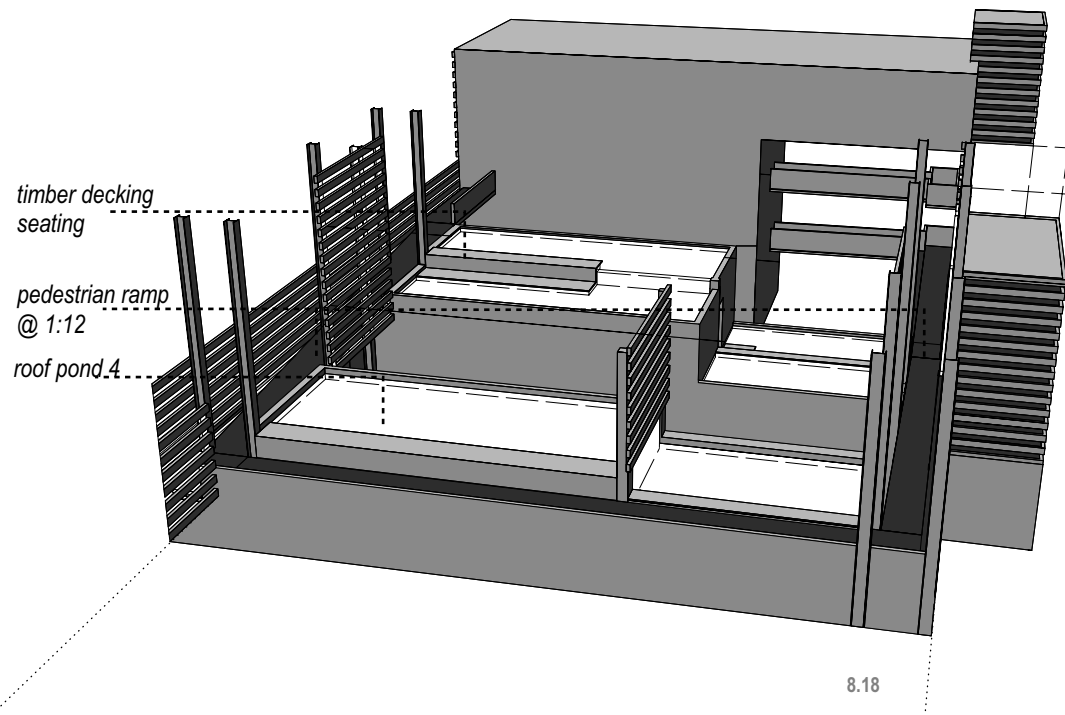

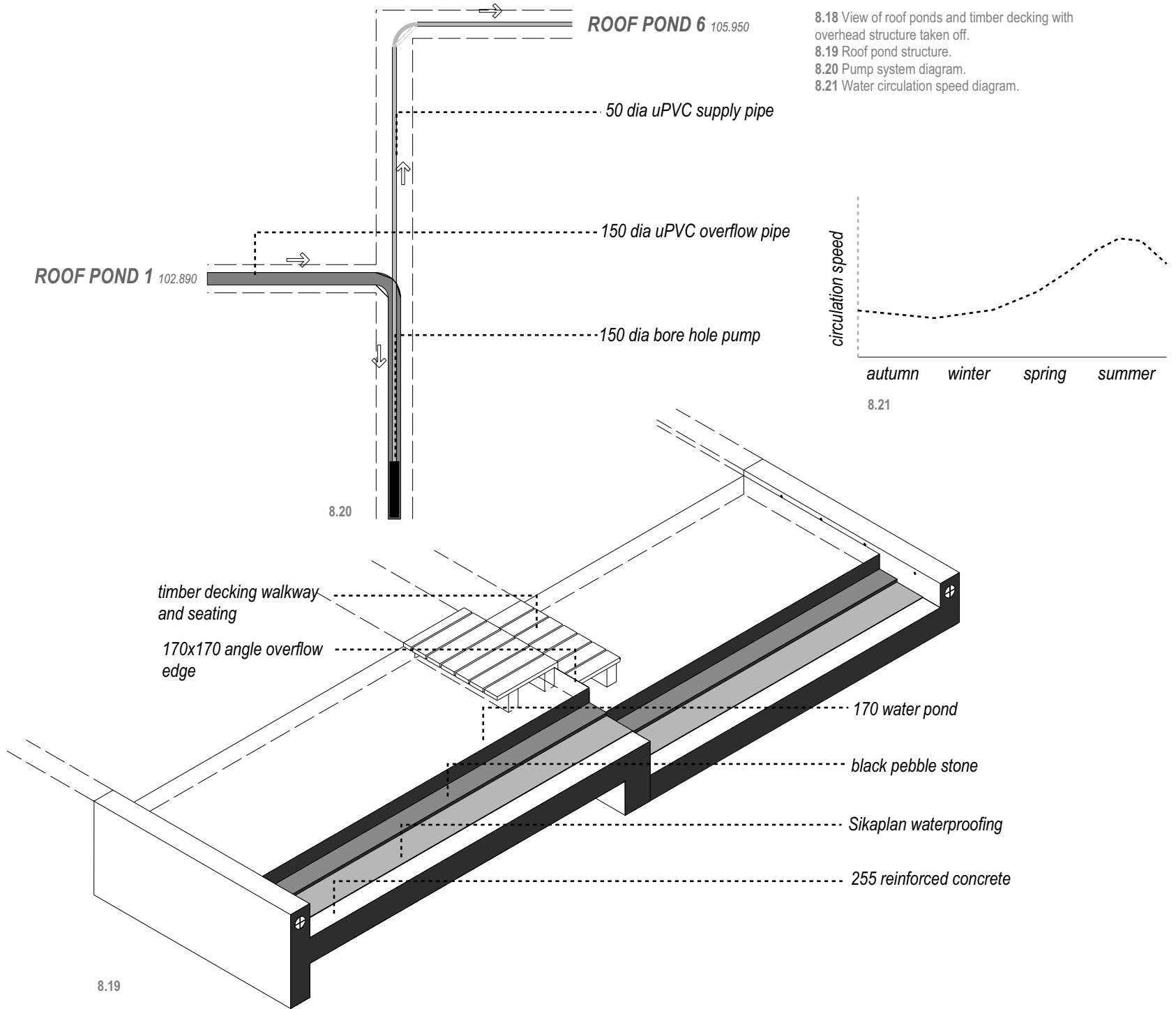

8.18 View of roof ponds and timber decking with overhead structure taken off.
 8.19 Roof pond structure.
 8.20 Pump system diagram.
 8.21 Water circulation speed diagram.

8.13 **DRAINAGE**

The 160m² In-situ cast concrete roof of the main computer rooms (office block 1) will be drained by down pipes cast into the columns. Waterproofing will be provided in the form of 4mm abe torchon™. A 30 mm loose gravel layer will protect the waterproofing and improve thermal properties. The rainwater drained from this roof will not be harvested and stored, but will be drained to the storm water system via an underground storm water pipe. The requirement for the inside cross diameter of drainage pipes for a concrete roof is 100mm² per m² of roof area. A 100mm dia. down pipe would therefore service a 85m² roof area. For safety against blockage the roof will therefore be drained by four 100mm dia. down pipes provided with 100mm dia. fullbore outlets.

A 100m² drainage capacity per m² roof area is required and one 100mm dia down pipe would suffice for half the roof area. Four 100mm dia donwpipes have however been specified to allow for blockages.

The construction covering the warehouse will be used to harvest rainwater. The water will be stored in the provided fiber cement rainwater tanks. The water is to be used for general cleaning purposes, and as a source of water for the roof pond system.

The total surface area covering the warehouse is 1008m². The average rainfall per month for Pretoria is:

- Jan : 101.3 mm
- Feb. 108.8 mm
- Mar. 63.8 mm
- Apr. 37.5 mm
- May. 48.8 mm
- Jun 3.8 mm
- Jul. 2.3 mm
- Aug. 2.3 mm
- Sept. 11.3 mm
- Oct. 82.5 mm
- Nov. 168.8 mm
- Dec. 112.5 mm

The water retained with the surface area for each month will therefore be:

- Jan.: 102.1 kL
- Feb.: 109.6 kL
- Mar.: 64.3 kL
- Apr.: 37.8 kL
- May.: 49.2 kL
- Jun.: 3.8 kL
- Jul.: 2.3 kL
- Aug.: 2.3 kL
- Sept.: 11.4 kL
- Oct.: 83.2 kL
- Nov.: 170.1 kL
- Dec.: 113.4kL

To harvest the water the accommodation units will be equipped with 100x150 gutters leading to 120 dia rain water pipes into six 3.5 kL fibre -reinforced barrel type water tanks.

65

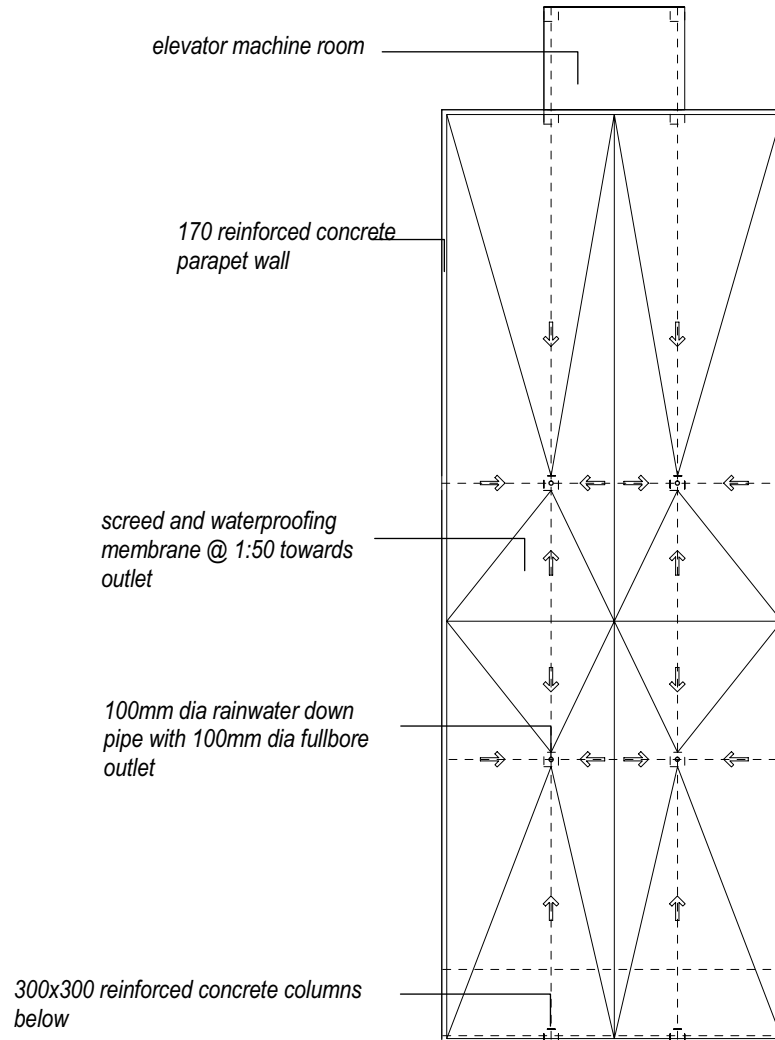

8.14 **MATERIALS**

Steel Sections. All steel sections for window and screen frames will be cold -formed 3CR12 stainless steel profiles. 3CR12 is relatively affordable, considering other stainless steels, with the benefit that it needs no protective coating or other maintenance. This stainless steel has a low chrome content, allowing the steel to oxidize to a point, giving a matt grey finish. Added benefits are that no fixing specification imposes limitations on fixing methods, as is the case with other alternative steels such as galvanized steel, which cannot be welded after galvanization.

Timber cladding. Timber cladding will be specified for the southern facades of the accommodation units, as well as an alternative for ballustrading. The cladding specified is 22mm 5 ply pine shutterboard treated with 2 layers of sanding sealer and topped with 2 layers polyurethane varnish.

To prevent absorption of water by the timber cladding the lower 120mm of all timber cladding will be substituted by 20x120x2mm rectangular hollow profile 3CR12 stainless steel skirting.

Timber decking. Timber decking is specified for all external walkways on the first and second floor, including those covering the office roofscape. Figured grade Eucalyptus Grandis timber decking treated with copper-chromium-arsenate (CCA) will be used. As is the case with most of the timber decking specified in the indicated positions, the surface beneath the decking need to be covered with a 2mm black polyethylene sheet, weighted down with a layer of gravel.

All decking will be 38x100 strips fixed with 6 mm openings to 50x100 joists @ 600 centers.

Paving. The courtyard spaces handling the most traffic will be paved with Corobrik Coropave Cedarberg 220x108x50mm paving stones. The remaining spaces will be covered with BG blocks with grass infill.



8.24

22mm 5-ply pine shutterboard both sides of 40x40 hollow section steel stud

100x50 timber top rail recessed to fit into 100x55x10 I-section top beam

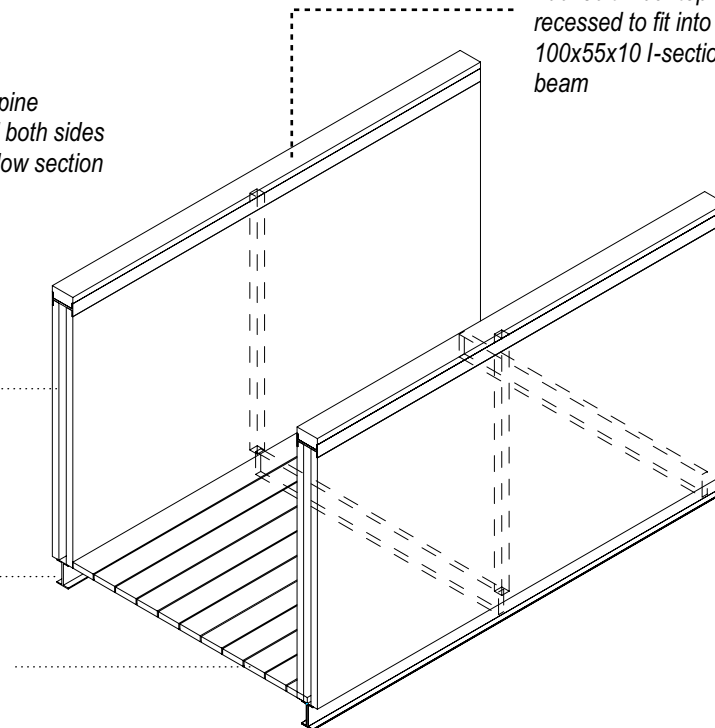

100x55x10 I-section bottom beam

38x100 Eucalyptus Grandis timber decking connected to 50x100 timber joists

8.23

8.22 Roof drainage plan of office block 1.

8.23 Isometric detail of walkways and ballustrades.

8.24 Rendered perspective of timber clad walkways.