



UNIVERSITEIT VAN PRETORIA
UNIVERSITY OF PRETORIA
YUNIBESITHI YA PRETORIA

THE DEVELOPMENT OF A THERMOPLASTIC ROAD MARKING MATERIAL STANDARD

SOMA NAIDOO

THE DEVELOPMENT OF A THERMOPLASTIC ROAD MARKING MATERIAL STANDARD

SOMA NAIDOO

A thesis submitted in partial fulfilment of the requirements for the degree of
MASTER OF SCIENCE (TRANSPORTATION)

In the
FACULTY OF ENGINEERING
UNIVERSITY OF PRETORIA

August 2016

THESIS SUMMARY

THE DEVELOPMENT OF A THERMOPLASTIC ROAD MARKING MATERIAL STANDARD

SOMA NAIDOO

Supervisor: Professor Doctor Wynand J vdM Steyn

Department: Civil Engineering

University: University of Pretoria

Degree: Master of Science (Transportation)

Public roads without road markings, especially roads carrying high traffic volumes, would lead to chaos and accidents resulting in injuries and loss of life. The road authorities need to ensure that all signage, both horizontal (road markings) and vertical (traffic signs), is well maintained and conforms to the Southern African Development Community Road Traffic Signs Manuals (SADC RTSM) (1999) and the South African Road Traffic Signs Manuals (SARTSM) (1999).

The most important aspect of road markings is that it must be retroreflective (brightness at night under headlights). The minimum retroreflectivity (R_L) for white and yellow road markings is 100 millicandelas/m²/lux (mcd/m²/lx) and 70 mcd/m²/lx respectively (SADC RTSM, 1999). There are other important parameters to which road markings should conform, such as the daytime visibility, colour, and skid resistance. There are various types of road marking paints and road marking materials, namely solvent-borne, water-borne, cold plastic, thermoplastic and preformed tape applied universally. In SA, solvent-borne paints, water-borne paints and thermoplastic materials are widely used, with cold plastic materials being increasingly used of late. There are SABS standards on solvent-borne and water-borne road marking paints covering a wide range of aspects. However, there are insufficient standards on plastic road marking materials and some road marking applicators could therefore be applying inferior quality plastic road marking materials.

The only specification related to thermoplastic road marking materials published by the SABS is the SABS EN 1424:1997 (1997) (Road marking materials - premix glass beads). This specification was adopted by the SABS exactly as per the European Standard EN 1424:1997 (1997) and it specifies the requirements for laboratory tests on aspects of premix glass beads such as the granulometry, refractive index, chemical resistance, quality and surface treatment. Since the European specifications are widely adopted by many countries, the BS EN 1436:2007 (2007) specification was used in conjunction with the available SA standards in this study to develop the thermoplastic road

marking standard. It is more advantageous for the road authority to stipulate the specifications with which the road marking product must comply than to give the detailed specification of each constituent. It would be time consuming and costly to test each constituent, besides which the equipment to test the constituents is not readily available in SA. The onus should be on the manufacturer to ensure that the formulation of the road marking material is such that the product meets the required specifications. In 2011, the SABS established a technical committee (TC1093) to develop a standard on thermoplastic road markings in SA but not much progress has been made by the SABS, hence the need for this study.

The objectives of this study are:

- To determine the retroreflectivity (night-time visibility) service lives of various road marking paints and road marking materials on asphalt and chip seal road surfaces;
- To determine the luminance (daytime visibility) service lives of various road marking paints and road marking materials on asphalt and chip seal road surfaces;
- To determine if there are significant differences in retroreflectivity, luminance and the colour of the road markings when washed with liquid soap mixed with water and hard brooms;
- To check if the colour of the road markings applied complies with the specification, and
- To check if the skid resistance of the road markings complies with the specification.

Four sets of measurements on R_L , Q_d and colour were conducted over at least one year. The skid resistance measurements were conducted only on test panels due to the unavailability of the skid resistance tester to conduct site measurements. Descriptive statistics were used to indicate the mean, standard deviation and coefficient of variation. Non-parametric methods were used to compare group means of the various types of road marking paints and materials due to the small sample size.

The service life of road markings is affected by the volume and type of vehicles passing over them, the type of road surface, sand and dirt, climatic conditions and application of the road markings. On clean roads, both asphalt and chip seal surfaces, thermoplastic road marking materials have longer R_L and Q_d service lives than water-borne road marking paints. White road marking paints and materials generally complied with the colour specification. However, yellow road markings complied minimally with the colour specification on both clean and dirty roads. Although thermoplastic road marking materials had longer R_L service lives on clean roads, it might not be economical to use them on dirty roads since the R_L service lives were similar for water-borne road marking paints and cold plastic road marking materials. The initial skid resistance of white and yellow 1.2 mm thermoplastic complied with the specification.

ABSTRACT

Title: The development of a thermoplastic road marking material standard

Author: Soma Naidoo

Supervisor: Professor Doctor Wynand J vdM Steyn

Department: Civil Engineering

University: University of Pretoria

Degree: Master of Science (Transportation)

Public roads without road markings, especially roads carrying high traffic volumes, would lead to chaos and accidents resulting in injuries and loss of life. The road authorities need to ensure that all signage is well maintained and conforms to the Southern African Development Community Road Traffic Signs Manuals (SADC RTSM) (1999) and the South African Road Traffic Signs Manuals (SARTSM) (1999).

The most important aspect of road markings is that they must be retroreflective. The minimum R_L for white and yellow road markings is $100 \text{ mcd/m}^2/\text{lx}$ and $70 \text{ mcd/m}^2/\text{lx}$ respectively (SADC RTSM, 1999). There are other important parameters to which road markings should conform, such as the Q_d , colour and skid resistance. There are various types of road marking paints and road marking materials, namely solvent-borne, water-borne, cold plastic, thermoplastic and preformed tape applied universally. In SA, solvent-borne paints, water-borne paints and thermoplastic materials are widely used, with cold plastic materials being increasingly used of late. There are SABS standards on solvent-borne and water-borne road marking paints covering a wide range of aspects. However, there are insufficient standards on plastic road marking materials and therefore some road marking applicators could be applying inferior quality plastic road marking materials.

The only specification related to thermoplastic road marking materials published by the SABS is the SABS EN 1424:1997 (1997) (Road marking materials - premix glass beads). This specification was adopted by the SABS exactly as per the European Standard EN 1424:1997 (1997) and it specifies the requirements for laboratory tests on aspects of premix glass beads such as the granulometry, refractive index, chemical resistance, quality and surface treatment. Since the European specifications are widely adopted by many countries, the BS EN 1436:2007 (2007) specification was used in conjunction with the available SA standards in this study to develop the thermoplastic road marking standard. It is more advantageous for the road authority to stipulate the specifications with which road marking products must comply than to give the detailed specification of each constituent.

It would be time consuming and costly to test each constituent, besides which the equipment to test the constituents is not readily available in SA. The onus should be on the manufacturer to ensure that the formulation of the road marking material is such that the product meets the required specifications.

The service life of road markings is affected by volume and type of vehicles passing over them, the type of road surface, sand and dirt, climatic conditions and application of the road markings. On clean roads, both asphalt and chip seal surfaces, thermoplastic road marking materials have longer R_L and Q_d service lives than water-borne road marking paints. The white road marking paints and materials generally complied with the colour specification. However, the yellow road markings complied minimally with the colour specification on both clean and dirty roads. Although thermoplastic road marking materials have a longer R_L service life on clean roads, it might not be economical to use them on dirty roads since the R_L service life was similar for water-borne road marking paints and cold plastic road marking materials. The initial skid resistance of white and yellow 1.2 mm thermoplastic complied with the specification.

ACKNOWLEDGEMENTS

I wish to express my appreciation to the following organisations and persons who made this thesis possible:

- a) Firstly, I wish to express my sincere thanks to the City of Tshwane Municipality, including Frikkie Rouwerd, Lorato Kegakilwe-Piki and Mary de Wijn, for supporting the project financially;
- b) Professor Wynand Steyn, my supervisor, for his guidance and support throughout this study;
- c) South African National Roads Agency Limited for providing historic retroreflectivity data and traffic counts. Special appreciation to Lawrence Chauke and Abdul Hay for arranging the information from the consultants contracted to SANRAL;
- d) Special appreciation to Joos Joubert for providing the testing equipment and also for his continuous support throughout the study;
- e) Almon Mashaba, Deon Honiball, Dewan Botha, Edwin Funyufunyu, Eugene Julies, Jaco Cronje, John William and Rolf Redelinghuis, for assistance in the practical part of the study;
- f) Thubeni Ntakakaze, Tebogo Lekalakala and Nanga Mawela for organizing the installation of the traffic counting equipment and providing the traffic counts in a professional manner;
- g) Arvin Sarjoo, Athol Agulhas, Elsabe van Aswegan, Frank Lambert, John Lynch, Mehboob Babamia and Wilson Mamabolo for administrative assistance;
- h) Dina Venter for the statistical analysis of the data and Tony van der Watt for editing the report;
- i) Thaven Gounden and my family, for their continuous support and prayer, and
- j) My wife Vanessa and daughters, Gabriella and Isabel, with whom I could not always spend important family time.

To Jesus Christ, my Lord and Saviour, for giving me the strength especially at my weakest moments to complete this study.

This thesis is dedicated to my mother who continuously supported and motivated me throughout my studies.



TABLE OF CONTENTS

1 INTRODUCTION AND BACKGROUND	1
1.1 INTRODUCTION	1
1.2 BACKGROUND	2
1.3 PROBLEM DEFINITION	5
1.4 OBJECTIVES OF THE STUDY.....	5
1.5 SCOPE OF THE STUDY	6
1.6 CONTRIBUTION TO STATE OF KNOWLEDGE	6
1.7 CHAPTER OVERVIEWS	6
2 LITERATURE STUDY	8
2.1 INTRODUCTION	8
2.2 THE TRAFFIC SYSTEM	8
2.3 REQUIREMENTS OF ROAD MARKINGS.....	8
2.4 HUMAN FACTORS AND THE ROAD ENVIRONMENT	10
2.5 TYPE OF ROAD MARKING PAINTS AND MATERIALS	11
2.6 ROAD MARKING STANDARDS.....	12
2.6.1 American standards	13
2.6.2 European standards	14
2.6.3 South African standards	17
2.7 THERMOPLASTIC ROAD MARKING MATERIAL	18
2.7.1 Glass beads	18
2.7.1.1 Gradation	20
2.7.1.2 Refractive Index	21
2.7.1.3 Roundness and clarity.....	21
2.7.1.4 Coatings	22
2.7.2 Binder	23
2.7.3 Pigment	24
2.7.4 Filler.....	25
2.8 APPLICATION OF THERMOPLASTIC ROAD MARKING MATERIALS	25
2.8.1 Spray thermoplastic.....	25
2.8.2 Extruded thermoplastic.....	26
2.8.3 Screed thermoplastic.....	26
2.8.4 Preformed thermoplastic	26
2.9 CALCULATION OF LUMINANCE	27
2.10 RETROREFLECTION UNDER VEHICLE HEADLAMP ILLUMINATION	28
2.11 DAYLIGHT ILLUMINATION AND ROAD LIGHTING	29
2.12 REFLECTION IN DAYLIGHT OR UNDER ROAD LIGHTING.....	30
2.13 PREVIEW TIME REQUIRED BY DRIVERS	31
2.14 COLOUR.....	33
2.15 SKID RESISTANCE.....	35
2.16 ACCEPTANCE CONTROL OF ROAD MARKINGS	35
2.17 CHARACTERISTICS WHICH AFFECT THE CHOICE OF ROAD MARKING PAINT.....	36
2.17.1 Geometry of road	37
2.17.2 Road surface type	37
2.17.3 Environment	38
2.17.4 Traffic.....	39
2.18 ROAD MARKING MAINTENANCE PROGRAM	40
2.19 PERFORMANCE-BASED ROAD MARKING CONTRACTS UNDERTAKEN BY SANRAL	41
2.20 CONCLUSION	48
3 METHODOLOGY.....	49
3.1 INTRODUCTION	49
3.2 RESEARCH DESIGN	49
3.3 NULL HYPOTHESES	58
3.4 EXAMINATION OF THE TEST ROAD MARKINGS	58
3.4.1 Measuring retroreflectivity	58
3.4.2 Measuring luminance	61



3.4.3 Measuring colour	62
3.4.4 Measuring skid resistance	63
3.5 STATISTICAL ANALYSIS OF THE DATA	63
3.6 LIMITATIONS	64
3.7 CONCLUSION	64
4 DATA ANALYSIS AND FINDINGS	65
4.1 INTRODUCTION	65
4.2 SITE BACKGROUND	65
4.3 ANALYSIS METHOD OF EACH PARAMETER	66
4.3.1 Retroreflectivity	66
4.3.2 Luminance	66
4.3.3 Colour	66
4.3.4 Skid resistance	66
4.4 DISCUSSION OF THE FOUR PARAMETERS	67
4.4.1 Retroreflectivity	67
4.4.2 Luminance	67
4.4.3 Colour	68
4.4.4 Skid resistance	68
4.5 RETROREFLECTIVITY SERVICE LIFE OF THE TEST ROAD MARKINGS	68
4.5.1 White transverse road markings	69
4.5.1.1 Long established clean asphalt road (Middel Street)	69
4.5.1.2 Long established dirty asphalt road (Mohwelere Street)	71
4.5.1.3 Newly established clean chip seal road (Doreen Street)	71
4.5.1.4 Newly established dirty chip seal road (Aubrey Matlala Road)	72
4.5.1.5 Long established clean chip seal road (Bushveld Road)	73
4.5.1.6 Long established dirty chip seal road (Road L 3)	73
4.5.1.7 Newly established clean asphalt road (Meiring Naude Road)	73
4.5.1.8 Newly established dirty asphalt road (M 44)	74
4.5.1.9 Long established asphalt road in the CBD (Madiba Street)	74
4.5.1.10 Overall discussion on white transverse road markings	75
4.5.2 Yellow transverse road markings	76
4.5.2.1 Long established clean asphalt road (Middel Street)	76
4.5.2.2 Long established dirty asphalt road (Mohwelere Street)	79
4.5.2.3 Newly established clean chip seal road (Doreen Street)	79
4.5.2.4 Newly established dirty chip seal road (Aubrey Matlala Road)	80
4.5.2.5 Long established clean chip seal road (Bushveld Road)	81
4.5.2.6 Long established dirty chip seal road (Road L 3)	81
4.5.2.7 Newly established clean asphalt road (Meiring Naude Road)	81
4.5.2.8 Newly established dirty asphalt road (M 44)	81
4.5.2.9 Long established asphalt road in the CBD (Madiba Street)	82
4.5.2.10 Overall discussion on yellow transverse road markings	82
4.5.3 White longitudinal road markings	84
4.5.3.1 Long established clean asphalt road (Middel Street)	84
4.5.3.2 Long established dirty asphalt road (Mohwelere Street)	86
4.5.3.3 Newly established clean chip seal road (Doreen Street)	86
4.5.3.4 Newly established dirty chip seal road (Aubrey Matlala Road)	87
4.5.3.5 Long established clean chip seal road (Bushveld Road)	87
4.5.3.6 Long established dirty chip seal road (Road L 3)	88
4.5.3.7 Newly established clean asphalt road (Meiring Naude Road)	88
4.5.3.8 Newly established dirty asphalt road (M 44)	88
4.5.3.9 Overall discussion on white longitudinal road markings	89
4.5.4 Yellow longitudinal road markings	90
4.5.4.1 Long established clean asphalt road (Middel Street)	90
4.5.4.2 Long established dirty asphalt road (Mohwelere Street)	92
4.5.4.3 Newly established clean chip seal road (Doreen Street)	92
4.5.4.4 Newly established dirty chip seal road (Aubrey Matlala Road)	93
4.5.4.5 Long established clean chip seal road (Bushveld Road)	94
4.5.4.6 Long established dirty chip seal road (Road L 3)	94
4.5.4.7 Newly established clean asphalt road (Meiring Naude Road)	94



4.5.4.8 Newly established dirty asphalt road (M 44)	95
4.5.4.9 Overall discussion on yellow longitudinal road markings.....	95
4.6 LUMINANCE SERVICE LIFE OF THE TEST ROAD MARKINGS	96
4.6.1 White transverse road markings	96
4.6.1.1 Long established clean asphalt road (Middel Street).....	97
4.6.1.2 Long established dirty asphalt road (Mohwelere Street)	99
4.6.1.3 Newly established clean chip seal road (Doreen Street)	99
4.6.1.4 Newly established dirty chip seal road (Aubrey Matlala Road).....	100
4.6.1.5 Long established clean chip seal road (Bushveld Road).....	100
4.6.1.6 Long established dirty chip seal road (Road L 3)	100
4.6.1.7 Newly established clean asphalt road (Meiring Naude Road)	101
4.6.1.8 Newly established dirty asphalt road (M 44).....	101
4.6.1.9 Long established asphalt road in the CBD (Madiba Street).....	101
4.6.1.10 Overall discussion on white transverse road markings.....	102
4.6.2 Yellow transverse road markings	104
4.6.2.1 Long established clean asphalt road (Middel Street).....	104
4.6.2.2 Long established dirty asphalt road (Mohwelere Street)	106
4.6.2.3 Newly established clean chip seal road (Doreen Street)	106
4.6.2.4 Newly established dirty chip seal road (Aubrey Matlala Road).....	107
4.6.2.5 Long established clean chip seal road (Bushveld Road).....	107
4.6.2.6 Long established dirty chip seal road (Road L 3)	107
4.6.2.7 Newly established clean asphalt road (Meiring Naude Road)	108
4.6.2.8 Newly established dirty asphalt road (M 44).....	108
4.6.2.9 Long established asphalt road in the CBD (Madiba Street).....	108
4.6.2.10 Overall discussion on yellow transverse road markings	109
4.6.3 White longitudinal road markings	110
4.6.3.1 Long established clean asphalt road (Middel Street).....	110
4.6.3.2 Long established dirty asphalt road (Mohwelere Street)	112
4.6.3.3 Newly established clean chip seal road (Doreen Street)	112
4.6.3.4 Newly established dirty chip seal road (Aubrey Matlala Road).....	113
4.6.3.5 Long established clean chip seal road (Bushveld Road).....	114
4.6.3.6 Long established dirty chip seal road (Road L 3)	114
4.6.3.7 Newly established clean asphalt road (Meiring Naude Road)	114
4.6.3.8 Newly established dirty asphalt road (M 44).....	115
4.6.3.9 Overall discussion on white longitudinal road markings	115
4.6.4 Yellow longitudinal road markings.....	116
4.6.4.1 Long established clean asphalt road (Middel Street).....	116
4.6.4.2 Long established dirty asphalt road (Mohwelere Street)	118
4.6.4.3 Newly established clean chip seal road (Doreen Street)	118
4.6.4.4 Newly established dirty chip seal road (Aubrey Matlala Road).....	119
4.6.4.5 Long established clean chip seal road (Bushveld Road).....	120
4.6.4.6 Long established dirty chip seal road (Road L 3)	120
4.6.4.7 Newly established clean asphalt road (Meiring Naude Road)	120
4.6.4.8 Newly established dirty asphalt road (M 44).....	120
4.6.4.9 Overall discussion on yellow longitudinal road markings.....	121
4.7 COLOUR.....	122
4.7.1 Long established clean asphalt road (Middel Street)	122
4.7.2 Newly established dirty chip seal road (Aubrey Matlala Road)	123
4.7.3 Long established clean chip seal road (Bushveld Road)	123
4.7.4 Newly established clean chip seal road (Doreen Street)	123
4.7.5 Newly established dirty asphalt road (M 44)	124
4.7.6 Long established asphalt road in the CBD (Madiba Street).....	124
4.7.7 Newly established clean asphalt road (Meiring Naude Road)	124
4.7.8 Long established dirty asphalt road (Mohwelere Street).....	125
4.7.9 Long established dirty chip seal road (Road L 3).....	125
4.8 SKID RESISTANCE.....	128
4.9 PERFORMANCE OF THERMOPLASTIC ROAD MARKING MATERIAL	128
5 CONCLUSIONS AND RECOMMENDATIONS	130
5.1 CONCLUSIONS	130

5.2 RECOMMENDATIONS 131

6 REFERENCES..... 132

APPENDICES

APPENDIX A: DESCRIPTIVE STATISTICS ON RETROREFLECTIVITY

APPENDIX B: DESCRIPTIVE STATISTICS ON LUMINANCE

APPENDIX C: NINETY FIVE PERCENT CONFIDENCE INTERVALS ON RETROREFLECTIVITY AND LUMINANCE

APPENDIX D: COLOUR ANALYSIS

LIST OF TABLES

Table 2.1: Prescribed constituents of thermoplastic road marking material (BS 3262: Part 1:1989)... 13

Table 2.2: Classes of retroreflectivity for dry road markings (BS EN 1436:2007, 2007). 29

Table 2.3: Classes of luminance for dry road markings (BS EN 1436:2007, 2007). 31

Table 2.4: Corner points of chromaticity regions for white and yellow markings (BS EN 1436:2007, 2007). 35

Table 2.5: Classes of skid resistance (BS EN 1436:2007, 2007). 35

Table 2.6: Summary of data on SANRAL’s road network (Hay, 2013)..... 45

Table 4.1: Descriptive statistics of white transverse markings in retroreflectivity on Middel Street..... 70

Table 4.2: Summary of longest performing white transverse markings in retroreflectivity. 76

Table 4.3: Descriptive statistics of yellow transverse markings in retroreflectivity on Middel Street. ... 78

Table 4.4: Summary of longest performing yellow transverse markings in retroreflectivity. 83

Table 4.5: Descriptive statistics of white longitudinal markings in retroreflectivity on Middel Street. ... 84

Table 4.6: Summary of longest performing white longitudinal markings in retroreflectivity. 90

Table 4.7: Descriptive statistics of yellow longitudinal markings in retroreflectivity on Middel Street... 91

Table 4.8: Summary of longest performing yellow longitudinal markings in retroreflectivity. 96

Table 4.9: Descriptive statistics of white transverse markings in luminance on Middel Street..... 97

Table 4.10: Summary of longest performing white transverse markings in luminance. 103

Table 4.11: Descriptive statistics of yellow transverse markings in luminance on Middel Street. 104

Table 4.12: Summary of longest performing yellow transverse markings in luminance..... 110

Table 4.13: Descriptive statistics of white longitudinal markings in luminance on Middel Street. 111

Table 4.14: Summary of longest performing white longitudinal markings in luminance. 116

Table 4.15: Descriptive statistics of yellow longitudinal markings in luminance on Middel Street..... 117

Table 4.16: Summary of longest performing yellow longitudinal markings in luminance. 122

Table 4.17: Summary of colour analysis for long established clean asphalt road (Middel Street). 126

Table 4.18: Summary of initial skid resistance..... 128

Table 4.19: Summary of thermoplastic road marking material performance..... 129

LIST OF FIGURES

Figure 1.1: Non-retroreflectorized road marking (SARTSM, 1999). 2

Figure 1.2: Retroreflectorized road marking (SARTSM, 1999)..... 2

Figure 1.3: South African road accident fatalities (Letsoalo, 2012). 3

Figure 1.4: Environmental factors contributing to road accidents (Letsoalo, 2012). 4

Figure 1.5: Percentage of road accidents per time of day (Letsoalo, 2012)..... 4

Figure 2.1: Decision sight distance model (Labuschagne and Grosskopff, 2004). 11

Figure 2.2: Road trial of road markings in the UK (Europe) (Owen, 2013)..... 15

Figure 2.3: Road trial of road markings in France (Europe) (Owen, 2013). 16

Figure 2.4: Turntable road marking test system (Zedler, 2014)..... 16

Figure 2.5: Retroreflected light ray (SARTSM, 1999). 21

Figure 2.6: Floatation glass beads (SARTSM, 1999). 23

Figure 2.7: Standard glass beads (SARTSM, 1999).	23
Figure 2.8: Angles defining the 30 m geometry (SANS 6261:2008, 2008).	27
Figure 2.9: Visibility programme (COST 331, 1999).	33
Figure 2.10: Chromaticity regions of white and yellow markings in the CIE diagram (BS EN 1436:2007, 2007).	34
Figure 2.11: Line wear of white traffic paint (SARTSM, 1999).	39
Figure 2.12: Paint marking affected by traffic density for both bituminous and concrete pavement (SARTSM, 1999).	40
Figure 2.13: Decline in retroreflectivity of white markings on SANRAL's road network.	46
Figure 2.14: Decline in retroreflectivity of yellow markings on SANRAL's road network.	47
Figure 3.1: Newly established dirty chip seal road (Aubrey Matlala Road).	52
Figure 3.2: Newly established clean chip seal road (Doreen Street).	52
Figure 3.3: Long established clean chip seal road (Bushveld Road).	53
Figure 3.4: Newly established dirty asphalt road (M 44).	53
Figure 3.5: Long established asphalt road in the CBD (Madiba Street).	54
Figure 3.6: Long established clean asphalt road (Middel Street).	54
Figure 3.7: Newly established clean asphalt road (Meiring Naude Road).	55
Figure 3.8: Long established dirty asphalt road (Mohwelere Street).	55
Figure 3.9: Long established dirty chip seal road (Road L 3).	56
Figure 3.10: Typical layout of the test markings on a link of road.	57
Figure 3.11: Typical detail of a section of transverse test markings.	57
Figure 3.12: LTL-X Retroreflectometer.	60
Figure 3.13: LTL-XL Retroreflectometer.	61
Figure 3.14: X-Rite Model SP60 colour machine.	62
Figure 3.15: Skid resistance tester.	63
Figure 4.1: Unwashed white transverse markings on Middel Street.	70
Figure 4.2: Washed white transverse markings on Middel Street.	70
Figure 4.3: Ninety five per cent Confidence Interval of unwashed white transverse markings on Middel Street.	71
Figure 4.4: Unwashed yellow transverse markings on Middel Street.	78
Figure 4.5: Washed yellow transverse markings on Middel Street.	78
Figure 4.6: Ninety five per cent Confidence Interval of unwashed yellow transverse markings on Middel Street.	79
Figure 4.7: Unwashed white longitudinal markings on Middel Street.	85
Figure 4.8: Ninety five per cent Confidence Interval of unwashed white longitudinal markings on Middel Street.	85
Figure 4.9: Unwashed yellow longitudinal markings on Middel Street.	91
Figure 4.10: Ninety five per cent Confidence Interval of unwashed yellow longitudinal markings on Middel Street.	92
Figure 4.11: Unwashed white transverse markings on Middel Street.	98
Figure 4.12: Washed white transverse markings on Middel Street.	98
Figure 4.13: Ninety five per cent Confidence Interval of unwashed white transverse markings on Middel Street.	98
Figure 4.14: Unwashed yellow transverse markings on Middel Street.	105
Figure 4.15: Washed yellow transverse markings on Middel Street.	105
Figure 4.16: Ninety five per cent Confidence Interval of unwashed yellow transverse markings on Middel Street.	105
Figure 4.17: Unwashed white longitudinal markings on Middel Street.	111
Figure 4.18: Ninety five per cent Confidence Interval of unwashed white longitudinal markings on Middel Street.	112
Figure 4.19: Unwashed yellow longitudinal markings on Middel Street.	117
Figure 4.20: Ninety five per cent Confidence Interval of unwashed yellow longitudinal markings on Middel Street.	118
Figure 4.21: Unwashed white markings on Middel Street.	127
Figure 4.22: Washed white markings on Middel Street.	127
Figure 4.23: Unwashed yellow markings on Middel Street.	127
Figure 4.24: Washed yellow markings on Middel Street.	127

1 INTRODUCTION AND BACKGROUND

1.1 INTRODUCTION

The road authorities in South Africa (SA) are mandated to display all signage as per the recommendations of the South African Development Community Road Traffic Signs Manuals (SADC RTSM) (1999) and the South African Road Traffic Signs Manuals (SARTSM) (1999) (National Road Traffic Act 93 of 1996). According to the SARTSM (1999), any traffic sign (including road marking) which is classified as a regulatory sign must be displayed, and failure to do so can result in the road authority being liable for damages. Warning and guidance signs have a lower priority but can also result in negative implications against the road authority should the road authority fail to display and maintain the signs. A typical regulatory road marking is a stop line which informs the vehicular traffic to come to a complete halt just before the line. All road markings on pavements in SA are predominantly white and yellow, with red and black rarely used. These markings can be longitudinal lines, transverse lines, words and symbols.

Public roads without road markings, especially roads carrying high traffic volumes, would lead to chaos and accidents with the possibility of injuries and loss of life. The road authorities must ensure that all signage, both horizontal (road markings) and vertical (traffic signs), is well maintained and conforms to the SARTSM (1999). The most important aspect of road markings is that they must be retroreflective (brightness at night under headlights). The minimum retroreflectivity (R_L) for white and yellow road markings in SA is 100 millicandelas/m²/lux (mcd/m²/lx) and 70 mcd/m²/lx respectively (SADC RTSM, 1999). The Virginia Tech Transportation Institute conducted a study to identify the minimum R_L required to ensure that the driver can view the road markings comfortably at night during rainy conditions, and found that a minimum R_L of 200 mcd/m²/lx is required to provide adequate visibility for drivers in wet night conditions (Gibbons, 2006). The Iowa Department of Transport (IDOT) recommends an initial R_L of 300 mcd/m²/lx and 200 mcd/m²/lx for white and yellow road markings respectively (Smadi *et al.*, 2013). The IDOT found that these R_L requirements were achievable and that setting this high initial requirement ensured good bead embedment and effective service life of the marking. Road markings also add positive value to the road user in adverse weather conditions, particularly in misty and rainy conditions. According to Martin *et al.*, (1996), an effective road marking system facilitates driver guidance, improves traffic flow, contributes to driving comfort and enhances traffic safety.

Figure 1.1 illustrates what happens to the light from vehicles' headlights when it strikes onto a road with non-reflective road markings. Instead of being reflected back to the driver, the light is dispersed in all directions, resulting in poor road marking visibility at night. Non-reflective road markings are markings to which glass beads have not been applied or markings which have reached a poor condition in which the glass beads have been worn off by vehicle wheels.

Figure 1.2 illustrates what happens to the light from vehicles' headlights when it strikes onto a road with reflective road markings. The light is reflected back to the driver, which enhances visibility. The retroreflectorized road marking is a result of glass beads in the road markings.

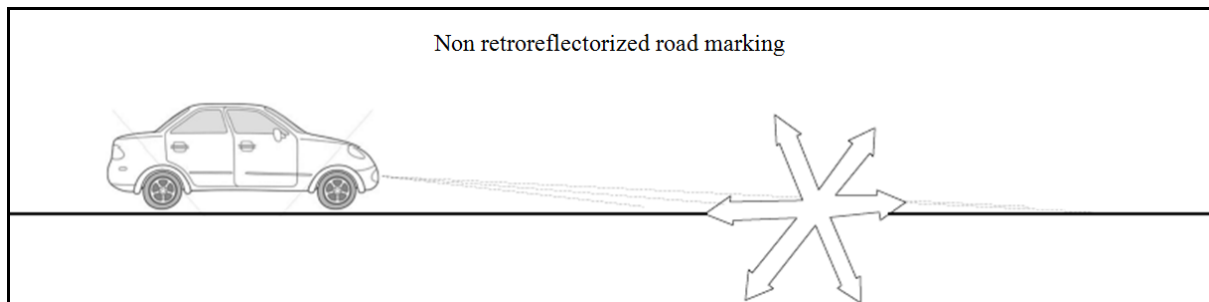

Figure 1.1: Non-retroreflectorized road marking (SARTSM, 1999).

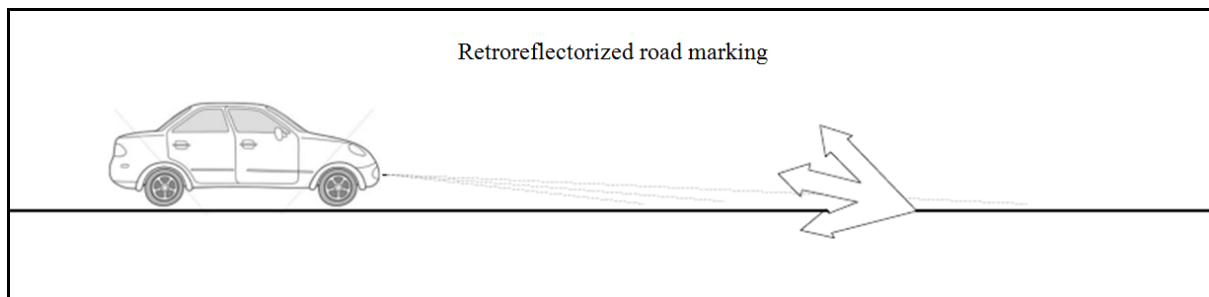

Figure 1.2: Retroreflectorized road marking (SARTSM, 1999).

1.2 BACKGROUND

According to Letsoalo (2012), there are approximately 27 road accident fatalities per 100 000 while globally it is approximately 10.3 road accident fatalities per 100 000. Middle and low income countries with low vehicle ownership experienced high road fatality rates compared with high income countries that have high vehicle ownership (Letsoalo, 2012). This could be attributed to the lack of road safety awareness campaigns and lack of maintenance on roads and roadside furniture. According to Figure 1.3, there was an increase in road fatalities in SA from 2001 to 2007, while there was a decrease from 2007 to 2009, after which the road fatalities stabilised. However, there is still cause for concern as approximately 14 000 people are killed annually on the roads in SA. The contributing factors to the high number of road accident fatalities are human factors, vehicle factors, road factors and environmental factors (Letsoalo, 2012).

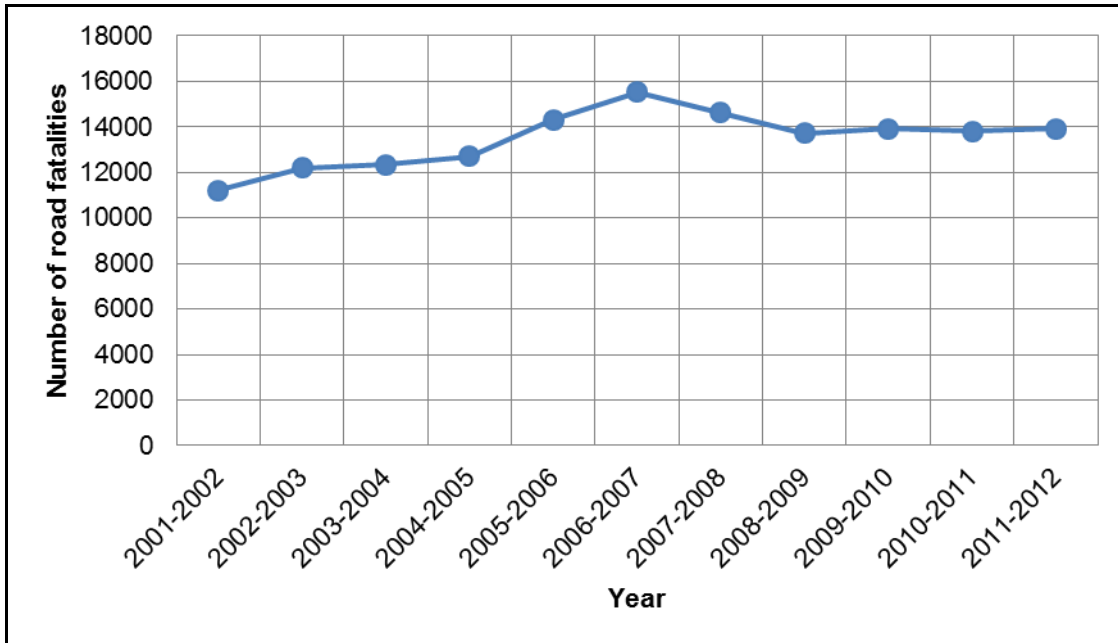

Figure 1.3: South African road accident fatalities (Letsoalo, 2012).

According to Figure 1.4 there was a slight reduction in road accidents caused by defective road signs and road markings from 2010 to 2012, but more effort should be placed on these environmental factors in order to reduce road accidents. Road authorities can use rumble road markings on the edge lines at sharp curves, which will alert the driver to being too close to the edge of the road when the wheels of the vehicle pass over the rumble road markings so that an appropriate action can be taken by the driver to prevent an accident from occurring. If there are clearer visible road markings, the driver may be able to see the curve from a distance and appropriate action can be taken to prevent an accident from occurring. At areas under construction, a high retroreflective specification for road markings may be prescribed to ensure that the area is adequately visible to the road user. Traffic signs can be supplemented with relevant road markings so that when the road user cannot see the traffic signs, the continuity of visible road markings can inform the road user of what action needs to be taken. Road accidents cost the SA economy approximately R 307 billion per year (Letsoalo, 2012).

According to Figure 1.5 the highest percentage of road crashes occur at night and this is the main reason why road markings must be retroreflective to be effective and guide the road user. It may not necessarily be that the road accidents have occurred as a result of defective road markings, but as road authorities have control over road markings, the authorities should ensure that the markings are continuously maintained to the required standards to eliminate road markings as a possible cause of accidents.

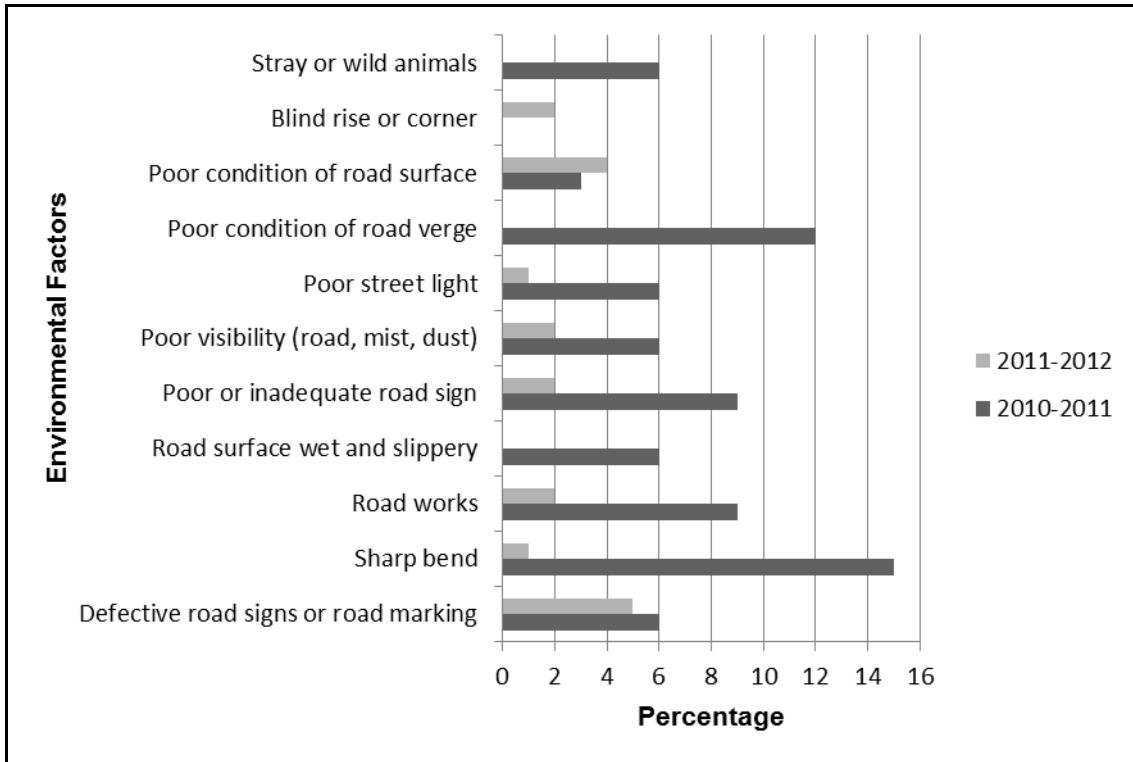

Figure 1.4: Environmental factors contributing to road accidents (Letsoalo, 2012).

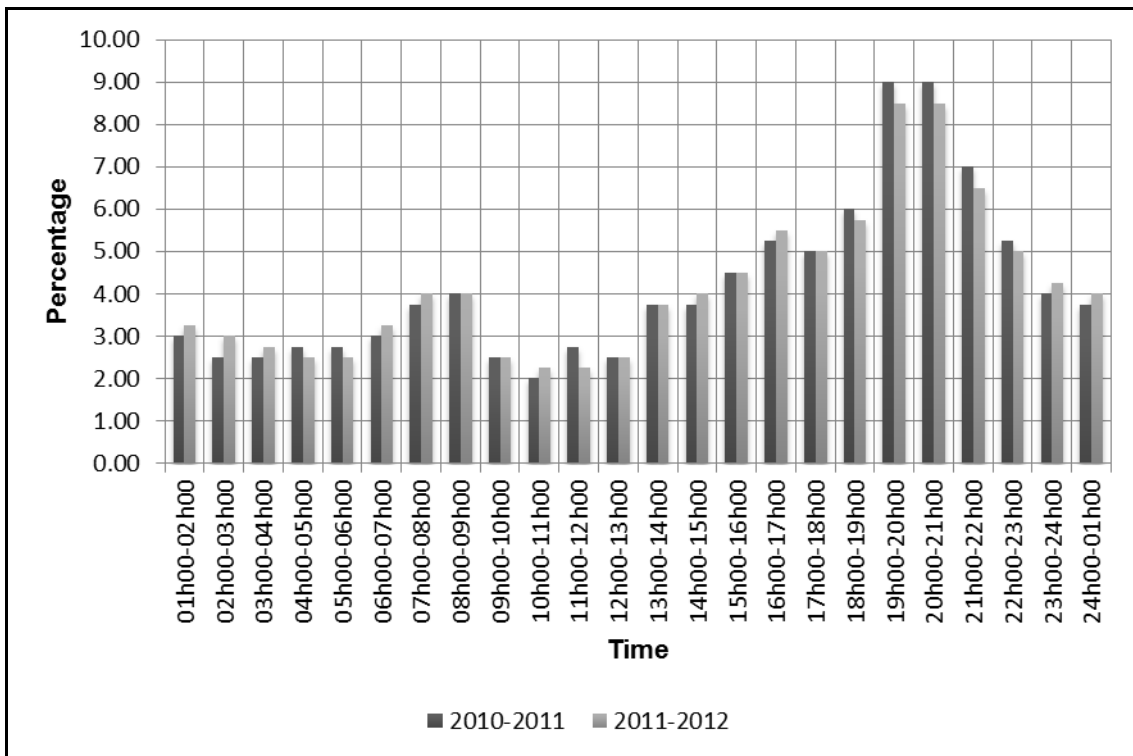

Figure 1.5: Percentage of road accidents per time of day (Letsoalo, 2012).

1.3 PROBLEM DEFINITION

The COLTO (1998) specifications refer to the use of hot melt thermoplastic as a possible road marking material, subject to its specification in the project specifications. No further guidance or specifications for this material is given. Thermoplastic road marking material is a 100 per cent solid, environmentally and user safe compound which consists of binder, pigment, filler and intermix glass beads. There are various suppliers of raw materials from countries such as the UK, US, China, India, Singapore and Saudi Arabia. Some of the local suppliers in SA are importing the constituents and formulating the mix, which is sold to road marking applicators who then apply it on the road network. It is important to draw up a specification and establish testing systems to ensure that imported road marking materials are suitable for the environment and climate and that it should perform to at least a certain degree. There is little published information specific to SA road marking practices and materials, and it remains necessary that on-going attention be given to the development of the local road marking materials and their application. It is advised in the SARTSM (1999) that each road authority should develop its own estimated service life based on local conditions and experience due to the variations in the parameters associated with the service life of road marking paints and materials.

Although thermoplastic road markings have been in use for a number of years, there is little agreement on their service life. The problem arises in attempting to establish an expected service life of a particular material on a given roadway. There are too many factors influencing performance to permit an average life to be predicted with any confidence without carrying out research. The South African National Roads Agency Limited (SANRAL) has adopted a performance-based specification in its road marking contracts. The specification indicates only the required R_L , but experience has shown that some of the important performance standards may not be satisfactory. For example, yellow road markings tend to look white at night and in SA yellow road markings have a different meaning to white road markings, and as such could lead to the wrong action taken by the driver. In the City of Tshwane (CoT) the current road marking maintenance programme is determined mostly by the visibility of the road marking. This is not objective, since each engineer may view the road markings differently and as such there may be inconsistencies in the road marking maintenance programme over the city roads.

1.4 OBJECTIVES OF THE STUDY

The objectives of this study are:

- To determine the retroreflectivity (night-time visibility) service lives of various road marking paints and road marking materials on asphalt and chip seal road surfaces;
- To determine the luminance (daytime visibility) service lives of various road marking paints and road marking materials on asphalt and chip seal road surfaces;

- To determine if there are significant differences in retroreflectivity, luminance and the colour of the road markings when washed with liquid soap mixed with water and hard brooms;
- To check if the colour of the road markings applied complies with the specification, and
- To check if the skid resistance of the road markings complies with the specification.

1.5 SCOPE OF THE STUDY

The scope of this study includes:

- A comparative analysis of the performance of various road marking paints and road marking materials on asphalt roads and chip seal roads within the CoT;
- The investigation of adverse effects of sand on road markings;
- The measurements of three parameters of road markings namely R_L , Q_d and colour over at least a year from the time of the application of the road markings, and
- The initial measurement of the skid resistance of various road marking paints and materials applied on test plates.

1.6 CONTRIBUTION TO STATE OF KNOWLEDGE

Thermoplastic road marking materials generally have longer service lives than solvent-borne and water-borne road marking paints, but the materials may not be suitable to SA climatic conditions as they are imported from various countries where extreme temperatures are a norm that is either very cold or very hot. There is currently no standard set by the South African Bureau of Standards (SABS) to define the performance criteria for thermoplastic road marking materials. Experience has shown that the useful life of road markings on metropolitan roads is not the same as on national roads. This is mainly due to sand retained on substandard roads, which causes an abrasive action on the road markings by the wheels of vehicles. There are considerably more transverse road markings on metropolitan roads than on national roads which are continuously driven over, and this action generally wears away the markings. Although the study is carried out in the CoT, it is likely that the outcomes of the study will be similar to other inland areas due to similar environmental conditions. The moisture in the atmosphere along coastal areas may have an additional influence on the service life of road markings, especially during the application process. After development of a standard, engineers will be able to confidently set out in invitations to tender and other documents, which materials are permitted and the performance criteria to be met.

1.7 CHAPTER OVERVIEWS

- Chapter 1 serves as an introduction to the report, in which the background to the problem is provided;

- Chapter 2 contains a literature study with more information on road markings and their importance;
- Chapter 3 describes the methodology used to develop the standard;
- Chapter 4 contains the analysis of the observations;
- Chapter 5 contains the conclusions and recommendations of the study, and
- Chapter 6 contains all the references used in this study.

2 LITERATURE STUDY

2.1 INTRODUCTION

Traffic signs erected on poles form the vertical signalisation on the road network, while road markings provide horizontal signalisation (SARTSM, 1999). These devices are low cost engineering safety measures on a road network but provide important safety aspects which the road user is highly reliant upon. Applications of pavement markings became necessary in the 1920s due to increases in automobile traffic (Martin *et al.*, 1996). Higher standards should be set on temporary road markings as diversions are usually constructed below the minimum design standards and the driver may find it difficult to manoeuvre through diversions which may be unfamiliar. Permanent road markings should have a long functional life so that the roads are safe to travel on, with avoidance of excessive delays due to repeated maintenance, while also preventing the risk to workers being too often on the roads during road marking maintenance cycles (BS EN 1436:2007, 2007).

2.2 THE TRAFFIC SYSTEM

The traffic system is described in terms of three interacting components namely:

- i) The human (or road user);
- ii) The vehicle, and
- iii) The road (a potential accident scene).

A road traffic accident, which may involve pedestrians and transport vehicles or combinations of them, is a consequence of a chain of events involving these three components (Labuschagne and Grosskopff, 2004). Traffic signs and road markings form an integral part of the road environment and should be maintained within the standards at all times in order to minimise the causes contributing to accidents. According to Labuschagne and Grosskopff (2004), road safety needs to be continuously managed with due consideration of dynamic traffic environments.

2.3 REQUIREMENTS OF ROAD MARKINGS

Road markings are traffic control devices applied to regulate, warn and guide traffic on the road system (Labuschagne and Grosskopff, 2004). To be effective, these devices should be installed such that they:

- Conform to required standards set by the road authority;
- Fulfil a road user need in that they must be visible;
- Command the attention to the road user;

- Be competitive with the environment as there are other devices that may distract the road user and command attention;
- Be convincing and command the respect of road users at all times;
- Display continuity of message when and where required;
- Give adequate time for proper response by drivers;
- Be comprehensive and give the information required (road user needs), and
- Be concise and convey a clear, simple meaning or message at a glance due to human and roadway limitations.

The five basic objectives associated with the above requirements are (Labuschagne and Grosskopff, 2004):

- i) Design: the combination of physical features (size, colour and shape) to command attention and convey a message. For example, a stop line in the City of Tshwane (CoT) must be painted at a minimum width of 300 mm and must be white in colour, while on Provincial Roads the stop line must be at least 500 mm wide in order to ensure that the driver can see the marking way in advance as the speeds are usually higher on Provincial Roads than on the Municipal Roads (SADC RTSM, 1999);
- ii) Placement: the installation of devices so that they are in the cone of vision of the road user and thus commands attention and gives time for response. For example, a stop line in SA must be painted in advance of the pedestrian crossing when approaching an intersection in order to avoid the vehicle stopping over the pedestrian crossing. It is often seen at intersections in the Central Business District (CBD) where there is high pedestrian movement and high traffic volumes, that it is a challenge for pedestrians to cross within the demarcated pedestrian crossing, especially when vehicles come to a stop over the pedestrian crossing;
- iii) Operation: the application of devices so that they meet the traffic requirements in a uniform and consistent manner fulfils a need, commands respect, and allows time for response;
- iv) Maintenance: the upkeep of devices in order to retain legibility and visibility. The removal of devices if not needed in order to aid in commanding respect and attention while fulfilling the needs of the road users, and
- v) Uniformity: the uniform application of similar devices for similar situations so that they fulfil the need of the road user and command their respect.

It is not always possible to be comprehensive and concise simultaneously. As such, the information displayed at any one time must be well considered to represent the most acceptable compromise.

Achievement of the above objectives depends on the compliance of signing practices with the following principles (Labuschagne and Grosskopff, 2004):

- Conformity involving disciplined compliance with National Road Traffic Act 1996 (Act 93 of 1996) together with the SADC RTSM (1999) and the SARTSM (1999) so that road users may be assured of the same signing principles wherever they may be in the system;
- Accuracy of the display of a sign-face or road marking to eliminate confusion which may be experienced by road users if the traffic sign or road marking message does not relate to what can be seen on the road ahead. For example, a speed hump symbol must be painted at least 30 m before the speed hump in order for the driver to be aware of the speed hump ahead and take the necessary action timeously (STD016, 2014);
- Uniformity of traffic sign-face or road marking layout, colour code and traffic sign and road markings display sequence to enhance the road users' ability to get the best from the system by reducing reading times;
- Consistency of signing (including marking) practice so that similar situations are signed in a like manner, and
- Continuity of message display until the information is no longer relevant.

Uniformity is becoming more important for the following reasons (Labuschagne and Grosskopff, 2004):

- Present-day driving involves higher speeds on a road system with complex interchanges and intersections. For example, the increase in the number of road lanes and construction of single point interchanges places higher demands on the ability of drivers;
- People prefer to reside in certain areas for various reasons such as safety and security but work in other areas, and as such increased travel occurs away from the home area on unfamiliar roads;
- Liability of government and local authorities for public safety is increasing as more roads are constructed and more people make use of the roads, and
- Ease and economy in the design and manufacturing of safety control devices is achieved using new technology.

2.4 HUMAN FACTORS AND THE ROAD ENVIRONMENT

Visual sensory processes are the only pertinent ones in maintaining course, and detecting obstacles and in reading road signs, signals, road markings and other forms of delineation. Drivers do not observe the roadway continuously as they blink, observe objects well off the line of the road, use the rear view mirror, read the vehicle instruments and talk to passengers. The reaction time of a road user is generally low on familiar roads, while reaction times are much higher for road users on unfamiliar roads. The distance at which a driver can detect a hazard in an environment of visual clutter, recognise it as a threat and select an appropriate speed and path in order to perform the required manoeuvre safely and efficiently, is called the "decision sight distance" (Figure 2.1). Drivers must obtain and receive reliable, credible and understandable information to minimise uncertainty in order to make sound decisions timeously (Labuschagne and Grosskopff, 2004).

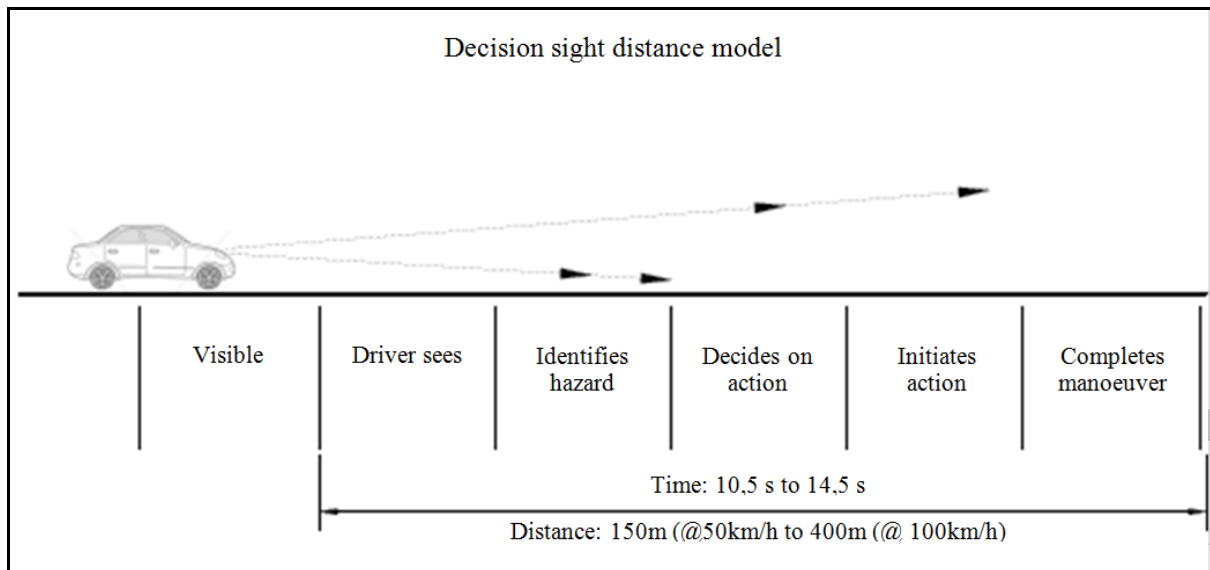

Figure 2.1: Decision sight distance model (Labuschagne and Grosskopff, 2004).

2.5 TYPE OF ROAD MARKING PAINTS AND MATERIALS

There are various types of road marking materials in the market which vary in price and performance. Commonly used road marking materials include solvent-borne and water-borne paints, thermoplastic including preformed tape and cold plastic. The most common road marking applied in SA for many years has been the solvent-borne paint as it has been the cheapest in the market and readily available, being locally manufactured. Solvents contain Volatile Organic Compounds (VOCs) which are carcinogenic. Concern over carcinogens prompted research to develop other pavement marking materials that contain no or lesser quantities of carcinogens (Martin *et al.*, 1996). Water-borne road marking paint is generally more expensive than solvent-borne road marking paint in SA (though this situation is reversed in other parts of the world), with the result that it has been less used in SA. The solvent-borne road marking paint made and traditionally supplied in SA has poor durability, though this is not the case elsewhere. Water-borne road marking paint is more environmentally friendly as it does not contain the same level of VOCs as solvent-borne road marking paint.

Some countries use lead in their mix designs and in SA the lead content should not exceed 5 per cent of the dry weight of the portion taken for analysis (Occupational Health and Safety Act 85 of 1993, 1993). The lead chromate used to manufacture thermoplastic road marking material is usually found in hydrocarbon resins, which is an important constituent in the manufacture of thermoplastic. The lead in the thermoplastic can become harmful only if the road markings are eaten. The percentage of lead in most glass beads is usually quite low and will hardly cause an effect to the ground water (Guder, 2013).

Preformed tape and cold plastic are much more expensive than solvent-borne road marking paint, water-borne road marking paint and thermoplastic road marking materials, but their performance periods are much longer in terms of R_L and durability. Due to their high cost factor they will not be

economical for use in large quantities for a city size like the CoT, which has approximately 6 500 km of surfaced roads within its jurisdiction. The durability of road markings varies on different pavement surfaces and as such it cannot be assumed that if the road markings are tested on one type of surface they can be expected to last the same time on all pavement surfaces.

Thermoplastic road marking materials were first used in SA on a small scale during the 1980s. They are more expensive than solvent-borne and water-borne road marking paints but can produce high R_L throughout their useful life. For many years politicians and senior management officials failed to understand the importance of road markings, with the result that an insufficient budget is allocated compared with what is actually required to ensure that the roads are maintained within specifications. Thermoplastic road marking materials were first developed in Britain during the 1930s (Martin *et al.*, 1996).

The CoT has been applying hot melt thermoplastic road marking materials since 1995 on the higher order roads but there has not been any research undertaken to determine their service life. The CoT recommends the use of thermoplastic road marking materials on newly developed roads and road marking maintenance due to its durability and thus its cost effectiveness (STD016, 2014). The challenge within the CoT and the country as a whole is that SA does not have a thermoplastic road marking material specification. The road authorities therefore have very little control over thermoplastic road marking material applied by road marking applicators. The CoT appointed three road marking applicators to maintain its road marking programme from February 2009 to January 2012. The technical team found that there were variances in terms of durability, colour and R_L of the thermoplastic road marking materials applied by the three different road marking applicators. These variances and some other challenges like difference in prices lead to the initiative of this research study.

2.6 ROAD MARKING STANDARDS

The standards commonly used for road marking materials worldwide are:

- American Association of State Highway and Transportation Officials (AASHTO) Standards;
- British Standards (BS), and
- European Standards (EN).

Almost all national standards are based on one or the other of these standards. BS has merged with EN and thus the current BS for thermoplastic road markings is BS EN 1436:2007. The BS indicates it as a British standard, while the EN indicates that it represents adoption by the British standard EN 1436. The year indicates when the standard came into effect. The original road marking standard was what is known as “recipe” standards. It specified the percentage of each material to be included in the thermoplastic. For example, a recent specification based on the old British standard BS 3262: Part

1:1989 (1989) (which was superseded more than 20 years ago) stipulated that thermoplastic for road markings should consist of light coloured aggregate, pigment and extender, bound together with hard-wearing resins, plasticised with oil as necessary in approximately the proportions by weight as shown in Table 2.1.

Table 2.1: Prescribed constituents of thermoplastic road marking material (BS 3262: Part 1:1989).

Material	Composition
Aggregate	40 per cent
Ballotini (tiny glass beads)	10 to 20 per cent
Pigment and extender	20 per cent
Binder	20 per cent

It included various qualifying criteria such as:

- The aggregate shall consist of white silica sand, crushed calcite, calcined flint or quartz, or other approved aggregate, and the colour shall comply with the requirements laid down in paragraph 4b of BS 3262: Part 1:1989 (1989), and
- The pigment shall be titanium dioxide in accordance with paragraph 6a of BS 3262: Part 1:1989 (1989)

These recipe standards have been discontinued for two decades in Europe, but are still widespread elsewhere in the world. Many countries are now switching to performance-based standards.

A recipe-based specification informs the manufacturer what has to be included in the material. Any particular thermoplastic made to this specification may perform well or badly, depending on the quality of the raw materials used, the skill with which they are blended and the application, but poor performance is not the manufacturer's problem as the manufacturer has met the specification. A performance-based specification, on the other hand, allows the manufacturer to use whatever raw materials he chooses but it lays down the performance standards that the thermoplastic road marking must meet in use. These performance standards are likely to include: softening point; skid resistance; luminance; R_L ; life of markings and colour. Most countries have adopted either the British (European) or American road marking standard and most of the SA road marking standards are based on the British standards.

2.6.1 American standards

The American standard for the application of white and yellow reflective reflectorized thermoplastic road marking material on the road surface is AASHTO M 249-12 (2012). This standard is a recipe-type standard in that it prescribes the percentages of binder, glass beads, titanium dioxide (TiO_2) and

filler for white thermoplastic road marking material. The standard prescribes the percentage of binder and glass beads for yellow thermoplastic but allows the manufacturer to determine the percentage of filler and yellow pigments provided that all other requirements in the specification are met. In addition to the specification of the composition, the physical characteristics of the thermoplastic material are also stipulated, namely the colour, drying time, crack resistance at low temperature, impact resistance, softening point, flowability, yellow index and storage life (AASHTO M 249-12, 2012). The American standard, AASHTO T 250-05 (2014) is used to test for compliance of the thermoplastic road marking materials, namely the percentages of the binder and glass beads. The standard specification for glass beads in road marking materials used in America is AASHTO M247-81 (1996) and it also specifies the drop-on glass beads used on road markings so as to produce retroreflectorized road markings.

According to the American standard, (AASHTO TT-P-1952E, 2007), road marking paints including airfield markings and water-borne paints are classified either into Type I, Type II or Type III road markings. Type I road markings are to be used under normal weather conditions while Type II road markings are to be used under adverse weather conditions. Type I and Type II road markings should not be used where greater thicknesses of road markings are required with larger diameter glass beads. Type III road markings should be used under normal weather conditions where higher durability and greater adhesion to glass beads are required and also be used when greater thicknesses are required with larger diameter glass beads.

2.6.2 European standards

BS EN 1436:2007 (2007) specifies the requirements related to the performance of the road markings during their functional life, namely the luminance coefficient (Q_d) for dry road markings, luminance factor (β) for dry road markings, retroreflection for dry and wet road markings, colour and skid resistance of white and yellow road markings. Each parameter is broken down into classes due to the varying useful life of the road marking, which is affected by vehicles passing over it, traffic volumes, type of surface and the use of studded tyres in some countries (BS EN 1436:2007, 2007). The classes enable different priorities to be given to the different aspects of performance of road markings depending on particular circumstances. For example, a road marking may have drop-on glass beads or drop-on anti-skid aggregates, aiming at high classes of either R_L or skid resistance and not both on the same road markings. According to BS EN 1436:2007 (2007), high classes of retroreflection and skid resistance cannot be obtained together. Further, the selection of performance classes implies a compromise between the needs of the drivers and the cost of supplying the performance. For skid resistance, emphasis is sometimes placed on those road markings which occupy a large percentage of the trafficked areas such as zebra crossings, arrows, transverse markings, text and symbols as these are the road markings which are continuously driven over. All aspects must be considered before selecting the performance class, as road markings are a complicated aspect on the road network. According to BS EN 1436:2007 (2007), in some countries the performance classes cannot

be maintained during a limited time period of the year during which the probability of lower performance of the road markings is high, due to the presence of water, dust, mud, etc. According to BS EN 1436:2007 (2007), the Q_d , the R_L and the chromaticity value (colour) are calculated as the average of the measurements of each parameter.

The physical properties of the road marking materials in European countries are tested in accordance with BS EN 1871:2000 (2000). This standard specifies the laboratory requirements and test methods for retroreflective and other road marking materials, both temporary and permanent. The test methods include determining chromaticity co-ordinates, luminance factor, storage stability, bleed resistance, alkali resistance, softening point, heat stability, cold impact resistance, indentation value and tröger wear. Tröger wear is the volume loss in cm^3 of the markings after UV ageing.

Europe uses the BS EN 1824:1998 (1998) standard to conduct road trials of road marking materials. According to this standard, the road marking materials are applied either transversely or longitudinally. In the transverse pattern, three lines of the same road marking material at least 100 mm wide are applied 350 mm apart on the lane to be tested (Figure 2.2). In the longitudinal pattern, lines of at least 150 mm wide are painted 2 m long within the lane of travel (Figure 2.3). The field measurements of the Q_d , the R_L , colour and skid resistance are conducted twice. The first set of measurements is conducted within ten days of application of the road marking materials and the second set of measurements for permanent road markings is conducted twelve months after the application of the road marking materials. The importance of the second test is to ensure that the road marking materials are subjected to a full climatic cycle (BS EN 1824:1998, 1998). For temporary markings, the second set of measurements is conducted six months after the application of the road marking materials.



Figure 2.2: Road trial of road markings in the UK (Europe) (Owen, 2013).



Figure 2.3: Road trial of road markings in France (Europe) (Owen, 2013).

The BS EN 13197:2011 (2011) standard is used to conduct laboratory measurements of the Q_d , the R_L , colour and skid resistance of the test road markings. This standard is used to measure road marking materials in the wear simulator. Road markings were tested only at road trials in real traffic until 1976 (Zedler, 2014). The field tests had the disadvantage that the results were available only after the real test time. As the number of road users increased, it became difficult to continue with road trials and as such the turntable road marking test system was developed and used extensively. This test system consists of a horizontally arranged turntable with a diameter of 6.40 m to which different road marking samples can be applied at the same time (Figure 2.4). The test samples are subjected to different wheel loads which produce the same degree of wear as real vehicles in traffic. The test markings are applied to special test substrates whose composition and surface correspond to a finely structured roadway surface. The number of wheel passages varies from 50 000 to 4 million depending on the class of traffic to which the test markings will be subjected to in real traffic conditions. The test markings which are subjected to 4 million wheel passages indicate an anticipated service life of the road markings between 4 and 6 years (BS EN 13197:2011, 2011).



Figure 2.4: Turntable road marking test system (Zedler, 2014).

2.6.3 South African standards

The South African National Standards, SANS 6261:2008 (2008), specifies the procedure of determining the R_L of road markings. SANS 6260:2007 (2007) provides the method for determining the skid resistance of the road markings in the laboratory. The British Portable Pendulum apparatus is used to determine the skid resistance of the road markings in the laboratory. The test methods to determine colour, resistance to sagging, resistance to bleeding, alkali resistance and resistance to artificial weathering of single-pack solvent-borne paints is described in SANS 731-1:2006 (2006). SANS 731-2:2006 (2006) describes the test methods to determine the colour, resistance to sagging, resistance to bleeding, alkali resistance, resistance to artificial weathering and resistance to early washout of single-pack water-borne paints.

The SABS has adopted the EN 1423:1997 (1997) specification and has published it as SABS EN 1423:1997 (1997) which specifies the test methods for drop-on glass beads. The SABS has also adopted the EN 1424:1997 (1997) specification and has published it as SABS EN 1424:1997 (1997) which specifies the test methods for premix glass beads in road marking materials.

Only a few road authorities in SA have been stringent on the performance of road markings as the only specification which is stipulated is the initial R_L . The South African National Roads Agency Limited (SANRAL) conducts three acceptance control tests on R_L over the performance period (either two or three years). The payment by SANRAL to the road marking applicators is divided over the performance period.

The only specification related to thermoplastic road marking materials published by the SABS is the SABS EN 1424:1997 (1997) (Road marking materials - premix glass beads). This specification was adopted by the SABS exactly as per the European Standard EN 1424:1997 (1997) and specifies the requirements for laboratory tests of aspects of premix glass beads such as the granulometry, refractive index, chemical resistance, quality and surface treatment. Since the European specifications are widely adopted by many countries, the BS EN 1436:2007 (2007) specification and the available SABS Standards were used to develop the thermoplastic road marking standard. It is better for the road authority to stipulate the specifications that the road marking product must comply with, as it would be time consuming and costly to test the constituents of the road marking paints and materials. The onus will be on the manufacturer to ensure that the formulation of the road marking material is good and proper to ensure that the product meets the required specifications. Road marking tests were conducted on the road marking products which were applied on the road surface. In 2011, the SABS established a technical committee (TC1093) to develop a standard on thermoplastic road markings in SA but not much progress has been made by the SABS, hence the need for this study.

In SA, the only road test on road markings conducted by the SABS on solvent-borne and water-borne road marking paints is the determination of wear index. Three 150 mm wide transverse stripes are applied 1 m apart and are tested at 6-monthly intervals (SANS 731-1:2006, 2006 and SAN 731-2:2006, 2006). The wear index is determined using a grid made of wire in a 500 mm x 100 mm mesh pattern consisting of 20 squares (SANS 6248:2007, 2007). Mesh is a metal wire cloth with square openings. According to the SABS, the wear index must not be more than 35 in order for the solvent-borne or water-borne road marking paint to obtain the SABS mark (SANS 731-1:2006, 2006 and SANS 731-2:2006, 2006).

2.7 THERMOPLASTIC ROAD MARKING MATERIAL

Thermoplastic road marking material is a mixture of glass beads, binder, pigment and filler material. Dry thermoplastic compound is generally heated in a thermostatically controlled pre-heater or boiler to a temperature of 220° C and agitated continuously until a homogenised liquid is achieved, before transferring it to an application vehicle (M 249-12, 2012). The hot melted liquid is applied onto the road surface with drop-on glass beads added on top to produce high initial R_L as may be stipulated in the specifications of the road authority. The material usually dries within a short space of time.

2.7.1 Glass beads

Road markings must be applied with glass beads on roads where R_L is required. If all roads had proper reliable lighting, glass beads in road markings may not be necessary. The cost of adding glass beads to the road marking paint or road marking material will outweigh the cost of continuous supply of electricity for lighting purposes. There is a risk in SA for continuous supply of electricity due to the theft of electrical cables and the increasing demand for electricity which was not adequately planned for. Road markings without reflective glass beads are not reflective road markings. The road markings will reflect very little light during the hours of darkness and as a result the most important purpose of the road markings will not be achieved.

The retroreflection of road markings in wet or rainy conditions is much lower than in dry conditions and as such the road markings should be enhanced with special properties to improve the R_L (BS EN 1436:2007, 2007). The water creates a film on top of the road markings which prevents the vehicle headlights from striking the glass beads in the road markings and reflecting back to the driver. The R_L can be increased by using thicker road markings, larger glass beads or drop-on road markings. The use of thicker road markings results in the road marking standing proud of the surface water and as such a greater proportion of the vehicle headlights can be reflected back to the driver, which can improve the visibility of the path of travel. Larger glass beads may stand above the film of water which may be on the road marking and as such the vehicle headlights entering the glass beads can be reflected back towards the driver. In the case of drop-on road markings, the water lies between the road marking spots and as such the vehicle headlights can result in reasonable retroreflection. Drop-

on road markings can also produce acoustic or vibration effects which may alert the driver that he may be in danger as he is close to the edge of his lane when the vehicle wheels pass over the road markings.

Standard BS EN 1423:1998 (1998) describes all aspects of the glass beads. The standard specifies the refractive index (RI), the roundness of the beads, the range of sizes (gradations) and the luminance of the beads. As glass beads are manufactured from various sources (pure virgin glass or recyclable glass) one needs to ensure that the beads do not contain hazardous materials. The way the glass beads are manufactured can also determine whether the product is hazardous or not. The determination of hazardous materials contained in glass beads is outside the scope of this study but it will be in the interest of all that the applicators of road markings should ensure that the glass beads used are guaranteed by the suppliers of not containing any hazardous materials that may adversely affect the environment.

Glass beads are applied either under pressure or by dropping under gravity. The two most important field control properties are bead embedment and the amount and dispersion of the beads on the road marking (Smadi *et al.*, 2013). The embedment and dispersion are influenced by characteristics such as bead drop rate, speed of the road marking equipment, distance between binder applicator and bead applicator, ambient temperature, and viscosity of the binder material (Smadi *et al.*, 2013). The faster the application vehicle travels, the higher the likelihood that the beads will either burrow or roll on the road marking and as such the beads will get coated with the wet markings. Ideally, the beads should drop onto the road marking and embed properly so that they do not burrow or roll (Smadi *et al.*, 2013). If the beads embed too deeply into the road marking or the beads roll, getting coated with the wet road marking material, then the initial R_L may not be achieved and as such a good road marking may be rejected on this account. Therefore the application process of the road marking and the glass beads is as important as each constituent meeting the specifications separately.

Drop-on glass beads are applied to the surface of both thermoplastic markings and liquid paint markings through a bead dispenser which should be an integral part of any paint sprayer. Thermoplastic road markings also contain intermix beads which become exposed as the surface of the thermoplastic wears off, thereby producing R_L throughout most of its service life.

The properties of the glass beads indicate the beads' ability to reflect light and can be controlled during manufacture. The beads can be tested and evaluated prior to applying a road marking to ensure that acceptable glass beads are used. The important properties of glass beads to be analysed in order for the beads to perform optimally includes gradation, refractive index, roundness and clarity, and coating (Gates *et al.*, 2003 and Miglets *et al.*, 1994).

2.7.1.1 Gradation

Gradation refers to the size of the beads, which have many different sizes when manufactured. Gradation is usually referred to by the mesh size, for example 20 to 80 or 100 mesh size. Mesh is a metal wire cloth with square or circular openings through which the glass beads are sieved. A range of bead sizes is recommended to achieve a high initial R_L and to maintain an adequate R_L level for as long as possible.

The recommendation is based on the following (Austin and Schultz, 2006, Miglets *et al.*, 1994):

- Changing weather conditions can affect drying time, which can affect bead embedment depths. Changes in marking temperature can have the same effect on drying time. It is therefore important to ensure that the applicator adheres to the manufacturer's specifications regarding application;
- Changes in marking application speed or pressure may vary the marking thickness, which may not allow enough marking for the larger beads to embed properly or may result in too much marking material, resulting in over-embedding of the smaller beads. Changing road surface textures can have the same effect on varying marking thickness. Ideally trials should be done by the applicator before attempting permanent application to avoid reapplication or even sand blasting of road markings which do not conform to the specified thickness. The road marking applicator can also use test plates to guide the road marking application team on the thickness of the application, and
- Beads which are initially over-embedded may become exposed as the road marking wears, renewing R_L as the marking ages. This is usually achieved in plastic road marking materials.

Larger glass beads have more advantages than smaller glass beads and can be used effectively in thicker pavement marking materials like thermoplastic. The larger glass beads will stand proud of the surface water when it rains and as such R_L may still be achieved. However, if the gradient of the road surface does not allow water run off, even the larger glass beads may not be effective in producing the required wet R_L . A study by the Texas Department of Transport found that Type III glass beads which are larger than the Type II glass beads provided higher levels of dry R_L for white and yellow road markings on chip seal road surfaces (Gates *et al.*, 2003). The recommended R_L on chip seal roads at CoT is much more difficult to achieve than on asphalt roads. One of the reasons for this is that the chip seal surface is much rougher than asphalt surfaces and more of the road marking paint or materials lies in the voids between the stones. One of the ways to overcome this is to recommend an increase in application thickness of the road marking material, but thicker road markings will be expensive.

2.7.1.2 Refractive Index

The refractive Index (RI) is a measure of the speed of light in a medium and is a function of the chemical makeup of the beads, which is determined by the raw material used to make the beads (Smadi *et al.*, 2013). The RI of road marking beads ranges from 1.5 to 2.4 (Miglets *et al.*, 1994). According to the South African Road Traffic Signs Manual (SARTSM), (1999), the recommended RI ranges from 1.5 to 1.9. Light rays from vehicles' headlights enter the glass beads, which are refracted down towards the binder and then reflected back towards the light source (Figure 2.5). The light which is reflected back is called the retroreflected light which is the critical light that the driver requires to assist him in ensuring that he remains in his path and takes the necessary actions to travel safely on the roads. Figure 2.5 illustrates the path taken by light through a glass bead and back to the driver as well as indicating the importance of proper glass bead embedment (SARTSM, 1999). For best results, approximately 60 per cent of the bead should be embedded in the road marking and 40 per cent of the bead should stand out above the road marking (Austin and Schultz, 2006). The maximum optical efficiency of a pavement marking bead occurs at an RI of approximately 1.9 under dry conditions (Smadi *et al.*, 2013). Glass beads with an RI of 1.5 are made from windowpanes called cullet, while glass beads with an RI of 1.9 are made from virgin glass. The density increases with an increase in the RI of the glass beads and as such the higher the RI of the glass beads the higher the quantity of glass beads that will be required for the same road marking. Glass beads with an RI of 1.5 are usually used on roads while beads with an RI of 1.9 are used at airport markings (Austin and Schultz, 2006).

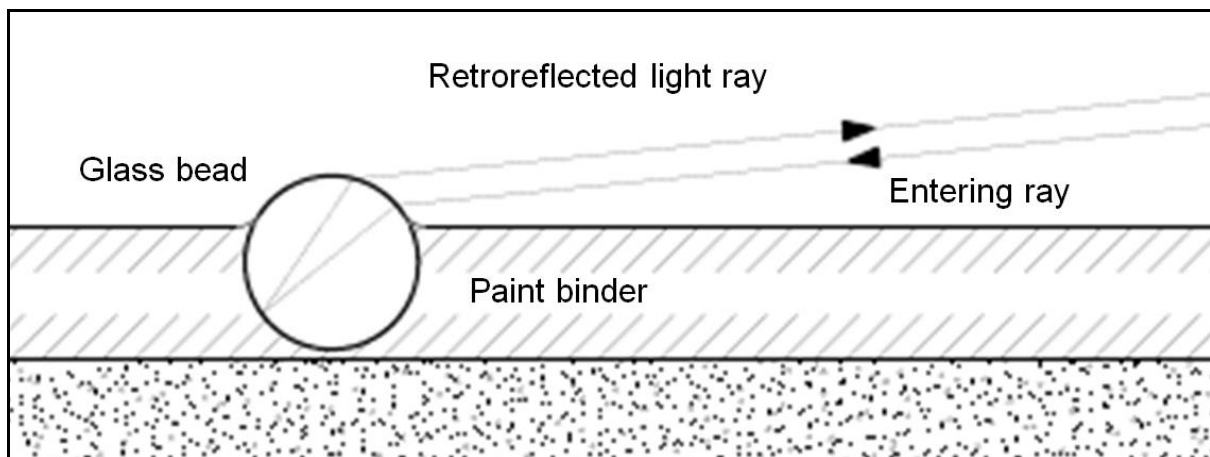

Figure 2.5: Retroreflected light ray (SARTSM, 1999).

2.7.1.3 Roundness and clarity

Roundness is influenced greatly by the properties of the blast furnace and the manufacturing process. While the manufacturing process generally produces round glass beads, some of them are not. Glass beads that are perfectly spherical and clear will reflect better than glass beads that are neither spherical nor clear (Smadi *et al.*, 2013). Generally the bead mix is made up of 80 per cent round

moisture-proofed glass beads and 20 per cent of tiny pieces of broken glass beads which provide the anti-skid properties. Moisture-proof beads do not have any voids or holes in them.

2.7.1.4 Coatings

Glass bead coatings are used to make glass beads easier to dispense, increase adhesion to the binder material, and improve embedment in the road marking and, therefore, R_L . The three most common forms of glass bead coatings are moisture proof coating, adhesion coating and floatation coating (Smadi *et al.*, 2013).

(i) Moisture-proof coating

Glass is impervious to water and water cannot damage glass beads. However, glass beads stored or used in humid conditions are likely to become coated with moisture which causes the glass beads to cling together in the glass bead dispenser, and this prevents the beads from flowing freely and uniformly. Glass beads which cling together can cause blockages in the dispensing gun and as such incorrect quantities of glass beads will be applied to the road marking which will most likely result in R_L failures. Each manufacturer has its own system to ensure that the glass beads flow without clumping. Some manufacturers use silicone oils or add inorganic particles such as China clay as a moisture-proof coating (Smadi *et al.*, 2013).

(ii) Adhesion coating

Larger glass beads are usually coated with an adhesion coating as they are usually more difficult to embed in the road marking than smaller glass beads (Smadi *et al.*, 2013). Research was carried out to identify the effect of adhesion coated glass beads and glass beads without adhesion coatings on a curved road where markings are usually worn off at a faster rate. After six months of testing, the adhesion coated glass beads remained, whereas most of the non-adhesion coated glass beads were driven off (Smadi *et al.*, 2013).

(iii) Floatation coating

Standard glass beads can be treated with a coating that causes all of them to float in wet paint rather than sink completely. Two major advantages of floatation glass beads involve application and performance (Smadi *et al.*, 2013). As all the glass beads float, a more consistent level of brightness is achieved. Floatation glass beads are not as durable as standard glass beads but the advantage is that initial high R_L is easily achievable (Miglets *et al.*, 1994).

There are various qualities of glass beads available but the CoT as well as SANRAL does not stipulate the type of glass beads to be used. One of the main reasons is that each manufacturer of

road marking paint or material prefers the applicator to use specific glass beads in order to achieve the full potential of the road marking paint or material. Currently, the initial R_L specified by CoT is $200 \text{ mcd/m}^2/\text{lx}$ for white road markings in order to ensure the longevity of the road marking, and as such the road marking applicator must ensure that the most appropriate glass beads are used. Usually floatation glass beads (indicated in Figure 2.6) are used as they do not sink deep into the road marking paint or material. Figure 2.7 illustrates the use of standard beads which may not produce high initial retroreflection and as such may be rejected by the road authority, although after the wearing away of the thermoplastic the glass beads may become exposed and may meet the minimum R_L specification when measured with a retroreflectometer. Here again it is important for the road marking applicator to understand the importance of using the correct glass beads as usually the supplier of the thermoplastic road marking materials does not supply the beads but usually recommends the type of glass beads to be used in order to comply with the specifications.

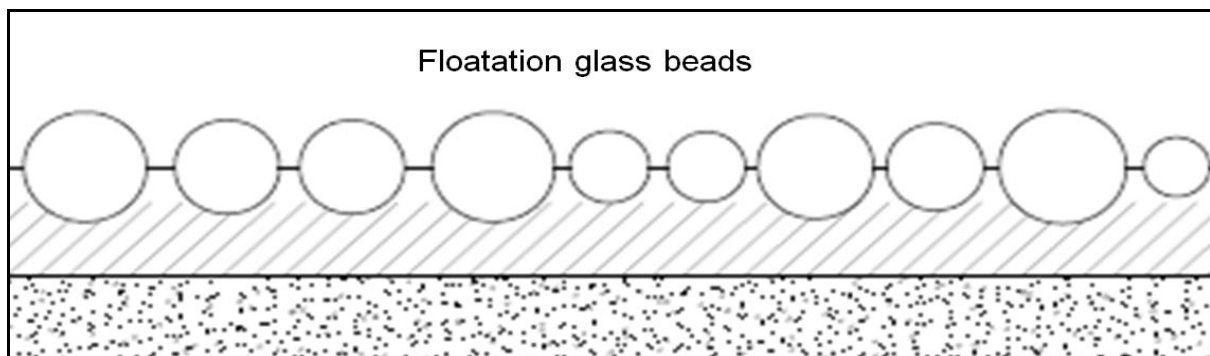

Figure 2.6: Floatation glass beads (SARTSM, 1999).

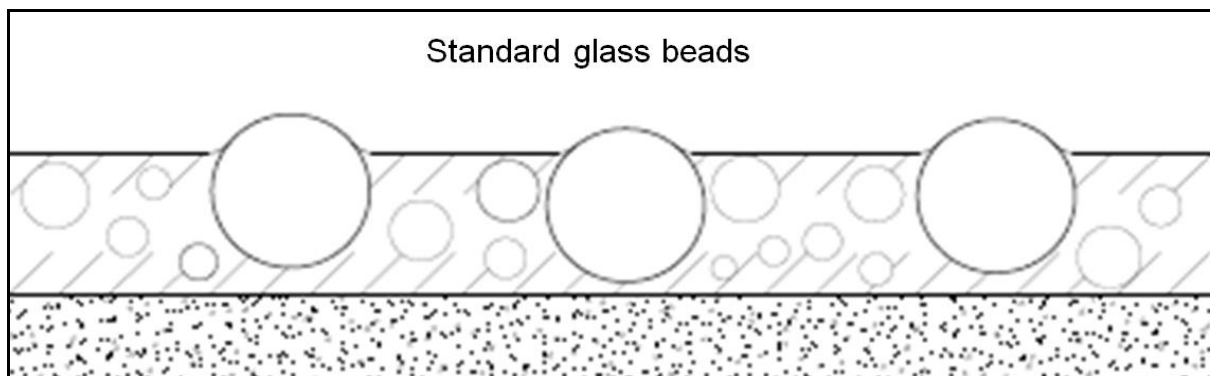

Figure 2.7: Standard glass beads (SARTSM, 1999).

2.7.2 Binder

Binder (resin) is the constituent that provides adhesion to the road surface and the other constituents, namely the pigments, fillers and glass beads (SS 498: Part 1: 2002). An effective road marking system requires not only quality glass beads but also a quality binder. If either part of the road marking system is not good, or they are not installed properly, then the road marking system will not perform as well as it could. Traditionally, thermoplastic road markings were made using hydrocarbon

resins. Hydrocarbon thermoplastic road markings are made from petroleum-derived resins which provide heat stability. Hydrocarbon-based materials are readily soluble in oil drippings, fuel and other petroleum-based products and as such are not recommended for high traffic areas like the city centre where vehicles move at low speeds or are stationary (Highways Department, 2010). In many parts of the world and especially in the Middle East, hydrocarbon resins are still used, which is unfortunate because hydrocarbon resins are not a good solution for hot countries. Discolouring is a commonly observed problem in white thermoplastic road markings in hot countries (Highways Department, 2010). The most common cause of discolouring is the combination of plasticising oils and cheap hydrocarbon resins. These oils are not colourless and over time they bleed through the binders and fillers, and discolouration occurs.

In order to keep costs low, many manufacturers reduce the amount of plasticising oils, but this is not really a solution because the plasticising oils are there to give the thermoplastic flexibility. When the amount of plasticisers is reduced, blackening may be eliminated but then the thermoplastic cracks. The correct solution is to use alkyd resins including rosin esters with the correct amount of plasticisers. These resins are more expensive than hydrocarbon resins but there is improvement in performance with no blackening or cracking (Highways Department, 2010). Alkyd thermoplastic contains a naturally occurring resin that is resistant to petroleum products, making it ideal for inner city markings and other high traffic areas where oil drippings are common. Along with being a great product for intersection markings such as pedestrian crossings, words and symbols, alkyd thermoplastic is also ideal for centreline, edge line and skip line road markings (Highways Department, 2012).

2.7.3 Pigment

Pigment is a fine powder added primarily to impart colour and opacity to the mixture. Titanium dioxide (TiO_2) is a common reflective pigment used in white road markings and higher levels in R_L can be achieved with an increase in TiO_2 (Smadi *et al.*, 2013). Too much TiO_2 used in yellow road markings may result in the road markings looking a lighter yellow, and this is usually observed on road markings where a high initial R_L is specified. There must be due consideration when specifying parameters of road markings so that the road marking can perform in all aspects. For example, if the R_L specification on yellow road markings is high then the colour of the yellow road markings may not comply with the colour specification. Yellow is less reflective than white because the yellow pigments absorb more of the light than the white road markings. In addition, the thick applications of paint markings such as thermoplastic materials and lack of opacity in the pigments often cause the yellow paints to have a dull or faded appearance as compared with the other road marking materials (Smadi *et al.*, 2013).

2.7.4 Filler

Filler is a powder added to assist the dispersion of the pigment thereby providing colour uniformity throughout the mix (SS 498: Part 1:2002, 2002). Fillers are made up of a mixture of calcium carbonate, sand and other inert materials to impart body to the mixture. The filler is also an important constituent to ensure that R_L is achieved and is important for the daylight appearance of the road markings.

2.8 APPLICATION OF THERMOPLASTIC ROAD MARKING MATERIALS

Thermoplastic road marking materials can be applied in either a liquid or a solid form. Liquid thermoplastic is applied in three ways, namely by spraying, extruding or by screed (MRTS45, 2012). Thermoplastic in a solid form is commonly referred to as preformed thermoplastic.

2.8.1 Spray thermoplastic

Spray thermoplastic is applied by mobile equipment at a rapid application rate and dries almost instantly. This results in the requirement for minimal traffic accommodation and shorter periods of road closures, which reduce travel time delays. Spray thermoplastic is usually applied at a thickness of 1.2 mm in SA while in most European countries the minimum application thickness is 1.5 mm, and 2 mm in the US. In Australia spray thermoplastic is applied at 2 mm (MRTS45, 2012). One of the reasons why thermoplastic road marking is applied more thickly in Europe and the US is due to the scraping away of some of the thermoplastic under the action of the snowplough where snow has settled on the road. The other reason is that the US, Australia and Europe consider road safety as a high priority and allocate sufficient budgets for road marking maintenance.

The operator of the road marking machine must ensure that the spray gun for the thermoplastic and the glass bead dispenser is adjusted such that the glass beads enter the thermoplastic at the correct time and correct angle. These simple adjustments, if not attended to, can result in failure of the product even though the correct quantity of each constituent is used. Spray thermoplastic is usually applied as longitudinal lines. Most thermoplastic machines only have one road marking tank for one road marking colour, hence there could be delays when having to apply white and yellow road markings as the tank has to be thoroughly cleaned before changing from one colour to the other. Road marking equipment is generally manufactured in overseas countries and thus when SA road marking applicators have equipment breakdowns there can be huge time delays before the equipment is fully functional as the mechanical parts have to be imported. Some road marking applicators in SA are experimenting in the manufacture of the smaller road marking equipment.

2.8.2 Extruded thermoplastic

Extruded thermoplastic is also applied by mobile equipment but the mix design of the material is different and the viscosity is also higher than spray thermoplastic. The applied product takes a longer time to dry than spray plastic as it is usually applied at a thickness of 3 mm in SA. In Singapore, extruded thermoplastic is applied between 2.5 mm and 3 mm while in Europe and the US it is applied up to 5 mm and 4.8 mm respectively (SS 498: Part 2:2002, 2002 and AASHTO M 249-12, 2012). Extruded thermoplastic is usually applied as longitudinal lines. Extruded thermoplastic is seldom used in SA as it is more expensive than spray thermoplastic. Extruded thermoplastic may have an advantage over spray thermoplastic due to its application thickness but care must be taken to ensure that it is applied correctly in order to avoid cracking and early failure.

2.8.3 Screed thermoplastic

Screed thermoplastic is generally applied by manual hand-push equipment for small road markings such as transverse road markings, arrows, words and symbols. Thermoplastic greater than 2 mm thick for small markings is usually applied by the screed method. It is this type of application where there is inconsistency in R_L as the glass beads are manually applied onto the thermoplastic material. The late application of the glass beads will result in the glass beads not adhering to the thermoplastic. On the other hand, if the glass beads are applied too early they sink into the thermoplastic material and then the initial R_L may not be achieved. The current road marking applicator at the CoT has invested in an additional attachment with a glass bead dispenser which results in a more controlled operation and as such the initial R_L of the small markings are achieved according to the current R_L specification. Although thermoplastic road markings were introduced over 20 years ago in SA, new ideas are still developing to ensure that the product can perform to its maximum potential.

2.8.4 Preformed thermoplastic

Preformed thermoplastic which is manufactured in sheets (commonly 600 mm x 900 mm) will have to be cut up into the road marking size required before application (MRTS45, 2012). It can be seen that due to the manufactured sheet size, preformed thermoplastic will be more conducive as road marking arrows and symbols. It is not practical to apply preformed thermoplastic as longitudinal lines, especially over long lengths. The road surface must be cleaned and then the cut up preformed thermoplastic is placed in its final position and heated with the flame of a blow torch between 150° C and 180° C (MRTS45, 2012). Care should be taken not to overheat the material as this will result in discolouration of the thermoplastic road marking. Drop-on glass beads are applied on the melted thermoplastic to comply with the initial R_L . The heated thermoplastic usually cools within few minutes after melting and as such the road can be open to traffic soon after application. Preformed thermoplastic is not commonly used in SA mainly due to it being more expensive than other available road marking paints and materials.

2.9 CALCULATION OF LUMINANCE

The luminance of a road marking or a road surface illuminated by a single light source is calculated as the product of the illuminance produced by the light source and a luminance coefficient (COST 331, 1999). According to COST 331 (1999), the luminance (L) measured in cd/m^2 at some point of a road marking or a road surface in headlamp illumination is calculated by:

$$L = \sum R_L \times E_{\perp}$$

Where

R_L is the coefficient of retroreflected luminance measured in $\text{cd/m}^2/\text{lx}$;

E_{\perp} is the illuminance by a headlamp at the point on a plane perpendicular to the direction of illumination measured in lx , and

\sum means summation for two or more headlamps.

$$E_{\perp} = I/D^2$$

Where

I is the luminous intensity of the headlamp in the direction towards the point measured in cd , and

D is the distance from the headlamp to the point measured in m .

The unit of R_L is in principle $\text{cd/m}^2/\text{lx}$ (ratio between luminance measured in cd/m^2 and illuminance measured in lx), but in practice, to obtain convenient values, the one thousand times smaller unit of $\text{mcd/m}^2/\text{lx}$ is used (COST 331, 1999).

The observation angle (α) is $2,29^\circ$ and the illumination angle (ϵ) is $1,24^\circ$ (COST 331, 1999). These angles are measured from the horizontal to the directions of observation and illumination respectively (Figure 2.8). This measuring geometry represents the situation obtained for a driver looking 30 m ahead with his eyes at a height of 1,2 m and a headlamp just below the eyes at a height of 0,65 m (COST 331, 1999).

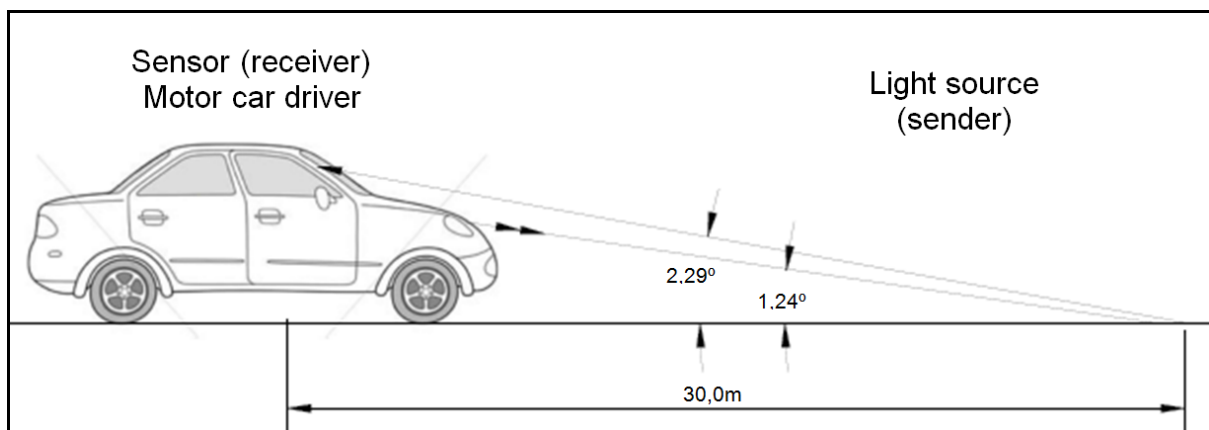

Figure 2.8: Angles defining the 30 m geometry (SANS 6261:2008, 2008).

For dry conditions, BS EN 1436:2007 (2007) provides classes of minimum R_L values of 100, 200 and 300 $\text{mcd/m}^2/\text{lx}$ for white road markings and classes of minimum R_L values of 80, 150 and 200 $\text{mcd/m}^2/\text{lx}$ for yellow road markings (COST 331, 1999). For most road markings in conditions during rain or wetness, R_L drops to very low values; BS EN 1436:2007 (2007) provides classes of minimum R_L values of 25, 35 and 50 $\text{mcd/m}^2/\text{lx}$. Road surfaces in dry conditions have R_L values in the range from 5 to 30 $\text{mcd/m}^2/\text{lx}$ and during rain or wetness R_L drops to low values of typically 0 to 10 $\text{mcd/m}^2/\text{lx}$ (COST 331, 1999). According to COST 331 (1999), the luminous intensity depends on the headlamp and on the direction. In general, it can be stated that background luminance in headlamp illumination is generally small, the relevant range to be considered being 0,001 to 0.1 cd/m^2 . With background luminance in this range, a high contrast is required for the visibility of relatively small targets. This is the basis for the use of micro-beads to enhance the R_L of road markings and thereby the contrast with the road surface (COST 331, 1999). The darker the road surface is, the greater the contrast will be between the road markings and the road surface.

2.10 RETROREFLECTION UNDER VEHICLE HEADLAMP ILLUMINATION

For the measurement of reflection under vehicle headlamp illumination, the coefficient of retroreflected luminance is used and expressed in $\text{mcd/m}^2/\text{lx}$. BS EN 1436:2007 (2007) also specifies minimum values of R_L for wet road markings and minimum values of R_L during actual rainfall. The R_L values specified under these adverse conditions must be between 25 $\text{mcd/m}^2/\text{lx}$ and 15 $\text{mcd/m}^2/\text{lx}$ but the determination of these parameters is outside the scope of this study. According to BS EN 1436:2007 (2007), permanent and temporary road markings in dry condition shall conform to Table 2.2. The road markings are classed into different levels of achievable R_L values. In SA, the minimum R_L for white and yellow road markings is 100 $\text{mcd/m}^2/\text{lx}$ and 70 $\text{mcd/m}^2/\text{lx}$ respectively.

Table 2.2: Classes of retroreflectivity for dry road markings (BS EN 1436:2007, 2007).

Road marking type and colour		Class	Minimum luminance coefficient under diffuse illumination mcd/m²/lx
Permanent	White	R0	No performance determined
		R2	$R_L \geq 100$
		R3	$R_L \geq 150$
		R4	$R_L \geq 200$
	Yellow	R0	No performance determined
		R1	$R_L \geq 80$
		R3	$R_L \geq 150$
		R4	$R_L \geq 200$
Temporary		R0	No performance determined
		R3	$R_L \geq 150$
		R5	$R_L \geq 300$
The class R0 is intended for conditions, where visibility of the road marking is achieved without retroreflection under vehicle headlamp illumination			

2.11 DAYLIGHT ILLUMINATION AND ROAD LIGHTING

According to COST 331 (1999), the luminance (L) measured in cd/m^2 at some point of a road marking or a road surface in diffuse illumination is calculated by:

$$L = Q_d \times E$$

Where

Q_d is the luminance coefficient in diffuse illumination measured in $\text{cd/m}^2/\text{lx}$, and

E is the diffuse illuminance at the point on the plane of the road marking or road surface measured in lx .

The luminance coefficient in diffuse illumination is defined in BS EN 1436:2007 (2007) which also introduces a standard measuring geometry and classes of minimum Q_d values. The unit of the Q_d is in principle $\text{cd/m}^2/\text{lx}$, but for the same reason as for the R_L , the one thousand times smaller unit of $\text{mcd/m}^2/\text{lx}$ is used (COST 331, 1999). The standard measuring geometry is defined by the value of the observation angle α of $2,29^\circ$ (the same angle for R_L). The Q_d value does not change much with the observation angle α and may be applied to some approximation for a range of distances and for different vehicles (COST 331, 1999).

For dry conditions, BS EN 1436:2007 (2007) provides classes of minimum Q_d values of 100, 130 and 160 $\text{mcd/m}^2/\text{lx}$ for white road markings and classes of minimum Q_d values of 80 and 100 $\text{mcd/m}^2/\text{lx}$ for yellow road markings. Road surfaces in a dry condition have Q_d values in the range from 50 to 100 $\text{mcd/m}^2/\text{lx}$, or even higher. The lower end of the range applies for asphaltic road surfaces with

dark stone aggregates, while the upper end of the range applies for asphaltic road surfaces with light stone aggregates and concrete surfaces (COST 331, 1999). Diffuse illumination is an approximation to daylight illumination in cloudy conditions, and to road lighting as an average for different locations on the road surface (COST 331, 1999).

2.12 REFLECTION IN DAYLIGHT OR UNDER ROAD LIGHTING

Some road markings have a tendency to retain dust, fumes and oils which tend to discolour the road marking to a certain extent. After rain the road markings washed to a certain degree and the colour of the original road markings becomes visible (some products to a certain extent while others to a greater extent). It is important for the road markings to be visible during the day so that the road user can keep within his lane and follow the instructions that the road markings present. At the CoT, it has been found that some road markings when visually inspected during the day look as if they needed to be repainted as it did not look very visible, but those same markings were found to be highly reflective under the lights at night. The applicators need to ensure that the road markings are visible and retroreflective. They must ensure that the various constituents used will be able to perform within the standard which is set. According to BS EN 1436:2007 (2007), reflection in daylight or under road lighting is measured either by the luminance coefficient under diffuse illumination Q_d and expressed in $\text{mcd/m}^2/\text{lx}$ or by the luminance factor β . Both parameters measure the brightness of a road marking as seen in typical or average daylight or under road lighting. The main difference lies in the viewing directions, which for the luminance coefficient under diffuse illumination Q_d corresponds to a fairly long viewing distance and for luminance factor β to viewing at close range (BS EN 1436:2007, 2007).

According to BS EN 1436:2007 (2007), the luminance coefficient under diffuse illumination Q_d shall conform to Table 2.3 for road markings in dry conditions. The road markings are classed into different levels of achievable daytime visibility. SA does not have a standard for Q_d so for the purpose of this study the minimum Q_d for white and yellow road markings will be $100 \text{ mcd/m}^2/\text{lx}$ and $80 \text{ mcd/m}^2/\text{lx}$ respectively based on Table 2.3.

Table 2.3: Classes of luminance for dry road markings (BS EN 1436:2007, 2007).

Road marking colour	Road surface type	Class	Minimum luminance coefficient under diffuse illumination $\text{mcd/m}^2/\text{lx}$
White	Asphaltic	Q0	No performance determined
		Q2	$Q_d \geq 100$
		Q3	$Q_d \geq 130$
		Q4	$Q_d \geq 160$
	Cement concrete	Q0	No performance determined
		Q3	$Q_d \geq 100$
		Q4	$Q_d \geq 130$
		Q5	$Q_d \geq 160$
Yellow		Q0	No performance determined
		Q1	$Q_d \geq 80$
		Q2	$Q_d \geq 100$
		Q3	$Q_d \geq 130$
The class Q0 is for when daytime visibility is achieved through the value of the luminance factor β			

2.13 PREVIEW TIME REQUIRED BY DRIVERS

The driver must be able to see at a minimum distance while travelling at a specific speed in order to keep the vehicle in his lane and feel comfortable at all times. At night this is not easily achievable by all drivers due to various reasons, namely eyesight condition, age, experience, familiarity with the road and others. The provision of retroreflective road markings can enhance the visibility of the road to ensure the safety of the road users. There is very little empirical evidence of preview times so ranges from 2 to 5 seconds have been proposed (COST 331, 1999). According to COST 331 (1999), Sweden carried out experiments in a driving simulator to identify the distance that road markings need to be visible. The simulated road scenarios are summarised as follows:

- Two-lane road;
- Lane width: 3,5 m;
- Centre line: 3 m lines and 9 m gaps;
- Edge line: 1 m line and 2 m gaps;
- Only horizontal curves on the route (no S curves and vertical curves);
- Length of straight stretches of road, 4 levels: 100 m, 110 m, 140 m and 180 m;
- Curve radii, 4 levels: 200 m, 300 m, 450 m and 675 m;
- Length of simulated road: 5000 m;
- Sight distance of the road ahead (controlled by making the road markings visible) was varied at 5 levels: 20 m, 30 m, 45 m, 67 m and 100 m, and
- Time: at night with no opposing traffic.

Two conditions of the driving speed were selected for the experiment, namely a free choice of speed using the accelerator and 90 km/h using the cruise control. A total of 24 drivers in 2 groups participated in this experiment from age groups 25 to 35 and age groups 55 to 65 with an equal number of men and women, and the following was observed (COST 331, 1999):

- The drivers adjusted the speed according to the sight conditions;
- The speed increased up to a distance of 67 m whereafter there was no increase in speed;
- Drivers were very good at compensating for poor visibility conditions by lowering speed and reducing their variation in lateral position in the driving lane;
- The drivers did not find it more difficult to drive with 67 m than with 100 m sight distance because there was no difference in choice of speed, and
- Somewhere between 45 m and 67 m the sight distance starts to affect the drivers' choice of speed.

From this experiment it could be concluded that the visibility of road markings need not be more than 67 m from the position of the driver.

When setting the lower limit for visibility of the road marking ahead, the safety aspect must be taken into consideration. The results indicate not one lower limit, rather a range of sight distances that varies for every driver and situation. This experiment indicates that a safe limit of visibility of road marking for the driver to keep the car in the driving lane is somewhere in the interval 30 to 45 m when driving at a speed of 90 km/h and for safety reasons 45 m should be chosen (COST 331, 1999). This corresponds to a preview time of 1.8 seconds, so for a speed of 120 km/h and a preview time of 1.8 seconds, a safe preview distance of 60 m is required. In real driving, the driver needs to check his mirrors and instruments on the dashboard and therefore additional time needs to be added to keep the vehicle safely within the lane. The preview time will then be in the region of 2 to 5 seconds.

A programme was developed to calculate the visibility distance of road markings by the European Commission and is illustrated in Figure 2.9 (COST 331, 1999). The various fields in the programme must be populated and the built-in algorithms produce the visible distance of the road markings. With a slight increase in the road marking width while all other fields are constant, the road markings will be visible at a greater distance. Wider road markings cost more than narrower road markings. It should be noted that it is not necessary to produce road markings that are visible at very great distances which may not be necessary as a safe preview distance of 60 m is required when travelling at a speed of 120 km/h (COST 331, 1999).

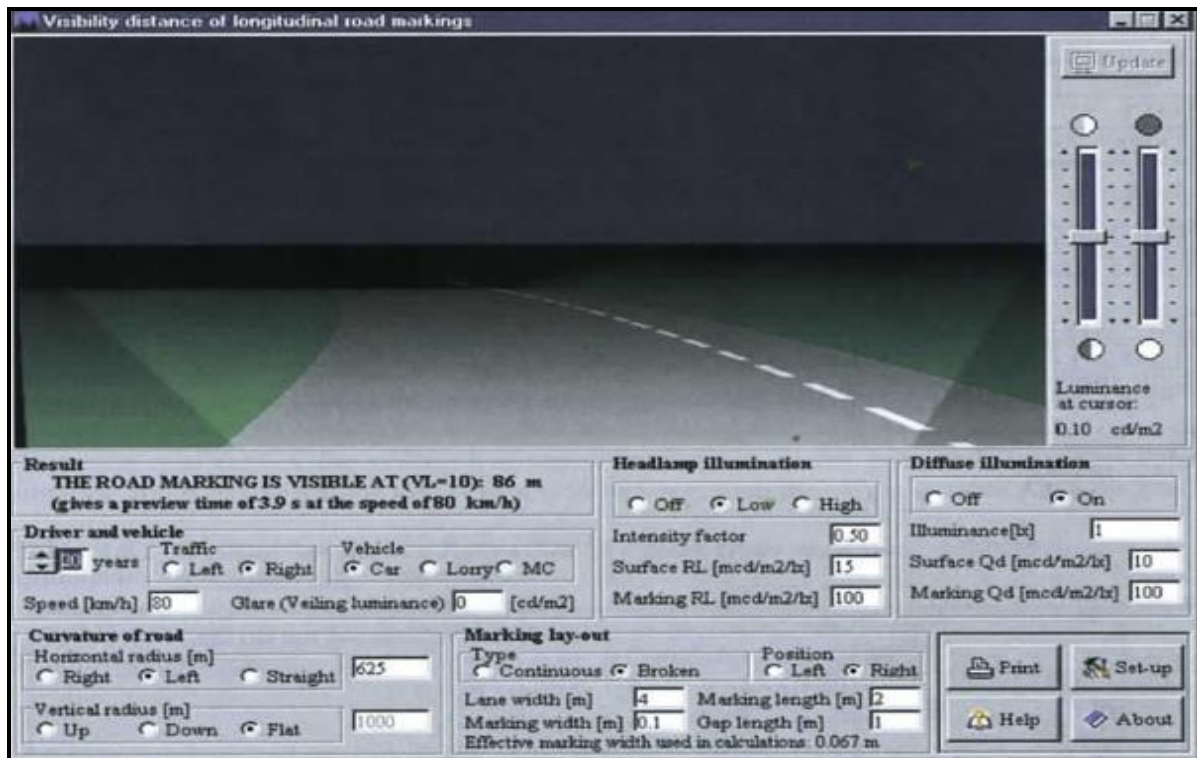

Figure 2.9: Visibility programme (COST 331, 1999).

2.14 COLOUR

In 1666, Isaac Newton developed the Newton colour circle which describes complementary colours and additive colour mixing. In 1802, Thomas Young speculated that there were three different types of colour sensitive receptors in the eye corresponding with red, green and blue. In 1860, James Clerk Maxwell recognised that the chromaticity of a coloured surface was relatively insensitive to the brightness, and this is the basis for modern day colorimetry. In 1931 the Commission International de l'Eclairage (CIE) developed the chromaticity diagram which is currently used to measure colour (Georgia State University, 2014). Three methods have been developed to determine the colour as viewed by the human eye, namely the Munsell System, the Ostwald System and the 1931 CIE Chromaticity Diagram. The 1931 CIE Chromaticity Diagram (Figure 2.10) has proved to be the most accurate system and is universally used. The human eye has three different types of colour sensitive cones and the response of the eye is best described in terms of three tristimulus values, namely X, Y and Z (Kerr, 2010). The CIE characterises colours by a luminance parameter Y and two colour coordinates x and y which specify the point on the chromaticity diagram (Kerr, 2010).

When the measuring equipment has a small measured area, sufficient readings shall be taken and an average calculated to obtain a representative measurement of the surface (BS EN 1436:2007, 2007). Commercially available instruments often use small measured areas, for instance less than 1 cm². Intermediate measuring values are the tristimuli values X, Y and Z. The tristimuli values are converted into the chromaticity co-ordinates x and y which are plotted on the chromaticity diagram to determine

the colour. Measurements can be made using laboratory equipment on road marking samples or using portable equipment on the actual road markings on the road. The instrument must be calibrated with the samples which are provided with the instrument to ensure that accurate measurements are obtained.

Some road markings will fade sooner than the others due to the constituents used, the position of the road markings in relation to the direction of the sun (ultraviolet light) and adverse weather conditions including rainfall. The yellow colour code for solvent-borne and water-borne road marking paints in SA is matt 356 from the BS 381 C colour chart and is called golden brown (SANS 731-1:2006, 2006 and SANS 731-2:2006, 2006). According to BS EN 1436:2007 (2007), the x and y chromaticity for dry road markings measured shall fall within the regions defined by the corner points indicated in Table 2.4 and illustrated in Figure 2.10. It can be seen in Figure 2.10 that the envelope for temporary yellow road markings is smaller than the envelope for permanent road markings, indicating that Europe is more stringent on short-term use of road markings, especially on construction sites.

As red road markings are used only as no-stopping lines which are a very small proportion of the total road marking network on the roads within CoT and also in SA, they will not be considered under this study. At the CoT, red solvent-borne road markings are applied instead of red thermoplastic road marking material as the quantities required for red road markings is generally low. Red thermoplastic road marking material is not readily available and also if it is used, there could be substantial delays when the road marking application equipment has to be cleaned before continuing with the application of white or yellow thermoplastic road marking materials.

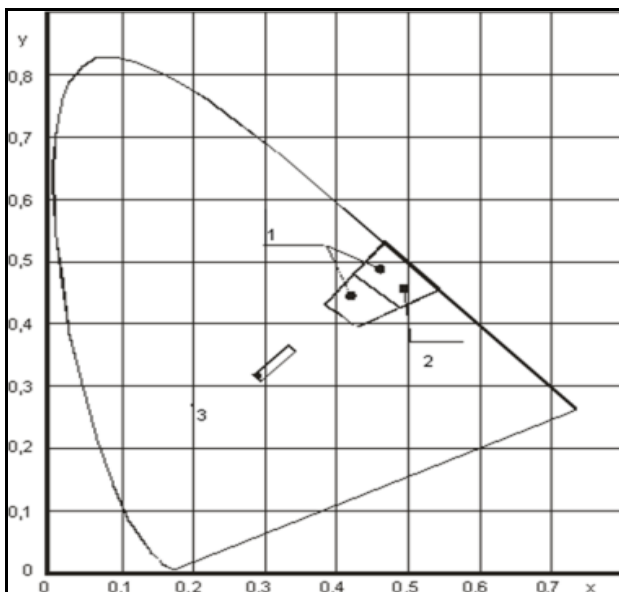

Figure 2.10: Chromaticity regions of white and yellow markings in the CIE diagram (BS EN 1436:2007, 2007).

(1) permanent yellow road markings, (2) temporary yellow markings, (3) white road markings

Table 2.4: Corner points of chromaticity regions for white and yellow markings (BS EN 1436:2007, 2007).

Corner point No.		1	2	3	4
White road markings	x	0.355	0.305	0.285	0.335
	y	0.355	0.305	0.325	0.375
Yellow road markings class Y1	x	0.443	0.545	0.465	0.389
	y	0.399	0.455	0.535	0.431
Yellow road markings class Y2	x	0.494	0.545	0.465	0.427
	y	0.427	0.455	0.535	0.483
The classes Y1 and Y2 for yellow road markings are intended for permanent and temporary road markings respectively					

2.15 SKID RESISTANCE

According to the SARTSM (1999), road markings must have a Skid Resistance Test (SRT) value of at least 50. Drop-on antiskid aggregates (and not the glass beads) usually provide the skid resistance (Highways Department, 2010). The skid resistance of road markings is important, especially for motorcyclists in urban areas (De Witt *et al.*, 2000). The high percentage of area that is covered with road markings ahead of intersections is extremely dangerous for motorcyclists if the skid resistance is not up to standard (De Witt *et al.*, 2000).

A skid resistance tester is used to measure the skid resistance of the road markings (SANS 6260:2007, 2007). According to BS EN 1436:2007 (2007), the Skid Resistance Test (SRT) value indicated in Table 2.5 is for flat road markings and road markings with low degree of texture.

Table 2.5: Classes of skid resistance (BS EN 1436:2007, 2007).

Class	Minimum SRT value
S0	No performance determined
S1	SRT \geq 45
S2	SRT \geq 50
S3	SRT \geq 55
S4	SRT \geq 60
S5	SRT \geq 65
The class S0 is for when the SRT value cannot be measured	

2.16 ACCEPTANCE CONTROL OF ROAD MARKINGS

At the CoT, the R_L measurements for acceptance control are conducted within two weeks of the application of the road markings with a hand-held (static) LTL-X retroreflectometer. Five measurements are conducted per road marking line type on road lengths up to 500 m. Ten

measurements are conducted per road marking line type on road lengths greater than 500 m up to 1000 m (Naidoo, 2012). The average R_L is calculated for each road marking line type in order to check if it complies with the minimum initial R_L (200 mcd/m²/lx for white road markings and 135 mcd/m²/lx for yellow road markings) (Naidoo, 2012). Should the average R_L be less than the minimum R_L , the road marking applicator is offered an opportunity to wash the road markings at the positions where the measurements are to be conducted and then the R_L is re-measured. The road marking applicator is obligated as per the road marking contract document to repaint the road should the minimum R_L not be achieved.

In Kentucky (USA), the R_L measurements for acceptance control are conducted over 500 m of the first third of the section of road where road markings have been applied (Babic *et al.*, 2014). The 500 m section of road is further divided into 50 m each, resulting in 10 measurement points. At each of the 10 points, three measurements are conducted and the average of the three measurements represents the R_L at that point. The main disadvantage of this method is that the test is performed only in the first third of the section of road which represents the entire road.

In Germany (Europe), five parameters, namely thickness of the road markings, dry R_L , wet R_L , Qd and skid resistance, are measured for acceptance control of the applied road markings within two months of application of the road markings (Babic *et al.*, 2014). Random 100 m sections are selected and five measurements of the five parameters are conducted over the 100 m section that is at 0 m, 25 m, 50 m, 75 m and 100 m. The number of sections selected depends on the length of road painted, namely for less than 1 km (one section), 1 to 5 km (two sections), 5 to 10 km (three sections) and more than 10 km (four sections) (Babic *et al.*, 2014). The measurement method used for obtaining the R_L conducted by Germany can provide a more realistic view of R_L as more sections can be measured.

According to BS EN 1436:2007 (2007), the value of a parameter for a particular road marking is dependent on the following but not limited to:

- Surface condition of the road marking which is influenced by the local conditions such as sand on the road;
- Time of year because after it rains the markings tend to become clean;
- Weather because the ambient temperature can affect the adhesion of the road marking paint;
- Type of road marking material on the road surface, and
- Type of vehicles because heavy vehicles, due to their mass, tend to wear out the road markings sooner than passenger vehicles.

2.17 CHARACTERISTICS WHICH AFFECT THE CHOICE OF ROAD MARKING PAINT

Technical specifications for road markings lay down performance levels for the parameters defining the R_L , the Qd, colour and skid resistance without having considered sufficiently the relationship

between what the driver needs for appropriate guidance, and what the road marking is able to provide. The emphasis is more on how durable and cost effective various road marking products are. The SARTSM, (1999) provides the various dimensions of road markings to be used in rural and urban roads. There are four important characteristics that determine the type of road marking paint or material to be used, namely the geometry of road, road surface type, the climatic conditions and the number of vehicles that will use the road.

2.17.1 Geometry of road

According to local experience, roads constructed without adequate cambers, crossfalls or drainage systems will retain sand and debris on the road surface. The sand will cause an abrasive action by the vehicles' tyres on the road markings and as such the road markings will rapidly wear off.

2.17.2 Road surface type

Different types of road surfaces can pose different problems of which the road marking applicator and the engineer responsible for road markings must be aware of so that the road markings will be durable as stipulated in the specifications. The bond of the road markings onto the road surface may be affected by dirt, texture, chemical or mechanical properties, curing compounds and road surface oils in new hot-mix asphalt or chip seals (Smadi *et al.*, 2013). However, with proper preparation a good bond can be achieved on the road surface.

The bond of the road markings on a chip seal surface (which is rougher than an asphalt surface) may be better but it may be more difficult to achieve higher R_L on a chip seal surface than on an asphalt surface. Road markings on rough surfaces generally have lower R_L and shorter service lives than identical markings on smooth surfaces (Gates *et al.*, 2003 and Lopez, 2004). The poor performance of the road markings on the chip seal surface is attributed to the drop-on glass beads which fall between the aggregate of the chip seal surface that is not totally exposed to the vehicles' light rays. Hence R_L will be lower than similar road markings on a flat asphalt surface. The other reason for the poor performance is that the binder is thinner on top of the aggregate of the chip seal surface and as such the adhesion of the glass beads is poor, resulting in a lower R_L being achieved. The impact of the vehicles' tyres may also wear off the markings easily on top of the aggregate of a chip seal surface where the markings are usually thinner (Gates *et al.*, 2003 and Lopez, 2004).

It is important that the testing of R_L of road markings be done with a correct retroreflectometer, otherwise it may be of detriment to the road marking applicator. Retroreflectometers vary in profile height capacity. For example, the LTL-X retroreflectometer measures up to 15 mm in depth while the LTL-XL retroreflectometer measures only up to 5 mm in depth. The direction of road marking application on a chip seal surface can also play a role in the R_L . In order to overcome this problem, a

dual spray system must be used with the nozzles angled towards one another at approximately 60° in order to achieve R_L specified in both directions (Smadi *et al.*, 2013).

2.17.3 Environment

Environmental conditions can have a major influence on the performance of the road marking material. The effect of environmental conditions on performance can be separated into two categories (Lopez, 2004):

- Weather conditions when the marking is applied
- Year-round climate

The weather conditions when the markings are applied are often said to be one of the most influential factors in the performance of the marking. This is especially true for environmentally sensitive materials such as thermoplastic road marking materials. Factors that should be considered include (Lopez, 2004):

- Air and road temperature
- Humidity
- Wind velocity
- Surface moisture at the time of application of the road marking

Most road marking paints and materials require a minimum air and road temperature in order to ensure proper drying and curing times. Humidity also affects the drying and curing times. Wind velocity affects the drying time but more especially the drop-on glass bead dispersion. Road surface moisture at the time of application can have a severe effect on the bonding capabilities of the road marking paints and materials to the road surface. Most road marking paints and materials require that the road surface be devoid of surface moisture prior to application to achieve bonding.

Year-round climatic conditions can also affect the long term performance of the road marking paints and materials (Lopez, 2004). Ultraviolet (UV) rays cause the chemical bonds of the constituents to break down and lose their original properties (Lopez, 2004 and Martin *et al.*, 1996). Road markings expand and contract with temperature changes. When the bond strength is greater than the tensile strength of road marking materials, cracks develop in the road marking materials and this is quite evident on thicker road markings (Martin *et al.*, 1996). Local experience has shown that rain tends to clean the road markings, resulting in the markings looking more visible. The disadvantage is that when it rains, some road markings become submerged in the water and the road markings become difficult to see even under lighting conditions.

2.17.4 Traffic

The traffic composition and volumes will affect the choice of road marking paint or material. According to the SARTSM, (1999), traffic volumes are important in that the Annual Average Daily Traffic (AADT) is the major criterion used to select specific types of delineation. The higher volume roads should be maintained with more durable road marking products which will avoid frequent road marking maintenance. Low volume roads can be maintained with less durable road marking products and even thinner road markings. Heavy duty vehicles can affect the rate of wear of the road markings faster than the passenger vehicles. According to Lopez (2004), some agencies base pavement marking material selection primarily on traffic volume levels.

The SARTSM, (1999) provides an indication of the service life of road marking paint in relation to the AADT whereby higher numbers of vehicles have an adverse effect on the life of the road markings as can be seen in Figures 2.11 and 2.12. The service life of road marking paint on the narrower roads is lower than on the wider roads due to the possibility of the vehicles constantly driving over the road markings as can be seen in Figure 2.11. The service life of road markings on concrete roads is lower than that on asphalt roads as can be seen in Figure 2.11. One of the main reasons is that on concrete roads, applicators fail to apply a primer coat before the road marking is applied (Lopez, 2004).

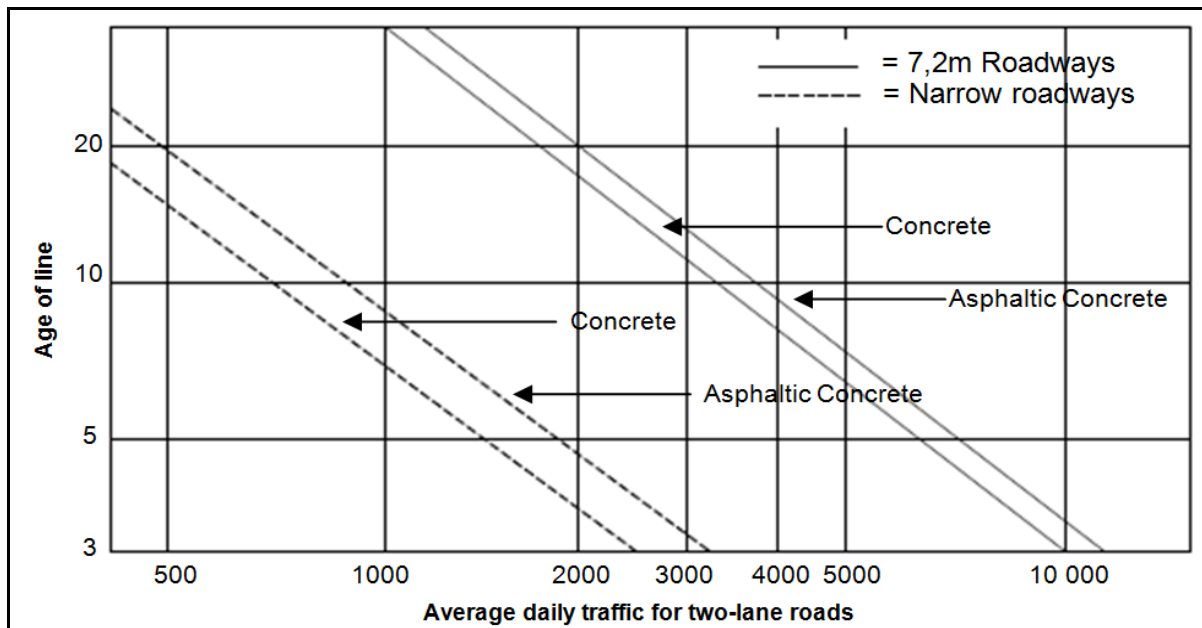

Figure 2.11: Line wear of white traffic paint (SARTSM, 1999).

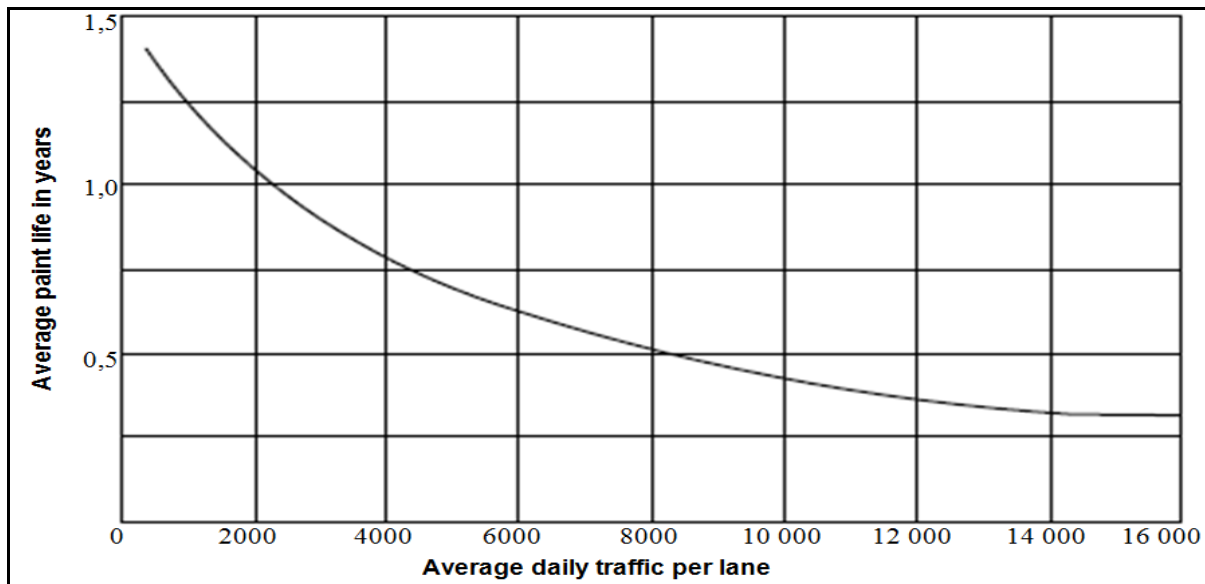

Figure 2.12: Paint marking affected by traffic density for both bituminous and concrete pavement (SARTSM, 1999).

2.18 ROAD MARKING MAINTENANCE PROGRAM

The road surface must be cleaned of all dust and sand and made dry before the application of the road markings in order to ensure that the road markings adhere to the substrate (Lopez, 2004). The sand should be totally removed from the road in order to prevent it from getting onto the road marking soon after the road markings are applied, which will wear off the road markings rapidly especially under the action of vehicles' tyres (Lopez, 2004). According to local experience, road marking applicators have the tendency to clear the dust and sand only off the area where the road markings are required and leave it adjacent to the edge of the road markings. As soon as the road is opened to traffic the sand is driven onto the road markings, causing immediate damage to them. The weather forecast should be taken into account when planning for the application of road markings as some road marking paints and materials may be adversely affected under certain weather conditions (Lopez, 2004). The road markings should be protected until such time that they have dried. In SA, traffic cones or delineators are generally used to prevent vehicles going over the wet road markings.

In California the roads need to be repainted three times per year with normal liquid paint or every two years with thermoplastic road marking materials in order to ensure that the R_L is generally greater than $100 \text{ mcd/m}^2/\text{lx}$ (Carlson, 2013). Approximately 85 per cent of the road markings in Michigan are repainted by the Michigan Department of Transport annually while only 15 per cent are subjected to testing for acceptance control. At the CoT, the operational teams (depots) paint approximately 30 per cent of the suburban roads (low traffic volume roads) annually with solvent-borne road marking paint applied with paint rollers. The glass beads are manually thrown onto the road markings. These roads are not subjected to any road marking tests as the operational teams do not possess the equipment to carry out the tests. The condition of road markings on the remainder of the suburban roads is

generally in a poor condition according to the annual visual inspections. The higher traffic volume roads are usually maintained by external road marking applicators and every road is subject to R_L tests.

According to Carlson (2013), in 2006 researchers in New Zealand studied the safety impacts of brighter road markings and concluded that there was not a conclusive improvement in safety and as such their minimum R_L is set at $70 \text{ mcd/m}^2/\text{lx}$. However, there are other retroreflective devices such as delineators and road studs which are used to enhance visibility. These devices can be costly initially and also can increase the maintenance cost and therefore they are not used very often on the roads within CoT.

There should be a schedule and method for maintenance of road markings so that the markings do not become too thick. When the road markings are unnecessarily thick, it may create a rough ride, especially to motorcycles and bicycles. The markings may become prone to breaking up due to the impact of the tyres against them and may even result in noise as the tyres pass over the road markings. When road markings are very faint, pre-marking may be required, which is an additional cost, so it should be avoided that markings such a state (SANS 731-2:2006).

According to the Accounting Standards Board (2010), it is compulsory for all road authorities to keep record of all their assets and expenditure as evidence needs to be provided to the relevant auditors for verification purposes. It is for this reason that appropriate management systems should be in place to ensure that all inventory is captured, with its condition and replacement cost.

The management system designed for road markings can be used to produce reports on various aspects namely:

- Roads with highest priority requiring maintenance of road markings;
- Budgeting for road marking maintenance;
- Condition of road markings;
- Value of the total road marking network, and
- Evidence should there be claims against the road authority

2.19 PERFORMANCE-BASED ROAD MARKING CONTRACTS UNDERTAKEN BY SANRAL

Performance-based contracts are specification orientated, depending on the nature of the road especially when it comes to traffic volumes. On higher volume roads, the intention is to limit the inconvenience to the road user, and therefore a 36-month performance period is recommended (Hay, 2013). This reduces the risk profile to both SANRAL and the road users. The recommendation on the non-critical roads is usually a 24-month performance period (Hay, 2013). The first R_L test is done within 3 months after the initial road marking. This takes into account the question of whether the

contractor has loaded his bead application; if so, the majority of the excess beads which would have yielded a higher R_L would have been driven off the road markings. There is an art to mixing the bead sizes, and loading additional beads in order to achieve false values in R_L must be eliminated. Payments to the road marking applicators are based on the specific section of the road that is divided into uniform 4 km sections for testing with a calibrated hand held portable retroreflectometer (Hay, 2013). According to Hay (2013), the acceptable R_L is calculated using the Student T statistical method as described below:

$$t_{n-1} = \frac{\sqrt{n}(\bar{x} - \mu)}{S_x}$$

where: n = number of samples

\bar{x} = average of samples

S_x = standard deviation of samples

μ = specification limit

At each inspection the following acceptance criteria will be applicable:

- Acceptable if the probability is greater than 90 per cent using the student's t-distribution statistic, that the sampling average for any road section under consideration is greater than the specification;
- Conditional acceptance if the probability is greater than 85 per cent and less than 90 per cent, using the student's t-distribution statistic, that the sampling average for any road marking item on any road section under consideration is greater than the specification, and
- Failed if the probability is less than 85 per cent, using the student's t-distribution statistic, that the sampling average for any road marking item on any road section under consideration is greater than the specification.

The payments to the road marking applicators are made in instalments. The initial payment on completion of the works is 60 per cent (20 per cent for visual assessment and 40 per cent if the road markings pass the initial R_L), at mid-point of the performance period another 20 per cent is paid and at the end of the performance period the final 20 per cent is paid to the road marking applicator (Hay, 2013). It is obvious that, should the results not meet the criteria at the different times, the road marking applicator would not be paid and the applicator would have to repaint. It is in the interest of the road marking applicator to ensure that the works are executed to a high standard so that the road markings will last at least over the stipulated performance period, as the road marking applicators' profits are usually achieved during the third test period. The risk is passed onto the road marking applicator to ensure that the product meets the criteria set in the tender specifications.

The movement of vehicles on national roads is different to that on city roads. There is more turning action, stop-and-go and parking on the city roads than the on the national roads. The slow movement

of vehicles and the parking of the vehicles on the city roads also result in oil deposits from vehicles, which can cause discolouration of the road markings.

According to Hay (2013), it is important for the range in R_L to be small in order to achieve consistent deterioration on the road markings. It is not of benefit if the result of a given line is $200 \text{ mcd/m}^2/\text{lx}$ to $400 \text{ mcd/m}^2/\text{lx}$, although the minimum and maximum are acceptable R_L values, because the line will not deteriorate uniformly which may complicate the decision of whether to remark the road and may also affect the driver's view due to inconsistency in R_L (Hay, 2013). The safety aspect to the driver may be compromised. For example, if lower levels of R_L are situated around a horizontal curve, this may adversely affect the driver's sight distance and the result could be that the driver may find it difficult to keep the vehicle within his lane. It should also be noted that road markings around a curve may be prone to a quicker rate of deterioration than on straight sections of road.

The decision of when to do maintenance of road markings on the national roads is based on life prediction of the road markings. This will be confirmed in the second testing period where SANRAL can ascertain if the road markings will last their full service life or may fall short (Hay, 2013). When the results do not fall within the acceptable limits, an intervention is done but to only get the road markings to their original design life. Thus, if the tender is set with a performance contract of 36 months, SANRAL usually will plan to repaint those roads at the end of the 36-month period. The CoT has limited staff responsible for road marking maintenance and limited equipment to verify if the road markings are still within the standards set. A visual inspection is done annually of the entire city road network and a priority list is developed according to the class of road. The primary and secondary roads receive the highest priority for road marking maintenance due to the higher volume of vehicles that use these roads.

Figures 2.13 and 2.14 illustrate the decline in R_L of white and yellow road markings on SANRAL's road network. Table 2.6 indicates all the details of the sections of roads tested on SANRAL's road network. It is evident that even water-borne road marking paints used on the national roads are quite durable (Figures 2.13 and 2.14). The road marking applicators chose to apply water-borne road marking paint on the N14 in North West Province (NW), the R33 in Mpumalanga Province (MP) and the R40 in Limpopo Province (LP) as they have found that in the past water-borne road marking paints could last over the performance period on these roads (Hay, 2013). These roads are generally clean and the traffic volumes are low as can be seen in Table 2.6. Thermoplastic road marking material was specified for use on the N1 highway in Gauteng Province (GP) from the Brakfontein interchange to Rigel Avenue (Hay, 2013). The reason for this decision was due to the anticipated high traffic volumes on the N1 highway over the performance period and also the confidence that SANRAL has in the durability of thermoplastic road marking materials over water-borne road marking paints. The performance period stipulated on the N1 was 36 months as opposed to 24 months on the N14, R33, and R40, in order to reduce the safety risk to the road marking applicators and road users. Another reason for the 36-month performance period stipulated on the N1 was the avoidance of more

frequent road closures and application of traffic accommodation, which interrupts traffic flow and adversely affects the economy of SA.

The gradient of the white thermoplastic road marking material is gentle, indicating that the R_L can be achieved over longer periods. However, after approximately 24 months the R_L was below $100 \text{ mcd/m}^2/\text{lx}$, which means that the thermoplastic road markings on the N1 did not comply with the specification over the stipulated performance period of 36 months (Figure 2.13). The road marking applicator did not receive the final payment for the thermoplastic road marking materials applied on the N1 (Hay, 2013). The second set of R_L measurements was conducted 18 months after the application of the thermoplastic road marking materials on the N1 and the result obtained was approximately $110 \text{ mcd/m}^2/\text{lx}$ (indicated in Figure 2.13), which is close to the minimum R_L of $100 \text{ mcd/m}^2/\text{lx}$ for white road markings. The engineer should have taken some additional precautions in order to achieve the requirements over the performance period. For example, the engineer should have requested another test on R_L after 24 months. Although approximately 76 million light vehicles and 32.5 million heavy vehicles used the N1 over the 24 months, not all these vehicles may have contributed directly to the decline in R_L of the white thermoplastic road markings as the traffic counts were taken for all road lanes.

Table 2.6: Summary of data on SANRAL's road network (Hay, 2013).

Province	Road	Section	Type of surfacing	No. of lanes per direction	Performance period	Road marking description	Road marking colour	Type of road marking paint / material	Average rainfall (mm)	Average minimum temperature (°C)	Average maximum temperature (°C)	Annual Average Daily Traffic (AADT)
Gauteng	N1	Brakfontein interchange to Rigel Avenue	Asphalt	3	March 2005 to March 2008	GM1 (lane line)	White	Thermoplastic	1953,9	12,2	25	Light =105417 Heavy =4535 Total =109952
Gauteng	N1	Brakfontein interchange to Rigel Avenue	Asphalt	3	March 2005 to March 2008	RM4.1 (left edge line)	Yellow	Thermoplastic	1953,9	12,2	25	Light =105417 Heavy =4535 Total =109952
North West	N14	Vryburg to Gauteng border	Chip seal	1	October 2006 to August 2008	WM3 (dividing line)	White	Water-borne	1145,2	12,1	27,1	Light =1642 Heavy =322 Total =1964
North West	N14	Vryburg to Gauteng border	Chip seal	1	October 2006 to August 2008	RM4.1 (left edge line)	Yellow	Water-borne	1145,2	12,1	27,1	Light =1642 Heavy =322 Total =1964
Mpumalanga	R33	Carolina to Stoffeberg	Chip seal	1	August 2007 to February 2009	WM3 (dividing line)	White	Water-borne	1615,6	10,5	23,4	Light =2415 Heavy =528 Total =2943
Mpumalanga	R33	Carolina to Stoffeberg	Chip seal	1	August 2007 to February 2009	RM4.1 (left edge line)	Yellow	Water-borne	1615,6	10,5	23,4	Light =2415 Heavy =528 Total =2943
Limpopo	R40	Marite to Tzaneen	Chip seal	1	August 2006 to April 2008	WM3 (dividing line)	White	Water-borne	1066,6	14,2	27	Light =3016 Heavy =341 Total =3357
Limpopo	R40	Marite to Tzaneen	Chip seal	1	August 2006 to April 2008	RM4.1 (left edge line)	Yellow	Water-borne	1066,9	14,2	27	Light =3016 Heavy =341 Total =3357

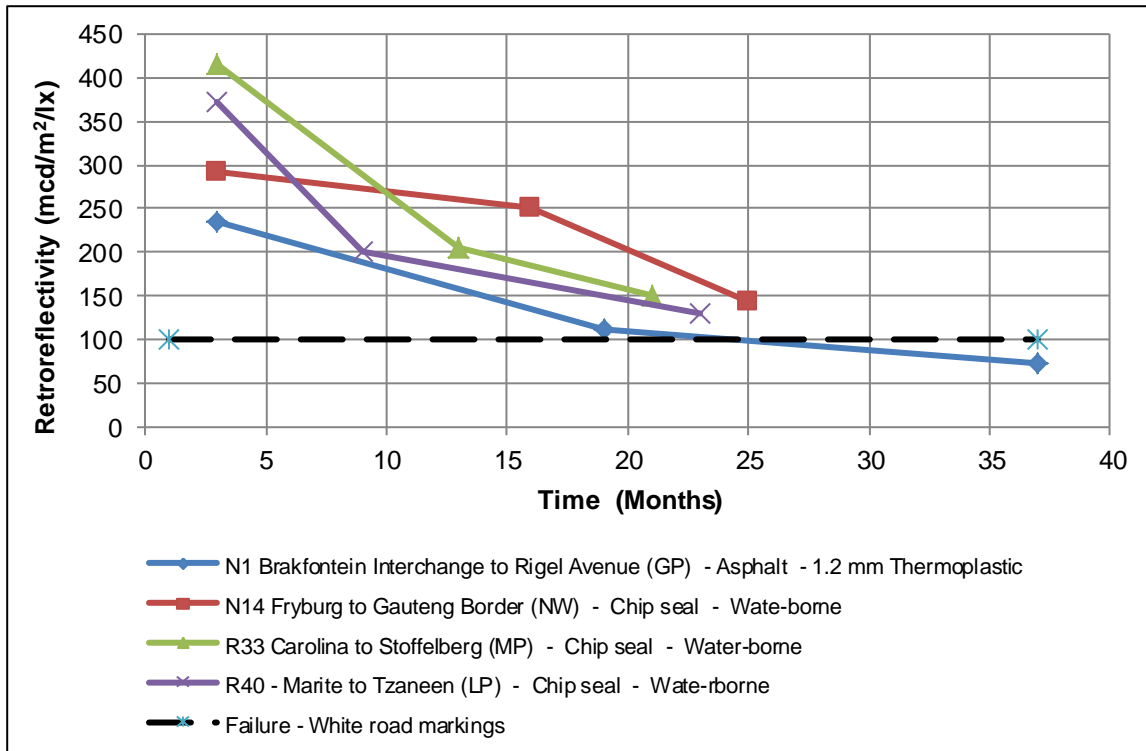

Figure 2.13: Decline in retroreflectivity of white markings on SANRAL's road network.

The yellow thermoplastic road marking material on the N1 yielded a service life of approximately 17 months as the minimum R_L on yellow road markings is $70 \text{ mcd/m}^2/\text{lx}$ (Figure 2.14). Approximately 54.7 million light vehicles and 2.3 million heavy vehicles used the N1 over the 17 months but not all these vehicles would have contributed to the decline in R_L of the yellow thermoplastic road markings as the vehicle count was over all the road lanes.

The gradients of each road marking in Figure 2.14 look similar for the first 15 months, but many more vehicles used the N1 where thermoplastic road marking material was applied than the R40, indicating that thermoplastic road marking materials are much more durable than water-borne road marking paints. Only 1.8 million light vehicles and approximately 0.2 million heavy vehicles used the R40 in 20 months, after which the road markings declined to below $70 \text{ mcd/m}^2/\text{lx}$.

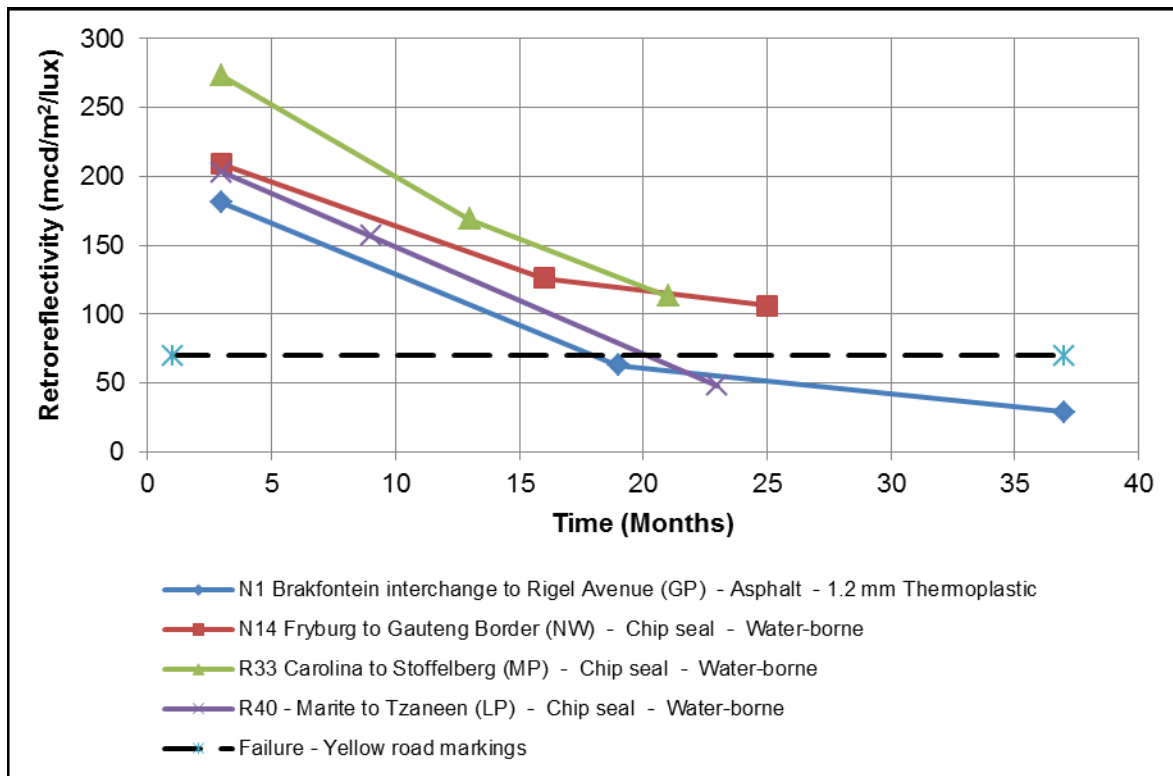

Figure 2.14: Decline in retroreflectivity of yellow markings on SANRAL's road network.

Road markings should generally wear off over time. However, some road markings tend to break off in pieces, which is quite evident on the thicker road markings. The likelihood is that when the road markings start breaking off, they will continue breaking off and as such the remainder of the road markings should rather be removed before applying new road markings on top of these road markings. The old road markings usually act as the base for the new road markings, but if the base is not stable the new road markings will come off together with the old road markings. The ideal way of removing road markings is by sand blasting or water jetting.

Redundant road markings must be removed by means of sand blasting or water jetting. Redundant road markings should never be blacked out unless under exceptional circumstances. For example, when the relevant equipment is not readily available to remove road markings or the surfacing may be fairly new, they can as a temporary measure be blacked out. Arrangements must then be made to remove them soon and not be left black.

Some of the main reasons to avoid the blacking out of redundant road markings are as follows:

- The black paint will eventually wear off and the redundant road markings will be exposed and then the road user will react incorrectly and this could lead to accidents;
- Black paint can be seen as a road marking at certain times of the day, and again the wrong action could be taken by the driver, and

- At night the black paint can be seen as a road marking and thereby confuse the road user in deciding which marking to adhere to. This is because the black paint does not blend into the black road surface due to the difference in shade between the black road surface and the black paint.

Trial tests should be conducted first to ensure that the equipment is fully functional to apply the road marking paint or material correctly, in order to avoid subsequent corrections to works which may become visible. The action of sand blasting or water jetting causes damage to the road surface and the surface will look like road markings especially at night which may confuse the road user.

2.20 CONCLUSION

From the literature study, there is a clear indication that Europe places a lot of emphasis on road markings to continuously improve road safety. SA is still far from European research studies and much more emphasis should be placed on all aspects of road markings in order to improve road safety. A low cost engineering measure like road markings can contribute towards improving road safety and is also an important control device in ensuring the smooth flow of traffic. Road marking applicators should ensure that the correct road marking constituents are used and that the road markings are applied correctly in order to ensure that they meet the specified requirements. All the constituents for a mix design are important, but glass beads stand out as the most important constituent. Therefore road marking applicators must ensure that they procure the correct glass beads and apply them correctly as per the manufacturers' specification in order to ensure that the primary need for road markings, which is R_L , complies with the specifications.

3 METHODOLOGY

3.1 INTRODUCTION

Road markings are horizontal traffic control devices applied on the surface of the road to regulate, warn and guide traffic on the road network. In order for the road markings to be effective, they must conform to the required standard specifications. Road markings are important to the road user at all times but more especially during the time of darkness. Many road authorities in SA determine the need for road marking maintenance on the daytime visibility of the road markings, which are generally inspected visually. Some road authorities react to road marking maintenance only when numerous complaints are received for roads to be repainted. As some road authorities have a substantial road network with limited staff, it is neither possible nor practical to test all the roads to determine if the road markings conform to the standard specifications. The development of a standard will assist in determining maintenance cycles and may also assist in determining more realistic budget allocations for road marking maintenance.

Road trials of permanent road markings should be conducted over the full climatic cycles of at least one year (BS EN 1824:1998, 1998, SANS 731-1:2006, 2006 and SANS 731-2:2006, 2006). According to BS EN 1824:1998 (1998), the test markings are applied transversely and longitudinally on a flat asphalt road which has been established for at least a year. The SABS conducts road trials only on transversely applied test markings (SANS 731-1:2006, 2006 and SANS 731-2:2006, 2006).

3.2 RESEARCH DESIGN

The following activities were undertaken as part of this study:

- A range of sites as can be seen in Figures 3.1 to 3.9 were selected for this study which included asphalt roads and chip seal roads, both new and long established. The long established roads were surfaced at least 3 years ago and also road markings had previously been applied. The roads were further categorised into “clean asphalt surfaced roads” (roads that are self-cleansing for example when it rains, if sand from the edge of the road is washed onto the road the sand will flow into the stormwater system due to the effective gradient and efficient stormwater system), “dirty asphalt surfaced roads” (sub-standard roads resulting in sand remaining on the roads due to the ineffective gradient and also due to a lack of stormwater systems), “clean sealed roads” and “dirty sealed roads”;
- There was communication with the resurfacing team at the CoT to identify newly resurfaced roads which could fit into the specific categories;
- A link of the road was selected and at least two blocks of transverse markings were applied depending on the length of the link. A link of the road is from one intersection to the next intersection as can be seen in Figure 3.10. On some of the links it was not possible to apply three

blocks of the test road markings due to the length of the link. In such case two blocks of transverse markings were applied close to the ends of the link. If the link was long enough to accommodate three blocks of transverse markings, two blocks of transverse markings were applied close to the ends of the link and one block of transverse markings was applied towards the middle of the link. The intention was to get a good indication of the performance of the road markings over a longer length than just focusing on markings close to the stop line. A set of transverse markings was comprised of various types of road markings, namely water-borne road marking paints, cold plastic and thermoplastic road marking materials;

- A block of transverse test road markings was made up of three sections of various white road marking paints and materials and various yellow road marking paints and materials as can be seen in Figure 3.11. Each road marking was applied to a width of 150 mm as recommended in SAN 731-1:2006 (2006) with a gap of 200 mm over the width of a lane selected;
- The position of the longitudinal test road markings were also broken up into blocks, the same as the transverse test road markings. Longitudinal test road markings were applied in the prescribed position where the markings must be under the normal road markings layout in order to determine a more realistic service life of the longitudinal road markings. The yellow longitudinal test road markings were applied on the left-hand edge of the lane. The white longitudinal test road markings were applied either on the centre line, lane line or right edge line. The length of each type of road marking product was approximately 10 m for both the left edge yellow line and the right edge white line in a block. The lane line or centre line was painted with different types of road marking products according to the length of the type of road marking. For example, the lane line is 1.5 m long with a gap between the lane line markings while the centre line may be a solid white line which was distributed with the road marking products available;
- The test road markings were applied on clean, dry surfaces and the temperature of the road surface was greater than 10° C as recommended in COLTO (1998). The application of all markings on each test site was completed on the same day. As the test sites were far apart, it was not possible to complete the application of all the road markings on all the sites in one day;
- Traffic accommodation was done in accordance with SARTSM, (1999) when applying the test road markings in order to ensure the safety of the road users and road marking application team;
- The test road markings were applied on the road surface as follows: water-borne road marking paints (0.42 l/m²), cold plastic (1 mm), and thermoplastic (1.2 mm and 3 mm). The road marking paints and materials were applied on test plates at the same time when applying the test road markings on the road surface to ensure that the correct application rates were achieved;
- European information according to BS EN 1436:2007 (2007) in conjunction with SA road marking standards were used in the study to obtain the standard;
- Initially five service providers agreed to provide road marking paints and road marking materials. At the time of applying the road marking paints and materials, only four service providers kept to the arrangements. The acronym SP1 means service provider one, SP2 means service provider two and so on. Some of the quantities of road marking paints and materials obtained from some of the service providers were insufficient to be applied on all the test sites. The service providers

of the road marking paints and materials were given the option to apply the products offered for the study or they could nominate the road marking applicator as some suppliers of road marking paints and materials did not possess the road marking application equipment;

- Traffic counts were arranged with the CoT's Traffic Engineering Section. The traffic counting system was set up such that the traffic counts were obtained from the lane where the transverse test road markings were applied. The traffic counts were categorised into light vehicles and heavy vehicles. Light vehicles are all vehicles up to 4.9 m in length including the same vehicles towing a trailer. Heavy vehicles are all vehicles greater than 4.9 m in length. The counts were obtained over 14 consecutive days during a period while schools were operational and converted into Annual Average Daily Traffic (AADT), and
- Four road marking parameters were measured, namely R_L , Qd, colour and skid resistance.

The following white and yellow road marking paints or road marking materials were applied on the test sites:

- Water-borne road marking paint which conformed to SANS 731-2:2006;
- Imported water-borne road marking paints;
- Cold plastic road marking material blended in SA;
- Imported cold plastic road marking material;
- Thermoplastic road marking material blended in SA, and
- Imported thermoplastic road marking material.

During the application of the test road markings, cold plastic road marking materials were only applied by hand in SA but lately road marking applicators have machines to apply cold plastic longitudinally. Therefore longitudinal cold plastic road marking materials were not applied for the study. Cold plastic is generally more expensive than thermoplastic and also produces a longer service life than thermoplastic road marking materials (Montebello and Schroeder, 2000)

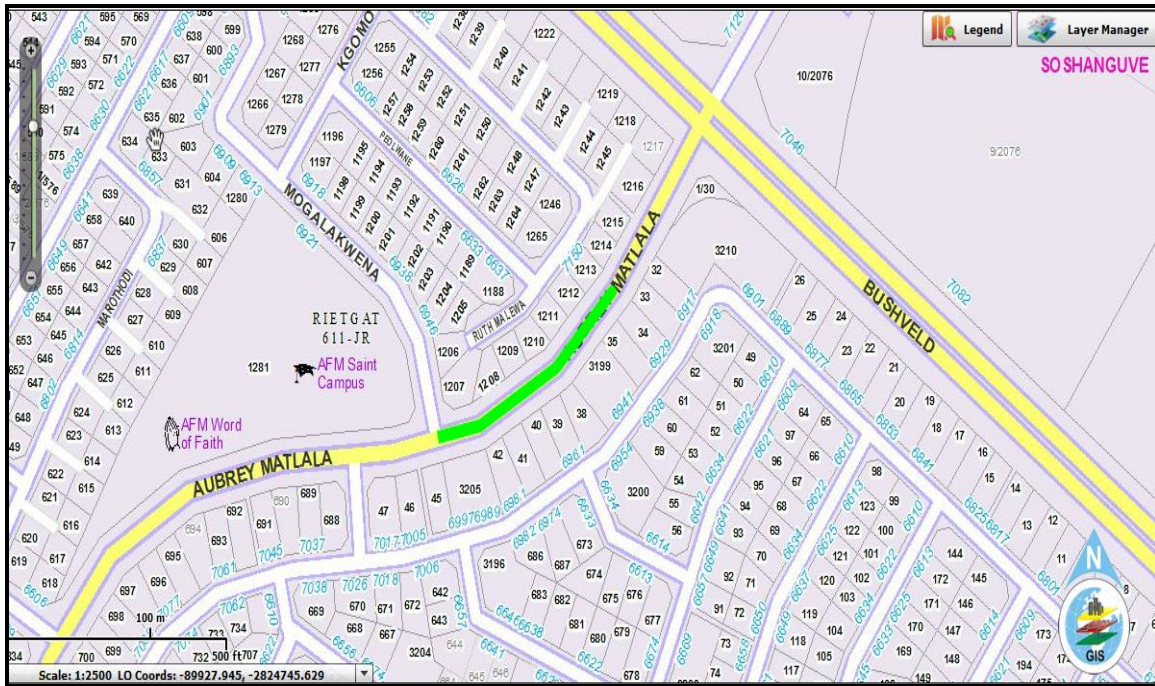

Figure 3.1: Newly established dirty chip seal road (Aubrey Matlala Road).



Figure 3.2: Newly established clean chip seal road (Doreen Street).



Figure 3.3: Long established clean chip seal road (Bushveld Road).

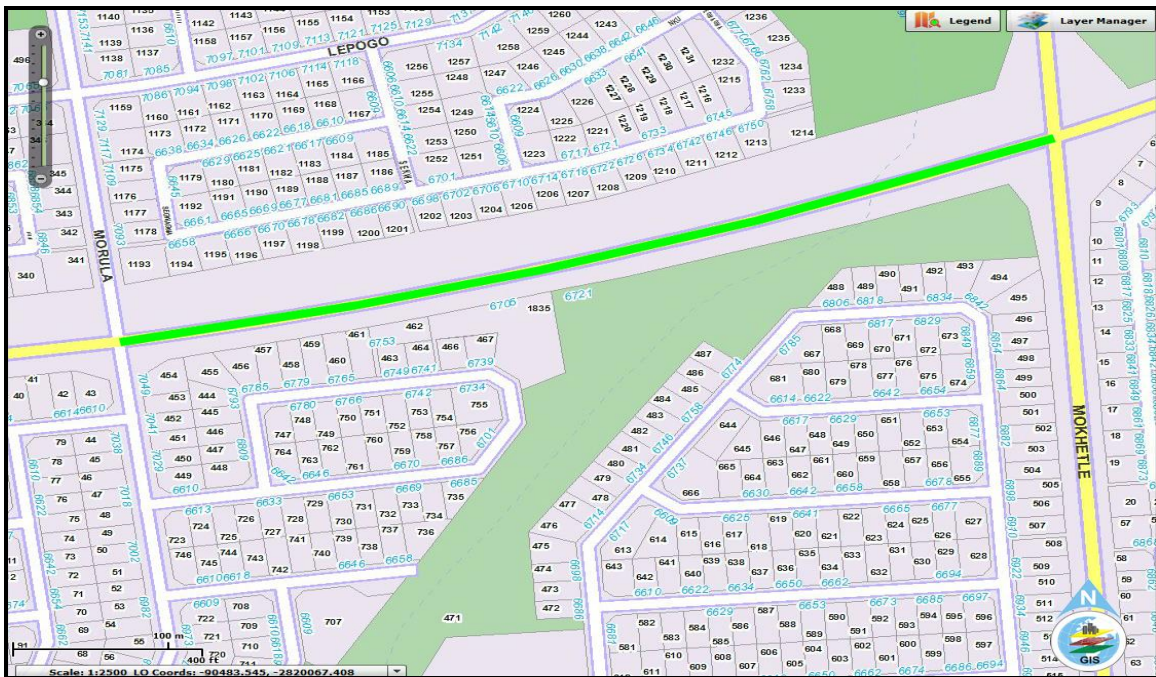

Figure 3.4: Newly established dirty asphalt road (M 44).

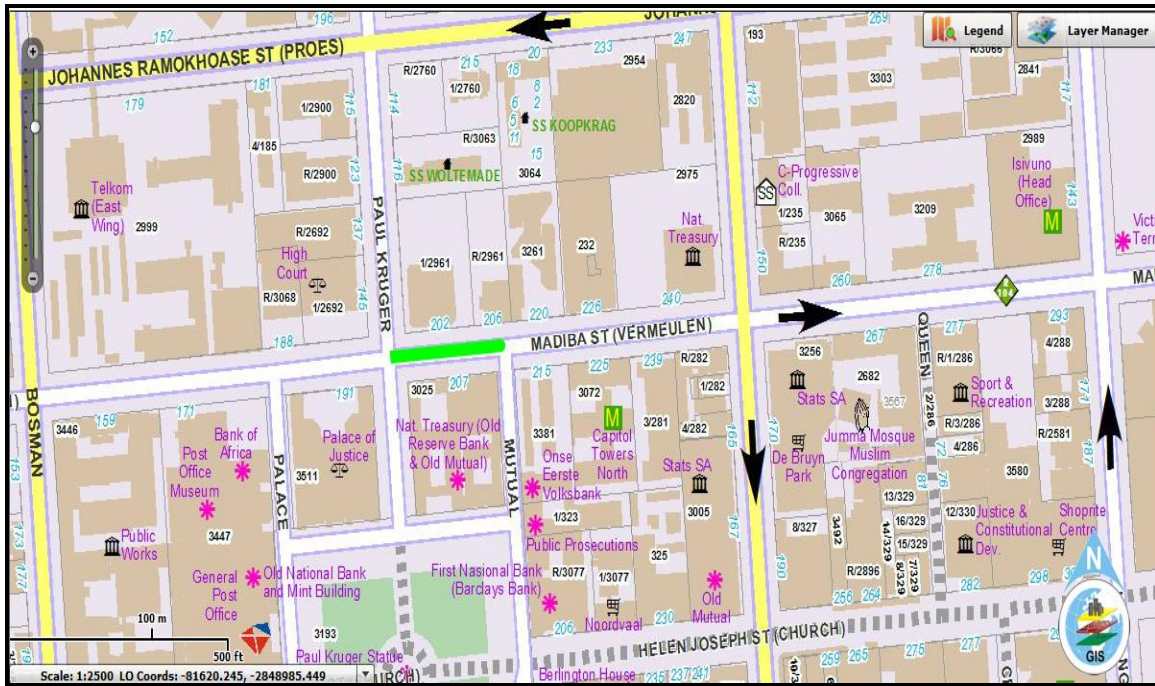

Figure 3.5: Long established asphalt road in the CBD (Madiba Street).



Figure 3.6: Long established clean asphalt road (Middel Street).

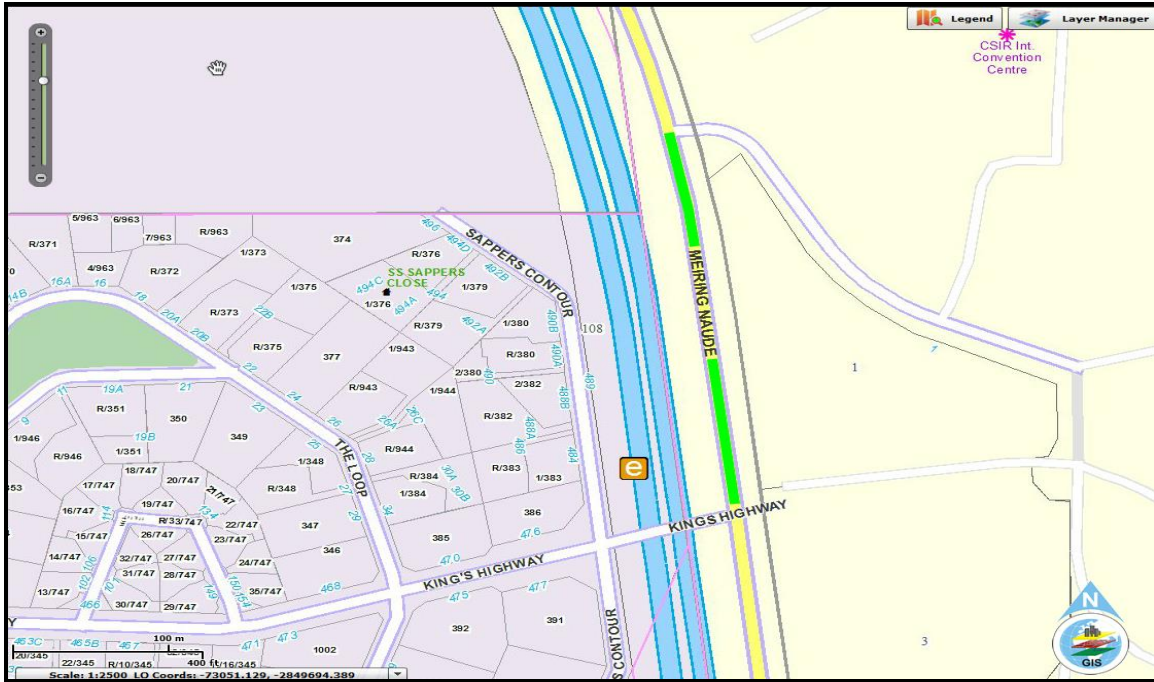

Figure 3.7: Newly established clean asphalt road (Meiring Naude Road).

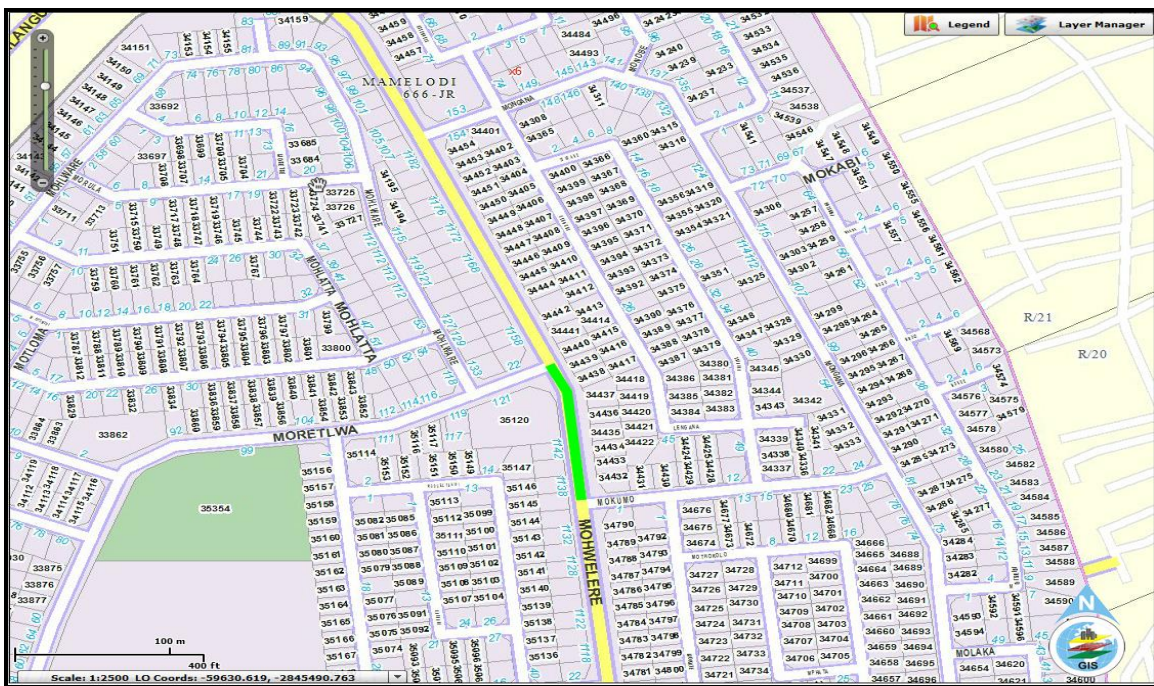

Figure 3.8: Long established dirty asphalt road (Mohwelere Street).

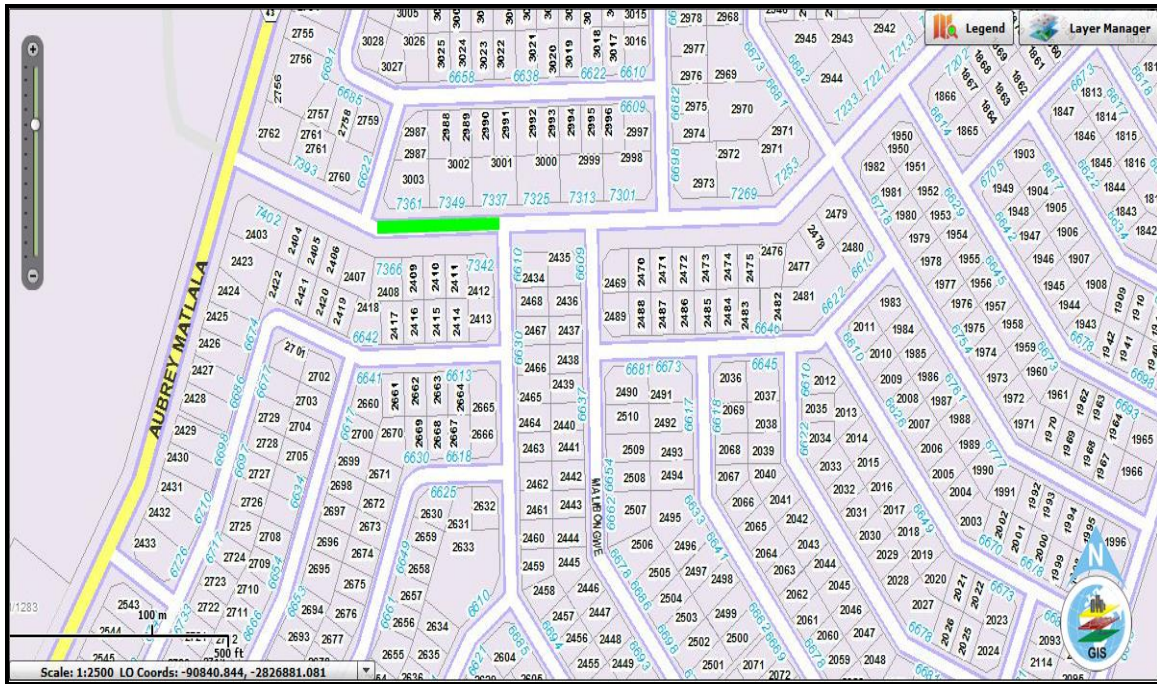

Figure 3.9: Long established dirty chip seal road (Road L 3).

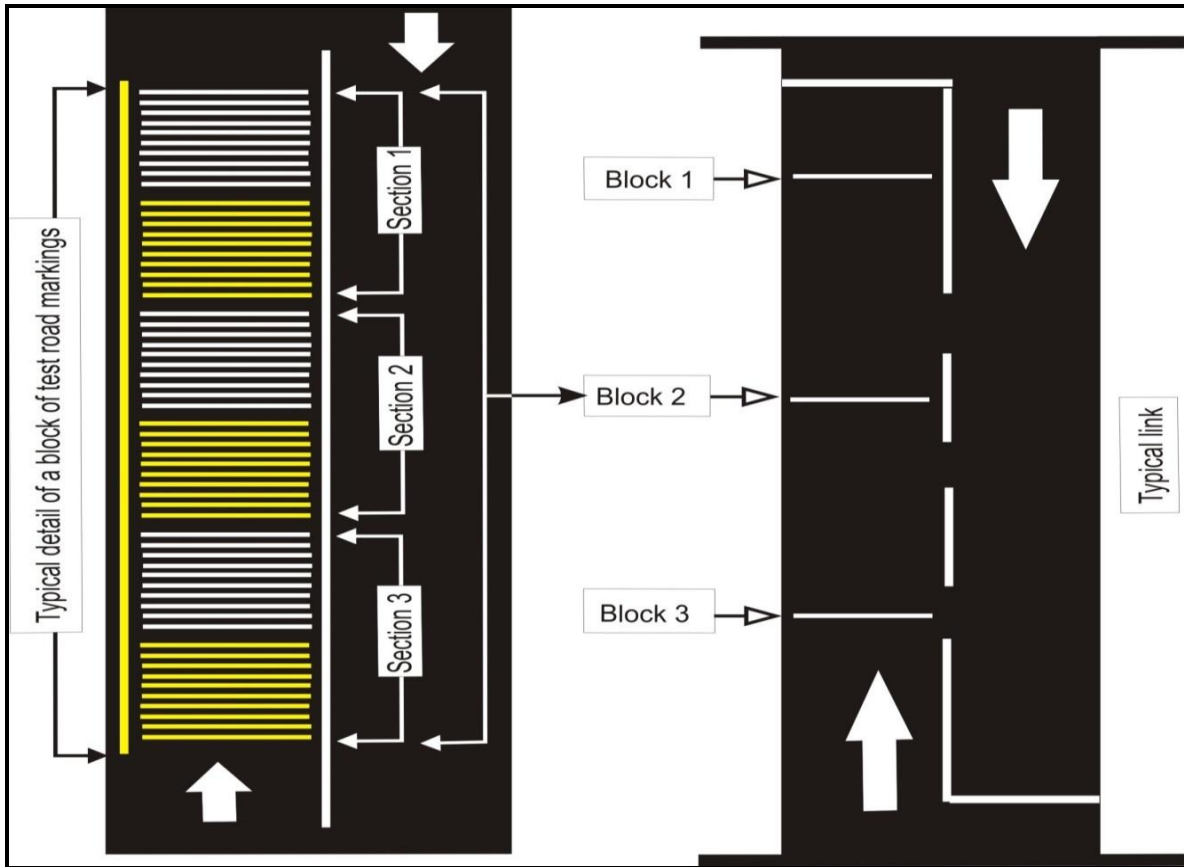

Figure 3.10: Typical layout of the test markings on a link of road.

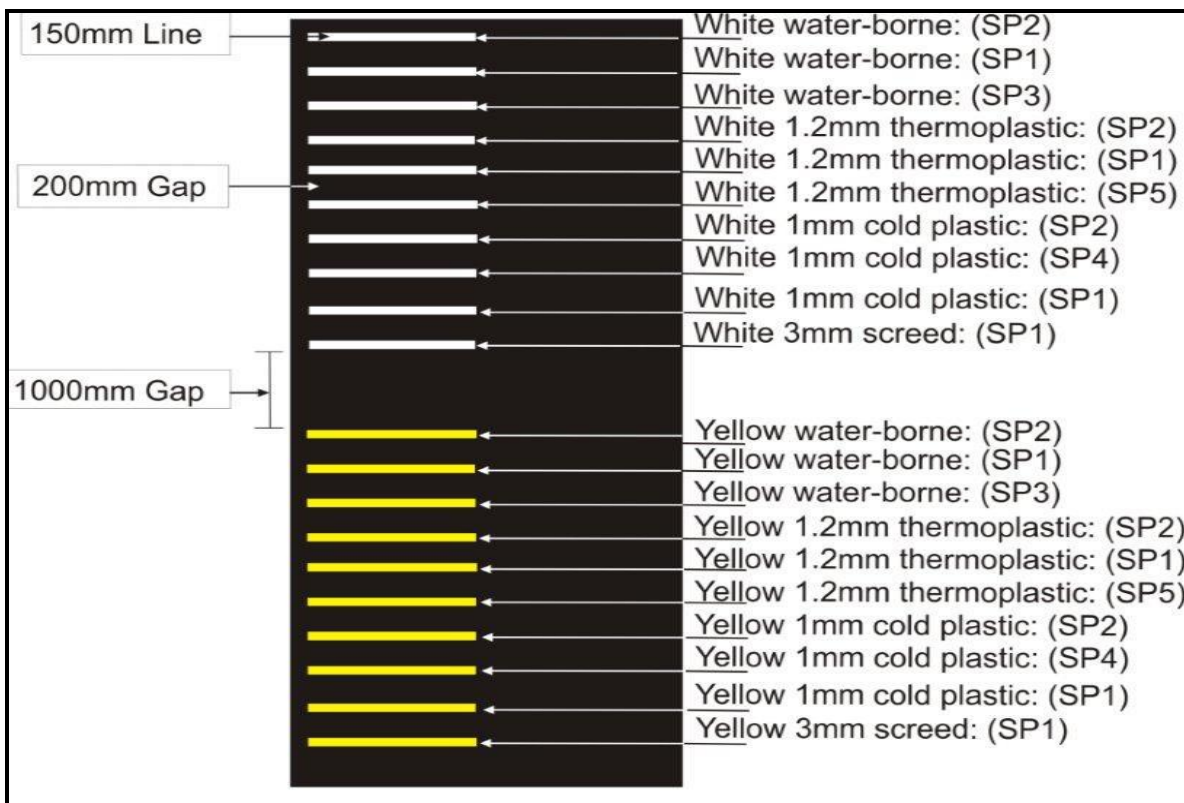

Figure 3.11: Typical detail of a section of transverse test markings.

3.3 NULL HYPOTHESES

The null hypotheses for this study are as follows:

- Road markings on clean flexible roads will have the same R_L service life as road markings on dirty flexible roads. The main reason for this is that there is generally no distinction between the different roads and condition of the roads when service providers offer their road marking products, and
- Thermoplastic road marking materials applied on all roads will have a R_L service life of at least two years irrespective of the volume of traffic and condition of the roads. The main reason for this is that roads are generally repainted after two years at the CoT.

3.4 EXAMINATION OF THE TEST ROAD MARKINGS

Four sets of R_L , Qd and colour measurements were conducted over at least one year on the applied test road markings. The first set of measurements on R_L and Qd was conducted within a month of application of the test road markings, and the remaining three sets of measurements were conducted more or less evenly depending on the availability of the testing equipment and weather conditions. The first set of colour measurements were conducted approximately 4 months after the application of the test markings due to the unavailability of the machine. The measurements were conducted during the day under appropriate traffic accommodation according to the SARTSM, (1999). Only one set of skid resistance measurements was conducted on the test plates.

3.4.1 Measuring retroreflectivity

A portable instrument or a vehicle-mounted instrument can be used to measure R_L . A calibration plate with a known R_L value is usually supplied with a retroreflectometer and this plate must be used to calibrate the retroreflectometer according to the instrument supplier prior to conducting the measurements. The majority of road lengths at the CoT are fairly short and as such portable instruments will be more conducive than vehicle-mounted instruments to conduct measurements on road marking maintenance work. There are generally more arrows and transverse road markings such as stop lines on municipal roads than on provincial and national roads which will require a portable instrument to conduct measurements for its conduciveness over a vehicle-mounted instrument. There are very few vehicle-mounted instruments in SA and these instruments are more conducive for use on provincial and national roads. The use of vehicle-mounted instruments reduces accident risks to the team responsible for conducting the measurements because the vehicle is driven in the normal flow of traffic and can travel at reasonably high speeds (Babic *et al.*, 2014). The other advantage for the use of a vehicle-mounted instrument is that it can take measurements at a very close range between the test points and as such a more accurate average result can be established (Babic *et al.*, 2014). The disadvantage of a vehicle-mounted instrument is that it can also give false

readings due to undulations on the surface of the road as the vehicle is not consistently at the same height and also can shift of the test points horizontally (BS EN 1436:2007, 2007).

It is important to ensure that the correct retroreflector is used in order to obtain more accurate measurements. There are a few portable retroreflectometers used in SA which can measure R_L but different instruments may produce different results and one of the main reasons for this is due to the limitation on the profile height measuring capacity of different instruments. The LTL-X retroreflector has a profile height measuring capacity of up to 15 mm while the LTL-XL has a profile height measuring capacity of up to 5 mm (Technical note RS 103, 2004). There are a lot of chip seal roads in the CoT and due to the size of the aggregates being greater than 5 mm it will be more accurate to use the LTL-X, especially on chip seal surfaces. The retroreflector to be used to measure R_L must have sufficient sensitivity and range to accommodate R_L values expected in use, typically 1 mcd/m²/lx to 2 000 mcd/m²/lx and it must be able to cope with the conditions expected in use such as stray light entering from the surroundings (BS EN 1436:2007, 2007). When using the retroreflector, the operator must ensure that the measurements are not affected by ambient light as the tests will be conducted during daytime. A black cloth can be used around the retroreflector to prevent stray light from entering the test point in order to avoid false measurements. Portable instruments may be tilted and shifted in height relative to the road marking surface because of the texture and curve of road markings on the road, particles on the surface and structure of structured road markings (BS EN 1436:2007, 2007). The standard measuring condition is intended to simulate a visual distance of 30 m for the driver of a passenger car with an eye height of 1.2 m and a headlamp mounting height of 0.65 m above the road (BS EN 1436:2007, 2007 and SAN 6261:2008, 2008).

The LTL-X retroreflector (Figure 3.12) was used on all test sites including the asphalt surfaced roads to measure R_L . The LTL-X retroreflector is the latest in the market and is currently used by CoT to conduct road marking acceptance control of permanent road markings applied by external road marking applicators. SANRAL also accepts the use of the LTL-X retroreflector for acceptance control of R_L on road markings.

Nine measurements were conducted on each test road marking line applied. Three measurements each were conducted in the region of the left and right wheel part of each transverse test road marking line painted and three measurements were conducted towards the centre of each of the transverse road marking lines painted. The wheels of vehicles affect the durability of markings, more especially when sand is driven over the road markings. The wheels passing over the road markings also have the advantage in that as the road markings wear off, the intermix glass beads of plastic road marking materials are exposed, restoring R_L to a certain degree. In the case of solvent-borne and water-borne road marking paints, as the wheels of the vehicles pass over the road markings, the R_L will decline over time due to the road markings becoming thinner, which may not be able to retain the drop-on glass beads that provide retroreflection. Oil leaks from vehicles usually tend to fall towards

the centre of the road; hence a set of measurements was conducted towards the centre of the transverse lines painted.

Two sets of measurements were conducted during the same day on transverse lines. The first set of measurements was conducted on the test road markings as found on that day and the second set of measurements was conducted after washing the test road markings with liquid soap added into clean drinkable water with brooms and left to dry. It is obvious that, especially on the “dirty roads”, sand and dirt had to be removed before the first set of measurements was conducted. Care was taken not damage the road markings while removing sand and dust from them. The intention of this “dirty test” and “washed test” was to determine if there was a significant difference in R_L . As road marking applicators do not have much control over the road environment, it is unfair for them to take full responsibility for the road markings which get dirty due to sand, dust, fumes and oils, and as such when failures occur during acceptance control, the road markings are washed to determine if higher measurements can be obtained to comply with the R_L specification. This is recommended by road marking paint manufacturers. Unfortunately, in reality the road user will at most times view the road markings in its dirty condition unless the decision by the road authority is taken to continuously wash the road markings, which will most likely not be a cost effective exercise.

Nine measurements were conducted over the length of the white and yellow longitudinal test road markings. The measurement points were distributed more or less evenly over the length of the longitudinally applied test road markings. The longitudinal lines were only measured in the dirty condition as the washing of only the transverse markings was sufficient to identify if there were significant differences of the various parameters in the “dirty” and “washed” condition. It was obvious that, especially on the “dirty roads”, sand and dirt had to be removed before the first set of measurements was conducted.



Figure 3.12: LTL-X Retroreflectometer.

3.4.2 Measuring luminance

Similarly to R_L , a portable instrument or a vehicle-mounted instrument can be used to measure Q_d . The number of Q_d measurements conducted was equal to the number of R_L measurements conducted in the dirty and washed condition.

It is important to ensure that the correct retroreflectometer is used in order to obtain the most accurate measurements. There are only a few types of retroreflectometers used in SA that can measure Q_d but for the purposes of this study, the LTL-XL (Figure 3.13) was used to measure all Q_d values. The LTL-XL retroreflectometer has functions to measure R_L and Q_d but only measures up to a maximum of 5 mm in depth. As this is the latest retroreflectometer available in the market it was used to measure the Q_d . The equipment must have sufficient sensitivity and range to accommodate Q_d values expected in use, typically 1 to 318 $\text{mcd/m}^2/\text{lx}$ and it must be able to cope with the conditions expected in use such as stray light entering from the surroundings (BS EN 1436:2007, 2007).

The standard measuring condition is intended to simulate a visual distance of 30 m for the driver of a passenger car with an eye height of 1,2 m and a headlamp mounting height of 0,65 m above the road (BS EN 1436:2007, 2007 and SANS6261:2008). The function to measure the R_L was switched off while measuring the Q_d in order to extend its daily use due to the limitations on the battery power. The LTL-XL retroreflectometer was used randomly, especially on asphalt surfaces, in conjunction with the LTL-X as a check on the R_L measurements. The Q_d value was established as the average of a number of measurements conducted with shifts of the instrument in steps along the marking, in total covering one or more spacing of structures (BS EN 1436:2007, 2007).



Figure 3.13: LTL-XL Retroreflectometer.

3.4.3 Measuring colour

An X-Rite Model SP60 colour machine as can be seen in Figure 3.14 was used to conduct the measurements of the test road markings. When conducting measurements with this machine, the tristimuli values of X, Y and Z are obtained and converted into chromaticity co-ordinates x and y which are plotted on the chromaticity diagram. The regions for white and yellow colours on the chromaticity chart allow for a range in white and yellow that the road marking paints and materials must comply with.

According to the X-Rite manual, the formulae to calculate x and y are as follows:

$$x = X/(X+Y+Z)$$

$$y = Y/(X+Y+Z)$$

One of the checks to confirm if the calculations are correct is to also calculate z [$z = Z/(X+Y+Z)$] and the summation of x, y and z must equal to 1.

The measurements were conducted only on the transverse lines of the middle section of each block due to the limitations on the battery. The transverse test road markings were subjected to severe adverse effects as compared with the longitudinal test road markings, and any improvement recommended on the colour of the transverse test road markings will positively affect all types of road markings including the longitudinal lines. Six measurements were conducted on each road marking line applied. Two measurements each were conducted in the region of the wheel part on the left and right of each transverse line painted and two measurements were conducted towards the centre of each of the transverse road marking line painted.

Two sets of measurements were conducted during the same day on transverse lines, similarly to the R_L and Q_d measurements.



Figure 3.14: X-Rite Model SP60 colour machine.

3.4.4 Measuring skid resistance

A British Portable Pendulum skid resistance tester as seen in Figure 3.15 was used to measure the skid resistance of the test markings applied on the test plates. A pendulum fitted with a spring loaded slider at its free end was released from a fixed position and the frictional energy loss caused by the dragging motion of the rubber rear edge of the slider over the markings was measured and expressed in Skid Resistance Tester (SRT) units. The test method used was in accordance with SANS 6260:2007 (2007).

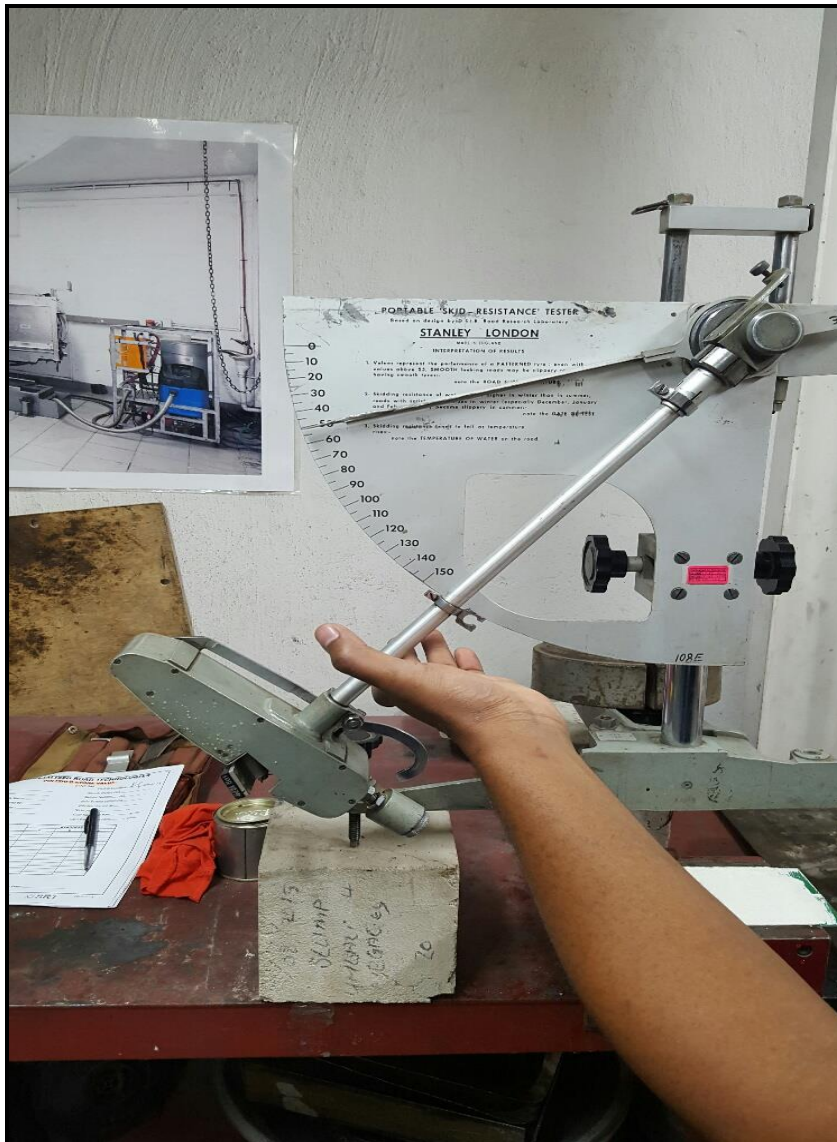

Figure 3.15: Skid resistance tester.

3.5 STATISTICAL ANALYSIS OF THE DATA

The use of non-parametric methods was applied to compare group means of the various types of road marking paints and materials due to the small sample size. When comparing between two

groups, Friedman's Chi Square Test was used. Descriptive statistics were used to indicate the mean, standard deviation and coefficient of variation.

3.6 LIMITATIONS

The measuring equipment is relatively expensive and had to be loaned from road marking service providers. As the service providers need to utilise the equipment for their own process control on road marking contracts, it was not possible to obtain the equipment on the desired dates and the four measurement dates were therefore not equally distributed over the research period. The colour meter and the retroreflectometers were purchased from overseas, so when problems occurred with the equipment, it had to be sent back overseas for repair, which delayed some of the measurements. The skid resistance measurements were conducted in the laboratory as there was no available equipment to conduct the measurements on site.

It was not possible to calculate the amount of sand that adversely affected the test road markings. The road markings were affected by ultraviolet light which did alter the colour of the markings, but it was not possible to distinguish the extent of adverse effects caused as there were other variables such as rainfall, vehicle tyre conditions, bitumen from the surfacing, the speed at which the vehicles travelled, vehicles braking over the markings, and possibly other aspects.

3.7 CONCLUSION

The application of the test road markings for the study was not limited to the transverse pattern only, as due consideration was given to the possibility that transverse markings and longitudinal markings produce different service lives. Although the intention was to develop a standard on thermoplastic road marking materials, water-borne road marking paints and cold plastic road marking materials were also included in the study. The measurements of the various parameters were conducted at shorter intervals than the recommendation by the SABS as the intention of the study was to determine more realistic service lives of road markings which can be used for planning and budgeting.

4 DATA ANALYSIS AND FINDINGS

4.1 INTRODUCTION

According to the SADC SARTSM (1999), the minimum R_L of white road markings and yellow road markings must be $100 \text{ mcd/m}^2/\text{lx}$ and $70 \text{ mcd/m}^2/\text{lx}$ respectively. These values were used to determine the R_L service life of the test road markings in this study. There is no standard published by the South African Bureau of Standards (SABS) with regard to Q_d on road markings and the BS EN 1436:2007 (2007) specification was thus used to analyse this parameter. According to BS EN 1436:2007 (2007), the minimum Q_d for white road markings and yellow road markings must be $100 \text{ mcd/m}^2/\text{lx}$ and $80 \text{ mcd/m}^2/\text{lx}$ respectively. These values were used to determine the Q_d service life of the test road markings in this study. There is a possible error with the colour coordinates indicated in Table 7.2 of the SADC SARTSM (1999) as the coordinates indicated for the yellow road marking colour specification do not form a logical envelope when plotted on the chromaticity diagram. Therefore the BS EN 1436:2007 (2007) specification was used to analyse the colour parameter. For the colour test, the coordinates from Table 2.3 were plotted on a graph and the calculated values of the actual measurements of the test road markings were plotted on the graph to determine if the white and yellow test road markings conformed to the colour range. According to Table 7.2 of the SADC SARTSM (1999), the minimum skid resistance of white and yellow road markings must be 50 Skid Resistance Test (SRT) units.

4.2 SITE BACKGROUND

Doreen Street was initially selected as a newly established clean chip seal road for this study, but after application of the test road markings it was found that heavy duty vehicles park alongside the test site and the vehicles re-enter the road at Block 1 (B 1) carrying sand on their wheels from the shoulder of the road onto the road. The amount of sand carried onto the road mainly depends on the moisture content of the sand. For example, when it rains more sand is likely to be carried by the wheels of the vehicles onto the road than when the sand is dry. The sand causes an abrasive action together with the wheels of the vehicles on the road markings, which adversely affects the service life of the road markings. Doreen Street was analysed in three different ways, namely B 1 on its own, Block 2 (B 2) and Block 3 (B 3) combined and then B's 1, 2 and 3 combined.

The longitudinal test road markings applied on Madiba Street were mistakenly repainted under the road marking maintenance program and as such the longitudinal test markings on this street were not considered for this study. Some of the test markings started breaking off the road surface early into the research after application. For example, in Madiba Street, the water-borne (SP1) broke up and came off the road surface after 4 months. This could be due to poor application or the abnormal use by heavily laden vehicles on this section of the road soon after the test road markings were applied as

some emergency construction work had to be completed on the same street within a short space of time.

4.3 ANALYSIS METHOD OF EACH PARAMETER

4.3.1 Retroreflectivity

The LTL-X retroreflectometer was used to measure the R_L at each test point. The R_L mean of the unwashed transverse lines of each product applied was calculated during each measurement period. Similarly, the R_L mean of the washed transverse lines of each product applied was calculated during each measurement period. On the longitudinal lines, only the R_L mean of the unwashed markings was calculated during each measurement period. The R_L mean of the test road markings at each measurement period were plotted on a graph and from the graph the R_L service life of each road marking or material was determined.

The decline in R_L over the time of the test road marking paints and materials is demonstrated on the 95 per cent Confidence Interval (CI) graphs. The R_L measurements were subjected to a Friedman's Chi Square Test to determine whether any pair or pairs of R_L measurements across time periods within each type of road marking paint or material were significantly different or not.

4.3.2 Luminance

The LTL-XL retroreflectometer was used to measure the Q_d at each test point. The analysis of the Q_d was similar to that of R_L .

4.3.3 Colour

The SP60 colour meter was used to determine the colour of the test road markings at each test point. The colour meter produces an output in the form of "X", "Y" and "Z" values. The value of "x" and "y" was calculated. The mean of the "x" values and the mean of the "y" values of unwashed transverse lines of each product was calculated during each measurement period and plotted onto the chromaticity diagram. The washed transverse lines were conducted similarly. The colour compliance was determined as a percentage of the test points falling within the area of the colour specification at each measurement period.

4.3.4 Skid resistance

The British Portable Pendulum skid resistance tester was used to conduct the skid resistance measurements. Three measurements were conducted on the test markings applied on test plates

using the skid resistance tester. The mean was calculated, which represents the initial skid resistance of each type of test road marking applied.

4.4 DISCUSSION OF THE FOUR PARAMETERS

4.4.1 Retroreflectivity

There was generally no significant increase in the R_L service life of the washed test road markings as can be seen in Appendix A, Tables A.1 to A.32. Some of the unwashed white test road markings had a longer R_L service life than washed markings. For example, on the M 44, unwashed white 1.2 mm thermoplastic (SP1) and 3 mm thermoplastic (SP1) produced R_L service lives of 4 to 7 months while the same markings when washed produced R_L service lives of 1 to 4 months as can be seen in Appendix A, Table A.16. There could be a few possible reasons for this, namely:

- the measurements of the washed test road markings could have been conducted before the road markings were completely dry, which possibly reduced the R_L measurements after washing;
- the method of washing the test road markings were not very effective;
- the measurements might not have been conducted at the exact spot before washing and after washing the test road markings, and
- certain amounts of dirt on road markings do not make a significant difference in the R_L .

In the analysis, the focus was on the unwashed test road markings as road markings are generally viewed by the road user in the dirty condition.

4.4.2 Luminance

There was generally an increase in the Qd measurement values of the washed test road markings as can be seen in Appendix B, Tables B.1 to B.16. As a result of this, some of the washed markings produced a longer Qd service than the unwashed markings. For example, on Bushveld Road, unwashed white water-borne (SP1) produced a Qd service life of 1 to 4 months as compared with 4 to 8 months on the same test road markings after being washed, as can be seen in Appendix B, Table B.4. Also, on the M 44, unwashed white 1.2 mm thermoplastic (SP1) produced a Qd service life of 4 to 7 months as compared with 7 to 10 months on the same test road marking after being washed, as can be seen in Appendix B, Table B.16. The possible reasons for the increase in the Qd after washing were:

- the fines from the sand particles which had been stuck to the test road markings were removed to a certain extent, exposing more of the actual area of the road marking, and
- some of the oils and exhaust fumes were removed from the test road markings.

4.4.3 Colour

It was unfortunate that the colour machine became faulty during the study and had to be sent to Denmark for repair. Therefore the first set of measurements was only conducted approximately 4 months after the test markings were applied. The fourth set of measurements was also delayed due to repairs that were required on the colour machine.

Higher percentages of the later measurements in some instances fell into the compliance regions and the possible reasons are:

- the measurements might not have been conducted on the exact spot as the machine measures approximately 1 cm in diameter, and
- it could also be that the rains might have cleaned the markings.

The washing of road markings did not positively contribute to colour compliance as can be seen in Appendix D, Table D.1 whereby only 50 per cent of the values measured on white water-borne (SP3) fell into the compliance region after being washed as compared with 100 per cent falling into the compliance region before being washed. Although the colour of road markings might comply with the specification after being washed, road markings are generally not washed by the road authorities and also the rainy season is usually of limited duration.

4.4.4 Skid resistance

The skid resistance of the test road markings was conducted on test plates in the laboratory, which might not be a true reflection of the road markings on the road surface. It is likely that the skid resistance of the road markings applied on the road surface will be higher due to the roughness of the road surface, especially road markings applied onto chip seal surfaces.

4.5 RETROREFLECTIVITY SERVICE LIFE OF THE TEST ROAD MARKINGS

The road markings were analysed as follows:

- White transverse road markings
- Yellow transverse road markings
- White longitudinal road markings
- Yellow longitudinal road markings

4.5.1 White transverse road markings

4.5.1.1 Long established clean asphalt road (Middel Street)

All the test road markings, except for 1 mm cold plastic (SP4), applied on the long established clean asphalt road, were higher than the minimum specification of 100 mcd/m²/lx over the 4 measurement periods as can be seen in Table 4.1 and Figure 4.1. In the fourth measurement period, the R_L mean of 1 mm cold plastic (SP4) was 86.7 mcd/m²/lx.

The cold plastic and thermoplastic road marking materials generally declined over the year. However, it can be seen in Table 4.1 and Figure 4.1 that the R_L mean of some of the measurements conducted later were higher than the R_L mean values of the measurements conducted earlier. For example, the R_L mean of unwashed 1.2 mm thermoplastic (SP2) was 130.7 mcd/m²/lx on 5 November 2013 and the same marking was 139.4 mcd/m²/lx on 20 March 2014, which is 4.5 months later. The intermix beads in the plastic road marking materials became exposed over time as a result of the wheels of the vehicles passing over the road markings, which contributed positively to the R_L.

Water-borne (SP1, SP2 and SP3), 1 mm cold plastic (SP1), 1.2 mm thermoplastic (SP1 and SP2) and 3 mm thermoplastic (SP1) produced R_L service lives of more than 12 months. The average decline in R_L of all test markings over the year was approximately 40 per cent and if the decline continues at the same rate then thermoplastic materials will produce a R_L service life of approximately 2 years. Although most of the test road markings applied on Middel Street complied with the specification for more than a year, the R_L means of 1.2 mm thermoplastic (SP1) and 3 mm thermoplastic (SP1) were in the region of 200 mcd/m²/lx after a year. This is an indication that thermoplastic road marking materials are much more durable on clean asphalt roads as compared with water-borne road marking paints, which seem to be getting closer to the minimum R_L of 100 mcd/m²/lx after a year.

The fact that there is no overlap between the 95 per cent CIs of the first and last measurements as can be seen in Figure 4.3 is an indication that the difference between them is statistically significant. Friedman's Chi Square Test revealed that there is at least one pair of measurements over time that is significantly different within each of the different road marking paints and materials, and referring to Figure 4.3 it seems as though these differences exist at least between the first and last repetitions.

Table 4.1: Descriptive statistics of white transverse markings in retroreflectivity on Middel Street.

Type of road marking paint / material		23-Jul-2013		05-Nov-2013		20-Mar-2014		29-Jul-2014	
		Unwashed	Washed	Unwashed	Washed	Unwashed	Washed	Unwashed	Washed
Water-borne (SP2)	Mean	215.2	196.3	175.3	176.3	151.8	149.5	136.4	138.4
	N	9	9	9	9	9	9	9	9
	Std. Deviation	37.6	35.7	28.5	28.3	30.8	18.0	23.7	14.0
	CV	0.18	0.18	0.16	0.16	0.20	0.12	0.17	0.10
Water-borne (SP1)	Mean	254.2	222.6	203.9	207.2	168.1	171.4	149.4	161.0
	N	9	9	9	9	9	9	9	9
	Std. Deviation	46.6	28.7	31.0	36.6	27.4	28.4	16.8	29.5
	CV	0.18	0.13	0.15	0.18	0.16	0.17	0.11	0.18
Water-borne (SP3)	Mean	220.5	202.3	170.9	173.0	147.2	152.5	128.3	128.7
	N	9	9	9	9	9	9	9	9
	Std. Deviation	31.0	21.6	19.2	17.5	22.7	14.7	18.1	16.2
	CV	0.14	0.11	0.11	0.10	0.15	0.10	0.14	0.13
1.2 mm Thermoplastic (SP2)	Mean	167.1	159.7	130.7	127.4	139.4	135.8	103.8	102.7
	N	9	9	9	9	9	9	9	9
	Std. Deviation	18.3	12.3	16.5	12.5	12.8	10.4	9.6	10.8
	CV	0.11	0.08	0.13	0.10	0.09	0.08	0.09	0.11
1.2 mm Thermoplastic (SP1)	Mean	352.2	294.5	285.7	273.6	285.9	270.1	213.6	223.0
	N	9	9	9	9	9	9	9	9
	Std. Deviation	57.9	79.7	53.7	44.6	69.4	52.0	48.2	30.0
	CV	0.17	0.27	0.18	0.16	0.24	0.19	0.23	0.14
1 mm Cold Plastic (SP1)	Mean	264.2	266.0	247.6	245.5	256.8	254.7	196.4	198.9
	N	9	9	9	9	9	9	9	9
	Std. Deviation	26.4	30.4	49.4	36.8	19.4	32.2	32.3	34.7
	CV	0.10	0.11	0.20	0.15	0.08	0.13	0.16	0.18
3 mm Screed (SP1)	Mean	370.4	304.6	285.2	292.9	308.2	291.1	223.0	227.7
	N	9	9	9	9	9	9	9	9
	Std. Deviation	46.7	55.3	49.0	25.9	50.4	37.8	40.0	43.6
	CV	0.12	0.18	0.17	0.08	0.16	0.13	0.18	0.19
1 mm Cold Plastic (SP4)	Mean	196.4	200.0	122.2	129.5	125.1	116.5	86.7	82.4
	N	9	9	9	9	9	9	9	9
	Std. Deviation	49.0	36.4	37.3	22.9	23.6	19.9	17.7	18.9
	CV	0.25	0.18	0.31	0.18	0.19	0.17	0.20	0.23

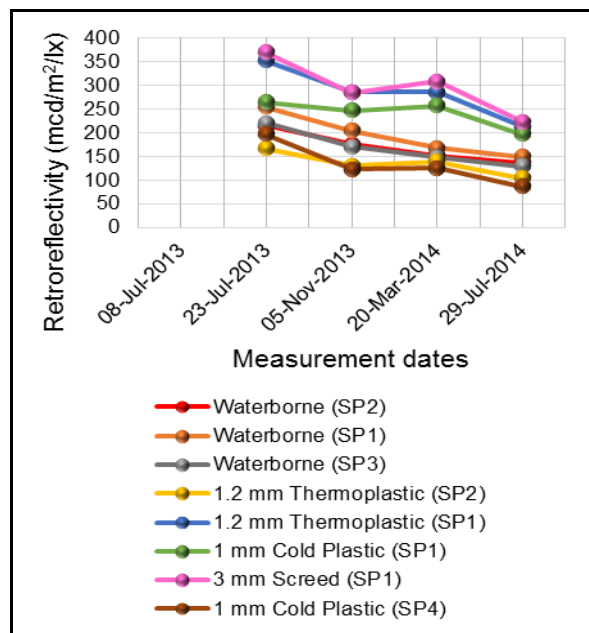

Figure 4.1: Unwashed white transverse markings on Middel Street.

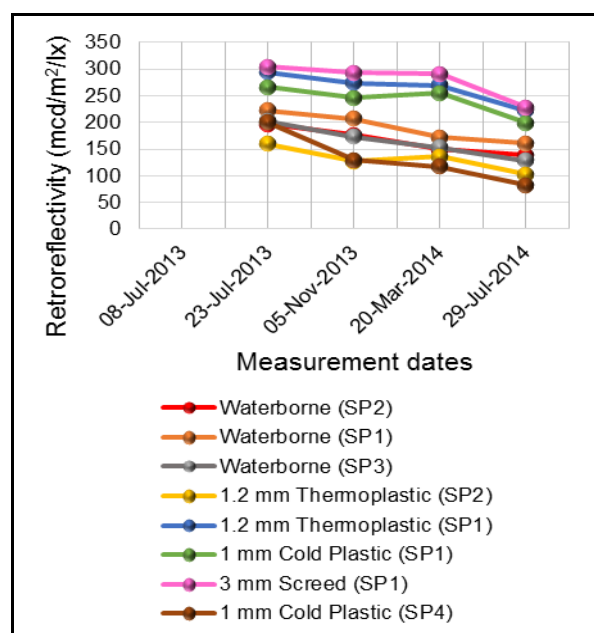

Figure 4.2: Washed white transverse markings on Middel Street.

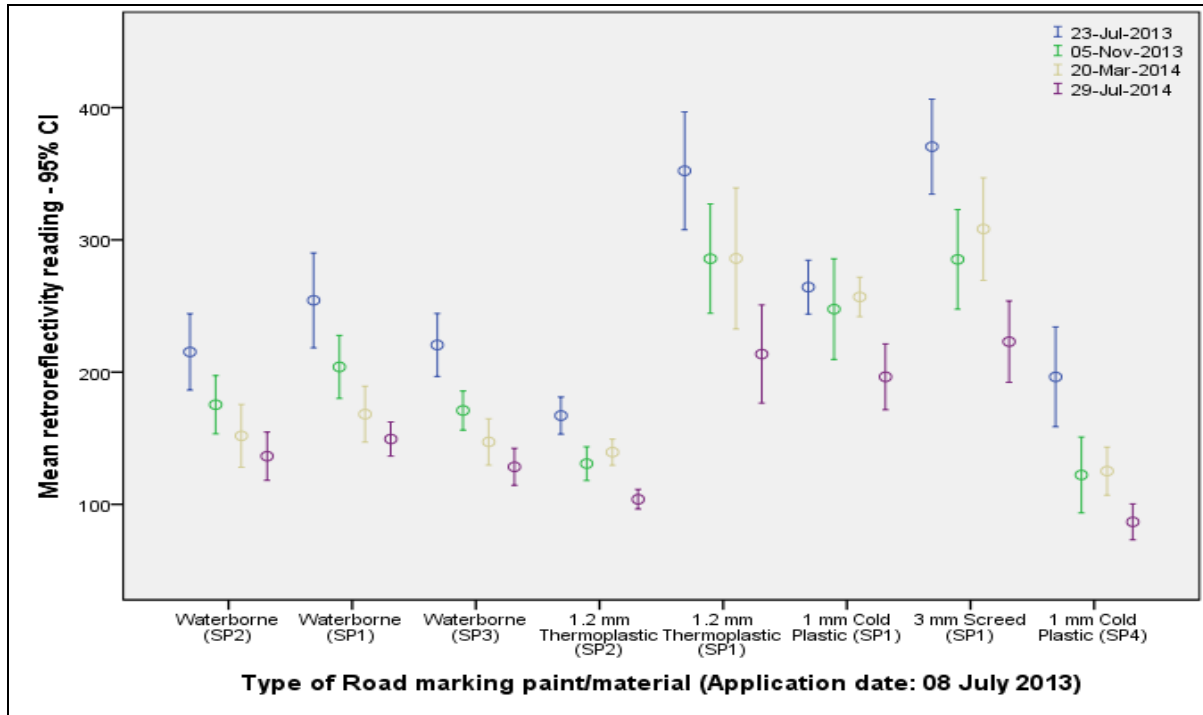

Figure 4.3: Ninety five per cent Confidence Interval of unwashed white transverse markings on Middel Street.

4.5.1.2 Long established dirty asphalt road (Mohwelere Street)

All the test road markings complied with the minimum R_L specification of $100 \text{ mcd/m}^2/\text{lx}$ in only the first measurement period, as can be seen in Appendix A, Table A.27 and Figure A.53. The second set of measurements was conducted 6 months after the application of the test road markings. None of the test road markings complied with the specification in the second measurement period. The test road markings became very thin, mainly due to the abrasive effect of sand and vehicles' wheels. All the test markings produced R_L service lives of 1 to 6 months.

Friedman's Chi Square Test revealed that there is at least one pair of measurements over time that is significantly different within each of the different road marking paints and materials, and referring to Appendix C, Figure C.1.10 it seems as though these differences are at least between the first and last repetitions.

4.5.1.3 Newly established clean chip seal road (Doreen Street)

Block 1

All test road markings only complied with the minimum R_L specification of $100 \text{ mcd/m}^2/\text{lx}$ in the first measurement period, as can be seen in Appendix A, Table A.7 and Figure A.13. The second set of measurements was conducted 4 months after the application of the test road markings. None of the test road markings complied with the specification in the second measurement period. Water-borne

(SP2) became so thin that the surfacing was exposed in some places and thus was not measured in measurement period 3. All other test markings became very thin, mainly due to the abrasive effect of sand and vehicles' wheels, and produced R_L service lives of 1 to 4 months.

Friedman's Chi Square Test revealed that there is at least one pair of measurements over time that is significantly different within each of the different road marking paints and materials, and referring to Appendix C, Figure C.1.3 it seems as though these differences are at least between the first and last repetitions.

Blocks 2 and 3

Water-borne (SP2) produced a R_L service life of 1 to 4 months, as can be seen in Appendix A, Table A.10 and Figure A.19. Water-borne (SP3), 1.2 mm (SP2) and 1 mm cold plastic (SP1) produced R_L service lives of 4 to 8 months. Water-borne (SP1), 3 mm thermoplastic (SP1) and 1 mm cold plastic (SP4) produced R_L service lives of 8 to 12 months. Although blocks 2 and 3 were generally clean, only 1.2 mm thermoplastic (SP1) produced a R_L service life of more than 12 months.

Friedman's Chi Square Test revealed that there is at least one pair of measurements over time that is significantly different within each of the different road marking paints and materials, and referring to Appendix C, Figure C.1.4 it seems as though these differences are at least between the first and last repetitions.

Blocks 1, 2 and 3

Water-borne (SP1 and SP2) produced R_L service lives of 1 to 4 months, as can be seen in Appendix A, Table A.1 and Figure A.2. Water-borne (SP3), 1.2 mm thermoplastic (SP2) and 1 mm cold plastic (SP1 and SP4) produced R_L service lives of 4 to 8 months. The 1.2 mm thermoplastic (SP1) and 3 mm thermoplastic (SP1) produced R_L service lives of 8 to 12 months.

Friedman's Chi Square Test revealed that there is at least one pair of measurements over time that is significantly different within each of the different road marking paints and materials, and referring to Appendix C, Figure C.1.5 it seems as though these differences are at least between the first and last repetitions.

4.5.1.4 Newly established dirty chip seal road (Aubrey Matlala Road)

Water-borne (SP2) did not comply with the minimum R_L specification of $100 \text{ mcd/m}^2/\text{lx}$ in the first measurement period, which was conducted approximately 3 weeks after the application of the test road markings, as can be seen in Appendix A, Table A.1 and Figure A.1. Water-borne (SP1 and SP3), 1 mm cold plastic (SP2) and 1.2 mm thermoplastic (SP2) produced R_L service lives of 1 to 4 months. The 1 mm cold plastic (SP1), 1.2 mm thermoplastic and 3 mm thermoplastic (SP1) produced R_L service lives of 4 to 9 months.

Friedman's Chi Square Test revealed that there is at least one pair of measurements over time that is significantly different within each of the different road marking paints and materials, and referring to Appendix C, Figure C.1.1 it seems as though these differences are at least between the first and last repetitions.

4.5.1.5 Long established clean chip seal road (Bushveld Road)

Water-borne (SP2) and 1 mm cold plastic (SP4) produced R_L service lives of 1 to 4 months, as can be seen in Appendix A, Table A.4 and Figure A.7. Water-borne (SP3) produced a R_L service life of 4 to 8 months. Water-borne (SP1) and 1.2 mm thermoplastic (SP2) produced R_L service lives of 8 to 12 months. The 1 mm cold plastic (SP1), 1.2 mm thermoplastic (SP1) and 3 mm thermoplastic (SP1) produced R_L service lives of just more than 12 months.

Friedman's Chi Square Test revealed that there is at least one pair of measurements over time that is significantly different within each of the different road marking paints and materials, and referring to Appendix C, Figure C.1.2 it seems as though these differences are at least between the first and last repetitions.

4.5.1.6 Long established dirty chip seal road (Road L 3)

All test road markings complied with the minimum R_L specification of $100 \text{ mcd/m}^2/\text{lx}$ in only the first measurement period, as can be seen in Appendix A, Table A.30 and Figure A.59. The second set of measurements was conducted 4 months after the application of the test road markings. None of the test markings complied with the specification in the second measurement period. Water-borne (SP3) became so thin that it was not measured in measurement period 3. All other test markings became very thin, mainly due to the abrasive effect of sand and vehicles' wheels. All the test markings produced R_L service lives of 1 to 4 months.

Friedman's Chi Square Test revealed that there is at least one pair of measurements over time that is significantly different within each of the different road marking paints and materials, and referring to Appendix C, Figure C.1.11 it seems as though these differences are at least between the first and last repetitions.

4.5.1.7 Newly established clean asphalt road (Meiring Naude Road)

Water-borne (SP1, SP2 and SP3), 1 mm cold plastic (SP4) and 1.2 mm thermoplastic (SP2) produced R_L service lives of 4 to 9 months, as can be seen in Appendix A, Table A.21 and Figure A.41. The 1 mm cold plastic (SP1) and 1.2 mm thermoplastic (SP1) produced R_L service lives of 9 to 13 months. Water-borne (SP1) and 1.2 mm thermoplastic (SP2) produced R_L service lives of 9 to 13 months. The 3 mm thermoplastic (SP1) produced a R_L service life of just more than 13 months.

Friedman's Chi Square Test revealed that there is at least one pair of measurements over time that is significantly different within each of the different road marking paints and materials, and referring to Appendix C, Figure C.1.8 it seems as though these differences are at least between the first and last repetitions.

4.5.1.8 Newly established dirty asphalt road (M 44)

The measurements were conducted over 10 months since the test road markings were applied, but in any case after 10 months all road marking paints and road marking materials were below the minimum R_L specifications of 100 mcd/m²/lx and 70 mcd/m²/lx for white and yellow road markings respectively, as can be seen in Appendix A, Table A.16 and Figure A.31.

Water-borne (SP2 and SP3) did not comply with the minimum R_L specification of 100 mcd/m²/lx in the first measurement period, which was conducted approximately 2 weeks after the application of the test markings. Water-borne (SP1), 1 mm cold plastic (SP1 and SP2) and 1.2 mm thermoplastic (SP2) produced R_L service lives of 1 to 4 months. The 1.2 mm thermoplastic (SP1) and 3 mm thermoplastic (SP1) produced R_L service lives of 4 to 7 months.

Friedman's Chi Square Test revealed that there is at least one pair of measurements over time that is significantly different within each of the different road marking paints and materials, and referring to Appendix C, Figure C.1.6 it seems as though these differences are at least between the first and last repetitions.

4.5.1.9 Long established asphalt road in the CBD (Madiba Street)

The measurements were conducted over 11 months instead of 12 months on Madiba Street, but in any case after 7 months of the test road markings being applied, all types of unwashed test markings were below the minimum R_L specifications of 100 mcd/m²/lx and 70 mcd/m²/lx for white and yellow road markings respectively, as can be seen in Appendix A, Table A.19 and Figure A.37.

The 1.2 mm thermoplastic (SP2) produced a R_L service life of 1 to 4 months. Water-borne (SP1) produced a R_L service life of 4 to 7 months. Water-borne (SP1) came off the surface after measurement period 2 and thus could not be measured in measurement period 3. This could be due to poor application of the test markings or damage caused by the high volumes of heavy vehicles using this road soon after the application of the test markings. Water-borne (SP2 and SP3) also produced R_L service lives of 4 to 7 months. The 1 mm cold plastic (SP1 and SP2), 1.2 mm thermoplastic (SP1) and 3 mm thermoplastic (SP1) produced R_L service lives of 7 to 11 months.

Friedman's Chi Square Test revealed that there is at least one pair of measurements over time that is significantly different within each of the different road marking paints and materials, and referring to

Appendix C, Figure C.1.7 it seems as though these differences are at least between the first and last repetitions.

4.5.1.10 Overall discussion on white transverse road markings

The longest performing road marking paints or materials in R_L per different road surface type and condition are indicated in Table 4.2. The R_L service lives are those of the unwashed white transverse test road markings due to the fact that this is how the road markings will generally be viewed by the road user. However, during the rainy season, the road markings may become cleaner with the water on road markings and tyres of the vehicles passing over them, but this is usually only of limited duration. It can be seen in Table 4.2 that all types of road markings generally have longer R_L service lives on clean roads than on dirty roads.

The test markings applied on the clean established asphalt road (Middel Street) seem to have the longest R_L service lives even with the application of water-borne road marking paint, which is about the cheapest road marking product available. In addition to the road being clean, it could also be that all the volatiles from the road surface have already evaporated, this being a long established road and as such did not discolour the road markings to an extent that adversely affected R_L . Although the AADT on Middel Street is high as compared with roads like Mohwelere and L 3, the R_L service lives for all types of road marking paints and materials on Middel Street are much longer, indicating that the main cause of decline in R_L is the adverse effect of sand on the road markings.

With water-borne road marking paints, as the paint film gets thinner over time with the vehicles' wheels passing over the road markings, the glass beads which are dropped onto the road marking during application are worn off as they are no longer sufficiently embedded in the paint, thereby reducing the R_L .

Although plastic road marking materials seem to be the common road marking material with the longest R_L service lives on each road where the test road markings were applied, it may not be cost effective to apply it them on long established dirty asphalt roads (like Mohwelere Street) and long established dirty chip seal roads (like Road L 3) where they will have a very low R_L service life similar to that of water-borne road marking paints.

Table 4.2: Summary of longest performing white transverse markings in retroreflectivity.

Name of road / street	Description of road / street	AADT	Longest performing road marking paints / materials	R _L service life (months)
Aubrey Matlala	Newly established dirty chip seal road	Light vehicles = 6557 Heavy vehicles = 255 Total vehicles = 6814	1 mm cold plastic (SP1), 1.2 mm thermoplastic (SP1), 3 mm thermoplastic (SP1)	4 to 9
Bushveld	Long established clean chip seal road	Light vehicles = 5508 Heavy vehicles = 739 Total vehicles = 6246	1 mm cold plastic (SP1), 1.2 mm thermoplastic (SP1), 3 mm thermoplastic (SP1)	8 to 12
Doreen (B 1)	Newly established clean chip seal road	Light vehicles = 7753 Heavy vehicles = 284 Total vehicles = 8037	Water-borne (SP1 & SP3), 1 mm cold plastic (SP1 & SP4), 1.2 mm thermoplastic (SP1 & SP2), 3 mm thermoplastic (SP1)	1 to 4
Doreen (B 2 & 3)	Newly established clean chip seal road	Light vehicles = 7753 Heavy vehicles = 284 Total vehicles = 8037	1.2 mm thermoplastic (SP1)	> 12
Doreen (B 1, 2 & 3)	Newly established clean chip seal road	Light vehicles = 7753 Heavy vehicles = 284 Total vehicles = 8037	1.2 mm thermoplastic (SP1), 3 mm thermoplastic (SP1)	8 to 12
M 44	Newly established dirty asphalt road	Light vehicles = 7822 Heavy vehicles = 434 Total vehicles = 8315	1.2 mm thermoplastic (SP1), 3 mm thermoplastic (SP1)	4 to 7
Madiba	Long established asphalt road in CBD	Light vehicles = 1764 Heavy vehicles = 548 Total vehicles = 2312	1 mm cold plastic (SP1 & SP2) 1.2 mm thermoplastic (SP1), 3 mm thermoplastic (SP1)	7 to 11
Meiring Naude	Newly established clean asphalt road	Light vehicles = 3981 Heavy vehicles = 629 Total vehicles = 4610	3 mm thermoplastic (SP1)	> 13
Middel	Long established clean asphalt road	Light vehicles = 5547 Heavy vehicles = 273 Total vehicles = 5821	Water-borne (SP1, SP2 & SP3), 1 mm cold plastic (SP1), 1.2 mm thermoplastic (SP1 & SP2), 3 mm thermoplastic (SP1)	> 12
Mohwelere	Long established dirty asphalt	Light vehicles = 1732 Heavy vehicles = 213 Total vehicles = 1945	All the road markings applied perform almost equally with very low service life	1 to 6
L 3	Long established dirty chip seal road	Light vehicles = 2454 Heavy vehicles = 109 Total vehicles = 2563	All the road markings applied perform almost equally with very low service life	1 to 4

4.5.2 Yellow transverse road markings

4.5.2.1 Long established clean asphalt road (Middel Street)

All the test road markings, except for 1 mm cold plastic (SP4), applied on the long established clean asphalt road were higher than the minimum specification of 70 mcd/m²/lx over the 4 measurement

periods as can be seen in Table 4.3 and Figure 4.4. In the fourth measurement period, the R_L mean of 1 mm cold plastic (SP4) was $67.8 \text{ mcd/m}^2/\text{lx}$.

The water-borne road marking paints declined steadily over the year. The cold plastic and thermoplastic road marking materials generally declined over the year. However, it can be seen in Table 4.3 and Figure 4.4 that the R_L mean of some of the measurements conducted later were higher than the R_L mean values of the measurements conducted earlier. For example, the R_L mean of unwashed 3 mm thermoplastic (SP1) was $168.3 \text{ mcd/m}^2/\text{lx}$ on 5 November 2013 and the same marking was $172.6 \text{ mcd/m}^2/\text{lx}$ on 20 March 2014 which is 4.5 months later. The intermix beads in the thermoplastic road marking material became exposed over time as a result of the wheels of the vehicles passing over the road markings, which positively contributed to the R_L .

Water-borne (SP1, SP2 and SP3), 1 mm cold plastic (SP1), 1.2 mm thermoplastic (SP1 and SP2) and 3 mm thermoplastic (SP1) produced R_L service lives of more than 12 months. If the decline in R_L continues like the first year, water-borne (SP1, SP2 and SP3) will produce R_L service lives of 27 months, 16 months and 20 months respectively. The 1.2 mm thermoplastic (SP1 and SP2) will produce R_L service lives of 17 months and 14 months respectively. The 1 mm cold plastic (SP1) will produce a R_L service life of 31 months while the 3 mm thermoplastic will produce a R_L service life of 20 months.

The fact that there is no overlap between the 95 per cent CIs of the first and last measurements as can be seen in Figure 4.6 is an indication that the difference between them is statistically significant. Friedman's Chi Square Test revealed that there is at least one pair of measurements over time that is significantly different within each of the different road marking paints and materials, and referring to Figure 4.6 it seems as though these differences are at least between the first and last repetitions.

Table 4.3: Descriptive statistics of yellow transverse markings in retroreflectivity on Middel Street.

Type of road marking paint / material		23-Jul-2013		05-Nov-2013		20-Mar-2014		29-Jul-2014	
		Unwashed	Washed	Unwashed	Washed	Unwashed	Washed	Unwashed	Washed
Water-borne (SP2)	Mean	107.6	114.6	96.7	100.6	92.7	90.1	78.8	80.5
	N	9	9	9	9	9	9	9	9
	Std. Deviation	11.9	11.5	14.7	9.2	13.6	14.0	14.4	12.0
	CV	0.11	0.10	0.15	0.09	0.15	0.16	0.18	0.15
Water-borne (SP1)	Mean	190.3	185.5	162.2	168.1	156.7	135.9	138.3	131.7
	N	9	9	9	9	9	9	9	9
	Std. Deviation	11.1	7.1	15.2	15.7	12.2	8.7	31.3	16.4
	CV	0.06	0.04	0.09	0.09	0.08	0.06	0.23	0.13
Water-borne (SP3)	Mean	148.2	138.9	128.0	131.9	118.7	110.6	101.0	104.5
	N	9	9	9	9	9	9	9	9
	Std. Deviation	21.7	8.2	13.8	11.8	19.8	14.9	22.3	11.3
	CV	0.15	0.06	0.11	0.09	0.17	0.14	0.22	0.11
1.2 mm Thermoplastic (SP2)	Mean	152.1	161.3	115.0	117.2	115.3	112.4	85.9	89.1
	N	9	9	9	9	9	9	9	9
	Std. Deviation	27.8	32.2	18.1	12.3	10.4	11.3	13.9	15.6
	CV	0.18	0.20	0.16	0.11	0.09	0.10	0.16	0.17
1.2 mm Thermoplastic (SP1)	Mean	187.2	198.1	144.5	130.0	141.5	136.0	104.5	105.2
	N	9	9	9	9	9	9	9	9
	Std. Deviation	25.2	39.2	14.2	14.2	23.7	22.4	19.3	16.9
	CV	0.14	0.20	0.10	0.11	0.17	0.17	0.19	0.16
1 mm Cold Plastic (SP1)	Mean	208.4	213.6	190.1	182.9	176.3	179.6	155.8	156.1
	N	9	9	9	9	9	9	9	9
	Std. Deviation	21.5	21.0	24.4	26.2	43.7	29.2	42.6	27.9
	CV	0.10	0.10	0.13	0.14	0.25	0.16	0.27	0.18
3 mm Screed (SP1)	Mean	203.4	216.2	168.3	157.7	172.6	156.8	125.2	129.3
	N	9	9	9	9	9	9	9	9
	Std. Deviation	30.6	20.5	36.8	24.0	36.6	17.8	21.4	25.0
	CV	0.15	0.10	0.22	0.15	0.21	0.11	0.17	0.19
1 mm Cold Plastic (SP4)	Mean	162.0	160.6	104.5	90.7	97.0	89.3	67.8	68.9
	N	9	9	9	9	9	9	9	9
	Std. Deviation	22.9	40.5	16.9	17.7	30.1	15.9	11.2	14.5
	CV	0.14	0.25	0.16	0.20	0.31	0.18	0.17	0.21

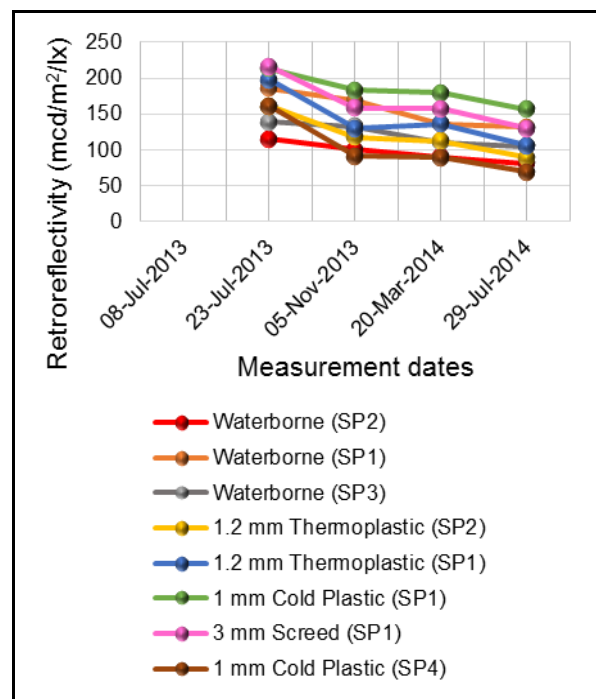
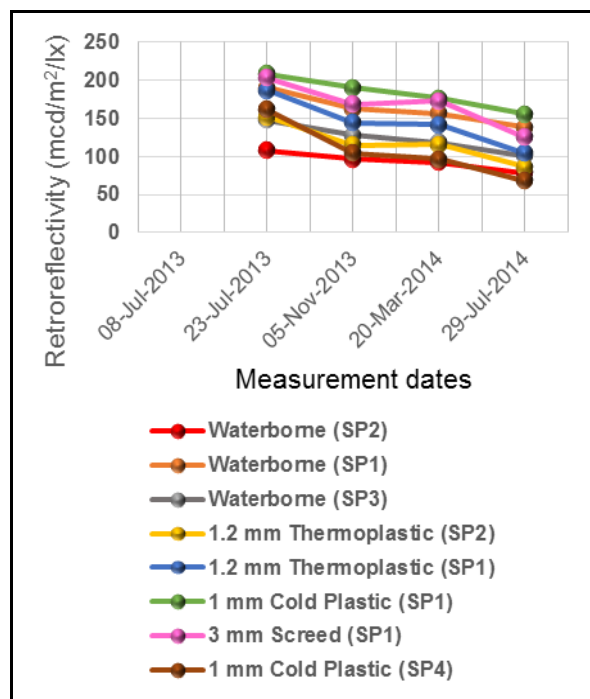

Figure 4.4: Unwashed yellow transverse markings on Middel Street.

Figure 4.5: Washed yellow transverse markings on Middel Street.

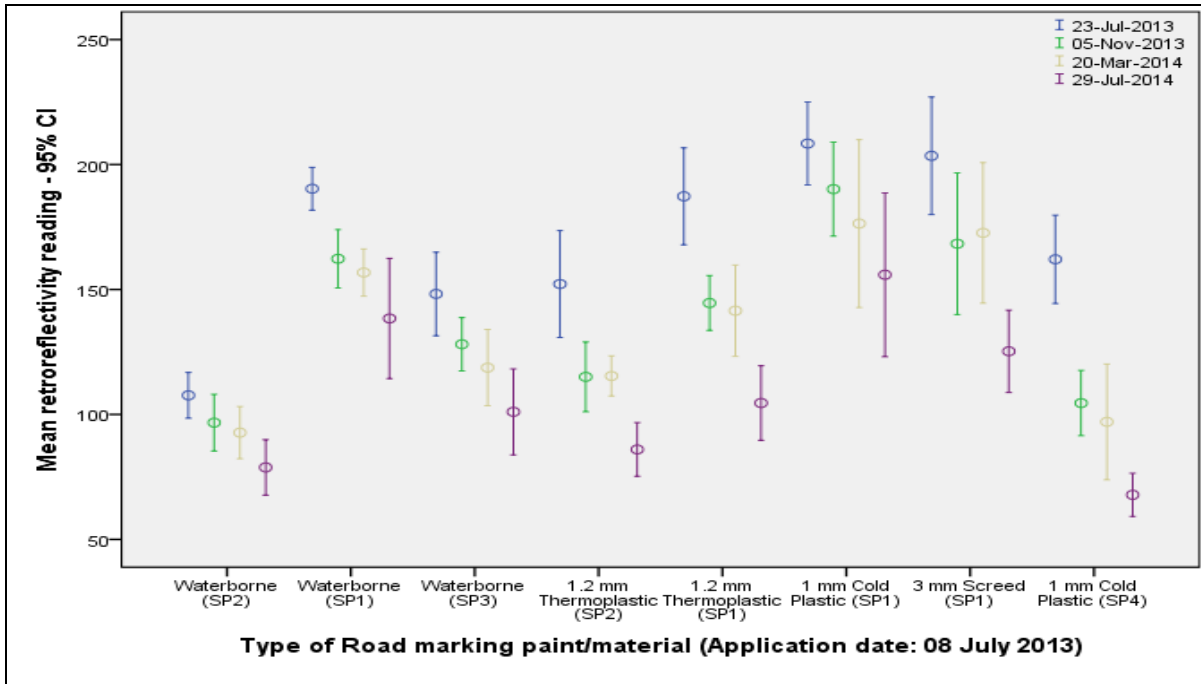

Figure 4.6: Ninety five per cent Confidence Interval of unwashed yellow transverse markings on Middel Street.

4.5.2.2 Long established dirty asphalt road (Mohwelere Street)

All test road markings complied with the minimum R_L specification of $70 \text{ mcd/m}^2/\text{lx}$ only in the first measurement period, as can be seen in Appendix A, Table A.28 and Figure A.55. The test markings became very thin, mainly due to the abrasive effect of sand and the vehicles' wheels. All the test road markings produced a R_L service life of 1 to 6 months.

Friedman's Chi Square Test revealed that there is at least one pair of measurements over time that is significantly different within each of the different road marking paints and materials, and referring to Appendix C, Figure C.2.10 it seems as though these differences are at least between the first and last repetitions.

4.5.2.3 Newly established clean chip seal road (Doreen Street)

Block 1

All test road markings, except for water-borne (SP2) and cold plastic (SP1), complied with the minimum R_L specification of $70 \text{ mcd/m}^2/\text{lx}$ only in the first measurement period, as can be seen in Appendix A, Table A.8 and Figure A.15. Water-borne (SP2) produced a R_L service life of less than 1 month and in measurement period 3 (12 months after application of the test road markings), the markings were totally removed by the abrasive action of the sand and vehicles' wheels passing over the markings. The second set of measurements was conducted 4 months after the application of the test road markings. The 1 mm cold plastic (SP1) produced a R_L service life of 4 to 8 months.

Friedman's Chi Square Test revealed that there is at least one pair of measurements over time that is significantly different within each of the different road marking paints and materials, and referring to Appendix C, Figure C.2.3 it seems as though these differences are at least between the first and last repetitions.

Blocks 2 and 3

Water-borne (SP2) and 1 mm cold plastic (SP4) produced R_L service lives of 1 to 4 months, as can be seen in Appendix A, Table A.11 and Figure A.21. Water-borne (SP1 and SP3) and 1.2 mm thermoplastic (SP1 and SP2) produced R_L service lives of 4 to 8 months. The 1 mm cold plastic (SP1) and 3 mm thermoplastic (SP1) produced R_L service lives of more than 12 months.

Friedman's Chi Square Test revealed that there is at least one pair of measurements over time that is significantly different within each of the different road marking paints and materials, and referring to Appendix C, Figure C.2.4 it seems as though these differences are at least between the first and last repetitions.

Blocks 1, 2 and 3

Water-borne (SP2 and SP3), 1 mm cold plastic (SP4) and 1.2 mm thermoplastic (SP1) produced R_L service lives of 1 to 4 months, as can be seen in Appendix A, Table A.14 and Figure A.27. Water-borne (SP1), 1 mm cold plastic (SP1), 1.2 mm thermoplastic (SP2) and 3 mm thermoplastic (SP1) produced R_L service lives of 4 to 8 months.

Friedman's Chi Square Test revealed that there is at least one pair of measurements over time that is significantly different within each of the different road marking paints and materials, and referring to Appendix C, Figure C.2.5 it seems as though these differences are at least between the first and last repetitions.

4.5.2.4 Newly established dirty chip seal road (Aubrey Matlala Road)

Water-borne (SP2 and SP3) did not comply with the minimum R_L specification of $70 \text{ mcd/m}^2/\text{lx}$ in the first measurement period, which was conducted approximately 3 weeks after the application of the test road markings, as can be seen in Appendix A, Table A.2 and Figure A.3. Water-borne (SP1), 1.2 mm thermoplastic (SP1 and SP2) and 3 mm thermoplastic (SP1) produced R_L service lives of 1 to 4 months. The 1 mm cold plastic (SP1) produced a R_L service life of 4 to 9 months.

Friedman's Chi Square Test revealed that there is at least one pair of measurements over time that is significantly different within each of the different road marking paints and materials, and referring to Appendix C, Figure C.2.1 it seems as though these differences are at least between the first and last repetitions.

4.5.2.5 Long established clean chip seal road (Bushveld Road)

Water-borne (SP2) produced a R_L service life of less than 1 month, as can be seen in Appendix A, Table A.5 and Figure A.9. The 1 mm cold plastic (SP1) produced a R_L service life of 1 to 4 months. Water-borne (SP1 and SP3) and 1.2 mm thermoplastic (SP2) produced R_L service lives of 4 to 8 months. The 1 mm cold plastic (SP1), 1.2 mm thermoplastic (SP1) and 3 mm thermoplastic (SP1) produced R_L service lives of 8 to 12 months.

Friedman's Chi Square Test revealed that there is at least one pair of measurements over time that is significantly different within each of the different road marking paints and materials, and referring to Appendix C, Figure C.2.2 it seems as though these differences are at least between the first and last repetitions.

4.5.2.6 Long established dirty chip seal road (Road L 3)

All test road markings complied with the minimum R_L specification of $70 \text{ mcd/m}^2/\text{lx}$ only in the first measurement period, as can be seen in Appendix A, Table A.31 and Figure A.61. All the test road markings produced R_L service lives of 1 to 4 months.

Friedman's Chi Square Test revealed that there is at least one pair of measurements over time that is significantly different within each of the different road marking paints and materials, and referring to Appendix C, Figure C.2.11 it seems as though these differences are at least between the first and last repetitions.

4.5.2.7 Newly established clean asphalt road (Meiring Naude Road)

Water-borne (SP1, SP2 and SP3) and 1 mm cold plastic (SP4) produced R_L service lives of 4 to 9 months, as can be seen in Appendix A, Table A.22 and Figure A.43. The 1 mm cold plastic (SP1), 1.2 mm thermoplastic (SP1 and SP2) and 3 mm thermoplastic (SP1) produced R_L service lives of 9 to 13 months.

Friedman's Chi Square Test revealed that there is at least one pair of measurements over time that is significantly different within each of the different road marking paints and materials, and referring to Appendix C, Figure C.2.8 it seems as though these differences are at least between the first and last repetitions.

4.5.2.8 Newly established dirty asphalt road (M 44)

Water-borne (SP2 and SP3) did not comply with the minimum R_L specification of $70 \text{ mcd/m}^2/\text{lx}$ in the first measurement period, which was conducted approximately 2 weeks after the application of the

test road markings, as can be seen in Appendix A, Table A.17 and Figure A.33. Water-borne (SP1), 1 mm cold plastic (SP1), 1.2 mm thermoplastic (SP1 and SP2) and 3 mm thermoplastic (SP1) produced R_L service lives of 1 to 4 months.

Friedman's Chi Square Test revealed that there is at least one pair of measurements over time that is significantly different within each of the different road marking paints and materials, and referring to Appendix C, Figure C.2.6 it seems as though these differences are at least between the first and last repetitions.

4.5.2.9 Long established asphalt road in the CBD (Madiba Street)

Water-borne (SP2 and SP3) and 1.2 mm thermoplastic (SP2) produced R_L service lives of 1 to 4 months, as can be seen in Appendix A, Table A.20 and Figure A.39. The 1.2 mm thermoplastic (SP1) and 3 mm thermoplastic (SP1) produced R_L service lives of 4 to 7 months. Water-borne (SP1) and 1 mm cold plastic (SP1) produced R_L service lives of 7 to 11 months.

Friedman's Chi Square Test revealed that there is at least one pair of measurements over time that is significantly different within each of the different road marking paints and materials, and referring to Appendix C, Figure C.2.7 it seems as though these differences are at least between the first and last repetitions.

4.5.2.10 Overall discussion on yellow transverse road markings

The longest performing road marking paints or materials in R_L per different road surface type and condition are indicated in Table 4.4. The R_L service lives are those of the unwashed yellow transverse test road markings. It can be seen in Table 4.4 that all types of road markings generally have longer R_L service lives on clean roads than on dirty roads.

Although the AADT on Middel Street is high as compared with roads like Mohwelere and L 3, the R_L service lives for all types of road marking paints and materials on Middel Street are much longer, indicating that the main cause of decline in R_L is the adverse effect of sand driven over road markings.

Although plastic road marking materials seem to be the common road marking material with the longest R_L service lives on each road where the test road markings were applied, it may not be cost effective to apply them on long established dirty asphalt roads (like Mohwelere Street) and long established dirty chip seal roads (like Road L 3) where they will have a very low R_L service life similar to that of water-borne road marking paints.

Table 4.4: Summary of longest performing yellow transverse markings in retroreflectivity.

Name of road / street	Description of road / street	AADT	Longest performing road marking paints / materials	R _L service life (months)
Aubrey Matlala	Newly established dirty chip seal road	Light vehicles =6557 Heavy vehicles =255 Total vehicles =6814	1 mm cold plastic (SP1)	4 to 9
Bushveld	Long established clean chip seal road	Light vehicles =5508 Heavy vehicles =739 Total vehicles =6246	1 mm cold plastic (SP1), 1.2 mm thermoplastic (SP1), 3 mm thermoplastic (SP1)	8 to 12
Doreen (B 1)	Newly established clean chip seal road	Light vehicles =7753 Heavy vehicles =284 Total vehicles =8037	1 mm cold plastic (SP1)	4 to 8
Doreen (B 2 & 3)	Newly established clean chip seal road	Light vehicles =7753 Heavy vehicles =284 Total vehicles =8037	1 mm cold plastic (SP1), 3 mm thermoplastic (SP1)	8 to 12
Doreen (B 1, 2 & 3)	Newly established clean chip seal road	Light vehicles =7753 Heavy vehicles =284 Total vehicles =8037	Water-borne (SP1), 1mm cold plastic (SP1), 1.2 mm thermoplastic (SP1), 3 mm thermoplastic (SP1)	4 to 8
M 44	Newly established dirty asphalt road	Light vehicles =7822 Heavy vehicles =434 Total vehicles =8315	Water-borne (SP1) 1 mm cold plastic (SP1), 1.2 mm thermoplastic (SP1 & SP2), 3 mm thermoplastic (SP1)	1 to 4
Madiba	Long established asphalt road in CBD	Light vehicles =1764 Heavy vehicles =548 Total vehicles =2312	Water-borne (SP1) 1mm cold plastic (SP1)	7 to 11
Meiring Naude	Newly established clean asphalt road	Light vehicles =3981 Heavy vehicles =629 Total vehicles =4610	Water-borne (SP1), 1 mm cold plastic (SP1), 1.2 mm thermoplastic (SP1), 1.2 mm thermoplastic (SP2), 3 mm thermoplastic (SP1)	9 to 13
Middel	Long established clean asphalt road	Light vehicles =5547 Heavy vehicles =273 Total vehicles =5821	Water-borne (SP1, SP2 & SP3), 1 mm cold plastic (SP1), 1.2 mm thermoplastic (SP1 & SP2), 3 mm thermoplastic (SP1)	> 12
Mohwelere	Long established dirty asphalt	Light vehicles =1732 Heavy vehicles =213 Total vehicles =1945	All the road markings applied perform almost equally with very low service life	1 to 6
L 3	Long established dirty chip seal road	Light vehicles =2454 Heavy vehicles =109 Total vehicles =2563	All the road markings applied perform almost equally with very low service life	1 to 4

4.5.3 White longitudinal road markings

4.5.3.1 Long established clean asphalt road (Middel Street)

Water-borne (SP2) produced a R_L service life of 4 to 8 months, as can be seen in Table 4.5 and Figure 4.7. Water-borne (SP1) produced a R_L service life of 8 to 12 months. The 1.2 mm thermoplastic (SP1 and SP2) and 3 mm thermoplastic (SP1) produced R_L service lives of more than 12 months. The first measurement period was conducted approximately 2 weeks after application of the test road markings. The R_L mean of the thermoplastic materials in the first measurement period were much higher than that of the water-borne paints. The decline in R_L of the water-borne paints after a year of application was approximately 50 per cent on average while it was 23 per cent on the thermoplastic materials. If the rate of decline in R_L continues at the same rate, the 1.2 mm thermoplastic (SP1 and SP2) will produce R_L service lives of 4 years and 2.5 years respectively. The 3 mm thermoplastic will produce a R_L service life of 6 years.

The fact that there is no overlap between the 95 per cent CIs of the first and last measurements, as can be seen in Figure 4.8, is an indication that the difference between them is statistically significant. Friedman's Chi Square Test revealed that there is at least one pair of measurements over time that is significantly different within each of the different road marking paints and materials, and referring to Figure 4.8 it seems as though these differences are at least between the first and last repetitions.

Table 4.5: Descriptive statistics of white longitudinal markings in retroreflectivity on Middel Street.

Type of paint / road marking material		23-Jul-2013	05-Nov-2013	20-Mar-2014	29-Jul-2014
Water-borne (SP2)	Mean	143.4	118.1	84.8	65.7
	N	3	3	3	3
	Std. Deviation	3.1	1.1	24.6	29.7
	CV	0.02	0.01	0.29	0.45
Water-borne (SP1)	Mean	157.5	137.9	113.3	83.1
	N	3	3	3	3
	Std. Deviation	6.8	5.9	40.7	42.2
	CV	0.04	0.04	0.6	0.51
1.2 mm Thermoplastic (SP2)	Mean	238.8	213.6	191.8	169.2
	N	3	3	3	3
	Std. Deviation	12.5	30.1	25.0	9.6
	CV	0.05	0.14	0.13	0.06
1.2 mm Thermoplastic (SP1)	Mean	307.8	280.1	263.9	238.0
	N	3	3	3	3
	Std. Deviation	41.7	25.9	22.8	22.3
	CV	0.14	0.09	0.09	0.09
3 mm Screed (SP1)	Mean	384.1	353.4	337.3	314.4
	N	3	3	3	3
	Std. Deviation	49.7	60.6	68.8	73.3
	CV	0.13	0.17	0.20	0.23

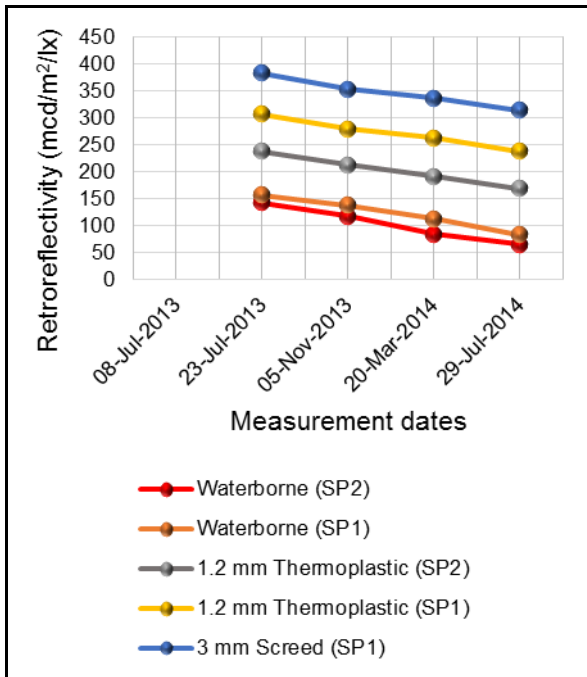

Figure 4.7: Unwashed white longitudinal markings on Middel Street.

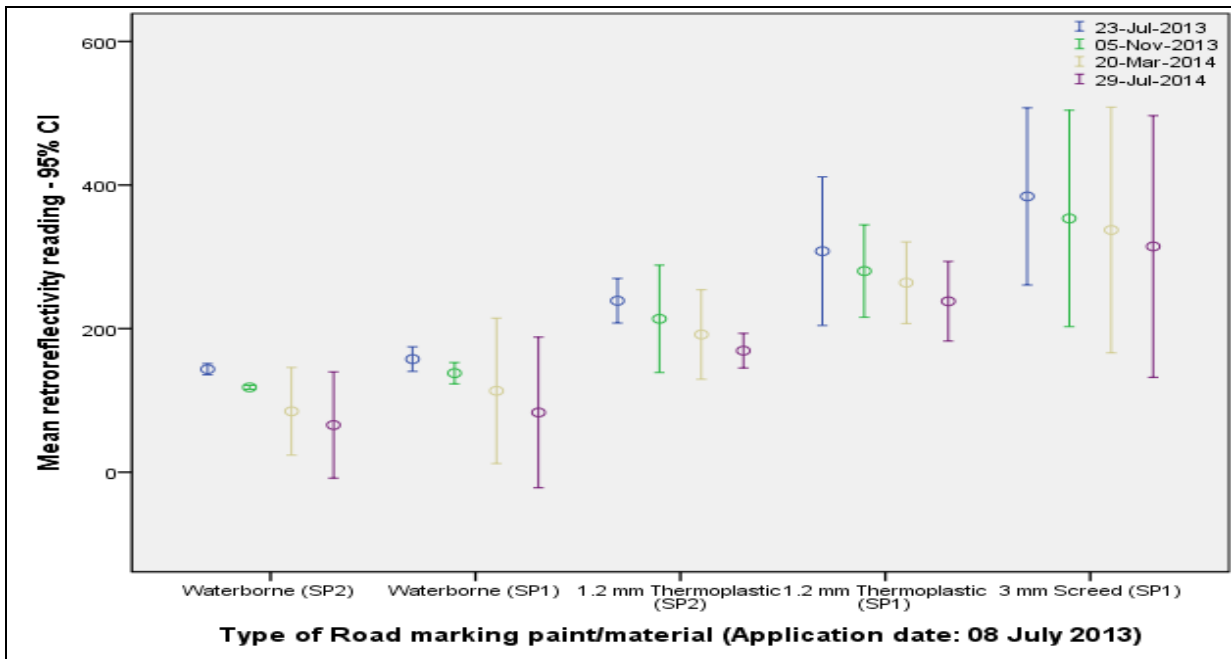

Figure 4.8: Ninety five per cent Confidence Interval of unwashed white longitudinal markings on Middel Street.

4.5.3.2 Long established dirty asphalt road (Mohwelere Street)

All test road markings complied with the minimum R_L specification of 100 mcd/m²/lx only in the first measurement period, as can be seen in Appendix A, Table A.29 and Figure A.57. None of the test markings complied with the specification in the second measurement period, which was conducted 6 months after application of the test markings. The test markings became very thin, mainly due to the abrasive effect of sand and the vehicles' wheels. All the markings produced R_L service lives of 1 to 6 months.

Friedman's Chi Square Test revealed that there is at least one pair of measurements over time that is significantly different within each of the different road marking paints and materials, and referring to Appendix C, Figure C.3.9 it seems as though these differences are at least between the first and last repetitions.

4.5.3.3 Newly established clean chip seal road (Doreen Street)

Block 1

Water-borne (SP2) produced a R_L service life of less than 1 month, as can be seen in Appendix A, Table A.9 and Figure A.17. Water-borne (SP2) was totally removed by the abrasive action of sand and vehicles' wheels and thus could not be measured during the second measurement period, which was conducted 4 months after the application of the test road markings. Water-borne (SP1) produced a R_L service life of 1 to 4 months and was also totally removed by the abrasive action of sand and vehicles' wheels, and thus could not be measured in the fourth measurement period. The 1.2 mm thermoplastic (SP1 and SP2) produced R_L service lives of 8 to 12 months and 4 to 8 months respectively. The 3 mm thermoplastic produced a R_L service life of just more than 12 months.

Friedman's Chi Square Test revealed that there are no pairs of readings over time that are significantly different within each of the different materials. Even though some 95 per cent CIs do not overlap, as can be seen in Appendix C, Figure C.3.3, the sample size of 1 does not allow for enough statistical power to find statistically significant differences and thus should be interpreted in the usual way.

Blocks 2 and 3

The same types of test road marking paints and materials were applied in B's 2 and 3. Although B's 2 and 3 were generally clean, all test markings produced similar R_L service lives to the test markings in B 1 as can be seen in Appendix A, Table A.12 and Figure A.23.

Friedman's Chi Square Test revealed that there are no pairs of readings over time that are significantly different within each of the different materials. Even though some 95 per cent CIs do not overlap, as can be seen in Appendix C, Figure C.3.4, the sample size of 2 does not allow for enough

statistical power to find statistically significant differences. The fact that the 95 per cent CIs extend into the negative with some of the road marking paints and materials further indicates the lack of statistical power and they should thus be interpreted in the usual way. For example, water-borne (SP1) and 1.2 mm thermoplastic (SP2) extend to approximately -500.

Blocks 1, 2 and 3

All test road markings produced similar R_L service lives to the test markings in B 1 and B's 2 and 3 combined, as can be seen in Appendix A, Table A. 15 and Figure A.29.

Friedman's Chi Square Test revealed that there are no pairs of readings over time that are significantly different within each of the different materials. The fact that the 95 per cent CIs extend into the negative, as can be seen in Appendix C, Figure C.3.5 indicates the lack of statistical power and they should thus be interpreted in the usual way. For example, water-borne (SP1) extends to approximately -500.

4.5.3.4 Newly established dirty chip seal road (Aubrey Matlala Road)

The 1.2 mm thermoplastic (SP2) produced a R_L service life of less than 1 month, as can be seen in Appendix A, Table A.3 and Figure A.5. Water-borne (SP2) produced a R_L service life of 1 to 4 months. Water-borne (SP1), 1.2 mm thermoplastic (SP1) and 3 mm thermoplastic (SP1) produced R_L service lives of 4 to 9 months.

Although there is no overlap between the first and last measurement periods, as can be seen in Appendix C, Figure C.3.1, Friedman's Chi Square Test revealed that there are no pairs of readings over time that are significantly different within each of the different materials. The sample size of 2 does not allow for enough statistical power to find statistically significant differences, as the test markings were applied at only 2 blocks and thus should be interpreted in the usual way.

4.5.3.5 Long established clean chip seal road (Bushveld Road)

All the test road markings produced R_L service lives of more than 12 months, as can be seen in Appendix A, Table A.6 and Figure A.11. If water-borne (SP1), 1.2 mm thermoplastic (SP1) and 3 mm thermoplastic (SP1) continue to decline in R_L as during the first year, the R_L service lives will be approximately 3 years. The white 1.2 mm thermoplastic (SP2) was insufficient to be applied longitudinally.

The white longitudinal test road markings were applied on the right edge line which is approximately 300 mm away from the non-mountable kerbs. These kerbs generally deter motorists from pulling over as they can cause damage to vehicles. With the longitudinal road markings being so close to the non-mountable kerb, motorists tend to keep away from this type of kerb and thus away from the

longitudinal road markings. Therefore damage to the road markings caused by vehicles' wheels is minimal. The longitudinal white test markings were unfortunately not applied on the lane lines where there would have been more wear caused by vehicles' wheels passing over them than on the right edge longitudinal line.

Friedman's Chi Square Test revealed that there is at least one pair of measurements over time that is significantly different within each of the different road marking paints and materials, and referring to Appendix C, Figure C.3.2 it seems as though these differences are at least between the first and last repetitions.

4.5.3.6 Long established dirty chip seal road (Road L 3)

All test road markings complied with the minimum R_L specification of 100 mcd/m²/lx only in the first measurement period, as can be seen in Appendix A, Table A.32 and Figure A.63. None of the test road markings complied with the specification in the second measurement period, which was conducted 5 months after application of the test markings. All the markings produced R_L service lives of 1 to 4 months.

Friedman's Chi Square Test revealed that there is at least one pair of measurements over time that is significantly different within each of the different road marking paints and materials, and referring to Appendix C, Figure C.3.10, it seems as though these differences are at least between the first and last repetitions.

4.5.3.7 Newly established clean asphalt road (Meiring Naude Road)

Water-borne (SP1 and SP2) and 1.2 mm thermoplastic (SP2) produced a R_L service life of 9 to 13 months, as can be seen in Appendix A, Table A.23 and Figure A.45. The 1.2 mm thermoplastic (SP1) and 3 mm thermoplastic (SP1) produced a R_L service life of just more than 13 months.

Friedman's Chi Square Test revealed that there is at least one pair of measurements over time that is significantly different within each of the different road marking paints and materials, and referring to Appendix C, Figure C.3.7 it seems as though these differences are at least between the first and last repetitions.

4.5.3.8 Newly established dirty asphalt road (M 44)

Water-borne (SP1) and 1.2 mm thermoplastic (SP2) produced a R_L service life of 1 to 4 months, as can be seen in Appendix A, Table A.18 and Figure A.35. Water-borne (SP2) and 3 mm thermoplastic (SP1) produced a R_L service life of 4 to 7 months. The 1.2 mm thermoplastic (SP1) produced a R_L service life of 7 to 10 months.

Although there is no overlap between the first and last measurement periods, as can be seen in Appendix C, Figure C.3.6, Friedman's Chi Square Test revealed that there are no pairs of readings over time that are significantly different within each of the different materials. The sample size of 2 does not allow for enough statistical power to find statistically significant differences as the test markings were applied at only 2 blocks. The fact that some of the 95 per cent CIs mean R_L extended into the negative further indicates the lack of statistical power and they should thus be interpreted in the usual way. For example 3 mm thermoplastic (SP1) extends to approximately -500.

4.5.3.9 Overall discussion on white longitudinal road markings

The longest performing road marking paints or materials in R_L per different road surface type and condition are indicated in Table 4.6. The R_L service lives are those of the unwashed white longitudinal test road markings. Road markings generally have longer R_L service lives on cleaner roads than on dirty roads.

Although the AADT on Bushveld Road is high as compared with roads like Mohwelere and L 3, the R_L service lives for all types of road marking paints and materials on Bushveld Road were much longer, indicating that the main cause of decline in R_L is the adverse effect of sand driven over the road markings. Thermoplastic longitudinal test markings produced R_L service lives of more than 12 months on the clean roads.

Although thermoplastic road marking materials were the common road marking material which produced the longest R_L service life on each road where the test markings were applied, it may not be cost effective to apply them on long established dirty asphalt roads (like Mohwelere Street) and long established dirty chip seal roads (like Road L 3) where they will have a very low R_L service life similar to that of water-borne road marking paints.

Table 4.6: Summary of longest performing white longitudinal markings in retroreflectivity.

Name of road / street	Description of road / street	AADT	Longest performing road marking paints / materials	R _L service life (months)
Aubrey Matlala	Newly established dirty chip seal road	Light vehicles = 6557 Heavy vehicles = 255 Total vehicles = 6814	Water-borne (SP1), 1.2 mm thermoplastic (SP1), 3 mm thermoplastic (SP1)	4 to 9
Bushveld	Long established clean chip seal road	Light vehicles = 5508 Heavy vehicles = 739 Total vehicles = 6246	Water-borne (SP1 & SP2), 1.2 mm thermoplastic (SP1), 3 mm thermoplastic (SP1)	> 12
Doreen (B 1)	Newly established clean chip seal road	Light vehicles = 7753 Heavy vehicles = 284 Total vehicles = 8037	3 mm thermoplastic (SP1)	> 12
Doreen (B's 2 & 3)	Newly established clean chip seal road	Light vehicles = 7753 Heavy vehicles = 284 Total vehicles = 8037	3 mm thermoplastic (SP1)	> 12
Doreen (B's 1, 2 & 3)	Newly established clean chip seal road	Light vehicles = 7753 Heavy vehicles = 284 Total vehicles = 8037	3 mm thermoplastic (SP1)	> 12
M 44	Newly established dirty asphalt road	Light vehicles = 7822 Heavy vehicles = 434 Total vehicles = 8315	1.2 mm thermoplastic (SP1)	7 to 10
Meiring Naude	Newly established clean asphalt road	Light vehicles = 3981 Heavy vehicles = 629 Total vehicles = 4610	1.2 mm thermoplastic (SP1), 3 mm thermoplastic (SP1)	> 13
Middel	Long established clean asphalt road	Light vehicles = 5547 Heavy vehicles = 273 Total vehicles = 5821	1.2 mm thermoplastic (SP1 & SP2), 3 mm thermoplastic (SP1)	> 12
Mohwelere	Long established dirty asphalt	Light vehicles = 1732 Heavy vehicles = 213 Total vehicles = 1945	All the road markings applied perform almost equally with very low service life	1 to 6
L 3	Long established dirty chip seal road	Light vehicles = 2454 Heavy vehicles = 109 Total vehicles = 2563	All the road markings applied perform almost equally with very low service life	1 to 4

4.5.4 Yellow longitudinal road markings

4.5.4.1 Long established clean asphalt road (Middel Street)

All the test road markings produced R_L service lives of more than 12 months, as can be seen in Table 4.7 and Figure 4.9. If the decline in R_L continues at the rate of the first year, water-borne (SP2) will have a R_L service life of 1.5 years. The 1.2 mm thermoplastic (SP1 and SP2) will have R_L service lives of 3.5 years and 3 years respectively, while 3 mm thermoplastic will produce a R_L service life of 2.5 years.

The fact that there is no overlap between the 95 per cent CIs of the first and last measurements, as can be seen in Figure 4.10, is an indication that the difference between them is statistically significant.

Friedman's Chi Square Test revealed that there is at least one pair of measurements over time that is significantly different within each of the different road marking paints and materials, and referring to Figure 4.10 it seems as though these differences are at least between the first and last repetitions.

Table 4.7: Descriptive statistics of yellow longitudinal markings in retroreflectivity on Middel Street.

Type of paint / road marking material		23-Jul-2013	05-Nov-2013	20-Mar-2014	29-Jul-2014
Water-borne (SP2)	Mean	130.8	109.2	90.8	75.9
	N	3	3	3	3
	Std. Deviation	1.8	6.2	6.2	11.8
	CV	0.01	0.06	0.07	0.16
Water-borne (SP1)	Mean	145.2	128.1	110.1	98.1
	N	3	3	3	3
	Std. Deviation	19.5	21.9	24.0	21.9
	CV	0.13	0.17	0.22	0.22
1.2 mm Thermoplastic (SP2)	Mean	165.7	149.7	136.4	125.8
	N	3	3	3	3
	Std. Deviation	45.4	45.9	42.5	35.8
	CV	0.27	0.31	0.31	0.29
1.2 mm Thermoplastic (SP1)	Mean	198.5	176.0	162.2	147.3
	N	3	3	3	3
	Std. Deviation	17.6	15.1	17.0	14.4
	CV	0.08	0.09	0.11	0.10
3 mm Screed (SP1)	Mean	176.9	153.2	140.8	125.4
	N	3	3	3	3
	Std. Deviation	29.8	17.2	17.7	11.5
	CV	0.17	0.11	0.13	0.09

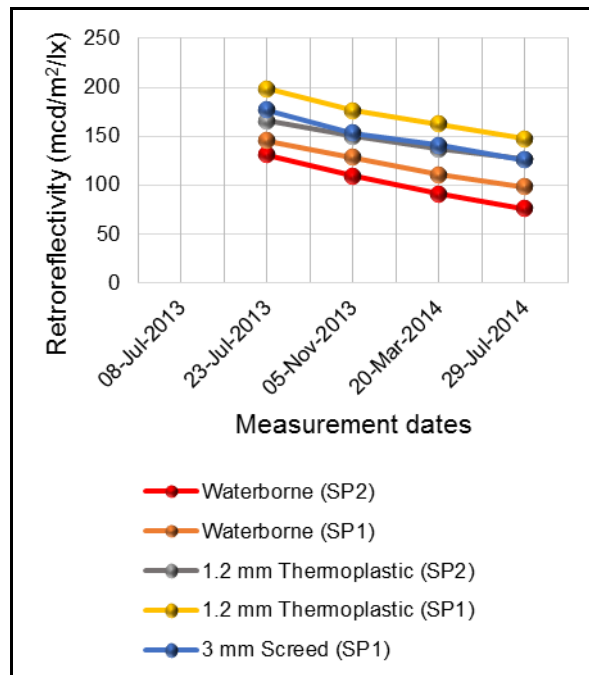

Figure 4.9: Unwashed yellow longitudinal markings on Middel Street.

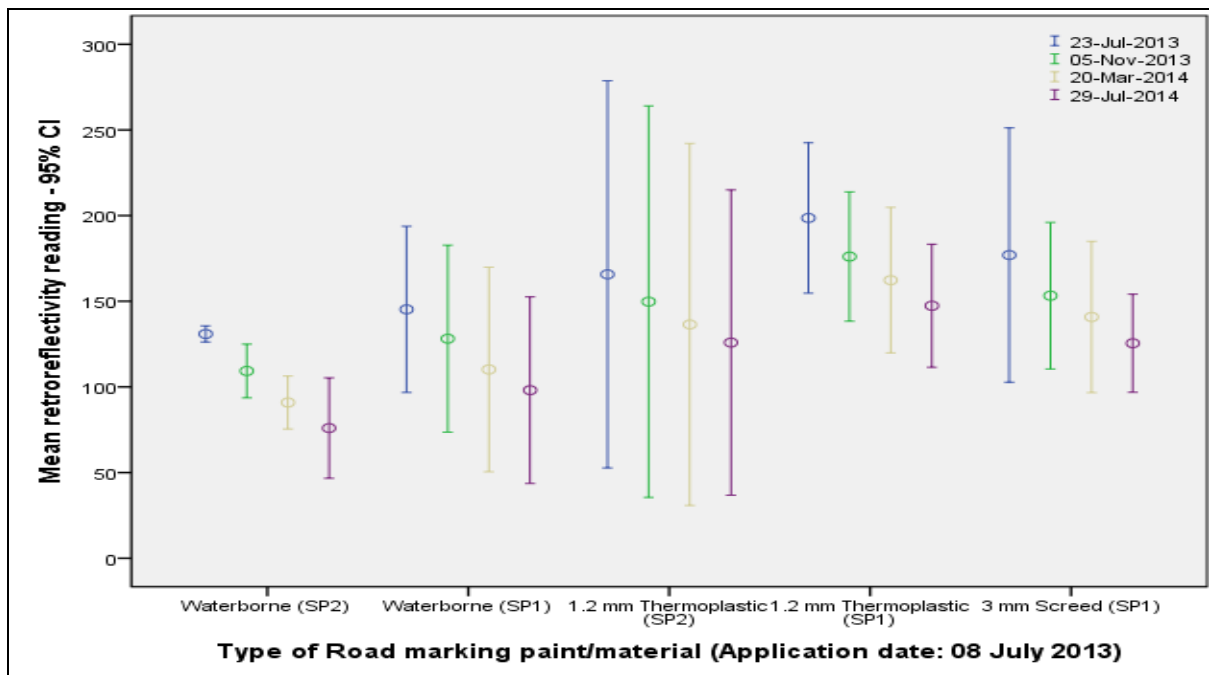

Figure 4.10: Ninety five per cent Confidence Interval of unwashed yellow longitudinal markings on Middel Street.

4.5.4.2 Long established dirty asphalt road (Mohwelere Street)

All test road markings complied with the minimum R_L specification of $70 \text{ mcd/m}^2/\text{lx}$ only in the first measurement period, as can be seen in Appendix A, Table A.29 and Figure A.58. None of the test markings complied with the specification in the second measurement period, which was conducted 6 months after the application of the test markings. The markings became very thin, mainly due to the abrasive effect of sand and the vehicles' wheels. All the markings produced R_L service lives of 1 to 6 months.

Friedman's Chi Square Test revealed that there is at least one pair of measurements over time that is significantly different within each of the different road marking paints and materials, and referring to Appendix C, Figure C.4.9 it seems as though these differences are at least between the first and last repetitions.

4.5.4.3 Newly established clean chip seal road (Doreen Street)

Block 1

The 1.2 mm thermoplastic (SP2) produced a R_L service life of less than 1 month, as can be seen in Appendix A, Table A.9 and Figure A.18. Water-borne (SP1 and SP2) produced R_L service lives of 4 to 8 months and 1 to 4 months respectively. The 1.2 mm thermoplastic (SP1) and 3 mm thermoplastic SP1 produced R_L service lives of more than 12 months.

Friedman's Chi Square Test revealed that there are no pairs of readings over time that are significantly different within each of the different materials. Even though some 95 per cent CIs do not overlap, as can be seen in Appendix C, Figure C.4.3, the sample size of 1 does not allow for enough statistical power to find statistically significant differences and thus should be interpreted in the usual way.

Blocks 2 and 3

Water-borne (SP2) and 1.2 mm thermoplastic (SP2) produced R_L service lives of 4 to 8 months, as can be seen in Appendix A, Table A.12 and Figure A.24. Water-borne (SP1), 1.2 mm thermoplastic (SP1) and 3 mm thermoplastic (SP1) produced R_L service lives of more than 12 months.

Friedman's Chi Square Test revealed that there are no pairs of readings over time that are significantly different within each of the different materials. Even though some 95 per cent CIs do not overlap, as can be seen in Appendix C, Figure C.4.4, the sample size of 2 does not allow for enough statistical power to find statistically significant differences. The fact that the 95 per cent CIs extend into the negative with some of the road marking paints and materials further indicates the lack of statistical power and they should thus be interpreted in the usual way. For example, water-borne (SP1) and 1.2 mm thermoplastic (SP2) extend to approximately -500.

Blocks 1, 2 and 3

Water-borne (SP2) and 1.2 mm thermoplastic (SP2) produced R_L service lives of 4 to 8 months as can be seen in Appendix A, Table A.15 and Figure A.30. Water-borne (SP1), 1.2 mm thermoplastic (SP1) and 3 mm thermoplastic (SP1) produced R_L service lives of more than 12 months.

Friedman's Chi Square Test revealed that there are no pairs of readings over time that are significantly different within each of the different materials. The fact that the 95 per cent CIs extend into the negative, as can be seen in Appendix C, Figure C.4.5, indicates the lack of statistical power and they should thus be interpreted in the usual way. For example, water-borne (SP1) extends to approximately -500.

4.5.4.4 Newly established dirty chip seal road (Aubrey Matlala Road)

Water-borne (SP2) produced a R_L service life of 1 to 4 months, as can be seen in Appendix A, Table A.3 and Figure A.6. The 1.2 mm thermoplastic produced a R_L service life of 4 to 9 months. Water-borne (SP1), 1.2 mm thermoplastic (SP1) and 3 mm thermoplastic (SP1) produced R_L service lives of 9 to 12 months.

Although there is no overlap between the first and last measurement periods, as can be seen in Appendix C, Figure C.4.1, Friedman's Chi Square Test revealed that there are no pairs of readings over time that are significantly different within each of the different materials. The sample size of 2

does not allow for enough statistical power to find statistically significant differences as the test markings were applied at only 2 blocks and thus should be interpreted in the usual way.

4.5.4.5 Long established clean chip seal road (Bushveld Road)

Water-borne (SP1) produced a R_L service life of 4 to 8 months, as can be seen in Appendix A, Table A.6 and Figure A.12. The 1.2 mm thermoplastic (SP1 and SP2) and 3 mm thermoplastic (SP1) produced R_L service lives of 8 to 12 months. The yellow longitudinal markings did not produce R_L service lives as long as those of the white longitudinal markings on the same road. It was observed during the measurement periods that minibus taxis pull off the road on the left and then re-enter the road, carrying sand on their wheels. The abrasive action of the sand with the wheels of the vehicles adversely affected the R_L of the test markings.

Friedman's Chi Square Test revealed that there is at least one pair of measurements over time that is significantly different within each of the different road marking paints and materials, and referring to Appendix C, Figure C.4.2 it seems as though these differences are at least between the first and last repetitions.

4.5.4.6 Long established dirty chip seal road (Road L 3)

Water-borne (SP1 and SP2) produced R_L service lives of 1 to 4 months, as can be seen in Appendix A, Table A.32 and Figure A.64. The 1.2 mm thermoplastic (SP2) and 3 mm thermoplastic (SP2) produced R_L service lives of 4 to 9 months. The 1.2 mm thermoplastic produced a R_L service life of 9 to 12 months.

Friedman's Chi Square Test revealed that there is at least one pair of measurements over time that is significantly different within each of the different road marking paints and materials, and referring to Appendix C, Figure C.4.10 it seems as though these differences are at least between the first and last repetitions.

4.5.4.7 Newly established clean asphalt road (Meiring Naude Road)

All the test road markings produced R_L service lives of more than 13 months, as can be seen in Appendix A, Table A.23 and Figure A.46. The left edge yellow line on Meiring Naude Road was painted close to the non-mountable kerb. Motorists tend to keep away from the kerb, as on Bushveld Road on the right edge, hence away from the left edge line causing minimal damage by the wheels of the vehicles. If the R_L continues to decline at the rate at which it did in the first year, water-borne (SP1 and SP2) will produce R_L service lives of approximately 1.5 years. The 1.2 mm thermoplastic (SP2) and the 3 mm thermoplastic (SP1) will produce R_L service lives of between 1.5 and 2 years respectively while 1.2 mm thermoplastic (SP1) will produce a R_L service life of 2 years.

Friedman's Chi Square Test revealed that there is at least one pair of measurements over time that is significantly different within each of the different road marking paints and materials, and referring to Appendix C, Figure C.4.7 it seems as though these differences are at least between the first and last repetitions.

4.5.4.8 Newly established dirty asphalt road (M 44)

Water-borne (SP1 and SP1) and 1.2 mm thermoplastic (SP1 and SP2) produced R_L service lives of 1 to 4 months, as can be seen in Appendix A, Table A.18 and Figure A.36. The 3 mm thermoplastic (SP1) produced a R_L service life of 4 to 7 months.

Although there is no overlap between the first and last measurement periods, as can be seen in Appendix C, Figure C.4.6, Friedman's Chi Square Test revealed that there are no pairs of readings over time that are significantly different within each of the different materials. The sample size of 2 did not allow for enough statistical power to find statistically significant differences as the test markings were applied at only 2 blocks. The fact that some of the 95 per cent CIs mean R_L extended into the negative further indicates the lack of statistical power and they should thus be interpreted in the usual way. For example, water-borne (SP1) extends to approximately -200.

4.5.4.9 Overall discussion on yellow longitudinal road markings

The longest performing road marking paints or materials in R_L per different road surface type and condition are indicated in Table 4.8. The R_L service lives are those of the unwashed yellow longitudinal test road markings. Road markings generally have longer R_L service lives on clean roads than on dirty roads.

Thermoplastic longitudinal test markings produced R_L service lives of more than 12 months on the clean roads. Water-borne paints can also produce long R_L service lives on clean roads, as can be seen with water-borne (SP1 and SP2) applied on Meiring Naude Road.

Although thermoplastic road marking materials were the common road marking material which produced the longest R_L service life on each road where the test markings were applied, it may not be cost effective to apply them on long established dirty asphalt roads (like Mohwelere Street) where they will have a very low R_L service life, similar to that of water-borne road marking paints.

Table 4.8: Summary of longest performing yellow longitudinal markings in retroreflectivity.

Name of road / street	Description of road / street	AADT	Longest performing road marking paints / materials	R _L service life (months)
Aubrey Matlala	Newly established dirty chip seal road	Light vehicles =6557 Heavy vehicles =255 Total vehicles =6814	Water-borne (SP1), 1.2 mm thermoplastic (SP1), 3 mm thermoplastic (SP1)	9 to 12
Bushveld	Long established clean chip seal road	Light vehicles =5508 Heavy vehicles =739 Total vehicles =6246	1.2 mm thermoplastic (SP1 & SP2), 3 mm thermoplastic (SP1)	8 to 12
Doreen (B 1)	Newly established clean chip seal road	Light vehicles =7753 Heavy vehicles =284 Total vehicles =8037	1.2 mm thermoplastic (SP1), 3 mm thermoplastic (SP1)	> 12
Doreen (B 2 & 3)	Newly established clean chip seal road	Light vehicles =7753 Heavy vehicles =284 Total vehicles =8037	Water-borne (SP1), 1.2 mm thermoplastic (SP1), 3 mm thermoplastic (SP1)	> 12
Doreen (B 1, 2 & 3)	Newly established clean chip seal road	Light vehicles =7753 Heavy vehicles =284 Total vehicles =8037	Water-borne (SP1), 1.2 mm thermoplastic (SP1), 3 mm thermoplastic (SP1)	> 12
M 44	Newly established dirty asphalt road	Light vehicles =7822 Heavy vehicles =434 Total vehicles =8315	3 mm thermoplastic (SP1)	4 to 7
Meiring Naude	Newly established clean asphalt road	Light vehicles =3981 Heavy vehicles =629 Total vehicles =4610	Water-borne (SP1 & SP2), 1.2 mm thermoplastic (SP1 & SP2), 3 mm thermoplastic (SP1)	> 13
Middel	Long established clean asphalt road	Light vehicles =5547 Heavy vehicles =273 Total vehicles =5821	Water-borne (SP1 & SP2), 1.2 mm thermoplastic (SP1 & SP2), 3 mm thermoplastic (SP1)	> 12
Mohwelere	Long established dirty asphalt	Light vehicles =1732 Heavy vehicles =213 Total vehicles =1945	All the road markings applied perform almost equally with very low service life	1 to 6
L 3	Long established dirty chip seal road	Light vehicles =2454 Heavy vehicles =109 Total vehicles =2563	1.2 mm thermoplastic (SP1)	9 to 12

4.6 LUMINANCE SERVICE LIFE OF THE TEST ROAD MARKINGS

The road markings were analysed as follows:

- White transverse road markings
- Yellow transverse road markings
- White longitudinal road markings
- Yellow longitudinal road markings

4.6.1 White transverse road markings

4.6.1.1 Long established clean asphalt road (Middel Street)

All the test road markings applied on the long established clean asphalt road were higher than the minimum specification of 100 mcd/m²/lx over the 4 measurement periods, as can be seen in Table 4.9 and Figure 4.11.

The average decline in Qd of all test markings over the year was approximately 26 per cent. If the decline in Qd continues at the same rate, 1.2 mm thermoplastic (SP1) and 3 mm thermoplastic (SP1) will produce Qd service lives of approximately 15 months and 17 months respectively. All the other road marking paints and materials produced Qd service lives of approximately 1 year.

The fact that there is no overlap between the 95 per cent CIs of the first and last measurements, as can be seen in Figure 4.13, is an indication that the difference between them is statistically significant. Friedman's Chi Square Test revealed that there is at least one pair of measurements over time that is significantly different within each of the different road marking paints and materials, and referring to Figure 4.13 it seems as though these differences are at least between the first and last repetitions.

Table 4.9: Descriptive statistics of white transverse markings in luminance on Middel Street.

Type of road marking paint / material		23-Jul-2013		05-Nov-2013		20-Mar-2014		29-Jul-2014	
		Unwashed	Washed	Unwashed	Washed	Unwashed	Washed	Unwashed	Washed
Water-borne (SP2)	Mean	141.7	145.4	128.7	136.5	108.1	107.0	103.6	105.8
	N	9	9	9	9	9	9	9	9
	Std. Deviation	11.7	12.5	9.8	9.1	1.7	1.5	1.7	1.6
	CV	0.08	0.09	0.08	0.07	0.02	0.01	0.02	0.02
Water-borne (SP1)	Mean	136.6	141.8	119.5	125.5	106.9	108.0	102.8	106.1
	N	9	9	9	9	9	9	9	9
	Std. Deviation	6.2	6.1	7.2	6.3	1.7	3.7	2.2	2.0
	CV	0.05	0.04	0.06	0.05	0.02	0.03	0.02	0.02
Water-borne (SP3)	Mean	138.0	141.3	122.5	129.1	106.4	106.9	101.5	103.5
	N	9	9	9	9	9	9	9	9
	Std. Deviation	7.0	6.8	8.6	7.8	2.4	1.6	1.7	2.1
	CV	0.05	0.05	0.07	0.06	0.02	0.02	0.02	0.02
1.2 mm Thermoplastic (SP2)	Mean	144.2	147.1	134.0	140.0	108.7	112.7	103.0	105.5
	N	9	9	9	9	9	9	9	9
	Std. Deviation	9.4	9.5	12.3	10.1	2.9	4.8	0.9	3.4
	CV	0.07	0.07	0.09	0.07	0.03	0.04	0.01	0.03
1.2 mm Thermoplastic (SP1)	Mean	153.7	158.1	143.8	152.3	116.1	122.1	111.0	108.3
	N	9	9	9	9	9	9	9	9
	Std. Deviation	9.9	8.7	10.9	9.6	6.9	4.0	3.9	3.6
	CV	0.07	0.06	0.08	0.06	0.05	0.03	0.04	0.04
1 mm Cold Plastic (SP1)	Mean	139.4	143.3	134.3	139.8	111.2	109.4	103.6	107.1
	N	9	9	9	9	9	9	9	9
	Std. Deviation	5.0	3.2	7.6	7.3	3.2	2.2	2.6	1.7
	CV	0.04	0.02	0.06	0.05	0.03	0.02	0.03	0.02
3 mm Screed (SP1)	Mean	155.5	160.0	144.8	151.2	121.8	122.8	116.9	121.1
	N	9	9	9	9	9	9	9	9
	Std. Deviation	12.2	9.6	15.1	15.2	2.5	2.6	3.3	3.1
	CV	0.08	0.06	0.10	0.10	0.02	0.02	0.03	0.03
1 mm Cold Plastic (SP4)	Mean	139.7	144.7	125.9	131.3	109.6	109.6	101.3	104.6
	N	9	9	9	9	9	9	9	9
	Std. Deviation	11.0	10.5	6.9	6.5	1.7	2.5	1.9	2.6
	CV	0.08	0.07	0.06	0.05	0.02	0.02	0.02	0.03

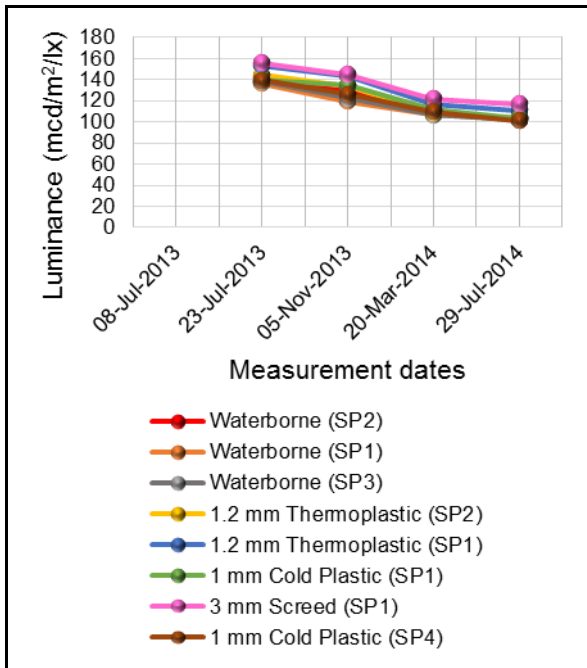

Figure 4.11: Unwashed white transverse markings on Middel Street.

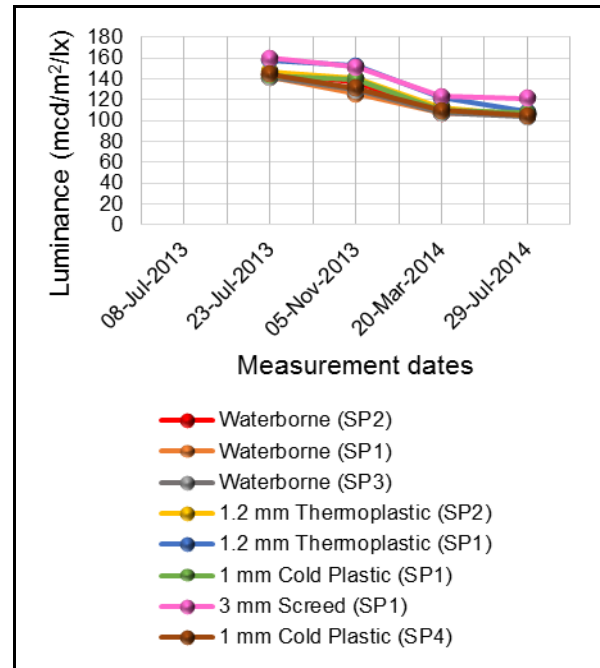

Figure 4.12: Washed white transverse markings on Middel Street.

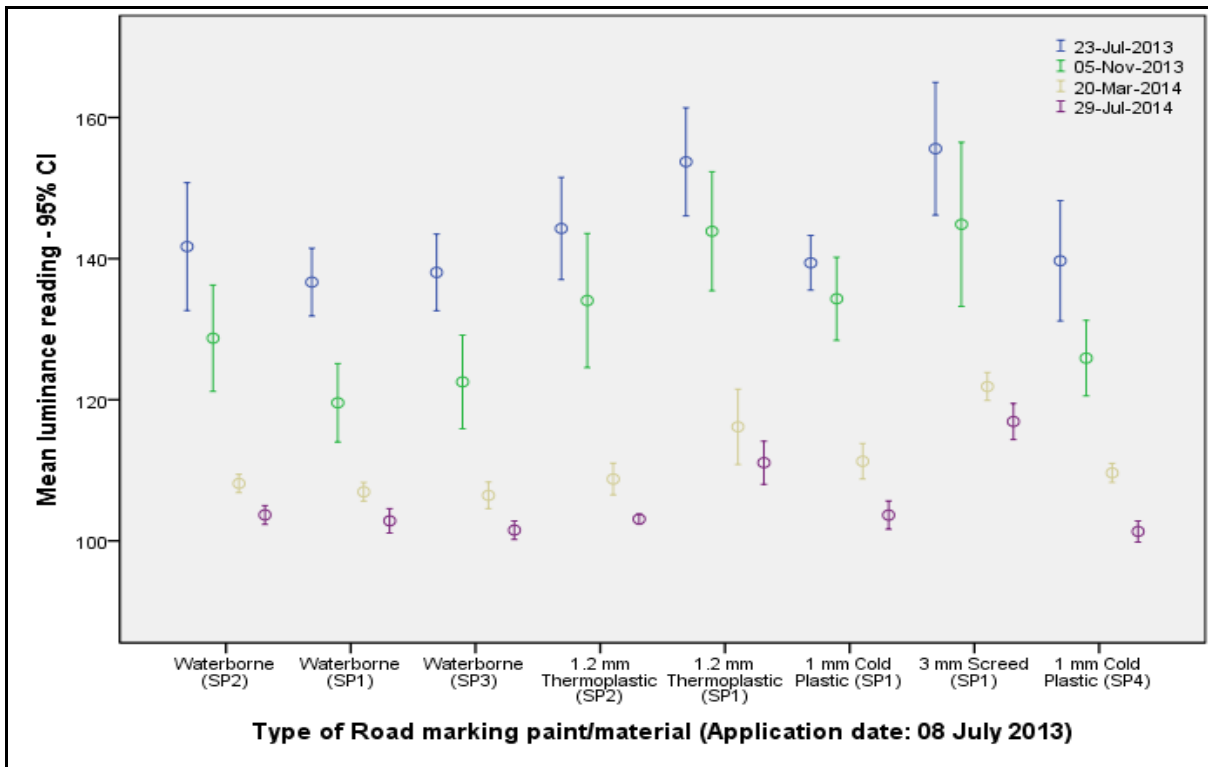

Figure 4.13: Ninety five per cent Confidence Interval of unwashed white transverse markings on Middel Street.

4.6.1.2 Long established dirty asphalt road (Mohwelere Street)

All test road markings complied with the minimum Qd specification of 100 mcd/m²/lx only in the first measurement period, as can be seen in Appendix B, Table B.27 and Figure B.53. Water-borne (SP1, SP2 and SP3) and 1 mm cold plastic (SP1 and SP4) produced Qd service lives of 1 to 6 months. The 1.2 mm thermoplastic (SP2) produced a Qd service life of 6 to 9 months. The 1.2 mm thermoplastic (SP1) and the 3 mm thermoplastic (SP1) produced Qd service lives of 9 to 12 months.

Friedman's Chi Square Test revealed that there is at least one pair of measurements over time that is significantly different within each of the different road marking paints and materials, and referring to Appendix C, Figure C.5.10 it seems as though these differences are at least between the first and last repetitions.

4.6.1.3 Newly established clean chip seal road (Doreen Street)

Block 1

Water-borne (SP2 and SP3) and 1 mm cold plastic (SP1 and SP3) produced Qd service lives of 1 to 4 months, as can be seen in Appendix B, Table B.7 and Figure B.13. Water-borne (SP1) and 1.2 mm thermoplastic (SP1 and SP2) produced Qd service lives of 4 to 8 months. The 3 mm thermoplastic (SP1) produced a Qd service life of 8 to 12 months. Water-borne (SP2) became so thin that it could not be measured in the third measurement period. The test road markings became thin mainly due to the abrasive effect of sand and vehicles' wheels.

Friedman's Chi Square Test revealed that there is at least one pair of measurements over time that is significantly different within each of the different road marking paints and materials, and referring to Appendix C, Figure C.5.3 it seems as though these differences are at least between the first and last repetitions.

Blocks 2 and 3

Water-borne (SP1, SP2 and SP3) and 1 mm cold plastic (SP1 and SP4) produced Qd service lives of 1 to 4 months, as can be seen in Appendix B, Table B.10 and Figure B.19. The 1.2 mm (SP1 and SP2) and 3 mm thermoplastic (SP1) produced Qd service lives of 4 to 8 months.

Friedman's Chi Square Test revealed that there is at least one pair of measurements over time that is significantly different within each of the different road marking paints and materials, and referring to Appendix C, Figure C.5.4 it seems as though these differences are at least between the first and last repetitions.

Blocks 1, 2 and 3

Water-borne (SP1, SP2 and SP3) and 1 mm cold plastic (SP1 and SP4) produced Qd service lives of 1 to 4 months, as can be seen in Appendix B, Table B.13 and Figure B.25. The 1.2 mm (SP1 and SP2) and 3 mm thermoplastic (SP1) produced Qd service lives of 4 to 8 months.

Friedman's Chi Square Test revealed that there is at least one pair of measurements over time that is significantly different within each of the different road marking paints and materials, and referring to Appendix C, Figure C.5.5 it seems as though these differences are at least between the first and last repetitions.

4.6.1.4 Newly established dirty chip seal road (Aubrey Matlala Road)

Water-borne (SP2 and SP3) did not comply with the minimum Qd specification of 100 mcd/m²/lx at the first measurement period, which was conducted approximately 3 weeks after the application of the test road markings, as can be seen in Appendix B, Table B.1 and Figure B.1. Water-borne (SP1), 1 mm cold plastic (SP1 and SP2), 1.2 mm thermoplastic (SP1 and SP2) and 3 mm thermoplastic (SP1) produced Qd service lives of 1 to 4 months.

Friedman's Chi Square Test revealed that there is at least one pair of measurements over time that is significantly different within each of the different road marking paints and materials, and referring to Appendix C, Figure C.5.1 it seems as though these differences are at least between the first and last repetitions.

4.6.1.5 Long established clean chip seal road (Bushveld Road)

Water-borne (SP1, SP2 and SP2) and 1 mm cold plastic (SP1 and SP4) produced Qd service lives of 1 to 4 months, as can be seen in Appendix B, Table B.4 and Figure B.7. The 1.2 mm thermoplastic (SP1 and SP2) and the 3 mm thermoplastic (SP1) produced Qd service lives of 4 to 8 months.

Friedman's Chi Square Test revealed that there is at least one pair of measurements over time that is significantly different within each of the different road marking paints and materials, and referring to Appendix C, Figure C.5.2 it seems as though these differences are at least between the first and last repetitions.

4.6.1.6 Long established dirty chip seal road (Road L 3)

Water-borne (SP3) produced a Qd service life of 1 to 4 months, as can be seen in Appendix B, Table B.30 and Figure B.59. Water-borne (SP1 and SP2), 1 mm cold plastic (SP1 and SP4), 1.2 mm thermoplastic (SP1 and SP2) and 3 mm thermoplastic (SP1) produced Qd service lives of 4 to 9 months.

Friedman's Chi Square Test revealed that there is at least one pair of measurements over time that is significantly different within each of the different road marking paints and materials, and referring to Appendix C, Figure C.5.11 it seems as though these differences are at least between the first and last repetitions.

4.6.1.7 Newly established clean asphalt road (Meiring Naude Road)

Water-borne (SP1 and SP3) and 1 mm cold plastic (SP4) produced Qd service lives of 1 to 4 months, as can be seen in Appendix B, Table B.21 and Figure B.41. The 1 mm cold plastic (SP1) and 1.2 mm thermoplastic (SP2) produced Qd service lives of 4 to 9 months. Water-borne (SP2), 1.2 mm thermoplastic (SP1) and 3 mm thermoplastic (SP1) produced Qd service lives of 9 to 13 months.

Friedman's Chi Square Test revealed that there is at least one pair of measurements over time that is significantly different within each of the different road marking paints and materials, and referring to Appendix C, Figure C.5.8 it seems as though these differences are at least between the first and last repetitions.

4.6.1.8 Newly established dirty asphalt road (M 44)

The 1 mm cold plastic (SP1) and 1.2 mm thermoplastic (SP1 and SP2) produced Qd service lives of 1 to 4 months, as can be seen in Appendix B, Table B.16 and Figure B.31. Water-borne (SP1, SP2 and SP2), 1 mm cold plastic (SP2) and 3 mm thermoplastic (SP1) produced Qd service lives of 4 to 7 months.

Friedman's Chi Square Test revealed that there is at least one pair of measurements over time that is significantly different within each of the different road marking paints and materials, and referring to Appendix C, Figure C.5.6 it seems as though these differences are at least between the first and last repetitions.

4.6.1.9 Long established asphalt road in the CBD (Madiba Street)

The first set of measurements was conducted 2 weeks after the application of the test road markings and water-borne (SP2) did not meet the minimum Qd specification of $100\text{mcd/m}^2/\text{lx}$, as can be seen in Appendix B, Table B.19 and Figure B.37. Water-borne (SP1 and SP3) and 1 mm cold plastic (SP2) produced Qd service lives of 1 to 4 months. Water-borne (SP1) came off the surface after measurement period 2 and thus could not be measured in the third measurement period. The 1 mm cold plastic (SP1), 1.2 mm thermoplastic (SP1 and SP2) and 3 mm thermoplastic (SP1) produced Qd service lives of 4 to 7 months.

Friedman's Chi Square Test revealed that there is at least one pair of measurements over time that is significantly different within each of the different road marking paints and materials, and referring to Appendix C, Figure C.5.7 it seems as though these differences are at least between the first and last repetitions.

4.6.1.10 Overall discussion on white transverse road markings

The longest performing road marking paints or materials in Qd per different road surface type and condition are indicated in Table 4.10. The Qd service lives are those of the unwashed white transverse test markings due to the fact that this is how the road markings will be generally viewed by the road user. However, during the rainy season the road markings may become cleaner with the water on the road markings and tyres of the vehicles passing over them, but this is usually only of limited duration. It can be seen in Table 4.10 that all types of road markings generally have longer Qd service lives on clean roads than on dirty roads.

The test markings applied on the clean established asphalt road (Middel Street) seem to have the longest Qd service lives, even with the application of water-borne road marking paints. In addition to the road being clean, it could also be that all the volatiles from the road surface have already evaporated, this being a long established road, and as such did not discolour the road markings to such an extent of adversely affecting the Qd. Although the AADT on Middel Street is high as compared with roads like Mohwelere and L 3, the Qd service lives for all types of road marking paints and materials on Middel Street are much longer, indicating that the main cause of decline in Qd is the adverse effects of sand on the road markings.

As the Qd is not directly affected by the glass beads in road markings, even water-borne road marking paints can produce long Qd service lives. However, as the road marking paint wears away, the road surface starts to become exposed, which adversely affects the Qd. It can be seen on the M44, which is a dirty type road, all water-borne road marking paints performed similarly to the plastic road marking materials whereby all the test markings produced Qd service lives of 4 to 7 months.

Table 4.10: Summary of longest performing white transverse markings in luminance.

Name of road / street	Description of road / street	AADT	Longest performing road marking paints / materials	Qd service life (months)
Aubrey Matlala	Newly established dirty chip seal road	Light vehicles =6557 Heavy vehicles =255 Total vehicles =6814	Ware-borne (SP1) 1 mm cold plastic (SP1 & SP2), 1.2 mm thermoplastic (SP1 & SP2), 3 mm thermoplastic (SP1)	1 to 4
Bushveld	Long established clean chip seal road	Light vehicles =5508 Heavy vehicles =739 Total vehicles =6246	1.2 mm thermoplastic (SP1 & SP2), 3 mm thermoplastic (SP1)	4 to 8
Doreen (B 1)	Newly established clean chip seal road	Light vehicles =7753 Heavy vehicles =284 Total vehicles =8037	3 mm thermoplastic (SP1)	8 to 12
Doreen (B 2 & 3)	Newly established clean chip seal road	Light vehicles =7753 Heavy vehicles =284 Total vehicles =8037	1.2 mm thermoplastic (SP1 & SP2), 3 mm thermoplastic (SP1)	4 to 8
Doreen (B 1, 2 & 3)	Newly established clean chip seal road	Light vehicles =7753 Heavy vehicles =284 Total vehicles =8037	1.2 mm thermoplastic (SP1 & SP2), 3 mm thermoplastic (SP1)	4 to 8
M 44	Newly established dirty asphalt road	Light vehicles =7822 Heavy vehicles =434 Total vehicles =8315	Water-borne (SP1, SP2 & SP3), 1 mm cold plastic (SP2), 3 mm thermoplastic (SP1)	4 to 7
Madiba	Long established asphalt road in CBD	Light vehicles =1764 Heavy vehicles =548 Total vehicles =2312	1 mm cold plastic (SP1) 1.2 mm thermoplastic (SP1 & SP2), 3 mm thermoplastic (SP1)	4 to 7
Meiring Naude	Newly established clean asphalt road	Light vehicles =3981 Heavy vehicles =629 Total vehicles =4610	Water-borne (SP2), 1.2mm thermoplastic (SP1), 3 mm thermoplastic (SP1)	9 to 13
Middel	Long established clean asphalt road	Light vehicles =5547 Heavy vehicles =273 Total vehicles =5821	Water-borne (SP1, SP2 & SP3), 1 mm cold plastic (SP1 & SP4), 1.2 mm thermoplastic (SP1 & SP2), 3 mm thermoplastic (SP1)	> 12
Mohwelere	Long established dirty asphalt	Light vehicles =1732 Heavy vehicles =213 Total vehicles =1945	1.2 mm thermoplastic (SP1), 3 mm thermoplastic (SP1)	9 to 12
L 3	Long established dirty chip seal road	Light vehicles =2454 Heavy vehicles =109 Total vehicles =2563	Water-borne (SP1 & SP2), 1 mm cold plastic (SP1 & SP4), 1.2 mm thermoplastic (SP1 & SP2), 3 mm thermoplastic (SP1)	4 to 9

4.6.2 Yellow transverse road markings

4.6.2.1 Long established clean asphalt road (Middel Street)

All the test road markings applied on the long established clean asphalt road were higher than the minimum specification of 80 mcd/m²/lx over the 4 measurement periods, as can be seen in Table 4.11 and Figure 4.14.

The average decline in Qd of all test markings over the year was approximately 19 per cent. If the decline in Qd continues at the same rate as the first year, 1.2 mm thermoplastic (SP2) will produce a Qd service life of 2 years. The 1.2 mm thermoplastic (SP1) and 3 mm thermoplastic (SP1) will produce Qd service lives of approximately 2.5 years.

The fact that there is no overlap between the 95 per cent CIs of the first and last measurements, as can be seen in Figure 4.16, is an indication that the difference between them is statistically significant. Friedman's Chi Square Test revealed that there is at least one pair of measurements over time that is significantly different within each of the different road marking paints and materials, and referring to Figure 4.16 it seems as though these differences are at least between the first and last repetitions.

Table 4.11: Descriptive statistics of yellow transverse markings in luminance on Middel Street.

Type of road marking paint / material		23-Jul-2013		05-Nov-2013		20-Mar-2014		29-Jul-2014	
		Unwashed	Washed	Unwashed	Washed	Unwashed	Washed	Unwashed	Washed
Water-borne (SP2)	Mean	105.3	107.5	97.5	98.4	91.9	95.0	84.1	85.8
	N	9	9	9	9	9	9	9	9
	Std. Deviation	0.7	1.3	0.9	0.9	2.4	3.2	3.3	1.6
	CV	0.01	0.01	0.01	0.00	0.03	0.03	0.04	0.02
Water-borne (SP1)	Mean	104.4	106.2	98.4	98.0	88.1	92.7	81.0	84.4
	N	9	9	9	9	9	9	9	9
	Std. Deviation	1.1	1.3	2.4	1.9	2.4	2.1	2.2	1.8
	CV	0.01	0.01	0.02	0.02	0.03	0.02	0.03	0.02
Water-borne (SP3)	Mean	102.5	104.2	97.2	98.3	88.8	92.9	81.4	84.0
	N	9	9	9	9	9	9	9	9
	Std. Deviation	2.1	2.3	1.4	0.9	2.9	1.8	2.4	1.6
	CV	0.02	0.02	0.02	0.01	0.03	0.02	0.03	0.02
1.2 mm Thermoplastic (SP2)	Mean	122.0	122.6	115.6	119.5	108.2	111.8	99.0	103.9
	N	9	9	9	9	9	9	9	9
	Std. Deviation	3.1	0.6	3.2	0.6	11.1	11.6	4.9	1.9
	CV	0.03	0.01	0.03	0.01	0.10	0.10	0.05	0.02
1.2 mm Thermoplastic (SP1)	Mean	121.2	122.0	114.4	117.7	110.8	115.7	102.7	103.7
	N	9	9	9	9	9	9	9	9
	Std. Deviation	1.4	1.8	4.7	1.0	12.5	13.7	2.2	2.7
	CV	0.01	0.02	0.04	0.01	0.11	0.12	0.02	0.03
1 mm Cold Plastic (SP1)	Mean	106.6	105.6	98.5	99.7	89.6	95.1	84.0	85.1
	N	9	9	9	9	9	9	9	9
	Std. Deviation	1.5	2.1	1.6	0.6	5.0	3.9	1.2	2.0
	CV	0.02	0.02	0.02	0.01	0.06	0.04	0.02	0.02
3 mm Screed (SP1)	Mean	121.7	123.0	119.3	119.4	102.2	105.5	103.6	105.1
	N	9	9	9	9	9	9	9	9
	Std. Deviation	3.0	1.6	1.1	1.6	9.3	8.0	1.5	3.3
	CV	0.03	0.01	0.10	0.01	0.09	0.08	0.02	0.03
1 mm Cold Plastic (SP4)	Mean	122.0	120.2	114.4	119.2	98.0	101.2	101.9	102.2
	N	9	9	9	9	9	9	9	9
	Std. Deviation	3.0	2.1	4.7	3.1	9.3	8.7	1.8	1.9
	CV	0.02	0.02	0.04	0.03	0.10	0.09	0.02	0.02

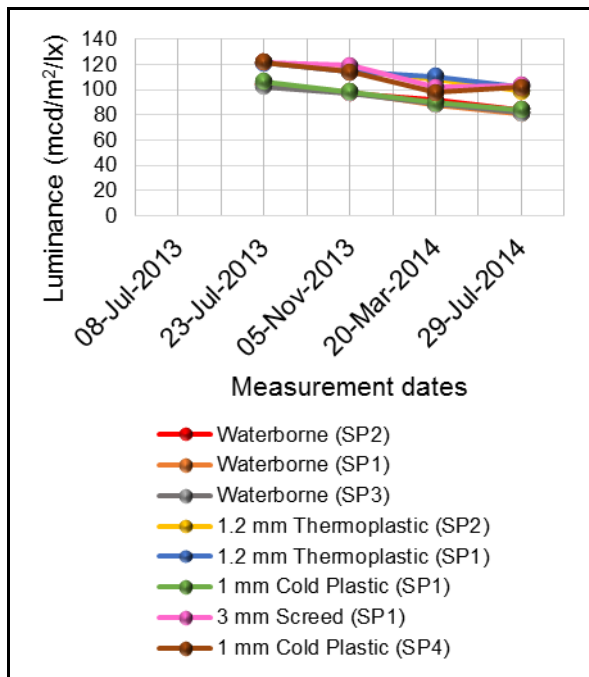

Figure 4.14: Unwashed yellow transverse markings on Middel Street.

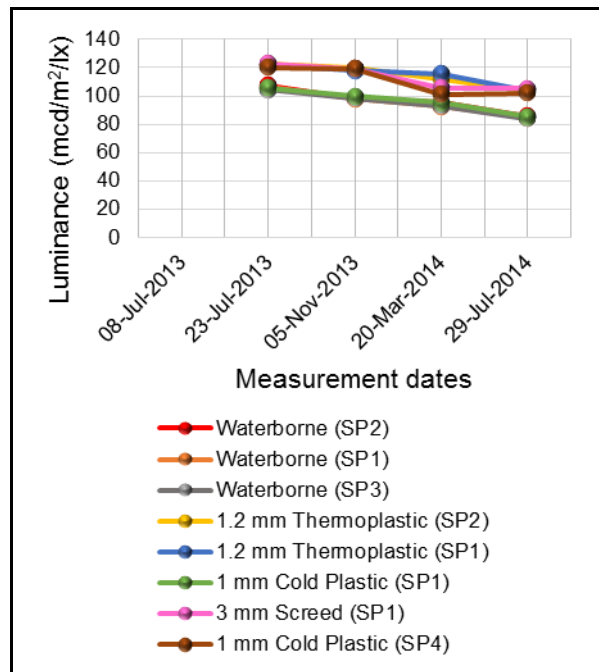

Figure 4.15: Washed yellow transverse markings on Middel Street.

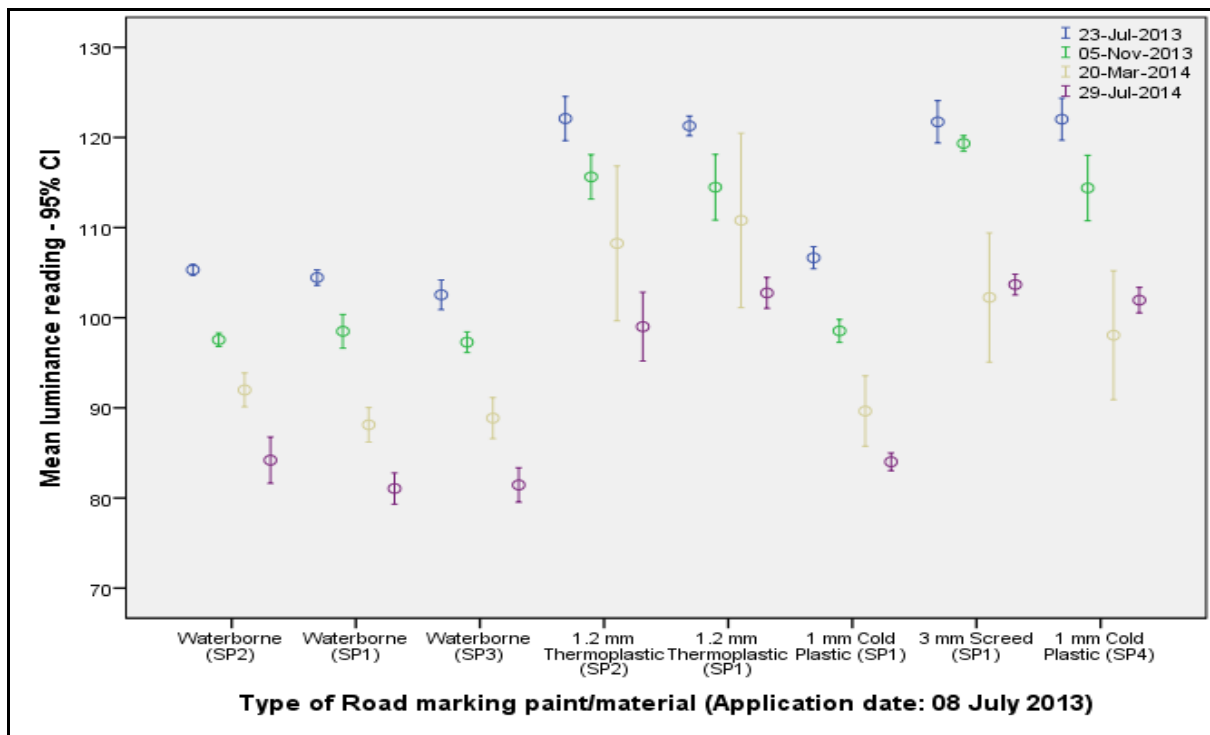

Figure 4.16: Ninety five per cent Confidence Interval of unwashed yellow transverse markings on Middel Street.

4.6.2.2 Long established dirty asphalt road (Mohwelere Street)

Water-borne (SP2 and SP3) produced Qd service lives of 1 to 6 months, as can be seen in Appendix B, Table B.28 and Figure B.55. Water-borne (SP1), 1 mm cold plastic (SP4) and 1.2 mm thermoplastic (SP2) produced Qd service lives of 6 to 9 months. The 1 mm cold plastic (SP1) and 1.2 mm thermoplastic (SP1) produced Qd service lives of 9 to 12 months. The 3 mm thermoplastic (SP1) produced a Qd service life of more than 12 months.

Friedman's Chi Square Test revealed that there is at least one pair of measurements over time that is significantly different within each of the different road marking paints and materials, and referring to Appendix C, Figure C.6.10 it seems as though these differences are at least between the first and last repetitions.

4.6.2.3 Newly established clean chip seal road (Doreen Street)

Block 1

Water-borne (SP2), 1 mm cold plastic (SP4) and 1.2 mm thermoplastic (SP1) produced Qd service lives of 1 to 4 months, as can be seen in Appendix B, Table B.8 and Figure B.15. Water-borne (SP1 and SP3), 1 mm cold plastic (SP1) and 1.2 mm thermoplastic (SP1) produced Qd service lives of 4 to 8 months. The 3 mm thermoplastic (SP1) produced a Qd service life of 8 to 12 months.

Friedman's Chi Square Test revealed that there is at least one pair of measurements over time that is significantly different within each of the different road marking paints and materials, and referring to Appendix C, Figure C.6.3 it seems as though these differences are at least between the first and last repetitions.

Blocks 2 and 3

Water-borne (SP1 and SP2) and 1.2 mm thermoplastic (SP2) produced Qd service lives of 1 to 4 months, as can be seen in Appendix B, Table B.11 and Figure B.21. Water-borne (SP3) and 1 mm cold plastic (SP1 and SP4) produced Qd service lives of 4 to 8 months. The 1.2 mm thermoplastic (SP1) and 3 mm thermoplastic (SP1) produced Qd service lives of 8 to 12 months.

Friedman's Chi Square Test revealed that there is at least one pair of measurements over time that is significantly different within each of the different road marking paints and materials, and referring to Appendix C, Figure C.6.4 it seems as though these differences are at least between the first and last repetitions.

Blocks 1, 2 and 3

Water-borne (SP1 and SP2) and 1.2 mm thermoplastic (SP2) produced Qd service lives of 1 to 4 months, as can be seen in Appendix B, Table B.14 and Figure B.27. Water-borne (SP3), 1 mm cold

plastic (SP1 and SP4) and 1.2 mm thermoplastic (SP1) produced Qd service lives of 4 to 8 months. The 3 mm thermoplastic (SP1) produced a R_L service life of 8 to 12 months.

Friedman's Chi Square Test revealed that there is at least one pair of measurements over time that is significantly different within each of the different road marking paints and materials, and referring to Appendix C, Figure C.6.5 it seems as though these differences are at least between the first and last repetitions.

4.6.2.4 Newly established dirty chip seal road (Aubrey Matlala Road)

Water-borne (SP1 and SP3) did not comply with the minimum Qd specification of 80 mcd/m²/lx in the first measurement period, which was conducted approximately 3 weeks after the application of the test road markings, as can be seen in Appendix B, Table B.2 and Figure B.3. Water-borne (SP2) produced a Qd service life of 1 to 4 months. The 1 mm cold plastic (SP1), 1.2 mm thermoplastic (SP1 and SP2) and 3 mm thermoplastic (SP1) produced Qd service lives of 4 to 9 months.

Friedman's Chi Square Test revealed that there is at least one pair of measurements over time that is significantly different within each of the different road marking paints and materials, and referring to Appendix C, Figure C.6.1 it seems as though these differences are at least between the first and last repetitions.

4.6.2.5 Long established clean chip seal road (Bushveld Road)

Water-borne (SP1 and SP3) produced Qd service lives of 1 to 4 months, as can be seen in Appendix B, Table B.5 Figure B.9. Water-borne (SP2) and 1mm cold plastic (SP4) produced Qd service lives of 4 to 8 months. The 1 mm cold plastic (SP1), 1.2 mm thermoplastic (SP1 and SP2) and 3 mm thermoplastic (SP1) produced Qd service lives of 8 to 12 months.

Friedman's Chi Square Test revealed that there is at least one pair of measurements over time that is significantly different within each of the different road marking paints and materials, and referring to Appendix C, Figure C.6.2 it seems as though these differences are at least between the first and last repetitions.

4.6.2.6 Long established dirty chip seal road (Road L 3)

Water-borne (SP1, SP2 and SP3) produced Qd service lives of 1 to 4 months, as can be seen in Appendix B, Table B.31 and Figure B.61. The 1 mm cold plastic (SP4) produced a Qd service life of 4 to 9 months. The 1 mm cold plastic (SP1), 1.2 mm thermoplastic (SP1 and SP2) and 3 mm thermoplastic (SP1) produced Qd service lives of 9 to 12 months.

Friedman's Chi Square Test revealed that there is at least one pair of measurements over time that is significantly different within each of the different road marking paints and materials, and referring to Appendix C, Figure C.6.11 it seems as though these differences are at least between the first and last repetitions.

4.6.2.7 Newly established clean asphalt road (Meiring Naude Road)

Water-borne (SP1, SP2 & SP3) and 1 mm cold plastic (SP4) produced Qd service lives of 1 to 4 months, as can be seen in Appendix B, Table B.22 and Figure B.43. The 1 mm cold plastic (SP1) produced a Qd service of 9 to 13 months. The 1.2 mm thermoplastic (SP1 and SP2) and 3 mm thermoplastic (SP1) produced Qd service lives of just more than 13 months.

Friedman's Chi Square Test revealed that there is at least one pair of measurements over time that is significantly different within each of the different road marking paints and materials, and referring to Appendix C, Figure C.6.8 it seems as though these differences are at least between the first and last repetitions.

4.6.2.8 Newly established dirty asphalt road (M 44)

Water-borne (SP3) produced a Qd service of 4 to 7 months, as can be seen in Appendix B, Table B.17 and Figure B.33. The 1 mm cold plastic (SP1), 1.2 mm thermoplastic (SP1 and SP2) produced Qd service lives of 7 to 10 months. Water-borne (SP2) produced a Qd service life of just more than 10 months. If the rate of decline in Qd continues as in the first 10 months, the water-borne (SP1) will produce a Qd service life of approximately 2.5 years. However, being a dirty road and water-borne thinly applied, the markings may be removed by the action of the sand and vehicles' wheels sooner than 2.5 years, which will result in the Qd not extending to 2.5 years.

Friedman's Chi Square Test revealed that there is at least one pair of measurements over time that is significantly different within each of the different road marking paints and materials, and referring to Appendix C, Figure C.6.6 it seems as though these differences are at least between the first and last repetitions.

4.6.2.9 Long established asphalt road in the CBD (Madiba Street)

Water-borne (SP3) produced a Qd service life of 1 to 4 months, as can be seen in Appendix B, Table B.20 and Figure B.39. Water-borne (SP1 and SP2), 1 mm cold plastic (SP1), 1.2 mm thermoplastic (SP1 and SP2) and 3 mm thermoplastic (SP1) produced Qd service lives of 4 to 7 months.

Friedman's Chi Square Test revealed that there is at least one pair of measurements over time that is significantly different within each of the different road marking paints and materials, and referring to Appendix C, Figure C.6.7 it seems as though these differences are at least between the first and last repetitions.

4.6.2.10 Overall discussion on yellow transverse road markings

The longest performing road marking paints or materials in Qd per different road surface type and condition are indicated in Table 4.12. The Qd service lives are those of the unwashed yellow transverse test road markings. It can be seen that all types of road markings generally have longer Qd service lives on clean roads than on dirty roads.

Similarly to the white transverse test road markings, it can be seen in Table 4.12 that the Qd is not positively affected by glass beads in the markings. On the newly established dirty asphalt road (M44), water-borne (SP1 and SP2) produced longer Qd service lives than the plastic road marking materials. The Qd service life of road markings is longer on clean roads (like Doreen and Middel) than on dirty roads (like Mohwelere and L 3).

Table 4.12: Summary of longest performing yellow transverse markings in luminance.

Name of road / street	Description of road / street	AADT	Longest performing road marking paints / materials	Qd service life (months)
Aubrey Matlala	Newly established dirty chip seal road	Light vehicles =6557 Heavy vehicles =255 Total vehicles =6814	1 mm cold plastic (SP1), 1.2 mm thermoplastic (SP1 & SP2), 3 mm thermoplastic (SP1)	4 to 9
Bushveld	Long established clean chip seal road	Light vehicles =5508 Heavy vehicles =739 Total vehicles =6246	1 mm cold plastic (SP1), 1.2 mm thermoplastic (SP1 & SP2), 3 mm thermoplastic (SP1)	8 to 12
Doreen (B 1)	Newly established clean chip seal road	Light vehicles =7753 Heavy vehicles =284 Total vehicles =8037	3 mm thermoplastic (SP1)	8 to 12
Doreen (B 2 & 3)	Newly established clean chip seal road	Light vehicles =7753 Heavy vehicles =284 Total vehicles =8037	1.2 mm thermoplastic (SP1), 3 mm thermoplastic (SP1)	8 to 12
Doreen (B1, 2 & 3)	Newly established clean chip seal road	Light vehicles =7753 Heavy vehicles =284 Total vehicles =8037	3 mm thermoplastic (SP1)	8 to 12
M 44	Newly established dirty asphalt road	Light vehicles =7822 Heavy vehicles =434 Total vehicles =8315	Water-borne (SP1 & SP2)	> 10
Madiba	Long established asphalt road in CBD	Light vehicles =1764 Heavy vehicles =548 Total vehicles =2312	Water-borne (SP1 & SP2), 1 mm cold plastic (SP1), 1.2 mm thermoplastic (SP1 & SP2), 3 mm thermoplastic (SP1)	4 to 7
Meiring Naude	Newly established clean asphalt road	Light vehicles =3981 Heavy vehicles =629 Total vehicles =4610	1.2 mm thermoplastic (SP1 & SP2), 3 mm thermoplastic (SP1)	> 13
Middel	Long established clean asphalt road	Light vehicles =5547 Heavy vehicles =273 Total vehicles =5821	Water-borne (SP1, SP2 & SP3), 1 mm cold plastic (SP1 & SP4), 1.2 mm thermoplastic (SP1 & SP2), 3 mm thermoplastic (SP1)	> 12
Mohwelere	Long established dirty asphalt	Light vehicles =1732 Heavy vehicles =213 Total vehicles =1945	3 mm thermoplastic (SP1)	> 12
L 3	Long established dirty chip seal road	Light vehicles =2454 Heavy vehicles =109 Total vehicles =2563	1 mm cold plastic (SP1), 1.2 mm thermoplastic (SP1 & SP2), 3 mm thermoplastic (SP1)	9 to 12

4.6.3 White longitudinal road markings

4.6.3.1 Long established clean asphalt road (Middel Street)

Water-borne (SP1 and SP2) produced Qd service lives of 4 to 8 months, as can be seen in Table 4.13 and Figure 4.17. The 1.2 mm thermoplastic (SP1 and SP2) produced Qd service lives of 8 to 12 months. The 3 mm thermoplastic (SP1) produced a Qd service life of more than 12 months.

The fact that there is no overlap between the 95 per cent CIs of the first and last measurements, as can be seen in Figure 4.18, is an indication that the difference between them is statistically significant. Friedman’s Chi Square Test revealed that there is at least one pair of measurements over time that is significantly different within each of the different road marking paints and materials, and referring to Figure 4.18 it seems as though these differences are at least between the first and last repetitions.

Table 4.13: Descriptive statistics of white longitudinal markings in luminance on Middel Street.

Type of road marking paint / material		23-Jul-2013	05-Nov-2013	20-Mar-2014	29-Jul-2014
Water-borne (SP2)	Mean	145.5	126.1	93.8	91.6
	N	3	3	3	3
	Std. Deviation	11.2	3.8	10.4	2.7
	CV	0.08	0.03	0.11	0.03
Water-borne (SP1)	Mean	143.9	124.1	88.7	89.7
	N	3	3	3	3
	Std. Deviation	3.7	4.6	12.2	1.4
	CV	0.03	0.04	0.14	0.02
1.2 mm Thermoplastic (SP2)	Mean	146.4	136.3	101.1	94.9
	N	3	3	3	3
	Std. Deviation	3.6	4.7	6.2	0.6
	CVC	0.03	0.04	0.06	0.01
1.2 mm Thermoplastic (SP1)	Mean	143.0	133.3	103.6	97.8
	N	3	3	3	3
	Std. Deviation	4.1	6.6	2.9	2.9
	CV	0.03	0.05	.03	0.03
3 mm Screed (SP1)	Mean	156.4	134.7	114.2	104.2
	N	3	3	3	3
	Std. Deviation	17.7	8.5	4.3	4.4
	CV	0.11	0.06	0.04	0.04

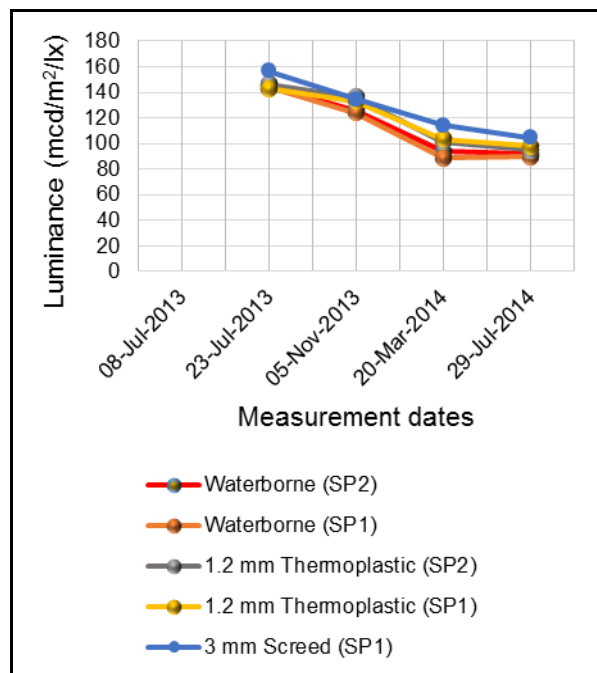

Figure 4.117: Unwashed white longitudinal markings on Middel Street.

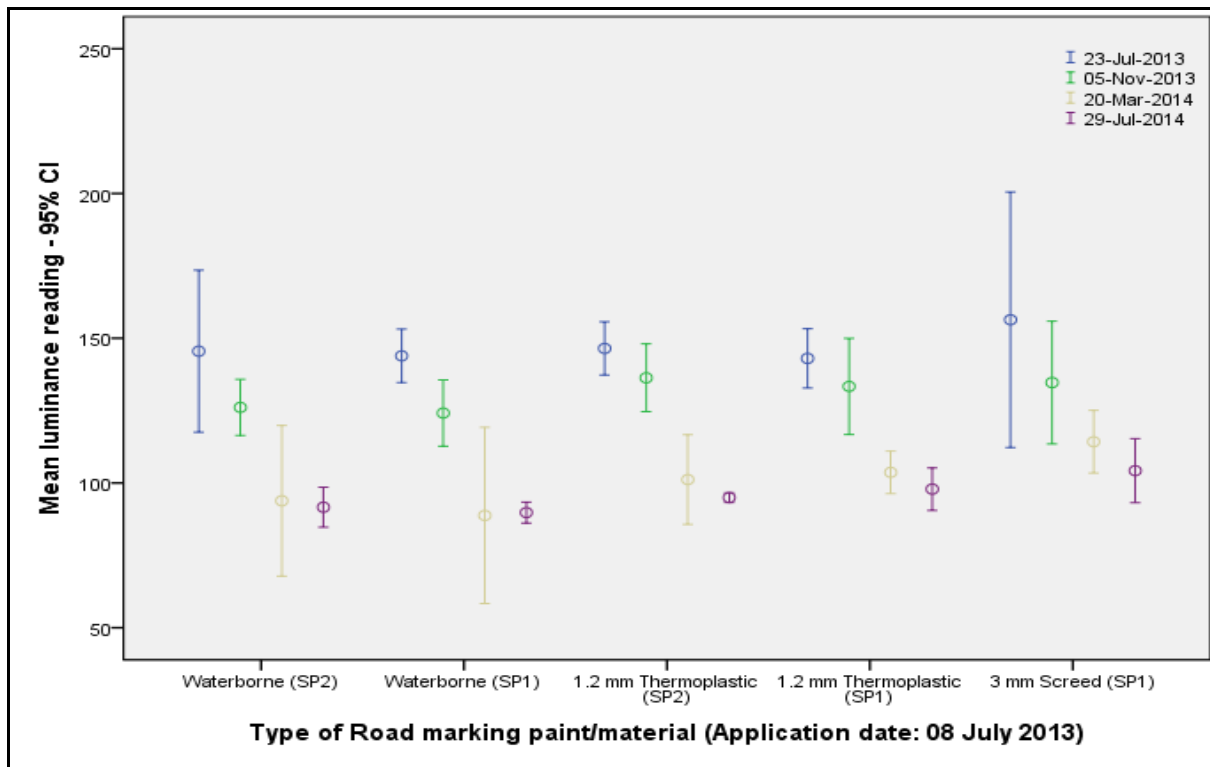

Figure 4.18: Ninety five per cent Confidence Interval of unwashed white longitudinal markings on Middel Street.

4.6.3.2 Long established dirty asphalt road (Mohwelere Street)

All test road markings complied with the minimum Qd specification of 100 mcd/m²/lx only in the first measurement period, as can be seen in Appendix B, Table B.29 and Figure B.57. None of the test road markings complied with the specification in the second measurement period, which was conducted 6 months after the application test markings. All the test markings produced Qd service lives of 1 to 6 months.

Friedman's Chi Square Test revealed that there is at least one pair of measurements over time that is significantly different within each of the different road marking paints and materials, and referring to Appendix C, Figure C.7.9 it seems as though these differences are at least between the first and last repetitions.

4.6.3.3 Newly established clean chip seal road (Doreen Street)

Block 1

Water-borne (SP2) produced a Qd service life of 1 to 4 months, as can be seen in Appendix B, Table B.9 and Figure B.17. Water-borne (SP2) was totally removed by the abrasive action of sand and vehicles' wheels and thus could not be measured during the second measurement period, which was conducted 4 months after the application of the test road markings. Water-borne (SP1), 1.2 mm

thermoplastic (SP1 and SP2) and 3 mm thermoplastic (SP1) produced Qd service lives of 4 to 8 months.

Friedman's Chi Square Test revealed that there are no pairs of readings over time that are significantly different within each of the different materials. Even though some 95 per cent CIs do not overlap, as can be seen in Appendix C, Figure C.7.3, the sample size of 1 does not allow for enough statistical power to find statistically significant differences and thus should be interpreted in the usual way.

Blocks 2 and 3

Water-borne (SP1 and SP2), 1.2 mm thermoplastic (SP1 and SP2) and 3 mm thermoplastic (SP1) produced Qd service lives of 4 to 8 months, as can be seen in Appendix B, Table B.12 and Figure B.23.

Friedman's Chi Square Test revealed that there are no pairs of readings over time that are significantly different within each of the different materials. Even though some 95 per cent CIs do not overlap, as can be seen in Appendix C, Figure C.7.4, the sample size of 2 does not allow for enough statistical power to find statistically significant differences. The fact that the 95 per cent CIs extend into the negative with some of the road marking paints and materials further indicates the lack of statistical power and they should thus be interpreted in the usual way. For example, 1.2 mm thermoplastic (SP1) and 3 mm thermoplastic (SP1) extends to approximately -50.

Blocks 1, 2 and 3

Water-borne (SP1 and SP2), 1.2 mm thermoplastic (SP1 and SP2) and 3 mm thermoplastic (SP1) produced Qd service lives of 4 to 8 months, as can be seen in Appendix B, Table B.15 and Figure B.29.

Friedman's Chi Square Test revealed that there is at least one pair of measurements over time that is significantly different within each of the different road marking paints and materials, and referring to Appendix C, Figure C.7.5 it seems as though these differences are at least between the first and last repetitions.

4.6.3.4 Newly established dirty chip seal road (Aubrey Matlala Road)

Water-borne (SP1 and SP2), 1.2 mm thermoplastic (SP1 and SP2) and 3 mm thermoplastic (SP1) produced Qd service lives of 4 to 9 months, as can be seen in Appendix B, Table B.3 and Figure B.5.

Friedman's Chi Square Test revealed that there is at least one pair of measurements over time that is significantly different within each of the different road marking paints and materials, and referring to

Appendix C, Figure C.7.1 it seems as though these differences are at least between the first and last repetitions.

4.6.3.5 Long established clean chip seal road (Bushveld Road)

Water-borne (SP2) produced a Qd service life of 8 to 12 months, as can be seen in Appendix B, Table B.6 and Figure B.11. Water-borne (SP1) produced a Qd service life of 8 to 12 months. The 1.2 mm thermoplastic (SP1) and 3 mm thermoplastic (SP1) produced Qd service lives of just more than 12 months.

Friedman's Chi Square Test revealed that there is at least one pair of measurements over time that is significantly different within each of the different road marking paints and materials, and referring to Appendix C, Figure C.7.2 it seems as though these differences are at least between the first and last repetitions.

4.6.3.6 Long established dirty chip seal road (Road L 3)

Water-borne (SP1 and SP2), 1.2 mm thermoplastic (SP1 and SP2) and 3 mm thermoplastic (SP1) produced Qd service lives of 4 to 9 months, as can be seen in Appendix B, Table B.32 and Figure B.63.

Friedman's Chi Square Test revealed that there is at least one pair of measurements over time that is significantly different within each of the different road marking paints and materials, and referring to Appendix C, Figure C.7.10 it seems as though these differences are at least between the first and last repetitions.

4.6.3.7 Newly established clean asphalt road (Meiring Naude Road)

Water-borne (SP1 and SP2) produced Qd service lives of 1 to 4 months, as can be seen in Appendix B, Table B.23 and Figure B.45. The 1.2 mm thermoplastic (SP2) and 3 mm thermoplastic (SP1) produced Qd service lives of 9 to 13 months. The 1.2 mm thermoplastic (SP1) produced a Qd service life of just more than 13 months.

Friedman's Chi Square Test revealed that there is at least one pair of measurements over time that is significantly different within each of the different road marking paints and materials, and referring to Appendix C, Figure C.7.7 it seems as though these differences are at least between the first and last repetitions.

4.6.3.8 Newly established dirty asphalt road (M 44)

The 3 mm thermoplastic (SP1) produced a Qd service life of 1 to 4 months as can be seen in Appendix B, Table B.18 and Figure B.35. Water-borne (SP1) produced a Qd service life of 4 to 7 months. Water-borne (SP2) and 1.2 mm thermoplastic (SP1 and SP2) produced Qd service lives of 7 to 10 months.

Friedman's Chi Square Test revealed that there are no pairs of readings over time that are significantly different within each of the different materials. Even though some 95 per cent CIs do not overlap, as can be seen in Appendix C, Figure C.7.6, the sample size of 2 does not allow for enough statistical power to find statistically significant differences. The fact that the 95 per cent CIs extend into the negative with some of the road marking paints and materials, further indicates the lack of statistical power and they should thus be interpreted in the usual way. For example, 3 mm thermoplastic (SP1) extends to approximately -200.

4.6.3.9 Overall discussion on white longitudinal road markings

The longest performing road marking paints or materials in Qd per different road surface type and condition are indicated in Table 4.14. The Qd service lives are those of the unwashed white longitudinal test road markings. Road markings generally have a longer Qd service lives on clean roads than on dirty roads.

Although the AADT on clean roads (like Bushveld, Meiring Naude and Middel) is higher than on dirty roads (like Mohwelere and L 3), the Qd service lives of the test markings were longer on the clean roads than on the dirty roads.

Table 4.14: Summary of longest performing white longitudinal markings in luminance.

Name of road / street	Description of road / street	AADT	Longest performing road marking paints / materials	Qd service life (months)
Aubrey Matlala	Newly established dirty chip seal road	Light vehicles =6557 Heavy vehicles =255 Total vehicles =6814	Water-borne (SP1 & SP2), 1.2 mm thermoplastic (SP1 & SP2), 3 mm thermoplastic (SP1)	4 to 9
Bushveld	Long established clean chip seal road	Light vehicles =5508 Heavy vehicles =739 Total vehicles =6246	1.2 mm thermoplastic (SP1), 3 mm thermoplastic (SP1)	> 12
Doreen (B 1)	Newly established clean chip seal road	Light vehicles =7753 Heavy vehicles =284 Total vehicles =8037	Water-borne (SP1), 1.2 mm thermoplastic (SP1 & SP2), 3 mm thermoplastic (SP1)	4 to 8
Doreen (B 2 & 3)	Newly established clean chip seal road	Light vehicles =7753 Heavy vehicles =284 Total vehicles =8037	Water-borne (SP1 & SP2), 1.2 mm thermoplastic (SP1 & SP2), 3 mm thermoplastic (SP1)	4 to 8
Doreen (B 1, 2 & 3)	Newly established clean chip seal road	Light vehicles =7753 Heavy vehicles =284 Total vehicles =8037	Water-borne (SP1 & SP2), 1.2 mm thermoplastic (SP1 & SP2), 3 mm thermoplastic (SP1)	4 to 8
M 44	Newly established dirty asphalt road	Light vehicles =7822 Heavy vehicles =434 Total vehicles =8315	Water-borne (SP2), 1.2 mm thermoplastic (SP1 & SP2)	7 to 10
Meiring Naude	Newly established clean asphalt road	Light vehicles =3981 Heavy vehicles =629 Total vehicles =4610	1.2 mm thermoplastic (SP1)	> 13
Middel	Long established clean asphalt road	Light vehicles =5547 Heavy vehicles =273 Total vehicles =5821	3 mm thermoplastic (SP1)	> 12
Mohwelere	Long established dirty asphalt	Light vehicles =1732 Heavy vehicles =213 Total vehicles =1945	All the road markings applied performed almost equally with very low service life	1 to 6
L 3	Long established dirty chip seal road	Light vehicles =2454 Heavy vehicles =109 Total vehicles =2563	Water-borne (SP1 & SP2), 1.2 mm thermoplastic (SP1 & SP2), 3 mm thermoplastic (SP1)	4 to 9

4.6.4 Yellow longitudinal road markings

4.6.4.1 Long established clean asphalt road (Middel Street)

All the test road markings produced Qd service lives of more than 12 months, as can be seen in Table 4.15 and Figure 4.19.

If the decline in Qd continues at the rate of the first year, water-borne (SP1 and SP2) will produce Qd service lives of approximately 14 months. The 1.2 mm thermoplastic (SP1 and SP2) and 3 mm thermoplastic (SP1) will produce Qd service lives of approximately 15 months.

The fact that there is no overlap between the 95 per cent CIs of the first and last measurements, as can be seen in Figure 4.20, is an indication that the difference between them is statistically significant. Friedman’s Chi Square Test revealed that there is at least one pair of measurements over time that is significantly different within each of the different road marking paints and materials, and referring to Figure 4.20 it seems as though these differences are at least between the first and last repetitions.

Table 4.15: Descriptive statistics of yellow longitudinal markings in luminance on Middel Street.

Type of road marking paint / material		23-Jul-2013	05-Nov-2013	20-Mar-2014	29-Jul-2014
Water-borne (SP2)	Mean	124.1	113.3	85.1	85.6
	N	3	3	3	3
	Std. Deviation	5.8	8.6	3.9	1.9
	CV	0.05	0.08	0.05	0.02
Water-borne (SP1)	Mean	121.9	112.1	88.6	87.6
	N	3	3	3	3
	Std. Deviation	6.0	5.9	2.2	5.2
	CV	0.05	0.05	0.03	0.06
1.2 mm Thermoplastic (SP2)	Mean	137.4	128.4	95.9	95.8
	N	3	3	3	3
	Std. Deviation	5.2	6.3	2.3	1.0
	CV	0.04	0.05	0.02	0.01
1.2 mm Thermoplastic (SP1)	Mean	135.1	124.4	87.3	92.6
	N	3	3	3	3
	Std. Deviation	5.6	5.5	0.7	2.1
	CV	0.04	0.04	0.01	0.02
3 mm Screed (SP1)	Mean	139.6	127.6	95.7	94.4
	N	3	3	3	3
	Std. Deviation	2.1	2.1	0.2	4.4
	CV	0.02	0.02	0.00	0.05

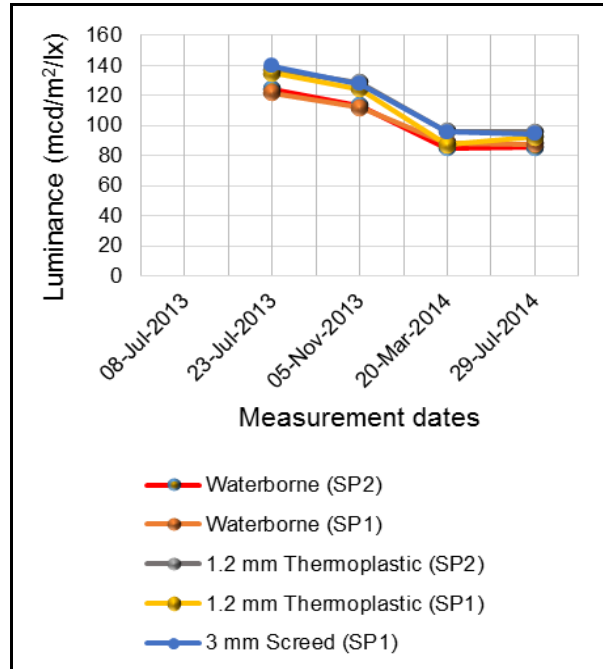

Figure 4.19: Unwashed yellow longitudinal markings on Middel Street.

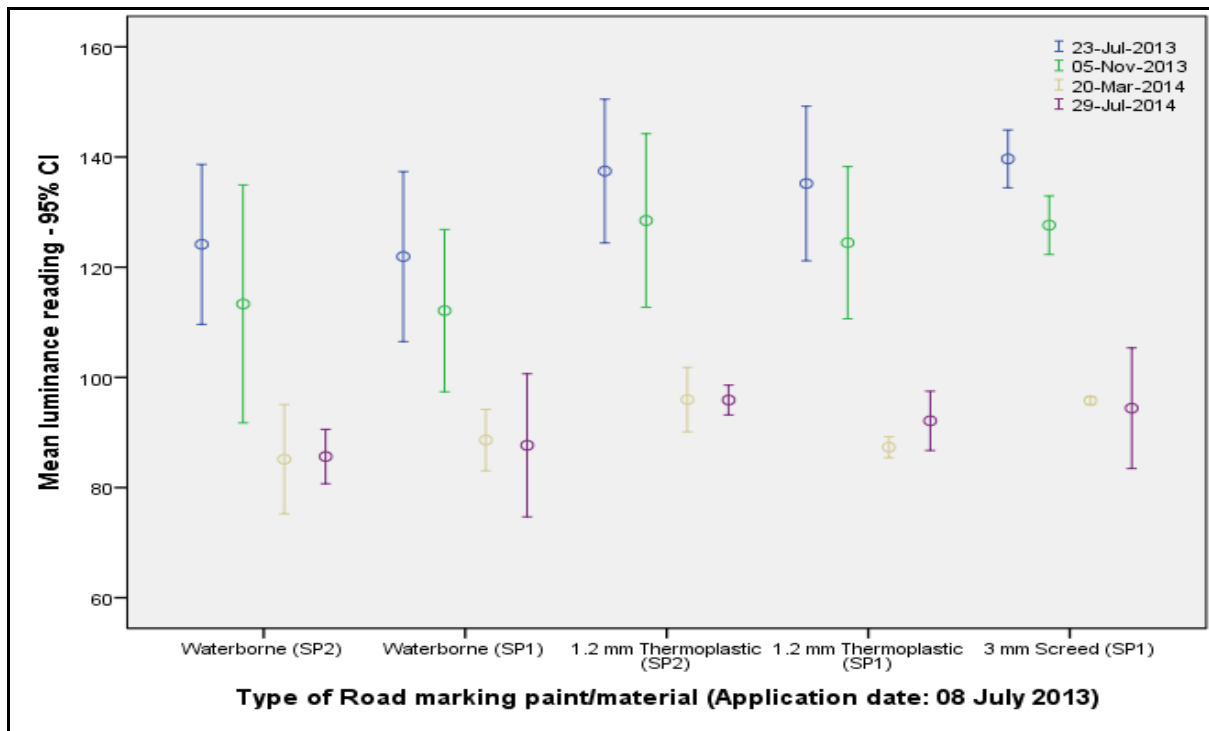

Figure 4.20: Ninety five per cent Confidence Interval of unwashed yellow longitudinal markings on Middel Street.

4.6.4.2 Long established dirty asphalt road (Mohwelere Street)

Water-borne (SP1 and SP2) produced Qd service lives of 1 to 6 months, as can be seen in in Appendix B, Table B.29 and Figure B.58. The 1.2 mm thermoplastic (SP1 and SP2) and 3 mm thermoplastic (SP1) produced Qd service lives of 6 to 9 months.

Friedman’s Chi Square Test revealed that there is at least one pair of measurements over time that is significantly different within each of the different road marking paints and materials, and referring to Appendix C, Figure C.8.9 it seems as though these differences are at least between the first and last repetitions.

4.6.4.3 Newly established clean chip seal road (Doreen Street)

Block 1

Water-borne (SP1 and SP2) and 1.2 mm thermoplastic (SP2) produced Qd service lives of 4 to 8 months, as can be seen in Appendix B, Table B.9 and Figure B.18. The 1.2 mm thermoplastic (SP1) and 3 mm thermoplastic (SP1) produced Qd service lives of 8 to 12 months.

Friedman’s Chi Square Test revealed that there are no pairs of readings over time that are significantly different within each of the different materials. Even though some 95 per cent CIs do not overlap, as can be seen in Appendix C, Figure C.8.3, the sample size of 1 does not allow for enough

statistical power to find statistically significant differences and thus should be interpreted in the usual way.

Blocks 2 and 3

Water-borne (SP2) produced a Qd service life of 4 to 8 months, as can be seen in Appendix B, Table B.12 and Figure B.24. Water-borne (SP1), 1.2 mm thermoplastic (SP1 and SP2) and 3 mm thermoplastic (SP1) produced Qd service lives of 8 to 12 months.

Friedman's Chi Square Test revealed that there are no pairs of readings over time that are significantly different within each of the different materials. Even though some 95 per cent CIs do not overlap, as can be seen in Appendix C, Figure C.8.4, the sample size of 2 does not allow for enough statistical power to find statistically significant differences. The fact that the 95 per cent CIs extend into the negative with some of the road marking paints and materials further indicates the lack of statistical power and they should thus be interpreted in the usual way. For example, water-borne (SP1) extend to approximately -500.

Blocks 1, 2 and 3

Water-borne (SP1 and SP2) produced a Qd service life of 4 to 8 months, as can be seen in Appendix B, Table B.15 and Figure B.30. The 1.2 mm thermoplastic (SP1 and SP2) and 3 mm thermoplastic (SP1) produced Qd service lives of 8 to 12 months.

Friedman's Chi Square Test revealed that there is at least one pair of measurements over time that is significantly different within each of the different road marking paints and materials, and referring to Appendix C, Figure C.8.5 it seems as though these differences are at least between the first and last repetitions.

4.6.4.4 Newly established dirty chip seal road (Aubrey Matlala Road)

Water-borne (SP1 and SP2) and 3 mm thermoplastic produced Qd service lives of 4 to 9 months, as can be seen in Appendix B, Table B.3 and Figure B.6. The 1.2 mm thermoplastic (SP1 and SP2) produced Qd service lives of 9 to 12 months.

Friedman's Chi Square Test revealed that there are no pairs of readings over time that are significantly different within each of the different materials. Even though some 95 per cent CIs do not overlap, as can be seen in Appendix C, Figure C.8.1, the sample size of 1 does not allow for enough statistical power to find statistically significant differences and they should thus be interpreted in the usual way.

4.6.4.5 Long established clean chip seal road (Bushveld Road)

Water-borne (SP1) and 1.2 mm thermoplastic (SP1) produced Qd service lives of 4 to 8 months, as can be seen in Appendix B, Table B.6 and Figure B.12. The 1.2 mm thermoplastic (SP2) and 3 mm thermoplastic (SP1) produced Qd service lives of 8 to 12 months.

Friedman's Chi Square Test revealed that there is at least one pair of measurements over time that is significantly different within each of the different road marking paints and materials, and referring to Appendix C, Figure C.8.2 it seems as though these differences are at least between the first and last repetitions.

4.6.4.6 Long established dirty chip seal road (Road L 3)

Water-borne (SP1 and SP2), 1.2 mm thermoplastic (SP1 and SP2) and 3 mm thermoplastic (SP1) produced Qd service life of 9 to 12 months, as can be seen in Appendix B, Table B.32 and Figure B.64.

Friedman's Chi Square Test revealed that there is at least one pair of measurements over time that is significantly different within each of the different road marking paints and materials, and referring to Appendix C, Figure C.8.10 it seems as though these differences are at least between the first and last repetitions.

4.6.4.7 Newly established clean asphalt road (Meiring Naude Road)

Water-borne (SP1 and SP2), 1.2 mm thermoplastic (SP1 and SP2) and 3 mm thermoplastic (SP1) produced Qd service lives of more than 13 months, as can be seen in Appendix B, Table B.23 and Figure B.46. If the Qd continues to decline at the rate at which it did in the first year, water-borne (SP1 and SP2), 1.2 mm thermoplastic (SP1 and SP2) and 3 mm thermoplastic (SP1) will produce Qd service lives of approximately 20 months.

Friedman's Chi Square Test revealed that there is at least one pair of measurements over time that is significantly different within each of the different road marking paints and materials, and referring to Appendix C, Figure C.8.7 it seems as though these differences are at least between the first and last repetitions.

4.6.4.8 Newly established dirty asphalt road (M 44)

Water-borne (SP1 and SP1), 1.2 mm thermoplastic (SP1 and SP2) and 3 mm thermoplastic produced Qd service lives of 7 to 10 months, as can be seen in Appendix B, Table B.18 and Figure B.36.

Friedman's Chi Square Test revealed that there are no pairs of readings over time that are significantly different within each of the different materials. Even though some 95 per cent CIs do not overlap, as can be seen in Appendix C, Figure C.8.4, the sample size of 2 does not allow for enough statistical power to find statistically significant differences. The fact that the 95 per cent CIs extend into the negative with some of the road marking paints and materials further indicates the lack of statistical power and they should thus be interpreted in the usual way. For example, 1.2 mm thermoplastic (SP2) extend to approximately -200.

4.6.4.9 Overall discussion on yellow longitudinal road markings

The longest performing road marking paints or materials in Qd per different road surface type and condition are indicated in Table 4.16. The Qd service lives are those of the unwashed yellow longitudinal test road markings. Road markings generally have a longer Qd service lives on clean roads than on dirty roads.

Although the AADT on clean roads (like Meiring Naude and Middel) is higher than on dirty roads (like Mohwelere and L 3), the Qd service lives of the test markings were longer on the clean roads than on the dirty roads.

Table 4.16: Summary of longest performing yellow longitudinal markings in luminance.

Name of road / street	Description of road / street	AADT	Longest performing road marking paints / materials	Qd service life (months)
Aubrey Matlala	Newly established dirty chip seal road	Light vehicles =6557 Heavy vehicles =255 Total vehicles =6814	1.2 mm thermoplastic (SP1 & SP2)	9 to 12
Bushveld	Long established clean chip seal road	Light vehicles =5508 Heavy vehicles =739 Total vehicles =6246	1.2 mm thermoplastic (SP2), 3 mm thermoplastic (SP1)	8 to 12
Doreen (B 1)	Newly established clean chip seal road	Light vehicles =7753 Heavy vehicles =284 Total vehicles =8037	1.2 mm thermoplastic (SP1), 3 mm thermoplastic (SP1)	8 to 12
Doreen (B 2 & 3)	Newly established clean chip seal road	Light vehicles =7753 Heavy vehicles =284 Total vehicles =8037	Water-borne (SP1), 1.2 mm thermoplastic (SP1 & SP2), 3 mm thermoplastic (SP1)	8 to 12
Doreen (B 1, 2 & 3)	Newly established clean chip seal road	Light vehicles =7753 Heavy vehicles =284 Total vehicles =8037	1.2 mm thermoplastic (SP1 & SP2), 3 mm thermoplastic (SP1)	8 to 12
M 44	Newly established dirty asphalt road	Light vehicles =7822 Heavy vehicles =434 Total vehicles =8315	Water-borne (SP1 & SP2), 1.2 mm thermoplastic (SP1), 3 mm thermoplastic (SP1)	7 to 10
Meiring Naude	Newly established clean asphalt road	Light vehicles =3981 Heavy vehicles =629 Total vehicles =4610	Water-borne (SP1 & SP2), 1.2 mm thermoplastic (SP1), 3 mm thermoplastic (SP1)	> 13
Middel	Long established clean asphalt road	Light vehicles =5547 Heavy vehicles =273 Total vehicles =5821	Water-borne (SP1 & SP2), 1.2 mm thermoplastic (SP1), 3 mm thermoplastic (SP1)	> 12
Mohwelere	Long established dirty asphalt	Light vehicles =1732 Heavy vehicles =213 Total vehicles =1945	1.2 mm thermoplastic (SP1 & SP2), 3 mm thermoplastic (SP1)	6 to 9
L 3	Long established dirty chip seal road	Light vehicles =2454 Heavy vehicles =109 Total vehicles =2563	Water-borne (SP1 & SP2), 1.2 mm thermoplastic (SP1 & SP2), 3 mm thermoplastic (SP1)	9 to 12

4.7 COLOUR

4.7.1 Long established clean asphalt road (Middel Street)

It can be seen in Table 4.17 that there was a general increase in colour compliance of the white test road markings, with all the markings fully complying to the BS EN 1436:2007 specification except for 1.2 mm thermoplastic (SP2) after one-and-a-half years of application. Figures 4.21 and 4.22 indicate the graphical positions of the white test road markings on the chromaticity diagrams.

Although 1 mm cold plastic (SP1) and 1.2 mm thermoplastic (SP1) yellow test road markings partially complied with the specification during the second set of measurements, the same markings did not comply with the specification during the third and fourth set of measurements. None of the other

yellow test road markings fell into the compliance region from measurements 1 to 4 indicated in Table 4.17. Figures 4.23 and 4.24 indicate the graphical positions of the yellow test road markings on the chromaticity diagrams.

4.7.2 Newly established dirty chip seal road (Aubrey Matlala Road)

One-and-a-half years from application of the white test road markings on this newly established dirty chip seal road, most of the markings still complied with the specification, as can be seen in Appendix D, Table D.1. In Appendix D, Figures D.1 and D.2 indicate the graphical positions of the white test road markings on the chromaticity diagrams.

None of the yellow test road markings fell into the compliance region as can be seen in Table D.1. Figures D.3 and D.4 indicate the graphical positions of the yellow test road markings on the chromaticity diagrams.

4.7.3 Long established clean chip seal road (Bushveld Road)

One-and-a-half years from application of the test road markings on this long established clean chip seal road, most of the white test markings still complied with the specification, as can be seen in Appendix D, Table D.2. Figures D.5 and D.6 in Appendix D indicate the graphical positions of the white test road markings on the chromaticity diagrams.

Most of the yellow test road markings fell out of the compliance region, as can be seen in Table D.2. Figures D.7 and D.8 indicate the graphical positions of the yellow test road markings on the chromaticity diagrams.

4.7.4 Newly established clean chip seal road (Doreen Street)

In B 1, none of the white test road markings measured approximately 4 months after the markings were applied complied with the specification, as can be seen in Appendix D, Table D.3. The second set of measurements improved slightly with only the 1.2 mm thermoplastic (SP1) and the 3 mm thermoplastic (SP1) falling into the compliance region. There were further improvements in the colour compliance of most of the white test road markings measured during the third and fourth measurement periods. There was an improvement in colour compliance for most of the white test road markings in B's 2 and 3 (Table D.4) combined as compared with B 1. Although the compliance of the white test road markings in B's 1, 2 and 3 (Table D.5) combined is not 100 per cent, especially during the first and second measurement periods, most of the markings performed better than the values measured in B 1 alone. Sand and dirt could have adversely affected the colour compliance of the white test road markings in B 1. Figures D.9, D.10, D.13, D.14, D.17 and D.18 in Appendix D indicate the graphical positions of the white test road markings on the chromaticity diagrams.

None of the yellow test road markings fell into the compliance region, as can be seen in Tables D.3, D.4 and D.5. Figures D.11, D.12, D.15, D.16, D.19 and D.20 indicate the graphical positions of the yellow test road markings on the chromaticity diagrams.

4.7.5 Newly established dirty asphalt road (M 44)

All the white test road markings generally fell into the compliance region, as can be seen in Appendix D, Table D.6. Although the M 44 was selected as a newly established dirty asphalt road, the colour compliance of the test road markings could be attributed to the road surface being flat and relatively smooth. Figures D.21 and D.22 indicate the graphical positions of the white test road markings on the chromaticity diagrams.

None of the yellow test road markings fell into the compliance region, as can be seen in Table D.6. Figures D.23 and D.24 indicate the graphical positions of the yellow test road markings on the chromaticity diagrams.

4.7.6 Long established asphalt road in the CBD (Madiba Street)

It can be seen in Appendix D, Table D.7 that all the white test road markings fell into the compliance region throughout the four measurement periods, but water-borne (SP1) started to break off the road surface early into the study and thus those markings did not comply from the second measurement period. Figures D.25 and D.26 indicate the graphical positions of the white test road markings on the chromaticity diagrams.

None of the yellow test road markings fell into the compliance region, as can be seen in Table D.7. Figures D.27 and D.28 indicate the graphical positions of the yellow test road markings on the chromaticity diagrams.

4.7.7 Newly established clean asphalt road (Meiring Naude Road)

It can be seen in Appendix D, Table D.8 that all the white test road markings generally fell into the compliance region throughout the four measurement periods except for 1.2 mm thermoplastic (SP1), which did not fall into the compliance region during measurement periods 1 and 2. Figures D.29 and D.30 indicate the graphical positions of the white test road markings on the chromaticity diagrams.

Although 1 mm cold plastic (SP1), 1.2 mm thermoplastic (SP1) and 3 mm thermoplastic (SP1) yellow test road markings partially complied with the specification during the first and second set of measurements, the same markings did not comply with the specification during the third and fourth set of measurements. None of the other yellow test road markings complied with the specification.

Figures D.31 and D.32 indicate the graphical positions of the yellow test road markings on the chromaticity diagrams.

4.7.8 Long established dirty asphalt road (Mohwelere Street)

None of the white test road markings fell into the compliance region according to Appendix D, Table D.10. Figures D.37 and D.38 indicate the graphical positions of the white test road markings on the chromaticity diagrams.

None of the yellow test road markings fell into the compliance region, as can be seen in Table D. Figures D.39 and D.40 indicate the graphical positions of the yellow test road markings on the chromaticity diagrams.

4.7.9 Long established dirty chip seal road (Road L 3)

One year from application of the white test road markings on this long established dirty chip seal road, some of the markings partially complied with the specification, namely water-borne (SP1 and SP2), 1 mm cold plastic (SP4) and 1.2 mm thermoplastic (SP2), as can be seen in Appendix D, Table D.11. Water-borne (SP3) did not comply with the specification. The 1 mm cold plastic (SP1), 1.2 mm thermoplastic (SP1) and 3 mm thermoplastic (SP1) complied with the specification. Figures D.41 and D.42 indicate the graphical positions of the white test road markings on the chromaticity diagrams.

None of the yellow test road markings fell into the region, as can be seen in Table D.11. Figures D.43 and D.44 indicate the graphical positions of the yellow test road markings on the chromaticity diagrams.

Table 4.17: Summary of colour analysis for long established clean asphalt road (Middel Street).

Middel Street		White transverse road markings								Yellow transverse road markings							
		Measurement 1 05 November 2013		Measurement 2 20 March 2014		Measurement 3 29 July 2014		Measurement 4 03 February 2015		Measurement 1 05 November 2013		Measurement 2 20 March 2014		Measurement 3 29 July 2014		Measurement 4 03 February 2015	
		Falling out of region (%)	Falling within region (%)	Falling out of region (%)	Falling within region (%)	Falling out of region (%)	Falling within region (%)	Falling out of region (%)	Falling within region (%)	Falling out of region (%)	Falling within region (%)	Falling out of region (%)	Falling within region (%)	Falling out of region (%)	Falling within region (%)	Falling out of region (%)	Falling within region (%)
Unwashed	Water-borne (SP1)	0.0	100.0	33.3	66.7	0.0	100.0	0.0	100.0	100.0	0.0	100.0	0.0	100.0	0.0	100.0	0.0
	Water-borne (SP2)	66.7	33.3	0.0	100.0	0.0	100.0	0.0	100.0	100.0	0.0	100.0	0.0	100.0	0.0	100.0	0.0
	Water-borne (SP3)	33.3	66.7	0.0	100.0	0.0	100.0	0.0	100.0	100.0	0.0	100.0	0.0	100.0	0.0	100.0	0.0
	1 mm Cold Plastic (SP1)	66.7	33.3	0.0	100.0	0.0	100.0	0.0	100.0	100.0	0.0	66.7	33.3	100.0	0.0	100.0	0.0
	1 mm Cold Plastic (SP4)	33.3	66.7	0.0	100.0	0.0	100.0	0.0	100.0	100.0	0.0	100.0	0.0	100.0	0.0	100.0	0.0
	1.2 mm Thermoplastic (SP1)	66.7	33.3	66.7	33.3	0.0	100.0	0.0	100.0	100.0	0.0	33.3	66.7	100.0	0.0	100.0	0.0
	1.2 mm Thermoplastic (SP2)	100.0	0.0	100.0	0.0	33.3	66.7	100.0	0.0	100.0	0.0	100.0	0.0	100.0	0.0	100.0	0.0
	3 mm Screed (SP1)	33.3	66.7	66.7	33.3	0.0	100.0	0.0	100.0	100.0	0.0	0.0	100.0	100.0	0.0	100.0	0.0
Washed	Water-borne (SP1)	0.0	100.0	0.0	100.0	0.0	100.0	0.0	100.0	100.0	0.0	100.0	0.0	100.0	0.0	100.0	0.0
	Water-borne (SP2)	0.0	100.0	0.0	100.0	0.0	100.0	0.0	100.0	100.0	0.0	100.0	0.0	100.0	0.0	100.0	0.0
	Water-borne (SP3)	33.3	66.7	0.0	100.0	0.0	100.0	0.0	100.0	100.0	0.0	100.0	0.0	100.0	0.0	100.0	0.0
	1 mm Cold Plastic (SP1)	66.7	33.3	0.0	100.0	0.0	100.0	0.0	100.0	66.7	33.3	66.7	33.3	100.0	0.0	66.7	33.3
	1 mm Cold Plastic (SP4)	0.0	100.0	66.7	33.3	0.0	100.0	0.0	100.0	100.0	0.0	100.0	0.0	100.0	0.0	100.0	0.0
	1.2 mm Thermoplastic (SP1)	33.3	66.7	33.3	66.7	0.0	100.0	0.0	100.0	100.0	0.0	33.3	66.7	100.0	0.0	66.7	33.3
	1.2 mm Thermoplastic (SP2)	100.0	0.0	100.0	0.0	0.0	100.0	100.0	0.0	100.0	0.0	100.0	0.0	100.0	0.0	66.7	33.3
	3 mm Screed (SP1)	66.7	33.3	100.0	0.0	33.3	66.7	0.0	100.0	100.0	0.0	0.0	100.0	100.0	0.0	66.7	33.3

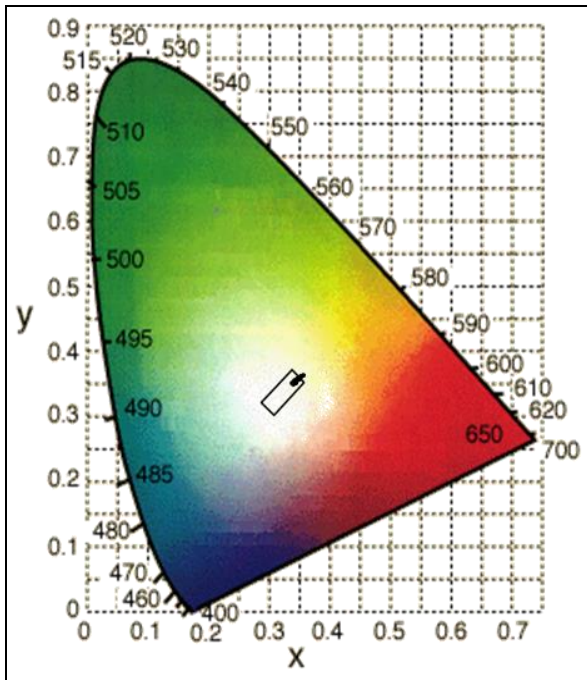

Figure 4.21: Unwashed white markings on Middel Street.

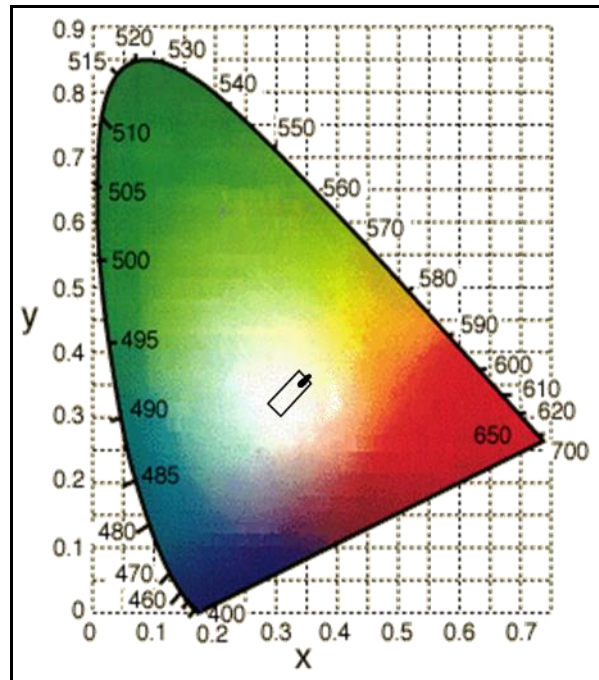

Figure 4.22: Washed white markings on Middel Street.

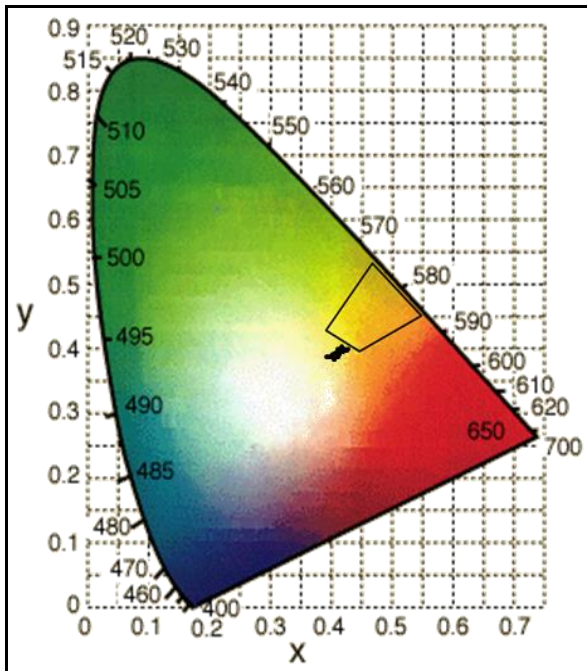

Figure 4.23: Unwashed yellow markings on Middel Street.

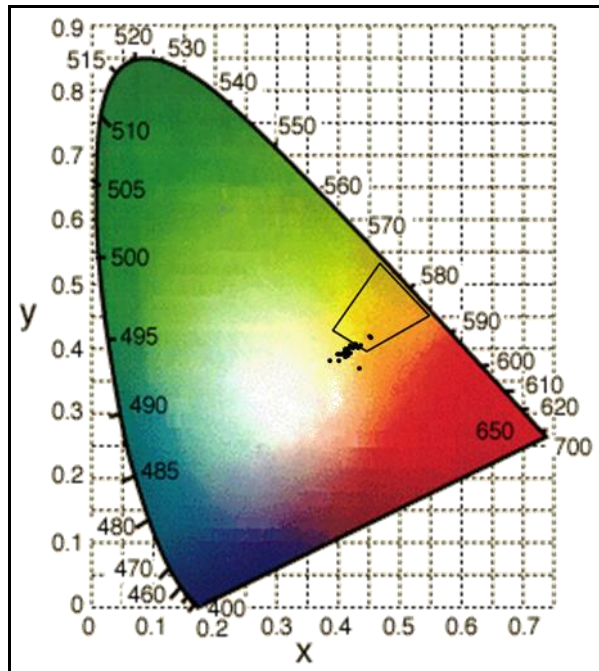

Figure 4.24: Washed yellow markings on Middel Street.

4.8 SKID RESISTANCE

It can be seen in Table 4.18 that only white water-borne (SP3), 1 mm cold plastic (SP1 and SP4), white 1.2 mm thermoplastic (SP1) and yellow 1.2 mm thermoplastic (SP1) meet the minimum specification of 50 SRT units. All other test markings were between 35 and 45 SRT units. It is likely that the skid resistance of road markings will be higher on the road surface due to the combined effect of the road surface and the markings. Road marking applicators need to consider increasing the amount of antiskid aggregates to improve the skid resistance of the markings.

Table 4.18: Summary of initial skid resistance.

Type of road marking paint or material	Service Provider	Colour	Initial skid resistance
Water-borne	SP1	White	45
Water-borne	SP1	Yellow	45
1 mm cold plastic	SP1	White	55
1 mm cold plastic	SP1	Yellow	45
1.2 mm thermoplastic	SP1	White	50
1.2 mm thermoplastic	SP1	Yellow	55
3 mm thermoplastic	SP1	White	45
3 mm thermoplastic	SP1	Yellow	40
Water-borne	SP2	White	45
Water-borne	SP2	Yellow	40
1.2 mm thermoplastic	SP2	White	40
1.2 mm thermoplastic	SP2	Yellow	35
Water-borne	SP3	White	50
Water-borne	SP3	Yellow	45
1 mm cold plastic	SP4	White	50
1 mm cold plastic	SP4	Yellow	44

4.9 PERFORMANCE OF THERMOPLASTIC ROAD MARKING MATERIAL

Based on the data in this document, the performance of thermoplastic road marking materials in retroreflectivity, luminance, colour and skid resistance is summarised in Table 4.19. Although thermoplastic road marking materials are generally known to produce high retroreflectivity over long periods of time, the outcome of the study indicates that retroreflectivity is not maintained for long periods on dirty type roads. It can be seen that road authorities are applying thermoplastic road marking materials that do not comply with the yellow colour specification. It can be further seen that the skid resistance of 3 mm thermoplastic road marking material does not comply with the specification.

Table 4.19: Summary of thermoplastic road marking material performance.

Road marking colour	Type of road surface	Newly / Long established	Condition of road	Class of road	AADT	Transverse / longitudinal	R _L service life (months)		Q _d service life (months)		Colour compliance		Initial skid resistance compliance	
							1.2 mm	3 mm	1.2 mm	3 mm	1.2 mm	3 mm	1.2 mm	3 mm
White	Chip seal	Newly	Dirty	3	Light =6557 Heavy =255 Total =6814	Transverse	4 to 9	4 to 9	1 to 4	1 to 4	Yes	Yes	Yes	No
						Longitudinal	4 to 9	4 to 9	4 to 9	4 to 9	N/A	N/A		
Yellow						Transverse	1 to 4	1 to 4	4 to 9	4 to 9	No	No		
						Longitudinal	9 to 12	9 to 12	9 to 12	4 to 9	N/A	N/A		
White	Chip seal	Long	Dirty	4	Light =2454 Heavy =109 Total =2563	Transverse	1 to 5	1 to 5	4 to 9	4 to 9	Yes	Yes	Yes	No
						Longitudinal	1 to 5	1 to 5	4 to 9	4 to 9	N/A	N/A		
Yellow						Transverse	1 to 5	1 to 5	9 to 12	9 to 12	No	No		
						Longitudinal	9 to 12	5 to 9	9 to 12	9 to 12	N/A	N/A		
White	Chip seal	Newly	Clean	2	Light =7753 Heavy =284 Total =8037	Transverse	> 12	> 12	4 to 8	4 to 8	Yes	Yes	Yes	No
						Longitudinal	8 to 12	> 12	4 to 8	4 to 8	N/A	N/A		
Yellow						Transverse	4 to 8	8 to 12	8 to 12	8 to 12	No	No		
						Longitudinal	> 12	> 12	8 to 12	8 to 12	N/A	N/A		
White	Chip seal	Long	Clean	2	Light =5508 Heavy =739 Total =6246	Transverse	> 12	> 12	4 to 8	4 to 8	Yes	Yes	Yes	No
						Longitudinal	> 12	> 12	> 12	> 12	N/A	N/A		
Yellow						Transverse	8 to 12	8 to 12	8 to 12	8 to 2	No	No		
						Longitudinal	8 to 12	8 to 12	8 to 12	8 to 12	N/A	N/A		
White	Asphalt	Newly	Dirty	3	Light =7822 Heavy =434 Total =8315	Transverse	4 to 7	4 to 7	1 to 4	4 to 7	Yes	Yes	Yes	No
						Longitudinal	7 to 10	4 to 7	7 to 10	1 to 4	N/A	N/A		
Yellow						Transverse	1 to 4	1 to 4	4 to 7	7 to 10	No	No		
						Longitudinal	1 to 4	4 to 7	7 to 10	7 to 10	N/A	N/A		
White	Asphalt	Long	Dirty	4	Light =1732 Heavy =213 Total =1945	Transverse	1 to 6	1 to 6	6 to 9	6 to 9	Yes	Yes	Yes	No
						Longitudinal	1 to 6	1 to 6	1 to 6	1 to 6	N/A	N/A		
Yellow						Transverse	1 to 6	1 to 6	9 to 12	> 12	No	No		
						Longitudinal	1 to 6	1 to 6	6 to 9	6 to 9	N/A	N/A		
White	Asphalt	Newly	Clean	3	Light =3981 Heavy =629 Total =4610	Transverse	9 to 13	> 13	9 to 13	9 to 13	Yes	Yes	Yes	No
						Longitudinal	> 13	> 13	> 13	9 to 13	N/A	N/A		
Yellow						Transverse	9 to 13	9 to 13	> 13	> 13	No	No		
						Longitudinal	> 13	> 13	9 to 13	9 to 13	N/A	N/A		
White	Asphalt	Long	Clean	3	Light =5547 Heavy =273 Total =5821	Transverse	> 12	> 12	> 12	> 12	Yes	Yes	Yes	No
						Longitudinal	> 12	> 12	9 to 12	> 12	N/A	N/A		
Yellow						Transverse	> 12	> 12	> 12	> 12	No	No		
						Longitudinal	> 12	> 12	> 12	> 12	N/A	N/A		
White	Asphalt	Long	Clean (CBD)	3	Light =1764 Heavy =548 Total =2312	Transverse	7 to 11	7 to 11	4 to 7	4 to 7	Yes	Yes	Yes	No
Yellow						Transverse	4 to 7	7 to 11	4 to 7	4 to 7	No	No		

Class 2 – Metropolitan Distributor, Class 3 – District Distributor, Class 4 - Collector

5 CONCLUSIONS AND RECOMMENDATIONS

5.1 CONCLUSIONS

Based on the data and discussions in this document, the following conclusions are drawn:

- The retroreflectivity (night-time visibility) service lives of various road marking paints and road marking materials on asphalt and chip seal road surfaces were determined as between 1 and 48 months;
- The luminance (daytime visibility) service lives of various road marking paints and road marking materials on asphalt and chip seal road surfaces were determined as between 1 and 30 months;
- There was no significant increase in retroreflectivity or colour compliance of the washed road markings while there was generally an increase in luminance;
- White road markings generally complied with the colour specification while yellow road markings did not comply with the specification, and
- The initial skid resistance of white and yellow 1.2 mm thermoplastic complied with the specification while all other road markings did not comply with the specification.

As retroreflectivity is the most critical parameter in road markings, the type of road marking selection should be mainly based on the retroreflectivity service life, but due consideration should be given to the other three parameters, namely the luminance, colour and skid resistance. For example, specifying a very high retroreflectivity on yellow road markings may result in the service provider applying lighter shade yellow markings which may cause confusion at night because they will tend to look white in colour. There can be a certain degree of compromise as all parameters cannot be easily achieved together, as indicated in BS EN 1436:2007 (2007). Retroreflectivity results should not be rejected if the values are lower but close to the specification on thermoplastic road marking material, since the values can increase as the road marking material is worn away by the action of the tyres. More test points should be considered, or measurements should be conducted a few days later.

Although thermoplastic road marking materials generally produced the longest service life, especially in respect of retroreflectivity, it might not be cost effective to apply them on roads where they will have similar service lives to those of cheaper road marking paints such as water-borne. After classifying the roads into the dirty and clean categories, and using the tendered rates, a more realistic road marking budget can be requested. The outcome of the results on the applied test road markings was not affected by extraordinary weather conditions, as the rainfall and temperature was similar to those of previous years.

The hypothesis is that road markings on clean flexible roads will have a longer retroreflectivity service life than road markings on dirty flexible roads. Also, the hypothesis is that thermoplastic road marking materials will produce approximately 6 months of retroreflectivity service life at best on roads which are subjected to sand getting onto it. Therefore both null hypotheses can be rejected.

5.2 RECOMMENDATIONS

The following recommendations are presented:

1. Measurements should be conducted for more than a year on the clean roads to identify the time when failure will possibly occur, as the R_L values were in excess of the minimum specified value of $100 \text{ mcd/m}^2/\text{lx}$ and $70 \text{ mcd/m}^2/\text{lx}$ on the white and yellow test road markings respectively.
2. In future research studies, measurement periods may have to be reduced to a monthly basis, especially on the dirty type roads, both asphalt and chip seal roads, to obtain more accurate R_L service lives as the service lives were in a wide range of 1 to 6 months.
3. Since there are many longitudinal road markings in the CBD which may not have similar service lives in R_L to the other roads where the study was carried out, a study should be carried out with all available road marking paints and materials as the longitudinal test road markings were repainted during the study and hence the measurements were not conducted. The transverse markings should also be tested on more streets within the CBD as the newly painted test markings on Madiba Street were subjected to abnormal vehicle loads.
4. As the colour of yellow test road markings did not comply with the specification, suppliers need to relook into the mix design of all yellow road marking paints and materials. The colour co-ordinates in Table 7.2, Volume 1, Chapter 7 of the SADC SARTSM (1999) need to be corrected.
5. Service providers need to improve on the skid resistance of the road marking paints and materials by increasing the quantity of antiskid aggregates.
6. When conducting measurements for acceptance control, isolate where possible the sections with sand on the road from cleaner sections, as the overall results might not meet the specification if all sections are combined.
7. Road authorities should consider grassing the road shoulders to prevent sand from entering the road, which damages the road markings.
8. The application thickness of cold plastic on chip seal surfaces should be greater than 1 mm. This research has prompted the City of Tshwane to increase the thickness to 2 mm.

6 REFERENCES

Accounting Standards Board, (2010). *'Standards of Generally Recognised Accounting Practice, Property, Plant and Equipment (GRAP 17)'*, New York, USA.

American Association for State and Highway Transportation Officials (AASHTO), M 247-81, (1996). *'Standard specification for glass beads used in traffic paints'*, Washington D.C., USA.

American Association for State and Highway Transportation Officials (AASHTO), T 250-05, (2014). *'Standard method of test for thermoplastic line material'*, Washington D.C., USA.

American Association for State and Highway Transportation Officials (AASHTO), M249-12, (2012). *'Standard specification for white and yellow reflective thermoplastic striping material (solid form)'*, Washington D.C., USA.

American Association for State and Highway Transportation Officials (AASHTO) TT-P-1952E, (2007). *'Federal specification. Paint, traffic and airfield marking, waterborne'*, Washington D.C., USA.

Austin, R.L. and Schultz, R.J. (2006). *'Guide to retroreflection safety principles and retroreflectivity measurements'*. Road Vista, Sand Diego, CA, USA.

Babic, D., Fiolic, M. and Prusa, P. (2014). *'Evaluation of road markings retroreflection measuring methods'*, Faculty of Traffic and Transport Science Zagreb, Croatia, Europe.

British Standards, BS 3262: Part 1 (1989). *'Hot-applied thermoplastic road marking materials'*, British Standards Institution, Europe.

British Standards, BS EN 1436 (2007). *'Road marking materials: Road marking performance for road users'*, British Standards Institution, Europe.

British Standards, BS EN 1824 (1998). *'Road marking materials - Road trials'*, British Standards Institution, Europe.

British Standards, BS EN 1871 (2000). *'Road marking materials - Physical properties'*. British Standards Institution, Europe.

British Standards, BS EN 13197 (2011). *'Road marking materials: Wear simulator turntable'*, British Standards Institution, Europe.

Carlson, P.J. (2013). '*An investigation of longitudinal pavement marking retroreflectivity and safety*', Proceedings of the 92nd annual meeting of the transportation research board, January 2013, Washington D.C., USA.

Committee of Land Transport Officials, COLTO (1998). '*Standard Specifications for Road and Bridge Works for State Road Authorities*', South African Institution of Civil Engineering, Halfway House, RSA.

COST 331 (1999). '*Requirements for horizontal road markings*', European Commission, Directorate General Transport, Europe.

De Witt, A.J., Smith, R.A.F., and Visser, A.T., (2000). '*Durability and cost effectiveness of road marking paint*', South African Road Transport Conference, 17-20 July, Pretoria, RSA.

Gates, T.J., Hawkins, H.G., and Rose, E.R. (2003). '*Effective pavement marking practices for sealcoat and hot-mix asphalt pavements*'. Report No. 0-4150-4. Texas Transportation Institute, Texas A & M University, College Station, Texas, USA.

Georgia State University (2014). '*The C.I.E. Color Space*', Available from: <<http://hyperphysics.phy-str.gsu.edu/hbase/vision/cie.html>> [Accessed: 13 May 2015].

Gibbons, R.B. (2006). '*Pavement marking visibility requirements during wet night conditions*', Virginia Tech Transportation Institute, Charlottesville, Virginia, USA.

Grosskopff, S.E. (2001). '*For safety's sake let's do road marking quality control*', Proceedings of the 20th Transport Conference, 16-20 July, Pretoria, RSA.

Guder, H. [herald.guder@limburgerlackfabrik.de] (2013). '*Re: Lead chrome in road marking*', Email to: Joubert, J. (lanino@mweb.co.za). 15 April.

Hay, A. [haya@nra.co.za] (2013). '*RE: Information on road markings*', Email to: Naidoo, S. [soma@tshwane.gov.za]. 13 March.

Highways Department (2010). '*Guidance notes on application of road marking materials*', Hong Kong, China.

Kerr, D.A. (2010). '*The CIE XYZ and xyY Color Spaces*'. Available from: <<http://dougkerr.net/Pumpkin/index.htm>> [Accessed: 09 December 2015].

Labuschagne, F.J.J. and Grosskopff, S.E. (2004). '*Better road markings*', CSIR technology transfer centre course notes, Nelspruit, RSA.

Letsoalo, C.P. (2012). *'State of the road safety report'*. Proceedings of the 2nd South African Road Federation / Road Traffic Management Corporation Conference, 23-24 October 2012, Johannesburg, RSA.

Lopez, C.A. (2004). *'Pavement marking handbook'*, Texas Department of Transportation, Texas, USA.

Martin, P.T.; Perrin, J.; Jitprasithsiri, S. and Hansen, B. (1996). *'A comparative analysis of the alternative pavement marking materials for The State of Utah'*, Presented to Utah Department of Transportation by The Civil and Environmental Engineering Department, University of Utah, USA.

Miglets, J., Fish, J.K. and Graham J.L. (1994). *'Roadway delineation handbook'*. Publication No. FHWA-SA-93-001. Federal Highway Administration, Washington, D.C., USA.

Montebello, D. and Schroeder, J. (2000). *'Cost of pavement marking materials'*, National Technical Information Services, Springfield, Virginia, USA.

Naidoo, S. (2012). *'Tender reference CB8/2012 – Tender for maintenance of permanent road traffic markings as well as updating of the inventories on the road traffic markings management database in accordance with the provisions of the National Road Traffic Act 93 of 1996 in City of Tshwane as and when required for a three year period'*, Transport and Roads Department, Roads and Stormwater Division, Pretoria, RSA.

National Road Traffic Act (1996). *'Act no. 93'*, RSA.

Occupational Health and Safety Act (1993). *'Act no. 85'*, RSA.

Owen, S. (2013). *'Product and application training'*, Presented to Mukhari Signs and Marketing Enterprises by Ennis Prismo Traffic Safety Solutions Department, 14-18 January, Pretoria, RSA.

Singapore Standard, SS 498: Part 1 (2002). *'Hot-applied thermoplastic road marking material, constituent materials and mixture'*, Spring Singapore, Singapore.

Singapore Standard, SS 498: Part 2 (2002). *'Hot-applied thermoplastic road marking material, road performance'*, Spring Singapore, Singapore.

Smadi, O., Hawkins, N., Bektas, B.A., Carlson, P., Pike, A. and Davies, C. (2013). *'Report 743: Predicting the initial retroreflectivity of pavement markings from glass bead quality'*, National Cooperative Highway Research Program, Transportation Research Board, Washington D.C., USA.

South African Bureau of Standards, SABS EN 1423 (1997). *'Road marking materials - drop-on materials - glass beads, antiskid aggregates and mixtures of the two'*, SABS Standards Division, Pretoria, RSA.

South African Bureau of Standards, SABS EN 1424 (1997). *'Road making materials - premix glass beads'*, SABS Standards Division, Pretoria, RSA.

Southern African Development Community Road Traffic Signs Manuals (SADC RTSM), Volume 1, Chapter 7 (1999). *'Uniform traffic control devices'*, Department of Transport, Government printer, Pretoria, RSA.

South African National Standards, SANS 731-1 (2006). *'Road markings: Single-pack solvent-borne paints'*, SABS Standards Division, Pretoria, RSA.

South African National Standards, SANS 731-2 (2006). *'Road markings: Single-pack water-borne paints'*, SABS Standards Division, Pretoria, RSA.

South African National Standards, SANS 6260 (2007). *'Paints and varnishes: Determination of skid resistance'*, SABS Standards Division, Pretoria, RSA.

South African National Standards, SANS 6261 (2008). *'Paints and varnishes: Determination of coefficient of retroreflected luminance by means of a portable retroreflectometer'*, SABS Standards Division, Pretoria, RSA.

South African National Standards, SANS 6248 (2007). *'Paints and varnishes: Determination of traffic wear index'*, SABS Standards Division, Pretoria, RSA

South African Road Traffic Signs Manual (SARTSM), Volume 2, Chapter 3 (1999). *'Regulatory and warning signs and markings applications'*, Department of Transport, Government printer, Pretoria, RSA.

South African Road Traffic Signs Manual (SARTSM), Volume 2, Chapter 18 (1999). *'Road marking materials'*, Department of Transport, Government printer, Pretoria, RSA.

STD016 (2014). *'Standard construction details and design standards for roads and stormwater drainage infrastructure'*, Transport Department, Pretoria, RSA.

Technical note RS 103 (2004). *'What to know about marking retrometers'*, [Brochure], Denmark, Europe.

Transport and main roads specification, MRTS45 (2012). '*Road surface delineation*', Queensland, Australia.

Wikipedia (2015). '*CIE 1931 color space*', Article published by Wikipedia the free encyclopaedia, 08 May 2015, on web page <http://en.wikipedia.org/wiki/CIE_1931_color_space> [Accessed: 13 May 2015].

Zedler, M. (2014). '*Turntable road-marking test system (RPA)*', Federal Highway Research Institute, Bergisch Gladbach, Germany, Europe.

APPENDIX A

TABLE OF CONTENTS

A. DESCRIPTIVE STATISTICS ON RETROREFLECTIVITY	A-1
A.1 DISCUSSION.....	A-1

LIST OF TABLES

Table A.1: Summary of white transverse markings on newly established dirty chip seal road (Aubrey Matlala Road).....	A-2
Table A.2: Summary of yellow transverse markings on newly established dirty chip seal road (Aubrey Matlala Road).....	A-3
Table A.3: Summary of longitudinal markings on newly established dirty chip seal road (Aubrey Matlala Road).....	A-4
Table A.4: Summary of white transverse markings on long established clean chip seal road (Bushveld Road).....	A-5
Table A.5: Summary of yellow transverse markings on long established clean chip seal road (Bushveld Road).....	A-6
Table A.6: Summary of longitudinal markings on long established clean chip seal road (Bushveld Road) .	A-7
Table A.7: Summary of white transverse markings on newly established clean chip seal road (Doreen Street - B 1).....	A-8
Table A.8: Summary of yellow transverse markings on newly established clean chip seal road (Doreen Street - B 1).....	A-9
Table A.9: Summary of longitudinal markings on newly established clean chip seal road (Doreen Street - B 1).	A-10
Table A.10: Summary of white transverse markings on newly established clean chip seal road (Doreen Street - B's 2 & 3).....	A-11
Table A.11: Summary of yellow transverse markings on newly established clean chip seal road (Doreen Street - B's 2 & 3).....	A-12
Table A.12: Summary of longitudinal markings on newly established clean chip seal road (Doreen Street - B's 2 & 3).....	A-13
Table A.13: Summary of white transverse markings on newly established clean chip seal road (Doreen Street - B's 1, 2 & 3).....	A-14
Table A.14: Summary of yellow transverse markings on newly established clean chip seal road (Doreen Street - B's 1, 2 & 3).....	A-15
Table A.15: Summary of longitudinal markings on newly established clean chip seal road (Doreen Street - B's 1, 2 & 3).....	A-16
Table A.16: Summary of white transverse markings on newly established dirty asphalt road (M 44).	A-17

Table A.17: Summary of yellow transverse markings on newly established dirty asphalt road (M 44).....	A-18
Table A.18: Summary of longitudinal markings on newly established dirty asphalt road (M 44).	A-19
Table A.19: Summary of white transverse markings on long established asphalt road in the CBD (Madiba Street).....	A-20
Table A.20: Summary of yellow transverse markings on long established asphalt road (Madiba Street). .	A-21
Table A.21: Summary of white transverse markings on newly established clean asphalt road (Meiring Naude Road).....	A-22
Table A.22: Summary of yellow transverse markings on newly established clean asphalt road (Meiring Naude Road).....	A-23
Table A.23: Summary of longitudinal markings on newly established clean asphalt road (Meiring Naude Road).....	A-24
Table A.24: Summary of white transverse road markings on long established clean asphalt road (Middel Street).....	A-25
Table A.25: Summary of yellow transverse road markings on long established clean asphalt road (Middel Street).....	A-26
Table A.26: Summary of longitudinal markings on long established clean asphalt road (Middel Street)....	A-27
Table A.27: Summary of white transverse markings on long established dirty asphalt road (Mohwelere Street).....	A-28
Table A.28: Summary of yellow transverse markings on long established dirty asphalt road (Mohwelere Street).....	A-29
Table A.29: Summary of longitudinal road markings on long established dirty asphalt road (Mohwelere Street).....	A-30
Table A.30: Summary of white transverse markings on long established dirty chip seal road (Road L 3)..	A-31
Table A.31: Summary of yellow transverse markings on long established dirty chip seal road (Road L 3).	A-32
Table A.32: Summary of longitudinal markings on long established dirty chip seal road (Road L 3).	A-33

LIST OF FIGURES

Figure A.1: Unwashed white transverse markings on Aubrey Matlala Road.....	A-2
Figure A.2: Washed white transverse markings on Aubrey Matlala Road.	A-2
Figure A.3: Unwashed yellow transverse markings on Aubrey Matlala Road.	A-3
Figure A.4: Washed yellow transverse markings on Aubrey Matlala Road.	A-3
Figure A.5: Unwashed white longitudinal markings on Aubrey Matlala Road.	A-4
Figure A.6: Unwashed yellow longitudinal markings on Aubrey Matlala Road.....	A-4
Figure A.7: Unwashed white transverse markings on Bushveld Road.....	A-5
Figure A.8: Washed white transverse markings on Bushveld Road.....	A-5
Figure A.9: Unwashed yellow transverse markings on Bushveld Road.	A-6

Figure A.10: Washed yellow transverse markings on Bushveld Road.	A-6
Figure A.11: Unwashed white longitudinal markings on Bushveld Road.	A-7
Figure A.12: Unwashed yellow longitudinal markings on Bushveld Road.	A-7
Figure A.13: Unwashed white transverse markings on Doreen Street (B 1).	A-8
Figure A.14: Washed white transverse markings on Doreen Street (B 1).	A-8
Figure A.15: Unwashed yellow transverse markings on Doreen Street (B 1).	A-9
Figure A.16: Washed yellow transverse markings on Doreen Street (B 1).	A-9
Figure A.17: Unwashed white longitudinal markings on Doreen Street (B 1).	A-10
Figure A.18: Unwashed yellow longitudinal markings on Doreen Street (B 1).	A-10
Figure A.19: Unwashed white transverse markings on Doreen Street (B's 2 & 3).	A-11
Figure A.20: Washed white transverse markings on Doreen Street (B's 2 & 3).	A-11
Figure A.21: Unwashed yellow transverse markings on Doreen Street (B's 2 & 3).	A-12
Figure A.22: Washed yellow transverse markings on Doreen Street (B's 2 & 3).	A-12
Figure A.23: Unwashed white longitudinal markings on Doreen Street (B's 2 & 3).	A-13
Figure A.24: Unwashed yellow longitudinal markings on Doreen Street (B's 2 & 3).	A-13
Figure A.25: Unwashed white transverse markings on Doreen Street (B's 1, 2 & 3).	A-14
Figure A.26: Washed white transverse markings on Doreen Street (B's 1, 2 & 3).	A-14
Figure A.27: Unwashed yellow transverse markings on Doreen Street (B's 1, 2 & 3).	A-15
Figure A.28: Washed yellow transverse markings on Doreen Street (B's 1, 2 & 3).	A-15
Figure A.29: Unwashed white longitudinal markings on Doreen Street (B's 1, 2 & 3).	A-16
Figure A.30: Unwashed yellow longitudinal markings on Doreen Street (B's 1, 2 & 3).	A-16
Figure A.31: Unwashed white transverse markings on M 44.	A-17
Figure A.32: Washed white transverse markings on M 44.	A-17
Figure A.33: Unwashed yellow transverse markings on M 44.	A-18
Figure A.34: Washed yellow transverse markings on M 44.	A-18
Figure A.35: Unwashed white longitudinal markings on M 44.	A-19
Figure A.36: Unwashed yellow longitudinal markings on M 44.	A-19
Figure A.37: Unwashed white transverse markings on Madiba Street.	A-20
Figure A.38: Washed white transverse markings on Madiba Street.	A-20
Figure A.39: Unwashed yellow transverse markings on Madiba Street.	A-21
Figure A.40: Washed yellow transverse markings on Madiba Street.	A-21
Figure A.41: Unwashed white transverse markings on Meiring Naude Road.	A-22
Figure A.42: Washed white transverse markings on Meiring Naude Road.	A-22
Figure A.43: Unwashed yellow transverse markings on Meiring Naude Road.	A-23
Figure A.44: Washed yellow transverse markings on Meiring Naude Road.	A-23
Figure A.45: Unwashed white longitudinal on Meiring Naude Road.	A-24
Figure A.46: Unwashed yellow longitudinal markings on Meiring Naude Road.	A-24

Figure A.47: Unwashed white transverse markings on Middel Street.	A-25
Figure A.48: Washed white transverse markings on Middel Street.	A-25
Figure A.49: Unwashed yellow transverse markings on Middel Street.	A-26
Figure A.50: Washed yellow transverse markings on Middel Street.	A-26
Figure A.51: Unwashed white longitudinal markings on Middel Street.	A-27
Figure A.52: Unwashed yellow longitudinal markings on Middel Street.	A-27
Figure A.53: Unwashed white transverse markings on Mohwelere Street.	A-28
Figure A.54: Washed white transverse markings on Mohwelere Street.	A-28
Figure A.55: Unwashed yellow transverse markings on Mohwelere Street.	A-29
Figure A.56: Washed yellow transverse markings on Mohwelere Street.	A-29
Figure A.57: Unwashed white longitudinal markings on Mohwelere Street.	A-30
Figure A.58: Unwashed yellow longitudinal markings on Mohwelere Street.	A-30
Figure A.59: Unwashed white transverse markings on Road L 3.	A-31
Figure A.60: Washed white transverse markings on Road L 3.	A-31
Figure A.61: Unwashed yellow transverse markings on Road L 3.	A-32
Figure A.62: Washed yellow transverse markings on Road L 3.	A-32
Figure A.63: Unwashed white longitudinal markings on Road L 3.	A-33
Figure A.64: Unwashed yellow longitudinal markings on Road L 3.	A-33

A. DESCRIPTIVE STATISTICS ON RETROREFLECTIVITY

A.1 DISCUSSION

The first date on the horizontal axis of Figures A.1 to A.64 represents the application date of the test road markings on the road surface. Some of the road markings could not be tested after a certain time as the markings had completely broken off the road surface or the markings were worn off to such an extent that a bigger area of the road surface was exposed than the actual test road markings. Therefore the number of samples measured during each measurement period might not be continuously the same but rather reduced as can be seen in some of the Tables in Appendix A. For example, there were only 5 samples instead of 6 for white transverse 1.2 mm thermoplastic (SP2) in the fourth measurement period, as can be seen in Table A.1. Some types of test road markings were also either completely worn off at each section of the test road markings or had completely broken off the road surface. In such a case it will be seen that some of the Figures in Appendix A do not indicate a decline line over the full four measurement periods. For example, white transverse water-borne (SP2) is represented in Figures A.13 and A.14 for only the first two measurement periods. Some of quantities of the road marking paints and materials obtained from some of the service providers were insufficient to be applied on all the test sites. For example, the cold plastic road marking material from Service Provider 4 (SP4) was not applied on Aubrey Matlala Road, as can be seen in Table A.1.

Table A.1: Summary of white transverse markings on newly established dirty chip seal road (Aubrey Matlala Road).

Type of road marking paint / material		05-Aug-2013		29-Nov-2013		02-Apr-2014		17-Jul-2014	
		Unwashed	Washed	Unwashed	Washed	Unwashed	Washed	Unwashed	Washed
Waterborne (SP2)	Mean	90.8	98.1	54.7	61.1	23.4	24.1	15.4	16.1
	N	6	6	6	6	6	6	6	6
	Std. Deviation	10.9	4.4	11.5	8.9	6.1	5.2	1.3	3.7
	CV	0.12	0.05	0.21	0.15	0.26	0.22	0.08	0.23
Waterborne (SP1)	Mean	158.9	164.6	90.7	96.2	39.4	39.6	20.8	23.0
	N	6	6	6	6	6	6	6	6
	Std. Deviation	23.8	28.0	25.6	23.9	16.3	12.7	5.0	3.5
	CV	0.15	0.17	0.28	0.25	0.41	0.32	0.24	0.15
Waterborne (SP3)	Mean	121.3	123.2	64.8	68.0	24.5	24.6	16.6	17.6
	N	6	6	6	6	6	6	6	6
	Std. Deviation	8.1	4.8	13.8	13.2	8.3	7.4	3.9	4.9
	CV	0.07	0.04	0.21	0.20	0.34	0.30	0.24	0.28
1.2 mm Thermoplastic (SP2)	Mean	115.7	117.4	79.0	84.7	39.8	37.8	28.5	30.9
	N	6	6	6	6	6	6	5	5
	Std. Deviation	8.7	4.6	16.2	12.5	18.3	14.9	9.8	12.3
	CV	0.08	0.04	0.21	0.15	0.46	0.40	0.34	0.40
1.2 mm Thermoplastic (SP1)	Mean	157.5	163.4	102.3	98.3	54.8	51.6	28.1	29.8
	N	6	6	6	6	6	6	6	6
	Std. Deviation	18.0	23.1	20.7	20.0	8.9	7.6	4.5	5.9
	CV	0.12	0.14	0.20	0.20	0.16	0.15	0.16	0.20
1 mm Cold Plastic (SP2)	Mean	116.7	117.7	56.5	57.1	29.3	30.6	19.9	19.6
	N	6	6	6	6	6	6	6	6
	Std. Deviation	12.3	8.5	13.3	15.5	8.6	8.3	6.2	4.8
	CV	0.11	0.07	0.24	0.27	0.29	0.27	0.31	0.25
1 mm Cold Plastic (SP1)	Mean	165.3	161.5	121.0	116.7	55.5	59.2	32.3	32.2
	N	6	6	6	6	6	6	6	6
	Std. Deviation	21.8	30.8	8.9	7.2	9.5	5.6	7.4	8.3
	CV	0.13	0.19	0.07	0.06	0.17	0.10	0.23	0.26
3 mm Screed (SP1)	Mean	157.4	153.2	117.6	119.6	70.2	67.7	38.7	40.2
	N	6	6	6	6	6	6	6	6
	Std. Deviation	17.8	35.3	9.2	9.0	9.1	6.3	10.3	9.6
	CV	0.11	0.23	0.08	0.08	0.13	0.09	0.27	0.24

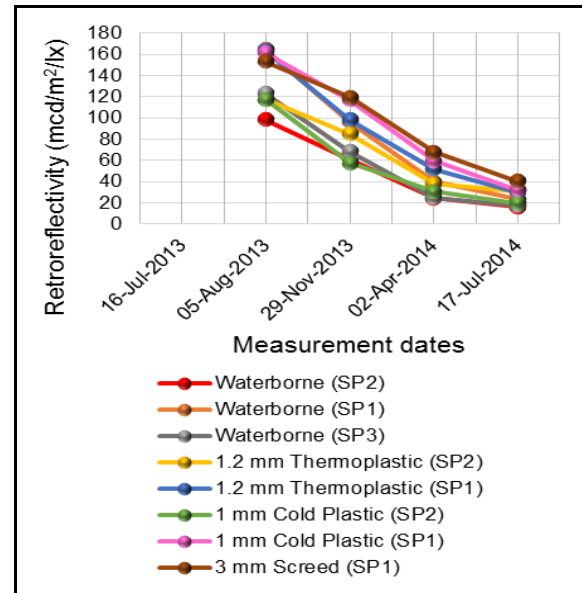
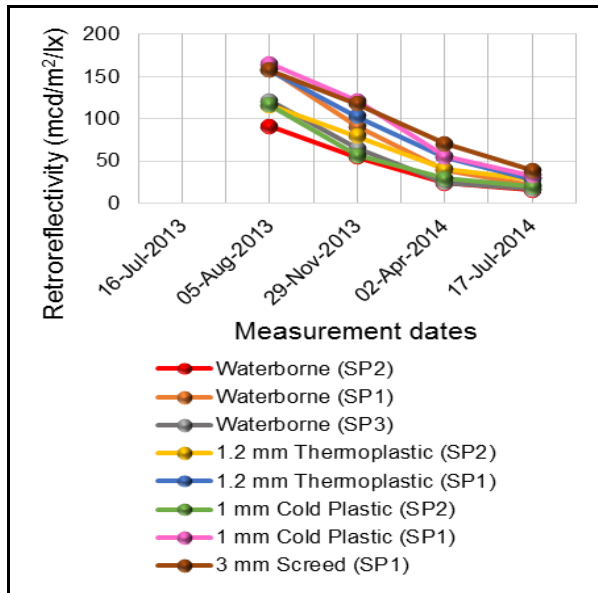

Figure A.1: Unwashed white transverse markings on Aubrey Matlala Road.

Figure A.2: Washed white transverse markings on Aubrey Matlala Road.

Table A.2: Summary of yellow transverse markings on newly established dirty chip seal road (Aubrey Matlala Road).

Type of road marking paint / material		05-Aug-2013		29-Nov-2013		02-Apr-2014		17-Jul-2014	
		Unwashed	Washed	Unwashed	Washed	Unwashed	Washed	Unwashed	Washed
Waterborne (SP2)	Mean	45.7	51.1	33.6	36.8	15.5	19.0	10.7	10.2
	N	6	6	6	6	6	6	6	6
	Std. Deviation	3.1	7.5	3.7	10.4	2.0	2.5	1.1	1.1
	CV	0.07	0.15	0.11	0.28	0.13	0.13	0.11	0.11
Waterborne (SP1)	Mean	93.5	97.6	46.8	44.6	18.1	20.4	12.7	11.1
	N	6	6	6	6	6	6	4	4
	Std. Deviation	16.4	12.1	6.8	8.4	4.8	4.1	1.8	0.4
	CV	0.011	0.12	0.15	0.19	0.27	0.21	0.14	0.04
Waterborne (SP3)	Mean	39.4	45.4	24.9	27.7	12.7	16.1	8.5	8.4
	N	6	6	6	6	6	6	5	5
	Std. Deviation	4.2	7.2	3.5	6.5	2.3	2.3	0.6	0.5
	CV	0.11	0.16	0.14	0.24	0.18	0.15	0.07	0.07
1.2 mm Thermoplastic (SP2)	Mean	94.6	99.0	63.8	66.3	28.1	34.6	19.3	19.2
	N	6	6	6	6	6	6	5	5
	Std. Deviation	5.9	7.4	11.3	6.2	13.6	7.8	6.3	4.5
	CV	0.06	0.08	0.18	0.10	0.48	0.23	0.33	0.23
1.2 mm Thermoplastic (SP1)	Mean	97.1	103.5	53.5	57.0	30.1	32.2	15.2	16.3
	N	6	6	6	6	6	6	6	6
	Std. Deviation	5.2	8.0	11.6	14.9	9.1	8.4	4.3	4.8
	CV	0.05	0.08	0.22	0.26	0.30	0.26	0.28	0.29
1 mm Cold Plastic (SP1)	Mean	123.6	131.0	85.3	92.7	36.8	38.4	18.4	18.9
	N	6	6	6	6	6	6	6	6
	Std. Deviation	15.7	17.1	6.3	17.7	8.6	10.6	3.7	4.1
	CV	0.13	0.13	0.08	0.19	0.29	0.28	0.20	0.22
3 mm Screed (SP1)	Mean	104.6	111.0	63.4	68.5	35.1	35.0	18.7	18.6
	N	6	6	6	6	6	6	6	6
	Std. Deviation	9.7	7.4	11.52	17.6	8.9	8.3	4.8	4.60
	CV	0.09	0.07	0.18	0.26	0.26	0.24	0.26	0.25

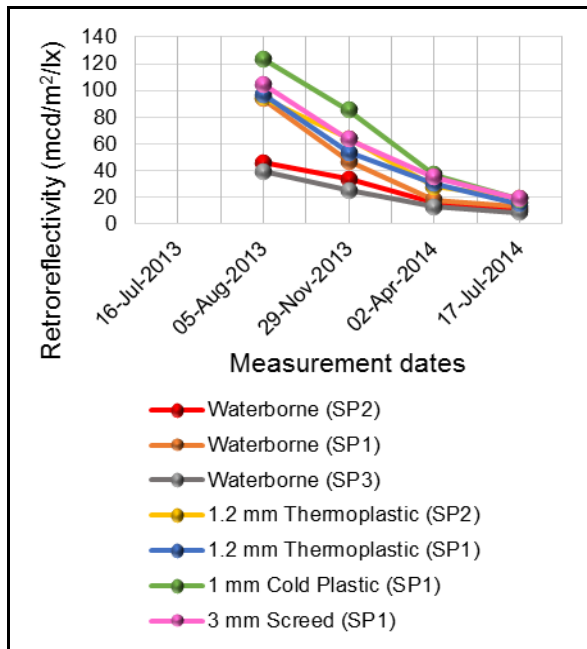

Figure A.3: Unwashed yellow transverse markings on Aubrey Matlala Road.

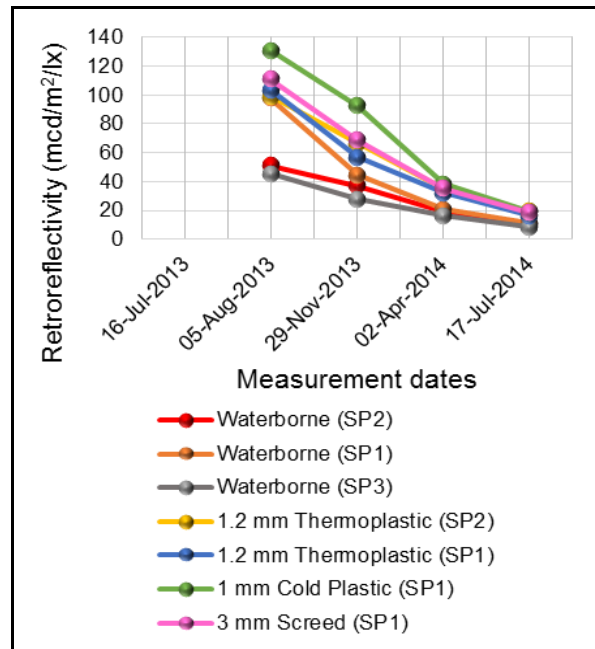

Figure A.4: Washed yellow transverse markings on Aubrey Matlala Road.

Table A.3: Summary of longitudinal markings on newly established dirty chip seal road (Aubrey Matlala Road).

Type of road marking paint / material		05-Aug-2013		29-Nov-2013		02-Apr-2014		17-Jul-2014	
		White	Yellow	White	Yellow	White	Yellow	White	Yellow
Waterborne (SP1)	Mean	135.8	118.8	113.8	107.5	83.8	78.1	59.9	65.5
	N	2	1	2	1	2	1	2	1
	Std. Deviation	4.8	0.0	6.9	0.0	1.0	0.0	0.5	0.0
	CV	0.04	0.00	0.06	0.00	0.01	0.00	0.01	0.00
Waterborne (SP2)	Mean	121.7	85.0	93.9	36.7	77.3	36.7	47.6	29.0
	N	2	1	2	1	2	1	2	1
	Std. Deviation	1.8	0.0	0.79	0.0	0.1	0.0	13.6	0.0
	CV	0.01	0.00	0.01	0.00	0.00	0.00	0.29	0.00
1.2 mm Thermoplastic (SP2)	Mean	96.8	106.0	70.6	78.6	66.2	62.4	49.6	54.8
	N	2	1	2	1	2	1	2	1
	Std. Deviation	2.0	0.0	13.0	0.0	7.4	0.0	13.8	0.0
	CV	0.02	0.00	0.19	0.00	0.11	0.00	0.28	0.00
1.2 mm Thermoplastic (SP1)	Mean	138.8	119.6	126.2	102.1	92.7	76.5	60.4	60.4
	N	2	1	2	1	2	1	2	1
	Std. Deviation	5.0	0.0	8.7	0.0	3.1	0.0	1.2	0.0
	CV	0.04	0.00	0.07	0.00	0.03	0.00	0.02	0.00
3 mm Screed (SP1)	Mean	151.9	179.4	132.4	148.1	95.4	89.7	71.1	67.1
	N	2	1	2	1	2	1	2	1
	Std. Deviation	5.8	0.0	4.3	0.0	0.1	0.0	0.6	0.0
	CV	0.04	0.00	0.03	0.00	0.00	0.00	0.01	0.00

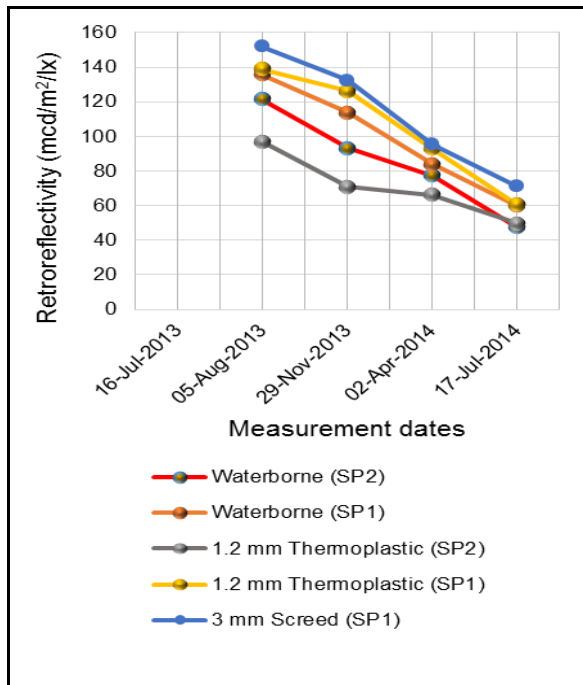

Figure A.5: Unwashed white longitudinal markings on Aubrey Matlala Road.

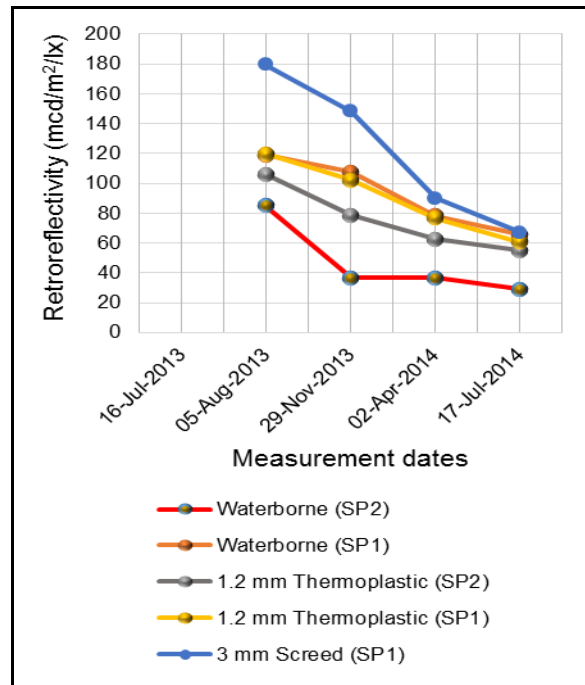

Figure A.6: Unwashed yellow longitudinal markings on Aubrey Matlala Road.

Table A.4: Summary of white transverse markings on long established clean chip seal road (Bushveld Road).

Type of road marking paint/material		02-Aug-2013		05-Nov-2013		28-Mar-2014		22-Jul-2014	
		Unwashed	Washed	Unwashed	Washed	Unwashed	Washed	Unwashed	Washed
Waterborne (SP2)	Mean	116.5	98.2	98.0	87.5	75.5	72.0	48.5	46.0
	N	9	9	9	9	9	9	9	9
	Std. Deviation	21.2	22.8	26.8	19.8	23.1	25.0	14.6	13.8
	CV	0.18	0.23	0.27	0.23	0.31	0.34	0.30	0.30
Waterborne (SP1)	Mean	218.6	172.9	184.5	154.5	149.8	148.6	96.1	86.6
	N	9	9	9	9	9	9	9	9
	Std. Deviation	38.5	12.5	16.0	17.1	12.7	20.9	25.2	27.6
	CV	0.18	0.07	0.09	0.11	0.09	0.14	0.26	0.31
Waterborne (SP3)	Mean	139.7	124.1	107.7	99.4	83.1	75.2	52.6	45.9
	N	9	9	9	9	9	9	9	9
	Std. Deviation	17.7	14.9	20.1	14.5	19.8	16.2	16.4	10.3
	CV	0.13	0.12	0.18	0.15	0.23	0.21	0.31	0.22
1.2 mm Thermoplastic (SP2)	Mean	147.0	164.0	160.8	151.1	113.4	111.3	65.8	63.9
	N	9	9	9	9	9	9	9	9
	Std. Deviation	9.4	13.8	17.3	36.3	15.6	19.5	13.5	15.0
	CV	0.06	0.08	0.11	0.24	0.13	0.18	0.21	0.23
1.2 mm Thermoplastic (SP1)	Mean	237.3	183.8	203.9	182.4	180.7	167.0	115.6	100.6
	N	9	9	9	9	9	9	9	9
	Std. Deviation	59.4	19.3	47.1	38.7	36.1	45.9	20.0	21.6
	CV	0.25	0.11	0.23	0.21	0.02	0.27	0.17	0.22
1 mm Cold Plastic (SP1)	Mean	211.4	173.4	202.7	180.8	165.0	158.9	113.4	106.9
	N	9	9	9	9	9	9	9	9
	Std. Deviation	31.6	14.7	15.8	31.0	24.9	32.0	22.2	19.3
	CV	0.15	0.08	0.07	0.17	0.15	0.20	0.20	0.18
3 mm Screed (SP1)	Mean	229.9	183.1	191.8	190.5	175.0	159.9	115.8	107.8
	N	9	9	9	9	9	9	9	9
	Std. Deviation	47.7	27.6	30.8	26.9	30.7	34.1	19.4	21.1
	CV	0.21	0.15	0.16	0.14	0.18	0.21	0.17	0.20
1 mm Cold Plastic (SP4)	Mean	105.4	92.8	59.3	68.2	48.5	47.3	24.8	27.6
	N	9	9	9	9	9	9	9	9
	Std. Deviation	31.8	13.6	21.9	19.0	15.9	13.4	8.7	8.8
	CV	0.30	0.15	0.37	0.30	0.33	0.29	0.35	0.32

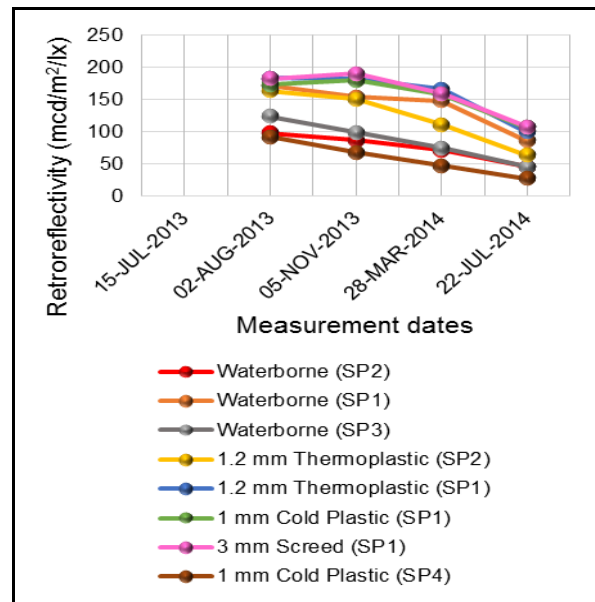
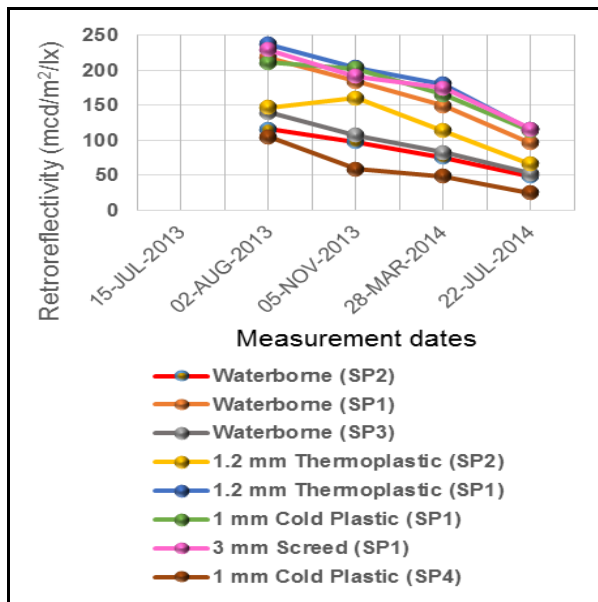

Figure A.7: Unwashed white transverse markings on Bushveld Road.

Figure A.8: Washed white transverse markings on Bushveld Road.

Table A.5: Summary of yellow transverse markings on long established clean chip seal road (Bushveld Road).

Type of road marking paint/material		02-Aug-2013		05-Nov-2013		28-Mar-2014		22-Jul-2014	
		Unwashed	Washed	Unwashed	Washed	Unwashed	Washed	Unwashed	Washed
Waterborne (SP2)	Mean	55.0	61.7	46.9	52.8	40.4	38.8	26.1	25.8
	N	9	9	9	9	9	9	9	9
	Std. Deviation	8.4	20.7	7.9	12.0	9.5	9.2	7.0	6.4
	CV	0.15	0.34	0.17	0.23	0.24	0.24	0.27	0.25
Waterborne (SP1)	Mean	116.1	120.9	84.0	84.0	70.9	64.3	49.7	50.1
	N	9	9	9	9	9	9	9	9
	Std. Deviation	17.3	28.6	22.3	16.4	13.5	14.5	9.9	18.5
	CV	0.15	0.23	0.27	0.20	0.19	0.23	0.20	0.37
Waterborne (SP3)	Mean	90.2	87.9	74.7	72.6	59.2	56.3	35.5	34.4
	N	9	9	9	9	9	9	9	9
	Std. Deviation	12.0	12.1	11.5	14.4	11.1	11.2	8.5	7.4
	CV	0.14	0.14	0.16	0.20	0.19	0.20	0.24	0.22
1.2 mm Thermoplastic (SP2)	Mean	95.8	104.8	98.5	82.8	66.2	64.4	39.3	39.4
	N	9	9	9	9	9	9	9	9
	Std. Deviation	6.8	10.1	11.4	11.7	11.6	9.0	8.2	8.4
	CV	0.07	0.10	0.11	0.14	0.18	0.14	0.21	0.21
1.2 mm Thermoplastic (SP1)	Mean	132.0	141.5	103.8	92.1	85.7	84.8	44.3	39.6
	N	9	9	9	9	9	9	9	9
	Std. Deviation	21.9	36.0	34.0	24.6	29.1	25.3	21.2	7.2
	CV	0.17	0.25	0.32	0.27	0.34	0.30	0.48	0.18
1 mm Cold Plastic (SP1)	Mean	141.9	134.0	140.2	122.0	110.4	99.2	66.1	66.3
	N	9	9	9	9	9	9	9	9
	Std. Deviation	24.4	15.4	9.0	19.6	20.5	16.9	15.4	12.6
	CV	0.17	0.12	0.07	0.16	0.19	0.17	0.23	0.19
3 mm Screed (SP1)	Mean	111.5	113.8	73.4	74.4	71.2	67.3	38.2	35.8
	N	9	9	9	9	9	9	9	9
	Std. Deviation	15.4	19.1	10.2	12.9	15.3	14.6	9.6	5.4
	CV	0.14	0.17	0.14	0.17	0.22	0.22	0.25	0.15
1 mm Cold Plastic (SP4)	Mean	80.0	79.6	47.4	47.5	42.6	39.5	22.4	23.0
	N	9	9	9	9	9	9	9	9
	Std. Deviation	11.3	13.8	9.6	11.8	8.4	6.9	5.9	4.9
	CV	0.14	0.17	0.20	0.25	0.20	0.18	0.15	0.21

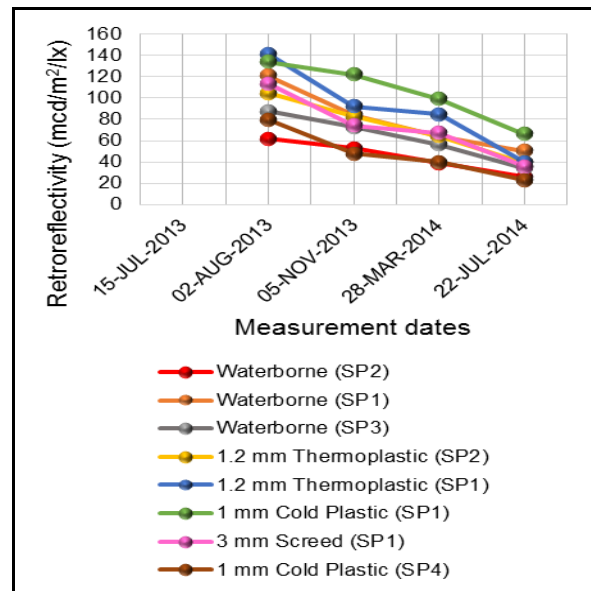
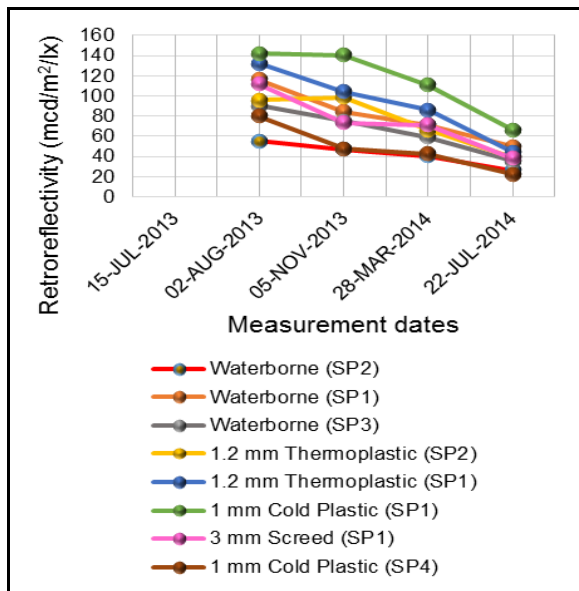

Figure A.9: Unwashed yellow transverse markings on Bushveld Road.

Figure A.10: Washed yellow transverse markings on Bushveld Road.

Table A.6: Summary of longitudinal markings on long established clean chip seal road (Bushveld Road).

Type of road marking paint/material		02-Aug-2013		05-Nov-2013		28-Mar-2014		22-Jul-2014	
		White	Yellow	White	Yellow	White	Yellow	White	Yellow
Waterborne (SP2)	Mean	151.0		137.2		125.3		110.6	
	N	3		3		3		3	
	Std. Deviation	15.2		9.6		7.4		2.5	
	CV	0.10		0.07		0.06		0.02	
Waterborne (SP1)	Mean	295.5	101.5	262.2	87.6	229.8	54.1	212.9	34.6
	N	3	3	3	3	3	3	3	3
	Std. Deviation	12.0	20.8	36.3	18.7	48.6	14.6	48.5	14.8
	CV	0.04	0.21	0.13	0.21	0.21	0.27	0.23	0.43
1.2 mm Thermoplastic (SP2)	Mean		113.7		96.3		78.5		53.4
	N		3		3		3		3
	Std. Deviation		12.1		10.9		8.7		2.5
	CV		0.11		0.11		0.11		0.05
1.2 mm Thermoplastic (SP1)	Mean	458.9	100.8	380.5	90.1	335.1	83.3	298.9	40.5
	N	3	3	3	3	3	3	3	3
	Std. Deviation	10.7	14.6	67.8	17.1	37.2	9.9	22.7	9.6
	CV	0.02	0.15	0.17	0.19	0.11	0.12	0.08	0.24
3 mm Screed (SP1)	Mean	494.7	98.0	385.6	93.7	366.9	85.7	317.3	68.3
	N	3	3	3	3	3	3	3	3
	Std. Deviation	79.1	21.1	57.4	18.1	7.5	11.4	10.6	3.9
	CV	0.16	0.22	0.15	0.19	0.02	0.13	0.03	0.06

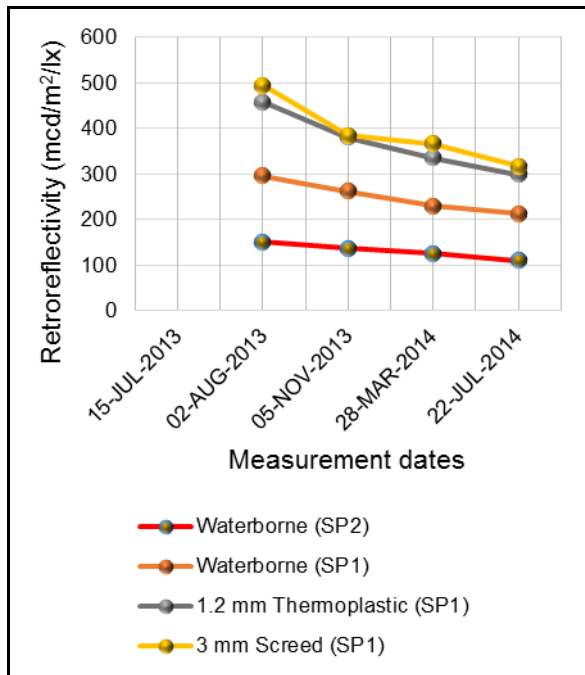

Figure A.11: Unwashed white longitudinal markings on Bushveld Road.

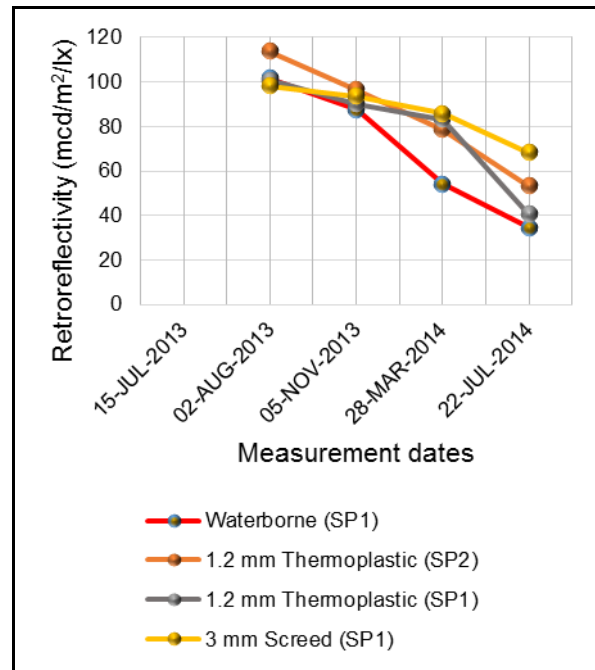

Figure A.12: Unwashed yellow longitudinal markings on Bushveld Road.

Table A.7: Summary of white transverse markings on newly established clean chip seal road (Doreen Street - B 1).

Type of road marking paint / material		01-Aug-2013		21-Nov-2013		26-Mar-2014		25-Jul-2014	
		Unwashed	Washed	Unwashed	Washed	Unwashed	Washed	Unwashed	Washed
Waterborne (SP2)	Mean	103.2	106.4	24.4	21.5				
	N	3	3	3	3				
	Std. Deviation	12.6	2.3	5.2	4.3				
	CV	0.13	0.02	0.22	0.20				
Waterborne (SP1)	Mean	152.3	140.6	53.4	48.7	26.7	31.5	18.4	19.2
	N	3	3	3	3	3	3	3	3
	Std. Deviation	13.6	6.6	8.0	7.8	0.8	5.2	1.6	1.0
	CV	0.09	0.05	0.15	0.16	0.03	0.17	0.09	0.05
Waterborne (SP3)	Mean	167.7	160.5	58.6	55.0	31.5	35.3	21.3	21.3
	N	3	3	3	3	3	3	3	3
	Std. Deviation	6.2	17.4	10.6	7.0	2.5	3.6	5.1	2.0
	CV	0.04	0.11	0.18	0.13	0.08	0.10	0.24	0.10
1.2 mm Thermoplastic (SP2)	Mean	156.2	145.8	58.7	56.7	43.0	45.3	31.5	30.9
	N	3	3	3	3	3	3	3	3
	Std. Deviation	4.5	10.9	5.6	7.0	4.3	2.7	2.3	1.1
	CV	0.03	0.08	0.10	0.12	0.10	0.06	0.07	0.04
1.2 mm Thermoplastic (SP1)	Mean	226.3	198.6	91.8	92.9	55.2	59.4	35.4	36.2
	N	3	3	3	3	3	3	3	3
	Std. Deviation	19.4	15.8	18.4	4.3	6.2	11.7	6.7	2.7
	CV	0.09	0.08	0.20	0.05	0.11	0.20	0.19	0.08
1 mm Cold Plastic (SP1)	Mean	170.2	169.2	56.2	40.1	21.1	25.2	13.5	15.1
	N	3	3	3	3	3	3	3	3
	Std. Deviation	25.8	5.1	10.6	5.8	1.6	2.6	1.4	1.5
	CV	0.15	0.03	0.19	0.15	0.08	0.10	0.11	0.10
3 mm Screed (SP1)	Mean	238.8	226.9	81.7	89.0	49.1	54.5	29.7	32.8
	N	3	3	3	3	3	3	3	3
	Std. Deviation	22.2	6.4	16.0	0.2	13.0	8.2	5.3	7.2
	CV	0.09	0.03	0.20	0.00	0.27	0.15	0.18	0.22
1 mm Cold Plastic (SP4)	Mean	126.5	129.0	36.8	35.8	18.7	22.0	12.2	13.9
	N	3	3	3	3	3	3	3	3
	Std. Deviation	9.0	7.4	7.1	5.9	3.3	3.6	2.5	2.1
	CV	0.07	0.06	0.19	0.16	0.18	0.1	0.21	0.15

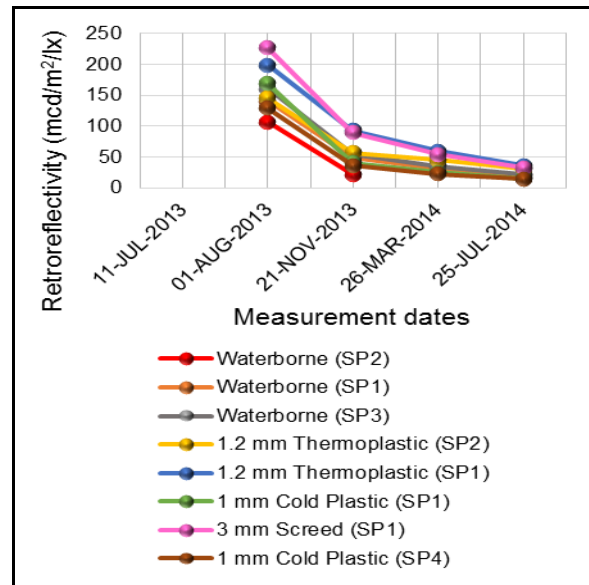
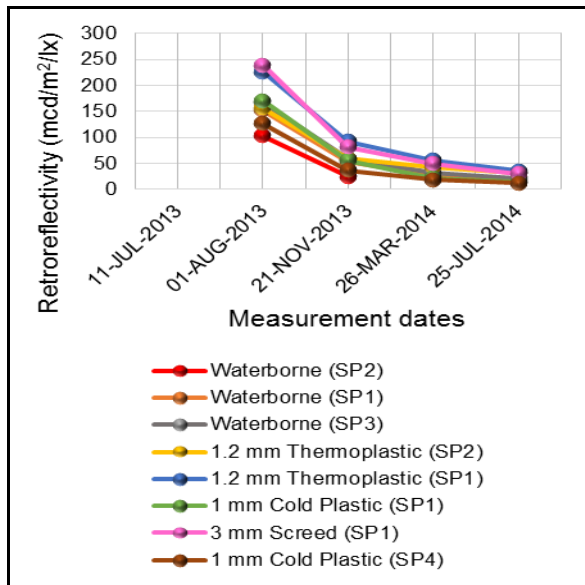

Figure A.13: Unwashed white transverse markings on Doreen Street (B 1).

Figure A.14: Washed white transverse markings on Doreen Street (B 1).

Table A.8: Summary of yellow transverse markings on newly established clean chip seal road (Doreen Street - B 1).

Type of road marking paint / material		01-Aug-2013		21-Nov-2013		26-Mar-2014		25-Jul-2014	
		Unwashed	Washed	Unwashed	Washed	Unwashed	Washed	Unwashed	Washed
Waterborne (SP2)	Mean	70.2	69.4	23.7	18.0	11.5	13.4		
	N	3	3	3	3	3	3		
	Std. Deviation	9.2	2.2	1.4	2.4	0.7	2.4		
	CV	0.13	0.03	0.06	0.14	0.06	0.18		
Waterborne (SP1)	Mean	123.2	119.4	63.0	61.7	16.2	18.2		
	N	3	3	3	3	3	3		
	Std. Deviation	7.3	1.3	17.0	1.7	2.7	0.7		
	CV	0.06	0.01	0.27	0.03	0.17	0.04		
Waterborne (SP3)	Mean	95.2	93.4	46.8	50.3	17.2	21.0	11.2	14.2
	N	3	3	3	3	3	3	3	3
	Std. Deviation	3.7	0.6	3.9	5.1	0.8	1.2	0.9	1.8
	CV	0.04	0.01	0.09	0.10	0.05	0.06	0.08	0.13
1.2 mm Thermoplastic (SP2)	Mean	73.9	72.4	53.0	51.0	31.3	38.0	23.1	25.6
	N	3	3	3	3	3	3	3	3
	Std. Deviation	8.5	3.7	5.6	4.4	4.2	5.6	5.4	3.7
	CV	0.12	0.05	0.11	0.09	0.14	0.15	0.23	0.14
1.2 mm Thermoplastic (SP1)	Mean	89.3	82.8	45.7	39.6	21.2	25.4	13.0	17.0
	N	3	3	3	3	3	3	3	3
	Std. Deviation	9.9	1.8	4.9	7.9	2.7	4.5	0.8	1.8
	CV	0.11	0.02	0.11	0.20	0.13	0.18	0.07	0.11
1 mm Cold Plastic (SP1)	Mean	144.2	138.8	94.5	95.8	22.6	27.6	15.3	19.4
	N	3	3	3	3	3	3	3	3
	Std. Deviation	12.2	1.6	4.5	0.2	10.0	8.6	5.6	9.9
	CV	0.09	0.01	0.05	0.00	0.44	0.31	0.37	0.51
3 mm Screed (SP1)	Mean	130.2	126.2	65.9	73.0	25.0	28.7	15.0	17.1
	N	3	3	3	3	3	3	3	3
	Std. Deviation	9.8	3.8	6.4	8.3	4.7	2.7	0.2	2.2
	CV	0.08	0.03	0.10	0.12	0.19	0.09	0.02	0.13
1 mm Cold Plastic (SP4)	Mean	103.2	100.4	40.2	39.4	17.2	19.6	10.7	12.3
	N	3	3	3	3	3	3	3	3
	Std. Deviation	5.6	6.2	3.1	1.6	1.6	1.4	0.6	0.8
	CV	0.06	0.06	0.08	0.04	0.10	0.07	0.06	0.07

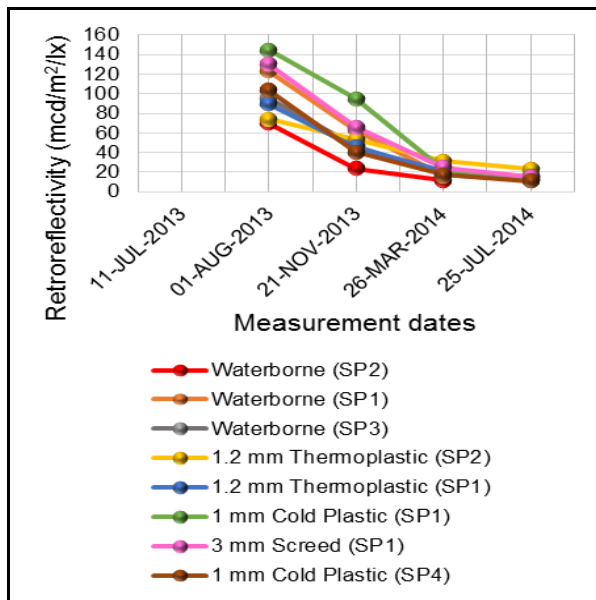

Figure A.15: Unwashed yellow transverse markings on Doreen Street (B 1).

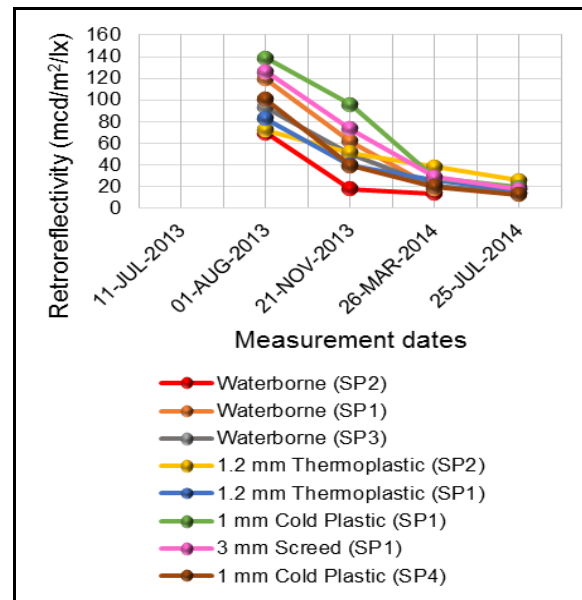

Figure A.16: Washed yellow transverse markings on Doreen Street (B 1).

Table A.9: Summary of longitudinal markings on newly established clean chip seal road (Doreen Street - B 1).

Type of road marking paint/material		01-Aug-2013		21-Nov-2013		26-Mar-2014		25-Jul-2014	
		White	Yellow	White	Yellow	White	Yellow	White	Yellow
Waterborne (SP2)	Mean	121.8	74.1		61.8		31.6		33.6
	N	1	1		1		1		1
	Std. Deviation	0.0	0.0		0.0		0.0		0.0
	CV	0.00	0.00		0.00		0.00		0.00
Waterborne (SP1)	Mean	140.2	89.2	99.3	77.1	31.2	49.4		53.0
	N	1	1	1	1	1	1		1
	Std. Deviation	0.0	0.0	0.0	0.0	0.0	0.0		0.0
	CV	0.00	0.00	0.00	0.00	0.00	0.00		0.00
1.2 mm Thermoplastic (SP2)	Mean	145.2	69.1	123.2	56.6	53.8	40.7	25.7	37.5
	N	1	1	1	1	1	1	1	1
	Std. Deviation	0.0	0.0	0.0	0.0	0.0	0.0	0.0	0.0
	CV	0.00	0.00	0.00	0.00	0.00	0.00	0.00	0.00
1.2 mm Thermoplastic (SP1)	Mean	341.5	213.7	214.4	157.4	130.4	120.7	43.8	104.1
	N	1	1	1	1	1	1	1	1
	Std. Deviation	0.0	0.0	0.0	0.0	0.0	0.0	0.0	0.0
	CV	0.00	0.00	0.00	0.00	0.00	0.00	0.00	0.00
3 mm Screed (SP1)	Mean	382.8	230.4	235.0	174.0	198.6	150.4	114.6	124.2
	N	1	1	1	1	1	1	1	1
	Std. Deviation	0.0	0.0	0.0	0.0	0.0	0.0	0.0	0.0
	CV	0.00	0.00	0.00	0.00	0.00	0.00	0.00	0.00

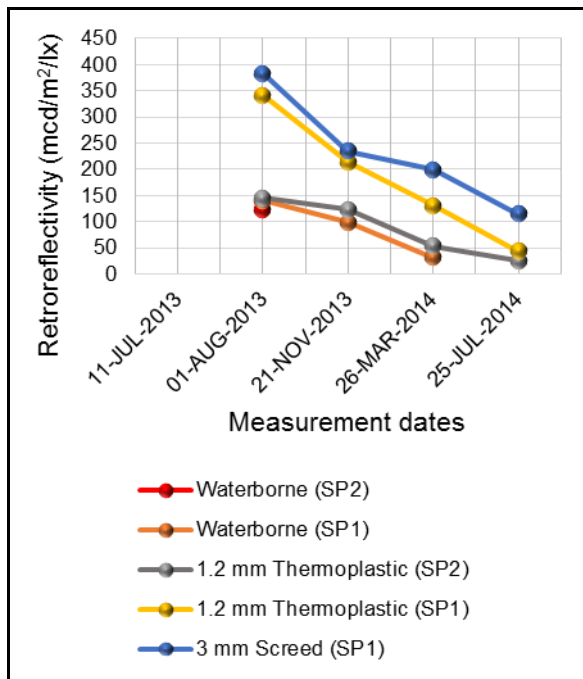

Figure A.17: Unwashed white longitudinal markings on Doreen Street (B 1).

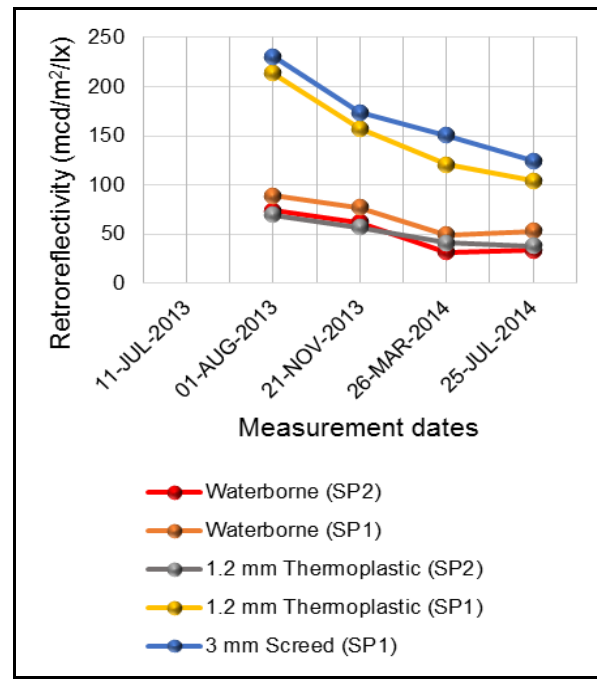

Figure A.18: Unwashed yellow longitudinal markings on Doreen Street (B 1).

Table A.10: Summary of white transverse markings on newly established clean chip seal road (Doreen Street - B's 2 & 3).

Type of road marking paint/material		01-Aug-2013		21-Nov-2013		26-Mar-2014		25-Jul-2014	
		Unwashed	Washed	Unwashed	Washed	Unwashed	Washed	Unwashed	Washed
Waterborne (SP2)	Mean	127.1	114.3	67.2	59.9	29.1	28.9	17.3	17.8
	N	6	6	6	6	6	6	6	6
	Std. Deviation	22.7	18.4	8.6	9.6	2.3	3.6	2.7	1.8
	CV	0.18	0.16	0.13	0.16	0.08	0.12	0.16	0.10
Waterborne (SP1)	Mean	221.0	200.8	170.9	167.7	109.5	92.9	70.0	60.4
	N	6	6	6	6	6	6	6	6
	Std. Deviation	32.7	24.4	13.9	14.0	16.7	13.1	14.0	10.6
	CV	0.15	0.12	0.08	0.08	0.15	0.14	0.20	0.18
Waterborne (SP3)	Mean	196.3	157.9	151.7	136.4	99.1	79.6	60.7	60.2
	N	6	6	6	6	6	6	6	6
	Std. Deviation	11.6	24.0	8.0	20.1	23.9	13.1	2.5	11.9
	CV	0.05	0.15	0.05	0.15	0.24	0.17	0.04	0.20
1.2 mm Thermoplastic (SP2)	Mean	124.9	135.9	145.0	138.3	99.6	86.5	57.6	54.2
	N	6	6	6	6	6	6	6	6
	Std. Deviation	12.0	14.6	13.3	22.2	14.6	17.2	9.6	13.8
	CV	0.10	0.11	0.09	0.16	0.15	0.20	0.17	0.26
1.2 mm Thermoplastic (SP1)	Mean	285.6	233.7	269.1	240.2	197.0	155.6	110.5	103.3
	N	6	6	6	6	6	6	6	6
	Std. Deviation	24.5	33.9	36.0	30.6	31.6	27.7	20.4	22.6
	CV	0.09	0.15	0.13	0.13	0.16	0.18	0.19	0.22
1 mm Cold Plastic (SP1)	Mean	173.6	162.7	145.0	135.7	92.3	75.7	60.8	58.2
	N	6	6	6	6	6	6	6	6
	Std. Deviation	27.7	38.3	10.8	20.1	19.8	15.3	15.8	16.7
	CV	0.16	0.24	0.08	0.15	0.22	0.20	0.26	0.29
3 mm Screed (SP1)	Mean	249.8	207.7	235.7	217.1	169.6	137.1	98.9	91.7
	N	6	6	6	6	6	6	6	6
	Std. Deviation	25.4	28.7	24.1	12.9	20.8	27.3	15.5	24.4
	CV	0.10	0.14	0.10	0.06	0.12	0.20	0.16	0.27
1 mm Cold Plastic (SP4)	Mean	262.7	233.7	216.7	202.2	129.2	112.6	86.7	80.8
	N	6	6	6	6	6	6	6	6
	Std. Deviation	32.2	19.6	23.8	23.0	30.6	32.4	20.2	24.0
	CV	0.13	0.08	0.11	0.11	0.24	0.29	0.23	0.30

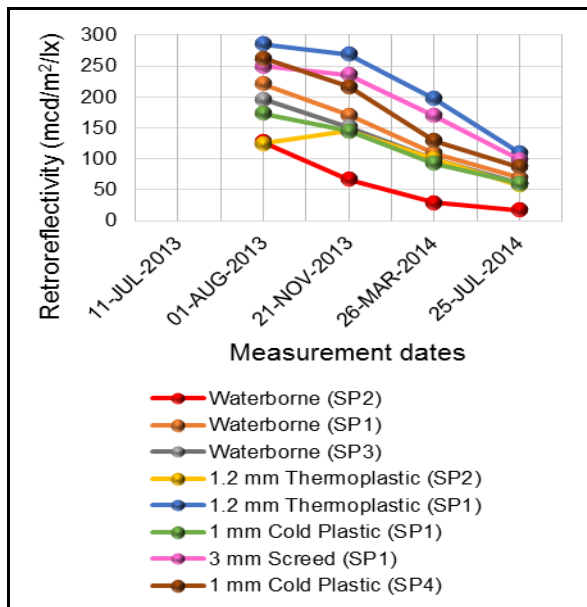

Figure A. 19: Unwashed white transverse markings on Doreen Street (B's 2 & 3).

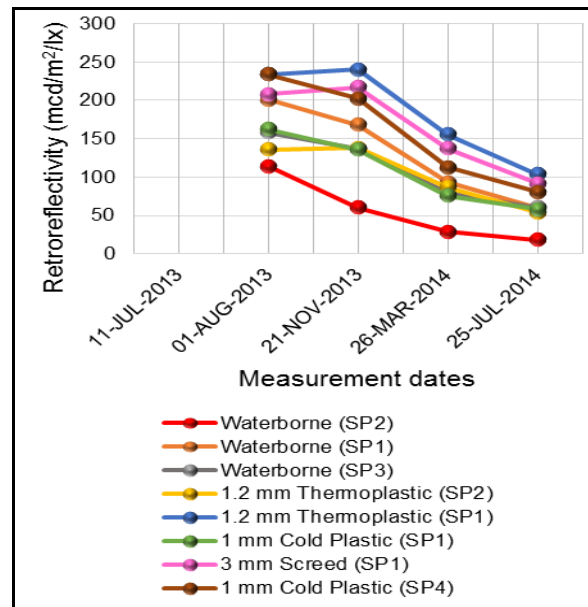

Figure A.20: Washed white transverse markings on Doreen Street (B's 2 & 3).

Table A.11: Summary of yellow transverse markings on newly established clean chip seal road (Doreen Street - B's 2 & 3).

Type of road marking paint/material		01-Aug-2013		21-Nov-2013		26-Mar-2014		25-Jul-2014	
		Unwashed	Washed	Unwashed	Washed	Unwashed	Washed	Unwashed	Washed
Waterborne (SP2)	Mean	91.3	77.2	39.6	41.3	28.2	27.2	17.0	18.0
	N	6	6	6	6	6	6	6	6
	Std. Deviation	18.6	7.3	2.9	2.8	3.9	2.9	2.2	5.2
	CV	0.20	0.10	0.08	0.07	0.14	0.11	0.13	0.29
Waterborne (SP1)	Mean	155.4	135.1	81.2	85.0	55.7	52.2	36.6	32.3
	N	6	6	6	6	6	6	6	6
	Std. Deviation	20.7	17.5	14.9	15.7	12.1	12.3	7.5	7.2
	CV	0.13	0.13	0.18	0.19	0.22	0.24	0.21	0.22
Waterborne (SP3)	Mean	120.6	104.7	69.6	73.1	53.3	48.9	33.3	34.7
	N	6	6	6	6	6	6	6	6
	Std. Deviation	11.4	21.7	5.3	8.8	6.5	10.3	4.8	7.2
	CV	0.10	0.21	0.08	0.12	0.12	0.21	0.15	0.21
1.2 mm Thermoplastic (SP2)	Mean	95.1	112.8	79.3	84.2	55.0	47.5	32.0	29.9
	N	6	6	6	6	6	6	6	6
	Std. Deviation	13.1	14.7	13.0	12.6	6.5	6.7	2.7	4.3
	CV	0.14	0.13	0.16	0.15	0.01	0.02	0.09	0.15
1.2 mm Thermoplastic (SP1)	Mean	116.7	115.1	70.1	77.0	60.0	51.1	34.2	31.4
	N	6	6	6	6	6	6	6	6
	Std. Deviation	21.1	9.6	6.9	6.2	5.3	4.4	1.1	4.8
	CV	0.18	0.08	0.10	0.08	0.09	0.09	0.03	0.15
1 mm Cold Plastic (SP1)	Mean	166.5	150.1	108.2	113.5	81.9	74.6	50.1	55.4
	N	6	6	6	6	6	6	6	6
	Std. Deviation	22.5	41.4	7.0	7.3	12.4	13.9	5.7	11.1
	CV	0.14	0.28	0.07	0.07	0.15	0.19	0.11	0.20
3 mm Screed (SP1)	Mean	142.4	133.0	97.4	105.5	83.2	66.3	47.1	41.5
	N	6	6	6	6	6	6	6	6
	Std. Deviation	7.6	20.1	13.8	15.3	12.9	11.2	9.0	8.9
	CV	0.05	0.15	0.14	0.15	0.16	0.17	0.19	0.22
1 mm Cold Plastic (SP4)	Mean	153.7	139.2	67.4	71.9	55.0	49.2	37.9	34.6
	N	6	6	6	6	6	6	6	6
	Std. Deviation	16.2	20.2	7.8	8.5	9.8	9.6	5.2	5.9
	CV	0.11	0.15	0.12	0.12	0.18	0.20	0.13	0.17

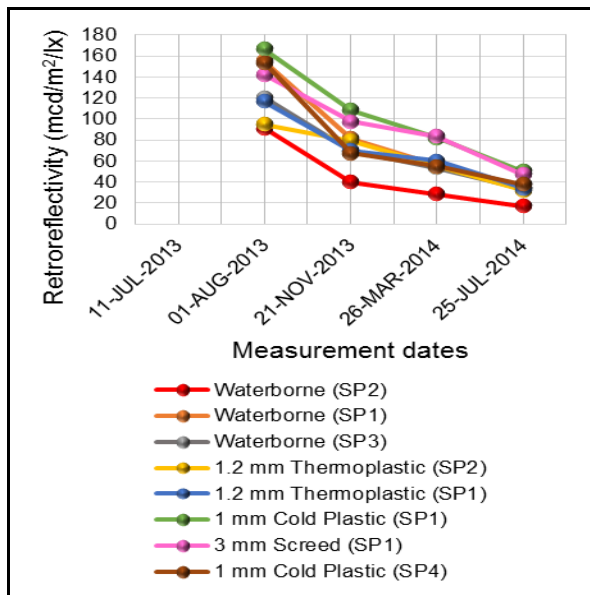

Figure A.21: Unwashed yellow transverse markings on Doreen Street (B's 2 & 3).

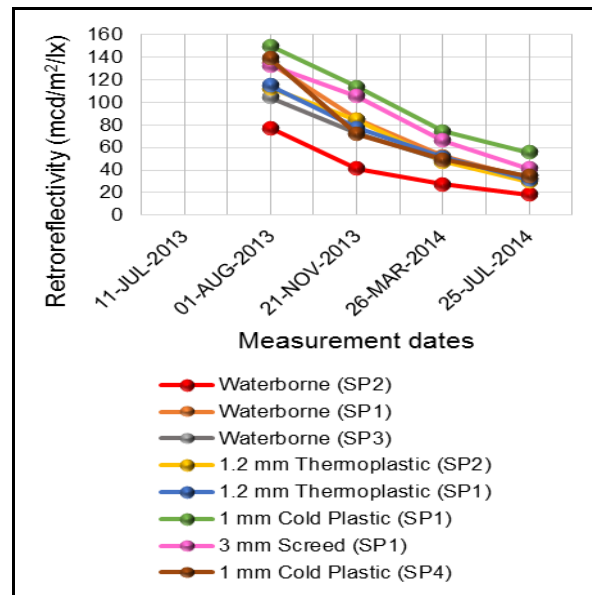

Figure A.22: Washed yellow transverse markings on Doreen Street (B's 2 & 3).

Table A.12: Summary of longitudinal markings on newly established clean chip seal road (Doreen Street - B's 2 & 3).

Type of road marking paint/material		01-Aug-2013		21-Nov-2013		26-Mar-2014		25-Jul-2014	
		White	Yellow	White	Yellow	White	Yellow	White	Yellow
Waterborne (SP2)	Mean	80.6	87.5	66.0	77.7	62.1	69.4	27.2	68.2
	N	2	2	2	2	2	2	2	2
	Std. Deviation	24.9	18.3	13.9	21.1	13.3	14.4	1.1	5.9
	CV	0.31	0.21	0.21	0.27	0.21	0.21	0.04	0.09
Waterborne (SP1)	Mean	190.2	164.1	177.1	136.7	85.0	134.7	78.6	108
	N	2	2	2	2	2	2	2	2
	Std. Deviation	70	76.6	88.6	60.4	16.8	38.8	4.1	7.6
	CV	0.37	0.47	0.50	0.44	0.20	0.29	0.05	0.07
1.2 mm Thermoplastic (SP2)	Mean	148.5	120.6	126.8	91.4	69.2	65.3	32.3	43.3
	N	2	2	2	2	2	2	2	2
	Std. Deviation	88.2	17.1	80.2	10.9	15.1	50.2	0.7	8.7
	CV	0.59	0.63	0.63	0.12	0.21	0.77	0.02	0.2
1.2 mm Thermoplastic (SP1)	Mean	245.1	162.8	186.0	137.4	147.1	123.9	89.2	124.2
	N	2	2	2	2	2	2	2	2
	Std. Deviation	28.2	47.5	55.7	11.6	40.2	9.9	57.1	10.6
	CV	0.12	0.29	0.30	0.08	0.27	0.08	0.64	0.09
3 mm Screed (SP1)	Mean	314.0	186.5	243.7	157.1	175.7	144.4	141.2	127.1
	N	2	2	2	2	2	2	2	2
	Std. Deviation	18.8	56.8	10.2	34.5	2.5	23.3	5.2	4.6
	CV	0.06	0.30	0.04	0.22	0.01	0.16	0.04	0.04

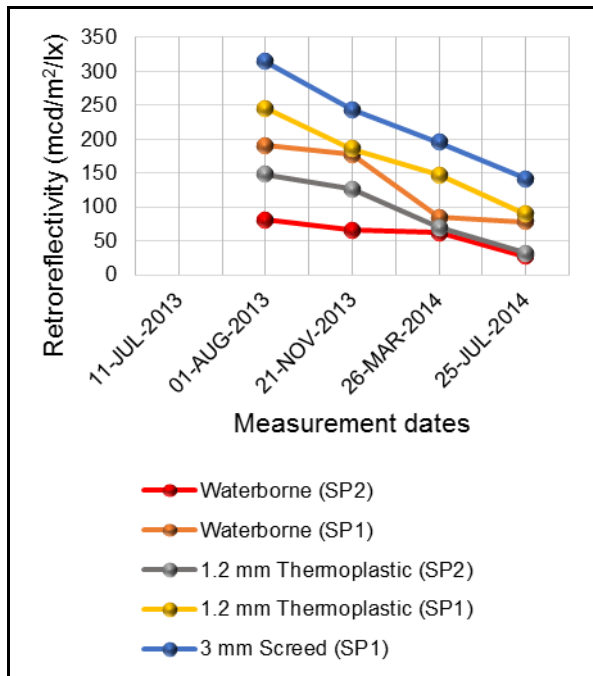

Figure A.23: Unwashed white longitudinal markings on Doreen Street (B's 2 & 3).

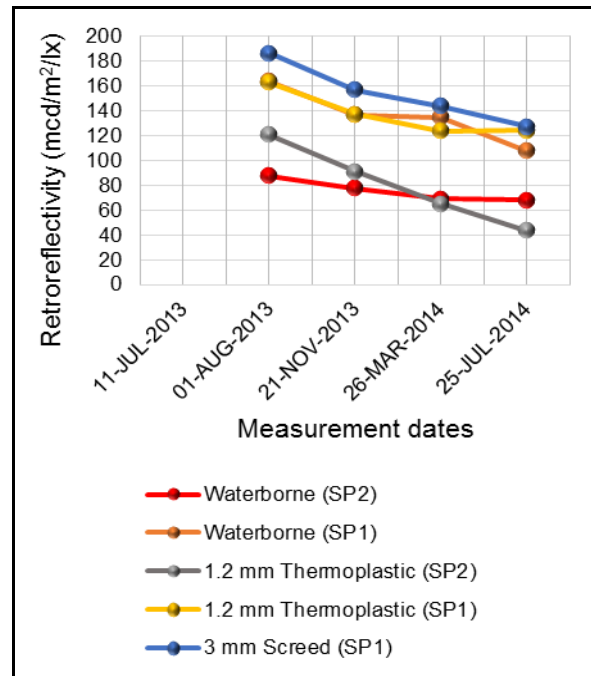

Figure A.24: Unwashed yellow longitudinal markings on Doreen Street (B's 2 & 3).

Table A.13: Summary of white transverse markings on newly established clean chip seal road (Doreen Street - B's 1, 2 & 3).

Type of road marking paint/material		01-Aug-2013		21-Nov-2013		26-Mar-2014		25-Jul-2014	
		Unwashed	Washed	Unwashed	Washed	Unwashed	Washed	Unwashed	Washed
Waterborne (SP2)	Mean	119.1	111.7	52.9	47.1	29.1	28.9	17.3	17.8
	N	9	9	9	9	6	6	6	6
	Std. Deviation	22.5	15.1	22.5	20.7	2.3	3.6	2.7	1.8
	CV	0.19	0.14	0.42	0.44	0.08	0.12	0.16	0.10
Waterborne (SP1)	Mean	198.1	180.7	131.7	128.1	81.9	72.4	52.8	46.6
	N	9	9	9	9	9	9	9	9
	Std. Deviation	43.5	35.9	59.9	60.6	43.4	32.4	28.0	22.2
	CV	0.22	0.20	0.45	0.47	0.53	0.45	0.53	0.48
Waterborne (SP3)	Mean	186.7	158.8	120.7	109.3	76.6	64.8	47.6	47.3
	N	9	9	9	9	9	9	9	9
	Std. Deviation	17.3	20.9	47.3	43.8	38.7	24.5	19.9	21.6
	CV	0.09	0.13	0.39	0.40	0.51	0.38	0.42	0.46
1.2 mm Thermoplastic (SP2)	Mean	135.3	139.2	116.3	111.1	80.7	72.	48.9	46.4
	N	9	9	9	9	9	9	9	9
	Std. Deviation	18.4	13.7	44.5	44.5	30.6	24.7	15.1	15.9
	CV	0.14	0.10	0.38	0.40	0.38	0.34	0.31	0.34
1.2 mm Thermoplastic (SP1)	Mean	265.8	222.0	210.0	191.1	149.7	123.54	85.5	80.9
	N	9	9	9	9	9	9	9	9
	Std. Deviation	36.7	33.0	93.5	77.5	75.2	53.1	41.0	38.0
	CV	0.14	0.15	0.45	0.41	0.50	0.43	0.48	0.47
1 mm Cold Plastic (SP1)	Mean	172.5	164.9	115.4	103.8	68.6	58.9	45.0	43.8
	N	9	9	9	9	9	9	9	9
	Std. Deviation	25.5	30.5	45.5	50.4	38.9	28.0	26.7	25.2
	CV	0.15	0.19	0.40	0.49	0.57	0.48	0.59	0.58
3 mm Screed (SP1)	Mean	246.1	214.1	184.3	174.4	129.4	109.5	75.8	72.0
	N	9	9	9	9	9	9	9	9
	Std. Deviation	23.6	24.8	79.7	64.8	62.7	46.7	36.8	35.3
	CV	0.10	0.12	0.43	0.37	0.49	0.43	0.49	0.49
1 mm Cold Plastic (SP4)	Mean	217.3	198.8	156.7	146.7	92.3	82.4	61.9	58.5
	N	9	9	9	9	9	9	9	9
	Std. Deviation	72.8	54.7	91.9	85.2	60.3	52.0	40.5	38.4
	CV	0.36	0.28	0.59	0.58	0.65	0.63	0.66	0.66

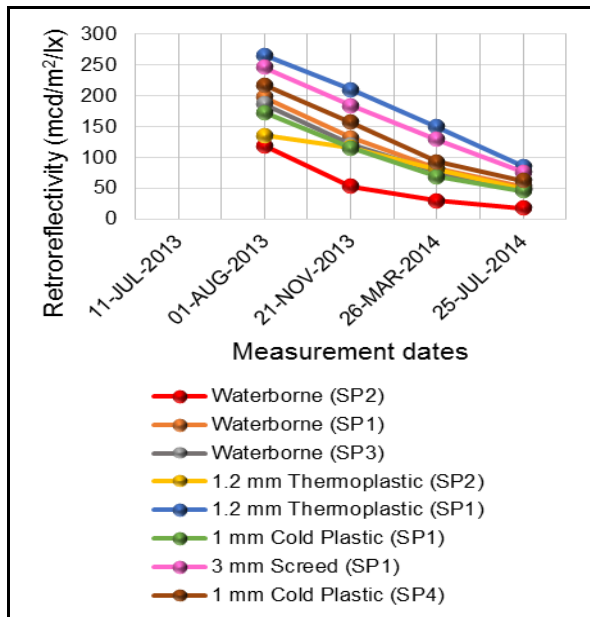

Figure A.25: Unwashed white transverse markings on Doreen Street (B's 1, 2 & 3).

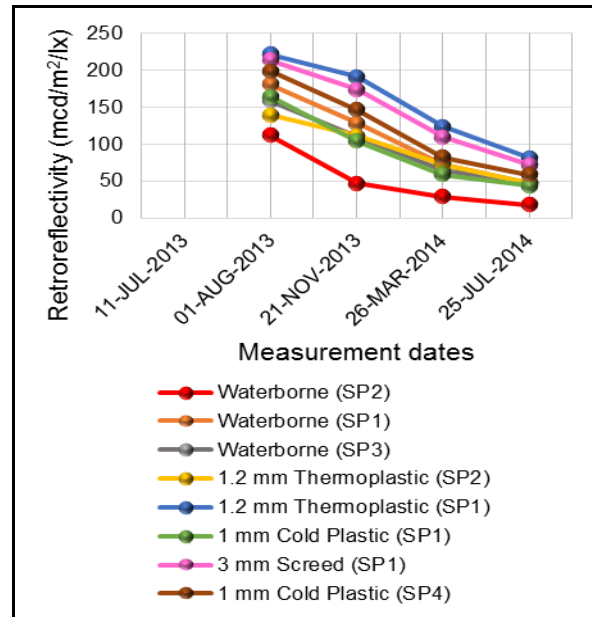

Figure A.26: Washed white transverse markings on Doreen Street (B's 1, 2 & 3).

Table A.14: Summary of yellow transverse markings on newly established clean chip seal road (Doreen Street - B's 1, 2 & 3).

Type of road marking paint / material		01-Aug-2013		21-Nov-2013		26-Mar-2014		25-Jul-2014	
		Unwashed	Washed	Unwashed	Washed	Unwashed	Washed	Unwashed	Washed
Waterborne (SP2)	Mean	84.3	74.6	34.3	33.5	22.6	22.6	17.0	18.0
	N	9	9	9	9	9	9	6	6
	Std. Deviation	18.7	7.0	8.3	11.9	8.9	7.3	2.2	5.2
	CV	0.22	0.10	0.24	0.36	0.39	0.33	0.13	0.29
Waterborne (SP1)	Mean	144.7	129.9	75.2	77.3	42.6	40.9	36.6	32.3
	N	9	9	9	9	9	9	6	6
	Std. Deviation	23.2	15.9	17.1	17.0	21.9	19.6	7.5	7.2
	CV	0.16	0.12	0.23	0.22	0.52	0.48	0.20	0.22
Waterborne (SP3)	Mean	112.1	100.9	62.0	65.5	41.3	39.6	26.0	27.9
	N	9	9	9	9	9	9	9	9
	Std. Deviation	15.6	18.0	12.3	13.6	18.7	16.1	11.7	11.8
	CV	0.14	0.18	0.20	0.21	0.45	0.41	0.45	0.42
1.2 mm Thermoplastic (SP2)	Mean	88.0	99.4	70.6	73.1	47.1	44.4	29.0	28.4
	N	9	9	9	9	9	9	9	9
	Std. Deviation	15.4	23.4	16.9	19.4	13.0	7.6	5.6	4.4
	CV	0.18	0.24	0.24	0.27	0.28	0.17	0.19	0.16
1.2 mm Thermoplastic (SP1)	Mean	107.6	104.3	62.0	64.5	47.1	42.5	27.1	26.6
	N	9	9	9	9	9	9	9	9
	Std. Deviation	22.1	17.9	13.6	19.7	19.8	13.5	10.6	8.2
	CV	0.21	0.17	0.22	0.31	0.42	0.32	0.39	0.31
1 mm Cold Plastic (SP1)	Mean	159.1	146.4	103.6	107.6	62.1	58.9	38.5	43.4
	N	9	9	9	9	9	9	9	9
	Std. Deviation	21.8	33.2	9.1	10.5	31.6	26.3	18.2	20.6
	CV	0.14	0.23	0.09	0.10	0.51	0.45	0.47	0.048
3 mm Screed (SP1)	Mean	138.3	130.7	86.9	94.6	63.8	53.7	36.4	33.3
	N	9	9	9	9	9	9	9	9
	Std. Deviation	9.8	16.3	19.4	20.7	30.9	20.8	17.5	14.1
	CV	0.07	0.13	0.22	0.22	0.49	0.39	0.48	0.42
1 mm Cold Plastic (SP4)	Mean	136.9	126.3	58.3	61.1	42.4	39.	28.8	27.1
	N	9	9	9	9	9	9	9	9
	Std. Deviation	28.5	25.3	15.0	17.6	20.4	16.6	14.2	12.0
	CV	0.21	0.20	0.26	0.29	0.48	0.42	0.49	0.45

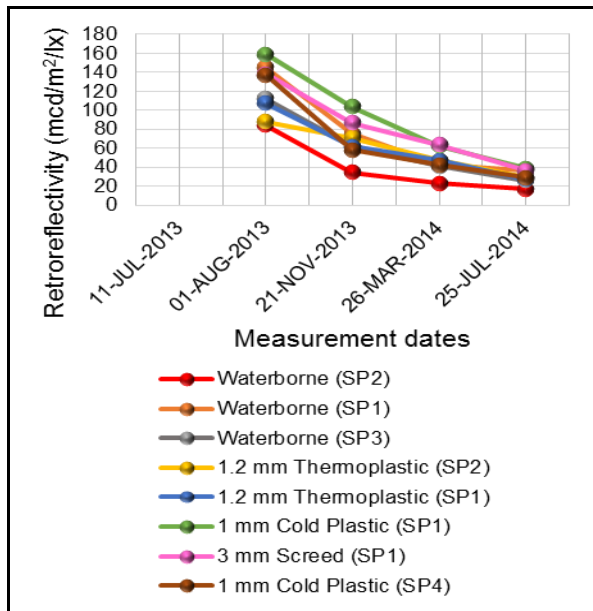

Figure A.27: Unwashed yellow transverse markings on Doreen Street (B's 1, 2 & 3).

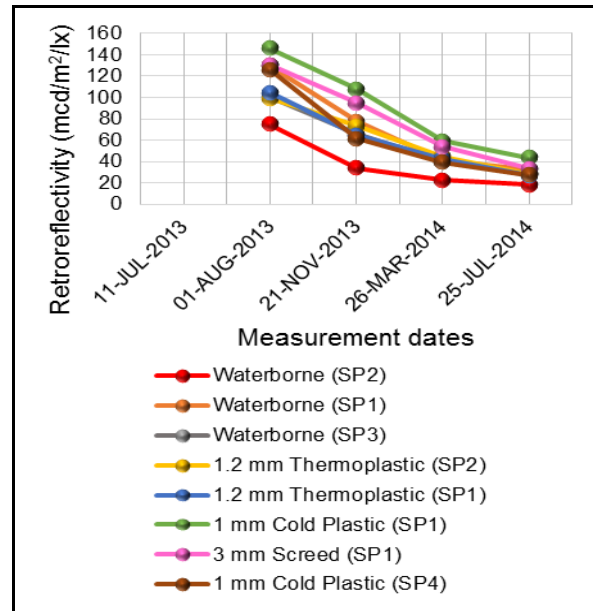

Figure A.28: Washed yellow transverse markings on Doreen Street (B's 1, 2 & 3).

Table A.15: Summary of longitudinal markings on newly established clean chip seal road (Doreen Street - B's 1, 2 & 3).

Type of road marking paint / material		01-Aug-2013		21-Nov-2013		26-Mar-2014		25-Jul-2014	
		White	Yellow	White	Yellow	White	Yellow	White	Yellow
Waterborne (SP2)	Mean	94.3	83.0	66.0	72.4	62.1	56.8	27.2	56.7
	N	3	3	2	3	2	3	2	3
	Std. Deviation	29.6	15.1	13.9	17.5	13.3	24.0	1.1	20.3
	CV	0.31	0.18	0.21	0.24	0.22	0.42	0.04	0.36
Waterborne (SP1)	Mean	173.5	139.1	151.1	116.8	67.1	106.2	78.6	89.6
	N	3	3	3	3	3	3	2	3
	Std. Deviation	57.3	69.3	77.0	54.9	33.2	56.3	4.1	32.2
	CV	0.33	0.50	0.51	0.47	0.50	0.53	0.05	0.36
1.2 mm Thermoplastic (SP2)	Mean	147.4	103.4	125.6	79.8	64.1	57.1	30.1	41.4
	N	3	3	3	3	3	3	3	3
	Std. Deviation	62.4	32.1	56.7	21.5	13.9	14.6	3.8	7.0
	CV	0.42	0.31	0.45	0.27	0.22	0.26	0.13	0.17
1.2 mm Thermoplastic (SP1)	Mean	277.2	179.8	195.4	144.1	141.5	122.8	74.1	117.5
	N	3	3	3	3	3	3	3	3
	Std. Deviation	59.1	44.6	42.6	14.1	30.0	7.2	48.1	13.8
	CV	0.21	0.25	0.22	0.10	0.21	0.06	0.65	0.12
3 mm Screed (SP1)	Mean	336.9	201.1	240.8	162.7	196.7	146.2	132.4	126.1
	N	3	3	3	3	3	3	3	3
	Std. Deviation	41.9	47.5	8.8	26.3	2.5	16.8	15.8	3.6
	CV	0.13	0.24	0.04	0.16	0.01	0.12	0.12	0.03

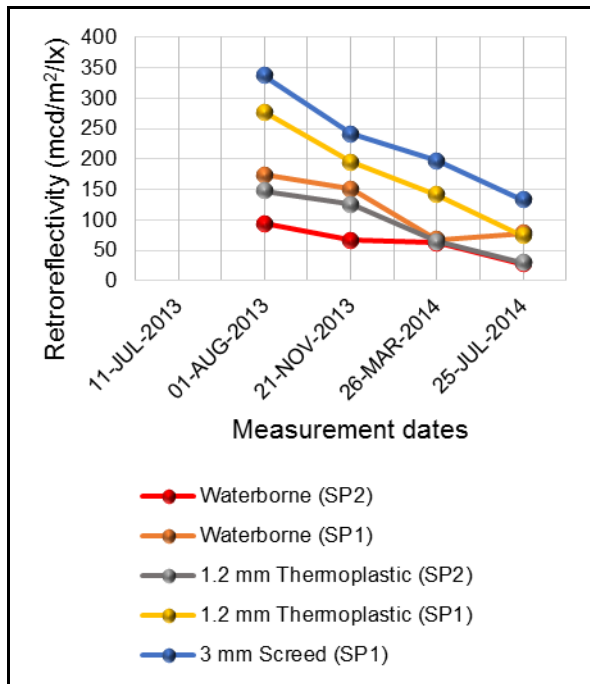

Figure A.29: Unwashed white longitudinal markings on Doreen Street (B's 1, 2 & 3).

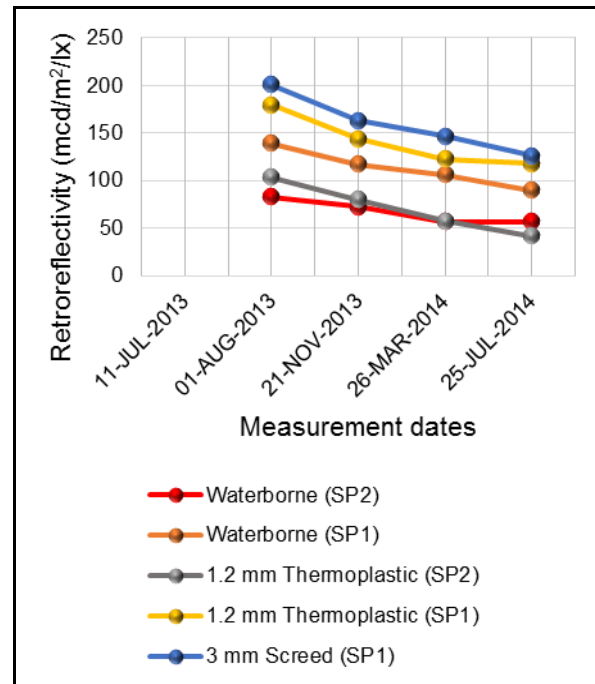

Figure A.30: Unwashed yellow longitudinal markings on Doreen Street (B's 1, 2 & 3).

Table A.16: Summary of white transverse markings on newly established dirty asphalt road (M 44).

Type of road marking paint / material		18-Sep-2013		17-Jan-2014		08-Apr-2014		14-Jul-2014	
		Unwashed	Washed	Unwashed	Washed	Unwashed	Washed	Unwashed	Washed
Waterborne (SP2)	Mean	90.1	96.9	55.3	50.4	32.5	32.8	15.8	18.1
	N	9	9	8	8	8	8	8	8
	Std. Deviation	48.1	45.7	38.4	46.1	24.4	27.3	8.0	8.7
	CV	0.54	0.47	0.69	0.91	0.75	0.83	0.51	0.48
Waterborne (SP1)	Mean	167.1	177.1	77.7	61.3	48.4	46.2	20.4	21.4
	N	9	9	8	8	8	8	7	7
	Std. Deviation	33.6	25.4	42.5	47.0	32.8	35.2	8.6	9.4
	CV	0.2	0.14	0.55	0.77	0.68	0.76	0.42	0.44
Waterborne (SP3)	Mean	87.4	86.6	37.0	33.0	24.6	21.7	15.1	15.3
	N	9	9	8	8	8	8	8	8
	Std. Deviation	44.8	48.7	21.9	28.1	15.8	14.5	6.0	5.6
	CV	0.51	0.56	0.59	0.85	0.64	0.67	0.40	0.37
1.2 mm Thermoplastic (SP2)	Mean	124.7	131.9	78.9	64.1	67.2	59.1	34.7	35.2
	N	9	9	8	8	7	7	7	7
	Std. Deviation	25.6	19.5	35.9	39.5	25.4	27.2	9.5	11.2
	CV	0.52	0.15	0.46	0.62	0.38	0.46	0.28	0.32
1.2 mm Thermoplastic (SP1)	Mean	171.7	180.5	101.6	75.5	76.1	68.5	36.0	38.1
	N	9	9	8	8	8	8	8	8
	Std. Deviation	24.8	19.8	49.3	46.6	37.3	37.5	16.8	15.3
	CV	0.15	0.11	0.49	0.62	0.49	0.55	0.47	0.40
1 mm Cold Plastic (SP2)	Mean	108.3	111.0	66.6	46.3	45.6	40.0	25.6	25.8
	N	9	9	8	8	8	8	8	8
	Std. Deviation	19.8	12.5	27.6	23.3	15.9	14.2	9.2	7.2
	CV	0.18	0.11	0.42	0.50	0.35	0.36	0.36	0.28
1 mm Cold Plastic (SP1)	Mean	121.2	124.4	91.6	70.9	53.9	49.7	27.7	29.7
	N	9	9	8	8	9	9	8	8
	Std. Deviation	15.9	13.4	46.7	44.5	37.6	37.8	17.5	17.4
	CV	0.13	0.11	0.51	0.63	0.70	0.76	0.63	0.59
3 mm Screed (SP1)	Mean	171.1	181.5	105.0	78.3	88.2	80.7	40.7	35.6
	N	9	9	8	8	8	8	8	8
	Std. Deviation	24.8	24.6	49.4	45.7	40.5	44.6	21.8	12.0
	CV	0.15	0.14	0.47	0.59	0.46	0.55	0.54	0.34

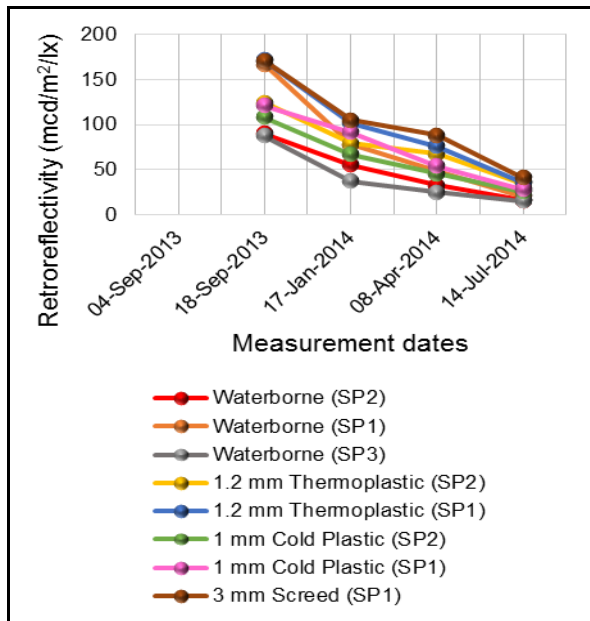

Figure A.31: Unwashed white transverse markings on M 44.

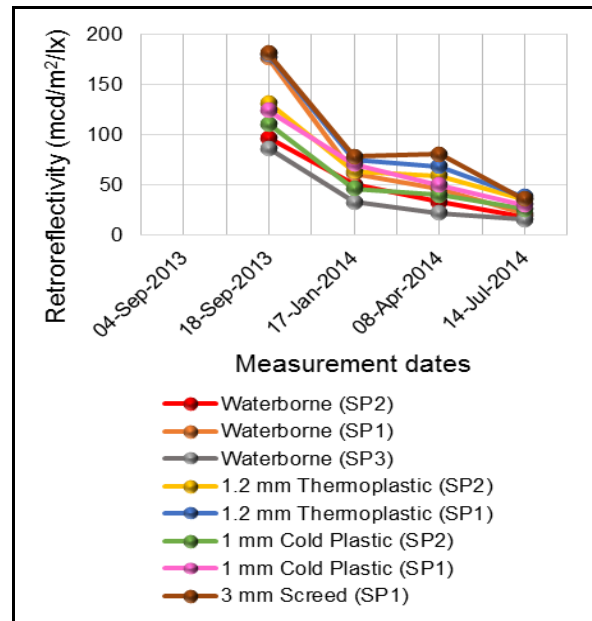

Figure A.32: Washed white transverse markings on M 44.

Table A.17: Summary of yellow transverse markings on newly established dirty asphalt road (M 44).

Type of road marking paint / material		18-Sep-2013		17-Jan-2014		08-Apr-2014		14-Jul-2014	
		Unwashed	Washed	Unwashed	Washed	Unwashed	Washed	Unwashed	Washed
Waterborne (SP2)	Mean	53.6	47.3	27.3	21.3	16.3	13.9	11.6	12.4
	N	9	9	7	7	7	7	7	7
	Std. Deviation	9.6	14.2	10.2	11.0	6.5	4.1	3.0	1.8
	CV	0.18	0.30	0.38	0.52	0.40	0.29	0.26	0.15
Waterborne (SP1)	Mean	120.8	115.4	65.4	49.6	29.2	29.0	18.7	17.7
	N	9	9	7	7	7	7	7	7
	Std. Deviation	15.5	21.4	25.4	30.1	11.3	14.8	9.9	5.7
	CV	0.13	0.19	0.39	0.61	0.38	0.51	0.53	0.32
Waterborne (SP3)	Mean	63.0	68.7	10.1	6.8	8.3	8.1	8.3	9.2
	N	3	3	1	1	1	1	1	1
	Std. Deviation	10.5	5.4	0.0	0.0	0.0	0.0	0.0	0.0
	CV	0.17	0.08	0.00	0.00	0.00	0.00	0.00	0.00
1.2 mm Thermoplastic (SP2)	Mean	101.1	93.6	56.7	39.1	52.3	41.1	31.8	26.2
	N	9	9	6	6	6	6	5	5
	Std. Deviation	15.0	27.0	16.8	5.1	11.6	9.0	10.0	7.7
	CV	0.15	0.29	0.30	0.13	0.22	0.22	0.32	0.30
1.2 mm Thermoplastic (SP1)	Mean	94.8	88.4	64.5	48.1	56.5	39.0	26.0	23.0
	N	9	9	7	7	7	7	6	6
	Std. Deviation	13.9	22.1	21.1	25.6	26.5	12.5	7.9	3.0
	CV	0.15	0.25	0.32	0.53	0.47	0.32	0.31	0.13
1 mm Cold Plastic (SP1)	Mean	102.1	94.6	59.4	44.9	42.7	26.7	18.9	18.2
	N	9	9	9	9	9	9	8	8
	Std. Deviation	14.1	18.9	36.0	32.2	32.2	15.5	9.4	6.1
	CV	0.14	0.20	0.61	0.72	0.75	0.58	0.50	0.34
3 mm Screed (SP1)	Mean	99.5	87.6	66.3	48.4	59.8	41.6	26.6	25.7
	N	9	9	7	7	7	7	6	6
	Std. Deviation	9.1	26.2	21.5	26.7	28.2	11.0	7.3	5.9
	CV	0.09	0.30	0.32	0.55	0.47	0.27	0.27	0.23

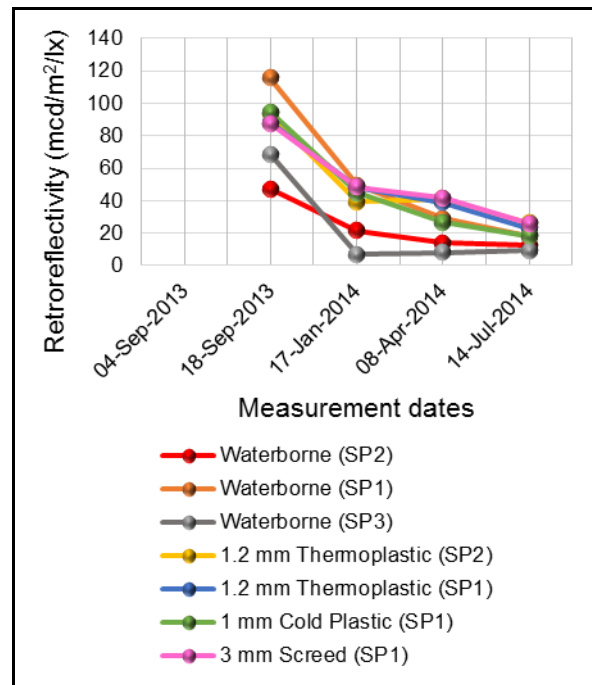
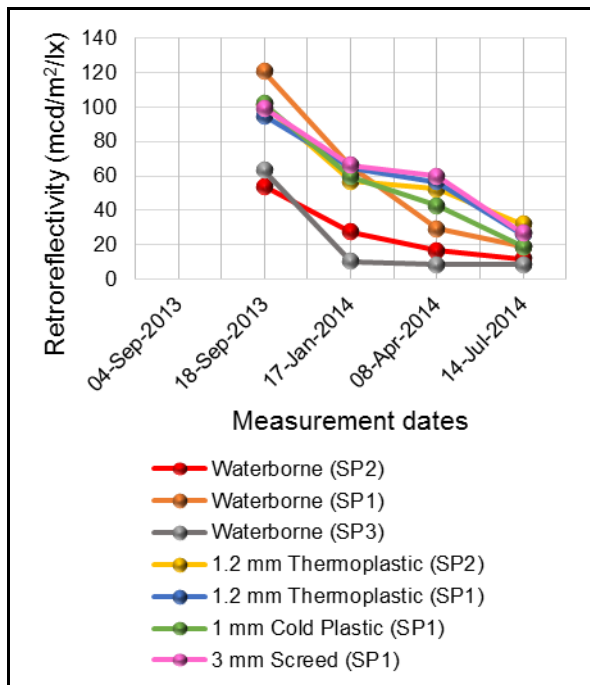

Figure A.33: Unwashed yellow transverse markings on M 44.

Figure A.34: Washed yellow transverse markings on M 44.

Table A.18: Summary of longitudinal markings on newly established dirty asphalt road (M 44).

Type of road marking paint / material		18-Sep-2013		17-Jan-2014		08-Apr-2014		14-Jul-2014	
		White	Yellow	White	Yellow	White	Yellow	White	Yellow
Waterborne (SP2)	Mean	121.4	105.7	101.0	55.0	43.3	24.5	31.5	17.7
	N	2	2	2	2	2	2	2	2
	Std. Deviation	16.1	5.1	23.9	3.6	21.5	9.4	11.5	6.6
	CV	0.13	0.05	0.24	0.07	0.50	0.38	0.37	0.38
Waterborne (SP1)	Mean	127.5	97.3	92.7	57.1	39.1	35.6	27.1	19.0
	N	2	2	2	2	2	2	2	2
	Std. Deviation	16.7	0.3	38.1	8.5	20.4	21.8	13.1	9.1
	CV	0.13	0.00	0.41	0.15	0.52	0.61	0.49	0.48
1.2 mm Thermoplastic (SP2)	Mean	254.8	81.5	78.3	45.9	48.7	28.5	28.2	19.0
	N	2	2	2	2	2	2	2	2
	Std. Deviation	35.0	12.2	55.5	6.0	7.7	16.8	5.3	7.3
	CV	0.14	0.15	0.71	0.13	0.16	0.59	0.19	0.38
1.2 mm Thermoplastic (SP1)	Mean	236.2	84.1	166.3	47.6	103.5	35.1	37.5	19.5
	N	2	2	2	2	2	2	2	2
	Std. Deviation	36.2	3.2	56.5	12.5	7.4	0.4	11.2	1.1
	CV	0.15	0.04	0.34	0.36	0.07	0.01	0.30	0.06
3 mm Screed (SP1)	Mean	250.4	139.9	139.4	73.7	96.3	44.8	49.8	23.2
	N	2	2	2	2	2	2	2	2
	Std. Deviation	56.0	3.2	85.0	13.7	74.7	5.5	31.1	7.7
	CV	0.22	0.02	0.61	0.19	0.78	0.12	0.62	0.33

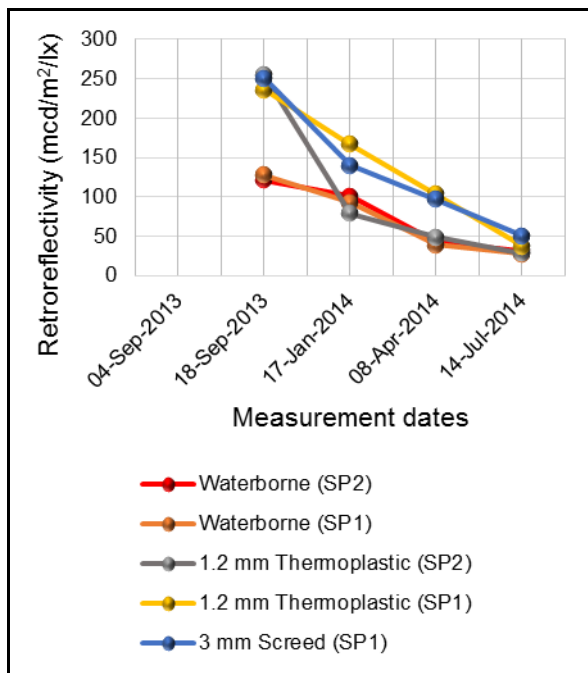

Figure A.35: Unwashed white longitudinal markings on M 44.

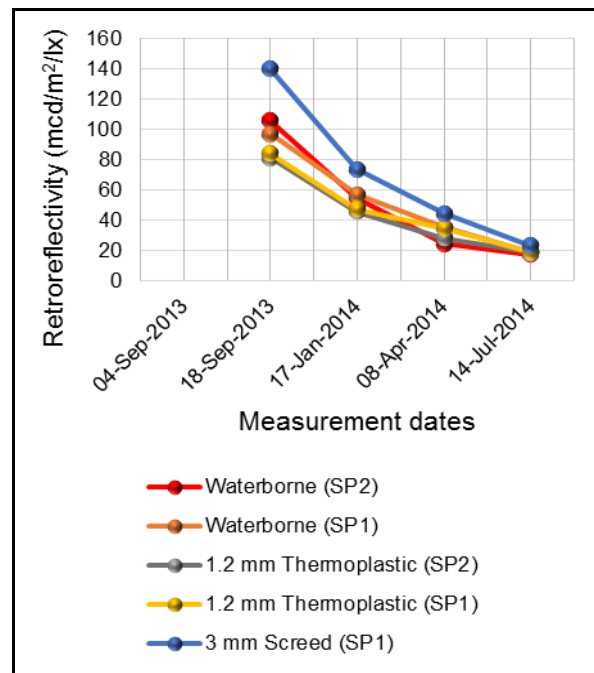

Figure A.36: Unwashed yellow longitudinal markings on M 44.

Table A.19: Summary of white transverse markings on long established asphalt road in the CBD (Madiba Street).

Type of road marking paint / material		25-Sep-2013		20-Jan-2014		10-Apr-2014		01-Aug-2014	
		Unwashed	Washed	Unwashed	Washed	Unwashed	Washed	Unwashed	Washed
Waterborne (SP2)	Mean	129.2	131.7	111.6	116.6	69.5	74.4	37.1	39.9
	N	6	6	5	5	5	5	5	5
	Std. Deviation	15.2	9.6	1.3	2.7	7.0	7.7	5.5	5.1
	CV	0.12	0.07	0.01	0.02	0.10	0.10	0.15	0.13
Waterborne (SP1)	Mean	206.1	213.3	125.8	130.6				
	N	6	6	2	2				
	Std. Deviation	9.5	6.8	2.1	7.6				
	CV	0.05	0.03	0.01	0.06				
Waterborne (SP3)	Mean	132.0	134.3	113.7	116.5	70.1	73.9	41.2	39.8
	N	6	6	5	5	5	5	5	5
	Std. Deviation	8.0	7.3	2.6	5.2	11.2	8.1	6.5	4.1
	CV	0.06	0.06	0.02	0.04	0.16	0.11	0.16	0.10
1.2 mm Thermoplastic (SP2)	Mean	134.9	141.6	79.1	81.9	58.2	63.6	39.7	38.8
	N	6	6	5	5	5	5	5	5
	Std. Deviation	14.1	4.0	12.0	6.8	7.4	3.3	8.16	5.8
	CV	0.11	0.03	0.15	0.08	0.13	0.05	0.21	0.15
1.2 mm Thermoplastic (SP1)	Mean	249.3	248.9	145.2	148.9	100.2	108.9	58.7	56.5
	N	6	6	5	5	5	5	5	5
	Std. Deviation	14.0	5.8	26.9	26.8	22.1	18.7	13.5	11.0
	CV	0.06	0.02	0.19	0.18	0.22	0.17	0.23	0.20
1 mm Cold Plastic (SP2)	Mean	170.1	168.2	158.4	160.4	111.4	113.0	56.9	56.0
	N	6	6	5	5	5	5	5	5
	Std. Deviation	11.0	8.2	8.5	6.6	15.8	10.0	6.4	7.5
	CV	0.07	0.05	0.05	0.04	0.14	0.09	0.11	0.14
1 mm Cold Plastic (SP1)	Mean	256.0	261.7	230.6	233.4	127.9	134.2	70.0	69.6
	N	6	6	5	5	5	5	5	5
	Std. Deviation	29.4	24.0	14.4	10.2	12.6	10.1	16.4	15.4
	CV	0.12	0.09	0.06	0.04	0.10	0.08	0.23	0.22
3 mm Screed (SP1)	Mean	257.4	259.9	150.6	155.3	108.0	106.2	52.8	53.8
	N	6	6	5	5	5	5	5	5
	Std. Deviation	11.6	9.3	23.1	15.7	20.9	17.8	11.1	10.5
	CV	0.04	0.04	0.15	0.10	0.19	0.17	0.21	0.20

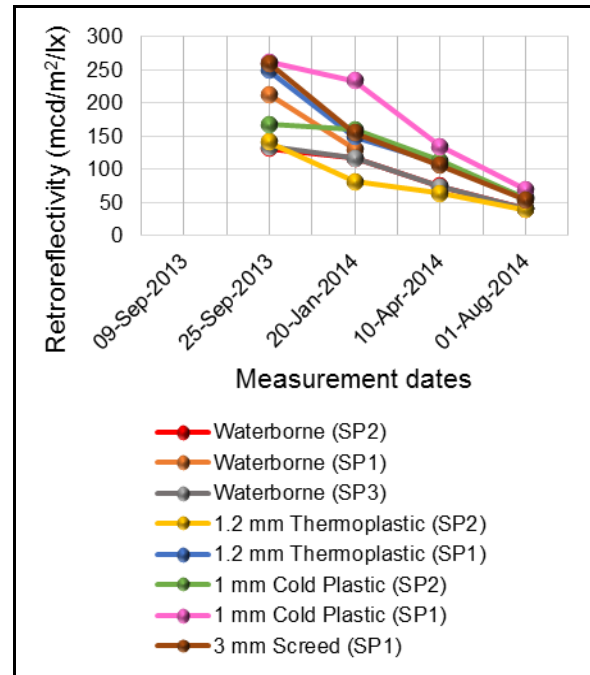
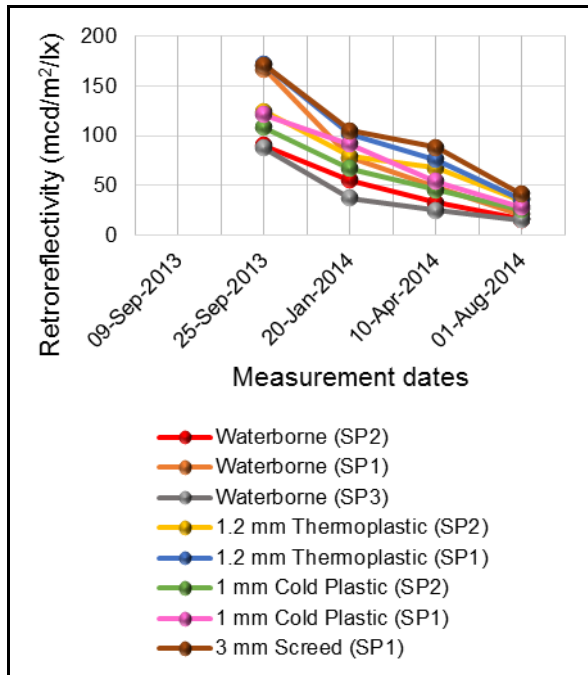

Figure A.37: Unwashed white transverse markings on Madiba Street.

Figure A.38: Washed white transverse markings on Madiba Street.

Table A.20: Summary of yellow transverse markings on long established asphalt road (Madiba Street).

Type of road marking paint / material		25-Sep-2013		20-Jan-2014		10-Apr-2014		01-Aug-2014	
		Unwashed	Washed	Unwashed	Washed	Unwashed	Washed	Unwashed	Washed
Waterborne (SP2)	Mean	82.9	87.2	62.5	69.6	36.8	36.0	21.8	21.7
	N	6	6	5	5	5	5	5	5
	Std. Deviation	2.7	4.1	7.3	1.9	7.4	3.1	4.9	5.4
	CV	0.03	0.05	0.12	0.03	0.20	0.09	0.22	0.24
Waterborne (SP1)	Mean	143.0	140.6	128.9	125.5	78.5	73.7	44.7	43.1
	N	6	6	5	5	5	5	5	5
	Std. Deviation	4.5	7.0	3.7	7.8	8.7	7.6	9.1	7.2
	CV	0.03	0.05	0.03	0.06	0.11	0.10	0.21	0.17
Waterborne (SP3)	Mean	78.1	83.0	66.7	72.0	47.1	48.2	27.2	26.3
	N	6	6	5	5	5	5	5	5
	Std. Deviation	6.7	7.2	10.9	5.1	10.4	5.8	5.9	6.4
	CV	0.09	0.09	0.16	0.07	0.22	0.12	0.22	0.25
1.2 mm Thermoplastic (SP2)	Mean	108.7	112.4	61.8	66.8	62.8	67.8	40.8	41.7
	N	6	6	5	5	5	5	5	5
	Std. Deviation	3.0	5.7	10.1	5.8	8.0	3.4	8.7	5.3
	CV	0.03	0.05	0.16	0.09	0.12	0.05	0.21	0.13
1.2 mm Thermoplastic (SP1)	Mean	123.4	127.3	89.4	100.3	66.2	65.8	33.7	36.1
	N	6	6	5	5	5	5	5	5
	Std. Deviation	5.9	4.9	8.4	9.8	13.4	13.0	4.4	8.5
	CV	0.05	0.04	0.09	0.1	0.20	0.20	0.13	0.24
1 mm Cold Plastic (SP1)	Mean	173.0	174.4	133.0	133.3	81.8	82.7	44.3	37.5
	N	6	6	5	5	5	5	5	5
	Std. Deviation	7.2	8.5	6.2	5.3	16.4	18.2	13.4	9.6
	CV	0.04	0.05	0.05	0.04	0.20	0.22	0.30	0.26
3 mm Screed (SP1)	Mean	119.4	124.9	84.2	94.3	66.1	66.7	36.8	32.6
	N	6	6	5	5	5	5	5	5
	Std. Deviation	4.3	4.4	12.0	14.2	12.2	12.2	3.7	7.3
	CV	0.04	0.04	0.14	0.15	0.19	0.19	0.10	0.22

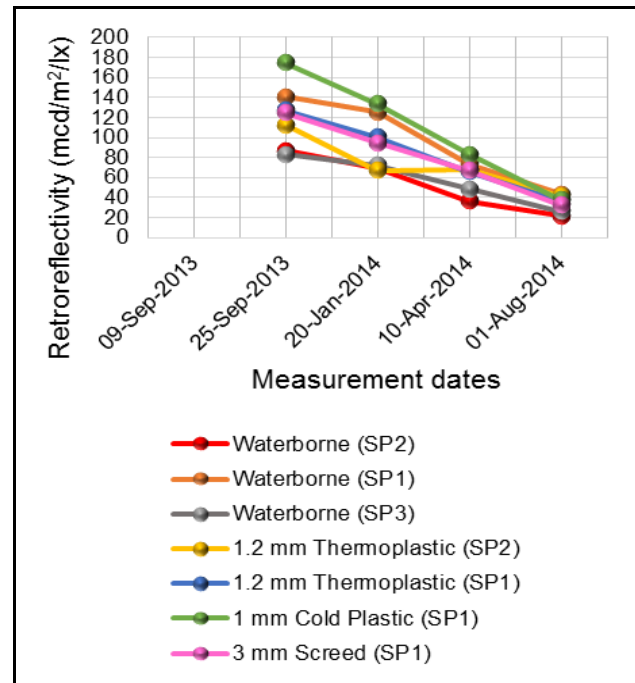
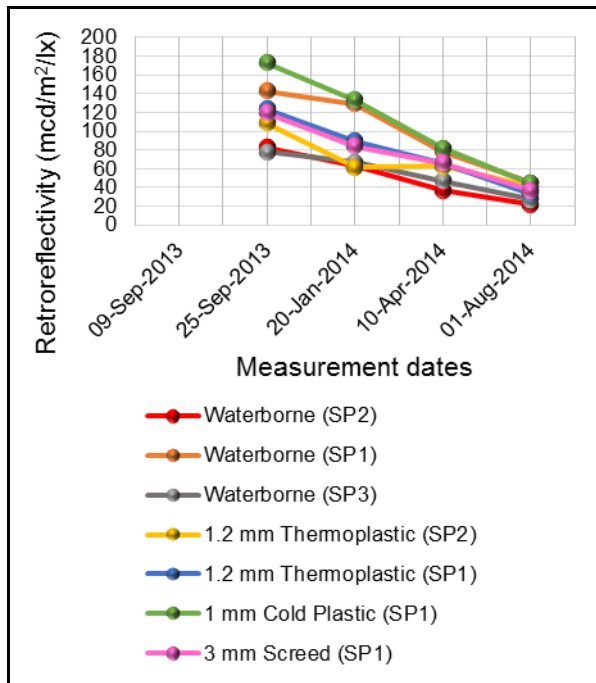

Figure A.39: Unwashed yellow transverse markings on Madiba Street.

Figure A.40: Washed yellow transverse markings on Madiba Street.

Table A.21: Summary of white transverse markings on newly established clean asphalt road (Meiring Naude Road).

Type of road marking paint / material		03-Jul-2013		23-Oct-2013		18-Mar-2014		16-Jul-2014	
		Unwashed	Washed	Unwashed	Washed	Unwashed	Washed	Unwashed	Washed
Waterborne (SP2)	Mean	157.5	145.2	128.9	117.3	71.7	63.6	32.9	45.2
	N	9	9	9	9	9	9	9	9
	Std. Deviation	29.8	26.3	25.8	28.4	16.9	21.3	19.8	12.0
	CV	0.19	0.18	0.20	0.24	0.24	0.34	0.60	0.26
Waterborne (SP1)	Mean	221.9	191.7	148.9	145.1	85.6	69.0	54.6	55.6
	N	9	9	9	9	9	9	9	9
	Std. Deviation	43.7	27.7	20.0	18.45	12.1	21.9	13.7	10.3
	CV	0.20	0.15	0.13	0.13	0.14	0.32	0.25	0.19
Waterborne (SP3)	Mean	179.2	177.9	135.5	118.6	69.9	62.1	34.5	44.9
	N	9	9	9	9	9	9	9	9
	Std. Deviation	27.7	31.5	20.4	34.4	18.5	24.6	18.7	13.7
	CV	0.16	0.18	0.15	0.29	0.27	0.40	0.54	0.31
1.2 mm Thermoplastic (SP2)	Mean	144.9	142.0	115.9	106.0	75.8	60.6	53.3	56.0
	N	9	9	9	9	9	9	9	9
	Std. Deviation	36.9	38.2	14.0	13.9	5.2	8.9	8.6	8.1
	CV	0.26	0.27	0.12	0.13	0.07	0.15	0.16	0.15
1.2 mm Thermoplastic (SP1)	Mean	361.7	336.3	246.0	236.0	130.5	104.7	96.4	95.4
	N	9	9	9	9	9	9	9	9
	Std. Deviation	26.6	47.6	19.9	27.6	30.9	12.8	17.5	12.6
	CV	0.07	0.14	0.08	0.12	0.24	0.12	0.18	0.13
1 mm Cold Plastic (SP1)	Mean	210.7	212.0	168.6	170.2	110.0	97.1	74.2	84.5
	N	9	9	9	9	9	9	9	9
	Std. Deviation	56.1	46.9	33.8	39.2	11.5	19.8	15.9	17.2
	CV	0.27	0.22	0.20	0.23	0.11	0.20	0.22	0.20
3 mm Screed (SP1)	Mean	374.7	350.6	265.2	265.7	143.0	109.7	106.3	105.6
	N	9	9	9	9	9	9	9	9
	Std. Deviation	36.8	24.8	22.5	19.1	25.4	21.0	24.7	11.1
	CV	0.10	0.07	0.09	0.07	0.18	0.19	0.23	0.11
1 mm Cold Plastic (SP4)	Mean	207.8	173.4	138.5	140.6	74.9	62.9	48.4	51.1
	N	9	9	9	9	9	9	9	9
	Std. Deviation	30.5	27.2	18.9	11.1	15.9	14.2	12.6	5.5
	CV	0.15	0.16	0.14	0.08	0.21	0.23	0.26	0.11

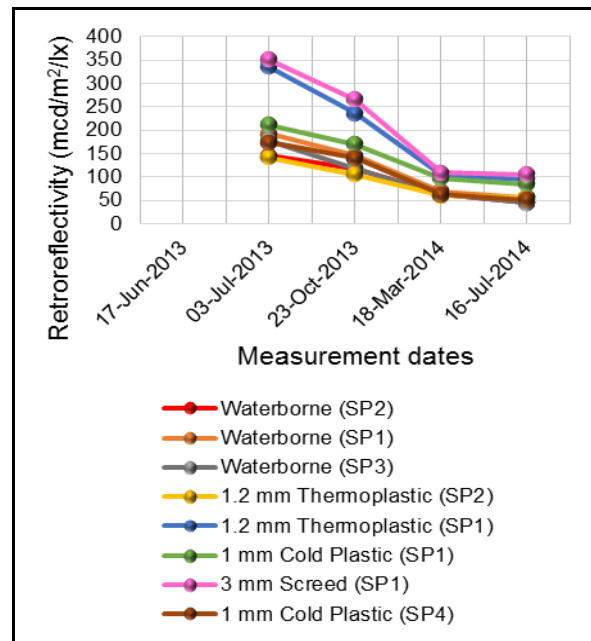
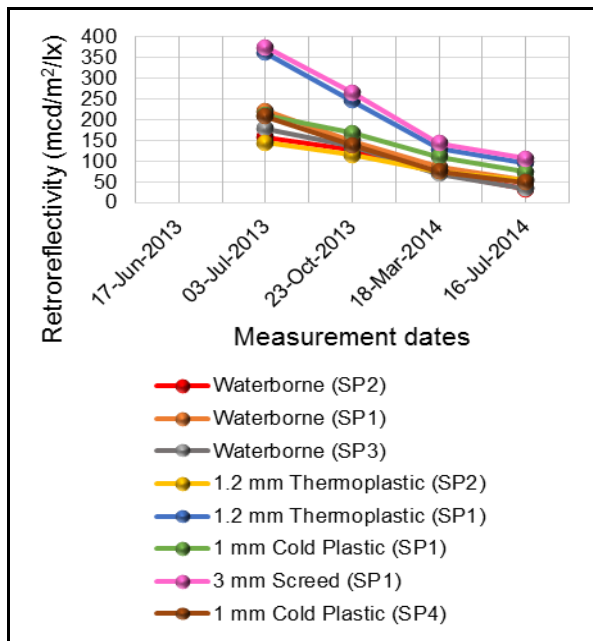

Figure A.41: Unwashed white transverse markings on Meiring Naude Road.

Figure A.42: Washed white transverse markings on Meiring Naude Road.

Table A.22: Summary of yellow transverse markings on newly established clean asphalt road (Meiring Naude Road).

Type of road marking paint / material		03-Jul-2013		23-Oct-2013		18-Mar-2014		16-Jul-2014	
		Unwashed	Washed	Unwashed	Washed	Unwashed	Washed	Unwashed	Washed
Waterborne (SP2)	Mean	102.8	95.1	86.1	85.3	56.6	57.5	33.1	42.5
	N	9	9	9	9	9	9	9	9
	Std. Deviation	17.8	14.1	13.7	14.6	10.2	5.4	16.2	9.2
	CV	0.17	0.15	0.16	0.17	0.18	0.10	0.49	0.22
Waterborne (SP1)	Mean	150.0	143.1	121.6	117.4	70.5	66.0	44.3	56.0
	N	9	9	9	9	9	9	9	9
	Std. Deviation	20.5	20.2	12.6	9.5	8.0	7.4	14.0	6.8
	CV	0.14	0.14	0.10	0.08	0.11	0.11	0.32	0.12
Waterborne (SP3)	Mean	106.7	100.9	96.8	94.6	60.6	59.2	37.3	46.8
	N	9	9	9	9	9	9	9	9
	Std. Deviation	10.1	25.1	10.8	8.2	5.8	4.0	18.3	3.3
	CV	0.10	0.25	0.11	0.09	0.10	0.07	0.49	0.07
1.2 mm Thermoplastic (SP2)	Mean	110.9	110.6	98.1	94.7	71.2	62.6	49.8	51.7
	N	9	9	9	9	9	9	9	9
	Std. Deviation	8.3	8.7	7.2	14.3	4.0	11.9	8.9	8.6
	CV	0.08	0.08	0.07	0.15	0.06	0.19	0.18	0.17
1.2 mm Thermoplastic (SP1)	Mean	183.9	166.7	126.7	113.2	93.9	80.4	55.6	60.9
	N	9	9	9	9	9	9	9	9
	Std. Deviation	31.4	27.7	38.3	15.9	10.4	17.8	15.9	13.2
	CV	0.17	0.17	0.3	0.14	0.11	0.22	0.28	0.22
1 mm Cold Plastic (SP1)	Mean	140.8	132.8	125.0	117.4	80.6	70.5	56.2	56.4
	N	9	9	9	9	9	9	9	9
	Std. Deviation	28.2	15.6	21.6	8.9	14.4	10.3	20.72	16.3
	CV	0.20	0.12	0.17	0.08	0.18	0.15	0.37	0.02
3 mm Screed (SP1)	Mean	195.6	185.5	125.4	115.5	94.8	68.0	56.4	59.9
	N	9	9	9	9	9	9	9	9
	Std. Deviation	33.3	25.2	16.3	11.6	15.8	15.5	16.8	9.9
	CV	0.17	0.14	0.13	0.10	0.17	0.23	0.30	0.17
1 mm Cold Plastic (SP4)	Mean	139.7	128.6	102.8	98.9	68.8	52.3	40.3	44.2
	N	9	9	9	9	9	9	9	9
	Std. Deviation	16.8	27.0	6.5	6.4	5.1	11.9	7.8	6.8
	CV	0.13	0.21	0.06	0.07	0.08	0.23	0.02	0.16

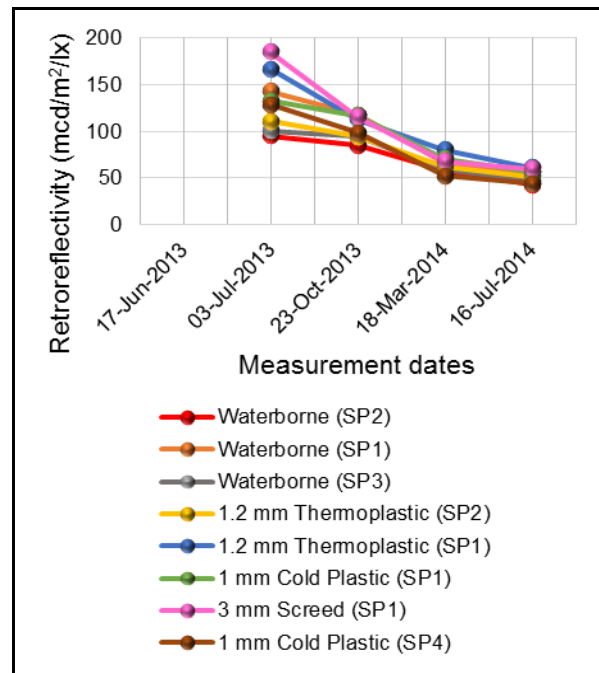
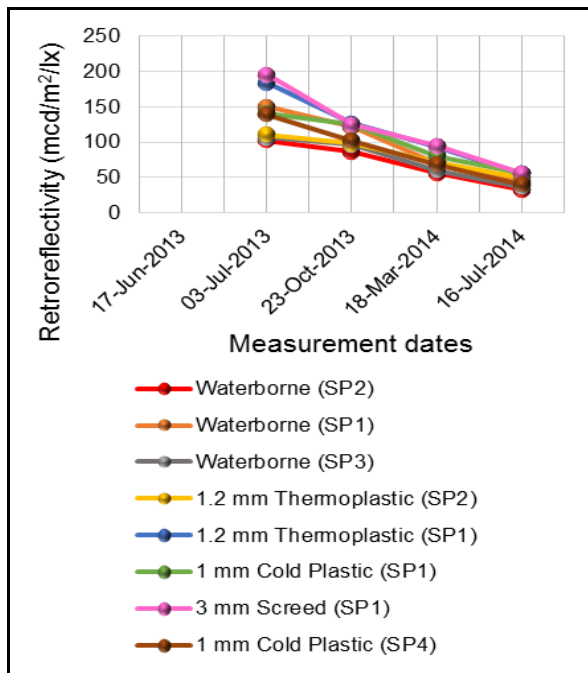

Figure A.43: Unwashed yellow transverse markings on Meiring Naude Road.

Figure A.44: Washed yellow transverse markings on Meiring Naude Road.

Table A.23: Summary of longitudinal markings on newly established clean asphalt road (Meiring Naude Road).

Type of road marking paint / material		03-Jul-2013		23-Oct-2013		18-Mar-2014		16-Jul-2014	
		White	Yellow	White	Yellow	White	Yellow	White	Yellow
Waterborne (SP2)	Mean	210.0	143.2	179.8	124.8	110.1	108.1	48.0	94.2
	N	3	3	3	3	3	3	3	3
	Std. Deviation	4.3	9.7	18.9	14.10	2.2	12.5	8.9	16.3
	CV	0.02	0.07	0.11	0.11	0.02	0.12	0.19	0.17
Waterborne (SP1)	Mean	223.6	195.7	172.5	166.9	118.7	143.8	69.7	112.7
	N	3	3	3	3	3	3	3	3
	Std. Deviation	8.2	17.0	6.1	14.6	3.1	22.4	33.8	34.2
	CV	0.04	0.09	0.04	0.09	0.03	0.16	0.49	0.30
1.2 mm Thermoplastic (SP2)	Mean	162.5	210.4	138.9	185.8	117.2	157.0	49.9	128.3
	N	3	3	3	3	3	3	3	3
	Std. Deviation	23.6	15.8	22.7	32.5	15.3	23.1	10.9	25.7
	CV	0.15	0.08	0.16	0.18	0.13	0.15	0.22	0.20
1.2 mm Thermoplastic (SP1)	Mean	314.2	230.6	260.0	197.4	161.6	161.9	101.7	148.3
	N	3	3	3	3	3	3	3	3
	Std. Deviation	80.7	14.2	55.8	12.9	16.3	21.7	51.7	28.1
	CV	0.26	0.06	0.22	0.07	0.10	0.13	0.51	0.19
3 mm Screed (SP1)	Mean	297.0	210.8	269.8	184.2	157.5	148.3	111.5	126.4
	N	3	3	3	3	3	3	3	3
	Std. Deviation	67.0	18.8	71.6	8.5	21.4	12.0	41.1	4.6
	CV	0.23	0.09	0.27	0.05	0.14	0.08	0.37	0.04

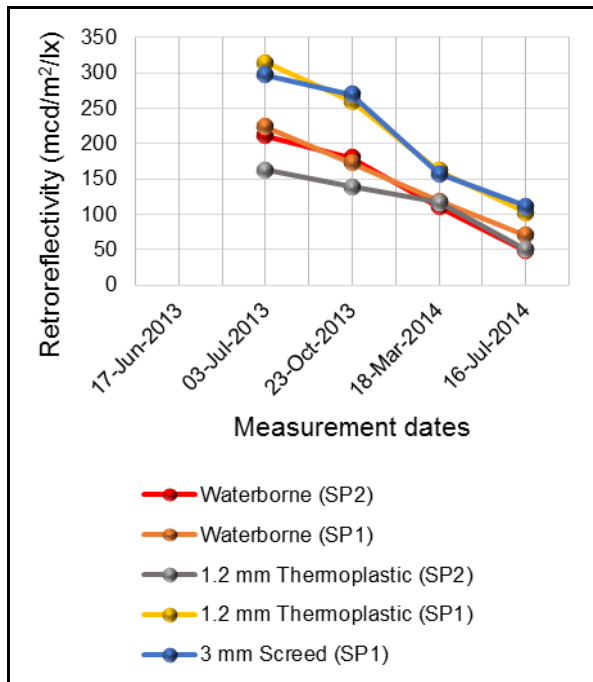

Figure A.45: Unwashed white longitudinal on Meiring Naude Road.

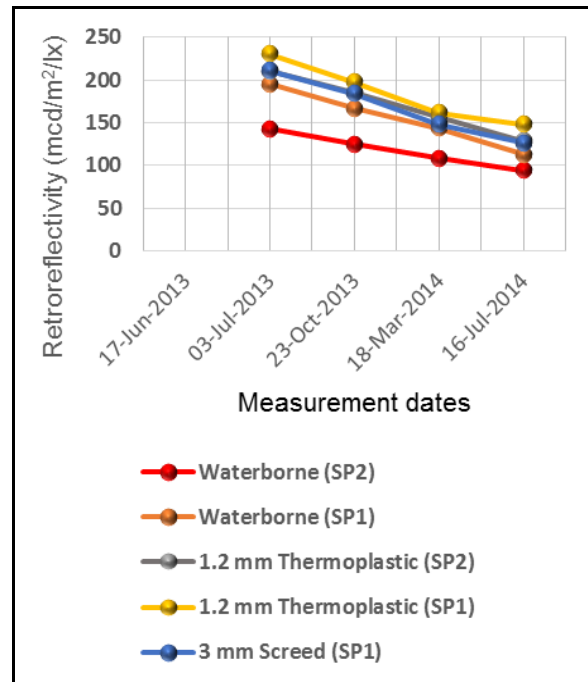

Figure A.46: Unwashed yellow longitudinal markings on Meiring Naude Road.

Table A.24: Summary of white transverse road markings on long established clean asphalt road (Middel Street).

Type of road marking paint / material		23-Jul-2013		05-Nov-2013		20-Mar-2014		29-Jul-2014	
		Unwashed	Washed	Unwashed	Washed	Unwashed	Washed	Unwashed	Washed
Waterborne (SP2)	Mean	215.2	196.3	175.3	176.3	151.8	149.5	136.4	138.4
	N	9	9	9	9	9	9	9	9
	Std. Deviation	37.6	35.7	28.5	28.3	30.8	18.0	23.7	14.0
	CV	0.18	0.18	0.16	0.16	0.20	0.12	0.17	0.10
Waterborne (SP1)	Mean	254.2	222.6	203.9	207.2	168.1	171.4	149.4	161.0
	N	9	9	9	9	9	9	9	9
	Std. Deviation	46.6	28.7	31.0	36.6	27.4	28.4	16.8	29.5
	CV	0.18	0.13	0.15	0.18	0.16	0.17	0.11	0.18
Waterborne (SP3)	Mean	220.5	202.3	170.9	173.0	147.2	152.5	128.3	128.7
	N	9	9	9	9	9	9	9	9
	Std. Deviation	31.0	21.6	19.2	17.5	22.7	14.7	18.1	16.2
	CV	0.14	0.11	0.11	0.10	0.15	0.10	0.14	0.13
1.2 mm Thermoplastic (SP2)	Mean	167.1	159.7	130.7	127.4	139.4	135.8	103.8	102.7
	N	9	9	9	9	9	9	9	9
	Std. Deviation	18.3	12.3	16.5	12.5	12.8	10.4	9.6	10.8
	CV	0.11	0.08	0.13	0.10	0.09	0.08	0.09	0.11
1.2 mm Thermoplastic (SP1)	Mean	352.2	294.5	285.7	273.6	285.9	270.1	213.6	223.0
	N	9	9	9	9	9	9	9	9
	Std. Deviation	57.9	79.7	53.7	44.6	69.4	52.0	48.2	30.0
	CV	0.17	0.27	0.18	0.16	0.24	0.19	0.23	0.14
1 mm Cold Plastic (SP1)	Mean	264.2	266.0	247.6	245.5	256.8	254.7	196.4	198.9
	N	9	9	9	9	9	9	9	9
	Std. Deviation	26.4	30.4	49.4	36.8	19.4	32.2	32.3	34.7
	CV	0.10	0.11	0.20	0.15	0.08	0.13	0.16	0.18
3 mm Screed (SP1)	Mean	370.4	304.6	285.2	292.9	308.2	291.1	223.0	227.7
	N	9	9	9	9	9	9	9	9
	Std. Deviation	46.7	55.3	49.0	25.9	50.4	37.8	40.0	43.6
	CV	0.12	0.18	0.17	0.08	0.16	0.13	0.18	0.19
1 mm Cold Plastic (SP4)	Mean	196.4	200.0	122.2	129.5	125.1	116.5	86.7	82.4
	N	9	9	9	9	9	9	9	9
	Std. Deviation	49.0	36.4	37.3	22.9	23.6	19.9	17.7	18.9
	CV	0.25	0.18	0.31	0.18	0.19	0.17	0.20	0.23

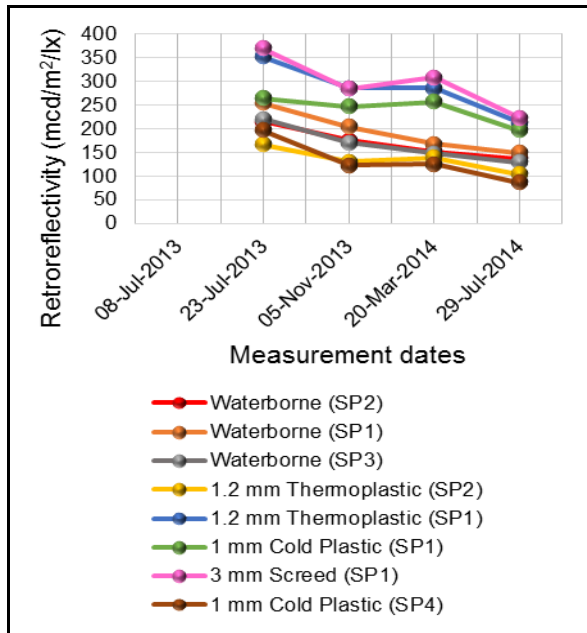

Figure A.47: Unwashed white transverse markings on Middel Street.

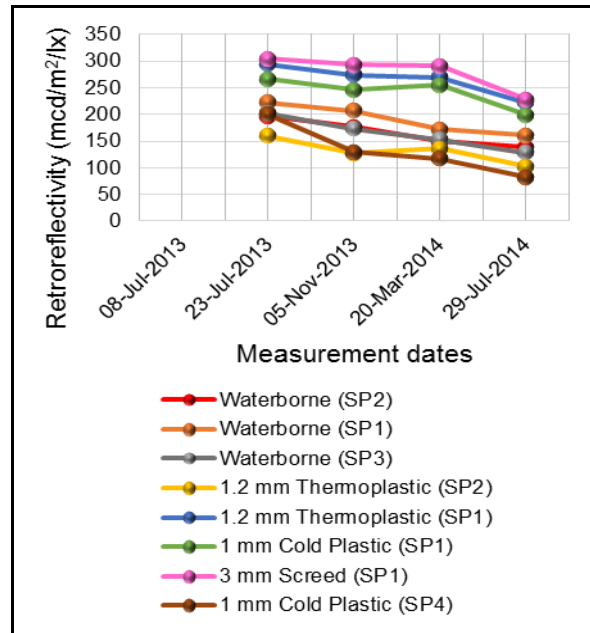

Figure A.48: Washed white transverse markings on Middel Street.

Table A.25: Summary of yellow transverse road markings on long established clean asphalt road (Middel Street).

Type of road marking paint / material		23-Jul-2013		05-Nov-2013		20-Mar-2014		29-Jul-2014	
		Unwashed	Washed	Unwashed	Washed	Unwashed	Washed	Unwashed	Washed
Waterborne (SP2)	Mean	107.6	114.6	96.7	100.6	92.7	90.1	78.8	80.5
	N	9	9	9	9	9	9	9	9
	Std. Deviation	11.9	11.5	14.7	9.2	13.6	14.0	14.4	12.0
	CV	0.11	0.10	0.15	0.09	0.15	0.16	0.18	0.15
Waterborne (SP1)	Mean	190.3	185.5	162.2	168.1	156.7	135.9	138.3	131.7
	N	9	9	9	9	9	9	9	9
	Std. Deviation	11.1	7.1	15.2	15.7	12.2	8.7	31.3	16.4
	CV	0.06	0.04	0.09	0.09	0.08	0.06	0.23	0.13
Waterborne (SP3)	Mean	148.2	138.9	128.0	131.9	118.7	110.6	101.0	104.5
	N	9	9	9	9	9	9	9	9
	Std. Deviation	21.7	8.2	13.8	11.8	19.8	14.9	22.3	11.3
	CV	0.15	0.06	0.11	0.09	0.17	0.14	0.22	0.11
1.2 mm Thermoplastic (SP2)	Mean	152.1	161.3	115.0	117.2	115.3	112.4	85.9	89.1
	N	9	9	9	9	9	9	9	9
	Std. Deviation	27.8	32.2	18.1	12.3	10.4	11.3	13.9	15.6
	CV	0.18	0.20	0.16	0.11	0.09	0.10	0.16	0.17
1.2 mm Thermoplastic (SP1)	Mean	187.2	198.1	144.5	130.0	141.5	136.0	104.5	105.2
	N	9	9	9	9	9	9	9	9
	Std. Deviation	25.2	39.2	14.2	14.2	23.7	22.4	19.3	16.9
	CV	0.14	0.20	0.10	0.11	0.17	0.17	0.19	0.16
1 mm Cold Plastic (SP1)	Mean	208.4	213.6	190.1	182.9	176.3	179.6	155.8	156.1
	N	9	9	9	9	9	9	9	9
	Std. Deviation	21.5	21.0	24.4	26.2	43.7	29.2	42.6	27.9
	CV	0.10	0.10	0.13	0.14	0.25	0.16	0.27	0.18
3 mm Screed (SP1)	Mean	203.4	216.2	168.3	157.7	172.6	156.8	125.2	129.3
	N	9	9	9	9	9	9	9	9
	Std. Deviation	30.6	20.5	36.8	24.0	36.6	17.8	21.4	25.0
	CV	0.15	0.10	0.22	0.15	0.21	0.11	0.17	0.19
1 mm Cold Plastic (SP4)	Mean	162.0	160.6	104.5	90.7	97.0	89.3	67.8	68.9
	N	9	9	9	9	9	9	9	9
	Std. Deviation	22.9	40.5	16.9	17.7	30.1	15.9	11.2	14.5
	CV	0.14	0.25	0.16	0.20	0.31	0.18	0.17	0.21

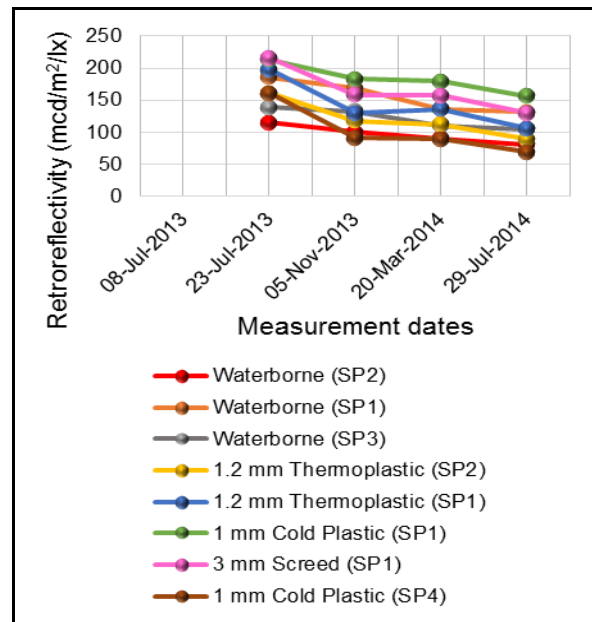
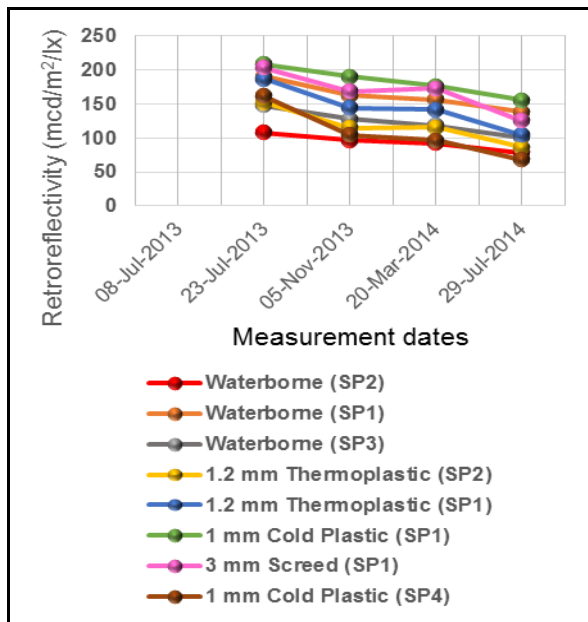

Figure A.49: Unwashed yellow transverse markings on Middel Street.

Figure A.50: Washed yellow transverse markings on Middel Street.

Table A.26: Summary of longitudinal markings on long established clean asphalt road (Middel Street).

Type of road marking paint / material		23-Jul-2013		05-Nov-2013		20-Mar-2014		29-Jul-2014	
		White	Yellow	White	Yellow	White	Yellow	White	Yellow
Waterborne (SP2)	Mean	143.4	130.8	118.1	109.2	84.8	90.8	65.7	75.9
	N	3	3	3	3	3	3	3	3
	Std. Deviation	3.1	1.8	1.1	6.2	24.6	6.2	29.7	11.8
	CV	0.02	0.01	0.01	0.06	0.29	0.07	0.45	0.16
Waterborne (SP1)	Mean	157.5	145.2	137.9	128.1	113.3	110.1	83.1	98.1
	N	3	3	3	3	3	3	3	3
	Std. Deviation	6.8	19.5	5.9	21.9	40.7	24.0	42.2	21.9
	CV	0.04	0.13	0.04	0.17	0.6	0.22	0.51	0.22
1.2 mm Thermoplastic (SP2)	Mean	238.8	165.7	213.6	149.7	191.8	136.4	169.2	125.8
	N	3	3	3	3	3	3	3	3
	Std. Deviation	12.5	45.4	30.1	45.9	25.0	42.5	9.6	35.8
	CV	0.05	0.27	0.14	0.31	0.13	0.31	0.06	0.29
1.2 mm Thermoplastic (SP1)	Mean	307.8	198.5	280.1	176.0	263.9	162.2	238.0	147.3
	N	3	3	3	3	3	3	3	3
	Std. Deviation	41.7	17.6	25.9	15.1	22.8	17.0	22.3	14.4
	CV	0.14	0.08	0.09	0.09	0.09	0.11	0.09	0.10
3 mm Screed (SP1)	Mean	384.1	176.9	353.4	153.2	337.3	140.8	314.4	125.4
	N	3	3	3	3	3	3	3	3
	Std. Deviation	49.7	29.8	60.6	17.2	68.8	17.7	73.3	11.5
	CV	0.13	0.17	0.17	0.11	0.20	0.13	0.23	0.09

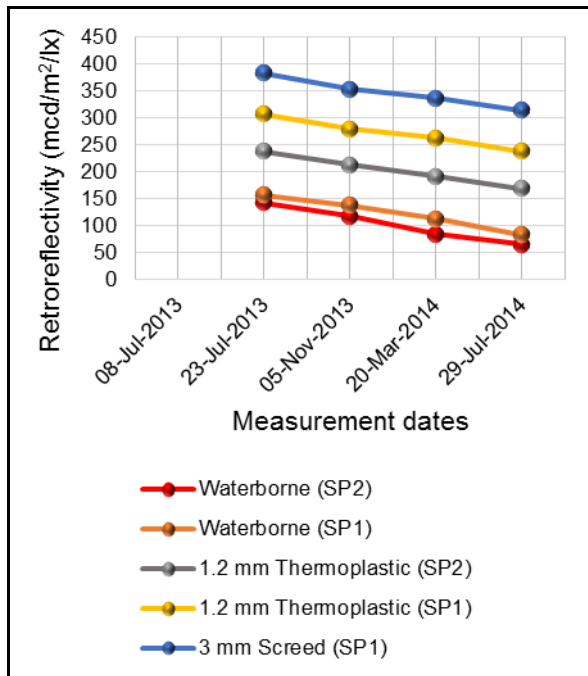

Figure A.51: Unwashed white longitudinal markings on Middel Street.

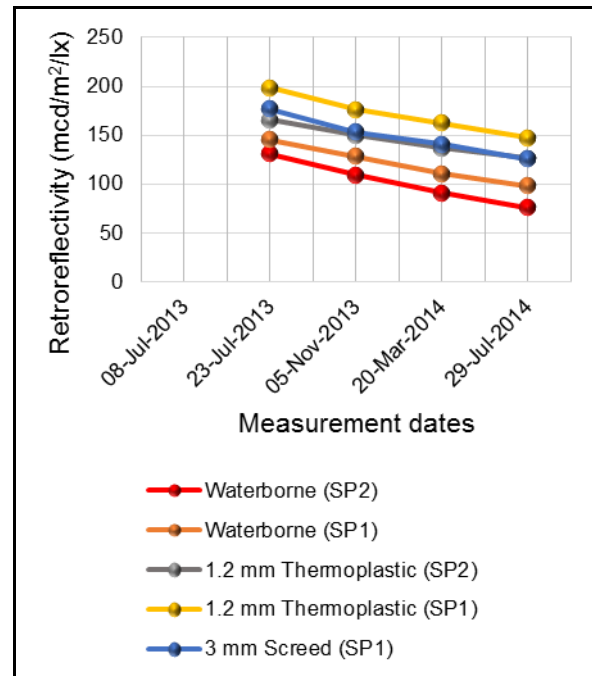

Figure A.52: Unwashed yellow longitudinal markings on Middel Street.

Table A.27: Summary of white transverse markings on long established dirty asphalt road (Mohwelere Street).

Type of road marking paint / material		05-Aug-2013		28-Jan-2014		11-Apr-2014		28-Jul-2014	
		Unwashed	Washed	Unwashed	Washed	Unwashed	Washed	Unwashed	Washed
Waterborne (SP2)	Mean	102.9	108.9	26.8	29.7	26.1	26.50	23.9	25.1
	N	9	9	9	9	9	9	9	9
	Std. Deviation	4.1	5.6	1.9	2.7	1.3	1.44	2.8	3.4
	CV	0.04	0.05	0.07	0.10	0.05	0.05	0.12	0.14
Waterborne (SP1)	Mean	123.9	127.4	26.1	31.2	27.8	25.9	25.4	24.8
	N	9	9	9	9	9	9	9	9
	Std. Deviation	10.2	4.4	2.2	3.5	1.9	1.30	3.7	1.9
	CV	0.08	0.01	0.09	0.11	0.07	0.05	0.15	0.08
Waterborne (SP3)	Mean	113.4	119.9	26.1	33.0	27.0	25.87	25.6	23.9
	N	9	9	9	9	9	9	9	9
	Std. Deviation	4.8	5.7	2.2	2.5	1.7	1.87	3.6	3.0
	CV	0.04	0.05	0.09	0.08	0.06	0.07	0.14	0.13
1.2 mm Thermoplastic (SP2)	Mean	101.7	114.1	50.0	65.0	38.7	46.55	36.2	43.4
	N	9	9	9	9	9	9	9	9
	Std. Deviation	12.8	5.5	5.7	6.9	2.9	11.07	3.1	8.7
	CV	0.13	0.05	0.12	0.11	0.08	0.24	0.09	0.2
1.2 mm Thermoplastic (SP1)	Mean	134.1	134.6	43.4	51.9	35.6	36.83	32.5	35.5
	N	9	9	9	9	9	9	9	9
	Std. Deviation	25.8	11.4	9.6	5.1	5.5	8.27	2.1	5.1
	CV	0.19	0.09	0.22	0.10	0.15	0.23	0.07	0.15
1 mm Cold Plastic (SP2)	Mean	153.3	155.0	41.3	47.0	31.6	31.18	26.9	31.6
	N	9	9	9	9	9	9	9	9
	Std. Deviation	16.3	10.5	17.2	9.0	2.6	5.96	2.9	4.1
	CV	0.11	0.07	0.42	0.19	0.08	0.19	0.11	0.13
3 mm Screed (SP1)	Mean	155.9	160.4	47.3	60.5	34.2	36.97	33.6	35.3
	N	9	9	9	9	9	9	9	9
	Std. Deviation	29.4	18.4	17.2	12.1	3.2	7.8	3.6	5.6
	CV	0.19	0.12	0.36	0.20	0.10	0.21	0.11	0.16
1 mm Cold Plastic (SP4)	Mean	117.5	122.5	31.8	39.9	30.8	31.58	26.9	26.9
	N	9	9	9	9	9	9	9	9
	Std. Deviation	14.9	6.2	4.3	6.3	1.9	6.57	2.3	2.3
	CV	0.13	0.05	0.14	0.16	0.07	0.21	0.09	0.09

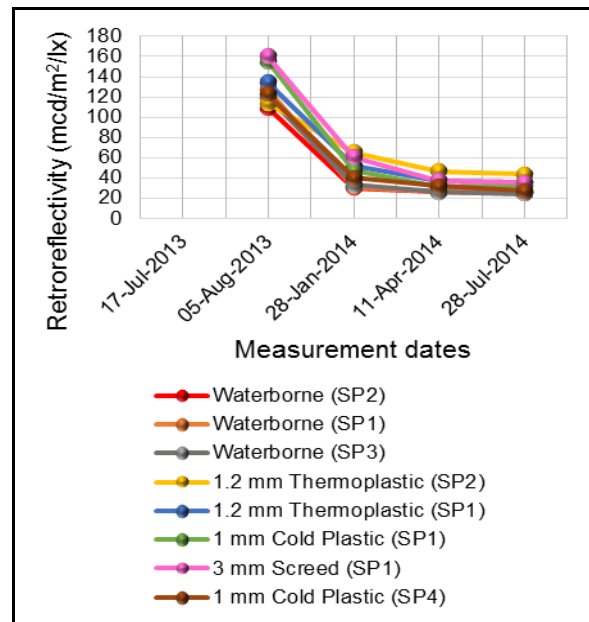
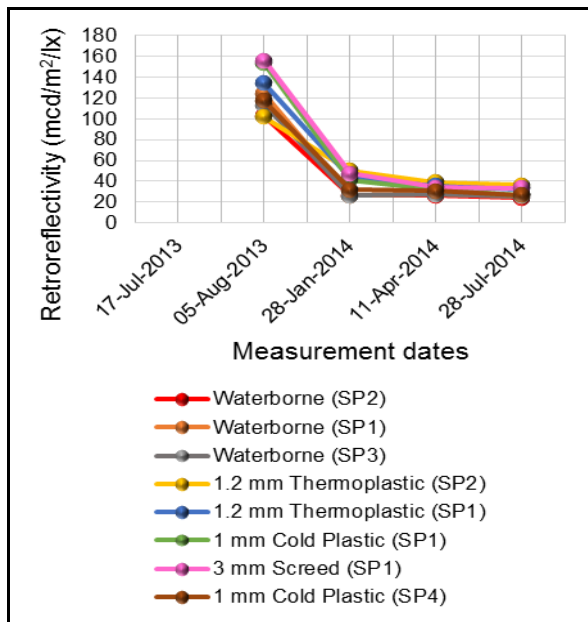

Figure A.53: Unwashed white transverse markings on Mohwelere Street.

Figure A.54: Washed white transverse markings on Mohwelere Street.

Table A.28: Summary of yellow transverse markings on long established dirty asphalt road (Mohwelere Street).

Type of road marking paint / material		05-Aug-2013		28-Jan-2014		11-Apr-2014		28-Jul-2014	
		Unwashed	Washed	Unwashed	Washed	Unwashed	Washed	Unwashed	Washed
Waterborne (SP2)	Mean	83.5	87.8	23.6	27.2	24.6	24.7	22.9	23.0
	N	9	9	9	9	9	9	9	9
	Std. Deviation	10.0	9.	2.4	3.3	2.3	1.97	2.1	2.3
	CV	0.12	0.11	0.10	0.12	0.10	0.08	0.01	0.10
Waterborne (SP1)	Mean	121.7	123.5	25.9	27.8	27.0	25.6	24.4	23.8
	N	9	9	9	9	9	9	9	9
	Std. Deviation	9.7	9.2	3.8	2.0	2.41	2.9	3.5	3.3
	CV	0.08	0.08	0.15	0.15	0.09	0.11	0.14	0.14
Waterborne (SP3)	Mean	99.6	102.3	22.7	26.4	26.4	25.8	25.0	24.5
	N	9	9	6	9	6	6	4	4
	Std. Deviation	5.2	5.0	1.8	3.0	2.9	1.0	1.2	1.5
	CV	0.05	0.05	0.08	0.12	0.11	0.04	0.05	0.06
1.2 mm Thermoplastic (SP2)	Mean	92.9	95.3	46.2	56.5	35.7	37.8	36.4	39.7
	N	9	9	3	3	3	3	2	2
	Std. Deviation	5.8	4.4	1.5	2.7	0.5	5.9	1.4	2.0
	CV	0.06	0.05	0.03	0.05	0.01	0.16	0.04	0.05
1.2 mm Thermoplastic (SP1)	Mean	107.7	111.9	32.7	43.0	30.0	29.5	28.9	30.9
	N	9	9	9	9	9	9	9	9
	Std. Deviation	10.0	8.2	4.9	12.1	2.4	2.5	3.4	8.9
	CV	0.09	0.07	0.15	0.28	0.08	0.09	0.12	0.29
1 mm Cold Plastic (SP2)	Mean	132.2	133.6	32.1	36.7	29.6	27.9	25.3	25.4
	N	9	9	9	9	9	9	9	9
	Std. Deviation	12.5	12.1	8.0	7.5	1.9	4.1	2.6	2.5
	CV	0.10	0.09	0.25	0.21	0.07	0.15	0.11	0.10
3 mm Screed (SP1)	Mean	119.6	123.7	31.7	39.3	30.0	30.9	28.5	29.7
	N	9	9	9	9	9	9	9	9
	Std. Deviation	9.4	8.5	3.0	5.1	1.9	3.6	2.7	4.1
	CV	0.08	0.07	0.10	0.13	0.07	0.12	0.10	0.14
1 mm Cold Plastic (SP4)	Mean	113.7	115.5	30.9	37.2	28.7	29.5	26.6	25.1
	N	9	9	9	9	9	9	9	9
	Std. Deviation	12.0	12.8	6.1	7.0	2.4	4.7	2.6	2.7
	CV	0.11	0.11	0.20	0.19	0.08	0.16	0.10	0.11

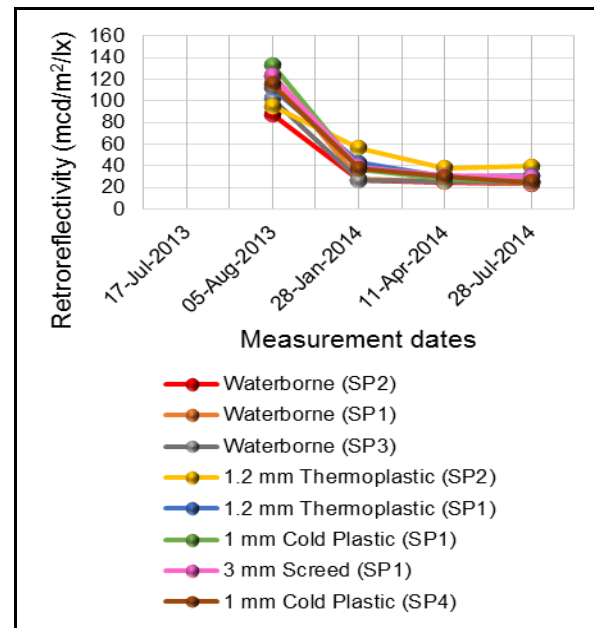
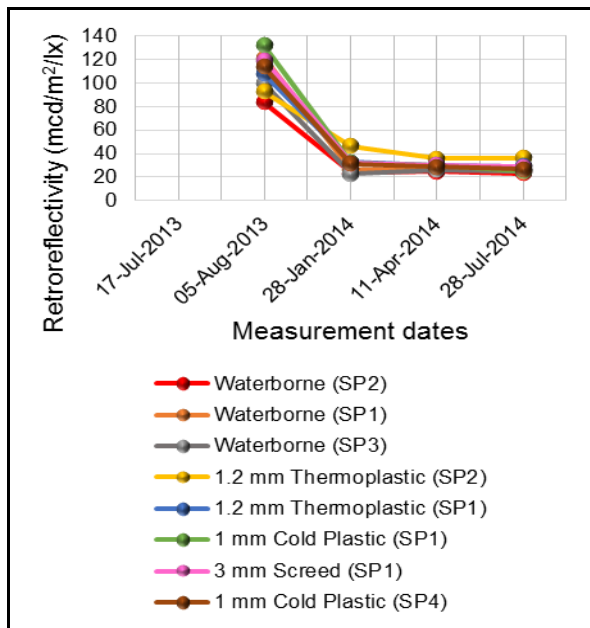

Figure A.55: Unwashed yellow transverse markings on Mohwelere Street.

Figure A.56: Washed yellow transverse markings on Mohwelere Street.

Table A.29: Summary of longitudinal road markings on long established dirty asphalt road (Mohwelere Street).

Type of road marking paint / material		05-Aug-2013		28-Jan-2014		11-Apr-2014		28-Jul-2014	
		White	Yellow	White	Yellow	White	Yellow	White	Yellow
Waterborne (SP2)	Mean	108.1	106.2	26.7	55.2	23.9	39.8	13.8	37.4
	N	3	3	3	3	3	3	3	3
	Std. Deviation	7.5	2.3	2.4	10.0	1.3	5.5	2.8	2.6
	CV	0.07	0.02	0.09	0.18	0.06	0.14	0.20	0.07
Waterborne (SP1)	Mean	121.4	116.0	28.0	58.8	26.4	35.4	16.2	32.8
	N	3	3	3	3	3	3	2	2
	Std. Deviation	5.3	7.3	3.7	4.0	3.4	1.6	6.0	2.9
	CV	0.04	0.06	0.13	0.07	0.13	0.05	0.37	0.09
1.2 mm Thermoplastic (SP2)	Mean	109.8	107.8	36.0	66.8	29.8	59.1	19.1	56.4
	N	3	3	3	3	3	3	3	3
	Std. Deviation	9.07	0.5	15.1	26.6	2.7	30.5	3.5	28.8
	CV	0.08	0.01	0.42	0.40	0.09	0.52	0.18	0.51
1.2 mm Thermoplastic (SP1)	Mean	128.6	113.9	48.5	72.4	41.3	49.5	27.1	43.7
	N	3	3	3	3	3	3	3	3
	Std. Deviation	5.5	7.5	14.0	15.7	7.1	19.9	4.0	14.7
	CV	0.04	0.07	0.29	0.22	0.17	0.40	0.15	0.34
3 mm Screed (SP1)	Mean	119.2	117.0	45.7	62.2	34.7	45.4	26.4	45.4
	N	3	3	3	3	3	3	3	3
	Std. Deviation	12.5	3.8	14.8	7.0	2.1	17.9	3.1	15.5
	CV	0.11	0.03	0.32	0.11	0.06	0.39	0.12	0.34

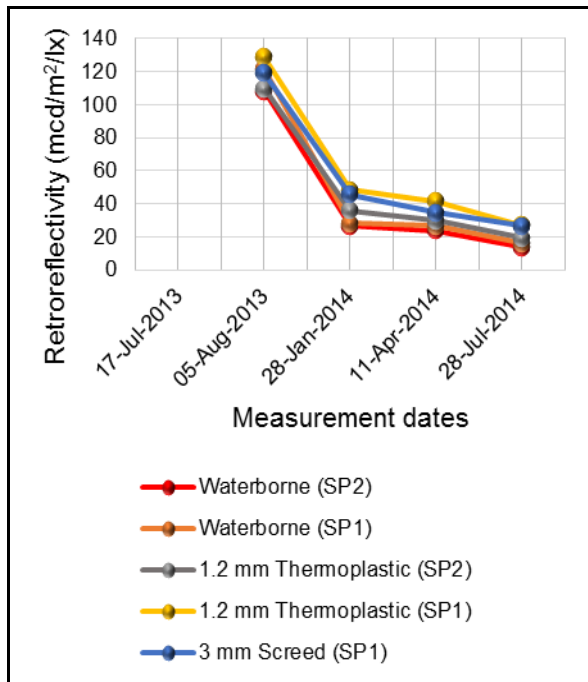

Figure A.57: Unwashed white longitudinal markings on Mohwelere Street.

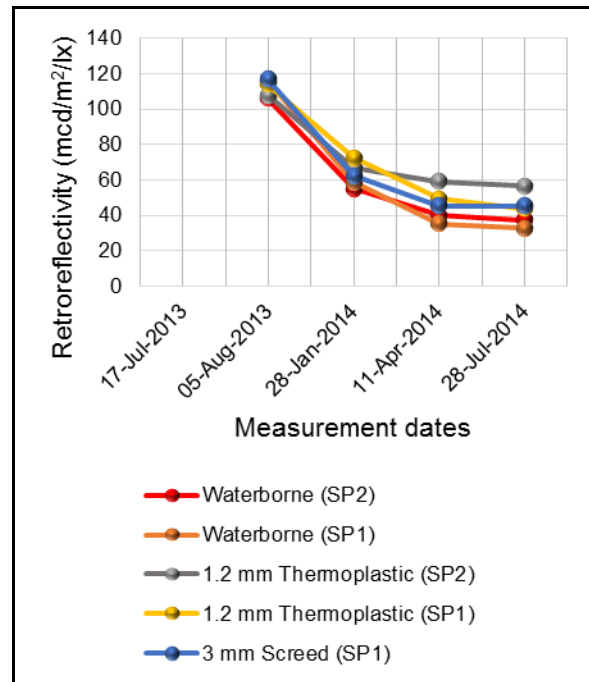

Figure A.58: Unwashed yellow longitudinal markings on Mohwelere Street.

Table A.30: Summary of white transverse markings on long established dirty chip seal road (Road L 3).

Type of road marking paint / material		05-Aug-2013		25-Nov-2013		03-Apr-2014		18-Jul-2014	
		Unwashed	Washed	Unwashed	Washed	Unwashed	Washed	Unwashed	Washed
Waterborne (SP2)	Mean	131.3	134.8	28.0	28.1	26.2	21.81	16.6	16.2
	N	9	9	9	9	6	6	6	6
	Std. Deviation	6.8	8.5	8.4	4.1	3.2	2.45	2.0	1.5
	CV	0.05	0.06	0.30	0.15	0.13	0.11	0.12	0.09
Waterborne (SP1)	Mean	192.8	194.6	23.5	21.1	19.2	17.77	15.6	14.3
	N	9	9	9	9	3	3	2	2
	Std. Deviation	13.9	10.5	7.3	3.1	0.7	0.29	0.2	1.0
	CV	0.07	0.05	0.31	0.15	0.04	0.02	0.01	0.07
Waterborne (SP3)	Mean	130.0	135.8	23.8	25.4				
	N	9	9	9	9				
	Std. Deviation	6.0	6.0	8.2	15.0				
	CV	0.05	0.05	0.34	0.59				
1.2 mm Thermoplastic (SP2)	Mean	136.4	144.8	53.4	55.9	46.3	50.51	29.4	32.2
	N	9	9	9	9	3	3	3	3
	Std. Deviation	7.4	2.7	15.1	14.9	7.3	3.30	1.3	4.0
	CV	0.05	0.02	0.28	0.27	0.16	0.07	0.05	0.13
1.2 mm Thermoplastic (SP1)	Mean	209.2	215.3	44.1	47.0	33.9	29.87	19.8	23.3
	N	9	9	9	9	9	9	9	9
	Std. Deviation	8.9	9.1	17.2	13.0	9.2	9.70	5.1	5.7
	CV	0.04	0.04	0.39	0.27	0.27	0.32	0.26	0.25
1 mm Cold Plastic (SP1)	Mean	185.1	192.0	46.3	44.9	28.9	23.48	16.4	20.4
	N	9	9	9	9	9	9	9	9
	Std. Deviation	7.5	15.0	18.1	9.0	3.8	4.38	3.7	3.2
	CV	0.04	0.08	0.39	0.20	0.13	0.19	0.23	0.16
3 mm Screed (SP1)	Mean	216.0	219.1	52.4	53.7	37.0	32.48	20.1	24.2
	N	9	9	9	9	9	9	9	9
	Std. Deviation	11.72	4.7	18.1	15.5	10.3	11.59	3.2	5.4
	CV	0.05	0.02	0.35	0.29	0.28	0.36	0.16	0.23
1 mm Cold Plastic (SP4)	Mean	143.3	144.2	35.5	34.1	39.8	31.17	24.8	26.2
	N	9	9	9	9	5	5	3	3
	Std. Deviation	7.5	4.4	12.4	7.9	10.9	8.45	3.9	2.4
	CV	0.05	0.03	0.35	0.23	0.28	0.27	0.16	0.10

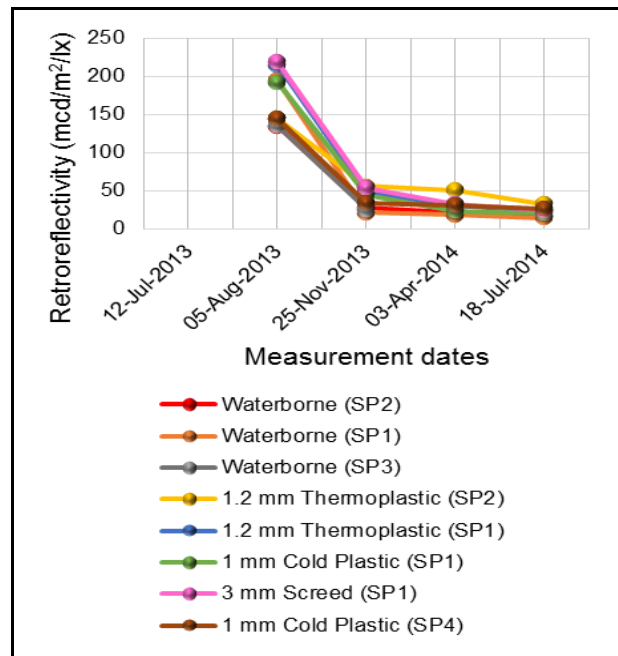
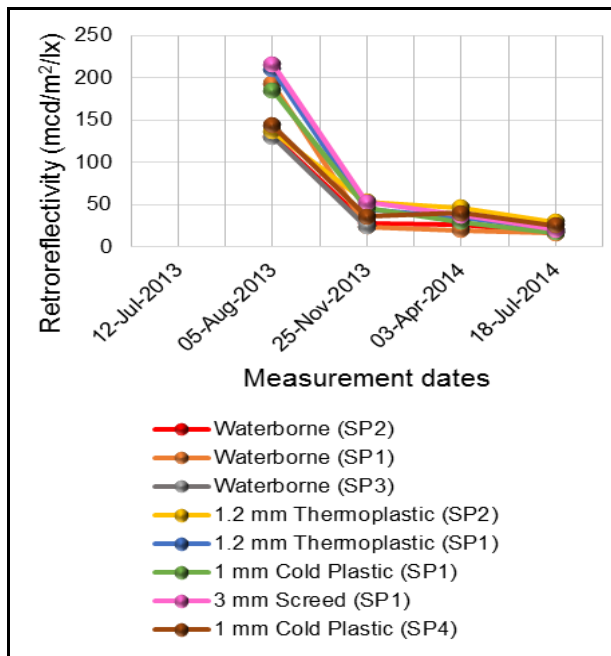

Figure A.59: Unwashed white transverse markings on Road L 3.

Figure A.60: Washed white transverse markings on Road L 3.

Table A.31: Summary of yellow transverse markings on long established dirty chip seal road (Road L 3).

Type of road marking paint / material		05-Aug-2013		25-Nov-2013		03-Apr-2014		18-Jul-2014	
		Unwashed	Washed	Unwashed	Washed	Unwashed	Washed	Unwashed	Washed
Waterborne (SP2)	Mean	79.4	83.4	23.7	22.35	29.4	24.3	15.2	17.4
	N	9	9	9	9	3	3	3	3
	Std. Deviation	4.3	7.7	6.0	4.73	5.0	1.4	0.6	2.4
	CV	0.05	0.09	0.25	0.21	0.17	0.06	0.04	0.14
Waterborne (SP1)	Mean	146.1	144.3	21.6	19.81	16.5	15.0	11.3	13.1
	N	9	9	9	9	6	6	4	4
	Std. Deviation	5.0	2.9	6.4	3.74	1.5	1.4	0.9	1.0
	CV	0.04	0.02	0.30	0.19	0.09	0.10	0.08	0.08
Waterborne (SP3)	Mean	97.4	102.0	23.0	21.17	18.0	15.8	11.6	13.0
	N	9	9	9	9	6	6	4	4
	Std. Deviation	6.0	9.7	5.4	4.43	3.0	2.1	1.0	1.5
	CV	0.06	0.10	0.23	0.21	0.17	0.13	0.10	0.12
1.2 mm Thermoplastic (SP2)	Mean	127.0	129.1	37.1	36.32	36.0	31.1	25.4	27.9
	N	9	9	9	9	5	5	3	3
	Std. Deviation	4.5	8.1	4.3	8.11	8.0	6.6	3.0	4.5
	CV	0.04	0.06	0.12	0.22	0.22	0.21	0.12	0.16
1.2 mm Thermoplastic (SP1)	Mean	130.3	131.4	22.6	21.24	24.2	20.6	15.8	16.4
	N	9	9	9	9	9	9	9	9
	Std. Deviation	4.8	5.8	3.2	2.49	4.9	4.4	2.5	2.3
	CV	0.04	0.05	0.14	0.12	0.20	0.22	0.16	0.14
1 mm Cold Plastic (SP1)	Mean	146.3	143.4	40.4	37.55	24.5	21.7	14.4	17.6
	N	9	9	9	9	9	9	9	9
	Std. Deviation	4.6	3.9	14.34	10.70	3.5	4.8	3.7	2.0
	CV	0.03	0.03	0.35	0.29	0.14	0.22	0.26	0.11
3 mm Screed (SP1)	Mean	132.9	136.5	26.9	27.91	26.6	24.2	16.1	17.7
	N	9	9	9	9	9	9	9	9
	Std. Deviation	4.7	5.3	7.9	7.51	6.3	7.9	3.0	3.4
	CV	0.04	0.04	0.30	0.27	0.24	0.33	0.19	0.19
1 mm Cold Plastic (SP4)	Mean	89.0	94.0	26.7	22.61	24.2	23.9	14.3	17.1
	N	9	9	9	9	5	5	4	4
	Std. Deviation	5.7	7.0	6.43	5.5	2.1	5.7	2.4	2.2
	CV	0.07	0.07	0.24	0.25	0.09	0.24	0.17	0.13

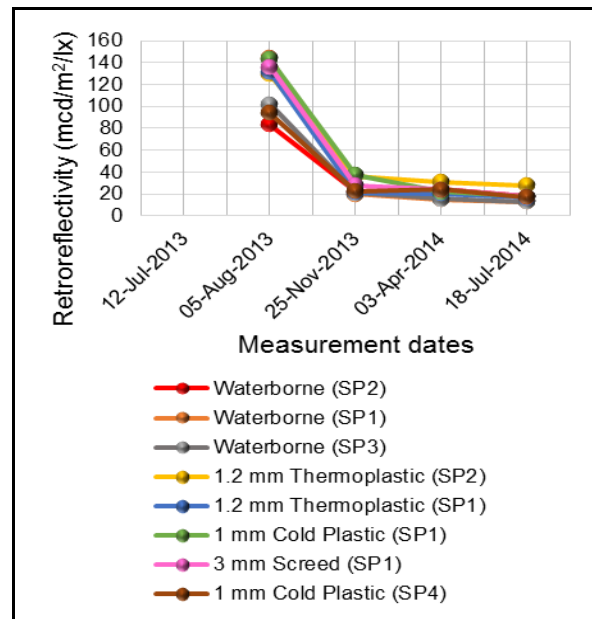
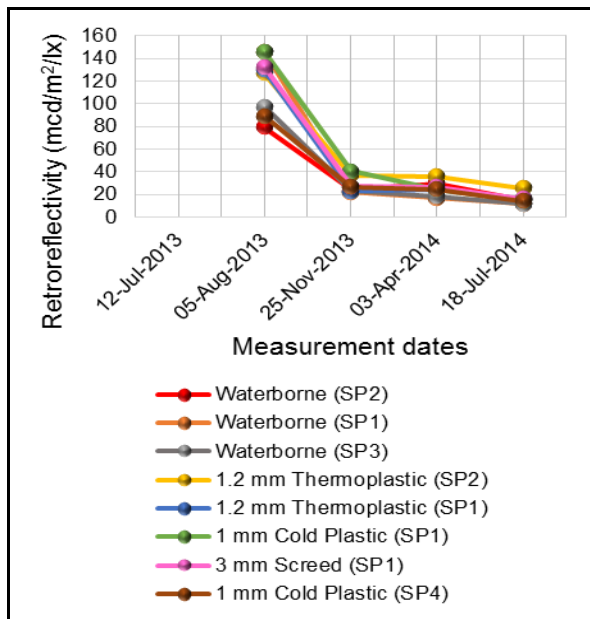

Figure A.61: Unwashed yellow transverse markings on Road L 3.

Figure A.62: Washed yellow transverse markings on Road L 3.

Table A.32: Summary of longitudinal markings on long established dirty chip seal road (Road L 3).

Type of road marking paint / material		05-Aug-2013		25-Nov-2013		03-Apr-2014		18-Jul-2014	
		White	Yellow	White	Yellow	White	Yellow	White	Yellow
Waterborne (SP2)	Mean	176.5	107.8	46.0	51.1	34.8	42.6	22.0	29.1
	N	3	3	3	3	3	2	3	2
	Std. Deviation	6.8	6.1	6.4	16.4	15.2	9.0	9.4	0.7
	CV	0.04	0.06	0.14	0.32	0.44	0.21	0.43	0.03
Waterborne (SP1)	Mean	182.2	137.8	51.2	50.0	35.4	38.2	19.7	27.8
	N	3	3	3	3	3	3	3	3
	Std. Deviation	5.6	2.3	13.9	3.7	16.6	0.2	5.3	4.8
	CV	0.03	0.02	0.27	0.07	0.47	0.01	0.27	0.17
1.2 mm Thermoplastic (SP2)	Mean	216.6	130.8	71.4	105.5	49.5	83.5	26.0	41.8
	N	3	3	3	3	3	3	3	3
	Std. Deviation	17.3	6.8	32.3	16.7	11.1	19.9	2.3	3.5
	CV	0.08	0.05	0.45	0.16	0.23	0.24	0.09	0.09
1.2 mm Thermoplastic (SP1)	Mean	198.2	139.3	85.9	107.3	50.1	99.4	26.1	48.4
	N	3	3	3	3	3	3	3	3
	Std. Deviation	16.1	5.27	32.3	17.8	10.1	4.8	3.0	7.6
	CV	0.08	0.04	0.37	0.17	0.20	0.05	0.12	0.16
3 mm Screed (SP1)	Mean	168.9	145.7	52.3	95.8	48.3	62.5	27.2	46.0
	N	3	3	3	3	3	3	3	3
	Std. Deviation	4.2	5.6	15.7	6.7	2.9	13.3	5.2	14.2
	CV	0.03	0.04	0.30	0.07	0.06	0.21	0.19	0.31

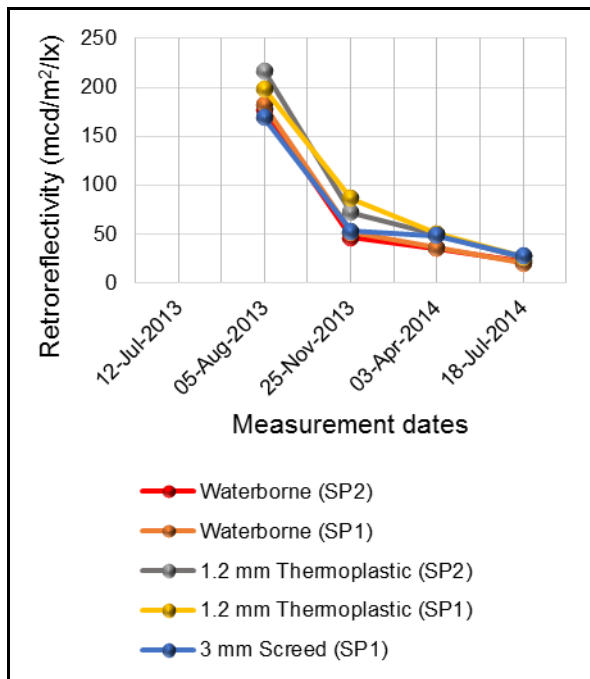

Figure A.63: Unwashed white longitudinal markings on Road L 3.

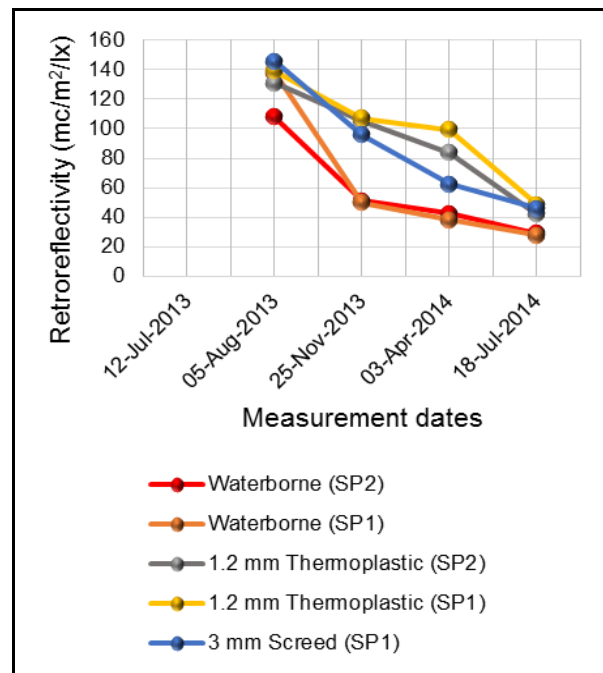

Figure A.64: Unwashed yellow longitudinal markings on Road L 3.

APPENDIX B

TABLE OF CONTENTS

B. DESCRIPTIVE STATISTICS ON LUMINANCE	B-1
B.1 DISCUSSION.....	B-1

LIST OF TABLES

Table B.1: Summary of white transverse markings on newly established dirty chip seal road (Aubrey Matlala Road).....	B-2
Table B.2: Summary of yellow transverse markings on newly established dirty chip seal road (Aubrey Matlala Road).....	B-3
Table B.3: Summary of longitudinal markings on newly established dirty chip seal road (Aubrey Matlala Road).....	B-4
Table B.4: Summary of white transverse markings on long established clean chip seal road (Bushveld Road).....	B-5
Table B.5: Summary of yellow transverse markings on long established clean chip seal road (Bushveld Road).....	B-6
Table B.6: Summary of longitudinal markings on long established clean chip seal road (Bushveld Road). ..	B-7
Table B.7: Summary of white transverse markings on newly established clean chip seal road (Doreen Street - B 1).....	B-8
Table B.8: Summary of yellow transverse markings on newly established clean chip seal road (Doreen Street - B 1).....	B-9
Table B.9: Summary of longitudinal markings on newly established clean chip seal road (Doreen Street - B 1).....	B-10
Table B.10: Summary of white transverse markings on newly established clean chip seal road (Doreen Street - B's 2 & 3).....	B-11
Table B.11: Summary of yellow transverse markings on newly established clean chip seal road (Doreen Street - B's 2 & 3).....	B-12
Table B.12: Summary of longitudinal markings on newly established clean chip seal road (Doreen Street - B's 2 & 3).....	B-13
Table B.13: Summary of white transverse markings on newly established clean chip seal road (Doreen Street - B's 1, 2 & 3).....	B-14
Table B.14: Summary of yellow transverse markings on newly established clean chip seal road (Doreen Street - B's 1, 2 & 3).....	B-15
Table B.15: Summary of longitudinal markings on newly established clean chip seal road (Doreen Street - B's 1, 2 & 3).....	B-16
Table B.16: Summary of white transverse markings on newly established dirty asphalt road (M 44).....	B-17

Table B.17: Summary of yellow transverse markings on newly established dirty asphalt road (M 44).....	B-18
Table B.18: Summary of longitudinal markings on newly established dirty asphalt road (M 44).....	B-19
Table B.19: Summary of white transverse markings on long established asphalt road in the CBD (Madiba Street).....	B-20
Table B.20: Summary of yellow transverse markings on long established asphalt road in the CBD (Madiba Street).....	B-21
Table B.21: Summary of white transverse markings on newly established clean asphalt road (Meiring Naude Road).....	B-22
Table B.22: Summary of yellow transverse markings on newly established clean asphalt road (Meiring Naude Road).....	B-23
Table B.23: Summary of longitudinal markings on newly established clean asphalt road (Meiring Naude Road).....	B-24
Table B.24: Summary of white transverse markings on long established clean asphalt road (Middel Street).....	B-25
Table B.25: Summary of yellow transverse markings on long established clean asphalt road (Middel Street).....	B-26
Table B.26: Summary of longitudinal markings on long established clean asphalt road (Middel Street)....	B-27
Table B.27: Summary of white transverse markings on long established dirty asphalt road (Mohwelere Street).....	B-28
Table B.28: Summary of yellow transverse markings on long established dirty asphalt road (Mohwelere Street).....	B-29
Table B.29: Summary of longitudinal markings on long established dirty asphalt road (Mohwelere Street).	B-30
Table B.30: Summary of white transverse markings on long established dirty chip seal road (Road L 3)...	B-31
Table B.31: Summary of yellow transverse markings on long established dirty chip seal road (Road L 3).	B-32
Table B.32: Summary of longitudinal markings on long established dirty chip seal road (Road L 3).....	B-33

LIST OF FIGURES

Figure B.1: Unwashed white transverse road markings on Aubrey Matlala Road.....	B-2
Figure B.2: Washed white transverse road markings on Aubrey Matlala Road.....	B-2
Figure B.3: Unwashed yellow transverse road markings on Aubrey Matlala Road.....	B-3
Figure B.4: Washed yellow transverse road markings on Aubrey Matlala Road.....	B-3
Figure B.5: Unwashed white longitudinal road markings on Aubrey Matlala Road.....	B-4
Figure B.6: Unwashed yellow longitudinal road markings on Aubrey Matlala Road.....	B-4
Figure B.7: Unwashed white transverse road markings on Bushveld Road.....	B-5
Figure B.8: Washed white transverse road markings on Bushveld Road.....	B-5
Figure B.9: Unwashed yellow transverse road markings on Bushveld Road.....	B-6
Figure B.10: Washed yellow transverse road markings on Bushveld Road.....	B-6
Figure B.11: Unwashed white longitudinal road markings on Bushveld Road.....	B-7
Figure B.12: Unwashed yellow longitudinal road markings on Bushveld Road.....	B-7
Figure B.13: Unwashed white transverse road markings on Doreen Street (B 1).....	B-8
Figure B.14: Washed white transverse road markings on Doreen Street (B 1).....	B-8
Figure B.15: Unwashed yellow transverse road markings on Doreen Street (B 1).....	B-9
Figure B.16: Washed yellow transverse road markings on Doreen Street (B 1).....	B-9
Figure B.17: Unwashed white longitudinal road markings on Doreen Street (B 1).....	B-10
Figure B.18: Unwashed yellow longitudinal road markings on Doreen Street (B 1).....	B-10
Figure B.19: Unwashed white transverse road markings on Doreen Street (B's 2 & 3).....	B-11
Figure B.20: Washed white transverse road markings on Doreen Street (B's 2 & 3).....	B-11
Figure B.21: Unwashed yellow transverse road markings on Doreen Street (B's 2 & 3).....	B-12
Figure B.22: Washed yellow transverse road markings on Doreen Street (B's 2 & 3).....	B-12
Figure B.23: Unwashed white longitudinal road markings on Doreen Street (B's 2 & 3).....	B-13
Figure B.24: Unwashed yellow longitudinal road markings on Doreen Street (B's 2 & 3).....	B-13
Figure B.25: Unwashed white transverse road markings on Doreen Street (B's 1, 2 & 3).....	B-14
Figure B.26: Washed white transverse road markings on Doreen Street (B's 1, 2 & 3).....	B-14
Figure B.27: Unwashed yellow transverse road markings on Doreen Street (B's 1, 2 & 3).....	B-15
Figure B.28: Washed yellow transverse road markings on Doreen Street (B's 1, 2 & 3).....	B-15
Figure B.29: Unwashed white longitudinal road markings on Doreen Street (B's 1, 2 & 3).....	B-16
Figure B.30: Unwashed yellow longitudinal road markings on Doreen Street (B's 1, 2 & 3).....	B-16
Figure B.31: Unwashed white transverse road markings on M 44.....	B-17
Figure B.32: Washed white transverse road markings on M 44.....	B-17
Figure B.33: Unwashed yellow transverse road markings on M 44.....	B-18
Figure B.34: Washed yellow transverse road markings on M 44.....	B-18
Figure B.35: Unwashed white longitudinal markings on M 44.....	B-19

Figure B.36: Unwashed yellow longitudinal road markings on M 44.....	B-19
Figure B.37: Unwashed white transverse road markings on Madiba Street.....	B-20
Figure B.38: Washed white transverse road markings on Madiba Street.....	B-20
Figure B.39: Unwashed yellow transverse road markings Madiba Street.....	B-21
Figure B.40: Washed yellow transverse road markings on Madiba Street.....	B-21
Figure B.41: Unwashed white transverse road markings on Meiring Naude Road.....	B-22
Figure B.42: Washed white transverse road markings on Meiring Naude Road.....	B-22
Figure B.43: Unwashed yellow transverse road markings on Meiring Naude Road.....	B-23
Figure B.44: Washed yellow transverse road markings on Meiring Naude Road.....	B-23
Figure B.45: Unwashed white longitudinal road markings on Meiring Naude Road.....	B-24
Figure B.46: Unwashed yellow longitudinal road markings on Meiring Naude Road.....	B-24
Figure B.47: Unwashed white transverse road markings on Middel Street.....	B-25
Figure B.48: Washed white transverse road markings on Middel Street.....	B-25
Figure B.49: Unwashed yellow transverse road markings on Middel Street.....	B-26
Figure B.50: Washed yellow transverse road markings on Middel Street.....	B-26
Figure B.51: Unwashed white longitudinal road markings on Middel Street.....	B-27
Figure B.52: Unwashed yellow longitudinal road markings on Middel Street.....	B-27
Figure B.53: Unwashed white transverse road markings on Mohwelere Street.....	B-28
Figure B.54: Washed white transverse road markings on Mohwelere Street.....	B-28
Figure B.55: Unwashed yellow transverse road markings on Mohwelere Street.....	B-29
Figure B.56: Washed yellow transverse road markings on Mohwelere Street.....	B-29
Figure B.57: Unwashed white longitudinal road markings on Mohwelere Street.....	B-30
Figure B.58: Unwashed yellow longitudinal road markings on Mohwelere Street.....	B-30
Figure B.59: Unwashed white transverse road markings on Road L 3.....	B-31
Figure B.60: Washed white transverse road markings on Road L 3.....	B-31
Figure B.61: Unwashed yellow transverse road markings on Road L 3.....	B-32
Figure B.62: Washed yellow transverse road markings on Road L 3.....	B-32
Figure B.63: Unwashed white longitudinal road markings on Road L 3.....	B-33
Figure B.64: Unwashed yellow longitudinal road markings on Road L 3.....	B-33

B. DESCRIPTIVE STATISTICS ON LUMINANCE

B.1 DISCUSSION

The first date on the horizontal axis of Figures B.1 to B.64 represents the application date of the test road markings on the road surface. Some of the road markings could not be tested after a certain time as the markings had completely broken off the road surface or the markings were worn off to such an extent that a bigger area of the road surface was exposed than the actual test road markings. Therefore the number of samples measured during each testing period might not be continuously the same but rather reduced, as can be seen in some of the Tables in Appendix B. For example, there are only 5 samples measured instead of 6 for white transverse 1.2 mm thermoplastic (SP2) in the fourth measurement period, as can be seen in Table B.1. Some types of test road markings were also either completely worn off at each section of the test road markings or had completely broken off the road surface. In such a case it will be seen that some of the Figures in Appendix B do not indicate a decline line over the full four measurement periods. For example, white transverse waterborne (SP2) is represented in Figures B.13 and B.14 for only the first two measurement periods. Some of quantities of the road marking paints and materials obtained from some of the service providers were insufficient to be applied on all the test sites. For example, the cold plastic road marking material from Service Provider 4 (SP4) was not applied on Aubrey Matlala Road, as can be seen in Table B.1.

Table B.1: Summary of white transverse markings on newly established dirty chip seal road (Aubrey Matlala Road).

Type of road marking paint / material		05-Aug-2013		29-Nov-2013		02-Apr-2014		17-Jul-2014	
		Unwashed	Washed	Unwashed	Washed	Unwashed	Washed	Unwashed	Washed
Waterborne (SP2)	Mean	98.5	103.8	83.7	85.8	75.2	78.4	59.0	62.4
	N	6	6	6	6	6	6	6	6
	Std. Deviation	5.3	3.6	8.4	8.6	10.8	9.4	4.0	2.3
	CV	0.06	0.04	0.10	0.1	0.14	0.12	0.07	0.04
Waterborne (SP1)	Mean	101.1	106.0	87.4	92.6	77.8	79.1	61.9	62.4
	N	6	6	6	6	6	6	6	6
	Std. Deviation	4.8	4.8	6.7	5.6	6.1	6.1	6.8	8.7
	CV	0.05	0.05	0.08	0.06	0.08	0.08	0.11	0.14
Waterborne (SP3)	Mean	98.5	101.6	82.4	88.3	71.7	73.6	59.9	61.8
	N	6	6	6	6	6	6	6	6
	Std. Deviation	5.5	6.2	9.0	6.6	10.0	8.9	4.4	2.3
	CV	0.06	0.06	0.11	0.08	0.14	0.12	0.07	0.04
1.2 mm Thermoplastic (SP2)	Mean	104.1	109.8	86.5	90.1	77.2	78.5	61.8	63.9
	N	6	6	6	6	6	6	5	5
	Std. Deviation	3.4	6.3	11.8	9.4	9.2	10.4	5.4	5.7
	CV	0.03	0.06	0.14	0.11	0.12	0.13	0.09	0.09
1.2 mm Thermoplastic (SP1)	Mean	124.1	129.9	97.9	102.3	88.2	90.8	71.7	72.5
	N	6	6	6	6	6	6	6	6
	Std. Deviation	8.6	2.8	6.6	6.2	6.2	5.0	4.7	5.4
	CV	0.07	0.02	0.06	0.06	0.07	0.06	0.07	0.08
1 mm Cold Plastic (SP2)	Mean	109.5	112.9	97.2	101.2	89.2	91.3	72.5	74.6
	N	6	6	6	6	6	6	6	6
	Std. Deviation	5.8	8.1	5.6	3.2	6.4	5.7	7.7	6.5
	CV	0.05	0.07	0.06	0.03	0.07	0.06	0.11	0.09
1 mm Cold Plastic (SP1)	Mean	116.4	120.0	93.5	97.9	85.4	87.7	72.6	72.7
	N	6	6	6	6	6	6	6	6
	Std. Deviation	3.6	5.4	5.4	4.0	4.9	6.3	6.5	7.6
	CV	0.03	0.05	0.06	0.04	0.06	0.07	0.09	0.11
3 mm Screed (SP1)	Mean	120.3	123.6	98.2	101.2	84.8	88.2	77.3	78.2
	N	6	6	6	6	6	6	6	6
	Std. Deviation	10.0	11.3	8.7	8.8	3.2	2.9	3.1	1.8
	CV	0.08	0.09	0.09	0.09	0.04	0.03	0.04	0.02

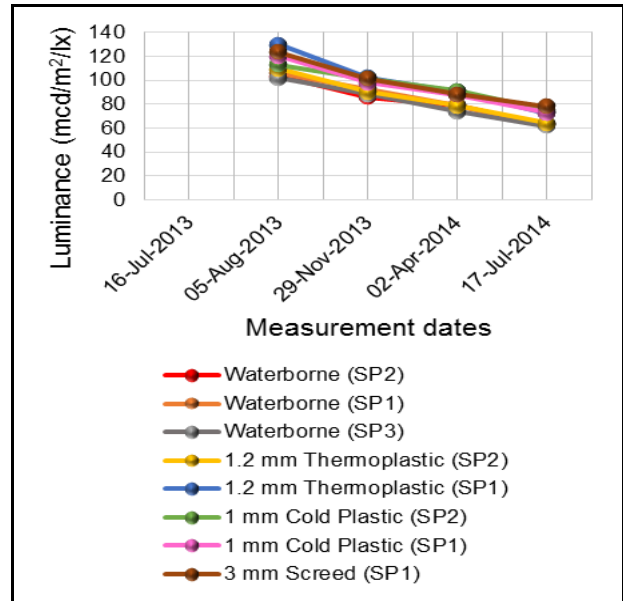
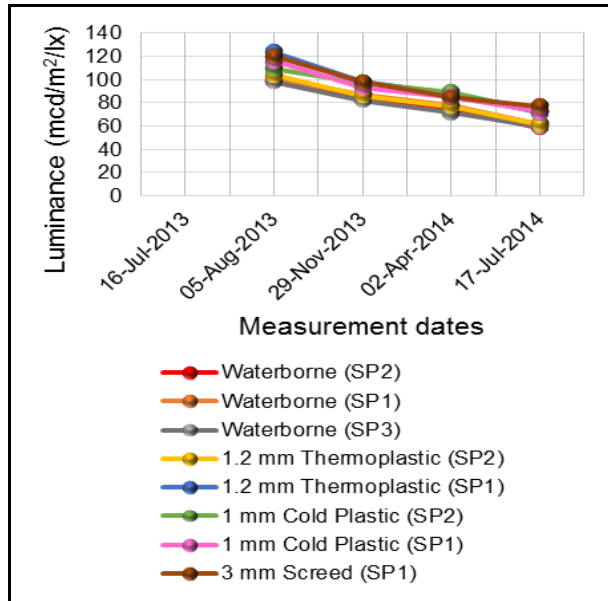

Figure B.1: Unwashed white transverse markings on Aubrey Matlala Road.

Figure B.2: Washed white transverse markings on Aubrey Matlala Road.

Table B.2: Summary of yellow transverse markings on newly established dirty chip seal road (Aubrey Matlala Road).

Type of road marking paint / material		05-Aug-2013		29-Nov-2013		02-Apr-2014		17-Jul-2014	
		Unwashed	Washed	Unwashed	Washed	Unwashed	Washed	Unwashed	Washed
Waterborne (SP2)	Mean	86.4	89.6	77.9	80.3	69.8	73.8	57.0	59.6
	N	6	6	6	6	6	6	6	6
	Std. Deviation	13.3	15.3	11.7	11.3	5.3	3.7	6.9	7.0
	CV	0.16	0.17	0.15	0.14	0.08	0.05	0.12	0.12
Waterborne (SP1)	Mean	76.1	79.5	69.6	79.2	64.5	68.1	46.5	48.3
	N	6	6	6	6	6	6	4	4
	Std. Deviation	10.2	10.9	7.0	11.3	4.7	4.5	4.5	2.1
	CV	0.13	0.14	0.10	0.14	0.07	0.07	0.10	0.04
Waterborne (SP3)	Mean	72.5	74.3	66.0	71.4	61.6	68.5	44.4	44.7
	N	6	6	6	6	6	6	5	5
	Std. Deviation	8.7	9.3	5.2	3.9	4.2	3.4	2.1	2.0
	CV	0.12	0.13	0.08	0.06	0.07	0.06	0.05	0.05
1.2 mm Thermoplastic (SP2)	Mean	101.3	107.5	87.7	92.0	78.2	80.2	47.4	46.6
	N	6	6	6	6	6	6	5	5
	Std. Deviation	21.6	19.0	18.9	16.7	12.6	11.7	3.9	4.0
	CV	0.21	0.18	0.22	0.18	0.16	0.15	0.08	0.25
1.2 mm Thermoplastic (SP1)	Mean	108.0	112.8	84.1	87.8	74.0	78.4	56.5	56.0
	N	6	6	6	6	6	6	6	6
	Std. Deviation	9.8	6.8	8.9	7.5	2.7	3.2	9.4	10.3
	CV	0.09	0.06	0.11	0.09	0.04	0.04	0.17	0.19
1 mm Cold Plastic (SP1)	Mean	90.3	100.9	83.1	89.0	74.8	79.0	52.2	53.8
	N	6	6	6	6	6	6	6	6
	Std. Deviation	8.9	3.2	9.8	5.1	5.3	5.6	2.8	4.1
	CV	0.10	0.03	0.12	0.06	0.07	0.07	0.06	0.08
3 mm Screed (SP1)	Mean	115.2	119.1	91.2	95.2	76.3	78.9	60.1	60.8
	N	6	6	6	6	6	6	6	6
	Std. Deviation	9.0	6.6	16.0	13.9	4.7	4.4	9.0	7.8
	CV	0.08	0.06	0.18	0.15	0.06	0.036	0.15	0.13

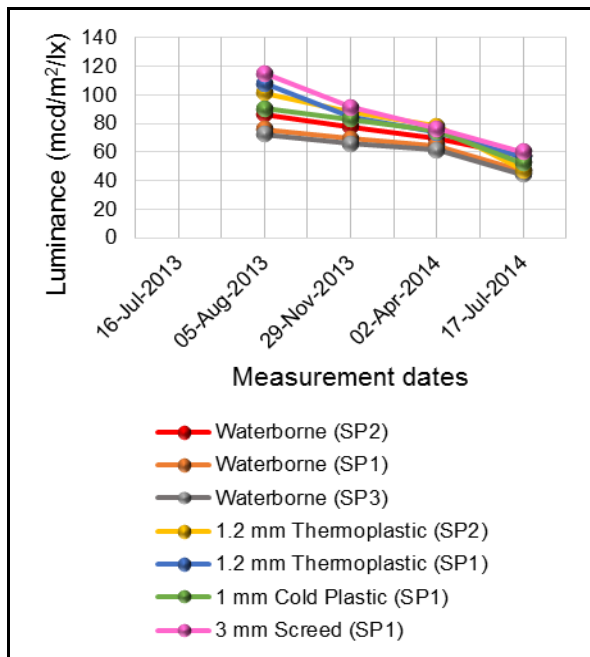

Figure B.3: Unwashed yellow transverse markings on Aubrey Matlala Road.

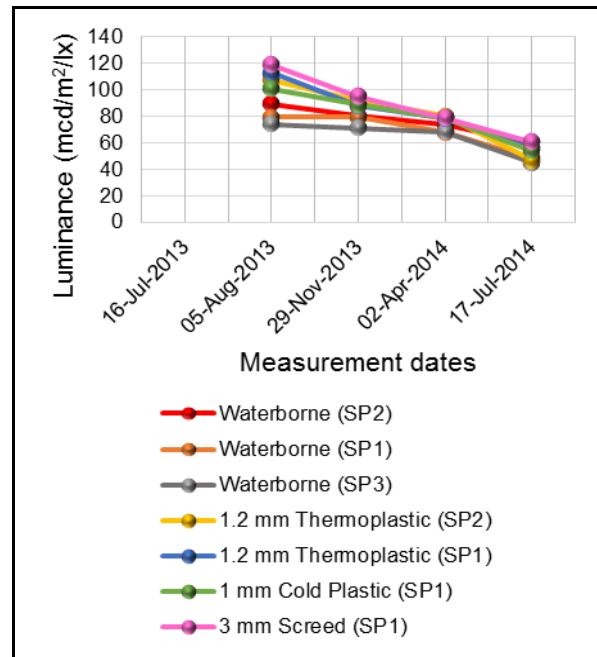

Figure B.4: Washed yellow transverse markings on Aubrey Matlala Road.

Table B.3: Summary of longitudinal markings on newly established dirty chip seal road (Aubrey Matlala Road).

Type of road marking paint / material		05-Aug-2013		29-Nov-2013		02-Apr-2014		17-Jul-2014	
		White	Yellow	White	Yellow	White	Yellow	White	Yellow
Waterborne (SP2)	Mean	133.6	124.5	119.6	113.1	89.4	76.6	72.5	66.5
	N	2	1	2	1	2	1	2	1
	Std. Deviation	3.6	0.0	5.9	0.0	5.4	0.0	2.6	0.0
	CV	0.03	0.00	0.05	0.00	0.06	0	0.04	0.00
Waterborne (SP1)	Mean	136.6	130.8	119.8	117.4	97.2	78.4	68.5	60.8
	N	2	1	2	1	2	1	2	1
	Std. Deviation	9.1	0.0	5.1	0.0	3.1	0.0	2.3	0.0
	CV	0.07	0.00	0.04	0.00	0.03	0.00	0.03	0.00
1.2 mm Thermoplastic (SP2)	Mean	136.2	138.6	122.1	117.4	93.5	87.2	73.6	74.1
	N	2	1	2	1	2	1	2	1
	Std. Deviation	1.4	0.0	3.2	0.0	0.5	0.0	1.2	0.0
	CV	0.01	0.00	0.03	0.00	0.01	0.00	0.02	0.00
1.2 mm Thermoplastic (SP1)	Mean	130.1	142.3	119.8	120.3	91.8	84.4	70.5	73.8
	N	2	1	2	1	2	1	2	1
	Std. Deviation	4.2	0.0	1.6	0.0	3.9	0.0	6.5	0.0
	CV	0.03	0.00	0.01	0.00	0.04	0.00	0.09	0.00
3 mm Screed (SP1)	Mean	140.5	145.2	131.1	129.6	91.6	78.5	72.2	72.4
	N	2	1	2	1	2	1	2	1
	Std. Deviation	0.4	0.0	1.2	0.0	5.0	0.0	1.0	0.0
	CV	0.00	0.00	0.01	0.00	0.06	0.00	0.01	0.00

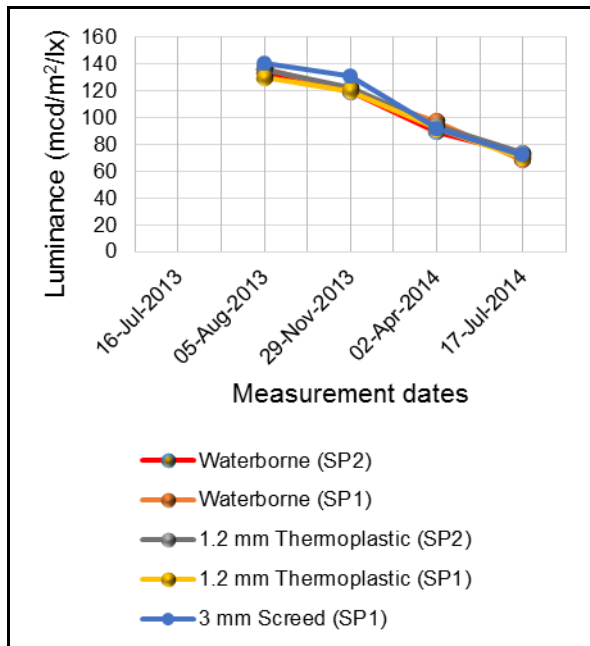

Figure B.5: Unwashed white longitudinal markings on Aubrey Matlala Road.

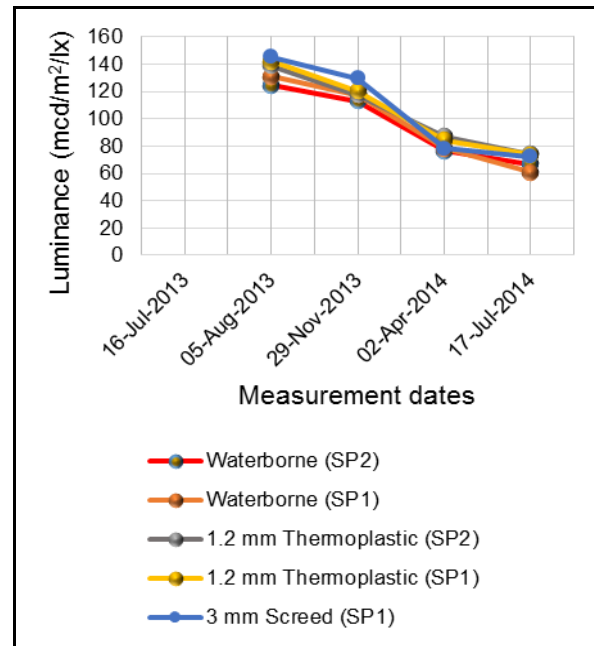

Figure B.6: Unwashed yellow longitudinal markings on Aubrey Matlala Road.

Table B.4: Summary of white transverse markings on long established clean chip seal road (Bushveld Road).

Type of road marking paint / material		02-Aug-2013		05-Nov-2013		28-Mar-2014		22-Jul-2014	
		Unwashed	Washed	Unwashed	Washed	Unwashed	Washed	Unwashed	Washed
Waterborne (SP2)	Mean	113.8	118.0	89.5	97.1	82.5	88.8	50.1	54.6
	N	9	9	9	9	9	9	9	9
	Std. Deviation	3.9	3.2	3.1	6.6	1.3	3.2	2.7	2.5
	CV	0.03	0.03	0.04	0.07	0.02	0.04	0.06	0.05
Waterborne (SP1)	Mean	114.2	117.9	94.2	100.6	86.4	91.5	56.7	61.0
	N	9	9	9	9	9	9	9	9
	Std. Deviation	3.5	1.9	3.7	5.1	3.0	4.4	3.7	6.2
	CV	0.03	0.02	0.04	0.05	0.04	0.05	0.07	0.10
Waterborne (SP3)	Mean	112.9	116.1	83.8	92.2	78.5	84.0	50.7	64.1
	N	9	9	9	9	9	9	9	9
	Std. Deviation	2.7	4.3	3.2	5.4	2.8	5.4	5.1	12.9
	CV	0.02	0.04	0.04	0.06	0.04	0.07	0.10	0.20
1.2 mm Thermoplastic (SP2)	Mean	113.2	117.0	104.9	113.6	85.8	96.6	79.1	88.4
	N	9	9	9	9	9	9	9	9
	Std. Deviation	4.5	4.4	3.4	4.3	5.3	8.0	2.9	3.8
	CV	0.04	0.04	0.03	0.04	0.06	0.08	0.04	0.04
1.2 mm Thermoplastic (SP1)	Mean	117.7	123.5	107.3	114.3	87.3	98.0	78.3	81.1
	N	9	9	9	9	9	9	9	9
	Std. Deviation	4.6	4.9	5.3	3.8	4.8	7.8	4.9	11.9
	CV	0.04	0.04	0.05	0.03	0.06	0.08	0.06	0.15
1 mm Cold Plastic (SP1)	Mean	115.8	116.5	98.4	106.8	93.5	99.0	64.5	68.2
	N	9	9	9	9	9	9	9	9
	Std. Deviation	2.7	7.0	5.2	4.0	5.5	2.5	3.9	3.8
	CV	0.02	0.06	0.05	0.04	0.06	0.03	0.06	0.06
3 mm Screed (SP1)	Mean	114.3	117.9	108.6	118.1	97.1	104.0	79.0	87.6
	N	9	9	9	9	9	9	9	9
	Std. Deviation	2.8	5.1	4.7	4.9	3.2	4.4	5.4	4.2
	CV	0.03	0.04	0.04	0.04	0.03	0.04	0.07	0.05
1 mm Cold Plastic (SP4)	Mean	105.4	105.9	94.0	99.8	88.3	92.6	49.8	56.2
	N	9	9	9	9	9	9	9	9
	Std. Deviation	2.4	3.2	2.2	3.2	2.3	3.7	2.8	4.6
	CV	0.02	0.03	0.02	0.03	0.03	0.04	0.06	0.08

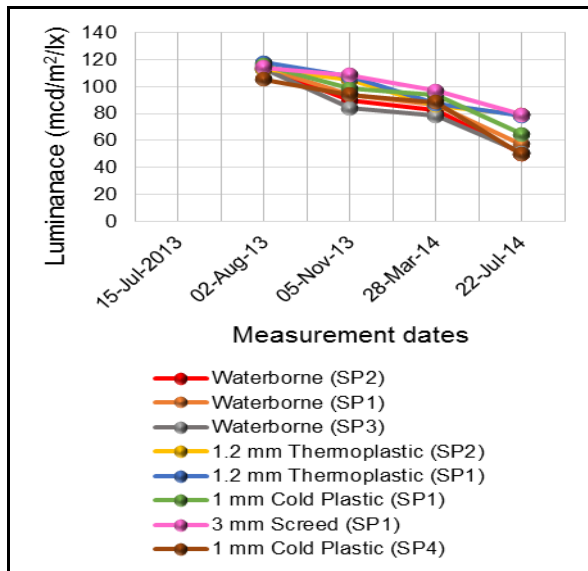

Figure B.7: Unwashed white transverse markings on Bushveld Road.

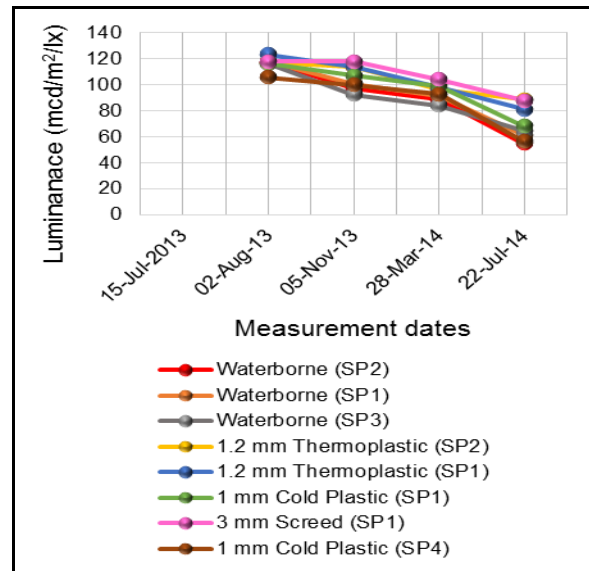

Figure B.8: Washed white transverse markings on Bushveld Road.

Table B.5: Summary of yellow transverse markings on long established clean chip seal road (Bushveld Road).

Type of road marking paint / material		02-Aug-2013		05-Nov-2013		28-Mar-2014		22-Jul-2014	
		Unwashed	Washed	Unwashed	Washed	Unwashed	Washed	Unwashed	Washed
Waterborne (SP2)	Mean	94.6	96.8	82.9	86.8	77.3	83.5	52.2	57.0
	N	9	9	9	9	9	9	9	9
	Std. Deviation	4.3	3.3	3.8	4.8	3.0	2.1	3.6	2.
	CV	0.05	0.03	0.05	0.06	0.04	0.02	0.07	0.05
Waterborne (SP1)	Mean	103.8	98.0	77.6	83.5	73.5	81.1	43.0	47.4
	N	9	9	9	9	9	9	9	9
	Std. Deviation	15.5	2.9	4.4	7.1	5.2	4.3	2.9	2.9
	CV	0.15	0.03	0.06	0.09	0.07	0.05	0.07	0.06
Waterborne (SP3)	Mean	91.8	94.5	76.6	81.4	71.9	78.8	42.6	46.9
	N	9	9	9	9	9	9	9	9
	Std. Deviation	3.8	3.0	5.4	6.5	6.0	4.6	1.8	2.5
	CV	0.04	0.03	0.07	0.08	0.08	0.06	0.04	0.06
1.2 mm Thermoplastic (SP2)	Mean	108.6	111.5	98.1	102.0	95.8	100.9	66.7	73.7
	N	9	9	9	9	9	9	9	9
	Std. Deviation	2.8	3.2	1.1	2.1	2.2	2.5	8.4	9.1
	CV	0.03	0.03	0.01	0.02	0.02	0.03	0.13	0.13
1.2 mm Thermoplastic (SP1)	Mean	115.2	118.0	101.9	105.3	96.8	103.2	62.8	72.9
	N	9	9	9	9	9	9	9	9
	Std. Deviation	1.8	3.7	1.0	2.6	1.1	1.9	2.1	3.9
	CV	0.02	0.03	0.01	0.03	0.01	0.02	0.03	0.06
1 mm Cold Plastic (SP1)	Mean	107.8	110.9	95.7	99.4	88.7	94.0	47.7	52.1
	N	9	9	9	9	9	9	9	9
	Std. Deviation	2.2	3.0	2.1	4.3	2.8	2.9	1.3	3.1
	CV	0.02	0.03	0.02	0.04	0.03	0.03	0.03	0.06
3 mm Screed (SP1)	Mean	116.5	120.0	102.3	105.7	96.7	102.8	63.9	71.5
	N	9	9	9	9	9	9	9	9
	Std. Deviation	1.6	2.4	1.9	2.6	2.3	2.1	1.7	3.0
	CV	0.01	0.02	0.02	0.03	0.03	0.02	0.03	0.04
1 mm Cold Plastic (SP4)	Mean	94.9	99.4	87.2	91.5	77.3	83.3	50.7	54.5
	N	9	9	9	9	9	9	9	9
	Std. Deviation	1.3	3.8	4.0	4.0	2.5	2.1	4.1	5.4
	CV	0.01	0.04	0.05	0.05	0.03	0.03	0.08	0.10

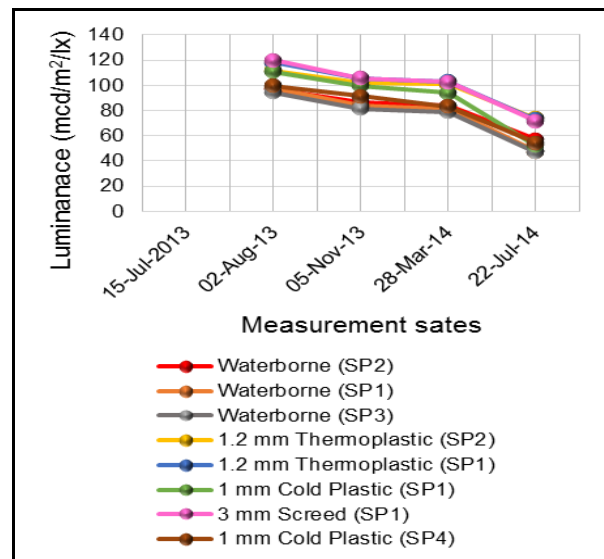
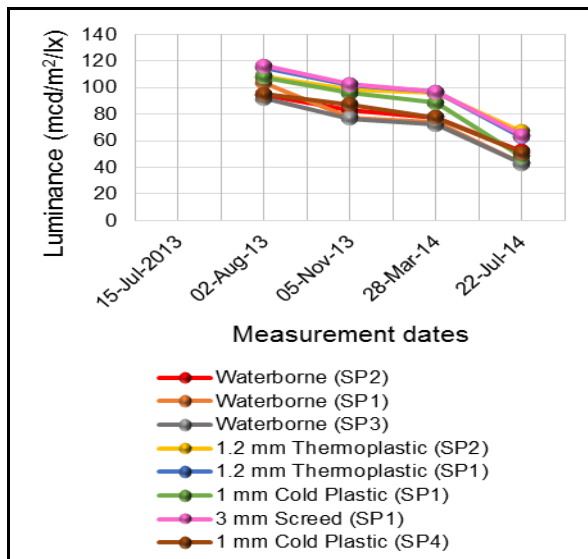

Figure B.9: Unwashed yellow transverse markings on Bushveld Road.

Figure B.10: Washed yellow transverse markings on Bushveld Road.

Table B.6: Summary of longitudinal markings on long established clean chip seal road (Bushveld Road).

Type of road marking paint / material		02-Aug-2013		05-Nov-2013		28-Mar-2014		22-Jul-2014	
		White	Yellow	White	Yellow	White	Yellow	White	Yellow
Waterborne (SP2)	Mean	145.7		125.7		98.8		78.4	
	N	3		3		3		3	
	Std. Deviation	8.2		12.8		11.5		4.0	
	CV	0.06		0.10		0.11		0.05	
Waterborne (SP1)	Mean	169.3	104.8	145.2	81.9	106.8	67.4	90.1	52.8
	N	3	3	3	3	3	3	3	3
	Std. Deviation	8.5	4.5	9.4	2.3	11.5	3.7	6.6	3.7
	CV	0.05	0.04	0.07	0.02	0.11	0.06	0.07	0.07
1.2 mm Thermoplastic (SP1)	Mean	216.4	133.8	175.5	97.3	129.3	79.7	107.4	71.4
	N	3	3	3	3	3	3	3	3
	Std. Deviation	19.2	1.5	20.4	3.0	11.3	0.8	12.0	4.0
	CV	0.09	0.01	0.12	0.03	0.09	0.01	0.11	0.01
1.2 mm Thermoplastic (SP2)	Mean		132.7		108.7		83.2		60.8
	N		3		3		3		3
	Std. Deviation		0.6		6.2		0.4		2.6
	CV		0.01		0.06		0.01		0.04
3 mm Screed (SP1)	Mean	248.1	133.0	201.8	109.1	136.1	84.1	118.6	66.6
	N	3	3	3	3	3	3	3	3
	Std. Deviation	3.0	2.7	18.5	7.9	10.3	6.5	4.1	7.5
	CV	0.01	0.02	0.09	0.07	0.08	0.08	0.04	0.11

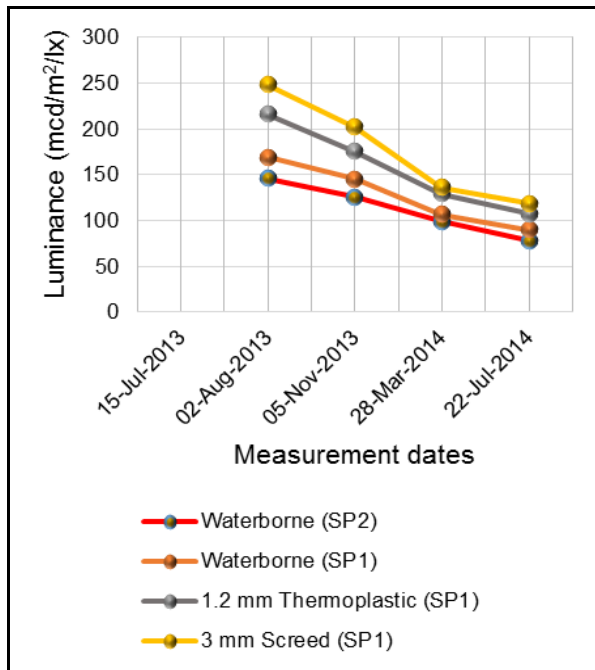

Figure B.11: Unwashed white longitudinal markings on Bushveld Road.

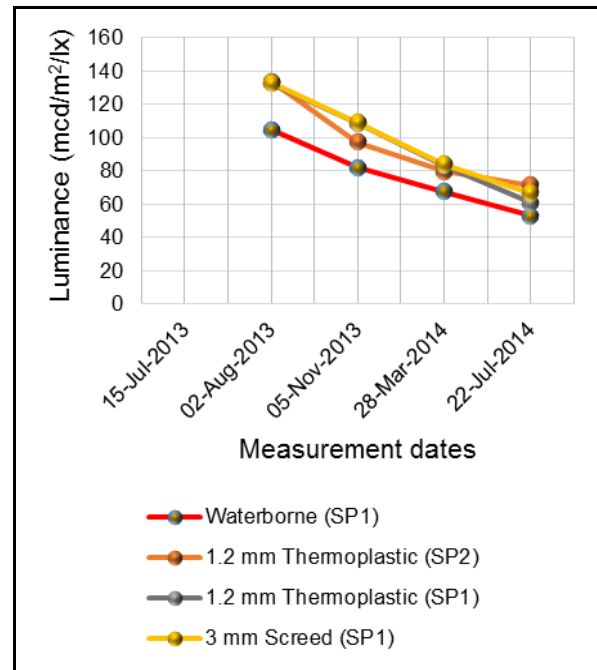

Figure B.12: Unwashed yellow longitudinal markings on Bushveld Road.

Table B.7: Summary of white transverse markings on newly established clean chip seal road (Doreen Street - B 1).

Type of road marking paint / material		01-Aug-2013		21-Nov-2013		26-Mar-2014		25-Jul-2014	
		Unwashed	Washed	Unwashed	Washed	Unwashed	Washed	Unwashed	Washed
Waterborne (SP2)	Mean	113.6	118.0	63.6	74.0				
	N	3	3	3	3				
	Std. Deviation	3.0	1.5	6.7	13.6				
	CV	0.03	0.01	0.11	0.22				
Waterborne (SP1)	Mean	130.7	146.0	105.7	109.2	89.1	97.5	67.7	71.8
	N	3	3	3	3	3	3	3	3
	Std. Deviation	7.1	16.3	9.3	7.5	6.4	0.5	1.2	3.4
	CV	0.06	0.11	0.09	0.07	0.07	0.01	0.02	0.05
Waterborne (SP3)	Mean	128.3	138.7	82.6	93.9	73.1	86.3	45.1	47.5
	N	3	3	3	3	3	3	3	3
	Std. Deviation	3.6	7.4	11.34	13.7	5.0	4.1	0.2	2.3
	CV	0.03	0.05	0.14	0.15	0.07	0.05	0.01	0.05
1.2 mm Thermoplastic (SP2)	Mean	112.1	127.3	103.5	117.0	91.2	95.0	61.9	68.1
	N	3	3	3	3	3	3	3	3
	Std. Deviation	3.6	6.6	2.3	5.5	3.6	2.9	3.	1.5
	CV	0.03	0.05	0.02	0.05	0.04	0.03	0.06	0.02
1.2 mm Thermoplastic (SP1)	Mean	146.5	150.2	116.7	128.8	93.0	111.5	77.4	85.9
	N	3	3	3	3	3	3	3	3
	Std. Deviation	8.9	10.4	5.3	18.3	2.8	3.7	4.0	5.1
	CV	0.06	0.07	0.05	0.14	0.03	0.03	0.05	0.06
1 mm Cold Plastic (SP1)	Mean	130.9	135.8	91.5	105.0	84.5	92.7	60.5	65.0
	N	3	3	3	3	3	3	3	3
	Std. Deviation	14.7	3.7	9.3	7.0	7.4	2.2	2.1	5.4
	CV	0.11	0.03	0.10	0.07	0.09	0.02	0.04	0.08
3 mm Screed (SP1)	Mean	141.8	153.2	130.6	133.0	113.1	118.2	72.9	79.4
	N	3	3	3	3	3	3	3	3
	Std. Deviation	5.2	3.5	7.9	8.0	5.5	3.0	7.1	7.4
	CV	0.04	0.02	0.06	0.06	0.05	0.03	0.10	0.09
1 mm Cold Plastic (SP4)	Mean	114.2	126.4	84.3	88.9	75.6	85.2	46.5	51.6
	N	3	3	3	3	3	3	3	3
	Std. Deviation	5.4	4.6	10.9	8.2	5.3	3.4	2.2	2.0
	CV	0.05	0.04	0.13	0.09	0.07	0.04	0.05	0.04

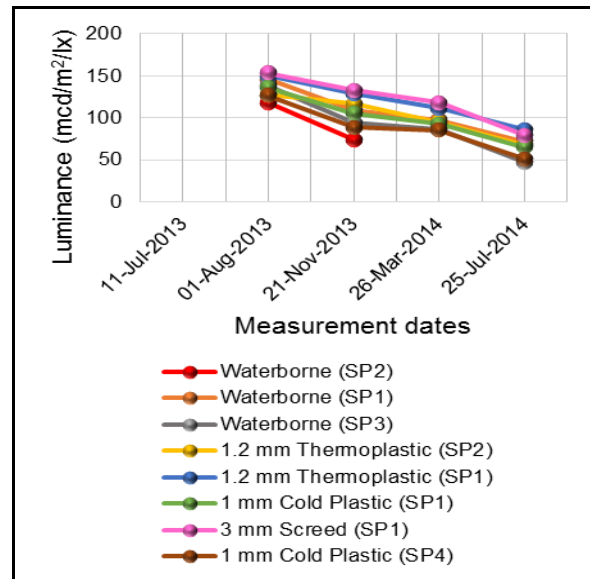
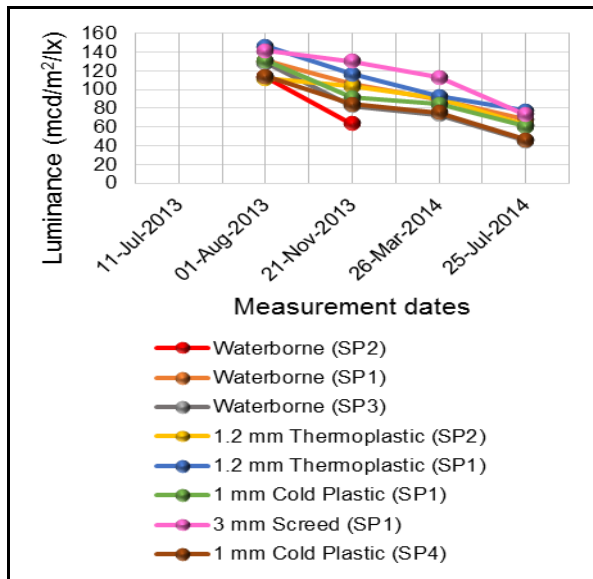

Figure B.13: Unwashed white transverse markings on Doreen Street (B 1).

Figure B.14: Washed white transverse markings on Doreen Street (B 1).

Table B.8: Summary of yellow transverse markings on newly established clean chip seal road (Doreen Street - B 1).

Type of road marking paint / material		01-Aug-2013		21-Nov-2013		26-Mar-2014		25-Jul-2014	
		Unwashed	Washed	Unwashed	Washed	Unwashed	Washed	Unwashed	Washed
Waterborne (SP2)	Mean	100.3	104.9	69.9	78.8	54.8	62.4		
	N	3	3	3	3	3	3		
	Std. Deviation	1.1	2.8	5.0	3.0	1.1	3.2		
	CV	0.01	0.03	0.07	0.04	0.02	0.05		
Waterborne (SP1)	Mean	114.5	122.2	81.8	85.1	59.5	68.3		
	N	3	3	3	3	3	3		
	Std. Deviation	1.9	3.5	4.5	2.2	4.8	1.9		
	CV	0.02	0.03	0.06	0.03	0.08	0.02		
Waterborne (SP3)	Mean	105.1	114.3	86.7	92.8	69.9	83.3	45.0	47.4
	N	3	3	3	3	3	3	3	3
	Std. Deviation	4.4	2.3	7.9	3.8	3.8	4.5	4.8	2.2
	CV	0.04	0.02	0.09	0.04	0.05	0.05	0.11	0.05
1.2 mm Thermoplastic (SP2)	Mean	99.6	103.1	69.7	76.0	60.5	72.1	52.3	52.8
	N	3	3	3	3	3	3	3	3
	Std. Deviation	3.0	0.6	1.8	2.2	4.1	3.9	2.9	5.6
	CV	0.03	0.01	0.03	0.03	0.07	0.06	0.06	0.11
1.2 mm Thermoplastic (SP1)	Mean	119.8	126.2	96.9	101.4	76.4	85.2	56.0	62.8
	N	3	3	3	3	3	3	3	3
	Std. Deviation	6.1	1.7	4.8	1.7	9.3	3.5	7.7	7.3
	CV	0.05	0.01	0.05	0.02	0.12	0.04	0.14	0.11
1 mm Cold Plastic (SP1)	Mean	101.3	108.0	92.0	102.5	76.4	87.6	50.4	53.1
	N	3	3	3	3	3	3	3	3
	Std. Deviation	5.6	3.1	2.1	5.4	0.8	4.8	2.8	6.4
	CV	0.06	0.03	0.02	0.05	0.01	0.06	0.06	0.12
3 mm Screed (SP1)	Mean	115.4	122.2	98.5	103.4	86.7	91.8	63.5	65.7
	N	3	3	3	3	3	3	3	3
	Std. Deviation	2.9	4.8	1.6	2.9	2.3	3.1	2.7	5.8
	CV	0.19	0.04	0.02	0.03	0.03	0.03	0.04	0.09
1 mm Cold Plastic (SP4)	Mean	89.5	109.1	78.2	82.7	69.9	80.7	46.8	50.6
	N	3	3	3	3	3	3	3	3
	Std. Deviation	16.4	2.2	8.9	4.1	3.9	2.6	2.8	3.0
	CV	0.18	0.02	0.11	0.05	0.06	0.03	0.06	0.06

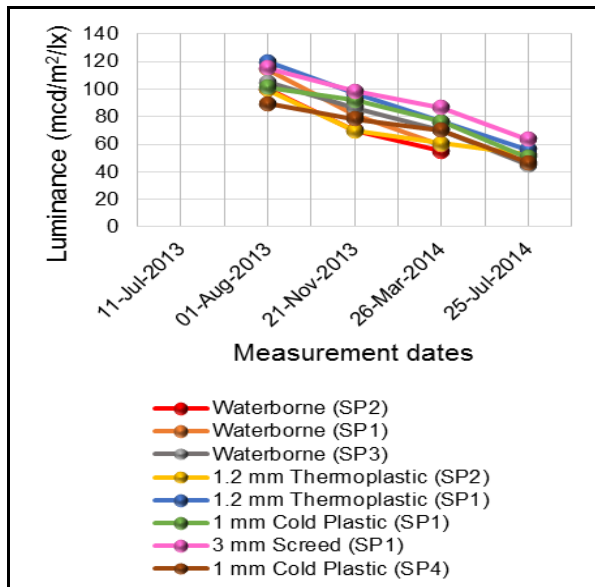

Figure B.15: Unwashed yellow transverse markings on Doreen Street (B 1).

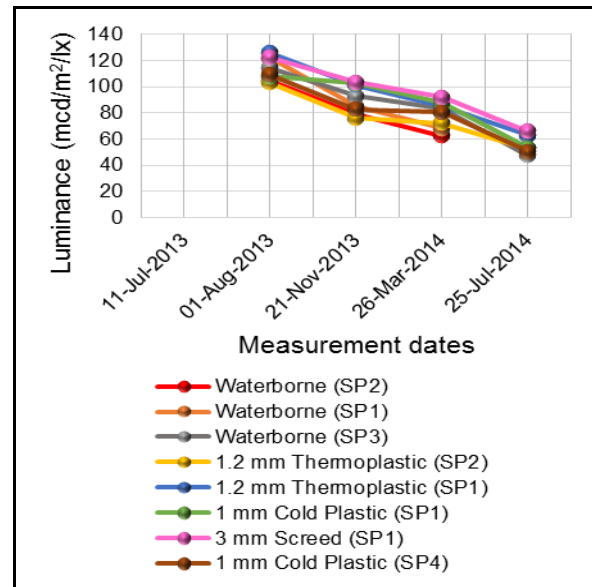

Figure B.16: Washed yellow transverse markings on Doreen Street (B 1).

Table B.9: Summary of longitudinal markings on newly established clean chip seal road (Doreen Street - B 1).

Type of road marking paint / material		01-Aug-2013		21-Nov-2013		26-Mar-2014		25-Jul-2014	
		White	Yellow	White	Yellow	White	Yellow	White	Yellow
Waterborne (SP2)	Mean	125.0	120.8		95.3		61.0		38.6
	N	1	1		1		1		1
	Std. Deviation	0.0	0.0		0.0		0.0		0.0
	CV	0.00	0.00		0.00		0.00		0.00
Waterborne (SP1)	Mean	119.2	119.0	104.3	95.5	78.4	62.3		38.5
	N	1	1	1	1	1	1		1
	Std. Deviation	0.0	0.0	0.0	0.0	0.0	0.0		0.0
	CV	0.00	0.00	0.00	0.00	0.00	0.00		0.00
1.2 mm Thermoplastic (SP2)	Mean	127.5	118.4	109.0	92.4	70.8	72.2	41.6	47.4
	N	1	1	1	1	1	1	1	1
	Std. Deviation	0.0	0.0	0.0	0.0	0.0	0.0	0.0	0.0
	CV	0.00	0.00	0.00	0.00	0.00	0.00	0.00	0.00
1.2 mm Thermoplastic (SP1)	Mean	124.8	115.0	108.0	99.4	83.6	87.8	46.1	63.8
	N	1	1	1	1	1	1	1	1
	Std. Deviation	0.0	0.0	0.0	0.0	0.0	0.0	0.0	0.0
	CV	0.00	0.00	0.00	0.00	0.00	0.00	0.00	0.00
3 mm Screed (SP1)	Mean	132.5	118.2	110.3	106.8	91.0	90.2	66.7	67.7
	N	1	1	1	1	1	1	1	1
	Std. Deviation	0.0	0.0	0.0	0.0	0.0	0.0	0.0	0.0
	CV	0.00	0.00	0.00	0.00	0.00	0.00	0.00	0.00

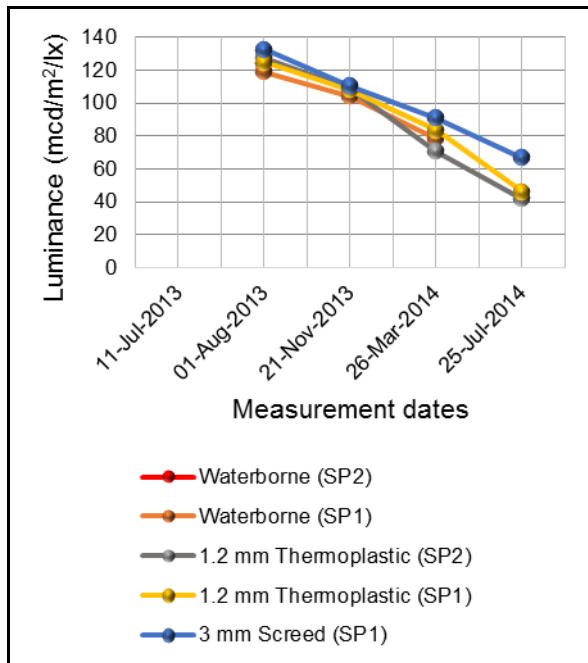

Figure B.17: Unwashed white longitudinal markings on Doreen Street (B 1).

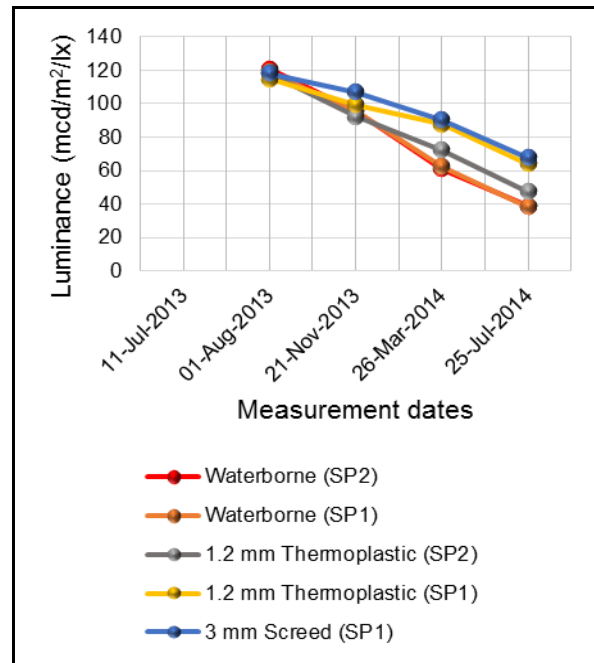

Figure B.18: Unwashed yellow longitudinal markings on Doreen Street (B 1).

Table B.10: Summary of white transverse markings on newly established clean chip seal road (Doreen Street - B's 2 & 3).

Type of road marking paint / material		01-Aug-2013		21-Nov-2013		26-Mar-2014		25-Jul-2014	
		Unwashed	Washed	Unwashed	Washed	Unwashed	Washed	Unwashed	Washed
Waterborne (SP2)	Mean	111.1	113.9	60.8	77.5	51.2	62.2	35.3	37.5
	N	6	6	6	6	6	6	6	6
	Std. Deviation	5.3	4.3	2.7	8.6	2.9	6.7	3.0	1.4
	CV	0.05	0.04	0.05	0.11	0.06	0.11	0.09	0.04
Waterborne (SP1)	Mean	139.4	144.2	84.9	92.9	69.6	78.1	49.0	53.3
	N	6	6	6	6	6	6	6	6
	Std. Deviation	6.2	6.2	7.3	7.4	9.5	9.3	8.0	8.9
	CV	0.04	0.04	0.09	0.08	0.14	0.12	0.17	0.17
Waterborne (SP3)	Mean	134.2	140.7	83.9	89.4	69.2	80.1	51.0	54.1
	N	6	6	6	6	6	6	6	6
	Std. Deviation	2.8	4.0	2.3	3.6	2.4	2.5	3.4	1.1
	CV	0.02	0.03	0.03	0.04	0.04	0.03	0.07	0.02
1.2 mm Thermoplastic (SP2)	Mean	134.0	140.2	101.5	105.8	83.6	89.6	68.3	77.3
	N	6	6	6	6	6	6	6	6
	Std. Deviation	3.0	2.6	5.5	5.4	6.4	2.7	8.3	10.1
	CV	0.02	0.02	0.05	0.05	0.08	0.03	0.12	0.13
1.2 mm Thermoplastic (SP1)	Mean	139.2	146.6	111.7	117.2	93.2	102.7	71.2	76.9
	N	6	6	6	6	6	6	6	6
	Std. Deviation	4.3	7.0	8.3	10.0	1.9	7.3	6.3	1.2
	CV	0.03	0.05	0.08	0.09	0.02	0.07	0.09	0.02
1 mm Cold Plastic (SP1)	Mean	131.0	135.2	84.2	89.8	69.7	83.0	50.2	53.1
	N	6	6	6	6	6	6	6	6
	Std. Deviation	3.0	5.0	4.0	3.9	3.9	6.4	3.7	3.6
	CV	0.02	0.04	0.05	0.04	0.06	0.08	0.08	0.07
3 mm Screed (SP1)	Mean	145.1	147.2	108.2	117.8	92.4	102.4	66.8	73.3
	N	6	6	6	6	6	6	6	6
	Std. Deviation	4.4	3.0	7.4	9.6	2.8	3.7	5.4	2.9
	CV	0.03	0.02	0.07	0.08	0.03	0.04	0.08	0.04
1 mm Cold Plastic (SP4)	Mean	137.2	142.8	91.3	95.9	75.3	93.0	56.2	60.7
	N	6	6	6	6	6	6	6	6
	Std. Deviation	3.6	2.5	8.4	5.9	2.9	7.3	3.3	3.8
	CV	0.03	0.02	0.09	0.06	0.04	0.08	0.06	0.06

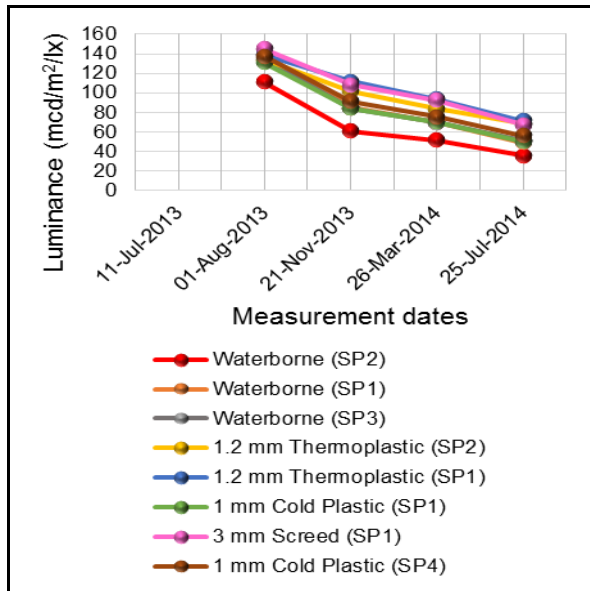

Figure B.19: Unwashed white transverse markings on Doreen Street (B's 2 & 3).

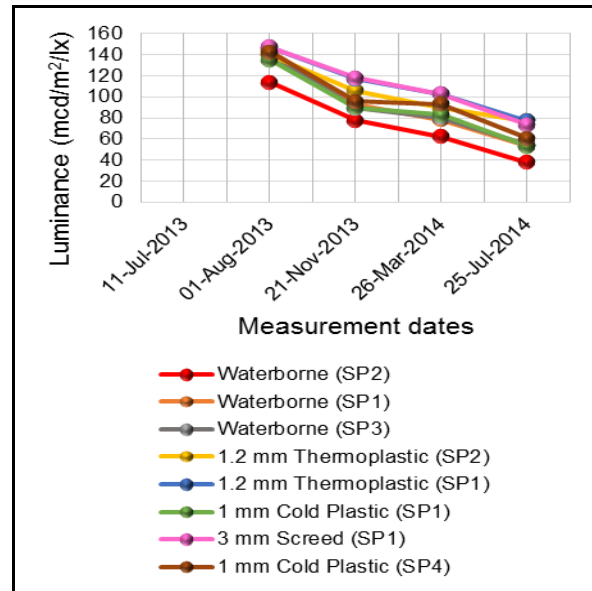

Figure B.20: Washed white transverse markings on Doreen Street (B's 2 & 3).

Table B.11: Summary of yellow transverse markings on newly established clean chip seal road (Doreen Street - B's 2 & 3).

Type of road marking paint / material		01-Aug-2013		21-Nov-2013		26-Mar-2014		25-Jul-2014	
		Unwashed	Washed	Unwashed	Washed	Unwashed	Washed	Unwashed	Washed
Waterborne (SP2)	Mean	105.5	97.7	66.8	73.3	55.7	60.5	33.0	35.0
	N	6	6	6	6	6	6	6	6
	Std. Deviation	5.1	19.9	4.2	3.0	1.4	2.4	2.7	0.7
	CV	0.05	0.20	0.06	0.06	0.03	0.04	0.08	0.02
Waterborne (SP1)	Mean	110.6	115.8	77.5	82.2	63.1	69.6	36.3	39.9
	N	6	6	6	6	6	6	6	6
	Std. Deviation	2.8	5.3	7.1	4.1	3.6	3.0	3.9	2.5
	CV	0.03	0.34	0.09	0.05	0.06	0.04	0.11	0.06
Waterborne (SP3)	Mean	104.4	110.6	85.6	89.3	69.4	73.7	39.4	42.2
	N	6	6	6	6	6	6	6	6
	Std. Deviation	3.1	2.4	3.3	3.0	2.5	1.7	2.2	2.1
	CV	0.03	0.02	0.04	0.03	0.04	0.02	0.06	0.05
1.2 mm Thermoplastic (SP2)	Mean	108.4	111.3	78.7	85.2	71.0	75.5	59.7	66.4
	N	6	6	6	6	6	6	6	6
	Std. Deviation	5.2	5.1	5.9	3.9	3.7	4.0	7.4	7.3
	CV	0.05	0.05	0.08	0.05	0.05	0.05	0.12	0.11
1.2 mm Thermoplastic (SP1)	Mean	127.0	129.1	98.1	103.8	80.5	87.0	53.1	59.9
	N	6	6	6	6	6	6	6	6
	Std. Deviation	3.3	7.2	14.1	8.5	7.9	8.6	6.7	4.0
	CV	0.03	0.03	0.15	0.08	0.10	0.10	0.13	0.07
1 mm Cold Plastic (SP1)	Mean	109.2	115.1	93.0	98.0	76.2	84.4	42.5	45.0
	N	6	6	6	6	6	6	6	6
	Std. Deviation	1.9	6.1	5.1	3.9	3.9	4.8	3.5	1.3
	CV	0.02	0.05	0.06	0.04	0.05	0.06	0.08	0.03
3 mm Screed (SP1)	Mean	120.8	124.9	100.5	105.6	85.9	93.3	56.0	63.1
	N	6	6	6	6	6	6	6	6
	Std. Deviation	4.3	2.0	4.5	3.4	1.9	2.2	6.4	4.1
	CV	0.04	0.02	0.05	0.03	0.02	0.02	0.12	0.07
1 mm Cold Plastic (SP4)	Mean	102.7	113.1	88.6	95.2	76.0	82.8	46.6	49.1
	N	6	6	6	6	6	6	6	6
	Std. Deviation	4.7	12.9	8.0	5.6	2.3	1.5	8.1	4.6
	CV	0.05	0.11	0.09	0.06	0.03	0.02	0.17	0.10

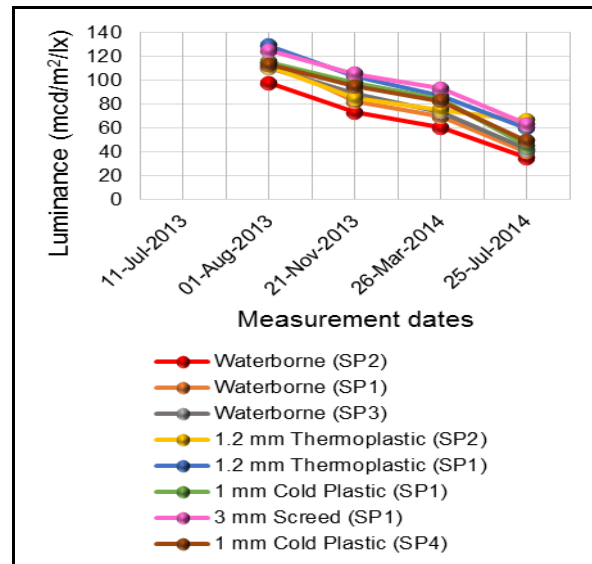
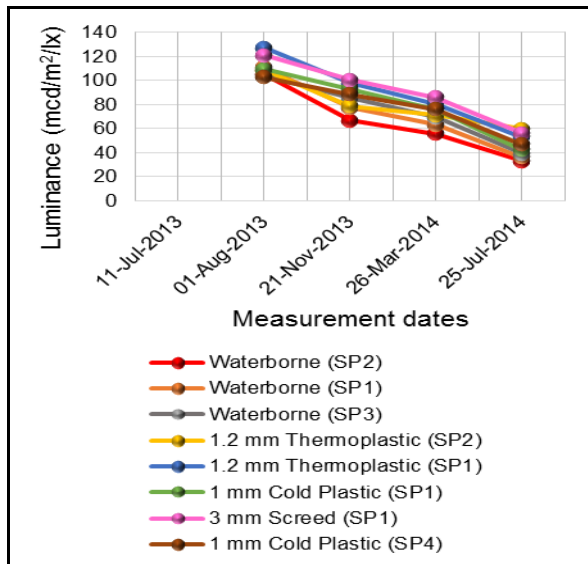

Figure B.21: Unwashed yellow transverse markings on Doreen Street (B's 2 & 3).

Figure B.22: Washed yellow transverse markings on Doreen Street (B's 2 & 3).

Table B.12: Summary of longitudinal markings on newly established clean chip seal road (Doreen Street - B's 2 & 3).

Type of road marking paint / material		01-Aug-2013		21-Nov-2013		26-Mar-2014		25-Jul-2014	
		White	Yellow	White	Yellow	White	Yellow	White	Yellow
Waterborne (SP2)	Mean	130.8	122.8	104.9	98.0	88.5	78.1	37.2	47.6
	N	2	2	2	2	2	2	2	2
	Std. Deviation	6.5	1.4	2.1	2.5	3.2	4.7	3.5	4.0
	CV	0.05	0.01	0.02	0.03	0.04	0.06	0.09	0.07
Waterborne (SP1)	Mean	133.3	120.5	106.0	97.7	83.2	81.6	45.0	50.3
	N	2	2	2	2	2	2	2	2
	Std. Deviation	4.9	0.5	3.7	0.8	1.4	8.4	4.4	1.8
	CV	0.04	0.00	0.04	0.01	0.02	0.10	0.10	0.04
1.2 mm Thermoplastic (SP2)	Mean	134.1	124.1	104.7	97.8	87.1	93.2	41.3	48.2
	N	2	2	2	2	2	2	2	2
	Std. Deviation	0.4	0.1	0.7	3.1	2.9	1.8	1.0	4.6
	CV	0.00	0.00	0.01	0.03	0.03	0.02	0.02	0.10
1.2 mm Thermoplastic (SP1)	Mean	127.7	122.7	102.6	102.1	91.2	91.6	52.7	59.7
	N	2	2	2	2	2	2	2	2
	Std. Deviation	0.9	3.7	1.7	3.5	5.2	1.3	8.2	0.3
	CV	0.01	0.03	0.02	0.03	0.03	0.01	0.16	0.01
3 mm Screed (SP1)	Mean	129.2	122.8	108.4	105.5	95.5	97.9	66.2	61.6
	N	2	2	2	2	2	2	2	2
	Std. Deviation	5.1	1.8	1.8	4.8	5.8	0.5	9.5	3.8
	CV	0.04	0.02	0.02	0.05	0.06	0.01	0.14	0.06

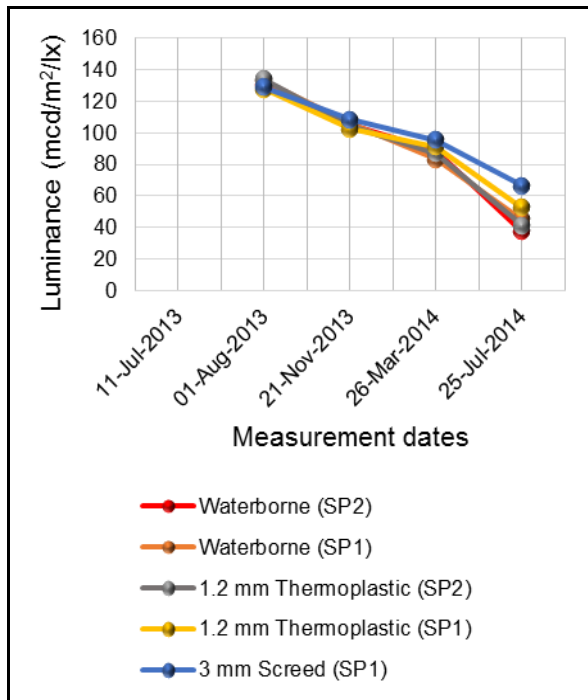

Figure B.23: Unwashed white longitudinal markings on Doreen Street (B's 2 & 3).

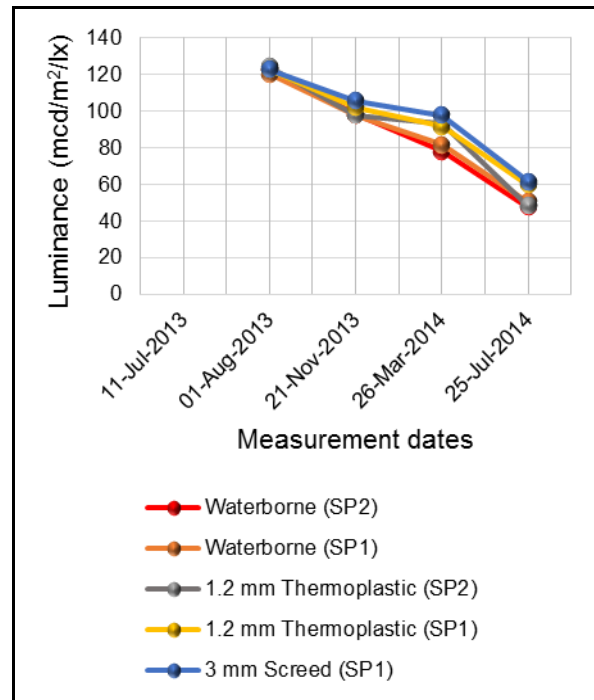

Figure B.24: Unwashed yellow longitudinal markings on Doreen Street (B's 2 & 3).

Table B.13: Summary of white transverse markings on newly established clean chip seal road (Doreen Street - B's 1, 2 & 3).

Type of road marking paint / material		01-Aug-2013		21-Nov-2013		26-Mar-2014		25-Jul-2014	
		Unwashed	Washed	Unwashed	Washed	Unwashed	Washed	Unwashed	Washed
Waterborne (SP2)	Mean	111.9	115.3	61.8	76.4	51.2	62.2	35.3	37.5
	N	9	9	9	9	6	6	6	6
	Std. Deviation	4.6	4.1	4.2	9.8	2.9	6.7	3.0	1.4
	CV	0.04	0.04	0.07	0.13	0.06	0.11	0.09	0.04
Waterborne (SP1)	Mean	136.5	144.8	91.9	98.3	76.1	84.5	55.2	59.5
	N	9	9	9	9	9	9	9	9
	Std. Deviation	7.4	9.6	12.8	10.7	12.7	12.2	11.3	11.7
	CV	0.06	0.07	0.14	0.11	0.17	0.14	0.14	0.20
Waterborne (SP3)	Mean	132.2	140.0	83.5	90.9	70.5	82.2	49.0	51.9
	N	9	9	9	9	9	9	9	9
	Std. Deviation	4.1	5.0	6.0	7.7	3.7	4.2	4.0	3.6
	CV	0.03	0.04	0.07	0.09	0.05	0.05	0.08	0.07
1.2 mm Thermoplastic (SP2)	Mean	126.7	135.9	102.2	109.5	86.1	91.4	66.2	74.3
	N	9	9	9	9	9	9	9	9
	Std. Deviation	11.3	7.5	4.6	7.6	6.5	3.7	7.5	9.2
	CV	0.09	0.06	0.05	0.07	0.08	0.04	0.11	0.13
1.2 mm Thermoplastic (SP1)	Mean	141.7	147.8	113.4	121.0	93.1	105.6	73.3	79.9
	N	9	9	9	9	9	9	9	9
	Std. Deviation	6.7	7.8	7.5	13.4	2.0	7.5	6.2	5.2
	CV	0.05	0.05	0.07	0.11	0.02	0.07	0.09	0.07
1 mm Cold Plastic (SP1)	Mean	130.9	135.4	86.6	94.9	74.7	86.2	53.6	57.1
	N	9	9	9	9	9	9	9	9
	Std. Deviation	7.7	4.3	6.7	8.9	8.8	7.1	6.0	7.1
	CV	0.06	0.03	0.08	0.09	0.12	0.08	0.11	0.13
3 mm Screed (SP1)	Mean	144.0	149.2	115.7	122.9	99.3	107.7	68.9	75.3
	N	9	9	9	9	9	9	9	9
	Std. Deviation	4.6	4.2	13.2	11.4	10.9	8.5	6.3	5.3
	CV	0.03	0.03	0.12	0.09	0.11	0.08	0.09	0.07
1 mm Cold Plastic (SP4)	Mean	129.5	137.3	89.0	93.5	75.4	90.4	52.9	57.7
	N	9	9	9	9	9	9	9	9
	Std. Deviation	12.1	8.7	9.2	7.1	3.5	7.1	5.6	5.6
	CV	0.09	0.06	0.10	0.08	0.05	0.08	0.11	0.10

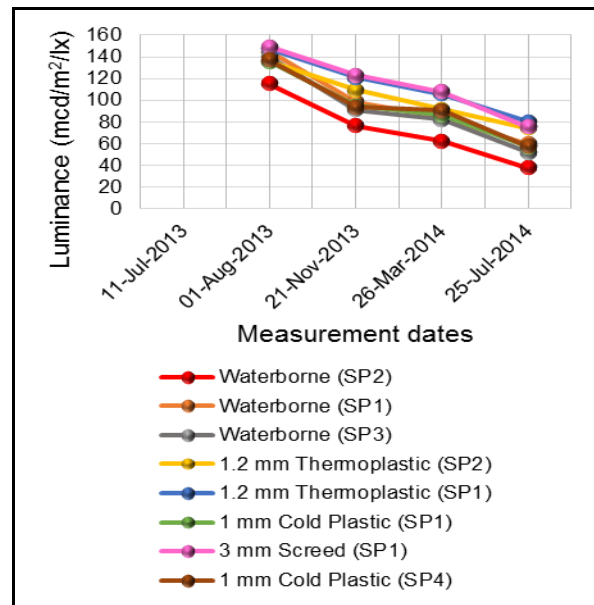
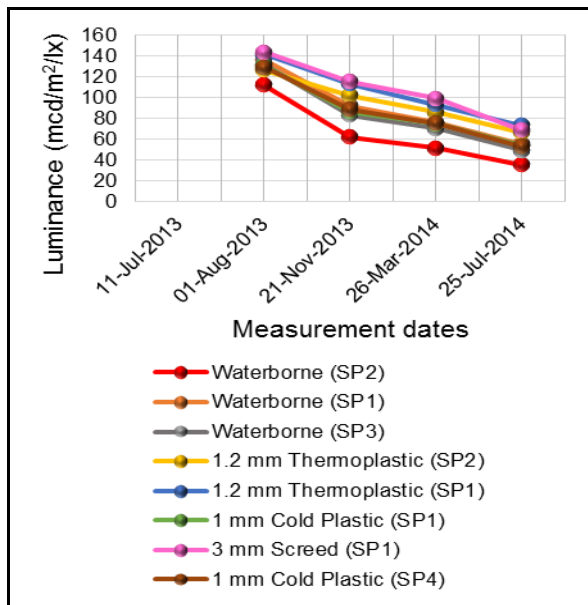

Figure B.25: Unwashed white transverse markings on Doreen Street (B's 1, 2 & 3).

Figure B.26: Washed white transverse markings on Doreen Street (B's 1, 2 & 3).

Table B.14: Summary of yellow transverse markings on newly established clean chip seal road (Doreen Street - B's 1, 2 & 3).

Type of road marking paint / material		01-Aug-2013		21-Nov-2013		26-Mar-2014		25-Jul-2014	
		Unwashed	Washed	Unwashed	Washed	Unwashed	Washed	Unwashed	Washed
Waterborne (SP2)	Mean	103.8	100.1	67.9	75.1	55.4	61.1	33.0	35.0
	N	9	9	9	9	9	9	6	6
	Std. Deviation	4.8	16.2	4.4	3.9	1.3	2.6	2.71	0.7
	CV	0.05	0.16	0.07	0.05	0.03	0.04	0.08	0.02
Waterborne (SP1)	Mean	111.9	118.0	78.9	83.1	61.9	69.2	36.3	39.9
	N	9	9	9	9	9	9	6	6
	Std. Deviation	3.1	5.5	6.4	3.7	4.1	2.7	3.9	2.5
	CV	0.03	0.05	0.08	0.05	0.07	0.04	0.11	0.06
Waterborne (SP3)	Mean	104.6	111.8	86.0	90.5	69.6	76.9	41.3	44.0
	N	9	9	9	9	9	9	9	9
	Std. Deviation	3.3	2.9	4.7	3.5	2.7	5.5	4.1	3.2
	CV	0.03	0.03	0.06	0.04	0.04	0.07	0.10	0.08
1.2 mm Thermoplastic (SP2)	Mean	105.5	108.6	75.7	82.2	67.5	74.4	57.2	61.9
	N	9	9	9	9	9	9	9	9
	Std. Deviation	6.2	5.8	6.5	5.6	6.4	4.1	7.0	9.4
	CV	0.06	0.05	0.09	0.07	0.10	0.06	0.12	0.15
1.2 mm Thermoplastic (SP1)	Mean	124.6	128.1	97.7	103.0	79.1	86.4	54.0	60.9
	N	9	9	9	9	9	9	9	9
	Std. Deviation	5.4	5.9	11.4	6.8	8.1	7.1	6.7	5.0
	CV	0.04	0.05	0.12	0.07	0.10	0.08	0.12	0.09
1 mm Cold Plastic (SP1)	Mean	106.6	112.7	92.7	99.5	76.2	85.4	45.1	47.7
	N	9	9	9	9	9	9	9	9
	Std. Deviation	5.0	6.2	4.2	4.7	3.1	4.8	5.0	5.2
	CV	0.05	0.06	0.05	0.05	0.04	0.06	0.11	0.11
3 mm Screed (SP1)	Mean	119.0	124.0	99.8	104.9	86.1	92.8	58.5	64.0
	N	9	9	9	9	9	9	9	9
	Std. Deviation	4.6	3.1	3.8	3.3	2.0	2.4	6.5	4.6
	CV	0.04	0.03	0.04	0.03	0.02	0.03	0.11	0.07
1 mm Cold Plastic (SP4)	Mean	98.3	111.8	85.1	91.0	74.0	82.1	46.7	49.6
	N	9	9	9	9	9	9	9	9
	Std. Deviation	11.1	10.4	9.3	7.9	4.0	2.1	6.5	4.0
	CV	0.11	0.09	0.10	0.09	0.05	0.03	0.14	0.08

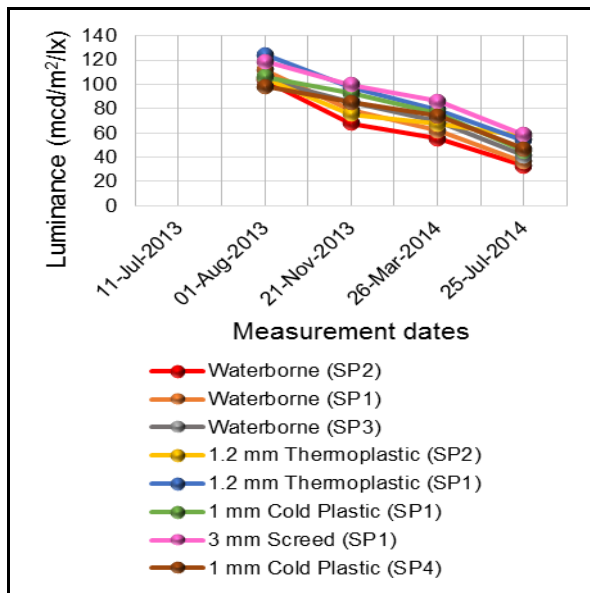

Figure B.27: Unwashed yellow transverse markings on Doreen Street (B's 1, 2 & 3).

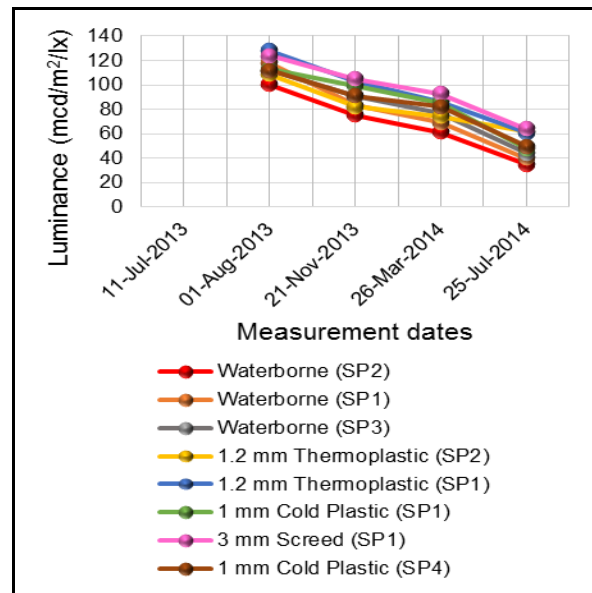

Figure B.28: Washed yellow transverse markings on Doreen Street (B's 1, 2 & 3).

Table B.15: Summary of longitudinal markings on newly established clean chip seal road (Doreen Street - B's 1, 2 & 3).

Type of road marking paint / material		01-Aug-2013		21-Nov-2013		26-Mar-2014		25-Jul-2014	
		White	Yellow	White	Yellow	White	Yellow	White	Yellow
Waterborne (SP2)	Mean	128.0	122.2	104.9	97.1	88.5	72.4	37.2	44.6
	N	3	3	2	3	2	3	2	3
	Std. Deviation	5.7	1.5	2.1	2.3	3.2	10.4	3.5	5.9
	CV	0.04	0.12	0.02	0.02	0.04	0.14	0.09	0.13
Waterborne (SP1)	Mean	128.6	120.0	105.4	97.0	81.6	75.2	45.0	46.4
	N	3	3	3	3	3	3	2	3
	Std. Deviation	8.8	0.9	2.8	1.3	2.9	12.6	4.4	6.9
	CV	0.07	0.01	0.03	0.01	0.04	0.17	0.10	0.15
1.2 mm Thermoplastic (SP2)	Mean	131.9	122.2	106.1	96.0	81.7	86.2	41.4	48.0
	N	3	3	3	3	3	3	3	3
	Std. Deviation	3.7	3.3	2.5	3.8	9.6	12.1	0.8	3.3
	CV	0.03	0.03	0.02	0.04	0.12	0.14	0.02	0.07
1.2 mm Thermoplastic (SP1)	Mean	126.8	120.1	104.4	101.2	88.7	90.3	50.5	61.1
	N	3	3	3	3	3	3	3	3
	Std. Deviation	1.7	5.2	3.3	2.9	5.7	2.3	6.9	2.4
	CV	0.01	0.04	0.03	0.03	0.06	0.03	0.14	0.04
3 mm Screed (SP1)	Mean	130.3	121.2	109.0	106.0	94.0	95.3	66.4	63.6
	N	3	3	3	3	3	3	3	3
	Std. Deviation	4.1	2.9	1.7	3.5	4.8	4.4	6.7	4.4
	CV	0.03	0.02	0.02	0.03	0.05	0.05	0.10	0.07

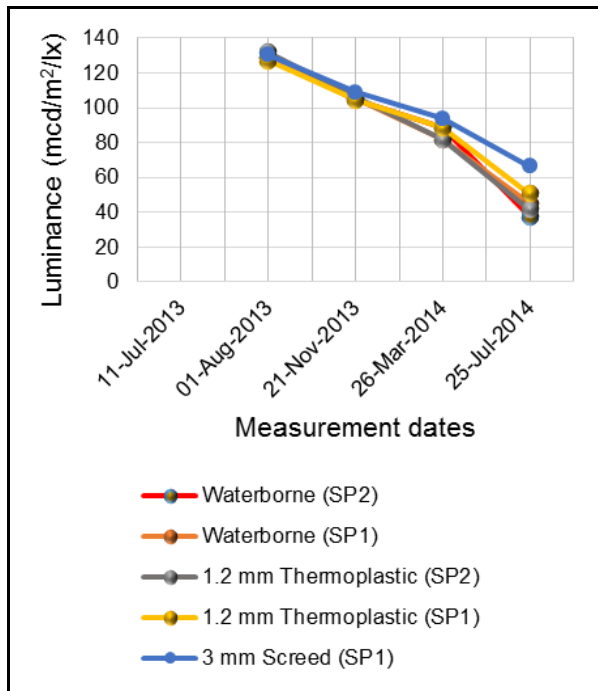

Figure B.29: Un washed white longitudinal markings on Doreen Street (B's 1, 2 & 3).

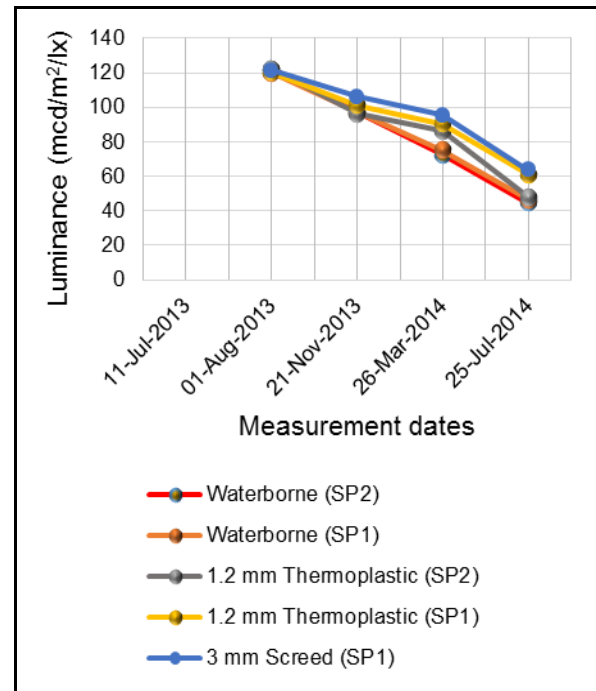

Figure B.30: Un washed yellow longitudinal markings on Doreen Street (B's 1, 2 & 3).

Table B.16: Summary of white transverse markings on newly established dirty asphalt road (M 44).

Type of road marking paint / material		18-Sep-2013		17-Jan-2014		08-Apr-2014		14-Jul-2014	
		Unwashed	Washed	Unwashed	Washed	Unwashed	Washed	Unwashed	Washed
Waterborne (SP2)	Mean	124.9	132.6	107.4	112.2	97.4	103.8	86.7	105.2
	N	9	9	8	8	8	8	8	8
	Std. Deviation	12.6	12.5	6.9	3.4	8.0	10.6	10.0	12.3
	CV	0.10	0.10	0.07	0.03	0.08	0.10	0.12	0.12
Waterborne (SP1)	Mean	109.6	116.7	100.5	108.2	92.2	100.1	83.2	93.7
	N	9	9	8	8	8	8	7	7
	Std. Deviation	5.0	7.4	3.1	4.8	6.9	7.7	7.5	7.6
	CV	0.05	0.06	0.03	0.04	0.08	0.08	0.09	0.08
Waterborne (SP3)	Mean	112.8	117.2	103.5	109.1	91.6	99.2	81.2	100.4
	N	9	9	8	8	8	8	8	8
	Std. Deviation	10.6	10.2	4.1	4.9	9.1	13.0	9.8	17.7
	CV	0.09	0.09	0.04	0.05	0.1	0.13	0.12	0.18
1.2 mm Thermoplastic (SP2)	Mean	109.1	116.0	98.6	105.5	91.8	98.9	76.3	84.2
	N	9	9	8	8	7	7	7	7
	Std. Deviation	10.4	14.2	2.6	5.1	3.2	4.5	7.3	11.7
	CV	0.10	0.12	0.03	0.05	0.04	0.05	0.10	0.14
1.2 mm Thermoplastic (SP1)	Mean	114.2	115.7	97.8	106.1	91.6	100.1	79.0	88.4
	N	9	9	8	8	8	8	8	8
	Std. Deviation	8.3	9.5	4.7	4.1	4.9	7.1	5.1	6.0
	CV	0.07	0.08	0.05	0.04	0.05	0.07	0.07	0.07
1 mm Cold Plastic (SP2)	Mean	113.4	120.3	104.6	111.0	95.8	103.3	80.0	86.6
	N	9	9	8	8	8	8	8	8
	Std. Deviation	8.3	7.3	3.4	5.9	7.1	11.5	7.7	15.1
	CV	0.07	0.06	0.03	0.05	0.08	0.11	0.10	0.18
1 mm Cold Plastic (SP1)	Mean	106.4	116.1	97.7	106.5	93.3	101.3	84.2	86.1
	N	9	9	8	8	9	9	8	8
	Std. Deviation	5.2	9.0	2.8	5.7	3.1	7.1	5.2	2.5
	CV	0.05	0.08	0.03	0.05	0.03	0.07	0.06	0.03
3 mm Screed (SP1)	Mean	108.1	114.3	100.5	107.4	95.4	104.0	85.4	89.8
	N	9	9	8	8	8	8	8	8
	Std. Deviation	6.7	8.5	4.9	6.8	3.1	8.1	4.4	4.4
	CV	0.06	0.07	0.05	0.06	0.03	0.08	0.05	0.05

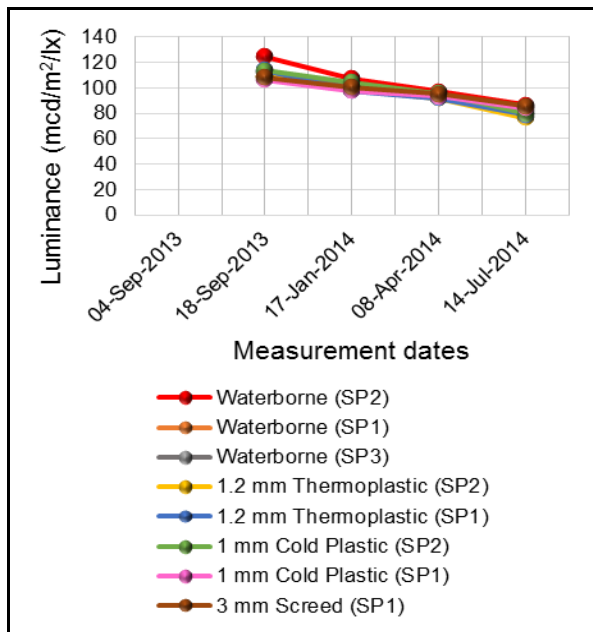

Figure B.31: Unwashed white transverse road markings on M 44.

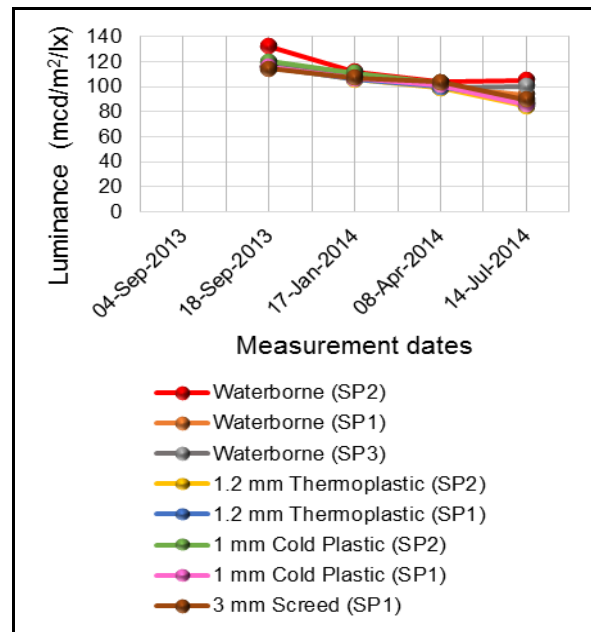

Figure B.32: Washed white transverse road markings on M 44.

Table B.17: Summary of yellow transverse markings on newly established dirty asphalt road (M 44).

Type of road marking paint / material		18-Sep-2013		17-Jan-2014		08-Apr-2014		14-Jul-2014	
		Unwashed	Washed	Unwashed	Washed	Unwashed	Washed	Unwashed	Washed
Waterborne (SP2)	Mean	102.8	106.2	96.7	104.4	97.8	112.8	94.3	107.7
	N	9	9	7	7	7	7	7	7
	Std. Deviation	7.3	11.2	4.6	8.8	13.8	12.5	14.8	15.2
	CV	0.07	0.10	0.05	0.09	0.14	0.11	0.16	0.14
Waterborne (SP1)	Mean	98.4	98.5	91.3	94.4	87.3	91.6	80.5	82.0
	N	9	9	7	7	7	7	7	7
	Std. Deviation	11.1	5.7	6.9	5.0	3.1	4.2	4.5	7.4
	CV	0.11	0.06	0.08	0.05	0.04	0.05	0.06	0.09
Waterborne (SP3)	Mean	88.5	96.4	87.1	94.7	76.6	87.6	72.6	79.1
	N	3	3	1	1	1	1	1	1
	Std. Deviation	2.0	0.7	0.0	0.0	0.0	0.0	0.0	0.0
	CV	0.02	0.01	0.00	0.00	0.00	0.00	0.00	0.00
1.2 mm Thermoplastic (SP2)	Mean	89.1	95.7	84.4	90.1	80.7	88.1	65.8	70.8
	N	9	9	6	6	6	6	5	5
	Std. Deviation	2.5	5.8	2.0	1.6	2.2	2.6	7.5	8.5
	CV	0.03	0.06	0.02	0.02	0.03	0.03	0.11	0.12
1.2 mm Thermoplastic (SP1)	Mean	92.9	98.0	88.1	93.8	81.0	89.8	71.7	77.0
	N	9	9	7	7	7	7	6	6
	Std. Deviation	6.2	6.4	5.8	4.7	3.0	4.5	3.9	4.6
	CV	0.07	0.07	0.07	0.05	0.04	0.05	0.06	0.06
1 mm Cold Plastic (SP1)	Mean	92.4	99.9	86.8	95.2	80.8	89.0	74.3	77.2
	N	9	9	9	9	9	9	8	8
	Std. Deviation	6.0	8.0	4.8	5.2	4.4	4.2	6.0	5.1
	CV	0.07	0.08	0.06	0.06	0.06	0.05	0.08	0.07
3 mm Screed (SP1)	Mean	90.7	102.4	86.0	97.0	82.0	94.1	72.3	76.0
	N	9	9	7	7	7	7	6	6
	Std. Deviation	3.8	4.9	3.3	2.4	2.5	3.1	3.0	6.6
	CV	0.04	0.05	0.04	0.03	0.03	0.03	0.04	0.09

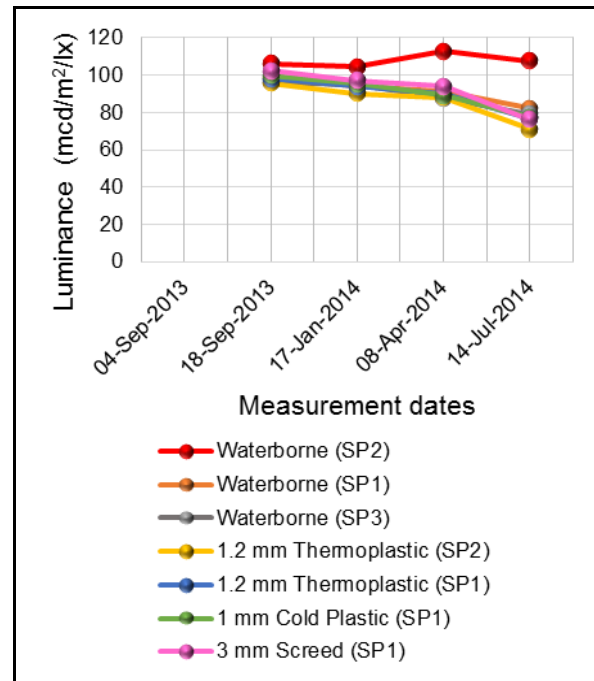
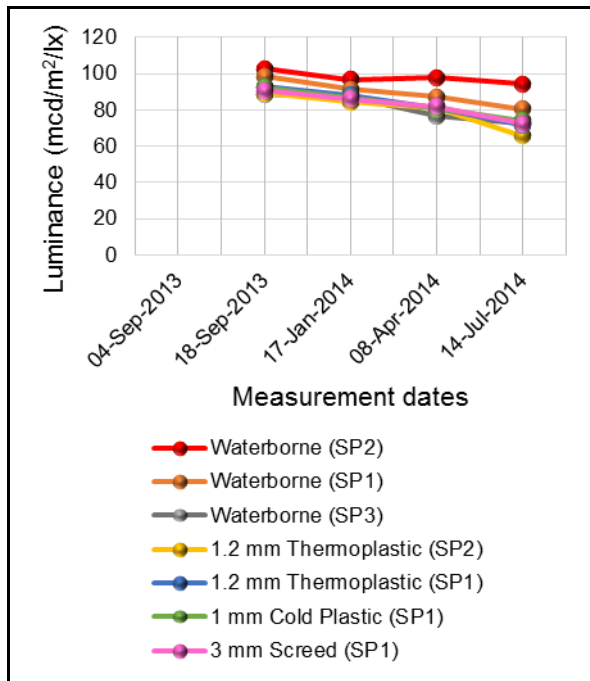

Figure B.33: Unwashed yellow transverse markings on M 44.

Figure B.34: Washed yellow transverse markings on M 44.

Table B.18: Summary of longitudinal markings on newly established dirty asphalt road (M 44).

Type of road marking paint / material		18-Sep-2013		17-Jan-2014		08-Apr-2014		14-Jul-2014	
		White	Yellow	White	Yellow	White	Yellow	White	Yellow
Waterborne (SP2)	Mean	149.2	121.1	117.7	113.2	101.8	95.5	68.3	71.7
	N	2	2	2	2	2	2	2	2
	Std. Deviation	7.4	0.7	3.7	3.2	6.9	0.0	0.0	4.0
	CV	0.05	0.01	0.03	0.03	0.07	0.00	0.00	0.06
Waterborne (SP1)	Mean	125.5	121.8	103.5	111.1	97.6	95.3	57.6	76.0
	N	2	2	2	2	2	2	2	2
	Std. Deviation	11.2	0.4	18.2	1.5	17.0	4.8	2.1	5.0
	CV	0.09	0.00	0.18	0.01	0.18	0.05	0.04	0.07
1.2 mm Thermoplastic (SP2)	Mean	156.0	104.3	116.2	103.8	105.6	96.6	70.3	76.8
	N	2	2	2	2	2	2	2	2
	Std. Deviation	13.9	2.5	13.5	6.5	15.8	3.7	0.9	30.9
	CV	0.09	0.02	0.12	0.06	0.15	0.04	0.01	0.40
1.2 mm Thermoplastic (SP1)	Mean	152.1	98.0	115.2	93.0	107.6	90.4	77.2	73.7
	N	2	2	2	2	2	2	2	2
	Std. Deviation	6.2	4.7	11.4	3.1	14.6	3.9	4.0	16.5
	CV	0.04	0.05	0.10	0.03	0.14	0.04	0.05	0.23
3 mm Screed (SP1)	Mean	135.4	100.3	99.1	102.3	92.0	98.3	76.5	71.7
	N	2	2	2	2	2	2	2	2
	Std. Deviation	10.3	14.2	28.8	5.6	14.9	1.9	9.6	15.6
	CV	0.08	0.14	0.29	0.05	0.16	0.20	0.13	0.22

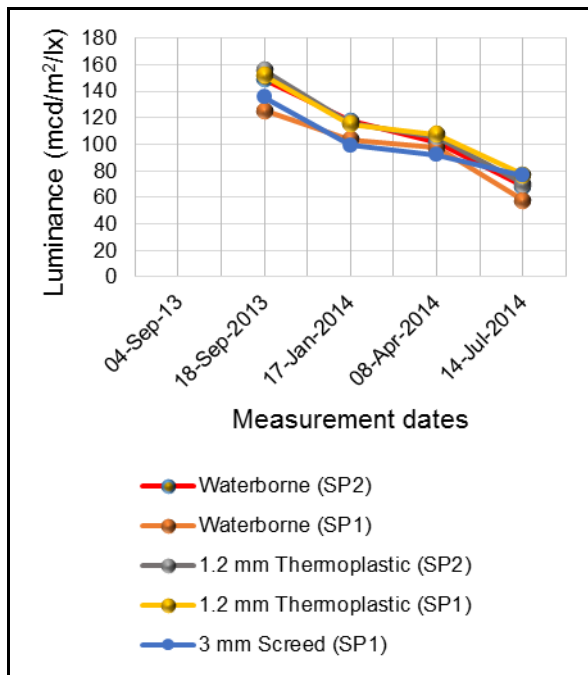

Figure B.35: Unwashed white longitudinal markings on M 44.

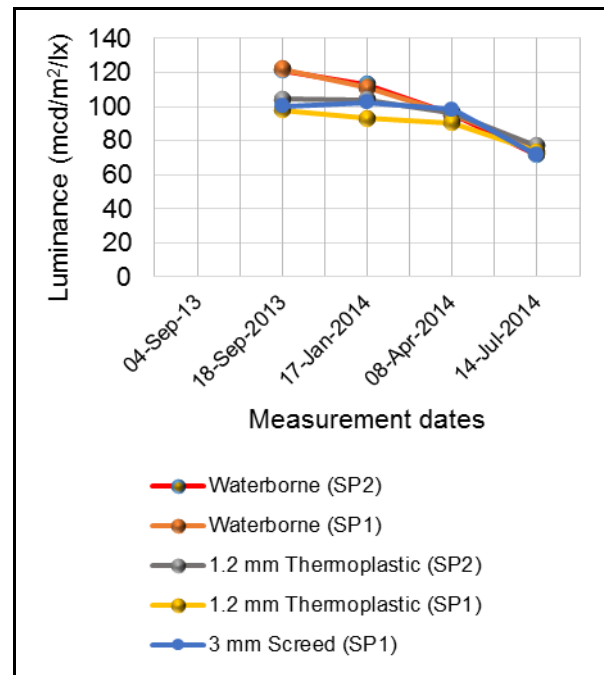

Figure B.36: Unwashed yellow longitudinal markings on M 44.

Table B.19: Summary of white transverse markings on long established asphalt road in the CBD (Madiba Street).

Type of road marking paint / material		25-Sep-2013		20-Jan-2014		10-Apr-2014		01-Aug-2014	
		Unwashed	Washed	Unwashed	Washed	Unwashed	Washed	Unwashed	Washed
Waterborne (SP2)	Mean	97.4	101.8	91.8	99.0	80.2	84.4	60.1	64.4
	N	6	6	5	5	5	5	5	5
	Std. Deviation	4.0	3.4	4.7	5.3	2.6	4.6	4.9	1.5
	CV	0.04	0.03	0.05	0.05	0.03	0.06	0.08	0.02
Waterborne (SP1)	Mean	107.7	112.9	89.1	98.4				
	N	6	6	2	2				
	Std. Deviation	4.3	2.2	3.6	11.4				
	CV	0.04	0.02	0.04	0.12				
Waterborne (SP3)	Mean	95.0	101.8	90.8	97.7	76.8	78.0	59.7	61.6
	N	6	6	5	5	5	5	5	5
	Std. Deviation	3.5	3.8	3.8	1.1	2.1	3.6	3.7	3.9
	CV	0.04	0.04	0.04	0.01	0.03	0.05	0.06	0.06
1.2 mm Thermoplastic (SP2)	Mean	136.1	139.4	121.7	127.1	92.3	94.4	70.6	73.3
	N	6	6	5	5	5	5	5	5
	Std. Deviation	6.5	6.0	4.4	4.5	2.9	2.3	8.3	5.6
	CV	0.05	0.04	0.04	0.04	0.03	0.02	0.12	0.08
1.2 mm Thermoplastic (SP1)	Mean	112.1	116.4	104.0	111.1	90.6	94.4	69.7	74.4
	N	6	6	5	5	5	5	5	5
	Std. Deviation	6.5	6.9	4.8	2.5	3.0	2.78	11.2	8.2
	CV	0.06	0.06	0.05	0.02	0.03	0.03	0.16	0.11
1 mm Cold Plastic (SP2)	Mean	103.8	108.1	99.7	104.8	86.1	92.0	60.1	64.1
	N	6	6	5	5	5	5	5	5
	Std. Deviation	5.9	5.0	5.3	6.3	3.5	1.6	4.5	0.8
	CV	0.06	0.05	0.05	0.06	0.04	0.01	0.08	0.01
1 mm Cold Plastic (SP1)	Mean	122.3	125.0	113.8	117.1	88.2	94.9	63.7	64.9
	N	6	6	5	5	5	5	5	5
	Std. Deviation	6.1	6.4	3.7	4.0	7.7	3.4	6.2	3.4
	CV	0.05	0.05	0.03	0.04	0.09	0.04	0.10	0.05
3 mm Screed (SP1)	Mean	112.2	117.2	105.6	112.1	92.1	97.5	68.2	72.7
	N	6	6	5	5	5	5	5	5
	Std. Deviation	8.3	7.2	5.5	3.3	3.6	2.6	10.6	5.8
	CV	0.07	0.06	0.05	0.03	0.04	0.03	0.16	0.08

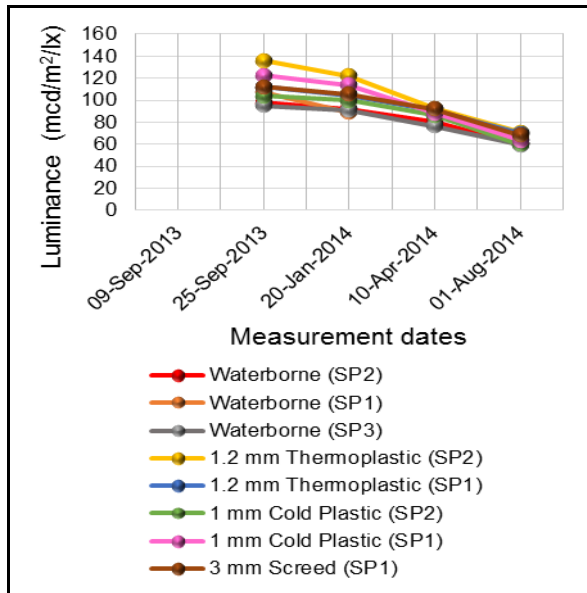

Figure B.37: Unwashed white transverse markings on Madiba Street.

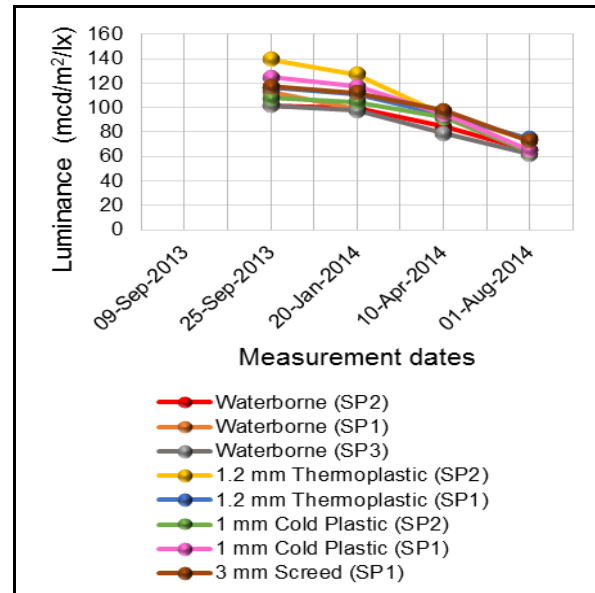

Figure B.38: Washed white transverse markings on Madiba Street.

Table B.20: Summary of yellow transverse markings on long established asphalt road in the CBD (Madiba Street).

Type of road marking paint / material		25-Sep-2013		20-Jan-2014		10-Apr-2014		01-Aug-2014	
		Unwashed	Washed	Unwashed	Washed	Unwashed	Washed	Unwashed	Washed
Waterborne (SP2)	Mean	99.8	103.3	91.8	96.1	79.5	83.7	57.9	60.6
	N	6	6	5	5	5	5	5	5
	Std. Deviation	2.9	4.0	3.9	4.4	3.4	4.3	8.4	6.9
	CV	0.03	0.04	0.04	0.05	0.04	0.05	0.15	0.12
Waterborne (SP1)	Mean	99.0	104.3	95.9	101.6	73.2	80.2	49.7	54.2
	N	6	6	5	5	5	5	5	5
	Std. Deviation	3.8	4.1	3.6	6.2	2.1	3.1	3.8	2.2
	CV	0.04	0.04	0.04	0.06	0.03	0.04	0.08	0.04
Waterborne (SP3)	Mean	84.1	91.9	78.9	87.7	71.0	76.4	51.0	54.8
	N	6	6	5	5	5	5	5	5
	Std. Deviation	4.2	6.9	4.1	9.5	2.8	2.6	3.1	2.52
	CV	0.05	0.08	0.05	0.11	0.04	0.03	0.06	0.05
1.2 mm Thermoplastic (SP2)	Mean	101.4	107.9	92.3	96.8	78.7	84.0	61.7	65.8
	N	6	6	5	5	5	5	5	5
	Std. Deviation	1.2	4.5	6.2	7.5	5.3	5.0	6.8	0.7
	CV	0.01	0.04	0.07	0.08	0.07	0.06	0.11	0.01
1.2 mm Thermoplastic (SP1)	Mean	100.2	106.0	92.4	100.6	73.8	79.7	54.0	57.2
	N	6	6	5	5	5	5	5	5
	Std. Deviation	3.9	5.1	3.6	3.6	4.3	4.8	4.9	1.1
	CV	0.04	0.05	0.04	0.04	0.06	0.06	0.09	0.02
1 mm Cold Plastic (SP1)	Mean	95.4	102.9	92.0	98.1	78.2	84.3	54.6	57.7
	N	6	6	5	5	5	5	5	5
	Std. Deviation	5.6	6.0	4.1	4.9	4.3	3.7	7.5	6.0
	CV	0.06	0.06	0.05	0.05	0.06	0.05	0.14	0.11
3 mm Screed (SP1)	Mean	87.4	94.7	83.4	94.2	73.1	79.2	54.4	58.9
	N	6	6	5	5	5	5	5	5
	Std. Deviation	7.8	7.1	4.6	5.0	4.3	3.0	5.1	2.7
	CV	0.09	0.08	0.06	0.05	0.06	0.04	0.10	0.05

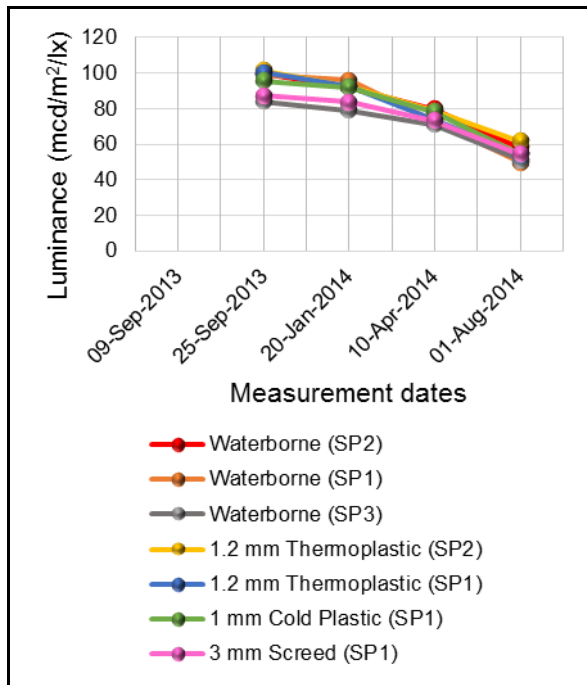

Figure B.39: Unwashed yellow transverse markings Madiba Street.

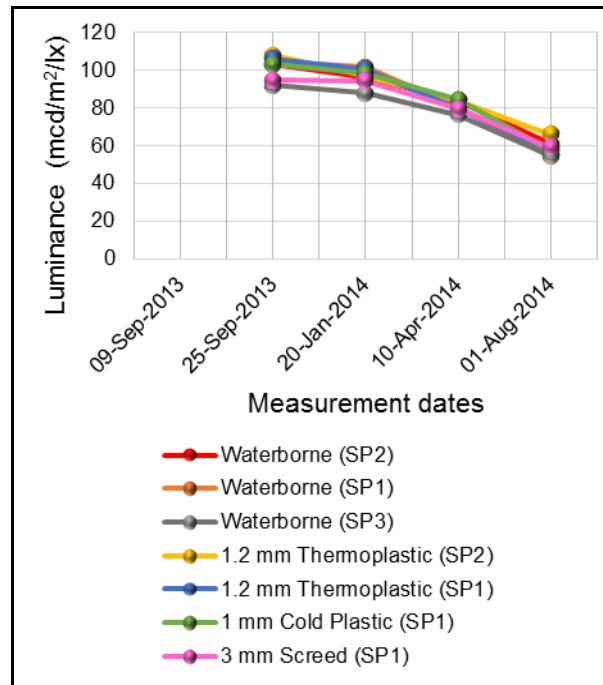

Figure B.40: Washed yellow transverse markings on Madiba Street.

Table B.21: Summary of white transverse markings on newly established clean asphalt road (Meiring Naude Road).

Type of road marking paint / material		03-Jul-2013		23-Oct-2013		18-Mar-2014		16-Jul-2014	
		Unwashed	Washed	Unwashed	Washed	Unwashed	Washed	Unwashed	Washed
Waterborne (SP2)	Mean	139.7	144.2	114.5	116.8	104.2	108.1	98.5	99.9
	N	9	9	9	9	9	9	9	9
	Std. Deviation	10.7	10.3	4.4	5.8	3.8	5.4	2.1	2.6
	CV	0.08	0.07	0.04	0.05	0.04	0.05	0.02	0.03
Waterborne (SP1)	Mean	106.4	113.0	91.8	98.6	83.7	87.6	75.1	79.0
	N	9	9	9	9	9	9	9	9
	Std. Deviation	7.8	9.3	4.4	6.5	6.62	6.2	5.9	6.0
	CV	0.07	0.08	0.05	0.07	0.08	0.07	0.08	0.08
Waterborne (SP3)	Mean	107.0	114.3	92.7	108.4	85.9	87.9	76.9	81.0
	N	9	9	9	9	9	9	9	9
	Std. Deviation	5.1	5.9	3.4	13.0	6.3	5.5	3.6	3.4
	CV	0.05	0.05	0.04	0.12	0.07	0.06	0.05	0.4
1.2 mm Thermoplastic (SP2)	Mean	113.7	120.1	103.2	117.3	96.8	100.6	86.9	92.9
	N	9	9	9	9	9	9	9	9
	Std. Deviation	7.7	9.5	5.6	5.3	5.4	2.9	4.1	3.5
	CV	0.07	0.08	0.05	0.05	0.06	0.03	0.05	0.04
1.2 mm Thermoplastic (SP1)	Mean	121.5	128.6	109.5	118.3	102.5	107.6	90.9	94.2
	N	9	9	9	9	9	9	9	9
	Std. Deviation	7.3	8.2	8.2	6.3	6.3	3.9	3.9	3.0
	CV	0.06	0.06	0.08	0.05	0.06	0.04	0.04	0.03
1 mm Cold Plastic (SP1)	Mean	114.3	124.9	103.1	114.9	96.6	103.5	85.8	88.2
	N	9	9	9	9	9	9	9	9
	Std. Deviation	5.5	10.9	5.0	8.8	4.9	5.5	5.4	4.3
	CV	0.05	0.09	0.05	0.08	0.05	0.05	0.06	0.05
3 mm Screed (SP1)	Mean	120.4	132.3	111.6	120.2	105.6	110.6	94.9	97.8
	N	9	9	9	9	9	9	9	9
	Std. Deviation	5.1	6.9	6.6	7.1	7.9	5.1	5.3	4.3
	CV	0.04	0.05	0.06	0.06	0.08	0.05	0.06	0.05
1 mm Cold Plastic (SP4)	Mean	104.0	108.6	94.1	104.3	89.8	96.9	82.1	85.6
	N	9	9	9	9	9	9	9	9
	Std. Deviation	3.8	4.0	3.42	6.2	4.8	5.0	4.5	4.7
	CV	0.04	0.04	0.04	0.06	0.05	0.05	0.06	0.06

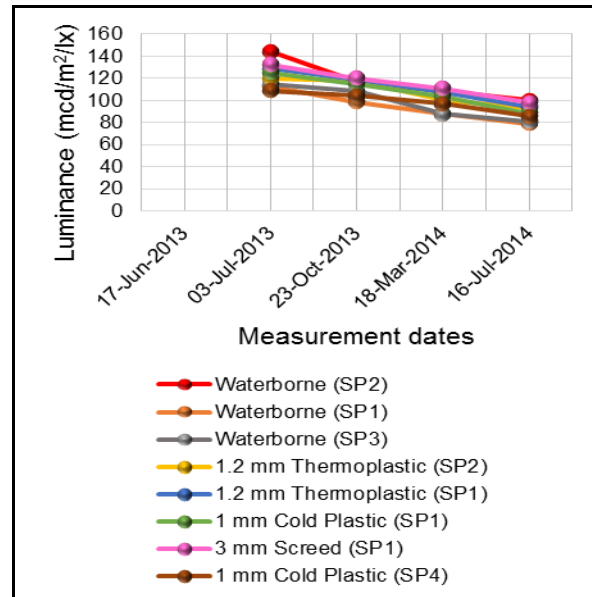
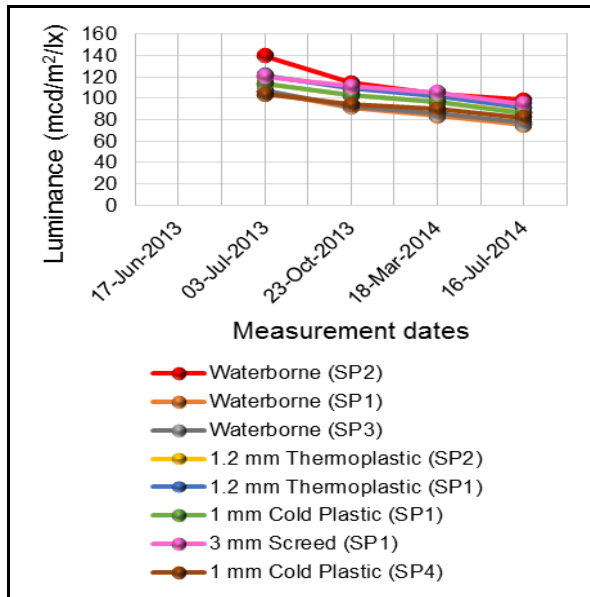

Figure B.41: Unwashed white transverse markings on Meiring Naude Road.

Figure B.42: Washed white transverse markings on Meiring Naude Road.

Table B.22: Summary of yellow transverse markings on newly established clean asphalt road (Meiring Naude Road).

Type of road marking paint / material		03-Jul-2013		23-Oct-2013		18-Mar-2014		16-Jul-2014	
		Unwashed	Washed	Unwashed	Washed	Unwashed	Washed	Unwashed	Washed
Waterborne (SP2)	Mean	101.1	102.8	72.7	79.9	69.6	75.8	63.2	68.9
	N	9	9	9	9	9	9	9	9
	Std. Deviation	3.7	2.2	2.4	3.1	1.8	1.4	4.0	2.8
	CV	0.04	0.02	0.03	0.04	0.03	0.02	0.06	0.04
Waterborne (SP1)	Mean	99.2	102.1	74.8	80.0	73.2	79.5	64.6	67.6
	N	9	9	9	9	9	9	9	9
	Std. Deviation	1.2	2.2	2.3	4.2	2.4	3.6	3.6	3.1
	CV	0.01	0.02	0.03	0.05	0.03	0.05	0.06	0.05
Waterborne (SP3)	Mean	100.3	101.0	73.2	78.5	69.8	75.4	65.9	71.1
	N	9	9	9	9	9	9	9	9
	Std. Deviation	1.2	1.3	1.5	1.6	2.1	2.6	1.8	2.8
	CV	0.01	0.01	0.02	0.02	0.03	0.04	0.03	0.04
1.2 mm Thermoplastic (SP2)	Mean	100.0	104.1	86.7	92.9	80.3	85.9	73.1	78.6
	N	9	9	9	9	9	9	9	9
	Std. Deviation	2.2	2.7	4.9	4.0	3.8	6.4	2.7	3.4
	CV	0.02	0.03	0.06	0.04	0.05	0.08	0.04	0.04
1.2 mm Thermoplastic (SP1)	Mean	103.1	111.1	93.9	100.7	89.4	93.8	82.7	85.9
	N	9	9	9	9	9	9	9	9
	Std. Deviation	3.2	4.4	3.0	3.6	2.0	3.6	5.0	5.4
	CV	0.03	0.04	0.03	0.04	0.02	0.04	0.06	0.06
1 mm Cold Plastic (SP1)	Mean	98.8	106.8	87.3	96.3	83.2	88.9	72.0	74.2
	N	9	9	9	9	9	9	9	9
	Std. Deviation	1.8	4.2	6.1	5.4	5.7	6.3	5.6	5.8
	CV	0.02	0.04	0.07	0.06	0.07	0.07	0.07	0.08
3 mm Screed (SP1)	Mean	106.9	113.0	96.6	103.2	93.5	97.8	84.0	87.1
	N	9	9	9	9	9	9	9	9
	Std. Deviation	4.9	5.4	2.6	3.3	2.1	2.4	2.1	3.4
	CV	0.05	0.05	0.03	0.03	0.02	0.03	0.03	0.04
1 mm Cold Plastic (SP4)	Mean	97.3	101.2	72.2	78.1	69.6	74.9	63.2	69.3
	N	9	9	9	9	9	9	9	9
	Std. Deviation	0.6	1.5	7.1	7.1	5.2	7.1	4.4	4.8
	CV	0.01	0.02	0.10	0.09	0.08	0.10	0.07	0.07

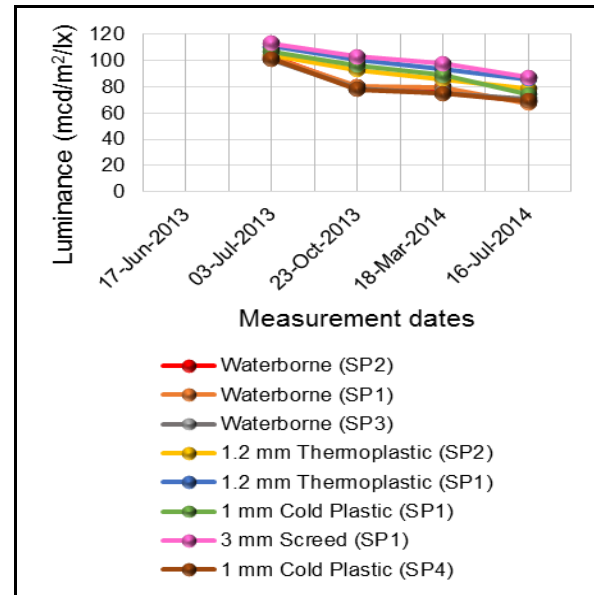
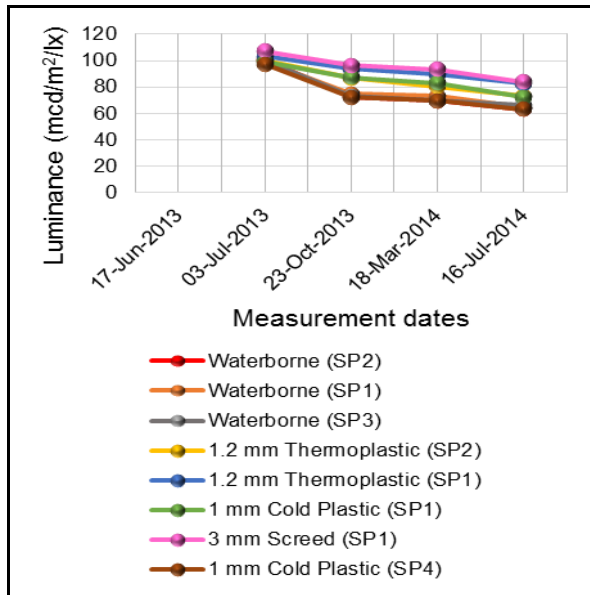

Figure B.43: Unwashed yellow transverse markings on Meiring Naude Road.

Figure B.44: Washed yellow transverse markings on Meiring Naude Road.

Table B.23: Summary of longitudinal markings on newly established clean asphalt road (Meiring Naude Road).

Type of road marking paint / material		03-Jul-2013		23-Oct-2013		18-Mar-2014		16-Jul-2014	
		White	Yellow	White	Yellow	White	Yellow	White	Yellow
Waterborne (SP2)	Mean	120.5	130.1	99.3	119.7	88.1	103.4	79.7	95.5
	N	3	3	3	3	3	3	3	3
	Std. Deviation	2.9	3.0	9.6	3.6	6.1	5.1	2.0	2.0
	CV	0.03	0.02	0.10	0.03	0.07	0.05	0.03	0.02
Waterborne (SP1)	Mean	122.5	131.3	99.7	117.7	89.8	106.8	84.0	97.3
	N	3	3	3	3	3	3	3	3
	Std. Deviation	0.1	1.8	13.2	2.6	11.9	6.4	7.6	1.6
	CV	0.00	0.01	0.13	0.02	0.13	0.06	0.09	0.02
1.2 mm Thermoplastic (SP2)	Mean	120.3	129.6	111.6	119.5	102.9	113.0	90.8	97.7
	N	3	3	3	3	3	3	3	3
	Std. Deviation	5.2	1.7	2.7	3.9	1.0	3.2	1.6	0.4
	CV	0.04	0.01	0.02	0.03	0.01	0.03	0.02	0.00
1.2 mm Thermoplastic (SP1)	Mean	121.3	131.1	117.3	118.5	106.8	111.8	100.2	97.4
	N	3	3	3	3	3	3	3	3
	Std. Deviation	0.1	2.0	4.5	0.8	5.0	1.0	0.3	1.0
	CV	0.00	0.02	0.04	0.01	0.05	0.01	0.00	0.01
3 mm Screed (SP1)	Mean	122.7	130.5	118.1	121.0	115.0	112.9	99.2	97.6
	N	3	3	3	3	3	3	3	3
	Std. Deviation	0.8	1.9	0.7	1.0	3.7	0.6	6.4	1.2
	CV	0.01	0.00	0.01	0.01	0.03	0.01	0.07	0.01

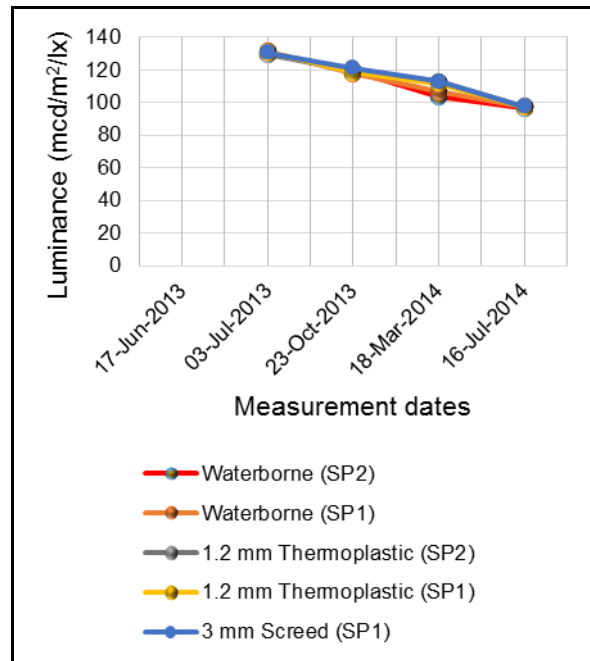
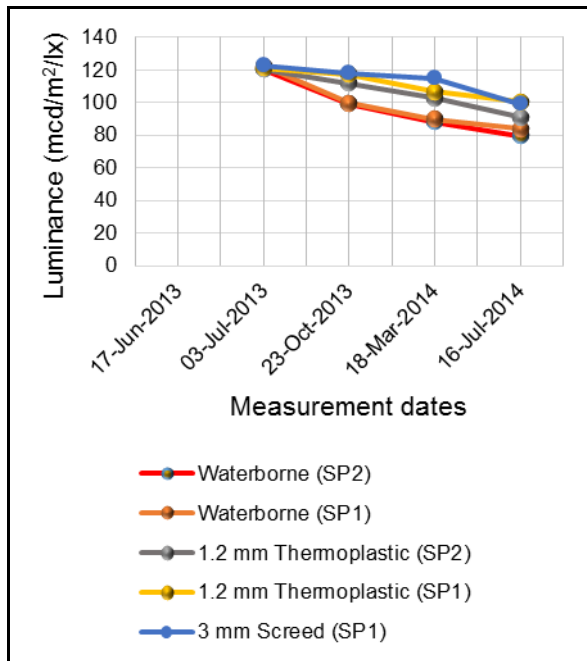

Figure B.45: Unwashed white longitudinal markings on Meiring Naude Road.

Figure B.46: Unwashed yellow longitudinal markings on Meiring Naude Road.

Table B.24: Summary of white transverse markings on long established clean asphalt road (Middel Street).

Type of road marking paint / material		23-Jul-2013		05-Nov-2013		20-Mar-2014		29-Jul-2014	
		Unwashed	Washed	Unwashed	Washed	Unwashed	Washed	Unwashed	Washed
Waterborne (SP2)	Mean	141.7	145.4	128.7	136.5	108.1	107.0	103.6	105.8
	N	9	9	9	9	9	9	9	9
	Std. Deviation	11.7	12.5	9.8	9.1	1.7	1.5	1.7	1.6
	CV	0.08	0.09	0.08	0.07	0.02	0.01	0.02	0.02
Waterborne (SP1)	Mean	136.6	141.8	119.5	125.5	106.9	108.0	102.8	106.1
	N	9	9	9	9	9	9	9	9
	Std. Deviation	6.2	6.1	7.2	6.3	1.7	3.7	2.2	2.0
	CV	0.05	0.04	0.06	0.05	0.02	0.03	0.02	0.02
Waterborne (SP3)	Mean	138.0	141.3	122.5	129.1	106.4	106.9	101.5	103.5
	N	9	9	9	9	9	9	9	9
	Std. Deviation	7.0	6.8	8.6	7.8	2.4	1.6	1.7	2.1
	CV	0.05	0.05	0.07	0.06	0.02	0.02	0.02	0.02
1.2 mm Thermoplastic (SP2)	Mean	144.2	147.1	134.0	140.0	108.7	112.7	103.0	105.5
	N	9	9	9	9	9	9	9	9
	Std. Deviation	9.4	9.5	12.3	10.1	2.9	4.8	0.9	3.4
	CV	0.07	0.07	0.09	0.07	0.03	0.04	0.01	0.03
1.2 mm Thermoplastic (SP1)	Mean	153.7	158.1	143.8	152.3	116.1	122.1	111.0	108.3
	N	9	9	9	9	9	9	9	9
	Std. Deviation	9.9	8.7	10.9	9.6	6.9	4.0	3.9	3.6
	CV	0.07	0.06	0.08	0.06	0.05	0.03	0.04	0.04
1 mm Cold Plastic (SP1)	Mean	139.4	143.3	134.3	139.8	111.2	109.4	103.6	107.1
	N	9	9	9	9	9	9	9	9
	Std. Deviation	5.0	3.2	7.6	7.3	3.2	2.2	2.6	1.7
	CV	0.04	0.02	0.06	0.05	0.03	0.02	0.03	0.02
3 mm Screed (SP1)	Mean	155.5	160.0	144.8	151.2	121.8	122.8	116.9	121.1
	N	9	9	9	9	9	9	9	9
	Std. Deviation	12.2	9.6	15.1	15.2	2.5	2.6	3.3	3.1
	CV	0.08	0.06	0.10	0.10	0.02	0.02	0.03	0.03
1 mm Cold Plastic (SP4)	Mean	139.7	144.7	125.9	131.3	109.6	109.6	101.3	104.6
	N	9	9	9	9	9	9	9	9
	Std. Deviation	11.0	10.5	6.9	6.5	1.7	2.5	1.9	2.6
	CV	0.08	0.07	0.06	0.05	0.02	0.02	0.02	0.03

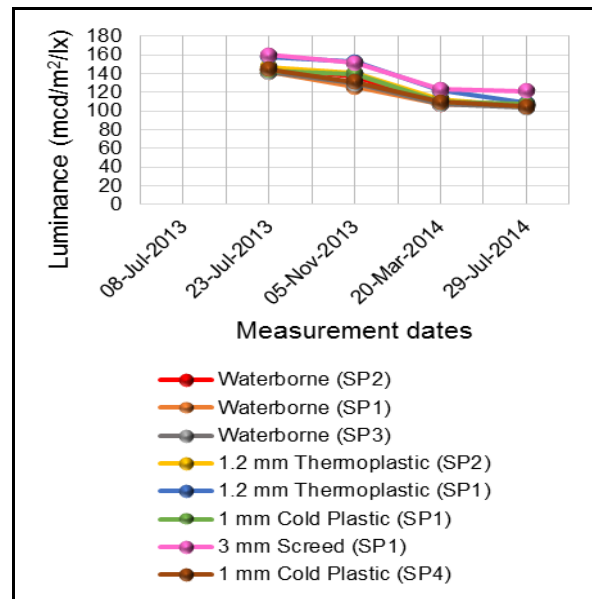
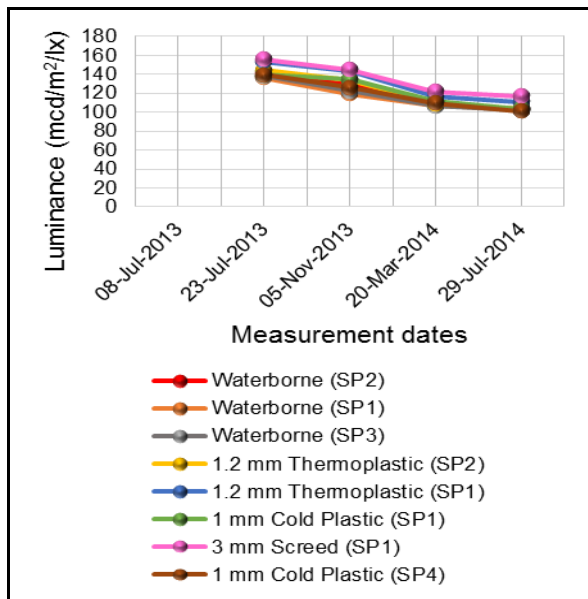

Figure B.47: Unwashed white transverse markings on Middel Street.

Figure B.48: Washed white transverse markings on Middel Street.

Table B.25: Summary of yellow transverse markings on long established clean asphalt road (Middel Street).

Type of road marking paint / material		23-Jul-2013		05-Nov-2013		20-Mar-2014		29-Jul-2014	
		Unwashed	Washed	Unwashed	Washed	Unwashed	Washed	Unwashed	Washed
Waterborne (SP2)	Mean	105.3	107.5	97.5	98.4	91.9	95.0	84.1	85.8
	N	9	9	9	9	9	9	9	9
	Std. Deviation	0.7	1.3	0.9	0.9	2.4	3.2	3.3	1.6
	CV	0.01	0.01	0.01	0.00	0.03	0.03	0.04	0.02
Waterborne (SP1)	Mean	104.4	106.2	98.4	98.0	88.1	92.7	81.0	84.4
	N	9	9	9	9	9	9	9	9
	Std. Deviation	1.1	1.3	2.4	1.9	2.4	2.1	2.2	1.8
	CV	0.01	0.01	0.02	0.02	0.03	0.02	0.03	0.02
Waterborne (SP3)	Mean	102.5	104.2	97.2	98.3	88.8	92.9	81.4	84.0
	N	9	9	9	9	9	9	9	9
	Std. Deviation	2.1	2.3	1.4	0.9	2.9	1.8	2.4	1.6
	CV	0.02	0.02	0.02	0.01	0.03	0.02	0.03	0.02
1.2 mm Thermoplastic (SP2)	Mean	122.0	122.6	115.6	119.5	108.2	111.8	99.0	103.9
	N	9	9	9	9	9	9	9	9
	Std. Deviation	3.1	0.6	3.2	0.6	11.1	11.6	4.9	1.9
	CV	0.03	0.01	0.03	0.01	0.10	0.10	0.05	0.02
1.2 mm Thermoplastic (SP1)	Mean	121.2	122.0	114.4	117.7	110.8	115.7	102.7	103.7
	N	9	9	9	9	9	9	9	9
	Std. Deviation	1.4	1.8	4.7	1.0	12.5	13.7	2.2	2.7
	CV	0.01	0.02	0.04	0.01	0.11	0.12	0.02	0.03
1 mm Cold Plastic (SP1)	Mean	106.6	105.6	98.5	99.7	89.6	95.1	84.0	85.1
	N	9	9	9	9	9	9	9	9
	Std. Deviation	1.5	2.1	1.6	0.6	5.0	3.9	1.2	2.0
	CV	0.02	0.02	0.02	0.01	0.06	0.04	0.02	0.02
3 mm Screed (SP1)	Mean	121.7	123.0	119.3	119.4	102.2	105.5	103.6	105.1
	N	9	9	9	9	9	9	9	9
	Std. Deviation	3.0	1.6	1.1	1.6	9.3	8.0	1.5	3.3
	CV	0.03	0.01	0.10	0.01	0.09	0.08	0.02	0.03

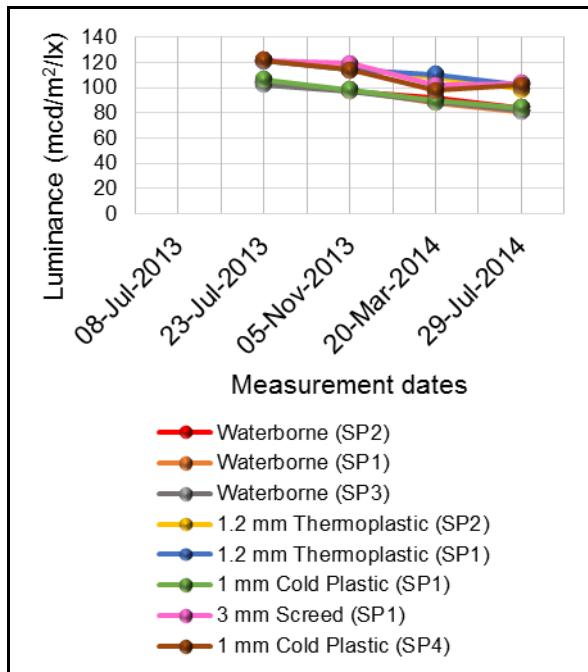

Figure B.49: Unwashed yellow transverse markings on Middel Street.

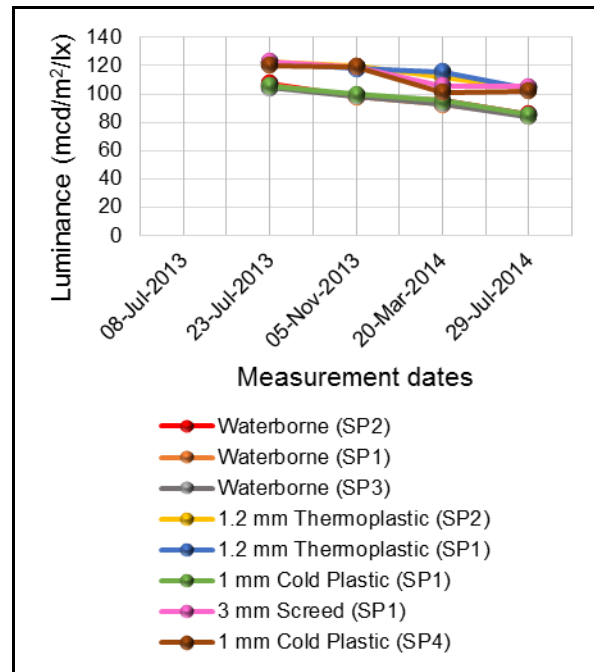

Figure B.50: Washed yellow transverse markings on Middel Street.

Table B.26: Summary of longitudinal markings on long established clean asphalt road (Middel Street).

Type of road marking paint / material		23-Jul-2013		05-Nov-2013		20-Mar-2014		29-Jul-2014	
		White	Yellow	White	Yellow	White	Yellow	White	Yellow
Waterborne (SP2)	Mean	145.5	124.1	126.1	113.3	93.8	85.1	91.6	85.6
	N	3	3	3	3	3	3	3	3
	Std. Deviation	11.2	5.8	3.8	8.6	10.4	3.9	2.7	1.9
	CV	0.08	0.05	0.03	0.08	0.11	0.05	0.03	0.02
Waterborne (SP1)	Mean	143.9	121.9	124.1	112.1	88.7	88.6	89.7	87.6
	N	3	3	3	3	3	3	3	3
	Std. Deviation	3.7	6.0	4.6	5.9	12.2	2.2	1.4	5.2
	CV	0.03	0.05	0.04	0.05	0.14	0.03	0.02	0.06
1.2 mm Thermoplastic (SP2)	Mean	146.4	137.4	136.3	128.4	101.1	95.9	94.9	95.8
	N	3	3	3	3	3	3	3	3
	Std. Deviation	3.6	5.2	4.7	6.3	6.2	2.3	0.6	1.0
	CVC	0.03	0.04	0.04	0.05	0.06	0.02	0.01	0.01
1.2 mm Thermoplastic (SP1)	Mean	143.0	135.1	133.3	124.4	103.6	87.3	97.8	92.6
	N	3	3	3	3	3	3	3	3
	Std. Deviation	4.1	5.6	6.6	5.5	2.9	0.7	2.9	2.1
	CV	0.03	0.04	0.05	0.04	0.03	0.01	0.03	0.02
3 mm Screed (SP1)	Mean	156.4	139.6	134.7	127.6	114.2	95.7	104.2	94.4
	N	3	3	3	3	3	3	3	3
	Std. Deviation	17.7	2.1	8.5	2.1	4.3	0.2	4.4	4.4
	CV	0.11	0.02	0.06	0.02	0.04	0.00	0.04	0.05

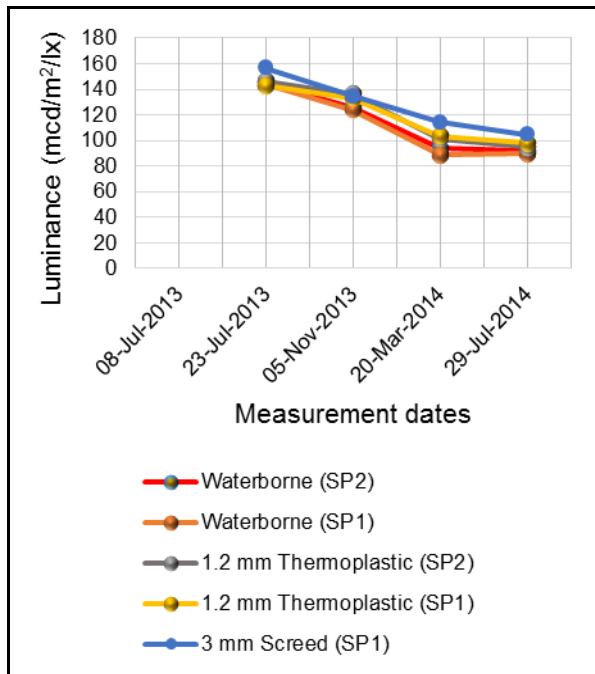

Figure B.51: Unwashed white longitudinal markings on Middel Street.

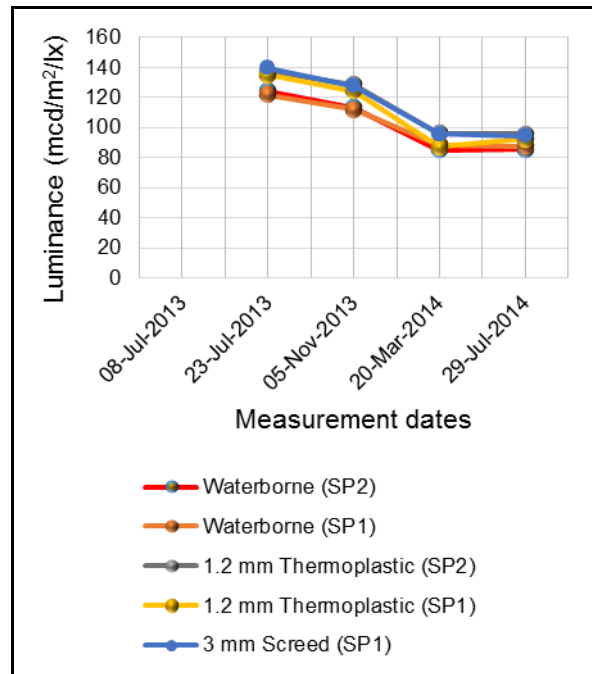

Figure B.52: Unwashed yellow longitudinal markings on Middel Street.

Table B.27: Summary of white transverse markings on long established dirty asphalt road (Mohwelere Street).

Type of road marking paint / material		05-Aug-2013		28-Jan-2014		11-Apr-2014		28-Jul-2014	
		Unwashed	Washed	Unwashed	Washed	Unwashed	Washed	Unwashed	Washed
Waterborne (SP2)	Mean	109.1	118.2	79.1	91.0	76.2	85.3	71.4	75.1
	N	9	9	9	9	9	9	9	9
	Std. Deviation	7.3	6.3	5.7	7.6	6.4	7.2	6.1	8.3
	CV	0.07	0.05	0.07	0.08	0.09	0.09	0.09	0.11
Waterborne (SP1)	Mean	113.5	123.8	96.3	99.3	88.3	95.1	71.5	73.1
	N	9	9	9	9	9	9	9	9
	Std. Deviation	9.0	4.9	11.5	9.3	6.6	2.7	2.8	5.7
	CV	0.08	0.04	0.12	0.09	0.08	0.03	0.04	0.08
Waterborne (SP3)	Mean	102.1	115.6	80.8	90.4	77.8	88.2	67.4	69.5
	N	9	9	9	9	9	9	9	9
	Std. Deviation	13.0	5.0	6.3	5.7	4.5	5.7	5.1	7.9
	CV	0.13	0.04	0.08	0.06	0.06	0.07	0.08	0.12
1.2 mm Thermoplastic (SP2)	Mean	112.1	118.7	102.0	109.1	96.6	101.0	74.2	80.0
	N	9	9	9	9	9	9	9	9
	Std. Deviation	6.9	2.9	8.3	6.4	7.5	6.9	6.9	10.0
	CV	0.06	0.03	0.08	0.06	0.07	0.07	0.09	0.13
1.2 mm Thermoplastic (SP1)	Mean	117.3	125.0	107.5	112.4	100.7	106.2	83.0	82.7
	N	9	9	9	9	9	9	9	9
	Std. Deviation	4.6	4.6	6.1	7.1	5.3	6.0	5.5	9.9
	CV	0.04	0.04	0.06	0.06	0.05	0.06	0.07	0.12
1 mm Cold Plastic (SP2)	Mean	125.5	131.3	89.1	98.7	83.0	88.7	78.6	85.5
	N	9	9	9	9	9	9	9	9
	Std. Deviation	6.0	6.2	5.7	7.8	2.6	4.6	2.6	5.6
	CV	0.05	0.05	0.07	0.08	0.03	0.05	0.03	0.07
3 mm Screed (SP1)	Mean	125.5	132.4	110.5	118.1	100.2	105.8	80.0	87.1
	N	9	9	9	9	9	9	9	9
	Std. Deviation	6.1	3.9	11.2	9.7	7.5	5.2	8.1	9.2
	CV	0.05	0.03	0.10	0.08	0.08	0.05	0.10	0.11
1 mm Cold Plastic (SP4)	Mean	122.4	127.7	88.4	99.7	84.9	95.3	73.2	77.8
	N	9	9	9	9	9	9	9	9
	Std. Deviation	4.7	9.3	7.8	2.4	7.3	4.3	5.4	9.0
	CV	0.04	0.07	0.09	0.03	0.09	0.05	0.07	0.12

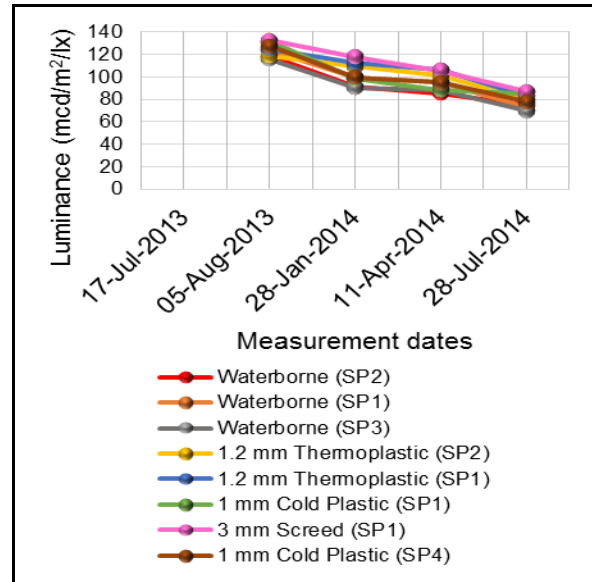
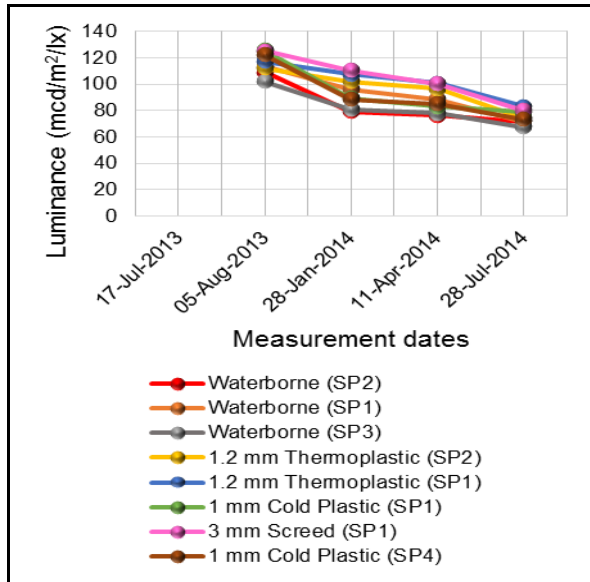

Figure B.53: Unwashed white transverse road markings on Mohwelere Street.

Figure B.54: Washed white transverse road markings on Mohwelere Street.

Table B.28: Summary of yellow transverse markings on long established dirty asphalt road (Mohwelere Street).

Type of road marking paint / material		05-Aug-2013		28-Jan-2014		11-Apr-2014		28-Jul-2014	
		Unwashed	Washed	Unwashed	Washed	Unwashed	Washed	Unwashed	Washed
Waterborne (SP2)	Mean	104.4	108.8	79.3	85.6	72.2	78.5	63.2	66.5
	N	9	9	9	9	9	9	9	9
	Std. Deviation	8.1	5.6	10.1	2.4	5.7	5.0	2.3	6.5
	CV	0.08	0.05	0.13	0.03	0.08	0.07	0.04	0.10
Waterborne (SP1)	Mean	114.2	119.5	85.6	89.6	79.0	87.8	67.4	70.3
	N	9	9	9	9	9	9	9	9
	Std. Deviation	6.7	3.2	13.4	6.3	5.4	6.4	5.1	10.3
	CV	0.06	0.03	0.16	0.07	0.07	0.07	0.08	0.15
Waterborne (SP3)	Mean	97.0	101.3	78.9	89.0	76.1	85.0	62.3	64.0
	N	9	9	6	9	6	6	4	4
	Std. Deviation	11.4	9.9	12.6	4.5	1.3	3.3	1.5	6.5
	CV	0.12	0.10	0.16	0.05	0.02	0.04	0.03	0.10
1.2 mm Thermoplastic (SP2)	Mean	99.5	102.6	84.6	86.6	79.0	89.7	70.8	69.1
	N	9	9	3	3	3	3	2	2
	Std. Deviation	14.4	5.2	7.4	7.9	3.4	7.7	4.9	6.2
	CV	0.15	0.05	0.09	0.09	0.04	0.09	0.07	0.09
1.2 mm Thermoplastic (SP1)	Mean	121.5	125.4	92.3	95.9	85.8	94.4	78.4	80.3
	N	9	9	9	9	9	9	9	9
	Std. Deviation	8.2	5.7	8.5	5.7	5.3	8.4	5.2	8.0
	CV	0.07	0.05	0.09	0.06	0.06	0.09	0.07	0.10
1 mm Cold Plastic (SP1)	Mean	121.1	125.6	88.6	94.8	85.4	91.4	74.2	77.8
	N	9	9	9	9	9	9	9	9
	Std. Deviation	7.7	5.9	8.9	10.2	5.3	5.2	3.7	5.6
	CV	0.06	0.0	0.10	0.10	0.06	0.06	0.05	0.07
3 mm Screed (SP1)	Mean	125.4	129.1	100.9	107.0	95.7	102.3	81.1	83.9
	N	9	9	9	9	9	9	9	9
	Std. Deviation	7.4	5.9	12.8	10.6	7.1	6.0	5.9	5.7
	CV	0.06	0.05	0.12	0.10	0.08	0.06	0.07	0.07
1 mm Cold Plastic (SP4)	Mean	110.0	112.5	83.7	89.4	78.6	88.8	67.5	70.1
	N	9	9	9	9	9	9	9	9
	Std. Deviation	7.7	6.3	10.0	6.2	6.7	6.3	8.3	4.5
	CV	0.07	0.06	0.09	0.07	0.09	0.07	0.12	0.07

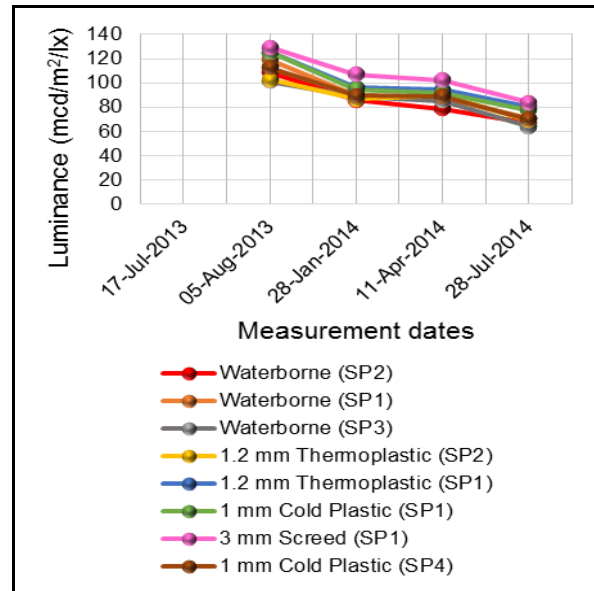
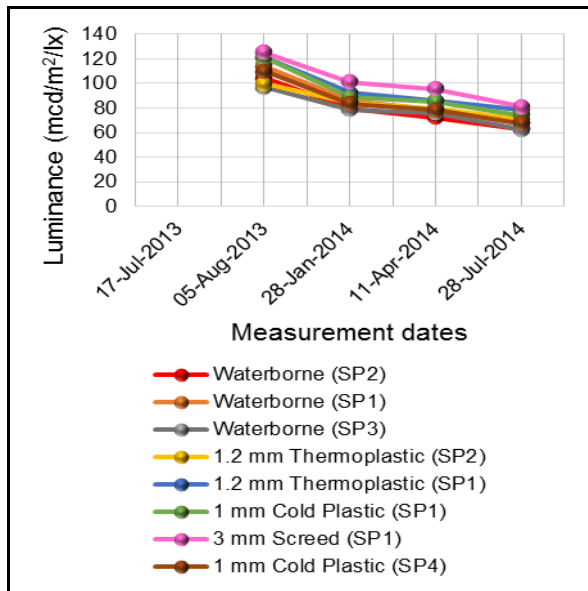

Figure B.55: Unwashed yellow transverse markings on Mohwelere Street.

Figure B.56: Washed yellow transverse markings on Mohwelere Street.

Table B.29: Summary of longitudinal markings on long established dirty asphalt road (Mohwelere Street).

Type of road marking paint / material		05-Aug-2013		28-Jan-2014		11-Apr-2014		28-Jul-2014	
		White	Yellow	White	Yellow	White	Yellow	White	Yellow
Waterborne (SP2)	Mean	102.7	111.4	89.7	76.1	85.1	76.1	73.7	61.2
	N	3	3	3	3	3	3	3	3
	Std. Deviation	2.5	3.2	3.5	9.9	3.8	11.0	14.7	5.9
	CV	0.02	0.03	0.04	0.13	0.05	0.15	0.20	0.10
Waterborne (SP1)	Mean	105.7	114.3	77.1	76.1	72.1	70.8	64.2	57.7
	N	3	3	3	3	3	3	2	2
	Std. Deviation	3.5	5.0	2.1	12.0	2.2	16.3	4.0	9.8
	CV	0.03	0.04	0.03	0.16	0.03	0.23	0.06	0.17
1.2 mm Thermoplastic (SP2)	Mean	113.6	115.0	77.9	80.5	73.0	73.9	65.0	70.1
	N	3	3	3	3	3	3	3	3
	Std. Deviation	7.3	3.0	1.3	11.2	3.9	14.5	7.5	16.4
	CV	0.06	0.02	0.02	0.15	0.05	0.20	0.12	0.23
1.2 mm Thermoplastic (SP1)	Mean	111.9	113.4	86.7	83.2	81.1	72.5	76.3	71.0
	N	3	3	3	3	3	3	3	3
	Std. Deviation	6.9	7.8	7.9	6.7	6.3	13.4	5.8	14.0
	CV	0.06	0.07	0.09	0.08	0.08	0.19	0.08	0.20
3 mm Screed (SP1)	Mean	110.5	114.7	88.7	82.0	80.2	73.3	76.3	72.6
	N	3	3	3	3	3	3	3	3
	Std. Deviation	1.8	5.0	2.7	4.3	7.4	10.2	7.1	10.3
	CV	0.02	0.04	0.03	0.05	0.09	0.14	0.09	0.14

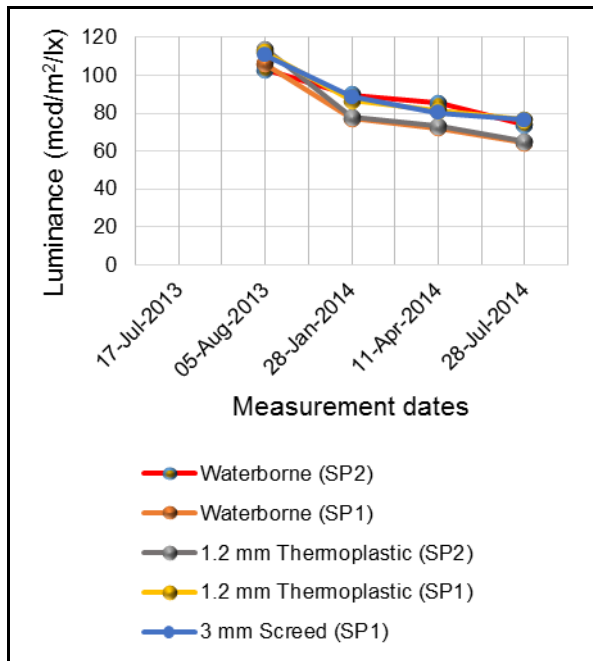

Figure B.57: Unwashed white longitudinal markings on Mohwelere Street.

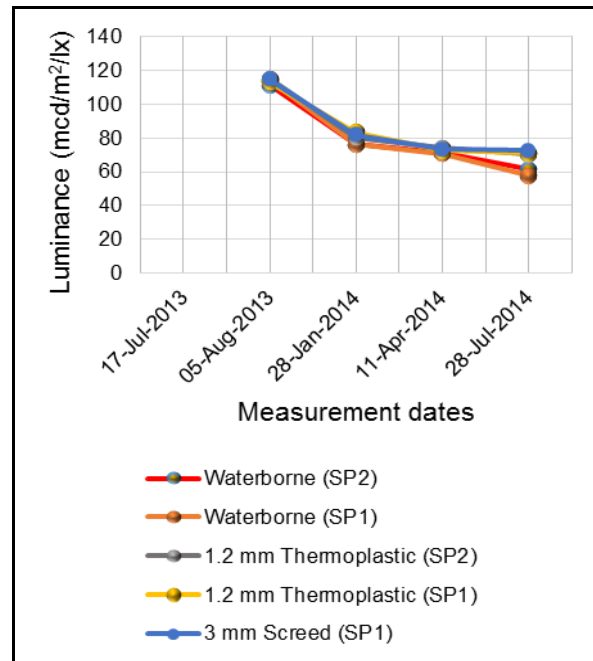

Figure B.58: Unwashed yellow longitudinal markings on Mohwelere Street.

Table B.30: Summary of white transverse markings on long established dirty chip seal road (Road L 3).

Type of road marking paint / material		05-Aug-2013		25-Nov-2013		03-Apr-2014		18-Jul-2014	
		Unwashed	Washed	Unwashed	Washed	Unwashed	Washed	Unwashed	Washed
Waterborne (SP2)	Mean	129.7	135.0	107.4	113.8	91.0	102.4	68.8	72.5
	N	9	9	9	9	6	6	6	6
	Std. Deviation	3.5	4.1	12.7	11.5	8.2	4.2	4.5	3.9
	CV	0.03	0.03	0.12	0.10	0.09	0.04	0.07	0.05
Waterborne (SP1)	Mean	144.9	145.4	104.4	111.0	90.2	97.4	66.6	67.3
	N	9	9	9	9	3	3	2	2
	Std. Deviation	13.6	10.8	7.0	6.9	3.4	2.1	4.8	10.6
	CV	0.09	0.07	0.07	0.06	0.04	0.02	0.07	0.16
Waterborne (SP3)	Mean	126.8	129.8	90.7	97.4				
	N	9	9	9	9				
	Std. Deviation	8.4	7.1	9.5	7.6				
	CV	0.07	0.06	0.11	0.08				
1.2 mm Thermoplastic (SP2)	Mean	136.6	140.1	110.6	122.4	95.1	101.0	70.7	73.7
	N	9	9	9	9	3	3	3	3
	Std. Deviation	7.3	5.1	9.4	8.5	2.9	2.9	1.5	2.7
	CV	0.05	0.04	0.09	0.07	0.03	0.03	0.02	0.04
1.2 mm Thermoplastic (SP1)	Mean	136.8	142.7	117.3	124.8	88.5	100.6	67.6	73.0
	N	9	9	9	9	9	9	9	9
	Std. Deviation	4.6	4.9	7.0	8.6	6.9	8.4	10.3	9.1
	CV	0.03	0.03	0.06	0.07	0.08	0.08	0.15	0.13
1 mm Cold Plastic (SP1)	Mean	139.8	145.0	118.1	122.2	94.0	101.1	70.7	79.0
	N	9	9	9	9	9	9	9	9
	Std. Deviation	5.1	8.7	5.8	6.6	2.0	3.1	4.5	7.5
	CV	0.04	0.06	0.05	0.05	0.02	0.03	0.07	0.10
3 mm Screed (SP1)	Mean	135.4	139.0	119.3	125.4	92.6	103.1	69.8	76.9
	N	9	9	9	9	9	9	9	9
	Std. Deviation	9.3	7.9	4.6	3.4	5.0	5.9	9.1	7.5
	CV	0.07	0.06	0.04	0.03	0.06	0.06	0.13	0.10
1 mm Cold Plastic (SP4)	Mean	124.3	132.0	110.8	116.7	90.3	105.0	75.4	78.7
	N	9	9	9	9	5	5	3	3
	Std. Deviation	4.9	4.0	4.4	5.1	3.2	7.3	5.5	8.1
	CV	0.04	0.03	0.04	0.04	0.04	0.07	0.07	0.10

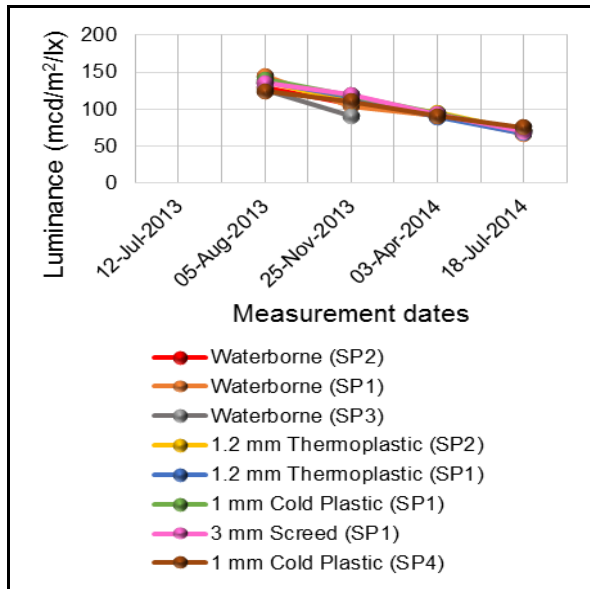

Figure B.59: Unwashed white transverse markings on Road L 3.

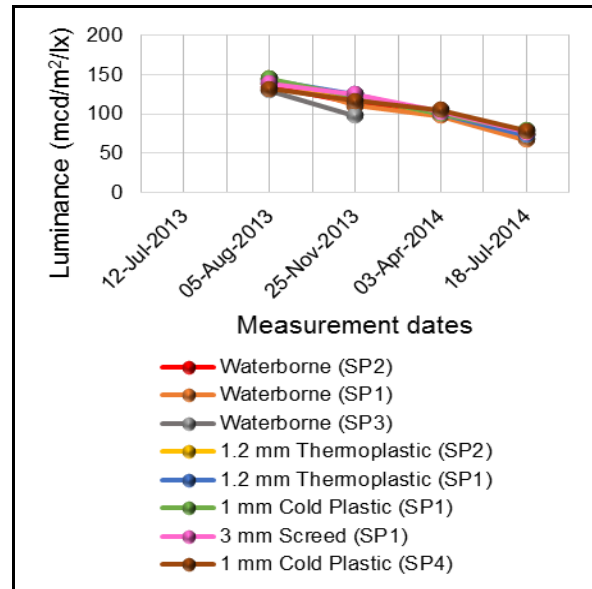

Figure B.60: Washed white transverse markings on Road L 3.

Table B.31: Summary of yellow transverse markings on long established dirty chip seal road (Road L 3).

Type of road marking paint / material		05-Aug-2013		25-Nov-2013		03-Apr-2014		18-Jul-2014	
		Unwashed	Washed	Unwashed	Washed	Unwashed	Washed	Unwashed	Washed
Waterborne (SP2)	Mean	96.2	101.1	76.7	83.1	60.4	69.0	52.0	56.1
	N	9	9	9	9	3	3	3	3
	Std. Deviation	5.1	3.3	3.2	4.7	1.3	1.7	3.7	4.0
	CV	0.05	0.03	0.04	0.06	0.02	0.03	0.07	0.07
Waterborne (SP1)	Mean	88.4	96.8	79.8	85.5	78.6	84.1	62.2	66.1
	N	9	9	9	9	6	6	4	4
	Std. Deviation	6.6	4.0	6.9	5.3	3.3	4.5	5.1	6.7
	CV	0.08	0.04	0.09	0.06	0.04	0.05	0.08	0.10
Waterborne (SP3)	Mean	85.6	93.9	78.4	85.7	71.7	77.7	59.7	64.0
	N	9	9	9	9	6	6	4	4
	Std. Deviation	6.7	2.9	4.9	4.0	6.4	6.2	3.3	7.0
	CV	0.07	0.03	0.06	0.05	0.09	0.08	0.06	0.11
1.2 mm Thermoplastic (SP2)	Mean	96.9	100.0	87.3	95.0	80.1	84.9	62.3	61.8
	N	9	9	9	9	5	5	3	3
	Std. Deviation	5.4	5.7	4.9	5.3	2.1	2.7	2.4	1.6
	CV	0.06	0.06	0.06	0.06	0.03	0.03	0.04	0.03
1.2 mm Thermoplastic (SP1)	Mean	117.2	122.1	102.4	105.8	89.3	95.3	61.6	68.5
	N	9	9	9	9	9	9	9	9
	Std. Deviation	8.1	5.2	5.5	3.1	9.9	9.7	5.1	7.9
	CV	0.07	0.04	0.05	0.03	0.11	0.10	0.08	0.12
1 mm Cold Plastic (SP1)	Mean	108.7	113.8	94.6	98.7	89.2	95.6	63.5	67.9
	N	9	9	9	9	9	9	9	9
	Std. Deviation	9.0	6.9	4.0	4.2	3.7	4.2	6.2	10.6
	CV	0.08	0.06	0.04	0.04	0.04	0.04	0.10	0.16
3 mm Screed (SP1)	Mean	111.7	116.0	97.0	100.6	86.0	93.9	65.5	70.1
	N	9	9	9	9	9	9	9	9
	Std. Deviation	5.8	6.6	6.4	5.6	6.7	5.4	5.6	4.0
	CV	0.05	0.06	0.07	0.06	0.08	0.06	0.09	0.06
1 mm Cold Plastic (SP4)	Mean	94.2	101.9	86.6	91.4	79.3	86.4	62.0	68.9
	N	9	9	9	9	5	5	4	4
	Std. Deviation	6.8	9.8	4.1	3.3	7.0	5.6	9.5	7.9
	CV	0.07	0.10	0.05	0.04	0.09	0.07	0.16	0.12

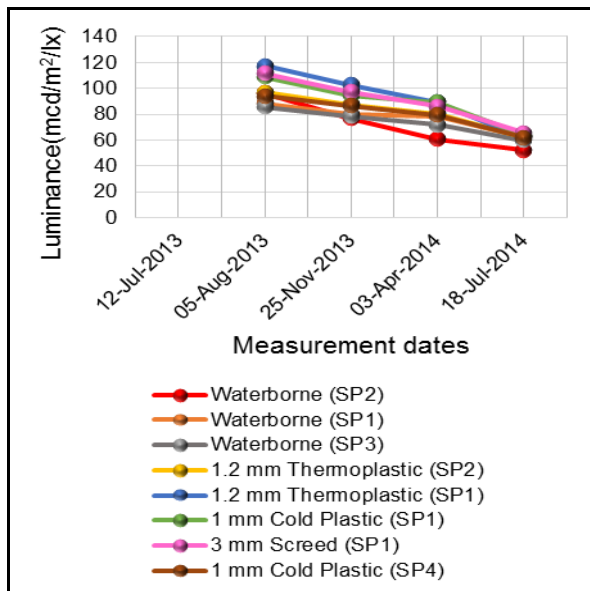

Figure B.61: Unwashed yellow transverse markings on Road L 3.

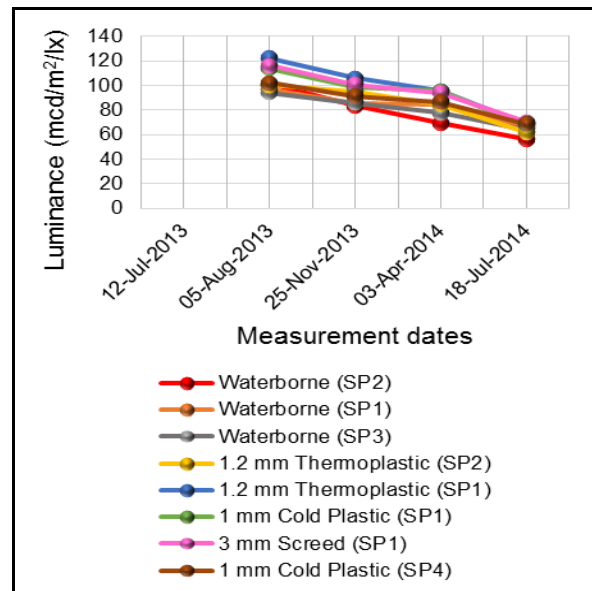

Figure B.62: Washed yellow transverse markings on Road L 3.

Table B.32: Summary of longitudinal markings on long established dirty chip seal road (Road L 3).

Type of road marking paint / material		05-Aug-2013		25-Nov-2013		03-Apr-2014		18-Jul-2014	
		White	Yellow	White	Yellow	White	Yellow	White	Yellow
Waterborne (SP2)	Mean	132.3	123.8	117.4	111.5	96.5	85.1	68.7	47.7
	N	3	3	3	3	3	2	3	2
	Std. Deviation	2.2	1.2	4.1	0.5	6.6	0.7	7.0	7.4
	CV	0.02	0.01	0.04	0.01	0.07	0.01	0.10	0.16
Waterborne (SP1)	Mean	128.2	117.2	118.3	106.1	94.6	92.9	64.1	58.2
	N	3	3	3	3	3	3	3	3
	Std. Deviation	3.1	4.5	1.6	3.0	7.6	1.7	6.0	3.7
	CV	0.02	0.04	0.01	0.03	0.08	0.02	0.09	0.06
1.2 mm Thermoplastic (SP2)	Mean	138.0	127.9	126.2	117.5	99.7	92.0	73.1	67.8
	N	3	3	3	3	3	3	3	3
	Std. Deviation	4.1	0.7	1.8	2.5	4.1	2.6	4.9	1.1
	CV	0.03	0.01	0.01	0.02	0.04	0.03	0.07	0.02
1.2 mm Thermoplastic (SP1)	Mean	130.7	125.7	120.9	112.7	97.7	91.4	76.4	63.9
	N	3	3	3	3	3	3	3	3
	Std. Deviation	2.1	0.7	2.7	2.6	5.2	1.7	7.4	3.6
	CV	0.02	0.01	0.02	0.02	0.05	0.01	0.10	0.06
3 mm Screed (SP1)	Mean	135.6	123.6	115.5	110.5	95.7	94.0	70.7	67.9
	N	3	3	3	3	3	3	3	3
	Std. Deviation	2.8	1.3	6.7	1.7	2.1	2.0	9.6	10.0
	CV	0.02	0.01	0.06	0.02	0.02	0.02	0.14	0.15

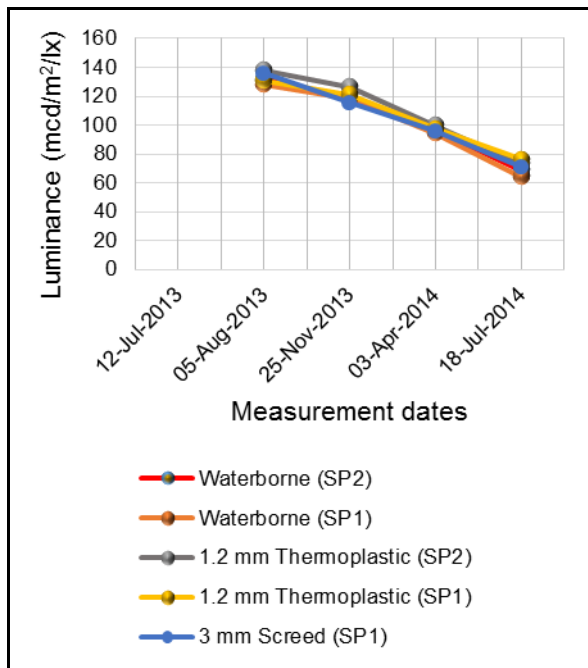

Figure B.63: Unwashed white longitudinal markings on Road L 3.

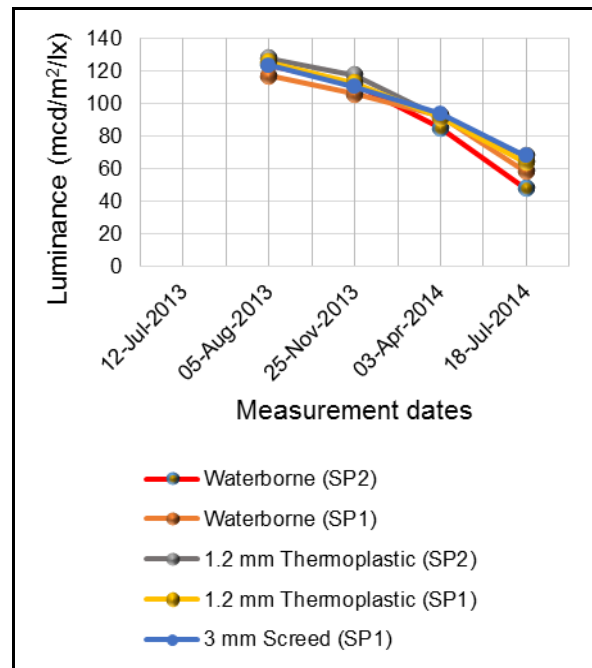

Figure B.64: Unwashed yellow longitudinal markings on Road L 3.

APPENDIX C

TABLE OF CONTENTS

C. NINETY FIVE PER CENT CONFIDENCE INTERVALS ON RETROREFLECTIVITY AND LUMINANCE.....	C-1
C.1. UNWASHED WHITE TRANSVERSE TEST ROAD MARKINGS IN RETROREFLECTIVITY	C-1
C.2. UNWASHED YELLOW TRANSVERSE TEST ROAD MARKINGS IN RETROREFLECTIVITY...	C-7
C.3. UNWASHED WHITE LONGITUDINAL TEST ROAD MARKINGS IN RETROREFLECTIVITY ..	C-13
C.4. UNWASHED YELLOW LONGITUDINAL TEST ROAD MARKINGS IN RETROREFLECTIVITYC-	19
C.5. UNWASHED WHITE TRANSVERSE TEST ROAD MARKINGS IN LUMINANCE	C-25
C.6. UNWASHED YELLOW TRANSVERSE TEST ROAD MARKINGS IN LUMINANACE	C-31
C.7. UNWASHED WHITE LONGITUDINAL TEST ROAD MARKINGS IN LUMINANCE	C-37
C.8. UNWASHED YELLOW LONGITUDINAL TEST ROAD MARKINGS IN LUMINANCE	C-43

LIST OF FIGURES

Figure C.1.1: Newly established dirty chip seal road (Aubrey Matlala Road).....	C-1
Figure C.1.2: Long established clean chip seal road (Bushveld Road).....	C-2
Figure C.1.3: Newly established clean chip seal road (Doreen Street - B 1).....	C-2
Figure C.1.4: Newly established clean chip seal road (Doreen Street - B's 2 & 3).....	C-3
Figure C.1.5: Newly established clean chip seal road (Doreen Street - B's 1, 2 & 3).....	C-3
Figure C.1.6: Newly established dirty asphalt road (M 44).....	C-4
Figure C.1.7: Long established asphalt road in CBD (Madiba Street).....	C-4
Figure C.1. 8: Newly established clean asphalt road (Meiring Naude Road).....	C-5
Figure C.1.9: Long established clean asphalt road (Middel Street).....	C-5
Figure C.1.10: Long established dirty asphalt road (Mohwelere Street).....	C-6
Figure C.1.11: Long established dirty chip seal road (Road L 3).....	C-6
Figure C.2.1: Newly established dirty chip seal road (Aubrey Matlala Road).....	C-7
Figure C.2.2: Long established clean chip seal road (Bushveld Road).....	C-8
Figure C.2.3: Newly established clean chip seal road (Doreen Street - B 1).....	C-8
Figure C.2.4: Newly established clean chip seal road (Doreen Street - B's 2 & 3).....	C-9
Figure C.2.5: Newly established clean chip seal road (Doreen Street - B's 1, 2 & 3).....	C-9
Figure C.2.6: Newly established dirty asphalt road (M 44).....	C-10
Figure C.2.7: Long established asphalt road in CBD (Madiba Street).....	C-10
Figure C.2.8: Newly established clean asphalt road (Meiring Naude Road).....	C-11
Figure C.2.9: Long established clean asphalt road (Middel Street).....	C-11

Figure C.2.10: Long established dirty asphalt road (Mohwelere Street).	C-12
Figure C.2.11: Long established dirty chip seal road (Road L 3).....	C-12
Figure C.3.1: Newly established dirty chip seal road (Aubrey Matlala Road).....	C-13
Figure C.3.2: Long established clean chip seal road (Bushveld Road).	C-14
Figure C.3.3: Newly established clean chip sea road (Doreen Street - B 1).	C-14
Figure C.3.4: Newly established clean chip seal road (Doreen Street - B's 2 & 3).	C-15
Figure C.3.5: Newly established clean chip seal road (Doreen Street - B's 1, 2 & 3).	C-15
Figure C.3.6: Newly established dirty asphalt road (M 44).	C-16
Figure C.3.7: Newly established clean asphalt road (Meiring Naude Road).	C-16
Figure C.3.8: Long established clean asphalt road (Middel Street).....	C-17
Figure C.3.9: Long established dirty asphalt road (Mohwelere Street).	C-17
Figure C.3.10: Long established dirty chip seal road (Road L 3).....	C-18
Figure C.4.1: Newly established dirty asphalt road (Aubrey Matlala Road).	C-19
Figure C.4.2: Long established clean chip seal road (Bushveld Road).	C-20
Figure C.4.3: Newly established clean chip seal road (Doreen Street - B 1).	C-20
Figure C.4.4: Newly established clean chip seal road (Doreen Street - B's 2 & 3).	C-21
Figure C.4.5: Newly established clean chip seal road (Doreen Street B's 1, 2 and 3).	C-21
Figure C.4.6: Newly established dirty asphalt road (M 44).	C-22
Figure C.4.7: Newly established clean asphalt road (Meiring Naude Road).	C-22
Figure C.4.8: Long established clean asphalt road (Middel Street).	C-23
Figure C.4.9: Long established dirty asphalt road (Mohwelere Street).	C-23
Figure C.4.10: Long established dirty chip seal road (Road L 3).....	C-24
Figure C.5.1: Newly established dirty chip seal road (Aubrey Matlala Road).....	C-25
Figure C.5.2: Long established clean chip seal road (Bushveld Road).	C-26
Figure C.5.3: Newly established clean chip road (Doreen Street - B 1).	C-26
Figure C.5.4: Newly established clean chip road (Doreen Street - B's 2 & 3).	C-27
Figure C.5.5: Newly established clean chip road (Doreen Street - B's 1, 2 & 3).	C-27
Figure C.5.6: Newly established dirty asphalt road (M 44).	C-28
Figure C.5.7: Long established asphalt road in CBD (Madiba Street).....	C-28
Figure C.5.8: Newly established clean asphalt road (Meiring Naude Road).	C-29
Figure C.5.9: Long established clean asphalt road (Middel Street).	C-29
Figure C.5.10: Long established dirty asphalt road (Mohwelere Street).	C-30
Figure C.5.11: Long established dirty chip seal road (Road L 3).....	C-30

Figure C.6.1: Newly established dirty chip seal road (Aubrey Matlala Road).....	C-31
Figure C.6.2: Long established clean chip seal road (Bushveld Road).....	C-32
Figure C.6.3: Newly established clean chip seal road (Doreen Street - B 1).	C-32
Figure C.6.4: Newly established clean chip seal road (Doreen Street - B's 2 & 3).	C-33
Figure C.6.5: Newly established clean chip seal road (Doreen Street - B'S 1, 2 & 3).....	C-33
Figure C.6.6: Long established dirty asphalt road (M 44).....	C-34
Figure C.6.7: Long established asphalt road in the CBD (Madiba Street).....	C-34
Figure C.6.8: Newly established clean asphalt road (Meiring Naude Road).	C-35
Figure C.6.9: Long established clean asphalt road (Middel Street).....	C-35
Figure C.6.10: Long established dirty asphalt road (Mohwelere Street).	C-36
Figure C.6.11: Long established dirty chip seal road (Road L 3).....	C-36
Figure C.7.1: Newly established dirty chip seal road (Aubrey Matlala Road).....	C-37
Figure C.7.2: Long established clean chip seal road (Bushveld Road).....	C-38
Figure C.7.3: Newly established clean chip seal road (Doreen Street - B 1).	C-38
Figure C.7.4: Newly established clean chip seal road (Doreen Street - B's 2 & 3).	C-39
Figure C.7.5: Newly established clean chip seal road (Doreen Street - B's 1, 2 & 3).	C-39
Figure C.7.6: Newly established dirty asphalt road (M 44).	C-40
Figure C.7.7: Newly established clean asphalt road (Meiring Naude Road).	C-40
Figure C.7.8: Long established clean asphalt road (Middel Street).....	C-41
Figure C.7.9: Long established dirty asphalt road (Mohwelere Street).	C-41
Figure C.7.10: Long established dirty chip seal road (Road L 3).....	C-42
Figure C.8.1: Newly established dirty chip seal road (Aubrey Matlala Road).....	C-43
Figure C.8.2: Long established clean chip seal road (Bushveld Road).....	C-44
Figure C.8.3: Newly established clean chip seal road (Doreen Street - B 1).	C-44
Figure C.8.4: Newly established clean chip seal road (Doreen Street - B's 2 & 3).	C-45
Figure C.8.5: Newly established clean chip seal road (Doreen Street - B's 1, 2 & 3).	C-45
Figure C.8.6: Newly established dirty asphalt road (M 44).	C-46
Figure C.8.7: Newly established clean asphalt road (Meiring Naude).....	C-46
Figure C.8.8: Long established clean asphalt road (Middel Street).....	C-47
Figure C.8.9: Long established dirty asphalt road (Mohwelere Street).	C-47
Figure C.8.10: Long established dirty chip seal road (Road L 3).....	C-48

C. NINETY FIVE PER CENT CONFIDENCE INTERVALS ON RETROREFLECTIVITY AND LUMINANCE

C.1. UNWASHED WHITE TRANSVERSE TEST ROAD MARKINGS IN RETROREFLECTIVITY

The decline in retroreflectivity (R_L) over time of the test road marking paints and materials is demonstrated in Figures C.1.1 to C.1.11. The fact that there is no overlap between the 95 per cent Confidence Intervals (CIs) of the first and last measurements on Aubrey Matlala Road, Bushveld Road, Doreen Street (B 1), Doreen Street (B's 2 & 3), Doreen Street (B's 1, 2 & 3), M 44, Madiba Street, Meiring Naude Road, Middel Street, Mohwelere Street and Road L 3 is an indication that the difference between them is statistically significant.

The R_L measurements were subjected to a Friedman's Chi Square Test to determine whether any pair or pairs of R_L measurements across time periods within each type of road marking paint or material is significantly different or not. Friedman's Chi Square Test revealed that there is at least one pair of measurements over time that is significantly different within each of the different road marking paints and materials, and referring to Figures C.1.1 to C.1.11, it can be seen that the differences are at least between the first and last repetitions.

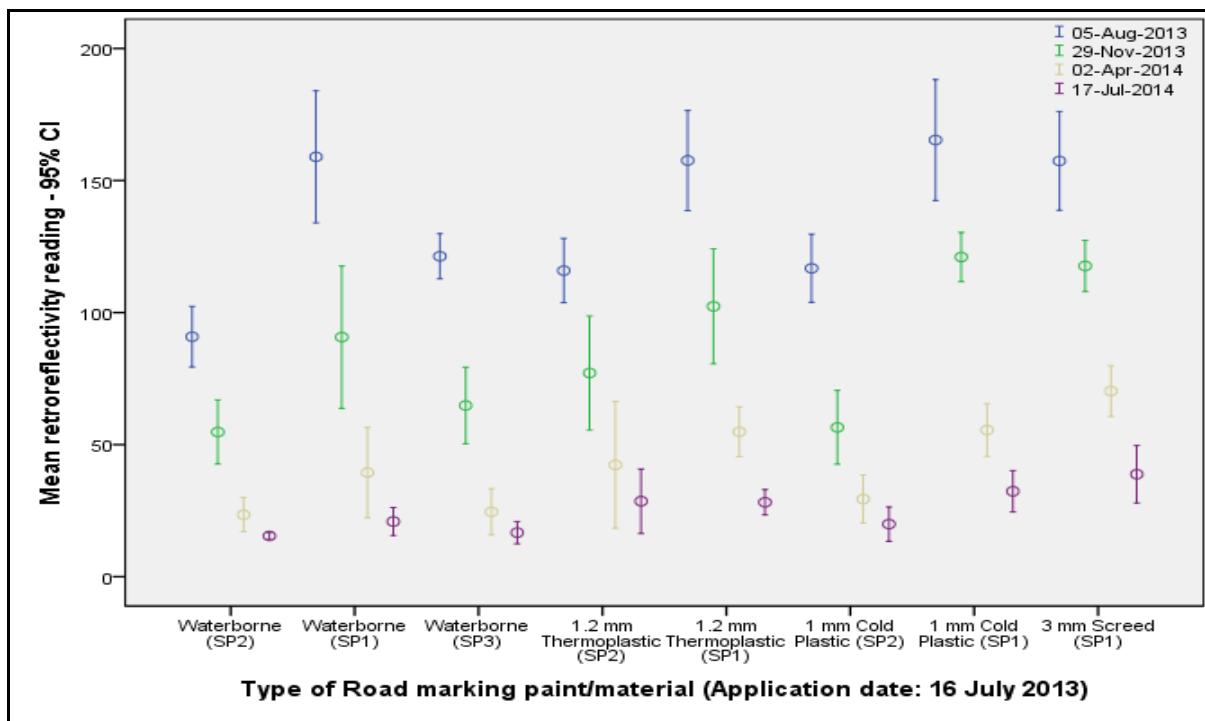

Figure C.1.1: Newly established dirty chip seal road (Aubrey Matlala Road).

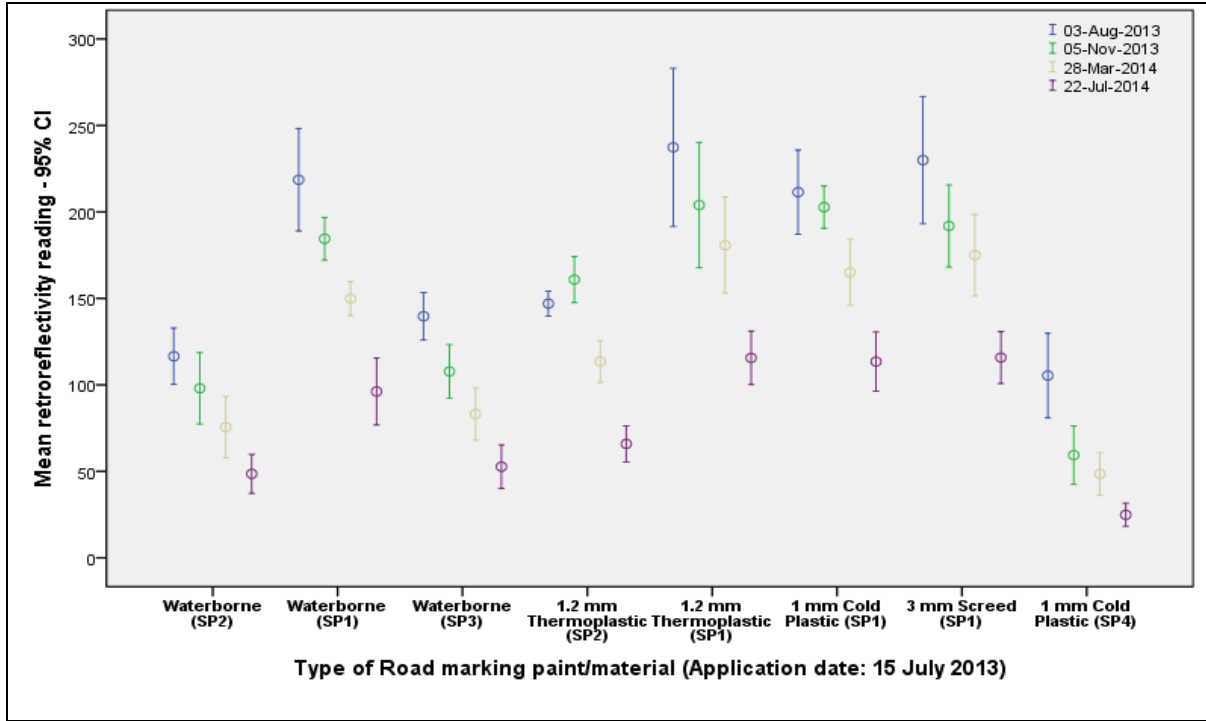

Figure C.1.2: Long established clean chip seal road (Bushveld Road).

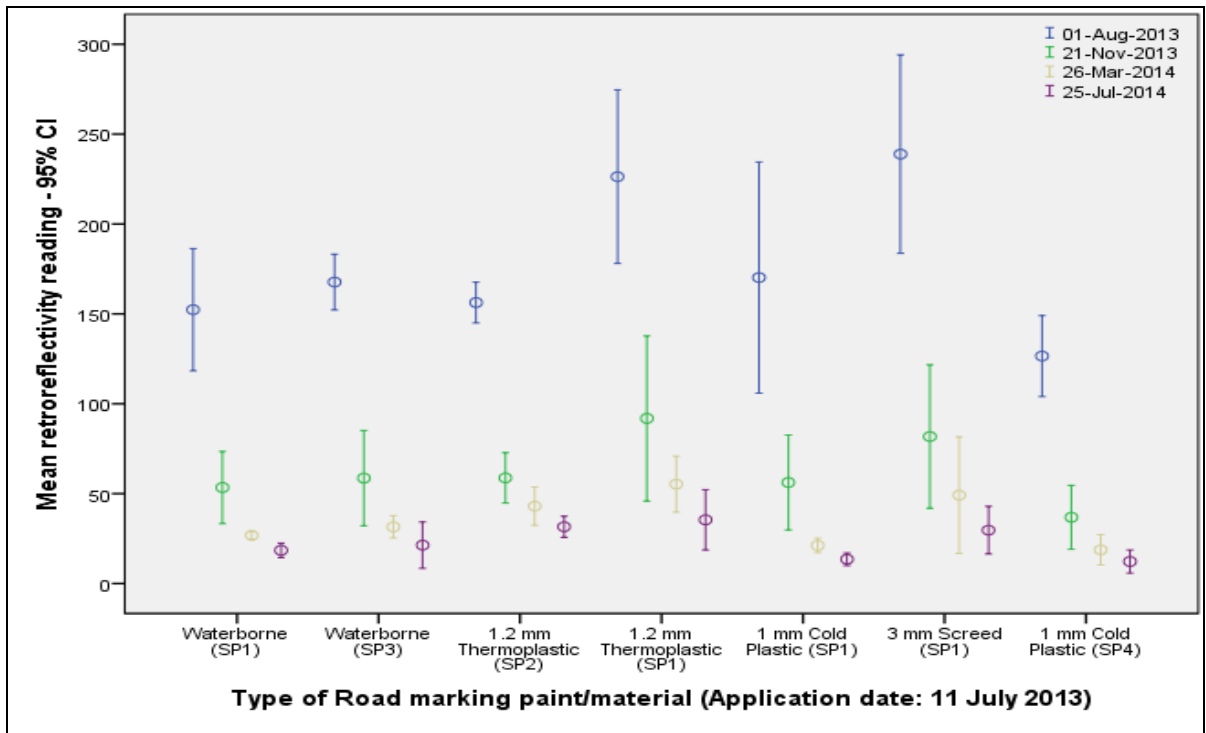

Figure C.1.3: Newly established clean chip seal road (Doreen Street - B 1).

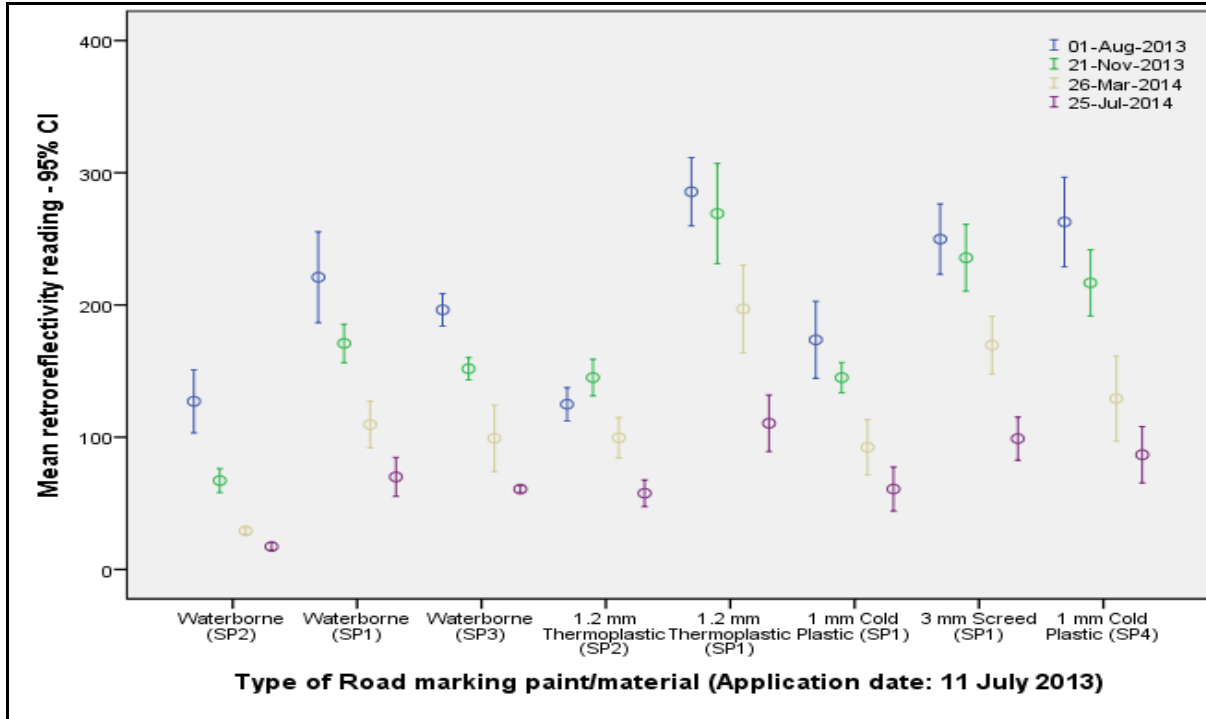

Figure C.1.4: Newly established clean chip seal road (Doreen Street - B's 2 & 3).

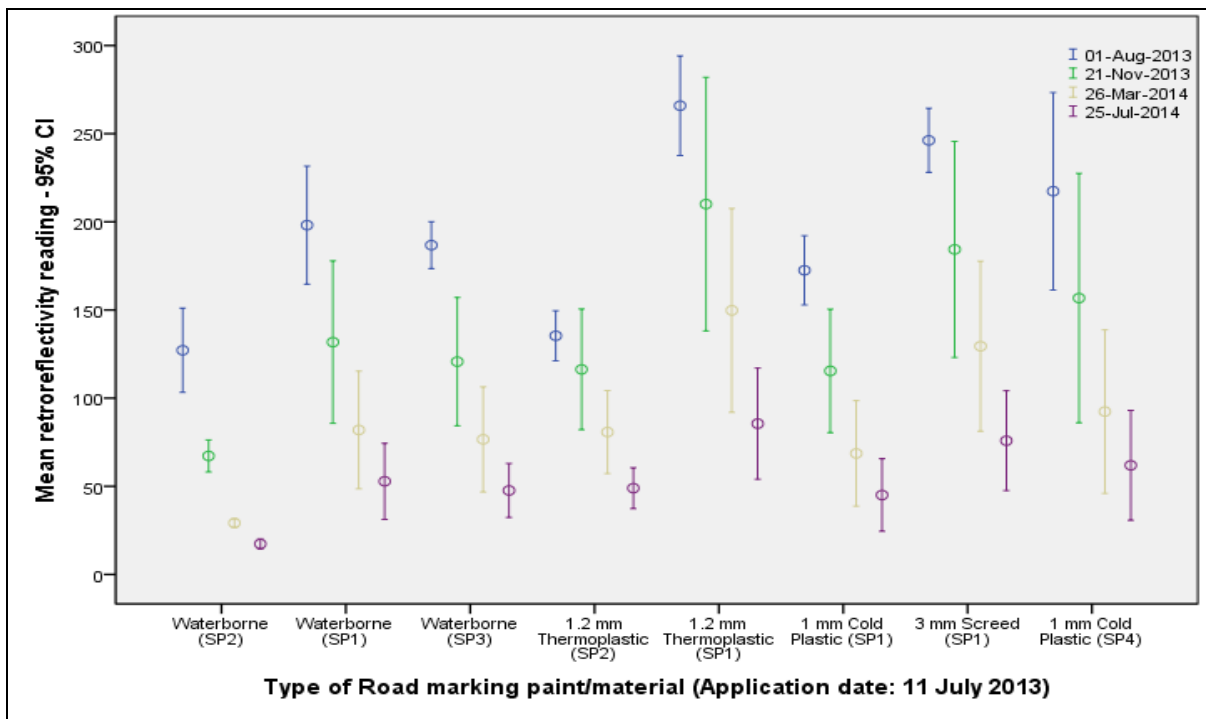

Figure C.1.5: Newly established clean chip seal road (Doreen Street - B's 1, 2 & 3).

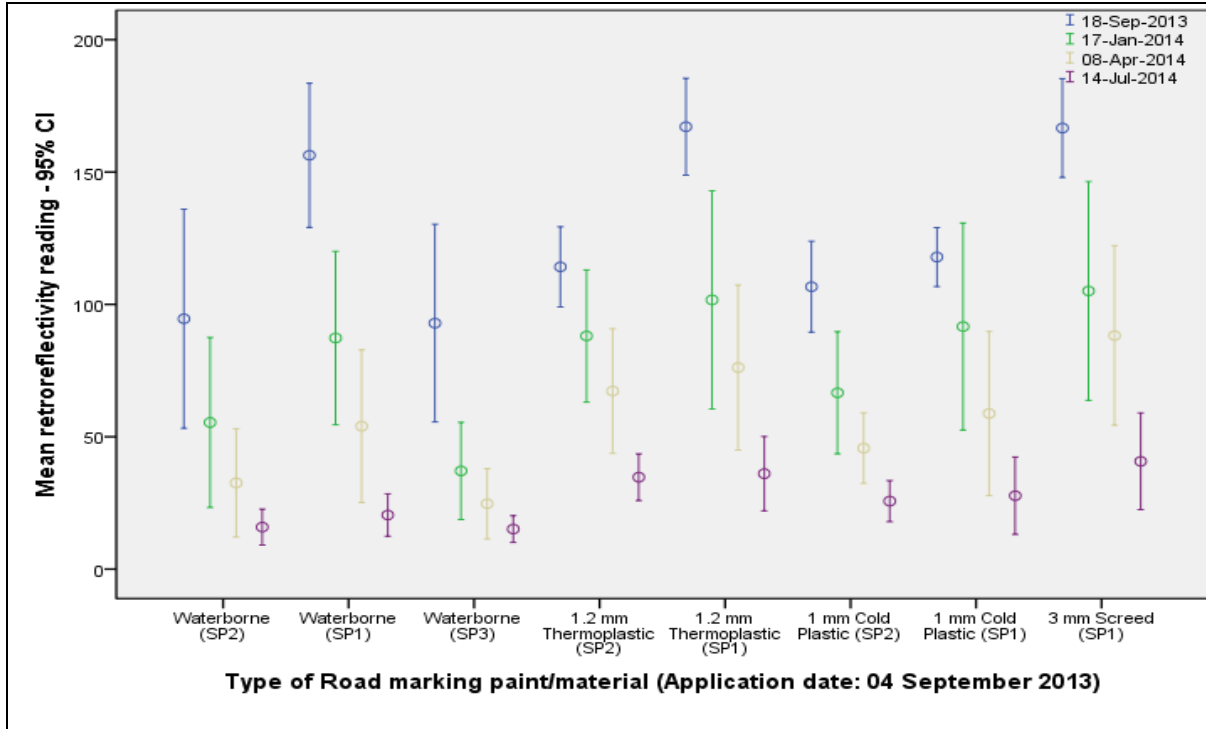

Figure C.1.6: Newly established dirty asphalt road (M 44).

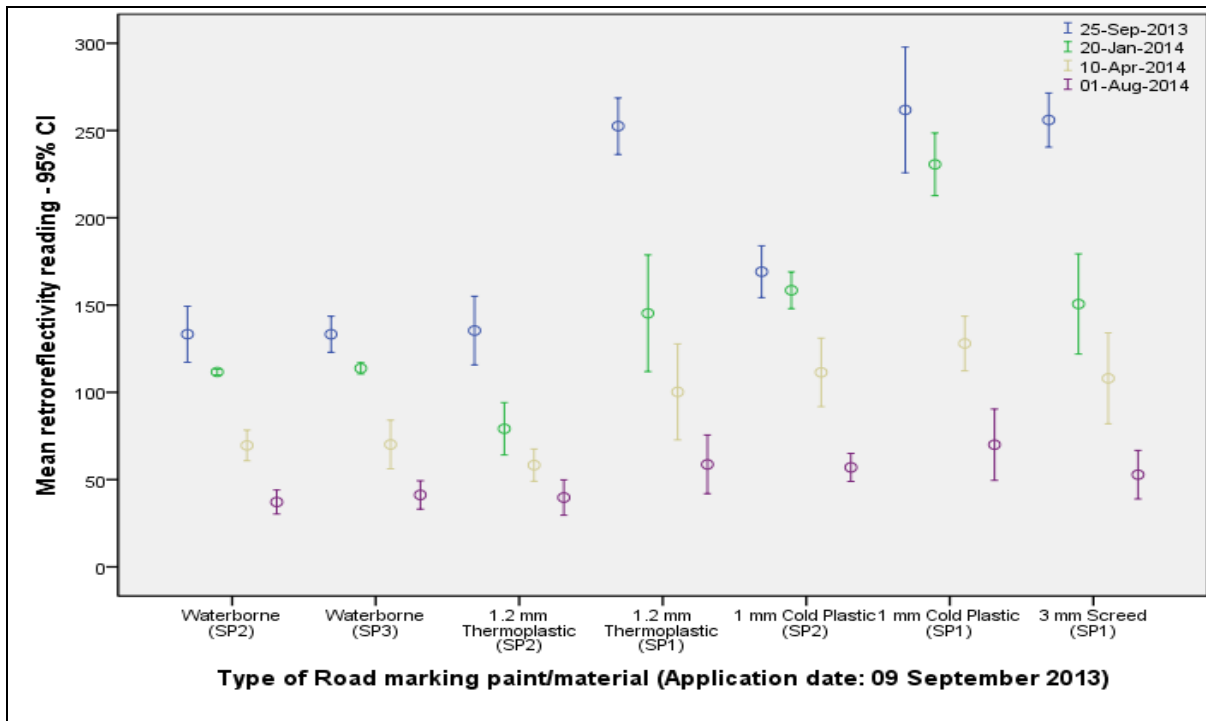

Figure C.1.7: Long established asphalt road in CBD (Madiba Street).

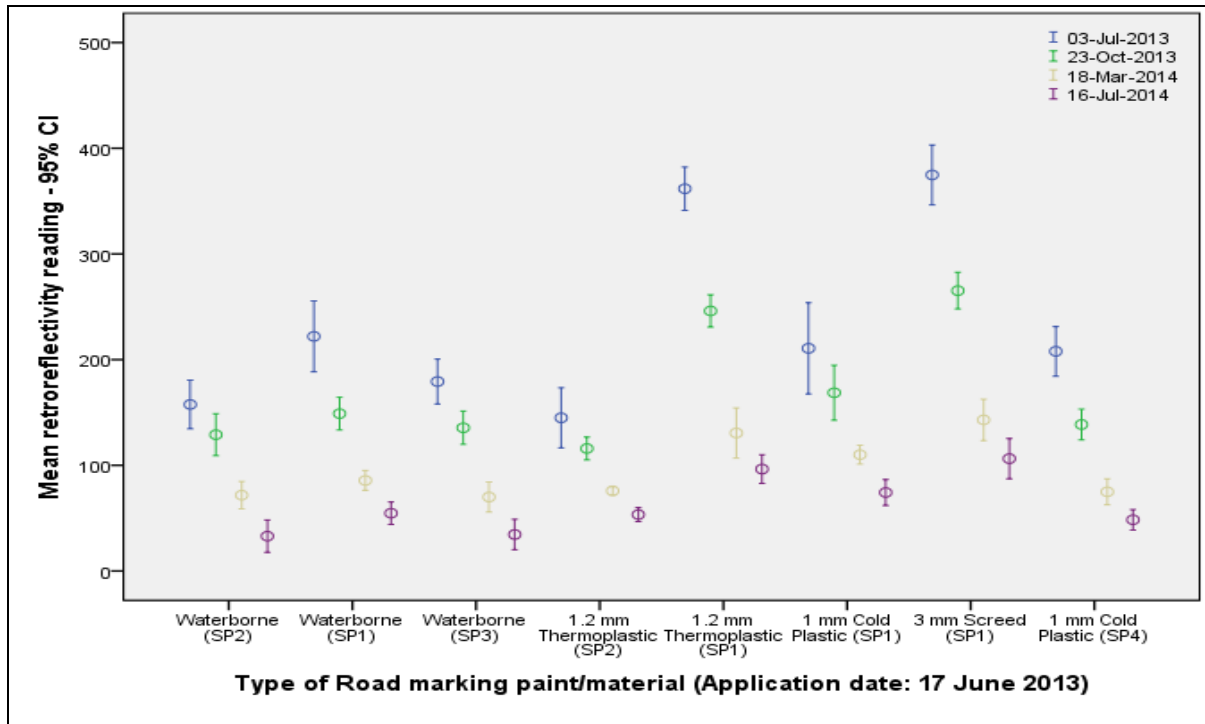

Figure C.1. 8: Newly established clean asphalt road (Meiring Naude Road).

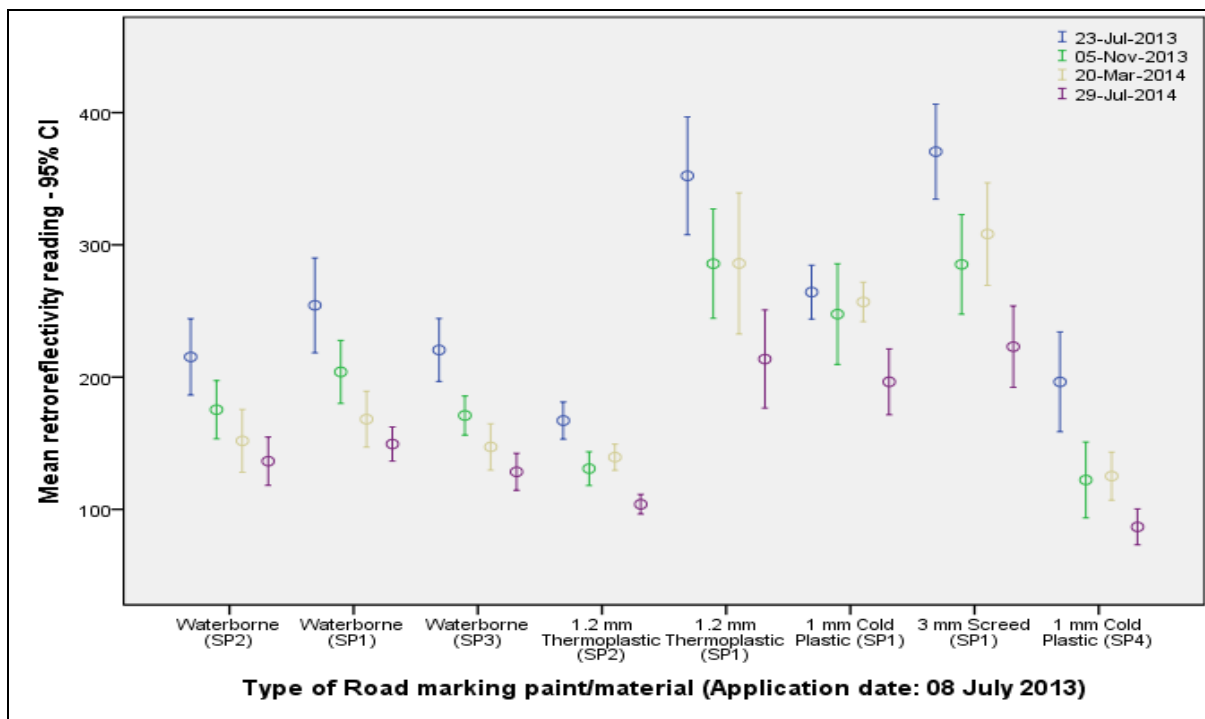

Figure C.1.9: Long established clean asphalt road (Middel Street).

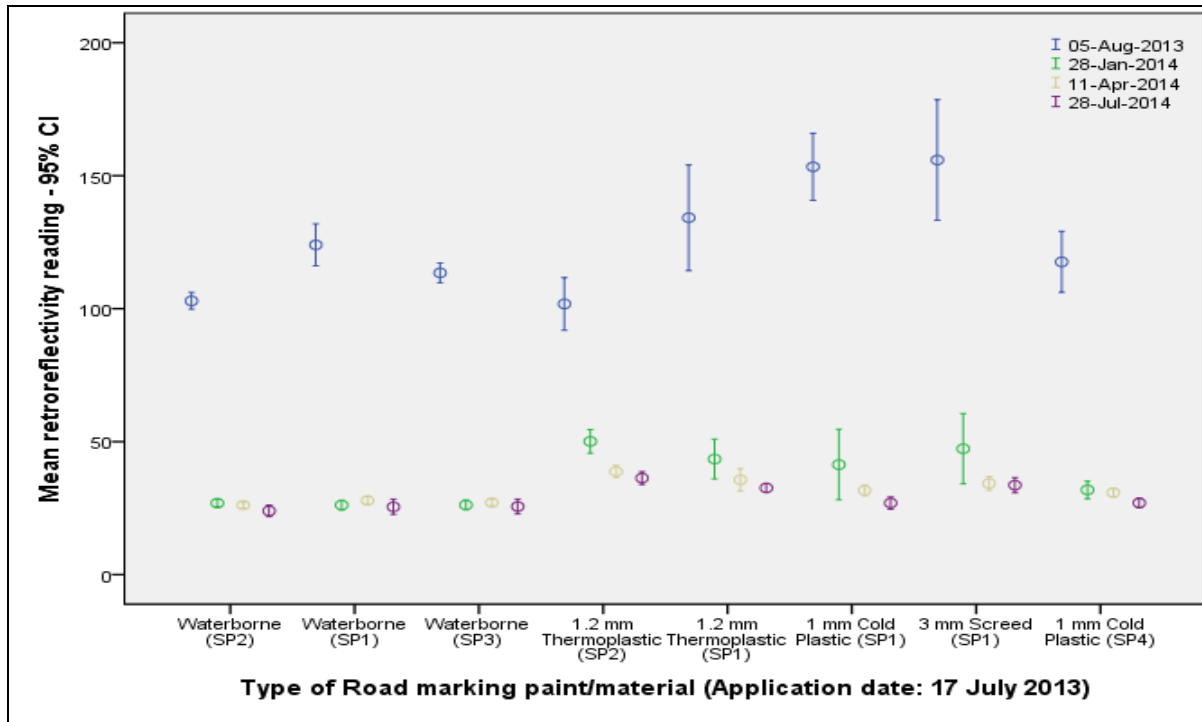

Figure C.1.10: Long established dirty asphalt road (Mohwelere Street).

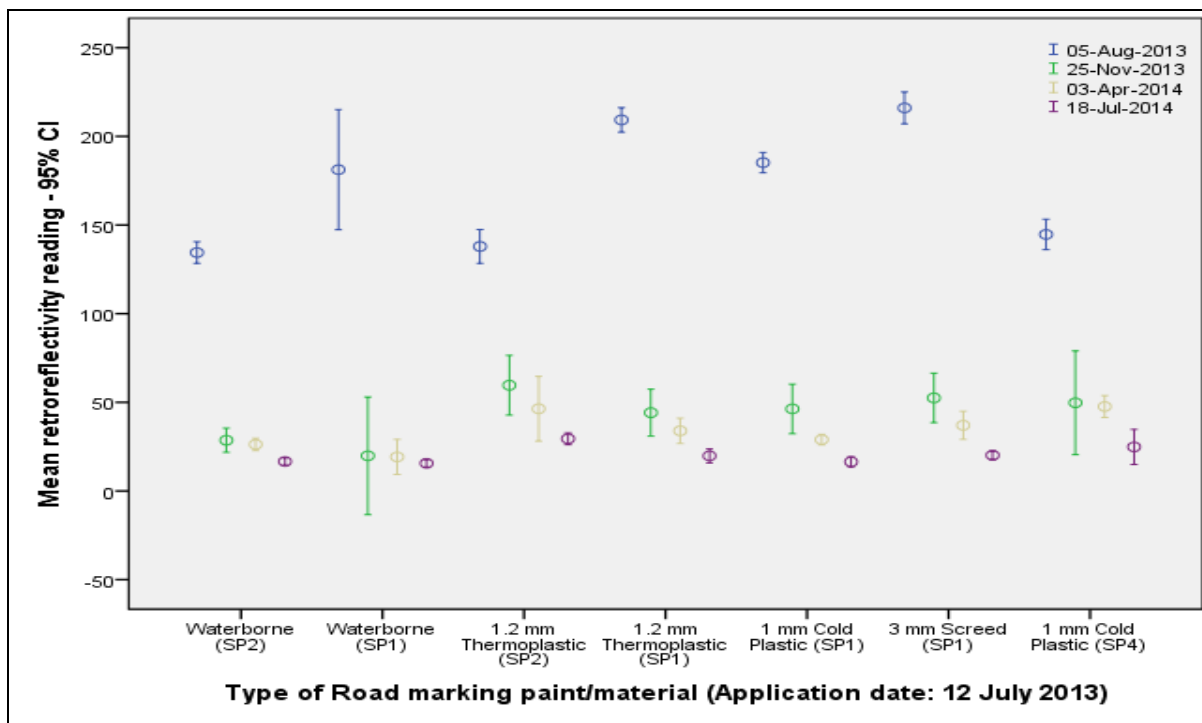

Figure C.1.11: Long established dirty chip seal road (Road L 3).

C.2. UNWASHED YELLOW TRANSVERSE TEST ROAD MARKINGS IN RETROREFLECTIVITY

The decline in retroreflectivity (R_L) over time of the test road marking paints and materials is demonstrated in Figures C.2.1 to C.2.11. The fact that there is no overlap between the 95 per cent CIs of the first and last measurements on Aubrey Matlala Road, Bushveld Road, Doreen Street (B 1), Doreen Street (B's 2 & 3), Doreen Street (B's 1, 2 & 3), M 44, Madiba Street, Meiring Naude Road, Middel Street, Mohwelere Street and Road L 3 is an indication that the difference between them is statistically significant.

The R_L measurements were subjected to a Friedman's Chi Square Test to determine whether any pair or pairs of R_L measurements across time periods within each type of road marking paint or material is significantly different or not. Friedman's Chi Square Test revealed that there is at least one pair of measurements over time that is significantly different within each of the different road marking paints and materials, and referring to Figures C.2.1 to C.2.11, it can be seen that the differences are at least between the first and last repetitions.

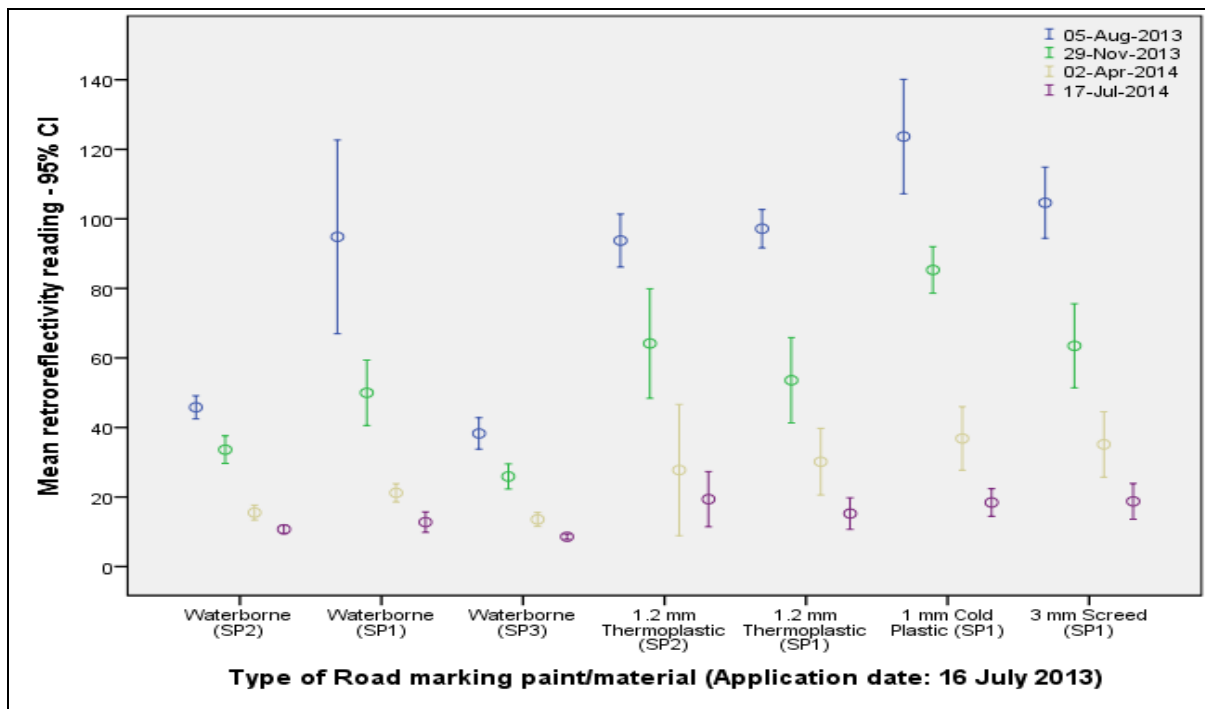

Figure C.2.1: Newly established dirty chip seal road (Aubrey Matlala Road).

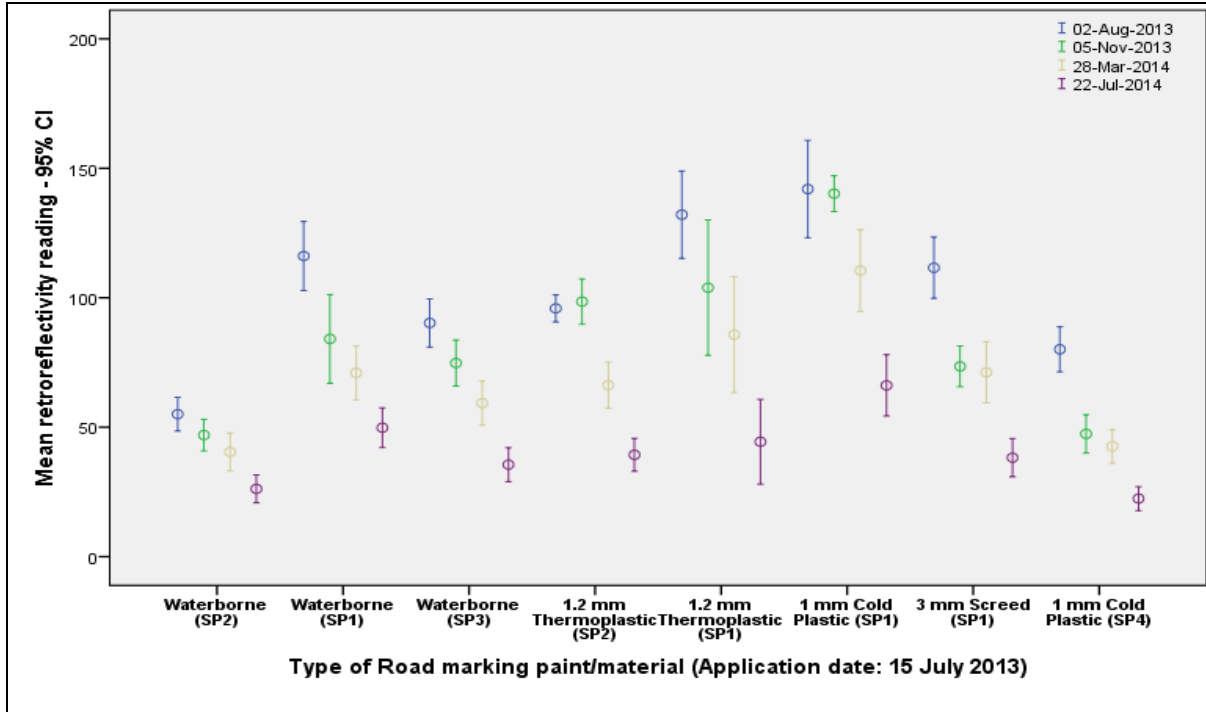

Figure C.2.2: Long established clean chip seal road (Bushveld Road).

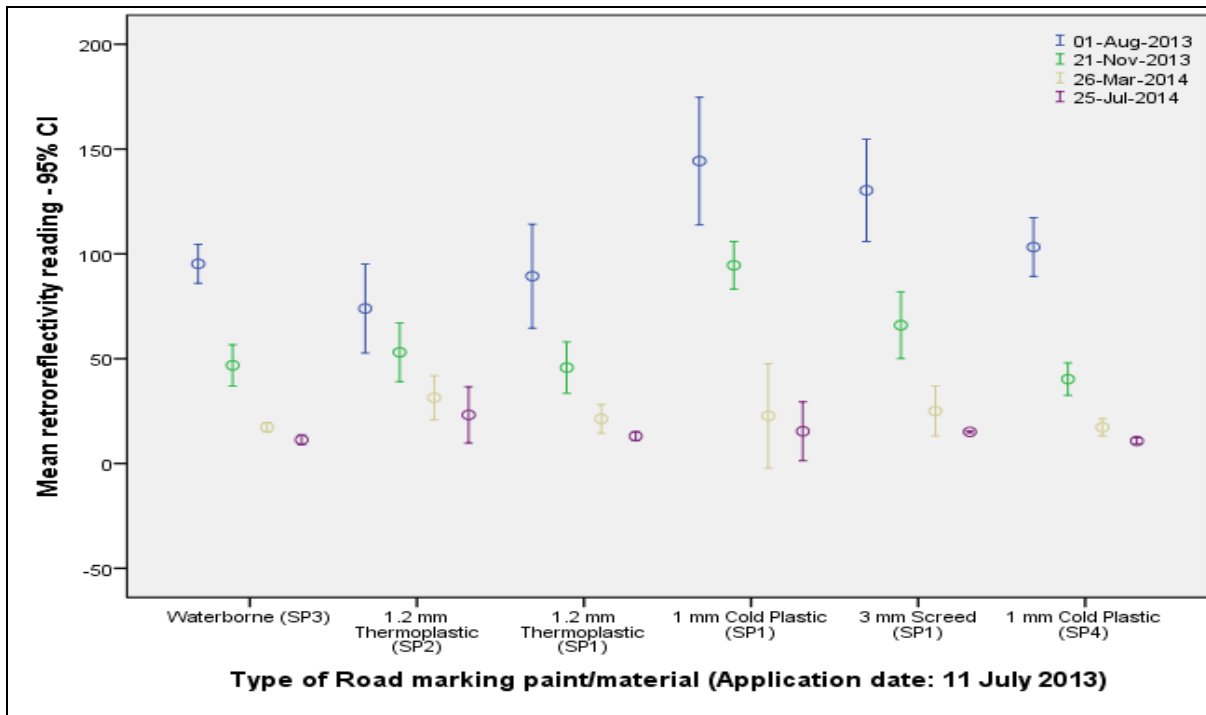

Figure C.2.3: Newly established clean chip seal road (Doreen Street - B 1).

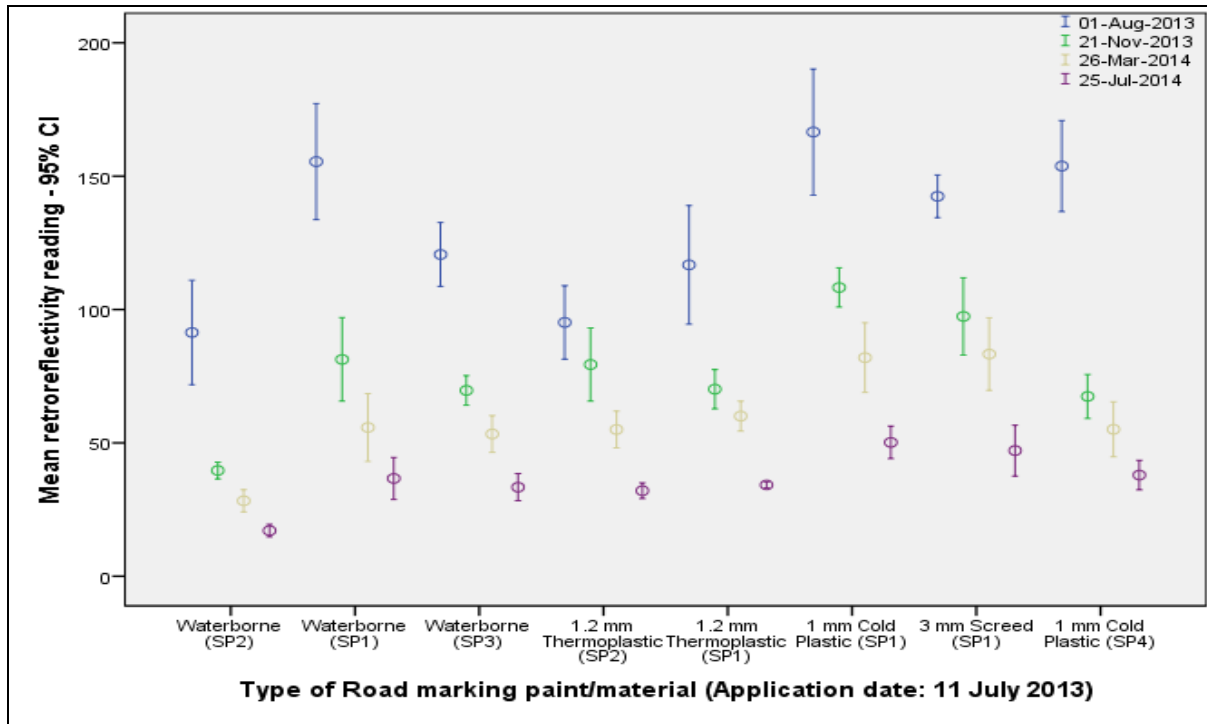

Figure C.2.4: Newly established clean chip seal road (Doreen Street - B's 2 & 3).

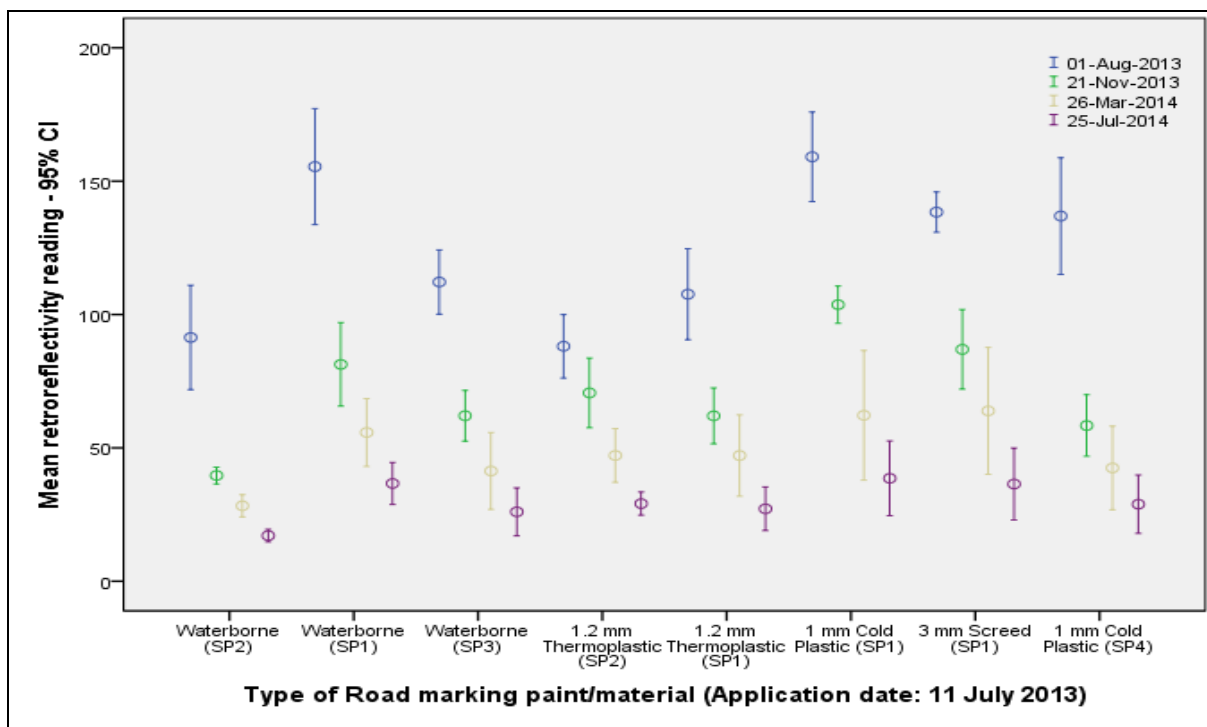

Figure C.2.5: Newly established clean chip seal road (Doreen Street - B's 1, 2 & 3).

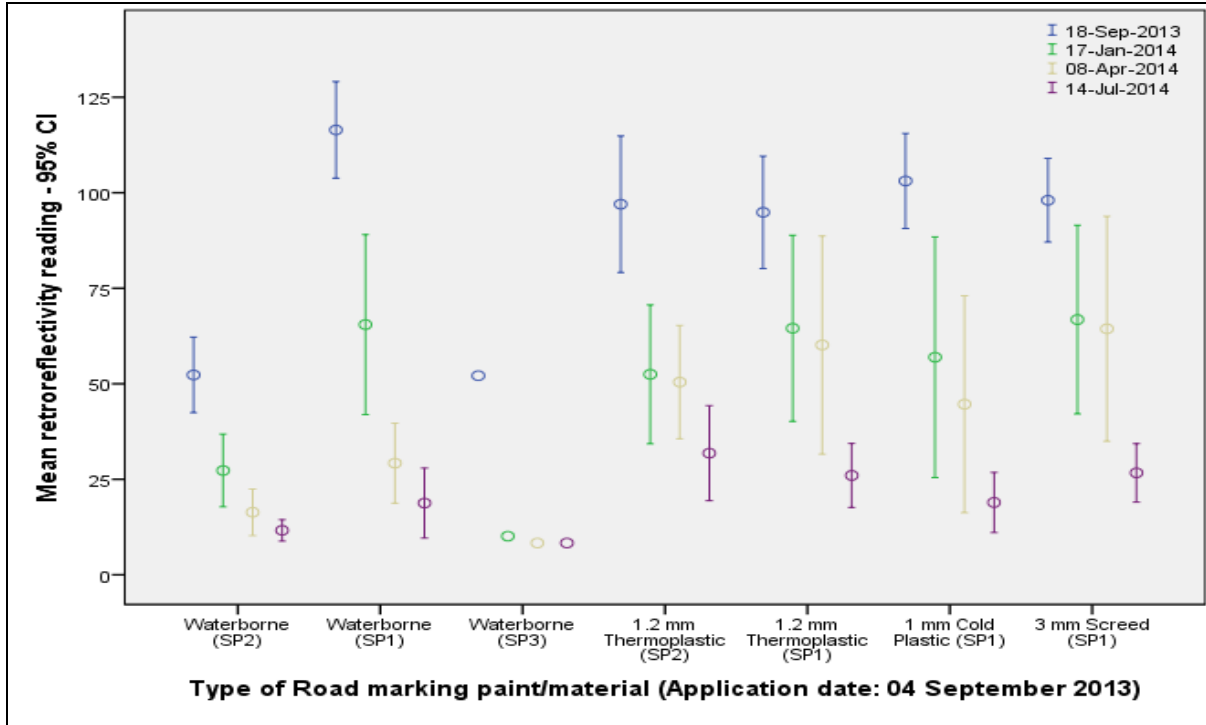

Figure C.2.6: Newly established dirty asphalt road (M 44).

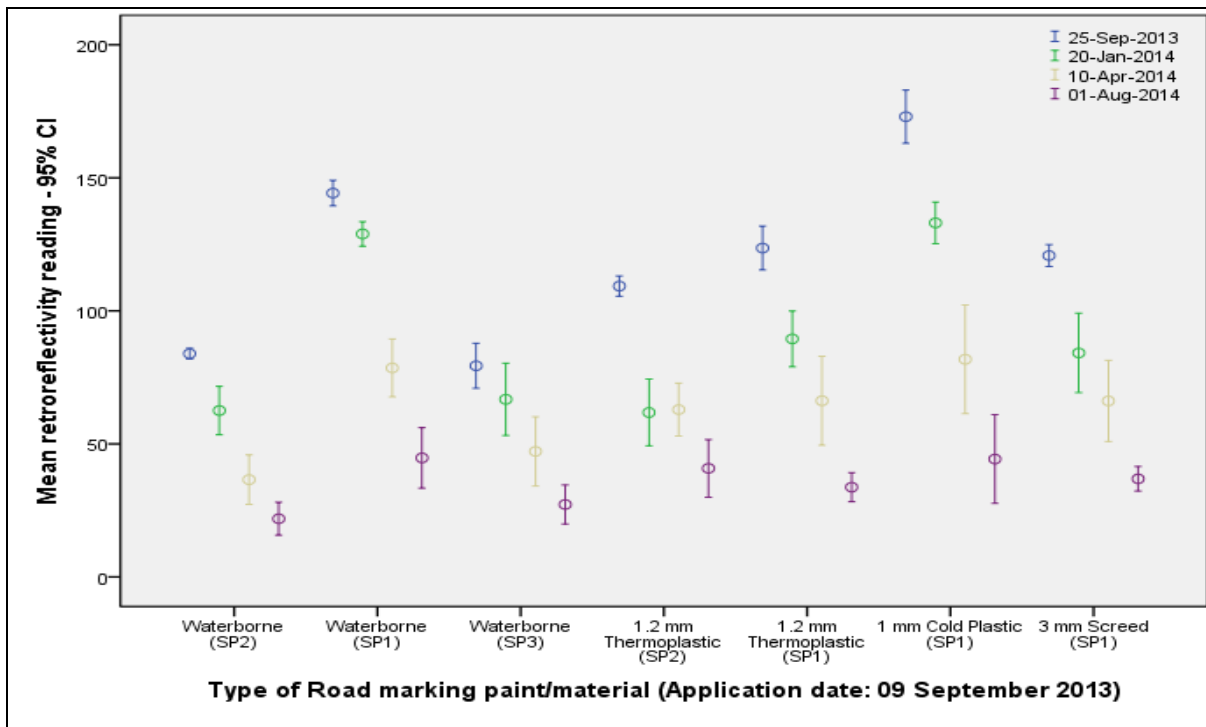

Figure C.2.7: Long established asphalt road in CBD (Madiba Street).

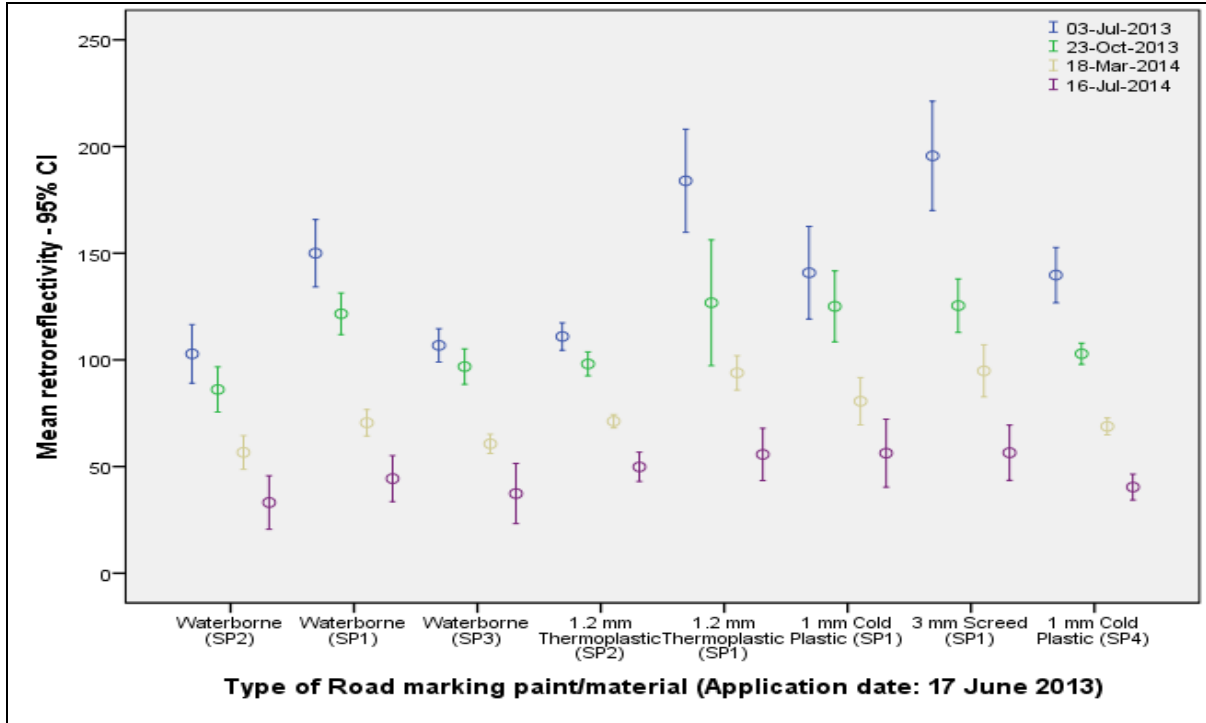

Figure C.2.8: Newly established clean asphalt road (Meiring Naude Road).

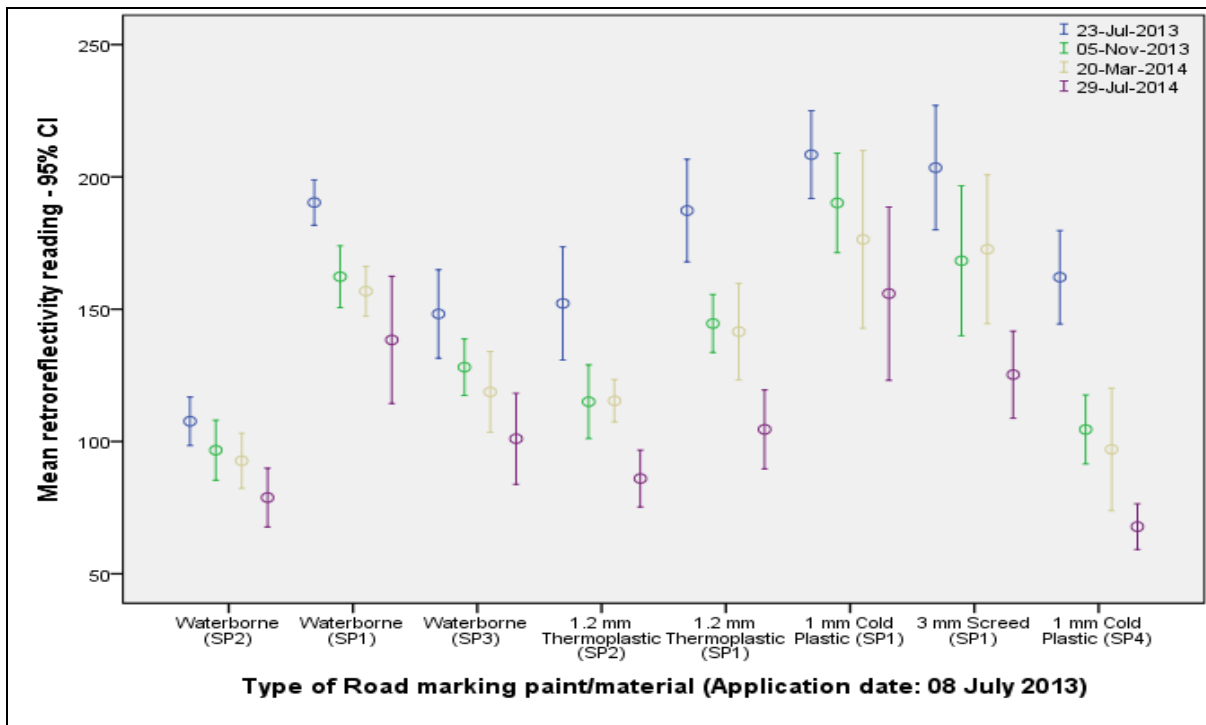

Figure C.2.9: Long established clean asphalt road (Middel Street).

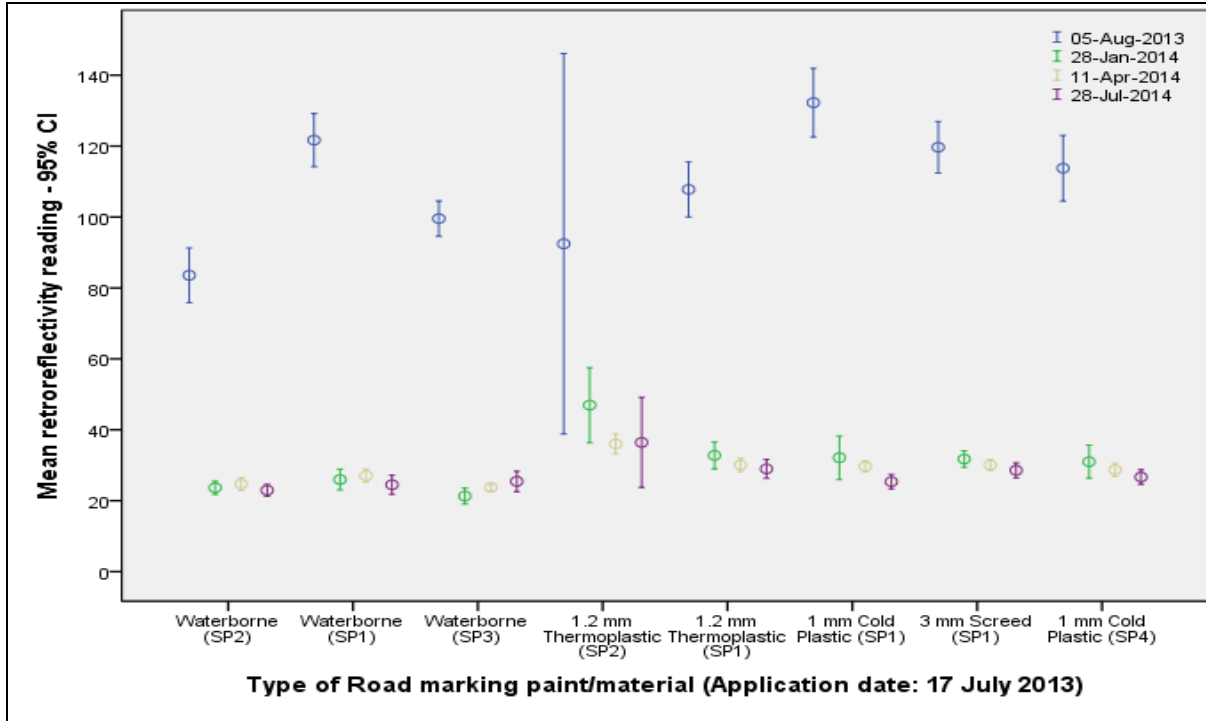

Figure C.2.10: Long established dirty asphalt road (Mohwelere Street).

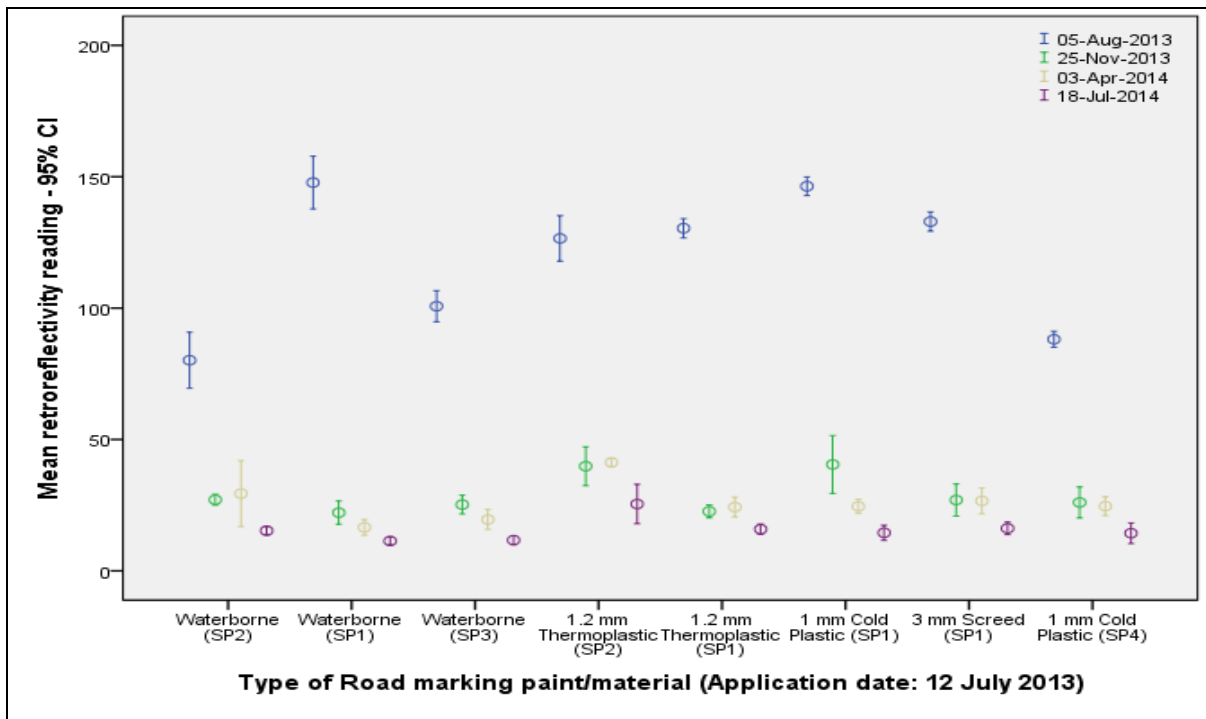

Figure C.2.11: Long established dirty chip seal road (Road L 3).

C.3. UNWASHED WHITE LONGITUDINAL TEST ROAD MARKINGS IN RETROREFLECTIVITY

The decline in R_L over time of the test road marking paints and materials is demonstrated in Figures C.3.1 to C.3.10. The fact that there is no overlap between the 95 per cent CIs of the first and last measurements on Bushveld Road, Meiring Naude Road, Middel Street, Mohwelere Street and on Road L 3 is an indication that the difference between them is statistically significant. Friedman's Chi Square Test revealed that there is at least one pair of readings over time that is significantly different within each of the different road marking paints and materials.

Friedman's Chi Square Test revealed that there are no pairs of readings over time that are significantly different within each of the different materials on Aubrey Matlala Road, Doreen Street (B 1), Doreen Street (B's 2 & 3), Doreen Street (B's 1, 2 & 3) and on the M 44. Even though some 95% CIs do not overlap, the sample size of less than 3 does not allow for enough statistical power to find statistically significant differences. The fact that the 95 per cent CIs extend into the negative with some of the road marking paints and materials further indicates the lack of statistical power, and they should thus be interpreted in the usual way. For example, the 95 per cent CI on Aubrey Matlala Road for 1.2 mm thermoplastic (SP2) extends to approximately -100 as indicated on Figure C.3.1.

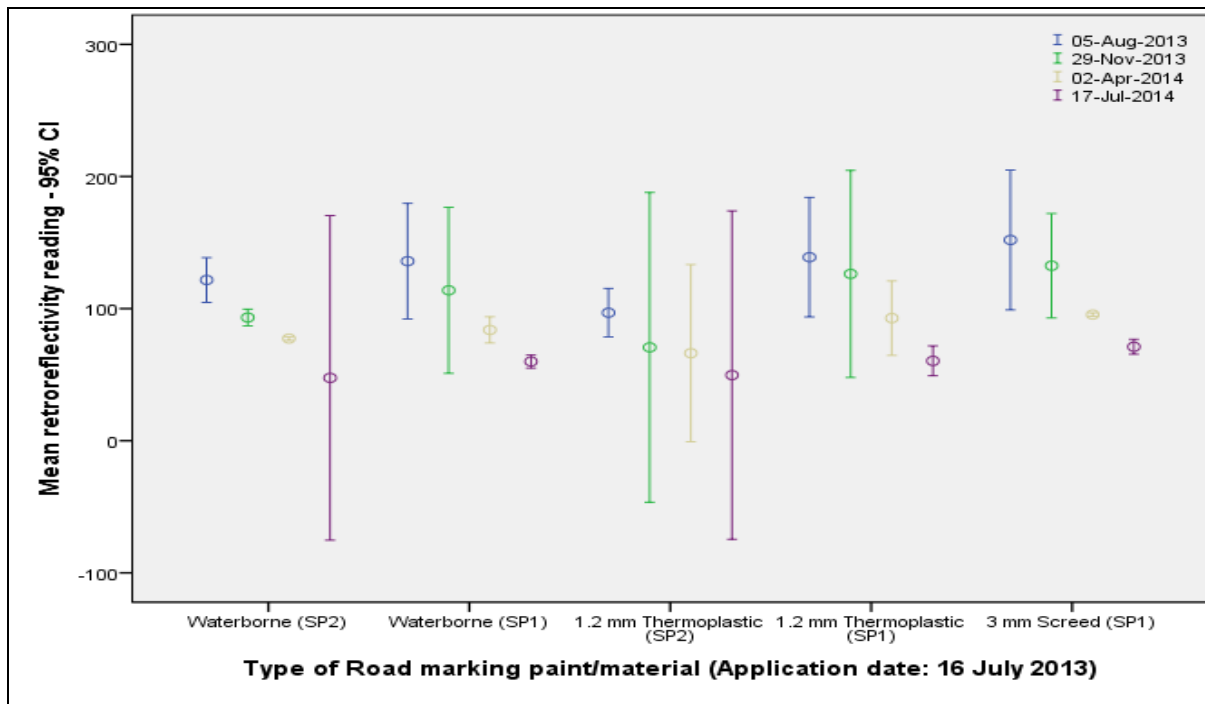

Figure C.3.1: Newly established dirty chip seal road (Aubrey Matlala Road).

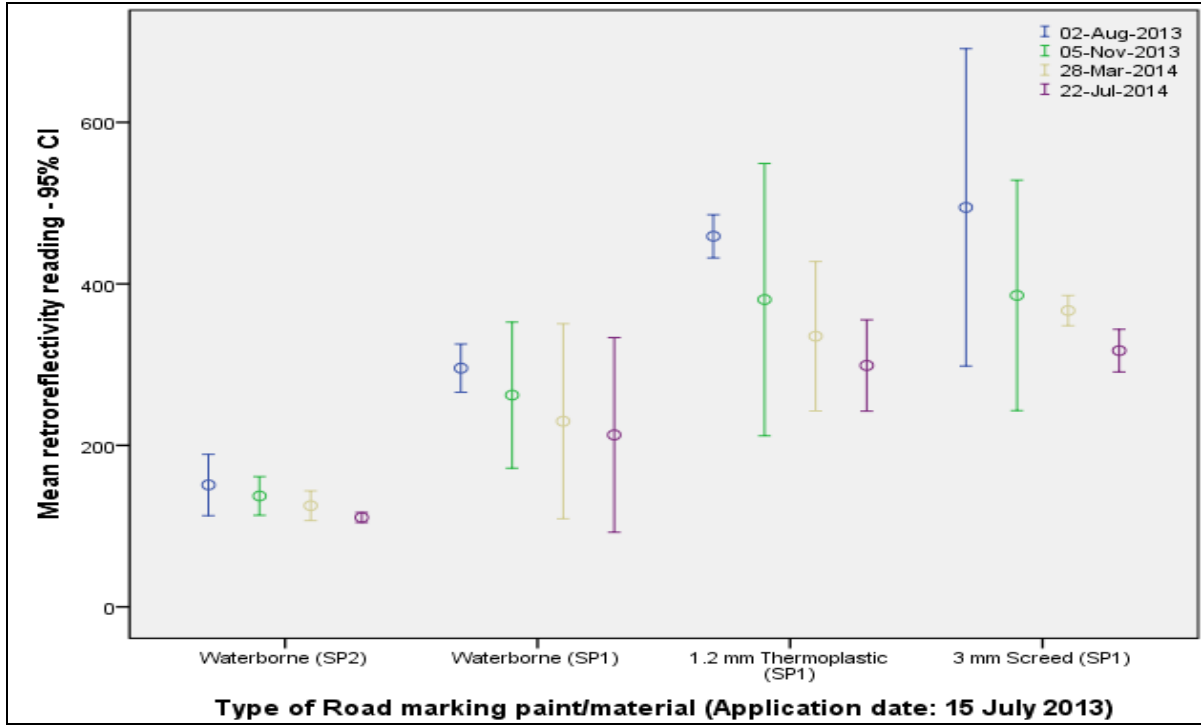

Figure C.3.2: Long established clean chip seal road (Bushveld Road).

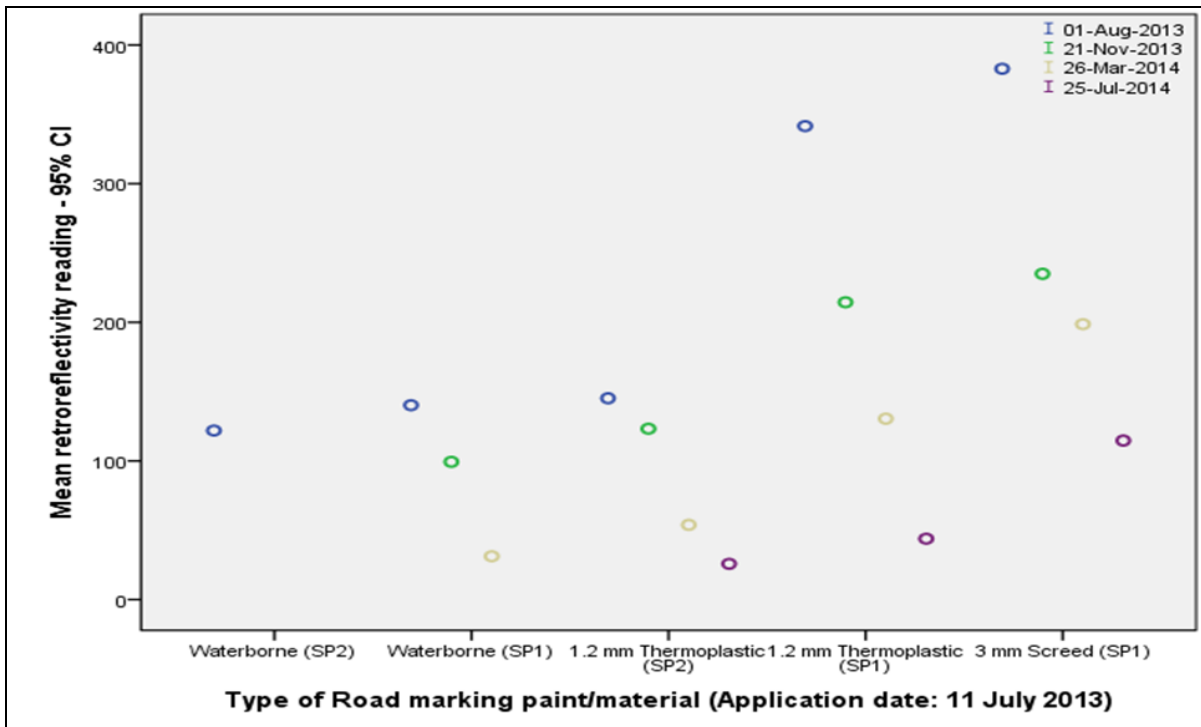

Figure C.3.3: Newly established clean chip sea road (Doreen Street - B 1).

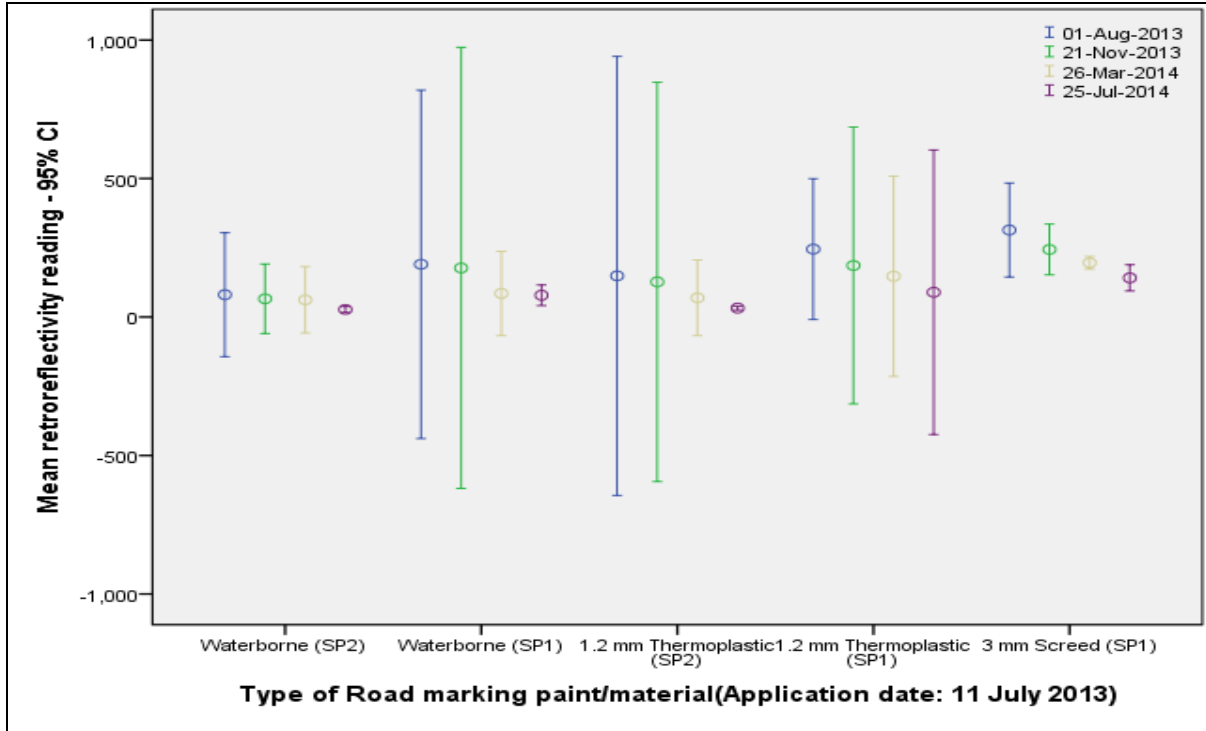

Figure C.3.4: Newly established clean chip seal road (Doreen Street - B's 2 & 3).

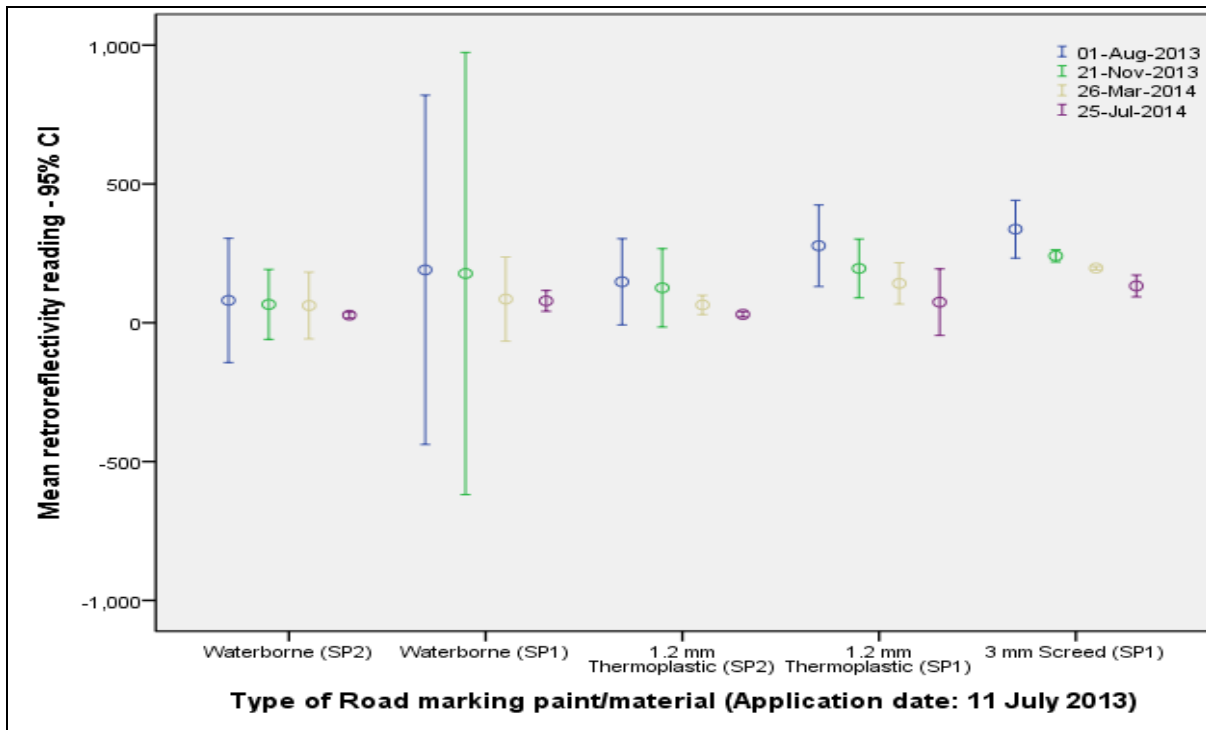

Figure C.3.5: Newly established clean chip seal road (Doreen Street - B's 1, 2 & 3).

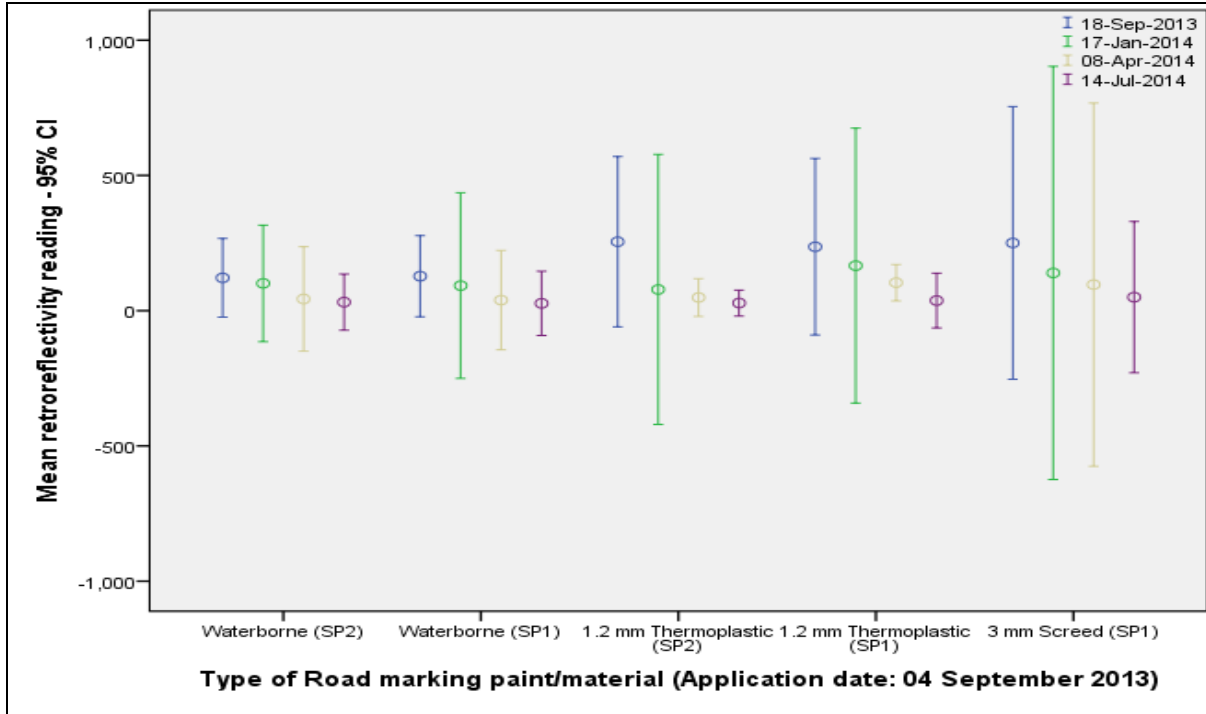

Figure C.3.6: Newly established dirty asphalt road (M 44).

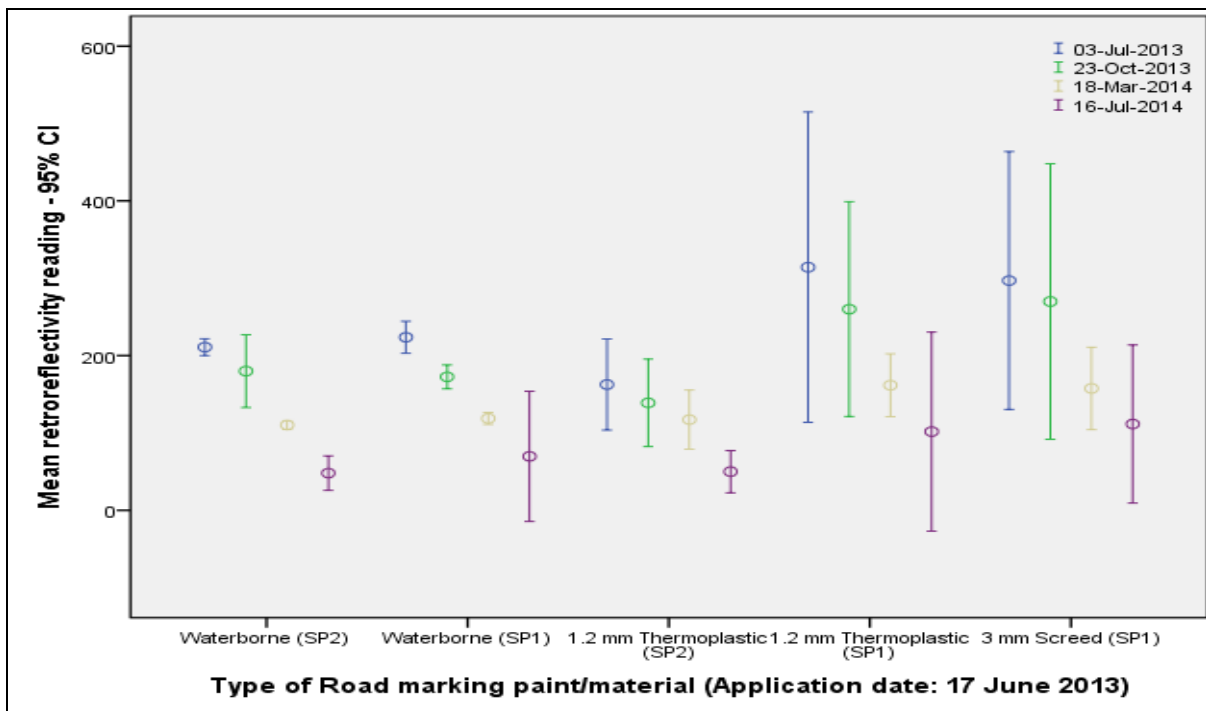

Figure C.3.7: Newly established clean asphalt road (Meiring Naude Road).

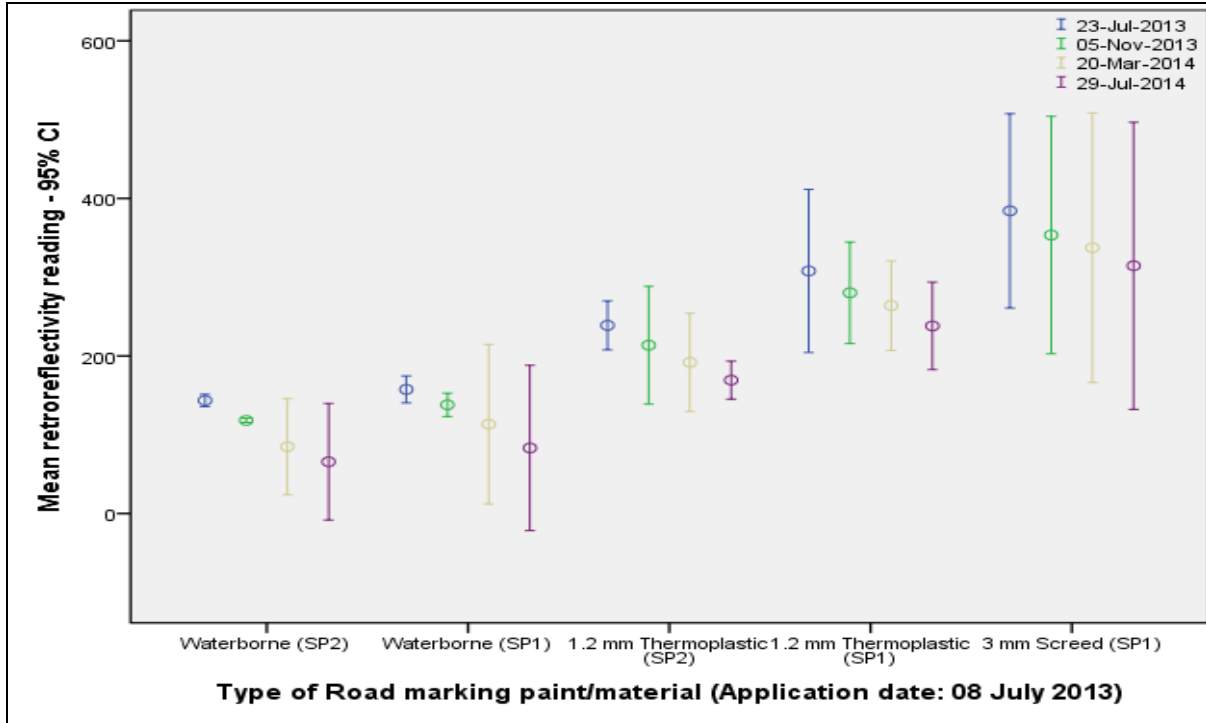

Figure C.3.8: Long established clean asphalt road (Middel Street).

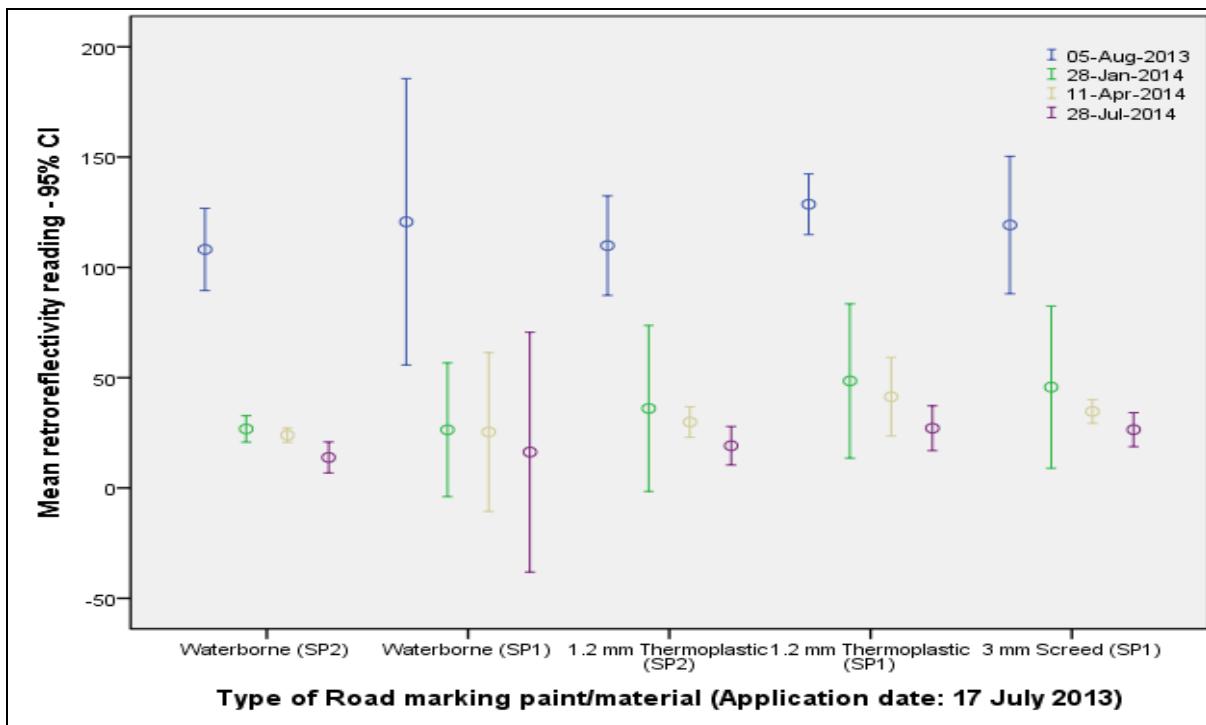

Figure C.3.9: Long established dirty asphalt road (Mohwelere Street).

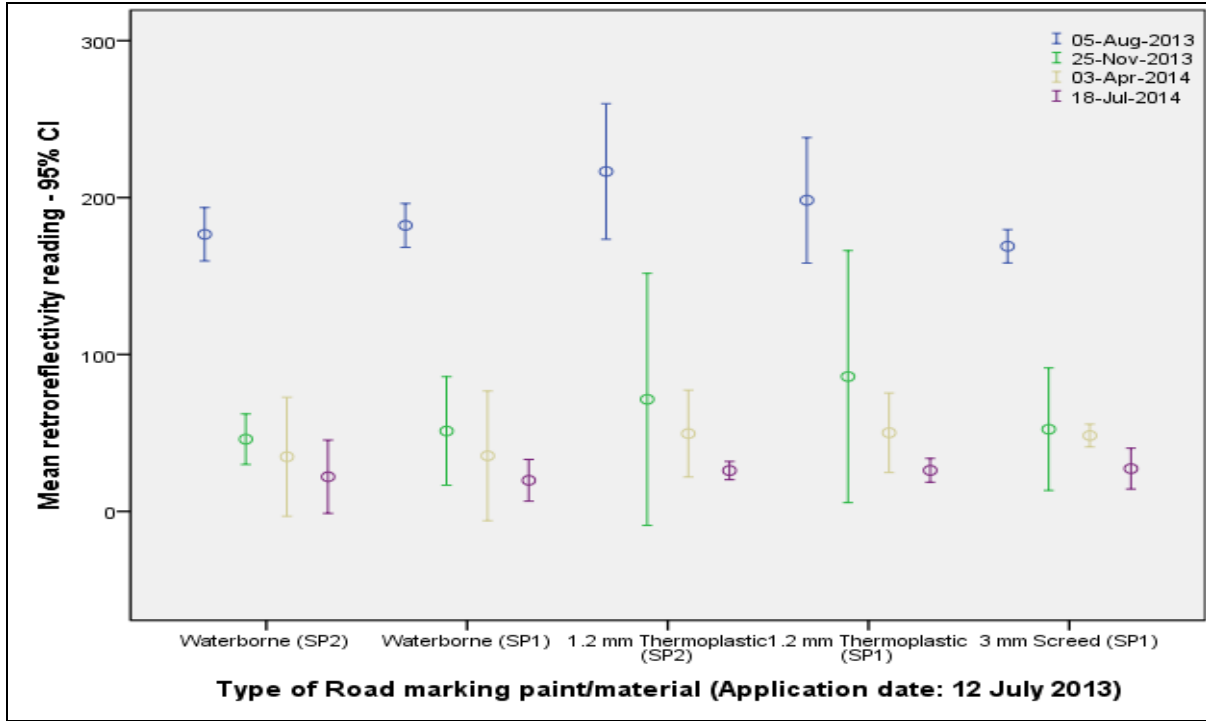

Figure C.3.10: Long established dirty chip seal road (Road L 3).

C.4. UNWASHED YELLOW LONGITUDINAL TEST ROAD MARKINGS IN RETROREFLECTIVITY

The decline in R_L over time of the test road marking paints and materials is demonstrated in Figures C.4.1 to C.4.10. The fact that there is no overlap between the 95 per cent CIs of the first and last measurements on, Bushveld Road, Doreen Street (B's 1, 2 & 3), Meiring Naude Road, Middel Street, Mohwelere Street and on Road L 3 is an indication that the difference between them is statistically significant. Friedman's Chi Squared Test revealed that there is at least one pair of readings over time that is significantly different within each of the different road marking paints and materials.

Friedman's Chi Squared Test revealed that there are no pairs of readings over time that are significantly different within each of the different road marking paints and materials on Aubrey Matlala Road, Doreen Street (B 1), Doreen Street (B's 2 & 3) and on the M 44. Even though some 95 per cent CIs do not overlap, the sample size of less than 3 does not allow for enough statistical power to find statistically significant differences. The lack of 95 per cent CIs on Aubrey Matlala Road as indicated in Figure C.4.1 is due to the fact that there is no variance available as there was only one reading per product. Inferential testing was not possible due to the lack of data. The fact that the 95 per cent CIs extend into the negative with some of the road marking paints and materials, further indicates the lack of statistical power, and they should thus be interpreted in the usual way. For example, on Doreen Street (B's 2 & 3), waterborne (SP1) extend to approximately -250 as indicated on Figure C.4.4.

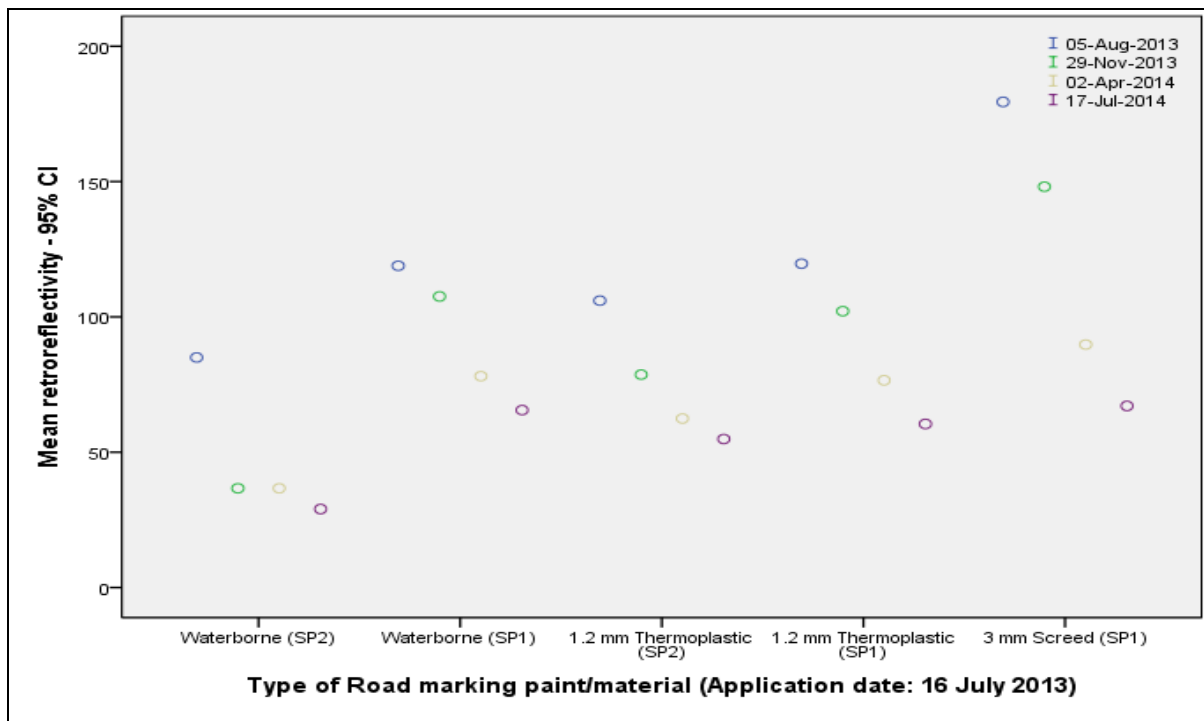

Figure C.4.1: Newly established dirty asphalt road (Aubrey Matlala Road).

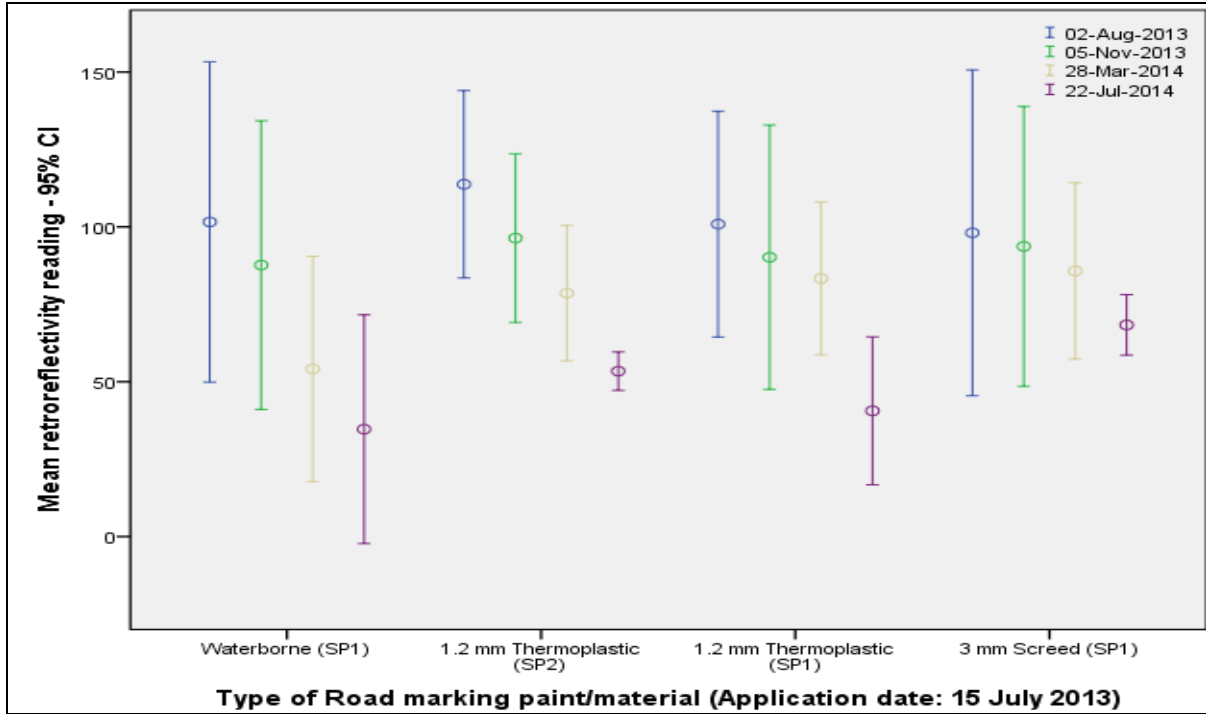

Figure C.4.2: Long established clean chip seal road (Bushveld Road).

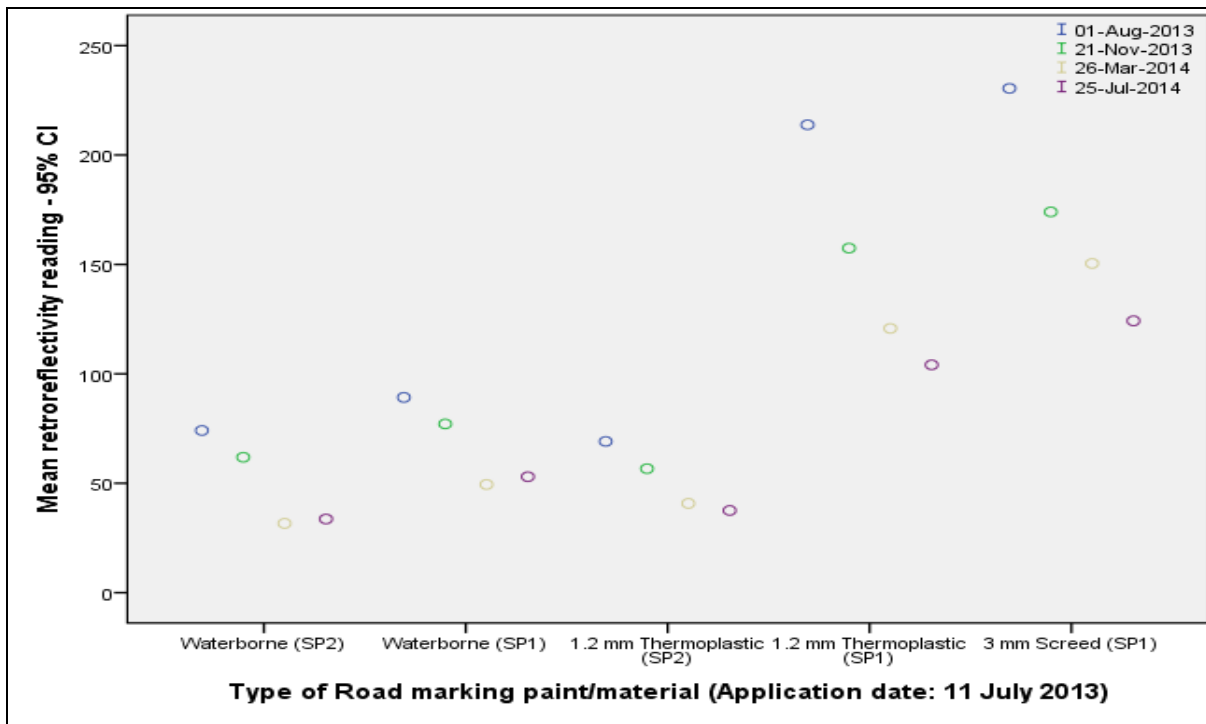

Figure C.4.3: Newly established clean chip seal road (Doreen Street - B 1).

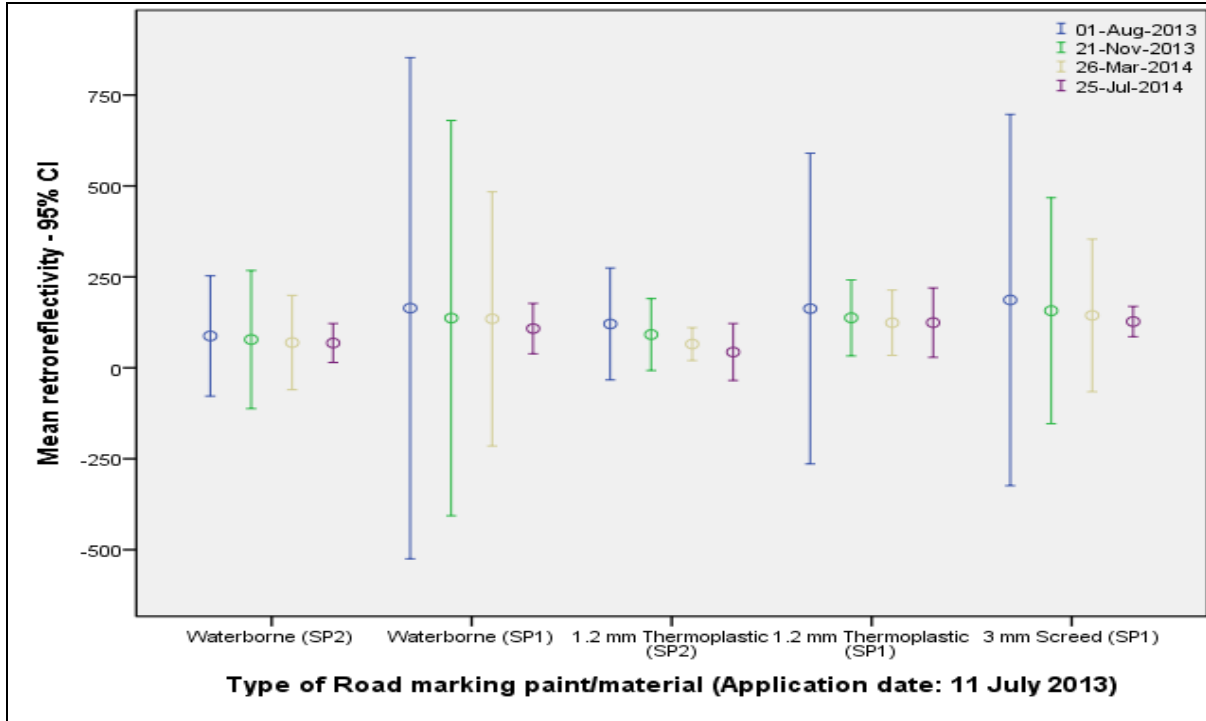

Figure C.4.4: Newly established clean chip seal road (Doreen Street - B's 2 & 3).

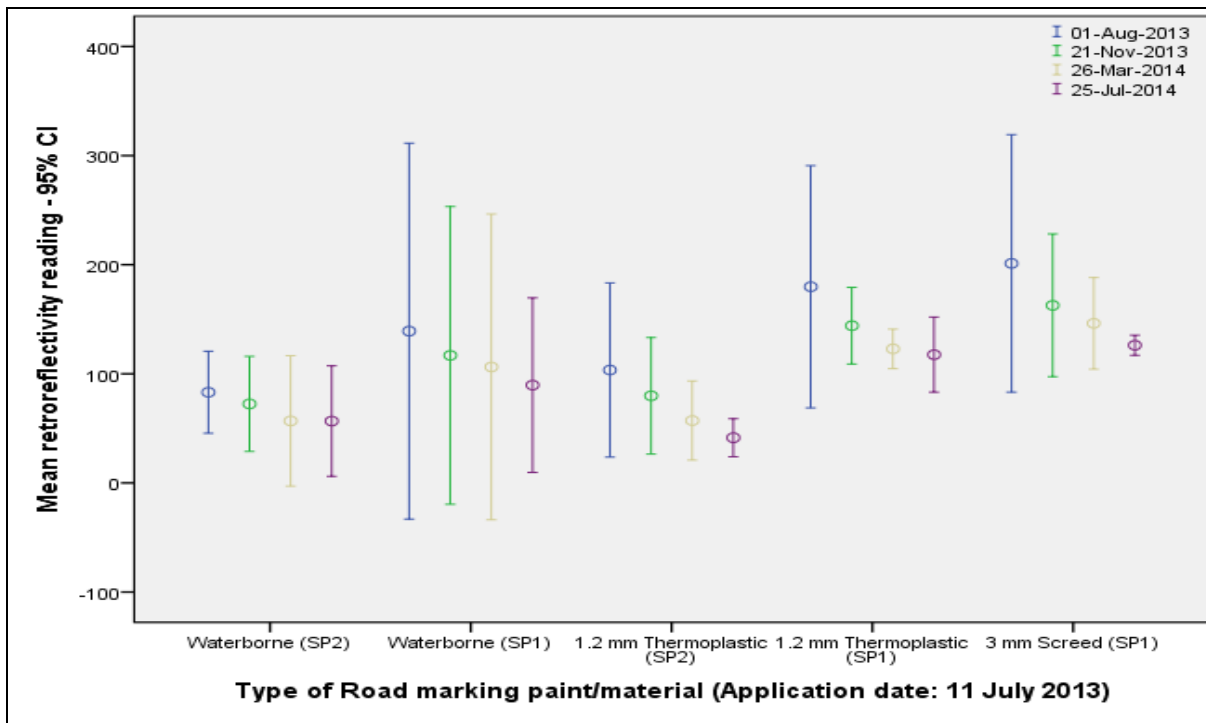

Figure C.4.5: Newly established clean chip seal road (Doreen Street B's 1, 2 and 3).

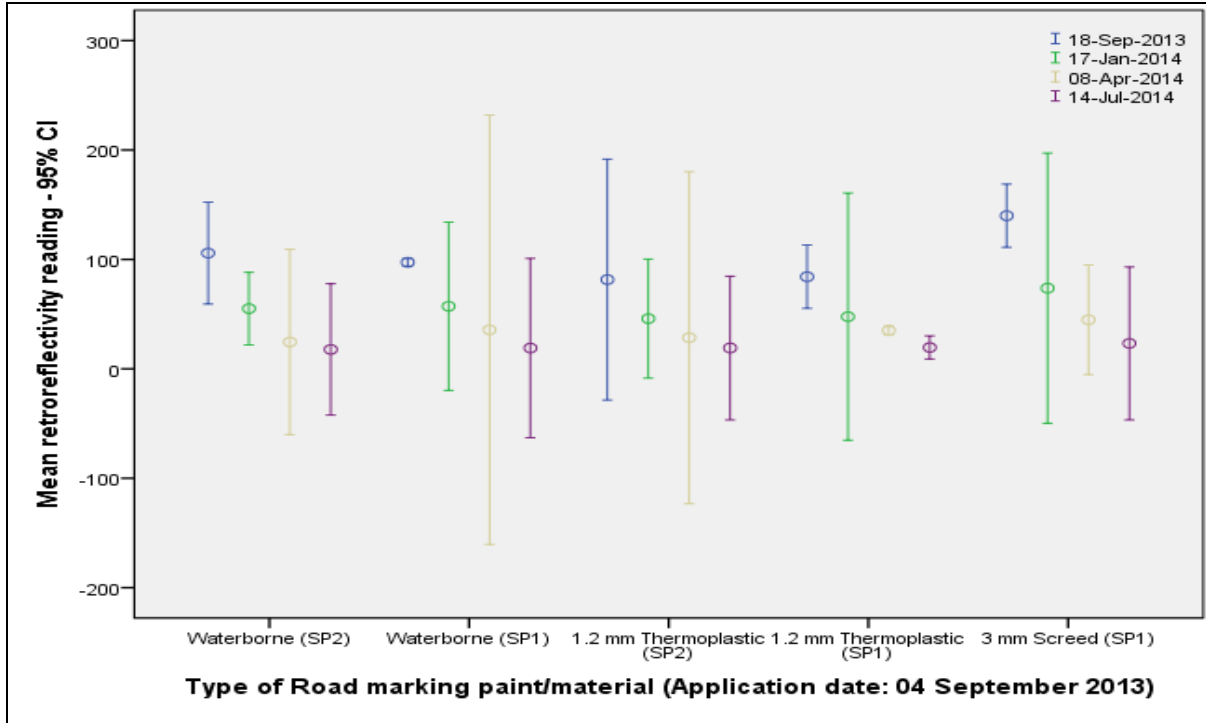

Figure C.4.6: Newly established dirty asphalt road (M 44).

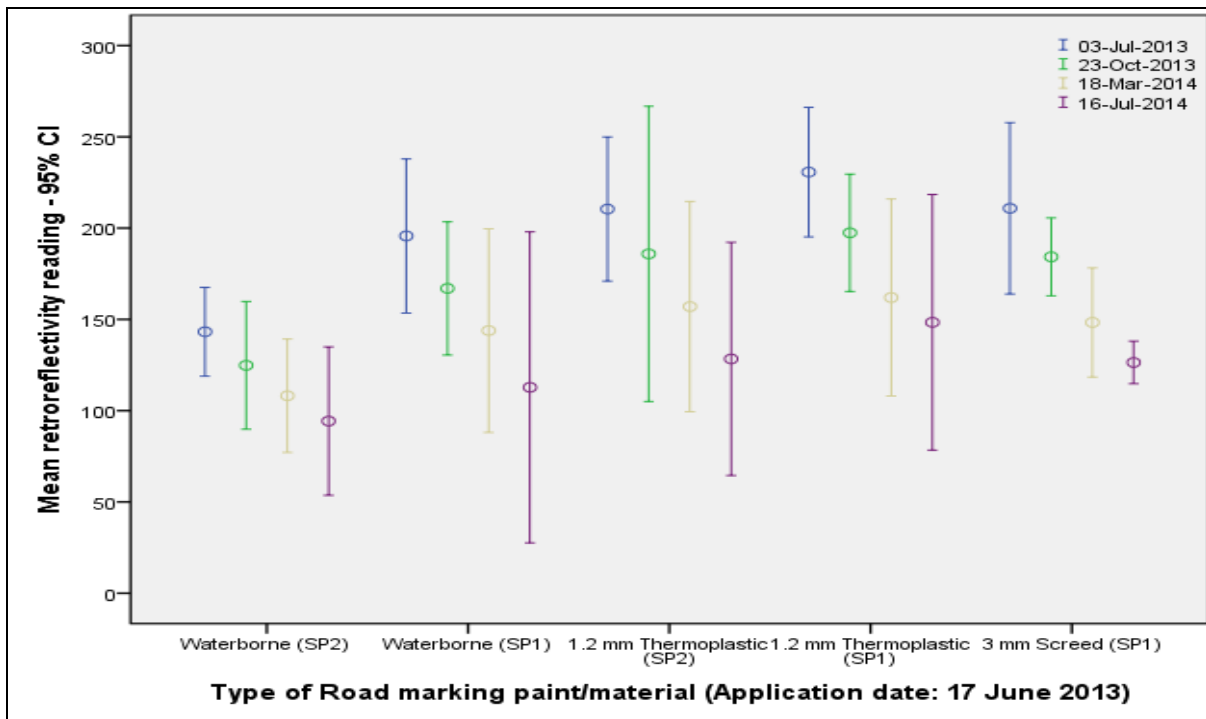

Figure C.4.7: Newly established clean asphalt road (Meiring Naude Road).

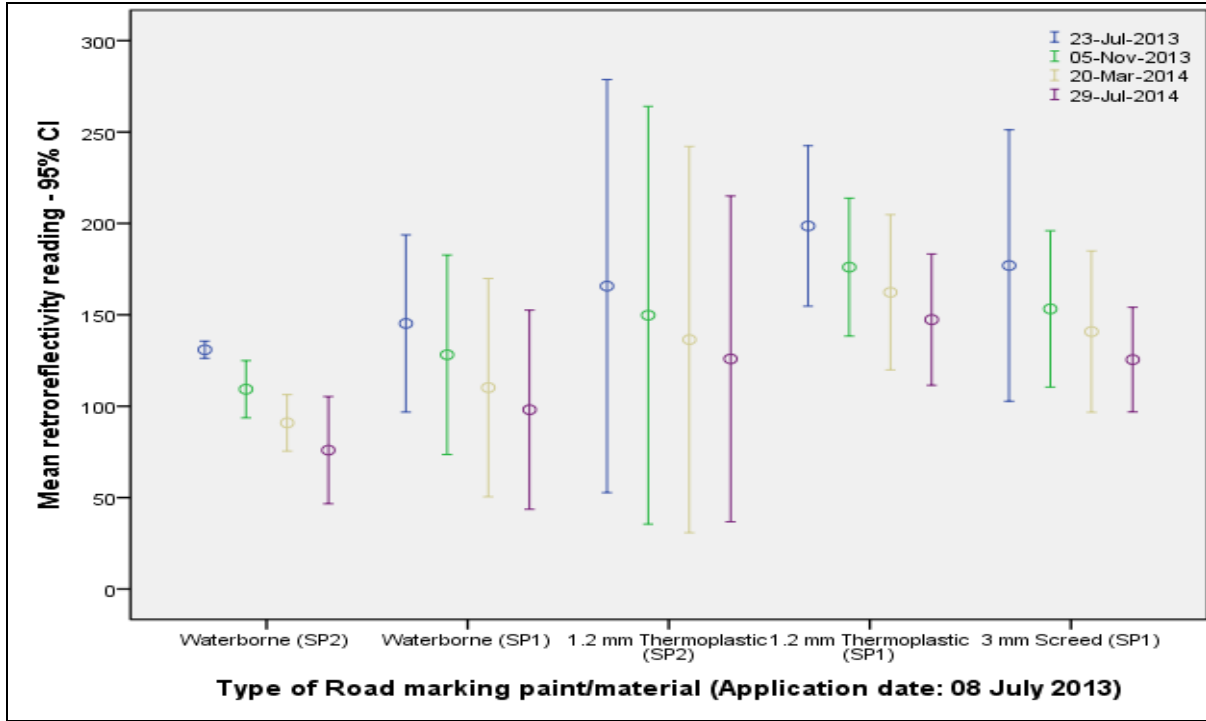

Figure C.4.8: Long established clean asphalt road (Middel Street).

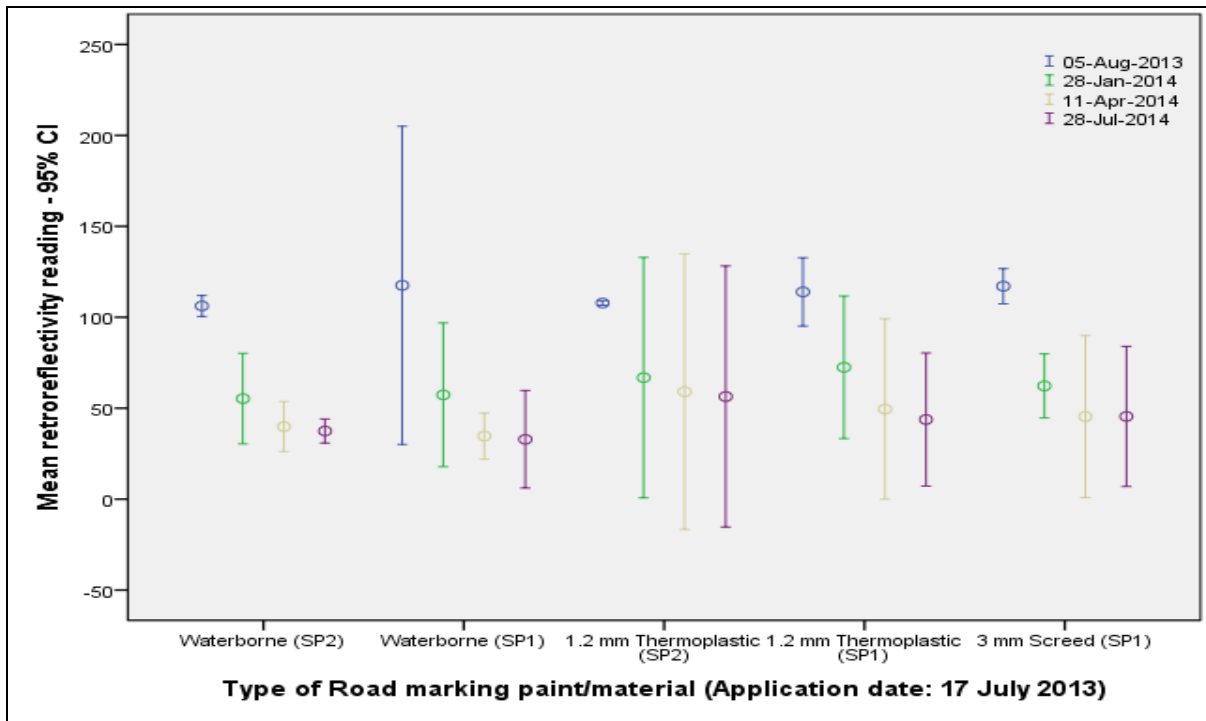

Figure C.4.9: Long established dirty asphalt road (Mohwelere Street).

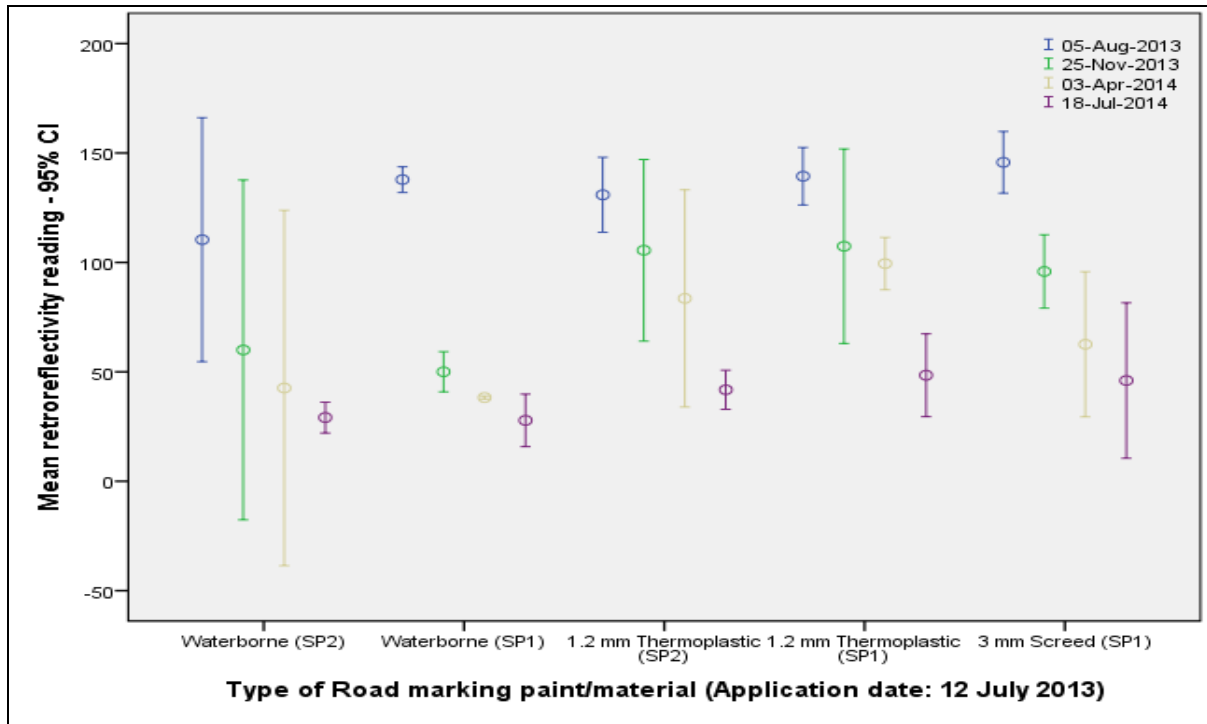

Figure C.4.10: Long established dirty chip seal road (Road L 3).

C.5. UNWASHED WHITE TRANSVERSE TEST ROAD MARKINGS IN LUMINANCE

The decline in Qd over time of the test road marking paints and materials is demonstrated in Figures C.5.1 to C.5.11. The fact that there is no overlap between the 95 per cent CIs of the first and last readings with all road marking paints and materials on Aubrey Matlala Road, Bushveld Road, Doreen Street, M 44, Madiba Street, Meiring Naude Road, Middel Street, Mohwelere Street and on Road L 3, as can be seen, is an indication that the difference between them is statistically significant.

Within each of the types of road marking paint and material, the Qd readings were subjected to a Friedman's Chi Square Test to determine whether any pair or pairs of Qd readings across time periods within each type of road marking paint and material are significantly different or not. Friedman's Chi Square Test revealed that there is at least one pair of readings over time that is significantly different within each of the different paints and materials.

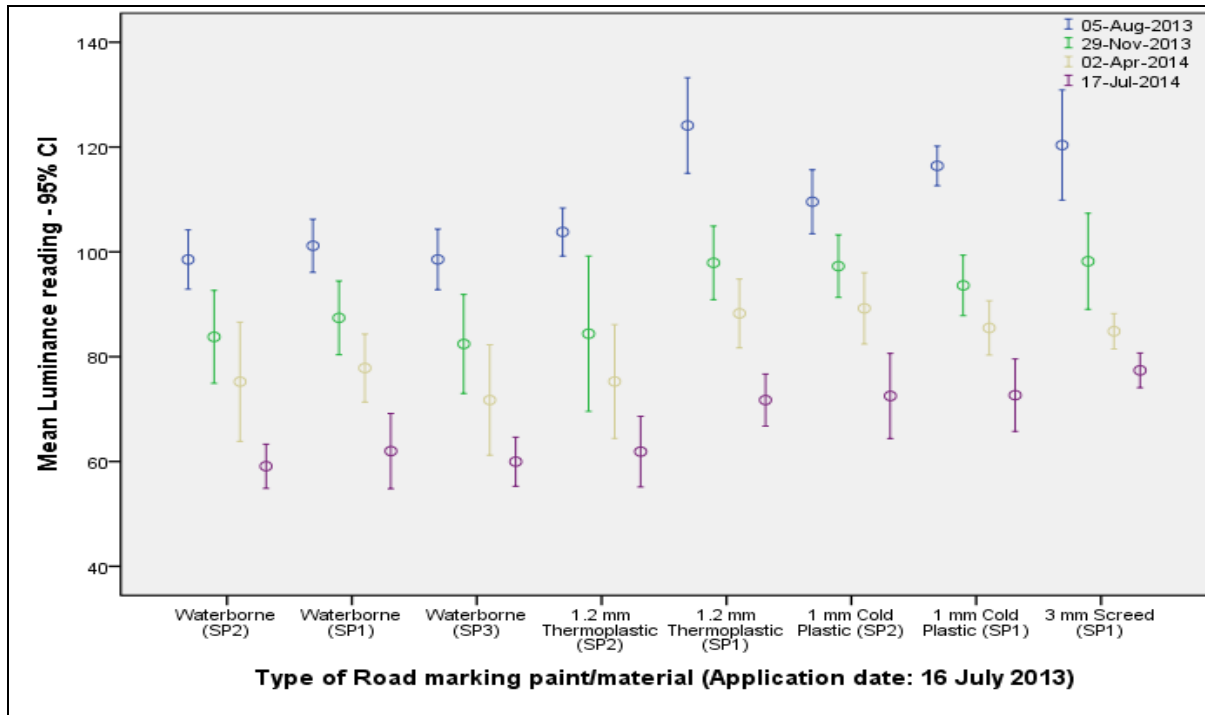

Figure C.5.1: Newly established dirty chip seal road (Aubrey Matlala Road).

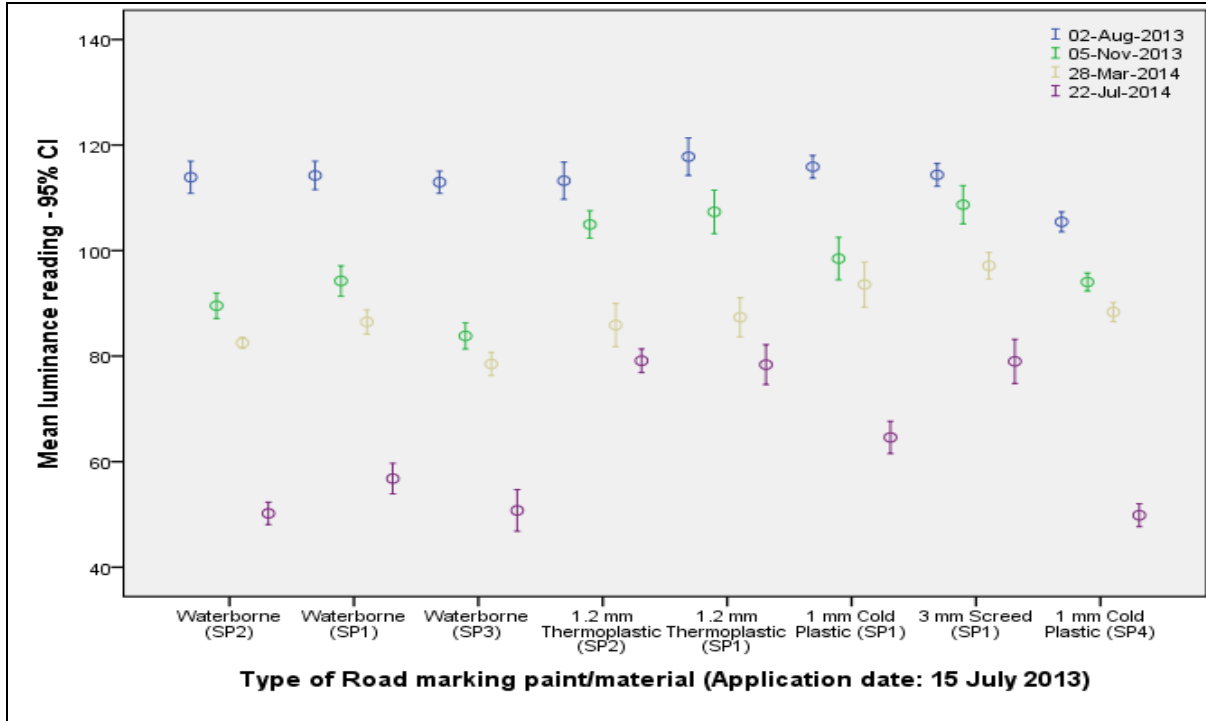

Figure C.5.2: Long established clean chip seal road (Bushveld Road).

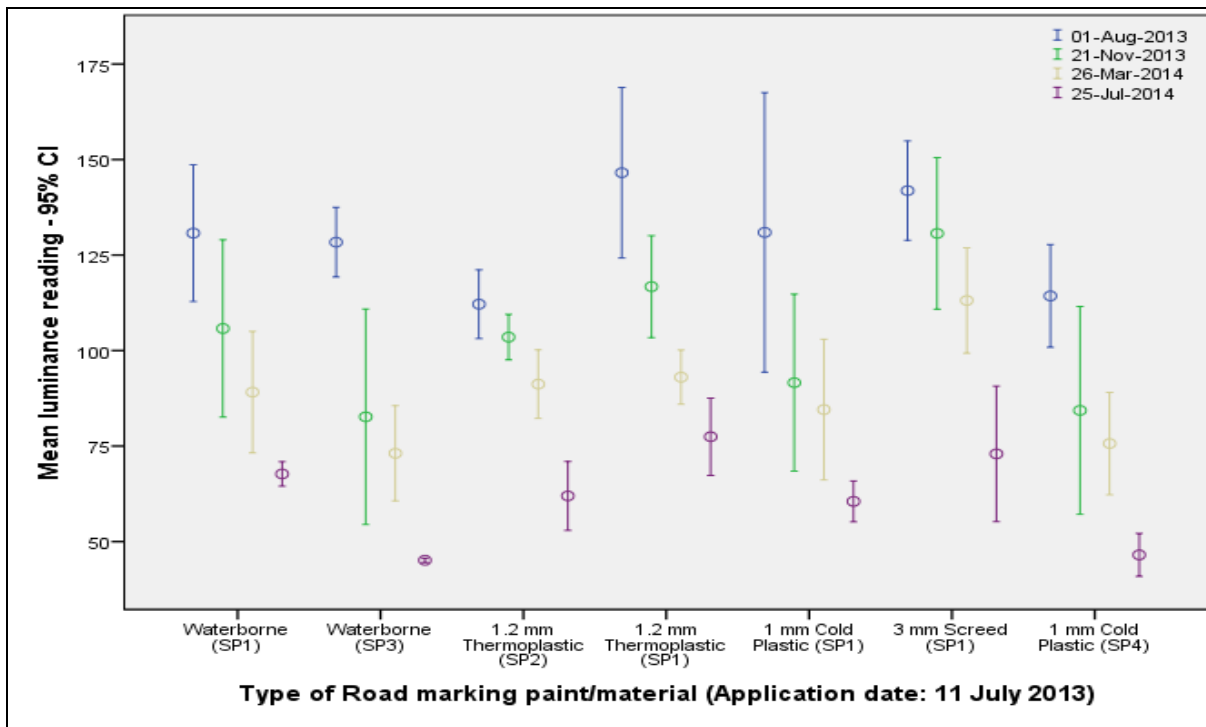

Figure C.5.3: Newly established clean chip road (Doreen Street - B 1).

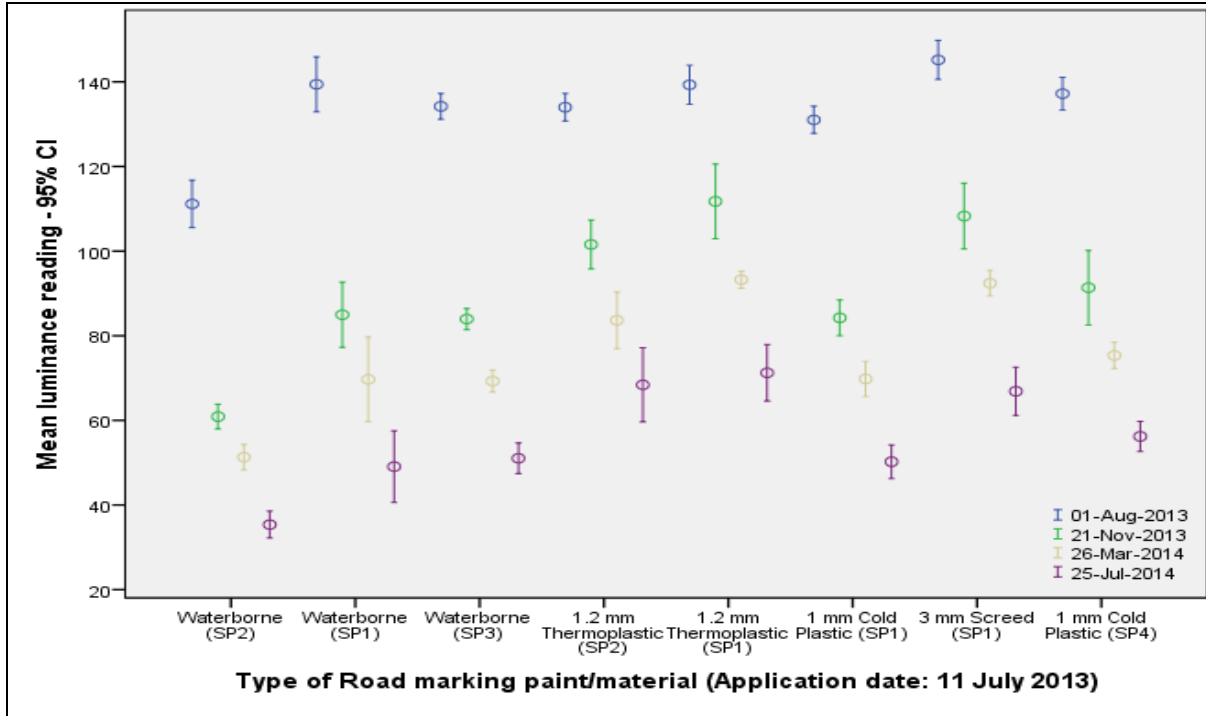

Figure C.5.4: Newly established clean chip road (Doreen Street - B's 2 & 3).

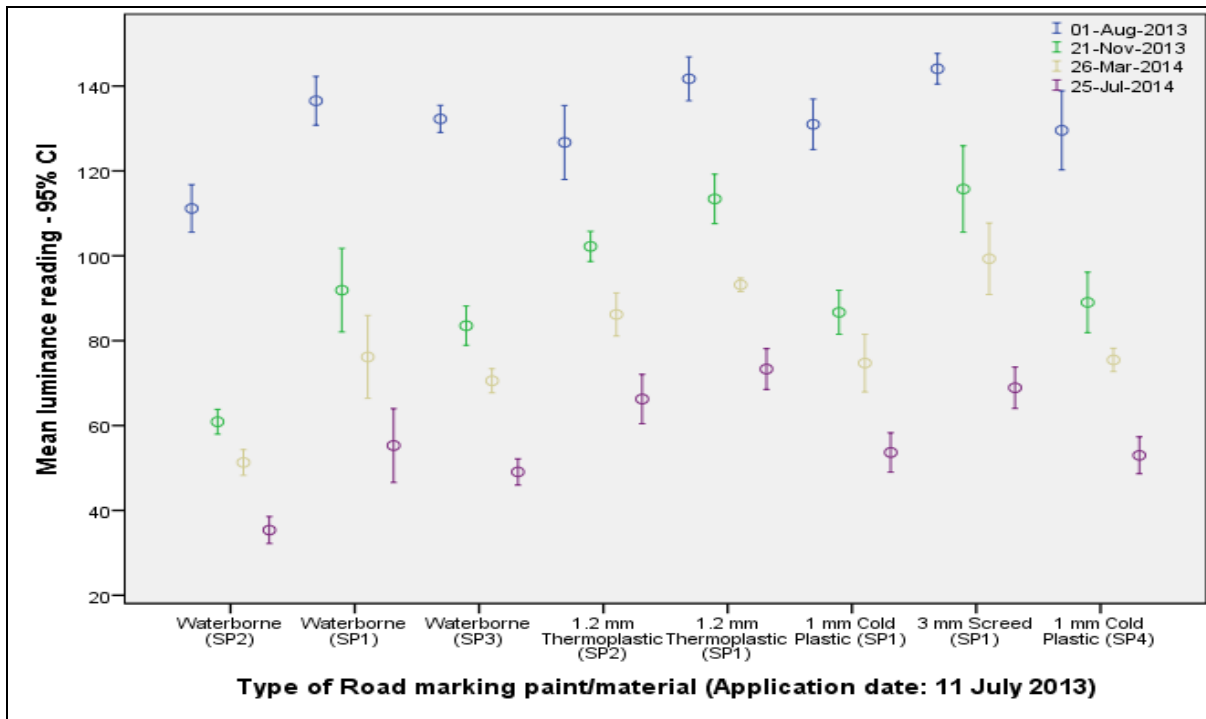

Figure C.5.5: Newly established clean chip road (Doreen Street - B's 1, 2 & 3).

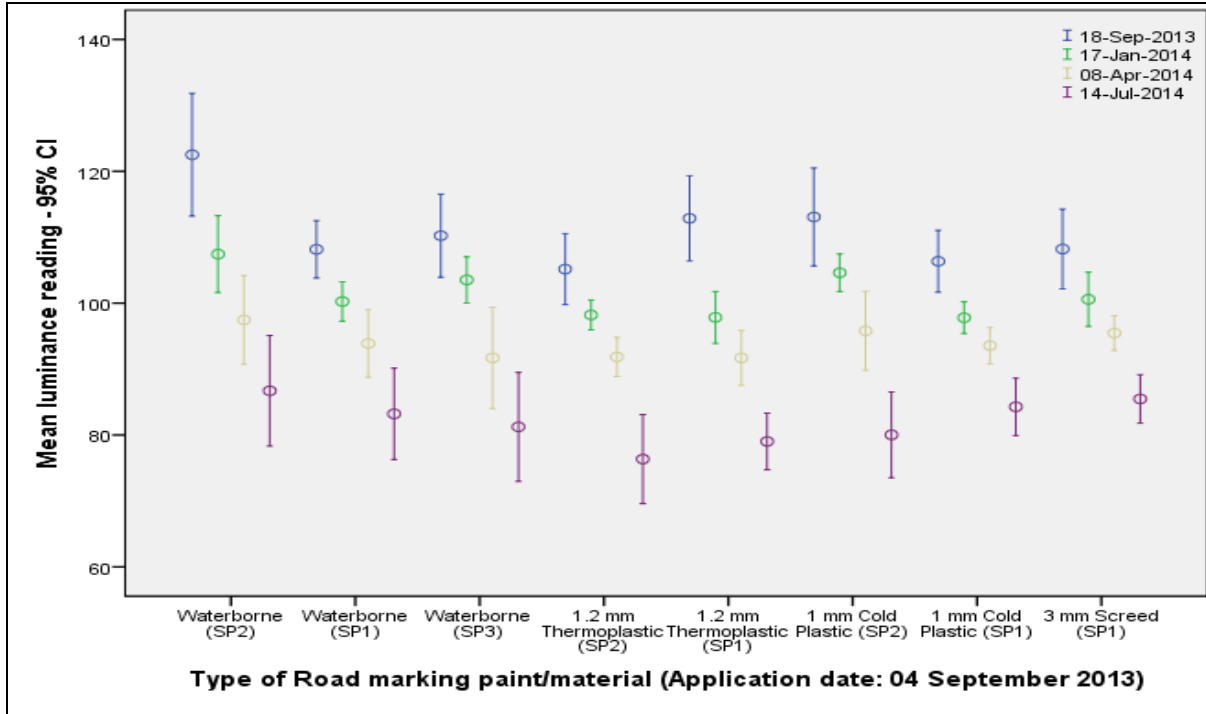

Figure C.5.6: Newly established dirty asphalt road (M 44).

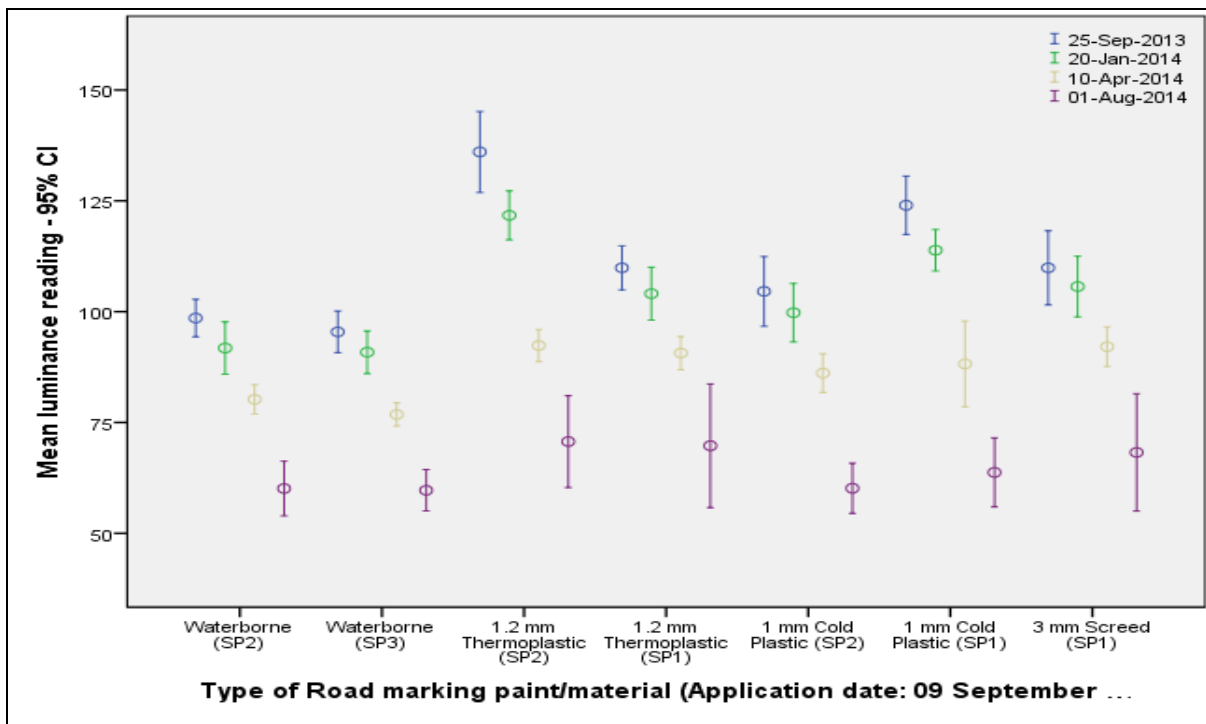

Figure C.5.7: Long established asphalt road in CBD (Madiba Street).

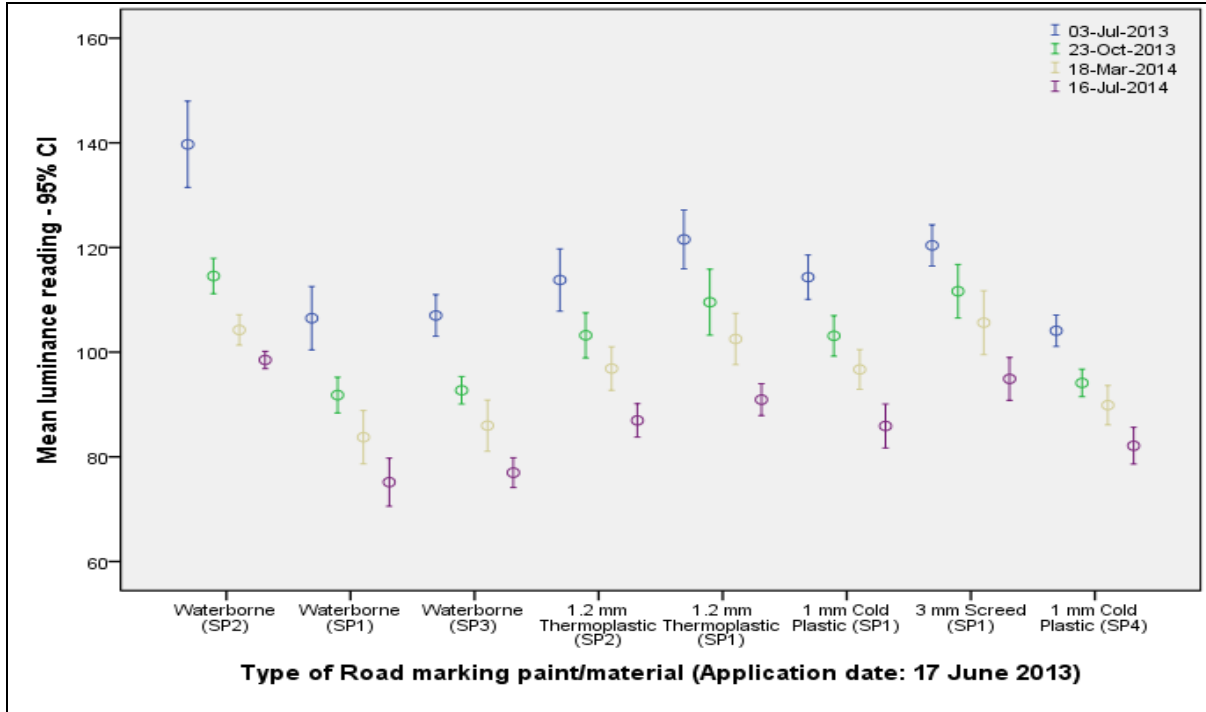

Figure C.5.8: Newly established clean asphalt road (Meiring Naude Road).

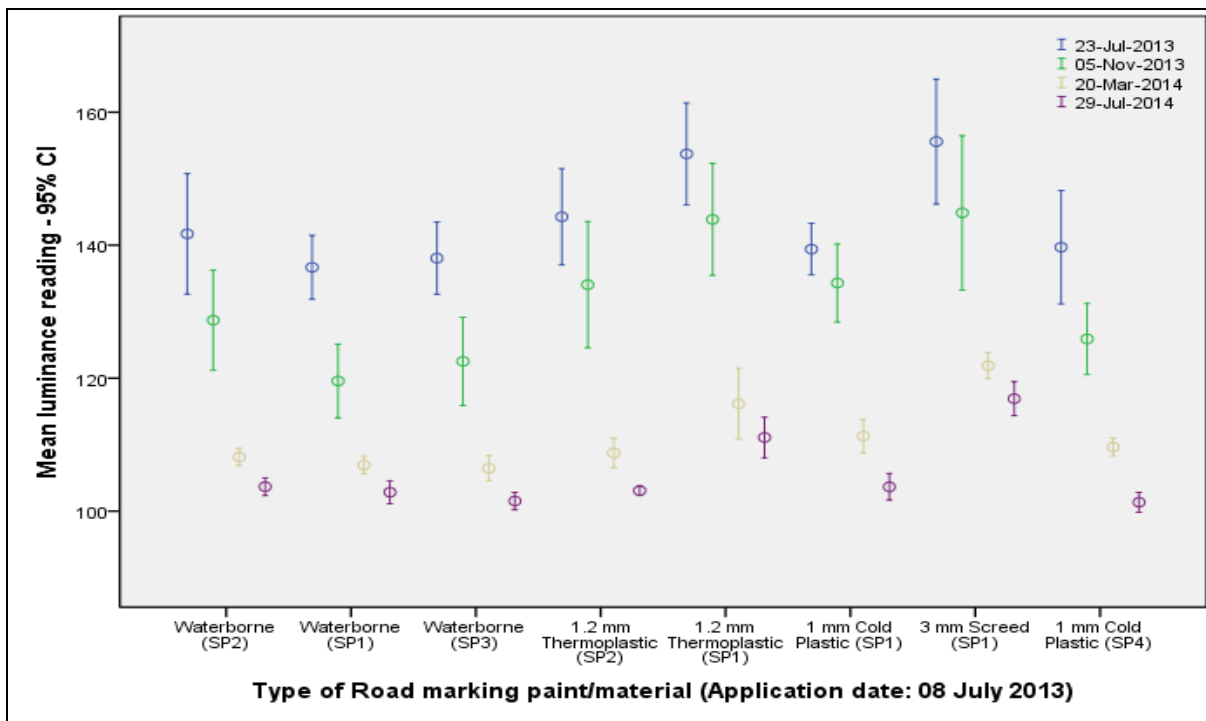

Figure C.5.9: Long established clean asphalt road (Middel Street).

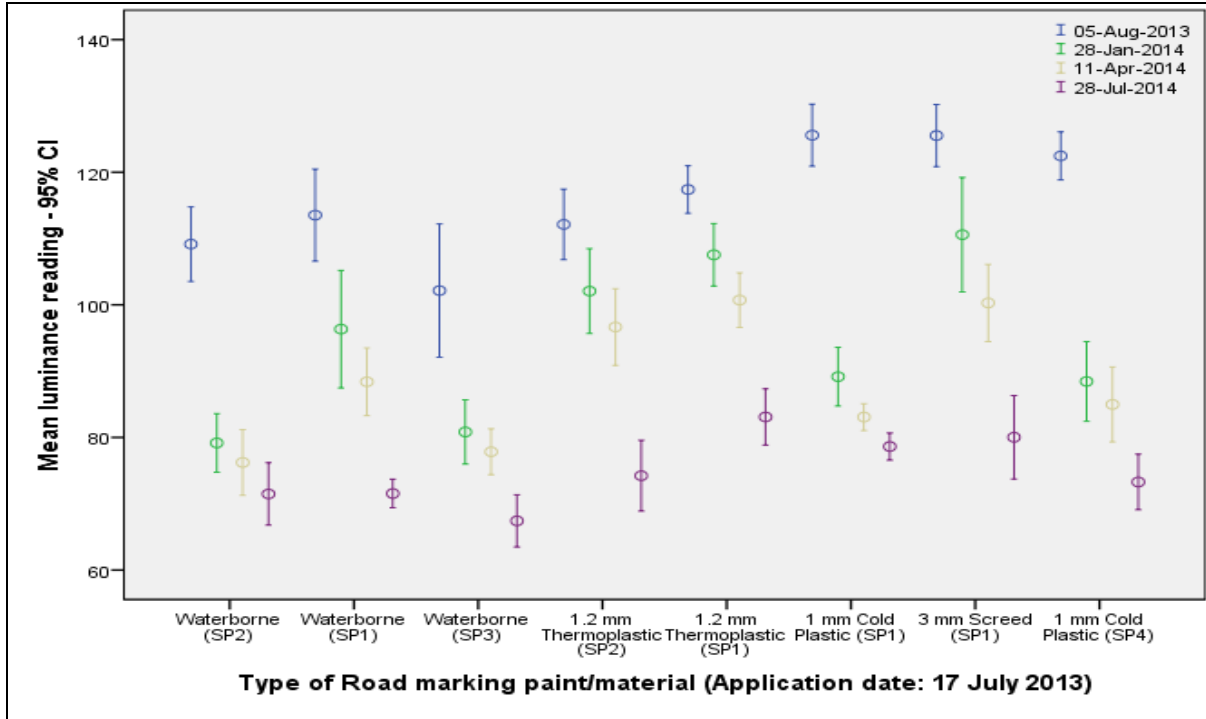

Figure C.5.10: Long established dirty asphalt road (Mohwelere Street).

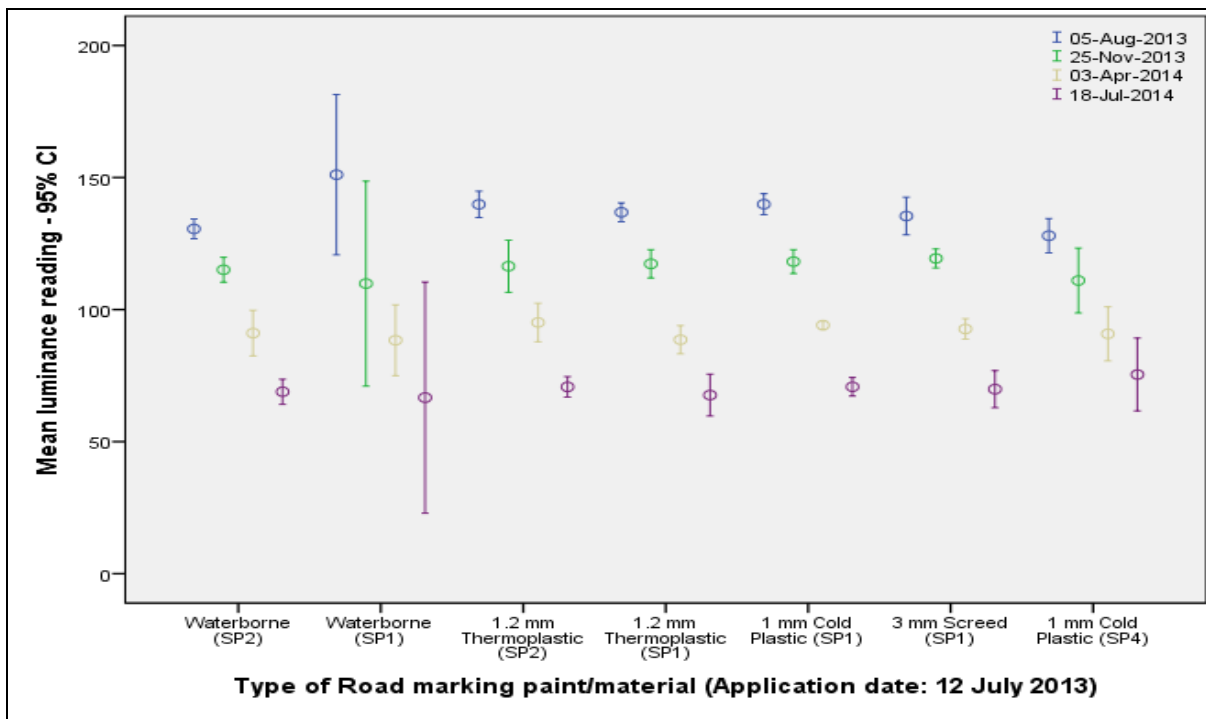

Figure C.5.11: Long established dirty chip seal road (Road L 3).

C.6. UNWASHED YELLOW TRANSVERSE TEST ROAD MARKINGS IN LUMINANCE

The decline in Qd over time of the test road marking paints and materials is demonstrated in Figures C.6.1 to C.6.11. The fact that there is no overlap between the 95 per cent CIs of the first and last readings with all road marking paints and materials on Aubrey Matlala Road, Bushveld Road, Doreen Street, M 44, Madiba Street, Meiring Naude Road, Middel Street, Mohwelere Street and on Road L 3, as can be seen, is an indication that the difference between them is statistically significant.

Within each of the types of road marking paint and material, the Qd readings were subjected to a Friedman's Chi Square Test to determine whether any pair or pairs of Qd readings across time periods within each type of road marking paint and material are significantly different or not. Friedman's Chi Square Test revealed that there is at least one pair of readings over time that is significantly different within each of the different paints and materials.

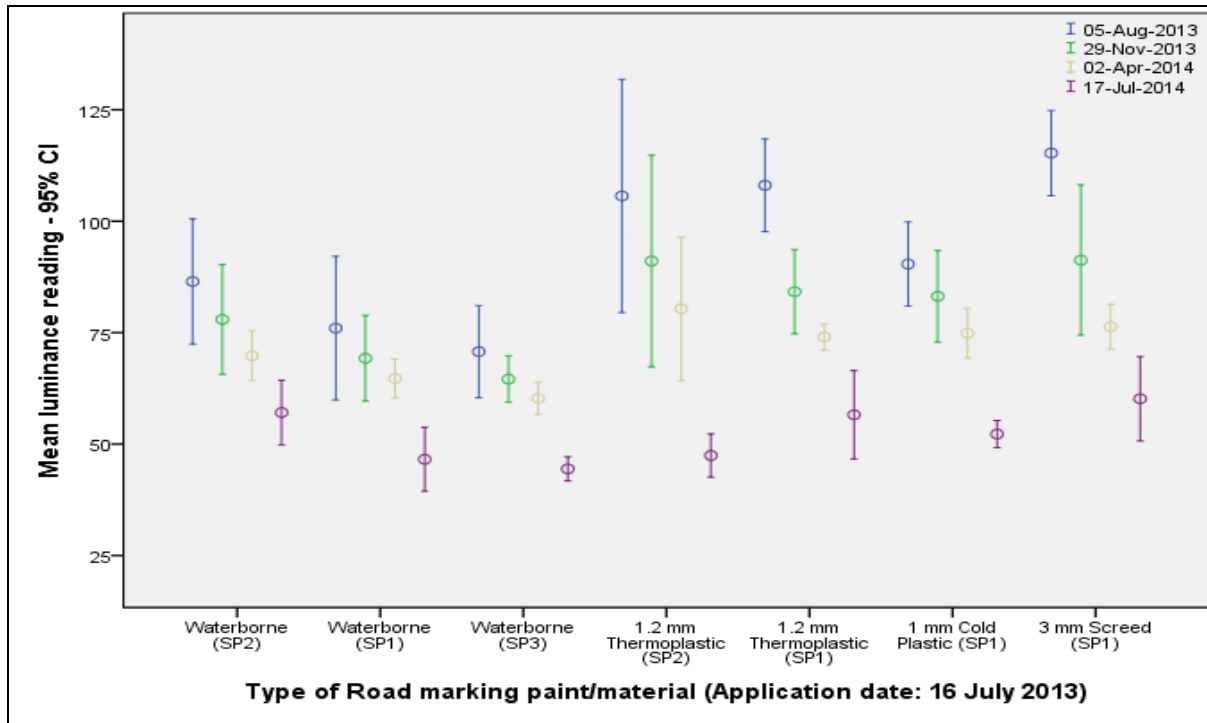

Figure C.6.1: Newly established dirty chip seal road (Aubrey Matlala Road).

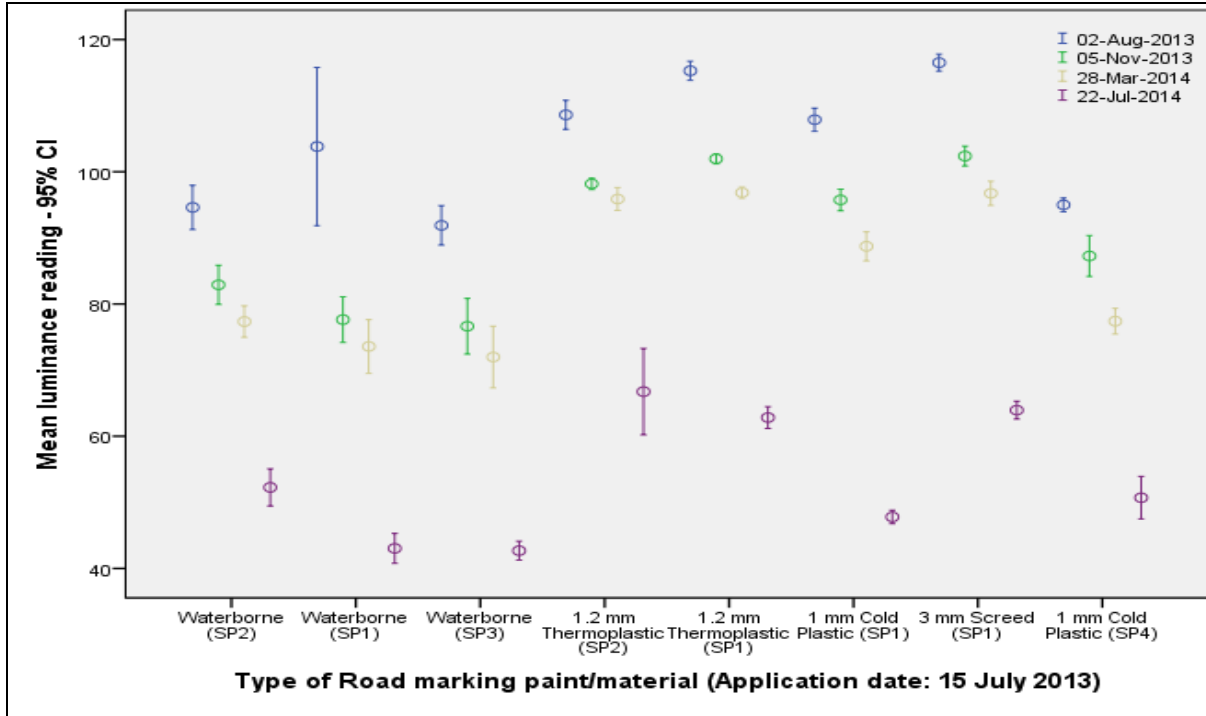

Figure C.6.2: Long established clean chip seal road (Bushveld Road).

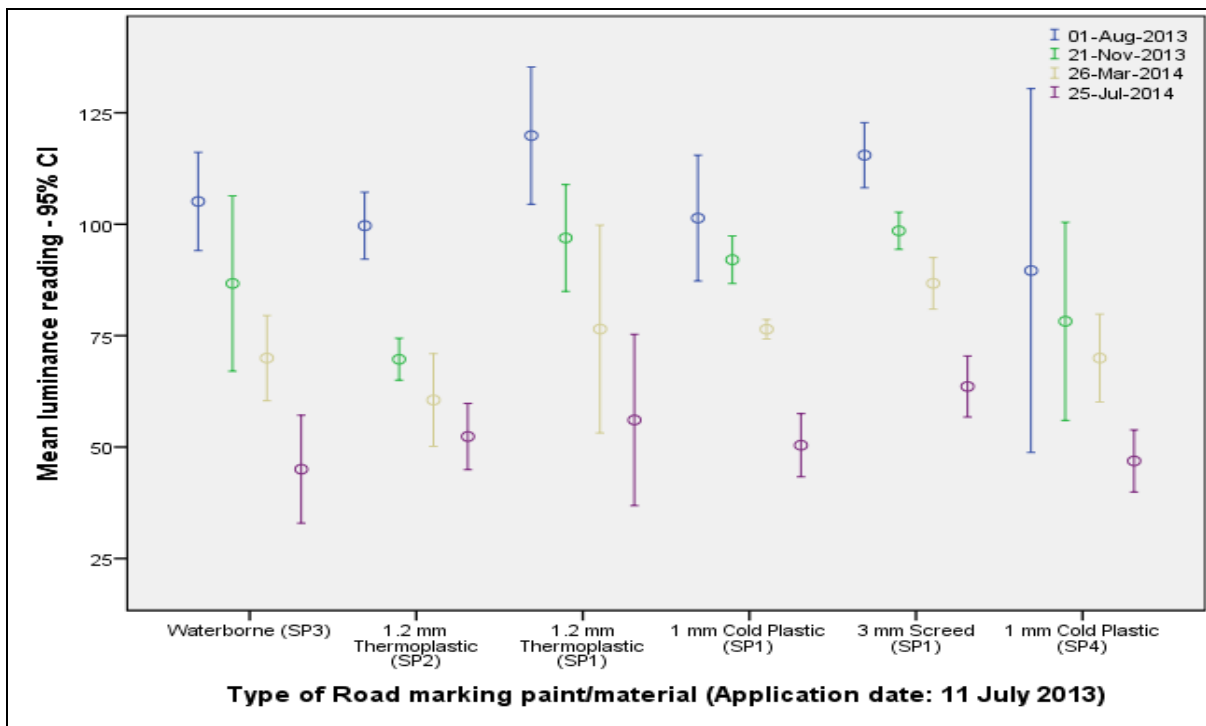

Figure C.6.3: Newly established clean chip seal road (Doreen Street - B 1).

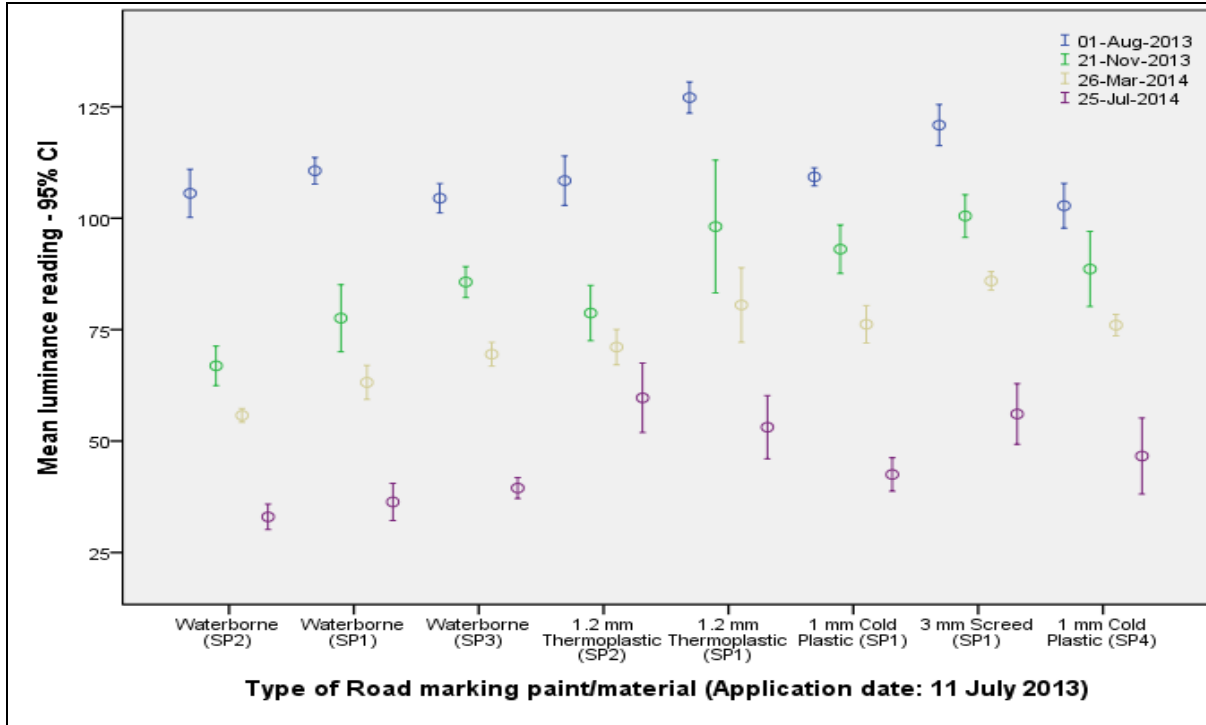

Figure C.6.4: Newly established clean chip seal road (Doreen Street - B's 2 & 3).

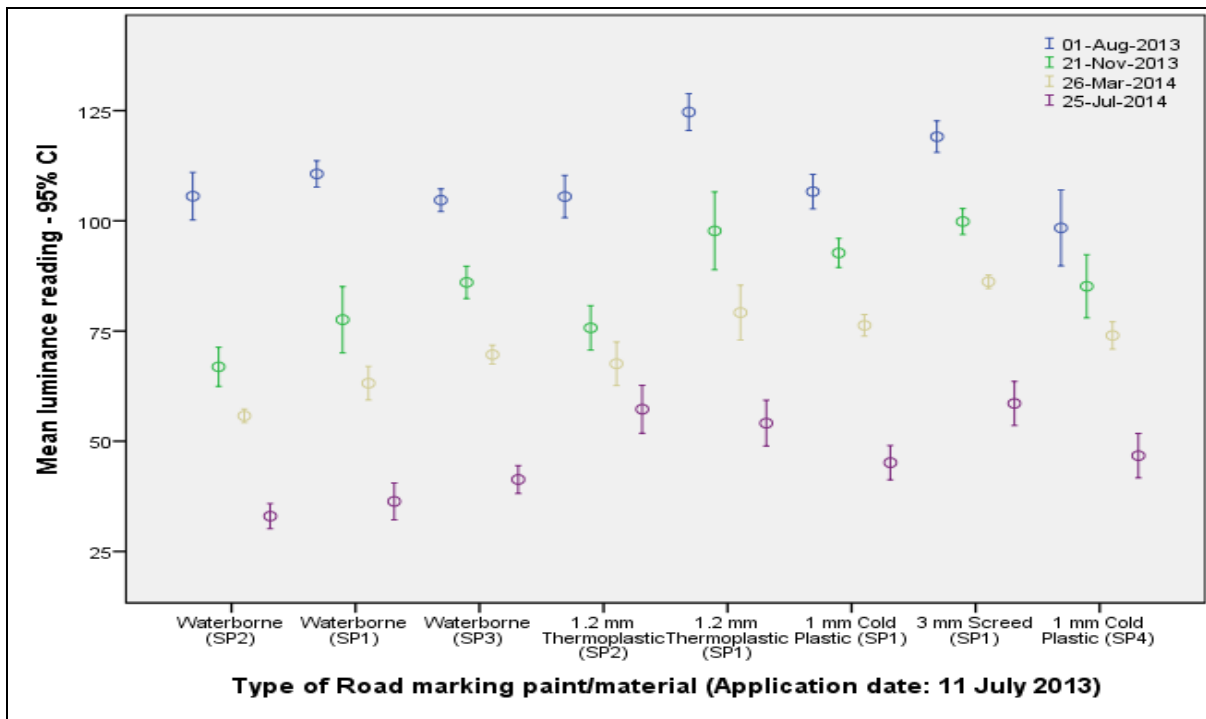

Figure C.6.5: Newly established clean chip seal road (Doreen Street - B'S 1, 2 & 3).

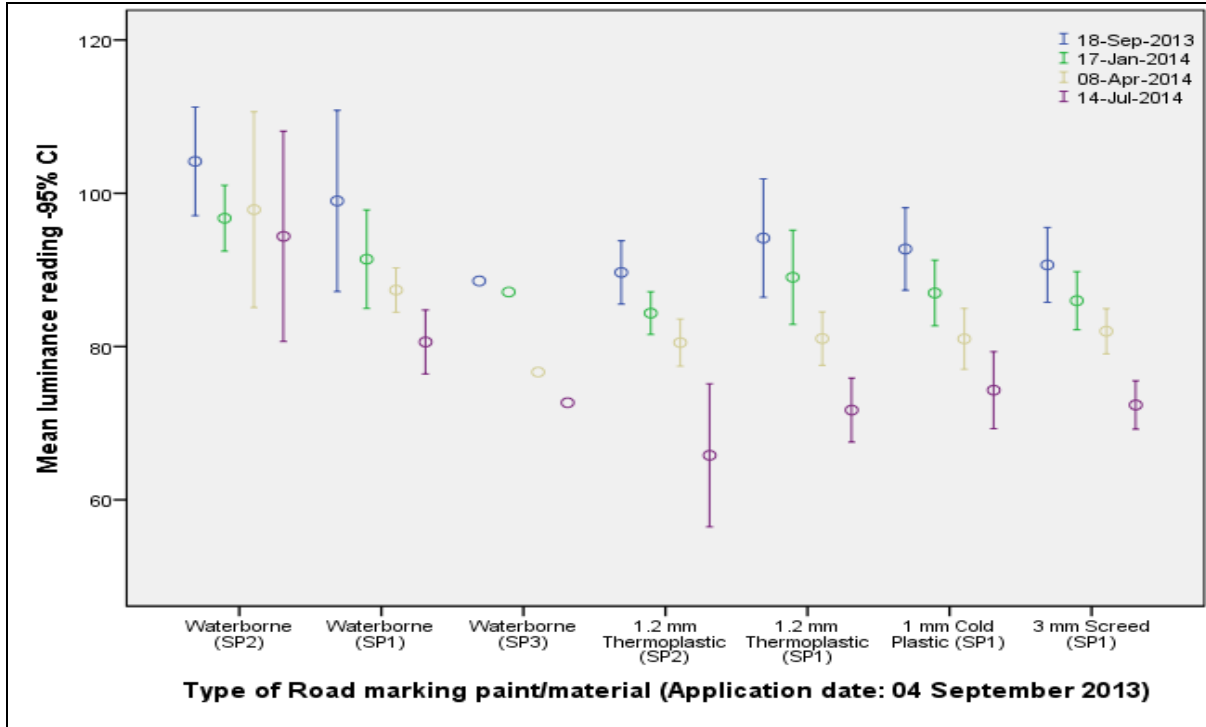

Figure C.6.6: Long established dirty asphalt road (M 44).

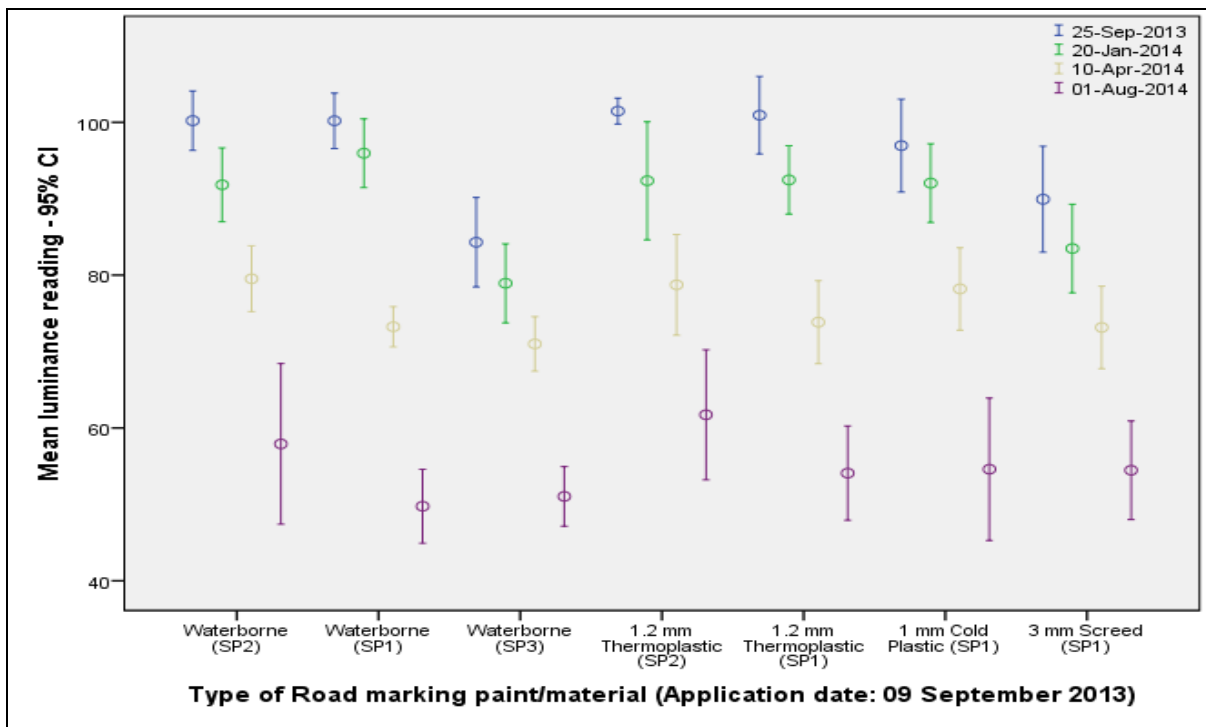

Figure C.6.7: Long established asphalt road in the CBD (Madiba Street).

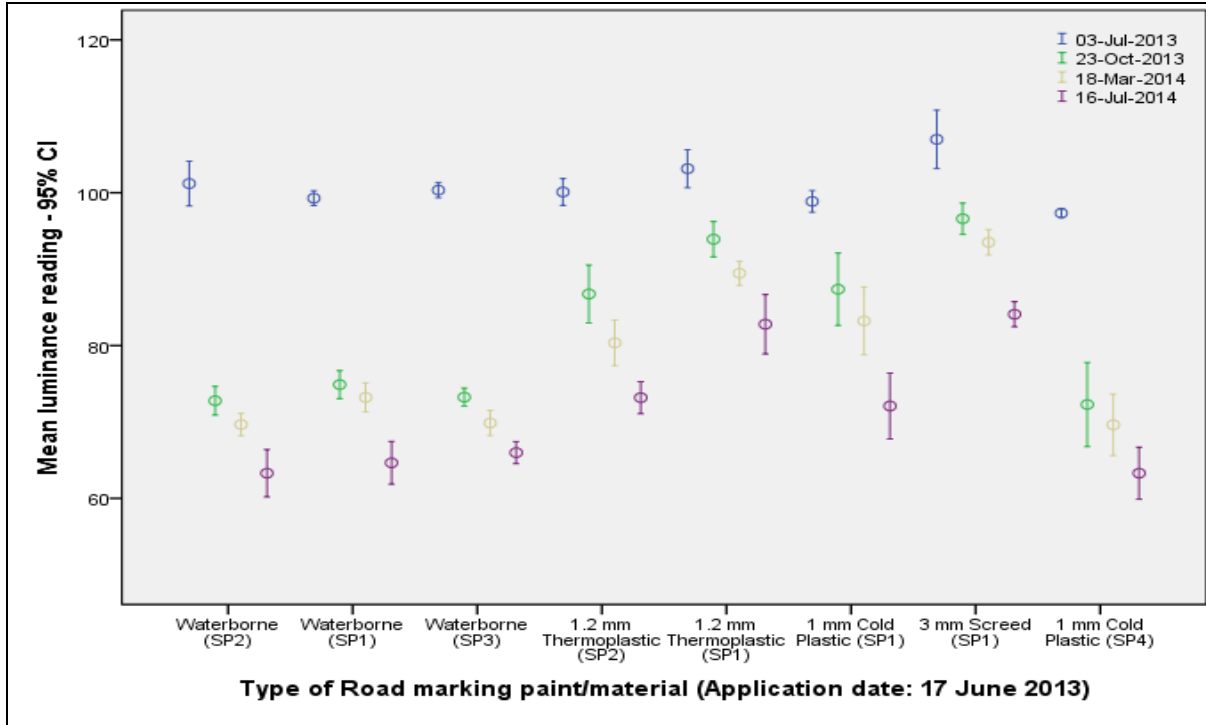

Figure C.6.8: Newly established clean asphalt road (Meiring Naude Road).

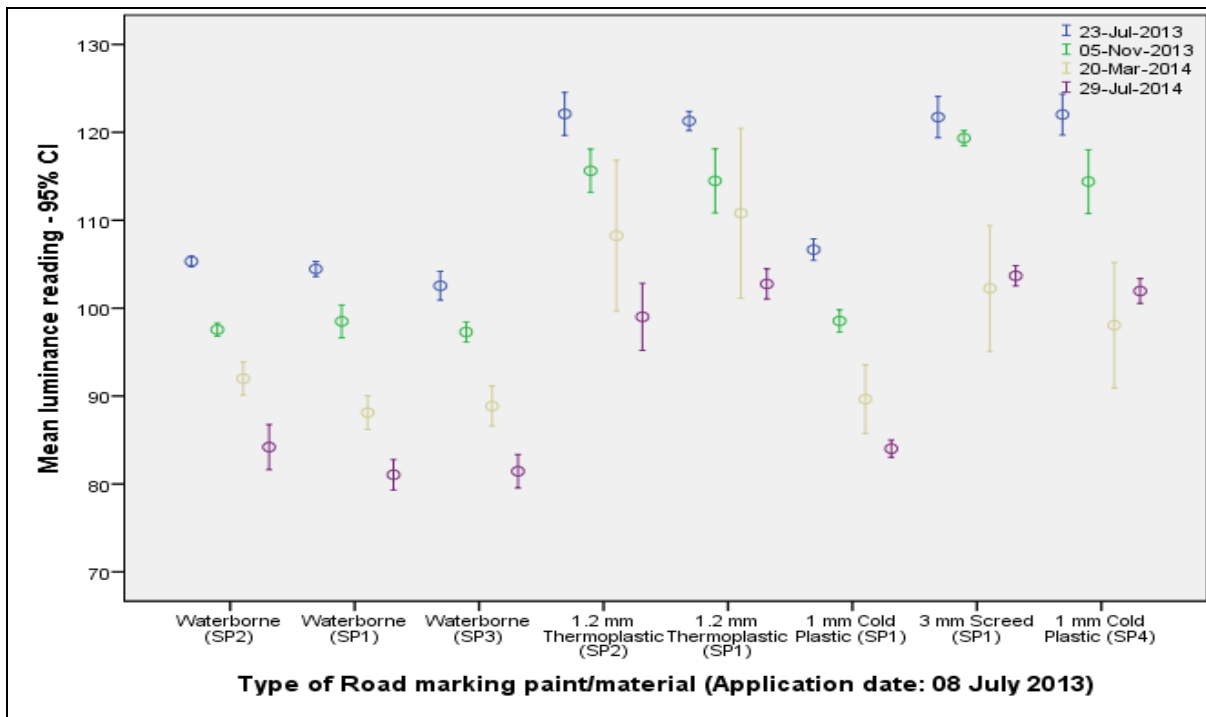

Figure C.6.9: Long established clean asphalt road (Middel Street).

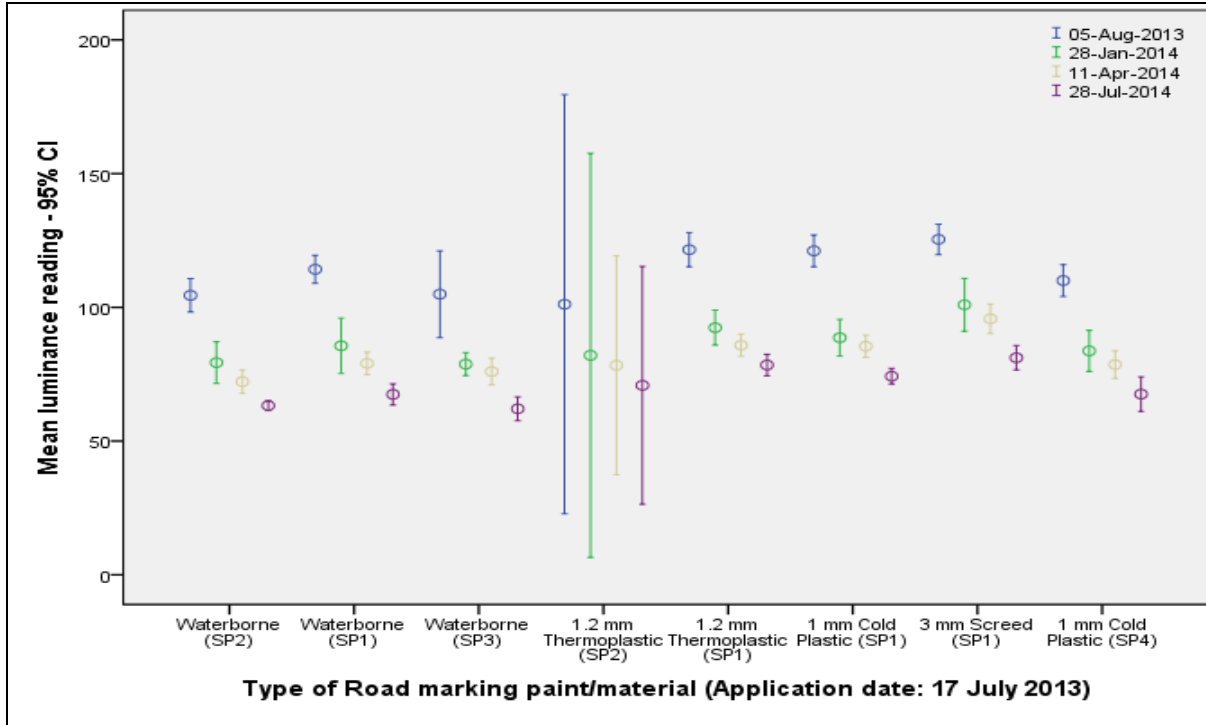

Figure C.6.10: Long established dirty asphalt road (Mohwelere Street).

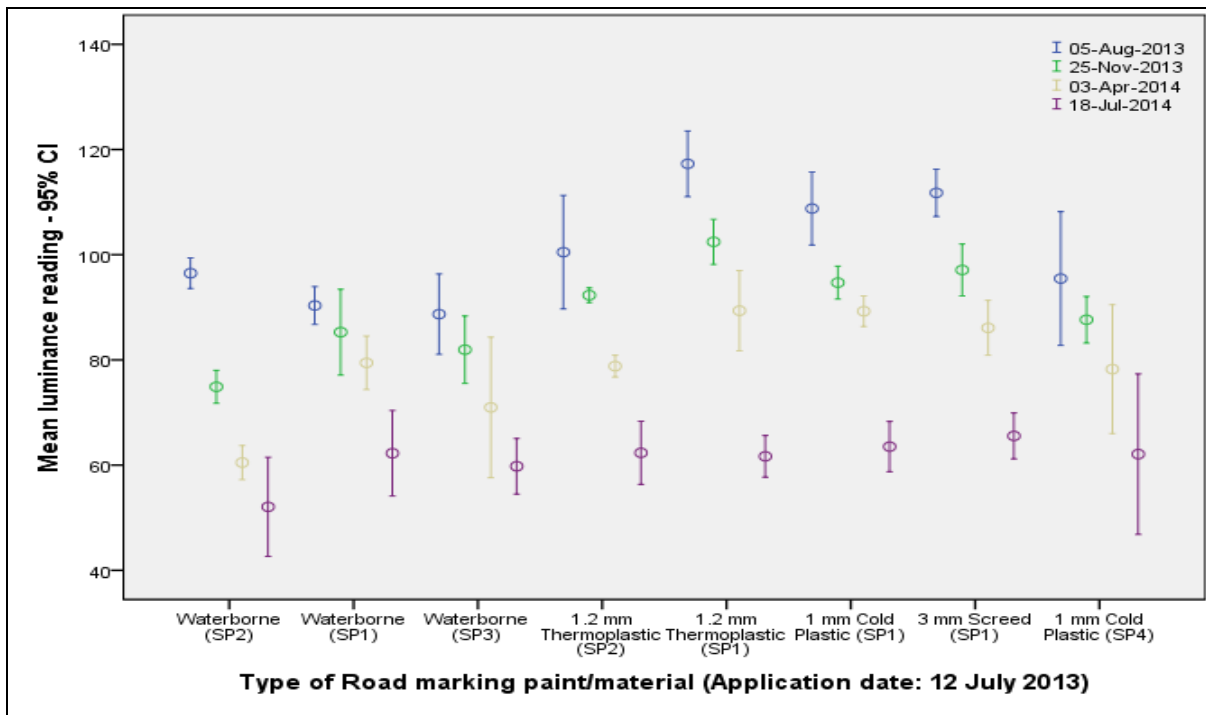

Figure C.6.11: Long established dirty chip seal road (Road L 3).

C.7. UNWASHED WHITE LONGITUDINAL TEST ROAD MARKINGS IN LUMINANCE

The decline in Qd over time of the test road marking paints and materials is demonstrated in Figures C.7.1 to C.7.10. The fact that there is no overlap between the 95 per cent CIs of the first and last readings with all road marking paints and materials on Aubrey Matlala Road, Bushveld Road, Doreen Street (B's 1, 2 & 3), Meiring Naude Road, Middel Street, Mohwelere Street and on Road L 3 is an indication that the difference between them is statistically significant. Friedman's Chi Square Test revealed that there is at least one pair of readings over time that is significantly different within each of the different road marking paints and materials.

Friedman's Chi Square Test revealed that there are no pairs of readings over time that is significantly different within each of the different materials on Doreen Street (B 1), Doreen Street (B's 2 & 3) and on the M 44. Even though some 95 per cent CIs do not overlap, the sample size of less than 3 does not allow for enough statistical power to find statistically significant differences.

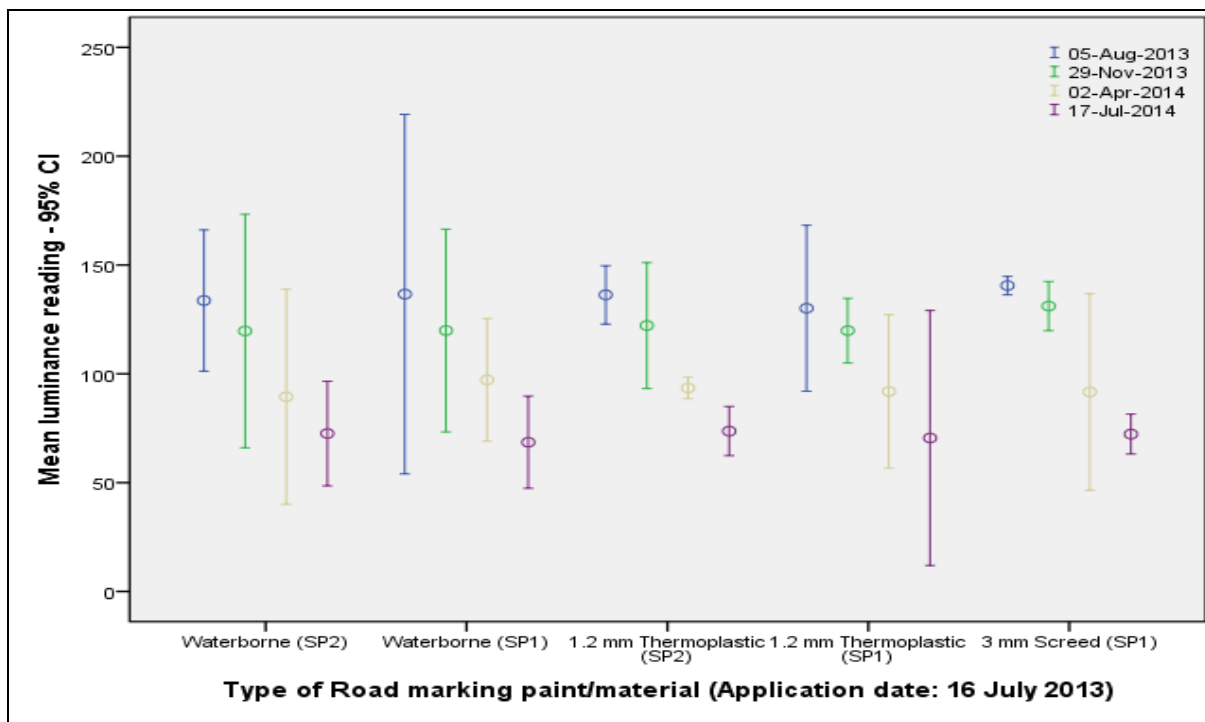

Figure C.7.1: Newly established dirty chip seal road (Aubrey Matlala Road).

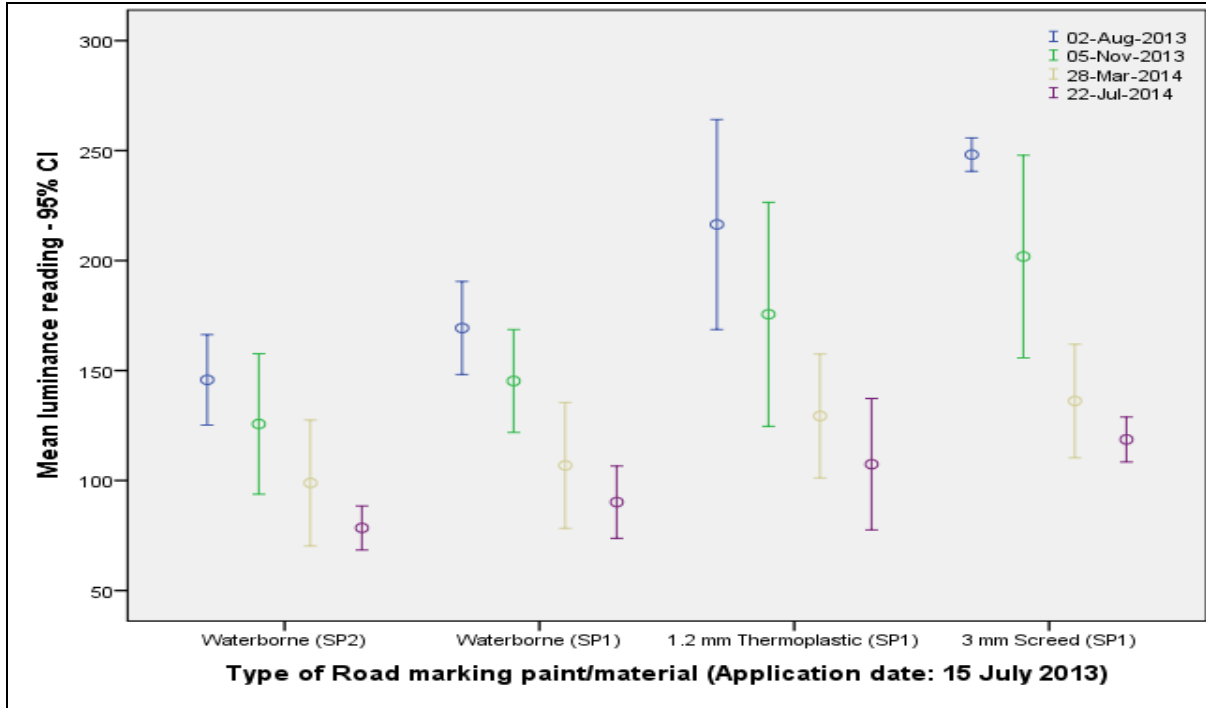

Figure C.7.2: Long established clean chip seal road (Bushveld Road).

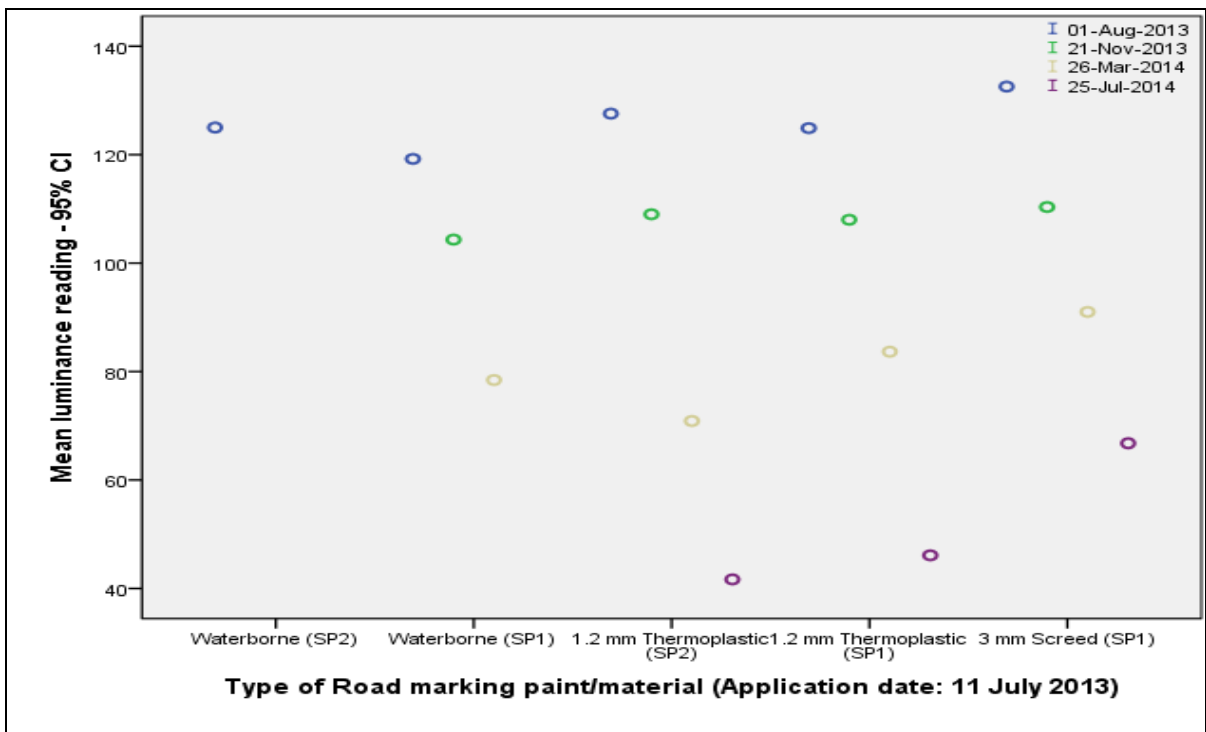

Figure C.7.3: Newly established clean chip seal road (Doreen Street - B 1).

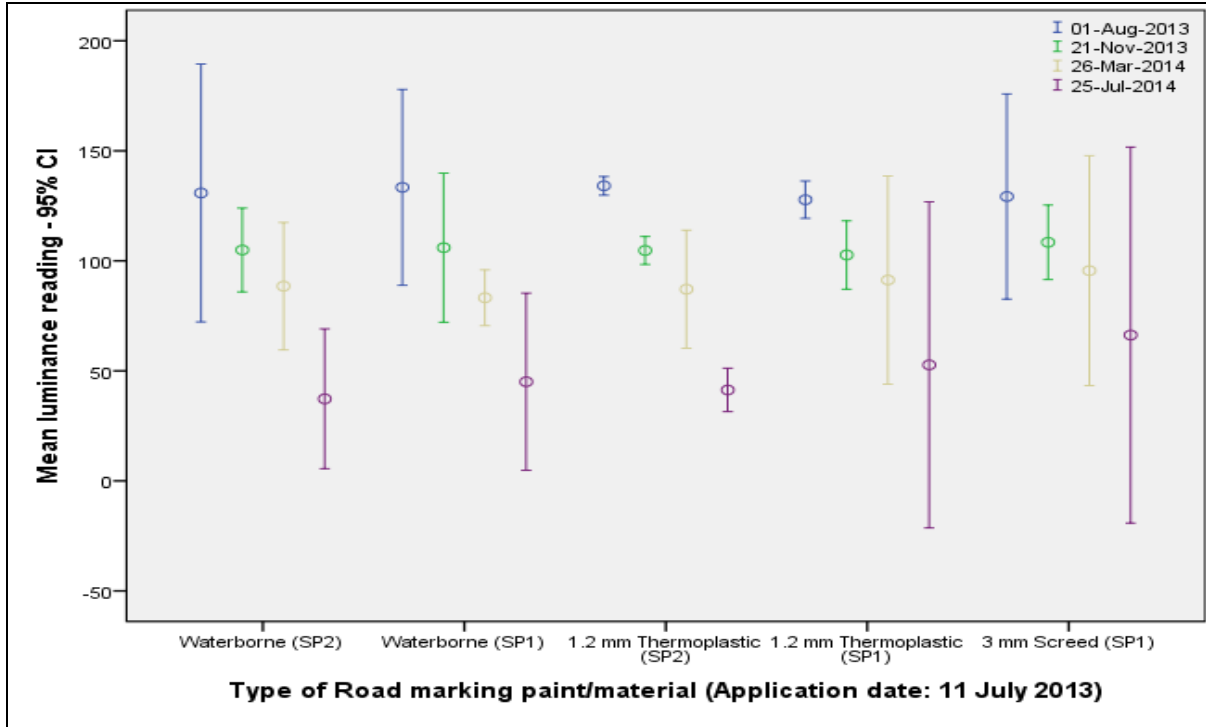

Figure C.7.4: Newly established clean chip seal road (Doreen Street - B's 2 & 3).

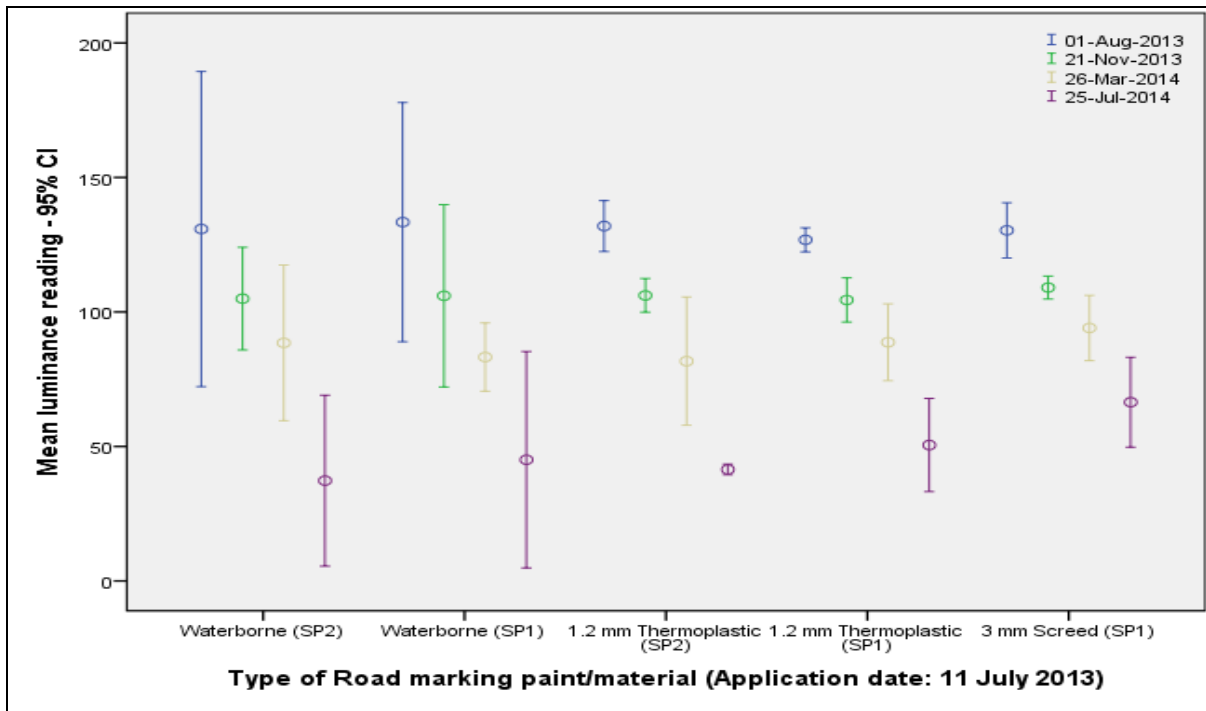

Figure C.7.5: Newly established clean chip seal road (Doreen Street - B's 1, 2 & 3).

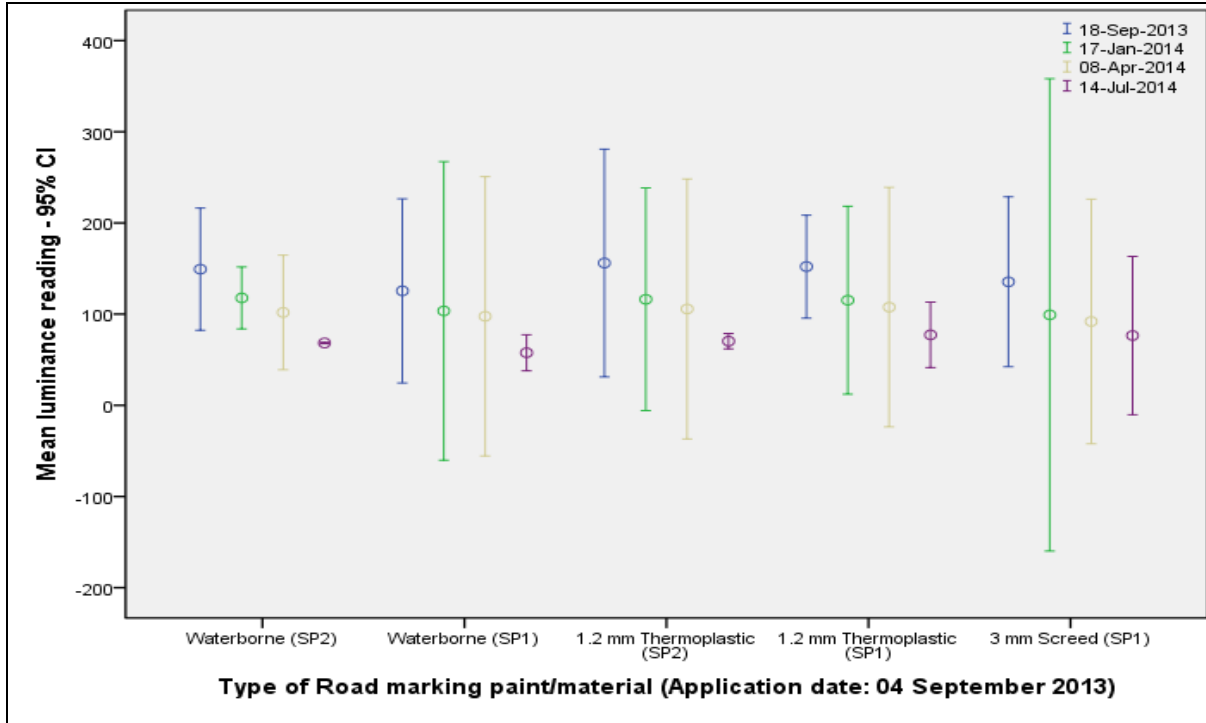

Figure C.7.6: Newly established dirty asphalt road (M 44).

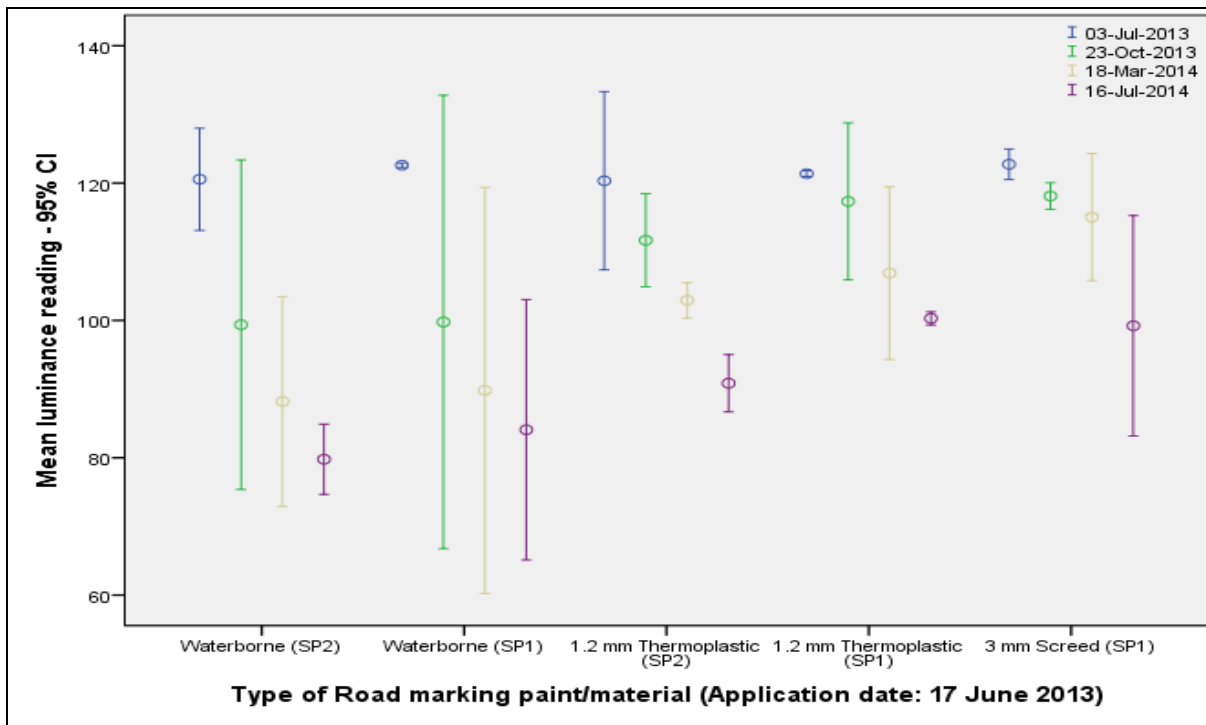

Figure C.7.7: Newly established clean asphalt road (Meiring Naude Road).

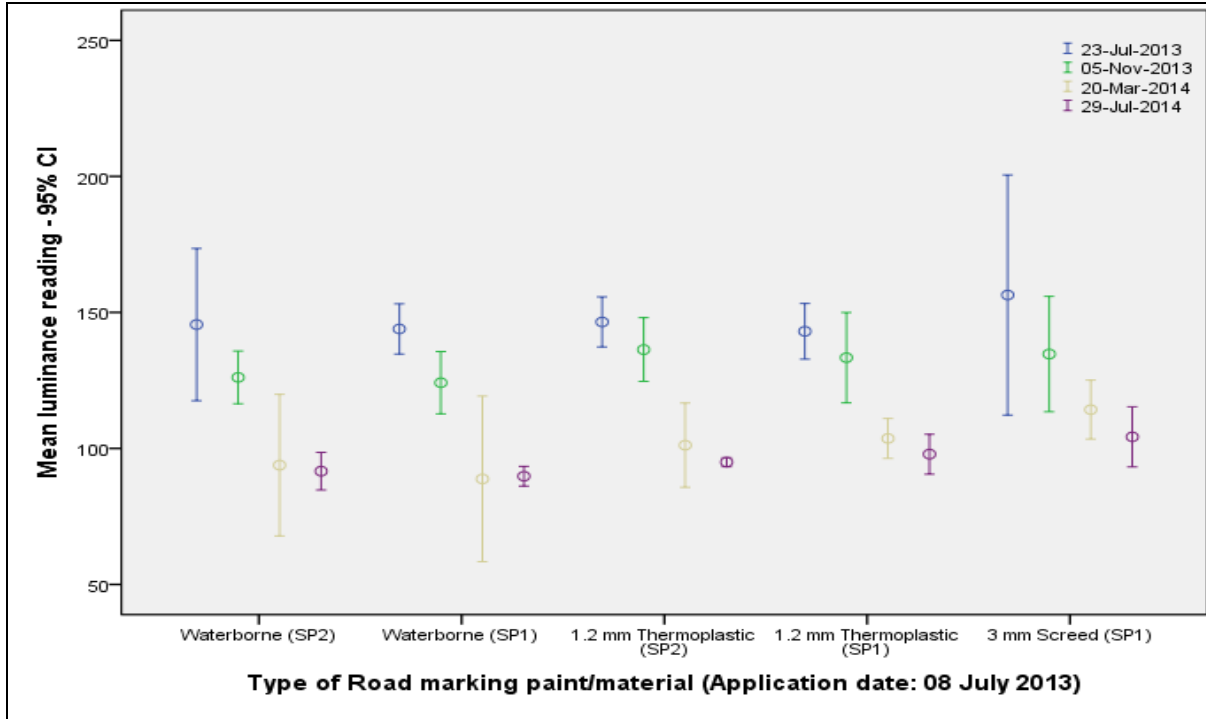

Figure C.7.8: Long established clean asphalt road (Middel Street).

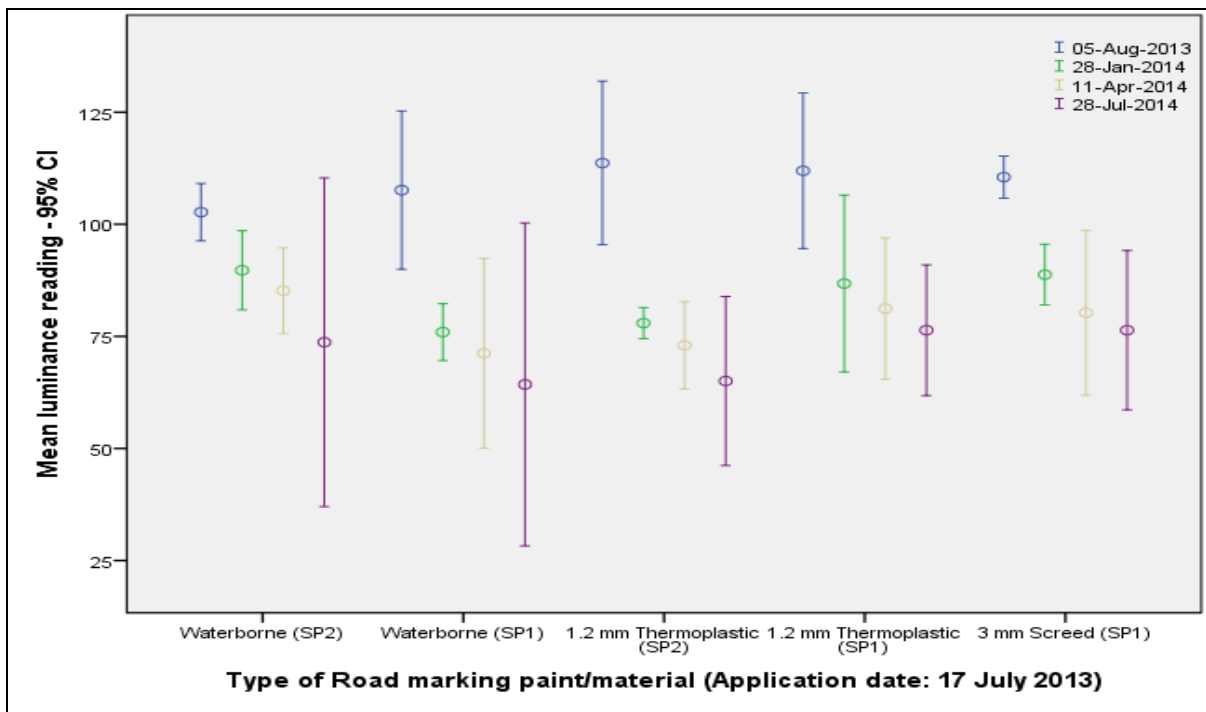

Figure C.7.9: Long established dirty asphalt road (Mohwelere Street).

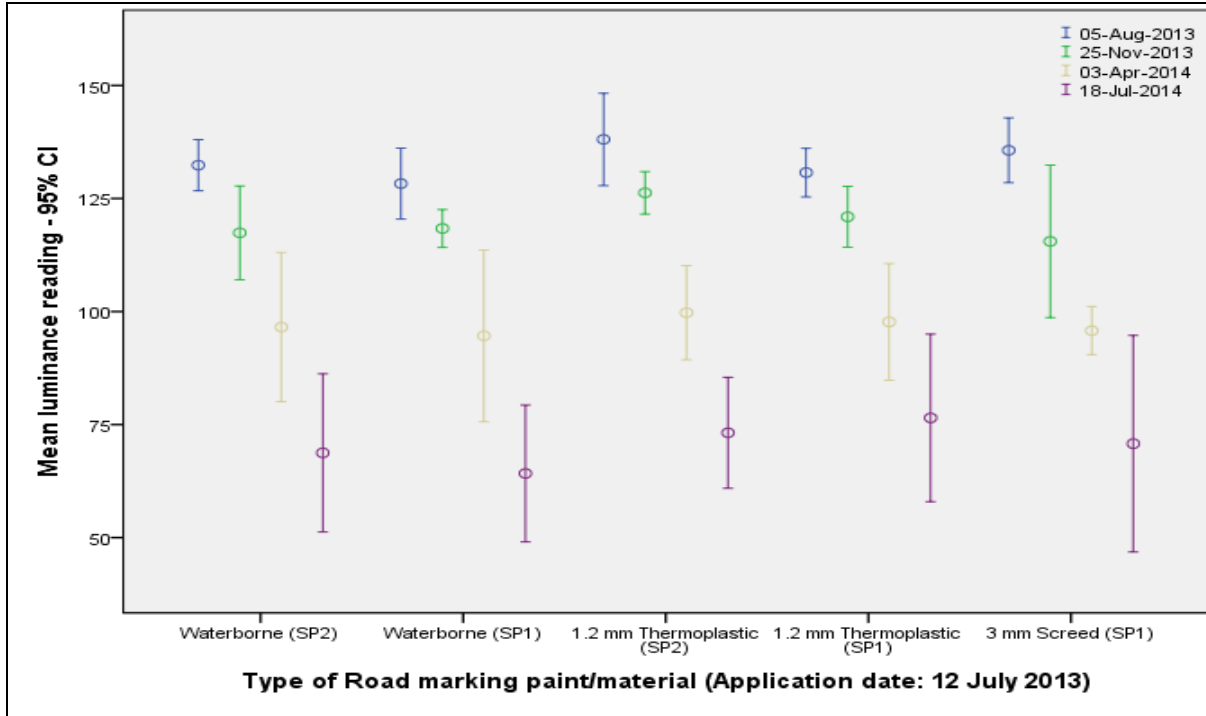

Figure C.7.10: Long established dirty chip seal road (Road L 3).

C.8. UNWASHED YELLOW LONGITUDINAL TEST ROAD MARKINGS IN LUMINANCE

The decline in Qd over time of the test road marking paints and materials is demonstrated in Figures C.8.1 to C.8.10. The fact that there is no overlap between the 95 per cent CIs of the first and last readings with all road marking paints and materials on Doreen Street (B's 1, 2 & 3), Meiring Naude Road, Middel Street, Mohwelere Street (except water-borne - SP1) and on Road L 3 is an indication that the difference between them is statistically significant. Friedman's Chi Square Test revealed that there is at least one pair of readings over time that is significantly different within each of the different road marking paints and materials.

Friedman's Chi Square Test revealed that there are no pairs of readings over time that are significantly different within each of the different road marking paints and materials on Aubrey Matlala Road, Doreen Street (B 1), Doreen Street (B's 2 & 3) and on the M 44. Even though some 95 per cent CIs do not overlap, the sample size of less than 3 does not allow for enough statistical power to find statistically significant differences. Inferential testing was not possible on Aubrey Matlala Road due to the lack of data.

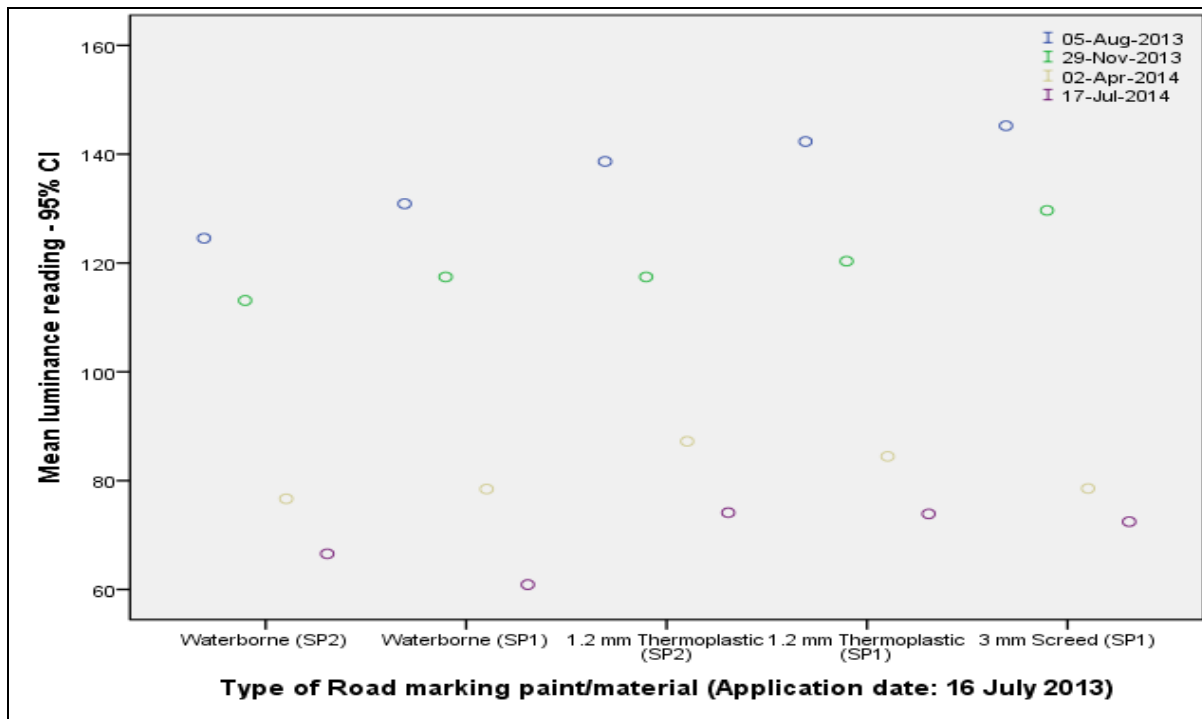

Figure C.8.1: Newly established dirty chip seal road (Aubrey Matlala Road).

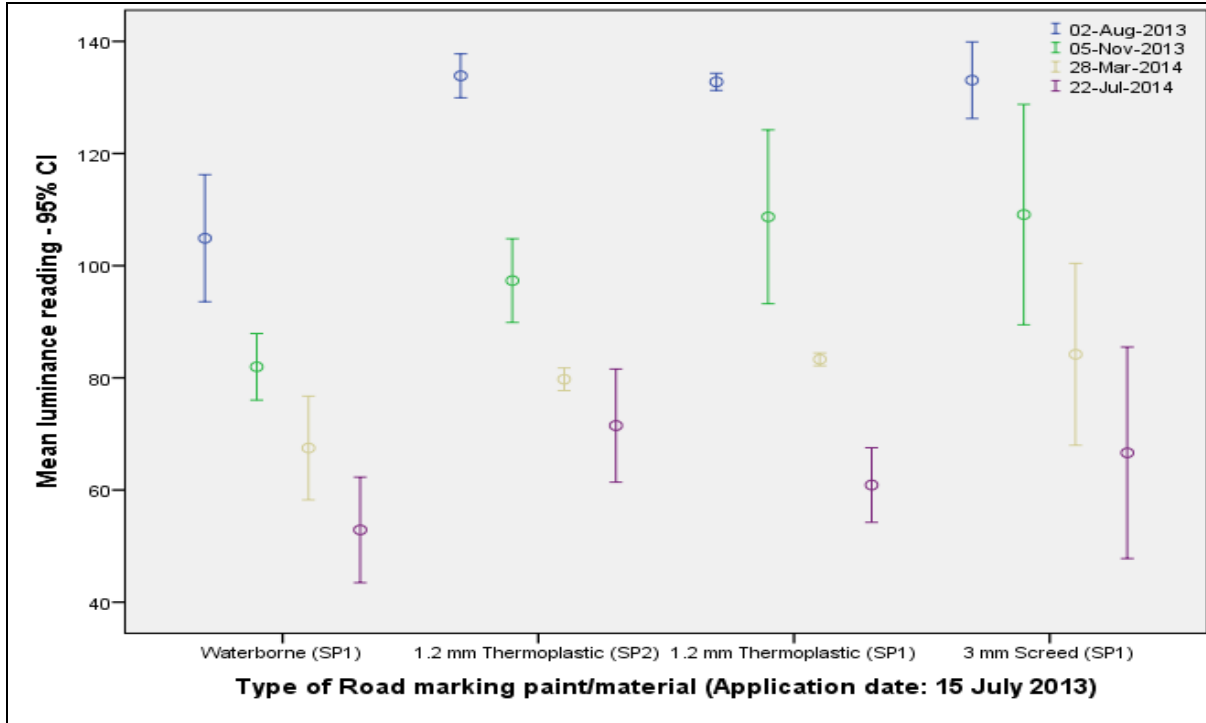

Figure C.8.2: Long established clean chip seal road (Bushveld Road).



Figure C.8.3: Newly established clean chip seal road (Doreen Street - B 1).

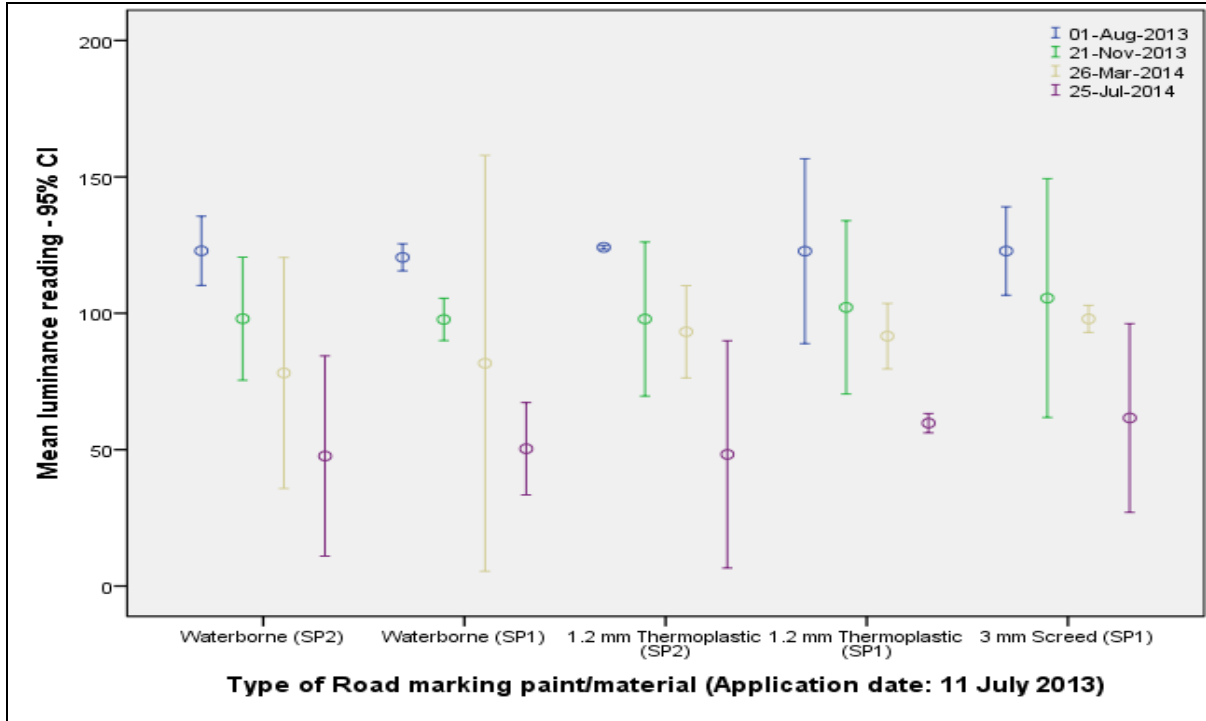

Figure C.8.4: Newly established clean chip seal road (Doreen Street - B's 2 & 3).

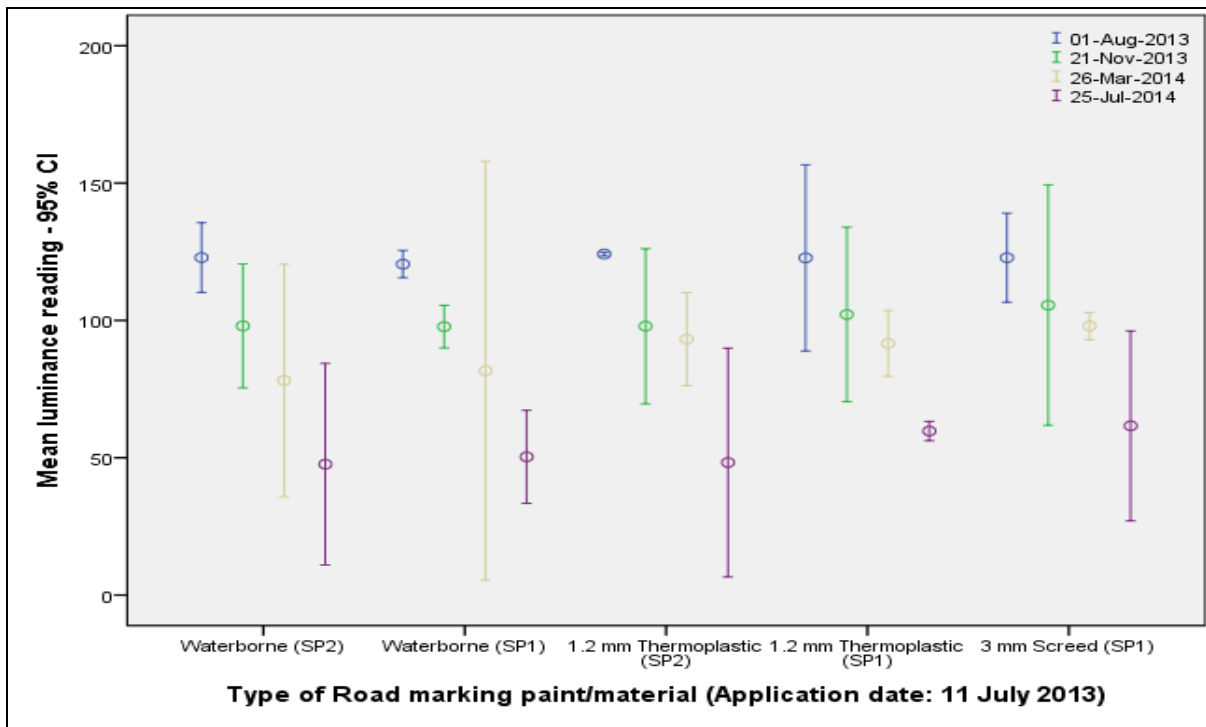

Figure C.8.5: Newly established clean chip seal road (Doreen Street - B's 1, 2 & 3).

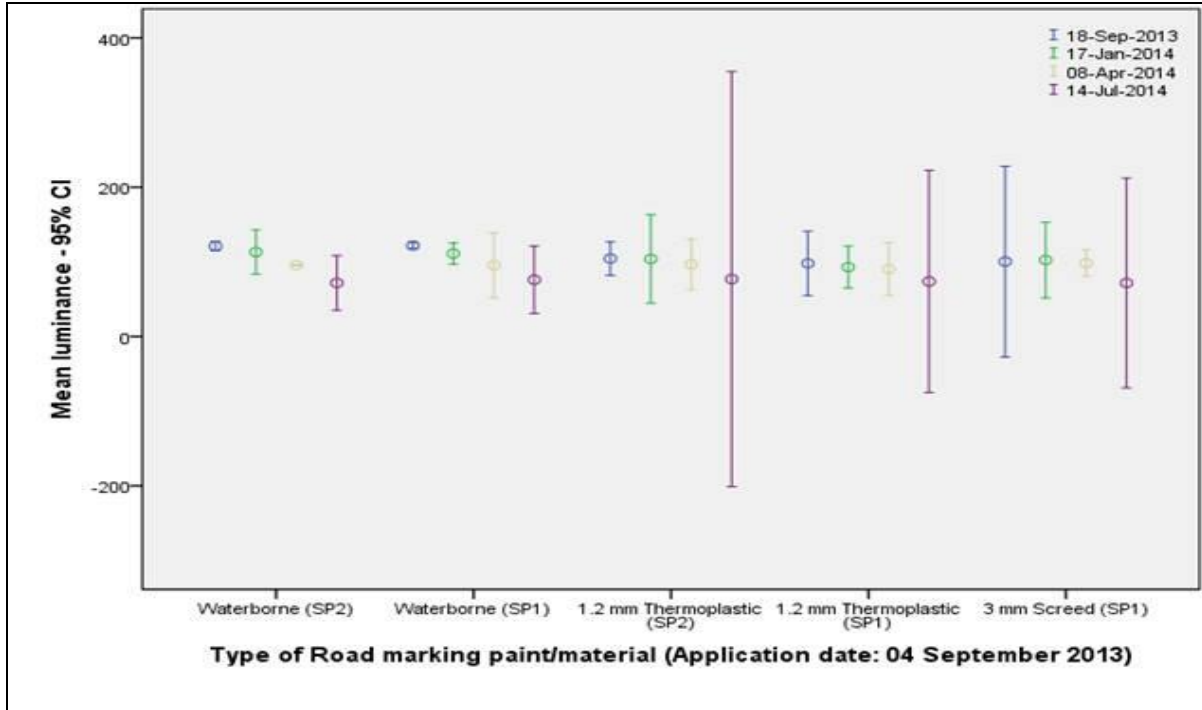

Figure C.8.6: Newly established dirty asphalt road (M 44).

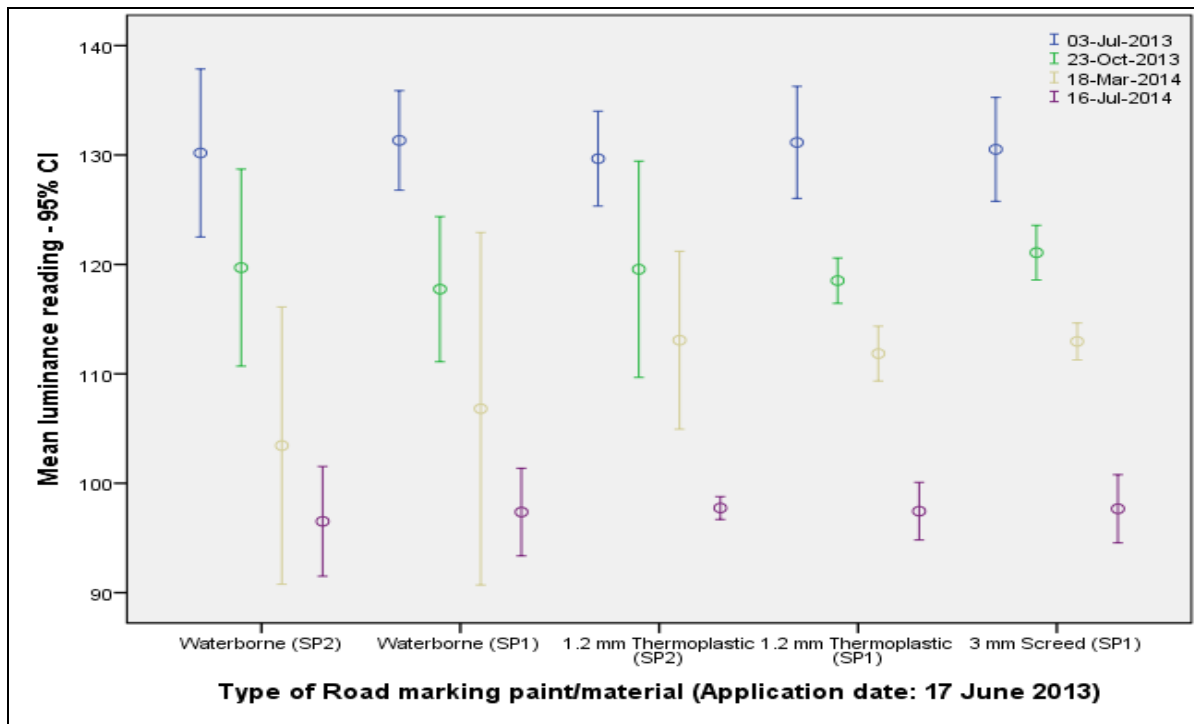

Figure C.8.7: Newly established clean asphalt road (Meiring Naude).

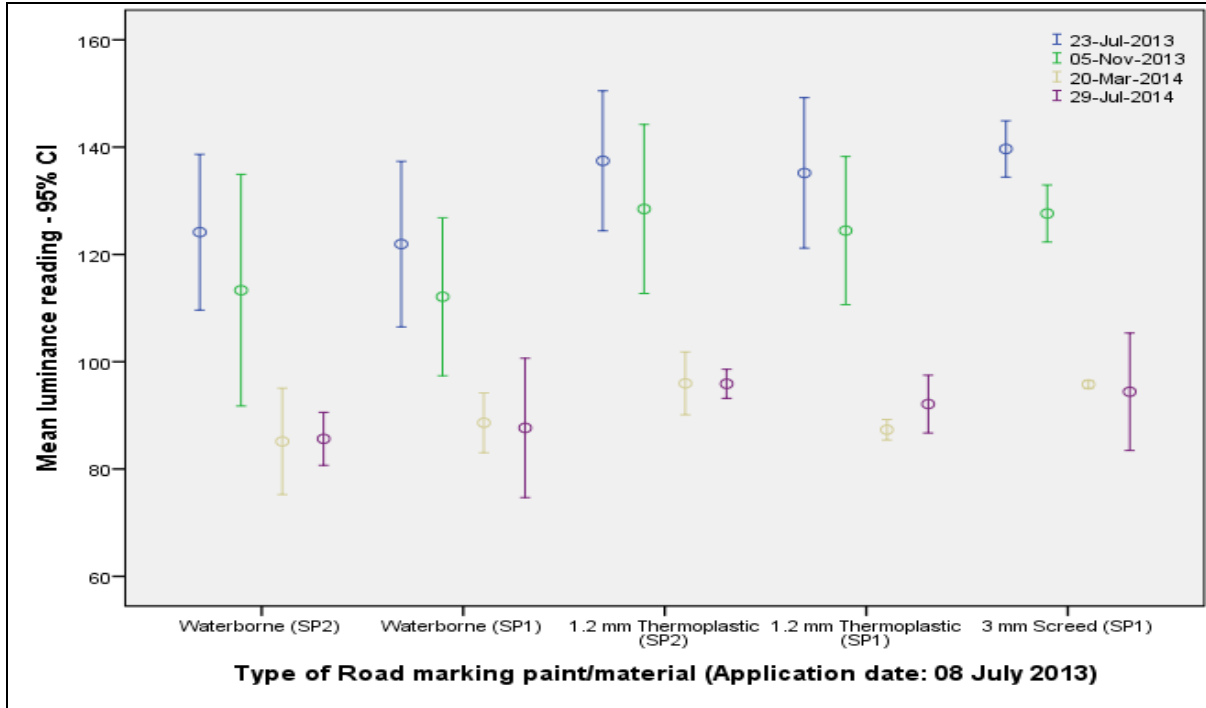

Figure C.8.8: Long established clean asphalt road (Middel Street).

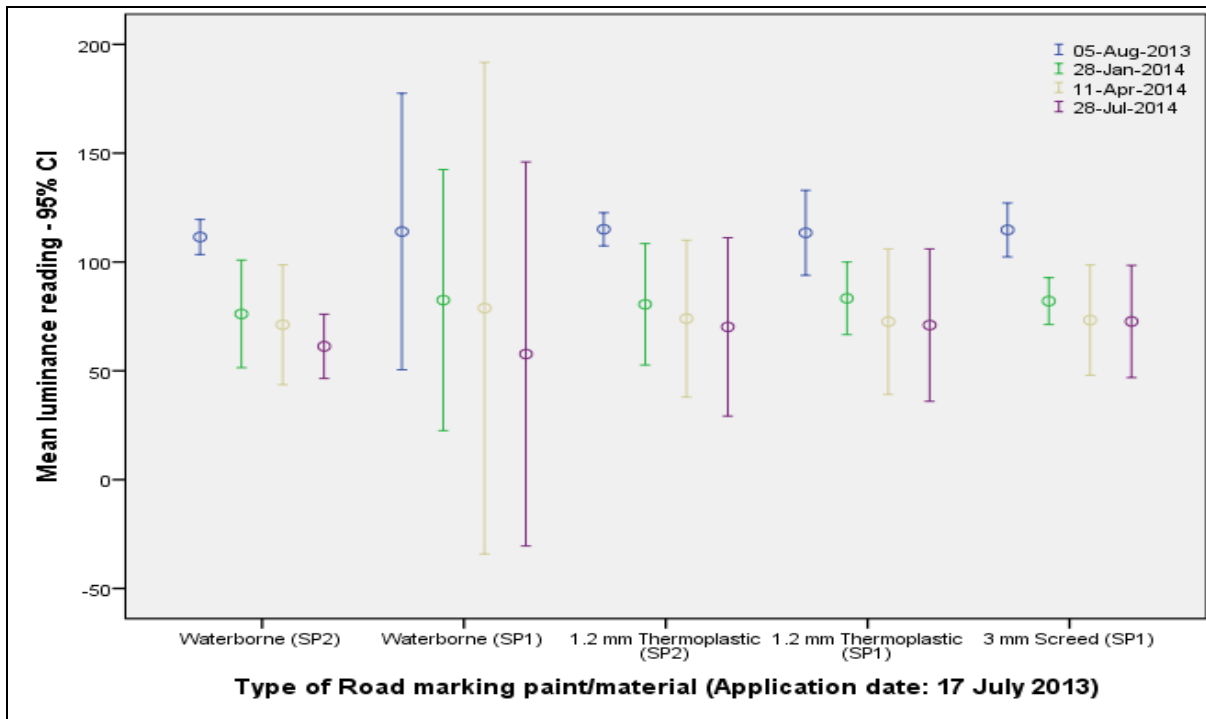

Figure C.8.9: Long established dirty asphalt road (Mohwelere Street).

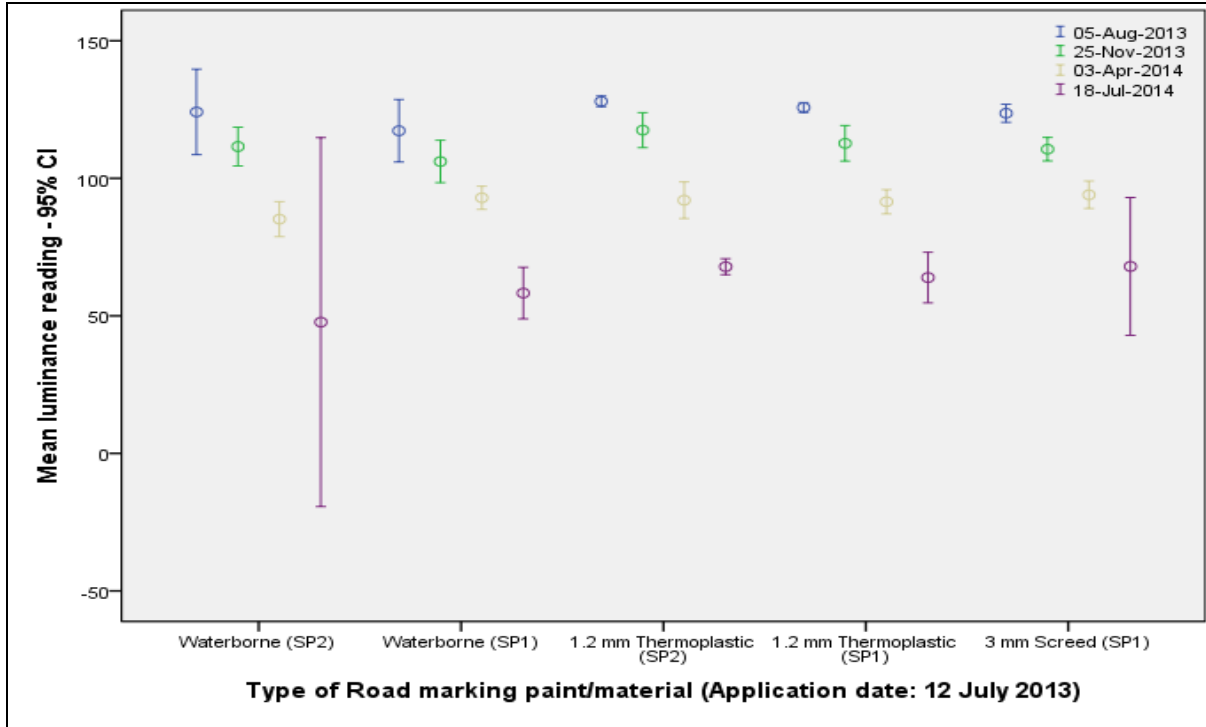

Figure C.8.10: Long established dirty chip seal road (Road L 3).

APPENDIX D

TABLE OF CONTENTS

D. COLOUR ANALYSIS	D-1
D.1 DISCUSSION	D-1

LIST OF TABLES

Table D.1: Summary of the colour analysis on newly established dirty chip seal road (Aubrey Matlala Road).....	D-2
Table D.2: Summary of the colour analysis on long established clean chip seal road (Bushveld Road).D-4	
Table D.3: Summary of the colour analysis on newly established clean chip seal road (Doreen Street - B 1).....	D-6
Table D.4: Summary of the colour analysis on newly established clean chip seal road (Doreen Street - B's 2 & 3).....	D-8
Table D.5: Summary of the colour analysis on newly established clean chip seal road (Doreen Street - B's 1, 2 & 3).....	D-10
Table D.6: Summary of the colour analysis on newly established dirty asphalt road (M 44).	D-12
Table D.7: Summary of the colour analysis on long established asphalt road in CBD (Madiba Street).D-14	
Table D.8: Summary of the colour analysis on newly established clean asphalt road (Meiring Naude Road).....	D-16
Table D.9: Summary of the colour analysis on long established clean asphalt road (Middel Street)....	D-18
Table D.10: Summary of the colour analysis on long established dirty asphalt road (Mohwelere Street).....	D-20
Table D.11: Summary of the colour analysis on long established dirty chip seal road (Road L 3).	D-22

LIST OF FIGURES

Figure D.1: Unwashed white markings on Aubrey Matlala Road.	D-3
Figure D.2: Washed white markings on Aubrey Matlala Road.	D-3
Figure D.3: Unwashed yellow markings on Aubrey Matlala Road.....	D-3
Figure D.4: Washed yellow markings on Aubrey Matlala Road.....	D-3
Figure D.5: Unwashed white markings on Bushveld Road.....	D-5
Figure D.6: Washed white markings on Bushveld Road.	D-5
Figure D.7: Unwashed yellow markings on Bushveld Road.	D-5
Figure D.8: Washed yellow markings on Bushveld Road.	D-5
Figure D.9: Unwashed white markings on Doreen Street (B 1).....	D-7
Figure D.10: Washed white markings on Doreen Street (B 1).....	D-7
Figure D.11: Unwashed yellow markings on Doreen Street (B 1).	D-7

Figure D.12: Washed yellow markings on Doreen Street (B 1).	D-7
Figure D.13: Unwashed white markings on Doreen Street (B's 2 & 3).	D-9
Figure D.14: Washed white markings on Doreen Street (B's 2 & 3).	D-9
Figure D.15: Unwashed yellow markings on Doreen Street (B's 2 & 3).	D-9
Figure D.16: Washed yellow markings on Doreen Street (B's 2 & 3).	D-9
Figure D.17: Unwashed white markings on Doreen Street (B's 1, 2 & 3).	D-11
Figure D.18: Washed white markings on Doreen Street (B's 1, 2 & 3).	D-11
Figure D.19: Unwashed yellow markings on Doreen Street (B's 1, 2 & 3).	D-11
Figure D.20: Washed yellow markings on Doreen Street (B's 1, 2 & 3).	D-11
Figure D.21: Unwashed white markings on M44.	D-13
Figure D.22: Washed white markings on M44.	D-13
Figure D.23: Unwashed yellow markings on M44.	D-13
Figure D.24: Washed yellow markings on M44.	D-13
Figure D.25: Unwashed white markings on Madiba Street.	D-15
Figure D.26: Washed white markings on Madiba Street.	D-15
Figure D.27: Unwashed yellow markings on Madiba Street.	D-15
Figure D.28: Washed yellow markings on Madiba Street.	D-15
Figure D.29: Unwashed white markings on Meiring Naude Road.	D-17
Figure D.30: Washed white markings on Meiring Naude Road.	D-17
Figure D.31: Unwashed yellow markings on Meiring Naude Road.	D-17
Figure D.32: Washed yellow markings on Meiring Naude Road.	D-17
Figure D.33: Unwashed white markings on Middel Street.	D-19
Figure D.34: Washed white markings on Middel Street.	D-19
Figure D.35: Unwashed yellow markings on Middel Street.	D-19
Figure D.36: Washed yellow markings on Middel Street.	D-19
Figure D.37: Unwashed white markings on Mohwelere Street.	D-21
Figure D.38: Washed white markings on Mohwelere Street.	D-21
Figure D.39: Unwashed yellow markings on Mohwelere Street.	D-21
Figure D.40: Washed yellow markings on Mohwelere Street.	D-21
Figure D.41: Unwashed white markings on Road L 3.	D-23
Figure D.42: Washed white markings on Road L 3.	D-23
Figure D.43: Unwashed yellow markings on Road L 3.	D-23
Figure D.44: Washed yellow markings on Road L 3.	D-23

D. COLOUR ANALYSIS

D.1 DISCUSSION

Tables D.1 to D.11 indicate the percentages of the measurements which fell either within the region according to the specification or out of the region. Figures D.1 to D.44 represent the fourth measurements of the white and yellow test road markings on the chromaticity diagrams.

Table D.1: Summary of the colour analysis on newly established dirty chip seal road (Aubrey Matlala Road).

Aubrey Matlala Road		White transverse road markings								Yellow transverse road markings							
		Measurement 1 29 November 2013		Measurement 2 02 April 2014		Measurement 3 17 July 2014		Measurement 4 06 February 2015		Measurement 1 29 November 2013		Measurement 2 02 April 2014		Measurement 3 17 July 2014		Measurement 4 06 February 2015	
		Falling out of region (%)	Falling within region (%)	Falling out of region (%)	Falling within region (%)	Falling out of region (%)	Falling within region (%)	Falling out of region (%)	Falling within region (%)	Falling out of region (%)	Falling within region (%)	Falling out of region (%)	Falling within region (%)	Falling out of region (%)	Falling within region (%)	Falling out of region (%)	Falling within region (%)
Unwashed	Water-borne (SP1)	0.0	100.0	0.0	100.0	0.0	100.0	50.0	50.0	100.0	0.0	100.0	0.0	100.0	0.0	100.0	0.0
	Water-borne (SP2)	50.0	50.0	0.0	100.0	0.0	100.0	0.0	100.0	100.0	0.0	100.0	0.0	100.0	0.0	100.0	0.0
	Water-borne (SP3)	0.0	100.0	0.0	100.0	0.0	100.0	0.0	100.0	100.0	0.0	100.0	0.0	100.0	0.0	100.0	0.0
	1 mm Cold Plastic (SP1)	0.0	100.0	0.0	100.0	0.0	100.0	0.0	100.0	100.0	0.0	100.0	0.0	100.0	0.0	100.0	0.0
	1 mm Cold Plastic (SP2)	50.0	50.0	0.0	100.0	0.0	100.0	0.0	100.0	100.0	0.0	100.0	0.0	100.0	0.0	100.0	0.0
	1.2 mm Thermoplastic (SP1)	50.0	50.0	0.0	100.0	0.0	100.0	50.0	50.0	100.0	0.0	100.0	0.0	100.0	0.0	100.0	0.0
	1.2 mm Thermoplastic (SP2)	50.0	50.0	0.0	100.0	0.0	100.0	0.0	100.0	100.0	0.0	100.0	0.0	100.0	0.0	100.0	0.0
	3 mm Screed (SP1)	100.0	0.0	0.0	100.0	0.0	100.0	0.0	100.0	100.0	0.0	100.0	0.0	100.0	0.0	100.0	0.0
Washed	Water-borne (SP1)	0.0	100.0	0.0	100.0	0.0	100.0	0.0	100.0	100.0	0.0	100.0	0.0	100.0	0.0	100.0	0.0
	Water-borne (SP2)	0.0	100.0	0.0	100.0	0.0	100.0	0.0	100.0	100.0	0.0	100.0	0.0	100.0	0.0	100.0	0.0
	Water-borne (SP3)	50.0	50.0	0.0	100.0	0.0	100.0	0.0	100.0	100.0	0.0	100.0	0.0	100.0	0.0	100.0	0.0
	1 mm Cold Plastic (SP1)	0.0	100.0	0.0	100.0	0.0	100.0	0.0	100.0	100.0	0.0	100.0	0.0	100.0	0.0	100.0	0.0
	1 mm Cold Plastic (SP2)	0.0	100.0	0.0	100.0	0.0	100.0	0.0	100.0	100.0	0.0	100.0	0.0	100.0	0.0	100.0	0.0
	1.2 mm Thermoplastic (SP1)	0.0	100.0	0.0	100.0	0.0	100.0	0.0	100.0	100.0	0.0	100.0	0.0	100.0	0.0	100.0	0.0
	1.2 mm Thermoplastic (SP2)	50.0	50.0	0.0	100.0	0.0	100.0	0.0	100.0	100.0	0.0	100.0	0.0	100.0	0.0	100.0	0.0
	3 mm Screed (SP1)	0.0	100.0	0.0	100.0	0.0	100.0	0.0	100.0	100.0	0.0	100.0	0.0	100.0	0.0	100.0	0.0

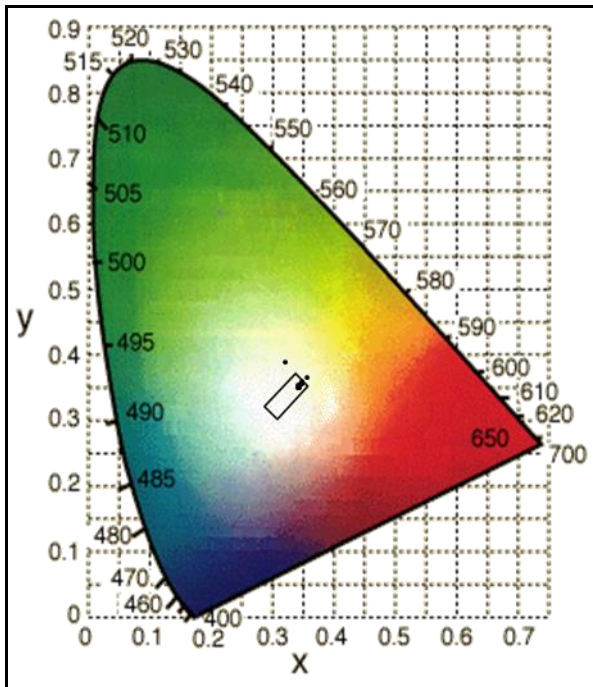

Figure D.1: Unwashed white markings on Aubrey Matlala Road.

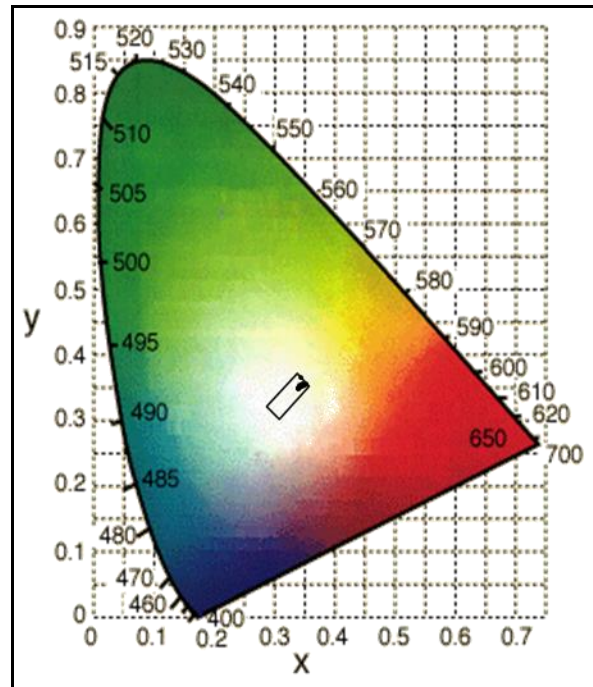

Figure D.2: Washed white markings on Aubrey Matlala Road.

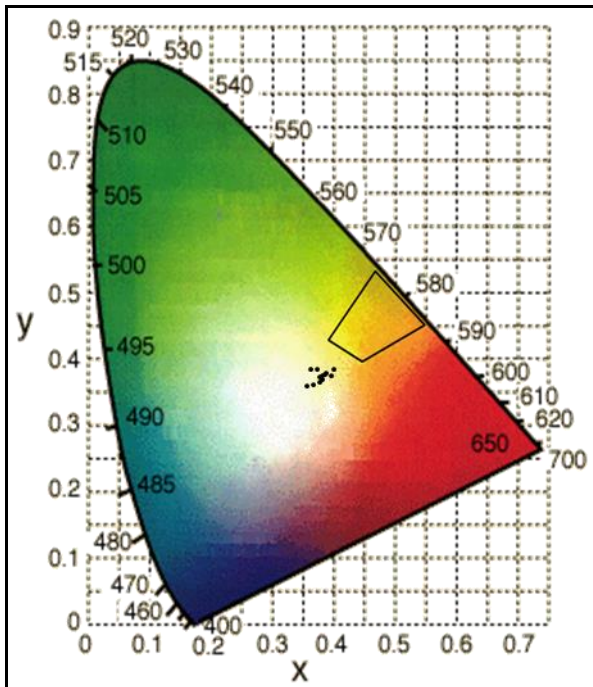

Figure D.3: Unwashed yellow markings on Aubrey Matlala Road.

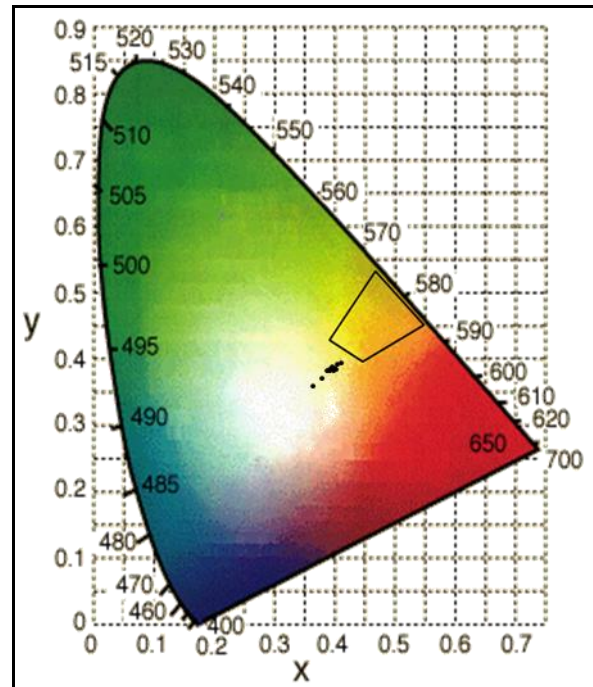

Figure D.4: Washed yellow markings on Aubrey Matlala Road.

Table D.2: Summary of the colour analysis on long established clean chip seal road (Bushveld Road).

Bushveld Road		White transverse road markings								Yellow transverse road markings							
		Measurement 1 05 November 2013		Measurement 2 28 March 2014		Measurement 3 22 July 2014		Measurement 4 06 February 2015		Measurement 1 05 November 2013		Measurement 2 28 March 2014		Measurement 3 22 July 2014		Measurement 4 06 February 2015	
		Falling out of region (%)	Falling within region (%)	Falling out of region (%)	Falling within region (%)	Falling out of region (%)	Falling within region (%)	Falling out of region (%)	Falling within region (%)	Falling out of region (%)	Falling within region (%)	Falling out of region (%)	Falling within region (%)	Falling out of region (%)	Falling within region (%)	Falling out of region (%)	Falling within region (%)
Unwashed	Water-borne (SP1)	0.0	100.0	0.0	100.0	0.0	100.0	0.0	100.0	100.0	0.0	100.0	0.0	100.0	0.0	100.0	0.0
	Water-borne (SP2)	0.0	100.0	0.0	100.0	0.0	100.0	0.0	100.0	100.0	0.0	66.7	33.3	100.0	0.0	100.0	0.0
	Water-borne (SP3)	0.0	100.0	0.0	100.0	0.0	100.0	0.0	100.0	100.0	0.0	100.0	0.0	100.0	0.0	100.0	0.0
	1 mm Cold Plastic (SP1)	0.0	100.0	0.0	100.0	0.0	100.0	0.0	100.0	66.7	33.3	66.7	33.3	100.0	0.0	100.0	0.0
	1 mm Cold Plastic (SP4)	0.0	100.0	0.0	100.0	0.0	100.0	0.0	100.0	100.0	0.0	100.0	0.0	100.0	0.0	100.0	0.0
	1.2 mm Thermoplastic (SP1)	0.0	100.0	0.0	100.0	0.0	100.0	0.0	100.0	100.0	0.0	66.7	33.3	100.0	0.0	100.0	0.0
	1.2 mm Thermoplastic (SP2)	0.0	100.0	0.0	100.0	0.0	100.0	33.3	66.7	100.0	0.0	100.0	0.0	100.0	0.0	100.0	0.0
	3 mm Screed (SP1)	0.0	100.0	0.0	100.0	33.3	66.7	0.0	100.0	100.0	0.0	66.7	33.3	100.0	0.0	100.0	0.0
Washed	Water-borne (SP1)	0.0	100.0	0.0	100.0	0.0	100.0	0.0	100.0	100.0	0.0	100.0	0.0	100.0	0.0	100.0	0.0
	Water-borne (SP2)	0.0	100.0	0.0	100.0	0.0	100.0	0.0	100.0	100.0	0.0	100.0	0.0	33.3	66.7	100.0	0.0
	Water-borne (SP3)	0.0	100.0	0.0	100.0	0.0	100.0	0.0	100.0	100.0	0.0	100.0	0.0	66.7	33.3	100.0	0.0
	1 mm Cold Plastic (SP1)	0.0	100.0	0.0	100.0	0.0	100.0	0.0	100.0	100.0	0.0	100.0	0.0	100.0	0.0	100.0	0.0
	1 mm Cold Plastic (SP4)	0.0	100.0	0.0	100.0	33.3	66.7	0.0	100.0	100.0	0.0	100.0	0.0	100.0	0.0	100.0	0.0
	1.2 mm Thermoplastic (SP1)	0.0	100.0	0.0	100.0	0.0	100.0	0.0	100.0	100.0	0.0	0.0	100.0	100.0	0.0	100.0	0.0
	1.2 mm Thermoplastic (SP2)	0.0	100.0	0.0	100.0	0.0	100.0	0.0	100.0	100.0	0.0	100.0	0.0	100.0	0.0	100.0	0.0
	3 mm Screed (SP1)	0.0	100.0	0.0	100.0	0.0	100.0	0.0	100.0	100.0	0.0	33.3	66.7	100.0	0.0	100.0	0.0

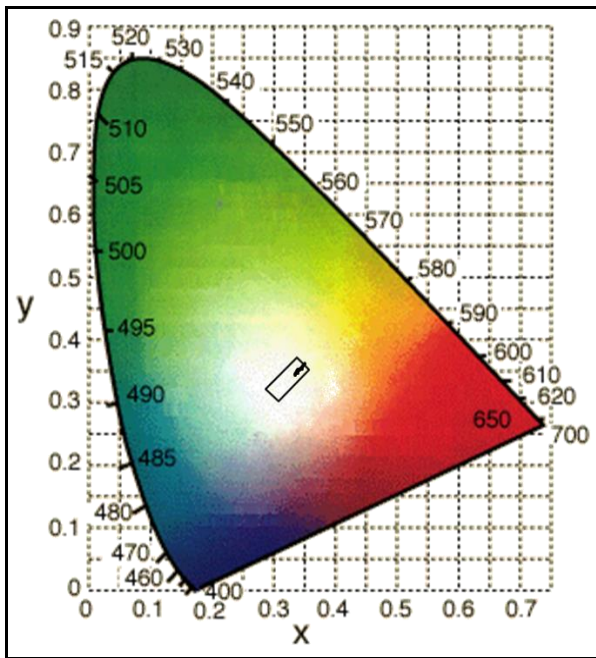

Figure D.5: Unwashed white markings on Bushveld Road.

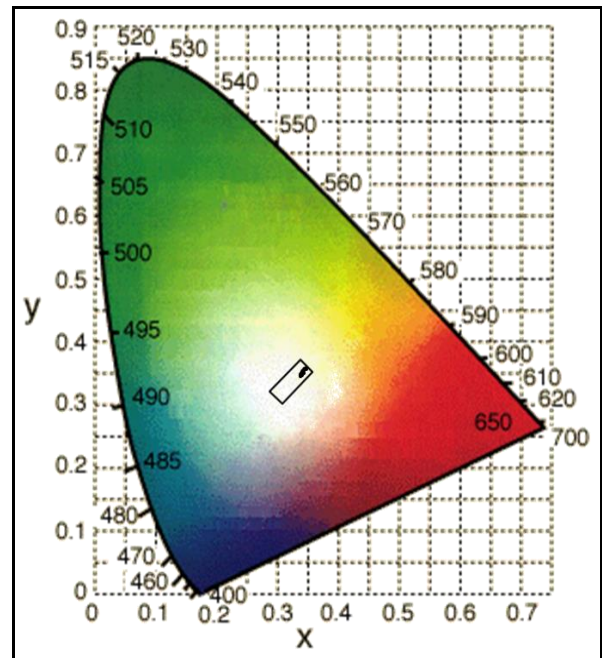

Figure D.6: Washed white markings on Bushveld Road.

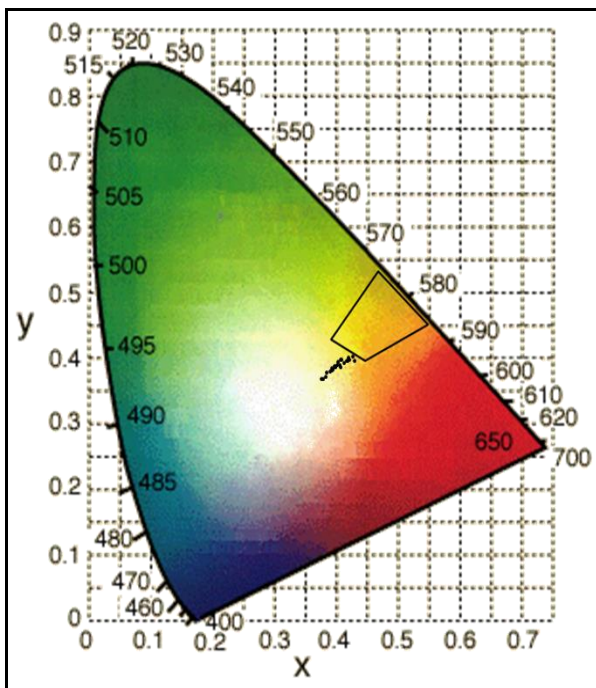

Figure D.7: Unwashed yellow markings on Bushveld Road.

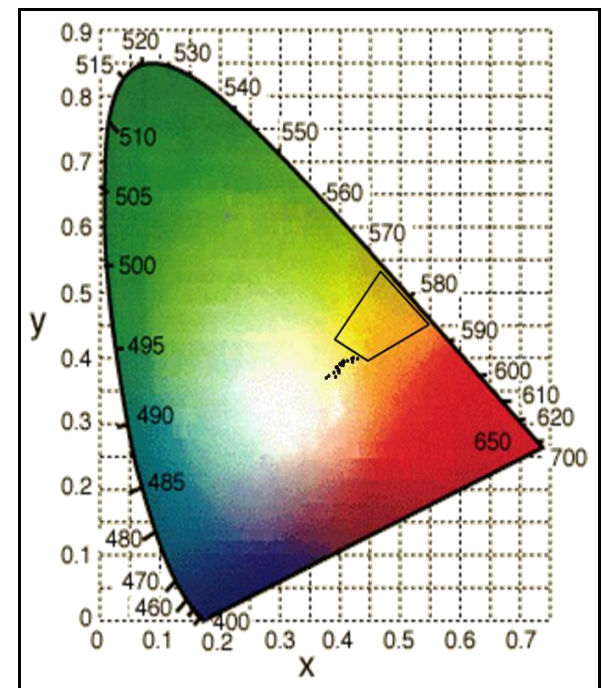

Figure D.8: Washed yellow markings on Bushveld Road.

Table D.3: Summary of the colour analysis on newly established clean chip seal road (Doreen Street - B 1).

Doreen Street (B 1)		White transverse road markings								Yellow transverse road markings							
		Measurement 1 21 November 2013		Measurement 2 26 March 2014		Measurement 3 25 July 2014		Measurement 4 05 February 2015		Measurement 1 21 November 2013		Measurement 2 26 March 2014		Measurement 3 25 July 2014		Measurement 4 05 February 2015	
		Falling out of region (%)	Falling within region (%)	Falling out of region (%)	Falling within region (%)	Falling out of region (%)	Falling within region (%)	Falling out of region (%)	Falling within region (%)	Falling out of region (%)	Falling within region (%)	Falling out of region (%)	Falling within region (%)	Falling out of region (%)	Falling within region (%)	Falling out of region (%)	Falling within region (%)
Unwashed	Water-borne (SP1)	100.0	0.0	100.0	0.0	0.0	100.0	0.0	100.0	100.0	0.0	100.0	0.0	100.0	0.0	100.0	0.0
	Water-borne (SP2)	100.0	0.0	100.0	0.0	100.0	0.0	100.0	0.0	100.0	0.0	100.0	0.0	100.0	0.0	100.0	0.0
	Water-borne (SP3)	100.0	0.0	100.0	0.0	0.0	100.0	0.0	100.0	100.0	0.0	100.0	0.0	100.0	0.0	100.0	0.0
	1 mm Cold Plastic (SP1)	100.0	0.0	100.0	0.0	0.0	100.0	0.0	100.0	100.0	0.0	100.0	0.0	100.0	0.0	100.0	0.0
	1 mm Cold Plastic (SP4)	100.0	0.0	100.0	0.0	0.0	100.0	0.0	100.0	100.0	0.0	100.0	0.0	100.0	0.0	100.0	0.0
	1.2 mm Thermoplastic (SP1)	100.0	0.0	0.0	100.0	0.0	100.0	0.0	100.0	100.0	0.0	100.0	0.0	100.0	0.0	100.0	0.0
	1.2 mm Thermoplastic (SP2)	100.0	0.0	100.0	0.0	0.0	100.0	0.0	100.0	100.0	0.0	100.0	0.0	100.0	0.0	100.0	0.0
	3 mm Screed (SP1)	100.0	0.0	0.0	100.0	0.0	100.0	0.0	100.0	100.0	0.0	100.0	0.0	100.0	0.0	100.0	0.0
Unwashed	Water-borne (SP1)	100.0	0.0	100.0	0.0	0.0	100.0	0.0	100.0	100.0	0.0	100.0	0.0	100.0	0.0	100.0	0.0
	Water-borne (SP2)	100.0	0.0	100.0	0.0	100.0	0.0	100.0	0.0	100.0	0.0	100.0	0.0	100.0	0.0	100.0	0.0
	Water-borne (SP3)	100.0	0.0	100.0	0.0	0.0	100.0	100.0	0.0	100.0	0.0	100.0	0.0	100.0	0.0	100.0	0.0
	1 mm Cold Plastic (SP1)	100.0	0.0	100.0	0.0	0.0	100.0	100.0	0.0	100.0	0.0	100.0	0.0	100.0	0.0	100.0	0.0
	1 mm Cold Plastic (SP4)	100.0	0.0	100.0	0.0	100.0	0.0	0.0	100.0	100.0	0.0	100.0	0.0	100.0	0.0	100.0	0.0
	1.2 mm Thermoplastic (SP1)	100.0	0.0	0.0	100.0	0.0	100.0	0.0	100.0	100.0	0.0	100.0	0.0	100.0	0.0	100.0	0.0
	1.2 mm Thermoplastic (SP2)	100.0	0.0	100.0	0.0	0.0	100.0	0.0	100.0	100.0	0.0	100.0	0.0	100.0	0.0	100.0	0.0
	3 mm Screed (SP1)	100.0	0.0	100.0	0.0	0.0	100.0	0.0	100.0	100.0	0.0	100.0	0.0	100.0	0.0	100.0	0.0

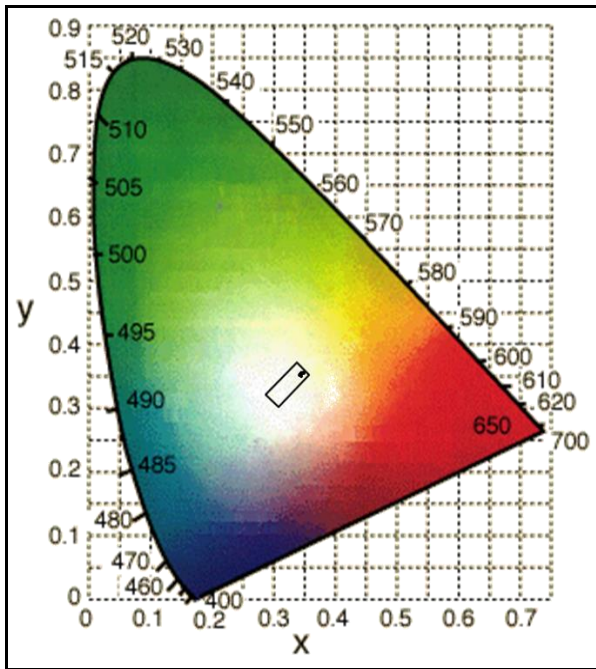

Figure D.9: Unwashed white markings on Doreen Street (B 1).

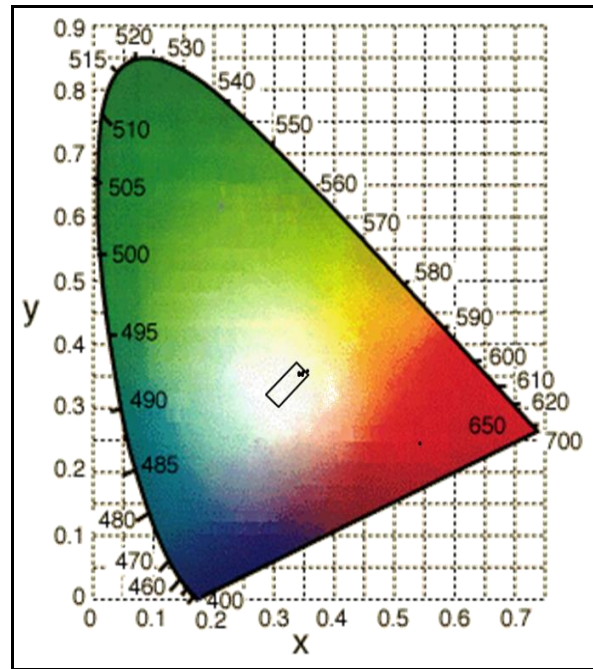

Figure D.10: Washed white markings on Doreen Street (B 1).

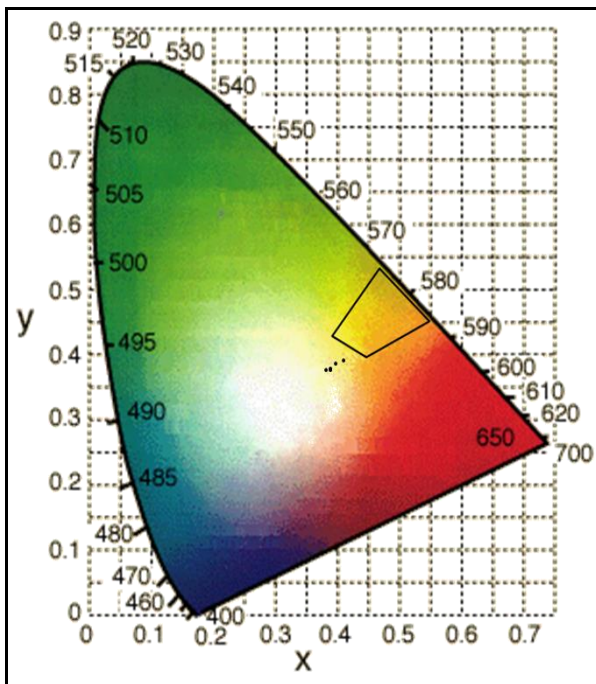

Figure D.11: Unwashed yellow markings on Doreen Street (B 1).

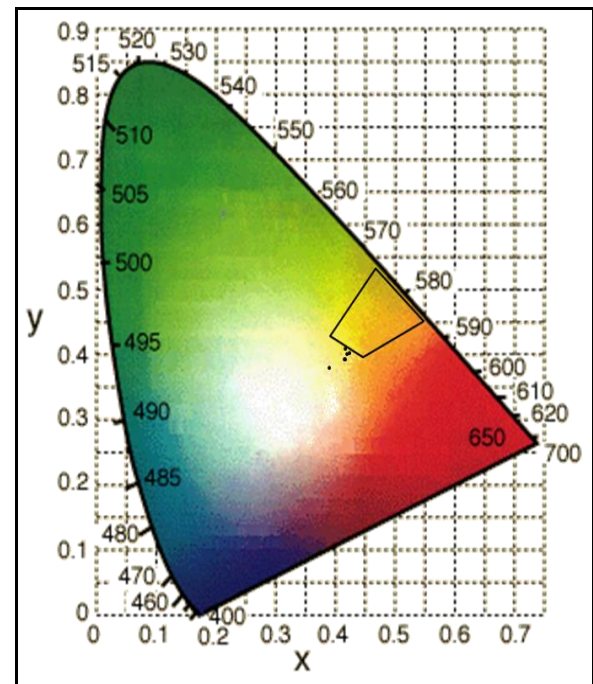

Figure D.12: Washed yellow markings on Doreen Street (B 1).

Table D.4: Summary of the colour analysis on newly established clean chip seal road (Doreen Street - B's 2 & 3).

Doreen (B 2 & 3)		White transverse road markings								Yellow transverse road markings							
		Measurement 1 21 November 2013		Measurement 2 26 March 2014		Measurement 3 25 July 2014		Measurement 4 05 February 2015		Measurement 1 21 November 2013		Measurement 2 26 March 2014		Measurement 3 25 July 2014		Measurement 4 05 February 2015	
		Falling out of region (%)	Falling within region (%)	Falling out of region (%)	Falling within region (%)	Falling out of region (%)	Falling within region (%)	Falling out of region (%)	Falling within region (%)	Falling out of region (%)	Falling within region (%)	Falling out of region (%)	Falling within region (%)	Falling out of region (%)	Falling within region (%)	Falling out of region (%)	Falling within region (%)
Unwashed	Water-borne (SP1)	50.0	50.0	50.0	50.0	0.0	100.0	0.0	100.0	100.0	0.0	100.0	0.0	100.0	0.0	100.0	0.0
	Water-borne (SP2)	0	100.0	50.0	50.0	0.0	100.0	0.0	100.0	100.0	0.0	100.0	0.0	100.0	0.0	100.0	0.0
	Water-borne (SP3)	50.0	50.0	50.0	50.0	0.0	100.0	50.0	50.0	50.0	50.0	100.0	0.0	100.0	0.0	100.0	0.0
	1 mm Cold Plastic (SP1)	50.0	50.0	50.0	50.0	0.0	100.0	0.0	100.0	100.0	0.0	100.0	0.0	100.0	0.0	100.0	0.0
	1 mm Cold Plastic (SP4)	0.0	100.0	0.0	100.0	0.0	100.0	0.0	100.0	100.0	0.0	100.0	0.0	100.0	0.0	100.0	0.0
	1.2 mm Thermoplastic (SP1)	0.0	100.0	50.0	50.0	0.0	100.0	0.0	100.0	50.0	50.0	100.0	0.0	100.0	0.0	100.0	0.0
	1.2 mm Thermoplastic (SP2)	0.0	100.0	50.0	50.0	0.0	100.0	0.0	100.0	100.0	0.0	100.0	0.0	100.0	0.0	100.0	0.0
	3 mm Screed (SP1)	0.0	100.0	0.0	100.0	0.0	100.0	0.0	100.0	100.0	0.0	100.0	0.0	100.0	0.0	100.0	0.0
Washed	Water-borne (SP1)	0.0	100.0	100.0	0.0	50.0	50.0	0.0	100.0	50.0	50.0	100.0	0.0	100.0	0.0	100.0	0.0
	Water-borne (SP2)	0.0	100.0	50.0	50.0	0.0	100.0	50.0	50.0	100.0	0.0	100.0	0.0	100.0	0.0	100.0	0.0
	Water-borne (SP3)	0.0	100.0	100.0	0.0	0.0	100.0	0.0	100.0	50.0	50.0	100.0	0.0	100.0	0.0	100.0	0.0
	1 mm Cold Plastic (SP1)	50.0	50.0	100.0	0.0	50.0	50.0	0.0	100.0	0.0	100.0	100.0	0.0	100.0	0.0	100.0	0.0
	1 mm Cold Plastic (SP4)	0.0	100.0	0.0	100.0	0.0	100.0	0.0	100.0	100.0	0.0	100.0	0.0	100.0	0.0	100.0	0.0
	1.2 mm Thermoplastic (SP1)	0.0	100.0	50.0	50.0	0.0	100.0	0.0	100.0	100.0	0.0	100.0	0.0	100.0	0.0	100.0	0.0
	1.2 mm Thermoplastic (SP2)	50.0	50.0	100.0	0.0	50.0	50.0	0.0	100.0	100.0	0.0	100.0	0.0	100.0	0.0	100.0	0.0
	3 mm Screed (SP1)	0.0	100.0	100.0	0.0	0.0	100.0	0.0	100.0	100.0	0.0	100.0	0.0	100.0	0.0	100.0	0.0

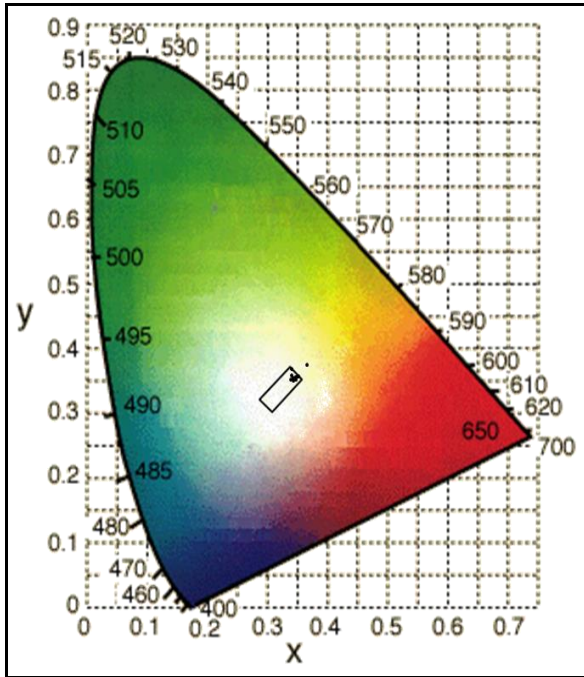

Figure D.13: Unwashed white markings on Doreen Street (B's 2 & 3).

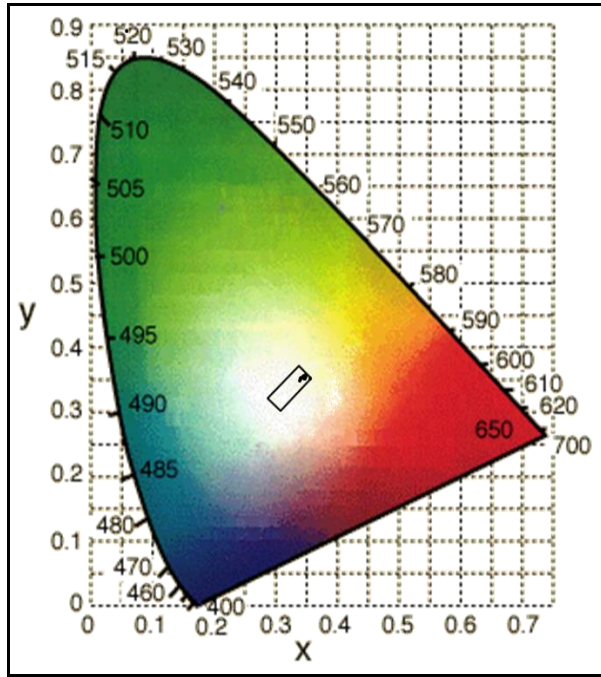

Figure D.14: Washed white markings on Doreen Street (B's 2 & 3).

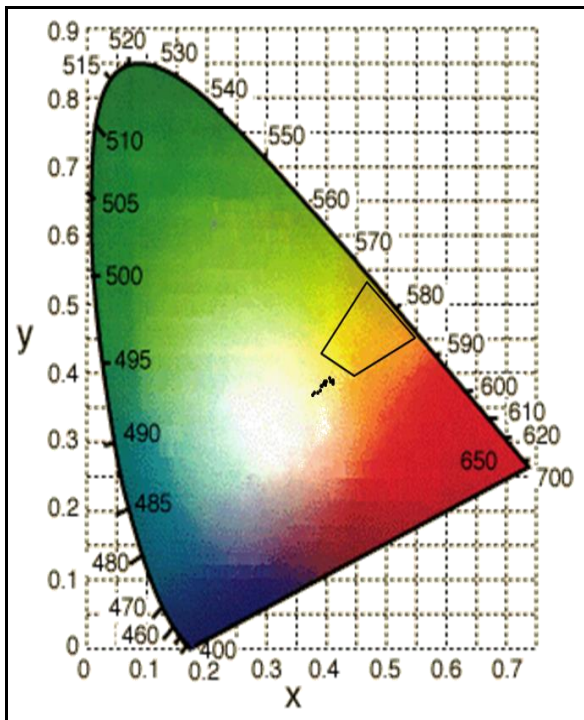

Figure D.15: Unwashed yellow markings on Doreen Street (B's 2 & 3).

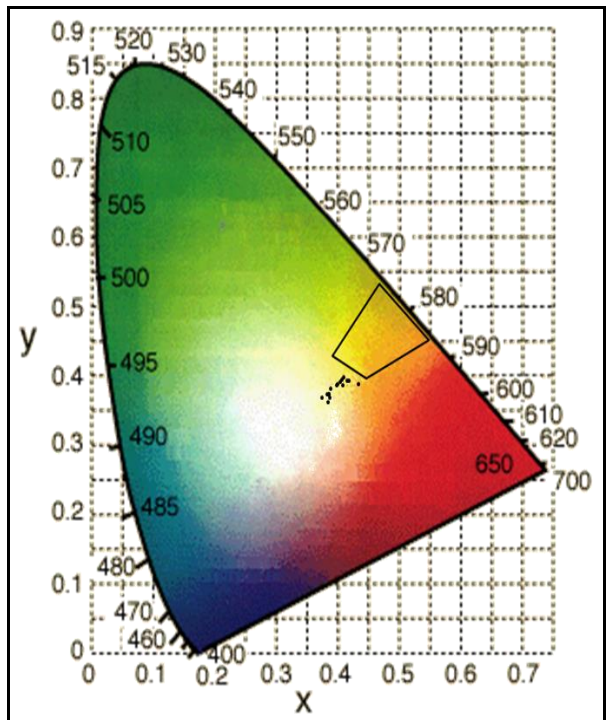

Figure D.16: Washed yellow markings on Doreen Street (B's 2 & 3).

Table D.5: Summary of the colour analysis on newly established clean chip seal road (Doreen Street - B's 1, 2 & 3).

Doreen Street (B 1, 2 & 3)		White transverse road markings								Yellow transverse road markings							
		Measurement 1 21 November 2013		Measurement 2 26 March 2014		Measurement 3 25 July 2014		Measurement 4 05 February 2015		Measurement 1 21 November 2013		Measurement 2 26 March 2014		Measurement 3 25 July 2014		Measurement 4 05 February 2015	
		Falling out of region (%)	Falling within region (%)	Falling out of region (%)	Falling within region (%)	Falling out of region (%)	Falling within region (%)	Falling out of region (%)	Falling within region (%)	Falling out of region (%)	Falling within region (%)	Falling out of region (%)	Falling within region (%)	Falling out of region (%)	Falling within region (%)	Falling out of region (%)	Falling within region (%)
Unwashed	Water-borne (SP1)	66.7	33.3	66.7	33.3	0.0	100.0	0.0	100.0	100.0	0.0	100.0	0.0	100.0	0.0	100.0	0.0
	Water-borne (SP2)	33.3	66.7	66.7	33.3	33.3	66.7	33.3	66.7	100.0	0.0	100.0	0.0	100.0	0.0	100.0	0.0
	Water-borne (SP3)	66.7	33.3	66.7	33.3	0.0	100.0	33.3	66.7	66.7	33.3	100.0	0.0	100.0	0.0	100.0	0.0
	1 mm Cold Plastic (SP1)	66.7	33.3	66.7	33.3	0.0	100.0	0.0	100.0	100.0	0.0	100.0	0.0	100.0	0.0	100.0	0.0
	1 mm Cold Plastic (SP4)	33.3	66.7	33.3	66.7	0.0	100.0	0.0	100.0	100.0	0.0	100.0	0.0	100.0	0.0	100.0	0.0
	1.2 mm Thermoplastic (SP1)	33.3	66.7	33.3	66.7	0.0	100.0	0.0	100.0	66.7	33.3	100.0	0.0	100.0	0.0	100.0	0.0
	1.2 mm Thermoplastic (SP2)	33.3	66.7	66.7	33.3	0.0	100.0	0.0	100.0	100.0	0.0	100.0	0.0	100.0	0.0	100.0	0.0
	3 mm Screed (SP1)	33.3	66.7	0.0	100.0	0.0	100.0	0.0	100.0	100.0	0.0	100.0	0.0	100.0	0.0	100.0	0.0
Washed	Water-borne (SP1)	33.3	66.7	100.0	0.0	33.3	66.7	0.0	100.0	66.7	33.3	100.0	0.0	100.0	0.0	100.0	0.0
	Water-borne (SP2)	33.3	66.7	66.7	33.3	33.3	66.7	66.7	33.3	100.0	0.0	100.0	0.0	100.0	0.0	100.0	0.0
	Water-borne (SP3)	33.3	66.7	100.0	0.0	0.0	100.0	33.3	66.7	66.7	33.3	100.0	0.0	100.0	0.0	100.0	0.0
	1 mm Cold Plastic (SP1)	66.7	33.3	100.0	0.0	33.3	66.7	33.3	66.7	33.3	66.7	100.0	0.0	100.0	0.0	100.0	0.0
	1 mm Cold Plastic (SP4)	33.3	66.7	33.3	66.7	33.3	66.7	0.0	100.0	100.0	0.0	100.0	0.0	100.0	0.0	100.0	0.0
	1.2 mm Thermoplastic (SP1)	33.3	66.7	33.3	66.7	0.0	100.0	0.0	100.0	100.0	0.0	100.0	0.0	100.0	0.0	100.0	0.0
	1.2 mm Thermoplastic (SP2)	66.7	33.3	100.0	0.0	33.3	66.7	0.0	100.0	100.0	0.0	100.0	0.0	100.0	0.0	100.0	0.0
	3 mm Screed (SP1)	33.3	66.7	100.0	0.0	0.0	100.0	0.0	100.0	100.0	0.0	100.0	0.0	100.0	0.0	100.0	0.0

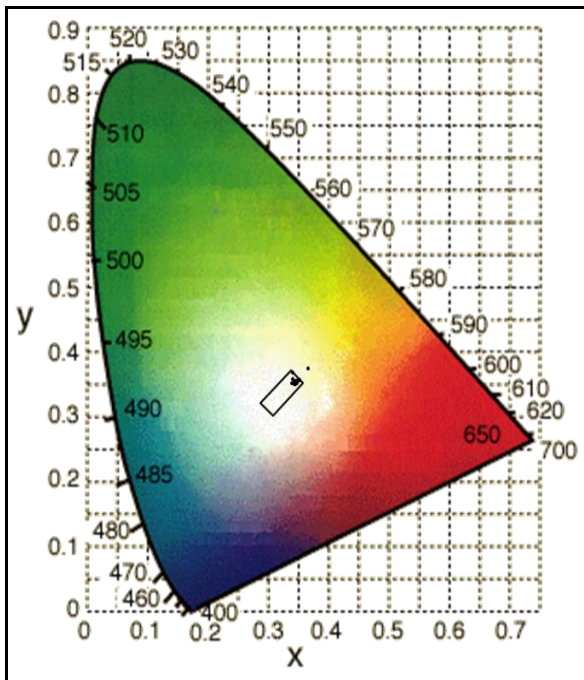

Figure D.17: Unwashed white markings on Doreen Street (B's 1, 2 & 3).

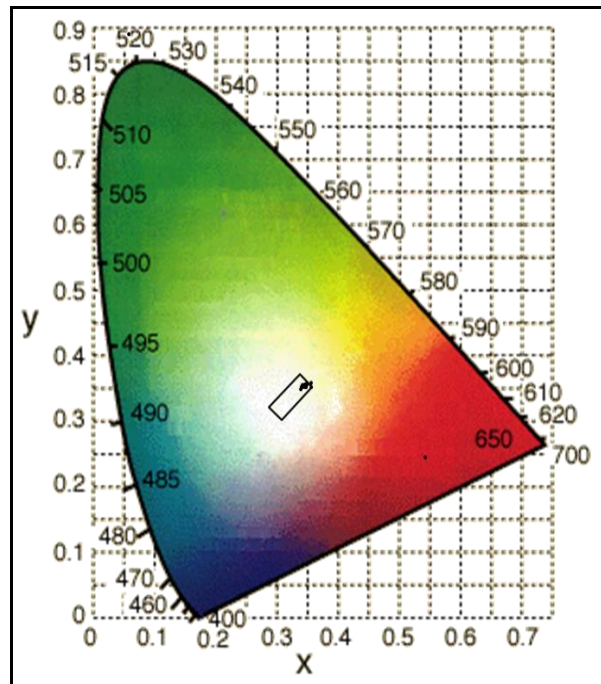

Figure D.18: Washed white markings on Doreen Street (B's 1, 2 & 3).

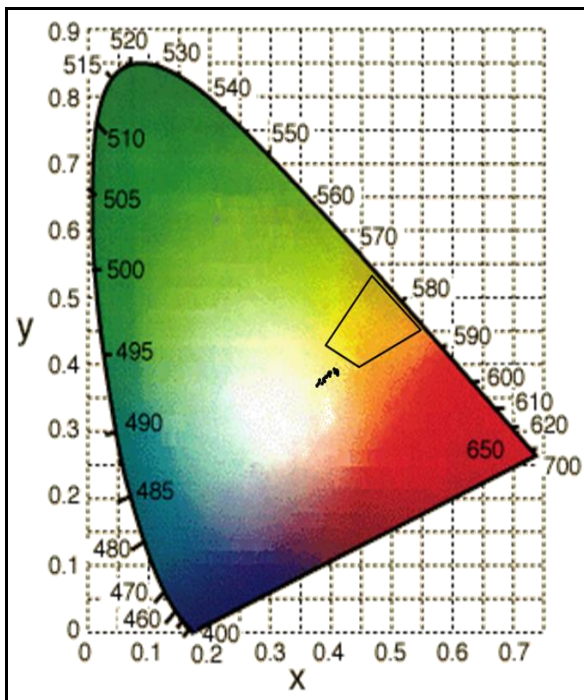

Figure D.19: Unwashed yellow markings on Doreen Street (B's 1, 2 & 3).

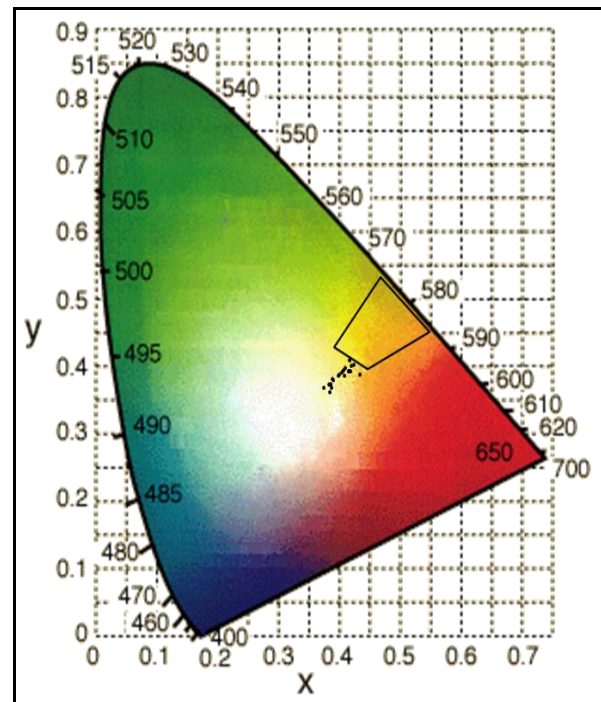

Figure D.20: Washed yellow markings on Doreen Street (B's 1, 2 & 3).

Table D.6: Summary of the colour analysis on newly established dirty asphalt road (M 44).

M 44		White transverse road markings								Yellow transverse road markings							
		Measurement 1 17 January 2014		Measurement 2 08 April 2014		Measurement 3 14 July 2014		Measurement 4 09 February 2015		Measurement 1 17 January 2014		Measurement 2 08 April 2014		Measurement 3 14 July 2014		Measurement 4 09 February 2015	
		Falling out of region (%)	Falling within region (%)	Falling out of region (%)	Falling within region (%)	Falling out of region (%)	Falling within region (%)	Falling out of region (%)	Falling within region (%)	Falling out of region (%)	Falling within region (%)	Falling out of region (%)	Falling within region (%)	Falling out of region (%)	Falling within region (%)	Falling out of region (%)	Falling within region (%)
Unwashed	Water-borne (SP1)	0.0	100.0	0.0	100.0	0.0	100.0	0.0	100.0	100.0	0.0	100.0	0.0	100.0	0.0	100.0	0.0
	Water-borne (SP2)	0.0	100.0	0.0	100.0	33.3	66.7	0.0	100.0	100.0	0.0	100.0	0.0	66.7	33.3	100.0	0.0
	Water-borne (SP3)	0.0	100.0	0.0	100.0	0.0	100.0	0.0	100.0	100.0	0.0	100.0	0.0	100.0	0.0	100.0	0.0
	1 mm Cold Plastic (SP1)	0.0	100.0	0.0	100.0	0.0	100.0	0.0	100.0	100.0	0.0	100.0	0.0	100.0	0.0	100.0	0.0
	1 mm Cold Plastic (SP2)	0.0	100.0	0.0	100.0	0.0	100.0	33.3	66.7	100.0	0.0	100.0	0.0	100.0	0.0	100.0	0.0
	1.2 mm Thermoplastic (SP1)	0.0	100.0	0.0	100.0	0.0	100.0	0.0	100.0	100.0	0.0	100.0	0.0	100.0	0.0	100.0	0.0
	1.2 mm Thermoplastic (SP2)	0.0	100.0	0.0	100.0	0.0	100.0	66.7	33.3	100.0	0.0	100.0	0.0	100.0	0.0	100.0	0.0
	3 mm Screed (SP1)	0.0	100.0	33.3	66.7	0.0	100.0	0.0	100.0	100.0	0.0	100.0	0.0	100.0	0.0	100.0	0.0
Washed	Water-borne (SP1)	0.0	100.0	0.0	100.0	0.0	100.0	33.3	66.7	100.0	0.0	100.0	0.0	100.0	0.0	100.0	0.0
	Water-borne (SP2)	0.0	100.0	0.0	100.0	0.0	100.0	0.0	100.0	100.0	0.0	100.0	0.0	33.3	66.7	100.0	0.0
	Water-borne (SP3)	0.0	100.0	0.0	100.0	0.0	100.0	0.0	100.0	100.0	0.0	100.0	0.0	100.0	0.0	100.0	0.0
	1 mm Cold Plastic (SP1)	0.0	100.0	0.0	100.0	0.0	100.0	0.0	100.0	100.0	0.0	100.0	0.0	100.0	0.0	100.0	0.0
	1 mm Cold Plastic (SP2)	0.0	100.0	0.0	100.0	0.0	100.0	33.3	66.7	100.0	0.0	100.0	0.0	100.0	0.0	100.0	0.0
	1.2 mm Thermoplastic (SP1)	0.0	100.0	33.3	66.7	0.0	100.0	0.0	100.0	100.0	0.0	100.0	0.0	100.0	0.0	100.0	0.0
	1.2 mm Thermoplastic (SP2)	0.0	100.0	0.0	100.0	0.0	100.0	66.7	33.3	100.0	0.0	100.0	0.0	100.0	0.0	100.0	0.0
	3 mm Screed (SP1)	0.0	100.0	0.0	100.0	33.3	66.7	0.0	100.0	100.0	0.0	100.0	0.0	100.0	0.0	100.0	0.0

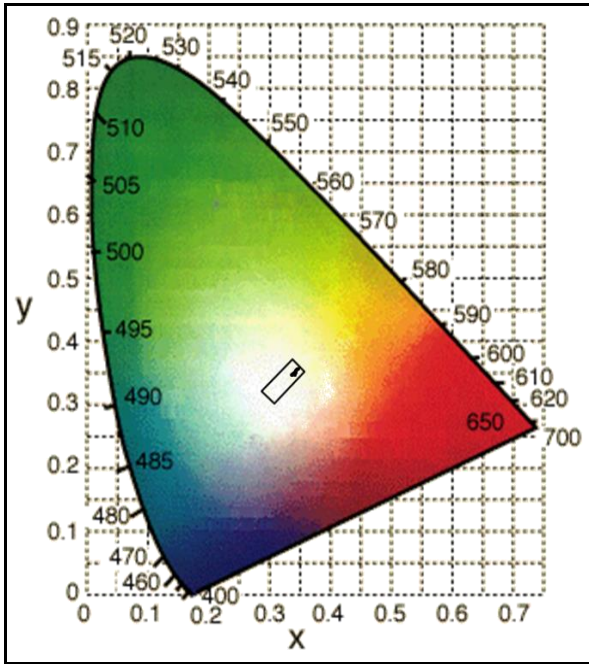

Figure D.21: Unwashed white markings on M44.

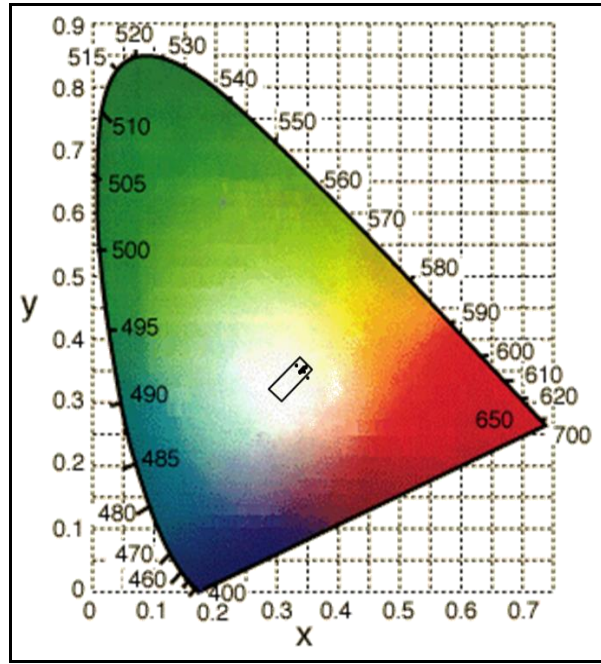

Figure D.22: Washed white markings on M44.

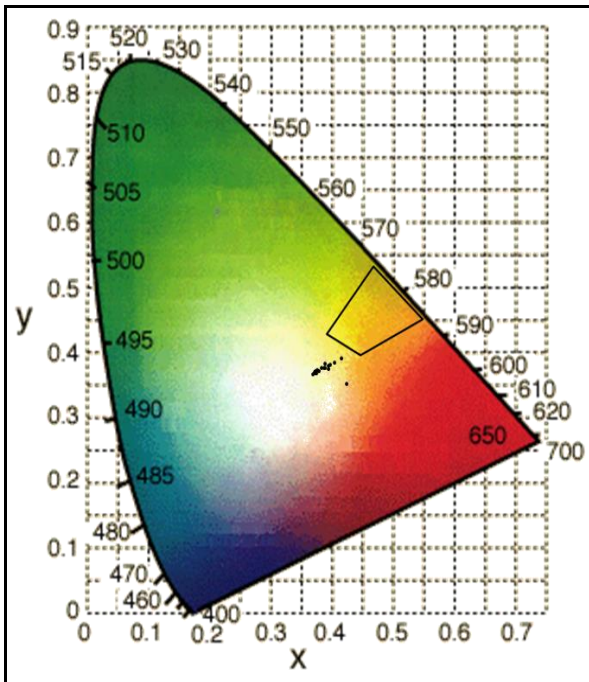

Figure D.23: Unwashed yellow markings on M44.

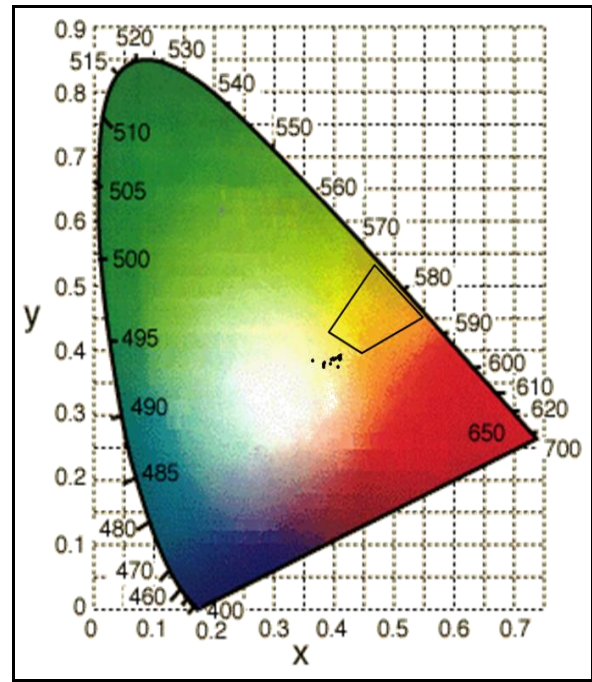

Figure D.24: Washed yellow markings on M44.

Table D.7: Summary of the colour analysis on long established asphalt road in CBD (Madiba Street).

Madiba Street		White transverse road markings								Yellow transverse road markings							
		Measurement 1 20 January 2014		Measurement 2 10 April 2014		Measurement 3 01 August 2014		Measurement 4 10 February 2015		Measurement 1 20 January 2014		Measurement 2 10 April 2014		Measurement 3 01 August 2014		Measurement 4 10 February 2015	
		Falling out of region (%)	Falling within region (%)	Falling out of region (%)	Falling within region (%)	Falling out of region (%)	Falling within region (%)	Falling out of region (%)	Falling within region (%)	Falling out of region (%)	Falling within region (%)	Falling out of region (%)	Falling within region (%)	Falling out of region (%)	Falling within region (%)	Falling out of region (%)	Falling within region (%)
Unwashed	Water-borne (SP1)	0.0	100.0	100.0	0.0	100.0	0.0	100.0	0.0	100.0	0.0	100.0	0.0	100.0	0.0	100.0	0.0
	Water-borne (SP2)	0.0	100.0	0.0	100.0	0.0	100.0	0.0	100.0	100.0	0.0	100.0	0.0	100.0	0.0	100.0	0.0
	Water-borne (SP3)	0.0	100.0	0.0	100.0	0.0	100.0	50.0	50.0	100.0	0.0	100.0	0.0	100.0	0.0	100.0	0.0
	1 mm Cold Plastic (SP1)	0.0	100.0	0.0	100.0	0.0	100.0	50.0	50.0	100.0	0.0	100.0	0.0	100.0	0.0	100.0	0.0
	1 mm Cold Plastic (SP2)	0.0	100.0	0.0	100.0	0.0	100.0	0.0	100.0	100.0	0.0	100.0	0.0	100.0	0.0	100.0	0.0
	1.2 mm Thermoplastic (SP1)	0.0	100.0	0.0	100.0	0.0	100.0	0.0	100.0	100.0	0.0	100.0	0.0	100.0	0.0	100.0	0.0
	1.2 mm Thermoplastic (SP2)	0.0	100.0	0.0	100.0	0.0	100.0	50.0	50.0	100.0	0.0	100.0	0.0	100.0	0.0	100.0	0.0
	3 mm Screed (SP1)	0.0	100.0	0.0	100.0	0.0	100.0	50.0	50.0	100.0	0.0	100.0	0.0	100.0	0.0	100.0	0.0
Washed	Water-borne (SP1)	0.0	100.0	100.0	0.0	100.0	0.0	100.0	0.0	100.0	0.0	100.0	0.0	100.0	0.0	100.0	0.0
	Water-borne (SP2)	0.0	100.0	0.0	100.0	0.0	100.0	0.0	100.0	100.0	0.0	100.0	0.0	100.0	0.0	100.0	0.0
	Water-borne (SP3)	0.0	100.0	0.0	100.0	0.0	100.0	50.0	50.0	100.0	0.0	100.0	0.0	100.0	0.0	100.0	0.0
	1 mm Cold Plastic (SP1)	0.0	100.0	0.0	100.0	0.0	100.0	0.0	100.0	100.0	0.0	100.0	0.0	100.0	0.0	100.0	0.0
	1 mm Cold Plastic (SP2)	0.0	100.0	0.0	100.0	0.0	100.0	0.0	100.0	100.0	0.0	100.0	0.0	100.0	0.0	100.0	0.0
	1.2 mm Thermoplastic (SP1)	0.0	100.0	0.0	100.0	0.0	100.0	0.0	100.0	100.0	0.0	100.0	0.0	100.0	0.0	100.0	0.0
	1.2 mm Thermoplastic (SP2)	0.0	100.0	0.0	100.0	0.0	50.0	50.0	50.0	100.0	0.0	100.0	0.0	100.0	0.0	100.0	0.0
	3 mm Screed (SP1)	0.0	100.0	0.0	100.0	0.0	100.0	0.0	100.0	100.0	0.0	100.0	0.0	100.0	0.0	100.0	0.0

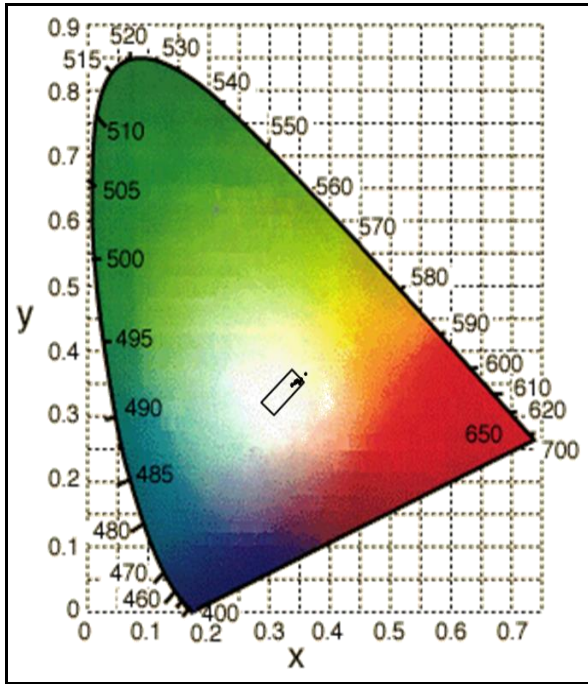

Figure D.25: Unwashed white markings on Madiba Street.

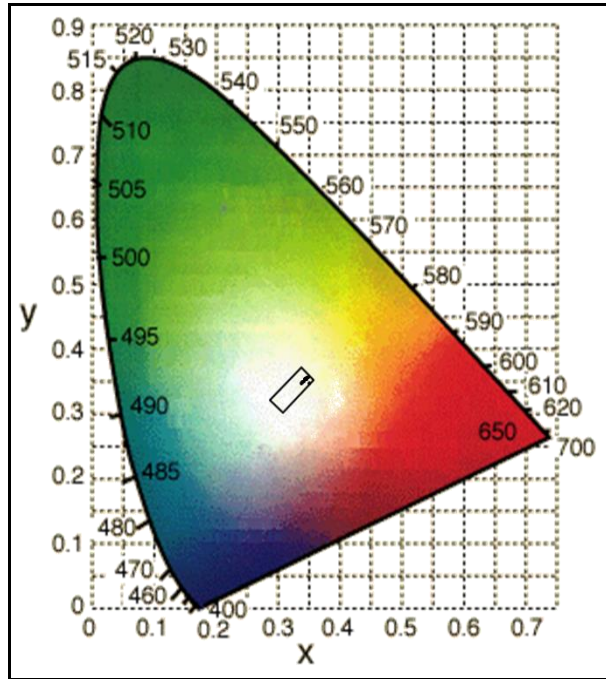

Figure D.26: Washed white markings on Madiba Street.

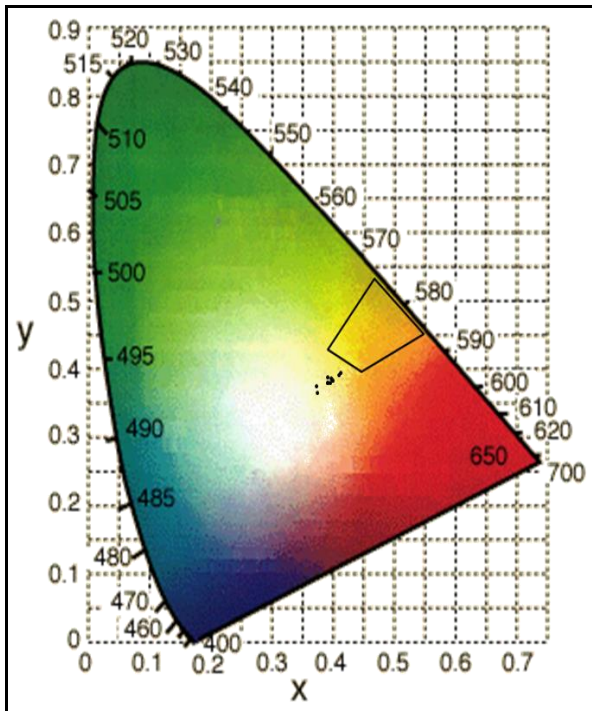

Figure D.27: Unwashed yellow markings on Madiba Street.

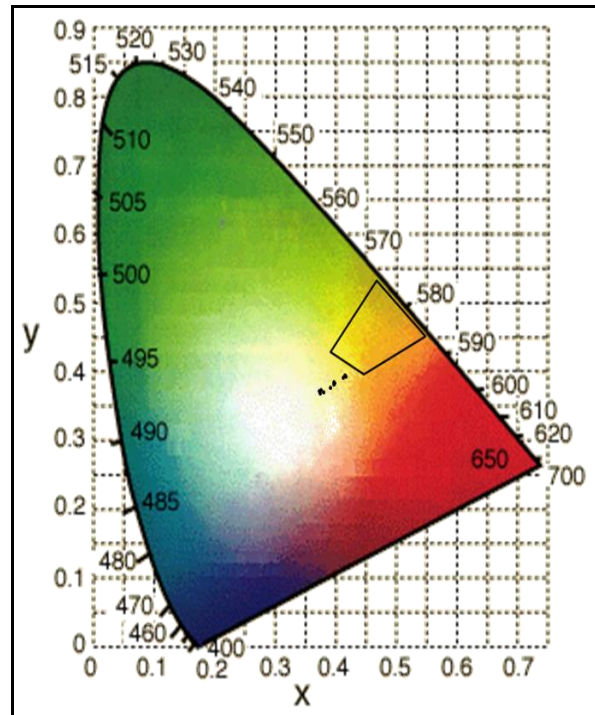

Figure D.28: Washed yellow markings on Madiba Street.

Table D.8: Summary of the colour analysis on newly established clean asphalt road (Meiring Naude Road).

Meiring Naude Road		White transverse road markings								Yellow transverse road markings							
		Measurement 1 23 October 2013		Measurement 2 18 March 2014		Measurement 3 16 July 2014		Measurement 4 04 February 2015		Measurement 1 23 October 2013		Measurement 2 18 March 2014		Measurement 3 16 July 2014		Measurement 4 04 February 2015	
		Falling out of region (%)	Falling within region (%)	Falling out of region (%)	Falling within region (%)	Falling out of region (%)	Falling within region (%)	Falling out of region (%)	Falling within region (%)	Falling out of region (%)	Falling within region (%)	Falling out of region (%)	Falling within region (%)	Falling out of region (%)	Falling within region (%)	Falling out of region (%)	Falling within region (%)
Unwashed	Water-borne (SP1)	33.3	66.7	33.3	66.7	33.3	66.7	66.7	33.3	100.0	0.0	100.0	0.0	100.0	0.0	100.0	0.0
	Water-borne (SP2)	33.3	66.7	33.3	66.7	33.3	66.7	33.3	66.7	100.0	0.0	100.0	0.0	100.0	0.0	100.0	0.0
	Water-borne (SP3)	0.0	100.0	0.0	100.0	0.0	100.0	33.3	66.7	100.0	0.0	100.0	0.0	100.0	0.0	100.0	0.0
	1 mm Cold Plastic (SP1)	0.0	100.0	0.0	100.0	33.3	66.7	33.3	66.7	66.7	33.3	100.0	0.0	100.0	0.0	100.0	0.0
	1 mm Cold Plastic (SP4)	33.3	66.7	33.3	66.7	0.0	100.0	33.3	66.7	100.0	0.0	100.0	0.0	100.0	0.0	100.0	0.0
	1.2 mm Thermoplastic (SP1)	100.0	0.0	100.0	0.0	66.7	33.3	33.3	66.7	100.0	0.0	66.7	33.3	100.0	0.0	100.0	0.0
	1.2 mm Thermoplastic (SP2)	66.7	33.3	66.7	33.3	66.7	33.3	33.3	66.7	100.0	0.0	100.0	0.0	100.0	0.0	100.0	0.0
	3 mm Screed (SP1)	66.7	33.3	66.7	33.3	33.3	66.7	33.3	66.7	100.0	0.0	33.3	66.7	100.0	0.0	100.0	0.0
Washed	Water-borne (SP1)	0.0	100.0	0.0	100.0	66.7	33.3	66.7	33.3	100.0	0.0	100.0	0.0	100.0	0.0	100.0	0.0
	Water-borne (SP2)	0.0	100.0	0.0	100.0	33.3	66.7	66.7	33.3	100.0	0.0	100.0	0.0	100.0	0.0	100.0	0.0
	Water-borne (SP3)	0.0	100.0	0.0	100.0	66.7	33.3	66.7	33.3	100.0	0.0	100.0	0.0	100.0	0.0	100.0	0.0
	1 mm Cold Plastic (SP1)	0.0	100.0	0.0	100.0	100.0	0.0	66.7	33.3	66.7	33.3	100.0	0.0	100.0	0.0	100.0	0.0
	1 mm Cold Plastic (SP4)	33.3	66.7	33.3	66.7	66.7	33.3	66.7	33.3	100.0	0.0	100.0	0.0	100.0	0.0	100.0	0.0
	1.2 mm Thermoplastic (SP1)	66.7	33.3	66.7	33.3	33.3	66.7	66.7	33.3	100.0	0.0	66.7	33.3	100.0	0.0	100.0	0.0
	1.2 mm Thermoplastic (SP2)	100.0	0.0	100.0	0.0	100.0	0.0	66.7	33.3	100.0	0.0	100.0	0.0	100.0	0.0	100.0	0.0
	3 mm Screed (SP1)	66.7	33.3	66.7	33.3	66.7	33.3	66.7	33.3	100.0	0.0	100.0	0.0	100.0	0.0	66.7	33.3

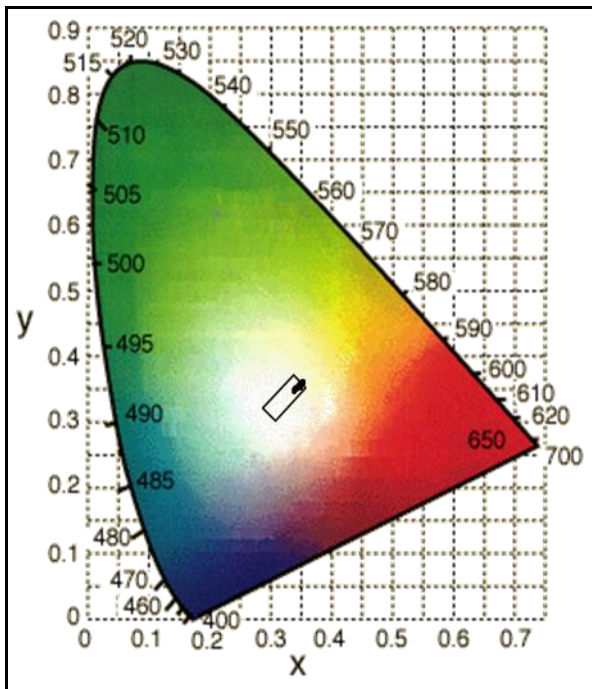

Figure D.29: Unwashed white markings on Meiring Naude Road.

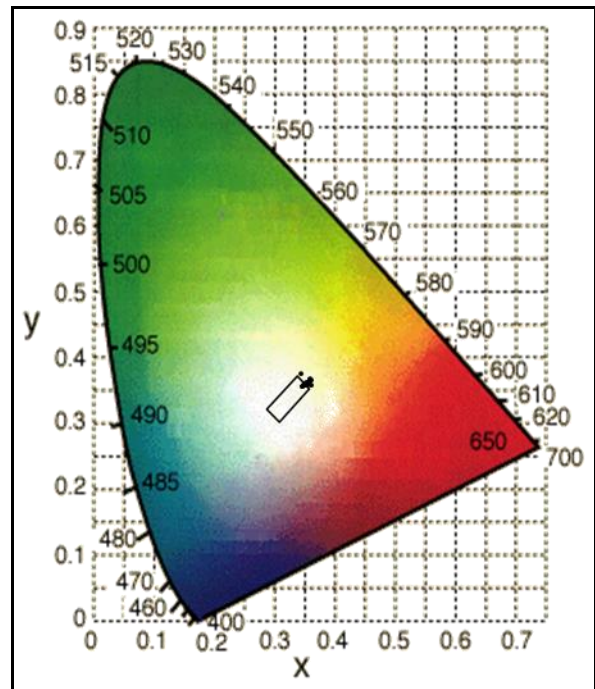

Figure D.30: Washed white markings on Meiring Naude Road.

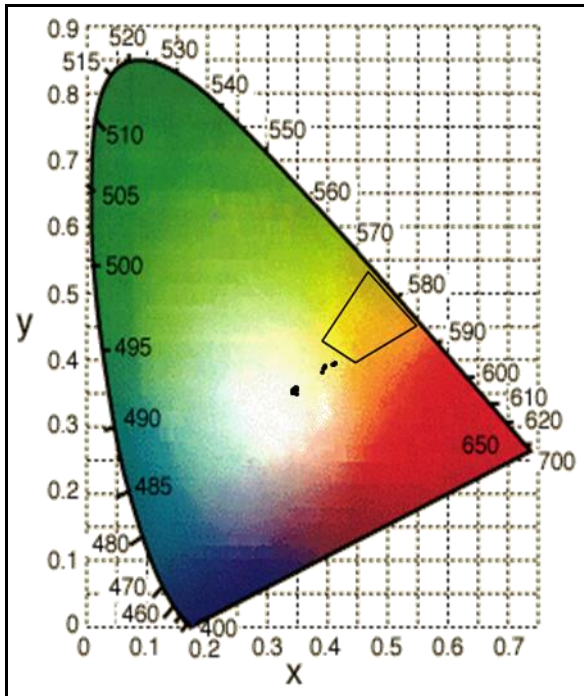

Figure D.31: Unwashed yellow markings on Meiring Naude Road.

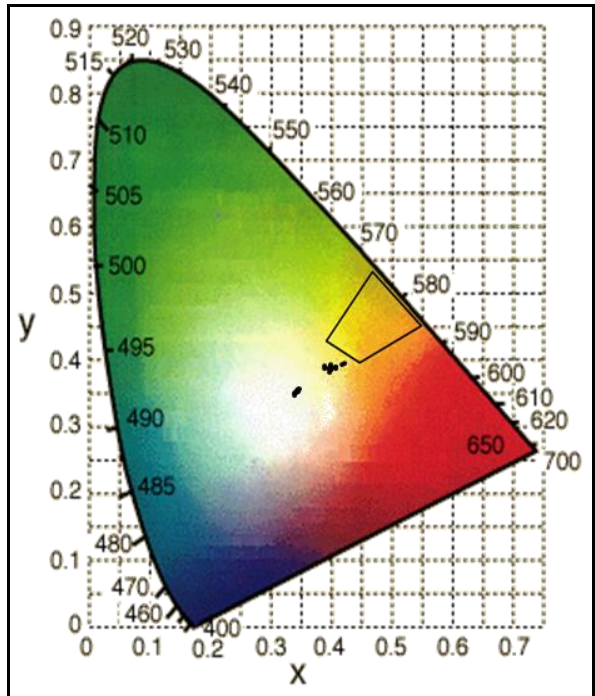

Figure D.32: Washed yellow markings on Meiring Naude Road.

Table D.9: Summary of the colour analysis on long established clean asphalt road (Middel Street).

Middel Street		White transverse road markings								Yellow transverse road markings							
		Measurement 1 05 November 2013		Measurement 2 20 March 2014		Measurement 3 29 July 2014		Measurement 4 03 February 2015		Measurement 1 05 November 2013		Measurement 2 20 March 2014		Measurement 3 29 July 2014		Measurement 4 03 February 2015	
		Falling out of region (%)	Falling within region (%)	Falling out of region (%)	Falling within region (%)	Falling out of region (%)	Falling within region (%)	Falling out of region (%)	Falling within region (%)	Falling out of region (%)	Falling within region (%)	Falling out of region (%)	Falling within region (%)	Falling out of region (%)	Falling within region (%)	Falling out of region (%)	Falling within region (%)
Unwashed	Water-borne (SP1)	0.0	100.0	33.3	66.7	0.0	100.0	0.0	100.0	100.0	0.0	100.0	0.0	100.0	0.0	100.0	0.0
	Water-borne (SP2)	66.7	33.3	0.0	100.0	0.0	100.0	0.0	100.0	100.0	0.0	100.0	0.0	100.0	0.0	100.0	0.0
	Water-borne (SP3)	33.3	66.7	0.0	100.0	0.0	100.0	0.0	100.0	100.0	0.0	100.0	0.0	100.0	0.0	100.0	0.0
	1 mm Cold Plastic (SP1)	66.7	33.3	0.0	100.0	0.0	100.0	0.0	100.0	100.0	0.0	66.7	33.3	100.0	0.0	100.0	0.0
	1 mm Cold Plastic (SP4)	33.3	66.7	0.0	100.0	0.0	100.0	0.0	100.0	100.0	0.0	100.0	0.0	100.0	0.0	100.0	0.0
	1.2 mm Thermoplastic (SP1)	66.7	33.3	66.7	33.3	0.0	100.0	0.0	100.0	100.0	0.0	33.3	66.7	100.0	0.0	100.0	0.0
	1.2 mm Thermoplastic (SP2)	100.0	0.0	100.0	0.0	33.3	66.7	100.0	0.0	100.0	0.0	100.0	0.0	100.0	0.0	100.0	0.0
	3 mm Screed (SP1)	33.3	66.7	66.7	33.3	0.0	100.0	0.0	100.0	100.0	0.0	0.0	100.0	100.0	0.0	100.0	0.0
Washed	Water-borne (SP1)	0.0	100.0	0.0	100.0	0.0	100.0	0.0	100.0	100.0	0.0	100.0	0.0	100.0	0.0	100.0	0.0
	Water-borne (SP2)	0.0	100.0	0.0	100.0	0.0	100.0	0.0	100.0	100.0	0.0	100.0	0.0	100.0	0.0	100.0	0.0
	Water-borne (SP3)	33.3	66.7	0.0	100.0	0.0	100.0	0.0	100.0	100.0	0.0	100.0	0.0	100.0	0.0	100.0	0.0
	1 mm Cold Plastic (SP1)	66.7	33.3	0.0	100.0	0.0	100.0	0.0	100.0	66.7	33.3	66.7	33.3	100.0	0.0	66.7	33.3
	1 mm Cold Plastic (SP4)	0.0	100.0	66.7	33.3	0.0	100.0	0.0	100.0	100.0	0.0	100.0	0.0	100.0	0.0	100.0	0.0
	1.2 mm Thermoplastic (SP1)	33.3	66.7	33.3	66.7	0.0	100.0	0.0	100.0	100.0	0.0	33.3	66.7	100.0	0.0	66.7	33.3
	1.2 mm Thermoplastic (SP2)	100.0	0.0	100.0	0.0	0.0	100.0	100.0	0.0	100.0	0.0	100.0	0.0	100.0	0.0	66.7	33.3
	3 mm Screed (SP1)	66.7	33.3	100.0	0.0	33.3	66.7	0.0	100.0	100.0	0.0	0.0	100.0	100.0	0.0	66.7	33.3

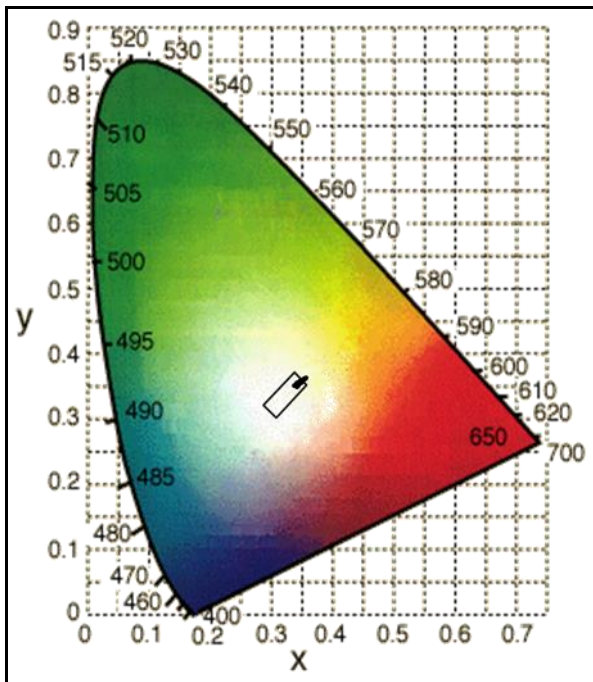

Figure D.33: Unwashed white markings on Middel Street.

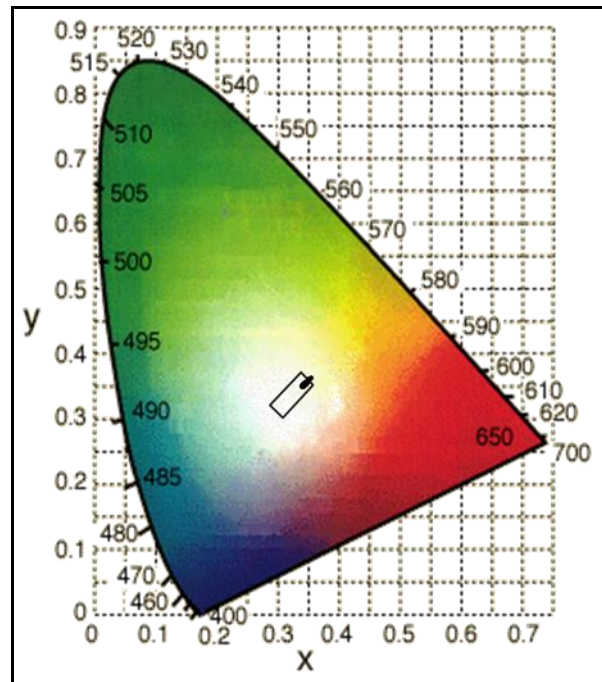

Figure D.34: Washed white markings on Middel Street.

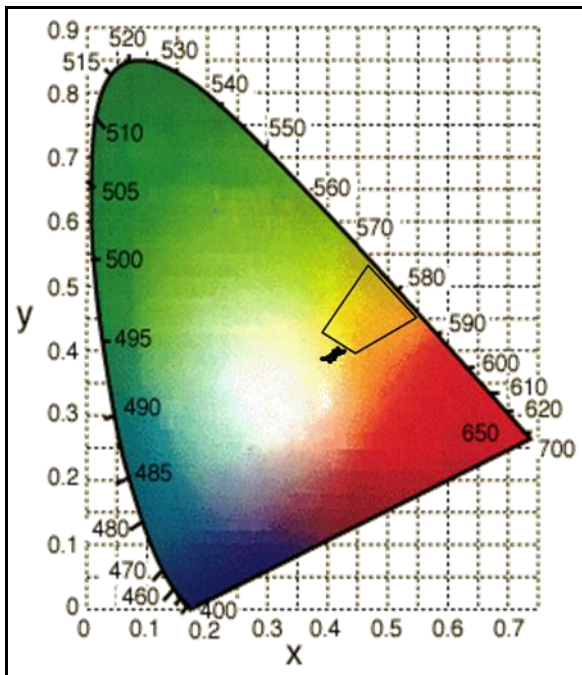

Figure D.35: Unwashed yellow markings on Middel Street.

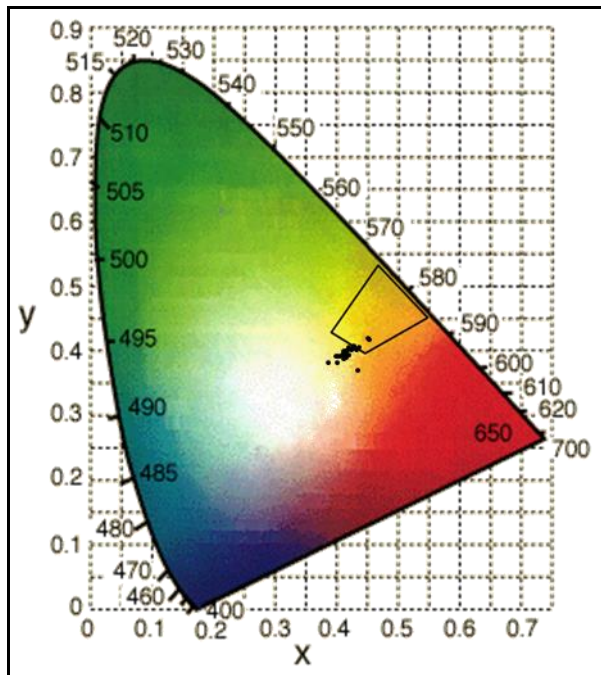

Figure D.36: Washed yellow markings on Middel Street.

Table D.10: Summary of the colour analysis on long established dirty asphalt road (Mohwelere Street).

Mohwelere Street		White transverse road markings								Yellow transverse road markings							
		Measurement 1 28 January 2014		Measurement 2 11 April 2014		Measurement 3 28 July 2014		Measurement 4 11 February 2015		Measurement 1 28 January 2014		Measurement 2 11 April 2014		Measurement 3 28 July 2014		Measurement 4 11 February 2015	
		Falling out of region (%)	Falling within region (%)	Falling out of region (%)	Falling within region (%)	Falling out of region (%)	Falling within region (%)	Falling out of region (%)	Falling within region (%)	Falling out of region (%)	Falling within region (%)	Falling out of region (%)	Falling within region (%)	Falling out of region (%)	Falling within region (%)	Falling out of region (%)	Falling within region (%)
Unwashed	Water-borne (SP1)	100.0	0.0	100.0	0.0	100.0	0.0	100.0	0.0	100.0	0.0	100.0	0.0	100.0	0.0	100.0	0.0
	Water-borne (SP2)	100.0	0.0	100.0	0.0	100.0	0.0	100.0	0.0	100.0	0.0	100.0	0.0	100.0	0.0	100.0	0.0
	Water-borne (SP3)	100.0	0.0	100.0	0.0	100.0	0.0	100.0	0.0	100.0	0.0	100.0	0.0	100.0	0.0	100.0	0.0
	1 mm Cold Plastic (SP1)	100.0	0.0	100.0	0.0	100.0	0.0	100.0	0.0	100.0	0.0	100.0	0.0	100.0	0.0	100.0	0.0
	1 mm Cold Plastic (SP4)	100.0	0.0	100.0	0.0	100.0	0.0	100.0	0.0	100.0	0.0	100.0	0.0	100.0	0.0	100.0	0.0
	1.2 mm Thermoplastic (SP1)	100.0	0.0	100.0	0.0	100.0	0.0	100.0	0.0	100.0	0.0	100.0	0.0	100.0	0.0	100.0	0.0
	1.2 mm Thermoplastic (SP2)	100.0	0.0	100.0	0.0	100.0	0.0	100.0	0.0	100.0	0.0	100.0	0.0	100.0	0.0	100.0	0.0
	3 mm Screed (SP1)	100.0	0.0	100.0	0.0	100.0	0.0	100.0	0.0	100.0	0.0	100.0	0.0	100.0	0.0	100.0	0.0
Washed	Water-borne (SP1)	100.0	0.0	100.0	0.0	100.0	0.0	100.0	0.0	100.0	0.0	100.0	0.0	100.0	0.0	100.0	0.0
	Water-borne (SP2)	100.0	0.0	100.0	0.0	100.0	0.0	100.0	0.0	100.0	0.0	100.0	0.0	66.7	33.3	66.7	33.3
	Water-borne (SP3)	100.0	0.0	100.0	0.0	100.0	0.0	100.0	0.0	100.0	0.0	100.0	0.0	66.7	33.3	100.0	0.0
	1 mm Cold Plastic (SP1)	100.0	0.0	100.0	0.0	100.0	0.0	100.0	0.0	33.3	66.7	66.7	33.3	33.3	66.7	0.0	100.0
	1 mm Cold Plastic (SP4)	100.0	0.0	100.0	0.0	100.0	0.0	100.0	0.0	100.0	0.0	66.7	33.3	100.0	0.0	100.0	0.0
	1.2 mm Thermoplastic (SP1)	100.0	0.0	100.0	0.0	100.0	0.0	100.0	0.0	0.0	100.0	66.7	33.3	66.7	33.3	33.3	66.7
	1.2 mm Thermoplastic (SP2)	100.0	0.0	100.0	0.0	100.0	0.0	100.0	0.0	100.0	0.0	100.0	0.0	100.0	0.0	100.0	0.0
	3 mm Screed (SP1)	100.0	0.0	100.0	0.0	100.0	0.0	100.0	0.0	33.3	66.7	66.7	33.3	66.7	33.3	66.7	33.3

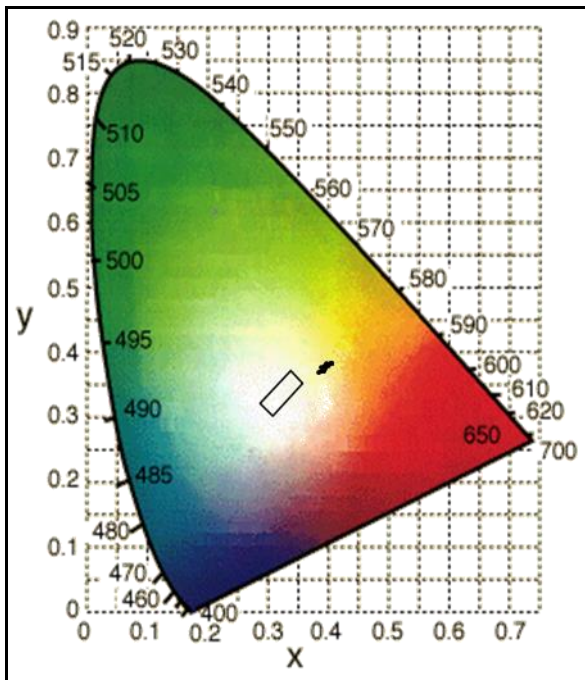

Figure D.37: Unwashed white markings on Mohwelere Street.

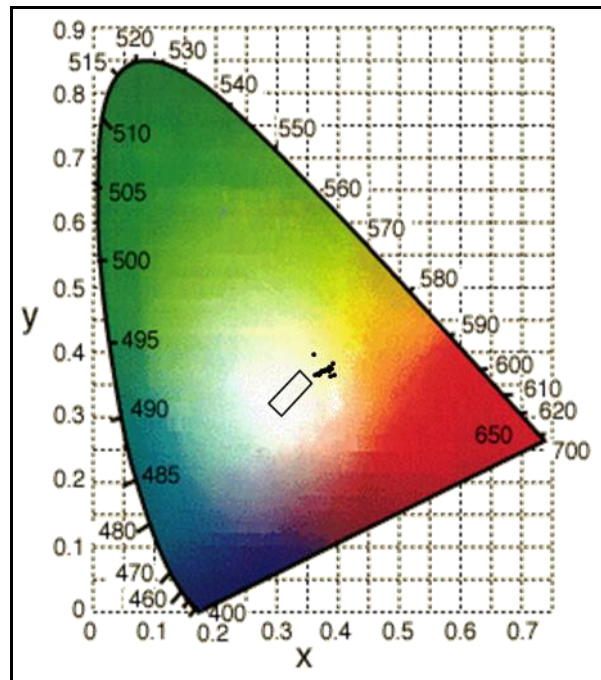

Figure D.38: Washed white markings on Mohwelere Street.

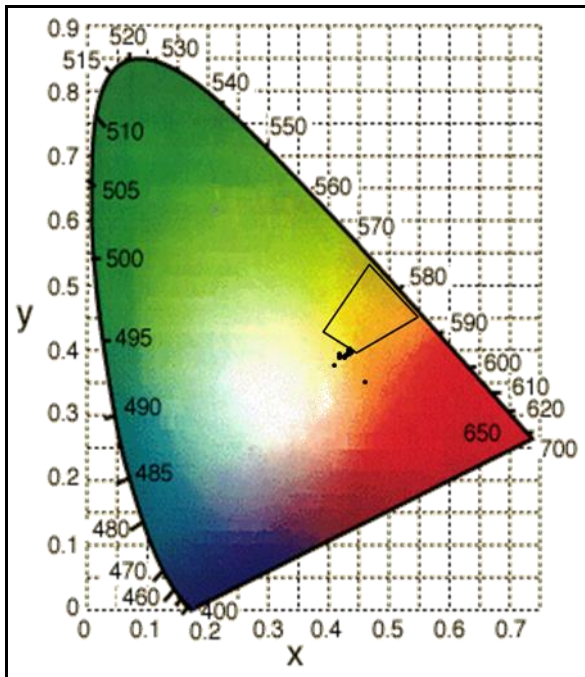

Figure D.39: Unwashed yellow markings on Mohwelere Street.

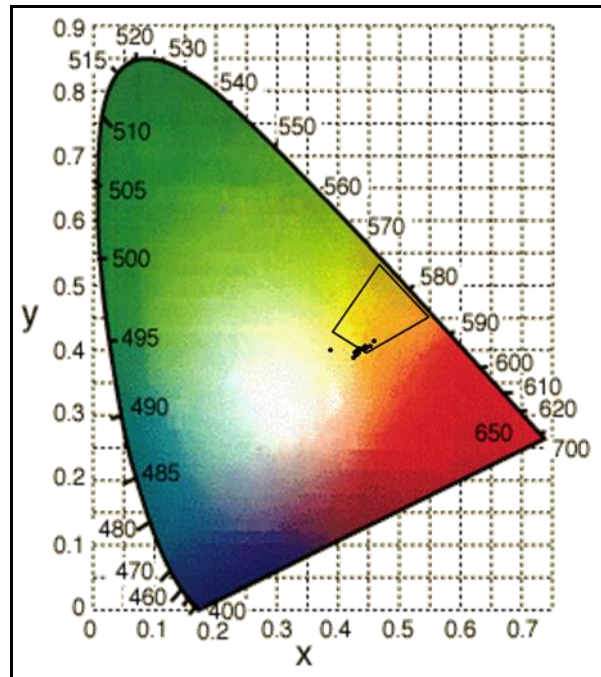

Figure D.40: Washed yellow markings on Mohwelere Street.

Table D.11: Summary of the colour analysis on long established dirty chip seal road (Road L 3).

Road L 3		White transverse road markings								Yellow transverse road markings							
		Measurement 1 25 November 2013		Measurement 2 03 April 2014		Measurement 3 18 July 2014		Measurement 4 10 February 2015		Measurement 1 25 November 2013		Measurement 2 03 April 2014		Measurement 3 18 July 2014		Measurement 4 10 February 2015	
		Falling out of region (%)	Falling within region (%)	Falling out of region (%)	Falling within region (%)	Falling out of region (%)	Falling within region (%)	Falling out of region (%)	Falling within region (%)	Falling out of region (%)	Falling within region (%)	Falling out of region (%)	Falling within region (%)	Falling out of region (%)	Falling within region (%)	Falling out of region (%)	Falling within region (%)
Unwashed	Water-borne (SP1)	33.3	66.7	100.0	0.0	66.7	33.3	100.0	0.0	100.0	0.0	100.0	0.0	100.0	0.0	100.0	0.0
	Water-borne (SP2)	0.0	100.0	100.0	0.0	33.3	66.7	66.7	33.3	100.0	0.0	100.0	0.0	100.0	0.0	100.0	0.0
	Water-borne (SP3)	0.0	100.0	100.0	0.0	100.0	0.0	100.0	0.0	100.0	0.0	100.0	0.0	100.0	0.0	100.0	0.0
	1 mm Cold Plastic (SP1)	0.0	100.0	100.0	0.0	0.0	100.0	33.3	66.7	100.0	0.0	100.0	0.0	100.0	0.0	100.0	0.0
	1 mm Cold Plastic (SP4)	33.3	66.7	100.0	0.0	66.7	33.3	66.7	33.3	100.0	0.0	100.0	0.0	100.0	0.0	100.0	0.0
	1.2 mm Thermoplastic (SP1)	0.0	100.0	100.0	0.0	0.0	100.0	33.3	66.7	100.0	0.0	100.0	0.0	100.0	0.0	100.0	0.0
	1.2 mm Thermoplastic (SP2)	0.0	100.0	100.0	0.0	66.7	33.3	100.0	0.0	100.0	0.0	100.0	0.0	100.0	0.0	100.0	0.0
	3 mm Thermoplastic (SP1)	0.0	100.0	100.0	0.0	0.0	100.0	33.3	66.7	100.0	0.0	100.0	0.0	100.0	0.0	100.0	0.0
Washed	Water-borne (SP1)	66.7	33.3	100.0	0.0	100.0	0.0	66.7	33.3	100.0	0.0	100.0	0.0	100.0	0.0	100.0	0.0
	Water-borne (SP2)	66.7	33.3	100.0	0.0	33.3	66.7	33.3	66.7	100.0	0.0	100.0	0.0	100.0	0.0	100.0	0.0
	Water-borne (SP3)	66.7	33.3	100.0	0.0	100.0	0.0	100.0	0.0	100.0	0.0	100.0	0.0	100.0	0.0	100.0	0.0
	1 mm Cold Plastic (SP1)	66.7	33.3	100.0	0.0	0.0	100.0	33.3	66.7	100.0	0.0	100.0	0.0	100.0	0.0	100.0	0.0
	1 mm Cold Plastic (SP4)	33.3	66.7	66.7	33.3	66.7	33.3	66.7	33.3	100.0	0.0	100.0	0.0	100.0	0.0	100.0	0.0
	1.2 mm Thermoplastic (SP1)	33.3	66.7	66.7	33.3	66.7	33.3	0.0	100.0	100.0	0.0	100.0	0.0	100.0	0.0	100.0	0.0
	1.2 mm Thermoplastic (SP2)	66.7	33.3	100.0	0.0	100.0	0.0	100.0	0.0	100.0	0.0	100.0	0.0	100.0	0.0	100.0	0.0
	3 mm Screed (SP1)	33.3	66.7	66.7	33.3	0.0	100.0	0.0	100.0	100.0	0.0	100.0	0.0	100.0	0.0	100.0	0.0

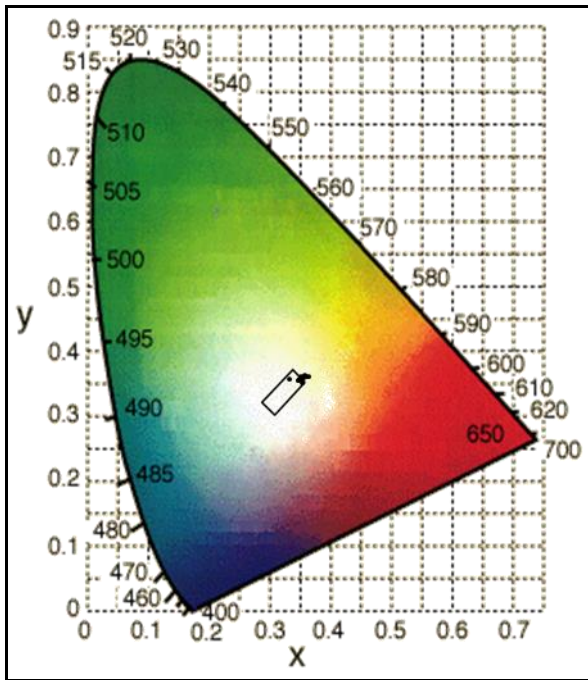

Figure D.41: Unwashed white markings on Road L 3.

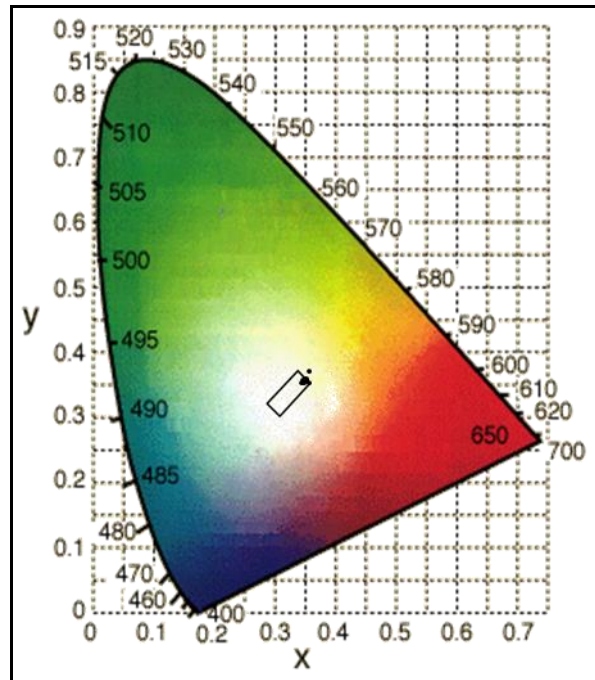

Figure D.42: Washed white markings on Road L 3.

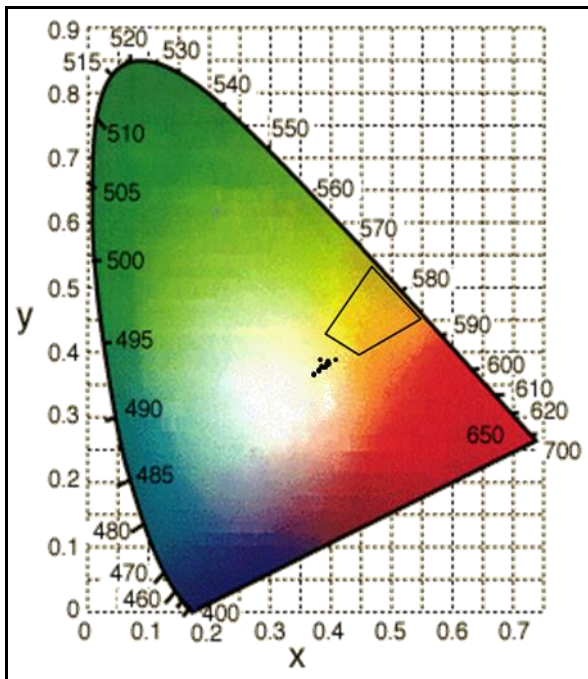

Figure D.43: Unwashed yellow markings on Road L 3.

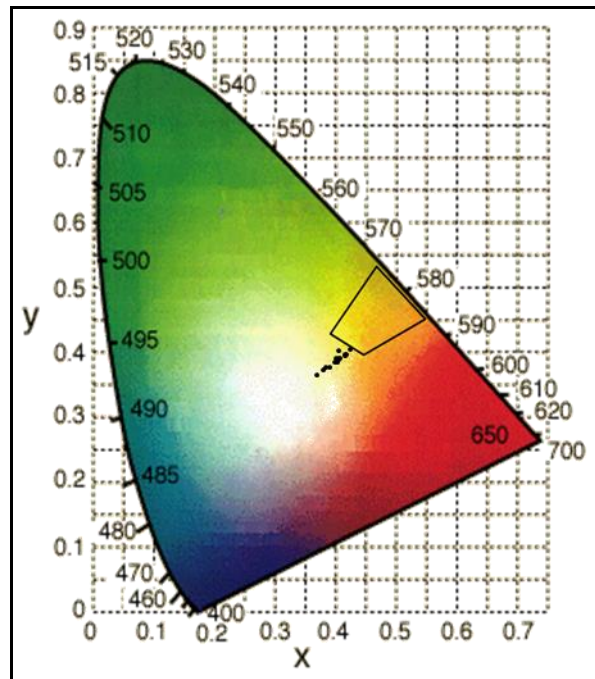

Figure D.44: Washed yellow markings on Road L 3.