

Improving product flow and storage
in a timber processing facility

by

SU-ANRIE MARAIS
27067956

Submitted in partial fulfilment of the requirements
for the degree of

BACHELORS OF INDUSTRIAL
ENGINEERING

in the

FACULTY OF ENGINEERING, BUILT ENVIRONMENT AND
INFORMATION TECHNOLOGY

UNIVERSITY
OF
PRETORIA

November 2012

Executive summary

York Timbers Pty Ltd is a South African timber processing company that has four saw mills in the Mpumalanga province. York Timbers manufacture high quality timber products for local and international markets. All four saw mills are controlled and monitored by their head office in Sabie, Mpumalanga.

Recently it has been observed that the Driekop dry mill in Graskop cannot fulfil all the orders that are received resulting from limited or no availability of products.

Each saw mill has among other areas, a dry mill and rework area. There are several employees working at each of the processes that occur in the dry mill. There is a constant flow of products through the dry mill.

The Driekop mill experiences difficulties with operations in their dry mill such as ineffective storage of work-in-progress and finished products and poor control over inventory. This is due to the absence of a fixed storage plan for work-in-progress and finished products. These problems are inhibiting optimum product flow and affect the functionality of the rest of the plant.

There is urgent need for improved product flow through the dry mill as well as a storage plan to improve inventory control.

A new layout will be developed for the dry mill area using Systematic Layout Planning (SLP) to better locate and access stacks. Industrial Engineering best practices for inventory management will assist in developing the storage plan and lean manufacturing techniques will be used to help eliminate the types of waste present.

Overall improved product flow through the dry mill and rework area will be achieved to increase the daily number of products produced.

Table of Contents

Chapter 1: Introduction	7
1.1 Background	7
1.2 Problem definition	8
1.2.1 Storage plan and accessibility of stock	8
1.2.2 Equipment schedule for overhead crane.....	9
1.2.3 Planer utilization	9
1.3 Project aim	12
1.5 Project deliverables	14
Chapter 2: Literature review	15
2.1 Introduction	15
2.2 Industrial plants	16
2.2.1 Space and size calculation for the dry mill storage area	16
2.3 Developing a storage plan for optimal inventory control	17
2.3.1 Systematic layout planning (SLP)	17
2.3.2 Case study: steel rod production facility	18
2.4 Inventory management	20
2.4.1 Strategies	21
2.4.2 Best Practice for inventory management	22
2.4.3 ABC inventory analysis method	24
2.5 Materials handling and equipment	25
2.6 The concept of Lean manufacturing.....	26
2.7 Conclusion.....	27
Chapter 3: Process analysis	28
3.1 Analysis of dry mill processes (handling of all dry timber).....	28
3.1.1 Grading after de-stacking.....	28
3.1.2 Stacking according to grade and dimensions	29
3.2.3 Strapping of half- and full stacks of work in progress.....	32
3.2 Critical activities in the dry mill.....	32
3.2.1 The transfer trolley	32

3.2.2 Moving stacks to temporary storage location or buffer area.....	33
3.3 Analysis of rework area processes.....	34
3.3.1 Placement of stacks on conveyer: stacks exit the dry mill area and move to the rework area	35
3.4 Analysis of overhead crane movement	36
Chapter 4: Problem analysis.....	38
4.1 Problems.....	38
4.1.1 Problem I: storage plan for accessibility of stock	38
4.4.2 Problem II: Crane utilization and schedule	40
Chapter 5: Data analysis and processing.....	41
5.1 Systematic layout planning.....	42
5.1.1 Operation process chart	42
5.1.2 Flow of materials chart	44
5.1.3 Flow process chart	45
5.1.4 Activity relationship chart.....	46
5.1.5 Space relationship diagram.....	48
5.1.6 Conclusion.....	49
5.2 ABC analysis	50
5.2.1 Product Grade S5P	51
5.2.2 Product Grade UTP.....	53
5.2.3 Product Grade BBB.....	54
5.2.4 Product Grade S5R	54
5.2.5 Product Grade UTL.....	54
5.2.6 Summary	55
5.3 Lean manufacturing.....	59
5.3.1 Stage 1: Identify waste.....	59
5.3.2 Stage 2: Analyse the waste, and find the root cause.....	60
5.3.3 Stage 3: Address the root cause, and repeat the cycle	60
Chapter 6: Storage plan.....	62
6.1 Introduction	62

6.2 Possible storage layout and Locator systems.....	63
6.2.1 Fixed (Dedicated) Location System.....	63
6.2.2 Memory system	64
6.2.3 Zoning systems.....	64
6.2.4 Random Location Systems	65
6.2.5 Combination systems.....	65
6.2. Proposed Layout and Locator system.....	66
6.2.1 The improved layout	66
6.3 Conclusion.....	68
Chapter 7: Reference.....	77
Chapter 8: Appendices	78
Appendix 1: Driekop mill	78
Appendix 2: Driekop process flow	79
Appendix 3: Direction of product flow	80
Appendix 4: Stacking areas	81
Appendix 5: Space calculations per product (Excel calculations).....	82
Appendix 6: Stock and orders.....	86

Table of figures

Figure 1: Different grades stacked together.	10
Figure 2: Different dimensions stacked together.	10
Figure 3: Red stock (Work in progress) mixed with Green stock (Finished products)	11
Figure 4: Different products stored together in dry mill.....	11
Figure 5: Safety hazard: products are not properly stacked.....	11
Figure 6: Systematic Layout Planning.....	19
Figure 7: De-stacking of kiln stacks	28
Figure 8: Trimming of planks.....	28
Figure 9: 5 sorting chains.....	29
Figure 10: Different lengths sorted at one sorting chain.	30
Figure 11: Sorting chain.....	31
Figure 12: Bays next to sorting chain	31
Figure 13: Different dry mill sections.	31
Figure 14: Rework areas and conveyers.....	34
Figure 15: Bottom: Conveyer 1 and Top: Conveyer 2	35
Figure 16: Operating areas of the overhead cranes.....	37
Figure 17: Operation process chart.....	43
Figure 18: Flow of materials chart.....	44
Figure 19: Flow process chart.....	45
Figure 20: Activity relationship chart between the different areas/operations in the current layout.....	46
Figure 21: A relationship chart depicting the reasons for relationship strength.....	47
Figure 22: Space relationship diagram	48
Figure 23: Sales budget prices.....	50
Figure 24: Pie chart of the annual income per product grade.....	55
Figure 25: Pie chart of annual sales per grade in cubic metres (m ³).....	56
Figure 26: Number of products available per grade	57
Figure 27: Storage plan zones	67

Figure 28: S5P products sold monthly.....	69
Figure 29: UTP products sold monthly	70
Figure 30: BBB products sold monthly	71
Figure 31: S5R products sold monthly.....	72
Figure 32: UTL products sold monthly	72
Figure 33: Scale drawing of products within zones.....	73
Figure 34: S5P Zone	74
Figure 35: UTP Zone	75
Figure 36: BBB Zone (Yellow), S5R Zone (Purple) and UTL Zone (Blue).....	76

Chapter 1: Introduction

1.1 Background

“The sawmilling industry of South Africa is the only one of its kind in the world and is based 100% on plantation resources”- York Timbers.

York Timbers is a forest Products Company located in the heart of Mpumalanga. It is one of the largest industrial businesses in the Mpumalanga province and plays a significant economic part in the lives of their employees and the towns in which they operate.

York Timbers owns four saw mills:

1. **Nicholson & Mullin**
Witklip Forest Reserve
District White River
Mpumalanga
2. **Jessievale**
Warburton
Mpumalanga
3. **Sabie Mill**
Sabie
Mpumalanga
4. **Driekop**
Graskop
Mpumalanga

The favourable climate, growing conditions and fertile soil of the Mpumalanga province has made it an ideal plantation area. The sustainable forestry practices of York Timbers have made it one of the leading plantation forests in the world.

York Timbers own and lease approximately 86,900 hectares of land. 29,500 of these hectares are reserved for conservation, streams, heritage sites, roads and access routes. Of the 57,400 hectares, 53,100 hectares are softwoods.

There are also several manufacturers and traders in Mpumalanga that supply York Timbers based on a contractual agreement.

1.2 Problem definition

During 2011, York Timbers was faced with several challenges associated with poor storage and inventory control at the Driekop dry mill in Graskop. Ineffective equipment scheduling inhibits smooth product flow and increases materials handling.

Recent observations at the mill have shown that work-in-progress and finished products flow in the dry mill area are not at an optimal level.

The main problems that the Driekop mill experiences is the absence of a fixed storage plan to control inventory and an equipment schedule for the overhead crane in the dry mill area for effective product flow and materials handling. This inefficiency affects the majority of the processes in the dry mill.

Dry mill processes include:

1. Grading after de-stacking.
2. Stacking according to dimension and grade.
3. Strapping of half- and full stacks of work in progress.

Upon further investigation the following critical activities were identified:

1. Placing and removing stacks to and from the transfer trolley
2. Moving stacks to temporary storage location or buffer area.
3. Moving stacks to conveyer (exit dry mill area, to planers)
4. Movement of overhead cranes

1.2.1 Storage plan and accessibility of stock

The absence of a storage plan leads to poor space utilization, poor inventory control and poor materials handling in the dry mill, which causes significant delays.

With no storage plan in place, the employees have resolved to place the work-in-progress or finished products anywhere in the dry mill where floor space is available. Different products are stacked together and it takes time to locate and remove them when needed. This is also seen as a safety concern and holds a threat to the employees. It could also cause unnecessary damage to the products if too many products are stacked on top of one another.

Unnecessary movement of planks and stacks in the dry mill area and over use of the overhead crane contributes to these delays.

1.2.2 Equipment schedule for overhead crane

The absence of a fixed schedule and work priorities for the overhead crane leaves important decisions to the crane operator. He has to use his own judgement when deciding which stacks have to be moved and in which order. Moving such stacks in the dry mill is done randomly and without method, priority or thought.

Poor materials handling practices prevent smooth product flow and because stacks are unnecessarily moved it only worsens the problem of locating and accessing stock.

1.2.3 Planer utilization

The Driekop mill has three planer machines that are used to smooth planks individually. The planer machines are located in the two rework areas that are connected to the dry mill. Products are moved from storage in the dry mill to the rework areas for further processing. The occurrence of delays due to no storage plan and no equipment schedule at the dry mill causes poor utilization of the 3 planer machines. The result is a reduction in the number of products completed in a specific time period.

(The cubic metres of stacks planed in a day equal the number of stacks that can be dispatched and equals the profit that can be made.

Recently the Driekop dry mill had to reject many orders resulting from limited or unavailability of the required products. (Appendix 6)



Figure 1: Different grades stacked together.



Figure 2: Different dimensions stacked together.



Figure 3: Red stock (Work in progress) mixed with Green stock (Finished products)



Figure 4: Different products stored together in dry mill.



Figure 5: Safety hazard: products are not properly stacked.

1.3 Project aim

The main objective of this project is to improve product flow in the dry mill by developing and implementing a storage plan and inventory control management principles together with best practices, improving materials handling and taking advantage of the full capacity of the dry mill area.

The following objectives act as the foundation for the project aim:

1. An analysis of the current level of red and green stock in the dry mill (and warehouse).
2. An innovative dry mill storage plan and process for the receiving, storing and locating of stacks without restricting or preventing the movement of materials and employees.
3. Formulation of inventory management policies to achieve improved inventory control.
4. Maintaining the correct levels of stock needed in the dry mill for optimal processing of products in the rework area.
5. Significant reduction in the unnecessary materials handling of stacks in the dry mill by minimizing overhead crane usage.
6. An equipment schedule for the overhead crane is required that will enable the crane operator to work according to certain priorities.
7. Ensuring stacks are identifiable and accessible at all times and can be retrieved with minimum effort to decrease delays.
8. Reducing idle time and increasing the utilization of the three planer machines in the rework areas to increase the finished product output per day.
9. Optimized storage layout, product flow and materials handling.

With the development of a storage plan, overall improvement of resources and space utilization will be achieved within the dry mill area

With the development of equipment schedule planer utilization will be improved and idle time reduced. Number of stacks planed and dispatched in a day can be increased.

1.4 Project scope

The project will focus on dry mill operations, specifically receiving, storing and retrieving of stacks. Stacks will be analysed from the moment a full stack is completed in a stacking bay and has to be moved by the overhead cranes. Planks and stacks that are processed or stored in any other location than the dry mill and rework areas are irrelevant to this project. (Appendix 1)

1. Using Systematic Layout Planning (SLP) principles to developing a storage plan that will improve the flow of products in the dry mill.
2. Improving inventory control by using Industrial Engineering best practices for inventory management.
3. Reducing materials handling in the dry mill by reducing the movement of planks and stacks (Appendix 5) and by minimizing overhead crane usage. (Appendix 6)
4. An equipment schedule according to which the crane operator should work to improve planer utilization.

1.5 Project deliverables

The following key deliverables are identified:

1. A Storage plan to improve product flow in the dry mill. The storage plan can be used to create the optimal product flow route for products in the dry mill. This will instruct employees exactly when to send which product to which destination to decrease operational costs. It will help to address delays associated with inventory management at the Driekop dry mill.
2. An optimized product flow route and schedule.
3. An improved inventory control plan.
4. An improved materials handling plan.
5. Improved processes in the dry mill, including receiving, storing of inventory, retrieving of inventory and improved space allocation for products within the dry mill
6. An improved layout for the dry mill.
7. Written instructions for proper operation of the dry mill storage area.
8. A literature review
9. Documentation of the improved product flow and production increase.

Chapter 2: Literature review

2.1 Introduction

The literature will aid in getting a better understanding of the storage methods, inventory control and materials handling techniques that are available to optimize product flow in the Driekop dry mill.

Plant layout and design

Process classification

The layout of a plant is primarily determined by the type of process it supports. Since these processes and layouts can vary widely, manufacturing industries are classified according to the characteristics of the process.

Manufacturing industries are classified as follows:

1. Continuous-process industry: carried on twenty-four hour basis.
2. Repetitive-process industry: products are processed in lots.
3. Intermittent-process industry: This is also called Job-lot industry. Products are processed when and as needed.

The size of the plant depends on the proposed volume of output. The desired output will also determine the size of the inventory area and quantity of inventory. (Moore, 1962)

To develop or improve a manufacturing facility in accordance with the current or chosen process a clear understanding of the process is required. Only a clear understanding of the processes will ensure efficient flow of materials through the dry mill.

It has been estimated that in a typical manufacturing plant materials handling accounts for approximately 25% of all employees, 55% of all factory space, and 87% of the production/processing time. It is estimated that materials handling also represents 15% to 70% of the total cost of producing/processing of a product. Materials handling is therefore unquestionably an area where cost reduction and quality improvements can be made. Furthermore, it is estimated that approximately 3% to 5% of materials handled is damaged. (Tompkins, White, Bozer, Frazelle, & Tanchoco, 2003)

The Driekop dry mill produces a large number of product types and this adds complexity to the production cycle, inventory control and layout of the storage facility.

In the case of established facilities, like the Driekop dry mill, the structure is already in place and it is difficult and not economically feasible to move or change the plant. It would be difficult and fraught with unnecessary expenses. The storage area inside the dry mill can however be organized and improved to significantly increase quantity of stacks that can be sent to the rework area in a day.

2.2 Industrial plants

In designing an ideal storage area in an industrial plant, the materials flow should be smooth, straight, unidirectional and coupled (one machine's output is another machine's input without a large inventory buffer between them). Materials flow should be such that it requires the least amount of re-handling, and that it is at a constant speed over the shortest route with the least amount of energy and cost.

Work-in-progress should move continuously through the plant with few interruptions as it is converted into finished products. An analysis of the dry mill's activities will determine the relative movements, resulting in the determination of the optimum product flow route and therefore the optimum quantity of each product held in the buffer area.

2.2.1 Space and size calculation for the dry mill storage area

Monthly or annual sales forecasts should provide an indication of the demand. An ideal plant would have a constant output of products every month without seasonal variations in demand. However, if plant that has the capacity to produce the highest month's demand it would mean that its capacity would be idle or underutilized during other months. The compromise would be a production schedule that builds up as little inventory as feasible without causing shortages, while allowing for equipment breakdowns, vacations, bad weather and interruptions. The result will be an industrial plant that needs more inventory space and associated materials handling equipment to produce and store finished products

The warehouse and other storage areas must be able to accommodate the maximum amount of inventory expected to be stored.

The proper size of storage space is determined by calculating the total space required for all its contents while bearing future changes in mind. This includes materials at all stages of production, employees, equipment for production, materials handling (overhead crane, transfer trolley and conveyers), support services and additional spaces required (working room, aisles). (Altamuro, 2011)

2.3 Developing a storage plan for optimal inventory control

2.3.1 Systematic layout planning (SLP)

Systematic Layout Planning (SLP) is a tool that is used to evaluate the current layout of a plant, plan a new layout as well as rearranging a current plant layout. SLP consists of a set of conventions for identifying, visualising and evaluating the elements and areas involved in plant layout and design.

SPL is one of the most helpful tools when it comes to facilities planning and plant layout. It is unique due to the fact that it is applicable to all types of layout methods. It is suitable for all types of industrial factories and includes the expansion, renovation and adjustment of facilities layout. It can also be used for the layout design of laboratories, warehouses and manufacturing offices. (Yaoxiang & Liqiang, Feb, 2002)

SLP evaluates two locations within a layout that are areas of high frequency by placing these locations close to, or next to each other. This change will allow the best materials flow in processing the product at the lowest cost and least amount of handling.

Richard Muther's steps for simplified SPL: (Watanapa and Wiyaratn: 2010)

1. Chart the relationships: Relationship chart
2. Establish space requirements
3. Diagram activity relationships: activity relationship chart
4. Draw space relationships
5. Evaluate alternative arrangements
6. Detail the selected layout plan

During 2011 and 2012 the Driekop dry mill had to reject many orders resulting from limited or unavailability of the required finished products. The Driekop dry mill has come to the realization that they need to increase their production and overall efficiency of the mill to compete with their market rivals. The Driekop dry mill also has to adhere to the same standards, rules and regulations of the other York Timber mills.

The Driekop dry mill needs to develop the ability to lower the cost of the production while striving for higher effectiveness. The dry mill storage area needs to be equipped with a storage plan that will enable it to effectively store work-in-progress and finished products for the shortest time possible. The storage plan needs to allow for an efficient inventory control system.

2.3.2 Case study: steel rod production facility

In the case study of a steel rod production facility, Khansuwan describes the original plant layout and the materials flow analysis that was conducted. This entailed analysing the area and distance between certain processes. From this study Khansuwan concluded that time was wasted because of delays in manufacturing. It was also found that there was movement of materials in a long line and interrupted flow of materials and products.

With reference to these problems the author wished to improve the plant layout and solve the problem of poorly utilized areas. The Systematic Layout Planning method was used to provide a new layout that would improve the product and process flow and increase the space in the plant.

The necessary data was collected among other things to determine the equipment used for manufacturing and the direction of materials and product flow. The following charts were used in the analysis of the captured data:

1. Operation process chart
2. Flow of materials chart
3. Activity relationship chart

The SLP method was used to analyse the problems in the steel rod manufacturing plant and determine the necessary relationships between equipment, products and the relevant areas.

From the data gathered on the steel rod product quantity, materials flow route, relationship between materials flow and time the following charts were constructed:

1. From-to-chart
2. Activity relation chart

With all the above mentioned charts the relationship between each operating unit could be observed.

The results were captured by comparing the existing manufacturing process with the new proposed way that was determined by SLP.

SLP can be seen as the production of following information: P (Plan), Q (quantity), R (Technology), S (Support) and T (Production timing). (Khansuwan, 1999)

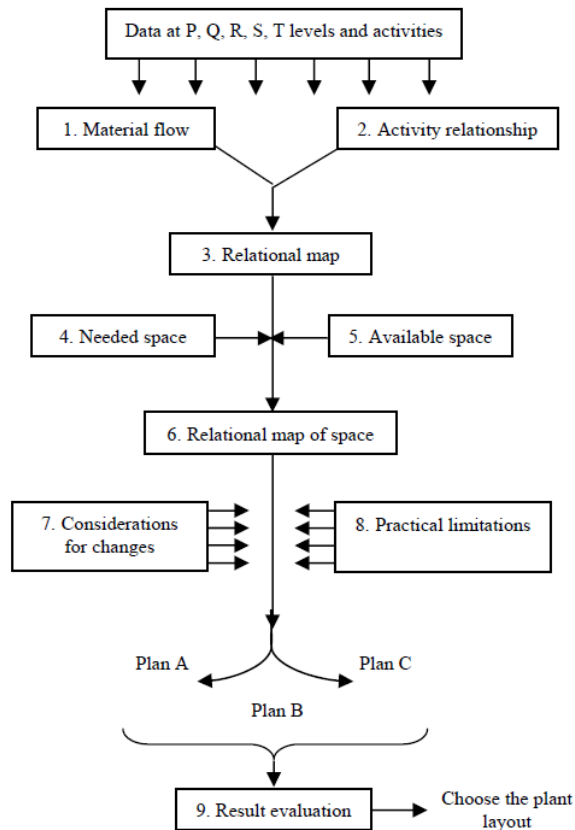

Figure 6: Systematic Layout Planning

In the case study the steel rods were made in response to an order (Lean Manufacturing policies). The flow of manufacturing processes was determined. The relationship between equipment's size and the area was tabulated.

The original plant layout was analysed under the following headings:

Flow of materials:

Materials were carried over long distances which caused time and energy to be wasted.

Utility of area:

The plant is not used to its full potential because the current layout causes the poor utilization of areas.

Materials handling equipment:

The materials handling equipment was inefficient causing materials to be moved unnecessarily.

Storage area:

After SLP the area that could be used for storage of billets could house more units.

The author studied the manufacturing process sequence and determined long distances between processes could be reduced by applying SLP to make the flow continuous by rearranging activities. The relationship and closeness of different activities were determined and documented on a relationship chart. The sequence of activities could thereafter be rearranged to determine a modified plant layout.

2.4 Inventory management

By examining manufacturing facilities with similar layouts, similar storage and inventory methods and similar materials handling systems/equipment the best possible solution should be obtained.

Inventory refers to short- or long term storage of products. It refers to materials or products held for future use or sale or materials waiting for conversion into finished products for a customer. Inventory is a buffer and is kept for different reasons. One of the most common reasons for keeping inventory is to be able to adapt the process to any variation that may occur in the system. The optimal inventory levels should be established to ensure smooth and effective flow of materials through the dry mill. (Zandin, 2001)

Recently inventory was viewed as very valuable to a company since it is seen as an asset on their balance sheet. However, recently with stronger competition between rival companies the cost of inventory is seen as tied-up capital, storage and materials handling. Companies can no longer afford the luxury of carrying large inventory or safety stock. Excessive inventory can be viewed as a liability.

The Driekop dry mill relies on its inventory for the smooth operation of the plant. The question however remains: what is the optimum quantity of inventory to maximize the company's profit?

Inventory can be classified as raw-materials, work-in-progress (WIP) or finished goods. In the case of the Driekop dry mill only work-in-progress (red stock) and finished products (green stock) will be considered.

Different methods of depletion of inventory:

1. First-in- First-out
2. Last-in-First-out
3. Order placed by a customer

At the Driekop mill, orders are placed by customers and upon receiving a specific order the products are to be depleted first-in-first-out. Unfortunately because the absence of a storage plan and proper inventory control, this is not always the case. The Driekop warehouse also has a policy of not keeping a product longer than two months. This policy cannot always be adhered to.

The lead time of a product is based on the cycle time of the processes and a company's inventory strategy to deliver products to its customers.

The common inventory strategies are:

1. Make-to-stock (MTS) strategy
2. Assemble-to-order (ATO) strategy
3. Make-to-order (MTO) strategy
4. Engineer-to-order (ETO) strategy

2.4.1 Strategies

There are several strategies available to help a company achieve accurate inventory. Accurate records of a company's inventory are all important. (Zandin, 2001)

1. Inventory Transaction Processing System (TPS)

An inventory TPS is required to track the movement, location, quantity, and status of materials or products as they physically move through the production process through the plant.

2. Annual physical inventory (API)

Traditionally a plant will close entirely for a few days a year to do a complete stock count. The difference between the value of materials counted and the inventory on book are reconciled.

3. Cycle counting

Instead of doing an API, cycle counting relies on continuous inventory counts on at regular intervals throughout the year.

4. Control group method

It is often better to select a small sample of items for daily counting before conducting a full-scale cycle count of all inventories.

Some control group methods are:

- ABC method
- Reorder method
- Free-count method
- Zone-count method

5. Process of Continuous Improvement

This involves eliminating all the problems that are causing inconsistencies. Inventory accuracy of at least 95% is required.

6. Measuring Performance

2.4.2 Best Practice for inventory management (Higgins, Mobley, & Wikoff, 2008)

Inventory accuracy is comparing the accuracy of the inventory at hand to that on the balance shown on the inventory records,

The following guidelines for Industrial Engineering best practices for inventory management were given by Higgins, Mobley and Wikoff (2008).

A best practice is any method that is believed to be better than the rest and more effective than any other method or technique when applied to a certain situation, in the attempt to deliver a certain outcome.

1. Inventory classification

Items must be classified into different categories to identify or develop the appropriate methods/measure for controlling and storage. Classification methods like ABC-analysis (in point 4) are used.

2. Implementing and sustaining lay-up maintenance for items in storage.

It is critical to ensure that stock is maintained under a preventive maintenance (PM) program when kept in inventory to prevent damage from occurring. PM should be developed in accordance with the specific items kept in inventory.

3. Vendor-managed inventories that are properly managed and have a good relationship between vendor and customer can be valuable.

4. Cycle counting as part of a daily routine

Cycle counting should be part of the daily routine in a storage area. Acceptable methods that are more popular to manage inventory in cycle counting are the ABC classification method or counting by selected areas.

5. Identification and removal of obsolete parts

To keep “dead” inventory at an acceptable level, parts that are obsolete must be identified and removed in accordance with the monthly budget.

6. Effective salvage of obsolete and scrapped materials.

7. Controls over the repair and return process are important for the storeroom to maintain.

8. The Storeroom or storage facility layouts need to stress efficiency and effectiveness.

An optimized storage facility will enforce control over its resources and maintain quality control. The storage layout must compliment the processes that occur in the area.

9. Operating levels should be optimized and inventory levels controlled.

All manufacturing facilities aim to maintain the optimal level of inventory, the minimum level while still having products available.

10. Proper housekeeping practices meet 5S standards.

Appropriate methods must be implemented to optimize the working environment and maintain the facility. Keeping the working environment organized, clean and free of obstacles and safety hazards is important.

11. A defined receiving process is in place

Inventory that is received must be inspected and placed in the correct location with the least amount of handling. Poor inventory control will be the result if products are not properly received and disposed of.

12. Stock in stores meet the FIFO (first in, first out) guidelines for shelf administration.

13. The workflow process for kitting is mapped and put in place for all planned work.

14. All storerooms are closed and physically secured.

15. A dashboard has been established to measure key performance indicators.

16. There is an approved supplier list.

17. There is a defined locator system for inventory and tools.

For efficient management and inventory control there must be methods in place for ease and effective location and removal of products. The correct locator system must be implemented

18. All processes are mapped and analyzed to streamline the workflow process. Step definitions, training plans, and job descriptions have been developed for effective inventory management.

Advantages and outcomes of implementing effective inventory control using IE best practices:

1. An increase in accurate inventory levels
2. An reduction in unnecessary inventory
3. Obsolete inventory can be identified and removed
4. Increased process efficiency
5. Reduction in materials handling
6. Decrease in idle time of equipment and downtime

2.4.3 ABC inventory analysis method

Cycle counting as part of a daily routine using the ABC inventory analysis method

The Pareto 20-80 is a popular principle often encountered in manufacturing and distribution companies. Pareto was an Italian economist who invented the theory that a small percentage of a group of items will contribute to the majority of the group costs, value and impact. For a manufacturing company like the Driekop dry mill it is likely that 20 percent of inventory stock accounts for 80 percent of the inventory's value and therefore 80 percent of the inventory will account for 20 percent of the value.

Stratification analysis applies the Pareto rule to inventory management by means of the ABC inventory analysis method.

According to the ABC method, inventory is classified into three categories according to their value. Usually items are classified according to monetary value but it can also be according to turnover, scarcity, demand or stock priority.

Items are listed in decreasing monetary value.

A=high monetary value

B=medium monetary value

C=low monetary value

There is always one category that will be given special attention. Category A will normally present a smaller quantity of the inventory than category B and C but will have a higher worth. A will be control and managed with more care.

There are 4 guidelines in implementing ABC analysis:

1. Calculate each item's annual monetary value to the company. This is done by compiling a list of all inventories in the company, their quantity and information.
2. Determine the worth of each item type and arrange it in descending order showing item numbers, annual usage, unit costs, annual monetary value volumes, and item counts.
3. Categorise inventory according to three classes and calculate the cumulative totals and percentages for item counts.
4. Define the A, B, and C categories based on the cumulative item count and volume percentages.

Based on an ABC analysis of inventory, the appropriate planning and control measures for each class of inventory can be implemented.

2.5 Materials handling and equipment

Materials handling equipment can be capable of moving materials horizontally, vertically, or in both directions, it can have a fixed path of travel, or its path of travel can be variable.

The Driekop dry mill only has materials handling equipment with a fixed path of travel.

1. The transfer trolley that links area A and B has horizontal movement.
2. The two conveyers that take stacks to the rework areas also have horizontal movement.
3. The overhead crane moves on a fixed horizontal track above the storage space in the dry mill, but it has vertical movement since it is responsible for picking and setting down products.

For better receiving and storing of stacks in the dry mill area and to ensure better control over inventory, fixed priorities should be given to the materials handling equipment, and a schedule according to which should be worked.

2.6 The concept of Lean manufacturing

When proposing any changes to a company it is important to bear the vision and mission of the company in mind. When considering York Timbers it is essential to keep to the company's policies to achieve success. York Timbers could improve their production output by implementing some of the principles of lean manufacturing.

Lean Manufacturing (LM) is a technique that originated in Japan in the 1970's but was only classified as "lean" in the 1990's. It was derived from the Toyota Production system (TPS) and today is still one of the most popular management philosophies.

The Lean Manufacturing practice attempts to continuously eliminate waste while preserving the value of products. From a theoretical point of view lean manufacturing focuses on manufacturing only what is needed, when it is needed and in the exact quantity.

York Timbers however rely on keeping inventory. However there are other principles of LM that would significantly improve the processes that take place in the dry mill.

Benefits of lean manufacturing

1. Increased production output
2. Decreased production costs
3. Shorter production lead times

Lean manufacturing focuses on reducing seven types of waste. (Wilson, 2010)

1. Inefficient Transportation

Transportation of products by the overhead crane does not add any value to the product. Unnecessary movement of stacks in the dry mill only increases the risk of product damage, cause delays and contributes to the problem of locating products without a storage plan.

With Lean manufacturing transportation movement distances of products may be reduced.

2. Unnecessary Inventory

The Driekop mill has a lack of control over their WIP and finished product inventory due to the lack of a storage plan in the dry mill. There is unnecessary work-in-progress that is kept in the dry mill for undetermined periods of time. With a storage plan and lean manufacturing these goods can be converted into finished products in a shorter period of time.

3. Motion: unnecessary motion

4. Waiting times

A large part of a product lifecycle is spent waiting to be worked on or processed. The same applies to stacks in the dry mill. When a part is not being transported and not being worked on it waits in the dry mill storage area. Since no storage plan is in place and there is limited control over inventory, products sometimes wait for extended periods of time.

5. Over processing or inappropriate processing

6. Over production

Overproduction occurs when more products than needed are produced. In the case of the Driekop dry mill more products than needed have to be produced. Because of limited control over the inventory there is often a lack of awareness of the available work-in-progress and finished products available and overproduction occurs. Overproduction occurs on those products that are less popular. Overproduction leads to over utilization of the storage space in the dry mill.

7. Defects and rejects

2.7 Conclusion

A new layout will be developed for the dry mill area using Systematic Layout Planning (SLP) to better locate and access stacks. Industrial Engineering best practices for inventory management will assist in developing the storage plan and lean manufacturing techniques will be used to help eliminate the waste types present.

Chapter 3: Process analysis

3.1 Analysis of dry mill processes (handling of all dry timber)

3.1.1 Grading after de-stacking

- 1 Planks arrive at the dry mill in kiln stacks. (A kiln is a large oven used for drying timber)
- 2 The stacks must be de-stacked after drying before they can be graded.
- 3 Once de-stacked, the most severe defects (knots, wane, etc.) are removed and the planks are trimmed to the most appropriate size.
- 4 After trimming, each plank is graded according to appearance.
- 5 Structural grade: good, strong structural timber with minimal defects.
- 6 Utility grade: more defects visible, not as strong, sold at a lower price.
- 7 Grading involves one trained grader who inspects each plank and writes the appropriate grade onto the plank with a crayon. The grader will use his own discretion when identifying the grade of the plank.



Figure 7: De-stacking of kiln stacks



Figure 8: Trimming of planks

3.1.2 Stacking according to grade and dimensions

1. Different plank lengths (m) are: 0.9, 1.2, 1.5, 1.8, 2.1, 2.4, 2.7, 3.0, 3.3, 3.6, 3.9, 4.2, 4.5, 4.8, 5.1, 5.4, 5.7, 6.0, 6.3, and 6.6.
2. A laser scanner determines plank lengths.
3. After the planks are scanned they are sent down a conveyor, one at a time, and then kicked off on the correct sorting chain.
4. Workers manually pull planks from the sorting chain and stack the planks in different bays according to their scanned length.
5. The right sorting chain is defined by the length of the plank. In other words, all 6.6m planks will be kicked off on the same chain.
6. Product thickness and width are standard for certain lengths and are determined before the planks enter the dry mill. The length of a plank is the most important dimension.
7. There are 5 sorting chains. Certain lengths are grouped together on a chain. Once kicked off onto a chain, planks are pulled off by workers into the correct parcel.
8. Planks are pulled off on both sides of the sorting chain.
9. Grades: UTP (utility grade), S5R/S5P (structural grade: R= rough, P=planed), BBB (Structural brandering)
10. The planks are then sorted into new stacks (parcels) according to their thickness, dimensions and grade.

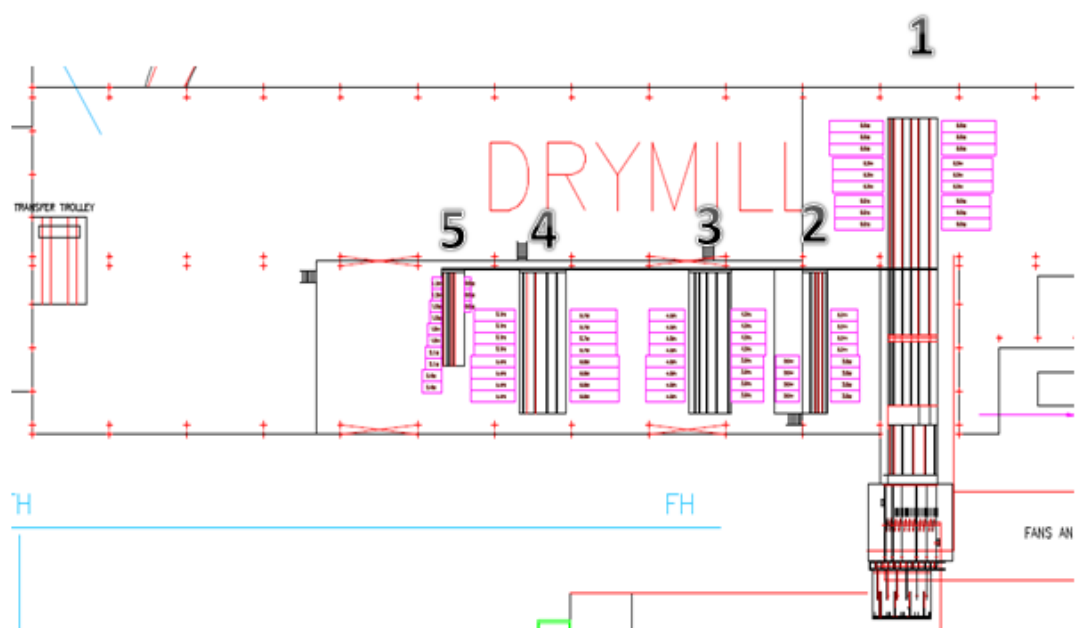

Figure 9: 5 sorting chains

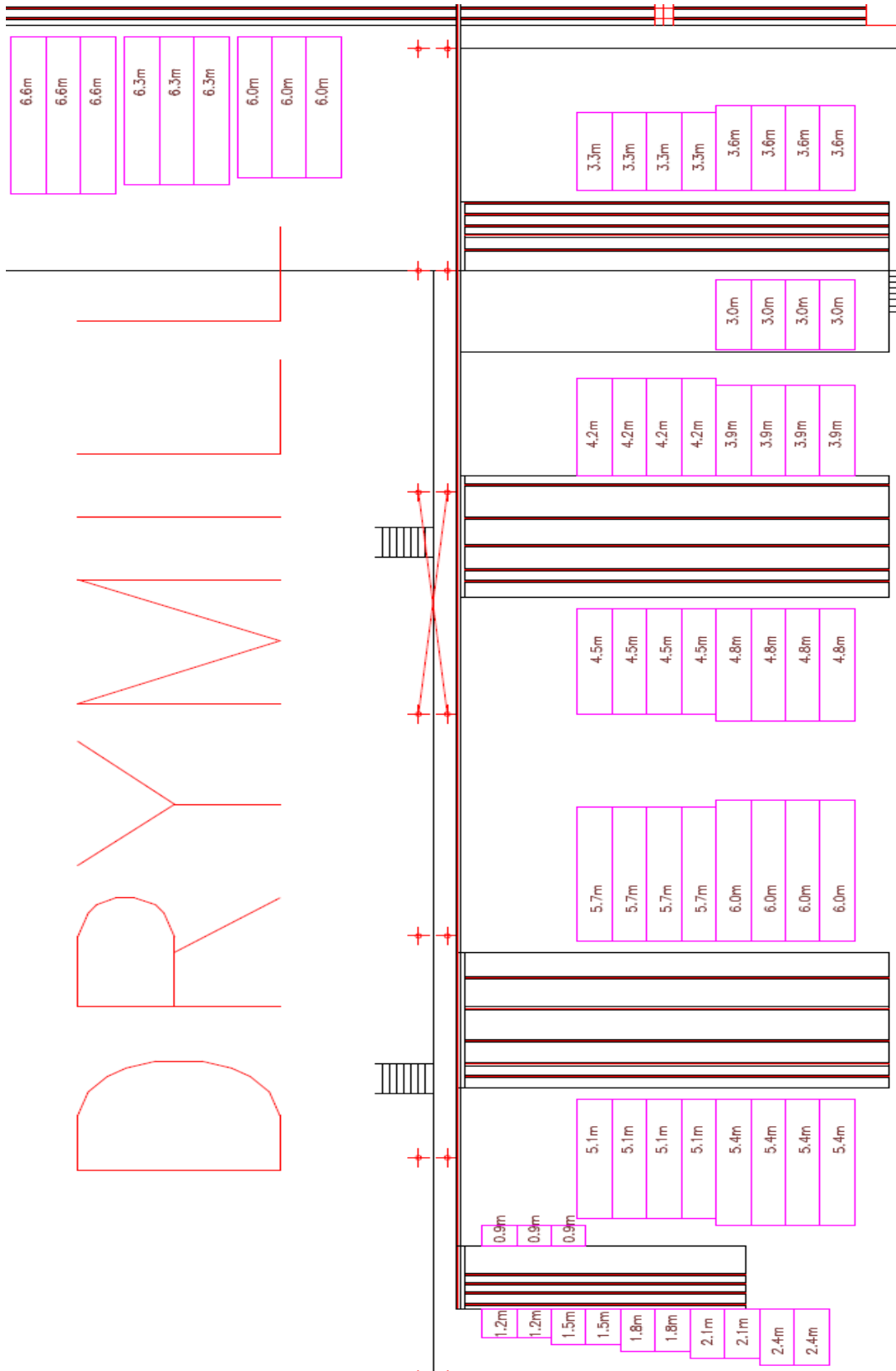

Figure 10: Different lengths sorted at one sorting chain.



Figure 11: Sorting chain



Figure 12: Bays next to sorting chain

11. For the purpose of this project the dry mill is divided into two sections:

A: Bottom half with overhead crane A.

B: Top half with overhead crane B.

12. The transfer trolley is the link between area A and area B.

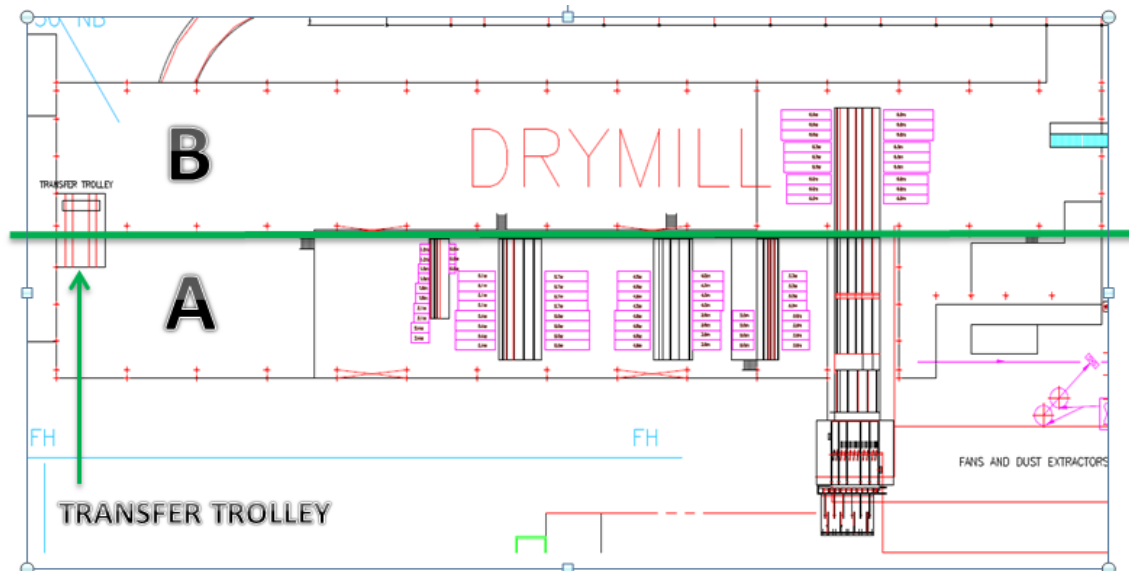

Figure 13: Different dry mill sections.

3.2.3 Strapping of half- and full stacks of work in progress

1. There are two types of stock: Red and green
2. Red stock is any product that is not yet handled to the point where it is ready to be sold. This can be half parcels or full parcels that have not been planed yet.
3. Green stock is finished products. A full stack that has been planed, strapped and spray painted with the York Timber logo and all product details. This product is ready to be dispatched.
4. When the parcels are full, they have to be strapped and moved by the overhead crane so that a new parcel may be started.
5. Half parcels are generated when a size change occurs. A new kiln stack arrives that is not the same product size as the previous one and all the parcels have not been filled. These half parcels have to be strapped and removed by the crane to create space for the new parcels.
6. Half parcels are moved by a crane to a holding area in area A.

3.2 Critical activities in the dry mill

3.2.1 The transfer trolley

1. Crane A places full stacks from area A on the transfer trolley.
2. Crane B removes the full stacks from the transfer trolley and places them in the buffer area or on one of the conveyers.
3. As mentioned the transfer trolley is the only link between area A and area B.
4. All shorter plank lengths are directed to sorting chain 2-5 and are stacked in bays in area A next to these sorting chains. These lengths are: 0.9, 1.2, 1.5, 1.8, 2.1, 2.4, 2.7, 3.0, 3.3, 3.6, 3.9, 4.2, 4.5, 4.8, 5.1, 5.4, 5.7 metres.
5. Stacks containing these lengths from Area A use the transfer trolley.
6. Lengths of 6.0, 6.3, and 6.6 m are exclusively directed to sorting chain 1 and stacked in bays in Area B next to sorting chain 1.
7. Stacks of these longer lengths will never use the transfer trolley since these stacks are already in Area B of the dry mill.
8. Crane B will remove these stacks and place them in the buffer area or directly onto one of the conveyers.

3.2.2 Moving stacks to temporary storage location or buffer area

Area A:

1. Half stacks are kept on area A until they can be filled later.
2. Full stacks from Area A are placed on the transfer trolley by Crane A.
3. The trolley moves the stack over the Area B.
4. Crane B lifts the stack and places it in storage in Area B.

Area B:

Full stacks from the sorting bays at sorting chain 1 are placed in the buffer area next to sorting chain 1.

3.3 Analysis of rework area processes

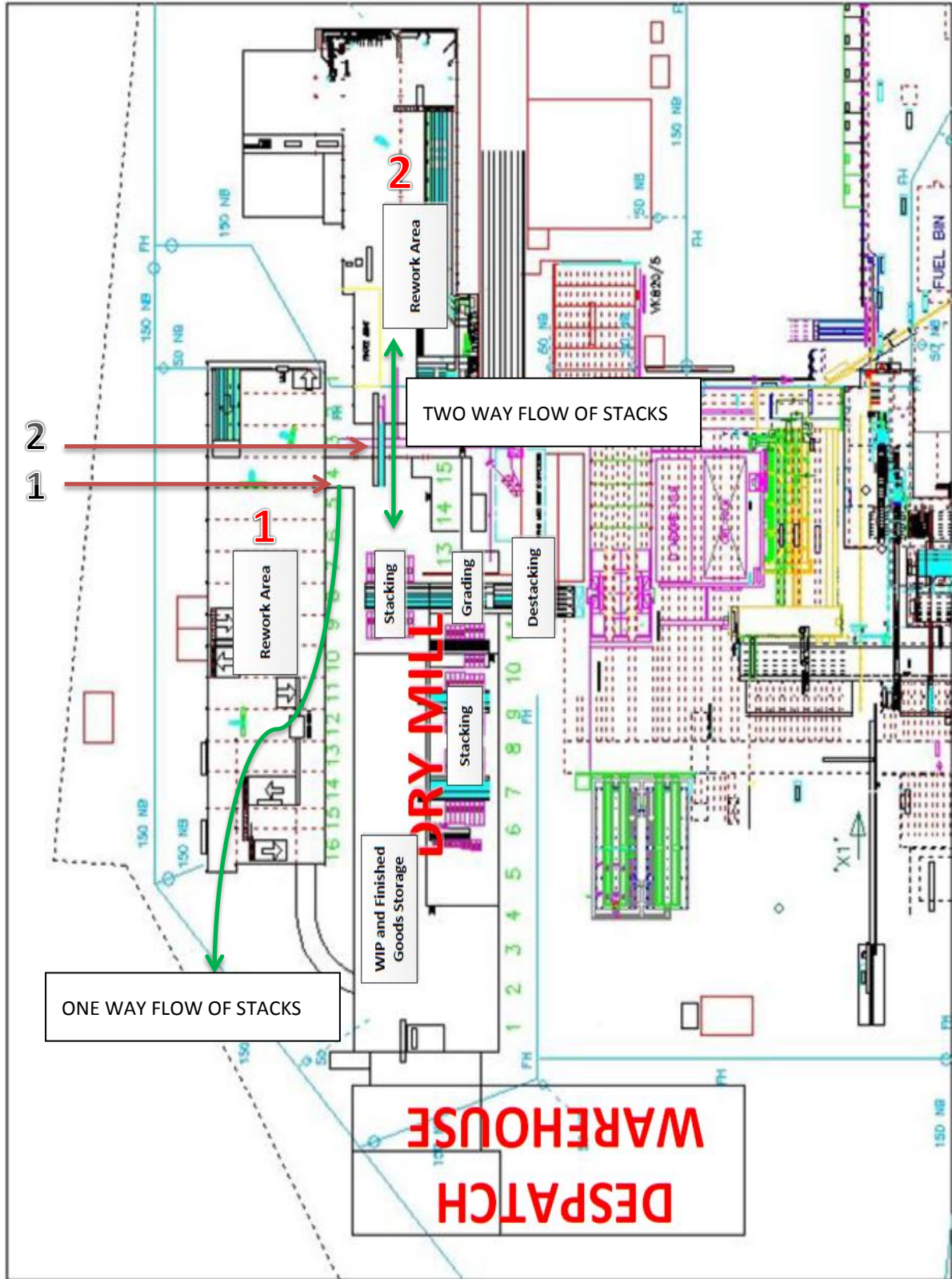

Figure 14: Rework areas and conveyers

Legend:

- 1: Rework area on the bottom level
- 2: Rework area on the top level
- 1: Conveyer 1 on bottom level
- 2: Conveyer 2 on top level



Figure 15: Bottom: Conveyer 1 and Top: Conveyer 2

3.3.1 Placement of stacks on conveyer: stacks exit the dry mill area and move to the rework area

There are two conveyers that lead to the rework areas. These conveyers are the link between the dry mill, where products are stacked and stored, and the rework areas, where the stacks are planed and prepared for dispatch.

Rework area 1:

1. Rework area 1 is on the bottom level and Conveyer 1 is used to move stacks to this rework area.
2. Rework area 1 has two planer machines: Robinson and FWM
3. This rework area has one entrance through it by means of conveyer 1 and a separate exit at the other side of the rework area. The conveyer is used only to move red stock to the rework area.
4. There is a one way flow of stacks to rework area 1.

Rework area 2:

1. Rework area 2 is on the top level and Conveyer 2 is used to move stacks to this rework area.
2. Rework area 2 has one planer machine: Hydromat.
3. This rework area has only one entrance that is also its exit.
4. Red stock is placed on the top conveyer. Stacks are planed and then the green stock comes out on same conveyer. The conveyer is used for the movement of red and green stock.
5. There is a 2 way flow of stacks between the dry mill and rework area 2

3.4 Analysis of overhead crane movement

There are two overhead cranes. For the purpose of the project cranes were named A and B to correspond with area A and B in the dry mill.

Crane A:

1. Bottom half of dry mill.
2. It is a smaller crane that is remote controlled by an operator who moves at ground level.

Crane B:

1. Top half of dry mill.
2. It is a larger crane that is operated by an employee that is seated within the overhead crane.

Area A only houses red stock (work in progress) and area B houses red and green stock (finished goods) (Appendix 7)

The cranes are responsible for all the movement of the planks and stacks (half and full) in the dry mill. The area is inaccessible to a forklift.

The project will only focus on minimizing the movement of crane B and calculate the optimum utilization.

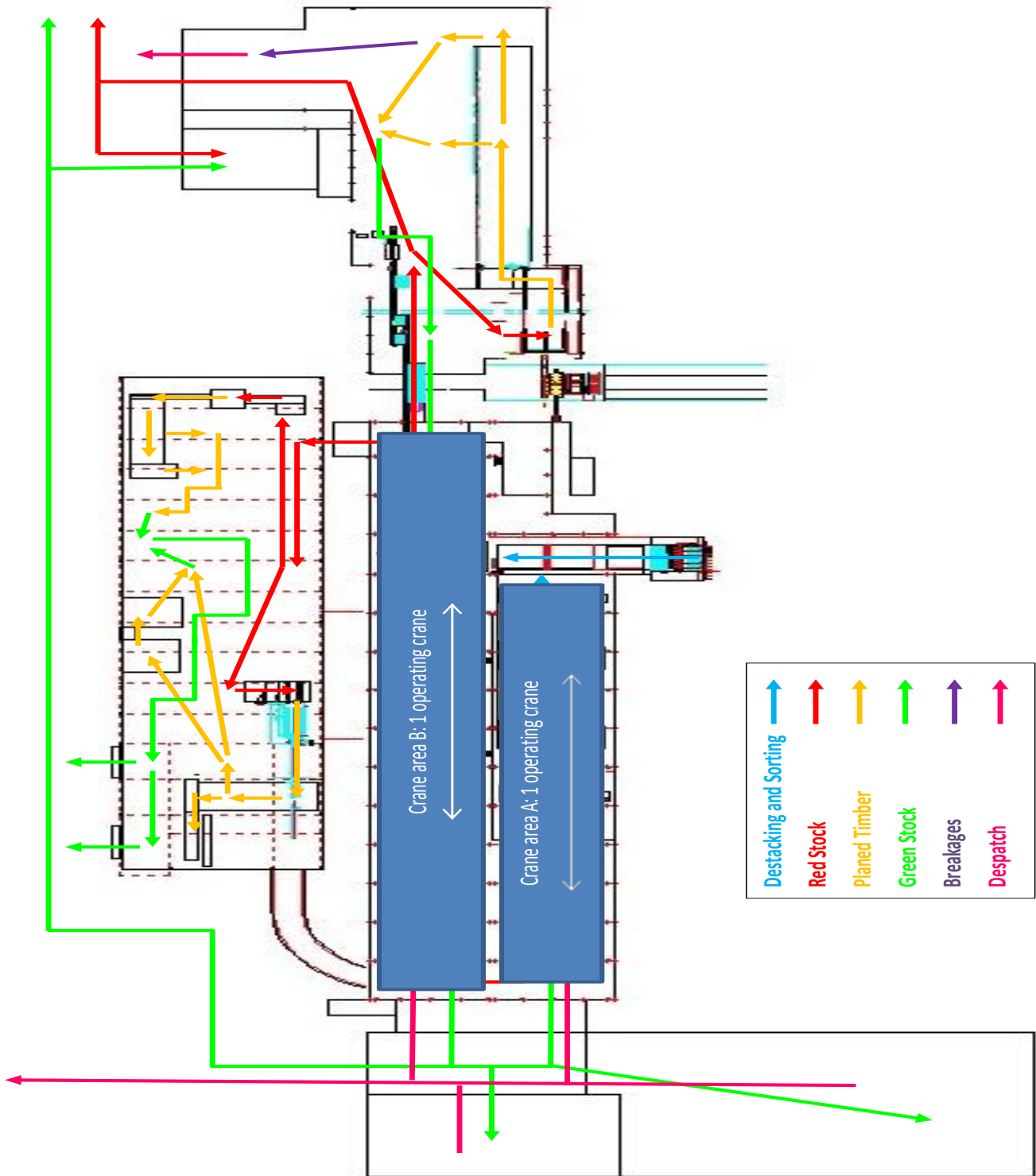

Figure 16: Operating areas of the overhead cranes.

Chapter 4: Problem analysis

Through the process analysis that was conducted in chapter three the following problems were identified and analysed.

4.1 Problems

- I) Storage plan and accessibility of stock
 - Green stock is mixed with red stock in dry mill area B.
 - A storage/stacking plan is required.
 - Need to calculate space (square metre and cubic metre) needed per product: excel spread sheet calculations to calculate space.
 - Insufficient space available.
- II) Equipment scheduling for overhead crane and materials handling practices
 - Crane utilization in dry mill area B.
 - Crane operator needs set instructions in the form of priorities in the dry mill.
 - Create crane schedule
 - Underutilization of overhead crane and planers

The following data gathering is required

4.1.1 Problem I: storage plan for accessibility of stock

(Appendix 5: Space calculations per product)

Since green stock is stacked on top of red stock it is often difficult to locate a specific red stock product. There are also no specific instructions to where in area B a specific product should be stacked. There is no order or strategy when it comes to the storage of products.

Currently many finished products (green stock) are taking up space that is supposed to be allocated to red stock. Area B of the dry mill is actually intended for red stock only. After investigation it was concluded that the dispatch warehouse does have enough space for all finished products if it is organized and if products are stored in the correct and intended way.

For the purpose of this project, dry mill area B will only be used for red stock as it was originally intended.

To design a storage plan the square metre area that each product will occupy on the floor needs to be calculated. Excel is used to determine the area required.

Driekop dry mill selected the following products for this project based on their popularity, importance and profit margin:

GREEN STOCK:

- S5R: STRUCTURAL ROUGH (structural planks but are sold rough)
- S5P: STRUCTURAL PLANED (structural planks)
- UTP: UTILITY GRADE PLANED (not for structural purposes)
- UTL: UTILITY GRADE ROUGH (not for structural purposes)
- BBB: BRANDERING PLANED (structural planks)

RED STOCK:

All of the above products are referred to as red stock when they are in the stages of being processed and are not ready to be dispatched.

It will also be necessary to determine how regularly floor space becomes available. This will be done by using the sales data and making the appropriate assumptions and estimations

An “in-out” relationship can be determined.

For the optimum storage plane it will also be necessary to determine the maximum quantity of red stock products that can be stacked on top of one another without being damaged and being a safety hazard.

Finally the optimum quantity of red and green stock to keep in the dry mill will be determined.

4.4.2 Problem II: Crane utilization and schedule

As mentioned in the problem definition the crane operator makes random decisions when it comes to operating overhead crane B. He decides the movement of the stacks. Unnecessary movement of crane B was observed. The crane movement is not at an optimum level. If there was a fixed set of instructions according to which the operator could work it could significantly increase the quantity of stacks that can be placed on the conveyers in a day. By increasing the quantity it would mean that more stacks would reach the rework areas and be planed in a day. It would increase planer utilization and the amount of finished product that can be dispatched in a day.

Crane stacking problem demonstrated: green stock mixed with red stock

Takes approximately 4 minutes to remove a single stack

Example: To get to red stock it will take 4min times 2 stacks that have to be removed and placed elsewhere = 8 min extra.

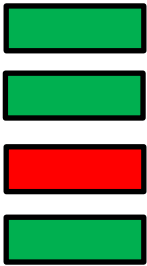

Need extra ground staff member to tell crane operator where the specific stack is.

Chapter 5: Data analysis and processing

In this chapter the data that was gathered from the Driekop dry mill is analysed.

The Driekop mill supplied the sales figure from June and July 2012. This included every order that was received, a list of customers and also every product that was sold and dispatched daily. The data was filtered to only analyse the orders of the five identified grades.

The different engineering methods that were applied to the data, and the results obtained are analysed and discussed in this chapter.

The following topics are discussed.

5.1 Using Systematic Layout Planning to analyse and improve the Driekop dry mill layout.

5.2 ABC analysis of the identified products to aid in the design a storage plan.

5.3 Using lean manufacturing to identify and eliminate the types of waste present.

5.1 Systematic layout planning

5.1.1 Operation process chart

In chapter three, entitled process analysis, the lifecycle of a single plank was analysed. All the processes that a single plank goes through from the moment it enters the dry mill area (from the kiln) until the moment it is planed in the rework area were examined.

Chapter three is summarised in 15 processes:

1. De-stack
2. Grade
3. Sort (from sorting chains to sorting bays)
4. Stack and strap
5. Move: Crane A *
6. Store: Area A *
7. Move: Crane A *
8. Move: Transfer trolley*
9. Move: Crane B
10. Store: Area B *
11. Move: Crane B *
12. Move: Conveyer 1 or Conveyer 2*
13. De-stack
14. Plane
15. Stack, strap and label.

*Lean manufacturing (5.3) was used to identify types of waste present and the non-value adding activities. The identified processes are non-value adding actions.

The processes were categorized as human or machine operations, and as human or machine decisions. The movement of products by the overhead cranes and the temporary storage of products are indicated.

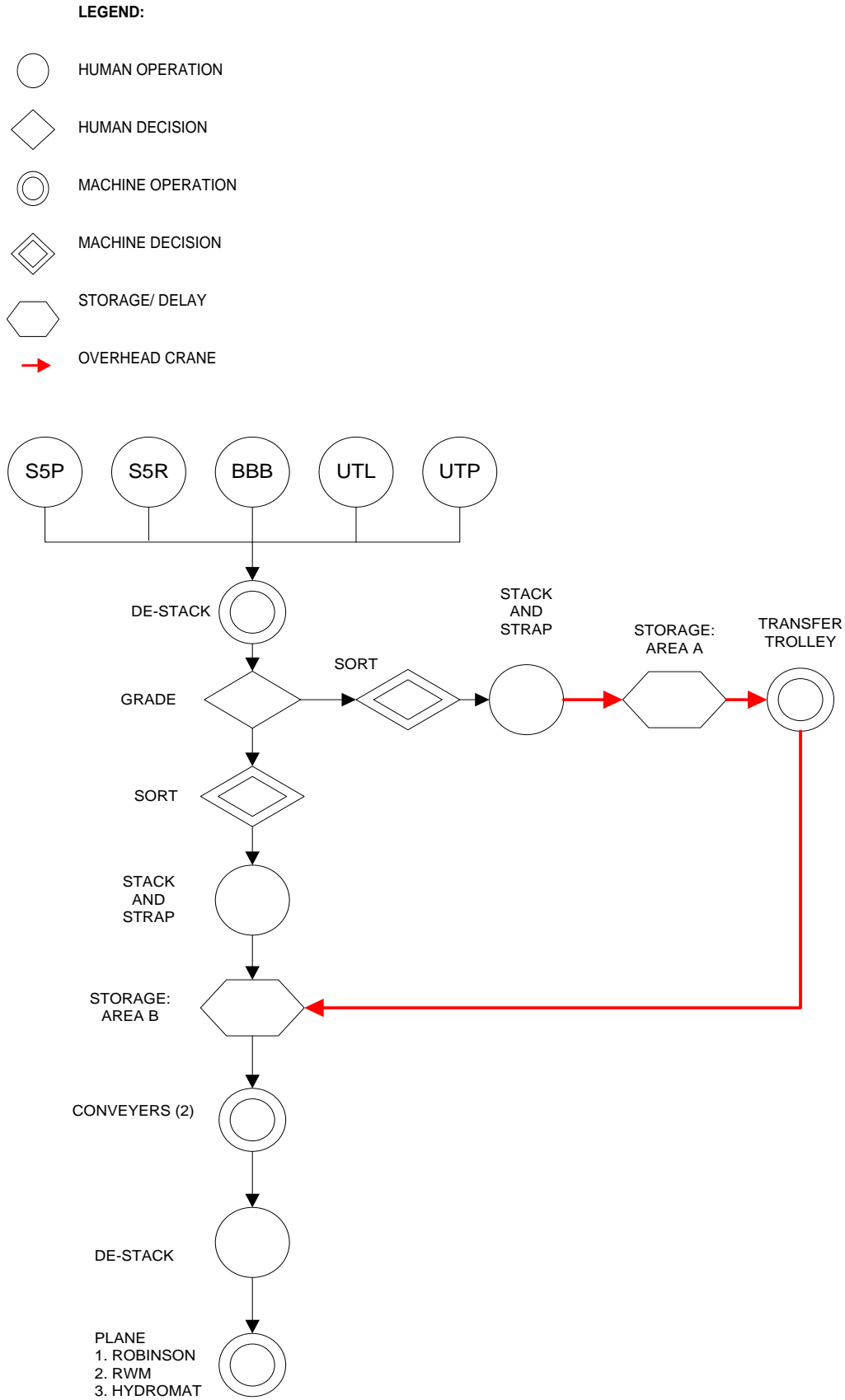

Figure 17: Operation process chart

5.1.2 Flow of materials chart

The 15 processes are analysed further to only look at the flow of materials and the route that the materials follows from entering the dry mill until it exits the dry mill and is planed in the rework area.

1. Kilns
2. De-stacker
3. Grader
4. Sorting bays
5. Storage: Area A
6. Storage: Area B
7. Planers

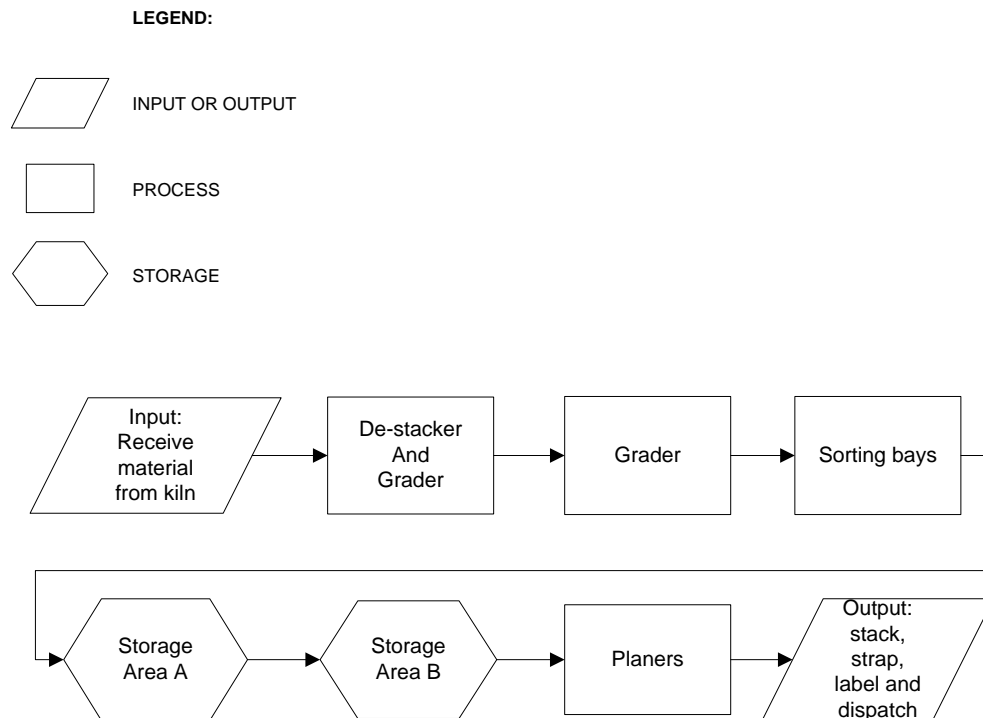

Figure 18: Flow of materials chart

The flow of materials chart makes it seem as if the materials flow route is unidirectional through storage area A and storage Area B. Unfortunately the current state of materials flow within each storage area is congested.

5.1.3 Flow process chart

A flow process chart is used to classify the 15 processes into types of method to further understand which actions materials are exposed to in the dry mill.

FLOW CHART	PROCESS	OPERATION	MOVE	INSPECTION	DELAY	STORAGE	DISTANCE
Details of method:		●	➔	■	D	▲	
1. De-stack		●	➔	■			
2. Grade			➔	■			
3. Sort		●	➔				
4. Stack and strap		●	➔				
5. Crane A			➔				45-95m
6. Area A						▲	
7. Crane B			➔				45-95m
8. Transfer trolley			➔				10m
9. Crane B			➔				95m
10. Area A						▲	
11. Crane B			➔				95-142m
12. Conveyers			➔				
13. De-stack		●	➔				
14. Plane		●	➔				
15. Stack, strap and label					D		

Figure 19: Flow process chart

Summary:

Operations: 6

Move: 7

Inspect: 1

Delay: 2

Transport: 3

Most actions are allocated to movement (transportation). Due to the fact that all operations, inspections and delays are essential processes and cannot be eliminated the only area to make improvements is to reduce the number of movement actions.

5.1.4 Activity relationship chart

Information obtained from the original layout

The Activity relationship chart was used to chart the relationships of activities related to each other.

The chart used to analyse the current layout of a facility and determine a better, more desirable layout that would improve product flow, productivity and yield. The Driekop dry mill (machinery) layout however is fixed and rearranging the machinery is impossible at this stage. The dry mill's function however is the temporary storage of products while it is being processed. Product storage position is not fixed and the aim is therefore to use SLP to design a new storage plan/layout for the products within the dry mill and not to generate a new layout for the machinery.

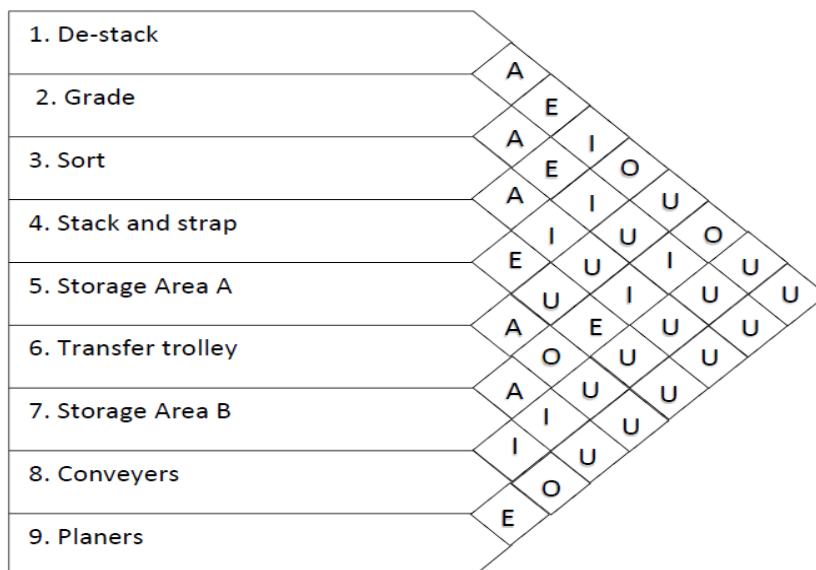

Figure 20: Activity relationship chart between the different areas/operations in the current layout.

Legend:

- A-Absolutely Important
- E-Extremely important
- I-Important
- O-Ordinary importance
- U-Unimportant/Undesirable

5.1.5 Space relationship diagram

The purpose is to establish the space requirements. The space relationship diagram of the current facility displays the relative relationship strengths and the size of the dry mill.

Legend:

- A-Absolutely Important —
- E-Extremely important —
- I-Important —
- O-Ordinary importance —
- U-Unimportant/Undesirable - - -

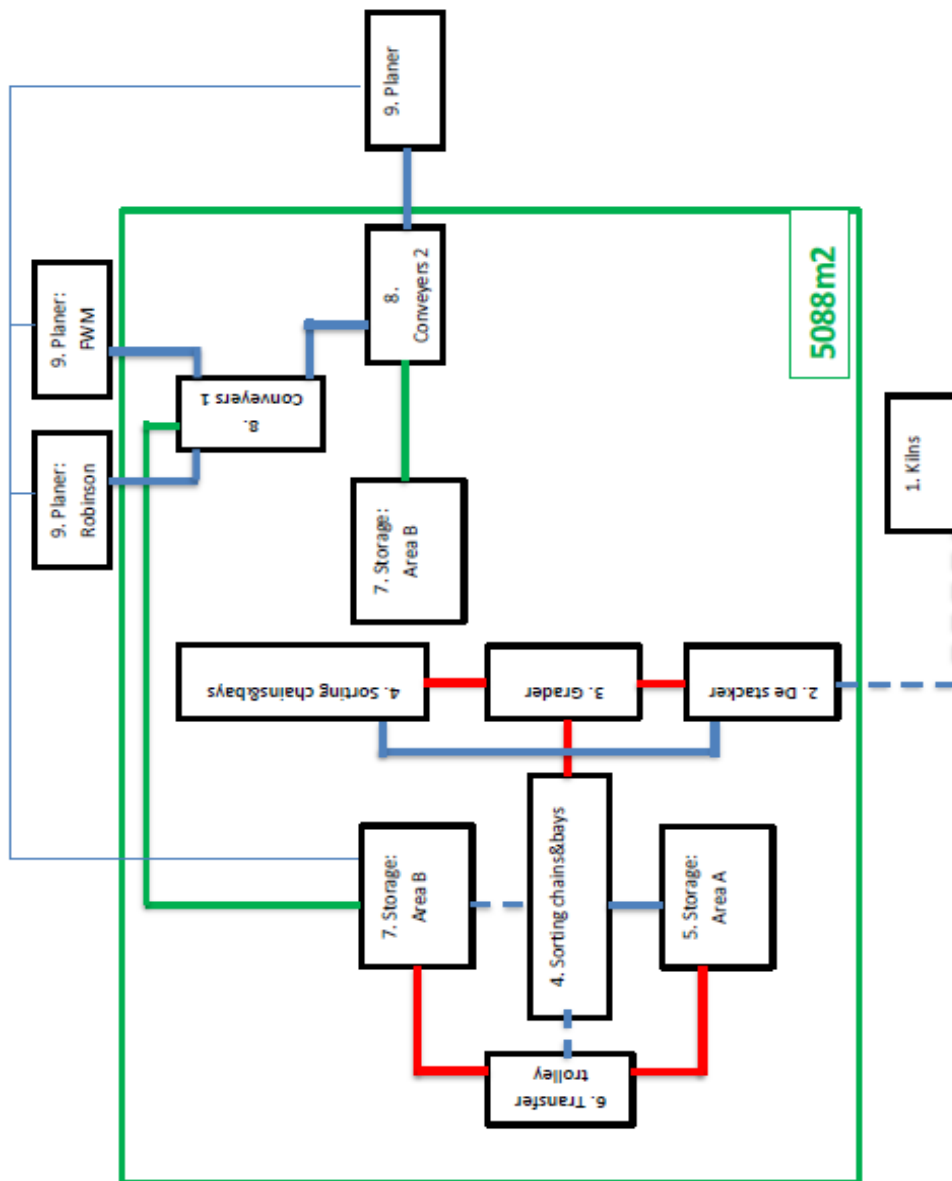

Figure 22: Space relationship diagram

5.1.6 Conclusion

All of the areas, relationships and processes within the Driekop dry mill have now been analysed. The final step of SLP is to design a new improved layout or in the case of the Driekop dry mill, a storage plan. However, before the storage plan can be completed for the specific products one needs to determine on which grounds these products will be chosen en how will they be placed within the dry mill to optimize product flow.

The ABC analysis method will be used to determine the optimum location for products before the storage plan can be completed.

5.2 ABC analysis

ABC analysis was identified as an appropriate inventory control method for the Driekop dry mill. As mentioned in before it is likely that a small number of product grades are responsible for most of the revenue of the mill in line with the Pareto principle.

The Driekop dry mill identified five product grades for the purpose of this project. Sales data from the months of June and July were used to make monthly and annual estimates.

The following sales prices for the five specified grades were received for 12 months. The average sales price in Rand/m³ for each grade was calculated and used in all calculations.

Sales Budget Prices			Jul-12	Aug-12	Sep-12	Oct-12	Nov-12	Dec-12	Jan-13	Feb-13	Mar-13	Apr-13	May-13	Jun-13	
R/m ³		Sales: Lumber Prices													
R/m ³	S5R, S5P	Structural (rough and planed)	2,549	2,622	2,622	2,622	2,622	2,622	2,622	2,723	2,723	2,723	2,723	2,723	R 2,657.81
R/m ³	BBB	Structural Resawn (brandering)	2,871	2,956	2,956	2,956	2,956	2,956	2,956	3,071	3,071	3,071	3,071	3,071	R 2,996.87
R/m ³	UTP, UTL	Utility (rough and planed)	2,183	2,247	2,247	2,247	2,247	2,247	2,247	2,331	2,331	2,331	2,331	2,331	R 2,276.83
R/m ³	BBB	Utility Resawn (brandering)	2,248	2,315	2,315	2,315	2,315	2,315	2,315	2,405	2,405	2,405	2,405	2,405	R 2,347.10

Figure 23: Sales budget prices

The classification of products and product grades through ABC analysis will be done as follows:

- Total cubic metres of each product sold within each grade separately, and also the total cubic metres sold from each grade.
- Total monthly and annual income per product within each grade, and also the total monthly and annual income per grade.
- The amount of products sold within each grade.

The calculations for each grade are summarized below:

Item number for each product refers to the thickness, width, length and the grade.

The average monthly and annual sales in cubic metres (m³) were estimated by using the physical sales data from June and July. This was repeated for every product within every grade.

The average annual income per product within each grade and the total annual income per grade were calculated by multiplying the average annual sales in cubic metres (m³) by the average price per cubic metre (R/m³).

5.2.1 Product Grade S5P

1	ITEMNUMBER	M3/PRODUCT	AVG MONTHLY SALES (M3)	AVG ANNUAL SALES (M3)	AVG ANNUAL INCOME/PRODUCT (RANDS)
2	0380 0114 06600 S5P	836.81	418.40	5020.84	R 13,344,452.85
3	0380 0114 06000 S5P	673.71	336.86	4042.28	R 10,743,605.11
4	0500 0076 06600 S5P	354.63	177.32	2127.79	R 5,655,256.18
5	0380 0114 04800 S5P	309.91	154.95	1859.45	R 4,942,058.35
6	0380 0114 04200 S5P	237.76	118.88	1426.59	R 3,791,597.30
7	0500 0076 06000 S5P	226.63	113.32	1359.79	R 3,614,070.11
8	0380 0114 03600 S5P	181.90	90.95	1091.41	R 2,900,773.38
9	0380 0152 06600 S5P	179.32	89.66	1075.94	R 2,859,655.88
10	0500 0076 04800 S5P	130.23	65.12	781.40	R 2,076,817.75
11	0380 0228 06600 S5P	109.79	54.90	658.74	R 1,750,809.72
12	0380 0114 05400 S5P	108.64	54.32	651.82	R 1,732,406.32
13	0500 0076 04200 S5P	107.25	53.63	643.51	R 1,710,320.50
14	0500 0076 03600 S5P	80.44	40.22	482.63	R 1,282,740.38
15	0380 0152 06000 S5P	72.78	36.39	436.67	R 1,160,574.63
16	0380 0152 04800 S5P	72.20	36.10	433.17	R 1,151,290.03
17	0380 0228 06000 S5P	65.50	32.75	393.00	R 1,044,517.16
18	0380 0114 05700 S5P	56.00	28.00	336.01	R 893,062.17
19	0380 0114 06300 S5P	47.16	23.58	282.96	R 752,052.36
20	0380 0114 03000 S5P	46.32	23.16	277.91	R 738,622.85
21	0380 0228 03000 S5P	36.02	18.01	216.15	R 574,484.44
22	0380 0114 03300 S5P	33.97	16.98	203.80	R 541,656.76
23	0380 0228 04800 S5P	32.44	16.22	194.63	R 517,284.69
24	0380 0114 04500 S5P	27.37	13.68	164.22	R 436,458.96
25	0380 0076 03000 S5P	26.20	13.10	157.20	R 417,806.87
26	0500 0152 06000 S5P	25.86	12.93	155.13	R 412,309.41
27	0380 0076 02700 S5P	22.27	11.13	133.62	R 355,135.84
28	0380 0152 04200 S5P	18.34	9.17	110.04	R 292,464.81
29	0500 0076 05700 S5P	18.19	9.10	109.17	R 290,143.66
30	0380 0152 03600 S5P	17.47	8.73	104.80	R 278,537.91
31	0380 0076 02400 S5P	17.47	8.73	104.80	R 278,537.91
32	0500 0076 06300 S5P	16.76	8.38	100.55	R 267,237.58
33	0380 0152 05400 S5P	15.72	7.86	94.32	R 250,684.12
34	0380 0076 01800 S5P	15.72	7.86	94.32	R 250,684.12
35	0500 0076 05400 S5P	14.36	7.18	86.18	R 229,060.78
36	0380 0228 05400 S5P	14.04	7.02	84.21	R 223,825.11
37	0380 0228 04200 S5P	13.10	6.55	78.60	R 208,903.43
38	0380 0228 03600 S5P	13.10	6.55	78.60	R 208,903.43
39	0500 0152 06600 S5P	12.64	6.32	75.84	R 201,573.49
40	0380 0228 04500 S5P	11.70	5.85	70.18	R 186,520.92
41	0380 0076 03300 S5P	11.21	5.60	67.25	R 178,728.49
42	0380 0114 03900 S5P	10.95	5.47	65.69	R 174,583.58
43	0380 0228 05100 S5P	10.60	5.30	63.63	R 169,112.30
44	0500 0228 04800 S5P	9.85	4.92	59.10	R 157,070.25
45	0500 0076 03000 S5P	9.58	4.79	57.46	R 152,707.19
46	0380 0114 05100 S5P	9.54	4.77	57.27	R 152,201.07
47	0380 0076 04800 S5P	9.32	4.66	55.89	R 148,553.55
48	0380 0076 03600 S5P	8.73	4.37	52.40	R 139,268.96
49	0380 0076 04200 S5P	8.15	4.08	48.91	R 129,984.36
50	0380 0228 03900 S5P	8.11	4.05	48.66	R 129,321.17

51	0380 0076 01200 SSP	8.01	4.00	48.03	R 127,663.21
52	0380 0076 03900 SSP	7.57	3.78	45.41	R 120,699.76
53	0380 0152 03000 SSP	7.28	3.64	43.67	R 116,057.46
54	0500 0076 04500 SSP	7.18	3.59	43.09	R 114,530.39
55	0380 0228 05700 SSP	5.93	2.96	35.56	R 94,503.93
56	0380 0076 06000 SSP	5.82	2.91	34.93	R 92,845.97
57	0380 0152 05700 SSP	5.53	2.77	33.19	R 88,203.67
58	0500 0076 03300 SSP	5.27	2.63	31.60	R 83,988.95
59	0380 0076 05400 SSP	5.24	2.62	31.44	R 83,561.37
60	0380 0076 05100 SSP	4.95	2.47	29.69	R 78,919.07
61	0500 0152 04800 SSP	4.60	2.30	27.58	R 73,299.45
62	0380 0114 02400 SSP	4.49	2.25	26.95	R 71,624.03
63	0380 0076 04500 SSP	4.37	2.18	26.20	R 69,634.48
64	0500 0076 03900 SSP	4.15	2.07	24.90	R 66,173.11
65	0380 0076 04200 SSP	4.08	2.04	24.45	R 64,992.18
66	0380 0076 02100 SSP	4.08	2.04	24.45	R 64,992.18
67	0380 0076 00900 SSP	3.93	1.96	23.58	R 62,671.03
68	0380 0114 01500 SSP	3.51	1.75	21.05	R 55,956.28
69	0380 0076 06600 SSP	3.20	1.60	19.21	R 51,065.28
70	0380 0152 06300 SSP	3.06	1.53	18.34	R 48,744.13
71	0380 0076 06300 SSP	3.06	1.53	18.34	R 48,744.13
72	0500 0152 06300 SSP	3.02	1.51	18.10	R 48,102.76
73	0380 0076 01500 SSP	2.91	1.46	17.47	R 46,422.99
74	0380 0114 01200 SSP	2.81	1.40	16.84	R 44,765.02
75	0500 0076 05100 SSP	2.71	1.36	16.28	R 43,267.04
76	0500 0152 05400 SSP	2.59	1.29	15.51	R 41,230.94
77	0380 0114 01800 SSP	2.53	1.26	15.16	R 40,288.52
78	0380 0152 05100 SSP	2.47	1.24	14.85	R 39,459.54
79	0500 0076 04500 SSP	2.39	1.20	14.36	R 38,176.80
80	0500 0152 04200 SSP	2.01	1.01	12.07	R 32,068.51
81	0380 0114 02100 SSP	1.96	0.98	11.79	R 31,335.51
82	0380 0152 03300 SSP	1.60	0.80	9.61	R 25,532.64
83	0380 0076 01500 SSP	1.46	0.73	8.73	R 23,211.49
84					
85		TOTAL:		27176.94	R 72,231,160.03

5.2.2 Product Grade UTP

1	ITEMNUMBER	M3/PRODUCT	AVG MONTHLY SALES (M3)	AVG ANNUAL SALES (M3)	AVG INCOME/PRODUCT (RANDS)
2	0380 0114 06600 UTP	731.93	365.97	4391.61	R 9,998,927.53
3	0380 0114 06000 UTP	687.75	343.87	4126.49	R 9,395,299.09
4	0500 0076 06600 UTP	294.94	147.47	1769.64	R 4,029,173.10
5	0380 0038 06600 UTP	259.38	129.69	1556.28	R 3,543,369.94
6	0380 0038 06000 UTP	250.35	125.18	1502.13	R 3,420,087.71
7	0500 0076 06000 UTP	172.37	86.18	1034.21	R 2,354,711.55
8	0500 0076 04800 UTP	114.91	57.46	689.47	R 1,569,807.70
9	0380 0114 04800 UTP	105.28	52.64	631.67	R 1,438,198.01
10	0380 0152 06600 UTP	86.46	43.23	518.76	R 1,181,123.31
11	0380 0038 04200 UTP	83.55	41.77	501.29	R 1,141,354.85
12	0380 0114 05400 UTP	80.85	40.42	485.07	R 1,104,427.00
13	0380 0114 04200 UTP	80.56	40.28	483.39	R 1,100,592.18
14	0500 0076 04200 UTP	75.97	37.98	455.82	R 1,037,817.31
15	0380 0038 04800 UTP	74.52	37.26	447.15	R 1,018,072.62
16	0380 0038 05400 UTP	65.50	32.75	393.00	R 894,790.39
17	0380 0038 03600 UTP	64.63	32.31	387.76	R 882,859.85
18	0380 0114 03600 UTP	62.32	31.16	373.91	R 851,329.14
19	0380 0076 03300 UTP	40.03	20.01	240.17	R 546,816.35
20	0380 0114 04500 UTP	35.79	17.90	214.75	R 488,939.03
21	0380 0038 04500 UTP	34.93	17.47	209.60	R 477,221.54
22	0380 0038 01500 UTP	33.48	16.74	200.87	R 457,337.31
23	0380 0038 01800 UTP	31.44	15.72	188.64	R 429,499.39
24	0380 0152 03600 UTP	30.64	15.32	183.86	R 418,615.39
25	0380 0038 01200 UTP	30.28	15.14	181.65	R 413,592.00
26	0380 0114 06300 UTP	29.47	14.74	176.85	R 402,655.68
27	0380 0114 03000 UTP	28.07	14.04	168.43	R 383,481.60
28	0380 0152 06000 UTP	26.20	13.10	157.20	R 357,916.16
29	0380 0114 05700 UTP	24.00	12.00	144.01	R 327,876.76
30	0380 0152 04800 UTP	23.29	11.64	139.73	R 318,147.69
31	0380 0038 03000 UTP	20.38	10.19	122.27	R 278,379.23
32	0500 0076 05400 UTP	20.11	10.05	120.66	R 274,716.35
33	0380 0076 02400 UTP	19.80	9.90	118.77	R 270,425.54
34	0380 0038 00900 UTP	18.34	9.17	110.04	R 250,541.31
35	0380 0076 02700 UTP	17.03	8.51	102.18	R 232,645.50
36	0380 0114 05100 UTP	16.70	8.35	100.21	R 228,171.55
37	0380 0076 03000 UTP	16.01	8.01	96.07	R 218,726.54
38	0380 0038 06300 UTP	15.28	7.64	91.70	R 208,784.42
39	0380 0152 04200 UTP	14.26	7.13	85.59	R 194,865.46
40	0380 0038 05100 UTP	12.37	6.19	74.23	R 169,015.96
41	0380 0076 01800 UTP	12.23	6.11	73.36	R 167,027.54
42	0380 0114 03900 UTP	10.95	5.47	65.69	R 149,557.82
43	0380 0152 05400 UTP	10.48	5.24	62.88	R 143,166.46
44	0380 0076 02100 UTP	9.17	4.58	55.02	R 125,270.65
45	0380 0114 03300 UTP	7.72	3.86	46.32	R 105,457.44
46	0380 0152 05100 UTP	7.42	3.71	44.54	R 101,409.58
47	0500 0076 06300 UTP	6.70	3.35	40.22	R 91,572.12
48	0500 0076 04500 UTP	4.79	2.39	28.73	R 65,408.65
49	0380 0228 06600 UTP	3.43	1.72	20.59	R 46,869.97
50	0380 0076 06600 UTP	3.20	1.60	19.21	R 43,745.31
51	0380 0152 06300 UTP	3.06	1.53	18.34	R 41,756.88
52	0500 0076 05700 UTP	3.03	1.52	18.19	R 41,425.48
53	0500 0152 06000 UTP	2.87	1.44	17.24	R 39,245.19
54	0500 0076 05100 UTP	2.71	1.36	16.28	R 37,064.90
55	0500 0152 04500 UTP	2.15	1.08	12.93	R 29,433.89
56	0380 0076 01200 UTP	2.13	1.06	12.77	R 29,068.85
57	0500 0076 03000 UTP	1.60	0.80	9.58	R 21,802.88
58	0380 0076 00900 UTP	1.31	0.65	7.86	R 17,895.81
59	0380 0038 05700 UTP	-8.30	-4.15	-49.78	-R 113,340.12
60					
61			TOTAL:	23495.06	R 53,494,151.39

5.2.3 Product Grade BBB

1	ITEMNUMBER	M3/PRODUCT	AVG MONTHLY SALES (M3)	AVG ANNUAL SALES (M3)	AVG ANNUAL INCOME/PRODUCT (RANDS)
2	0380 0038 06600 BBB	3.20	209.75	2,516.94	R 7,542,943.40
3	0380 0038 06000 BBB	2.91	208.14	2,497.73	R 7,485,363.68
4	0380 0038 03600 BBB	1.75	65.50	786.00	R 2,355,534.03
5	0380 0038 04200 BBB	2.04	65.21	782.50	R 2,345,064.98
6	0380 0038 04800 BBB	2.33	55.89	670.72	R 2,010,055.70
7	0380 0038 05700 BBB	2.77	44.25	530.99	R 1,591,294.10
8	0380 0038 05400 BBB	2.62	39.30	471.60	R 1,413,320.42
9	0380 0038 03000 BBB	1.46	29.11	349.33	R 1,046,904.01
10	0380 0038 05100 BBB	2.47	18.56	222.70	R 667,401.31
11	0380 0038 06300 BBB	3.06	16.81	201.74	R 604,587.07
12	0380 0038 04500 BBB	2.18	13.09	157.03	R 470,590.24
13	0380 0038 03900 BBB	1.89	9.46	113.53	R 340,243.80
14	0380 0038 03300 BBB	1.60	8.01	96.07	R 287,898.60
15					
16			TOTAL:	9,396.87	R 28,161,201.33

5.2.4 Product Grade S5R

1	ITEMNUMBER	M3/PRODUCT	AVG MONTHLY SALES (M3)	AVG ANNUAL SALES (M3)	AVG ANNUAL INCOME/PRODUCT (RANDS)
2	0500 0228 06600 S5R	60.94	30.47	365.67	R 971,872.17
3	0500 0228 06000 S5R	49.25	24.62	295.49	R 785,351.25
4	0380 0114 02700 S5R	24.00	12.00	144.01	R 382,740.93
5	0380 0152 02700 S5R	20.96	10.48	125.76	R 334,245.49
6	0380 0152 04800 S5R	20.96	10.48	125.76	R 334,245.49
7	0380 0152 02400 S5R	20.96	10.48	125.76	R 334,245.49
8	0380 0114 02400 S5R	14.60	7.30	87.58	R 232,778.11
9	0380 0152 02100 S5R	13.25	6.62	79.47	R 211,224.58
10	0380 0114 02100 S5R	12.77	6.39	76.63	R 203,680.85
11	0380 0152 01800 S5R	9.61	4.80	57.64	R 153,195.85
12	0380 0114 01800 S5R	9.26	4.63	55.58	R 147,724.57
13	0500 0228 05700 S5R	8.77	4.39	52.63	R 139,890.69
14	0380 0152 01500 S5R	8.01	4.00	48.03	R 127,663.21
15	0380 0114 04800 S5R	6.74	3.37	40.42	R 107,436.05
16	0500 0228 05100 S5R	5.23	2.62	31.40	R 83,443.57
17	0380 0114 01500 S5R	4.91	2.46	29.47	R 78,338.79
18	0380 0114 01800 S5R	4.21	2.11	25.26	R 67,147.53
19	0500 0228 03600 S5R	3.69	1.85	22.16	R 58,901.34
20	0500 0228 05400 S5R	2.77	1.39	16.62	R 44,176.01
21	0500 0228 04800 S5R	2.46	1.23	14.77	R 39,267.56
22					
23			TOTAL:	1820.13	R 4,837,569.55

5.2.5 Product Grade UTL

1	ITEMNUMBER	M3/PRODUCT	AVG MONTHLY SALES (M3)	AVG ANNUAL SALES (M3)	AVG INCOME/PRODUCT (RANDS)
2	0380 0152 02700 UTL	11.79	5.89	70.74	R 161,062.27
3	0380 0114 02100 UTL	10.65	5.33	63.92	R 145,527.71
4	0380 0152 01800 UTL	9.61	4.80	57.64	R 131,235.92
5	0380 0152 02100 UTL	9.17	4.58	55.02	R 125,270.65
6	0380 0114 02700 UTL	8.84	4.42	53.05	R 120,796.70
7	0380 0114 01800 UTL	7.58	3.79	45.48	R 103,540.03
8	0380 0152 02400 UTL	6.99	3.49	41.92	R 95,444.31
9	0380 0152 01500 UTL	5.09	2.55	30.57	R 69,594.81
10	0380 0114 01500 UTL	3.50	1.75	20.98	R 47,757.66
11	0380 0114 02400 UTL	1.12	0.56	6.74	R 15,339.26
12					
13			TOTAL:	446.046	R 1,015,569.34

5.2.6 Summary

5.2.6.1 The total annual income per grade

1. S5P: R72, 231,160. 03
2. UTP: R53, 494,151. 39
3. BBB: R28, 161,201. 33
4. S5R: R4, 837,569. 55
5. UTL: R1, 015,569. 34

Total annual income by these five grades: R159, 739,652. 60

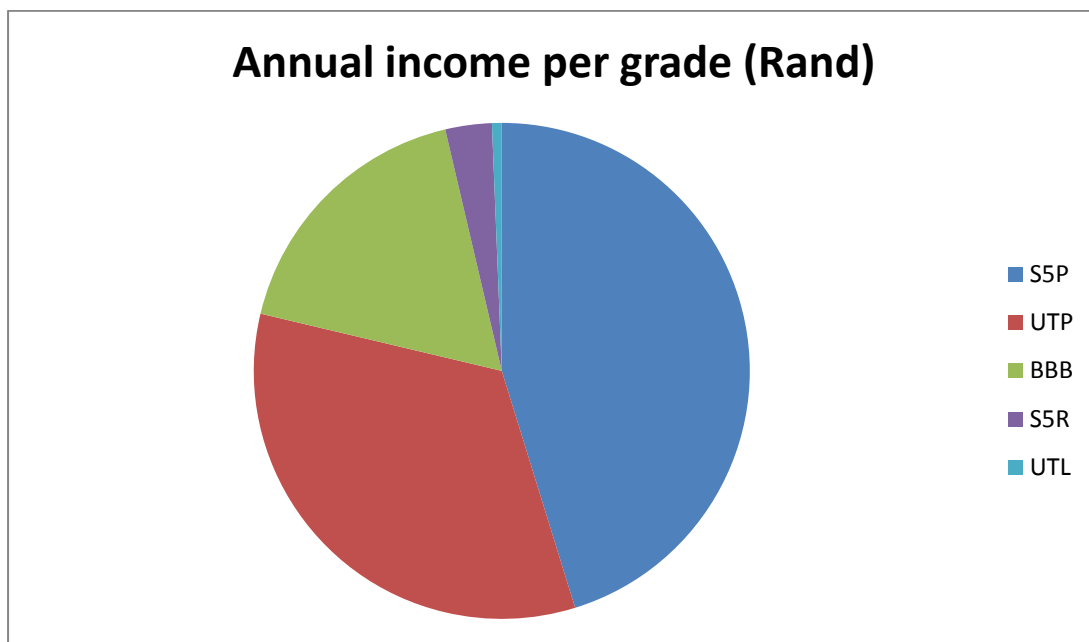

Figure 24: Pie chart of the annual income per product grade.

S5P is by far the most important grade followed by UTP and BBB. These 3 products have the highest priority and must be placed in the most convenient location for ease of accessibility.

There is only a small market for products from grades S5R and UTL and their demand is very low. Together these two products have a small contribution of only R5, 853,138. 89. Their contribution can be seen as negligible and one does not need to make special provision for these products in the storage plan. These products can be stored in the area that will be allocated to “other products”.

Items listed in decreasing monetary value.

A=high monetary value: **S5P**

B=medium monetary value: **UTP**

C=low monetary value: **BBB**

5.2.6.2 The total cubic metres sold per grade

1. S5P: 27 179. 94 m³
2. UTP: 23 495. 06 m³
3. BBB: 9 396. 87 m³
4. S5R: 1 820. 13 m³
5. UTL: 446, 05 m³

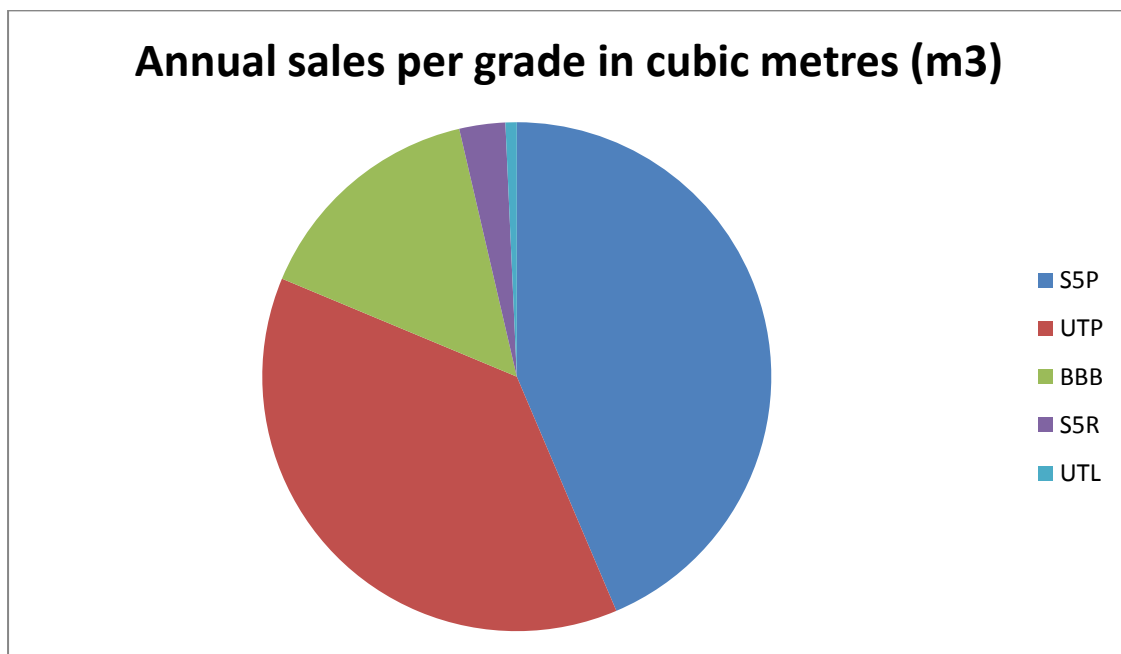

Figure 25: Pie chart of annual sales per grade in cubic metres (m³)

The largest volumes of product grades are from the S5P and UTP grades. There is only a small difference in volume.

BBB is a very expensive product and although it makes a significant contribution when it comes to the total annual income per grade, the volume of product grade sold annually is small when compared to S5P and UTP. BBB remains a very important product grade despite of this.

Items listed in decreasing volume.

A=high volume: **S5P**

B=medium volume: **UTP**

C=low volume: **BBB**

6.2.6.3 Total number of products per grade

1. S5P: 82 products
2. UTP: 58 products
3. S5R: 20 products
4. BBB: 13 products
5. UTL: 10 products

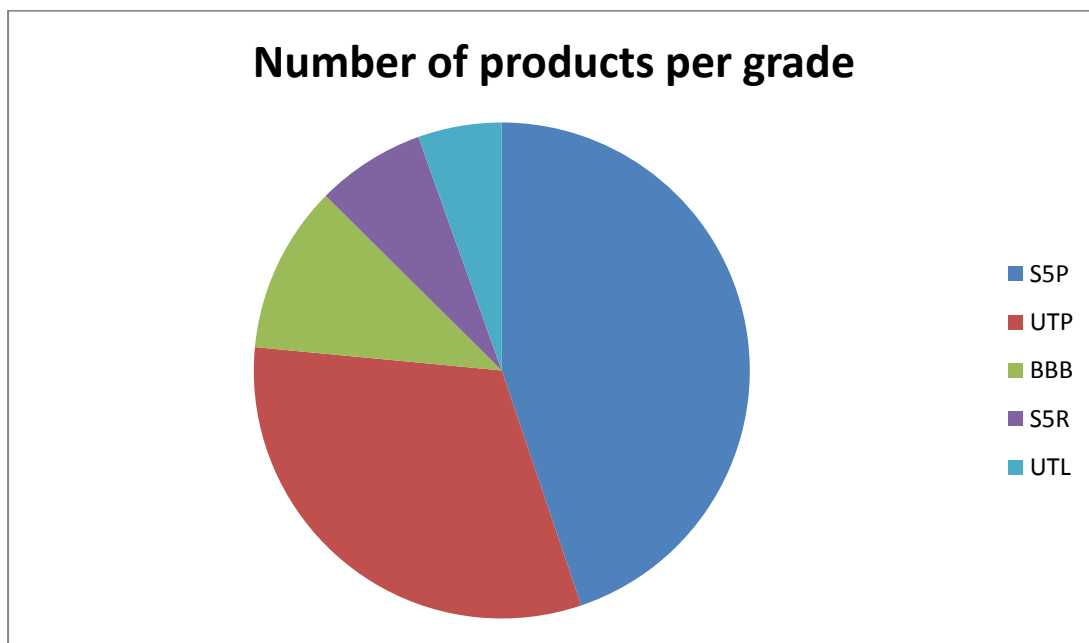

Figure 26: Number of products available per grade

It can again be seen that the major variety of products are within grade S5P followed by UTP. BBB however only has 13 different products but it still makes a large contribution to the total annual income because of the high selling price and volume sold.

Items listed in decreasing product quantity.

A=large quantity: **S5P**

B=medium quantity: **UTP**

C=small quantity: **S5R**

6.2.6.4 Conclusion

It is clear that S5P is the most important product and in the largest quantity. Most floor space will be allocated to this product and the product will be placed closest to the conveyers for improved product flow. Second priority will be given to UTP and third priority to BBB.

UTL and SR5 will be stored in the area allocated to “other products”

A storage plan can now be designed based on the ABC analysis assumptions.

5.3 Lean manufacturing

The storage plan alone will only partly improve the product flow in the dry mill. It is also necessary to reduce or eliminate all unnecessary actions, processes and wastes that cause delays. The integration of the storage plan with lean manufacturing principles will significantly improve working conditions.

The lean manufacturing process is composed of three stages.

5.3.1 Stage 1: Identify waste

To identify the types of waste present the 15 processes that were summarised in 5.1 are divided into value adding and non-value adding processes.

Value adding processes:

1. De-stack
2. Grade
3. Sort (from sorting chains to sorting bays)
4. Stack and strap
13. De-stack
14. Plane
15. Stack, strap and label.

Non-value adding processes:

5. Move: Crane A
6. Store: Area A
7. Move: Crane A
8. Move: Transfer trolley
9. Move: Crane B
10. Store: Area B
11. Move: Crane B
12. Move: Conveyer 1 or Conveyer 2

Through the process analysis conducted in chapter three, SLP charts and considering non value adding processes the following wastes were identified:

1. Unnecessary Inventory
2. Motion
3. Waiting times

All of the value adding processes are essential and cannot be eliminated completely but they can be done more efficiently.

The non-value adding processes that cannot be eliminated or improved are motion by the conveyers and motion by the transfer trolley.

Motion by the overhead cranes cannot be eliminated completely but the unnecessary delays; long storage times and inventory that cannot be located are the immediate result of the absence of a storage plan and no crane schedule.

5.3.2 Stage 2: Analyse the waste, and find the root cause

The root causes have already been identified in chapters three and four.

The root causes are:

- The absence of a storage plan. Green and especially red stock is mixed in storage area B and which takes time to locate and retrieve, and leads to significant delays.
- The absence of a work schedule and priorities for the overhead cranes. Unnecessary motion takes place.

Product flow is inhibited and the quantity of products that can be produced in a day is reduced.

5.3.3 Stage 3: Address the root cause, and repeat the cycle

The root causes will be solved with the implementation of the storage plan and the crane schedule will ensure continuous improvement in the dry mill.

Crane schedule and work priorities

After crane movement investigation the following crane priority order was determined for Crane B:

Priority 1:

- Feed all three planers from the buffer area (see storage plan) by feeding conveyers 1 and 2 (Top and bottom).
- It is a direct link to how many stacks (green stock) are available for dispatch daily.
- Cubic metre dispatched daily=profit.

Priority 2:

- Empty the stacking bays at chain 1: remove full parcels of 6m, 6.3m, and 6.6m.
- Place on conveyer 1 or 2, if it is open. Otherwise place in red stock buffer area. (see storage plan)

Priority 3:

- Remove short full stacks from transfer chain.
- Place on conveyer 1 or 2 if one of them is open.
- Place in buffer area if the transfer trolley or conveyers are occupied.

*The crane operator should above all always feed the planer machines with stock from the buffer area so that the stock is replenished on a first-in first-out basis to ensure stock does not stay in the dry mill longer than 3 months. Deformation starts to occur after 3 months if stacks are too heavily piled.

Chapter 6: Storage plan

6.1 Introduction

An analysis of the dry mill storage areas revealed congestion with green and red stacks that are piled randomly due to the absence of a storage plan. As previously mentioned, there is little control over the inventory in the dry mill and the employees have trouble locating and retrieving stock. Stacks are currently located by the crane operator and ground staff manually searching the facility.

A proper locator system for the storage plan will improve product flow and working conditions.

The following key aspects need to be considered when developing the storage plan and selecting the inventory locator system:

- The availability of floor space in dry mill area A and B.
- The product dimensions (m²) and also the weight of the item.
- The product characteristics: stackable, breakable, crushable, solid, heavy etc.
- The storage method: products stacked on the floor in piles.
- Availability of labourers.
- Materials handling and other equipment.
- Locator system

Chapter 5 indicated that the dry mill would only store the 5 product grades that were identified.

The extreme weight of a stack limits its storage options and the most feasible solution is to pile stacks on top of one another. Stacks are separated by scrap wood blocks to protect the stacks from damage.

ISO states that any object can be stacked at a height of three times the smallest base. In the case of most products in the dry mill, it limits the stacks to between 4 and 7. This will also prevent deformation of the products.

6.2 Possible storage layout and Locator systems

There are five common locator systems available:

6.2.1 Fixed (Dedicated) Location System

In Fixed locator systems each Stock Keeping Unit (SKU) has a fixed location. Every SKU has a home and only the specific item can live there. In some fixed location systems two SKU may have the same location, but again only those two items may be stored there. The position or positions are the only locations where the SKU may exist in the facility and under no circumstances, may any other SKU be kept there.

Fixed Location Systems require more space than any other system. If the number of SKU's are large then a large storage space is required. This becomes problematic when storage space is limited.

Pros:

- Immediate knowledge of where all SKU's are located
- Receiving and stock replenishment is simplified.
- SKU's can be aligned sequentially.
- Individual lots are controlled.
- SKU's can be positioned close to their point-of-use.
- SKU's can be placed in the most convenient location according to size, weight or other characteristics.

Cons:

- Layout can contribute to honeycombing in the storage area.
- Space planning must work around the maximum quantity of SKU's that may be in the facility at any given time.

6.2.2 Memory system

Memory systems are simplistic and entirely dependent on human recall. It relies on the stock keeper's ability to recall the location of the SKU but limits the amount of SKU that can be kept. This system provides freedom from data entering and paperwork while ensuring maximum utilization of space due to the random nature of the storage of SKU's.

The most complete space. No item has a fixed location that would prevent other SKU from occupying that same location if it were empty.

Pros:

- Full utilization of the storage space.
- A specific SKU is not tied to a specific location
- A memory system is simple to understand
- No information updating is required electronically or manually.

Cons:

- The organizations ability to function relies on the stock keepers memory and health.
- Once an item is misplaced it counts as being lost to the system.
- There are always decreases in accuracy when changes occur to the placement of items.
- Employees need longer training.

6.2.3 Zoning systems

Zoning systems focus on the characteristics of an SKU and the collective feature of a group of SKU's. The characteristics of a SKU would result in its placement in a specific area, level or zone within a storage facility. Only items with that feature will then live in the designated area.

Zoning systems allow for decisions concerning item placement based on the desired characteristics that the stock keeper feels are important. Zoning systems allow for more freedom. SKU's can be moved freely within an area as required because an item is fixed to the designated area and not a specific location.

Pros:

- SKU's can be isolated according to characteristics.
- Different zones can be created quickly and efficiently.
- Zoning systems allow flexibility when moving items.

- SKU's can be easily added to a zone without having to move other items (as in the case of a fixed system).
- Flexibility in planning. Does not need to plan 100% according to cubic requirements.

Cons:

- Needless zones may be added
- May cause administrative complexity
- Zoning may contribute to honeycombing in the storage area.
- Zoning systems require frequent updating of stock movement information

6.2.4 Random Location Systems

Random Location Systems are the most flexible systems and make the best use of the available space. SKU can be placed anywhere as long as the location of that SKU is accurately captured on a database or noted manually on paper. No SKU has a home but yet the stock keeper will know where everything is. It is similar to a memory system but with the added benefits of a fixed or zoning system because the location is accurately recorded and not just in the memory of the stock keeper. When a SKU is moved it is deleted from its location.

Random locator systems provide the stock keeper with the best use of space with the most flexibility.

Pros:

- Maximization and optimal use of space.
- Control over where items are at all times

Cons:

- Constant updating of information on item location is required.
- Updating information must be done electronically through data entry or manually through paper based recording.
- Can become unnecessarily complicated

6.2.5 Combination systems

This type of system is a combination between a fixed location system and a random system. Some SKU have a fixed location while everything else is stored according to random system principles.

Very few systems will be purely one type of system. The combination system provides the stock keeper with the best of both worlds because the benefits of both systems can be enjoyed.

6.2. Proposed Layout and Locator system

Since there are so many different products within each grade a fixed location system would be unpractical (see 5.2 for product lists). It is apparent that the zoning system will be the most appropriate system for the dry mill area considering the stock take and the benefits of a zoning location system. If the location of a stack is not fixed, the stack can be moved within an area and less space is required. Stacks can be piled and if a stack at the bottom of the pile needs to be accessed the stacks on top can be moved to another location within the current area and no additional effort is needed to update the location of a stack each time it is moved.

The grade of a stack can be used to determine the area in which to store a stack, in return the overhead crane only has to operate in a specific area to access the stacks and not across the entire storage area B to try locating a stack. Additional stacks can be added to an area when needed or moved from one area to another making the system more flexible to a change in schedule to satisfy an urgent customer order.

6.2.1 The improved layout

The layout consists of open area storage zones. The beams, indicated in red, on the left side if the dry mill divides the mill into approximately 9m areas.

Because there are so many products within a specific product grade there has to be a way of organizing the products within the allocated zones. Products are sent to a specific sorting chain and bay according to length as this is the most important dimension of a plank. Products will therefore be stacked in piles according to their lengths within each of the allocated zones.

See fig 27 for the storage zones. Zones are colour-coded to easily distinguish between them

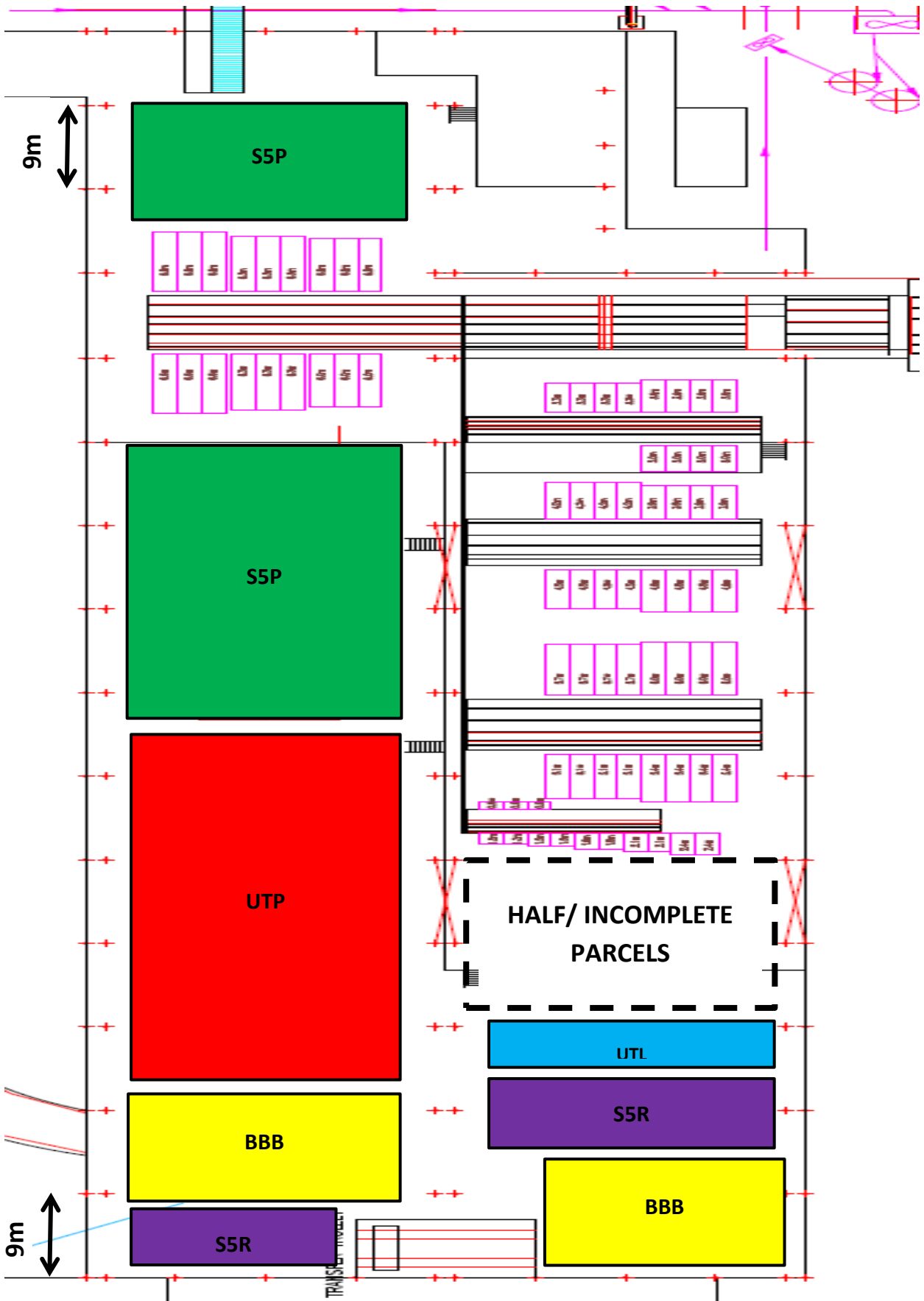

Figure 27: Storage plan zones

Before the different products could be allocated to each zone it was determined which products were the most important by revising the sales data.

The number of products sold per month was used to estimate how many products must fit into each zone. Products were sorted according to their lengths, irrespective of individual plank width and height.

Zones within zones were created. Products are organised as follows within each zone:

- 6.0m-6.6m
- 5.1m-5.7m
- 4.2m-4.8m
- 3.0m-3.9m
- 0.9-2.7m

It may clearly be seen which products are more important within each product grade.

Seven parcelled products can be stacked on top of one another and eight parcels fit in one row.

Important products are highlighted in green, critical products within each product grade are indicated with a red asterisk.

6.3 Conclusion

The locator zoning system and storage plan will enable the effective storage, locating and retrieval of stock. The dry mill will now be able to significantly improve products flow and increase the number of products reworked in a day.

The new layout can store approximately one week's work-in progress.

S5P Length (m)	Number of products per grade		
	MONTH	WEEK	
	6.6	267	
6.3	13	3	
6	248	62	*
5.7	19	5	
5.4	33	8	
5.1	8	2	
4.8	129	32	
4.5	20	5	
4.2	110	28	
3.9	12	3	
3.6	110	28	
3.3	23	6	
3	60	15	
2.7	12	3	
2.4	13	3	
2.1	3	1	
1.8	11	3	
1.5	6	2	
1.2	10	3	
0.9	9	2	

Figure 28: S5P products sold monthly

UTP Length (m)	Number of products per grade		
	MONTH	WEEK	
6.6	221	55	*
6.3	9	2	
6	209	52	*
5.7	18	5	
5.4	34	9	
5.1	8	2	
4.8	67	17	
4.5	18	5	
4.2	77	19	
3.9	3	1	
3.6	46	12	
3.3	15	4	
3	23	6	
2.7	7	2	
2.4	9	2	
2.1	5	1	
1.8	25	6	
1.5	23	6	
1.2	28	7	
0.9	23	6	

Figure 29: UTP products sold monthly

BBB Length (m)	Number of products per grade	
	MONTH	WEEK
6.6	80	20 *
6.3	6	2
6	79	20 *
5.7	16	4
5.4	15	4
5.1	8	2
4.8	31	8
4.5	6	2
4.2	34	9
3.9	5	1
3.6	47	12
3.3	5	1
3	28	7

Figure 30: BBB products sold monthly

S5R Length (m)	Number of products per grade	
	MONTH	WEEK
	6.6	9
6	8	2
5.7	2	1
5.4	1	0
5.1	1	0
4.8	7	2
3.6	1	0
2.7	18	5
2.4	16	4
2.1	13	3
1.8	14	4
1.5	9	2

Figure 31: S5R products sold monthly

UTL Length (m)	Number of products per grade	
	MONTH	WEEK
	2.7	16
2.4	17	4
2.1	20	5
1.8	20	5
1.5	12	3

Figure 32: UTL products sold monthly

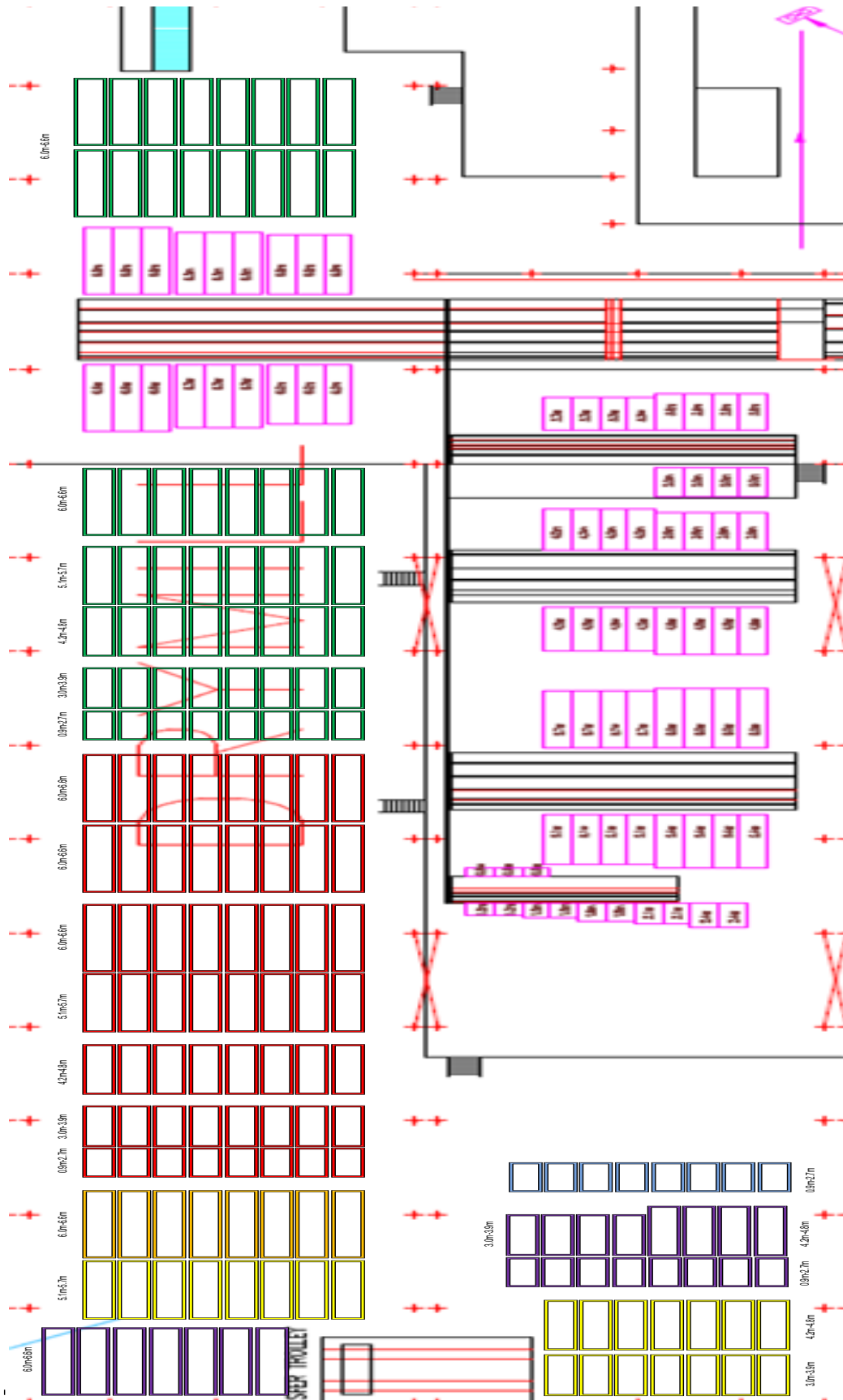

Figure 33: Scale drawing of products within zones

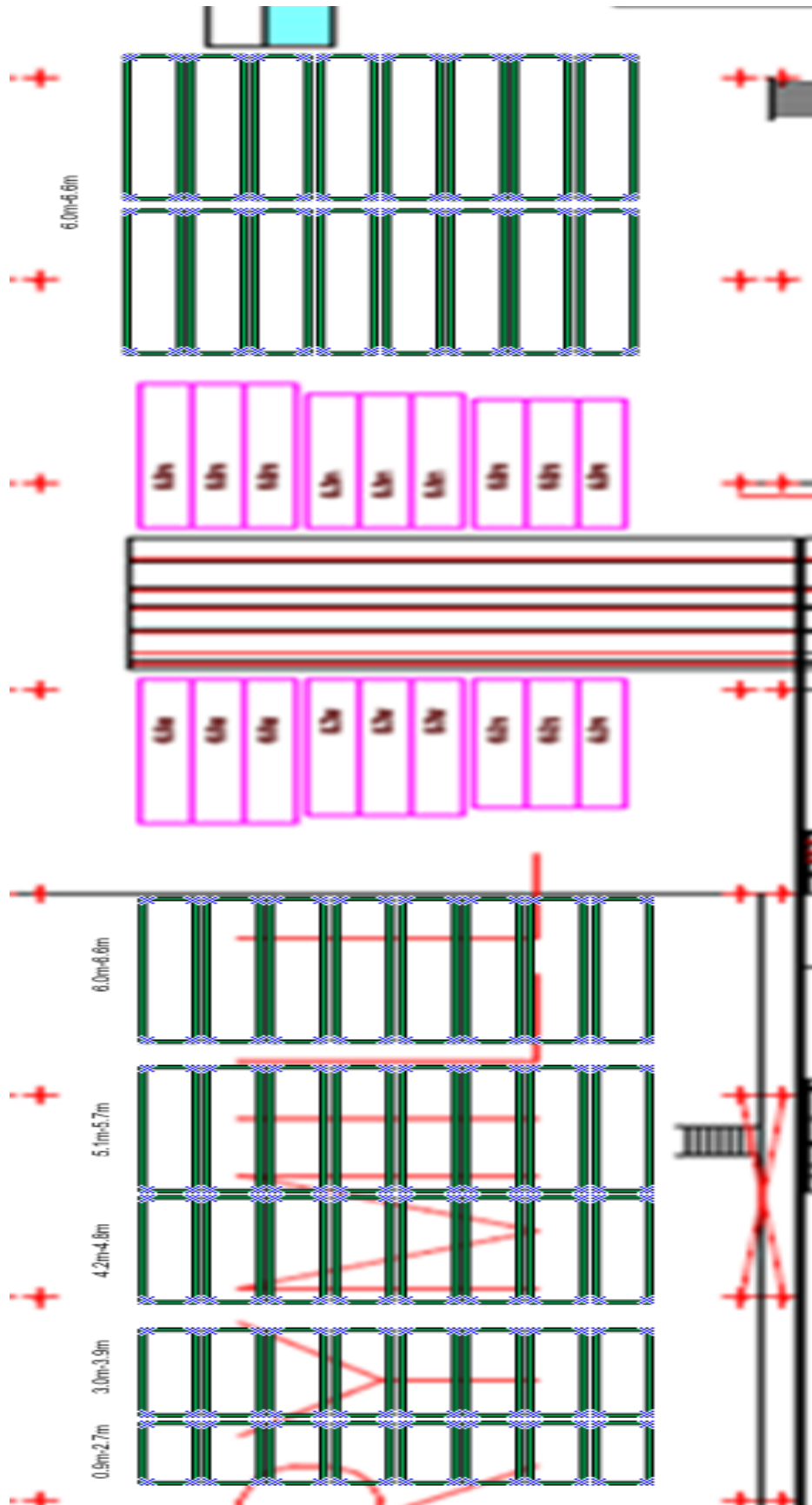

Figure 34: S5P Zone

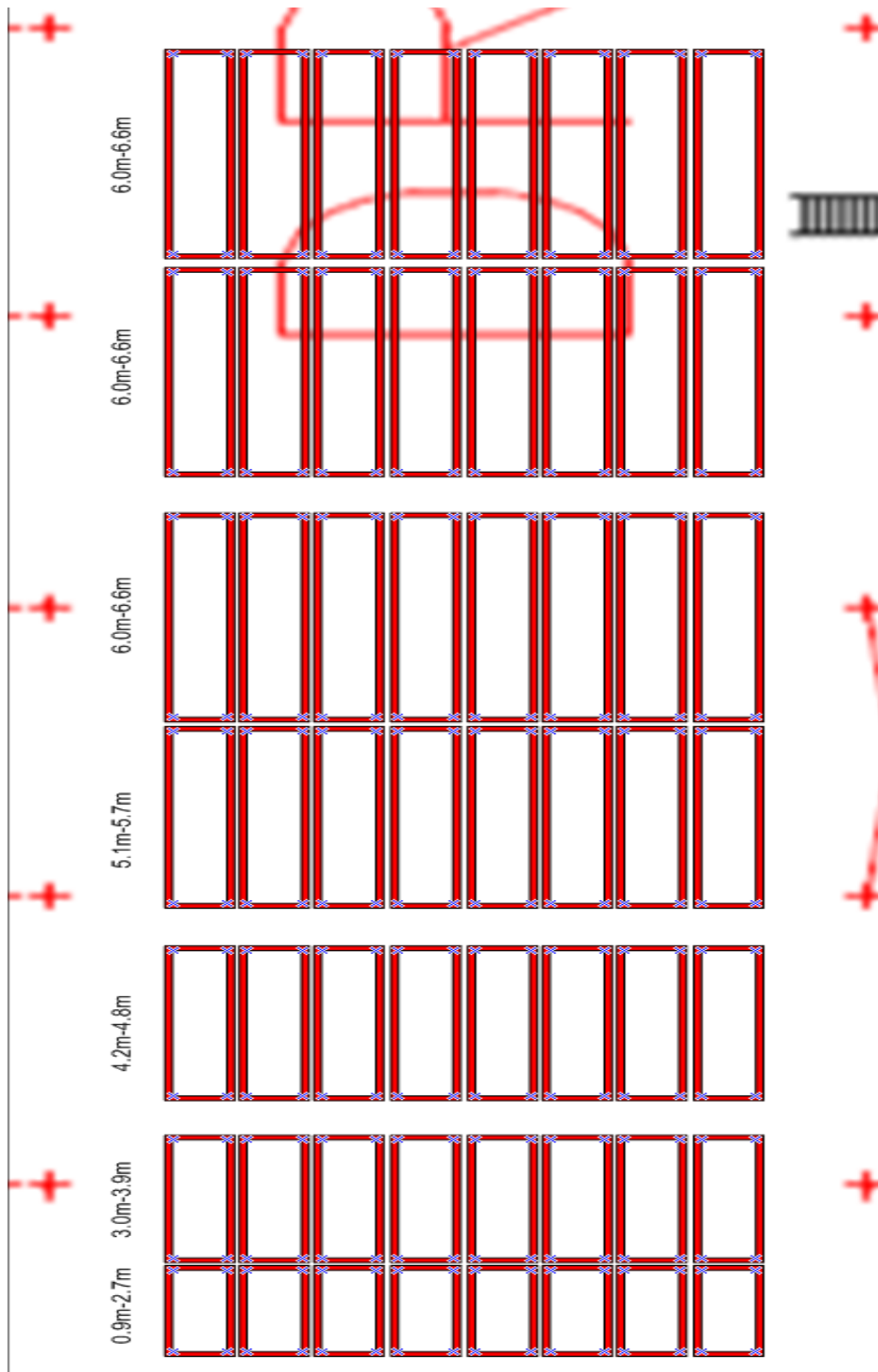

Figure 35: UTP Zone

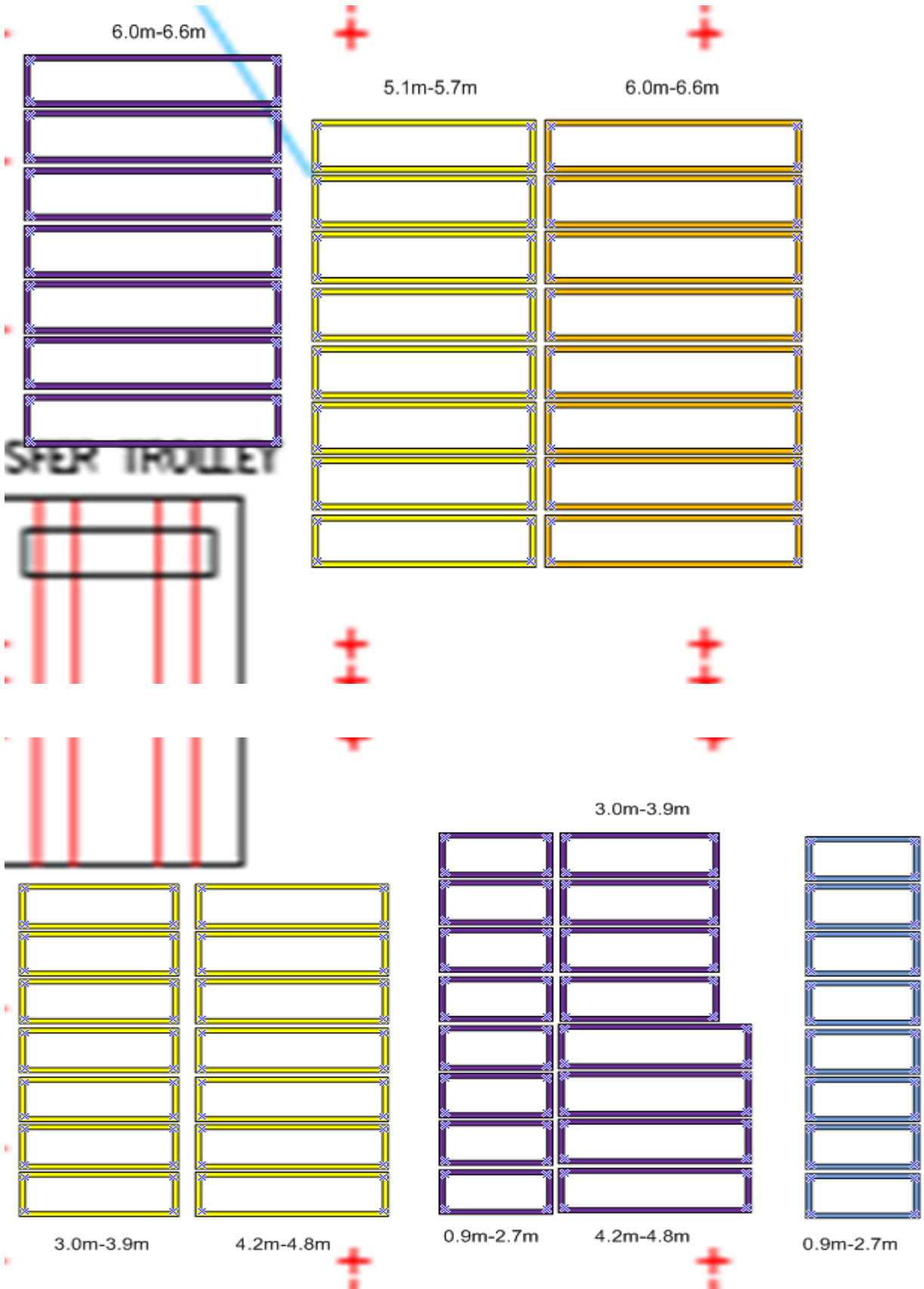

Figure 36: BBB Zone (Yellow), S5R Zone (Purple) and UTL Zone (Blue)

Chapter 7: Reference

1. Altamuro, V. M. (2011). Industrial plants.
2. De Jager, C. Personal interview and Correspondence. 16-18, 24, 25 March 2012, Pretoria.
3. Higgins, L. R., Mobley, K., & Wikoff, D. (2008). Maintenance repair and operations-storeroom excellence. In *Maintenance Engineering Handbook* (p. Chapter 13). McGraw-Hill Professional.
4. Khansuwan, M. P. (1999). A study on Plant Layout Improvement. *A case study at Kritchai Mechanical Company Pty.* Faculty of Engineering, Thammasat University.
5. Moore, J. M. (1962). *Plant layout and design*. New York: The Macmillian Company.
6. Tompkins, J., White, J., Bozer, Y., Frazelle, E., & Tanchoco, J. (2003). *Facilities Planning* (3rd ed.). New York: Wiley.
7. Wilson, L. (2010). Lean Manufacturing and the Toyota Production system. In L. Wilson, *How to Implement Lean: The Prescription for the Lean Project* (p. Chapter 2). McGraw-Hill Professional.
8. Yaoxiang, Z., & Liqiang, Z. (Feb, 2002). Facilities Planning and Enterprise Logistics. *China Machine Press*, 87.
9. Zandin, K. B. (2001). *Maynard's Industrial engineering Handbook*. McGraw-Hill Professional.

Chapter 8: Appendices

Appendix 1: Driekop mill

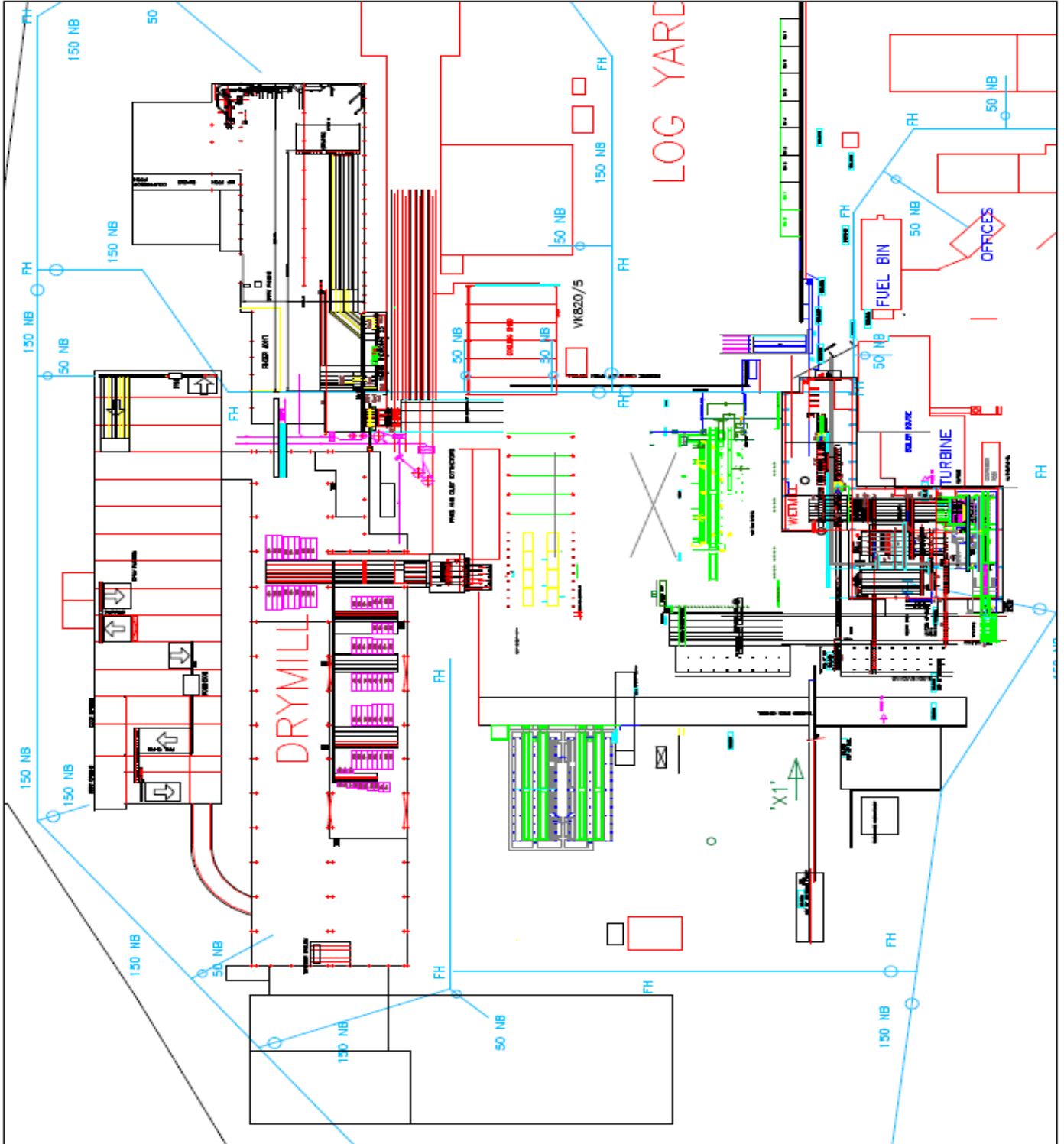

Appendix 2: Driekop process flow

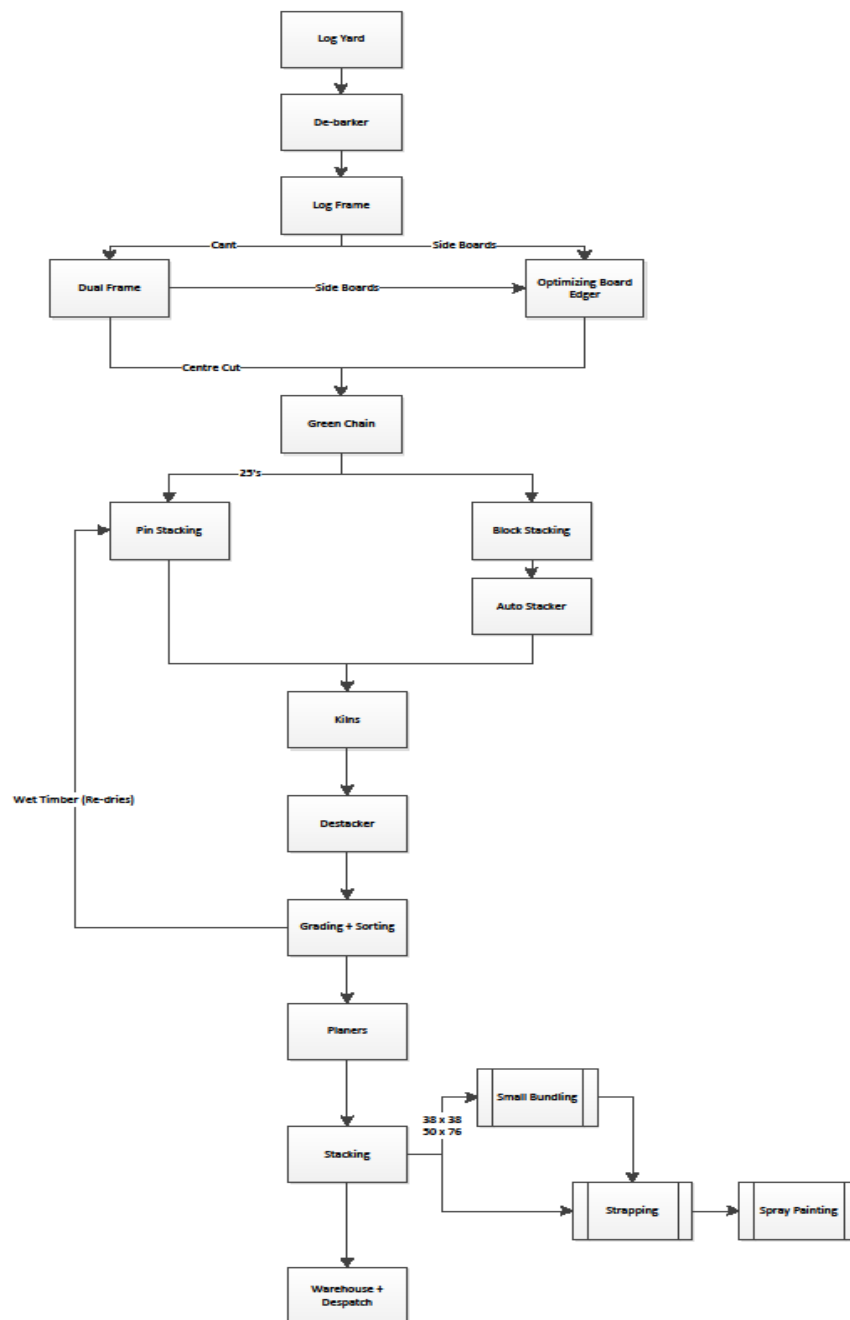

Appendix 3: Direction of product flow

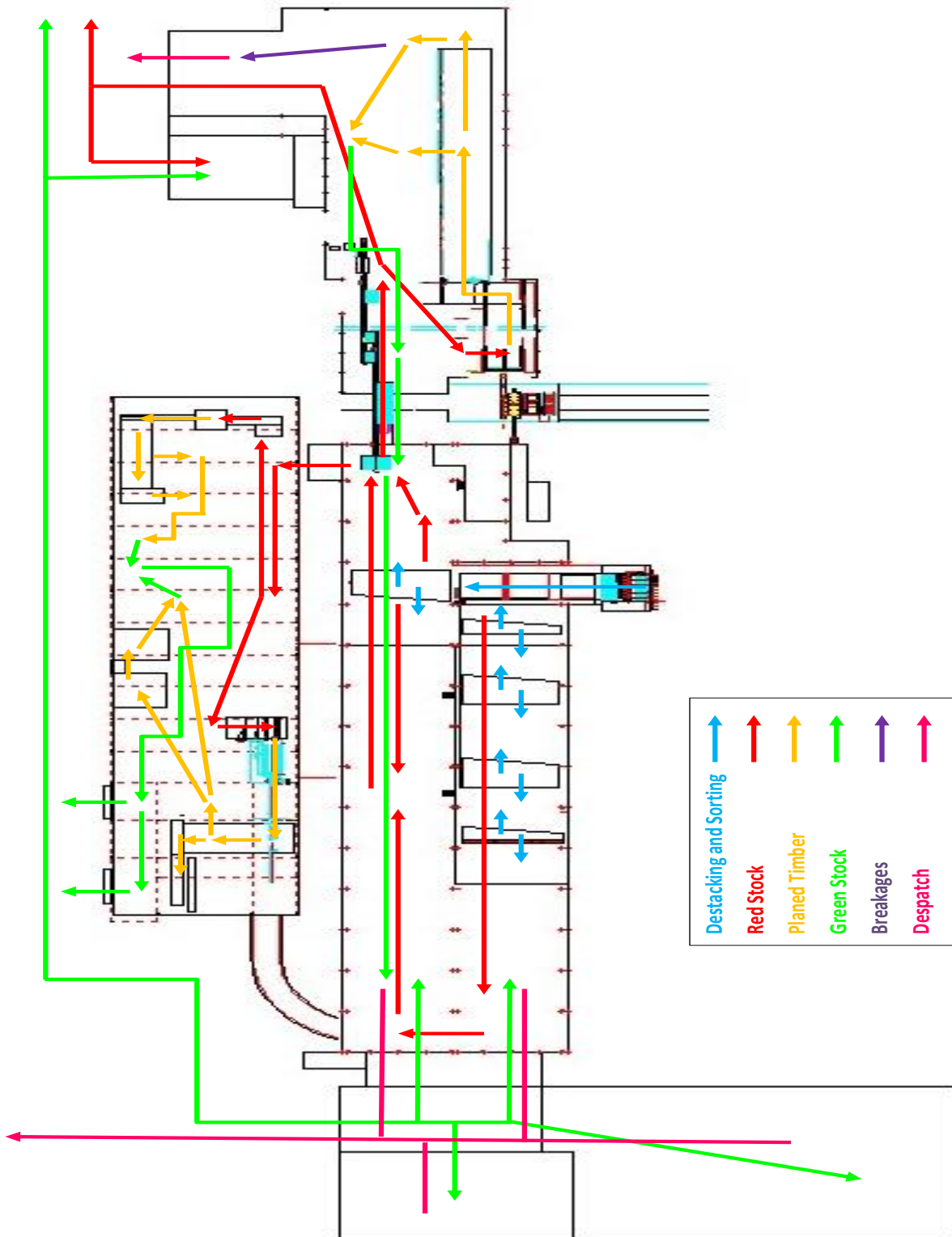

Appendix 4: Stacking areas

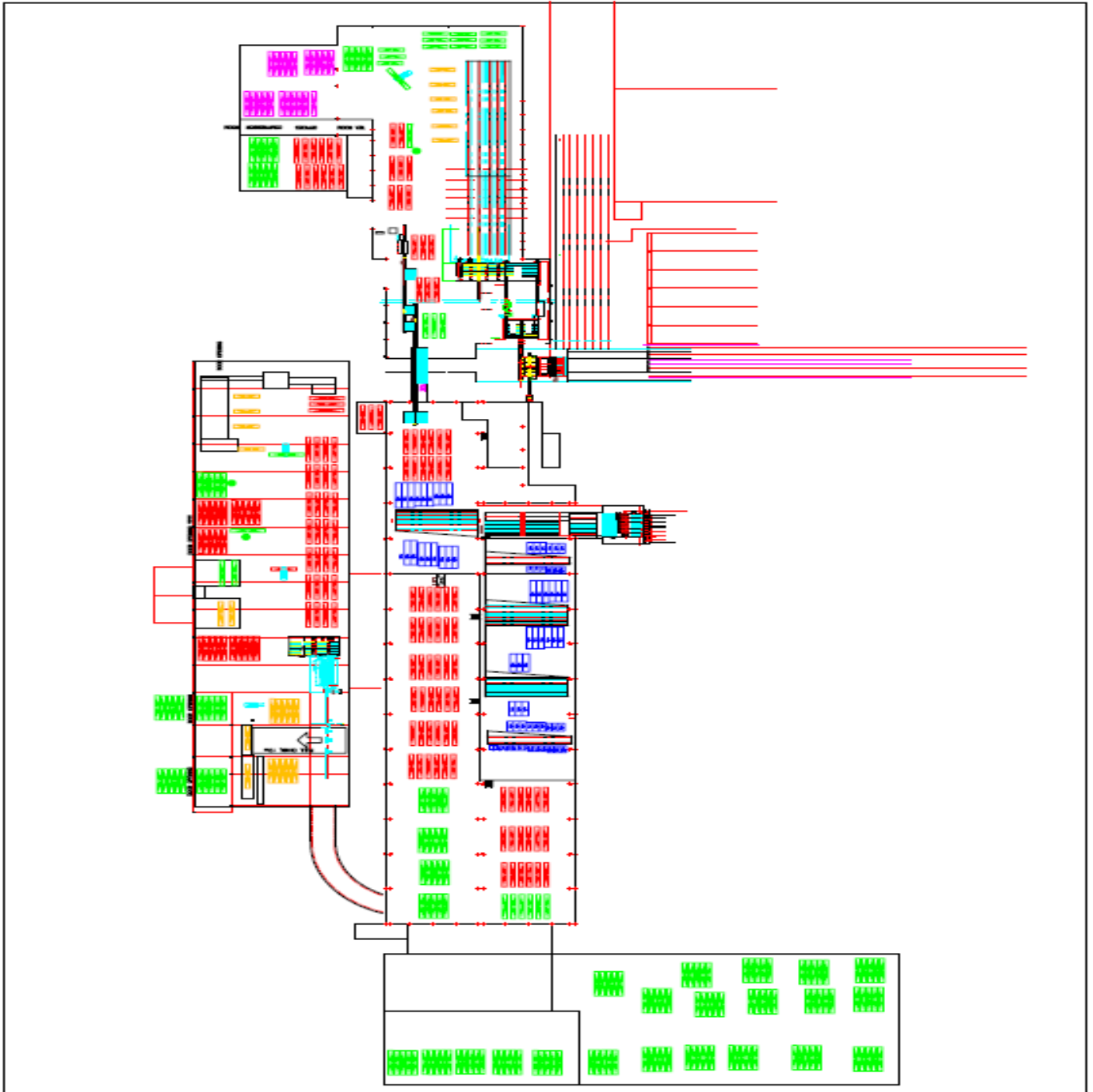

1. Blue blocks: parcel stacking areas next to sorting chains
2. Red blocks: red stock stacks (work-in-progress)
3. Green blocks: green stock stacks (finished goods)

Appendix 5: Space calculations per product (Excel calculations)

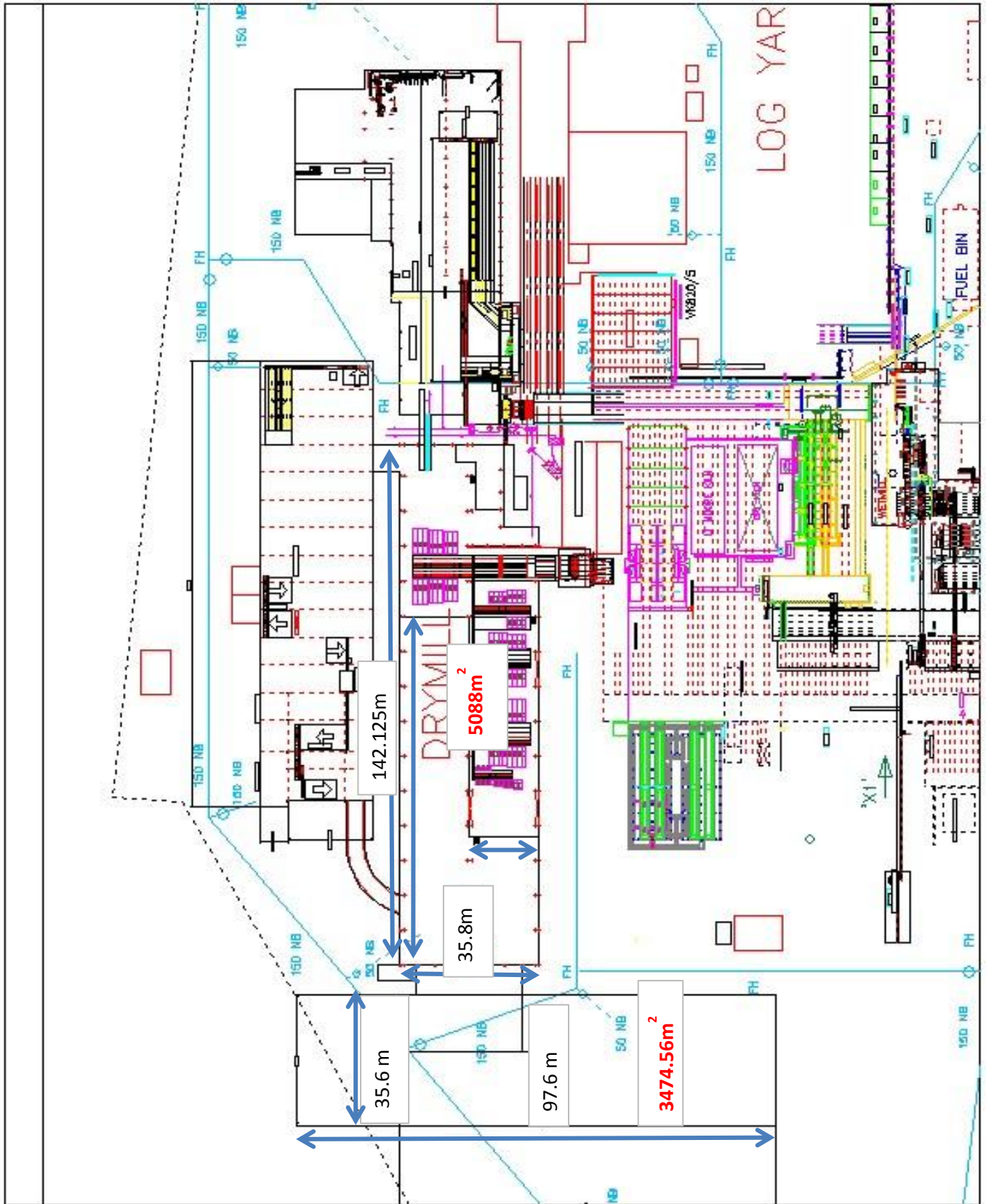

Dimension	Thickness	Width	Pieces	Layers	Total	Boards/layer	Pieces	Area required per bundle (m ²)						
								0.9	1.2	1.5	1.8	2.1	2.4	2.7
0.019	0.076	495	24	14	336	0.9576	1.2768	1.596	1.9152	2.2344	2.5536	2.8728		
0.025	0.076	252	9	14	252	0.9576	1.2768	1.596	1.9152	2.2344	2.5536	2.8728		
0.025	0.114	162	9	18	162	0.9234	1.2312	1.539	1.8468	2.1546	2.4624	2.7702		
0.025	0.152	126	9	18	126	0.9576	1.2768	1.596	1.9152	2.2344	2.5536	2.8728		
0.038	0.038	336	6	12	336	0.9576	1.2768	1.596	1.9152	2.2344	2.5536	2.8728		
0.038	0.05	240	20	20	240	0.54								
0.038	0.076	168	12	14	168	0.9576	1.2768	1.596	1.9152	2.2344	2.5536	2.8728		
0.038	0.114	108	6	12	108	0.9234	1.2312	1.539	1.8468	2.1546	2.4624	2.7702		
0.038	0.152	84	6	7	84	0.9576	1.2768	1.596	1.9152	2.2344	2.5536	2.8728		
0.038	0.228	60	6	5	60	1.026	1.368	1.71	2.052	2.394	2.736	3.078		
0.05	0.076	140	10	14	140	0.9576	1.2768	1.596	1.9152	2.2344	2.5536	2.8728		
0.05	0.152	63	5	7	63	0.9576	1.2768	1.596	1.9152	2.2344	2.5536	2.8728		
0.05	0.228	45	5	5	45	1.026	1.368	1.71	2.052	2.394	2.736	3.078		

Dimension		Pieces	Layers	Total	Boards/layer	calculated	Area required per bundle (m ²)						
Thickness	Width	Pieces	Layers	Total	Boards/layer	Pieces	3	3.3	3.6	3.9	4.2	4.5	4.8
0.019	0.076	495	24	24	14	336	3.192	3.5112	3.8304	4.1496	4.4688	4.788	5.1072
0.025	0.076	252	9	18	14	252	3.192	3.5112	3.8304	4.1496	4.4688	4.788	5.1072
0.025	0.114	162	9	18	9	162	3.078	3.3858	3.6936	4.0014	4.3092	4.617	4.9248
0.025	0.152	126	9	18	7	126	3.192	3.5112	3.8304	4.1496	4.4688	4.788	5.1072
0.038	0.038	336	6	12	28	336	3.192	3.5112	3.8304	4.1496	4.4688	4.788	5.1072
0.038	0.05	240	20	20	12	240							
0.038	0.076	168	12	12	14	168	3.192	3.5112	3.8304	4.1496	4.4688	4.788	5.1072
0.038	0.114	108	6	12	9	108	3.078	3.3858	3.6936	4.0014	4.3092	4.617	4.9248
0.038	0.152	84	6	12	7	84	3.192	3.5112	3.8304	4.1496	4.4688	4.788	5.1072
0.038	0.228	60	6	12	5	60	3.42	3.762	4.104	4.446	4.788	5.13	5.472
0.05	0.076	140	10	10	14	140	3.192	3.5112	3.8304	4.1496	4.4688	4.788	5.1072
0.05	0.152	63	5	9	7	63	3.192	3.5112	3.8304	4.1496	4.4688	4.788	5.1072
0.05	0.228	45	5	9	5	45	3.42	3.762	4.104	4.446	4.788	5.13	5.472

Dimension		Pieces		Layers	Total	Boards/layer	calculated	Area required per bundle (m ²)					
Thickness	Width						Pieces	5.1	5.4	5.7	6	6.3	6.6
0.019	0.076	495	24	24	14	336	5.4264	5.7456	6.0648	6.384	6.7032	7.0224	
0.025	0.076	252	9	18	14	252	5.4264	5.7456	6.0648	6.384	6.7032	7.0224	
0.025	0.114	162	9	18	9	162	5.2326	5.5404	5.8482	6.156	6.4638	6.7716	
0.025	0.152	126	9	18	7	126	5.4264	5.7456	6.0648	6.384	6.7032	7.0224	
0.038	0.038	336	6	12	28	336	5.4264	5.7456	6.0648	6.384	6.7032	7.0224	
0.038	0.05	240	20	20	12	240							
0.038	0.076	168	12	12	14	168	5.4264	5.7456	6.0648	6.384	6.7032	7.0224	
0.038	0.114	108	6	12	9	108	5.2326	5.5404	5.8482	6.156	6.4638	6.7716	
0.038	0.152	84	6	12	7	84	5.4264	5.7456	6.0648	6.384	6.7032	7.0224	
0.038	0.228	60	6	12	5	60	5.814	6.156	6.498	6.84	7.182	7.524	
0.05	0.076	140	10	10	14	140	5.4264	5.7456	6.0648	6.384	6.7032	7.0224	
0.05	0.152	63	5	9	7	63	5.4264	5.7456	6.0648	6.384	6.7032	7.0224	
0.05	0.228	45	5	9	5	45	5.814	6.156	6.498	6.84	7.182	7.524	

Excel was used to calculate the square metre area that a product would occupy.

Appendix 6: Stock and orders

19/03/2012

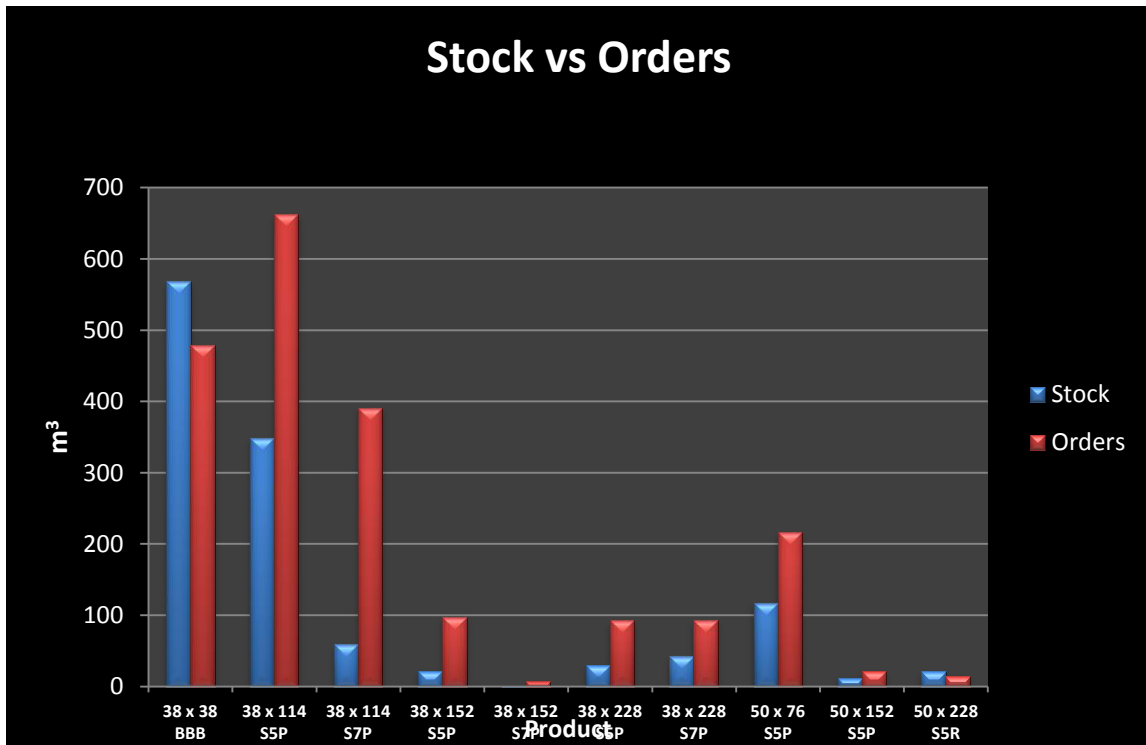

Biggest problem with product grade S5P: stock is less than orders in the case of all products.