



## 06. Design Development

## A Spatial Field in Tension

From the analysis of the tensions that exist within the city, four were highlighted in hierarchical order. These tensions highlight pertinent aspects that need to be addressed in order for the new architectural intervention to be successful.

Figure 6.1  
Concept Collage (Author, 2010).

### 1. Passive | Active

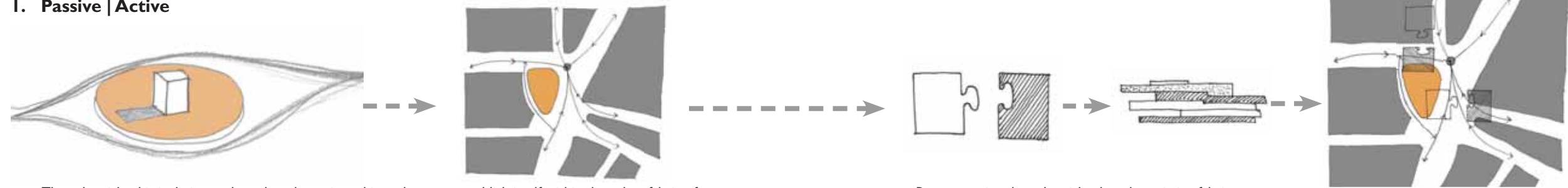

- The urban island is isolation and needs to be activated in order to re-establish itself within the urban fabric of the city. By connecting to the existing fabric functionally, spatially and physically, the urban island will be able to accommodate a variety of different functions.

- Re-connecting the urban island to the existing fabric.

### 2. Park | City



- Creating an urban park that will provide public green space that is much needed within the city.

- The urban park will accommodate a variety of functions. This will prevent the urban park from becoming an isolated homogeneous entity within the city.

### 3. Old | New

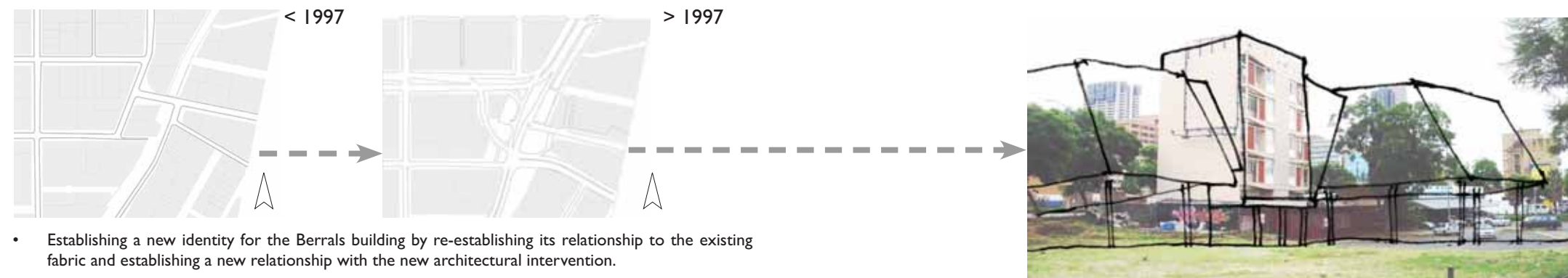

- Establishing a new identity for the Berrals building by re-establishing its relationship to the existing fabric and establishing a new relationship with the new architectural intervention.

### 3. Centre | Edge

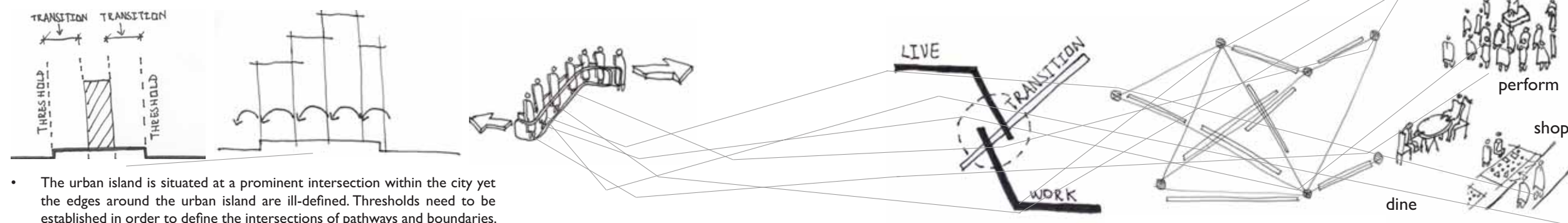

- The urban island is situated at a prominent intersection within the city yet the edges around the urban island are ill-defined. Thresholds need to be established in order to define the intersections of pathways and boundaries.

**Concept : A Hybrid of Relationships**

“While the countryside represented eternal sameness, the city was always the work of man and thus subject to the caprices of human nature. In this respect, any city is always in motion, a place of transition and in transition. The city is thus trans-urban.” (Bouman, Mulder 2002: 72 - 74).

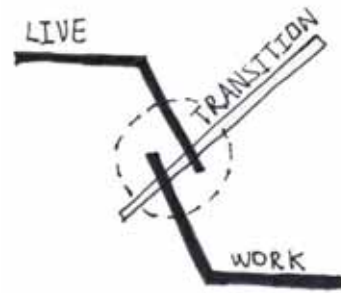

Figure 6.2.  
The idea of transition within a city (Author, 2010).

The idea of the city of Pretoria being trans-urban is evident along the periphery of the urban island. It is at this intersection that people move from their place of work - the city - to where they live - Sunnyside District. Along this path people are moving within a space of transition. In this space, moments of spontaneity occur. The space has allowed people to experiment with the city and to make it work in new ways. The city has constructed new definitions of place replacing the old, race-based seclusions with new boundaries, identities and enclosures. The city has become a interweaving of institutions, practices and value systems of different worlds that overlap onto one another in increasingly complex ways. This complex interweaving of different practices have resulted in hybrid conceptions of space and society that are evident within the city (Bremner 2004 : 24). Can the urban island replace the current space of transition and offer more opportunity for hybridity?

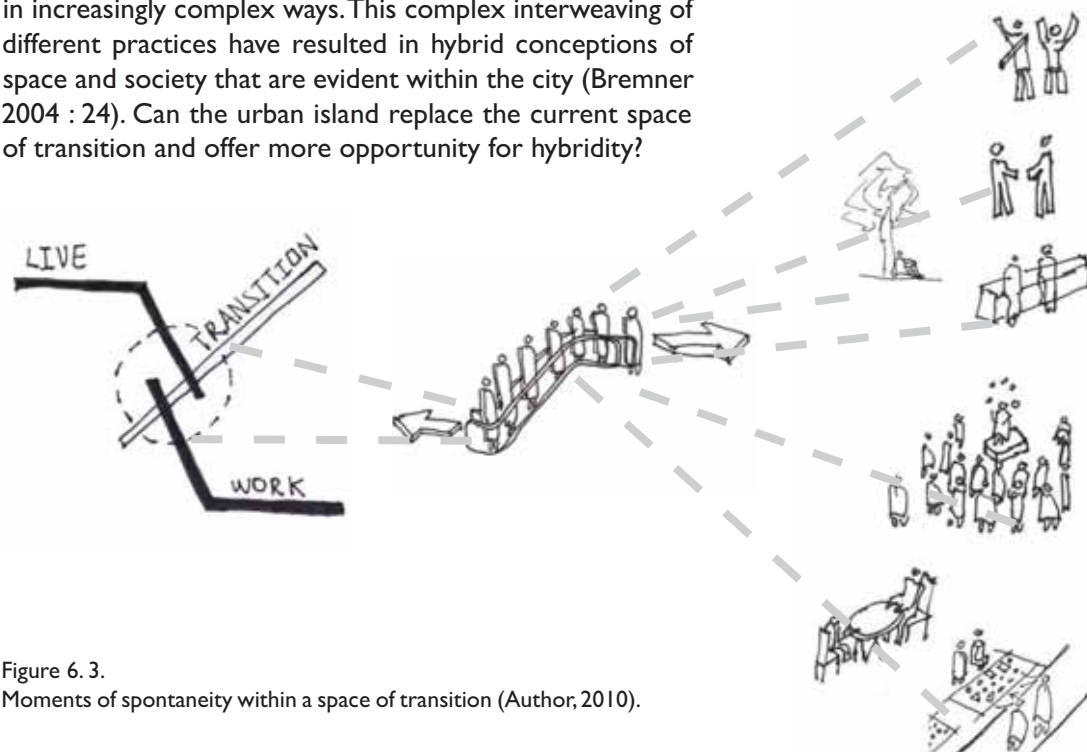

Figure 6.3.  
Moments of spontaneity within a space of transition (Author, 2010).



Figure 6.4. The intersection of Nelson Mandela and Skinner Street - A transitional zone between living and working within a trans-urban city (Author, 2010)



Figure 6.5 : Moments of spontaneity :Appropriation of space along the path of transition (Author, 2010)

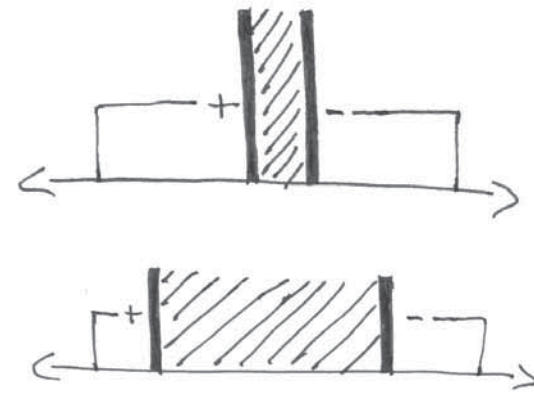

Figure 6.6. Tensions in conflict (Author, 2010)

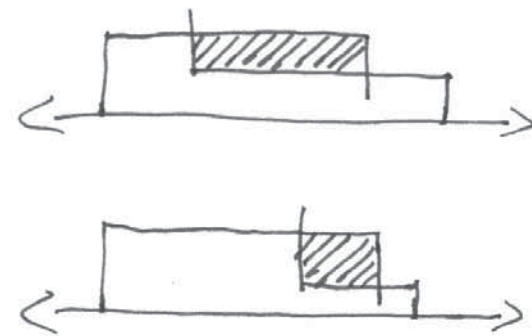

Figure 6.7. Tensions merging (Author, 2010)

Figures 6.6 & .6.7.

Tensions manifesting themselves as two sides of a sliding scale thereby creating opposing forces that are active and not passive (Author, 2010)

The tensions that exist within the context of the urban island are inter-connected to each other while still being inter-dependance (Woods 2009). They are not simply magnetic poles that sit in opposition to each other. Within the context of an individual project and its specific demands, tensions manifest themselves as two sides of a sliding scale. A calibrated judgement is made when dealing with a particular tension at hand. Opportunities and limitations emerge out of these judgements (Wolff 2009 : 178).

The city is in constant transition. It is tran-urban. Tensions exist within this hybrid conception of society and space. It is within this space that tensions merge together or further oppose each other thereby activating space either negatively or positively. The reconciling and conflicting of different tensions creates a hybrid of relationships that is in constant transition.

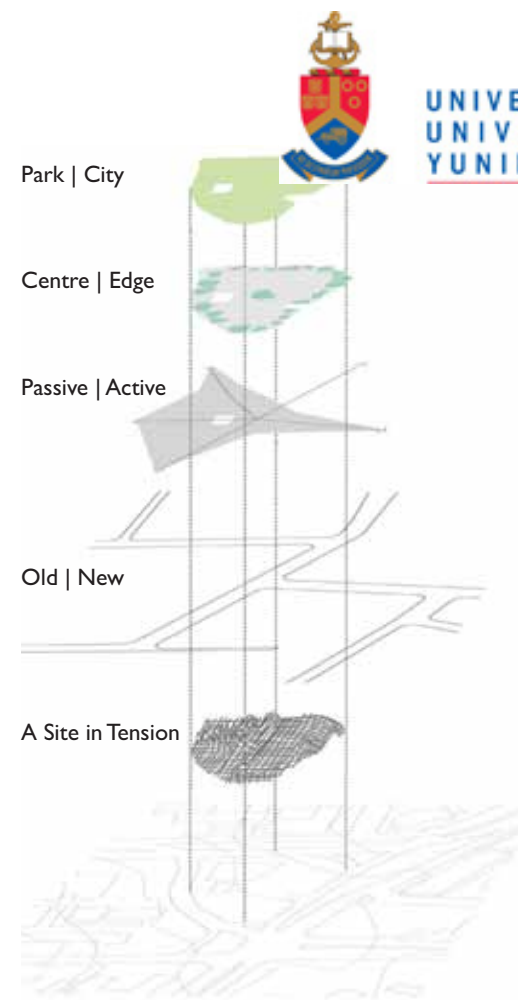

Figure 6.8.

Tensions inter-connected to each other while still being inter-dependent (Author, 2010)

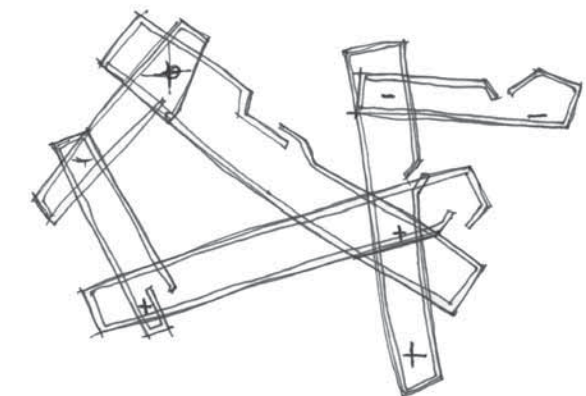

Figure 6.9.  
Inter-connected tensions (Author, 2010)

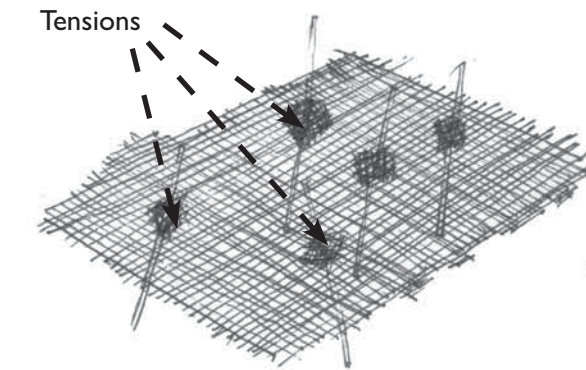

Figure 6.10.  
The city of Pretoria sketched as a piece of fabric. (Author, 2010)

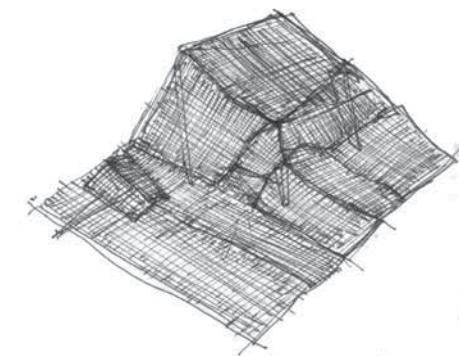

Figure 6.11.  
The affect of tensions on the 'fabric' of the city (Author, 2010)

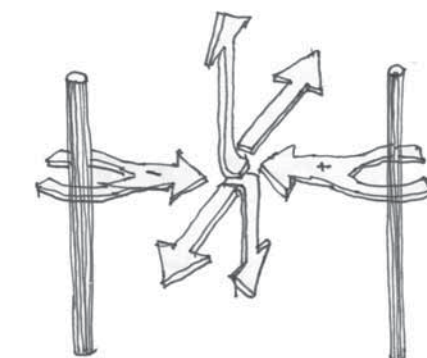

Figure 6.12.  
A hybrid of relationships (Author, 2010)

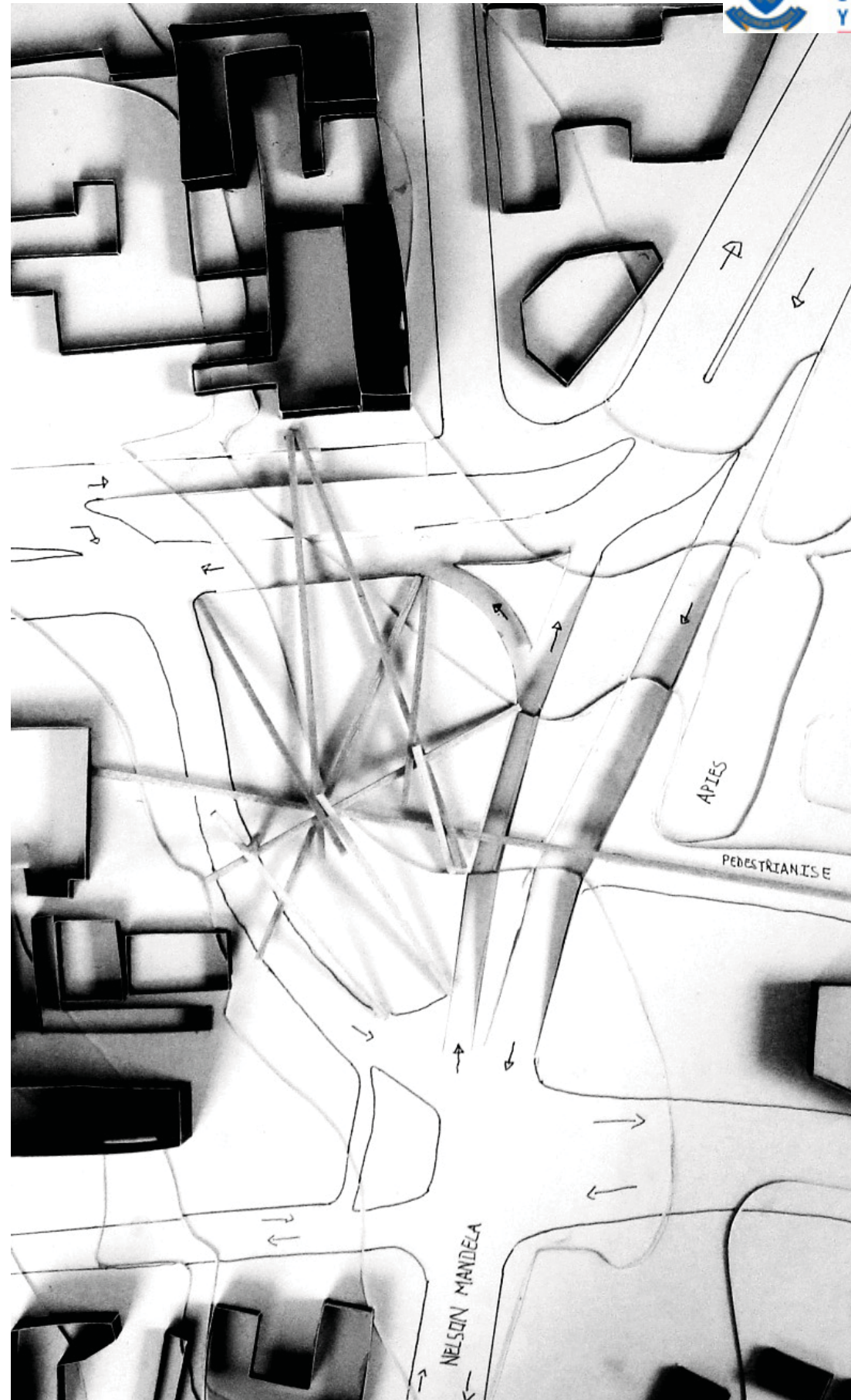

Figure 6.13. Concept Model (Author, 2010)

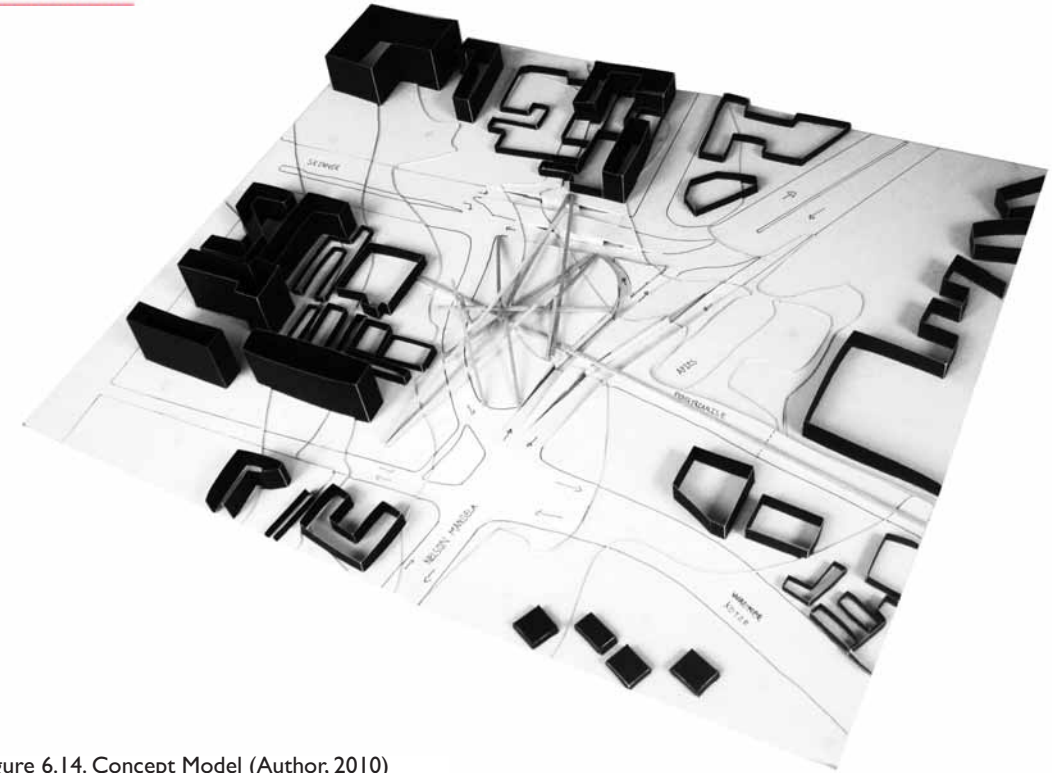

Figure 6.14. Concept Model (Author, 2010)

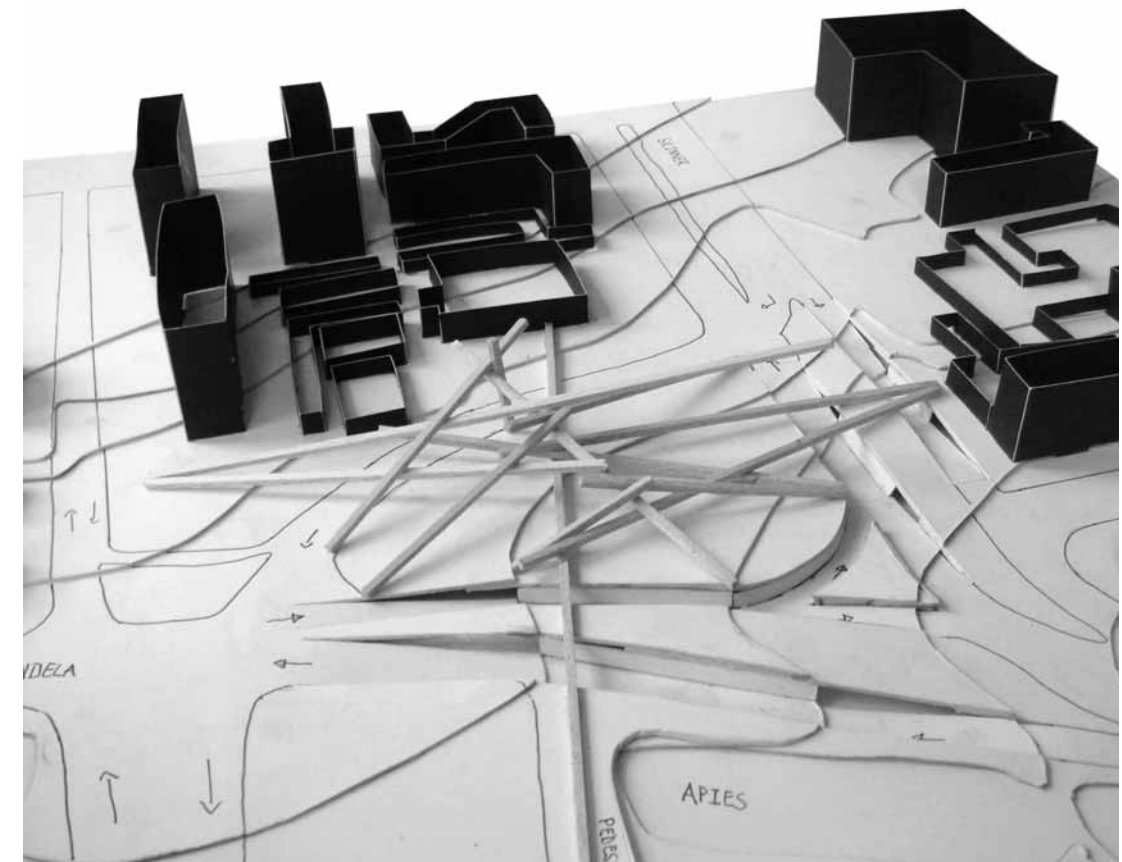

Figure 6.15. Concept Model (Author, 2010)

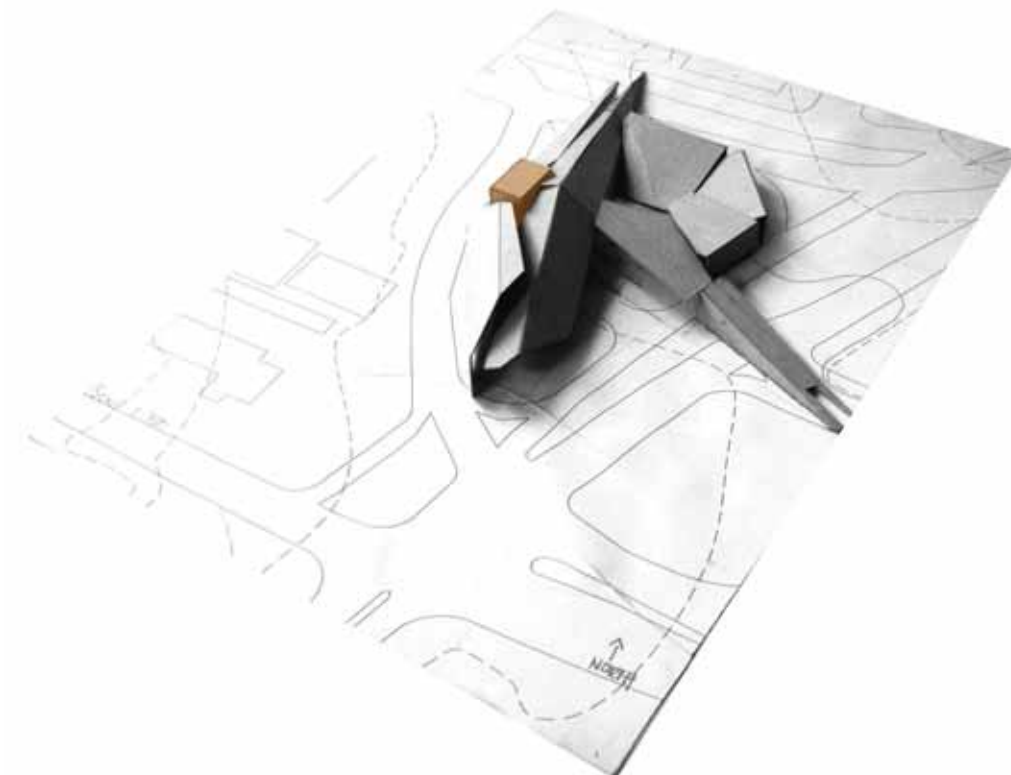
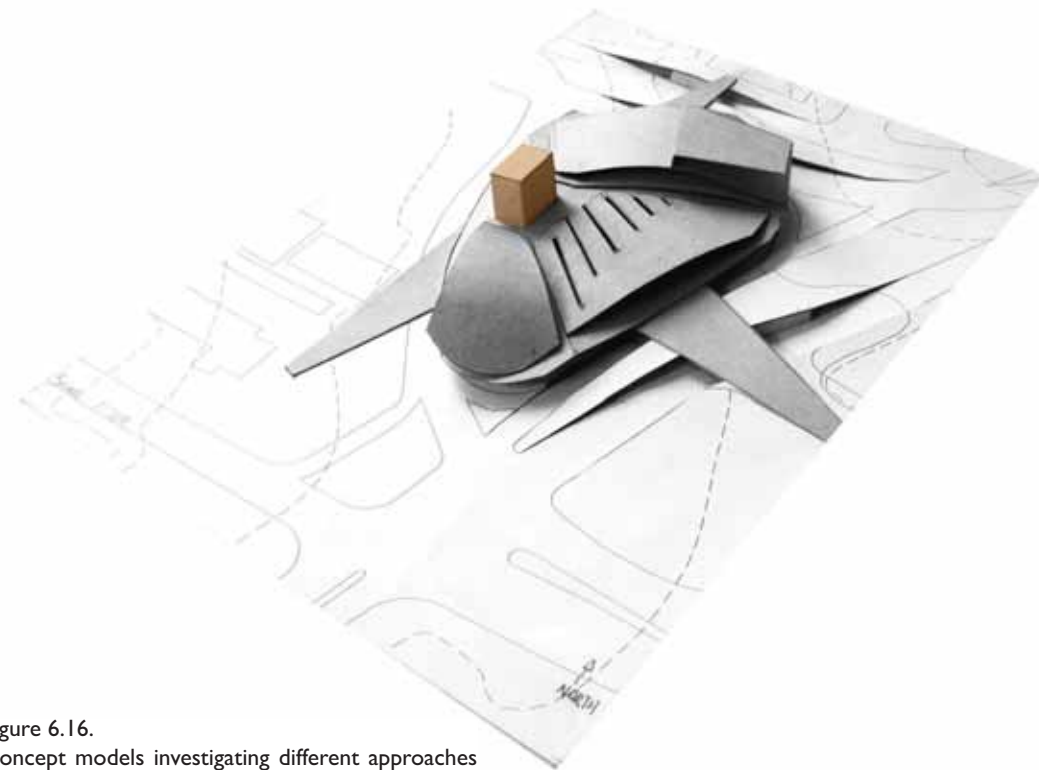
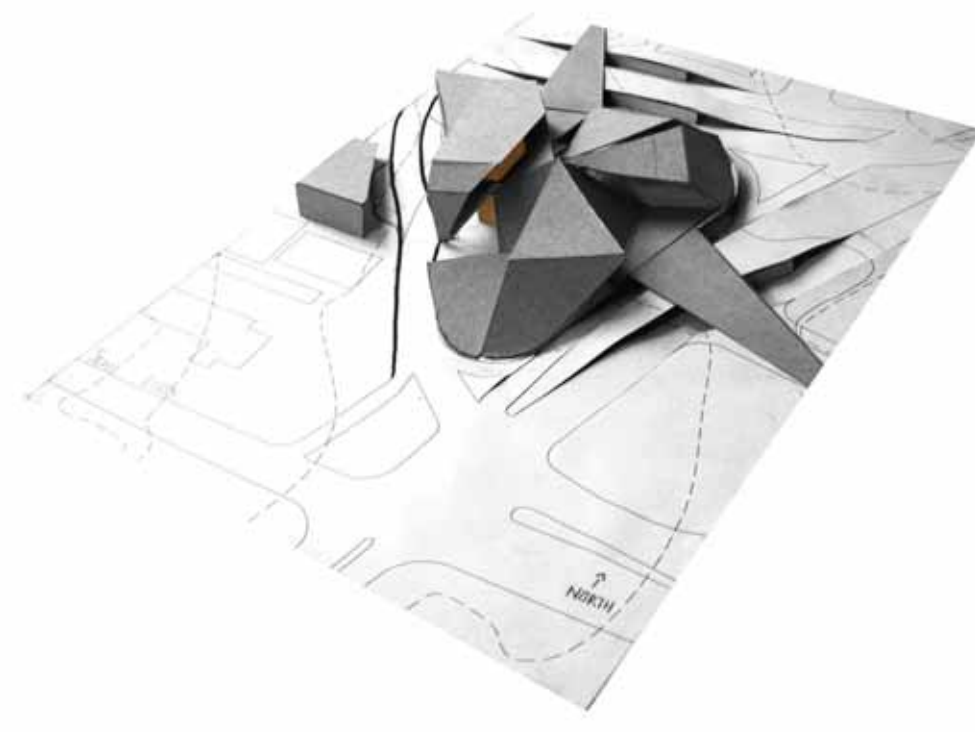
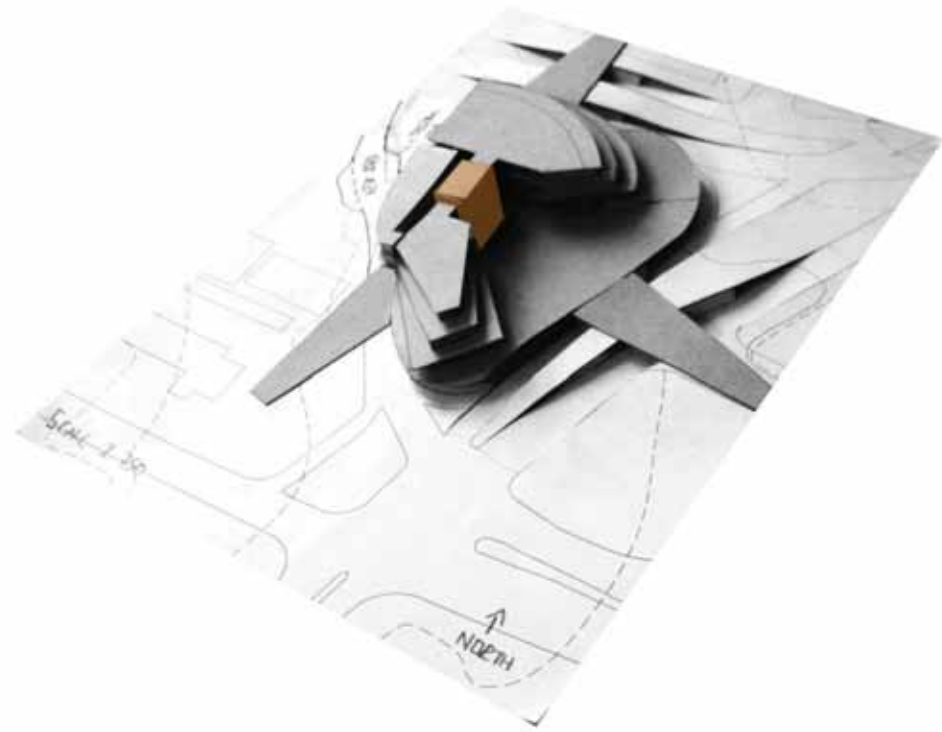

Figure 6.16.  
Concept models investigating different approaches  
in dealing with tensions (Author, 2010)



Figure 6.17. Concept model (Author, 2010)

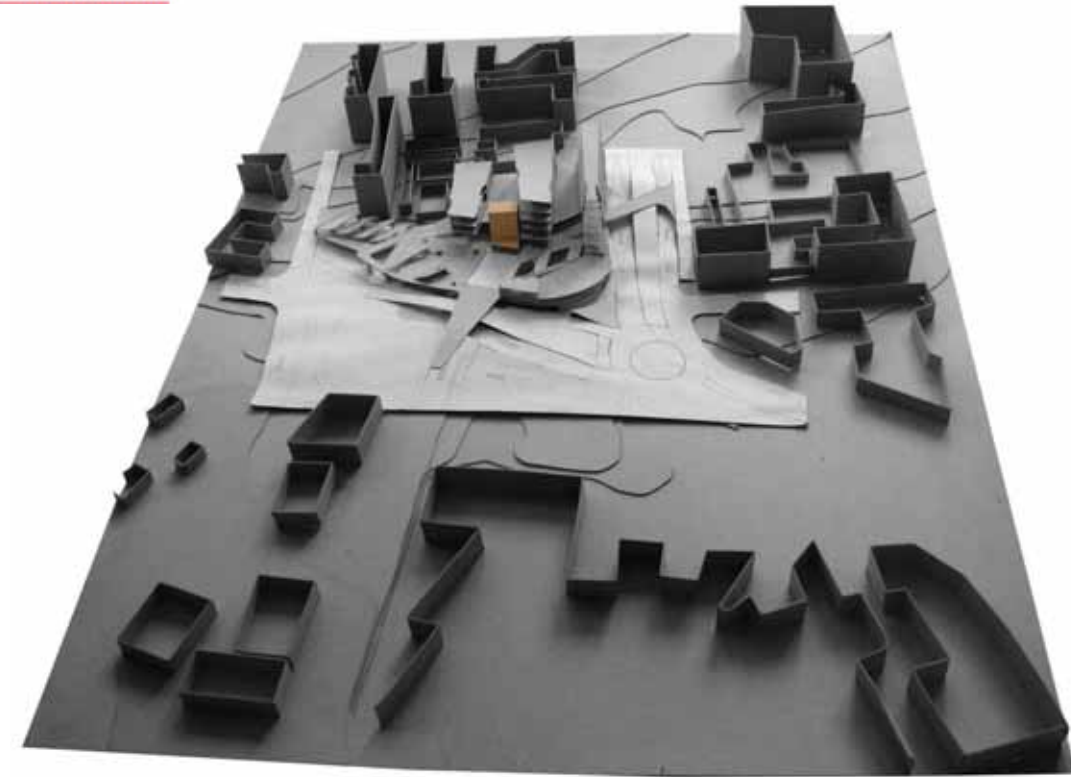

Figure 6.18. Concept Model (Author, 2010)



Figure 6.19. Concept Model (Author, 2010)

Passive | Active

Activating the urban block to connect it to the existing fabric physically, spatially and functionally.

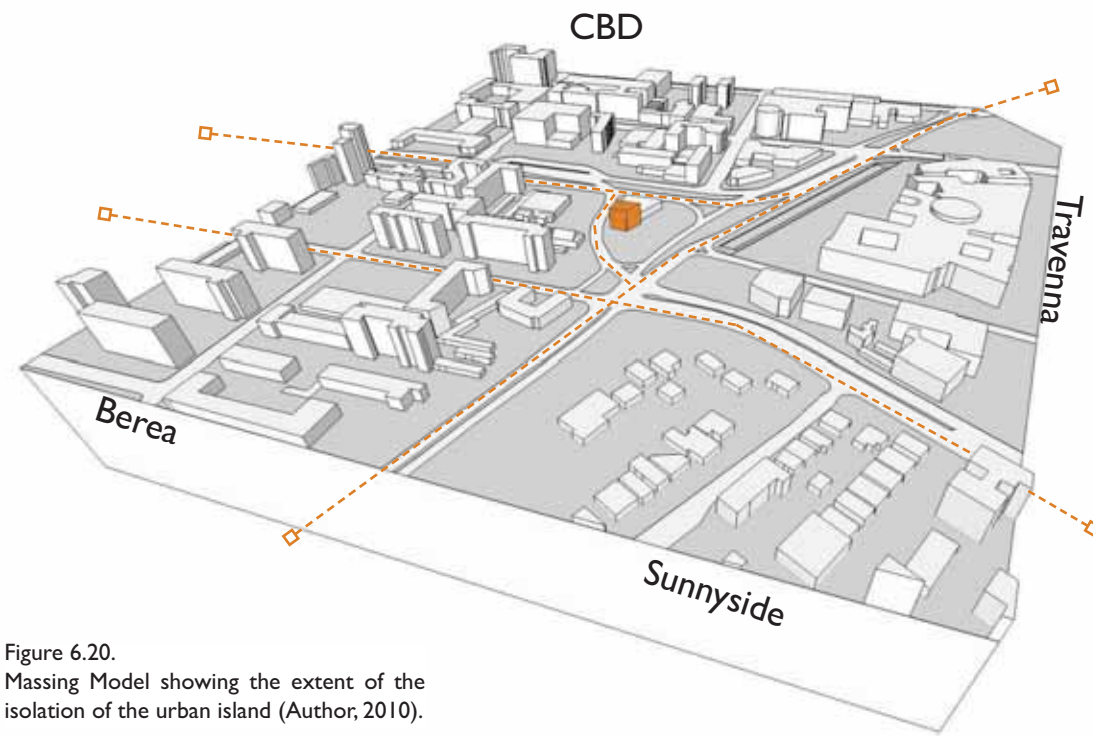

Figure 6.20. Massing Model showing the extent of the isolation of the urban island (Author, 2010).

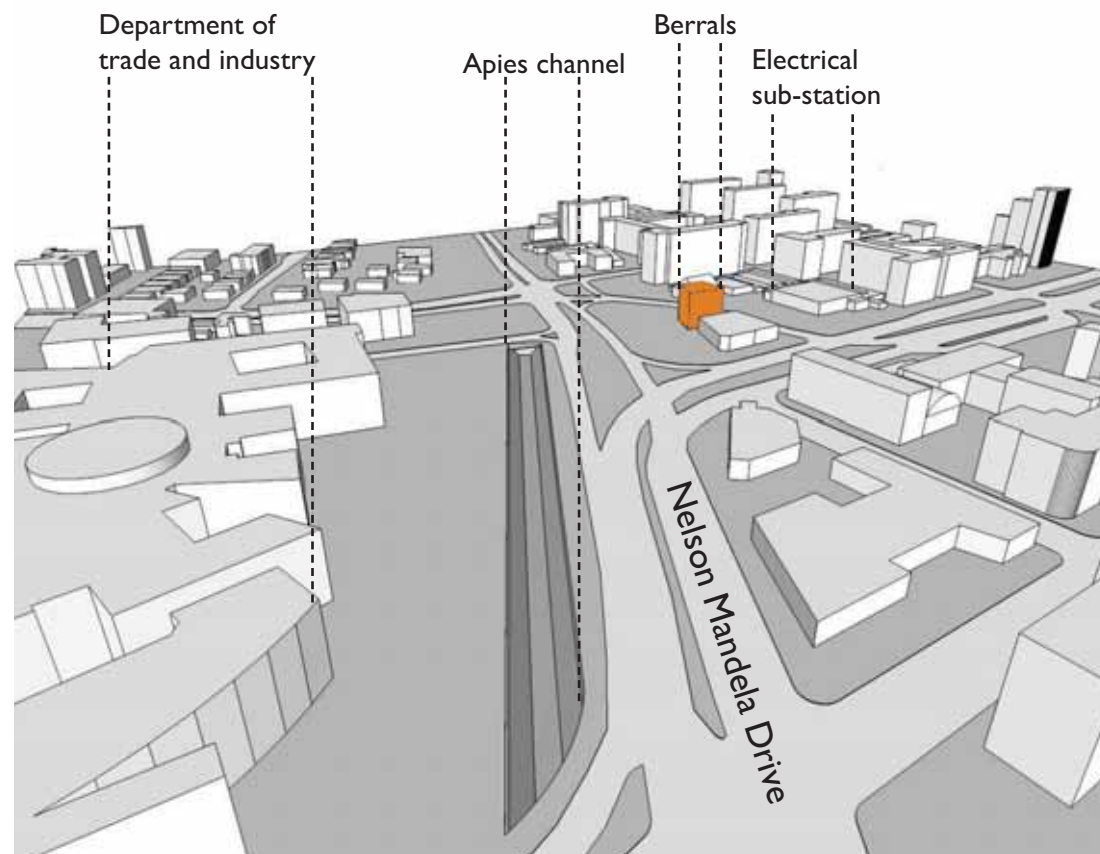

Figure 6.21. Massing Model showing the immediate context around the urban island (Author, 2010)

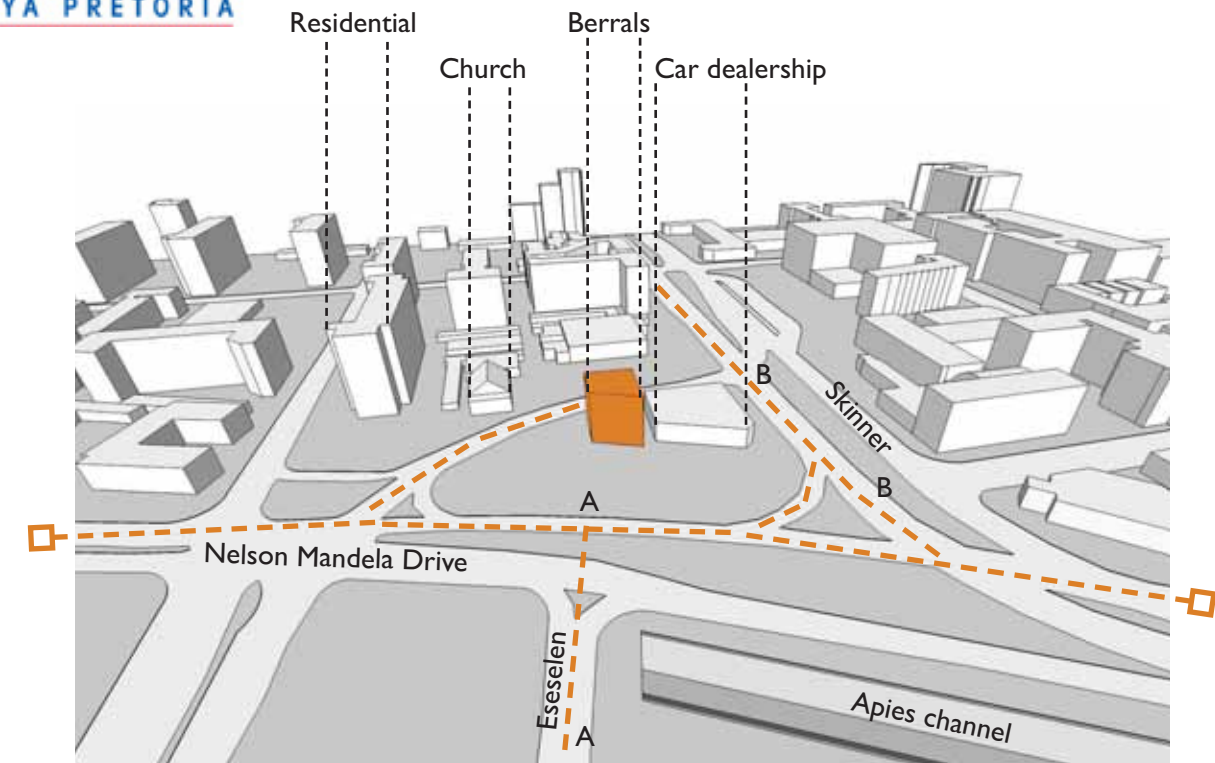
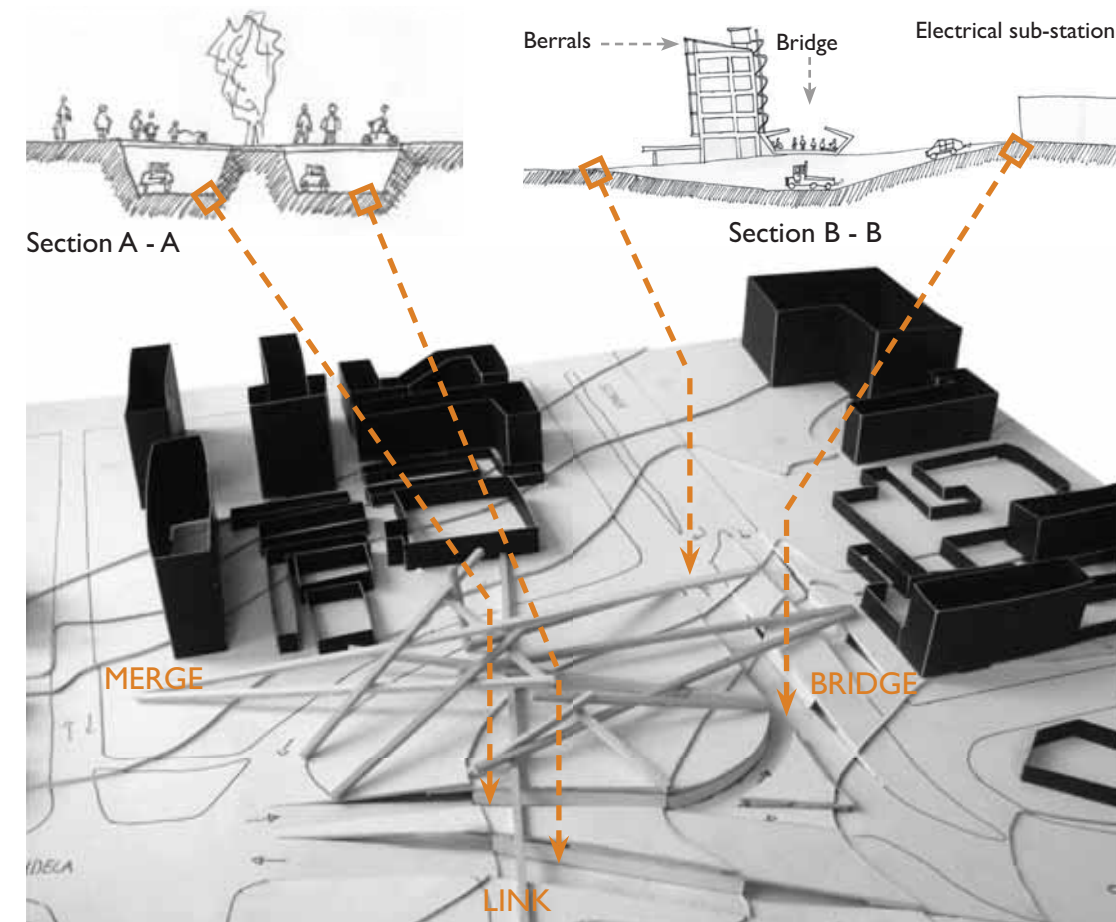

Figure 6.22. Massing Model showing the immediate context around the urban island (Author, 2010)



- Submerging the high volume of traffic along the edges of the urban island, allows for pedestrian pathways to bridge over both Skinner and Nelson Mandela Streets.

Figure 6.23. Concept model showing the submersion of vehicular traffic around the site (Author, 2010)

Traffic circle needed at the intersection of Nelson Mandela and Skinner street to allow for vehicles to turn left when driving down skinner street.

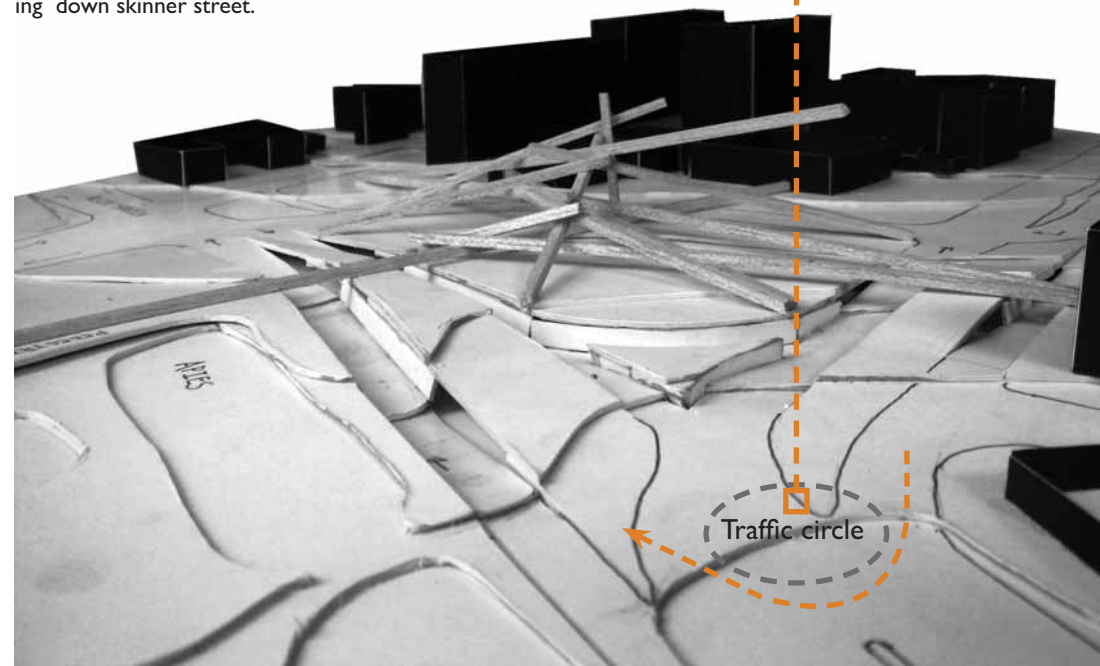

Figure 6.24. Concept model of the corner of Nelson Mandela and Skinner Street accommodating both vehicular and pedestrian movement (Author , 2010)

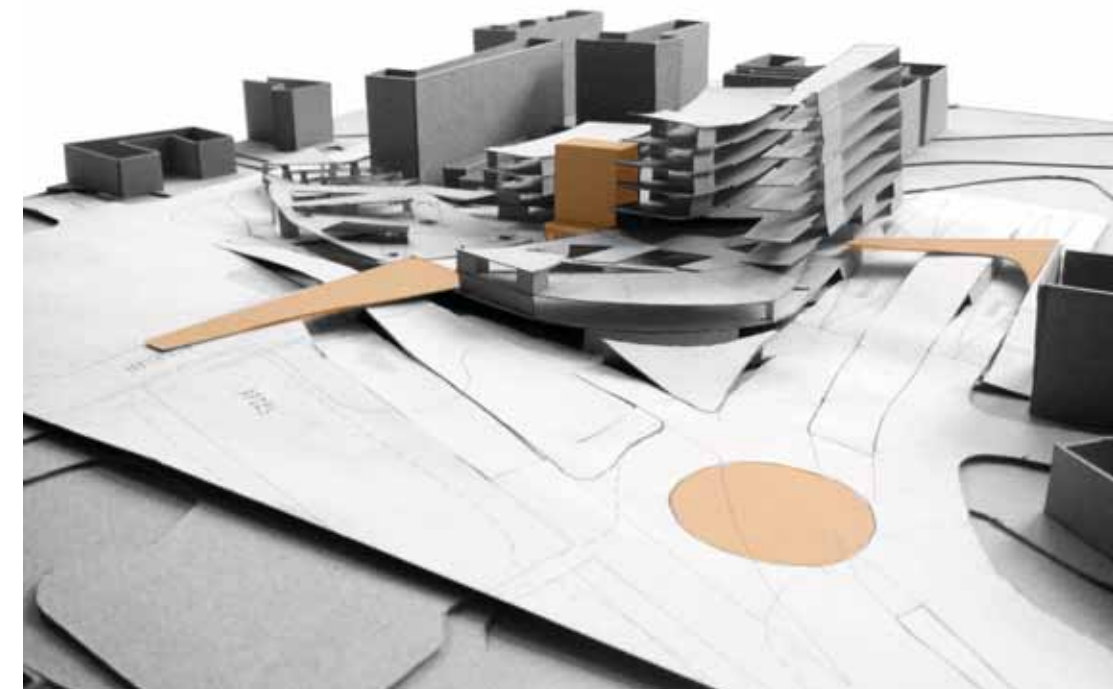

Figure 6.26. Concept model of the mixed-use development indicating how the new architectural intervention connects the urban island to the existing fabric spatially, physically and functionally (Author 2010)

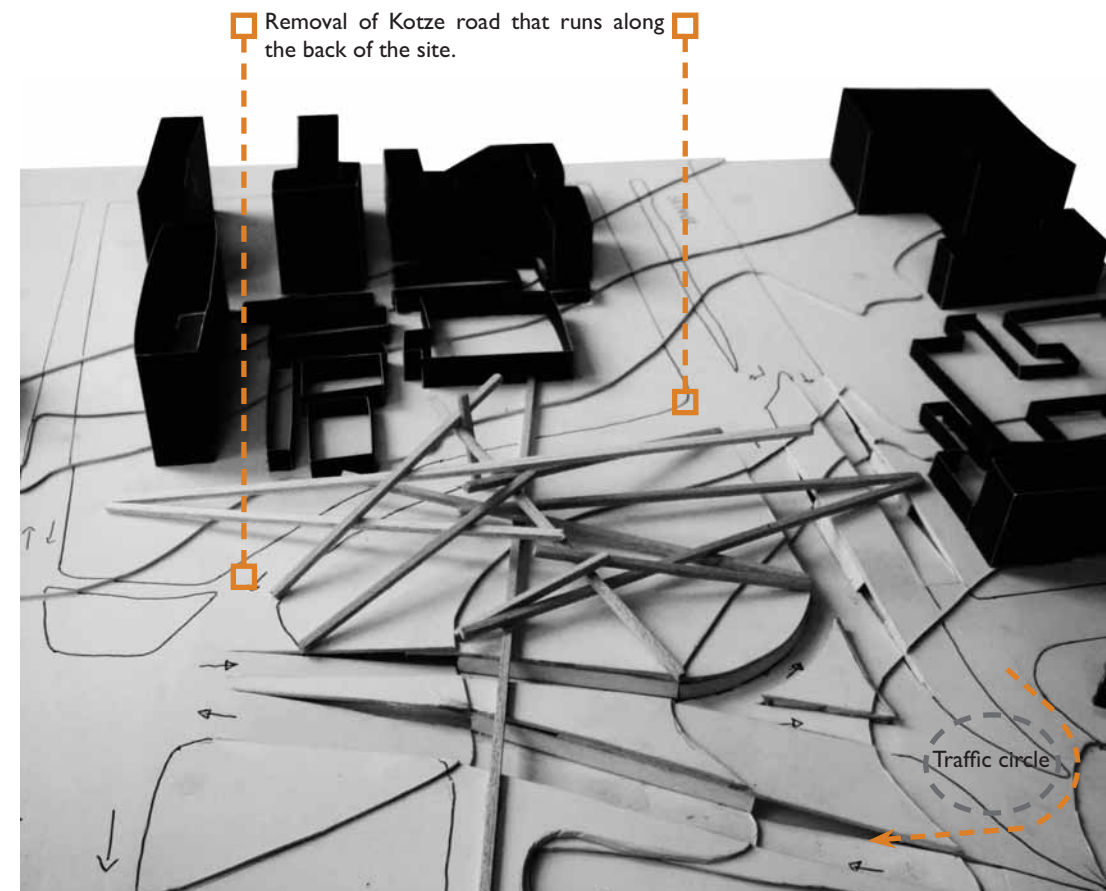
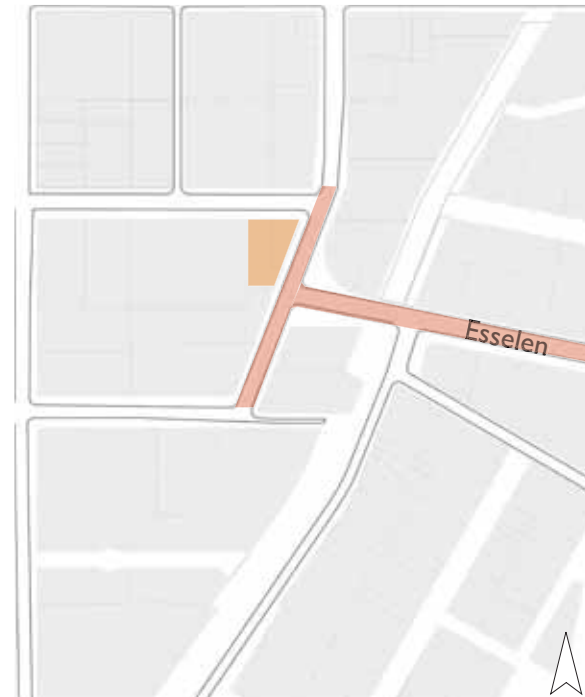

Figure 6.25. Concept model of the corner of Nelson Mandela and Skinner Street accommodating both vehicular and pedestrian movement (Author , 2010)

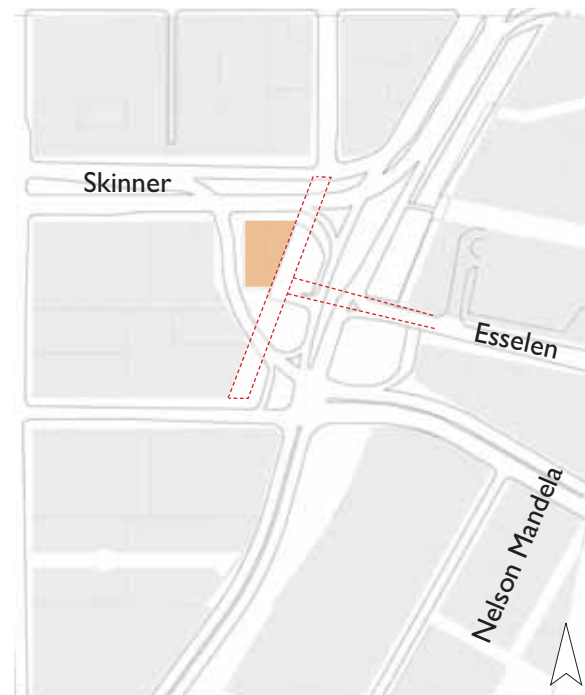

Figure 6.27. Concept model of the mixed-use development indicating how the new architectural intervention connects the urban island to the existing fabric spatially, physically and functionally (Author 2010)



The historical pathways that lead to or ran alongside the Berrals building are brought back. The original relationship the Berrals had to the road is re-established by the new pedestrian paths that link the urban island to the surrounding building fabric.

Figure 6.28.  
< 1997 : Road layout before the construction of Nelson Mandela Drive & Skinner Street (Author, 2010)



--- roads removed

Figure 6.29.  
> 1997 : Road layout after the construction of Nelson Mandela Drive & Skinner Street (Author, 2010)

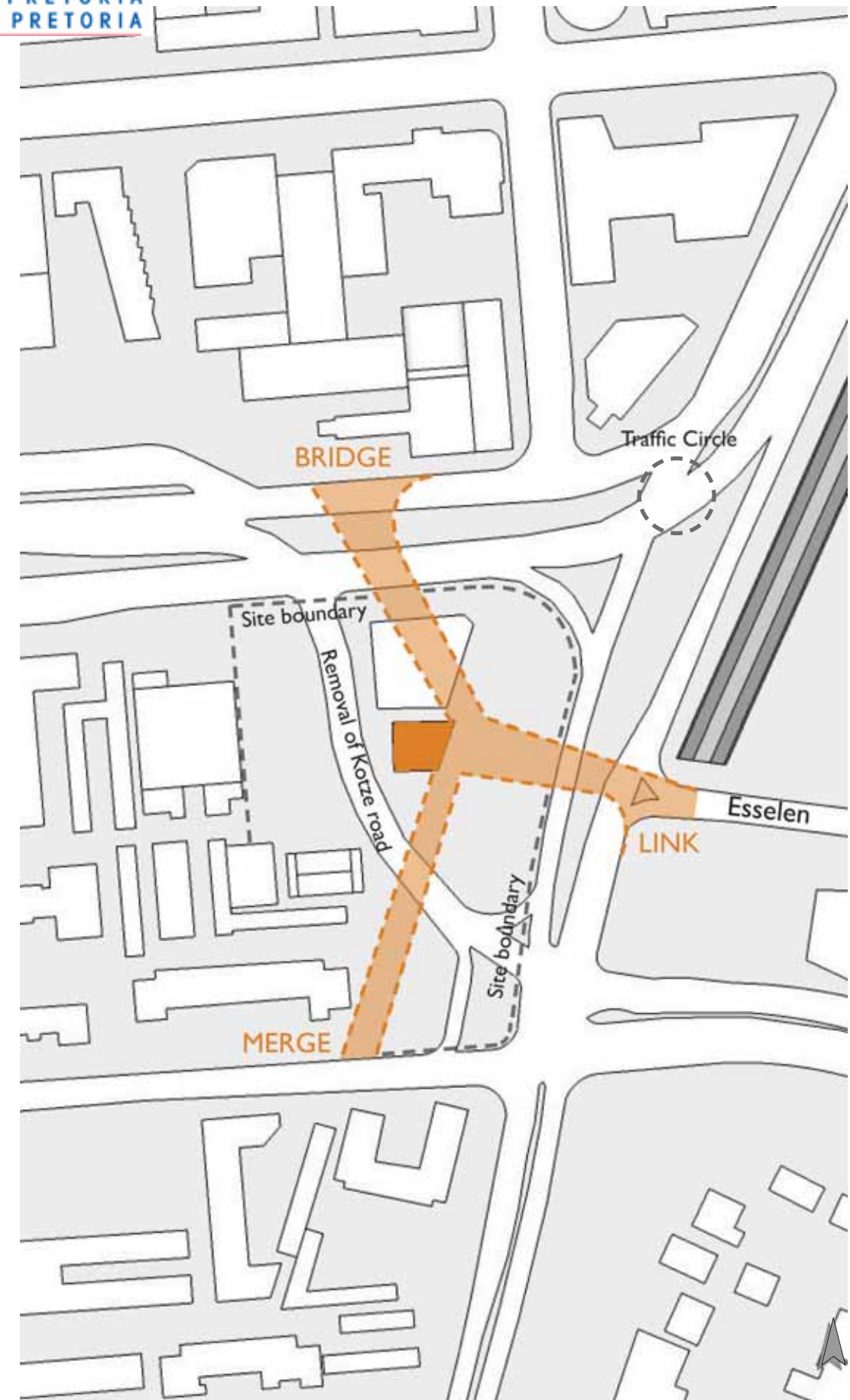

Figure 6.30. Plan showing the connections made to the existing fabric to allow pedestrian movement (Author, 2010)

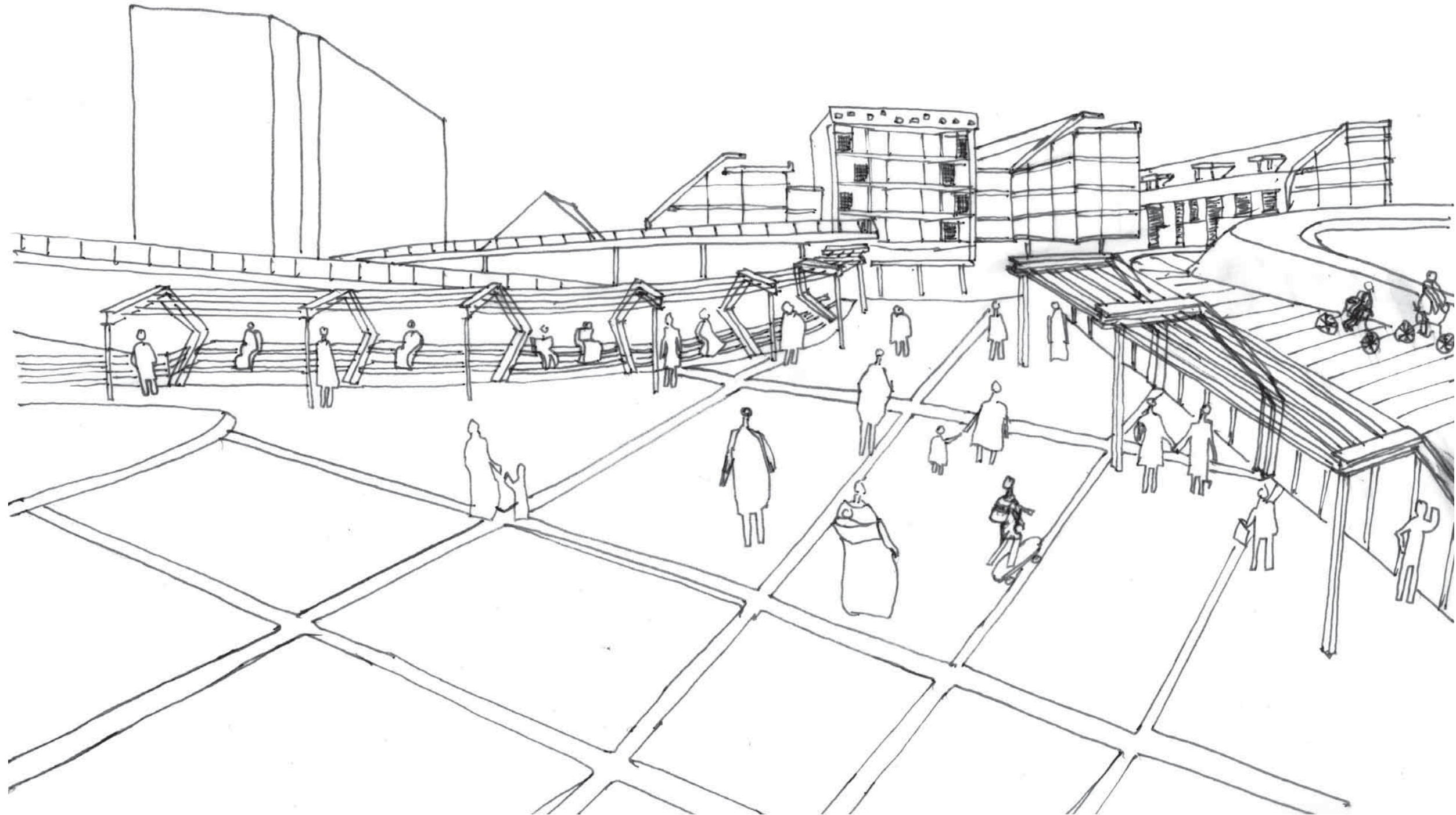

Figure 6.31. Approach from Esselen street - Bridging onto the urban island over Nelson Mandela Drive (Author, 2010)

Program - Mixed-use development

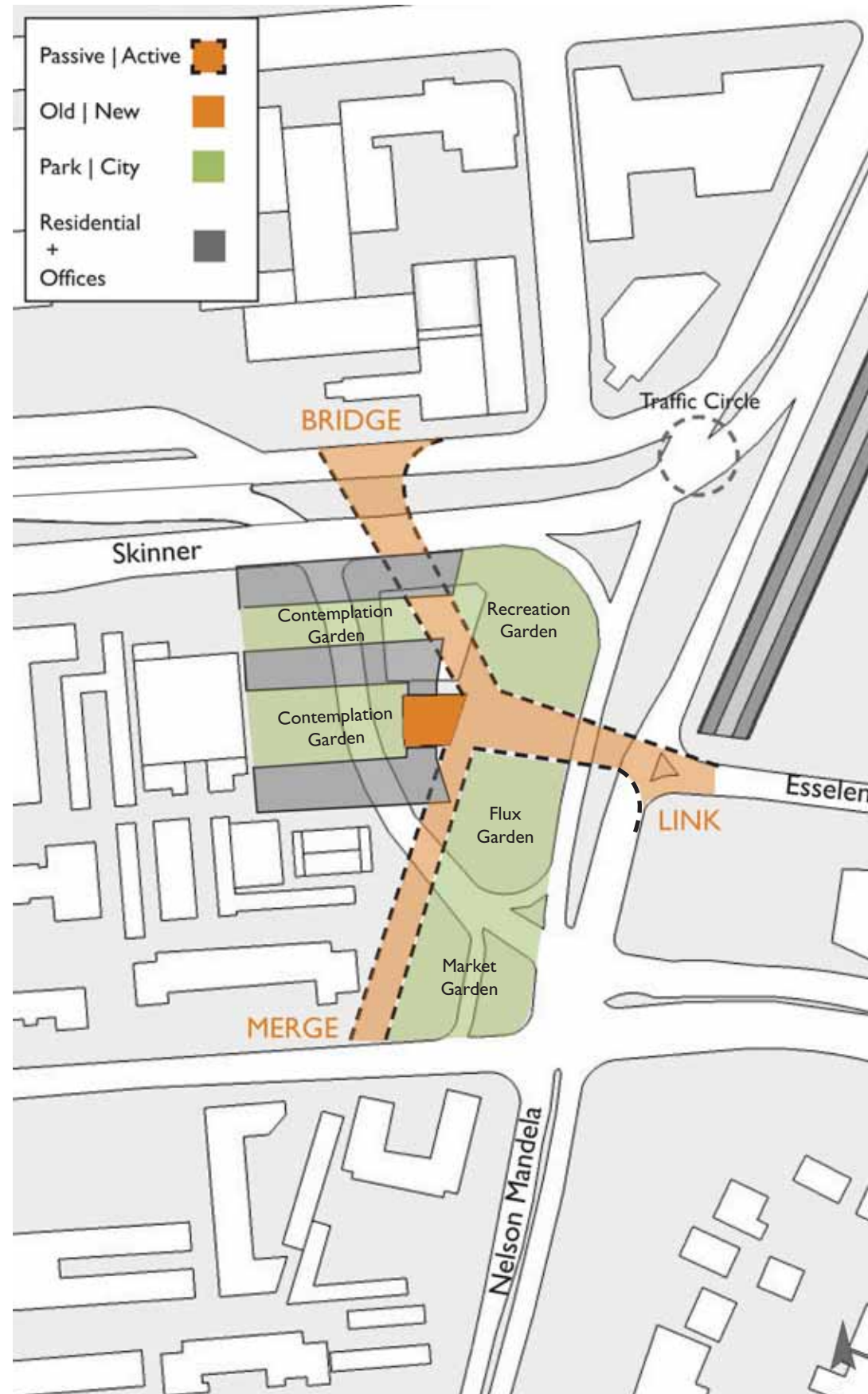
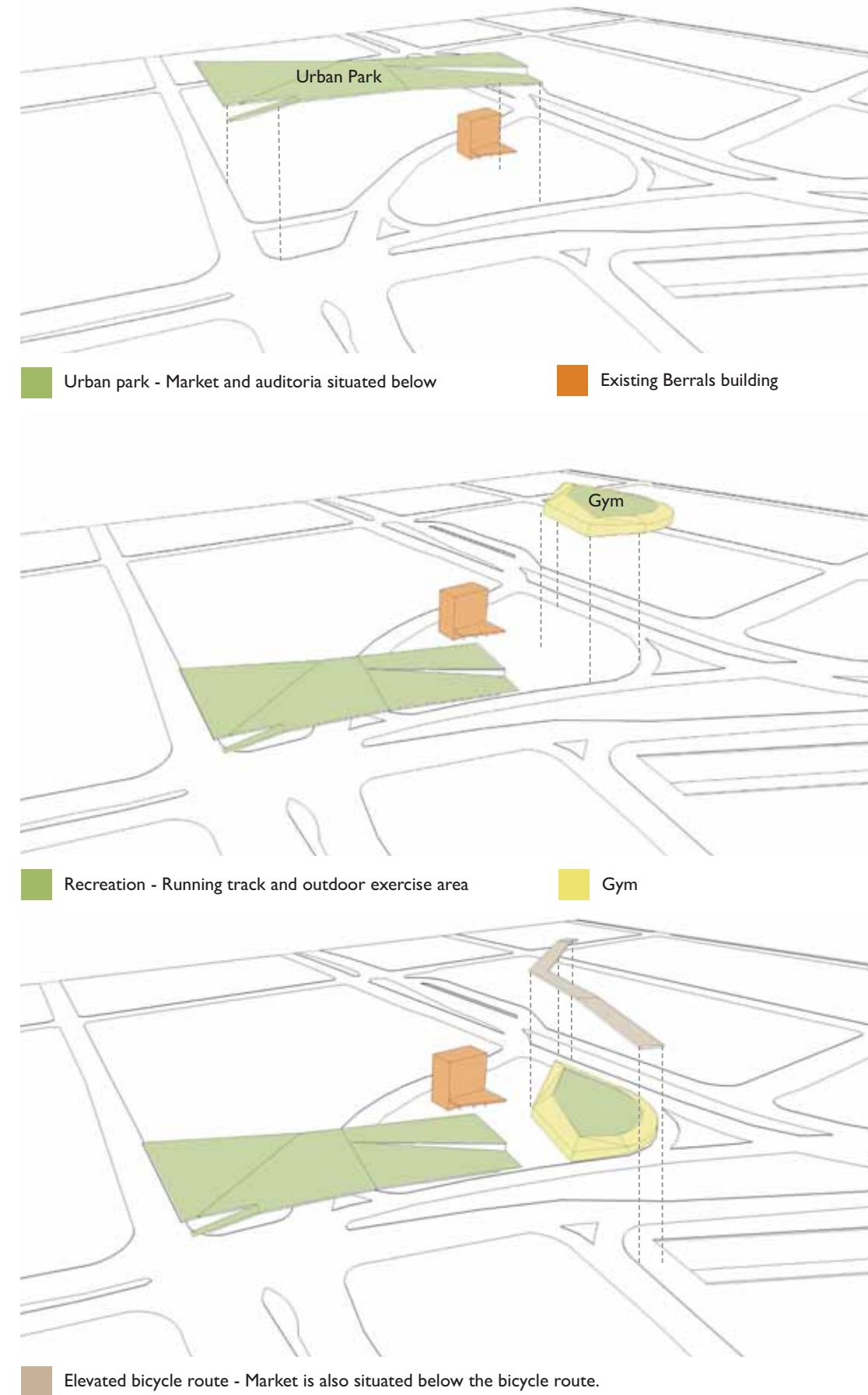
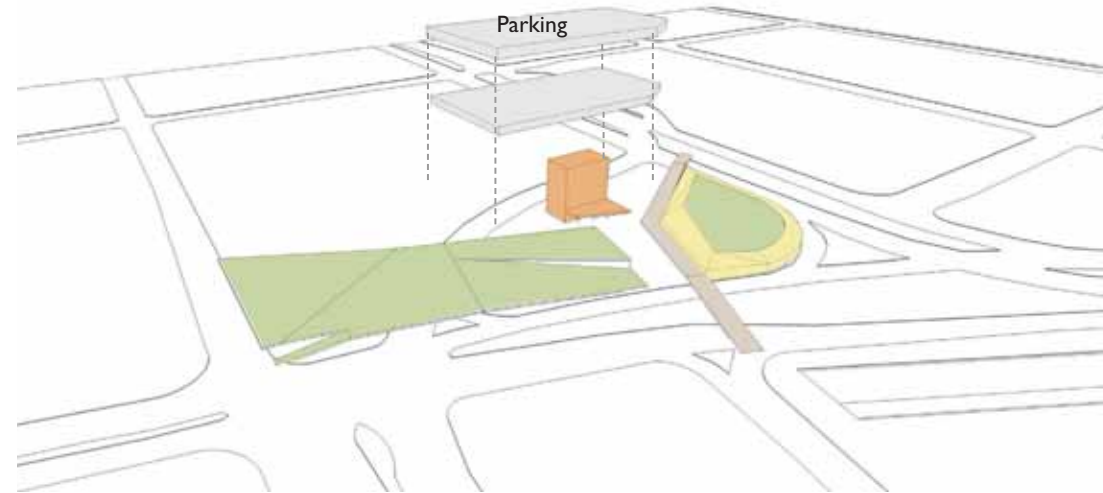
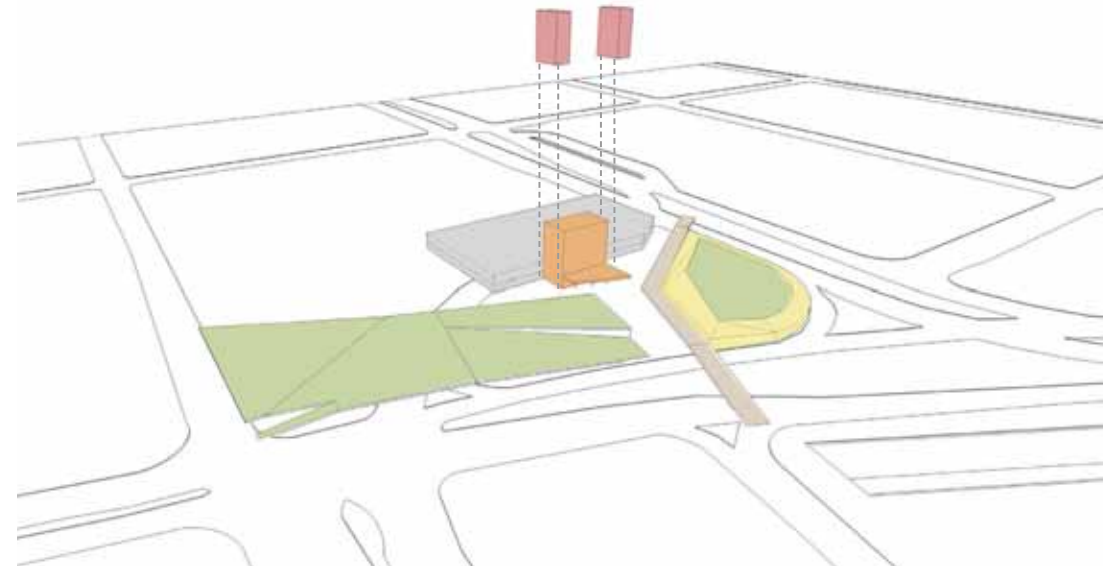

Figure 6.32. Program generated by tensions. (Author, 2010)





Parking situated behind the Berrals building



Offices

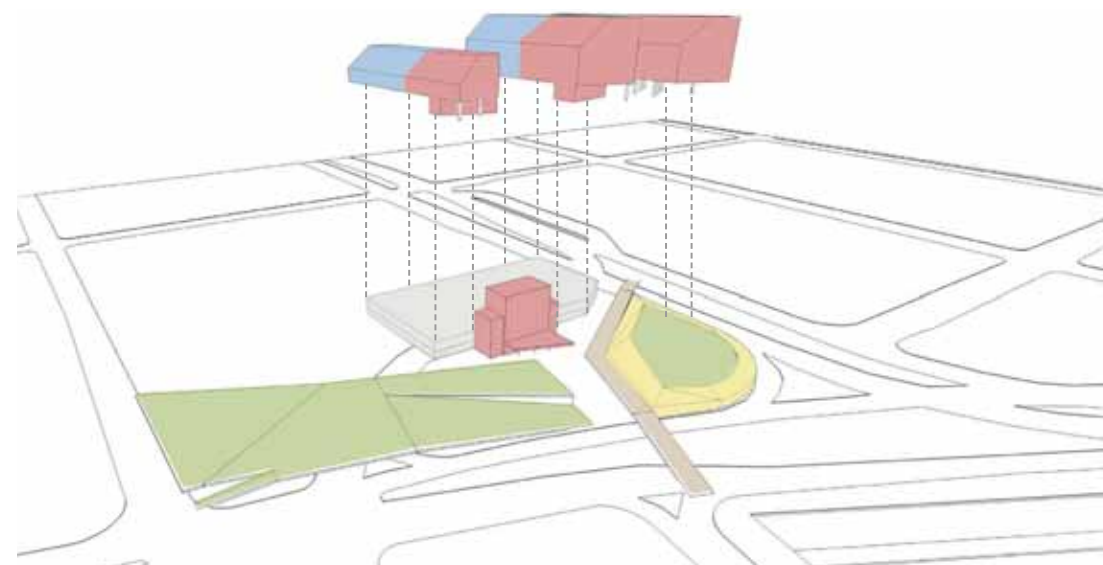

Residential



- Park with other functions situated below it i.e market, retail, auditoria and restaurant.
- Gym
- Bicycle route
- Parking
- Offices
- Residential

Figure 6.33. Layering of program (Author, 2010)

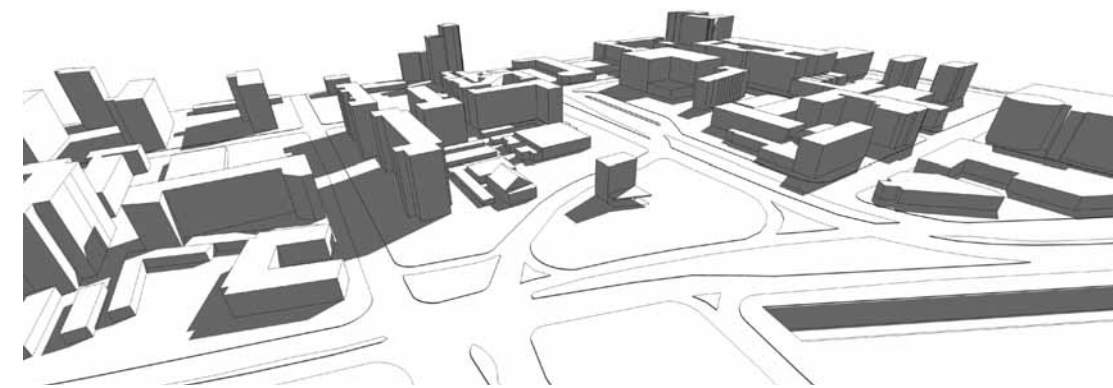

Figure 6.34. Before: The Berrals building in isolation (Author, 2010)

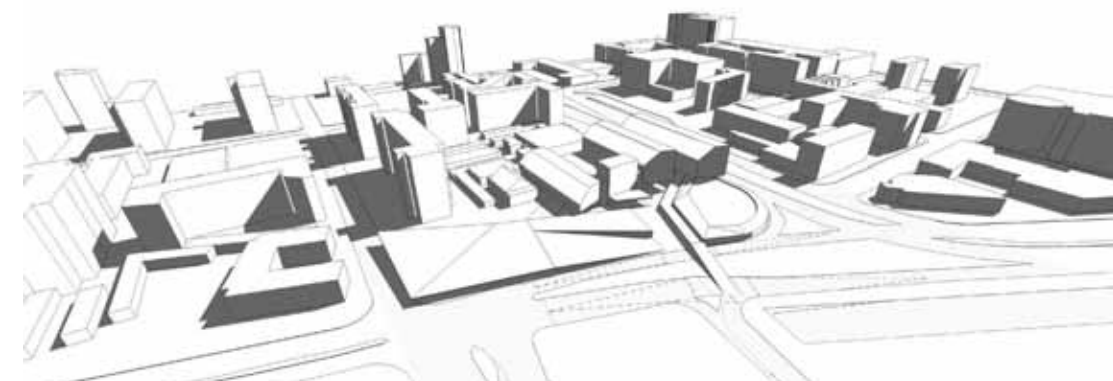

Figure 6.34.I. After: Mixed-use development in context (Author, 2010)

## Park | City

The city of Pretoria, as many other cities have been the victims of urban sprawl. Cities are competing with the suburbs in order to attract people back into the city in order to prevent the city from turning into a ghetto. In order to do so, cities must emphasize the unique advantages of social integration and pedestrian access to amenities. By knitting together physical and social space, parks and open space play a crucial role in defining and strengthening the advantages of city living. Urban neighbourhoods with access to open space may be particularly suited to compete with the suburbs. Thus, there are solid economic reasons for increasing urban investment in parks and open space (Garvin, Berens 1997: 30).

From the analysis of the relationships between park and city, it can be concluded that the urban grid of Pretoria seems flexible enough to accommodate future developments and is expected to have a lasting future (Corten and van Dun 2009: 11). The point at which the orthogonal grid breaks its rhythm, lost space exists. This occurs where the rigid grid meets the natural course of the Apies river resulting in left over segments of land. These lost spaces have the opportunity to become manmade built urban landscapes that knit together physical and social space. An urban park can create a sense of place, a landmark and a community focal point which in turn can create incentive for new development.



Figure 6.35. Stitching back the urban grid (Author 2010)

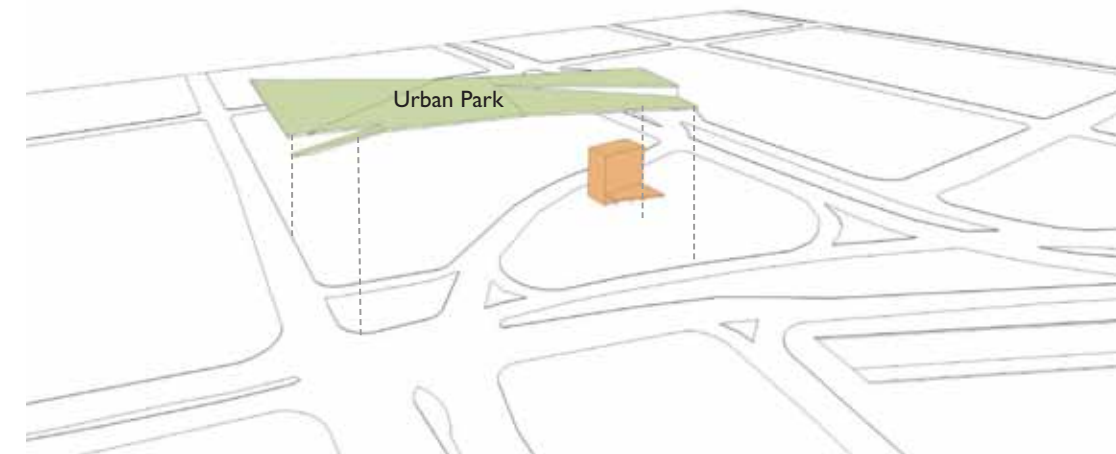

Figure 6.35. Multi- functional urban park (Author 2010)

The traditional idea of a park is that it homogenous in function. If a urban park is to remain in use and become a viable entity within the physical and social space of the urban fabric it must provide the trans-urban city with a diversity of functions. Therefore the urban park includes a market, retail, restaurant and auditoria under its roof(park).

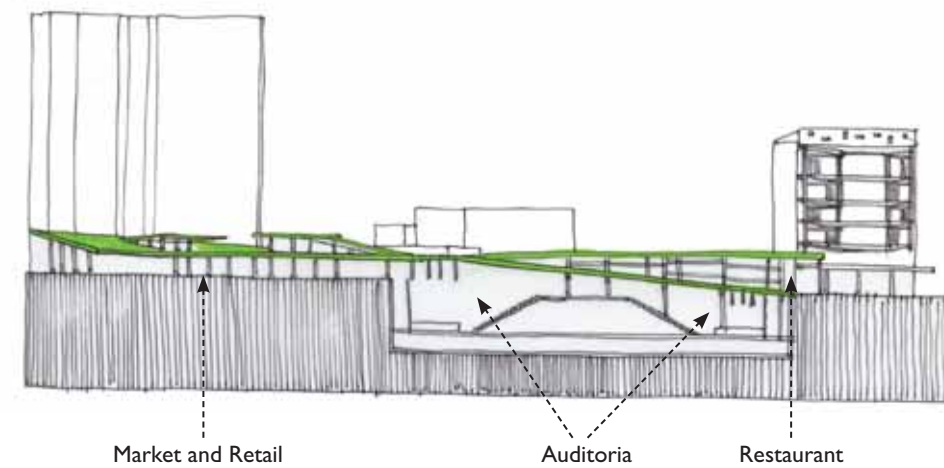

Figure 6.36. Section through the urban park (Author 2010)



Figure 6.37. Perspective sketch of the approach towards the urban park (Author 2010)

## Old | New

The Berrals building designed by Wynand smit is one of the last few remaining examples of Brazilian influenced Pretoria Regionalism. The eastern facade of the building consists of a 'brise soleil' screen that is constructed from hollow clay bricks that are placed in a concrete frame. This screen is a clear indication of the Brazilian influence on Pretoria Regionalism, however the screen is only applied for effect and has no real climatic influence.

The isolation of the Berrals building and its location at a major intersection within the city, has lead to the Berrals building in becoming a landmark. The eastern facade with the 'brise soleil' screen has become the dominant facade. This facade of the Berrals building is the only one that has been articulated as it was meant to be the only visible facade when the building was constructed. This has changed, since all four facades of the building are now exposed.

The public not only identify with the Berrals building as a result of its isolation but also because of its unique facade treatment. Therefore the Berrals building especially its eastern facade need to be treated with sensitivity as new buildings attach to it giving it new functions. The northern and southern facades are blank facades and allow for outward expansion. The addition of these new layers to the Berrals building will extend the history and life of the building, giving it a new identity and existence.

Figure 6.38. (below)  
The Berrals building - Eastern facade with the brise soleil screen (Author, 2010)



Figure 6.39  
South eastern perspective - The Berrals building has become a landmark (Author, 2010)



Figure 6.40.  
The Berrals building - Western facade (Author, 2010)

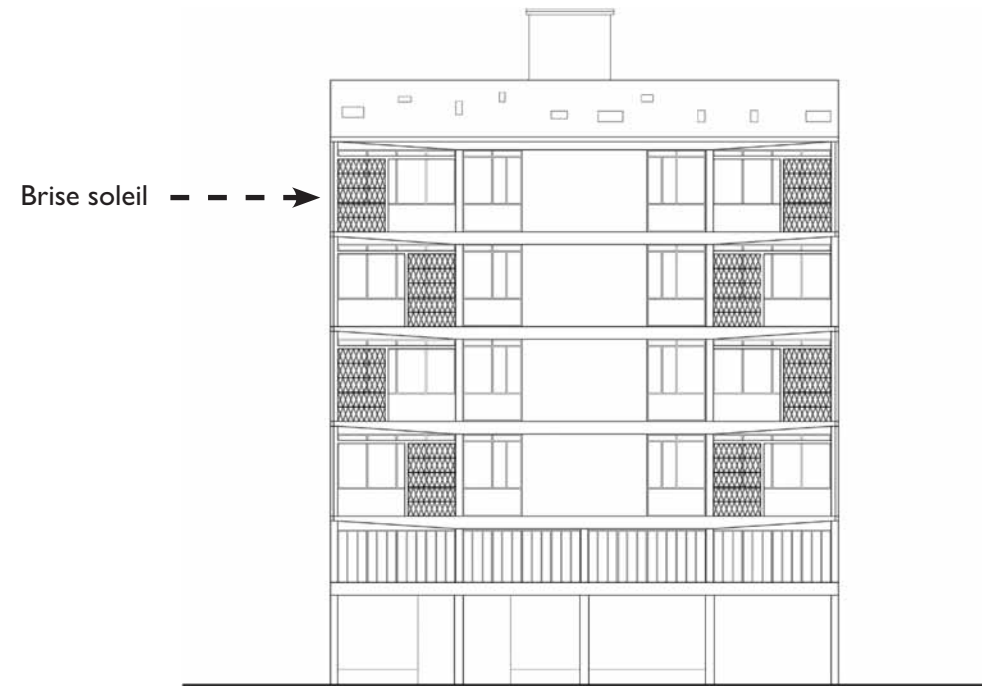

Figure 6.41. The Berrals Building - Eastern elevation (Author, 2010).

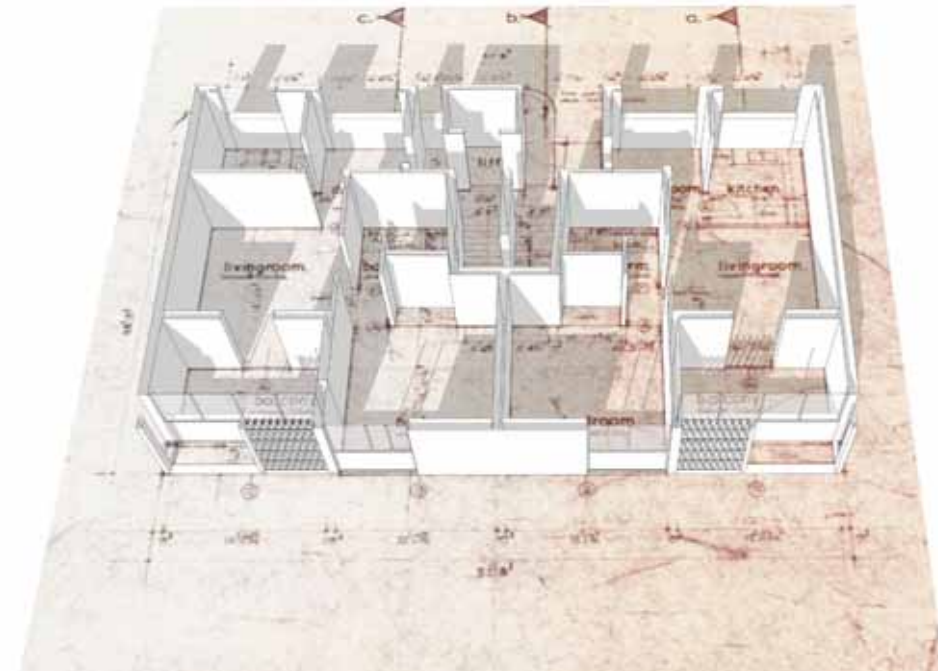

Figure 6.43. Existing plan layout for floors 1 - 4 (Author, 2010).



Figure 6.42. Existing ground floor plan (Author, 2010).

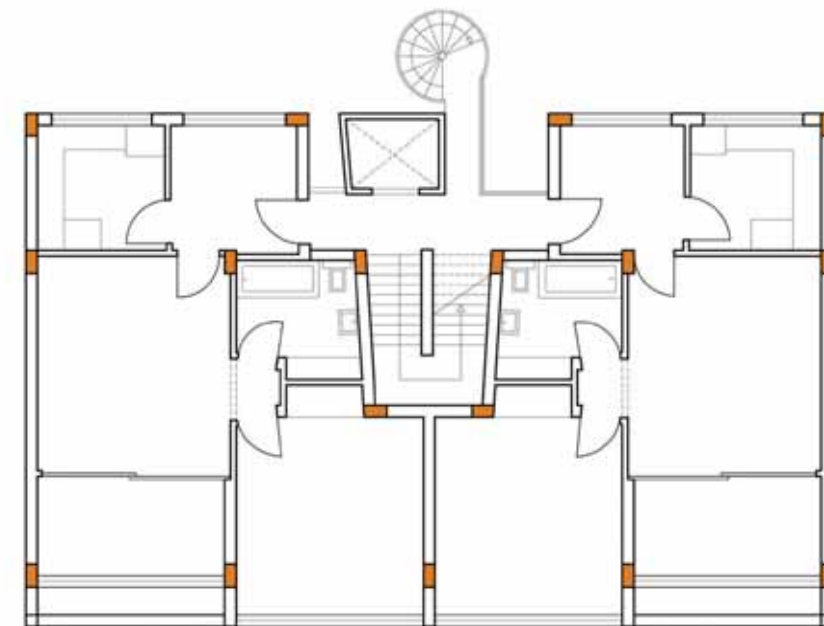

Figure 6.44. Existing first floor plan indicating the structural column system (Author, 2010).

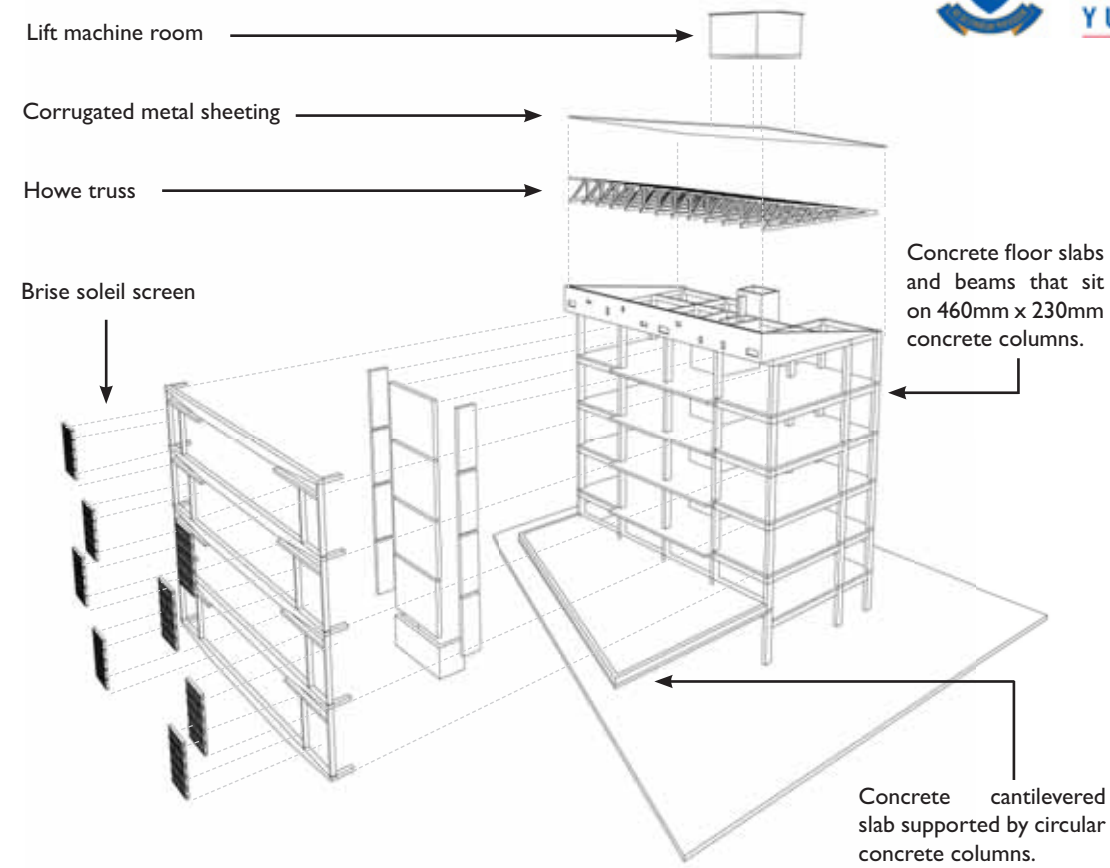

Figure 6.45. Exploded axonometric of the Berrals building indicating the primary components of the building (Author, 2010).

The Berrals building is built on a structural grid system, of 230mm x 460mm concrete columns. This structure constitutes as the load-bearing structure, therefore most of the interior walls can be removed as long as the load-bearing skeleton remains intact. This allows the opportunity for freeing the interior space and also facilitates outward expansion on the northern and southern facades.

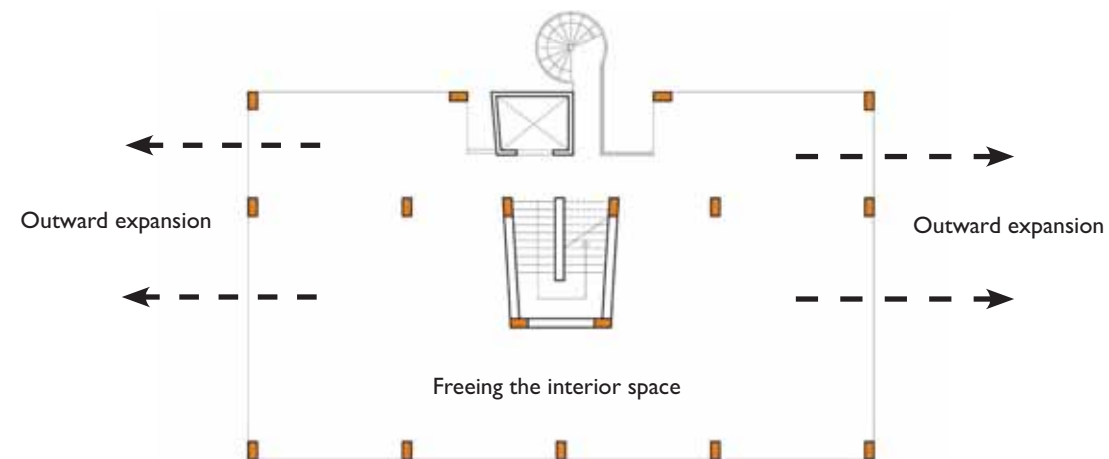

Figure 6.46. The interior space of the Berrals building can be opened up by the removal the interior walls. The exterior walls can be removed as well to provide outward expansion (Author, 2010).

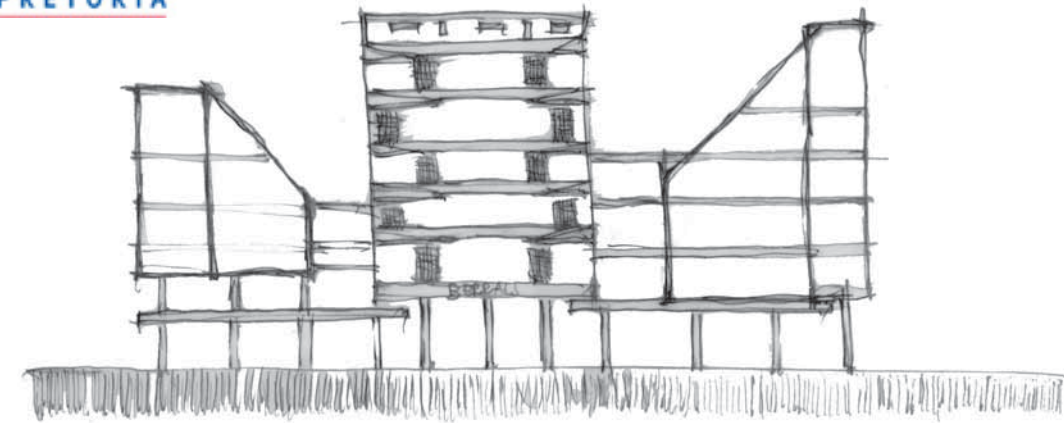

Figure 6.47. East elevation (front facade of Berrals) - The new intervention plugging into the Berrals building on the northern and southern facades (Author, 2010).

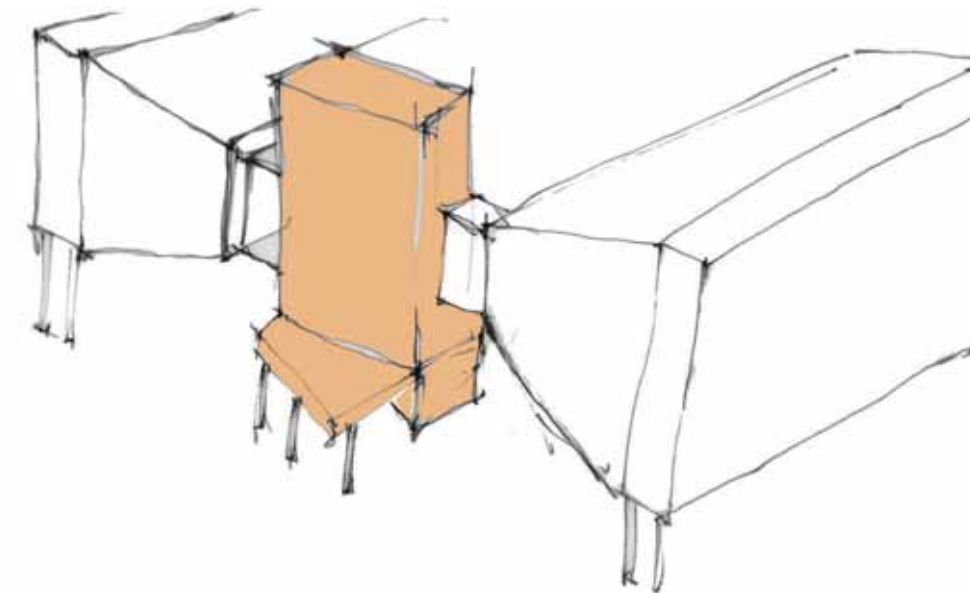

Figure 6.48. A sketch of the new connecting to the old (Author, 2010).

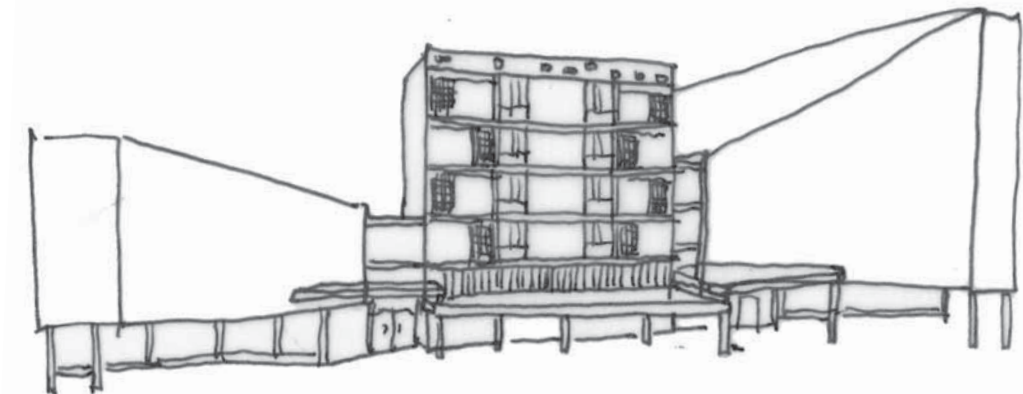

Figure 6.49. The form of the new interventions slant away from the Berrals as to not overpower the existing building so that the Berrals retains its importance as a landmark building (Author, 2010).

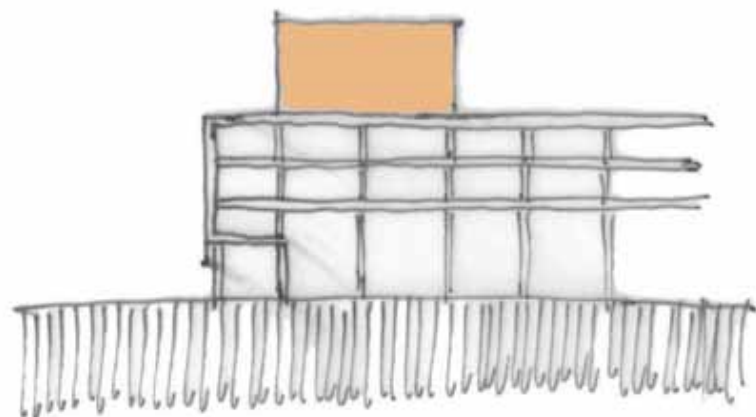
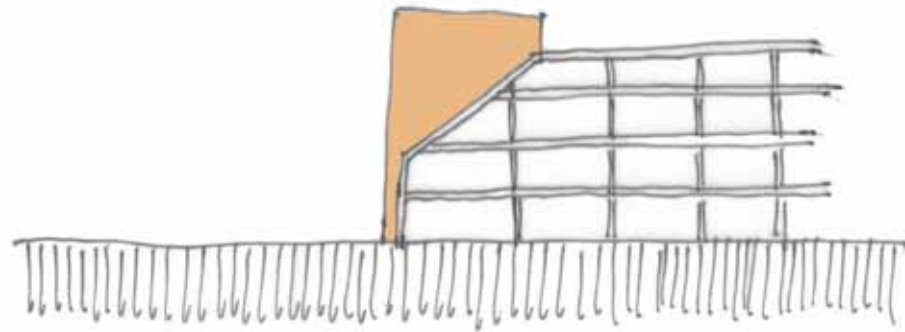
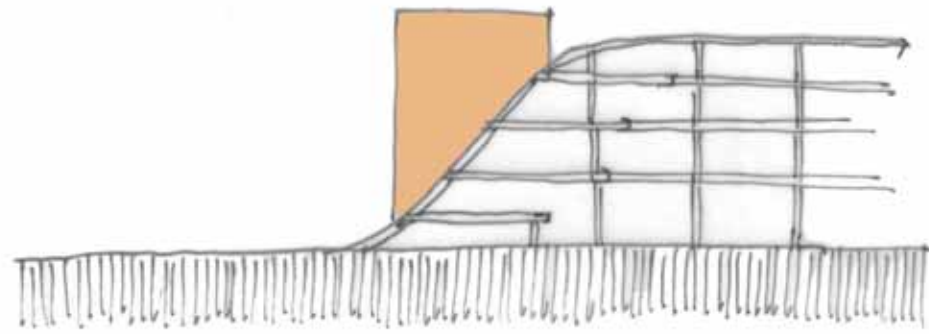

Figure 6.50.  
Sketches demonstrating the different ways in which the new building's eastern edge can terminate (Author, 2010).

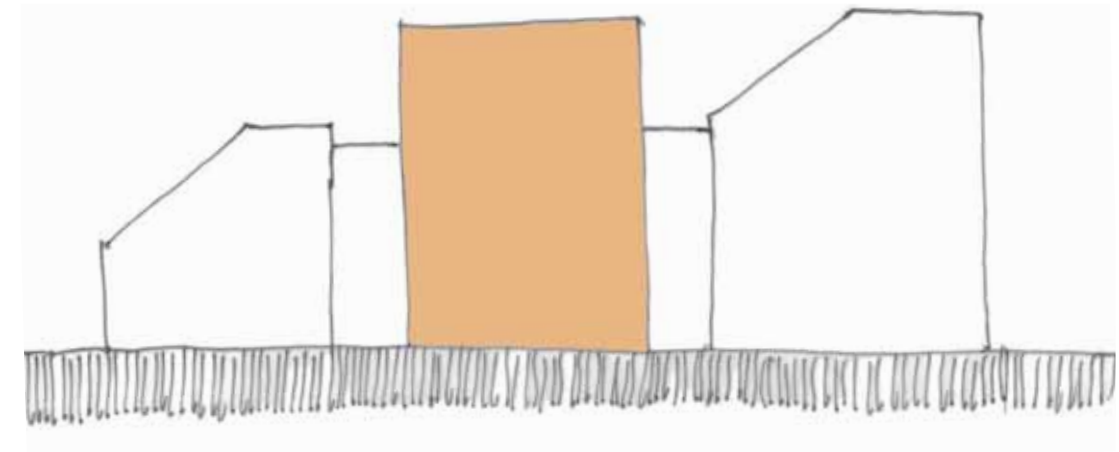
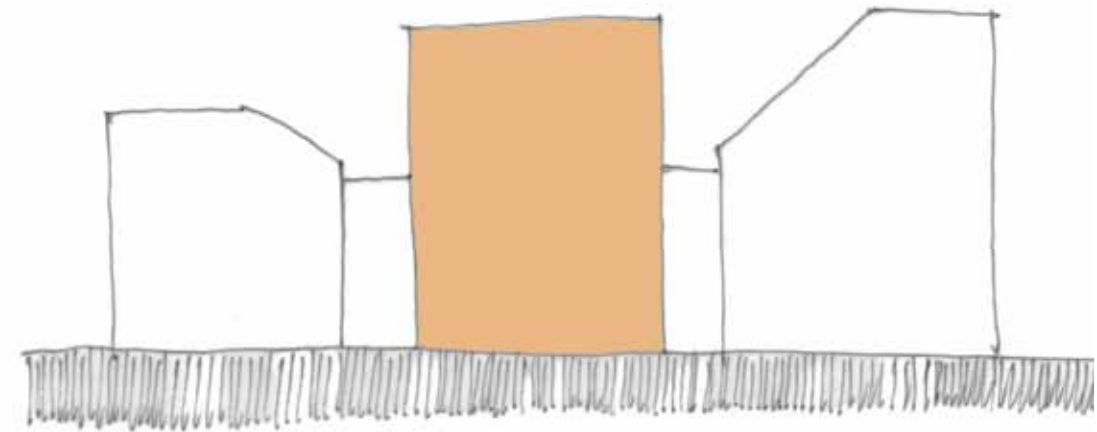

Figure 6.51.  
The new intervention plugging into the Berrals building. (Author, 2010).

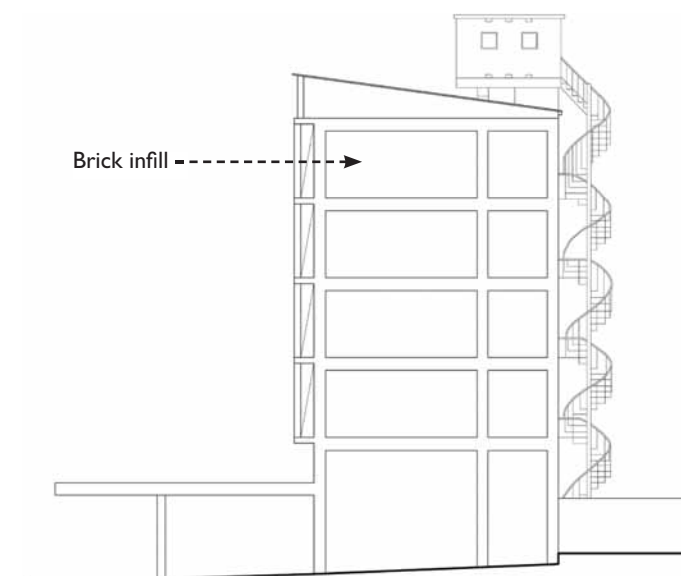

Figure 6.52.  
Northern elevation of the Berrals building. Brick infill between the column grid can be removed to allow for outward expansion on the northern and southern facades (Author, 2010).

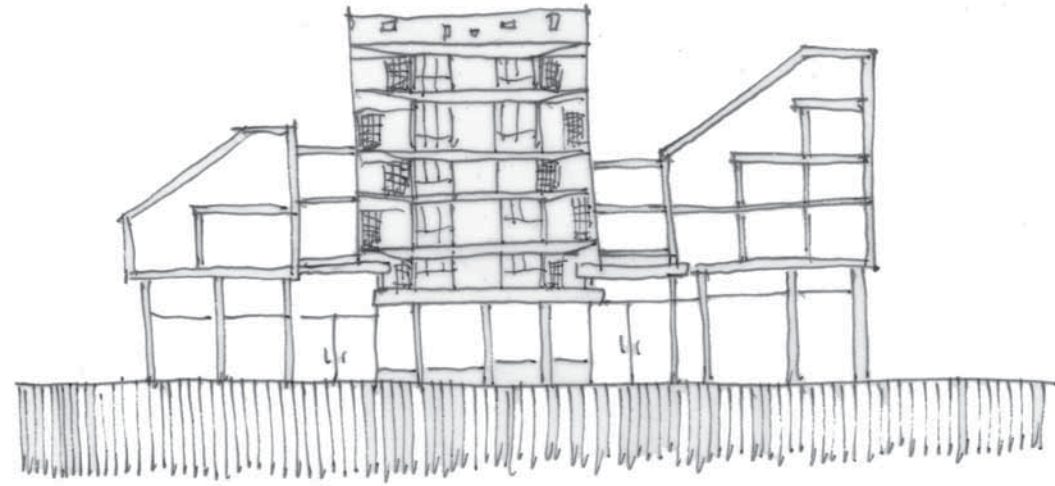

Figure 6.53.  
East elevation (front facade of Berrals) - The new intervention plugging into the Berrals building on the northern and southern facades (Author, 2010)

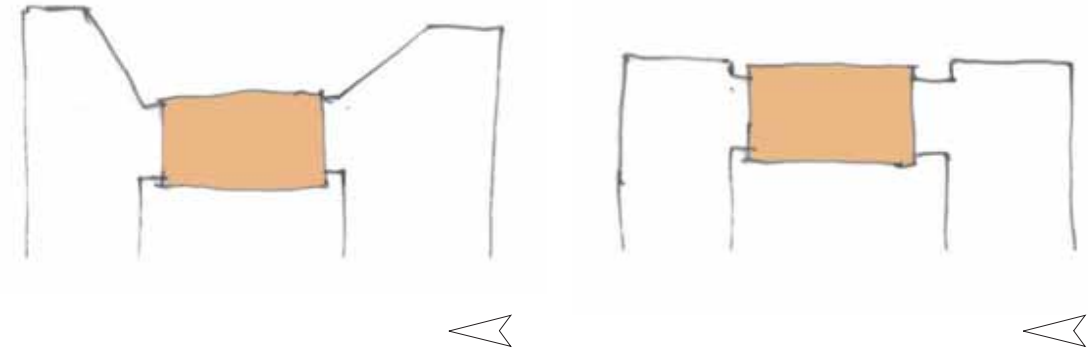

Figure 6.56.  
Sketch plans indicating the different approaches in which the new intervention can frame the existing Berrals building (Author, 2010)



Figure 6.54.  
A massing model demonstrating the new relationship that is formed between the new buildings and the existing Berrals building ( Author, 2010)

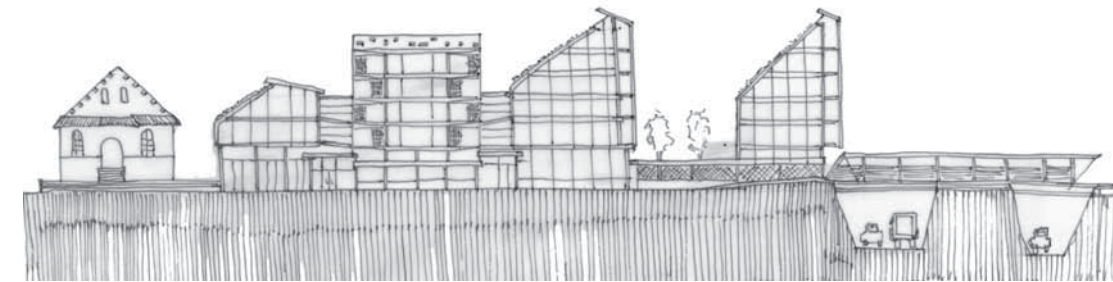

Figure 6.57.  
A sketch of the new connecting to the old (Author, 2010)

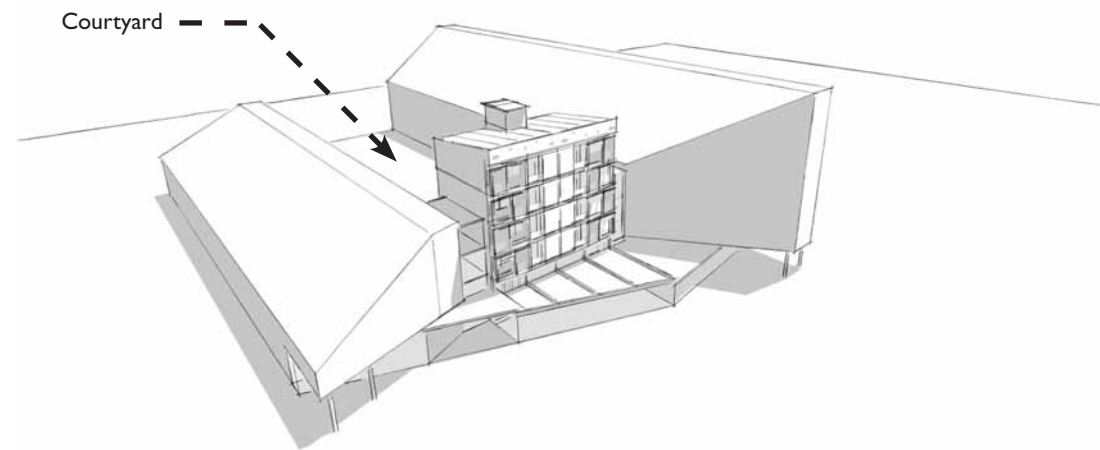

Figure 6.55.  
A massing model indicating the creation of a courtyard space due to the Berrals building being framed by two new buildings (Author, 2010)

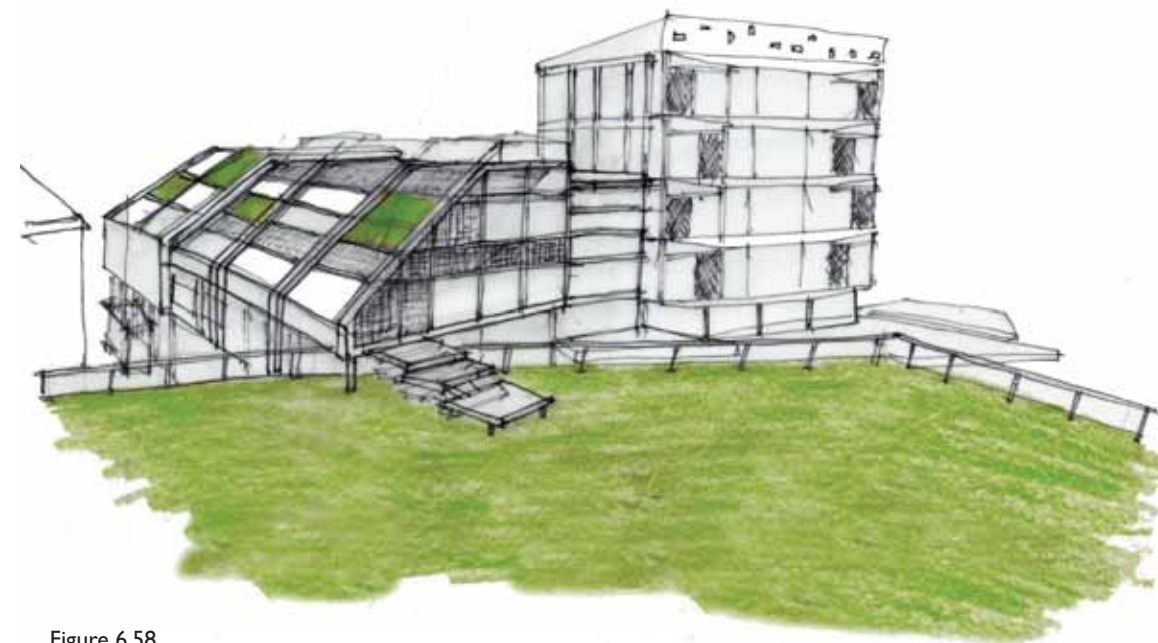

Figure 6.58.  
Perspective sketch (Author, 2010)