

Xstrata Coal: Calibrating and Using a
Simulation Model to Motivate Capital
Expenditure of a Stockpile

by

ROLAND WAND
26335884

Submitted in partial fulfilment of the requirements for the
degree of

BACHELORS OF INDUSTRIAL ENGINEERING

in the

FACULTY OF ENGINEERING, BUILT ENVIRONMENT AND INFORMATION
TECHNOLOGY

UNIVERSITY OF
PRETORIA

October 2012

XSTRATA COAL: CALIBRATING AND USING A SIMULATION MODEL TO MOTIVATE CAPITAL EXPENDITURE OF A STOCKPILE



Final Project Report

Roland Wand

Study Leader: Prof. P S Kruger

17 October 2012



UNIVERSITEIT VAN PRETORIA
UNIVERSITY OF PRETORIA
YUNIBESITHI YA PRETORIA



EXECUTIVE SUMMARY

Xstrata Coal's Goedgevonden Colliery (GGV) is an opencast coal mine that started operating in 2007. A simulation model was developed by Ceenex (Pty) Ltd to simulate the coal handling system for the future expansion of GGV.

This project aims to adjust and calibrate the previous simulation model such that it can accurately be used for present day analysis and decision making purposes.

In this report, the processes that were followed in achieving the project aims are discussed. The simulation model was adjusted, calibrated and used to determine the system's bottleneck and to motivate the capital expenditure for a Raw coal sized stockpile.

The outcome of the project concludes that the Coal Processing Plant (CPP) is the bottleneck in the system and that a Raw coal sized stockpile would increase the annual throughput by 800,000 tonnes. Revenue gained from this increase in production would entail a pay-off-period of 11 months for the infrastructure expansion and a R 160,000,000 annual return on investment thereafter.

TABLE OF CONTENTS

| | |
|--|------|
| EXECUTIVE SUMMARY | iii |
| TABLE OF CONTENTS..... | iv |
| LIST OF FIGURES..... | vi |
| LIST OF ACRONYMS..... | viii |
| 1. Introduction and Background | 1 |
| 2. Problem Statement..... | 2 |
| 3. Project Aim..... | 3 |
| 4. Project Scope | 3 |
| 5. Literature Review..... | 4 |
| 5.1 Introduction | 4 |
| Themes of Focus | 4 |
| 5.2 Identifying Potential Processes Constraining System Performance | 5 |
| Theory of Constraints (TOC)..... | 5 |
| Simulation and Modelling using Simio..... | 8 |
| 5.3 Establishing the Relation and Interaction between System Processes | 10 |
| System Thinking | 10 |
| 6. Project Approach | 12 |
| 7. System Analysis..... | 13 |
| System Description | 13 |
| Coal Seam Switch Over | 18 |
| Operational Factors | 18 |
| Process Flow Diagram | 20 |
| 8. Data Gathering and Analysis..... | 21 |
| 8.1 Trucks and Loaders | 21 |
| Loader Fleet | 21 |
| Truck Fleet..... | 21 |
| Truck Load Capacity | 22 |
| Reliability..... | 22 |

| | | |
|-----|---|----|
| 8.2 | Coal Handling Time Study | 24 |
| | Method | 24 |
| | Measured Parameters | 24 |
| | Loading Cycle Time | 24 |
| | Offloading Cycle Time | 26 |
| | Truck Travel Speed..... | 27 |
| 8.3 | Life of Mine Plan | 29 |
| 8.4 | Stockpiles | 30 |
| 8.5 | Coal Handling Processing Plant (CHPP)..... | 31 |
| | CHPP Operating Parameters | 31 |
| | Reliability..... | 33 |
| 9. | Adjusting of the Simulation Model | 37 |
| | Disconnection of the Zaaiwater Expansion..... | 37 |
| | Re-architecture of the Mining Location..... | 37 |
| | Updating of Parameter Values..... | 37 |
| | Updating of Process Control Logic | 38 |
| 10. | Calibration of the Simulation Model..... | 39 |
| | Mining Section | 39 |
| | ROM Section | 40 |
| | Plant Modules | 42 |
| 11. | Scenario Runs..... | 43 |
| | Base Case | 43 |
| | Raw Coal Sized Stockpile..... | 45 |
| | Process Flow Diagram | 47 |
| 12. | Cost Analysis | 48 |
| 13. | Conclusion..... | 49 |
| | REFERENCES..... | 50 |
| | APPENDIX A..... | 52 |
| | Current Estimated Stockpile Tonnes..... | 52 |

LIST OF FIGURES

| | |
|---|----|
| Figure 1: The ROM Pad with its Tip Bin and Stockpiles..... | 3 |
| Figure 2: Constrained Resource Located in the Middle of System | 7 |
| Figure 3: Constrained Resource Located at Start of System..... | 7 |
| Figure 4: Delay Times for Multiple Scenario Runs | 9 |
| Figure 5: An Analysis Paralyzes Cycle..... | 10 |
| Figure 6: Analysis vs. Synthesis Thinking Approach..... | 11 |
| Figure 7: The Pit and its Coal Seam Layering | 13 |
| Figure 8: Truck Offloading at Tip Bin..... | 14 |
| Figure 9: Process Flow between Stockpiles and Tip at the ROM pad..... | 15 |
| Figure 10: Process Flow to Raw Coal Bin | 15 |
| Figure 11: Process Flow through the Plant to End User Port..... | 16 |
| Figure 12: Primary and Secondary Stackers..... | 17 |
| Figure 13: Rail Load Out Bin | 17 |
| Figure 14: Discard Bin | 18 |
| Figure 15: Process Flow Diagram for GGV Operations | 20 |
| Figure 16: CAT 785 Coal Body Truck | 21 |
| Figure 17: CAT 785 Fleet | 22 |
| Figure 18: Komatsu 1200 FEL Breakdown..... | 22 |
| Figure 19: Reliability for Trucks and Loaders | 23 |
| Figure 20: Truck Positioning Time Results | 25 |
| Figure 21: Bucket Load Time Results | 25 |
| Figure 22: Bucket Count Results | 25 |
| Figure 23: Load Cycle Time Results | 26 |
| Figure 24: Truck Offload Cycle Time Results..... | 27 |
| Figure 25: Constant Truck Speed Results..... | 27 |
| Figure 26: Empty Truck Speed Results | 28 |
| Figure 27: Full Truck Speed Results..... | 28 |
| Figure 28: Mining Blocks Overlay in Google Earth..... | 29 |
| Figure 29: Mining Nodes in the Simulation Model | 29 |
| Figure 30: Distribution for the ROM Section Feed Rate | 31 |
| Figure 31: Distribution for the Modules Feet Rate | 32 |
| Figure 32: SCADA Data for 4 July 2012 | 32 |
| Figure 33: Utilization Graph for the CHPP..... | 33 |
| Figure 34: ROM Section MTBF Results..... | 34 |
| Figure 35: ROM Section MTTR Results..... | 34 |
| Figure 36: Module 1 MTBF Results | 34 |
| Figure 37: Module 2 MTBF Results | 35 |
| Figure 38: Module 1 MTTR Results | 35 |
| Figure 39: Module 2 MTTR Results | 36 |
| Figure 40: Simio Process for Assigning Truck Fatigue Break..... | 38 |

| | |
|--|----|
| Figure 41: Uncalibrated Result for the Tonnes Mined..... | 39 |
| Figure 42: Calibrated Result for the Tonnes Mined..... | 40 |
| Figure 43: Uncalibrated Result for the ROM Feed Rate..... | 41 |
| Figure 44: Calibrated Result for the ROM Feed Rate..... | 41 |
| Figure 45: Uncalibrated Result for the Plant Feed Rate | 42 |
| Figure 46: Calibrated Result for the Plant Feed Rate..... | 42 |
| Figure 47: ROM Pad Stockpile Levels..... | 43 |
| Figure 48: CHPP Utilization Chart..... | 44 |
| Figure 49: Total Annual Plant Feed for Base Case vs. Raw Coal Sized Stockpile | 45 |
| Figure 50: Plant Feed Rate for Base Case vs. Raw Coal Sized Stockpile..... | 46 |
| Figure 51: Raw Coal Sized Stockpile Level..... | 46 |
| Figure 52: Process Flow Diagram for GGV Operations with a Raw coal sized stockpile | 47 |
| Figure 53: Static Financial Model..... | 48 |
| Figure 54: Increase in Revenue vs. CAPEX | 48 |

LIST OF ACRONYMS

| | |
|-------|--------------------------------|
| CAPEX | Capital Expenditure |
| CCR | Capacity Constrained Resource |
| CHHP | Coal Handling Processing Plant |
| CPP | Coal Processing Plant |
| CSV | Common Separated Values |
| DES | Discrete Event Simulation |
| FCFS | First-Come-First-Serve |
| FEL | Front End Loader |
| GGV | Goedgevonden |
| JIT | Just-In-Time |
| LOM | Life of Mine |
| MTBF | Mean-Time-Between-Failures |
| MTTR | Mean-Time-To-Repair |
| PLC | Program Logic Controller |
| PPE | Personal Protective Equipment |
| RBCT | Richards Bay Coal Terminal |
| ROM | Run of Mine |
| TOC | Theory of Constraints |
| VAT | Value Added Tax |

1. Introduction and Background

Xstrata Coal's Goedgevonden Colliery is an opencast coal mine located near Ogies Mpumalanga. Operations started in 2007 and mining has since steadily increased to 11,000,000 tonnes per annum.

The engineering consulting company Ceenex (Pty) Ltd specialize in providing simulation services for the mining industry. In 2010 Ceenex was assigned the project to develop a simulation model for the future expansion of the GGV mine. The objective of the project was to simulate the coal handling system for the remaining 30 year life time of the operation after the 2017 expansion with the Xstrata Coal Zaaiwater mine.

The simulation modelling software Simio was used to build the model. Simio is an object orientated simulation modelling framework which is used worldwide in industry including the mining sector with great success.

Since the 2010 project, the client has requested that the simulation model is adjusted and calibrated to the current operation for present day use prior to the 2017 expansion. The model aims to identify the bottleneck of the system believed to be the cause for a lower than expected annual throughput and to examine the feasibility for an earlier than planned introduction of the Raw coal sized stockpile.

2. Problem Statement

The Coal Handling Processing Plant (CHPP) at GGV is designed to produce at a plant feed rate of one million tonnes a month. During the start of operations at the mine, coaling from the pit was identified as the bottleneck in the system preventing the target from being reached. Capital was invested in the addition of more mining machinery to increase the mining rate.

Since then, a Just-In-Time (JIT) approach is used at the mine with sufficient buffer capacity in the form of trucks and loaders. However, the plant is still not able to produce at its target despite the rate of mining exceeding 1 million tonnes a month. This has resulted in the stockpiles saturating with tonnes faster than they can be re-claimed for re-handling. Stockpiled coal degrades over time reducing its quality and selling price and should thus not be stocked for long periods.

It is clear that the bottleneck has now shifted downstream in the system but its exact location needs to be determined. The 2010 GGV simulation model was built for a different purpose and is thus not suitable in its current state for this task. This model must first be adapted and calibrated for the present day operations before it can be used to locate the bottleneck.

A 75,000 tonne Raw coal sized stockpile is planned for the 2017 Zaaiwater expansion for GGV. Other mines that have employed such a stockpile have reported greater operational flexibility and an increase in throughput. Once the simulation model has been adapted, it will be used to motivate the Capital Expenditure (CAPEX) for the proposed Raw coal sized stockpile at GGV.

3. Project Aim

The project aims to fulfil the following requirements:

- A re-development of the simulation model to capture the current day operation in detail
- Identifying the bottleneck in the system
- Determining the impact of a Raw coal sized stockpile
- Verifying the feasibility of a Raw coal sized stockpile in terms of throughput and CAPEX

4. Project Scope

The scope of the simulation model includes all the processes of current starting at the pit where Run of Mine (ROM) is loaded onto trucks, the carrying of coal to the ROM pad, stockpiling and re-handling, through to the various material handling and sizing processes prior to the Coal Preparation Plant (CPP), the washing of coal at the plant itself and the stockpiling and selling of the final product thereafter. Factors such as the future tonnes mined, maintenance, breakdowns, operational process delays and weather conditions are also taken into account.

Apart from the Raw coal sized stockpile, the future Zaaiwater expansion is not included in the project scope.



(Xstrata Coal 2011)

Figure 1: The ROM Pad with its Tip Bin and Stockpiles

5. Literature Review

5.1 Introduction

The objective of the literature review is to provide background and insight into past engineering problem solving approaches to form the basis for the research component of the design solution. It aims to deduce a project approach and establish the best engineering techniques and methods to be used to achieve the project's scope

Most publications reflect on Industrial Engineering practices in isolation. Real world problems are often a cause originating from various sources which may not have a direct link to each other but impact the overall performance of the system. For this reason, the literature review will focus on the integration of various techniques such that the system can be optimized as a whole.

Themes of Focus

Focus will be designated to the following subject areas:

1. Identifying potential processes constraining system performance
 - Using Theory of Constraints (TOC) to identify constraints within a system
 - Inspection for bottlenecks using a Simio simulation model
2. Establishing the relation and interaction between system processes
 - System Thinking

5.2 Identifying Potential Processes Constraining System Performance

Theory of Constraints (TOC)

Operations at the GGV opencast coal mine follow a series of batch processes as well as continuous processes. Identifying the Capacity Constraint Resource (CCR), the resource constraining throughput, in such a mixed system is often difficult due to the lack of continuous flow between such processes.

'The Theory of Constraints is an overall philosophy developed by Dr. Eliyahu M. Goldratt, usually applied to running and improving an organization. TOC is applied to logically and systematically answer these three questions essential to any process of ongoing improvement:

1. "What to change?"
2. "To what to change?"
3. "How to cause the change?"

(TOC Southern Africa (Pty) Ltd 2012)

Goldratt's view on TOC focuses on five steps which concentrate on the improvement efforts of the operation that is constraining a critical process and limiting the performance of the system as a whole. Goldratt's five step strategy is listed below:

1. 'Identify the system constraints
 - No improvement is possible unless the constraint or weakest link is found
2. Decide how to exploit the system constraints
 - Make the constraints as effective as possible
3. Subordinate everything else to that decision
 - Align every other part of the system to support the constraints even if this reduces the efficiency of non-constraint resources
4. Elevate the system constraints
 - If output is still inadequate, acquire more of this resource so it no longer is a constraint

5. If, in the previous steps, the constraints have been broken, go back to step 1, but do not let inertia become the system constraint
 - After this constraint problem is solved, go back to the beginning and start over. This is a continuous process of improvement: Identifying constraints, breaking them, and then deciding the new ones that result'

(Jacobs – Chase – Aquilano 2009, p. 681)

In a Mining Weekly editorial interview with Goldratt for Mining MD Henning du Preez by Natasha Odendaal, du Preez says that 'the theory of constraint (TOC), developed by Dr Eliyahu Goldratt, has been translated for the mining environment – TOC Mining – to improve daily average output by about 40% or up to 85% of a mine's highest historical output. This method can be implemented without incurring significant additional capital expenditure or operating costs and, in all cases, the cost per ton is reduced' (Odendaal 2011).

According to du Preez a mine has many sources of variations and interdependencies. To improve production, the constraining factor (weakest link in the system) must be addressed 'by means of strategically placed and managed buffers to ensure that if a mining process becomes inactive for any reason, it will not hold back the performance of the weakest link. When the flow is restored, standard production can continue as usual' (Odendaal 2011).

The engineering consulting company Ceenex (Pty) Ltd who have years of experience in the development planning and process optimization of South African and International mines, employ a TOC approach to identify bottlenecks at mines.

Ceenex (Viljoen 2011) argues that 'in a well designed batch-continuous system the throughput capacity is determined by the constrained resource. In a system where the constrained resource is in the middle of the system and there is sufficient buffer capacity the following holds true: A buffer before the constrained resource ensures constant production through the resource. The buffer after the constrained resource prevents congestion of the resource (Figure 2). The processes before and after the constrained resource are supporting the system throughput. The supporting processes should have adequate spare capacity in order to ensure that the buffer before the constrained resource never runs dry and that the buffer

after the constrained resource never saturates. Any delay on the constrained resource reduces throughput as lost production on the constrained resource can never be made up.

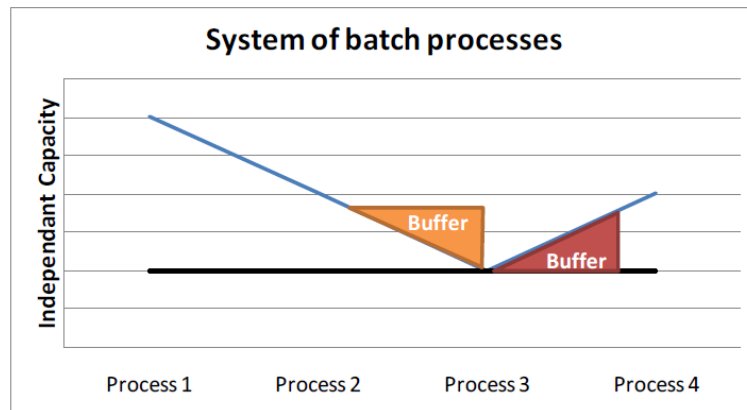

(Viljoen 2011)

Figure 2: Constrained Resource Located in the Middle of System

In a system where the first resource is constraining the throughput, it is necessary to have a buffer after the resource to prevent the constrained resource being influenced by downtime on the downstream resources. Also, in a system with a perfectly balanced design capacity in every process, disturbances have a cumulative effect as illustrated in the graph below (Figure 3)'.

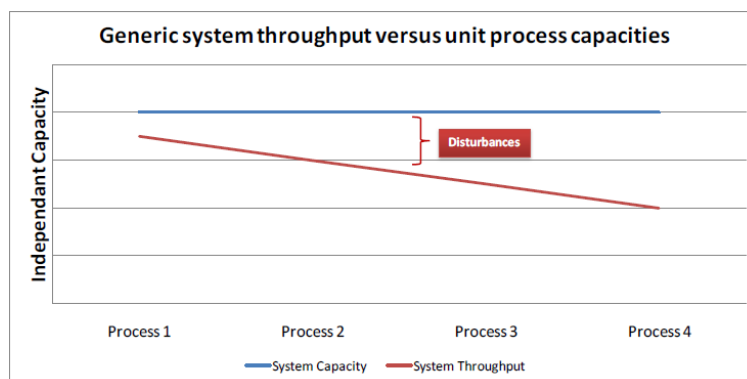

(Viljoen 2012)

Figure 3: Constrained Resource Located at Start of System

TOC can be used to identify bottlenecks within the system. The system's throughput capacity is determined by the Capacity Constrained Resource. By using buffers, operations may continue for a certain period of time even when the weakest link in the system is unable to equal the throughput of upstream processes.

Simulation and Modelling using Simio

Simulation allows a system to be analyzed by its dynamic behaviour. This makes it a powerful tool to perform what-if analysis such as system optimization.

'In Discrete Event Simulation (DES) the operation of a system is represented as a chronological sequence of events. Each event occurs at an instant in time and marks a change of state in the system' (Wikipedia 2012).

Simio is based on a DES modelling platform. This allows the user to compare the performance of adjacent processes to each other for an instant in time. Multiples of such measurements for different simulation run times and system states will not only reveal where the bottleneck is located but also show when and under which conditions such an occurrence may take place.

Ceenex employs an adoption of the TOC on DES whereby the simulation model is analyzed in real time during a run cycle. Analysis is started up stream in the system where the entities are created. For an opencast coal mine, this point represents the extraction site where ROM is loaded onto trucks. The engineer evaluates the throughput of the process in question by evaluating the input received from the preceding process and the output delivered to the proceeding process. If the process is starved from the expected input, the constraining factor must lie upstream. If the process itself is the bottleneck, upstream processes will accumulate up to their capacity limits (to the point of incapacitating some processes) while downstream processes will be starve from input. In this manner, all processes are analyzed and eliminated as subjects up to the final process in the system. Verifying whether a process is constraining the system can simply be tested by increasing its capacity parameter value.

It is worth noting however that the impact of a bottleneck may not necessarily be visible in adjacent processes. Often the effect of a bottleneck accumulates through the system and may first become apparent at a different location in the system.

A primary benefit of a simulation model is that competing scenarios can be tested to discover a better solution. The case study "Using Simulation to Understand Bottlenecks,

Delay Accumulation and Rail Network Flow” by Michael K. Williams (Williams 2012, pp. 1-11) reports on how he addressed the bottleneck between two adjacent train yards connected by a single track using DES Arema. Williams compared two potential scenarios with the base case. Scenario one introduced a rail siding at the midpoint distance between the two existing yards. Scenario two introduced two rail sidings between the adjacent existing yards.

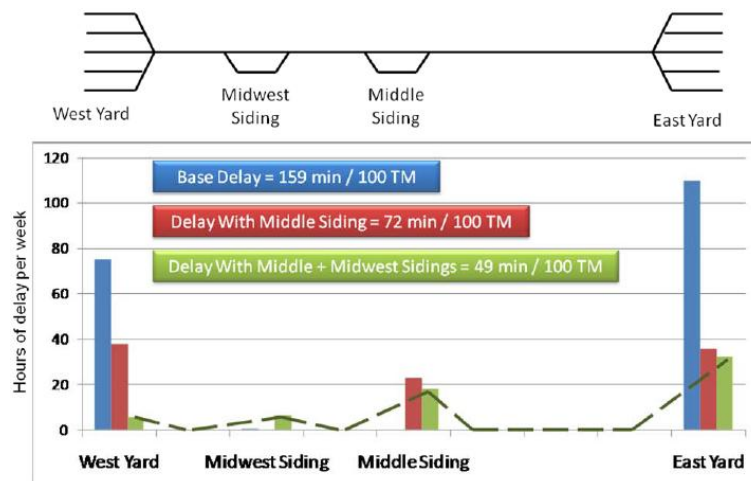

(Williams 2012, p. 7)

Figure 4: Delay Times for Multiple Scenario Runs

The simulated scenario runs showed a decrease in delay for both yards suggesting that the bottleneck is the single track. ‘In this sense, the siding is not just a place to pass trains; it is the strategic tolerance of delay at one location in order to reduce overall delay of the system. Delay now accumulates at three locations in the sample network, and each delay is influenced by the other two’ (Williams 2012, pp. 5). Scenario two showed the same effect with even better network fluidity. William expresses that the simulation’s scenario comparison identified the root location of the bottleneck and helped save the company a substantial amount of money by not going through with the initial request of both yardmasters to invest in additional capacity.

Simulation can assist an Industrial Engineer to identify, verify and manage system bottlenecks while using few resources, time and funds. Multiple scenario runs, also known as Experiments in Simio, allow for base case comparisons and multiple alternative decision making. Furthermore simulation is an effective tool when using the TOC methodology.

5.3 Establishing the Relation and Interaction between System Processes

System Thinking

A mine relies on its chain of processes to operate without breaking their link. It is thus important to understand the relationship between the processes, their impact on each other and the overall system.

‘Systems Thinking has been defined as an approach to problem solving, by viewing "problems" as parts of an overall system, rather than reacting to specific parts, outcomes or events and potentially contributing to further development of unintended consequences’ (Wikipedia 2012).

Aronson (Aronson 1996, pp. 1-3) reasons that traditional analysis focuses on separating individual pieces of what is being studied in contrast to system thinking which focuses on how these pieces interact with other constituents of the system.

Barlett (Barlett 2001, pp. 1-7) argues that when analysis breaks elements down into smaller and smaller components, perspective is lost of the interaction between these components and the system as a whole. This can lead to a vicious cycle whereby one element continues to be broken down and analysed further and further, diminishing the insight into the interaction between processes. This is known as an analysis paralysis.

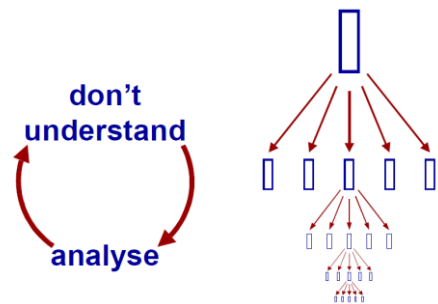

Figure 5: An Analysis Paralysis Cycle

Barlett claims that a thinking tool such as synthesis which is designed to understand interactions is a much better approach to analysing systems as the engineer is able to see the bigger picture. Both analysis and synthesis have limited value without the other; their combination is preferred and referred to as systemic thinking.

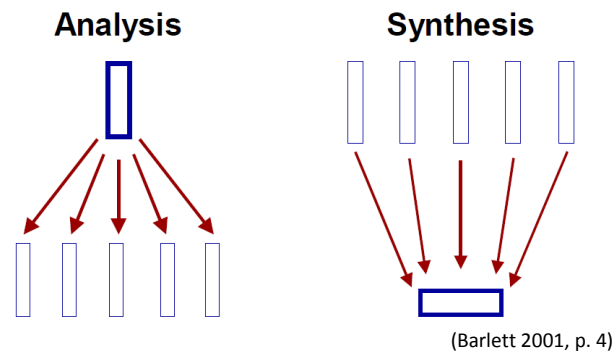

Figure 6: Analysis vs. Synthesis Thinking Approach

Systemic thinking focuses on the element that will improve overall system performance the most rather than the element with the highest improvement potential.

A mine's main objective is to maximize its throughput. System thinking allows this to be achieved economically by optimizing the system to improve overall performance rather than improving individual processes in isolation.

6. Project Approach

The approach is based on the methods and techniques discussed in the Literature Review. The following section describes how these techniques were implemented to achieve the project aim.

Analysis of the mine was accomplished through regular site visits. Data gathering and time studies were conducted to obtain the required parameter values. A full understanding of all the operations was required to accurately design the process control logic of the simulation model. This was achieved through personal observations and discussion with the various departments, operations and personnel at the mine.

The simulation model was adapted to represent the current operations of the mine. The new parameter values and control logic was implemented and the model calibrated with the actual operational data retrieved during the data gathering phase.

An adoption of TOC on simulation was used to analyze the run results of the simulation model. Analysis is started up stream in the system where the coal is mined from the pit and progressively moved to downstream operations. The throughput of a process in question is analyzed by evaluating the input received from the preceding process and the output delivered to the proceeding process. If the process is starved from input, the constraining factor must lie upstream. If the process itself is the bottleneck, upstream processes will accumulate coal (to the point of incapacitating some processes) while downstream processes will be starve from coal. In this manner, all processes are analyzed and eliminated as the bottleneck. Verifying whether a process is constraining the system can simply be tested by increasing the capacity of its parameters and re-evaluating the simulation model.

Scenario runs were performed with and without the inclusion of the proposed Raw coal sized stockpile. The difference in annual throughput was compared and a decision made regarding the feasibility of the stockpile.

A cost analysis was done based on the results obtained from the scenario runs. The analysis took into account the gain in throughput to determine the increase in revenue expected for utilizing the Raw coal sized stockpile.

7. System Analysis

System Description

GGV is an opencast coal mine that extracts coal from a surface pit. The mining operations follow a push system designed to operate on the JIT philosophy and are categorized as follows:

1. Coaling
2. Re-handling
3. Washing
4. Discard and Waste

Coaling

The coaling process refers to the extraction of ROM from the pit and the transfer by truck to the ROM pad. The following three seams are extracted from the pit:

1. 2 Seam (High Grade/Low Grade)
2. 4 Seam (High Grade/Low Grade)
3. 5 Seam

The difference between the coal seams is their quality. High Grade designated ROM is high in quality and used to produce Export product suitable for selling to Export clients. Low Grade ROM is low in quality and used to produce ESKOM product only utilized by the power utility to fuel its power stations. If ESKOM product is short in supply, the mine will deliver Export product as a substitute to ESKOM.



Figure 7: The Pit and its Coal Seam Layering

At most two seams are mined at any moment in time. Coal seams are mined sequentially from the top downwards. The most upper coal seam layer is the 5 Seam, followed by the

underneath lying 4 Seam and 2 Seam. Each seam is separated from the other by a layer of rock which is removed and classified as waste. Each coal seam in turn contains an upper and lower level referring to their designated Low and High Grade qualities respectively. Strip mining is applied such that adjacent strips mined are separated by one coal seam layer. The period of mining a specific seam per block is between a few hours to a couple of days.



Figure 8: Truck Offloading at Tip Bin

Front End Loaders (FEL) and excavators load coal onto trucks at the pit. Loading takes place through a sequential queuing system with a First-Come-First-Serve (FCFS) service process. From the pit trucks travel a distance to the ROM pad where they either offload on the stockpiles or at the tip directly. Offloading directly at the tip occurs when the truck's load is the same seam and grade as that being washed by the CPP. A truck will stockpile if this

is not the case or if offloading at the tip is not possible due to the tip being full, clogged or the presence of a long queue.

Re-handling

The re-handling process refers to feeding the Tip Bin from stockpiled coal. Trucks are loaded by FEL from one of the five re-handling stockpiles containing the ROM that the plant requires. Depending on the operational circumstances, re-handling can be the primary feed of ROM to the plant or can take place in parallel with the coaling operation.

Washing

Up to this point, the system represented batch processing. The tip accumulates ROM and releases it at a certain outflow rate onto a conveyer. This allows the system to undergo continuous processing for blocks of time (batch-continuous system). The conveyer moves a continuous flow of ROM through the Primary - and Secondary Sizers. Both these processes reduce the rock size of the ROM.

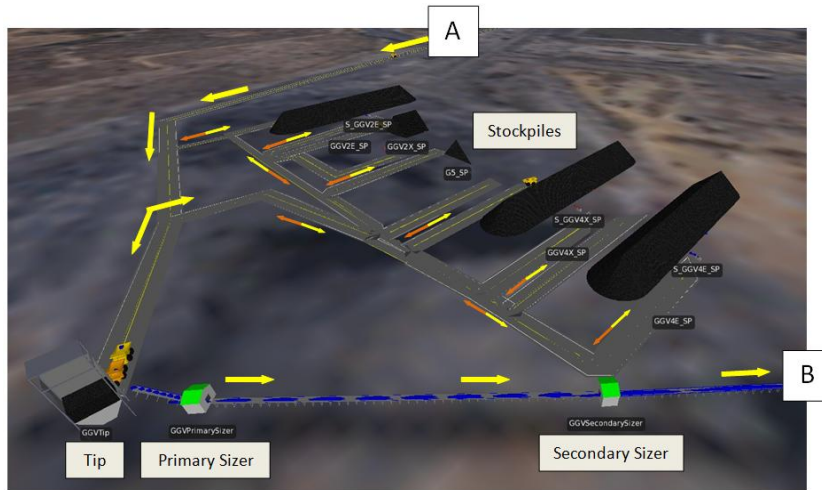

Figure 9: Process Flow between Stockpiles and Tip at the ROM pad

Similarly from point B a conveyer moves the ROM through Tertiary Sizers that further reduce the ROM rock size. The flow then continues to the Raw Coal Bin (Surge Bin).

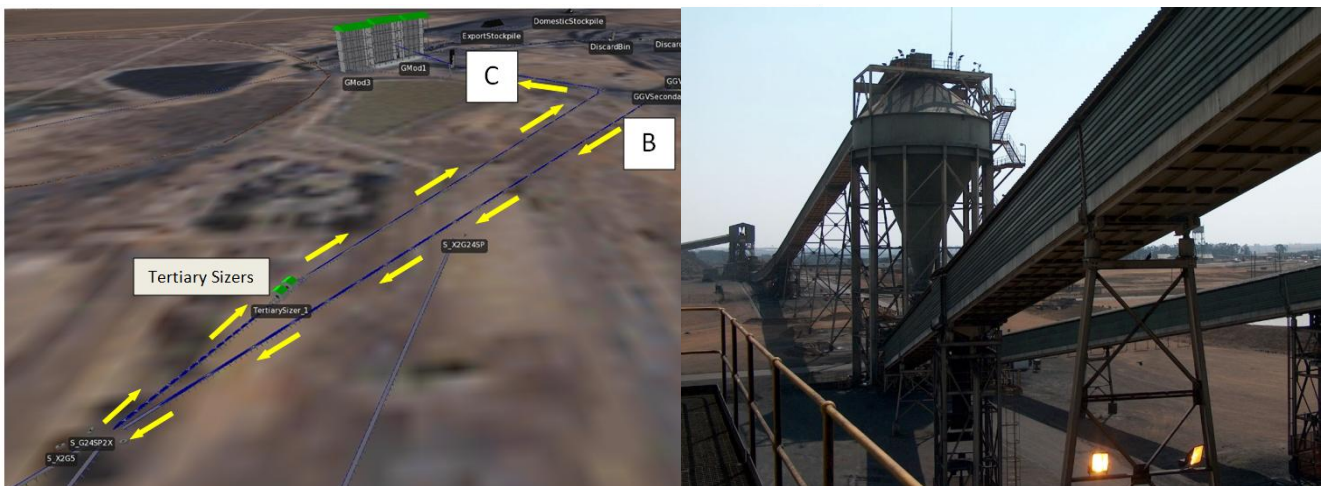

Figure 10: Process Flow to Raw Coal Bin

The Raw Coal Bin accumulates the sized ROM and releases its load by varying the feed rate onto the two conveyors enabling each of the plant's separate but identical modules to be fed with a constant supply of ROM. The modules wash the ROM to their finished product.

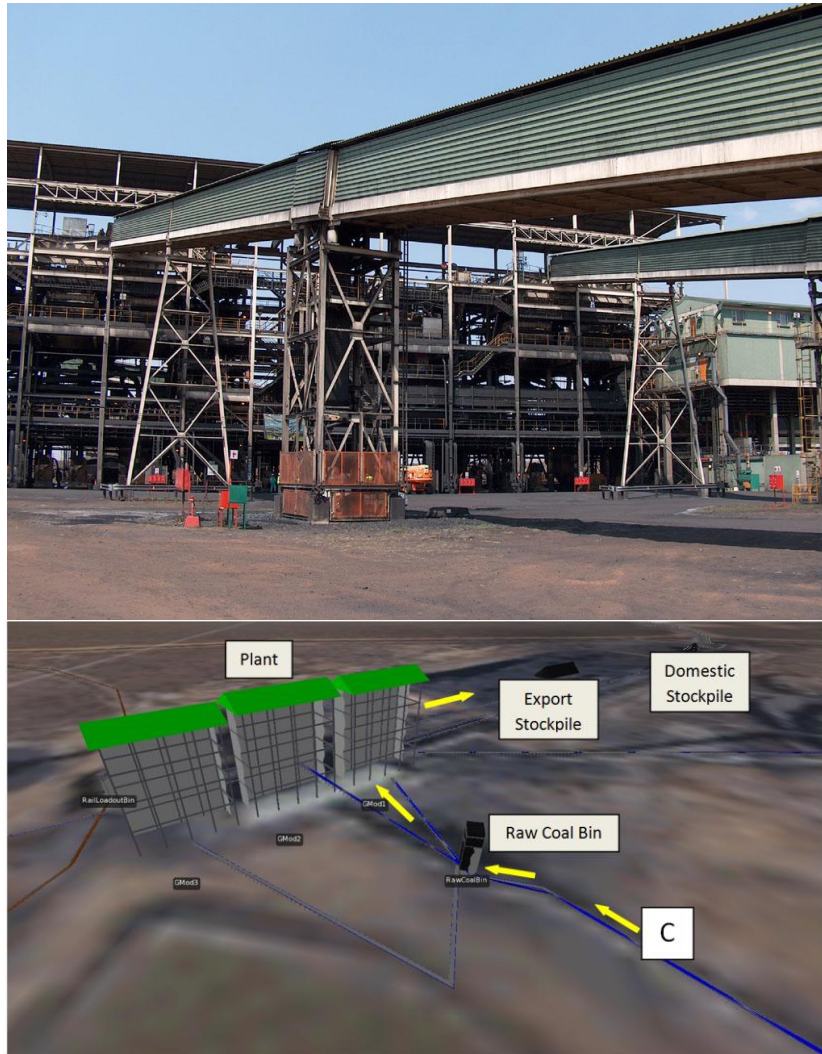

Figure 11: Process Flow through the Plant to End User Port

The CPP either washes single stage or double stage. During single stage washing the plant produces either Export product or ESKOM product. During double stage washing the plant produces both ESKOM and Export product simultaneously.

A primary stacker and a secondary stacker build the stockpiles with the plant's outputted product. The primary stacker is dedicated to the Export stockpile while the secondary stacker can serve both stockpiles.



Figure 12: Primary and Secondary Stackers

The ESKOM stockpile is reclaimed using FEL loading trucks which haul the product to the coal power stations. The Export stockpile which contains both products, uses six gravity valve feeders (3 per product) to feed the rail load out bin conveyor. Daily scheduled Transnet trains rail the Export product to the Richards Bay Coal Terminal (RBCT).



Figure 13: Rail Load Out Bin

Discard and Waste

The CPP disposes discard via a conveyor into a Discard Bin. The Discard Bin is emptied through a feed valve loading a truck. Waste is removed from the pit by the dragline and loaded onto waste trucks. Both discard and waste are used to rehabilitate previously mined sections of the mine.



Figure 14: Discard Bin

Coal Seam Switch Over

A certain ROM feed is required depending on the product that is washed for by the plant. During a switch over from one ROM seam to another, the system will flush the remaining coal before being fed the new type coal. The stockpiles, Tip Bin and Raw Coal Bin are used in this regard to provide a buffer between the affected processes.

Operational Factors

Rain and Mist

During severe rain no trucks operate due to safety concerns. Trucks continue operating during mist if visibility is reasonable. All other operations in the system such as the CHPP continue functioning until they are starved from ROM.

Breakdowns

All operations which are not affected by the breakdown continue running. Usually ROM is stockpiled if the coal handling system becomes incapacitated.

CHPP Scheduled Maintenance

Scheduled maintenance is carried out every Wednesday for 12 hours. All operations which are not affected by the maintenance continue running. ROM is stockpiled during scheduled maintenance.

Operational Times and Working Shifts

The mine operates on a twenty four hour basis and only shuts down three days in a year during Easter, Christmas and New Year. Two shifts from 07:00 to 19:00 and 19:00 to 07:00 are worked per day. The shift change for the coaling trucks occurs after the shift change for the re-handling trucks to ensure that the ROM feed to the plant is not disrupted.

Process Flow Diagram

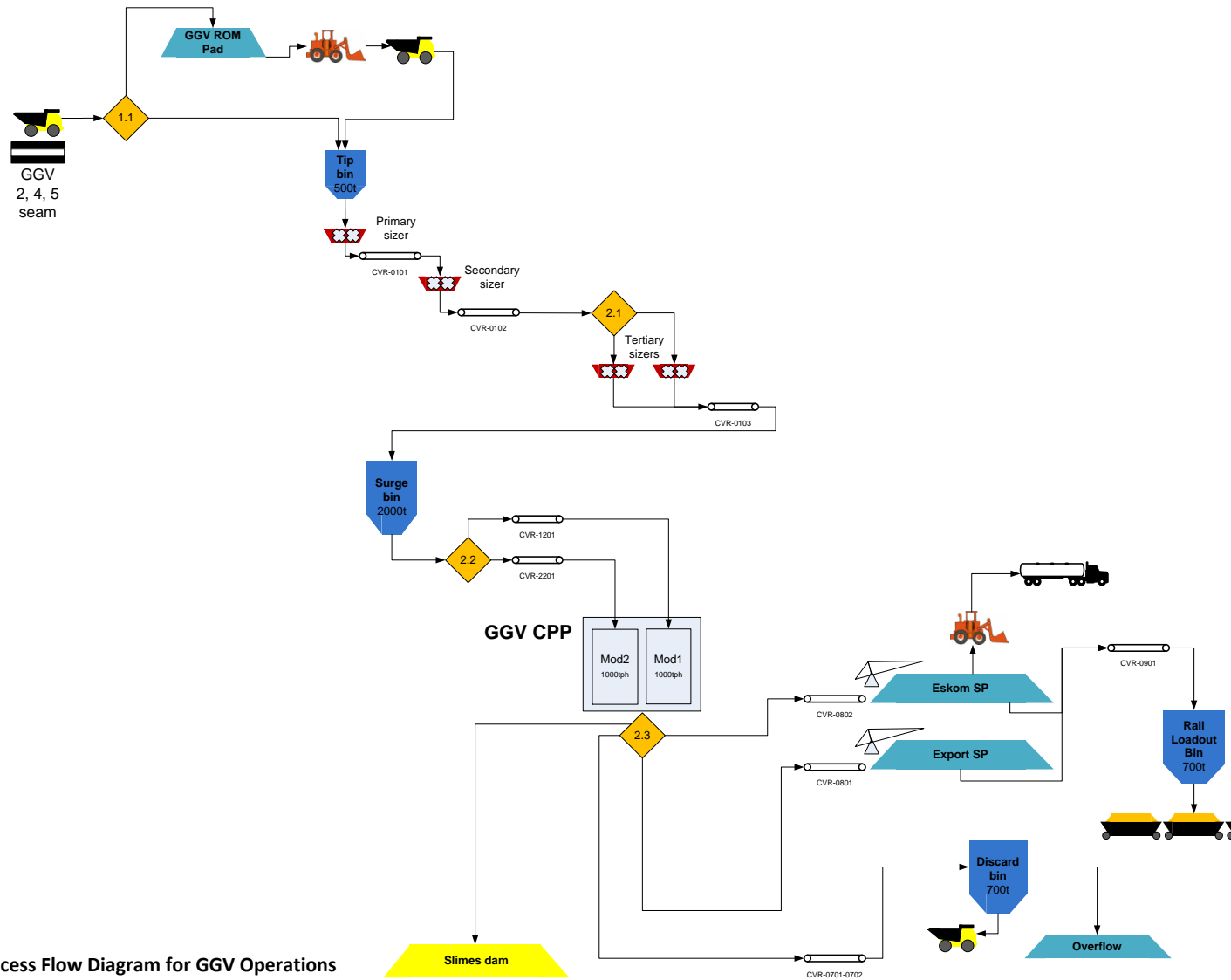

Figure 15: Process Flow Diagram for GGV Operations

8. Data Gathering and Analysis

Data was gathered on site at Xstrata Coal GGV over a six week period. It comprises personal observations, measurements taken and the sourcing of data and information from various departments, operations and personnel at the mine.

8.1 Trucks and Loaders

Loader Fleet

Two Front End Loaders (FEL) and one excavator make up the loader fleet. The CAT 993 FEL is used mainly at the ROM pad for re-handling and has a smaller bucket capacity than the Komatsu 1200 used at the pit. Both Front End Loaders may relocate to where they are required.

The excavator only loads from the pit and has the lowest bucket capacity of the three. For this reason, the Excavator is dedicated to the coal seam of lowest available tonnes mined.

During the unavailability of a loader, operations may be limited to either coaling or re-handling.

Truck Fleet

The mine utilizes two truck and body types. The CAT 785 coal body is dedicated to coaling and discard operations. During normal operations, eight 785 trucks operate from the pit and two are dedicated to do re-handling.

The CAT 789 rock body is used for the waste operation which does not form part of the simulation study.



Figure 16: CAT 785 Coal Body Truck

CAT 785 Coal Body

| Truck No. | Primary Duty | Secondary Duty | Serviced by Loader |
|-----------|--------------|----------------|-------------------------|
| T104 | Coal | Discard | Excavator / 1200 at pit |
| T105 | Coal | Discard | Excavator / 1200 at pit |
| T106 | Coal | - | Excavator / 1200 at pit |
| T107 | Discard | Coal | Excavator / 1200 at pit |
| T108 | Coal | - | Excavator / 1200 at pit |
| T109 | Coal | Discard | Excavator / 1200 at pit |
| T110 | Coal | Discard | Excavator / 1200 at pit |
| T111 | Coal | Discard | Excavator / 1200 at pit |
| T116 | Coal | - | CAT 993 at ROM pad |
| T117 | Coal | - | CAT 993 at ROM pad |

Figure 17: CAT 785 Fleet

Truck Load Capacity

The coaling trucks are specified to carry a load of 140 tonnes. Trucks are not weighed on a weighbridge but rather employ an onboard load mass sensor. During the time study conducted on the trucks, load mass measurements were recorded from numerous trucks and a triangular distributed truck load capacity of mean 147 tonnes determined.

Reliability

The truck and loader reliability parameters include the following:

- Mean Time Between Failures (MTBF) for planned maintenance
- Mean Time to Repair (MTTR) for planned maintenance
- MTBF for unplanned breakdowns
- MTTR for unplanned breakdowns



Figure 18: Komatsu 1200 FEL Breakdown

Data was retrieved from two sources. Monthly machine downtime data was sourced from the mine for a period of two years and daily workshop repair data was sourced from the workshop for a period of seven months.

MTBF were measured from the time passed between consecutive maintenance activities for each individual truck and loader. The MTTR was calculated from the workshop data and calibrated using the mine sourced data. This was necessary as the workshop only measures actual book-in time which excludes on-site diagnostic and towing time.

A distribution expression (see section 8.2 for a similar method description) for each parameter value was calculated using Arena Input Analyzer.

The mean reliability values are given below:

Trucks

| | |
|-------------------------------------|-----------|
| MTBF - Planned Maintenance: | 500 Hours |
| MTTR - Planned Maintenance: | 10 Hours |
| MTBF - Unplanned Breakdowns: | 40 Hours |
| MTTR - Unplanned Breakdowns: | 6 Hours |

Excavator

| | |
|-------------------------------------|-----------|
| MTBF - Planned Maintenance: | 250 Hours |
| MTTR - Planned Maintenance: | 10 Hours |
| MTBF - Unplanned Breakdowns: | 75 Hours |
| MTTR - Unplanned Breakdowns: | 4 Hours |

Front End Loaders

| | |
|-------------------------------------|-----------|
| MTBF - Planned Maintenance: | 250 Hours |
| MTTR - Planned Maintenance: | 10 Hours |
| MTBF - Unplanned Breakdowns: | 70 Hours |
| MTTR - Unplanned Breakdowns: | 7 Hours |

Figure 19: Reliability for Trucks and Loaders

8.2 Coal Handling Time Study

A time study was conducted for the coal handling operations:

1. Coaling from the pit
2. Re-handling from the stockpiles

Method

The time study was done from inside the trucks, loaders and various outside locations. A sufficient number of recordings were taken to ensure result accuracy. Time measurements were recorded for actual time to the nearest second. The data was inputted into a spreadsheet which calculated the time duration for each component measured. Results were analyzed with Arena Input Analyzer to obtain a distribution expression that is used for the simulation model's parameter values.

Measured Parameters

The time study results measure the following parameter values:

- Loading cycle time
- Offloading cycle time
- Empty truck travel speed for a mixed route cycle
- Loaded truck travel speed for a mixed route cycle
- Constant truck travel speed

Loading Cycle Time

A loading cycle time was established for each loader. The excavator and Komatsu 1200 FEL operate from the pit and the smaller CAT 993 FEL is used for re-handling. The loading cycle time is broken down into the following time components:

- Truck positioning time
- Load time per bucket
- Number of buckets loaded
- Wait time before depart

The truck positioning time was measured from arrival (excluding truck waiting time) to the truck being positioned ready for loading. This measurement is not dependant on the loader in question and its distribution was determined from all the measure points taken.

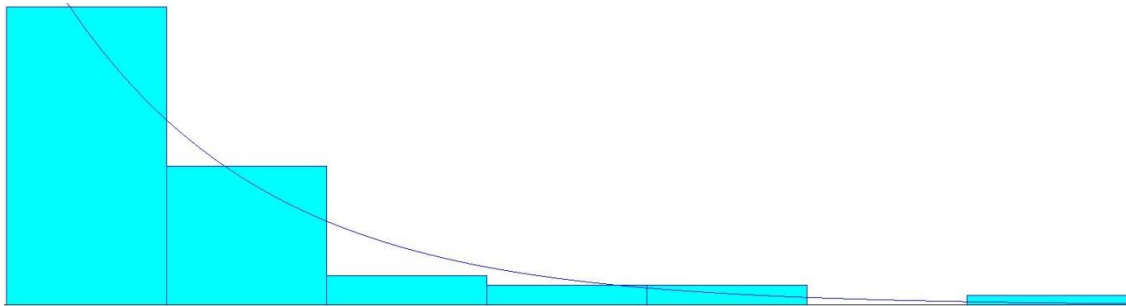

| | |
|---------------------------------|-------------|
| Distribution Expression: | EXPO(0.654) |
| Square Error: | 0.001 |
| Mean: | 0.7 Minutes |

Figure 20: Truck Positioning Time Results

Each loader has a different bucket size. It was established that the load time per bucket is less dependent on the bucket size but possess more variability in terms of the loading conditions. To accurately capture this variability, measurements from all loaders were included to obtain a distribution representative for the various loading conditions.

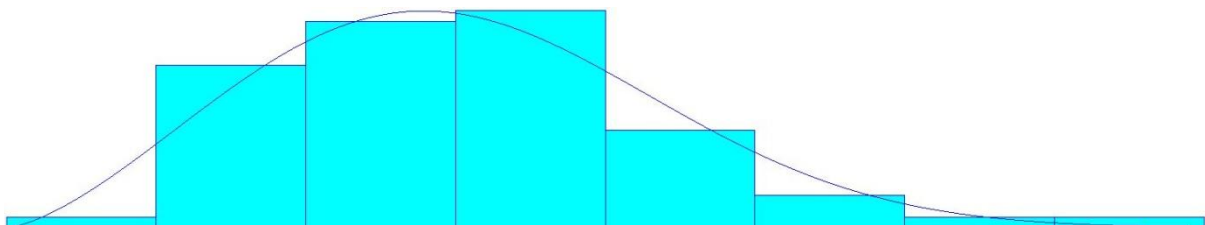

| | |
|---------------------------------|----------------------------|
| Distribution Expression: | 0.32 + WEIBULL(0.20, 2.46) |
| Square Error: | 0.04 |
| Mean: | 0.5 Minutes |

Figure 21: Bucket Load Time Results

The number of buckets loaded was determined for each loader and a triangular distributed bucket count calculated.

| | Excavator | 1200 | 993 |
|---------------------------------|--------------------|----------------------|---------------------|
| Distribution Expression: | TRIA(4.5, 8, 10.5) | TRIA(3.5, 4.76, 6.5) | TRIA(5.5, 6.5, 7.5) |
| Square Error: | 0.01 | 0.03 | 0 |
| Mean: | 7.5 | 5 | 6.5 |

Figure 22: Bucket Count Results

The truck departure occurs immediately after the last bucket has been loaded onto the truck. Results of the wait time to depart averaged a time of 5 seconds and this parameter value is taken as a constant.

The loading cycle time expression for each loader is calculated using the below formula:

$$\begin{aligned}
 \text{Load cycle time} &= \text{Truck positioning time} \\
 &+ (\text{Load time per bucket} * \text{Number of buckets loaded}) \\
 &+ \text{Wait time before depart}
 \end{aligned}$$

The final loading cycle time per loader is given below:

Excavator

| | |
|--------------------|---|
| Expression: | $\text{EXPO}(0.654) + [(0.32 + \text{WEIBULL}(0.20, 2.46) * \text{TRIA}(4.5, 8, 10.5))] + 0.08$ |
| Mean: | 4 Minutes 31 Seconds |

Komatsu 1200

| | |
|--------------------|---|
| Expression: | $\text{EXPO}(0.654) + [(0.32 + \text{WEIBULL}(0.20, 2.46) * \text{TRIA}(3.5, 4.76, 6.5))] + 0.08$ |
| Mean: | 3 Minutes 17 Seconds |

CAT 993

| | |
|--------------------|--|
| Expression: | $\text{EXPO}(0.654) + [(0.32 + \text{WEIBULL}(0.20, 2.46) * \text{TRIA}(5.5, 6.5, 7.5))] + 0.08$ |
| Mean: | 4 Minutes 2 Seconds |

Figure 23: Load Cycle Time Results

Offloading Cycle Time

The offload cycle time was measured for offloading at the tip and offloading at the stockpiles. Both locations hold the same offloading procedure allowing for a shared parameter value.

A complete cycle time was measured from the truck arriving to its departure.

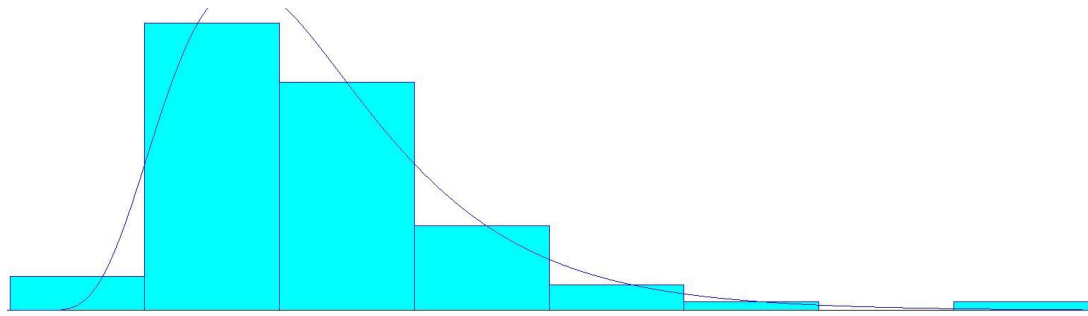

| | |
|---------------------------------|---------------------------|
| Distribution Expression: | 0.68 + LOGN(0.514, 0.235) |
| Square Error: | 0.001 |
| Mean: | 1 Minutes 11 Seconds |

Figure 24: Truck Offload Cycle Time Results

Truck Travel Speed

Three truck travel speed parameters were measured during the time study. The constant truck travel speed applies to both loaded and empty trucks travelling on a straight road without stoppages at a constant velocity. The truck empty and truck full travel speed measures for their respective load statuses and includes intersection stoppages. Two routes representative of most travelling occurrences were used to measure the travel time between route markers. The route distances were measured in Google Earth to calculate the travel speed for each recorded measurement.

Constant Truck Travel Speed

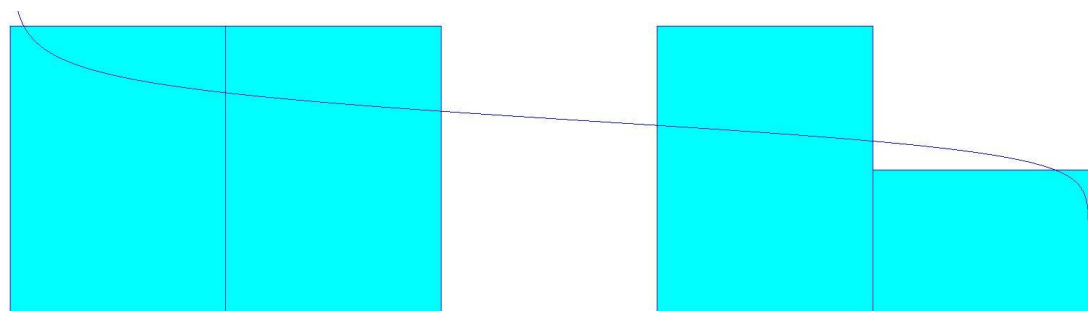

| | |
|---------------------------------|-----------------------------|
| Distribution Expression: | 45 + 10 * BETA(0.911, 1.09) |
| Square Error: | 0.05 |
| Mean: | 50 Kilometers per Hour |

Figure 25: Constant Truck Speed Results

Empty Truck Travel Speed

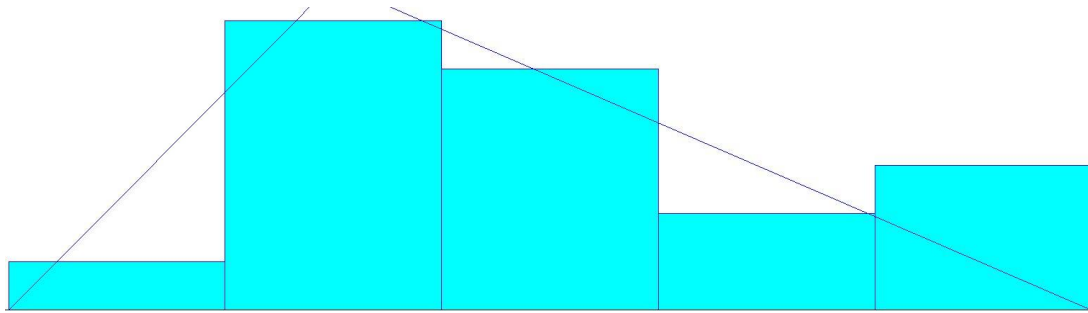

| | |
|---------------------------------|------------------------|
| Distribution Expression: | TRIA(36, 41.7, 55) |
| Square Error: | 0.02 |
| Mean: | 45 Kilometers per Hour |

Figure 26: Empty Truck Speed Results

Full Truck Travel Speed

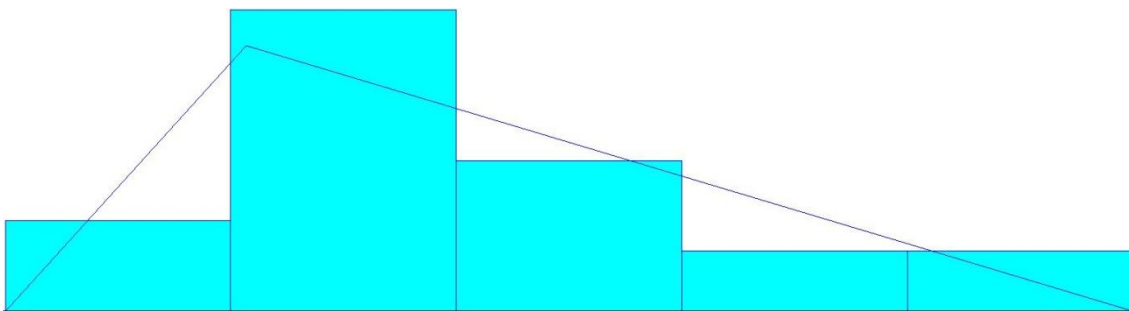

| | |
|---------------------------------|------------------------|
| Distribution Expression: | TRIA(21, 27, 49) |
| Square Error: | 0.02 |
| Mean: | 32 Kilometers per Hour |

Figure 27: Full Truck Speed Results

8.4 Stockpiles

The simulation model uses the current estimated tonnes contained on the stockpiles for September 2012 as an initial parameter value – see APPENDIX A.

Mining must ensure that ROM stockpiles do not saturate. The stockpiles have a large capacity but it is aimed that only sufficient tonnes to feed the plant for a couple of days are stocked. Stockpiled coal degrades over time reducing its quality and selling price.

The product stockpiles are limited by their surface area for any future capacity expansion; however constant product sales maintain the stockpile levels within their capacity range. In this regard, the mine could represent a pull system regulating production to the market demand. Historically this has not happened as the demand outweighs the supply capacity from the plant.

8.5 Coal Handling Processing Plant (CHPP)

The following parameters were determined from the data analysis:

- ROM section feed rate
- Module 1 and Module 2 feed rate
- MTBF for ROM section breakdowns
- MTTR for ROM section breakdowns
- MTBF for Module breakdowns
- MTTR for Module breakdowns

CHPP Operating Parameters

SCADA PLC data was retrieved for the CHPP and processed in a spreadsheet. All bin levels and conveyor rates for a 12 week period measured at 30 second intervals were analysed. Data for the feed rates was filtered to isolate only those measure points representing a constant coal feed under operating conditions.

The distribution expressions for the ROM section feed rate and the plant feed rate are shown below.

ROM Section Feed Rate

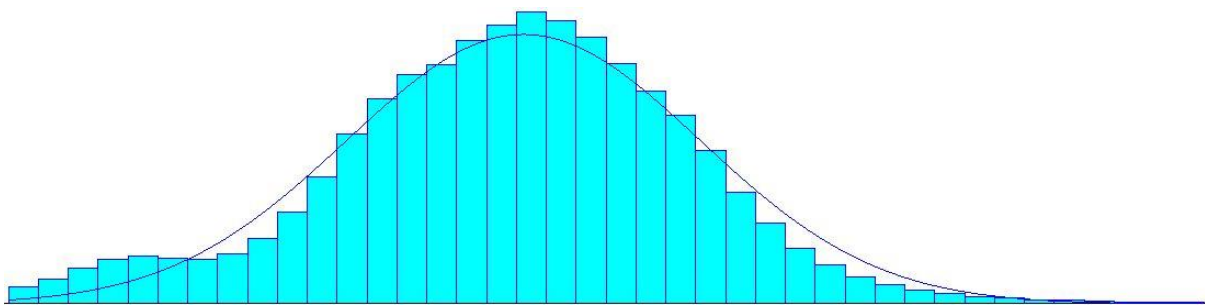

| | |
|---------------------------------|----------------------|
| Distribution Expression: | NORM(2300, 132) |
| Square Error: | 0.001 |
| Mean: | 2300 Tonnes per Hour |

Figure 30: Distribution for the ROM Section Feed Rate

Module 1 and 2 Feed Rate

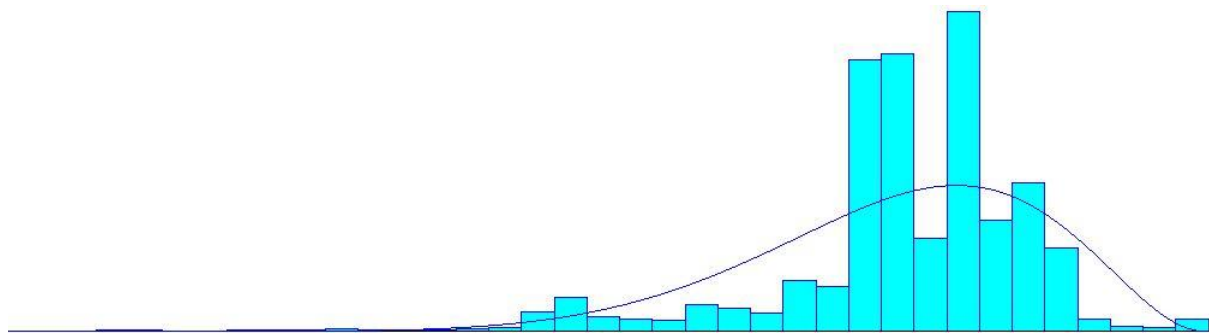

| | |
|---------------------------------|---------------------------------------|
| Distribution Expression: | $400 + 800 * \text{BETA}(10.5, 3.28)$ |
| Square Error: | 0.03 |
| Mean: | 1010 Tonnes per Hour |

Figure 31: Distribution for the Modules Feet Rate

SCADA Spreadsheet

The SCADA spreadsheet was used to validate the accuracy of the CHPP breakdown reports for the months July and August 2012. During a recorded breakdown of the ROM section or the plant, the SCADA telemetry should show a coal feed rate of zero tonnes per hour. This was verified and it was concluded that the breakdown data logged by the plant control room is trustworthy.

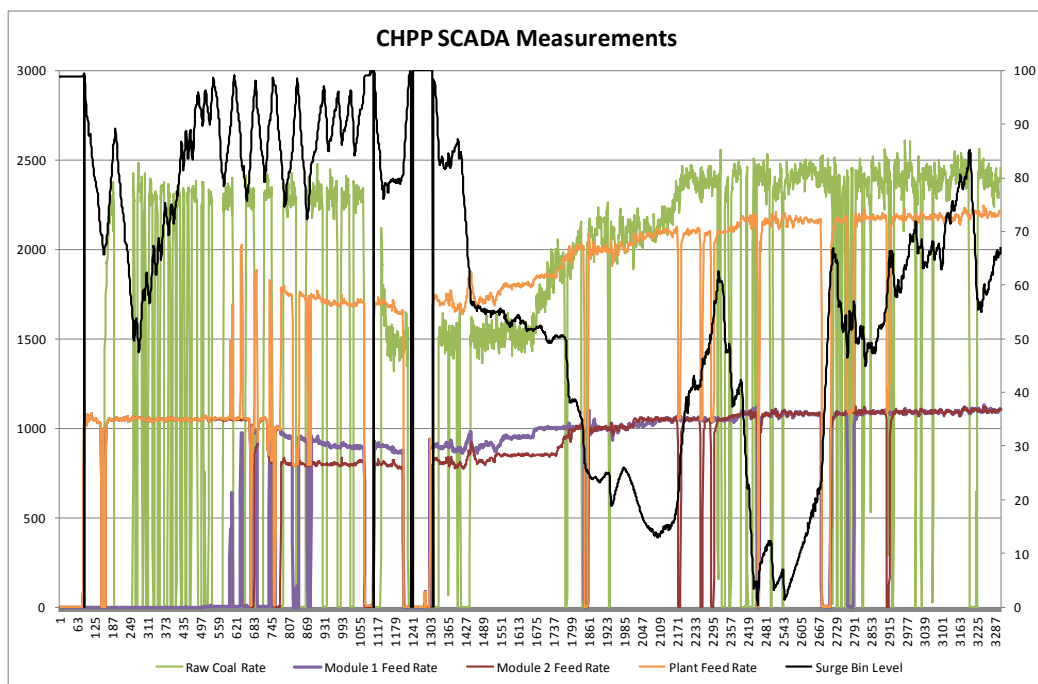

Figure 32: SCADA Data for 4 July 2012

Utilization charts were prepared from the SCADA data and used for the calibration of the simulation model. This kind of chart shows the percentage of time the system operates within a certain range giving a good indication of the performance and capabilities that can be expected.

The utilization chart below illustrates that for 12% of the time, the CHPP was not feeding any coal. For 15% of the time (the flat gradient between 25% and 40%) only one plant module was operational. The plant feed rate is almost identical to the ROM feed rate. Its slightly higher feed-rate over the latter is attributed towards the 2000 tonne Raw coal bin (surge bin) acting as buffer capacity. The surge bin is below its 60% level for 50% of the time measured.

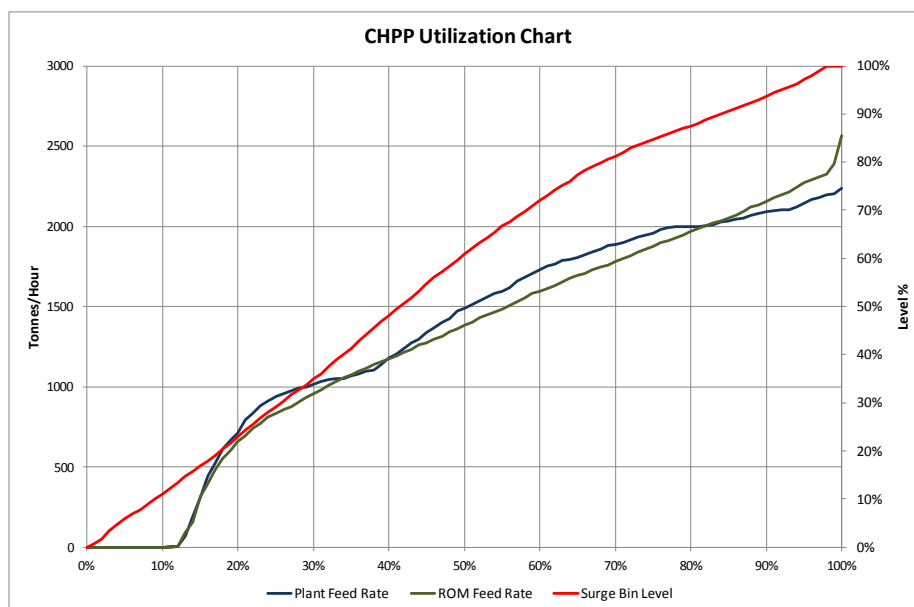

Figure 33: Utilization Graph for the CHPP

Reliability

Daily CHPP breakdown reports were obtained for the period 2011 to September 2012. The reliability parameters capture unplanned maintenance delays and unplanned process delays for the ROM section, the coal handling operation between the tip bin and the plant, and for both plant modules. The MTBF was calculated for the time passed between consecutive failures that stopped the operation. The MTTR is the time it took to repair the breakdown.

A distribution expression was calculated from the analyzed breakdown data for all MTBF and MTTR measurements recorded.

ROM Section MTBF

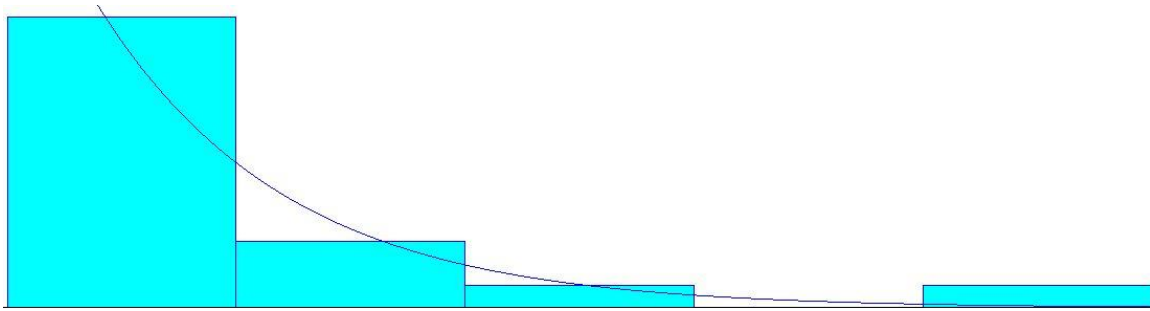

| | |
|---------------------------------|----------------|
| Distribution Expression: | 10 + EXPO(108) |
| Square Error: | 0.004 |
| Mean: | 118 Hours |

Figure 34: ROM Section MTBF Results

ROM Section MTTR

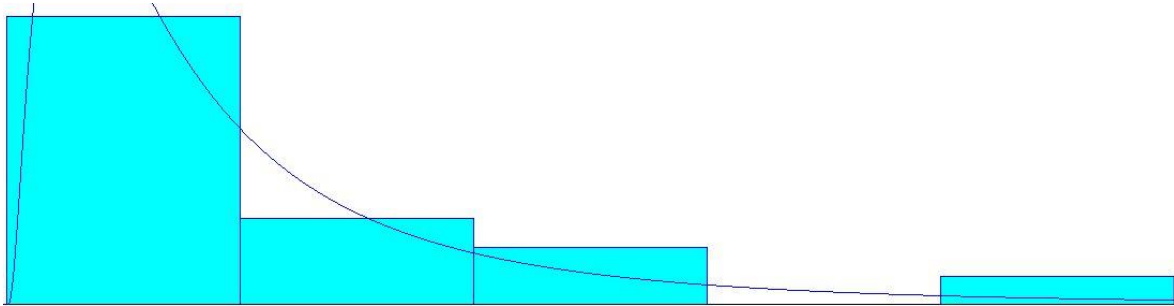

| | |
|---------------------------------|-----------------|
| Distribution Expression: | LOGN(1.76, 2.2) |
| Square Error: | 0.007 |
| Mean: | 1.8 Hours |

Figure 35: ROM Section MTTR Results

Module 1 MTBF

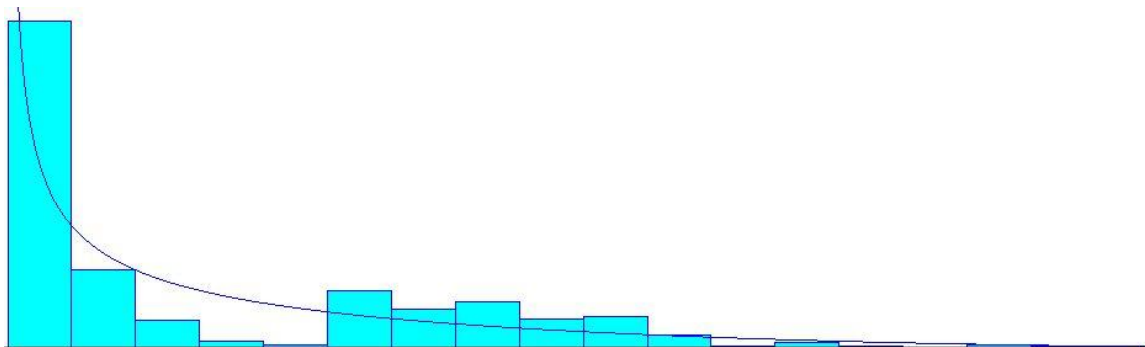

| | |
|---------------------------------|------------------------|
| Distribution Expression: | 92 * BETA(0.478, 2.69) |
| Square Error: | 0.02 |
| Mean: | 13.9 Hours |

Figure 36: Module 1 MTBF Results

Module 2 MTBF

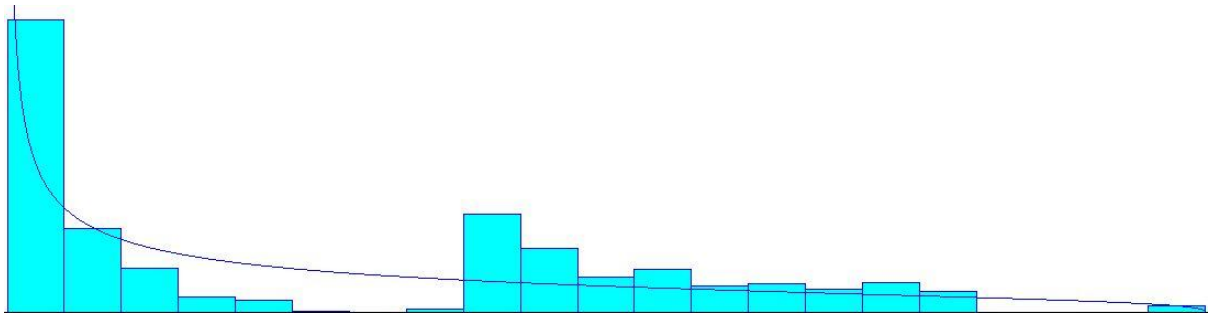

| | |
|---------------------------------|------------------------|
| Distribution Expression: | 59 * BETA(0.511, 1.33) |
| Square Error: | 0.03 |
| Mean: | 16.4 Hours |

Figure 37: Module 2 MTBF Results

Module 1 MTTR

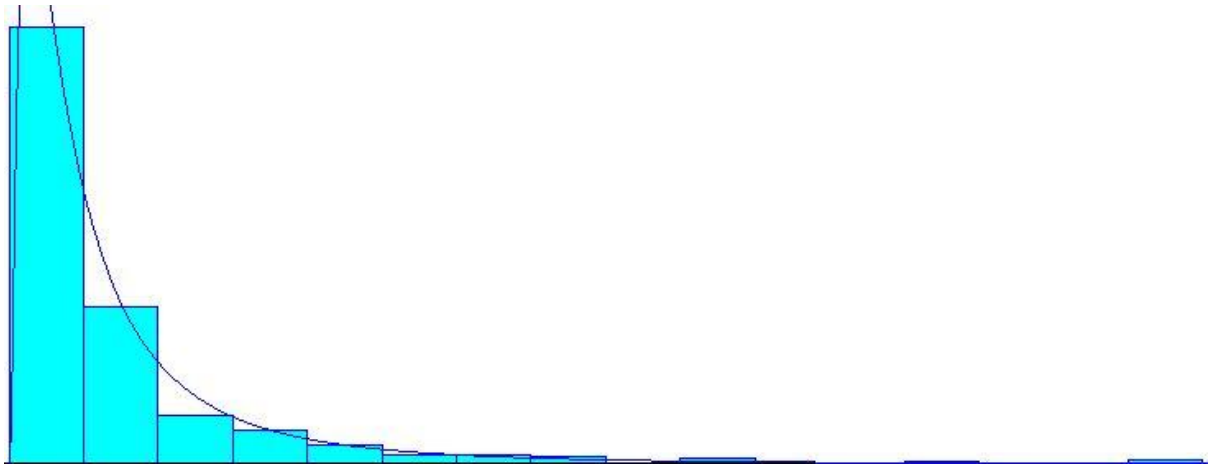

| | |
|---------------------------------|------------------|
| Distribution Expression: | LOGN(1.22, 1.82) |
| Square Error: | 0.002 |
| Mean: | 1.33 Hours |

Figure 38: Module 1 MTTR Results

Module 2 MTTR

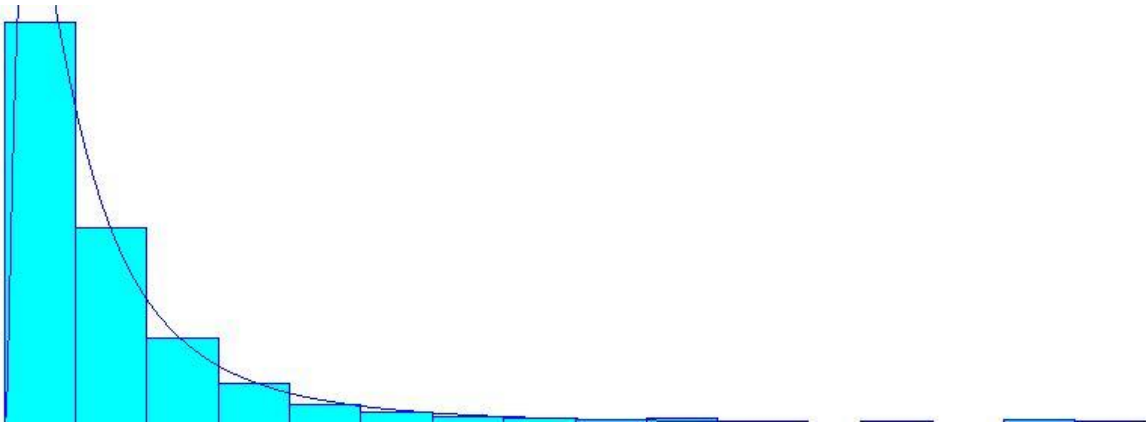

| | |
|---------------------------------|-----------------|
| Distribution Expression: | LOGN(1.36, 1.8) |
| Square Error: | 0.001 |
| Mean: | 1.44 Hours |

Figure 39: Module 2 MTTR Results

Planned Maintenance

Twelve hour planned maintenance is carried out every Wednesday simultaneously for the ROM section and plant modules. During planned maintenance the plant stops producing.

9. Adjusting of the Simulation Model

The previous simulation model was used as the starting point and adjusted as follows:

Disconnection of the Zaaiwater Expansion

A parameter value that disconnects the Zaaiwater expansion from the GGV mine was built into the previous model. This parameter was set to only simulate the GGV mine.

Re-architecture of the Mining Location

The mining nodes and entities in the simulation model symbolize the pit and the five coal types that are extracted. The previous model simulated the pit from a central location. The new model was re-built such that the actual future mining locations are animated in the simulation model. This also allows for the actual route distances between the pit and the ROM pad to be taken into account as the simulation model is built to scale.

The Life of Mine (LOM) plan obtained during the data gathering phase was used for this purpose. The actual geographical positions for the eight hundred mine blocks in question were grouped and allocated to one of fifty nodes placed on the simulation model's aerial photograph backdrop. A 'CSV' file tabulating the mining nodes and each mining block's tonnes per coal type was constructed such that it represents the actual sequence of mining.

This file is imported into Simio and a process reads the data one row at a time. The entities captured in a row are released to their respective mine object and transferred to their mining nodes. Only once all entities have been mined (picked up by transporter from the node) is the next row read and the process repeated.

Updating of Parameter Values

The distributions obtained from the data analysis were updated for their respective parameters. These were capped to a minimum and maximum limit to avoid a possible extreme value resulting from the distribution. Parameters not taken into account previously were added to the simulation model. The following parameters were added:

- Truck/Loader planned maintenance

- Truck/Loader unplanned breakdowns
- Truck/Loader fatigue (lunch) breaks
- Truck speed (empty, full, constant)

Updating of Process Control Logic

Processes were updated and added to facilitate the new parameters and the re-architecture of the mining locations.

The shift changes, fatigue breaks, unplanned breakdowns and planned maintenance for both trucks and loaders is controlled through various processes executed by the ‘AssignTruckFatigue’ process on the event of a truck/loader entering certain nodes. Each individual truck/loader is assigned its next time of stoppage from a parameter for each of the stoppage activities. The process compares this time with either the simulation’s current run time for the shift change and fatigue breaks or the truck/loader’s operational time for the breakdowns and planned maintenance and decides if the stoppage is due. The truck/loader is delayed for its parameter value and reassigned its next stoppage time.

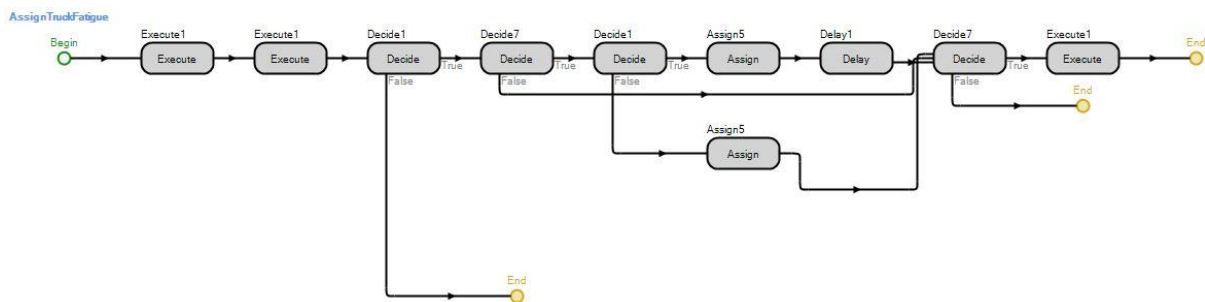

Figure 40: Simio Process for Assigning Truck Fatigue Break

The following control logic determines the coal type washed by the plant. If a stockpile has the highest reserves from those coal types mined, it is chosen to be the preferred coal type washed by the plant. The plant can switch its feed to another coal type at most once every twenty-four hours. If a stockpile exceeds its high capacity trigger level, mining of that coal type is temporarily halted until re-handling has reclaimed sufficient tonnes for it to fall within range again.

10. Calibration of the Simulation Model

The simulation was run for a period of one year and utilization charts graphed from the simulation results outputted by Simio. Calibration of the model was done for the mining section, ROM section and plant modules. This was achieved by altering those parameter values that were identified to require possible calibration. The simulation's utilization graphs were compared to the SCADA data's utilization graphs for the same attributes measured. Shape, off-set and shift of the graphs are compared during the calibration process. The above procedure is repeated until both graphs approximately (within 5%) overlap. The simulation is then considered to be calibrated.

The calibrated model should approximately equal GGV's plant feed of the past 12 months.

Mining Section

Initial simulation results for the mining section showed a similar graph shape with a large offset.

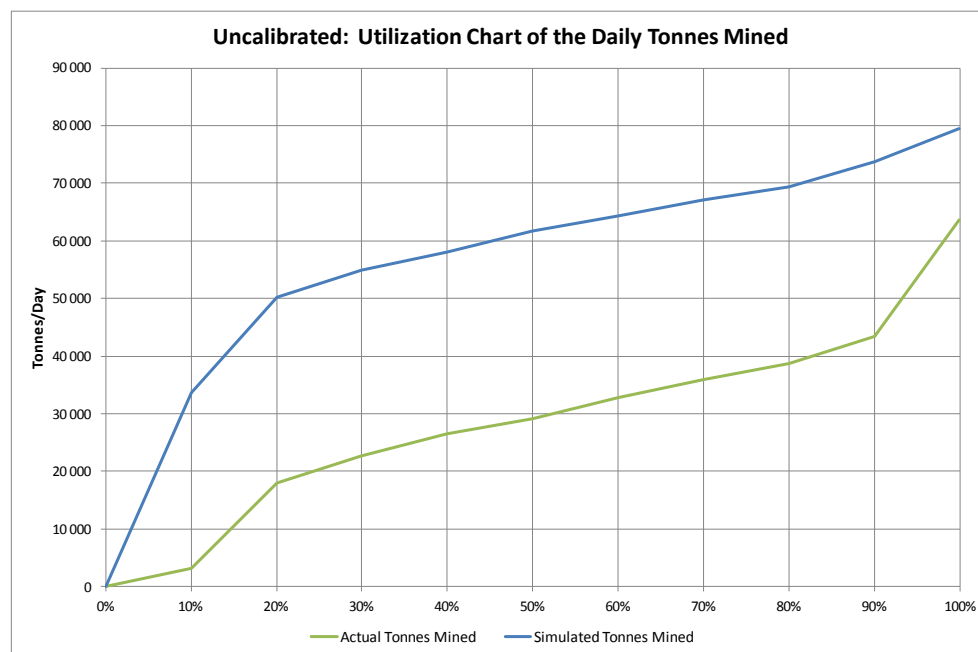

Figure 41: Uncalibrated Result for the Tonnes Mined

The problem was identified to be an incorrect process logic used for the choice of coal type washed by the plant. Certain mining delays that could not be captured by the loader reliability parameters were also attributed towards this discrepancy. The MTBF was reduced and the MTTR increased to capture delays such as pit preparations, blasting and terrain obstacles. The calibrated solution is shown below.

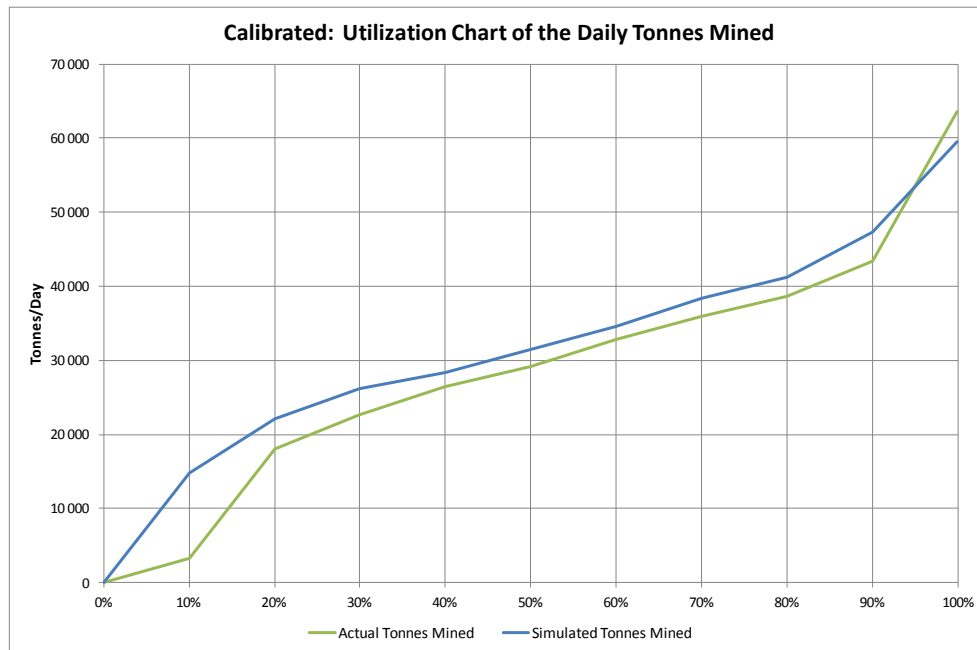

Figure 42: Calibrated Result for the Tonnes Mined

ROM Section

The feed rate for the ROM section was used as the calibration measure. Both the ROM section and the plant section have a direct influence on each other's feed rates which was taken into account during the calibration. The initial result showed a slightly higher simulation ROM feed rate for the majority of time and a 4% longer no coal feed period.

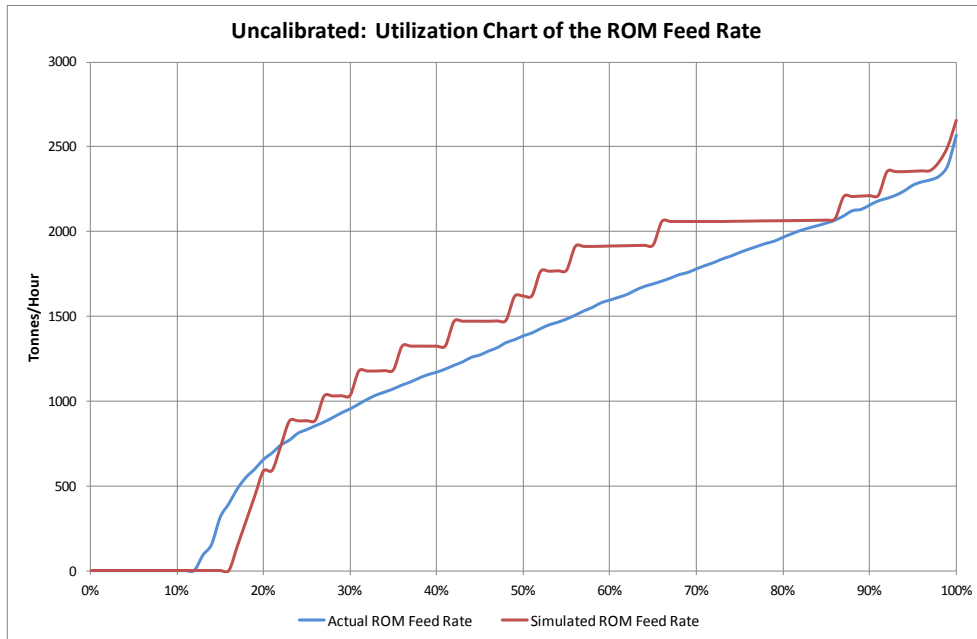

Figure 43: Uncalibrated Result for the ROM Feed Rate

Conveyor rate parameters were not calibrated as they are expected to be accurate (based on 200,000 PLC measure points). The plant module's reliability was decreased to lower the ROM feed rate. The calibrated solution is shown below.

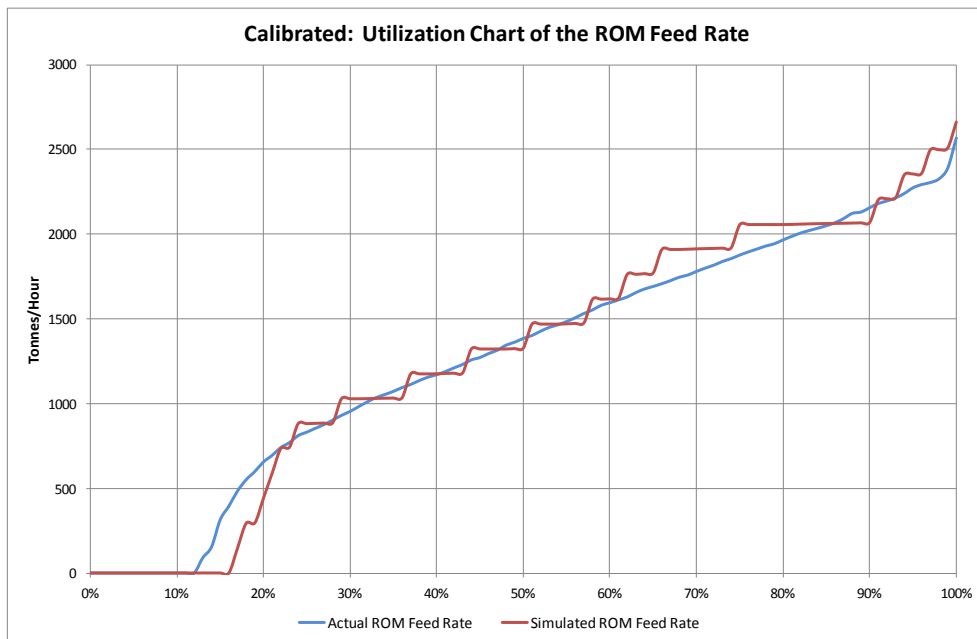

Figure 44: Calibrated Result for the ROM Feed Rate

Plant Modules

In the simulation model, the CPP operates both modules at a combined 2000 tonnes per hour rate for longer periods than the mine does in reality. The cause for this was the similar MTBF parameter values of both plant modules. These were given different MTBF parameters to calibrate the system without altering the overall plant availability.

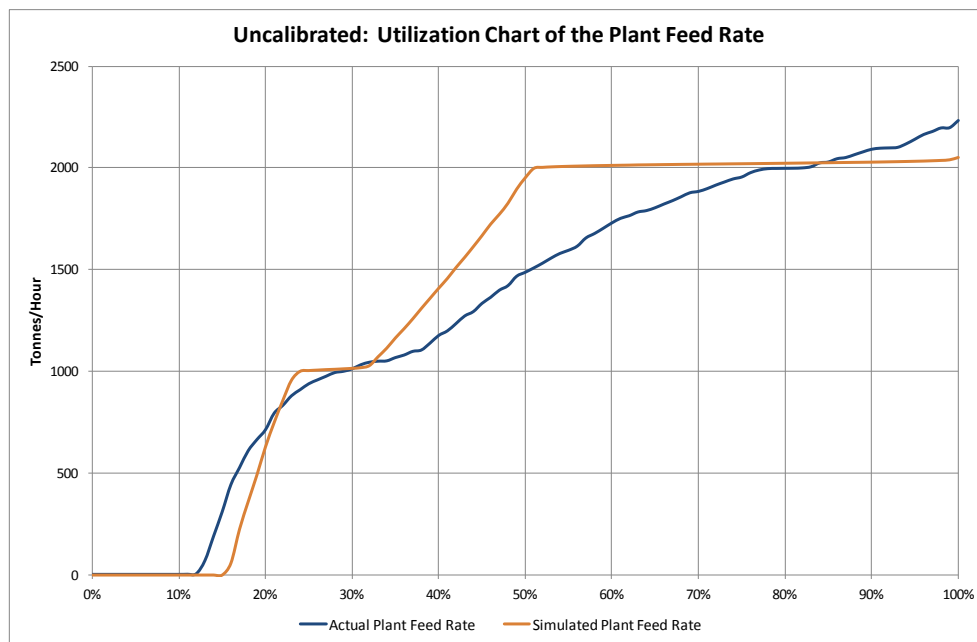

Figure 45: Un calibrated Result for the Plant Feed Rate

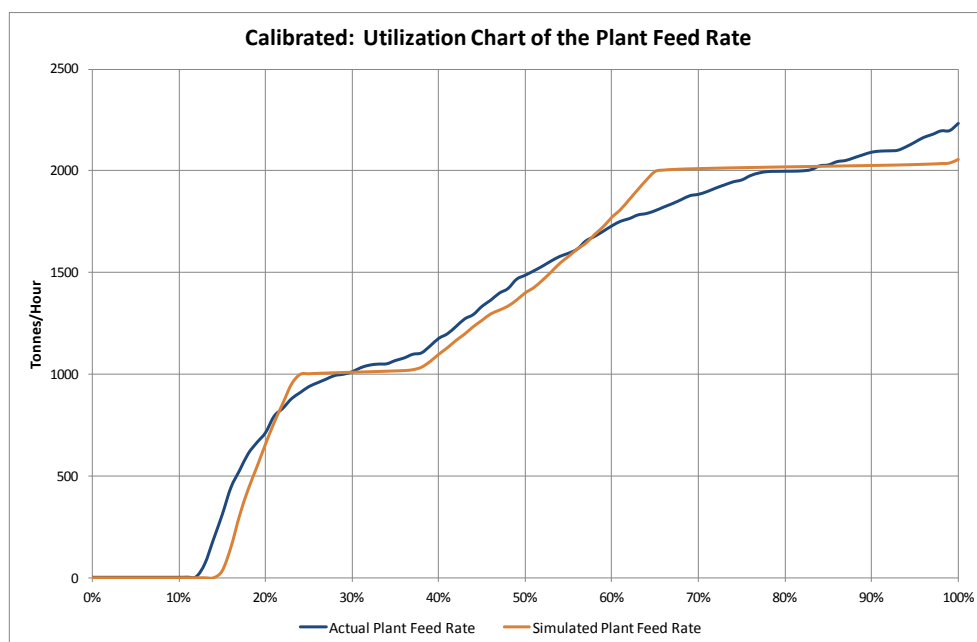

Figure 46: Calibrated Result for the Plant Feed Rate

11. Scenario Runs

A Simio Experiment with five repetitions per run was performed for the scenarios:

- Base Case
- Raw Coal Sized Stockpile

Base Case

The base case represents the current day GGK operation. The scenario run aims to determine the bottleneck of the system. Annual plant coal feed for the base case was measured at 11,350,000 tonnes per year.

The below graph proves that the ROM pad stockpiles hold coal most of the time. In addition, the control logic of the system ensures that the plant only washes for coal types with stockpiled reserves.

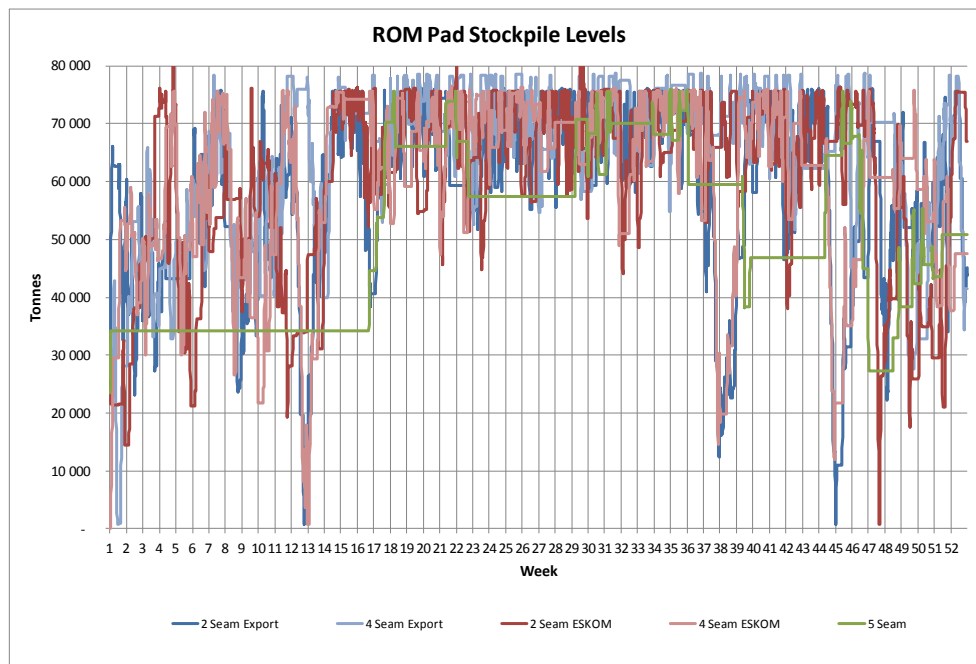

Figure 47: ROM Pad Stockpile Levels

The Tip bin is 92% of the time above its 50 tonne low level. 80% of the time, the Raw coal bin level is above 1800 tonnes. A temporary running dry of the tip bin, which only occurs 1% of the time if flushing due to planned maintenance is taken into account, would allow the plant with 80% certainty to maintain operating at its maximum rate for a period of 55 minutes. It is unlikely that mining and re-handling are unable to supply any coal during this time given the sufficient coal stockpiled reserves and the two dedicated coal re-handling trucks available.

This is confirmed by the below utilization chart.

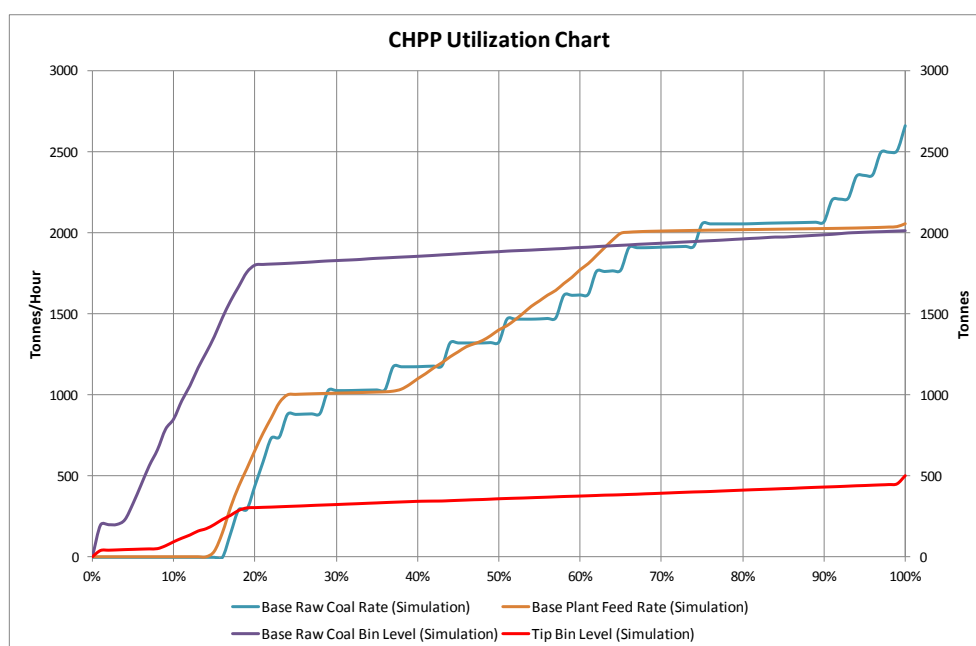

Figure 48: CHPP Utilization Chart

The Tip bin level graph's gradient is the same as the Raw coal bin level's gradient. This confirms that the ROM feed rate always is able to match the plant feed rate. Nor a bottleneck in terms of throughput or availability is present between the two bins.

Given that the Raw coal bin maintains its level and is thus fed with coal, the **plant** and not the ROM section is the **bottleneck** in the system constraining the capacity of all the other resources.

Raw Coal Sized Stockpile

A 75,000 tonne Raw coal sized stockpile located between the secondary sizer and the tertiary sizers was added to the base case – see Process Flow Diagram. The stockpile can accommodate all coal types and is reclaimed through valves feeding a conveyor to the tertiary sizers.

The 12 hour planned maintenance for the ROM section located upstream from the stockpile was schedule one day after that of the plant's. This ensured that the sized stockpile was filled during CPP planned maintenance and feeds tonnes to the CPP during the ROM planned maintenance.

The annual plant feed increased by **775,000 tonnes** to 12,125,000 tonnes.

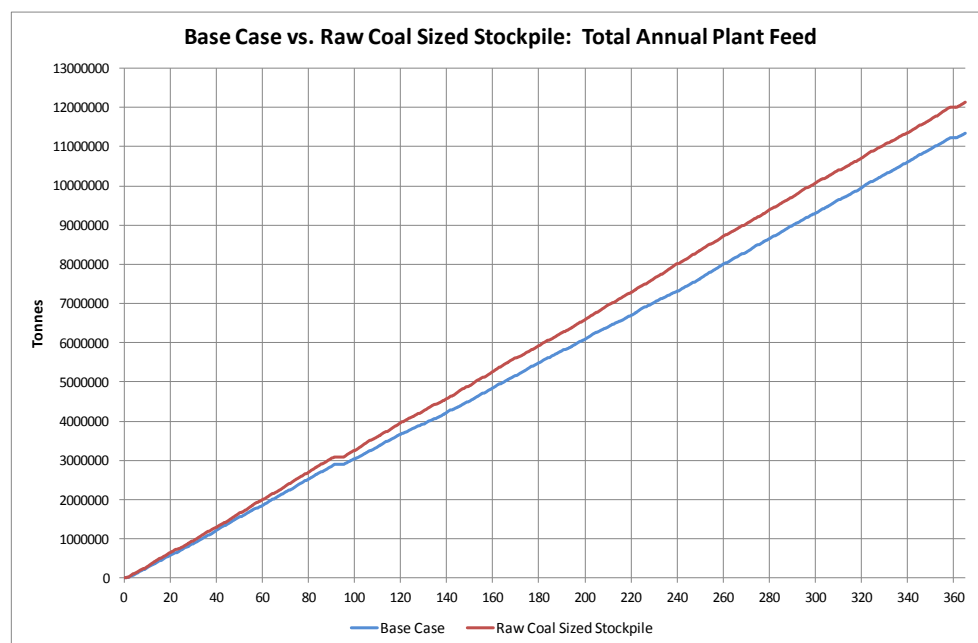

Figure 49: Total Annual Plant Feed for Base Case vs. Raw Coal Sized Stockpile

The plant feed rate utilization chart shows a 20% increase of both plant modules running simultaneously for the Raw coal sized stockpile scenario. This is due to the stockpile allowing for the plant section to be separated from the mining and coal handling section of the system, effectively acting as a buffer that regulates the fluctuation of each sides operation. Provided that the sized stockpile has sufficient coal, the CPP will not be influenced by a ROM section breakdown or a no coal scenario.

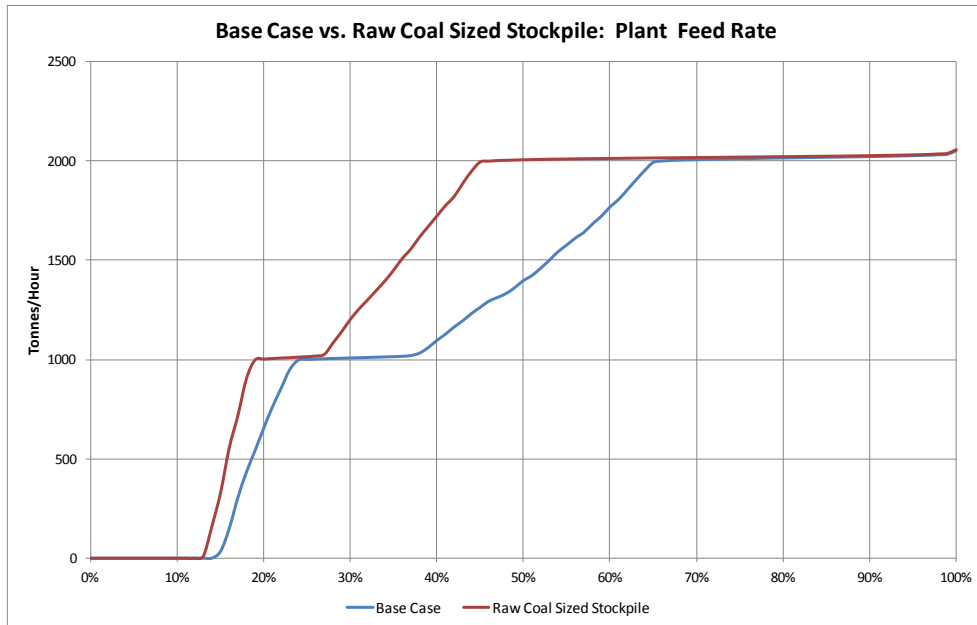

Figure 50: Plant Feed Rate for Base Case vs. Raw Coal Sized Stockpile

The Raw coal sized stockpile never reached a level lower than 20,000 tonnes and was capable of attaining its maximum capacity. It is concluded that the stockpile is sufficiently sized.

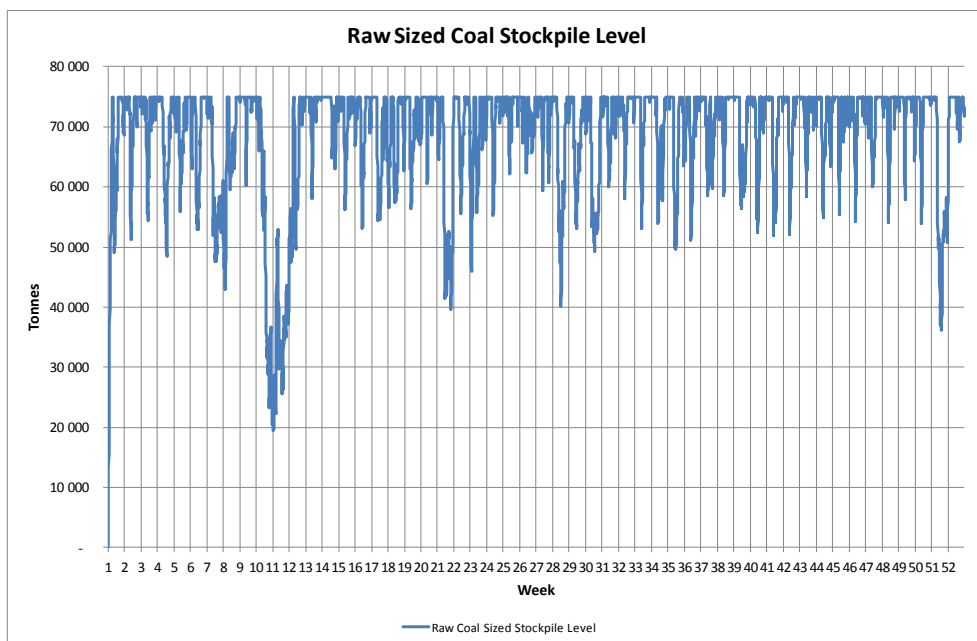

Figure 51: Raw Coal Sized Stockpile Level

Process Flow Diagram

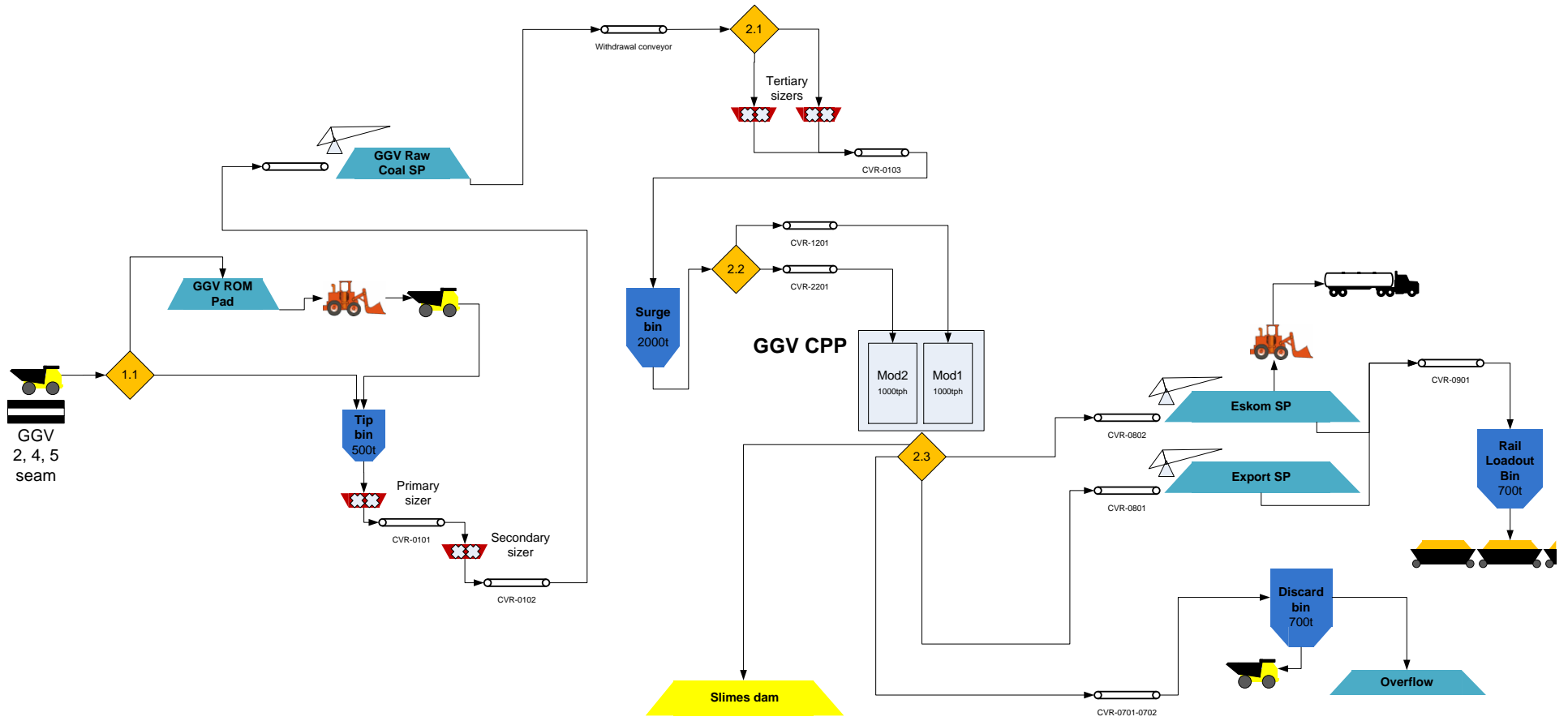

Figure 52: Process Flow Diagram for GGV Operations with a Raw coal sized stockpile

12. Cost Analysis

The cost analysis contains fictitious values to protect the client but the overall results are similar in magnitude. Variable costs were not taken into account but are insignificant.

| | VALUE | UNIT |
|-----------------------------------|----------------------|---------------|
| GGV Production Cost Per Tonne | R 45 | ZAR/Tonne |
| Market Sell Price per Tonne | R 250 | ZAR/Tonne |
| GGV Profit per Tonne | R 205 | ZAR/Tonne |
| Annual Increase in Throughput | 775 000 | Tonne |
| Annual Increase in Revenue | R 158 875 000 | ZAR |
| CAPEX Raw Coal Sized Stockpile | R 150 000 000 | ZAR |
| Pay-off Period | R 11.33 | Months |

Figure 53: Static Financial Model

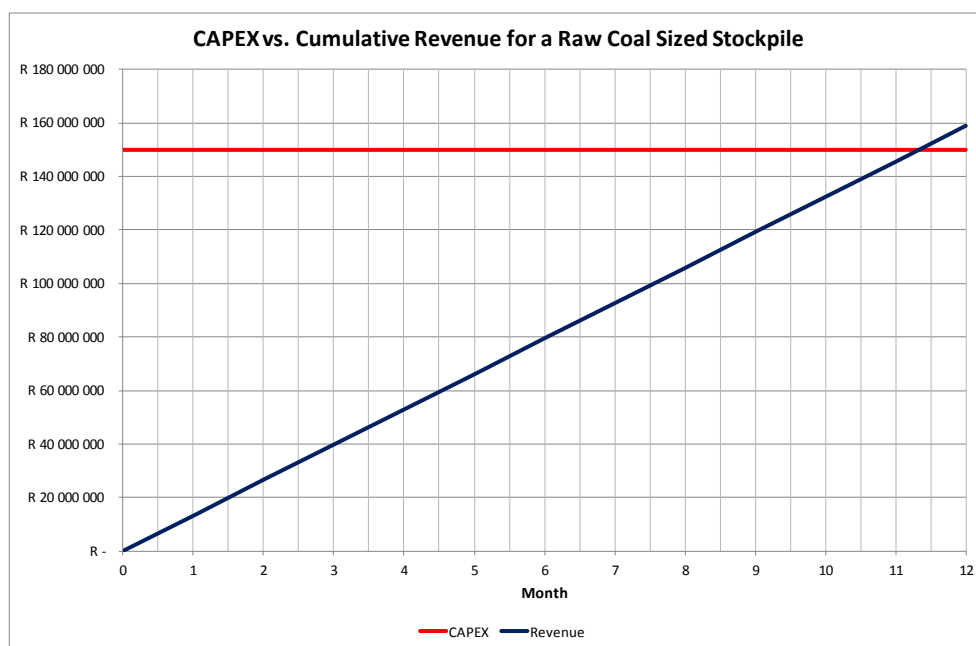

Figure 54: Increase in Revenue vs. CAPEX

13. Conclusion

The simulation model was successfully adjusted and calibrated for GGV's present day operations. It was used to locate the bottleneck in the system and to motivate the feasibility of a Raw coal sized stockpile.

The Coal Processing Plant (CPP) is the bottleneck of the mine. A Raw coal sized stockpile will increase annual plant feed throughput by 775,000 tonnes. Its proposed capacity of 75,000 tonnes is adequate. The pay-off period for the stockpile is 11 months and a return on investment of R 160,000,000 per annum can be expected thereafter.

The stockpile does not shift the bottleneck but provides a buffer that enables operational flexibility and reduced dependency between the ROM section and the Coal Processing Plant.

It is recommended that the Raw coal sized stockpile is implement prior to the 2017 Zaiwater expansion.

REFERENCES

- Aronson, D 1996, 'Overview of System Thinking', pp. 1-3, accessed 03 May 2012, <http://www.thinking.net/Systems_Thinking/OverviewSTarticle.pdf>
- Barlett, G 2001, 'SYSTEMIC THINKING: A simple thinking technique for gaining systemic focus', pp. 1-7, accessed 03 May 2012, <http://www.probsolv.com/systemic_thinking/Systemic%20Thinking.pdf>
- Breytenbach, W P 2012, 'Guidelines for Implementing Effective SPC Systems' Notes, pp. 6.2 – 6.3.
- Ceenex 2012, 'Corporate Identity', accessed 15 February 2012, <<http://www.ceenex.com/documents/ceenexlogo710x273.gif>>
- International Business Times 2012, 'Xstrata admits fire in NSW mine site, launches probe', accessed 24 March 2012, <<http://img.ibtimes.com/www/data/images/full/2010/08/23/18117-xstrata-company-logo.jpg>>
- Jacobs – Chase – Aquilano 2009, 'Operations & Supply Management', 12th edn, McGraw-Hill, p. 681.
- Mining Weekly 2012, Unknown, accessed 24 March 2012, <http://us-cdn.creamermedia.co.za/assets/articles/images/resized/0000110582_resized_goedgevoندن01.jpg>
- Odendaal, N 2011, 'Theory of constraint will help increase SA mine production – business consultant', accessed 28 April 2012, <<http://www.miningweekly.com/article/toc-mining-to-up-sa-mine-production-2011-10-07>>
- TOC Southern Africa (Pty) Ltd 2012, 'Overview', accessed 02 April 2012, <<http://www.tocsa.co.za/>>
- Viljoen, I 2011, 'Application of TOC', Ceenex
- Wikipedia 2012, 'TOC', accessed 15 April 2012, <<http://en.wikipedia.org/wiki/TOC>>
- Williams, M K 2012, 'Using Simulation to Understand Bottlenecks, Delay Accumulation, and Rail Network Flow', pp. 1-11, accessed 01 May 2012, <http://www.arena.org/files/library/2011_Conference_Proceedings/Using_Simulation-to_Understand_Bottlenecks_Delay_Accumulation_and_Rail_Network_Flow.pdf>

- Xstrata Coal 2012a, 'About Xstrata Coal', accessed 27 March 2012, <Available at: http://www.xstratacommunity.com.au/EN/PublishingImages/about_coal_image1.jpg>
- Xstrata Coal 2012b, 'Corporate Identity', accessed 12 March 2012, <<http://www.xstratacoal.com/EN/Operations/Pages/GoedgevondenColliery.aspx>>

