

# **Beneficiation of Wastewater streams from Gold Mine Process Water Systems with Recovery of Value-Adding Liquid Waste Products**

by

**Lelanie Bester**

A dissertation submitted in partial fulfilment of the requirements for the degree

**Master of Engineering (Water Utilisation Engineering)**

in the

Department of Chemical Engineering Faculty of Engineering, the Built  
Environment and Information Technology

University of Pretoria

Pretoria

July 2012

# **Beneficiation of Wastewater streams from Gold Mine Process Water Systems with Recovery of Value-Adding Liquid Waste Products**

Author: Lelanie Bester  
Supervisor: Prof Evans Chirwa  
Department: Chemical Engineering  
University of Pretoria  
Degree: MEng (Water Utilisation Engineering)

---

## **Synopsis**

A strategy for beneficiation of wastewater streams from fissure and process water developed for a gold mine operation in the west of Johannesburg was tested for viability in a pilot study. The investigation was aimed at evaluating the compliance of the finally discharged effluent streams with the current Water Use Licence (WUL). The core of the water recovery process consisted of softening to remove divalent cationic species, followed by ion exchange processes employing Strong Acid Cationic (SAC) resins and Weak Acid Cationic (WAC) resins.

An operational design limitation was that the crystalactor used in the softening stage had a minimum capacity of 20 000 L/h, whereas the rest of the system could be operated at flow rates of as low as 2 000 L/h. For this reason, the softening step was done in semi-batch mode. Calcium hardness was decreased from 70 mg/L to values lower than 40 mg/L (as Ca<sup>2+</sup>).

During the ion exchange (water recovery) process, columns using SAC resin produced better quality water than the WAC resins. The SAC columns produced water compatible with South African Water Quality Standards. Additionally, the use of SAC proved to be a more financially favourable option, since the regenerant stream contained high concentrations of calcium nitrate, magnesium nitrate and sodium nitrate fertilizer. The latter could be sold as a liquid fertilizer to farmers.

In addition to the above findings, the pilot system reduced the concentration of toxic and radiotoxic metals such as uranium. The final concentration of the uranium in the effluent (0.01 mg/L) was below the regulation limit 0.07 mg/L. The selective removal of uranium is crucial in order to produce high-quality fertilizer from the ion exchange regeneration streams.

**KEYWORDS:** wastewater beneficiation, crystalactor, ion exchange, recovery system optimization, liquid fertilizers, strong acid cationic resins, weak acid cationic resins.

# Declaration

I, **Lelanie Bester**, hereby declare that the work contained in this document was compiled and set out by myself and it has not been submitted to any other university.

Signed on the 6<sup>th</sup> of August 2012

---

Lelanie Bester

# Acknowledgements

To God who has graciously blessed me with talents, family, friends and prosperity.

To my supervisor, Prof Evans Chirwa, for assistance and education.

To my colleagues, Chris le Roux and Alwyn Smit, for sharing with me their knowledge and granting me this opportunity.

To my family and friends, I appreciate all the support and encouragement.

# Table of Contents

Synopsis.....	ii
Declaration.....	iv
Acknowledgements.....	v
Table of Contents.....	vi
List of tables.....	viii
List of Figures.....	ix
Chapter 1 Introduction.....	1
1.1 Background and problem statement.....	1
1.2 Objectives.....	2
1.3 Thesis Layout.....	3
Chapter 2 Literature Survey.....	5
2.1 Water Treatment.....	5
2.1.1 Conventional Water treatment.....	5
2.1.2 Chemical precipitation.....	6
2.1.3 Ion Exchange.....	8
2.1.4 CO <sub>2</sub> stripping.....	10
2.1.5 Water Treatment Plant Residue.....	11
2.1.6 Membranes.....	12
2.1.7 Coagulation and Sedimentation (Settling Tanks).....	13
2.2 Water Management.....	14
2.3 Water use in mining.....	16
Chapter 3 Experimental Set-up.....	21
3.1 Fissure Water Pilot Plant.....	21
3.2 Mine Water Pilot Plant.....	24
3.3 Water Management Methodology.....	28
Chapter 4 Fissure Water Results and Discussions.....	29
4.1 Chemical composition of fissure water.....	29
4.2 Cold Lime Precipitation.....	31
4.2.1 Relationship between Calcium reduction and pH.....	31
4.2.2 Effect of Temperature on Calcium reduction.....	32
4.2.3 Effect of alkalinity on Calcium reduction.....	33
4.2.4 Different Flow rates.....	34

4.2.5 Calcium carbonate pebbles .....	35
4.2.6 Feed Fluctuations .....	36
4.3 Cation Exchange.....	37
4.4 Anion Reduction.....	40
4.5 Product Water.....	42
4.6 Chemical consumptions.....	48
Chapter 5 Mine Water Results and Discussions .....	49
5.1 Chemical composition of the mine water .....	49
5.2 Coagulation and Sand Filtration .....	50
5.3 Granular Activated Carbon (GAC) Filtration .....	51
5.4 Uranium removal .....	52
5.4.1 Performance of anionic and cationic resins for uranium removal.....	53
5.4.2 Uranium removal at different feed concentrations.....	54
5.4.3 Nickel, cobalt and iron removal .....	55
5.4.4 Plant capacity .....	56
5.4.5 Regeneration of resin .....	58
5.5 Strong Acid Cationic Ion Exchange.....	59
5.6 Weak Base Anionic Ion Exchange.....	63
5.7 Regenerant Product Concentration .....	67
5.7.1 Strong acid cationic resin.....	67
5.7.2 Weak base anionic resin.....	69
5.7.3 Chemical composition of products .....	71
5.8 Chemical Consumptions .....	74
Chapter 6 Water Management .....	75
6.1 Shaft Water reticulation.....	75
6.2 Plant Water Reticulation.....	80
6.3 Water reticulation on a mine.....	82
Chapter 7 Conclusion and Recommendations .....	84
7.1 Fissure Water .....	84
7.2 Mine Process Water .....	85
7.3 Water Management .....	85
Chapter 8 References .....	87

# List of tables

<i>Table 4-1 Fissure Water Analysis</i> .....	30
<i>Table 4-2 Pebble Analysis</i> .....	35
<i>Table 4-3 Feed Quality Fluctuations</i> .....	36
<i>Table 4-4 Comparison between SAC and WAC</i> .....	39
<i>Table 4-5 Fissure Water Cationic Regenerant</i> .....	39
<i>Table 4-6 Blending Summary</i> .....	48
<i>Table 5-1 Mine water Analysis</i> .....	49
<i>Table 5-2 Cation Equivalence</i> .....	61
<i>Table 5-3 Cation Valence for Start-up conditions</i> .....	62
<i>Table 5-4 Equivalence calculations for steady-state conditions</i> .....	64
<i>Table 5-5 Equivalence calculations for start-up conditions</i> .....	66
<i>Table 5-6 Analyses of Cationic fertilizer</i> .....	71
<i>Table 5-7 Detailed Anionic Regenerant Analysis</i> .....	73
<i>Table 6-1 Water Equilibrium Qualities</i> .....	79

# List of Figures

<i>Figure 2-1 Crystalactor</i> .....	7
<i>Figure 2-2 Counter-current Ion Exchange Configuration</i> .....	10
<i>Figure 2-3 Reverse Osmosis</i> .....	12
<i>Figure 2-4 Settling Tank</i> .....	13
<i>Figure 3-1 Fissure Water Pilot Plant</i> .....	21
<i>Figure 3-2 Fissure Water Pilot Plant Schematic</i> .....	24
<i>Figure 3-3 Mine Water Pilot Plant</i> .....	25
<i>Figure 3-4 Mine Water Pilot Plant Schematic</i> .....	27
<i>Figure 4-1 Relationship between pH and Calcium reduction</i> .....	31
<i>Figure 4-2 Relationship between Ca removal and alkalinity</i> .....	33
<i>Figure 4-3 Efficiency at various flow rates</i> .....	34
<i>Figure 4-4 Comparison between SAC and WAC performance</i> .....	38
<i>Figure 4-5 Degas Tower performance</i> .....	40
<i>Figure 4-6 Anion Exchange performance</i> .....	41
<i>Figure 4-7 Product-Water Blending</i> .....	42
<i>Figure 4-8 Product Water - First Blending ratio</i> .....	43
<i>Figure 4-9 Product Water - Second Blending ratio</i> .....	44
<i>Figure 4-10 Product Water - Third Blending Ratio</i> .....	45
<i>Figure 4-11 Product Water - Fourth Blending Ratio</i> .....	46
<i>Figure 4-12 Product Water - Fifth Blending Ratio</i> .....	47
<i>Figure 5-1 Sand Filtration Performance</i> .....	50
<i>Figure 5-2 GAC Performance</i> .....	51
<i>Figure 5-3 Uranium complexes at different pH's</i> .....	52
<i>Figure 5-4 Anionic vs. Cation Performance</i> .....	53
<i>Figure 5-5 Uranium Removal</i> .....	54
<i>Figure 5-6 Nickel Removal</i> .....	55
<i>Figure 5-7 Uranium concentration in feed water</i> .....	57
<i>Figure 5-8 Plant performance at start-up conditions</i> .....	57
<i>Figure 5-9 Uranium Regeneration</i> .....	58
<i>Figure 5-10 Steady state cationic loading curve</i> .....	60
<i>Figure 5-11 Start-up loading performance</i> .....	62
<i>Figure 5-12 Steady State anionic loading curve</i> .....	64

<i>Figure 5-13 Start-up anionic loading performance</i> .....	65
<i>Figure 5-14 Cationic Regeneration Curve</i> .....	67
<i>Figure 5-15 Fertilizer concentration through Reverse Osmosis</i> .....	68
<i>Figure 5-16 Anionic regeneration curve</i> .....	70
<i>Figure 6-1 Water Circulation at a Shaft Complex</i> .....	76
<i>Figure 6-2 Settler Performance</i> .....	77
<i>Figure 6-3 Precipitation in the Settler</i> .....	77
<i>Figure 6-4 Filter Performance at the shaft</i> .....	79
<i>Figure 6-5 Water Control at a metallurgical plant</i> .....	81
<i>Figure 6-6 Current water reticulation</i> .....	82
<i>Figure 6-7 Proposed locations of plants</i> .....	83

# Chapter 1 Introduction

## 1.1 Background and problem statement

The mining industry of South Africa has many active operations in the West Rand. Gold mining operations at 3 km below surface are common practice. This has resulted in the deterioration of water resources critical to South African ecological and sustainable development. The water quality deteriorates during the recovery of gold due to exposure to leachable surfaces and the usage of various chemicals. Water quality is impacted by exposing mining surfaces underground to water and oxygen, but also due to metallurgical processes, tailings deposits, and pollution migration through dust plumes. Water discharged from these operations has an increased salt load and metal contamination, placing stress on the water and ecosystems located in the vicinity.

Notably, water is a strategic resource for our often drought-stricken country and a number of mining and power generation projects were recently placed at risk due to a limited supply of water. This has resulted in an amplified utilisation of ‘gray’ water as well as directives from the regulators instructing the industry to reduce water consumption. The regulators are currently focusing on the apportionment of water liabilities as a result of the costs related to the treatment of contaminated mine water. Most gold mines have embarked on a strategic process to minimize the liabilities associated with water. It became evident that, without a clearly formulated action plan related to water management, the associated liabilities would certainly impact the bottom line of mines in the future.

Rainfall and water from Rand Water Board (RWB) are the current sources of fresh water to operations’ water systems. Rain water is collected in the upper levels of the mine and pumped to the surface, where it is allowed to drain into the river systems. This is generally good quality water, but may contain some hardness. A small proportion is used for make-up within the mine’s process-water system to compensate for losses due to evaporation in the Tailings Storage Facilities (TSF) and saturated underground air being vented into the atmosphere. Salt

build-up within the mine's process-water circuits results due to water losses and the recycling of the process-water. To counteract the salt build-up, water is discharged into the environment and fresh water is used to recharge the circuit.

Salts deposited into the TSF eventually enter the near-surface water system, resulting in heavy metal and metal salt plumes around the TSFs. These plumes will inevitably enter the rivers at some point in the future.

The Department of Water Affairs (DWA) recently revised their water-use licences to clearly focus on addressing the current and potential future discharges and pollution. Accordingly, mining operations need to prepare relevant action plans, actively pursue means to reduce water usage and make financial provision for water management.

A short definition of the problem is the following: Water quality in mining regions is deteriorating due to mining activities. Polluted water is detrimental to the environment, especially in a country where water is scarce.

## **1.2 Objectives**

The study investigated:

- Water treatment for the fissure-water, which could be utilized as drinking water.
- Water treatment to improve the quality of the mine process water. This will in turn reduce discharge streams and minimise the risk to the environment.
- A review of the water balance and the identification of areas within mining operations where water management can be improved.

## 1.3 Thesis Layout

Two water treatment plants were constructed for the pilot study: one for the treatment of the fissure-water and another for the mine process-water treatment. These plants were operated at different locations to test the feasibility of the chosen technology. Samples were sent to Rand Water Analytical Services as well as SGS Laboratories for analysis. A literature review of applicable technologies is provided in Chapter 2. Chapter 3 contains a description of the pilot plants and experiments conducted. The fissure water pilot plant consisted of a crystalactor followed by a strong acid cation exchange resin and a weak base anion exchange resin. The crystalactor successfully achieved a reduction in hardness.

For further reduction of cations, a cationic resin section was selected. A trade-off study between strong acid cationic (SAC) resin and weak acid cationic (WAC) resin was done. The study showed that the SAC resin was superior in this application. The associated anions present in the water were removed with an anion exchange resin. Initially a degas tower was tested for the removal of carbon dioxide, however this was unsuccessful as the carbon dioxide concentration in the water was too low.

Blending of feed water, crystalactor water, cation and anion exchange water proved to be successful in producing water of potable quality. By-passing certain streams achieved different product-water qualities. This proved to be useful due to the fluctuation of feed-water quality during operation. This fluctuation dictated the type of blending to be done in the full-scale water treatment facility. Results from the fissure-water pilot plant campaign are discussed in Chapter 4.

The water used in mining processes is of a much poorer quality than the fissure water. The pre-treatment of the mine water consists of a sand filter followed by granular activated carbon filtration. The mine water is contaminated with some metals; the most serious of these is uranium. Both cationic and anionic resins were tested for the removal of uranium. But due to the high pH uranium is present as an anionic complex and is removed with the anionic resin.

After uranium removal, all cations present were removed by means of a strong acid cationic resin. The water leaving the cation exchange sections had a low pH, a high conductivity and also contained anions. Therefore an anion exchange section followed. The anion section contained a weak base anionic resin that removed all the anions associated with the cations removed in the cation exchange section. The anionic section also increased the pH to 6.5 and decreased the conductivity to below 10 mS/m.

Both the fertilizer solutions produced by cationic and anionic resin can be increased by recycling the solution. The regenerant solution is reused in the next regeneration by adding more nitric acid for cationic resin and ammonium hydroxide for anionic resin. Results from the mine water pilot plant campaign are discussed in Chapter 5.

Typical mining water reticulation was also reviewed. Chapter 6 explains the water management on the mine in detail. A shaft was selected and an investigation was launched to determine the optimized water management plan. A sampling campaign was initiated to determine possible contamination sources. A test was done to determine the effect of diluting the mine-process water. The water reticulation on the plant is better controlled than at a shaft complex. The water on the plant is always recycled back to one of five water tanks.

The locations of the desired plants also depended on the optimized water management plan. The mine water plant would be situated on the mine water reticulation system and would only treat a bleed stream of the circuit. The product water would then be used for dilution and shift the equilibrium of the contaminants. After a while a steady-state would be achieved and any uncontrolled discharges would be within the limits of the mine's Water-Use Licence. The fissure water plant will produce drinking quality water and will be used for the mine and surrounding villages' domestic needs.

## Chapter 2 Literature Survey

The literature survey covers the review of three different sections: water treatment; water management, and water use in mining. The water treatment section covers all applicable technologies. Different management strategies are explained in the water management section. The gold mining process is described in the last section with reference to where water is used in the process.

### 2.1 Water Treatment

#### 2.1.1 Conventional Water treatment

Filtration is the removal of particulate matter through granular media. Water enters the filter, flow through the filter media (suspended solids are trapped) and then exit the filter. The flow of water inside a filter changes direction at least once in the path of every grain passed. Two types of capture mechanisms exist: mechanical straining and deposits on filtering media (Degrémont, 1995a). The particulate matter in the water then attaches to the filter media. The important factors to consider during filtration are: smaller filter media filters better; a high filtration rate leads to poorer performance; flow fluctuations may disrupt the specific deposit and colder water filters less efficiently. Kim and Cho (2011) proved that filtration is a mitigation action for scaling in heat exchange systems.

In order to strip the deposit in the filter, the flow direction is reversed and the flow rate is increased. All filters include a filtration period followed by a final wash. By making use of air during backwash in an air scouring process, more deposits are dislodged (Schutte, 2006). Water consumption through backwash is directly related to suspended solids content, nature and water temperature (Degrémont, 1995b). After a few years of operation, filter media is unacceptably dirty and remedial action or replacement of filter media is required (Van Staden & Haarhoff, 2011). Khadse, *et al.* (2011) proved that, in some cases, filtration followed by disinfection is sufficient treatment for the production of drinking water.

Adsorption of a substance onto activated carbon involves its accumulation at the interface between two phases due to the hydrophobic behavior of the organic material. Activated carbon removes dissolved organic substances responsible for taste and odour as well as chlorinated compounds. Granular activated carbon (GAC) is commonly used as a component of sand filters or GAC-only filter beds. During the adsorption process water comes into close contact with the carbon while flowing through a granular carbon bed. As result of the close contact, the organic molecules diffuse into the pores of the carbon through forces that keep the molecule weakly attached to the carbon surface. Adsorbed material is removed from the carbon through a regeneration process at high temperatures ( $> 700^{\circ}\text{C}$ ).

The performance of activated carbon is affected by the particle shape and size distribution. Particle robustness will influence the amount of attrition during backwash, transport and reactivation. The performance is also influenced by the contact time, bed depth, hydraulic loading rate, backwashing and biological activity (Schutte, 2006).

The thermal reactivation process consists of four stages: drying at  $200^{\circ}\text{C}$ , vaporization of volatile adsorbates, and decomposition of unstable adsorbates to form volatile fragments at temperatures of  $200^{\circ}\text{C}$  to  $500^{\circ}\text{C}$ , pyrolysis of non-volatile adsorbates and adsorbates fragments to form carbonaceous residue at temperatures from  $500^{\circ}\text{C}$  to  $700^{\circ}\text{C}$  and oxidation of the pyrolysed residue using steam as the oxidizing agent at temperatures above  $700^{\circ}\text{C}$  (AWWA, 1999).

### 2.1.2 Chemical precipitation

Hard water contains excess amounts of calcium and magnesium ions and causes scaling. Chemical softening involves the addition of chemicals to hard water to remove calcium and magnesium ions from water through precipitation in the form of calcium carbonate and magnesium hydroxide. The softening reactions are illustrated below:

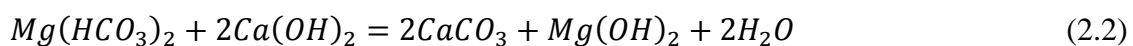
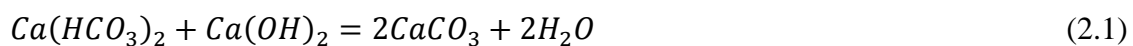

The calcium carbonate formed will be crystalline and in the absence of crystallization seeds precipitation will be very slow. Possible scaling will take place. In the presence of crystals, precipitation takes place very fast on the available crystal surface (Giesen, 2008). A pellet softener is a fluidised bed of grains on which the crystallization of  $\text{CaCO}_3$  takes place. The softening reactions take place in the presence of lime and a suspended bed of fine particles (0.2 mm in diameter) that acts as a catalyst. The source water and chemicals (lime) enter at the bottom of the reactor, also referred to as a crystalactor (see *Figure 2-1*).



***Figure 2-1 Crystalactor***

The particles are fluidised through the upward movement of the water. Precipitated hardness particles attach to the surface of the fluidised particles (Giesen, 2009). As the particles grow, some of the larger particles are removed from the bottom of the reactor while smaller particles are added to the top of the reactor in order to increase the surface area. During treatment the pH should not be raised too high, in order to prevent the precipitation of magnesium hydroxide (Schutte, 2006). Seeded fluidised bed reactors are used for several precipitation reactions such as that of copper sulphide (Van Hille *et al.*, 2005). An important mechanism for softening in a fluidised bed is the aggregation of primarily formed particles. The optimized grain size for this type of softening was found to be 1-0.3 mm (Seckler *et al.*, 1996).

### 2.1.3 Ion Exchange

The cations and anions in water are selectively removed when water is percolated through beds containing cation and anion exchange resins. The common types of resins are:

- Strong Acid Cation (SAC) – absorbs all cations
- Weak Acid Cation (WAC) - removes alkalinity by exchanging their hydrogen ions for the cations associated with the bicarbonate ion
- Strong Base Anion (SBA) – removes all anions including carbon dioxide or silica
- Weak Base Anion (WBA) - efficiently removes strong acids such as sulphuric and hydrochloric acid

Resin applications stretch from the primary recovery of metals, as well as the removal of low levels of impurities from highly concentrated solutions. Ion exchange resins are used to recover metals from clarified solutions, “dirty” solutions and pulps. It also reduces metals and contaminants in waste streams and in the supply of process water of a suitable quality. The resin exchange capacity is measured as the number of fixed charged sites per volume of resin. The most useful ion-exchange reactions are reversible. The exhausted resin bed is regenerated using an excess of the required ion. No permanent structural change takes place during exhaustion or regeneration. Regeneration requires between one and five bed volumes of regenerant followed by at least two bed volumes of rinse water. The amount of wastewater is approximately 2% of the treated water. However, the disposal of the wastewater warrants major consideration.

The resin reactions for loading are shown below:

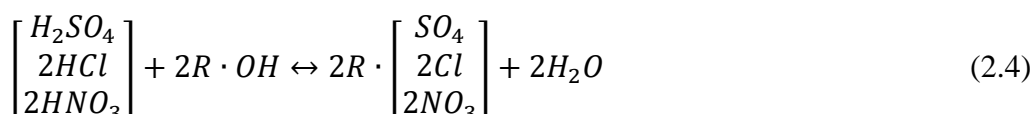
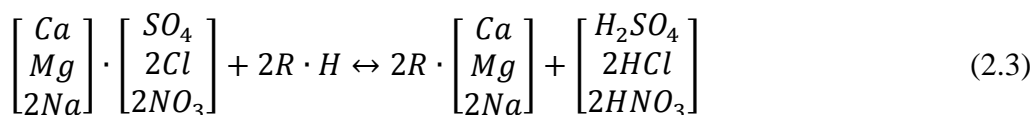

The regeneration reactions for resin are shown below:

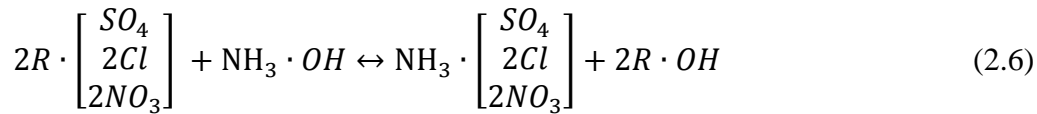
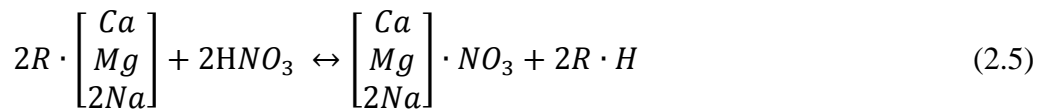

Resins are typically used for softening through the removal of calcium and magnesium. The resin selectivity determines the run length to breakthrough for the contaminant ion. Resins with chelating functional groups such as iminodiacetate have been manufactured that have high affinities for hardness ions and troublesome metals such as uranium. These resins are used to remove trace-metals in water. Strong base anionic resins are efficient for the removal of some heavy metals, as the resin can be engineered to remove a specific heavy metal ion (Wong *et al.*, 2009).

An ion exchange resin consists of cross-linked polymers to which charged functional groups are attached through covalent bonding. Cation exchange resins are produced through the introduction of an acid group such as SO<sub>3</sub>H into the polymer (Schutte, 2006).

The general configuration for ion exchangers is a counter-current line, where production can take place either through up or down-flow. The regeneration of the resin then occurs in the opposite direction as production. Counter-current regeneration prevents ionic contamination of the lower layers and systematically exhausts the regenerant as it comes into contact with layers in the state of decreasing saturation (Degrémont, 1995a). The concept is shown in the *Figure 2-2*. The system can be operated as a continuous process through utilization of a multicolumn set-up operating on different time shifts. Continuous processes can significantly outperform the periodic operation (Bochenek, *et al.*, 2011).

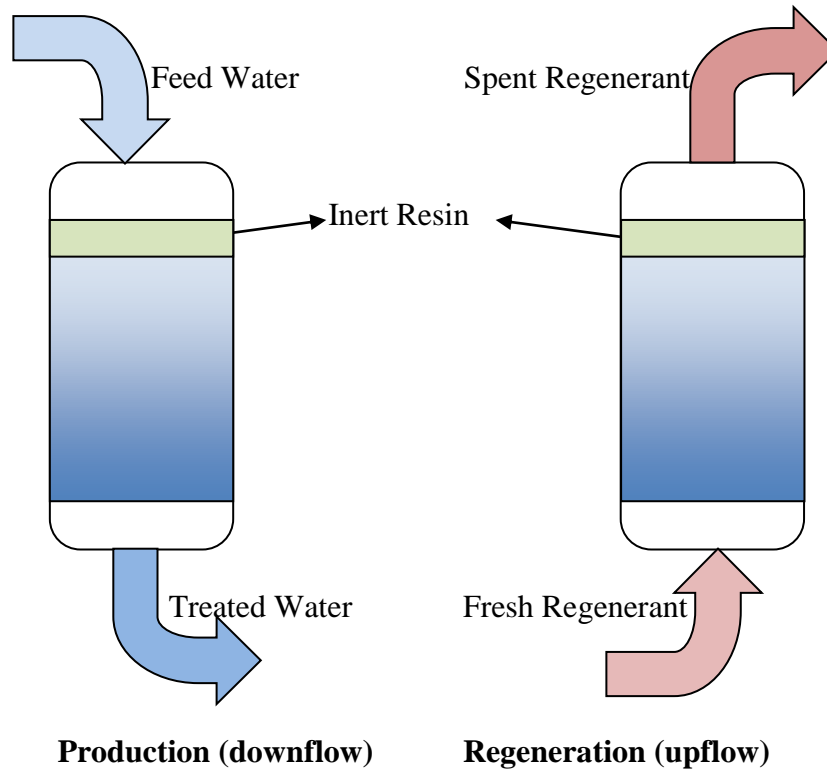

**Figure 2-2 Counter-current Ion Exchange Configuration**

### 2.1.4 CO<sub>2</sub> stripping

A packed tower with spray nozzles is used to remove CO<sub>2</sub> from water. The displacement of a system from equilibrium is the driving force for mass transfer between one phase and another. The contaminant concentration in water is high compared to the equilibrium concentration between air and water. The tendency to achieve equilibrium is sufficient for mass transfer to occur between the two phases. In a packed tower water is pumped from the top of the tower and through a distributor allowing it then to gravitate over packing material. At the same time a blower is used to introduce fresh air into the tower at the bottom. The air flows counter-current to the water (AWWA, 1999). The CO<sub>2</sub> mass transfer of a packed column is largely unaffected by differing salinities, but salinity can significantly affect CO<sub>2</sub> stripping. This implies that CO<sub>2</sub> removal will be more problematic for saline systems (Moran 2010).

The packing provides a large air-water interfacial area where the transfer takes place between air and water. The contaminant-free water leaves the tower at the bottom, while the air with the contaminant leaves the tower at the top where it is discharged into the atmosphere. The packing materials are pieces randomly dumped into the column. Because CO<sub>2</sub> is acidic, the removal thereof will raise the pH of the water and reduce the aggressive nature of the water. As the pH rises, the alkalinity forms change, with the result that carbon dioxide can also be exerted from bicarbonates as well as carbonate in accordance with the following reactions (AWWA, 1999):



## 2.1.5 Water Treatment Plant Residue

Four major types of residuals produced during water treatment include sludges, concentrates (brines), resins, and carbon from filter media and air emissions. The chemical characteristics and concentrations of the residuals will dictate the appropriate disposal option. The aim with residual management is always to reduce the volume of residuals that needs to be disposed of (AWWA, 2007).

Waste products from filtration are produced through the backwash process. The sludge quality will depend on the contaminants within the wastewater. The aim of sludge handling is to reduce the water content of the sludge through a mechanical dewatering process such as a filter press. A filter press achieves solid-liquid separation through the high pressure filtration principle. The filter press is able to reduce the moisture content (Degrémont, 1995b). The dried sludge and precipitates from softening are generally disposed to landfills or used in land applications.

When resin is regenerated, the regenerant (brine) contains very high concentrations of ions as well as excess regenerant chemicals. Great care should be taken in the disposal of the waste regenerant to ensure that no pollution of surface or groundwater sources occurs. Typically, the brine is sent to evaporation ponds. Non-hazardous gas emissions are discharged into the atmosphere.

Spent GAC, resin and filter media must be analyzed for radioactive contamination and non-radioactive material can be disposed to landfills, whereas, if radioactive, it can be put in long-term storage or be incinerated (National Drinking Water Clearing House, 1998).

Many utilities recycle various streams back to the beginning of the treatment process. Recycling is most often included as part of water conservation measures, improved plant performance, or due to the inability to discharge the liquids into a watercourse or sewer (Schutte, 2006).

## 2.1.6 Membranes

Many membrane processes and applications are used in water reclamation operations. The common practice entails pre-treatment of polluted water with coarse membranes such as microfiltration followed by precipitation and finer membrane technologies such as reverse osmosis. Reverse osmosis is capable of removing a wide range of pollutants including ionic and non-charged molecules. Pure solvent is allowed to pass to the other side, while retaining the solute on the pressurised side of the membrane (as shown in *Figure 2-3*).

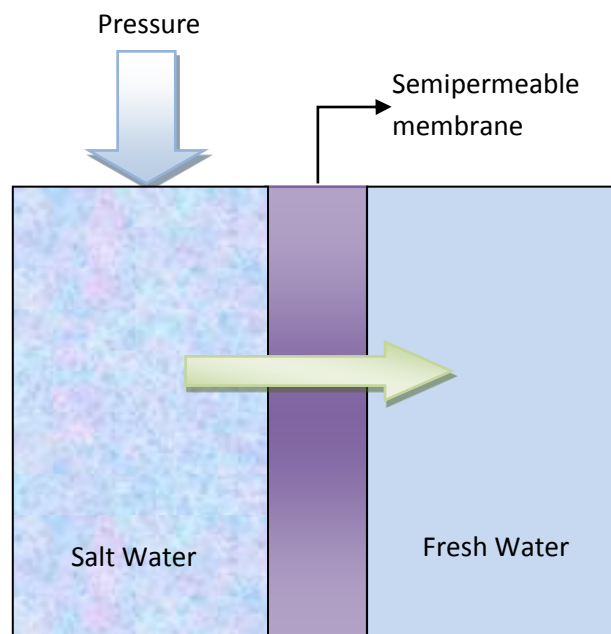
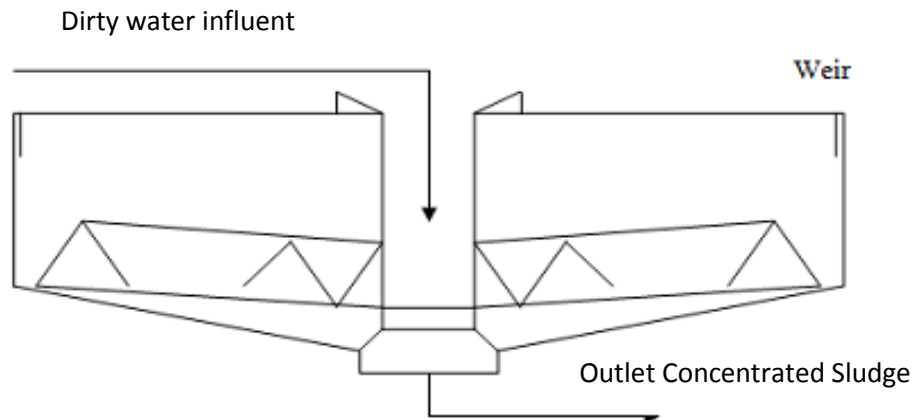

*Figure 2-3 Reverse Osmosis*

The membrane should not allow molecules or ions through the pores, but should allow smaller components of the solution to pass freely. Reverse osmosis is primarily used for removing salts from brackish water. Reverse osmosis can be used to effectively separate and concentrate ammonium and nitrate effluents. The permeate from the reverse osmosis process could be reused and the concentrated ammonium sulphate solution could be utilized as a liquid fertilizer (Fu *et al.*, 2011). Membranes have been used in many applications for concentrating various products such as apple juice (Onsekizoglua *et al.*, 2010)

### 2.1.7 Coagulation and Sedimentation (Settling Tanks)

Coagulation increases the tendency of small particles in an aqueous suspension to attach to one another, forming flocs that attach to the surfaces such as the grains in a filter bed. The particles present in water are not regular in shape, density or size. Turbidity is caused by suspended solids and colloidal matter. The treatment could rectify defects in water caused by inert or living particulate fractions as well as organic matter able to flocculate (Degrémont, 1995a). A schematic of a settling tank is shown in *Figure 2-4*.



*Figure 2-4 Settling Tank*

Coagulants are added before the water enters the settling tank. The pH of the water is increased to ensure optimum performance by the coagulant. Circular settling tanks make use of a scraper system with more than one blade to push the sludge along to the floor of the tank. These blades rotate around the centre of the tanks. Typically, water enters the settling tanks at the top in the middle of the tanks. The flocculated solid particles then settle to the bottom,

while the clarified water overflows at the top of the tank (Degrémont, 1995b). Various settling approaches have been tested and are able to reduce suspended solids and precipitation of metal ions (Silva *et al.*, 2009).

## 2.2 Water Management

According to best practice guidelines, the objectives for managing water in South Africa (Department of Water Affairs and Forestry, 2008) are:

- To achieve equitable access to water
- To achieve the sustainable use of water (ecological and economical)

In South Africa, the national government acts as the custodian of all national water resources. All individuals have the right to use water. Regional and local institutions are responsible for water resource management. As the mining industry does not enjoy the right to use water, an administrative authorization process must be undertaken that would require consideration of the objectives as mentioned above. A key component of the national water strategy, aimed at addressing water management, is the implementation of water conservation and water demand management (Department of Water Affairs, 1996). The key principles of water conservation and water demand management as specified in the *Best Practice Guideline – H1: Integrated Mine Water Management* (December, 2008) are:

- Avoid water wastage
- Reduce water wastage
- Reuse and recycle used water
- Prevent pollution of water bodies by treating effluents
- Implement adaptive management of water resources

Most water management actions within a mining operation can be defined as source-based measures; however, the mine will invariably have some impact on the national water resource via ground and surface water and point and diffuse-pollution pathways. The mine will

therefore need to take cognizance of the resource-directed measures. The mining sector has a significant impact on water resources in terms of water abstraction and water quality.

A quality management plan relies on planning, following, checking and acting upon the protocol as discussed in the *Best Practice Guideline – H1: Integrated Mine Water Management* (December, 2008). In order to successfully implement mine water management that complies with directed measures required by the relevant legislation, the principles listed below must be adhered to:

- Compliance with the water management decision-taking hierarchy
- Include the life-cycle approach view for management over the lifetime of the mine
- Include a plan for closure
- Mine must retain responsibility for pollution at all times
- Management decisions should be based on conservative assumptions that fall within the precautionary principles
- Management plan should be based on current water-conservation and water-demand management
- All temporal variability of water quality and quantity must be considered
- Follow a risk-based approach
- Aim for continual improvement
- Consider cumulative impacts in the management plan
- Regional impacts should also be considered
- Include public participation
- Use suitably qualified persons
- Management must be committed to the management plan

In order to develop a Water Management plan the performance objectives should firstly be defined. Alternatives should be researched for the mining aspects being evaluated. Assessment of all alternatives must be conducted. Quantify whether the alternative meets the performance objectives both in a financially and environmentally viable way. The approach should be applied to all alternatives and the best option should be selected. A key component of a management plan is an effective and supportive structure operating within the

management plan. For successful implementation it is necessary to establish an appropriate corporate culture. In order to achieve continual success monitoring, auditing and review systems should be installed (Department of Water Affairs and Forestry, 2008).

Precautionary principles to follow during water management are, firstly, to prevent or minimize pollution of water used. Secondly, to reuse or reclaim contaminated water, otherwise to treat water and re-use treated water and discharge any excess water (Department of Water Affairs and Forestry, 2006). The mining industry's intimate association with water use, provision, access and transformation has a unique role to play in terms of universal human rights; this role has arisen from the growing trend towards recognition of water as a distinct human right (Kemp *et al.*, 2010).

## **2.3 Water use in mining**

Water is used for the extraction of gold in the following processes (Sub-Committee of Consulting Metallurgists of the Chamber of Mine of South Africa, 1987):

- Metal extracted by acid or alkali attack (leaching)
- Solid-liquid separation (filtration/ thickening)
- Metal concentration
- Mining processes (drilling)
- Cooling processes (fridge plants)
- Tailings Storage Facility seepage

These processes are mostly carried out at ambient temperatures and reduce corrosion. The following constitute the most important parameters in mine process water: suspended solids, colloidal silica, calcium sulphate and organic matter. Typical pollutants in effluent streams are aluminium, gold, uranium and zinc.

The Chamber of Mines explains the gold recovery process in detail in “*Extractive Metallurgy of Gold in South Africa*”: The method of mining is firstly to excavate, by drilling and blasting horizontal tunnels or drives just below the reef plane at intervals down the dip, and then to

establish connecting tunnels in the plane of the reef between the drives. Actual mining of the reef consists of widening the winze-raise connections laterally (by means of drilling and blasting) to form stopes. Wet drilling is achieved by continuously feeding water down a central channel in the drill steels or jumpers used for drilling. Conditions in stopes are almost always wet because of water ingress from rock fissures, so that generally the fines in any broken rock are very quickly converted to mud. The ore is hoisted to the surface for further treatment. The hoisted ore is generally wet and muddy, containing about 8 percent water. Some of the water is collected at the bottom of the shaft and pumped to surface where it is reused in the cooling process.

High gold recovery is only possible if the gold was made accessible through milling. In gold ores, the valuable constituent usually occupies only an extremely small proportion of the ore volume. Most rod mills and some ball mills are run in open circuit. Dilution water is added to the mill at the feed to provide a constant solid-to-water ratio. The water dilution ratio influences the efficiency of the classification system. Generally, the basis of control is the adjustment of the cyclone feed water-to-solids ratio. The aim of the classification system is to control the size fraction of the mill product by returning oversize particles to the mill for dilution of the incoming ore.

The grinding process requires a very high ratio of liquid to solids, whereas reagent economy, size of equipment, and reaction contact time in the downstream operations require that the liquid content of the pulp be low. The solids therefore have to be dewatered, separating water from pulp usually in continuous thickeners. The feed pulp is introduced to the centre of the thickener. The solids settle and are continuously removed via pumping through an opening in the centre of the bottom of the tank. The overflow from the thickeners is collected in a peripheral launder and returned to the milling process. The primary object of thickening is to dewater the solids. Absolute clarity of the overflow is somewhat less important, since the solution is returned to the mill.

Following the thickening process, the gold is leached to take it into aqueous solution. This is done through contact with a soluble cyanide salt such as sodium cyanide. The main reason for high alkalinity in most leaching circuits is the lime contained in the thickener underflow pulp,

which is pumped into the leaching plant; and also the need to maintain a fairly high level of alkalinity for the cementation or precipitation process which follows. It is necessary to ensure that the pulp progresses down a train of tanks through a hydraulic gradient down the train which involves raising the tanks so that each one is at a suitably raised elevation with respect to the next in line.

In leaching vessels the control of the pulp dilution is of importance. If the dilution level is too low the pulp viscosity inhibits mass transfer of both reagents and products with a resultant adverse effect on the dissolution process. On the other hand, if the pulp is excessively diluted then the overall residence in the leaching plant is reduced with the same effect. In most plants the leaching section is designed to operate at a water-to-solids ratio in the range 1.1 to 1.0. Because the thickener underflow pulp normally has a water-to-solids ratio of around 0.6, it requires dilution before entering the leaching circuit. In most modern plants part or all of this dilution is provided by recycled barren solutions.

Activated carbon is used to recover gold from solution which is an integral part of a slurry. The carbon-in-pulp process recovers gold in solution from slurry streams by contacting the carbon with the pulp and separating the two with screening. This occurs in a number of adsorption vessels in series. Pulp flows continuously from the first tank to the last, while carbon flows against the current from the last to the first tank. Loaded carbon from the adsorption tank is transferred to an external screen where the carbon is recovered and washed before entering the elution circuit. Carbon is transported with water from the adsorption tanks to the acid wash and elution tanks.

Calcium has been shown to have a very detrimental effect on the ability of activated carbon to recover gold, by lowering the activity of the carbon and inhibiting the elution process. Its removal is therefore an essential part of the process. Removal of the calcium deposit has been shown to be very easily achieved if sufficient hydrochloric acid and adequate contact with the carbon are provided. The acid treatment is placed before elution, enabling the acid to be fully neutralised by the eluting solutions prior to regeneration.

A caustic solution, normally 2 % NaOH (eluate), is pumped to the elution column to strip the gold from the carbon. Gold is recovered from the eluate by electrowinning. The electrowinning cell and the elution unit form a closed circuit; the eluted gold is removed from the eluate through electro-depositioning as rapidly as they are desorbed from the carbon. The barren electrolyte becomes the eluent and is recycled to the elution circuit. The eluting solution is continuously circulated through the column and an electro-winning cell in series.

After elution thermal regeneration is the main operation which maintains the quality of the carbon in the adsorption circuit. During the period that the carbon is in contact with the pulp it becomes progressively poisoned and loses its activity. To counteract this loss, restoration through regeneration of the carbon's activity is required. During adsorption, organic and inorganic adsorbates can accumulate within the porous structure of activated carbon. The objective during regeneration is to remove adsorbates that have accumulated during the adsorption operation, thus recovering the original structure and activity of the activated carbon. Thermal regeneration involves three types of reaction corresponding to three types of adsorbates on the spent carbon: desorption of volatile organic compounds; decomposition of organic compounds not sufficiently volatile for desorption; and pyrolysis of the remaining compounds. After regeneration the carbon is dropped into water where it is quenched before it is returned to the circuit.

The pulp separated from the carbon is referred to as tailings. Tailings are pumped from the plant to a tailings storage facility, TSF (also known as a slimes dam). A large amount of water is used to pump the pulp vast distances. Once the pulp reaches the TSF, water is recovered from the pulp and returned to the gold recovery plant where it is reused in various processes. Some of the water is however lost to the environment through evaporation and seepage through the TSF into the groundwater systems. Ideally, water should be decanted off the TSF concurrently with deposition so as to maintain a minimum pool area and a depth just sufficient to ensure adequate water clarity. Any storm-water reporting to the TSF is controlled and stored in a dam for use later on. Adding vegetation to the TSF surface minimises and reduces wind and water erosion from the top of the dam (Sub-Committee of Consulting Metallurgists of the Chamber of Mine of South Africa, 1987).

Acid Mine Drainage, AMD, emanates from both surface and underground workings, waste and development rock, and tailings piles and ponds. Impacts from tailings and rock dumps adversely affect both groundwater and surface water quality. Underground impacts are generally characterized by the inflow of water into the underground workings and the subsequent dewatering of the aquifer. Elaborate pumping systems employed in the beginning of the 20th century to increase profits resulted in the modification of the water table, appearance of sinkholes, and elevated levels of water, air, and soil pollution. The rebound of water levels after mine closure can lead to contaminated groundwater being discharged. Acid mine drainage is produced when sulphide-bearing material is exposed to oxygen and water. The production of AMD usually occurs in iron sulphide-aggregated rocks. Releases of AMD have low pH, high electrical conductivity, elevated concentrations of iron, aluminium and manganese and raised concentrations of toxic heavy metals. The acid produced dissolves salts and mobilizes heavy metals from mine workings. AMD follows the same flow pathways as water; therefore AMD can best be controlled by controlling water entry into the site of acid formation by the diversion of surface water away from the residue storage areas, prevention of groundwater infiltration into the mine workings, prevention of hydrological seepage into the affected areas and controlled placement of acid-generating waste. Diversions most commonly consist of ditches, which are difficult to maintain for long periods of time. Groundwater discharge areas should be avoided as isolation and interception of contaminated groundwater is very difficult to achieve. Under-drains can be installed in locations of the dumps, and the infiltration by meteoric water can be further retarded through the use of sealing layers (Oelofse and Hobbs, *et al.*, 2007).

Acid mine drainage occurs from pyrite ( $\text{FeS}_2$ ) through the following reaction:



Mine water treatment has been using different technologies to address the concerns such as bioreactors utilising bacterially mediated sulphate reduction (BSR) have been tested for treating metal-rich waters, but sustained treatment of mobile metals (Mayes *et al.*, 2011). Another method for mine water treatment is used to spiral reverse osmosis (Schoeman & Steyn 2001).

## Chapter 3 Experimental Set-up

This chapter describes the water treatment processes that were selected for the treatment of mine and fissure water. It explains the operating of the pilot-scale units and illustrates how it fits together. A method for the mine's water management review is briefly described at the end of this chapter.

### 3.1 Fissure Water Pilot Plant

The fissure water pilot plant (*Figure 3-1*) is located at a pumping shaft in the West Rand.

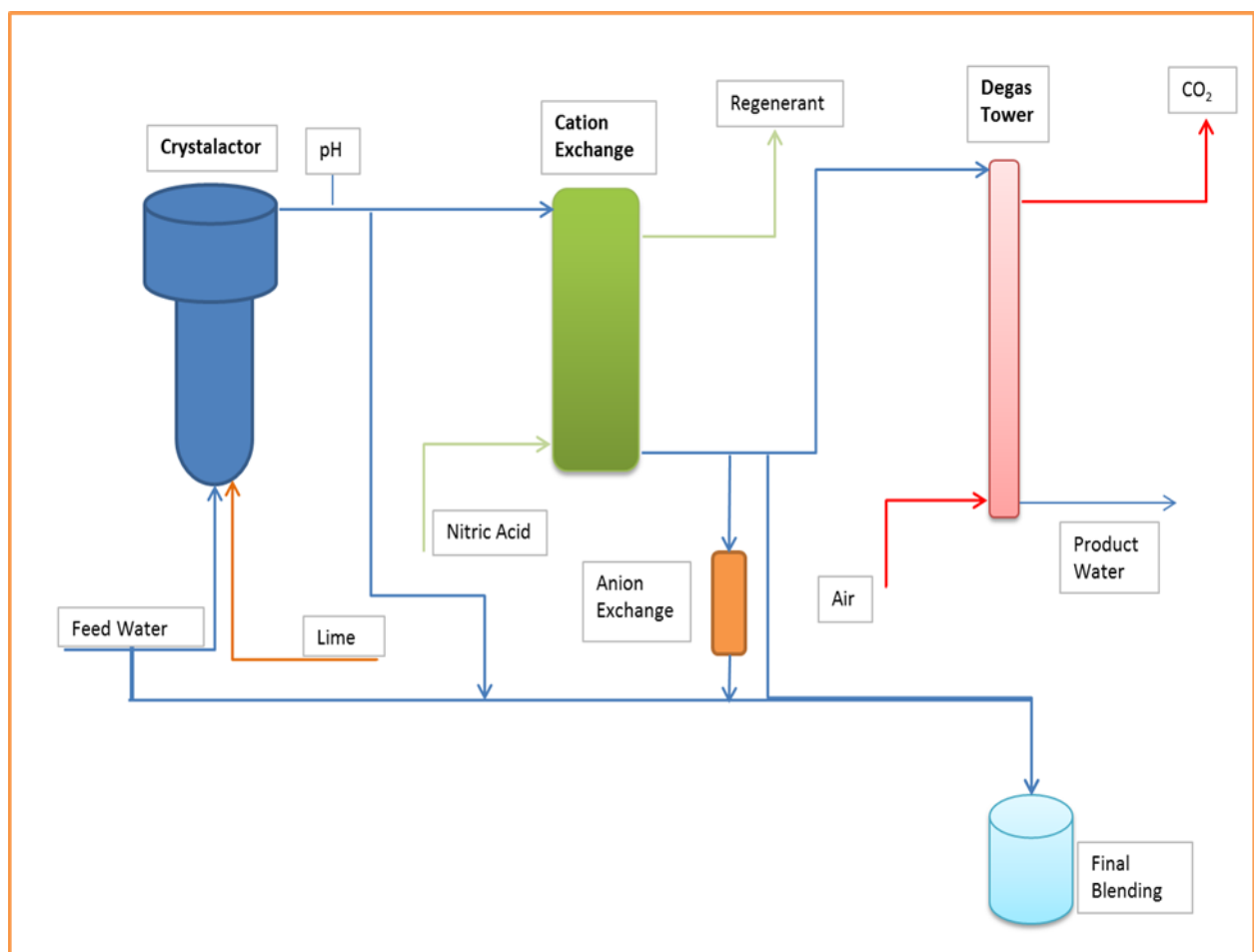

*Figure 3-1 Fissure Water Pilot Plant*

The water is pumped from underground to surface level and collected in a fissure water tank. From this tank the water is disinfected before entering a dual medium filter. The filter media

consists of granular activated carbon and silica sand. After filtration the water is distributed to different sources on the mine. A small portion of the filtrated water is used for testing in a pilot plant.

The pilot plant consists of three processes namely: crystalactor (cold lime softening), cation exchange and degassing (CO<sub>2</sub> stripping). The crystalactor is a fluidised bed reactor and used for cold lime precipitation in order to remove calcium and soften the water. The feed flow rate to the crystalactor is 20 000 L/h. The water enters at the bottom through six nozzles to achieve good distribution inside the reactor. The water flows through the reactor and exits at the top, where it overflows to the next process. The objective of the reactor is to maintain a pH of 9 in order for cold lime precipitation to take place. The pH is sustained through the addition of lime to the bottom of the reactor. The lime addition is controlled with a PID (proportional integral derivative) controller which increases or decreases the pumping speed according to the pH measured on the crystalactor overflow.

Inside the crystalactor seed material is fluidised. The seed material provides a large surface area for the precipitation to take place. At a pH of 9, calcium carbonate forms from the reaction of the water and the lime. The calcium carbonate then precipitates on the seed material. As the precipitation takes place, the seed material grows, and the heavier particles moves to the bottom. As the particles grow, the level of suspended particles rises. Due to this constant growth taking place inside the reactor some of the larger particles are removed daily and replaced with fresh seed material, to increase the available surface area. The particles discharged from the reactor are sent to a drying bay to remove most of the moisture present. The particles are then referred to as pebbles.

The lime used for the pH control of the crystalactor is slaked in a 1 000 L batching tank; if the tank is empty a pump will start feeding product water to the tank. Once the tank starts filling up, agitation is applied through a mixer agitating at a low speed to prevent turbulent behaviour and introduce air into the water. As the level rises in the tank, lime in powder form is fed into the tank through a screw feeder above the tank. The screw feeder will be in operation for short durations as the water reaches certain levels inside the tank. Once the tank

is full the lime is pumped to the lime storage tank from where it is fed to the crystalactor and the next batch is prepared.

After the cold lime precipitation process, only 2 000 L/h of the treated water continues to the cation exchange section of the plant. The reason for this is that the crystalactor cannot be scaled down any further than 2 000 L/h without compromising efficiency. The water enters the resin column at the top and flows down through a strong-acid cationic resin bed to the bottom of the column where it exits. Inside the column cations such as calcium, magnesium and sodium are exchanged through adsorption onto the resin for hydrogen ions, which are released into the water. The water exiting the column has a high conductivity and a low pH due to the hydrogen ions released into the water. Once all available adsorption sites of the resin are loaded with cations, breakthrough is achieved and the resin requires regeneration. The pH of the water exiting the cation exchange column is monitored continuously. As the resin approaches breakthrough, less hydrogen ions are released into the water and the pH begins to rise; once the pH reaches 5, the plant automatically begins regeneration.

The first step of regeneration is the release of all cations on the resin sites. This is achieved by pumping 1.5 bed volumes of 4 % nitric acid through the column at a flow rate of 900 L/h (2 bed volumes per hour). The nitric acid will exchange hydrogen for cations such as calcium, magnesium and sodium to form calcium nitrate, magnesium nitrate and sodium nitrate. After the regeneration with nitric acid the column is rinsed with 3.5 bed volumes of product water to wash any regenerant left in the column. Rinsing takes place at 2 500 L/h (8.3 bed volumes per hour). After rinsing the system returns to its initial conditions.

The water exiting the cation exchange column proceeds to a degassing tower at a flow rate of 2 000 L/h. The water enters the tower at the top then cascades down through a packed bed and exits at the bottom of the tower. The tower has a blower at the bottom which blows air upward through the packing and exits at the top of the tower. The aim of the degassing tower is to remove any carbon dioxide present in the water. The carbon dioxide is released by the packing and will move with the air to the top of the tower where it is released into the

atmosphere. An alternative to the degassing tower is a weak base anionic resin column. This column removes all anions present in the water.

The treated fissure water will be used as drinking water. In order to achieve the specified drinking water standard, water blending is extremely important. The blending takes place between the feed water, the crystalactor overflow, the cation product water and the anion product water. The blending is established through control over the different flow rates of the different streams. *Figure 3-2* is an illustration of the constructed pilot plant.

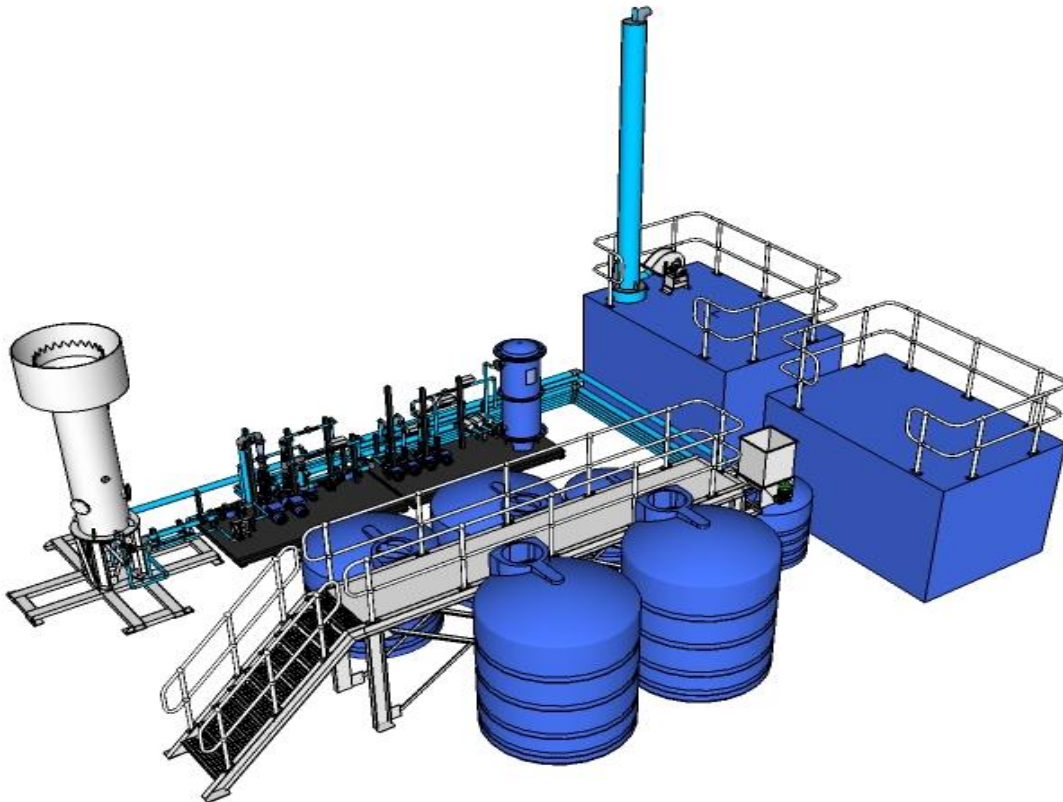
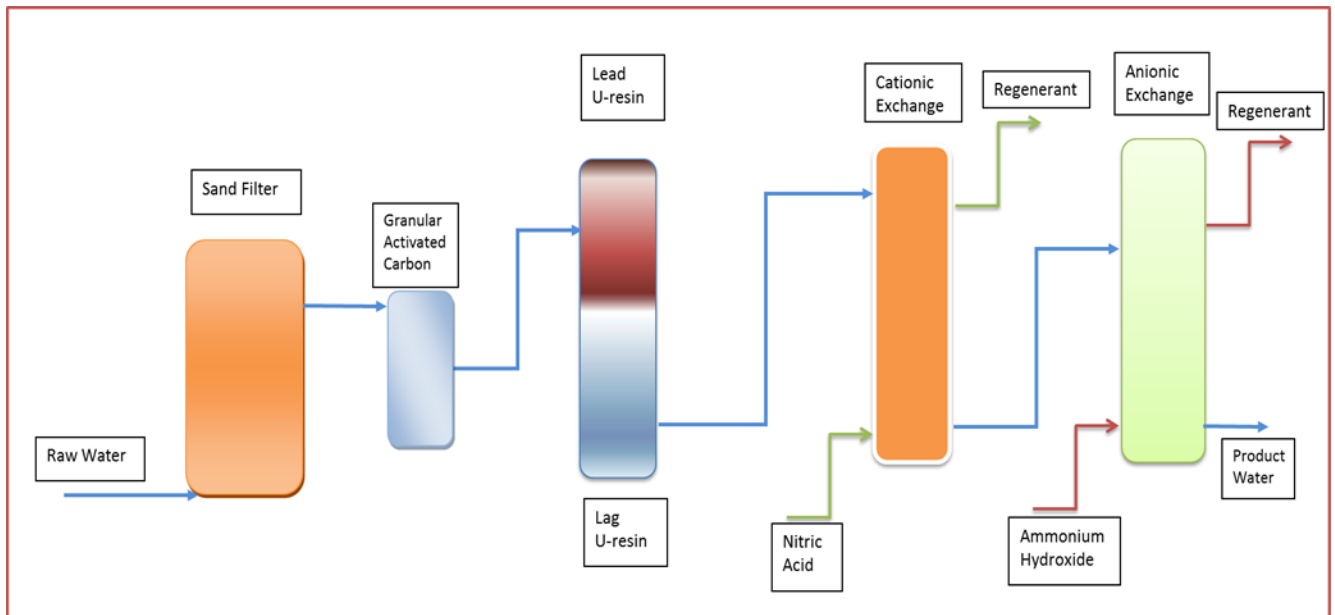

*Figure 3-2 Fissure Water Pilot Plant Schematic*

## 3.2 Mine Water Pilot Plant

The mine process-water pilot plant is situated at a mining shaft. The pilot plant treats mine process water from underground. A diagram illustrating the treatment flow of the mine water

is shown in *Figure 3-3*. The water is used in mining activities before it is collected in a settler where the water is neutralized with lime and a coagulant is added for improved settling performance. The water is then pumped to surface where it is either re-used or discharged.



***Figure 3-3 Mine Water Pilot Plant***

The mine process water enters the pilot plant at the sand filter at a flow rate of 2 000 L/h. The filter removes suspended solids present in the water. On a daily basis the filter is backwashed with product water at a flow rate of 4 000 L/h. The backwash water is sent to collection tank before being discharged to the current water circuit.

The filtered water stream is split into two equal streams each flowing through a granular activated carbon filter at a rate of 1 000 L/h. The granular activated carbon filter removes any organic material present in the water as well as any residual suspended solids. The GAC filter is backwashed on a daily basis by reversing the flow through the filter and collecting the backwash in a tank before discharge. The sand filter and the GAC filter helps to protect and prolong the life and activity of the downstream ion exchange processes.

The water then enters the ion exchange section of the plant. The first part of the ion exchange section is uranium removal. A strong base anion resin is selected and treats 2 000 L/h of mine process water. The anion resin is highly selective for uranium and will not remove any other ion from the water. Uranium is removed as the first step to prevent uranium contamination in the anion regenerant solutions. Once the resin has reached breakthrough the resin is replaced with fresh resin. The resin has a capacity of 4 g uranium per litre of resin (proved in earlier testwork), meaning that breakthrough will be achieved less than once a month. However, due to the fact that analysis has a lag time before results are available, the resin is replaced monthly.

After uranium removal the water is subjected to a cation removal section. This section utilizes strong acid cationic resin (LEWATIT MonoPlus SP 112 H) for the removal of calcium, magnesium and sodium. Strong acid cationic resin is used as the aim of this plant is to produce demineralised water. The water is fed to the cationic resin at a rate of 2 000 L/h. The water exiting the cation exchange vessel flows directly to the anion exchange vessel. This water is acidic at a pH of 2.2, and has a high conductivity of 500 mS/m. Breakthrough of the resin is indicated by a rise in pH and a decrease in conductivity. When the pH increases to 3, the regeneration cycle starts.

A 4 % nitric acid solution is pumped through the ion exchange column at a rate of 1 200 L/h (3 bed volumes per hour) for 30 minutes. The resin is then rinsed with product water at a flow rate of 2 500 L/h for 30 minutes. The regenerant reports to the drain collection tank for the first 7 minutes after which it reports to the regenerant tank for 30 minutes and then again to the drain collection tank for the remainder of the rinse process. The loading cycle then proceeds as normal. The regenerant collected in the regenerant tank will be used for the next regeneration after the acid content has once again been increased to 4 % nitric acid. The regenerant continues with recycling until the regeneration process is not able to return the resin to its original state. The recycling ensures that the concentration of the regenerant increases until a maximum concentration has been reached. The regenerant solution contains calcium nitrate, magnesium nitrate and sodium nitrate.

The anion exchange section removes sulphates, chlorides and nitrates. The resin utilized in the anion IX column is LEWATIT MP64. The water exiting the anion exchange section has a pH of 6 and a conductivity of 30 mS/m. When the anion exchange resin has reached breakthrough the conductivity of the product water increases and regeneration of the resin is necessary.

A 3 % ammonium hydroxide solution is pumped through the ion exchange column at a rate of 1 200 L/h (3 bed volumes per hour) for 30 minutes. The resin is then rinsed with product water at a flow rate of 2 500 L/h for 30 minutes. The regenerant reports to the drain collection tank for the first 7 minutes after which it reports to the regenerant tank for 30 minutes and then again to the drain collection tank for the remainder of the rinse process. The loading cycle then proceeds as normal. The regenerant collected in the regenerant tank is used for the next regeneration after the ammonium hydroxide content has once again been increased to 3 %. The regenerant continues with recycling until the regeneration process is unsuccessful. The recycling ensures that the concentration of the regenerant increases until a maximum concentration has been reached. The regenerant solution will contain ammonium sulphate and ammonium chloride. *Figure 3-4* represents the constructed pilot plant.

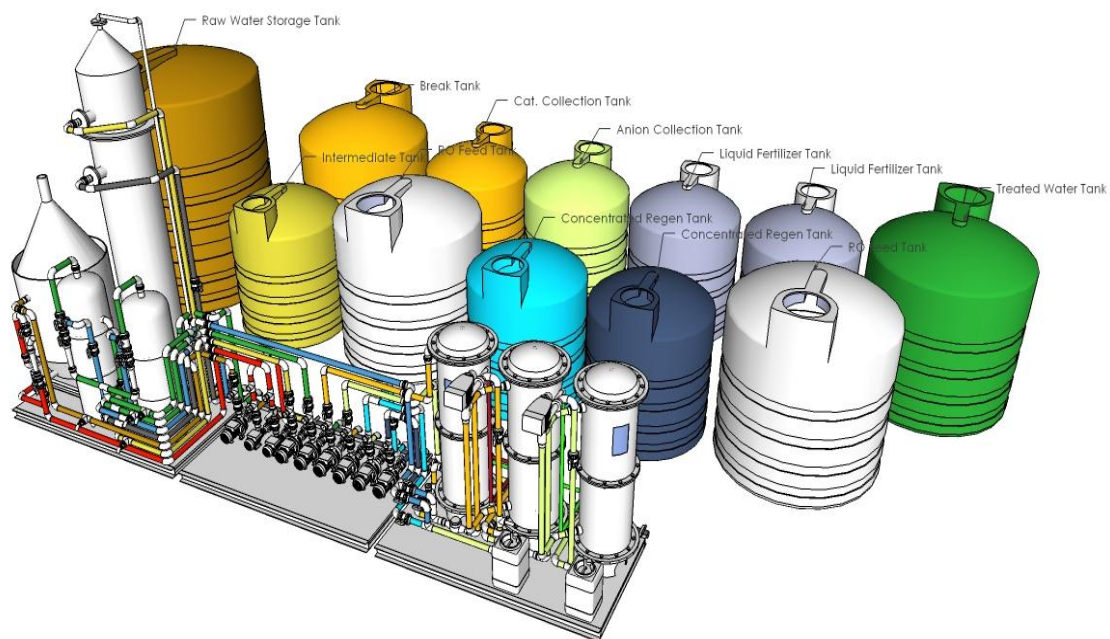

***Figure 3-4 Mine Water Pilot Plant Schematic***

A membrane was also tested on the mine water regenerant for the concentration of the regenerants. The regenerant was pumped from the regenerant storage tank through a cartridge filter to the membrane at a flow rate of 3000 L/h. The trial was carried out at 40 Bar for low concentrations (1 - 2 %), and at 80 Bar for higher concentrations (6 - 8 %). The permeate was returned to the feed water and the concentrate was recycled to the regenerant storage tank. The samples were then sent to accredited laboratories for analyses.

### **3.3 Water Management Methodology**

In order to identify the critical areas for improvement in the water management structure, it was important to investigate all the water discharges from the various shafts and water treatments. The different water qualities of the discharges were reviewed and where contamination exceeded legal limits a detailed investigation was launched.

Each structure (a shaft for example) was reviewed in terms of water circulation, recharge, water balances and current water treatment. Sampling campaigns were launched to determine where point sources were located and the extent of pollution at a certain source. All the data was combined and a suitable action plan was formulated. A full description is given in Chapter 6.

## Chapter 4 Fissure Water Results and Discussions

The results obtained in the fissure water pilot plant will be presented and discussed in the chapter. Trade-off studies between different processes are displayed and various options that were tested are discussed.

### 4.1 Chemical composition of fissure water

The analysis for the fissure water compared to SANS 241:2011 is shown in *Table 4-1*. The water is not contaminated by any mine process or infiltrated with any bad quality water at the mine.

The fissure water input is mainly rain water infiltration through the top layers of the underground workings of the mine. The water is kept separate from the mine water at high levels and pumped separately to the surface. The water contains a little bit of temporary hardness, but is otherwise suitable for human consumption. Biological non-compliance still needs to be tested and a disinfection process still needs to be developed. The aim of the pilot plant was to produce water that would comply with the SANS 241:2011 standard for drinking water. The fissure water was compared with SANS 241, and had very few non-compliances. The conductivity and hardness of the fissure water was the biggest concern. Heavy metals were within the specifications required by Rand Water, except for selenium which would be removed through ion exchange. The fissure water required only softening and a small reduction in overall salt load. Although the plate count was above the limit, it was not consistent and caused no concern as the water still needed to undergo a disinfection process prior to usage (Bester, 2009a).

**Table 4-1 Fissure Water Analysis**

<b>Element</b>	<b>Fissure water Analysis</b>	<b>SANS 241</b>
pH	8.1	7.6 -8.8
Conductivity (mS/m)	58	45
Hardness (mg CaCO <sub>3</sub> /L)	262	20 - 200
Standard Plate count	511	30
Suspended solids (mg/L)	10	
Oil & grease (mg/L)	6	
COD (mg/L)	10	
Lithium (mg/L)	0.001	
Sulphate (mg/L)	136	200
Calcium (mg/L)	53	80
Magnesium (mg/L)	34	50
Sodium (mg/L)	22	200
Nitrate (mg/L)	1	6
Potassium (mg/L)	0.044	25
Aluminium (mg/L)	0.011	0.15
Selenium (mg/L)	5.7	0.01
Manganese (mg/L)	0.001	0.05
Tellurium (mg/L)	0.001	
Colour	5.5	15
Chloride (mg/L)	28	100
M Alkalinity	181	60-120
P Alkalinity	0.078	
Ammonia (mg/L)	0.243	1
Fluoride (mg/L)	0.42	0.7
Uranium (mg/L)	0.02	
Chrome (mg/L)	0.0018	0.05
Nickel (mg/L)	<0.005	0.02
Cobalt (mg/L)	0.015	0.25
Copper (mg/L)	<0.001	0.5
Iron (mg/L)	0.018	0.15
Barium (mg/L)	0.015	
Strontium (mg/L)	0.100	
Zinc (mg/L)	0.008	3
Lead (mg/L)	0.008	0.01
Arsenic (mg/L)	0.01	0.01
Cadmium (mg/L)	0.002	0.003

## 4.2 Cold Lime Precipitation

### 4.2.1 Relationship between Calcium reduction and pH

The relationship between calcium reduction and pH during the pilot campaign is shown in *Figure 4-1*.

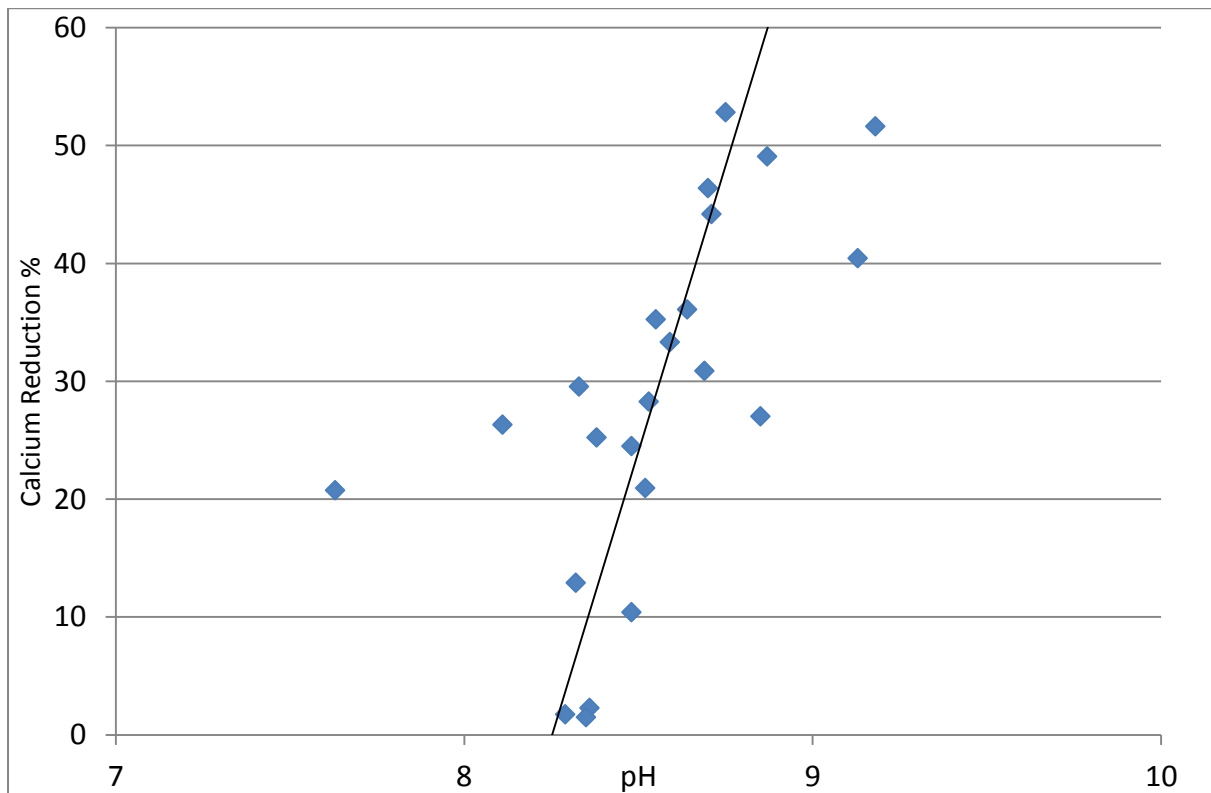

*Figure 4-1 Relationship between pH and Calcium reduction*

The calcium reduction in the plant depends on the alkalinity and the pH of the feed water. The available bicarbonates were all used in the precipitation reaction. During the operation of the fissure water pilot plant the highest reduction in calcium concentration was at a pH of 8.9 (*Figure 4-1*). At this pH a reduction of 30 mg/L Ca was observed from a feed concentration of 61 mg/L. The aim of the cold lime softening process is to reduce the hardness associated with calcium cost effectively, while producing a saleable by-product. Therefore precipitation of magnesium is not desired as it would contaminate the high purity calcium carbonate product which is produced. This is also why the pH was not increased to above 9.

## 4.2.2 Effect of Temperature on Calcium reduction

Another factor that influenced the performance of the crystalactor was the temperature of the feed water from underground. Therefore seasonal changes need to be taken into account during the design of the crystalactor. The pilot plant test work was conducted during the two extreme seasons (summer and winter), during which the temperature fluctuated between 25 °C and 16 °C.

The solubility constant is calculated below at 25°C (AWWA,1999):

$$K_{sp} = 10^{[13.870 - 3059/T - 0.04035T]}$$

$$\text{If } T = 298 \text{ K}$$

$$K_{sp} = 3.095 \times 10^{-9}$$

The solubility constant is calculated below at 16°C (AWWA, 1999):

$$K_{sp} = 10^{[13.870 - 3059/T - 0.04035T]}$$

$$\text{If } T = 289 \text{ K}$$

$$K_{sp} = 3.420 \times 10^{-9}$$

Therefore  $K_{sp}$  at 25 °C <  $K_{sp}$  at 16 °C, meaning that at lower temperatures, calcium carbonate is more soluble in water; the precipitate reaction is slower and takes place higher in the column (Bosklopper *et al.*, 2004). This, in turn, means that more lime is needed to precipitate calcium carbonate at lower temperatures than at higher temperatures. The temperature of the water was somewhat increased through the pumping from underground and could serve as mitigation to some extent. Alternatively, the crystalactors could be operated in-house to alleviate some of the temperature changes.

### 4.2.3 Effect of alkalinity on Calcium reduction

The performance of the crystalactor in relation to the alkalinity concentration in the water is shown in *Figure 4-2*.

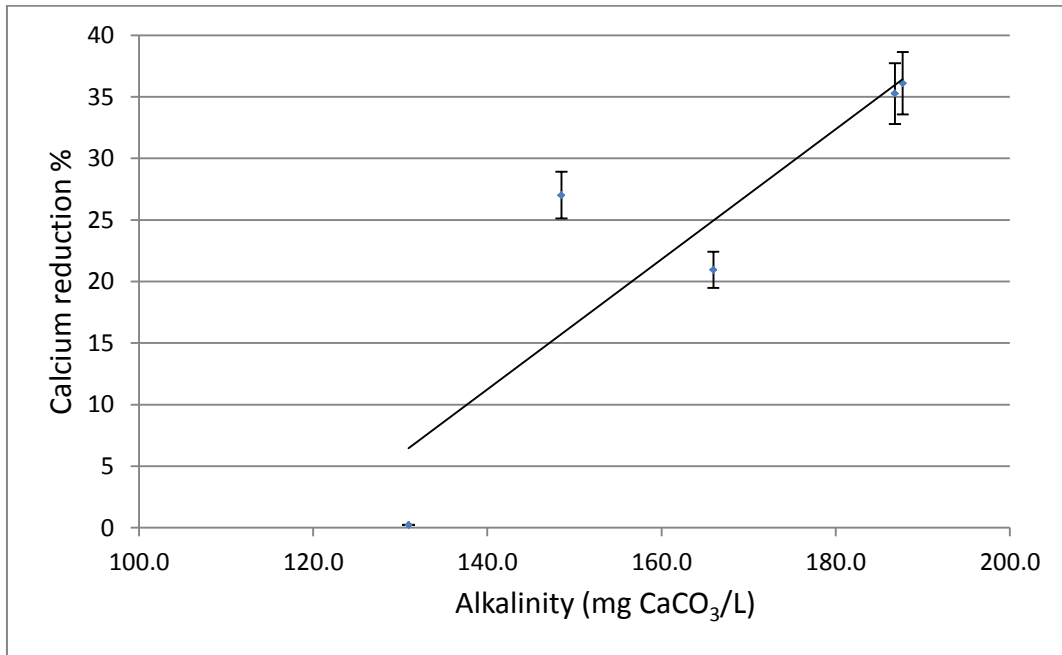

*Figure 4-2 Relationship between Ca removal and alkalinity*

The performance of the crystalactor is more efficient at higher alkalinity concentrations. At the feed pH of 8.3, it can be assumed that all alkalinity is present as bicarbonate which favours the precipitation reaction. The reaction for calcium carbonate to precipitate (below) shows that the less bicarbonate is available, the less calcium carbonate will precipitate. The alkalinity in the water is dependent on the amount of rainfall received in the area. The water is pumped from a dolomitic geological structure and will promote alkalinity in the water naturally due to the high concentration of calcium and carbonates in the dolomites.

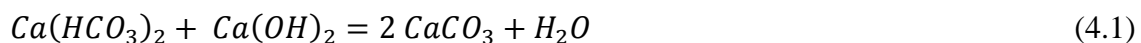

## 4.2.4 Different Flow rates

The efficiencies at different flow rates were recorded to establish the optimized column size. The efficiency of the crystalactor for calcium removal at different flowrates is shown in *Figure 4-3*.

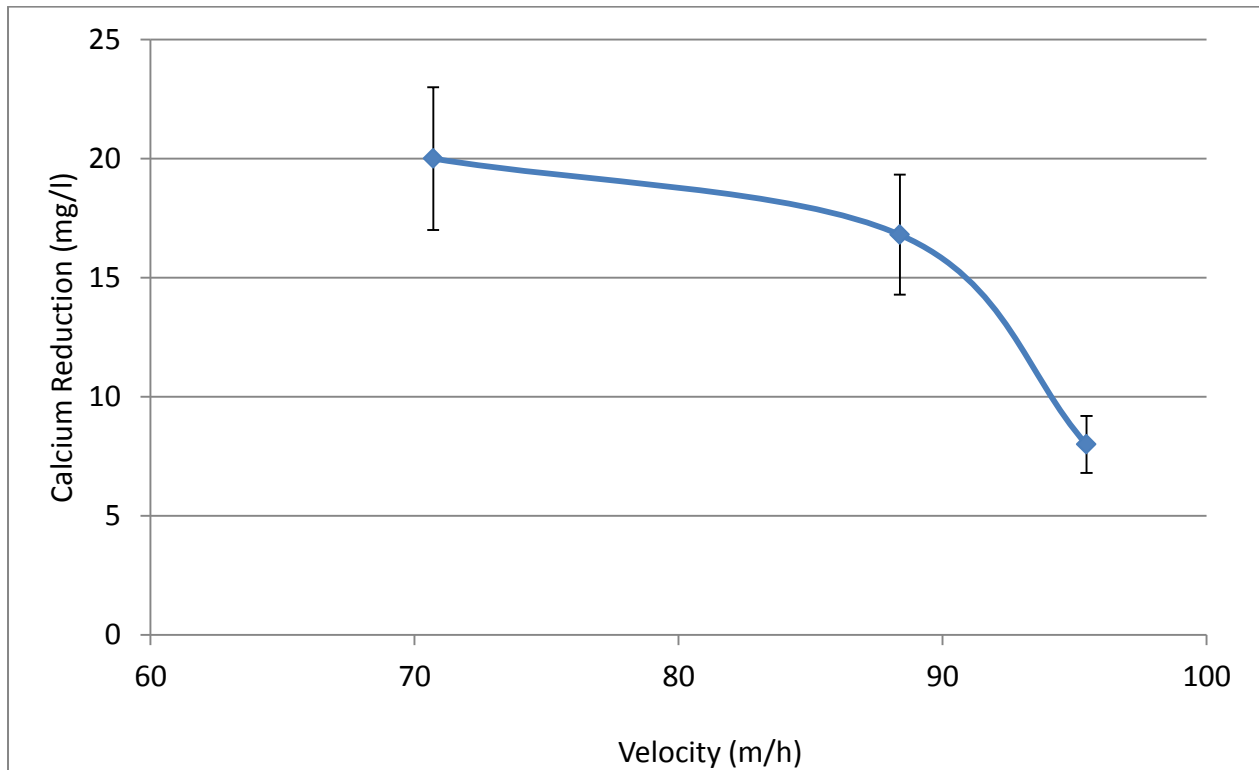

*Figure 4-3 Efficiency at various flow rates*

Three flow rates were tested: 20 m<sup>3</sup>/h, 25 m<sup>3</sup>/h and 27 m<sup>3</sup>/h. These flow rates corresponded to the following velocities: 71 m/h, 88m/h and 95 m/h. The highest reduction of calcium was achieved at a velocity of 71 m/h, resulting in the longest retention time as expected. At a velocity of 88 m/h an acceptable calcium reduction was obtained. However, when the velocity was increased further the efficiency of the cold lime softening reduced dramatically. The different flow rates were each tested for a period of 4 weeks.

A larger column size would also be beneficial, as less precipitation will take place in the pipes and downstream columns due to super-saturated water leaving the crystalactor. This means less scaling in the pipes and columns due to the residual lime and calcium carbonate present in the water.

## 4.2.5 Calcium carbonate pebbles

The calcium carbonate precipitation in the crystalactor takes place on a seed material, which is suspended through the up-flow of the water. The pebbles produced in the plant contained less than 5 % moisture. The moisture content reduced to less than 2 %, after three days of natural drying. The pebbles grew from 300  $\mu\text{m}$  (fresh seed material) to about 1 000  $\mu\text{m}$   $\text{CaCO}_3$  pebbles. Initially silica sand was used as seed material. The precipitated pebbles were crushed and then used as seed material instead of the silica sand. This increased the calcium content of the pebbles, without influencing the performance of the crystalactor. The properties of these pebbles are shown in *Table 4-2* and compares well to metallurgical grade lime. Normal metallurgical grade lime has a lower calcium content than the lime produced in the water treatment plant. The magnesium analysis of the water shows that almost no magnesium precipitated on the pebbles.

$$C_{\text{Mg\_feed}} = 43 \text{ mg/L}$$

$$C_{\text{Mg\_product}} = 42.3 \text{ mg/L}$$

**Table 4-2 Pebble Analysis**

Element	Concentration
Calcite ( $\text{Mg}_{0.03}\text{Ca}_{0.97}(\text{CO}_3)$ (%)	>50
Aragonite $\text{Ca}(\text{CO}_3)$ (%)	20
Quartz $\text{SiO}_2$ (%)	3
Cu (g/t)	22
Fe (g/t)	270
Pb (g/t)	<30
Mn (g/t)	<10
Ni (g/t)	18
Co (g/t)	<10
Zn (g/t)	36
Cr (g/t)	<10
U (g/t)	11
Th (g/t)	<10

The highest contamination from a metal was from iron, which was 270 g/t. The other metals were much lower and most below detection limits. Calcining tests were performed by Drytech. The calcined pebbles were able to reach a temperature of 100  $^{\circ}\text{C}$  within ten

minutes. After calcining the pebbles were in powder form. The crystalactor produces calcium carbonate pebbles which, when calcined, produces calcium oxide (quick lime) according to the reaction below:



## 4.2.6 Feed Fluctuations

The efficiency of the crystalactor decreases when the feed to the reactor is unstable; fluctuations of the feed is shown in *Table 4-3*. Variability in the feed water is due to the variability of the underground source water. This is influenced by rainfall, seepages, etc. If the crystalactor is unable to reduce calcium to the desired level, the cation exchange will ensure that the levels are still achieved. The feed variability makes it difficult for the chosen control system to keep the pH of the water inside the crystalactor at 8.9. The feed water pH ranged between 7.67 and 8.35, while the calcium concentration varied between 41 mg/L and 65 mg/L.

Feed water containing a low calcium content, also had the following properties: low conductivity (53 mS/m) and low sulphate content (120 mg/L). Compared to the SANS 241:2011 of 45 mS/m for conductivity, 80 mg/L for calcium and 200 mg/L for sulphate, these readings suggested that no or very little treatment was required. Therefore, for a full-scale application it might be best to let a certain percentage of the feed water bypass the crystalactor whenever low values such as these are observed.

*Table 4-3 Feed Quality Fluctuations*

	Minimum	Maximum
pH	7.67	8.35
Conductivity	53	71
Magnesium (mg/L)	31	46
Calcium (mg/L)	41	65
Sulphate (mg/L)	118	165

Simulation of ideal full-scale softening performance could not be achieved in the pilot unit, due to the following reasons:

- The concentration and ratio of Ca, Mg, Na and alkalinity varied by up to 30 % from time to time. The pilot design, specifically the lime addition and pH control system, was not sophisticated enough to adjust to these variations.
- The minimum recommended height of a crystalactor is 12 m. The height of the crystalactor in the pilot plant was only 3 m.
- The alignment of the reactor is important to prevent bypassing in the column. In our case the crystalactor was oval in the middle which resulted in some turbulence inside the column, which influenced the contact between the pebbles and the reaction taking place.

### 4.3 Cation Exchange

An ion exchanger exchanges one ion for another, holds it temporarily, and then releases it in a regenerant solution. Undesirable ions are replaced with more acceptable ions. In order to remove cations such as calcium, magnesium and sodium, a weak or strong acid cationic resin is used. During the pilot operation, the option was available to use either strong acid cationic (SAC) resin or weak acid cationic (WAC) resin. SAC resins convert neutral salts into their corresponding acids, removing nearly all the raw water cations and replacing them with hydrogen ions (reaction 4.3). This reaction is reversible. WAC resins remove cations associated with alkalinity as shown in reaction 4.4.

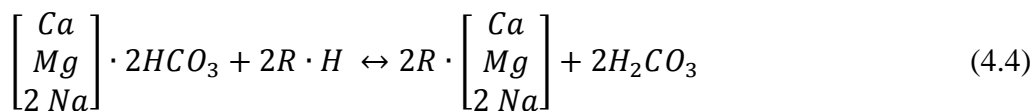
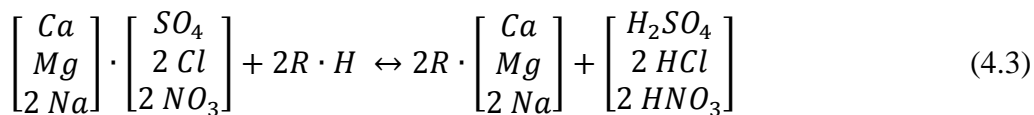

When the resin capacity reaches exhaustion, the resin can be regenerated with an excess of acid such as nitric acid. When the resin is exhausted, sodium ions in the resin will be replaced by calcium and magnesium ions. SAC exchangers can be operated at all pH ranges. WAC on the other hand is not able to remove all cations, but has a higher regeneration efficiency [Unknown, 1991].

The performance of the cationic resin is shown in *Figure 4-4*. The cationic resin was successful in the removal of the cations present in the water. The SAC removes all cations, while the WAC only partially removes the cations (it removes alkalinity by exchanging their hydrogen ions for the cations associated with the bicarbonate ion). The SAC produces water with a much lower pH and higher conductivity. However, when using SAC resin only a slip stream will be treated and not the full volume as in the case with WAC. Therefore SAC was considered in preference to WAC.

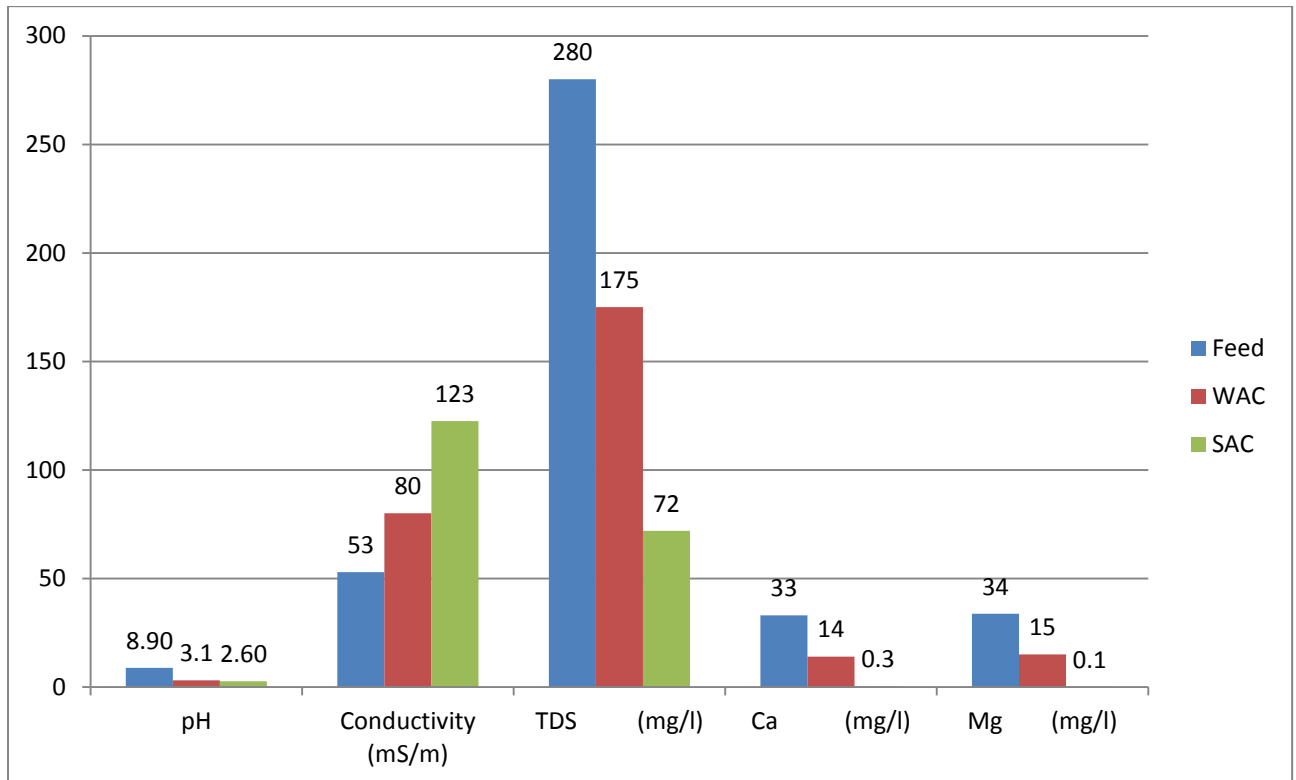

*Figure 4-4 Comparison between SAC and WAC performance*

A comparison between SAC and WAC in terms of operation is shown in *Table 4-4*. Accordingly, SAC was chosen for the full-scale application mainly due to the fact that less resin was necessary.

**Table 4-4 Comparison between SAC and WAC**

<b>Weak Acid Cationic Resin</b>	<b>Strong Acid Cationic Resin</b>
1. Removes only cations associated with alkalinity (temporary hardness)	1. Removes all cations
2. Full volume of water to be treated	2. Only a part of the stream has to be treated to achieve the same TDS removal as WAC
3. Product water contains predominantly Mg and Na as cations	3. Product water contains a more balanced ratio of Ca, Mg and Na
4. Moderate pH product	4. Very low pH product suitable for blending and degassing
5. Regenerated with nitric acid	5. Regenerated with nitric acid
6. Highest regeneration efficiency	6. Slightly lower regeneration efficiency
	7. Lower total resin volume than WAC

The chemical composition of the SAC spent regenerant is shown in *Table 4-5*.

**Table 4-5 Fissure Water Cationic Regenerant**

<b>Element</b>	<b>Concentration</b>
pH	1.93
Conductivity (mS/m)	31.9
Calcium (Ca mg/L)	2580
Magnesium (Mg mg/L)	1995
Sodium (Na mg/L)	1288
Potassium (K mg/L)	117.3
Aluminium (Al mg/L)	2.490
Boron (B mg/L)	0.027
Barium (Ba mg/L)	0.275
Cadmium (Cd mg/L)	<0.001
Cobalt (Co mg/L)	0.088
Chromium (Cr mg/L)	0.032
Copper(Cu mg/L)	0.410
Iron (Fe mg/L)	0.602
Lead(Pb mg/L)	0.058
Manganese (Mn mg/L)	0.133
Nickel (Ni mg/L)	0.454
Strontium (Sr mg/L)	<0.001
Uranium (U <sub>385.958</sub> mg/L)	0.011
Zinc(Zn mg/L)	0.680
Gold (Au mg/L)	<0.001

The solution contains predominantly calcium nitrate, magnesium nitrate and sodium nitrate, which is useful as liquid fertilizer. The fertilizer contains low levels of heavy metals, with only a little contamination of aluminium at 2.5 mg/L. Other contaminants are at very low concentrations in comparison to calcium and magnesium.

The cation resin was regenerated with 4 % Nitric acid to return the resin to its original form, ready for another loading cycle. The regenerant product consists mostly of calcium and magnesium nitrate, with a small amount of sodium nitrate. This solution can be used as a liquid fertilizer.

## 4.4 Anion Reduction

Initially it was assumed that the cation exchange would release a large amount of carbon dioxide into the water due to the alkalinity present, which would be released to the atmosphere through a degas tower. This, however, was not the case as the test work in *Figure 4-5* shows.

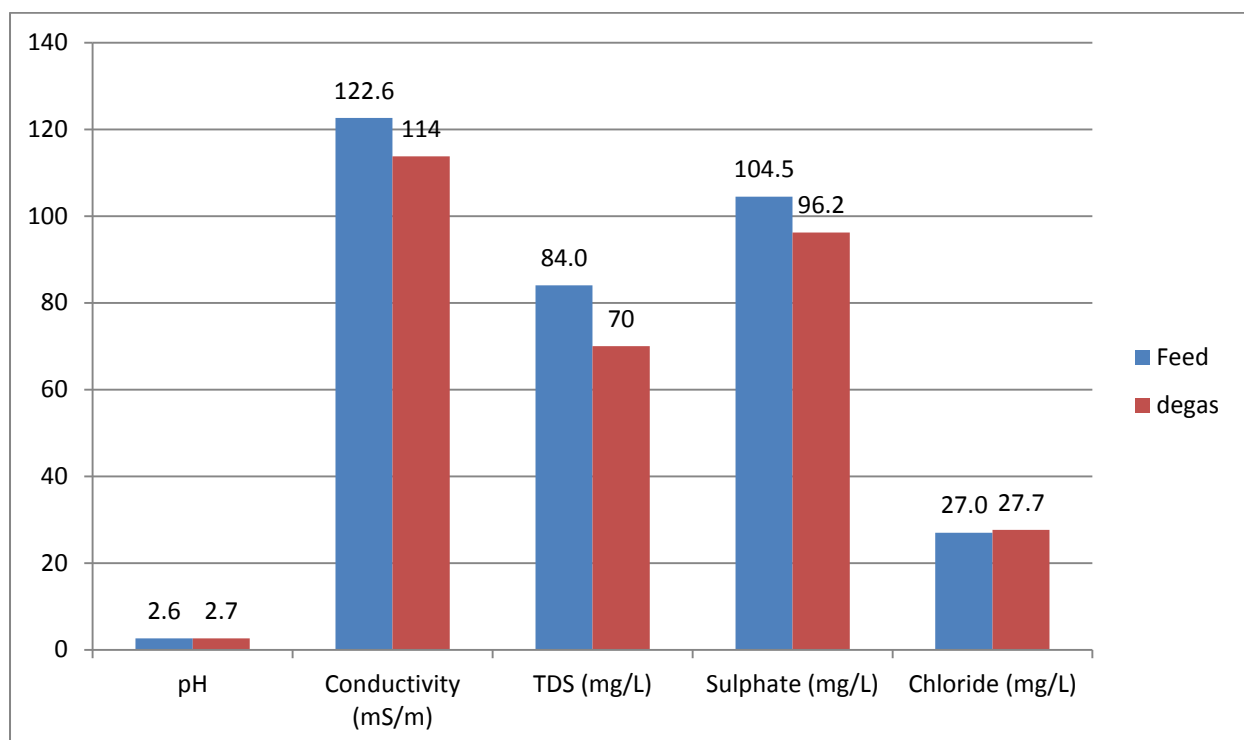
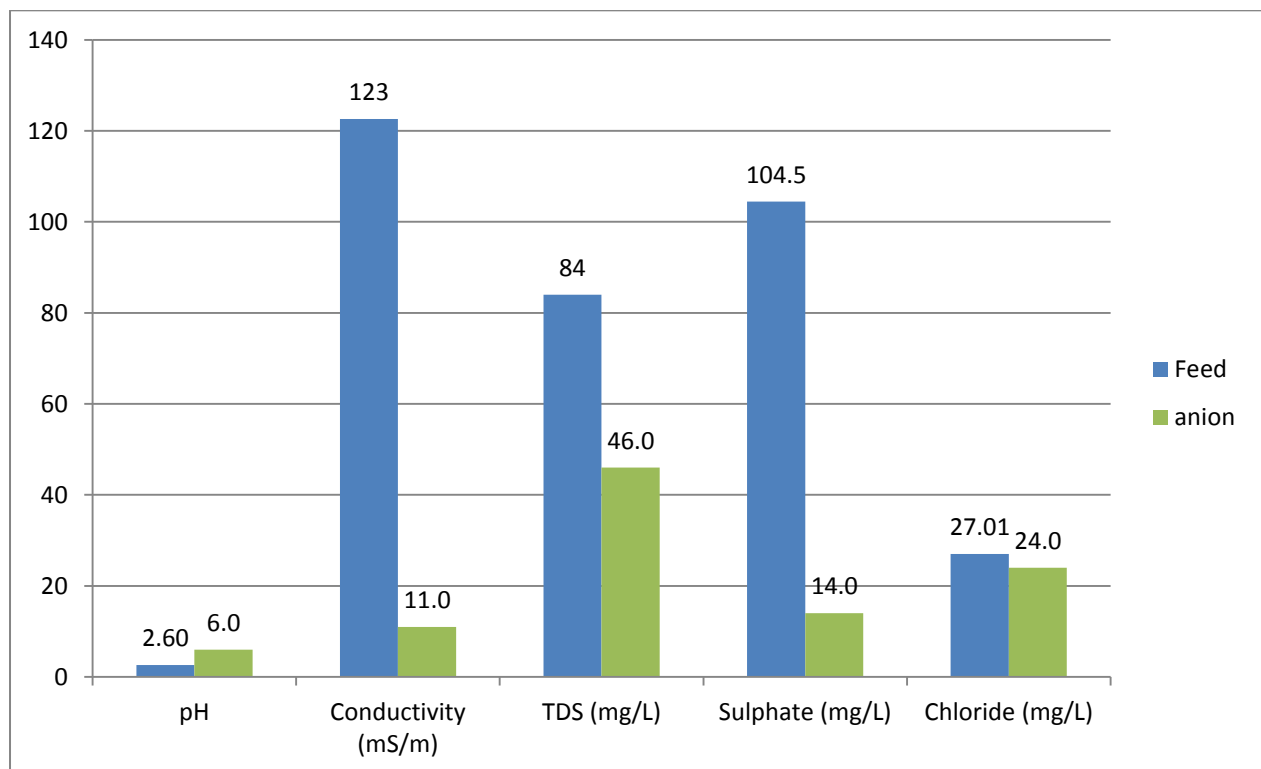

*Figure 4-5 Degas Tower performance*

From this graph it is evident that the degas tower was not able to produce the desired water quality. The tower was not able to increase the pH to 7, and only achieved a small reduction in total dissolved solids. This was due to the fact that, after the cation exchange section, very little alkalinity was present. Therefore very little carbon dioxide was present in the water.

Alternatively, anion exchange was considered as the final processing step to neutralize the low pH of the cation exchange product water and in addition reduce the sulphate and chloride concentrations. This would also reduce the TDS further and ensure compliance with the drinking water standards.

The product water from the anion exchange is shown in *Figure 4-6*. The anion exchange was able to reduce the conductivity as well as the dissolved solids significantly. Compared to the degas tower, the anion exchange achieved a better performance. The pH was increased from 2.6 to 6.



***Figure 4-6 Anion Exchange performance***

The degassing tower and anion exchange column was fed with water containing a high conductivity ( $3500\mu\text{S/m}$ ) and low pH (2.5). The aim of both these units was to increase the pH and decrease the conductivity. Therefore the biggest advantage of the anion exchange section is the significant increase in pH. The anion exchange is also able to reduce the sulphate concentrations. With the anion exchange the brine solution is a valuable liquid fertilizer, where the degas tower exhausts carbon dioxide into the atmosphere.

## 4.5 Product Water

The aim of the fissure water plant is to produce drinking water compliant with SANS 241:2011 (*Table 4-1*). Therefore the plant works towards a treatment option that will produce drinking water at the lowest cost. The feed water is mostly compliant with the standard, but does require softening through the crystalactor, magnesium reduction through cation exchange, and sulphate reduction through anion exchange which would also rectify the pH of the cation product water and bring about a final reduction of total dissolved solids.

The envisaged product blending (a mixture of crystalactor [cold lime softening] water, cation exchange product water and anion exchange product water) is shown in

. The final water is then produced through a ratio of stream A, B, C and D.

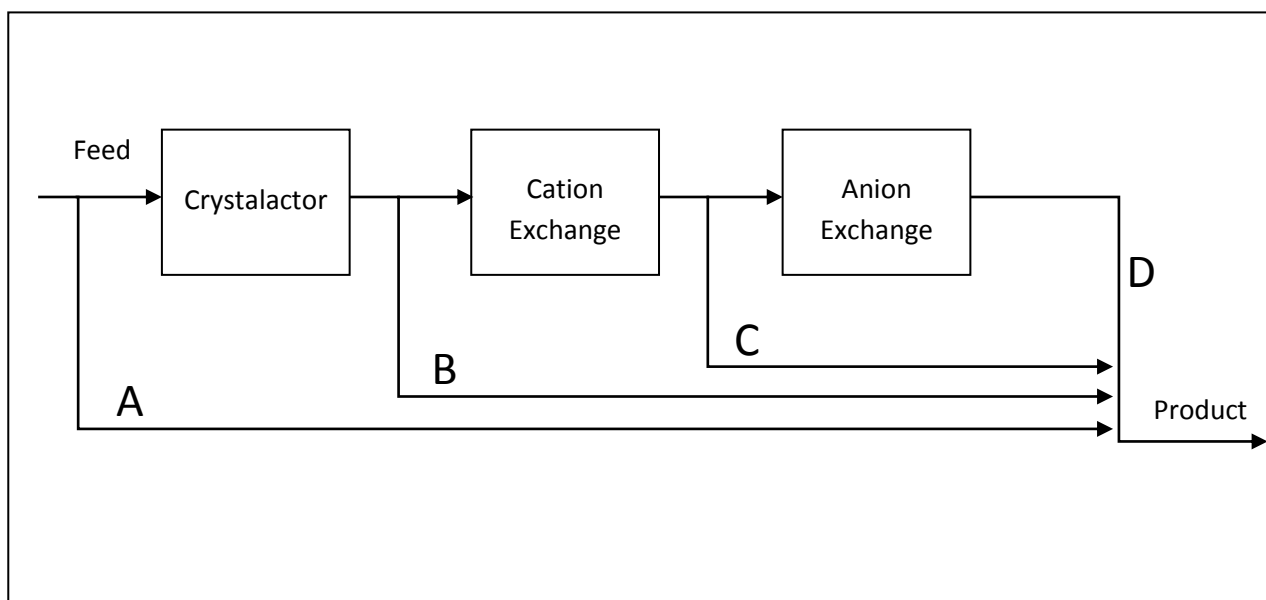

**Figure 4-7 Product-Water Blending**

As mentioned earlier, when the quality of the feed water is good, some of this water bypasses all the treatment steps and reports directly to the final water.

The mixing ratio of the first blending is shown below:

A = 0 %

B = 60 %

C = 15 %

D = 25 %

The quality of the final water compared to SANS 241:2011 is shown in *Figure 4-8*. The product water complied with the standard on all the major elements. The only concern with this ratio was that the pH was 7, which was below the lower limit of 7.6 that was set by Rand Water. The conductivity was just below the required 45 ms/m. The hardness of the final water was 157 mg CaCO<sub>3</sub> per litre – well below the specified 200 mg CaCO<sub>3</sub> per litre. A huge reduction in sulphates was seen from 200 mg/L to 72 mg/L.

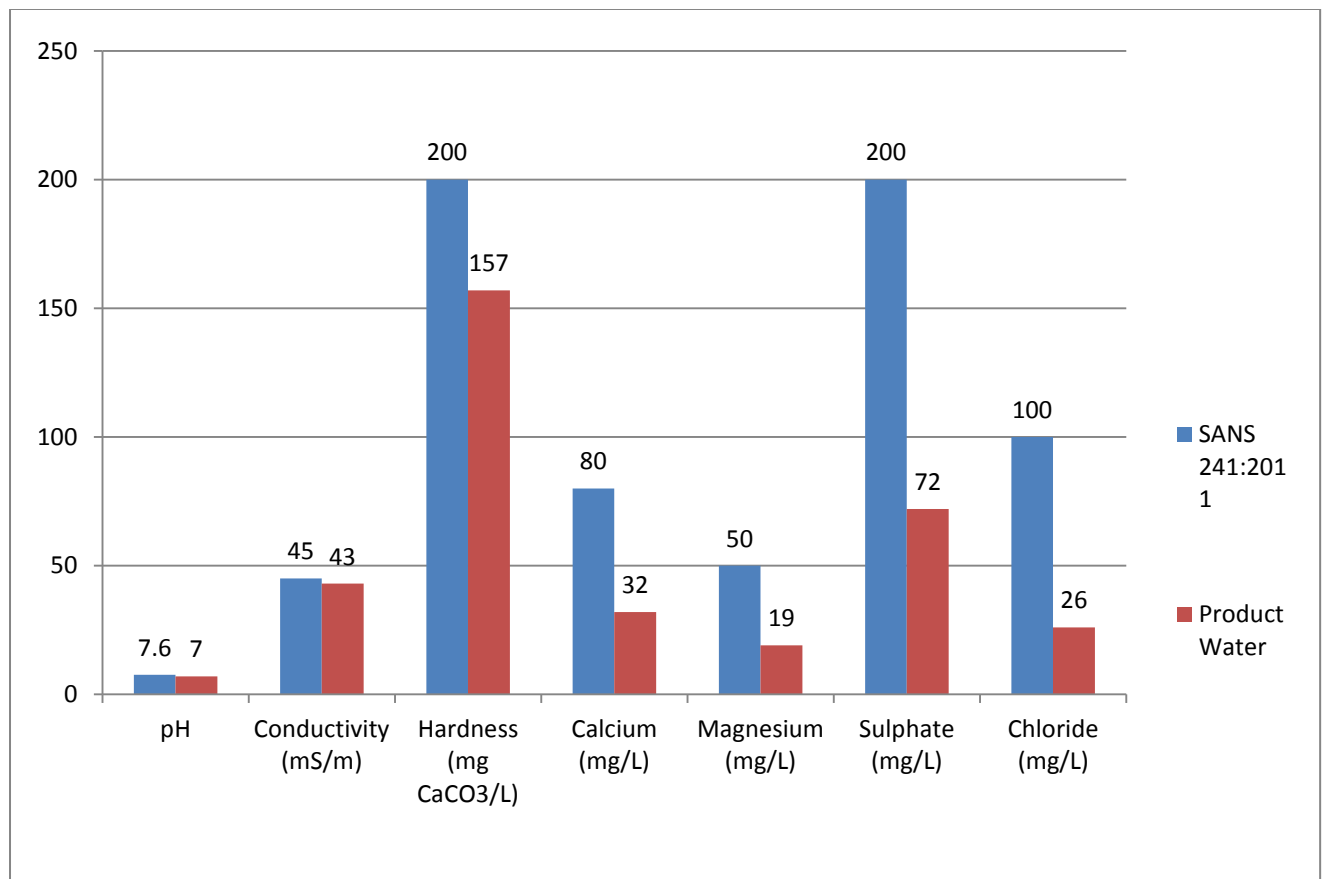

**Figure 4-8 Product Water - First Blending ratio**

The mixing ratio of the second blending is shown below:

A = 13.6 %

B = 40.9 %

C = 13.6 %

D = 31.8 %

The quality of the water from the second blending was compared to Rand Water's Standards as shown in *Figure 4-9*. The product water once again complied with the standard on all the major elements, but achieved better results than the first blend. The pH was slightly better at 7.4, but it was still below the lower limit of 7.6 set by Rand Water. The conductivity was lower (40 mg/L) than the first blending ratio. The hardness of the second ratio was also more acceptable at 148 mg CaCO<sub>3</sub> per litre.

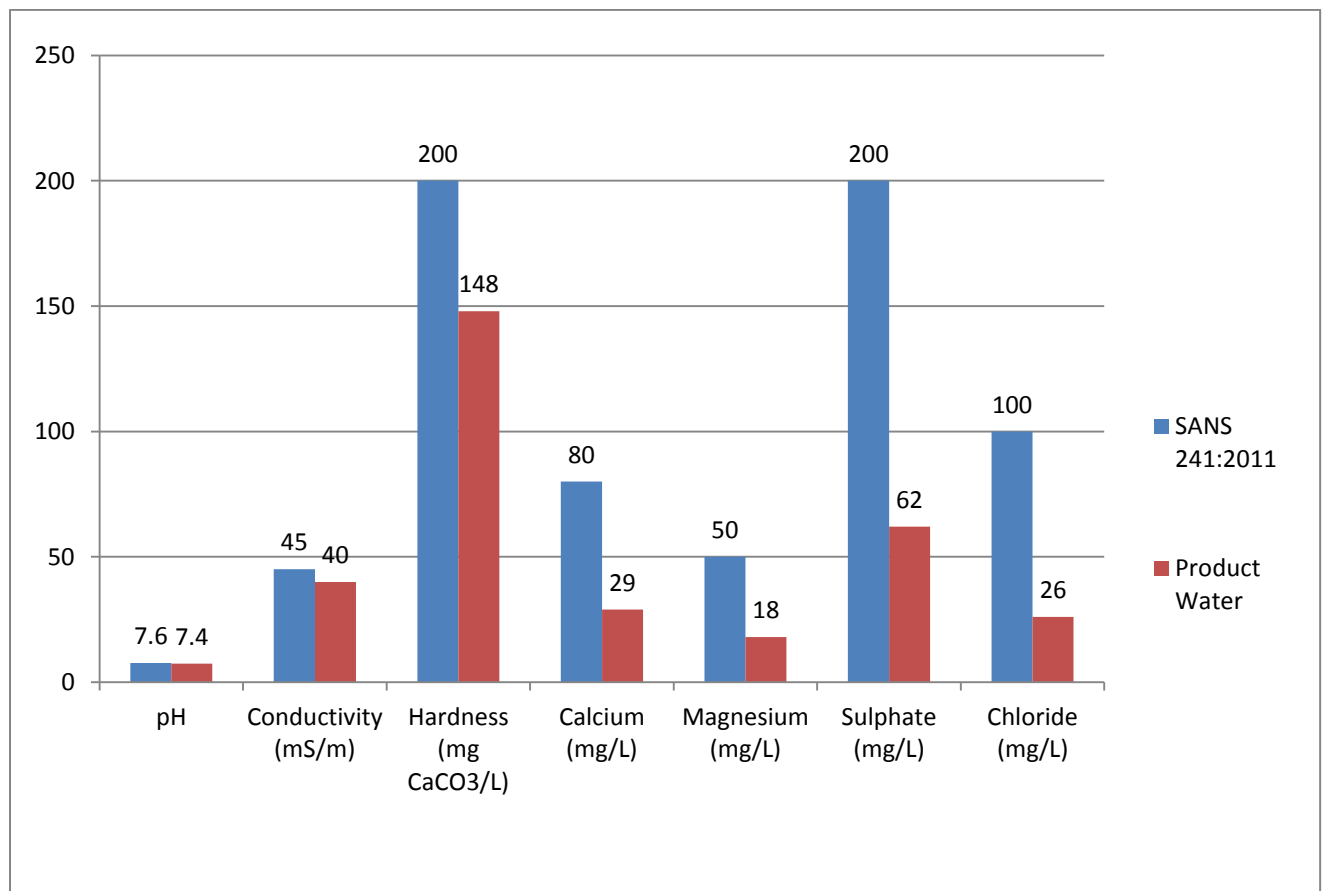

**Figure 4-9 Product Water - Second Blending ratio**

The mixing ratio of the third blending is shown below:

A = 25 %

B = 25 %

C = 25 %

D = 25 %

A comparison between the quality of the final water after the third blending and Rand Water's Standards is shown in *Figure 4-10*. The product water again complied with the standard on all the major elements, but achieved better results than the first blend. The pH was worse at 6.3, which was still below the lower limit of 7.6 as set by Rand Water. However the conductivity and hardness was much lower than those from the previous tests. The readings were 34 mS/m and 125 mg CaCO<sub>3</sub> per litre. Another observation was that the water contained no residual alkalinity after treatment. The sulphate concentration was higher than the second test (83 mg/L).

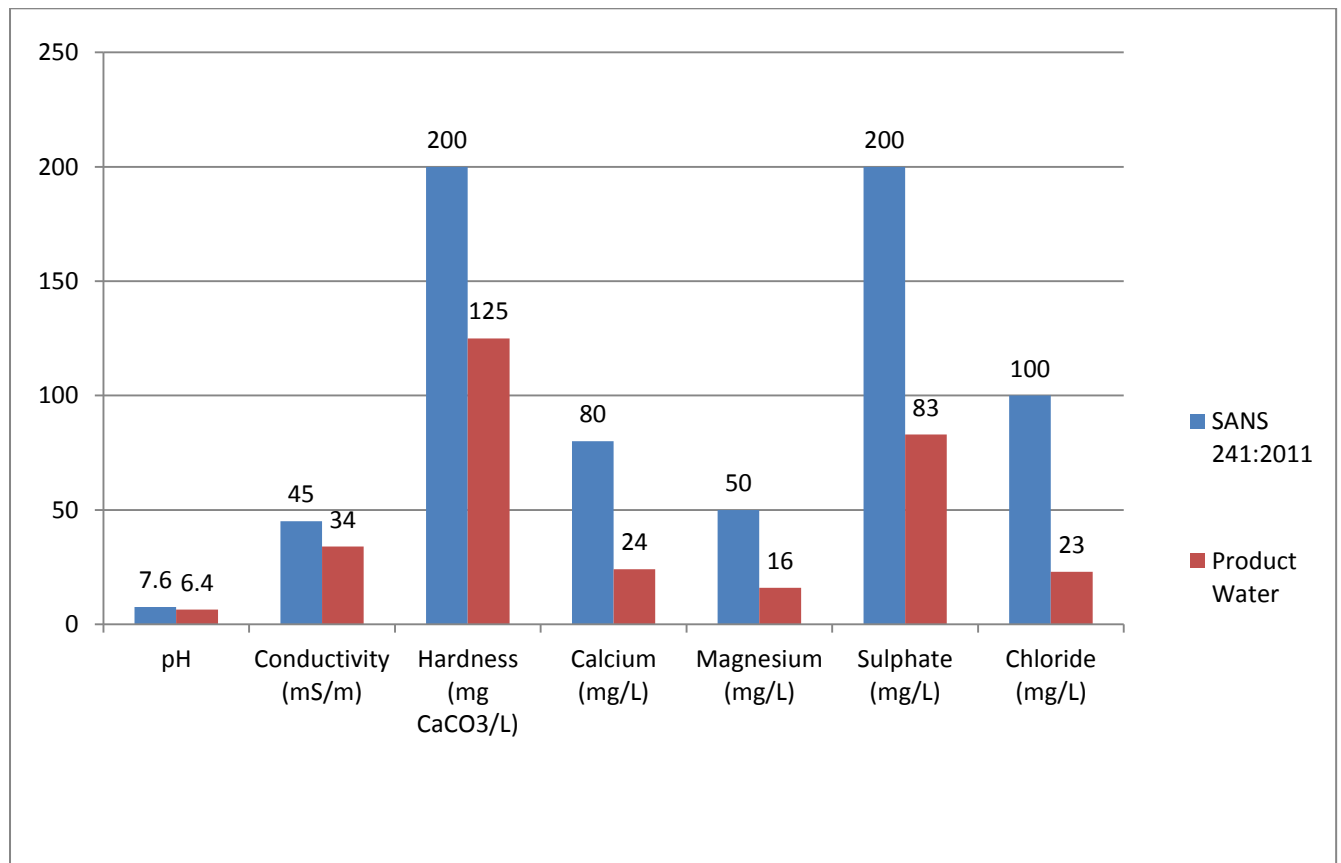

*Figure 4-10 Product Water - Third Blending Ratio*

The mixing ratio of the fourth blending is shown below:

A = 33.3 %

B = 0 %

C = 33.3 %

D = 33.3 %

The quality of the final water from the fourth blending compared to Rand Water's standards is shown in *Figure 4-11*. The product water complied again with the standard on all the major elements, but not with pH and conductivity. The pH was much lower at 3.6, which is still below the lower limit of 7.6 set by Rand Water. The conductivity of the water was 48 mS/m, slightly higher than the limit of 45 mS/m. The hardness was only 90 mg CaCO<sub>3</sub> per litre, the best result of the various blendings; however, this ratio cannot be considered due to the low pH.

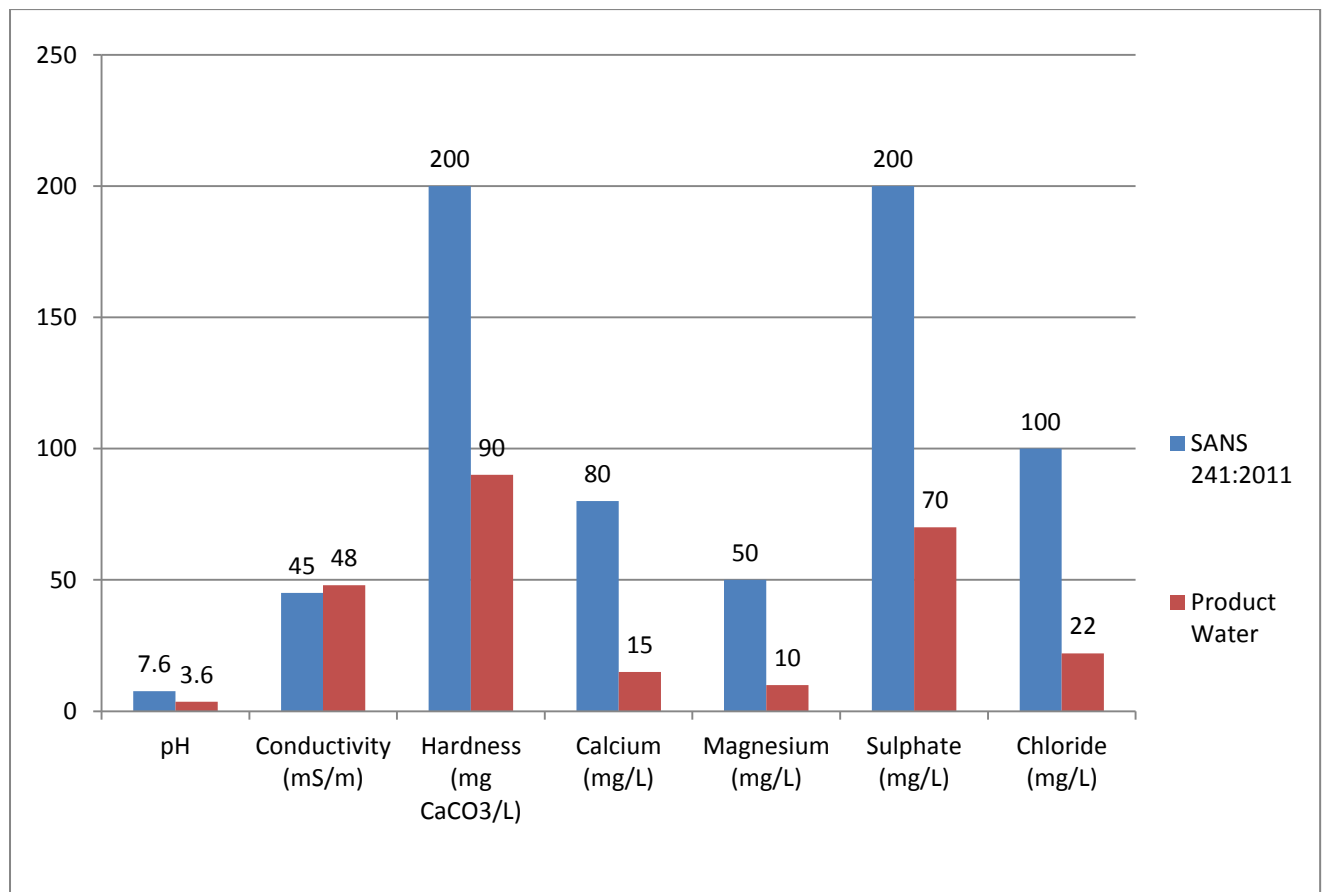

**Figure 4-11 Product Water - Fourth Blending Ratio**

The mixing ratio of the fifth blending is shown below:

A = 30 %

B = 30 %

C = 0 %

D = 40 %

The quality of the final water of the fifth blending as compared to Rand Water's standards is shown in *Figure 4-12*. The product water complied again with the standard on all the major elements, but achieved better results than other blends. The pH was 7.7, complying with the limit of 7.6 set by Rand Water. The conductivity was 37 mS/m and the hardness was 144 mg CaCO<sub>3</sub> per litre. This mixing ratio achieved the best water quality when taking all parameters into consideration.

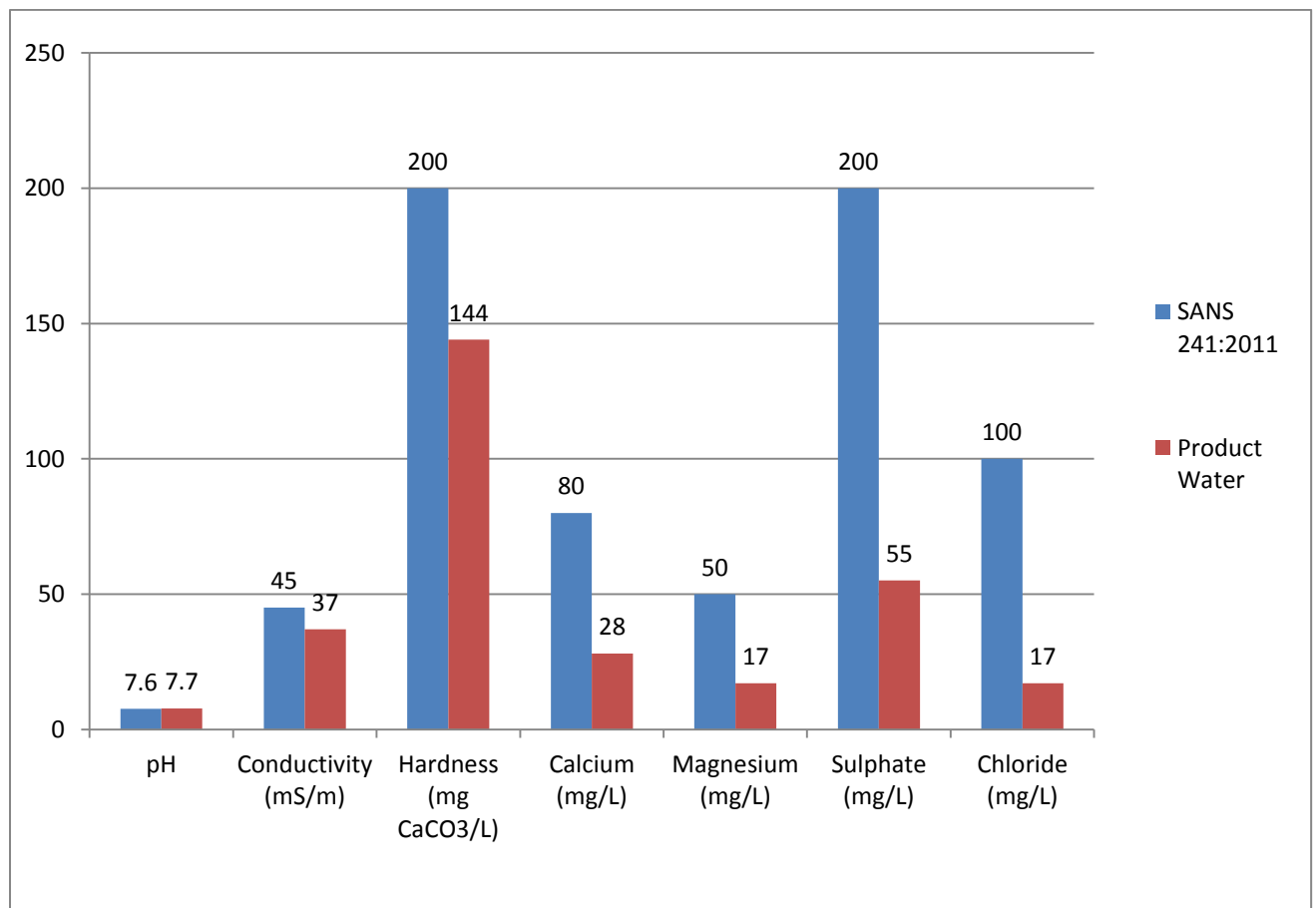

**Figure 4-12 Product Water - Fifth Blending Ratio**

A summary of the results are shown in *Table 4-6*.

**Table 4-6 Blending Summary**

<b>Blending</b>	<b>1</b>	<b>2</b>	<b>3</b>	<b>4</b>	<b>5</b>
pH	7	7.4	6.4	3.6	7.7
Conductivity (mS/m)	43	40	34	48	37
Hardness (mgCaCO <sub>3</sub> /L)	157	148	125	90	144
Calcium (mg/L)	32	29	24	15	28
Magnesium (mg/L)	19	18	16	10	17
Sulphate (mg/L)	72	62	83	70	55
Chloride (mg/L)	26	26	23	22	17

The blending summary shows that the pH of blending 3 and 4 is too low compared to the standard of 7.6. Comparing the conductivity of blending 1, 2 and 5 indicates that blending 5 is superior as the conductivity is lower than the other two. Comparing the total quality of these three blending ratios, blending 5 achieved superior quality and was therefore selected as the blending ratio to be used in a full scale application.

## 4.6 Chemical consumptions

The plant has two consumables: lime and 55% nitric acid. The lime is used in the crystalactor to precipitate calcium carbonate. Theoretically, for every one mole of lime added two moles of calcium carbonate are precipitated. In the pilot plant operation the lime consumption was 40 kg Ca(OH)<sub>2</sub> per ML treated for a 20 mg/L reduction in calcium. This means that theoretically 9.5 kg of calcium was precipitated daily. The calculated consumption of lime is 38 kg Ca(OH)<sub>2</sub> per ML treated, therefore only 5 % excess lime was used.

The consumption of nitric acid at the plant was 500 kg HNO<sub>3</sub> per ML treated. The calculated consumption was 470 kg HNO<sub>3</sub> per ML treated, therefore the excess nitric acid was 6.4 %.

## Chapter 5 Mine Water Results and Discussions

This chapter displays and discusses the results obtained in the pilot scale test work programme of the mine- water. All the studies that were conducted are shown in this section together with the discussion of all the findings that were made.

### 5.1 Chemical composition of the mine water

The chemical composition of the raw mine process-water is shown in *Table 5-1*. The main concern with mine water is the salt load especially that of calcium, sodium, nitrate and sulphate (Bester, 2009b). Another concern is the heavy metals present – in particular uranium – which is much higher than the 70 µg/L stipulated in the licence agreement.

*Table 5-1 Mine water Analysis*

Element	Concentration	Element	Concentration
Gold Au (mg/L)	0.006	Barium (Ba mg/L)	0.048
Silver Ag (mg/L)	<0.001	Cadmium (Cd mg/L)	0.010
Salinity (EC, µS/m)	2310	Cobalt (Co mg/L)	0.045
Fluoride (F mg/L)	0.446	Chromium (Cr mg/L)	0.019
Chloride (Cl mg/L)	177.134	Copper(Cu mg/L)	0.011
Nitrate (NO <sub>3</sub> mg/L)	101.902	Iron (Fe mg/L)	0.573
Phosphate (PO <sub>4</sub> mg/L)	0.300	Lead(Pb mg/L)	<0.042
Sulphate (SO <sub>4</sub> mg/L)	987.424	Manganese (Mn mg/L)	0.057
Calcium (Ca mg/L)	267.00	Nickel (Ni mg/L)	0.198
Magnesium (Mg mg/L)	49.07	Strontium (Sr mg/L)	1.288
Sodium (Na mg/L)	209.90	Uranium (U mg/L)	0.473
Potassium (K mg/L)	20.45	Zinc(Zn mg/L)	0.030
Aluminium (Al mg/L)	0.491	pH	7.71
Boron (B mg/L)	0.285	Solids in suspension (ppm)	78

## 5.2 Coagulation and Sand Filtration

The results of the sand filter are shown in *Figure 5-1*.

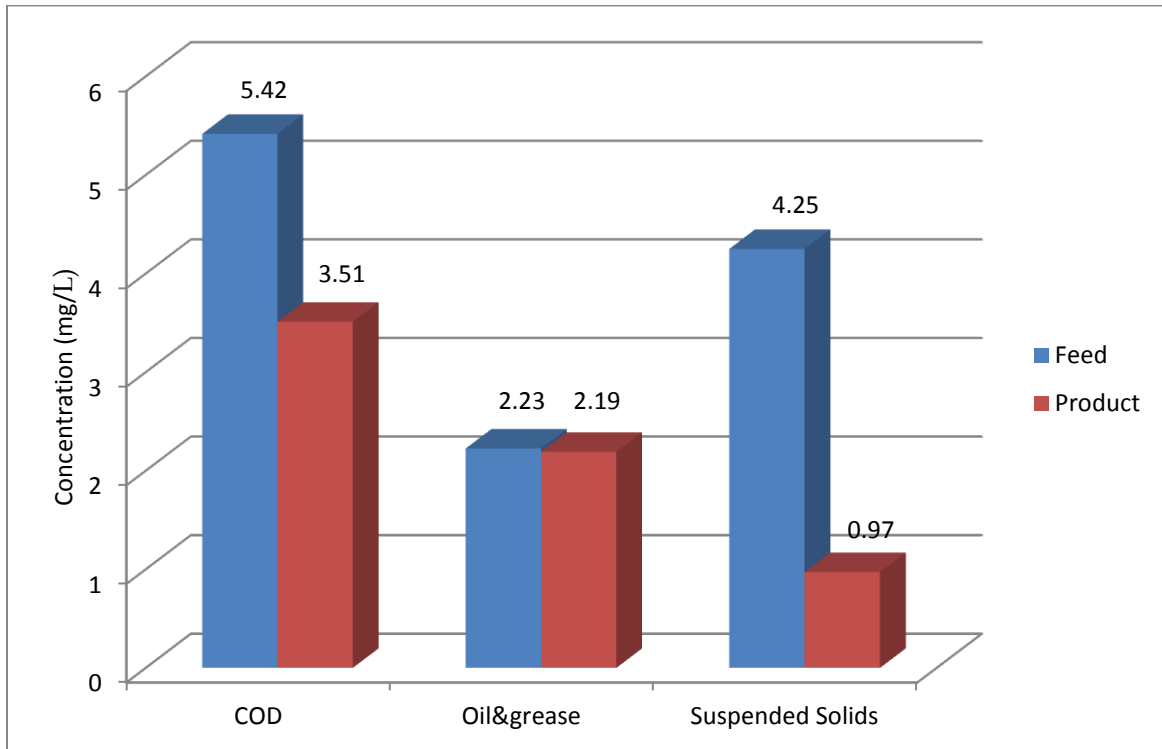

**Figure 5-1 Sand Filtration Performance**

Only a small amount (1.9 mg/L) of COD was removed in the sand filter. In a full scale water treatment facility this would be 14.3 kg per day when treating 7.5 ML per day. The reduction of oil and grease in the mine water pilot plant was 0.04 mg/L, but in the full scale plant this would mean that 0.23 kg of oil and grease would be removed per day. However, it should be noted that only a very low concentration of oil and grease is present in the mine water.

A significant reduction in suspended solids was achieved through the filter. The reduction in the pilot plant was 3.3 mg/L, resulting in a 25 kg reduction per day in the full scale plant. The concentration of suspended solids is low, due to the fact that settling is done underground as part of the shaft infrastructure.

## 5.3 Granular Activated Carbon (GAC) Filtration

The performance of the GAC is shown in *Figure 5-2*. GAC was used to remove some of the organic material in the water in order to protect the anion resin from fouling of the organic material.

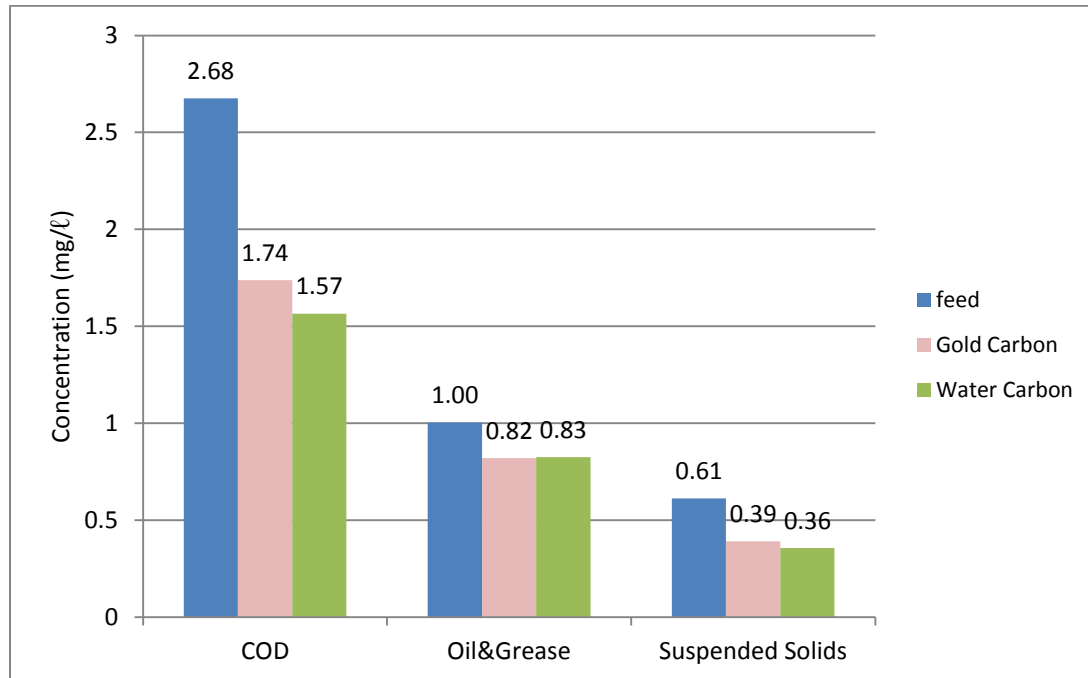

*Figure 5-2 GAC Performance*

A comparison was done in the pilot plant between carbon used in water purification and carbon used for metal recovery in metallurgical processes. The metallurgical carbon was compared to the performance of the water carbon in order to establish whether metallurgical carbon will remove organic material effectively. Using metallurgical carbon will make the full scale plant more cost effective as the carbon can be sent to the metallurgical plant for regeneration and re-use. The carbon successfully reduced the COD content in the water to below 2 mg/L. The water carbon (removing 42 %) performed slightly better than the metallurgical carbon (removing 35 %). The ion exchange section of the plant was not influenced by the remainder.

The carbon had very little impact on the oils and greases in the water, however the oil and grease content was so low that it had no effect on the downstream processes. A small amount

of suspended solids was trapped in the carbon bed resulting in a reduction of suspended solids over the carbon bed. A reduction of 0.24 mg/L (0.61 mg/L to 0.39 and 0.36 mg/L) will result in the removal of 1.8 kg of solids per day in the full-scale plant. Although it was predicted that the water carbon would be more efficient than the metallurgical carbon, the metallurgical carbon should still be considered for design purposes as other advantages such as ease of disposal outweighs the slightly reduced efficiency. Breakthrough of the carbon column was achieved after operating the plant for approximately six months: 6 ML was treated in total and 6.1 kg was removed.

## 5.4 Uranium removal

The charge of the uranium in the water will determine which type of resin to use. High levels of  $\text{UO}_2(\text{CO}_3)_3^{4-}$  were detected in the mine process water (pH=8) as shown in *Figure 5-3* and therefore required an anionic resin for treatment. The anionic resin chosen for this application was Lewatit S6368. It contained a sulphate ion on the active sites, due to the high selectivity of resin for  $\text{UO}_2(\text{CO}_3)_3^{4-}$ , the uranium compound displaces the sulphate on the resin.

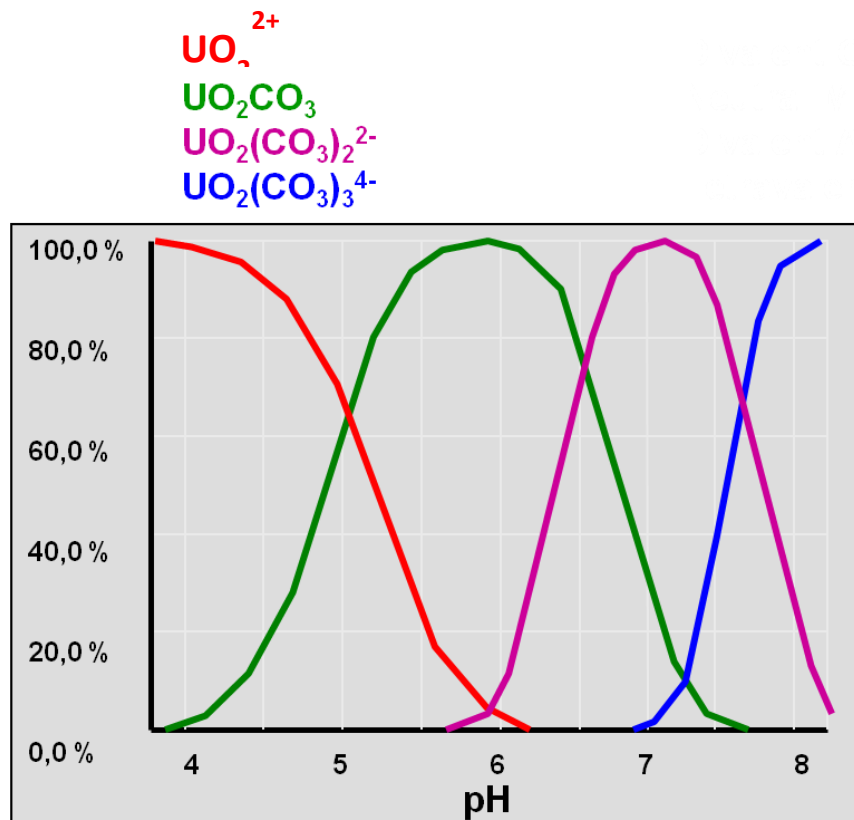

*Figure 5-3 Uranium complexes at different pH's*

### 5.4.1 Performance of anionic and cationic resins for uranium removal

Initial tests were also conducted with anionic as well as cationic resin just to confirm the ionic state of the uranium. These results are shown in *Figure 5-4*.

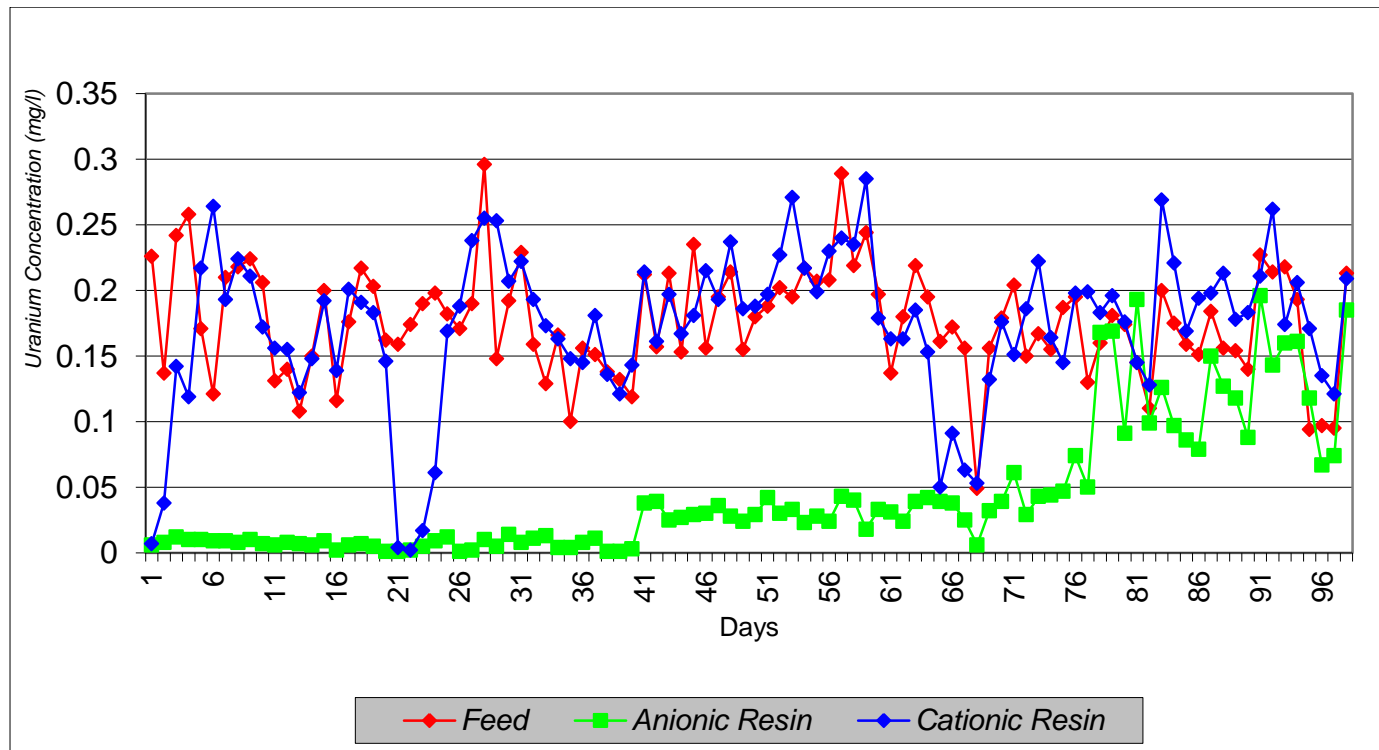
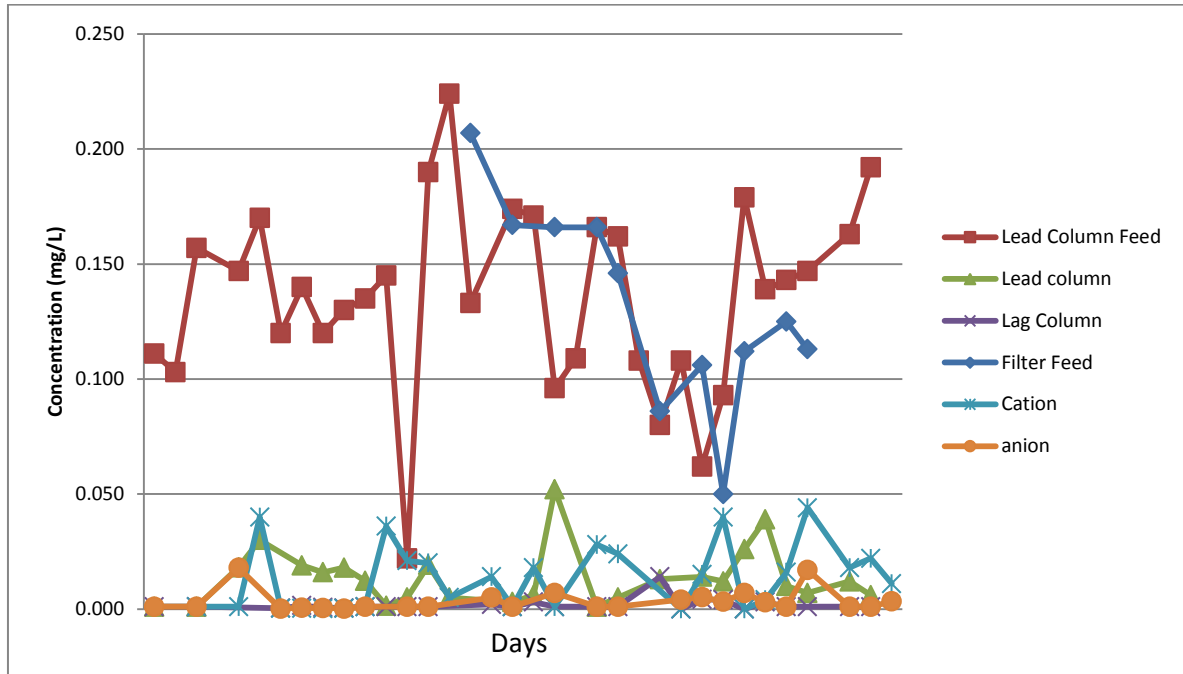

**Figure 5-4 Anionic vs. Cation Performance**

This figure shows that the anionic resin was successful in the removal of uranium, but that the cationic resin had very little effect on the concentration of uranium. It was observed, however, that the cationic resin was effectively able to reduce the nickel concentration in the water. The uranium loading was calculated during the initial test work as 4 g uranium per litre resin (Botha *et al.*, 2009).

## 5.4.2 Uranium removal at different feed concentrations

Two tests were conducted: the first being at a low uranium concentration of 0.13 mg/L in the feed water and the second at 0.55 mg/L. The uranium removal over the total plant for low feed concentrations is shown in *Figure 5-5*.



*Figure 5-5 Uranium Removal*

Colloidal uranium was removed from the water with the coagulating filter. However, when considering the data shown in *Figure 5-5* the results are either inconclusive or very little uranium was removed through the filter. The bulk of the uranium was removed through the lead uranium resin column (88 %). The uranium was reduced from 0.150 mg/L to about 0.020 mg/L by the lead column. The lag or polishing column reduced the residual uranium in the water to 0.010 mg/L. The water now complies with 2008 World Health Organisation standards at <0.03mg/L. This leaves very little uranium still present in the water to be absorbed by downstream processes. The cation resin did not absorb any uranium as the uranium present was in the anionic form. The anion resin was able to absorb any uranium present in the water.

### 5.4.3 Nickel, cobalt and iron removal

The copper concentration in the mine water during the duration of this pilot plant campaign was very low (<0.001 mg/L). At these levels copper does not pose a concern – any sudden increases would load onto the cationic resin.

The nickel concentration in the mine water varied between 0.030 mg/L and 0.040 mg/L. The nickel in the water was adsorbed onto the cation resin, as can be seen from *Figure 5-6* (as was also discovered in the initial test work). The final concentration of the nickel was below 0.005 mg/L. The nickel can be removed with a cationic resin and will not have an impact on the quality of the products being sold as fertilizer, as further treatment of the fertilizer is possible.

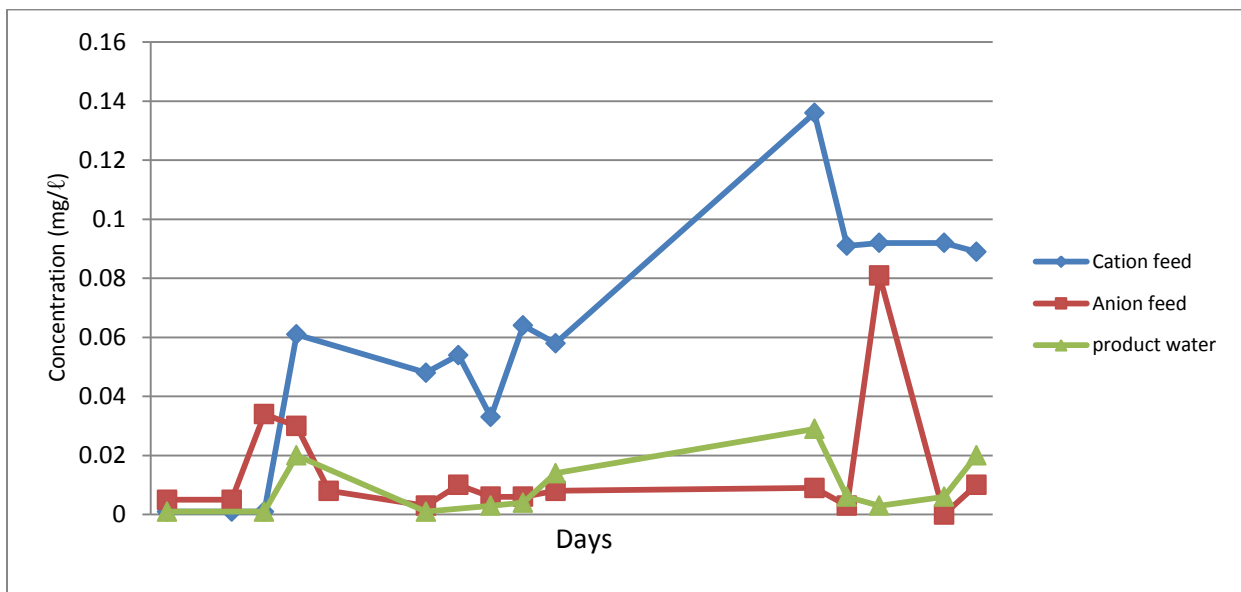

*Figure 5-6 Nickel Removal*

The cobalt concentration in the mine water during the duration of this pilot plant campaign averaged at 0.040 mg/L. The concentration in the pilot plant was 0.010 mg/L. The concentration was too low to see any removal that might have taken place.

The iron concentration in the mine water averages at 0.030 mg/L. The iron concentration in the feed to the mine water pilot plant was below 0.010 mg/L; therefore the removal of iron could not be seen in the plant.

#### 5.4.4 Plant capacity

The volume of water treated in the uranium removal section per week was calculated below. Breakthrough occurred after 106 hours. The feed was constant at 2 m<sup>3</sup>/h.

$$V = Q \times t$$

$$V = 2 \text{ m}^3/\text{h} \times 106 \text{ h}$$

$$V = 212 \text{ m}^3$$

The average uranium concentration was estimated at 0.17 g/m<sup>3</sup> and could be used to calculate the total mass of uranium removed in the plant:

$$m = \text{Volume} \times \text{Concentration}$$

$$m = 212 \text{ m}^3 \times 0.17 \text{ g/m}^3$$

$$m = 36 \text{ g}$$

The capacity of the uranium resin was 4 g/L (proved in the test work) therefore the total capacity of the column containing 100 L was calculated below.

$$m_{\text{load}} = V_{\text{resin}} \times \text{Capacity}$$

$$m_{\text{load}} = 100 \text{ L} \times 4.5 \text{ g/L}$$

$$m_{\text{load}} = 450 \text{ g}$$

Weeks until breakthrough = 12.5.

The uranium concentration in the mine water was quite high and fluctuated a lot (as seen in *Figure 5-7*). The average concentration of the mine water was 0.546 mg/L – much higher than the South African standard of 0.070 mg/L.

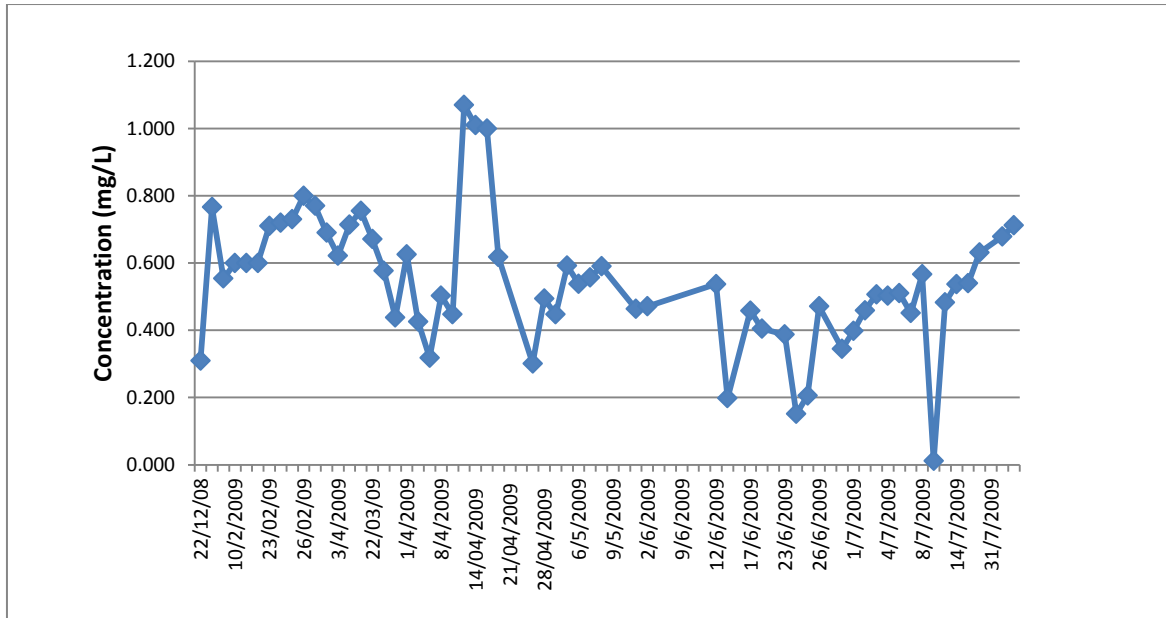

**Figure 5-7 Uranium concentration in feed water**

The test work was repeated by treating water with these high uranium concentrations. The performance of the plant is shown in *Figure 5-8*. This proves that the uranium can be reduced to below 0.010 mg/L even when the feed concentrations are high.

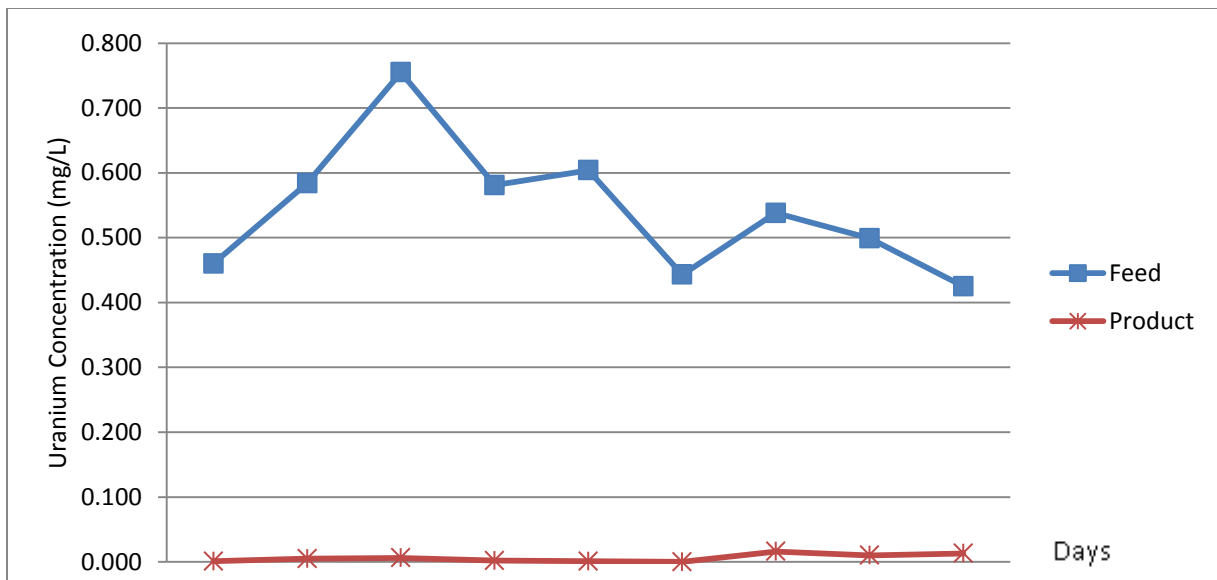

**Figure 5-8 Plant performance at start-up conditions**

## 5.4.5 Regeneration of resin

The regeneration curve of the resin is shown in *Figure 5-9*.

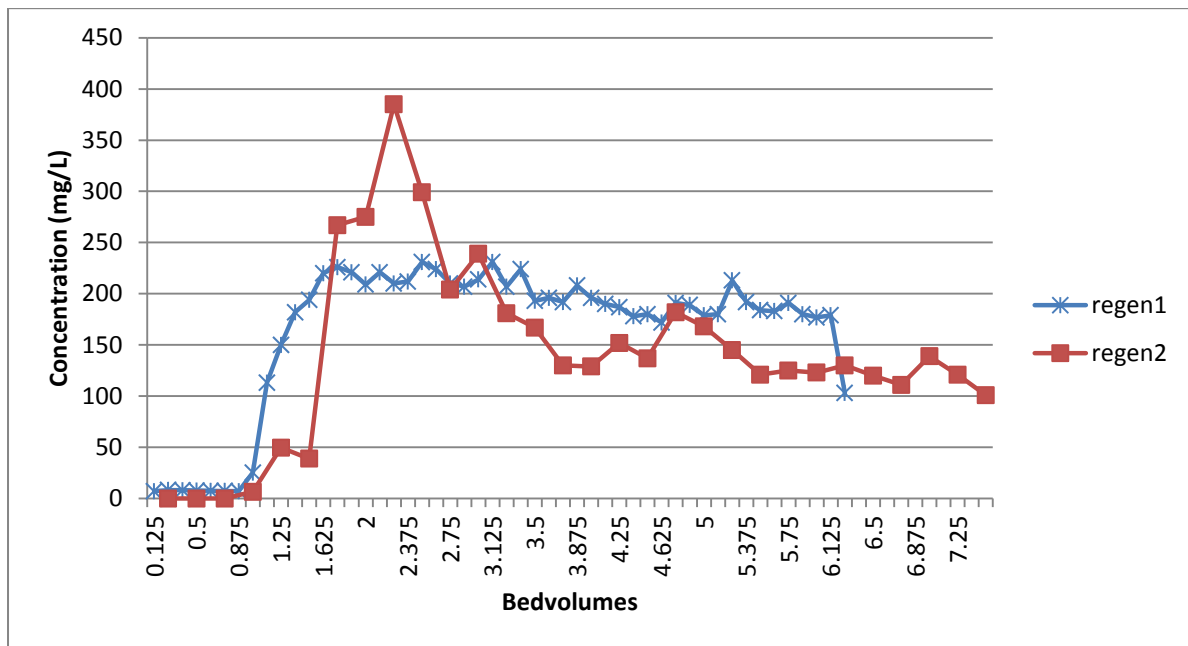

*Figure 5-9 Uranium Regeneration*

The regeneration of the uranium resin proved to be successful. (1 Bedvolume = 300L) The outlet of the column was sampled at regular intervals and analysed for uranium. Initially, in both of the regeneration cycles, the uranium concentration was very low. The regeneration took place in a down-flow configuration. The uranium concentration decreased very slowly during rinsing due to the slow rinsing flow rate. This process could be optimized with a different rinsing procedure and the testing of alternative acids for regeneration.

The average uranium concentration in the regenerant solution was 170 mg/L. The solution had a very low pH (<1) with approximately 7.5 % sulphuric acid.

The resin column was used for four weeks before the column was regenerated. The total amount of uranium loaded onto the resin was therefore:

$$m_{\text{load}} = 36 \times 4$$

$$m_{\text{load}} = 144 \text{ g}$$

The amount of uranium stripped from the resin was calculated:

$$m_{\text{stripped}} = C_{\text{uranium}} \times V_{\text{regen}}$$

$$m_{\text{stripped}} = 0.17 \text{ mg/L} \times 800 \text{ L}$$

$$m_{\text{stripped}} = 136 \text{ g}$$

The uranium recovery was 94 %.

The difference between the stripped and loaded amount was very small, meaning that almost all of the uranium was removed from the resin.

The water recovery of the uranium process was determined as indicated below.

$$\text{Recovery} = (1 - V_{\text{regen}} / V_{\text{treated}}) \times 100$$

$$\text{Recovery} = (1 - 800 \text{ L} / 80\,000 \text{ L}) \times 100$$

$$\text{Recovery} = 99 \%$$

The radioactivity was monitored during the entire operation of the pilot plant and no build-up of radioactivity was observed.

## 5.5 Strong Acid Cationic Ion Exchange

The mine water pilot plant uses strong acid cationic (SAC) resin. SAC resins convert neutral salts into their corresponding acids, removing nearly all the raw water cations and replacing them with hydrogen ions (5.1). This reaction is reversible.

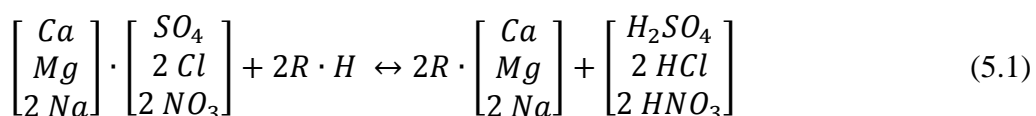

The loading cycle of the cation resin depends on the amount of resin, the feed water quality and the flow rate. The conductivity increases as the resin starts to load. When the resin is fully loaded the conductivity decreases to that of feed water quality. The pH decreases at the

beginning of the loading cycle, where it remains stable until the end of the cycle. The pH increases significantly if the resin is exhausted, therefore pH was a good control parameter for the full-scale plant.

Two scenarios were tested: the first was steady-state, where a shift in the equilibrium had already been achieved, and the second was start-up conditions. The steady-state scenario was estimated for feed water with an average conductivity of 600  $\mu\text{S}/\text{m}$ , which is the limit according to the Water Use Licence. The average loading curve of the cationic resin is shown *Figure 5-10*. The water exiting the cationic exchange contained very little calcium and magnesium. This shows that the conductivity had increased to 1200  $\mu\text{S}/\text{m}$ , and the pH had decreased to 2.8. As soon as breakthrough was reached, the conductivity and pH returned to feed-water quality.

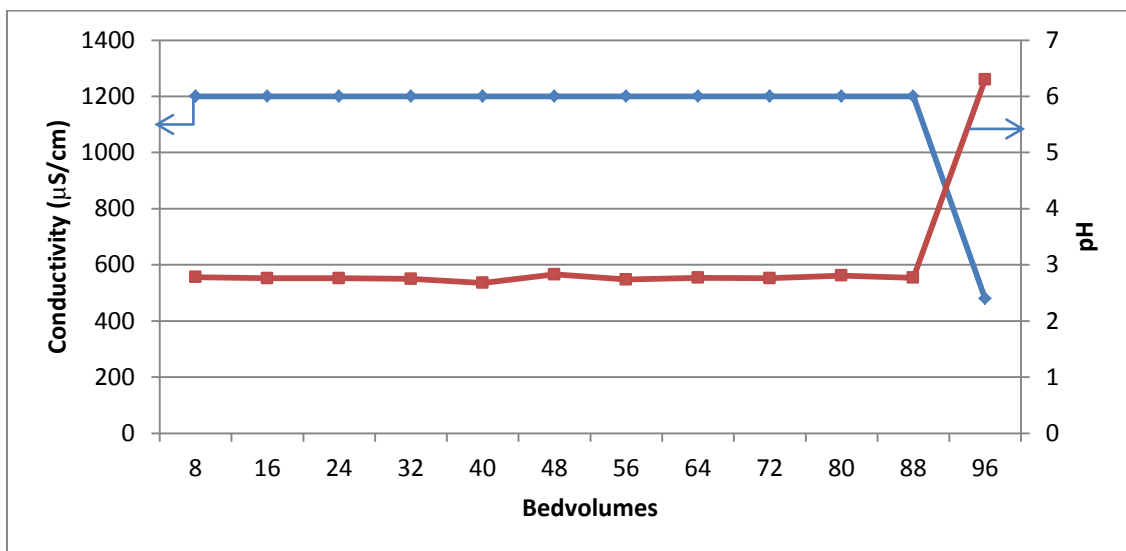

*Figure 5-10 Steady state cationic loading curve*

The resin capacity can be calculated by using the average loading cycle data. On average when the feed TDS was 450 mg/L, the resin column was able to treat 160 bed volumes at a flow rate of 2 000 L/h before breakthrough. The resin volume in the column was 250 L. The total volume of water treated before breakthrough was:

$$V = N_{\text{bedvolumes}} \times V_{\text{bedvolumes}}$$

$$V = 160 \times 250 \text{ L}$$

$$V = 40\,000 \text{ L}$$

The total amount of cations in terms of equivalence was calculated using the feed concentrations of calcium, magnesium and sodium (*Table 5-2 Table 5-2 Cation Equivalence*).

**Table 5-2 Cation Equivalence**

<b>Feed</b>	<b>mg/L</b>	<b>valence</b>	<b>MM</b>	<b>g/ew</b>	<b>geq/L</b>
Calcium	60	2	40	20	0.0030
Magnesium	40	2	24	12	0.0033
Sodium	25	1	23	23	0.0011
Sum					0.0074

Therefore the total amount of equivalence loaded onto the resin was:

$$40\,000\text{ L} \times 0.0074 = 296\text{ geq}$$

Thus the capacity of the resin was:

$$\text{Capacity} = \text{EQ}/V_{\text{resin}}$$

$$\text{Capacity} = 296/250$$

$$\text{Capacity} = 1.2\text{ geq/L}$$

The theoretical capacity of 1.6 eq/L compared well to the observed capacity. The theoretical capacity was higher, as the plant was stopped at the beginning of breakthrough.

The performance of the SAC resin at higher concentrations is shown in *Figure 5-11*. The cationic resin was able to reduce the concentrations of calcium, magnesium and sodium dramatically. The hardness of the water was reduced by 650 mg CaCO<sub>3</sub>/L. As before, the pH decreased while the conductivity increased. An observation was made during the test work that, as breakthrough approached, sodium, calcium and magnesium would be displaced on the resin.

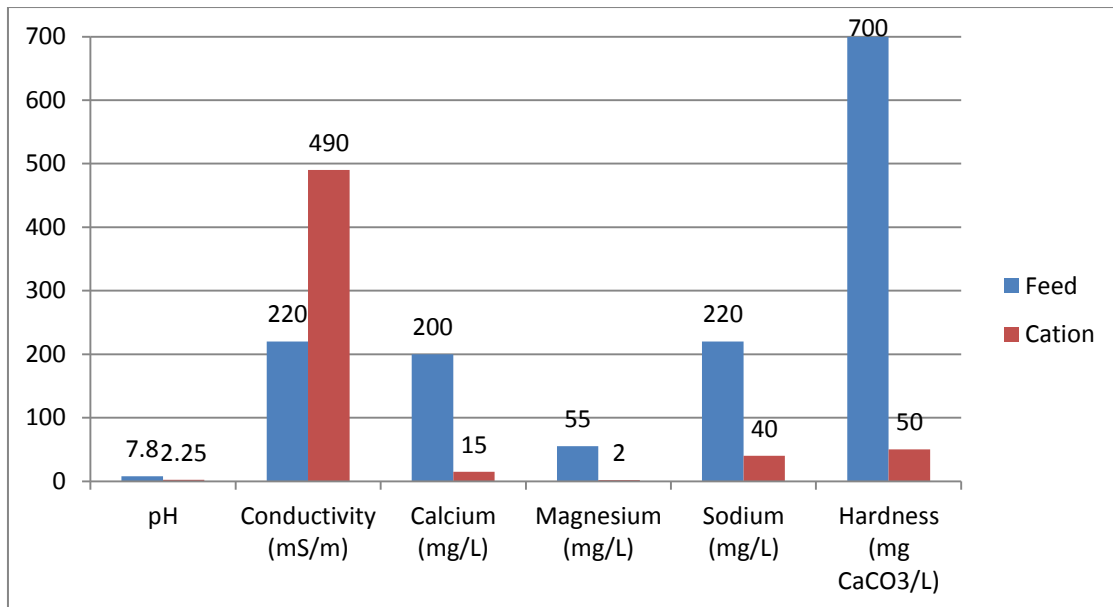

**Figure 5-11 Start-up loading performance**

The resin capacity can be calculated by using the average loading cycle data. On average, when the feed TDS was 1800 mg/L, the resin column was able to treat 22 bed volumes at a flow rate of 2 000 L/h before breakthrough. The resin volume in the column was 350 L. The total volume of water treated before breakthrough was:

$$V = N_{\text{bedvolumes}} \times V_{\text{bedvolumes}}$$

$$V = 22 \times 350 \text{ L}$$

$$V = 7700 \text{ L}$$

The total amount of cations in terms of equivalence was calculated using the feed concentrations of calcium, magnesium and sodium (*Table 5-3*).

**Table 5-3 Cation Valence for Start-up conditions**

Feed	mg/L	valence	MM	g/ew	geq/L
Calcium	240	2	40	20	0.0120
Magnesium	60	2	24	12	0.0050
Sodium	220	1	23	23	0.0096
Sum					0.0266

Therefore the total amount of equivalence loaded onto the resin was:

$$12\,000\text{ L} \times 0.0266 = 320\text{ geq}$$

Thus the capacity of the resin was:

$$\text{Capacity} = \text{EQ}/V_{\text{resin}}$$

$$\text{Capacity} = 320/350$$

$$\text{Capacity} = 0.91\text{ geq/L}$$

The theoretical capacity is 1.6 geq/L. The calculated capacity is much lower than the theoretical value, due to the fact that at high feed concentrations, the efficiency of the resin is much lower. This compares well with the capacity at steady-state conditions.

## 5.6 Weak Base Anionic Ion Exchange

Anionic resins are used to remove all the anions associated with the cations removed with the cationic resin. Weak Base Anion (WBA) resins readily remove sulphuric, nitric and hydrochloric acids as represented in equation 5.2. The anionic resin will neutralize the acids by replacing the anions present in the water with hydroxide. The hydroxide from the resin will react with the hydrogen ion from the acid to form water and thereby neutralize the reaction.

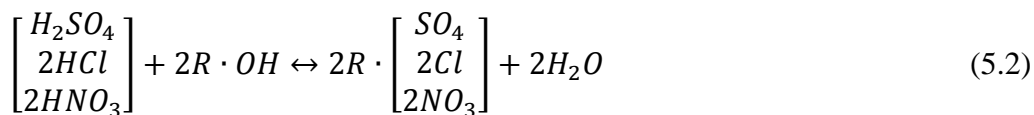

The loading cycle of the anion resin will depend on the amount of resin, the feed water quality and the flow rate. The feed quality entering the anion exchange section was 1 200  $\mu\text{S/m}$  (TDS  $\approx$  450 mg/L) to simulate steady-state conditions. The average loading curve for the anion resin is shown in *Figure 5-12*. The anion resin will absorb all the acids as produced by the cation resin. If the cation column has reached its breakthrough, it will not produce acids for the anion column to absorb and the anion resin will not be able to produce demineralised water. The conductivity decreases as the resin starts to load. When the resin is fully loaded the conductivity will increase to feed-water conductivity. The pH will be slightly

below neutral as the resin will neutralise most of the acids from the cation resin but not all as the SAC resin was paired with WBA resin. If the anion column reaches breakthrough before the cation resin, the conductivity will increase and the pH will decrease. If the cation resin reaches breakthrough before the anion resin the pH and conductivity will increase. The conductivity will always increase significantly if the resin is exhausted, therefore conductivity was a good control parameter for the anion section in the full-scale plant.

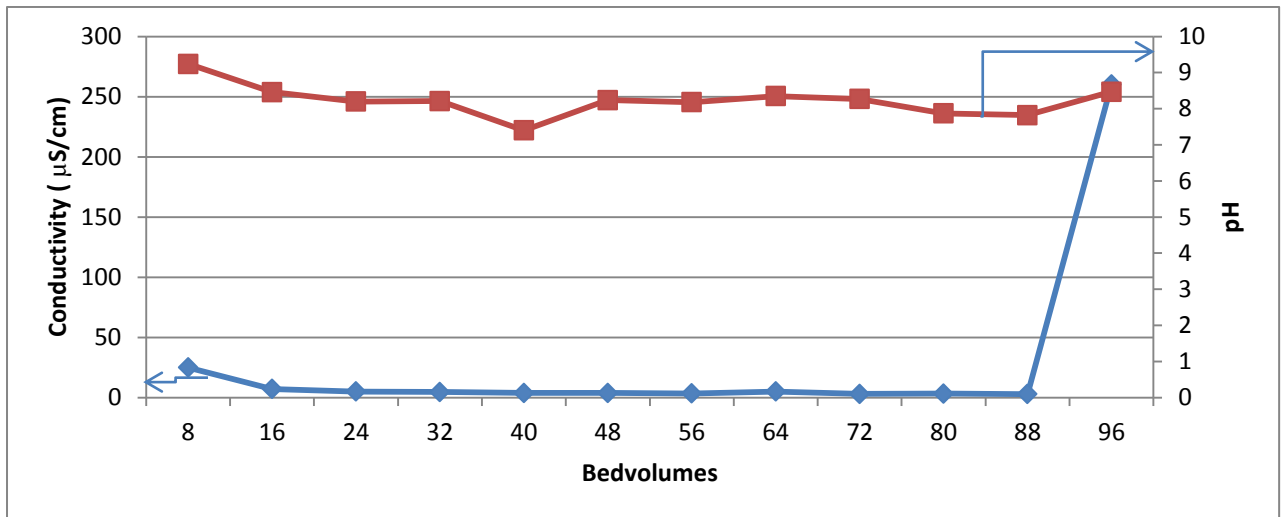

**Figure 5-12 Steady State anionic loading curve**

The resin capacity of the anionic resin for start-up conditions can be calculated by using the average loading cycle data. On average, when the feed TDS was 450 mg/L, the resin column was able to treat 160 bed volumes at a flow rate of 2 000 L/h before breakthrough. The resin volume in the column was 250 L. The total volume of water treated was:

$$V = N_{\text{bedvolumes}} \times V_{\text{bedvolumes}}$$

$$V = 160 \times 250 \text{ L}$$

$$V = 40\,000 \text{ L}$$

The total amount of anions in terms of equivalence was calculated using the feed concentrations of sulphate and chloride (Table 5-4).

**Table 5-4 Equivalence calculations for steady-state conditions**

Feed	mg/L	valence	MM	g/ew	geq/L
Sulphate	240	2	96	48	0.0050
Chloride	50	1	35	35	0.0014
Sum					0.0064

Therefore the total equivalence loaded onto the resin is:

$$40\,000\text{ L} \times 0.0064 = 257\text{ geq}$$

The capacity of the resin was therefore:

$$\text{Capacity} = \text{EQ}/V_{\text{resin}}$$

$$\text{Capacity} = 257/250$$

$$\text{Capacity} = 1.03\text{ geq/L}$$

The theoretical capacity was 1.3 geq/L. The calculated capacity was slightly lower than the theoretical value.

At higher concentrations the anionic resin was still successful in the removal of anions from the water (*Figure 5-13*). The resin was able to reduce the conductivity, but not to the level of the steady-state tests. The performance of the resin will improve as the concentration of the mine water decreases.

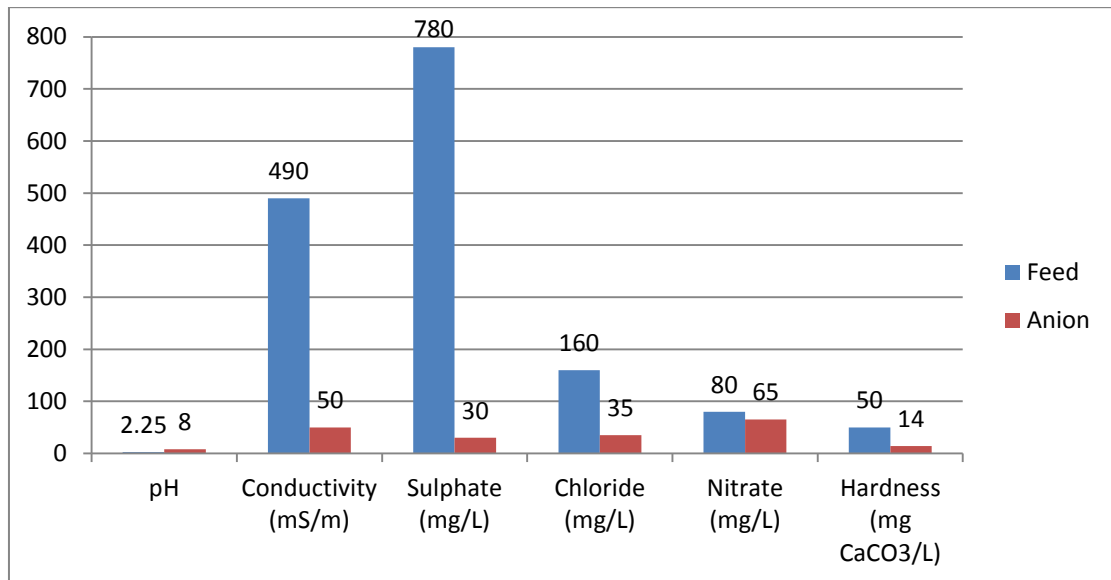

**Figure 5-13 Start-up anionic loading performance**

The resin capacity could be calculated by using the average loading cycle data. On average, with a feed TDS of 1 800 mg/L, the resin column was able to treat 30 bed volumes at a flow

rate of 2 000 L/h before breakthrough. The resin volume in the column was 250 L. The total volume of water treated was:

$$V = N_{\text{bedvolumes}} \times V_{\text{bedvolumes}}$$

$$V = 30 \times 250 \text{ L}$$

$$V = 7\,500 \text{ L}$$

The total amount of anions in terms of equivalence was calculated using the feed concentrations of sulphate and chloride (*Table 5-5*).

*Table 5-5 Equivalence calculations for start-up conditions*

<b>Feed</b>	<b>mg/L</b>	<b>valence</b>	<b>MM</b>	<b>g/ew</b>	<b>geq/L</b>
Sulphate	950	2	96	48	0.0198
Chloride	150	1	35	35	0.0043
Sum					0.0241

Therefore the total amount of equivalence loaded onto the resin was:

$$7\,500 \text{ L} \times 0.0241 = 180 \text{ geq}$$

The capacity of the resin was therefore:

$$\text{Capacity} = EQ/V_{\text{resin}}$$

$$\text{Capacity} = 180/250$$

$$\text{Capacity} = 0.72 \text{ geq/L}$$

The theoretical capacity was 1.3 geq/L. The calculated capacity was lower than the theoretical value, which is to be expected when treating such high feed concentrations. But the capacity was equal to the capacity at steady-state conditions.

## 5.7 Regenerant Product Concentration

### 5.7.1 Strong acid cationic resin

The SAC resin was regenerated with a 3 % nitric acid solution. Three bed volumes of the acid solution were pumped through the cation column at a speed of 600 ℓ/h. The second step was to wash the regenerant out of the column before the loading cycle started again, with 4.5 bed volumes of rinse water. A typical regeneration curve is shown in *Figure 5-14*. The regenerant solution was collected and re-used in the next regeneration after the acid concentration was increased back to 3 %. The concentration of the regenerant was increased up to a maximum of 22 %.

The regeneration efficiency can be calculated by determining the amount of acid used. One drum of 55 % nitric acid was used per regeneration.

$$m_{\text{acid}} = C_{\text{acid}} \times M_{\text{acid}}$$

$$m_{\text{acid}} = 0.55 \% \times 33 \text{ kg}$$

$$m_{\text{acid}} = 18.15 \text{ kg}$$

This amounts to 288 eq, which compared well to the 296 eq that loaded onto the resin. Therefore regeneration was very efficient.

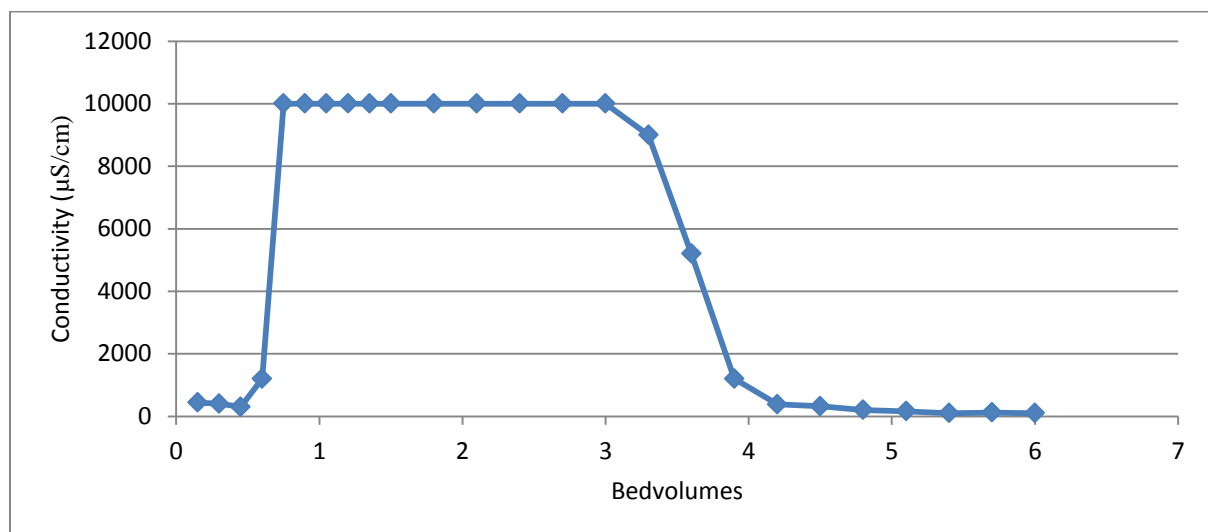

*Figure 5-14 Cationic Regeneration Curve*

The regenerants of the cation resin will contain magnesium nitrate, calcium nitrate and sodium nitrate. This solution can be used as a liquid fertilizer or explosives. The higher the concentration of this solution, the more feasible it becomes. Two methods were identified for this purpose: reverse osmosis (RO) and regenerant recycling.

The RO plant was able to perform at a low pressure (40 bar) and high pressure (80 bar). When operating the RO plant at a low pressure (see *Figure 5-15*) the concentration was increased from 2 % to 6.5 %. The concentration increased slowly at the beginning of the run and then increased drastically towards the end of the run. The pressure remained constant for the first part but then increased slightly for the second part of the run.

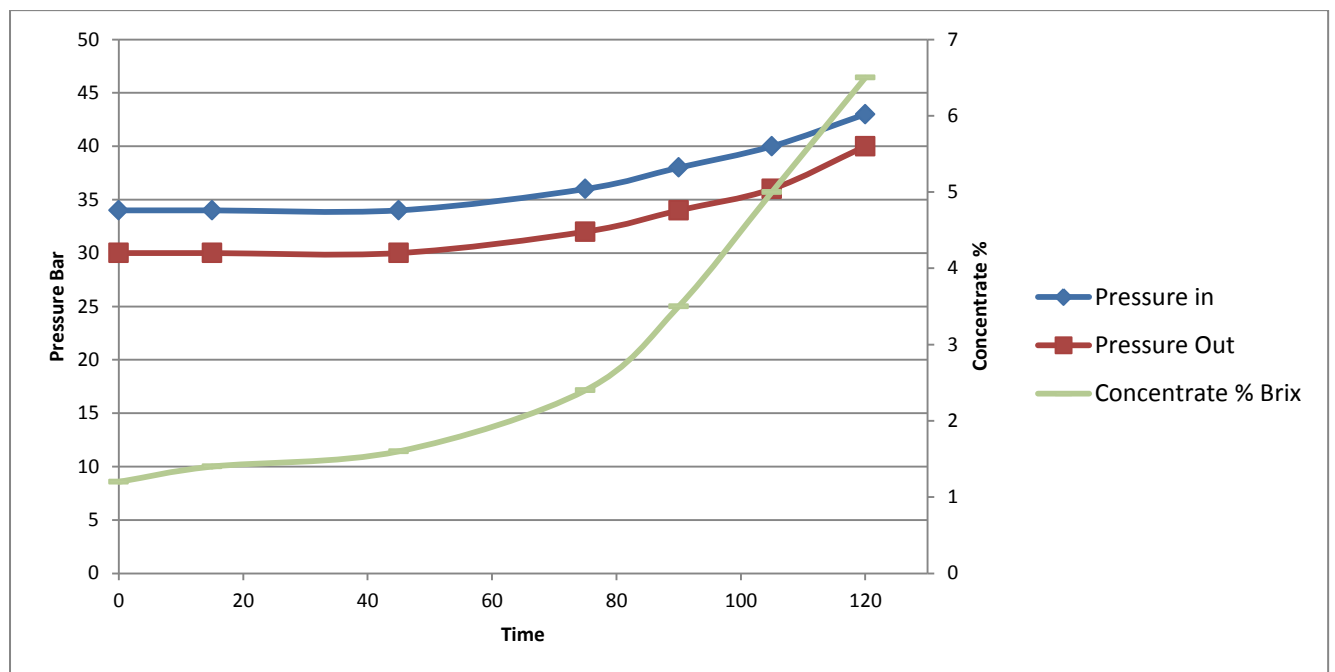

*Figure 5-15 Fertilizer concentration through Reverse Osmosis*

The high pressure increased the concentration from 6 % to 14 %. During low pressure the RO was able to concentrate the solution until the volume of regenerant left was too little. The quality of the permeate was better than the mine-water quality and could be returned to the cation resin feed.

The alternative option was to recycle the regenerant solution. This was achieved by re-using the regenerant from the previous regeneration in each instance. Acid was added to the regenerant solution before regeneration. The concentration of the regenerant increased during each acid make-up.

The maximum recycling concentration achieved at the plant was 22 %.

The cation regenerant product showed enrichment of the following metals in a 6% regenerant product:

K from 6.1 mg/L to 180 mg/L

Sr from 0.4 mg/L to 11 mg/L

V from 0.16 mg/L to 3.2 mg/L

Cr from 0.0028 mg/L to 0.035 mg/L

The recycling method proved to be superior to the reverse osmosis concentration. The reverse osmosis method would still be useful in concentration of the rinse water for the regeneration process.

## 5.7.2 Weak base anionic resin

The anion regeneration uses 3 bed volumes of 2.8 % ammonium hydroxide to return the resin to its original form. The regeneration cycle was divided into two steps. The first was to pump the regeneration solution through the resin column and divert the acid into a salt solution. The second step was to wash the salts out of the column with 4.5 bed volumes of rinse water before the loading the resin again. *Figure 5-16* shows the typical regeneration curve of the resin.

The regeneration efficiency can be calculated by determining the amount of ammonia used. One drum of 25 % ammonium hydroxide was use per regeneration.

$$m_{\text{Ammonia}} = C_{\text{Ammonia}} \times M_{\text{Ammonia}}$$

$$m_{\text{Ammonia}} = 0.25 \% \times 25 \text{ kg}$$

$$m_{\text{Ammonia}} = 6.25 \text{ kg}$$

This amounts to 180 eq, compared to the 257 eq that loaded onto the resin.

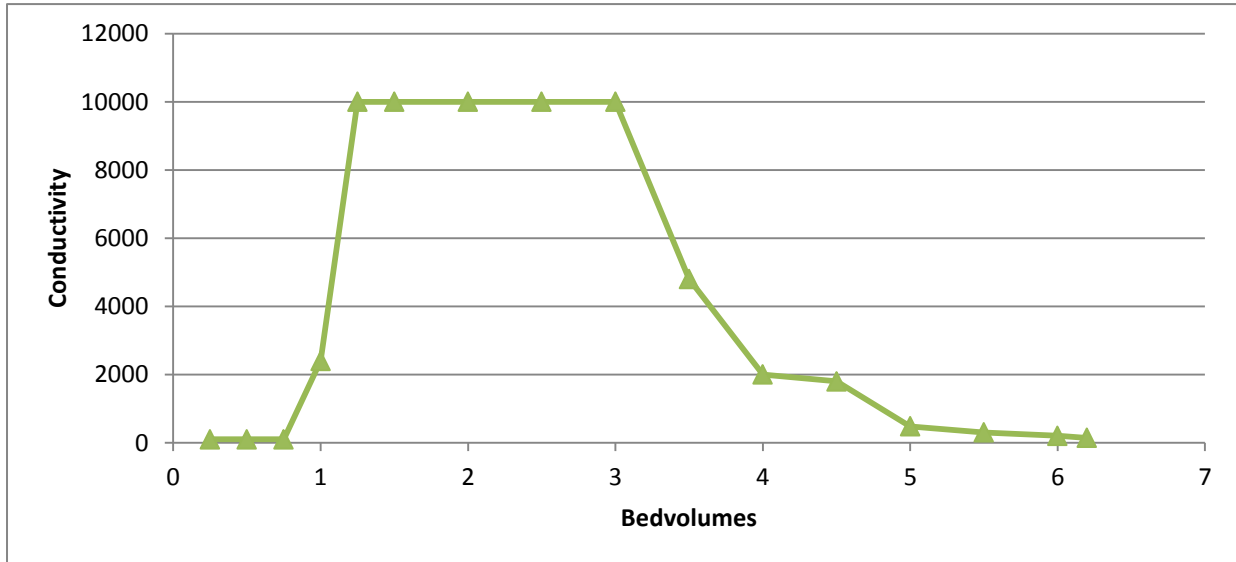

*Figure 5-16 Anionic regeneration curve*

The anion regenerant solution consists of mainly ammonium sulphate and some ammonium chloride. This solution could be used as a liquid fertilizer if the excess ammonia in the solution is neutralised with sulphuric acid. During a normal regeneration process a 2.8 % salt solution is produced. Selling liquid fertilizer is much more feasible if the concentration can be increased. Two methods were tested to achieve the concentration of regenerants. The same two methods were identified for this purpose: reverse osmosis and regenerant recycling.

The RO plant when used for the anionic regenerant concentration was operated at the same conditions as described for the cation regenerant and achieved similar results. The alternative option was to recycle the regenerant solution. This achieved better results than the membrane. The maximum recycling concentration achieved at the plant was 23 %. The rinse cycle of the resin was kept the same throughout the trail

The anion regenerant product showed enrichment of the following metals in a 3.5 % regenerant product:

Cu from 0.03 mg/L to 0.18 mg/L

F from 0.23 mg/L to 5.2 mg/L

As from 0.0034 mg/L to 0.14 mg/L

Se from 0.01 mg/L to 0.12 mg/L

### 5.7.3 Chemical composition of products

The detailed analysis of the cationic spent regenerant is shown in *Table 5-6*.

*Table 5-6 Analyses of Cationic fertilizer*

Analysis	Results
Salinity (EC, mS/m)	19700
Chloride (Cl mg/L)	145.9
Nitrate (NO <sub>3</sub> mg/L)	51504
Calcium (Ca mg/L)	3090
Magnesium (Mg mg/L)	753
Sodium (Na mg/L)	498
Potassium (K mg/L)	74.2
Cobalt (Co mg/L)	0.182
Copper(Cu mg/L)	<0.050
Iron (Fe mg/L)	0.629
Lead(Pb mg/L)	<0.420
Nickel (Ni mg/L)	4.190
Uranium (U <sub>238</sub> mg/L)	<0.010
Zinc(Zn mg/L)	0.053
Total Dissolved Solids (mg/L)	23980
pH	0.42

Liquid fertilizers is inorganic material that is added to soil to supply one or more plant nutrients essential to the growth of plants. A recent assessment found that about 40 % to 60 % of crop yields are attributable to commercial fertilizer use. Inorganic fertilizer use has also significantly supported global population growth — it has been estimated that almost half the people on the earth are currently fed as a result of synthetic nitrogen fertilizer use (Unknown author, 2011). Fertilizers typically provide, in varying proportions:

- six macronutrients: nitrogen (N), phosphorus (P), potassium (K), calcium (Ca), magnesium (Mg), and sulphur (S);
- seven micronutrients: boron (B), chlorine (Cl), copper (Cu), iron (Fe), manganese (Mn), molybdenum (Mo), and zinc (Zn).

The macronutrients are consumed in larger quantities and are present in plant tissue in quantities from 0.15 % to 6.0 % on a dry matter basis. Micronutrients are consumed in smaller quantities. Only three other macronutrients are required by all plants: carbon, hydrogen, and oxygen. These nutrients are supplied by water and carbon dioxide. The nitrogen-rich fertilizer ammonium nitrate is also used as an oxidizing agent in improvised explosive devices, sometimes called fertilizer bombs, leading to sale regulations. The advantages of liquid fertilizer are its immediate effect and wide coverage.

Inorganic fertilizer is often synthesized using the Haber-Bosch process, which produces ammonia as the end product. This ammonia is used as a feedstock for other nitrogen fertilizers, such as anhydrous ammonium nitrate and urea. These concentrated products may be diluted with water to form a concentrated liquid fertilizer.

Synthetic fertilizers are commonly used to treat fields used for growing maize, also barley, sorghum, rapeseed, soy and sunflower. One study has shown that application of nitrogen fertilizer on off-season cover crops can increase the biomass of these crops, while having a beneficial effect on soil nitrogen levels for the main crop planted during the summer season.

Nutrients in soil can be thrown out of balance with high concentrations of fertilizers. Stability of the system is reduced by the use of nitrogen-containing fertilizers, which cause soil acidification.

Uranium is another example of a contaminant often found in phosphate fertilizers. Eventually these heavy metals can build up to unacceptable levels and build up in vegetable produce.

The average annual intake of uranium by adults is estimated to be about 0.5 mg from ingestion of food and water and 0.6 µg from breathing air.

Also, highly radioactive Polonium-210 contained in phosphate fertilizers is absorbed by the roots of plants and stored in its tissues; tobacco derived from plants fertilized by rock phosphates contains Polonium-210 which emits alpha radiation estimated to cause about 11700 lung cancer deaths each year worldwide.

The detailed analysis of the recycled regenerant is shown in *Table 5-7*

***Table 5-7 Detailed Anionic Regenerant Analysis***

<b>Analysis</b>	<b>Result</b>
Salinity (EC, mS/m)	3370
Fluoride (F mg/L)	0.57
Chloride (Cl mg/L)	963
Nitrate (NO <sub>3</sub> mg/L)	6637
Phosphate (PO <sub>4</sub> mg/L)	<0.30
Sulphate (SO <sub>4</sub> mg/L)	9725
Calcium (Ca mg/L)	35.6
Magnesium (Mg mg/L)	18.9
Sodium (Na mg/L)	229
Potassium (K mg/L)	14.3
Cobalt (Co mg/L)	<0.070
Copper (Cu mg/L)	0.067
Iron (Fe mg/L)	<0.050
Lead (Pb mg/L)	<0.420
Nickel (Ni mg/L)	0.466
Uranium (U <sub>238</sub> mg/L)	<0.010
Aluminium (Al mg/L)	<0.280
Manganese (Mn mg/L)	<0.010
Chromium (Cr mg/L)	0.156
Zinc (Zn mg/L)	<0.020
Ammonia (mg/L)	14800
pH	10.07

## 5.8 Chemical Consumptions

The actual nitric acid consumption was 968 kg per ML treated. The minimum calculated nitric acid needed was 850 kg per ML treated. The actual consumption was higher than the calculated consumption. This means that there will still be room for improvement in the full scale application.

The actual ammonium hydroxide consumption was 440 kg per ML treated. The minimum calculated ammonium hydroxide needed was 330 kg per ML treated. The actual consumption was higher than the calculated consumption. This means that there will still be room for improvement in the full scale application.

## Chapter 6 Water Management

### 6.1 Shaft Water reticulation

The water reticulation at a shaft is shown in *Figure 6-1*. The warm water from underground is pumped to the sand filter on surface for suspended solids removal. The filter is designed to deliver a reduction of 30 ppm suspended solids. The filters are backwashed automatically once an increase in differential pressure is observed over the filter. The mud recovered inside the filter is collected in a sump area and disposed to the metallurgical plant. Water is recovered from the backwash through a clarifier which returns the water to the filters.

The filtered water is collected in the warm water tanks before being pumped to the primary cooling towers, where the first cooling step takes place. This is followed by a disinfection step before the water enters the secondary cooling towers. The final cooling takes place in the fridge plant followed by another disinfection process. Disinfection is achieved through hypochloride. The chilled water is collected in the chilled water tanks, soda ash is added for additional alkalinity before it is pumped to the bulk cooler underground.

From the bulk cooler the water is transferred to 21 level and then distributed to a neighbouring shaft, 24 level bulk cooler and 21 level winder cooler. The remainder of the water goes to 42 level. At 42 level chilled water, service water make-up and water from the bulk cooler are collected in warm water dams before entering the fridge plant. The water then flows to 44 level, 46 level 48 level and 50 level. At 50 level the pH of the water is adjusted to 8.5, while flocculent is added before the water enters the settlers. The settlers are designed to deliver water with a suspended solids content of 10 mg/L. The clarified water is collected in the 52 level tanks, then pumped to the 50 level tanks and then to the 23 level tanks. From 23 level the water is pumped to the ICP and then pumped to surface filter plant, consequently circulating the process water again.

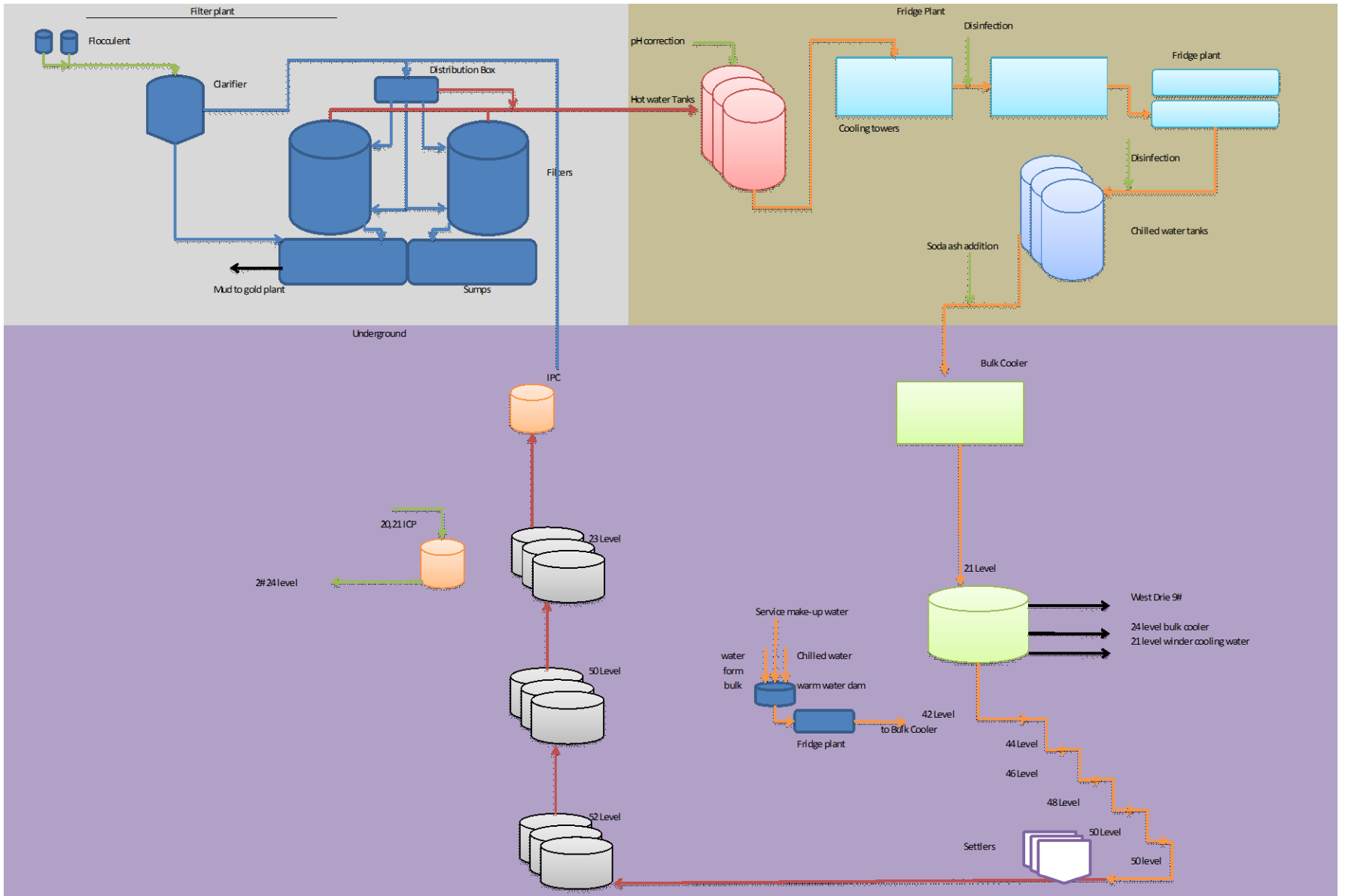
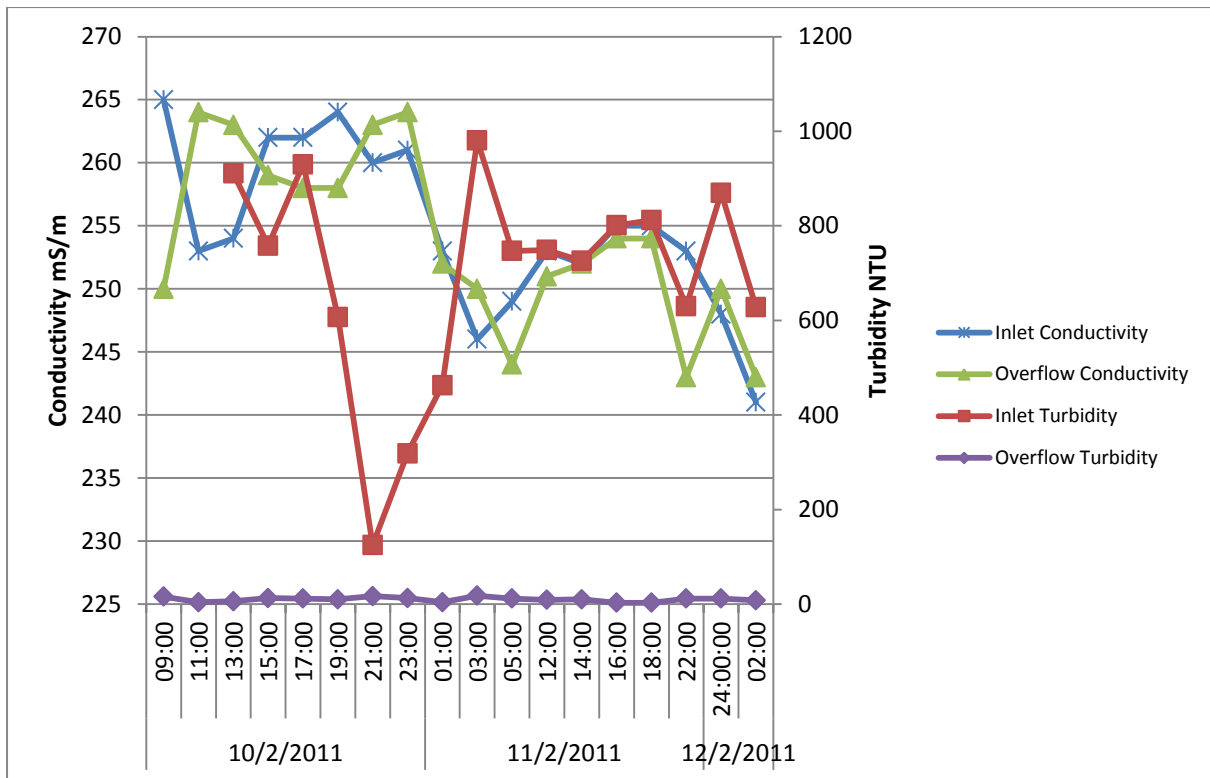
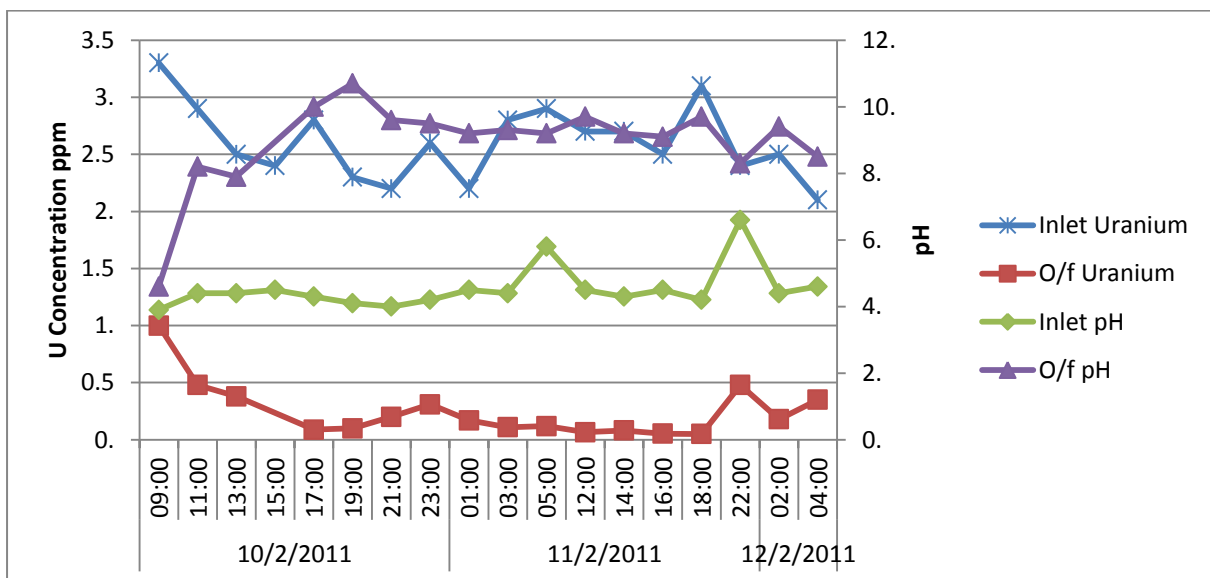

Figure 6-1 Water Circulation at a Shaft Complex



**Figure 6-2 Settler Performance**



**Figure 6-3 Precipitation in the Settler**

The first focus of the investigation was the underground settler. This is a very important process in the water management on the shaft. The settler removes most of the solids present

in the water (*Figure 6-2*) and will also assist in precipitation of some metals when the pH of the water is increased. The turbidity reduced from an average of 600 NTU to less than 10 NTU in the settler. However, the settler had a very small influence on the salinity of the water. A sampling campaign on the settler showed that uranium will precipitate fairly easily when the pH is increased to 9 (*Figure 6-3*). The settler also reduced the turbidity of the water considerably. It is therefore crucial to control the pH and the addition of coagulants.

The second focus of the investigation was the sand filter. The results are shown in *Figure 6-4* and *Table 6-1*. The aim of the filter is to remove the fines present in the water, but the suspended solids concentration never reduced below 48 mg/L. However if a filter is not operated correctly it can be a source of contamination. When the filter was opened it was full of mud, meaning it was not operated optimally. A filter needs to be backwashed regularly and air scouring can be used to optimal backwash. If the settler underground produces clear enough water, the filter might even be bypassed. The filter media needs to be replaced on regular intervals.

The make-up water to the shaft was changed to Rand Water Board instead of fissure water. The volume of make-up water was increased from 1 ML/day to 5 ML/day. The changes were made to the system in order to observe the changes brought about in water quality. The system was changed back to normal operations after a while to determine what the extent was of flushing the system. The results are shown in *Table 6-1*.

The pH of the water in the circuit at the shaft did not change significantly on average at the different sampling points. A weekend effect could be observed on the pH during January where the pH dropped during the Sunday when little staff were operating the shaft and then increased again during the Monday (*Figure 6-4*) when full shifts were operated. This could be prevented with better control of the system.

The conductivity of the water was reduced on average by 20 % when the make-up water volume was increased. The conductivity of the water stayed at the reduced level even after the circuit was changed back to normal, reducing the make-up volume to 1 ML/day.

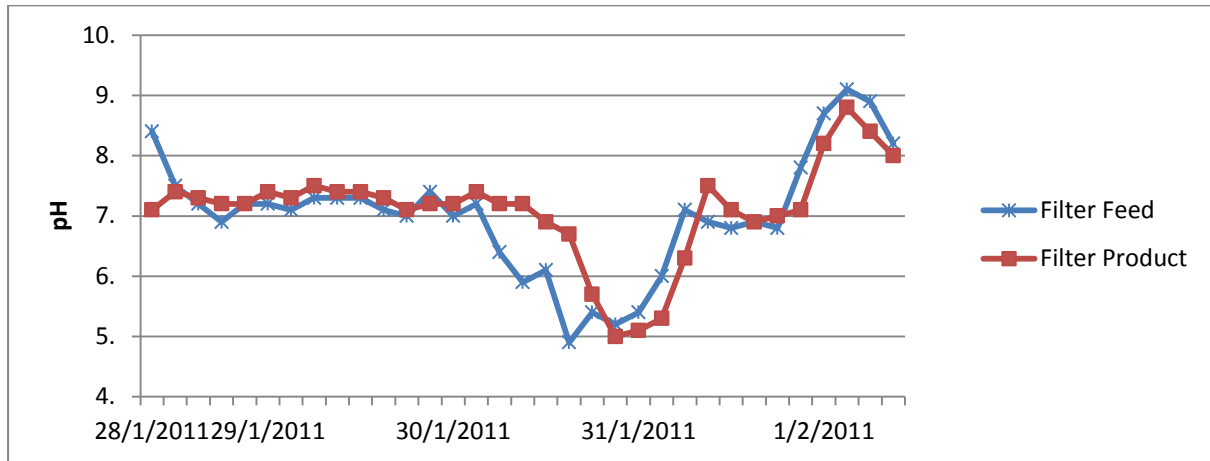

**Figure 6-4 Filter Performance at the shaft**

Uranium was the target for this exercise due to the dangers involved. The uranium was reduced when the make-up water volume was increased; however the concentration increased again when the volume was reduced again. Therefore continual treatment is required for the effective removal of uranium.

**Table 6-1 Water Equilibrium Qualities**

	Filter Feed			Filter Product			Chilled Water		
	Pre-Flush	Flush	Post-Flush	Pre-Flush	Flush	Post-Flush	Pre-Flush	Flush	Post-Flush
<b>pH</b>	7.02	8.04	7.99	7.08	8.12	8.21	7.87	7.77	7.84
<b>Conductivity mS/m</b>	318	256	240	322	265	242	301	216	191
<b>SO<sub>4</sub> mg/L</b>	1322	891	757	1412	881	781	1315	843	701
<b>Cl mg/L</b>	217	181	155	222	185	144	210	145	136
<b>Ca mg/L</b>	473	378	363	468	326	358	432	335	262
<b>Mg mg/L</b>	25	20	16	24	19	16	27	18	14
<b>Alkalinity mg/L</b>	31	44	46	30	42	46	50	47	52
<b>CaCO<sub>3</sub></b>									
<b>Suspended solids</b>	63	121	132	59	71	48	39	30	23
<b>Uranium mg/L</b>	0.343	0.181	0.431	0.183	0.194	0.325	0.221	0.090	0.287

The magnesium concentration is very low and therefore raises no concerns. The calcium concentration did reduce during the flushing period from 480 mg/L to 360 mg/L. Calcium is added to the system in the form of lime at the underground settlers for pH control.

The chloride concentration decreased gradually over the sampling period. Chlorides are added into the system at one of two disinfection steps where hypo-chloride is used. The sulphate concentration made a step change from the original concentration of 1350 mg/L to 820 mg/L. The suspended solids concentration was reduced in the settler, again over the filter and in the cooling towers.

The alkalinity of the water used underground averaged at 50 mg/L CaCO<sub>3</sub>. This does not provide a large buffering capacity against pH changes. During the sampling campaign a soda ash addition point was commissioned in order to raise the alkalinity. The alkalinity was not influenced by the increase in make-up water.

## 6.2 Plant Water Reticulation

The water flow in the plant is complex but can be best explained by reviewing the water tanks on the plant. The water used in the different processes always returns to these tanks. There are five tanks on the plant. The first collects good quality water used for gland services on the plant. The service water tank collects the cooling water used in the smelt house, slimes dam return water, good quality water from underground and water from Rand Water. The two process water tanks receive water from the thickener overflow, the slimes dam, good quality underground water and the backfill thickener. This tank overflows into the backfill water tank, which also collects water from the backfill thickener and the slimes dam.

The water reticulation at the plants is shown in the diagram below (*Figure 6-5*). The first problem to address was the spillages and cleaning in the plant. A lot of water is lost through spillages. Sometimes these cannot be controlled. The make-up water should only be used

when all the tanks are empty. The make-up water should be from the mine process water. Rand Water should only be used in the elution circuit for make-up.

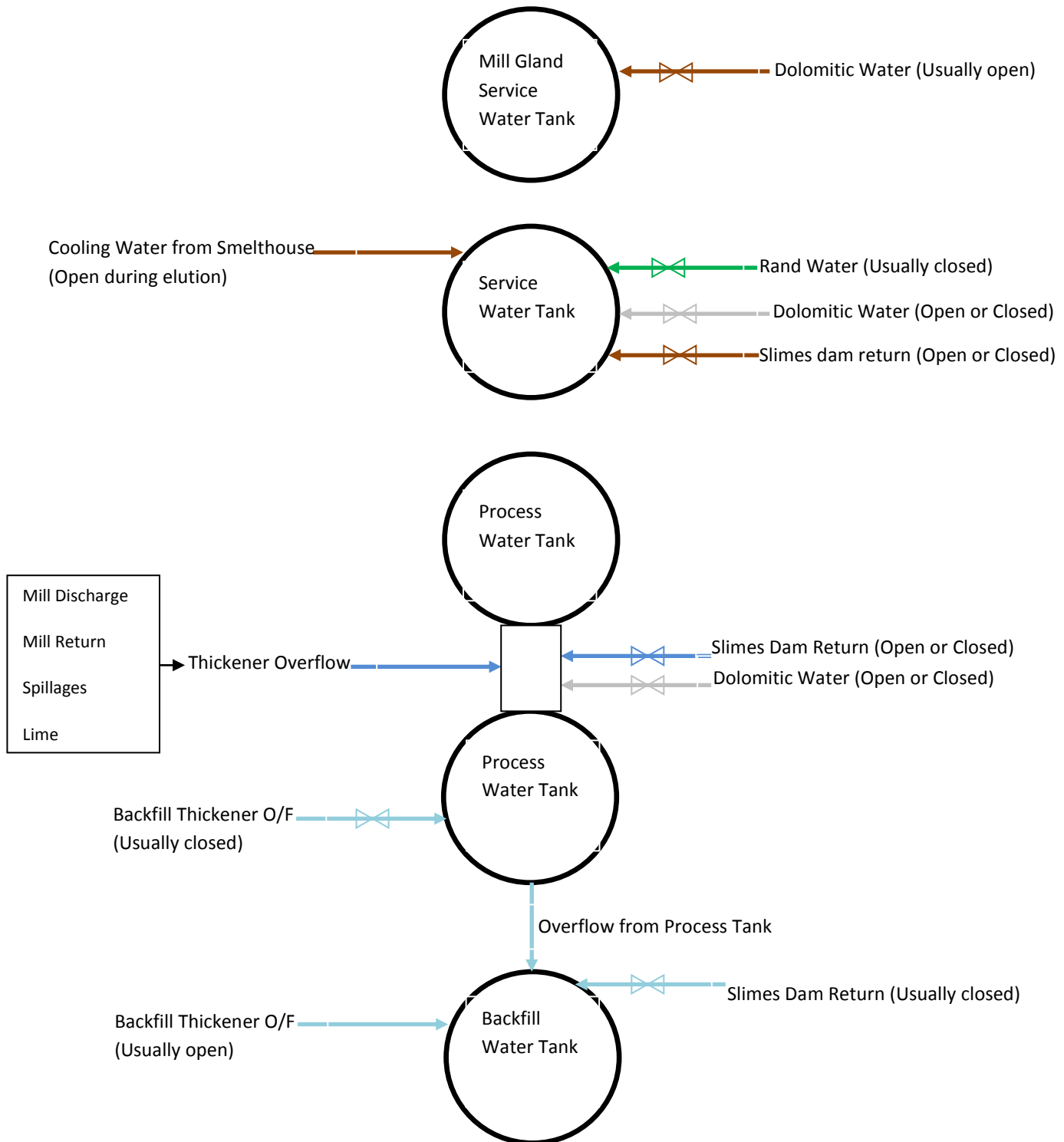

**Figure 6-5 Water Control at a metallurgical plant**

## 6.3 Water reticulation on a mine

The overall water reticulation of a typical mine is shown in *Figure 6-6*. There are three water sources, the slimes dam, rain water and RWB water. The RWB water and the fissure water are supplied as domestic water, water make-up to the mine water circuit and dilution for the controlled and uncontrolled discharges. The water used in the mining processes is circulated between the stopes and the fridge plant. The discharges on the mine comes from the fissure water, overflow from the mine process water circuit and the sewage works.

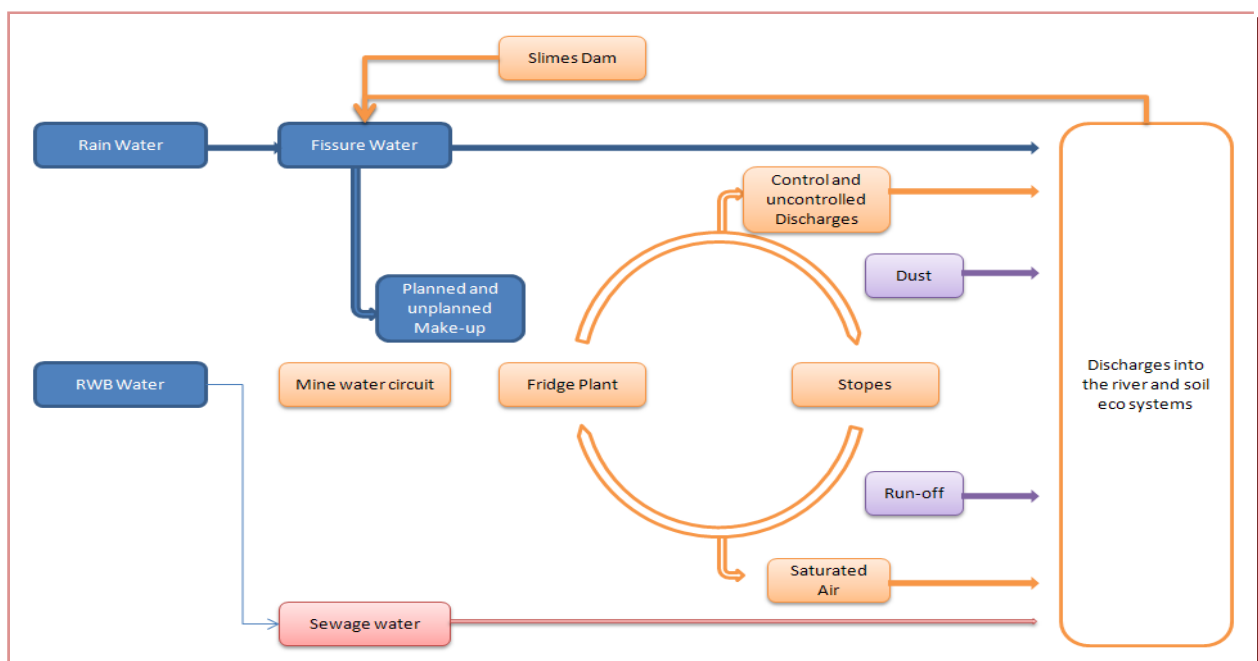

*Figure 6-6 Current water reticulation*

The aim would be to situate the two plants in such a strategic position as to optimize the water management on the mine. The proposed locations for the plants are shown in *Figure 6-7*. The mine water plant will be located in the process water circuit and will only act as a kidney by treating a small portion of the total volume and then return this to the circuit. The fissure water plant will be constructed to treat all the fissure water to drinking water quality and supply the water to the mine community. The make-up needed for the mine water circuit will reduce making more fissure water available for treatment and supply to other mines or the municipality.

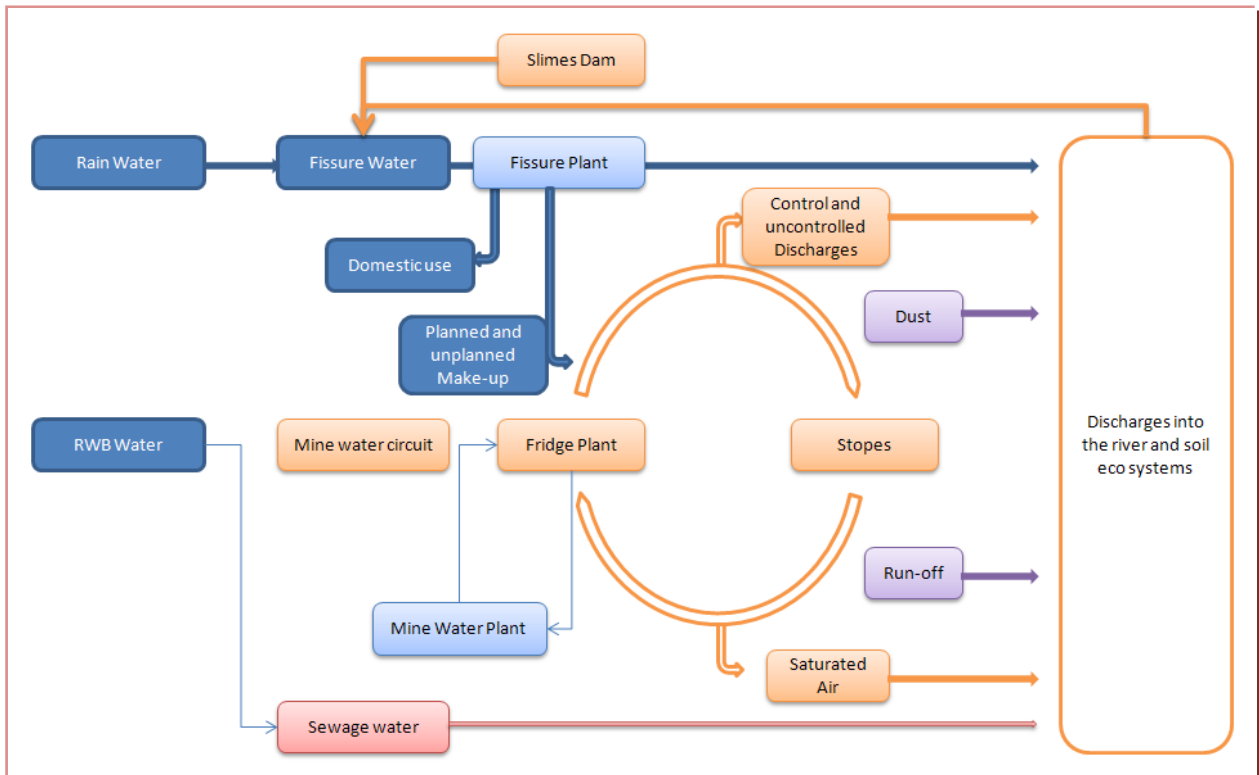

*Figure 6-7 Proposed locations of plants*

## Chapter 7 Conclusion and Recommendations

The aim of the investigation was to address:

- Water treatment for the good quality water, which could be utilized as drinking water.
- Water treatment to improve the quality of the mine process water. This will in turn reduce the discharge streams and minimise the risk to the environment.
- Review water balance and identify areas within mining operations for improved water management.

### 7.1 Fissure Water

The crystalactor was able to reduce the calcium hardness of the water to between 40 mg/L and 35 mg/L. The lowest flow rate removed more calcium hardness, but will require a bigger unit in the full scale operation. In larger units a higher flow rate can achieve the same efficiency. The performance of the crystalactor was better at higher alkalinities. The feed pH, calcium content and alkalinity should determine the lime dosing.

The alignment of the reactor is important to prevent bypassing in the column. Therefore care needs to be taken in the manufacturing of the column to prevent any bypassing in the column.

The crystalactor produced calcium carbonate pebbles of high value, with very low metals content.

The strong and weak acid cationic resins were successful in softening of the fissure water. It is suggested to use SAC instead of WAC due to the fact that a small portion of water is treated when using SAC.

The anionic resin was more efficient than the degas tower in reducing the dissolved solids as well as increasing the pH of the cationic water. Blending of the different water streams

produced good quality drinking water. The best results were achieved when only a small portion of cationic product water was mixed with the blend. It is also good to add a relative portion of the anionic water as this water contains the least amount of salts.

## 7.2 Mine Process Water

The sand filter performed adequately. Granular activated carbon used in water treatment and in gold recovery are both successful in reducing the organic material present in the water. Although the performance of the water carbon was superior to the gold carbon, the gold carbon should be used in the full scale plant, because the spent carbon can be used again in the metallurgical plant at the mine.

Uranium was removed successfully to international standards in a lead-lag configuration. The uranium present in the water is in the anionic form. The resin was successfully regenerated with 15 %  $H_2SO_4$ .

Demineralization was achieved through Strong Acid Cationic resin followed by Weak Base Anionic resin. The product water contained less than 30 mg/L dissolved solids. The SAC resin produced liquid fertilizer consisting of calcium nitrate, magnesium nitrate and sodium nitrate. The WBA resin produced ammonium sulphate liquid fertilizer. Fertilizer concentration was most effective when using the recycling method. The reverse osmosis membrane can be used to concentrate the rinse water.

## 7.3 Water Management

Water management is extremely important for optimized water use efficiency. The underground settlers efficiently remove a large amount of uranium and the majority of the suspended solids. All the discharges of the shaft should be minimized. The important factor to remember on a plant is to control the inflow of the water as to avoid having excess water on the plant that eventually needs to be discharged. The fissure water plant will be producing

good quality drinking water. The mine water plant will be treating a slip stream of the mine water circuit and then return the treated water to the circuit to act as dilution water.

## Chapter 8 References

American Water Works Association (AWWA), Letterman, R.D. (Technical Editor) 1999, *Water Quality & Treatment, a Handbook of Community Water Supplies*. McGraw Hill, United States of America.

AWWA Research Foundation 2007, *Advancing the Science of Water: Awwa RF and Water Treatment Residuals*. AWWA Research Foundation.

Bester, L 2009, *Fissure water Pilot Plant*, Pre-Feasibility Report 1, Gold Fields, Carletonville, South Africa.

Bester, L 2009, *Mine Water Pilot Plant*, Pre-Feasibility Report 1, Gold Fields, Carletonville, South Africa

Bochenek, R, Sitarz, R & Antos, D 2011, 'Design of continuous ion exchange process for the waste water treatment' *Chemical Engineering Science*, vol. 66, pp. 6209–6219.

Bosklopper, ThGJ, Rietveld, LC, Babuska, R, Smaal, B & Timmer, J 2004, 'Integrated operation of drinking water treatment plant at Amsterdam water supply' *Water Science Technology: Water Supply*, vol. 4 (5-6), pp. 263-270.

Botha, M, Bester, L & Hardwick, E 2009, 'Removal of Uranium from Mine Water using Ion Exchange at Driefontein Mine', *International Mine Water Conference*, Pretoria, South Africa.

Degrémont and Ondeo Industrial Solutions 1995a, *Water Treatment Handbook*, Volume 1, Rovel, J (Ed.) Degrémont, France.

Degrémont and Ondeo Industrial Solutions 1995b, *Water Treatment Handbook*, Volume 2, Rovel, J (Ed.) Degrémont, France.

Department of Water Affairs and Forestry (DWAF), 1996. *South African Water Quality Guidelines (second edition)*, Volume 1: Domestic Use, Department of Water Affairs and Forestry (DWAF), South Africa.

Department of Water Affairs and Forestry 2006, *Best Practise Guideline H3: Water Reuse and Reclamation*, Department of Water Affairs and Forestry (DWAF), South Africa.

Department of Water Affairs and Forestry 2008, *Best Practise Guideline H1: Integrated Mine Water Management*, Department of Affairs and Forestry (DWAF), South Africa.

Fu, G, Cai, T & Li, Y 2011, 'Concentration of ammoniacal nitrogen in effluent from wet scrubbers using reverse osmosis membrane', *Biosystems Engineering*, vol. 109, pp. 235 -240.

Giesen, A 2008 *Crystalactor*, viewed September 28 2008, < <http://www.phosphorus-recovery.tu-darmstadt.de>>

Giesen, A, Erwee, H, Wilson, R, Botha, M & Fourie, S 2009, Experience with crystallization as sustainable zero-waste technology for treatment of wastewater, *International Mine Water Conference*, Pretoria, South Africa.

Kemp, D, Bond, CJ, Franks, DM & Cote, C 2010, 'Mining, water and human rights: making the connection', *Journal of Cleaner Production*, vol. 18, pp. 1553-1562.

Khadse, GK, Kalita, MD, Pimppalkar, SN & Labhasetwar, PK 2011, 'Surveillance of Drinking Water Quality for Safe Water Supply—A Case Study from Shillong, India', *Water Resource Manage*, vol. 25, pp. 3321–3342.

Kim, W & Cho, YI 2011 'Benefit of filtration in physical water treatment for the mitigation of mineral fouling in heat exchangers' *International Communications in Heat and Mass Transfer* vol. 38, pp. 1008–1013.

Mayesa, WM, Davisa, J, Silva, V and Jarvis, AP 2011, 'Treatment of zinc-rich acid mine water in low residence time bioreactors incorporating waste shells and methanol dosing', *Journal of Hazardous Materials* vol. 193 pp. 279– 287

Moran, D 2010, 'Carbon dioxide degassing in fresh and saline water. I: Degassing performance of a cascade column', *Aquacultural Engineering*, vol. 43, pp. 29–36.

National Drinking Water Clearing House 1998, *Tech Brief: Water Treatment Plant Residuals Management*, National Drinking Water Clearinghouse Fact Sheet.

Oelofse, SHH, Hobbs, PJ, Rascher, J & Cobbing, JE 2007, *The pollution and destruction threat of gold mining waste on the Witwatersrand - A West Rand case stud.,.* CSIR, Natural Resources and the Environment, Pretoria.

Onsekizoglua, P, Bahcecib, KS and Acara, MJ 2010, Clarification and the concentration of apple juice using membrane processes: A comparative quality assessment, *Journal of Membrane Science* vol. 352, pp. 160–165.

Schoeman, JJ and Steyn, A 2001, ‘Investigation into alternative water treatment technologies for the treatment of underground mine water discharged by Grootvlei Proprietary Mines Ltd into the Blesbokspruit in South Africa’, *Desalination* vol. 133, pp. 13-30

Schutte, F (Editor) 2006 *Handbook for the Operation of Water Treatment Works*, The Water Research Commission, The Water Institute of Southern Africa, Pretoria.

Seckler, MM, Leeuwen, MLJ, Bruinsma, OSL & Rosmalen, GM 1996 ‘Phosphate removal in a fluidised bed- II Process optimization’ *Water. Resource.* vol. 30 (7), pp. 1589-1596.

Silva, R & Rubio, J 2009, ‘Treatment of Acid Mine Drainage (AMD) from Coal Mines in South Brazil’, *International Journal of Coal Preparation and Utilization*, vol. 29 (4), pp. 192-202.

Sub-Committee of Consulting Metallurgists of the Chamber of Mine of South Africa 1987, *The Extractive Metallurgy of Gold in South Africa*, Volume 1 and 2, GG Stanley (Editor-in-Chief), The South African Institute of Mining and Metallurgy, Johannesburg.

Unknown (1991) *External Treatment* in Betz Handbook of Industrial Water Conditioning, 9th Edition.

Unknown author (-) *Fertilizer*, viewed 19 August 2011, <<http://en.wikipedia.org/wiki/fertilizer>>

Van Hille, RP, Peterson, KA & Lewis AE 2005 ‘Copper sulphide precipitation in a fluidised bed reactor’ *Chemical Engineering Science*, vol. 60, pp. 2571 – 2578.

Van Staden, SJ & Haarhoff, J 2011, ‘The use of filter media to determine filter cleanliness’ *Physics and Chemistry of the Earth*, vol. 36, pp. 1135–1140.

Wong, AS, Stalnakeri, ND, Laffers, CJ, Roberts, JD and Khur, JH 2009 ‘The Ion Exchange properties of Low Rank Coals on Actinides and other Heavy Metals’, pp. 481-483.

World Health Organization 2008, *Guidelines for drinking-water Quality, third edition, volume1: recommendations*, World Health Organization, Geneva.