

An optimal facilities layout plan for the manufacturing of replaceable traffic lights

By

Raymond Charles Biddulph

26081122

Group leader: Ms Jozine Botha

Submitted in partial fulfillment of the requirements for the degree of

BACHELORS OF INDUSTRIAL ENGINEERING

In the

FACULTY OF ENGINEERING, BUILT ENVIRONMENT AND INFORMATION
TECHNOLOGY

UNIVERSITY OF PRETORIA

05 October 2010



UNIVERSITEIT VAN PRETORIA
UNIVERSITY OF PRETORIA
YUNIBESITHI YA PRETORIA

DEPARTEMENT BEDRYFS- EN SISTEEMINGENIEURSWESE

DEPARTMENT OF INDUSTRIAL AND SYSTEMS ENGINEERING

FRONT PAGE FOR FINAL PROJECT DOCUMENT (BPJ 420) - 2010	
Information with regards to the mini-dissertation	
Title (e.g. A Contingency framework for the after-sales inventory at Nissans Part Distribution Centre)	Facilities layout plan for the assembly of replaceable modular traffic lights.
Author (Last name, Initial(s) e.g. Botha, P.J.)	Biddulph, R.C.
Student number	26081122
Supervisor/s (Last name, Initial(s) e.g. Botha, P.J.)	Botha, P.J.
Date (month/day/year e.g. 10/05/2010)	10/05/2010
Keywords (Provide keywords from your project (for searching purposes). The first word of two words must always have a capital first letter and the rest of the words following must be lower case. In the event of an abbreviation, use as it is known. E.g. Economic recession, ABSA, ERP, Simulation modelling)	Replaceable traffic light, Modular, Assembly line, Facilities planning.
Abstract (Provide an abstract of the mini-dissertation. An abstract is a short summary of the contents covered in the item.)	The conceptualization and implementation of a facilities plan for the assembly of replaceable traffic lights. The study includes material flow and handling, and the layout plan to run a smooth and optimal assembly line.
Category (Enter the category in which the project was done. E.g. Operations Research, Simulation, Logistics...)	Facilities Planning.

Declaration	
1.	I understand what plagiarism is and I am aware of the University's policy in this regard.
2.	I declare that this is my own original work
3.	Where other people's work has been used (either from a printed source, internet or any other source) this has been carefully acknowledged and referenced in accordance with departmental requirements
4.	I have not used another student's past work to hand in as my own
5.	I have not allowed and will not allow, anyone to copy my work with the intention of handing it in as his/her own work
Handtekening	
Signature	

Executive Summary

Due to the high rate of failures and damages occurring with current traffic light assemblies because of motorists striking them or the nature of the components, there is a need for optimizing the production rate. This need is specifically aimed at accommodating replacement at a quicker rate as well as a new method of assembly by using different materials and components. Therefore it is necessary to implement a new facilities plan to improve the current situation and reduce costs associated with a prolonged repair programme. A modular replaceable traffic light is an innovative and cost efficient solution to the conventional traffic light assemblies.

This report outlines the key principles and activities that occur in optimizing a facilities plan layout for the assembly of a replaceable traffic light. The details of the entire assembly line project and facilities layout are explained and investigated in this report. Facilities layout planning is the critical component in a company's future growth and development plans; it provides the company with a long-term solution for reaching its desired goals and vision. By implementing the correct facilities planning tools and techniques a number of benefits will be achieved namely a reduction in costs associated with a production line assembly; bottlenecks will be reduced thus increasing material flow and an improved working environment all contribute to the success of a correctly implemented facilities layout.

The modular replaceable traffic light is constructed out of the latest polymer plastic which allows for quick assembly due to its light weight and manoeuvrability. By implementing the steps necessary to create an optimal facilities plan layout the replacement time for damaged or broken traffic lights currently on the roads today will be significantly reduced. Facilities' planning allows managers to do a better job and ensures that all employees are working towards achieving the company's goals and objectives.



Table of Contents

Executive Summary	i
Chapter 1	1
1.1 Introduction and Background	1
1.2 Problem Statement	2
1.3 Project Aim and Objectives	3
1.4 Project Scope	4
Chapter 2 – Literature Review	5
2.1.1 Introduction to Facilities Planning and Design	5
2.1.2 Objectives of Facilities Planning	6
2.2 Layout Identification	6
2.2.1 Importance of Facility Layout design	6
2.2.2 Layout Types	6
2.3 Material Handling and Flow	8
2.3.1 Material Handling	8
2.3.2 Material Flow	9
2.4 Facility Layout Design	10
2.4.1 Stages of Planning	10
2.4.2 Design Process	11
2.4.3 Specifications - Workstations	11
2.4.4 Fixed Space Requirements	12
2.5 Methods, Tools and Techniques	12
2.5.1 Systematic Layout Planning	13
2.5.2 The Winning Facilities Planning Process	17
2.6 Problem Identification and Analysis of Operations	19
Chapter 3 – Conceptual Design and Information Gathering	22
3.1 Data Specifications	22
3.2 Conceptual Design Implementation	26
3.2.1 The Layout Plan	26
3.2.2 Material Flow	27
3.2.3 Systematic Layout Planning (SLP)	28
3.3 Root Cause Analysis	30
Chapter 4 – Design and Problem Solving	31

4.1 Introduction to Plant Layout and Material Handling	31
4.2 Flow Patterns	32
4.2.1 Measuring Flow.....	33
4.2.1.1 Quantitative flow measurements	34
4.2.1.2 Qualitative Flow Measures – Activity Relationship Chart.....	36
4.3 Space Relationship Diagram	39
4.4 Develop Layout Alternatives.....	41
4.5 Evaluate Alternative Facility Layout Designs	41
4.5.1 Weighted Factor Comparison	41
4.6 Material Handling	44
Chapter 5 – Budget	46
Chapter 6 – Recommendations and Conclusion	47
6.1 Recommendations	47
6.2 Conclusion.....	47
List of References	49
Appendices	50
Appendix A	51
Capital Expenditure.....	51
Building costs and installation	51
New plant machinery and equipment	52
New office furniture and equipment.....	53
Catered for the unforeseen	53
Appendix B – Alternative Layout 1	54
Alternative Layout 1 – Second Floor	55
Alternative layout 2	56
3D View of Assembly Plant for Replaceable Traffic Lights.....	57

List of Figures

Figure 2.2.1 – Alternative Types of Layouts	7
Figure 2.3.1 – Flow Planning Hierarch	9
Figure 2.3.2 – Flow within Product Departments	10
Figure 2.5.1 – The Framework for Systematic Layout Planning	13
Figure 2.5.2 – An Example of a Flow-Chart	14
Figure 2.5.3 – An Example of an Activity Relationship Diagram	15
Figure 2.5.4 – An Example of a Relationship Diagram	15
Figure 2.5.5 – An Example of a Space Relationship Diagram	16
Figure 2.5.6 – Alternative Block Layouts	16
Figure 2.5.7 – Winning Facilities Planning Process	17
Figure 2.5.8 – The Model of Success “Winning Circle”	18
Figure 2.6.1 – Operation Analysis for Material Handling	20
Figure 3.1.1 – A Detailed Design of a Modular Traffic Light	22
Figure 3.1.2 – A Detailed Diagram Illustrating an Exploded View of the Housing and Base Plate	24
Figure 3.1.3 – Dimensions of LED Light Bulbs	25
Figure 3.2.1 – Product Planning Layout	27
Figure 3.2.2 – End-to-end Flow	27
Figure 3.2.3 – Examples of Entrance and Exits Located at Opposite Side of the Layout.....	28
Figure 4.2.1 – Various Flow Patterns	33
Figure 4.2.2 – End –to –end Flow	33
Figure 4.2.3 – Explanation of the Activity Relationship Diagram	38
Figure 4.2.4 – Activity Relationship Diagram	38
Figure 4.3.1 – Systematic Layout Planning Procedure	39
Figure 4.3.2 – Space Relationship Diagram	40

List of Tables

Table 2.2.1 – Advantages and Limitations for Production vs. Product Layout	8
Table 2.5.1 – Comparison of Engineering Design Process, Facilities Planning Process, and Winning Facilities Planning Process	18
Table 2.6.1 – Critical Analyses Template	20
Table 3.1.1 – LED Light Specifications	25
Table 3.3.1 – Assembly Line Root Cause Analyses	30
Table 3.3.2 – Manning Root Cause Analyses	31
Table 3.3.3 – Equipment Root Cause Analyses	31
Table 4.2.1 – Key Code for Stations	35
Table 4.2.2 – Allocated values on From-to-Chart	36
Table 4.2.3 – From-to-Chart	36
Table 4.2.4 – Closeness Rating	37
Table 4.2.5 – Reasons behind Closeness Values	37
Table 4.3.1 – Table Indicating Line Styles for Space Relationship Diagram	40
Table 4.5.1 – Weighted Factors	41
Table 4.5.2 – Weighted Factor Comparison Matrix	42
Table 4.5.3 – Weight Factor Comparison Form	43

Chapter 1

1.1 Introduction and Background

The idea of a replaceable modular traffic light is to ensure the quick replacement or repair of a damaged or out of order traffic light due to the interchangeable components. A replaceable traffic light works on the basis of a 'plug and play' process, similar to a wireless kettle, which is designed to collapse on impact. This concept is developed due to the high number of serious injuries and fatalities on South African roads due to motorists impacting traffic lights. After being knocked down the entire assembly needs to be replaced and on many occasions the pavement surface is also damaged. Replacing the current assembly is time consuming and costly.

The modular traffic light comprises of the latest polymer plastics, thus enabling the quick and easy assembly and construction of the light. The main electrical components of the light will be housed underground in a precast concrete block and the light pole will be coupled above ground level onto this block by a socket and four shearing bolts. Thus if the light is struck the bolts will shear and the light will fall over but will leave the cables intact, allowing for the quick replacement of the light pole or certain components and not the entire system with all the components.

A replaceable traffic light is manufactured in eight components made from various polymer materials. By finding the optimal facilities layout for assembly and storage of these components the throughput will be increased resulting in a more efficient service delivery and reducing the cost involved in manufacturing and assembling the traffic light.

The traffic light comprises of these eight components:

1. Concrete housing block
2. Main electrical power supply
3. Base plate attached to housing block
4. Socket joint attached to base plate
5. Shearing bolts
6. Modular light pole
7. Bracket for light box
8. Light box

The current department for replacing damaged traffic lights requires a facilities layout plan which will help to increase the reliability in the assembly line, installation rate and reduce costs throughout the process. By analyzing several layout options, which will include cost analysis, ergonomics and materials flow throughout the plant, an optimal solution may be found.

1.2 Problem Statement

The current installation process for replacing damaged traffic lights is very outdated and expensive. The lack of quick assembly and manufacturing rates, outdated equipment and materials, inadequate working methods, and the lack of appropriate assembly systems and techniques have caused the current operation to become a non feasible solution.

A correct approach to establishing a new facilities layout, assembly structure and material handling techniques can improve the installation rates and thus reduce the time a traffic light remains out of order. The current traffic light assembly and installation process is lacking in performance and effectiveness because of inadequate process flow and materials.

Thus there is a need to implement a new replaceable traffic light product and assembly line to improve the current system.

1.3 Project Aim and Objectives

The aim of this project is to find the optimal assembly plant layout for a replaceable traffic light production line, by using industrial engineering techniques such as assembly line analysis, quality control, ergonomics and cost analysis.

Objectives acting as a basis for the aim:

- Create a detailed plan to illustrate the optimal facilities layout in order to increase production rates of the assembled traffic light.
- Create a storage location for the finished product, making it easier for the installation team to access.
- Reduced/eliminated assembly blockage as well as more equipment and assembly points in working order resulting in higher output.
- Improved quality control for parts assembly.
- Lower ergonomics risk for periodic work.
- Reduced cost for space utilization resulting in less waste.
- Better understanding of the facilities layout preventing stoppages in the assembly line.
- Attempt to make it a viable solution to the current method of replacing damaged traffic lights.

1.4 Project Scope

The first section of the project will entail an in-depth literature review. This will demonstrate the techniques used in determining the optimal layout plan and will determine if it is a viable solution that can be implemented at a relatively low cost. Alternative layout plans will be identified and investigated. The literature review will also focus on identifying current and similar solutions and methods of replaceable traffic lights and analyse the impact they have had on the service delivery sector and what they entail.

For the second part of the project the identified alternative layout plans will be analysed to determine the best layout plan. This chosen facilities layout plan will be refined to make it a viable solution and a working plan that can be implemented in the current service delivery environment. It will be important to implement various methods and techniques to make this a justifiable model with significant and improved results.

The project will not entail the actual manufacturing of the components from various materials but mainly on how the components will be assembled together and the structure needed to optimize the plant layout to improve throughput and reduce the costs involved in the assembly line and the facilities layout.

Chapter 2 – Literature Review

2.1.1 Introduction to Facilities Planning and Design

Facilities' planning has become a critical component for companies to keep up with the current market trends in the last few years. In the past facilities planning was primarily considered to be a science. In today's competitive global marketplace, facilities' planning has become a strategy, (Tompkins et al, 2003).

Facilities' planning is a strategy used to achieve supply chain excellence. It is concerned with the design, layout and accommodation of various categories within a business environment. The main requirement for any facilities planning project to be successful is its ability to adapt and become suitable for new use. By implementing facilities planning in an assembly line a greater rate of production and throughput will be achieved.

Design, layout, accommodation of people, machines and activities of a system or enterprise within a physically restricted environment are the primary concerns for facilities planning. Haung (2003) states that facility layout design determines how to arrange, locate, and distribute the equipment and support activities in an assembly line facility to achieve overall production and the increase of assembly output.

An optimal facilities layout plan contributes to the overall efficiency of assembly operations and can reduce up to 50% of the total operating expenses, (Tompkins and White, 2003). When deciding on an optimal facilities layout structure, basic principles must be used. The necessary tools and methods required to optimize a facilities layout plant vary depending on the type of operation at hand.

According to Tompkins (Tompkins et al, 2003), the following are common reasons for the redesigning of facilities:

- Material handling problems, bottlenecks and high costs that normally occur due to inefficient layouts.
- Introducing of a new service or product.
- Changes in assembly methods, processes or equipment.
- Changes in legal requirements or environmental requirements.

Due to the high demand for replacing traffic lights there is an ever increasing pressure to improve and deliver products on time. However the quality of the product must not be compromised and thus finding an optimal facilities layout plan is critical for the assembly of replaceable traffic lights.

2.1.2 Objectives of Facilities Planning

The facilities planning objectives as defined in Tompkins and White, (2003) are to:

- Increase return on assets (ROA) by maximizing inventory turns, minimizing obsolete inventory, maximizing employee participation, and maximizing continuous improvement
- Improve customer satisfaction by delivering products on time and ensuring the quality adheres to the customer's specifications.
- Reduce costs and increase the assembly lines profitability
- Form an integrated supply chain by using partnerships and communication
- Effectively utilize people, equipment, space and energy

2.2 Layout Identification

2.2.1 Importance of Facility Layout design

The overall effectiveness of an assembly line can be greatly affected by insufficient layouts or facility layout problems which can occur in many ways. A study done by Tompkins, (1996), shows that since 1955, at least 10% to 30% of material handling costs can be reduced by an effective facilities layout plan. The vast amount of capital invested into facilities planning each year makes this an important aspect.

2.2.2 Layout Types

When analyzing, designing and implementing certain solutions to problems identified on an assembly line, it is critical to evaluate the requirements and activities for each type of scenario in order to make an informed decision.

Facilities' planning focuses on four main layout types namely, (Tompkins and White, 2003);

- Fixed material layout
- Production line layout
- Product family layout
- Process layout

An example of each facility layout is given below, (Tompkins and White, 2003):

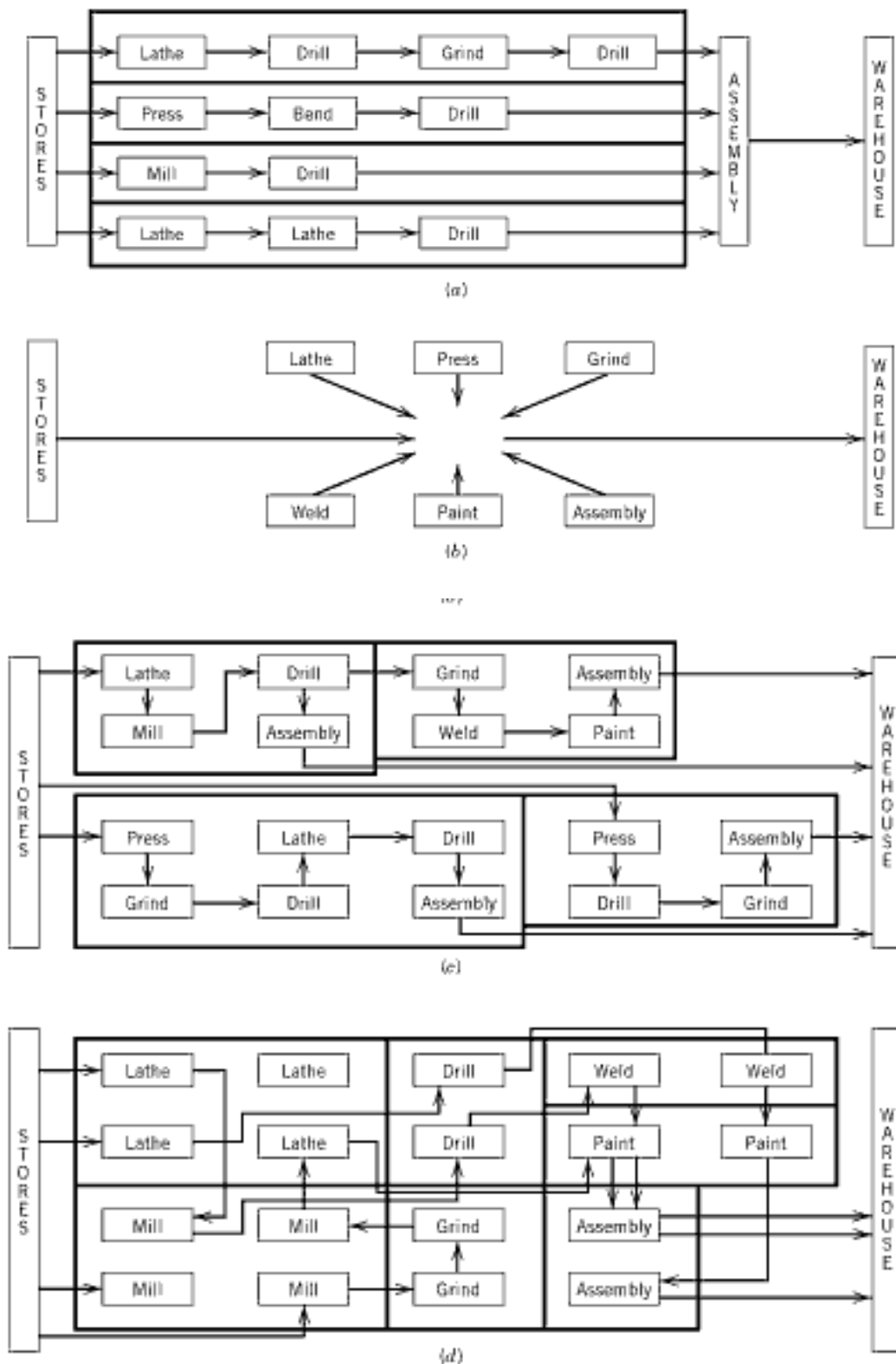

Figure 2.2.1 – Alternative Types of Layouts. (a) Production line product layout. (b) Fixed product layout. (c) Product family layout. (d) Process layout

For an assembly line project, such as assembling a replaceable traffic light, the two main layout plans that will be focused on are the production line layout and the product family layout. The production line facility is implemented if there is a large, stable demand for standardized products, whereas the product family facility focuses on a medium demand for a medium number of similar components.

The following table indicates the advantages and limitations for both layouts, (Tompkins and White, 2003):

	Advantages	Limitations
Production line layout	1. Smooth, simple, logical and direct flow line result	1. Machine stoppage stops the line
	2. Total production time per unit is short	2. Product design changes cause the layout to be obsolete
	3. Material handling requirements are reduced	3. Slowest station paces the line
Product layout	1. By grouping products, higher machine utilization can result	1. general supervision required
	2. Smoother flow lines and shorter travel distances	2. Greater labour skills required for team members
	3. Encourages consideration of general purpose equipment	3. Critically dependant on production control balancing the flows

Table 2.2.1 – Advantages and Limitations for Production vs. Product Layout

2.3 Material Handling and Flow

2.3.1 Material Handling

One of the most important components of the overall facilities design is the design of the materials handling system. The layout design and material handling system design are inseparable, (Tompkins et al, 2003). The integration of these two design functions is particularly critical in the design of a new facility. Materials handling is defined in Tompkins and White, (2003), as the art and science of moving, storing, protecting, and controlling material.

Transportation or idle time makes up more than 90% of the time material spends on the floor. Due to material handling being a non-value added activity efficient handling will save a considerable amount of capital. Material handling according to Tompkins, (2003), can account for 15% to 70% of the total cost of an assembly line. The objective for material

handling is to simplify and eliminate material handling activities, thus reducing the operational costs by 15% to 30% according to Tompkins and White, (2003).

The objectives of material handling, (Tompkins et al, 2003), are as follows:

- Increase efficiency of material flow
- Increase productivity
- Improve safety and working conditions
- Reduce material handling costs
- Improve facility utilization
- Facilitate the assembly process

2.3.2 Material Flow

Flow planning involves the effective combining of various flow patterns required for the specific operation with adequate aisles to obtain progressive movement from origination to destination. This implies that effective flow planning is a hierarchical planning process as indicated below, (Sule, 1994).

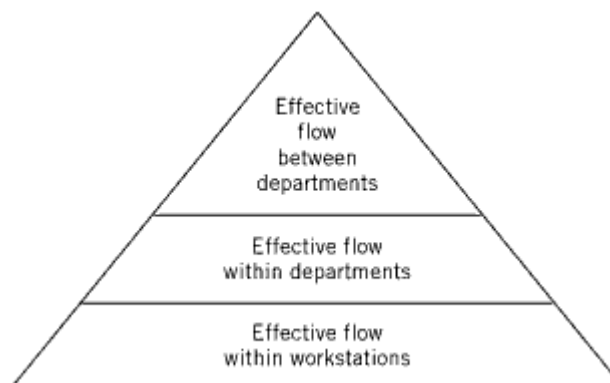

Figure 2.3.1 – Flow Planning Hierarchy

There are a number of flow patterns to consider when planning an assembly line facility layout. Flow patterns can be determined by the flow within workstations, within departments, and between departments. In a production line and/or product family department the flow of work follows the product flow. Thus the three main flow patterns that occur in these layouts are: end-to-end, back-to-back, and odd-angle, (Tompkins and White, 2003). These patterns are effective when one operator works at each workstation which is the case for the assembly of the replaceable traffic light.

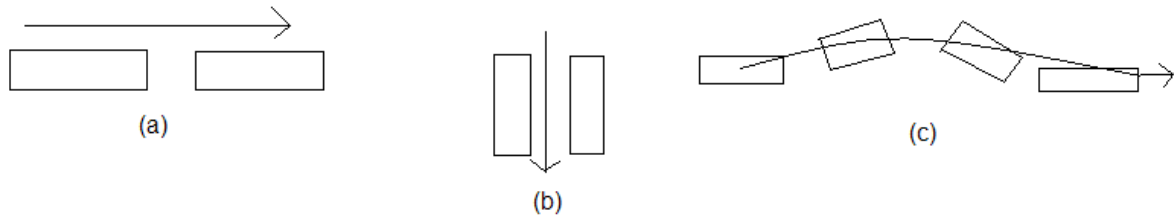

Figure 2.3.2 – Flow within Product Departments. (a) End-to-end. (b) Back-to-back. (c) Odd-angle

2.4 Facility Layout Design

As with materials handling there are three fundamental areas to consider when implementing a new facilities design, namely, (Tompkins et al, 2003):

- Relationships between the activities in the layout
- Space for each activity area, in amount, kind, and shape
- Adjustments of relationships and space into an effective plan

It is important to apply these three fundamental requirements to optimize a facilities plan, thus each one can and must be analyzed separately.

Relationships refer to the proximity between pairs of activities and the affect they have on one another to achieve the optimal assembly flow. Space calculations allow the facilities planner to accurately establish the amount of space required by each operation to fulfil its required purpose effectively. These calculations take the amount of space, type and configuration into account thus providing a specific size requirement for each individual operation. Adjustment refers to the location and arrangement of the space needed by each operation to fulfil its specific assembly process.

In the case of an assembly line operation neither the layout nor the material handling methods are fixed, thus explained by, Kulwiec, (1985:62), the following requirements need to be met.

2.4.1 Stages of Planning

There are many sequences of planning that exist between facility layouts although no two layouts are identical due to the nature of the process, (Kuhl, 2005).

Stage 1 – The external movement of material to and from a location must be laid out to the location area.

Stage 2 – An overall plan for the blocked out layout and overall handling plan for the total area.

Stage 3 – Detailed layouts for each specific piece of machinery, equipment or storage area, and specific handling methods.

Stage 4 – Installation of approved plans, procurement and/or rearrangement.

2.4.2 Design Process

Only once an optimal facilities plan exists can further improvements and changes be made. The overall layout sets out to achieve the best possible results concerning various components in optimizing the assembly line. Some of these components include, (Tompkins et al 2003:108):

1. Operator must be able to collect or discharge materials without having to make awkward reaches or travel long distances.
2. The operator should be involved efficiently in the workplace to perform the required operation.
3. The time spent on handling the material during assembly should be minimized.
4. A continuous work flow should exist within the workstation to minimize cycle and idle times.

2.4.3 Specifications - Workstations

Workstations for materials areas should consist of the following, (Tompkins and White, 2003):

1. Receiving and storing of inbound materials
2. In-process materials
3. Storing outbound materials and shipping
4. Storing and shipping waste and scrap
5. Tools, fixtures, jigs, dies and maintenance materials

Included in the workstation space requirements is the space for the personal area:

1. The operator(s)
2. Material Handling
3. Operator ingress and regress

2.4.4 Fixed Space Requirements

Each workstation requirements should be incorporated into the facilities layout plan. Paths assigned to forklifts included a minimum of 2.75 metres for the specified forklift operating on the assembly line, (Tompkins et al, 2003). An important fixed space requirement is the consideration of the entry and exit points to determine which flow patterns to use. Accessibility to certain areas is critical, including minimal allowed aisle space within the storage areas and material handling equipment areas, (Tompkins and White, 2003). Accessibility to each workstation by an individual should also be provided for in the layout plan.

2.5 Methods, Tools and Techniques

There are several approaches to be considered when implementing a facilities layout plan. A facility planning process is understood to be a life cycle, although only planned once it is frequently replanned and improved to satisfy its continuously changing objectives.

The traditional engineering design process is the simplest method for optimizing a facility plan, however all methods have similar steps to this process which include:

1. Define the problem
2. Analyze the problem
3. Determine the space requirements for all activities and generate alternative designs
4. Evaluate the alternatives
5. Select the preferred design
6. Implement the design

When implementing a facility planning project there are two popular and effective approaches to consider, the Systematic Layout Planning (SLP) method by Richard Muther and the Winning Facilities Planning Process.

2.5.1 Systematic Layout Planning

Muther's Systematic Layout Planning (SLP) Procedure

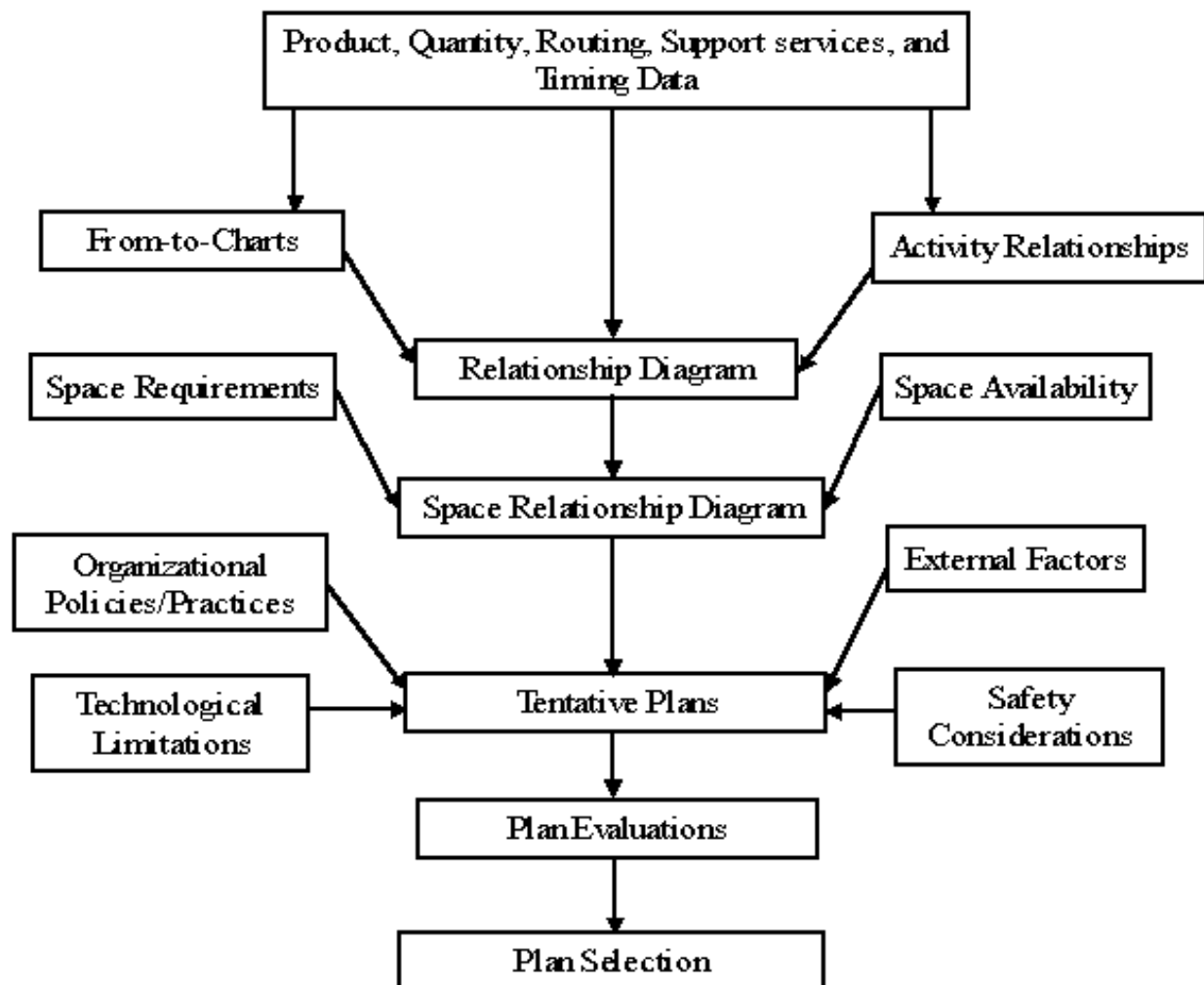

Figure 2.5.1 – The Framework for Systematic Layout Planning (SLP), (Tompkins, White, Bozer, Tranchoco, 3rd edition, 2003)

Muther implements the following steps in his layout design process:

1. Document the present operation by applying flow charts to document the material and information flow. In addition, the present equipment layout and current methods must be documented. The flow chart will indicate steps that are redundant or may no longer be necessary. Steps that will improve the operation may be added.

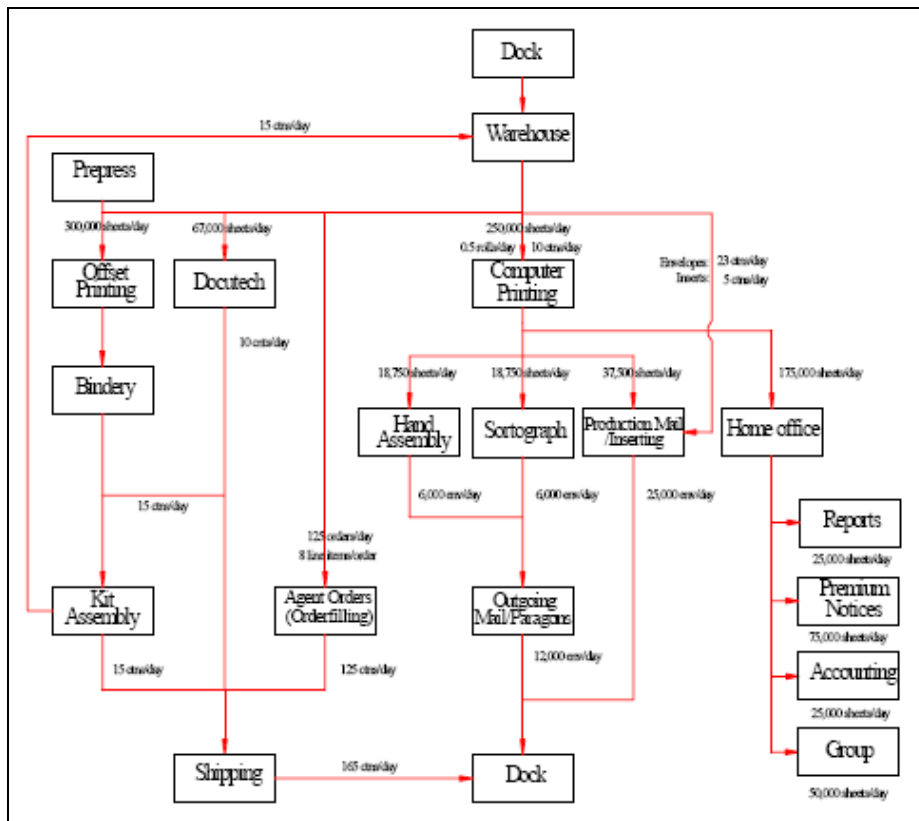

Figure 2.5.2 – An Example of a Flow-Chart taken from (Baeseman, 2003)

2. Define the activities within the present process and include future operations. Activities are operations, equipment, workstations, or areas that make up the space that is being planned. In this step an activity relationship chart is used to link all necessary activities. A relationship diagram is then produced to position activities spatially. Proximities are typically used to reflect the relationships between pairs of activities. Thus the following examples taken from, Tompkins et al (2003), indicate the relationships between various operations.

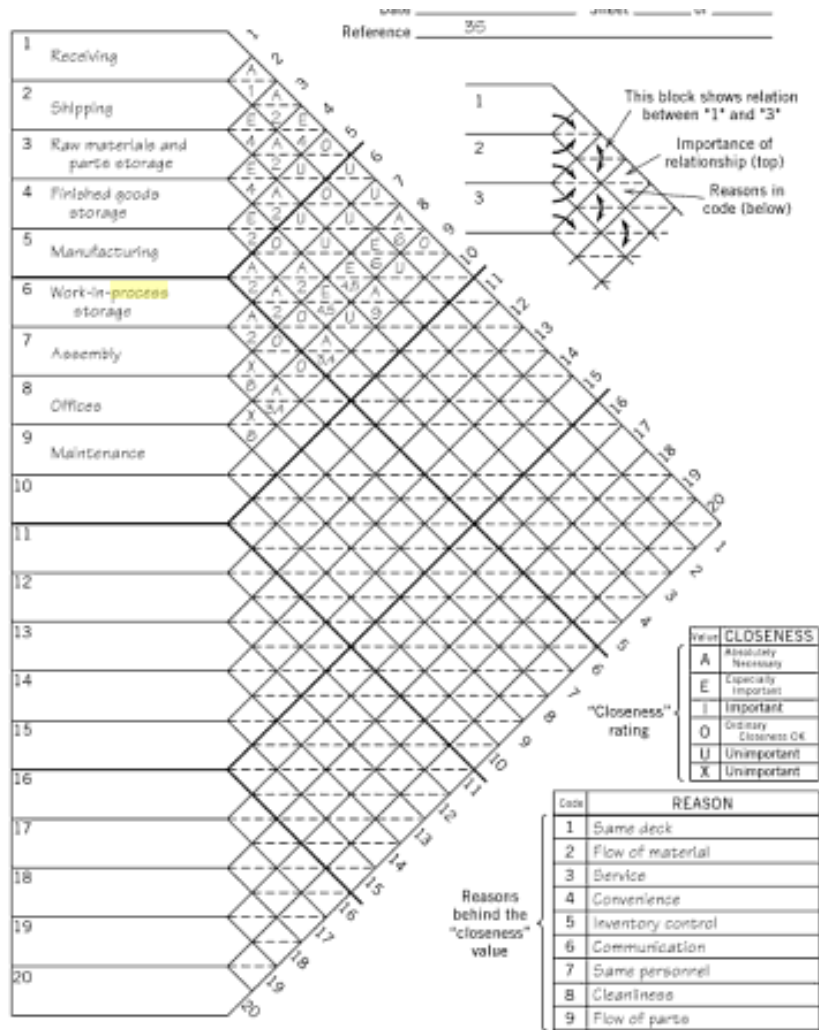

Figure 2.5.3 – An Example of an Activity Relationship Diagram

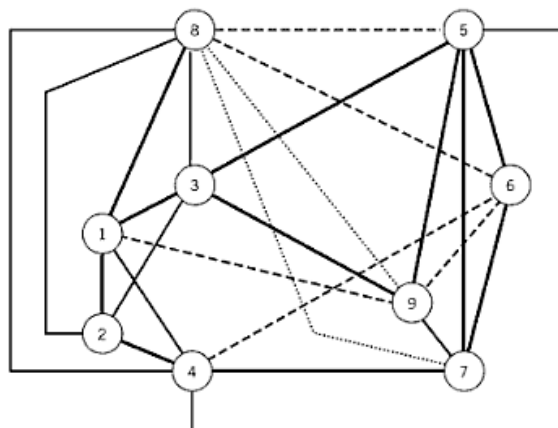

Figure 2.5.4 – An Example of a Relationship Diagram

3. Develop space requirements in terms of size, equipment, and operational improvements for each activity. It is necessary to look at each activity individually as these requirements vary from activity to activity. The space relationship diagram is

drawn up from the space considerations and the relationship diagram. This diagram indicates the proximity and importance of each operation to one another.

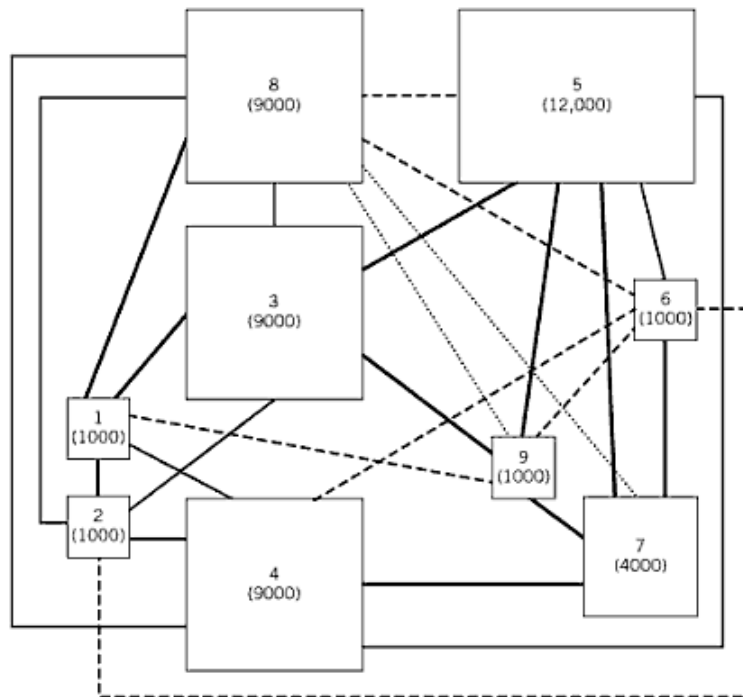

Figure 2.5.5 – An Example of a Space Relationship Diagram according to closeness ratings, (Tompkins and White, 2003)

4. A number of alternative block layouts are designed and evaluated according to prior criteria. There are three main block layouts to consider as indicated in the figure below:

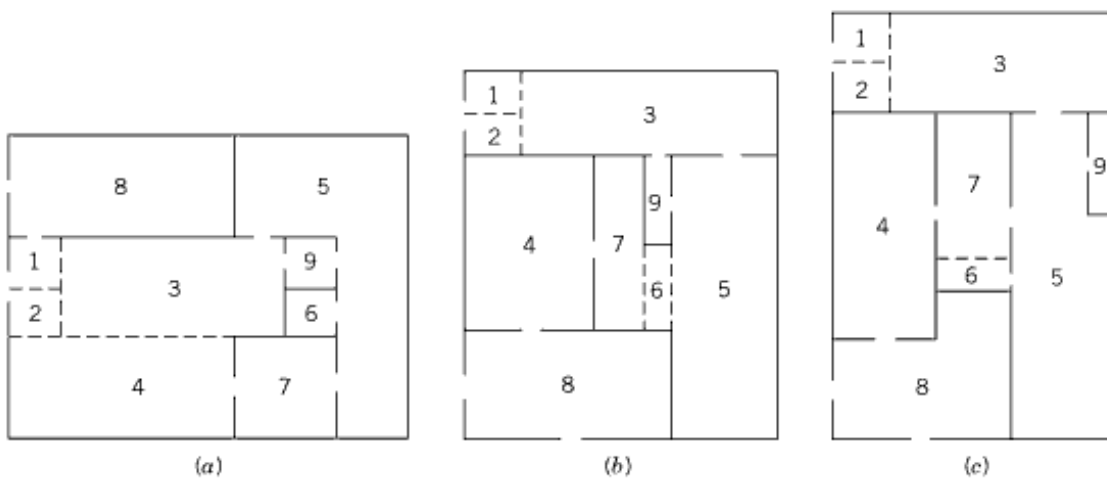

Figure 2.5.6 – Alternative Block Layouts, (Tompkins and White, 2003)

5. A final layout is chosen for implementation based on this evaluation.

2.5.2 The Winning Facilities Planning Process

As indicated in figure 2.5.7, the winning facilities planning process is a novel approach to solving contemporary facilities layout planning. This model of success presents a clear direction of where a business is headed. In the facilities planning process a clear understanding of the vision is needed as well as the mission, the requirements of success, the guiding principles, and the evidence of success which make the facilities plan an optimal solution to the current problem. It is the combination of these five elements (Vision, Mission, Requirements of Success, Guiding Principles and Evidence of Success) that forms an organization's Model of Success.

The definition of these five elements as given in Tompkins and White, (2003) are:

- *Vision*: A description of where you are headed
- *Mission*: How to accomplish the vision
- *Requirements of Success*: The science of the business
- *Guiding Principles*: The values to be used while pursuing the vision
- *Evidence of Success*: Measurable results that will demonstrate when an organization is moving toward its vision.

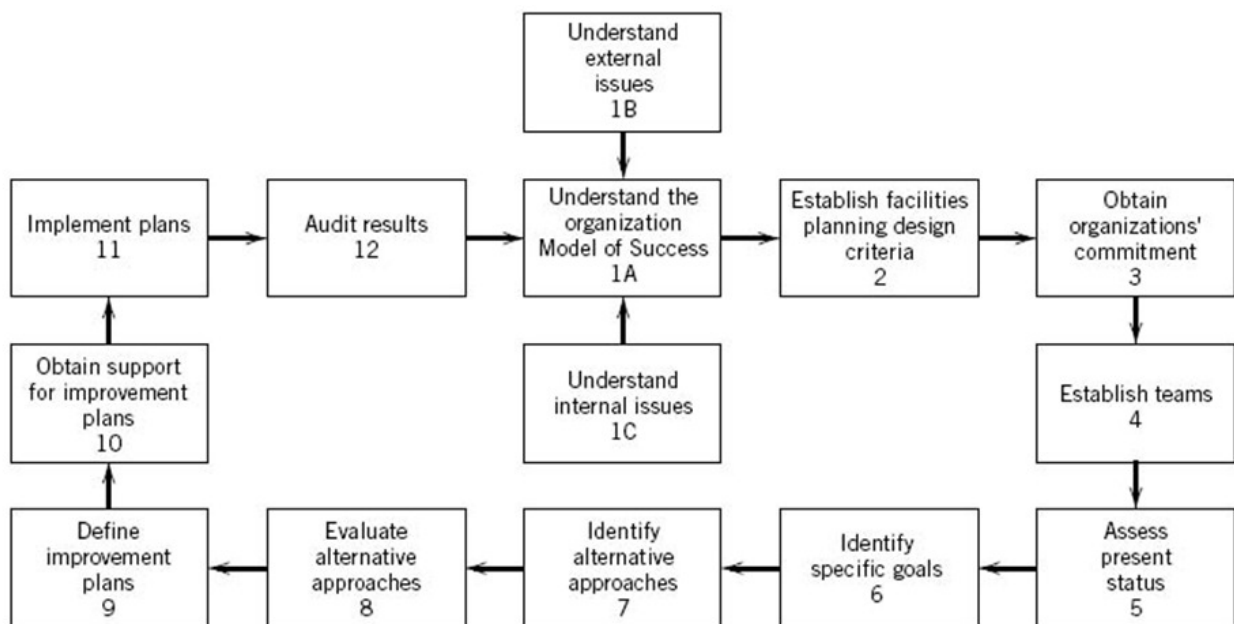

Figure 2.5.7 – Winning Facilities Planning Process
(Tompkins, White, Bozer, Tanchoco, 2003 3rd edition: 15)

To help management and employees understand where their business is headed, it is often useful to illustrate the first four elements of the Model of Success in graphical form, (Tompkins et al, 2003) as shown below. This graphical representation is often called the winning circle and is viewed as the company’s bull’s eye.

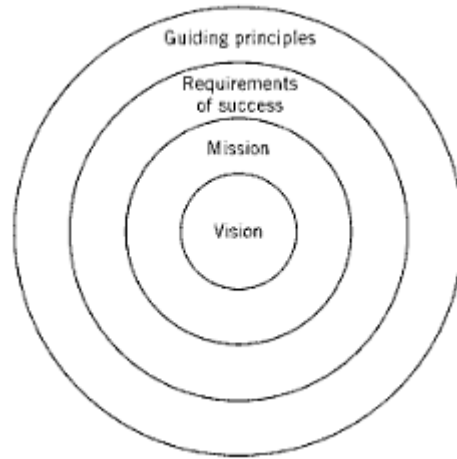

Figure 2.5.8 – The Model of Success “Winning Circle”
(Tompkins, White, Bozer, Tranchoco, 2003:16)

In table 2.5.1 a comparison of the Engineering Design Process, Facilities Planning Process, and Winning Facilities Planning Process is made. Each describing what is done in the respective phase of designing a facility layout plan.

Phase	The Engineering Design Process	The Facilities Planning Process	The Wining Facilities Planning Process
Phase I	Define problem.	<ol style="list-style-type: none"> 1. Define or redefine objective of the facility. 2. Specify primary and support activities. 	<ol style="list-style-type: none"> 1A Understand the organization Model of Success. 1B Understand external issues. 1C Understand internal issues. 2. Establish facilities planning design criteria. 3. Obtain organizational commitment.
Phase II	Analyze the problem. Generate alternatives. Evaluate the alternatives. Select the preferred design.	<ol style="list-style-type: none"> 3. Determine the inter-relationships. 4. Determine space requirements. 5. Generate alternative facilities plan. 6. Evaluate alternative facilities plan. 7. Select a facilities plan. 	<ol style="list-style-type: none"> 4. Establish teams. 5. Assess present status. 6. Identify specific goals. 7. Identify alternative approaches. 8. Evaluate alternative approach. 9. Define improvement plans. 10. Obtain support for improvement plans.
Phase III	Implement the design.	<ol style="list-style-type: none"> 8. Implement the plan. 9. Maintain and adopt the facilities plan. 10. Redefine the objective of the facility 	<ol style="list-style-type: none"> 11. Implement plans. 12. Audit results

Table 2.5.1 - Comparison of the Engineering Design Process, Facilities Planning Process, and Winning Facilities Planning Process

2.6 Problem Identification and Analysis of Operations

According to Niebel, B. & Freivalds, A. (Niebel et al, 2003) the root cause analysis and critical analysis techniques are necessary steps that must be taken at the start of a project for it to have an orderly approach and allows the project to end with the implementation of the final design.

If these methods are implemented and executed correctly, the facts can be presented clearly and accurately. The methods can then be examined critically to identify the most practical, economical, and effective facilities plan which can be installed, (Niebel et al, 2003).

Wikipedia, (Wikipedia, 2008) states that Root Cause Analysis is a class of problem solving techniques aimed at identifying the root causes of problems or events. It is a problem solving technique structured to investigate and identify the true cause of a problem and the necessary actions needed to be taken to eliminate it.

By implementing a critical analysis approach throughout the assembly line will allow for inspections of standards, material handling, working methods and conditions, and tool equipment.

When implementing a new facilities design with new material handling techniques it is important to analysis the system critical thus allowing for the appropriate improvements to be made. According to Niebel and Freivalds (Niebel et al, 2003), method analysts use operation analysis to increase productivity per unit of time by means of studying all productive and non-productive operations of a system. By using the questioning approach on all operations of the facility an efficient facilities layout plan can be developed.

Eliminating inefficient material handling processes without sacrificing safety can be achieved through analyzing the entire system critically. The Material Handling Institute (1998) has developed 10 principles of material handling, these are:

- Planning principle
- Work principle
- Unit load principle
- Space utilization principle
- Automation principle
- Standardization principle
- Ergonomic principle
- Life-cycle-cost principle
- System principle
- Environment principle

Table 2.6.1 shows a template of the critical analysis technique that uses the questioning approach to study all operations within the system. Thus allows focus to be placed on the areas likely to provide improvements.

CRITICAL ANALYSIS TECHNIQUE			
METHOD:			
PRESENT METHOD		ALTERNATIVES	SELECTED ALTERNATIVE
Purpose: What is achieved?	Is it necessary? (Y/N) If Yes - Why?	What else could be done?	What is the purpose?
Means: What is done?	Why that way?	How else could it be done?	How should it be done?
Place: Where is it?	Why There?	Where else can it be done?	Where should it be done?
Sequence: When is it done?	Why then?	When else could it be done?	When should it be done?
Person: Who does it?	Why that person?	Who else could do it?	Who should do it?

Table 2.6.1 – Critical Analysis Template

Figure 6.2.1 illustrates the questions that should be considered to achieve a preferred design in the system with regards to analysing material handling operations.

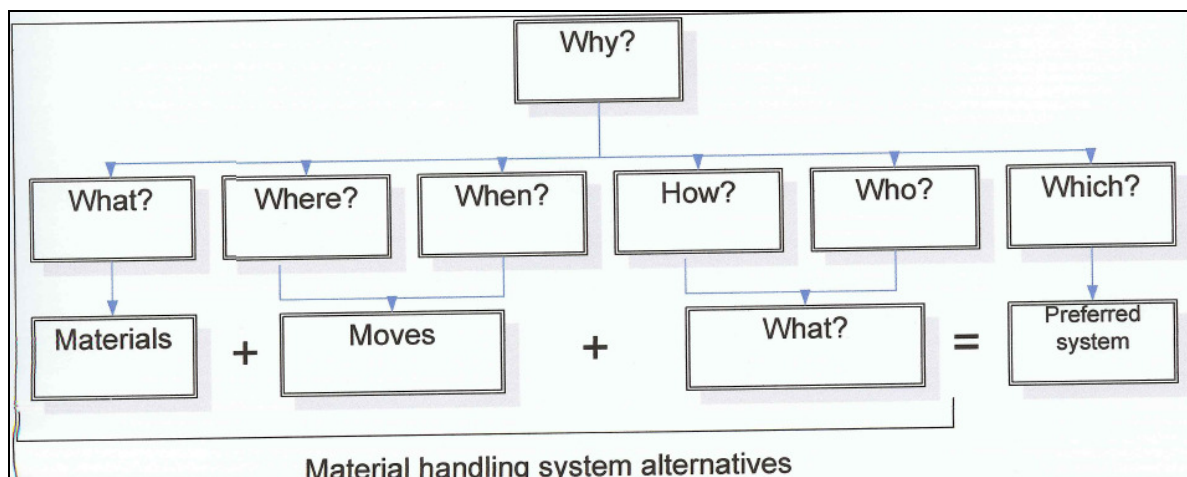

Figure 2.6.1 – Operation analysis for material handling

Niebel, B. & Freivalds, A. (Niebel et al, 2003) predetermined 9 primary operation analysis approaches that the critical analysis is based on:

1. Operational Purpose
2. Part Design
3. Tolerances and Specifications
4. Material
5. Manufacturing Sequence and Process
6. Set-up and Tools
7. Material Handling
8. Plant Layout
9. Work Design

Not all of these approaches are applicable to each operation within the system. Using the correct approach, overall improvements can be achieved and finding an optimal plant layout can become possible. Niebel, B (Niebel et al), states that whenever this procedure is followed by competent engineers and analysts, beneficial results have been achieved.

Chapter 3 – Conceptual Design and Information Gathering

3.1 Data Specifications

It is important to note that the modular replaceable traffic light is a new design feature for traffic lights and does not exist in assembly at this present time, thus there is no current facility layout plan and ideas put forward in this project are based on guidelines and advantages of one application over another.

The modular replaceable traffic light comprises of eight components listed below with an accompanying diagram:

1. Concrete housing block
2. Main electrical power supply
3. Base plate attached to housing block
4. Socket joint attached to base plate
5. Shearing bolts
6. Modular light pole
7. Bracket for light box
8. Light box

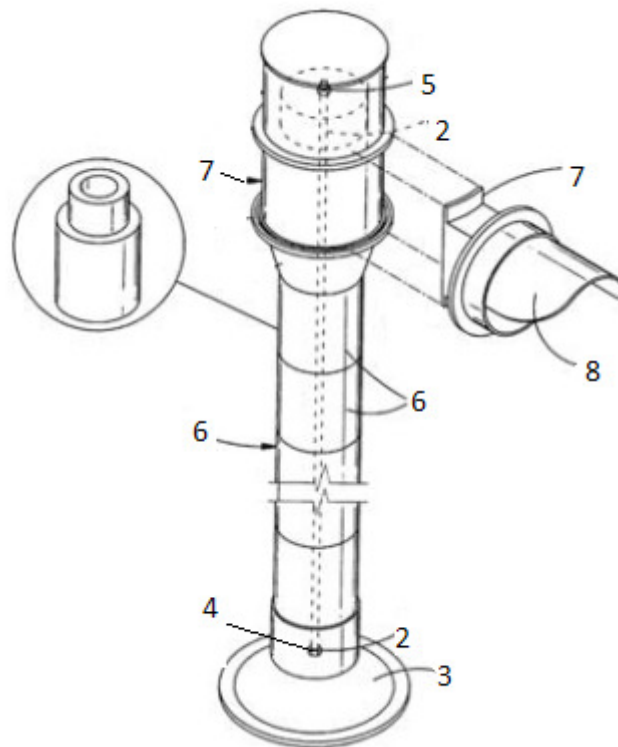

Figure 3.1.1 – A Detailed Design of Modular Traffic Light showing components

The concrete housing block, light box and light pole are outsourced components from various suppliers. Once these components are all stored together in the arrivals storage unit of the facility the assembly line can begin to assemble the parts in a straight line material flow pattern.

The following specifications are an initial guideline to the various components to indicate the space required for assembly:

1. The housing block is pre-cast from cement by a reliable supplier and shipped directly to the assembly plant. Due to it not being necessary in the production line it can be stored in the finished good warehouse where it is accessible by the installation team.
2. The power supply will be installed by a team of electricians on the assembly line and will be wired to the light system before entering the finished goods warehouse. The power cable will be connected to the existing power cable on site where necessary.
3. The base plate will be manufactured on site and cast out of a polymer plastic and can be attached to the housing block and modular pole by shearing bolts as illustrated in figure 2. The base plate is durable and due to it being coated with a ultra-violet resistant paint it is resistant to rust thus increasing its life span. The plate has a minimum yield strength of 30,000 psi.
4. The socket joint is cast together with the base plate thus making it a single component. The socket protrudes out of the base plate and will be coupled with the modular pole. The socket will have a 'female' connection and the pole a 'male' connection thus allowing the coupling to take place. This couple will allow the current to pass through and operate the light system. If the traffic light is struck by a car this couple will break leaving the base plate intact meaning only the pole will have to be replaced and not the entire system.
5. The shearing bolts will hold the base plate and modular pole to the house block. The four bolts required for each traffic light will be fabricated from hot-rolled carbon steel with a minimum yield strength of 55,000 psi. The thread end is galvanized a minimum of 12mm and each bolt is furnished with two flat washers and two hex nuts. These bolts are designed to shear at the head if struck with a force thus allowing the pole to fall over in the direction of the force and not risk injury to the motorist.
6. The modular light pole is made from a polymer plastic and is extruded to a specific length depending on the size required for a specific intersection. Each modular piece is interchangeable and assembled end to end as indicated in figure 1. This design allows for quick replacement to damaged parts and often only a small part is damaged but in the current method of a fixed pole the entire pole must be replaced at a large cost. The material will also reduce the amount of damaged caused to the car and reduce risk of injury.

7. The mounting bracket for the light box is also made from a polymer plastic and can be replaced very efficiently as it is light weight and easy to handle. It will be mounted to the pole by means of two locking bolts.

8. The light box is outsourced from the current manufacturer as it is a standard part and already meets the requirements from the South African Bureau of Standards. This box will be mounted by means of the bracket to the pole using the same two bolts.

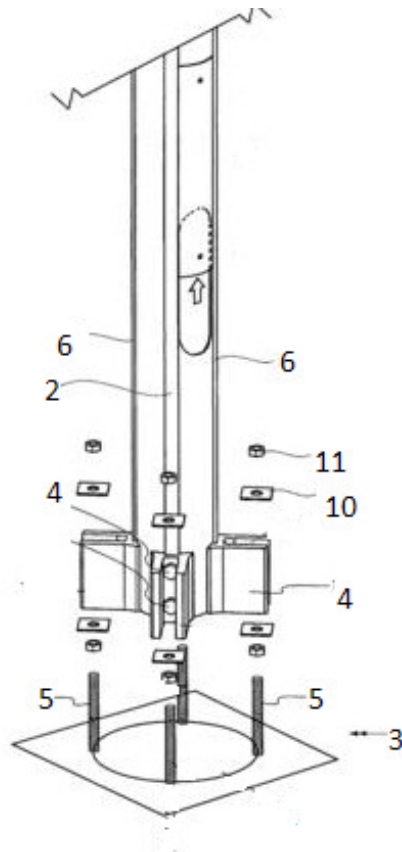

Figure 3.1.2 – A Detailed Diagram Illustrating an Exploded View of the Housing and Base Plate System

- Item numbers 10 and 11 are the flat washers and hex nuts used to tighten the bolts to the base plate.

The new modular replaceable traffic light will make use of LED light signals. These lights have the benefit of reducing power consumption, only using 10% power, and have a longer life span lasting up to 70 000 hours. The dimensions are 280mm wide x 762mm tall by approximately 140mm deep. The cap visors extend a further 180mm from the face and are easily removable. The lens diameter is a standard 200mm. The bulbs require 120 volts of electricity, equivalent to the standard household bulb. The weight of the light box is 5kg,

due to it being manufactured out of polycarbonate materials, about half that of a standard aluminum signal.

The following table indicates the specifications of LED light bulbs used in traffic systems:

LED Colour	Dia	LED Qty	Colour Wavelength	Brightness	Viewing Angle	Power Consumption
Red	200mm	90 LED	630 nM	>400cd	+/- 30 Deg	< 8W
Yellow	200mm	90 LED	590 nM	>400cd	+/- 30 Deg	< 8W
Green	200mm	90 LED	505 nM	>400cd	+/- 30 Deg	< 8W
Operating Temperature			Input Voltage		Ingress Protection	
-40°C ~+ 80°C			AC 85-265 50/60Hz Universal Input		IP54	
Material UV stable Polycarbonate / lens with silicon seal						

Table 3.1.1 - LED Light Specifications adapted from LIGHTS TO GO!

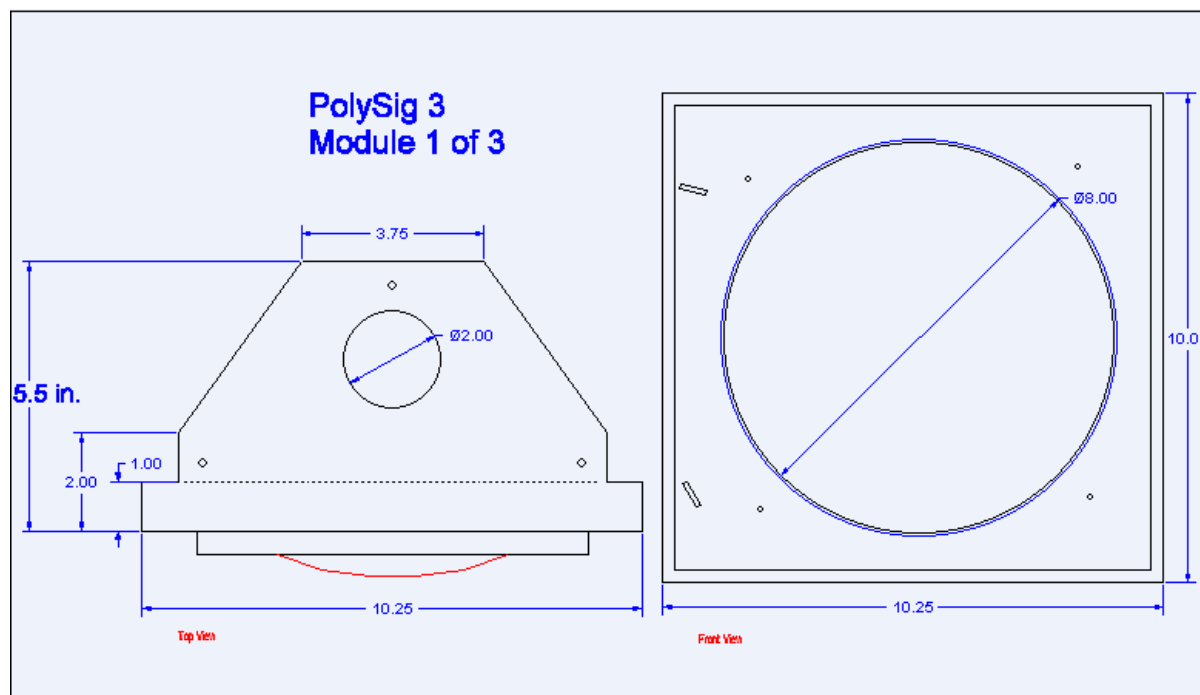

Figure 3.1.3 - Dimensions of LED Light Bulbs

3.2 Conceptual Design Implementation

The design of a new facility must be done in sectors. Each sector must be analyzed and solved to completion individually, once this is done all sectors can be assembled together to create the final layout. This process is done according to the functional and physical requirements of each activity on the assembly line.

The following aspects that will be analyzed individually are:

- The layout plan
- Material handling
- Material flow

Once these aspects are finalised they will be incorporated into Muther's Systematic Layout Planning (SLP) methodology as it is the most comprehensive and detailed method when building a facilities layout for an assembly line process. However Muther's methodology will not be followed exclusively as no two assembly layouts are identical, thus various aspects of different design processes will be used to optimize the layout plan for the assembling of replaceable traffic lights.

3.2.1 The Layout Plan

There are two main facilities layout options to consider when trying to optimize an assembly line production plant. A production/process line layout is based on the processing sequence for the parts being produced on the assembly line. When there exists a large demand for standardized products and the materials flow from one workstation directly to the next in a straight line this layout allows for the workstations to be combined into a single department producing a single product. This layout allows for the parts to flow without disruptions resulting in high output numbers.

When there is a medium demand for similar components to be assembled the components can be grouped to form a product family. The combination of grouping similar workstations results in a product planning department that is interlinked based on common process sequences, tooling requirements or material composition thus resulting in a high degree of intradepartmental flow.

As indicated in table 2.2.1 in chapter 2, there are advantages to using both these layouts as properties of both these layouts are prevalent in an assembly line. Reid et al (2007) classifies an assembly line as a Hybrid Layout which combines elements of both the process and product layout into a more effective and optimal layout.

However for the process of assembling a modular traffic light the best layout to implement is the production line layout, with certain elements adapted from the product family layout, because there is a significantly high demand for replacing damaged or broken lights. Due to many of the components being outsourced by local suppliers and delivered to the assembly plant the production line layout allows for the quick and smooth flow of components from the storage units to the assembly point then to the inspection site and finally to the finished goods warehouse, where the light is stored for transportation to the required site where it can be inserted by a small team.

The layout will be based on the following diagram:

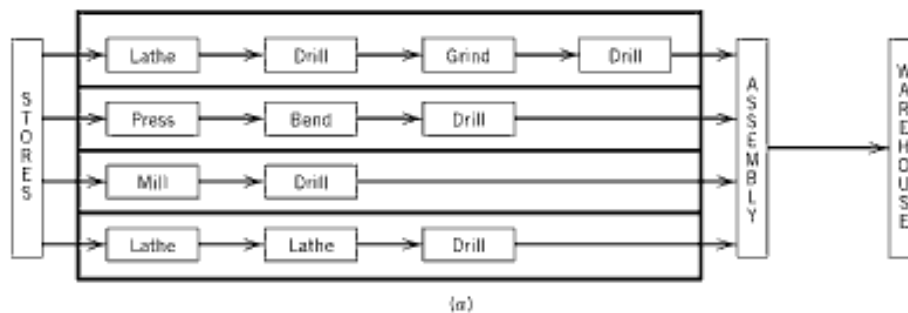

Figure 3.2.1 – Product Planning Layout (Tompkins and White, 2003)

3.2.2 Material Flow

For the process of assembling a replaceable traffic light the materials should flow in a straight line with the workstations in an end-to-end arrangement, as indicated in the figure below, this allows for one operator to work at each workstation and then move the component along to the next operator by means of a conveyor belt system.



Figure 3.2.2 – End-to-end Flow (Tompkins and White, 2003)

When considering the entrance and exit points to the improved facility it is best to use the opposite side approach as this allows incoming components to first be stored then move along the production line with all necessary steps being performed and the out into a storage bay.

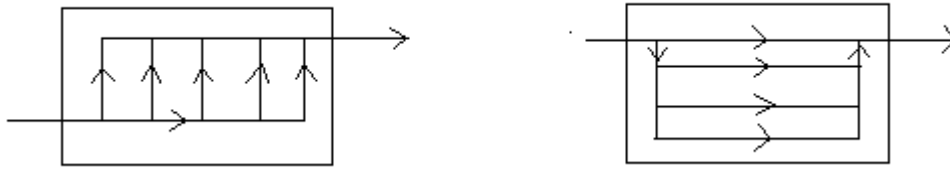

Figure 3.2.3 – Examples of entrance and exits located at opposite sides of the layout (Tompkins and White, 2003)

In the facilities plan there should be two large storage warehouses in the front of the plant for storing outsourced components and at the rear of the plant for storing the finished product in such an order that first in first out goods takes preference. This will allow for a smooth and interruption free operation benefiting in reduced operational costs and an improved turn around rate with delivery time to a particular site minimized.

In the case of suppliers being inconsistent or the product being assembled is heavily regulated, which is the case for a traffic light, and needs to be inspected throughout the entire assembly line inspection and quality control is necessary. For the facilities layout plan for the assembly of the replaceable traffic light many of the components are outsourced thus inspection must take place on delivery before the parts enter the assembly line. At the end of the assembly line a final quality assessment will take place before the completed traffic light enters the finished goods warehouse.

3.2.3 Systematic Layout Planning (SLP)

A fundamental step in solving the facilities layout problem is identifying any problems occurring in the current layout. The following industrial engineering tools and techniques can be used to identify problems occurring in the operation:

- Pareto Analysis
- Cause and Effect diagram, also known as a Fish Bone diagram
- Process Flow Charts
- Root cause analysis (RCA)
- Critical Analysis Technique

These steps can all be included in the Systematic Layout Planning approach which uses effective steps that have many beneficial advantages over other various approaches when implementing an assembly line layout. The goal of the Systematic Layout Planning approach is to locate two areas with high frequency and logical relationships next to each other. These steps are listed below and are taken from Baeseman (2003):

1. Document present operation
2. Define activities
3. Develop space requirements
4. Define block layout alternatives
5. Implement final layout design

These operations will form the basis for the facility layout operation and aid in the decision taking steps to optimize a layout for the assembly line of a modular replaceable traffic light.

3.3 Root Cause Analysis

The following Root Cause Analysis was done on the problems that might be encountered when the facilities layout is implemented and fully operational. As mentioned in the literature review (chapter 2.6) the assembly line for the replaceable traffic light, manning once the assembly line is operational and equipment needed to operate the assembly line efficiently where analysed with the following cause and possible counter measures to be put in place. See table 3.3.1, 3.3.2 and 3.3.3 for the results.

Table 3.3.1 – Assembly line Root Cause Analysis

Assembly for replaceable traffic lights				
Nr.	Description	Root Cause	Effect	Possible Countermeasures
Delivery				
1	Parts not delivered by supplier on time or not according to specifications	Alternative supplier not in place	Assembly production can not start in time therefore delays in output of traffic lights	Implement two competing suppliers thus allowing for interruption free assembling to meet demand
2	Delivery time does not follow part movement	Process not enforce	Bottlenecks occur when parts pile up	Enforce warehouse transfers by better transportation methods
Assembly line				
3	Parts transferred before initial quality sign off	Attempt to achieve weekly target	Parts not assembled correctly due to incorrect specifications	Investigate new process to control inspection of traffic light parts
4	Incomplete traffic lights move forward to next station	No demarcation sequencing and signage	Incomplete parts cause congestion and double handling	Investigate process to find alternative layout plans for assembly lines
5	Unable to meet weekly assembly demands	No assembly capabilities after hours & weekends	Unable to complete assembly and installation orders	Improve layout to increase assembly rates thus allowing for a storage build-up
double working on parts				
6	No indication of work in process	No identification method and process undefined	Double working on parts causing delays	Investigate assembly line to control working processes

Table 3.3.2 – Manning Root Cause Analysis

Manning				
Nr	Description	Root Cause	Effect	Possible Countermeasures
Manning				
1	No personnel or process available for after-hour or weekend emergency assembly duties.	No contingency plan	Traffic lights remain out of order for long periods of time.	Multi skill training on current personnel Introduce conveyor belt to transport goods quickly

Table 3.3.3 – Equipment Root Analysis

Equipment				
Nr.	Description	Root Cause	Effect	Possible Countermeasures
Forklift				
1	Delay in transporting completed traffic lights	Bottleneck occurs	Causes delays in transfer	Eliminate forklift and incorporate conveyor belts for the assembly line
Large parts				
2	Not all parts can be easily moved	Forklift size not adequate for parts being moved	Double handling on parts to finished goods store	Introduce conveyor belts to handle the large parts
Computer				
3	No computer to resolve delivery delays	No computer to check order status	Delays in finalizing transfer documentation	Obtain computer and train accordingly

Chapter 4 – Design and Problem Solving

4.1 Introduction to Plant Layout and Material Handling

Facilities layout planning uses the company's physical facilities to promote the efficient use of equipment, material, people and energy. Plant layout is a division of the entire facilities design project. Facilities design incorporates plant location, building design, placement of departments, work groups, allocation of workstations and material handling. (Meyers. E, 1993:1).

The objective of the plant layout is to optimize and smooth the work flow of materials, machines and equipment throughout the assembly of the replaceable traffic light. This being a new design (as previously mentioned), the focus will be placed on the plant layout, material flow and material handling.

Material handling is defined as moving material throughout a system. Fred E. Meyers (1993:2) states that "...if you improve the flow of material, you will automatically reduce production costs. The shorter the flow throughout the plant, the better" (Meyers. E, 1993:2).

Plant layout is dependent on material handling and thus it is important to make the correct choices when considering material handling equipment and the allocation of these parts in the system. We must never forget that material handling and plant layout are inseparable in the real world. (Meyers. E, 1993:2).

The mission statement for this plant is to design a feasible yet functional assembly line in order to reduce the time taken to deliver and replace a damaged traffic light. By finding an optimal material flow and assembly line pattern the current costs incurred for replacing damaged traffic lights can be reduced.

The following goals were of main importance:

- Increasing throughput
- Reducing material costs
- Safe working environment (ergonomics)
- First in, first out.

The most visible waste is not scrap but good materials sitting idle. – George W. Plossl

4.2 Flow Patterns

There are a number of flow patterns to be considered when developing a facility layout design as this is an important aspect of the entire system as it dictates the assembly rate. The two primary layouts for an assembly of a replaceable traffic light are shown below:

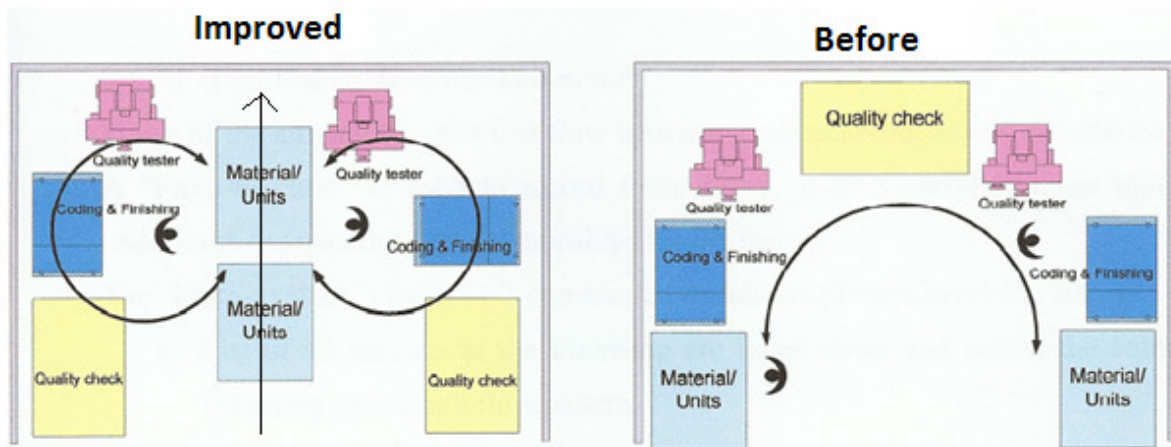

Figure 4.2.1 – Various flow patterns in an assembly line



Figure 4.2.2 – End-to-end Flow (Tompkins and White, 2003)

In figure 4.2.1, the before material flow is known as an “operator’s birdcage” (Chas et al, 2005). If there is an increase in demand it is very difficult to increase output by introducing a third operator if this layout is operational. The improved process flow is a straight line outlay; this pattern allows operators to help one another if necessary as there are no obstacles between them. This pattern creates the potential to increase output due to the possibility of a third operator being placed in the system.

Figure 4.2.2 is the end-to-end process flow. For the assembly of replaceable traffic lights, this flow is optimal as it allows for the easy transport of large parts such as the traffic light pole. By implementing this pattern, conveyor belts can be installed and the operators can have work stations located alongside the belt at their allocated work stations. This flow pattern allows for conveyor belts to transport the cement housing blocks through the assembly line and limits the need for the employees to move the housing block.

4.2.1 Measuring Flow

As the entire assembly line operation is dependant on the flow of material among the work stations it is one of the most critical factors in designing and arranging the plant layout. Material flow among the stations needs to be measured. These measurements can be done in a quantitative and qualitative manner. Quantitative measures may include the measurement of material, information and people between stations by pieces per hour, moves per day or units per week. Qualitative measures focuses on the intangible factors that need to be considered between two stations, these include, communication, noise, cost and pollution. Stations that have significant communications and organizational interrelations but have little material or people influence should be considered as qualitative candidates and must be placed towards the end of the assembly line as they do not control the rate of assembly.

It is essential that both qualitative and quantitative measures of flow should be used to achieve an optimal solution for the design of a facilities plant layout.

The following techniques were incorporated as part of Murther's Systematic Layout Planning approach to determine the optimal process flow and layout design for the new plant layout for the assembling of replaceable modular traffic lights.

4.2.1.1 Quantitative flow measurements

The amounts of units of flow between work stations and through the assembly line are measured quantitatively. A "From-to-chart" is used to record these flows. This tool indicates the material flow relationships for the assembly line of the traffic light.

The From-to-chart is constructed as follows for the necessary stations needed to assembly a replaceable traffic light according to Murther's Systematic Layout Planning Procedure (Tompkins et al, 2003):

1. All the stations needed to complete the assembly of the replaceable traffic light are listed down and across the columns. These stations follow in order from initial delivery to final storage of completed parts.
2. The units that flow between stations are recorded in the From-to-chart. The From-to-chart represents the relationship of flow of units between stations.

The process for the assembly line is as follows:

- The outsourced products or materials arrive at the delivery bay by the suppliers.
- The material is then transported by forklift to the initial storage area and stored in designated departments.
- The components are split into the necessary parts for the three conveyor belts, line 1 and 2 assemble the same parts (light pole with attachments) and line 3 assembles the housing block and base plate.
- The replaceable traffic light is assembled at the specific workstations along the conveyor belt, socket station, bracket station, light box station and finally the electricity supply station.
- If the assembled traffic light needs painting it moves along to the paint booth.
- Once the traffic light is assembled it is transported by forklift to the inspection room where final checks and testing takes place.
- The completed replaceable traffic light is stored in the finished goods department, ready for dispatch following the first in first out process.
- Finally the traffic light with housing block is loaded onto the installation truck for dispatch to the required site.

S Room:	Initial Storage and Inspection Room
SS:	Socket Installation Station
SB:	Bracket Station
SL:	Light Box Fitting Station
SE:	Electrical Supply Station
Paint:	Paint Booth
I Room:	Inspection Room
FS Room:	Finished Goods Storage Room
Out:	Out of System

Table 4.2.1 – Key code for stations in sequence they appear to complete assembly of replaceable traffic light

Code	Reason
1	Frequency of use high

2	Frequency of use medium
3	Frequency of use low
4	Information flow high
5	Information flow medium
6	Information flow low

Table 4.2.2 – Allocated values for From-to-chart

From/To	S Room	SS	SB	SL	SE	Paint	I Room	FS Room	Out
S Room	1	-	-	-	-	4	-	6	-
SS	-	1	-	-	-	-	-	-	-
SB	-	-	1	-	-	-	-	-	-
SL	-	-	-	1	-	-	-	-	-
SE	-	-	-	-	1	-	-	-	-
Paint	-	-	-	-	-	1	-	-	-
I Room	-	-	-	-	-	-	1	1	4
FS Room	-	-	-	-	-	-	6	1	1
Out	-	-	-	-	-	5	-	6	1

Table 4.2.3 – From-to-chart: Flow of units between stations

The allocated values indicate the relationship of each activity on one another and the effect they have on the overall assembly process.

4.2.1.2 Qualitative Flow Measures – Activity Relationship Chart

To measure the qualitative flow, closeness relationship values must be determined by implementing Murther’s strategy. This step in the designing of a facility layout is adjusted to fit the requirements of assembling a traffic light. A relationship chart is constructed for the assembly line by using these values. A relationship chart may be constructed as follows (Tompkins et al, 2003):

1. List all the assembly line stations on the relationship diagram.
2. Once the assembly line and facilities plan is operational, conduct interviews with employees from each station and management overseeing the assembly of the traffic light to see where improvements can be made.
3. Define the criteria for assigning closeness relationships (Table 4.2.4) and itemize and record the criteria as the reasons for the relationship values on the relationship chart.

Value	Closeness
A	Absolutely Necessary
E	Especially Important
I	Important
O	Ordinary Closeness OK
U	Unimportant
X	Not Desirable

Table 4.2.4 – Closeness Rating

4. Establish the relationship value and the reason (Table 4.2.5) for the value relating to all pairs of departments.

Code	Reason
1	Inventory control
2	Interrelated Product
3	Interrelated Process
4	Interrelated Workstations
5	Flow of System

Table 4.2.5 – Reasons behind the “closeness” value

5. Allow for each employee that participated in the development of the relationship diagram to evaluate and discuss changes in the relationship chart. Figure 4.2.3 explains the construction of the activity relationship chart.

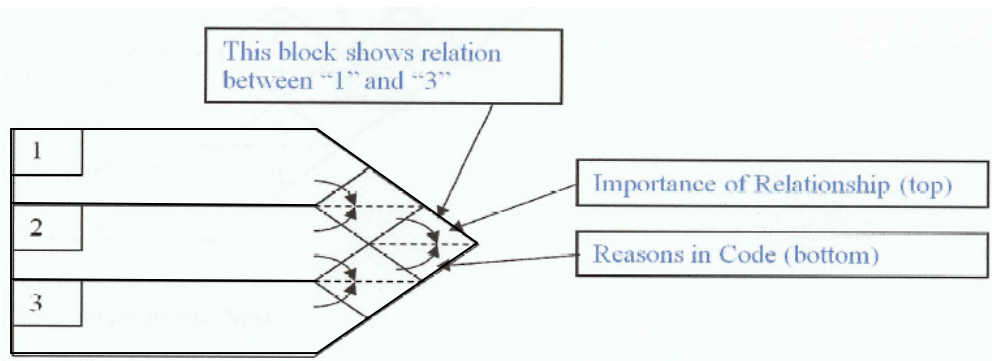

Figure 4.2.3 – Explanation of the Activity Relationship Diagram

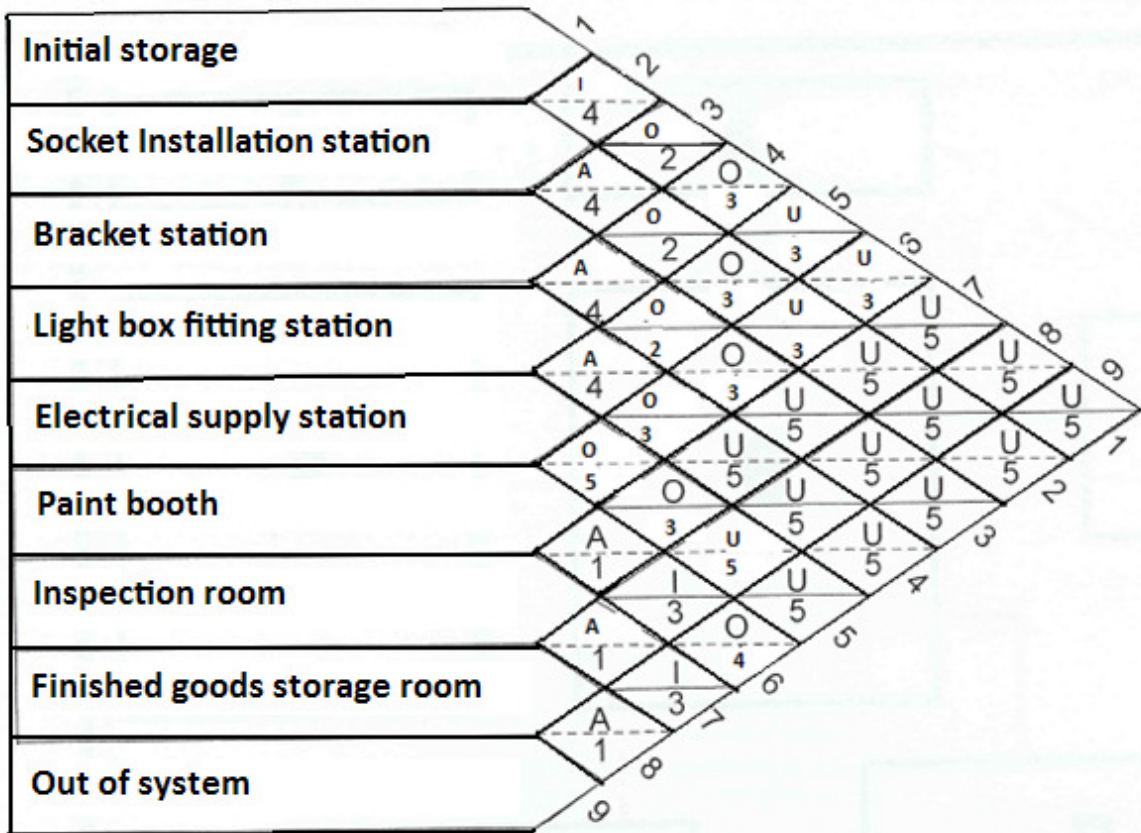

Figure 4.2.4 – Activity Relationship Diagram for each step in the assembly line for the modular replaceable traffic light

4.3 Space Relationship Diagram

The third step in the Systematic Layout Planning procedure involves the determination of the amount of space allocated to each activity within the assembly line for the replaceable traffic light. Each activity within the system are analysed individually as the requirements in terms of size, equipment and operations vary from activity to activity. This diagram indicates the importance of one activity being next to another. The lines represent the traffic between stations and departments. The size measurements for each activity were taken as an approximation necessary to complete each task.

Alternative layouts can be designed once the space relationship diagram is constructed as this diagram influences the shape and area that each station in the assembly line requires. Designing alternative layouts requires the completion of the flow of units (“From-to-chart”), the activity relationship diagram and the space relationship diagram as indicated in the figure of Murther’s Systematic Layout Planning (SLP) procedure.

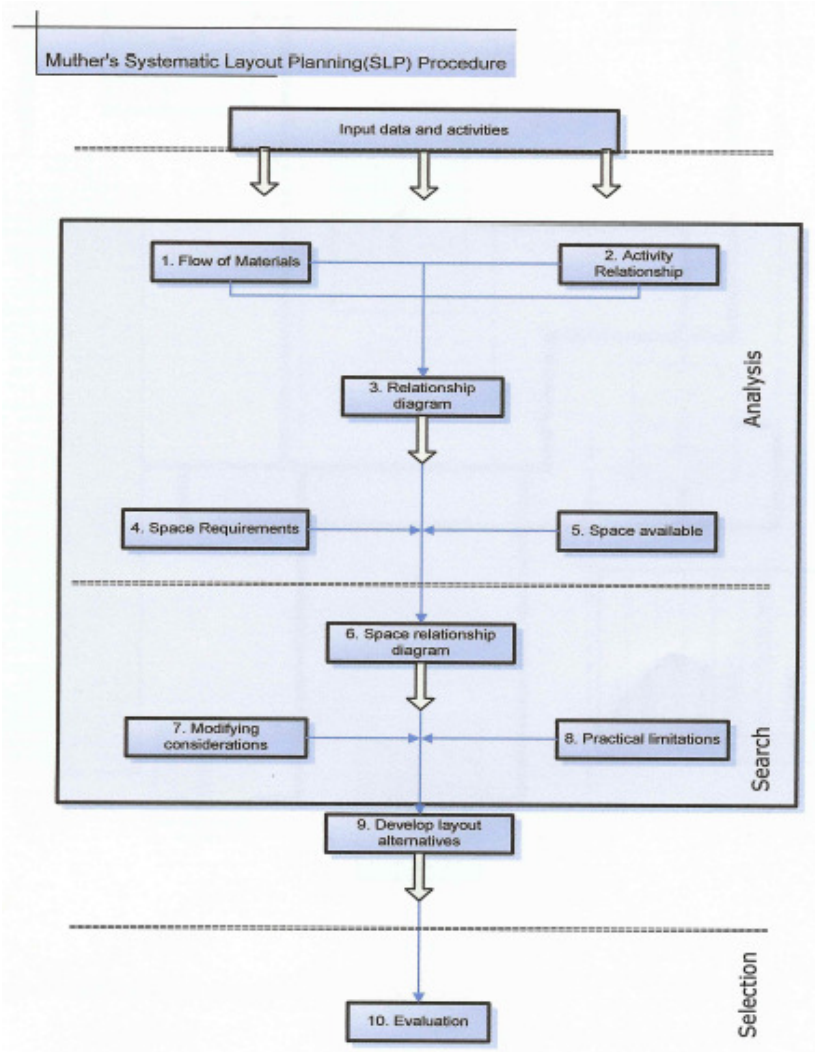

Figure 4.3.1 – Systematic Layout Planning (SLP) Procedure (Tompkins et al, 2003)

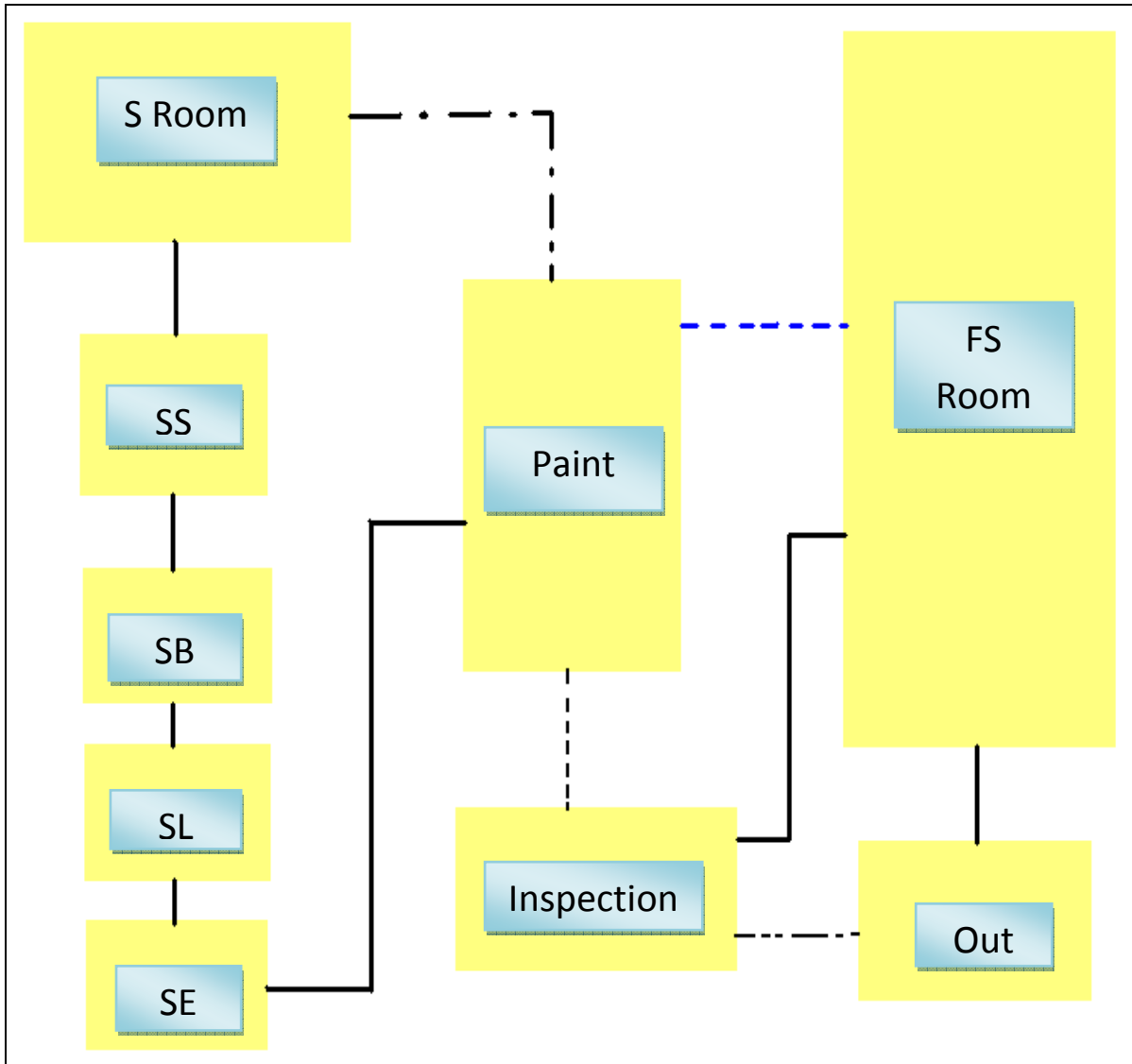

Figure 4.3.2 – Space Relationship Diagram

Value	Closeness	Line Style
A	Absolutely Necessary	—————
E	Especially Important	- - - - -
I	Important	- · - · -
O	Ordinary Closeness OK	- · - - -
U	Unimportant	- · - · -
X	Not Desirable	

Table 4.3.1 – Table indicating line styles

4.4 Develop Layout Alternatives

Two alternative facility layout plans have been designed for the assembly line. The layouts to assemble a replaceable traffic light to fulfill demand and meet the correct specifications needed for the modern day traffic light can be seen in Appendix B.

4.5 Evaluate Alternative Facility Layout Designs

Two alternative facilities layouts have been designed so that a comparison can be made and the best layout can be implemented to assemble the replaceable traffic light with the most efficient output. These layouts were designed and analysed based on Murther's Systematic Layout Planning procedure. Murther's approach locates two stations with high frequency and their interlinked relationship close to one another. By implementing and adapting the steps obtained from Murther's procedure an optimal facility layout can be identified that will provide a smooth and efficient assembly line for the traffic light.

4.5.1 Weighted Factor Comparison

Each alternative is assessed in terms of the criteria and role each station plays within the system. A weighted factor comparison matrix was constructed as a tool to evaluate each layout and provide the possibility of finding an optimal solution. In table 4.5.1 important factors are listed and weight values assigned to each of them.

	Factor
A	Cost - Initial Investment
B	Noise in Customer Area
C	Flow (Ease)
D	Space Utilisation
E	Implementation Time
F	Flexibility for change and Improvements
G	Specification Fulfillments

Table 4.5.1 – Weighted Factors

By placing weights, or points, on to each factor within a station the entire system can be evaluated appropriately. The weighted factor comparison method is a quantitative analyses

tool for obtaining decisions based on evaluation and is a complex combination of awarding points and weights to each factor. Each factor in the above table is compared to one another to determine the order they should be prioritized. For example: Noise in a workstation is compared to cost. For the traffic light assembly line to be functional it is necessary for cost to be twice as important as the noise factor and thus the value of 2A is assigned to the specific block in the matrix.

Weighted Factor Comparison Matrix							
A	B	C	D	E	F	G	
	2A	A	2A	A	A	A	A
		C	D	E	F	G	B
			C	C	C	C	C
				E	F	D	D
					F	E	E
						F	F
							G

Table 4.5.2 – Weight Factor Comparison Matrix for each station

Once the weighted factor matrix is defined and the correct points awarded to each factor, the weighted comparison form must be completed (see table 4.5.3). The two alternative layout designs are compared to the corresponding factors and the score obtained is then multiplied with the factor in the weight factor matrix.

WEIGHTED FACTOR COMPARISON FORM					
Objective: Replaceable Modular Traffic Lights			Prepared by: R.C Biddulph		
Description of Investment: Finishing Layout			Date: October 05, 2010		
Factor	Wt.	1		2	
		Rt	Sc	Rt	Sc
A Cost - Initial Investment	7	6	42	5	35
B Noise in Customer Area	3	3	9	5	15
C Flow (Ease)	6	8	48	6	36
D Space Utilisation	2	7	14	4	8
E Implementation Time	3	8	24	3	9
F Flexibility for Change and Improvements	5	5	25	6	30
G Specification Fulfillments	4	4	16	8	32
TOTAL		41	178	37	165

Table 4.5.3 – Weight Factor Comparison Form

The rating (Rt) is assigned to each factor with a score between 0 – 10, zero being unacceptable and ten being excellent. A total was calculated to indicate which alternative layout will be the most suitable for the implementation of an assembly line for replaceable traffic lights. The layout with the highest overall score is the one most acceptable to be implemented in the facilities layout plan.

After the evaluation is conducted and all requirements are met, it turns out the layout plan 1 is the best for the new facility to assemble the replaceable traffic light.

4.6 Material Handling

Material handling is the process of moving the correct material to the correct place, at the right time, in the required amount, in sequence, and in allocating it to the correct position or having it in the required specifications to minimize production costs. Material handling involves the handling of equipment, storage facilities, and the controlling methods, (Fred E. Meyers, 1993:157)

Material handling is an important component in facilities design as they are interlinked. A change in the material handling system will change the layout, and a layout alteration will change the material handling process. In a typical industrial facility, material handling accounts for 25% of all employees, 55% of all factory space, and 87% of production time, (Franzelle, 1986).

In assembly line for the replaceable traffic lights, project material is moved by hand and by automated methods. Each component will have a fixed path and location that it will travel to. A forklift will transport the components from the storage facilities to the conveyor belts where work will be done on them by hand and then transported to the finished goods storage by forklift. By introducing the JIT process emphasis will be placed on pulling the material rather than pushing the components through the assembly line, thus reducing queues and work in process.

By following the operation analyses for material handling (Figure 2.6.1) the correct flow can be determined and helps identify opportunities in the facility layout design for improvements. The new assembly line must be able to:

- Be user friendly
- Increase flexibility
- Increase efficiency of material flow
- Increase productivity
- Reduce material handling costs
- Improve facility utilization
- Reduce assembly time

These following steps indicate the movement of material through the assembly line and the order of stations required to complete the process and ultimately result in an efficient and cost effective assembly line for the traffic lights, (A diagram will be constructed to illustrate the procedure):

Step 1: Delivery trucks from suppliers deliver the outsourced parts to the docks and are transported by forklift to the initial storage warehouse where an inspection takes place.

Step 2: Once the components are ready to be assembled forklifts transport the parts to one of three conveyor belts, which will pull the components through each workstation so the traffic light can be assembled.

Step 3: The traffic light is assembled at each specific work station, with a testing station at the end to make sure the replaceable traffic light is operational.

Step 4: On completion of the assembled traffic light it will move to a paint booth for final painting, making it ready for installation according to the required specifications and regulations.

Step 5: From the paint booth a forklift will transport the finished component to the final storage and inspection warehouse, awaiting final delivery to the necessary site.

Chapter 5 – Budget

With reference to the new design and building of the assembly facility for the replaceable traffic light (as indicated in Appendix A), finances will be accessed and acquired to construct the facilities layout in order to fulfill all demand requirements and achieve a smooth running assembly plant. All the necessary equipment and tools required to assemble the traffic light have been budgeted for and will be bought to fulfill the required demand.

An amount of R 11 million will be needed to construct the necessary facilities plant and to purchase all the tools and material handling equipment.

The funds needed to develop this project will be a large short term investment but the long term investment will be reduced as the initial cost for installation will be high but the replacement costs for the necessary parts that need to be replaced will be low as they make up the smaller parts of the replaceable traffic light.

Chapter 6 – Recommendations and Conclusion

6.1 Recommendations

When deciding on the correct facilities layout it tends to follow the satisfactory process rather than the optimizing process. With this in mind further testing and validation can take place to determine which layout fulfills all the necessary requirements needed to meet the modern day demand placed on replacing damaged or out of order traffic lights. There are a number of testing processes that can be performed namely, excel spreadsheets to determine economic factors, simulation modeling to determine where improvements and backlogs are located and Facilities Layout Applet/Application program (FLAP) heuristics which achieves the lowest cost and travel between stations thus ensuring one layout is better than another.

Many other departments and factors can be investigated once the finding in this report have been implemented such as: expansion in the assembly plant to accommodate future growth, parking and exterior environments, an in-depth look at the outsourced suppliers and whether it is more prosperous to incorporate in-house development, and most importantly if the entire assembly system should become automated which will ultimately result in a much higher output and greater accuracy in the finished product.

6.2 Conclusion

Facilities planning, when implemented correctly, will result in a number of advantages over a standard layout structure. A correctly laid out assembly line will benefit from an increased return on assets, improved customer satisfaction resulting in a larger demand for the product, reduced costs in the region of transporting the goods, storage, an integrated supply chain focusing on the ultimate customer and inventory carrying costs.

The analysis of facilities design such as layout and material handling is very important to optimize an assembly line. Many improvements can result from an optimized facilities layout plan, such as a decrease in bottleneck rates, minimize operational costs, reduce idle times throughout the assembly, and raise the production rate effectively increasing profit.

With such a large demand on today's manufacturing and assembly lines it is critical to have an uninterrupted flow through a plant, thus optimal facility planning is necessary in order to stay ahead of the competition.

This project has provided an insight to the necessary requirements needed to implement a feasible solution for the assembly of replaceable traffic lights. This project focuses on three

phases, facility layout planning, material handling and material flow throughout the assembly line. However this is only a small part of facilities design but is done in order to show how industrial engineering tools can be implemented and the problem can be approached from various angles in order to produce a feasible solution.

Facilities layout design and correct material handling techniques are the fundamental starting points for an assembly project as they are interlinked and determine the size of the facility that is needed to run an efficient system.

The replaceable traffic light is a new design that strives to improve the current situation of replacing damaged lights that take extended time periods to fix or replace. Using new materials and procedures the replaceable traffic light can make large inroads into improving the overall road safety and reducing delays in traffic congestion for all South Africans.

The goal of this project is to find a new facility layout for the assembly of replaceable traffic lights in order to reduce replacing time for damaged traffic lights on street corners. The facility will be designed to accommodate future forecasted growth, expansion for assembly and the flexibility to change according to the required specifications put forward by the traffic department.

List of References

- Baeseman, J. (2003). *Facilities Planning Methodology*. Bodi Engineering LLC.
- Chase, R.B. and Jacobs, F.R. (2006). *Operations Management for Competitive Advantage with Global Cases*. McGraw-Hill, 11th edition.
- Coyle, J.J. and Bardi, E.J. (2003). *The Management of Business Logistics: A Supply Chain Perspective*. South-Western – Thomson Learning, 7th edition.
- Dwijayanti, K. and Aoyama, H. (2010). *A Proposed Study on Facilities Planning and Design in Manufacturing Process*. ISSN: 2078-0958. Hong Kong.
- Geer, B. (2005). *Traffic Light with Modular Pole*. Patent WO/2005/057520. www.wipo.int/pctdb/en/wo.jsp
- Greasley, A. (2008). *Using Simulation for Facility Design: A case study*. Elsevier International journal of Simulation Modelling Practice and Theory 16. Pages 670-677.
- Haung, H. (2003). *Facility Layout using Layout Models*. Ph.D. Thesis. The Ohio State University.
- Kuhl, M.E. and Streiger, N.M. and Armstrong, F.B. and Joines, J.A. (2005). *For effective facilities planning Layout Optimization then simulation or visa versa*. Proceedings of the 2005 Winter Simulation Conference, University at Buffalo.
- Kulmiec, R.A. (1985). *Materials Handling Handbook*. John Wiley and Sons, the American Society of Mechanical Engineers and the International Material Management Society, USA. 2nd edition.
- LIGHTS TO GO! <http://www.trafficlights.com/LEDsigs.htm>
- Madumo, L. (2008). *Futuristic Traffic Light System for Jozi*. <http://www.joburg.org.za/content/view/2034/168>
- Muther, R. (1961). *Systematic Layout Planning*. McGraw-Hill, New York.
- Reid, R.D. and Sanders, N.R. (2007). *Operations Management*. John Wiley and Sons. New York. 3rd edition.
- Sule, D.R. (1994). *Manufacturing Facilities: Location, Planning, and Design*. PWSKent Publishing Company, 2nd edition.
- Tompkins, J.A. and White, J.A. (2003). *Facilities Planning*. John Wiley and Sons, INC, 3rd edition.
- TransAmerican Power Products, Inc. *TR Series*. www.tappinc.com

Appendices

Appendix A

Capital Expenditure

Building costs and installation

		Estimated	Quotation received	Estimated cost
Building Requirements	A new assembly plant has to be built to be fully operational and meet the necessary demands. Machinery and equipment need to be place on the floor and the paint booth must be a clean environment	3500m ²	R1500/m ²	R5 250 000.00
Walls, windows, roof	The required windows and doors need to be installed as well as a slanted roof to maximize sunlight exposure		R234/m ²	R900 000.00
Electricity Supply	Electricity needed will be investigated and the appropriate factory supply (sub-station) according to demand must be catered for. All machinery and equipment must have independent power supplies. All wiring throughout the plant must be done.			R200 000.00
External area and main entry.	Parking area and loading area must be constructed and must be filled	200m ²	R187/m ²	R37 400.00
Plumbing	All plumbing done for bathrooms, kitchen and paint room			R185 000.00
Painting	The interior and exterior walls need painting as well as demarcated areas on assembly floor			R165 228.00
Sub TOTAL				R6 727 628.00

New plant machinery and equipment

		Estimated	Quotation received	Estimated cost
Conveyor belts	3 roller conveyors to transport the replaceable traffic light from one station to the next			R800 000.00
Forklifts	2 forklifts needed to transport any equipment or material			R400 000.00
Workstations	10 workstations placed along the assembly line to complete the traffic light			R350 000.00
Work bins	10 work bins located next to the work stations holding all the necessary parts to complete each specific job			R150 000.00
Hand tools	Grinding, hand cutting and drilling if necessary	Bought out items - estimated		R190 000.00
Welding Machines	If parts need to be welded but will only be done so after inspection		43 286.00 x 2	R86 572.00
Shelves, racks and storage	These will be designed and manufactured according to the parts that need to be stored before transported to the work bins. The will be strategically placed to allow for easy access and placement		Tailor made by contractor Bought out	R35 000.00 R45 000.00
Work benches	Work benches will be purchased and placed in the designated work station along the conveyor belt to accommodate for the needs of each employee and accommodate for ergonomic factors. Benches will also be placed in the inspection rooms		Bought out 8 440.00 x 10	R84 400.00

Spray booth	Must be a clean room		Bought out	R1 165 563.00
Sub TOTAL				R3 302 535.00

New office furniture and equipment

		Estimated	Quotation received	Estimated cost
Computers and overhead projector	New computers for managers and sales employees with printers	8 250 each X 9		R74 250.00
	Overhead projector for boardroom	12 000		R12 000.00
	Digital camera	3 500		R3 500.00
New furniture	Boardroom table and chairs, furniture for reception area, furniture for all offices, kitchen necessities, etc			R200 000.00
Business system	Minolta copier (centralized copier on each floor)		94 999.00 X 2	R189 998.00
Sub Total				R479 748.00

Catered for the unforeseen

		Estimated	Quotation received	Estimated cost
Unforeseen	This is to cater for the unforeseen – installation, repairs, commissioning, consumables, etc	250 000		R250 000.00
Sub TOTAL				R250 000.00

GRAND TOTAL

R10 759 911.00

Appendix B - Alternative Layout 1

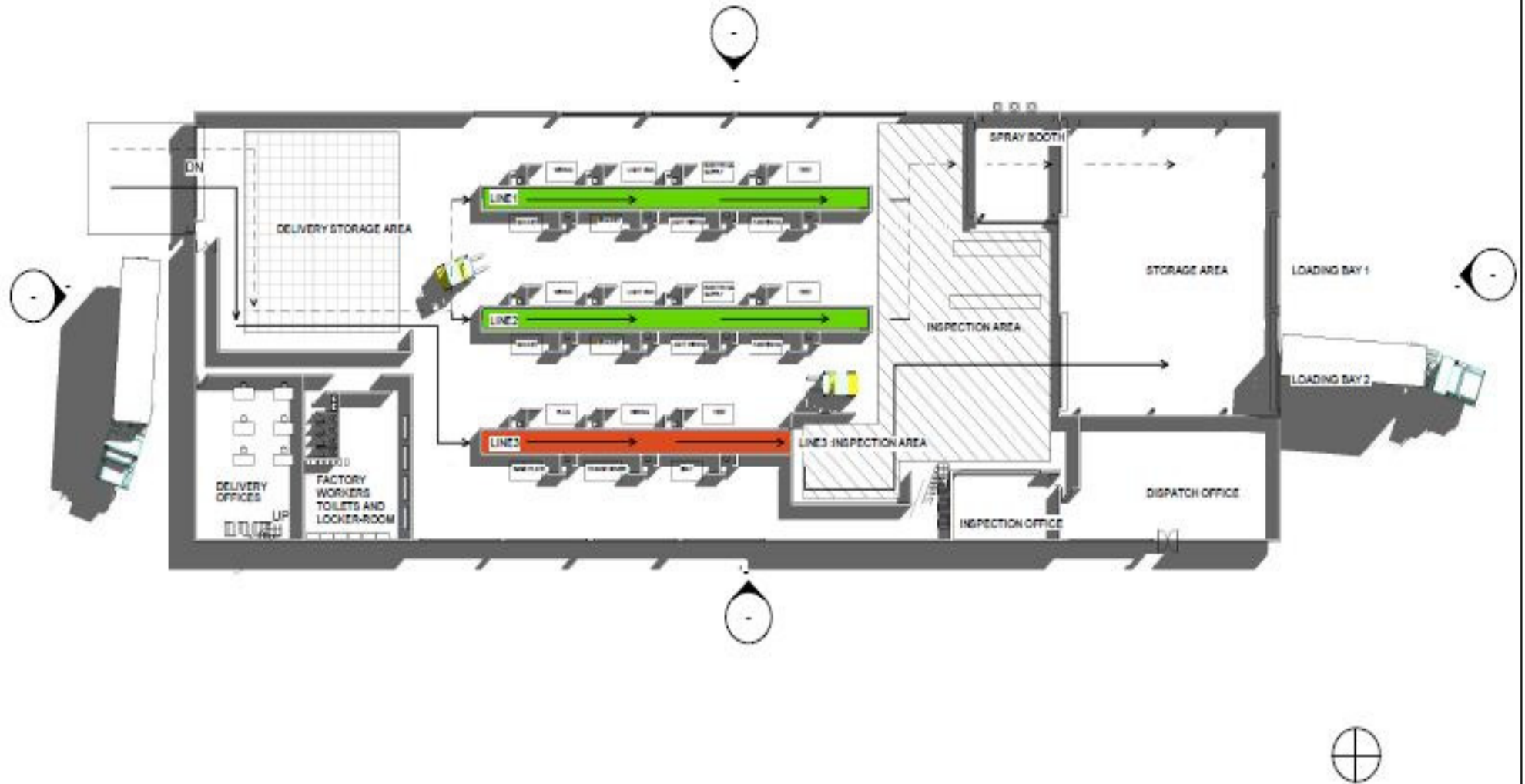

Alternative Layout 1 - Second Floor

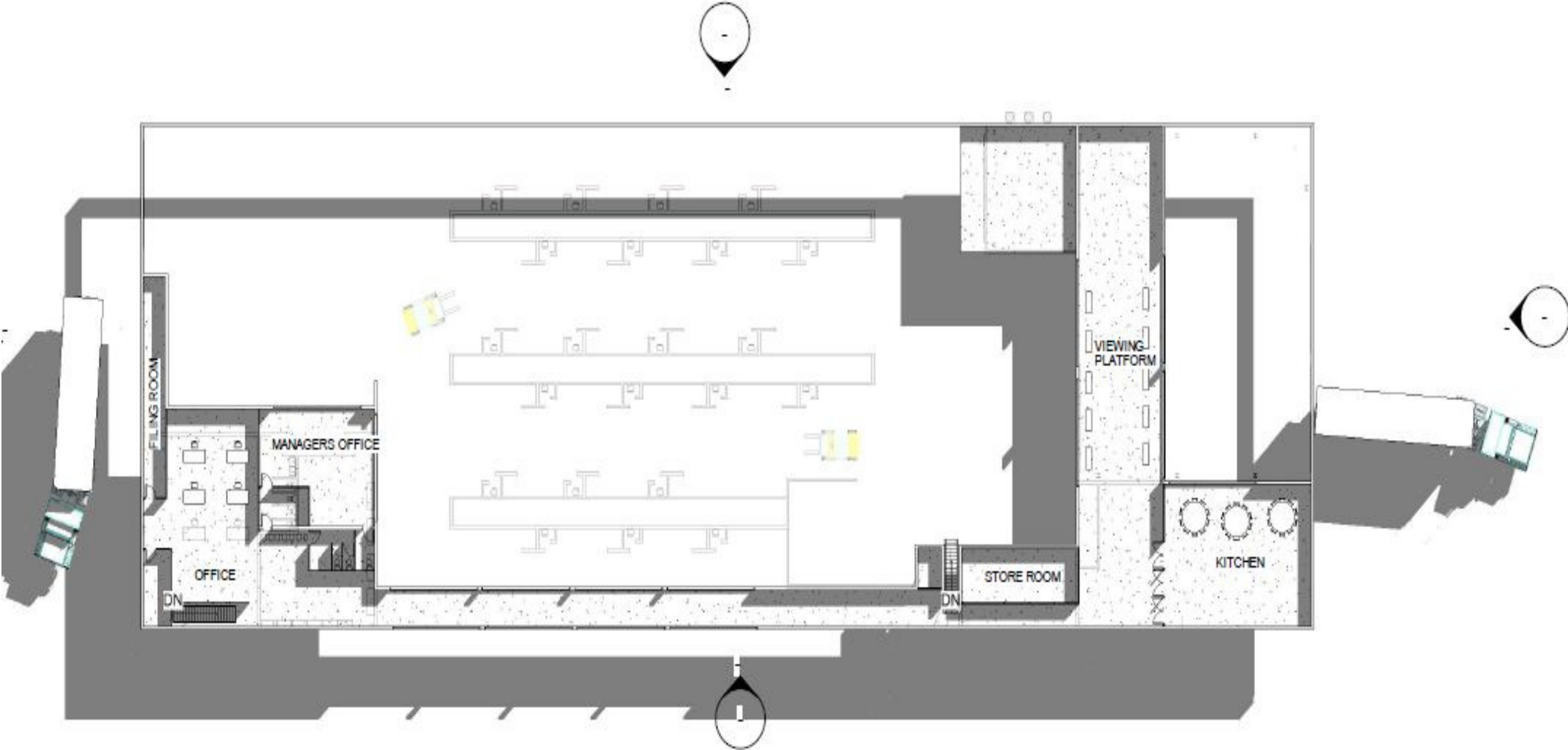

Alternative layout 2

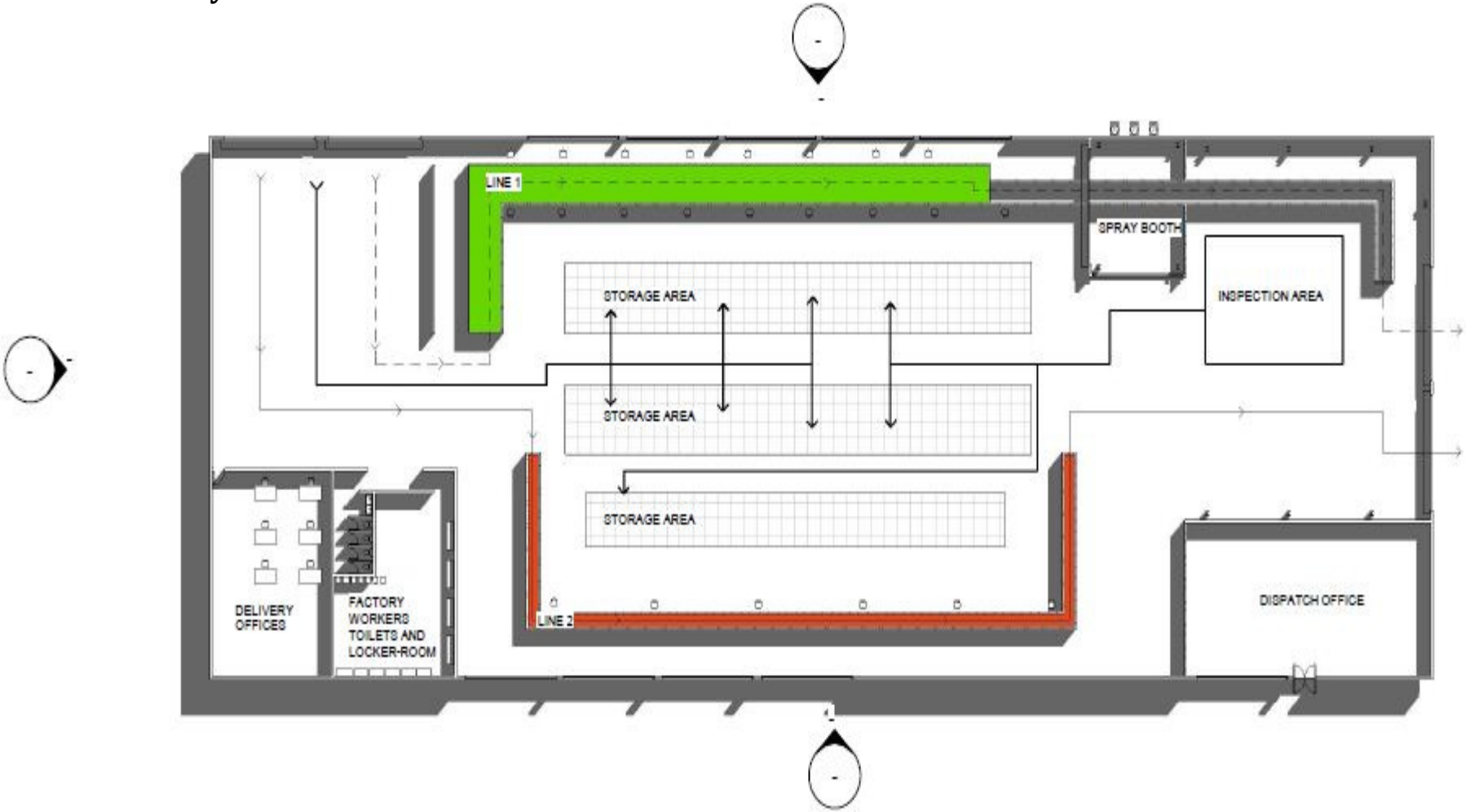

3D View of Assembly Plant for Replaceable Traffic Lights

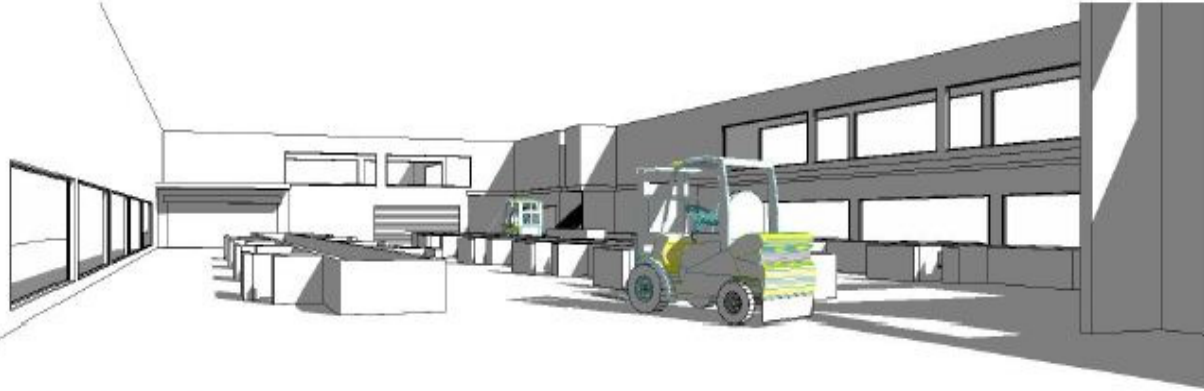

2 3D View 1

