



UNIVERSITEIT VAN PRETORIA
UNIVERSITY OF PRETORIA
YUNIBESITHI YA PRETORIA

AUTHOR

Jordan Close | 18043811
MLArch 2023
DPD 802

SUPERVISOR

Karen Botes

DISCIPLINE COORDINATOR

Ida Breed

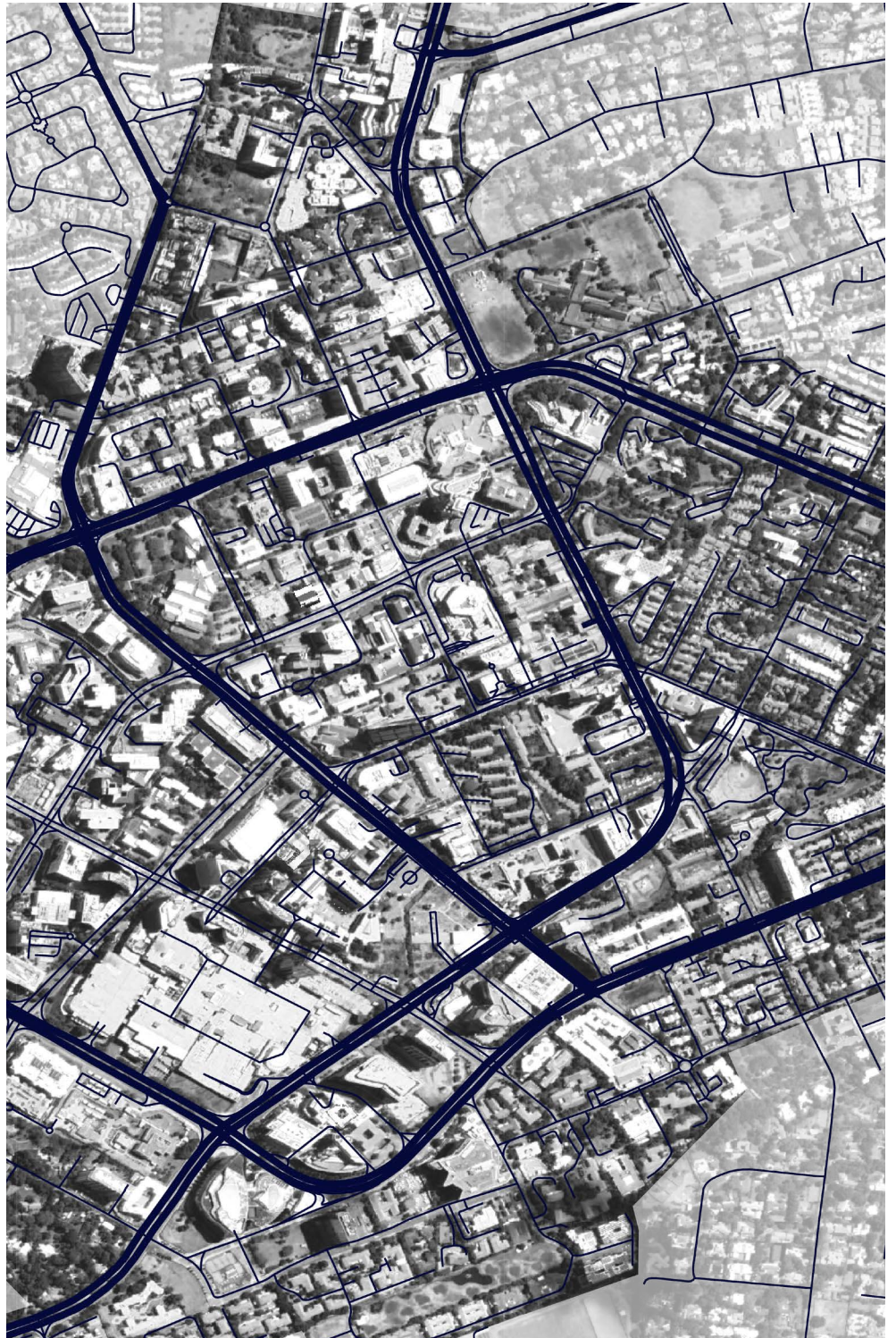

HIGH-RISE HARVESTS

CULTIVATING COMMUNITY ON SANDTON'S TERRAIN

Sandton Central, City of Johannesburg, Gauteng

Urban Agriculture, Education, Continuous Productive Urban Landscapes

CONTENTS

1.

ABSTRACT

2.

PROJECT
INTRODUCTION

7.

HIGH-RISE
HARVESTS

13.

THE ITERATIVE
PROCESS

15.

TECHNICAL
INVESTIGATIONS

21.

CRITICAL
REFLECTIONS

ABSTRACT

With levels of food waste soaring and carbon emissions reaching catastrophic highs, it is becoming clear that South Africa will not meet the 2030 Sustainable Development Goals set by the United Nations. At a nationwide level, we need a dramatic shift to restore resilience in our urban spaces and minimise our reliance on carbon-intensive food systems – an urban revolution, if you will. However, we lack a role model on this front: our cities will require a real-world precedent to strive towards, effectively addressing the Sustainable Development Goals in an African Context. I envision these shoes being filled by Sandton Central through the High-Rise Harvests Framework.

Continuous Productive Urban Landscapes (CPULs) and Urban Agriculture (UA) have been proven to be the way forward in constructing resilient cities. The City of Johannesburg confirms in their Food Resilience Policy that within the next seven years, it will be crucial to initiate smart, innovative UA approaches and to elevate UA to a strategic, sustainable level to impact food systems. The High-Rise Harvests initiative aims to kickstart this in Sandton Central, beginning with Phase 1: Terrain Innovation Park. When aiming to cultivate a city, it is necessary to provide an anchor point from which future initiatives can grow. Terrain Innovation Park serves as a platform for the growth and expansion of the High-Rise Harvests initiative by showcasing the potential of vertical, innovative food production systems to champion circularity, versatility, and social engagement while simultaneously producing restaurant-quality vegetables. The park aims to foster collaboration between educational institutions, local businesses, and the surrounding community to instigate a widespread uptake of local food production throughout the precinct – and country.



12th highest emitter of CO₂
globally (Godfrey, 2021)



10.3 million tons of food lost
through system (Godfrey, 2021)



20.9 million tons of CO₂
annually (CoJ, 2021)

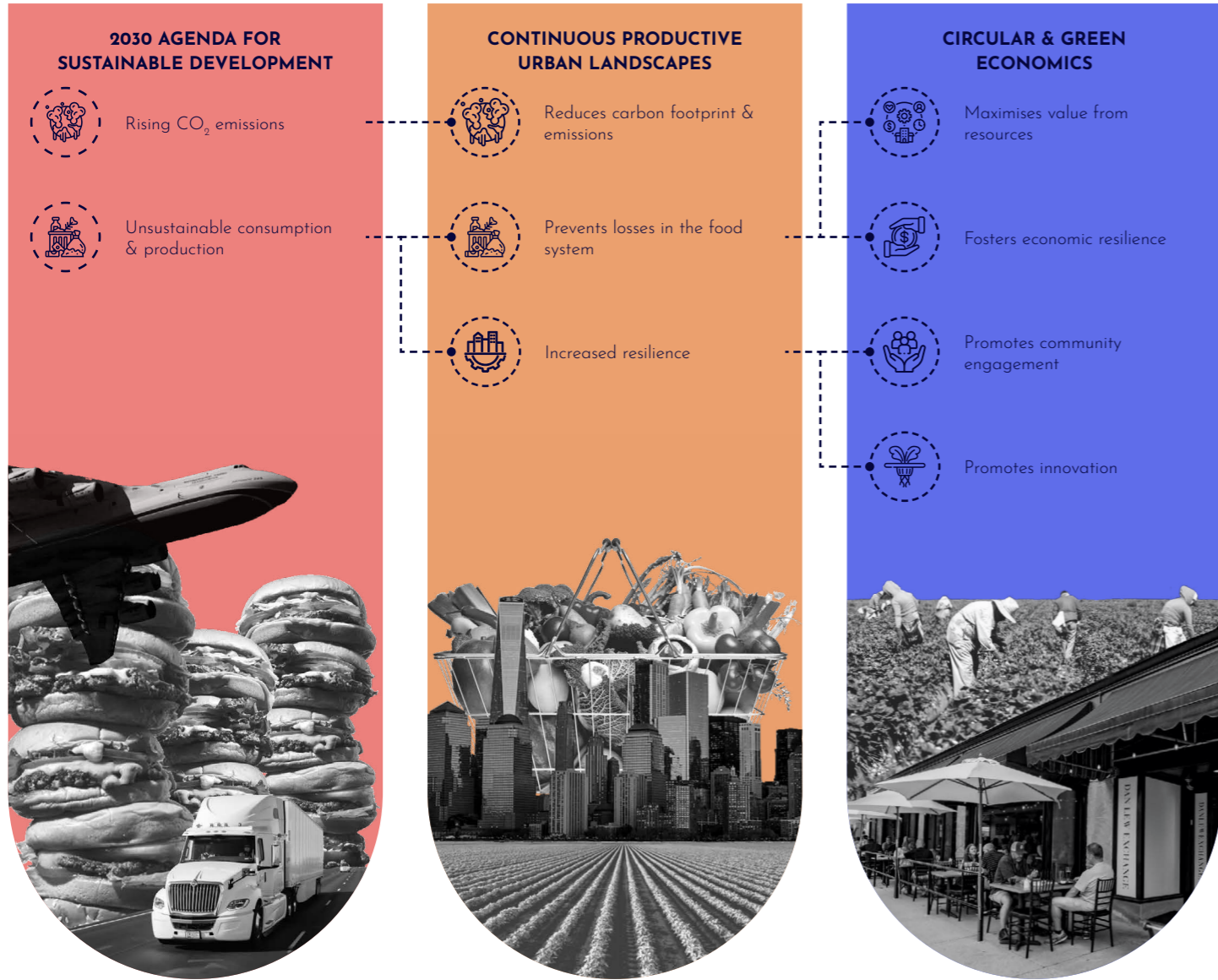

Figure 02: Problem, Solution, Approach (Author, 2023)

PROJECT INTRODUCTION

With the 2030 deadline for the United Nations Sustainable Development Goals fast approaching, it is becoming imperative for South Africa to acknowledge the lack of resilience and sustainability in its cities. The City of Johannesburg alone is responsible for 20.9 million tons of carbon dioxide emissions annually (City of Johannesburg, 2021). This significantly contributes to South Africa’s ranking as the 12th largest emitter of carbon dioxide globally (Godfrey, 2021). Additionally, South Africa sees a loss of 10.3 million tons of food each year – 34.3% of our total local production – all of which is still transported by road. With most of our transport sector driven by petroleum products, our food system is highly carbon-intensive. As can be seen in Figure 02, this project responds to these issues through the theories of Continuous Productive Urban Landscapes (CPULs).

CPULs embody the principle that “the urban land itself, as well as the activity happening on it, will become productive,” referring to productivity in terms of the environment, economy, and society (Viljoen et al., 2005).

-  Epicenter of green buildings in Africa & national leader for sustainable development
-  Well established connectivity & is easily accessible to commuters
-  Africa’s most important financial & business hub
-  Sandton Retail Node offers wide range of attractions for visitors & tourists
-  Significant tourist attraction due to link via Gautrain & high-end accommodation

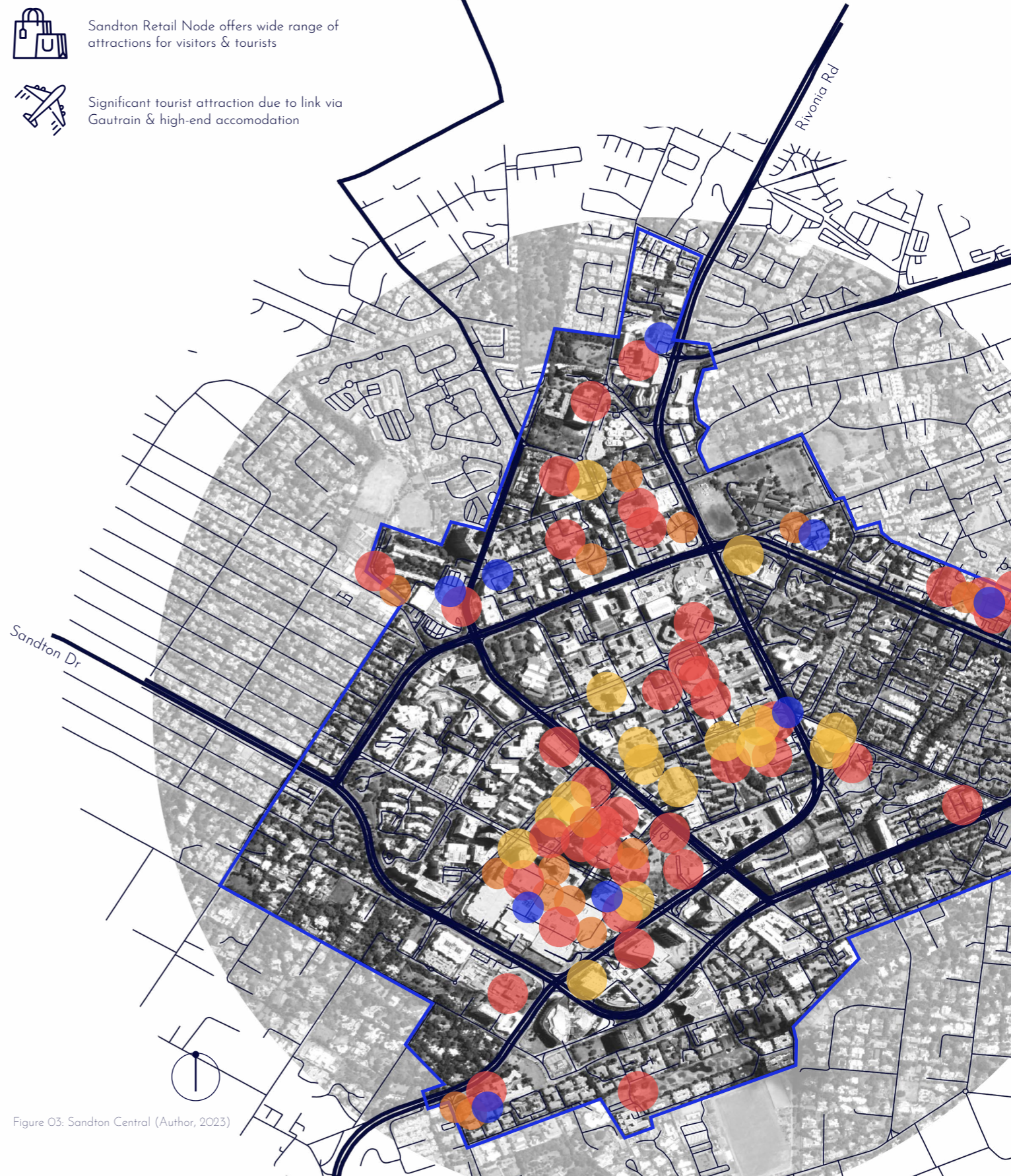
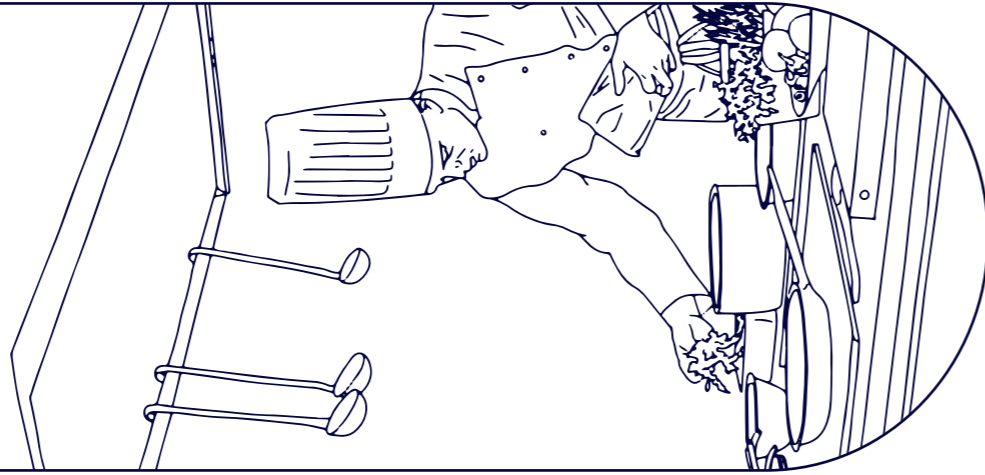

Figure 03: Sandton Central (Author, 2023)

01.

Lower carbon emissions & food system reliance through **LOCAL VEGETABLE PRODUCTION**



02.

Increase community engagement & collaboration through **ENJOYMENT & EDUCATION**

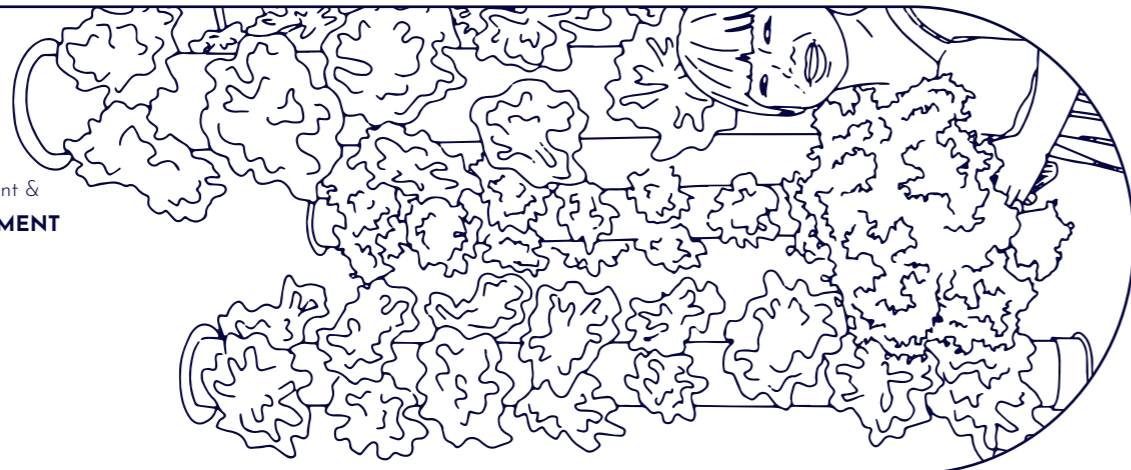

03.

Improve **REGULATING & SUPPORTING ECOSYSTEM SERVICES** of existing natural systems



04.

Support a circular economy through **SUSTAINABLE RESOURCE MANAGEMENT**

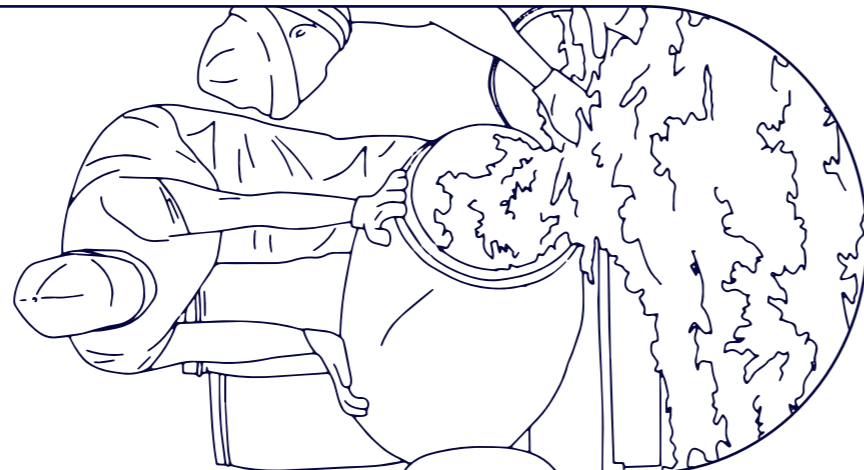

Figure 04: Objectives (Author, 2023)

Additionally, it is stated by Viljoen et al. (2005) that “producing food where one wants to eat it or consuming food where it has just grown, establishes a healthy and sustainable balance of production and consumption. It is an effective and practical but at the same time self-beneficial way of reducing the energy embodied in contemporary food production.” Through establishing a network of productive open spaces running continuously through the urban environment, CPULs aim to reduce the embodied energy in contemporary food production by bringing food production closer to the consumer (Viljoen et al., 2005). Through implementing CPULs in Sandton Central, the precinct would be able to demonstrate a feasible method of minimising its carbon emissions associated with the transportation of food to local restaurants and preventing losses in the food system, thus increasing its resilience. Realistically, with Sandton being Africa’s most important financial and business hub, this solution will need to be economically grounded. The approach to this is through green and circular economics. As stated by Godfrey (2021), a circular economy is less about waste management and more about the sustainable management of our resources. The coloured dots in Figure 03 show all of the restaurants, bars, cafés, and fast food outlets in a 1.5km radius in Sandton Central – over 80 establishments all relying on delivering fresh produce to their doorstep. Were the resource of food to be sourced locally, greater economic, environmental, and social value could be created within this 1.5km radius. It is stated by Dembo (2014) that community collaboration, engagement, and shifts in behaviour play a significant role in making a place more resilient. This community engagement could be instigated through the implementation of productive landscapes which benefit the people.

Another precious resource in Sandton Central and most South African cities is land – often prioritised for new developments rather than food production. However, Godfrey (2021) also states that innovation and the implementation of new technologies are essential in developing a successful circular economy. In densifying urban spaces, the potential area for crop cultivation is far greater on the vertical plane than on the limited ground plane (Botes and Breed, 2022). This leads to the focus of this project: smart, innovative, vertical farming. Overall, the project seeks to understand the following:

- What landscape architectural interventions should be implemented to support a productive, resilient, and circular urban environment in Sandton Central?
- How can community engagement in this productive, resilient, and circular urban environment be enhanced through landscape architecture and urban agriculture?



Rivonia Rd is highly dominated by vehicles and fails to provide a comfortable pedestrian environment



“Local Landmark” Hyundai Ballon is outdated & currently unsuccessful in attracting engagement



Jukskei tributary running through park is polluted, eroded, & dominated by alien species

Figure 05: Sandton Central - not doing enough (Author, 2023)

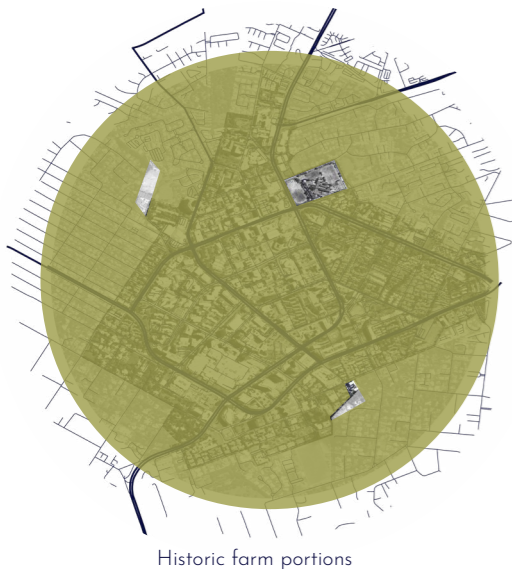

Historic farm portions



±1960's farm portions & green space



Present day green space

Figure 06: Sandton Central green space (Author, 2023)

In answering these questions, four main guiding objectives and key results have been put in place (illustrated in Figure 04):

- Lower carbon emissions and food system reliance through local vegetable production.
 - o Leafy vegetables do not travel more than 1km from the production to the consumption site.
- Increase community engagement and collaboration through education and enjoyment.
 - o The precinct provides opportunities for all community members to spend at least 60 minutes per week interacting with food production interventions.
- Improve regulating and supporting ecosystem services of existing natural systems.
 - o Indigenous plant species richness is increased by 50% in existing natural systems within seven years.
- Support a circular economy through sustainable resource management
 - o All organic agricultural and kitchen waste is repurposed through accessible composting facilities.
 - o All crop production systems are adaptable and modular.

Figure 05 shows how the Sandton Central precinct is currently not doing enough to meet the objectives of this project. The streets are highly vehicle-dominated with little provision for pedestrians or green infrastructure, local landmarks stationed throughout the precinct are not conducive to community engagement or productivity, and the existing natural systems are polluted, eroded, and dominated by invasive species. However, the existing urban development framework (UDF) (studioMAS et al., 2008) shows great promise for a diverse and integrated node. Although the UDF demonstrates positive urban design principles for a business district, it has compromised on its open green spaces. The only two publicly accessible parks – Sandton Central Park and Mushroom Farm Park – are on opposite ends of the node and are poorly supported by community members.

While Sandton has been named “the epicentre of green buildings in Africa” (Creamer Media, 2016), it has neglected its green infrastructure and ecosystem services over time. In the late 1800’s and early 1900’s, Sandton was unrecognisable as the bustling node it is today and was instead characterised by rolling hills of farmland (seen in Figure 06). However, with a wave of urbanisation in the 1930’s and the opening of Sandton City in 1974, the Sandton Central skyline saw a swift influx of cranes and construction to build it up to what it is today (Sandton Central, n.d.). It is evident that with development comes the abandonment of public open green space and local food production. Nonetheless, this project aims to reconnect Sandton Central with its history and reinvigorate the desire for environmental and agricultural productivity in this urban precinct.

HIGH-RISE HARVESTS

Sowing Sandton & Cultivating Community



Figure 07: High-Rise Harvests (Author, 2023)

HIGH-RISE HARVESTS

My 2030 vision for Sandton Central is that of a precinct which places equal value on social, environmental, economic, and agricultural productivity. In line with the four main objectives for the precinct, this vision aims to accomplish an urban agricultural network emphasising community collaboration and sustainable resource management whilst utilising green infrastructure to improve regulating and supporting ecosystem services. The High-Rise Harvests Framework entails adding three new green infrastructural, urban agricultural layers to the node: lightweight rooftop farms (The Canopy), green non-motorised transport (NMT) corridors (The Roots), and innovation parks (The Terrain) (see Figure 08). Through the implementation of High-Rise Harvests, Sandton Central will be transformed into a feasible precedent for cities nationwide to look up to and use as a blueprint for implementing resilient, circular, and productive principles. Over the next seven years, a phased approach to implementing this framework will commence with Terrain Innovation Park. The terrain plays a crucial role in anchoring plants and providing them with nutrients in traditional in-ground farming techniques. When



The Canopy



The Roots



The Terrain

Figure 08: High-Rise Harvests layers (Author, 2023)

aiming to cultivate a city, much of the same becomes necessary. Terrain Innovation Park aims to showcase the potential of innovative vertical food production systems to champion circularity, versatility, and social engagement while simultaneously producing restaurant-quality vegetables. This park has been prioritised as the first phase to foster the initial and long-lasting collaboration between educational institutions, local businesses, and the surrounding community and to instigate the widespread uptake of vertical food production throughout the precinct. The community must understand and develop a personal connection with the importance and necessity of this initiative for it to grow successfully throughout Sandton Central and South Africa.

When deciding which smart vertical farming systems would be best suited for this application, circularity and resilience were kept in mind. Due to the scarce and unstable resource of water in the City of Johannesburg (Njilo, 2023), any farming initiative would need to utilise as little water as

possible and be able to operate on a closed-loop system. This led to the Nutrient Film Technique (NFT) and Floating Raft Deep Water Culture (DWC) Hydroponics systems (illustrated in Figure 09), which boast a 13 times lower water demand while producing a yield per square meter 11 times greater than conventional farming methods, according to Barbosa et al. (2015).

Figure 10 illustrates the High-Rise Harvests strategy for the implementation of smart, innovative vertical farming at the Canopy, Roots, and Terrain levels. The Canopy rooftop farms will cultivate produce solely for the food and beverage industry of the Sandton Central node – these will be comprised of NFT and DWC hydroponic systems due to their lightweight nature and efficiency in yield. The agricultural NMT arteries – the Roots – will showcase the benefits of Traditional African Vegetables (TAVs) as a resilient solution to local crop cultivation. While not necessarily ‘smart,’ TAVs present an alternative, innovative solution to growing food in South African cities due to their high tolerance for adverse climatic conditions in comparison to mainstream vegetables (Uusiku et al., 2010). Akinola et al. (2020) report that TAVs are well-adapted to pests and poor soil conditions while reducing water requirements. Additionally, these crops can be incorporated on the vertical plane through living wall systems to maximise their presence and yield in the precinct. For Terrain Innovation Park to successfully engage the surrounding community with the above-mentioned initiatives, it will host a collection of hydroponics systems, living wall systems, and TAVs to truly showcase a broad range of innovative solutions. In the context of this park, the various approaches to smart, innovative vertical farming will be arranged to instigate interaction, interest, and ultimately, education.

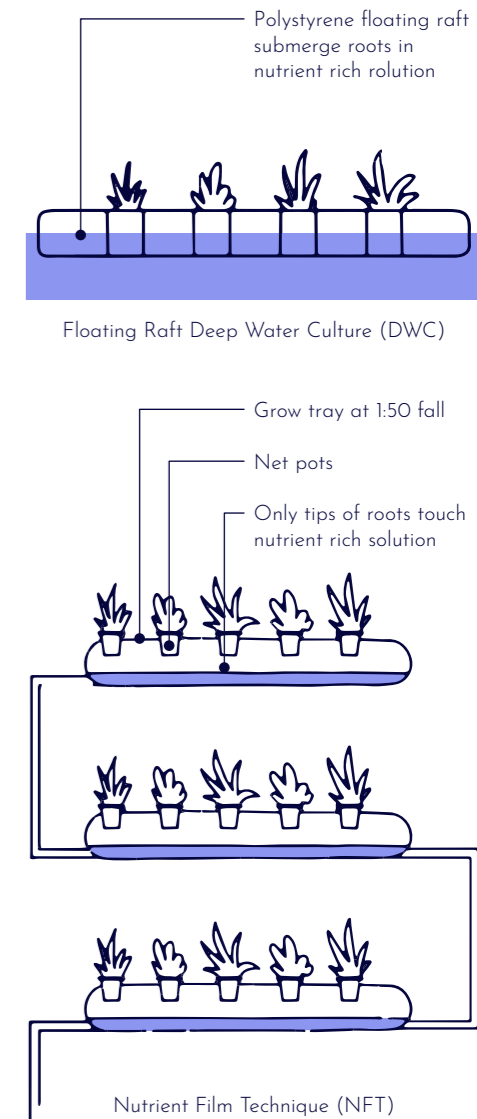

Figure 09: Hydroponics systems (Author, 2023)

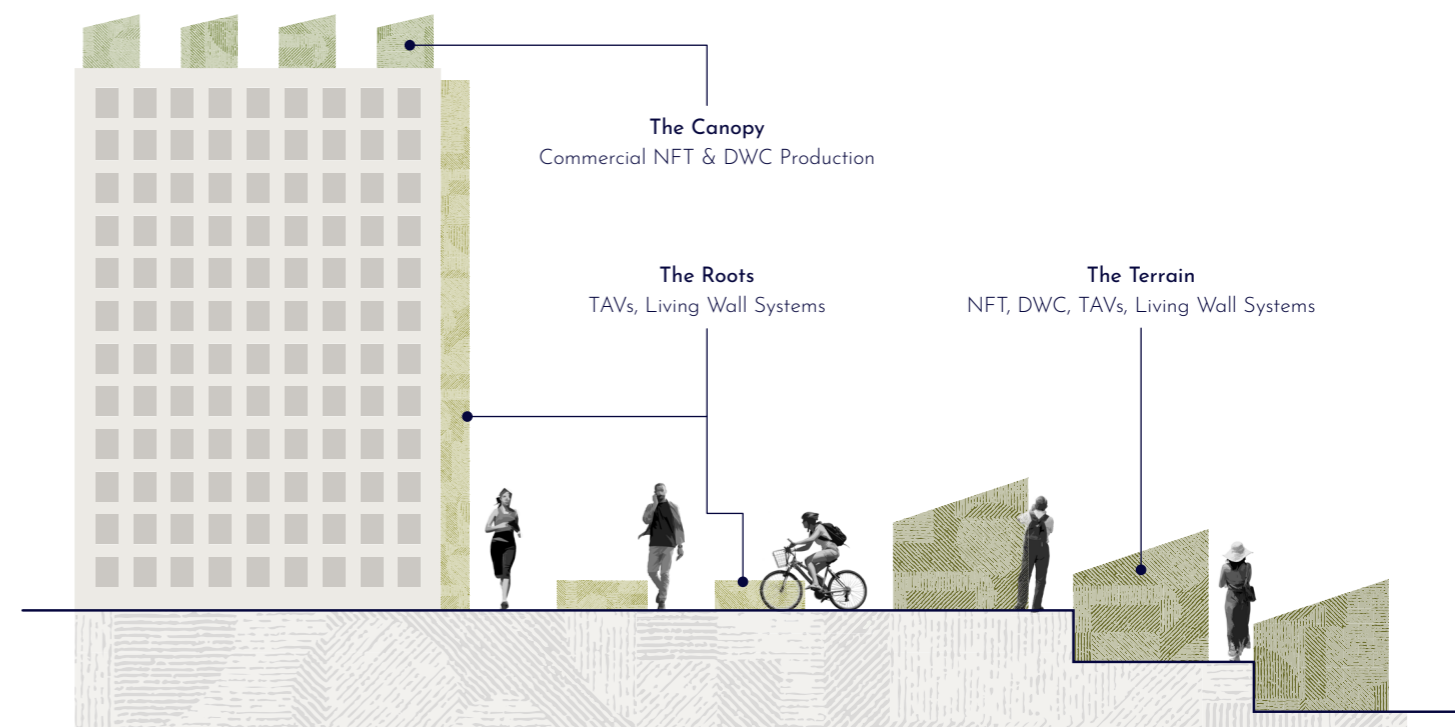

Figure 10: High-Rise Harvests strategy (Author, 2023)

- PLAY**
 Families
 Nanny's & young children
 Dog owners
- REST**
 Sitting alone
 Eating lunch
 Lying on bench
- EAT**
 Business men at restaurant
 Couples at restaurant
 Street vendor
- WALK**
 Parents with older kids
 Couples
 People alone

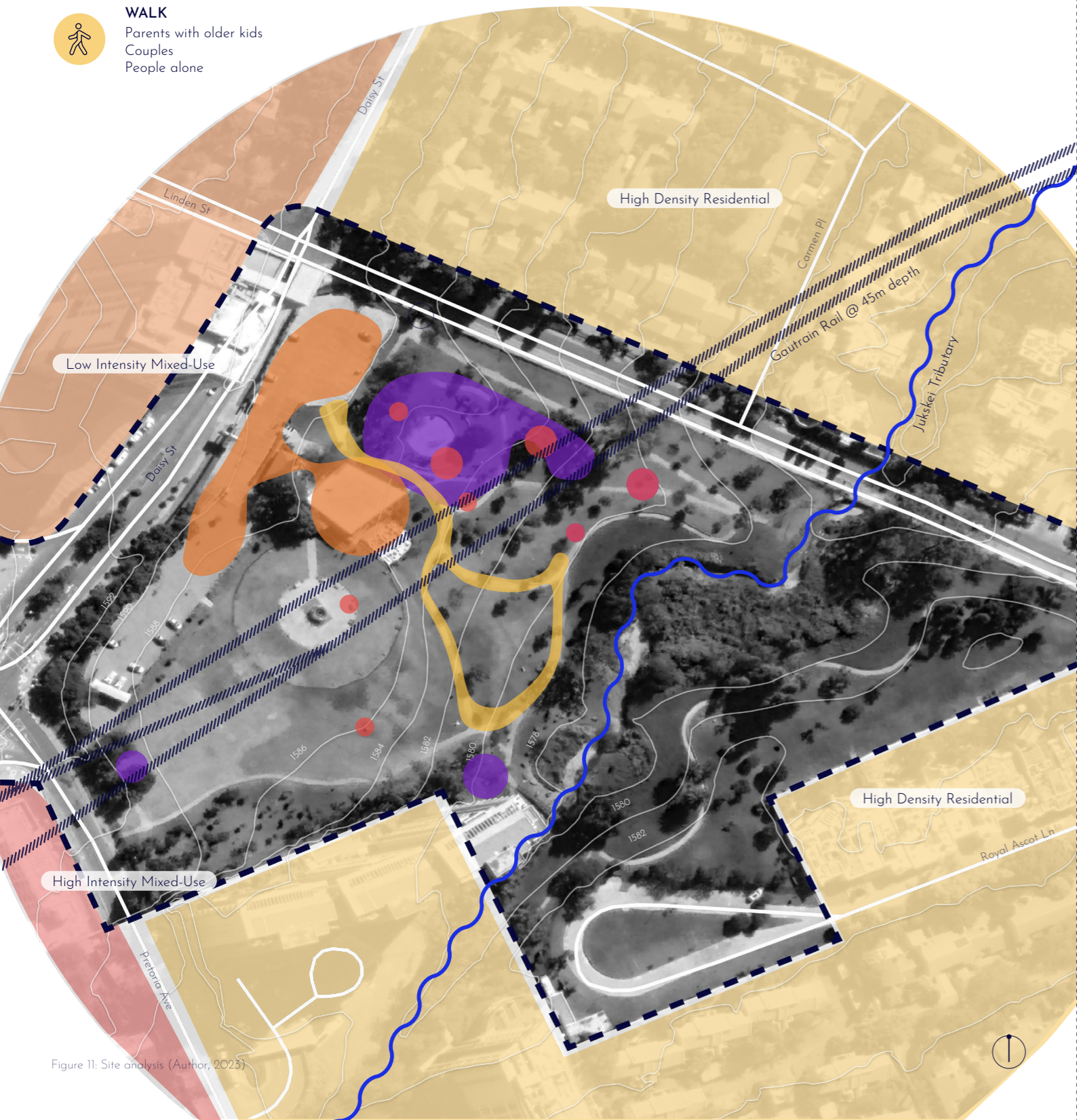

Figure 11: Site analysis (Author, 2023)

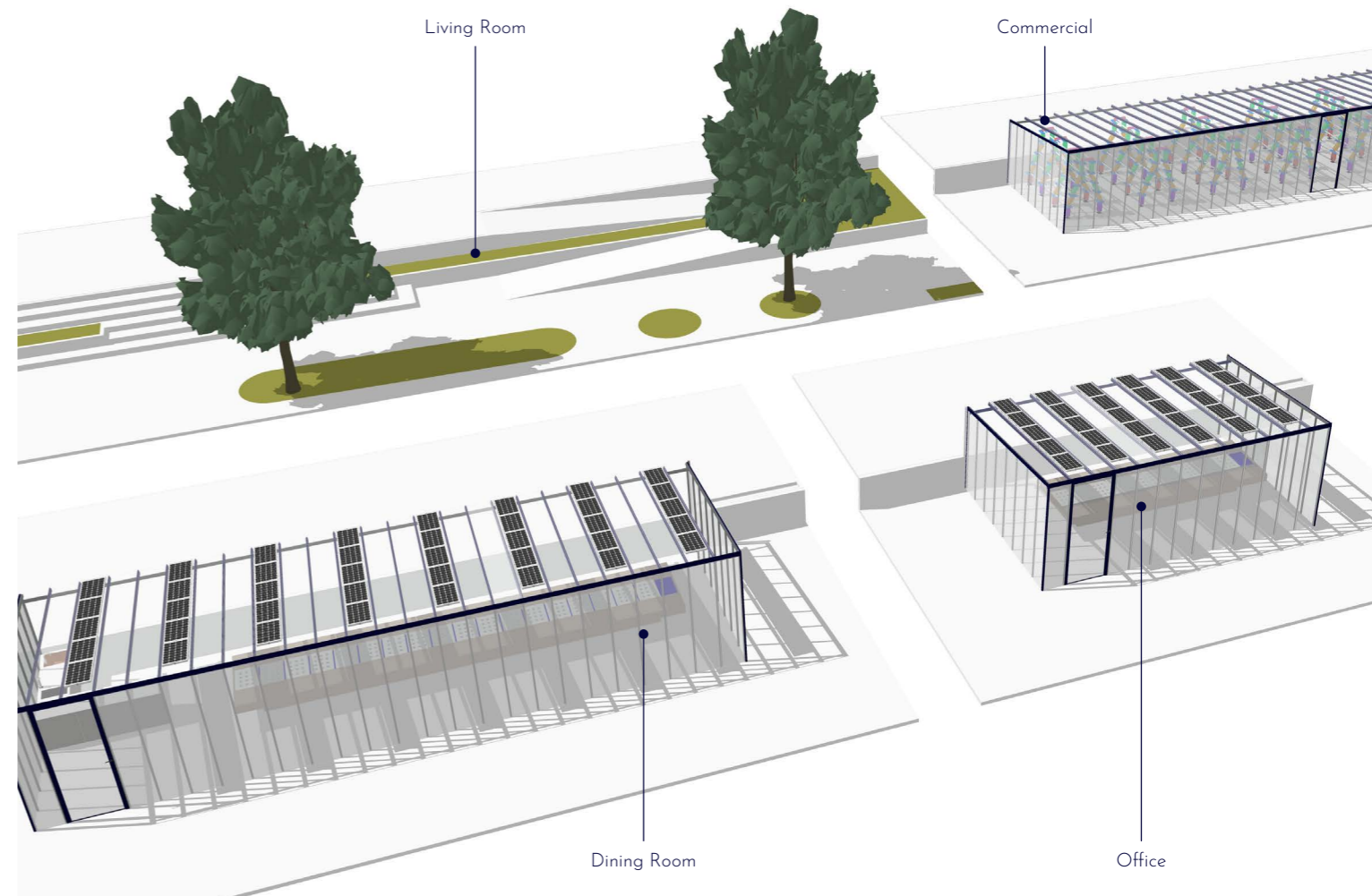
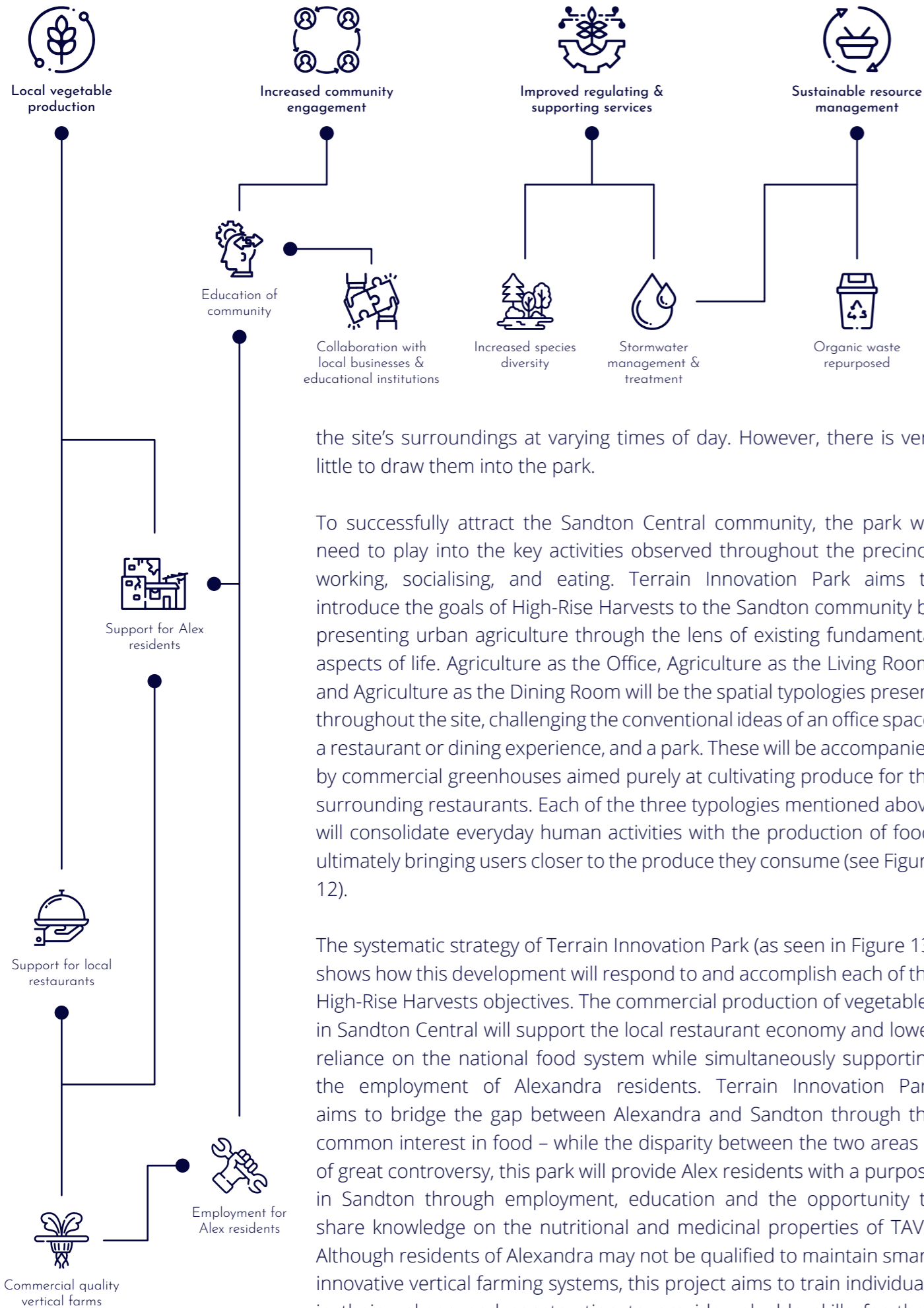

Figure 12: Greenhouse Typologies (Author, 2023)

TERRAIN INNOVATION PARK

Terrain Innovation Park will be situated on what is currently Mushroom Farm Park (see Figure 11), a 4.6-hectare park characterised by an eroded, polluted Jukeskei tributary, rolling hills of lawn, and poorly maintained pathways. The park coined its title from the 'Silver Stream' mushroom farm, which thrived on the land in the 1950s and 60s. However, with rapid urbanisation, the farm was moved away from Sandton and the land was acquired by the Sandton Council (Reid, 2016). Figure 11 shows the dominant programmes observed on the site: children playing on the jungle gyms, people sitting alone or sleeping on benches, visitors of the restaurant, and people walking along the pathways. While sporadic activities occur at the park, attendance is consistently low, with a maximum of 15 people scattered across the open space daily – this is not conducive to community collaboration or increased engagement. From my observations, the Sandton Central community does not sufficiently support this park due to its failure to provide for the specific needs of its potential users. The adjacent land uses – high-density residential and low to high-intensity mixed-use – draw a rich diversity of individuals to



the site's surroundings at varying times of day. However, there is very little to draw them into the park.

To successfully attract the Sandton Central community, the park will need to play into the key activities observed throughout the precinct: working, socialising, and eating. Terrain Innovation Park aims to introduce the goals of High-Rise Harvests to the Sandton community by presenting urban agriculture through the lens of existing fundamental aspects of life. Agriculture as the Office, Agriculture as the Living Room, and Agriculture as the Dining Room will be the spatial typologies present throughout the site, challenging the conventional ideas of an office space, a restaurant or dining experience, and a park. These will be accompanied by commercial greenhouses aimed purely at cultivating produce for the surrounding restaurants. Each of the three typologies mentioned above will consolidate everyday human activities with the production of food, ultimately bringing users closer to the produce they consume (see Figure 12).

The systematic strategy of Terrain Innovation Park (as seen in Figure 13) shows how this development will respond to and accomplish each of the High-Rise Harvests objectives. The commercial production of vegetables in Sandton Central will support the local restaurant economy and lower reliance on the national food system while simultaneously supporting the employment of Alexandra residents. Terrain Innovation Park aims to bridge the gap between Alexandra and Sandton through the common interest in food – while the disparity between the two areas is of great controversy, this park will provide Alex residents with a purpose in Sandton through employment, education and the opportunity to share knowledge on the nutritional and medicinal properties of TAVs. Although residents of Alexandra may not be qualified to maintain smart, innovative vertical farming systems, this project aims to train individuals in their upkeep and construction to provide valuable skills for their implementation outside of the park.

Figure 13: Systematic strategy (Author, 2023)

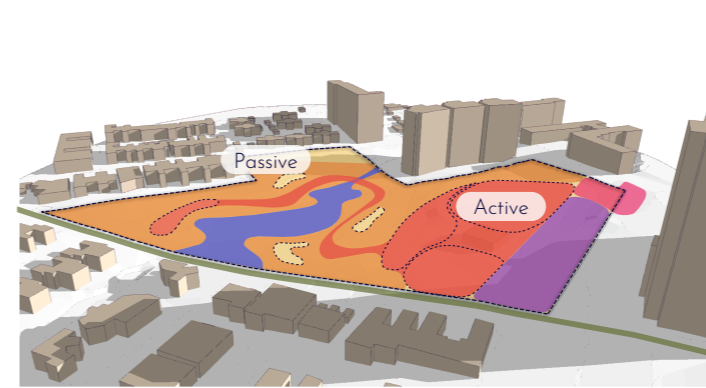

Figure 14.1: Spatial strategy V1 (Author, 2023)

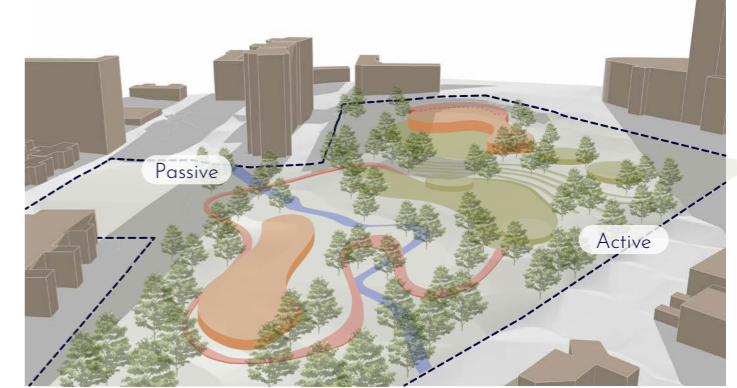

Figure 14.4: Spatial strategy V4 (Author, 2023)

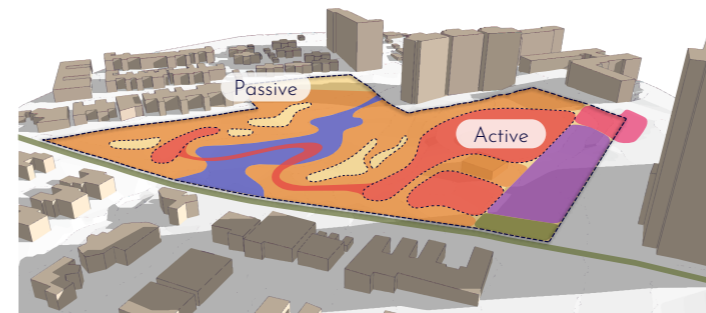

Figure 14.2: Spatial strategy V2 (Author, 2023)



Figure 14.5: Spatial strategy V5 (Author, 2023)

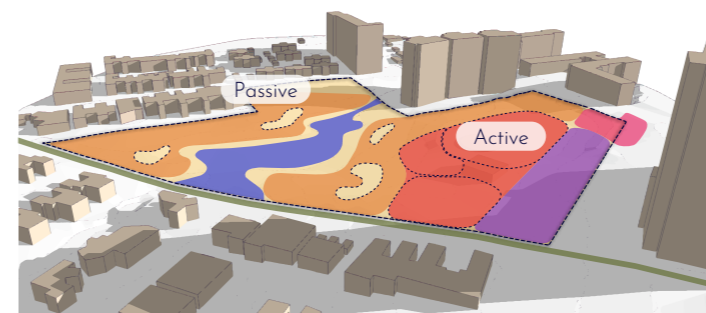

Figure 14.3: Spatial strategy V3 (Author, 2023)

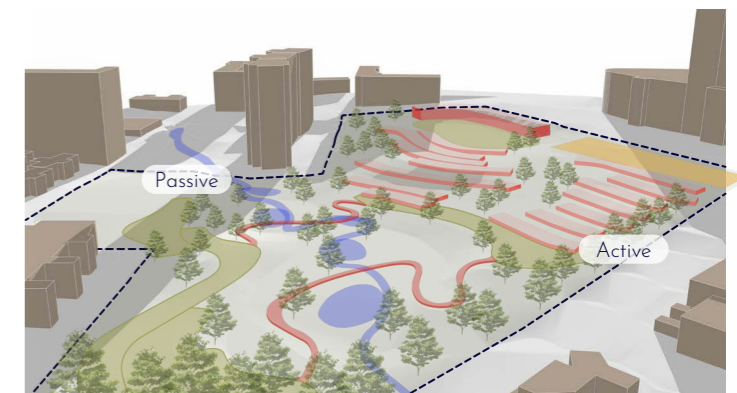

Figure 14.6: Spatial strategy V6 (Author, 2023)

THE ITERATIVE PROCESS

As this project has progressed over the months, it has gone through numerous spatial iterations. However, as can be seen from Figure 14.1 to Figure 14.6, the strategic placement of 'active' and 'passive' space has remained consistent. While this park aims to address all four High-Rise Harvests objectives, its two key priorities are community engagement and rehabilitating natural systems. As of the most recent iteration (seen in Figures 20 and 21), community engagement is tackled mainly in the Northern 'active' or 'programmed' portion of the site, while the Southern portion is focused on rehabilitating the stream and its connected systems, providing passive opportunities for users to engage with nature organically.

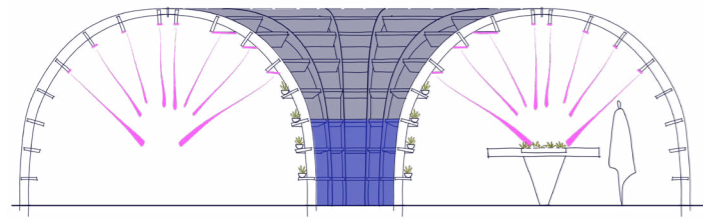

Figure 15.1: Hydroponic support structure exploration (Author, 2023)

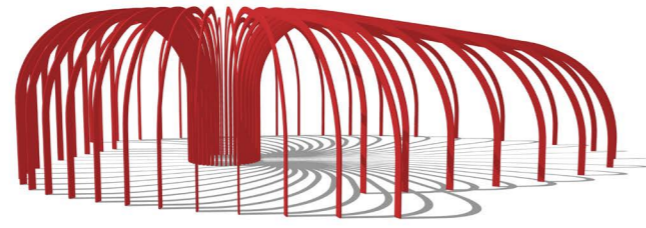

Figure 15.2: Hydroponic support structure V1 (Author, 2023)

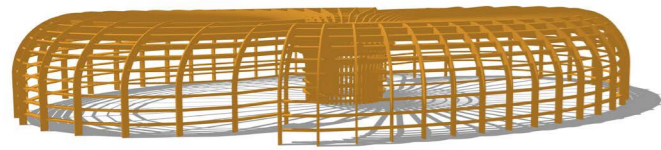

Figure 15.3: Hydroponic support structure V2 (Author, 2023)

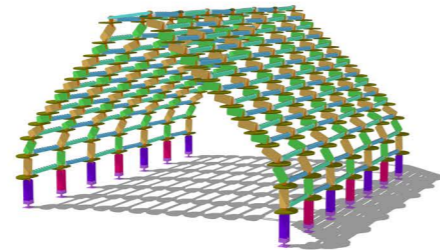

Figure 15.4: Hydroponic support structure V3 (Author, 2023)

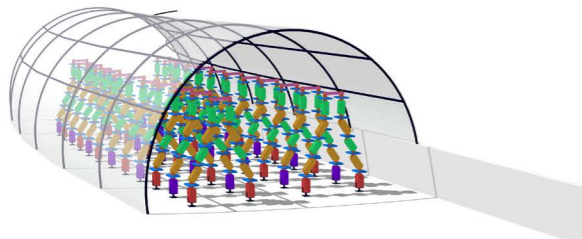

Figure 15.5: Greenhouse V1 (Author, 2023)

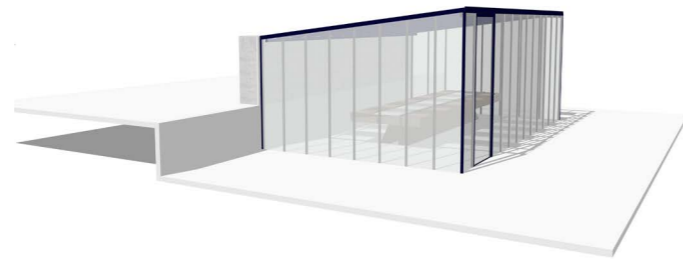

Figure 15.6: Greenhouse V2 (Author, 2023)

The terraced approach to the site’s northern portion (see Figures 20 and 21) was inspired by the steeply sloping topography – with an overall fall of 14 meters from the street edge to the stream. Within the active zone, structures have been revised to accommodate hydroponics. This point in the process involved going off on a bit of an iteration tangent. However, as can be seen from Figure 15.1 to Figure 15.6, the unrealistic cocoons eventually evolved into more practical greenhouse structures. With the objective of circularity in mind, the forms initially began with the intention of harvesting water and being self-sufficient. However, other aspects of self-sufficiency, such as light requirements for solar collection and crop production were compromised. The current version of the greenhouse pavilions addresses all the needs of self-sufficiency and circularity with simple, elegant, and modular construction methods.

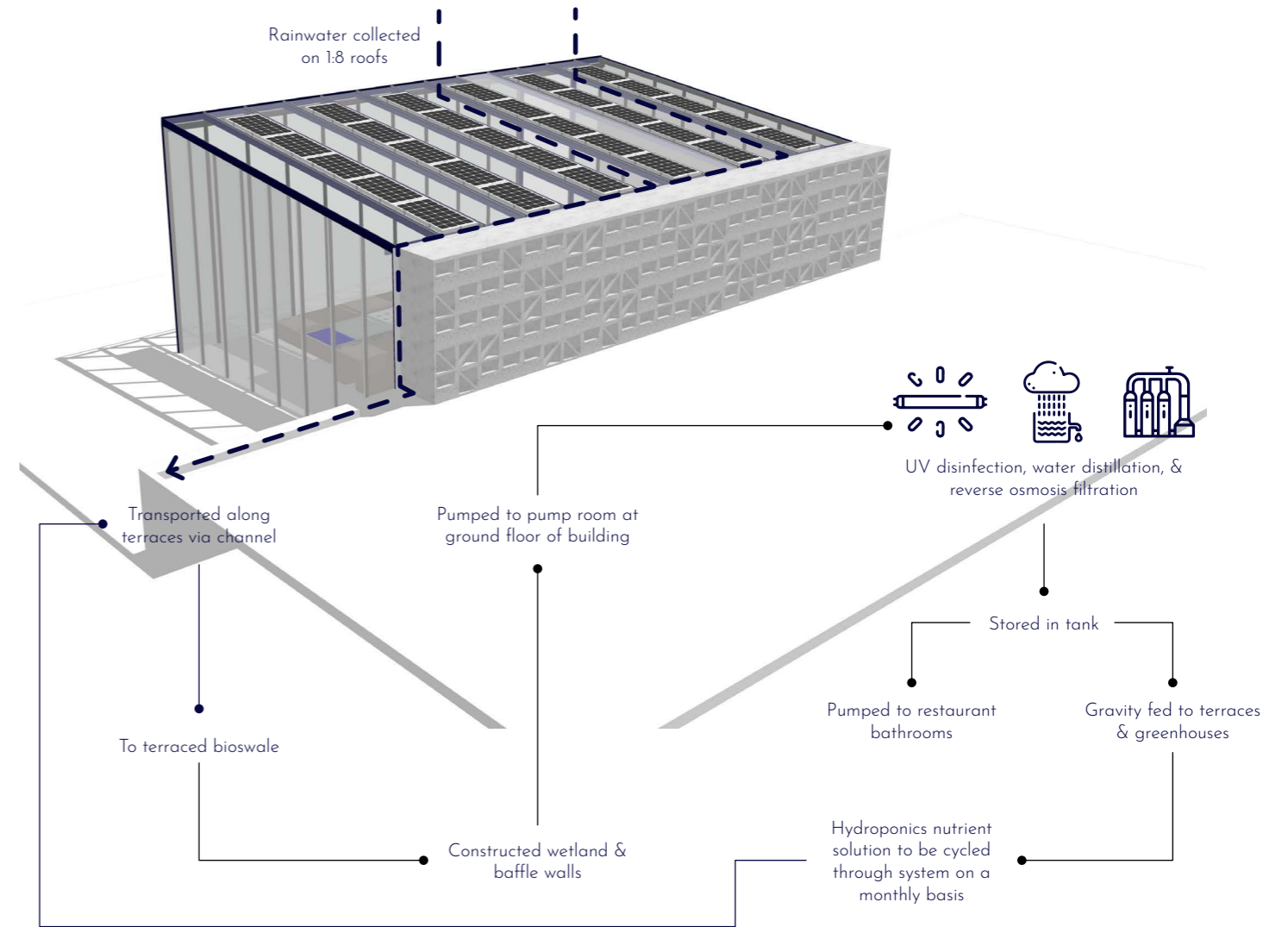

Figure 16: Water system (Author, 2023)

TECHNICAL INVESTIGATIONS

While the High-Rise Harvests framework has been guided by the overall research questions stated previously, Terrain Innovation Park seeks to answer the following technical question in addition:

- How can circularity and resilience be achieved by cultivating edible plants in Sandton Central?

CIRCULARITY

It is stated by Godfrey (2021) that circular economies involve the “radical transformation of the ways in which resources are used and products are designed” to improve resource security, reduce materials and energy consumption, and offer new opportunities for economic growth. In the context of this site, the principle of circularity has been explored mainly through the resource of water and construction methods. Currently, South Africa’s agricultural sector is responsible for 61% of our total water demand, and our cities for 30% (Godfrey, 2021); this makes it imperative for urban agricultural initiatives to take a new approach to water use. Figure 16 shows how circularity has been celebrated through the park’s

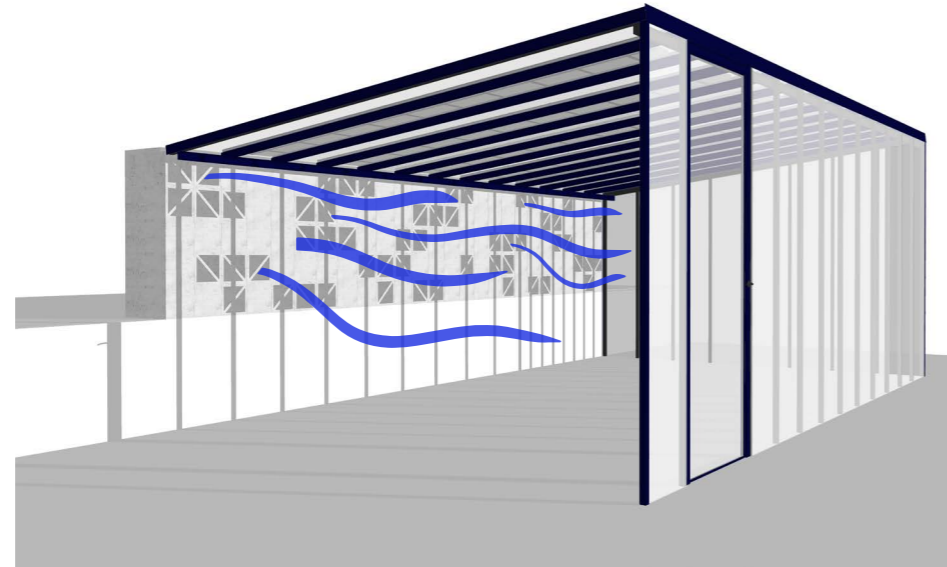
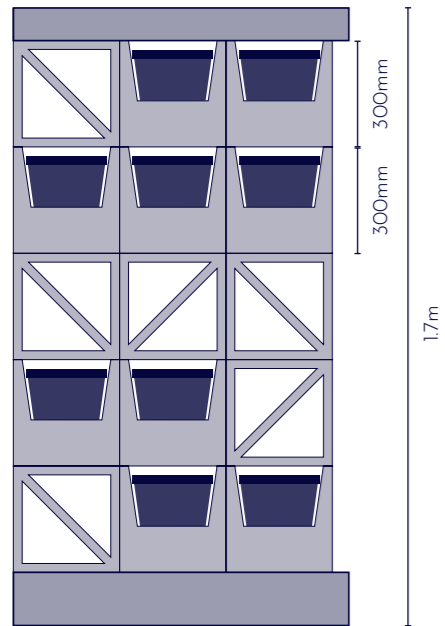
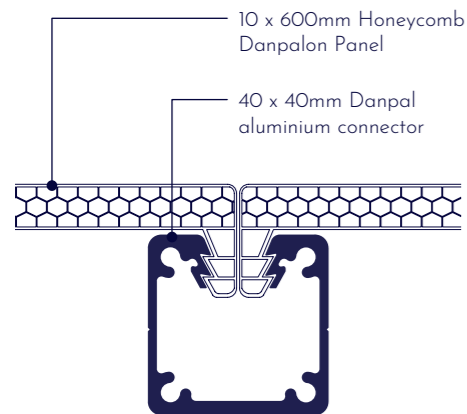
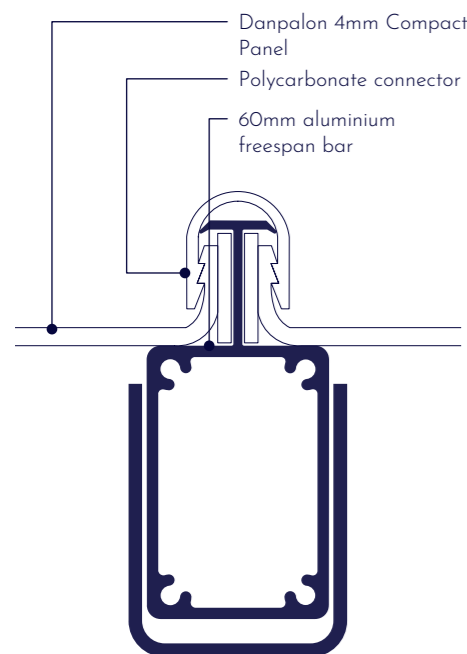

Figure 18: Eco Green Wall and Breeze Block facade (Author, 2023)



Danpal Seamless Façade interlocking polycarbonate system



Danpal Compact Roofing interlocking polycarbonate system

Figure 17: Danpal Façade & Roofing systems (Danpal, n.d.)

water harvesting, treatment, and irrigation system – using greenhouse roofs and hard surfaces for rainwater collection allows the site to gather enough water to sustain crops for the entirety of the year (see Figure 19).

In terms of the greenhouse construction, circularity is explored through modularity. According to Lawson and Ogden (2019), lightweight, modular construction assists with the reduction of carbon emissions associated with transportation, minimising site waste, and increasing the speed of installation. In addition to this, modular structures can be dismantled and re-used if need be. In light of this, the two systems chosen for the Terrain Innovation Park greenhouses are the Danpal polycarbonate façade and roofing systems (Danpal, n.d.) and the Eco Green Wall blocks developed locally by Arbus Horticulture (Arbus Horticulture, 2020). The Danpal Compact Roofing system and Seamless Façade system (see Figure 17) both involve a simple interlocking installation process which results in a thermally insulated, UV-protected, and high-impact resistant structure to house NFT and DWC hydroponics systems. While crops need to be protected from the elements, they require airflow – in response, Eco Green Wall blocks have been used with breezeblocks on the northern sides of the greenhouses to allow air to pass through into the greenhouse (see Figure 18). The Eco Green Wall blocks provide a resilient solution to living wall systems in South Africa due to their cost-effective and ‘low-tech’ development – the blocks are created from durable materials and utilise recycled polystyrene as a cement additive (Arbus Horticulture, 2020). Their modular form allows for easy transportation, storage on site, and a simple stacking process of installation. In addition, the blocks champion resilience through their effective drip irrigation system and their ability to retain moisture due to only one-third of the planting tray being exposed to the atmosphere.

PLANTING

The selection of mainstream crops and TAVs throughout the site have been chosen to produce a year-round yield. As the mainstream crops such as lettuce, cabbage, or herbs are less hardy to Gauteng’s hot summers and cold winters, they will be cultivated for restaurant use in the commercial-quality NFT and DWC hydroponic greenhouses. Due to TAVs being more tolerant of harsh climatic conditions, they will be grown in the ‘Living Room’ spaces outside the greenhouses and in the Eco Green Wall systems. To give a rudimentary estimation of the yield of this site, the commercial greenhouses are host to 955m² of NFT hydroponic structures producing 60 plants/m² – this results in around 57 300 plants per growth cycle (between 30 and 50 days for NFT-grown lettuce). The entire High-Rise Harvests framework has designated roughly 401 100m² of unused rooftop space for the production of vegetables in NFT systems. This would yield an estimated 24 million plants per growth cycle to be utilised throughout the Sandton Central precinct.

As seen from the planting chart shown in Figure 19, leafy vegetables (shown in blue) are generally harvestable year-round – especially those grown in greenhouse environments – however, fruiting species of TAVs and indigenous trees (shown in pink) allow for dynamic harvesting periods. These fruits can support alternative programmes at the park to encourage community engagement, such as berry harvesting, jam and cordial-making workshops, or TAV cooking classes.

While Terrain Innovation Park aims to invigorate community engagement with agriculture, it is also a practical, working farm. Therefore, the operational system has been factored into the layout of the site. All commercial crops will be grown from seedlings sourced from partnered nurseries within 15km of the site and delivered to the site’s cold room and processing facilities. Each greenhouse will have work benches and maintenance facilities to remove planting trays to harvest, plant, or attend to the crops. Once plants intended for nearby restaurants are harvested, they are transported to the processing facilities and cold room, where they are cleaned, sorted and packaged before being collected by restaurateurs.

The introduction of TAVs aims to demonstrate ‘low-tech’ solutions to local vegetable production in urban areas – in terms of resilience, they are the champions. While these crops boast many nutritional benefits (Uusiku et al., 2010), they are notably underutilised due to many associating them with a ‘poor image,’ or entirely ignorant of their existence (Cloete and Idsardi, 2013). As seen from the planting chart in Figure 19, these crops are well adapted to hot summers and cold winters and are viable for harvesting for most of the year. Their presence throughout the park’s social ‘Living Room’ spaces aims to passively educate visitors on the vast selection of options, while the ‘Dining Room’ greenhouses will actively provide opportunities for guests to taste, smell, and interact with these crops.

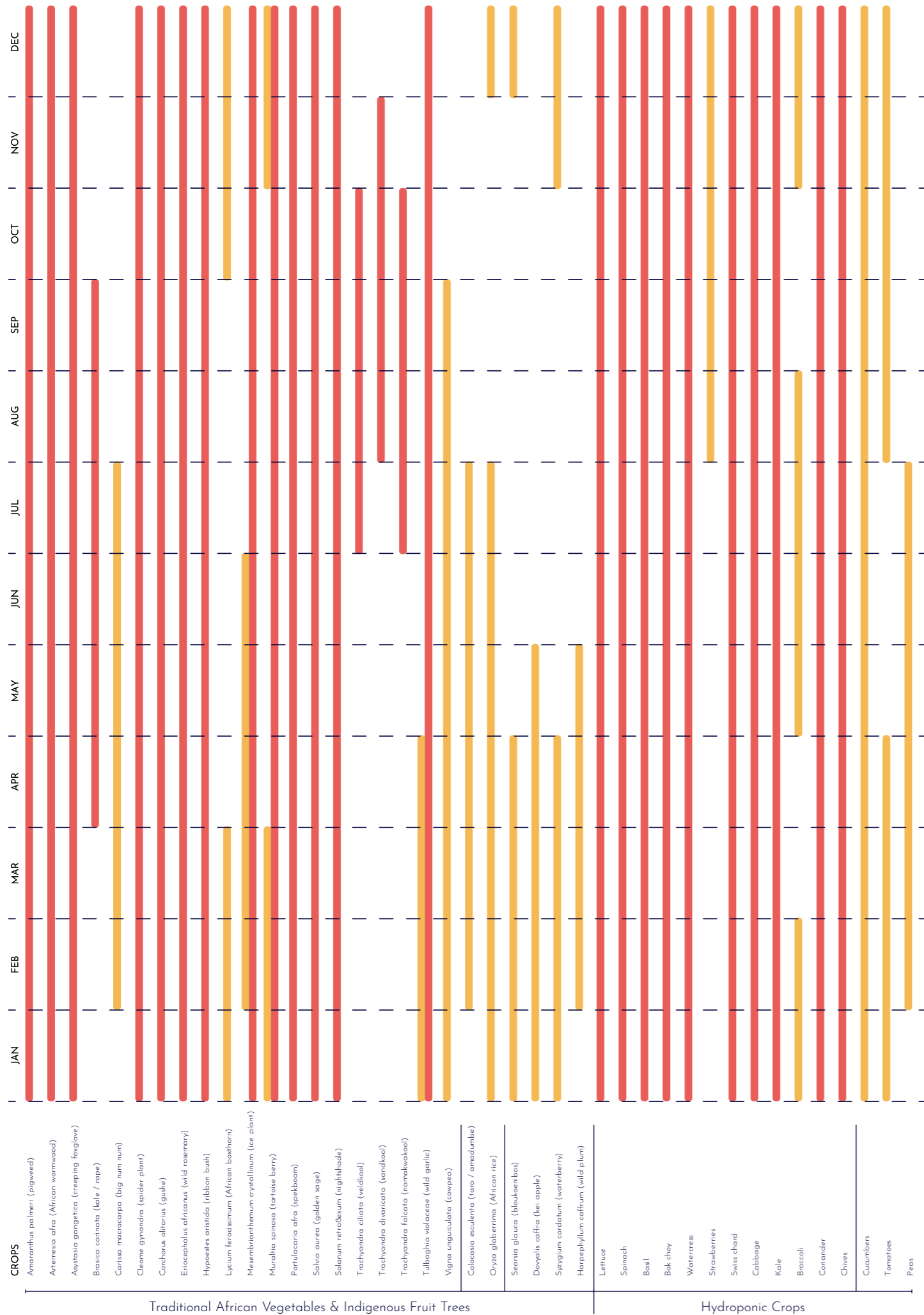

Figure 19: Planting chart (Author, 2025)

CONCLUSION

This project has been continually spurred on by the idea of impacting food system reliance in South African cities and the corresponding effects on carbon emissions and lack of resilience to climate change. Through the theories of Continuous Productive Urban Landscapes, Urban Agriculture, Green Economics, and Circularity, this project has aimed to answer the following questions:

- What interventions should be implemented to support a productive, resilient, and circular urban environment in Sandton Central?
- How can community engagement in this productive, resilient, and circular urban environment be enhanced through landscape architecture and urban agriculture?

With a technical sub-question of:

- How can circularity and resilience be achieved by cultivating edible plants in Sandton Central?

Although these questions can only truly be answered through the design itself and its associated details and systems, this document has illustrated a feasible approach to their achievement.

The introduction of hydroponic systems is essential in making a strong impact on food system reliance and improving the resilience and economic viability of urban agriculture. While these systems are commonly considered complex and high-tech, this project showcases their worth through their high yields, low water demand, and inherent simplicity. The High-Rise Harvests framework's Canopy, Roots, and Terrain layers exemplify how social, economic, and agricultural productivity can be infused into our cities.

While many factors contribute to urban resilience, this project has chosen to focus on the people. Resilience and sustainability are not purely mechanical and rely heavily on human collaboration, investment, and engagement. The solution to increasing community engagement with urban agricultural initiatives explored by this project has been by combining agriculture with activities familiar to people's everyday lives – such as socialising, eating, and working. Given the current practice of 'working remotely' or the culture of dining out in Sandton, Terrain Innovation Park could present a fresh standpoint for these pursuits while igniting interest amongst participants for the produce they consume daily.

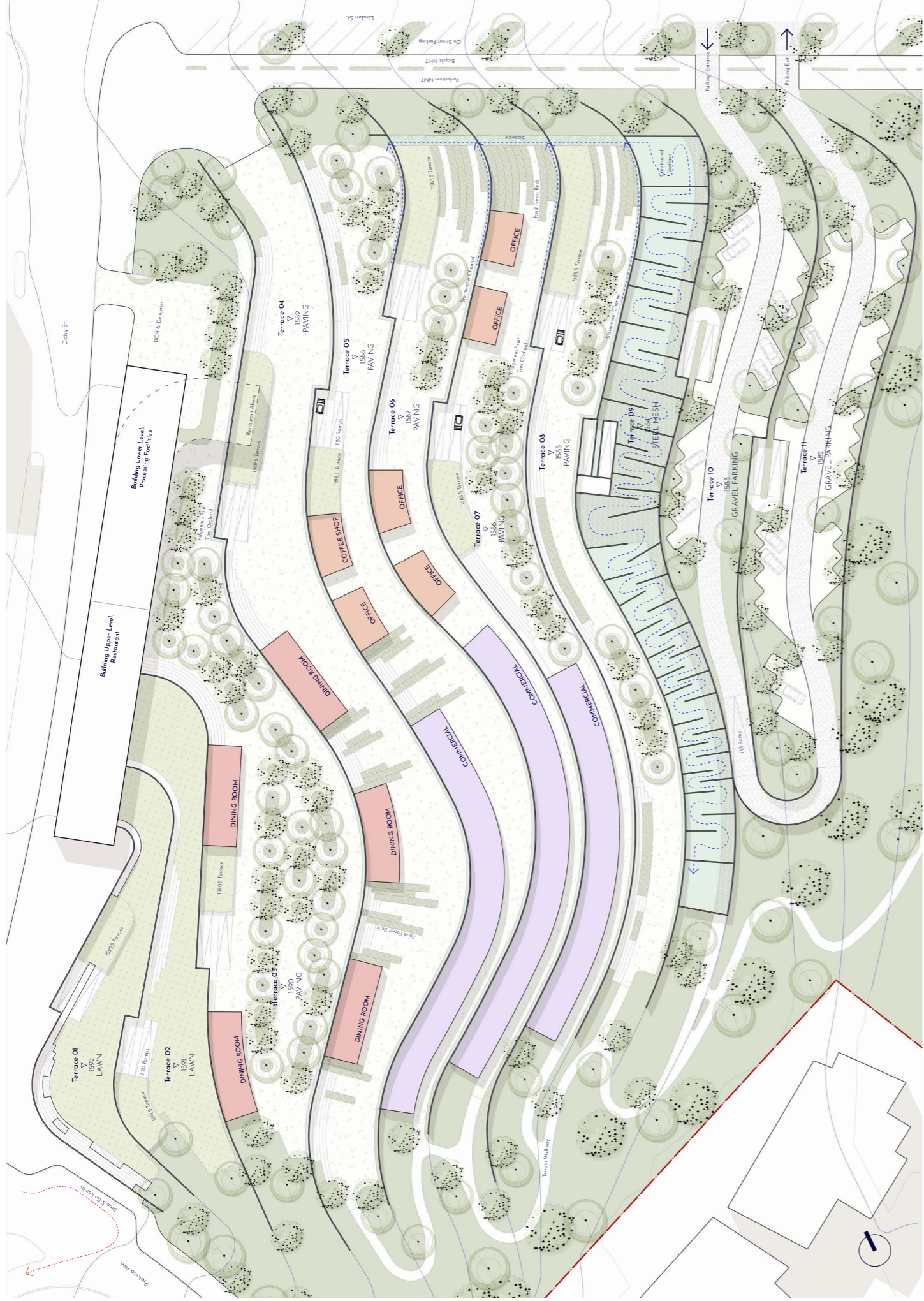

Figure 20: Terrain Innovation Park - Active Zone Plan (NTS) (Author, 2023)

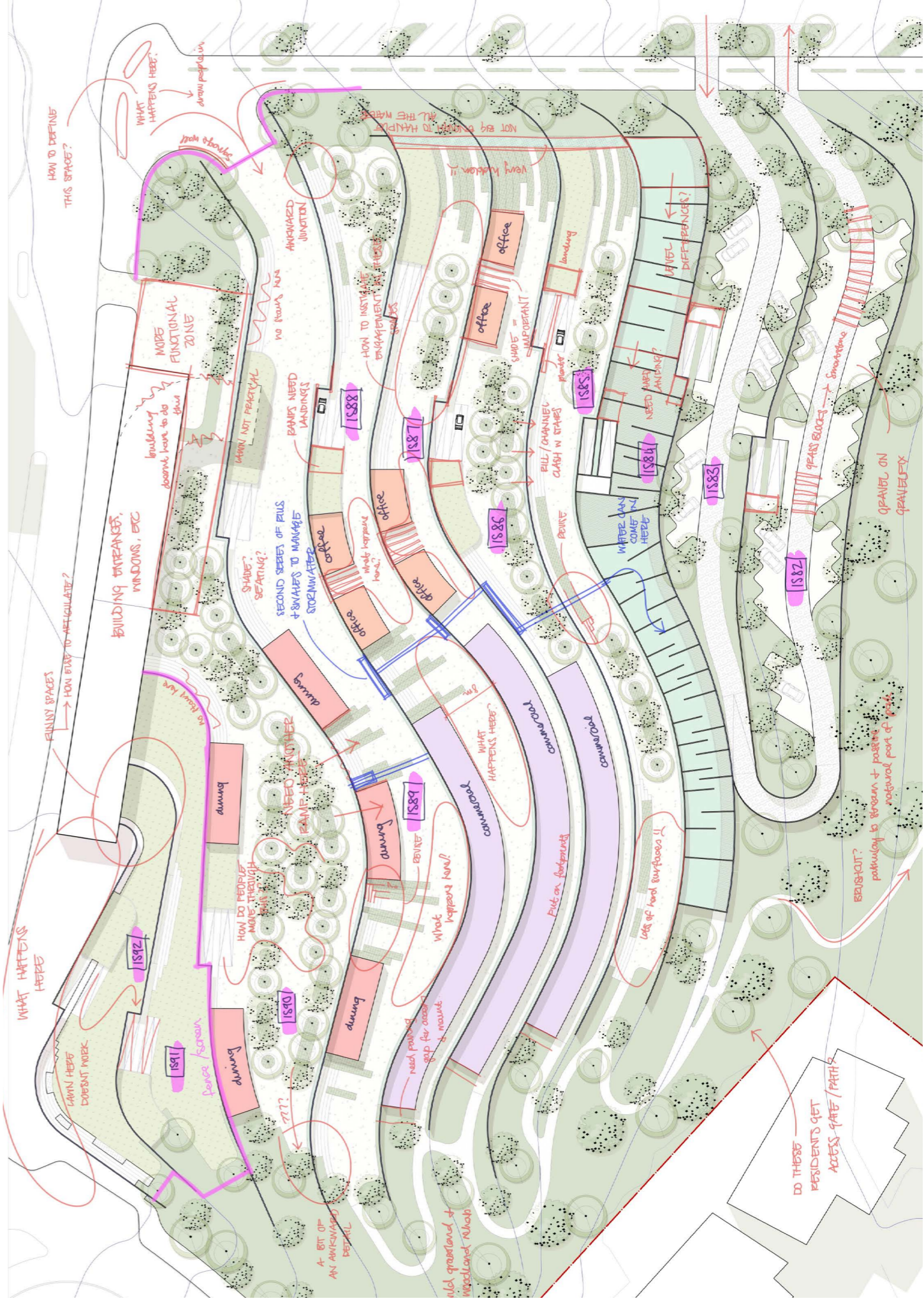

Figure 21: Terrain Innovation Park - Active Zone Plan marked up for revisions (NTS) (A author, 2023)

CRITICAL REFLECTIONS

MAJOR-PROJECT

It has always been important to me that my Masters project be something that I can have fun with. Despite the many moments of overwhelming frustration, I can truly say that I have had a blast. Surprisingly, this year has not been as dreadfully difficult as the rumours said it would be. While it has definitely challenged me from beginning to end, I have experienced it as more of a personal challenge and an exercise in consistency and determination, rather than a purely landscape architectural one. I have found this year that there is a fine line between knowing when to be stubborn and knowing when to let go – not to be confused with knowing when to open a Reb Bull and when to go to bed. While determination has been an important factor in my Masters year, it has also led me down many roads where I relentlessly pushed on with ideas and concepts which, in all honesty, were quite rubbish (see Figures 15.2 to 15.4). In this case, being headstrong despite the countless iterations was not productive – if I had not stopped myself I would still be fiddling around with those forms. However, later on in the year when I found myself in a bout of uncertainty regarding my choice of hydroponics, the decision to be stubborn and push on with a couple more layers of bumf felt like the right one. In these situations it became important to understand my personal limitations and strengths, as well as whether it would be more beneficial and time efficient to improve upon the limitation holding me back, or to simply choose a different method.

I have joked with classmates that every evening I make a to-do list for the next day, and the first item on every single one is “wake up.” While I can't recall how I found myself in this habit, being able to cross something off of the list first thing in the morning does bring me a little sense of accomplishment. The main challenge of this year has been consistency and diligence – in measuring my progress, managing my time, and in meeting the goals I set for myself. While this has not always been easy, especially in moments of panic and doubt, making a list and meticulously crossing items off has never failed me.



Figure 20: Mini-project installation (Author, 2023)

MINI-PROJECT

2023 began with more pom-poms than I had expected a Masters year to involve. While I admit to not being entirely on board with the mini-project, I found it a delightfully calm start to a very busy year. The hanging pom-pom carpet plays on the calming sensation that a layer of vegetation can bring to the hard and brutal urban context. While sitting on my couch winding wool endlessly around a piece of cardboard, I did not expect the task to have anything to do with my ‘actual’ Masters project. However, as time has passed and as I watch people thoughtlessly brush their hands against the wool on their way through the studio, I realise that it might connect more to my Sandton Central interventions than I thought. Bringing a community together involves introducing a common goal, passion, or interest – a hand from each household occasionally reaching out to investigate the same thing, be it a soft-looking pom-pom or a new way of growing food.

LIST OF REFERENCES

- Akinola, R., Pereira, L. M., Mabhaudhi, T., De Bruin, F. M. & Rusch, L. 2020. A Review of Indigenous Food Crops in Africa and the Implications for more Sustainable and Healthy Food Systems. *Sustainability*, 12, 3493.
- Arbus Horticulture 2020. Eco Green Wall.
- Barbosa, G. L., Gadelha, F. D., Kublik, N., Proctor, A., Reichelm, L., Weissinger, E., Wohlleb, G. M. & Halden, R. U. 2015. Comparison of Land, Water, and Energy Requirements of Lettuce Grown Using Hydroponic vs. Conventional Agricultural Methods. *Int J Environ Res Public Health*, 12, 6879-91.
- Botes, K. & Breed, C. 2022. Traditional African Vegetables in Modular Living Walls: a Novel Approach Towards Smart Cities. *World Building Congress*.
- City of Johannesburg 2021. Climate Action Plan. In: Environment and Infrastructure Services Department (ed.). City of Johannesburg.
- Cloete, P. C. & Idsardi, E. F. 2013. Consumption of Indigenous and Traditional Food Crops: Perceptions and Realities from South Africa. *Agroecology and Sustainable Food Systems*, 37, 902-914.
- Creamer Media. 2016. Sandton is an epicentre for green buildings in Africa [Online]. Available: <https://www.engineeringnews.co.za/article/sandton-is-an-epicentre-for-green-building-in-africa-2016-03-31> [Accessed 6 April 2023].
- Danpal. n.d. The Danpal Way [Online]. Available: <https://danpal.com.au/the-danpal-way/> [Accessed 29 September 2023].
- Ron Dembo - Citizen Roles in Resilient Cities, 2014. Video file. Directed by Dembo, R.
- Department of Social Development 2022. Food Resilience Policy. City of Johannesburg Council.
- Godfrey, L. 2021. The Circular Economy as Development Opportunity, Pretoria, Council for Scientific and Industrial Research.
- Lawson, R. M. & Ogden, R. G. 2019. Sustainability and Process Benefits of Modular Construction.
- Njilo, N. 2023. Johannesburg Water's haemorrhaging supply continues to dry up leaving desperate residents pleading for relief [Online]. *Daily Maverick*. Available: <https://www.dailymaverick.co.za/article/2023-09-22-johannesburg-waters-haemorrhaging-supply-continues-to-dry-up-leaving-desperate-residents-pleading-for-relief/#:~:text=Experts%20have%20warned%20that%20as,reason%20for%20the%20intermittent%20supply.> [Accessed 23 September 2023].
- Reid, A. 2016. Was there really a Mushroom Farm in Sandton Central? [Online]. *The Heritage Portal*. Available: <https://www.theheritageportal.co.za/article/was-there-really-mushroom-farm-sandton-central> [Accessed 17 March 2023].
- Sandton Central. n.d. The History of Sandton Central: From Settlement to City, the History and Legacy of Sandton Central [Online]. Sandton Central. Available: <https://sandtoncentral.co.za/our-history> [Accessed 6 April 2023].
- Sla. 2017. SUND Nature Park [Online]. Available: <https://www.sla.dk/cases/sund-nature-park/> [Accessed 30 August 2023].
- Studiomas, Akanya Development Solutions & Karabo Consulting 2008. Sandton Urban Development Framework. In: Management, D. P. a. U. (ed.). City of Johannesburg.
- Uusiku, N. P., Oelofse, A., Duodu, K. G., Bester, M. J. & Faber, M. 2010. Nutritional value of leafy vegetables of sub-Saharan Africa and their potential contribution to human health: A review. *Journal of Food Composition and Analysis*, 23, 499-509.
- Viljoen, A., Bohn, K. & Howe, J. 2005. Continuous Productive Urban Landscapes: Designing Urban Agriculture for Sustainable Cities. Architectural Press.