

# DECARBONISING SOUTH AFRICA'S PARATRANSIT WITH HYDROGEN: A SIMULATED CASE STUDY

**CJ ABRAHAM<sup>1\*</sup>, T ZENNER<sup>2</sup>, MJ BOOYSEN<sup>1\*\*</sup> and AJ RIX<sup>1\*\*\*</sup>**

<sup>1</sup>Department of E&E Engineering, Stellenbosch University, South Africa;  
\*Tel: +27 81 540 4218; Email: [24540463@sun.ac.za](mailto:24540463@sun.ac.za); \*\*Tel: 021 808 4013;  
Email: [mjbooyesen@sun.ac.za](mailto:mjbooyesen@sun.ac.za); \*\*\*Tel: 021 808 3623; Email: [rix@sun.ac.za](mailto:rix@sun.ac.za)

<sup>2</sup>Faculty of Engineering, Reutlingen University, Germany; Tel: +49 7121 271 7030;  
Email: [thorsten.zenner@reutlingen-university.de](mailto:thorsten.zenner@reutlingen-university.de)

## ABSTRACT

As fuel prices climb and the global automotive sector migrates to more sustainable vehicle technologies, the future of South Africa's minibus taxis is in flux. The authors' previous research has found that battery electric technology struggles to meet all the mobility requirements of minibus taxis. They investigate the technical feasibility of powering taxis with hydrogen fuel cells instead. The following results are projected using a custom-built simulator, and tracking data of taxis based in Stellenbosch, South Africa. Each taxi requires around 12 kg of hydrogen gas per day to travel an average distance of 360 km. 465 kWh of electricity, or 860 m<sup>2</sup> of solar panels, would electrolyse the required green hydrogen. An economic analysis was conducted on the capital and operational expenses of a system of ten hydrogen taxis and an electrolysis plant. Such a pilot project requires a minimum investment of € 3.8 million (R 75 million), for a 20 year period. Although such a small scale roll-out is technically feasible and would meet taxis' performance requirements, the investment cost is too high, making it financially unfeasible. They conclude that a large scale solution would need to be investigated to improve financial feasibility; however, South Africa's limited electrical generation capacity poses a threat to its technical feasibility. The simulator is uploaded at: <https://gitlab.com/eputs/ev-fleet-sim-fcv-model>.

## 1. INTRODUCTION

Present-day combustion vehicles are soon to become remnant of the past. This is especially true in Africa, which is likely the continent most vulnerable to the effects of climate change (UNEP, 2021). Global cooperation is essential to curb this problem. The Paris Agreement has led to 47 out of Africa's 54 countries to pledge their *National Determined Contributions* (NDCs), which plan out their climate change mitigation, adaptation and finance strategies (Abudu et al., 2023). Africa has led the way by achieving higher quality standards for their NDCs over any other continent. Despite this, the feasibility scores of Africa's NDCs averaged at only 42%, indicating the challenges that it may face as it tries to implement its strategies (Mukarakate, 2022)

One of the strategies that African countries are contemplating, is to migrate the transport sector to more efficient technologies. The transport sector currently contributes 23% of global carbon emissions (Sims et al., 2014). The combustion of fossil fuels is clearly not a sustainable option for society's transport needs. Already, major vehicle manufacturers have committed to plans to switch to battery-electric or fuel-cell technologies in the next 5 to 20 years (Lowell & Huntington, 2020; Motavalli, 2021).

The big question is whether these new technologies will actually be beneficial for developing countries and whether these countries will be ready to meet the drastically different infrastructure requirements of these new technologies. To start with, the ailing electric utilities of developing countries are often unable to meet current electricity demands, let alone the high demands of a vast population of Electric Vehicles (EVs). Studies have shown that in some African studies, switching private vehicles to EV technologies would be unsupported by the grid (Agunbiade & Siyan, 2020; Dioha et al., 2022) and could even have a *negative* impact on the environment (Buresh et al., 2020; Buresh, 2021).

Public transport, albeit predominantly informal - paratransit, still constitutes the majority of the modal share in most developing countries (Behrens et al., 2016). According to Kumar et al. (2008), besides walking, minibuses have the highest modal share in Africa (as calculated from 14 African cities). Since this form of public transport constitutes such a high modal share, it would be natural to optimise and plan EV migration for this sector first, before looking at private vehicles. African public transport is fraught with old, undermaintained minibuses, which would greatly benefit from this transition. However, in the context of developing countries, a literature gap exists on public transport electrification.

To address this literature gap, the authors have previously performed feasibility analyses of the Battery Electric Vehicle (BEV) technology for the taxi industry in South Africa. This made use of a custom simulation software<sup>1</sup>, which they developed as part of their previous studies (Abraham et al., 2021; Abraham et al., 2022b). The results of these analyses showed various challenges that would manifest if the taxi industry adopted BEV technology (Booyesen et al., 2022a; Booyesen et al., 2022b; Rix et al., 2022), as summarised in Section 1.1. In response, the authors decided to investigate other EV technologies. The Fuel Cell Vehicle (FCV) technology had come to the fore, the feasibility of which is evaluated in this article.

## 1.1 Opportunities and Challenges of Paratransit Electrification

The authors' previous research studied paratransit in South Africa (Booyesen et al., 2022a), Uganda (Booyesen et al., 2022b), and other African countries (Rix et al., 2022). Various opportunities were found that favour the adoption of BEV taxis in those cities, which can be adopted in other African countries with similar paratransit conditions.

Among these include:

- Favourability for photovoltaic charging, since most taxis pause operations at midday, when solar irradiance is at its peak.
- The fact that most of the taxi's operation is intra-city, means that it has a non-constant speed profile, and a high frequency of stop-starts. BEV technology greatly minimises the losses of this type of driving profile.
- The taxi's intra-city operation and the facts that they consist of old vehicles and constitute the main mode of transport for 62% of South Africa's households (Statistics South Africa, 2021), means that the localised pollution produced by these vehicles would be greatly curtailed.

---

<sup>1</sup> Available at: <https://gitlab.com/eputs/ev-fleet-sim>.

Despite the opportunities, there are technical challenges that will arise from minibus taxi electrification. First of all, taxis have much higher energy demands than private vehicles. Hence they will require bigger batteries, and will require more time to charge. Although modern “quick chargers” are able to charge batteries to 80% capacity in less than one hour, it remains to be seen whether the surrounding electrical network’s infrastructure will be able to cope with the high demand of charging multiple taxis at a high rate. With many taxis requiring to charge, and with limited power delivery from the electrical network, there may be a challenge to sufficiently charge the many taxis.

Another challenge is that some taxis make long distance *inter-city* journeys over the weekends (Booyesen et al., 2013). These long distance journeys would require a huge amount of energy, requiring the taxi to stop multiple times to charge. This reduces the quality of service of the journey for customers, decreases profitability for the taxi owner, and creates range anxiety for the driver. Furthermore, having multiple charging stations along the countryside would require high infrastructure investment.

It can be seen that the advantages are common to EVs in general, while the disadvantages are specific to the limitations of *Battery-EVs*. Thus, the *Fuel-Cell-EV* was considered as a suitable alternative to enjoy the numerous advantages of employing EV taxis, while avoiding the disadvantages of BEVs.

## 1.2 Objectives

While the FCV technology may seem like the silver-bullet for the future of South African taxis, the truth is that its energy efficiency is lower and infrastructure requirements are different than the BEV technology. Therefore, it is important to quantify the exact energy demands and infrastructure costs of running FCV taxis, with the aim of eventually comparing that to those of BEV taxis. This study therefore quantifies the following metrics:

- Technical feasibility:
  - Amount of hydrogen required per day to power each FCV taxi.
  - The hydrogen tank size required in the vehicle.
  - Energy required to produce this hydrogen.
  - Photovoltaics (PV) required for producing this energy.
- Economic feasibility:
  - Operating and capital expenses (opex and capex).
  - Equivalent daily cost-burden on the taxi owner.
  - Levelized cost of energy for the PV installation.

## **2. METHOD**

The overall simulation process is demonstrated in Figure 1. The approach extends the BEV model system by Abraham et al. (2022b), so that the BEV model can be easily interchanged with the FCV model which is developed in this study. The following sections delve into these steps into more detail.

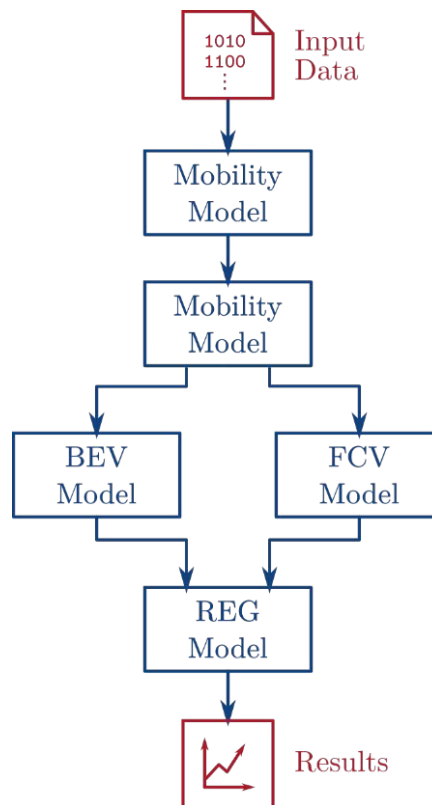

**Figure 1: Modelling approach**

## 2.1 Input Data

As discussed in Section 1.1, minibus taxis are extremely unregulated. As a result, mobility data for minibus taxis is extremely scarce. Taxis routes and schedules, are poorly understood by government and transport authorities, as described by Klopp & Cavoli (2019). Privately obtaining GPS traces was therefore necessary. A team from Stellenbosch University was commissioned to track a fleet of ten taxis based in Stellenbosch, South Africa, over a course of two years. This was done using GPS trackers, obtained from a local fleet management service provider, Mix Telematics. These trackers were installed in the vehicles, allowing full temporal coverage of the spatial location information. It consisted of timestamped geographical coordinates, speed and direction, logged at one-minute intervals (Akpa et al., 2016).

## 2.2 Mobility Model

Following the model diagram in Figure 1, the next step was to feed the input data into a mobility model. The simulation tool interacted with a mobility model from the SUMO mobility platform (Lopez et al., 2018). This model generated *route plans*, which are files that describe the routes that the taxi takes as a sequence of roads, and the times that the taxi makes its stops as it traverses its route. These route plans filter out outlier datapoints, up-samples the data, and snap datapoints to the roads which are nearest to them. Additionally, it provides statistics such as the average distance travelled by the taxi, and the average stopping time. The process of generating routes and identifying stops is shown in Figure 2.

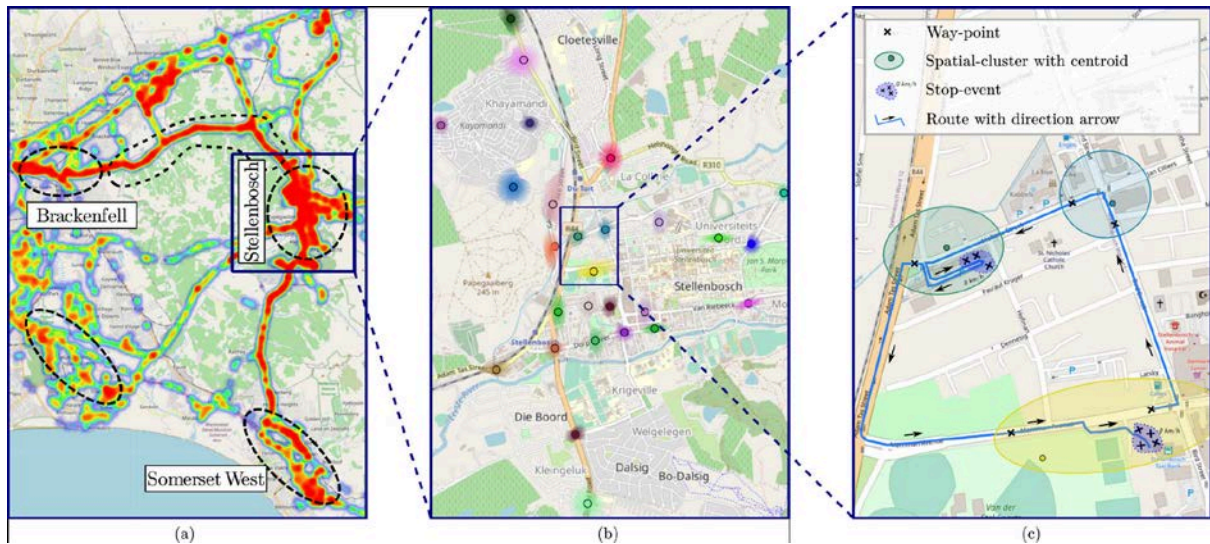

**Figure 2: Route plan generation process**

### 2.3 EV Model

To measure the temporal variation of power and energy usage, and the relationship between power consumption and the electric taxi's speed, the developed simulation tool interacted with an EV model from the SUMO mobility platform (Lopez et al., 2018). Details about the model's implementation are published by Kurczveil et al. (2014). This model's parameters were specifically designed to be similar to those of the prevailing model of minibus taxis presently used in South Africa, the Toyota Quantum. Accordingly, the weight and front surface area of the electric taxi model were taken from an existing Quantum. The rest of the parameters, summarised in Table 1, were approximated on the basis of recommendations by Fridlund and Wilen (2020).

**Table 1: EV model parameters**

Parameter	Value	Unit
Height	2.3	m
Width	1.9	m
Front surface area	4	m <sup>2</sup>
Mass	2,900	kg
Constant power intake	100	W
Internal moment of inertia	0.01	kg·m <sup>4</sup>
Air drag coefficient	0.35	-
Propulsion efficiency	0.8	-
Recuperation efficiency	0.5	-

This electric taxi model was applied to the simulation route plans which were generated from the mobility data. The simulation program initialised the electric taxi model for each date that was simulated. For every second of simulation time, the simulator logged the energy consumption and speed of the electric taxi as it progressed along its route plan.

## 2.4 FCV Model and Related Components

In order to simulate the hydrogen FCVs, the output of the electric model was fed into an FCV model. This model is shown at the bottom of Figure 3. The FCV model calculate the energy required as hydrogen to power the FCV. The energy requirements for producing that hydrogen are computed by the remaining components of the system's model in Figure 3 (viz. storage tank, compressor, electrolyser, battery buffer and electricity supply). Each component consisted of a technical model and financial model. The technical models are used to compute the energy requirements for each day of the taxis' operation, while the financial models compute the operating and capital costs.

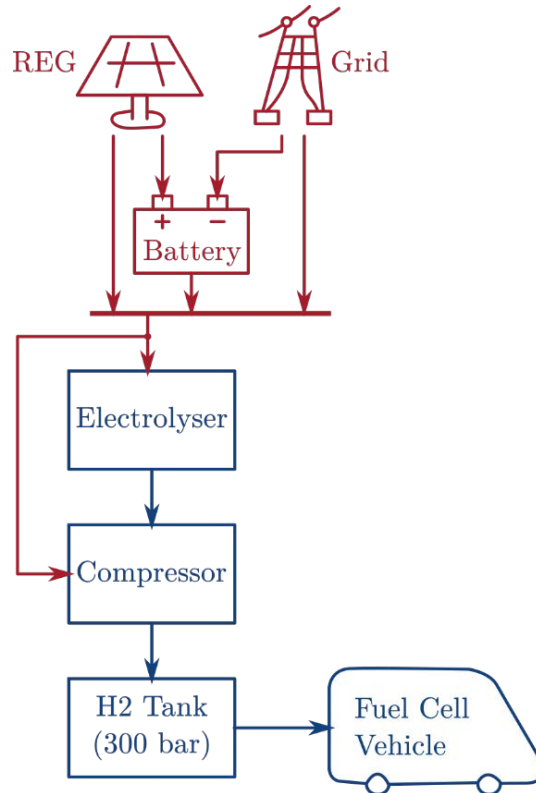

**Figure 3: Model of FCV system**

The technical models make use of energy based calculations. Therefore, many of the results reported in this article refer to the *chemical energy* of hydrogen, rather than the actual weight of hydrogen. This makes it easier to compare results with the energy consumption of BEV simulations. However, the chemical energy,  $E$ , is related to the hydrogen mass,  $m$ , via the equation:

$$m = \frac{E}{\eta \times HHV_{H_2}} \quad (1)$$

where  $\eta$  is the fuel cell efficiency, and  $HHV_{H_2}$  is the higher heating value of hydrogen (141.8 MJ/kg). The model parameters of the various components are shown in Table 2.

**Table 2: Model parameters of FCV and related components**

<b>(a) FCV</b>		<b>(b) Tank</b>	
Parameter	Value	Parameter	Value
	0.6	Pressure	300 bar
Energy efficiency	kWh/km	Storage efficiency	95 %
Fuel cell efficiency	70 %		
Capex	€ 60 000		
Lifetime	20 years		
Maintenance rate (Pistoia, 2010)	0.035 €/km		

<b>(c) Compressor</b>		<b>(d) Electrolyser</b>	
Parameter	Value	Parameter	Value
Compression energy factor <sup>a</sup>	10 %	Energy efficiency (Hägele, 2021)	75 %
Capex rate (Hägele, 2021)	8000 €/kW	Capex rate (Hägele, 2021)	4000 €/kW
Lifetime	20 years	Lifetime	20 years
		Maintenance factor <sup>b</sup>	5 %

<sup>a</sup>The amount of energy required to compress the Hydrogen gas, as a fraction of the chemical energy present in the Hydrogen.

<sup>b</sup>The annual maintenance cost as a fraction of the capex.

## 2.5 Renewable Energy Generator (REG) Model

The Photovoltaics (PV) model used in this study is from the SAM simulation suite, by NREL (2020). The suite contains numerous other Renewable Energy Generator (REG) models, such as wind turbines, concentrated solar power, hydropower, etc. The parameters which were used in the PV model are shown in Table 3.

**Table 3: PV model parameters**

Parameter	Value
Tilt angle	35°
Azimuth	180°
PV losses	14 %
Inverter efficiency	96 %
Opex rate	12.2 €/kW
Lifetime	20 years
Capex rate	975 €
Ground coverage ratio <sup>a</sup>	0.3

<sup>a</sup>The ratio of the PV area to the ground area.

## 2.6 Economic Analysis

In order to do an economic analysis, each of the components in Figure 3 were equipped with a financial model<sup>2</sup>. The financial model would account for a capex and an opex part. The capex part would account for the initial purchase price of the equipment, while the opex part would account for yearly maintenance and electricity costs (staff wages and insurance was ignored). The yearly opex was discounted to the equivalent present value  $P$  using the following equation:

$$P = A \frac{1 - (1 + i)^{-t}}{i} \quad (2)$$

where interest rate  $i$  is 8%, the instalment  $A$  is the yearly opex, and the number of instalments  $t$  is the years of operation (Bradley, 2013).

## 3. RESULTS

### 3.1 Data Inspection

Figure 4a shows the complete mobility trace of one of the tracked taxis. Some outlier datapoints can be seen in the ocean and the North West of the map. These datapoints were cropped away. Additionally, the taxis made long-distance trips to other cities (such as East London and Mthatha) on the weekends, as shown in Figure 4a. In the authors' previous research, this posed a huge feasibility challenge for BEV taxis, since the taxi would need to make numerous stops to charge its battery. Therefore, the BEV simulations were limited to the region shown in Figure 4b. In this research, however, the FCV technology was expected to cope with the additional energy demand, and hence, the weekend trips were not filtered out.

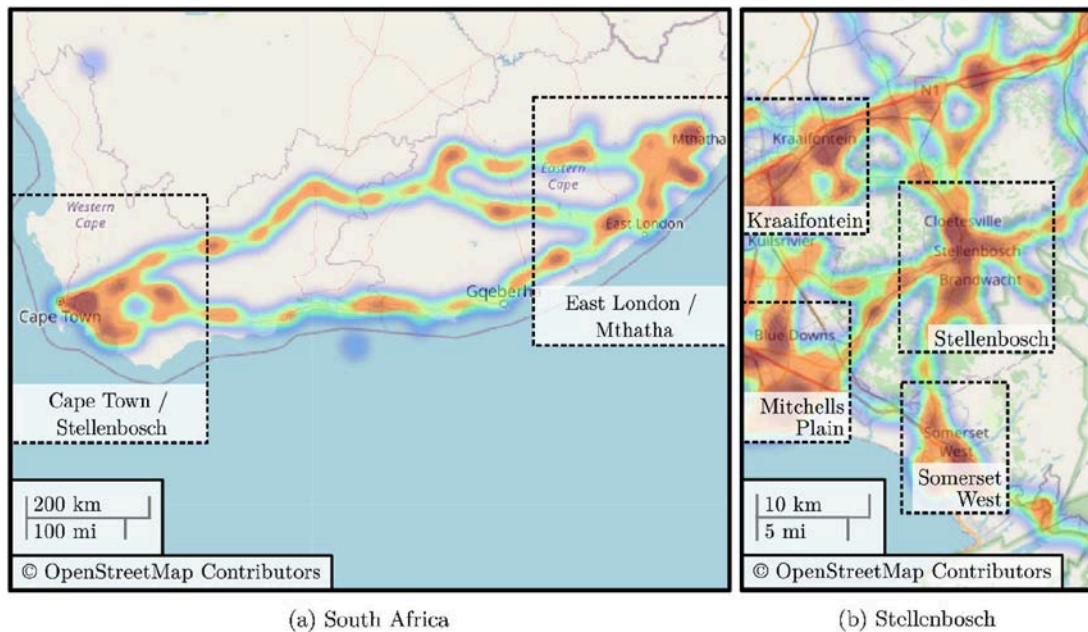

Figure 4: GPS data visualisation

<sup>2</sup>The battery was left out of the economic analysis for simplicity. It was assumed that all the PV energy was directly absorbed into the electrolyser.



### 3.2 Mobility Model

For the short distance trips in Figure 4b, the daily average distance was 230 km, and the stopping time 10 hours. When including the long distance trips shown in Figure 4a, the daily average distance increased to 358 km. The average stopping time also increased to 14.2 hours, due to the overall reduced activity during the weekend. The stopping behaviour varied greatly between taxis and also between the days of each taxi, as shown in the box-and-whisker plots in Figure 5.

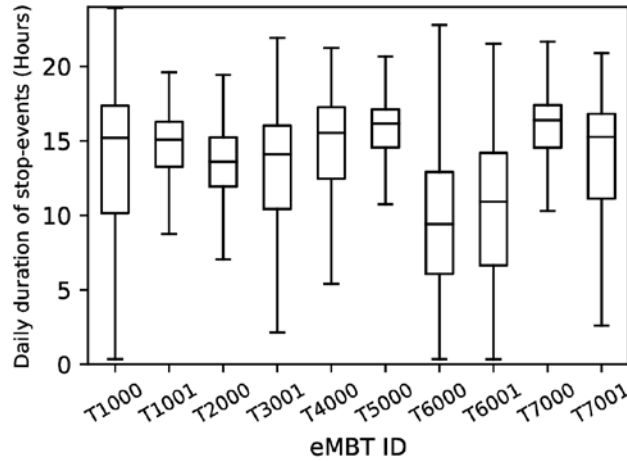

Figure 5: Distribution of daily stopping time for each taxi in the fleet

### 3.3 EV Model

The EV model yielded an energy efficiency of 0.58 kWh/km. The distribution in the energy efficiency is shown in Figure 6. The variation in the energy efficiency between the taxis was minimal. A few outlier datapoints can be seen, which correspond to days that the taxi rode predominantly uphill/downhill, as especially seen in Taxi T7001. The average daily energy consumption of all the taxis was 255 kWh, as required by the motor to overcome the vehicles drag forces.

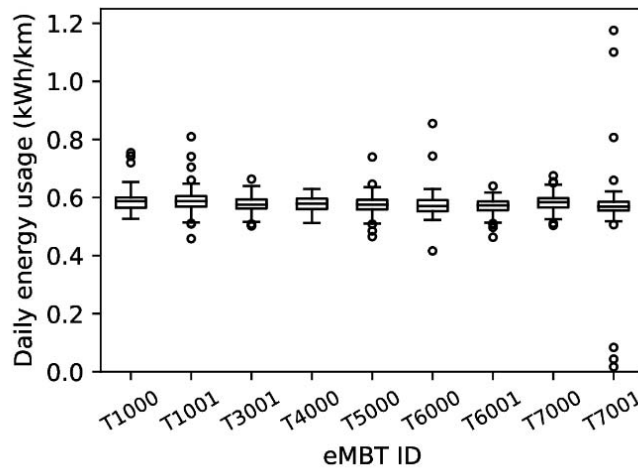
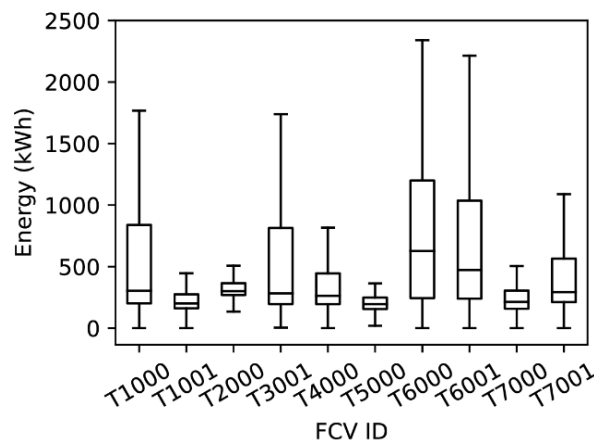

Figure 6: Distribution of energy efficiency for each taxi in the fleet

### 3.4 FCV Model and Related Components

The energy efficiency yielded by the EV model was fed into the FCV model to account for the losses caused the fuel cell. The following result was computed:

An average of 324 kWh of hydrogen chemical energy was used by each FCV to travel an average distance of 360 km. Using Equation 1, this is around 12 kg of hydrogen gas, leading to an efficiency of 3.28 kg/100km<sup>3</sup>. The distribution of FCVs' hydrogen usage is shown in Figure 7.



**Figure 7: Distribution of energy required as hydrogen for each taxi in the fleet**

To store the required 12 kg of Hydrogen at 300 bars<sup>4</sup>, 0.7 m<sup>3</sup> of tank storage would be required. At least 0.3 m<sup>3</sup> should be storable in the vehicle itself for the short distance trips (e.g. those in Figure 4b), while extra tank storage for the long-distance weekend trips (Figure 4a) could be added using a trailer.

By feeding the FCVs' net hydrogen usage to the electrolyser and compressor models to the electrolyser, compressor, battery and power utility models, the net energy required to produce the required hydrogen was found. This amounted to an average of 465 kWh of electricity per taxi.

If all 300 000 of South Africa's taxis were converted to FCV technology, this would require 22% (140 GWh) of the country's current national daily generation capacity.

### 3.5 REG Model

The final step in the process was to evaluate the amount of REG capacity that would be required to meet this electricity demand. PV was focused on in this study, although other REG models are available in the SAM package which was used (NREL, 2020).

In order to generate the total 424 kWh of electricity, the REG model computed that a PV nameplate (i.e. peak) capacity of 164 kW would be required for each taxi. This would require a total PV area of 864 m<sup>2</sup> and, assuming an open rack system, a land area of 2880 m<sup>2</sup> (roughly a third of a professional soccer field).

<sup>3</sup>For comparison, the popular Toyota Mirai Z sedan has a manufacturer-claimed efficiency of 0.74 kg/100km (Toyota Motor Corporation, 2020).

<sup>4</sup>Industry standard for heavy vehicles.

### 3.6 Economic Analysis

An economic assessment was done to identify the capex and opex of the proposed FCV system. A 20 year system lifetime was assumed, for both the PV infrastructure and the FCVs.

The total cost of the system was calculated as € 3.77 million (R 75 million). The breakdown of this cost can be shown in Figure 8. 79% of the cost was capex, while the remaining 21% was opex. The disproportionately high capex can be attributed to the fact that the system consists of a small fleet, of only ten taxis. As a result, the cost per taxi was high, at €377 000 (R 7.5 million) for the 20 year life cycle.

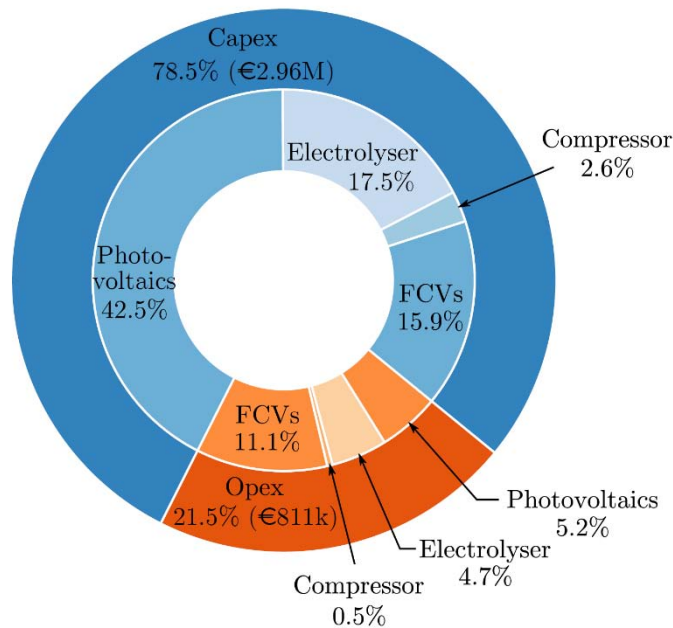

Figure 8: Cost breakdown

Rearranging Equation 2 for the daily instalment,  $A$ , and substituting the relevant values<sup>5</sup>, gives an equivalent daily cost of € 104 (R 2 100) per day. Under these assumptions, if a taxi owner is able to earn more than this amount per day, then he will be able to meet his debt.

The levelized cost of electricity of the PV installation was 9.72 ¢/kWh (1.93 R/kWh), which is competitive with respect to current European electricity prices. These results were computed using the technical and financial models of SAM (NREL, 2020).

## 4. CONCLUSIONS

As the world has been combating climate change, through various technological means, Africa has been struggling to play its part in the process. As the climate change threatens to increase the already high rates of poverty and starvation in Africa, there has never been a more critical time for research on climate adaption in Africa's public transport. For the first time, an attempt has been made to quantify the technical requirements of FCV technology in Africa's largest mode of transport, minibus taxis.

<sup>5</sup>  $P = 3.77$  million,  $i = 0.8365$ ,  $t = 20 \times 365$

The overall research objective was to obtain metrics that quantify the performance and feasibility of the FCV technology in Africa. This was done by developing a simulation tool with technical and financial models for the various components involved. Due to the unavailability of public GPS data, privately obtained data from Stellenbosch, South Africa was used to feed the simulation tool.

The key technical metrics produced by the simulation tool help to answer the research questions surrounding the techno-economic feasibility of migrating South Africa's paratransit to FCV technology. The results are as follows:

Firstly, the technical feasibility was analysed. From the vehicle's perspective, it was established that the average daily hydrogen requirement was quantified as around 12 kg of hydrogen gas (i.e. 324 kWh in chemical energy) to travel an average distance of 360 km. This amounted to an efficiency of 3.3 kg/100km. The amount of hydrogen required for the full day, 12 kg, would require 0.7 m<sup>3</sup> of tank storage. It is certainly feasible to store this in a trailer and at least 0.3 m<sup>3</sup> should be storable in the vehicle.

In order to produce this hydrogen through electrolysis and compress this hydrogen, it was found that a total of 465 kWh of electrical energy would be required. If one was to use PV to generate this energy, the PV installation would require a nameplate capacity of 164 kW, based on the specific weather patterns of Stellenbosch. Hence, this would require around 860 m<sup>2</sup> of solar panels, and 2880 m<sup>2</sup> of land area, for an open rack system.

From the grid's perspective, if all 300 000 taxis registered in South Africa were converted to FCVs, it would require 22% of South Africa's current national daily generation capacity. South Africa's grid currently wouldn't be able to support the extra demand, and would hence need to build significantly more generation capacity. The land area required to power them completely with PV, would be 80 000 ha. This amounts to 0.2% of the Northern Cape's land area, which consists of large quantities of undeveloped semi-desert land. While these figures may seem colossal in scale, it comes as no surprise, since the transport system is relied upon by 62% of the country's households as their main mode of transport (Statistics South Africa, 2021). Additionally, the actual energy demand may be less, since these calculations were based on a sample size of only ten taxis, which are based in one of South Africa's busiest cities.

Secondly, to answer the economic feasibility question, an economic assessment was done for the fleet of ten taxis. A total expense of € 3.77 million (R 75 million) was projected for this project (discounted to the present value). 79% of this was capex and 21% opex. If the capital is not available, this would amount to a daily cost € 104 (R 2 100) per day per taxi to cover the debt. The real cost is likely to be higher, as labour and insurance costs were not incorporated into the financial model. The levelized cost of energy for the PV installation was found to be 9.72 ¢/kWh (1.93 R/kWh). More precise financial modelling is left as future work to experts in that field.

These results show that technically, major infrastructure investment is needed to deploy FCV taxis on a large scale. On a small scale, FCV taxis are technically feasible, but the economic analysis, has shown that this will be difficult. Further economic analysis is required to definitively comment on the economic feasibility and to compare the economics of FCV taxis to that of petrol/diesel taxis. Additionally, a comparison between the FCV taxi results in this article and the BEV taxi results by Abraham et al. (Abraham et al., 2021), would also complete the picture, and is left as future work.

Nonetheless, this research project has greatly contributed to the research body, by providing, for the first time, metrics which quantify the needs of FCV taxis in an African context. This was done using detailed simulation models, as well as real-life data.

The project also contributes to the research body, by providing an open source simulation tool, that can be used to do similar FCV fleet simulations in other contexts. The simulator can easily be configured to work with other types of vehicles, other geographic locations, and other forms of REGs. The modular approach taken in the programming stages can allow fellow researchers to reuse components that were modelled or to replace models with their own in the simulation flow.

## 5. ACKNOWLEDGEMENTS

The GIZ bursary and the ERASMUS foundation for funding the research and providing a research network.

## 6. REFERENCES

- Abraham, CJ & Zenner, T. 2022a. *Fuel-Cell-Vehicle Fleet Simulator ( fcv-fleet-sim)*. Available at: <https://gitlab.com/eputs/ev-fleet-sim-fcv-model>
- Abraham, CJ, Rix, AJ & Booyesen, MJ. 2022b. *Electric-Vehicle Fleet Simulator (ev-fleet-sim)*. Available at: <https://gitlab.com/eputs/ev-fleet-sim>
- Abraham, CJ, Rix, AJ, Ndibatya, I & Booyesen, MJ. 2021. Ray of hope for sub-Saharan Africa's paratransit: Solar charging of urban electric minibus taxis in South Africa. *Energy for Sustainable Development*, 64:118-127. doi: <https://doi.org/10.1016/j.esd.2021.08.003>.
- Abudu, H, Wesseh, P & Lin, B. 2023. Are African countries on track to achieve their NDCs pledges? Evidence from difference-in-differences technique. *Environmental Impact Assessment Review*, 98:106917. doi: 10.1016/j.eiar.2022.106917.
- Agunbiade, O & Siyan, P. 2020. Prospects of Electric Vehicles in the Automotive Industry in Nigeria. *European Scientific Journal, ESJ*, 16:201. doi:10.19044/esj.2020.v16n7p201.
- Akpa, NE, Booyesen, MJ & Sinclair, M. 2016. *Publicly available annotated dataset of tracked taxis*. Available at: <https://gitlab.com/eputs/data/fcd-stellenbosch>
- Booyesen, MJ, Abraham, CJ, Ndibatya, I & Rix, AJ. 2023. e-Quantum leap: Planning for electric minibus taxis in sub-Saharan Africa's paratransit system. In R. A. Acheampong, K. Lucas, M. Poku-Boansi, & C. Uzundu (Eds.). *Transport and Mobility Futures in Urban Africa* (1 ed.). Springer Cham. Available at: <https://link.springer.com/book/9783031173264>
- Booyesen, MJ, Abraham, CJ, Rix, AJ & Giliomee, JH. 2022a. Electrification of minibus taxis in the shadow of load shedding and energy scarcity. *South African Journal of Science*, 118. doi:10.17159/sajs.2022/13389.
- Booyesen, MJ, Abraham, CJ, Rix, AJ & Ndibatya, I. 2022b. Walking on sunshine: Pairing electric vehicles with solar energy for sustainable informal public transport in Uganda. *Energy Research & Social Science*, 85:102403-102413. doi:10.1016/j.erss.2021.102403.

Booyesen, MJ, Andersen, SJ & Zeeman, AS. 2013. Informal public transport in Sub-Saharan Africa as a vessel for novel Intelligent Transport Systems. *16th International IEEE Conference on Intelligent Transportation Systems (ITSC 2013)*, (pp. 767-772). doi:10.1109/ITSC.2013.6728324

Bradley, T. 2013. *Essential mathematics for economics and business*. John Wiley & Sons.

Buresh, KM. 2021. Impacts of Electric Vehicle Charging in South Africa and Photovoltaic Carports as a Mitigation Technique. doi:10019.1/109807.

Buresh, KM, Apperley, MD & Booyesen, MJ. 2020. Three shades of green: Perspectives on at-work charging of electric vehicles using photovoltaic carports. *Energy for Sustainable Development*, 57:132-140. doi: <https://doi.org/10.1016/j.esd.2020.05.007>.

Dioha, MO, Duan, L, Ruggles, TH, Bellocchi, S & Caldeira, K. 2022. Exploring the role of electric vehicles in Africa's energy transition: A Nigerian case study. *iScience*, 25, 103926. doi: <https://doi.org/10.1016/j.isci.2022.103926>.

Directorate-General for Climate Action. 2020. *Stepping up Europe's 2030 climate ambition*. Communication, European Commission, Brussels. Available at: <https://eur-lex.europa.eu/legal-content/EN/TXT/?uri=CELEX:52020DC0562>. Accessed 3 February 2022.

Fridlund, J & Wilen, O. 2020. *Parameter Guidelines for Electric Vehicle Route Planning*. KTH, School of Electrical Engineering and Computer Science (EECS).

Hägele, N. 2021. *Analyse stationärer Energiespeicher auf Wasserstoffbasis*. Reutlingen University.

Klopp, JM & Cavoli, C. 2019. Mapping minibuses in Maputo and Nairobi: engaging paratransit in transportation planning in African cities. *Transportation Reviews* 39. doi: 10.1080/01441647.2019.1598513.

Kumar, AM, Foster, V & Barrett, F. 2008. Stuck in traffic: urban transport in Africa. Available at: <http://siteresources.worldbank.org/EXTAFRSubSAHTRA/Resources/Stuck-in-Traffic.pdf>

Kurczveil, T, López, PÁ & Schnieder, E. 2014. Implementation of an Energy Model and a Charging Infrastructure in SUMO. In M. Behrisch, D. Krajzewicz, & M. Weber (Ed.), *Simulation of Urban Mobility* (pp. 33-43). Berlin: Springer Berlin Heidelberg.

Lopez, PA, Behrisch, M, Bieker-Walz, L, Erdmann, J, Flötteröd, Y-P, Hilbrich, R & Wießner, E. 2018. Microscopic Traffic Simulation using SUMO. *2019 IEEE Intelligent Transportation Systems Conference (ITSC)* (pp. 2575-2582). IEEE. Available at: <https://elib.dlr.de/127994/>

Lowell, D & Huntington, A. 2020. Electric Vehicle Market Status - Update. Available at: [https://mjbradley.com/sites/default/files/EDF\\_EV\\_Market\\_Report\\_September\\_2020\\_Update.pdf](https://mjbradley.com/sites/default/files/EDF_EV_Market_Report_September_2020_Update.pdf)

Motavalli, J. 2021. *Every Automaker's EV Plans Through 2035 And Beyond*. Available at: <https://www.forbes.com/wheels/news/automaker-ev-plans>. Accessed 11 June 2022.

Mukarakate, D. 2022. *In the race against climate change, there's still hope for Africa – here are 5 reasons why*. Available at: <https://climatepromise.undp.org/news-and-stories/race-against-climate-change-theres-still-hope-africa-here-are-5-reasons-why>

NREL (National Renewable Energy Laboratory). 2020. System Advisor Model Version 2020.11.29. Golden, CO. Available at: <https://sam.nrel.gov>

Pistoia, G. 2010. *Electric and hybrid vehicles: Power sources, models, sustainability, infrastructure and the market*. Elsevier.

Rix, AJ, Abraham, CJ & Booyesen, MJ. 2022. Why taxi tracking trumps tracking passengers with apps in planning for the electrification of Africa's paratransit. *iScience*, 25, 104943. doi:10.1016/j.isci.2022.104943.

Sims, R, Schaeffer, R, Creutzig, F, Cruz-Núñez, X, D'Agosto, M, Dimitriu, D & Tiwari, G. 2014. Transport. In O. Edenhofer, R. Pichs-Madruga, Y. Sokona, E. Farahani, S. Kadner, K. Seyboth, J. C. Minx (Eds.), *Climate Change 2014: Mitigation of Climate Change. Contribution of Working Group III to the Fifth Assessment Report of the Intergovernmental Panel on Climate Change* (p. 603). Cambridge, United Kingdom and New York, NY, USA: Cambridge University Press. Available at: <https://www.ipcc.ch/report/ar5/wg3/>. Accessed 3 May 2022.

Statistics South Africa. 2021. *P0320 - National Household Travel Survey, 2020*. Available at: <https://www.statssa.gov.za/publications/P0320/P03202020.pdf>

Toyota Motor Corporation. 2020. *New Mirai Press Information 2020*. Available at: [https://global.toyota/pages/news/images/2020/12/09/1200/20201209\\_01\\_02\\_en.pdf](https://global.toyota/pages/news/images/2020/12/09/1200/20201209_01_02_en.pdf)

UNEP (United Nations Environment Programme). 2021. *Responding to Climate Change*. Available at: <https://www.unep.org/regions/africa/regional-initiatives/responding-climate-change>.