



BRIDGING THE DIGITAL DIVIDE



Bridging the digital divide: an ethnographic investigation to develop a digitalised interface to educate learners within vulnerable communities

by
Brendon Creighton

Submitted in fulfilment of part of the requirements for the degree
Master of Architecture (Professional)

in the
Faculty of Engineering, Built Environment and Information Technology
University of Pretoria
November 2021

PROJECT SUMMARY

TITLE: Bridging the digital divide: an interface to educate learners within vulnerable communities.

BUILDING TYPE: Youth development center

ADDRESS: Cnr Garsfontein Rd &, De Villebois Mareuil Dr, Pretoriuspark, Pretoria (Plastic View Informal Settlement)

RESEARCH FIELD: Urban Citizenship (UC)

GPS CO-ORDINATES: 25°49'55.45"S, 28°18'19.00"E

CLIENT: Tebelo Non-profit

KEYWORDS: Education, spatial agency, indigenous learning, digital inclusivity

THEORETICAL PREMISE/
ARCHITECTURAL APPROACH: Prototyping a digital learning interface through interior architecture.

PROOFREAD BY: Jan Nel

PLAGIARISM DECLARATION

In accordance with Regulation 4(c) of the General Regulations (G.57) for dissertations and theses, I declare that this mini-dissertation, which I hereby submit for the degree Master of Architecture (Professional) at the University of Pretoria, is my own work and has not previously been submitted by me for a degree at this or any other tertiary institution.

I further state that no part of my mini-dissertation has already been, or is currently being, submitted for any such degree, diploma or other qualification.

I further declare that this thesis is substantially my own work. Where reference is made to the works of others, the extent to which that work has been used is indicated and fully acknowledged in the text and list of references.

SIGNED BY:
BRENDON CREIGHTON
15 NOVEMBER 2021



ABSTRACT

“The evidence is clear: early investments in children’s health, education, and development have benefits that compound throughout the child’s lifetime, for their future children, and society as a whole” (The Lancet , 2020). The aim of this mini-dissertation is to investigate the vulnerable community of Plastic View to enable development of a contextually relevant design proposal through a human-centred approach. Through extensive on-site investigations using a human-centred design approach to study Plastic View, it was found that learner education was impacted by socio-economic circumstances. The COVID-19 pandemic enlarged the existing gap of providing learners who live in vulnerable communities with a right to education.

Conversely, digital technology is investigated to bridge digital inclusivity, and offers a platform for educational and social development through merging existing indigenous learning practices by creating a versatile design solution. By contextually and theoretically analysing research and on-site informants a design solution was achieved that contextually applies sustainable building practice that creates an approach for future informal community educational development.

TABLE OF CONTENT

POSITION AND SITUATION 1

- 1.1 Introduction 3
- 1.2 Background 5
- 1.3 Problem Statement 7
- 1.4 Research Methodology 9
- 1.5 Theoretical Framework 15
- 1.6 Site Selection 17
- 1.7 User 35
- 1.8 Normative Position 39

DESIGN RESEARCH 41

- 2.1 Developed Argument 43
- 2.2 Contextual Informants 44
- 2.3 Theoretical Informants 47
- 2.4 Process of learning 51
- 2.5 Design Brief 53
- 2.6 Site for Intervention 55
- 2.7 Design Intent 57
- 2.8 Defining a Programme 59
- 2.9 Design Iteration 63

DESIGN SYNTHESIS 65

- 3.1 Feasibility 67
- 3.2 Spatial Concept 69
- 3.2 Spatial Development 71
- 3.3 Design Resolution 75
- 3.4 Technical Resolution 99

REFLECTION AND CONCLUSION 145

- 4.1 Reflection 147
- 4.2 Conclusion 152



BIBLIOGRAPHY AND FIGURES

- 5.1 Bibliography **153**
- 5.2 List of Figures **159**
- 5.3 List of Tables **163**

SUPPORTING CONTENT

APPENDIX A

Designing for
children

APPENDIX B

Case study: Learners
from informal
settlements

APPENDIX C

Educational
Psychology

APPENDIX D

Digital Learning

APPENDIX E

Ethics Approval

01

DISCOVERY



POSITION AND SITUATION



CHAPTER INTRODUCTION

This chapter aims at identifying a contextual and industry relevant problem by understanding the background, the community and relevant theory for substantiating a research stance. The contextual and theoretical research is led by a research methodology that uses the research gathered in Chapter 2 to formulate a design synthesis.

One

INTRODUCTION

1.1

2020
COVID-19



In March 2020, the COVID-19 pandemic changed the lives of South Africans, and challenged their freedom. With strict regulations and restrictions, individuals were stripped from the ability to interact and engage in their daily lives (Department of Health (RSA), 2021). As a result, many companies, organisations, and people relied on digital technology for communication, work, school, and the transfer of knowledge.

The field of education entered uncharted territories, as COVID-19 caused all learning facilities to stop contact classes with immediate effect in an effort to contain the spread of the virus. For many learners and students, the continuation of learning was possible through on-line learning. Unfortunately, those living in vulnerable conditions and/or poverty were unable to continue classes owing to limited accessibility to technology (National Institute for Communicable Diseases (NICD), 2020).

This mini-dissertation aims at conducting an ethnographic research study into environmental constraints of residents within informal settlements by inductively understanding livelihoods, knowledge, and systems (Reeves, et al., 2008). Problems and needs of vulnerable communities will be used to approach the design project. The methodology is derived from IDEO's Human-centred Design Field Research Guide (IDEO, 2015).

Figure 1.1 - COVID-19 Diagram of transformational events



In Plastic View, learners face daily challenges that influence their ability to learn. Moreover, the difficulties that learners faced were exacerbated by the COVID-19 restrictions. Learners without access to digital technology could not continue classes, and schools that reopened were restricted in the number of learners allowed, leaving many helpless (MPIP, 2021).

The COVID-19 pandemic has been one of the major disruptors in society. However, it has also acted as a catalyst for change in conventional pedagogies, and for informal settlements, the opportunity to access affordable and quality education has never been in closer reach.



Figure 1.2 - Pure Hope "Hope" wall, (Author, 2021)

**INDUCTIVE PROCESS
CONTEXTUAL UNDERSTANDING**

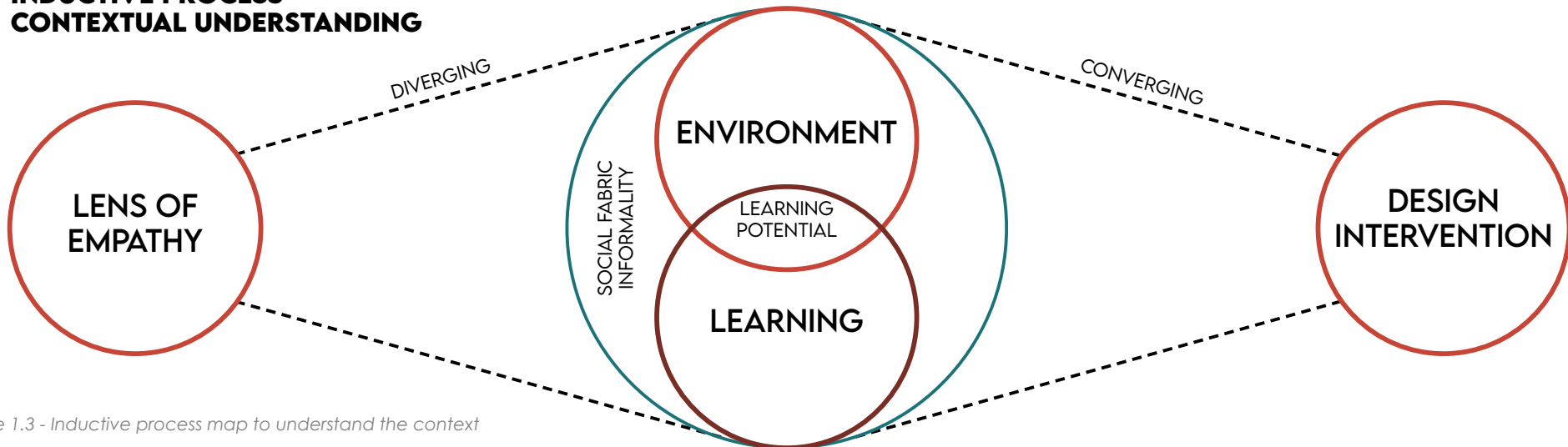


Figure 1.3 - Inductive process map to understand the context

BACKGROUND

1.2

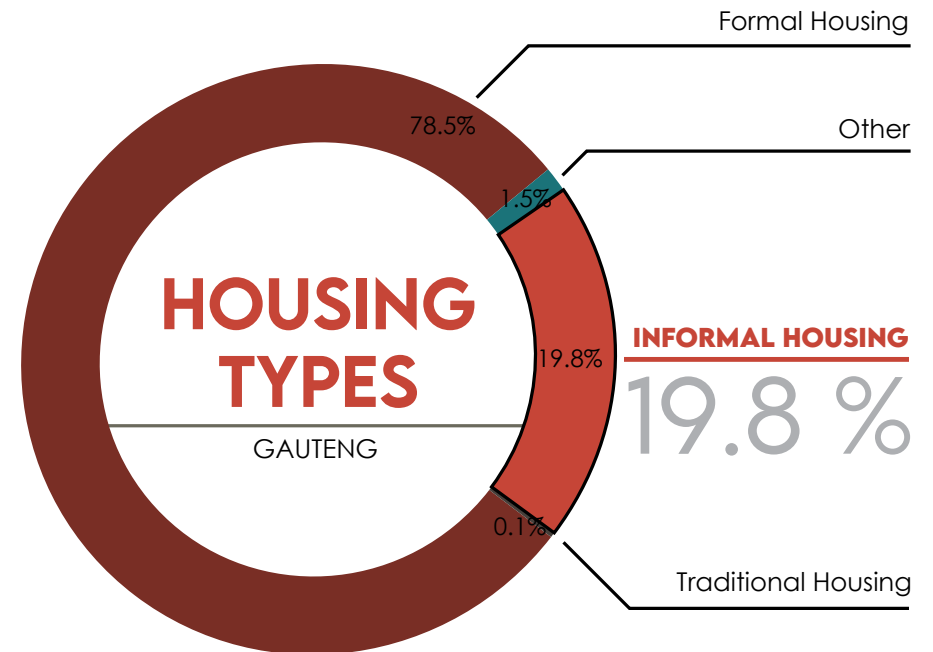
According to the General Household Survey (2017) in Gauteng, 19.8% of people reside within informal housing (Anon., 2017). This is fueled by the permanent migration of workers to urban areas, which is defined as urbanisation, for better work opportunities, (Pieter & Collinson, 2006). Moreover, informal settlements expand owing to job markets not being able to sustain rapid numbers of migrant workers (Pieter & Collinson, 2006).



Figure 1.4 - Informal housing roofing photo, (MPIP, 2021)

1.2.1 URBANISATION

Urbanisation can best be defined as the growth of urban populations owing to urban sprawl. Residents are primarily from rural towns located outside urban areas. In search of a better future, many find a new home in outlying urban surroundings such as townships or informal settlements to gain access to nearby jobs (Pieter & Collinson, 2006). Moreover, urban areas host 70% of South Africa's employment population, creating a catalyst for urbanisation (O'Neill, 2020). Thus, leading to the increase of informal settlements in urban areas with low socio-economic dwellers who have limited access to quality education and job opportunities.



(General Household Survey, 2017)



1.2.2 SPONTANEOUS URBAN INFORMAL SETTLEMENTS

Informal settlements can be defined as a group of dwellings that are temporary, and are often built from rudimentary materials, such as plastic and wood scraps. As such, informal settlements can be described as spontaneous, as dwellers construct their shelters in an unplanned way. In addition, the land on which communities are built is typically illegally occupied, and often lacks services for housing, such as adequate sanitation, water provisions, robust housing, and adequate space (Marutlulle , 2017).

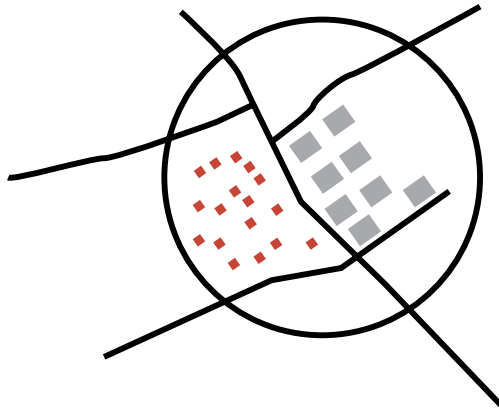


Figure 1.5 - Children outside of bar within Plastic View, (Author, 2021)

PROBLEM STATEMENT

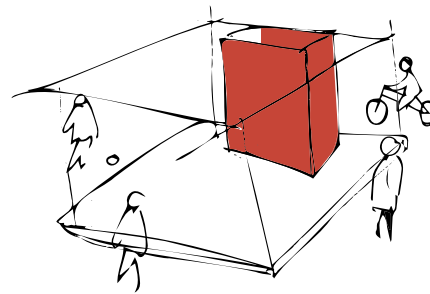
1.3

1.3.1 PROBLEM STATEMENTS



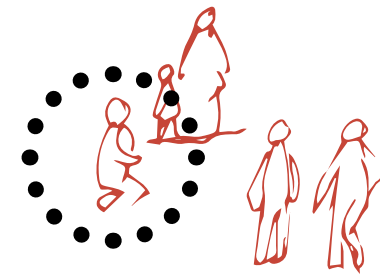
General/urban Issue

Informal settlements are increasing in cities around the world. In vulnerable communities such as informal settlements, it is important to enable communities with education, to become more sustainable and empowered to contribute to the urban fabric (UN-Habitat, 2016).



Theoretical Issue

Digital education has proven that children can self-educate within their natural environments (Mitra & Dangwal, 2017), and an alternative pedagogy to child education needs to be resolved to aid those who do not have access to conventional learning environments.



Interior/Design Issue

When designing interventions for vulnerable communities, designers need to consider a human-centred design approach that understands the needs and context of communities, and applies contextually relevant theories. Thus, in informal communities the role of the designer needs to be balanced with the role of the community.



1.3.2 PRIMARY RESEARCH QUESTION

How can **bridging the digital divide** enable **learning** within the constrained learning environment of Plastic View, through a **versatile intervention** with **indigenous learning** and **spatial agency** for **vulnerable learners**?

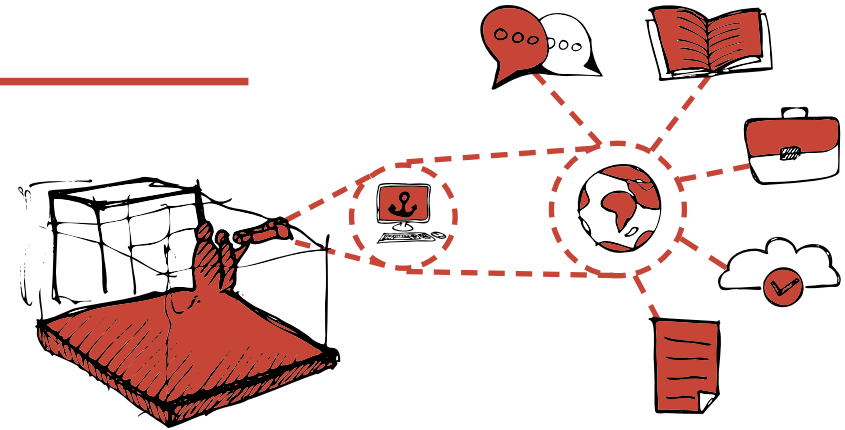


Figure 1.6 - A platform of future digital inclusivity, (Author, 2021)

SUB-QUESTIONS

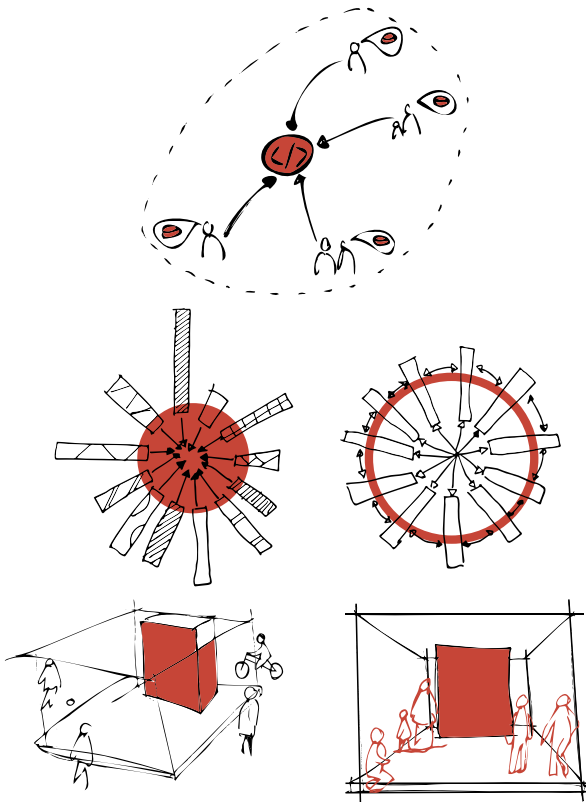


Figure 1.7 - Research sub-question diagram summaries, (Author, 2021)

Contextual sub-question

What are the environmental constraints within the informal settlement of Plastic View that influence indigenous learning during activities and rituals?

Theoretical sub-question

How can bridging the digital divide enable learning within informal settlements by enabling self-organisation through spatial agency?

Design sub-question

How can versatile design intervention with digital innovation generate a catalyst for learning in informal settlements assisted by existing indigenous learning systems?

RESEARCH METHODOLOGY

1.4

1.4.1 METHODOLOGICAL APPROACH

Human-centred design is a philosophy that empowers an individual or team to address the core needs of those who experience a problem (DC Design, 2017). It is an adaptable methodology that tackles human-related problems such as, poverty, gender equality, and clean water. Human-centred design allows for the collaboration with communities to understand people and groups to discover empathetical design solutions (IDEO, 2015).

QUALITATIVE DATA

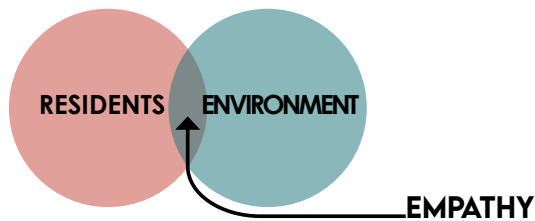


Figure 1.8 - Empathy within qualitative research, (Author, 2021)

ETHNOGRAPHIC STUDY

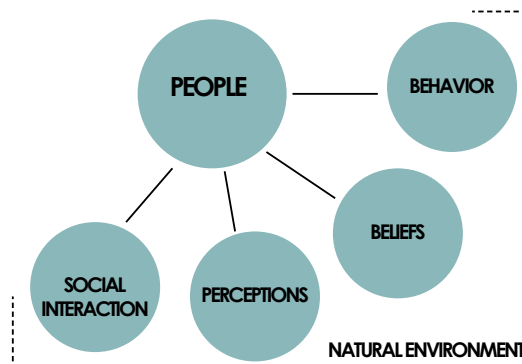
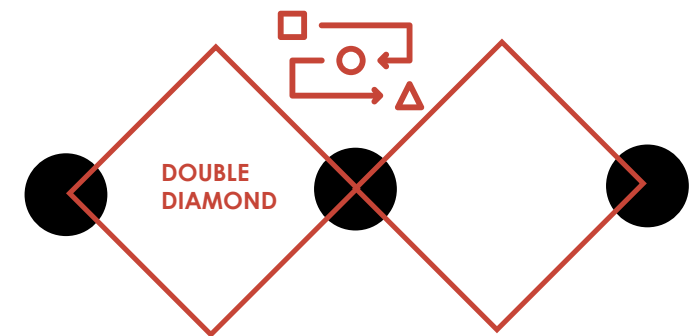


Figure 1.9 - Ethnographic study diagram, (Reeves, et al., 2008)

CONCEPTUAL FRAMEWORK



IDEO: HUMAN-CENTRED DESIGN FIELD RESEARCH GUIDE

Figure 1.10 - IDEO - double diamond approach for ethnographic research, (IDEO (Firm), 2015)

RESEARCH PURPOSE



1.4.2 METHODOLOGY PROCESS

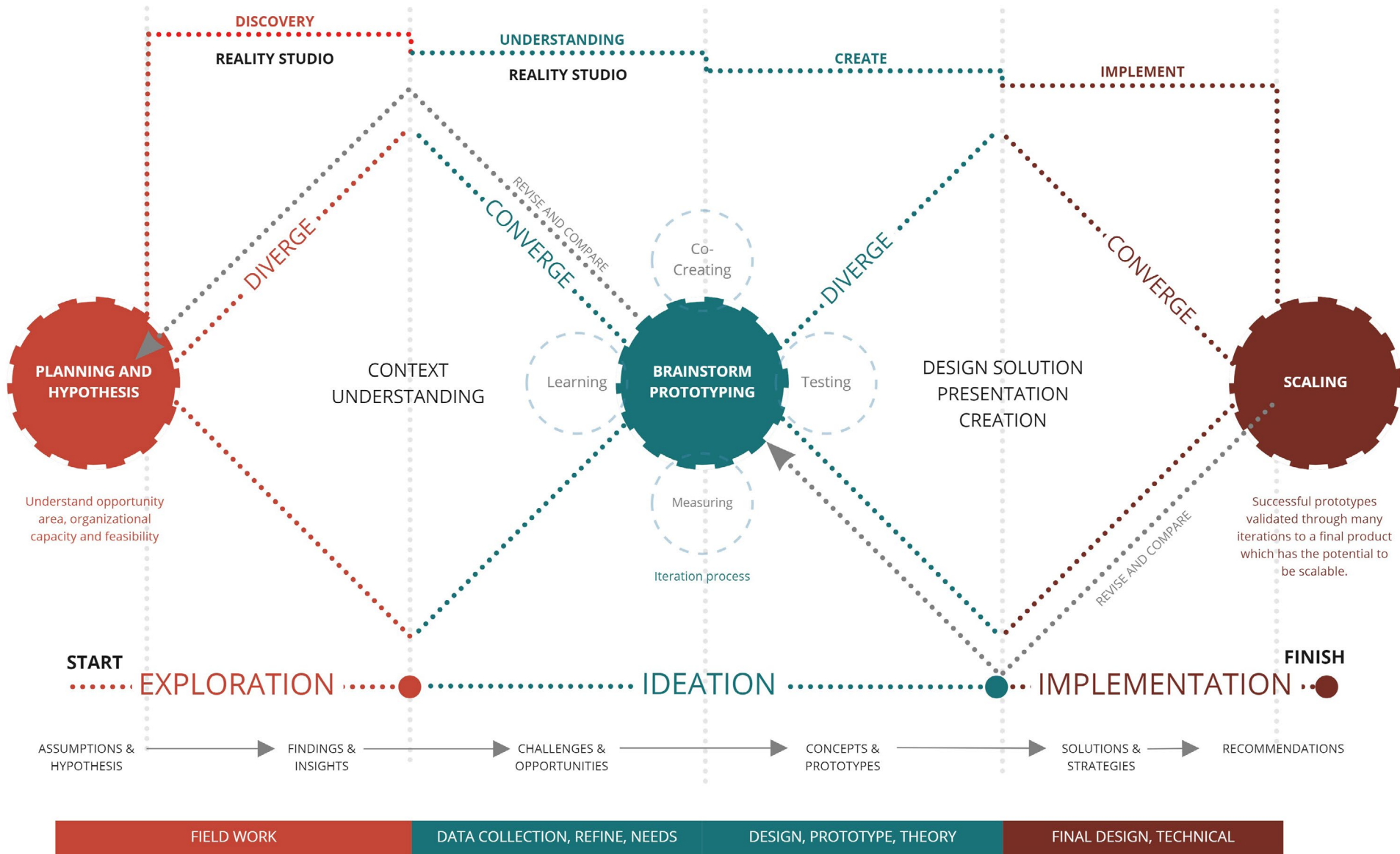


Figure 1.11 - Research methodology process within the framework of bridging the digital divide, (Author, 2021)

1.4.3 HUMAN-CENTRED DESIGN FRAMEWORK

The human-centred design framework consists of a three-phase research approach: exploration (inspiration), ideation, and implementation. By taking these steps, the research aims at building deep empathy with communities and individuals.

Exploration (Inspiration)

The phase of exploration includes conducting on-site investigations of the community of Plastic View. This includes immersing within the community through observations and interviews. Secondary research will be used to understand the existing contexts of history and issues. This is cross referenced with on-site observations and external stakeholder interviews. (IDEO, 2015).

Ideation

The ideation phase analyses data and identifies opportunities, relevance, and design impact. The process becomes iterative, narrowing down on relevant solutions for the user group selected. During this phase, diagrams and graphic representations of findings reassure contextual relevance and potential design informants. Thus, possible programmes and prototypes that are reinforced by theoretical literature (IDEO, 2015) are identified.

Implementation

The final phase aims at creating a feasible design solution. Although the design solution will not be physically constructed, an analysis of funding, construction, material, and community engagement will determine the feasibility of the project. A business model canvas would be used to understand a holistic approach to activities, resources, spaces, partners, role players, and revenue streams (IDEO, 2015).



1.4.4 RESEARCH PARADIGM

A constructivist/interpretivist approach was used to conduct research that includes voices, rituals, experiences that are interpreted to understand diverse and inclusive communities. This paradigm initiates interpretive thinking by focusing on the sociology of people through observation of people's behaviour with concise documentation (Scwandt, 1998).

1.4.5 ETHNOGRAPHIC RESEARCH

An ethnographic research methodology was adopted for this study. Ethnography involves an in-depth study on groups of people through observation and/or participation of their daily lives. Ethnographic studies focus on social interactions, behaviours, beliefs, and perceptions. This is important for the researcher to bridge empathy with the community members, rather than to have pre-determined opinions of the livelihoods and beliefs of the community (Muratovski, 2016).

A full immersion of the researcher into the community would not be viable owing to time limits. Thus, an auto-ethnographic approach was deduced, where the researcher would include his own thoughts and perspectives from social interactions that the researcher experiences (Reeves, et al., 2008). This research process can be viewed on the following Figure.

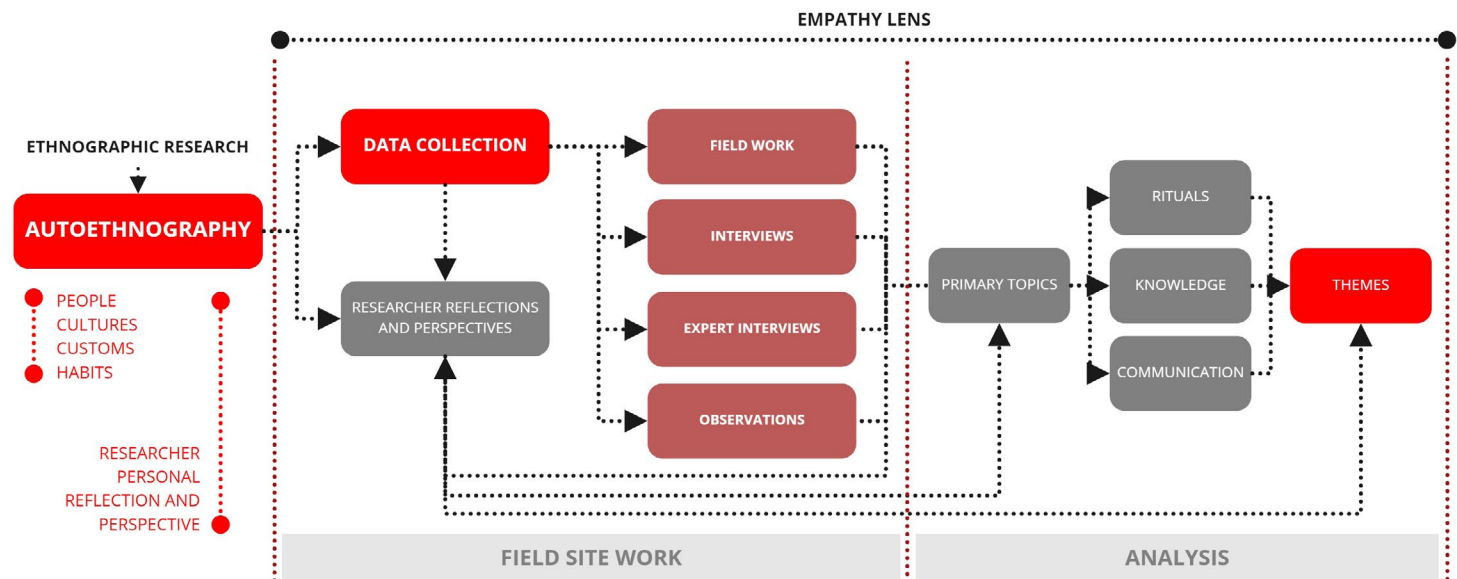


Figure 1.12 - Auto-ethnographic research diagram through a lens of empathy, (Author, 2021)

1.4.6 RESEARCH TECHNIQUES

Qualitative research

Qualitative research will be used to develop in-depth research questions regarding social and environmental variables on site. Research questions will be generalised through observations, and strengthened through research interviews to formulate a phenomenon about the selected research topics. Through the collection of multiple social and environmental factors a multi-faceted and complex situational picture is realised (Reeves, et al., 2008).

Ethics and obtaining clearance

Informed consent was used during the data collection of informal and formal interviews, photos, videos and site documentation. Informed consent would grant consent, deception in research, debriefing, and anonymity. The ethics required for doing interviews will strictly remain within the blanket ethics of UP Urban Citizens ethics clearance. This application approval can be viewed in Appendix E, Reference number: EBIT/79/2021.

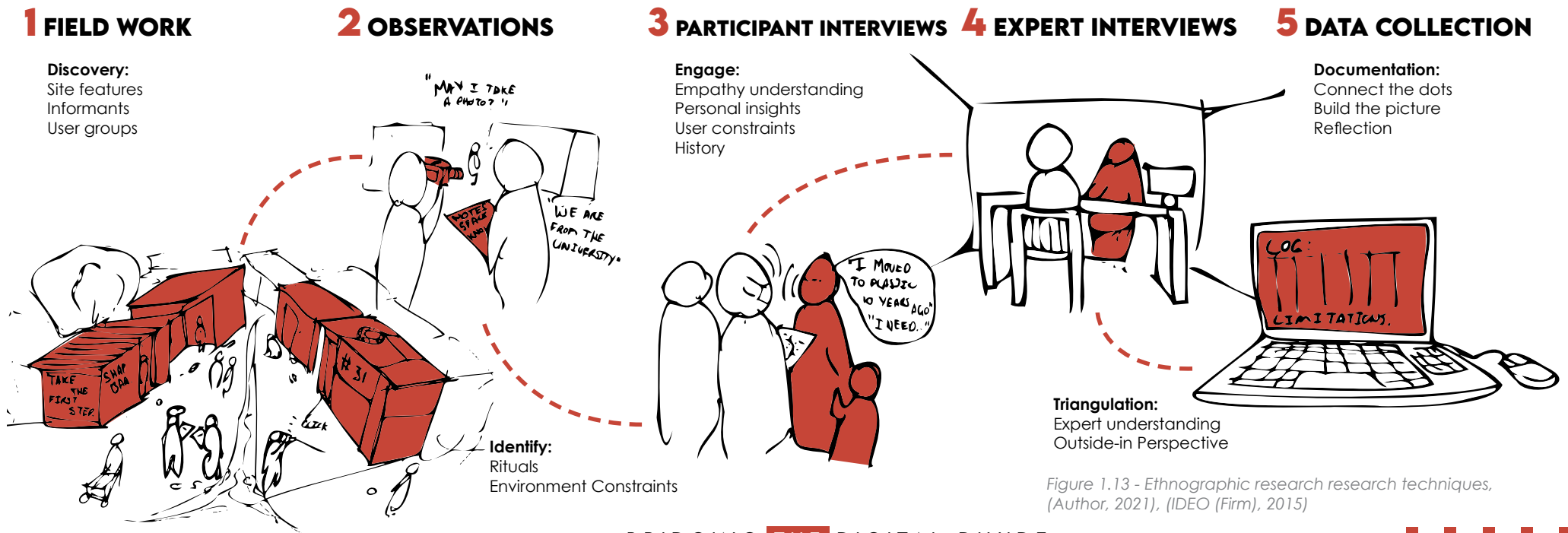


Figure 1.13 - Ethnographic research techniques, (Author, 2021), (IDEO Firm), 2015)



1.4.7 DATA COLLECTION

Fieldwork

Fieldwork entails the on-site activities that are needed to collect specific data (eg, observations, interviews, and site documents) (Edmonds & Kennedy, 2017).

Participant observations

Participant data is a central method of ethnographic research. It becomes essential to do multiple visits with short visits focusing on specific goals, as observations generate on-site notes, photographs, and detailed descriptions of sightings. Observations focus on understanding cultures and daily rituals of participants (Edmonds & Kennedy, 2017).

Interviews

Ethnographic interviews focus on understanding the individual rather than the environment. Ethnographic interviews are centrally open-ended, generating a narrative serving as a timeline of daily rituals. After interviews are completed, general notes and comments highlight the researchers' experience of interviews and important themes (Edmonds & Kennedy, 2017).

Expert interview

Expert interviewees include leaders from Pure Hope, LIFT and other organisations who work closely with the community, and who have useful insight on general issues within the community. Moreover, experts provide a holistic perspective.

Data collection

During fieldwork, the researcher made use of field notes, informal and formal conversations, video, and photo documentation to understand the context to the socio-environmental problems of learners. This research approach is best suited in painting the picture while an emotional narrative from pupil experiences would reinforce circumstances (Reeves, et al., 2008).

THEORETICAL FRAMEWORK

1.5

According to the UN-Habitat (2016:8), creating peer learning platforms is a key driver for action in uplifting informal settlements. Platforms should engage the knowledge of stakeholders who already have key insight into the community. The community member should further be prioritised to provide appropriate solutions and encourage the experience of exchange for peer learning opportunities. Platforms could engage in communication strategies and multi-media mechanisms (UN-Habitat, 2016).



THEMES

DIGITAL DIVIDE

INDIGENOUS
LEARNING

SPATIAL AGENCY

BRIDGING DIGITAL DIVIDE
IMPLEMENTATION
CHALLENGES

INDIGENOUS LEARNING
DIGITAL DOCUMENTATION

REAL SPACE
VIRTUAL SPACE
VERSATILE SPACE

VERSATILE DESIGN ANALYSIS
IMPLEMENTATION OF DIGITAL
INTO EXISTING KNOWLEDGE

INFORM DESIGN

1.5.1 THEORY: INDIGENOUS LEARNING

Indigenous learning is a form of learning defined within a specific culture or society. Indigenous knowledge is transferred by communities over generations to cope with ecological, economic, and social environments (Fernandez, 1994). Through a systematic process, observations of local conditions become experiments in which solutions re-adapt previous solutions to modify environmental, social and technological situations (Brouwers, 1993).

SHARED KNOWLEDGE BANK

Community is seen as a shared data base with multiple nodes of knowledge.

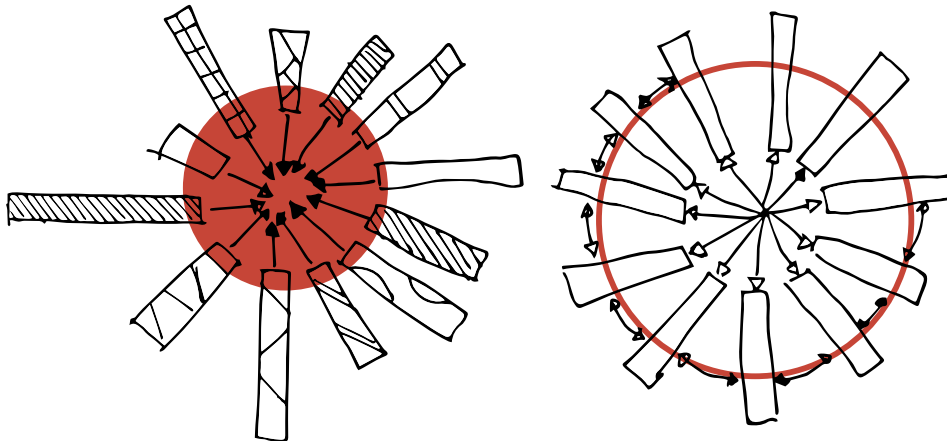


Figure 1.14 - Indigenous learning, potential of knowledge sharing, (Author, 2021)

Knowledge transfer occurs locally but could become dis-located and deformed if transferred in another location. Transferral occurs verbally or through imitation by observation and experimentation. Indigenous knowledge could be documented in writing making it portable, although this could also influence the relatability to the viewer/reader. Thus, documenting could reinforce permanence, but also dislocate knowledge (Senanayake, 2006).

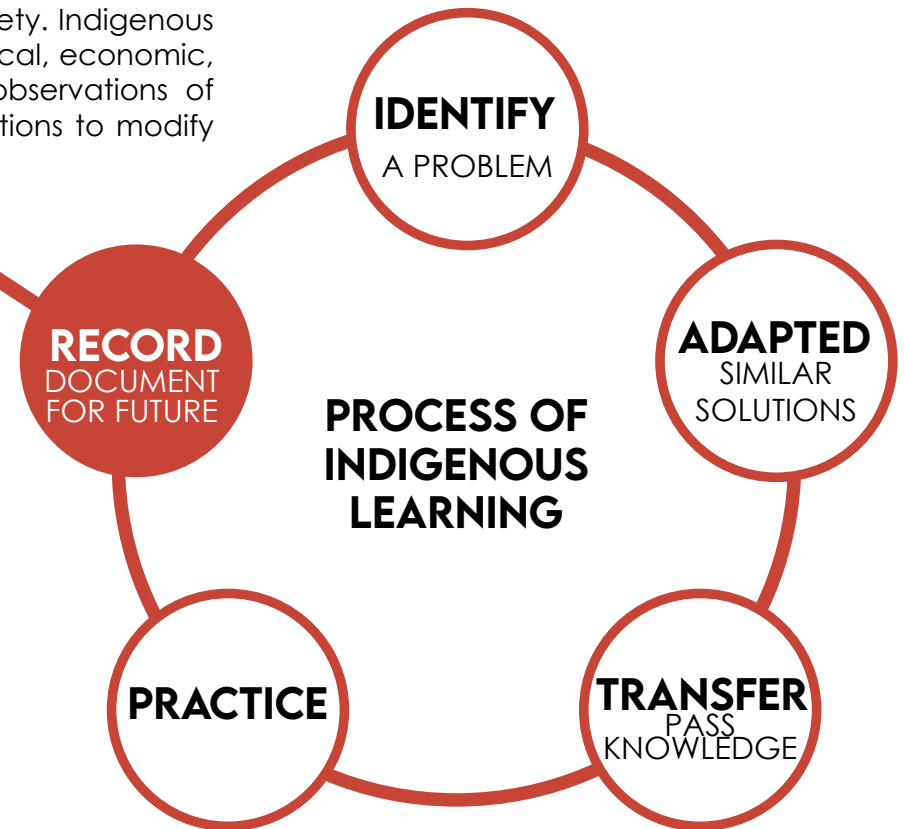


Figure 1.15 - Process of indigenous learning, (Author, 2021), (Brouwers, 1993)



Indigenous learning is a resultant of practical daily activities, fueled by trial and error. These experiences are products of generations and give indigenous learning a sense of intelligence that results in knowledge becoming fragmentary (Warren , 1989). Repetition becomes an essential reinforcer of ideas and practice, making indigenous learning very fluid and transformable. This learning can constantly change and reproduced (Senanayake, 2006).

Digitalized indigenous learning

In a technological age, indigenous learning practices can occur with more transparency. Knowledge can be easily documented with digital devices and encourage iteration and reinforcement (Parrish, 2010). This style of learning follows a holistic approach to developing character conscience, values, and social attitudes (Senanayake, 2006).



Figure 1.16 - Digital recording of indigenous knowledge, (Author, 2021)

1.5.2 PRECEDENT STUDY: INDIGENOUS LEARNING

SILINDOKUHLE PRE-SCHOOL

Building type: Pre-school
 Architects: Collectif saga
 Year: 2017
 Location: Joe Salvo, Port Elizabeth, South Africa

DESIGN INTENT

The design creates a multi-functional community center which primarily serves to educate children.

Figure 1.17 - Silindokuhle Pre-school, courtyard, (ArchDaily, 2017)



Figure 1.18 - Silindokuhle Pre-school, plastering, (ArchDaily, 2017)

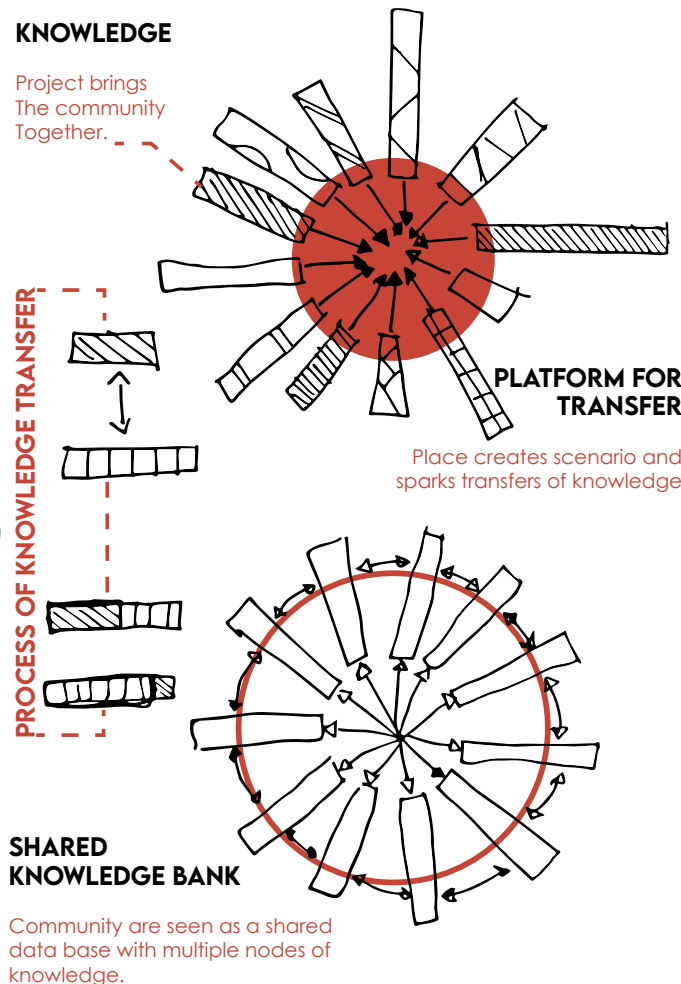


Figure 1.19 - Silindokuhle Pre-school, knowledge transferal (ArchDaily, 2017)

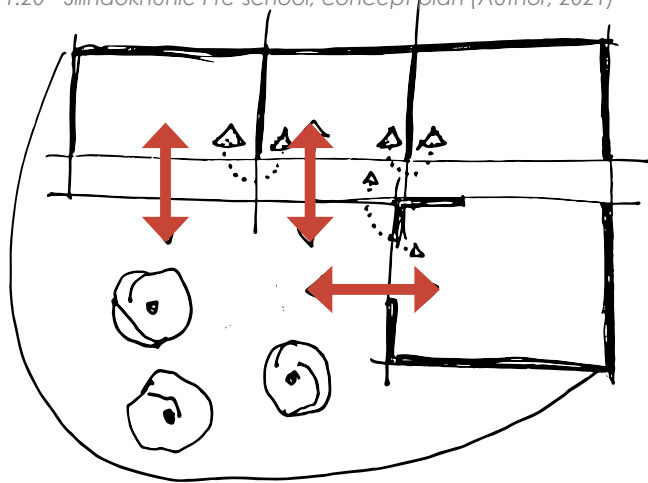


PROJECT SUMMARY

From 2014, Collectif saga has been engaged in community projects in informal suburbs of Port Elizabeth, South Africa. The pre-school was one of multiple projects which have been completed over several years, projects such as a community hall. With government intervention in housing, residents are now aiming their efforts at more community-built infrastructure. In the community growing children have been kept within disadvantaged circumstances, without a school or proper facility (ArchDaily, 2017).



Figure 1.20 - Silindokuhle Pre-school, concept plan (Author, 2021)



CONNECTED SPACE

Spatial agency is permitted through a negotiation of interior and exterior space.

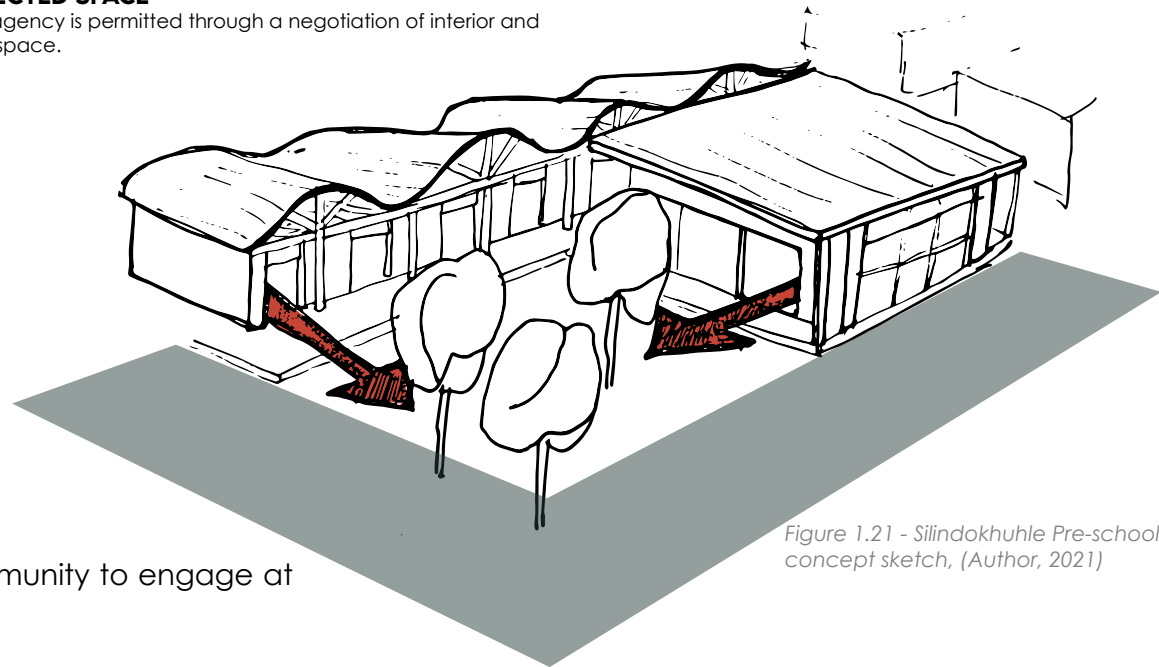


Figure 1.21 - Silindokuhle Pre-school, concept sketch, (Author, 2021)

Reflection and key insights

Designing for a vulnerable community requires the community to engage at all levels, from design to construction.

Through the process of designing and construction, there is a transferal of local/user knowledge and expert knowledge that connects when project becomes physical. The building becomes a symbol of pride and gives the community agency.

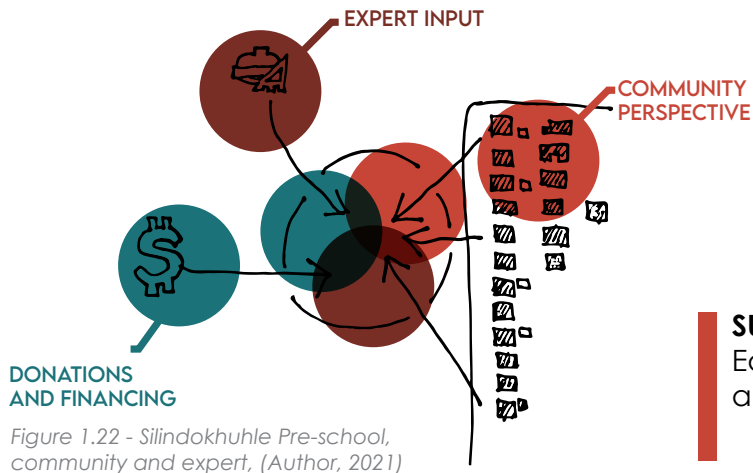


Figure 1.22 - Silindokuhle Pre-school, community and expert, (Author, 2021)

SUSTAINABILITY

Educating users and residents about sustainable practice.

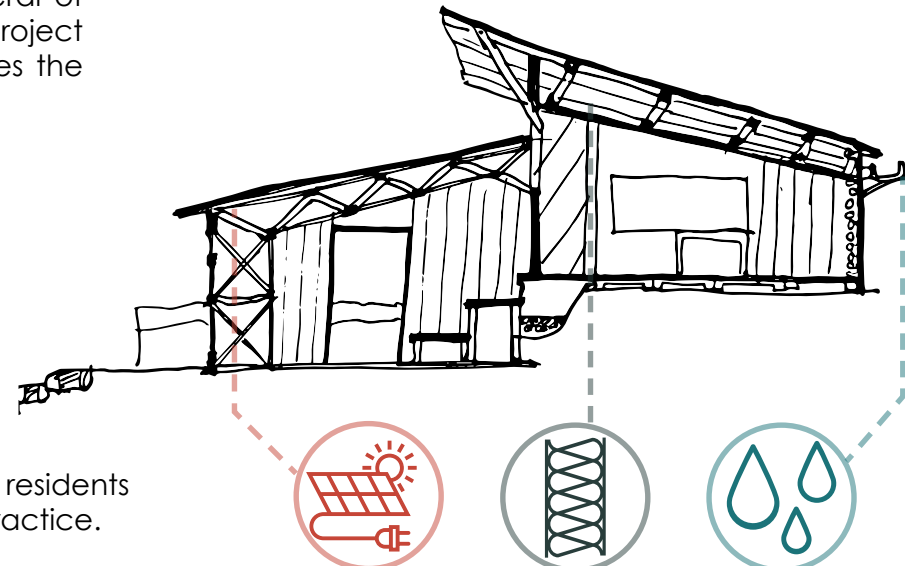


Figure 1.23 - Silindokuhle Pre-school, sustainability, (Author, 2021)

1.5.3 THEORY: DIGITAL INCLUSION

Digital Inclusion

Digital Inclusion can be defined as the ability of individuals or communities to have access to information and communication through technology (Lembani, et al., 2019).

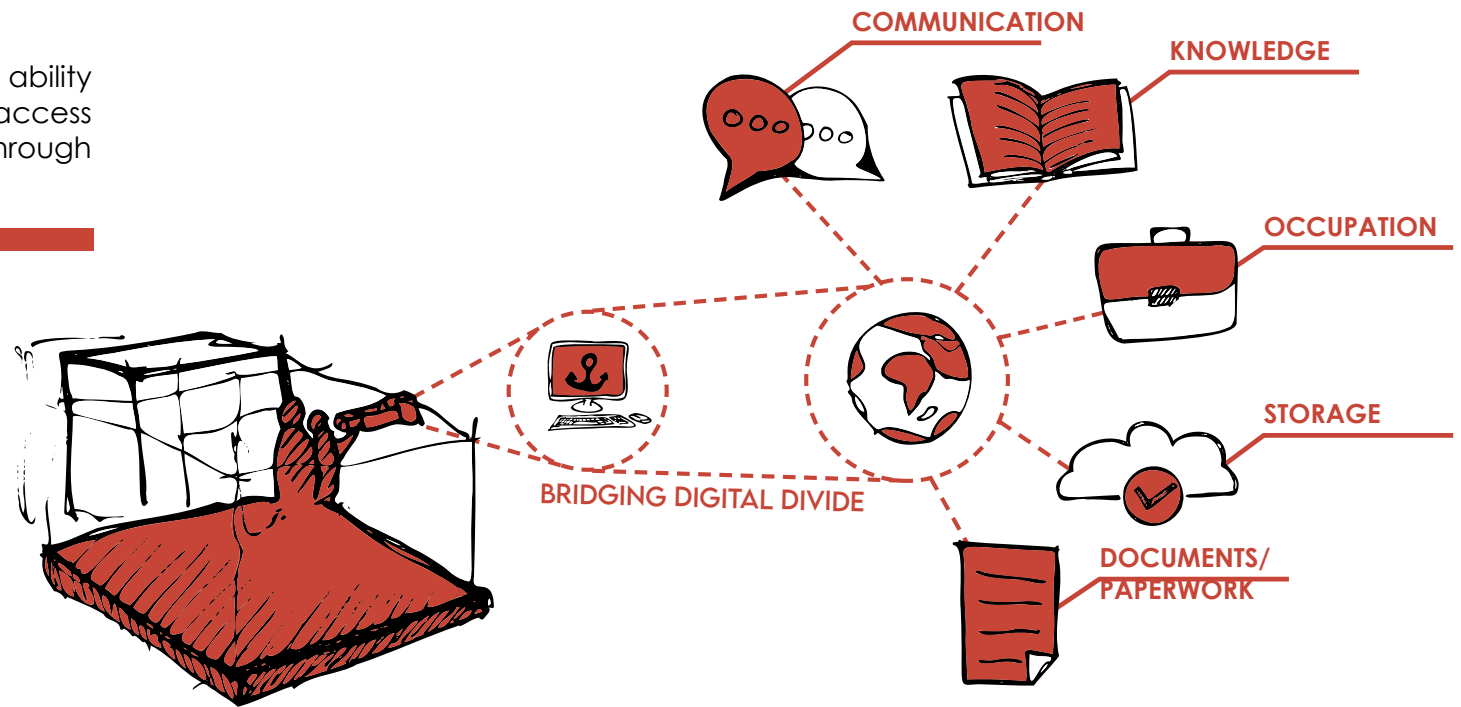


Figure 1.24 - A platform of future digital inclusivity, (Author, 2021)

What is a digital community?

A digital community comprises a connected and optimised network of community members through technology (Becker, et al., 2012). A digital community has access to permanent communication, databases of knowledge and information with many interests (Foth, 2009).

In poor communities, social networks are critical for livelihoods. Transactions of communication and knowledge are generally static and defined within a space, while in a digital world, there is endless space in which data is tracked, stored, and collected (Foth, 2009). Most often, digital literacy becomes a steppingstone to educate people in digital technology (Becker, et al., 2012).

In communities, technology offers multiple advantages in education, economic, and social spheres. However, owing to finances and geographical location, the challenge to bridge the digital divide is ongoing (Oyelaran-Oyeyinka & Lal, 2005).



What is the digital divide?

The digital divide is defined as a lack of access to digital technology. The digital divide is postulated in a variety of contexts, including access according to economic, geographic, social, and cultural barriers or the inability to use digital technology owing to knowledge, approach, or motivation. (Becker, et al., 2012).

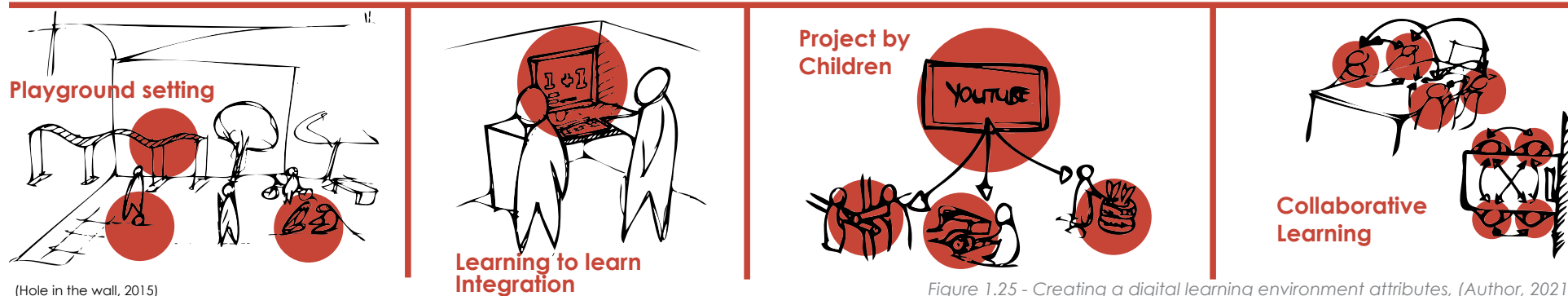
DIGITAL DIVIDE

The digital divide within South Africa

In South Africa, access to ICTs (Information Communication Technologies) is diverse between different populations and households. Notably, 22% of South African households have access to computers whereas in developed countries, such as the United States, 89% of households have access. It can be concluded that the divide is directly equitable to the wealth within households and the affordability of access from providers (Lembani, et al., 2019).

Digital Learning

Traditional computer-based learners rely on a one-way transmission of knowledge. This relationship exists with the user and computer which act as the extension of the classroom. Computers create unrestricted learning, a new pedagogy where learners have unrestricted access to knowledge (Mitra & Dangwal, 2017). The vital ingredients to adopting computer-based learning include:



1.5.4 PRECEDENT STUDY: DIGITAL INCLUSION

HOLE-IN-THE-HOLE (HIWEL)

Building type: Public Learning
 Organisation: Sugata Mitra
 Year: 1999-Present
 Location: India

DESIGN INTENT

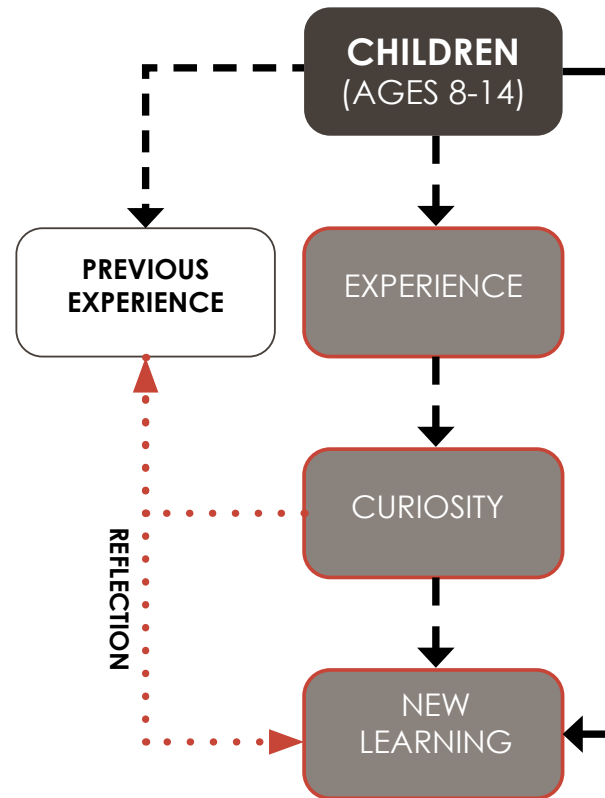
A public intervention to test the ability for children to self-learn and educate themselves in digital literacy. A study which questioned conventional pedagogy.

Figure 1.26 - Hole-in-the-wall children, (Mitra & Dangwal, 2017)



Figure 1.27 - Hole-in-the-wall interaction, (Mitra & Dangwal, 2017)

PLAY LEARNING STATION INTERVENTION



(Mitra & Dangwal, 2017)

Figure 1.28 - Hole-in-the-wall street wall, (Mitra & Dangwal, 2017)



PROJECT SUMMARY

The "Hole in the wall" (HiWEL) project was a multi-locational study which aimed to teach children, aged 8-14 years, basic computing skills. Research studies found that children could learn basic computer skills irrespective of their culture, social, and intellectual background or where they were from. Studies found that a new learning environment could be creating by connecting children in shared or public spaces with technology (Mitra & Dangwal, 2017).



A HOLE TO NEW LIFE

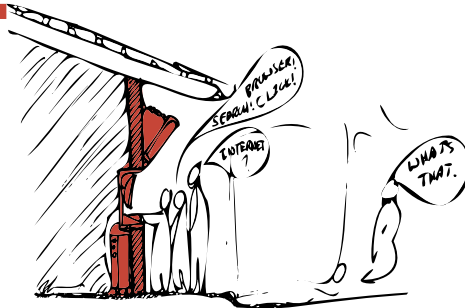
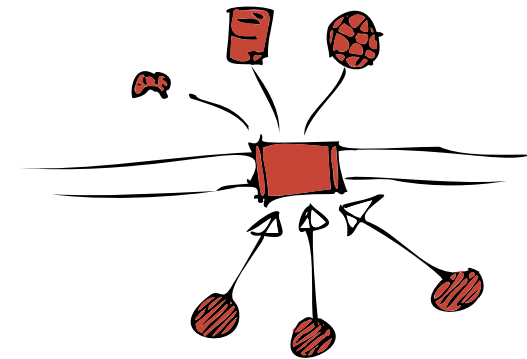
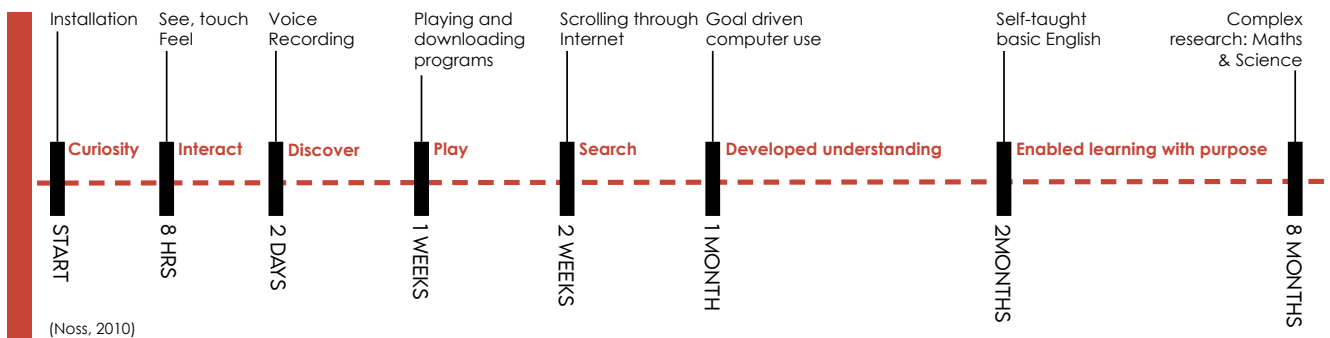


Figure 1.29 - Hole-in-the-wall concept sketch, (Author, 2021)



SELF LEARNING - HOLE IN THE WALL EXPERIMENTS



(Noss, 2010)

"Children aged 8-14 can learn basic computing skills on their own, Irrespective of their social, cultural, religious, and intellectual background or their geographical locations... Provided children with computers in their natural environments... In safe publicly accessible locations"
(Mitra & Dangwal, 2017)

SOLE: SELF-ORGANISED LEARNING ENVIRONMENTS



Figure 1.30 - Hole-in-the-wall concept sketch 2, (Author, 2021)

"Minimally invasive architecture"

REFLECTION AND KEY INSIGHTS

A space is a platform for users to experience purpose. This purpose is driven by the individual and their perception. The role of a designer is to create the platform in which experience can manifest engagement.

An attractor is important to initiate other programs. Access to the internet was the attractor and the users learn through not being forced to learn, but rather curiously adventuring through knowledge.

Children in a group learn together through experimentation and conversations. Self-organization takes place in who's turn it is. Also what is priority to search and discover.

1.5.5 THEORY: SPATIAL AGENCY

Spatial agency

Real and virtual space

A building is conventionally defined as a “usually roofed and walled structure built for permanent use” (MWOD, n.d.). Nevertheless, the definition of a “building” is being challenged by digital innovation, as technology enhances environments that permanently adjust function. The use of electronic interface has added another layer of purpose. Examples of this include space, lighting, HVAC systems and mechanical electronic that are versatile in its use (Thompson, 2008).

Moreover, architecture is assumed to be about real space, the tangible construction. However, the notion of space is questioned when technology is incorporated, pushing the boundaries of real space into a virtual space which is “accessible anywhere and located nowhere” (Riewoldt, 1997).

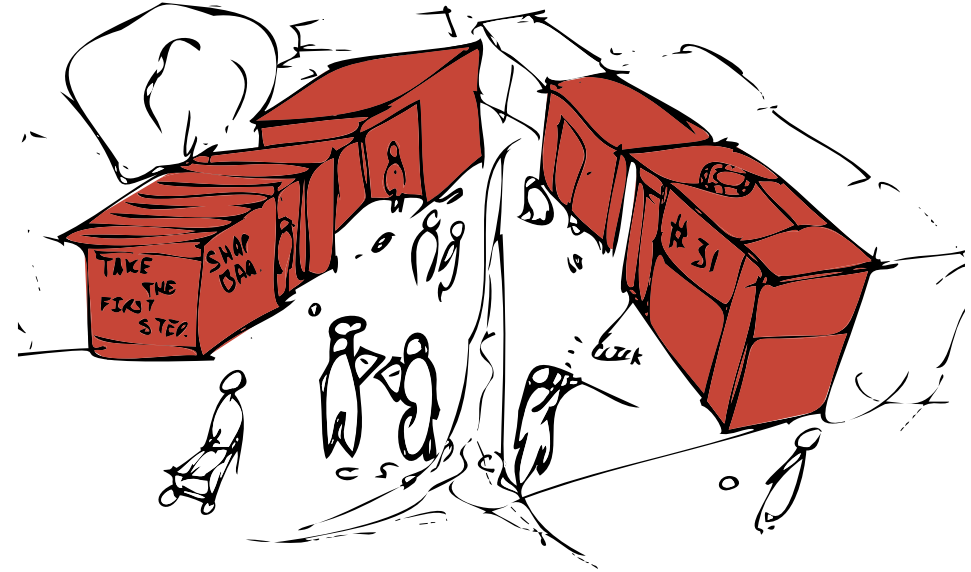


Figure 1.31 - Plastic View Street sketch, (Author, 2021)

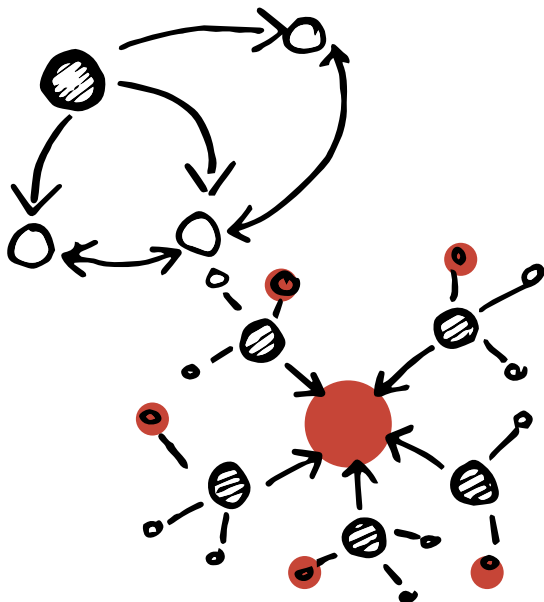


Figure 1.32 - Diagram sharing and agency, (Author, 2021)

Virtual space is fundamentally anti-spatial, which is not defined by a particular space. Mitchell (1995) describes it as “nowhere in particular but everywhere at once.” Movement within a physical space is defined by objects and tangible barriers, while virtual movement is endless (Mitchell, 1995).



Place-making

Although digital technology has altered the notion of space and place-making, the layering of place and agency is merged between the real and virtual space (Mitchell , 2003). The combination of real and virtual space accommodates adaptive and versatile activities that bring virtual activities into the physical environment. There is a new paradigm shift in design whereby architecture does not aim at pushing the programme or purpose onto a user, but rather provides the platform for the user to have agency over the dynamic flexibility of the real space which is enriched by a virtual environment (Mitchell , 2003).

In recombinant architecture, digital technology can be incorporated to allow for the process of place-making. Informal spaces should be able to provide wireless networks and flexible digital and physical environments allowing for face-to-face interactions. Thus, for users to have spatial agency, there should be the ability to seamlessly transition between the real space and the virtual space (Mitchell, 1999). Architecture in the 21st century should allow for users within a real space to have the ability to exist within the virtual space (Thompson, 2008).

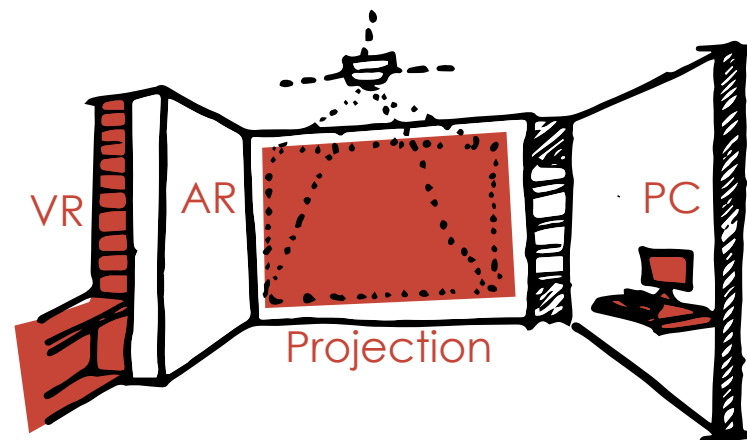
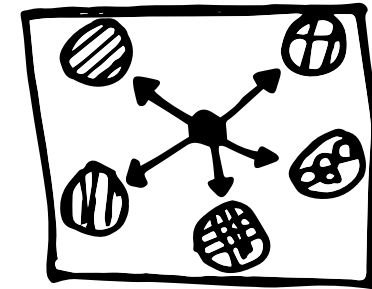


Figure 1.33 - Digital Agency and devices, (Author, 2021)

1.5.6 PRECEDENT STUDY: SPATIAL AGENCY

EL PARQUE DE LA CIENCIA (SCIENCE PARK PAVILION)

Building type: Community Center
Architects: LAAR
Year: 2018
Location: Dzan, Yucatan, Mexico

DESIGN INTENT

The design creates a multi-functional community center which primarily serves to educate children.

Figure 1.34 - Science Park Pavilion event outside, (ArchDaily, 2021)



INTERNAL & EXTERNAL ENGAGEMENT

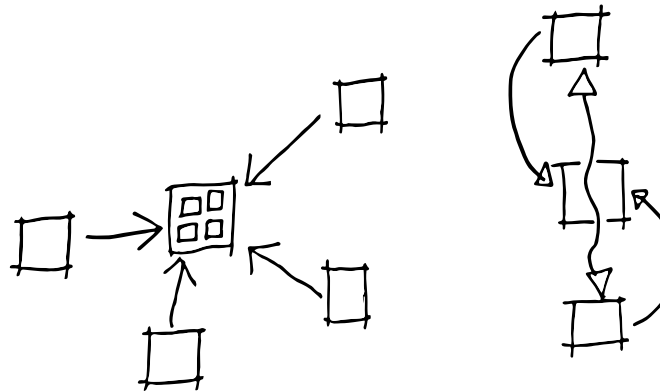
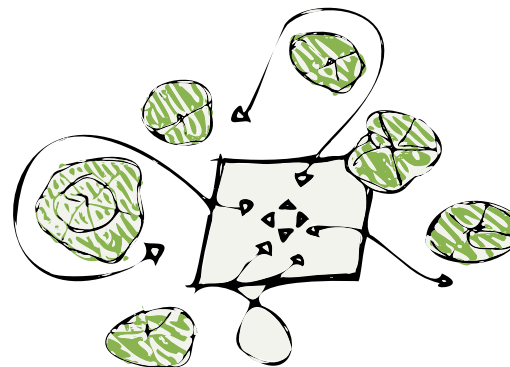


Figure 1.36 - Science Park Pavilion event outside 2, (ArchDaily, 2021)



PROJECT SUMMARY

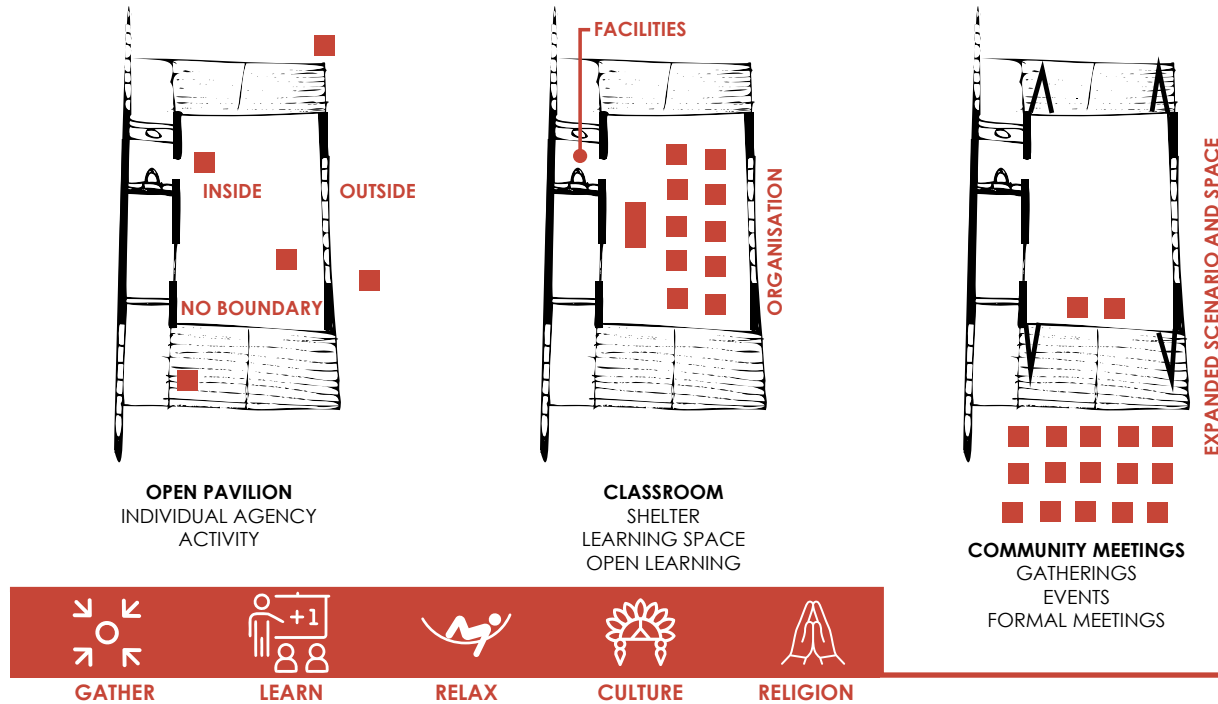
In 2009 a rural community located in southern Yucatan, in Mexico grouped together to change the lives of the communities' children and young adolescent. Children who were growing up in farming communities were found to be vulnerable to school dropouts, substance abuse and poor motivation. Through a local non-profit, the "Scientific Community of Dzan" who were in pursuit of uplifting their own community through science and culture as a tool. The site is located near main roadways which other local communities and villages have access too (ArchDaily, 2021).

27 Figure 1.35 - Science Park Pavilion event inside, (ArchDaily, 2021)



ADAPTABILITY AND MULTI-FUNCTIONAL

Figure 1.37 - Science Park Pavilion scenarios, (Author, 2021)



REFLECTION AND KEY INSIGHTS

The space offers adaptive use with minimal design. The exterior provides a expansion of programs. While the original pavilion still provides a focal point for engagements to pause at.

The materials used were locally relevant, but also uniquely inspired by ancient patterns and techniques.

The original purpose of a space is but only an idea from an expert perspective. The programs within a space gets determined by the users.

SITE SELECTION

1.6 In this chapter, the selected site of Plastic View will be analysed in terms of contextual relevance to the study's aims and objectives. An in-depth analysis through ethnographic research aims to bridge an empathetic understanding of community activities and the users which bring the community to life (Snowman & McCown, 2013).

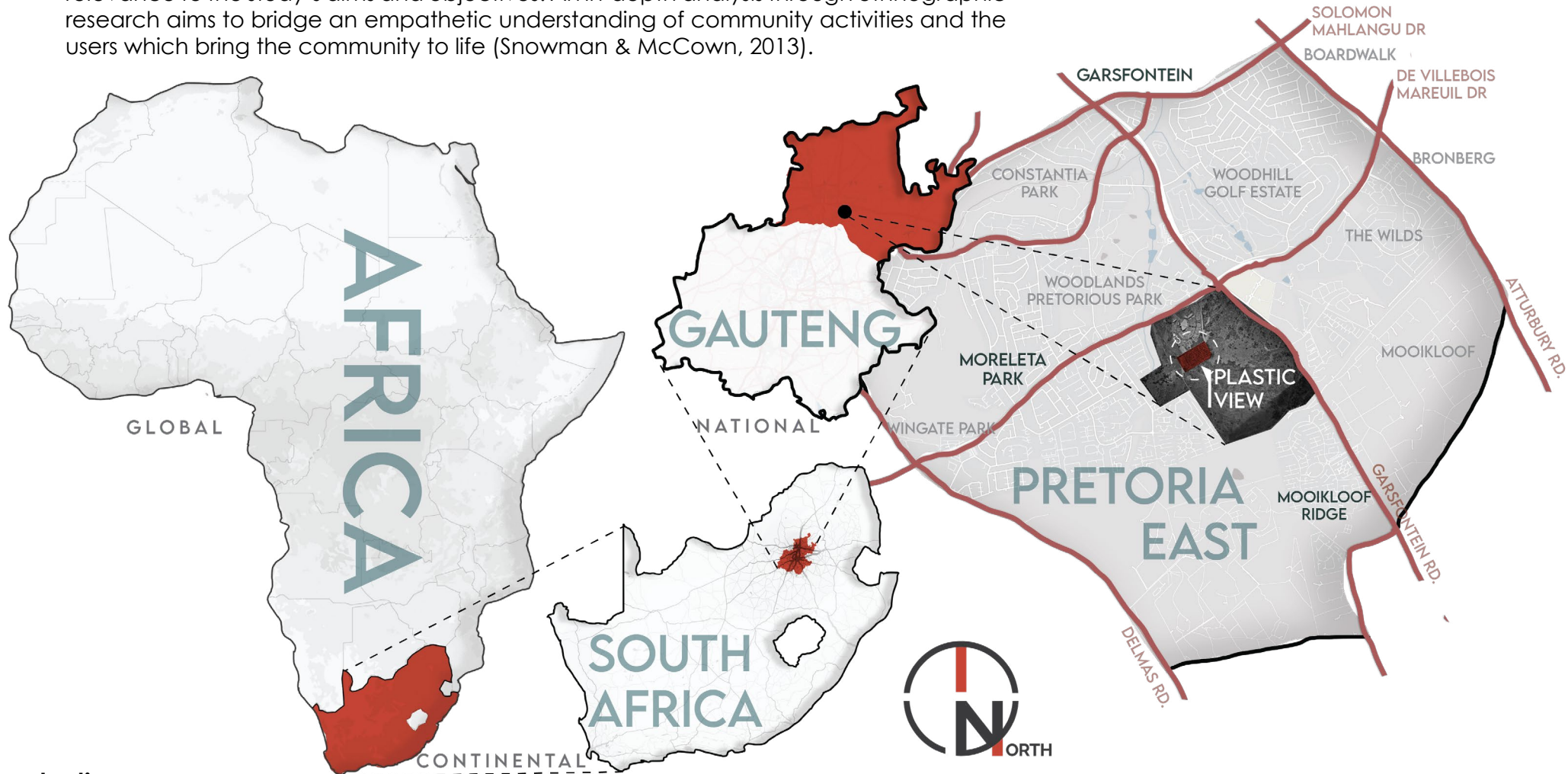


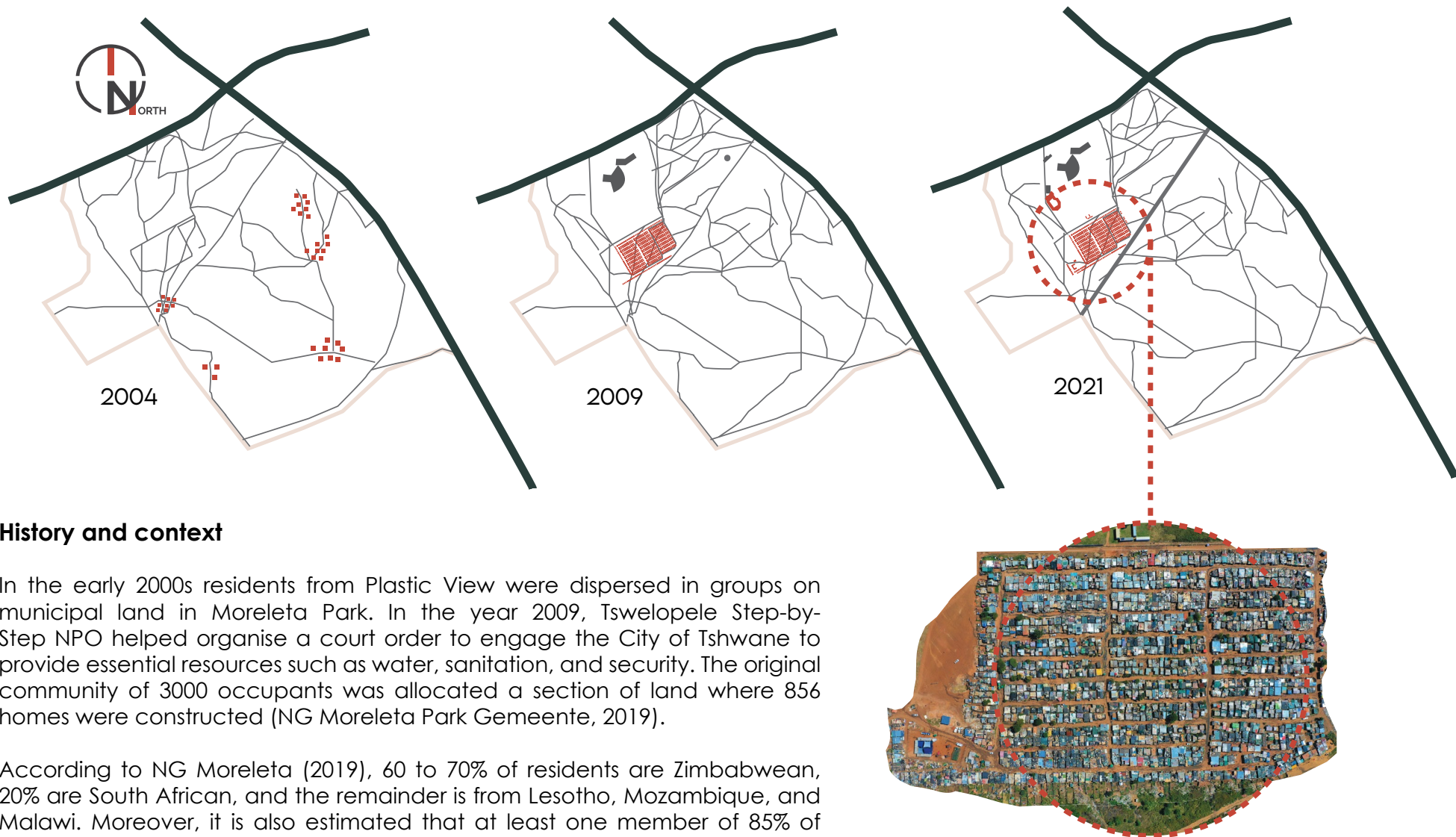
Figure 1.38 - Plastic View site macro map analysis, (Author, 2021)

Site selection

The site selected is the informal settlement of Plastic View, located in Moreleta Park, Pretoria East. The site was selected owing to its nature of existence. Plastic View is located between gated communities and has to an extent been formalised within the urban fabric.



1.6.1 PLASTIC VIEW HISTORY



History and context

In the early 2000s residents from Plastic View were dispersed in groups on municipal land in Moreleta Park. In the year 2009, Tswelopele Step-by-Step NPO helped organise a court order to engage the City of Tshwane to provide essential resources such as water, sanitation, and security. The original community of 3000 occupants was allocated a section of land where 856 homes were constructed (NG Moreleta Park Gemeente, 2019).

According to NG Moreleta (2019), 60 to 70% of residents are Zimbabwean, 20% are South African, and the remainder is from Lesotho, Mozambique, and Malawi. Moreover, it is also estimated that at least one member of 85% of households is employed (NG Moreletpark Gemeente, 2019). At present an estimated 9000 residents live within Plastic view (MPIP, 2021).

Figure 1.39 - Plastic View site history, (Author, 2021)

1.6.2 MICRO ANALYSIS

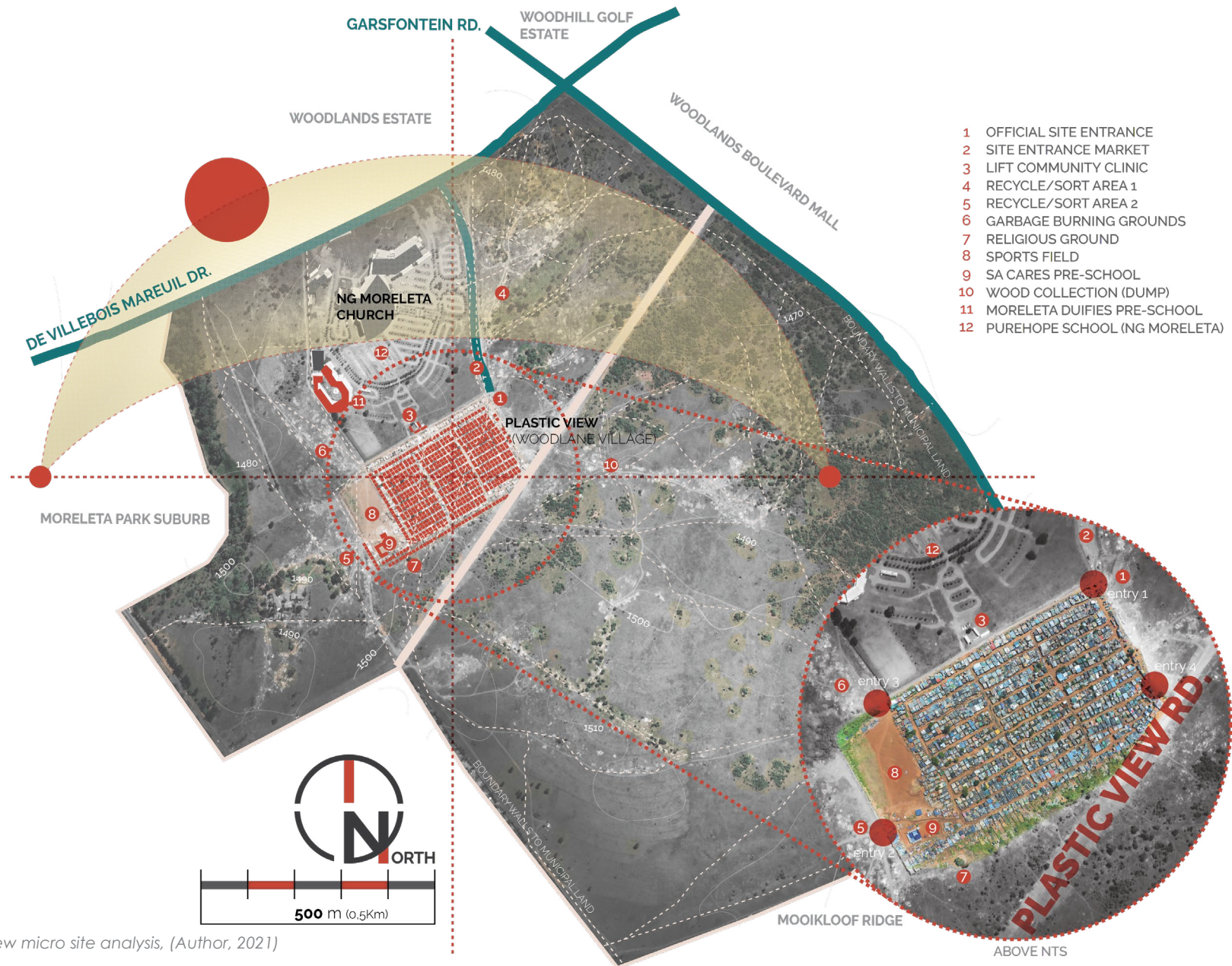


Figure 1.40 - Plastic View micro site analysis, (Author, 2021)



1.6.3 SITE FEATURES

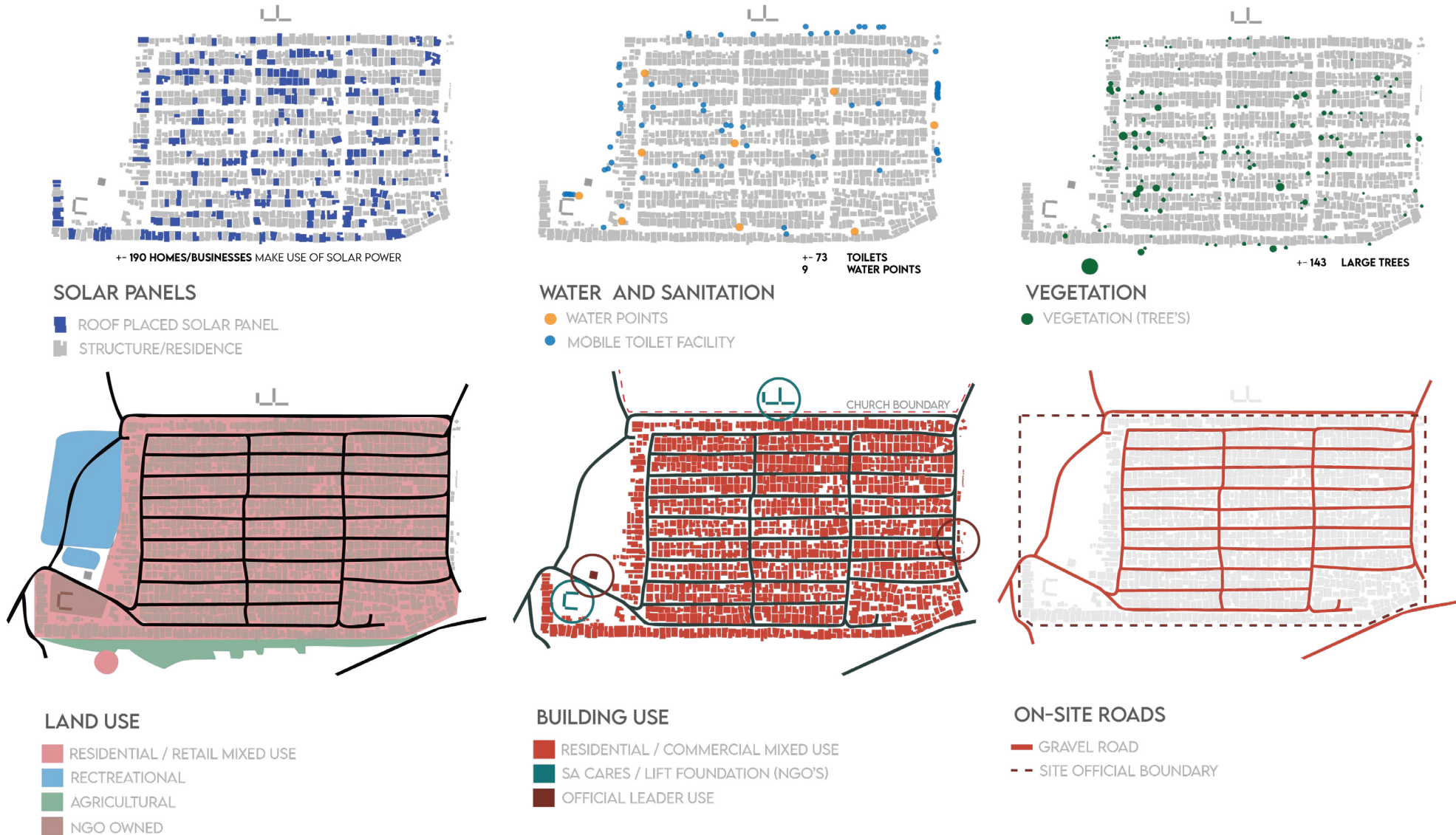


Figure 1.41 - Plastic View site features, (Author, 2021)

1.6.4 RITUALS AND ACTIVITIES

Categorising activities and rituals in which residents engage are especially important to identify different actors within the site, spatial requirements for activities, and where most activities occur on-site. Through an understanding of rituals and space, challenges and constraints for users can be contextually understood.

Rituals and activities

Themes were identified through site investigations a thematic analysis of rituals and activities of different age groups. The primary ritual themes found included resources, recreation, occupation, and knowledge.

- **Resources** are classified as necessary for living or basic needs. These could include buying or growing food, cleaning, and collecting resources.

- **Recreational** rituals are any activities that are not seen as work or needs-based, but rather an activity that brings joy to residents. This encompasses sports, social gatherings, and any non-work community activities.

- **Occupation** can be divided primarily into a resident's time spent at a job or school.

- **Knowledge** can be defined during a process of learning or a transferal of personal experiences and knowledge. Knowledge activities can take place during a conversation, observation, or religious gatherings.

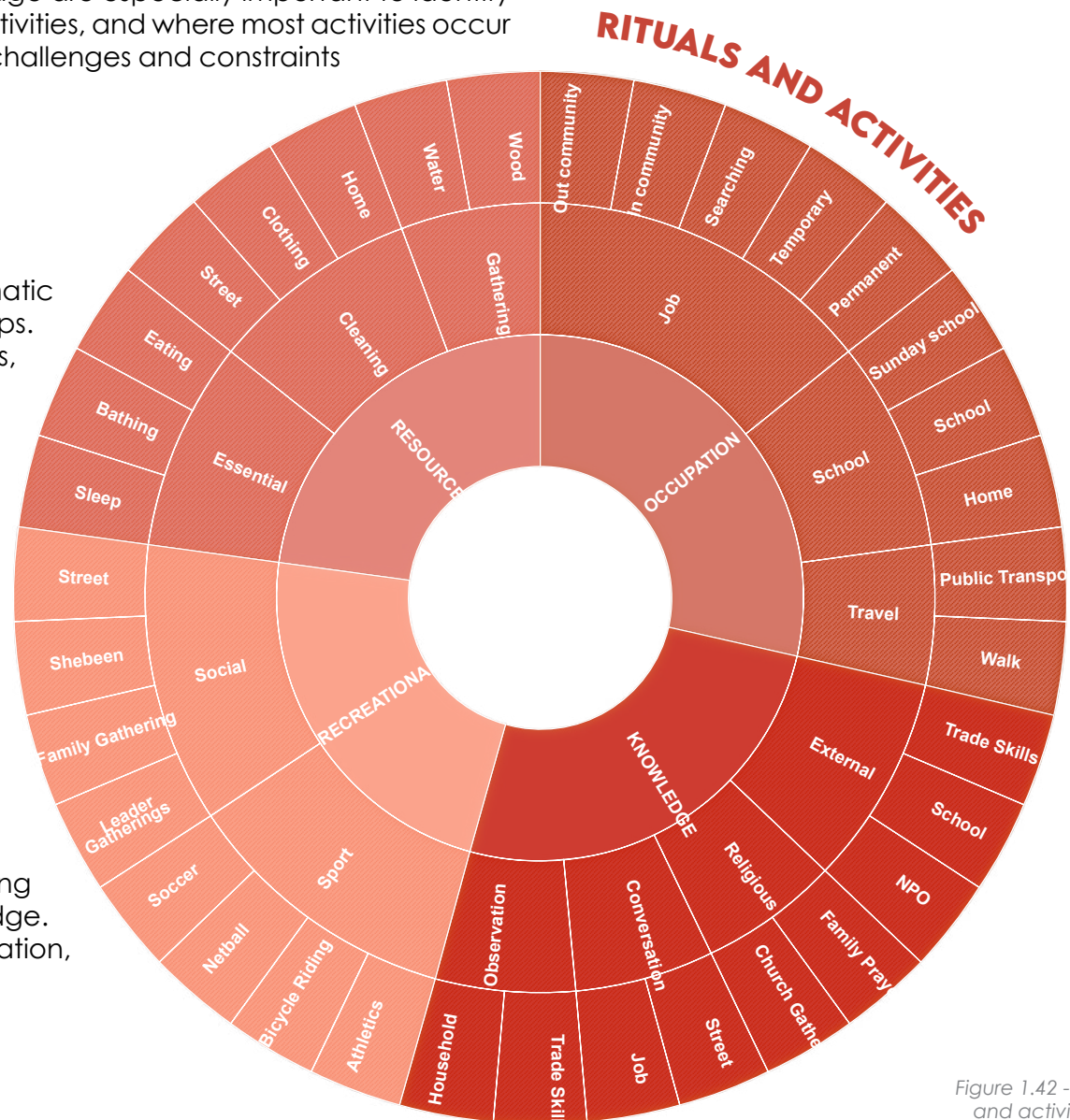
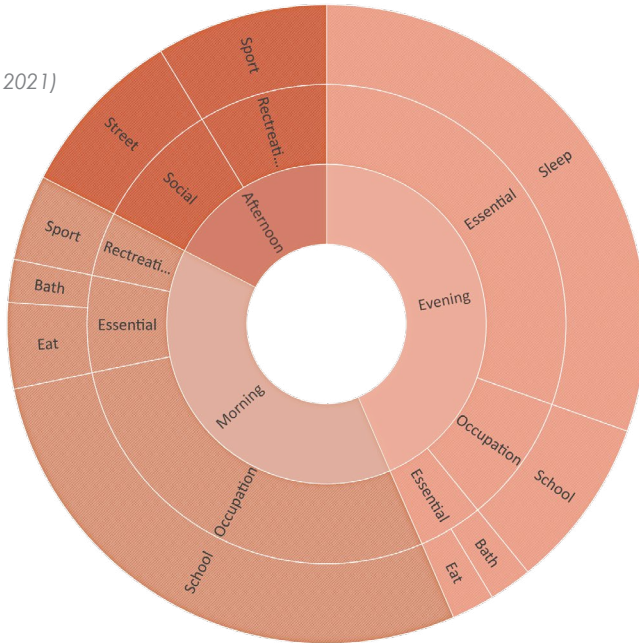


Figure 1.42 - Site user rituals and activities categories, (Author, 2021)

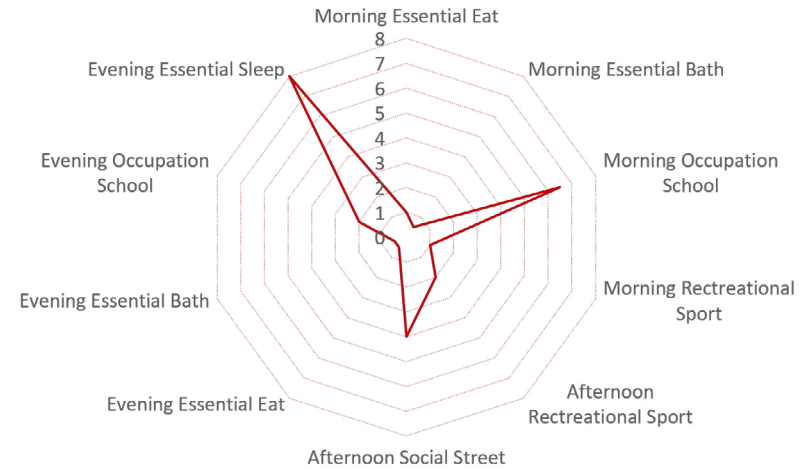


CHILDREN

(Author & MPIP, 2021)

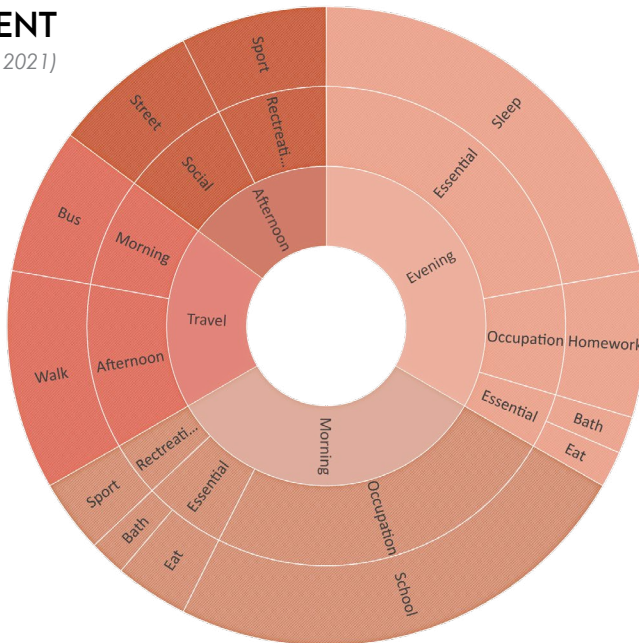


HOUR DISTRIBUTION



ADOLESCENT

(Author & MPIP, 2021)



Observations

Learners are seen at any time within the community, whether they are in the streets, at the soccer field or at dumping sites. Learners are curious and adventurous, and make Plastic View a hub for children's engagement (MPIP, 2021).

HOUR DISTRIBUTION

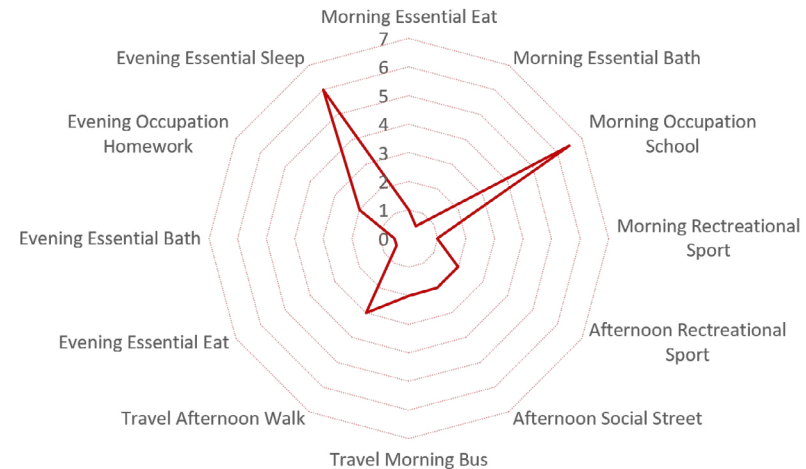


Figure 1.43 - User rituals and activities children and adolescent, (Author, 2021)

USER

1.7



CHILDREN / ADOLESCENT LEARNERS

AGES 8-18

GROWING POPULATION OF CHILDREN WITHIN THE COMMUNITY. SOON BE ADOLESCENTS IN A FEW YEARS. THE FIRST GENERATION TO HAVE GROWN UP IN PLASTIC VIEW.

Figure 1.44 - Selected user photomontage children playing, (Author, 2021)

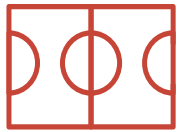
1.7.1 ABOUT THE USER

The user group selected include children aged 8 to 18 years. This specific group are learners who are currently growing up within the settlement, who either migrated to Plastic View with their parents or were born in the settlement. The divide between learners who go to school and those who do not is evenly distributed. Local schools, such as Pure Hope, provide schooling for some learners, but unfortunately many are still unable to attend schooling owing to documentation, finances, or the lack of motivation. This informs the required intervention to assist children who are not able to attend school, but also to tackle environmental challenges that constrain learning abilities at home or in the streets (MPIP, 2021).

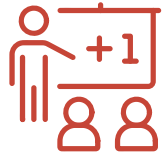


ASPIRATIONS AND REQUESTS

PARENT OPINION



SPORTS
GROUNDS



SCHOOLING

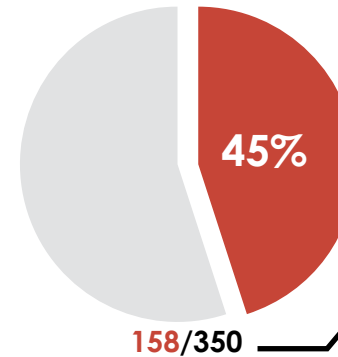


SUCCESS



ADEQUATE
HOUSING

PURE HOPE SCHOOL



(Creighton & MPIP, 2021)

SCHOOL CONSTRAINTS

Paperwork / Passports
Disinterest
Space

Number of foreign learners
versus local learners,
government requirements

Principal of Pure Hope:

"Media center for movies
and games. A space for
interaction.."



IN SCHOOL / NOT IN SCHOOL

ACCESSIBILITY GAP

Figure 1.45 - Selected user photomontage children playing 2, (Author, 2021)

1.7.2 CHALLENGES OF LEARNERS

Challenges of learners

In an interview with Pure Hope School's Principal, it was found that many school children were negatively affected by their circumstances. Anderson claimed many prospective learners were still unable to receive any schooling owing to the lack of correct legal documentation. Circumstances drive children and teens into participating in risky behaviour. Many learners are exposed to negative environments such as drinking places (shebeens), and witness others abusing substances in the streets or end up doing so themselves (MPIP, 2021).

Some of the challenges that learners face within Plastic View were:

- No place to do homework, or small spaces.
- There is not electricity for lighting to do homework, candles or fire is often used for light,
- Learners would be required to do chores till the evening after school,
- There are no recreational spaces for children to play,
- After school children had no place to go,
- During Covid-19 children were in dangerous and tense households,
- Children cannot attend school because they or their parents are not legally in South Africa,
- At night children would not be able to sleep or do homework owing to noise until late hours,
- Air pollution was common, especially at night when fires are used for cooking and heat.

Sadly, Covid-19 impacted the operation of Pure Hope School as well, as the school's library and the after-school programme which assisted children in doing their homework and engaged them in sports, was forced to close (MPIP, 2021).



Figure 1.46 - Plastic View street scene, dumping and condition (Author, 2021)



1.7.3 CHALLENGES WITHIN PLASTIC VIEW

Challenges within Plastic View

While conducting interviews with residents, the residents were asked what their primary challenges were. The largest challenge was found to be the lack of jobs. Many residents had skills in construction and trade. Skills were learnt through indigenous and peer learning. A common theme that was also established was the influence of language on the ability to get work. Being able to speak English is for many community members a commodity, as it is advantageous for employment prospects and decreases community language barriers, serving as a common language between the multi-national dialects within the community (MPIP, 2021).

Moreover, other problems that was mentioned included safety, drinking of alcohol, noise, water shortages, and sanitation. Regardless, many residents were proud of their community, and most felt that the leadership was creating a difference within the community (MPIP, 2021).

Figure 1.47 - Plastic View arial footage, (MPIP, 2021)



NORMATIVE POSITION

1.8

1.8.1 NORMATIVE POSITION

“Architecture is about people” - Diébédo Francis Kéré

A normative position on interior architecture is human-centred design. In essence, human-centred design aims at allowing the integration of participants to solve design problems. “It is a value-centered design approach because of its commitment to the democratic and collective shaping of a better future” (Karasti, 2001). One of the core principles of human-centred design is mutual learning. The user's engagement with the design process expands beyond practical knowledge, values and skills of others and users learn more about themselves and their work abilities (Karasti, 2001).

Human-centred design branches design and the users. It connects the community or individuals to a space, expanding its purpose to be an extension to users. Collective contribution will create a value-centred design inspiring a better future, a flagship for design.

Alternatively, within practice the focus of people is swiftly misplaced with aesthetic and contemporary influence. As designers it is important to develop a research-based approach and start by understanding “who” you are designing for, to develop “what” the most effective solution would be.

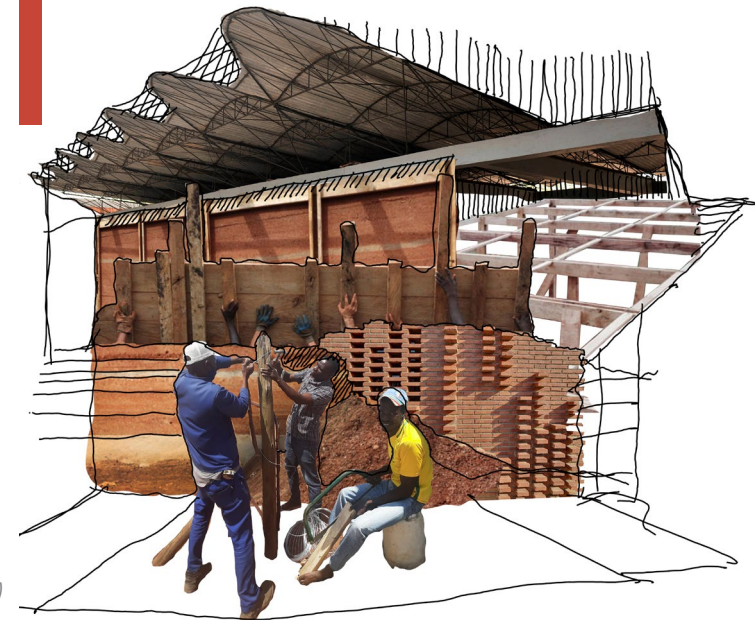


Figure 1.48 - Diagram community driven design and construction, (Author, 2021)

1.8.2 INDUSTRY CONTRIBUTION

The contribution to industry questions the conventional approach to educational environments. Moreover, new digital technology is used as symbiotic partner with the tangible building. Through a user-centred design strategy, user needs, and experience are central to the design approach. Beyond corporate and commercial projects which interior design usually aspires towards, my contribution aims at proving a multi-disciplinary design approach, investigating the possibilities for better education, informal settlements, human-centred design, and the possibility of digital technology being a golden thread for multi-disciplinary design approaches.

Figure 1.49 - Plastic View arial footage, (Author, 2021)



DESIGN RESEARCH

02



UNDERSTANDING



CHAPTER INTRODUCTION

Chapter 2 aims at using the research gathered in the previous chapter to select design informants who guide the project into a design brief aimed at resolving the research question appropriately. Moreover, this chapter is the initial design stage that uses context and theory in a converging process to formulate a meaningful design prototype which is conceptualised and provides a relevant programme.

Two

DEVELOPED ARGUMENT

2.1

In contemporary cities informal settlements often rise between fragments of open land and space. New residents stitch into the urban fabric, having closer work opportunities, and aim to achieve a higher standard of living. For the children living within informal settlements, the dream of success is even further behind. Children living within informal settlements suffer from several internal environmental constraints as well as access to adequate education owing to financial and legality issues.

Bridging the digital divide aims at uncovering learning constraints within informal settlements through a comprehensive ethnographic research study. This data will be used to identify contextually relevant solutions in which digital case studies will provide a minimally invasive new strategy to educating youth holistically. The project aims to incorporate existing indigenous knowledge practices. The overarching objective for the design is to serve as an example or precedent for future design considerations of education for informal settlement children who do not have access to adequate education.



CONTEXTUAL INFORMANTS

2.2

Contextual informants

Contextual informants are design informants that are derived from on-site research investigations. Context informants rely on existing systems and issues on site which could be spatially resolved through analysing spatial possibilities. There are three main contextual informants: environmental constraints, indigenous learning, and activities and rituals.



Services



Safety



Hygiene



Education



Relocation

2.2.1 ENVIRONMENTAL CONSTRAINTS

Environmental constraints

In an informal settlement, there are multiple complex humanitarian and environmental problems. For learners, specifically children, informal settlements do not offer adequate space for learning and motivation for schooling. The most pertinent learning constraints are:

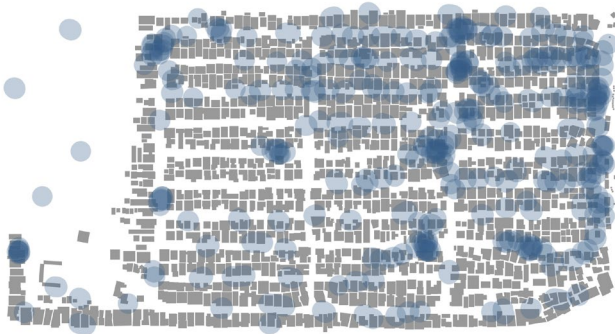
- The lack of adequate space for learning within homes and the community,
- Smoke and sewerage create toxic air pollution that impairs concentration,
- Substance abuse and alcoholism distract and influence children in the street and at home,
- Noise from speakers playing music does not allow for rested or night homework to be possible.

Thus, the key informants for creating adequate learning environment are:

- Away from the street noise, drinking, violence, and air pollution,
- A safe learning environment with space to study,
- Access to services during learning such as water and ablutions.

SITE CONTEXT

DRINKING ON SITE



NOISE POLLUTION POINTS

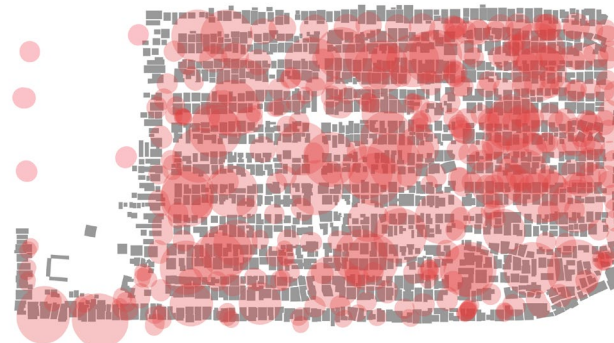


Figure 2.1 - Plastic View drinking and noise distribution map, (Author, 2021)

2.2.2 INDIGENOUS LEARNING

Indigenous learning

In a community that invests in verbal communication as a primary tool for conversation, streets and homes are filled with stories, music, and indigenous knowledge. This generational knowledge teaches children valuable life skills. Thus, the community can be viewed as a large bank of knowledge and these knowledge transfers need to be used as a design informant.

The table on the below describes the relationship between the three primary spaces of activity on site. These include the street, the entrance, and the field. Spaces are areas where knowledge transfers occur during specific activities. The spatial requirement for transfers to occur can be summarised into four primary informants: shelter, safety, trees, and open air. These inform spatial requirements creating peer learning spaces.

Space	Ritual (Knowledge transfer)	Spatial requirements	Key Informants
Street	Games Stories Play Housework Trades kills Shops	Seating, Shelter Seating, Shelter Open streets, Safe space Open-air, natural lighting Lighting, seating, workspace Porch, Shelter	Shelter Safety Trees Open Air
Site Entrance	Market Material sorting	Linear along the fence Open space, Tree shade	
Field	Sports Playground Conversation	Soccer field, Netball court Field, open-air Field, open-air	

Table 1 - Plastic View knowledge transferal environments, (Author, 2021)

THEORETICAL INFORMANTS

2.3

Theoretical informants

Theoretical informants assist in bridging contextual problems with digital and spatial programmes. These programmes will be reinforced by precedent studies that are similar in their context in enabling communities.

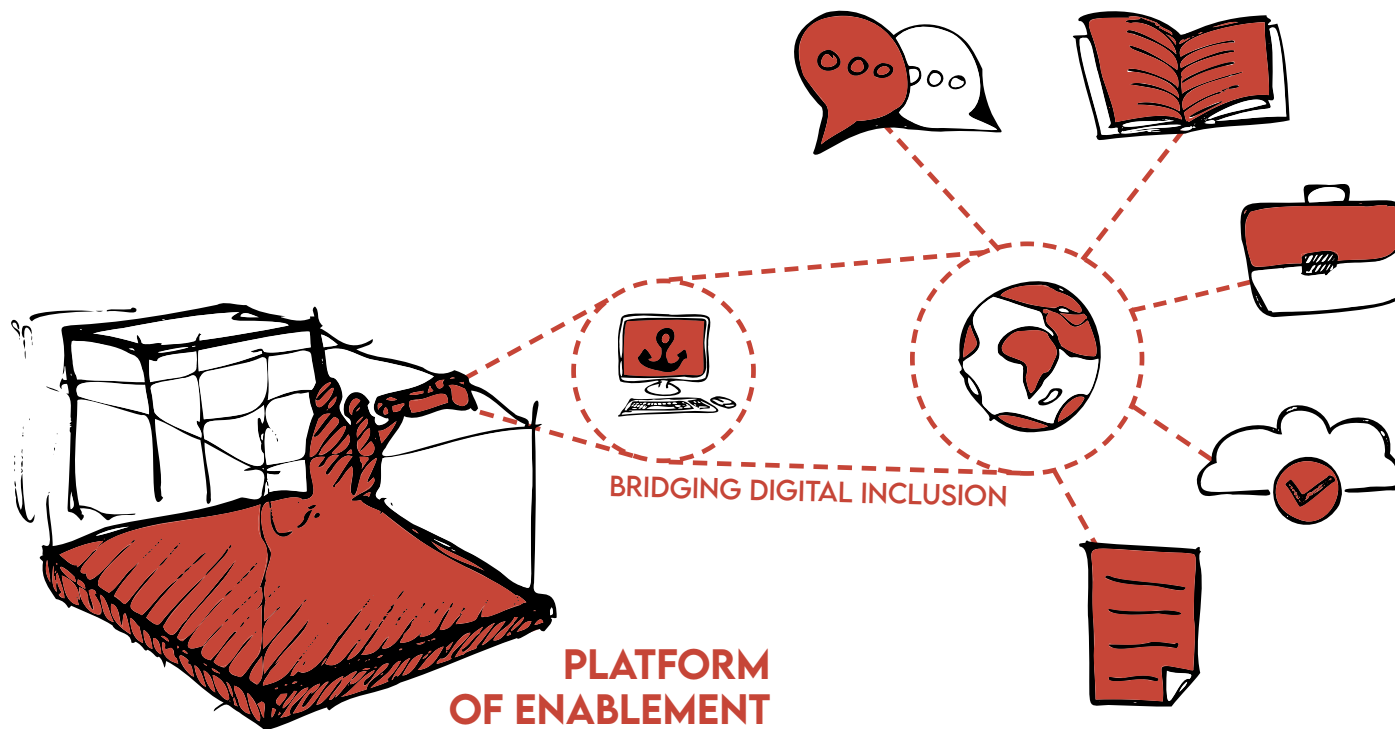


Figure 2.2 - Digital inclusivity platform for enablement, (Author, 2021)



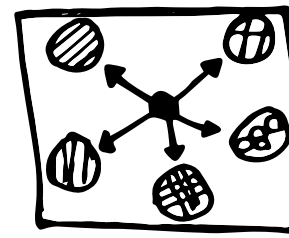
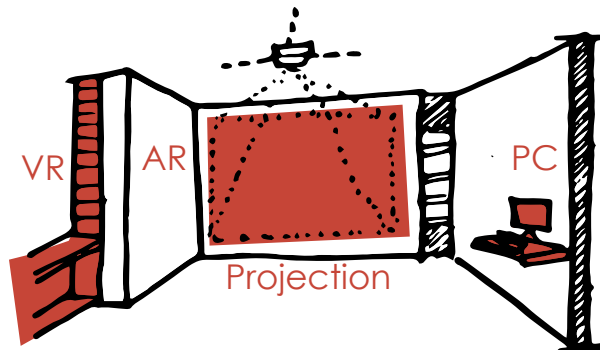
2.3.1 DIGITAL DIVIDE

Digital Divide

Bridging the digital divide is the most viable learning solution. Owing to inaccessibility to formalised classrooms, curricula, and teachers, digital learning offers an alternative virtual environment for learning. Communities can take advantage of the Internet beyond school, but also of a process of exploration and learning.

Digital divide design informants:

- Learners can educate themselves within their natural environment.
- Digital classrooms replace conventional classrooms,
- Learners gain agency over their virtual space,
- Learners engage in groups with computers building bonds,
- Access to the internet creates multi-layered interventions.



Learning tools

Figure 2.3 - Theory: Digital Divide, (Author, 2021)

2.3.2 SPATIAL AGENCY

Spatial agency

The spatial agency allows users to explore and engage freely. Within real space, users define the programme, creating, analyzing, exploring, and learning. While a virtual space breaks down the walls of accessibility, it allows users to be anywhere at any time. If space offers a seamless environment between real and virtual space, space becomes “anti-spatial” and users can choose where they would like to be, giving users environmental agency (Thompson, 2008).

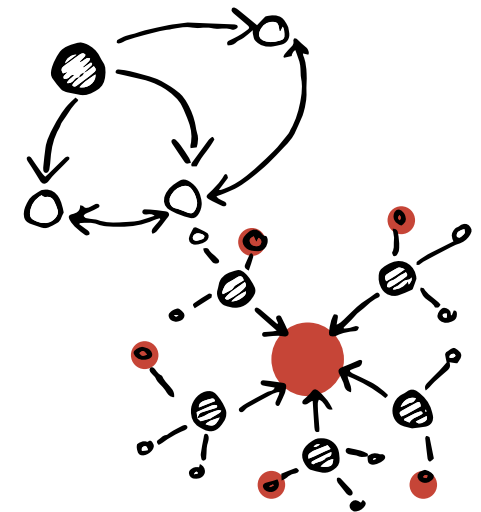
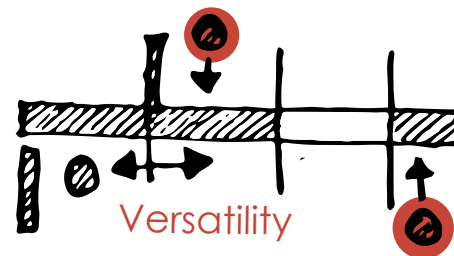


Figure 2.4 - Theory: Spatial agency, (Author, 2021)



2.3.3 INDIGENOUS LEARNING

Indigenous learning

Children living within informal settlements are constrained by many socio-economic and environmental problems. These learning constraints can be analysed and be found in a digital solution. With the use of theoretical informants, a contextually relevant programme is discovered that enables learning for children through bridging the digital divide and creating spatial agency both physically and virtually.

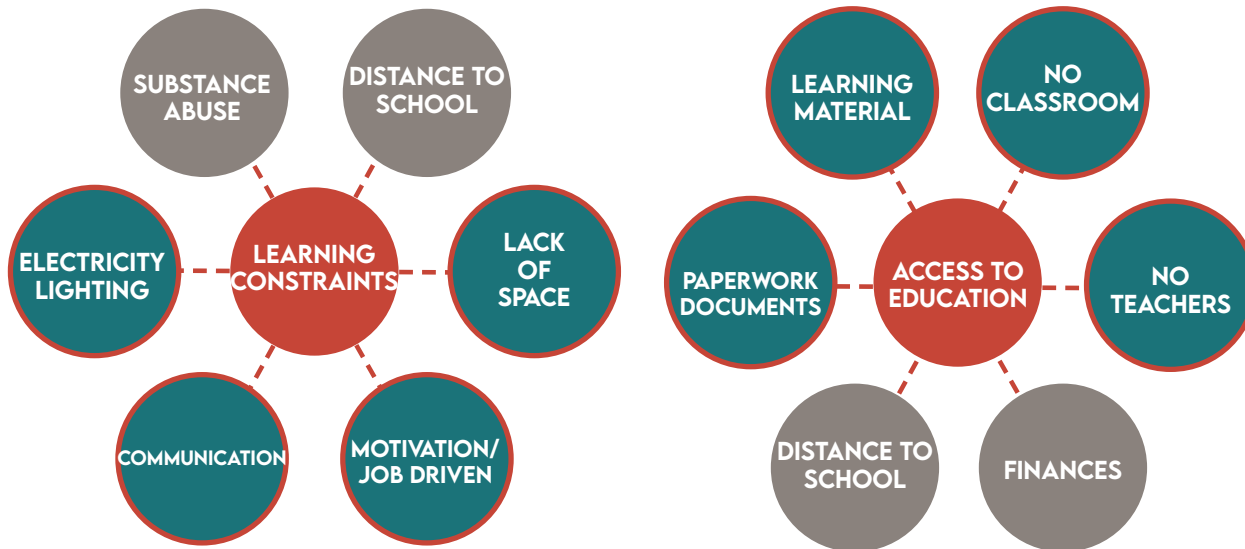
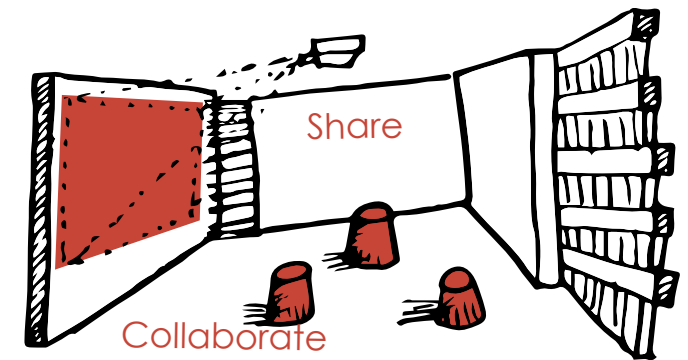


Figure 2.5 - Diagram: learning constraints for learners of Plastic View, (Author, 2021)



PROCESS OF LEARNING

2.4

Process of learning

Education systems have been under immense pressure for an alteration in traditional pedagogy. According to Olaniran (2016) good teaching is dependent on the teacher's abilities to teach content in a method that keeps learners attentive and ordered (Olaniran, 2016). However, developing lifelong learners who have the tools to survive in global economies, and who are able to adapt and creatively apply learning skills are more needed for the complex world than conventional learning techniques (Blaschke, 2012).

UNESCO: Four pillars of learning

In 1996, UNESCO proposed a valuable structure to encourage meaningful learning. This meaningful learning rests on four pillars, namely,

- learning to know,
- learning to do,
- learning to be,
- learning to live together (share).

These educational pillars shed light on creating a learner focused approach (Olaniran, 2016). Curriculum becomes a background and the input processes to assist learners to learn become the focus. Education thus becomes a learner/teacher cooperation, rather than a hierarchical structure (Nan-Zhao, n.d.).

Learning pillars through a digital learning lens

The importance of considering "UNESCO's Four pillars of Learning" through a digital spatial lens provides informants through which multiple theory intersect to become a design solution.



FOUR PILLARS OF LEARNING

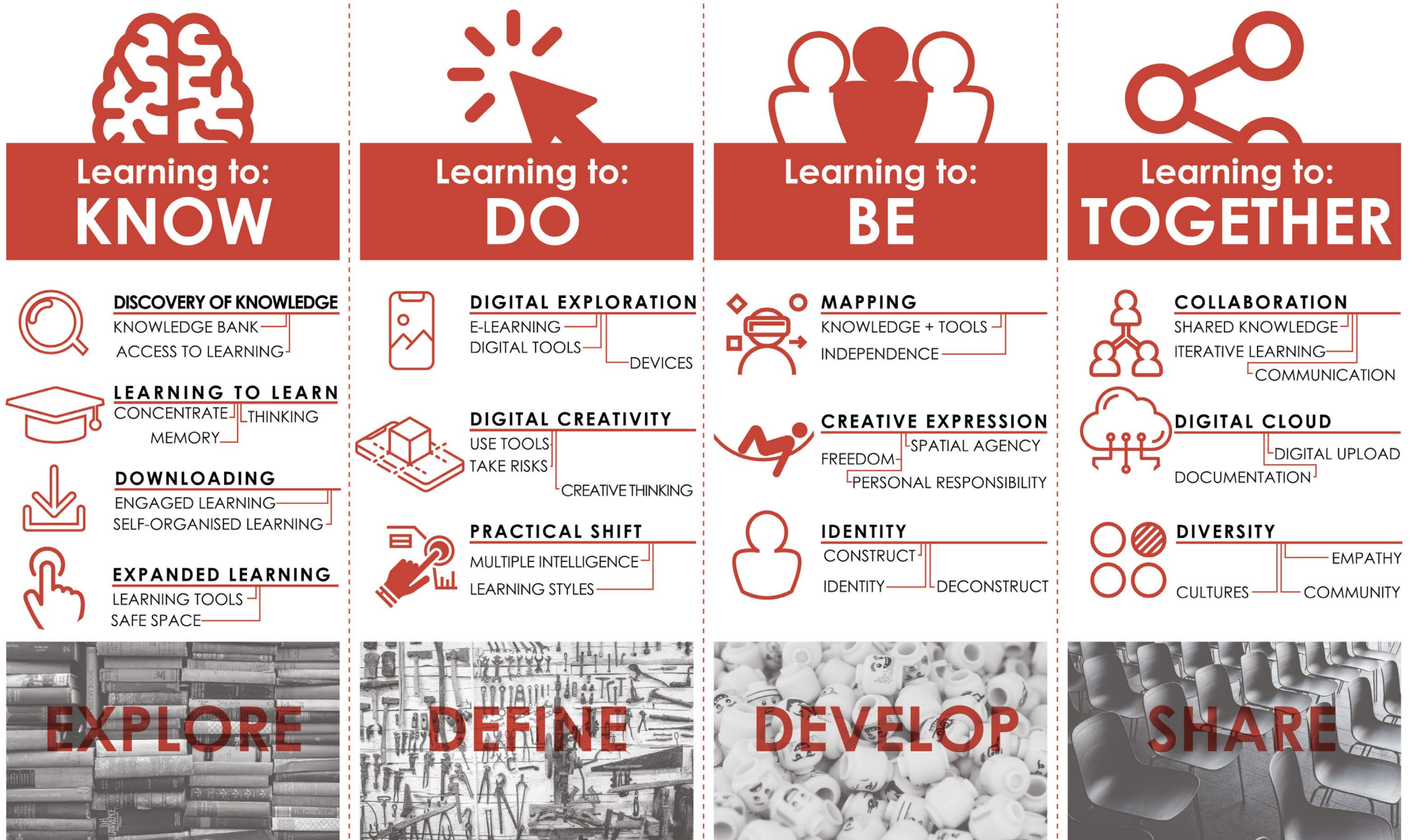


Figure 2.6 - Four pillars of learning infographic, (Author, 2021)

DESIGN BRIEF

2.5

2.5.1 DESIGN BRIEF

PROJECT TITLE:



AUDIENCE

Youth of Plastic View are a ever growing population. The design solution would need to consider the growth and the engagement of multiple age groups working in similar space.

CLIENT

The client Tebelo and their investors would like to create a flagship design for their new approach to understanding local contexts and responding to create maximum change within communities.

DESIGN

INTERIOR INTENTION

The primary objective for interiors, is to create safe spaces where scholars have the ability to explore and learn by themselves and with groups.

EXTERIOR INTENTION

The exterior aims to create a digital enhanced playground, where learning occurs through exploration and imagination.

MATERIAL

On site materials:

Local contractors use the local veld to dump construction material such as large quantities of building rubble, sand, garbage, and refuse.

These materials with contemporary building practice becomes a hybrid construction. Similar to existing site practice.

Site inspired Material:

- Rammed earth
- Natural stone
- Crushed stone

TECHNOLOGY

Digital technology would become a phased approach to enable learning through digital platforms and devices.

Sustainable building technology would be required, owing to the lack of accessibility to water or electricity.

- Solar power
- Bore hole
- Sewerage compositing

SPATIAL AGENCY

Virtual space acts as the enabler of the physical world and enables activity. These programmes would require the users intervention and their action to create and augment the space provided.

**INNOVATIVE
THINKING**



2.5.2 DESIGN AIM

Design aim

The design aim to uplift the learners and the community of Plastic View through a physical design intervention on site which is enabled through digital inclusivity. Moreover, this project serves to motivate alternative methodologies for educating learners within vulnerable communities, which could be used as a research template to address similar contexts.

The design aims to integrate the community in the construction process to promote spatial agency and authorship over the intervention. This agency further developed with a digital interface that promotes learning through digital tools and safe learning environments.

The design criteria include:

- Safe learning environments that are healing and promote identity finding.
- A versatile functionality which allows for multiple programmes within one environment.
- Making use of local materials and labour to educate the community with experts.
- Ablutions which offer accessible usage.
- Digital technology is promoted to educate in all spaces.
- Green scaping unify spaces promoting natural knowledge sharing.
- The intervention operates sustainably.

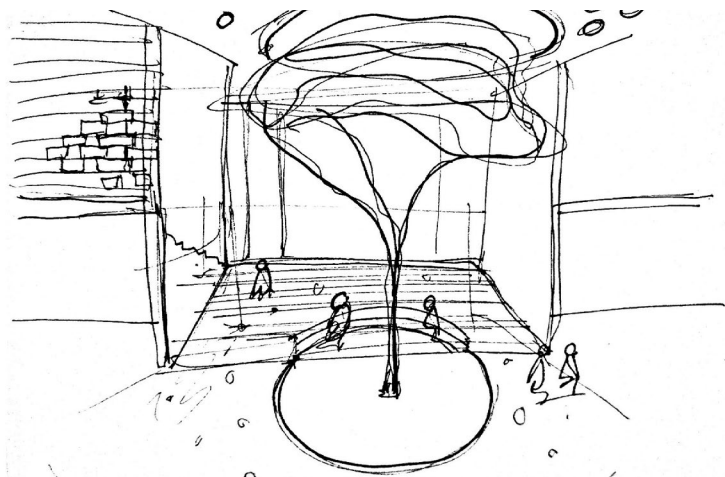
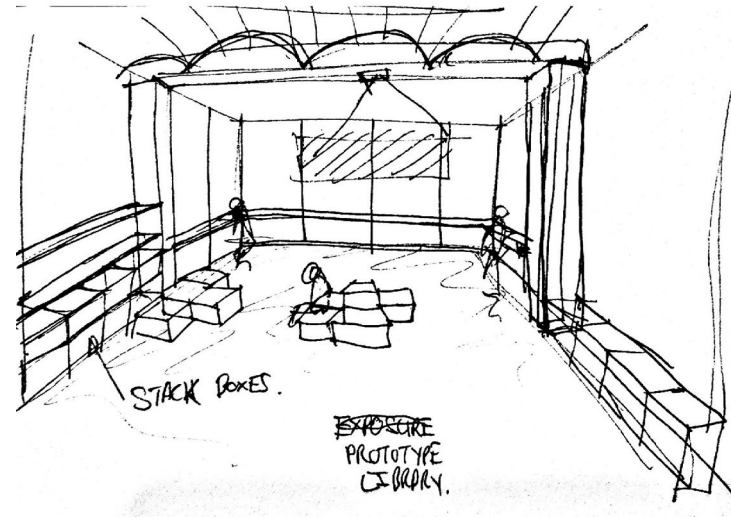


Figure 2.7 - Design concept sketch: nature within interiors, (Author, 2021)



SITE FOR INTERVENTION

2.6

Site selection

The site selection process is aimed at investigating plausible spaces for intervention through on-site exploration and macro-studies. The site selected would provide an adequate space in which an intervention can be positioned to attach itself to existing community functions. The purpose of the intervention is to provide a safe and enabling learning environment where learners can learn and play through digital inclusivity. The space should allow for spatial agency and a neutral gathering space for the community.

Site requirements

The site requirements are motivated by theoretical and contextual informants. The theoretical requirements are as follows:

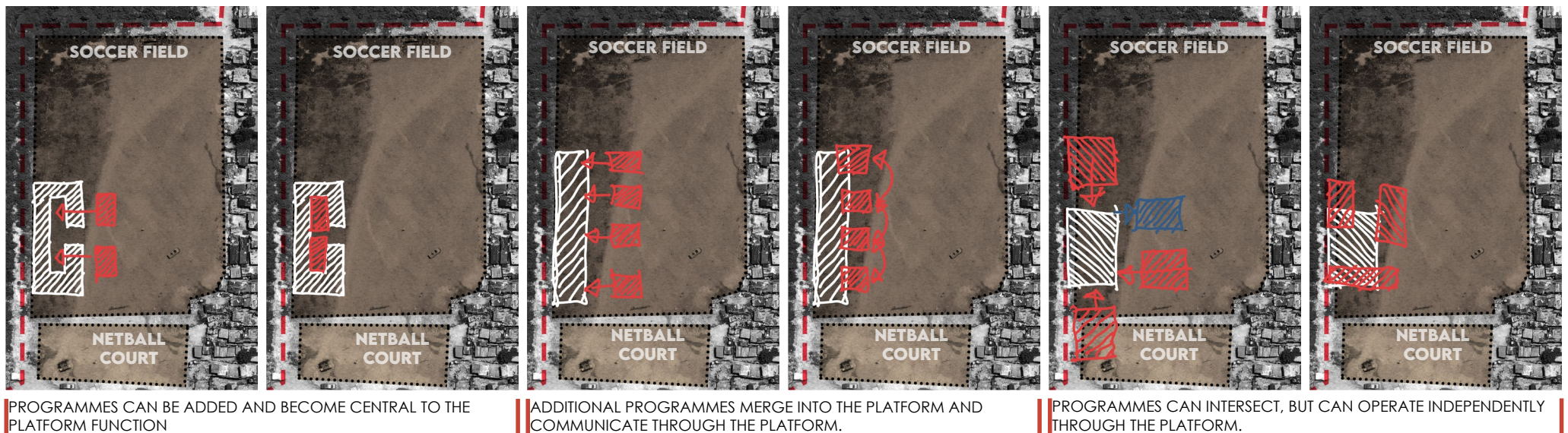
- line of site for internet access,
- a playground space that is existing on site,
- open space for communication and collaboration.

Moreover, the contextual informants are as follows:

- near to construction materials,
- where learners are currently engaging,
- away from noise, pollution, and violence.

The site requirements thus led the site to be by the existing soccer field where learners and the community gather regularly for sporting and social activities.






Figure 2.8 - Site intervention concept sketch, (Author, 2021)



SITE FOR INTERVENTION

25°49'55"S | 28°18'18"E

The provides an intersection of multi-generations.
Existing activities include:

- SPORTS 
- PLAY 
- RESOURCES 
- GATHERING 
- LEADERSHIP 

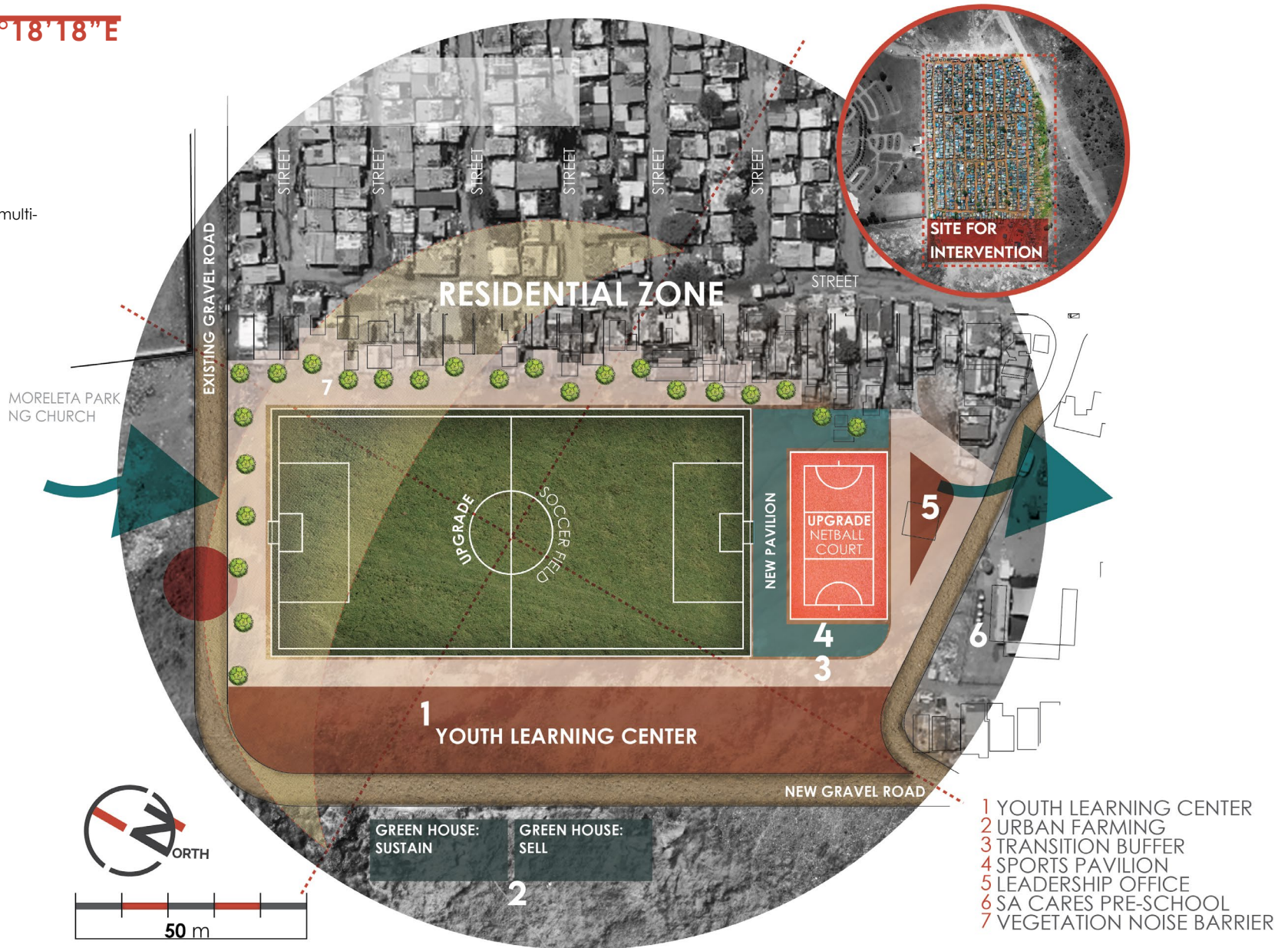


Figure 2.9 - Site for intervention plan, (Author, 2021)

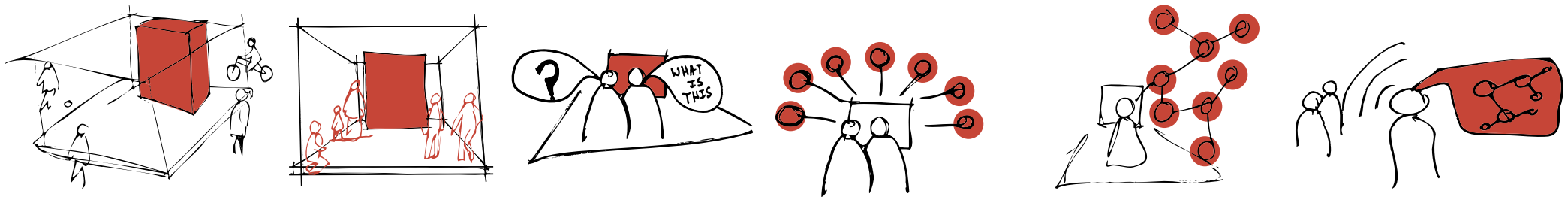
DESIGN INTENT

2.7

2.7.1 DESIGN STRATEGY

Design Strategy

The design strategy begins by extracting key site features to maximise the effectivity of a safe and non-constrained learning environment. The project aims to identify an existing space where children are already engaged, and interact. The design aims to plug into and support the existing functions. Materials and design will be appropriated by community design to allow for the community's engagement. Also educating residents in sustainable practice of construction, all design phases emphasise creative re-use of material and is educational along the way.



1 INTERVENTION

A platform is installed, with digital inclusivity successfully delivered. Users wonder curiously if they are allowed to engage.

2 ENGAGEMENT

Once courage is developed, users curiously engage with each other on the platform.

3 UNDERSTANDING

Once comfortable, users begin to engage with the components. With their existing knowledge, they start to experiment. Touching, feeling, and clicking.

4 PURPOSE

When understood, purpose drives activity. Users begin to search, play, and experiment with purpose.

5 KNOWLEDGE

The purpose then alters from digital literacy to understanding broader meaningful knowledge to aid circumstance or questions.

6 ENABLE

When knowledge is driven by purpose it creates enablement within the lives of users. This is then used and also shared through existing knowledge transfers.

Figure 2.10 - Design Strategy: including a digital interface, (Author, 2021)



2.7.2 THE INTERVENTION AS A CIRCULAR SYSTEM OF LEARNING

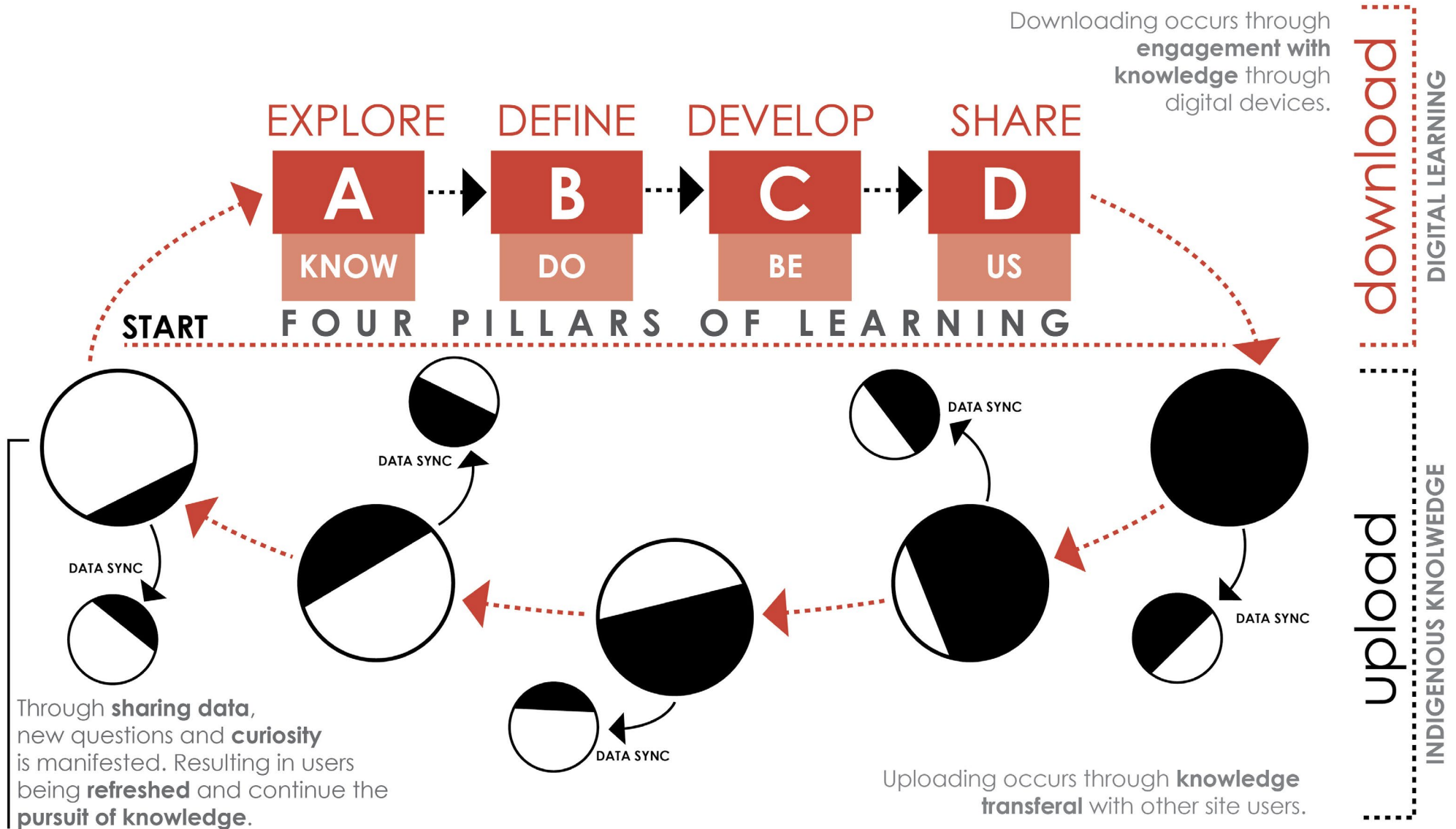


Figure 2.11 - Design concept: Circular learning system concept, (Author, 2021)

DEFINING A PROGRAMME

2.8

2.8.1 DEFINING A PROGRAMME

Context includes understanding the lives of residents and the daily activities that take place. Activities and rituals are spatial and aid in transferring indigenous knowledge. These processes will be documented and analysed into themes. Later precedent studies will be analysed to discover specific themes that are relatable to the context of Plastic View. Theory including the digital divide and precedent studies, such as “Hole-in-the-wall” (Hole in the wall, 2015), shows how digital technology can be introduced successfully into informal communities for learning. The existing indigenous knowledge systems may then be used as additional plug-ins to aid the building's programme.

Programmes within a digital interface

Digital technology allows for a device guided by the user to define a programme. A classroom which would most often require many physical learning tools such as posters, books, etc., can now be replaced with a singular or multiple devices which allows for instant curriculum shifts or alterations without the requirement of costly goods which could go missing.

Moreover, programmes can be recorded or documented for future demonstrations or classes. This documented data can also be used for progress documentation and the development of new programmes to best suit the needs of learners within a vulnerable context.

The building programme is divided into three primary categories, the workshop, the playground, and the library. Within these categories various programmes of learning occur whether it be within a classroom, a courtyard or on the field. All programmes aim to use digital technology as a plug in for elevated learning programmes and versatile functionality.



2.8.2 BUILDING PROGRAMME

Table 2 - Building Programme

LEVEL	PRIMARY SPACE	PROGRAMME	FUNCTION	COMPONENTS	
GF	Workshop	Classroom	Facilitated classes	Projector unit, projection wall, desks, chairs	
		Skills Development	Teaching electrical, crafts, contextual tools	Electrical Points, deployable tools, adjustable tables, storage	
		Exhibitions	Virtual Sports, virtual Exhibition	Mobile devices, projectors, internet	
			Gatherings	Community Meetings, games (virtual and real), story telling, markets, movies	
		Client Mixed-Use	Pop-up Clinic	Services: water, waste, electrical	
			Pop-up Kitchen	Services: water, waste, electrical	
	Playground	Sports	Fixed	Soccer field, netball Court, pavilion	
			Temporal	Digital sports, VR sporting, recorded activity	
		Learning	Projected engagement	Field as stage, field as audience	
			Coaching	Deployable projectors, speakers, cameras, sensors	
	Services	Ablutions	Youth Center Ablutions (Facilitators & Clients)	SANS 10400 Requirements Accessible toilet	
	FF	Library	Classrooms	Versatile digital learning	Internet access, reduced Noise (acoustic panels), hybrid Desks, seating, projector
			Office	Client office	Open plan office, fitted by client
Computer Room			After school During Breaks	Fixed desk computer units, library (physical and virtual)	

2.8.3 SPATIAL PROGRAMME

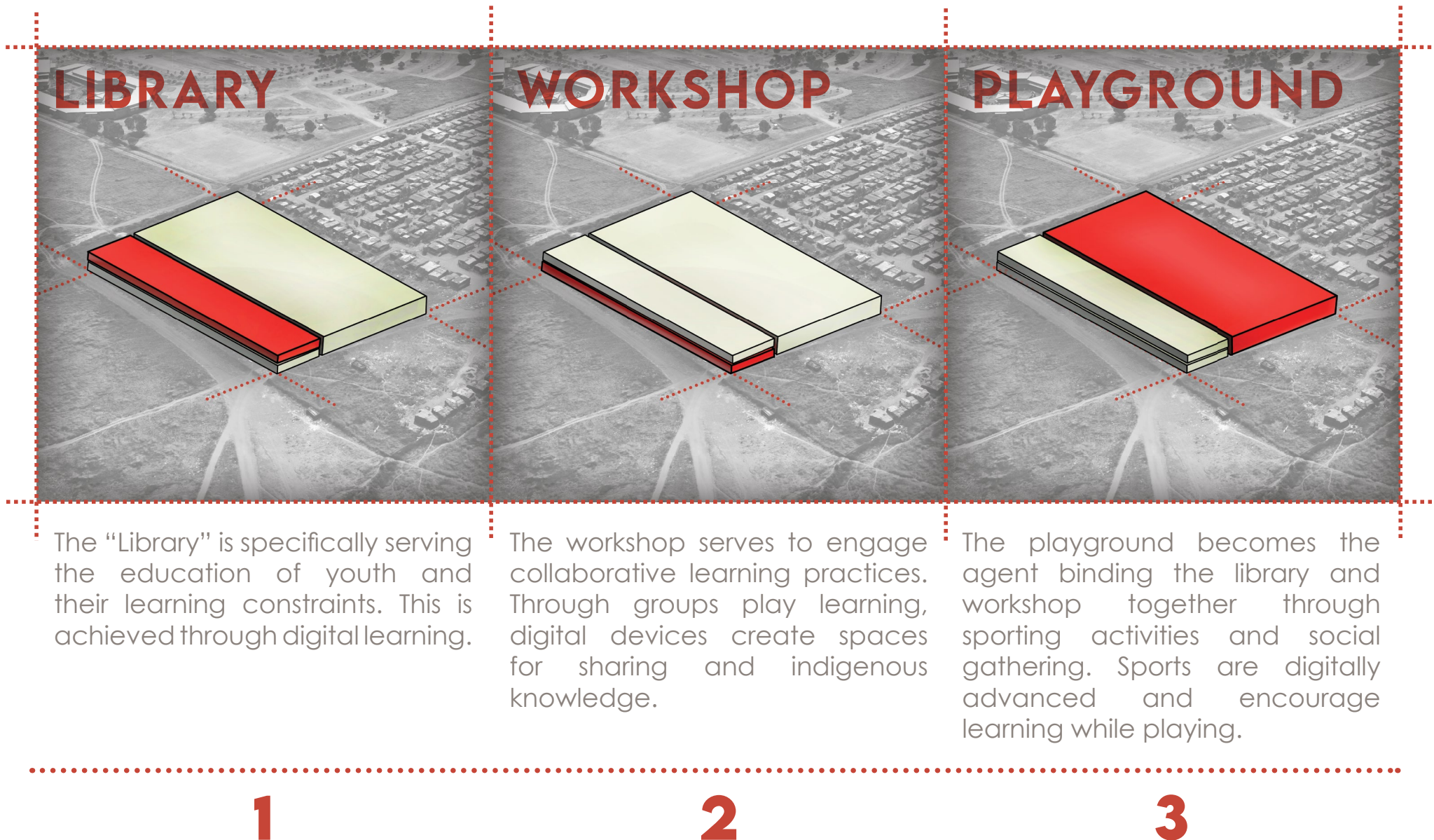


Figure 2.12 - Spatial programme, (Author, 2021)



2.8.4 SPATIAL PROGRAMME



1+2+3 TOGETHER AS ONE CLASSROOM

As three spaces serve as a holistic classroom. Each allowing for learning possibilities.



(1) LIBRARY & (2) WORKSHOP

The library offers learner the ability to download knowledge, while the workshop through collaboration uploads data to other users.



(2) WORKSHOP & (3) PLAYGROUND

The workshop offers the digital bridge to engage the playground in digitally rich activities and engagements.



(1) LIBRARY & (3) PLAYGROUND

The library becomes the audience for the stage being the playground during activity. During events the playground becomes the audience while the library becomes the digital stage.

Figure 2.13 - Spatial programme, three spaces. (Author, 2021)

DESIGN ITERATION

2.9

The design intention was to create the ideal solution to educate learners and create world class sporting facility. The design was architecturally motivated in size and was found to be invasive to the intetion of the design.

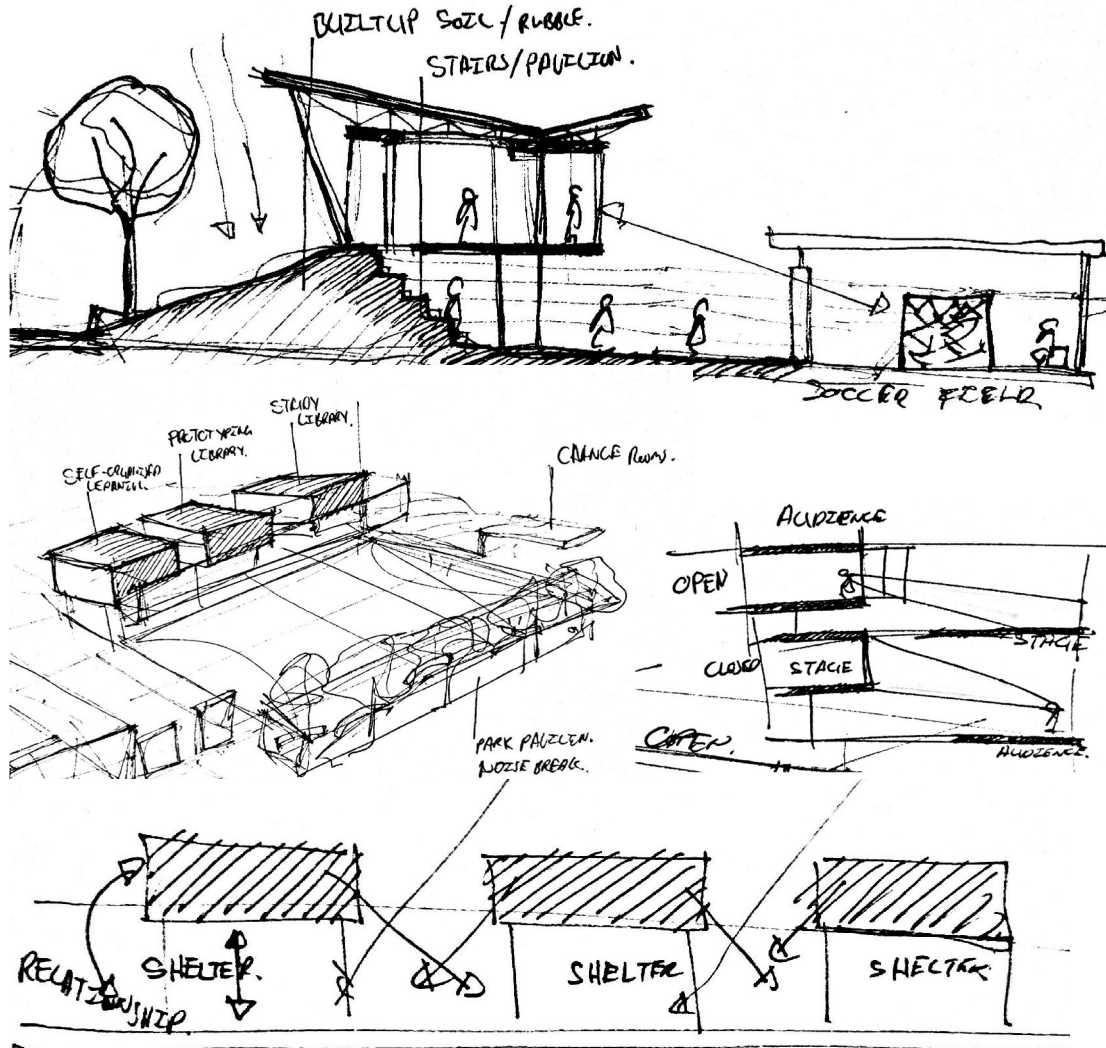
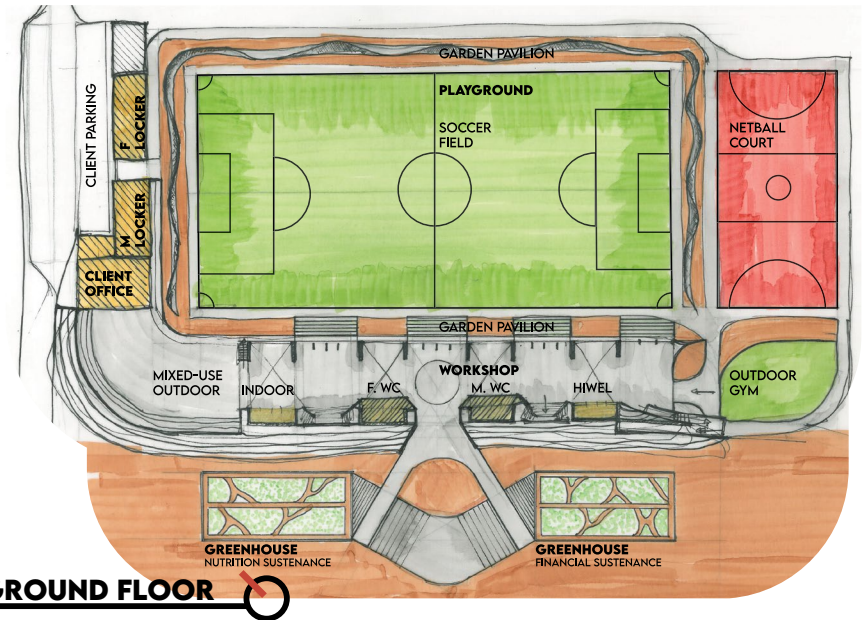
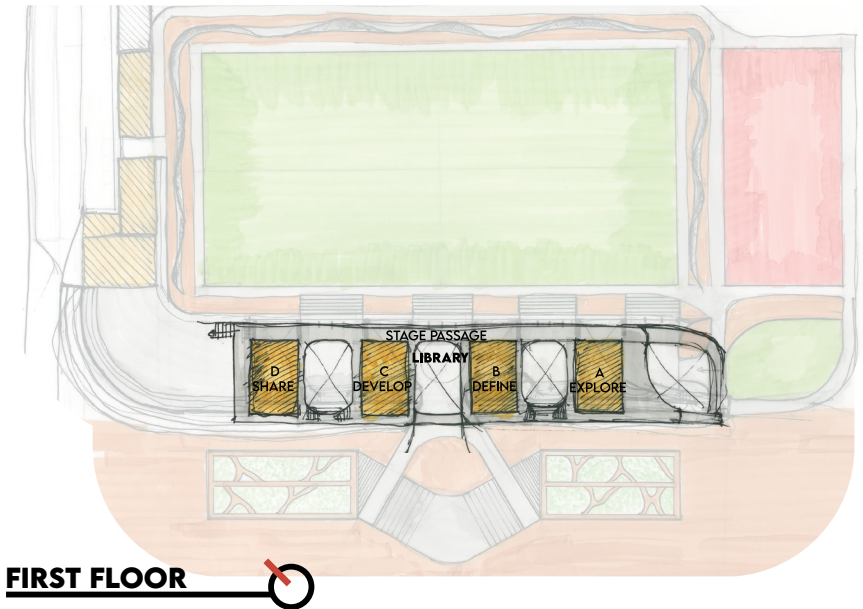


Figure 2.14 - Design iteration 1: concept sketches, (Author, 2021)



GROUND FLOOR



FIRST FLOOR



Reflection: The first design iteration was found to be a top down approach and did not address the context to create a design intervention which engages the community and is a viable solution for alternative contexts.

EXPLORE LEARNING TO KNOW

SPATIAL PROGRAMME

OCCUPANCY	DIGITAL LEARNING	INTEGRATION
40 LEARNERS	Interactive Projector wall Digital Table Virtual Reality Augmented Reality	Multi-layered digital learning Facilitator/assistant Stand Desking – movable desks



SHARE LEARNING TO LEARN TOGETHER

SPATIAL PROGRAMME

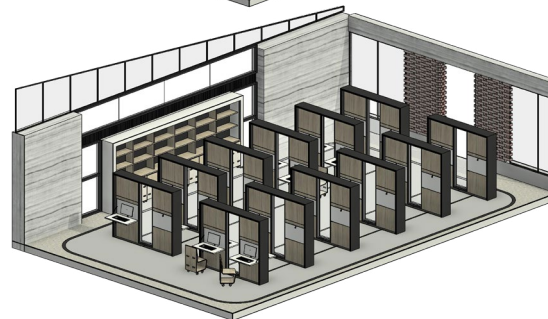
OCCUPANCY	DIGITAL LEARNING	INTEGRATION
30 LEARNERS	Open collaborative space Movable seating into concentration groups	Collaboration wall desks Stackable seating Flexible lighting



DEFINE LEARNING TO DO

SPATIAL PROGRAMME

OCCUPANCY	DIGITAL LEARNING	INTEGRATION
40 LEARNERS	Expandable Computers Individual learning desks White boards/digital boards	Internet Access Reduced Noise (acoustic panels) Hybrid Desks Seats with Backrests (under-seat locker)



DEVELOP LEARNING TO BE

SPATIAL PROGRAMME

OCCUPANCY	DIGITAL LEARNING	INTEGRATION
20 LEARNERS	Plug in central hub Movable dividers Learning nooks	Power Wall Movable dividers (magnetic screens built in)

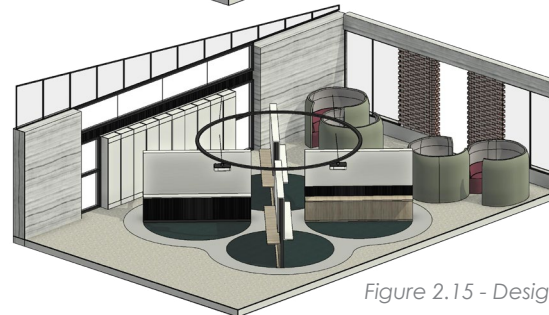


Figure 2.15 - Design iteration 1: design resolution, (Author, 2021)

DESIGN SYNTHESIS



03

CREATION



CHAPTER INTRODUCTION

Chapter 3 finalises the design resolution which is then technically resolved through a series of design examples expressing sustainable, versatile, and digitalised design integration. Moreover, the technification integrates into the design to express the relationship between design and materiality.

Three

FEASIBILITY

3.1

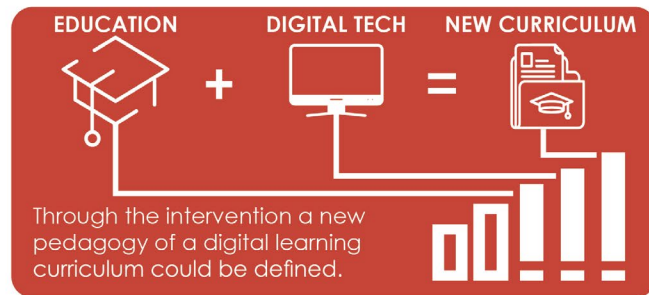
The NPO "Tebelo" is viewed as the primary investor, and through a process of investigating a plausible solution a feasibility breakdown is conducted.

Investment goal:

Producing a sustainable youth development centre flagship for future testing of digital learning platform integration into informal settlements.

INVESTMENT OPPORTUNITY

New digital learning pedagogies can be developed and these curriculum's could be profitable and sustainable for the future.



COMMUNITY INPUT

CONSTRUCT
Community with expert construction effort. Learning process.

SECURE
Community ownership to safeguard the center.

COMMUNITY
Community + Experts
Relationship with NPO's
Existing Leadership.

SUSTAIN
Financially sustaining the intervention.
Community sustainability.

TECHNOLOGY

DONATIONS
↓
UP-CYCLED
↓
INTEGRATED

INCOME GENERATION

SPORTS
Community + Experts
Relationship with NPO's
Existing Leadership.

DIGITAL COMMERCE
Community + Experts
Relationship with NPO's
Existing Leadership.

EVENTS
Community + Experts
Relationship with NPO's
Existing Leadership.

MARKETS
Community + Experts
Relationship with NPO's
Existing Leadership.



CONSTRUCTION

LOCALLY SOURCED
↓
DONATED
↓
EXPERT LED

Figure 3.1 - Feasibility infographic, (Author, 2021)

3.1.1 CLIENT PROPOSAL

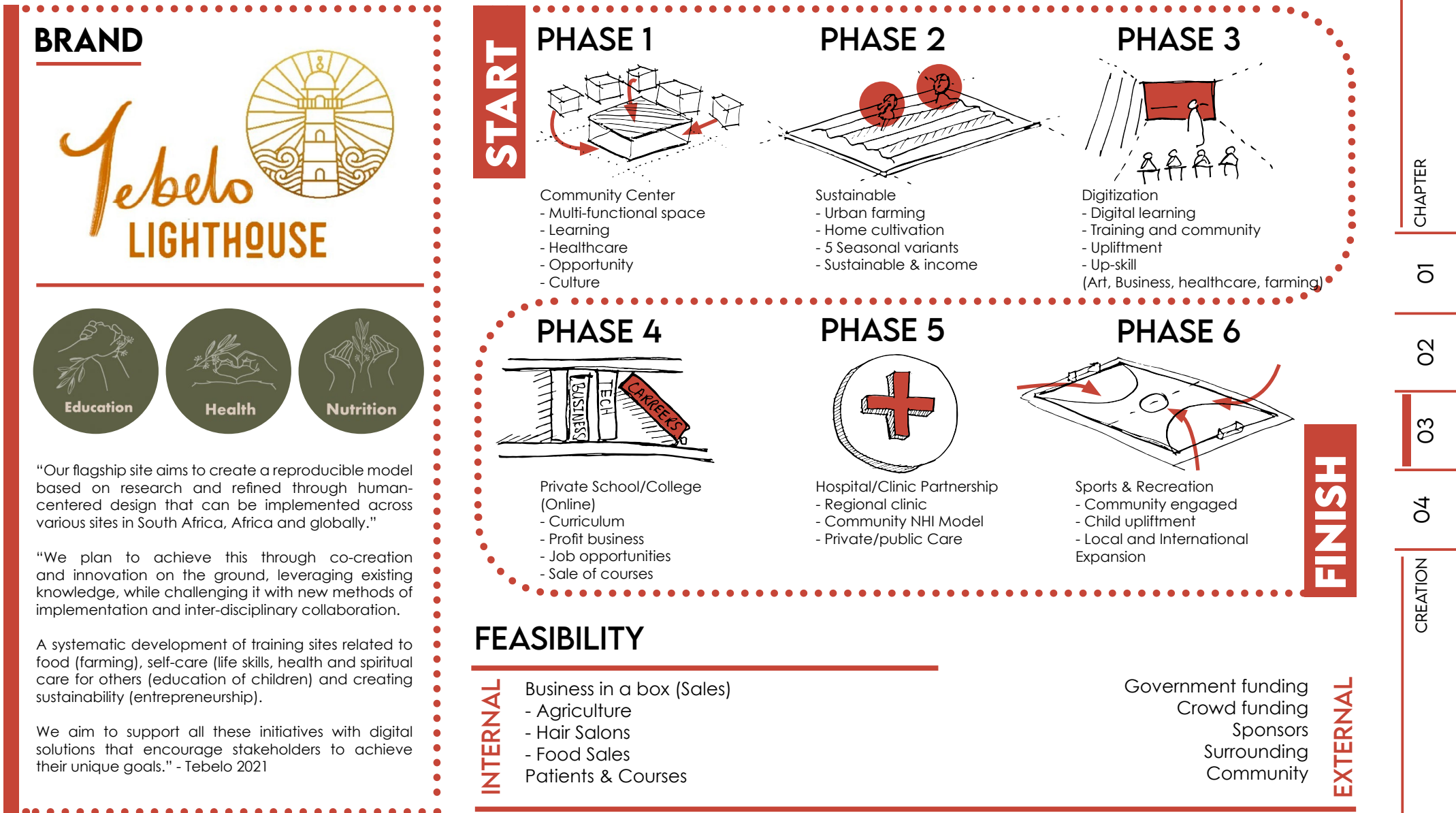
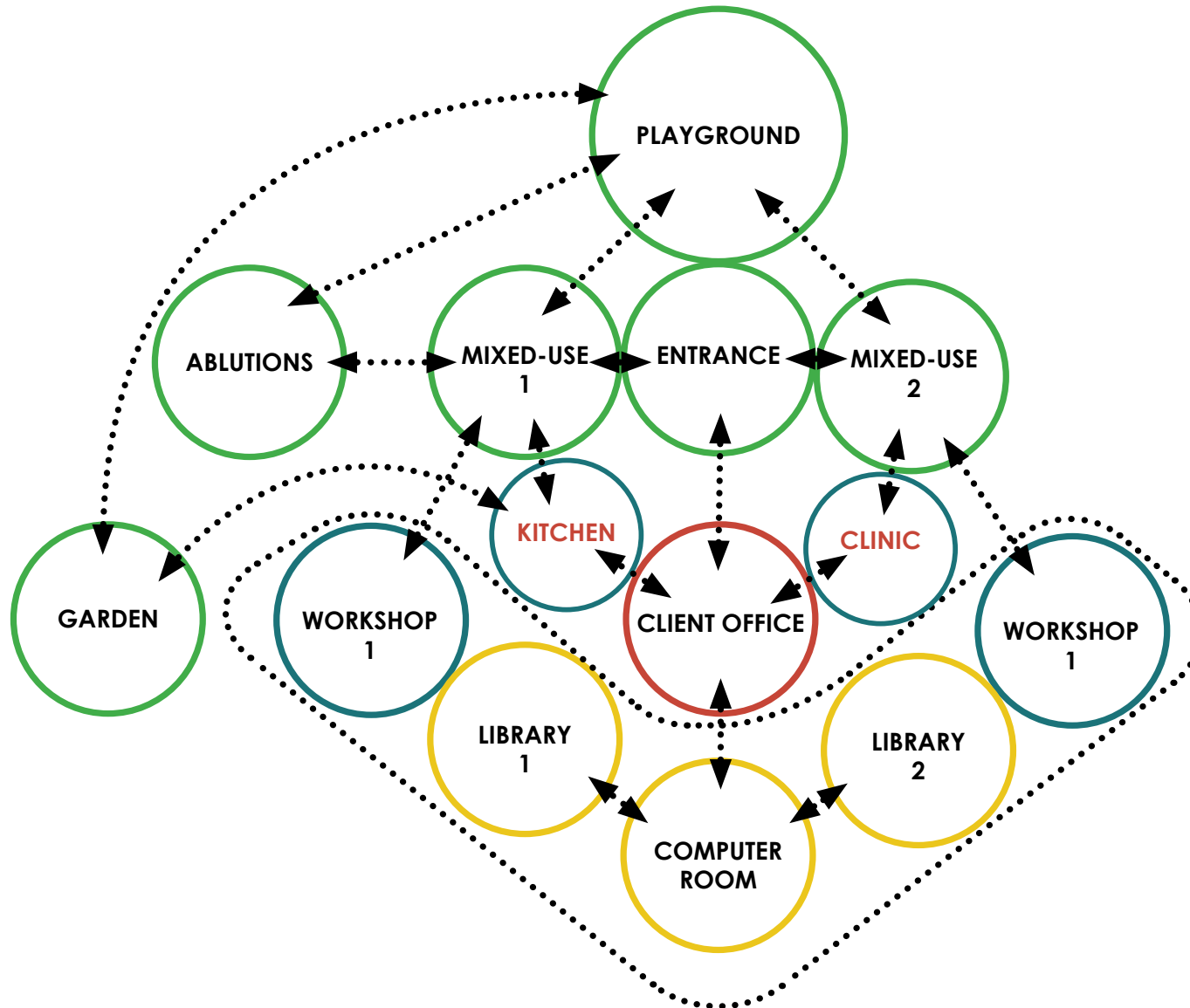


Figure 3.2 - Feasibility: Client proposal, (Author, 2021)

SPATIAL CONCEPT

3.2



- KEY:**
- SEMI-PRIVATE (GF)
 - PRIVATE
 - SEMI-PRIVATE (FF)
 - PUBLIC

Figure 3.3 -Spatial concept diagram, (Author, 2021)



SPATIAL CONCEPT DEVELOPMENT

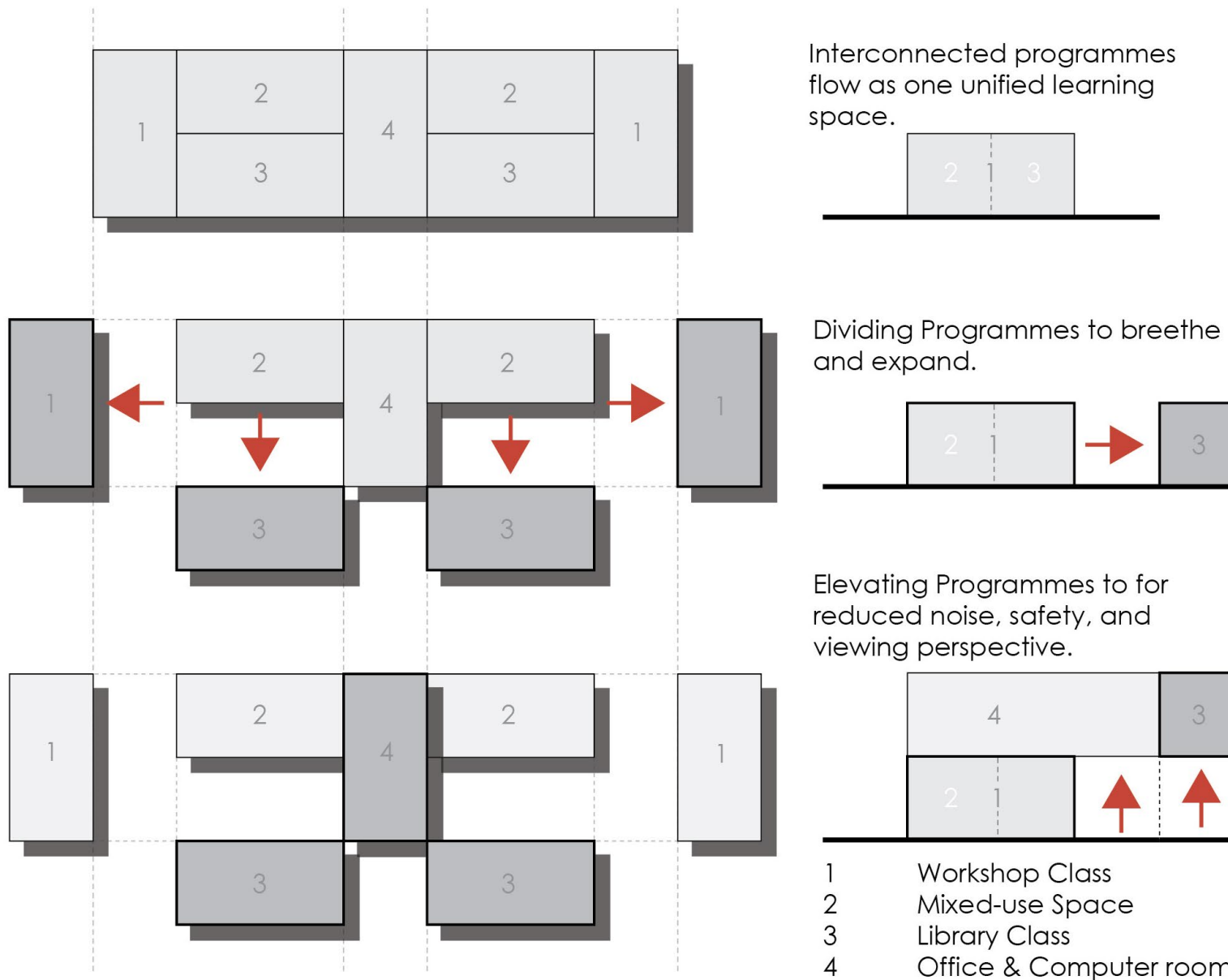


Figure 3.4 -Spatial concept development, (Author, 2021)

SPATIAL DEVELOPMENT

3.2

3.2.1 INTERVENTION EXPLAINED

The design intervention aims at aligning and intersecting existing site activities, and allows for a learning extension that offers a safe and versatile learning environment. The youth development centre is designed to be constructed at the existing site soccer field where sports become an important learning environment in conjunction with digitally enabled learning environments.

Ground floor

The ground floor offers mixed-age engagements where workshops aim to teach learners creative skills and ways in which to use their hands, while still planning, managing, and executing small projects either in groups or individually. The mixed-use spaces expand into an open courtyard that is protected by the architecture. These spaces offer the versatility of exhibitions, markets, and gatherings. This extends the open courtyards, with large breathable openings which offer learner versatility. Moreover, a deployable clinic and kitchen offer both educational and rapid response assistance to the community, while the community gardens offer sustenance and income to the community.

First floor

The first floor continues with learning environments that offer more focus-based learning, two library classrooms offer versatile classrooms where conventional and group orientated classes can be held. Moreover, a computer room offers during break and after-school studying to continue, where learners can log onto their profiles and do homework or additional research. The office provides a safe environment for Tebelo staff to work during the day with an open plan office. The elevated first floor allows for better security and access control, but also gives learners a higher perspective of the community by looking into the distance out the windows.



3.2.2 SPATIAL DEVELOPMENT

Figure 3.5 - Spatial development axonometric site, (Author, 2021)



3.2.3 PHASING APPROACH

The project phasing is divided into three primary phases. The phased approach allows for a systematic integration into the community, firstly establishing key organisational structures, such as mixed-use spaces, where the community can plan, create, and learn together in the development of the project.

Phase 1

Phase one initiates site activity, by installing a mixed space which becomes the enabler of initial learning. Services then follow, to plan sustainability and wellbeing, this includes the bathroom facility as well as water and waste management.

KEY PHASE 1

1. Mixed-use Space
2. Water-tanks
3. Open Courtyard
4. Ablutions Facilities

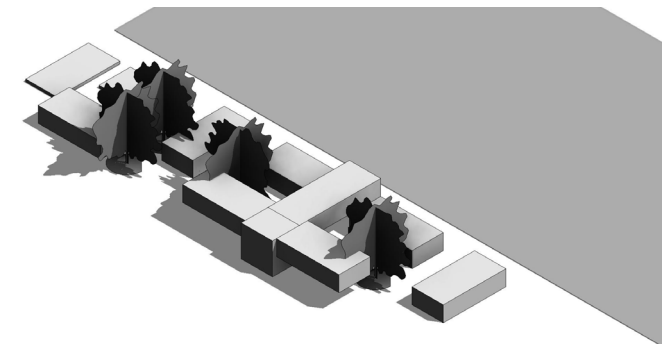
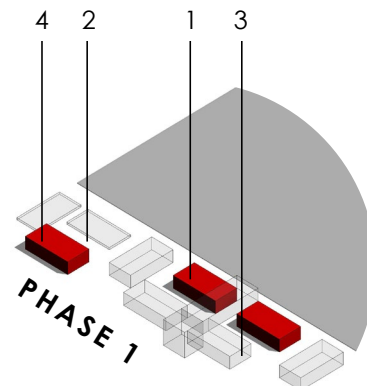
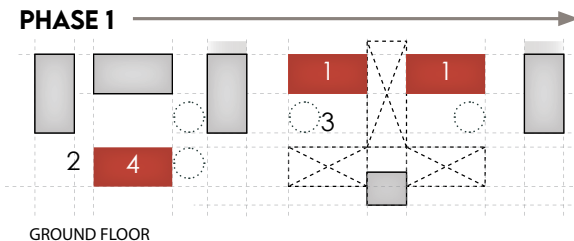
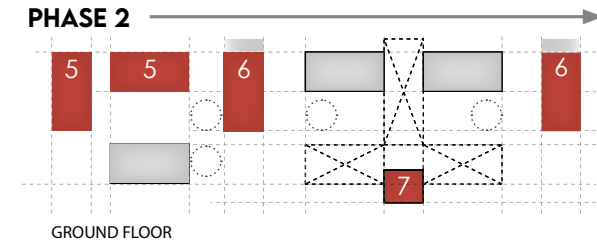


Figure 3.6 - Project phasing: phase 1, (Author, 2021)



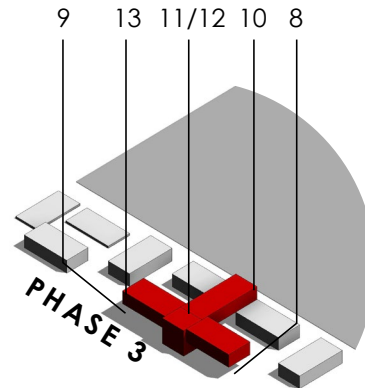
Phase 2

Phase 2 begins with the cultivating of the vegetable gardens to enable nourishment. Moreover, vegetables that are sold are the first steps in generation an income and small-scale profits. The workshops are then built, which are used to construct interior finishes and learning continues through new building practices to be taught. The central stairway begins to create the bridge to plugging in digital technology.



KEY PHASE 3

- 8. Outdoor Clinic
- 9. Outdoor Kitchen and Dining Space
- 10. Office
- 11. Computer Room
- 12. Storage
- 13. Library: Digital Classroom



PHASE 3

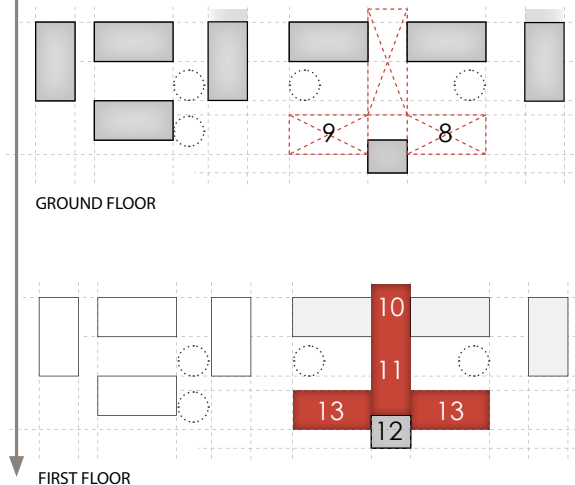


Figure 3.8 - Project phasing: phase 3, (Author, 2021)

KEY PHASE 2

- 5. Vegetation / orchard
- 6. Workshop Classroom
- 7. Stairway

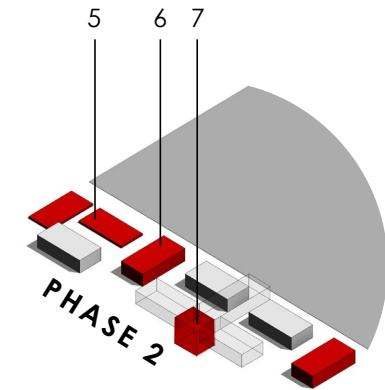


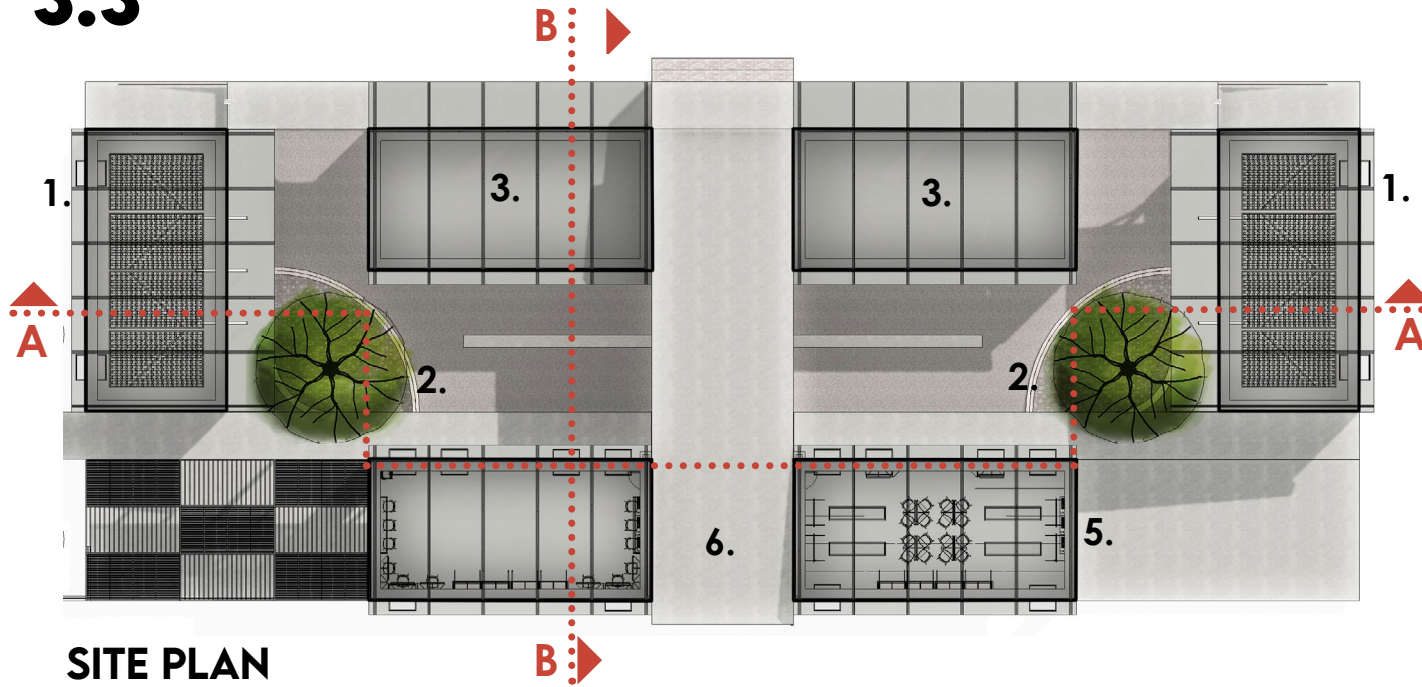
Figure 3.7 - Project phasing: phase 2, (Author, 2021)

Phase 3

Phase 3 is the final phase creating elevated learning spaces, opening additional volume underneath where an outdoor clinic and kitchen can serve the community. On the first floor a client office will facilitate all site programmes. A computer room allows learners to have continuous learning after school hours and during breaks. The solar battery storage is also located on the first floor for safety and central distribution. Lastly the fully digitalised classroom is fitted and enabled through facilitated learning. By this stage learners would be familiarised with digitalised learning and can be easily integrated into the third phase.

DESIGN RESOLUTION

3.3



SITE PLAN

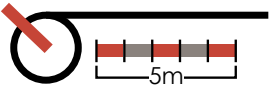


Figure 3.9 - Design resolution: site plan, (Author, 2021)



SECTION

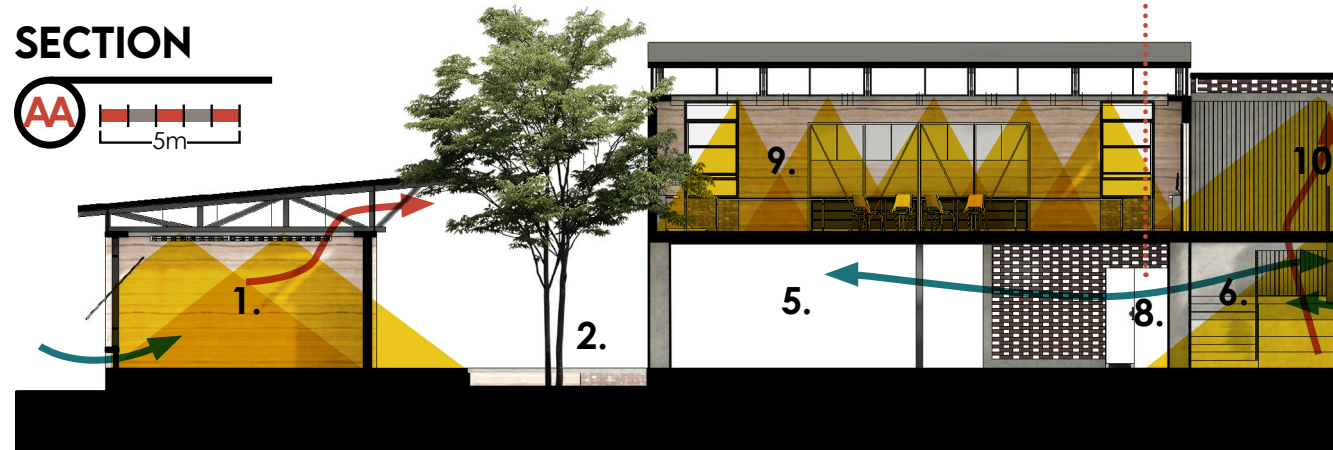
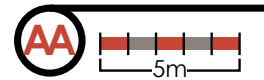


Figure 3.10 - Design resolution: section AA, (Author, 2021)

KEY:

- 1. WORKSHOP SPACE
- 2. AGORA
- 3. MIXED-USE SPACE
- 4. OPEN COURTYARD
- 5. COVERED COURTYARD
- 6. STAIRWAY ACCESS
- 7. EXPANDABLE KITCHEN
- 8. EXPANDABLE CLINIC
- 9. LIBRARY CLASSROOMS
- 10. PAUSE SPACE
- 11. COMPUTER ROOM
- 12. OPEN PLAN OFFICE



3.3.1 SECTIONAL PERSPECTIVE

DEPLOYABLE KITCHEN



SECTION

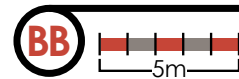
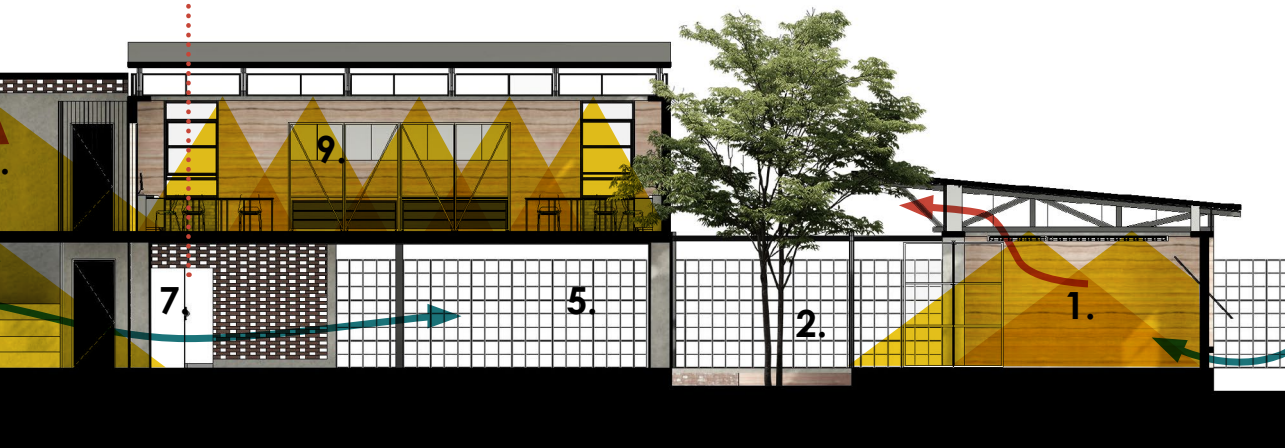


Figure 3.11 - Design resolution: section BB, (Author, 2021)

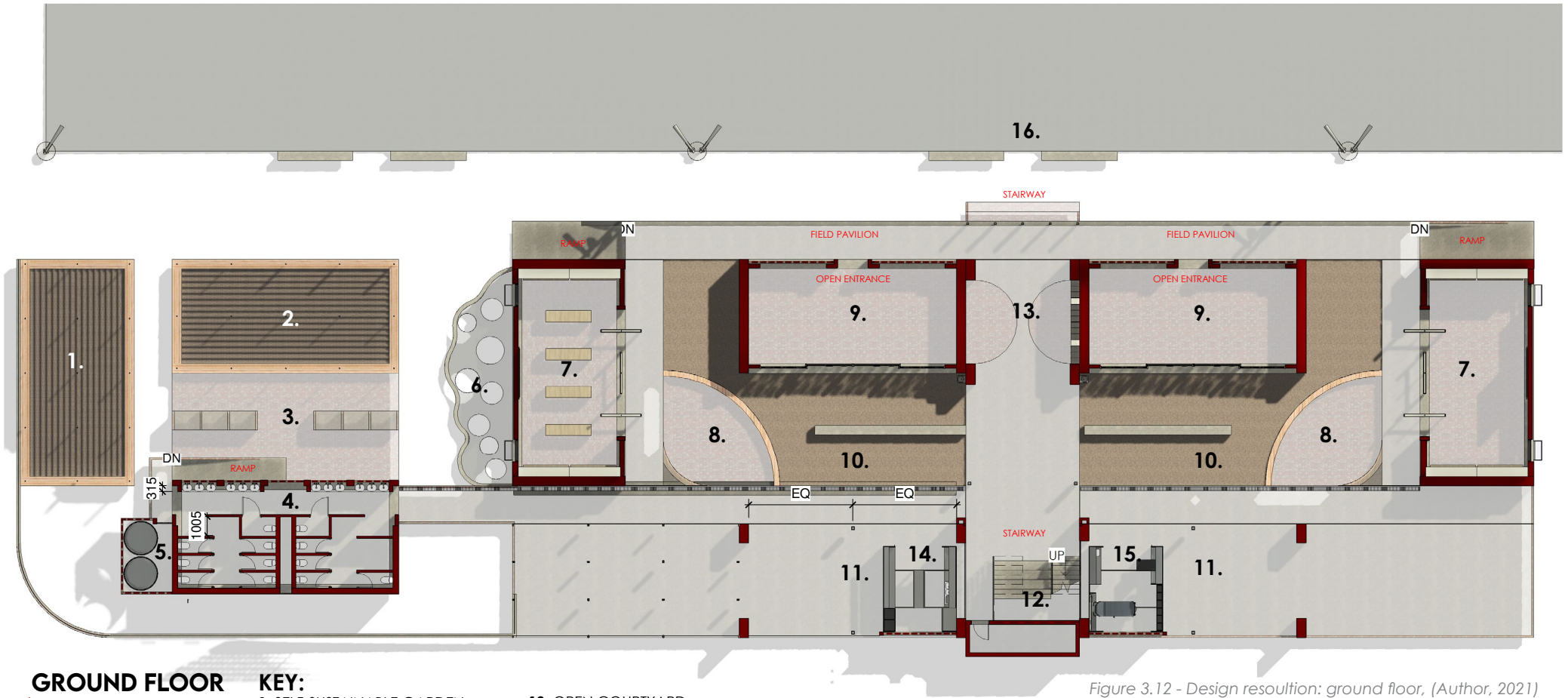


KEY:

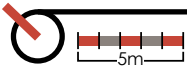
- 1. WORKSHOP SPACE
- 2. AGORA
- 3. MIXED-USE SPACE
- 4. OPEN COURTYARD
- 5. COVERED COURTYARD
- 6. STAIRWAY ACCESS
- 7. EXPANDABLE KITCHEN
- 8. EXPANDABLE CLINIC
- 9. LIBRARY CLASSROOMS
- 10. PAUSE SPACE
- 11. COMPUTER ROOM
- 12. OPEN PLAN OFFICE

3.3.2 GROUND FLOOR

RENDERED PLAN



GROUND FLOOR



SCALE: 1:200 on A3

KEY:

- | | |
|----------------------------|--------------------------|
| 1. SELF-SUSTAINABLE GARDEN | 10. OPEN COURTYARD |
| 2. PROFIT GARDEN | 11. COVERED COURTYARD |
| 3. SORTING AND PREP SPACE | 12. STAIRWAY ACCESS |
| 4. BATHROOMS | 13. ENTRANCE |
| 5. WATER STORAGE | 14. EXPANDABLE KITCHEN |
| 6. PLANT GARDEN | 15. EXPANDABLE CLINIC |
| 7. WORKSHOP SPACE | 16. EXISTING SPORT FIELD |
| 8. AGORA | |
| 9. MIXED-USE SPACE | |

Figure 3.12 - Design resolution: ground floor, (Author, 2021)



3.3.3 FIRST FLOOR

RENDERED PLAN

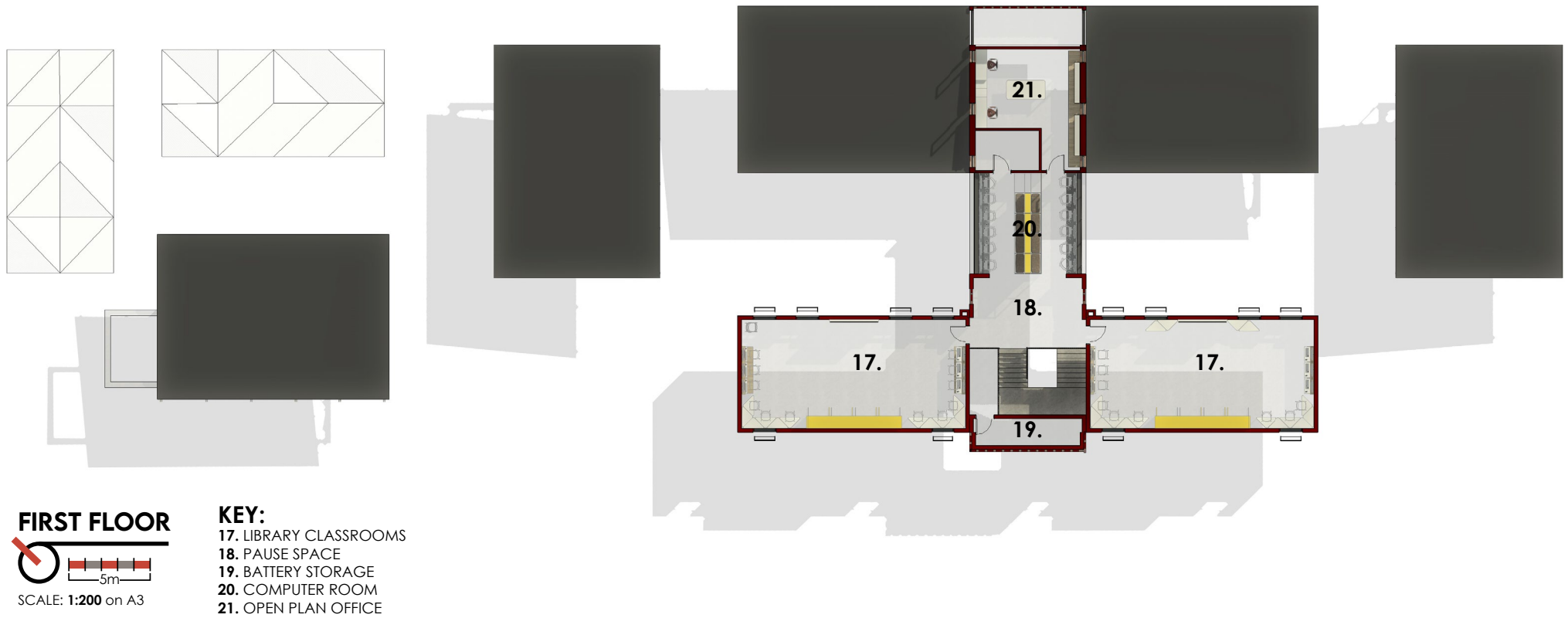


Figure 3.13 - Design resolution: first floor, (Author, 2021)

3.3.4 INTERIOR WELL-BEING

Interior well-being: designing educational spaces

With ongoing pandemic disruption of world routine, the lines between rest and work are ever blurring. During these times, the adaptability of work and home spaces become questioned. In primary education, schools play a vital role in social and cognitive development of children. The design of interiors and exterior space becomes a merged interactive experience which designers need to better educational experience and promote cognitive development (Maganga, 2021).

Although the digital world offers a layered intangible educational experience, it is still important to design an engaging platform, which requires a dynamic interior space which offers multiple features. In terms of spatial agency and indigenous learning, the design needs to firstly create a learning environment that is conducive to promote learning. Some of the interior considerations for educational interiors include the following:

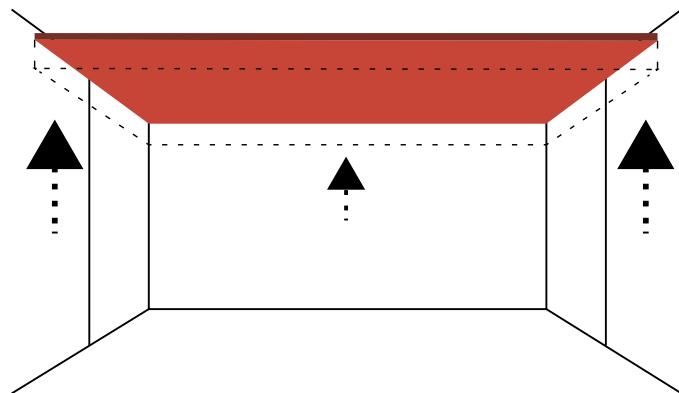


Figure 3.14 - Interior well-being illustration: high ceilings, (Author, 2021)

HIGH CEILINGS

High ceiling allows for plenty of natural light to fill the space. High ceilings expand the room giving more space for expression of learner imagination. In addition, high ceilings decrease a feeling of being enclosed, allowing for more comfortable learning (Maganga, 2021).

NEAR TO NATURE

Studies have proven that plants in classrooms improve the learning potential of classrooms. The presence of nature also aspires to create natural communications and relationships (Maganga, 2021).

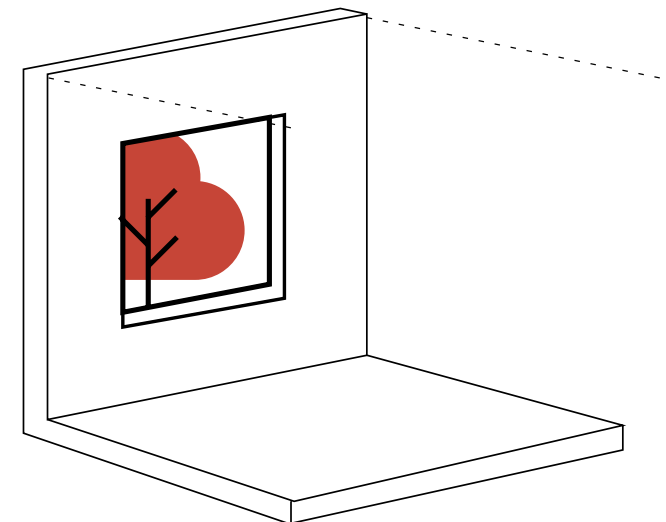
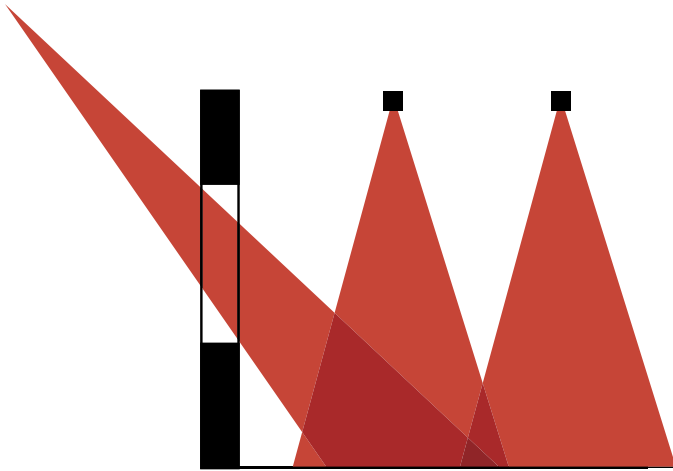


Figure 3.15 - Interior well-being illustration: near to nature, (Author, 2021)



LIGHTING

According to Alexander (1977), low light levels within classrooms influenced children's natural ability to concentrate and affected their natural sleep cycles. The use of natural light not only allows for less usage of artificial lighting, but also provides emotional healing (Maganga, 2021).

Figure 3.16 - Interior well-being illustration: lighting, (Author, 2021)

FLEXIBILITY

Co-working spaces can be similarly used within classrooms, with more fluid layouts. With the ability for classrooms to be multi-purpose spaces, and provide accommodation for multiple functions it assists learners to have more agency and have a self-organised space with movable furniture (Maganga, 2021).

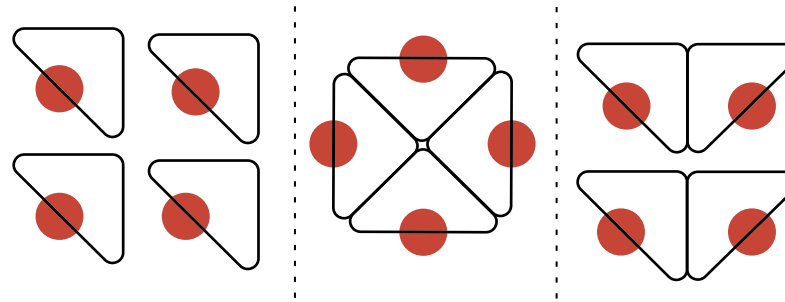


Figure 3.17 - Interior well-being illustration: flexibility, (Author, 2021)

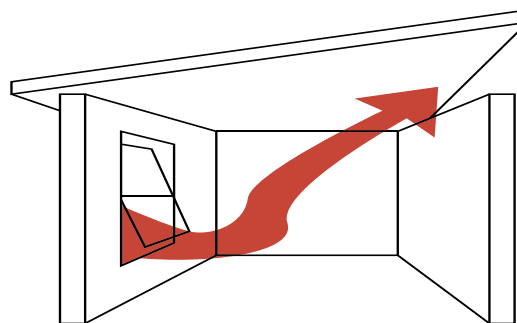


Figure 3.18 - Interior well-being illustration: natural ventilation, (Author, 2021)

NATURAL VENTILATION

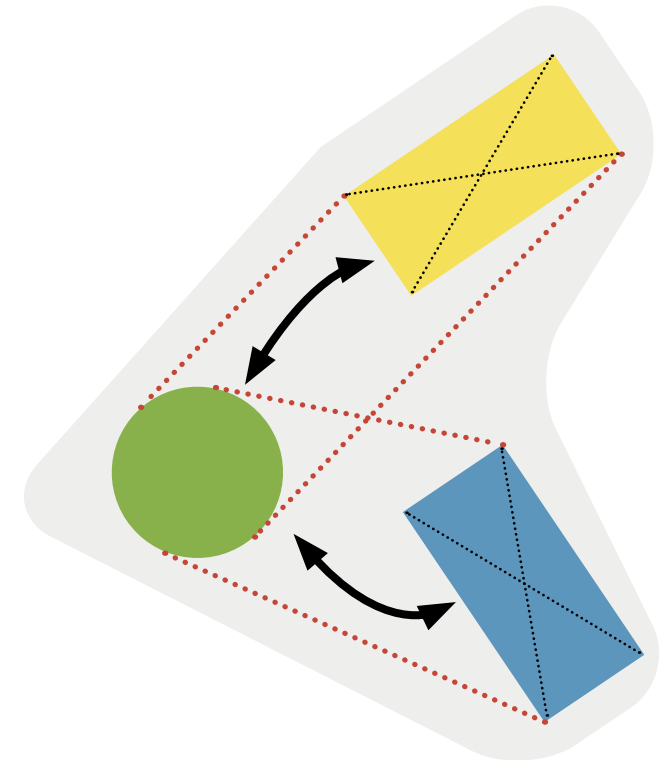
Natural ventilation offers fresh, replaced air to interior spaces through externally accessible voids. This fresh air assists not only in supplying constant fresh air, but also in controlling temperature within spaces. Thermal comfort assists with mental focus (Maganga, 2021).

3.3.5 COLOUR

Between 2013 and 2016, a study of a primary school in Colombo, Sri Lanka aimed to define the psychological and behavioural effects that colours have on children (Hettiarachchi & Nayanathara, 2017). The found that colour had an effect on both creative (arts and drama) and logical functioning (mathematics, language, and science), making colour an important variable to create successful learning environments, especially in developing well-balanced future adults. Not only does colour stimulate a neutral calm environment for learning but could also cause visual pleasure that could provoke left, or right brain activity under stimulation.

Thus, warmer colours such as yellow and orange were found to have a positive effect on improving logical and analytical thinking. On the other hand, colours such as blue with long exposure would promote school attendance and creative thinking. Green was found to be a balanced colour that improved both logical and creative thinking (Mahnke , 1996).

Colours spatially suite particular learning environments.



LIBRARY SPACE

The library space responds to yellow to be an accent as well as a potential wall colour. The library space requires long durational logical thinking (Hettiarachchi & Nayanathara, 2017). Pantone “Illuminating yellow” (13-0647) is a soft yellow tone that brightens classrooms but does not easily distract learners.

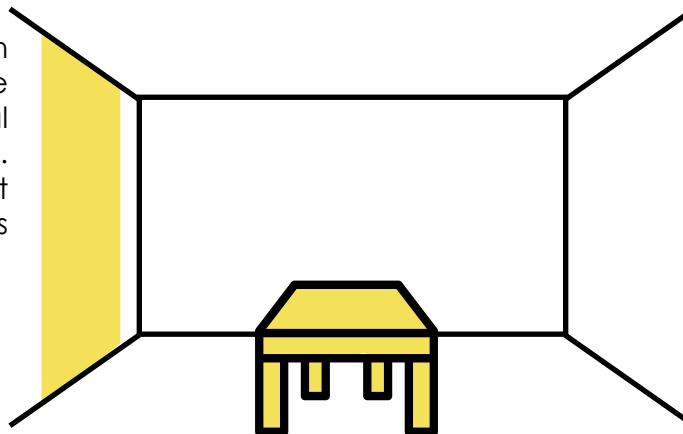


Figure 3.19 - Colour: Illustration - Library space, (Author, 2021)



WORKSHOP SPACE

The workshop space requires spontaneous creative thinking, creating, building, and ideating, and becomes a central focus of the workshop. Thus, blue will be best suited to allow for positive reinforcement of a creative environment (Hettiarachchi & Nayanathara, 2017). Pantone “Heritage Blue” (16-4127 TCX) is a soft natural blue that offers calmness for creative work.

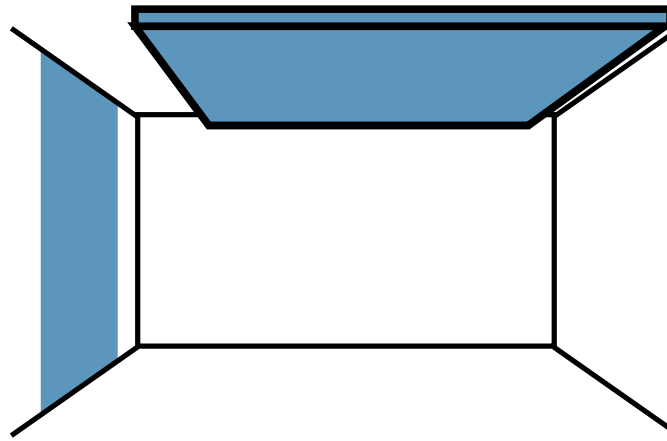
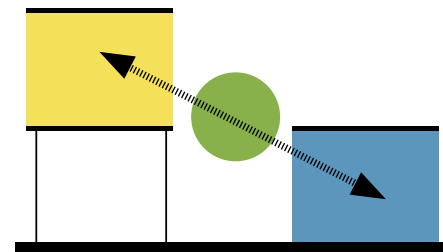


Figure 3.20 - Colour: Illustration - Workshop space, (Author, 2021)



The in between:

Shopfitted pieces which will be used for long periods such as desks and chairs will be monochromatic so that if there are preferences between learners it will be avoided.

PLAYGROUND

The soccer field, as well as the extended courtyards, will use natural vegetation to bring green into these learning environments. The colour green gives balance to both hemispheres of the brain in allowing for agency in thinking to take place during spontaneous activities and blended learning with technology (Hettiarachchi & Nayanathara, 2017).

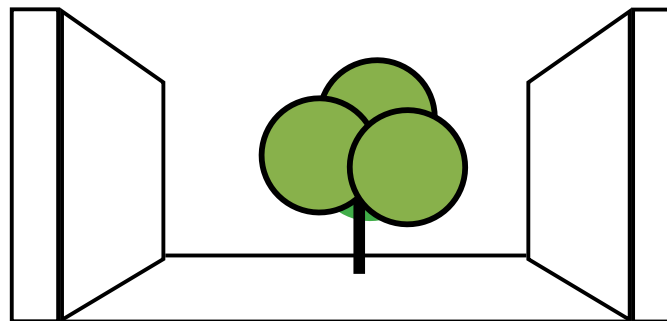


Figure 3.21 - Colour: Illustration - Playground, (Author, 2021)



3.3.6 ACOUSTICS

Listening comprises 45% of people's daily communication, and in schools learners rely on 60% of listening during the learning process (Picheny, et al., 1985). Good acoustics within classroom and learning environments increase concentration and allows for clear communication during activities.

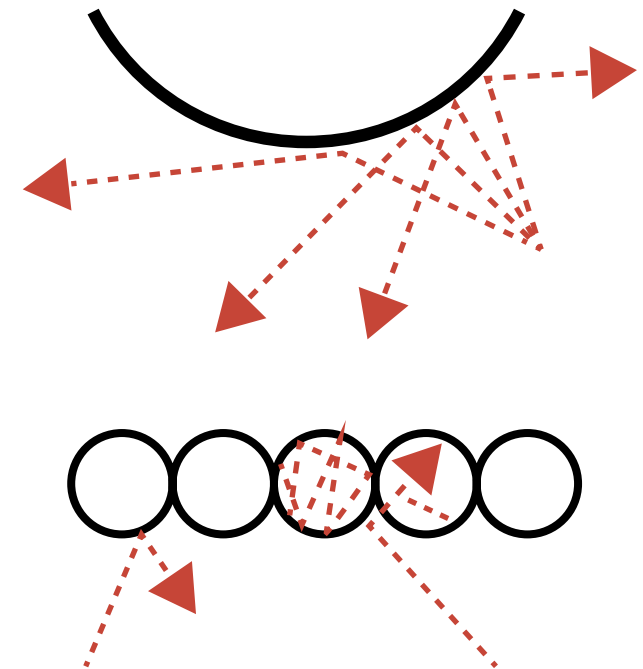
Sound within the classroom will be determined by learners and facilitators. Verbal and digital noise can be maintained within classrooms primarily using acoustic materials and the angle of deflection of acoustic features. Owing to classrooms being versatile, the movement of objects and layouts is fluid, meaning there is no strategic placement possible for an acoustic feature. Thus, the ceiling that has a large surface area will comprise an acoustic suppressor. More so, isotherm insulation will also serve as an acoustic membrane under the roof sheeting.

The Library

The library space will make use of a curved community made acoustic panel. The selected material will be paper, which when used with glue becomes papier-mâché, which is a tough composite material that holds its form, but also absorbs sound waves. The curved shape allows for continuous deflection and refraction of waves, eliminating echoes.

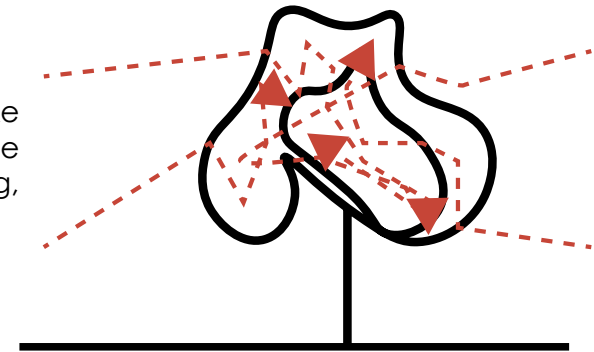
The Workshop

The workshop would encompass several physical activities, where learners would be engaging verbally as well as making things. The acoustic ceiling will be the first of these activities, engaging videos will teach learners how to create a bottle acoustic ceiling. The ceiling serves to work as a volumetric ceiling, sound waves enter the bottle and refract and reverberate for short periods before fading away.



The Playground:

The playground is a large existing field where many sporting and social activities will take place. Thus, sound waves from the community will be constantly vibrating in the air, to enable concentration and focused learning. Trees will be planted alongside the communities housing, creating greener space, and absorbing and refracting continuous noise.



Speakers and digital sound:

Imagery and visuals are essential to digital learning, but sound enables the emotional connection through activating another sensor of the body, namely, hearing. Speakers are key to creating sound and within classrooms large speakers could be obstructive and a central device which requires more power to reach further. Thus, smaller speakers would be spread across learning environments to create equal sound distribution. The speakers would face directly downwards, so that the acoustic ceiling also works more efficiently during class periods.

Digital learning is at the foreground of future educational pedagogies. But this fast-developing industry is reacting uncreatively to the needs of a growing population of uneducated scholars around the world (Lembani, et al., 2019). Digital technology offers a fluid, but precise educational system that can be tailored to individual needs and requirements. User interface (UI) is a crucial component in making digital learning successful. More so, it evokes interest while learning, and creates focus that allows users to express their identity through a versatile platform (Hanna, 2008). UI can be seen and designed as the virtual ergonomics through while learners operate and use software to learn.

3.3.7 LIGHTING

Library space

Learning classrooms require diffused task lighting. Track lighting allows for adaptable and versatile arrangements as the class alters programmes around the digital device.

Workshop space

The workshop space requires quality lighting. Learners would participate in physical learning activities and for safety and effective working defused stationary lighting will create an evenly lit room.

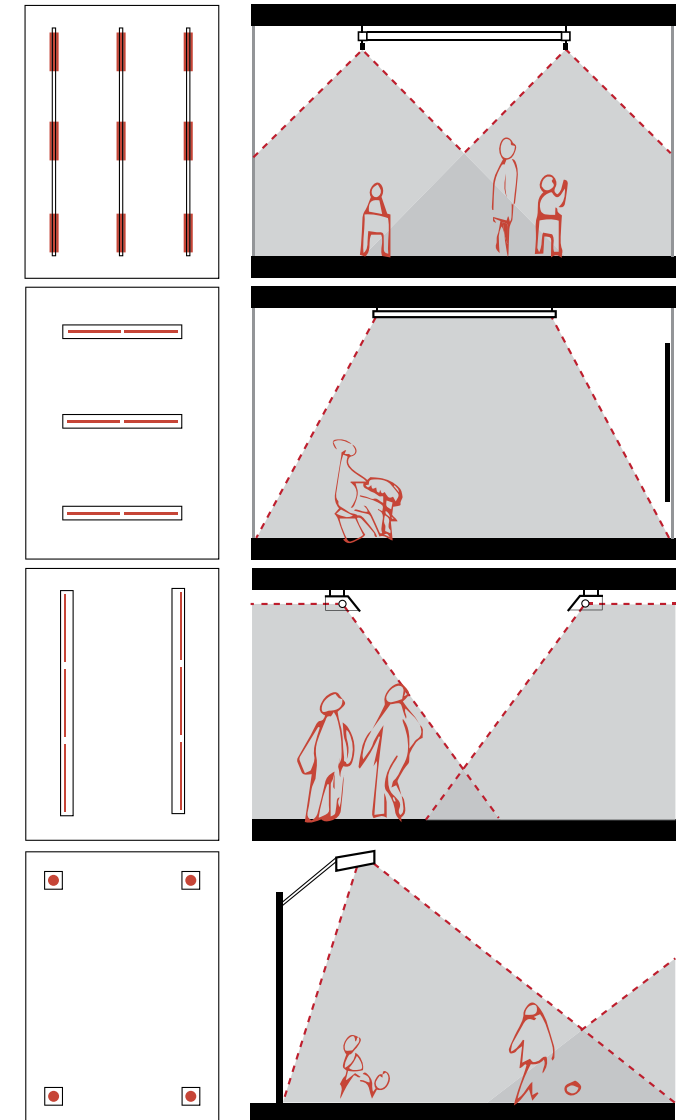
Open covered space

Open covered space will be used for mixed-use functions, and will require an evenly lit space. Also, light should emit into the open-air spaces to provide additional lighting for the in-between spaces.

Playground space

At night the field could host several programmes including markets and exhibitions. LED lamps will illuminate the field with soft ambient light.

Figure 3.22 - Lighting: Illustrations of various light usage, (Author, 2021)



LIGHTING REQUIREMENTS

Space	Min. Illuminance (lx)	Light types	Lumens required (lm.)	Area	Light Spec
Corridor	50	TC	3 600 lm	6 x 12m: 72 sqm	LED Tube 18w 6000k 1.2m 1 600 lm No: 3
Stairs	100	TC	2 000 lm	3 x 5m: 15 sqm	LED Tube 18w 6000k 1.2m 1 600 lm No: 2
Bathroom, WC	100	TC	7 200 lm	6 x 12m: 72 sqm	LED Tube 18w 6000k 1.2m 1 600 lm No: 5
Canteen	200	TC	14 400 lm	6 x 12m: 72 sqm	LED Tube 18w 6000k 1.2m 1 600 lm No: 10
Multi-purpose space	100-200	TC,TL	7 200 lm	6 x 12m: 72 sqm	LED Tube 18w 6000k 1.2m 1 600 lm No: 4-8
Classroom	300 - 500 (350)	TL, TC	25 000 lm (Dimmable)	6 x 12m: 72 sqm	LED Tube 18w 6000k 1.2m 1 600 lm No: 4-8
Media Library	300	DL, TC	21 600 lm	5 x 5.5m: 27.5 sqm	LED Tube 18w 6000k 1.2m 1 600 lm No: 8
Sporting Field	200	FL	1 000 000 lm	50 x 100m: 5000 sqm	500W Gold-RN LED Flood Light 60 000lm No: 16
Open Plan office	500	DL, TC	12 500 lm	5 x 5m: 25 sqm	LED Tube 18w 6000k 1.2m 1 600 lm No: 8

Abbreviations:

- TC Compact Fluorescent LED Lamp
- TL Track lighting (Variation)
- DL Standard down-lighting
- FL LED Floodlight

Table 3 - Lighting requirements as per designed space, (Author, 2021)

LIGHTING FITOUTS

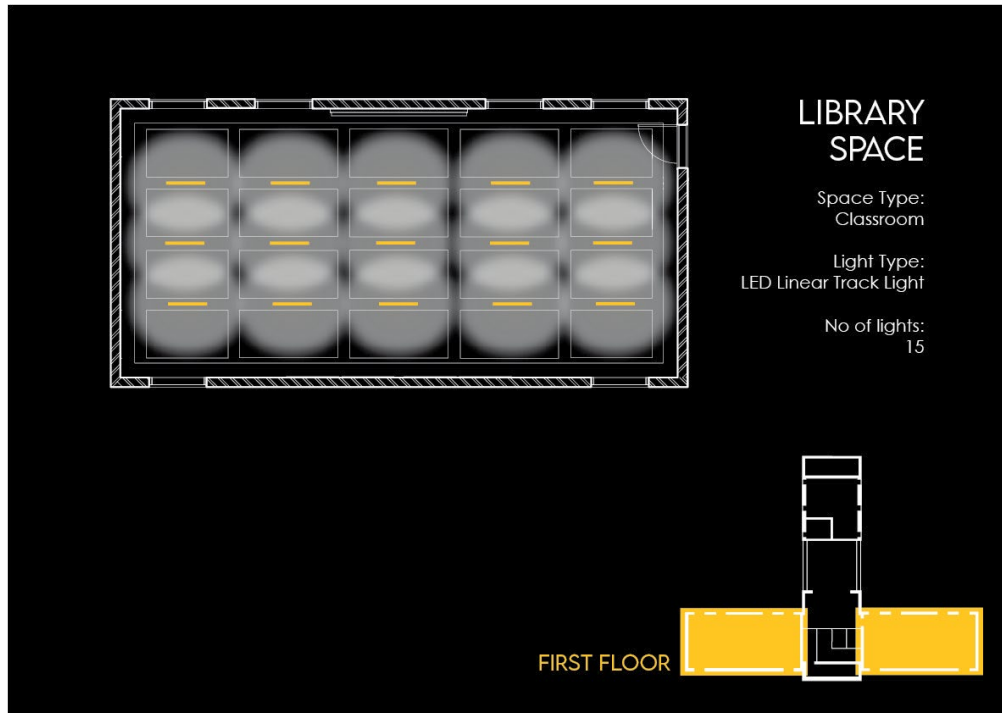


Figure 3.23 - Lighting: Illustrated plan of lighting for the Library, (Author, 2021)

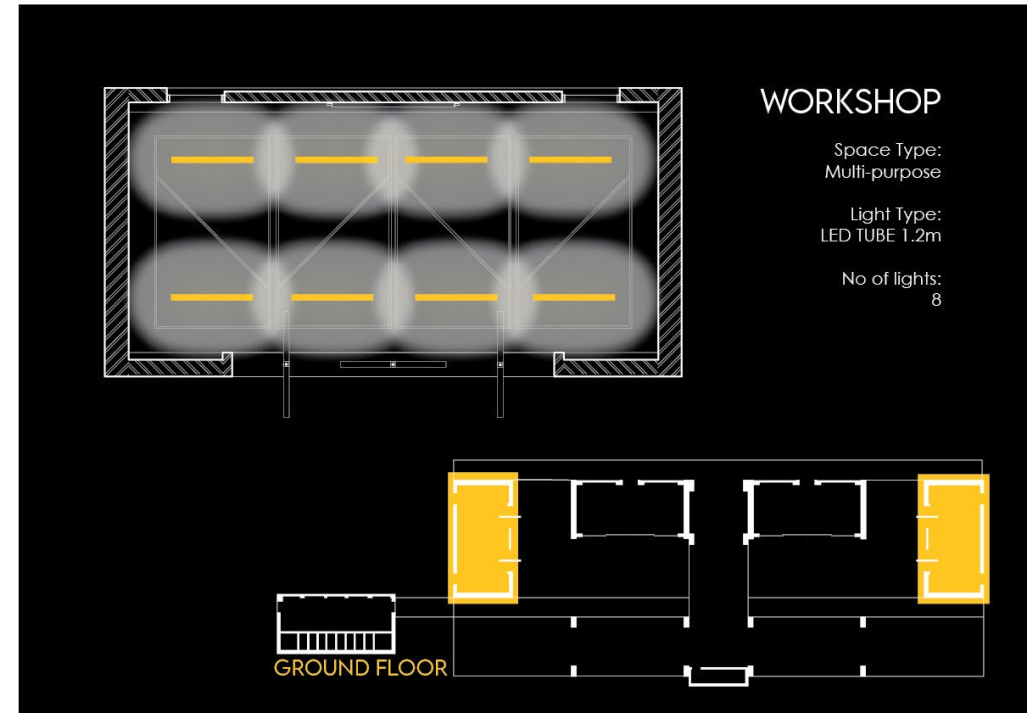


Figure 3.24 - Lighting: Illustrated plan of lighting for the Workshop, (Author, 2021)



LIGHTING FITOUTS

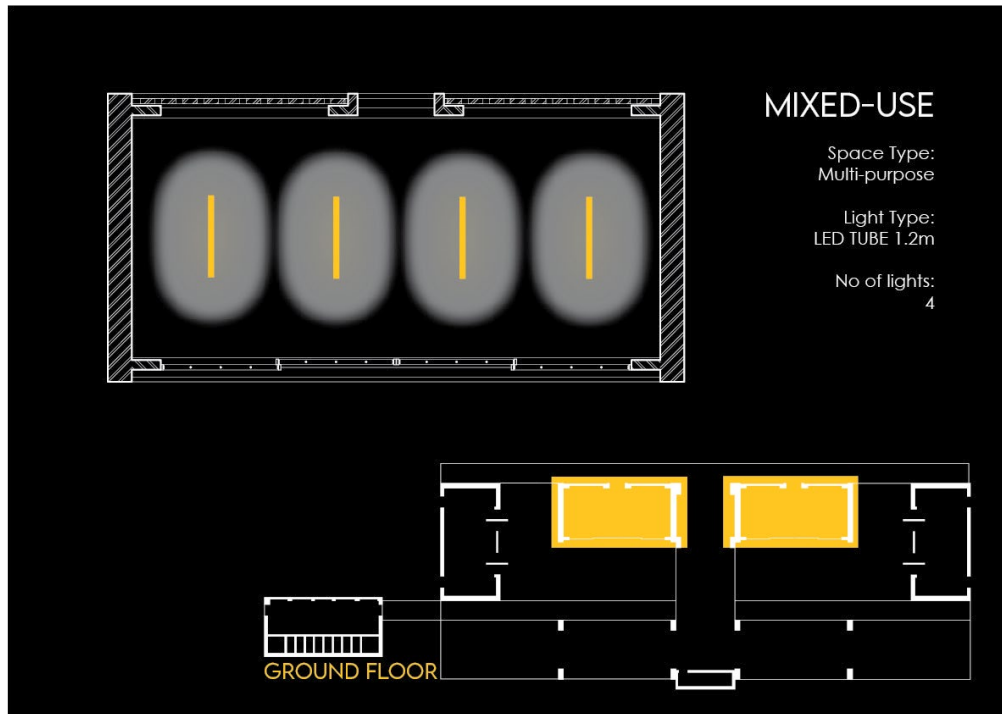


Figure 3.25 - Lighting: Illustrated plan of lighting for mixed-use space, (Author, 2021)

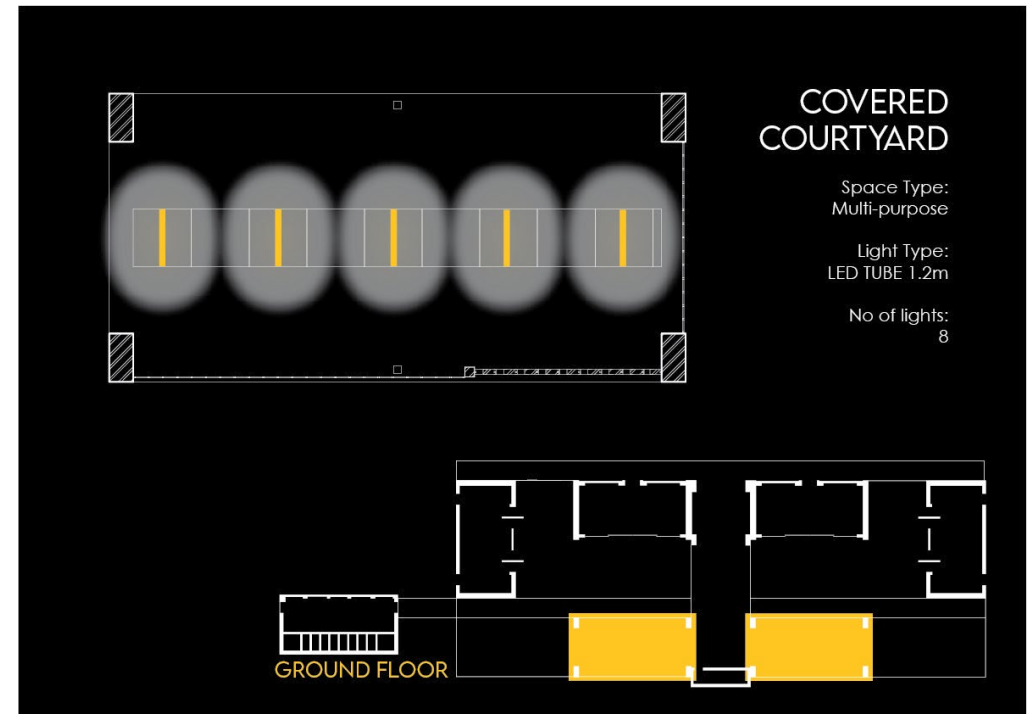
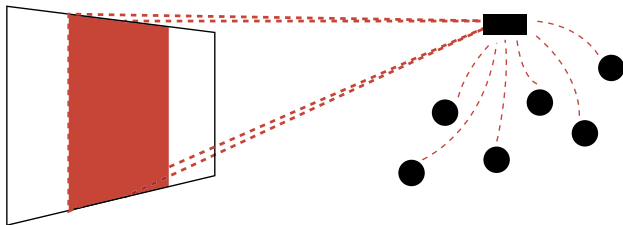


Figure 3.25 - Lighting: Illustrated plan of lighting for the covered courtyard, (Author, 2021)

3.3.8 DIGITAL DEVICES

Digital Devices:

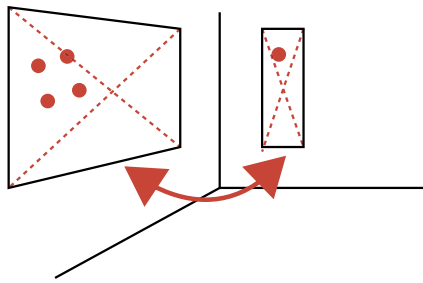
Digital devices have opened the world of knowledge through access to the Internet. Learners now have the ability to self-educate with digital technology, creating safe, monitored environments for the access to devices, and it becomes a design consideration. Devices for learning would include projectors, touch displays, computers, and cell phones. Each device has different qualities and values. This will be considered when designing.



Projectors:

Projectors provide a single source-emitted image projection onto a flat surface. The benefit of projectors is the size of projections for large audiences. Projectors are easily connected through WIFI allowing many users to have instant access to share or display knowledge.

Touch screen displays



Touch screen displays are the costliest digital intervention, and will be safeguarded through elevating these classrooms from the ground floor for safety. Touch displays allow for extended screen displays that could work collective for large group learning, or as smaller independent displays for group work. These screens allow for touch engagement and through a digital interface host multiple purposes such as games, drawing, brain-storming, and problem-solving. All activities are stored to a central drive which can be accessed through computers or the internet. Touch screens will be used within the library classrooms for long durational learning.

Computers

Computers act as endless libraries of data and knowledge. Individual User profiles allow a computer to have endless users create their own identity and learning preferences on their profile. Computers are used to do homework and in-depth research. All classes and recorded data will be accessible for users to reflect and iterate their learning experiences. Computers provide group learning engagements as well, so earphones would serve as an immersive aid into the virtual world while working.

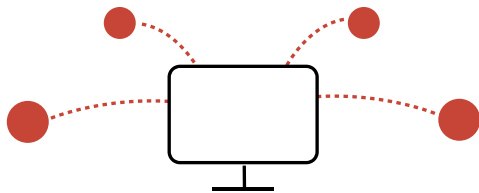
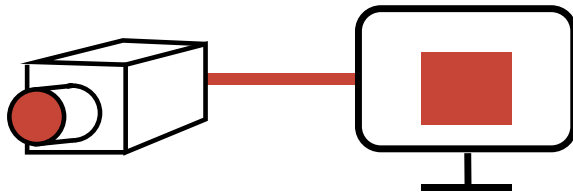


Figure 3.27 - Digital devices illustration of spatial integration, (Author, 2021)



Cell Phones

Cell phones allow for mobile learning to continue, although not conducive for long periods of learning, games and learning are activated through the digitalised architecture. A series of QR scannable codes around the learning centre allow for new and engaged topics to be discovered such as nature, building, eco-systems, and 3D characters. This is achieved through augmented reality where the camera and the device create virtual worlds within the real world through the devices display.



Cameras

Cameras will be used to connect digital facilitators to on-site audiences. Moreover, cameras will also be used for documentation of activities and for security purposes.

Speakers

Speakers are placed as an additional sensory learning enabler; sound allows for an emotional response of learners aided by visuals. Speakers will be used for direct verbal explanations or animated sounds.

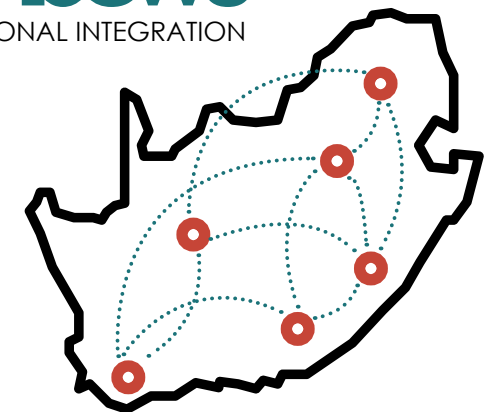
Figure 3.28 - Digital devices illustration of spatial integration 2. (Author, 2021)

Curriculum

Tebelo with the Department of Education and other digital educational investors will create a new curriculum that can be used around the country. With new artificial intelligence (AI) technologies, behavioural education can be implemented through user interface of individual computer users (Whittle, 2021). In addition to this, AI can be used to track progress and analyse focus areas for children to maximise their learning potential.

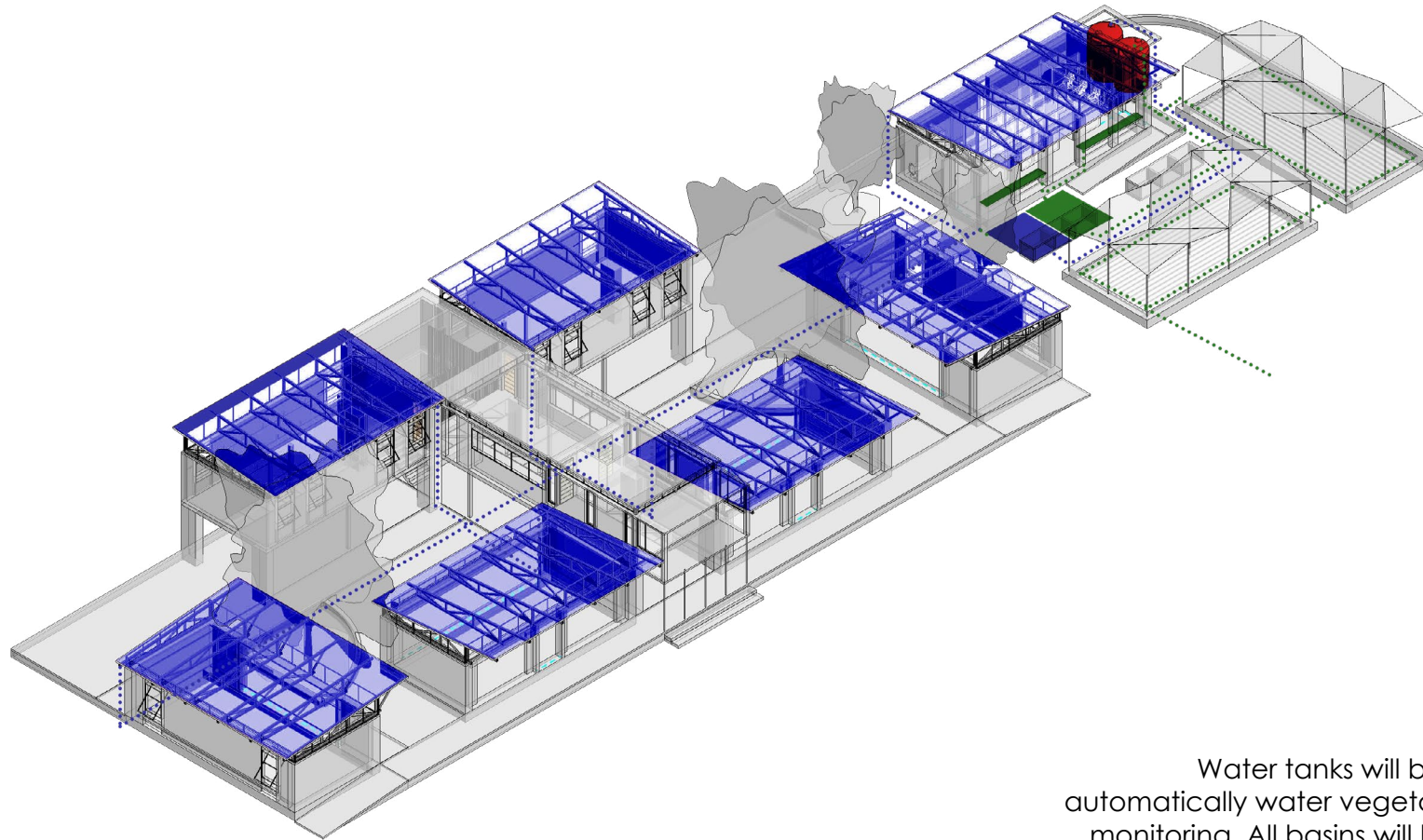
Collaboration

Through the Internet one teacher can become a facilitator for multiple schools and through digital technology does not have to geographically be present, but through digital technology, will enable a presence within the classrooms. Digital technology also allows for the expansion of collaboration, social media and digital communication allowing for learners across the country to communicate and make friends, expanding the lives of learners beyond the community.



3.3.9 WATER AND RETICULATION

Access to water is a community-based issue, with multiple manual filled tanks scattered around the community. Imbewu Youth Center will make use of a borehole which will provide a sustainable water source from ground water from the nearby stream. Moreover, rain and grey water will be collected into tanks and re-used. Grey water will be used in toilets and vegetation. While rainwater will be purified and used for basins and hand wash stations.

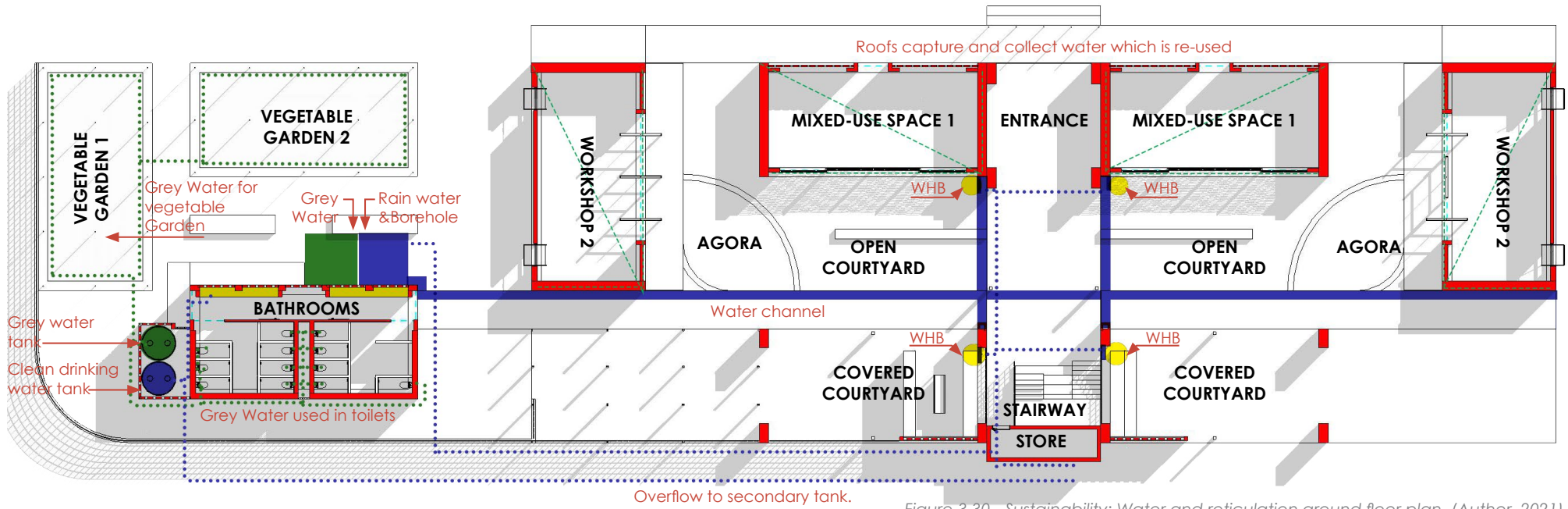


Digital integration:

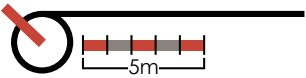
Water tanks will be monitored and will automatically water vegetation through growth monitoring. All basins will be limited with water use and have beepers to indicate water leakages or water wasted.

Figure 3.29 - Sustainability: Water and reticulation axonometric, (Author, 2021)





GROUND FLOOR



KEY:

- WALLS
- GREY WATER
- RAIN/FRESH WATER
- WATER POINTS

FIRST FLOOR

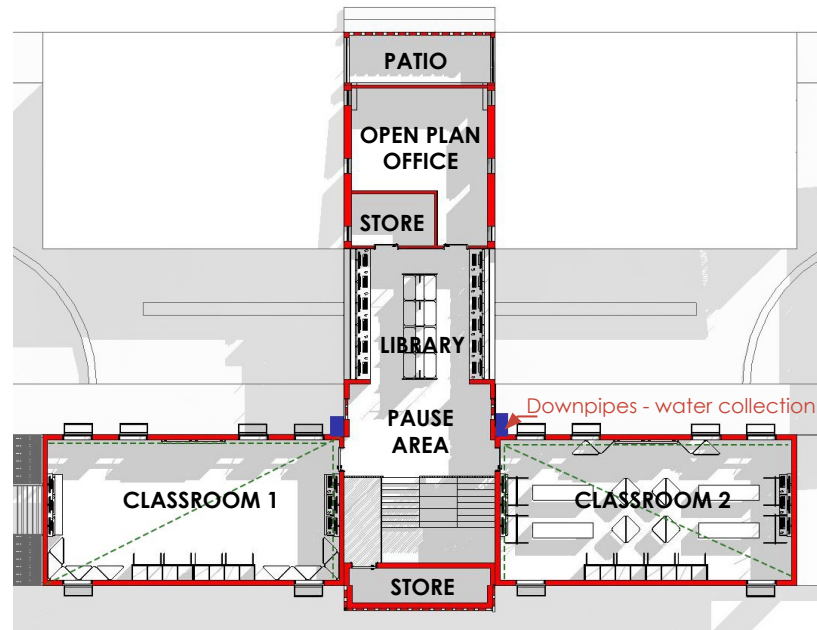
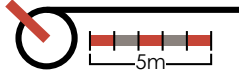


Figure 3.30 - Sustainability: Water and reticulation ground floor plan, (Author, 2021)

Figure 3.31 - Sustainability: Water and reticulation first floor plan, (Author, 2021)

3.3.10 CIRCULATION

Passages and walkways all define additional space of activity as well extensions of the interior programmes to continue or grow to the courtyards. To minimise wasted space, the courtyards provide covered and open spaces which symbolically connect to the nature within the space, allowing for spontaneous conversations and the transfer of knowledge.

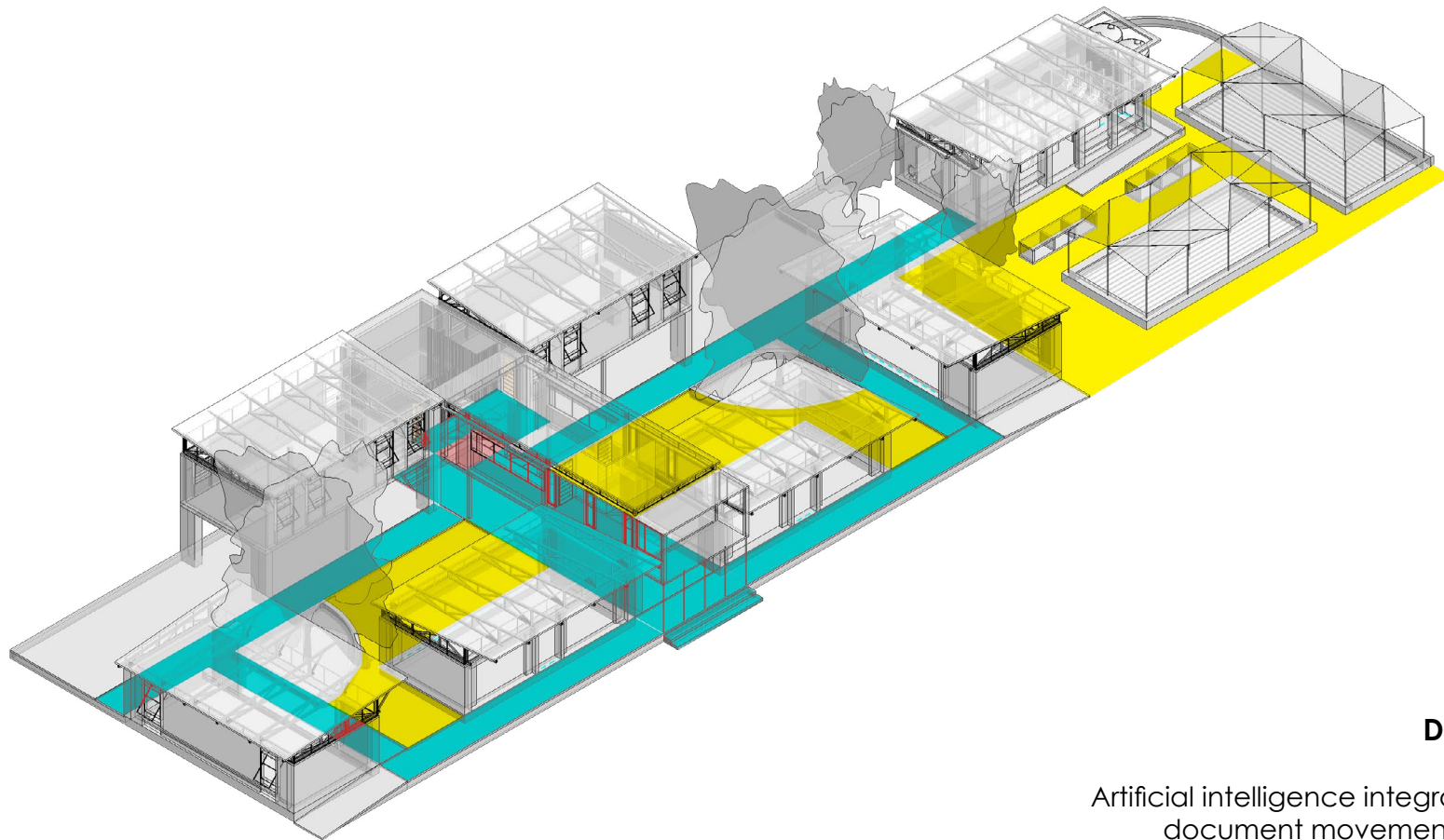
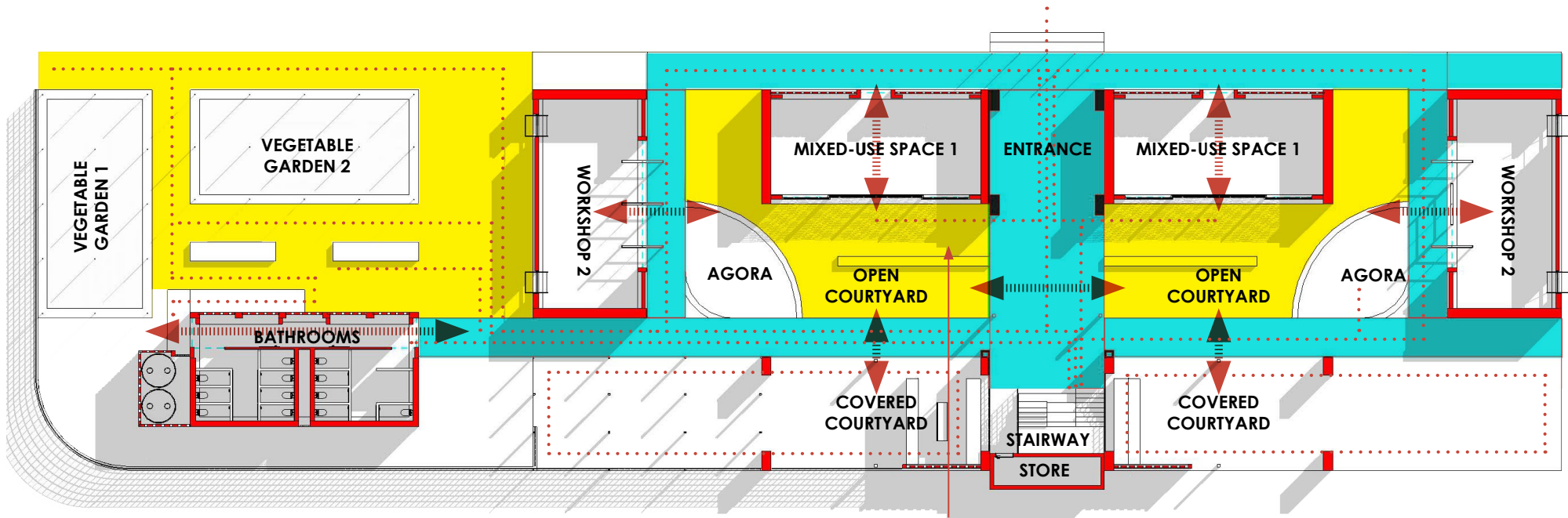


Figure 3.32 - Sustainability: Building circulation axonometric, (Author, 2021)

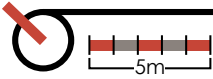
Digital integration:

Artificial intelligence integrated into cameras document movement and traffic within passages and this data is then used to reorganise programmes to better noise, congestion and to fully optimise building use.





GROUND FLOOR



Open Courtyard becomes an expansion of the mixed use space, the workshops and the covered courtyard.

Figure 3.30 - Sustainability: Building circulation ground floor plan, (Author, 2021)

KEY:

- WALLS
- DESIGNATED PASSAGES
- IN BETWEEN NAVIGATION
- SPACE ACCESS
- MOST WALKED

FIRST FLOOR

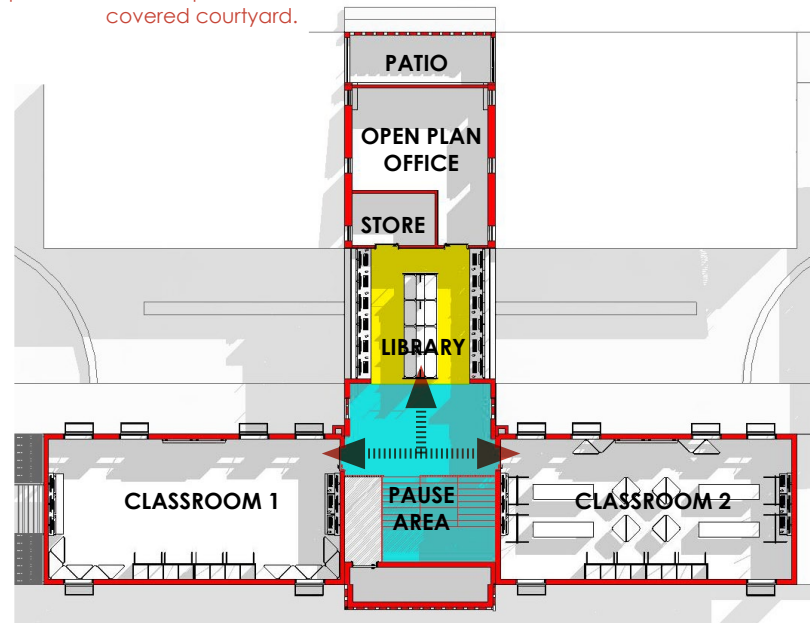
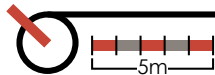
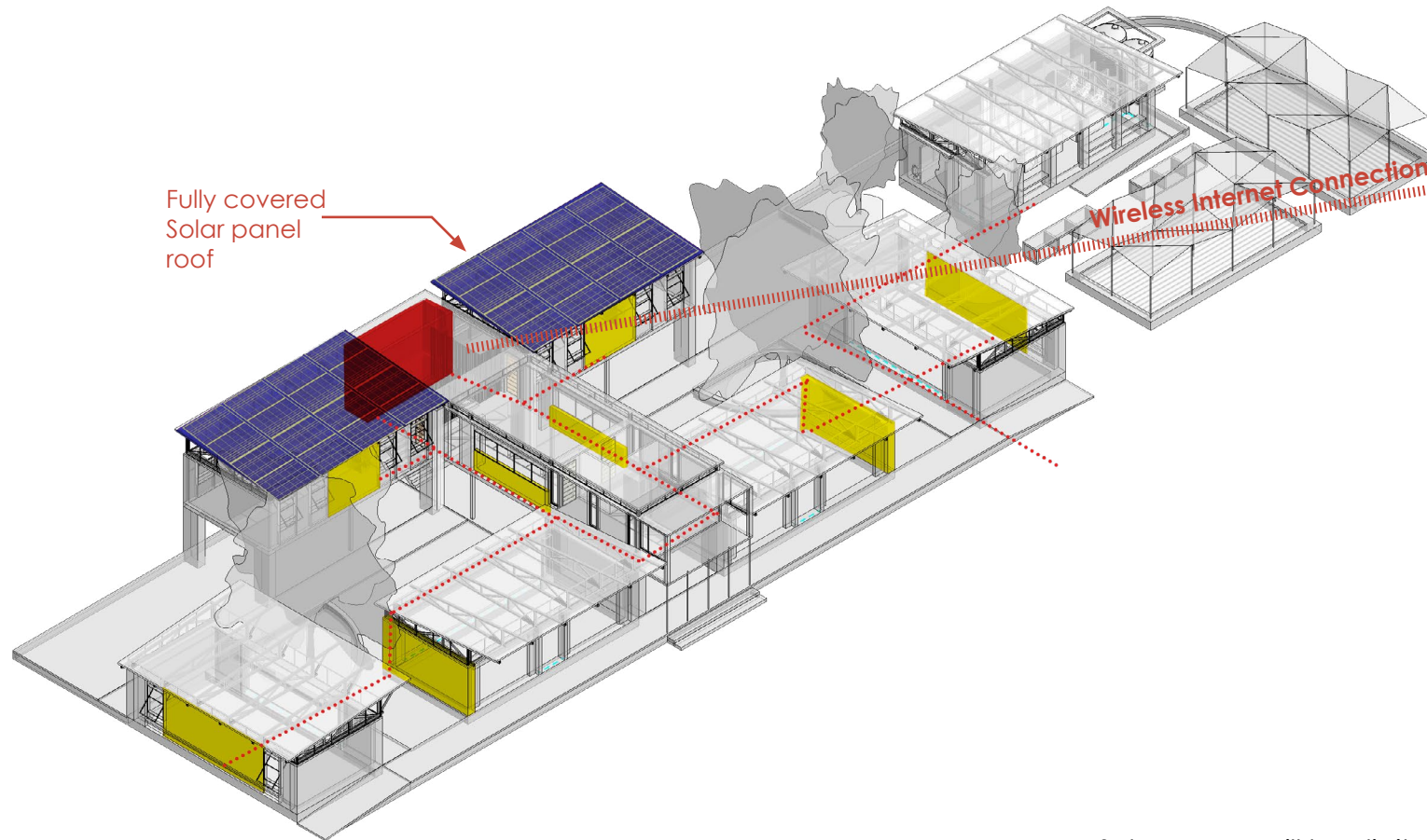


Figure 3.31 - Sustainability: Building circulation first floor plan, (Author, 2021)

3.3.11 SOLAR AND POWER

Solar power will be used to power the digitally integrated learning environments during the day. At night, back-up batteries will be used to power lights for safety and night programmes. Power becomes an important sustainable integration element, with load-shedding and high-power costs solar becomes a continuous and long-term solution to creating digitally enabled learning environments.



Digital integration:

Solar power will be digitally distributed, and programmes will be organised to never overload the programme. All lighting will be automated, and sensors will be activated to save power where possible.

Figure 3.35 - Sustainability: Solar and power axonometric, (Author, 2021)



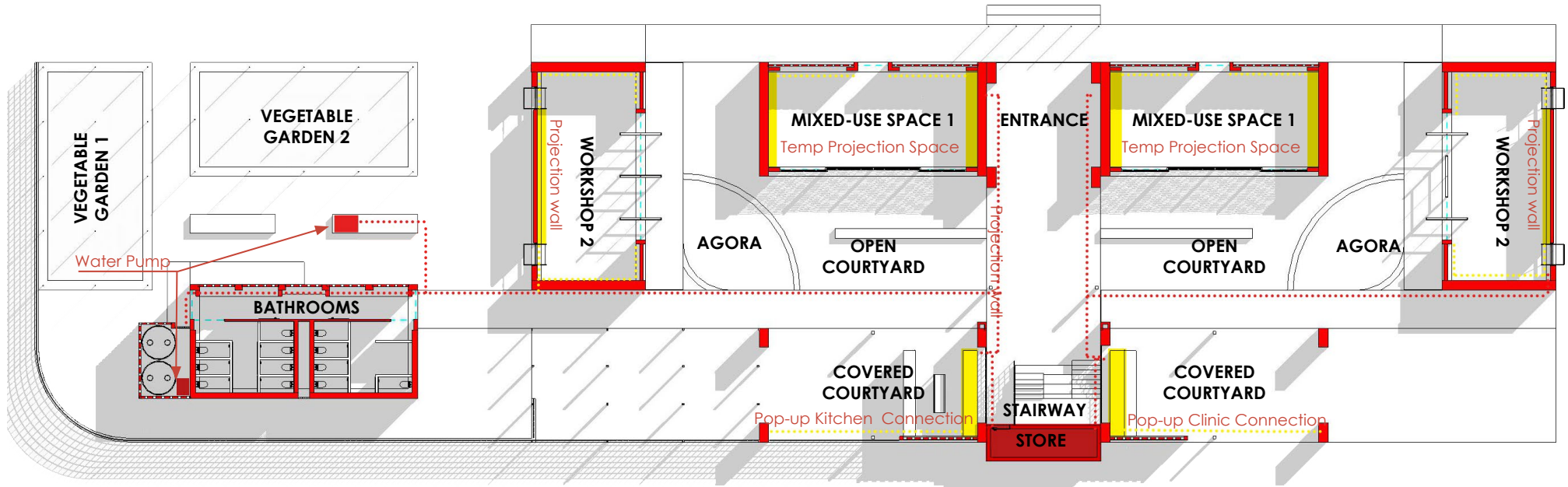
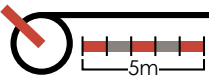


Figure 3.36 - Sustainability: Solar and power ground floor plan, (Author, 2021)

GROUND FLOOR



- KEY:**
- WALLS
 - SOLAR POINTS
 - DIGITAL ZONES
 - ELECTRICAL SUPPLY

FIRST FLOOR

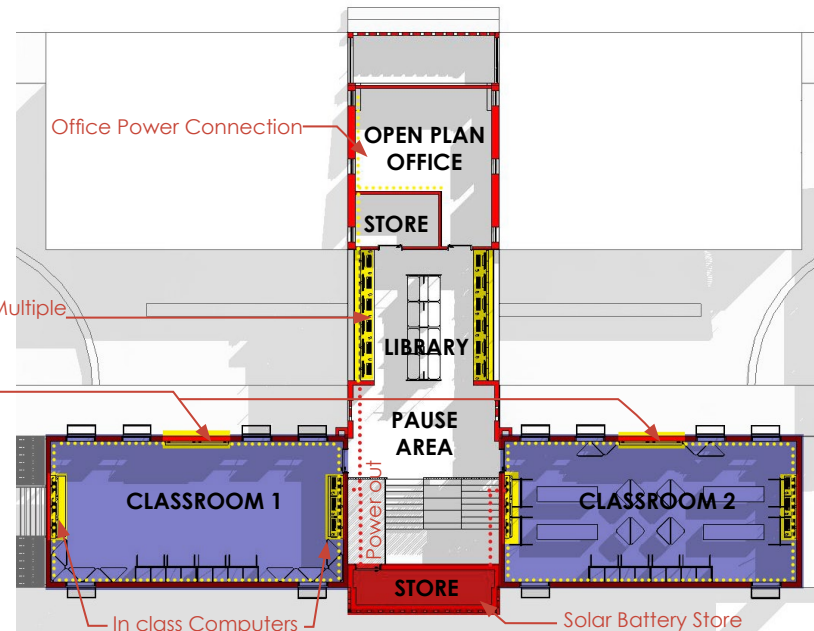
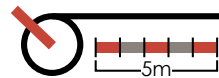
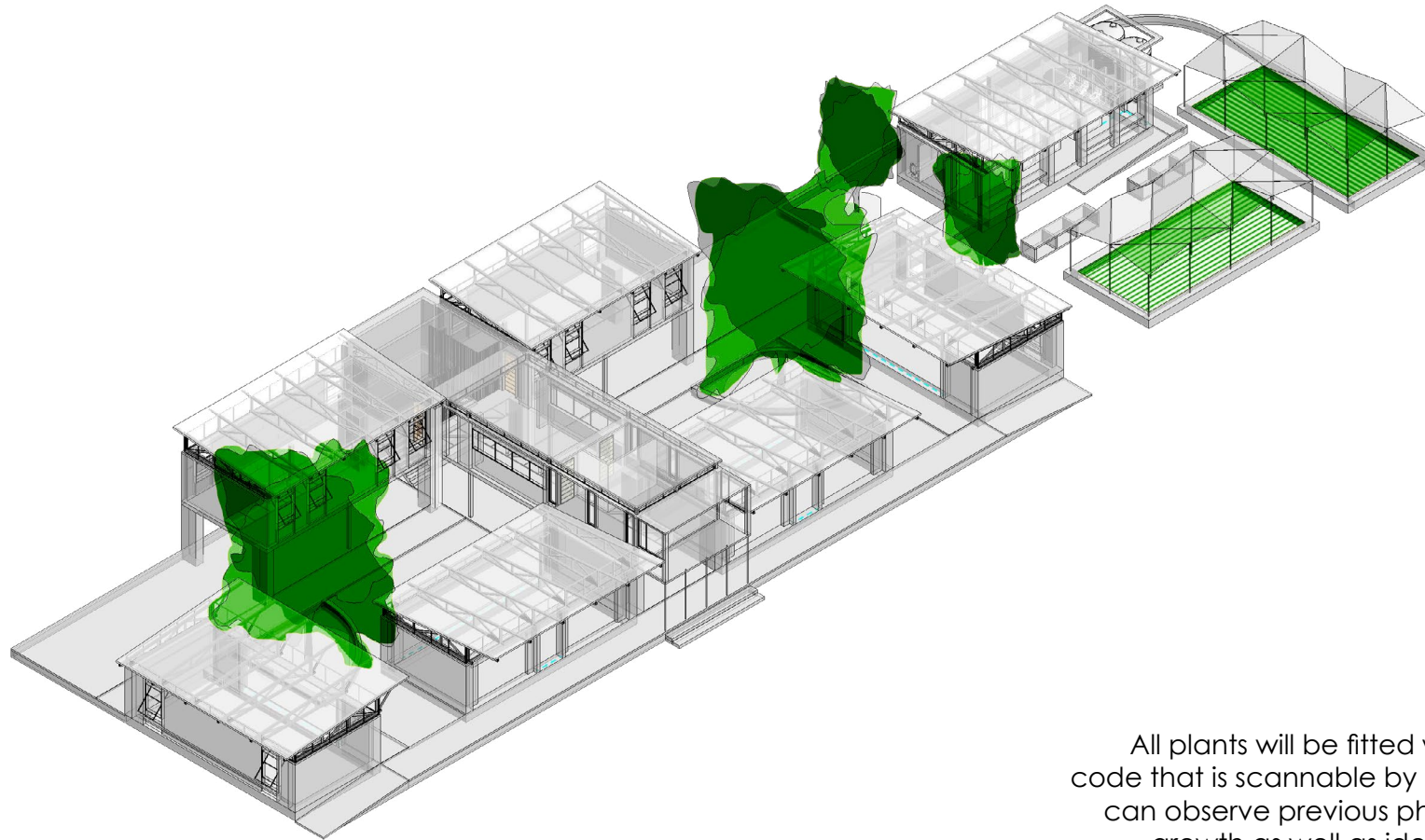


Figure 3.37 - Sustainability: Solar and power first floor plan, (Author, 2021)

3.3.12 GREEN SCAPING

Trees and natural elements are often destroyed within the community to allow for more space for housing and street space. Children grow up and learn in environments without vegetation, which is an important emotional and mental enabler to safe learning environments. Trees will be positioned within the courtyards of the learning center to serve as visual motivators of learning, but also serve a poetic inspiration to the start of informal conversations.



Digital integration:

All plants will be fitted with a post with a QR code that is scannable by cell phones. Learners can observe previous photo logs of the tree's growth as well as identify and understand tree types and ecosystems which provide an augmented reality illustration and documentary.

Figure 3.38 - Sustainability: Green scaping axonometric, (Author, 2021)

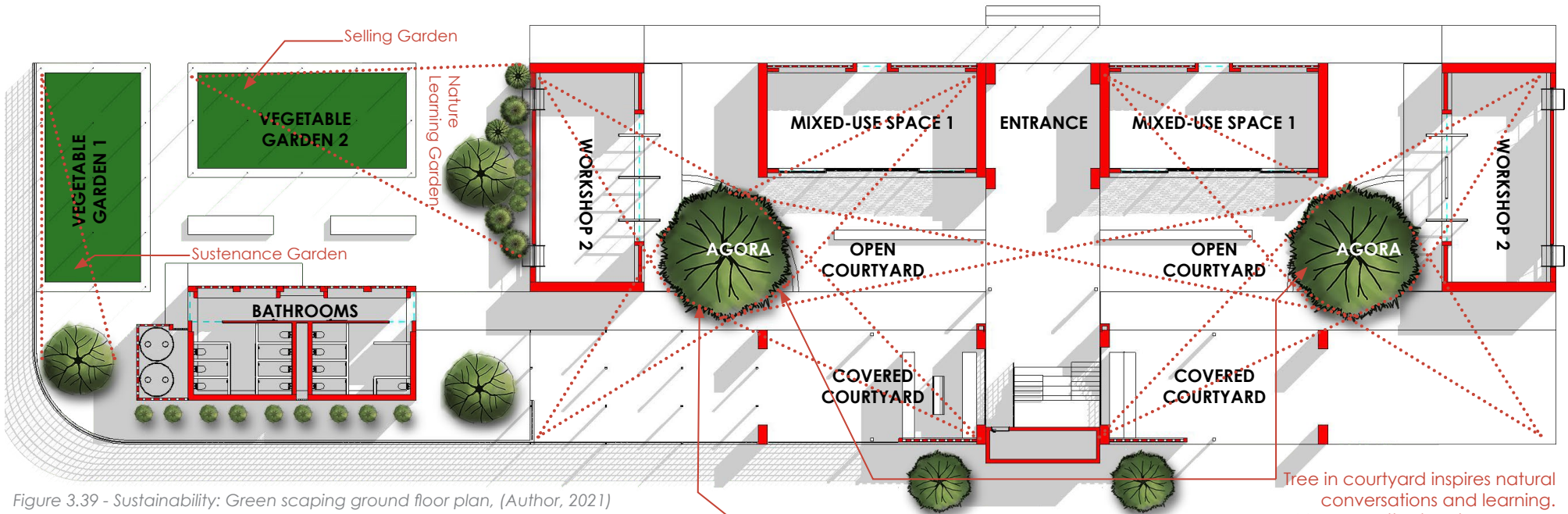
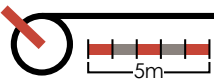


Figure 3.39 - Sustainability: Green scaping ground floor plan, (Author, 2021)

GROUND FLOOR



KEY:

- WALLS
- AGRICULTURE
- VIEWING PERSPECTIVE

FIRST FLOOR

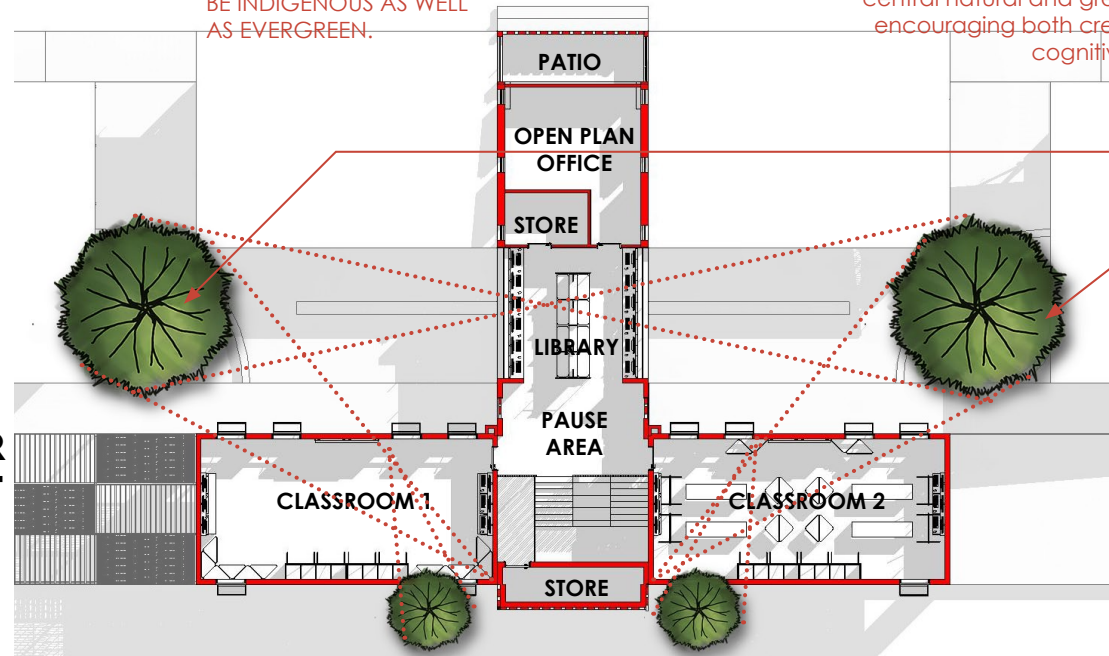
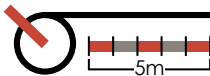


Figure 3.40 - Sustainability: Green scaping first floor plan, (Author, 2021)

SELECTED TREES ARE TO BE INDIGENOUS AS WELL AS EVERGREEN.

Tree in courtyard inspires natural conversations and learning. Moreover, the tree becomes a central natural and green feature encouraging both creativity and cognitive thinking.

TECHNICAL METHODOLOGY

3.4

Technical Issue

The design aim is to create safe and versatile learning environments where children can access information through digital technology to enable learning. From a technical investigation, how can the architecture create the shell in which both fixed and moveable components collectively offer a safe and motivating digital learning environment with versatile programmes and promote interior well-being.

Technical question

Through a series of technical details, drawings, and analysis, how can architectural shell with the interior components create responsive learning environment to express the relationship between interior and architecture?

Technical question criteria:

Architectural:

- The structure complies with standard building conventions.
- Ablutions are resolved.

Safe interior learning environment:

- A space that offers adequate lighting.
- Has good acoustics for a learning environment.
- Moveable furniture is versatile and secured.
- Offers greenery which engages learners.
- Digital learning tools that are safely secured and functional.
- Ventilation and climate control.

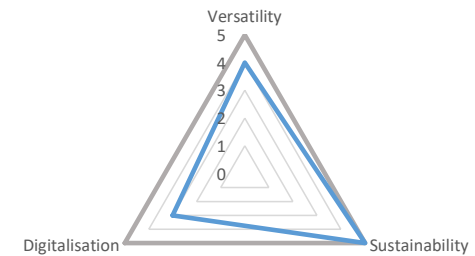
Criteria for detail components:

- Versatile in design.
- Sustainable in materiality
- Digitalised for learning.



Technical methodology:

The technical criteria will be investigated through a series of details investigating the materiality, fixings, and function. The technical question aims to analyse and compare material choice through a lens of sustainability while considering a product's versatility and how each would serve the digital learning environment. Moreover, all could serve as a feasibility analysis to ensure the technification for project brief is well considered and be re-used for future contexts of application. Through a series of analysis testing and diagrams, the feasibility study will analyse sustainability, versatility, and digital integration.



ECONOMIC
ENVIRONMENTAL
SOCIAL

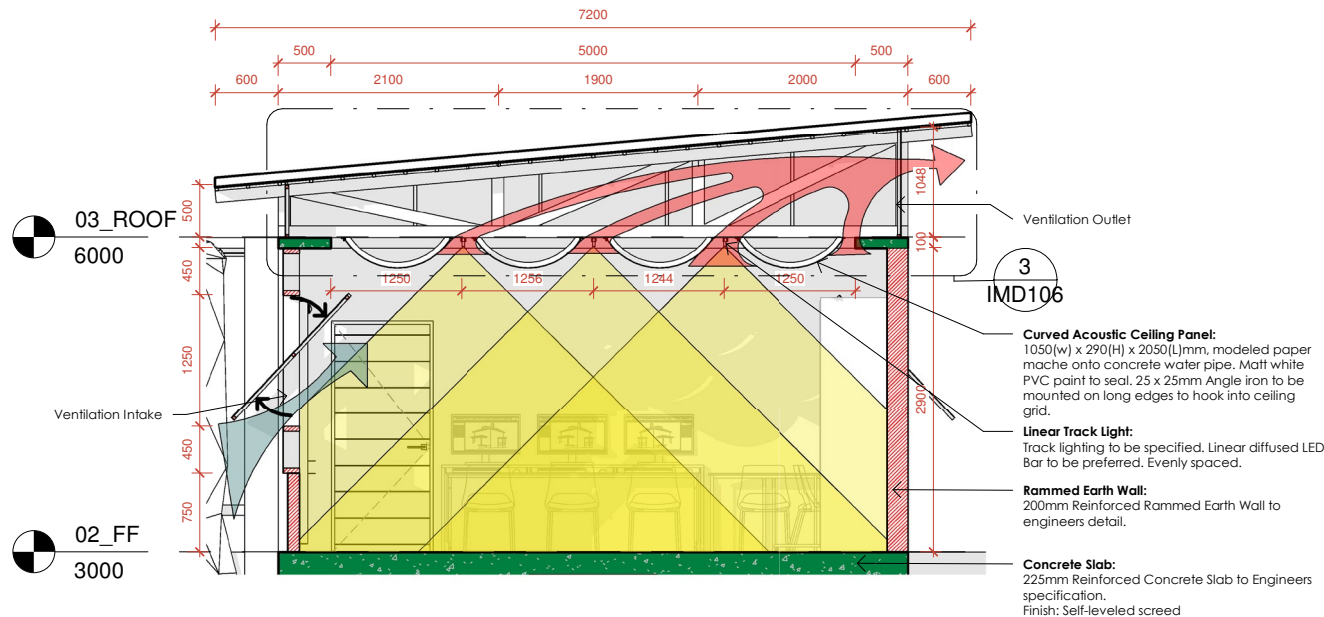


MODULARITY
ADAPTABILITY
USABILITY



INTEGRATION
EXPANSION
LEARNING

3.4.2 SECTIONAL DETAIL - DESIGN TO TECHNICAL



Acoustics: The curved acoustic feature is made by the community with molded paper mache and left to dry, and then later is seal with a white pvc paint. The curved allows for continues refraction of noise, while the 10mm thick paper mache absorbs sound.

Ventilation: Vents are placed on either side of the room. While hot air rises, the sloped roof guides air out and is replaced with new cool air from the tilting polycarbonate windows. On either end of the roof vents can be opened or closed to optimize natural cooling mechanics.

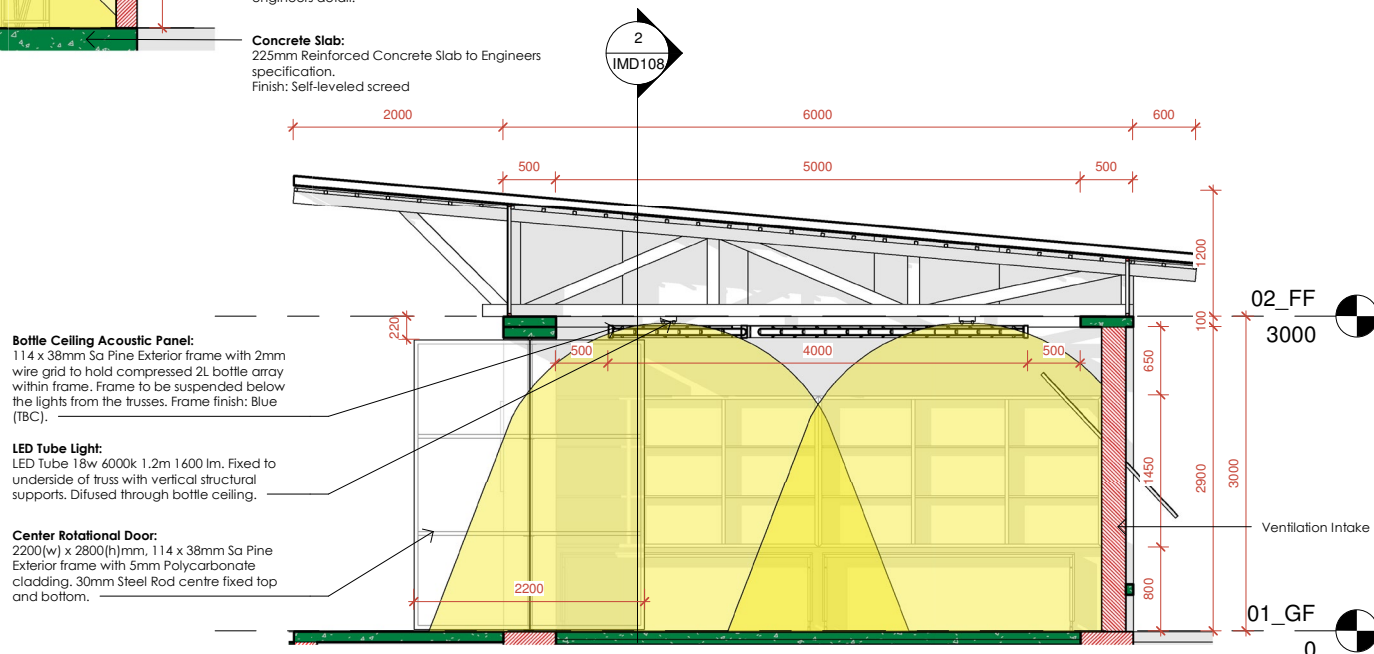
1 | LIBRARY SECTIONAL DETAIL

1 : 50

Figure 3.41 - Sectional detail: Library section, (Author, 2021)

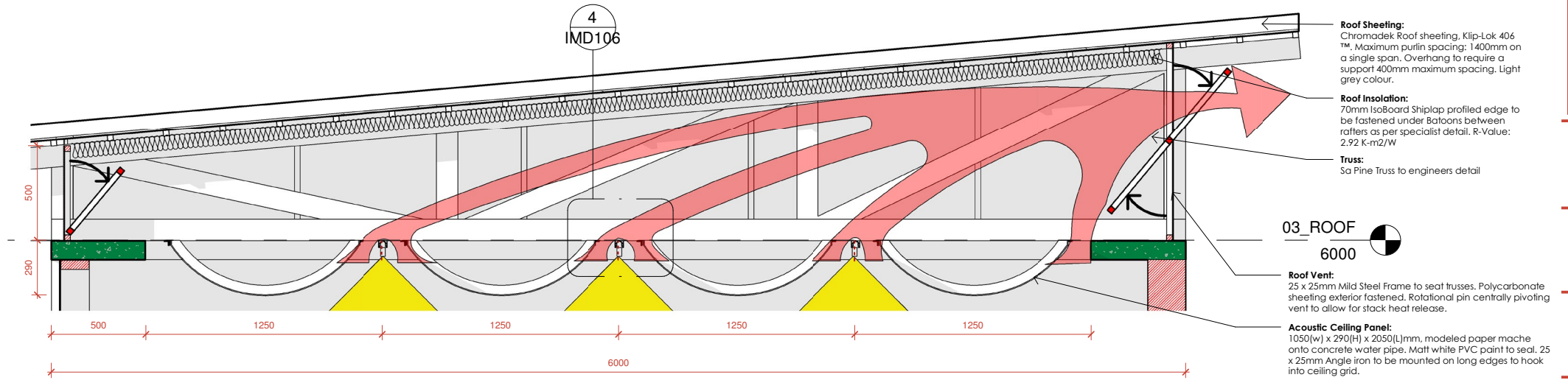
The sectional details aim to highlight the defined technical outcome of lighting, acoustics, and natural ventilation systems.

Lighting: Within the library space track lighting with a diffused LED luminaire creates diffused task lighting. Moreover with dimming capabilities, the classroom can become versatile in its atmosphere.



2 | WORKSHOP SECTIONAL DETAIL

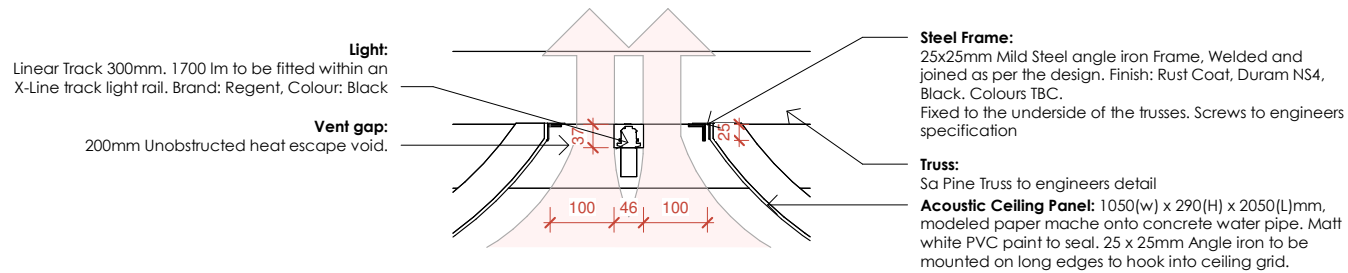
Figure 3.42 - Sectional detail: Workshop section, (Author, 2021)



3 ROOF SECTION

1 : 20

Figure 3.43 - Sectional detail: Roof ventilation section, (Author, 2021)



4 CEILING VENT DETAIL

1 : 10

Figure 3.44 - Sectional detail: Ceiling vent detail - Library, (Author, 2021)

3.4.3 LIBRARY - DESIGN TO TECHNICAL

Number of classrooms: 2

Classroom Size: 72M²

Number of Learners: 42 max.

Digital Tools:

- 8x Speakers (9dB Speakers, 1W, 11M²/Speaker)
- 6x 50 Inch Touch Screen Displays
- 1x Wide Angle HD Camera
- 6x Compact Screen Computer
- Wi-Fi Point

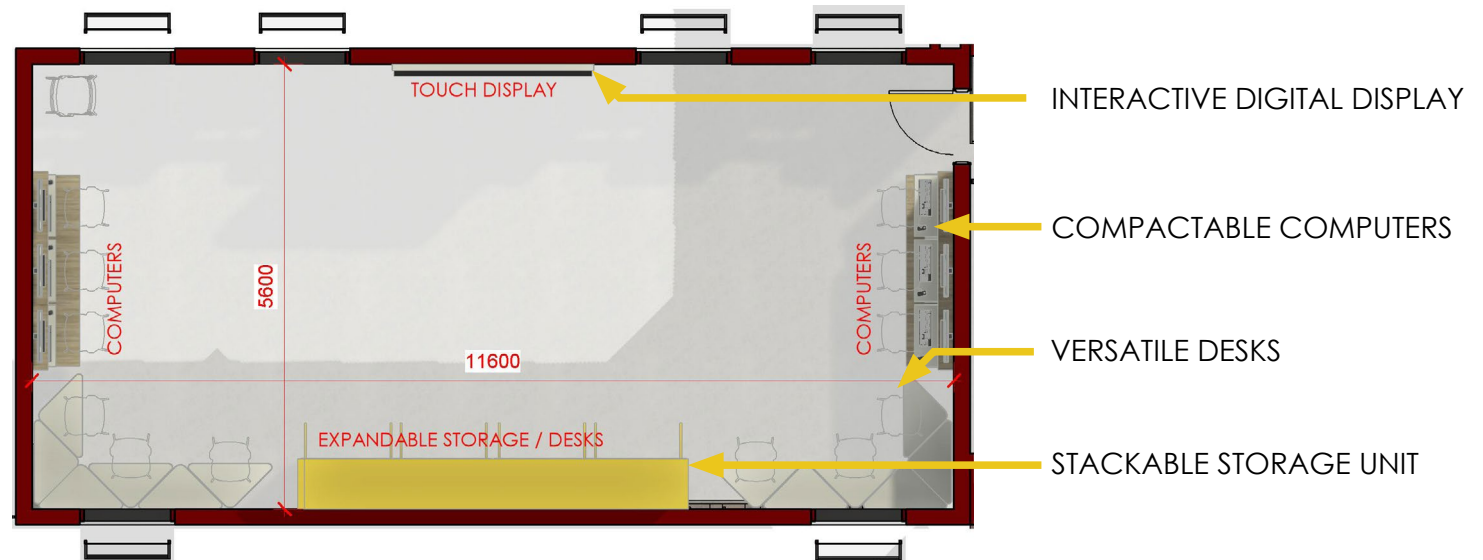
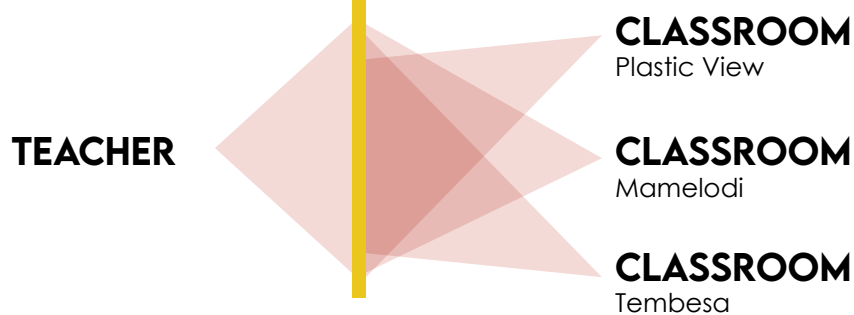


Figure 3.45 - Library design: Floor plan rendered, (Author, 2021)



The library space offers a unique digitalised learning environment such as conventional classroom practice. Learners engage and interact with each other in a single learning environment with a facilitator. But, through digital technology the boundary walls of classes expand to accommodate for facilitators which are not geographically located specifically to on site classes. Through interactive digital screens, facilitators can teach, interact, and communicate directly through camera and screen interfaces. A series of speakers provide equal sound distribution for a passive learning environment.

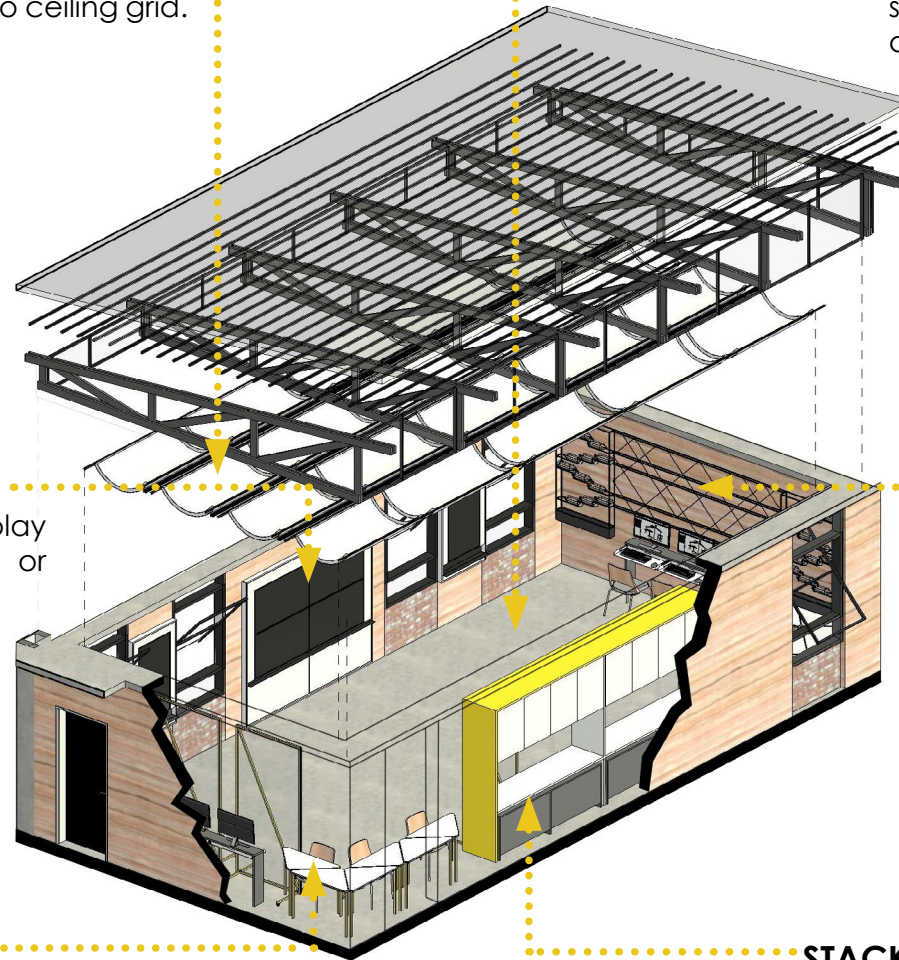


ACOUSTIC CEILING PANEL:

1050(w) x 290(H) x 2050(L)mm, modeled paper mache onto concrete water pipe. Matt white PVC paint to seal. 25 x 25mm Angle iron to be mounted on long edges to hook into ceiling grid.

MULTI-CONFIGURABLE LAYOUTS:

Height adjustable desks to be shopfitted by the community with upcycled materials. Mechanical scissor hinge is manually turned to adjust the table to suitable heights.



INTERACTIVE DIGITAL DISPLAY:

4 x Interactive touch display screens. Screens work seamlessly or independently for group work.

GREEN WALL:

Interactive green wall unit. Hydroponic system with a mechanical water pump.

VERSATILE DESKS:

Triangular desks with a 90° angle, allow for versatile functionality with an array of options. Moreover, they can easily be stored on the edge of the classroom.

STACKABLE STORAGE UNIT:

Stacked storage unit, 4 Whiteboard polycarbonate screens, 2x Height adjustable Desks, Storage Space, Stationary drawers.

Figure 3.46 - Library design: Rendered Axonometric, (Author, 2021)

3.4.4 LIBRARY – OPEN PLAN CLASSROOM

Versatility

The classroom could be open and used for games, where all the furniture place against the walls to maximise the space.

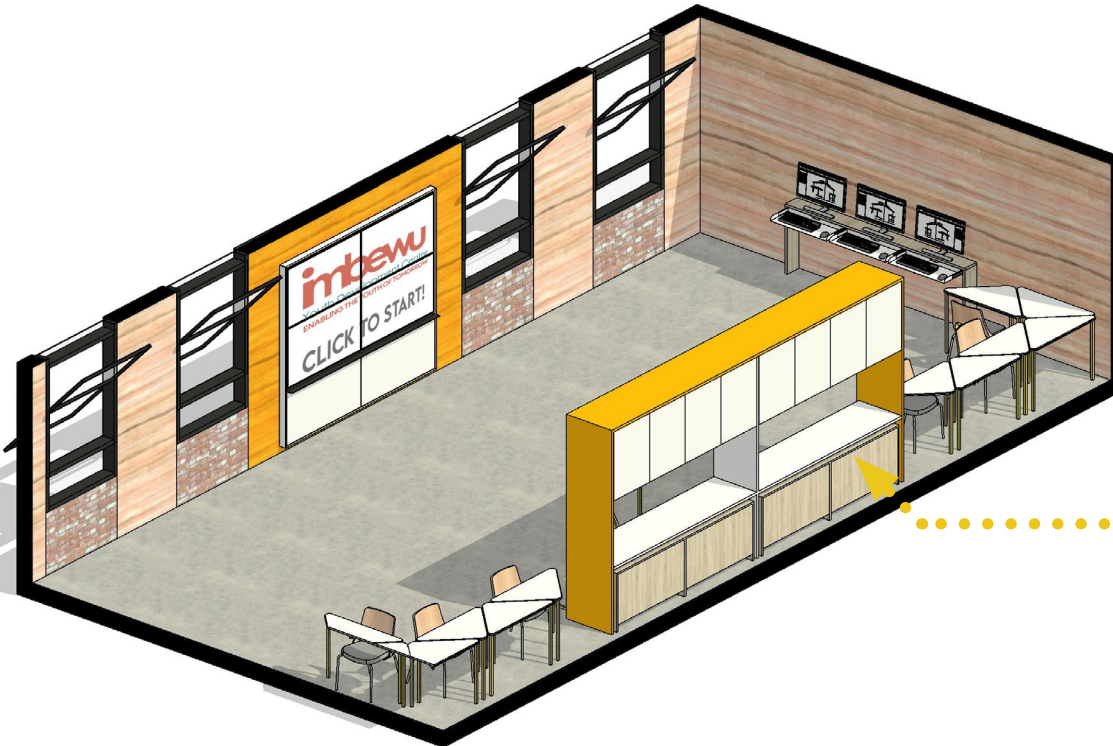


Figure 3.47 - Library design: Open plan class axonometric, (Author, 2021)

ACOUSTIC CEILING PANEL:

1050(w) x 290(H) x 2050(L)mm, modeled paper mache onto concrete water pipe. Matt white PVC paint to seal. 25 x 25mm Angle iron to be mounted on long edges to hook into ceiling grid.

STACKABLE STORAGE UNIT:

Stacked storage unit, 4 Whiteboard polycarbonate screens, 2 x Height adjustable Desks, Storage Space, Stationary drawers.

PERSPECTIVE

OPEN PLAN CLASSROOM

Figure 3.48 - Library design: Open plan class rendered perspective, (Author, 2021)



CHAPTER

01

02

03

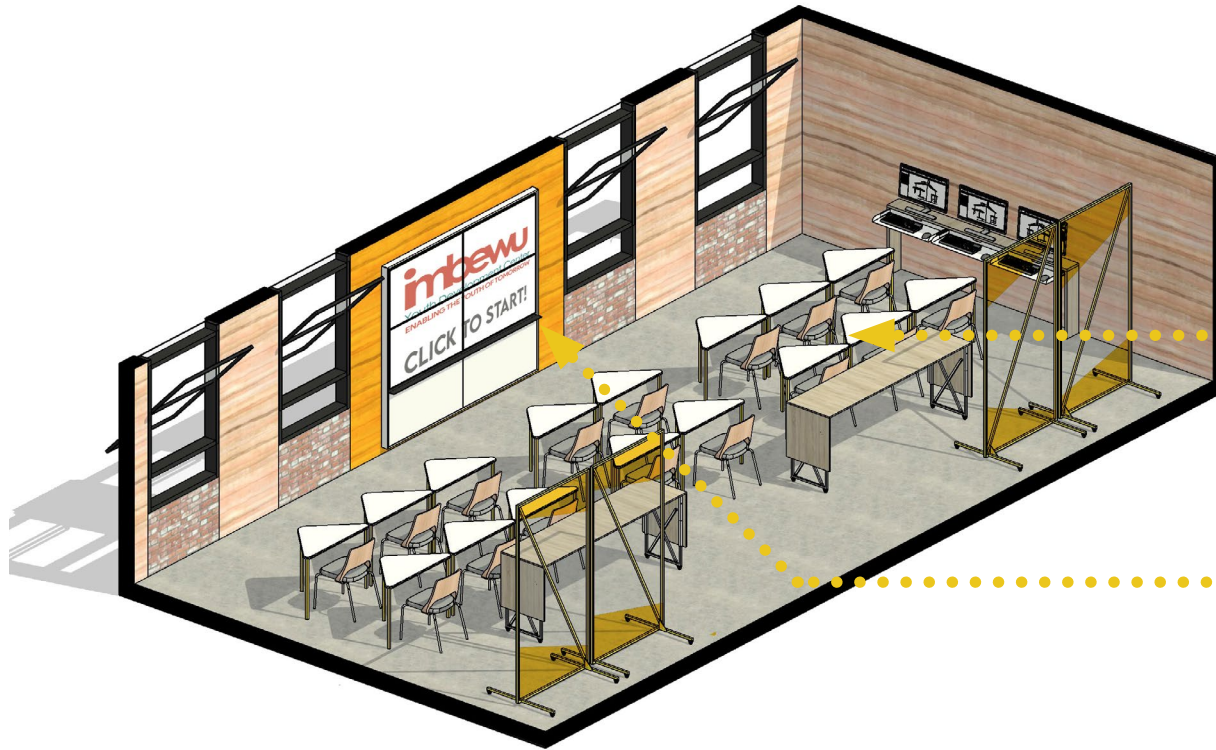
04

CREATION

3.4.5 LIBRARY - CONVENTIONAL

Versatility

Right-angled desks allow for versatile layouts of grouping, pairing and individual learning. Adaptable layouts allow for conventional learning setups to easily occur, but also allowing for self-driven educational methods to occur.



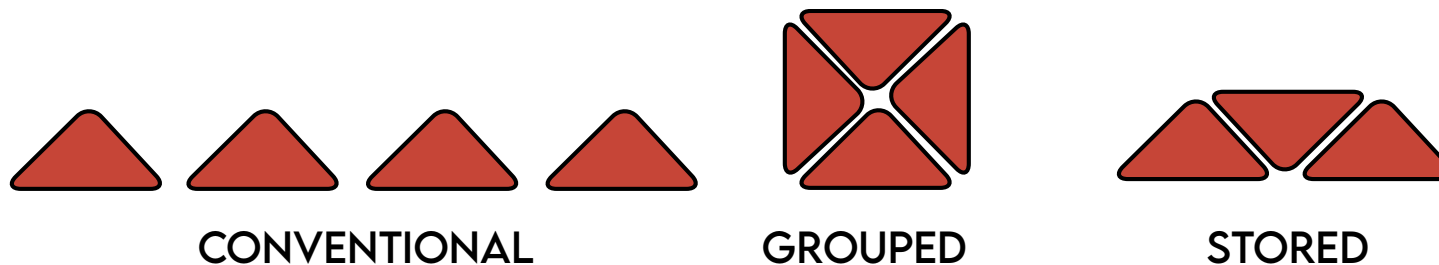
VERSATILE DESKS:

Triangular desks with a 90° angle, allow for versatile functionality with an array of options. Moreover, they can easily be stored on the edge of the classroom.

INTERACTIVE DIGITAL DISPLAY:

4 x Interactive touch display screens. Screens work seamlessly or independently for group work.

Figure 3.49 - Library design: Conventional class axonometric, (Author, 2021)



PERSPECTIVE

CONVENTIONAL CLASSROOM

Figure 3.50 - Library design: Conventional class rendered perspective, (Author, 2021)



CHAPTER

01

02

03

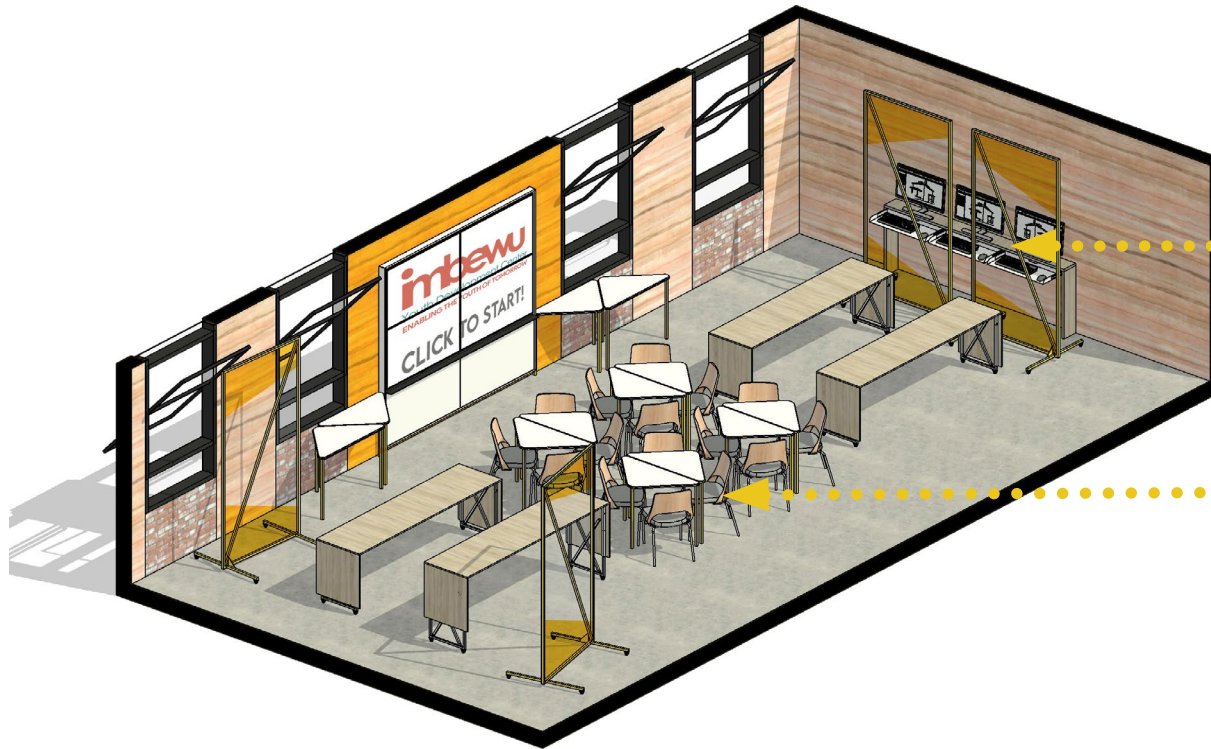
04

CREATION

3.4.6 LIBRARY – GROUP LEARNING

Versatility

Group sessions combine all furniture features together. Whiteboards allow for group brainstorming while learners stand and work together on an adjustable long table.



MOVEABLE WHITEBOARDS:

Writable Polycarbonate sheeted panels.
Square tubing steel frame to be painted with rust protector and final coat paint. Illuminating Yellow.

MULTI-CONFIGURABLE LAYOUTS:

Height adjustable desks to be shopfitted by the community with upcycled materials.
Mechanical scissor hinge is manually turned to adjust the table to suitable heights.

Figure 3.51 - Library design: Group learning class axonometric, (Author, 2021)

PERSPECTIVE

GROUP LEARNING CLASSROOM

Figure 3.52 - Library design: Group learning class rendered perspective, (Author, 2021)



CHAPTER

01

02

03

04

CREATION

3.4.7 LIBRARY - CURVED ACOUSTIC CEILING

Description

The curved acoustic ceiling has a convex shape which reflects sound and light complementing the interior comfort. The acoustic panel is made with papier-mâché, which is a tough composite material that holds its form, but also absorbs sound waves. This is further technically designed in Figure 3.55 on the following page.

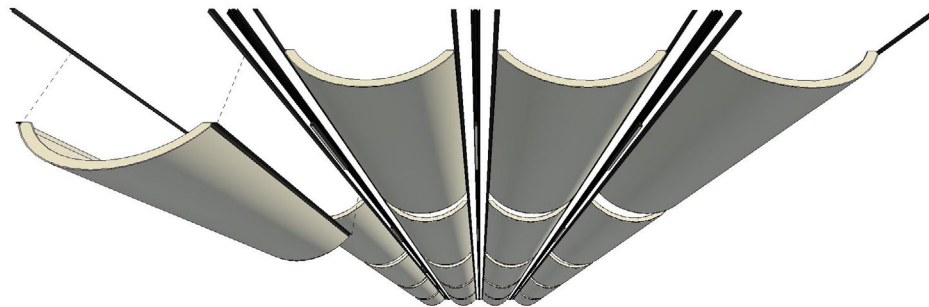
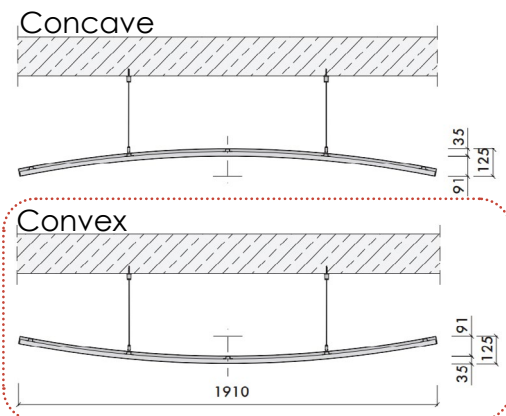


Figure 3.53 - Library detail: Curved acoustic ceiling diagram, (Author, 2021)

CEILING PRECEDENT

Material: Biosoluble Wool
Thickness:
Colour: White

Knauf Ceiling Solutions
AMF Thermatex Sonic Arc



Sound absorption



Light reflection



Cleanability

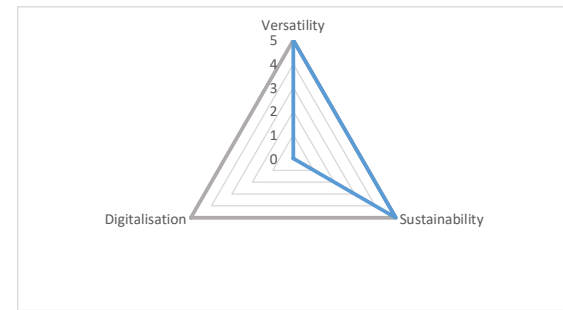


Humidity resistance



Figure 3.54 - Library detail: Curved Acoustic Ceiling precedent, (Knauf Ceiling Solutions, 2021)

LIBRARY: CURVED CEILING PANEL			ACHIEVED
	Potential	Actual	3,33
	5	0	
Indicators			
Versatility	5	5	
Sustainability	5	5	
Digitalisation	5	0	



Criteria

Indicator: Versatile Design		
Versatile in function within an educational environment		
	Potential	Actual
Mixed-age usage	2	2
Easily Moveable	1	1
Easily Stored	1	1
Modular	1	1

5

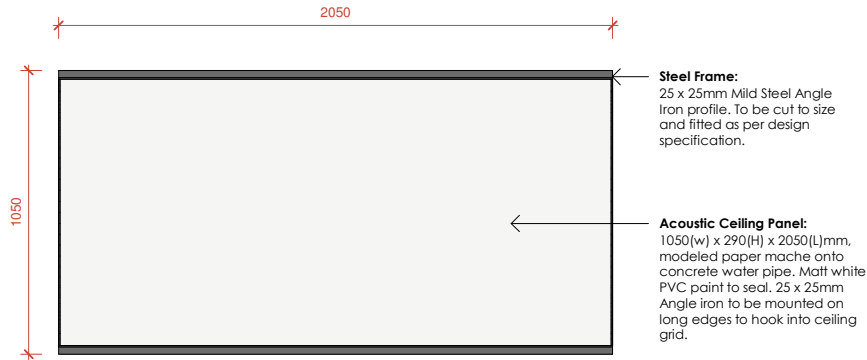
Indicator: Sustainable Design		
Sustainable manufacturing and impacts		
	Potential	Actual
Local labour	2	2
Locally sourced material	1	1
Scalability	1	1
Interior Safe	1	1

5

Indicator: Digitalisation		
How digital technology is integrated		
	Potential	Actual
Is digital or can be activated	2	0
Allows for digital add-ons	1	0
Real/Vitual integration	1	0
Interacts with other digital tools	1	0

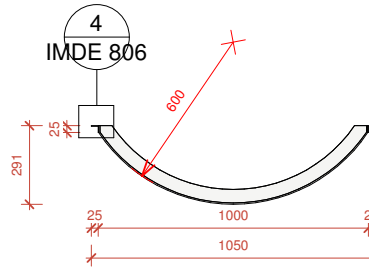
0





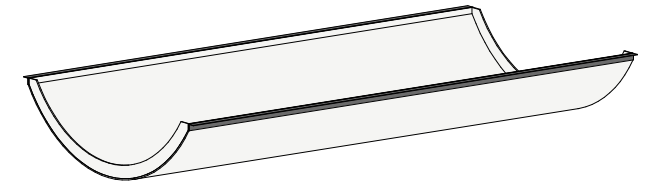
1 PLAN

1 : 20

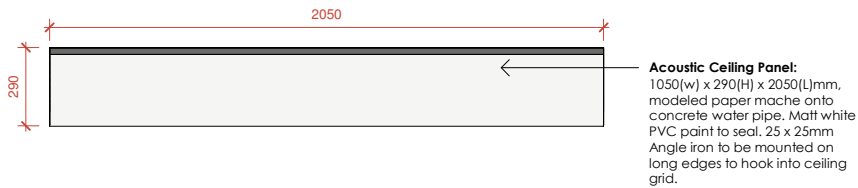


2 FRONT

1 : 20

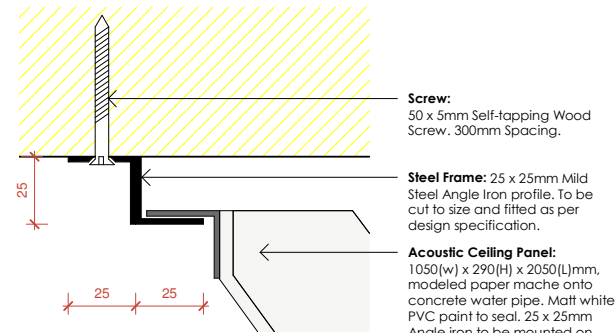


5 3D Ortho



3 SIDE

1 : 20



4 FIXING DETAIL

1 : 2

Figure 3.55 - Library detail: Curved Acoustic Ceiling technical resolution, (Author, 2021)

3.4.8 LIBRARY - EXPANDABLE STORAGE

Description

A singular compact storage unit is centrally located within the space. This allows for fast access, but also the storing of other furniture. The unit stores a variety of stationery and work material. More so, it allows for scholars to leave personal belongings safely in a visible area of the room. The storage unit allows of the compact stacking of the moveable whiteboards and the adjustable tables, to relieve clutter and allow for a versatile classroom. This is further technically designed in Figure 3.57 on the following page.

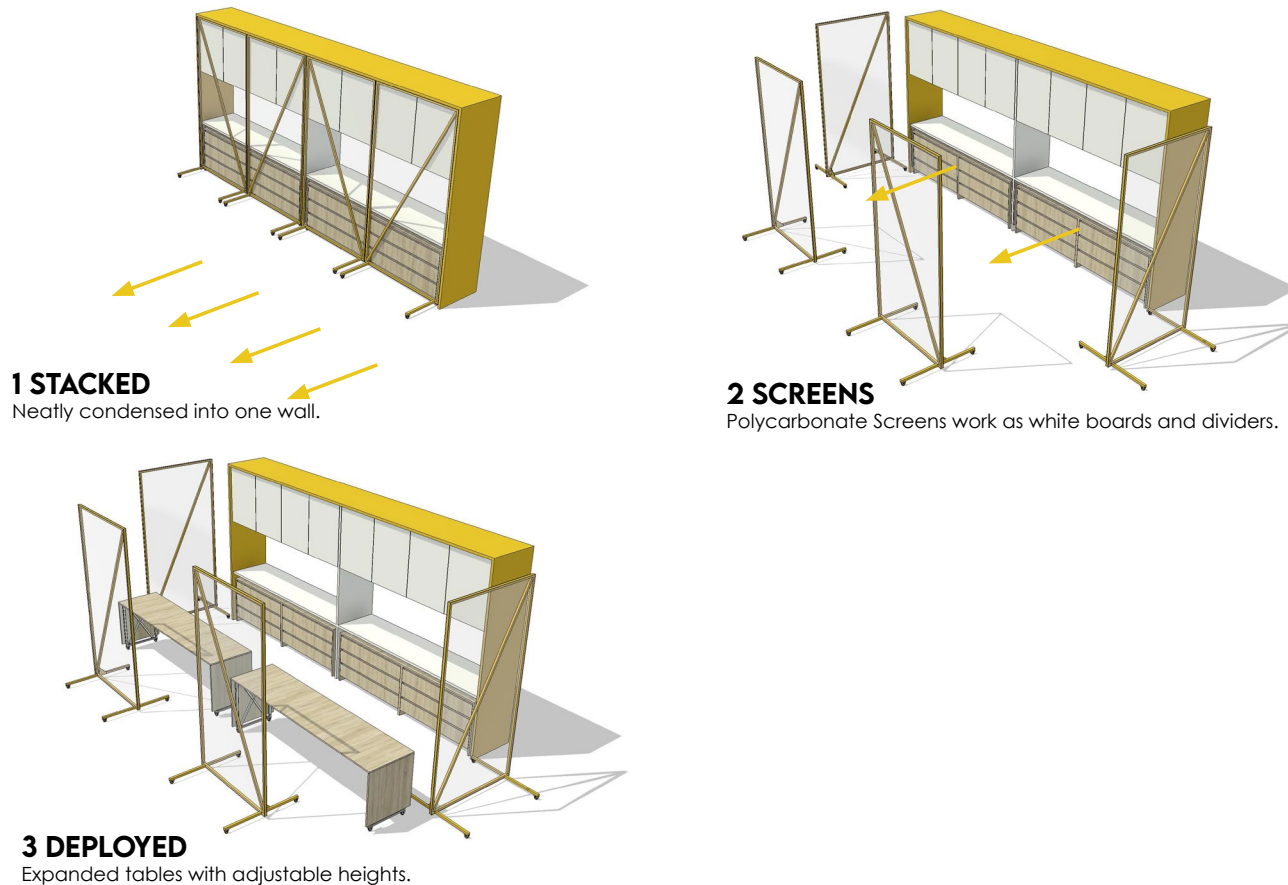
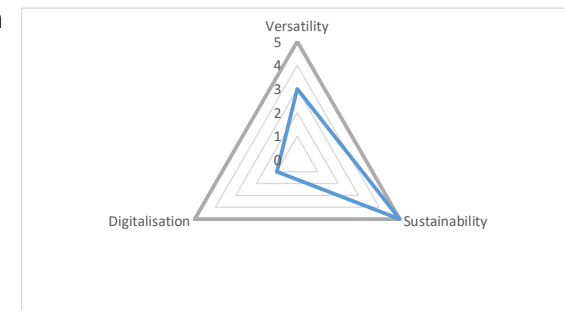


Figure 3.56 - Library detail: Expandable Storage diagram, (Author, 2021)

LIBRARY: EXPANDABLE STORAGE UNIT			ACHIEVED
	Potential	Actual	3
	5	0	
Indicators			
Versatility	5	3	
Sustainability	5	5	
Digitalisation	5	1	



Criteria

Indicator: Versatile Design		
Versatile in function within an educational environment		
	Potential	Actual
Mixed-age usage	2	1
Easily Moveable	1	0
Easily Stored	1	1
Modular	1	1

3

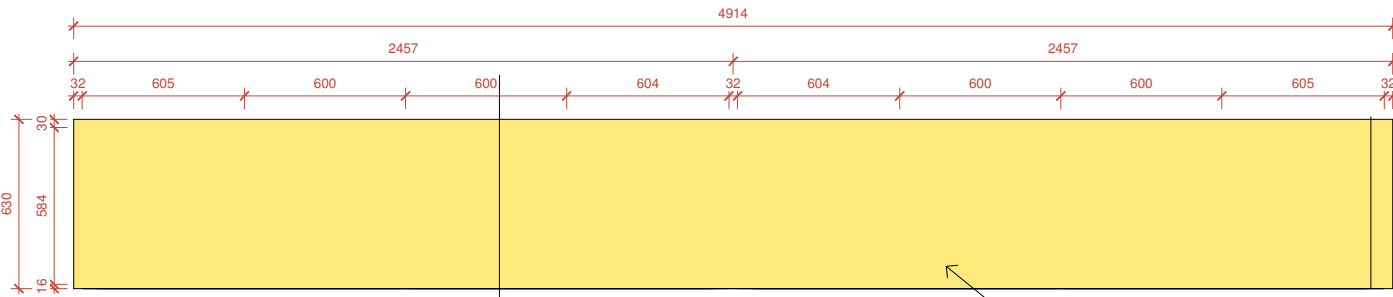
Indicator: Sustainable Design		
Sustainable manufacturing and impacts		
	Potential	Actual
Local labour	2	2
Locally sourced material	1	1
Scalability	1	1
Interior Safe	1	1

5

Indicator: Digitalisation		
How digital technology is integrated		
	Potential	Actual
Is digital or can be activated	2	0
Allows for digital add-ons	1	1
Real/Vitual integration	1	0
Interacts with other digital tools	1	0

1



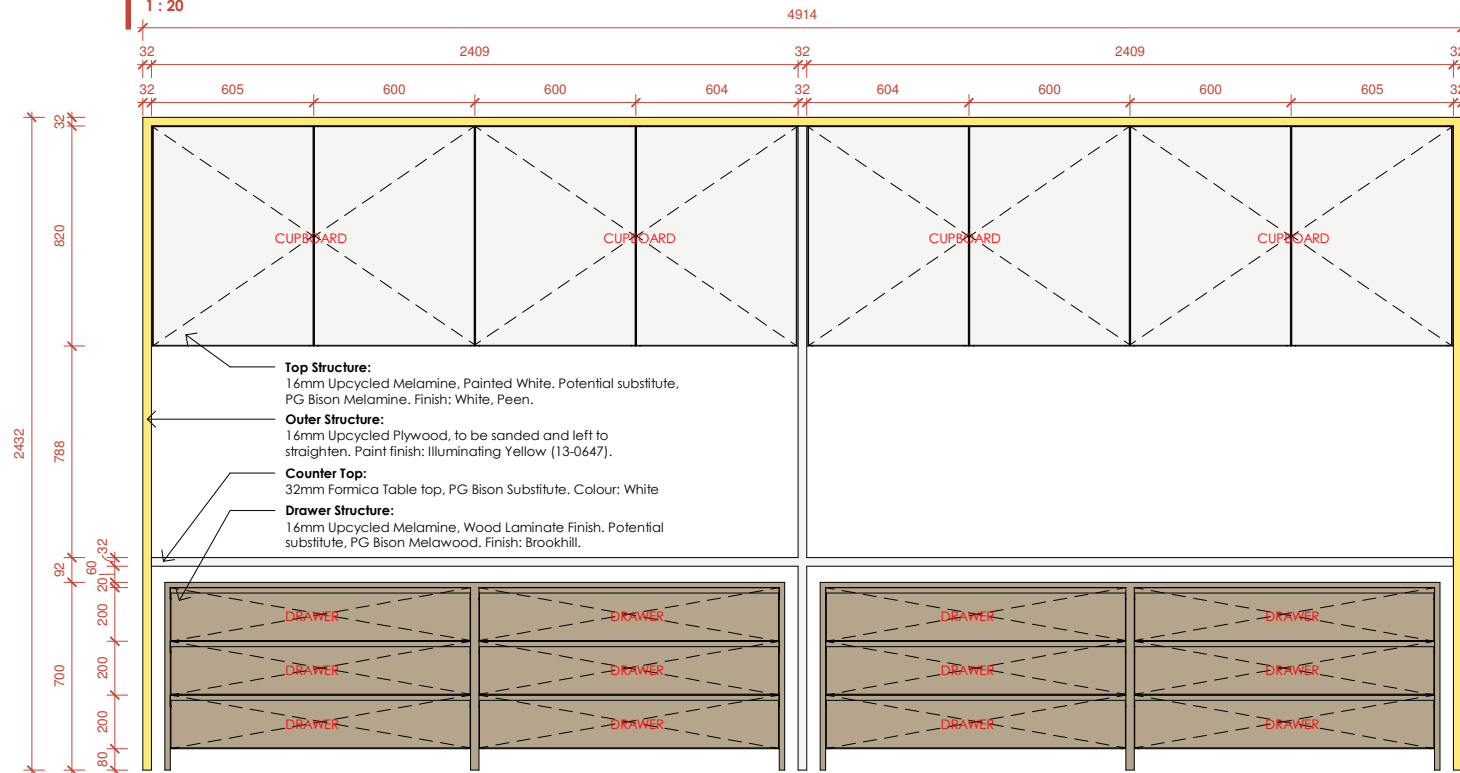


1 PLAN

1 : 20

4
IMDE 802(A)

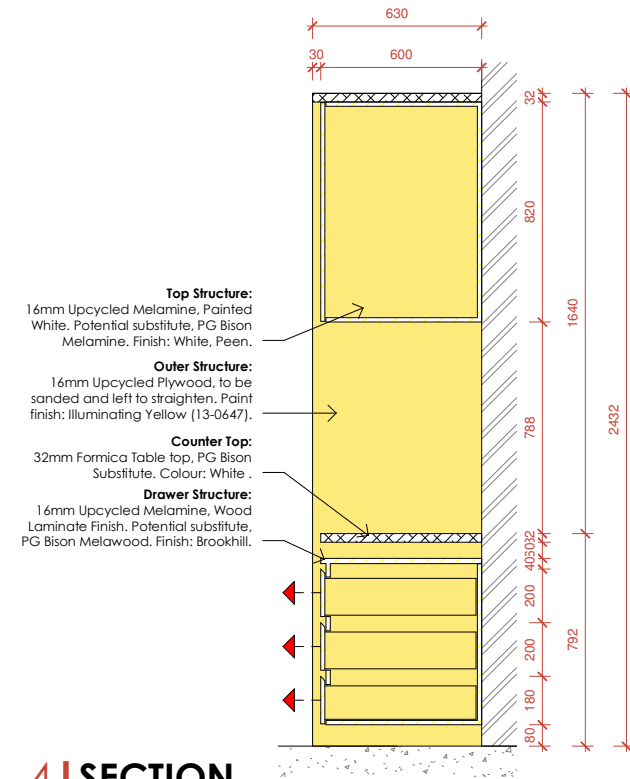
Outer Structure:
16mm Upcycled Plywood, to be sanded and left to straighten. Paint finish: Illuminating Yellow (13-0647).



2 FRONT

1 : 20

QTY: 2 LIBRARY SPACE 1 & 2



4 SECTION

1 : 20

Figure 3.57 - Library detail: Expandable Storage technical resolution, (Author, 2021)

3.4.9 LIBRARY - WHITE BOARD DIVIDER

Description

Steel-framed whiteboards on caster wheels allow for a versatile arrangements and spontaneous group or individual brainstorming and conceptualising. The polycarbonate cladded surfaces offer a natural lit surface which can be visibly used for writing. This is further technically designed in Figure 3.59 on the following page.

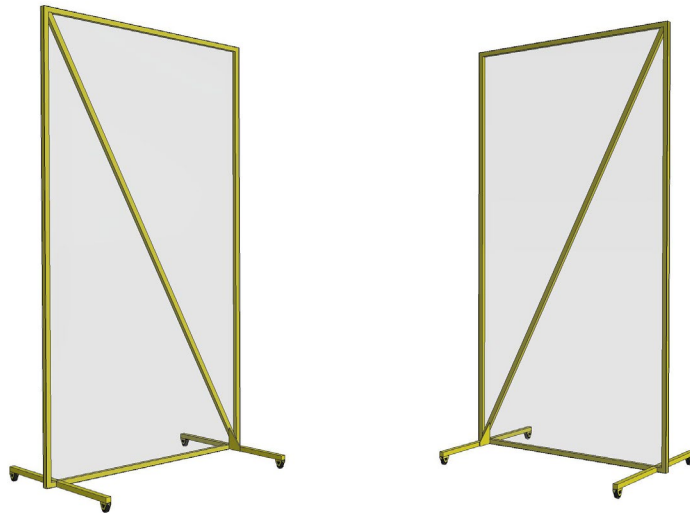
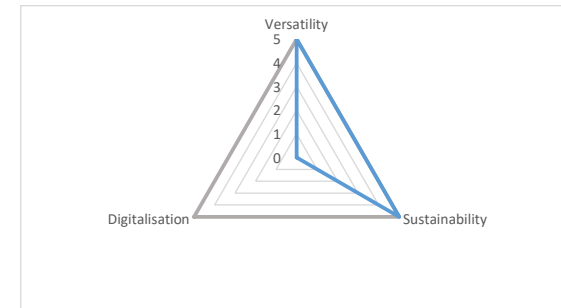


Figure 3.58 - Library detail: White Board Divider Diagram, (Author, 2021)

LIBRARY: WHITE BOARD SCREEN			ACHIEVED
	Potential	Actual	3,33
	5	0	
Indicators			
Versatility	5	5	
Sustainability	5	5	
Digitalisation	5	0	



Criteria

Indicator: Versatile Design

Versatile in function within an educational environment		
	Potential	Actual
Mixed-age usage	2	2
Easily Moveable	1	1
Easily Stored	1	1
Modular	1	1

5

Indicator: Sustainable Design

Sustainable manufacturing and impacts		
	Potential	Actual
Local labour	2	2
Locally sourced material	1	1
Scalability	1	1
Interior Safe	1	1

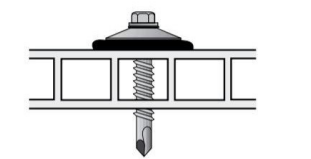
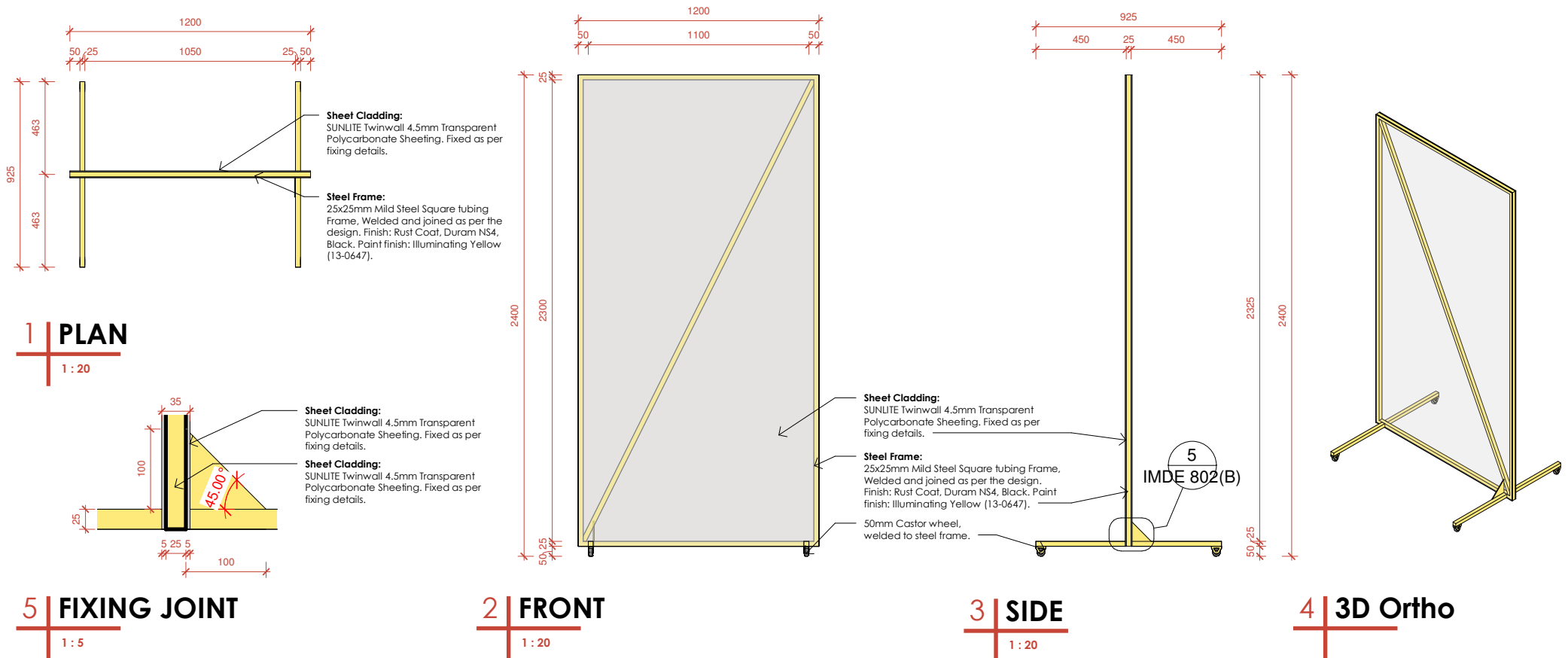
5

Indicator: Digitalisation

How digital technology is integrated		
	Potential	Actual
Is digital or can be activated	2	0
Allows for digital add-ons	1	0
Real/Vitual integration	1	0
Interacts with other digital tools	1	0

0





POLYCARBONATE SHEET
FIXING DETAIL

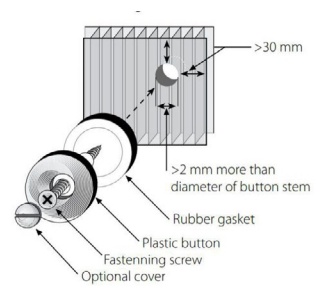


Figure 3.59 - Library detail: White Board Divider technical resolution, (Author, 2021)

3.4.10 LIBRARY – EXPANDABLE DESK

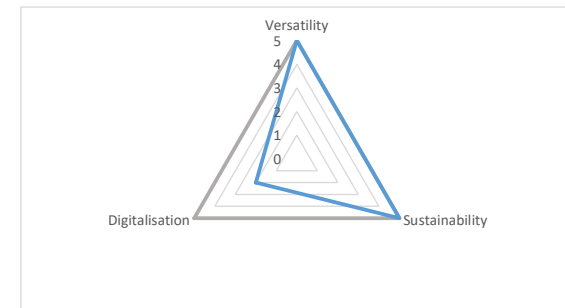
Description

Adjustable desks allow for learners to seamlessly adjust desks vertically for sit-stand flexibility and multi-age usage. The steel frame uses a dual treaded scissor hinge lift system which is adjustable by hand. This is further technically designed in Figure 3.61 on the following page.



Figure 3.60 - Library detail: Expandable desk Diagram, (Author, 2021)

LIBRARY: EXPANDABLE DESK			ACHIEVED
	Potential	Actual	4
	5	0	
Indicators			
Versatility	5	5	
Sustainability	5	5	
Digitalisation	5	2	



Criteria

Indicator: Versatile Design

Versatile in function within an educational environment		
	Potential	Actual
Mixed-age usage	2	2
Easily Moveable	1	1
Easily Stored	1	1
Modular	1	1

5

Indicator: Sustainable Design

Sustainable manufacturing and impacts		
	Potential	Actual
Local labour	2	2
Locally sourced material	1	1
Scalability	1	1
Interior Safe	1	1

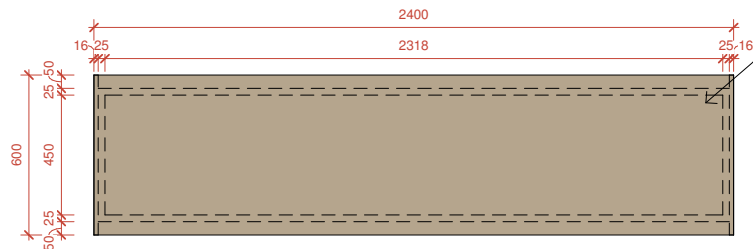
5

Indicator: Digitalisation

How digital technology is integrated		
	Potential	Actual
Is digital or can be activated	2	0
Allows for digital add-ons	1	1
Real/Vitual integration	1	0
Interacts with other digital tools	1	1

2

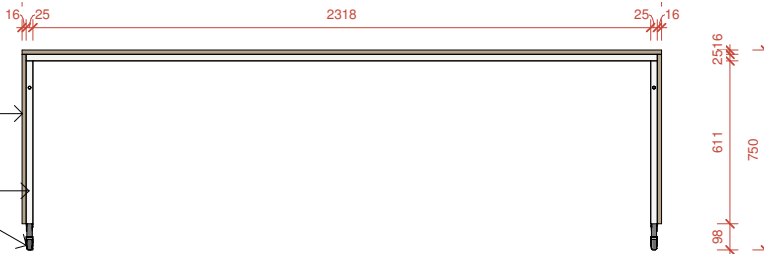




Structure:
16mm Upcycled Melamine, Wood Laminate Finish. Potential substitute, PG Bison Melawood. Finish: Brookhill.

Steel Frame:
25x25mm Mild Steel Square tubing Frame. Welded and joined as per the design. Finish: Rust Coat, Duram NS4, Black. Colours TBS.

50mm Castor wheel, welded to steel frame.

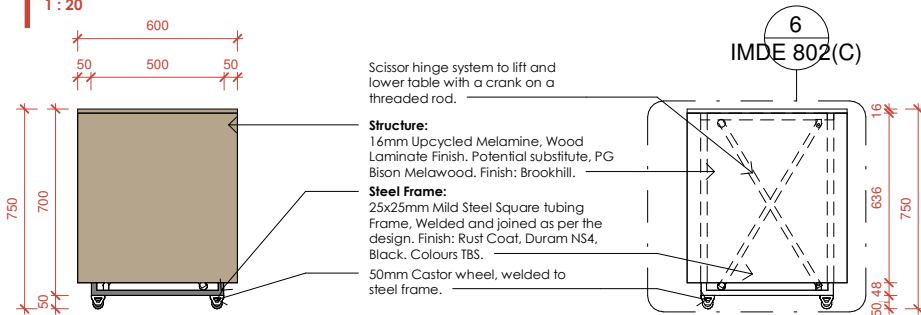


1 | PLAN

1 : 20

2 | FRONT

1 : 20

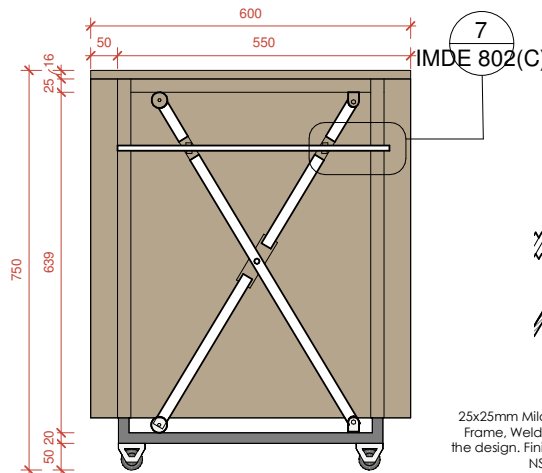


3 | SIDE

1 : 20

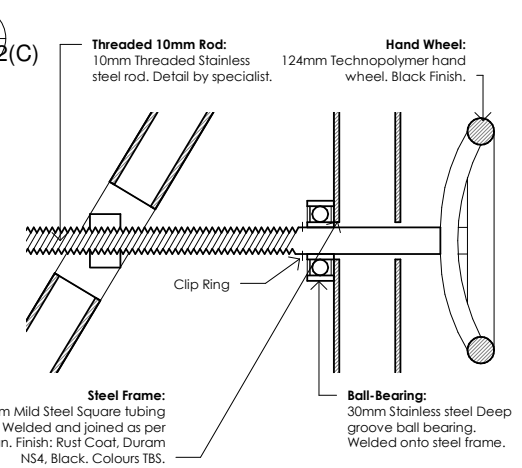
4 | SECTION

1 : 20



6 | HINGE

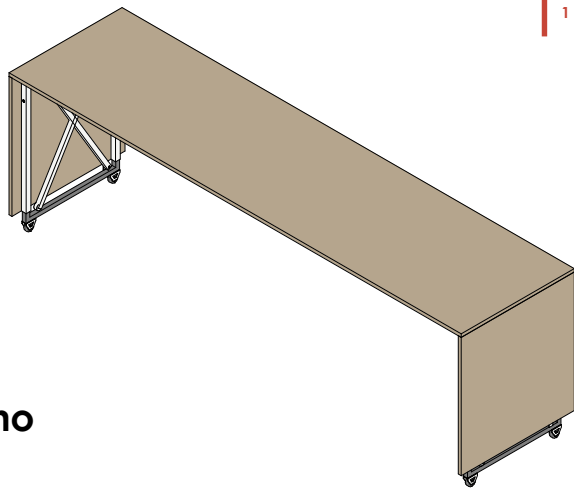
1 : 10



7 | Detail 0

1 : 2

5 | 3D Ortho

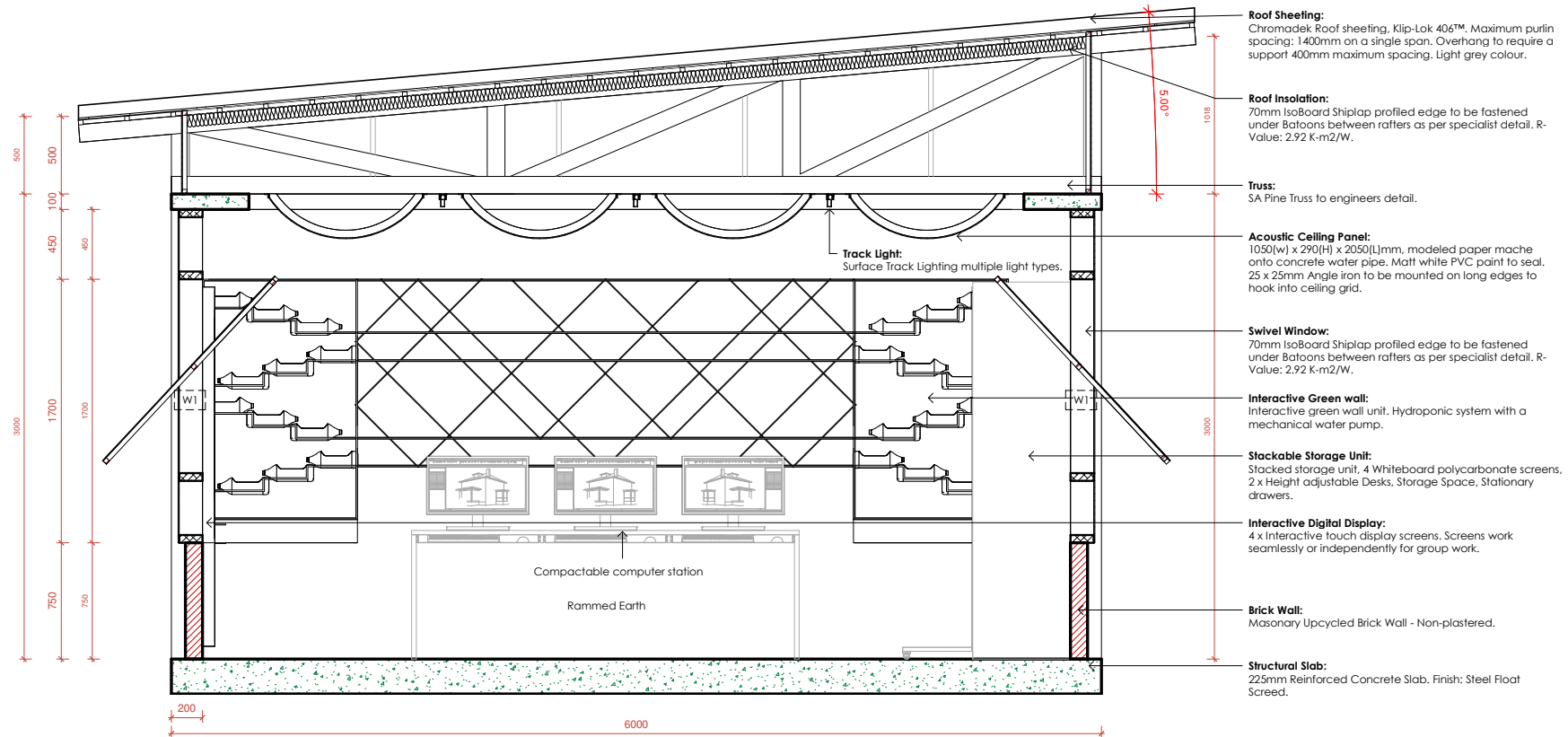


QTY: 16

LIBRARY SPACE 1 (4 Units)
LIBRARY SPACE 2 (4 Units)
WORKSHOP SPACE 1 (4 Units)
WORKSHOP SPACE 2 (4 Units)

Figure 3.61 - Library detail: Expandable desk technical resolution, (Author, 2021)

3.4.11 LIBRARY - SECTIONAL DETAILS

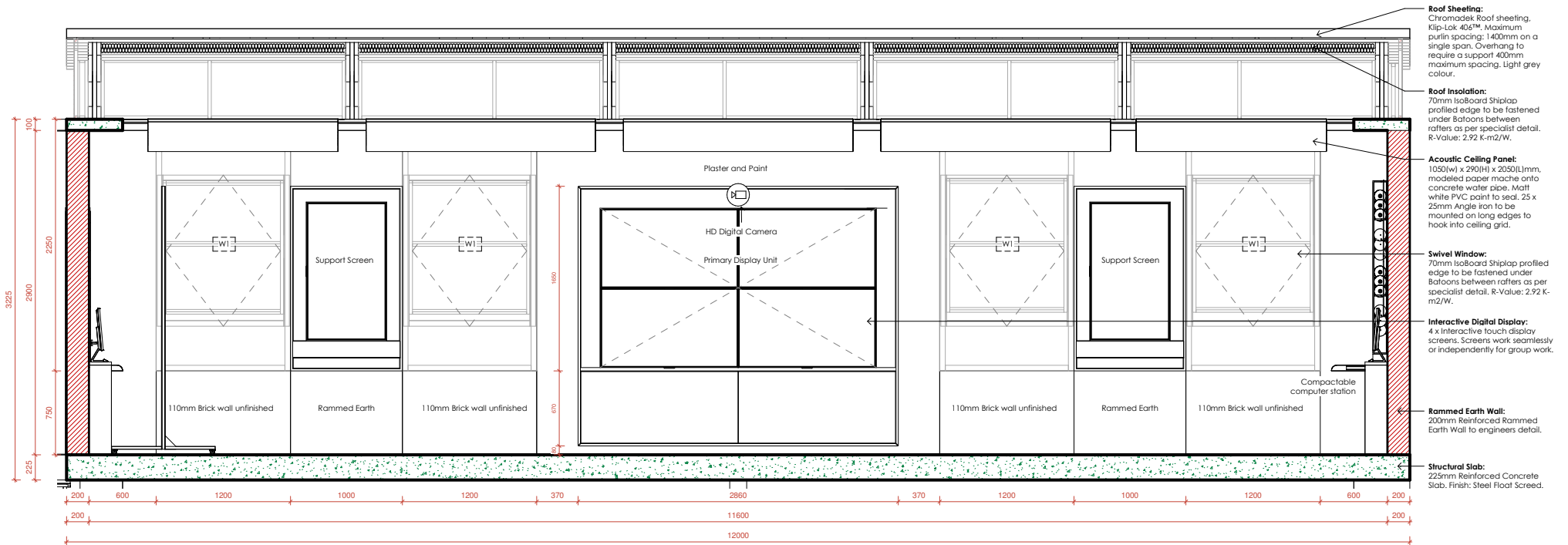


01_LIBRARY SECTION AA

1:20

Figure 3.62 - Library section 1: section detail interior, (Author, 2021)





2 | 02_LIBRARY SECTION BB

1:20

Figure 3.63 - Library section 2: section detail interior, (Author, 2021)

3.4.12 WORKSHOP - DESIGN TO TECHNICAL

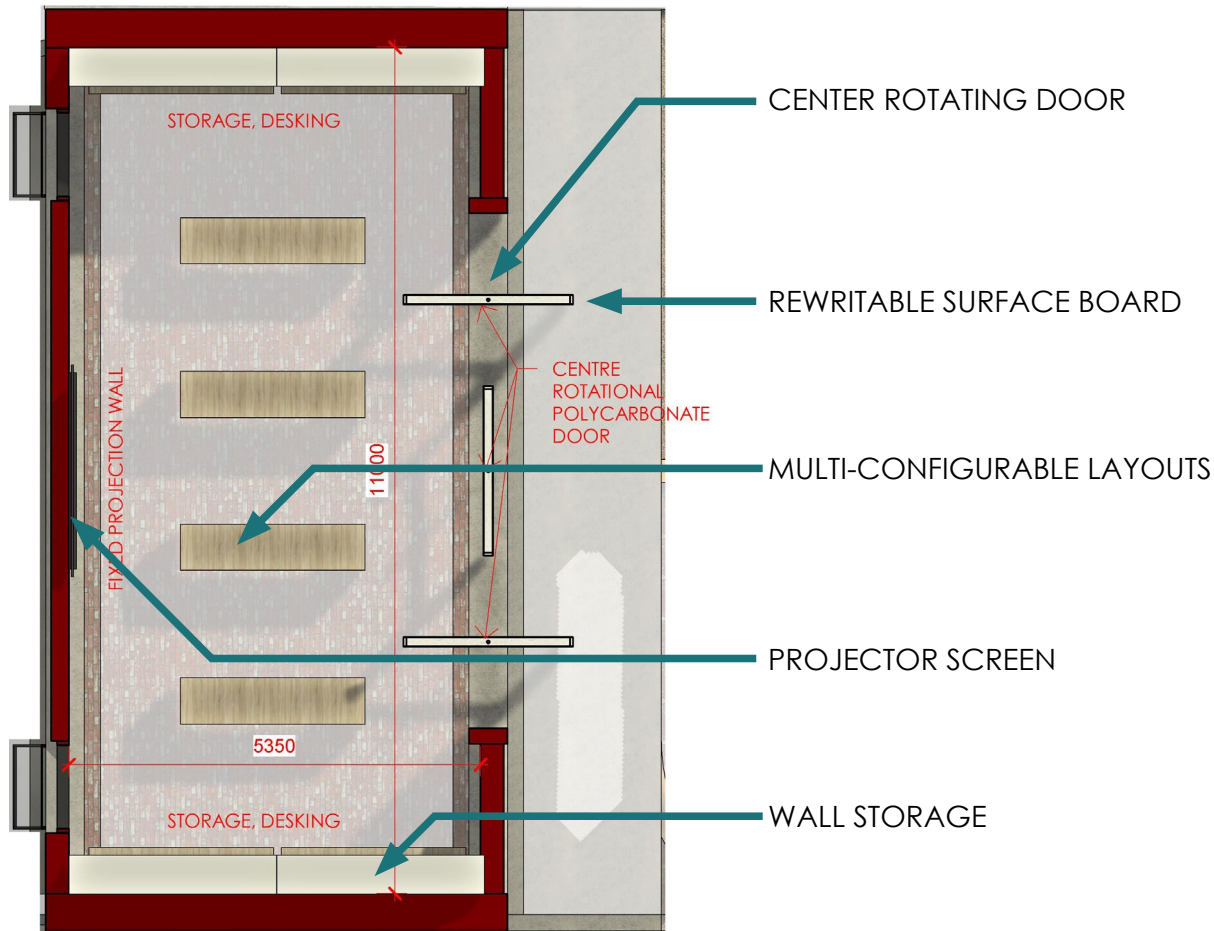


Figure 3.64 - Workshop design: Floor plan rendered, (Author, 2021)

The workshop space exposes learners to a creative environment. With minimally invasive design the space is quick to undertake new projects which teach learners about building technology or conceptualising ideas. Through a single projection learner can follow facilitators or chose their own topics of learning through a group-orientated learning process. Four large adjustable desks offer a variety of configurations and learning practice. Moreover, the spaces allow learners to document activities and present it to their peers in a process of sharing, questioning, and developing a creative learner identity.

Number of classrooms: 2

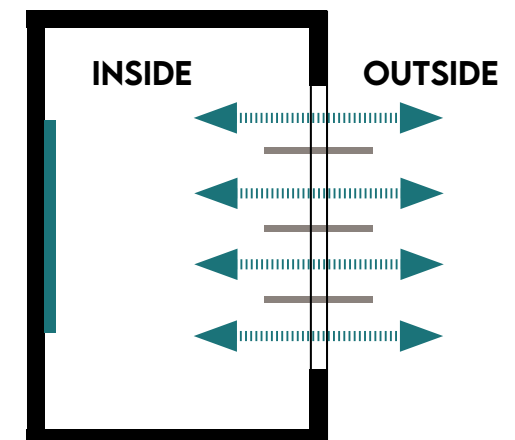
Classroom Size: 72M²

Number of Learners: 42 max.

Digital Tools:

- 1x 4k Projector which projects onto a fixed panel
- 8x Speakers (9dB Speakers, 1W, 11M²/Speaker)
- 1x Wide Angle HD Camera
- Wi-Fi Point

Interior extends to outside.
Creating larger more versatile programmes

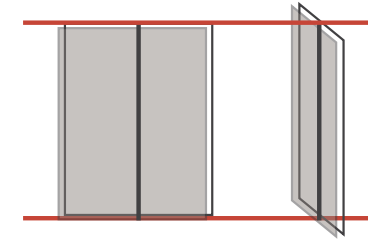


BOTTLE ACOUSTIC CEILING:

114 x 38mm Sa Pine Exterior frame with 2mm wire grid to hold compressed 2L bottle array within frame. Frame to be suspended below the lights from the trusses. Frame finish: Blue (TBC).

CENTER ROTATING DOOR:

114 x 38mm Sa Pine Exterior frame with 5mm Polycarbonate cladding. 30mm Steel Rod centre.

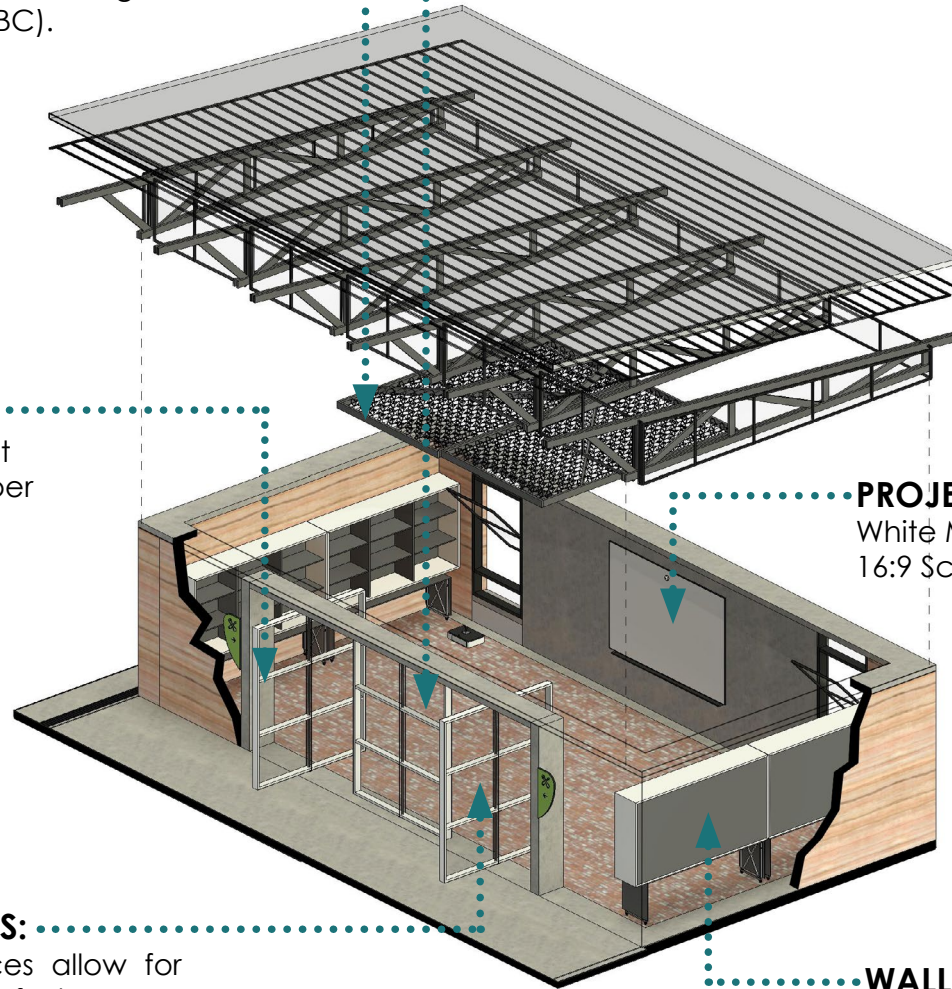


REWITABLE SURFACE:

SUNLITE Twinwall 4.5mm Transparent Polycarbonate Sheeting. Fixed as per fixing details.

PROJECTOR SCREEN:

White Melamine 2400(w) x 1800(h)mm, 16:9 Screen Ratio. Mounted to wall.



MULTI-CONFIGURABLE LAYOUTS:

Modular move-able furniture pieces allow for fast and effective arrangements of classroom layouts. The digital screen always remains the center node which ties the attention to learning.

WALL STORAGE:

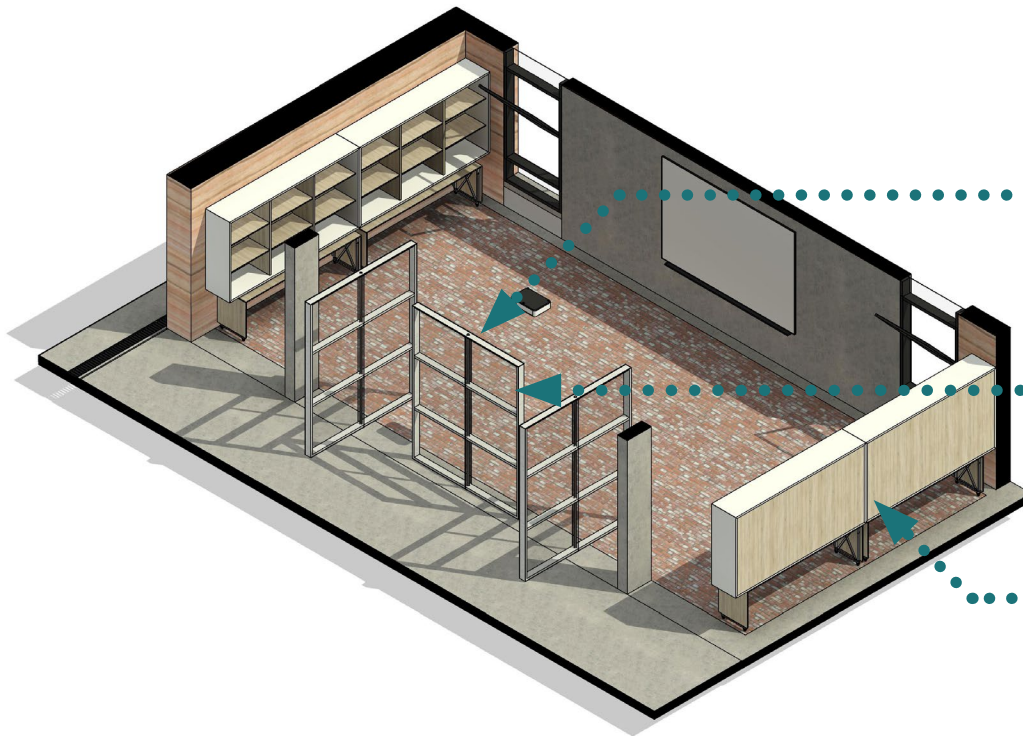
Wall Fixed open storage unit. Materials to be upcycled and fitted as per design detail.

Figure 3.65 - Workshop design: Rendered Axonometric, (Author, 2021)

3.4.13 WORKSHOP – STORED OPEN PLAN

Specified programme

Creative activity is a focus within workshops, the space offers a clear space in which activities can be adapted and manifested with deployable tools, such as computer component assembly or experimenting with new materials. Programmes will operate during the day from 07:30 to 13:30 but can still be used for further learning by students till the evening.



CENTER ROTATING DOOR:
114 x 38mm Sa Pine Exterior frame with 5mm Polycarbonate cladding. 30mm Steel Rod centre.

REWITABLE SURFACE:
SUNLITE Twinwall 4.5mm Transparent Polycarbonate Sheeting. Fixed as per fixing details.

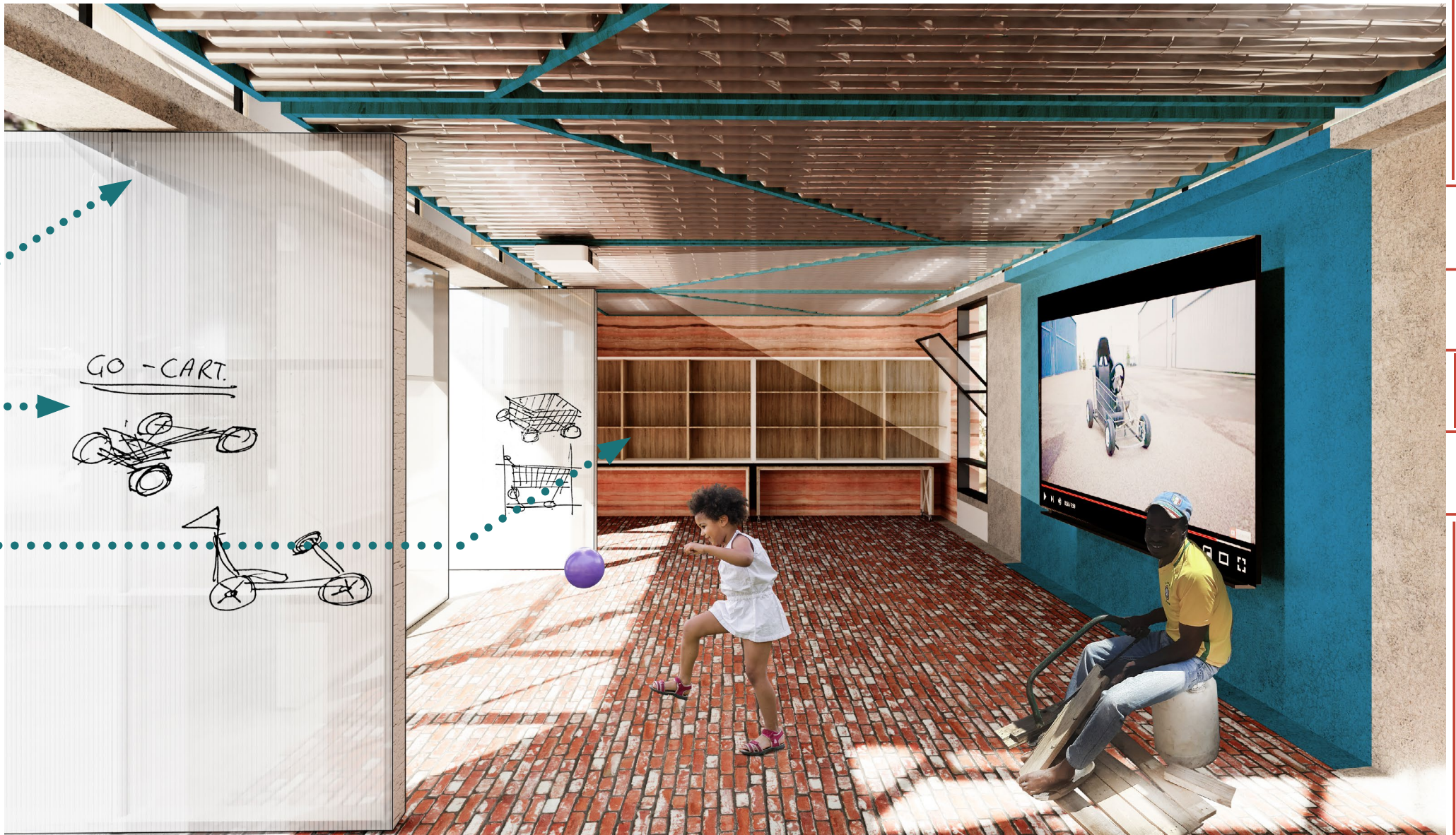
WALL STORAGE:
Wall Fixed open storage unit. Materials to be upcycled and fitted as per design detail.

Figure 3.66 -Workshop design: Stored open plan axonometric, (Author, 2021)

PERSPECTIVE

OPEN WORKSHOP SPACE

Figure 3.67 - Workshop design: Open plan rendered perspective, (Author, 2021)



CHAPTER

01

02

03

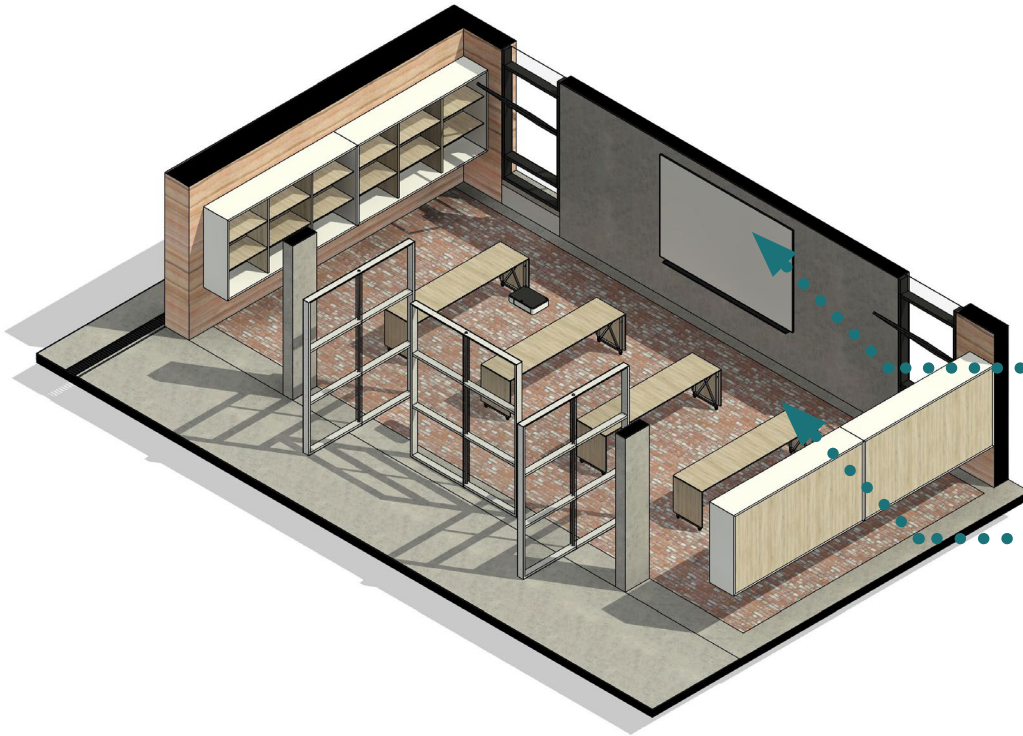
04

CREATION

3.4.14 WORKSHOP – WORKSHOP SPACE

Versatility

The workshop offers the ability to spontaneously rearrange programmes specifically aimed at expanded creative experimental learning. The digital projector allows for endless media streaming and the facilitation of teachers to connect to other communities to share practices and learn from one another.



BOTTLE ACOUSTIC CEILING:
114 x 38mm Sa Pine Exterior frame with 2mm wire grid to hold compressed 2L bottle array within frame. Frame to be suspended below the lights from the trusses. Frame finish: Blue (TBC).

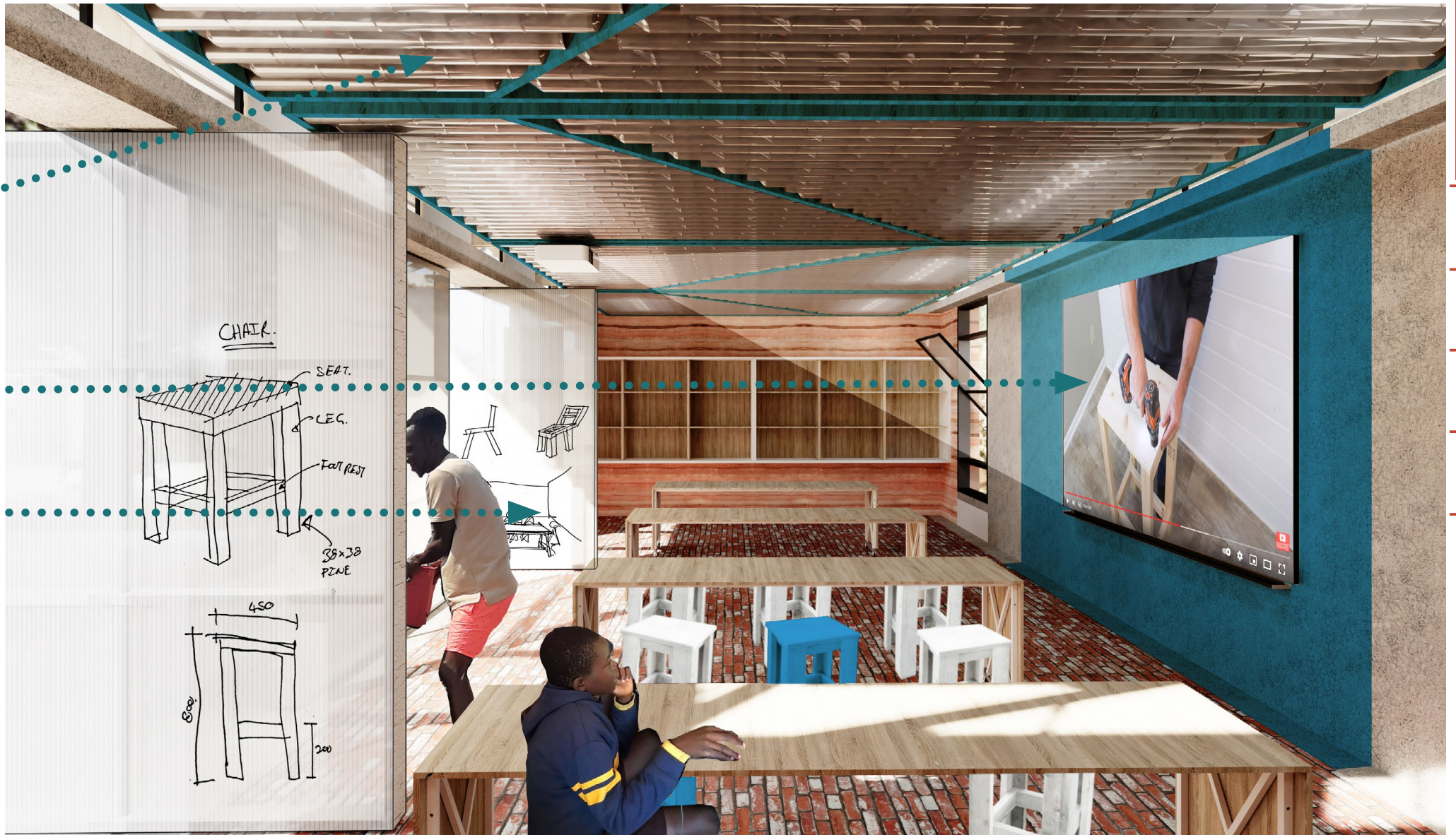
PROJECTOR SCREEN:
White Melamine 2400(w) x 1800(h)mm, 16:9 Screen Ratio. Mounted to wall.

MULTI-CONFIGURABLE LAYOUTS:
Modular move-able furniture pieces allow for fast and effective arrangements of classroom layouts. The digital screen always remains the center node which ties the attention to learning.

Figure 3.68 -Workshop design: Workshop space axonometric, (Author, 2021)

PERSPECTIVE WORKSHOP CLASS

Figure 3.69 - Workshop design: Workshop space rendered perspective, (Author, 2021)



3.4.15 WORKSHOP - BOTTLE ACOUSTIC CEILING

Description

The bottle acoustic ceiling aims to upcycle locally collected 2 litre bottles in order to create a semi-transparent ceiling feature which difuses artificial lighting as well as reducing noise by absorbing sound and refracting it. This is further technically designed in Figure 3.71 on the following page.

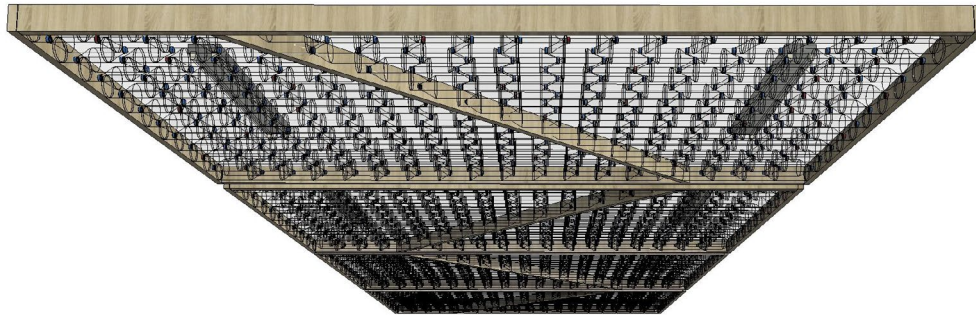
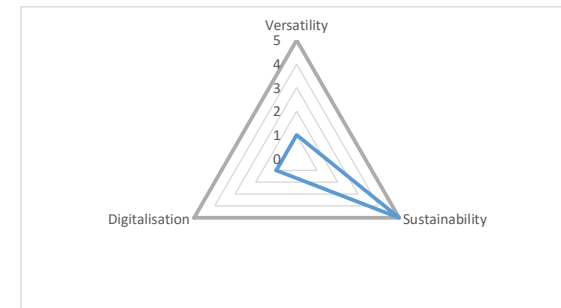


Figure 3.70 - Workshop detail: Bottle acoustic ceiling, (Author, 2021)

WORKSHOP: BOTTLE ACOUSTIC CEILING			ACHIEVED
	Potential	Actual	2,33
	5	0	
Indicators			
Versatility	5	1	
Sustainability	5	5	
Digitalisation	5	1	



Criteria

Indicator: Versatile Design		
Versatile in function within an educational environment		
	Potential	Actual
Mixed-age usage	2	0
Easily Moveable	1	0
Easily Stored	1	0
Modular	1	1

1

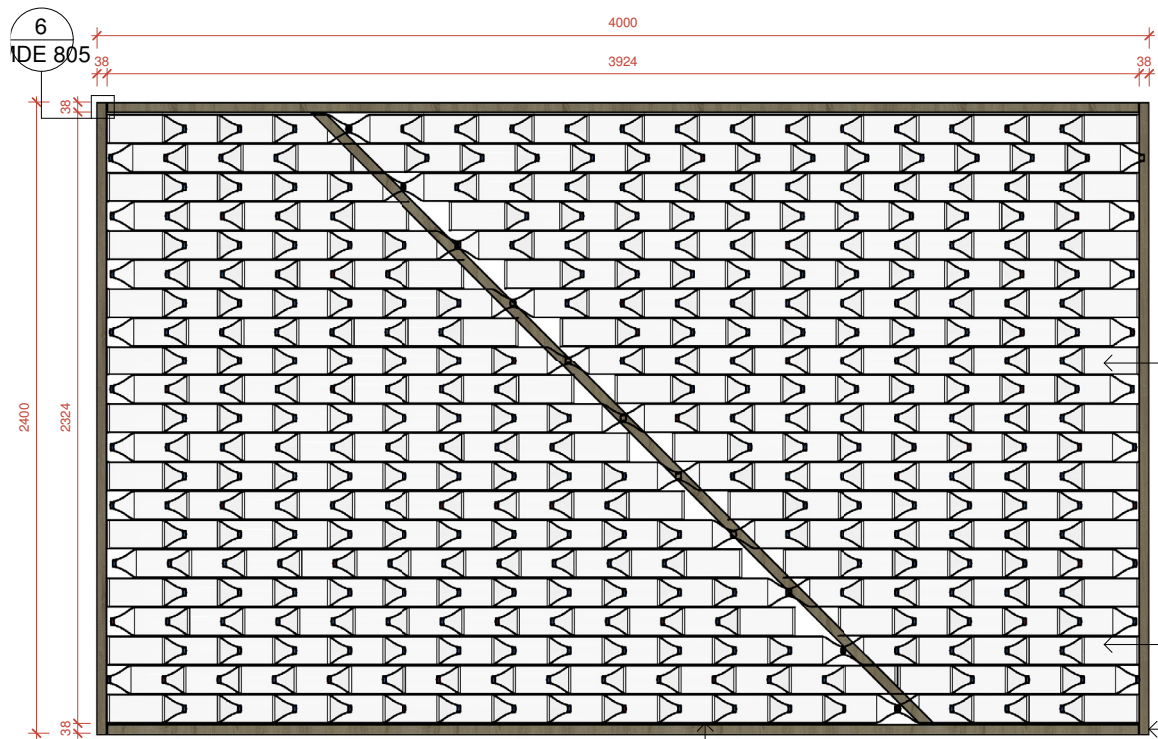
Indicator: Sustainable Design		
Sustainable manufacturing and impacts		
	Potential	Actual
Local labour	2	2
Locally sourced material	1	1
Scalability	1	1
Interior Safe	1	1

5

Indicator: Digitalisation		
How digital technology is integrated		
	Potential	Actual
Is digital or can be activated	2	0
Allows for digital add-ons	1	0
Real/Vitual integration	1	0
Interacts with other digital tools	1	1

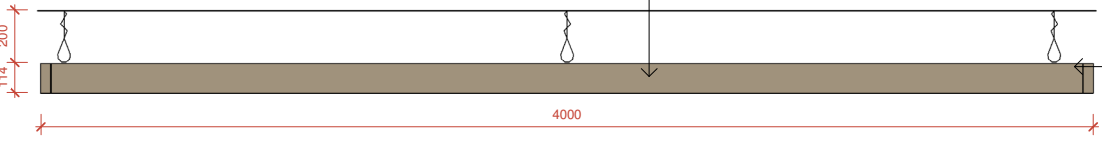
1



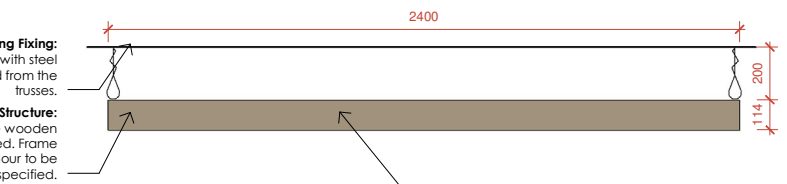


1 PLAN
1 : 20

Bottle Ceiling Acoustic Panel: 114 x 38mm Sa Pine Exterior frame with 2mm wire grid to hold compressed 2L bottle array within frame. Frame to be sanded and colour to be specified. Frame finish: Blue (TBC).



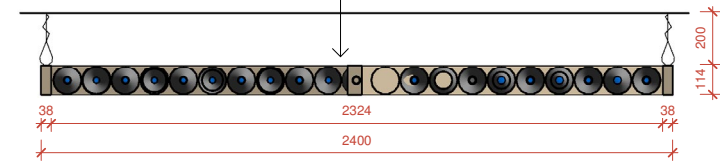
4 LONG SIDE
1 : 20



2 SHORT SIDE
1 : 20

Ceiling Fixing: Corners to be fixed with steel wire and suspended from the trusses.
Wood Structure: 114 x 38mm Sa Pine wooden frame to be repurposed. Frame to be sanded and colour to be specified.

Bottle Ceiling Acoustic Panel: 114 x 38mm Sa Pine Exterior frame with 2mm wire grid to hold compressed 2L bottle array within frame. Frame to be suspended below the lights from the trusses. Frame finish: Blue (TBC).

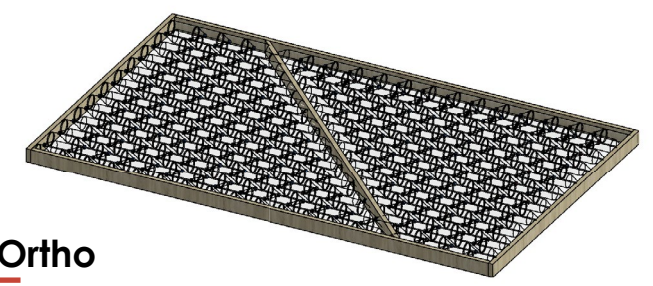


3 SECTION
1 : 20

Plastic Embodied: 380 2l Bottles Upcycled PET Plastic

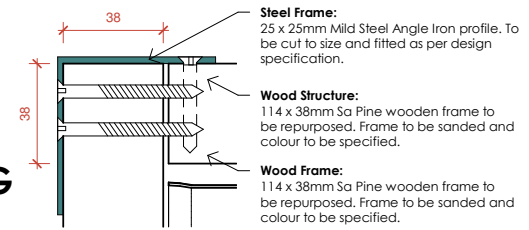
2L Bottle: Upcycled 2l bottles, 50mm end cut off, which fitted into each other. 2mm steel wire fed through the center to fix to the timber frame.

Wood Structure: 114 x 38mm Sa Pine wooden frame to be repurposed. Frame to be sanded and colour to be specified.



5 3D Ortho

Wood Structure: 114 x 38mm Sa Pine wooden frame to be repurposed. Frame to be sanded and colour to be specified.



6 CORNER FIXING
1 : 2

Steel Frame: 25 x 25mm Mild Steel Angle Iron profile. To be cut to size and fitted as per design specification.

Wood Structure: 114 x 38mm Sa Pine wooden frame to be repurposed. Frame to be sanded and colour to be specified.

Wood Frame: 114 x 38mm Sa Pine wooden frame to be repurposed. Frame to be sanded and colour to be specified.

Figure 3.71 - Workshop detail: Bottle acoustic ceiling technical resolution, (Author, 2021)

3.4.16 WORKSHOP - ROTATIONAL DOORS

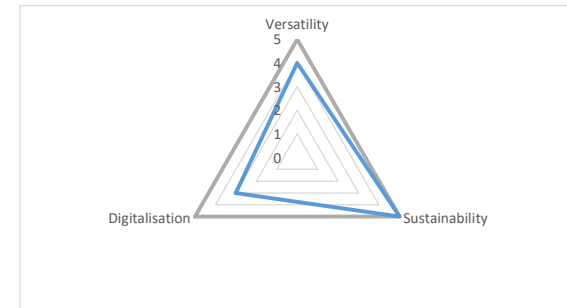
Description

Writable door panels rotate on a singular axis allowing for dynamic versatility, either closing the workshop of creating group learning spaces where learners can sketch, draw, and conceptualise on the polycarbonate sheeting doors. This is further technically designed in Figure 3.73 on the following page.



Figure 3.72 - Workshop detail: Rotational doors, (Author, 2021)

WORKSHOP: SWIVEL DOOR			ACHIEVED
	Potential	Actual	4
	5	0	
Indicators			
Versatility	5	4	
Sustainability	5	5	
Digitalisation	5	3	



Criteria

Indicator: Versatile Design		
Versatile in function within an educational environment		
	Potential	Actual
Mixed-age usage	2	2
Easily Moveable	1	1
Easily Stored	1	0
Modular	1	1

4

Indicator: Sustainable Design		
Sustainable manufacturing and impacts		
	Potential	Actual
Local labour	2	2
Locally sourced material	1	1
Scalability	1	1
Interior Safe	1	1

5

Indicator: Digitalisation		
How digital technology is integrated		
	Potential	Actual
Is digital or can be activated	2	2
Allows for digital add-ons	1	0
Real/Vitual integration	1	0
Interacts with other digital tools	1	1

3



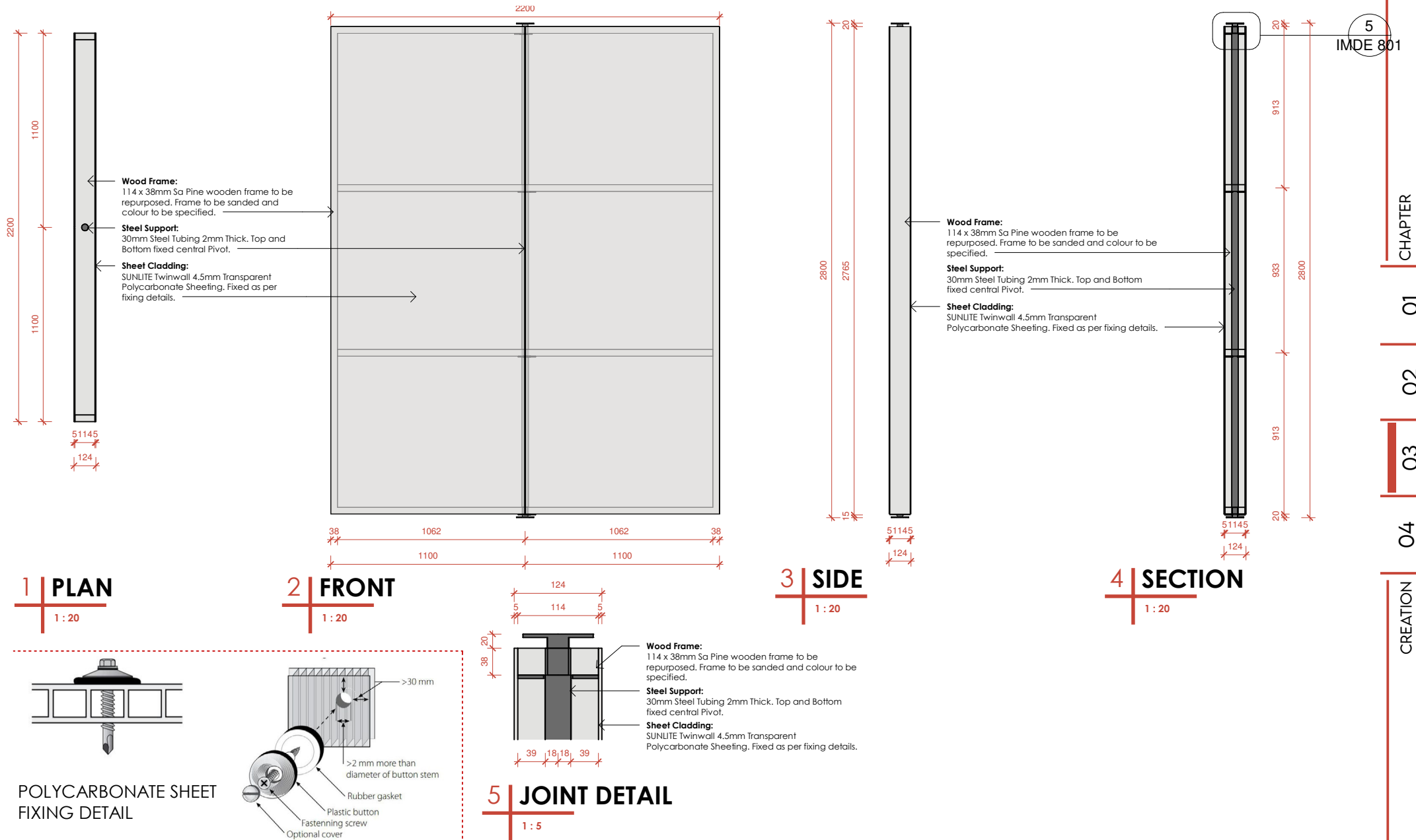
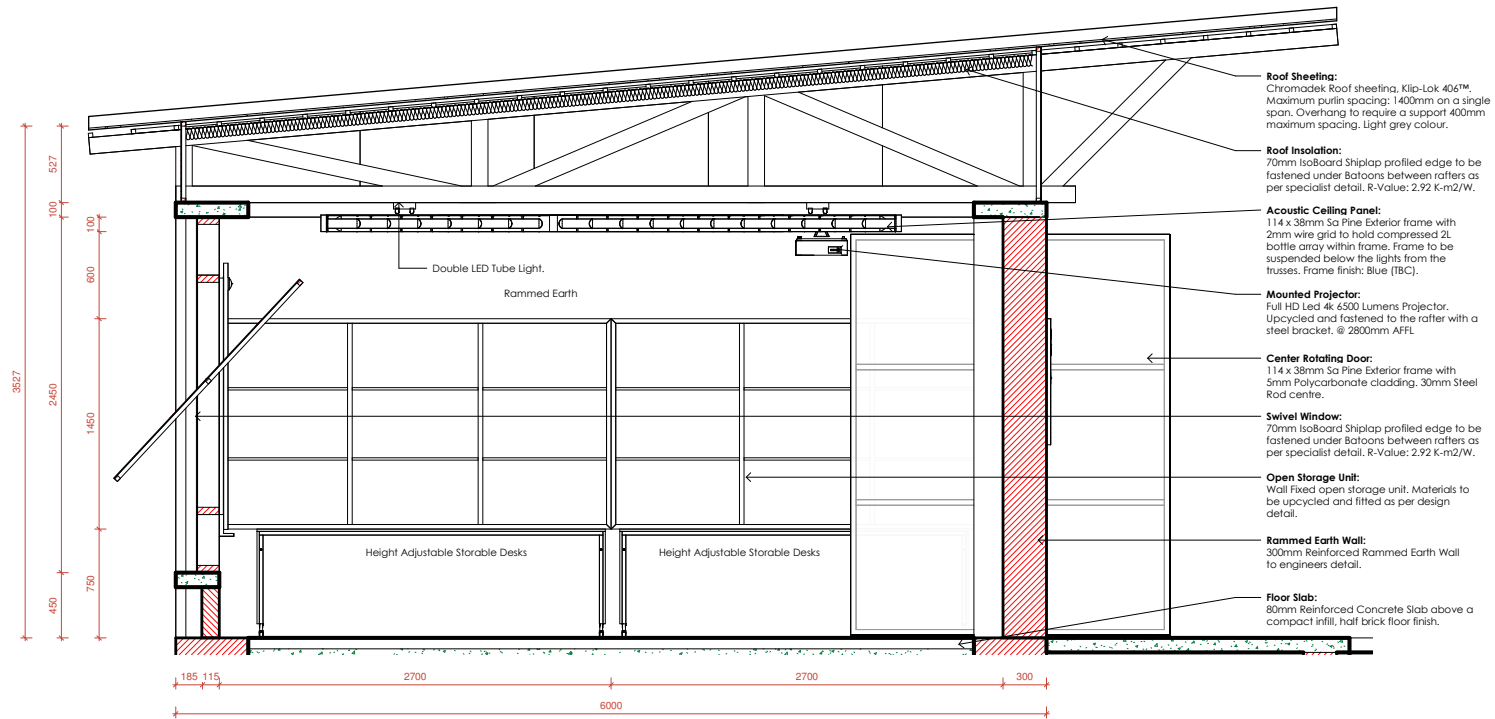


Figure 3.73 - Workshop detail: Rotational doors technical resolution, (Author, 2021)

3.4.17 WORKSHOP - SECTIONAL DETAILS



1 | 03 WORKSHOP AA

1:20

Figure 3.74 - Workshop section 1: section detail interior, (Author, 2021)



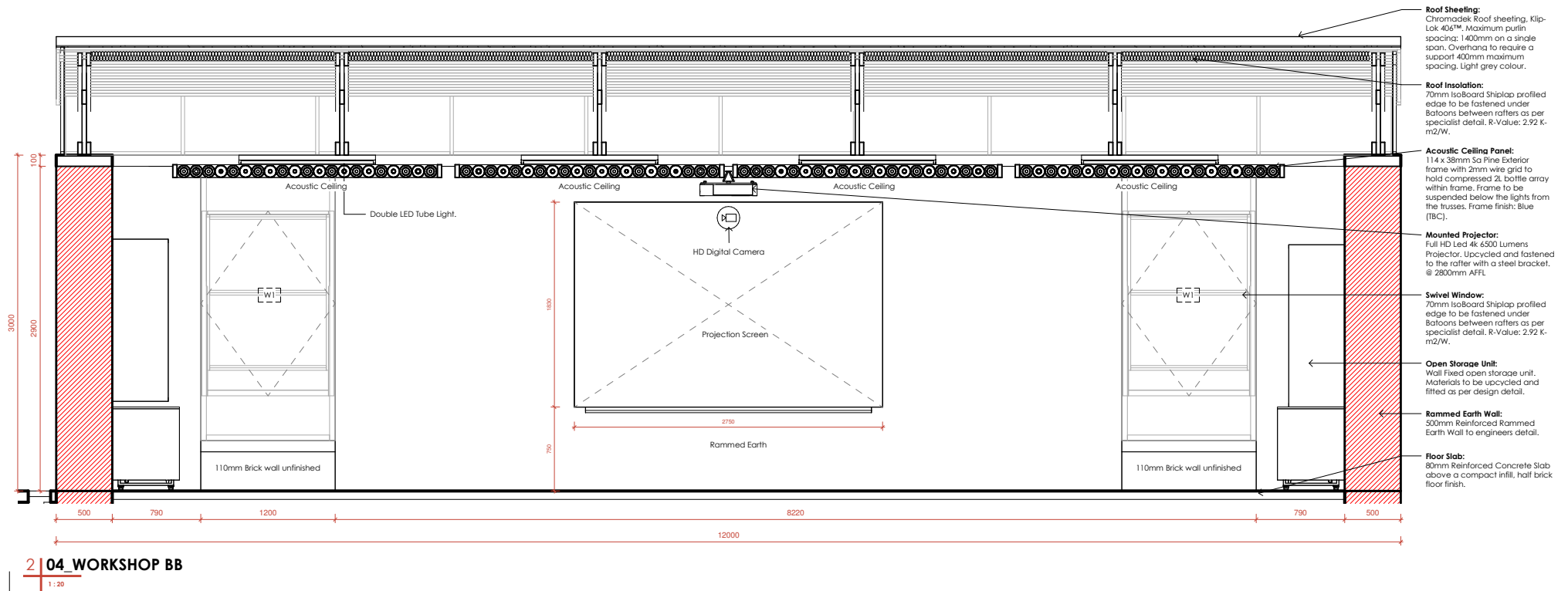


Figure 3.75 - Workshop section 2: section detail interior, (Author, 2021)

3.4.18 PLAYGROUND - DESIGN TO TECHNICAL

Number of versatile playgrounds: 3 (multiple layouts)

Classroom Size: 3200M²

Number of Learners: 20 – 200 max.

Digital Tools:

- 8x HD Zoomable cameras
- 8x Low angled proximity sensors
- 16x VR boundary Sensors
- 8x Waterproof outdoor speakers
- 2x Deployable projector screens and projectors
- Wi-Fi Point

The playground promotes existing sporting activities with the integration of technology. Learners through existing practices of sport subdivide the field according to their needs, thus no set lines will define boundaries, but a series of digital sensors and markers, will allow for a digital mesh to be subdivided as per user's needs, giving them agency of their sport and game activities.

MESH NETWORK

- Virtual mesh over real field
- Connects users to digital network.
- Smart Sports

VIDEO CAMERA

- Recorded footage
- Digital Facilitators
- Replay stored in library

SPEAKERS & SENSORS

- Sound expressed sports "Goal"
- Virtual coach



Figure 3.75 - Playground design: design objective axonometric, (Author, 2021)



PERSPECTIVE

SOCCER FIELD

Figure 3.76 - Playground design: Open field rendered perspective, (Author, 2021)



CHAPTER

01

02

03

04

CREATION

3.4.19 PLAYGROUND - DESIGN TO TECHNICAL

OPEN FIELD

The existing open field offers a infinite number of possible programmes. Programmes include sports, markets, gatherings, and events. Through digital technology the field can be enabled further. Tech could include projectors, sensors, wifi, Bluetooth, VR (Virtual Reality), and AR (Augmented Reality).

VERSATILE PLAYGROUND

No tangible boundaries of field lines define activities, allowing users to seamlessly formulate their own boundaries through objects such as buckets, stones, or a digital interface.

DIGITAL PLAYGROUND

Through a series of sensors, speakers, and camera's the field becomes digitally enabled. Collectively the technology wirelessly connects users to the virtual world.

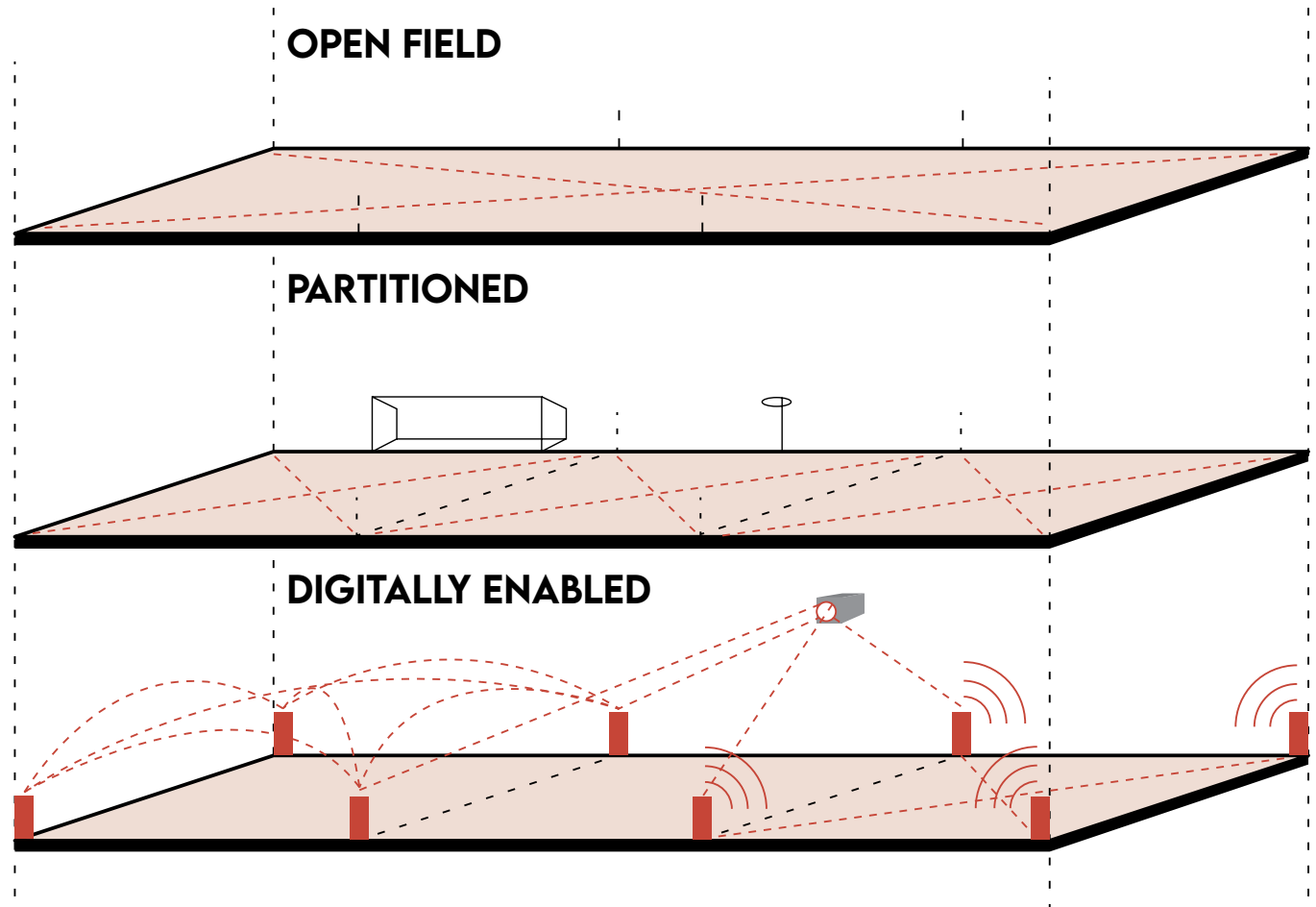


Figure 3.77 - Playground design: spatial diagram, (Author, 2021)

SPORTS FIELD

Sports and outdoor activities form a large part of learners' lives whether it occurs within the streets or on the soccer field. By augmenting and integrating digital technology, learners can have more agency over their playgrounds, growing and developing a physical world into an endless digital playground. Children can partake in existing sports like soccer, rugby, or athletics, while being monitored by camera systems.

PERSPECTIVE SPORTS FIELD

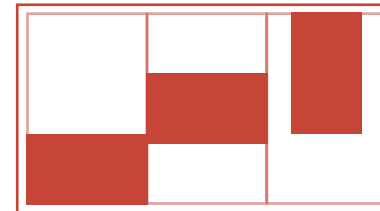
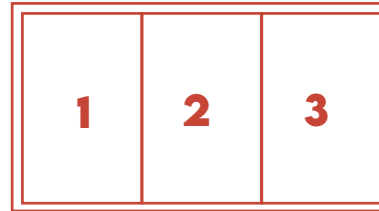
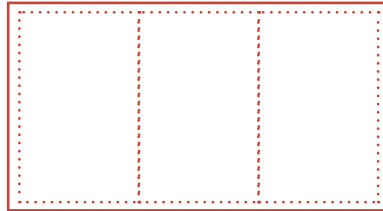


Figure 3.78 - Playground design: sports field rendered perspective, (Author, 2021)

3.4.20 FIELD MARKETPLACE

The open field creates an opportunity to unite the youth development centre to the community. The field being the mediator within the community can offer many events, markets, and gatherings. This invites the community's engagement and brings everyone together. Through digital technology exhibitions can be displayed, markets can be hosted on site and offline, and the community can share experiences.

PERSPECTIVE FIELD MARKET

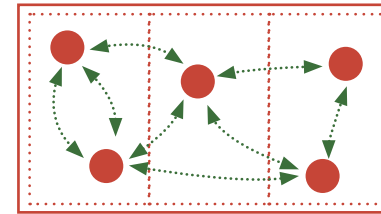
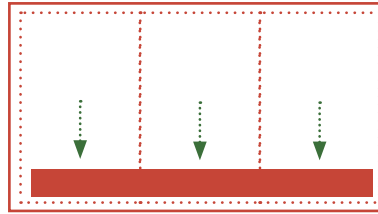
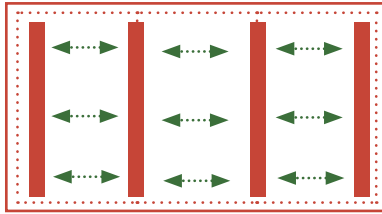
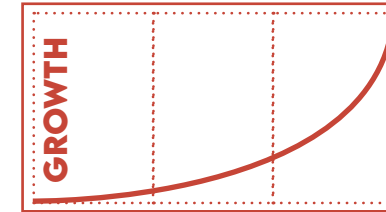
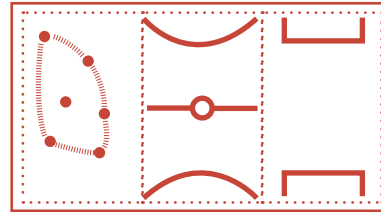
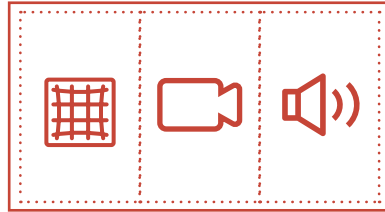


Figure 3.79 - Playground design: field market rendered perspective, (Author, 2021)



3.4.21 DIGITAL PLAYGROUND

Digital technology aims to integrate and upgrade endless programmes and sports. Learners can play sports and a digital coach can teach them new skills and monitor their progress.

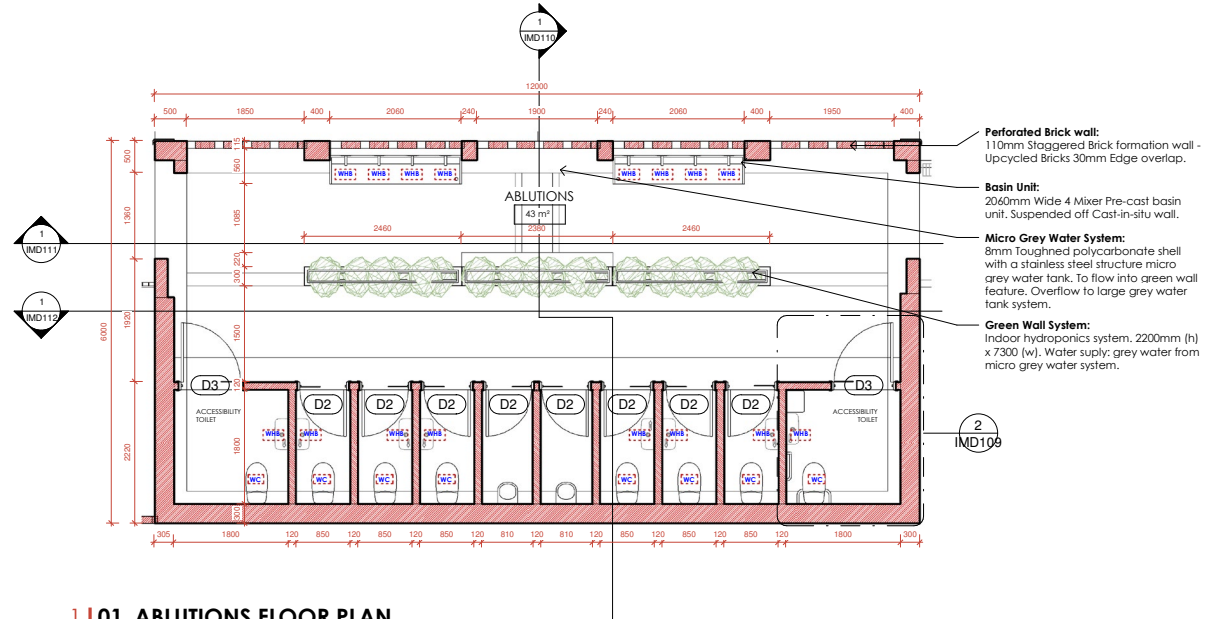


PERSPECTIVE DIGITAL PLAYGROUND

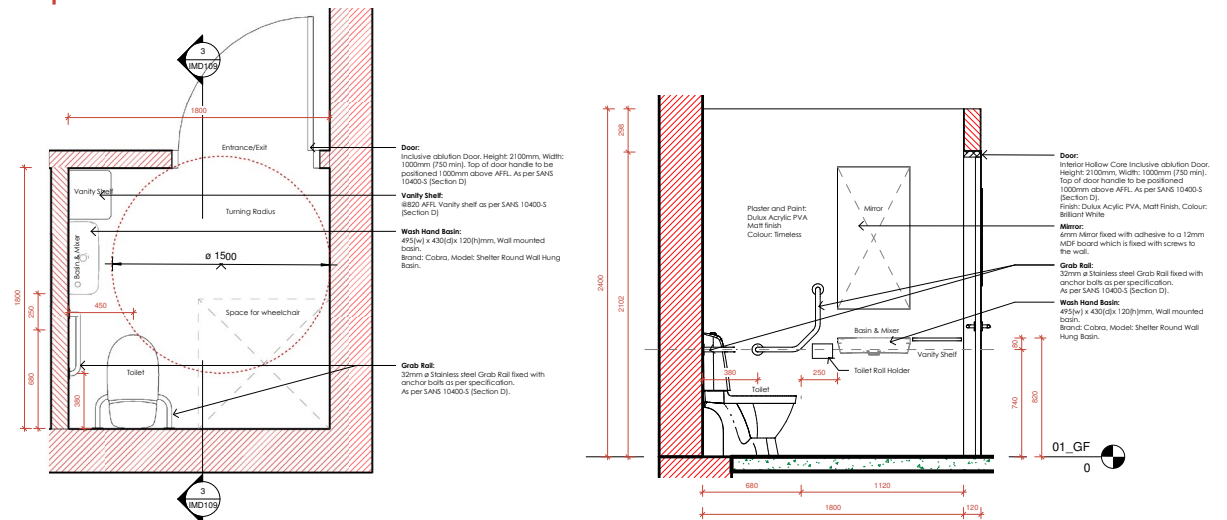


Figure 3.80 - Playground design: digital playground rendered perspective, (Author, 2021)

3.4.22 ABLUTIONS - DESIGN TO TECHNICAL



1 | 01_ABLUTIONS FLOOR PLAN



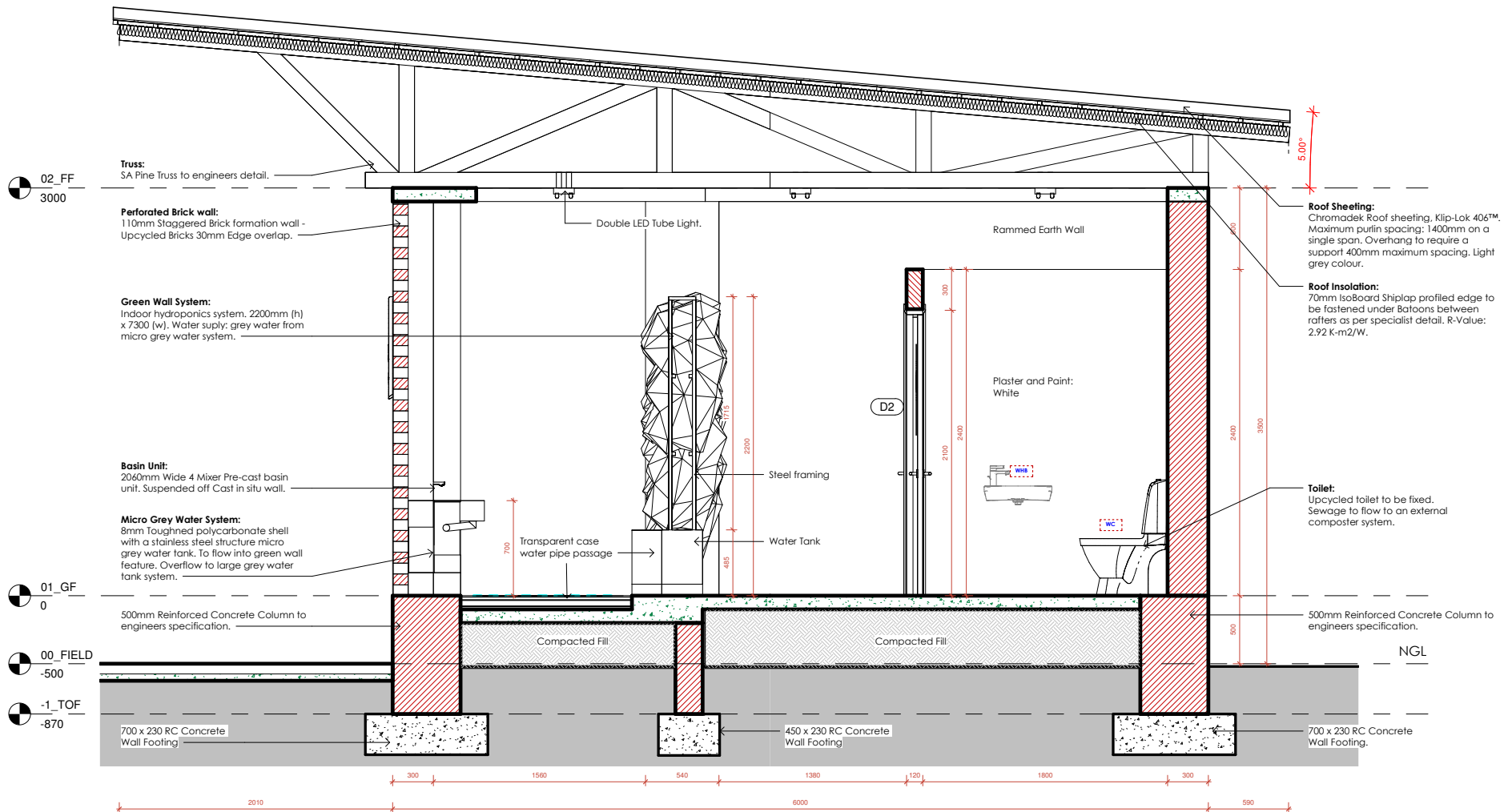
2 | 01_ACCESSIBILITY TOILET

3 | ACCESSIBILITY SECTION



Figure 3.81 - Ablution design: Interior rendered perspective, (Author, 2021)

Figure 3.82 - Ablution detail: Floor plans, accessibility toilet, (Author, 2021)

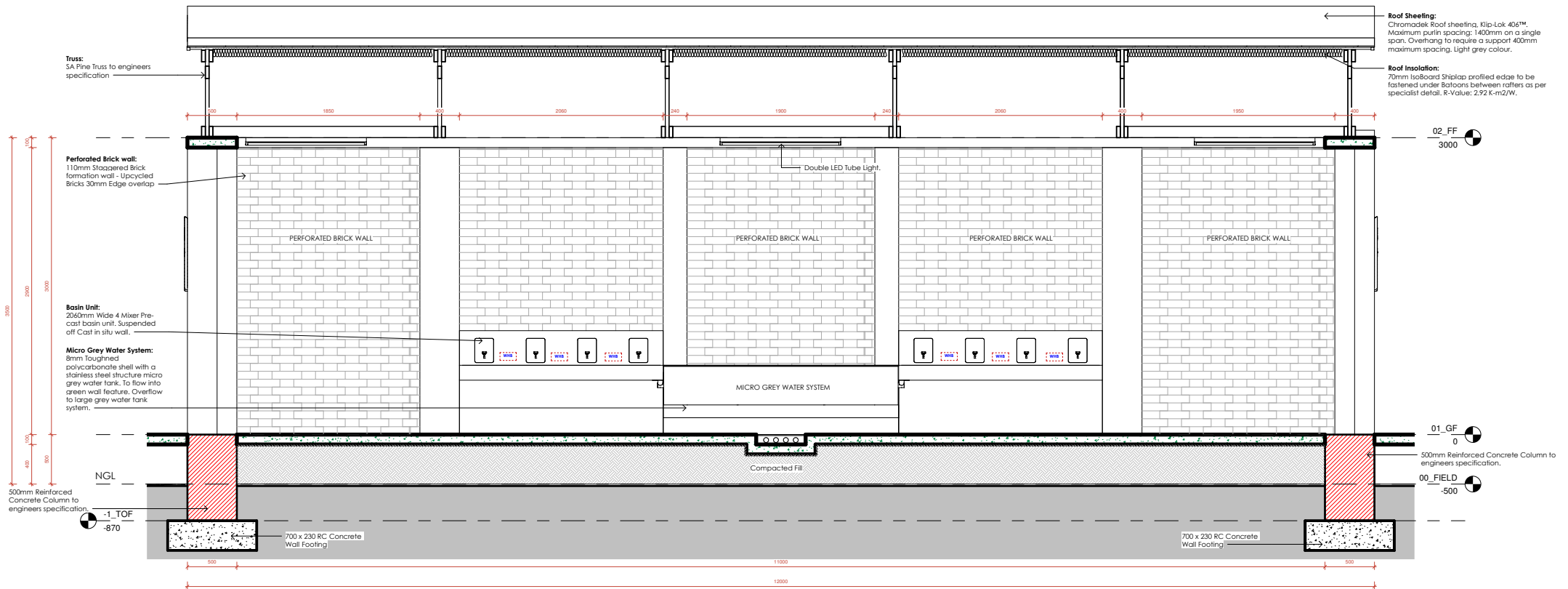


1 | 05_ABLUTION SECTION AA

1:20

Figure 3.83 - Ablution section AA: sectional detail interior, (Author, 2021)

3.4.23 ABLUTIONS - SECTIONAL DETAILS



06_ABLUTION SECTION BB

1:20

Figure 3.84 - Ablution section BB: sectional detail interior, (Author, 2021)



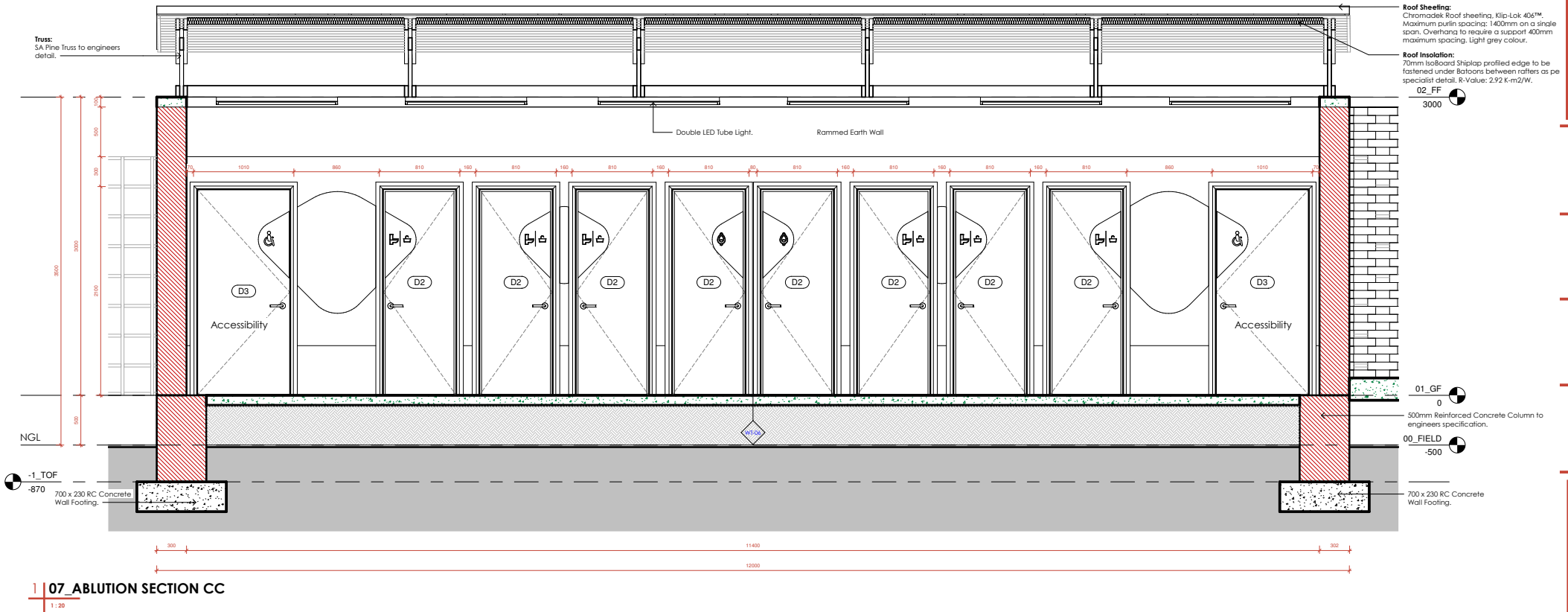


Figure 3.85 - Ablution section CC: sectional detail interior, (Author, 2021)

3.4.24 SUSTAINABLE BUILDING ASSESSMENT TOOL

Sustainable Building Assessment Tool

Moreover, testing the sustainability will be determined through the Sustainable Building Assessment Tool (SBAT). The SBAT supports a sustainable building approach to ensure a holistic sustainable performance of buildings. The focus areas address social, economic, and environmental criteria. This is specifically relevant to developing country contexts.

The use of SBAT for Imbewu Youth Development Center is to identify whether the design intervention is sustainably resolved with regards to the context, but also to use SBAT to identify any technical gaps within the design with hinders the feasibility for future intervention of digital inclusive learning facilities.

SUSTAINABLE BUILDING ASSESSMENT TOOL RESIDENTIAL

1,04

Achieved

SB SBAT REPORT

4,2

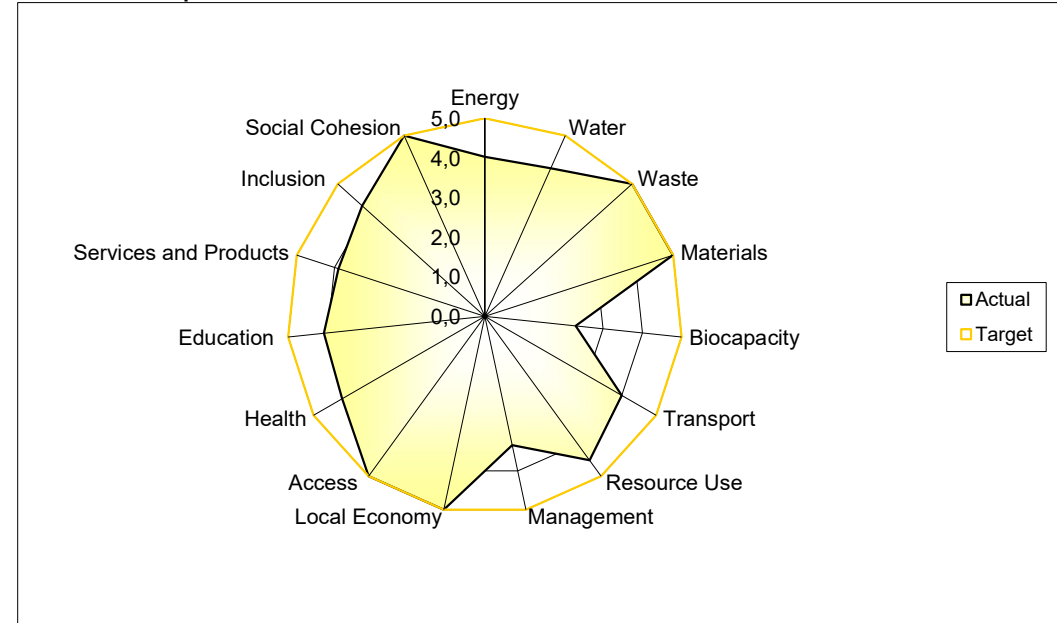
SB1 Project

IMBEWU Youth Development Center

SB2 Address

1353 De Villebois Mareuil Dr, Pretoriuspark, Pretoria, 0081

SB3 SBAT Graph



SB4 Environmental, Social and Economic Performance

Score

Environmental	4,1
Economic	4,4
Social	4,3
SBAT Rating	4,2

Figure 3.86 - SBAT testing tool results, (Author, 2021)



SUSTAINABLE BUILDING ASSESSMENT TOOL RESIDENTIAL

1,04

Test Results:

The test found that the design intervention scored high overall as a sustainable building intervention by fulfilling majority of the criteria in social, economic, and environmental sustainability.

		Target	Achieved
BI	Building Information	5,0	4,2
BI 1	Building Targets	Target	Achieved
EN	Energy	5,0	4,0
WA	Water	5,0	4,1
WE	Waste	5,0	5,0
MA	Materials	5,0	5,0
BI	Biocapacity	5,0	2,3
TR	Transport	5,0	4,0
LE	Local Economy	5,0	5,0
MN	Management	5,0	3,3
RE	Resources	5,0	4,5
SP	Services and Products	5,0	5,0
AC	Access	5,0	4,2
HE	Health	5,0	4,1
ED	Education	5,0	3,9
IN	Inclusion	5,0	4,2
SC	Social Cohesion	5,0	5,0
BI 2	Priority Key (Not Performance Key)		
VH	Very High	5,0	
HI	High	4,0	
ME	Medium	3,0	
LO	Low	2,0	
VL	Very Low	1,0	
NA	None / Not Applicable	0,0	
BI 3	Project Name		
		IMBEWU Youth Development Center	
BI 4	Address		
		1353 De Villebois Mareuil Dr, Pretoriuspark, Pretoria, 0081	
BI 5	Site Area	1800	m2
BI 6	Gross Floor Area (GFA)	1500	m2
BI 7	Gross Internal Area (GIA)	630	m2
BI 8	Number of Useable Rooms	9	
BI 9	Number of Bedrooms	0	
BI 10	Architect		
		Brendon Creighton	
		Tebelo NGO	

Figure 3.87 - SBAT testing tool detail results, (Author, 2021)

REFLECTION AND CONCLUSION



04

IMPLEMENTATION



CHAPTER INTRODUCTION

Chapter Four aims to reflect on this mini-dissertation, the process that was derived throughout the year, and the affect the project had on the author as a professional and the future within the profession.

Four

REFLECTION

4.1

Description

At the start of any investigative process a diverging process takes place, identifying a series of problems within a context. The process of unpacking “bridging the digital divide” underwent an iterative process, firstly by understanding the community and later integrating possible proposals which best suited the context. Moreover, after expert interviews were conducted it was clear that there was an educational divide which stems from socio-economic variables within the context of Plastic View, the need to assist immigrant learners was evident, and conventional educational paradigms were evidently not viable.

In an iterative process the project originally aimed to assist learners and their ability to find identity and role within society, especially owing to the negative environment of an informal settlement. Through the analysis of precedents, it was obvious that to provide a solution for learners, it would need to be integrated into everyday rituals, thus it led the intervention being on site and introduced digital technology.



4.1.2 SITE VISITS

Site visits

Site visits became a key component to understanding the community, thus an auto-ethnographic study took place. The selected research methodology, “Field Research Guild” – IDEO gave a concise structure that was used to document the community ethically. This methodological approach can be viewed in the figure below.

At first, it was challenging to grasp the circumstances which residents within the community face. The challenge as a researcher was to not be too emotionally involved but remain professional during interviews. During the on-site research process, I found that it was to an extent consuming my daily life emotionally. But, with guidance was overcome by setting strict goals and strategies when conducting site visits. Some challenges during site visits can be viewed below.

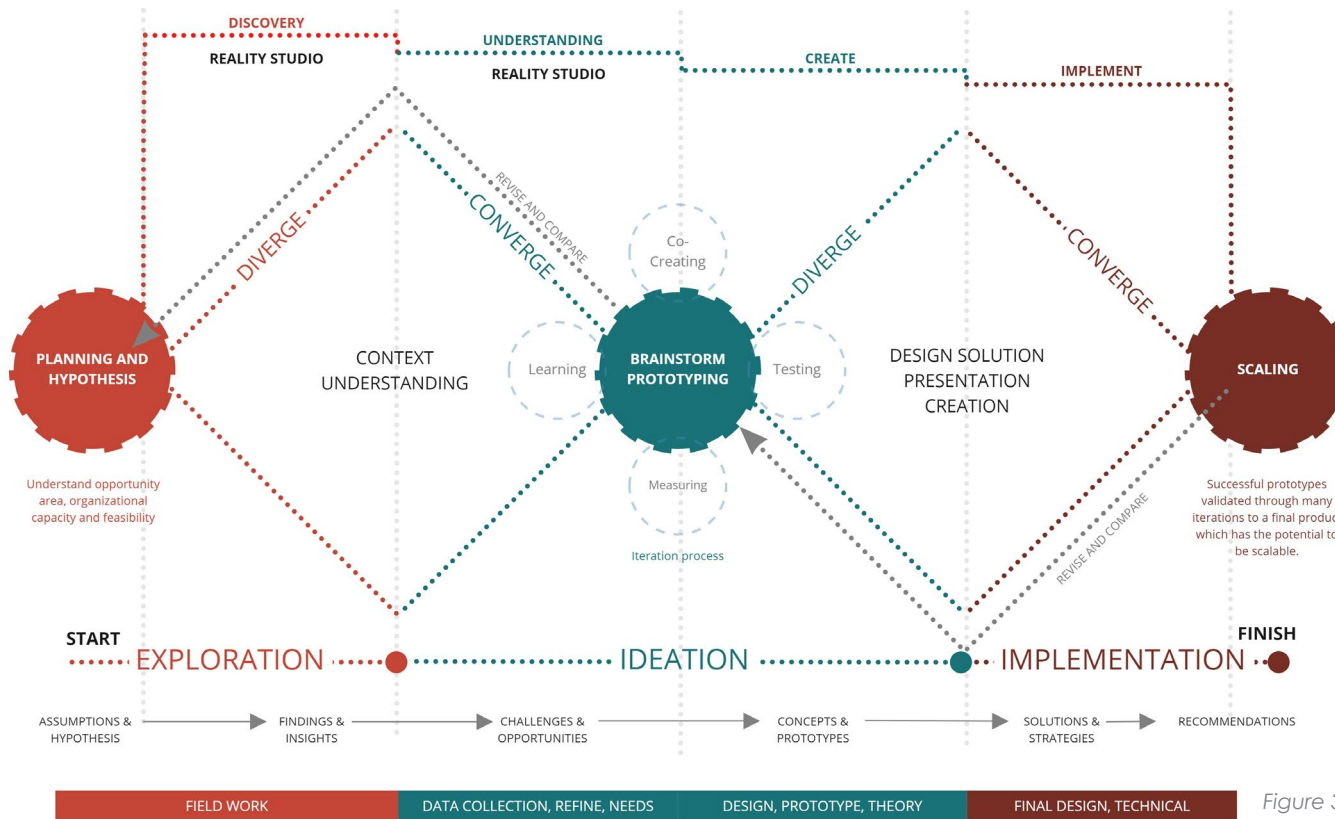


Figure 3.88 - Methodology reflection, (Author, 2021)

4.1.2 EVALUATION & ITERATION

Adapting and overcoming

A human-centred design process promoted an iterative design. The design process originally began from an expert intervention with a programme in mind but had an absent consideration for user ergonomics and experience. By creating a refined building programme balanced by theory and context, the design created offers a solution which becomes contextually relevant in material use, the user, and the client requirements in creating a flagship.

An iterative learning processes

Moreover, it can be noted that the biggest challenge was to trust the process of iteration, for iteration creates a refined design which carries poetic and symbolic meaning in all aspects. It allows for the combination of elements and elimination of unnecessary components, which is vital when focusing on user needs and a vulnerable context such as an informal settlement.



4.1.3 KEY LEARNINGS

Through extensive research and investigation, it was found that there are few guidelines to prepare a researcher for vulnerable community investigations. Thus, it was important to fully understand the community by immersion oneself and analysing the environment and the community empathetically in order to create a human-centred research approach. Some of the key tools learnt this year include:

Digital learning

As technology continues to develop and communities further fall behind in the digital divide, it is important to not forget the potential for technological possibility to assist vulnerable communities. With many students unable to gain access to school, a non-geographical classroom is possible. Moreover, technology made it possible for universities to continue online learning and can be noted that online communities are essential to remain motivated. Bringing a humanised aspect to learning such as online discussions and group sessions to stimulate emotional and intellectual learning.

Exerts advice

Through detailed research investigation it can be difficult to identify key informants within the context of investigation owing to the lack of time or experience. Existing organisations and on-site experts offered valuable insight in refining questions and getting solid facts about Plastic View. Tebelo NPO assisted a lot in gaining insight into possible solutions and aligning with their goals gave a good foundation for a design resolution. Some examples of the criteria of Tebelo included urban farming, multi-aged classrooms, funding, and a sustainable repetitive solution.



FROM ACADEMIC TO PRACTICE

Normative Position

A human-centred design approach is an approach which swallows, chews, and then reconstructs any misconceptions of researchers. In any design approach, experts creatively piece together design solutions with existing knowledge and a client brief, but this approach is primarily expert driven. This year has allowed me to test my normative position, through a process of understanding the livelihoods, rituals, and circumstances of a new community through an empathetical lens. Consequently, it was found that precedents are the most important way of comparing and analysing a researcher's own on-site experiences and research discovered of communities. Precedent's students in conjunction with on-site research, assist a designer in "fill the gaps" to design appropriately, most often, a unique circumstance most often has previous historical similarities.

Career stance before and after

Within a constrained year of digital and on-line learning the most important tool learnt was the power of consistent research and developing ideas in an iterative process. Within industry, research for the most part is secondary, where I believe that if research is applied within design, it contributes to one's industry, but also reduces iterative mistakes and creates new avenues of design possibility led by research.

The university's programme of urban citizenship familiarises students within informal settlements and the endless opportunities of potential stored within communities. This exposure showed the contextual issues which are local to our communities and are easily ignored. Thus, I would like to continue working with vulnerable communities in the future especially in collaboration with Tebelo, Living Word, and NG Moreleta Church. As designers we have an inherent ability to solve problems, inform communities are constantly growing and the urban fabric will require a designer's intervention and not left for society to segregate fellow people.



CONCLUSION

4.2

In conclusion informal settlements are a wicked problem with constant new urban constraints. Urban informality will always create strain on city services and illegal land occupation, but learners who grow up within vulnerable communities should have the right to an education. The bridging of the digital divide has proven not only in the past, but also during the time of a pandemic such as COVID-19, that educational practices through digital tools not only allow for the access to education, but a faster more personalized learning operation. Digital education should be user-centred and allow for adaptive learning styles with various user interfaces to not segregate learners, but to allow for virtual spatial agency to entice learning.

Within vulnerable communities such as urban informal settlements, indigenous learning practices should be forgotten within digital education, but should be motivated through existing leaning practices such as group conversations and exploratory learning. An architectural interface becomes the platform where indigenous learning practices are extended through digital learning and can offer a versatile functionality where learners can seamlessly shift between real and virtual space, but also have a learning environment which is contextually able to offer multiple programmes.

Thus, the digital divide is an appropriate conduit through which a design intervention can be contextually introduced, and will enable the youth of today, to enable the future informality in the future.

WORD COUNT:

12 894 words

BIBLIOGRAPHY

5.1

- Statistics South Africa. 2017. General Household Survey. [Online]
Available at: <http://www.statssa.gov.za/publications/P0318/P03182017.pdf>
[Accessed 07 03 2021]
- Becker, S., Coward, C., Crandall, M., Sears, R., Hasbargen, C., Hasbargen, K. 2012. Building Digital Communities: A Framework for Action. Washington: institute of Museum and Library Services.
- Blaschke, L. M. 2012. Heutagogy and lifelong learning: A review of hauntological practice and self-determined learning. *The International Review of Research in Open and Distance Learning*, 3(11), pp. 1378-1386.
- Brouwers, J. H. A. M. 1993. Rural people's response to soil fertility decline: The Adja case (Benin), 93(4).
- DC Design. 2017. What Is Human-Centered Design? [Online]
Available at: <https://medium.com/dc-design/what-is-human-centered-design-6711c09e2779>
[Accessed 18 03 2021].
- Department of Health (RSA). 2021. About COVID-19 (Coronavirus). [Online]
Available at: <https://sacoronavirus.co.za/information-about-the-virus-2/> [Accessed 27 04 2021].
- Donald, D., Lazarus, S. & Lolwana, P. 1997. Educational Psychology in Social Context. In: *Challenges of Development, Social Issues & Special Need in Southern Africa*. Cape Town: Oxford University Press.
- Edmonds, A. W. & Kennedy, T. D. 2017. Ethnographic Perspective. In: *An Applied Guide to Research Designs: Quantitative, Qualitative, and Mixed Methods*. s.l.:SAGE, pp. 149-163.
- Fernandez, M. E. 1994. Gender and indigenous knowledge. *Indigenous Knowledge & Development Monitor*, Volume 2, pp. 6-7.
- Foth, M. 2009. *Handbook of Research on Urban Informatics: The Practice and Promise of the Real-time City*. Queensland: IGI Global.
- Hanna, L. 2008. Designing Electronic Media for Children. In: R. Lueder & V. J. Berg Rice, eds.



Ergonomics for Children. New York: Taylor & Francis, pp. 753-780.

Hettiarachchi, A. A. & Nayanathara, A. S. 2017. The effect of classroom colour on learning with reference to primary education; a case study in Sri Lanka. Colombo, International Conference on Global Education and E-Learning.

Hole-in-the-wall. 2015. A New Way to Learn. [Online]
Available at: <http://www.hole-in-the-wall.com/new-way-to-learn.html> [Accessed 21 04 2021].

IDEO. 2015. The Field Guide to Human-Centered Design: Design Kit. 1st Edition ed. Canada: IDEO.

Karasti, H. 2001. Increasing Sensitivity towards Everyday Work Practice in System Design.

Knauf Ceiling Solutions. 2021. AMF THERMATEX Sonic Arc. [Online]
Available at: <https://www.knaufceilingsolutions.com/en/products/amf-thermatex-sonic-arc/> [Accessed 10 11 2021].

Lembani, R., Gunter, A., Breines, M. & Dalu, M. T. B. 2019. The same course, different access: the digital divide between urban and rural education students in South Africa. *Journal of Geography in Higher Education*, 44(1), pp. 70-84.

Maganga, M. 2021. Interior Wellbeing: The Design of Educational Spaces. [Online]
Available at: <https://www.archdaily.com/959085/interior-wellbeing-the-w-of-educational-spaces> [Accessed 10 07 2021].

Mahnke, F. H. 1996. Color, environment, & human response. New York: Wiley.

Marcia, J. E. 1980. Identity in Adolescence. In: *Handbook of Adolescence Psychology*. New York: Wiley & Sons, pp. 109-130.

Marutlulle, N. 2017. Causes of informal settlements in Ekurhuleni Metropolitan Municipality: An exploration. *Africa's Public Service*

Delivery and Performance, Review 5(1) (<http://dx.doi.org/10.4102/apsdpr.v3i4.101>), p. 131.

Mitchell, J. W. 1995. *City of Bits Space, Place, and the Infobahn*. Cambridge: MA: The MIT Press.

Mitchell, J. W. 2003. *The Cyborg Self and the Networked City*. Cambridge: The MIT Press.

Mitchell, J. W. 1999. *Urban Life Jim-But not as we know it*. Cambridge: The MIT Press.

Mitra, S. & Dangwal, R. 2017. Acquisition of computer literacy skills through self-organizing systems of learning among children in Bhutan and India. *Prospects*, Volume 47, pp. 276-292.

MPIP. 2021. Reality Studio: Data Collection Plastic View. [Online]
Available at: <https://sites.google.com/tuks.co.za/mpip-2021/home> [Accessed 01 05 2021].

Munley, P. H. 1975. Erik Erikson's theory of psychosocial development and vocational behavior. *Journal of Counseling Psychology*, pp. 314-319.

Muratovski, G., 2016. Ethnographic Research. In: *Research For Designers: A guide to methods and practice*. New York: SAGE, pp. 56-78.

MWOD, n.d. Building. [Online]
Available at: <https://www.merriam-webster.com/dictionary/building> [Accessed 26 04 2021].

Nan-Zhao, Z, n.d. Four 'Pillars of Learning' for the Reorientation and Reorganization of Curriculum. UNESCO.

National Institute for Communicable Diseases (NICD). 2020. Guidelines for Quarantine and Isolation in relation to COVID-19. [Online]
Available at: <https://www.nicd.ac.za/wp-content/uploads/2020/05/Guidelines-for-Quarantine-and-Isolation-in-relation-to-COVID-19.pdf> [Accessed 28 04 2021].

Newman, P. R. & Newman, B. M. 2009. *Running Head: Self Socialization: A Case Study*. Self-Socialization: A Case Study of a Parachute Child.

NG Moreleta Park Gemeente, 2019. Fact sheet: Woodlane Village (Plastic View). [Online]
Available at: http://moreleta.org/wp-content/uploads/2019/04/Woodlane_Village_info.pdf [Accessed 26 April 2021].

Norris, B. & Smith, S. A. 2008. Child Anthropometry. In: R. Lueder & V. J. Berg Rice, eds. *Ergonomics for Children: Designing products and places for toddlers to teens*. New York: Taylor & Francis Group, pp. 39-64.

Olaniran, S. O. 2016. *Revisiting UNESCO Four Pillars of Education*. Johannesburg, University of Johannesburg.

O'Neill, A. 2020. Urbanization in South Africa 2019. [Online]
Available at: <https://www.statista.com/statistics/455931/urbanization-in-south-africa/> [Accessed 26 04 2021].



Oyelaran-Oyeyinka, B. & Lal, K. 2005. Internet diffusion in sub-Saharan Africa: A cross-country. *Telecommunication Policy*, 27(7), pp. 507-527.

Parrish, P. 2010. Cultural Dimensions of Learning: Addressing the Challenges of Multicultural Instruction. *International Review of Research in Open and Distance Learning*, p. 11.

Picheny, M., Durlach, N. & Vraida, L. 1985. Acoustical Characteristics of clear conversational speech. *Journal of Speech and Hearing Research*, pp. 434-446.

Pieter, K. & Collinson, M. 2006. *Migration and Urbanization in South Africa*. Pretoria: Statistics South Africa.

Pillay, J., 2006. Experiences of learners from informal settlements. *South African Journal of Education*, Volume 24, pp. 5-9.

Reeves, S., Kuper, A. & Hodges, B. D. 2008. Qualitative and Quantitative Methodologies: Ethnography. *British Medical Journal*, Issue 337, pp. 512-14.

Riewoldt, O., 1997. *Intelligent Spaces: Architecture for the Information Age*. 1 ed. London: Books Nippan.

Rotter, J., 1954. *Social learning and clinical psychology*. New York & London: Prentice-Hall.

Senanayake, S. G. J. N. 2006. Indigenous Knowledge as a key to sustainable development. *Journal of Agricultural Sciences - Sri Lanka*, pp. 86-94.

Snowman, J. & McCown, R. 2013. *ED PSYCH*. Belmont: Wadsworth, Cengage Learning.

Sobe, N. W. 2021. *Reworking Four Pillars of Education to Sustain the Commons*. [Online] Available at: <https://en.unesco.org/futuresofeducation/ideas-lab/sobe-reworking-four-pillars-education-sustain-commons> [Accessed 30 06 2021].

The Lancet. 2020. *A future for the world's children? s.l.: The Lancet Commission*.

Thompson, E. M. 2008. *Is Today's Architecture About Real Space, Virtual Space, or What?*. Northumbria Working Paper Series: Interdisciplinary

Studies in the Built and Virtual Environment, 1(2), pp. 171-178.

UN-Habitat. 2016. *Issue Paper on informal settlements*, Quito: UN-Habitat.



United Nations. 2020. The Sustainable Development Goals Report 2020: United Nations.

Warren , D. M. 1989. The impact of nineteenth century social science in establishing negative values and attitudes towards indigenous knowledge systems. *Indigenous Knowledge Systems: Implications for Agriculture and International Development, Studies in Technology and Social Change*, Volume 11, pp. 171-183.

Whittle, J. 2021. Ai can now learn to manipulate human behaviour. [Online]
Available at: <https://theconversation.com/ai-can-now-learn-to-manipulate-human-behaviour-155031> [Accessed 11 November 2021].

Yakimishyn , J. E. & Magill-Evans, j. 2002. Comparisons among tools, surface orientation and pencil grasp for. *American Journal of Occupational Therapy*, Volume 56, pp. 564-572.





LIST OF FIGURES

5.2

- Figure 1.1 COVID-19 Diagram of transformational events
- Figure 1.2 Pure Hope “Hope” wall, (Author, 2021)
- Figure 1.3 Inductive process map to understand the context
- Figure 1.4 Informal housing roofing photo, (MPIP, 2021)
- Figure 1.5 Children outside of bar within Plastic View, (Author, 2021)
- Figure 1.6 A platform of future digital inclusivity, (Author, 2021)
- Figure 1.7 Research sub-question diagram summaries, (Author, 2021)
- Figure 1.8 Empathy within qualitative research, (Author, 2021)
- Figure 1.9 Ethnographic study diagram, (Reeves, et al., 2008)
- Figure 1.10 IDEO - double diamond approach for ethnographic research, (IDEO (Firm), 2015)
- Figure 1.11 Research methodology process within the framework of bridging the digital divide, (Author, 2021)
- Figure 1.12 Auto-ethnographic research diagram through a lens of empathy, (Author, 2021)
- Figure 1.13 Ethnographic research research techniques, (Author, 2021), (IDEO (Firm), 2015)
- Figure 1.14 Indigenous learning, potential of knowledge sharing, (Author, 2021)
- Figure 1.15 Process of indigenous learning, (Author, 2021), (Brouwers, 1993)
- Figure 1.16 Digital recording of indigenous knowledge, (Author, 2021)
- Figure 1.17 Silindokhuhle Pre-school, courtyard, (ArchDaily, 2017)
- Figure 1.18 Silindokhuhle Pre-school, plastering, (ArchDaily, 2017)
- Figure 1.19 Silindokhuhle Pre-school, knowledge transferal (ArchDaily, 2017)
- Figure 1.20 Silindokhuhle Pre-school, concept plan (Author, 2021)
- Figure 1.21 Silindokhuhle Pre-school, concept sketch, (Author, 2021)
- Figure 1.22 Figure 1.22 - Silindokhuhle Pre-school, community and expert, (Author, 2021)
- Figure 1.23 Silindokhuhle Pre-school, sustainability, (Author, 2021)
- Figure 1.24 A platform of future digital inclusivity, (Author, 2021)
- Figure 1.25 Figure 1.25 - Creating a digital learning environment attributes, (Author, 2021)
- Figure 1.26 Hole-in-the-wall children, (Mitra & Dangwal, 2017)
- Figure 1.27 Hole-in-the-wall interaction, (Mitra & Dangwal, 2017)
- Figure 1.28 Hole-in-the-wall street wall, (Mitra & Dangwal, 2017)
- Figure 1.29 Hole-in-the-wall concept sketch, (Author, 2021)
- Figure 1.30 Hole-in-the-wall concept sketch 2, (Author, 2021)
- Figure 1.31 Plastic View Street sketch, (Author, 2021)
- Figure 1.32 Diagram sharing and agency, (Author, 2021)
- Figure 1.33 Digital Agency and devices, (Author, 2021)
- Figure 1.34 Science Park Pavilion event outside, (ArchDaily, 2021)
- Figure 1.35 Science Park Pavilion event inside, (ArchDaily, 2021)



- Figure 1.36 Science Park Pavilion event outside 2, (ArchDaily, 2021)
- Figure 1.37 Science Park Pavilion scenarios,(Author, 2021)
- Figure 1.38 Plastic View site macro map analysis, (Author, 2021)
- Figure 1.39 Plastic View site history, (Author, 2021)
- Figure 1.40 Plastic View micro site analysis, (Author, 2021)
- Figure 1.41 Plastic View site features, (Author, 2021)
- Figure 1.42 Site user rituals and activites catagories, (Author, 2021)
- Figure 1.43 User rituals and activtiies children and adolescent, (Author, 2021)
- Figure 1.44 Selected user photomontage children playing, (Author, 2021)
- Figure 1.45 Selected user photomontage children playing 2, (Author, 2021)
- Figure 1.46 Plastic View street screne, dumping and condition (Author, 2021)
- Figure 1.47 Plastic View arial footage, (MPIP, 2021)
- Figure 1.48 Diagram community driven design and construction, (Author, 2021)
- Figure 1.49 Plastic View arial footage, (Author, 2021)
-
- Figure 2.1 Plastic View drinking and noise distribution map, (Author, 2021)
- Figure 2.2 Digital inclusivity platform for enablement, (Author, 2021)
- Figure 2.3 Theory: Digital Divide, (Author, 2021)
- Figure 2.4 Theory: Spatial agency, (Author, 2021)
- Figure 2.5 Diagram: learning constraints for learners of Plastic View, (Author, 2021)
- Figure 2.6 Four pillars of learning infographic, (Author, 2021)
- Figure 2.7 Design concept sketch: nature within interiors, (Author, 2021)
- Figure 2.8 Site intervention concept sketch, (Author, 2021)
- Figure 2.9 Site for intervention plan, (Author, 2021)
- Figure 2.10 Design Strategy: including a digital interface, (Author, 2021)
- Figure 2.11 Design concept: Circular learning system concept, (Author, 2021)
- Figure 2.12 Spatial programme, (Author, 2021)
- Figure 2.13 Spatial programme, three spaces, (Author, 2021)
- Figure 2.14 Design iteration 1: concept sketches, (Author, 2021)
- Figure 2.15 Design iteration 1: design resolution, (Author, 2021)
-
- Figure 3.1 Feasibility: Inforgraphic, (Author, 2021)
- Figure 3.2 Feasibility: Client proposal, (Author, 2021)
- Figure 3.3 Spatial concept diagram, (Author, 2021)
- Figure 3.4 Spatial concept development, (Author, 2021)
- Figure 3.5 Spatial development axonometric site, (Author, 2021)
- Figure 3.6 Project phasing: phase 1, (Author, 2021)
- Figure 3.7 Project phasing: phase 2, (Author, 2021)
- Figure 3.8 Project phasing: phase 3, (Author, 2021)

- Figure 3.9 Design resolution: site plan, (Author, 2021)
- Figure 3.10 Design resolution: section AA, (Author, 2021)
- Figure 3.11 Design resolution: section BB, (Author, 2021)
- Figure 3.12 Design resolution: ground floor, (Author, 2021)
- Figure 3.13 Design resolution: first floor, (Author, 2021)
- Figure 3.14 Interior well-being illustration: high ceilings, (Author, 2021)
- Figure 3.15 Interior well-being illustration: near to nature, (Author, 2021)
- Figure 3.16 Interior well-being illustration: lighting, (Author, 2021)
- Figure 3.17 Interior well-being illustration: flexibility, (Author, 2021)
- Figure 3.18 Interior well-being illustration: natural ventilation, (Author, 2021)
- Figure 3.19 Colour: Illustration - Library space, (Author, 2021)
- Figure 3.20 Colour: Illustration - Workshop space, (Author, 2021)
- Figure 3.21 Colour: Illustration - Playground, (Author, 2021)
- Figure 3.22 Lighting: Illustrations of various light usage, (Author, 2021)
- Figure 3.23 Lighting: Illustrated plan of lighting for the Library, (Author, 2021)
- Figure 3.24 Lighting: Illustrated plan of lighting for the Workshop, (Author, 2021)
- Figure 3.25 Lighting: Illustrated plan of lighting for mixed-use space, (Author, 2021)
- Figure 3.26 Lighting: Illustrated plan of lighting for the covered courtyard, (Author, 2021)
- Figure 3.27 Digital devices illustration of spatial integration, (Author, 2021)
- Figure 3.28 Digital devices illustration of spatial integration 2, (Author, 2021)
- Figure 3.29 Sustainability: Water and reticulation axonometric, (Author, 2021)
- Figure 3.30 Sustainability: Water and reticulation ground floor plan, (Author, 2021)
- Figure 3.31 Sustainability: Water and reticulation first floor plan, (Author, 2021)
- Figure 3.32 Sustainability: Building circulation axonometric, (Author, 2021)
- Figure 3.33 Sustainability: Building circulation ground floor plan, (Author, 2021)
- Figure 3.34 Sustainability: Building circulation first floor plan, (Author, 2021)
- Figure 3.35 Sustainability: Solar and power axonometric, (Author, 2021)
- Figure 3.36 Sustainability: Solar and power ground floor plan, (Author, 2021)
- Figure 3.37 Sustainability: Solar and power first floor plan, (Author, 2021)
- Figure 3.38 Sustainability: Green scaping axonometric, (Author, 2021)
- Figure 3.39 Sustainability: Green scaping ground floor plan, (Author, 2021)
- Figure 3.40 Sustainability: Green scaping first floor plan, (Author, 2021)
- Figure 3.41 Sectional detail: Library section, (Author, 2021)
- Figure 3.42 Sectional detail: Workshop section, (Author, 2021)
- Figure 3.43 Sectional detail: Roof ventilation section, (Author, 2021)
- Figure 3.44 Sectional detail: Ceiling vent detail - Library, (Author, 2021)
- Figure 3.45 Library design: Floor plan rendered, (Author, 2021)
- Figure 3.46 Library design: Rendered Axonometric, (Author, 2021)
- Figure 3.47 Library design: Open plan class axonometric, (Author, 2021)
- Figure 3.48 Library design: Open plan class rendered perspective, (Author, 2021)
- Figure 3.49 Library design: Conventional class axonometric, (Author, 2021)



- Figure 3.50 Library design: Conventional class rendered perspective, (Author, 2021)
- Figure 3.51 Library design: Group learning class axonometric, (Author, 2021)
- Figure 3.52 Library design: Group learning class rendered perspective, (Author, 2021)
- Figure 3.53 Library detail: Curved acoustic ceiling diagram, (Author, 2021)
- Figure 3.54 Library detail: Curved Acoustic Ceiling precedent, (Author, 2021)
- Figure 3.55 Library detail: Curved Acoustic Ceiling technical resolution, (Author, 2021)
- Figure 3.56 Library detail: Expandable Storage, (Author, 2021)
- Figure 3.57 Library detail: Expandable Storage technical resolution, (Author, 2021)
- Figure 3.58 Library detail: White Board Divider Diagram, (Author, 2021)
- Figure 3.59 Library detail: White Board Divider technical resolution, (Author, 2021)
- Figure 3.60 Library detail: Expandable desk Diagram, (Author, 2021)
- Figure 3.61 Library detail: Expandable desk technical resolution, (Author, 2021)
- Figure 3.62 Library section 1: section detail interior, (Author, 2021)
- Figure 3.63 Library section 2: section detail interior, (Author, 2021)
- Figure 3.64 Workshop design: Floor plan rendered, (Author, 2021)
- Figure 3.65 Workshop design: Rendered Axonometric, (Author, 2021)
- Figure 3.66 Workshop design: Stored open plan axonometric, (Author, 2021)
- Figure 3.67 Workshop design: Open plan rendered perspective, (Author, 2021)
- Figure 3.68 Workshop design: Workshop space axonometric, (Author, 2021)
- Figure 3.69 Workshop design: Workshop space rendered perspective, (Author, 2021)
- Figure 3.70 Workshop detail: Bottle acoustic ceiling, (Author, 2021)
- Figure 3.71 Workshop detail: Bottle acoustic ceiling technical resolution, (Author, 2021)
- Figure 3.72 Workshop detail: Rotational doors, (Author, 2021)
- Figure 3.73 Workshop detail: Rotational doors technical resolution, (Author, 2021)
- Figure 3.74 Workshop section 1: section detail interior, (Author, 2021)
- Figure 3.75 Playground design: design objective axonometric, (Author, 2021)
- Figure 3.76 Playground design: Open field rendered perspective, (Author, 2021)
- Figure 3.77 Playground design: spatial diagram, (Author, 2021)
- Figure 3.78 Playground design: sports field rendered perspective, (Author, 2021)
- Figure 3.79 Playground design: field market rendered perspective, (Author, 2021)
- Figure 3.80 Playground design: digital playground rendered perspective, (Author, 2021)
- Figure 3.81 Ablution design: Interior rendered perspective, (Author, 2021)
- Figure 3.82 Ablution detail: Floor plans, accessibility toilet, (Author, 2021)
- Figure 3.83 Ablution section AA: sectional detail interior, (Author, 2021)
- Figure 3.84 Ablution section BB: sectional detail interior, (Author, 2021)
- Figure 3.85 Ablution section CC: sectional detail interior, (Author, 2021)
- Figure 3.86 SBAT testing tool results, (Author, 2021)
- Figure 3.87 SBAT testing tool detail results, (Author, 2021)
- Figure 3.88 Methodology reflection, (Author, 2021)

LIST OF TABLES

5.3

Table 1	Plastic View knowledge transferal environments, (Author, 2021)
Table 2	Building Programme, (Author, 2021)
Table 3	Lighting requirements as per designed space, (Author, 2021)





APPENDIX A

A DESIGNING FOR CHILDREN

A-1 Designing for children

Designing for educational and social environments specifically where multi-age users interact, require in depth analysing of safety, ergonomics, usage, and adaptability. For children architectural features such as doors, stairs, railings, windows, and products need to consider child usage, and specifically electrical goods to accommodate for children. Regarding anthropometry, adjustable dimensions to products allow for the maximum percentage of population usage, more so, dimensions could also protect users at risk, such as children climbing onto balustrades (Norris & Smith, 2008).

Anthropometric Data (Ages 7-18, UK Mean) (Norris & Smith, 2008: 60)

AGE	7	8	9	10	11	12	13	14	15	16	17	18
Male	1.25	1.31	1.36	1.41	1.47	1.52	1.59	1.66	1.72	1.75	1.76	1.76
Female	1.24	1.23	1.36	1.42	1.48	1.54	1.58	1.61	1.62	1.63	1.63	1.63

According to UK anthropometric data, between the ages of 7 and 18, it can be deduced that a maximum height variance of 520mm can be used as an ergonomic indicator to observe effectivity of furniture and spatial usage.



A-2 Ergonomics

During the day learners are exposed to long periods of stationary activities. Ergonomics of furniture and space aid in increasing attentiveness, performance, emotional well-being, and comfort. During learning, learners will sit or stand within their environments, thus, in a multi-age classroom furniture must be adaptable and adjustable to cater for individual needs (Burt & Benbow, 2008: 690).

Postural stability

Postural stability is the ability for children to use their “core muscles” to support themselves either while sitting or standing. These, muscles are essential in the development of children's growth, and within learning environments, incorrect posture could lead to insufficient development. Using both sit and standing working facilities, learners gain strength in these muscles. Moreover, children find it easier to work or write at a desk while standing, where the legs are used to stabilise their bodies, but also exercising the core stability (Burt & Benbow, 2008: 695).

For many children the development of eye-hand coordination, especially in handwriting, is a challenge owing to the ergonomics within an environment. Handwriting on horizontal surfaces has proven to decrease eye-hand coordination, while vertical surfaces promote wrist stability and postural control (Yakimishyn & Magill-Evans, 2002). From the age of seven, children can work on vertical surfaces such as whiteboards or blackboards. Working surfaces for mixed-age classrooms should be long enough to allow for height variations of learners. Although sitting can be promoted after long durations of standing, sit-stand desks and chairs offer a choice for learners to free fulfill their comfort requirements (Burt & Benbow, 2008: 705).



A-3 Furniture for learning environments

Furniture provides functionality to space through objectifying functions. For learners it provides comfort, aid, and a tool to learn. Furniture should provide several important ergonomic features including (Burt & Benbow, 2008:713):

- A seat should have a supportive lower back curve when seated.
- Seats should be adjustable to allow for learners to better shoulder and back posture while working.
- Back support should support learner when working on horizontal surfaces.
- Desks should be five cm above the seated elbow level to provide a relaxed shoulder position.
- Movable or slanting surfaces can assist with bettering postures. While vertical surfaces can be used to assist with postural stabilization (Yakimishyn & Magill-Evans, 2002).

Age-specific developmental considerations:

Ages 7 to 12

Younger learners tend to grow at faster extremes; thus, furniture design should account for fast paced growth.

Adolescent 13 to 18

Adolescent growth takes place largely within the spine and the spine develops quickly. Supportive back rests assist with age-related support.



A-4 Way-finding for learners (aged 8 to 18)

Way-finding for learners is a skill that is practiced by natural exploration and over time is improved. Learners are natural explorers and want to travel, observe, and play within their natural environments. In most cases, exploration is self-directed, and is important to gain skills of way-finding, and not remaining a passenger to navigation of others.

Moreover, to effectively create a well-navigational space, designers should consider the following requirements (Allen, 2008: 863-864):

	Description	Design solution
Inborn search tendencies	Way finding occurs naturally through reenacting search behavioral tendencies.	Signage and maps should not over complicate way-finding, still allowing for a sense of exploration and self-directed navigation.
Path integration	Movement should be maintained on a known path and know where to start.	A central navigational path should be accented. And easily navigational to signage which enables way finding.
Route-following	Learners generally through habit start to determine safe and comfortable routes. This responds to sight, sound and tactile cues.	Signage can be placed along the route to navigate. Learners respond to colour coding and symbols rather than text.
Cognitive maps	Knowledge about spatial relation can be mapped and used to navigate.	Physical maps can be difficult for learners who have not fully developed spatial cognition. Digital maps and augmented navigation could create an interactive navigational tool.



A-5 Four pillars of learning continued

Learning to know (EXPLORE)

“Learning to know” fundamentally alternate to “acquiring itemized codified information” but is rather “masting of the instruments of knowledge themselves” (Sobe, 2021). The role of a computer is to access digital data. This data can be viewed as a library with endless access to knowledge. Naturally, learners master the navigation of this virtual library and become fulfilled through a process of discovery. In a learning environment, access to computers for learning becomes the key aspect. Teachers facilitate, rather than teach, also encourage learners, by asking prompt questions to promote curiosity (Mitra & Dangwal, 2017).

Learning to do (DEFINE)

“Learning to do” becomes the first stage for application of what has been learnt. Once learners have mastered the digital world, they “experience the pleasure of knowing” (Nan-Zhao, n.d.). This knowledge can be then used in practical application. Learners are exposed to new experimental learning which creates a creative environment for practical learning. This is where learners take risks and solve problems. Digitally this environment becomes an immersive experience with play and exploration with new tools such as projectors, animators, immersion, and digital fabrication.

Learning to be (DEVELOP)

Purpose then drives learners, putting knowledge and practicality together. Spatial agency is the key, giving learners the ability to find identity and ways in which knowledge can be used to enhance their own circumstances and their community. In reaction, education now develops independence and personal responsibility. In this environment, agency allows users to construct and deconstruct their environment creatively with purpose (Sobe, 2021).

Learning to live together (SHARE)

Sharing and collaboration is an important variable to create an iterative learning process. Within this environment, learners should be able to share physically and virtually. Sharing could become a point of gathering intersecting the community with the learners, enabling the learner and the community to engage and express. Within vulnerable communities, the act of sharing and communication allows people to live together and build trust and substantiates a process of indigenous learning.





APPENDIX B

B CASE STUDY: LEARNERS EXPERIENCE FROM INFORMAL SETTLEMENTS

B-1 Experiences of learners from informal settlements

In 1994 the schools in Lenasia admitted many learners who resided in nearby informal settlements. In a short period of time, it was found that the integration process of learners from informal settlements was finding difficulty in adjusting socially with other learners. However, the school's psychologist was unable to narrow down on specific issues which from educators or the physical environment. But the study was of deeper underlying behavioural problem. The study led to gain an understanding of secondary school learners from informal settlements (Pillay, 2006).

The study was comprised of three focus groups with 10 scholars in each group. The central questions asked to the scholars were:

- "What are your experiences in your present school as a learner from the informal settlement?"
- and
- "What are your experiences as a resident of the informal settlement?"

The research was then documented, analysed, categorised and underlying relationships between participants were made. The common feelings of participants of their experiences at schools in Lenasia are as follows:

Fear and anxiety

Many learners experienced a fear of educators and embarrassment from other learners. Some felt educators were trying to embarrass them when they would need to read or write. "I fright when I spell or read" and "I don't want to get the answers wrong" is some of cases which were social anxiety related. Many would fear going to school because they had not completed their homework and others would tell the educators. These cases are formed from the lack of educational environments to grow within socially. The scholars' anxiety was exacerbated by the fact they are a minority group within schools and are ashamed from coming from an informal settlement. These show that scholars do have a sense of identity and social classification (Pillay, 2006).



Anger

Anger would be manifested from individual consumption of feeling decentralised from other learners. Some students would be teased according to race. This was a feeling that was coming from both learners and teachers (Pillay, 2006).

Sadness

Scholars felt sadness because of the inability to create valuable bonds and interpersonal relationships with other scholars. The feeling of sadness was tested through a sentence completion test, and 43 out of 50 learners indicated feelings of sadness, while 37 learners said they were unhappy at their schools (Pillay, 2006).

Loneliness

In some of the statements, some learners expressed that they had no friends and that they were lonely during the duration of the day. It was found that scholars felt lonely because they were from an informal settlement, social inclusion was evident. Unexpectedly it was found that scholars from the township did not want to be associated with scholars from an informal settlement, although they were both from Soweto (Donald, et al., 1997).

Shame and Embarrassment

Learners from the informal settlement felt embarrassed and ashamed because a lot of the time they are unable to complete their homework because of their environment. Many would characterize scholars as lazy and stupid, one student stated, "I feel shame because I did not complete my homework, but I know that I am not lazy. They think that I am stupid and lazy, but I am not". Many do not have access to basic physiological needs such as a shower, "I am ashamed ... the children say I smell" (Pillay, 2006).

Misunderstanding

The feeling of being misunderstood is common. Pupils who are not from informal settlements lack the knowledge to understand circumstances. Many could not comprehend the tension and problems within informal settlements, "They need to understand the problems at the camp. They say I am lazy". At night for instance, there is no light to work, neither the space to work in overcrowded households and many chores needed to be completed before study time (Pillay, 2006).



Envy and privilege

Learners from the informal settlement were envious of the more privileged pupils. The positive aspect that coming out of the combination of mixed socio-economic statuses is that low-income scholars observe and gain goals for the future (Rotter, 1954). Many saw the benefit of being at a privileged school, “I am here to get education” and “I get education then I get good job”. Moreover, the students believed school was good for your future, 40 out of 50 pupils indicated they liked the school in Lenasia (Pillay, 2006).

Behavioural experiences

Out of the data analysis emerged specific behavioural traits from the school learners such as racial discrimination, bullying, ganging-up, avoidance, language difficulties, and the value of education.

Language difficulties

Both learners and educators found it difficult to communicate and found that language was a big barrier between all groups. Although many understood the importance of English, all claimed it was secondary to their vernacular and “I don’t understand the English”.

This fact was further supported when 22 out of 50 pupils indicated in a projective assessment said English was difficult (Pillay, 2006). The inability to make use of first language also decreases the ability for cognitive development and scholastic performance (Donald, et al., 1997).

Value of education

Learners were conscious to the impact that education has on future careers. “I get education then I get good job” is a common statement in hope for better circumstances and life. One learner stated “I watched the other children who go to college and university. I need to and want to be like them”.

Experience in informal settlements

Domestic settlements appear to be mostly negative with the environment offering a large problem. According to McCoy and Sherman (1994) the place of residence of a learner is often the source of separateness and group antagonism. Out of the analysis, the two largest categories that came from difficulties in informal settlements were study difficulties and practical problems (Pillay, 2006).



Study Difficulties

Studying for any school learner is a challenge and requires discipline and motivation. Pupils in informal settlements wake up at 04:30 in the morning to start washing themselves. Then they go and get wood in the morning to start a fire that could be used to make breakfast or boil hot water for a bath. At times this makes pupils arrive late for school. Overcrowded rooms do not allow for space in the very badly lit room. This is made worse with people abusing substances, making noise which is easily heard through the thin sheet walls. A study found that 32 of 50 pupils in informal settlements found it a daily problem that people abuse substances and create noise meaning the pupils cannot study or do homework. At night candles are a luxury and are expensive, so pupils cannot work at nights (Pillay, 2006).

Practical Problems

Informal settlements established in unplanned city spaces leave them without many planned public transport routes. After walking long distances to school owing to the lack of money or distance from affordable transportation, pupils arrive at school often dirty, exhausted, and in an ill condition. Many do not have access to water at home. This makes schools an important aspect to their lives. Many other learners are bully informal settlement learners because of dirty clothing, and bad odour because they were not able to bath: "Sometimes we don't have water to wash our school clothes." "We feel bad when the other children say we smell." After a projective study was done, it was found that out of 50 learners, all identified water and lights as a serious difficulty. In addition, 41 were dissatisfied with toilets and 39 did not like their homes (Pillay, 2006).

It was identified from scholars that unemployment and poverty underwrote to the negativity in informal settlements. Further it was found that 36 learners indicated poverty and 29 identified that their parents were unemployed (Pillay, 2006).



APPENDIX C

C EDUCATIONAL PSYCHOLOGY

C-1 What is educational psychology?

Educational psychology is a branch of psychology which aims to create understanding and improvement in the ability of student learning and capabilities within formal education practices. Topics also include instrumental process, individual learning potential and the methods through which knowledge gets retained (Snowman & McCown, 2013).

Erikson: Psychosocial Development

Erikson describes that the emotional and educational development of any person are the bases of infancy and continues through to adulthood, thus implications could occur at every level of education (Snowman & McCown, 2013). People themselves play an active role in their own psychological development by attempting to understand, organise and integrate their everyday experiences. These are especially seen in cultural goals, opportunities, and aspirations (Newman & Newman, 2009).

Self-socialisation

The process of self-socialisation suggests that individuals develop their own sense of agency in selecting the most suited social context to support their development. This process within children is found in social groups based on gender, friendships and environment. The environment can consist of playing preferences could be gender based. At a young age gender groups tend to select same gender types, boys with boys and girls with girls, these characterised groups of friend's strengths gender-based socialisation. If children are unable to form self-socialisation bonds, it later affects relationships in school. Children feel vulnerable and are challenged with social peer belonging, resulting in negative performance (Newman & Newman, 2009).

Epigenetic principle

Erikson's theory on personality development is grounded on the epigenetic principle. According to Erikson, all biological organisms develop sequentially, with certain parts developing prior to others. An example of a tree is proposed, as a seedling the tree does not bear fruit as it would in its full developmental state, but rather grows and becomes shaped according to the environment. This is true as each tree develops differently according to the physical environment, such as weather, earth quality and accessibility to resources. This interaction between environment and development in which a genetic sequence emerges establishes Erikson's view of the development of children and how they grow (Snowman & McCown, 2013).



Psychosocial crisis

Erikson believes that personality development occurs when points of conflict are successfully resolved. Each challenge in the development stage is classified as "a crisis" and threatens well-being. The successful completion is called the "acquisition of basic virtues" (strengths of the human ego to resolve conflicts). Furthermore, Erikson describes these crises as opposing qualities that individuals develop. For every crisis a desired quality emerges and a corresponding undesired characteristic (Newman & Newman, 2009). Although this is not necessarily negative, because individuals create adaptive responses to be able to handle both positive and negative characteristics. These positive and negative capabilities are required for development, and are described in the eight stages to building identity to adulthood (Snowman & McCown, 2013).



C-2 The stages of psychosocial development (ages 0 to 18)

Trust vs. mistrust (birth to 1 year)

Infants are born dependent on their parent's care and involvement to protect their well-being. The first crisis that arises is the ability to for trust and create bonds. In a positive environment and involved care, the infant thinks of the world as safe and dependable. In contrast, a negative environment develops into fear and suspension (Snowman & McCown, 2013).

Autonomy vs shame (2 to 3 years)

The first task for any toddler is to gain independence, to start to roam and engage with surroundings. This should be granted at one's own pace, for example, playing with toys, engaging with nature and the environment, and even learning to use the toilet. All these activities motivate a sense of autonomy otherwise described as the virtue of will. If parents are unable to assist in creating such environmental opportunities, it could create feelings of shame and self-doubt (Snowman & McCown, 2013).

Initiative vs guilt (4 to 5 years)

The ability to interact with physical activities with the use of language, which "adds to the autonomy the quality of undertaking, planning, and 'attacking' a task for the sake of being active and on the move" (Munley, 1975). Build interpersonal relationships by building relationships with others. Creating games and imaginary thinking, asking questions, children require a virtue of hope. If children are given the ability to decide what they want, how they want to, and when they are going to. It allows for the ability of initiative to be developed and children make better decisions. If they are unable to construct their own thoughts and actions, tendencies of guilt occur when they do act autonomously (Munley, 1975).

Industry vs inferiority (6-11 years)

Industry is the competence through which daily intellectual activities become mentally accessible, for instance reading, writing and learning to work to achieve goals independently. Children win recognition if competence builds confidence. Learning tasks are created to be longer and over extended periods, this would be evident from pre-school to primary school in different learning styles. This stage is one of the most crucial to be successfully confident in during schooling periods. The effects of negativity within group settings create a feel of inferiority and incompetence (Snowman & McCown, 2013).



Identity vs role confusion (12 to 18 years)

At this stage, learners have built up confidence in themselves and social expectations of adult society start to filter through. Learners begin taking up the roles of adulthood and attempt to distinguish role orientation for their future careers. This period is also the same time where bodily changes occur, scholars identify their roles and identity within social groups, there is a perception of self and one's identity develops (Snowman & McCown, 2013).

Developing a sense of industry

When children come out of pre-school and start primary school, there is a shift from playfulness to a goal orientated learning operation. Scholars are given tasks and their outcome is complete the task, initially reward based once tasks have been completed, these rewards are generally limited, but openly expressed to promote group action within an entire class, (Snowman & McCown, 2013).

Formulating an identity

According to Erikson, to form a sense of who we are is reliant of three factors: being comfortable with physical self, orientated towards future goals, confidence to involve significant role players such as parents, in their lives.

Identity statuses

James Marcia developed a scientific method to measure identity status according to the Erikson's notions of identity in adolescence. Identity has been termed an "attitude", "a sense" or "a resolution" and so on. Marcia proposed a new structure in understanding identity as a self-structure that is led by internal self-constructed derives dynamic organization drives, abilities, beliefs, and an individual past. The structure is dynamic, rather than static, which compare individuals against worldly norms, but rather on their own distinctive environment (Marcia, 1980).



APPENDIX D

D DIGITAL LEARNING

D-1 Digital Learning

Capabilities of digital learning

In educational structures, digital learning allows for a new paradigm shift for increasing classroom sizes and communication tools disadvantaged populations where challenges such as attendance and environment prevent access to learning. The potential of ICTs offers larger capacity and flexibility compared to traditional classrooms. It enables classrooms to function in a digital space, it also requires less resources such as facilities, books, traveling, and time management. For mature individuals, the ability to learn at your own pace is offered (Lembani, et al., 2019).

Covid -19 Developments of digital learning

During the Covid-19 pandemic, the closure of schools impacted many scholars, especially the poor in accessing remote learning. According to the United Nations Development Goals Report (2020) in 2019, 18% of homes had access to the Internet in Africa, while only 11% had access to a home computer. The success of remote learning is dependent on computer literacy of not only learners, but also parents and teachers. Basic computer literacy can be defined as copying an electronic file (United Nations, 2020).



D-2 Bridging the digital divide

Implementation

Bridging the digital divide is an essential in building prosperous communities. This improves the sustainability and growth of individuals within the community, having access to education, economic development, health care, emergency services, social connections, and civic engagement.

The framework of implementation for each community is different in terms of context and priorities, the fundamental needs are consistent:

- high-speed infrastructure to carry the internet traffic of large quantities of households;
- education of basic computer literacy to navigate the digital world safely;
- creating publicly accessible temporary usable devices; and
- addressing needs that could drive local economy (Becker, et al., 2012).

For a community to be digitally inclusive, the needs of the community need to be incorporated and considered. The process involves the community and larger stakeholders to understand the community needs and interests to bridge the digital divide successfully.

Digital divide for learning

Educational institutions ensure the use of digital technology as a tool for learning. Digital education extends beyond basic digital literacy but enables users to acquire knowledge through digital networks. This is supplied either through curricula or having access to the hundreds of educational sites that are available through the Internet.



D-3 Adopting computer-based learning

Traditional computer-based learners rely on a one-way transmission of knowledge. This relationship exists with the user and the computer which acts as the extension of the classroom. HiWEL aims to create unrestricted learning, a new pedagogy where learners have unrestricted access to computers and is open to groups of children within a playground setting which places children in natural space of curiosity to stimulate learning (Hole in the wall, 2015). The essential features include the following:

Playground setting

The learning stations are set up outside where access at any time is ensured. This allows for the boundaries of a classroom to break-away. Children both in and out of school can use the facilities anytime during the day. The unstructured environment allows children to organise themselves in taking ownership of the learning station and forming self-organised groups (Hole in the wall, 2015).

Collaborative learning

The learning stations invite many different groups of children, through self-organisation children learn collaboratively. Unlike traditional school models which are led by a curriculum, children can explore, share and learn more at once and this is enriched with exchanges of conversations within groups (Hole in the wall, 2015).

Optimum utilization

In traditional classrooms learning is "instruction based" where learners are focused on specific information. To provoke curiosity, learning stations allow for exploratory learning, with the twin advantage of collaborating in groups which leads to much more effective learning (Hole in the wall, 2015).

Integration with the school system

Where teachers are not present informal learning occurs. In traditional schooling, structure is reinforced and learning stations can create a discussion-based learning process where peer discussion can increase curiosity and learning retention (Hole in the wall, 2015).



Learning to learn

Other than educational skills the process of learning becomes the core of learning stations. By allowing children use learning stations out of curiosity rather than instruction builds fundamental skills in problem-solving and testing while learning make learners critical thinking and give them the ability to reflect on what was learnt by repeating actions and observing reactions (Hole in the wall, 2015).

Projects by children

The learning stations use real-life projects and situations to educate learners. The use of authentic tasks creates relevance to their daily lives. If projects are locally relevant projects can be considered contextually among peers and described individually and shared to gain perspective which build learners personality and empathy towards others (Hole in the wall, 2015).



D- 4 Relevance of bridging the digital divide

In a modern world digital technology is relied on in every industry. For communities, becoming digitally inclusive would uplift the community, giving the community the ability for self-help practice regarding their own interests and priorities. In venerable communities' digital access will allow for the following to manifest:

- People can digitally store their personal information and access it anywhere safely;
- Children and adults are able to gain knowledge from the internet which could uplift their livelihoods.
- People can communicate with other communities through networked groups;
- Communities that are marginalised within the urban fabric have access to a virtual endless space.

Challenges

Access to ICTs from locations other than home creates concerns of privacy. Computer users would be hesitant to download or store any information on the computer in consideration of other users who would be using the computer. Moreover, there is a decrease in use and engagement of a shared computer (Lembani, et al., 2019). Users who have less ownership of the digital hardware would use the Internet less frequently compared to someone who had their own device (Oyelaran-Oyeyinka & Lal, 2005).

The cost of initiating projects on a large scale is high. Devices and access to internet are monthly costs other than the initial project installation. Thus, the use of external stakeholders and sponsors are incredibly important. For venerable communities, donations are made regularly, and digital technology could form part of future donations to initiate projects. A stakeholder analysis should be considered to discover what various existing stakeholders could offer in initiating a project, such as nearby internet access (Mitra & Dangwal, 2017).



D- 5 Artificial intelligence

Digital technology within informal settlements is seen as a foreign and alien artifact. The integration of technology allows for versatile and developed educational practice, but for children coming from unequal learning conditions, it is difficult to install a singular educational system. Using AI, the curriculum can be versatile, while individual user interfaces understand the users' needs through continuous engagement and learning. For example, a child who has reading difficulty would be identified with through a camera, which the AI can use to enlarge text, or through headphones read with learners, to boost their learning experience and grow confidence. Moreover, AI will be used to understand the behaviours of users to offer safe and inclusive learning models.

As children build their confidence in learning with technology, the AI also understands unique students as if both are within a symbiotic relationship, learning together and from each other.

Moreover, AI can also monitor and engage with the architecture of the learning environment, with a series of sensors and cameras, the movement and flow of users can be organised and programmatically arranged according to real-time data. For example, classes that end concurrently could influence congestion and safety of learners. Or that classes which make noise could be held while other classrooms are held on the sports field.

Privacy with AI

AI models make use of input data to generate predictions and grow a model. But because child users are essentially the source of data, the identities, as well as the nature of investigation, should be ethical and preserve the privacy of users.

The AI systems should be used as a tool extension to assist with learning only, by monitoring and adjusting to improve user interface and learning experience. Moreover, the data found will only be used to improve curricula, and not subject to deforming social behaviourism studies (Responsible AI practices – Google AI, 2021).



APPENDIX E

E ETHICS APPROVAL



Faculty of Engineering,
 Built Environment and
 Information Technology

Fakulteit Ingenieurswese, Bou-omgewing en
 Inligtingtegnologie / Lefapha la Boetsenere,
 Tikologo ya Kago le Theknolotshi ya Tshedimošo

Reference number: EBIT/259/2020

Dr C Combrinck
 Department: Architecture
 University of Pretoria
 Pretoria
 0083

Dear Dr C Combrinck

FACULTY COMMITTEE FOR RESEARCH ETHICS AND INTEGRITY

Your recent application to the EBIT Research Ethics Committee refers.

Conditional approval is granted.

This means that the research project entitled "Urban Citizen Studios: Public Interest Design" is approved under the strict conditions indicated below. If these conditions are not met, approval is withdrawn automatically.

Conditions for approval

Conditional approval on the understanding that:

- Applications from each student (including application forms and all necessary supporting documents such as questionnaire/interview questions, permission letters, informed consent form, researcher declaration etc) will need to be checked internally by the supervisor. A checklist will need to be signed off after the checking.
- All of the above will need to be archived in the department and at the end of the course a flash disc / CD clearly marked with the course code and the protocol number of this application will be required to be provided to EBIT REC administrator.
- Any personal and demographic data (eg gender, income, education) have provided the motivation that is acceptable based on the supervisor's evaluation.
- Students using organizations data not publicly available or collecting data from employees have the permissions in place.
- No data to be collected without first obtaining permission letters. The permission letter from the organisation(s) must be signed by an authorized person and the name of the organisation(s) cannot be disclosed without consent.
- Images and observation of people will require consent. Images and observation of minors are prohibited.

This approval does not imply that the researcher, student or lecturer is relieved of any accountability in terms of the Code of Ethics for Scholarly Activities of the University of Pretoria, or the Policy and Procedures for Responsible Research of the University of Pretoria. These documents are available on the website of the EBIT Ethics Committee.

If action is taken beyond the approved application, approval is withdrawn automatically.

According to the regulations, any relevant problem arising from the study or research methodology as well as any amendments or changes, must be brought to the attention of the EBIT Research Ethics Office.

The Committee must be notified on completion of the project.

The Committee wishes you every success with the research project.

Prof K.-Y. Chan

Chair: Faculty Committee for Research Ethics and Integrity
 FACULTY OF ENGINEERING, BUILT ENVIRONMENT AND INFORMATION TECHNOLOGY

