

**Occurrence and Diversity of Tick-Borne Viruses in the Pastoral Eco-Zone of Ijara District,
North Eastern Province of Kenya**

By

Olivia Wesula Lwande

Submitted in Partial Fulfillment of the Requirements for the Degree of

Doctor of Philosophy

In the Faculty of Health Sciences

Department of Medical Virology

University of Pretoria

Supervisors: Prof. Marietjie Venter

Dr. Rosemary Sang

2013

Ethics

This study has been approved by University of Pretoria Research Ethics Committee, protocol number **61/2012**.

Declaration

I declare that the thesis, which I hereby submit for the degree of Doctor of Philosophy (Medical Virology) at the University of Pretoria, is my own original work and has not been previously submitted by me for a degree at this or any other tertiary institution.

Signed:

Date:

Acknowledgements

I would like to express my sincere gratitude to all those who supported me in the process of preparing this thesis:

- ✚ I would like to thank: Prof. Marietjie Venter for her guidance, encouragement, enthusiasm and advice and comments on all aspects of the thesis. It is an honor and privilege to work for someone of such great professional capability and character; thank you. Dr. Rosemary Sang for the patient guidance, encouragement and advice she has provided throughout my time as her student. I have been extremely privileged to have a supervisor and a mentor who cared so much about my work, and who responded to my queries promptly.

- ✚ I wish to thank the African Regional Post-graduate Programme in Insect Science (ARPPIS) and the Arbovirus Incidence and Diversity Project (AVID) not only for providing the funding which allowed me to undertake this research, but also for giving me the opportunity to attend conferences and meet so many resourceful people.

- ✚ I wish to acknowledge the support provided to me by the staff of Zoonoses Research Unit: Prof. Robert Swanepoel for his guidance; Stephanie van Niekerk for helping out in sorting, compilation and printing of my university documents; Marthi Pretorius for providing me with transport during my stay in Pretoria. Angella Musisi for assisting me in my university registration and facilitating the necessary reservations that made my stay in Pretoria worthwhile.

- ✚ Completing this work would have been impossible were it not for the support and friendship provided by the members of the Capacity Building and Institutional Development; Mario Margiotta, Lillian Igweta-Tonnang, Lisa Omondi and Margaret Ochanda.

- ✚ I also thank the AVID Project consortium-led by the International Centre of Insect Physiology and Ecology (*icipe*) and including; International Livestock Research Institute, Kenya Agricultural Research Institute, Ministry of Livestock Development-Central Veterinary Laboratories, Kenya Medical Research Institute, Ministry of Public Health and Sanitation and Kenya Wildlife Service; The Director of *icipe*, Prof. Christian Borgemeister, for providing all the necessary support in securing funding and spearheading the project. This research was funded by Google.org, the philanthropic arm of Google.

- ✚ I would like to thank the staff of Viral Hemorrhagic Fever Laboratory, Kenya Medical Research Institute for their support in the various aspects of laboratory work: Dr. Samoel Khamadi, Dr. Samson Limbaso, Albina Makio, Albert Anyunja, Caroline Ochieng, Caroline Tigoi, Collins Mutai, Collins Odhiambo, Edith Chepkorir, Edith Koskei, Hellen Koka, Samwel Arum, Samson Owaka, Victor Ofula, John Gachoya, Dunston Betti, Joel Lutomiah, James Mutisya, Reuben Lugalia, Francis Mulwa, Samson Arum and Caroline Wasonga.

- ✚ I wish to appreciate the tremendous work of Sangailu Dispensary and Ijara Health Centre staff: Mr. Saidi, the District Chief Laboratory Technologist, Ijara; Dr. Sonde, the District Medical Officer of Health and the District Health Management Team, Ijara District

for their support.

- ✦ I thank the families of Ijara District who participated in the study by allowing blood samples to be collected from those with febrile illness and also ticks to be sampled from their animals.

- ✦ I would like to thank my family for their support - my parents (Henifrey Lwande and Beatrice Maero Ndombi) for putting me through school and believing in me, my brothers (Ronald and Dennis) and sisters (Linda and Verah) for their advice, and my late grandparents (Martha Maero Ndombi, Zipporah Taka Lwande, Humprey Lwande and Johnson Maero Ndombi) for inspiring me to follow my dreams. Prof. Stanley and Judith Waudu for providing me with moral support.

Contents

Ethics	ii
Declaration	iii
Acknowledgements	iv
List of Figures	xi
List of Tables	xv
List of Abbreviations	xvii
Presentations and Publications Related to this Work	xxi
Summary	xxiv
Chapter 1	1
Literature Review	1
1.1 Introduction	1
1.2 Classification of Arboviruses	3
1.2.1 Classification of Tick-Borne Viruses	4
1.2.2 Classification of Mosquito-Borne Viruses	7
1.3 General Classification of Ticks	9
1.3.1 Basic Tick Biology	9
1.3.2 Life Cycle of Ticks	13
1.3.3 Tick Ecology	15
1.4 Epidemiology of Arboviruses	17
1.4.1 Epidemiology of Tick-Borne Viruses	17
1.4.2 Tick-Borne Viruses in Kenya	27
1.4.3 Epidemiology of Mosquito-Borne Viruses	31
1.5 Clinical Features of Tick-Borne Virus Infections	41
1.6 Diagnosis of Arbovirus Infections	44

1.7 Molecular Biology of Arboviruses	48
1.7.1 Togaviridae	48
1.7.2 Bunyaviridae	49
1.7.3 Flaviviridae	51
1.7.4 Orthomyxoviridae	53
1.8 Diversity of Tick-Borne Viruses	53
1.9 Conclusions	55
1.10 Hypothesis	56
1.11 Aim	56
1.12 Objectives	56
Chapter 2	58
Prevalence of Crimean-Congo hemorrhagic fever antibodies in humans that attend health facilities in Ijara District, North Eastern Province of Kenya	58
2.1 Introduction	58
2.2 Materials and Methods	60
2.2.1 Study Area	60
2.2.2 Study Design	61
2.2.3 Study Population	61
2.2.4 Ethical Considerations	62
2.2.5 CCHFV Antibody Testing	62
2.2.6 Indirect IgG Capture ELISA	63
2.2.7 Indirect IgM Capture ELISA	64
2.2.8 Interpretation of Results of both IgM and IgG ELISA	65
2.2.9 Questionnaire and Data Analysis	65
2.3 Results	65

2.3.1 Patient Demographics	65
2.3.2 IgM and IgG Results	66
2.3.3 Prevalence and Risk Factors for CCHFV	66
2.4 Discussion	68
Chapter 3	74
Identification of Tick-Borne Viruses among Tick Vectors in Pastoral Eco- Zone of Ijara District, North Eastern Province of Kenya	74
3.1 Introduction	74
3.2 Materials and Methods	77
3.2.1 Study Design.....	77
3.2.2 Study Area	77
3.2.3 Ethical Considerations	79
3.2.4 Tick Collection and Transport.....	79
3.2.5 Tick Processing and Identification	79
3.2.6 Virus Isolation.....	80
3.2.7 Reverse Transcriptase Polymerase Chain Reaction	81
3.3 Results	84
3.3.1 Tick Collection.....	84
3.3.2 Virus Isolation and Identification	84
3.3.2 PCR Identification.....	86
3.4 Discussion	92
Chapter 4	97
Investigation of Genetic Diversity by Next Generation Sequencing of Arbovirus Isolates Obtained from Ticks Sampled from Livestock and Wildlife in North Eastern Kenya, Pastoral Eco- Zone Ijara	97

4.1 Introduction	97
4.2 Materials and Methods	101
4.2.1 Tick Collection and Transport.....	101
4.2.2 Tick Processing and Identification	101
4.2.3 Virus Isolation.....	101
4.2.4 RNA Sample Preparation for 454 Sequencing	101
4.2.6 RNA Extraction, RT-PCR for Sanger Sequencing	102
4.2.7 Sanger Sequencing, Analysis and Phylogeny	102
4.2.8 Ethical Considerations	103
4.3 Results	103
4.3.1 Virus Isolates	103
4.3.2 Genetic and Phylogenetic Grouping of Sequence Data	105
4.4 Discussion	123
Chapter 5	129
Concluding Remarks.....	129
Chapter 6	135
References	135
Appendixes.....	155
Appendix A	155
Appendix B	160
Appendix C.....	164
Appendix D.....	168
Appendix E	171
Appendix F	200

List of Figures

Figure 1. Tick life cycle.....	14
Figure 2. Geographic distribution of Crimean-Congo hemorrhagic fever virus	18
Figure 3. Typical arbovirus infection with timing of specific diagnostics.....	45
Figure 4. Genomic organization of the first publicly available CHIKV genome (Ross strain, GenBank accession no. AF490259). Genomic organization of the first publicly available CHIKV genome (Ross strain, GenBank accession no. AF490259). The four non-structural proteins (nsP1–4) are translated as a single polyprotein directly from the positive-sense RNA genome. The structural proteins (C, E3, E2, 6K and E1) are translated from a subgenomic RNA (26S) transcribed from a separate promoter within the non-translated (NTR) junction region. 5' and 3' NTR regions flank the coding region source: (Powers and Logue, 2007).	49
Figure 5. Schematic representation of genomic RNAs belonging to prototypic members of the five genera classified within the family Bunyaviridae. Schematic representation of genomic RNAs belonging to prototypic members of the five genera classified within the family Bunyaviridae. All <i>Bunyaviruses</i> possess three RNA segments named small (S), medium (M) and large (L). Arrows below each segment indicate ORFs expressed using a negative-sense coding strategy, whereas arrows above the segments denote ORFs transcribed as mRNAs from positive-sense, ambisense templates (Source: (Walter and Barr, 2011).	52
Figure 6. CCHF IgG positive individuals (n=96) by age groups in health facilities in Ijara and Sangailu locations, October 2010-March 2011.	68
Figure 7. A map of the study sites within Ijara District in North Eastern Province, Kenya.	78

- Figure 8. RT-PCR gel results for CPE positive tick-homogenates using Alphavirus primers. L- represents the 100 bp molecular ladder, +1 positive control for Middelberg virus, +2 positive control for SFV, – negative control and 1 to 30 are the CPE positive tick homogenates. 86
- Figure 9. RT-PCR gel results for cpe positive tick homogenates with Orthobunya and Phleboviruses primers. L-represents the 100 bp molecular ladder, +1 positive control for RVFV, +2 positive control for BUNV, – negative control and 31 to 50 are the CPE positive tick homogenates. 87
- Figure 10. Phylogenetic relationship between Kenyan SFV isolates and other Alphaviruses identified in this study based on partial nucleotide sequences of SFV nonstructural protein gene (RdRp nsP4) region position 6812 to 6945. The tree was generated by MEGA5 (Tamura et al., 2011) using the Maximum Likelihood method based on the Tamura-Nei model (Tamura and Nei, 1993). The values on the branches indicate bootstrap values. The blue right braces represent SFV study and virus isolates. 106
- Figure 11. Phylogenetic relationship between Kenyan NDUV isolates and other *Alphaviruses* identified in this study based on partial 6775 to 6911 for NDUV 26S junction region. The tree was generated by MEGA5 (Tamura et al., 2011) using the Maximum Likelihood method based on the Tamura-Nei model (Tamura and Nei, 1993). The values on the branches indicate bootstrap values. The blue right braces represent NDUV study and virus isolates. 107
- Figure 12. Phylogenetic relationship between Kenyan SFV isolate and other SFV strains identified this study based on nucleotide sequences of a gene fragment (7334bp) of the genome that encodes the non-structural proteins (nsP1–4). The tree was generated by MrBayes software using the generalized time-reversible (GTR)

model. The values on the branches indicate posterior probability values. The arrow indicates the SFV isolate sequenced in this study. 108

Figure 13. Phylogeny of Kenyan NDUV isolate and other NDUV identified in this study based on nucleotide sequences of gene fragment (408bp) position 6775 to 7182 that encodes the 26S junction. The tree was generated by MrBayes software using the generalized time-reversible (GTR) model. The values on the branches indicate posterior probability values. The arrow indicates the NDUV isolate sequenced in this study. 109

Figure 14. Phylogeny of N and the NSs gene nucleotide sequences (Partial) of BUNV strains identified in Kenya and other selected viruses of the genus *Orthobunyavirus* used in this study. The values on the branches indicate posterior probability values. The tree was generated by MrBayes software using the GTR model. Region sequenced nucleotide position 113 to 363. The arrow indicates the BUNV isolates sequenced in this study. 112

Figure 15. Phylogeny of M polyprotein gene (Partial NSm and Gc) nucleotide sequences of the BUNV strain identified in Kenya and other BUNV strains used in this study. The value on the branches indicate posterior probability values. The tree was generated by MrBayes software using the GTR model. Region sequenced nucleotide position 1165 to 1516. The arrow indicates the BUNV isolate sequenced in this study. 113

Figure 16. Phylogenetic tree based on partial non-structural protein 5 (NS5) nucleotide sequences of WNV strains identified in Kenya and selected previously characterized WNV strains demonstrating genetic relatedness. The tree was generated by MrBayes software using the GTR model. The values on the branches indicate posterior probability values. Regions sequenced; positions 9254 to 9609. The arrow indicates the WNV isolates sequenced in this study. 116

Figure 17. Phylogenetic tree based on nucleotide sequences position 4 to 10,867 that corresponds to the structural (C, E and M) and non-structural (1, 2A, 2B, 3, 4A, 4B and 5) proteins of WNV strain identified in Kenya and selected previously characterized WNV strains demonstrating genetic relatedness. The tree was generated by MrBayes software using the GTR model. The values on the branches indicate posterior probability values. The Kenyan tick-borne WNV (marked with a blue arrow) segregated into a cluster of Lineage 1 viruses along with previously isolated Kenyan mosquito-borne WNV in the cluster highlighted in Blue. 118

Figure 18. Phylogenetic tree of partial nucleotide sequences of L protein gene of Dugbe virus (DUGV) L segment strains identified in Kenya and other *Nairoviruses* used in this study. The tree was generated by MrBayes software using the GTR model. The values on the branches indicate posterior probability values. The arrow indicates the Dugbe viruses sequenced in this study. Region sequenced; position 32 to 179.... 120

Figure 19. Phylogenetic tree of partial nucleotide sequences of nucleoprotein gene (position 1 to 174) of THOV isolated in Kenya, other THOV and Influenza virus strains. The tree was generated by MEGA5 (Tamura et al., 2011) using the Maximum Likelihood method based on the Tamura-Nei model (Tamura and Nei, 1993). The values on the branches indicate bootstrap values. The blue arrow indicates the THOV isolate sequenced in this study and the blue right braces represent THOV and Influenza virus isolates. 122

List of Tables

Table 1. Distribution of tick-borne viruses with associated tick species and animals	6
Table 2. Distribution of mosquito-borne viruses with associated mosquito species and animal hosts	8
Table 3. Basic key in tick classification	12
Table 4. Arboviruses associated with diverse tick species in different areas in Africa	16
Table 5. Documented outbreaks of Crimean-Congo hemorrhagic fever virus	20
Table 6. Clinical features of tick-borne virus infections	43
Table 7. Overview of the most used diagnostic methods for selected tick-borne virus infections	47
Table 8. Sero-prevalence and associated risk factors for CCHFV.....	67
Table 9. Reverse Transcription Polymerase Chain Reaction Primers used for identification of key arboviruses.....	82
Table 10. Proportion of virus isolated from tick species sampled from livestock and wildlife.....	85
Table 11. Proportion of virus isolated from domestic and wild hosts from which ticks were sampled in Ijara district	88
Table 12. Virus isolates obtained from ticks collected from animal hosts in Ijara District, Kenya	89
Table 13. Virus isolates obtained from diverse tick species sampled from livestock and wildlife	90
Table 14. Virus isolates obtained from ticks sampled from livestock and wildlife	91
Table 15. List of virus isolates, identification numbers and sequencing method used	104
Table 16. Amino acid substitution table for Semliki forest virus non-structural protein gene (nsP1–4).	171
Table 17. Nucleotide substitutions at the 26S junction region of Ndumu virus	180

Table 18. Amino acid substitutions at Nucleocapsid (N) and Non- structural (NSs) gene regions of Bunyamwera virus.	182
Table 19. Amino acid substitutions at M protein gene (NSm and Gc) of Bunyamwera virus ...	184
Table 20. Amino acid substitutions of the WNV polyprotein gene that corresponds to the structural (C, E and M) and non-structural (1, 2A, 2B, 3, 4A, 4B and 5) proteins	185
Table 21. Amino acid substitutions at nucleoprotein gene of Thogoto virus	195
Table 22. Nucleotide substitutions of the 5' non-coding region of the non-structural protein of SFV	196
Table 23. Nucleotide sequence alignment of the 5' non-coding region of WNV polyprotein gene	197
Table 24. Nucleotide sequence alignment of the 3' non-coding region of WNV polyprotein gene	198

List of Abbreviations

ARPPIS	African Regional Post-graduate Programme in Insect Science
BHAV	Bhanja Virus
BLAST	Basic Local Alignment Search Tool
BT	Bluetongue
BUN	Bunyamwera
BUNV	Bunyamwera Virus
CEV	California encephalitis virus
CCHF	Crimean Congo Hemorrhagic Fever
CCHFV	Crimean Congo Hemorrhagic Fever Virus
CHF	Crimean Hemorrhagic Fever
CHFV	Crimean Hemorrhagic Fever Virus
CDC	Centre for Disease Control
cDNA	Complementary Deoxyribonucleic Acid
CHIK	Chikungunya
CHIKV	Chikungunya Virus
CNS	Central Nervous System
CPE	Cytopathic Effect
DEN	Dengue
DENV	Dengue Virus
DHOV	Dhori Virus
DNA	Deoxyribonucleic Acid
DUG	Dugbe
DUGV	Dugbe Virus
EEE	Eastern Equine Encephalitis

EEEV	Eastern Equine Encephalomyelitis Virus
ELISA	Enzyme Linked Immunosorbent Assay
ERC	Ethical Review Committee
FBS	Fetal Bovine Serum
FMDV	Foot and Mouth Disease Virus
GTR	Generalized Time Reversible
HJV	Highland J Virus
HRPO	Horse Radish Peroxidase
<i>icipe</i>	International Centre for Insect Physiology and Ecology
ICTV	International Code of Virus Classification
IgG	Immunoglobulin G
IgM	Immunoglobulin M
ILRI	International Livestock Research Institute
IFA	Indirect Florescent Antibody Assay
JE	Japanese Encephalitis
JEV	Japanese Encephalitis Virus
KAD	Kadam
KADV	Kadam Virus
KEMRI	Kenya Medical Research Institute
KFD	Kyasanur Forest Disease
KFDV	Kyasanur Forest Disease Virus
LACV	Lacrosse Virus
LIV	Louping ill Virus
Mabs	Monoclonal antibodies
MAC-ELISA	Antibody Capture Enzyme Linked Immunosorbent Assay

MEM	Minimum Essential Medium
N	Nucleocapsid
NDU	Ndumu
NDUV	Ndumu Virus
NGS	Next Generation Sequencing
NS	Nonstructural
NSD	Nairobi Sheep Disease
NSDV	Nairobi Sheep Disease Virus
OD	Optical Density
OHF	Omsk Hemorrhagic Fever
OHFV	Omsk Hemorrhagic Fever Virus
ONN	O'nyong'nyong
ONNV	O'nyong'nyong Virus
PCR	Polymerase Chain Reaction
R	Statistical Packages
RdRP	RNA-dependent RNA polymerase
RNA	Ribonucleic Acid
RNP	Recombinant Nuclear Protein
RRV	Ross River virus
RT-PCR	Reverse Transcriptase Polymerase Chain Reaction
RVF	Rift Valley Fever
RVFV	Rift Valley Fever Virus
SD	Standard Deviation
SF	Semliki Forest
SFV	Semliki Forest Virus

SIN	Sindbis
SINV	Sindbis Virus
SLEV	St. Louis Encephalitis Virus
SSC	Scientific Steering Committee
TBEV	Tick-borne encephalitis virus
THO	Thogoto
THOV	Thogoto Virus
UAE	United Arab Emirates
U.S.A	United States of America
USSR	Union of Soviet Socialist Republics
USU	Usutu
USUV	Usutu Virus
VEEV	Venezuelan Equine Encephalitis Virus
WEEV	Western Equine Encephalitis Virus
WHO	World Health Organization
WN	West Nile
WNV	West Nile Virus
YF	Yellow Fever
YFV	Yellow Fever Virus
ZIKV	Zika Virus

Presentations and Publications Related to this Work

Presentations

Lwande, O.W., Venter, M., Fischer, A. and Sang, R. 2011. Sero-prevalence of Crimean Congo hemorrhagic fever virus in out-patients attending Sangailu and Ijara Health Centres Kenya. First Medical Veterinary and Virus Symposium, Silver Springs Hotel, Nairobi, Kenya.

Lwande, O.W., Venter, M., Fischer, A. and Sang, R. 2011. Sero-prevalence of Crimean Congo hemorrhagic fever virus in out-patients attending Sangailu and Ijara Health Centres Kenya. Genetics and Disease Control International Workshop, University of Cape Coast, Cape Coast, Ghana.

Lwande, O.W., Venter, M., Fischer, A. and Sang, R. 2011. Isolation of arboviruses from ticks collected from livestock in pastoral eco-zone of Ijara District. Arbovirus Incidence and Diversity Scientific Conference International Centre of Insect Physiology and Ecology, *duduville* Campus, Nairobi, Kenya.

Lwande, O.W., Lutomiah, J., Obanda, V., Gakuya, F., Mutisya, J., Mulwa, F., Michuki, G., Fischer, A., Venter, M. and Sang, R. 2012. Co-circulation of mosquito and tick-borne arboviruses among ticks and their animal hosts in the pastoral eco-zone of Ijara District, Kenya. 61st Annual Meeting of the American Society of Tropical Medicine and Hygiene, Hilton Hotel, Atlanta, Georgia.

Lwande, O.W., Venter, M., Obanda, V., Gakuya, F. and Sang, R. 2013. Tick & mosquito-borne viruses among ticks sampled from wildlife in Ijara district, Kenya. 2nd ICOPHAI-International Congress on Pathogens at the Human-Animal Interface, held from August 14th to 17th, 2013, at the Summerville Beach Resort, in Porto de Galinhas, Pernambuco, Brazil.

Publications

Lwande, O.W., Lutomiah, J., Obanda, V., Gakuya., Venter, M., Sang, R. 2013. Isolation of tick & mosquito-borne arboviruses from ticks sampled from livestock & wild animal hosts in Ijara, District, Kenya. *Vector-Borne & Zoonotic Diseases*,13(9):637-42

Lwande, O.W., Irura, Z., Tigoi, C., Chepkorir, E., Orindi, B., Musila, L., Venter, M., Fischer, A. and Sang, R. 2012. Seroprevalence of Crimean Congo hemorrhagic fever virus in Ijara District, Kenya. *Vector-Borne and Zoonotic Diseases*, 12 (9):727-32.

Lwande, O.W., Venter, M. and Sang, R. 2013. Detection of West Nile Virus Lineage 1 in the Tick, *Rhipicephalus pulchellus* from Cattle in Ijara District, Kenya. Manuscript assigned number: PNTD-D-13-00708 after pre-submission inquiry to PLOS Neglected Tropical Diseases

Lwande, O.W., Venter, M. and Sang, R. 2013. Investigation of the genetic diversity of arbovirus isolates obtained from ticks sampled from livestock and wildlife in North Eastern Kenya pastoral eco-zone of Ijara. Manuscript ready for submission to a peer reviewed journal.

**Occurrence and Diversity of Tick-Borne Viruses in the Pastoral Eco-Zone of Ijara District,
North Eastern Province of Kenya**

By

Olivia Wesula Lwande

Supervisors: Prof. Marietjie Venter

Dr. Rosemary Sang

Department: Medical Virology

Degree: Doctor of Philosophy (Medical Virology)

Summary

Most arbovirus isolations in East Africa have been recorded from mosquitoes but less information is available about tick-borne viruses including Crimean-Congo hemorrhagic fever virus (CCHFV), which is prevalent in Africa with a mortality rate of up to 40%. The study envisioned gaining an in-depth understanding of the circulation, transmission and diversity of tick-borne viruses in Ijara District of North Eastern Kenya, a pastoral ecozone with a defined population size of 19,259 that are served by 8 health facilities where arbovirus activity among mosquitoes, animals and humans is frequently reported. The study aimed at determining the prevalence of CCHF antibodies in humans that attend selected health facilities in Ijara District,

identify tick-borne viruses among tick vectors and genetic diversity of the tick-borne viruses circulating among ticks and/or their host animals.

A total of 517 human serum samples were screened for the presence of IgG and IgM antibodies to CCHF using CCHF-IgG and IgM ELISA test kits (VectoCrimean-CHF-IgG and IgM ELISA; Vector-Best, Novosibirsk, Russia). A multivariable logistic regression model was used to investigate the exposure to CCHFV in patients enrolled in this study. In this first part of the study, a single patient tested positive for anti-CCHF IgM, while 96 were positive for anti-CCHF IgG, suggesting an overall seroprevalence of CCHFV in Ijara District of 19%. The results indicate the possibility of acute CCHFV infections occurring without being detected in this population.

A total of 10,488 ticks were also sampled from livestock and wild animal hosts and processed in 1,520 pools of up to 8 ticks per pool. The sampled ticks were classified to species, processed for virus screening by cell culture using Vero cells, RT-PCR, and sequencing. Bunyamwera (BUN), Dugbe (DUG), Ndumu (NDU), Semliki forest (SF), Thogoto (THO), and West Nile (WN) virus strains were isolated and identified.

Phylogenetic analysis based on nucleotide sequences showed that the Kenyan isolates clustered closely to their respective reference strains. Semliki forest virus (SFV) isolate (ATH00510) sequence obtained by 454 sequencing, clustered closely to the Kenyan strains (HQ848388 and JF972635) isolated from mosquitoes sampled in North Eastern Province of Kenya. Ndumu virus (NDUV) (ATH002166) was similar to the Ugandan strain (JN989958). All BUNV strains isolated in the study clustered distinctively on a tree branching comprising viruses of Bunyamwera serogroup. The two Dugbe viruses detected in this study were highly similar to

each other and formed a cluster with the United Kingdom (NC004159 and U15018) strains. Thogoto virus was divergent from strains obtained from Germany, Senegal, Turkey, USA and Vietnam. WNV strains isolated in Kenya clustered relatively close to viruses isolated in Russia, Europe and the United States belonging to lineage 1 of WNV. The identification of WNV Lineage 1 in Ijara District brings in to light the ability of this virus to spread across wide geographical regions taking into consideration that this virus lineage is also found in Europe, America, India and the Middle East. These study findings provide additional evidence on the potential role of ticks and animals (both livestock and wildlife) in the circulation of tick-borne viruses as well as viruses previously known to be mosquito-borne. It also provides a basis in understanding the genetic diversity of arboviruses circulating in Ijara District.

Chapter 1

Literature Review

1.1 Introduction

Arboviruses are viruses that survive in nature by transmission from infected arthropods (mosquitoes, ticks, sandflies and midges) to susceptible hosts (vertebrates) (Ochieng et al., 2013). These viruses multiply within the tissues of the arthropod to produce high titres of virus in the salivary glands and are then passed on to vertebrates (humans and animals) by the bites of the infected arthropods (Kuno and Chang, 2005). Arboviruses constitute the largest biologic group of vertebrate viruses. At present, more than 550 arboviruses have been identified, among which are more than 130 virus species which can cause disease in susceptible vertebrate hosts including humans (Gao et al., 2010). Arboviruses of public health significance include members of the Flaviviridae, Bunyaviridae, and Togaviridae families (Donald et al., 2012). Approximately half of the isolations from field-collected arthropods are from mosquitoes and a third are from ticks; however, this difference may represent a sampling bias, since many more mosquitoes are collected and tested for viruses than ticks (Karabatsos, 1985, Sang et al., 2006).

Tick-borne viruses are classified according to their antigenic relationships, morphology and replicative mechanisms (Alatoon and Payne, 2009). They are found in six different viral families (Asfarviridae, Reoviridae, Rhabdoviridae, Orthomyxoviridae, Bunyaviridae, and Flaviviridae) and at least nine genera (Lwande et al., 2013). Some as yet unassigned tick-borne viruses may belong to a seventh family, the Arenaviridae. With only one exception (African swine fever virus, [ASFV]), all tick-borne viruses are RNA viruses. Tick-borne viruses pose a significant threat to

the health of humans (tick-borne encephalitis virus [TBEV], CCHFV) and animals (ASFV, Nairobi sheep disease virus [NSDV]) (Labuda and Nuttall, 2004).

Tick-borne viruses predominantly cause acute central nervous system illness ranging from mild aseptic meningitis to encephalitis with coma, paralysis and death; acute short benign fevers with or without an exanthema; hemorrhagic fever that might be extensive, internal or external and associated with capillary leakage, shock, jaundice, liver damage and death; and polyarthritis and rash (Chin, 2000). The majority of human infections are asymptomatic or may result in a nonspecific flu-like syndrome and only a small proportion of infected patients' progress to encephalitis (Alatoom and Payne, 2009). Humans are incidental hosts because they do not produce significant viremia and do not contribute to the transmission cycle (Alatoom and Payne, 2009). They acquire infection during blood feeding by an infected arthropod vector. Laboratory-acquired infections can also occur after handling of infected tissues and body fluids (Calisher, 1994). These viruses can be diagnosed by serology, virus isolation in cell culture and molecular based assays (Hall et al., 2012).

It is clear that certain demographic and societal changes in the past years have had a major impact on the ecology of tick-borne viral diseases. Modern transportation ensures faster and increased movement of humans, animals and commodities and their pathogens between regions and population centers of the world. Although the reasons behind this dramatic resurgence of tick-borne viral diseases are complex, Gubler (2002) listed the following factors: Demographic changes including global population growth, population movements and unplanned and uncontrolled urbanization; Societal changes such as human encroachment on natural disease foci, modern transportation, containerized shipping; Agricultural changes including changes in land use, irrigation systems, deforestation; Changes in pathogens due to

increased movement in humans and animals and genetic changes leading to increased epidemic potential; Changes in public health operations including lack of effective vector control, deterioration of public health infrastructure to deal with tick-borne viral diseases, lack of disease surveillance and prevention programs and probable climate change (Gubler, 2002).

Surveillance reports based on virus isolations and serologic studies in cattle from Kenya, the Central African Republic and South Africa have identified tick-borne viruses from the families Bunyaviridae, Flaviviridae, Rhabdoviridae, Reoviridae and Orthomyxoviridae (Sang et al., 2006, Butenko et al., 1981, Burt et al., 1996, Guilherme et al., 1996, Johnson et al., 1980). The most serious human pathogen among the tick-borne viruses in African regions is Crimean Congo hemorrhagic fever (CCHF) virus, a member of the *Nairovirus* genus that can cause fatal hemorrhagic disease (Elliott, 1997, Shepherd et al., 1987). Outbreaks of CCHF have occurred in China, South Africa, Pakistan and Russia (Burt et al., 1998, Khan et al., 1995, Weaver and Barrett, 2004).

The identification of CCHFV in a patient in Kenya (Dunster et al., 2002) prompted the investigation of the prevalence of this virus and other tick-borne viruses in humans and vectors in Kenya.

1.2 Classification of Arboviruses

Arboviruses are classified into seven major virus families (Asfarviridae, Reoviridae, Rhabdoviridae, Orthomyxoviridae, Bunyaviridae, Togaviridae and Flaviviridae) and are transmitted by arthropods, mainly mosquitoes and ticks (Moreli and da Costa, 2013). Togaviridae (*Alphavirus*), Flaviviridae (*Flavivirus*) and Bunyaviridae (*Bunyavirus*) are the three

main virus families in which most clinically significant arboviruses belong. *Alphaviruses* and *Bunyaviruses* are usually transmitted by mosquitoes, *Flaviviruses* transmitted by either mosquitoes and ticks and *Phleboviruses* which are transmitted by sandflies (apart from Rift Valley fever virus (RVFV), which is mosquito-borne) (Calisher and Karabatsos, 1988, Karabatsos, 1985, Van Regenmortel and Fauquet, 2000). Examples of these arboviruses include O'nyong'nyong (ONN), Chikungunya (CHIK), Semliki forest (SF), Ndumu (NDU), Sindbis (SIN), West Nile (WN), Bunyamwera (BUN), Thogoto (THO), dengue (DEN), yellow fever (YF), CCHF, Usutu (USU) and Kyasanur forest disease (KFD) amongst others. Arboviruses replicate in the arthropod vector (tick, mosquito, sandfly and midge) preceding transmission to the vertebrate host (animal and human) (Weaver et al., 1997). Arboviruses persist in the vector population by vertical transmission which involves passage of the virus from an infected arthropod vector to its progeny (Kuno and Chang, 2005).

1.2.1 Classification of Tick-Borne Viruses

Tick-borne viruses belong to 6 virus families (Asfaviridae, Orthomyxoviridae, Rhabdoviridae, Flaviviridae, Bunyaviridae and Reoviridae) (Nuttall, 2009). Each family is characterized by a unique genome organization and replication strategy. Thus tick-borne virus transmission has evolved independently at least six times during the phylogenetic period that can be traced today (Labuda and Nuttall, 2004). Among virus families containing arboviruses, only the Togaviridae (genus *Alphavirus*) does not contain any tick-borne members, although some mosquito-borne *Alphaviruses* (e.g. SIN) have occasionally been isolated from ticks (Gresikova et al., 1978). Eighty percent (80%) of tick-borne viruses are members of the *Orbivirus*, *Nairovirus*, *Phlebovirus* and *Flavivirus* genera in the Reoviridae, Bunyaviridae and Flaviviridae families respectively.

In general, the association between the arthropod and the transmitted virus is very intimate and highly specific. Comparatively few arthropod species act as vectors. In fact, less than 10% of the known tick species are incriminated as virus vectors and they are mostly found in large tick genera. For argasid ticks these are *Ornithodoros* and *Argas* and among ixodid ticks, virus vectors are found mostly in the genera *Ixodes*, *Haemaphysalis*, *Hyalomma*, *Amblyomma*, *Dermacentor*, *Rhipicephalus* and *Boophilus*. Some tick vector species transmit one or two virus species and a few transmit several species; *Ixodes ricinus* is a good example of the latter. It is widespread across most of the European continent reaching northern parts of Africa. In many forested areas, it is the most abundant tick species with a very broad vertebrate host range. All these features make it a highly efficient vector of several arboviruses and also a main vector of viruses from three different virus families, e.g. TBEV and louping ill Virus (LIV) of Flaviviridae, Tribec virus and Eyach virus of Reoviridae, and Uukuniemi virus of Bunyaviridae (Table 1).

Table 1. Distribution of tick-borne viruses with associated tick species and animals

Virus	Classification: family genus	Vector	Animals affected	Disease	Endemic presence
African swine fever	Asfarviridae; <i>Asfivirus</i>	<i>Argasid</i> spp.	Pigs	Systemic febrile illness	Africa
Colorado tick fever	Reoviridae; <i>Coltivirus</i>	<i>Dermocentor andersonii</i>	Humans, small mammals	Systemic febrile illness	North America
Crimean-Congo hemorrhagic fever	Bunyaviridae; <i>Nairovirus</i>	<i>Hyalomma</i> spp.	Humans	Systemic febrile illness/Hemorrhagic fever	Africa, Asia, Europe
Dugbe virus	Bunyaviridae; <i>Nairovirus</i>	<i>A. variegatum</i> , <i>A. gemma</i> , <i>A. Lepidum</i> , <i>R. pulchellus</i>	Humans	Systemic febrile illness	Africa
Kemerovo	Reoviridae; <i>Orbivirus</i>	<i>Ixodes</i> spp.	Humans, Rodents, birds	Systemic febrile illness	Asia
Kyasanur Forest	Flaviviridae; <i>Flavivirus</i>	<i>Haemophysalis</i> spp.	Humans, small mammals	Encephalitis	India
Louping ill virus	Flaviviridae; <i>Flavivirus</i>	<i>Ixodes ricinus</i>	Sheep, cattle	Encephalitis	British Isles
Nairobi sheep disease	Bunyaviridae; <i>Nairovirus</i>	<i>Rhipicephalus appendiculatus</i>	Sheep, goats	Hemorrhagic fever/gastroenteritis	East Africa
Omsk hemorrhagic fever	Flaviviridae; <i>Flavivirus</i>	<i>Dermocentor reticulatus</i>	Humans	Hemorrhagic fever	Asia
Tick-borne encephalitis virus	Flaviviridae; <i>Flavivirus</i>	<i>Ixodes</i> spp.	Humans, wildlife	Encephalitis	Europe, Asia
Thogoto	Orthomyxoviridae; <i>Thogotovirus</i>	<i>Boophilus</i> , <i>Amblyomma</i> , <i>Rhipicephalus</i> , <i>Hyalomma</i>	Sheep	Abortion	Africa

Source: (Whitley and Gnann, 2002, Labuda and Nuttall, 2004, Pfeffer and Dobler, 2010)

1.2.2 Classification of Mosquito-Borne Viruses

Mosquito-borne viruses belong to the families *Togaviridae*, *Flaviviridae* and *Bunyaviridae* (Karabatsos, 1985, Gubler, 2001). They are found in the genus *Alphavirus*, *Flavivirus* and *Bunyavirus* (Feng et al., 2012) which include: eastern equine encephalitis virus (EEEV), western equine encephalitis virus (WEEV), Venezuelan equine encephalitis virus (VEEV), SINV, Ross River virus (RRV), CHIKV, Lacrosse virus (LACV), RVFV, California encephalitis virus (CEV), DENV, YFV, Zika virus (ZIKV), WNV, St. Louis encephalitis virus (SLEV), and Japanese encephalitis virus (JEV) (Table 2). The main focus of this study was on tick-borne viruses.

Table 2. Distribution of mosquito-borne viruses with associated mosquito species and animal hosts

Virus	Classification: family genus	Vector	Animals affected	Disease
eastern equine encephalitis	Togaviridae; <i>Alphavirus</i>	<i>Culex melanura</i> , <i>Culex (Melanoconion)</i> spp. (Latin America)	Passerine, birds	Febrile illness, encephalitis
Venezuelan equine encephalitis	Togaviridae; <i>Alphavirus</i>	<i>Culex (Melanoconion)</i> spp.	Rodents	Febrile illness, encephalitis
western equine encephalitis	Togaviridae; <i>Alphavirus</i>	<i>Culex tarsalis</i> , <i>Culex quinquefasciatus</i> (North America)	Birds	Febrile illness, encephalitis
Chikungunya	Togaviridae; <i>Alphavirus</i>	<i>Aedes</i> spp.	Primates	Arthralgia/rash
O'nyong'nyong	Togaviridae; <i>Alphavirus</i>	Unknown	Unknown	Arthralgia/rash
Ross River	Togaviridae; <i>Alphavirus</i>	<i>Culex annulirostris</i> , <i>Oculerotatis vigilax</i>	Marsupials	Arthralgia/rash
Dengue 1,2,4 (sylvatic genotypes)	Flaviviridae; <i>Flavivirus</i>	Arboreal <i>Aedes</i> spp.	Primates	Febrile illness, hemorrhagic syndrome
Dengue 1-4 (endemic genotypes)	Flaviviridae; <i>Flavivirus</i>	<i>Aedes aegypti</i> , <i>Aedes albopictus</i>	Humans	Febrile illness, hemorrhagic syndrome
Japanese encephalitis	Flaviviridae; <i>Flavivirus</i>	<i>Culex tritaeniorhynchus</i> , <i>Culex</i> spp.	Birds	Febrile illness, encephalitis
St. Louis encephalitis	Flaviviridae; <i>Flavivirus</i>	<i>Culex quinquefasciatus</i>	Birds	Encephalitis
West Nile	Flaviviridae; <i>Flavivirus</i>	<i>Culex</i> spp.	Birds	Febrile illness, encephalitis
Yellow Fever	Flaviviridae; <i>Flavivirus</i>	<i>Aedes</i> , <i>Sabethes</i> and <i>Haemagogus</i> spp.	Primates	Hepatitis, hemorrhagic disease

Source: (Weaver and Barrett, 2004)

1.3 General Classification of Ticks

Ticks belong to a relatively small group of arthropods, comprising of approximately 860 species (Horak et al., 2002, Furman and Loomis, 1984). Ticks can be separated from insects and other mandibulate forms (Centipedes, Millipedes, and Crustaceans) into the subphylum Chelicerata on the basis of the presence of anterior pair of chelicerae that function as trophic appendages. The suborder of Ixodides (order Acarina) contains the hard and soft ticks of the families Ixodidae and Argasidae (Beaver et al., 1984). The Superfamily of Ixodiodea includes the families of ticks, namely Argasidae, Ixodidae and Nuttalliedae (Keirans, 2009). The Ixodidae family contains more than 650 species which fall into four subfamilies and thirteen genera. The Argasidae family contains approximately 150 species and five genera. The Nuttalliedae family contains only one species in one genus (Hoogstraal, 1956). The Ixodidae are known as hard ticks due to their hard dorsal shield (scutum) and they attach to their host for prolonged periods. The Argasid ticks, known as soft ticks and feed secretively for short periods. The lone species *Nuttalliella namaqua* infests hyraxes in Africa (South Africa and Tanzania) and is of minor veterinary or medical importance (Bedford, 1934, Keirans et al., 1976) (Table 3).

1.3.1 Basic Tick Biology

Ticks are dorso-ventrally flat, non-segmented blood sucking parasites (Anderson and Magnarelli, 2008). The adult and nymph consist of four pairs of legs whereas the larvae consist of 3 pairs of legs. The synganglion, eyes and salivary glands are all found in the body of the tick. The mouth parts are found on a moveable part of the body called the basis capituli. The basis capituli, mouthparts and palps form the capitulum. The mouthparts comprise; two palps

which serve as sensory apparatus, two chelicerae for cutting and one hypostome for anchorage and feeding (Sonenshine, 1993). Hard and soft ticks can be differentiated by examining several biological and morphological criteria for example the presence or absence of scutum, oviposition and their feeding patterns (Krantz, 1978).

1.3.1.1 Soft Ticks (Argasidae)

The soft ticks lack a dorsal cuticular shield known as scutum but possess a soft leathery exoskeleton. Mouth parts of soft ticks project ventrally (Molyneux, 1994). Although sexual dimorphism is limited in these ticks, the male genital opening is small and curved. Soft ticks lay eggs in several batches of hundreds after each blood meal and have more than one nymphal stages. These ticks are found in cracks, crannies, nests, burrows and buildings where they attach to sleeping hosts. Soft ticks belong to the genera *Antricola*, *Argas*, *Nothaspis*, *Ornithodoros* and *Otobius* (Guglielmone et al., 2010).

1.3.1.2 Hard Ticks (Ixodidae)

The hard ticks consist of a dorsal cuticular shield and their mouth parts project anteriorly. In male ticks, the scutum covers the entire dorsal surface but only covers approximately a third of the entire dorsal surface in females (Mehlhorn, 2010). Hard ticks lay eggs in a single batch of thousands and undergo only one nymphal stage. The male ticks die after mating whereas the females die after oviposition. These ticks can be found on grass or attached on animal hosts. Hard ticks are found in the genera *Rhipicephalus*, *Amblyomma*, *Aponomma*, *Dermacentor*, *Haemophysalis*, *Hyalomma* and *Ixodes* (Sonenshine, 1993).

The *Ixodes* spp. have an anal groove which curves around anterior to the anus. *Ixodes* spp. have no eyes, festoons, or scutal ornamentation. Their palpi are thickest at the junction of palpal segments II and III. *Amblyomma* spp. have large mouthparts which are longer than the basis capituli; the second palpal segment is at least twice as long as it is width. They possess eyes and have an ornate scutum. Reptiles and ground-feeding birds serve as hosts for the immature *Amblyomma* ticks whereas mammals serve as hosts for the mature ticks. Their long mouthparts make *Amblyomma* ticks especially difficult to remove manually and frequently cause severe wounds on their hosts that may become infected by bacteria or screwworms. Several African *Amblyomma* ticks that infest livestock are vectors of *Ehrlichia ruminantium*, the rickettsial agent that causes heart water. *Amblyomma* ticks have also been found on various species of wildlife which serve as hosts (Sonenshine, 1991).

Hyalomma ticks are moderately large ticks with long mouthparts. Most *Hyalomma* ticks undergo a 3-host life cycle whereas a few undergo either a 1- or 2-host cycle. A unique feature of *Hyalomma* ticks is the ability of some of the 3-host species to develop in 1- or 2-host cycles. *Hyalomma* ticks are found in central and southwest Asia, southern Europe and Africa (Kampen et al., 2007) (Table 4). Livestock and wildlife serve as hosts of *Hyalomma* ticks. *Hyalomma* ticks are the most abundant in livestock, including camels. Although *Hyalomma* ticks consists of about 25 species only 15 are important vectors of infectious agents to livestock and humans for example *H. anatolicum anatolicum* has the ability to transmit *Theileria annulata*, *Babesia equi*, *B. caballi*, *Anaplasma marginale*, *Trypanosoma theileri*, and arboviruses such as CCHFV to humans (Latif et al., 2004).

Aponomma spp. have palpi elongate, eyes absent, frequently ornate, tarsi of male is humped and armed with ventral spurs) (Horak et al., 2007). They feed mainly on reptiles. *Haemaphysalis*

spp. have palpi with flared second segments. Like *Ixodes*, these ticks lack eyes, but they differ in having festoons and a posterior anal groove. *Rhipicephalus* spp. have a roughly hexagonal basis capituli, festoons and cleft coxae I. *Boophilus* spp. also have a hexagonal capitulum but they lack festoons. The coxae I are not cleft but have anterior projections. They possess eyes but they lack the anal groove. *Dermacentor* spp. have a rectangular basis capituli and 11 festoons. The scutum is ornamented (brightly coloured). The coxae, especially of the males, progress in size from I to IV. *Otocentor* spp. resemble *Dermacentor* but have only seven festoons (Spickett, 1994a).

Table 3. Basic key in tick classification

FAMILY	MORE COMMON GENERA	NUMBER OF SPECIES
Argasidae	<i>Antricola</i>	4
Soft tick	<i>Argas</i>	140
	<i>Otobius</i>	2
	<i>Ornithodoros</i>	90
Ixodidae - Group 1: Prostriata	Purely the genus	Approx 250
Hard tick	<i>Ixodes</i>	
Ixodidae - Group 2: Metastriata	<i>Amblyomma</i>	100
Hard tick	<i>Aponomma</i>	26
The difference between the two groups is determined by the location of an anal groove, anterior to the anus in Prostriata, and posterior to the anus in Metastriata.	<i>Anocentor</i>	1
	<i>Boophilus</i>	5
	<i>Dermacentor</i>	31
	<i>Haemaphysalis</i>	150
	<i>Hyalomma</i>	21
	<i>Rhipicephalus</i>	63
	<i>Margaropus</i>	3
Nuttalliellidae - morphological features of both the Argasidae and Ixodidae	<i>Nuttalliella namaqua</i>	Lone species found in South Africa and Tanzania.

Source: (Guglielmone et al., 2010)

There are three families of ticks: the Ixodidae (hard ticks), Argasidae (soft ticks) and Nuttalliellidae (one species only).

1.3.2 Life Cycle of Ticks

All tick species undergo a six-legged larval stage, one or more eight-legged nymphal stages and an eight-legged adult stage. Hard ticks have a single nymphal stage, while soft ticks may have as many as eight (Furman and Loomis, 1984) (Figure 1). The life cycle of ticks involves interaction with a great variety of hosts, which are classified as “one-host,” “two-host,” “three-host,” or “many-host” species. One-host ticks complete all feeding and molting on a single animal, usually a large-sized, wandering host (sheep, cow, horse, deer, antelope, buffalo). In two-host ticks, the molt from larva to nymph occurs on the first host, which is usually a small mammal or bird and the engorged nymph drops to the ground, where it molts to the adult stage. The adult must then find a second, usually much larger host. Like one-host ticks, there are only about a dozen two-host ticks, almost all of them ixodids, including several associated with livestock. All other ixodid ticks are three-host species that detach after engorging at each life stage, with molts taking place off the host Figure 1 (Walker and Bouattour, 2003).

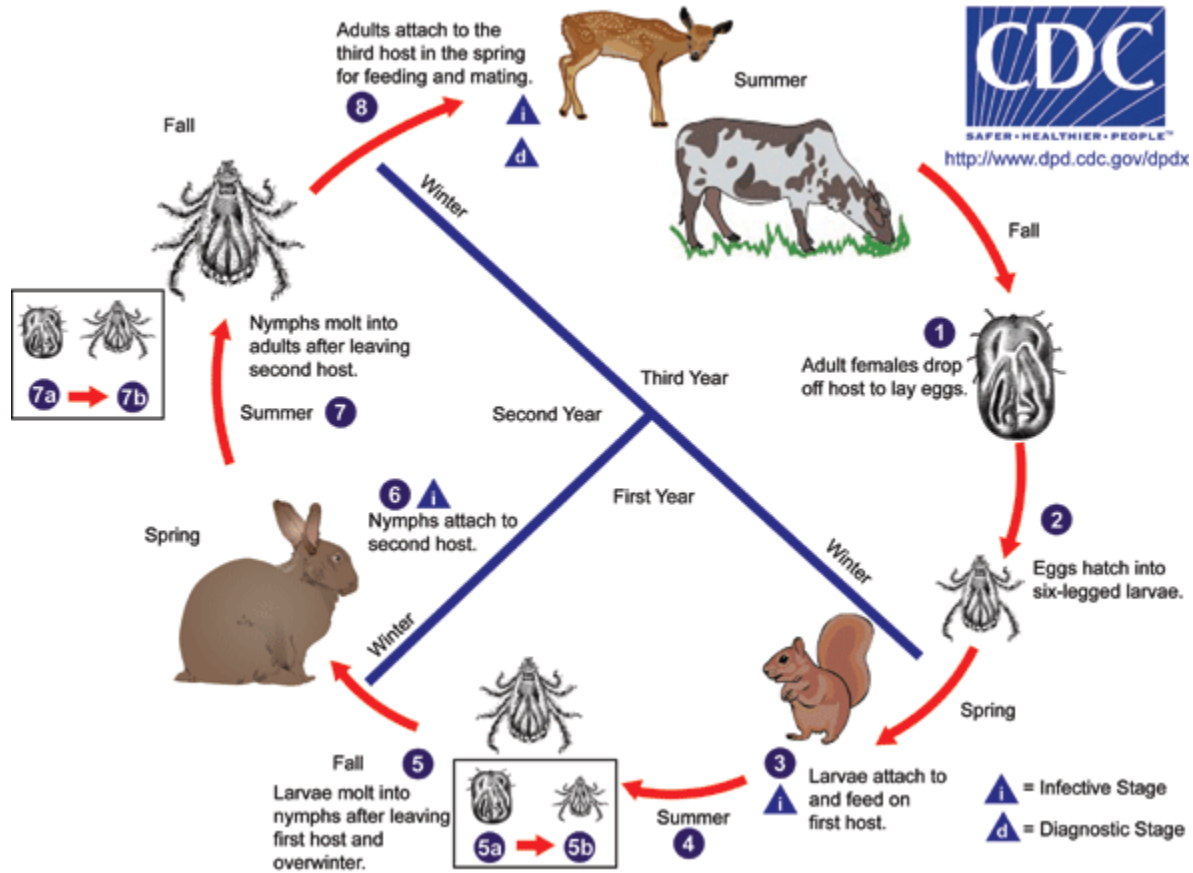

Figure 1. Tick life cycle

Many-host ticks are typically argasids, which feed on a number of different animals during their life cycle, the adults feeding several times (Sonenshine, 1991). Copulation takes place following the last molt, after which the female engorges and produces eggs, which are laid on the ground or in some sheltered location (Furman and Loomis, 1984).

1.3.3 Tick Ecology

The interaction of ticks with their environment is essential to the spatial and temporal variations in the risk of infection by tick-borne pathogens (Randolph, 2004). The environment is composed of biotic factors (such as the hosts on which the ticks feed on) that may affect the physiology, population and evolution of ticks. Abiotic factors such as climate and habitat structure can also determine the survival of the various developmental stages of the tick since the tick has to take a blood meal from the host and detach from the host and molt to the next stage. It is only under suitable climatic conditions that a developmental stage of a tick is able to molt to the next stage (Spickett, 1994b).

Abiotic factors such as humidity and moisture content affect tick survival and development. Humidity has an intense effect on tick activity since it plays a major role in determining the questing time of a tick. Seasonal variations in temperature as a result of global warming can also affect the number of times hosts and pathogen-carrying vectors come into contact (Greenfield, 2011).

Table 4. Arboviruses associated with diverse tick species in different areas in Africa

Family	Genus	Virus species	Main tick vector species	Geographical distribution
Asfaviridae	<i>Asfivirus</i>	<i>African swine fever virus</i>	<i>O. moubata</i> , <i>O. erraticus</i>	sub-Saharan Africa
Orthomyxoviridae	Novel	<i>Quaranfil</i>	<i>Argas arboreus</i>	Egypt
		<i>Johnston Atoll</i>	<i>Ornithodoros capensis</i>	central Pacific, eastern Australia, New Zealand and Hawaii
	<i>Thogotovirus</i>	<i>Thogoto virus</i> <i>Dhori virus</i>	<i>Rhipicephalus</i> , <i>Boophilus</i> , <i>Hyalomma</i> spp, <i>A. variegatum</i> <i>H. dromedarii</i> , <i>H. marginatum</i>	central and East Africa Egypt
Rhabdoviridae	<i>Vesiculovirus</i>	<i>Barur virus</i>	<i>H. intermedia</i>	Kenya and Somalia
Reoviridae	<i>Orbivirus</i>	<i>Chenuda virus</i>	<i>Argas hermanni</i>	Egypt
		<i>Essaouria virus</i>	<i>O. maritimus</i>	Morocco
		<i>Kala Iris virus</i>	<i>O. maritimus</i>	Morocco
		<i>Wad Medani virus</i>	<i>R. sanguineus</i> , <i>Hyalomma</i> spp	East Africa
Bunyaviridae	<i>Bunyavirus</i>	<i>Bahig virus</i>	<i>Hyalomma</i> spp	Egypt
		<i>Matruh virus</i>	<i>H. marginatum</i>	Egypt
	<i>Nairovirus</i>	<i>Crimean-Congo hemorrhagic fever virus</i>	<i>H. marginatum</i> ; isolated from many ixodid spp	Many countries in Africa
		<i>Abu Hammad virus</i>	<i>Argas hermanni</i>	Egypt
		<i>Pretoria virus</i>	<i>Argas africanus</i>	South Africa
		<i>Dugbe virus</i>	<i>A. variegatum</i>	sub-Saharan Africa
		<i>Nairobi sheep disease virus</i>	<i>R. appendiculatus</i>	East and central Africa
		<i>Bandia virus</i>	<i>O. sonrai</i>	Senegal
		<i>Qalyub virus</i>	<i>O. erraticus</i>	Egypt
	<i>Phlebovirus</i>	<i>Tunis virus</i>	<i>A. reflexus</i>	Tunisia
		<i>Bhanja virus</i>	<i>H. punctata</i>	Africa
		<i>Forecariah virus</i>	<i>B. geigy</i>	Guinea
		<i>Kismayo virus</i>	<i>R. pulchellus</i>	Somalia
		<i>Wanowrie virus</i>	<i>Hyalomma</i> spp	Egypt
Flaviviridae	<i>Flavivirus</i>	<i>Kadam virus</i>	<i>R. pravus</i>	Uganda
Unassigned tick-borne viruses		<i>Nyaminini virus</i>	<i>Argas arboreus</i> , <i>Argas walkerae</i>	Egypt, Nigeria, South Africa
		<i>Aride virus</i>	<i>A. loculosum</i>	Seychelles
		<i>Jos virus</i>	<i>A. variegatum</i> , <i>B. decoloratus</i>	Nigeria, Senegal

Source: (Labuda and Nuttall, 2004, Presti et al., 2009)

1.4 Epidemiology of Arboviruses

1.4.1 Epidemiology of Tick-Borne Viruses

Tick-borne viruses have a worldwide distribution and pose a significant threat to the health of humans (CCHFV, TBEV) or livestock (ASFV, NSDV) (Donald et al., 2012). Most tick-borne viruses belong to the genus *Orthobunyavirus*, *Nairovirus*, *Flavivirus* in the Bunyaviridae and Flaviviridae families respectively (Labuda and Nuttall, 2004) (Table 4).

CCHFV, (family Bunyaviridae, genus *Nairovirus*) is a combination of two (virus names) Crimean (Russia) and Congo and later found to be the same antigenically with similar symptoms (Casals, 1969). Crimean hemorrhagic fever virus (CHFV) was first discovered in Crimea during the 1944-1945 epidemic where approximately 200 military personnel were infected with the virus (Chumakov, 1945). Congo virus was first isolated in the Democratic Republic of Congo and Uganda from blood collected from two patients suspected to have the virus (Simpson et al., 1967, Woodall et al., 1967). Despite the geographical differences in terms of their isolation, CHF and Congo viruses were found to be similar and thus this led to the name CCHFV (Hoogstraal, 1979).

CCHFV is an acute, highly-contagious viral zoonosis transmitted to humans mainly by ticks of the genus *Hyalomma* and also through direct contact with blood or tissues of viremic hosts (Vorou et al., 2007). However evidence indicates that *Rhipicephalus*, *Boophilus*, *Dermacentor*, and *Ixodes* spp. also transmit CCHFV (Appannanavar and Mishra, 2011, Bell-Sakyi et al., 2012) for example; CCHFV has been isolated from *Rhipicephalus bursa* sampled from goats in Greece (Papadopoulos and Koptopoulos, 1980). Experimental studies performed in the

laboratory have shown that soft ticks such as *Argas walkerae*, *Ornithodoros savignyi*, *Ornithodoros porcinus* and *Ornithodoros sonrai* are incapable to transmit CCHFV (Shepherd et al., 1989, Soneshine, 1993).

In humans CCHF typically presents with high fever of sudden onset, malaise, severe headache and gastrointestinal symptoms. Prominent hemorrhages associated with leucopenia and thrombocytopenia may occur in late stages of the disease with fatality rates ranging from 10% to 50% (Vorou et al., 2007, Ergönül, 2006).

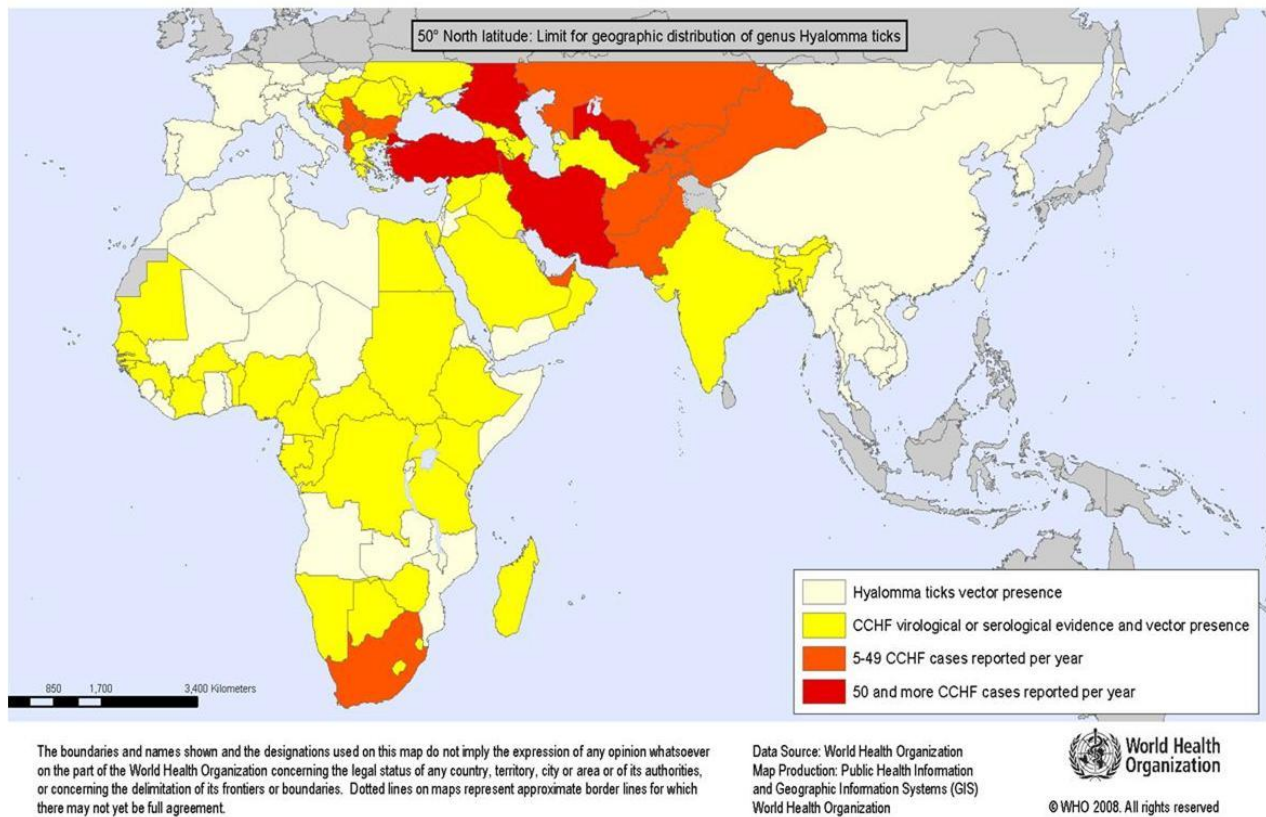

Figure 2. Geographic distribution of Crimean-Congo hemorrhagic fever virus

CCHFV is widely distributed throughout large areas of sub-Saharan Africa, the Balkans, northern Greece, European Russia, Pakistan, the Xinjiang province of Northwest China, the Arabian Peninsula, Turkey, Iraq and Iran, in a total of 28 countries in Africa, Asia, the Middle East and Europe (Appannanavar and Mishra, 2011).

CCHF manifests itself in four major phases namely: incubation, pre-hemorrhagic, hemorrhagic and convalescence (Appannanavar and Mishra, 2011). The incubation phase occurs immediately after exposure to a tick-bite, which lasts up to a period of 1 to 3 days (Swanepoel et al., 1987). During the pre-hemorrhagic phase the patient manifests with the following symptoms; fever, chills, severe headache, dizziness, photophobia, back pain, abdominal pains, vomiting, diarrhea and loss of appetite. This phase can last up to a period 5 to 12 days (Swanepoel et al., 1987). Hemorrhagic phase occurs in severe cases and lasts up to a period of 3 to 6 days. Hemorrhagic manifestations such as bleeding in the form of melena, hematemesis, epistaxis occurs.

CCHFV is widely distributed in more than 30 countries in Africa, Asia, southeast Europe and the Middle East (Rodrigues et al., 2012) (Figure 2). CCHFV has been reported in many parts of the world including some parts of Africa such as: South Africa, Democratic Republic of Congo, Mauritania, Burkina Faso, Tanzania, Kenya and Senegal; In Asia they include Pakistan and China; In the middle east countries such as Iraq, the United Arab Emirates (UAE), Saudi Arabia and Oman; Southeast Europe in Crimea, Astrakhan, Rostov, Bulgaria, Albania, Kosovo and Turkey. In the year 2000 new outbreaks of CCHFV were reported from Pakistan, Iran, Senegal, Albania, Yugoslavia, Bulgaria and Turkey, Kenya and Mauritania (Ergönül, 2006) (Table 5).

Table 5. Documented outbreaks of Crimean-Congo hemorrhagic fever virus

Location	Years	Numbers of cases	Case fatality rate (%)	Occupation
Southeast Europe				
Crimea	1944-45	200	10	Military members
Astrakhan	1953-63	104	17	Agricultural workers
Rostov	1963-69	323	15	Agricultural workers
Bulgaria	1953-74	1105	17	Agricultural workers, health-care workers
	1975-96	279	11	Agricultural workers
	1977-03	138	21	Agricultural workers
Albania	2001	7	0	Agricultural workers, health-care workers
Kosovo	2001	18	33	Agricultural workers
Turkey	2002-05	500	5	Agricultural workers
Asia				
China	1965-94	260	21	Agricultural workers
	1997	26	24	Agricultural workers
Kazakhstan	1948-68	75	50	Agricultural workers
Tajikistan	1943-70	97	23	Agricultural and laboratory workers
Pakistan	1976	14	29	Shepherd, health-care workers
	1994	3	Not known	Health-care workers
	2000	9	18	Agricultural workers, health-care workers
Middle east				
United Arab Emirates (UAE)	1979	6	50	Health-care workers
	1994-95	11	73	Agricultural workers
Sharjah	1980	1	0	Storekeeper
Iraq	1979-80	55	64	Agricultural workers
Saudi Arabia	1990	7		Agricultural workers
Oman	1995-96	4	Not known	Agricultural workers
Iran	2003	81	18	Agricultural workers
Africa				
Zaire (DRC)	1956	2	0	Physician
Uganda	1958-77	12	8	Laboratory workers
Mauritania	1983	1	0	Camel herd owner
	2004	38	29	Agricultural workers, health-care workers
Burkina Faso	1983	1	0	
South Africa	1981-86	32	31	Farmers, health-care workers
Tanzania	1986	1	0	Student
Southwest Africa	1986	1	0	
Kenya	2000	1	100	Agricultural worker

Source: (Ergönül, 2006)

Serological studies indicate that the virus is present in Egypt, France, India, Portugal and Turkey (Karti et al., 2004). CCHFV has the potential to cause community and nosocomial outbreaks. An outbreak of CCHF for the first time in India was reported from Gujarat, in January 2011 (Lahariya et al., 2012).

CCHFV transmission cycle involves tick-vertebrate-tick. Main animal hosts include domestic and wild vertebrates, including cattle and goats (Woodall et al., 1965, Causey et al., 1970), sheep (Yu-Chen et al., 1985), hares (Chumakov, 1974), hedgehogs (Causey et al., 1970), a *Mastomys* spp. mouse (Saluzzo et al., 1985), and even domestic dogs (Shepherd et al. 1987a). Antibodies to CCHFV have been detected in cattle, horses, donkeys, sheep, goats and pigs from various parts of Europe, Asia and Africa (Watts, 1989). Though paucity of data exists on CCHFV infection in birds, few experimental studies conducted suggest resistance of domestic fowl and passerine species to the virus, though experimental infections of birds have been less well documented. Guinea fowls and ostriches have been confirmed to show a transient viremia (Mostafavi et al., 2013). Ostriches serve as hosts for CCHFV and have been associated with the 1984 to 1996 CCHF outbreak which occurred in ostrich abattoirs (Swanepoel et al., 1998).

CCHFV can be diagnosed using virus isolation, serological and molecular assays such as virus inoculation in Vero cells, intracerebral inoculation in mice, immunofluorescence (Shepherd et al., 1986), ELISA targeting IgM and IgG antibodies and reverse transcriptase polymerase chain reaction (RT-PCR) (Burt et al., 1996).

NSDV (Bunyaviridae, *Nairovirus*), is probably the most pathogenic tick-borne virus known for sheep and goats. It is transmitted by an Ixodid tick, both transstadially and transovarially and causes an acute gastroenteritis. In totally susceptible populations mortality rates of over 90%

regularly occur. The infection also causes abortion in sheep and goats. The disease is known to occur in East Africa, Somalia and Rwanda. It may exist in the South East of Ethiopia. No evidence for its existence has been found in those parts of Africa where the principle vector tick, *Rhipicephalus appendiculatus* has a seasonal breeding cycle. Thus countries like Zambia, Zimbabwe and Botswana appear to be free from the disease (Davies, 1997a). Antibodies to NSDV have been detected in cattle sera and cross-reactivity for Nairobi sheep disease, Hazara, and Dugbe viruses have also been detected in human patients who were positive for CCHFV infection during a study carried out by (Burt et al., 1996) in South Africa. Cross-reactions within the Bunyaviridae family may be a limitation in epidemiological studies based on serology only.

DUGV, (Bunyaviridae, *Nairovirus*) is also member of the Nairobi sheep disease group. DUGV has been reportedly isolated from several tick species, including *A. gemma* and *R. pulchellus*, the species from which Kupe virus was isolated (Honig et al., 2004, David-West and Porterfield, 1974). In the 1999 Kenya abattoir survey, DUGV was isolated from 4 species of ticks, *A. variegatum*, *A. gemma*, *A. lepidum*, and *R. pulchellus* (Sang et al., 2006). A study conducted by Burt et al. (1996) confirmed that DUGV causes mild febrile illness and thrombocytopenia in humans. Little is known about the epidemiology of Kupe virus other than its isolation from ticks infesting cattle. The pathogenesis, if any, of Kupe virus in mammals is unknown (Sang et al., 2006).

Bhanja virus (BHAV) is, together with two African tick-borne viruses Kismayo (Butenko, 1979) and Forecariah (Boiro et al., 1986), a member of Bhanja group (family Bunyaviridae) (Matsuno et al., 2013) that has not yet been assigned to a recognized genus ((ICTV), 2009, Van Regenmortel and Fauquet, 2000). The virus was first isolated from the tick *Haemaphysalis intermedia* collected from a paralyzed goat in Bhanjanagar District, India (Ganjam, Orissa State, India) in 1954 (Shah and Work, 1969). The known geographic

distribution of BHAV (Hubalek, 1987) involves Southern and Central Asia, Africa and Southern (partially central) Europe. In Europe, BHAV has so far been isolated in Italy (Verant et al., 1970), Croatia (Vesenjok-Hirjan et al., 1977), Bulgaria (Pavlov et al., 1978), Slovakia (Hubálek et al., 1988), Romania (Ungureanu et al., 1990), and Portugal (as Palma virus) (Filipe and Casals, 2008).

TBEV (Flaviviridae, *Flavivirus*), is transmitted to people by ixodid ticks that thrive in rich, moist, undergrowth found on forest floors (Briggs et al., 2011). They feed during spring and summer-hence the first isolate was called Russian spring and summer encephalitis. Between 3500 and 10,000 cases of encephalitis occur in rural and urban Russia every year, largely because the city boundaries frequently overlap with the forests (Gritsun et al., 2003). In Russia, up to 5% of ticks carry this virus and 1-5% of infections result in clinical disease, with case fatality rates of 30-60%. 3-7 days after an infected tick bite, people infected with tick-borne encephalitis in western and central Europe characteristically present with a biphasic illness commencing with an influenza-like illness that lasts up to 1 week. Subsequently, the patient could become transiently asymptomatic before 20-30% may develop the neurological phase of the disease, which can affect the meninges, brain parenchyma, spinal cord and nerve roots in various combinations to give aseptic meningitis, meningoencephalitis, meningoencephalomyelitis or meningoencephaloradiculitis with a case fatality rate of 1-2%. 10-20% of severe cases show long-lasting or permanent neuropsychiatric sequelae.

LIV, a UK descendant of TBEV, (Zanotto et al., 1995) is found in ticks on the Irish, Scottish, Welsh and English moorlands where sheep graze. It is the only tick-borne *Flavivirus* found in the British Isles and is geographically the most westerly virus in this group. Although this virus causes encephalitis, (Davidson et al., 1991) there is only one record of a human fatality (Cooper et al., 1964). LIV causes encephalomyelitis in sheep and red grouse, both of which

are reared on lowlands and then introduced onto moorlands where they have little opportunity to develop immunity or resistance to this disease.

Powassan virus (Flaviviridae, *Flavivirus*), emerged in East Russia about 2000 years ago (Zanotto et al., 1996) and is related to tick-borne encephalitis from East Asia. They share the forest ecosystem and both produce biphasic fever and encephalitis in people. However, Powassan virus is also found in Canada and North America, where it occasionally produces encephalitic disease in human beings. This disease was possibly introduced into America by infected ticks on animals or associated foodstuffs, arriving from East Asia.

Omsk hemorrhagic fever (OHF) (Flaviviridae, *Flavivirus*), is an acute viral disease prevalent in some regions of western Siberia in Russia (Holbrook et al., 2005). The symptoms of this disease include fever, headache, nausea, severe muscle pain, cough and moderately severe hemorrhagic manifestations. A third of patients develop pneumonia, nephrosis, meningitis or a combination of these complications. The only treatment available is for control of symptoms. No specific vaccine has been developed, although the vaccine against tick-borne encephalitis might provide a degree of protection against Omsk hemorrhagic fever virus (OHFV). The virus is transmitted mainly by *Dermacentor reticulatus* ticks, but people are mainly infected after contact with infected muskrats (*Ondatra zibethicus*). Muskrats are very sensitive to OHFV (Růžek et al., 2010).

Kyasanur Forest disease virus (KFDV) (Flaviviridae, *Flavivirus*) and the closely related Alkhumra virus (Charrel et al., 2001) cause hemorrhagic disease in human. KFDV was isolated from sick and dying monkeys in 1957 in Shimoga District (Karnataka State), India. It had probably circulated in ticks (*haemaphysalis* spp.) and forest animals for many years, rarely causing infections in people (Nichter, 1987). However, forest clearances for urbanisation during the 1950s brought scavenging monkeys into closer contact with ticks

infected with KFDV on the exposed forest floor (Trapido et al., 1959). Veterinary scientists investigating the sick monkeys were bitten by infected ticks and developed hemorrhagic disease (Banerjee, 1988, Mehla et al., 2009). KFDV has subsequently caused epidemic outbreaks of hemorrhagic fever annually, affecting 100-500 people with a case fatality rate of 2-10% (Gould and Solomon, 2008).

Kadam virus (KADV) (Flaviviridae, *Flavivirus*) was isolated from a pool of male *Hyalomma dromedarii* ticks taken near a dead camel in Wadi Thamamah, Riyadh, Saudi Arabia (Al-Khalifa et al., 2007). The virus was previously isolated from *Rhipicephalus* and *Amblyomma* ticks in Uganda and Kenya, where results of seroepidemiological survey showed KADV infection of humans and cattle. The question of pathogenicity of Kadam viremia in camels, other domestic and wild vertebrates and humans remain to be answered. The natural history and epidemiology of KAD virus are unstudied (Sang et al., 2006, Wood et al., 1982).

THOV, (Orthomyxoviridae, *Thogotovirus*) was first isolated from a pool of ticks collected from cattle in 1960 in Thogoto forest near Nairobi, Kenya (Haig et al., 1965). Subsequently the virus has been repeatedly isolated from ticks as well as vertebrates (humans and livestock) in Africa, Asia and Europe. Neutralizing antibodies have been detected in man and a wide variety of animals including cattle, camel, sheep and goats (Davies et al., 1986). THOV has constantly been established in areas where tick-infested domestic animals reside and has been isolated from ticks in the genera *Boophilus*, *Amblyomma*, *Rhipicephalus* and *Hyalomma*, as well as humans and domestic animals (cattle and camels) (Ogen-Odoi et al., 1999, Karabatsos, 1985) Furthermore this virus was first isolated from mongoose indicating possible transmission of this virus to wildlife (Ogen-Odoi et al., 1999). This virus can also be passed on by co-feeding ticks through non-viremic transmission (Jones et al., 1990). In Kenya THOV was first isolated from a pool of ticks comprising of *Boophilus decoloratus*, *Rhipicephalus appendiculatus*, *R. simus* and *R. ewertsi* in 1960 in the Thogoto forest near

Nairobi (Haig et al., 1965). THOV has been shown to cause widespread abortion (Davies et al., 1984) and pyrexia in sheep (Haig et al., 1965). During a surveillance carried out by Sang et al (2006) on tick-borne arbovirus in market livestock in Nairobi, this virus was isolated from *A. gemma*, *A. lepidum* and *Rhipicephalus pulchellus*.

Dhori virus (DHOV) (Orthomyxoviridae, *Thogotovirus*) has a wide distribution; it has been isolated in southern and eastern Europe, Central Asia and Africa from ticks, mainly species of the genus *Hyalomma* (Anderson and Casals, 1973, Sang et al., 2006, Karabatsos, 1985) Antibodies against DHOV have been detected in large domestic animals (camels, horses, and goats), as well as in humans living in endemic regions (Anderson and Casals, 1973, Filipe and Casals, 2008). Dhori virus has also been isolated from large breeding colony of sea gull on the Malyi Zhemchuzhnyi Island in the north-western area of the Caspian Sea. Furthermore antibodies against this virus were also detected in the sea gulls (Iashkulov et al., 2008). Dhori virus has been detected in *Hyalomma marginatum* ticks sampled from cattle in southern Portugal (Filipe and Casals, 2008). Five human cases of accidental aerosol infection with DHOV were reported among a group of laboratory workers in the former USSR (Butenko et al., 1987). These individuals developed an acute febrile illness characterized by headache, retro-orbital pain, myalgia, general weakness and a prolonged period of convalescence; two of these people also developed mild symptoms of cranial nerve involvement with radicular syndrome (Butenko et al., 1987).

1.4.2 Tick-Borne Viruses in Kenya

Tick-borne arbovirus surveillance studies carried out in Kenya indicate the presence of tick-borne viruses circulating amongst pastoral communities. DUGV, DUGV-like and DHOV have been isolated from ticks species (*A. gemma*, *Rh. Pulchellus* and *Boophilus annulatus*) sampled from livestock especially camels and cattle in pastoral zones of Kenya (Mutisya, 2011). CCHFV a tick-borne virus that causes severe hemorrhagic fever has also been detected in *hyalommid* ticks sampled in North eastern, Kenya which is essentially a pastoral eco-zone (Sang et al., 2011). A surveillance study conducted at abattoirs in Nairobi, Kenya detected tick-borne viruses such as DUGV, an unknown virus related to DUGV, THOV, Bhanja, Kadam, DHOV, Barur and foot-and-mouth disease (FMDV) viruses obtained from *Rhipicephalus pulchellus*, *Amblyomma gemma*, *R. appendiculatus* and *A. variegatum* species (Sang et al., 2006).

The first reported human case of CCHF in Kenya occurred at a farm that was heavily infested by ticks (Dunster et al., 2002). The patient was a 25 year old male farmer who presented with fever, headache, nausea, vomiting, severe muscle pains, neck stiffness and diarrhea four days before being admitted at a mission hospital in western Kenya. On the fifth day the patient's condition deteriorated leading to massive bleeding from the nose, mouth and upper and lower gastrointestinal tract. The patient died on the sixth day after resuscitation efforts turned futile. Differential diagnosis of malaria parasites, typhoid, dysentery and meningitis deemed negative. The patient's serum sample was later shipped to the Viral Hemorrhagic Fever Reference Laboratory in Nairobi for further screening. The sample tested positive by RT-PCR for CCHFV and negative for both anti-CCHFV specific IgM and IgG antibodies (Dunster et al., 2002). This virus has also been detected in *Rhipicephallus pulchellus* ticks sampled from dying sheep in a veterinary laboratory in Kabete, Nairobi and in *hyalommid* ticks sampled from livestock in North eastern region of

Kenya during an arbovirus surveillance aimed at determining the level of human exposure to tick-borne viruses (Sang et al., 2006, Hoogstraal, 1979)

NSDV, also in the genus *Nairovirus*, causes fever, hemorrhagic gastroenteritis and abortion in sheep and goats in East Africa (Davies, 1978). Epizootics of NSDV have been reported in various parts of Africa where susceptible herds of sheep have been moved to NSDV-endemic areas, resulting in decimation of whole herds (Davies, 1978). NSDV was first discovered in Nairobi, Kenya by Montgomery in 1917. NSDV is endemic in Kenya, Uganda, Tanzania, Somalia, Ethiopia, Botswana, Mozambique and Democratic Republic of Congo though recent sequence data indicate that the same virus can also be found in many places in India and Sri Lanka where it is called Ganjam virus. NSD is a viral infection known to affect sheep and goats. In Kenya NSD epidemics have been linked to livestock trading in the surrounding areas of Kenya's main capital. Studies have shown that prognosis in susceptible sheep and goats are poor, although mild infection may occur. Though studies have been conducted on other animals such as; cattle, buffalo, equids and other mammals no virus has been detected. NSD is highly pathogenic in small ruminants with a mortality rate of 90% due to acute hemorrhagic fever. Human infections are uncommon however they can acquire the virus through accidental needle stick injury especially among laboratory personnel ensuing in mild febrile illness. The African field rat (*Arvicathus abyssinicus nubilans*) is known to serve as a potential reservoir host of NSD. NSDV can be transmitted transovarially and transstadially by diverse tick species with *Rhipicephalus appendiculatus* serving as the primary vector. Though the virus is shed in urine and faeces of infected animals NSD is transmissible through contact (Holzer et al., 2011).

DUGV which is another member of the *Nairovirus* genus, has been repeatedly confirmed in tick-borne virus surveys in Africa and causes mild febrile illness and thrombocytopenia in humans (Burt et al., 1996). In Kenya, DUGV has been isolated from diverse tick species

including; *A. variegatum*, *A. gemma*, *A. Lepidum* and *R. pulchellus*. In a survey conducted by Sang et al. (2006) on ticks infesting market livestock in Nairobi, Kenya, approximately 26 isolates of DUGV were made (Sang et al., 2006). Kupe virus which is closely related to DUGV is also found in the genus *Nairovirus* and has been isolated from *A. gemma* and *R. pulchellus* ticks sampled from hides of cattle in Nairobi, Kenya (Sang et al., 2006). The impact of Kupe virus on human and animal health is yet to be established (Crabtree et al., 2009b).

BHAV, an unassigned member of the Bunyaviridae family, has also been isolated in this region (Burt et al., 1996, Johnson et al., 1980). BHAV is a tick-borne virus first identified from the *Haemaphysalis intermedia* species sampled from a paralyzed goat in Bhanjanagar (district Ganjam, Orissa State, India) in 1954. BHAV is endemic Africa, southern and central Asia and southern (partially central) Europe. Subsequent isolations of this virus have been obtained from diverse tick species including; *Haemaphysalis punctata*, *H. sulcata*, *Dermacentor marginatus*, *Hyalomma marginatum*, *H. detritum*, *H. dromedarii*, *H. truncatum*, *H. asiaticum*, *Rhipicephalus bursa*, *R. appendiculatus*, *Boophilus decoloratus*, *B. annulatus*, *B. geigy* and *Amblyomma variegatum*. Sheep, goat, cattle, African hedgehog and African ground squirrel serve as vertebrate hosts of BHAV. The virus causes apparent infection characterized by fever and encephalitis in young ruminants of sheep, goat and cattle. In humans BHAV causes symptoms such as; photophobia, vomiting, meningo-encephalitis and pareses (Hubálek et al., 1988).

Other tick-borne viruses present in Africa include THOV from the genus *Thogotovirus*, Orthomyxoviridae family, isolated in Kenya. THOV has been isolated from diverse tick species in Africa and southern Europe. THOV has been associated to cause widespread abortion in large sheep flocks. THOV is known to infect humans in natural settings. DHOV which belongs to the same family as THOV has been isolated from ticks in Africa, India,

eastern Russia, Egypt and southern Portugal. DHOV causes febrile illness and encephalitis in humans; Barur virus, Rhabdoviridae family, isolated from adult *Rhipicephalus pulchellus* ticks collected from camels near Mogadisho, Somalia; and Kadam virus (KADV) from the genus *Flavivirus*, Flaviviridae family; and Chenuda virus from genus *Orbivirus*, Reoviridae family, confirmed serologically in cattle in South Africa (Butenko et al., 1981, Burt et al., 1996, Johnson et al., 1980).

Genetic diversity in tick-borne viruses is generally thought to reflect dispersal and movement patterns of the typical enzootic reservoir host(s), with more localized hosts of limited home-range (such as small mammals) leading to greater virus diversity and spatial structure than more mobile long range hosts (such as birds) that presumably spread viruses over large geographical regions (Brault et al., 1999, Sammels et al., 1999, Gould et al., 2001). Movement of vectors can also potentially influence tick-borne virus molecular epidemiology through reassortment with new members of their genus (Tabachnick, 1992, Merrill et al., 2005).

Most of the evidence used to relate host or vector movement to genetic variability in viruses, however, is either indirect (e.g. estimates of migration in tick vectors using molecular data; (Merrill et al., 2005), anecdotal (e.g. reports of migrant birds with active virus infections; (Calisher, 1971, Lord and Calisher, 1970, Crans et al., 1994) , or relies on assumptions based on broad-scale information about animal dispersal and movement patterns (e.g. (Rappole and Hubalek, 2003, Reed et al., 2003). By knowing how animal movement influences the prevalence of virus at a site (Brown et al., 2007) and the virus genetic diversity, we can better predict spatial variation in infection rates or epizootic potential.

Knowledge on how tick-borne viruses vary genetically in space is important in identifying where strains that potentially infect humans or animals may occur. Studies on a continental

scale have suggested that tick-borne viruses show greater genetic diversity, often with multiple strains or subtypes sometimes co-circulating in the same geographical area. For example studies on the evolution and dispersal of Tick-borne Encephalitis group of viruses on the Eurasian continent conducted by Zanotto et al. (1995) suggest that these viruses expanded their range over a time period of approximately 1700–2100 years in a westerly direction from Far-Eastern Asia (Hayasaka et al., 1999). Further research indicates that the latest TBE group of viruses evolved around 300 years ago (Zanotto et al., 1995). Studies in Russia and the Baltics show that human activities play a major role in what may have contributed to the circulation of different TBEV strains in the European and Siberian parts of Russia (Kovalev et al., 2009). The number of western TBEV isolates from central Europe is less hence paucity of data on their genetic variability (Suss, 2008). Little is known about the genetics of African tick-borne viruses other than CCHF in South Africa.

1.4.3 Epidemiology of Mosquito-Borne Viruses

Mosquito-borne viruses have a wide geographical distribution. They cause both human and animal diseases worldwide. All mosquito-borne viruses are RNA viruses that undergo high error rates that cause mutations at some point during RNA transcription due to mistakes caused by viral polymerase. Mosquito-borne viruses are the most abundant of the arboviruses (Karabatsos, 1985). Mosquito-borne viruses such as YF, DEN, SIN, WN, Usutu (USU) and RVF constitute some of the major emerging viruses (Jones et al., 2008). The major mosquito transmitted arboviruses in East Africa are WNV, SFV, NDUV, RVFV, DENV, YFV, USUV, SINV, CHIKV and Zika (ZIKV). These viruses fall into Flaviviridae, Togaviridae and Bunyaviridae arbovirus families.

1.4.3.1 Flaviviridae

WNV is a member of the Japanese encephalitis (JE) antigenic complex in the family *Flaviviridae*, genus *Flavivirus*. WNV was first isolated in West Nile District of Uganda (Smithburn et al., 1940). It was later on isolated in Europe (Hubalek and Halouzka 1999), followed by Asia (Zeller and Schuffenecker, 2004), Australia where it is called Kunjin virus (Mackenzie et al., 1994) and United States of America (Lanciotti et al., 1999, Hayes and Gubler, 2006).

WNV fall into five lineages namely, Lineages 1, 2, 3, 4 and 5. Lineage 1 consists of three sub-lineages: 1a found in Africa, Middle East, Europe and the United States; 1b found in Australia; and 1c found in India. Lineage 2 is widely distributed in Sub-Saharan Africa (Petersen and Roehrig, 2001). Lineage 5 is found in India (Bondre et al., 2007).

WNV is primarily transmitted by mosquitoes mainly in the genus *Culex*. WNV transmission cycle involves passeriform birds and *Culex* mosquitoes with human and equids serving as dead-end hosts (Malkinson and Banet, 2002). WNV can be transmitted by diverse species of mosquitoes and ticks (hard and soft) (Hoogstraal, 1985).

WNV has been isolated from soft ticks of *Ornithodoros capensis* (Mirzoeva et al., 1974, Lvov et al., 1975) and *Argas hermanni* (Schmidt and Said, 1964) found in Africa and Eurasia. Further, the virus has also been isolated from *O. savignyi* (Hurlbut, 1956), *O. moubata* (Whitman and Aitken, 1960), *O. erraticus*, *O. capensis* (Vermeil et al., 1960). *A. arboreus* (Abbassy et al., 1993) has been shown to be a possible vector through experimental studies carried out in the Laboratory. WNV has also been isolated from hard ticks such as: *Hyalomma asiaticum*, *H. detritum*, *H. marginatum*, *Rhipicephalus turanicus*, *R. bursa*, *Amblyomma variegatum*, *Ixodes ricinus* and *Dermacentor marginatus* (Shalunova et al.,

1968, Chumakov et al., 1968, Mirzoeva et al., 1974, Lvov et al., 1975, Darwish and Hoogstraal, 1981, Hayes and Monath, 1989, Hubálek and Halouzka, 1999).

Though WNV has been isolated from ticks, the potential role of ticks in the natural history of WNV transmission remains unknown (Hoogstraal, 1985). WNV lineage 1 has been implicated as a major cause of neurological disease in humans and horses in the USA and Europe. A study carried out by (Venter et al., 2009) on lineage 2 WNV as cause of fatal neurologic disease in horses, highlights the potential of this virus to cause neurologic disease in both horses and humans in southern Africa. WNV causes infection in both domestic and wild animals such as: horse, striped skunk, eastern chipmunk, eastern gray squirrel and domestic rabbit (Anderson et al., 2001). WNV can present mild symptoms such as: fever, headache, body aches, eye pain, rash, vomiting and swollen lymph nodes. In severe cases the virus causes encephalitis, myelitis, meningitis and death (Carson et al., 2006).

DENV is a member of the Flaviviridae family genus *Flavivirus*. DENV has four serotypes namely: DENV-1, DENV-2, DENV-3 and DENV-4. DENV is a mosquito-borne virus transmitted by mosquitoes of the genus *Aedes*. *Aedes aegypti* species of mosquitoes are the principal vectors of DENV whereas *Aedes albopictus* are the secondary vectors (Gubler and Kuno, 1997). Humans serve as amplifying and reservoir hosts of DENV. DENV can also be transmitted through blood transfusion and organ transplants (Wilder-Smith et al., 2009). The possibility of DENV being transmitted from pregnant mother to the fetus has been documented (Wiwanitkit, 2009).

DENV is endemic to more than 100 countries in the world. DENV has a significant impact in public health. Approximately 2.5 billion people are at risk of DENV infection and 50 to 100 million people are infected each year (Gubler and Kuno, 1997). DENV is known to cause

outbreaks in different parts of the world. In Mogadishu, Somalia, probable cases of dengue were identified in August 2012. DENV cases were identified in May 2012 in Mandera, Kenya. Approximately 1,148 cases of DENV were reported in the Atlantic Islands as of November 4, 2012. An outbreak of DENV occurred from September 2011 to April 2012 in South Pacific and Southeast Asia specifically in the Federated States of Micronesia where 1,200 cases and two deaths were reported. More DENV cases have been reported to be present amongst US travelers returning from DENV endemic zones such as: Singapore, Malaysia, Cambodia, Taiwan, Philippines, Vietnam, India, Sri Lanka and Thailand in 2012. In Australia sporadic cases of Dengue have been reported in northern Queensland. Cases of Dengue have also been associated with travelers in the Middle East that is; Jeddah in Saudi Arabia, Pakistan and Yemen. In America and the Caribbean, Dengue has been identified in Latin America, and amongst US travelers from Brazil, Cuba, the Dominican Republic, Ecuador, Haiti, Jamaica and Puerto Rico (Ranjit and Kissoon, 2011).

DENV infection causes mild febrile illness which manifests itself by the following symptoms: fever, headache, muscle pain, joint pain and rash to life-threatening dengue hemorrhagic fever that results in bleeding, thrombocytopenia and shock syndrome or organ dysfunction due to low blood pressure (Whitehorn and Farrar, 2010).

YFV belongs to Flaviviridae family genus *Flavivirus*. It is closely related to WNV, St. Louis encephalitis virus (SLEV) and JEV. YFV is a mosquito-borne virus transmitted by mosquitoes in the genus *Aedes*. *Aedes aegypti*, *Aedes luteocephalus*, *Aedes furcifer*, *Aedes bromeli* and *Aedes simpsoni* species of mosquitoes serve as potential vectors of YFV. Mosquitoes can transmit YFV by biting infected human and monkeys and then disseminating the virus to other susceptible hosts (Fontenille et al., 1997).

There are three transmission cycles of the YFV namely: sylvatic, intermediate and urban. The sylvatic cycle involves transmission of the virus between monkeys and the mosquitoes. In this cycle humans are the incidental hosts since they can acquire the virus especially when they visit forests. The intermediate cycle involves transmission of the virus between humans to humans and monkeys to human by a variety of wild mosquitoes, mainly *Ae. luteocephalus*, *Ae. Furcifer*. The urban cycle involves transmission of the virus between humans and urban mosquitoes, primarily *Aedes aegypti* (Barrett and Higgs, 2007).

YFV causes acute febrile illness characterized by sudden onset of fever, chills, severe headache, back pain, general body aches, nausea and vomiting, fatigue and weakness. In some cases YFV can cause severe illness characterized by high fever, jaundice, bleeding and eventually shock and failure of multiple organs (Chastel, 2003).

YFV is endemic in South America, West (Benin, Ghana and Togo), Central (Angola, Cameroon and Burundi) and East Africa (Kenya, Uganda and Tanzania) (Karunamoorthi, 2013). Though evidence suggests that past YFV outbreaks have occurred, the first documented epidemic of YFV in Kenya was reported between 1992 and 1993 in Kerio Valley (Reiter et al., 1998, Sanders et al., 1998). There is no specific treatment for YF; care is based on symptoms. YFV can be prevented by vector control, protective clothing and vaccination (Johansson et al., 2010).

Usutu virus (USUV) belongs to family Flaviviridae genus *Flavivirus*. Like WNV, USUV belongs to the JE serogroup (Calisher and Gould, 2003). USUV is a mosquito-borne virus transmitted by mosquitoes of the genus *Culex*, *Coquillettidia* and *Mansonia* (Meister et al., 2008). The transmission cycle of USUV involves mosquitoes, which serve as vectors and birds which serve as the vertebrate hosts for the virus. USUV is known to be emerging since it has been established in new regions of the world. Evidence indicates that the first isolation

of USUV was in South Africa in 1959 from *Culex* mosquitoes. Subsequently, the virus has been isolated from other mosquitoes, rodents and birds in sub-Saharan Africa (Weissenböck et al., 2002). Though paucity of data exists on the association of USUV with febrile illness, it is documented that the virus causes a neuroinvasive infection in immunosuppressed individuals (Weissenböck et al., 2010). Outbreaks of USUV have occurred in Vienna, south-east Hungary, south Italy, west Switzerland and north Czech Republic, Poland causing death amongst bird species (Hubálek, 2008, Meister et al., 2008, Manarolla et al., 2010).

ZIKV is a mosquito-borne virus classified in the Flaviviridae family genus *Flavivirus* related to YF, DEN, WN, and JE viruses. *Ae. africanus*, *Ae. apicoargenteus*, *Aedes luteocephalus*, *Aedes aegypti*, *Aedes vitattus*, *Aedes hensilli* and *Aedes furcifer* species of mosquitoes serve as potential vectors of ZIKV (Fagbami, 1979, Marchette et al., 1969, McCrae and Kirya, 1982). ZIKV was isolated from *Aedes africanus* mosquitoes trapped in the Zika forest Uganda in 1948 (Dick et al., 1952). Experimental studies conducted in a laboratory in 1956 indicate that artificially infected *Aedes aegypti* can transmit the virus to mice and monkeys (Boorman and Porterfield, 1956). ZIKV was first isolated from a rhesus monkey in Zika forest in 1947 (Dick, 1952). Subsequent isolations of ZIKV in humans have been documented in Uganda and Nigeria (Dick, 1952). Antibodies to ZIKV has also been detected in humans in Uganda, Tanzania, Egypt, Central African Republic, Sierra Leone and Gabon, and in parts of Asia including India, Malaysia, the Philippines, Thailand, Vietnam, and Indonesia. ZIKV is associated with the 2007 outbreak that occurred on Yap Island in the Federated States of Micronesia (Lanciotti et al., 2008). ZIKV causes Zika illness which is characterized by mild headache, maculopapular rash, transient fever, malaise, anorexia, diarrhea, vomiting, constipation, abdominal pain, dizziness, conjunctivitis, retro-orbital pain, edema and back pain (Filipe et al., 1973, Olson and Ksiazek, 1981, Lanciotti et al., 2008, Duffy et al., 2009).

1.4.3.2 Togaviridae

SFV is a virus of the genus *Alphavirus* of the family Togaviridae. SFV is a mosquito-borne virus which was first isolated in Uganda by the Uganda Virus Research Institute in 1942 (Smithburn and Haddow, 1944). In Kenya SFV was isolated from *Aedes mcintoshi*, *Aedes circumluteolus* and *Aedes ochraceus* sampled from El-humow and Garissa (Crabtree et al., 2009a). SFV is endemic to Central, Eastern and Southern Africa. SFV is known to cause disease in both human and animals. SFV is known to cause mild febrile illness in humans. SFV has been documented to have caused an outbreak among French soldiers serving in the Central African Republic (Mathiot et al., 1990). Though SFV poses a low risk to laboratory personnel compared to other *Alphaviruses* (Winkler, 1995, Winkler and Blendon, 1995), a single death has been reported due to laboratory infection (Willems et al., 1979).

NDUV family Togaviridae genus *Alphavirus* was first isolated from *Mansonia uniformis* and *Aedes circumluteolus* species of mosquitoes in a field station in Ndumu, Northern Natal, South Africa in 1956 (Kokernot et al., 1961). In Kenya NDUV was isolated from *Aedes mcintoshi*, *Aedes ochraceus* and *Mansonia uniformis* species of mosquitoes sampled from Desai, El-humow, Garissa, Logumgum and Baringo. Antibodies against NDUV have been detected in humans in various parts of southern Africa (Kokernot et al., 1961, Karabatsos, 1985). A study carried out by Masembe et al., (2012) showed that pigs are potential reservoirs of NDUV.

SINV is a member of the Togaviridae family, genus *Alphavirus*. It is a mosquito-borne virus transmitted mainly by *Culex* species. The transmission cycle of SINV involves arthropod vectors (mosquitoes) and vertebrate hosts (birds). Humans acquire this virus through a bite of infected mosquito. SINV was first isolated in Egypt in 1952 and since then it has been detected in South and East Africa, Israel, Philippines and Australia. In Kenya SINV was isolated from *Cx. quinquefasciatus* and *Ae. sudanensis* sampled from Garissa (Crabtree et

al., 2009a). In Africa the virus has been isolated from humans in Cameroon, Madagascar and the Central African Republic (Karabatsos, 1985) and South Africa (Shirako et al., 1991). SINV causes sindbis fever in humans which presents with arthralgia, rash and malaise. It has also been associated with pogo disease whose symptoms include: rash, fever, chills, sore throat, muscle pains, headache, coughing, fatigue and arthritis (Kurkela, 2007).

CHIKV belongs to the family *Togaviridae* genus *Alphavirus* (Brooks et al., 2004). CHIKV is a mosquito-borne virus transmitted by mosquitoes belonging to the genus *Aedes*. *Aedes aegypti* serves as the principal vector whereas *Aedes albopictus* serves as a secondary vector to CHIKV transmission (Robinson, 1955, Jupp and McIntosh, 1988, Diallo et al., 1999). CHIKV transmission cycle involves mosquitoes which serve as arthropod vectors and humans who serve as vertebrate hosts. Though during epidemics humans serve as the reservoirs whereas during the inter-epidemic periods, monkeys, rodents, birds serve as reservoirs of CHIKV (Diallo et al., 1999).

CHIKV was first discovered in 1952 during an outbreak that occurred on the *Makonde* Plateau, along the border between Tanganyika and Mozambique (Robinson, 1955). Subsequent outbreaks of CHIKV have been reported in India, Pakistan, Sri Lanka, Myanmar, Thailand, the Philippines, Cambodia, Vietnam, Hong Kong and Malaysia. Other CHIKV outbreaks have occurred in the islands such as Madagascar, Comoros, Mayotte the Seychelles and Mauritius, Mombasa and the Reunion (Enserink, 2006, Mourya and Mishra, 2006). Evidence of CHIKV amongst travelers from endemic areas to Europe, Canada, the Caribbean (Martinique) and South America is well documented (Parola et al., 2006). CHIKV is also known to have caused an outbreak in the Democratic Republic of the Congo between 1999 and 2000 with concomitant outbreaks occurring in Indonesia (Pastorino et al., 2004). In Kenya CHIKV affected communities living in Lamu and Mombasa situated near the Indian

Ocean. In Lamu for example approximately 13, 500 people were infected with the virus (Sergon et al., 2008).

CHIKV is associated with high morbidity which is experienced during outbreaks. Though CHIK is a self-limiting disease just like most arboviral infection it causes mild febrile illness to severe disease. Febrile illness is characterized by fever, severe arthralgias, myalgias, skin rash and arthritis. The severe form of CHIK infection is characterized by asthenia, exacerbation of arthralgias, inflammatory polyarthritis, meningoencephalitis, fulminant hepatitis and bleeding. The latter form of CHIK infection can be life-threatening and eventually lead to death (Johnston and Peters, 1996, Brink and Lloyd, 1994).

1.4.3.3 Bunyaviridae

RVFV is belongs to the family Bunyaviridae, genus *Phlebovirus*. RVFV is transmitted through bite of infected mosquitoes, exposure to infected blood, body fluids and tissues (Gerdes, 2004). RVFV has been associated with intermittent epizootics and sporadic epidemics in East Africa (Bird et al., 2009, Daubney and Hudson, 1932). RVFV was first isolated in Kenya in 1930 (Meegan and Bailey, 1988). It has caused outbreaks in the Rift Valley of Kenya and Tanzania (Megan and Bailey, 1989). Subsequent outbreaks of RVFV have occurred in South Africa and Sudan. In 1977 to 1979 RVFV caused an outbreak in Egypt that resulted in the infection of 200,000 people of which 600 died. There was also loss in livestock with 50% of the cattle dying (Meegan, 1979). In West Africa RVFV has been documented to have caused an outbreak in Mauritania (Faye et al., 2007, Nabeth et al., 2001).

RVFV has been reported to cause three major epidemics in South Africa. The first Epidemic was occurred between 1950-1951 (Alexander, 1951), followed by 1973-1975 (Coetzer,

1977) and the most recent outbreak occurring between 2008-2011. This virus has been shown to affect livestock and wildlife in South Africa (Métras et al., 2011).

RVFV poses a significant impact in both human and animal health. RVFV affects livestock especially sheep and cattle causing severe infection with sporadic spill over to other domestic animals and humans. RVFV causes hepatitis, encephalitis, retinitis, blindness and/or a hemorrhagic fever; with a case fatality rate of approximately 10–20% (Madani et al., 2003). It causes abortion especially in sheep and other livestock (Bird et al., 2009).

BUNV belongs to family Bunyaviridae genus *Orthobunyavirus* which was first isolated from *Aedes* mosquitoes sampled from Semliki forest in Uganda in 1943 (Smithburn et al., 1946). It is widely distributed in sub-Saharan Africa especially in tropical regions (Smithburn et al., 1946). BUNV is known to cause febrile illness in human (Smithburn et al., 1946). BUNV is a RNA virus composed of three segments (small, medium and large). BUNV has the ability to undergo reassortment and recombinations which results in new viruses which are more virulent such as Ngari virus which causes hemorrhagic fever in human (Bowen et al., 2001). Ngari virus a BUNV reassortant is composed of a medium segment of Batai virus and small and large segment of BUNV (Bowen et al., 2001). Antibodies to BUNV have been detected in human sera of patients presenting with febrile illness (Smithburn et al., 1946). The transmission cycle of BUNV involves mosquitoes which serve as vectors and rodents which serve as vertebrate hosts, probably small rodents (Smithburn et al., 1946).

1.5 Clinical Features of Tick-Borne Virus Infections

Tick-borne virus infections can be classified into four main entities: Acute central nervous system illness ranging from mild aseptic meningitis to encephalitis with coma, paralysis, and death; acute short benign fevers with or without an exanthema; hemorrhagic fever that might be extensive, internal or external, and associated with capillary leakage, shock, jaundice, liver damage, and death; and polyarthrititis and rash (Chin, 2000). The majority of human infections is asymptomatic or may result in a nonspecific flu-like syndrome whose onset may be insidious or sudden with fever, headache, myalgia, malaise and occasionally prostration. Infection may, however, lead to encephalitis, with a fatal outcome or permanent neurologic sequelae. Fortunately only a small proportion of infected patients progress to severe encephalitis. Experimental studies have shown that invasion of the CNS follows initial virus replication in various peripheral sites and a period of viremia. Viral transfer from the blood to the CNS through the olfactory tract has been suggested (Alatoom and Payne, 2009). Although most tick-borne viruses present with the above mentioned syndromes, these viruses have their specific clinical manifestations for example: Patients infected with CCHFV present with Myalgia, fever, lack of appetite, headache, nausea and/or vomiting, bleeding, diarrhea, cough, hepatomegaly, jaundice, rash and splenomegaly (Çevik et al., 2008). Dugbe virus which falls in the same family as CCHFV has been associated to cause febrile illness and thrombocytopenia in humans (Burt et al., 1996).

Clinical signs of NSDV that also belongs to the same family as CCHFV and DUGV begin with fever, leukopenia, diarrhea, depression, anorexia, mucopurulent, blood-stained, nasal discharge, occasional conjunctivitis and fetid dysentery. In pregnant animals, NSDV causes frequent abortion (Yadav et al., 2011). Patients infected with TBEV presents with symptoms such as; fever, malaise, anorexia, muscle aches, headache, nausea, leukopenia,

thrombocytopenia and/or vomiting. The viremic phase lasts up to 4 days. The second phase of the disease occurs in 20% to 30% of patients after approximately 8 days of remission, and involves the central nervous system with symptoms of meningitis or encephalitis (Lindquist and Vapalahti, 2008). Table 6.

Table 6. Clinical features of tick-borne virus infections

Tick-borne virus	Clinical features
Tick-borne encephalitis	Fever, malaise, headache, nausea, vomiting, myalgia and muscle fasciculation, meningitis, encephalitis or myelitis
Dhori	Febrile illness and encephalitis
Dugbe	Mild-febrile illness and thrombocytopenia in humans
Bhanja	Apparent infection characterized by fever and encephalitis in young ruminants of sheep, goat and cattle
Nairobi sheep disease	Fever, hemorrhagic gastroenteritis and abortion in sheep and goats
Kyasanur forest disease	Fever, headache, severe muscle pain, cough, dehydration, gastrointestinal symptoms and bleeding problems. Patients may experience abnormally low blood pressure, and low platelet, red blood cell, and white blood cell counts. After 1-2 weeks of symptoms, some patients recover without complication. However, in most patients, the illness is biphasic and the patient begins experiencing a second wave of symptoms at the beginning of the third week. These symptoms include fever and signs of encephalitis (inflammation of the brain).
Omsk hemorrhagic fever	Fever, headache, severe muscle pain, cough, dehydration, gastrointestinal symptoms and bleeding problems. Patients may experience abnormally low blood pressure, and low platelet, red blood cell, and white blood cell counts. After 1-2 weeks of symptoms, some patients recover without complication. However, in most patients, the illness is biphasic and the patient begins experiencing a second wave of symptoms at the beginning of the third week. These symptoms include fever and signs of encephalitis (inflammation of the brain).
Crimean-Congo hemorrhagic fever	Headache, high fever, back pain, joint pain, stomach pain, and vomiting. Red eyes, a flushed face, a red throat, and petechiae (red spots) on the palate are common. Symptoms may also include jaundice, and in severe cases, changes in mood and sensory perception. As the illness progresses, large areas of severe bruising, severe nosebleeds, and uncontrolled bleeding at injection sites can be seen, beginning on about the fourth day of illness and lasting for about two weeks.
Thogoto	Abortion and pyrexia in sheep

Source: (Davies, 1997b, Gritsun et al., 2003, Sang et al., 2006, Mehla et al., 2009).

1.6 Diagnosis of Arbovirus Infections

Laboratory diagnosis of arboviruses has changed greatly over the last few years. In the past, identification of antibody relied on four tests: hemagglutination-inhibition, complement fixation, plaque reduction neutralization test, and the indirect fluorescent antibody (IFA) test. Positive identification using IgM and IgG-based assays requires a four-fold increase in titer between acute and convalescent serum samples. With the advent of solid-phase antibody-binding assays, such as enzyme-linked immunosorbent assay (ELISA), the diagnostic algorithm for identification of viral activity has changed (Hall et al., 2012). Early in infection, IgM antibody is more specific, while later in infection, IgG antibody is more reactive. Inclusion of monoclonal antibodies (MAbs) with defined virus specificities in these solid phase assays has allowed for a level of standardization that was not previously possible. Virus isolation and identification have also been useful in defining viral agents in serum and tick vectors. While virus isolation still depends upon growth of an unknown virus in cell culture or neonatal mice, virus identification has also been greatly facilitated by the availability of virus-specific MAbs for use in IFA assays. Similarly, MAbs with avidities sufficiently high to allow for specific binding to virus antigens in a complex protein mixture (e.g tick pool suspensions) have enhanced the ability to rapidly identify virus agents *in situ* (Alatoom and Payne, 2009). An accurate molecular diagnostic method for tick-borne virus detection is RT-PCR that is highly specific and sensitive, enabling the identification of viruses in minute samples (Kong et al., 2006).

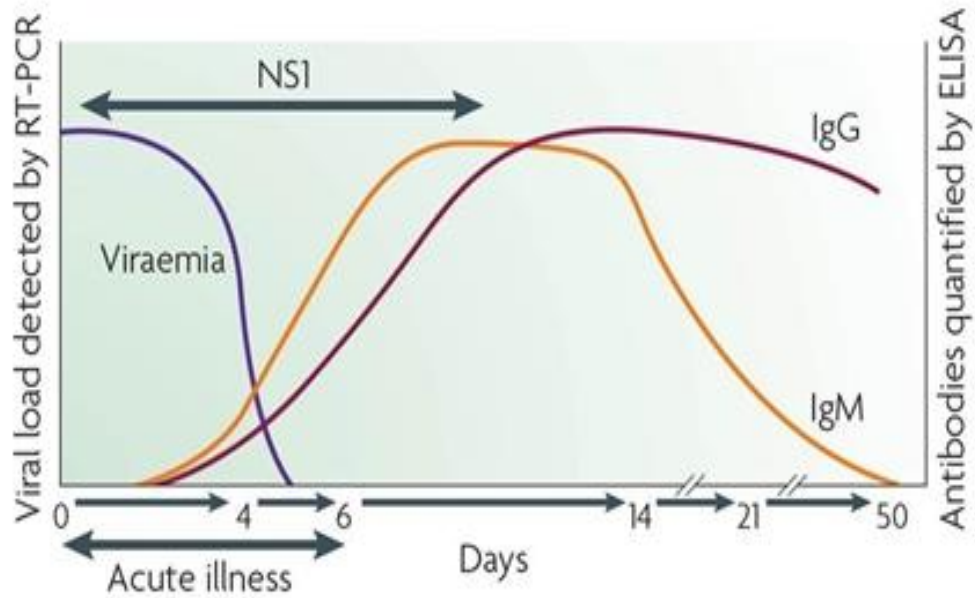

Figure 3. Typical arbovirus infection with timing of specific diagnostics

Source: (Guzman and Istúriz, 2010, Fry et al., 2011)

Most arboviruses inclusive of tick-borne viruses undergo a short period of viremia of between 5 to 6 days after infection and disease onset. IgM starts to appear as viremia declines and peaks approximately 14 days after onset of disease. IgM may persist up to 3 months. IgG appears at the end of the first week of illness and slowly increases. IgG may be detectable over the lifetime of the individual. In secondary infections, high levels of IgG are detectable even in the acute phase of illness, whereas IgM levels are significantly lower. The structural protein, NS1 for Dengue virus is expressed during the first 10 days of illness (Figure 3). All of these markers have been proven useful for arbovirus diagnostic methods.

The diagnosis of CCHFV can be conducted using serology which entails antibody detection by ELISA, virus isolation and molecular assays (Table 7). IgG and IgM antibodies can be detected in positive serum by ELISA from about seven days after the onset of disease. Specific IgM declines to undetectable levels by 4 months post-infection whereas IgG remains detectable for years. CCHF can also be isolated from blood in cell culture within five days of illness (Zavitsanou et al., 2009). Detection of CCHFV antigens in tissue samples can be performed using immunofluorescence. CCHFV RT-PCR is the most sensitive, specific and rapid test which is used for diagnosis of this virus (Drosten et al., 2003).

The recent discovery of the next generation sequencing technologies such as 454 and illumina has greatly contributed to the genetic characterization of arboviruses and the discovery of unknown viruses which could not be previously identified. These high throughput platforms have provided a basis for the rapid and accurate diagnosis of arboviruses (Hall et al., 2012).

Table 7. Overview of the most used diagnostic methods for selected tick-borne virus infections

Viral pathogen	Diagnostic		
	Acute/early phase	Acute/late phase	Convalescent phase
West Nile virus	PCR ^{a,b} , VI ^b , IH	IgM EIA ^a , IgM IFA ^a , HIA	IgM/IgG EIA ^a , IgM/IgG IFA ^a , HIA
Tick-borne encephalitis virus	PCR ^b , VI ^b , IH	IgM EIA ^a , IFA ^a , HIA	IgM/IgG EIA ^a , IgM/IgG IFA ^a , HIA
Crimean Congo hemorrhagic fever virus	PCR ^b , VI ^b	IgM/IgG EIA ^a , IgM IFA	IgM/IgG EIA, IgG IFA
Rift Valley fever virus	PCR ^b , VI ^b	IaM/IaG EIA ^a , IaM IFA, HIA, inhibition EIA	IgM/IgG EIA, IgG IFA, HIA
<p>* Adapted from (Niedrig et al., 2010).</p> <p>^a Commercial assays available.</p> <p>^b Methods useful for analysis of environmental or vector (mosquitoes, ticks, phlebotomes) samples.</p> <p><u>Abbreviations:</u> EIA- Enzyme immunoassay; HIA- Hemagglutination inhibition assay; IB- immunoblot; IFA- immunofluorescence assay; IH- Immunohistological analysis of tissue samples; PCR- Polymerase chain reaction; VI- Virus isolation on cells.</p>			

1.7 Molecular Biology of Arboviruses

Most arboviruses are classified according to their genome structure based on the number of strands, type of nucleic acid and according to the sense of their strands (positive (+) or negative (-) sense) (Perng and Chen, 2013).

1.7.1 Togaviridae

Togaviridae family, genus *Alphaviruses* consists of a genome consisting of a linear, positive-sense, single stranded RNA molecule of approximately 11.8kb (Figure 4). These viruses encode both structural and non-structural proteins. The non-structural proteins that encompass two-thirds of the genome are required for viral replication while the structural genes are collinear covering one-third of the genome. The structural proteins are produced by translation of an mRNA that is generated from an internal, sub-genomic promoter downstream of the non-structural open reading frame. The 5' end of the genome has a 7-methylguanosine cap, while the 3' end is polyadenylated. The structural gene products are generated by translation of a sub-genomic mRNA to produce a polyprotein that is processed to produce a capsid protein, two major envelope surface glycoproteins (E1 and E2) as well as two small peptides, E3 and 6K (Simizu et al., 1984, Weaver et al., 2005). E1 and E2 are post-translationally modified in the endoplasmic reticulum and golgi apparatus before being transported to the plasma membrane (Schlesinger and Schlesinger, 1986) where they maintain a close association with each other, forming a trimeric heterodimer spike structure (Anthony and Brown, 1991, Paredes et al., 1993). As virion formation proceeds, the cytoplasmic nucleocapsids are transported to the cell

membrane where they bind to the surface glycoproteins before budding from the cell (Garoff and Simons, 1974, Ekström et al., 1994, Garoff et al., 1998).

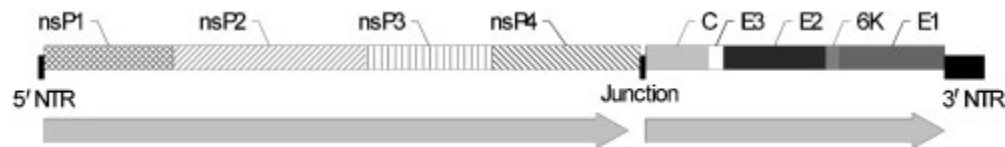

Figure 4. Genomic organization of the first publicly available CHIKV genome (Ross strain, GenBank accession no. AF490259). The four non-structural proteins (nsP1–4) are translated as a single polyprotein directly from the positive-sense RNA genome. The structural proteins (C, E3, E2, 6K and E1) are translated from a subgenomic RNA (26S) transcribed from a separate promoter within the non-translated (NTR) junction region. 5' and 3' NTR regions flank the coding region source: (Powers and Logue, 2007).

Semliki forest virus like any other *Alphavirus* is composed of a positive-stranded RNA with a genome size of approximately 11.4kb. SFV genome codes for two thirds of nonstructural and a third structural proteins.

1.7.2 Bunyaviridae

Bunyaviridae family of viruses are enveloped, spherical/pleomorphic viruses whose genomes consist of three linear minus-sense (-) ssRNA segments of approximately 11 kb. This family consists of over 350 named isolates classified in five genera, namely *Orthobunyavirus*, *Hantavirus*, *Nairovirus*, *Phlebovirus* and *Tospovirus*. The *bunyavirus* genome consists of the small (S), medium (M), and large (L) segments (Elliott, 1997, Elliott, 1990). These segments serve as templates for RNA replication and mRNA transcription. The S segment encodes nucleocapsid (N) protein that is involved in the packaging of encapsulated

genomes into virions (Weber et al., 2001) and the non-structural protein (NSs) which are translated from overlapping reading frames in the same mRNA (Dunn et al., 1994). The M segment encodes a polyprotein that is cleaved into glycoproteins (Gn and Gc) as well as non-structural protein (NSm) (Fazakerley et al., 1988). Viral polymerase is encoded by the L segment. The genetic organization of the segments is similar across all genera; each template strand possesses non-translated regions (NTRs) located at the 3' and 5' termini, which surround a single transcriptional unit (Figure 5). These NTRs exhibit highly conserved, genus-specific sequences at their extreme termini that comprise cis-acting signals involved in RNA synthesis and segment packaging (Schmaljohn and Nichol, 2007). In addition, the 3' and 5' NTRs of each segment display extensive nucleotide complementarity, which is often broken by a single conserved nucleotide mismatch, allowing the possibility of NTRs interaction through canonical Watson-Crick base pairing. In line with this, there is evidence from both biochemical analyses and direct observation to suggest that *Bunyavirus* RNA segments exist as circular molecules within infected cells and virus particles (Raju and Kolakofsky, 1989), further suggesting that NTR interaction is required for segment function. The internal regions of the NTRs show considerable variation, both between segments of the same virus and between members of the same genus, and these segment-specific sequences have been shown to play roles in the regulation of RNA synthesis for both BUNV and RVFV (Barr et al., 2003, Gaudiard et al., 2006). Analysis of recombinant BUNV bearing altered S segments has shown that many of these segment-specific NTR sequences are dispensable for virus multiplication; however, they do make a significant contribution to virus fitness (Lowen et al., 2005). The possibility that additional signal elements are located outside the segment NTRs cannot be ruled out. For BUNV, most segments in which the cognate pairings of NTR and ORF sequences are rearranged cannot be rescued into viable infectious virus (Lowen and Elliott, 2005), suggesting interplay between the two regions.

1.7.3 Flaviviridae

Flaviviridae family, genus *Flaviviruses* are enveloped spherical viruses whose genome consists of a positive-sense (+), single-stranded (ss) RNA molecule of approximately 11kb. Their virion contains a nucleocapsid core of 20–30 nm composed of a single capsid protein. The envelope contains envelope and membrane proteins. Immature, intracellular virions contain a precursor membrane protein, which are proteolytically cleaved during virus maturation. The virion RNA appears to be identical to the mRNA. Three structural proteins and seven non-structural proteins are encoded from one long open reading frame flanked by terminal noncoding regions that form specific secondary structures required for genome replication, translation or packaging. Viral proteins are synthesized as part of a polyprotein of more than 3000 amino acids, which is co- and post-translationally cleaved by viral and cellular proteases (Lindenbach and Rice, 2001). The envelope glycoprotein is the major structural protein that plays an important role in membrane binding and inducing a protective immune response following virus infection. It carries epitopes detected by neutralization and haemagglutination inhibition tests that have been used to identify different subgroups and species of *Flaviviruses*.

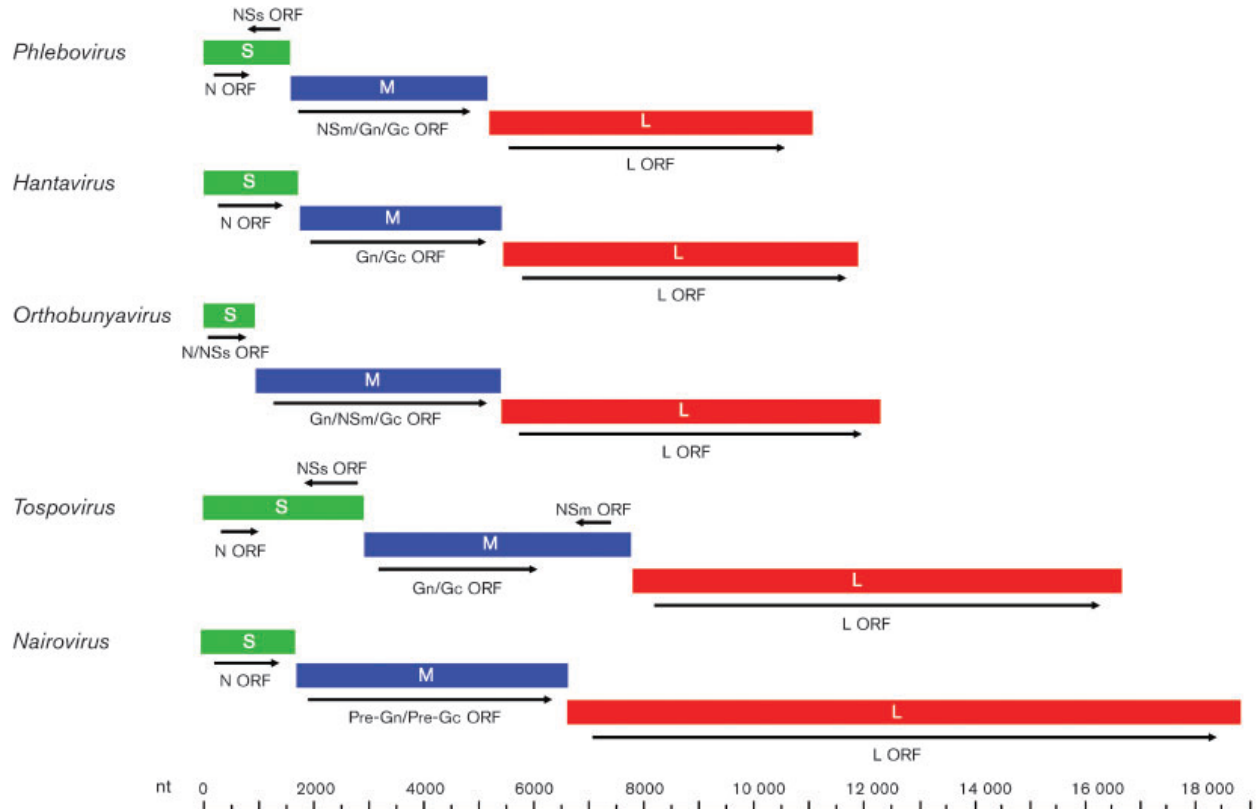

Figure 5. Schematic representation of genomic RNAs belonging to prototypic members of the five genera classified within the family Bunyaviridae. Schematic representation of genomic RNAs belonging to prototypic members of the five genera classified within the family Bunyaviridae. All *Bunyaviruses* possess three RNA segments named small (S), medium (M) and large (L). Arrows below each segment indicate ORFs expressed using a negative-sense coding strategy, whereas arrows above the segments denote ORFs transcribed as mRNAs from positive-sense, ambisense templates (Source: (Walter and Barr, 2011).

1.7.4 Orthomyxoviridae

Orthomyxoviridae family, genus *Thogotovirus* consists of approximately 10kb genome that contains six to seven segments of linear, negative sense single-stranded RNA. *Thogotovirus* virions are spherical or pleomorphic and measure between 80–120 nm in diameter. The virion envelope is derived from cell membrane lipids and bear surface glycoprotein projections. *Thogotovirus* viral RNA segment possesses conserved region NS of semi-complementary nucleotides at the 3' and 5' termini and mRNA synthesis is primed by host-derived cap structures. Both the 3' and 5' sequences of virion RNA are required for viral RNA promoter activity and the cap-snatching mechanism appears unique (Leahy et al., 1997). Thogoto virus (THOV), a virus within the genus *Thogotovirus* contains six single-stranded RNA segments. Four of them encode gene products that correspond to the viral polymerase (PB1, PB2 and PA) and nucleocapsid protein (NP) of influenza viruses (Weber et al., 1998).

1.8 Diversity of Tick-Borne Viruses

Knowing how tick-borne viruses vary genetically in space is important in identifying where strains that potentially impact humans or animals may occur. There is paucity of data on genetic diversity of tick-borne viruses.

Studies on a continental scale have suggested that some arboviruses are relatively genetically homogenous, such as eastern equine encephalomyelitis virus (EEEV) in the Americas (Weaver et al., 1993, Weaver et al., 1994, Brault et al., 1999) and Highlands J Virus (HJV; (Cilnis et al., 1996) in eastern North America, western equine encephalomyelitis virus (WEEV) in western

North America (Weaver et al., 1997) and Barmah Forest Virus (Poidinger et al., 1997) and Sindbis Virus (SINV) in Australia (Sammels et al., 1999). Others show greater genetic diversity, often with multiple strains or subtypes sometimes co-circulating in the same geographical area, such as EEEV in South America (Brault et al., 1999), dengue virus (Gould et al., 2001, Carrington et al., 2005) and Venezuelan equine encephalitis (Weaver and Barrett, 2004) in Central and South America, Ross River Virus in Australia (Lindsay et al., 1993), SINV in the Old World (Norder et al., 1996), and tick-borne encephalitis viruses throughout northern Eurasia (Zanotto et al., 1995).

Genetic diversity study on CCHFV was conducted in Turkey on isolates obtained from 48 patients between 2009 and 2010. Sequences of both S and M segments were obtained and analyzed. The results indicated that these isolates had high genetic homology in the S segment and slight variation in the M segment. Phylogenetic analysis also revealed that these isolates clustered closely to the lineage 1 CCHFV isolated from Eastern European-Russian and Balkan Peninsula (Kalaycioglu et al., 2012). The variation in the M segment might be due to the fact that M segment is a highly variable region which undergoes more frequent reassortment than the S and L segments (Deyde et al., 2006, Morikawa et al., 2007). Worldwide genetic diversity of CCHFV has been attributed to its segmented RNA genome that undergoes recombination and reassortment regardless of the existence of diverse genetic lineages associated with different geographical locations (Deyde et al., 2006, Mild et al., 2010).

Genetic diversity in arboviruses is generally thought to reflect dispersal and movement patterns of the typical enzootic reservoir host(s), with more sedentary hosts (such as small mammals) leading to greater virus diversity and spatial structure than more mobile hosts (such as birds) that presumably spread viruses over large geographical regions (Brault et al., 1999, Sammels et

al., 1999, Gould et al., 2001). Movement of vectors can also potentially influence virus genetic composition (Tabachnick, 1992, Merrill et al., 2005) although less emphasized to date, perhaps owing to the short lifespans and presumed reduced dispersal capabilities of small arthropods (Traore et al., 2005, Sellers, 1989, Zanotto et al., 1995).

Therefore this study aimed at investigating the diversity of tick-borne viruses in Ijara District, Kenya which will aid in assessing the risk of tick-borne disease, monitoring emerging tick-borne viral diseases and investigation of the phylogenetic evidence of the history of host range shifts in arboviruses to comprehend disease transmission, pathogenesis, and to understand the biology of vectors and their role in transmission.

1.9 Conclusions

Tick-borne viruses threaten health and security of human and animals and may spread by competent vectors across great distances (Gubler, 2002). They circulate in sylvatic and peri-domestic cycles involving animals and humans (LaBeaud et al., 2008). Approximately 50% of arbovirus isolations are from mosquitoes whereas 25% are from ticks (Sang et al., 2006). The true/factual prevalence of tick-borne viruses within the population and their potential vectors is not known by the relevant health authorities in Kenya. As a result, diagnosis and treatment is often delayed by health care professionals who are unaware of the presence of these viral diseases and thus do not take them into consideration when attempting to determine the cause of a patient's illness. In the absence of major and dramatic outbreaks, health authorities often fail to allocate adequate funding for the surveillance and control of these viral diseases. It is therefore important that those engaged in all aspects of public health surveillance in Kenya, be aware of the epidemiology of this group of viral diseases in order to prepare for their control. This study will provide useful information on the circulation, transmission and diversity of tick-

borne viruses, their principal vectors in the Ijara District, which represents the pastoral rural region of North Eastern Kenya. This will help in understanding the importance of these viral diseases in a region with close human-animal contact and inform the allocation of resources for their control by health authorities. This study will also aid in assessing the risk of tick-borne disease, monitoring emerging tick-borne viral diseases and investigation of the phylogenetic evidence of the history of host range shifts in arboviruses to comprehend disease transmission and pathogenesis, and to understand the biology of vectors and their role in transmission. This will ensure timely diagnosis, prevention and treatment of these tick-borne viruses by the medical personnel.

1.10 Hypothesis

- ✚ Tick-borne viruses are present and diverse in North Eastern pastoral zones of Kenya.

1.11 Aim

- ✚ To gain in-depth understanding of the circulation, transmission and diversity of tick-borne viruses in Pastoral Eco-zone of Ijara District, North Eastern Province of Kenya as a reflection of what may be expected in North Eastern pastoral zones of Kenya.

1.12 Objectives

- ✚ To determine prevalence of Crimean-Congo hemorrhagic fever antibodies in humans that attend health facilities in Ijara District, North Eastern Province of Kenya.
- ✚ To determine the prevalence of tick-borne viruses among tick vectors in Pastoral Eco-zone of Ijara District, North Eastern Province of Kenya.

- ✚ To determine the genetic diversity of the tick-borne viruses circulating among ticks and/or their host animals in Pastoral Eco- zone of Ijara District, North Eastern Province of Kenya.

Chapter 2

Prevalence of Crimean-Congo hemorrhagic fever antibodies in humans that attend health facilities in Ijara District, North Eastern Province of Kenya

2.1 Introduction

CCHF is a disease caused by a virus of the *Nairovirus* genus, family Bunyaviridae. The disease is endemic in many countries in Europe, Asia and Africa (Burt and Swanepoel, 2005). It was first reported in the Crimean peninsula in the mid 1940's, when a large outbreak of severe hemorrhagic fever with a case fatality rate of > 30% was recorded (Hoogstraal, 1979, Karti et al., 2004) and designated as CHF. The virus was later shown to be antigenically identical to Congo virus isolated from a febrile patient in the Democratic Republic of Congo in 1956 (Hoogstraal, 1979), and subsequently named CCHFV (Casals, 1969).

Members of the tick genus *Hyalomma* are the principal vectors of CCHFV. There is evidence that the virus causes infection in birds such as ostriches, guinea fowls, hornbills (Hoogstraal, 1979) and antibodies against CCHFV have been detected in the sera of horses, donkeys, goats, cattle, sheep and pigs in various regions of Europe, Asia and Africa (Shimshony, 2010). Birds and domesticated ruminants including cattle, sheep and goats become viremic for one week after experimental infection (Shimshony, 2010).

Humans become infected through a bite of, or crushing an infected tick with open skin wound; through contact with animal blood or tissues and by drinking unpasteurized milk from infected animals. Aerosol transmission has been documented in Russia under nosocomial conditions

(Shimshony, 2010). Possible horizontal transmission has also been reported from mother to child in Russia (Shimshony, 2010).

The signs and symptoms of CCHF disease/infection include: hemorrhagic manifestations such as ecchymosis, petechia, epistaxis, hematemesis, and hemorrhagic enteritis as reflected by bloody diarrhoea accompanied by one or more of the following symptoms: Fever, severe headache, joint pain, chills, and nausea (Elata et al., 2011).

Epidemiologically, CCHF cases are distributed mainly among rural actively working age groups exposed to tick bites and animals (Gao et al., 2010) with the most at-risk group being livestock farmers living in endemic areas. Almost 90% of the cases in a recent outbreak in Turkey were farmers (Shimshony, 2010). Abattoir workers who work with large domestic animals are also at risk through either slaughtering viremic animals or exposure to ticks which dislodge from the animal hides. Ingestion of meat itself is not a risk because the virus is inactivated by post-slaughter acidification of the tissues. Gender distribution varies between countries, depending on the relative participation of men and women in agricultural work (Shimshony, 2010)

The geographic range of CCHFV is the most extensive of the tick-borne viruses affecting humans (Ergönül, 2006). In Kenya, CCHFV has been detected in ticks on only two occasions: in a pool of *Rhipicephallus pulchellus* ticks collected in 1970s from a dying sheep in Kabete veterinary laboratory (Hoogstraal, 1979) and most recently in multiple pools of *Hyalomma* ticks collected in North Eastern Kenya (Sang et al., 2011). However, only one human case of CCHFV infection has been documented in western Kenya in October 2000 which represents the first and only documented case of acute human CCHFV infection in Kenya (Dunster et al., 2002).

Although evidence of circulation of CCHFV amongst ticks suggests that humans may be exposed in parts of Kenya, CCHFV transmission among human population has not been well characterized. In this study, serum samples collected from acute febrile illness surveillance patients in Ijara District, a pastoralist community in rural northern Kenya, were screened for the presence of both anti-CCHF IgM and IgG antibody to determine the extent of CCHFV circulation amongst human population. IgM antibodies are a hallmark of acute infection whereas IgG antibodies are present in convalescent phase or indicate previous exposure to the infection. This study aimed at identifying acute cases of CCHF disease and determining the extent of previous exposure to CCHFV in outpatient population attending Sangailu and Ijara health centres, Ijara District, North Eastern Province, Kenya with complaints of acute febrile illness.

2.2 Materials and Methods

2.2.1 Study Area

The study was conducted in Ijara District of the North Eastern province of Kenya (Figure 7). This is an arid and semi-arid region where 90% of the people practice nomadic pastoralism keeping indigenous cattle, goats, sheep, donkeys and camels. Prolonged dry seasons trigger the movement of people and livestock to the Tana River Delta, Boni forest, area near the Indian Ocean coastline where water and pasture are abundant long after the rains have gone. This migration pattern facilitates the movement of potentially infected ticks across great distances presenting opportunity for exchange of diverse tick species and populations among huge animal and human populations and hence risk of exposure to tick-borne disease.

2.2.2 Study Design

This was a descriptive, cross-sectional, and laboratory-based study conducted between October 2010 and March 2011. Blood samples were obtained from patients presenting with acute febrile illness, with complaints including fever, chills, cough, headache, joint aches, general body weakness and any hemorrhagic signs.

2.2.3 Study Population

The population was mainly rural. Many of these were herdsmen who graze cattle or collect firewood into forests. Human samples were obtained from patients attending Sangailu dispensary and Ijara health centre, which are the main health facilities that serve most of the inhabitants of this region. A total of 517 patients were enrolled into the study.

2.2.3.1 Inclusion Criteria

The following inclusion criteria was used to enroll patients:

- ✚ Subjects referred by the clinician for laboratory blood tests, either due to febrile illness, or for routine examinations e.g. malaria
- ✚ Subjects who gave informed consent
- ✚ Subjects above 5 years of age

2.2.3.2 Exclusion Criteria

- ✚ Subjects who declined to give consent
- ✚ Subjects aged below 5 years

2.2.4 Ethical Considerations

The samples used in this study were de-identified and only study codes used with no reference to the patients names on sample vial. Data and sample was collected only from consenting patients after consent explanation. Approval to carry out the study was obtained from KEMRI National ERC and University of Pretoria Research Ethics Committee, protocol number **61/2012**. The patient informed consent forms are included in Appendix A.

2.2.5 CCHFV Antibody Testing

Detection of all CCHF virus specific IgM and IgG antibodies utilized the indirect ELISA format previously described by (Albayrak et al., 2010). This was done using a commercial kit which came with its own negative and positive control (VectoCrimean-CHF-IgG and IgM ELISA test kits, Vector-Best, Novosibirsk, Russia). The sensitivity to the standard panel of positive samples is indicated as 100% and the specificity of the standard panel of negative samples 100%. (www.vector-best.ru).

2.2.6 Indirect IgG Capture ELISA

All samples were heat inactivated at 56°C for 30 minutes. Inactivated lysates of tissue culture cells infected with the CCHF virus and a similarly diluted mock antigen made from uninfected cells were used as positive and negative antigens respectively. A positive anti-CCHF IgG human serum served as positive control sera and serum negative by ELISA for CCHF IgG specific antibodies served as a negative control (Vector-Best, Novosibirsk, Russia). HRP conjugated anti-human IgG, Fc specific diluted in Serum dilution buffer (1:4000) was used as a conjugate and ABTS peroxidase (Vector-Best, Novosibirsk, Russia) Parts A and B combined 1:1 as a substrate. Wash buffer was phosphate buffer saline (Vector-Best, Novosibirsk, Russia). One half of the plate was coated with 100µl per well of positive antigen diluted at 1:1000. The second half of the plate was coated with 100µl per well of mock control antigen diluted at 1:1000. The plates were incubated in a moist environment overnight at 2°C to 8°C then washed 3 times with 300µl of wash buffer. One hundred microlitre of sample serum (as well as positive and negative controls) were added to both positive and negative wells at 1:100 dilution (hence each sample was tested against both positive and negative antigens), incubated for 1 hour in moist condition at 35°C to 37°C and then washed 3 times with 300 µl per well of wash buffer. One hundred microlitre of diluted HRP labeled with anti-human IgG antibody was added and the plates incubated for 1 hour at 35°C to 37°C. One hundred microlitre of the ABTS peroxidase substrate was added to each well. The plates were incubated for 30 minutes at 35°C to 37°C and then read spectrophotometrically at 405 nm on the ELISA reader (EL X800, Biotek, USA).

2.2.7 Indirect IgM Capture ELISA

All samples positive for anti-CCHF IgG were heat inactivated at 56°C for 30 minutes. Inactivated lysates of tissue culture cells infected with the CCHF virus and a similarly diluted mock antigen made from uninfected cells were used as positive and negative antigens respectively. A CCHF virus positive human serum served as positive control sera and serum negative by ELISA for CCHF virus-specific antibodies served as a negative control (Vector-Best, Novosibirsk, Russia). HRP conjugated anti-human IgM, Fc specific diluted in Serum dilution buffer (1:4000) was used as a conjugate and ABTS peroxidase (Vector-Best, Novosibirsk, Russia) Parts A and B combined 1:1 as a substrate. Wash buffer was phosphate buffer saline (Vector-Best, Novosibirsk, Russia). One half of the plate was coated with 100µl per well of positive antigen diluted at 1:1000. The second half of the plate was coated with 100µl per well of mock control antigen diluted at 1:1000. The plates were incubated in a moist environment overnight at 2°C to 8°C then washed 3 times with 300µl of wash buffer. One hundred microlitre of sample serum (as well as positive and negative controls) were added to both positive and negative wells at 1:100 dilution (hence each sample was tested against positive and negative antigens), incubated for 1 hour in moist condition at 35°C to 37°C and then washed 3 times with 300 µl per well of wash buffer. One hundred microlitre of diluted HRP labelled with anti-human IgM antibody was added and the plates incubated for 1 hour at 35°C to 37°C. One hundred microlitre of the ABTS peroxidase substrate was added to each well. The plates were incubated for 30 minutes at 35°C to 37°C and then read spectrophotometrically at 405 nm on the ELISA reader (EL X800, Biotek, USA).

2.2.8 Interpretation of Results of both IgM and IgG ELISA

The adjusted OD was calculated by subtracting the OD of the negative antigen coated wells from the positive antigen coated wells. The OD cut-off was calculated as the mean of the adjusted OD of the negative control sera plus three times the standard deviations, generally an OD of ≤ 0.2 at a 1:100 sample dilution. A serum sample was considered positive if the adjusted OD value was greater than or equal to the assay cut-off or 0.2, whichever value was higher.

2.2.9 Questionnaire and Data Analysis

Socio-demographic and risk factor data were gathered using a questionnaire which was pilot tested and then filled at the health facilities during the patient's visit by trained interviewers. IgM and IgG sero-status was recorded as positive or negative and seroprevalence expressed as a percentage of the numbers sampled and tested. Exploratory analysis was performed to explore variables potentially associated with exposure to CCHF virus including age, occupation, contact with animals (camels, donkeys and goats), location and gender. Multivariable logistic regression model was used to investigate risk factors associated with testing positive for anti-CCHFV antibody. Model reduction was based on likelihood ratio (LR) test at 5% level. The analyses were performed using R v 2.11.0 (Team, 2009, Pinheiro et al., 2011).

2.3 Results

2.3.1 Patient Demographics

A total of 517 serum samples were collected from the patients presenting with febrile illness including fevers of unknown origin at Ijara Health Centre (248 samples) and Sangailu dispensary (269 samples), Ijara District in North Eastern Kenya (Figure 7) that consisted of 62%

females and 38% males aged between 5 and 90 years. The patients enrolled in the study presented the following symptoms: fever (98%), chills (59%), cough (34%), headache (91%), joint aches (79%), abdominal pain (52%) and vomiting (30%).

2.3.2 IgM and IgG Results

The presence of both CCHF IgM and IgG antibodies were investigated among sampled patients. An acute case (1/517) from Sangailu tested positive for anti-CCHF IgM and 96 of 517 sera were positive for anti-CCHF IgG of which 62 (65%) were patients sampled from Sangailu and 34 (35%) from Ijara.

2.3.3 Prevalence and Risk Factors for CCHFV

Overall, 96 (19%: 95% CI 15-22%) of the patients tested CCHF IgG antibody positive. This proportion was significantly greater in Sangailu (23%) than Ijara (14%; $p=0.0063$) and overall, males had a higher prevalence (23%) compared to females (15%). In Sangailu, 51.6% of those testing positive were females and 48.4% males; In Ijara, 52.9% of those testing positive were females and 47.1% males. The results indicated that those testing positive clustered within the age range of 40-49 years (Figure 6). In terms of occupation, farmers had the highest prevalence (29.3%), followed by housewives (18%) and businessmen (8%). Contact with some of the animals presented a risk of CCHFV-with prevalence among those who had contact with goats, camels and donkeys observed at 18.8%, 20% and 20.2%, respectively.

Multivariable logistic regression analysis precluded the need for correcting for contact with camels and goats (LR test p-values equal 0.981 and 0.4107, respectively) – and were therefore

excluded from the final model. The final model results, presented in Table 8, indicated that age, location, and contact with donkeys were significantly associated with having anti-CCHF IgG antibody. The results showed that the odds of CCHF increases by 1.02 for a one year increase in age after controlling for the other factors. The Odds of being CCHF positive was higher in Sangailu as compared to Ijara (OR=0.55, 95% CI: 0.33-0.90). Individuals who had contact with donkeys were highly likely to be CCHF positive than those who did not (OR=1.92, 95% CI: 1.05-3.72). Although, overall higher proportion of males than females tested positive for CCHF IgG this difference was not statistically significant (OR=2.65, 95% CI: 0.89-9.20; $p=0.096$). Further analysis indicated that occupation of the subjects was also not significantly associated with being CCHF positive (Chi Sq = 4.1, df = 3, $p=0.25$).

Table 8. Sero-prevalence and associated risk factors for CCHFV

Risk factors		anti-CCHF IgG Prevalence	OR (95% CI)	P-values
Age	5 to 19	9.02		
	20 to 29	18.33		
	30 to 39	25		
	40 to 59	36.84		
	≥50	28.57	1.02 (1.01-1.04)	0.0038*
	Sex	Female	15	
Male		23	2.65 (0.89-9.20)	0.096
Occupation	Farmers	29.3		
	Businessmen	8	0.30 (0.02-1.72)	0.2659
	Housewives	18	1.58 (0.50-5.77)	0.4558
	Other	9.4	0.60 (0.24-1.40)	0.2478
Contact	Donkeys	20.2	1.92 (1.05-3.72)	0.0427*
Location				
	Sangailu	23		
	Ijara	14	0.55 (0.33-0.90)	0.0186*

*=Significantly associated with being positive for anti-CCHF IgG antibody at 5% level; OR= odds ratio; CI=confidence interval.

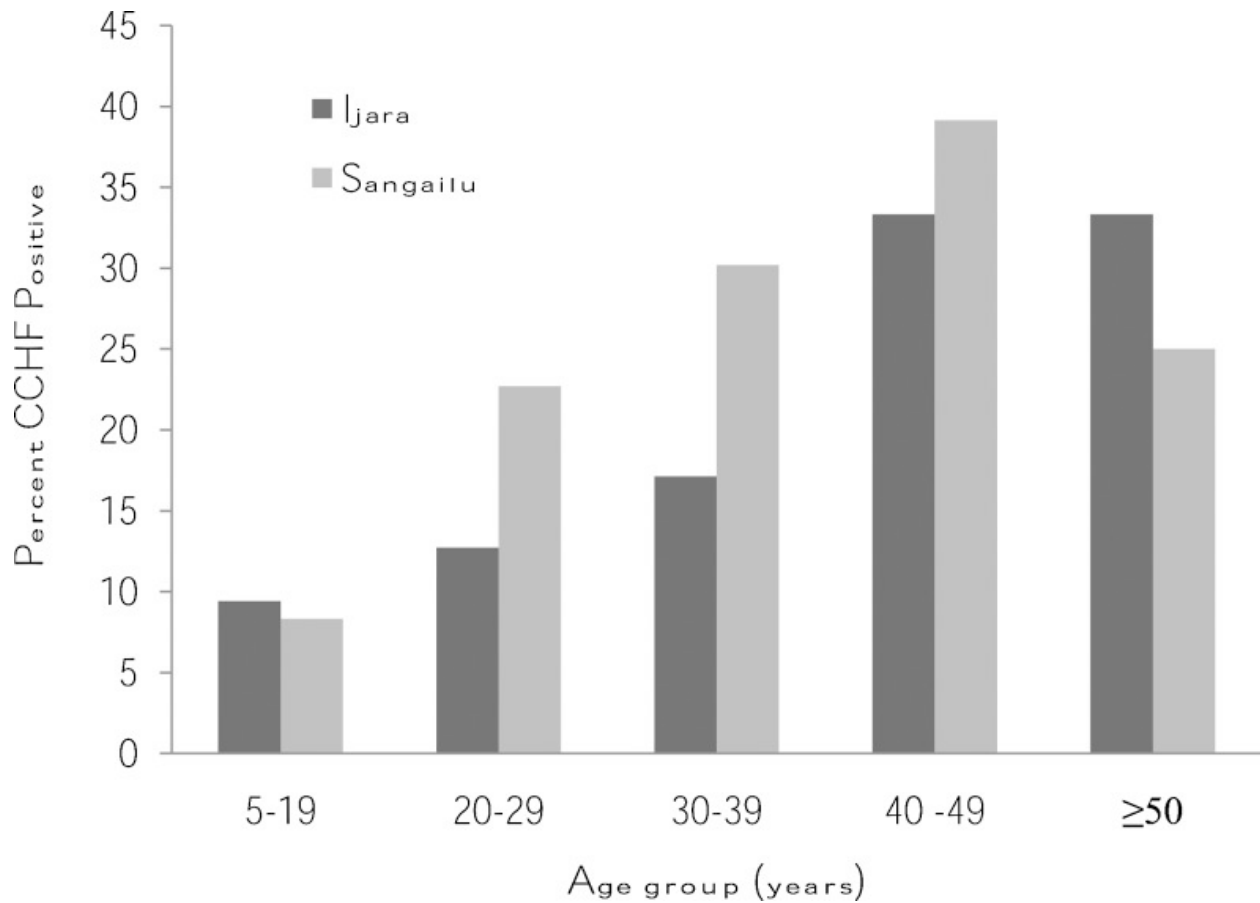

Figure 6. CCHF IgG positive individuals (n=96) by age groups in health facilities in Ijara and Sangailu locations, October 2010-March 2011.

2.4 Discussion

CCHF outbreaks constitute a threat to public health because of its epidemic potential, the severity of disease it causes and associated mortality rates, its potential to cause nosocomial outbreaks and the limited options available for treatment and management of infected persons (Lwande et al., 2012, Lahariya et al., 2012). This being a zoonotic disease associated mainly with domestic animals, this study was designed with the aim of determining if the human

population in Ijara District, North Eastern Kenya which is essentially a pastoralist community living in the region where CCHFV has been detected among hyalommatid ticks, is getting exposed to CCHFV (Sang et al., 2011).

A single case out of the 517 patients with acute febrile disease tested positive for anti-CCHFV IgM. This was a female patient seen in Sangailu Health Centre, Ijara District who had manifested with the following clinical signs: malaria smear positive, fever (37.8 °C), cough, sore throat, headache, abdominal pain, dizziness, muscle aches and joint pains. The outcome of this patient's disease is not known, as there was no follow-up of the sampled cases. This patient represents the first documented case of acute human CCHFV infection in the area. The patient had contact with goats and donkeys, which might have placed her at high risk. CCHFV was first detected in a 25-year-old farmer on a farm that was heavily infested by ticks in western Kenya. The patient had symptoms characterized by fever, headache, nausea, vomiting, severe muscle pains, neck stiffness, massive bleeding from the nose, mouth and upper and lower gastrointestinal tract. Differential diagnosis of malaria parasites, typhoid, dysentery and meningitis tested negative. The sample tested positive by RT-PCR for CCHFV and negative for both anti-CCHFV specific IgM and IgG antibodies (Dunster et al., 2002). A study carried out in Central Europe by (Pak, 1975) revealed that natural infection of large domestic mammals such as donkeys, cattle, camels and horses does occur. This indicates that donkeys elsewhere are potential reservoirs for CCHFV transmission and may be the case in this region.

The overall prevalence of CCHF IgG antibodies, which is indicative of prior exposure to CCHFV in the present study population, was 19%. This is indicative of significant circulation of CCHF virus, not only among ticks as recently observed in the region (Sang et al., 2011) but also infecting and affecting the human population. The failure of the public health system to detect

acute cases could be attributed to the non-specific nature of the clinical presentation that makes it difficult for the health workers to differentiate CCHFV infection from other endemic causes of such severe febrile illness like malaria, brucellosis and typhoid. The observed prevalence is fairly comparable to a survey conducted elsewhere among nomadic tribes in Senegal where a sero-prevalence rate of 13.1% was observed (Chapman et al., 1991).

The age group 40-49 years had the highest sero-prevalence rate, which is comparable to a study carried out in Iran by (Izadi et al., 2004) and which confirms that the important risk factors for CCHFV exposure include high-risk occupations (butchers, physicians, veterinarians), having contact with livestock, and age above 40 years. In this study, sero-prevalence of CCHFV increased significantly with age to a maximum of 36.23% at 40-49 years old. This, however, contradicts a study carried out in nomadic populations in Senegal where it was reported that the sero-prevalence increased significantly with age to a maximum of 31.6% among those of 31-39 years old (Chapman et al., 1991)- although these age groups are adjacent. In another study in South Africa, CCHF IgG antibody prevalence among farmers increased with age (Fisher-Hoch et al., 1992). The high prevalence in the age group 40-49 years might be due to the fact that this is a mature age group that most actively herds domestic animals or actively handles them for purposes of trade or transportation (in case of milking, food preparation and slaughter) and are thus at a higher risk of contact with infected ticks and/or animal excrement.

The sero-prevalence of CCHFV in Sangailu was significantly higher than that in Ijara. The population in Sangailu therefore appears to be at higher risk of exposure to CCHFV than the population in Ijara. Ijara (S01.57415 E040.12800) is closer to the Boni forest and enjoys more humid conditions and rain episodes than Sangailu (S01.27170 E040.66958) which is about 40km away from Ijara with more arid conditions that are considered favourable for the

Hyalomma tick species, the primary vectors of CCHFV. The conditions prevailing in Sangailu may be more favourable providing great risk of exposure due to increased virus activity among ticks or viremic animals.

Farmers were at a higher risk than housewives and businessmen. Farmers in the pastoralist communities in North Eastern Province interact closely with their animals during milking, slaughtering and caring for sick animals. During dry seasons, the farmers graze their livestock far from home, along the Tana River Delta, Boni forest all the way to the coast where water and pasture are abundant even during the dry season. In these habitats livestock from most of parts of North Eastern Kenya and Somalia converge and there is also opportunity for interaction with wild animals with possible risk of transmission of CCHF virus as possible reservoirs of CCHFV (Vorou et al., 2007, Estrada-Peña, 2001, Tonbak et al., 2006).

Housewives were the second most affected occupational risk group. This could be through participation in high-risk activities such as taking care of livestock especially the small stocks (sheep and goat), milking and assisting in slaughtering animals. This finding is consistent with studies carried out in Africa, Europe and Middle East by Heymann (2004) and Izadi et al. (2004) which show that people working with animals such as farmers living in endemic areas, medical personnel, veterinarians, abattoir workers, shepherds, animal workers, butchers, and tanners having the highest prevalence of CCHF antibodies/infection (Heymann, 2004, Izadi et al., 2004).

Other factors including age, location, and contact with donkeys were also shown to be risk factors for exposure to CCHFV. The fact that donkeys are widely used in the study area for domestic purposes essentially as a means of transportation of wares including grains and other food stuffs, commercial commodities to the market for sale and movement of water for domestic

use over long distances increases human/donkey contact and potential risk of tick bites. These animals are rarely slaughtered and because of their limited commercial value coupled with the fact that they do not die from tick-borne diseases, donkeys are not often prioritized during acaricide treatment of livestock. This could make them a better source of tick infestation and with potential to carrying infectious ticks. Enhancing community awareness of their potential role in the spread of tick-borne diseases and importance of acaricide treatment could present a more acceptable way to reduce transmission of CCHFV. A study reported by Shimshony (2010), detected CCHF antibodies in sera from horses, donkeys, goats, cattle, sheep and pigs in various parts of Europe, Asia and Africa. Although there is no evidence of CCHFV causing disease in animals, wildlife species such as hedgehogs and hares have been found to be viremic (Ergönül, 2006)

This study confirms the transmission of CCHF virus to the human population in Ijara District. Age, location and contact with donkeys are risk factors to CCHF virus exposure with Sangailu being more at risk than Ijara. Health providers should be informed of the prevalence of CCHF in the area and equipped with clear case definition and identification of cases, possible therapies and resources to care for CCHFV patients including infection control measures and resources which often lack in rural hospitals in order to empower them to deal with CCHFV infection. The community should further be educated on the risks of disease and how to protect themselves against infection through tick control and identified high risk activities and on good animal husbandry to control tick infestation on all domestic animals including donkeys. Donkeys should be treated for ticks. Further research is recommended to investigate the possible role of goat, donkeys and other potential animal reservoirs of disease in the tick-CCHF life cycle. Seroprevalence of CCHFV in cattle should be carried out to determine the exposure of this virus, which has been isolated from hyalommatid ticks sampled from cattle in this region. This

will assist in focusing on control efforts and understanding CCHFV epidemiology in North Eastern Kenya. There is also need to characterize the clinical presentation of this infection in this population to improve detection and control of disease. Investigation of the seroprevalence and burden of disease of the other tick and mosquito-borne viruses detected in this study is also needed to determine the impact of arboviruses on human morbidity and mortality in the area.

Chapter 3

Identification of Tick-Borne Viruses among Tick Vectors in Pastoral Eco- Zone of Ijara District, North Eastern Province of Kenya

3.1 Introduction

Tick-borne viruses have a significant impact on human and animal health. They are responsible for some of the serious emerging and re-emerging infectious disease problems facing the world today, which frequently occur in epidemic form (LaBeaud et al., 2011). Examples of these tick-borne viruses include CCHF, TBE, ASFV and NSD which pose threat to the health of humans and animals (Labuda and Nuttall, 2004) Table 4. They fall within six different viral families (Asfarviridae, Reoviridae, Rhabdoviridae, Orthomyxoviridae, Bunyaviridae and Flaviviridae) and at least nine genera. Some as yet unassigned tick-borne viruses may belong to a seventh family, the Arenaviridae. With one exception (ASFV) all tick-borne viruses (as well as all other arboviruses) are RNA viruses (Karabatsos, 1985, Van Regenmortel and Fauquet, 2000).

Previous arbovirus surveillance conducted in various parts of Africa such as Kenya, South Africa, Central African Republic and Niger have revealed the presence of these viruses. In Kenya arboviruses such as THO, DHO, DUG, BHA, KAD and Kupe virus have been isolated from ticks sampled from Livestock at abattoirs in Nairobi (Sang et al., 2011). Evidence of mosquito-borne viruses being detected in ticks has been documented for example: WNV has been isolated from *I. pavlovskyi* and *I. persulcatus* species sampled from small mammals, lizards and birds in Tomsk city (Moskvitina et al., 2008); SINV has also been found in *Hyalomma marginatum* species in Sicily (Gresikova et al., 1978). WNV neutralizing antibodies were found

in sera and cerebrospinal fluid (CSF) of febrile patients in South Africa (Zaayman and Venter, 2012). Outbreaks of WNV and SINV have also been documented in South Africa (McIntosh et al., 1976, Jupp and McIntosh, 1988). Antibodies against CCHF, DUGV and RVF viruses have been detected in sera sampled from Zebu cattle in Central African republic (Guilherme et al., 1996). In Niger, antibodies to CCHF and RVF viruses were identified in domestic livestock (cattle, sheep, goats and camels) (Mariner et al., 1995).

The majority of human infections by tick-borne viruses are asymptomatic or may result in a nonspecific flu-like syndrome and only a small proportion of infected patients' progress to severe disease (Alatoom and Payne, 2009). In severe infections, tick-borne viruses may cause systemic illness ranging from hemorrhagic fever associated with capillary leakage, shock, jaundice, liver damage, mild aseptic meningitis to encephalitis with coma, paralysis and death (Chin, 2000). Examples include viruses like CCHF, DUG, HAZ and KFD (Hoogstraal, 1979, Morikawa et al., 2002, Mehla et al., 2009). Humans are incidental hosts because they do not produce significant viremia (Weaver and Reisen, 2010). They are infected through the bite of infected ticks during opportunistic blood feeding, through crushing of ticks by hand and through contact with tissue fluids of infected viremic animals. Nosocomial infections can also occur after handling of infected tissues and body fluids from infected persons (Calisher, 1994). These viruses can be diagnosed by serology, virus isolation in cell culture and molecular based assays (Hall et al., 2012).

Ijara District of Kenya is home to a pastoralist community for whom livestock keeping is a way of life. The animals are highly valued and are often maintained in enclosures close to human dwellings or temporary nomadic sheds, and small ruminants are sometimes held inside homes overnight to secure them from wild animals. Such practices increase the risk of tick-borne virus

transmission. Poor husbandry, value systems and grazing practices put great pressure on land resources, which results in the need to continuously move large numbers of animals, especially cattle, in search of pasture which often brings livestock to share pasture with wild animals in forest ecosystem. With this in mind, tick-borne arbovirus survey was conducted in a pastoral eco-zone where intense livestock farming is practiced. Arboviruses such as RVF and WN have been isolated from mosquitoes sampled from homesteads in North Eastern Province of Kenya during the 2006-2007 RVF outbreak (LaBeaud et al., 2011). CCHFV activity has also been demonstrated amongst hyalommid ticks in the region (Sang et al., 2011). Antibodies to CCHFV have been detected in human sera sampled from febrile patients attending Sangailu dispensary and Ijara health centre within Ijara district indicating the level of human exposure to CCHFV (Lwande et al., 2012). This study will aim at improving the understanding of the role of ticks in arbovirus circulation in North Eastern pastoral zones of Kenya as a means of preventing virus emergence and dissemination. It will provide information on the actual burden of disease caused by tick-borne viruses, which will enable the relevant health authorities to put measures in place to prevent and control these viruses. This study will also provide a current update on the tick-borne viruses circulating in the region.

3.2 Materials and Methods

3.2.1 Study Design

This was a field based descriptive cross-sectional and laboratory-based study. Ticks were sampled from animal hosts (livestock and wildlife) and sent to the KEMRI Entomology laboratory for identification. Identified ticks were pooled into groups of maximum 8 ticks and homogenized for virus isolation in culture using Vero cells. CPE positive pools were subjected to RT-PCR using virus specific primers. All *Hyalomma* species were prescreened for CCHFV using RT-PCR.

3.2.2 Study Area

The study was conducted in Ijara District of North Eastern Province of Kenya (Figure 7). This is a low altitude (ranging between 0 and 90 meters above sea level) arid and semi-arid region where 90% of the people practice nomadic pastoralism, keeping indigenous cattle, goats, sheep, donkeys and camels. Approximately one quarter of the District is covered by the Boni forest bordering the Indian Ocean, which is an indigenous open canopy forest that forms part of the Northern Zanzibar-Inhamdare coastal forest mosaic (Antipa, 2007). A section of the forest, the Boni National Reserve is under the management of the Kenya Wildlife Service as a protected conservation area and is home to a range of wildlife species, including hirola antelope (also known as Hunter's hartebeest), reticulated giraffe, elephant, buffalo, lion, leopard, cheetah, African wild dog, lesser kudu, desert warthog and bushbuck. Rainfall is unreliable in Ijara District since it does not follow a seasonal pattern hence the District is prone to frequent droughts, and annual temperature varies from 20 to 38°C. Prolonged dry seasons trigger the movement of people and livestock to the Tana River delta and the Boni forest area near the Indian Ocean coastline where water and pasture are abundant long after the rains have gone (Antipa, 2007). This migration pattern facilitates the

movement of potentially virus-infected ticks across great distances, presenting opportunity for exchange of diverse tick species between the domestic, wild animals and even human populations, hence risk of exposure to tick-borne diseases.

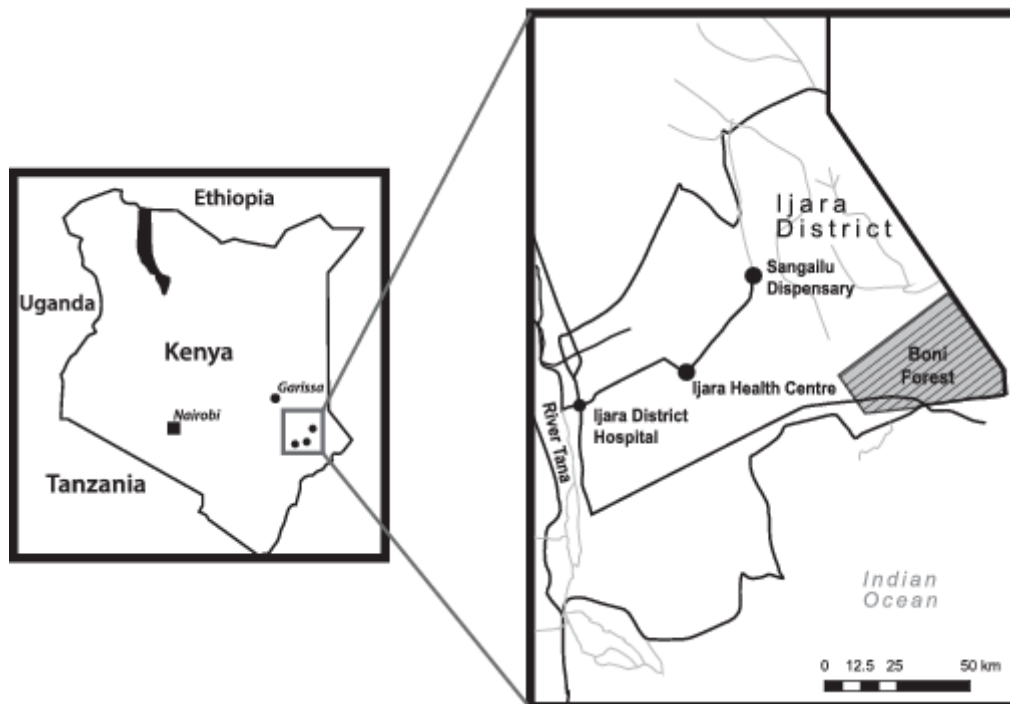

Figure 7. A map of the study sites within Ijara District in North Eastern Province, Kenya.

3.2.3 Ethical Considerations

Approval to carry out this study was obtained from the Kenya Medical Research Institute (KEMRI) National Ethical Review Committee and University of Pretoria Research Ethics Committee, protocol number **61/2012**.

3.2.4 Tick Collection and Transport

Sampling of ticks from both domestic animals and wildlife was undertaken in Ijara District, including Boni National Game Reserve. Qualified animal handlers who adorned the necessary protective gear (such as gloves, coveralls with trouser cuffs taped to shoes, high-top shoes, socks pulled over trouser cuffs and long-sleeved shirts) performed the tick collections. Livestock (goats, sheep and cattle) were physically restrained, whereas Kenya Wildlife Service veterinarians immobilized the wild animals (giraffe, warthog, lesser kudu and zebra) using a combination of 6 mg etorphine hydrochloride (M99R, Novartis, South Africa) and 50 mg xylazine hydrochloride (Kyron, South Africa) (Mutinda et al., 2012). Both livestock and wild animals were visually examined for ticks, with special attention to the abdomen, back, anal area, and hind legs. When the ticks were found they were pulled off manually and placed in sterile plastic vials, and transported to the laboratory in dry ice.

3.2.5 Tick Processing and Identification

The sampled ticks were washed twice with sterile water to remove excess particulate contamination from animal skin, and rinsed once with 70% ethanol, and twice with minimum essential medium (MEM) containing antimicrobial agents (100 U/mL penicillin, 100 µg/mL streptomycin and 1 µL/mL amphotericin B). Ticks identification was performed using appropriate identification keys (Matthysse and Colbo, 1987, Okello-Onen et al., 1999) and scutum coverage was used to confirm the sex of the ticks. The ticks were transferred to

sterile vials, and stored at -80°C until processed for virus isolation. Ticks were later thawed in ice (4°C), identified and pooled into groups of 1 to 8 (depending on size) by species, sex and animal host. Each pool was homogenized using 90-mesh alundum in a pre-chilled, sterile mortar and pestle with 1.6 to 2 mL ice-cold MEM with 15% fetal bovine serum (FBS), 2% glutamine, 100 U/mL penicillin, 100 µg/mL streptomycin, and 1 µL/mL amphotericin B. The homogenates were clarified by low-speed centrifugation at 1,500 rpm for 15 minutes at 4°C and supernatants aliquoted and stored at -80°C. In the case of *Hyalomma* species, the primary vectors of CCHFV, each pool was prescreened for CCHF by RT-PCR to exclude this virus prior to cell culture screening.

3.2.6 Virus Isolation

Vero cells were obtained from the American Type Culture Collection, Rockville, Md. Vero cells were grown in 25-cm² cell culture flasks to 80% confluency in EMEM (Lonza, Basel, Switzerland) containing 10% FBS (Invitrogen, Carlsbad, CA), 2% glutamine (Invitrogen), 100 U/mL penicillin, 100 µg/mL streptomycin (Lonza, Basel, Switzerland), and 1 µL/mL amphotericin B. The cells were then rinsed with sterile phosphate buffered saline (PBS) and 0.2 mL clarified tick homogenate added followed by incubation at 37°C for 45 minutes to allow virus adsorption. After incubation, MEM supplemented with 2% FBS, 2% glutamine, 100 U/mL penicillin, 100 µg/mL streptomycin, and 1 µL/mL amphotericin B was added into the flasks and the cells incubated at 37 °C for fourteen (14) days while observing cytopathic effects (CPE) on a daily basis. The supernatants of virus infected Vero cell cultures exhibiting CPE of approximately 70% were harvested from the flasks for virus identification. The pooled infection rate program (PooledInfRat, Centers for Disease Control and Prevention, Fort Collins, CO, USA; <http://www.cdc.gov/ncidod/dvbid/westnile/software.htm>) was used to compare virus infection rates in the tick species collected and processed in this study.

3.2.7 Reverse Transcriptase Polymerase Chain Reaction

Viral RNA was extracted from the culture isolates using TRIzol Plus RNA Purification Kit (Invitrogen) according to the manufacturer's recommended protocol. Extracted RNA was reverse transcribed to cDNA with the Transcriptor First Strand cDNA Synthesis Kit (Roche Applied Science) using Random hexamers followed by PCR using Phusion High-Fidelity PCR Kit (Finnzyme OY, Espoo, Finland) with primers targeting key arboviruses (Table 9). Using the PCR cycling conditions described in the respective references listed in Table 9. The PCR products were visualized on a 2% agarose gel stained with ethidium bromide (0.5µg/ml) using 100bp molecular weight marker (Invitrogen, Milan, Italy) and purified using shrimp alkaline phosphatase-exonuclease (ExoSapI) (USB Corp, Cleveland, OH) according to the manufacturer's instructions. Isolates obtained in this study were confirmed with sequencing before indicating their identity and this is referred in Chapter 4 section; 4.2.5 and 4.2.7.

Table 9. Reverse Transcription Polymerase Chain Reaction Primers used for identification of key arboviruses

Virus Target	Target gene	Primer Designation	Primer Sequences 5'- 3'	Annealing Temperature	Reference
<i>Alphaviruses</i>	NS	Vir 2052 For	TGGCGCTATGATGAAATCTGGAATGTT	59°C	(Eshoo et al., 2007)
		Vir 2052 Rev	TACGATGTTGTCGTCGCCGATGAA		
<i>Orthobunyavirus</i>	NS	OrthoBun For	CTGCTAACACCAGCAGTACTTTTGAC	57°C	(Lambert and Lanciotti, 2008)
		OrthoBun Rev	TGGAGGGTAAGACCATCGTCAGGAACTG		
Thogoto	N	THO NF	CCTGCAGGGGCGGAAGTTATG	57°C	(Sang et al., 2006)
		THO NR	AAAATCCTCGCAGTTGGCTATCA		
Dugbe	N	DG S1	TCTCAAAGACAAACGTGCCGACG	57°C	(Sang et al., 2006)
		DG S5	TGCAACAACCTGGATGTGTGA		
<i>Flaviviruses</i>	NS5	FLAVI fu2	GCTGATGACACCGCCGGCTGGGACAC	59°C	(Bryant et al., 2005)
		FLAVI cfd3	AGCATGTCTTCCGTGGTCATCCA		
Ndumu	Envelope (E1) gene	ND 124F	CACCCTAAA AGTGAC GTT	59°C	(Bryant et al., 2005)
		ND 632R	ATTGCAGAT GGG ATA CCG		
West Nile	Helicase	WN1315F	GCCAATTTGCCTGC TCT AC	59°C	(Turell et al., 2005)
		WN1824R	CCA TCT TCA CTC TAC ACT TC		
Babanki	E1 envelope glycoprotein	Bab 3368F	CAG CAG ATT GCG CGA CTG ACC	59°C	(Bryant et al., 2005)
		Bab 4203R	GCT CAC GAT ATG GTC AGC AGG		
Batai	Polyprotein M segment	BATAIM3F	CCTGGGGAAGCATTGTGATTACT	59°C	(Yandoko et al., 2007)
		BATAIM3R	CTAGCCAGCGACTCTTGCCTTCC		
Sindbis	Non Structural Protein	SINV1	TTTAGCGGATCGGACAATTC	59°C	(Bryant et al., 2005)
		SINV2	GCGGTGACGAACTCAGTAG		
Chikungunya	5'NTR	CHIK3F	CACACGTAGCCTACCAGTTTC	59°C	(Smith et al., 2009)
		CHIK3R	GCTGTCAGCGTCTATGTCCAC		
O'nyong'nyong	5'NTR	ONN3F	GATACACACACGCAGCTTACG	59°C	(Smith et al., 2009)
		ONN3R	TACATACACTGAATCCATGATGGG		

Yellow Fever	Polyprotein	CAG	CGAGTTGCTAGGCAATAAACACATTTG GA	59°C	(Ayers et al., 2006)
		YF7	AATGCTCCCTTTCCCAAATA		
Dengue	Structural polyprotein	D1	TCAATATGCTGAAACGCGCGAGAAACCG	60°C	(Lanciotti et al., 1992)
		D2	TTGCACCAACAGTCAATGTCTTCAGGTTT		
Crimean-Congo hemorrhagic fever	N	CCHF F2	TGGACACCTTCACAAACTC	57°C	(Sang et al., 2006)
		CCHF R3	GACAAATTCCTGCACCA		
Nairobi sheep disease	N	NSD 12f	GAATGGTCGAACGTGGAC	57°C	(Sang et al., 2006)
		NSD 16r	TGCTGTCAGGACACCAGG		
Bunyamwera and California serogroups	N	BCS82C	ATGACTGAGTTGGAGTTTCATGATGTCGC	57°C	(Sang et al., 2006)
		BCS332V	TGTTCTGTTGCCAGGAAAAT		
Dhori	N	DHO NF2	TGGTACCCTTTTCTTGCTTCACTCC	57°C	(Sang et al., 2006)
		DHO NR2	TGCTCTCCTCGGCTCAAACACCA		
Hazara	N	HAZ 803f	CTGGTTGAGCTAGAGGGGAAAGACG	57°C	(Sang et al., 2006)
		HAZ 1304r	GGGCGGCATCATCGGGACTG		
Koutango	NS5	KOU 176f	TCAGGGAGGTGGGAGGTA AAC	57°C	(Sang et al., 2006)
		KOU 734r	TCATGCCATCCAACAGAAGGT		
Saboya	NS5	SAB 226f	GCAGGCTGGGACACAAAGAT	57°C	(Sang et al., 2006)
		SAB 815r	CTACAAGGGGCAATGATGGTTC		
Middleburg	E2	MID 1939f	TACATGCCCCGAAGGTGACT	57°C	(Sang et al., 2006)
		MID 2458r	CGGGATGGTGTTCGGTAAAG		

3.3 Results

3.3.1 Tick Collection

A total of 10,488 ticks were collected and processed for virus isolation in 1,520 pools. Species of ticks collected and their proportions are shown in (Table 12). The predominant species collected was *Rh. pulchellus* (76.12%) followed by *H. truncatum* (8.68%), *A. gemma* (5.00%), *A. lepidum* (4.34%), *H. marginatum* (2.24%), *Hyalomma* spp. (0.92%), *Rh. appendiculatus* (0.59%), *H. dromedarii* (0.59%), *B. annuatus* (0.53%), *A. hebraem* (0.39%), *Rh. pravus* (0.20%), *D. rhinoceros* (0.07%) and unidentified nymph (0.20%). However, the calculated virus pooled infection rate was highest in *Hyalomma* spp. (142.86) than for other species (Table 12).

3.3.2 Virus Isolation and Identification

A total of 155 tick pools showed CPE in Vero cells yielding virus isolates. CPE was observed using an inverted microscope by comparing the tick homogenates with a positive and negative control for a period of 14 days. Though all isolates were subjected to RT-PCR with primers targeting key arboviruses (Table 9), only 82 isolates were identified, distributed among the tick species as follows: *Rh. pulchellus* (67), *A. gemma* (6), *A. lepidum* (4), *H. truncatum* (3) and *Hyalomma* spp. (2). There was no virus isolated from *H. marginatum*, *Rh. appendiculatus*, *H. dromedarii*, *B. annuatus*, *A. hebraem*, *Rh. pravus*, *D. rhinoceros* and the unidentified nymph pools. *Rh. pulchellus* had the highest number of virus-infected pools (46) followed by *A. gemma* (5), *A. lepidum* (3), *H. truncatum* (2) and *Hyalomma* spp. (2) (Table 12).

Table 10. Proportion of virus isolated from tick species sampled from livestock and wildlife

Tick species	Bunyamwera	Dugbe	Ndumu	Semliki forest	Thogoto	West Nile
<i>A. gemma</i>	3(68%)	1(20%)	0 (0%)	1 (4%)	0 (0%)	33.33%
<i>A. lepidum</i>	2(4.55%)	0 (0%)	0 (0%)	2 (8%)	0 (0%)	0 (0%)
<i>H. truncatum</i>	2(4.55%)	0 (0%)	0 (0%)	1 (4%)	0 (0%)	0 (0%)
<i>Hyalomma spp</i>	2(4.55%)	0 (0%)	0 (0%)	0 (0%)	0 (0%)	0 (0%)
<i>R. pulchellus</i>	35 (79.55%)	4 (80%)	2 (100%)	21 (84%)	3 (100%)	66.67%
Total	44 (100%)	5 (100%)	2 (100%)	25% (100%)	3 (100%)	3 (100%)

3.3.2 PCR Identification



Figure 8. RT-PCR gel results for CPE positive tick-homogenates using Alphavirus primers. L- represents the 100 bp molecular ladder, +1 positive control for Middelberg virus, +2 positive control for SFV, - negative control and 1 to 30 are the CPE positive tick homogenates.

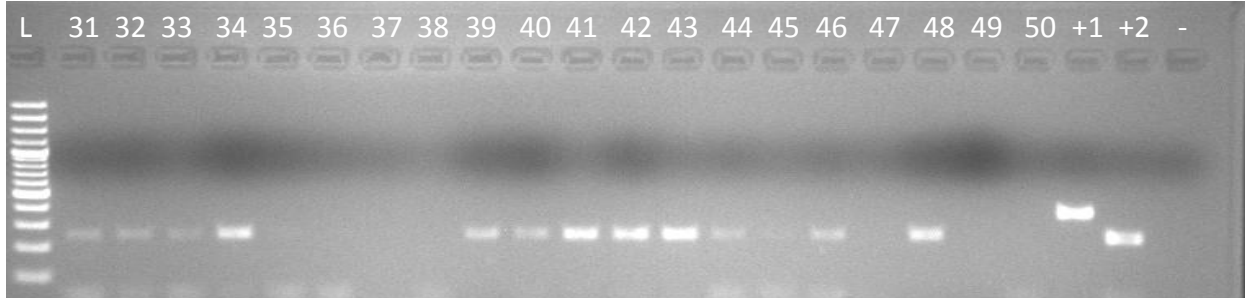

Figure 9. RT-PCR gel results for cpe positive tick homogenates with Orthobunya and Phleboviruses primers. L-represents the 100 bp molecular ladder, +1 positive control for RVFV, +2 positive control for BUNV, – negative control and 31 to 50 are the CPE positive tick homogenates.

The 82 virus strains were obtained from 52 tick pools of which 27 had single viral infection, 22 contained mixed infections of two different viruses, 2 contained three different viruses and 1 contained five different viruses (Table 12). The mixed infections were determined by RT-PCR and further confirmed by both Sanger and 454 sequencing.

The observed onset of CPE among the isolates ranged from 3–12 days post infection. The identified isolates included BUN- (44), DUG- (5), NDU- (2), SF- (25), THO- (3), and WN- (3) virus strains, respectively. Of all the tick species processed for virus isolation, *Rh. pulchellus* had the highest infection with BUN-(35), SF-(21), DUG-(4), NDU-(2), THO- (3) and WN- (2) viruses (Table 12). WNV was also isolated from the *A. gemma* and *Rh. pulchellus* species sampled from cattle and warthogs. THOV was isolated from *Rh. pulchellus* species sampled from cattle, goats and warthogs. DUGV was isolated from *Rh. pulchellus* and *A. gemma* species sampled from cattle, goats and sheep (Table 10).

Table 11. Proportion of virus isolated from domestic and wild hosts from which ticks were sampled in Ijara district

Animal host	Bunyamwera	Dugbe	Ndumu	Semliki forest	Thogoto	West Nile
Cattle	13 (29.55%)	2 (40%)	1 (50%)	7 (28%)	1 (33.33)%	1 (33.33)%
Goat	14 (31.82)%	2 (40%)	0 (0%)	8 (32%)	1 (33.33)%	0 (0%)
Sheep	15 (34.09%)	1 (20%)	0 (0%)	8 (32%)	0 (0%)	0 (0%)
Giraffe	1 (2.27%)	0 (0%)	0 (0%)	0 (0%)	0 (0%)	0 (0%)
Warthog	1 (2.27%)	0 (0%)	1 (50%)	2 (8%)	1 (33.33)%	2 (66.67)%
Total	44 (100%)	5 (100%)	2 (100%)	25 (100%)	3 (100%)	3 (100%)

BUNV and SFV were predominantly isolated from *Rh. pulchellus*. Ticks sampled from livestock had the highest number of virus isolates. BUNV was isolated from *A. gemma* species sampled from giraffe and *Rh. pulchellus* species sampled from warthog (Table 11). *A. gemma* and *Rh. pulchellus* species were the major virus carriers amongst wildlife (Table 15). There was no virus isolated from ticks sampled from camel, lesser kudu and zebra (Table 15).

Table 12. Virus isolates obtained from ticks collected from animal hosts in Ijara District, Kenya

Species	Total # tick pools	Animal Hosts																								# virus isolated	Infected pools	Pooled IR															
		Cattle							Goat							Sheep							Giraffe							Warthog													
		# tick pools	BU	DU	ND	SE	TH	WN	# tick pools	BU	DU	ND	SE	TH	WN	# tick pools	BU	DU	ND	SE	TH	WN	# tick pools	BU	DU				ND	SE	TH	WN	# tick pools	BU	DU	ND	SE	TH	WN				
<i>A.gemma</i>	76	29	2	0	0	0	0	0	0	14	0	1	0	0	0	0	0	9	0	0	0	0	0	0	0	2	1	0	0	0	0	0	0	21	0	0	0	1	0	1	6	5	65.79
<i>A.hebraem</i>	6	1	0	0	0	0	0	0	0	4	0	0	0	0	0	0	0	0	0	0	0	0	0	0	0	0	0	0	0	0	0	0	0	0	0	0	0	0	0	0	0		
<i>A.lepidum</i>	66	29	1	0	0	1	0	0	0	30	1	0	0	1	0	0	0	5	0	0	0	0	0	0	0	0	0	0	0	0	0	0	0	2	0	0	0	0	0	0	4	3	45.45
<i>B.annulatus</i>	8	2	0	0	0	0	0	0	0	0	0	0	0	0	0	0	0	0	0	0	0	0	0	0	0	0	0	0	0	0	0	0	6	0	0	0	0	0	0	0	0	0	
<i>D.rhinocerinus</i>	1	0	0	0	0	0	0	0	0	0	0	0	0	0	0	0	0	1	0	0	0	0	0	0	0	0	0	0	0	0	0	0	0	0	0	0	0	0	0	0	0	0	
<i>H.dromedarii</i>	9	0	0	0	0	0	0	0	0	0	0	0	0	0	0	0	0	0	0	0	0	0	0	0	0	0	0	0	0	0	0	0	0	0	0	0	0	0	0	0	0	0	
<i>H.marginatum</i>	34	6	0	0	0	0	0	0	0	12	0	0	0	0	0	0	0	10	0	0	0	0	0	0	0	0	0	0	0	0	0	0	0	0	0	0	0	0	0	0	0	0	0
<i>H.truncatum</i>	132	20	0	0	0	0	0	0	0	37	1	0	0	1	0	0	0	61	1	0	0	0	0	0	0	0	0	0	0	0	0	0	0	14	0	0	0	0	0	0	3	2	15.15
<i>Hyalomma spp</i>	14	1	0	0	0	0	0	0	0	2	1	0	0	0	0	0	0	4	1	0	0	0	0	0	0	0	0	0	0	0	0	0	0	0	0	0	0	0	0	2	2	142.86	
<i>Rh.Pravus</i>	3	1	0	0	0	0	0	0	0	0	0	0	0	0	0	0	0	0	0	0	0	0	0	0	0	0	0	0	0	0	0	0	0	0	0	0	0	0	0	0	0	0	
<i>Rh.appendiculatus</i>	9	1	0	0	0	0	0	0	0	6	0	0	0	0	0	0	0	0	0	0	0	0	0	0	0	0	0	0	0	0	0	0	0	0	0	0	0	0	0	0	0	0	0
<i>Rh.evertsi evertsi</i>	2	2	0	0	0	0	0	0	0	0	0	0	0	0	0	0	0	0	0	0	0	0	0	0	0	0	0	0	0	0	0	0	0	0	0	0	0	0	0	0	0	0	
<i>Rh.pulchellus</i>	1157	283	10	2	1	6	1	1	486	11	1	0	6	1	0	0	275	13	1	0	8	0	0	0	0	0	0	0	0	0	0	0	90	1	0	1	1	1	1	67	40	34.57	
<i>Unidentified nymph</i>	3	0	0	0	0	0	0	0	0	0	0	0	0	0	0	0	0	0	0	0	0	0	0	0	0	0	0	0	0	0	0	0	0	0	0	0	0	0	0	0	0	0	
Total	1520	375	13	2	1	7	1	1	591	14	2	0	8	1	0	0	365	15	1	0	8	0	0	0	2	1	0	0	0	0	0	137	1	0	1	2	1	2	82	52			

KEY: #-Number; BU-Bunyamwera virus; DU-Dugbe virus; ND-Ndumu virus; SE-Semliki virus; TH-Thogoto virus; WN-West Nile virus;

IR-Infection rate. 73 unidentified CPE positive tick pools

Table 13. Virus isolates obtained from diverse tick species sampled from livestock and wildlife

Tick species	Bunyamwera	Dugbe	Ndumu	Semliki forest	Thogoto	West Nile	Total
<i>A.gemma</i>	3	1	0	1	0	1	6
<i>A.hebraem</i>	0	0	0	0	0	0	0
<i>A.lepidum</i>	2	0	0	2	0	0	4
<i>B.annulatus</i>	0	0	0	0	0	0	0
<i>D.rhinocerinus</i>	0	0	0	0	0	0	0
<i>H.dromedarii</i>	0	0	0	0	0	0	0
<i>H.marginatum</i>	0	0	0	0	0	0	0
<i>H.truncatum</i>	2	0	0	1	0	0	3
<i>Hyalloma</i> spp.	2	0	0	0	0	0	2
<i>Rh.Pravus</i>	0	0	0	0	0	0	0
<i>Rh.appendiculatus</i>	0	0	0	0	0	0	0
<i>Rh.evertsi evertsi</i>	0	0	0	0	0	0	0
<i>Rh.pulchellus</i>	35	4	2	21	3	2	67
<i>Unidentified nymph</i>	0	0	0	0	0	0	0
Total	44	5	2	25	3	3	82

Table 14. Virus isolates obtained from ticks sampled from livestock and wildlife

Animal host	Bunyamwera	Dugbe	Ndumu	Semliki forest	Thogoto	West Nile	Total virus isolates	Total number of ticks
Camel	0	0	0	0	0	0	0	224
Cattle	13	2	1	7	1	1	25	2646
Goat	14	2	0	8	1	0	25	4557
Sheep	15	1	0	8	0	0	24	2590
Giraffe	1	0	0	0	0	0	1	6
Lesser Kudu	0	0	0	0	0	0	0	7
Warthog	1	0	1	2	1	2	7	536
Zebra	0	0	0	0	0	0	0	55
Total	44	5	2	25	3	3	82	10621

3.4 Discussion

Tick vectors are known to be an important route for virus transmission and dissemination where one host may act as a reservoir of infection, pass it via the tick to a more vulnerable host, which then suffers disease (Hudson and Greenman, 1998). Tick-borne viruses cause significant morbidity/mortality and economic loss to humans, livestock and wildlife hosts in the tropics (Sonenshine and Mather, 1994). Wildlife serves as potential reservoirs for tick-borne pathogens of livestock and humans. Domestic animals are infected when livestock and wild animals share pasture and water during adverse weather conditions (Jongejan and Uilenberg, 1994).

The factual prevalence of tick-borne viruses in Ijara district remains unknown considering the fact that there were some unidentified tick homogenates that showed clear CPE which could have been detected by RT-PCR.

Despite detecting a higher number of virus isolates, in ticks sampled from livestock, similar viruses (such as BUN, SF and NDU) were also isolated from wildlife signifying the potential of arbovirus transmission across animal species. Although CCHFV was not isolated from ticks sampled from diverse animal hosts in this study, DUGV which belongs to same family and genus (Bunyaviridae; *Nairovirus*) was isolated. Antibodies against CCHFV have been found in domestic and wild vertebrates (Vorou et al., 2007). CCHFV is also known to cause asymptomatic infection in wild animals (Ergönül, 2006).

Among ticks collected from livestock, cattle (6.6%) and sheep (6.57%) showed the highest prevalence of virus-positive ticks, whereas tick sampled from warthogs had the highest prevalence among wildlife. In Ijara, warthogs live in close proximity to households and

interact closely with livestock (especially sheep and goats), which provide increased opportunity for transfer of ticks between domestic animals and warthogs in the villages.

Two classical tick-borne viruses were isolated during this survey, namely THOV and DUGV. These viruses have been isolated in previous surveys conducted in South Africa and Kenya (Burt et al., 1996, Sang et al., 2006). THOV was first isolated in Kenya from *Rhipicephalus* species and *Boophilus decoloratus* in the 1930s (Karabatsos, 1985) and has been isolated repeatedly from various tick species in Kenya, West Africa, Europe and Asia (Calisher and Karabatsos, 1988, Sang et al., 2006). Two THOV infections have been reported in humans, with one fatality (Moore et al., 1975). There is thus a need to assess the public health impact of this virus in Kenya. THOV affects both livestock especially sheep causing widespread abortions (Davies, 1997b). DUGV has also been commonly isolated in surveillance studies conducted in Africa and is known to affect livestock particularly cattle (Camicas, 1980, Johnson et al., 1980, Burt et al., 1996, Sang et al., 2006). The implications of DUGV circulation to public health has not been evaluated in Kenya, although reports from South Africa suggest that it causes thrombocytopenia in humans (Burt et al., 1996, Boyd et al., 2006). In an earlier study conducted around Lake Victoria, DUGV was isolated from *Rh. pulchellus* more commonly than any other virus with a single isolate from *A. gemma*, and where it was observed that more tick pools from dry scrubland were infected with DUGV than pools from the swamp edge (Johnson et al., 1980). This is consistent with our findings since most of our DUG isolates were from *Rh. pulchellus* and a single isolate from *A. gemma*.

In this study *Rh. pulchellus* was the predominant tick species collected and had the highest number of virus isolates. BUN, DUG, NDU, SF, WN and THO viruses were isolated from *Rh. pulchellus* collected from cattle, goats, sheep and warthogs. *Rh. pulchellus* species is known to be a vector of both mosquito and tick-borne viruses. A previous survey carried out in

abattoirs in Kenya also demonstrates the importance of this species in arbovirus transmission and maintenance (Sang et al., 2006). Arboviruses such as DHO, DUG, THO and Barur have been isolated from *Rh. pulchellus* species in Kenya (Sang et al., 2006). *Rh. pulchellus* is a known ectoparasite of both livestock and wildlife in savannah habitats east of the Rift Valley (Hopla et al., 1994). It is also a vector of several viruses such as: NSD, DUG, Barur and CCHF (Butenko et al., 1981). The abundance of *Rh. pulchellus* within the study region might be due to favorable ecological conditions which range from: semi-arid to arid zone with predominant acacia; cammiphora shrubs interspersed with grassy bushes and close proximity to the Tana Delta and the Indian Ocean. This tick is therefore able to survive diverse climatic conditions where arbovirus populations may be found. *Rh. pulchellus* is also known to be a three host tick, a situation that provides multiple opportunities for acquiring, transmitting and disseminating more virus strains. *Rh. pulchellus* is a tick of both livestock and wildlife especially ungulates. This tick species has been found on sheep, zebra, antelopes, gazelles and black rhino (Walker et al., 2000). These study findings provide additional information on the significance of *Rh. pulchellus* species as vectors of arboviruses.

The most significant finding in the current study is the number of mosquito-borne virus strains isolated from pooled engorged ticks sampled from livestock and wild animals in Ijara District, North Eastern Province of Kenya. The detection of mosquito-borne viruses such as BUNV, NDUV, SFV and WNV in ticks may suggest that the ticks might have acquired the virus through ingestion of a blood meal from infected hosts during feeding and therefore there is need to conduct vector competence studies to ascertain the possible role of ticks and animals in the transmission cycle of these viruses. Three of the WNV isolates in this study were isolated from ticks (*A. gemma* and *Rh. pulchellus*) sampled from cattle and warthogs. However, there is no documented role of these animals in WNV transmission and maintenance. The migration birds over long distances has been shown to play a role in the

dispersion of arboviruses such as WNV, Usutu and tick-borne encephalitis virus (TBEV) (Pfeffer and Dobler, 2010). A study carried out by (Waldenström et al., 2007) detected the presence of TBEV in ticks sampled from migrating birds. Although studies on WNV provide evidence of the virus being transmitted by mosquitoes and ticks (Moskvitina et al., 2008), none has been able to demonstrate the role of ticks in transmission of BUNV, NDUV and SFV.

BUNV, DUGV and SFV were isolated from ticks sampled from livestock whereas NDU and WN viruses were isolated from ticks sampled from both livestock and wild animals. This study provides new information on isolation of BUNV and SFV from ticks sampled from livestock. Ngari virus a BUNV reassortant has been documented to have caused a large outbreak of hemorrhagic fever that occurred in 1997 to 1998 in East Africa (Gerrard et al., 2004). A study carried out by Sang et al. (2006) points to isolation of DUGV virus from ticks sampled from livestock at two major abattoirs in Nairobi, Kenya. One of our NDUV isolates was obtained from engorged pooled ticks sampled from warthogs. Viral meta-genomics demonstrate that domestic pigs are potential reservoirs of NDUV (Masembe et al., 2012). Warthogs being the wild members of the pig family Suidae there is possibility that they can also be potential reservoirs of NDUV just like the domestic pigs. WNV has been detected in diverse tick species in eastern Europe and also from *Hyalomma marginatum* ticks found on passerine birds in the Volga delta (Lvov et al., 1975, L'vov et al., 2002, Moskvitina et al., 2008)). However, the significant role of tick vectors in the transmission of WNV remains unknown.

Although ticks may be involved in the transmission and dissemination of the viruses detected in this study, there is also a possibility that ticks sampled in this study fed on viremic animals and, therefore, could have picked up the viruses from host blood. Though there is scarcity of information on tick vector competence, (Steele and Nuttall, 1989) were

able to demonstrate that *Amblyomma variegatum* is a more competent vector of DUGV than *Rhipicephalus appendiculatus* since the virus was ingested by *A. variegatum* nymphs during capillary feeding, replicated and persisted through moulting to adult stage whereas in *R. appendiculatus* the virus was ingested but did not persist to adult stage. Therefore further investigations using actual animal (domestic and wild) samples are needed to conclusively determine their role as reservoirs of the viruses in question. Similarly, vector competence studies should be performed to investigate the role of implicated tick species in the natural transmission cycle of the viruses isolated from the ticks in this study.

Although no CCHFV was detected in this study, DUGV which belongs to the same family (Bunyaviridae) and genus (*Nairovirus*) was isolated from ticks sampled from livestock and wild animals. Moreover antibodies to CCHFV were found in sera of febrile patients attending health facilities suggesting the possibility of acute cases occurring without being detected in the region (Lwande et al., 2012).

Our findings suggest a possible role for ticks in the maintenance, distribution and possible transmission of viruses normally associated with mosquitoes in Africa. The observed circulation of multiple arbovirus strains among pooled engorged ticks may provide opportunities for genetic recombinations and reassortments that could result in emergence of new arbovirus strains, some of which could be significant human pathogens (Bowen et al., 2001). Therefore, continued tick based arbovirus surveillance among diverse host systems is valuable for monitoring arbovirus emergence.

Chapter 4

Investigation of Genetic Diversity by Next Generation Sequencing of Arbovirus Isolates Obtained from Ticks Sampled from Livestock and Wildlife in North Eastern Kenya, Pastoral Eco-Zone Ijara

4.1 Introduction

Arboviruses are transmitted biologically among vertebrate hosts by blood feeding arthropod vectors such as mosquitoes, ticks, midges and sandflies. These viruses circulate among vectors and animals causing disease in humans (incidental hosts) by spillover transmission (Weaver and Reisen, 2010). Epidemics caused by arboviruses result in considerable mortality, morbidity with economic loss (LaBeaud et al., 2008, Sonenshine and Mather, 1994). Abundance of competent vectors for many arboviruses in sub-Saharan Africa suggests frequent circulation of these viruses in the region (Jentes et al., 2011).

Arboviruses of Togaviridae, Flaviviridae and Bunyaviridae families remain endemic in most parts of Kenya (Sang et al., 2006, LaBeaud et al., 2011, Mease et al., 2011, Sang et al., 2011, Lwande et al., 2012). Arboviruses such as YF, DEN, WN, CHIK, ONN, RVF, DUG and BUN have previously been detected especially in North Eastern Province of Kenya. Although most of the isolations are mosquito-borne, tick-borne viruses such as CCHFV have also been detected in the area (Sang et al., 2011, Lwande et al., 2012). Most arbovirological studies have been limited to serology and/or virus isolation via cell culture. Evidence of human infection through serology has been documented for YFV and CCHFV (Henderson et al., 1970, Lwande et al., 2012). CCHFV has also been isolated from hyalommatid ticks sampled from cattle (Sang et al., 2006, Sang et al., 2011) and WN and RVFV from mosquitoes (LaBeaud et al., 2011) all in the North Eastern Province of Kenya.

Classical methods of virus detection like neutralization assay, cell culture and polymerase chain reaction have continuously been used to determine the causative agents of viral diseases during outbreaks. Although these tests remain important in viral diagnosis, virus isolation, which is still considered the gold standard is time consuming while PCR and serology necessitate knowledge of the disease agent in order to design specific primers and antibodies for viral detection (Bishop-Lilly et al., 2010). It is not possible to culture all viruses without potentially leading to false negatives if growth is not observed. Further probing using molecular methods is needed to identify viral agents in positive culture. Moreover, strain variation due to point mutations, re-assortment or recombination exists among virus agents, that may have a bearing on the severity of outbreaks, yet such subtle differences are not easy to unravel using conventional methods. This limitation makes virus diagnosis difficult especially when dealing with a novel virus or variant.

There is paucity of genetic data on arboviruses circulating in Kenya even though such studies conducted elsewhere in Africa have indicated diversity in most emerging arboviruses. A few studies have investigated the major arboviruses such as WN reviewed in (Venter and Swanepoel, 2010); RVF (Grobbelaar et al., 2011); CCHF (Burt and Swanepoel, 2005) but limited data is available on the less common African arboviruses and even less on these viruses in Kenya. Most of these studies have used specific Sanger sequencing. Next generation sequencing have been used to describe arboviruses such as DEN and NDU in Africa (Bishop-Lilly et al., 2010, Masembe et al., 2012) and for virus discovery for example the detection of Ebola virus as the causative agent of hemorrhagic fever in an outbreak in Uganda (Towner et al., 2008).

The development of the next generation sequencing (NGS) is a very important milestone in the discovery of new arboviruses that may be of significant value to public health and also

generation of the entire genomes within a short span of time with high specificity and sensitivity (Ronaghi, 2001, Schuster, 2008). Examples of NGS platforms include: Genome Sequencer FLX 454 (GSFLX 454; Roche Life Science, Germany), Solexa (Illumina, USA), and SOLID (Applied Biosystem, USA). These platforms provide high genome coverage and smaller reads compared to the Sanger-based sequencers (Sanger et al., 1977). In order to circumvent the highlighted challenges of the current conventional tools, NGS analyses is important to unravel the identity of new variants/agents in addition to providing a complete sequence of nucleotides which will aid in locating regulatory and gene sequences, making comparisons between homologous genes across species and identifying mutations that may exist amongst arboviruses.

454 sequencing was the first next generation sequencing platform to be successfully applied in research. 454 sequencing entails the use of pyrosequencing technology that relies on the detection of pyrophosphate released during nucleotide incorporation. This technique involves denaturation of the DNA library together with the with 454-specific adaptors into single strand which are then captured by amplification beads followed by emulsion PCR. Each of the dinucleotide triphosphates placed on a picotitre plate will attach on to their respective complementary bases on the template. This reaction is facilitated by ATP sulfurylase, luciferase, luciferin, DNA polymerase, and adenosine 5 phosphosulfate (APS) which release pyrophosphate (PPi) that is proportional to the amount of nucleotide incorporated in the reaction (Balzer et al., 2010). The ATP transformed from PPi converts luciferin into oxyluciferin and generates visible light. 454 sequencing is of great advantage since it is very fast in terms of speed and generates a read length of up to 700 bp with an accuracy rate 99.9% after filter and output 0.7G data per run within 24 hours. One of the major shortcomings of this technique is the high error rate in terms of poly-bases longer than 6 bp and the high cost involved (approximately $\$12.56 \times 10^{-6}$ per base) (Liu et al., 2012).

This study sought to investigate arbovirus genetic diversity by sequencing isolates obtained from ticks sampled from livestock and wildlife in North Eastern Kenya using the GSFLX 454 sequencing method to detect variation and potential recombination.

4.2 Materials and Methods

4.2.1 Tick Collection and Transport

As described in 3.2.4.

4.2.2 Tick Processing and Identification

As described in 3.2.5.

4.2.3 Virus Isolation

As described in 3.2.6.

4.2.4 RNA Sample Preparation for 454 Sequencing

CPE positive tissue culture isolates from tick homogenates were filtered through a 0.22 µm filter, followed by RNA extraction using TRIzol reagent (Invitrogen). RNA was amplified using the modified random priming mediated sequence independent single primer amplification (RP-SISPA) methodology (Djikeng et al., 2008)

4.2.5 454 Sequencing

Each amplified sample was further processed as described for shotgun library preparation in GS FLX 454 technology. GS FLX 454 sequencing was performed at the International Livestock Research Institute (ILRI), Nairobi, Kenya. The sequencing reads were trimmed to remove SISPA primers and barcodes and only reads with a length greater than 50 bp were retained (Djikeng et al., 2008). Low complexity repeats were masked using Repeatmasker (Repeat-Masker Open-3.0.1996-2010 <http://www.repeatmasker.org>) and sequences with more than 50% repeats were excluded. The sequences in each pool were assembled using the Newbler assembler version 2.5.3 with default settings (Roche. Genome Sequencer FLX Data Analysis Software Manual. Mannheim, Germany: Roche Applied Science, 2007). Contiguous sequences and reads which did not assemble into contigs were categorized using BLASTN and BLASTX homology searches against the non-redundant nucleotide and amino acid databases from NCBI (version June 2011). Taxonomic classification of each contig/read was investigated using MEGAN 4.0 (Huson et al., 2007).

4.2.6 RNA Extraction, RT-PCR for Sanger Sequencing

As described in 3.2.7.

4.2.7 Sanger Sequencing, Analysis and Phylogeny

A total of 26 amplicons were sequenced by both Sanger and 454 that is; 10 BUNV, 2 DUGV, 2 NDUV, 9 SFV, 1 THOV and 2 WNV. Purified RT-PCR amplicons were sequenced in an automated ABI 3500 series Genetic Analyzer (Applied Biosystems) using the ABI Big Dye Terminator v3.1 cycle sequencing kit (Applied Biosystems) according to the manufacturers' instructions. Sequencing primers included one forward and one reverse of the same primers

used for RT-PCR amplification (Table 6). Nucleotide sequences generated were assembled into contigs using DNA baser v3.5 (HB, 2012) and identified by Basic Local Alignment Search Tool (BLAST, www.ncbi.nlm.nih.gov/blast) search against Gen bank databases. Comparison of nucleotide and deduced amino acid sequences with reference strains and previously characterized viruses was conducted using Fasta algorithm (Pearson and Lipman, 1988) applying default parameters. Multiple sequence alignments were performed using Muscle v3.8 (Edgar, 2004b, Edgar, 2004a). Phylogenetic analyses were done using MrBayes v3.1 (Ronquist and Huelsenbeck, 2003) and MEGA5 (Tamura et al., 2011).

4.2.8 Ethical Considerations

Approval to carry out the study was obtained from KEMRI National ERC. SSC protocol number 2050 and University of Pretoria Research Ethics Committee, protocol number **61/2012**.

4.3 Results

4.3.1 Virus Isolates

BUN, NDU, SF, WN and THO viruses could be sequenced using both 454 and Sanger sequencing methods, while DUGV could only be sequenced using Sanger sequencing only. A single isolate was attempted with 454 sequencing of each virus genus due to the cost of this technique while all PCR positive strains was attempted with Sanger sequencing (Table 15).

Table 15. List of virus isolates, identification numbers and sequencing method used

Virus isolates	Identification number	Sequencing method
Bunyamwera	ATH002298	Sanger
	ATH001860	Sanger
	ATH002318	Sanger
	ATH002016	Sanger
	ATH002274	Sanger
	ATH000652	Sanger
	ATH001182	Sanger
	ATH001136	Sanger
	ATH002346	Sanger
	ATH002166	454
Dugbe	ATH003026	Sanger
	ATH003040	Sanger
Ndumu	ATH002166	Sanger and 454
	ATH002274	Sanger
Semliki forest	ATH000756	Sanger
	ATH002442	Sanger
	ATH000092	Sanger
	ATH001868	Sanger
	ATH001866	Sanger
	ATH002286	Sanger
	ATH002258	Sanger
	ATH002276	Sanger
	ATH000510	454
Thogoto	ATH000258	454
West Nile	ATH002166	Sanger
	ATH002316	Sanger and 454

4.3.2 Genetic and Phylogenetic Grouping of Sequence Data

4.3.2.1 *Alphaviruses* (Semliki forest and Ndumu)

Ten isolates were subjected to Sanger sequencing of the SFV nonstructural protein gene (RdRp nsP4) region position 6812 to 6945 and 6775 to 6911 for NDUV 26S junction region used for identification and confirmed to be SF and NDU viruses (Figure 10 and 11). One isolate of each virus was subjected to 454 sequencing using random/shotgun sequencing to attempt full genome sequencing and a region of 7334 nucleotides of the non-structural protein gene (nsP1-4) was obtained for SFV while the 26S junction region of 407 nucleotides was obtained for NDUV (Figure 12 and 13).

Alignments with reference strain identified twelve amino acid substitutions with the Kenyan (ATH002166) NDU 26S junction region (Table 17) Appendix E. The Kenyan NDUV isolate (ATH002166) was found to be 98% identical to the reference strain (NC_016959) based on nucleotide sequences. Phylogenetic analysis of the NDUV isolate (ATH002166) together with USA (NC_016959, HM147989 and AF398375), South Africa (AF339487 and EU498008), Germany (U94600 and AF023281) and Uganda (JN989958 and JN989957) demonstrated that the Kenyan Isolate clusters closely with the Ugandan (JN989958) and South African (EU498008) strains (Figure 13). A total of thirty nine amino acid substitutions were identified between the Kenyan SFV isolate (ATH000510) obtained in this study and the reference strain (NC_003215) (Table 16) Appendix E. Isolate ATH000510 had similar amino acid pattern in comparison to a SFV strain (AMH001859) isolated in 2009 in Kenya. This isolate was 99% identical to the Kenyan strain (AMH001859) and 44% identical to the reference strain (NC_003215) based on amino acid sequence of the non-structural protein gene region (nsP1-4). Phylogenetic analysis reveals that this isolate clustered closely to the Kenyan isolates (JF972635 and HQ848388) (Figure 12).

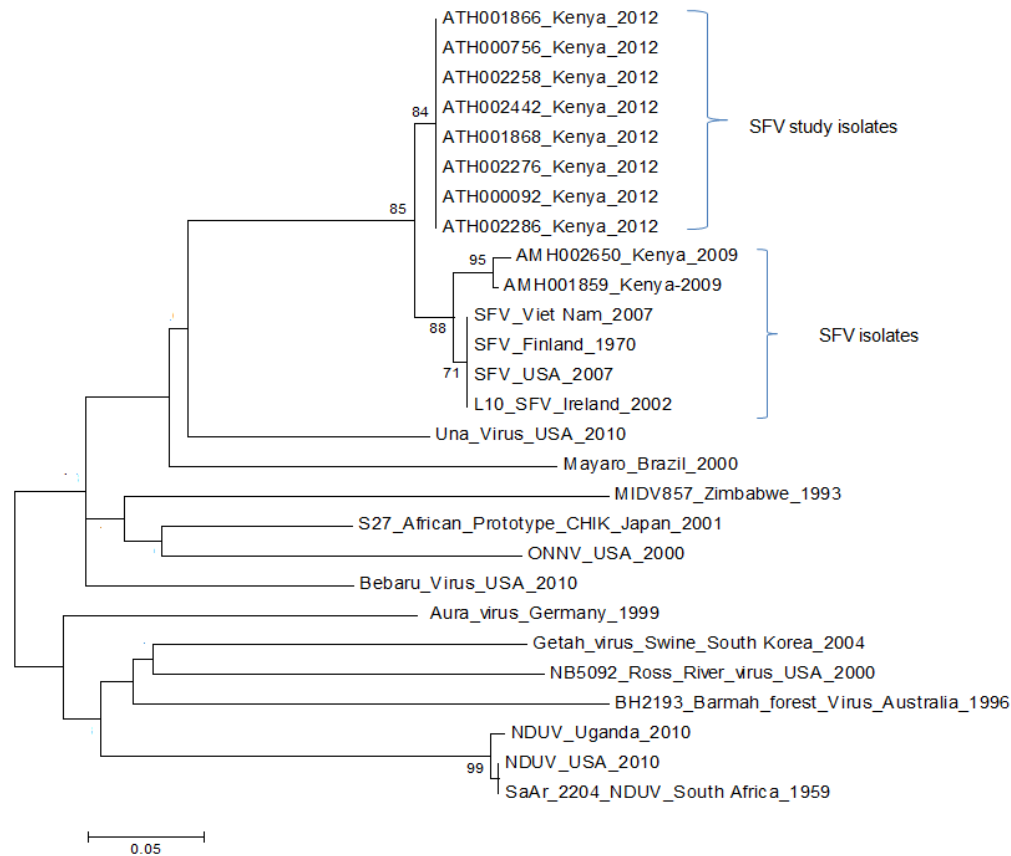

Figure 10. Phylogenetic relationship between Kenyan SFV isolates and other Alphaviruses identified in this study based on partial nucleotide sequences of SFV nonstructural protein gene (RdRp nsP4) region position 6812 to 6945. The tree was generated by MEGA5 (Tamura et al., 2011) using the Maximum Likelihood method based on the Tamura-Nei model (Tamura and Nei, 1993). The values on the branches indicate bootstrap values. The blue right braces represent SFV study and virus isolates.

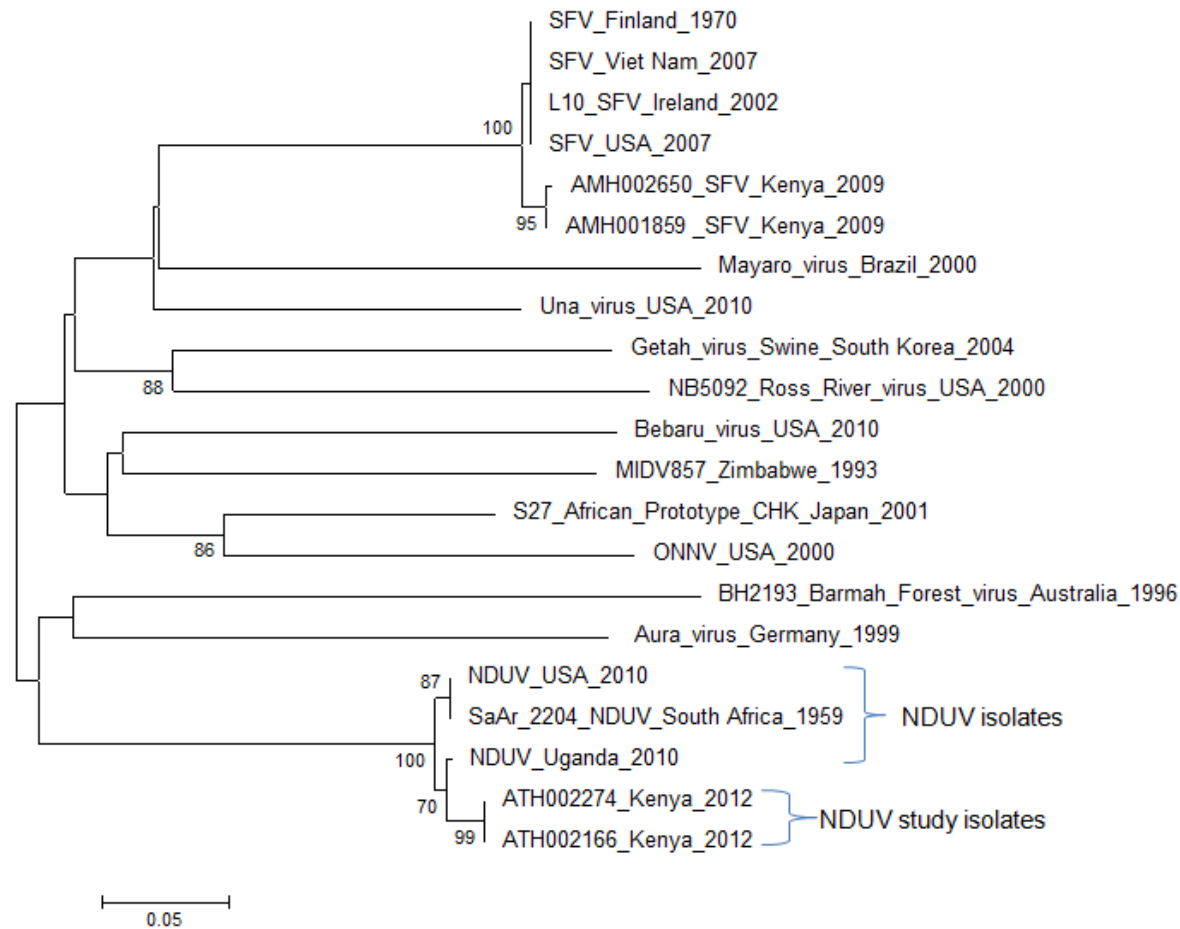

Figure 11. Phylogenetic relationship between Kenyan NDUV isolates and other *Alphaviruses* identified in this study based on partial 6775 to 6911 for NDUV 26S junction region. The tree was generated by MEGA5 (Tamura et al., 2011) using the Maximum Likelihood method based on the Tamura-Nei model (Tamura and Nei, 1993). The values on the branches indicate bootstrap values. The blue right braces represent NDUV study and virus isolates.

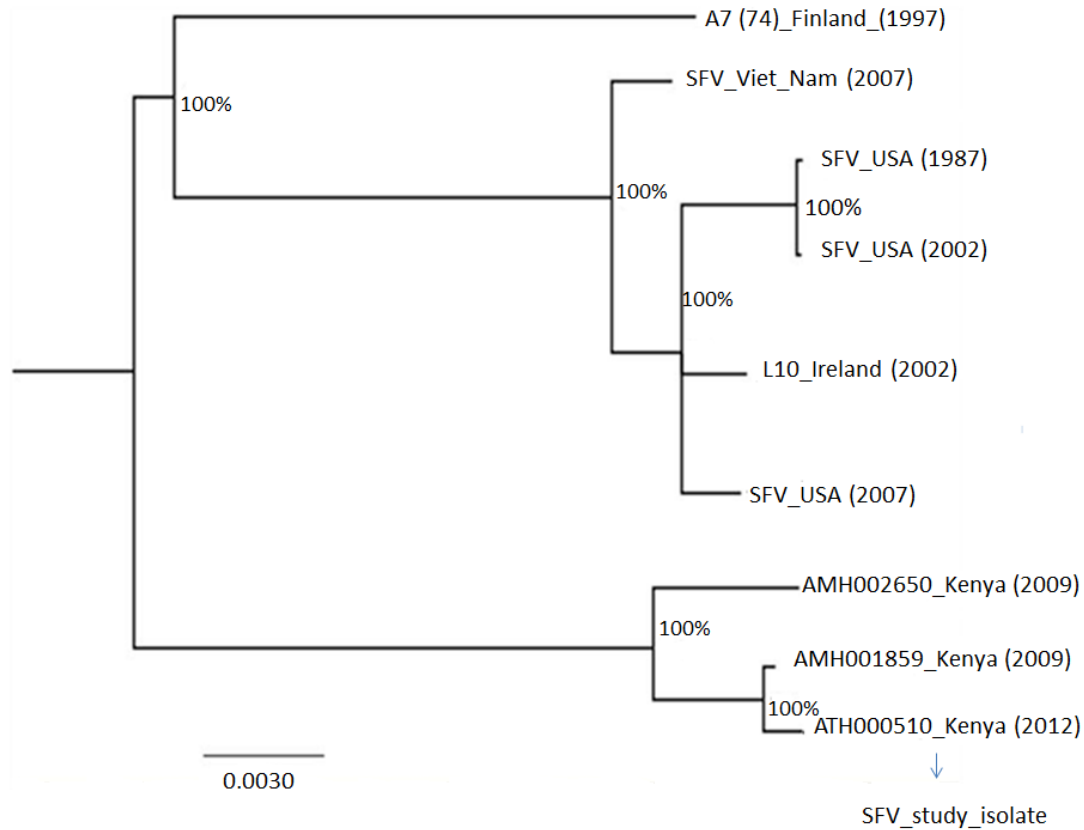

Figure 12. Phylogenetic relationship between Kenyan SFV isolate and other SFV strains identified this study based on nucleotide sequences of a gene fragment (7334bp) of the genome that encodes the non-structural proteins (nsP1–4). The tree was generated by MrBayes software using the generalized time-reversible (GTR) model. The values on the branches indicate posterior probability values. The arrow indicates the SFV isolate sequenced in this study.

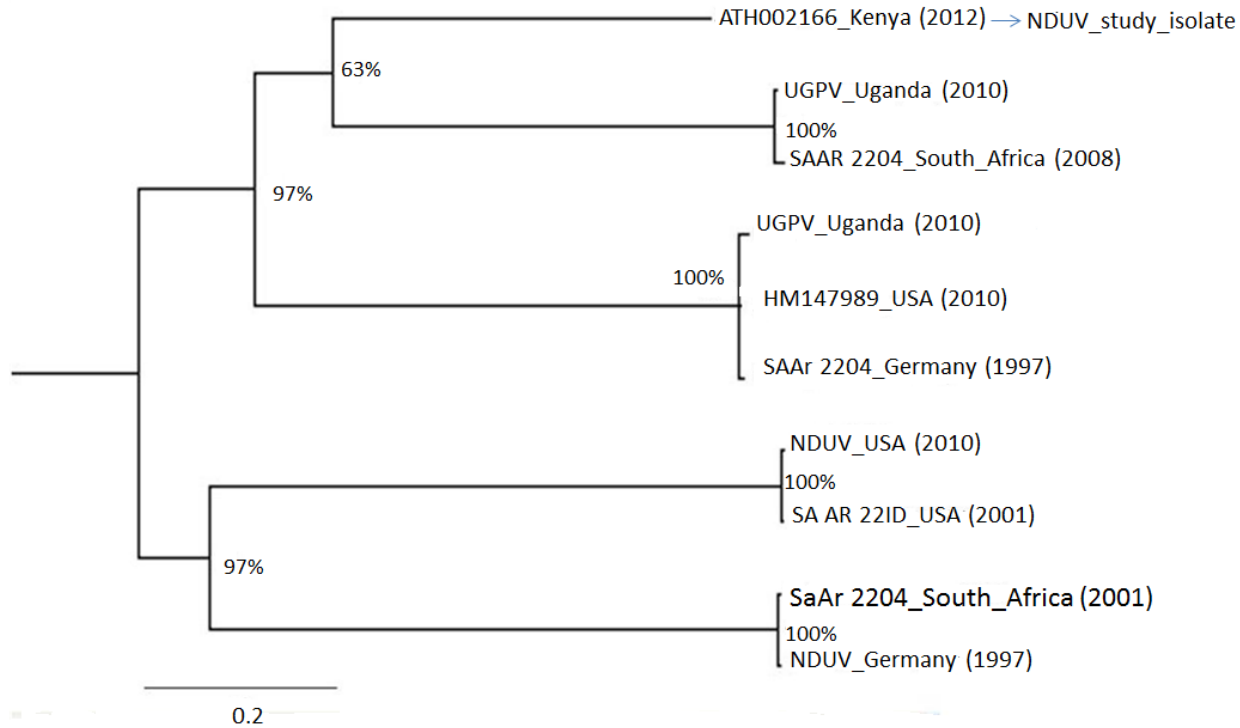

Figure 13. Phylogeny of Kenyan NDUV isolate and other NDUV identified in this study based on nucleotide sequences of gene fragment (408bp) position 6775 to 7182 that encodes the 26S junction. The tree was generated by MrBayes software using the generalized time-reversible (GTR) model. The values on the branches indicate posterior probability values. The arrow indicates the NDUV isolate sequenced in this study.

4.3.2.2 *Orthobunyavirus* (Bunyamwera)

Nine isolates were subjected to Sanger sequencing of the N and the NSs gene regions (position 113 to 363) used for identification and confirmed to be BUNV (Figure 14). BUNV isolate (ATH002166) was sequenced by 454 to attempt full genome sequencing but only 351 nucleotides of the M protein gene (position 1165 to 1516) was obtained (Figure 15).

Partial N and the NSs gene sequences of BUNV isolates were also analyzed by comparing them with those of BUNV reference strain (NC_001927) and representative *Orthobunyavirus* strains belonging to California, Simbu and BUN serogroups (Gen bank accession nos: AM711130, AM709778, JF961342, EU879062, AY593727, EU564831, M28380, EU564828, U47138, X73464, AM709780, AF362395, AB000819, U12800). Sequence analysis showed that the Kenyan BUNV isolates were similar to the reference strain (99.6% based on nucleotide sequences; and 98.8% based on amino acid sequences) and members of BUN serogroup used in the study (91.6-99.6%, based on nucleotide sequences; and 94.0-98.8% based on amino acid sequences). The Kenyan isolates were (57.1-59.9%, based on nucleotide sequences; and 57.6-64.4%, based on amino acid sequences) similar to viruses of California serogroup and (54.1-58%, based on nucleotide sequences; and 49.4-53.4% based on amino acid sequences) similar to viruses of Simbu serogroup. Phylogenetic analysis based on nucleotide sequences showed Kenyan viruses clustered distinctively on a branch comprising of viruses of BUN serogroup (Figure 14).

A single amino acid substitution of Serine (S) to Leucine (L) at position 44 was observed after alignment of the partial N and the NSs gene sequences of the Kenyan isolates (ATH002298, ATH001860, ATH002318, ATH002016, ATH002274, ATH000652, ATH001182, ATH001136, ATH002346) with the reference strain (NC_001927) (Table 18). A total of 6 amino acid substitutions from; Asparagine (N) to Serine (S) at position 65, Arginine

(R)to Lysine (K) at 68, Lysine (K) to Methionine (M) at 111, Cysteine (C) to Arginine (R) at 113, Aspartic acid (D) to Glycine (G) at 115 and Aspartic acid (D) to Histidine (H) at 117 were identified after alignment of the M protein gene amino acid sequences of the Kenyan isolate (ATH002166) and the reference strain (NC_001926) (Table 19) Appendix E. Isolate ATH002166 was 93% identical to the reference strain (NC_001926). Phylogenetic analysis of the M protein gene of the BUNV (ATH002166) isolate together with other strains (KC512388, KC512387, KC512386, M11852, NC_001926 and JF961341) indicated that this virus clustered closely with the Kenyan (JF961341) strain (Figure 15).

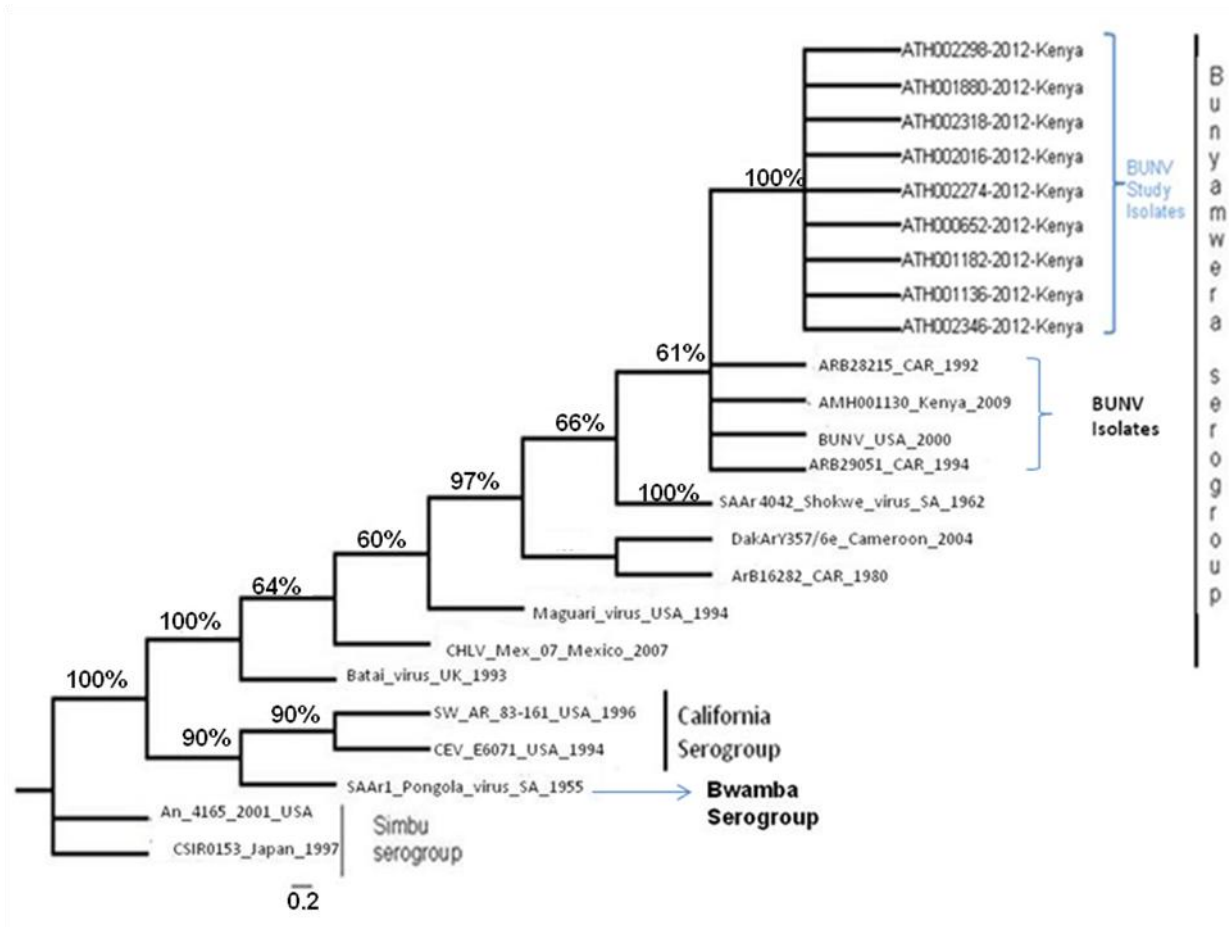

Figure 14. Phylogeny of N and the NSs gene nucleotide sequences (Partial) of BUNV strains identified in Kenya and other selected viruses of the genus *Orthobunyavirus* used in this study. The values on the branches indicate posterior probability values. The tree was generated by MrBayes software using the GTR model. Region sequenced nucleotide position 113 to 363. The arrow indicates the BUNV isolates sequenced in this study.



Figure 15. Phylogeny of M polyprotein gene (Partial NSm and Gc) nucleotide sequences of the BUNV strain identified in Kenya and other BUNV strains used in this study. The value on the branches indicate posterior probability values. The tree was generated by MrBayes software using the GTR model. Region sequenced nucleotide position 1165 to 1516. The arrow indicates the BUNV isolate sequenced in this study.

4.3.2.3 *Flavivirus* (West Nile)

Two isolates were subjected to Sanger sequencing of the non-structural protein 5 (NS5) gene region (position 9254 to 9609) used for identification and confirmed to be WNV (Figure 16). Burt et al. conducted a phylogenetic study on 29 Southern African WNV isolates together with 23 WNV, Kunjin and Japanese Encephalitis viruses obtained from Gen Bank. The results indicated that all Southern African isolates belonged to only one of the two major WNV Lineages (1 and 2). Lineage 1 isolates were distributed to Central and North Africa, Europe, Israel and North America whereas Lineage 2 to Central, Southern Africa and Madagascar.

The partial sequences of non-structural protein 5 (NS5) gene of WNV isolates were also compared with other previously characterized WNV strains belonging to lineages 1a, 1b, 2 and putative lineages 3, 4 and 5 available in Gen bank (EF429199, DQ786572, AY688948, DQ318019, AY277252, JX556213, DQ116961, AY765264, D00246, AY701413, AB185917, AY262283, DQ256376, AY277251) as identified in Africa, Europe, Asia, Australia and America (Papa et al. 2010). Sequence analysis showed that the Kenyan WNV isolates were highly similar in the NS5 region (97.2-100%, based on nucleotide sequences; and 100% based on amino acid sequences) to previously characterized viruses belonging to lineage 1 clade a. Multiple sequence alignment of deduced amino acids showed that the non-structural protein 5 (NS5) gene in the Kenyan isolates was highly conserved relative to the reference strains. Phylogenetic analysis based on nucleotide sequences showed that Kenyan WNV strains though genetically distinct clustered relatively close with the viruses isolated in Russia, Europe and the United States, belonging to lineage 1 clade a (Figure 16).

One isolate was subjected to 454 sequencing using random/shotgun sequencing to attempt full genome sequencing. Ninety nine percent (99%) of the WNV genome was obtained by

454 sequencing. WNV genome position 4 to 10,867 corresponding to polyprotein which consist of both structural (C, E and M) and non-structural (1, 2A, 2B, 3, 4A, 4B and 5) proteins and amino acid position 1-3434 was obtained (Figure 17).

The WNV genome sequence (ATH002316) that was identified via 454 sequencing was compared with those of the reference strains obtained from Africa, Australia, Asia, USA and Europe (Figure 17). Sequence analysis revealed thirty one amino acid substitutions between the Kenyan WNV (ATH002316) isolate and the reference strain (NC_009942.1) from the USA (Table 20) Appendix E.

The Kenyan WNV (ATH002316) isolate was 99% identical to the reference strain (NY99) based on nucleotide sequence of WNV genome sequence that corresponds to the same region of the WNV structural (C, E and M) and non-structural (1, 2A, 2B, 3, 4A, 4B and 5) proteins sequenced in this study. It was observed that the Kenyan tick isolate (ATH002316) clustered with WNV lineage 1 strains, NY99 from USA isolated from New York in 1999 and used a reference strain in this study (Figure 17).

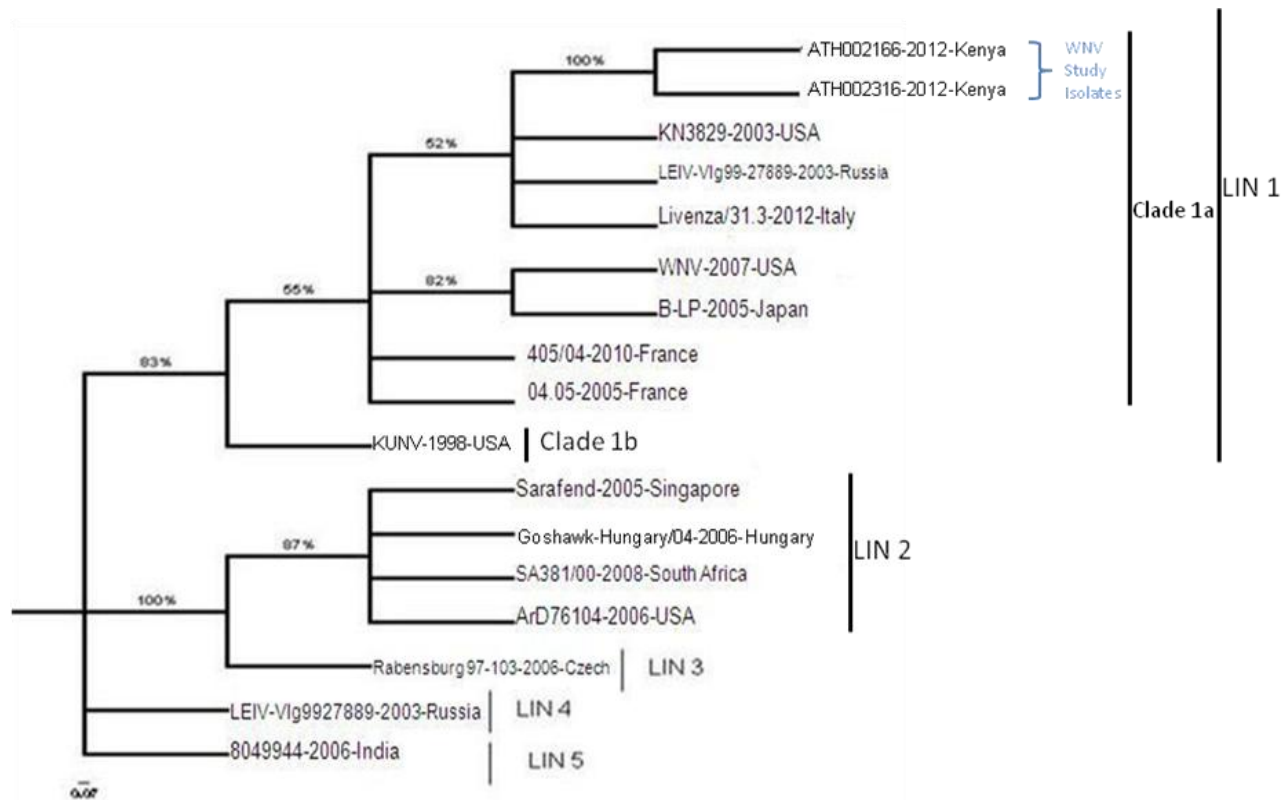

Figure 16. Phylogenetic tree based on partial non-structural protein 5 (NS5) nucleotide sequences of WNV strains identified in Kenya and selected previously characterized WNV strains demonstrating genetic relatedness. The tree was generated by MrBayes software using the GTR model. The values on the branches indicate posterior probability values. Regions sequenced; positions 9254 to 9609. The arrow indicates the WNV isolates sequenced in this study.

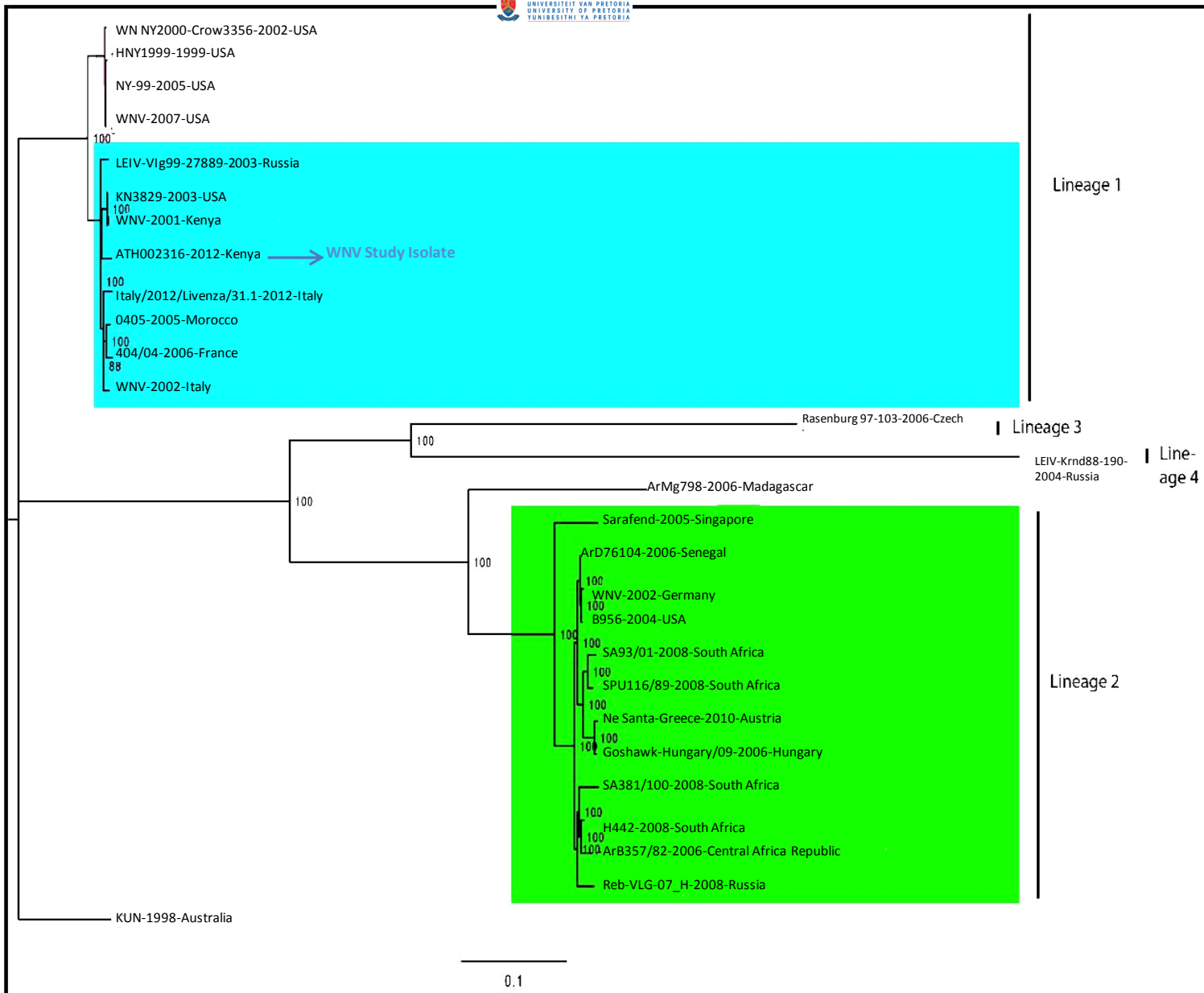

Figure 17. Phylogenetic tree based on nucleotide sequences position 4 to 10,867 that corresponds to the structural (C, E and M) and non-structural (1, 2A, 2B, 3, 4A, 4B and 5) proteins of WNV strain identified in Kenya and selected previously characterized WNV strains demonstrating genetic relatedness. The tree was generated by MrBayes software using the GTR model. The values on the branches indicate posterior probability values. The Kenyan tick-borne WNV (marked with a blue arrow) segregated into a cluster of Lineage 1 viruses along with previously isolated Kenyan mosquito-borne WNV in the cluster highlighted in Blue.

4.3.2.4 *Nairovirus* (Dugbe)

Two isolates (ATH003026 and ATH003040) were subjected to Sanger sequencing of the L protein gene region (position 32 to 179) used for identification and confirmed to be DUGV (Figure 18).

Partial sequences of the L protein gene of DUGV isolated in the study were compared with those of reference strain (NC_004159) and other previously characterized *Nairoviruses* available in Gen bank (NC_004159, U15018, EU697949, HM991306, EU697951, DQ076419, NC_005301, HQ378183, JN572092, JF911697, EU257628). Sequence analysis showed that the Kenyan isolates were 97.3%, based on nucleotide sequences; and 98%, based on amino acid sequences, similar to each other. Kenyan DUGV isolates were 92.6-93.9%, based on nucleotide sequences and 98-100% based on amino acid sequences and 57.1-83.1%, based on nucleotide sequences; and 82.6-98%, based on amino acid sequences, similar to the reference strain and other *Nairoviruses* such as CCHFV, NSDV, Hazara, Kupe and Erve used in the study respectively. Phylogenetic analysis based on nucleotide sequences showed slight divergence of Kenyan DUGV isolates to the reference strain (Figure 18).

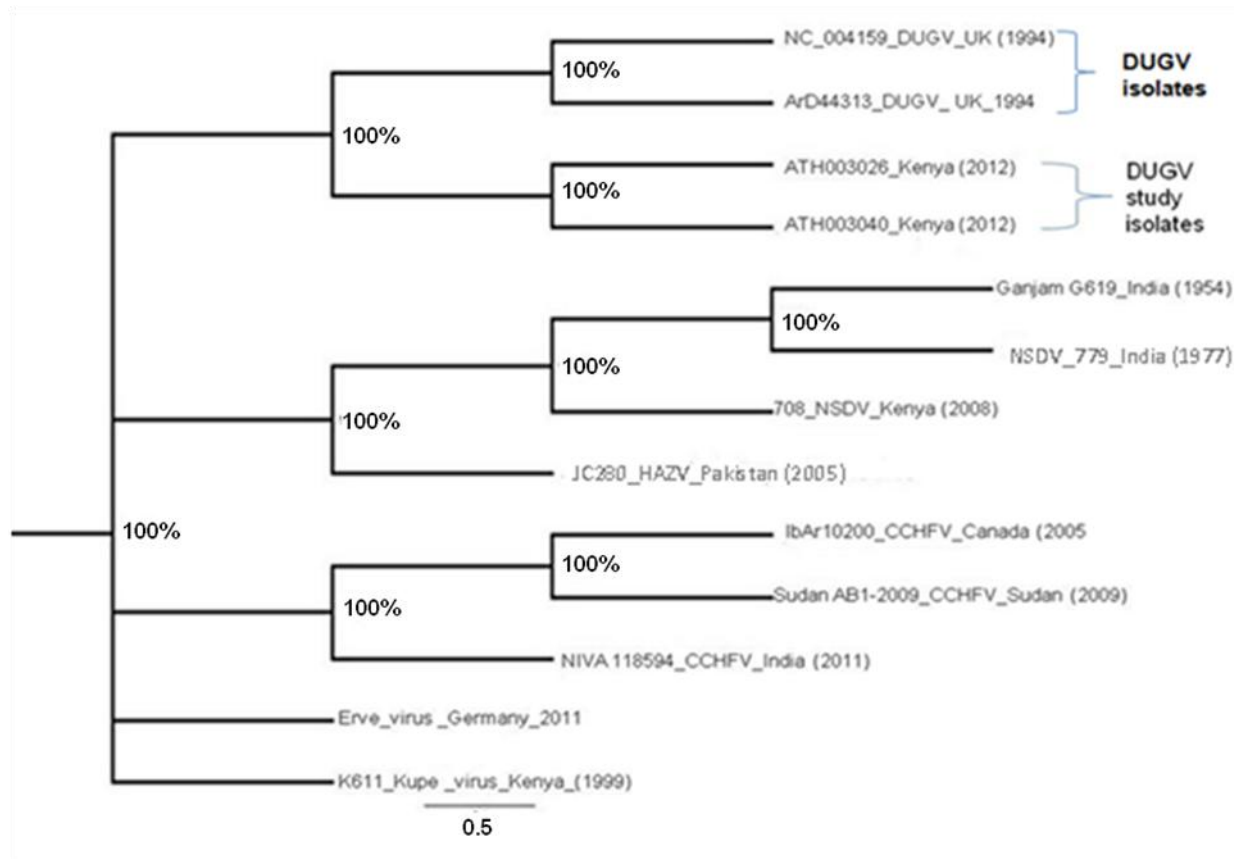

Figure 18. Phylogenetic tree of partial nucleotide sequences of L protein gene of Dugbe virus (DUGV) L segment strains identified in Kenya and other *Nairoviruses* used in this study. The tree was generated by MrBayes software using the GTR model. The values on the branches indicate posterior probability values. The arrow indicates the Dugbe viruses sequenced in this study. Region sequenced; position 32 to 179.

4.3.2.4 *Thogotovirus* (Thogoto)

A single isolate (ATH000258) was subjected to 454 sequencing using random/shotgun sequencing to attempt full genome sequencing. Only partial sequences of genomic RNA for nucleoprotein gene region (position 1 to 174) of THOV was obtained (Figure 19). The sequences of the Kenyan THOV isolate (ATH000258) were analyzed alongside Thogoto, Jos, Dhori, and Influenza virus reference strains (NC_006507.1, X96872.1, HM627173.1, HM627173.1, GU969311.1, AF242181.1, EU794576.1, JX497769.1 and JX497777.1). A total of two amino acid substitutions were observed to occur between reference strain (NC_006507.1) and the Kenyan isolate that is; from Threonine (T) to Serine (S) at position 3 and from Aspartic acid (D) to Glutamic acid (E) at position 19 (Table 21) Appendix E. The Kenyan THOV (ATH000258) isolate was 90% identical to the reference strain (NC_006507.1) based on amino acid sequence of the genomic RNA for nucleoprotein gene region. The Kenyan isolate clustered closely to THOV isolates obtained from Germany and USA on the phylogenetic tree (Figure 19).

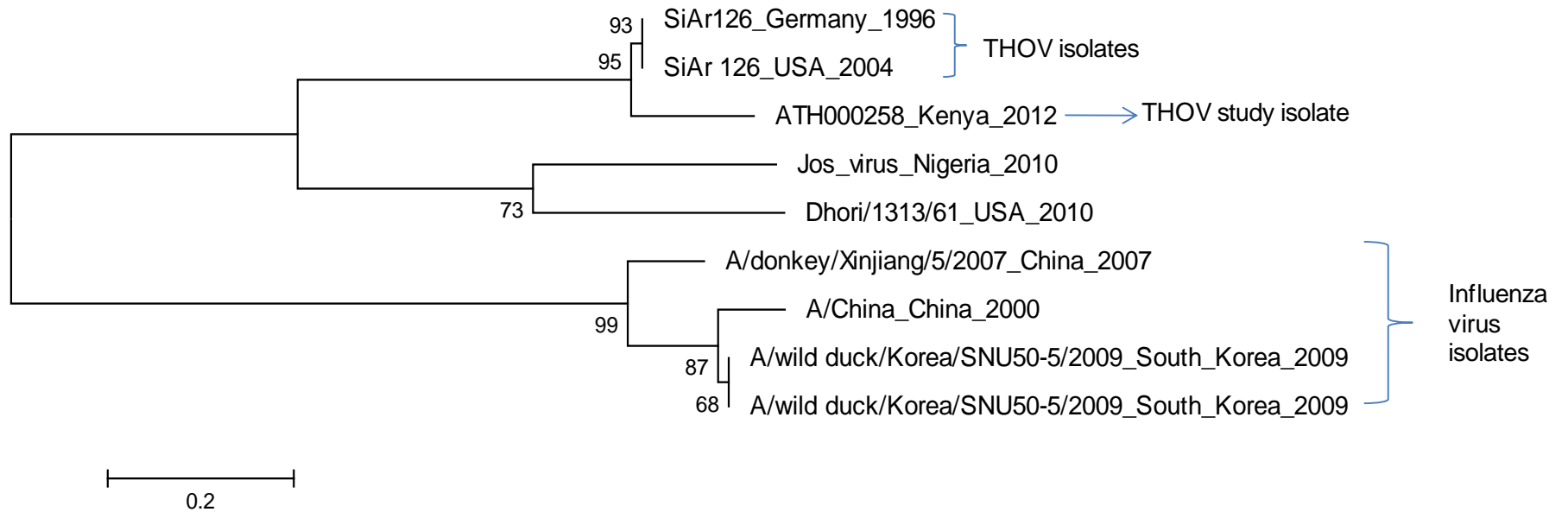

Figure 19. Phylogenetic tree of partial nucleotide sequences of nucleoprotein gene (position 1 to 174) of THOV isolated in Kenya, other THOV and Influenza virus strains. The tree was generated by MEGA5 (Tamura et al., 2011) using the Maximum Likelihood method based on the Tamura-Nei model (Tamura and Nei, 1993). The values on the branches indicate bootstrap values. The blue arrow indicates the THOV isolate sequenced in this study and the blue right braces represent THOV and Influenza virus isolates.

4.4 Discussion

PCR products identity from strains identified in Chapter 3 were confirmed by both Sanger and 454 sequencing. Sanger sequencing technique is the most widely used technique for small-scale projects and for sequencing long contiguous sequences DNA sequence reads greater than 500 nucleotides. It requires a forward primer that extends in the direction of the reverse primer and vice versa until the sequencing is complete. However, Sanger method has been supplanted by next generation sequencing platforms such as the Roche 454, Illumina Genome Analyzer (GA) and Applied Biosystems (ABI) SOLiD which are applied in large scale projects and automated genome analysis. These high throughput platforms generate more sequence data at a faster rate compared to Sanger sequencing. They can be used to analyze complex genome data, sequence mRNA, copy number variants and single nucleotide polymorphisms (SNPs) (Kircher and Kelso, 2010). Sanger sequencing is however still the best way of generating short specific sequencing reads for confirmation of identity of PCR products and phylogenetic analysis of specific genes.

In this study Sanger sequencing was used to confirm all sequences and next generation sequencing was performed to attempt identify different regions of the genome and only a full genome of WNV was obtained. Tick homogenates that showed reproducible cytopathic effect on vero cells were sequenced using 454 and Sanger sequencing. BUNV, NDUV, SFV, THOV and WNV sequences were obtained by both 454 sequencing and Sanger sequencing whereas DUGV could only be sequenced by the later sequencing technique although only WNV's near full genome could be obtain. 454 sequencing involves; a random process that has no control of the region to be sequenced and the sequences generated overlap many regions. The identification of DUGV using only Sanger sequencing might be due to the fact too much

background was permitted and not deep enough sequencing achieved for validation of sequence data more so DUGV specific primers were used unlike in 454 sequencing where degenerate primers are used (Kircher and Kelso, 2010)

SFV isolate (ATH00510) sequence obtained by 454 sequencing, clustered closely to the Kenyan strains (HQ848388 and JF972635) isolated from mosquitoes sampled in North Eastern Province of Kenya. However this isolate was highly divergent from the SFV strains isolated from USA and Ireland. The similarity of the Kenyan SFV strains maybe attributed to the fact that these isolates were identified in vectors originating from the same geographical region whereas the differences observed between the Kenyan SFV and the USA and Ireland strains were due to their diverse geographical origins. One significant finding of this study was the similar pattern of amino acid substitution amongst the Kenyan strains (Appendix E). Although there is no literature pointing towards significance of these amino acid changes, there is a possibility that they may lead to increased virulence of SFV circulating in Kenya specifically Ijara district due to recombinations that have been shown to occur in most *Alphaviruses*. Further more since the vector species involved in the transmission of Kenyan, USA and Ireland are different, this study suggests the role of ticks other than mosquitoes (which are the know vectors of SFV) in this virus transmission. According to literature arboviruses under Togaviridae family are not known to be transmitted by tick vectors except for rare cases like SINV. The non-structural protein gene of the SFV was sequenced by 454 sequencing. Non-structural proteins are mainly found in virus infected cells and do not play a role in virion maturation. These proteins play a part in the formation of viral structural components of a cell. Although paucity of data exists on these proteins, few studies have demonstrated that these proteins play a vital role in virus replication that is; molecular folding, intracellular sorting and transport, genome packaging, capsid assembly, virus release and control of cellular responses to infection (Kohl et al., 2003). Non-

structural proteins are also involved in the establishment and maintenance of virus infection in animal host cells thereby contributing towards viral pathogenesis (Blaney et al., 2003). The genes coding for the non-structural proteins are conserved and therefore useful for virus survival and antiviral therapy (Owens et al., 2004).

NDUV (ATH002166) was similar to the Ugandan strain (JN989958) but different from the USA (HM147989 and NC_016959), Germany (U94600 and AF023281) and South African (AF339487 and EU498008) strains. Kenya is close to Uganda geographically and there is a possibility of NDUV circulating between these countries through animal hosts such as domestic pigs, cattle and warthogs, which interact with the inhabitants of these two countries. NDUV 26 S junction region was sequenced in this study. This region plays a role in RNA synthesis of *Alphaviruses* (Hertz and Huang, 1992).

BUNV (ATH002166) sequenced by 454 clustered was similar to the Kenyan strain (JF961341) but divergent from the USA strains (NC001926 and M11852). All the BUNV isolates obtained from this study, clustered closely with viruses belonging to the BUN serogroup. The M protein gene and the nucleocapsid gene were obtained in this study. The nucleocapsid protein surrounds and protects the S, M and L segment of *Bunyaviruses*. The nucleocapsid gene is encoded by the S segment and its main function is to encapsidate the viral RNA-replication products to form the ribonucleoprotein (RNP) complex of all *Bunyaviruses* whereas the M protein gene is involved in viral attachment and entry (Walter and Barr, 2011).

WNV (ATH002316) obtained in this study was shown to belong to lineage 1. This virus formed a cluster with viruses belonging to WNV lineage 1 isolated from Kenya (AF146082), USA (NC_009942), Tajikistan (JX070655) and Australia (JX123030 and JX123031). This was the

only virus for which a near full genome (99%) could be obtained with 454 sequencing. Though WNV lineage 1 isolation from mosquitoes has been reported in Kenya (Miller et al., 2000), this study constitutes the first report of WNV lineage 1 isolation from ticks sampled from diverse animals hosts within Ijara District, Kenya and the world at large. It is plausible that wild migratory birds may have dispersed this lineage among these continents through tick vectors that might have attached to them though, evidence of *Rh. pulchellus* infesting birds is lacking. Both highly and less neuroinvasive strains have been shown to exist in both lineage 1 and 2 (Venter and Swanepoel, 2010). Experimental or clinical data on the neurovirulence of lineage 1 strains from Kenya is not yet available and investigation of WNV as a cause of neurological disease in humans and animals in Kenya is warranted.

The Kenyan WNV tick-borne isolate showed similar amino acid substitutions commonly observed in other strains belonging to lineage 1 isolated from ticks and other vectors from different locations worldwide. These results resonate well with previous studies that have attempted to elucidate genetic markers for the virulence and pathogenicity of different lineages of the WNV strains. The identification of WNV Lineage 1 in Ijara District may elucidate the possible geographic range between lineage 1 and 2 strains in Africa. Lineage 2 strains have been described as far North as Tanzania and is almost exclusively found in South Africa (Venter et al., 2009) while lineage 1 strains are the majority of strains reported in America, India and the Middle East. The close vicinity of Europe to Africa may be the reason that both lineages have emerged in European and tick vectors could be a possible mechanism.

DUGV (ATH003026 and ATH003040) large (L) protein gene was obtained via Sanger sequencing. The two DUGV detected in this study, were highly similar to each other and formed a cluster with the United Kingdom strains (NC_004159 and U15018). Few amino acid

substitutions were seen in the two isolates because the L protein is a highly conserved region relative to other *Bunyaviruses*, vectors and hosts.

The THOV strain (ATH000258) identified in this study was compared with other Thogoto virus strains and was found to be divergent from the Senegal (AF168988), Germany (X96872) and USA (NC006507). The THOV strains were also compared to some Influenza strains obtained from Italy (AJ584648), Vietnam (AJ715873) and Turkey (AJ867076) since both virus belong to the same family; Orthomyxoviridae. The nucleoprotein (NP) is the most important structural protein that is involved in the assembly of the RNA segments of viruses within the Orthomyxoviridae family into nucleocapsids that protect the nucleus. Viruses within this family can be differentiated using this protein which also serves as the main type-specific antigen (Lamb, 1989). Though NP sequences have been applied in the evolution of influenza viruses, this has not been done with THOV (Webster et al., 1992). Few amino acid substitutions were detected in all isolates obtained by Sanger sequencing since the regions that were sequenced are known to be conserved. The Kenyan isolate clustered closely to THOV isolates analyzed in the study.

454 sequencing was able to generate large genome fragments for viruses such as WN and SF. Part of BUNV M segment genome, which is known to be highly variable, was obtained. Though NGS provide more detailed sequence information, genome assembly is a challenge since it entails the analysis of similarity between two reads that generate a given scaffold sequence. Furthermore, these techniques require expertise and high financial resources to process and mine the generated sequence data (Hernandez et al., 2008, Nijkamp et al., 2010). This study experienced some shortfalls in that there was inconsistency in the number of reads obtained in the study. Some isolates such as THOV had very short sequences. Since this is a shotgun

technique that involves a random process, some viruses such as DUGV were not detected. Therefore 454 sequencing should be validated in order to increase the specificity and sensitivity of the method if used as routine confirmatory technique. Deeper sequencing is needed for full genomes

Genetic diversity of arboviruses is known to be influenced by abiotic (climate) and biotic (vectors and hosts) factors. Climate change plays a major role in the distribution, life cycle, dispersal, transmission efficiency and evolution of arboviruses and their potential vectors (Gould and Higgs, 2009). Viruses such as BUNV, SFV, WNV, NDUV obtained from this study clustered relatively close to their respective reference strains obtained from Kenya compared to other reference strains obtained from other geographical regions. These viruses have a wide geographic distribution and have the potential to spread across continents and in diverse species and hosts for example WNV is known to be primarily transmitted by mosquitoes in many countries but in this case it has been detected in ticks sampled from diverse animal hosts in Kenya. It is therefore clear that differences in geography, vectors and hosts can have an effect on the genetic diversity of arboviruses. Therefore knowledge on the genetic and phylogenetic characteristics of these viruses is vital for the investigation of the history of host range shifts in arboviruses to comprehend disease transmission and pathogenesis, and to understand the biology of vectors and their role in transmission in Ijara District and beyond.

Chapter 5

Concluding Remarks

Arboviruses are transmitted by hematophagous arthropods such as: mosquitoes, ticks, midges and sandflies (Ochieng et al., 2013). Most arboviruses are relevant to human and veterinary medicine since they threaten the health of human and animals (Donald et al., 2012). Approximately 50% of arbovirus isolations are from mosquitoes and 25% from ticks (Karabatsos, 1985, Sang et al., 2006). This difference might be due to sampling bias as more mosquitoes are sampled than ticks although the vector distribution and potential of human contact also affects their impact on human health.

Tick-borne viruses have a significant impact on both human and animal health worldwide (Sonenshine and Mather, 1994). Tick-borne viruses infect humans and animals through the bite of infected ticks during opportunistic feeding. They are responsible for some of the most serious emerging and re-emerging infectious diseases facing the world today that occur more frequently in epidemic form (Sang et al., 2006). Their ability to replicate in diverse hosts (arthropod vectors, animals and humans) offers distinct survival benefits for these viruses enabling them to easily invade new ecological zones, creating new variants through recombination and reassortment which have led to new category of pathogens (Weaver and Reisen, 2010).

Ijara District, an arid to semi-arid region in northern Kenya, is home to a pastoralist community for whom livestock keeping is a way of life. Part of Ijara District lies within the boundaries of a Kenya Wildlife Service protected conservation area. Arbovirus activity among mosquitoes, animals and humans is reported in the region, mainly because prevailing conditions necessitate

that people continuously move their animals in search of pasture. Whereas arbovirus studies have been carried out in North Eastern Province of Kenya, most have focused on mosquito-borne viruses such as: DN, RVF, WN, NDU and Sindbis (LaBeaud et al., 2011). CCHFV a tick-borne pathogen that causes severe hemorrhagic fever has been isolated from hyalommid ticks sampled from cattle within this region (Sang et al., 2006, Sang et al., 2011). According to a seroprevalence study carried on patients' attending health facilities (Sangailu dispensary and Ijara health centre) within Ijara District, a single case was found to be anti-CCHFV IgM positive whereas 19% out of the 517 patients' screened were anti-CCHFV IgG indicating the possibility of the presence acute cases and circulation of CCHFV in the region. Despite the fact that isolation of CCHFV has been carried out in this region, paucity of data exists on other tick-borne viruses. The actual prevalence of tick-borne viruses remains unknown. Furthermore, molecular studies on tick-borne viruses have not been conducted. Little attention has been given to tick-borne viruses such as CCHFV, (which is especially common in East and South Africa). Severe infections have been described in humans in the DRC, Senegal, Mauritania, South Africa and Kenya (Grard et al., 2011, Nabeth et al., 2004, Dunster et al., 2002, Fisher-Hoch et al., 1992). Therefore, Chapters 2 and 3 aimed at determining the level of human exposure to CCHFV and gaining an in-depth understanding of the circulation, transmission and diversity of tick-borne viruses in the region. The objectives of Chapter 3 and 4 were to determine the prevalence of tick-borne viruses among tick vectors and genetic diversity of the tick-borne viruses circulating among ticks and/or their host animals.

Chapter 2 describes the prevalence of CCHF antibodies in humans that attend health facilities in Ijara District, North Eastern Province of Kenya. A total of 517 human serum samples were collected from patients presenting with febrile illness at Sangailu dispensary and Ijara health centre within Ijara District. The samples were screened for the presence of IgM and IgG

antibodies to CCHF using CCHF-IgG and IgM ELISA test kits, Vector-Best, Novosibirsk, Russia). The VectoCrimean-CHF-IgG and IgM ELISA test kit is highly sensitive and specific since it was able to detect a single case of anti-CCHF IgM and 96 cases of anti-CCHF IgG out of the 517 patients screened. Socio-demographic data was collected using questionnaires from the sampled patients. Exposure to CCHFV was detected in 19% of the patients. Most exposed persons were aged 40-49 years. The likelihood of exposure was highest among farmers. Age, location and contact with donkeys were significantly associated with exposure to CCHFV. Acute CCHFV infections could be occurring without being detected in this population. This study confirms human exposure to CCHF virus in Ijara District, Kenya and identifies several significant risk factors associated with exposure to CCHFV.

Chapter 3 describes the isolation of viruses from ticks sampled from livestock and wild hosts in Ijara District. Ticks sampled from diverse animal hosts were analyzed using culture and molecular assays for the presence of tick-borne viruses. Tick-borne viruses such as THOV and DUGV were detected which have previously been identified in ticks. Thogoto virus has been associated with abortions in sheep (Davies, 1997b) whereas DUGV is of veterinary importance in that it affects livestock especially cattle and also causes thrombocytopenia in humans (Boyd et al., 2006). According to the findings of a study carried out by Sang et al. 2006 on arbovirus surveillance on market livestock in Nairobi Kenya, DUGV had a prevalence of 46.42% whereas THOV had 10.71% prevalence in animal sera. DUGV which belongs to the same family and genus (Bunyaviridae, *Nairovirus*) as CCHFV was isolated from ticks sampled from livestock and wildlife in Ijara District. Although antibodies against CCHFV were detected in human sera sampled from patients' in Ijara District, this virus was not detected in the ticks. Sampling of sera from animals (both livestock and wildlife) might indicate whether the source of CCHFV

transmission was via direct contact of humans with animals since this virus was not detected in ticks.

The most significant finding in this chapter was the detection of viruses such as NDUV, SFV, WNV and BUNV, which are known to be essentially mosquito-borne, from ticks sampled from both wildlife and livestock hosts. Mosquitos serve as competent vectors of arboviruses by their ability to acquire, transmit and infect susceptible hosts. For effective transmission to take place, the virus must be able to get away from the mosquito midgut, spread in other organs, replicate in the salivary glands and infect susceptible host through ingestion of a blood meal. However, mosquitoes are not spread easily across continents due to intrinsic and extrinsic factors that interfere with viral replication (Black et al., 2002). Infected ticks have been shown to have the potential of transmitting arboviruses such as CCHFV over long distances even across continents through their attachment on migratory birds and livestock movement (Labuda and Nuttall, 2004). This study also constitutes a previously unreported association of WNV with *A. gemma* and *Rh. pulchellus* ticks in North Eastern Province of Kenya. Vector competence studies are needed to determine the epidemiological link.

Chapter 4 explains the investigation of arbovirus genetic diversity by Sanger and next generation sequencing of isolates obtained from ticks sampled from livestock and wildlife in North Eastern Kenya, pastoral eco-zone Ijara. Virus isolates (both tick and mosquito-borne) obtained in Chapter three were subjected to RT-PCR and sequencing performed. Sanger sequencing confirmed the identities of strains in conserved areas of the genome while next generation attempted amplification of larger regions of the genome. Nucleotide sequences generated were assembled into contigs and identified by BLAST search against Gen bank databases. Comparison of nucleotide and deduced amino acid sequences with reference strains and previously characterized viruses was conducted using Fasta algorithm. Multiple

sequence alignments and phylogenetic analyses were performed using MrBayes v3.1 since it allows convenient formulation of priors. The virus isolates obtained from this study clustered closely with their respective reference strains in exception of DUGV that showed slight distant relatedness to the reference strain. The WNV strains isolated in this study clustered relatively close to viruses belonging to lineage 1 of WNV giving an indication on the split between lineage 1 and 2 geographical ranges in Africa. This is the first finding of WNV lineage 1 in ticks isolated from diverse animal hosts in Kenya. Research has shown that lineage 1 is widely distributed and highly invasive in America, Europe, Middle East and Africa whereas lineage 2 is mainly found in sub-Saharan Africa (Kramer et al., 2008) although it recently emerged in Central Europe. The major shortcoming of this study was the short sequences generated by 454 sequencing that yielded low sequence output which might have been caused by the RNA extraction method used. Therefore, an extraction method that could have enriched the virus and got rid of the host background could have improved my results

Active surveillance of tick-borne viruses needs to be conducted in this region to predict outbreaks before they occur. Vector competent studies should be performed to ascertain the role of ticks and animal hosts in arbovirus transmission. Genetic studies should be carried out to understand the distribution of arbovirus across Africa and differences between isolates from different vectors/hosts.

This study suggests that CCHF exposure occurs frequently in humans but that other arboviruses both mosquito and tick-borne occur more frequently in ticks and should be monitored for their contribution to human and animal disease in the region. The identified viruses are similar to previously identified members of their respective genus but unique to

Kenya suggesting geographical/vector sequence clustering. Next generation sequencing would also be useful for virus discovery and identification of the unknown isolates.

Chapter 6

References

- ABBASSY, M. M., OSMAN, M. & MARZOUK, A. S. 1993. West Nile virus (Flaviviridae: *Flavivirus*) in experimentally infected *Argas* ticks (Acari: Argasidae). *The American Journal of Tropical Medicine And Hygiene*, 48, 726.
- AL-KHALIFA, M. S., DIAB, F. M. & KHALIL, G. M. 2007. Man-threatening viruses isolated from ticks in Saudi Arabia. *Saudi Medical Journal*, 28, 1864.
- ALATOOM, A. & PAYNE, D. 2009. An overview of arboviruses and *Bunyaviruses*. *Laboratory Medicine*, 40, 237-240.
- ALBAYRAK, H., OZAN, E. & KURT, M. 2010. An antigenic investigation of Crimean-Congo hemorrhagic fever virus (CCHFV) in hard ticks from provinces in northern Turkey. *Tropical Animal Health and Production*, 42, 1323-1325.
- ALEXANDER, R. 1951. Rift Valley fever in the Union. *Journal of the South African Veterinary Medical Association*, 22, 105-111.
- ANDERSON, C. & CASALS, J. 1973. Dhori virus, a new agent isolated from *Hyalomma dromedarii* in India. *Indian Journal of Medical Research*, 61, 1416-1420.
- ANDERSON, J. F. & MAGNARELLI, L. A. 2008. Biology of ticks. *Infectious Disease Clinics of North America*, 22, 195-215.
- ANDERSON, J. F., VOSSBRINCK, C. R., ANDREADIS, T. G., ITON, A., BECKWITH III, W. H. & MAYO, D. R. 2001. A phylogenetic approach to following West Nile virus in Connecticut. *Proceedings of the National Academy of Sciences*, 98, 12885-12889.
- ANTHONY, R. P. & BROWN, D. T. 1991. Protein-protein interactions in an *Alphavirus* membrane. *Journal of Virology*, 65, 1187-1194.
- ANTIPA, R. S., ALI, M. H. AND HUSSEIN, A. A 2007. Assessment of the potential of eco/cultural tourism as viable enterprises in southern Garissa, Ijara and Lamu districts: A community conservation and enterprise support initiative. *In: Kenya. National Environmental Management Authority of Kenya*.
- APPANNANAVAR, S. B. & MISHRA, B. 2011. An update on Crimean Congo hemorrhagic fever. *Journal of Global Infectious Diseases*, 3, 285.
- AYERS, M., ADACHI, D., JOHNSON, G., ANDONOVA, M., DREBOT, M. & TELLIER, R. 2006. A single tube RT-PCR assay for the detection of mosquito-borne *Flaviviruses*. *Journal of Virological Methods*, 135, 235-239.
- BALZER, S., MALDE, K., LANZÉN, A., SHARMA, A. & JONASSEN, I. 2010. Characteristics of 454 pyrosequencing data-enabling realistic simulation with flowsim. *Bioinformatics*, 26, i420-i425.
- BANERJEE, K. 1988. Kyasanur forest disease. *The Arboviruses: Epidemiology And Ecology*, 3, 93-116.
- BARR, J. N., ELLIOTT, R. M., DUNN, E. F. & WERTZ, G. W. 2003. Segment-specific terminal sequences of Bunyamwera *Bunyavirus* regulate genome replication. *Virology*, 311, 326.
- BARRETT, A. D. & HIGGS, S. 2007. Yellow fever: a disease that has yet to be conquered. *Annual Review of Entomology*, 52, 209-229.
- BEAVER, P. C., JUNG, R. C., CUPP, E. W. & CRAIG, C. F. 1984. *Clinical parasitology*, Lea & Febiger Philadelphia.
- BEDFORD, G. 1934. South African ticks. *Onderstepoort Journal of Veterinary Science and Animal Industry*, 249-99.
- BELL-SAKYI, L., KOHL, A., BENTE, D. A. & FAZAKERLEY, J. K. 2012. Tick cell lines for study of Crimean-Congo hemorrhagic fever virus and other arboviruses. *Vector-Borne and Zoonotic Diseases*, 12, 769-781.

- BIRD, B. H., KSIAZEK, T. G., NICHOL, S. T. & MACLACHLAN, N. J. 2009. Rift Valley fever virus. *Journal of the American Veterinary Medical Association*, 234, 883-893.
- BISHOP-LILLY, K. A., TURELL, M. J., WILLNER, K. M., BUTANI, A., NOLAN, N. M., LENTZ, S. M., AKMAL, A., MATECZUN, A., BRAHMBHATT, T. N. & SOZHAMANNAN, S. 2010. Arbovirus detection in insect vectors by rapid, high-throughput pyrosequencing. *PLoS Neglected Tropical Diseases*, 4, e878.
- BLACK, I., WILLIAM C, BENNETT, K. E., GORROCHÓTEGUI-ESCALANTE, N., BARILLAS-MURY, C. V., FERNÁNDEZ-SALAS, I., DE LOURDES MUÑOZ, M. A., FARFÁN-ALÉ, J. A., OLSON, K. E. & BEATY, B. J. 2002. *Flavivirus* Susceptibility in *Aedes aegypti*. *Archives of Medical Research*, 33, 379-388.
- BLANEY, J., MANIPON, G., MURPHY, B. & WHITEHEAD, S. 2003. Temperature sensitive mutations in the genes encoding the NS1, NS2A, NS3, and NS5 nonstructural proteins of dengue virus type 4 restrict replication in the brains of mice. *Archives of Virology*, 148, 999-1006.
- BOIRO, I., LOMONOSSOV, N., MALENKO, G., BALDE, C. & BAH, A. 1986. Forécariah virus, a new representative of the Bhanja antigenic group, isolated in the Republic of Guinea]. *Bulletin de la Societe de Pathologie Exotique et de ses Filiales*, 79, 183.
- BONDRE, V. P., JADI, R., MISHRA, A., YERGOLKAR, P. & ARANKALLE, V. 2007. West Nile virus isolates from India: evidence for a distinct genetic lineage. *Journal of General Virology*, 88, 875-884.
- BOORMAN, J. & PORTERFIELD, J. 1956. A simple technique for infection of mosquitoes with viruses transmission of Zika virus. *Transactions of the Royal Society of Tropical Medicine and Hygiene*, 50, 238-242.
- BOWEN, M. D., TRAPPIER, S. G., SANCHEZ, A. J., MEYER, R. F., GOLDSMITH, C. S., ZAKI, S. R., DUNSTER, L. M., PETERS, C., KSIAZEK, T. G. & NICHOL, S. T. 2001. A reassortant *Bunyavirus* isolated from acute hemorrhagic fever cases in Kenya and Somalia. *Virology*, 291, 185-190.
- BOYD, A., FAZAKERLEY, J. K. & BRIDGEN, A. 2006. Pathogenesis of dugbe virus infection in wild-type and interferon-deficient mice. *Journal of General Virology*, 87, 2005-2009.
- BRAULT, A. C., POWERS, A. M., CHAVEZ, C., LOPEZ, R., CACHÓN, M. F., GUTIERREZ, L., KANG, W., TESH, R. B., SHOPE, R. E. & WEAVER, S. C. 1999. Genetic and antigenic diversity among eastern equine encephalitis viruses from North, Central, and South America. *The American Journal of Tropical Medicine and Hygiene*, 61, 579-586.
- BRIGGS, B. J., ATKINSON, B., CZECHOWSKI, D. M., LARSEN, P. A., MEEKS, H. N., CARRERA, J. P., DUPLECHIN, R. M., HEWSON, R., JUNUSHOV, A. T. & GAVRILOVA, O. N. 2011. Tick-borne encephalitis virus, Kyrgyzstan. *Emerging Infectious Diseases*, 17, 876.
- BRINK, N. S. & LLOYD, G. 1994. *Alphaviruses. Principles and Practice of Clinical Virology*, 4, 4, 67-484.
- BROOKS, G., BUTEL, J. & MORSE, S. 2004. Human arboviral infections. *Jawetz, Melnick and Adelberg's Medical microbiology. 23rd edn. Singapore: Mc Graw Hill*, 514-24.
- BROWN, C. R., BROWN, M. B., MOORE, A. T. & KOMAR, N. 2007. Bird movement predicts Buggy Creek virus infection in insect vectors. *Vector-Borne and Zoonotic Diseases*, 7, 304-314.
- BRYANT, J. E., CRABTREE, M. B., NAM, V. S., YEN, N. T., DUC, H. M. & MILLER, B. R. 2005. Isolation of arboviruses from mosquitoes collected in northern Vietnam. *The American Journal of Tropical Medicine and Hygiene*, 73, 470-473.
- BURT, F., LEMAN, P., SMITH, J. & SWANEPOEL, R. 1998. The use of a reverse transcription–polymerase chain reaction for the detection of viral nucleic acid in the diagnosis of Crimean–Congo haemorrhagic fever. *Journal of Virological Methods*, 70, 129-137.

- BURT, F., SPENCER, D., LEMAN, P., PATTERSON, B. & SWANEPOEL, R. 1996. Investigation of tick-borne viruses as pathogens of humans in South Africa and evidence of dugbe virus infection in a patient with prolonged thrombocytopenia. *Epidemiology and Infection*, 116, 353-362.
- BURT, F. & SWANEPOEL, R. 2005. Molecular epidemiology of African and Asian Crimean-Congo haemorrhagic fever isolates. *Epidemiology and Infection*, 133, 659-666.
- BUTENKO, A., GROMASHEVSKY, V., LVOV, D. & POPOV, V. 1981. First isolations of Barur virus (Rhabdoviridae) from ticks (Acari: Ixodidae) in Africa. *Journal of Medical Entomology*, 18, 232-234.
- BUTENKO, A., LESHCHINSKAIA, E., SEMASHKO, I., DONETS, M. & MART'IANOVA, L. 1987. Dhori virus-a causative agent of human disease. 5 cases of laboratory infection. *Voprosy Virusologii*, 32, 724.
- BUTENKO, A. M., GROMASHEVSKY, V.L., LVOV, D.K. & POPOV, V.F. 1979. "Kisemayo virus, a member of the Bhanja antigenic group,". *Voprosy Virusologii*, 24, 661-665.
- CALISHER, C. & KARABATSOS, N. 1988. Arbovirus serogroups: definition and geographic distribution. *The Arboviruses: Epidemiology and Ecology*, 1, 19-57.
- CALISHER, C. H. 1994. Medically important arboviruses of the United States and Canada. *Clinical Microbiology Reviews*, 7, 89.
- CALISHER, C. H. & GOULD, E. A. 2003. Taxonomy of the virus family Flaviviridae. *Advances in Virus Research*, 59, 1-19.
- CALISHER, H., MANESS, KATHRYN, SC, LORD, REXFORD, D, COLEMAN, PHILIP, H 1971. Identification of two South American strains of eastern equine encephalomyelitis virus from migrant birds captured on the Mississippi delta. *American Journal of Epidemiology*, 94, 172-178.
- CAMICAS, J. 1980. Les arbovirus à tiques en zone tropicale. *Tropical Medicine*, 40, 499-508.
- CARRINGTON, C. V., FOSTER, J. E., PYBUS, O. G., BENNETT, S. N. & HOLMES, E. C. 2005. Invasion and maintenance of dengue virus type 2 and type 4 in the Americas. *Journal of Virology*, 79, 14680-14687.
- CARSON, P. J., KONEWKO, P., WOLD, K. S., MARIANI, P., GOLI, S., BERGLOFF, P. & CROSBY, R. D. 2006. Long-term clinical and neuropsychological outcomes of West Nile virus infection. *Clinical Infectious Diseases*, 43, 723-730.
- CASALS, J. Antigenic similarity between the virus causing Crimean hemorrhagic fever and Congo virus. Proceedings of the Society for Experimental Biology and Medicine. Society for Experimental Biology and Medicine (New York, NY), 1969. *Royal Society of Medicine*, 233-236.
- CAUSEY, O. R., KEMP, G. E., MADBOULY, M. H. & DAVID-WEST, T. S. 1970. Congo virus from domestic livestock, African hedgehog, and arthropods in Nigeria. *American Journal of Tropical Medicine and Hygiene*, 19, 846-850.
- ÇEVİK, M. A., ERBAY, A., BODUR, H., GÜLDEREN, E., BAŞTUĞ, A., KUBAR, A. & AKINCI, E. 2008. Clinical and laboratory features of Crimean-Congo hemorrhagic fever: predictors of fatality. *International Journal of Infectious Diseases*, 12, 374-379.
- CHAPMAN, L. E., WILSON, M. L., HALL, D. B., LEGUENNO, B., DYKSTRA, E. A., BA, K. & FISHER-HOCH, S. P. 1991. Risk factors for Crimean-Congo hemorrhagic fever in rural northern Senegal. *Journal of Infectious Diseases*, 164, 686-692.
- CHARREL, R. N., ZAKI, A. M., ATTOUI, H., FAKEEH, M., BILLOIR, F., YOUSEF, A. I., DE CHESSE, R., DE MICCO, P., GOULD, E. A. & DE LAMBALLERIE, X. 2001. Complete coding sequence of the Alkhurma virus, a tick-borne *Flavivirus* causing severe hemorrhagic fever in humans in Saudi Arabia. *Biochemical and Biophysical Research Communications*, 287, 455-461.

- CHASTEL, C. 2003. Centenary of the discovery of yellow fever virus and its transmission by a mosquito (Cuba 1900-1901)]. *Bulletin de la Société de Pathologie Exotique*, 96, 250.
- CHIN, J. (ed.) 2000. Arthropod-borne viral diseases. *American Public Health Association*, 17,39-43
- CHUMAKOV, M., BELYAEVA, A., BUTENKO, A. & MART'YANOVA, L. 1968. West Nile virus in the USSR. I. Isolation of West Nile virus strains from *Hyalomma plumbeum plumbeum* Panz *Tr Inst Poliomielitov Virus Entsefalitov Akad. Med. Nauk SSSR*, 12, 365-373.
- CHUMAKOV, M. P. (ed.) 1945. A new tick-borne virus disease—Crimean hemorrhagic fever, Moscow: Izd. Otd. Primorskoi Armii, Simferopol, 13-43.
- CHUMAKOV, M. P. 1974. On 30 years of investigation of Crimean hemorrhagic fever. *Tr. Inst. Polio Virusn Entsefalitov Akad. Med. Nauk*, 22, 5-18.
- CILNIS, M. J., KANG, W. & WEAVER, S. C. 1996. Genetic conservation of Highlands J viruses. *Virology*, 218, 343-351.
- COETZER, J. 1977. The pathology of Rift Valley fever lesions occurring in natural cases in newborn lambs. *The Onderstepoort Journal of Veterinary Research*, 44, 205.
- COOPER, W. C., GREEN, I. J. & FRESH, J. W. 1964. Laboratory infection with louping-ill virus: a case study. *British Medical Journal*, 2, 1627.
- CRABTREE, M., SANG, R., LUTOMIAH, J., RICHARDSON, J. & MILLER, B. 2009a. Arbovirus surveillance of mosquitoes collected at sites of active Rift Valley fever virus transmission: Kenya, 2006-2007. *Journal of Medical Entomology*, 46, 961-964.
- CRABTREE, M. B., SANG, R. & MILLER, B. R. 2009b. Kupe virus, a new virus in the family bunyaviridae, genus nairovirus, kenya. *Emerging Infectious Diseases*, 15, 147.
- CRANS, W. J., CACCAMISE, D. F. & MCNELLY, J. R. 1994. Eastern Equine Encephalomyelitis Virus in Relation to the Avian Community of a Coastal Cedar Swamp. *Journal of Medical Entomology*, 31, 711-727.
- DARWISH, M. & HOOGSTRAAL, H. 1981. Arboviruses infecting humans and lower animals in Egypt: a review of thirty years of research. *Journal of the Egyptian Public Health Association*, 56, 1-112
- DAUBNEY, R. & HUDSON, J. 1932. Rift Valley fever. *The Lancet*, 219, 611-612.
- DAVID-WEST, T. S. & PORTERFIELD, J. 1974. Dugbe virus: a tick-borne arbovirus from Nigeria. *Journal of General Virology*, 23, 297-307.
- DAVIDSON, M. M., WILLIAMS, H. & MACLEOD, J. A. 1991. Louping ill in man: a forgotten disease. *Journal of Infection*, 23, 241-249.
- DAVIES 1997a. Nairobi sheep disease. *Parasitologia*, 39, 95-98.
- DAVIES, C. R., JONES, L. D. & NUTTALL, P. A. 1986. Experimental studies on the transmission cycle of Thogoto virus, a candidate *Orthomyxovirus*, in *Rhipicephalus appendiculatus*. *The American Journal of Tropical Medicine and Hygiene*, 35, 1256.
- DAVIES, F. 1978. Nairobi sheep disease in Kenya. The isolation of virus from sheep and goats, ticks and possible maintenance hosts. *Journal of Hygiene*, 81, 259-265.
- DAVIES, F. 1997b. Nairobi sheep disease. *Parassitologia*, 39, 95.
- DAVIES, F., SOI, R. & WARIRU, B. 1984. Abortion in sheep caused by Thogoto virus. *Veterinary Record*, 115, 654-654.
- DEYDE, V. M., KHRISTOVA, M. L., ROLLIN, P. E., KSIAZEK, T. G. & NICHOL, S. T. 2006. Crimean-Congo hemorrhagic fever virus genomics and global diversity. *Journal of Virology*, 80, 8834-8842.
- DIAILO, M., THONNON, J., TRAORE-LAMIZANA, M. & FONTENILLE, D. 1999. Vectors of Chikungunya virus in Senegal: current data and transmission cycles. *American Journal of Tropical Medicine and Hygiene*, 60, 281-286.
- DICK, G. 1952. Zika virus (II). Pathogenicity and physical properties. *Transactions of the Royal Society of Tropical Medicine and Hygiene*, 46, 521-534.

- DICK, G., KITCHEN, S. & HADDOW, A. 1952. Zika Virus (I). Isolations and serological specificity. *Transactions of the Royal Society of Tropical Medicine and Hygiene*, 46, 509-520.
- DJIKENG, A., HALPIN, R., KUZMICKAS, R., DEPASSE, J., FELDBLYUM, J., SENGAMALAY, N., AFONSO, C., ZHANG, X., ANDERSON, N. & GHEDIN, E. 2008. Viral genome sequencing by random priming methods. *BMC Genomics*, 9, 5.
- DONALD, C. L., KOHL, A. & SCHNETTLER, E. 2012. New insights into control of arbovirus replication and spread by insect RNA interference pathways. *Insects*, 3, 511-531.
- DROSTEN, C., KÜMMERER, B. M., SCHMITZ, H. & GÜNTHER, S. 2003. Molecular diagnostics of viral hemorrhagic fevers. *Antiviral Research*, 57, 61-87.
- DUFFY, M. R., CHEN, T.-H., HANCOCK, W. T., POWERS, A. M., KOOL, J. L., LANCIOTTI, R. S., PRETRICK, M., MARFEL, M., HOLZBAUER, S. & DUBRAY, C. 2009. Zika virus outbreak on Yap Island, Federated States of Micronesia. *New England Journal of Medicine*, 360, 2536-2543.
- DUNN, E. F., PRITLOVE, D. C. & ELLIOTT, R. M. 1994. The s RNA genome segments of Batai, Cache Valley, Guaroa, Kairi, Lumbo, Main Drain and Northway *Bunyaviruses*: sequence determination and analysis. *The Journal of General Virology*, 75, 597.
- DUNSTER, L., DUNSTER, M., OFULA, V., BETI, D., KAZOوبا-VOSKAMP, F., BURT, F., SWANEPOEL, R., DECOCK, K. M., DUNSTER, L. & DUNSTER, M. 2002. First documentation of human Crimean-Congo hemorrhagic fever, Kenya. *Emerging Infectious Diseases*, 8, 1005.
- EDGAR, R. C. 2004a. MUSCLE: a multiple sequence alignment method with reduced time and space complexity. *BMC Bioinformatics*, 5, 113.
- EDGAR, R. C. 2004b. MUSCLE: multiple sequence alignment with high accuracy and high throughput. *Nucleic Acids Research*, 32, 1792-1797.
- EKSTRÖM, M., LILJESTRÖM, P. & GAROFF, H. 1994. Membrane protein lateral interactions control Semliki Forest virus budding. *The EMBO Journal*, 13, 1058.
- ELATA, A., KARSANY, M., ELAGEB, R., HUSSAIN, M. A., ELTOM, K. H., ELBASHIR, M. I. & ARADAIB, I. E. 2011. A nosocomial transmission of crimean-congo hemorrhagic fever to an attending physician in north kordufan, Sudan. *Virology Journal*, 8, 1-7.
- ELLIOTT, R. 1997. Emerging viruses: the Bunyaviridae. *Molecular Medicine*, 3, 572.
- ELLIOTT, R. M. 1990. Molecular biology of the Bunyaviridae. *Journal of General Virology*, 71, 501-522.
- ENSERINK, M. 2006. Massive outbreak draws fresh attention to little-known virus. *Science*, 311, 1085-1085.
- ERGÖNÜL, Ö. 2006. Crimean-Congo haemorrhagic fever. *The Lancet Infectious Diseases*, 6, 203-214.
- ESHOO, M. W., WHITEHOUSE, C. A., ZOLL, S. T., MASSIRE, C., PENNELLA, T.-T. D., BLYN, L. B., SAMPATH, R., HALL, T. A., ECKER, J. A. & DESAI, A. 2007. Direct broad-range detection of *Alphaviruses* in mosquito extracts. *Virology*, 368, 286-295.
- ESTRADA-PEÑA, A. N. 2001. Forecasting habitat suitability for ticks and prevention of tick-borne diseases. *Veterinary Parasitology*, 98, 111-132.
- FAGBAMI, A. 1979. Zika virus infections in Nigeria: virological and seroepidemiological investigations in Oyo State. *Journal of Hygiene (London)*, 83, 213-219.
- FAYE, O., DIALLO, M., DIOP, D., BEZEID, O. E., BÂ, H., NIANG, M., DIA, I., MOHAMED, S. A. O., NDIAYE, K. & DIALLO, D. 2007. Rift Valley fever outbreak with East-Central African virus lineage in Mauritania, 2003. *Emerging Infectious Diseases*, 13, 1016.
- FAZAKERLEY, J., GONZALEZ-SCARANO, F., STRICKLER, J., DIETZSCHOLD, B., KARUSH, F. & NATHANSON, N. 1988. Organization of the middle RNA segment of snowshoe hare Bunyavirus. *Virology*, 167, 422-432.

- FENG, Y., FU, S., ZHANG, H., LI, M., ZHOU, T., WANG, J., ZHANG, Y., WANG, H., TANG, Q. & LIANG, G. 2012. Distribution of mosquitoes and mosquito-borne viruses along the China-Myanmar border in Yunnan province. *Japanese Journal of Infectious Diseases*, 65, 215-221.
- FILIPE, A., MARTINS, C. & ROCHA, H. 1973. Laboratory infection with Zika virus after vaccination against yellow fever. *Archiv für die gesamte Virusforschung*, 43, 315-319.
- FILIPE, A. R. & CASALS, J. 2008. Isolation of Dhori virus from *Hyalomma marginatum* ticks in Portugal. *Intervirology*, 11, 124-127.
- FISHER-HOCH, S., MCCORMICK, J., SWANEPOEL, R., VAN MIDDLEKOOP, A., HARVEY, S. & KUSTNER, H. 1992. Risk of human infections with Crimean-Congo hemorrhagic fever virus in a South African rural community. *The American Journal of Tropical Medicine and Hygiene*, 47, 337.
- FONTENILLE, D., DIALLO, M., MONDO, M., NDIAYE, M. & THONNON, J. 1997. First evidence of natural vertical transmission of yellow fever virus in *Aedes aegypti*, its epidemic vector. *Transactions of the Royal Society of Tropical Medicine and Hygiene*, 91, 533-535.
- FRY, S. R., MEYER, M., SEMPLE, M. G., SIMMONS, C. P., SEKARAN, S. D., HUANG, J. X., MCELNEA, C., HUANG, C.-Y., VALKS, A. & YOUNG, P. R. 2011. The diagnostic sensitivity of dengue rapid test assays is significantly enhanced by using a combined antigen and antibody testing approach. *PLoS Neglected Tropical Diseases*, 5, e1199.
- FURMAN, D. P. U. & LOOMIS, E. C. 1984. The ticks of California (Acari: Ixodida). *Bulletin of the California Insect Survey*, 25, 1-239
- GAO, X., NASCI, R. & LIANG, G. 2010. The neglected arboviral infections in mainland China. *PLoS Neglected Tropical Diseases*, 4, e624.
- GAROFF, H., HEWSON, R. & OPSTELTEN, D.-J. E. 1998. Virus maturation by budding. *Microbiology and Molecular Biology Reviews*, 62, 1171-1190.
- GAROFF, H. & SIMONS, K. 1974. Location of the spike glycoproteins in the Semliki forest virus membrane. *Proceedings of the National Academy of Sciences*, 71, 3988-3992.
- GAULIARD, N., BILLECOCQ, A., FLICK, R. & BOULOY, M. 2006. Rift Valley fever virus noncoding regions of L, M and S segments regulate RNA synthesis. *Virology*, 351, 170-179.
- GERDES, G. 2004. Rift valley fever. *Revue Scientifique et Technique-Office International des Epizooties*, 23, 613-624.
- GERRARD, S. R., LI, L., BARRETT, A. D. & NICHOL, S. T. 2004. Ngari virus is a Bunyamwera virus reassortant that can be associated with large outbreaks of hemorrhagic fever in Africa. *Journal of Virology*, 78, 8922-8926.
- GOULD, E. & SOLOMON, T. 2008. Pathogenic flaviviruses. *The Lancet*, 371, 500-509.
- GOULD, E. A., DE LAMBALLERIE, X., DE A ZANOTTO, P. M. & HOLMES, E. C. 2001. Evolution, epidemiology, and dispersal of *Flaviviruses* revealed by molecular phylogenies. *Advances in Virus Research*, 57, 71-103.
- GOULD, E. A. & HIGGS, S. 2009. Impact of climate change and other factors on emerging arbovirus diseases. *Transactions of the Royal Society of Tropical Medicine and Hygiene*, 103, 109-121.
- GRARD, G., DREXLER, J. F., FAIR, J., MUYEMBE, J.-J., WOLFE, N. D., DROSTEN, C. & LEROY, E. M. 2011. Re-emergence of Crimean-Congo hemorrhagic fever virus in Central Africa. *PLoS Neglected Tropical Diseases*, 5, e1350.
- GREENFIELD, B. 2011. Environmental parameters affecting tick (*Ixodes ricinus*) distribution during the summer season in Richmond Park, London. *Bioscience Horizons*, 4, 140-148.

- GRESIKOVA, M., SEKEYOVA, M., TEMPERA, G., GUGLIELMINO, S. & CASTRO, A. 1978. Identification of a Sindbis virus strain isolated from *Hyalomma marginatum* ticks in Sicily. *Acta virologica*, 22, 231.
- GRITSUN, T., NUTTALL, P. & GOULD, E. A. 2003. Tick-borne flaviviruses. *Advances in Virus Research*, 61, 317-371.
- GROBBELAAR, A. A., WEYER, J., LEMAN, P. A., KEMP, A., PAWESKA, J. T. & SWANEPOEL, R. 2011. Molecular epidemiology of Rift Valley fever virus. *Emerging Infectious Diseases*, 17, 2270.
- GUBLER, D. J. 2001. Human arbovirus infections worldwide. *Annals of the New York Academy of Sciences*, 951, 13-24.
- GUBLER, D. J. 2002. The global emergence/resurgence of arboviral diseases as public health problems. *Archives of Medical Research*, 33, 330-342.
- GUBLER, D. J. & KUNO, G. 1997. *Dengue and dengue hemorrhagic fever*, Cab International, 313-333.
- GUGLIELMONE, A. A., ROBBINS, R. G., APANASKEVICH, D. A., PETNEY, T. N., ESTRADA-PEÑA, A., HORAK, I. G., SHAO, R. & BARKER, S. C. 2010. The Argasidae, Ixodidae and Nuttalliellidae (Acari: Ixodida) of the world: a list of valid species names. *Zootaxa*, 2528, 1-28
- GUILHERME, J., GONELLA-LEGALL, C., LEGALL, F., NAKOUME, E. & VINCENT, J. 1996. Seroprevalence of five arboviruses in Zebu cattle in the Central African Republic. *Transactions of the Royal Society of Tropical Medicine and Hygiene*, 90, 31-33.
- GUZMAN, A. & ISTÚRIZ, R. E. 2010. Update on the global spread of dengue. *International Journal of Antimicrobial Agents*, 36, S40-S42.
- HAIG, D., WOODALL, J. & DANSKIN, D. 1965. Thogoto virus: a hitherto undescribed agent isolated from ticks in Kenya. *Journal of General Microbiology*, 38, 389-394.
- HALL, R. A., BLITVICH, B. J., JOHANSEN, C. A. & BLACKSELL, S. D. 2012. Advances in Arbovirus Surveillance, Detection and Diagnosis. *Journal of Biomedicine and Biotechnology*, 2012.
- HAYASAKA, D., SUZUKI, Y., KARIWA, H., IVANOV, L., VOLKOV, V., DEMENEV, V., MIZUTANI, T., GOJOBORI, T. & TAKASHIMA, I. 1999. Phylogenetic and virulence analysis of tick-borne encephalitis viruses from Japan and far-eastern Russia. *Journal of General Virology*, 80, 3127-3135.
- HAYES, C. & MONATH, T. 1989. West Nile fever. *The Arboviruses: Epidemiology and Ecology. Volume V.*, 59-88.
- HAYES, E. B. & GUBLER, D. J. 2006. West Nile Virus: Epidemiology and Clinical Features of an Emerging Epidemic in the United States. *Annual Review of Medicine*, 57, 181-194.
- HB, S. 2012. DNA Baser Sequence Assembler 3X ed.
- HENDERSON, B., METSELAAR, D., KIRYA, G. & TIMMS, G. 1970. Investigations into yellow fever virus and other arboviruses in the northern regions of Kenya. *Bulletin of the World Health Organization*, 42, 787.
- HERNANDEZ, D., FRANÇOIS, P., FARINELLI, L., ØSTERÅS, M. & SCHRENZEL, J. 2008. De novo bacterial genome sequencing: millions of very short reads assembled on a desktop computer. *Genome Research*, 18, 802-809.
- HERTZ, J. M. & HUANG, H. V. 1992. Utilization of heterologous *Alphavirus* junction sequences as promoters by Sindbis virus. *Journal of Virology*, 66, 857-864.
- HEYMANN, D. 2004. Control of communicable diseases manual: an official report of the American Public Health Association. Washington DC. *World Health Organization/American Public Health Association*.

- HOLBROOK, M. R., ARONSON, J. F., CAMPBELL, G. A., JONES, S., FELDMANN, H. & BARRETT, A. D. 2005. An animal model for the tickborne flavivirus—Omsk hemorrhagic fever virus. *Journal of Infectious Diseases*, 191, 100-108.
- HOLZER, B., BAKSHI, S., BRIDGEN, A. & BARON, M. D. 2011. Inhibition of interferon induction and action by the nairovirus Nairobi sheep disease virus/Ganjam virus. *PLoS One*, 6, e28594.
- HONIG, J. E., OSBORNE, J. C. & NICHOL, S. T. 2004. The high genetic variation of viruses of the genus (*Nairovirus*) reflects the diversity of their predominant tick hosts. *Virology*, 318, 10-16.
- HOOGSTRAAL, H. 1956. African Ixodoidea. Vol. I. Ticks of the Sudan (with special reference to Equatoria Province and with Preliminary Reviews of the Genera *Boophilus*, *Margaropus*, and *Hyalomma*). *African Ixodoidea*, 1.
- HOOGSTRAAL, H. 1979. The epidemiology of tick-borne Crimean-Congo hemorrhagic fever in Asia, Europe, and Africa. *Journal of Medical Entomology*, 15, 307-417.
- HOOGSTRAAL, H. 1985. Argasid and nuttalliellid ticks as parasites and vectors. *Advances in Parasitology*, 24, 135-238.
- HOPLA, C., DURDEN, L. & KEIRANS, J. 1994. Ectoparasites and classification. *International Office of Epizootics*, 13, 985.
- HORAK, I. G., CAMICAS, J.-L. & KEIRANS, J. E. 2002. The Argasidae, Ixodidae and Nuttalliellidae (Acari: Ixodida): a world list of valid tick names. *Experimental and Applied Acarology*, 28, 27-54.
- HORAK, I. G., GOLEZARDY, H. & UYS, A. 2007. Ticks associated with the three largest wild ruminant species in southern Africa. *Onderstepoort Journal of Veterinary Research*, 74, 231-242.
- HUBÁLEK, Z. 1987. Geographic distribution of Bhanja virus. *Folia Parasitologica*, 34, 77.
- HUBÁLEK, Z. 2008. Mosquito-borne viruses in Europe. *Parasitology Research*, 103, 29-43.
- HUBÁLEK, Z. & HALOUZKA, J. 1999. West Nile fever--a reemerging mosquito-borne viral disease in Europe. *Emerging Infectious Diseases*, 5, 643.
- HUBÁLEK, Z., MITTERMAYER, T., HALOUZKA, J. & ČERNÝ, V. 1988. Isolation of "exotic" Bhanja virus (Bunyaviridae) from ticks in the temperate zone. *Archives of Virology*, 101, 191-197.
- HUDSON, P. & GREENMAN, J. 1998. Competition mediated by parasites: biological and theoretical progress. *Trends in Ecology and Evolution*, 13, 387-390.
- HURLBUT, H. S. 1956. West Nile virus infection in arthropods. *The American Journal of Tropical Medicine and Hygiene*, 5, 76.
- HUSON, D. H., AUCH, A. F., QI, J. & SCHUSTER, S. C. 2007. MEGAN analysis of metagenomic data. *Genome research*, 17, 377-386.
- IASHKULOV, K. B., SHCHELKANOV, M., L'VOV S, S., DZHAMBINOV, S. D., GALKINA, I. V., FEDIAKINA, I. T., BUSHKIEVA, B., MOROZOVA, T. N., KIREEV, D. E., AKANINA, D. S., LITVIN, K. E., USACHEV, E. V., PRILIPOV, A. G., GREBENNIKOVA, T. V., GROMASHEVSKII, V. L., IAMNIKOVA, S. S., ZABEREZHNYI, A. D. & L'VOV D, K. 2008. Isolation of influenza virus A (Orthomyxoviridae, Influenza A virus), Dhori virus (Orthomyxoviridae, Thogotovirus), and Newcastle's disease virus (Paromyxoviridae, Avulavirus) on the Mal'yi Zhemchuzhnyi Island in the north-western area of the Caspian Sea]. *Vopr Virusol*, 53, 34-8.
- IZADI, S., NAIENI, K. H., MADJDZADEH, S. R. & NADIM, A. 2004. Crimean-Congo hemorrhagic fever in Sistan and Baluchestan Province of Iran, a case-control study on epidemiological characteristics. *International Journal of Infectious Diseases*, 8, 299-306.
- JENTES, E. S., POUMEROL, G., GERSHMAN, M. D., HILL, D. R., LEMARCHAND, J., LEWIS, R. F., STAPLES, J. E., TOMORI, O., WILDER-SMITH, A. & MONATH, T. P. 2011. The

- revised global yellow fever risk map and recommendations for vaccination, 2010: consensus of the Informal WHO Working Group on Geographic Risk for Yellow Fever. *The Lancet Infectious Diseases*, 11, 622-632.
- JOHANSSON, M. A., ARANA-VIZCARRONDO, N., BIGGERSTAFF, B. J. & STAPLES, J. E. 2010. Incubation periods of yellow fever virus. *The American Journal of Tropical Medicine and Hygiene*, 83, 183.
- JOHNSON, B., CHANAS, A., SQUIRES, E., SHOCKLEY, P., SIMPSON, D., PARSONS, J., SMITH, D. & CASALS, J. 1980. Arbovirus isolations from ixodid ticks infesting livestock, Kano Plain, Kenya. *Transactions of the Royal Society of Tropical Medicine and Hygiene*, 74, 732-737.
- JOHNSTON, R. E. & PETERS, C. 1996. Alphaviruses. *Fields Virology*, 3, 843-898.
- JONES, K. E., PATEL, N. G., LEVY, M. A., STOREYGARD, A., BALK, D., GITTLEMAN, J. L. & DASZAK, P. 2008. Global trends in emerging infectious diseases. *Nature*, 451, 990-993.
- JONES, L. D., DAVIES, C. R., WILLIAMS, T., CORY, J. & NUTTALL, P. A. 1990. Non-viraemic transmission of Thogoto virus: vector efficiency of *Rhipicephalus appendiculatus* and *Amblyomma variegatum*. *Transactions of the Royal Society of Tropical Medicine and Hygiene*, 84, 846-848.
- JONGEJAN, F. & UILENBERG, G. 1994. Ticks and control methods. *Office International des Epizooties*, 1201-1226.
- JUPP, P. & MCINTOSH, B. 1988. Chikungunya virus disease. *The Arboviruses: Epidemiology and Ecology*, 2, 137-57.
- KALAYCIOGLU, A. T., DURMAZ, R., UYAR, Y., UNALDI, O., AKSEKILI, E., OZKUL, A., KORUKLUOGLU, G. & ERTEK, M. 2012. Lack of genetic diversity in Crimean-Congo hemorrhagic fever viruses in Turkey: Assessment of present and future patterns of disease. *Journal of Medical Virology*, 84, 471-478.
- KAMPEN, H., POLTZ, W., HARTELT, K., WÖLFEL, R. & FAULDE, M. 2007. Detection of a questing *Hyalomma marginatum marginatum* adult female (Acari, Ixodidae) in southern Germany. *Experimental and Applied Acarology*, 43, 227-231.
- KARABATSOS, N. 1985. International catalog of arboviruses including certain other viruses of vertebrates. *American Society of Tropical Medicine and Hygiene*.
- KARTI, S. S., ODABASI, Z., KORTEN, V., YILMAZ, M., SONMEZ, M., CAYLAN, R., AKDOGAN, E., EREN, N., KOKSAL, I. & OVALI, E. 2004. Crimean-Congo hemorrhagic fever in Turkey. *Emerging Infectious Diseases*, 10, 1379.
- KARUNAMOORTHY, K. 2013. Yellow Fever Encephalitis: An Emerging and Resurging Global Public Health Threat in a Changing Environment.
- KEIRANS, J. 2009. Order Ixodida. *A manual of acarology, 3rd edn. Texas Tech University Press, Lubbock*, 111-123.
- KEIRANS, J. E., CLIFFORD, C. M., HOOGSTRAAL, H. & EASTON, E. R. 1976. Discovery of *Nuttalliella namaqua* Bedford (Acarina: Ixodoidea: Nuttalliellidae) in Tanzania and Redescription of the Female Based on Scanning Electron Microscopy. *Annals of the Entomological Society of America*, 69, 926-932.
- KHAN, J., REHMAN, S., FISHER-HOCH, S., MIRZA, S., KHURSHID, M. & MCCORMICK, J. 1995. Crimean Congo-haemorrhagic fever treated with oral ribavirin. *The Lancet*, 346, 472-475.
- KIRCHER, M. & KELSO, J. 2010. High-throughput DNA sequencing—concepts and limitations. *Bioessays*, 32, 524-536.
- KOHL, A., CLAYTON, R. F., WEBER, F., BRIDGEN, A., RANDALL, R. E. & ELLIOTT, R. M. 2003. Bunyamwera virus nonstructural protein NSs counteracts interferon regulatory factor 3-mediated induction of early cell death. *Journal of Virology*, 77, 7999-8008.

- KOKERNOT, R., MCINTOSH, B. & WORTH, C. B. 1961. Ndumu Virus, a hitherto unknown agent, isolated from culicine mosquitoes collected in northern natal, union of South Africa. *The American Journal of Tropical Medicine And Hygiene*, 10, 383-386.
- KONG, Y. Y., THAY, C. H., TIN, T. C. & DEVI, S. 2006. Rapid detection, serotyping and quantitation of dengue viruses by TaqMan real-time one-step RT-PCR. *Journal of Virological Methods*, 138, 123-130.
- KOVALEV, S. Y., CHERNYKH, D., KOKOREV, V. S., SNITKOVSKAYA, T. & ROMANENKO, V. V. 2009. Origin and distribution of tick-borne encephalitis virus strains of the Siberian subtype in the Middle Urals, the north-west of Russia and the Baltic countries. *Journal of General Virology*, 90, 2884-2892.
- KRAMER, L. D., STYER, L. M. & EBEL, G. D. 2008. A global perspective on the epidemiology of West Nile virus. *Annu. Rev. Entomol.*, 53, 61-81.
- KRANTZ, G. 1978. A manual of acarology, 2nd edn. Oregon State University Book Stores. Inc., Corvallis, 509.
- KUNO, G. & CHANG, G.-J. J. 2005. Biological transmission of arboviruses: reexamination of and new insights into components, mechanisms, and unique traits as well as their evolutionary trends. *Clinical Microbiology Reviews*, 18, 608-637.
- KURKELA, S. 2007. Sindbis virus and Pogosta disease in Finland.
- L'VOV, D., DZHARKENOV, A., L'VOV, D., ARISTOVA, V., KOVTUNOV, A., GROMASHEVSKIĬ, V., VYSHEMIRSKIĬ, O., GALKINA, I., AL'KHOVSKIĬ, S. & SAMOKHVALOV, E. 2002. Isolation of the West Nile fever virus from the great cormorant *Phalacrocorax carbo*, the crow *Corvus corone*, and *Hyalomma marginatum* ticks associated with them in natural and synanthropic biocenosis in the Volga delta (Astrakhan region, 2001)]. *Voprosy Virusologii*, 47, 7.
- LABEAUD, A. D., GORMAN, A.-M., KOONCE, J., KIPPES, C., MCLEOD, J., LYNCH, J., GALLAGHER, T., KING, C. H. & MANDALAKAS, A. M. 2008. Rapid GIS-based profiling of West Nile virus transmission: defining environmental factors associated with an urban-suburban outbreak in Northeast Ohio, USA. *Geospatial Health*, 2, 215.
- LABEAUD, A. D., SUTHERLAND, L. J., MUIRURI, S., MUCHIRI, E. M., GRAY, L. R., ZIMMERMAN, P. A., HISE, A. G. & KING, C. H. 2011. Arbovirus prevalence in mosquitoes, kenya. *Emerging Infectious Diseases*, 17, 233.
- LABUDA, M. & NUTTALL, P. 2004. Tick-borne viruses. *Parasitology-Cambridge*, 129, S221.
- LAHARIYA, C., GOEL, M., KUMAR, A., PURI, M. & SODHI, A. 2012. Emergence of viral hemorrhagic fevers: Is recent outbreak of crimean congo hemorrhagic fever in India an indication? *Journal of Postgraduate Medicine*, 58, 39.
- LAMB, R. A. 1989. Genes and proteins of the influenza viruses. *The influenza viruses*. Springer.
- LAMBERT, A. J. & LANCIOTTI, R. S. 2008. Molecular characterization of medically important viruses of the genus Orthobunyavirus. *Journal of General Virology*, 89, 2580-2585.
- LANCIOTTI, R., ROEHRIG, J., DEUBEL, V., SMITH, J., PARKER, M., STEELE, K., CRISE, B., VOLPE, K., CRABTREE, M. & SCHERRET, J. 1999. Origin of the West Nile virus responsible for an outbreak of encephalitis in the northeastern United States. *Science*, 286, 2333-2337.
- LANCIOTTI, R. S., CALISHER, C. H., GUBLER, D. J., CHANG, G.-J. & VORNDAM, A. V. 1992. Rapid detection and typing of dengue viruses from clinical samples by using reverse transcriptase-polymerase chain reaction. *Journal of clinical microbiology*, 30, 545-551.
- LANCIOTTI, R. S., KOSOY, O. L., LAVEN, J. J., VELEZ, J. O., LAMBERT, A. J., JOHNSON, A. J., STANFIELD, S. M. & DUFFY, M. R. 2008. Genetic and serologic properties of Zika virus associated with an epidemic, Yap State, Micronesia, 2007. *Emerging Infectious Diseases*, 14, 1232.

- LATIF, A., BAKHEIT, M., MOHAMED, A. E. & ZWEYGARTH, E. 2004. High infection rates of the tick *Hyalomma anatolicum anatolicum* with *Trypanosoma theileri*. *Onderstepoort Journal of Veterinary Research*, 71, 251-256.
- LEAHY, M. B., DESSENS, J. T., WEBER, F., KOCHS, G. & NUTTALL, P. A. 1997. The fourth genus in the Orthomyxoviridae: sequence analyses of two Thogoto virus polymerase proteins and comparison with influenza viruses. *Virus Research*, 50, 215-224.
- LINDENBACH, B. D. & RICE, C. 2001. Flaviviridae: the viruses and their replication. *Fields Virology*, 1, 991-1041.
- LINDQUIST, L. & VAPALAHTI, O. 2008. Tick-borne encephalitis. *The Lancet*, 371, 1861-1871.
- LINDSAY, M., COELEN, R. J. & MACKENZIE, J. S. 1993. Genetic heterogeneity among isolates of Ross River virus from different geographical regions. *Journal of Virology*, 67, 3576-3585.
- LIU, L., LI, Y., LI, S., HU, N., HE, Y., PONG, R., LIN, D., LU, L. & LAW, M. 2012. Comparison of next-generation sequencing systems. *Journal of Biomedicine and Biotechnology*, 2012.
- LORD, R. D. & CALISHER, C. H. 1970. Further evidence of southward transport of arboviruses by migratory birds. *American Journal of Epidemiology*, 92, 73-78.
- LOWEN, A. C., BOYD, A., FAZAKERLEY, J. K. & ELLIOTT, R. M. 2005. Attenuation of bunyavirus replication by rearrangement of viral coding and noncoding sequences. *Journal of Virology*, 79, 6940-6946.
- LOWEN, A. C. & ELLIOTT, R. M. 2005. Mutational analyses of the nonconserved sequences in the Bunyamwera orthobunyavirus S segment untranslated regions. *Journal of Virology*, 79, 12861-12870.
- LVOV, D., TIMOPHEEVA, A., SMIRNOV, V., GROMASHEVSKY, V., SIDOROVA, G., NIKIFOROV, L., SAZONOV, A., ANDREEV, A., SKVORTZOVA, T. & BERESINA, L. 1975. Ecology of tick-borne viruses in colonies of birds in the USSR. *Medical Biology*, 53, 325.
- LWANDE, O. W., IRURA, Z., TIGOI, C., CHEPKORIR, E., ORINDI, B., MUSILA, L., VENTER, M., FISCHER, A. & SANG, R. 2012. Seroprevalence of Crimean Congo Hemorrhagic Fever Virus in Ijara District, Kenya. *Vector-Borne and Zoonotic Diseases*, 12, 727-732.
- LWANDE, O. W., LUTOMIAH, J., OBANDA, V., GAKUYA, F., MUTISYA, J., MULWA, F., MICHUKI, G., CHEPKORIR, E., FISCHER, A. & VENTER, M. 2013. Isolation of Tick and Mosquito-Borne Arboviruses from Ticks Sampled from Livestock and Wild Animal Hosts in Ijara District, Kenya. *Vector-Borne and Zoonotic Diseases*, 13, 637-642.
- MACKENZIE, J., LINDSAY, M., COELEN, R., BROOM, A., HALL, R. & SMITH, D. 1994. Arboviruses causing human disease in the Australasian zoogeographic region. *Archives of Virology*, 136, 447-467.
- MADANI, T. A., AL-MAZROU, Y. Y., AL-JEFFRI, M. H., MISHKHAS, A. A., AL-RABEAH, A. M., TURKISTANI, A. M., AL-SAYED, M. O., ABODAHISH, A. A., KHAN, A. S. & KSIAZEK, T. G. 2003. Rift Valley fever epidemic in Saudi Arabia: epidemiological, clinical, and laboratory characteristics. *Clinical Infectious Diseases*, 37, 1084-1092.
- MALKINSON, M. & BANET, C. 2002. The role of birds in the ecology of West Nile virus in Europe and Africa. *Japanese Encephalitis and West Nile Viruses*. Springer.
- MANAROLLA, G., BAKONYI, T., GALLAZZI, D., CROSTA, L., WEISSENBOCK, H., DORRESTEIN, G. & NOWOTNY, N. 2010. Usutu virus in wild birds in northern Italy. *Veterinary Microbiology*, 141, 159-163.
- MARCHETTE, N., GARCIA, R. & RUDNICK, A. 1969. Isolation of Zika virus from *Aedes aegypti* mosquitoes in Malaysia. *The American Journal of Tropical Medicine and Hygiene*, 18, 411-415.

- MARINER, J. C., MORRILL, J. & KSIAZEK, T. 1995. Antibodies to hemorrhagic fever viruses in domestic livestock in Niger: Rift Valley fever and Crimean-Congo hemorrhagic fever. *American Journal of Tropical Medicine and Hygiene*, 53, 217-221.
- MASEMBE, C., MICHUKI, G., ONYANGO, M., RUMBERIA, C., NORLING, M., BISHOP, R. P., DJIKENG, A., KEMP, S. J., ORTH, A. & SKILTON, R. A. 2012. Viral metagenomics demonstrates that domestic pigs are a potential reservoir for Ndumu virus. *Virology Journal*, 9, 218.
- MATHIOT, C. C., GRIMAUD, G., GARRY, P., BOUQUETY, J. C., MADA, A., DAGUISY, A. M. & GEORGES, A. J. 1990. An outbreak of human Semliki Forest virus infections in Central African Republic. *The American Journal of Tropical Medicine and Hygiene*, 42, 386.
- MATSUNO, K., WEISEND, C., DA ROSA, A. P. T., ANZICK, S. L., DAHLSTROM, E., PORCELLA, S. F., DORWARD, D. W., YU, X.-J., TESH, R. B. & EBIHARA, H. 2013. Characterization of the Bhanja Serogroup Viruses (Bunyaviridae): A Novel Species of the Genus Phlebovirus and Its Relationship with Other Emerging Tick-Borne Phleboviruses. *Journal of Virology*, 87, 3719-3728.
- MATTHYSSE, J. G. & COLBO, M. H. 1987. The ixodid ticks of Uganda, together with species pertinent to Uganda because of their present known distribution. *Entomological Society of America*.
- MCCRAE, A. & KIRYA, B. 1982. Yellow fever and Zika virus epizootics and enzootics in Uganda. *Transactions of the Royal Society of Tropical Medicine and Hygiene*, 76, 552-562.
- MCINTOSH, B., JUPP, P., DOS SANTOS, I. & MEENEHAN, G. 1976. Epidemics of West Nile and Sindbis viruses in South Africa with *Culex* (*Culex*) *univittatus* Theobald as vector. *South African Journal of Science*, 72, 295-300.
- MEASE, L. E., COLDREN, R. L., MUSILA, L. A., PROSSER, T., OGOLLA, F., OFULA, V. O., SCHOEPP, R. J., ROSSI, C. A. & ADUNGO, N. 2011. Seroprevalence and distribution of arboviral infections among rural Kenyan adults: A cross-sectional study. *Virology Journal*, 8, 371.
- MEEGAN, J. & BAILEY, C. L. 1988. Rift valley fever. The arboviruses: *Epidemiology and Ecology*. Boca Raton, FL: CRC Press.
- MEEGAN, J. M. 1979. The Rift Valley fever epizootic in Egypt 1977–1978 1. Description of the epizootic and virological studies. *Transactions of the Royal Society of Tropical Medicine and Hygiene*, 73, 618-623.
- MEEGAN, J. & BAILEY, C. 1989. Rift Valley fever, The Arboviruses: *Epidemiology and Ecology* (TP Monath, editor), Vol. IV. CRC Press Inc., Boca Raton, Florida.
- MEHLA, R., KUMAR, S. R., YADAV, P., BARDE, P. V., YERGOLKAR, P. N., ERICKSON, B. R., CARROLL, S. A., MISHRA, A. C., NICHOL, S. T. & MOURYA, D. T. 2009. Recent ancestry of Kyasanur Forest disease virus. *Emerging Infectious Diseases*, 15, 1431.
- MEHLHORN, H. A., P.M. 2010. *Encyclopedic Reference of Parasitology*. <http://parasitology.informatik.uni-wuerzburg.de>.
- MEISTER, T., LUSSY, H., BAKONYI, T., ŠIKUTOVÁ, S., RUDOLF, I., VOGL, W., WINKLER, H., FREY, H., HUBÁLEK, Z. & NOWOTNY, N. 2008. Serological evidence of continuing high Usutu virus (Flaviviridae) activity and establishment of herd immunity in wild birds in Austria. *Veterinary Microbiology*, 127, 237-248.
- MERRILL, S. A., RAMBERG, F. B. & HAGEDORN, H. H. 2005. Phylogeography and population structure of *Aedes aegypti* in Arizona. *The American Journal of Tropical Medicine and Hygiene*, 72, 304-310.
- MÉTRAS, R., COLLINS, L. M., WHITE, R. G., ALONSO, S., CHEVALIER, V., THURANIRAMCKEEVER, C. & PFEIFFER, D. U. 2011. Rift Valley fever epidemiology, surveillance,

- and control: what have models contributed?. *Vector-Borne and Zoonotic Diseases*, 11, 761-771.
- MILD, M., SIMON, M., ALBERT, J. & MIRAZIMI, A. 2010. Towards an understanding of the migration of Crimean–Congo hemorrhagic fever virus. *Journal of General Virology*, 91, 199-207.
- MILLER, B. R., NASCI, R. S., GODSEY, M. S., SAVAGE, H. M., LUTWAMA, J. J., LANCIOTTI, R. S. & PETERS, C. J. 2000. First field evidence for natural vertical transmission of West Nile virus in *Culex univittatus* complex mosquitoes from Rift Valley Province, Kenya. *The American Journal of Tropical Medicine and Hygiene*, 62, 240-246.
- MIRZOEVA, N., SULTANOVA, Z. & KANBAI, I. 1974. Biological properties of West Nile virus strains isolated in Azerbaijan. *Arboviruses*. Moscow: *Akademiya Meditsinskikh Nauk SSR*, 119-123.
- MOLYNEUX, D. 1994. Vectors. *Modern Parasitology: A Textbook of Parasitology, Second Edition*, 53-74.
- MOORE, D., CAUSEY, O., CAREY, D., REDDY, S., COOKE, A., AKINKUGBE, F., DAVID-WEST, T. & KEMP, G. 1975. Arthropod-borne viral infections of man in Nigeria, 1964-1970. *Annals of Tropical Medicine and Parasitology*, 69, 49-64.
- MORELI, M. L. & DA COSTA, V. G. 2013. A systematic review of molecular diagnostic methods for the detection of arboviruses in clinical specimens in Brazil and the importance of a differential diagnosis. *Virology Discovery*, 1, 1.
- MORIKAWA, S., QING, T., XINQIN, Z., SAIJO, M. & KURANE, I. 2002. Genetic diversity of the M RNA segment among Crimean-Congo hemorrhagic fever virus isolates in China. *Virology*, 296, 159-164.
- MORIKAWA, S., SAIJO, M. & KURANE, I. 2007. Recent progress in molecular biology of Crimean–Congo hemorrhagic fever. *Comparative Immunology, Microbiology and Infectious Diseases*, 30, 375-389.
- MOSKVIKINA, N. S., ROMANENKO, V. N., TERNOVOI, V. A., IVANOVA, N. V., PROTOPOPOVA, E. V., KRAVCHENKO, L. B., KONONOVA IU, V., KURANOVA, V. N., CHAUSOV, E. V., MOSKVIN, S. S., PERSHIKOVA, N. L., GASHKOV, S. I., KONOVALOVA, S. N., BOL'SHAKOVA, N. P. & LOKTEV, V. B. 2008. Detection of the West Nile Virus and its genetic typing in ixodid ticks (Parasitiformes: Ixodidae) in Tomsk City and its suburbs. *Parazitologiya*, 42, 210-25.
- MOSTAFAVI, E., CHINIKAR, S., MORADI, M., BAYAT, N., MESHKAT, M., FARD, M. K. & GHIASI, S. M. 2013. A Case Report of Crimean Congo Hemorrhagic Fever in Ostriches in Iran. *The Open Virology Journal*, 7, 81.
- MOURYA, D. & MISHRA, A. 2006. Chikungunya fever. *The Lancet*, 368, 186-187.
- MUTISYA, J., LUTOMIAH, J., OCHIENG, C., KOKA, H., CHERUIYIOT, P., MUSILA, L., WARIGIA, M., SCHNABEL, D., & SANG, R. 2011. Isolation of tickborne viruses from ticks: Health risk implications among pastoralists in Kenya. *KEMRI Annual Scientific and Health Conference*, 2011 Nairobi, Kenya.
- NABETH, P., CHEIKH, D. O., LO, B., FAYE, O., VALL, I. O. M., NIANG, M., WAGUE, B., DIOP, D., DIALLO, M. & DIALLO, B. 2004. Crimean-Congo hemorrhagic fever, mauritania. *Emerging Infectious Diseases*, 10, 2143.
- NABETH, P., KANE, Y., ABDALAH, M. O., DIALLO, M., NDIAYE, K., BA, K., SCHNEEGANS, F., SALL, A. & MATHIOT, C. 2001. Rift Valley fever outbreak, Mauritania, 1998: seroepidemiologic, virologic, entomologic, and zoologic investigations. *Emerging Infectious Diseases*, 7, 1052.
- NICHTER, M. 1987. Kyasanur Forest Disease: An Ethnography of a Disease of Development. *Medical Anthropology Quarterly*, 1, 406-423.
- NIEDRIG, M., NITSCHKE, A. & DONOSO-MANTKE, O. 2010. Arthropod-borne viruses.

- NIJKAMP, J., WINTERBACH, W., VAN DEN BROEK, M., DARAN, J.-M., REINDERS, M. & DE RIDDER, D. 2010. Integrating genome assemblies with MAIA. *Bioinformatics*, 26, i433-i439.
- NORDER, H., LUNDSTRÖM, J. O., KOZUCH, O. & MAGNIUS, L. O. 1996. Genetic relatedness of Sindbis virus strains from Europe, Middle East, and Africa. *Virology*, 222, 440-445.
- NUTTALL, P. A. 2009. Molecular characterization of tick-virus interactions. *Frontiers in Bioscience: Journal and Virtual Library*, 14, 2466.
- OCHIENG, C., LUTOMIAH, J., MAKIO, A., KOKA, H., CHEPKORIR, E., YALWALA, S., MUTISYA, J., MUSILA, L., KHAMADI, S. & RICHARDSON, J. 2013. Mosquito-borne arbovirus surveillance at selected sites in diverse ecological zones of Kenya; 2007--2012. *Virology Journal*, 10, 140.
- OGEN-ODOI, A., MILLER, B. R., HAPP, C. M., MAUPIN, G. O. & BURKOT, T. R. 1999. Isolation of thogoto virus (Orthomyxoviridae) from the banded mongoose, *Mungos mungo* (Herpestidae), in Uganda. *The American Journal of Tropical Medicine and Hygiene*, 60, 439-440.
- OKELLO-ONEN, J., HASSAN, S. M. & ESSUMAN, S. 1999. Taxonomy of African ticks: an identification manual. *International Centre of Insect Physiology and Ecology (ICIPE)*.
- OLSON, J. & KSIAZEK, T. 1981. Zika virus, a cause of fever in Central Java, Indonesia. *Transactions of the Royal Society of Tropical Medicine and Hygiene*, 75, 389-393.
- OWENS, R. J., LIMN, C. & ROY, P. 2004. Role of an arbovirus nonstructural protein in cellular pathogenesis and virus release. *Journal of Virology*, 78, 6649-6656.
- PAK, T. 1975. Structure of the distribution of Crimean-Congo hemorrhagic fever. *Tadzhikistan. Mater*, 9, 39-43.
- PAPADOPOULOS, O. T. & KOPTOPOULOS, G. 1980. Crimean-Congo hemorrhagic fever (CCHF) in Greece: isolation of the virus from *Rhipicephalus bursa* ticks and a preliminary serological survey. *Zentralblatt Bakteriologie Hygiene*, 1, 189-193.
- PAREDES, A. M., BROWN, D. T., ROTHNAGEL, R., CHIU, W., SCHOEPP, R. J., JOHNSTON, R. E. & PRASAD, B. 1993. Three-dimensional structure of a membrane-containing virus. *Proceedings of the National Academy of Sciences*, 90, 9095-9099.
- PAROLA, P., DE LAMBALLERIE, X., JOURDAN, J., ROVERY, C., VAILLANT, V., MINODIER, P., BROUQUI, P., FLAHAULT, A., RAOULT, D. & CHARREL, R. N. 2006. Novel chikungunya virus variant in travelers returning from Indian Ocean islands. *Emerging Infectious Diseases*, 12, 1493.
- PASTORINO, B., MUYEMBE-TAMFUM, J., BESSAUD, M., TOCK, F., TOLOU, H., DURAND, J. & PEYREFITTE, C. 2004. Epidemic resurgence of Chikungunya virus in democratic Republic of the Congo: identification of a new central African strain. *Journal of Medical Virology*, 74, 277-282.
- PAVLOV, P., ROSICKÝ, B., HUBÁLEK, Z., DANIEL, M., BARDOS, V., MINAR, J. & JURICOVA, Z. 1978. Isolation of Bhanja virus from ticks of the genus *Haemaphysalis* in southeast Bulgaria and presence of antibodies in pastured sheep. *Folia Parasitologica*, 25, 67.
- PEARSON, W. R. & LIPMAN, D. J. 1988. Improved tools for biological sequence comparison. *Proceedings of the National Academy of Sciences*, 85, 2444-2448.
- PERNG, G.-C. & CHEN, W.-J. 2013. Arboviral Encephalitis.
- PETERSEN, L. R. & ROEHRIG, J. T. 2001. West Nile virus: a reemerging global pathogen. *Review of Biomed*, 12.
- PFEFFER, M. & DOBLER, G. 2010. Review Emergence of zoonotic arboviruses by animal trade and migration.
- PINHEIRO, J., BATES, D., DEBROY, S. & SARKAR, D. 2011. R Development Core Team (2011) nlme: linear and nonlinear mixed effects models. R package version 3.1-98. *R Foundation for Statistical Computing, Vienna*.

- POIDINGER, M., ROY, S., HALL, R. A., TURLEY, P. J., SCHERRET, J. H., LINDSAY, M. D., BROOM, A. K. & MACKENZIE, J. S. 1997. Genetic stability among temporally and geographically diverse isolates of Barmah Forest virus. *The American Journal Of Tropical Medicine and Hygiene*, 57, 230.
- POWERS, A. M. & LOGUE, C. H. 2007. Changing patterns of chikungunya virus: re-emergence of a zoonotic arbovirus. *Journal of General Virology*, 88, 2363-2377.
- PRESTI, R. M., ZHAO, G., BEATTY, W. L., MIHINDUKULASURIYA, K. A., DA ROSA, A. P. T., POPOV, V. L., TESH, R. B., VIRGIN, H. W. & WANG, D. 2009. Quarantfil, Johnston Atoll, and Lake Chad viruses are novel members of the family Orthomyxoviridae. *Journal of Virology*, 83, 11599-11606.
- RAJU, R. & KOLAKOFSKY, D. 1989. The ends of La Crosse virus genome and antigenome RNAs within nucleocapsids are base paired. *Journal of Virology*, 63, 122-128.
- RANDOLPH, S. 2004. Tick ecology: processes and patterns behind the epidemiological risk posed by ixodid ticks as vectors. *Parasitology-Cambridge*, 129, S37.
- RANJIT, S. & KISSOON, N. 2011. Dengue hemorrhagic fever and shock syndromes. *Pediatric Critical Care Medicine*, 12, 90-100.
- RAPPOLE, J. & HUBALEK, Z. 2003. Migratory birds and West Nile virus. *Journal of Applied Microbiology*, 94, 47-58.
- REED, K. D., MEECE, J. K., HENKEL, J. S. & SHUKLA, S. K. 2003. Birds, migration and emerging zoonoses: West Nile virus, Lyme disease, influenza A and enteropathogens. *Clinical Medicine and Research*, 1, 5-12.
- REITER, P., CORDELLIER, R., OUMA, J. O., CROPP, C. B., SAVAGE, H. M., SANDERS, E. J., MARFIN, A. A., TUKEI, P. M., AGATA, N. N., GITAU, L. G., RAPUODA, B. A. & GUBLER, D. J. 1998. First recorded outbreak of yellow fever in Kenya, 1992-1993. II. Entomologic investigations. *American Journal of Tropical Medicine and Hygiene*, 59, 650-6.
- ROBINSON, M. C. 1955. An epidemic of virus disease in Southern Province, Tanganyika Territory, in 1952-53. *Transactions Royal Society of Tropical Medicine and Hygiene*, 49, 28-32.
- RODRIGUES, R., PARANHOS-BACCALÀ, G., VERNET, G. & PEYREFITTE, C. N. 2012. Crimean-Congo hemorrhagic fever virus-infected hepatocytes induce ER-stress and apoptosis crosstalk. *PLoS One*, 7, e29712.
- RONAGHI, M. 2001. Pyrosequencing sheds light on DNA sequencing. *Genome Research*, 11, 3-11.
- RONQUIST, F. & HUELSENBECK, J. P. 2003. MrBayes 3: Bayesian phylogenetic inference under mixed models. *Bioinformatics*, 19, 1572-1574.
- RŮŽEK, D., YAKIMENKO, V. V., KARAN, L. S. & TKACHEV, S. E. 2010. Omsk haemorrhagic fever. *The Lancet*, 376, 2104-2113.
- SALUZZO, J. F., DIGOUTTE, J. P., CAMICAS, J. L. & CHAUVANCY, G. 1985. Crimean-Congo haemorrhagic fever and Rift Valley fever in south-eastern Mauritania. *Lancet*, 1, 116.
- SAMMELS, L. M., LINDSAY, M. D., POIDINGER, M., COELEN, R. J. & MACKENZIE, J. S. 1999. Geographic distribution and evolution of Sindbis virus in Australia. *Journal of General Virology*, 80, 739-748.
- SANDERS, E. J., MARFIN, A. A., TUKEI, P. M., KURIA, G., ADEMBA, G., AGATA, N. N., OUMA, J. O., CROPP, C. B., KARABATSOS, N., REITER, P., MOORE, P. S. & GUBLER, D. J. 1998. First recorded outbreak of yellow fever in Kenya, 1992-1993. I. Epidemiologic investigations. *American Journal of Tropical Medicine and Hygiene*, 59, 644-9.
- SANG, R., LUTOMIAH, J., HELLEN KOKA, A. M., CHEPKORIR, E., OCHIENG, C., YALWALA, S., MUTISYA, J., MUSILA, L., RICHARDSON, J. H. & MILLER, B. R. 2011. Crimean-

- Congo hemorrhagic fever virus in hyalommid ticks, northeastern Kenya. *Emerging Infectious Diseases*, 17, 1502.
- SANG, R., ONYANGO, C., GACHOYA, J., MABINDA, E., KONONGOI, S., OFULA, V., DUNSTER, L., OKOTH, F., COLDREN, R. & TESH, R. 2006. Tickborne arbovirus surveillance in market livestock, Nairobi, Kenya. *Emerging Infectious Diseases*, 12, 1074.
- SANGER, F., NICKLEN, S. & COULSON, A. R. 1977. DNA sequencing with chain-terminating inhibitors. *Proceedings of the National Academy of Sciences*, 74, 5463-5467.
- SCHLESINGER, M. J. & SCHLESINGER, S. 1986. Formation and assembly of alphavirus glycoproteins. *The Togaviridae and Flaviviridae*. Springer.
- SCHMALJOHN, C. & NICHOL, S. 2007. Bunyaviridae, p 1741–1789. *Fields virology, 5th ed. Lippincott Williams & Wilkins, Philadelphia, PA*.
- SCHMIDT, J. R. & SAID, M. I. 1964. Isolation of West Nile Virus from the African Bird Argasid, Argas Reflexus Hermannii, in Egypt. *Journal of Medical Entomology*, 1, 83-86.
- SCHUSTER, S. C. 2008. Next-generation sequencing transforms today's biology. *Nature*, 200, 16-18.
- SELLERS, R. 1989. Eastern equine encephalitis in Quebec and Connecticut, 1972: introduction by infected mosquitoes on the wind? *Canadian Journal of Veterinary Research*, 53, 76.
- SERON, K., NJUGUNA, C., KALANI, R., OFULA, V., ONYANGO, C., KONONGOI, L. S., BEDNO, S., BURKE, H., DUMILLA, A. M. & KONDE, J. 2008. Seroprevalence of chikungunya virus (CHIKV) infection on Lamu Island, Kenya, October 2004. *The American Journal of Tropical Medicine And Hygiene*, 78, 333-337.
- SHAH, K. & WORK, T. 1969. Bhanja virus: a new arbovirus from ticks Haemaphysalis intermedia Warburton and Nuttall, 1909, in Orissa, India.
- SHALUNOVA, N., ZGURSKAYA, G. & BEREZIN, V. 1968. West Nile virus in the USSR. 3. Isolation of another strain of West Nile virus from Hyalomma plumbeum plumbeum Panz in Astrakhan Oblast in 1965. *Tr. Tnst. Poliomielitov Virus Entsefalitov Akad. Med. Nauk SSSR*, 12, 389-393.
- SHEPHERD, A., SWANEPOEL, R., CORNEL, A. & MATHEE, O. 1989. Experimental studies on the replication and transmission of Crimean-Congo hemorrhagic fever virus in some African tick species. *The American Journal of Tropical Medicine and Hygiene*, 40, 326.
- SHEPHERD, A., SWANEPOEL, R., LEMAN, P. & SHEPHERD, S. 1986. Comparison of methods for isolation and titration of Crimean-Congo hemorrhagic fever virus. *Journal of Clinical Microbiology*, 24, 654-656.
- SHEPHERD, A., SWANEPOEL, R., LEMAN, P. & SHEPHERD, S. 1987. Field and laboratory investigation of Crimean-Congo haemorrhagic fever virus (*Nairovirus*, family Bunyaviridae) infection in birds. *Transactions of the Royal Society of Tropical Medicine and Hygiene*, 81, 1004-1007.
- SHIMSHONY, A. 2010. Crimean-Congo hemorrhagic fever: A re-emerging, potentially deadly illness.
- SHIRAKO, Y., NIKLASSON, B., DALRYMPLE, J. M., STRAUSS, E. G. & STRAUSS, J. H. 1991. Structure of the Ockelbo virus genome and its relationship to other Sindbis viruses. *Virology*, 182, 753-764.
- SIMIZU, B., YAMAMOTO, K., HASHIMOTO, K. & OGATA, T. 1984. Structural proteins of Chikungunya virus. *Journal of Virology*, 51, 254-258.
- SIMPSON, D., KNIGHT, E., COURTOIS, G., WILLIAMS, M., WEINBREN, M. & KIBUKAMUSOKE, J. 1967. Congo virus: a hitherto undescribed virus occurring in Africa. I. Human isolations--clinical notes. *East African Medical Journal*, 44, 86.
- SMITH, D. R., LEE, J. S., JAHRLING, J., KULESH, D. A., TURELL, M. J., GROEBNER, J. L. & O'GUINN, M. L. 2009. Development of Field-Based Real-Time Reverse Transcription–

- Polymerase Chain Reaction Assays for Detection of Chikungunya and O'nyong-nyong Viruses in Mosquitoes. *The American Journal of Tropical Medicine and Hygiene*, 81, 679-684.
- SMITHBURN, K. & HADDOW, A. 1944. Article Usage Statistics Center Semliki Forest Virus: I. Isolation and Pathogenic Properties. *Journal of Immunology*, 1944, 141-157.
- SMITHBURN, K., HADDOW, A. & MAHAFFY, A. 1946. A neurotropic virus isolated from Aedes mosquitoes caught in the Semliki Forest. *The American Journal of Tropical Medicine and Hygiene*, 1, 189-208.
- SMITHBURN, K., HUGHES, T., BURKE, A. & PAUL, J. 1940. A neurotropic virus isolated from the blood of a native of Uganda. *American Journal of Tropical Medicine*, 20, 471-2.
- SONENSHINE, D. E. & MATHER, T. N. 1994. *Ecological Dynamics of Tick-Borne Zoonoses*, Oxford University Press.
- SONENSHINE, D. 1991. *Biology of ticks*. Vol.1. Oxford University press, New York.
- SONENSHINE, D. 1993. *Biology of ticks*, Vol. 2. Oxford University Press, New York.
- SPICKETT, A. 1994a. Tick ecology. *International journal for parasitology*, 24, 845.
- SPICKETT, A. 1994b. Tick ecology. *Int J Parasitol*, 24, 845-849.
- STEELE, G. M. & NUTTALL, P. A. 1989. Difference in vector competence of two species of sympatric ticks, *Amblyomma variegatum* and *Rhipicephalus appendiculatus*, for Dugbe virus (*Nairovirus*, Bunyaviridae). *Virus Research*, 14, 73-84.
- SUSS, J. 2008. Tick-borne encephalitis in Europe and beyond--the epidemiological situation as of 2007. *European communicable disease bulletin*, 13.
- SWANEPOEL, R., LEMAN, P., BURT, F., JARDINE, J., VERWOERD, D., CAPUA, I., BRÜCKNER, G. & BURGER, W. 1998. Experimental infection of ostriches with Crimean-Congo haemorrhagic fever virus. *Epidemiology and Infection*, 121, 427-432.
- SWANEPOEL, R., SHEPHERD, A. J., LEMAN, P. A., SHEPHERD, S. P., MCGILLIVRAY, G. M., ERASMUS, M. J., SEARLE, L. A. & GILL, D. E. 1987. Epidemiologic and clinical features of Crimean-Congo hemorrhagic fever in southern Africa. *American Journal of Tropical Medicine and Hygiene*, 36, 120-32.
- TABACHNICK, W. 1992. Microgeographic and temporal genetic variation in populations of the bluetongue virus vector *Culicoides variipennis* (Diptera: Ceratopogonidae). *Journal of Medical Entomology*, 29, 384-394.
- TAMURA, K. & NEI, M. 1993. Estimation of the number of nucleotide substitutions in the control region of mitochondrial DNA in humans and chimpanzees. *Molecular biology and Evolution*, 10, 512-526.
- TAMURA, K., PETERSON, D., PETERSON, N., STECHER, G., NEI, M. & KUMAR, S. 2011. MEGA5: molecular evolutionary genetics analysis using maximum likelihood, evolutionary distance, and maximum parsimony methods. *Molecular Biology and Evolution*, 28, 2731-2739.
- TEAM, R. D. C. 2009. R version 2.9. 2. R Project for Statistical Computing Vienna, Austria.
- TONBAK, S., AKTAS, M., ALTAY, K., AZKUR, A. K., KALKAN, A., BOLAT, Y., DUMANLI, N. & OZDARENDELI, A. 2006. Crimean-Congo hemorrhagic fever virus: genetic analysis and tick survey in Turkey. *Journal of Clinical Microbiology*, 44, 4120-4124.
- TOWNER, J. S., SEALY, T. K., KHRISTOVA, M. L., ALBARIÑO, C. G., CONLAN, S., REEDER, S. A., QUAN, P.-L., LIPKIN, W. I., DOWNING, R. & TAPPERO, J. W. 2008. Newly discovered Ebola virus associated with hemorrhagic fever outbreak in Uganda. *PLoS Pathogens*, 4, e1000212.
- TRAORE, O., SORHO, F., PINEL, A., ABUBAKAR, Z., BANWO, O., MALEY, J., HÉBRARD, E., WINTER, S., SERE, Y. & KONATE, G. 2005. Processes of diversification and dispersion of Rice yellow mottle virus inferred from large-scale and high-resolution phylogeographical studies. *Molecular Ecology*, 14, 2097-2110.

- TRAPIDO, H., RAJAGOPALAN, P., WORK, T. & VARMA, M. 1959. Kyasanur Forest disease. VIII. Isolation of Kyasanur Forest disease virus from naturally infected ticks of the genus *Haemaphysalis*.
- TURELL, M. J., DOHM, D. J., SARDELIS, M. R., O'GUINN, M. L., ANDREADIS, T. G. & BLOW, J. A. 2005. An update on the potential of North American mosquitoes (Diptera: Culicidae) to transmit West Nile virus. *Journal of Medical Entomology*, 42, 57-62.
- UNGUREANU, A., POPOVICI, V., CĂTĂNAȘ, F., IONIȚĂ, I., TUTOVEANU, A. & SAFTA, M. 1990. Isolation of Bhanja virus in Romania. *Archives Roumaines de Pathologie Experimentales et de Microbiologie*, 49, 139.
- VAN REGENMORTEL, M. & FAUQUET, C. M. 2000. Virus taxonomy: classification and nomenclature of viruses: seventh report of the International Committee on Taxonomy of Viruses.
- VENTER, M., HUMAN, S., ZAAYMAN, D., GERDES, G. H., WILLIAMS, J., STEYL, J., LEMAN, P. A., PAWESKA, J. T., SETZKORN, H. & ROUS, G. 2009. Lineage 2 West Nile virus as cause of fatal neurologic disease in horses, South Africa. *Emerging Infectious Diseases*, 15, 877.
- VENTER, M. & SWANEPOEL, R. 2010. West Nile virus lineage 2 as a cause of zoonotic neurological disease in humans and horses in southern Africa. *Vector-Borne and Zoonotic Diseases*, 10, 659-664.
- VERANT, P., BALDUCCI, M., LOPES, M. & SACCA, G. 1970. Isolation of Bhanja virus from *Haemaphysalis* ticks in Italy. *American Journal of Tropical Medicine and Hygiene*, 19, 103-105.
- VERMEIL, C., LAVILLAUREIX, J. & BEEB, E. 1960. Sur la conservation et la transmission du virus West Nile par quelques arthropodes. *Bulletin de la Societe de Pathologie Exotique*, 53, 273-279.
- VESENJAK-HIRJAN, J., CALISHER, C. H., BRUDNJAK, Z., TOVORNIK, D., SKRTIC, N. & LAZUICK, J. S. 1977. Isolation of Bhanja virus from ticks in Yugoslavia. *The American Journal of Tropical Medicine And Hygiene*, 26, 1003.
- VOROU, R., PIERROUTSAKOS, I. N. & MALTEZOU, H. C. 2007. Crimean-Congo hemorrhagic fever. *Current Opinion In Infectious Diseases*, 20, 495-500.
- WALDENSTRÖM, J., LUNDKVIST, Å., FALK, K. I., GARPMO, U., BERGSTRÖM, S., LINDEGREN, G., SJÖSTEDT, A., MEJLON, H., FRANSSON, T. & HAEMIG, P. D. 2007. Migrating birds and tickborne encephalitis virus. *Emerging Infectious Diseases*, 13, 1215.
- WALKER, A. R. & BOUATTOUR, A. 2003. Ticks of domestic animals in Africa: a guide to identification of species. *Bioscience Reports*.
- WALKER, J. B., KEIRANS, J. E. & HORAK, I. G. 2000. The genus *Rhipicephalus* (Acari, Ixodidae): a guide to the brown ticks of the world, Cambridge University Press.
- WALTER, C. T. & BARR, J. N. 2011. Recent advances in the molecular and cellular biology of bunyaviruses. *Journal of General Virology*, 92, 2467-2484.
- WATTS, D. M., KSIAZEK, T.G., LINTHICUM, K.J. & HOOGSTRAAL, H. 1989. Crimean–Congo hemorrhagic fever. *The Arboviruses: Epidemiology and Ecology*. Boca Raton, FL: CRC Press.
- WEAVER, S., FREY, T., HUANG, H., KINNEY, R., RICE, C., ROEHRIG, J., SHOPE, R. & STRAUSS, E. 2005. Togaviridae. *Virus Taxonomy: Eighth Report of the International Committee on Taxonomy of Viruses*, 999.
- WEAVER, S. C. & BARRETT, A. D. 2004. Transmission cycles, host range, evolution and emergence of arboviral disease. *Nature Reviews Microbiology*, 2, 789-801.

- WEAVER, S. C., BELLEW, L. A., GOUSSET, L., REPIK, P. M., SCOTT, T. W. & HOLLAND, J. J. 1993. Diversity within natural populations of eastern equine encephalomyelitis virus. *Virology*, 195, 700-709.
- WEAVER, S. C., HAGENBAUGH, A., BELLEW, L. A., GOUSSET, L., MALLAMPALLI, V., HOLLAND, J. J. & SCOTT, T. W. 1994. Evolution of *Alphaviruses* in the eastern equine encephalomyelitis complex. *Journal of Virology*, 68, 158-169.
- WEAVER, S. C., KANG, W., SHIRAKO, Y., RUMENAPF, T., STRAUSS, E. G. & STRAUSS, J. H. 1997. Recombinational history and molecular evolution of western equine encephalomyelitis complex alphaviruses. *Journal of Virology*, 71, 613-623.
- WEAVER, S. C. & REISEN, W. K. 2010. Present and future arboviral threats. *Antiviral Research*, 85, 328.
- WEBER, F., DUNN, E. F., BRIDGEN, A. & ELLIOTT, R. M. 2001. The Bunyamwera virus nonstructural protein NSs inhibits viral RNA synthesis in a minireplicon system. *Virology*, 281, 67-74.
- WEBER, F., JAMBRINA, E., GONZÁLEZ, S., DESSENS, J. T., LEAHY, M., KOCHS, G., PORTELA, A. N., NUTTALL, P. A., HALLER, O. & ORTÍN, J. 1998. In vivo reconstitution of active Thogoto virus polymerase: assays for the compatibility with other *Orthomyxovirus* core proteins and template RNAs. *Virus Research*, 58, 13-20.
- WEBSTER, R. G., BEAN, W. J., GORMAN, O. T., CHAMBERS, T. M. & KAWAOKA, Y. 1992. Evolution and ecology of influenza A viruses. *Microbiological Reviews*, 56, 152-179.
- WEISSENBOCK, H., HUBÁLEK, Z., BAKONYI, T. & NOWOTNY, N. 2010. Zoonotic mosquito-borne *Flaviviruses*: worldwide presence of agents with proven pathogenicity and potential candidates of future emerging diseases. *Veterinary Microbiology*, 140, 271-280.
- WEISSENBOCK, H., KOLODZIEJEK, J., URL, A., LUSSY, H., REBEL-BAUDER, B. & NOWOTNY, N. 2002. Emergence of Usutu virus, an African mosquito-borne *Flavivirus* of the Japanese encephalitis virus group, central Europe. *Emerging Infectious Diseases*, 8, 652-656.
- WHITEHORN, J. & FARRAR, J. 2010. Dengue. *British Medical Bulletin*, 95, 161-173.
- WHITLEY, R. J. & GNANN, J. W. 2002. Viral encephalitis: familiar infections and emerging pathogens. *The Lancet*, 359, 507-513.
- WHITMAN, L. & AITKEN, T. 1960. Potentiality of *Ornithodoros moubata* Murray (Acarina, Argasidae) as a Reservoir-Vector of West Nile Virus. *Annals of Tropical Medicine and Parasit.*, 54, 192-204.
- WILDER-SMITH, A., CHEN, L. H., MASSAD, E. & WILSON, M. E. 2009. Threat of dengue to blood safety in dengue-endemic countries. *Emerging infectious diseases*, 15, 8.
- WILLEMS, W., KALUZA, G., BOSCHEK, C., BAUER, H., HAGER, H., SCHUTZ, H. & FEISTNER, H. 1979. Semliki forest virus: cause of a fatal case of human encephalitis. *Science*, 203, 1127-1129.
- WINKLER, W. & BLENDEN, D. 1995. Transmission and control of viral zoonoses in the laboratory. *Laboratory safety: principles and practices, 2nd ed. American Society for Microbiology, Washington, DC*, 105-117.
- WINKLER, W. G., BLENDEN, D.C. 1995. Transmission and control of viral zoonoses in the laboratory. *In Laboratory Safety: Principles and Practices, 2.*
- WIWANITKIT, V. 2009. Unusual mode of transmission of dengue. *The Journal of Infection in Developing Countries*, 4, 051-054.
- WOOD, O. L., MOUSSA, M. I., HOOGSTRAAL, H. & BUTTIKER, W. 1982. Kadam virus (Togaviridae, Flavivirus) infecting camel-parasitizing *Hyalomma dromedarii* ticks (Acari: Ixodidae) in Saudi Arabia. *Journal of Medical Entomology*, 19, 207-208.
- WOODALL, J., WILLIAMS, M. & SIMPSON, D. 1967. Congo virus: a hitherto undescribed virus occurring in Africa. II. Identification studies. *East African Medical Journal*, 44, 93.

- WOODALL, J., WILLIAMS, M., SIMPSON, D., ARDOIN, P., LULE, M. & WEST, R. 1965. The Congo group of agents. *East African Virus Research Institute*, 14, 34-36.
- YADAV, P. D., VINCENT, M. J., KHRISTOVA, M., KALE, C., NICHOL, S. T., MISHRA, A. C. & MOURYA, D. T. 2011. Genomic analysis reveals Nairobi sheep disease virus to be highly diverse and present in both Africa, and in India in the form of the Ganjam virus variant. *Infection, Genetics and Evolution*, 11, 1111-1120.
- YANDOKO, E. N., GRIBALDO, S., FINANCE, C., LE FAOU, A. & RIHN, B. 2007. Molecular characterization of African *Orthobunyaviruses*. *Journal of General Virology*, 88, 1761-1766.
- YU-CHEN, Y., LING-XIONG, K., LING, L. & YU-QIN, Z. 1985. Characteristics of Crimean Congo Haemorrhagic Fever virus (Xinjiang strain) in China. *American Journal Tropical & Medical Hygiene*, 34, 1179-1182.
- ZAAVMAN, D. & VENTER, M. 2012. West Nile Virus Neurologic Disease in Humans, South Africa, September 2008–May 2009. *Emerging Infectious Diseases*, 18, 2051.
- ZANOTTO, D. A. P., GAO, G., GRITSUN, T., MARIN, M., JIANG, W., VENUGOPAL, K., REID, H. & GOULD, E. 1995. An arbovirus cline across the northern hemisphere. *Virology*, 210, 152-159.
- ZANOTTO, P. D., GOULD, E. A., GAO, G. F., HARVEY, P. H. & HOLMES, E. C. 1996. Population dynamics of *Flaviviruses* revealed by molecular phylogenies. *Proceedings of the National Academy of Sciences*, 93, 548-553.
- ZAVITSANOU, A., BABATSIKOU, F. & KOUTIS, C. 2009. Crimean Congo hemorrhagic fever: An emerging tick-borne disease. *Health Science Journal*, 3, 10-18.
- ZELLER, H. & SCHUFFENECKER, I. 2004. West Nile virus: an overview of its spread in Europe and the Mediterranean basin in contrast to its spread in the Americas. *European Journal of Clinical Microbiology and Infectious Diseases*, 23, 147-156.

Appendixes

Appendix A

Informed Consent Agreement

Request: I wish to request for your participation in the following research project:

Project title: Tick-Borne Virus Prevalence and Diversity in Pastoral Eco-Zone of Ijara District, North Eastern Province of Kenya

Study information: We are interested in finding out causes of illness in adults and children who have fever and/or malaria like illness. We want to use new methods that can detect any germs even those that are difficult to detect usually or have not been detected before. We want to draw a small amount of blood and test it in the lab to see if you have been exposed to germs that are carried by ticks.

Expertise in the study: The study is being run by Olivia Wesula Lwande a PhD student in Medical Virology at the Department of Medical Virology, University of Pretoria (Student number:11346192), Dr. Rosemary Sang and a team of doctors and scientists from Kenya Medical Research Institute (KEMRI), Ministry of Public Health and Sanitation (MPH&S), International Centre of Insect Physiology and Ecology (ICIPE), International Livestock Research Institute (ILRI) and Ministry of Livestock/Department of Veterinary Services (MOL/DVS).

Participation: Participation in this study is voluntary. There is no penalty for refusing to participate. We will need only one sample from you but if need arises, we may come back to you to take a second sample to confirm our finding. If you start the study you (or your child) may discontinue your (or your child's) participation at any time. The principal investigators

and co- investigators from KEMRI and MOP&S may decide to withdraw you (or your child) from the study if we are unable to obtain a blood sample from you (or your child).

Study procedure: You will be asked some questions about where you live, your illness and any medications you may have taken recently. Then about a tablespoon of blood will be taken from a vein in your arm. The blood will be put into small tubes so we can test for germs that may be causing your illness. We will not test for Human Immunodeficiency Virus (HIV).

Risks involved in the study: There is the possibility of mild discomfort, bruising and very rarely infection at the site where the blood is taken. But, should you (or your child) be injured as a direct result of participating in this research project, you (or your child) will be provided medical care, at no cost to you (or your child), for that injury. You (or your child) will not receive any injury compensation, only medical care. You (your child) should also understand that this is not a waiver or release of your (your child's) legal rights. If you wish, you should discuss this issue thoroughly with the principal investigator before you (your child) enroll in this study.

Benefits from the study: The study can lead to a better understanding of the causes of acute febrile illnesses in Kenya and improve the medical care in Kenya by improving detection methods and identifying some of the hidden germs that may be causing disease. The Ministry of Health (MoH) and supporting medical community can benefit from the knowledge of the identification of new or emerging diseases as the cause of acute febrile illnesses so that they know how to care for you and others in the future. Epidemics can be more readily identified, allowing the MoH to respond in a timely manner hence reducing the number of people who get affected.

Compensation for being in the study: There is no compensation to volunteers for their participation.

Duration: This study requires only completion of a short questionnaire and one blood draw. There is no follow-up or further information needed. The questionnaire and blood draw will take about 15 minutes.

Study participants: Anyone can participate in the study if you have a fever without a source after evaluation by the clinician. If there is an obvious source of infection causing the fever, like an abscess or pneumonia, you need not (your child should not) participate.

Confidentiality: Any information about you (your child's) will remain confidential. Only the people involved in the study will be able to see your information. We will keep all files in locked cabinets when they are not in use, and all blood stored in locked freezers. Your (your child's) name will not be used in any report resulting from this study. Any report from this study will refer to you/your child only by a study identification number and not by a name. All blood samples collected will be labeled with a study identification number; no names will be used. Your (your child's) blood will be tested for things that could cause fever. Your blood will not be tested for HIV. A sample of your blood will be kept frozen in case we want to do more testing on it in the future. These samples will be labeled with only your study number. They will be secured in freezers at KEMRI, ILRI or ICIPE facilities and only study investigators and their authorized staff will have access. All safeguards ensuring privacy and confidentiality that are in place during this study period will also continue to be in place for the long-term storage of samples and if samples are sent outside of Kenya, no personal identifiers will be included.

If we do need to use the stored blood in the future we will first get permission from the Kenya National Ethical Review Committee.

Study contact on information about the study or my rights as a volunteer in this research

study: If during the course of this study, you have questions concerning the nature of the research or you believe you have sustained a research-related injury, you should contact either:

Ms. Olivia Wesula Lwande International Centre for Insect Physiology and Ecology, P.O. Box 30772-00100, NAIROBI Tel: 0725984059 or Dr. Rosemary Sang, Centre for Virus Research, KEMRI PO Box 54628, NAIROBI Tel. 0722 759492.

Who should I contact if I have questions on my rights as a volunteer in this research

study: If you have any question on your rights as a volunteer, you or your parent should contact: **The Secretary, National Ethical Review Committee, Kenya Medical Research Institute, P.O. Box 54840, Nairobi, Kenya Tel. 254-20-2722541.**

IF THERE IS ANY PORTION OF THIS CONSENT AGREEMENT THAT YOU DO NOT UNDERSTAND, PLEASE TALK TO SOMEONE ON THE STUDY TEAM BEFORE SIGNING.

Subject Name _____

Subject's or Parent/Guardian's Signature: _____ Date: _____

Physical Address/Home Description: _____

Family Name/Homestead Name: _____

Witness's Name: _____

Witness's Signature: _____

Date: _____

Study Number: _____

Thumbprint of Volunteer or Volunteer's
Parent/Guardian if Unable to Sign

Person Administering Consent:

Name: _____ Signature: _____

Stick Barcode Label here

Interviewer's Name:

Appendix B

Assent Form for Individuals above 5 through 17 Years of Age

NOTE: This form should be signed by children above 5 years of age through 17 years of age who should give their assent when a parent or guardian has given permission to enroll.

What is the study called: Tick-borne virus prevalence and diversity in pastoral eco-zone of Ijara district, North Eastern Province of Kenya.

Who is running the study: The study is being run by Ms. Olivia Wesula Lwande and Dr Rosemary Sang, and a team of doctors and scientists from Kenya Medical Research Institute (KEMRI), Ministry of Public Health and Sanitation (MPH&S), International Centre of Insect Physiology and Ecology (ICIPE), International Livestock Research Institute (ILRI) and Ministry of Livestock/Department of Veterinary Services (MOL/DVS).

Introduction: We are interested in finding out what germs cause fever and/or malaria like illness. We want to draw a small amount of blood and test it in the lab to see if we can find the germ that is causing your illness. We are asking you to be in this research study because you may have signs and symptoms that may have come due to this germ.

Purpose: The purpose of this study is to find out what germs cause fever and/or malaria like illness.

Procedures: You will be asked some questions about where you live and your illness. You may participate in this study by giving only blood. About a tablespoon of blood will be taken from a vein in your arm. The blood will be put into small tubes so we that can test for germs that may be causing your illness. These samples are only for this study.

Long Term Storage of Specimens

After the tests have been performed, we will store samples that are left in a confidential manner for future testing. After this study is over, we may do new tests for germs that might have caused your illness. We will not report the results of these tests to your doctor or to you. We will not do human genetic testing or test for evidence of HIV (human immunodeficiency virus) infection of the samples that you provide. If at a later date you change your mind, you may ask to remove these samples from long term storage and destroy them. If you choose to do so, please contact: **Dr. Rosemary Sang, Centre for Virus Research, Kenya Medical Research Institute, PO Box 54628, NAIROBI, Tel. 0722 759492** or **Dr. Charles Nzioka, Division of Disease surveillance and response (DDSR), Ministry of Public Health and Sanitation P. O. Box 30016-00100, NAIROBI Tel: 0721234904.**

Risks and Discomforts

Your doctor will take blood from your arm using a needle. Drawing the blood may hurt a little. It may also cause some bruising, bleeding, and slight soreness at the puncture site. There is a small chance you could get germs in the spot where the blood was taken and become infected. If the area around the spot gets red and sore, you would need to go to the clinic.

Benefits: You will not directly benefit from the study. There is a benefit to society in general, through finding the cause of germs that may be causing your illness.

Confidentiality: We will keep the data collection, informed consent/permission and assent forms in a locked filing cabinet. Only study staff will be allowed to look at them. We will keep the forms private as much as legally possible. To protect your privacy, we will keep records and samples under code numbers rather than by name. However, we will maintain a link between code numbers and the forms that we keep in locked files. Your name or other facts that might point to you will not appear when we present this study or publish its results.

Costs/Compensation: Your parent/guardian will be responsible for the routine medical costs from your visit. These are costs that you would have if you were not in the research study. You will have no charge for collection of blood samples. You will not pay for the research tests that we will do on these samples.

Right to Refuse or Withdraw: You do not have to be in this study. We will give you the usual care for your condition whether or not you are in the study, or if you leave the study later. You may leave the study at any time.

Persons to Contact: By signing this consent form and agreeing to be in this study, you are not giving up any of your rights. If you believe that you have been harmed, please contact: **Dr. Rosemary Sang, Centre for Virus Research, Kenya Medical Research Institute, PO Box 54628, NAIROBI, Tel. 0722 759492 or Dr. Charles Nzioka, Division of Disease surveillance and response (DDSR), Ministry of Public Health and Sanitation P. O. Box 30016-00100, NAIROBI Tel: 0721234904.**

If you have any question on your rights as a volunteer, you or your parent should contact.

The Secretary, National Ethical Review Committee

C/o Kenya Medical Research Institute

P.O. Box 54840, Nairobi, Kenya

Tel. 254-20-2722541

IF THERE IS ANY PORTION OF THIS CONSENT AGREEMENT THAT YOU DO NOT UNDERSTAND, PLEASE ASK STUDY TEAM BEFORE SIGNING.

Subjects Name: _____

Subject's or Guardian's Signature: _____

Permanent Address: _____ Date: _____

Witness's Name: _____

Witness's Signature: _____

Study Number: _____ Date: _____

Thumbprint of Volunteer or Volunteer's
Parent/Guardian if Unable to Sign

Person Administering Consent:

Name: _____ Signature: _____

Stick Barcode Label here

Appendix C

Parent/Guardian Permission Form for Individuals above 5 through 17 Years of Age

NOTE: This form should be signed by patients 18 years of age or older who are able to give their legal consent. Minor children ages 5 to 17 should sign this form to give their assent when a parent or guardian has given permission to enroll.

What is the study called: Tick-borne virus prevalence and diversity in pastoral eco-zone of Ijara district, North Eastern Province of Kenya.

Who is running the study: The study is being run by Ms. Olivia Wesula Lwande and Dr Rosemary Sang and a team of doctors and scientists from Kenya Medical Research Institute (KEMRI), Ministry of Public Health and Sanitation (MPH&S), International Centre of Insect Physiology and Ecology (ICIPE), International Livestock Research Institute (ILRI) and Ministry of Livestock/Department of Veterinary Services (MOL/DVS).

Introduction: We are interested in finding out what germs cause fever and/or malaria like illness. We want to draw a small amount of blood and test it in the lab to see if we can find the germ that is causing your illness. We are asking you/your child to be in this research study because you/your child may have illness that may have come due to this germ.

Purpose: The purpose of this study is to find out what germs cause fever and/or malaria like illness.

Procedures: You/your child will be asked some questions about where you live, your illness and any medications you may have taken recently. You/your child may participate in this study by giving only blood. About a tablespoon of blood will be taken from a vein in your arm. The blood will be put into small tubes so we can test for germs that may be causing your illness. These samples are only for this study.

Long Term Storage of Specimens

After the tests have been performed, we will store samples that are left in a confidential manner for future testing. After this study is over, we may do new tests for germs that might have caused your/your child's rash as these tests become available. We will not report the results of these tests to your doctor or to you. We will not do human genetic testing or test for evidence of HIV (human immunodeficiency virus) infection of the samples that you or your child provide. If at a later date you change your mind, you may ask to remove these samples from long term storage and destroy them. If you choose to do so, please contact: **Dr. Rosemary Sang, Centre for Virus Research, Kenya Medical Research Institute, PO Box 54628, NAIROBI, Tel. 0722759492 or Dr. Charles Nzioka, Division of Disease surveillance and response (DDSR), Ministry of Public Health and Sanitation P. O. Box 30016-00100, NAIROBI Tel: 0721234904.**

Risks and Discomforts

Your doctor will take blood from your/your child's arm using a needle. Drawing the blood may hurt a little. It may also cause some bruising, bleeding, and slight soreness at the puncture site. There is a small chance you/your child could get germs in the spot where the blood was taken and become infected. If the area around the spot gets red and sore, you/your child would need to go to the clinic.

Benefits: You/your child will not directly benefit from the study. There is a benefit to society in general, through finding the cause of germs that may be causing your illness.

Confidentiality: we will keep the data collection, informed consent/permission and assent forms in a locked file. Only study staff will be allowed to look at them. We will keep the forms private as much as legally possible. To protect your/your child's privacy, we will keep records and samples under numbers rather than by name. However, we will maintain a link between code numbers and the forms that we keep in locked files. Your/your child's

name or other facts that might point to you/your child will not appear when we present this study or publish its results.

Costs/Compensation: You will be responsible for the routine medical costs from your/your child's visit. These are costs that you would have if you/your child were not in the research study. You will have no charge for collection of blood samples. You will not pay for the research tests that we will do on these samples.

Right to Refuse or Withdraw: You/your child does not have to be in this study. We will give you/your child the usual care for your/your child's condition whether or not you/your child are in the study, or if you/your child leave the study later. To leave the study, please contact your doctor. You/your child may leave the study at any time.

Persons to Contact: By signing this consent form and agreeing to be in this study, you are not giving up any of your rights. If you believe that you/your child have been harmed, please contact: **Dr. Rosemary Sang, Centre for Virus Research, Kenya Medical Research Institute, PO Box 54628, NAIROBI, Tel. 0722 759492** or **Dr. Charles Nzioka, Division of Disease surveillance and response (DDSR), Ministry of Public Health and Sanitation P. O. Box 30016-00100, NAIROBI Tel: 0721234904.**

If you have any question on your rights as a volunteer, you or your parent should contact.

The Secretary, National Ethical Review Committee

C/o Kenya Medical Research Institute

P.O. Box 54840, Nairobi, Kenya

Tel. 254-20-2722541

IF THERE IS ANY PORTION OF THIS CONSENT AGREEMENT THAT YOU DO NOT UNDERSTAND, PLEASE ASK STUDY TEAM BEFORE SIGNING.

Subjects Name: _____

Subject's or Guardian's Signature: _____

Permanent Address: _____

Date: _____

Witness's Name: _____

Witness's Signature: _____

Study Number: _____

Date: _____

Thumbprint of Volunteer or
Volunteer's Parent/Guardian if Unable
to sign

Person Administering Consent:

Name: _____ Signature: _____

Stick Barcode Label here

Appendix D

QUESTIONNAIRE ON HUMAN EXPOSURE TO CRIMEAN-CONGO HEMORRHAGIC FEVER

Patient details:

Date of collection: _____ (dd/month/yr)

Sex: 1. Male 2. Female Age: _____ years

Where is you (your child's) current residence?

Village _____ District _____

Province: _____

How long have you (your child) been living in this district?

_____ years

_____ months

During the past five days, where have you (your child) been mostly (check one)?

- Village of residence
- In the country, but not in residence, Where? _____
- Out of the country, Where? _____

How many times have you (your child) traveled outside of your district in the last two months: _____

How long ago: <2 weeks 2-4 weeks 1-2 months

Where: _____

How long ago: <2 weeks 2-4 weeks 1-2 months

Where: _____

How long ago: <2 weeks 2-4 weeks 1-2 months

Where: _____

Have you (your child) ever received a yellow fever vaccine?

1. Yes 2. No 3. Unknown

Date of vaccination (if known) _____(day/month/year)

If adult: What is your occupation: _____ If child:

Where do you go to school: _____ Do you

have contact with any of the following species of animals?

1. Bats
2. Geese
3. Ducks
4. Chickens
5. Other- Specify_____

Indicate which birds using the codes above (1-5):_____

6. Goats
7. Cows
8. Donkeys
9. Camels
10. Monkeys

Indicate which animals using the codes above (6-10): _____ Tick

Bites: Yes/No _____

Others bites

For each species checked above:

List the species using the given codes _____

2) Describe the contact, e.g., trapping, farming, slaughter, food preparation, veterinary work, casual contact (e.g., a neighbor keeps chickens, there is a slaughterhouse nearby), eating raw fowl products or drinking blood_

3. Were the animals showing signs of illness? Yes No

If **Yes** above, Specify the signs.

YOUR CURRENT ILLNESS:

Why did you (your child) come to the hospital:

Did you (your child) have any of the following:

Signs/Symptoms	Yes	No	Uncertain
Fever/Chills			
Rash			
Abdominal pain			
Muscle pain			
Vomiting			
Headache			

Do you (your child) have any symptoms we did not mention: _ If bleeding, where:

1. N/A 2. Gums 3. Nose 4. Injection sites

5. Other, Specify _____

How many days have you (your child) been sick: _____ Date of Onset: ____ How

many days of school or work have you (your child) missed: ____

Does anyone you know have a similar illness? Yes No

Who: _____ When did they become ill _____ Who: _____

_____ When did they become ill _____ Who: _____

_____ When did they become ill _____

What was your temperature in the clinic: _____ °C

DIAGNOSES MADE BY MINISTRY OF HEALTH PROVIDER:

1. _____

2. _____

TREATMENT PRESCRIBED BY MINISTRY OF HEALTH PROVIDER:

1. _____

2. _____

3. _____

Appendix E

Table 16. Amino acid substitution table for Semliki forest virus non-structural protein gene (nsP1–4).

X04129_USA_1987	M	A	A	K	V	H	V	D	I	E	A	D	S	P	F	I	K	S	L	Q	K	A	F	P	S	F	E	V	E	S	[30]
ATH000510_KENYA_2012	[30]
AMH001859_KENYA_2009	[30]
X04129_USA_1987	L	Q	V	T	P	N	D	H	A	N	A	R	A	F	S	H	L	A	T	K	L	I	E	Q	E	T	D	K	D	T	[60]
ATH000510_KENYA_2012	[60]
AMH001859_KENYA_2009	[60]
X04129_USA_1987	L	I	L	D	I	G	S	A	P	S	R	R	M	M	S	T	H	K	Y	H	C	V	C	P	M	R	S	A	E	D	[90]
ATH000510_KENYA_2012	[90]
AMH001859_KENYA_2009	[90]
X04129_USA_1987	P	E	R	L	D	S	Y	A	K	K	L	A	A	A	S	G	K	V	L	D	R	E	I	A	G	K	I	T	D	L	[120]
ATH000510_KENYA_2012	V	C	[120]
AMH001859_KENYA_2009	V	C	[120]
X04129_USA_1987	Q	T	V	M	A	T	P	D	A	E	S	P	T	F	C	L	H	T	D	V	T	C	R	T	A	A	E	V	A	V	[150]
ATH000510_KENYA_2012	K	[150]
AMH001859_KENYA_2009	K	[150]
X04129_USA_1987	Y	Q	D	V	Y	A	V	H	A	P	T	S	L	Y	H	Q	A	M	K	G	V	R	T	A	Y	W	I	G	F	D	[180]
ATH000510_KENYA_2012	[180]
AMH001859_KENYA_2009	[180]
X04129_USA_1987	T	T	P	F	M	F	D	A	L	A	G	A	Y	P	T	Y	A	T	N	W	A	D	E	Q	V	L	Q	A	R	N	[210]
ATH000510_KENYA_2012	[210]
AMH001859_KENYA_2009	[210]
X04129_USA_1987	I	G	L	C	A	A	S	L	T	E	G	R	L	G	K	L	S	I	L	R	K	K	Q	L	K	P	C	D	T	V	[240]
ATH000510_KENYA_2012	S	.	.	.	[240]
AMH001859_KENYA_2009	S	.	.	.	[240]

X04129_USA_1987	M	F	S	V	G	S	T	L	Y	T	E	S	R	K	L	L	R	S	W	H	L	P	S	V	F	H	L	K	G	K	[270]
ATH000510_KENYA_2012	[270]
AMH001859_KENYA_2009	[270]
X04129_USA_1987	Q	S	F	T	C	R	C	D	T	I	V	S	C	E	G	Y	V	V	K	K	I	T	M	C	P	G	L	Y	G	K	[300]
ATH000510_KENYA_2012	[300]
AMH001859_KENYA_2009	[300]
X04129_USA_1987	T	V	G	Y	A	V	T	Y	H	A	E	G	F	L	V	C	K	T	T	D	T	V	K	G	E	R	V	S	F	P	[330]
ATH000510_KENYA_2012	H	[330]
AMH001859_KENYA_2009	H	[330]
X04129_USA_1987	V	C	T	Y	V	P	S	T	I	C	D	Q	M	T	G	I	L	A	T	D	V	T	P	E	D	A	Q	K	L	L	[360]
ATH000510_KENYA_2012	[360]
AMH001859_KENYA_2009	[360]
X04129_USA_1987	V	G	L	N	Q	R	I	V	V	N	G	R	T	Q	R	N	T	N	T	M	K	N	Y	L	L	P	I	V	A	V	[390]
ATH000510_KENYA_2012	[390]
AMH001859_KENYA_2009	[390]
X04129_USA_1987	A	F	S	K	W	A	R	E	Y	K	A	D	L	D	D	E	K	P	L	G	V	R	E	R	S	L	T	C	C	C	[420]
ATH000510_KENYA_2012	[420]
AMH001859_KENYA_2009	[420]
X04129_USA_1987	L	W	A	F	K	T	R	K	M	H	T	M	Y	K	K	P	D	T	Q	T	I	V	K	V	P	S	E	F	N	S	[450]
ATH000510_KENYA_2012	K	[450]
AMH001859_KENYA_2009	K	[450]
X04129_USA_1987	F	V	I	P	S	L	W	S	T	G	L	A	I	P	V	R	S	R	I	K	M	L	L	A	K	K	T	K	R	E	[480]
ATH000510_KENYA_2012	[480]
AMH001859_KENYA_2009	[480]
X04129_USA_1987	L	I	P	V	L	D	A	S	S	A	R	D	A	E	Q	E	E	K	E	R	L	E	A	E	L	T	R	E	A	L	[510]
ATH000510_KENYA_2012	.	.	.	A	[510]
AMH001859_KENYA_2009	.	.	.	A	[510]
X04129_USA_1987	P	P	L	V	P	I	A	P	A	E	T	G	V	V	D	V	D	V	E	E	L	E	Y	H	A	G	A	G	V	V	[540]
ATH000510_KENYA_2012	.	.	.	I	R	[540]

AMH001859_KENYA_2009	. . .	I R	[540]
X04129_USA_1987	E T P	R S A L K V T A Q P N D V L L G N Y V V L S P Q T V L	[570]
ATH000510_KENYA_2012	[570]
AMH001859_KENYA_2009	[570]
X04129_USA_1987	K S S	K L A P V H P L A E Q V K I I T H N G R A G G Y Q V D	[600]
ATH000510_KENYA_2012 R	[600]
AMH001859_KENYA_2009 R	[600]
X04129_USA_1987	G Y D	G R V L L P C G S A I P V P E F Q A L S E S A T M V Y	[630]
ATH000510_KENYA_2012	[630]
AMH001859_KENYA_2009	[630]
X04129_USA_1987	N E R	E F V N R K L Y H I A V H G P S L N T D E E N Y E K V	[660]
ATH000510_KENYA_2012	[660]
AMH001859_KENYA_2009	[660]
X04129_USA_1987	R A E	R T D A E Y V F D V D K K C C V K R E E A S G L V L V	[690]
ATH000510_KENYA_2012 I	[690]
AMH001859_KENYA_2009 I	[690]
X04129_USA_1987	G E L	T N P P F H E F A Y E G L K I R P S A P Y K T T V V G	[720]
ATH000510_KENYA_2012	[720]
AMH001859_KENYA_2009	[720]
X04129_USA_1987	V F G	V P G S G K S A I I K S L V T K H D L V T S G K K E N	[750]
ATH000510_KENYA_2012	[750]
AMH001859_KENYA_2009	[750]
X04129_USA_1987	C Q E	I V N D V K K H R G K G T S R E N S D S I L L N G C R	[780]
ATH000510_KENYA_2012 L D I Q A K T V	[780]
AMH001859_KENYA_2009 L D I Q A K T V	[780]
X04129_USA_1987	R A V	D I L Y V D E A F A C H S G T L L A L I A L V K P R S	[810]
ATH000510_KENYA_2012	[810]
AMH001859_KENYA_2009	[810]

X04129_USA_1987	K	V	V	L	C	G	D	P	K	Q	C	G	F	F	N	M	M	Q	L	K	V	N	F	N	H	N	I	C	T	E	[840]
ATH000510_KENYA_2012	[840]
AMH001859_KENYA_2009	[840]
X04129_USA_1987	V	C	H	K	S	I	S	R	R	C	T	R	P	V	T	A	I	V	S	T	L	H	Y	G	G	K	M	R	T	T	[870]
ATH000510_KENYA_2012	[870]
AMH001859_KENYA_2009	[870]
X04129_USA_1987	N	P	C	N	K	P	I	I	I	D	T	T	G	Q	T	K	P	K	P	G	D	I	V	L	T	C	F	R	G	W	[900]
ATH000510_KENYA_2012	[900]
AMH001859_KENYA_2009	[900]
X04129_USA_1987	A	K	Q	L	Q	L	D	Y	R	G	H	E	V	M	T	A	A	A	S	Q	G	L	T	R	K	G	V	Y	A	V	[930]
ATH000510_KENYA_2012	V	[930]
AMH001859_KENYA_2009	V	[930]
X04129_USA_1987	R	Q	K	V	N	E	N	P	L	Y	A	P	A	S	E	H	V	N	V	L	L	T	R	T	E	D	R	L	V	W	[960]
ATH000510_KENYA_2012	[960]
AMH001859_KENYA_2009	[960]
X04129_USA_1987	K	T	L	A	G	D	P	W	I	K	V	L	S	N	I	P	Q	G	N	F	T	A	T	L	E	E	W	Q	E	E	[990]
ATH000510_KENYA_2012	[990]
AMH001859_KENYA_2009	[990]
X04129_USA_1987	H	D	K	I	M	K	V	I	E	G	P	A	A	P	V	D	A	F	Q	N	K	A	N	V	C	W	A	K	S	L	[1020]
ATH000510_KENYA_2012	[1020]
AMH001859_KENYA_2009	[1020]
X04129_USA_1987	V	P	V	L	D	T	A	G	I	R	L	T	A	E	E	W	S	T	I	I	T	A	F	K	E	D	R	A	Y	S	[1050]
ATH000510_KENYA_2012	[1050]
AMH001859_KENYA_2009	[1050]
X04129_USA_1987	P	V	V	A	L	N	E	I	C	T	K	Y	Y	G	V	D	L	D	S	G	L	F	S	A	P	K	V	S	L	Y	[1080]
ATH000510_KENYA_2012	.	E	[1080]
AMH001859_KENYA_2009	.	E	[1080]
X04129_USA_1987	Y	E	N	N	H	W	D	N	R	P	G	G	R	M	Y	G	F	N	A	A	T	A	A	R	L	E	A	R	H	T	[1110]
ATH000510_KENYA_2012	[1110]

X04129_USA_1987	K	G	A	A	T	P	V	G	T	I	K	T	V	M	C	G	S	Y	P	V	I	H	A	V	A	P	N	F	S	A	[1410]
ATH000510_KENYA_2012	G	[1410]
AMH001859_KENYA_2009	G	[1410]
X04129_USA_1987	T	T	E	A	E	G	D	R	E	L	A	A	V	Y	R	A	V	A	A	E	V	N	R	L	S	L	S	S	V	A	[1440]
ATH000510_KENYA_2012	[1440]	
AMH001859_KENYA_2009	[1440]	
X04129_USA_1987	I	P	L	L	S	T	G	V	F	S	G	G	R	D	R	L	Q	Q	S	L	N	H	L	F	T	A	M	D	A	T	[1470]
ATH000510_KENYA_2012	[1470]	
AMH001859_KENYA_2009	[1470]	
X04129_USA_1987	D	A	D	V	T	I	Y	C	R	D	K	S	W	E	K	K	I	Q	E	A	I	D	M	R	T	A	V	E	L	L	[1500]
ATH000510_KENYA_2012	[1500]	
AMH001859_KENYA_2009	[1500]	
X04129_USA_1987	N	D	D	V	E	L	T	T	D	L	V	R	V	H	P	D	S	S	L	V	G	R	K	G	Y	S	T	T	D	G	[1530]
ATH000510_KENYA_2012	[1530]	
AMH001859_KENYA_2009	[1530]	
X04129_USA_1987	S	L	Y	S	Y	F	E	G	T	K	F	N	Q	A	A	I	D	M	A	E	I	L	T	L	W	P	R	L	Q	E	[1560]
ATH000510_KENYA_2012	L	[1560]	
AMH001859_KENYA_2009	L	[1560]	
X04129_USA_1987	A	N	E	R	I	C	L	Y	A	L	G	E	T	M	D	N	I	G	S	K	C	P	V	N	D	S	D	S	S	T	[1590]
ATH000510_KENYA_2012	.	.	.	Q	R	D	[1590]	
AMH001859_KENYA_2009	.	.	.	Q	R	D	[1590]	
X04129_USA_1987	P	P	R	T	V	P	C	L	C	R	Y	A	M	T	A	E	R	I	A	R	L	R	S	H	Q	V	K	S	M	V	[1620]
ATH000510_KENYA_2012	[1620]	
AMH001859_KENYA_2009	[1620]	
X04129_USA_1987	V	C	S	S	F	P	L	P	K	Y	H	V	D	G	V	Q	K	V	K	C	E	K	V	L	L	F	D	P	T	V	[1650]
ATH000510_KENYA_2012	[1650]	
AMH001859_KENYA_2009	[1650]	
X04129_USA_1987	P	S	V	V	S	P	R	K	Y	A	A	S	T	T	D	H	S	D	R	S	L	R	G	F	D	L	D	W	T	T	[1680]
ATH000510_KENYA_2012	[1680]	

AMH001859_KENYA_2009	[1680]					
X04129_USA_1987	D	S	S	S	T	A	S	D	T	M	S	L	P	S	L	Q	S	C	D	I	D	S	I	Y	E	P	M	A	P	I	[1710]	
ATH000510_KENYA_2012	V	[1710]
AMH001859_KENYA_2009	V	[1710]
X04129_USA_1987	V	V	T	A	D	V	H	P	E	P	A	G	I	A	D	L	A	A	D	V	H	P	E	P	A	D	H	V	D	L	[1740]	
ATH000510_KENYA_2012	A	[1740]
AMH001859_KENYA_2009	A	[1740]
X04129_USA_1987	E	N	P	I	P	P	P	R	P	K	R	A	A	Y	L	A	S	R	A	A	E	R	P	V	P	A	P	R	K	P	[1770]	
ATH000510_KENYA_2012	.	S	[1770]
AMH001859_KENYA_2009	.	S	[1770]
X04129_USA_1987	T	P	A	P	R	T	A	F	R	N	K	L	P	L	T	F	G	D	F	D	E	H	E	V	D	A	L	A	S	G	[1800]	
ATH000510_KENYA_2012	V	[1800]
AMH001859_KENYA_2009	V	[1800]
X04129_USA_1987	I	T	F	G	D	F	D	D	V	L	R	L	G	R	A	G	A	Y	I	F	S	S	D	T	G	S	G	H	L	Q	[1830]	
ATH000510_KENYA_2012	[1830]
AMH001859_KENYA_2009	[1830]
X04129_USA_1987	Q	K	S	V	R	Q	H	N	L	Q	C	A	Q	L	D	A	V	Q	E	E	K	M	Y	P	P	K	L	D	T	E	[1860]	
ATH000510_KENYA_2012	[1860]
AMH001859_KENYA_2009	[1860]
X04129_USA_1987	R	E	K	L	L	L	L	K	M	Q	M	H	P	S	E	A	N	K	S	R	Y	Q	S	R	K	V	E	N	M	K	[1890]	
ATH000510_KENYA_2012	[1890]
AMH001859_KENYA_2009	[1890]
X04129_USA_1987	A	T	V	V	D	R	L	T	S	G	A	R	L	Y	T	G	A	D	V	G	R	I	P	T	Y	A	V	R	Y	P	[1920]	
ATH000510_KENYA_2012	[1920]
AMH001859_KENYA_2009	[1920]
X04129_USA_1987	R	P	V	Y	S	P	T	V	I	E	R	F	S	S	P	D	V	A	I	A	A	C	N	E	Y	L	S	R	N	Y	[1950]	
ATH000510_KENYA_2012	[1950]
AMH001859_KENYA_2009	[1950]

X04129_USA_1987	P	T	V	A	S	Y	Q	I	T	D	E	Y	D	A	Y	L	D	M	V	D	G	S	D	S	C	L	D	R	A	T	[1980]
ATH000510_KENYA_2012	E	[1980]
AMH001859_KENYA_2009	E	[1980]
X04129_USA_1987	F	C	P	A	K	L	R	C	Y	P	K	H	H	A	Y	H	Q	P	T	V	R	S	A	V	P	S	P	F	Q	N	[2010]
ATH000510_KENYA_2012	[2010]
AMH001859_KENYA_2009	[2010]
X04129_USA_1987	T	L	Q	N	V	L	A	A	A	T	K	R	N	C	N	V	T	Q	M	R	E	L	P	T	M	D	S	A	V	F	[2040]
ATH000510_KENYA_2012	[2040]
AMH001859_KENYA_2009	[2040]
X04129_USA_1987	N	V	E	C	F	K	R	Y	A	C	S	G	E	Y	W	E	E	Y	A	K	Q	P	I	R	I	T	T	E	N	I	[2070]
ATH000510_KENYA_2012	[2070]
AMH001859_KENYA_2009	[2070]
X04129_USA_1987	T	T	Y	V	T	K	L	K	G	P	K	A	A	A	L	F	A	K	T	H	N	L	V	P	L	Q	E	V	P	M	[2100]
ATH000510_KENYA_2012	[2100]
AMH001859_KENYA_2009	[2100]
X04129_USA_1987	D	R	F	T	V	D	M	K	R	D	V	K	V	T	P	G	T	K	H	T	E	E	R	P	K	V	Q	V	I	Q	[2130]
ATH000510_KENYA_2012	[2130]
AMH001859_KENYA_2009	[2130]
X04129_USA_1987	A	A	E	P	L	A	T	A	Y	L	C	G	I	H	R	E	L	V	R	R	L	N	A	V	L	R	P	N	V	H	[2160]
ATH000510_KENYA_2012	[2160]
AMH001859_KENYA_2009	[2160]
X04129_USA_1987	T	L	F	D	M	S	A	E	D	F	D	A	I	I	A	S	H	F	H	P	G	D	P	V	L	E	T	D	I	A	[2190]
ATH000510_KENYA_2012	[2190]
AMH001859_KENYA_2009	[2190]
X04129_USA_1987	S	F	D	K	S	Q	D	D	S	L	A	L	T	G	L	M	I	L	E	D	L	G	V	D	Q	Y	L	L	D	L	[2220]
ATH000510_KENYA_2012	[2220]
AMH001859_KENYA_2009	[2220]
X04129_USA_1987	I	E	A	A	F	G	E	I	S	S	C	H	L	P	T	G	T	R	F	K	F	G	A	M	M	K	S	G	M	F	[2250]
ATH000510_KENYA_2012	[2250]

Table 17. Nucleotide substitutions at the 26S junction region of Ndumu virus

NDUV_USA_2010	T	T	T	A	A	G	T	T	T	G	G	G	G	C	C	A	T	G	A	T	G	A	A	G	T	C	C	G	G	A	[6805]	
ATH002166_KENYA_2012	[6805]	
NDUV_USA_2010	A	T	G	T	T	T	C	T	G	A	C	G	T	T	A	T	T	T	G	T	T	A	A	C	A	C	G	C	T	G	[6835]	
ATH002166_KENYA_2012	[6835]	
NDUV_USA_2010	C	T	T	A	A	C	G	T	C	G	T	T	A	T	A	G	C	T	A	G	T	C	G	C	G	T	C	C	T	A	[6865]	
ATH002166_KENYA_2012	G	[6865]		
NDUV_USA_2010	G	A	A	T	C	C	A	A	A	T	T	G	A	C	G	G	G	G	T	C	G	C	G	A	T	G	T	G	C	C	[6895]	
ATH002166_KENYA_2012	T	[6895]		
NDUV_USA_2010	G	C	C	T	T	C	A	T	T	G	G	G	G	A	C	G	A	T	A	A	C	A	T	C	G	T	G	C	A	T	[6925]	
ATH002166_KENYA_2012	[6925]		
NDUV_USA_2010	G	G	C	G	T	G	G	T	C	T	C	A	G	A	T	A	A	G	T	T	G	A	T	G	G	C	A	G	A	A	[6955]	
ATH002166_KENYA_2012	[6955]		
NDUV_USA_2010	A	G	G	T	G	T	G	C	C	A	C	C	T	G	G	A	T	G	G	A	A	C	A	T	G	G	A	G	G	T	G	[6985]
ATH002166_KENYA_2012	C	G	T	G	C	[6985]		
NDUV_USA_2010	A	A	A	A	T	T	A	T	C	G	A	C	G	C	A	G	T	C	A	T	C	G	G	A	G	A	A	A	A	A	[7015]	
ATH002166_KENYA_2012	[7015]		
NDUV_USA_2010	C	A	C	C	C	G	T	A	T	T	T	C	T	G	C	G	G	C	G	G	G	T	T	C	A	T	C	C	T	A	[7045]	
ATH002166_KENYA_2012	[7045]		
NDUV_USA_2010	C	A	G	G	A	T	G	C	T	G	T	G	A	C	C	G	G	C	A	C	G	G	C	G	T	G	C	C	G	A	[7075]	
ATH002166_KENYA_2012	[7075]		

NDUV_USA_2010	G	T	A	T	C	C	G	A	C	C	C	A	T	T	G	A	A	G	A	G	A	C	T	G	T	T	T	A	A	G	[7105]
ATH002166_KENYA_2012	T	C	[7105]
NDUV_USA_2010	T	T	G	G	G	T	A	A	A	C	C	A	C	T	G	C	C	T	G	C	G	G	A	C	G	A	T	G	A	G	[7135]
ATH002166_KENYA_2012	[7135]
NDUV_USA_2010	C	A	G	G	A	T	G	A	G	G	A	C	C	G	C	A	G	A	C	G	A	G	C	A	C	T	C	C	G	T	[7165]
ATH002166_KENYA_2012	[7165]
NDUV_USA_2010	G	A	C	G	A	G	G	T	G	A	T	G	A	G	A	T	G	[7182]													
ATH002166_KENYA_2012	C	.	G	A	.	.	.	[7182]													

Sequence alignment of the 26S junction region of the nucleotide sequences of NDUV isolated in Kenya and reference strain (NC_016959). Region sequenced; position 6775 to 7182. Study isolate highlighted in red.

Table 18. Amino acid substitutions at Nucleocapsid (N) and Non- structural (NSs) gene regions of Bunyamwera virus.

BUNV_USA_1989	L	L	T	P	A	V	L	L	T	Q	R	S	H	T	L	T	L	S	V	S	T	P	L	G	L	V	M	T	T	Y	[30]
ATH002298_KENYA_2012	[30]
ATH001860_KENYA_2012	[30]
ATH002318_KENYA_2012	[30]
ATH002016_KENYA_2012	[30]
ATH002274_KENYA_2012	[30]
ATH000652_KENYA_2012	[30]
ATH001182_KENYA_2012	[30]
ATH001136_KENYA_2012	[30]
ATH002346_KENYA_2012	[30]
BUNV_USA_1989	E	S	S	T	L	K	D	A	R	L	K	L	V	S	Q	K	E	V	N	G	K	L	H	L	T	L	G	A	G	R	[60]
ATH002298_KENYA_2012	L	[60]
ATH001860_KENYA_2012	L	[60]
ATH002318_KENYA_2012	L	[60]
ATH002016_KENYA_2012	L	[60]
ATH002274_KENYA_2012	L	[60]
ATH000652_KENYA_2012	L	[60]
ATH001182_KENYA_2012	L	[60]
ATH001136_KENYA_2012	L	[60]
ATH002346_KENYA_2012	L	[60]

BUNV_USA_1989	L	L	Y	I	I	R	I	F	L	A	T	G	T	T	Q	F	L	T	M	V	L	P	S	[83]	
ATH002298_KENYA_2012	[83]
ATH001860_KENYA_2012	[83]
ATH002318_KENYA_2012	[83]
ATH002016_KENYA_2012	[83]
ATH002274_KENYA_2012	[83]
ATH000652_KENYA_2012	[83]
ATH001182_KENYA_2012	[83]
ATH001136_KENYA_2012	[83]
ATH002346_KENYA_2012	[83]

Sequence alignment of N and the NSs gene amino acid sequences of Kenyan BUNV isolates alongside BUNV reference strain (NC_001927). Region sequenced; position 1 to 83. Study isolates highlighted in red.

Table 19. Amino acid substitutions at M protein gene (NSm and Gc) of Bunyamwera virus

BUNV_USA_1986	I	L	E	V	L	T	K	I	N	V	I	F	C	N	E	C	N	M	Y	H	S	K	K	S	I	K	Y	V	G	D	[30]	
ATH002166_KENYA_2012	[30]
BUNV_USA_1986	F	T	N	K	C	G	F	C	T	C	G	L	L	E	D	P	E	G	V	V	V	H	K	A	K	K	S	C	T	Y	[60]	
ATH002166_KENYA_2012	[60]	
BUNV_USA_1986	S	Y	Q	I	N	W	V	R	G	I	M	I	F	V	A	F	L	F	V	I	Q	N	T	I	I	M	V	A	A	E	[90]	
ATH002166_KENYA_2012	S	.	.	K	[90]		
BUNV_USA_1986	E	D	C	W	K	N	E	E	L	K	E	D	C	V	G	P	L	I	A	P	K	D	C	T	D	K	D	[117]				
ATH002166_KENYA_2012	M	.	R	.	G	.	H	[117]				

Sequence alignment of M polyprotein gene (NSm and Gc) amino acid sequences of Kenyan BUNV isolate alongside BUNV reference strain (NC_001926). Region sequenced; position 1 to 117. Study isolate highlighted in red.

Table 20. Amino acid substitutions of the WNV polyprotein gene that corresponds to the structural (C, E and M) and non-structural (1, 2A, 2B, 3, 4A, 4B and 5) proteins

NY99_USA_2005	M	S	K	K	P	G	G	P	G	K	S	R	A	V	N	M	L	K	R	G	M	P	R	V	L	S	L	I	G	L	[30]	
ATH002316_Kenya_2012	[30]
NY99_USA_2005	K	R	A	M	L	S	L	I	D	G	K	G	P	I	R	F	V	L	A	L	L	A	F	F	R	F	T	A	I	A	[60]	
ATH002316_Kenya_2012	[60]
NY99_USA_2005	P	T	R	A	V	L	D	R	W	R	G	V	N	K	Q	T	A	M	K	H	L	L	S	F	K	K	E	L	G	T	[90]	
ATH002316_Kenya_2012	[90]
NY99_USA_2005	L	T	S	A	I	N	R	R	S	S	K	Q	K	K	R	G	G	K	T	G	I	A	V	M	I	G	L	I	A	S	[120]	
ATH002316_Kenya_2012	N	[120]
NY99_USA_2005	V	G	A	V	T	L	S	N	F	Q	G	K	V	M	M	T	V	N	A	T	D	V	T	D	V	I	T	I	P	T	[150]	
ATH002316_Kenya_2012	[150]
NY99_USA_2005	A	A	G	K	N	L	C	I	V	R	A	M	D	V	G	Y	M	C	D	D	T	I	T	Y	E	C	P	V	L	S	[180]	
ATH002316_Kenya_2012	[180]
NY99_USA_2005	A	G	N	D	P	E	D	I	D	C	W	C	T	K	S	A	V	Y	V	R	Y	G	R	C	T	K	T	R	H	S	[210]	
ATH002316_Kenya_2012	[210]
NY99_USA_2005	R	R	S	R	R	S	L	T	V	Q	T	H	G	E	S	T	L	A	N	K	K	G	A	W	M	D	S	T	K	A	[240]	
ATH002316_Kenya_2012	[240]
NY99_USA_2005	T	R	Y	L	V	K	T	E	S	W	I	L	R	N	P	G	Y	A	L	V	A	A	V	I	G	W	M	L	G	S	[270]	
ATH002316_Kenya_2012	[270]

NY99_USA_2005	N	T	M	Q	R	V	V	F	V	V	L	L	L	L	V	A	P	A	Y	S	F	N	C	L	G	M	S	N	R	D	[300]
ATH002316_Kenya_2012	[300]
NY99_USA_2005	F	L	E	G	V	S	G	A	T	W	V	D	L	V	L	E	G	D	S	C	V	T	I	M	S	K	D	K	P	T	[330]
ATH002316_Kenya_2012	[330]
NY99_USA_2005	I	D	V	K	M	M	N	M	E	A	A	N	L	A	E	V	R	S	Y	C	Y	L	A	T	V	S	D	L	S	T	[360]
ATH002316_Kenya_2012	[360]
NY99_USA_2005	K	A	A	C	P	T	M	G	E	A	H	N	D	K	R	A	D	P	A	F	V	C	R	Q	G	V	V	D	R	G	[390]
ATH002316_Kenya_2012	[390]
NY99_USA_2005	W	G	N	G	C	G	L	F	G	K	G	S	I	D	T	C	A	K	F	A	C	S	T	K	A	I	G	R	T	I	[420]
ATH002316_Kenya_2012	T	[420]
NY99_USA_2005	L	K	E	N	I	K	Y	E	V	A	I	F	V	H	G	P	T	T	V	E	S	H	G	N	Y	S	T	Q	V	G	[450]
ATH002316_Kenya_2012	I	.	.	[450]
NY99_USA_2005	A	T	Q	A	G	R	L	S	I	T	P	A	A	P	S	Y	T	L	K	L	G	E	Y	G	E	V	T	V	D	C	[480]
ATH002316_Kenya_2012	F	[480]
NY99_USA_2005	E	P	R	S	G	I	D	T	N	A	Y	Y	V	M	T	V	G	T	K	T	F	L	V	H	R	E	W	F	M	D	[510]
ATH002316_Kenya_2012	[510]
NY99_USA_2005	L	N	L	P	W	S	S	A	G	S	T	V	W	R	N	R	E	T	L	M	E	F	E	E	P	H	A	T	K	Q	[540]
ATH002316_Kenya_2012	[540]
NY99_USA_2005	S	V	I	A	L	G	S	Q	E	G	A	L	H	Q	A	L	A	G	A	I	P	V	E	F	S	S	N	T	V	K	[570]
ATH002316_Kenya_2012	G	.	R	S	C	I	K	.	W	L	E	P	S	L	W	I	[570]
NY99_USA_2005	L	T	S	G	H	L	K	C	R	V	K	M	E	K	L	Q	L	K	G	T	T	Y	G	V	C	S	K	A	F	K	[600]
ATH002316_Kenya_2012	[600]
NY99_USA_2005	F	L	G	T	P	A	D	T	G	H	G	T	V	V	L	E	L	Q	Y	T	G	T	D	G	P	C	K	V	P	I	[630]

ATH002316_Kenya_2012	V	[630]
NY99_USA_2005	S	S	V	A	S	L	N	D	L	T	P	V	G	R	L	V	T	V	N	P	F	V	S	V	A	T	A	N	A	K	[660]
ATH002316_Kenya_2012	S	[660]
NY99_USA_2005	V	L	I	E	L	E	P	P	F	G	D	S	Y	I	V	V	G	R	G	E	Q	Q	I	N	H	H	W	H	K	S	[690]
ATH002316_Kenya_2012	[690]
NY99_USA_2005	G	S	S	I	G	K	A	F	T	T	T	L	K	G	A	Q	R	L	A	A	L	G	D	T	A	W	D	F	G	S	[720]
ATH002316_Kenya_2012	[720]
NY99_USA_2005	V	G	G	V	F	T	S	V	G	K	A	V	H	Q	V	F	G	G	A	F	R	S	L	F	G	G	M	S	W	I	[750]
ATH002316_Kenya_2012	[750]
NY99_USA_2005	T	Q	G	L	L	G	A	L	L	L	W	M	G	I	N	A	R	D	R	S	I	A	L	T	F	L	A	V	G	G	[780]
ATH002316_Kenya_2012	[780]
NY99_USA_2005	V	L	L	F	L	S	V	N	V	H	A	D	T	G	C	A	I	D	I	S	R	Q	E	L	R	C	G	S	G	V	[810]
ATH002316_Kenya_2012	[810]
NY99_USA_2005	F	I	H	N	D	V	E	A	W	M	D	R	Y	K	Y	Y	P	E	T	P	Q	G	L	A	K	I	I	Q	K	A	[840]
ATH002316_Kenya_2012	[840]
NY99_USA_2005	H	K	E	G	V	C	G	L	R	S	V	S	R	L	E	H	Q	M	W	E	A	V	K	D	E	L	N	T	L	L	[870]
ATH002316_Kenya_2012	S	[870]
NY99_USA_2005	K	E	N	G	V	D	L	S	V	V	V	E	K	Q	E	G	M	Y	K	S	A	P	K	R	L	T	A	T	T	E	[900]
ATH002316_Kenya_2012	[900]
NY99_USA_2005	K	L	E	I	G	W	K	A	W	G	K	S	I	L	F	A	P	E	L	A	N	N	T	F	V	V	D	G	P	E	[930]
ATH002316_Kenya_2012	[930]
NY99_USA_2005	T	K	E	C	P	T	Q	N	R	A	W	N	S	L	E	V	E	D	F	G	F	G	L	T	S	T	R	M	F	L	[960]
ATH002316_Kenya_2012	[960]

NY99_USA_2005	K	V	R	E	S	N	T	T	E	C	D	S	K	I	I	G	T	A	V	K	N	N	L	A	I	H	S	D	L	S	[990]	
ATH002316_Kenya_2012	[990]
NY99_USA_2005	Y	W	I	E	S	R	L	N	D	T	W	K	L	E	R	A	V	L	G	E	V	K	S	C	T	W	P	E	T	H	[1020]	
ATH002316_Kenya_2012	[1020]
NY99_USA_2005	T	L	W	G	D	G	I	L	E	S	D	L	I	I	P	V	T	L	A	G	P	R	S	N	H	N	R	R	P	G	[1050]	
ATH002316_Kenya_2012	[1050]
NY99_USA_2005	Y	K	T	Q	N	Q	G	P	W	D	E	G	R	V	E	I	D	F	D	Y	C	P	G	T	T	V	T	L	S	E	[1080]	
ATH002316_Kenya_2012	[1080]
NY99_USA_2005	S	C	G	H	R	G	P	A	T	R	T	T	T	E	S	G	K	L	I	T	D	W	C	C	R	S	C	T	L	P	[1110]	
ATH002316_Kenya_2012	A	[1110]
NY99_USA_2005	P	L	R	Y	Q	T	D	S	G	C	W	Y	G	M	E	I	R	P	Q	R	H	D	E	K	T	L	V	Q	S	Q	[1140]	
ATH002316_Kenya_2012	[1140]
NY99_USA_2005	V	N	A	Y	N	A	D	M	I	D	P	F	Q	L	G	L	L	V	V	F	L	A	T	Q	E	V	L	R	K	R	[1170]	
ATH002316_Kenya_2012	[1170]
NY99_USA_2005	W	T	A	K	I	S	M	P	A	I	L	I	A	L	L	V	L	V	F	G	G	I	T	Y	T	D	V	L	R	Y	[1200]	
ATH002316_Kenya_2012	[1200]
NY99_USA_2005	V	I	L	V	G	A	A	F	A	E	S	N	S	G	G	D	V	V	H	L	A	L	M	A	T	F	K	I	Q	P	[1230]	
ATH002316_Kenya_2012	[1230]
NY99_USA_2005	V	F	M	V	A	S	F	L	K	A	R	W	T	N	Q	E	N	I	L	L	M	L	A	A	V	F	F	Q	M	A	[1260]	
ATH002316_Kenya_2012	M	[1260]
NY99_USA_2005	Y	H	D	A	R	Q	I	L	L	W	E	I	P	D	V	L	N	S	L	A	V	A	W	M	I	L	R	A	I	T	[1290]	
ATH002316_Kenya_2012	[1290]

NY99_USA_2005	F	T	T	T	S	N	V	V	V	P	L	L	A	L	L	T	P	G	L	R	C	L	N	L	D	V	Y	R	I	L	[1320]	
ATH002316_Kenya_2012	[1320]
NY99_USA_2005	L	L	M	V	G	I	G	S	L	I	R	E	K	R	S	A	A	A	K	K	K	G	A	S	L	L	C	L	A	L	[1350]	
ATH002316_Kenya_2012	[1350]
NY99_USA_2005	A	S	T	G	L	F	N	P	M	I	L	A	A	G	L	I	A	C	D	P	N	R	K	R	G	W	P	A	T	E	[1380]	
ATH002316_Kenya_2012	[1380]
NY99_USA_2005	V	M	T	A	V	G	L	M	F	A	I	V	G	G	L	A	E	L	D	I	D	S	M	A	I	P	M	T	I	A	[1410]	
ATH002316_Kenya_2012	[1410]
NY99_USA_2005	G	L	M	F	A	A	F	V	I	S	G	K	S	T	D	M	W	I	E	R	T	A	D	I	S	W	E	S	D	A	[1440]	
ATH002316_Kenya_2012	[1440]
NY99_USA_2005	E	I	T	G	S	S	E	R	V	D	V	R	L	D	D	D	G	N	F	Q	L	M	N	D	P	G	A	P	W	K	[1470]	
ATH002316_Kenya_2012	[1470]
NY99_USA_2005	I	W	M	L	R	M	V	C	L	A	I	S	A	Y	T	P	W	A	I	L	P	S	V	V	G	F	W	I	T	L	[1500]	
ATH002316_Kenya_2012	A	[1500]
NY99_USA_2005	Q	Y	T	K	R	G	G	V	L	W	D	T	P	S	P	K	E	Y	K	K	G	D	T	T	T	G	V	Y	R	I	[1530]	
ATH002316_Kenya_2012	[1530]
NY99_USA_2005	M	T	R	G	L	L	G	S	Y	Q	A	G	A	G	V	M	V	E	G	V	F	H	T	L	W	H	T	T	K	G	[1560]	
ATH002316_Kenya_2012	[1560]
NY99_USA_2005	A	A	L	M	S	G	E	G	R	L	D	P	Y	W	G	S	V	K	E	D	R	L	C	Y	G	G	P	W	K	L	[1590]	
ATH002316_Kenya_2012	[1590]
NY99_USA_2005	Q	H	K	W	N	G	Q	D	E	V	Q	M	I	V	V	E	P	G	K	N	V	K	N	V	Q	T	K	P	G	V	[1620]	
ATH002316_Kenya_2012	[1620]
NY99_USA_2005	F	K	T	P	E	G	E	I	G	A	V	T	L	D	F	P	T	G	T	S	G	S	P	I	V	D	K	N	G	D	[1650]	

NY99_USA_2005	G	G	H	T	N	E	D	D	S	N	F	A	H	W	T	E	A	R	I	M	L	D	N	I	N	M	P	N	G	L	[2010]
ATH002316_Kenya_2012	[2010]
NY99_USA_2005	I	A	Q	F	Y	Q	P	E	R	E	K	V	Y	T	M	D	G	E	Y	R	L	R	G	E	E	R	K	N	F	L	[2040]
ATH002316_Kenya_2012	[2040]
NY99_USA_2005	E	L	L	R	T	A	D	L	P	V	W	L	A	Y	K	V	A	A	A	G	V	S	Y	H	D	R	R	W	C	F	[2070]
ATH002316_Kenya_2012	[2070]
NY99_USA_2005	D	G	P	R	T	N	T	I	L	E	D	N	N	E	V	E	V	I	T	K	L	G	E	R	K	I	L	R	P	R	[2100]
ATH002316_Kenya_2012	[2100]
NY99_USA_2005	W	I	D	A	R	V	Y	S	D	H	Q	A	L	K	A	F	K	D	F	A	S	G	K	R	S	Q	I	G	L	I	[2130]
ATH002316_Kenya_2012	[2130]
NY99_USA_2005	E	V	L	G	K	M	P	E	H	F	M	G	K	T	W	E	A	L	D	T	M	Y	V	V	A	T	A	E	K	G	[2160]
ATH002316_Kenya_2012	[2160]
NY99_USA_2005	G	R	A	H	R	M	A	L	E	E	L	P	D	A	L	Q	T	I	A	L	I	A	L	L	S	V	M	T	M	G	[2190]
ATH002316_Kenya_2012	[2190]
NY99_USA_2005	V	F	F	L	L	M	Q	R	K	G	I	G	K	I	G	L	G	G	A	V	L	G	V	A	T	F	F	C	W	M	[2220]
ATH002316_Kenya_2012	V	[2220]
NY99_USA_2005	A	E	V	P	G	T	K	I	A	G	M	L	L	L	S	L	L	L	M	I	V	L	I	P	E	P	E	K	Q	R	[2250]
ATH002316_Kenya_2012	[2250]
NY99_USA_2005	S	Q	T	D	N	Q	L	A	V	F	L	I	C	V	M	T	L	V	S	A	V	A	A	N	E	M	G	W	L	D	[2280]
ATH002316_Kenya_2012	[2280]
NY99_USA_2005	K	T	K	S	D	I	S	S	L	F	G	Q	R	I	E	V	K	E	N	F	S	M	G	E	F	L	L	D	L	R	[2310]
ATH002316_Kenya_2012	[2310]

NY99_USA_2005	P	A	T	A	W	S	L	Y	A	V	T	T	A	V	L	T	P	L	L	K	H	L	I	T	S	D	Y	I	N	T	[2340]
ATH002316_Kenya_2012	[2340]	
NY99_USA_2005	S	L	T	S	I	N	V	Q	A	S	A	L	F	T	L	A	R	G	F	P	F	V	D	V	G	V	S	A	L	L	[2370]
ATH002316_Kenya_2012	[2370]	
NY99_USA_2005	L	A	A	G	C	W	G	Q	V	T	L	T	V	T	V	T	A	A	T	L	L	F	C	H	Y	A	Y	M	V	P	[2400]
ATH002316_Kenya_2012	S	[2400]		
NY99_USA_2005	G	W	Q	A	E	A	M	R	S	A	Q	R	R	T	A	A	G	I	M	K	N	A	V	V	D	G	I	V	A	T	[2430]
ATH002316_Kenya_2012	[2430]		
NY99_USA_2005	D	V	P	E	L	E	R	T	T	P	I	M	Q	K	K	V	G	Q	I	M	L	I	L	V	S	L	A	A	V	V	[2460]
ATH002316_Kenya_2012	[2460]		
NY99_USA_2005	V	N	P	S	V	K	T	V	R	E	A	G	I	L	I	T	A	A	A	V	T	L	W	E	N	G	A	S	S	V	[2490]
ATH002316_Kenya_2012	[2490]		
NY99_USA_2005	W	N	A	T	T	A	I	G	L	C	H	I	M	R	G	G	W	L	S	C	L	S	I	T	W	T	L	I	K	N	[2520]
ATH002316_Kenya_2012	[2520]		
NY99_USA_2005	M	E	K	P	G	L	K	R	G	G	A	K	G	R	T	L	G	E	V	W	K	E	R	L	N	Q	M	T	K	E	[2550]
ATH002316_Kenya_2012	.	D	[2550]		
NY99_USA_2005	E	F	T	R	Y	R	K	E	A	I	I	E	V	D	R	S	A	A	K	H	A	R	K	E	G	N	V	T	G	G	[2580]
ATH002316_Kenya_2012	[2580]		
NY99_USA_2005	H	P	V	S	R	G	T	A	K	L	R	W	L	V	E	R	R	F	L	E	P	V	G	K	V	I	D	L	G	C	[2610]
ATH002316_Kenya_2012	[2610]		
NY99_USA_2005	G	R	G	G	W	C	Y	Y	M	A	T	Q	K	R	V	Q	E	V	R	G	Y	T	K	G	G	P	G	H	E	E	[2640]
ATH002316_Kenya_2012	[2640]		
NY99_USA_2005	P	Q	L	V	Q	S	Y	G	W	N	I	V	T	M	K	S	G	V	D	V	F	Y	R	P	S	E	C	C	D	T	[2670]

NY99_USA_2005	S	R	A	I	W	F	M	W	L	G	A	R	F	L	E	F	E	A	L	G	F	L	N	E	D	H	W	L	G	R	[3030]	
ATH002316_Kenya_2012	[3030]
NY99_USA_2005	K	N	S	G	G	G	V	E	G	L	G	L	Q	K	L	G	Y	I	L	R	E	V	G	T	R	P	G	G	K	I	[3060]	
ATH002316_Kenya_2012	[3060]
NY99_USA_2005	Y	A	D	D	T	A	G	W	D	T	R	I	T	R	A	D	L	E	N	E	A	K	V	L	E	L	L	D	G	E	[3090]	
ATH002316_Kenya_2012	[3090]
NY99_USA_2005	H	R	R	L	A	R	A	I	I	E	L	T	Y	R	H	K	V	V	K	V	M	R	P	A	A	D	G	R	T	V	[3120]	
ATH002316_Kenya_2012	[3120]
NY99_USA_2005	M	D	V	I	S	R	E	D	Q	R	G	S	G	Q	V	V	T	Y	A	L	N	T	F	T	N	L	A	V	Q	L	[3150]	
ATH002316_Kenya_2012	[3150]
NY99_USA_2005	V	R	M	M	E	G	E	G	V	I	G	P	D	D	V	E	K	L	T	K	G	K	G	P	K	V	R	T	W	L	[3180]	
ATH002316_Kenya_2012	[3180]
NY99_USA_2005	F	E	N	G	E	E	R	L	S	R	M	A	V	S	G	D	D	C	V	V	K	P	L	D	D	R	F	A	T	S	[3210]	
ATH002316_Kenya_2012	[3210]
NY99_USA_2005	L	H	F	L	N	A	M	S	K	V	R	K	D	I	Q	E	W	K	P	S	T	G	W	Y	D	W	Q	Q	V	P	[3240]	
ATH002316_Kenya_2012	[3240]
NY99_USA_2005	F	C	S	N	H	F	T	E	L	I	M	K	D	G	R	T	L	V	V	P	C	R	G	Q	D	E	L	V	G	R	[3270]	
ATH002316_Kenya_2012	[3270]
NY99_USA_2005	A	R	I	S	P	G	A	G	W	N	V	R	D	T	A	C	L	A	K	S	Y	A	Q	M	W	L	L	L	Y	F	[3300]	
ATH002316_Kenya_2012	[3300]
NY99_USA_2005	H	R	R	D	L	R	L	M	A	N	A	I	C	S	A	V	P	V	N	W	V	P	T	G	R	T	T	W	S	I	[3330]	
ATH002316_Kenya_2012	[3330]

NY99_USA_2005	H	A	G	G	E	W	M	T	T	E	D	M	L	E	V	W	N	R	V	W	I	E	E	N	E	W	M	E	D	K	[3360]
ATH002316_Kenya_2012	I	.	.	.	[3360]
NY99_USA_2005	T	P	V	E	K	W	S	D	V	P	Y	S	G	K	R	E	D	I	W	C	G	S	L	I	G	T	R	A	R	A	[3390]
ATH002316_Kenya_2012	T	[3390]
NY99_USA_2005	T	W	A	E	N	I	Q	V	A	I	N	Q	V	R	A	I	I	G	D	E	K	Y	V	D	Y	M	S	S	L	K	[3420]
ATH002316_Kenya_2012	[3420]
NY99_USA_2005	R	Y	E	D	T	T	L	V	E	D	T	V	L	*	[3434]																
ATH002316_Kenya_2012	[3434]																

Sequence alignment of the WNV polyprotein gene that corresponds to the structural (C, E and M) and non-structural (1, 2A, 2B, 3, 4A, 4B and 5) proteins sequences of the Kenyan WNV isolate (ATH002316) and the reference strain (NC_009942.1). Region sequenced; position 1 to 3434. Study isolate highlighted in red.

Table 21. Amino acid substitutions at nucleoprotein gene of Thogoto virus

SiAr126_Germany_1996	M	A	T	D	Q	M	D	I	S	G	P	P	P	K	K	Q	H	V	D	T	E	S	Q	I	P	K	M	Y	E	M	[30]
ATH000258_Kenya_2012	.	.	S	E	[30]
SiAr126_Germany_1996	I	R	D	Q	M	R	T	L	A	S	T	H	K	I	P	L	N	I	D	H	N	C	[52]								
ATH000258_Kenya_2012	[52]								

Sequence alignment of Nucleoprotein gene amino acid sequences of Thogoto virus strains isolated in Kenya and reference strain (NC_006507). Regions sequenced; position 1-174. Study isolate highlighted in red.

Table 22. Nucleotide substitutions of the 5' non-coding region of the non-structural protein of SFV

X04129_USA_1987	A	T	G	G	C	G	G	A	T	G	T	G	T	G	A	C	A	T	A	C	A	C	G	A	C	G	C	C	A	A	[30]	
ATH000510_KENYA_2012	[30]
AMH001859_KENYA_2009	[30]
X04129_USA_1987	A	A	G	A	T	T	T	T	G	T	T	C	C	A	G	C	T	C	C	T	G	C	C	A	C	C	T	C	G	G	[60]	
ATH000510_KENYA_2012	C	C	.	[60]	
AMH001859_KENYA_2009	C	C	.	[60]	
X04129_USA_1987	C	T	A	C	G	C	G	A	G	A	G	A	T	T	A	A	C	C	A	C	C	C	A	C	G	[85]						
ATH000510_KENYA_2012	A	G	.	.	[85]						
AMH001859_KENYA_2009	A	G	.	.	[85]						

Sequence alignment of the 5' non-coding region of the non-structural protein of SFV isolated in Kenya, reference strain (NC_003215) and HQ848388 (SFV AMH001859 strain isolated in Kenya). Region sequenced; position 1 to 85. Study isolate highlighted in red.

Table 24. Nucleotide sequence alignment of the 3' non-coding region of WNV polyprotein gene

NY99_USA_2005	A T A T T T A A T C A A T T G T A A A T	A G A C A A T A T A	[10428]
ATH002316_Kenya_2012	. . . C . . T	[10428]
NY99_USA_2005	A G T A T G C A T A A A A G T G T A G T	T T T A T A G T A G	[10458]
ATH002316_Kenya_2012	. . C . . . T . C . T . G . C A . . A G G .	[10458]
NY99_USA_2005	T A T T T A G T G G T G T T A G T G T A	A A T A G T T A A G	[10488]
ATH002316_Kenya_2012	C A C . A	[10488]
NY99_USA_2005	A A A A T T T T G A G G A G A A A G T C	A G G C C G G G A A	[10518]
ATH002316_Kenya_2012 A G A . .	[10518]
NY99_USA_2005	G T T C C C G C C A C C G G A A G T T G	A G T A G A C G G T	[10548]
ATH002316_Kenya_2012	T	[10548]
NY99_USA_2005	G C T G C C T G C G A C T C A A C C C C	A G G A G G A C T G	[10578]
ATH002316_Kenya_2012	[10578]
NY99_USA_2005	G G T G A A C A A A G C C G C G A A G T	G A T C C A T G T A	[10608]
ATH002316_Kenya_2012	[10608]
NY99_USA_2005	A G C C C T C A G A A C C G T C T C G G	A A G G A G G A C C	[10638]
ATH002316_Kenya_2012	[10638]

NY99_USA_2005	C C A C A T G T T G T A A C T T C A A A	G C C C A A T G T C	[10668]
ATH002316_Kenya_2012	[10668]
NY99_USA_2005	A G A C C A C G C T A C G G C G T G C T	A C T C T G C G G A	[10698]
ATH002316_Kenya_2012 C . . C	[10698]
NY99_USA_2005	G A G T G C A G T C T G C G A T A G T G	C C C C A G G A G G	[10728]
ATH002316_Kenya_2012	[10728]
NY99_USA_2005	A C T G G G T T A A C A A A G G C A A A	C C A A C G C C C C	[10758]
ATH002316_Kenya_2012	[10758]
NY99_USA_2005	A C G C G G C C C T A G C C C C G G T A	A T G G T G T T A A	[10788]
ATH002316_Kenya_2012 T	[10788]
NY99_USA_2005	C C A G G G C G A A A G G A C T A G A G	G T T A G A G G A G	[10818]
ATH002316_Kenya_2012	[10818]
NY99_USA_2005	A C C C C G C G G T T T A A A G T G C A	C G G C C C A G C C	[10848]
ATH002316_Kenya_2012 G	[10848]
NY99_USA_2005	T G G C T G A A G C T G T A G G T C A	[10867]	
ATH002316_Kenya_2012	. . A A . . . -	[10867]	

Sequence alignment of the 3' non-coding region of WNV polyprotein gene WNV isolate (ATH002316) isolated in Kenya and the reference strain (NC_009942.1). Region sequenced; position 10,399 to 10,867. Study isolate highlighted in red.

Appendix F

Semliki forest virus isolate ATH00510 nonfunctional nonstructural polyprotein gene, partial sequence; and structural polyprotein and truncated structural polyprotein genes, partial cds

GenBank: KF283988.1

ORIGIN

```

1  cggatgtgtg  acatacacga  cgccaaaaga  ttctgttcca  gtcctgcca  cctccgctac
61  gcgagagaat  aaccacccgc  gatggccgcc  aaagtgcattg  ttgatattga  ggctgacagc
121  ccattcatca  agtctttgca  gaaggcattt  ccgtcgttcg  aggtggagtc  attgcaggtc
181  acaccaaagt  accatgcaaa  cgccagagca  ttttcgcatc  tggctaccaa  attgattgag
241  caggagactg  acaaagacac  actcatcttg  gatatcggca  gtgcgcttc  caggagaatg
301  atgtctacgc  acaaatatca  ctgctgtgtc  cctatgcgca  gcgcagaaga  ccccgaagg
361  ctcgatgct  acgcaaagaa  actggcagcg  gcctccggga  agtgctgga  tagagagatc
421  gcagggaaaa  tcaccgacct  gcagaccgtc  atggcaacgc  cagacgctga  atctcctacc
481  ttttgtctgc  atacagacgt  cacatgtcgt  aaggcagctg  aagtggccgt  ataccaggac
541  gtgtatgctg  tacatgcacc  gacatcgtg  taccatcagg  cgatgaaagg  tgtcagaacg
601  gcgtattgga  ttgggtttga  caccaccccg  tttatgtttg  acgcgcttgc  aggcgctat
661  ccaacctacg  ccacaaactg  ggccgacgag  caggtgttac  aggccaggaa  cataggactg
721  tgtgcagcat  cttgactga  gggaaagactc  ggcaaactgt  ccattctccg  caagaagcaa
781  ttgaaacct  gcgacacagt  catgttctcg  gtaggatcta  cattgtacac  tgagagcaga
841  aagctactga  ggagctggca  cttaccctcc  gtattccacc  tgaaagggaa  acaatccttt
901  acctgtaggt  gtgataccat  cgtatcatgt  gaagggtagc  tagttaagaa  aatcactatg
961  tgccccggcc  tgtacggtaa  aacggtaggg  tacgccgtga  cgcacacgc  ggagggattc
1021  ctagtgtgca  agaccacaga  cactgtcaag  ggagaaagag  tctcgttccc  tgtatgcacc
1081  tacgtcccct  caaccatctg  cgatcaaatg  actggtatcc  tagcgaccga  tgtcacaccg
1141  gaggacgcac  agaagtgtgt  agtgggattg  aatcagagga  tagttgtgaa  cggaagaaca
1201  cagcgaaca  ctaacacgat  gaagaactat  ctgcttccga  ttgtggctgt  cgcatttagc
1261  aagtgggcga  gggaaataca  ggcagacctt  gatgatgaaa  aacctctggg  tgtccgagag
1321  agatcactta  cttgctgctg  cttgtgggca  tttaaaacaa  agaaaatgca  cacatgtac
1381  aagaaaccag  acaccagac  tatagtgaag  gtgccttcag  agttcaactc  gttcgtcatc
1441  ccgagcctat  ggtctacagg  cctcgcaatc  ccagtcagat  cacgattaa  gatgcttttg
1501  gccagaaga  ccaagcgaga  gttaatacct  gctctcgacg  cgtcgtcagc  cagggatgct

```

1561 gagcaagagg agaaggagag gttggaggcc gagctgacta gagaagcctt accaccctc
 1621 atccccatcg cgccggcgga gacgggagtc gtcgacgtcg acgttgaaga actagagtat
 1681 cgcgcaggtg caggggtcgt ggaaacacct cgcagcgcgt tgaaagtcac cgcacagccg
 1741 aacgacgtac tactaggaaa ttacgtagtt ctgtccccgc agaccgtgct caagagctcc
 1801 aagctggccc ccgtgcaccc tctagcagag caggtgaaaa taataacaca caacgggagg
 1861 gctggccggtt accaggtcga cggatacgac ggcaggggtcc tactaccatg tggatcagcc
 1921 attccggtcc ctgagttcca agctttgagc gagagcgcca ctatggtgta caacgaaagg
 1981 gagttcgtca acaggaact ataccatatt gccgttcacg gaccgtcgtt gaacaccgac
 2041 gaggagaact acgagaaagt cagagctgaa agaactgacg ccgagtacgt gttcgacgta
 2101 gacaaaaaat gctgcatcaa gagagaggaa gcgtcggggtt tgggtgttggg gggagagcta
 2161 accaaccctc cgttccatga attcgcctac gaagggctga agatcaggcc gtcggcaccg
 2221 tataagacta cagtagttgg agtctttggg gttccgggat caggcaagtc tgctattatc
 2281 aagagcctcg tgaccaaaaca cgatctggtc accagtggca agaaggagaa ttgccaggaa
 2341 atagtcaacg acgtgaagaa gcaccgcgga ctggacatcc aggcaaaac agtggactcc
 2401 atcctgctaa acgggtgtcg tcgcgccgtg gatatacctat atgtggacga ggctttcgtc
 2461 tgccattccg gtactctgct ggccttaatt gctcttgtca aacctcggag caaagtgggtg
 2521 ctatgcbgag accccaagca atgcbgattc ttcaatatga tgcagcttaa ggtgaacttc
 2581 aaccacaaca tctgactga agtatgtcac aaaagtatat ccagacgttg cacgctcca
 2641 gtcacggcca tcgtgtctac gttgcattac ggaggcaaga tgcgcacgac caaccctgc
 2701 aataaaccca taatcataga tactacagga cagaccaagc ccaagccagg agacattgtg
 2761 ttaacatgct tccgaggctg ggtaaagcag ctgcagttgg actaccgtgg acacgaagtc
 2821 atgacagcag cagcatccca gggcctcact cgcaaagggg tatacgccgt gaggcagaag
 2881 gtgaatgaaa atcccttgta tgccctgctg tcggagcacg tgaacgtact gctgacgcgc
 2941 actgaggata ggctgggtgtg gaaaacgcta gccggcgatc cctggattaa ggtcctatca
 3001 aacattccac agggtaactt tacggccaca ttggaagaat ggcaagaaga acacgacaaa
 3061 ataataagag tgattgaagg accggccgcg cctgtggacg cgttccagaa caaagcgaac
 3121 gtgtggtggg cgaaaagcct ggtgcctgtc ctggacactg ccgggatcag attgacagca
 3181 gaggagtggg gtactataat tacagcattt aaggaggaca gagcttactc tccagagggtg
 3241 gccttaaatg aaatttgcac caagtactac ggagtcgact tggacagtgg cctgttttcc
 3301 gccccgaagg tgtccctgta ttacgagaac aaccattggg ataacagacc aggtggaagg
 3361 atgtatgat tcaacgccgc aacagctgcc aggtggaag ctagacatac cttcctgaag
 3421 gggcagtgcc atacgggcaa gcaggcagta atcgcagaaa gaaaaatcca accgctttct
 3481 gtgatggaca acgtgattcc catcaaccgc aggtaccgc acgccctggg ggctgagtac
 3541 aagacgggta aaggcagtag ggttgagtgg ctggtcaata aagtaagagg gtaccacgtc
 3601 ctgctgggtga gcgagtacaa cctggctttg cctcgacgca gggtcacttg gctgtcaccg
 3661 ctgaatgtca caggtgccga taggtgctac gacctaaagt taggactgcc agctgacgcc
 3721 ggcagattcg acttggctct tgtaaacatt cacacggaat ttaggatcca ccattaccag
 3781 cagtgtgtcg accacgcat gaagctgcag atgctcgggg gagacgcatt acgactgcta

3841 aaaccggtcg gcaacctctt gatgagagct tacggatacg cgcacaaaat cagcgaagcc
 3901 gttgttttcc ccttaagcag aaagttctcg tctgcaagag tattgcccgg ggattgtgtc
 3961 accagcaata cagaagtgtt cttgctgttc tccaactttg acaacggaaa gagaccctct
 4021 acgctacacc agatgaatac caagctgagt gccgtgatg ctggagaagc catgcacaca
 4081 gccgggtgcy caccatccta cagagttaag agagcagaca tagccacgtg tacagaagcg
 4141 gctgtggtta acgcagctaa cgcccgtgga actgtagggg acggtgatg cagggccgtg
 4201 gcgaagaaat ggccgtcagc ctttaaggga gcagcaacac cagtgggcac aattaaacg
 4261 gtcattgtgc gctcgtatcc cgtcatccat gccgtagggc ctaatttctc tgcaacgact
 4321 gaagcgggag gggaccgcca attggccgct gtctatcggg cagtggccgc cgaagtaaac
 4381 agactgtcat tgagcagcgt agccatcccg ctgctgtcca caggagtgtt cagcggcgga
 4441 agagataggc tgcagcagtc cctcaacat ctattcacag caatggacgc cacggacgct
 4501 gacgtgacca tctactgcag agacaaaagt tgggagaaga aaatccagga agccatagac
 4561 atgaggacgg ctgtggagtt gctcaatgat gacgtggagc tgaccacaga cttggtgaga
 4621 gtgcaccggg atagcagcct ggtgggtcgt aagggtaca gtaccactga cgggtctctg
 4681 tactcgtact tggaaggtac gaaattcaac caggctgcca ttgacatggc agagatactg
 4741 acgttgtggc ccagattgca ggaggcaaac gaacagatat gcctatacgc actgggagaa
 4801 acaatggaca acatcagatc caaatgtccg gtggacgatt ccgattcatc aacacctccc
 4861 aggacagtgc cctgcctgtg ccgctacgca atgacagcag aacggattgc ccgccttagg
 4921 tcacaccaag ttaaaagcat ggtggtttgc tcatcttttc ccctcccaa ataccatgtc
 4981 gatggggtgc agaaggtaaa atgcgagaag gttctcctgt tcgaccgcac agtaccttca
 5041 gtggttagtc cgcggaagta tgccgcacgc acgacggacc actcagaccg gtcgctgcga
 5101 gggttcgcact tggactggac caccgactcg tcttcgactg ctagcgatac catgtcgcta
 5161 cccagcttgc agtcgtgtga catcgactcg atctacgagc caatggctcc tgtagtgtg
 5221 acggccgacg tgcaccctga acccgcaggc attgcccgac tggcggcagc tgacgtgcat
 5281 cctgaacccg cagaccatgc ggaccttgag agcccgatc ctccacgcgc cccgaagaga
 5341 gctgcatacc ttgcctcccg cgcggcggag cgaccagtgc cggcgcggag aaaaccgacg
 5401 cctgccccaa ggactacgtt taggaacaag ctgcctttga cgttcggcga ctttgacgag
 5461 cacgaggtcg atgtgttggc ctccgggatt actttcggag acttcgacga tgtcctgtga
 5521 ctaggccgcy cgggtgcata tatcttctcc tcggacactg gcagcggaca tttacaacaa
 5581 aaatccgtta ggcagcacia tctccagtgc gcgcaactgg atgcccgtcg ggaggagaag
 5641 atgtaccgcy cgaaattgga cactgaaagg gagaagctgt tgctactgaa aatgcagatg
 5701 caccgctcgg aggctaataa gactcgatac cagtctcgca aagtggagaa catgaaagcc
 5761 acggtggtgg acaggctcac atcggggggc agattgtaca cgggagcggg cgtaggccgc
 5821 ataccaacat acgcggttcg gtatccccgc cccgtatatt cccctaccgt gatcgaaaga
 5881 ttctcaagcc ccgatgtagc aatcgcagcy tgtaacgaat acctatccag aaattacca
 5941 acggtggcgt cgtaccaa ataacagatgaa tacgacgcat acctggatat ggttgacggg
 6001 tcggagagtt gcttgagcag agcgacatc tgcccggcta agctccgggtg ttaccgaaa
 6061 catcatgcgt accaccagcc gactgtacgc agtgccctcc cgtcaccctt tcagaacaca

6121 ctacagaacg tgctggcggc cgctaccaag agaaactgca acgtcacgca aatgcgagaa
 6181 ctgcccacta tggactcggc agtgttcaat gtggagtgtc tcaagcgata tgcctgctcc
 6241 ggagaatatt gggaagaata cgctaaacia cctatccgga taacctga gaacatcact
 6301 acctatgtaa ccaaactgaa agggccgaaa gctgcgcct tgtttgctaa gaccataac
 6361 ttggttccgc tgcaggaggt tcccatggac agattcacgg tcgacatgaa acgagatgtc
 6421 aaagtcaccc cagggacgaa acacacagag gaaagacca aagtccaggt aattcaagca
 6481 gcgagaccat tggcgaccgc ttacttgtgt ggcattccaca ggggaattagt aaggaggta
 6541 aatgctgtgt tacgccctaa cgtgcacaca ttgtttgata tgcggcga agacttcgac
 6601 gcaatcatcg cctctcactt ccaccagga gaccgggttc tagagacgga cattgcatca
 6661 ttcgacaaaa gccaggatga ctccctggct cttacaggtc taatgatcct cgaagatcta
 6721 ggggtggatc agtacctgct agacttgatc gaggcagcct ttggggaaat atccagctgt
 6781 cacctaccaa ctggcacgcg cttcaagttc ggagctatga tgaatcagg catgtttctg
 6841 actttgttta ttaaacactgt tttgaacatc accatagcaa gcagggtact ggagcagaga
 6901 ctactgact ccgcctgtgc ggccttcac ggcgatgaca atatcgttca cggagtgtc
 6961 tccgacaagc tgttggcggg gaggtgcgag tcgtgggtca acatggaggt gaagatcatt
 7021 gacgtgtca tgggcgaaaa accccatgat ttttggggg gattcatagt ttttgacagc
 7081 gtcacacaga ccgcctgccg tgtttcagac ccactcaaac gcctgttcaa gttgggtaag
 7141 ccgctaacag ctgaagacaa gcaggacgaa gacaggcgac gagcactgag cgacgaggtc
 7201 agcaagtggg tcaggacagg cttggggggc gaactggagg tggcactaac atctaggat
 7261 gaggtagagg gctgcaagag tatectcata gccatggcca ccctggcaag ggacattaag
 7321 gcgtttaaga gattgagagg acctgttata cacctctacg gcggtcctaa attggtgctg
 [gap 107 bp] Expand Ns
 7488 tgg ccggtgcagg
 7501 ccaactccggt ggcaccgctc gtccccgact tccaggccca gcagatgcag caactcatca
 7561 gcgccgtaaa tgcgctgaca atgagacaga acgcaattgc tcctgctagg cctcccaaac
 7621 caaagaagaa gaagacgacc aaaccaaagc cgaaaacgca gcccaagaag agcaaaggaa
 7681 aaacgcagca gcaaaaagaag aaagacaagc aagccgacaa gaagaagaag aaaccggaa
 7741 aaagagaacg aatgtgcatg aagattgaaa acgactgtat cttcgagggtc aaatacgaag
 7801 gaaaggtcac tgggtacgcc tgcctgggtg gtgataaagt catgaaacct gccacgtga
 7861 aaggagtcac cgacaatgcy gacctggcaa aactagcttt caagaaatcg agcaagtatg
 7921 accttgagtg tgcccagata ccagttcaca tgaggtcggg tgcttcgaag tacacgcatg
 7981 agaagcccga ggggcactat aactggcacc acggggctgt tcagtacagc ggaggcagg
 8041 tcaactatacc gacaggagcg ggcaaacgg gagacagtgg ccggcccac tttgacaaca
 8101 agggggagggg ggtcgctatc gtccctgggcg gggccaacga gggctcacgc acagcactgt
 8161 cggtggtcac ctggaacaaa gatatggtga ctagagtjac ccagagggg tccgaagagt
 8221 ggtccgcccc gctgattact gccatgtgtg tccctcgcaa tgctactttc ccgtgcttcc
 8281 agcccccgty tgcaccttgc tgcctacgaaa acaatgcaga ggcacacta cggatgctcg
 8341 aggacaacgt ggacaggcca gggattatg acctcctca ggcagcctg acgtgccgaa

8401 acggaacaag acaccggcgc agcgtgtcgc aacacttcaa cgtgtataag gccacacgcc
 8461 cttacatcgc gtactgcgcc gactgcggag cagggcactc gtgtcacagc cccgtagcaa
 8521 tcgaagcgat caggtccgag gctaccgacg ggatgctgaa gattcagttc tcggcacaaa
 8581 ttggcataga taagagtgac aatcatgact acacgaagat aaggtagcga gacgggcacg
 8641 ccatagagaa tgccgtccgg tcatctttga aggtagccac ctccggagat tgtttcgtcc
 8701 atggcacaat gggacatttc aactaggcaa cgtgccacc ggggtaattt ctacaggttt
 8761 cgatccagga cactagaaat gcggtccgtg cctgcagaat acaataccat catgaccctc
 8821 aaccggtggg gagagaaaaa tttacaatta gaccacacta tggaaaagag atcccttgca
 8881 ccacttatca gcaaacaca gcgagaccg tggaggaaat cgacatgcat atgccgccag
 8941 atacgccgga caggacgttg ctatcacagc aatctggcaa cgtaaagatc acagtcggag
 9001 gaaagaaggt gaaatacaac tgcacctgtg gaaccggaaa cgtcggcact actaatcgg
 9061 acaagacgat caacgcgtgt ctaatagagc agtgccacgt ctcagtgaca gaccataaga
 9121 aatggcagtt taactcacct tttgtcccga gagccgacga accggctaga aaaggcaaag
 9181 tccatattcc gttcccgttg gacaacatca catgcagagt cccaatggcg cggaaccaa
 9241 ccgtcatcca cggcaaaaaga gaagtgcac tgcacctca ccagatcat cccacgctct
 9301 tctcctaccg cacactgggt gaggaccac agtatcacga ggaatgggtg acagcggcgg
 9361 tggaacggac catacccgtc ccagtggaa ggtatggagta ccaactgggga aacaacgacc
 9421 cagtgaggct ttggtctcaa ctactactg aagggaaacc gcacggctgg ccgcatcaga
 9481 tcgtacagta ctactatggg ctttaccgg ccgctacagt atccgcggtc gccgggatga
 9541 gcttactggc gttgatatcg atcttgcgat cgtgctacat gctggctgcg gcccgcagca
 9601 agtgtttgac cccttatgct ttaacaccag gagctgcagt tccgtggacg ctggggatag
 9661 tctgttgccg cccacgggcg catgcagcca gtgtggcaga gactatggcc tacttgtggg
 9721 accaaaacca agcgtgttcc tggttggagt ttgcagcccc tgttgccctgc atcctcatca
 9781 tcacgtattg cctcagaaac gtgctgtgtt gctgtaagag cttttctttt ttagtgctac
 9841 tgagcctcgg ggccaccgcc agagcttacg aacattcgac agtaatgccg aacgtggtgg
 9901 ggttcccgtc taaggctcac attgaaaggc caggatatag ccccctcact ttgcagatgc
 9961 aggttgtgga gaccagcctt gaaccaacc ttaatttggg atacataacc tgtgagtaca
 10021 agacggtcgt cccgtcgccg tacgtgaagt gctgtggcac ctacagagtgc tccactaaag
 10081 agaagcctga ctaccaatgc aaggtttaca caggcgtgta cccatttatg tggggagggg
 10141 cttattgctt ttgcgactca gaaaacacgc aactcagcga agcgtacgtc gatcgatcgg
 10201 acgtatgcaa gcatgatcac gcatctgctt acaaagccca cacagcatcg ctgaaggcca
 10261 aagtgagggg tatgtacggc aacgtaaacc agaccgtgga tgtttacgtg aacggagacc
 10321 atgccgtcac gatagggggg actcagttca tattcgggcc gttgtcatcg gcctggacgc
 10381 cgttcgacaa caagataatc gtgtacaaa acgaagtgtt caatcaggac ttcccgccgt
 10441 atggatctgg gcaaccaggg cgcttcggcg acatcaaag cagaacagtg gagagtaatg
 10501 acctgtacgc gaacacggca ctgaagctgg cacgcccttc acccggcacg gtccatgtac
 10561 cttacacaca gacaccttca gggttcaaat attggctaaa ggaaaaaggg acagccctaa
 10621 atacgaaggc tccttttggc tgccaaatca aaacgaacc tgtcagggcc atgaactgcg

10681 ccgtgggaaa catccctgtc tccatgaatt tgcctgacag cgcctttact cgcattgtcg
10741 aggcaccgac catcaactgac ctgacttgca cagtggctac ctgtacgcac tcctcggatt
10801 tcggcgggcgt cttgacattg acgtacaaga ccgacaagaa cggggactgc tctgtacact
10861 cgcactctaa tgtagctact ctgcaggagg ccacagcaaa agtgaagaca gcaggcaagg
10921 tgaccttaca cttctccaca gcaagcgcac caccttcttt tgtgggtgctg ctatgcagtg
10981 ccaaggccac ctgttcagcg tcgtgtgagc ccccgaaaga tcacatagtc ccatatgcgg
11041 ctagccacag taacgtagtg ttcccagaca tgtcggggcac cgcattatca tgggtgcaga
11101 aaatctcggg tggctctggg gccttcgcaa tcggcgctat tctgggtgcta gttgtggta
11161 cttgcattgg gctccgcaga taatgagggg aggcaatggc attgatatag caagaaaatt
11221 gaaaacagaa gaagttaggg taagcaatgg cattaacat aactatataa cttataataa
11281 agcgcaaca gacctgcga atcggcctcg tgatccgctt cacggaaact cggggcaact
11341 catattgaca cattaattgg caataattgg aagcttacat aagcttaatt cgacgaataa
11401 ttggatTTTT atTTTTTTTT gcaattggt

//

West Nile virus isolate ATH002316, partial genome

GenBank: KC243146.1

ORIGIN

```

1 agttcgctg tgtgagctga caaacttagt agtgtttgtg aggattaaca acaattaaca
61 cagtgcgagc tgtttcttag cacgaagatc tcgatgtcta agaaaccagg agggcccggc
121 aagagccggg ctgtcaatat gctaaaacgc ggtatgcccc gcgtgttgtc cttgattgga
181 ctgaagaggg caatgttgag cctgatcgac ggcaaggggc caatacgatt cgtgttggct
241 ctcttggcgt tcttcagggt cacagcaatt gctccgaccc gagcagtgtc ggatcgatgg
301 agaggtgtga acaaacaaac agcgatgaaa caccttctga gttttaagaa agaactaggg
361 accttgacca gcgctatcaa tcggcggagc tcaaaacaaa agaaaagagg aggaaatacc
421 ggaattgcag tcatgattgg cctgatcgcc agcgtaggag cagttaccct ctctaacttc
481 caagggaaag ttatgatgac ggtaaatgct actgacgtca cagatgtcat cacgattcca
541 acagctgctg gaaagaacct atgcattgtc agagcaatgg atgtgggata catgtgtgat
601 gacactatca catatgaatg cccagtgtcg tcggccggta atgatccaga agacatcgac
661 tgttggtgca caaagtcagc agtctacgtc aggtatggaa gatgcaccaa gacacgccac
721 tcaagacgca gtcggaggtc actgacagtg cagacacacg gagaaagcac tctagcgaac
781 aaaaaggggg cttggatgga cagcaccaag gctacaaggt atctggtaaa aacagaatca
841 tggatcttga ggaaccctgg atatgccctg gtggcagctg tcattggttg gatgcttggg
901 agcaacacca tgcagcgagt tgtgtttgtc gtgctgttgc tcttgggtggc tccagcctac
961 agcttcaact gccttggaat gagcaacaga gacttcttgg agggagtatc tggagcaaca
1021 tgggtggatt tggttctcga aggcgacagc tgcgtgacta tcatgtctaa ggacaagcct
1081 accattgatg tgaagatgat gaatatggag gcagccaacc tggcagaggt ccgcagttat
1141 tgctatthgg ctaccgtcag cgatctctcc actaaagctg catgcccagc catgggagaa
1201 gctcacaatg acaaacgtgc tgaccagct tttgtgtgca gacaaggagt ggtggatagg
1261 ggctggggca acggctgagg actatthggc aaaggaagca ttgacacatg cgccaaattc
1321 gcctgctcca ccaaggcaac aggaagaacc atcttgaaag agaatatcaa gtatgaagtg
1381 gccatctttg tccatggacc aaccactgtg gagtcgcatg gaaactactc cacacagatt
1441 ggggccactc aggcagggag attcagcatc actcctgagg ctcctcata cactactaaag
1501 cttggagaat atggagaagt gacagtggac tgtgaaccac ggtcagggat tgacaccaat
1561 gcttactacg tgatgactgt tggaaacaaag acgtttttgg tccatcgtga gtggttcatg
1621 gacctcaacc tcccttggag cagtgtgga agcactgtgt ggaggaacag agagacgtta
1681 atggagtttg aggaaccaca cgccacaaag cagtctgtga tagcattggg ctcaaacagg
1741 gggagatcgt gcatcaagct ttggctggag ccatccctgt ggatttcaag caacactgtc
1801 aagttgacgt cgggtcattt gaagtgtaga gtgaagatgg aaaaattgca gttgaagggg
1861 caacctacgg cgtctnnnnn nnnnnnnnnn nnnnnnnnca gtcacagtca
1921 cggcactgtg gtgttggaac tgcagtacac tggcacggat ggaccttgca aagttcccat
  
```

1981 ctcgtcagtg gcttcattga acgacctaac accagtgggc agattgggtca ctgtcaaccc
 2041 ttttgtttca gtgtccacgg ccaatgccaa ggtcctgatt gaattggaac cacccttcgg
 2101 agactcatac atagtgggtg gcagaggaga acaacagatc aatcaccatt ggcataagtc
 2161 tggaagcagc attggcaaag cctttacaac cactctcaa ggggcgcaga gattagccgc
 2221 tctaggagac acagcttggg actttggatc agttggaggg gtgttcacct cagtagggaa
 2281 ggctgttcat caagtgttcg gtggagcatt ccgctcactg ttcggaggta tgcctggat
 2341 aacgcagggg ttgctggggg ctcttctgtt gtggatgggc atcaacgctc gtgacaggtc
 2401 catagctctc acgtttctcg cagttggagg agtcctgctc ttcctctccg tgaatgtgca
 2461 cgctgacact ggggtgtgcca tagacatcag ccggcaagag ctgagatgtg gaagtggagt
 2521 gttcatacac aatgatgtgg aggcttggat ggaccgatac aagtactacc ctgaaacgcc
 2581 acaaggccta gccaaagatca ttcaaaaagc ccataaggaa ggagtgtgcg gtctacggtc
 2641 agtttccaga ctggagcadc aaatgtggga atcagtgaag gacgagctga aactctttt
 2701 gaaagagaat ggtgtggacc ttagtgtcgt ggttgagaaa caggagggaa tgtataagtc
 2761 ggcacctaiaa cgtctcaccg ccaccacgga aaaattggaa attggctgga aggcctggg
 2821 aaagagcadc ctatttgcac cagaacttgc caacaacacc tttgtggttg atggtccgga
 2881 gaccaaggaa tgcccaactc agaatcgcgc ttggaatagc ttggaagtgg aggattttgg
 2941 atttggtctc accagtactc ggatgttcc taaaggtcaga gagagcaaca caactgagtg
 3001 tgactcgaag atcatcggaa cggccgtcaa gaacaacttg gcgatccaca gtgacctgtc
 3061 ctattggatt gaaagccggc tcaatgatac gtggaagctt gaaagggcgg ttctgggtga
 3121 agtcaaatca tgcacgtggc ctgagacgca caccttgttg ggcgatggaa tcctcgagag
 3181 tgacctgata ataccagtca cactggcggg accacgaagc aaccacaatc ggagacctgg
 3241 gtacaagaca caaaaccagg ggccatggga cgaaggctcg gtagagattg atttcgatta
 3301 ctgcccaggg accacggtca ccctgagtga gagctgcgga caccgtggac ctgccactcg
 3361 caccaccaca gagagcggaa agttgatagc agattgggtg tgcaggagct gcaccttacc
 3421 accattgcgc taccagacgg acagcggctg ttggtatggc atggagatta gaccacagag
 3481 acatgatgaa aagacccttg tgcagtcaca agtgaatgct tacaatgctg acatgattga
 3541 cccttttcag ttgggccttc tggctcgtgtt cttggccacc caggaggtcc ttcgcaagag
 3601 gtggacagcc aagatcagca tgccagctat actgattgct ctgctagtcc tgggtgtttgg
 3661 gggcattacc tacactgatg tgttgcgcta tgtcatcttg gtgggagcgg ccttcgcaga
 3721 atctaattcg ggaggagacg tggtagactt ggcgcttatg ggcacctta agatacagcc
 3781 agtgtttatg gtggcatcgt ttctcaaagc gagatggacc aaccaggaga acatcttgtt
 3841 gatgatggcg gctgttttct tccaaatggc ttaccacgat gcccgnnnnn nnnnnnnnnn
 3901 nnnnnnnnnn nngtgtttga attcactggc agtagcttgg atgatattga gagccataac
 3961 attcacaacg acatcaaacg tcgttgttcc gttgctggcc ctgctaacac ccgggctgag
 4021 atgcttgaat ctggatgtgt acagatcctg ctggtgatgg tcggaatagg cagtttgatc
 4081 agggagaaga gaagtgcagc tgcaaaaaag aaaggagcaa gtctgttatg cttggctcta
 4141 gcctcaacag gacttttcaa ccccatgatc cttgcccgtg gactgattgc atgtgatccc
 4201 aaccgtaaac gcgggtggcc cgcaactgaa gtgatgactg ctgctcggctt gatgtttgcc

4261 attgtcggag ggctggcaga gcttgacatt gactccatgg ccattccaat gactatcgcg
 4321 gggctcatgt ttgctgcttt cgtgatttct gggaaatcaa cagacatgtg gatcgagagg
 4381 acggcggaca tctcctggga aagtgatgca gaaatcacag gctcgagcga aagagttgat
 4441 gtgctggctt atgatgatgg aaacttccag ctcatgaatg atccaggagc accttggaaa
 4501 atatggatgc tcagaatggc ctgcctcgcg attagtgcgt acacccttg ggctatcctg
 4561 ccctcagtag ttggattttg gataactctc caatacacia agagaggagg cgtgctgtgg
 4621 gacaccctt caccaaagga gtacaaaaag ggggacacga ccaccggagt ctacaggatc
 4681 atgactcgtg ggctgctcgg cagttatcaa gcaggagcgg gcgtgatggt tgaaggcgtt
 4741 ttccacactc tttggcatac aacaaaagga gccgctttga tgagcggaga aggccgcctg
 4801 gaccataact ggggtagtgt caaggaggac cgactttgtt acggaggacc ctggaaattg
 4861 cagcataagt ggaacgggca ggatgaggtg cagatgattg tgggtggaacc tggcaagaac
 4921 gtcaaaaacg tccagacgaa accaggggtg ttcaaaacac ctgaaggaga aattggggcc
 4981 gtgacttttg acttccccac tggaacatca ggctcacaa tagtggacia aaacgggtgat
 5041 gtgatcgggc tctatggcaa tggagtcata atgcccacg gctcatacat aagcgcgata
 5101 gtgcagggtg aaaggatgga tgagccaatc ccagccggat tcgaacctga gatgctgagg
 5161 aaaaaacaga tcaactgttct ggatcttcat cctgggtgccc gtaaaacaag gaggattctg
 5221 ccacagatca tcaagaggc cataaataga agactgagaa cagccgtgct agcaccaact
 5281 agggttgtgg ctgctgagat ggctgaagcc ctgagaggac tgcctatccg gtatcagaca
 5341 tctgcagtga ccagagaaca caatggaaat gagattgttg atgtcatgtg ccatgccacc
 5401 ctcaactcaca ggctgatgtc tcctcacagg gtgcctaact acaatctgtt tgtgatggat
 5461 gaggctcatt tcaccgatcc agctagcatt gcagcaagag gttatatttc cacaaggctc
 5521 gagctggggg aggcggcggc aatattcatg acagccacc caccaggcac ttcagatcca
 5581 ttcccagagt ccaattcacc tatttctgac ttgcagactg agatcccgga tcgggcctgg
 5641 aattctggat acgaatggat cacagagtac atcgggaaga cggtttggtt tgtgcctagt
 5701 gtgaaaatgg ggaatgagat tgccctttgt ttacaacgtg ccggaagaa agtagtcaa
 5761 ttgaacagaa agtcgtatga gacggagtac caaaaatgca agaacgatga ttgggacttt
 5821 gttatcacia cagacatata tgaaatgggg gctaacttca aggcgagcag ggtgatcga
 5881 agtcggaaga gcgtgaagcc aacctacata acagaaggag aagggagagt gatcctggga
 5941 gaacatctg cagtgcggc agctagtgcc gccagagac gtggacgcat cggtagaat
 6001 ccgtcgcaag ttggtgatga gtactgttat ggagggcaca cgaatgaaga cgactcgaac
 6061 ttgcgccatt ggactgaggc acgaatcatg ctggacaaca tcaacatgcc aaacggactg
 6121 atcgctcaat tctaccaacc agagcgtgag aaggatata ccatggatgg ggaataccgg
 6181 ctgagaggag aagagaggaa aaacttctct gaattgttga ggactgcaga tctgccagtt
 6241 tggctggctt acaagggtggc agcggctgga gtgtcatacc acgatcggag gtgggtgttt
 6301 gatggcccta ggacaaacac gatttttaga gacaacaacg aagtggaagt catcaciaag
 6361 cttggtgaaa ggaagattct gaggcctcgc tggattgacg ctagggtgta ctcgaccac
 6421 caggcactaa aggcgttcaa ggactttgct tcgggaaagc gttcccagat agggctcatt
 6481 gaggtcctgg gaaagatgcc tgagcatttc atggggaaga catgggaagc actcgacacc

6541 atgtacgttg tggccactgc agagaaagga ggaagagctc acagaatggc cctggaggag
 6601 ctgccggatg ctctccagac aattgccttg attgccttat tgagtgtgat gaccatggga
 6661 gtattctttc tcctcatgca gcgaaagggc attggaaaga taggtttggg aggcgttgtc
 6721 ttgggagtcg cgaccttctt ctggttgatg gctgaagtcc caggaacgaa gattgccgga
 6781 atggttgctac tttcccttct cttgatgatt gtgctaattc ctgagccaga gaagcaacgt
 6841 tcgcagacag acaaccagct agccgtgttt ctgatttgtg ttatgaccct tgtgagcgca
 6901 gtggcagcca acgaaatggg ttggctagat aagaccaaga gtgacataag cagtttgttc
 6961 gggcaaagaa ttgaggtcaa ggagaatttc agtatgggag agtttcttct ggacttgaga
 7021 ccggcaacag cctggtcact gtacgctgtg accacagcgg tcctcactcc actgctaaag
 7081 catctgatca cgtcagatta cattaacact tcattgacct caatcaatgt tcaagcaagt
 7141 gcattattca cactcgcgcg aggcttcccc ttcgtcgatg ttggagtgtc agctctcttg
 7201 cagcagccgg atcgtgactg ggacaagtca ccctcaccgt gacggtgaca gcggcaacac
 7261 tcctgtttctg ccactatgcc tacatggttc ccggatggca ggctgaggca atgcgctcag
 7321 cccagcgcag gacagcggct ggaatcatga aaaacgctgt agtggatggc atcgtggcca
 7381 cggacgtccc agaattagag cgcaccacac ccatcatgca gaagaaagt cggacaaatca
 7441 tgctgatctt ggtgctctta ggtcagtggt tagtgaacc gtctgtgaag acagtgcgag
 7501 aagctggaat cttgatcacg gcagcagcgg tgacgctttg ggagaaatgga gcaagctctg
 7561 tttggaacgc aacaaccgcc atcggactct gccacatcat gcgtgggggt tggttgtcat
 7621 gcctatccat aacatggaca ctcataaaga acatggacaa accaggacta aaaagagggtg
 7681 gggcaaaaagg acgcaccttg ggagaggttt ggaaagaaag actcaaccag atgacaaaag
 7741 aggagttcac taggtaccgc aaagaggcca tcatcgaagt cgatecgtca gcagcaaaac
 7801 atgccaggaa agaaggcaat gtcaccggag ggcattccagt ctcgagaggc acagcaaaac
 7861 tgagatggct ggtcgaacgg aggtttctctg aaccggctcg aaaagtgatt gaccttggat
 7921 gtggaagagg cggttggtgt tactatatgg caacccaaaa gagagtccaa gaagtccagag
 7981 ggtacacaaa gggcgggtccc ggacatgaag agccccact agtgcaaagt tatggatgga
 8041 atattgtcac catgaagagt ggagtggatg tgttctacag accttctgag tgttgtgata
 8101 ctctcctttg tgacatcgga gaatcttctg caagtgtgta ggttgaagag cataggacga
 8161 ttcgggtcct tgaatggtt gaggactggc tgcaccgagg gccaaaggaa ttttgtgtga
 8221 aggtgctctg cccctacatg ccaaaagtca tagagaagat ggagctactc cagcgcgggt
 8281 atgggggagg actggtcaga aaccactct cgcggaattc cacgcatgag atgtactggg
 8341 taagccgagc ttcaggcaat gtggtacact cagtgaacat gactagccaa gtgcttctgg
 8401 gaaggatgga gaagaggacc tggaaaggac cccaatacga ggaagatgta aacttgggaa
 8461 gtggaactag ggcgggtgggg aaacccttac tcaactcaga caccagtaaa atcaagaaca
 8521 ggattgaacg actcagcgtg gactacagtt caacgtggca ccacgatgag aaccacccat
 8581 atagaacctg gaactatcac ggcagttatg acgtgaagcc cacaggctcc gctagttcgc
 8641 tggttaatgg agtagttagg ctccctctca aaccatggga caccatcacg aatgtacca
 8701 ccatggccat gactgacaca actcccttcg gacagcagcg ggtgttcaa gagaagggtg
 8761 acacgaaagc tcctgaaccg ccagaaggag tgaagtatgt gctcaatgaa accaccaatt

8821 ggttgtgggc gtttctggcc agagaaaaac gtcccagaat gtgctctcga gaggaattca
 8881 taagaaaggt caacagcaat gcagcttttg gtgccatggt tgaagaacag aatcaatgga
 8941 ggagcgccag agaagcagtt gaagacccaa agttttggga gatggtagat gaggagcgag
 9001 aggcacacct gcggggggaa tgtcacactt gcatctacaa catgatggga aagagagaga
 9061 aaaaacccgg agagttcggga aaggccaagg gaagcagagc catatgggtc atgtggctcg
 9121 gagctcgctt tctggagttc gaagctctgg gatttctcaa tgaagatcac tggcttgaa
 9181 gaaagaactc aggaggaggt gtcgagggct tgggcctcca aaaactgggt tacatcctgc
 9241 gtgaagttgg cacccgacct gggggcaaga tctatgctga cgacacagct ggctgggaca
 9301 cccgcatcac gagagctgac ttggaaaatg aagctaaggt gcttgagctg cttgatgggg
 9361 aacatcggcg tcttgccagg gccatcattg agctcaccta tcgtcaaaa gttgtgaaag
 9421 tgatgcgccc agctgctgat ggaagaactg tcatggatgt catctccaga gaagatcaga
 9481 gggggagcgg acaagtgtc acctacgcc taaacttt caccaacctg gccgtccagc
 9541 tggtgaggat gatggaaggg gaaggagtga ttggcccaga tgatgtggag aaactcaaa
 9601 aggggaaggg acccaaagtc aggacctggc tgtttgagaa cggggaagag agactcagcc
 9661 gcatggctgt cagcggagat gactgtgtgg taaagcctct ggatgatcgc tttgccactt
 9721 cgctccactt tctcaacgcc atgtcaaagg tccgcaaaga cattcaagag tggaaacct
 9781 caactggatg gtatgattgg cagcaggtcc cattctgctc aaaccatttc actgaattga
 9841 tcatgaaaga tggagaaca ttggtggttc catgcccagg acaggacgaa ctggtaggca
 9901 gagctcgcac ttctccagg gccggatgga acgtccgca caccgcttgt ctggctaagt
 9961 catatgceca gatgtggctg cttctgtact tccacagaag agacctgca ctcatggcca
 10021 acgccatttg ctccgctgtc cctgtgaact ggggtccccac cggagaacc acatggtcca
 10081 tccatgcagg aggagaatgg atgacaacag aggacatgct ggaggtttg aaccgtgttt
 10141 ggatagagga gaatgaaatg gatcggaga caaaaccca gtggagaaat ggagtgacgt
 10201 cccatactca ggaaaacgga cggacatctg gtgtggcagc ctgattggca caagagccc
 10261 ggccacgtgg gcagaaaacg atccaggtgg ccatcaacca agtcagagca atcattggag
 10321 atgagaagta tgtggattac atgagttcac taaagagata tgaagacaca actttggttg
 10381 aggacacagt actgtaaata ctttatcaat tgtaaataga caatataagc atgtacatag
 10441 gcataagttt atagtggcat ttaacgatgt tagtgtaaat agttaagaaa attttaagga
 10501 ggaagtcagg ccggaattt ccgccaccgg aagttgagta gacggtgctg cctgcgactc
 10561 aaccccagga ggactgggtg aacaaagccg cgaagtgatc catgtaagcc ctcagaaccg
 10621 tctcggaagg aggaccccac atgttgtaac ttcaaagccc aatgtcagac cacgctacgg
 10681 cgcgccactc tgcggagagt gcagtctgcg atagtgcccc aggaggactg ggtaacaaa
 10741 ggcaaaccaa cgccccacgc ggccctagcc ctggtaatgg tgttaaccag ggcgaaagga
 10801 ctagaggtta gaggagaccg ccgcggtttg aagtgcacgg ccagcctgac tgaagctgta
 10861 agtc

//