

Scheduling of a grid-tied photovoltaic system considering HESS and PHEV

Sedigheh Taghizadeh, Lijun Zhang, Xiaohua Xia

Department of Electrical, Electronic and Computer Engineering, University of Pretoria, Pretoria 0002, South Africa

1. INTRODUCTION

Grid-connected microgrids (MG) are one of the solutions to the depletion of fossil fuels, the environmental impact and high carbon emission produced by current infrastructure. They are cost-effective and helps to decrease the environmental impacts (Jiayi, Chuanwen and Rong, 2008). An MG is defined as a number of sources and loads that can operate as a stand-alone or grid-connected controllable systems providing electricity and heat ((Jiayi, Chuanwen and Rong, 2008), (Driesen, Katiraei and Leuven, 2008)). Distributed generation (DG) technologies are being used in MGs vastly, and due to the intermittent nature of DGs, employment of energy storage systems (ESS) is crucial (Zhang, Tang and Qi, 2010). Amongst various types of ESS, battery and supercapacitor combination is one of the best combinations because of their complementary characteristics. The battery supercapacitor hybrid storage (BSHS) combination has the advantages including high power density of supercapacitor and high energy density of batteries (Zhang, Tang and Qi, 2010). Therefore, the BSHS can achieve fast response and long term energy supply support (Abbey, Strunz and Joos, 2009). In addition, adopting supercapacitor in an MG results in a smaller ESS size, improvement of frequency regulation and extension of battery lifespan.

In this paper an optimal scheduling strategy is presented for an MG installed with a BSHS. This problem has not been studied in the current literature. The goal is to increase the revenue of the MG and to maximize the lifespan of the battery bank taking advantage of the supercapacitor.

2. SYSTEM DESCRIPTION

The schematic diagram of the system is shown in Fig.1. In Fig. 1, P_1 represents the power generated by PV modules that fed into the system, P_2 and P_3 represent the charging and discharging powers of the battery system, respectively; P_4 and P_5 represent the charging and discharging powers of the supercapacitors, respectively; P_6 and P_7 represent the charging and discharging powers of PEV, respectively; and P_8 and P_9 represent the power injected into the system by the grid and the power sold to the grid. The power supplied to a residential house within the MS is represented by P_L .

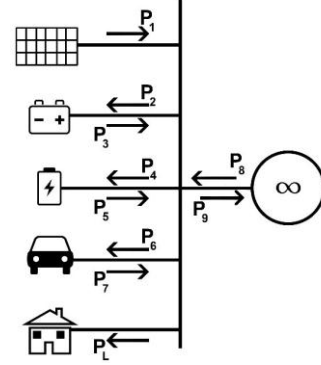

Fig 1: Power system topology

3. MATHEMATICS MODEL FORMULATION

The objective of the proposed model is to minimize the use of battery bank and maximize the cost function over a 24-hour period.

3.1 Power Flow Control Strategy

In the proposed system, the customers' demand is primarily met by the output of the PV arrays. If the demand is less than the PV's output, the excess PV power will charge the battery bank, the supercapacitor, the plug-in hybrid electric vehicle (PEHV) or will feed the power back to the grid. If the demand is higher than the PV output then the battery bank, PHEV or the grid will meet the deficient power. The grid can also charge the battery, the supercapacitor or the PHEV during the off-peak period. The PHEV, the supercapacitor and the battery bank can discharge during the peak period to save cost. The supercapacitor is used in the system to help sustain the batteries life. The duration of the study is based on a 24-hour actual data of the PV arrays and the load demand of a residential house.

3.2 Optimization Model

The objective function of the model is given first followed by constraints. A weighting method is used to integrate the sub-objective functions into one. The advantage of this method is that the customer can choose the weighting factors to strike a balance among different targets.

$$\min J = w_1 \frac{J_{1,1}}{J_{1,1}^{max}} - w_2 \frac{J_{1,2}}{J_{1,2}^{max}} + w_3 \frac{J_2}{J_2^{max}} \quad (1)$$

where w_1 , w_2 and w_3 are weighting factors, and $\sum_{j=1}^3 w_j = 1$. $J_{1,1}$ is the cost related to the purchase of electricity from the main grid given in (2), $J_{1,2}$ is the revenue from sales of electricity to the main grid presented in (3) and J_2 is the component referring to the battery use shown in (4).

$$J_{1,1} = \sum_{i=1}^N C_b(i) P_8(i) \Delta T \quad (2)$$

$$J_{1,2} = \sum_{i=1}^N C_s P_9(i) \Delta T \quad (3)$$

$$J_2 = \sum_{i=1}^N (P_2(i) + P_3(i))^2 \quad (4)$$

where C_b is the time-of-use tariff defined in (5) and C_s is the feed-in-tariff rate which is equal to 0.3656 R/kWh according to ESKOM tariff and ΔT represents the sampling period.

$$C_b(t) = \begin{cases} P_o = 0.3656 \frac{R}{kWh} \text{ if } t \in [0,7] \cup [23,24] \\ P_s = 0.6733 \frac{R}{kWh} \text{ if } t \in [7,8] \cup [11,19] \cup [21,23] \\ P_p = 2.2225 \frac{R}{kWh} \text{ if } t \in [8,11] \cup [19,21] \end{cases} \quad (5)$$

where P_o is the electricity price for the off-peak period, P_s is the price for the standard period and P_p is the price for the peak load period. The problem is subject to the following constraints:

$$0 \leq P_1(i) \leq P_{pv,max}(i) \quad (6)$$

$$0 \leq P_2(i) \leq P_{batt,max}(i) \quad (7)$$

$$0 \leq P_3(i) \leq P_{batt,max}(i) \quad (8)$$

$$P_2(i) P_3(i) = 0 \quad (9)$$

$$SOC_{batt,min} \leq SOC_{batt}(i) \leq SOC_{batt,max} \quad (10)$$

$$0 \leq P_4(i) \leq P_{sc,max}(i) \quad (11)$$

$$0 \leq P_5(i) \leq P_{sc,max}(i) \quad (12)$$

$$P_4(i) P_5(i) = 0 \quad (13)$$

$$SOC_{sc,min} \leq SOC_{sc}(i) \leq SOC_{sc,max} \quad (14)$$

$$0 \leq P_6(i) \leq P_{PEV,max}(i) \quad (15)$$

$$0 \leq P_7(i) \leq P_{PEV,max}(i) \quad (16)$$

$$P_6(i) P_7(i) = 0 \quad (17)$$

$$SOC_{PEV,min} \leq SOC_{PEV}(i) \leq SOC_{PEV,max} \quad (18)$$

$$P_6(i) = 0, \text{ for } 29 \leq i \leq 39 \quad (18)$$

$$P_7(i) = 0, \text{ for } 29 \leq i \leq 39 \quad (19)$$

$$0 \leq P_8(i) \leq P_{gr,max}(i) \quad (20)$$

$$0 \leq P_9(i) \leq P_{gr,max}(i) \quad (21)$$

$$P_8(i) P_9(i) = 0 \quad (22)$$

$$P_L = P_1 - P_2 + P_3 - P_4 + P_5 - P_6 + P_7 + P_8 - P_9 \quad (23)$$

In the above equations or inequalities, all P_j are control variables, for $j=1, \dots, 9$ and P_L denotes the demand profile.

Equations (9), (13), (17) and (22) describe that the system cannot be charged and discharged simultaneously. Eq (18) and (19) describe the absence time of the PHEV.

The energy content of the battery, supercapacitor and PEHV, denoted by SOC_{batt} in (10), SOC_{sc} in (14) and SOC_{PEV} in (18), respectively, are calculated as follows:

$$SOC_{batt}(t) = SOC_{batt}(0) + \Delta T \eta_{c,b} \sum_{\tau=1}^t P_2(\tau) - \frac{\Delta T}{\eta_{D,b}} \sum_{\tau=1}^t P_3(\tau) \quad (24)$$

$$SOC_{sc}(t) = SOC_{sc}(0) + \Delta T \eta_{c,s} \sum_{\tau=1}^t P_2(\tau) - \frac{\Delta T}{\eta_{D,s}} \sum_{\tau=1}^t P_3(\tau) \quad (25)$$

$$SOC_{PEV}(t) = SOC_{PEV}(0) + \Delta T \eta_{c,p} \sum_{\tau=1}^t P_6(\tau) - \frac{\Delta T}{\eta_{D,p}} \sum_{\tau=1}^t P_7(\tau) \quad (26)$$

where $\eta_{c,p}$ and $\eta_{D,p}$ are the PEHV battery charge and discharge efficiencies; $\eta_{c,s}$ and $\eta_{D,s}$ are the supercapacitor charge and discharge efficiencies; $\eta_{c,b}$ and $\eta_{D,b}$ are the battery charge and discharge efficiencies, respectively. $SOC_{batt}(0)$, $SOC_{sc}(0)$ and $SOC_{PEV}(0)$ are the initial state of charges of the battery, supercapacitor and PHEV, respectively.

6. CONCLUSION

An optimal power flow scheduling strategy for a grid-tied microgrid supported by a batter/supercapacitor hybrid energy storage system is presented in this paper. The potential of using plug-in hybrid electric vehicles as an auxiliary energy storage component within a microgrid is also considered in the problem formulation. The overall objective of the proposed model is to maximize the economic benefits of the microgrid considering power feed back to the grid and to minimize the battery stress making use of a hybrid energy storage system.

REFERENCES

- Abbey, C., Strunz, K. and Joos, G. (2009). A knowledge-based approach for control of two-level energy storage for wind energy systems. *IEEE Transactions on Energy Conversion*, 24(2), pp.539-547.
- Driesen, J., Katiraei, F. and Leuven, K. (2008). Design for distributed energy resources. *IEEE Power and Energy Magazine*, 6(3), pp.30-40.
- Jiayi, H., Chuanwen, J. and Rong, X. (2008). A review on distributed energy resources and microgrid. *Renewable and Sustainable Energy Reviews*, 12(9), pp.2472-2483.
- Zhang, G., Tang, X. and Qi, Z. (2010). Research on battery supercapacitor hybrid storage and its application in microgrid. In: *IEEE Asia-Pacific Power and Energy Engineering Conference*, 28-31 March, Chengdu China, 2010.