

LANDSCAPE ARCHITECTURE FOR A MINING SOLUTION: AN EXPLORATION OF PATTERN

HS Jansen van Vuuren
2017

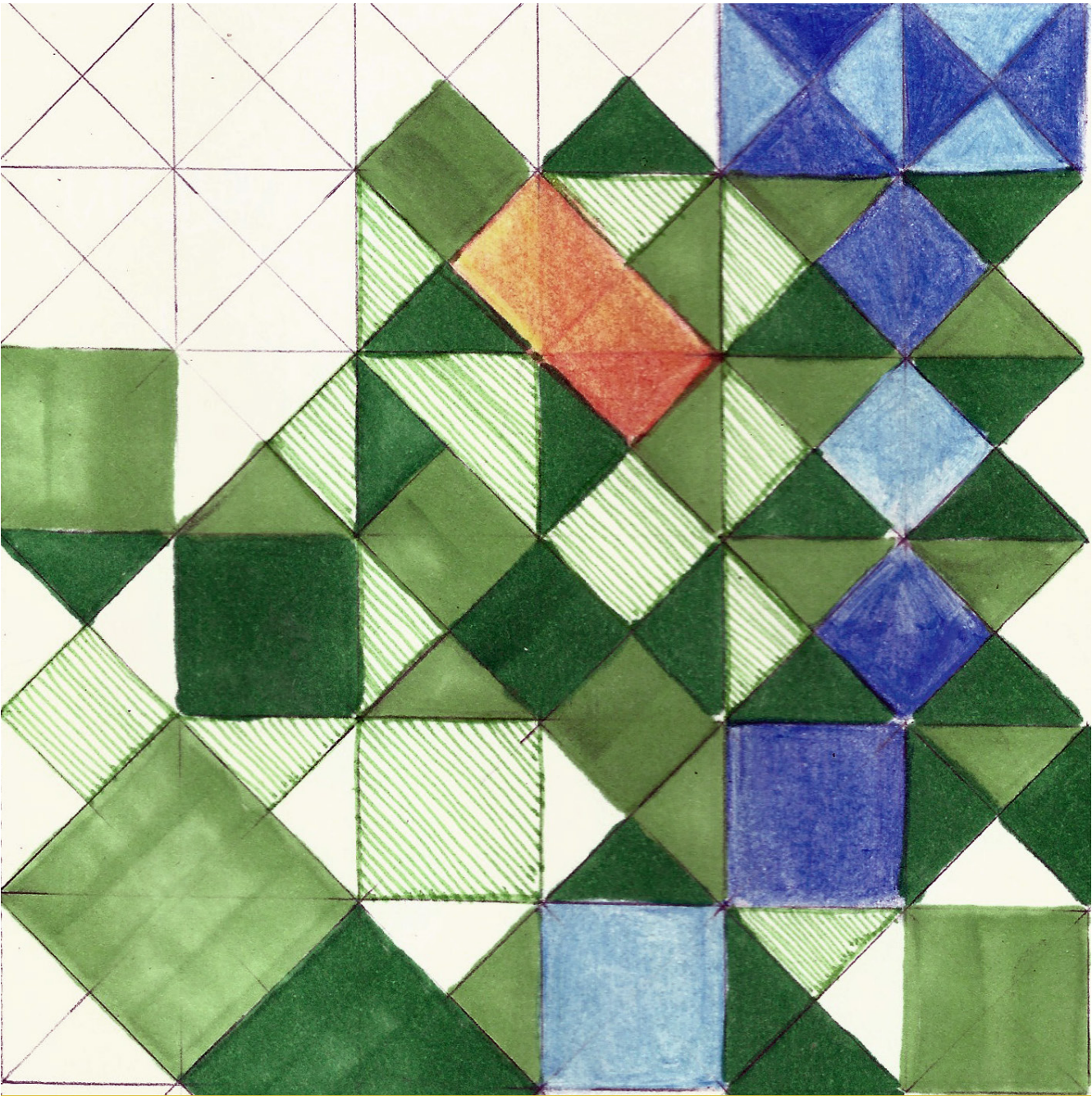

Exploration of urban grid over the landscape (Author 2017)

ACKNOWLEDGMENTS

Thank you to my family, and especially my mother for reading every word. For friends like Hazel that helped me with the sneaky 'is' and 'are'. To my salsa family for understanding my absence from my teaching responsibilities, Jonas for waking me with a phone call every morning so I could get a head start and to Smita for housing and feeding me. The support through this difficult year did not go unnoticed.

ABSTRACT

Mining has a lasting effect on our communities and urban environments and is especially visible in the City of Johannesburg. The industrial processes that formed the gold mine tailings sites and the natural processes that effect these sites create enchanting port industrial sites. The current remediation includes either unaccessible engineered solutions or a site is left derelict and unsafe. Exploring these processes on the project site, the study investigated how pattern making, derived form residual patterns, can inform the landscape for a recreation space. The combination of natural processes and proposed new processes to form the basis of a recreational landscape is explored.

Robinson Deep Mine tailings 81-IR
Robinson Deep 81-IR, Erf 21, Booysen Road, Ophirton
Johannesburg
E'28o 2'5.14" S 26o13'39.34"

Study leader: Graham Young
Studio master: Johan Nel Prinsloo
Course coordinator: Arthur Barker

Submitter in fulfillment as part of the requirements for
the degree Master in Landscape Architecture [Prof]
Department of Landscape Architecture,
Faculty of Engineering,
The Built Environment and Information Technology.
University of Pretoria
Pretoria South Africa
2017

Landscape Architecture for a mining solution: An
exploration of pattern

Contents

ACKNOWLEDGMENTS	3
ABSTRACT	4
CHAPTER ONE	15
1.1 Introduction to gold mining in Johannesburg	15
1.2 The profession of landscape architecture and mining issues in Johannesburg	15
1.3 The site location and client	16
1.4 Problem statement	16
1.5 Hypothesis	16
1.7 Methodology	17
1.8 Aims of study	17
1.9 Delimitation and assumptions	17
CHAPTER TWO	19
2.1.1 Urban issues	19
2.1.2 Ecological issues	20
3.3.1 Phase one – Stockpiling (approximately 1-5 years)	25
3.3.2 Phase two – Establishment of buildings (Approximately 5-15 years)	25
3.3.3 Phase three – Principle Metropolitan Robinson Deep Sub-centre (15-45 years)	25
CHAPTER THREE	29
3.1.1 Pond one: The acid pool	30
3.1.2 Ponds two to four: Treatment system	30
3.1.3 Pond five: Vertical flow pond	30
3.1.4 Pond six: Settling pond	30
3.2 Site	30
3.3 Palimpsest	30
3.3.1 The mound:	31
3.3.2 The plain:	31
3.3.3 The ridge	31
3.3.3 Recreation areas	33
3.4 Sub-programs and functions	33
3.5 Conclusion	34
CHAPTER FOUR	39
4.2.1 The emotive landscape of the ‘not so pretty’	41
4.3.1 Potential pattern pitfalls	43

4.3.2 Patterns on site	43
CHAPTER FIVE	47
5.1.1 Contextual case study	47
The Towers & Merriam Square in Cape Town, South Africa by Square One:	47
5.1.2 Formal case study	48
Museum Park Louvre in Lens, France, by Mosbach Paysagistes	48
5.1.3 Functional case study	51
Qunli Stormwater Park in Haerbin City, China by Turenscape	51
5.1.4 Technical case study	51
Vintondale AMD & Art Park, Vintondale, United State of America, Team SPLASH.	51
CHAPTER SIX	55
6.1.1 Site	55
6.1.2 Program	55
6.1.2.1 Water system	55
6.1.2.2 Movement system	56
6.1.2.3 Remembrance on site	57
6.1.3 Form	57
6.2 Final concept	58
6.3 Conceptual scenarios	60
6.3.1 Conceptual scenario one:	60
6.3.2 Conceptual scenario two:	60
6.3.3 Conceptual scenario three	60
CHAPTER SEVEN	63
7.1.1 Master plan	63
7.1.2 Design solutions sketch plan	66
7.1.2.1 Remembrance on site	66
7.1.2.2 Pattern on site	68
7.1.2 Sketch plan development	69
CHAPTER EIGHT	79
8.1 Technical description	79
8.2 Systems on site	79
8.2.1 Storm water	79
8.2.1.1 Phase one - Stockpiling (Ponding of stormwater)	79
8.2.1.2 Storm water calculations	79
8.2.2. Phase two – Establishment of the buildings	81
8.2.2.1 Storm water calculations	81
8.2.3 Phase three – Principle metropolitan Robinson Deep sub centre	83

8.2.3.1 Storm water calculations	83
8.2.4 Artificial wetland	87
8.3 Movement	87
8.3.1 Ramp regulations	87
8.2.2.2 Size of routes	87
8.3 Materials and technification	90
8.3.1 Materials around the remnants	93
9.3.2 Materials for the different walkways	97
8.4 Planting plan	107
8.4.1 Planting strategy	107
CHAPTER NINE	121
Can landscape systems be expressed through pattern making?	121
How can picturesque ideals cater for a mining identity?	121
Exam presentation	123
List of references	126

List of Figures

Figure1.2 Panoramic view of site looking towards Booyens street (Author 2017)	16
Figure2.1 Job-housing disparity for the Johannesburg (City of Johannesburg Metropolitan Municipality 2016)	18
Figure2.2 Urban sprawl over time (City of Johannesburg Metropolitan Municipality 2016)	19
Figure2.3 Land use diagram of Johannesburg (City of Johannesburg Metropolitan Municipality 2016)	19
Figure2.4 Klip River catchment in relation with the Robinson Deep mine tailings site (Author 2017)	20
Figure2.7 Proximity of site to other important nodes (Author 2017)	21
Figure2.6 Proposed activation of mining-belt (De Villiers, 2017)	22
Figure2.8 Land form of existing heaps (Author 2017)	23
Figure2.9 Pampas grass on the left and Eucalyptus on site (Author,2017)	23
Figure2.10 Polycentricity model : Current Johannesburg scenario, ideal model and proposed model (City of Johannesburg Metropolitan Municipality 2016)	24
Figure2.11 Phase one - Stockpiling (Author 2017)	26
Figure2.12 Phase three - Principle Metropolitan Robinson Deep sub-center (Author 2017)	26
Figure2.12 Phase two - built form (Author 2017)	26
Figure2.13 Ridge on site (Author 2017)	27
Figure3.1 Acid pond (Author 2017)	30
Figure3.2 Artificial wetland (Author 2017)	30
Figure3.3 Vertical flow (Author 2017)	30
Figure3.4 Settling pond (Author 2017)	30
Figure3.5 Mound on site to be retained (Author 2017)	31
Figure3.6 Erosion caused by drainage (Author 2017)	31
Figure3.7 Ridge with settling layers (Author 2017)	31
Figure3.8 Movement on site and possible important nodes(Author 2017)	32
Figure3.9 Main movement on proposed site (Author 2017)	33
Figure3.10 Proposed activity areas (Author 2017)	33
Figure3.11 Planting zones (Author 2017)	33
Figure3.12 Main route archetype (Author 2017)	34
Figure3.13 Promenade route archetype (Author 2017)	34
Figure3.14 Ridge route archetype (Author 2017)	34
Figure3.15 Robinson deep site with proposed urban development overlay on a Google Earth image (Author 2017)	36
Figure3.16 Views of proposed urban vision model(Author 2017)	37
Figure4.1 Paradigm comparison (Author 2017)	39
Figure4.2 Author collage of experience of site with a vision for site (Author 2017)	40

Figure4.3 Author collage of potential 'look and feel' of site (Author 2017)	40
Figure4.4 Ian McHarg, Design with Nature (McHarg 1992)	42
Figure4.5 Patterned landscape at Trinity Collage by gh3 (Landezine 2017)	44
Figure4.6 Turenscape concept sketch for park (Landezine 2017)	44
Figure5.1 Detention pond for excess roof water from The Towers roof space (Square One Landscape Architects 2017)	46
Figure5.2 Storm water systems to treat and replenish ground water at The Towers (Square One Landscape Architects 2017)	46
Figure5.3 Pedestrian interaction with detention facility (Square One Landscape Architects 2017)	47
Figure5.4 Louvre Lens park (Landezine 2017)	48
Figure5. 5 Vegetation growing over hard surface (Landezine 2017)	48
Figure5. 6 Patterns implemented in the park space (Landezine 2017)	49
Figure5. 6 Variety of intimate and vast spaces within the park (Landezine 2017)	49
Figure5. 7 Qunli strom water park progress photos (Turenscape 2017)	50
Figure5. 8 Pattern informants and pattern generator (Turenscape 2017)	50
Figure5. 9 The meeting of urban and natural spaces (Turenscape 2017)	51
Figure5. 10 Sketch plan of Vintodale AMD&ART (AMD&ART 2016)	52
Figure5. 11 View of the ponds at Vintondale AMD&ARTS (AMD&ART 2016)	52
Figure5. 12 Aeration pipe at the Vintondale AMD&ARTS park's pond 6 (AMD&ART 2016)	52
Figure6.1 Mound remnants in Vida Nova Park	54
Figure6.2 Ridge remnants in Vida Nova Park	54
Figure6.3 Plain remnants in Vida Nova Park	54
Figure6.4 Concept driver (Author 2017)	55
Figure6.5 Existing water bodies and drainage on site (Author 2017)	56
Figure6.7 From urban to natural landscape (Author 2017)	56
Figure6.6 Movement over site to connect activities (Author 2017)	56
Figure6.8 Urban edge and park exploration (Author 2017)	57
Figure6.9 Remnant elements on the site (Author 2017)	57
Figure6.10 Approach to mound(Author 2017)	57
Figure6. 11 Dimple effect concept model (Author 2017)	58
Figure6.12 Urban edge and park exploration (Author 2017)	58
Figure6.13 Concept overlaid onto model (Author 2017)	58
Figure6.14 Collage of 'look and feel' for proposed park: a view of the urban edge (Author 2017)	59
Figure6.15 Collage of look and feel for proposed park: a view of viewing decks and ponds (Author 2017)	59
Figure6.16 Conceptual scenario 1 (Author 2017)	60
Figure6.17 Conceptual scenario 2 (Author 2017)	60
Figure6.18 Conceptual scenario 3 (Author 2017)	60
Figure6.19 Concept process drawings (Author 2017)	61

Figure7.1 Progress model of master plan (Author 2017)	62
Figure7.2 Sketch of a dam in the Thamboti river (Author 2017)	63
Figure7.3 Three different movement types on site (Author 2017)	63
Figure7.4 Master plan exploration (Author 2017)	64
Figure7.5 Master plan -not to scale (Author 2017)	65
Figure7.6Patterns on site and proposed grass secession (Author 2017)	66
Figure7.7 Sketch plan area in red (Author 2017)	66
Figure7.8 Exploration of the use of a glade for emphasis (Author 2017)	67
Figure7.9 Exploration of the approach to remnant elements (Author 2017)	67
Figure7.10 Mound exploration (Author 2017)	68
Figure7.11 Progress sketch plan first application not to scale(Author 2017)	69
Figure7.12 Section CC not to scale	70
Figure7.13 Section BB not to scale	70
Figure7.14 Sections DD- not to scale (Author 2017)	70
Figure7.15 final sketch plan not to scale (Author 2017)	72
Figure7.16 Sections not to scale (Author 2017)	74
Figure7.17 Axonometric view of ketch plan area not to scale (Author 2017)	77
Figure8.1 Water system in the different phases (Author 2017)	78
Figure8.2 Phase one stormwater management (Author 2017)	80
Figure8.3 Tailing stockpile limited to 3m (Author 2017)	80
Figure8. 4 G-Tech technology to establish grass species (Author 2017)	80
Figure8.5 Phase two stormwater management (Author 2017)	81
Figure8. 6 Phase three stormwater plan (Author 2017)	82
Figure8. 7 Artificial wetland pond volumes (Author 2017)	83
Figure8. 8 Sketch plan not to scale (Author 2017)	84
Figure8.9 Artificial wetland section BB scale 1:20 (Author 2017)	86
Figure8. 10 Artificial wetland section BB scale 1:20 continue(Author 2017)	86
Figure8. 11 Pond drainage connection (Author 2017)	88
Figure8.12 Stone heaps on site (Author 2017)	90
Figure8.13 Concrete blocks cast <i>in situ</i> (Pinterest 2017)	90
Figure8. 14 Basket brick paving pattern (Menarek Stamped Concrete 201)	90
Figure8.15 Soil crete pathway in Green point park Cape Town (Author 2012)	90
Figure8. 16 Mentis grid pathways in Cap de Crues (Pinterest 2017)	90
Figure8.17 View of mound at the urban edge (Author 2017)	91
Figure8. 18 Spacial use around mound (Author 2017)	91
Figure8.19 Section AA scale 1:50	92
Figure8. 20 Detail A1 scale 1:20: retaining wall with mentis grid (Author 2017)	94
Figure8.21 Detail AA1:plan detail of mentis grid fixing not to scale	95
Figure8. 22 View of plain facing the mound	96

Figure8. 23 Section CC scale 1:50	96
Figure8.24 Detail Shuttering detail to formulate concrete blocks	98
Figure8.25 Detail C1: Paving detail around mound 1:20 scale (Author 2017)	98
Figure8.26 Detail C1:paving detail continue 1:20 scale (Author 2017)	99
Figure8.27 Detail C1:paving detail continue 1:20 scale (Author 2017)	99
Figure8.28 Perspective of bio-filter area (Author 2017)	100
Figure8. 29 Rain events effects on bio-filter area (Author 2017)	100
Figure8. 30 Section DD 1:50 scale (Author 2017)	101
Figure8. 31 Section EE scale 1:100 (Author 2017)	102
Figure8. 32 Elevation of viewing deck scale 1:100 (Author 2017)	102
Figure8. 33 Detail 1 of detail E1 of viewing deck scale 1:10	102
Figure8. 34 Detail E1 1:20 scale (Author 2017)	103
Figure8. 35 Detail 2 of detail E1 1:10 scale (Author 2017)	103
Figure8. 36 perspective view of ridge mentis grid walkways (Author 2017)	105
Figure8.37 Planting strategy (Author 2017)	106
Figure8.38 Planting communities (Author 2017)	106
Figure8.39 Specie choice criteria as derived from strategy (Author 2017)	108
Figure8. 40 SCxb9 Gold reef (Mucina & Rutherford, 2010)	109
Figure8.41 GM8 Soweto Highveld Grassland (Mucina & Rutherford, 2010)	109
Figure8.42 SVcb11 Andosite Mountain Buschveld (Mucina & Rutherford, 2010)	109
Figure8.43 Indigenous grass area planting plan scale 1:200	110
Figure8.44 Species for indigenous grass mix and respective criteria that they adhere to	113
Figure8. 45 Wetland mix application	114
Figure8. 46 Species considered for water mix (Planzafrica 2017)	115
Figure8. 47 Bio-filter application (Author 2017)	116
Figure8. 48 Specie for the bio-filter area (Author 2017)	117
Figure8. 49 Glade area with artwork (Author 2017)	119
Figure8.50 AMD treatment facility in West Rand (Author 2017)	120

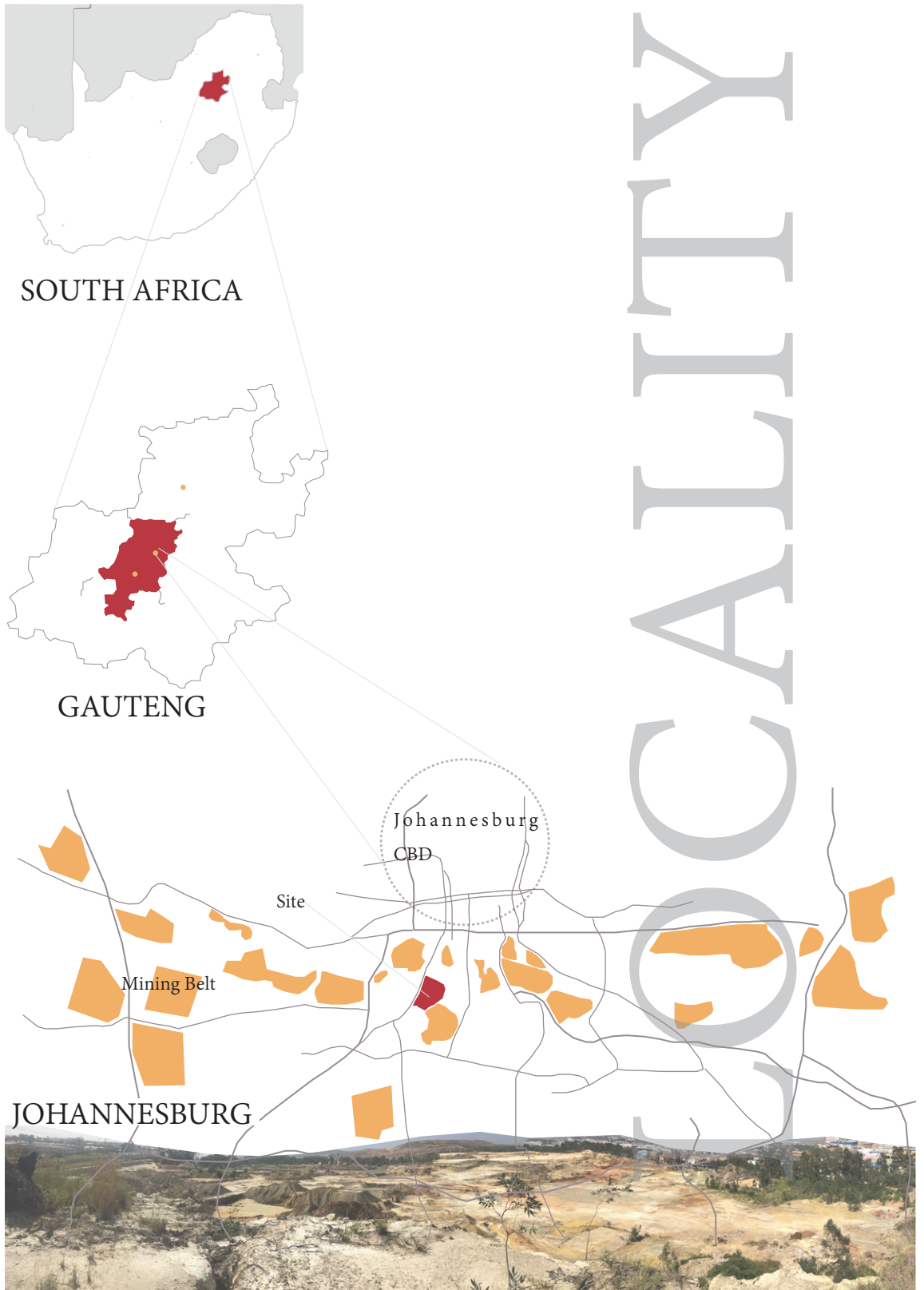

Figure 1.1 Locality of site in the mining belt context (Author 2017)

Introduction

1.1 Introduction to gold mining in Johannesburg

Johannesburg is the primary example of South Africa's dependence on mining as a source of wealth (Swart 2003). The remnants of mining activities are still evident in the urban fabric, with derelict tailings and poorly protected mine portal sites. These sites pose a risk to the people and surrounding environment (Lieverink 2017). To extract gold from the ore, a process of gold cyanidation is used. The application of cyanide to isolate gold particles before it is melted to form gold bars is the most effective method of extraction and the one most commonly used in the South African gold industry since 1889. This method of cyanidation was introduced after it was found that the pyrite gold ores in Johannesburg were difficult to extract gold from (Wise Uranium Project 2017). This and other dangerous substances such as uranium, magnesium, cobalt and other heavy metals, are present in the silt at 380 mine tailings sites and slime dams in and around Johannesburg which are polluting groundwater and water streams (Wise Uranium Project 2017).

After the gold is extracted the silt is pumped to silt dams in tailing sites and, over time, these sites have added to Johannesburg's iconic landscape (Walker 2015). The Johannesburg landscape has been depicted in various art forms over the 130 years of mining history (Thurman 2010).

The reprocessing of tailings sites started in 1977, which transformed these landmark landscape features in Johannesburg into a flattened-out sterile landscape (Walker 2015). After reprocessing, the silts are either pumped into pits, old mining shafts or into mega tailing sites on the outskirts of urban areas (Wise Uranium Project 2017).

1.2 The profession of landscape architecture and mining issues in Johannesburg

The subject of mining in the landscape architecture profession is not as common as one would think given South Africa's rich mining history. In the 'Identification of Work for Landscape Architects' document, as supplied by the South African Council for the Landscape Architectural Profession (2011), possible projects that professional landscape architects can participate in, include: projects in environmental management, derelict and contaminated sites, landfill sites and mining operations. Further stated within the scope of work for landscape architects, the document refers to preparing and auditing of environmental management plans (South African Landscape Architecture Profession 2011). Environmental management planning is what Swart (2003) had identified as the basis for any mine closure.

Currently, in the landscape architecture profession in South Africa, as investigated by the author, minimal brown-field and no mining-related projects have received an award in the past four years which are merited by the Institute for Landscape Architects in South Africa (VdW & Co 2017). This leads to the conclusion that landscape architects are not deeply involved in the rehabilitation or reclamation of old mining sites, despite having the opportunity to be involved as set out in the Identification of Works document referred to above.

The issues with mining and the perceived lack of involvement in the landscape architecture profession have led to this study of the possibility to redevelop a mine tailings site.



Figure 1.2 Panoramic view of site looking towards Booyens street (Author 2017)

1.3 The site location and client

The site refers to a 34-hectare, municipal-owned land in the south of Johannesburg marked in red as seen in Figure 2.1. The site is bordered by a railway line and the Booyens train station to the north, the police academy and the Pikitup waste site to the east, a City Power depot to the south and commercial and light industrial developments to the west. This site was previously the Robinson Deep mine tailings site.

In Figure 2.2, the site's seemingly vast landscape stands in contrast to the surrounding industries with the Johannesburg skyline in the background. The important Booyens Road connector, located on the western edge of the site, is used by the community travelling to the central business district (CBD) and was noticeable on the first site visit. This road connects to other communities like Soweto and Lenasia with many inhabitants regularly travelling to and through the area.

The responsibility of the local government and previous mining companies to rehabilitate the mine site is also covered under legislation such as the National Environmental Management Act (Lieverink 2017). The investment opportunity for the redevelopment of the site is enhanced by the high potential of the existing infrastructure surrounding the site. Thus, it is foreseen that the client would be a property developer.

1.4 Problem statement

Mining sites in Johannesburg are an issue for the urban environment as they lead to long-lasting negative effects on the environment and its users. These are usually dealt with, if at all, in a highly engineered realm that cater for nothing more than a functional requirement; mostly limited to treating the symptoms such as acid mine drainage (AMD). The Robinson Deep site is currently a hazardous site, forgotten and neglected but highly valuable in terms of its locality within the urban fabric.

1.5 Hypothesis

Solutions for the problems caused by mining sites can be optimised by applying the holistic approach of landscape architects. This approach will not only cater for solution-driven interventions but also considers both the users and the surrounding spaces. The systematic requirements may best be achieved through pattern making as a driver to facilitate form making, there by enhancing the user experience. The rich history of the mining industry that essentially formed the city of Johannesburg can not be erased but should rather be celebrated, by retaining a mining identity for the site.



1.6 Research Questions

Can landscape systems be expressed through pattern making?

Can the use of pattern for a systems design enhance the landscape and make it more relatable to its users?

How can picturesque ideals cater for a mining identity?

1.7 Methodology

Evaluation always includes a process by which one measures one aspect with another to determine its relevance and success (Deming 2011). This thesis will aim to find a solution to the real-world problems through the study of theory and precedent. After an analysis of the site, problems and opportunities are identified. Solutions will be synthesised to unlock the site potential. The solutions will then be tested against the theories and site analysis to ensure an optimum solution is achieved.

1.8 Aims of study

The development of a park space that will house the systematic requirements as required by the 'real-world' problem as well as serving as a recreational space for the users of the site.

To explore ways in which to not only rehabilitate a site but also celebrate the site. The crude beauty that is inherent in the site and its past would be incorporated.

To facilitate the expression of system through pattern and process.

1.9 Delimitation and assumptions

Financially, the project will be supported by the mining company and other responsible stakeholders.

The toxicity of site will be solved by the proposed systems as the chemical composition of site is out of the authors body of knowledge.

The future developments will progress to include multi-functional developments as outlined by the urban vision and supported by the Johannesburg Spatial Framework.

The site as documented will experience no further human interference in the form of dumping of rock or waste products.

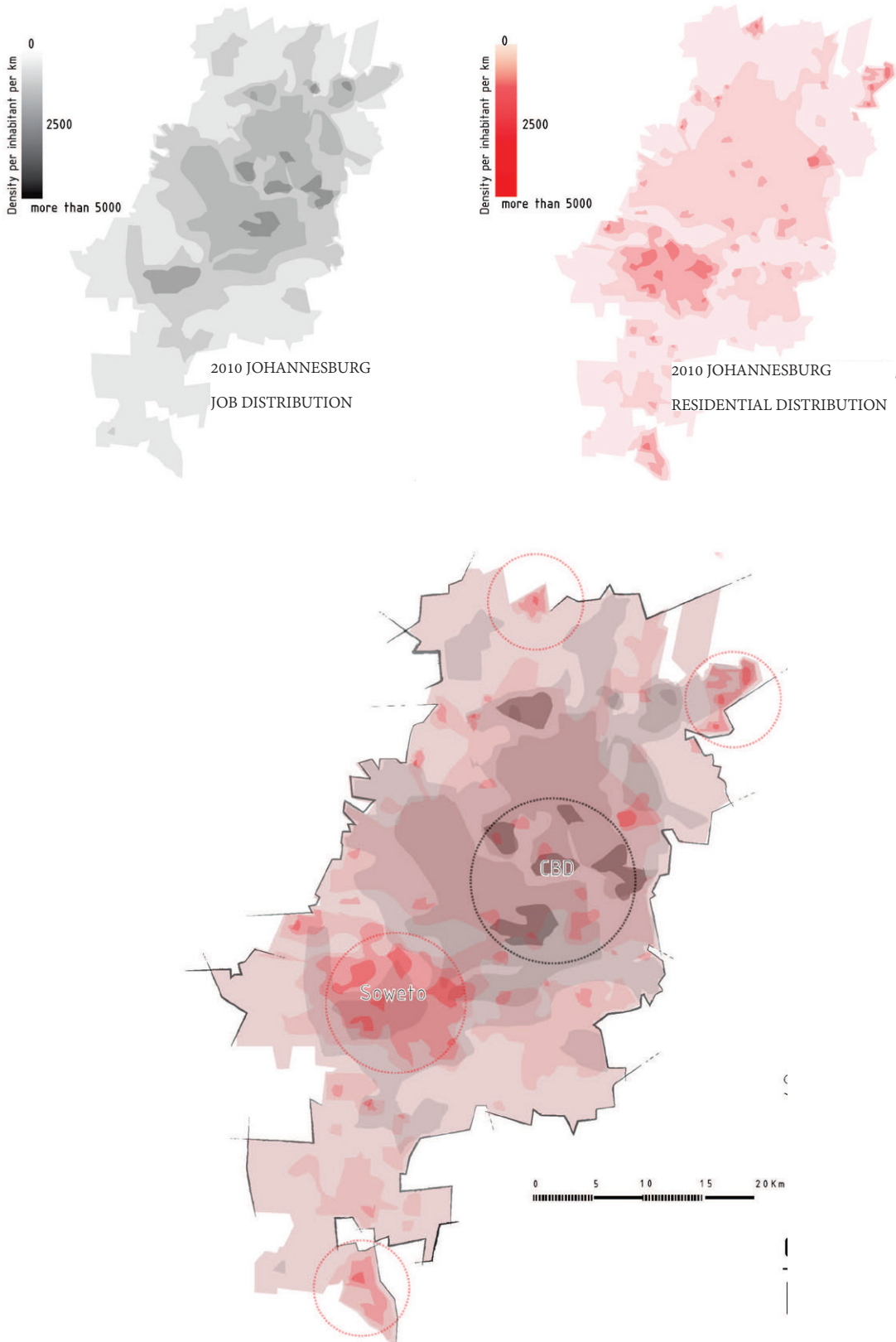

Figure 2.1 Job-housing disparity for the Johannesburg (City of Johannesburg Metropolitan Municipality 2016)

CHAPTER TWO

Introduction

This chapter aims to form an understanding of the Robinson Deep mine tailings site within the larger spatial context for the development of an urban framework. The site opportunities and constraints will then be identified in terms of the urban framework and site analysis.

2.1 Urban analysis

According to the Johannesburg Spatial Development Framework (JSF) of Johannesburg for 2040, the City of Johannesburg has numerous urban issues. From these, a few problems were identified as applicable to the specific area and site (City of Johannesburg Metropolitan Municipality 2016).

1. Fragmented urban sprawl,
2. Pressure placed on the natural environment,
3. The housing and job mismatch (Figure 2.1),
4. Inefficient residential density and inefficient land use diversity.

2.1.1 Urban issues

“The apartheid practices of planning and urbanisation have led to the development of a spatial structure with many shortcomings.” (City of Johannesburg Metropolitan Municipality 2016:26). See Figure 2.2.

Urban sprawl in Johannesburg is due to apartheid planning, by placing most of the population on the city’s peripheral. So, too, has the post-apartheid era generated a car-orientated development. This has, in turn, lead to higher household and services costs (City of Johannesburg Metropolitan Municipality 2016). See Figure 3.2.

One of Johannesburg’s identifying characteristics of the development pattern is the job-housing mismatch. Formal jobs in Johannesburg are scattered in an area of approximately 75% of the urban area and are an asset for the city centre. However, residential density, especially for lower income housing, is on the outskirts of the urban

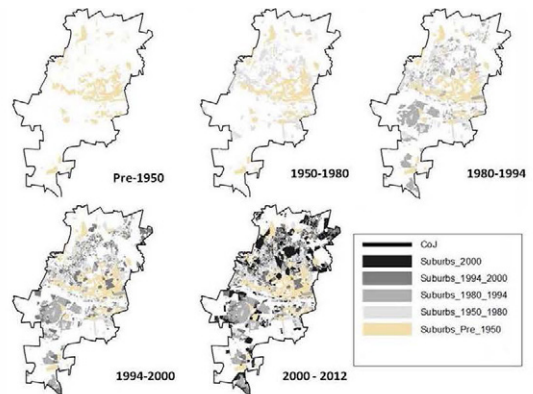

Figure 2.2 Urban sprawl over time (City of Johannesburg Metropolitan Municipality 2016)

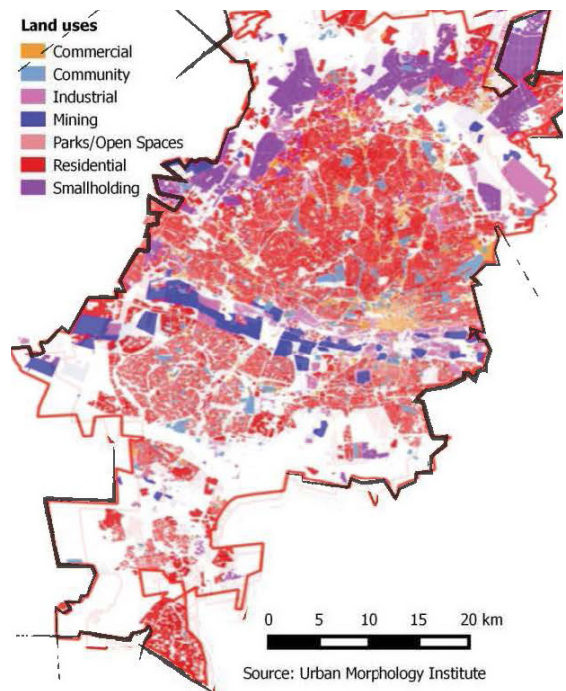

Figure 2.3 Land use diagram of Johannesburg (City of Johannesburg Metropolitan Municipality 2016)

area due to cheap, available land (City of Johannesburg Metropolitan Municipality 2016). See Figure 2.3.

2.1.2 Ecological issues

The south of Johannesburg is predominantly an industrial area with large derelict mine residue sites or tailings sites. These sites, as seen in orange in Figure 2.4, lie south of the M2 freeway and within the Klip River catchment (McCarthy et al 2007). The Klip River catchment is an important contributor in the socio-economic sector of the area. Industries include compost farming, irrigation of agricultural fields, and water recycling, with the Olifantsvlei and Bushkoppies sewage treatment works

discharging treated water into the wetlands. Recent studies have determined that this important wetland system is degrading due to heavy metals settling out and damaging unique and important species. The heavy metals are traced back to the mining activities and mining belt in the south of Johannesburg (McCarthy et al 2007). These tailings sites are poorly managed and result in non-compliance with general mine closure regulation. The sites lack signage to warn against the possible risk of these sites and inadequate storm water management leads to polluted water flowing to other areas. Accountable stakeholders abandoned these sites or companies declared insolvency in order to avoid the

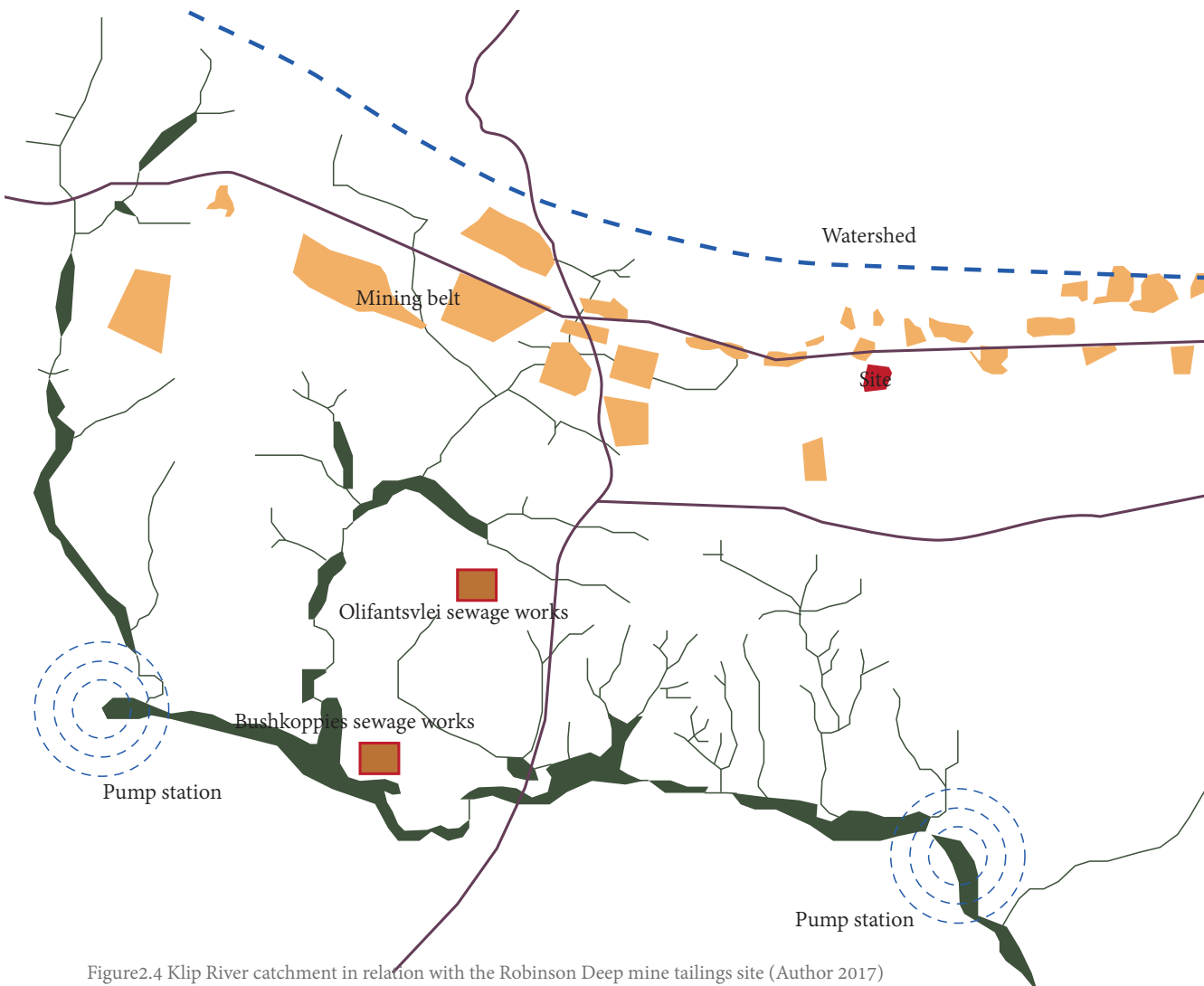

Figure 2.4 Klip River catchment in relation with the Robinson Deep mine tailings site (Author 2017)

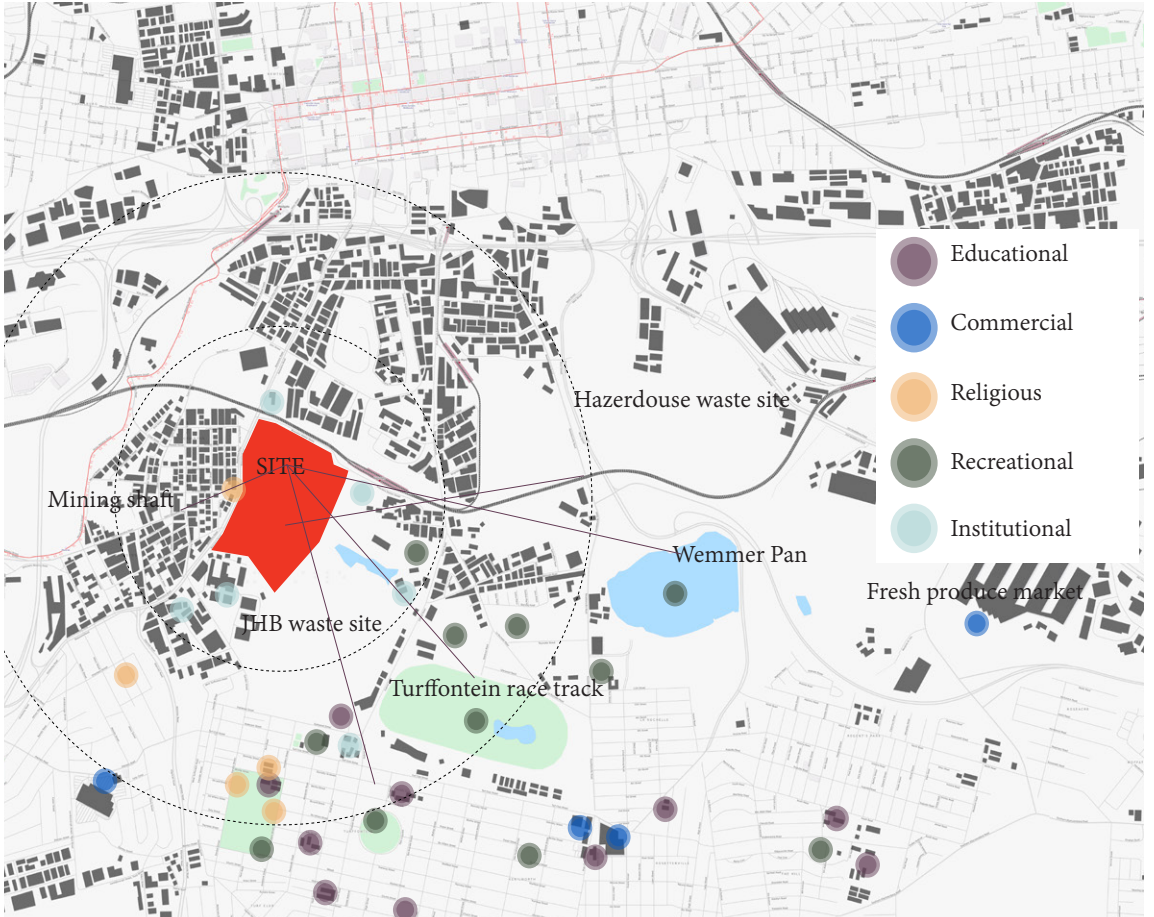

Figure2.7 Proximity of site to other important nodes (Author 2017)

2.2 Site Analysis

financial obligations of mine closures (Liefferink 2017). According to the Johannesburg Spatial Framework 2040 (JSF), the mine residue areas in the south of Johannesburg offer an opportunity to be developed into an east-west corridor as shown in Figure 2.6 (City of Johannesburg Metropolitan Municipality 2016). The site identified for this study lies south of the CBD next to Booyens Road and is centrally located in the mining belt. It covers an area of approximately 36 hectares. See Figure 2.7.

Known as the Robinson Deep mine site, it is located at the junction of the Opium, Booyens and Turffontein suburbs. The current surrounding land uses include industrial, commercial, residential, institutional and recreational.

The man-made nature of the site and the processes that formed it created a changing landscape in terms of the land form. As seen in Figure 2.8, older land forms are visible on previous aerial photos of the site and, with newer landforms created by illegal dumping or new

mining waste brought to the site, the processes involved in forming the site are variable and ongoing.

The potential for the site to be rehabilitated with the use of eco-systems services is recognised with the existing water bodies present on site. The transportation node just north of the site provides a portal for users from other locations. Furthermore, the proximity of the site to the CBD, makes this site ideal for future development, including habitation.

The site exhibits stable zones on marginal areas as shown in Figure 2.8 to the east and south, which is also the only area with permanent vegetation. However, the vegetation is predominantly invasive, including Eucalyptus and pampas grass. Its management should adhere to the National Environmental Management Act of 107 of 1998. In the case of Eucalyptus species in urban areas, according to its invasive classification of 1b, landowners bear no responsibility to remove the tree. If the trunk circumference is more than one metre it is preferred that the tree remains (Invasive Species South

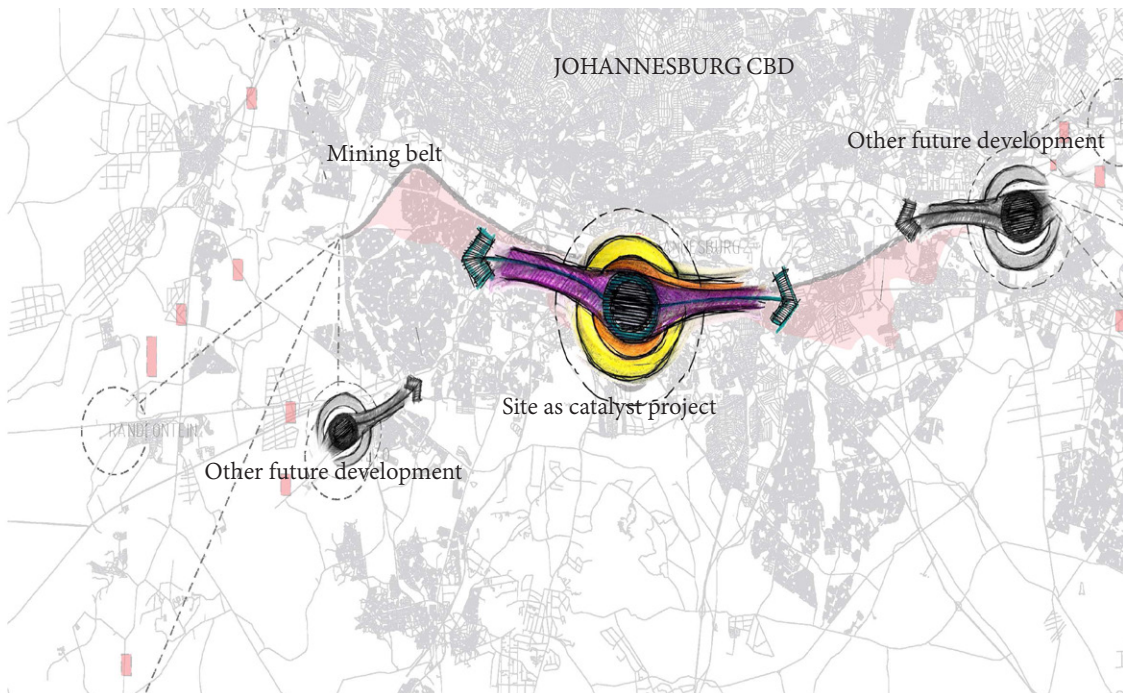

Figure 2.6 Proposed activation of mining-belt (De Villiers, 2017)



View 1



View 2



View 3

Original land form



Processed land form



Residual land form



Beautiful land form



Figure 2.8 Land form of existing heaps (Author 2017)



Figure 2.9 Pampas grass on the left and Eucalyptus on site (Author, 2017)

Africa 2017). The Eucalyptus species does, however, prohibit undergrowth and smaller specimens could be removed and the wood sold or re-worked. Pampas grass, *Cortaderia selloana*, is also found on site. This is also a Class 1b invasive. It does bear health risks caused by the inflorescence that flowers from February to April. The pollen is a silica-like substance and, when inhaled,

may cause respiratory problems (Invasive Species South Africa 2017). It is recommended that these species be removed off site and properly destroyed.

There is also a working PPC depot on site that is utilising the toxic material on site for premix. This business is an opportunity to expand on for the urban area.

“A city’s life comes from its connectivity -Dupuy (1991)”

2.3 Urban development: Re-connecting

(Salingaros 2003:2)

Based on the concepts of Corridors of Freedom and a Polycentric City as identified in the Johannesburg Spatial Development Plan for 2040, an urban framework was developed in this study for the Robinson Deep site.

Corridors of Freedom (CoF) is based on Transit-Orientated Development (TOD). This TOD, in summary as coined by (Calthorpe 1992), is a development that focuses on higher residential density supported by commercial, office and recreational spaces (City of Johannesburg Metropolitan Municipality 2016).

A Polycentric City is a city model where the CBD is supported by sub-metropolitan centres with connecting transport arteries. These arteries are well serviced and edged by high-density residential and commercial properties (City of Johannesburg Metropolitan Municipality 2016).

From this information, it was identified that the site

may be developed as a principal sub-metropolitan centre as shown in Figure 2.10, well connected with different transport mediums. This urbanisation of the site will support the current city centre as a new business district. The Booyens Station was also recognised in the Turffontein Spatial Development Framework as a potential transportation hub (City of Johannesburg Metropolitan Municipality 2016). However, this study proposes that the existing transportation infrastructure be extended onto and past the site and to include the Gautrain line and Bus Rapid Transport (BRT) bus routes with a station and bus stop approximately central to the site. This will aid in “new” feet travelling to and through the site.

Multi-zoned development will assist in alleviating the current mismatched job-housing development, identified as one of the main issues associated with Johannesburg urban areas (City of Johannesburg

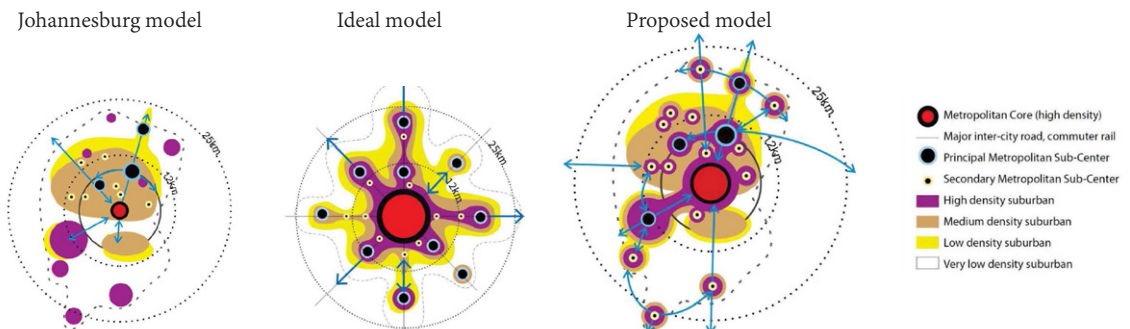

Figure 2.10 Polycentricity model : Current Johannesburg scenario, ideal model and proposed model (City of Johannesburg Metropolitan Municipality 2016)

Metropolitan Municipality 2016). An additional 5 000 to 7 000 people may reside within the 36-hectare (ha) area with a possible 10 000 commuters per day that travel to and from the transit development on site. A planned 7,5-ha recreational area located along the eastern edge of the site will also be partly utilized by the proposed water purification system. This system will reduce the acid mine drainage and treat the toxic soil so that the proposed urban vision is feasible. The recreational space will act as threshold space for the landfill reserve area. The urban vision is foreseen to be implemented in three main phases as follows;

3.3.1 Phase one – Stockpiling (approximately 1-5 years)

In phase one, it is foreseen that a majority of the material on the southern side of the site will be excavated to an estimated depth of 500mm and stockpiled on the northern part to facilitate an INCO Sulphur dioxide leaching process supported by a constructed wetland as described in Chapter 3. This process will leach out cyanide and the heavy metals on site to be disposed of in the hazardous waste site a kilometre north of site. The cleaned stockpiled material will be removed over time by the existing PPC depot for the use in premises. In addition, the extension of the facilities is proposed to provide a brick making facility that will supply the future development on site. The establishment of erosion controls on the southern part of site will be implemented in conjunction with the excavation for the stockpiling to ensure the control of dust and erosion. The use of berms and G-tech grids for the establishment of indigenous grass as erosion control is proposed.

The pampas grasses will also be eradicated at this stage and discarded at the bio-hazardous site two kilometres

north of site. The eradication of the pampas grass will not be done in the flowering months to ensure that the seeds are not spread across site.

3.3.2 Phase two – Establishment of buildings (Approximately 5-15 years)

The first building development is proposed to occur on Booyens Road in conjunction with the establishment of the main vehicular routes on site. The edge development will be predominantly commercial and light industrial to establish work opportunities for individuals residing in the area. The establishment of a skills development centre will feature a nursery and building skills training for individuals. The INCO Sulphur dioxide leaching process will continue on the now smaller stockpile heap. The proposed routing of the BRT to an onsite transit hub that includes a market space, which will attract users to the site. The site now features a skills development centre, commercial activities, and a recreational park.

The Eucalyptus species on site under the one-metre circumference will be removed and the wood will be used in the skills development centre. The Eucalyptus plantation will be replaced by endemic pioneer species as space becomes available.

3.3.3 Phase three – Principle Metropolitan Robinson Deep Sub-centre (15-45 years)

In this phase, the remaining residential and commercial buildings are to be erected. The purpose of the INCO Sulphur dioxide leaching system and wetlands will be to supply the irrigation needs for the park. The cleaning of top-up water for the system will come from a mining shaft, one kilometre west of the site.

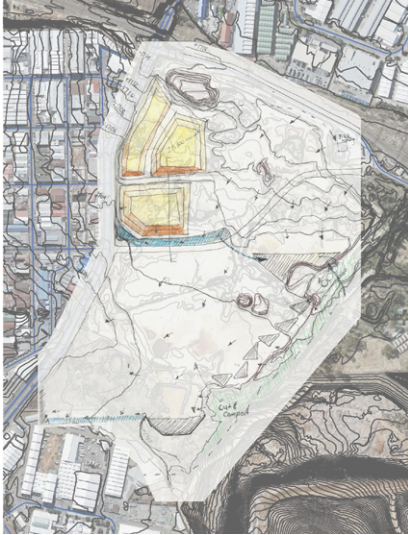

Figure 2.11 Phase one - Stockpiling (Author 2017)

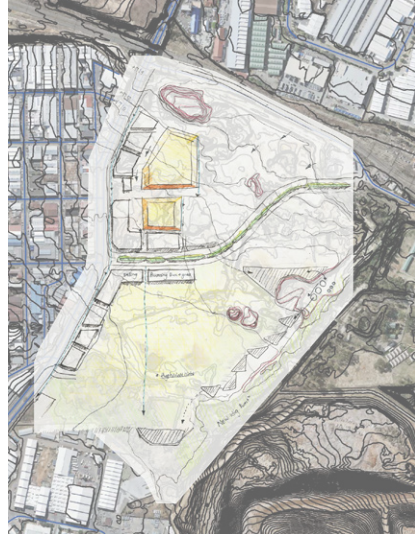

Figure 2.12 Phase two - built form (Author 2017)



Figure 2.12 Phase three - Principle Metropolitan Robinson Deep sub-center (Author 2017)

2.4 Site possibilities

According to the Council for Scientific and Industrial Research (CSIR), a minimum requirement of 0,5 hectare of recreational space per 1000 people is needed in urban areas (City of Johannesburg Metropolitan Municipality 2016). The highlighted area, as seen in Figure 3.12, is approximately 7 ha which can cater for 14 000 people and is in excess recreational space that can carry other neighboring developments. The landfill reserve to the south-east side of site is foreseen to be a closed off reserve where an entrance fee will contribute to the maintenance and security of the reserve.

The proximity of the site to the urban edge may have mutual benefits. According to Diane E. Pataki, urban green spaces reduce greenhouse-gas emissions, remove air and water pollutants, cool local climate and

improve public health (Pataki 2011). The use of eco-service systems will help to reduce the negative effects of urbanisation for a healthier urban area. So, too, will the commercial planned activities on the urban edge stimulate passive surveillance within the park and bring “feet” to the park.

A ridge present on site to the eastern side creates a visual boundary and acts to scale down the landfill heap. This ridge is also seen as a possible connector from the current train station to the site. The patterns on site that have been formed by various processes, such as the movement of pedestrians, weather patterns, and previous slurry dams, are evident in all aspects of site as seen in Figure 3.12.

2.5 Conclusion

The area, see Figure2.12, now referred to as the site, lends itself, in its synthetic nature, to the idea of process and pattern. It is observed that pattern can be generated by a variety of methods, be it natural form, man-made or a combination of the these to create a striking landscape.

The cleaning of the site and those processes are proposed to happen within the site and form part of the threshold/ recreational space planned for the proposed urban vision.



Figure2.13 Ridge on site (Author 2017)

CHAPTER THREE

Introduction

The aim of this chapter is to compile a program that will attempt to solve the problems identified in chapter 2. The program is an implementation of the urban vision and include development of the systematic requirements.

3.1 Program

“An explicit programming process provides a more dependable basis for design” (Lynch 1984:p107).

Systematic requirements on site is the main structure to the recreational space and a key part of the urban proposals. A phased approach to the site leads to the early completion of income-generation components of the scheme while healing the site. The process proposed to rehabilitate the contaminated soil is a leaching system. Current approaches to the rehabilitation of tailings sites are rather a best management practice than a long-term solution to eradicate the issues (Lieferrink 2017). Current approaches include the establishment of pioneer grass species such as *Hyparrhenia hirta* to ensure that the side of these tailing sites are at a lesser slope to prevent erosion. Unfortunately, the acid mine drainage seeps into the groundwater due to the acidic nature of the material (Walker 2015).

The feasibility of developing the site will depend on the successful removal of the heavy metals, especially cyanide. Three methods that may be used to decommission cyanide-contaminated ore tailings are described below (U.S Environmental Protection Agency 1994).

1. Leave the heap to enable natural processes to act on the soils until an acceptable quality balance is reached. This is, however, a lengthy process and the site remains in structure and form a tailings site.
2. Remove the tailings in smaller batches off-site because insufficient pads under tailings (pollution control layer

under tailings heap) were constructed; or because the tailings are impermeable and methods not feasible.

3. The third method involves the “rinsing” of the heap to leach the cyanide with the leachate, to be captured in tanks, as described in detail below.

Flushing the cyanide is the most effective process in that it treats the heap on site and does not dispose of the toxic material to another site where it will still be problematic (U.S Environmental Protection Agency 1994).

The proposed INCO (The International Nickel Company) sulfar dioxide/air process consists of four process tanks and a clarifier tank with a pump house, which makes for simple assembly on site. The wastewater containing cyanide is pumped into the first tank, a mixing vessel, where copper sulphate form another tank is added which reacts with the cyanide. The mixture is pumped to the next mixing vessel through an aeration valve. A lime solution in a third tank is circulated to assist with maintaining the required acidity of the mixture as the pH of the water determines the effectiveness of the process (U.S Environmental Protection Agency 1994). The final stage of the process is a clarifier tank to settle out the particles which are then disposed of in an existing hazardous waste site just north of site.

From there, the water is released into an on-site eco-service system (an artificial wetland system). This system treats the acidity and the remaining heavy metals, such as manganese, iron, and aluminum. The system requires a total of six ponds that function as follows (AMD&ART

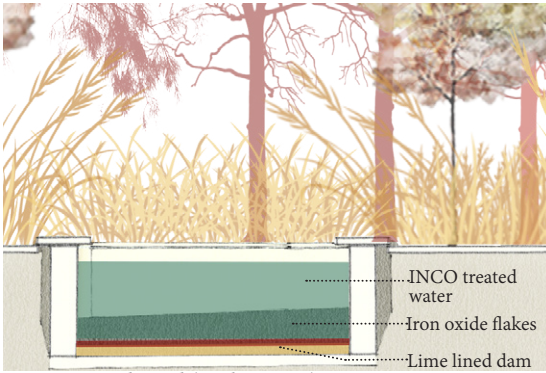

Figure 3.1 Acid pond (Author 2017)

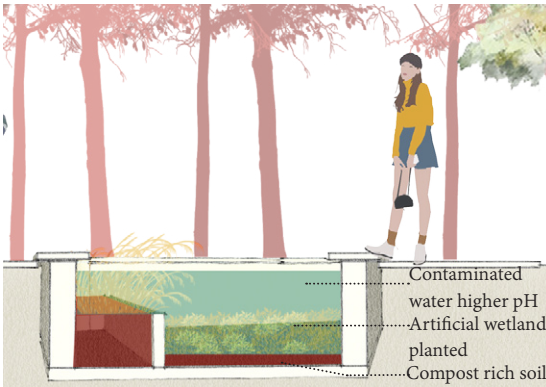

Figure 3.2 Artificial wetland (Author 2017)



Figure 3.3 Vertical flow (Author 2017)



Figure 3.4 Settling pond (Author 2017)

2016):

3.1.1 Pond one: The acid pond

This pond, in Figure 3.1, is lined with limestone. The red/ orange particles in the water flake out in reaction to the lime lining (AMD&ART 2016).

3.1.2 Ponds two to four: Treatment system

These ponds, Figure 3.2, are the artificial wetlands that provide for phytoremediation to take place. Specific plants contain certain micro-organisms and can take up heavy metals (AMD&ART 2016).

3.1.3 Pond five: Vertical flow pond

This stratified pond, Figure 3.3, has a thick top layer of compost that strips the water of oxygen. Below this is a thick layer of lime where the acidity is reduced. Water is conveyed to the next pond by an underflow vertical pipe system creating vertical flow through the lime that improves the effectiveness of the lime in treating the acidity (AMD&ART 2016).

3.1.4 Pond six: Settling pond

Water from pond five then flows through an aeration system into pond six, Figure 3.4. This settling pond reduces the flow velocity so that left-over iron oxide settles out (AMD&ART 2016).

3.2 Site

The site for the system is identified as the space on-site that links the existing silt pond with the other existing pond on the southern side of the site.

3.3 Palimpsest

As identified in the site analysis, the site has a unique identity. The main forms on site are the mound, the ridge and the plain.

3.3.1 The mound:

The mound in Figure 3.5 will be a viewing area and seating area for visitors will be provided at the trees planted as a background for the mound.



Figure3.5 Mound on site to be retained (Author 2017)

3.3.2 The plain:

The plain as seen in Figure 3.6 is retained to illustrate the effects natural processes can have on the sandy material on site. The formation of patterns occurs from natural actions such as flowing water to the footstep patterns on the plain. Currently on site, the vastness of the specific area was identified as an unique characteristic of site. As an intervention and approach to this specific feature, the plain will be considered with “soft landscape” to enhance the specific characteristics.



Figure3.6 Erosion caused by drainage (Author 2017)

3.3.3 The ridge

The ridge, Figure 3.7, is left in place as a viewing zone onto the system to illustrate the water flow pattern and processes that treat the water. The ridge also acts as a backdrop for the water system and is planned to form part of a set of pathways which includes a running track.



Figure3.7 Ridge with settling layers (Author 2017)

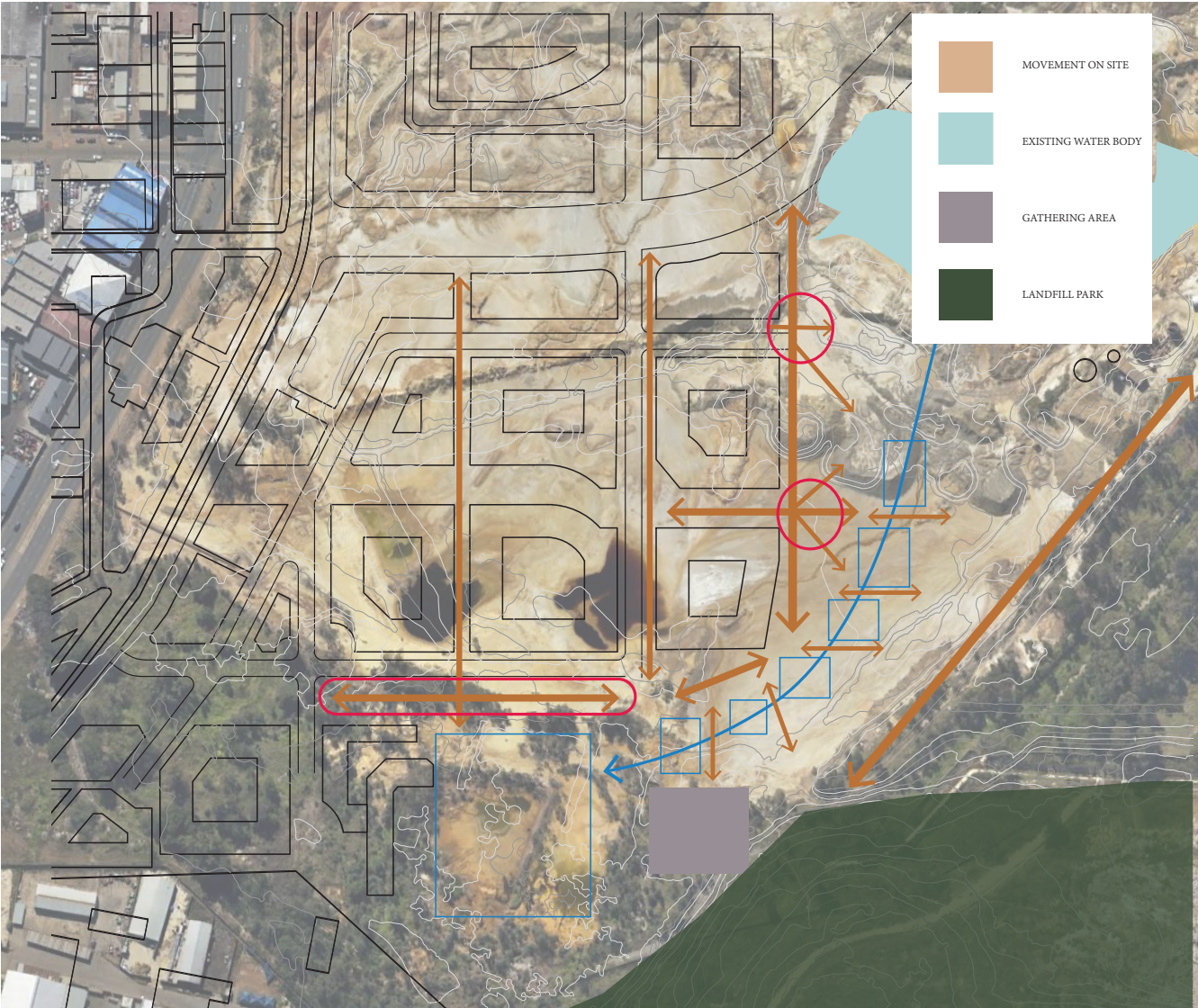

Figure3.8 Movement on site and possible important nodes(Author 2017)

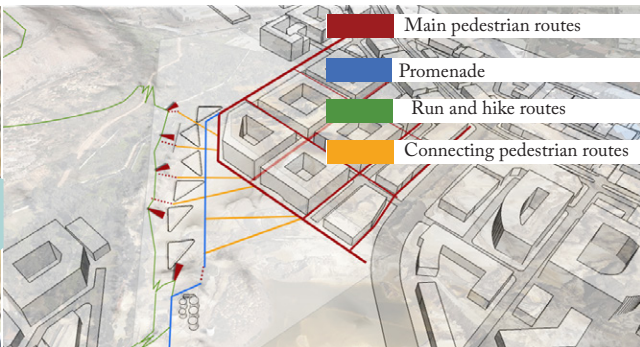

Figure 3.9 Main movement on proposed site (Author 2017)

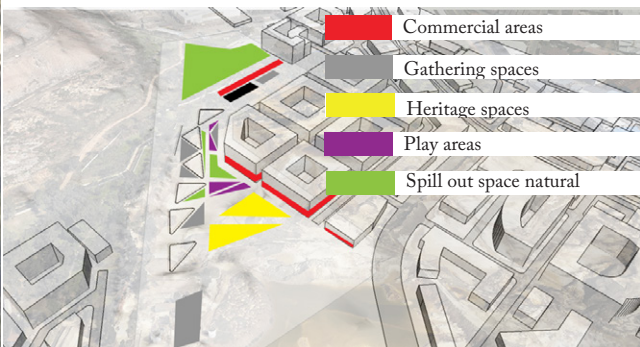

Figure 3.10 Proposed activity areas (Author 2017)

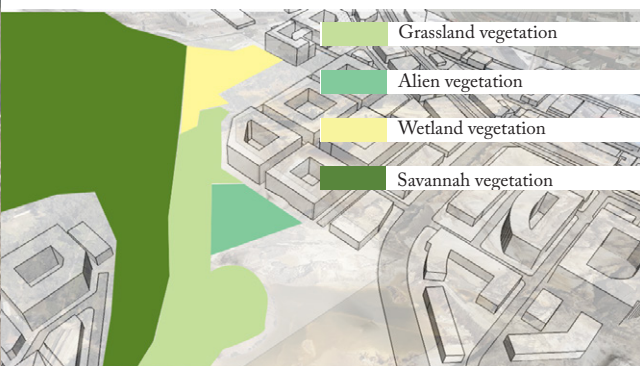

Figure 3.11 Planting zones (Author 2017)

3.3.3 Recreation areas

The site will assist as a transition area from the train station to the landfill park and event/park space on the southern part of the site. The park space on the edge will also feature sports facilities and vehicle parking lot.

The main walk way on the western side of the site is edged by commercial activities. The promenade walkway from the station through the site has various spill out spaces. The user is led from the northern side, unprogrammed, to the southern side that is more programmed. The third walkway is for runners and walkers to use and leads to viewing decks that overlook the water system.

3.4 Sub-programs and functions

The entrance space to the proposed landfill reserve is linked to the transport node with the site forming the threshold for the reserve. This land fill park is closed and an entrance fee will be charged to ensure the safety of the users. Proceeds will go to the upkeep of the land fill park. Play spaces on the urban edge cater for families to use the commercial side of the park where parents can keep watch over their children.

The introduction of key indigenous species to the park will create habitat and green areas that are connected to the Wemmer pan green fingers as proposed by the Turffontein Development corridor framework (City of Johannesburg: Johannesburg Development Agency 2014).

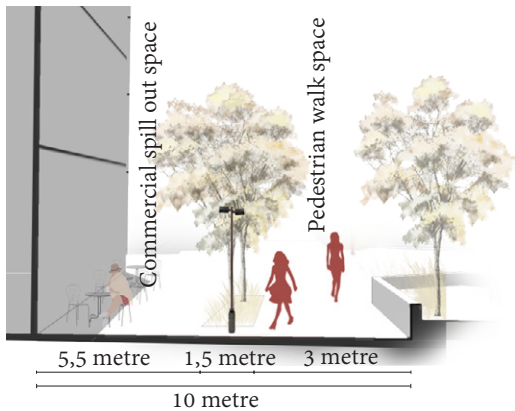

Figure 3.12 Main route archetype (Author 2017)

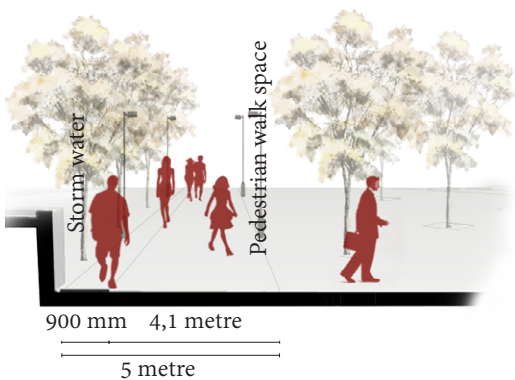

Figure 3.13 Promenade route archetype (Author 2017)

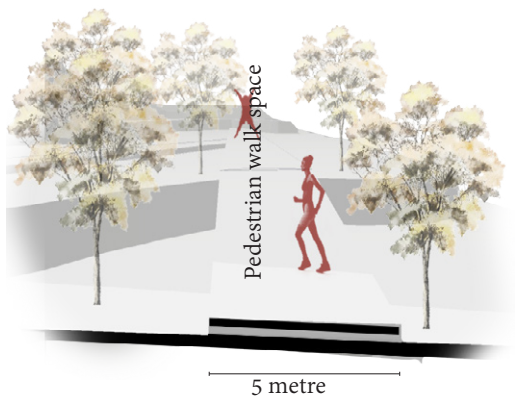

Figure 3.14 Ridge route archetype (Author 2017)

3.5 Conclusion

The park will serve predominantly as a threshold space for users to travel to and from the transit node and activities linked to the southern side of the park and the landfill reserve. The space will also provide the residents on site with a formal recreational area, i.e. basketball courts, events area and playscapes.

The main structuring element will be the pattern of the systems for processing the toxins on site and the pattern of the user movement across site. These will be the main form drivers for the parkscape.

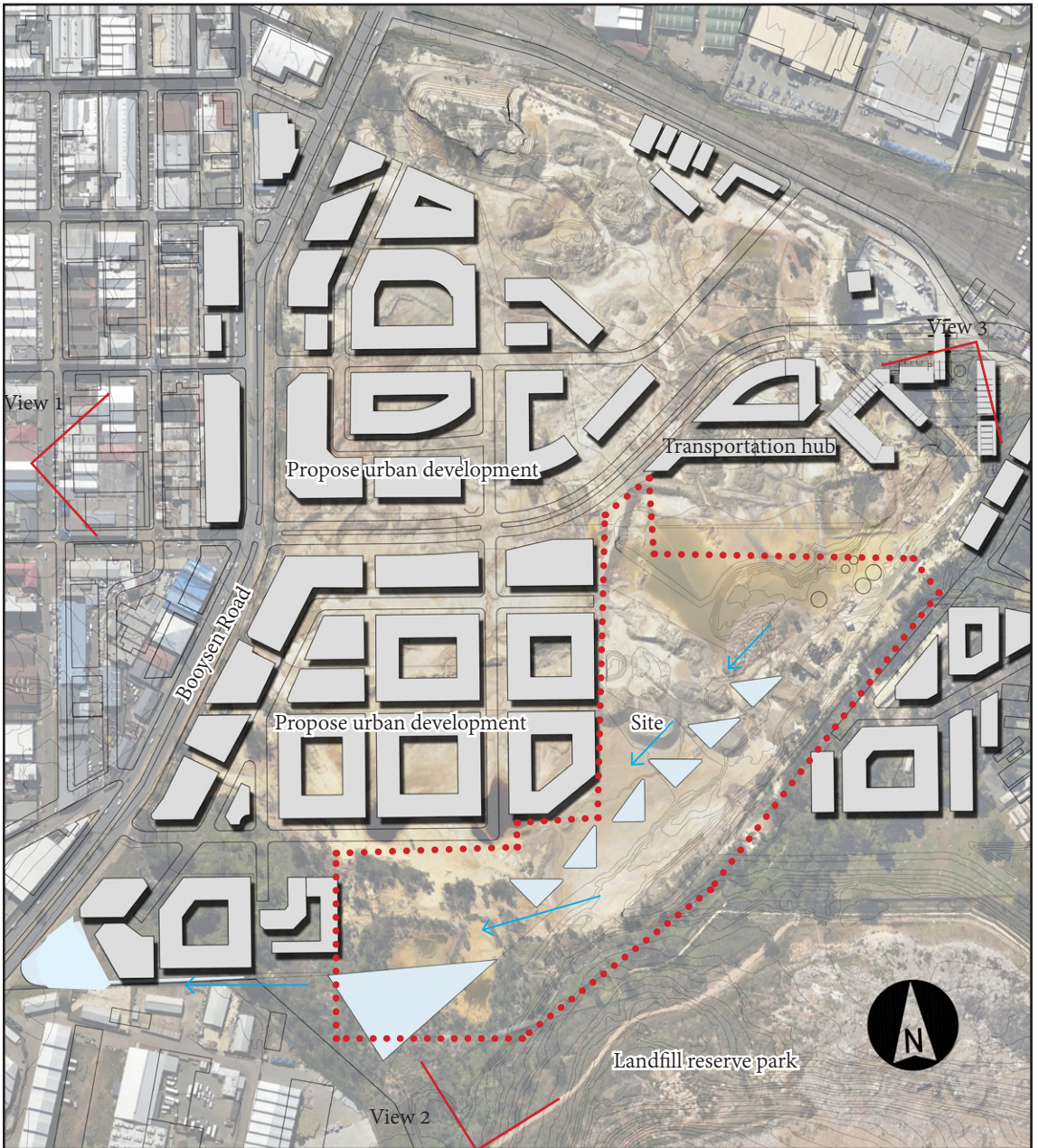

Figure3.15 Robinson deep site with proposed urban development overlay on a Google Earth image (Author 2017)

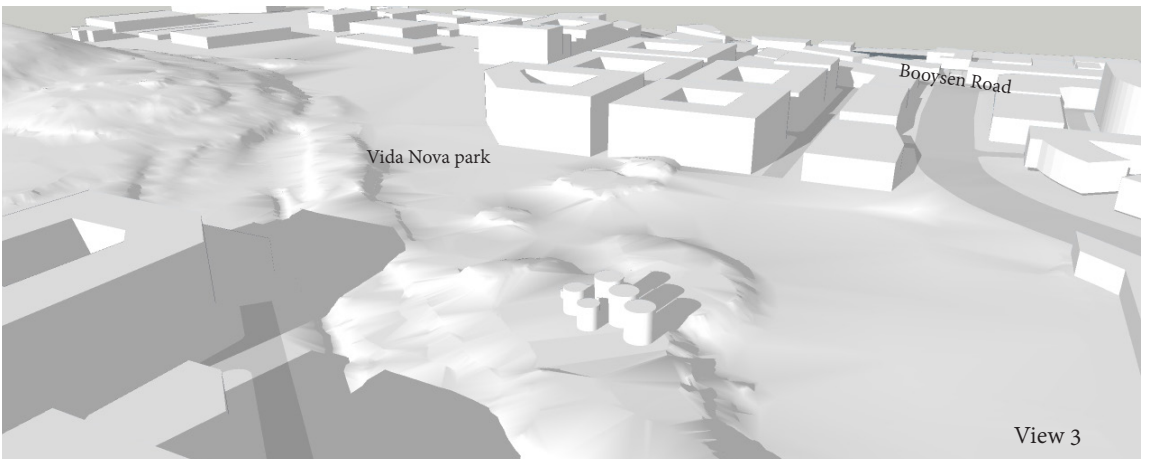
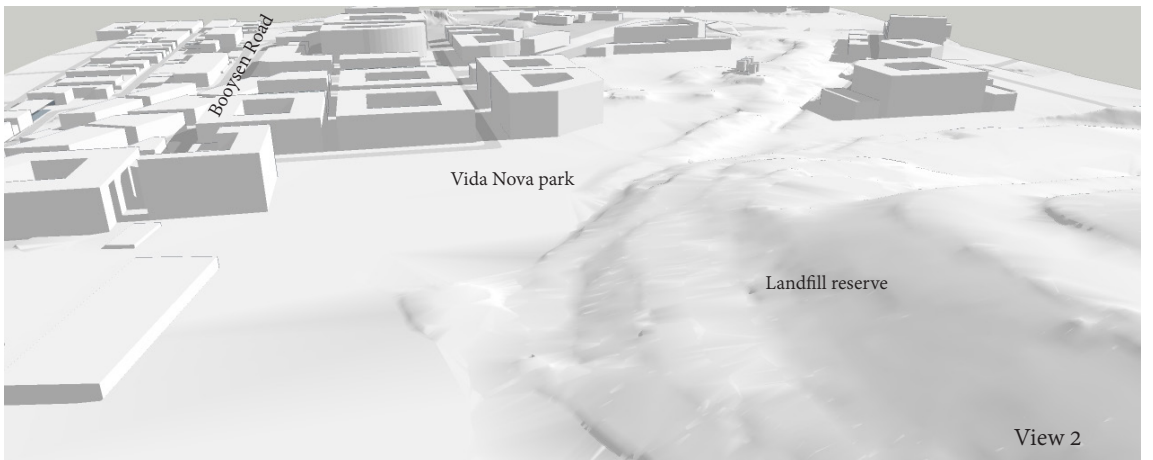
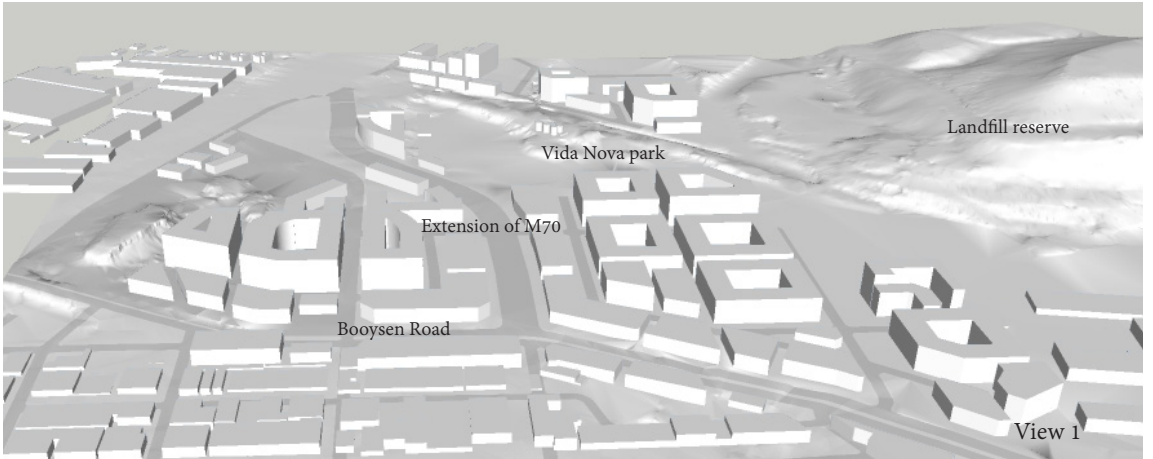

Figure3.16 Views of proposed urban vision model(Author 2017)

CHAPTER FOUR

Introduction

The purpose of this chapter is to formulate a landscape approach based on landscape theory. This will facilitate in a “golden thread” for the project and in design decision making.

4.1 Theoretical approach

The current paradigm in landscapes has seen a re-emergence of two approaches to landscape architecture, not new to the profession but used to celebrate a site while solving related real-world issues, as illustrated in Figure 4.1. The first is the use of Picturesque aesthetics within landscape architecture, especially in parks.

“[...] or parks that feature abandoned refrigerator towers, still tread upon the familiar territory of the Picturesque” (Herrington 2016).

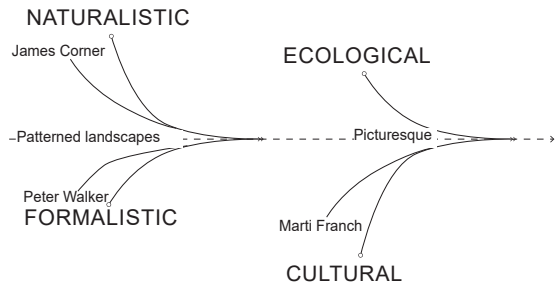

Figure 4.1 Paradigm comparison (Author 2017)

The other is one of Patterned landscapes and the use of pattern for systems design and process as pattern (M’Closkey 2013).

4.2 Picturesque for the “not conventionally pretty”

“The recognition of Picturesque aesthetics in contemporary landscape architecture is important now because during the past century the study of human interactions and experiences with landscape has been dominated primarily by environmental psychologists preoccupied with landscape preferences and behaviours” (Herrington 2006:23).

In Susan Herrington’s article *Framed Again: The Picturesque Aesthetics of Contemporary Landscapes*, Herrington recognises that the re-appreciation of landscapes for the bettering of the human psyche has been a recent point of interest in other professions. She attributes this to the re-emergence of picturesque qualities and ideologies.

“These projects are captivating because they create the possibility for appreciating landscapes that are not

conventionally pretty” (Herrington 2006:29). This emotive evoking design towards industrial (synthetic) landscapes engages the users on an emotional, imaginative level as well as evoking memories of place. By doing so, these projects participate in Picturesque aesthetics (Herrington 2006).

Socio-political conditions have been a symptom of this Picturesque ideology but Herrington is critical of the lack of attention given to the Picturesque as an aesthetic and that other studies on the matter have only investigated Picturesque as a historic style. Herrington goes on to identify Three Faces of Picturesque: Picturesque style; Picturesque ideology; Picturesque as aesthetic (Herrington 2006).

Picturesque style is defined as an important defining element of this style. Inspiration was drawn from Roman artists and their techniques. These techniques were



Figure 4.2 Author collage of experience of site with a vision for site (Author 2017)

incorporated into landscape design such as extending the ground plane. This created a formal quality within the work of this style (Herrington 2006).

Picturesque ideology is a movement within the Picturesque where the owners of large properties and wealth attempted to “naturalise” their wealth through mossed-over buildings and rolling landscapes, which created an authorless appearance. These spaces gave the user an impression of informality and a sense of natural order, which only the rich could afford (Herrington 2006).

Picturesque as aesthetic is the face of the Picturesque identified most in contemporary landscapes. The three major identifiers as Picturesque as aesthetic response according to Herrington are: “(1) the primacy given to the role of the imaginative spectator; (2) the use of artefacts that would be deemed unsightly or even ugly without picturesque aesthetics; and (3) content in these works that is typically unfamiliar to a 21st century, service-oriented culture” (Herrington 2006).

It is often argued that with Picturesque landscapes such as the Stourhead Estate, it is important for the user to



Figure 4.3 Author collage of potential ‘look and feel’ of site (Author 2017)

have sufficient knowledge of Virgil's Aeneid and King Alfred to appreciate the landscape (Herrington 2006). It is prevalent that Picturesque landscape is created from a poem, artist's expression or a story.

In these landscapes, the structure or checkboxes for creating such is not as tangible as that of, for instance, the modern movement where applying the five principles will achieve a modern "styled" landscape, but rather depends on the user experience and emotive response to the landscape. These emotions might be that of nostalgia or melancholy (Herrington 2006).

The site that once represented the might of the gold industry that moved tons of earth for the search of wealth and an improved life, is now a visibly degraded, neglected piece of earth representing the damage of years of ill-managed mining practises (Lieverink 2017). Can these left-over heaps have an emotive impact and add to the Picturesque aesthetic of site? See Figure 4.3. To not just *tabula rasa* the site, as warned against by John Ormsbee Simonds. Rather, by re-imagining these (industrial) sites with a focus on a theoretical enquiry, rather than an exclusive artistic exploration, could the

ugly become the picturesque now (Herrington 2006)?

4.2.1 The emotive landscape of the 'not so pretty'

Jacky Bowring entered the discussion on emotive landscapes with her book *Melancholy and the Landscape: Locating Sadness, Memory and Reflection in the Landscape*. Investigating the emotions of melancholy and tragedy, she explores the definition of landscapes and its all-encompassing meaning that can possibly include everything seen outdoors: buildings, cities, parks, etcetera. and the rich history we as humans endured in defining landscape. How then have we reduced landscapes into reality shows where landscapes are installed in backyards in a few hours? She argues that recent mainstream landscape works have been reduced to "eye candy" projects. Important notions such as tragedy and melancholy are avoided but, in her opinion, it is an important emotion (Bowring 2017).

"Defining melancholy is evidently impossible"(Bowring 2017). With this, Bowring suggests that landscape architecture is no stranger to difficult definition and that other challenging subject matters have been expressed in



landscapes such as romantic beauty, abnormal grief and so on. She states that an elusive term like melancholy is open-ended for interpretation and can add a richness to landscapes (Bowring 2017).

The site in the south of Johannesburg causes a definite emotive response. As identified by Herrington, an industrial landscape has hereditary emotive elements that need to be celebrated within landscapes. Having visited the site several times and with different individuals, the overwhelming reactions that I observed were that of awe and surprise. This is experienced especially as one travels from the built-up city centre to the industrial area of the site and the surrounding areas such as Booyens. Entering the site from Booyens Road, vast soil heaps of monotone yellow confront one in contrast with the corrugated iron and brick buildings surrounding the site.

A visit to similar tailings sites in the West Rand created a completely different emotive response. On this trip, activist Mariette Liefferink accompanied a group of mechanical engineers on a day excursion to different tailings sites at varying stages of degradation, reprocessing and standstill. Through her wide knowledge, understanding the effects of these sites on the environment and communities gave rise to a sense of angst and worry. The knowledge of the potential effect of these sites on one person and others as well as to the environment, created a different experience but left one still in awe of the vastness of these sites located in the midst of urban areas.

Based on the theory of the beautiful in the ugly, the proposed site development will engage with the pollutants on site. The proposed systems will play a central part on the site and, in dealing with it, the implementation of pattern as form making is explored.

4.3 The use of pattern

Furthermore, in reaction to an article by Karen M’Closkey, namely *Synthetic Patterns: Fabricating Landscapes in the Age of ‘Green’*, a critical look at pattern making and the use of pattern as a design approach for the site and proposed system were undertaken. She wrote the article as a response to growing discussions in the landscape architectural field focusing on problem-solving approaches, and not how these landscapes can cater for expression, experience, and art (M’Closkey 2013).

What does it mean to use pattern in landscape architecture? Pattern is defined as a diagram of process (Bell 1999). Bell observed a relationship between every process or *façade* of activity and the pattern created by them. Thus, patterns occur naturally and can be observed from a micro scale, such as a DNA string, to a macro scale, such as galaxies (Bell 1999). Pattern is what helps us process information and make sense out of chaos (M’Closkey 2013).

“[...] pattern can be used as a bridging mechanism between a landscape’s utilitarian and aesthetic functions: between systems and signs” M’Closkey.

The use of pattern, according to M’Closkey, can relate users to the landscape by the pattern that caters for the utilities on site. She states this as one of the benefits of the use of pattern in landscapes. Pattern in landscape provides order and structure to a landscape without



Figure4.4 Ian McHarg, Design with Nature (McHarg 1992)

looking like nature. M'Closkey is critical of a landscape that imitates nature and its processes, in that natural landscapes lack expression and are only fully appreciated as views and not immersing the user in experience. As with Ian McHarg's approach to landscape, as seen in his book *Designing with Nature*, imitating nature is adopted as an approach to landscape design. See Figure 4.4.

Working with a synthetic site, the prospect of rehabilitating the site to a previous ecological state seems redundant as the new "ecology" of the site has a positive quality captured in years as the tailings have been exposed to natural and man-made processes and degradation. Can the pattern cater for a certain "new synthetic ecology" that will transform this derelict space into a more immersive landscape? Can pattern bring an identity to the site?

4.3.1 Potential pattern pitfalls

According to M'Closkey's research, some of the critiques on pattern in landscape are as follows (M'Closkey 2013):

1. Using Geometric shapes, pattern tends to be on a flat surface and thus considered to be visual and pictorial only.
2. Patterned Landscape implies repetition and thus these landscapes are monotonous. Variety should invoke difference in kind and not, as the case with pattern, difference in degree.
3. The use of computer-based drawing programs has made it easier to copy and paste a pattern on a landscape and patterns are uncritically adopted on site.
4. Patterns are too static and not mutable for the fluctuations of landscapes.
5. Applying a geometry to landscapes is self-explanatory by the geometry itself and thus not site-specific.

Some patterned landscapes focus more on the visual strengths of pattern, as the Trinity College Quadrangle by gh3 as seen in Figure 4.5. This is a patterned ground plain that serves an activity courtyard for formal and

informal events.

In my opinion, the pattern serves as a datum for the surrounding buildings. It is one-dimensional but still successful. The meaning of the chi icon that is repeated, connects the landscape with the cultural significance of the college as a place where students, staff, and alumni meet. The implementation of the landscape also ensured the survival of existing trees that were degrading due to root compaction, thus catering to some ecological function of a vertical fertilisation program, while still allowing for infiltration of stormwater. This project breaks one of the critiques on pattern and is still successful. So, what pattern can be incorporated on site? How would one express a system then with pattern?

4.3.2 Patterns on site

M'Closkey categorises recent patterns in landscape architecture into Pattern of Field and Pattern of Figure. 'Field' refers to pattern derived from a response of energy of the site, for example, a pedestrian route across a site with a type of vegetation growing on-site in clumps. "The changes from unstable high energy to stable low energy states, processes of weathering, erosion, transport, deposition, cycling, capture, release, growth, seed dispersal and so on, all directly or indirectly affect the patterns that emerge at any time" (Bell 1999). Field patterns are identified by gradual changes across their surfaces as opposed to a rhythmic repetition as seen in the work of Peter Walker (M'Closkey 2013).

Figure patterns are patterns derived from an image, seemingly unrelated to site, and incorporated to define spaces and hierarchy of the design. Like Parc del Este by Brule Marx, the patterns implemented were on different scales, repeating a figure with variation, ensuring that the pattern does not become redundant. The use of figure patterns is seen more in the use of expressing systems like water systems in landscapes (M'Closkey 2013).

Bell introduces a play on American architect, Louis Sullivan's 'form follows function' into 'pattern follows process' or even 'process follow pattern'. The site is

being created by various processes and needs processes to make it viable, implementing a figure pattern that pattern follows process.

Projects such as the Qunli National Urban Wetland done by Turenscape Landscape architects, as seen in



Figure4.5 Patterned landscape at Trinity Collage by gh3 (Landezine 2017)

Figure 4.10 is a key example of utilising field and figure as a generator of pattern. Figures were used to configure the water system and ensure a unity. The field generated the flows on site from main flow routes to meandering smaller routes.

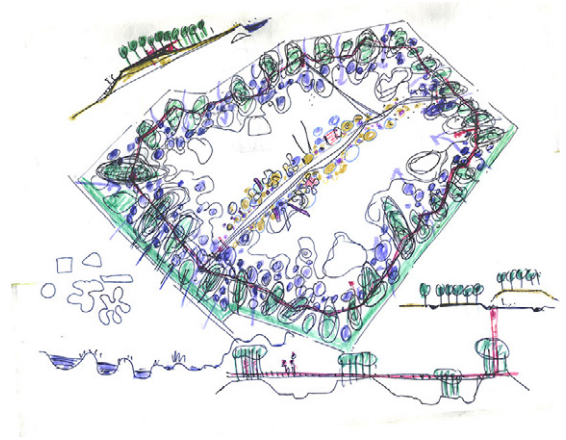

Figure4.6 Turenscape concept sketch for park (Landezine 2017)

4.4 Conclusion

Creating a landscape that is dependent on technical solutions to make it viable, the approach can easily be driven by just the solution. Not negating the fact that the project will have an ecological and systems solution that need to be addressed, but approaching them in a more aesthetical approach such as that of the picturesque movement and pattern making, a pattered landscape can be aesthetically pleasing and an exciting emotive landscape that deals with the real-world problems.

Bell delves into aesthetics and concludes that the following elements ensure a landscape of some sort of aesthetical value namely: diversity/complexity, spirit of place (*genius loci*), mystery, multiple scales, strength (Bell 1999).

These approaches are an attempt at creating a unique

response that will create an identity of place and not just a bulldozed site with a landscape superimposed onto it. “Many recently acclaimed works purposefully frame the landscape to heighten its sublime qualities and awaken a chain of mental connections, sensations, and memory” (Herrington 2006). Having a strong ecological component to rehabilitate site, the first response might be to create a natural landscape (or a landscape resembling a natural one). As seen with the pattern making approach, this might not be the best approach for a synthetic site such as this. “To design with nature today, we should not attempt to camouflage the fact of our manufactured sites” (M’Closkey 2013).



Figure5.1 Detention pond for excess roof water from The Towers roof space (Square One Landscape Architects 2017)

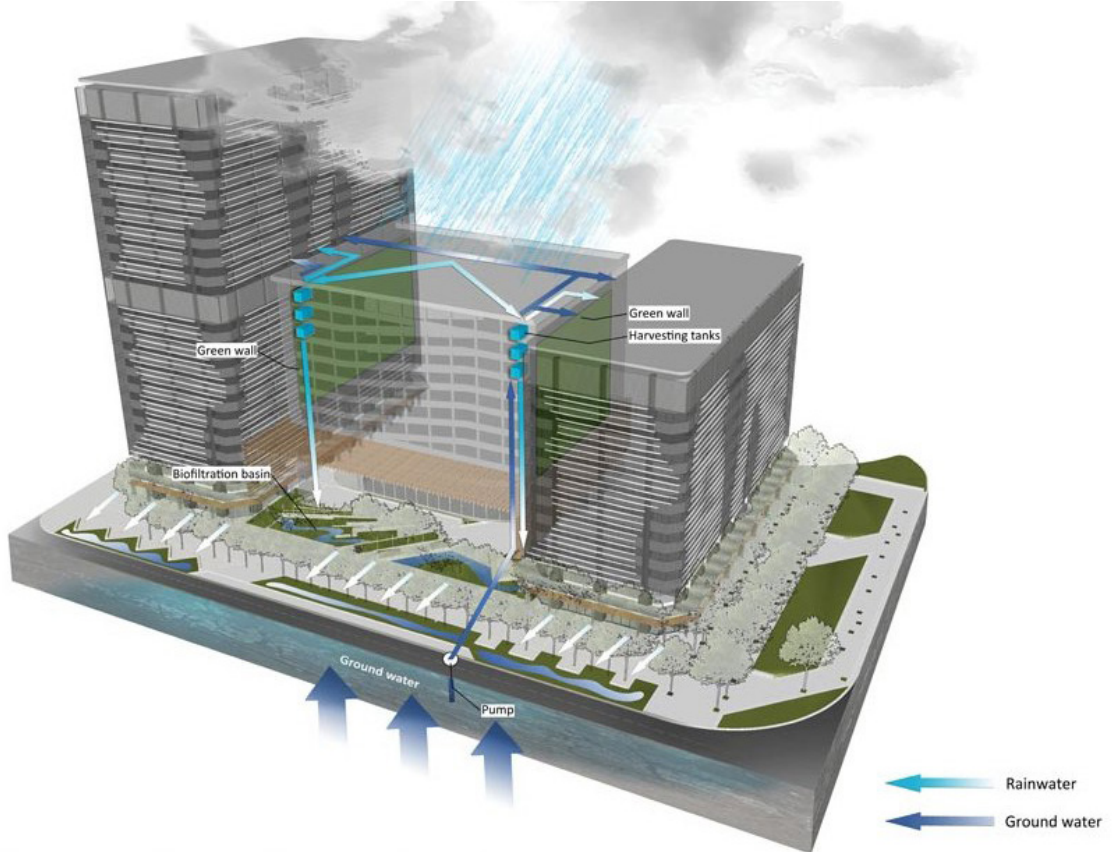

Figure5.2 Storm water systems to treat and replenish ground water at The Towers (Square One Landscape Architects 2017)

Introduction

“Case study analysis is an effective way for landscape architecture to advance and mature as a profession, providing a promising tool for the profession to train students, develop a research base and improve practice” (Francis 2001). This chapter will analyse case studies to

establish a project “look and feel”, analyse projects that have a similar intention, and identify possible technical solutions as well as theoretical resolve.

5.1 Case studies

5.1.1 Contextual case study

The Towers & Merriam Square in Cape Town, South Africa by Square One: Landscape Architects

This project was planned by Square One in conjunction with an urban plan developed by the company that proposed the Foreshore. A network of green infrastructure and stormwater management strategies to soften the harsh urban environment was proposed (Square One 2015).

Stormwater is collected on the roof in tanks and used to irrigate the expansive green facades. Overflow runs into a rain garden at street level. The rain garden acts as a bio-filter, thereby improving the water quality, enabling it to be used as recharge to groundwater. The

design is done in such a manner so as to facilitate space making and provide comfortable pedestrian movement on the pavement. The detail design components within the space evoke a sense of the wharf environment, the geology, and landscape that once existed in the Foreshore (Square One 2015).

The application of technology to resolve a real-world problem thereby integrating the user with technology is an example of possibilities for landscapes in South Africa. Eco-services and user considerations are merged in this approach.

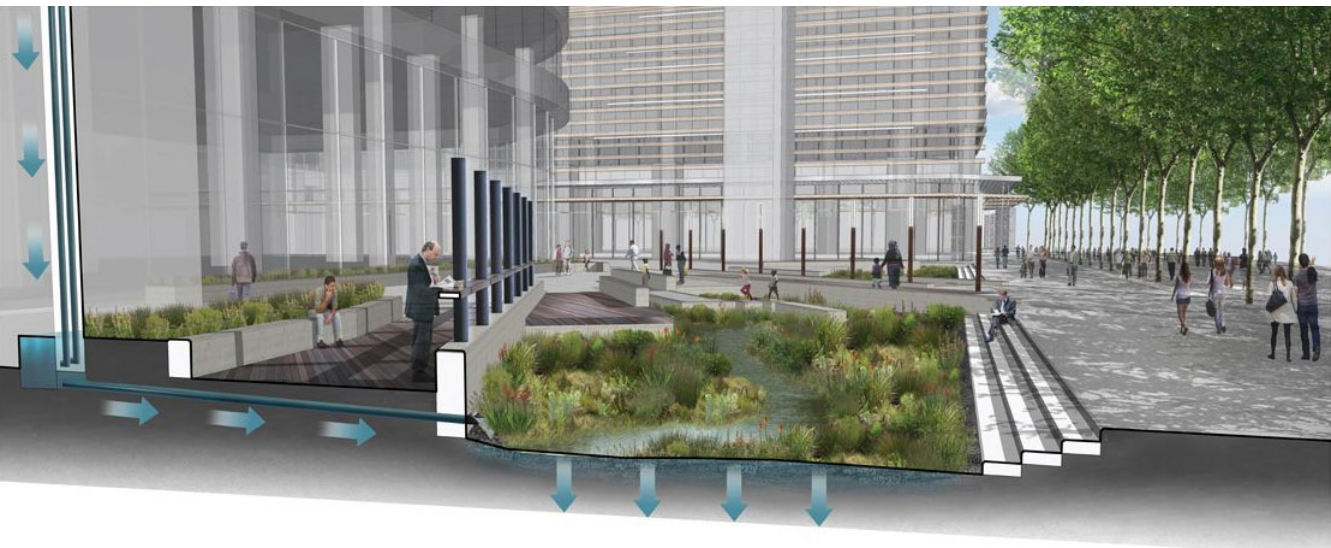

Figure 5.3 Pedestrian interaction with detention facility (Square One Landscape Architects 2017)



Figure 5.4 Louvre Lens park (Landezine 2017)

5.1.2 Formal case study

Museum Park Louvre in Lens, France, by Mosbach Paysagistes

The 20-hectare park surrounding the new wing of the Louvre Museum in Lens is a thought-provoking project developed on an old mine site. Located only one hour by speed train from Paris, this museum and park will serve as event space and extend the exhibition space of the Louvre Museum. The park features grasslands, picnic areas, a forest, an esplanade in front of the building, and several promenades (Santiago 2015).

“Our strategy restores the disturbed link between skin (recording surface) and depth (resource of yesterday and tomorrow). It opens the door to future ages by introducing the art as mediator of all the ages and as bridges to new mentalities” (Landezine 2017).

The landscape serves as a place for gathering, a link between the museum and the city, and preserves

memory of the history of the site. The park also adheres to environmental principles as well as extending the boundary of the museum with community involvement in the establishment and daily workings in the park. This ensures the park’s role in the community as a recreational area with the community taking ownership (Landezine 2017). The landscape and its elements were designed as a performative landscape where the interventions cause the effect for landscape to start but the end results are unknown as the landscape transforms over time (Santiago 2015).

This park is an excellent merge of a functional-, poetic- and rehabilitation-driven park that merges these concepts. Like the Robinson Deep site, the visual quality of the mine tailings site and the emotive quality would be conserved in the new intervention. This will be done by retaining some of the key features. In the Louvre-Lens Park, the process of landscape was explored by creating a canvas for landscape to happen, for example, leaving cracks in the concrete floor so that vegetation can grow, thereby letting the pattern of nature take over and fill open areas.



Figure 5.5 Vegetation growing over hard surface (Landezine 2017)

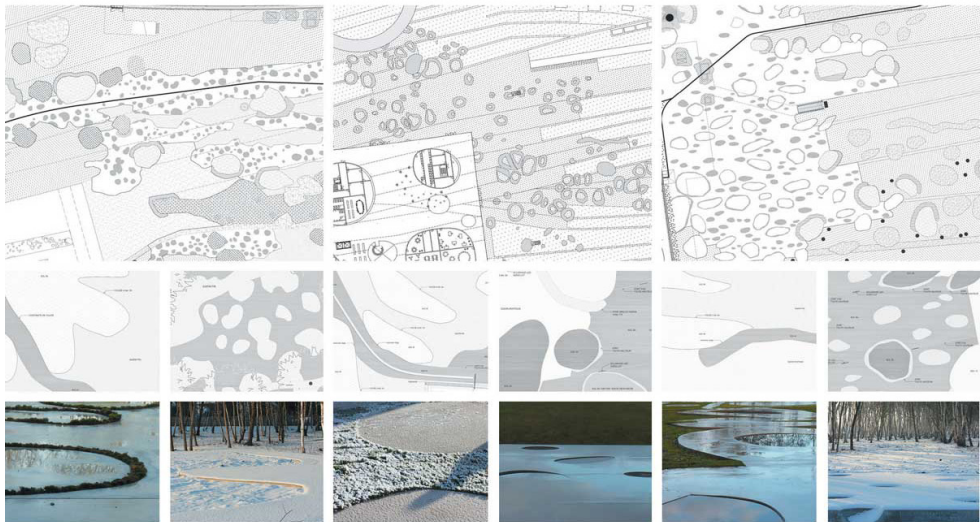

Figure5. 6 Patterns implemented in the park space (Landezine 2017)



Figure5. 6 Variety of intimate and vast spaces within the park (Landezine 2017)



Year 2011 one year after the stormwater park was built



Year 2014, 4 years after the wetland park was built; residential development was catalyzed by the stormwater park

Figure 5.7 Qunli storm water park progress photos (Turenscape 2017)

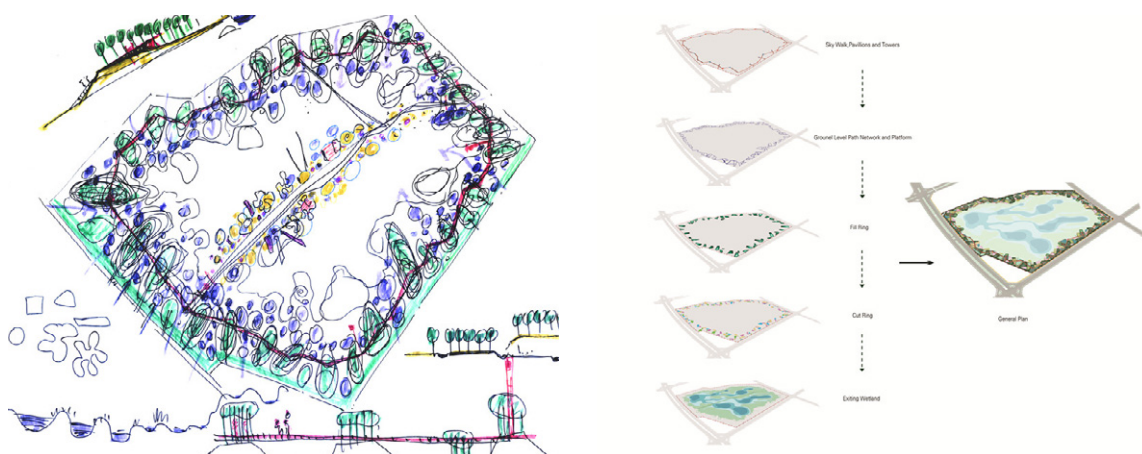

Figure 5.8 Pattern informants and pattern generator (Turenscape 2017)

5.1.3 Functional case study

Qunli Stormwater Park in Haerbin City, China by Turenscape

Turenscape's founder, Kongjian Yu, has a passion for changing the perception of landscape in urban China from a superficial use of landscape to a more functional one, by implementing eco-services as a structure for the park (Ryerson Department of Architectural Sciences 2014).

The name of the firm, Turenscape, is broken down as follows: TU = earth, dirt or land and Ren = people, the man or human being. Together it means nature, man and spirit as one. The Turenscape office has developed concepts named Sponge City and Bigfoot Revolution with the aim of conceiving nature as construct in their landscapes and ensuring the longevity of their projects (Turenscape 2017).

Qunli Stormwater Park 'greenfield' planning started in 2006 on a new urban district. The 2 733 hectares of urban environment is centred around a 30-hectare park in an area historically known for its flooding and for being waterlogged. The stormwater from the surrounding new urban areas will drain into the wetland. The park is surrounded on four sides by roads. The landscape was planned and built with a simple cut-and-fill technique to form a ring of ponds with raised walkways. The centre of the park is left in a natural wetland state. The ring of ponds acts as a threshold for the urban to natural landscape. This water urbanism approach transformed the dying wetland to a stormwater park that serves the



Figure 5.9 The meeting of urban and natural spaces (Turenscape 2017)

urban areas (Turenscape 2017).

The main elements of this park are the water ponds (wetlands), walkways, viewing decks and skywalks. Walkways on different levels allow users to experience the landscape on different levels (Turenscape 2017).

The park and urban edge surrounding the park have a similarity with the Robinson Deep site as the proposed site development will see a growth in urban development in the area. There will also be an increase in the need for eco-services to relieve the stress on the current systems. The park's spatial organisation from a programmed to a less formal site with the functionality of the park as an eco-service works well to involve the user but also keeps the user on the safer edges.

The repetition of simple landscape "tools" make for an inconspicuous pattern that users can occupy in any way they want to. This pattern of field is formed by the simple need for ponds to process stormwater at certain points in the park where the stormwater daylights, access routes through the park on different levels, and viewing platforms so users can observe the processing of the water.

5.1.4 Technical case study

Vintondale AMD & Art Park, Vintondale, United State of America, Team SPLASH.

Team SPLASH was conceived in 1994 with the start of this project as a sustainable partnership of landscape architects, scientists and historians. The team was to address the after-effects of a worked out coal mine in Vintondale, Pennsylvania. The Acid Mine Drainage (AMD) from the site affects the micro-organisms that serve as the base of the food chain (AMD&ART 2016).

The solution was the creation of a series of pools that captures the AMD from a mine portal named Portal 6 and the water draining from the surrounding stockpiles into a series of ponds. This artificial wetland serves as the skeleton of the park that contains art exhibitions, picnic areas, and walkways. The other main interaction with the site is the educational aspects of the park.



Figure5. 10 Sketch plan of Vintondale AMD&ART (AMD&ART 2016)



Figure5. 11 View of the ponds at Vintondale AMD&ARTS (AMD&ART 2016)



Figure5. 12 Aeration pipe at the Vintondale AMD&ARTS park's pond 6 (AMD&ART 2016)

Infographic boards inform users how the system works and described the history of the site (AMD&ART 2016). This park is operated as an ongoing process, with a team continually testing and analysing variables such as water qualities, soil parameters etc. to ensure the landscape performance is kept at a high yield. The planting on-site was done with indigenous plants that speak to the process of water quality. Indigenous trees planted along the wetland ponds imitate the polluted red water that has been transformed to a green/blue colour (AMD&ART 2016).

The use of wetlands and recreational space to transform this industrial site to its previous, more natural state is evidence of the power of the landscape to heal itself. At Robinson Deep, the site is synthetic and man-made,

completely surrounded by urban environment. The transformation of the site to previous natural state will be costly and cause the past identity of site to be lost.

The process of the wetland treatment used at Vintondale is, similar to the proposed AMD treatment system at the site. The heavy metals of both sites are similar, except that uranium and cyanide are also present at the Robinson Deep site. As stated before, this will be treated in a chemical process. The park's spatial organisation is reactive to the construction methods used and organised around the tailings of the old mine from where the AMD originates. This organisation led to a pattern that is resembled in the different spaces happening around these ponds.

5.2 Conclusion

The above case studies all included the application of a system to resolve the problem, be it movement on-site as at the Qunli Stormwater Park in China, to the Museum Louvre Lens Park that serves as a threshold to the museum interior and the museum that extends out into the landscape.

The local case study, The Towers & Merriam Square, takes stormwater, which is traditionally dealt with in hidden systems, to the surface so that the user can see and use the urban areas that the eco-service creates. In contrast, the Vintondale AMD&Art park strives for a "natural" landscape. Here the systematic requirement

for the Robinson site will align to the Vintondale Park but have a more urban approach as that of the Towers project.

The Louvre Lens project attempts to create a sense of combined identity of what the site was and what it is now. The pattern at the Louvre Lens is pattern of figure in combination with pattern of field. With appropriate materials, the pattern creates a new identity for the site with a hint of what the site once was through the 'cracks' and openings in the walkways. This, combined identity, will also be one of the aims of the proposal at the Robinson Deep site.

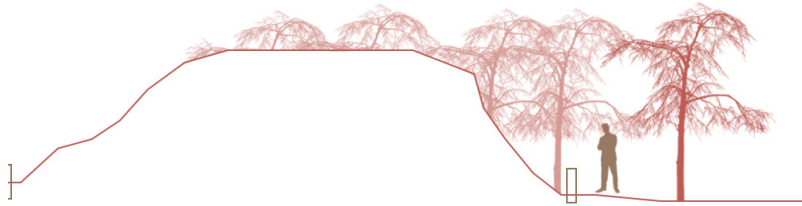

Figure6.1 Mound remnants in Vida Nova Park

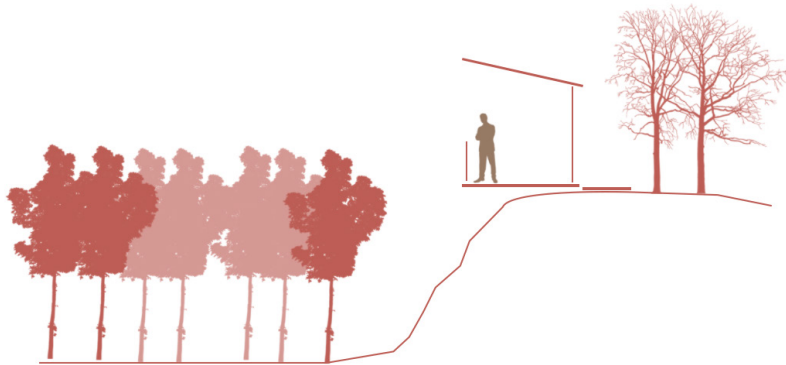

Figure6.2 Ridge remnants in Vida Nova Park

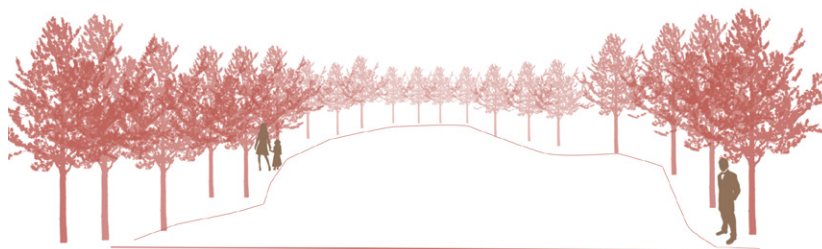

Figure6.3 Plain remnants in Vida Nova Park

Introduction

This chapter is an outline of the approach to the design idea and conceptual scenarios. concept, the concept generators and final conceptual

6.1 Conceptual generators

The author's approach to concept is a reactive one, based on the requirements of the site, its future users as envisaged the urban development framework and the theory of pattern and picturesque ideals. The use of program, site and form in concept will be the generators of the concept. (See Figure 7.1)

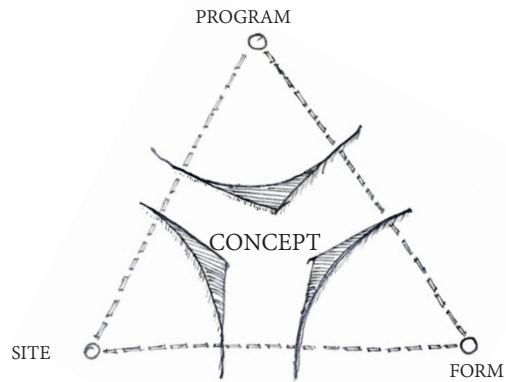

Figure6.4 Concept driver (Author 2017)

6.1.1 Site

“A site deals with three elements: the pattern of activity, the pattern of circulation, and the pattern of sensible form that support them” (Lynch 1984:24).

The area of interest is a relatively flat area with a fall of three metres over a distance of 200 metres, thus it has an average surface slope of 1.5%. The significant ridge of the eastern edge creates a design opportunity and is one of the unique features on site. Similarly, the mound and plain on site will be incorporated into the layout to good effect. The urban area, the mound, plain and ridge identified create a potential for contrast with softer landscape interventions, thereby the visual experience for the user is intensified.

6.1.2 Program

6.1.2.1 Water system

The proposed purification system on site forms the backbone of the project as it serves a critical function in the feasibility of the project. The direction of water

flow on-site dictates the direction in which the series of ponds will be arranged to connect two existing water bodies on site. See Figure 6.5.

From case studies and research, it was established that a minimum of six ponds is required. These need to have a surface area of at least 500m² each to work effectively and to host the variety of species needed. This is in line with the Vintondale case study where the average surface area of the wetland ponds was also 500m² (AMD&ART 2016). However, these proposed site ponds will have to be excavated as the construction of berms to contain the water is not possible due to relatively flat site.

6.1.2.2 Movement system

The movement on site will be from the transportation node, just north of the first retention pond, to the east of site with an events area and sports facilities as a recreational space for the residents of the new urban node and for commuters traveling through the area. See Figure 6.5 for a diagram illustrating movement over the site.

The movement in an east-west direction is to facilitate a connection to the ridge and a secondary route to the transportation node from the urban area. These routes will also connect to the pond system where more intimate spaces are planned. The progression encourages the user to move from the urban area to the more softer landscape and culminating in the landfill park or events area in the east as illustrated in Figure 6.6.

The edge of the site bordering on the proposed urban edge presents possibilities for more activities to happen. The transition of the edge between the urban zone and the park is also important as it serves as a reception space to the park. The edge is also the energy driver for the park as the proposed commercial activities will occur here.

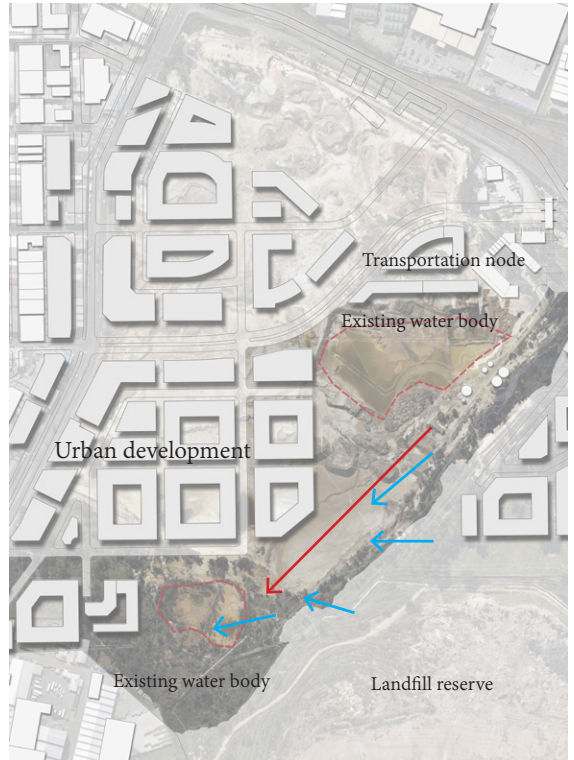

Figure6.5 Existing water bodies and drainage on site (Author 2017)

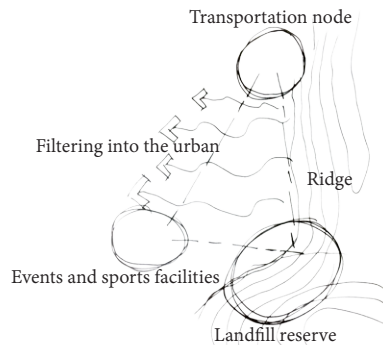

Figure6.6 Movement over site to connect activities (Author 2017)

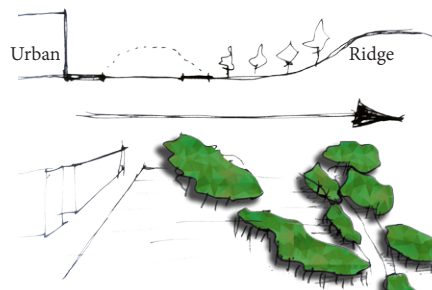

Figure6.7 From urban to natural landscape (Author 2017)

As seen in Figure 6.8 the fading of the edge into the landscape, or the extension of the urban grid into the park will create different effects on the park. The extension from the urban grid leads the users to more specific points in the park and more opportunities for visual anchors and activities to happen.

6.1.2.3 Remembrance on site

The heritage of site can be sub-categorised into three categories, namely: the ridge, the plain and the mound. (See figure 6.9)

The mounds on site are unique and formed through the previous and ongoing processes on site. The erosion of these mounds, ridges, and plains create unique shapes and textures that can feature in the park. The texture of these three elements is also different. The ridge material is different to that of the rest of the site because crusher materials were used in creating the edge berms for the slurry dams (Vermeulen 2001).

The approach to these elements is to highlight them, as done in the Picturesque movement (Herrington 2006), with contrast and framing certain views as users move through site. Figure 6.6 illustrates the approach for a mound: trees or walls are used as a background for the mound, the plain or indigenous grasses create a foreground to the mound and habitable spaces will be placed around it to stand in contrast to the harshness of the plain and mound.

6.1.3 Form

The site has, over time, been cut out with processes, thus the approach to form will be that of cut out or carving out material and fill where required. Dimple spaces will be created by cutting out intimate spaces to be located at the transition of urban to park areas. Raised beds to contrast with the sunken areas will lead the users into the park. Sunken spaces can also act as stormwater collectors and subsequent bio-filter action as explored with an

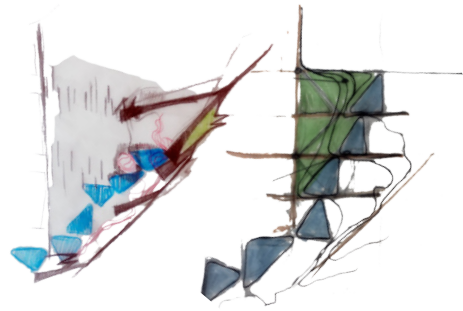

Figure 6.8 Urban edge and park exploration (Author 2017)

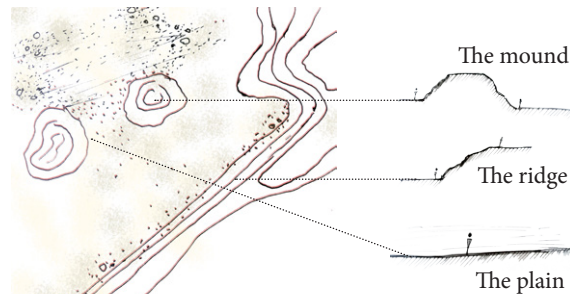

Figure 6.9 Remnant elements on the site (Author 2017)

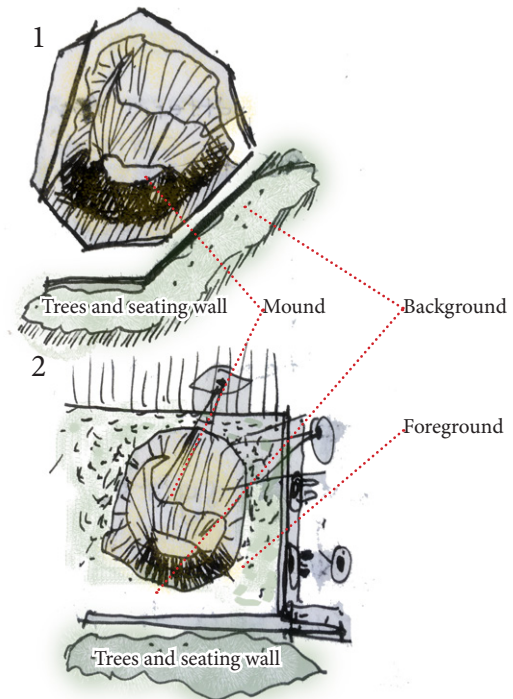

Figure 6.10 Approach to mound (Author 2017)

electronic model as seen in Figure 6.11.

Merging the systematic parameters, remnants and movement on site, the form then follows the patterns created as mentioned above.

The exploration of what the form might be is illustrated in Figure 6.12. Here the systematic requirement for the system was translated to basic shapes. This shows the number of ponds that can be fitted within that space and the movement which is possible between the ponds. According to M'Closkey theory on pattern making, process forms pattern, the expression of the water system into a pattern will also influence the form.

6.2 Final concept

The final concept is an amalgamation of the above-mentioned elements to form a park that will serve the people in the community as well as the commuters traveling to the area. The concept of process as pattern and dimpled landscape will contribute to the systematic requirements and the user experience. The water pattern is held together by the red line as seen in Figure 6.9.

Creating a pattern from the above concepts also implies repetition with variation. As stated by M'Closkey, patterned landscapes do not need to be in a two-dimensional plan only, but rather be explored on all dimensions as a reaction to existing or proposed forces (M'Closkey 2013). Here the concept diagram attempt at variation and imagining desire lines (in red) that can become overhead structures or pathways. The in-between spaces to dimple will create the intimate spaces.

The proposed look and feel of the site is illustrated in Figure 6.14 and 6.15. Contrasting the mound and plain with user activities to emphasis the mounds in an attempt at an emotive response for the users of the park. Contrasting the harsh plain space with "oasis" spaces will enhance the experience of both.

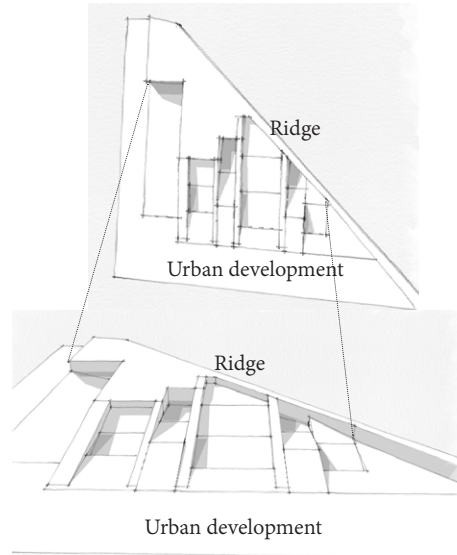

Figure6. 11 Dimple effect concept model (Author 2017)

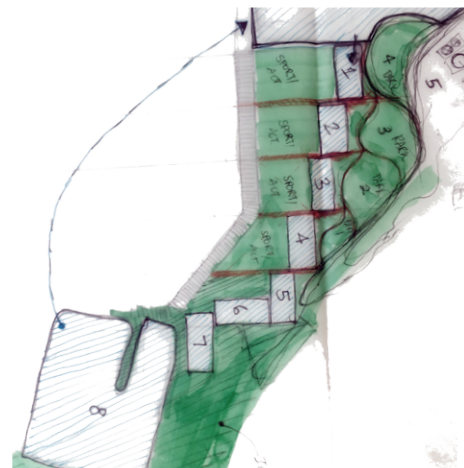

Figure6.12 Urban edge and park exploration (Author 2017)



Figure6.13 Concept overlaid onto model (Author 2017)

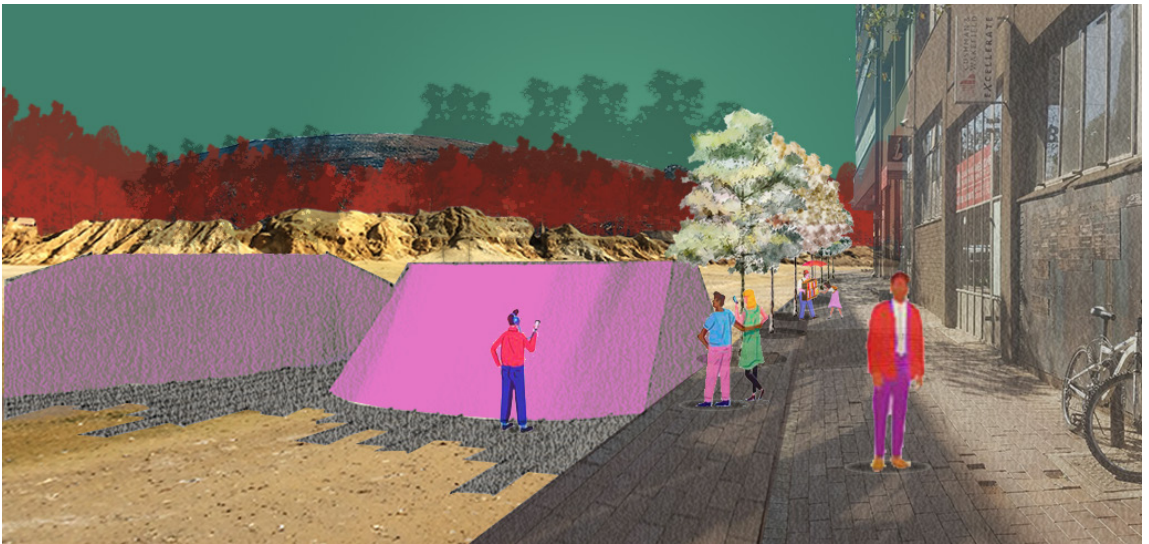

Figure6.14 Collage of 'look and feel' for proposed park: a view of the urban edge (Author 2017)

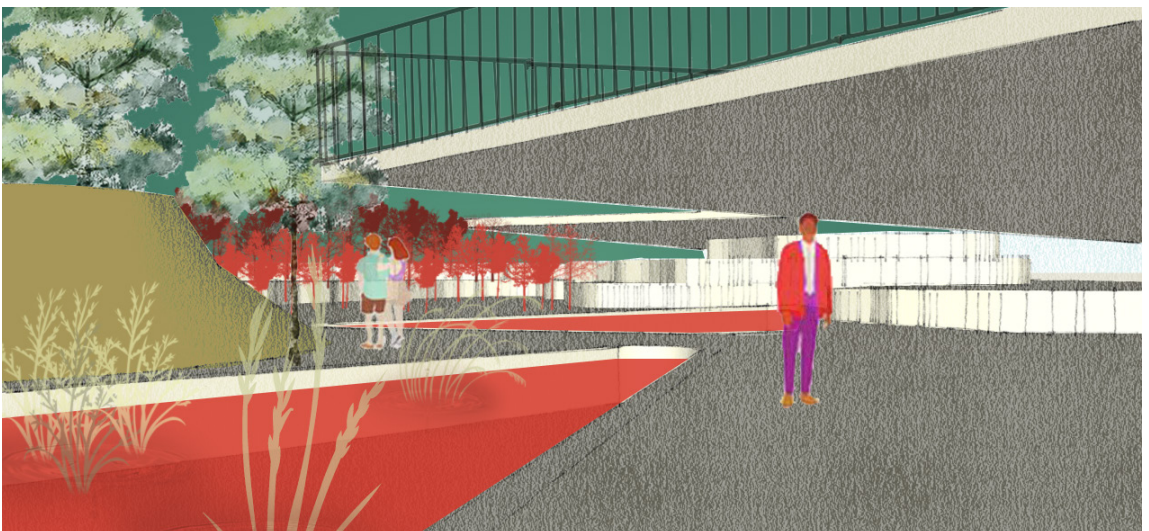

Figure6.15 Collage of look and feel for proposed park: a view of viewing decks and ponds (Author 2017)

6.3 Conceptual scenarios

6.3.1 Conceptual scenario one:

As a response to the movement on site, the main walkway on the urban edge is supported by a secondary walkway on the ridge and these are connected by three major walkways, thereby extending the urban grid into the park. The proposed water system forms part of a bigger segment that represents the natural meandering pattern with which water tends to flow. The water system is also an attempt at pattern making by applying figure ground approach. The pedestrian routes passing the water bodies complete the pattern to form water-like “DNA strings”. However, this scenario of pattern was forced onto site and deemed unsuccessful with the shapes being unpractical in constructing. See Figure 6.16.

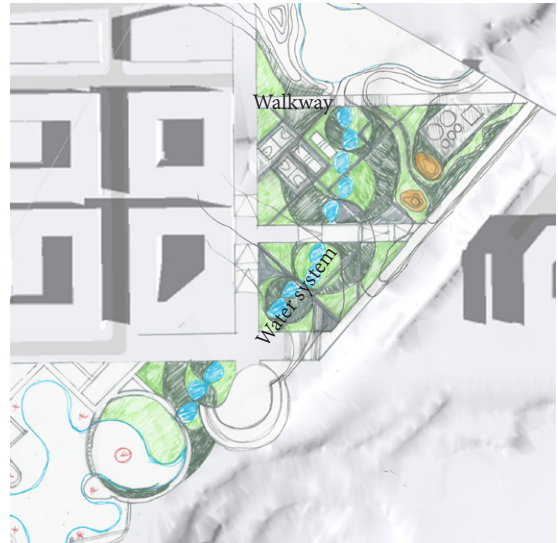

Figure6.16 Conceptual scenario 1 (Author 2017)

6.3.2 Conceptual scenario two:

This scenario, Figure 6.17, is based on dam shapes. When a river is intercepted by a weir, the water dams up in an approximately triangular shape. The incorporation of the heritage elements is more successful in this scenario as based on the theory of the beautiful in the ugly but the proportions of the open spaces were deemed impractical.



Figure6.17 Conceptual scenario 2 (Author 2017)

6.3.3 Conceptual scenario three

This scenario, Figure 6.18, makes use of a main route for pedestrians on the urban edge to lead users around the first water body and into the park. This movement was an attempt at pattern making with the movement on site. The incorporation of a tertiary running track with viewing decks provides the user an opportunity to view the process as the water is cleansed. The progression from urban to a softer landscape is considered more successful in this scenario to emphasise the beautiful in the ugly.



Figure6.18 Conceptual scenario 3 (Author 2017)

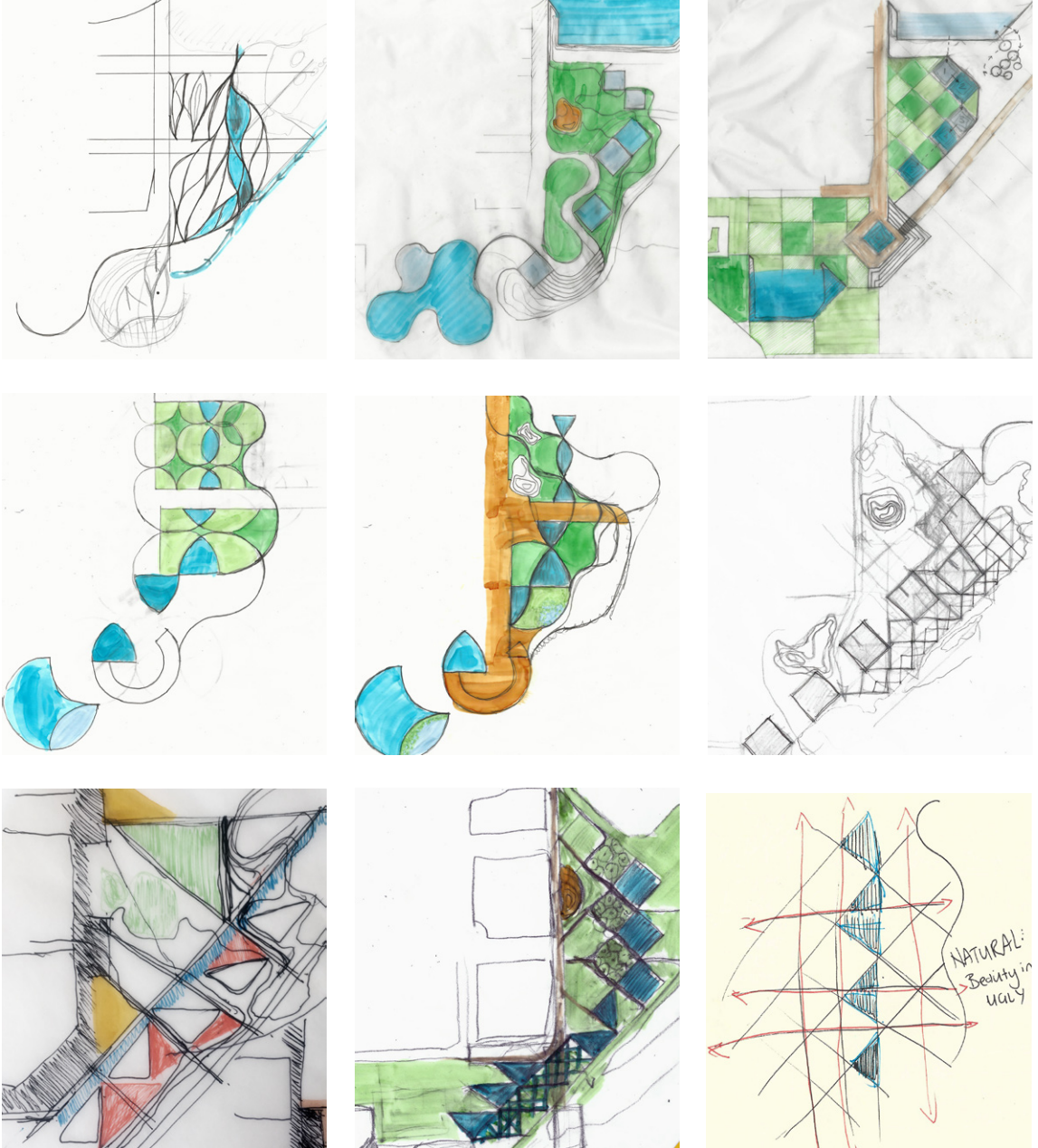

Figure 6.19 Concept process drawings (Author 2017)

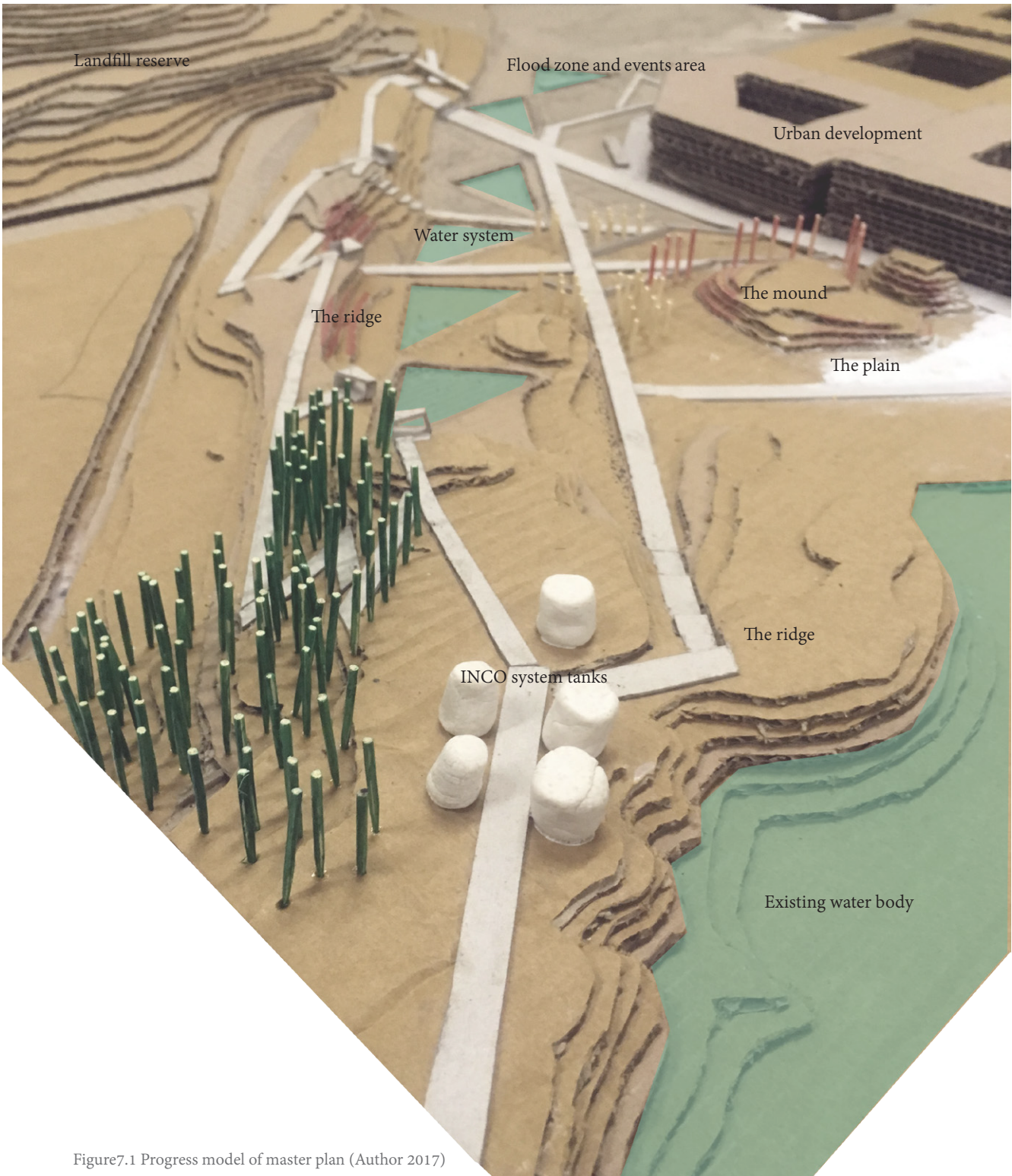

Figure7.1 Progress model of master plan (Author 2017)

CHAPTER SEVEN

Introduction

The design development from the concept, where movements and eco-service systems form the drivers for pattern is, elaborated on in this chapter.

7.1 Design development

7.1.1 Master plan

In the master planning, as shown in Figure 7.1, the different site programs as mentioned in previous chapters are illustrated in Figure 7.1.

The use of a triangular shape for the water system was generated from the previous concept scenario's and from the tendency for water to level out in and form a triangular shape negated by the contours as illustrated in Figure 7.2. It was established from the contour information that the water bodies will have to excavated due to the flat gradient on site.

Key activity areas as identified in previous chapters, include for programmed sport activities and events areas. The formal nature of the ponds is interrupted by a more organic shapes and are used for the events area as seen in Figure 7.3. The water process by that point is completed and therefore the change to organic forms is validated for the events area. The event space also serves as a flood retention area in times of heavy rain, thus berms are required to protect the infrastructure as well as serving as seating space for event goers. See Figure7.4 for the progress master plan. The movement on site is divided in to three categories: the primary access route, the promenade and a running track with viewing decks for the adventurous. The purpose of the movement routes are as follows:

- Transportation hub and events area,
- Transportation hub and Landfill reserve,
- Sports recreation and running track,
- The urban area and running track and,
- The water ponds with one another,

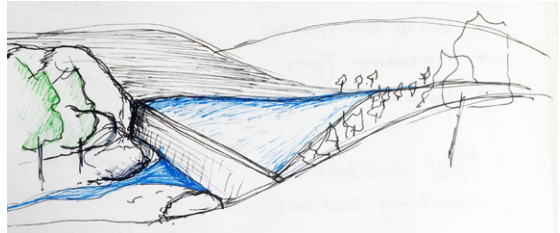

Figure 7.2 Sketch of a dam in the Thamboti river (Author 2017)

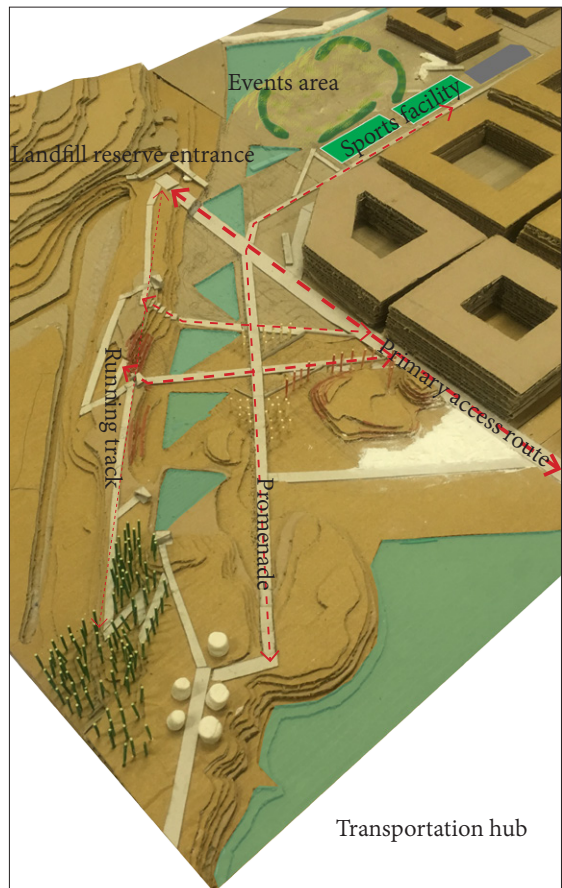

Figure 7.3 Three different movement types on site (Author 2017)

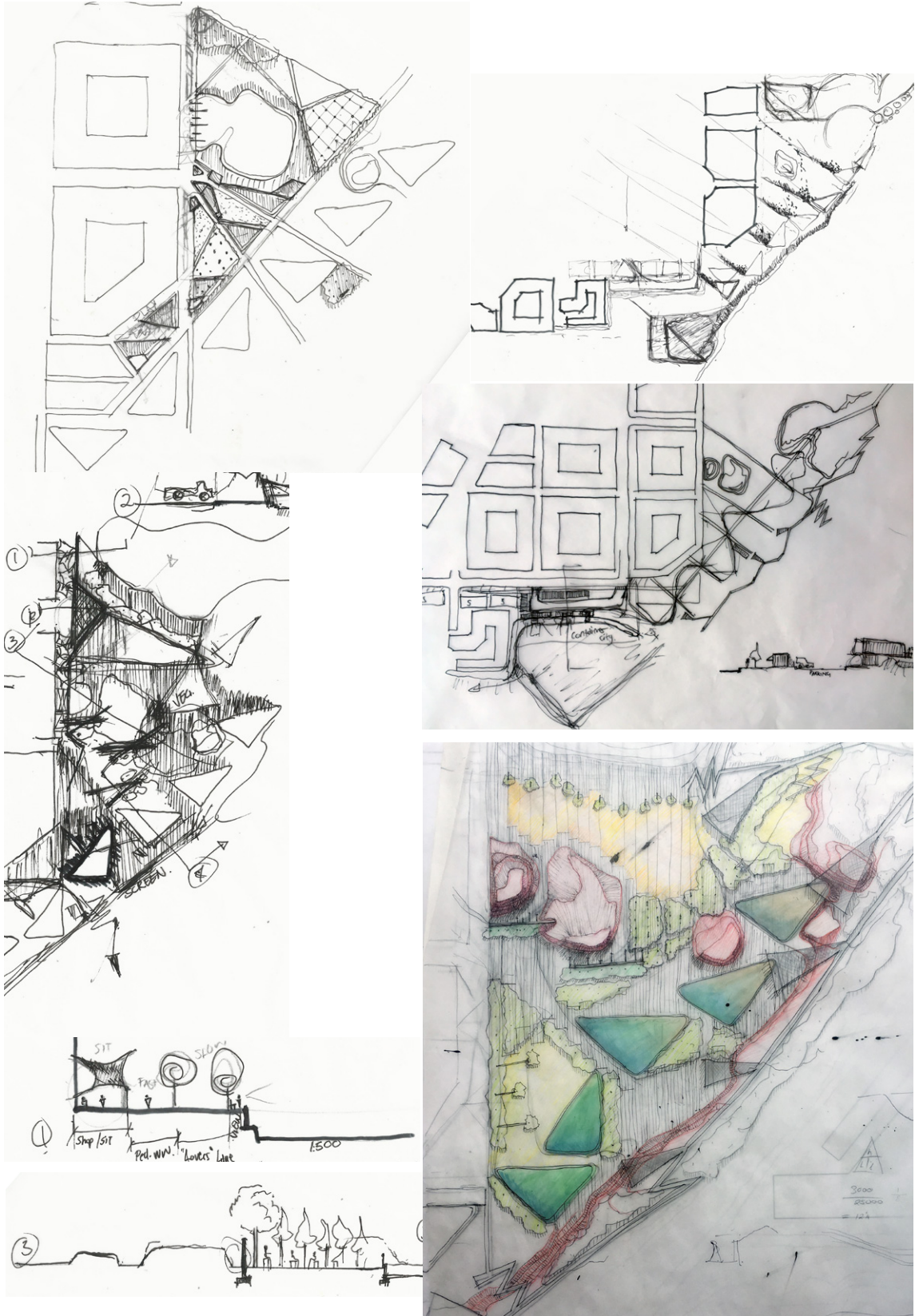

Figure 7.4 Master plan exploration (Author 2017)



Figure 7.5 Master plan -not to scale (Author 2017)

Further more, the running track will also extend into the reserve.

The movement from the urban edge is encouraged by an art installation in the park that forms part of the overall movement on site and that includes the mound, ridge and plain as part of the permanent exhibition.

The mound on site as per the beauty in the ugly theory is celebrated and incorporated as spill out space for people from the urban area. The plain is undisturbed to illustrate natural pattern of nature by incorporating an indigenous veldt grass area that is located north of the plain. This will over time distribute seeds onto the plain by wind and water action, depending on the grass specie. See patterns on site and proposed grass succession on site in Figure 7.6.

7.1.2 Design solutions sketch plan

The area surrounding the mound and plain was identified as a sketch plan area as it illustrates the application of the theory and main concepts of water system, remembrance and the main movement types on site. See Figure 7.7 were the area is marked in red.

7.1.2.1 Remembrance on site

The mound, plain and ridge were all approach with the following guiding principles:

1. Contrasting the old with the new
2. Are the remnants celebrated (i.e. not covered up)
3. Sealing of the remembrance to pause the process and thus the pattern that has formed over time (See image 7.5 for patterns currently on site)

The ridge edge is contrasted by the green of trees. The forming of glades at specific points will serve to contrast with the ridge in colour and texture. In Figure 7.8, the exploration of the effectiveness of a glade is explored. These areas will be planted with lawn to provide users with calm spaces where they can appropriate the space as they see fit.

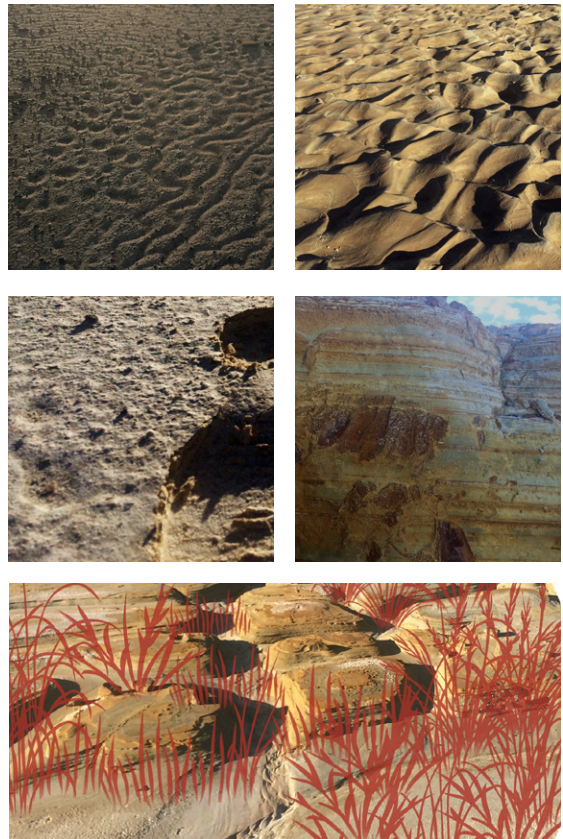

Figure7.6Patterns on site and proposed grass secession (Author 2017)

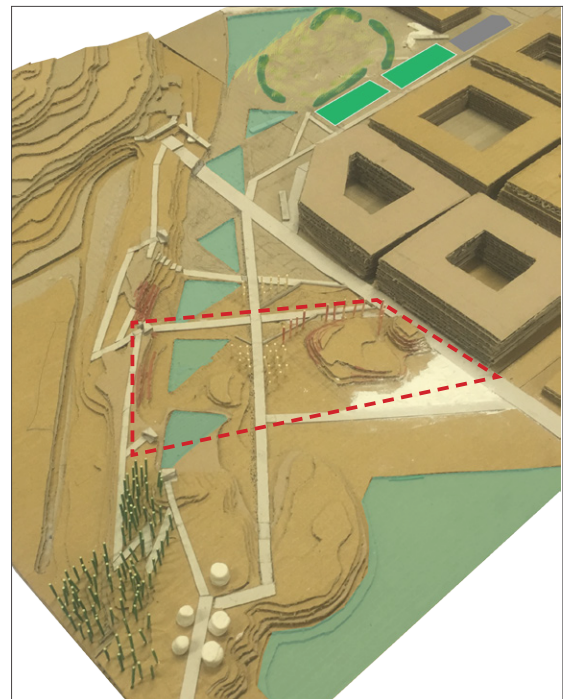

Figure7.7 Sketch plan area in red (Author 2017)

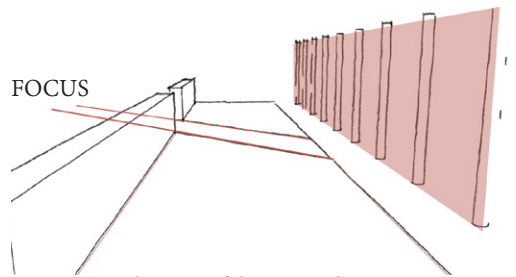
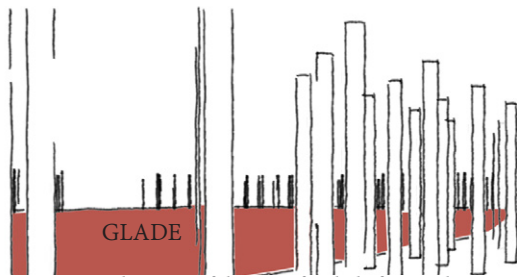
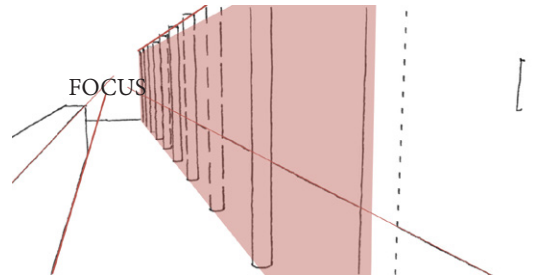
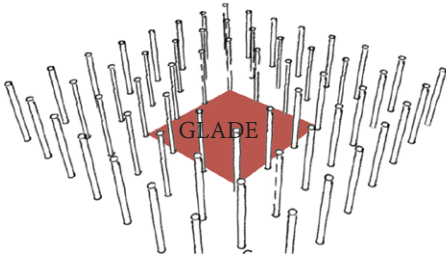
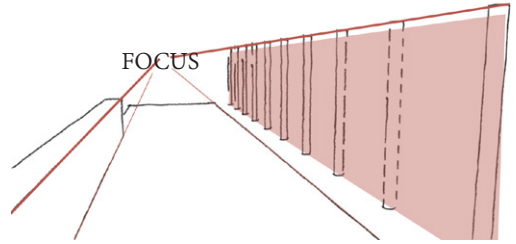
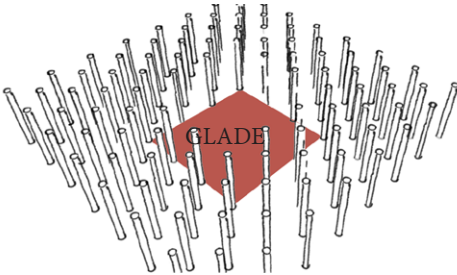
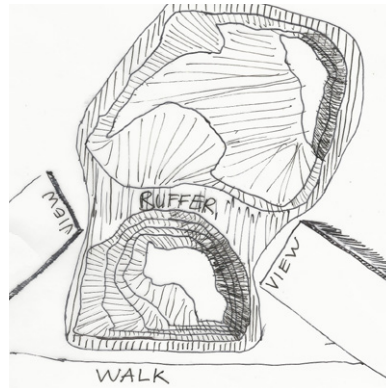

Figure7.8 Exploration of the use of a glade for emphasis (Author 2017)

Figure7.9 Exploration of the approach to remnant elements (Author 2017)

The approach of the mound is explored in Figure 7.9 and is a critical element for site. The mound has more formal spaces, contrasted by concrete slabs that form a datum for the mound. A wall around the mound will function as a lean-on wall and is placed in such a manner that the user can have a close look at the mound and also serve as a barrier. The areas around the mound will include low seating walls and benches for users working and living in the area. See Figure 7.9 the authors exploration of these spaces.



7.1.2.2 Pattern on site

Movement is linear on site to facilitate the shortest route between to the elements as seen in Figure 7.3.

The promenade movement was instrumental in having users from the transportation node walking next to the water bodies from which they can explore out into the park or to the urban edge. This movement is offset by 'oasis' spaces in two forms namely: dimple spaces and plaza or grove spaces. This is to serve as meeting spaces or watching space as well as creating ecologies to curb the effects of urbanisation.

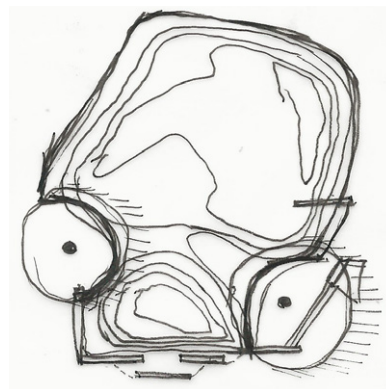

From the urban edge a reception area serves as orientation space for the user. This is done by raised planter to frame different walkways that is linear so that the end destination is visible to the user. The end destination is that of the running route and ridge. These west east routes are intercepted by the promenade and seen as another meeting areas. Offsetting the west east route is more intimate space for families to picnic and view art that is on routes leading off from the west-east connection.

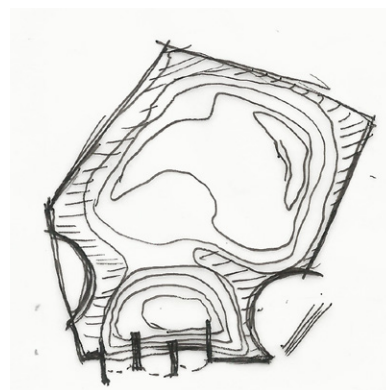

Figure 7.10 Mound exploration (Author 2017)

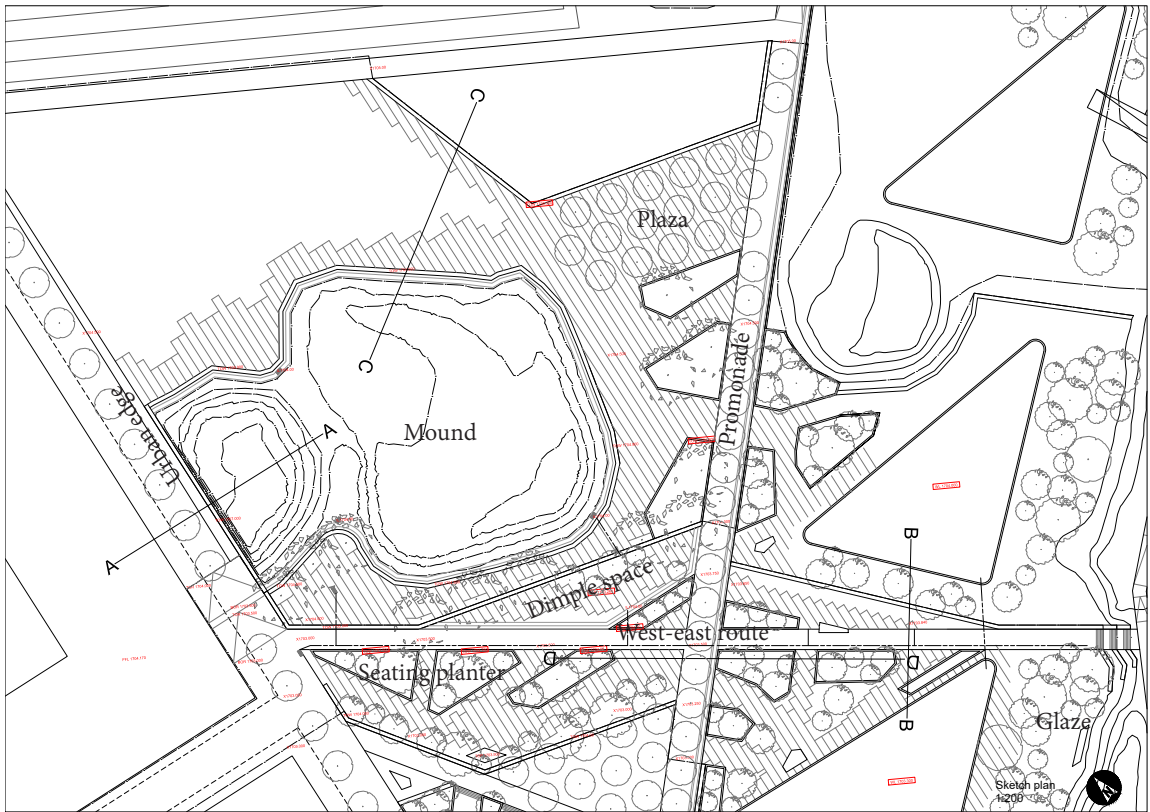

Figure 7.11 Progress sketch plan first application not to scale (Author 2017)

7.1.2 Sketch plan development

As seen in Figure 7.11, the space making around the mounds is supported by seating planters for comfortable, shaded spaces. Shattered form of the planter-box's plan view was placed to guide the user through the park, as seen in Figure 7.12: Section CC, and emphasizes the idea that the park progression is that of programmed to unprogrammed. The treatment and management of the storm water on site and especially around the mound area was done in such a manner to create space.

A glade area to showcase the ridge is planned off the west-east route. The area is populated by artwork and utilises the ridge as a backdrop for the art. The scale of the mound is off set with the plain and its vastness.

In Figure 7.15 the access to the mound is improved for park permeability and the sunken garden concept was repeated to aid in stormwater management. The opening of the spaces where two routes meet aid in 'breathing' spaces for users to sit and look at people. Plaza areas that

offset the promenade provide users with resting spaces and gartering areas.

The plain area now edged by a tree lined plaza serves to receive users from the urban edge and as a threshold area to the plain remembrance.

The creation of more intimate space around the water body was attempted. Tertiary routes that connect the in-between space created by the main movement routes, are proposed.

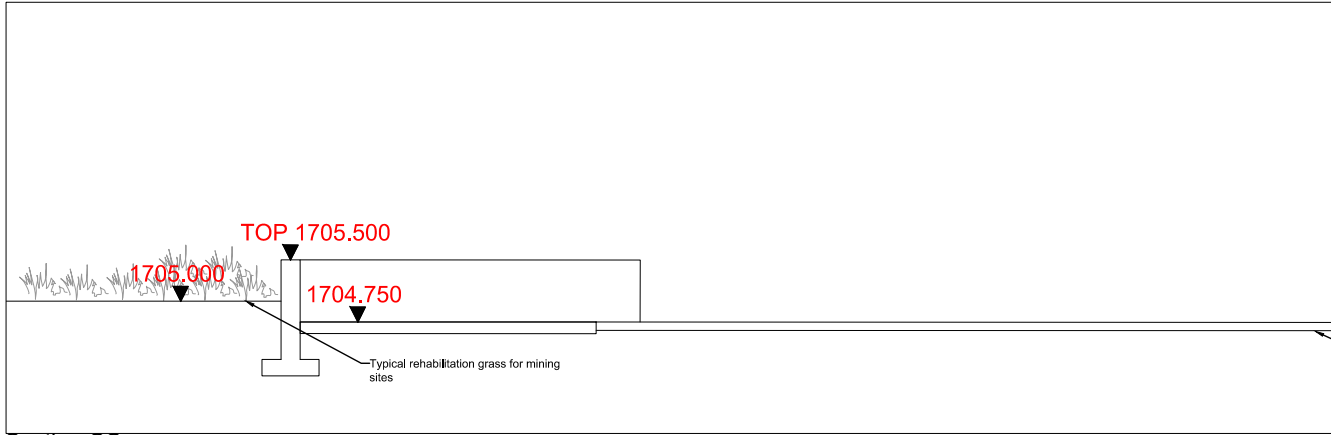

Figure 7.12 Section CC not to scale

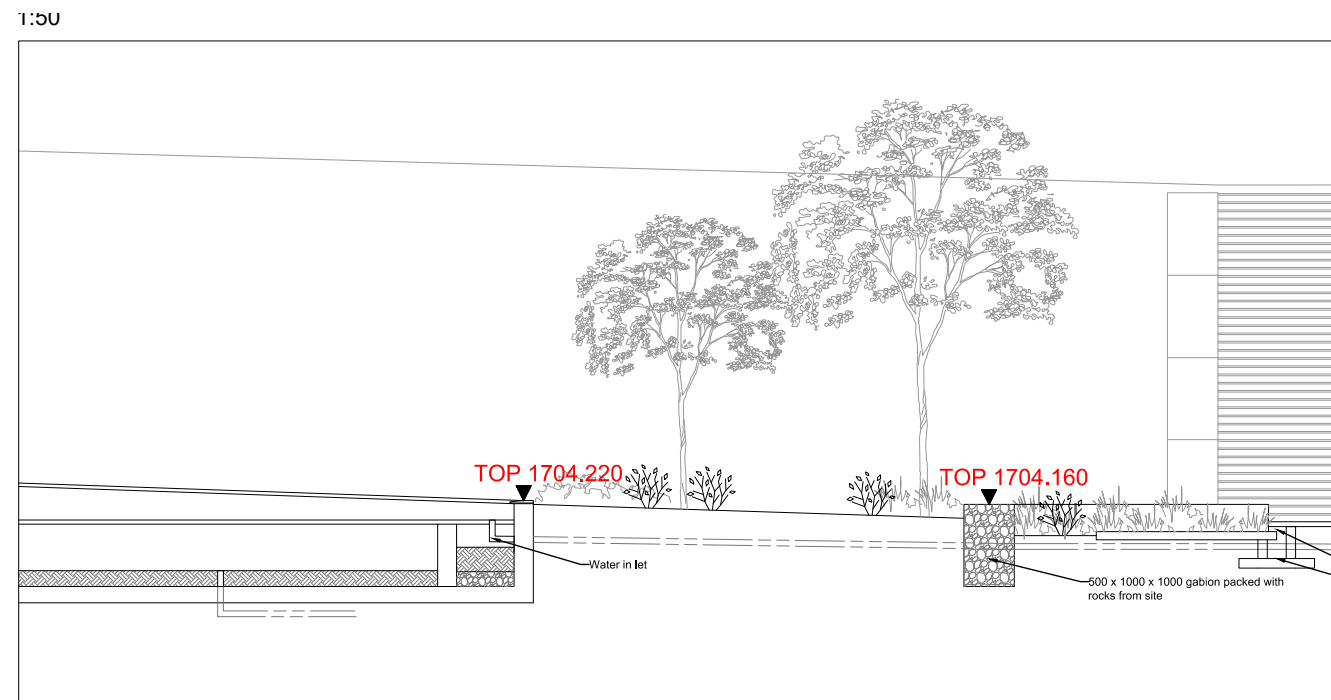

Figure 7.13 Section BB not to scale

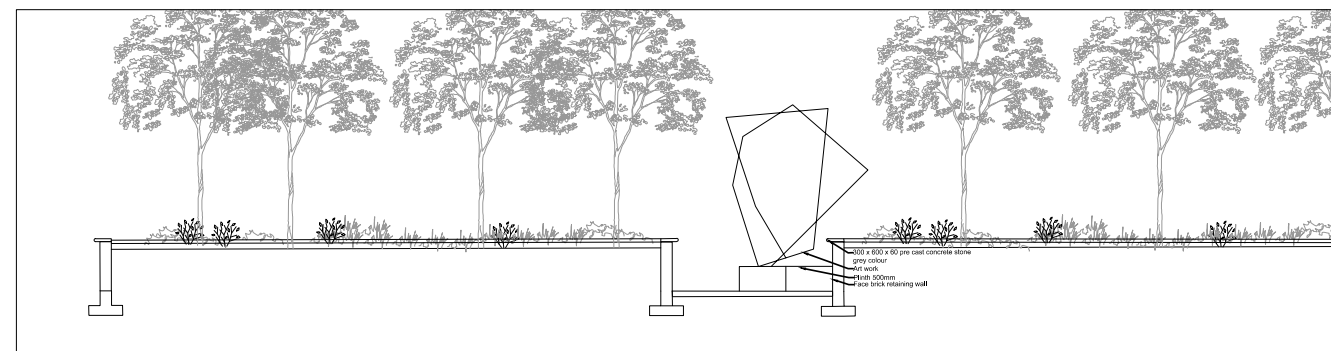
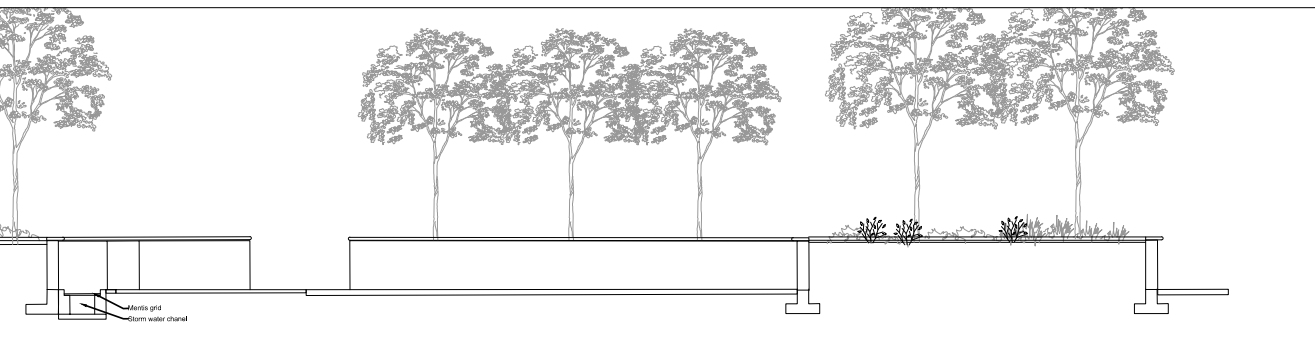
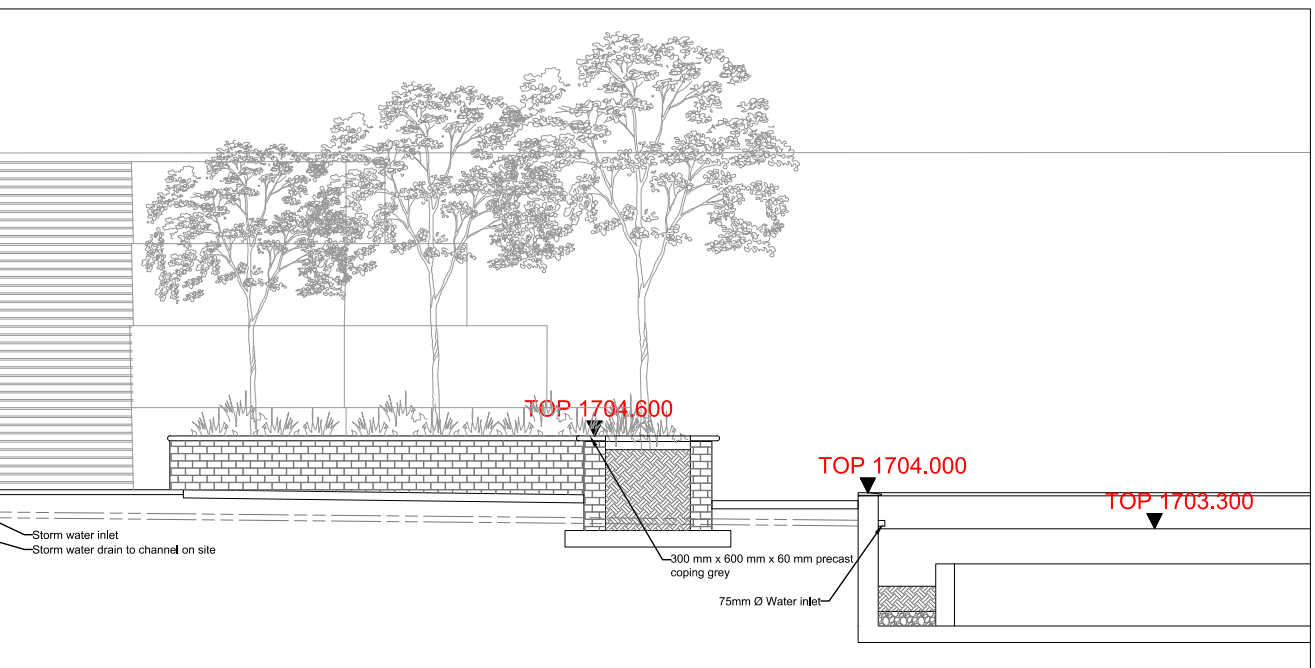
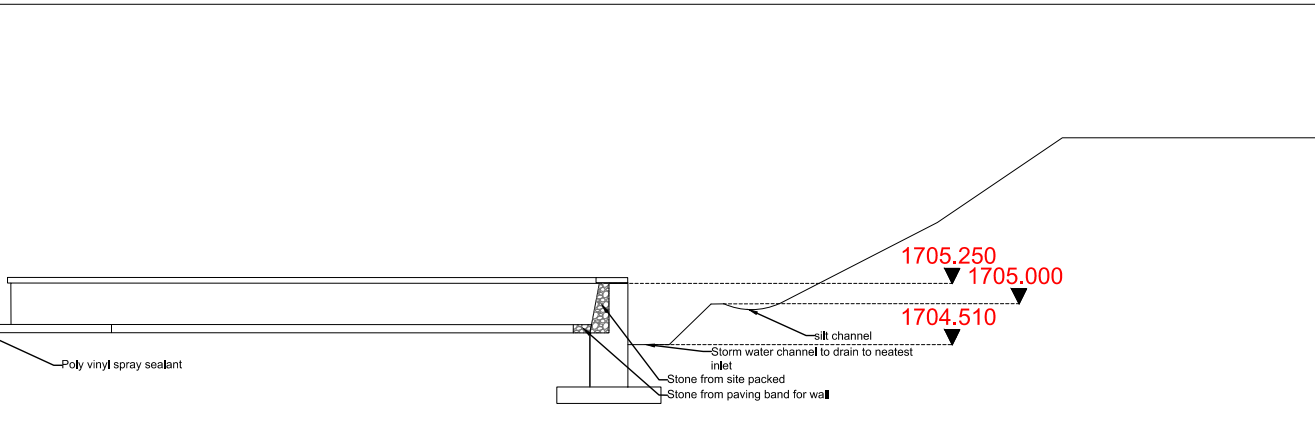

Figure 7.14 Sections DD- not to scale (Author 2017)



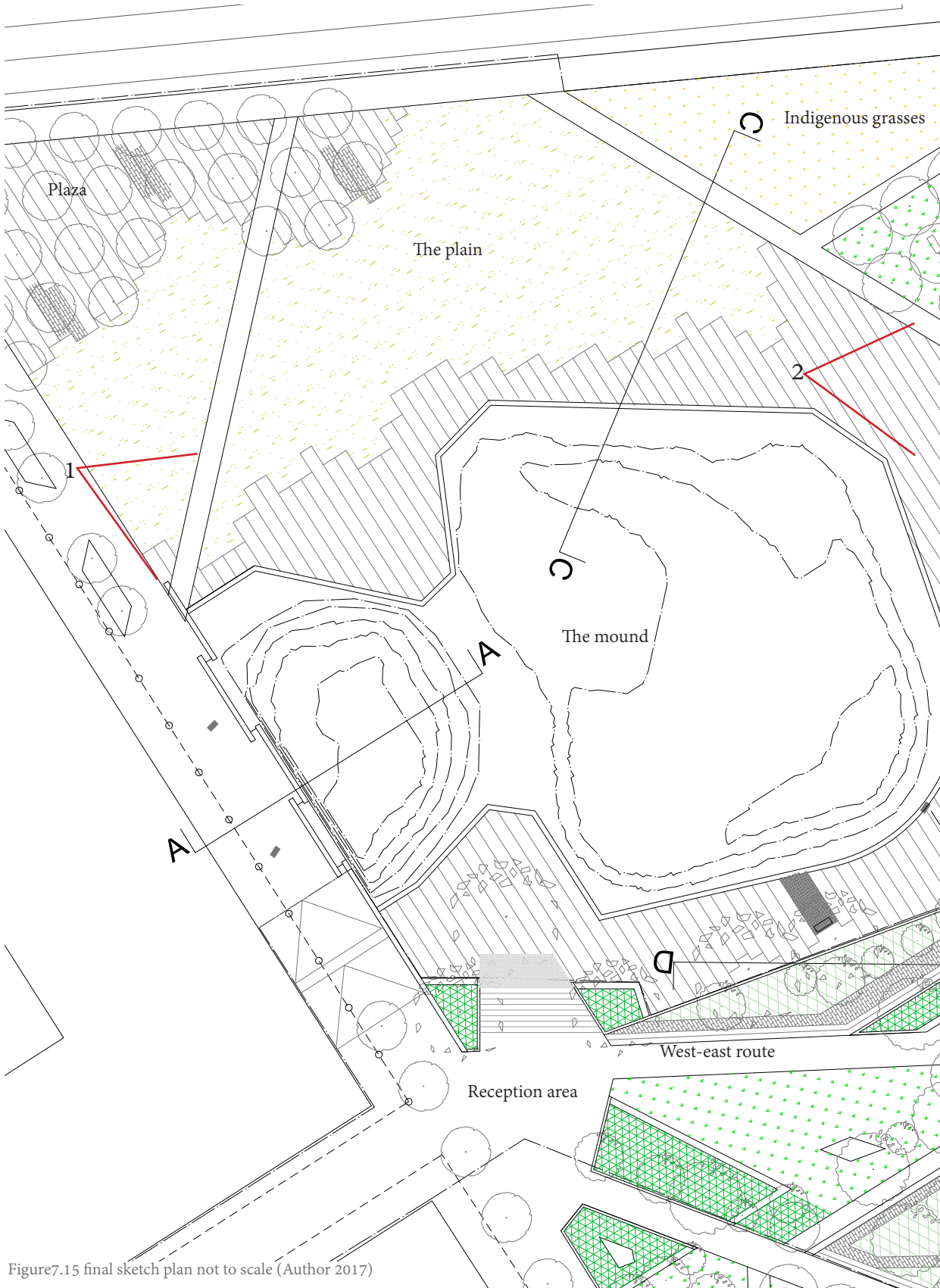
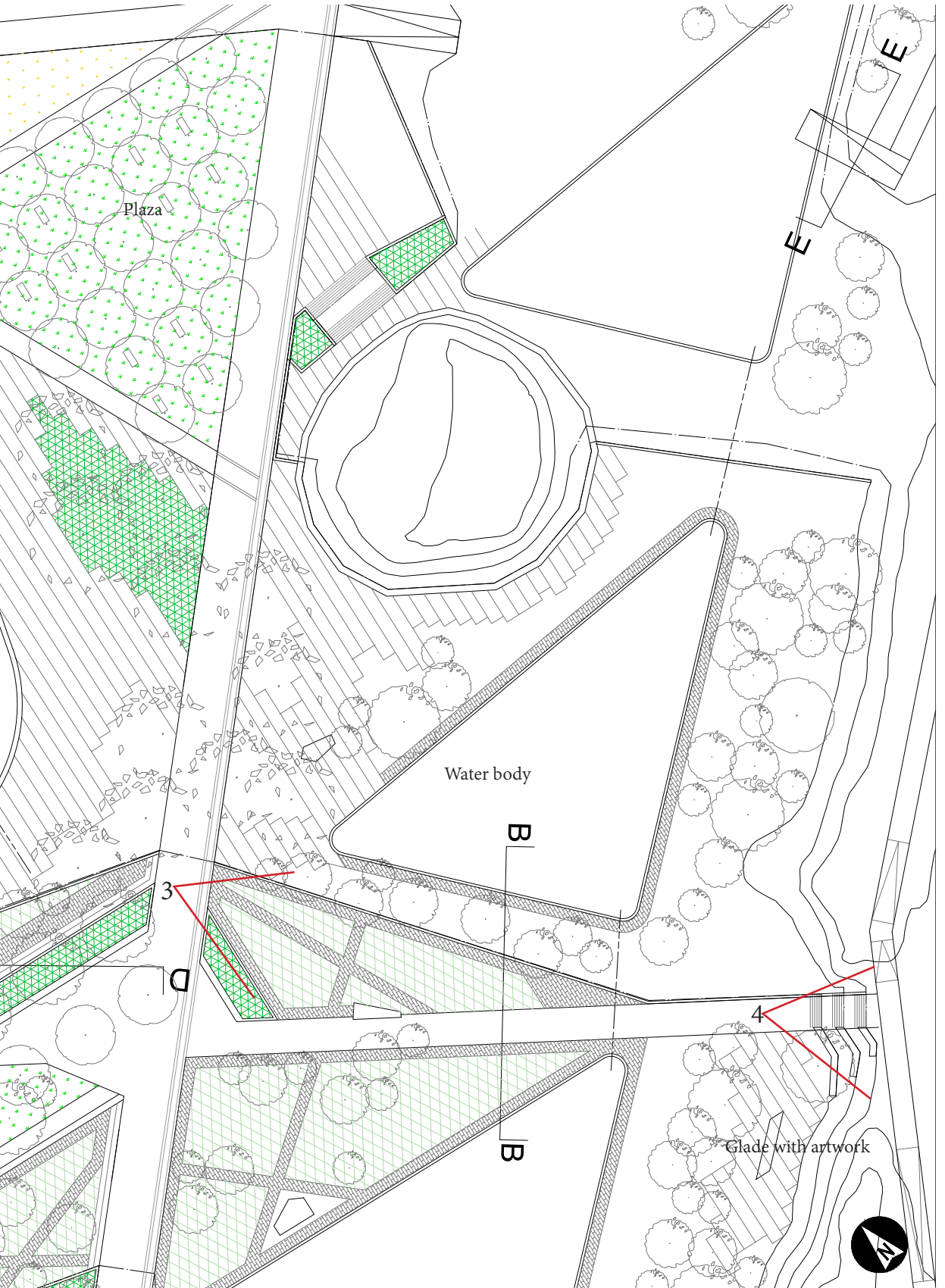
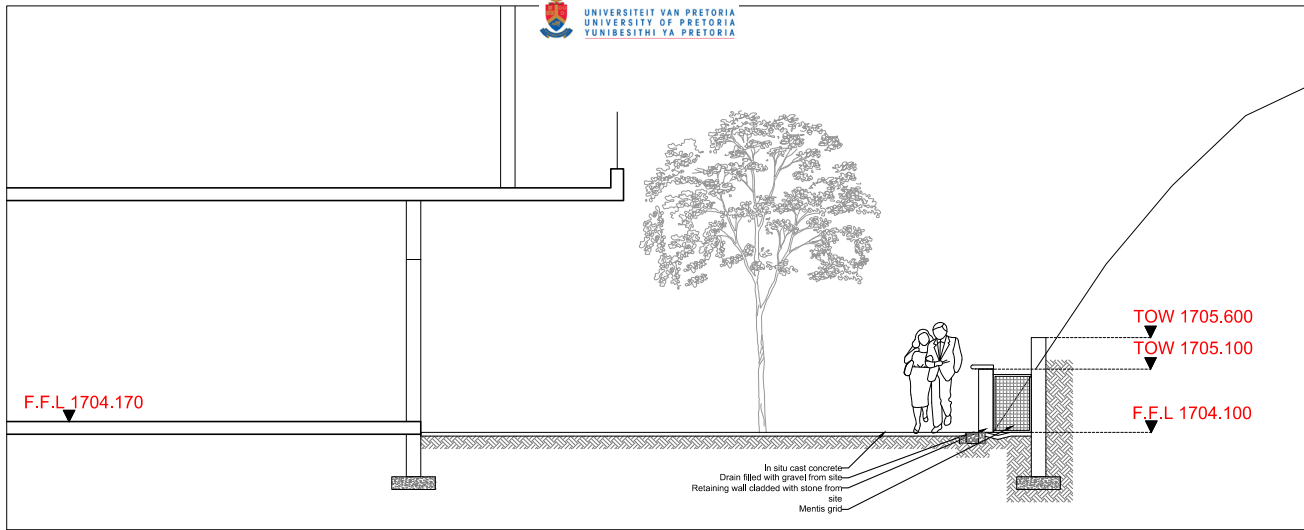
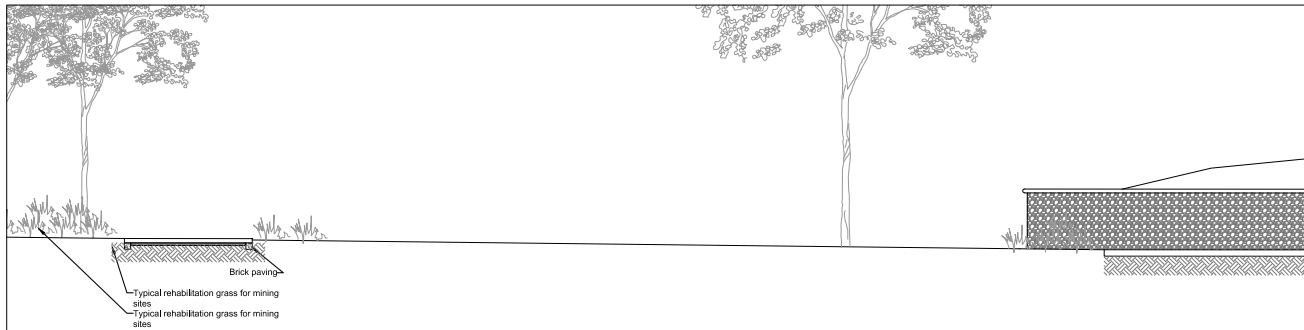

Figure 7.15 final sketch plan not to scale (Author 2017)





Section AA
1:50



Section CC
1:50

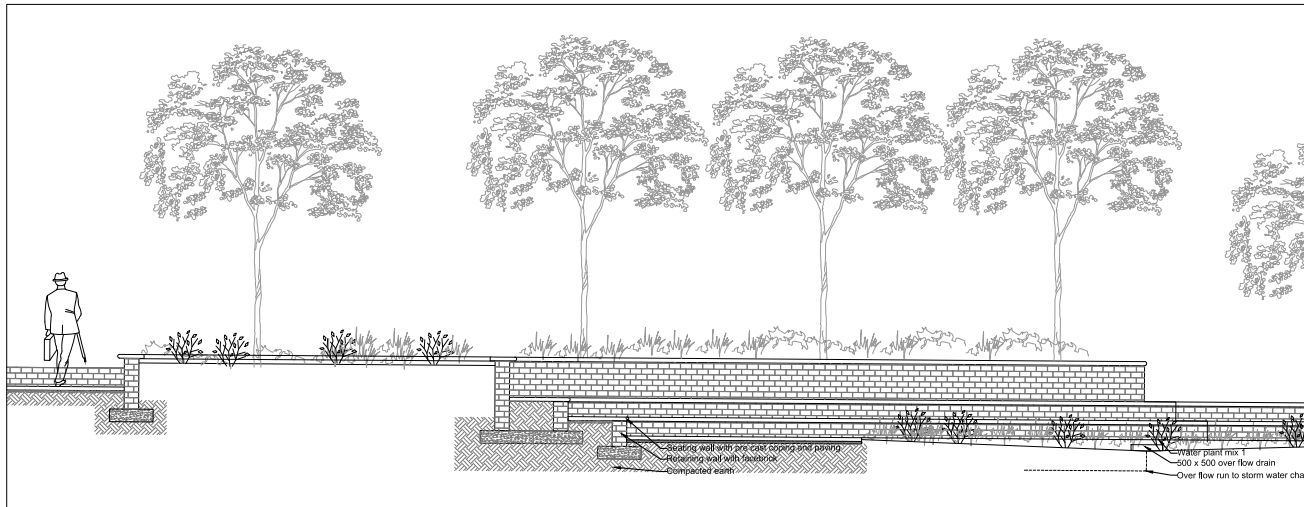

Section DD
1:50

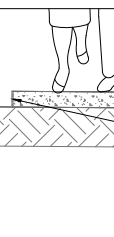

Detail: Rock cladding
1:20

Figure 7.16 Sections not to scale (Author 2017)

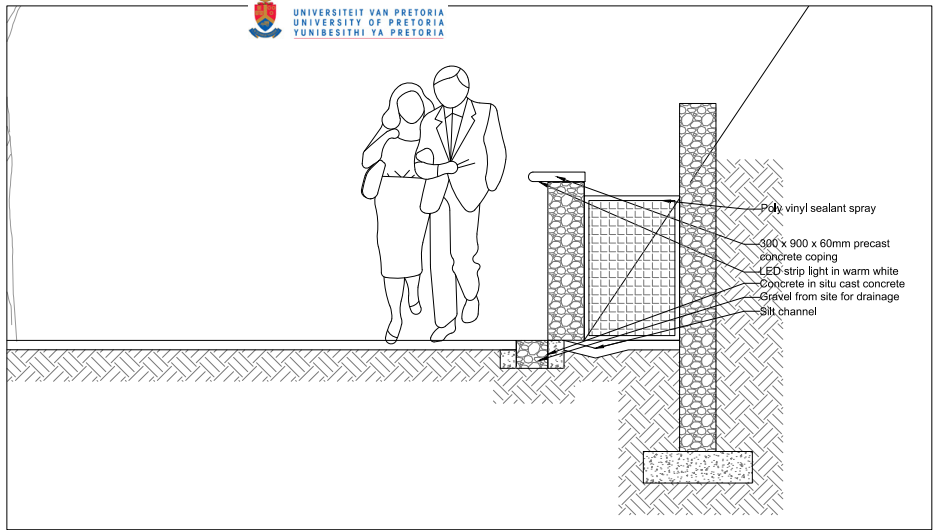

Detail: Mound drainage detail
1:20

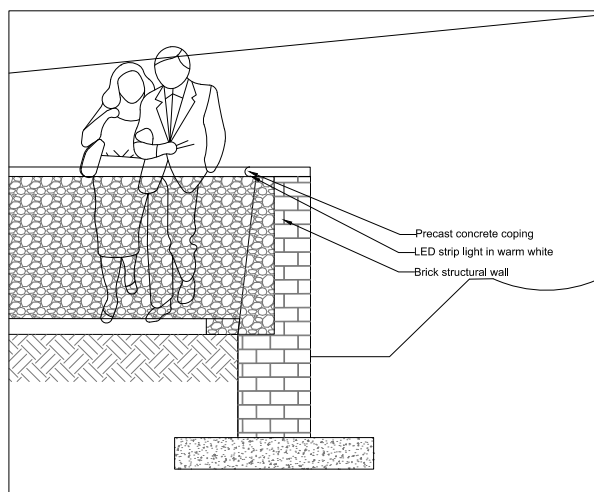
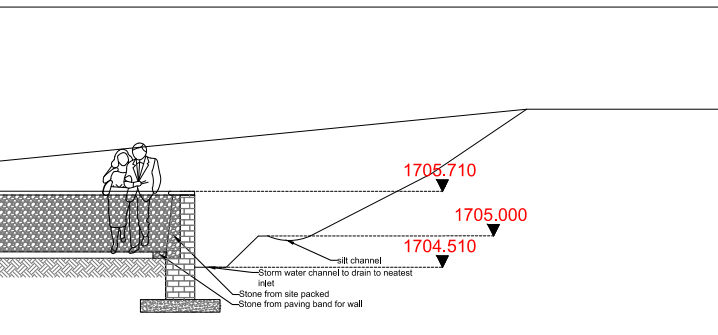

Detail: Rock cladding wall
1:20

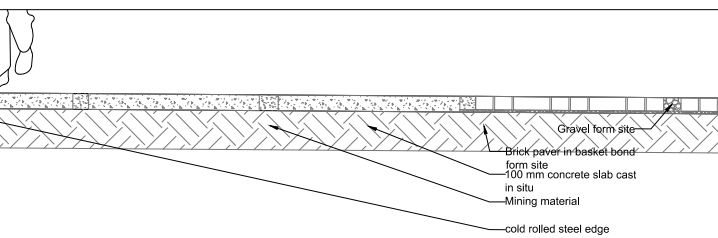
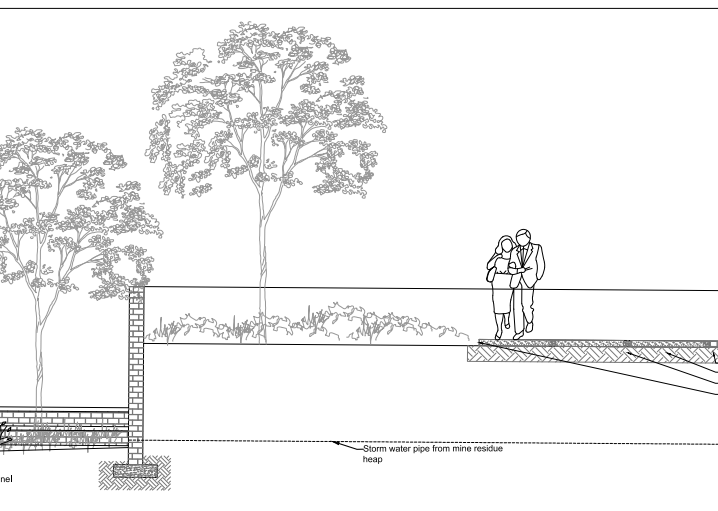

adding wall

7.2 Conclusion

1. Illustrated in Figure 7.14, as the user approaches the area on the main access route from the transit hub, the user is confronted by the vast plain. In the background the mound is visible and framed with eucalyptus trees. On the plain area, erosion caused by the Johannesburg thunderstorm left the ground eroded but, this in turn, transported seeds. The lines of grass follow the erosion lines across the plain. Creating a new pattern on site as informed by patterns of field.

2. The scale of the mound next to the grove of trees invites the user to the mound, either by crossing the plain or walking round the mound. The uncomfortable heat of the plain is quickly subdued by the shade of the eucalyptus trees and the grove of indigenous trees that many come to sit and enjoy nature as a break away from the urban environment. It may also function as a meeting place for family and friends.

3. The promenade leads the user from the mound area deeper into the park. The viewing deck is visible from the promenade and the user is led onto the west-east route to be confronted by a large water body buzzing with bird life. Between the trees the faint vision of artwork is visible and the intimate walkway leads the user to explore. The artwork is placed in an glade and is backdropped by the ridge. Families gather here for the day to picnic under the trees.

4. The progression with stairs up to the ridge lets the user view the site from the viewing deck. It is here that the users can see the process of water from the red acid type water to more the clean natural colour. The colour however, is variable in terms of the season where the highest acid levels will occur in the dry seasons and thus turning the water more red. This is due to the water levels that are maintained by shaft water pumped to site. The water is constantly reticulated.

Pattern of field and figure, as coined by M'Closkey, was utilised on site. The pattern making of existing processes

on site was utilised as well as the more prominent patterns like that of the water system. This attempted at a richness on site that combines the existing identity and proposed functions for site.

Beauty in the ugly was directly translated in the retention of the mound, plain and ridge. These elements are not the 'conventionally beauty' for existing parks like the Walter Sisulu Botanical gardens. The retention of the mound plain and ridge challenges the user's idea of beauty and can evoke memory and emotion as Herrington identified in the redevelopment of industrial sites.

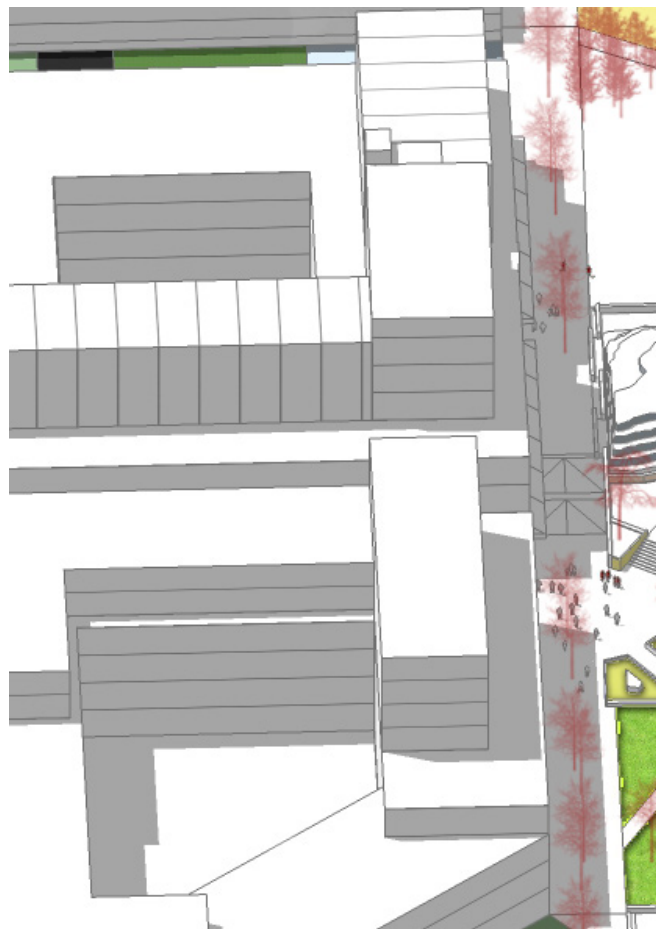

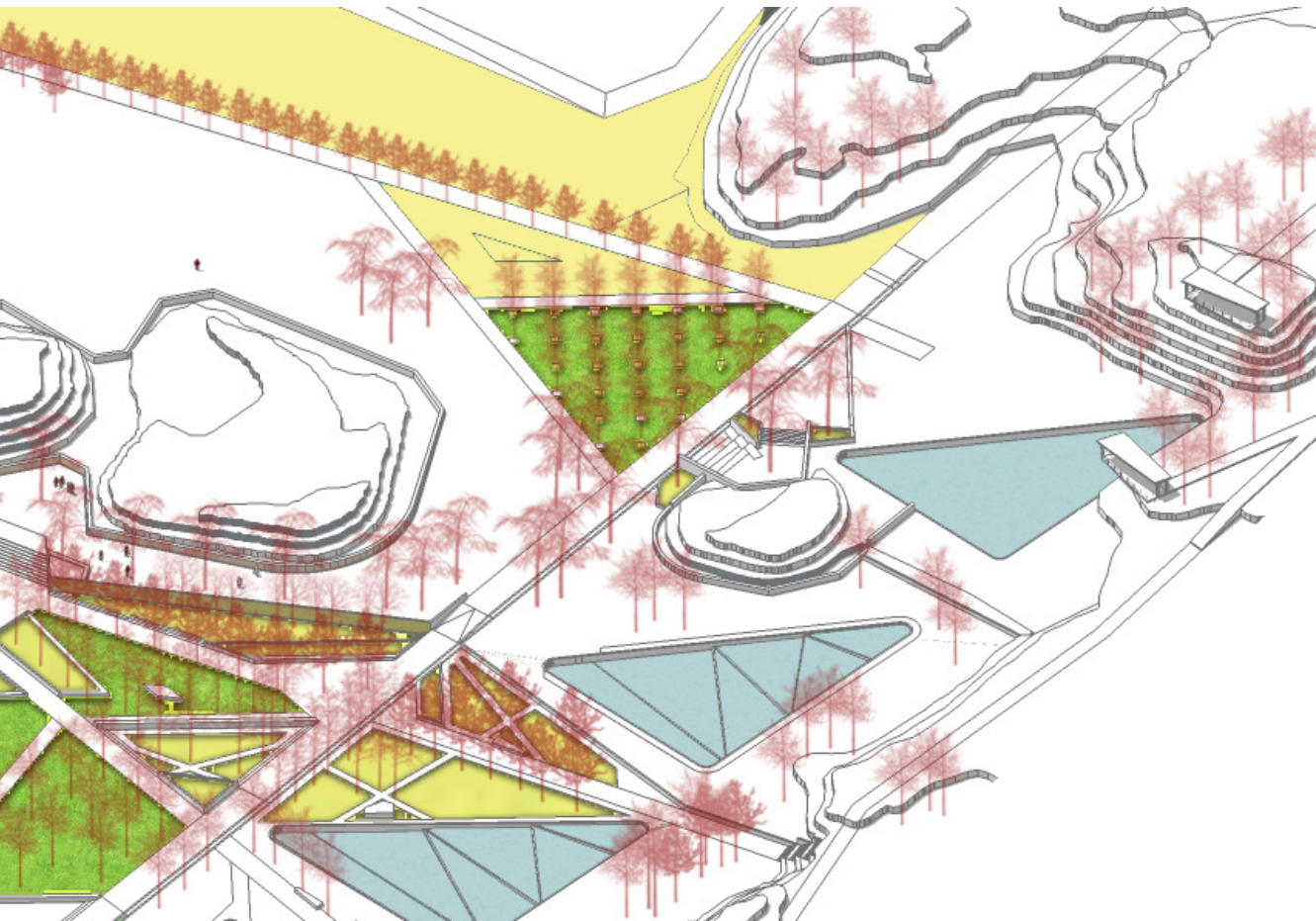

Figure7.17 Axonometric view of ketch plan area not to scale (Author 2017)

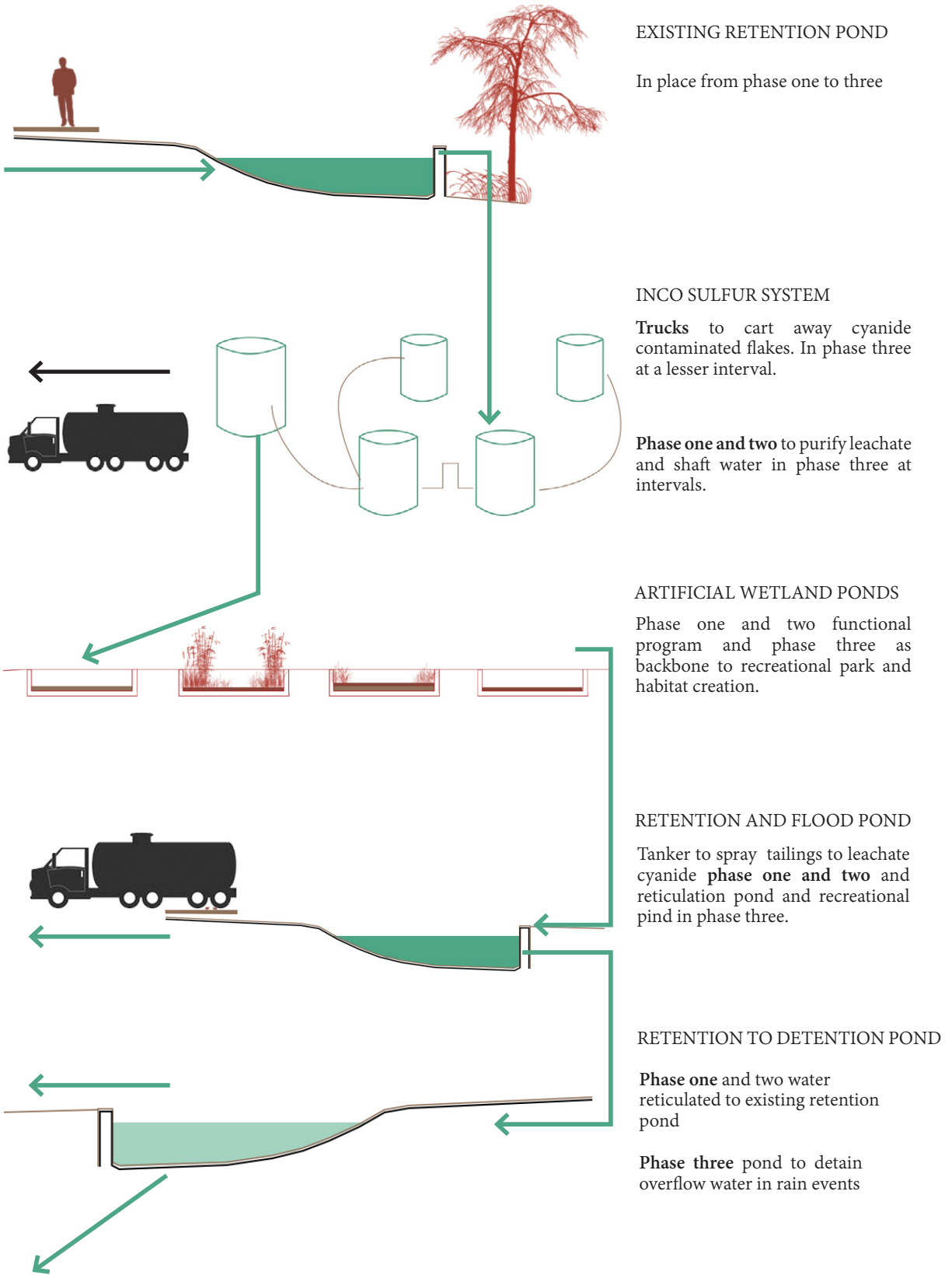

Figure8.1 Water system in the different phases (Author 2017)

CHAPTER EIGHT

Introduction

Based on the design described in the previous chapter, this chapter aims to realise the design in terms of the approach of pattern making and the implementation of such in the workings of the site.

8. Technical resolution

8.1 Technical description

The technification of the site is separated into three categories namely: systems, planting and materiality. As user movement and the water system were the drivers to formulate pattern, it is proposed in this chapter that planting plans and material choices will add another layer of pattern making to the park.

8.2 Systems on site

The user movement and water system will evolve with the site as the need on site changes. These systems will function within the phased approach in the following manner:

8.2.1 Storm water

The strategy for storm water management on site is critical for the proposed INCO and wetland system, in that the storm water is retained on site to enable these processes. The water will be retained on site as a preventative measure to improve the environmental problems as described in Chapter 2; the deterioration of the Klip River wetlands. The leaching systems and supporting artificial wetlands will be implemented within the three phases of site development

8.2.1.1 Phase one - Stockpiling (Ponding of stormwater)

The catchment area for the collection of storm water is as seen in Figure 8.1. It is presumed that the road network has an existing system that will deal with the storm water on the roads and surrounds. The ridge and landfill serves

as the other catchment boundaries. The storm water on site is collected and circulated in a closed system on a permanent basis for phase one. This system will run till the soils are cleansed in an estimated period of 5 to 10 years.

The INCO and wetland system will require an over flow retention pond to ensure contaminated water is retained and treated on site. The water required for the site will be collected from rain water and backup water will be supplied by a connection to the nearby mining shaft. Thus, the contaminated shaft water will be treated in the dry seasons to maintain the leachate system.

As seen in Figure 8.1, the water is collected on site into the various ponds and reticulated. The down stream retention pond water is pumped to the INCO process pond, described in detail in chapter 3, while the toxic material from the clarifier tank is carted away to the nearby hazardous waste site. The water then flows into the wetland system and over flows to, the on-site retention facilities during rain events.

8.2.1.2 Storm water calculations

A 1 in 10-year design flood is used in the storm water calculations as it is required by building regulations in the SANS 10400 Section R. According to the document the owner must provide measures to control the disposal of accumulated stormwater, generated on paving, buildings or any earthworks. (South African Bureau of Standards 1990). Due to the unknown chemical composition of the tailings, the time required for the leaching process is an



Figure 8.2 Phase one stormwater management (Author 2017)

estimate only. The water requirement for the system to function is calculated on the amount of water available rather than the 'need' as the need is dependent on the time it takes for water to move through the stockpiled tailings and the dissolving rate of the cyanide. This information is currently not available for the specific site at the time of the study. The 36 ha site's stormwater run off (illustrated in Figure 8.2) is calculated by the rational method as follows:

C=Run off coefficient, estimated as 0,15

I= Time of concentration,

A=Catchment area

$Q=CIA$

$Q=0,15 \times 0,000021 \times 360\ 000m^2$

$Q= 1,139m^3/sec$

The stockpile, at an estimate of 7 000 000m³ collected by excavation at 500mm depth over site, is rinsed by a truck applying the water at controlled intervals. (See Figure 8.3) The stockpiles are limited to three metres height as that is the maximum height the trucks can spray. The implementation of the G-Tech technology is implemented after the stockpile has been to establish vegetation for erosion control and the start of phytoremediation. See figure 8.4.

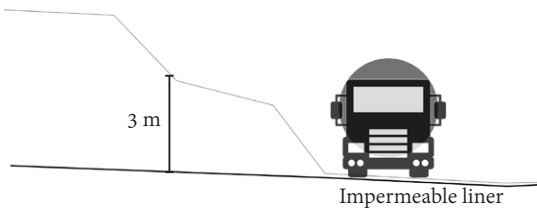

Figure 8.3 Tailing stockpile limited to 3m (Author 2017)

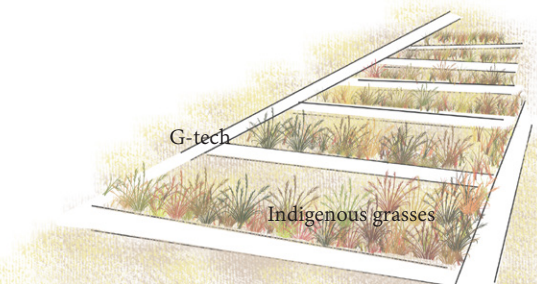

Figure 8. 4 G-Tech technology to establish grass species (Author 2017)

8.2.2. Phase two – Establishment of the buildings

In phase two, illustrated in Figure 8.5, the establishment of the buildings will start on the edge of Booyens Road. The soil is now free of harmful toxins and development can proceed. The development also brings with it the establishment of trees to replace the Eucalyptus plantation. The irrigation for the new species establishment will be provided from the water system.

8.2.2.1 Storm water calculations

The stormwater layout for phase two consist of the formalising of stormwater systems on site and pipes to daylight in a retention pond in the south west corner of site. This retention overflow will be connected to the existing stormwater grid of the area. Run off peak is as follows:

$$Q=CIA$$

$$Q=0,30 \times 0,00001556 \times 360\ 000m^2$$

$$Q= 1,681m^3/sec$$

The peak flow has only increased minimally. This is due to the hardening of surface on the edge being countered by the softening of the remainder of site with the establishment of veldt grasses. The PPC depot will be continually working away the stockpile in the form of bricks and pre-mixes that are sold. As seen in the figure, the water remainder is less and the estimated water required from the mine shaft will increase.

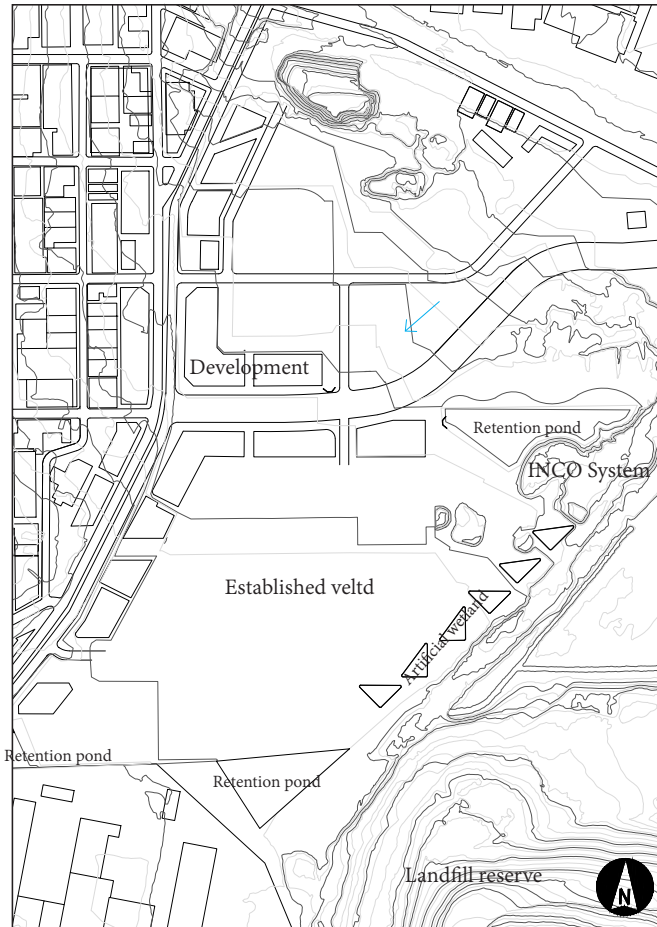

Figure 8.5 Phase two stormwater management (Author 2017)



Figure8. 6 Phase three stormwater plan (Author 2017)

8.2.3 Phase three – Principle metropolitan Robinson Deep sub centre

Phase three, shown in Figure 8.6, is the final phase of the urban metropolitan sub-centre. The retention pond for this phase is modified to become a detention facility. This is to ensure that the developed buildings are protected in rain events. The stockpile is worked off site and the only contaminated water is the water pumped from the shaft in dry seasons and diluted with the clean water on site before being applied for irrigation.

8.2.3.1 Storm water calculations

The peak flow for the final development is calculated as the following.

$$Q=CI(t)A$$

$$Q=0,565 \times 0,038m (722sek) \times 360\,000m^2$$

$$Q= 5,580 m^2/sec$$

The increase in urban development has almost tripped the peak flow due to the increase of hard surfaces. The reduction of this peak flow is done by utilising the courtyard space with in the various buildings as water collection and retention areas. The stormwater infrastructure is to terminate in the detention facility to minimise the effects on the stormwater systems and slowly release the water into the system and regenerate the groundwater table

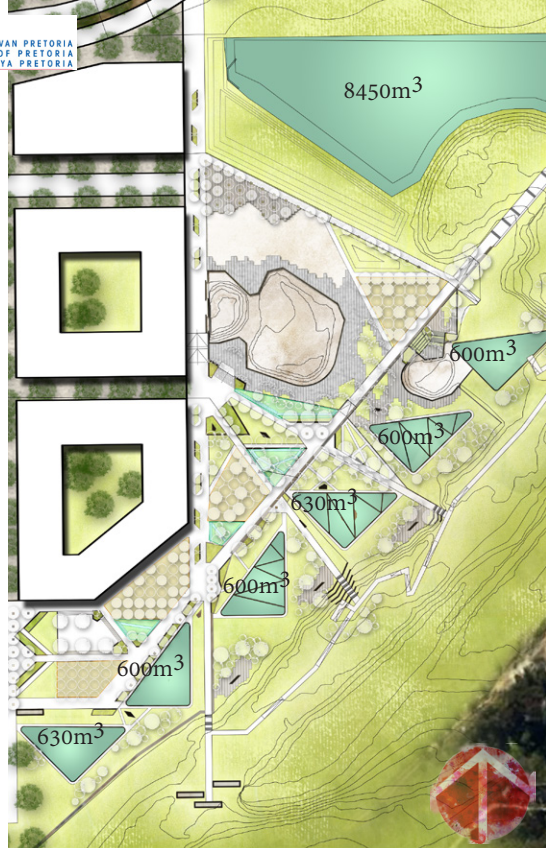
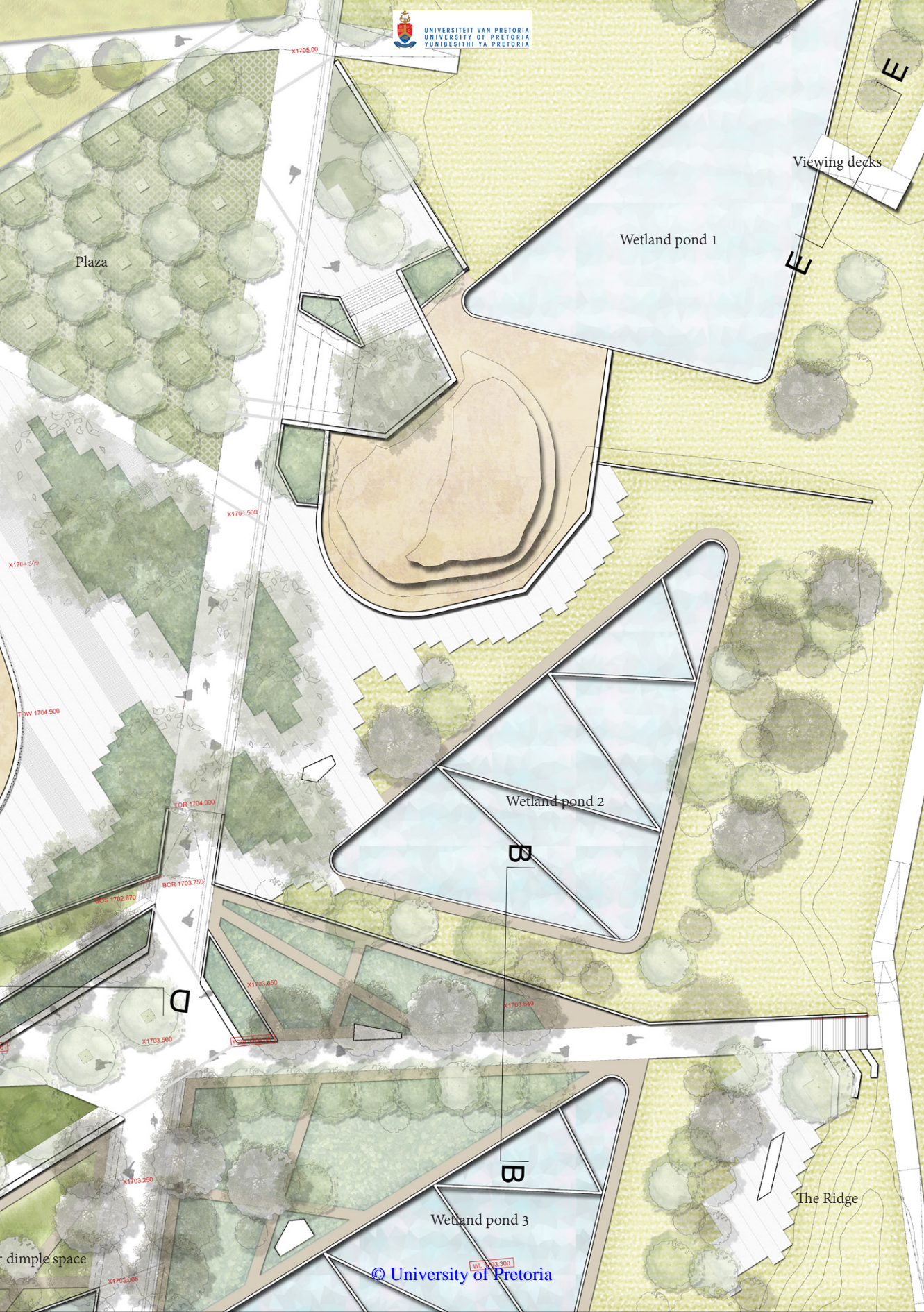

Figure8. 7 Artificial wetland pond volumes (Author 2017)

PHASE ONE			
	Yield annually	Dam size	Yield after evaporation
At a depth capacity of 2 meter			
Area 1	14734,34 m ³	7367,17 m ²	3683,585 m ³
At a depth capacity of 2 meter			
Area 2	30062,4 m ³	15031 m ²	7515,602 m ³
TOTAL	44796,74 m³	22398,17 m²	11199,187 m³
Measured dam surface in m2			115167 m ²
Actual annual capacity			30334 m ³
Defecate capacity filled by AMD from nearby shaft			19135 m ³
Total water available for leachate system annually			1199,187 m ³

PHASE TWO			
	Yield annually	Need Annually	Surplus
Area 1	34954,39 m ³	4272 m ³	30682,39 m ³
Area 2	83232,7714 m ³	4970 m ³	78262,7714 m ³
TOTAL			108945,1614 m³
Capacity annually			30334 m ³
Polished water for neighbouring industrial activities, bricks and water overflow to the greater Clarifier catchment			78611,1614 m ³

PHASE THREE			
	Yield annually	Need Annually	Surplus
Area 1	56222,988 m ³	35600 m ³	20622,988 m ³
Area 2	88881,8045 m ³	84960 m ³	3921,8045 m ³
TOTAL			24544,7925 m³
Excess water for irrigation of parks capes for area at 7,12m irrigation per year and additional m2 of:			3447,302317 m ³



Plaza

Viewing decks

Wetland pond 1

Wetland pond 2

Wetland pond 3

The Ridge

simple space



Figure8.9 Artificial wetland section BB scale 1:20 (Author 2017)

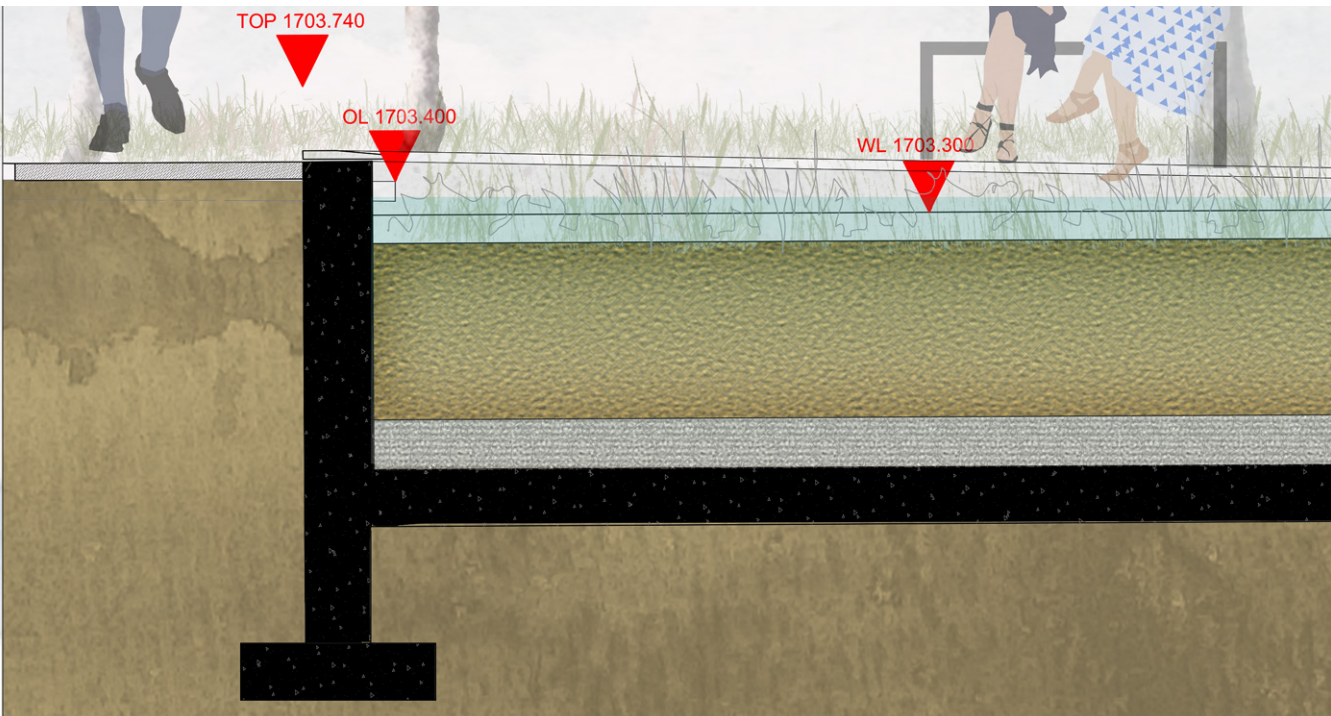
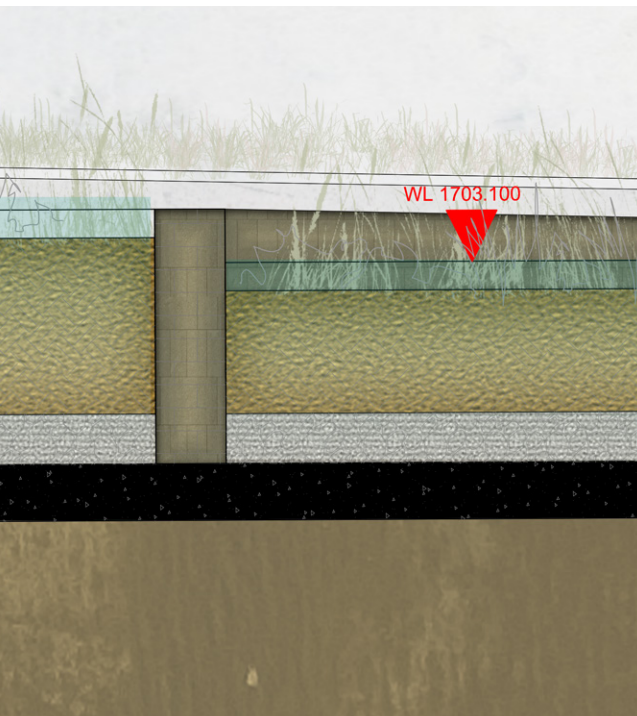
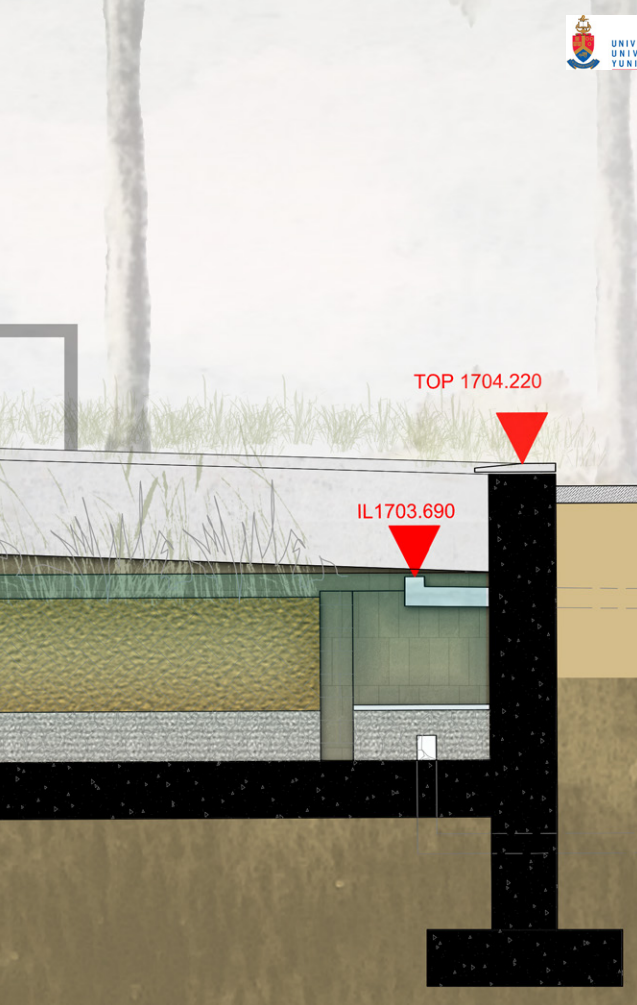

Figure8. 10 Artificial wetland section BB scale 1:20 continue(Author 2017)



8.2.4 Artificial wetland

The wetland construction, as seen in Figure 8.9, is built constructed in concrete to ensure the longevity of the pond to form part of a recreational space for the final phase of development. As seen in Figure 8.8, the water level in the ponds is controlled by the technology used to reticulate water. Utilizing gravity, the water is fed into a pipe placed at the level of water required. The water is pumped to the first pond and flows through the planted wetlands to the bottom pond and recirculated back.

The installation of planters around these pipes is done so to ensure the effectiveness of the phytoremediation. The construction of the ponds was dealt with in such a manner to ease the entry point for maintenance workers to clean and repair the ponds in time.

8.3 Movement

8.3.1 Ramp regulations

According to the South African National Bureau of Standard's SANS10400 regulations, public ramps should have a fall of 1 to 12 with a landing at a minimum of 1000mm for every 500mm rise the ramp has. This is expressed on site where applicable. The installation of handrails at the edge of the ramp and at 2400mm intervals to adhere to SANS regulations are prescribed.

8.2.2.2 Size of routes

Different route types on site is assigned with a typology to create a consistency of the language on site and ensure the park caters for the prospective users.

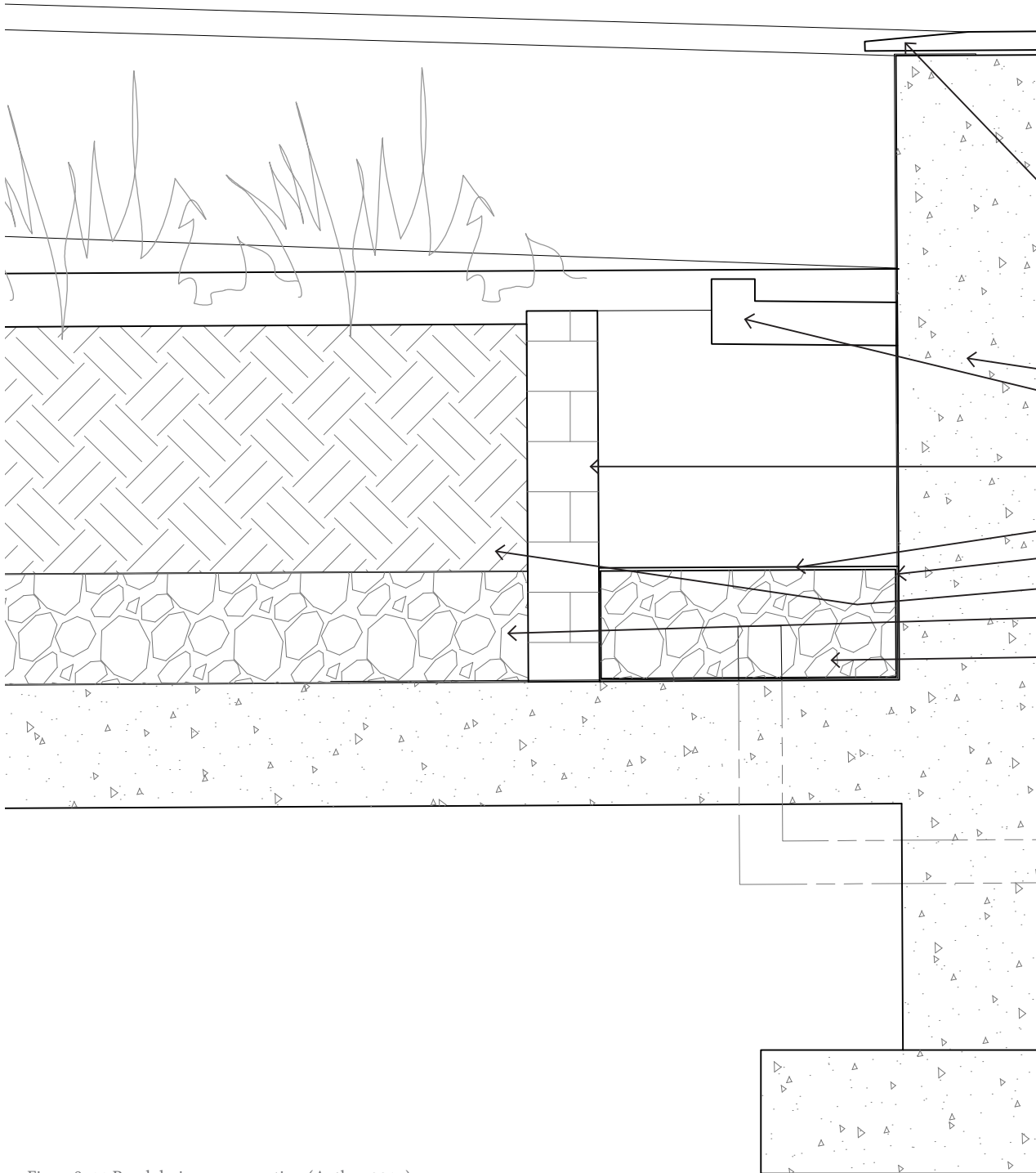
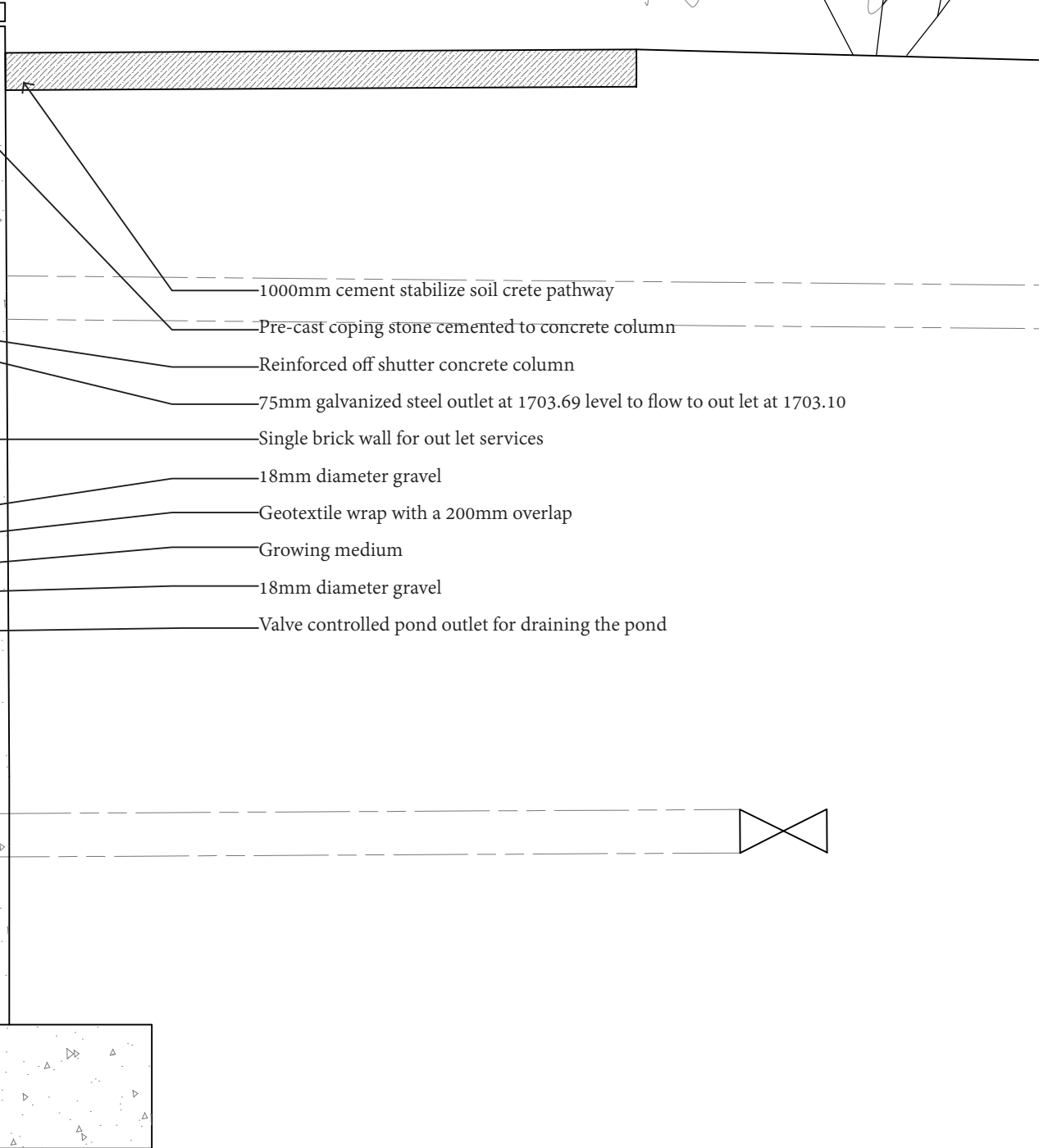
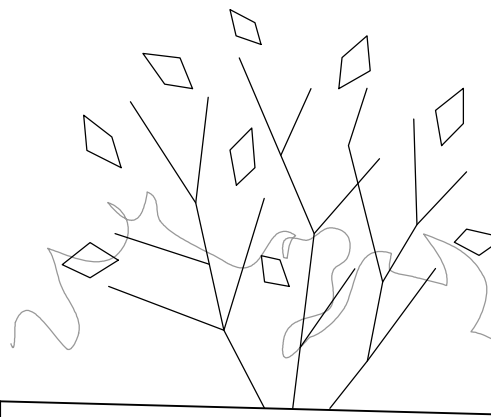
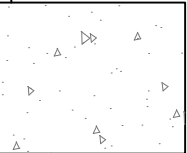

Figure8. 11 Pond drainage connection (Author 2017)



- 1000mm cement stabilize soil crete pathway
- Pre-cast coping stone cemented to concrete column
- Reinforced off shutter concrete column
- 75mm galvanized steel outlet at 1703.69 level to flow to out let at 1703.10
- Single brick wall for out let services
- 18mm diameter gravel
- Geotextile wrap with a 200mm overlap
- Growing medium
- 18mm diameter gravel
- Valve controlled pond outlet for draining the pond



8.3 Materials and technification

The existing materials on site is used as the inspiration to the materiality on site. The use of the existing stone heaps that is on site is proposed as construction materials for site. An estimated 12 m³ of stone is on site. See Figure 8.12.



Figure8.12 Stone heaps on site (Author 2017)

The bricks being manufactured on site will also be incorporated in the development. This introduces the use of concrete. See Figure 8.13. Concrete will be utilized where the solidity is necessary to ground the elements and it is used for i.e. paving material. The more intimate walking routes that serve as connection routes to the main routes will be utilising cemcrete. See Figure 8.15.



Figure8.13 Concrete blocks cast *in situ* (Pinterest 2017)

To contrast the solidity of the concrete the introduction of steel as a material for the viewing deck is proposed. Currently steel pipes are also evident on site but will be re-appropriated elsewhere on site. Using steel in the form of mentis grids, see Figure 8.16, will enable the user to view the processes in the park and be confronted with the more natural side of the park as opposed to the urban edge. Also, to ensure a smooth transition over the ridge and difficult areas in term of height differences on the ridge area where ramps are crucial for the running track to function.



Figure8. 14 Basket brick paving pattern (Menarek Stamped Concrete 201)

The utilization of different materials is thus done on site to help the user interpret the landscape. On the ridge light steel will feature and in contracts, at the mound , use of solid concrete is proposed.



Figure8..15 Soil crete pathway in Green point park Cape Town (Author 2012)



Figure8. 16 Mentis grid pathways in Cap de Crues (Pinterest 2017)



Figure8.17 View of mound at the urban edge (Author 2017)



Figure8. 18 Spatial use around mound (Author 2017)

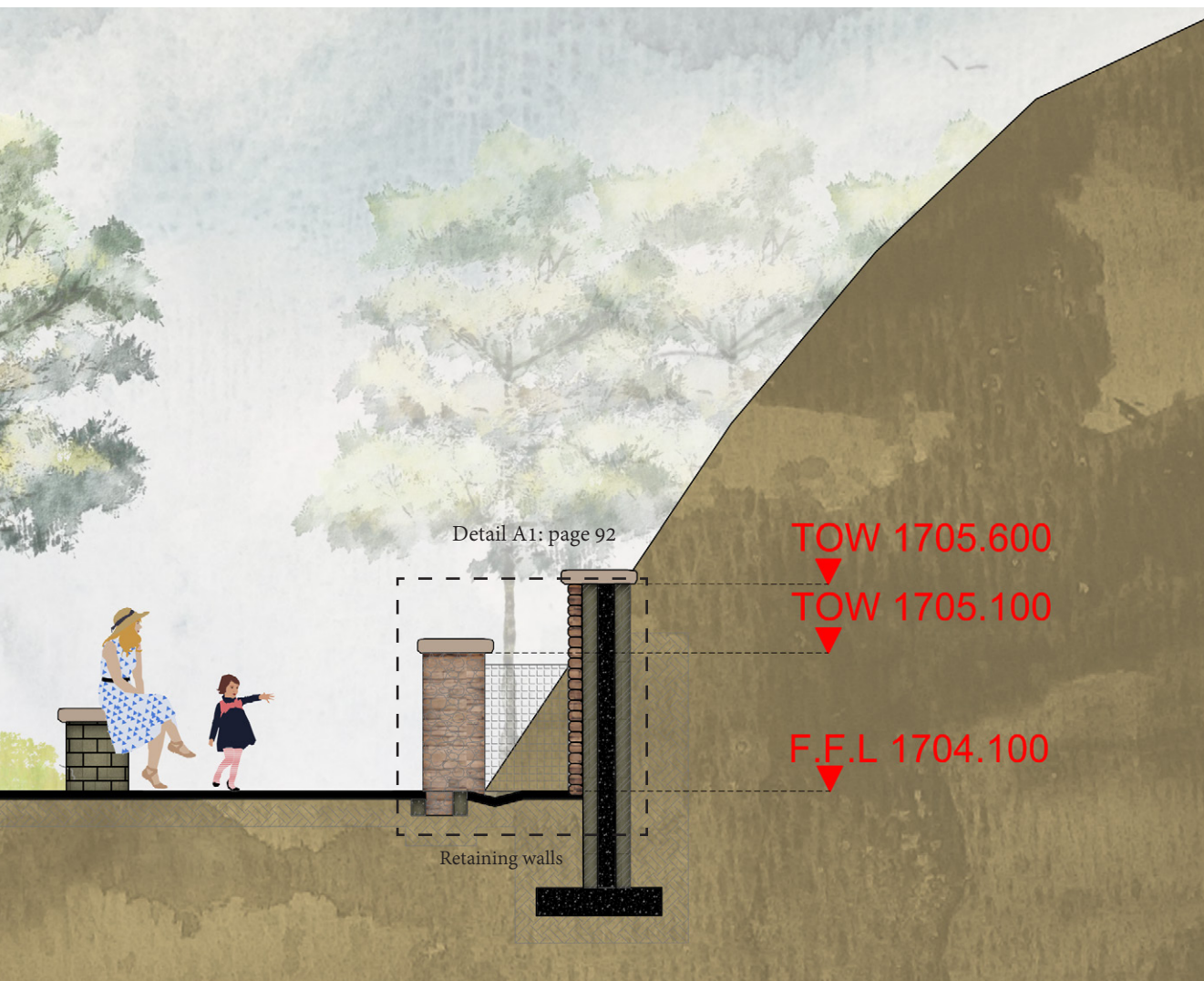

Figure8.19 Section AA scale 1:50

8.3.1 Materials around the remnants

The use of materials will follow a pattern by field approach as materials will be applied as an expression of the intention of the items i.e. the use of stone, currently on site, will be utilized around the remnants of site as an indication as such. The stone will be applied as a cladding to the retaining wall surrounding the mound as seen in Figure 8.18. The stone is extended onto the vertical plain as a border to the vertical element

For the use of concrete to contrast the mound and plain, see Figure 8.17 and 8.18. Bricks made on site will be applied as breaks in the concrete. At these breaks the use of benches will provide the user with comfortable space to site.



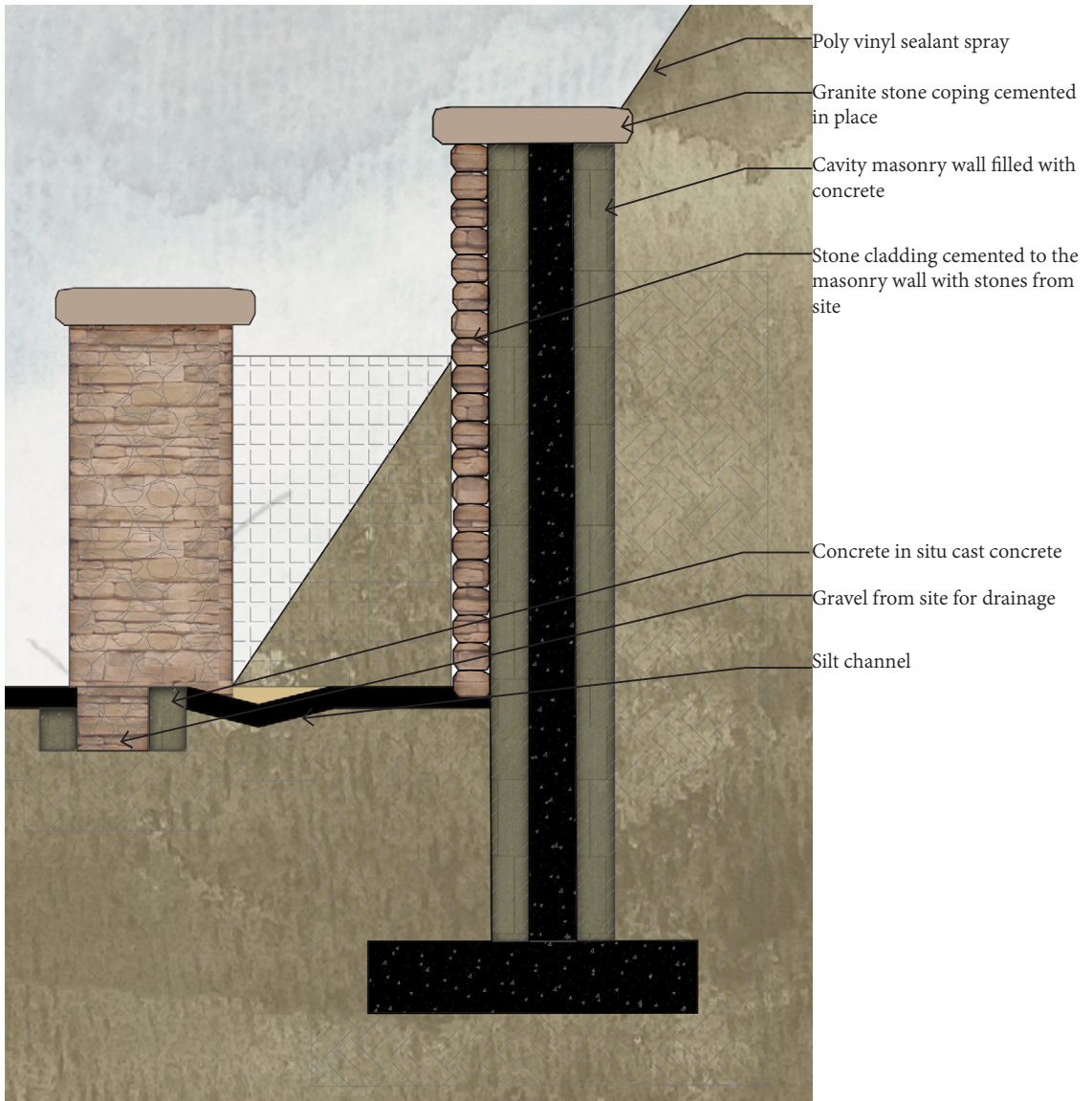

Figure 8.20 Detail A1 scale 1:20: retaining wall with mentis grid (Author 2017)

The construction of retaining walls on the western side of the mound is off set and lowered to expose the mound to users as seen in Figure 8.20. The installation of these walls at the onset of phase three will ensure that the mound erodes over the time period before the park opening. This in turn will erode the tails soil up to the retaining wall and through the mentis grid. The mentis grid, see grid detail Figure 8.19, will retain some

soil but will let the soil spill out onto the walkway. The mound will be sealed at the final construction stage with a polymer sealant to prevent dust being swept up by the wind.

The use of a channel as a first step in managing drainage around the mound will help keep silts that will spill off when the polymer fails, and forms part of the maintenance of the area.

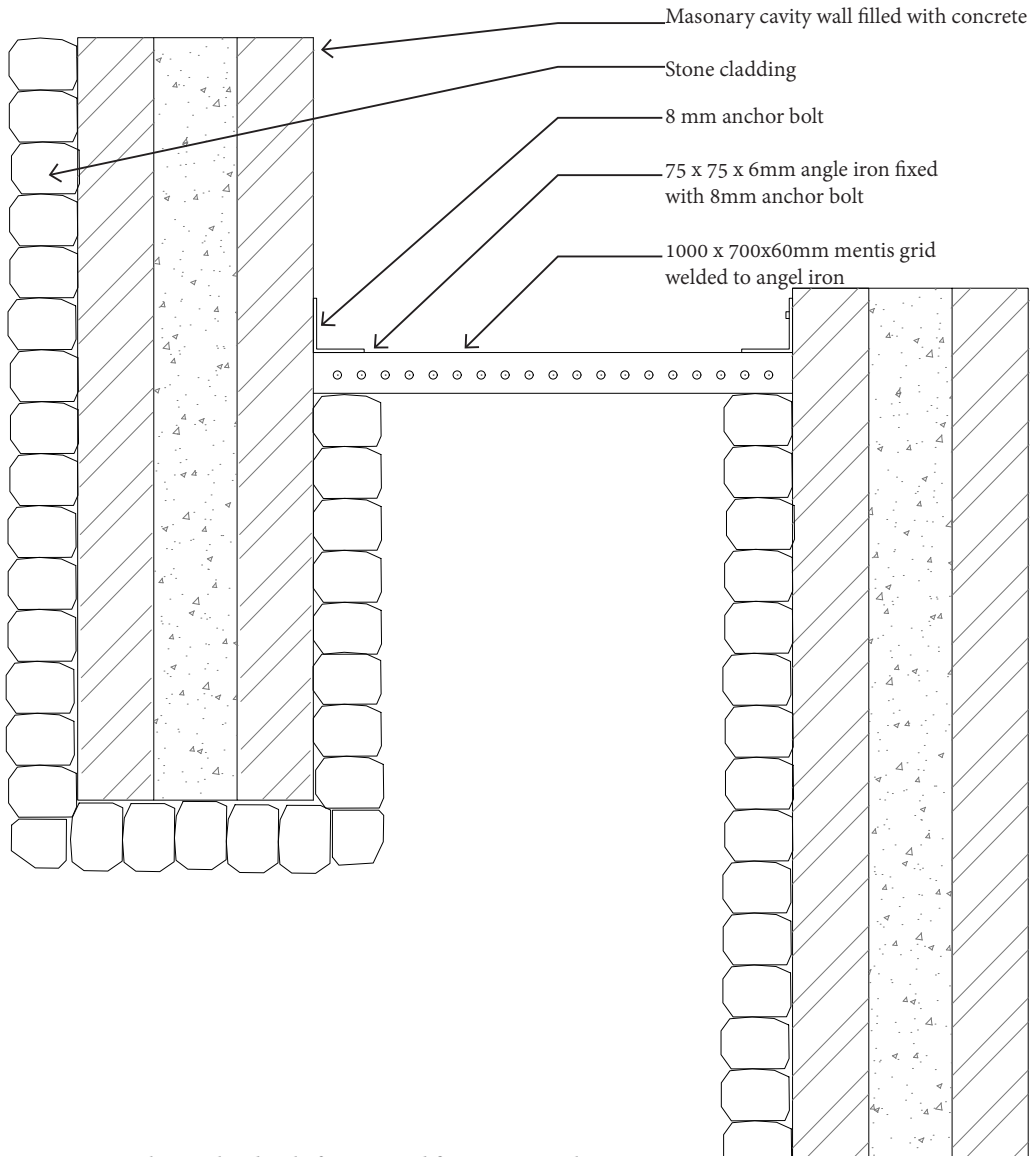

Figure8.21 Detail AA1:plan detail of mentis grid fixing not to scale



Figure8. 22 View of plain facing the mound

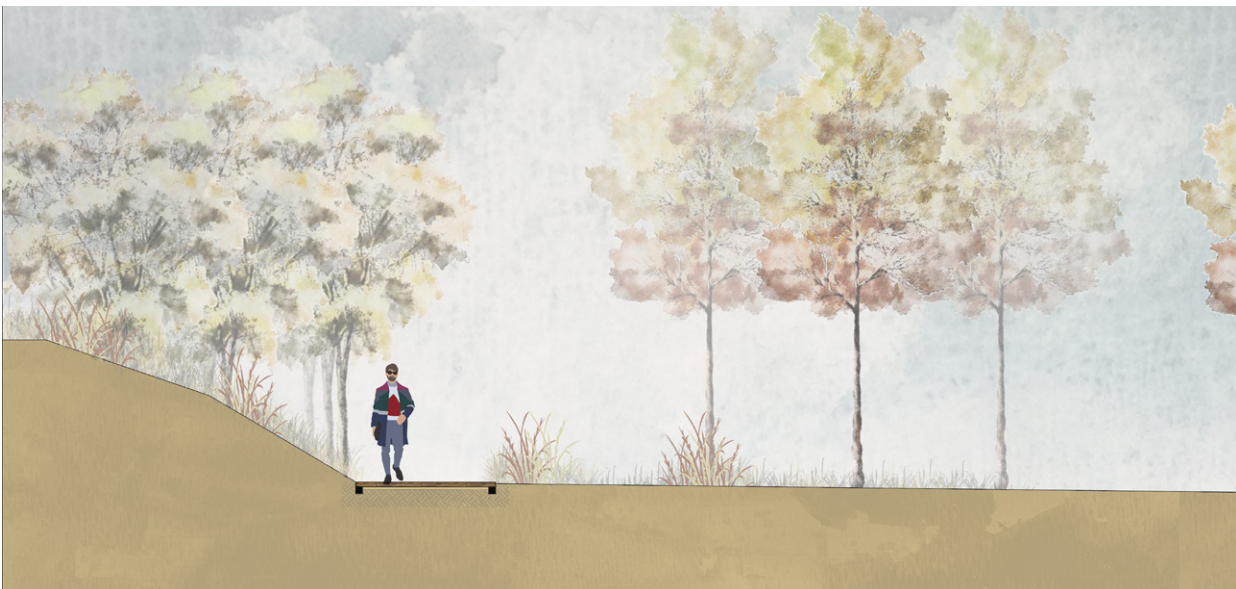
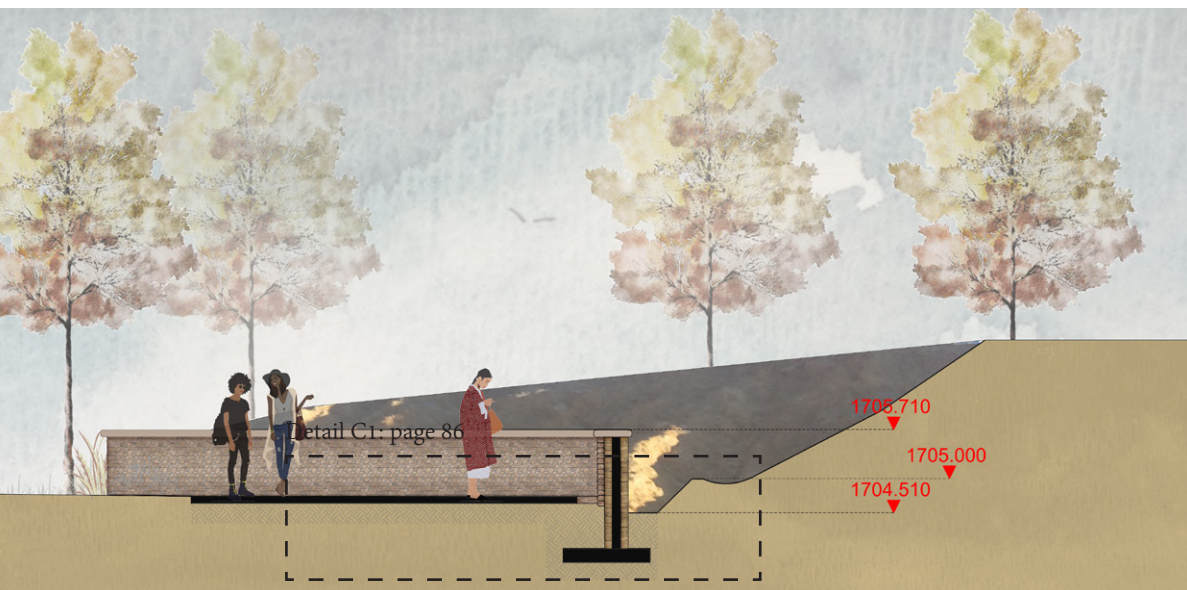

Figure8. 23 Section CC scale 1:50

9.3.2 Materials for the different walkways

The hierarchy of movement is also expressed in the materiality of them. *In situ* concrete slabs to form a jagged edge will be used as shown in Figure 8.22. The size of these gaps between blocks are determined by the shuttering of the *in situ* blocks. The combination of two 38x76x6000mm pine with 25x76x100 mm spacers will leave a 101mm gap between two separate slabs. See Figure 8.25. These spaces are to be filled and compacted with treated tailings material. The eventual succession of grass species planted nearby will take place as describe in Chapter 7. The movement over certain areas will trample potential species. The eventual pattern of movement and pattern of succession will merge to form another layer of pattern on site.

The use of pre-cast concrete dry cast pavers on main access routes will ensure easy transition across the park. The use of the stone at junctions will inform the user of a possible change of direction.



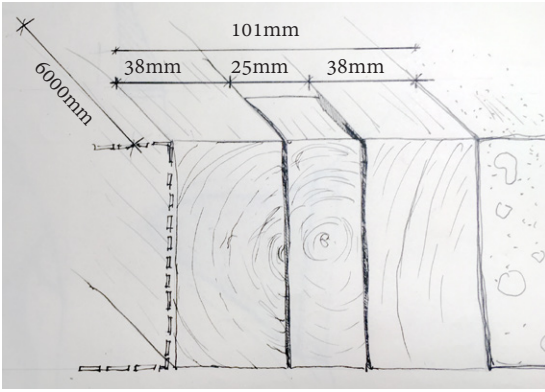

Figure8.24 Detail Shuttering detail to formulate concrete blocks

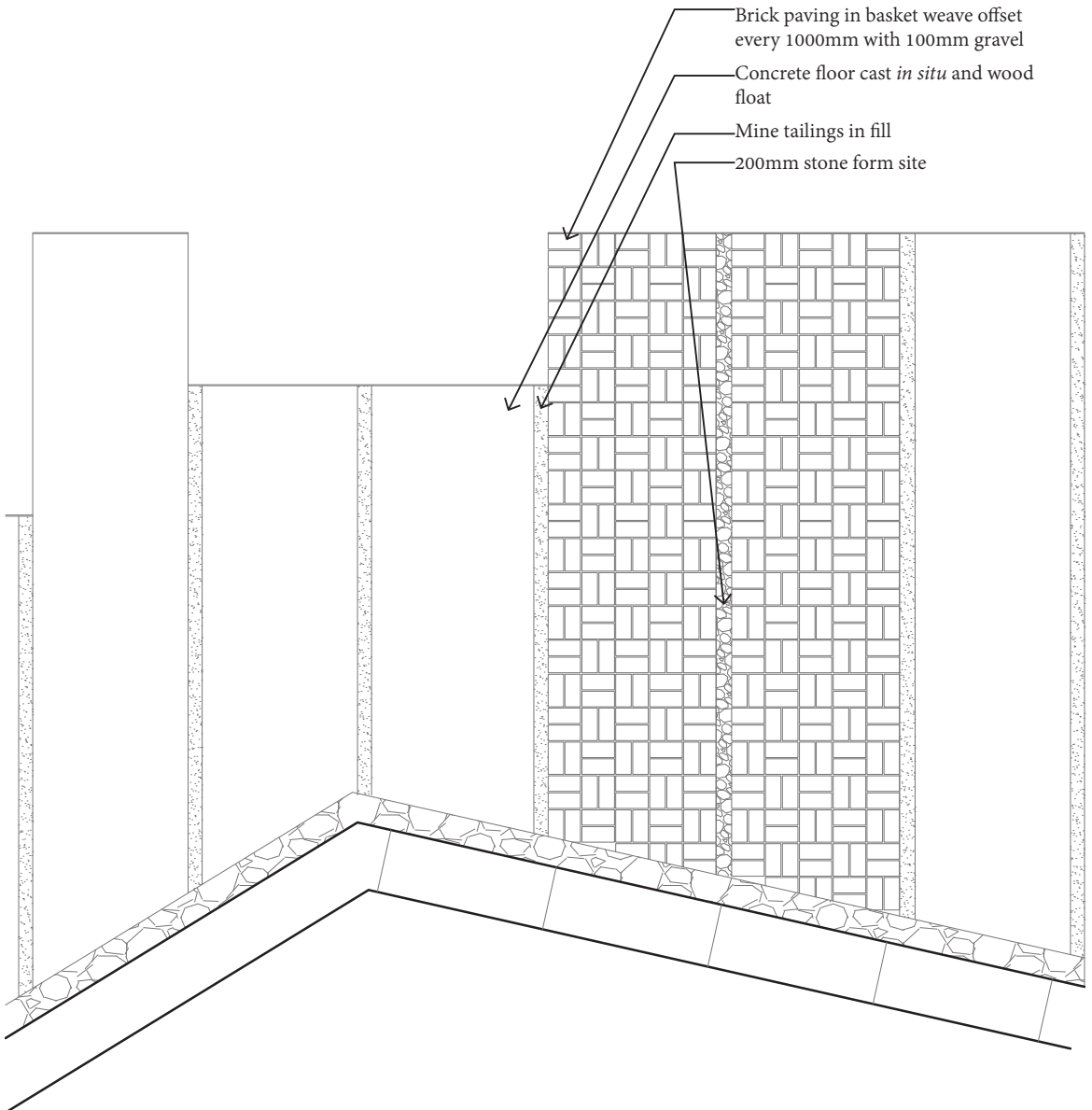

Figure8.25 Detail C1: Paving detail around mound 1:20 scale (Author 2017)

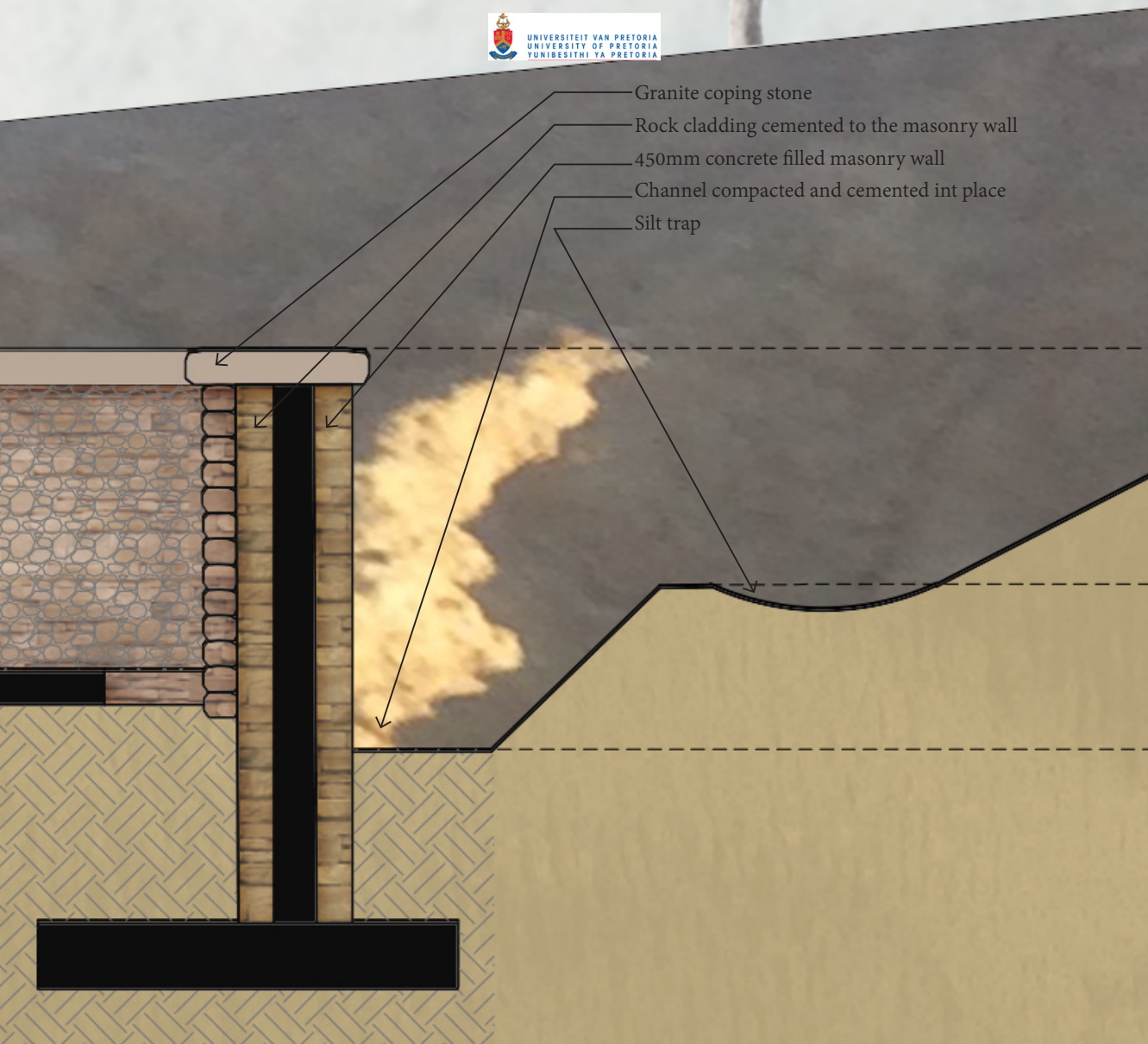

Figure8.26 Detail C1:paving detail continue 1:20 scale (Author 2017)

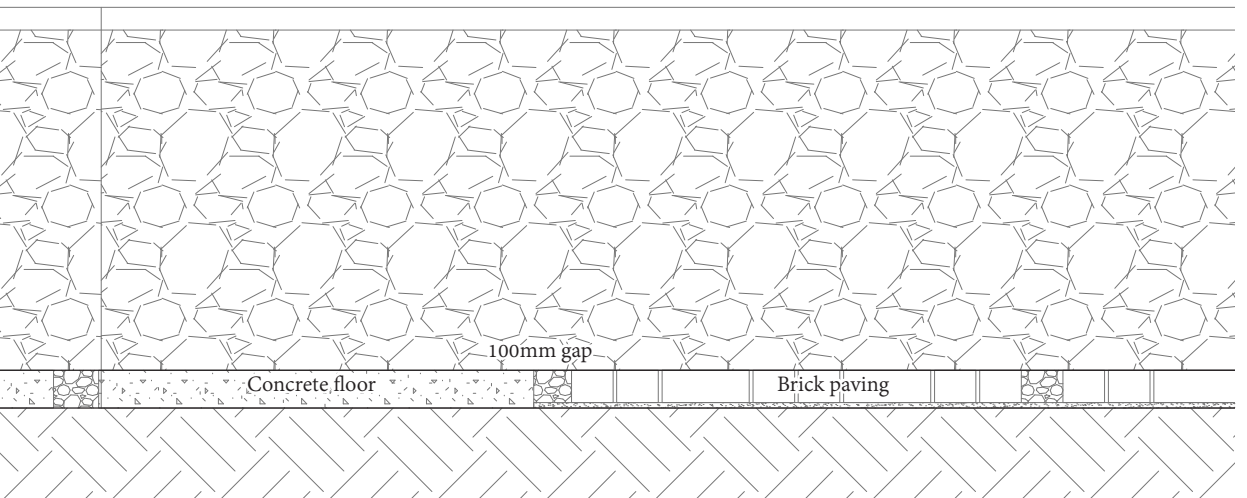

Figure8.27 Detail C1:paving detail continue 1:20 scale (Author 2017)



Figure8. 28 Perspective of bio-filter area (Author 2017)

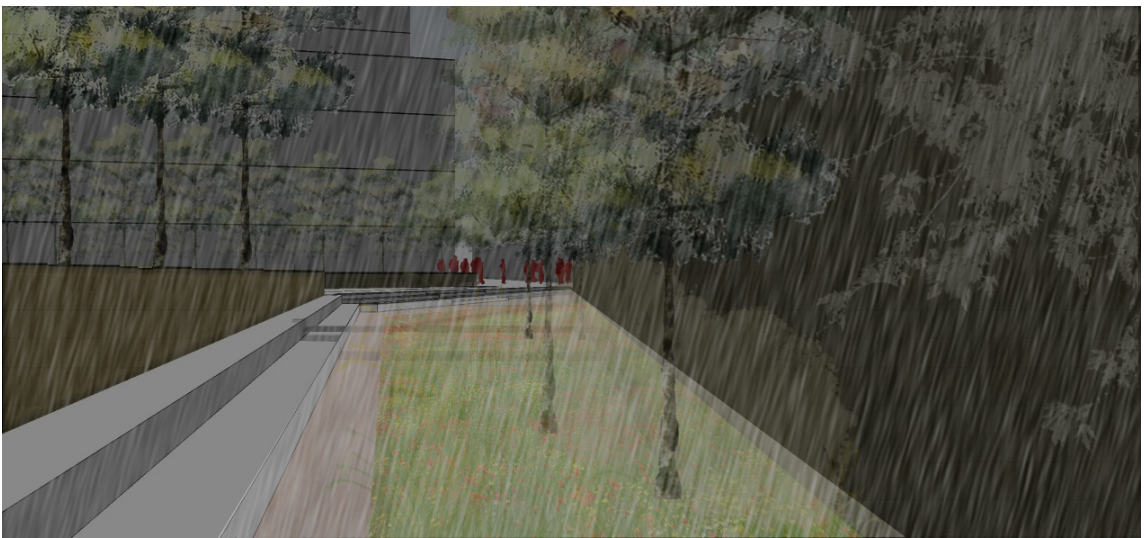
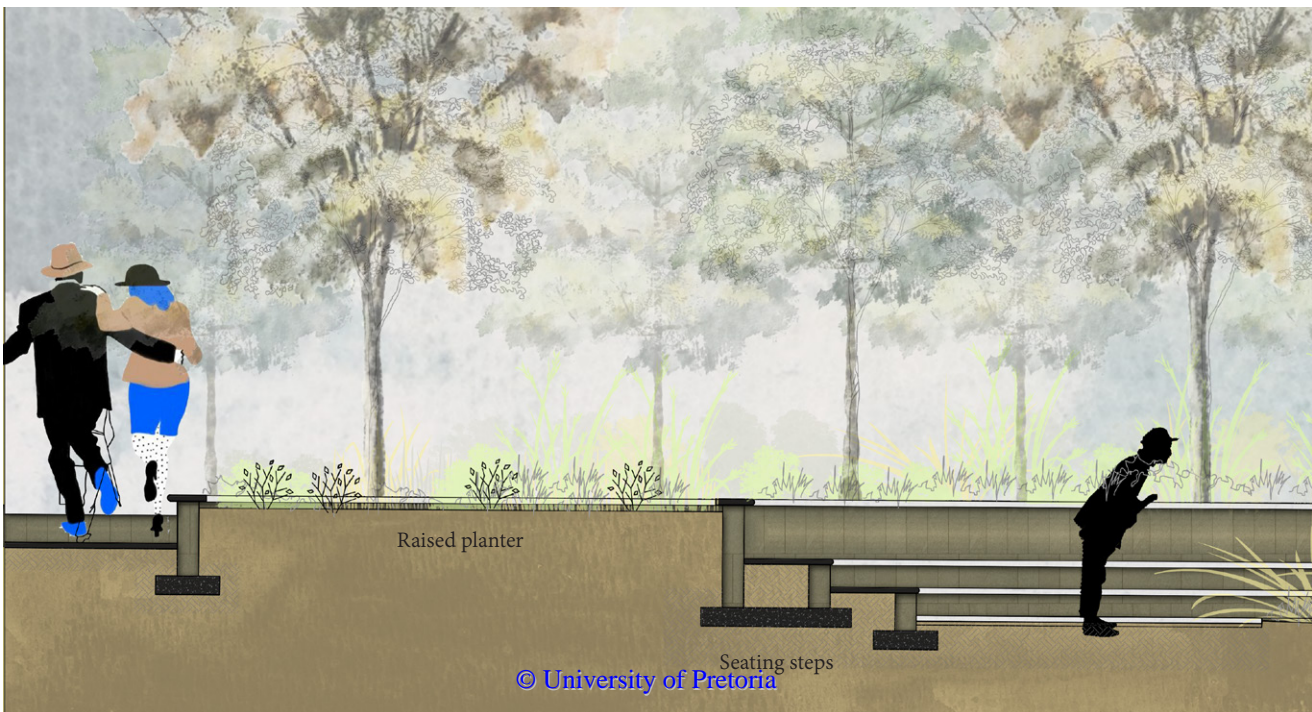

Figure8. 29 Rain events effects on bio-filter area (Author 2017)



In the dimple areas, soilcrete will be used for pathways as seen in Figure 8.28. This is to maintain an informal nature to the site. The soilcrete is a reminder of the soil texture and colour of the original strata that is different to that of the tailings and also adds a texture to the park. As mentioned (in previous chapters) the main function of these dimple spaces is to act as bio-filter to the park and the use of the soilcrete will most effective. The clean up will be less after rain events than it would be for traditional paving as the.

A field drain in the centre will drain the stormwater to a channel running parallel to the ponds and to the retention and detention facilities on site.

Figure8. 30 Section DD 1:50 scale (Author 2017)

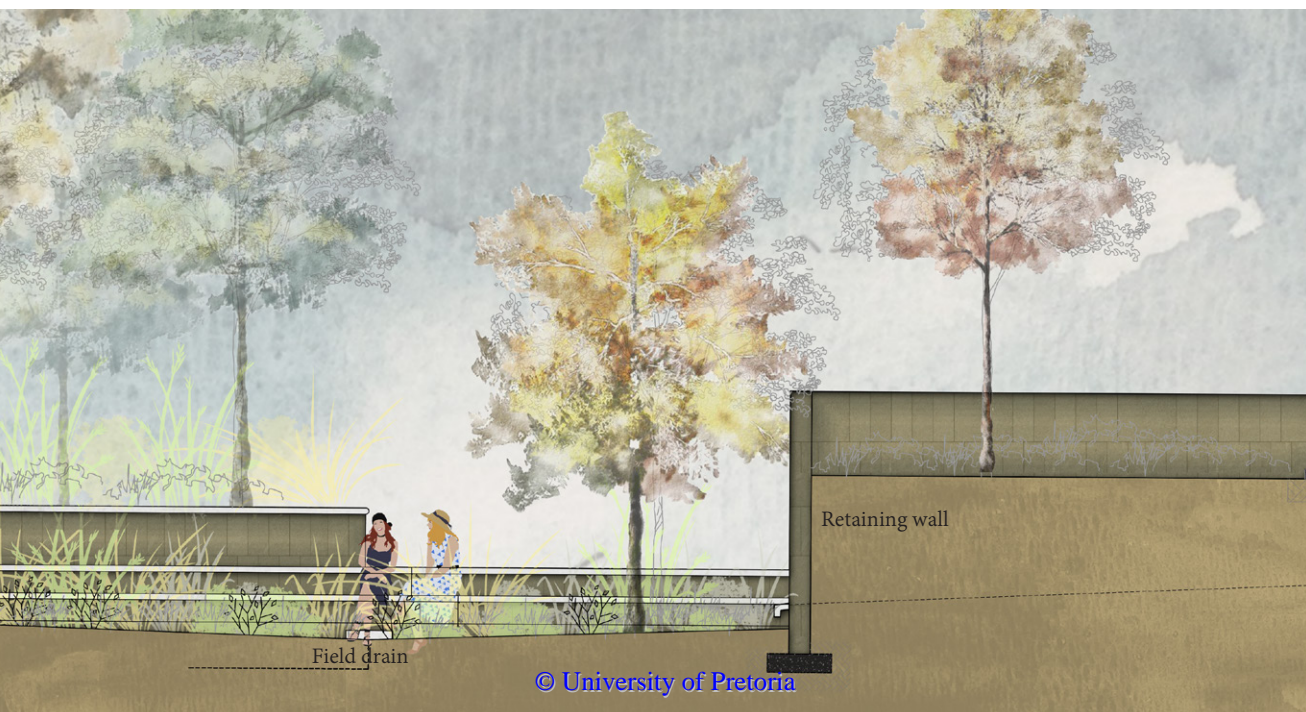

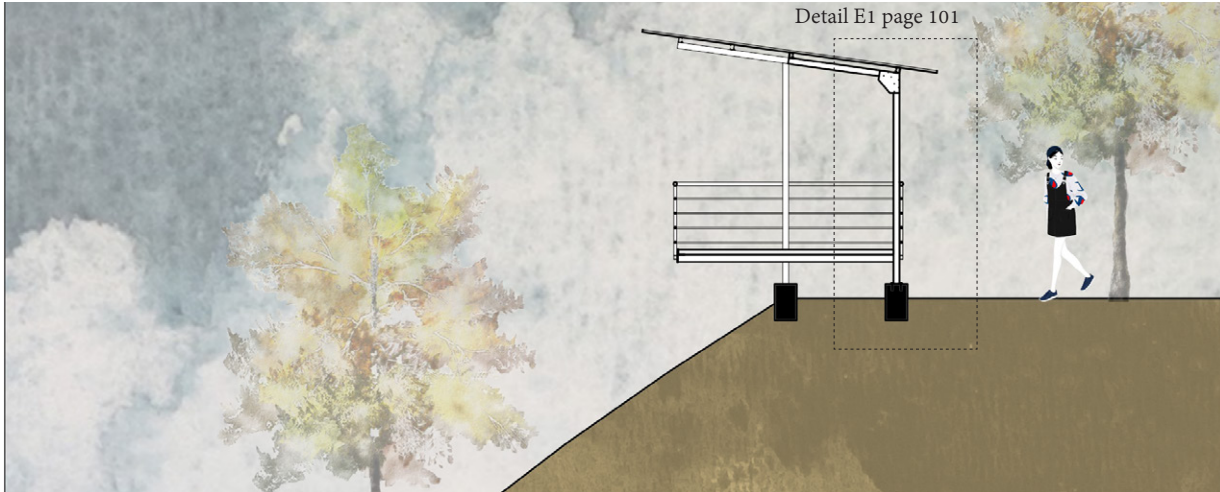

Figure8. 31 Section EE scale 1:100 (Author 2017)

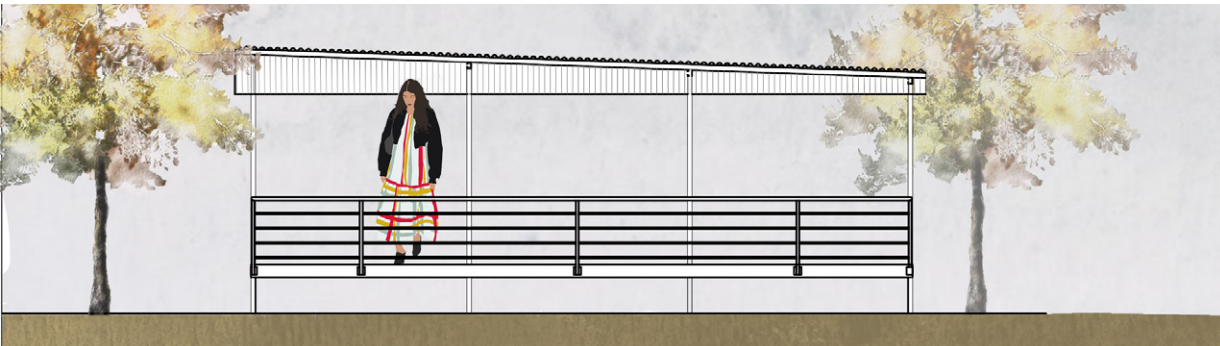

Figure8. 32 Elevation of viewing deck scale 1:100 (Author 2017)

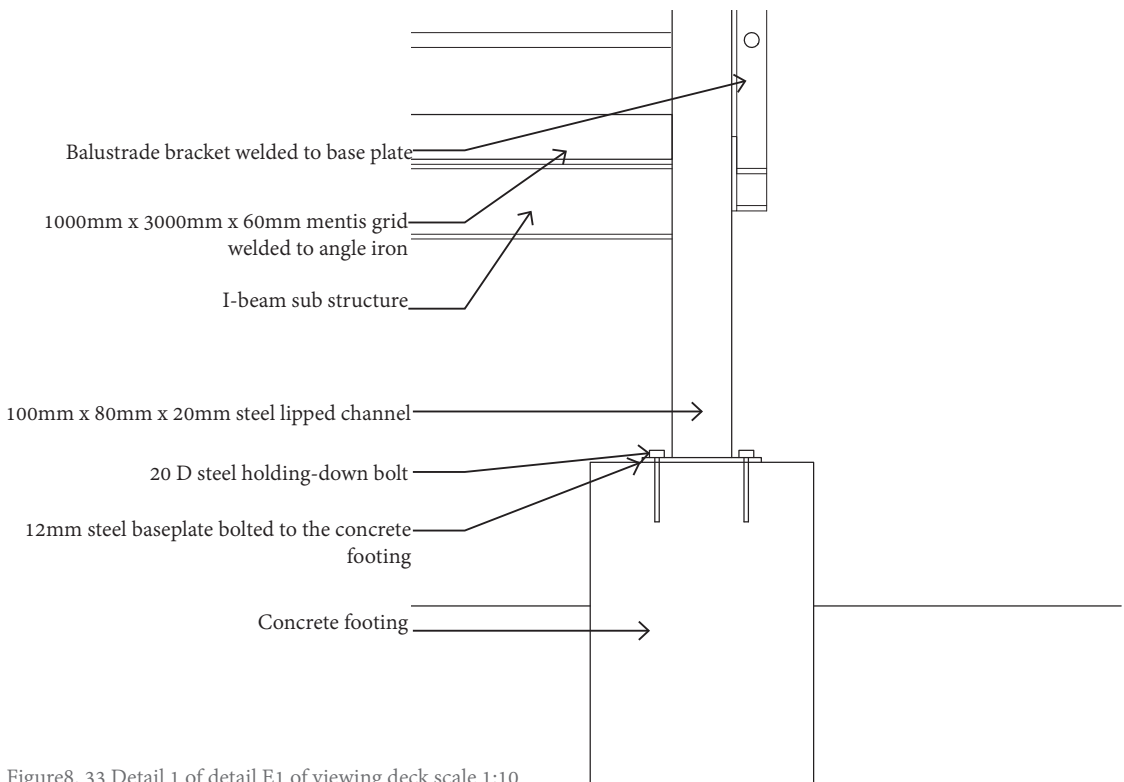

Figure8. 33 Detail 1 of detail E1 of viewing deck scale 1:10

The use of steel, namely mentis grid, for the ridge walk way is for a user experience. The ridge was also the site for the old silt pump station and will now be used for the new INCO system. The use of steel pipes that were in the vicinity motivates the the use of steel structures as a current materiality choice.

The steel construction of the viewing decks, Figure 8.34, will mainly be a sub-structure of I-beams that is connected by angle iron to the mentis grid with a light weight super structure

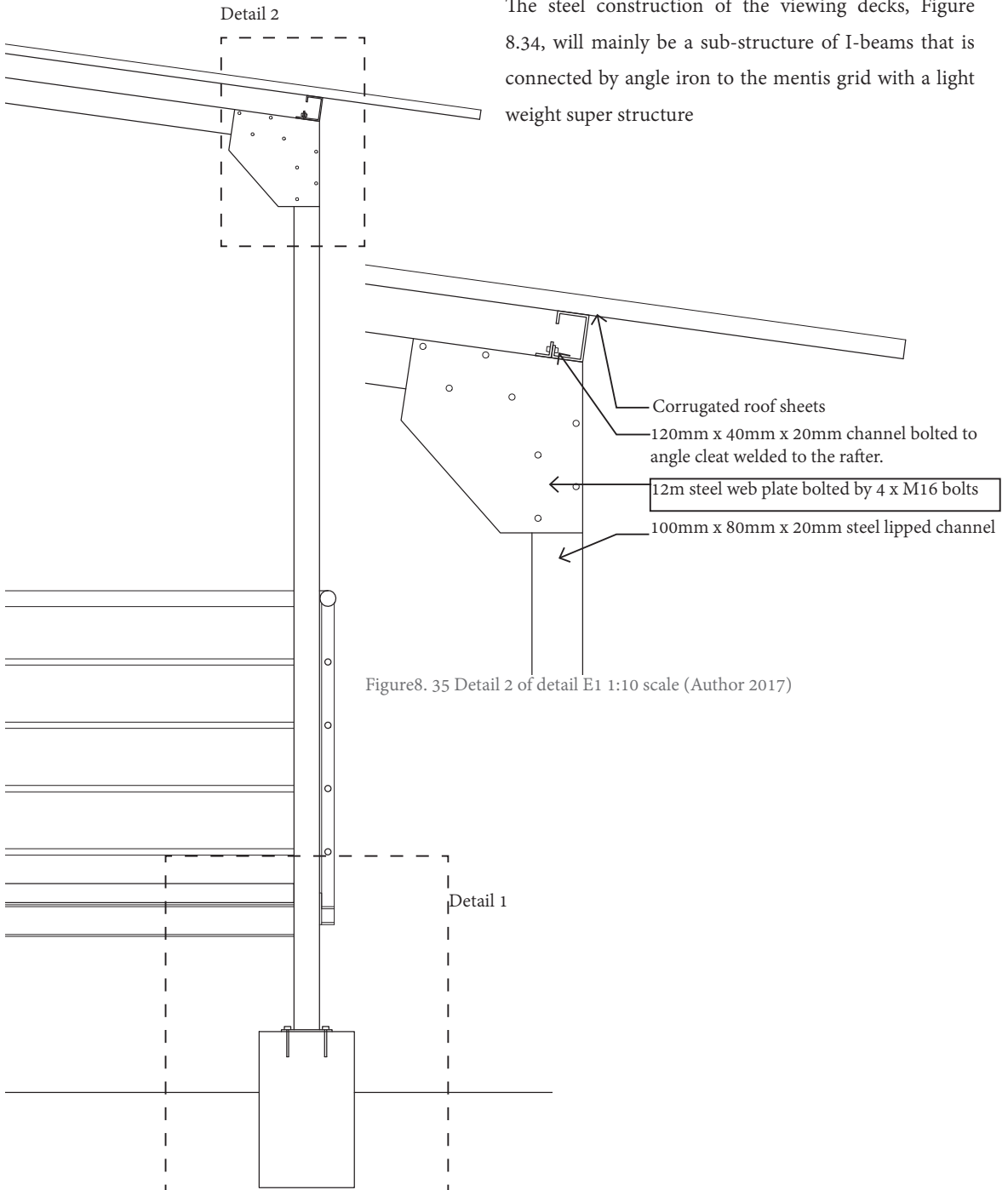
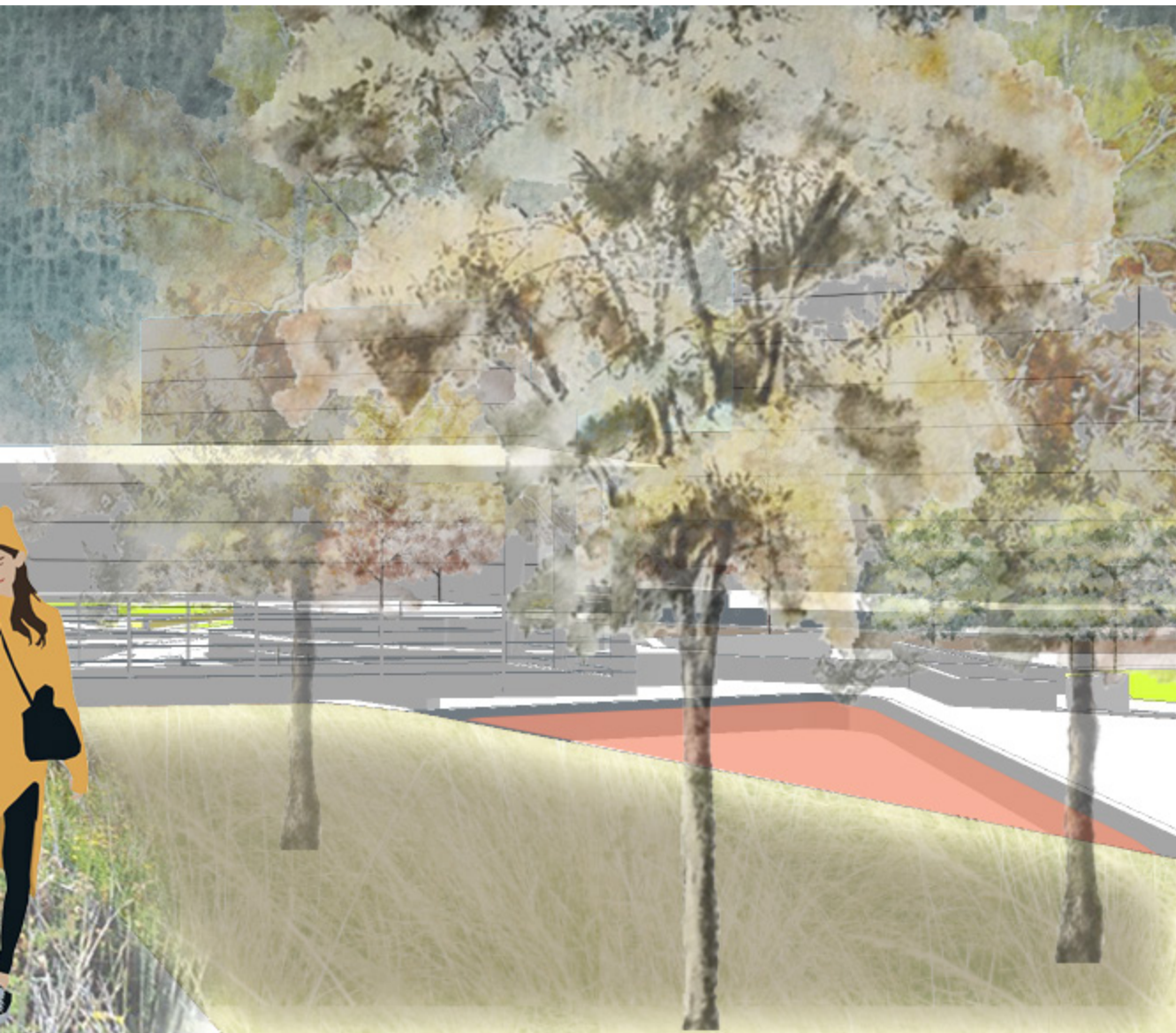

Figure8. 35 Detail 2 of detail E1 1:10 scale (Author 2017)

Figure8. 34 Detail E1 1:20 scale (Author 2017)



Figure8. 36 perspective view of ridge mentis grid walkways (Author 2017)



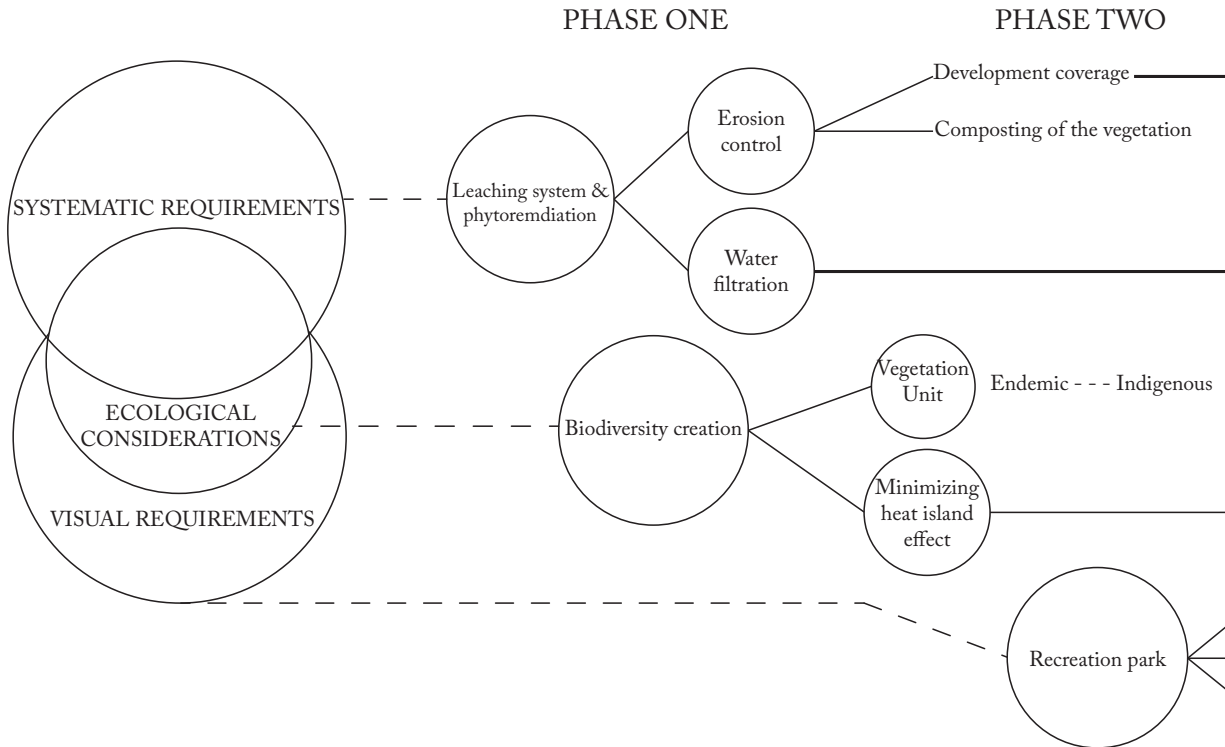

Figure8.37 Planting strategy (Author 2017)

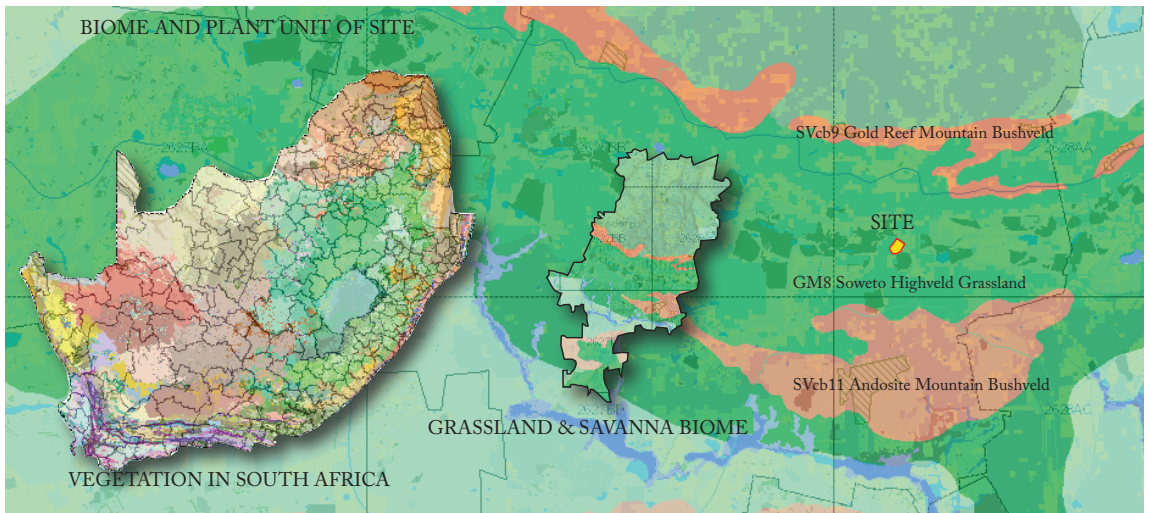
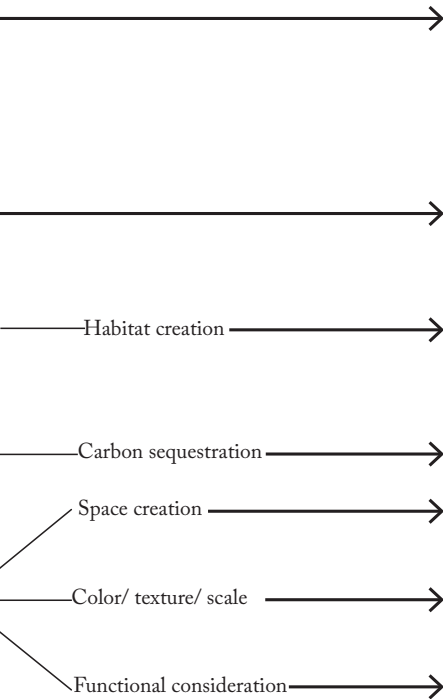

Figure8.38 Planting communities (Author 2017)

PHASE THREE



8.4 Planting plan

8.4.1 Planting strategy

The plant strategy for site has three main drivers that needed resolve as illustrated in Figure 8.27, namely:

1. the systematic requirement,
2. ecological considerations and
3. visual requirements.

The systematic requirements are the requirement for the water system to be effective in terms of ponds 2 to 4, which are the primary planted ponds to extract heavy metals from the water. This is especially important in the first and second phases of the project. The phytoremediation and erosion control on site also determine the criteria for selected species. These phytoremediation species are critical in the first phase.

Ecological consideration is a driver for species selection to ensure the success of species. The ecological criteria leads to the selection of species which are endemic to the area and thus recreate the ecologies to provide habitat for other species. Species like falcon, noticed on the initial site visit, is probable attracted by the rodents

present on the landfill and the nesting provided by the high Eucalyptus trees. The provision of habitat for these species will ensure for a balanced and self-sustaining project. The creation of feeding, breeding, nesting and resting for species is required in order to have a 'lively' park for user interaction and a more self sustaining park.

The biome region, illustrated in Figure 8.38, for which the vegetation units occur is unique for the site as it is with in the threshold area where the Grassland and Savanna biomes meet. Bioregions of the site include the mesic highveld and central bushveld bioregions. The vegetation units include the Soweto Highveld Grasslands, Gold reef Mountain Bushveld and Androsite Mountain Bushveld (Mucina & Ruterford 2010). As illustrated in Figure 8.40-42. The use of endemic species will be of such that illustrate the concept of pattern making using specie according to their colours, textures and seeding patterns. This brings the final requirement and that is of visual effects is species such as above mentioned.

The following mixes of plant species are compiled from the strategy. Areas were identified and zoned as the following:

Indigenous grass mix: Mix of grasses to be predominantly planted on southern slopes. Grasses that is to be spread by seed to aid in future pattern making.

Wetland mix 1-3: This mix is required to sequestrate heavy metals out of the water as part of the purify water process.

Bio-Filter: The bio-filter areas is sunken areas that will receive stormwater from the area to treat stormwater before entering the system.

Plaza and glade: The specie required here is to provide comfortable space for users to enjoy the areas. Mostly tree species will be planted in these areas.

SPECIE SELECTION CRITERIA

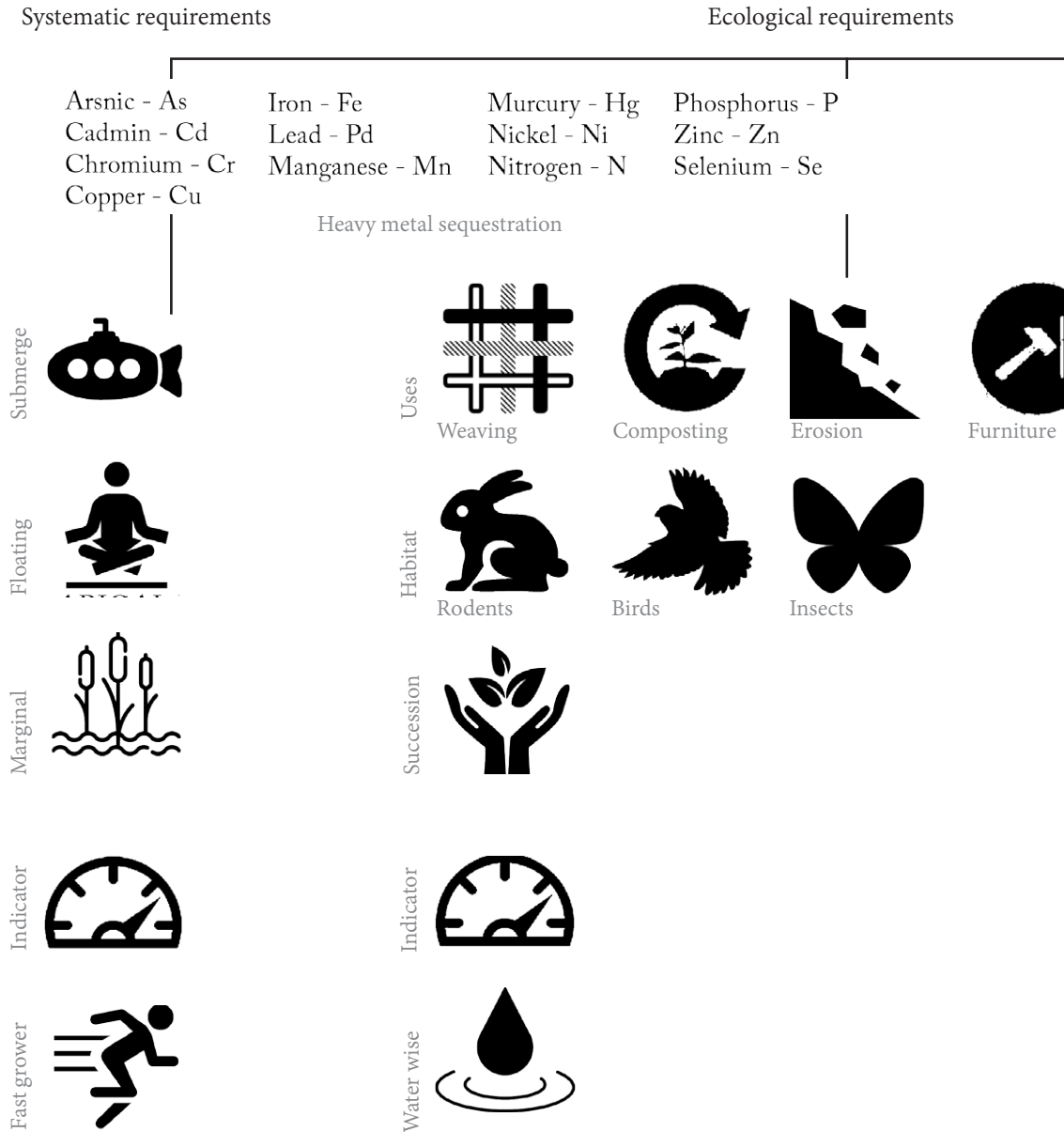

Figure8.39 Specie choice criteria as derived from strategy (Author 2017)

Visual requirements

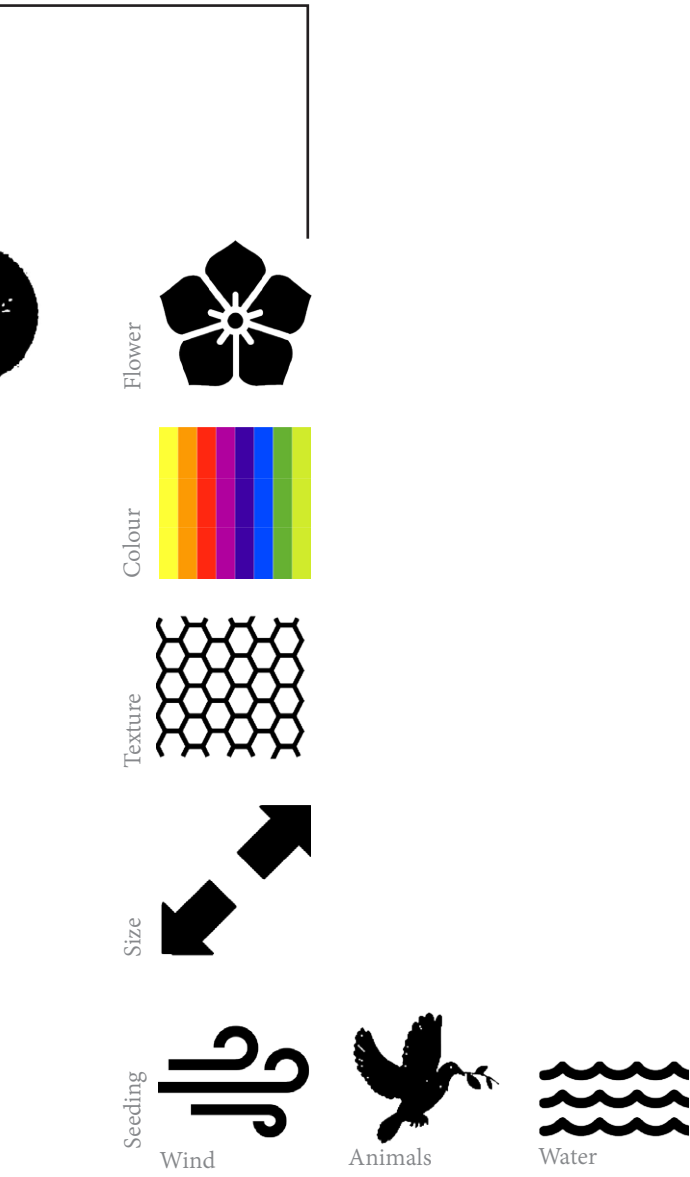

Figure8.40 SCxb9 Gold reef (Mucina & Rutherford, 2010)



Figure8.41 GM8 Soweto Highveld Grassland (Mucina & Rutherford, 2010)



Figure8.42 SVcb11 Andosite Mountain Buschveld (Mucina & Rutherford, 2010)



Figure8.43 Indigenous grass area planting plan scale 1:200



http://wildflownursery.co.za/wp-content/uploads/2015/07/Panicum_natalensis_500X500.jpg



http://www.mswn.com/media/fbver/info_sheets/eragrostis_curvula_1gal_ver_587.jpg



<http://www.mountmorelandconservancy.co.za/images/Hyparrhenia%20hirta.jpg>



https://upload.wikimedia.org/wikipedia/commons/5/53/Themeda_triandra_-_kangaroo_grass.jpg



http://wildflownursery.co.za/wp-content/uploads/2015/05/Digitaria_eriantha_Elandsdrift_7517.jpg



<http://www.up.ac.za/media/shared/Legacy/sitefiles/image/48/2056/20987/chlorisvirgata.jpg>



<http://luirig.altervista.org/cpm/albums/bot-037/heteropogon-contortus508.jpg>



http://snowbirdpix.com/images/sd/plants/jorgensen/aristida_adscensionis_plant.jpg

Indigenous grass mix:

Grass species are used in the rehabilitation of site and is reused within the last phase of the recreational area as seen in Figure 8.43. The use of the grasses chosen is as follows: pioneer species to ensure quick establishment and indicator species like *Themeda triandra* and *Chloros virgata*. See Figure 8.41. The Chloris is an indicator that the veld is recovering from damage and the themeda is an indicator of a healthy, well established veldt. Thus, the movement of people around the mound and plain will see more Chloris species and the centre of the indigenous grass area will have the taller Themeda grasses over time.



http://www.finegardening.com/sites/finegardening.com/files/images/image-collection/eragrostis_chloromelas_lg_0.jpg



http://snowbirdpix.com/images/sd/plants/jorgensen/aristida_ascensionis_plant.jpg



http://wildflowernursery.co.za/wp-content/uploads/2015/05/Digitaria_eriantha_Elandsdrift_7517.jpg



<http://www.greenplanet.co.za/plant/Acacia-caffra>

Figure 8.44 Species for indigenous grass mix and respective criteria that they adhere to



Figure8. 45 Wetland mix application

Wetland mix:

The use of wetland species were chosen from the systematic category. The use of indigenous species is not enforced as the systematic requirements is the main goal.

The use of species that sequester certain heavy metals is important and adhere thus to the ecological category. The different species will be used at different water levels. For example the eel grass is used as a submerged species that is essential for the purification of the water. The Typha grass is an essential for every wetland as its absorption rate of heavy metals is significant. The rhizome nature of the Typha does require the species to be planted in a container as it can spread quickly. See Figure 8.46





<http://pza.sanbi.org/elegia-cuspidata>



<http://pza.sanbi.org/nymphaea-nouchali-var-caerulea>



<http://pza.sanbi.org/gunnera-perpensa>



[http://copperflora.org/eflora/photos/HQ/Trachypogon%20spicatus%20\(L.f.\)%20Kuntze%20-1371116474.jpg](http://copperflora.org/eflora/photos/HQ/Trachypogon%20spicatus%20(L.f.)%20Kuntze%20-1371116474.jpg)



<http://pza.sanbi.org/crinum-campanulatum>



<https://aquaticmag.com/wp-content/uploads/2016/02/Vallisneria-Caresheet-information-aquarium-plants-Vallisneria-for-sale-and-where-to-buy-AquaticMag-6.jpg>



<http://pza.sanbi.org/crinum-campanulatum>



http://herbgarden.co.za/mountainherb/webherbphotos/big_Bulrush.JPG

Figure8. 46 Species considered for water mix (Planzafrica 2017)

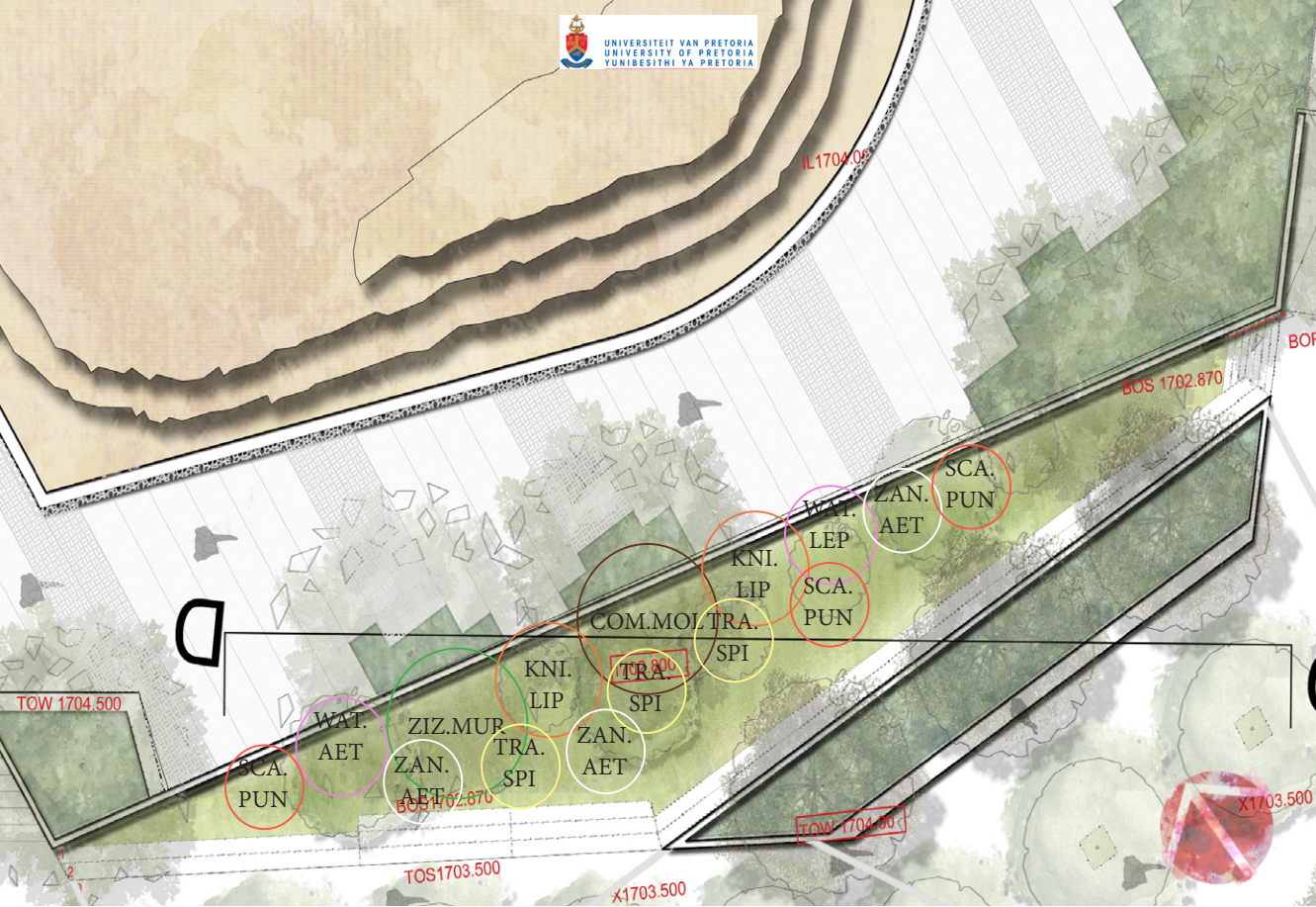

Figure8. 47 Bio-filter application (Author 2017)

The bio-filter area require species that can withstand wet conditions as these areas will flood in rain events. The use of colorful species that attracts other species was also inconsideration as the area will be a quite space away form the urban area but still with in close proximity to be able to walk to the area in a lunch break. Specie like the *Scadoxus* make for a great specie as it flowers at the start of the rain season and ensures a different 'look' and point of interest for the area.



<http://pza.sanbi.org/kniphofia-linearifolia>



<http://wildflowernursery.co.za/indigenous-plant-database/watsonia-lepida/>



<http://pza.sanbi.org/zantedeschia-aethiopica>



http://wildflowernursery.co.za/wpbdp_listing/watsonia-pulchra-2/



<http://pza.sanbi.org/scadoxus-puniceus>



[http://copperflora.org/eflora/photos/HQ/Trachypogon%20spicatus%20\(L.f.\)%20Kuntze%20-1371116474.jpg](http://copperflora.org/eflora/photos/HQ/Trachypogon%20spicatus%20(L.f.)%20Kuntze%20-1371116474.jpg)



<http://pza.sanbi.org/scadoxus-puniceus>



<http://pza.sanbi.org/ziziphus-mucronata>

Figure8. 48 Specie for the bio-filter area (Author 2017)

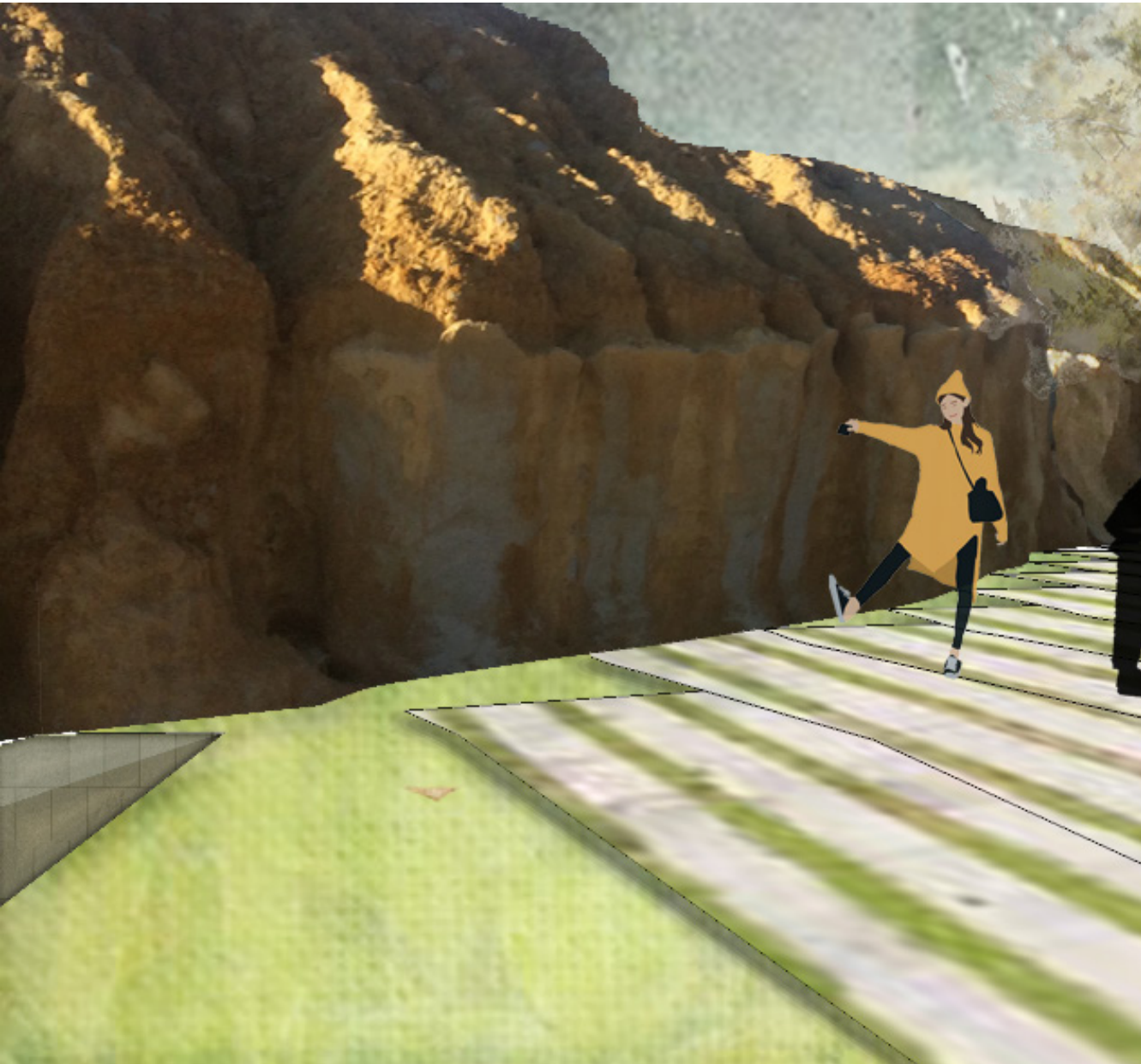

Figure8. 49 Glade area with artwork (Author 2017)



Conclusion

The use of pattern in technification of the project has a multitude of effects. The more intimate, undetermined pattern of grass succession around the mound and plain to the water system where the colour of the water and its processes varies the seemingly identical ponds. The repetition with variation on site is attempted to include the user in the pattern making on site. As the succession of grass species will naturally occur the movement of users will create pathways as they trample pathways over the species.

The proposed water system at the Robinson Deep site, in contrast with the water systems shown in Figure 8.50, does not need fencing, daily working activities are less and less maintenance is required in terms of cleaning of the ponds. The utilizing of nature to heal itself will

create a more accessible site than the current engineered systems, that is removed from the urban fabric to solve a problem that originates in the urban areas.



Figure 8.50 AMD treatment facility in West Rand (Author 2017)

CHAPTER NINE

9.1 Conclusion

Pattern making in landscape architecture has evoked some negative responses from the landscape architecture profession, as is stated by M'Closkey. The critique focuses on the lack of space making within these patterned landscapes; as spacial qualities are lacking since it is designed on a single dimension. This can however be curbed by having process informing patterns as proposed on the Robinson Deep site; the critical processes for the working of the site, informed the pattern of movement, water purification and stormwater management.

Can landscape systems be expressed through pattern making?

The expression of landscape systems through pattern is not only possible but is a natural consequence to the forming of a system. The effect of dealing with water serves as the driving factor for the system and the variation is then translated in the detailing of different functions within the various water bodies. In other words, water systems will need a containing element like a pond structure but the pattern is derived by the functioning of these structures.

The project outcome is an expression of pattern generated from a combination of patterns influenced by existing and proposed processes for the site. The existing process is intended to form pattern over time. In a similar way the current state of the site was generated by processes over time. The species growing on the plain area and the spaces between the concrete blocks are interrupted by the movement on site

to form patterns.

How can picturesque ideals cater for a mining identity?

The principles of picturesque landscapes on site are based on the existing industrial nature of the site. Herrington identified the inherent quality industrial sites have and the similarity of these to the picturesque ideals, especially the ideal of emotive landscape. The remnant areas have qualities of vastness, mystery, multiple scale and the fact that the site is by nature a manufactured site: all of this contribute to these ideals of the picturesque.

Landscapes like the Louvre Lens that strive to merge the identity of mining with that of a museum with the use of pattern are exemplar in generating patterns on site but also having the existing processes form other patterns over time. The liquid form of wet concrete was extruded to form the 'liquid' nature of the walkways in the Louvre Lens project. On the Robinson site the robust nature of the existing mound was supported by the use of robust concrete to ground the user next to the mound.

The totality of the effect of the patterns on the site will only become clear with time as it is ever changing with seasons, users and climate.



EXAM PRESENTATION

Pin up



Master plan model



Sketch plan model

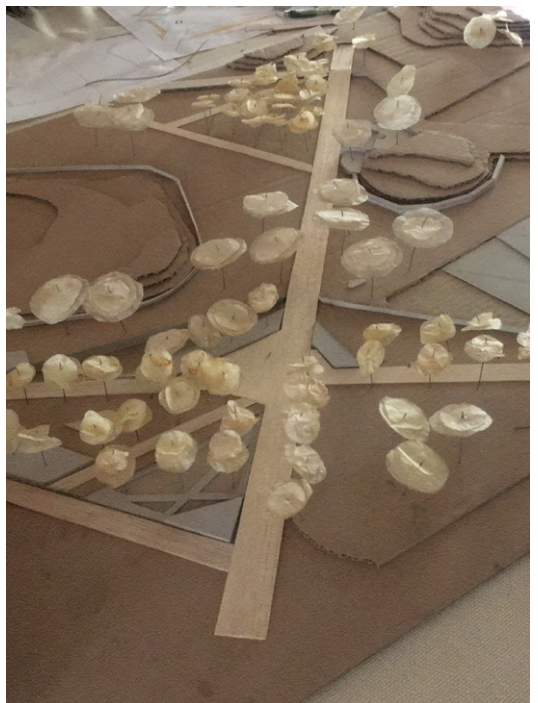
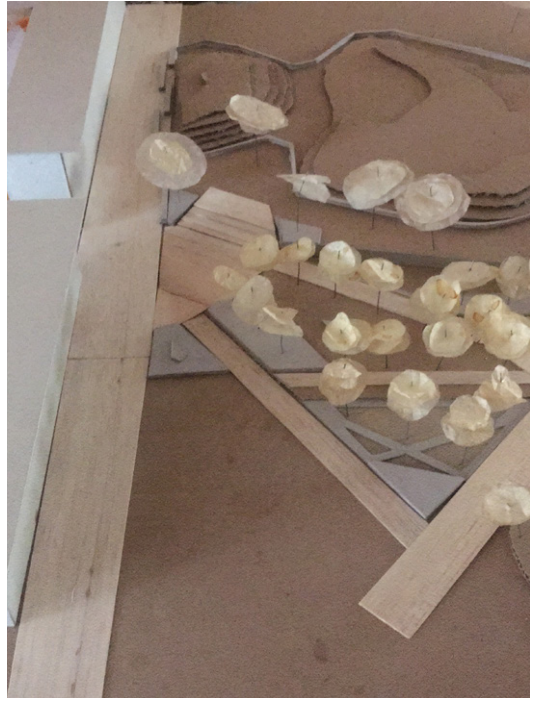

LIST OF REFERENCES

- AggreBind, 2017. How to Stabilize Soil Roads. [Online]
Available at: <https://aggrebind.com/roads/how-to-stabilize-soil-roads/>
[Accessed 10 October 2017].
- AMD&ART, 2016. AMD&ART Project in Vintondale, Pennsylvania, Dr. T Allan Comp, acid mine drainage, AMD&ART reclamation site and treatment process. [Online]
Available at: <http://www.amdandart.info/>
[Accessed 15 August 2017].
- Andrew Mentis, 2017. Andrew Mentis. [Online]
Available at: <http://www.mentis.co.za/>
[Accessed 20 September 2017].
- Bell, S., 1999. Landscape Pattern, Perception and Process. New York: Routledge.
- Bowring, J., 2017. Melancholy and the Landscape: Locating Sadness, Memory and Reflection in the Landscape. London: Routledge.
- Calthorpe Associates, 1992. Transit-Oriented Development Design, California: Prepared for City San Diego.
- Catherine Chang, 2017. Catherine Chang Design Studio. [Online]
Available at: <http://www.catchangdesignstudio.com/>
[Accessed 20 July 2017].
- City of Johannesburg Metropolitan Municipality, 2016. Spatial Development Framework 2040, Johannesburg: s.n.
- City of Johannesburg: Johannesburg Development Agency, 2014. Turffontein Development Corridor Strategic Area Framework, Johannesburg: s.n.
- Deming, M. E., 2011. Landscape architecture research. Hoboken, NJ: Wiley.
- Francis, M., 2001. A Case Study Method For Landscape Architecture. Landscape Journal, 20(1), pp. 15-29.
- Google Earth, 2017. Google Earth. [Online]
Available at: <https://www.google.com/earth/>
[Accessed 20 June 2017].
- Herrington, S., 2006. The Picturesque Aesthetic of Contemporary Landscapes. Landscape Journal, 25(1), pp. 22-37.
- Invasive Species South Africa, 2017. Invasive Species South Africa. [Online]
Available at: <http://www.invasives.org.za/>
[Accessed 20 July 2017].
- Joffe, P., 2007. Skeppende Tuimaak met Inheemse Plante. 1st ed. Pretoria: Briza Publikasie.

Kaplan, A., 2009. Landscape architecture's commitment to landscape concept: a missing link?. *Journal of Landscape Architecture*, 6 February, 4(1), pp. 56-65.

Landezine, 2017. Museum Park Louvre Lens. [Online]
Available at: <http://www.landezine.com/index.php/2016/09/museum-park-louvre-lens-by-mosbach-paysagistes/>
[Accessed 5 September 2017].

Landezine, 2017. Trinity College Quadrangle by gh3 - Landscape Architecture Works. [Online]
Available at: <http://www.landezine.com/>

Larkin, J., 2017. Tales From The City Of Gold: Jason Larkin. [Online]
Available at: <http://jasonlarkin.co.uk/work/tales-from-the-city-of-gold-3/>
[Accessed 10 March 2017].

Liefferink, M., 2017. West Rand Mining sites [Interview] (30 June 2017).

Lynch K, H. G., 1984. *Site Planning*. 2 ed. Massachusetts: MIT Press.

McCarthy, T. S., Arnold, V., Venter, J. & Ellery, W. N., 2007. The collapse of the Johannesburg's Klip River wetland. *South African Journal of Science*, Sept/Oct, pp. 9-10.

McHarg, I. L., 1992. *Design with nature*. New York: J.Wiley.

M'Closkey, K., 2013. Synthetic patterns: Fabricating landscapes in the age of 'green'. *Journal of Landscape Architecture*, pp. 16-27.

Menarek Stamped Concrete, 2017. Menarek Stamped Concrete. [Online]
Available at: <http://www.menarekstampedconcrete.com/patterns.html>
[Accessed 25 September 2017].

Mucina, L. & Rutherford, M. C., 2010. *The Vegetation of South Africa, Lesotho and Swaziland*. 19 ed. Pretoria: South African National Biodiversity Institute.

Pataki, D. E. et al., 2011. Coupling biochemical cycles in urban environments: ecosystems services, green solutions and misconceptions. *Frontiers in Ecology and the Environment*, 1 February, pp. 27-36.

Pinterest, 2017. Patio. [Online]
Available at: <https://za.pinterest.com/pin/416583034272961539/>
[Accessed 20 10 2017].

Pinterest, 2017. Wetland. [Online]
Available at: <https://za.pinterest.com/pin/778559854302318060/>
[Accessed 31 10 2017].

Ryerson Department of Architectural Sciences, 2014. *Designed Ecologies* by Dr. Kongjian Yu. [Online]
Available at: https://www.youtube.com/watch?v=8jXJiqms_D4&t=2s
[Accessed 20 April 2017].

Salingaros, N. A., 2003. Connecting the Fractal City, San Antonio: Department of Mathematics, University of Texas.

Santiago, Z. V., 2015. A collection of stories: Euralens Centralite and the Louvre-Lens Museum Park. *Journal of Landscape Architecture*, 10(2), pp. 44-57.

South African Bureau of Standards, 2011. South African National Standard 10400, Pretoria: South African Bureau of Standards.

South African Council for Landscape Architects, 2011. Identification of work, Johannesburg: South African Council for the Landscape Architectural Profession.

Square One, 2015. Square One Landscape Architects. [Online]
Available at: <http://sq1.co.za/portfolio/the-towers-merriman-square/>
[Accessed 22 September 2017].

Swart, E., 2003. The South African legislative framework for mine closure. *The South African institute of mining and metallurgy*, 103(8), pp. 489-492.

Thurman, C., 2010. Brand South Africa. [Online]
Available at: <https://www.brandsouthafrica.com/tourism-south-africa/melrose-211210>
[Accessed 5 March 2017].

Turescape, 2017. Turescape Landscape Architects. [Online]
Available at: <https://www.turescape.com/en/project/detail/435.html>

U.S Environmental Protection Agency, 1994. Technical Report: Treatment of Cyanide Heap Leaches and Tailings, Washington: U.S Environmental Protection Agency.

VdW & Co, 2017. Institute for Landscape Architecture in South Africa. [Online]
Available at: <http://www.ilasa.co.za/>
[Accessed 25 March 2017].

Vermeulen, N. J., 2001. The Composition and State of Gold Tailings, Pretoria: University of Pretoria.

Walker, S., 2015. Tailings management strategies to meet today's demands. *E & MJ engineering and Mining Journal*, 05 November, pp. 1-10.

Wegelin, H., 2009. Construction Primer for South Africa. 1st ed. Pretoria: Visual books.

Woolshed Thugoon, 2017. Woolshed Thugoon Landscape Group. [Online]
Available at: <http://wtlandcare.org/wp-content/uploads/2016/01/eucalyptus-blakelyi-flora-ala-source.jpg>
[Accessed 15 November 2017].

