

4

CHAPTER

spatial design development



This chapter will initiate the conceptual development of the spatial intervention proposed for both the host and the habitant. In order to evidently differentiate between the various proposed mechanisms of design, all mediations are classified as either contributing towards the inner or outer interior of the proposed intervention.



Figure 4.1. Below the Cutty Sark (Unknown, 2013)

THE INNER AND OUTER INTERIOR DESIGN DEVELOPMENT

*"If the highest aim of a captain was to preserve his ship,
he would keep it in port forever"*

Thomas Aquinas, 1274

Founding portion of the requirements for the successful completion of a professional degree, the **tangible conveyance of the reconnoitered theories** and concepts are to be **illustrated spatially**. Moreover, as outlined by these degree requirements, the envisioned design should be of an **interior nature**. Working within two distinct artifacts (dock as host and ship as habitant), this **novel intervention** will require design that is **not conventional to the field of interior architecture**.

As uttered by indomitable verdicts, it was essential that the design **refrain from a mere museum typology**. As conventional re-use of ships on land either **follow tradition** in terms of **adaptation into a mere landmark or once-visited museum**, the assurance of **continuous call on to site governs an innovative intervention**. Henceforth, the proposal of a **brewery and craft establishment** that will attract tourism and entice locals is envisioned. Positioning the brewery inside the SS Nomadic, and the craft market amid the existing dock, the creation of **two dissimilar interior areas is proposed**. Given that the **brewery** will be framed within the existing structure of the ship, it will be referred to as the **inner interior**. As it will be an enclosed area, its relevance as a traditional interior is quite evident. The latter mentioned interior, referred to

as the **outer interior**, is reserved for the **craft market** and will be incased between the dock and ship. The **partial enclosure and nested position** thereof renders it an **exposed, outer interior**.

As a point of departure, the **current infrastructure** on site was inspected in order to **assure structural viability**. Once approved, the **construction of a steel armature** was designed which allowed **elevation, panoramic accessibility and structural support**. Upon elevation, the creation of an inner and outer interior could commence. In this chapter, attention is directed towards the **design development of the spatial intercession**, from intention to conclusion as an **iterative process**. In assurance of ample visibility, the **insertion of a platform** allows raised approachability and **esteems existing heritage apparatuses embedded atop the docks floor**. The newly instituted podium platform permits the recreation of **craft and exhibition**, whilst still directing prominence towards the surviving fabric. Given the scale of this endeavor, the establishment of ample spatial features will be designed, taking the **holistic nature of the entire host and habitant into continuous consideration**. Upon conclusion, all individual constituents will **piece together as layers that total into an absolute and viable potential destination**.

4.1 DESIGN CONSIDERATIONS

Afore any conceptions can be translated into a **tangible resolution**, certain considerations are to be conscripted which will form part of a **universal design manifesto**. These reflections are not only derived from the **actual structure in terms of scale and inheritance**, but likewise from the **theoretical discourse of materiality**.



MATERIALITY

Existing fabric of the weathered host and renovated habitant must be **celebrated**. Following the principles of **protection, preservation and premeditation**, all **current and newly introduced materiality** must showcase the potential of **corrosion as a tool of beautification**.



OLD VS. NEW

Given the fact that the intervention will **transpire within a location rich in prior occurrences**, **sensitive addition** must be comprehended. These additions will act as **additional layers that highlight the existing from the proposed**, permitting **symbiotic convergence with time**.



SCALE

In view of the identified host and habitant, the principle of **proportion** is quite evident. Using selective strategies, several areas will require the emphasis thereof, whereas other **seamless annexation**. Sheer size governs **distinctiveness and abundant design probabilities**.



RELATIVITY

Linking with scale, the notion of **relativity** is of great importance considering the **association between host and habitant**. When designing **holistically**, yet individually, allowance for **relational placement, constant visualisation and actual accessibility** is governed.



LOCATION

Locality will influence design decisions associated with programme and **material selection**. A dense selection of recreation permits innovative solutions in activity, whilst a **coastal setting** requires **adequate material protection against saline corrosion**.



HERITAGE

Working within a culturally significant environment, the presence of **sacred artifacts** becomes evident. **Sensitivity governs alteration and possible design restrictions**. Presently on site, the **existing structure and berthing blocks** are of prominent historical concern.



REGULATIONS

As with any design initiate, adherence to **strict regulatory standards** must be employed in order to assure **viable, universal and structural design**. In addition to typical **building regulations and ergonomics**, obedience to **brewing and naval standards** is to be charted.



QUALITY

Above all, **quality in terms of experience** must be encouraged through design. Attention will be directed towards the eminence of the created spatial intervention through **comfort and inclusivity - an interiority that evokes a habitual, and human-centered occurrence**.

4.2 BERTHING CONSIDERATIONS

Before any concrete design can occur, the **positioning of the ship in relation to the dock** must be comprehended. Based on the current condition of the SS Nomadic, **structural integrity limits continuous change in elevation and mobility**, thus proposing to uphold the ship **stationary**. Scrutinising various options for possible positioning, ultimate placement in terms of **accessibility, optimal use of space and aesthetics** was used as guidelines to assess these possibilities. Additional dynamics that subsidised placement was founded on **context and daylight**, which will be investigated as part of the technical resolution in the chapter to follow (page 194).

ORIENTATION

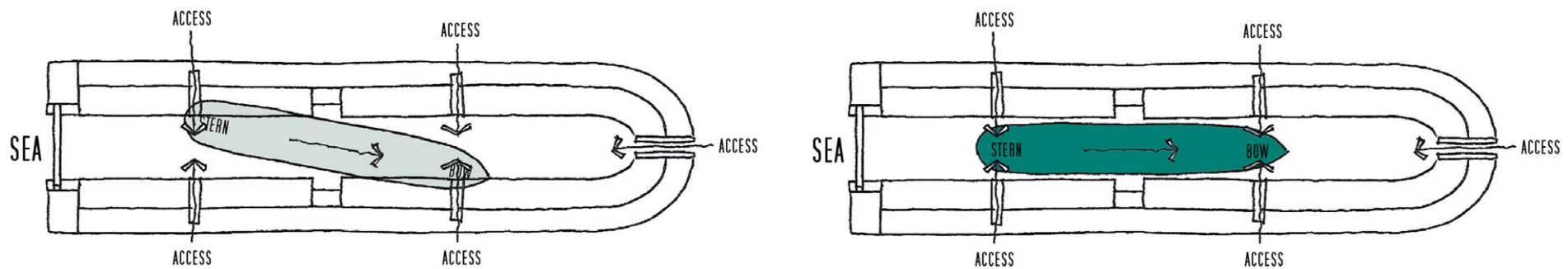

Figure 4.2. Diagonal or Parallel Orientation (Author, 2016)

- DIAGONAL vs PARALLEL -

Due to the **structural support required and precedents undertaken, the diagonal layout was not feasible**. The overall hull size would also have to be risen above water level in order to accommodate this angle of positioning, thus **decreasing visibility**. The parallel positioning of the vessel allows for **better utilisation of dock space, even distribution of weight and symmetrical outline of the keel as framed by the dock**.

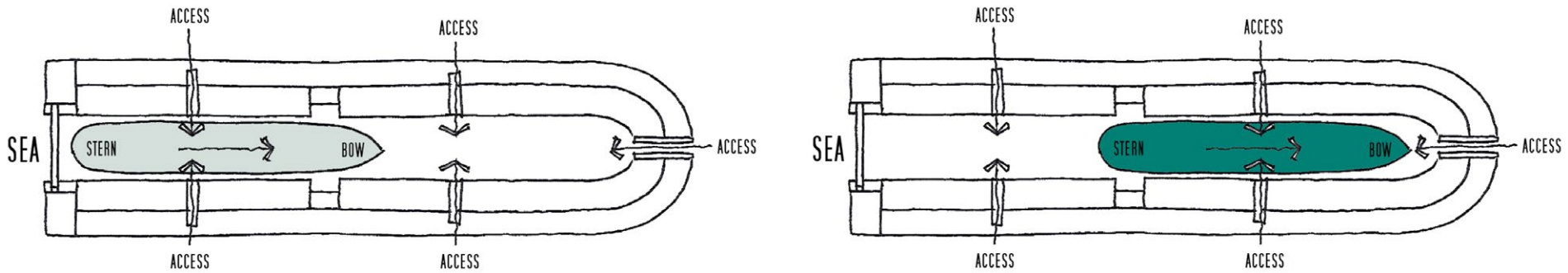

Figure 4.3. Left and Right Orientation (Author, 2016)

- LEFT vs CENTRAL vs RIGHT -

Due to the dock's **secondary sill**, central positioning would be challenging in terms of **structure and accessibility**. In addition to this, the adjacent space on either side will be **wasted**, as the ship merely **utilises half of the unfilled footprint**. As opposed to right positioning, **left is preferred** due to **aesthetics and dramatic effect** of downward decent through the main chute. The vacant space near the caisson will be used accordingly.

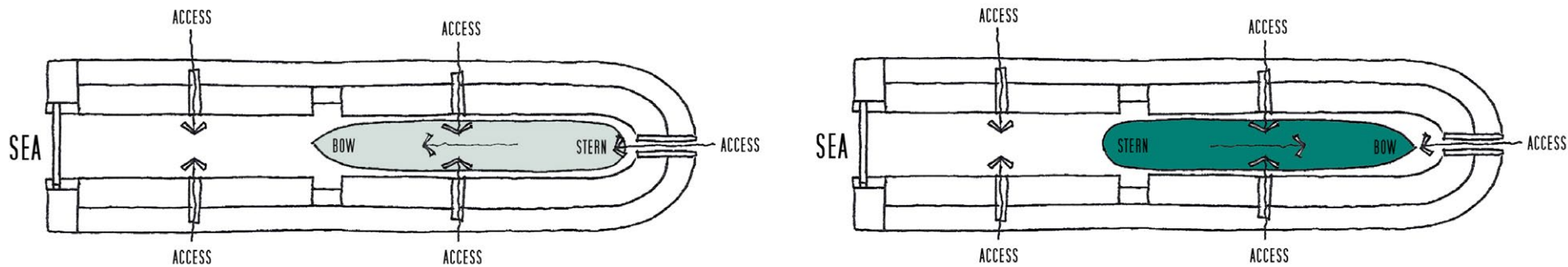

Figure 4.4. Bow and Stern Orientation (Author, 2016)

- BOW vs STERN -

In addition to the dramatic effect achieved upon visitors' downward decent from the main access chute, the positioning of the **bow facing inland** will provide **addition circulation and flow**. Furthermore, the positioning of a forward bow permits a **tailored install** of the hull as **per the outline of the dock**. The vessel will also appear to be **docked in place, sailing into its berthing position** after her final voyage at sea.

ELEVATION

- BERTHED -

When a ship is moored into a dock for repairs, it is centered and raised on berthing blocks. In order to **prevent structural damage to the hull**, this process **cannot be permanent** as the downward force can cause structural impurities to the keel plates. Moreover, this recessed position will **hide the ship and eliminate any possible opportunities for intervention below hull**.

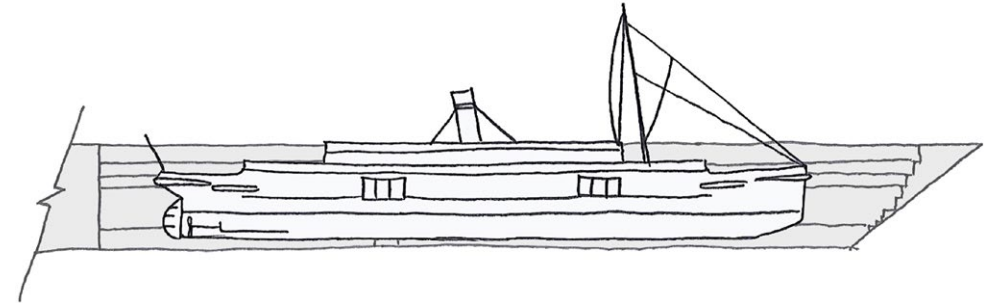

Figure 4.5. Berthed Elevation (Author, 2016)

- WATERLINE -

As opposed to berthing the ship, a raised option is presented. Raising the ship to its original waterline position will provide **aesthetic interest, structural feasibility, all-round visibility** and permit **additional activity below the ship's hull**. Moreover, this elevated preference ties in with the **definite orientation** that seeks to **romanticise the notion of the ship sailing into its final resting position**.

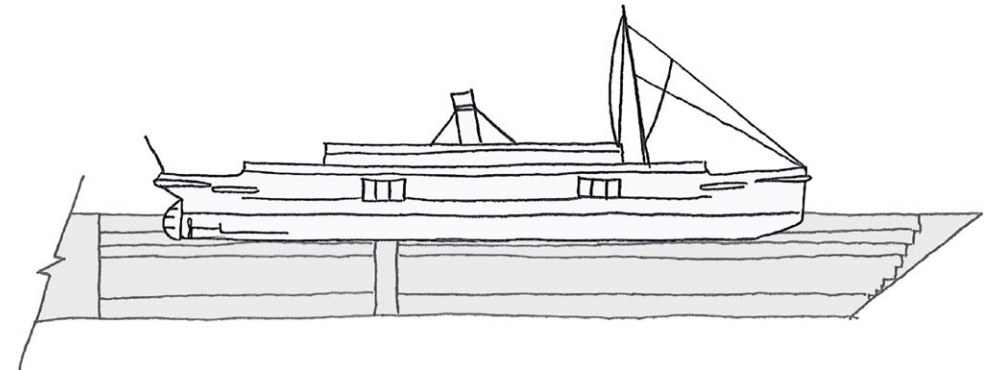

Figure 4.6. Waterline Elevation (Author, 2016)

- STRANDED -

Even though the third option provides full visibility, it allows for the **ship to seem disconnected from the dock**. The steel armature and connecting canopy structure will also prove problematic when connected to the ship's hull, as the point of connectivity will have to be elongated. Raising the hull so high will also **limit optical approachability**, as the introduction of a platform already aims to compensate for the **scale differentiation between dock and ship**.

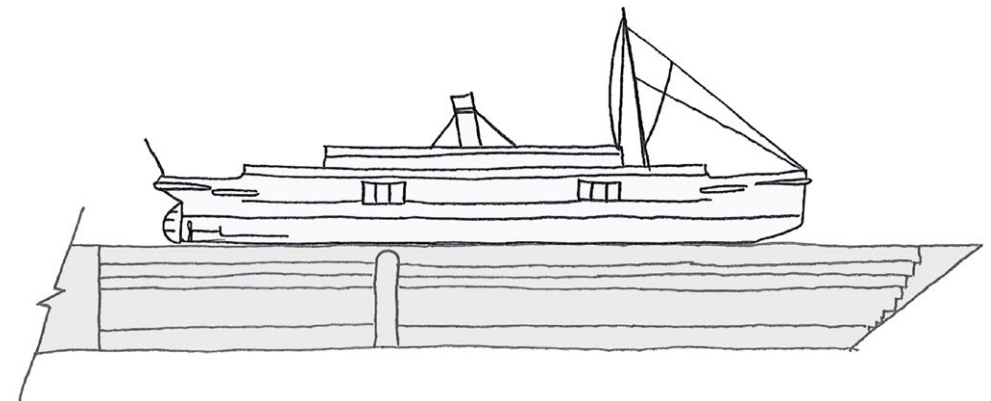

Figure 4.7. Stranded Elevation (Author, 2016)

4.3

ARMATURE DESIGN DEVELOPMENT

Secondary to the institution of orientation, the method in which permanent install between host and habitant will occur, was to be advocated. As mentioned previously, precedent consultation instructed the erection of a **frame-like ring structure that would elevate the vessel**. Founded upon the analysis of the specific construction of the SS Nomadic, **the attachment of the struts to the keel are to be positioned in alignment with the rib steel structure of the hull**. According to the classification of hull types (refer to figure 4.8), the SS Nomadic **hull's shape is bottom round**, thus requiring **multifaceted support** in order to **distribute force uniformly**. As per consultation with a structural engineer, the creation of several iterations were presented and assessed, based on **structural integrity, visual assimilation and intrusiveness**. This was the final structural formality to be addressed in terms of permanent positioning, before the actual design of the outer interior could commence.

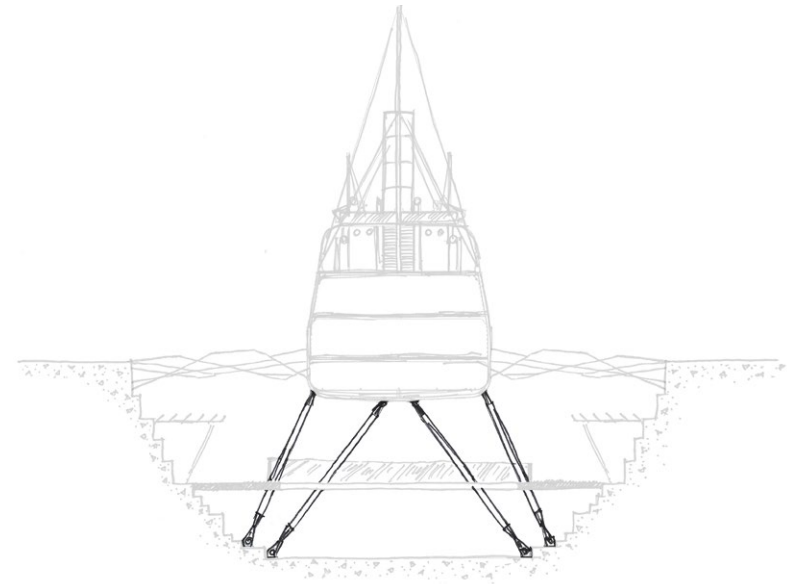

Figure 4.8. Armature Design (Author, 2016)



STRUCTURAL INTEGRITY

This primary assessment norm is based on **engineering principles** and was evaluated under strict observation. As suggested by name, **structural viability** is determined by this criterion.



NON INTRUSIVENESS

As a form of secondary evaluation, the **minimization or complete elimination** of actual **harm to heritage fabric** was to be ensured (safekeeping of **berthing blocks and dock alters**).



VISUAL ASSIMILATION

Visually monitors the **amount of newly introduced infrastructure** to site. The addition thereof **should not subtract from existing fabric, nor excessively cover up** any part of the dock.

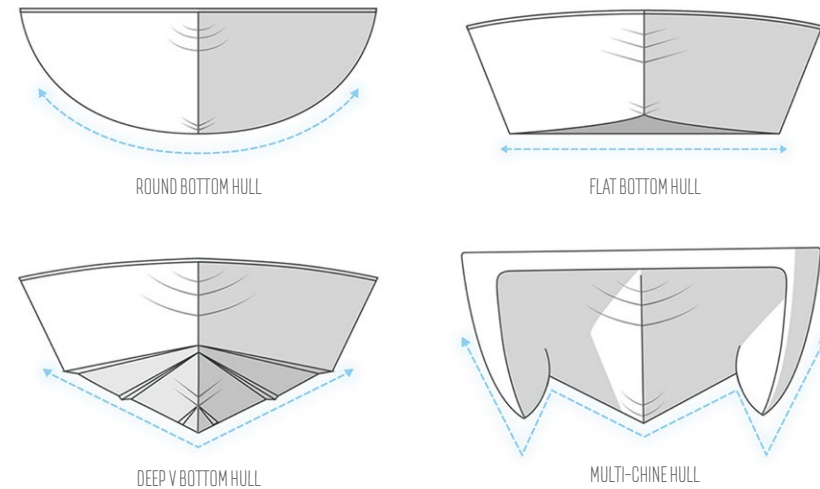

Figure 4.9. Hull Classification of Ships (Boat Smart, 2015)

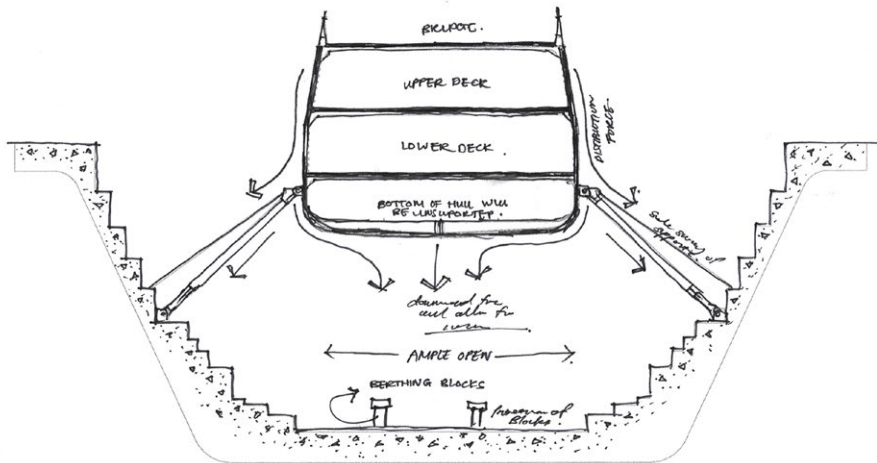
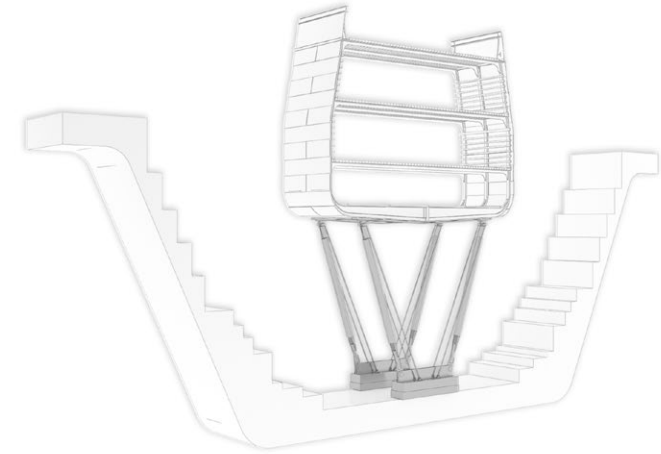
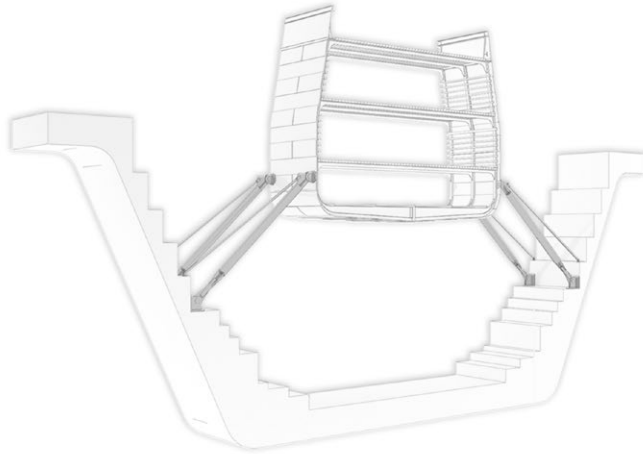

Figure 4.10. Steel Armature Configuration 1 (Author, 2016)

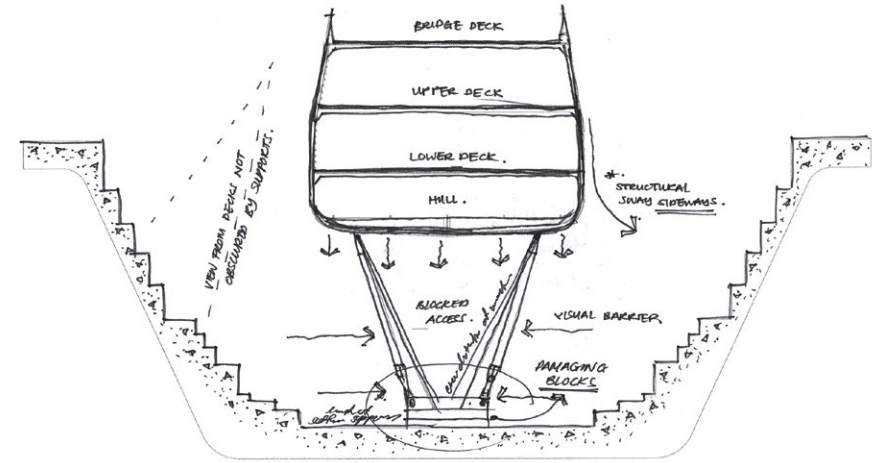

Figure 4.11. Steel Armature Configuration 2 (Author, 2016)

- CONFIGURATION 1 -

The first configuration employs the **frame constructed to elevate the Cutty Sark precedent**. As the hull of the Cutty Sark is classified as a v-shaped hull, a **one-brace support** was sufficient, as the load was distributed vertically downwards to the keel central plate. However, the **round hull construction of the Nomadic will require both a horizontal and vertical load distribution** structure brace.



- CONFIGURATION 2 -

Though not as visually invasive as the first configuration, the second iteration only made provision for **vertical distribution of weigh and disregarded the heritage fabric** situated on the bed of the dock (**berthing blocks would have to be removed or displaced**). Structural integrity is compromised by **possible capsizing** potential's should load be dispersed horizontally.



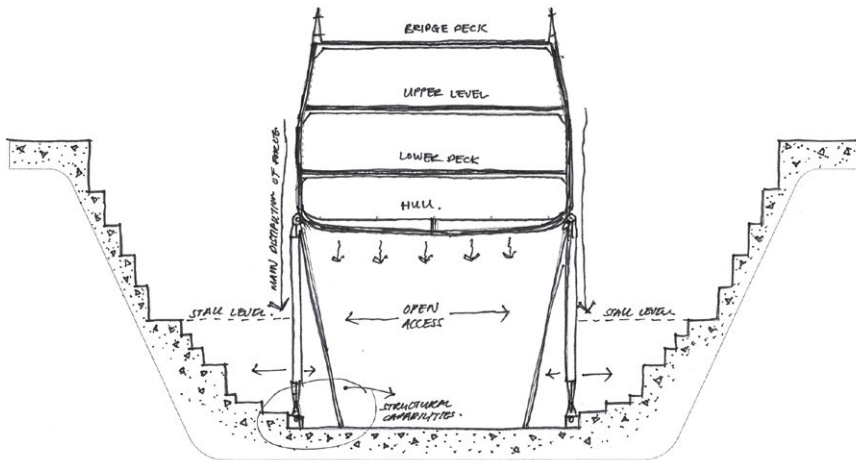
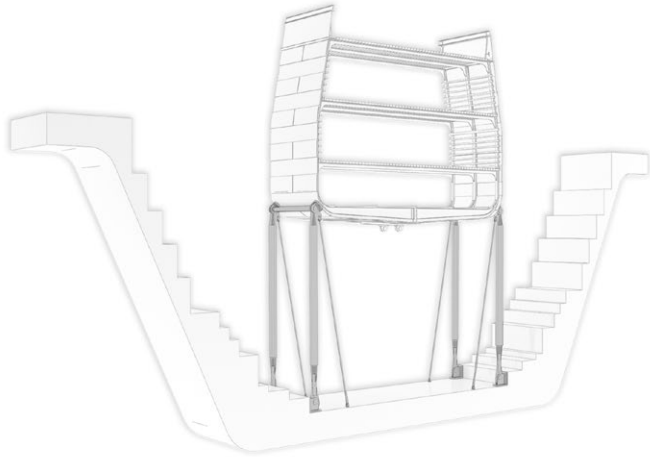

Figure 4.12. Steel Armature Configuration 3 (Author, 2016)

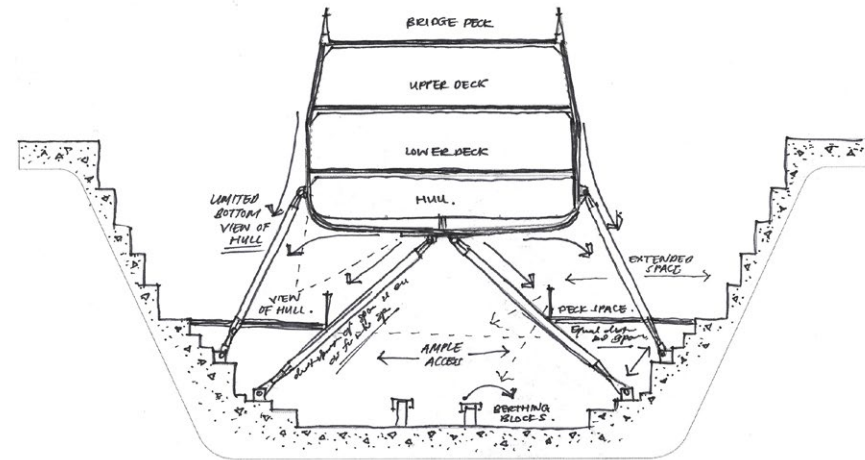

Figure 4.13. Steel Armature Configuration 4 (Author, 2016)

- CONFIGURATION 3 -

The third configuration responded to the intrusive nature of the second iteration, yet again **neglects to accommodate complete loadbearing requirements**. **Lateral positioning of the braces will only ensure crosswise support**. The **bottom of the hull will require supplementary support**, as brewing equipment and atrium induction will provide additional downward force.

- CONFIGURATION 4 -

Paying homage to the surviving berthing blocks, responsiveness was directed back towards the Cutty Sark precedent's lateral armature, which was **affixed to the docks alters** (side steps). The addition of a **subordinate strut allowed lateral and central attachment to the hull, ensuring sound construction**. Additionally, this configuration provides **bracing opportunity for the platform, bringing the hull closer to view**.



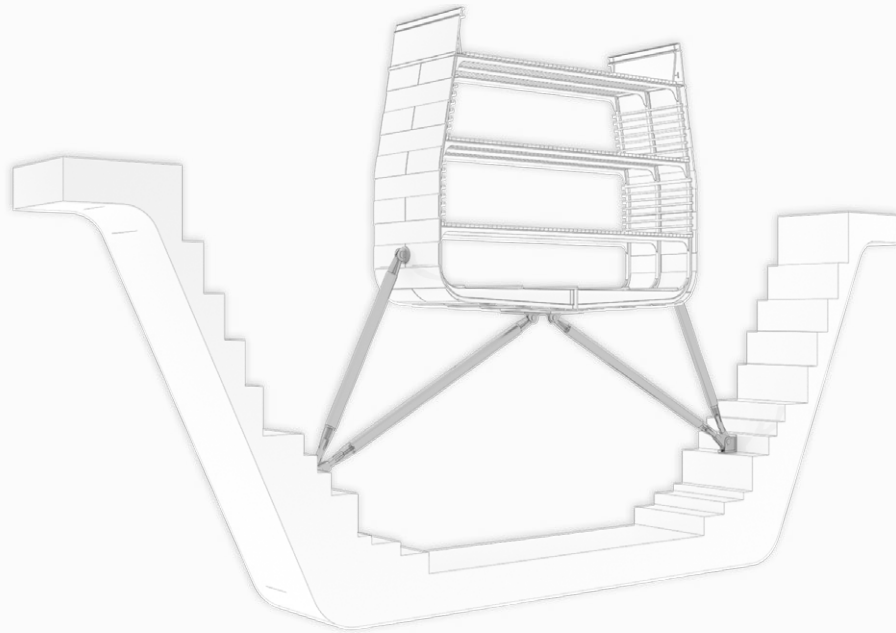

- FINAL CONFIGURATION -

The final armature arrangement stems from the fourth configuration, with the only exception being that the **support piers are joined**. Originally the piers were disconnected in order to **provide superfluous support**, should one support fail to function appropriately. However, upon consultation with a structural engineer, it was **deemed unnecessarily intrusive**. This singular connection to the dock permits **contemporary design and clean constructs which bounds visual abstraction**.



STRUCTURAL INTEGRITY

Structural integrity is maximised through the utilisation of a **two-braced armature structure** that compensates for **horizon and vertical load displacement**. Double support also permits greater distance between struts, which elongates possibilities of intervention on the market platform below.



NON INTRUSIVE

Given that the armature is fixed to the side alters of the dock, **abstraction on the lower levels and berthing blocks are completely eliminated** and remain thus entirely untouched. Moreover, the raised market platform **restricts actual approachability, whilst permitting residual accessibility** as a conspicuous feature.



VISUAL ASSIMILATION

In addition to restricted invasiveness, the combination of strut supports and the **longitudinal decrease thereof consents greater assimilation**. The addition of hosting sustenance to the market platform above **amplifies functionality and abolishes the need for additional support**.

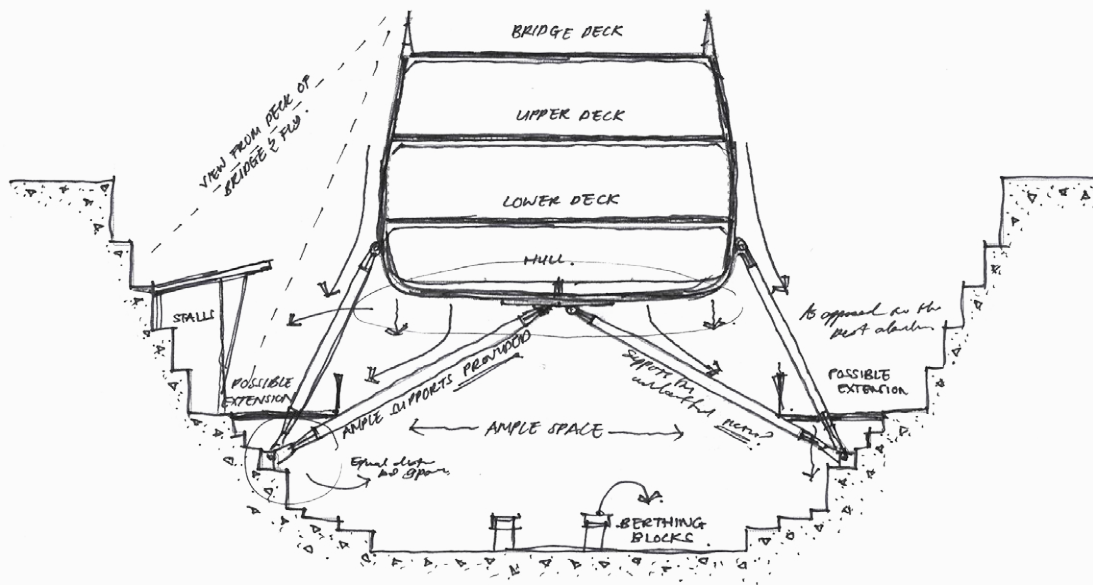
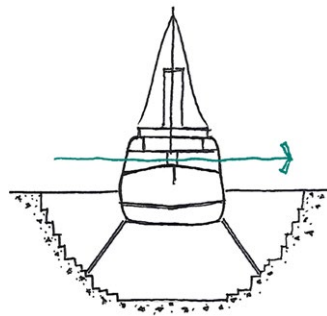

Figure 4.14. Final Steel Armature Configuration (Author, 2016)

4.4 ACCESSIBILITY

As a way to **administer undeviating accessibility** between the **host and the habitant**, four methods of admittance, refer to figure 4.15, are proposed that governs novel forms of **horizontal and vertical circulation**.



ACROSS

The first route of accessibility is the most conventional. Utilising the **existing gangway planks and enclosing them, access onboard the ship is granted**. Visitors will enter the ship through the four existing **entrance vestibules**, which are located on the **upper deck**.

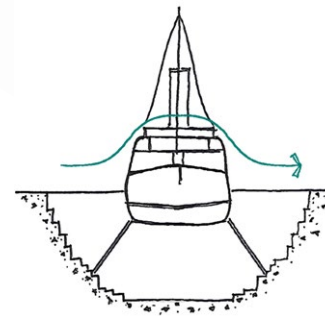

OVER

The second route of actual accessibility is governed by the **existing horizontal circulation** onboard the SS Nomadic. A variety of **staircases are present** that permit **perpendicular movement** to and from levels below the bridge and flying bridge deck.

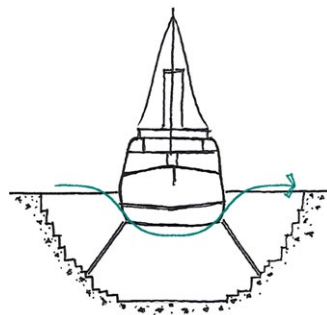

UNDER

The third form as accessibility is derived from the desired **connection wished to be substantiated between the host and habitant**. The introduction of a **possible platform** is envisioned that will permit **visual approachability** of the **hull below**.

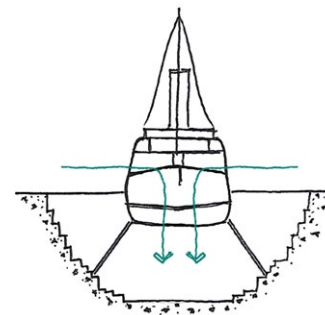

DIAGONAL

The final method of transcendence permits a **migration** between both the host and the habitant through **direct vertical circulation**. The newly proposed atrium will allow for the inclusion of an **elevator shaft** that **actively connects** the dock with the ship.

Figure 4.15. Accessibility Across, Over, Under and Diagonal (Author, 2016)

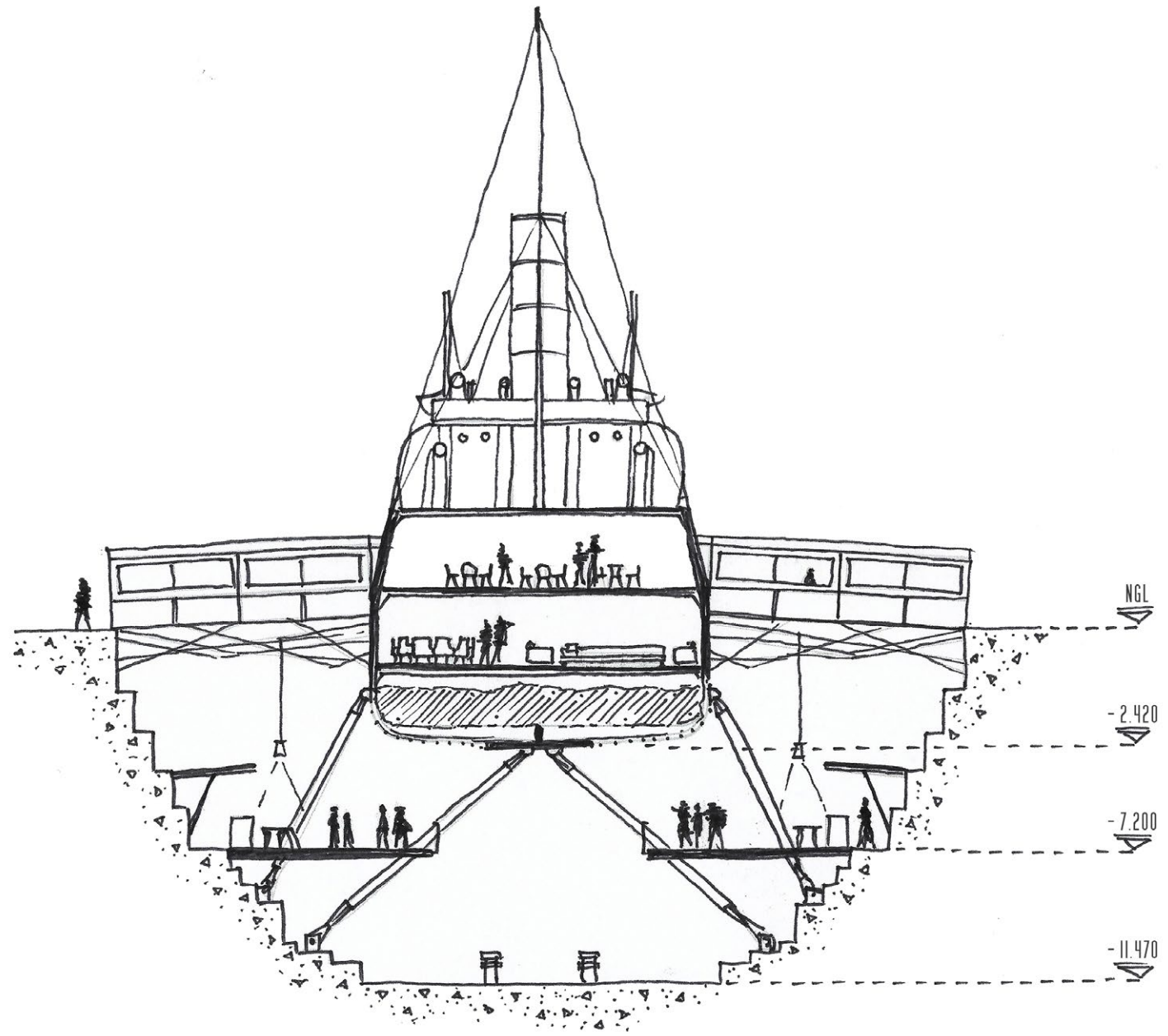
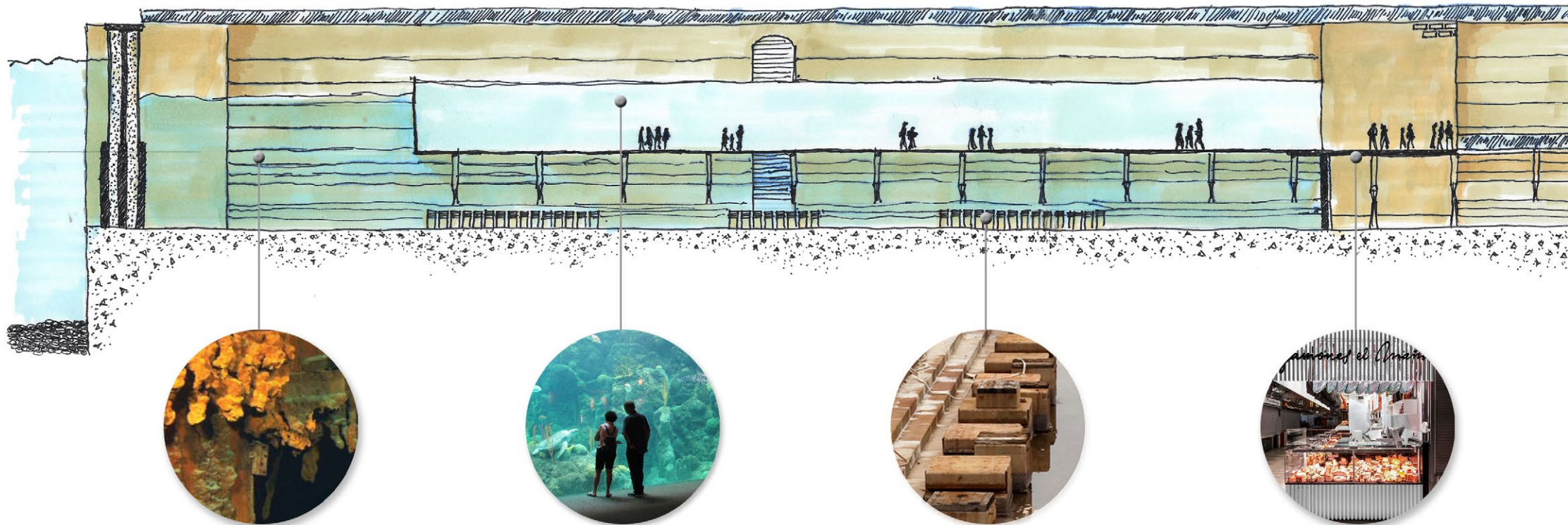

Figure 4.16. Latitudinal Section of Robinson Dry Dock (Author, 2016)

4.5 CONCEPTUAL OVERVIEW

In an attempt to express the initial spatial intention of the envisioned dock, a longitudinal section was created to exemplify the various interventions envisioned for all areas. In addition to the aforementioned **brewery and craft market**, the introduction of a **dock platform**, **exposed fermentation tank and atrium shaft** is considered. Regardless of this being the initial concept, later revisions merely **amended the enclosure of the entire dock** and the sacrificial implementation of using half of the dock for mere display purposes. These revisions will be discussed momentarily.

Figure 4.17. Longitudinal Section of Dock - not to scale (Author, 2016)



RUSTICLE REEF

As opposed to creating a ridge of rock in the sea formed by the growth and deposit of coral, the creation of a rusticle reef is envisioned. A rusticle is a formation of rust similar to an icicle or stalactite in appearance that occurs underwater when wrought iron oxidizes. As this occurs only underwater, exposing the process of reefing will make for an educational and interesting experience.



DOCK CATWALK

As a method to respond pragmatically to the additional dock space, the introduction of an enclosed glass catwalk is envisioned that will provide visitors with a 270 degree panoramic view of the berthing blocks below. In addition, this will also allow for the original function of the filled dock to be displayed. Displaying ship wreckage will also provide additional continuous interest.



BERTHING BLOCKS

The display of the berthing blocks will be visible from the enclosed catwalk. The blocks will allow for inventive opportunities to display underlying objects on the podium of the dock. The deteriorating state will also allow for the theory of concrete corrosion to occur. As this occurs only underwater, exposing the berthing process will allow for an alluringly educational experience.



CRAFT MARKET

In order to provide additional feasibility to the overall intervention, the introduction of an arts and craft market is proposed. The incorporation of craft within the context is ideal, allowing for spatial design to occur in the form of retail stand design using repurposed materials, primarily consisting out of steel. It is still to be determined if the stalls will be permanent, mobile, seasonal, craft specific.

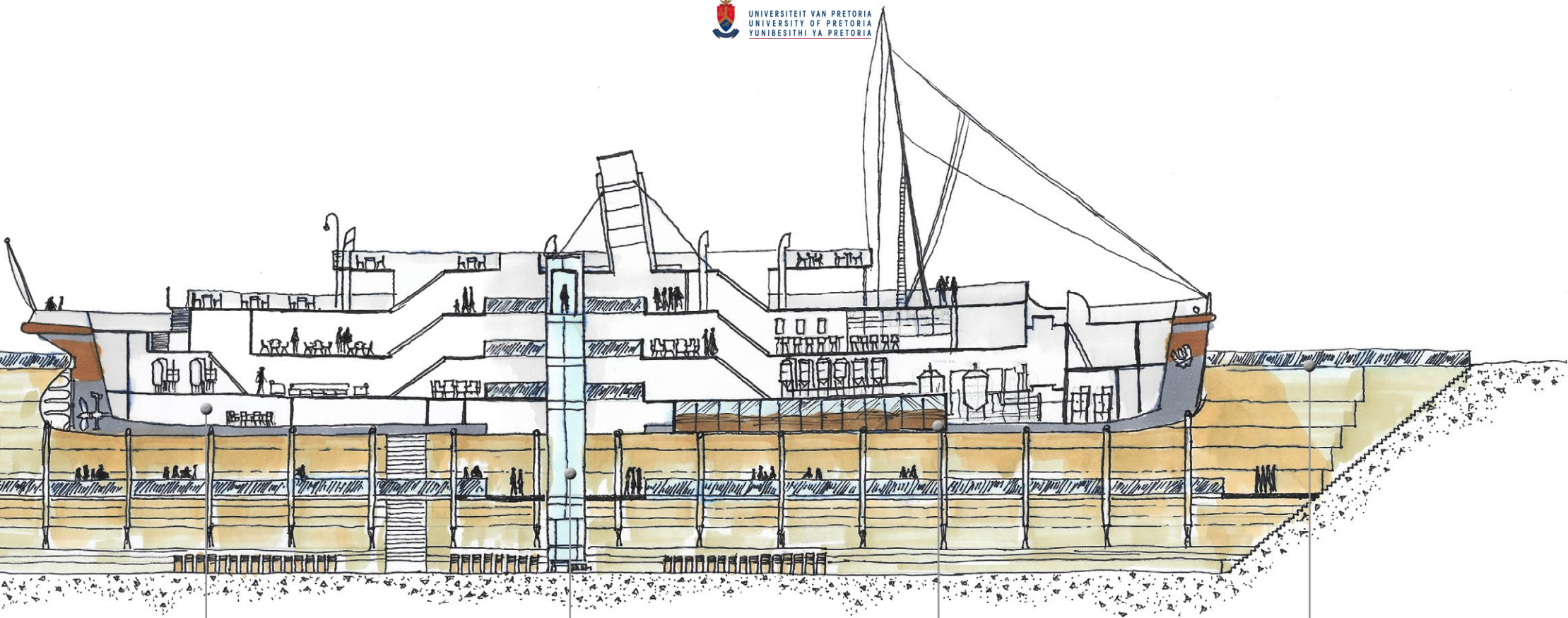

BEER CAFÉ

The main incentive to the interior program allows for a distillery of saltwater beer. In order to ensure that activity remains constant within the interior of the ship, a coffee café is envisioned where craft beer can be sampled. Due to renovation and typology, this will be ideal. Additional hull space can also allow for conference facilities in conjunction with Workshop/Colab 17 next door.



ATRIUM CIRCULATION

Upon declaration of decommission, all boiler machinery is removed in order to decrease hull weight and allow repurposing on another vessel. Once removed in 1974, the boiler room was left vacant and converted into a double volume auditorium. Restoration in 2012 left the void unoccupied, permitting the insertion of an atrium that will connect the host with the habitat.



EXPOSED BREWERY TANK

In addition to the incorporation of a beer café onboard, the actual brewing and fermentation process will accompany the act of consumption. In order to outline the actual process of aging in a tangible fashion, the process will be transparent, allowing visibility from the dock into the ship and vice versa through the replacement of selected unfastened keel plates with Pyrex glass laminates.



GLASS CANOPY

In order to provide shelter from the elements, the addition of a steel and glass sculpture-like canopy is envisioned. This will be positioned at ship's water level to create an illusion of a floating ship. A glazed structure surrounding the ship forms a roof canopy over this hall, bridging the space between the ground and the hull. This structure will also integrate the enclosed gangplank bridges.

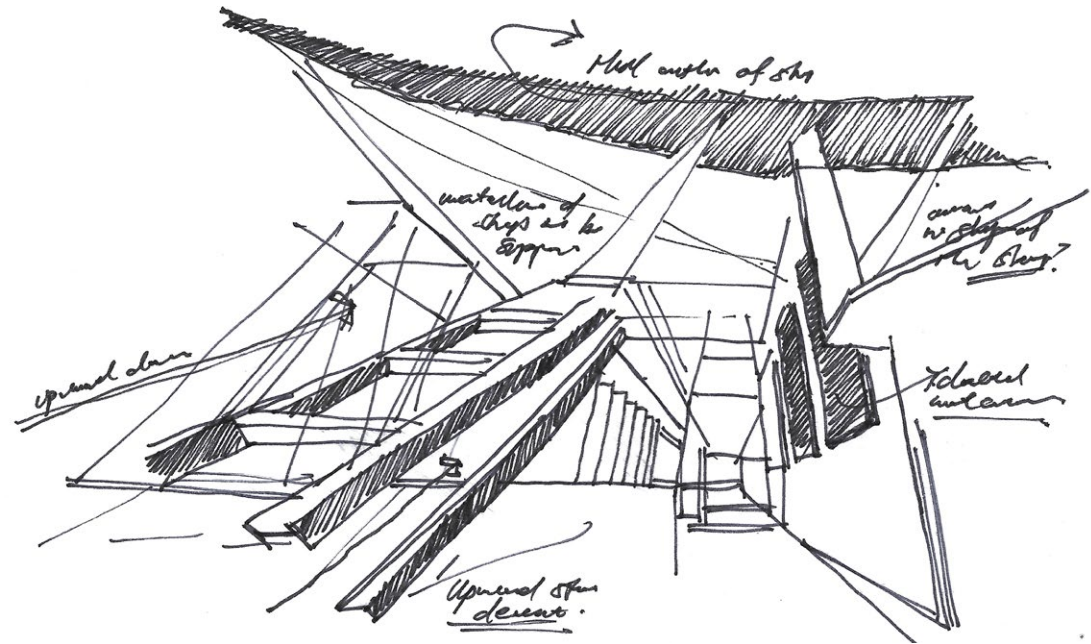

Figure 4.18. Conceptually illustrating horizontal circulation onto the ship through method of **enclosed gangplanks**. Furthermore, the **notion of scale is emphasised** through the introduction of vertical elements that **direct visual attention and flow**.

Figure 4.19. In addition to figure 4.18, this sketch illustrates **association between visitor, host and habitant**. Positive infill created by elevation creates additional **outer interiors**. Moreover, **layering** is illustrated through **simultaneous activity and level differentiation** between ground, sea and dock level.

Figure 4.18. Conceptual Exploration of Circulation (Author & Unknown , 2016)

Figure 4.20. Visually illustrates the proposed outer **interior market area**. **Stalls are embedded onto a platform** which allows **elevation and visual accessibility** to all heritage components. This symmetrical arrangement **emphasises the central berthing blocks** of the host and the **hull** of the habitant.

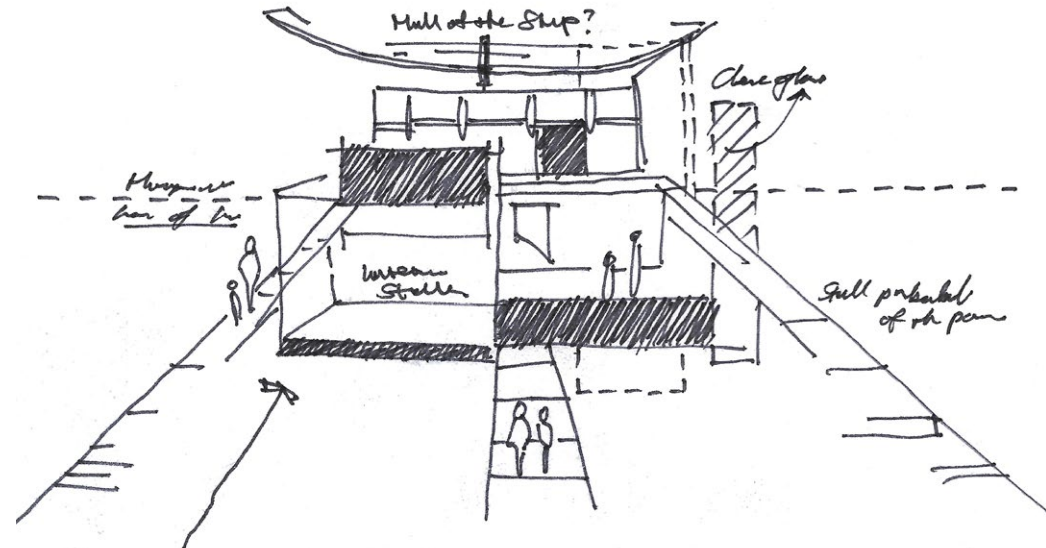

Figure 4.19. Conceptual Exploration of Scale and Space (Author & Loder, 2016)

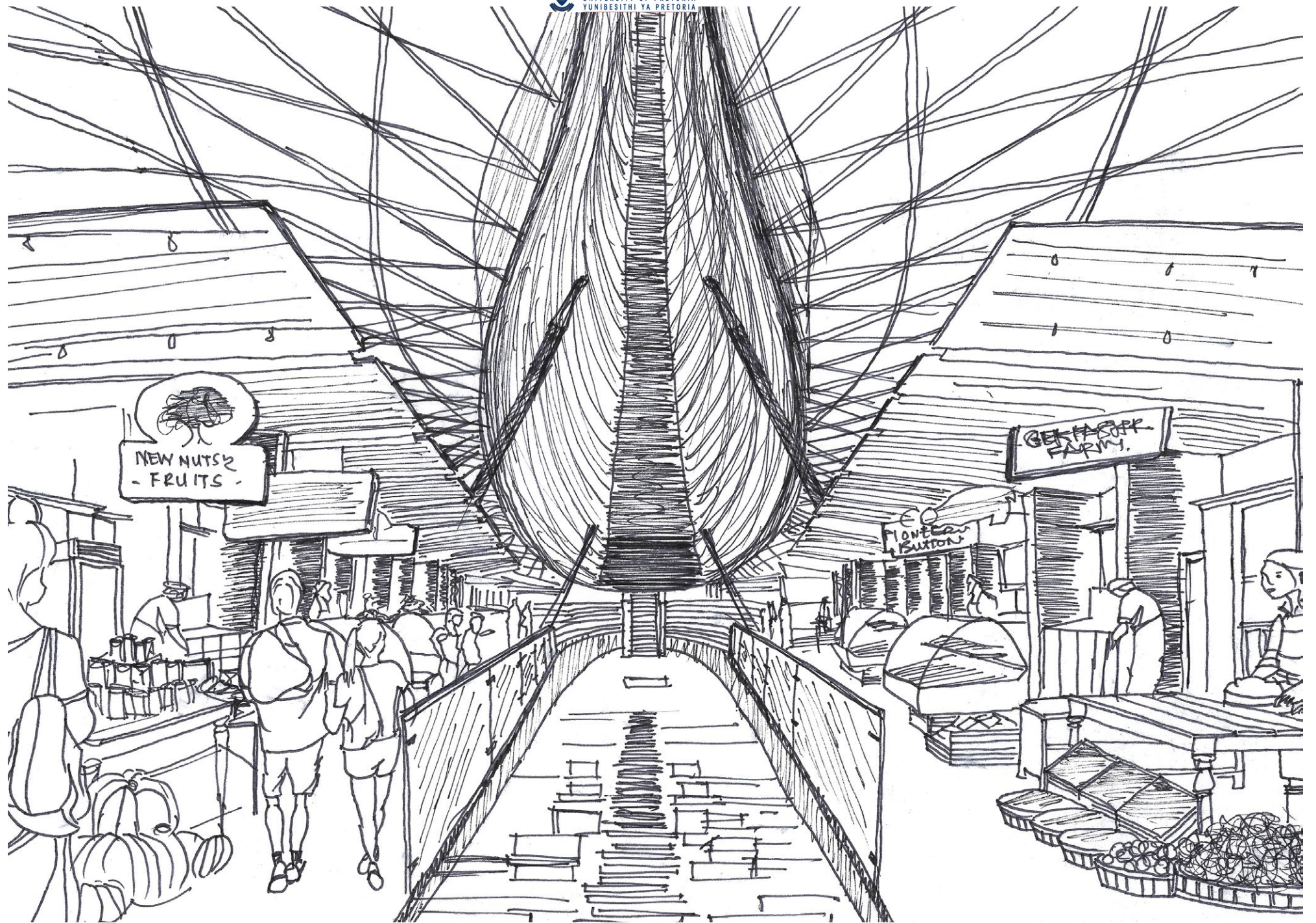

Figure 4.20. Conceptual Exploration of Market Platform (Author, 2016)

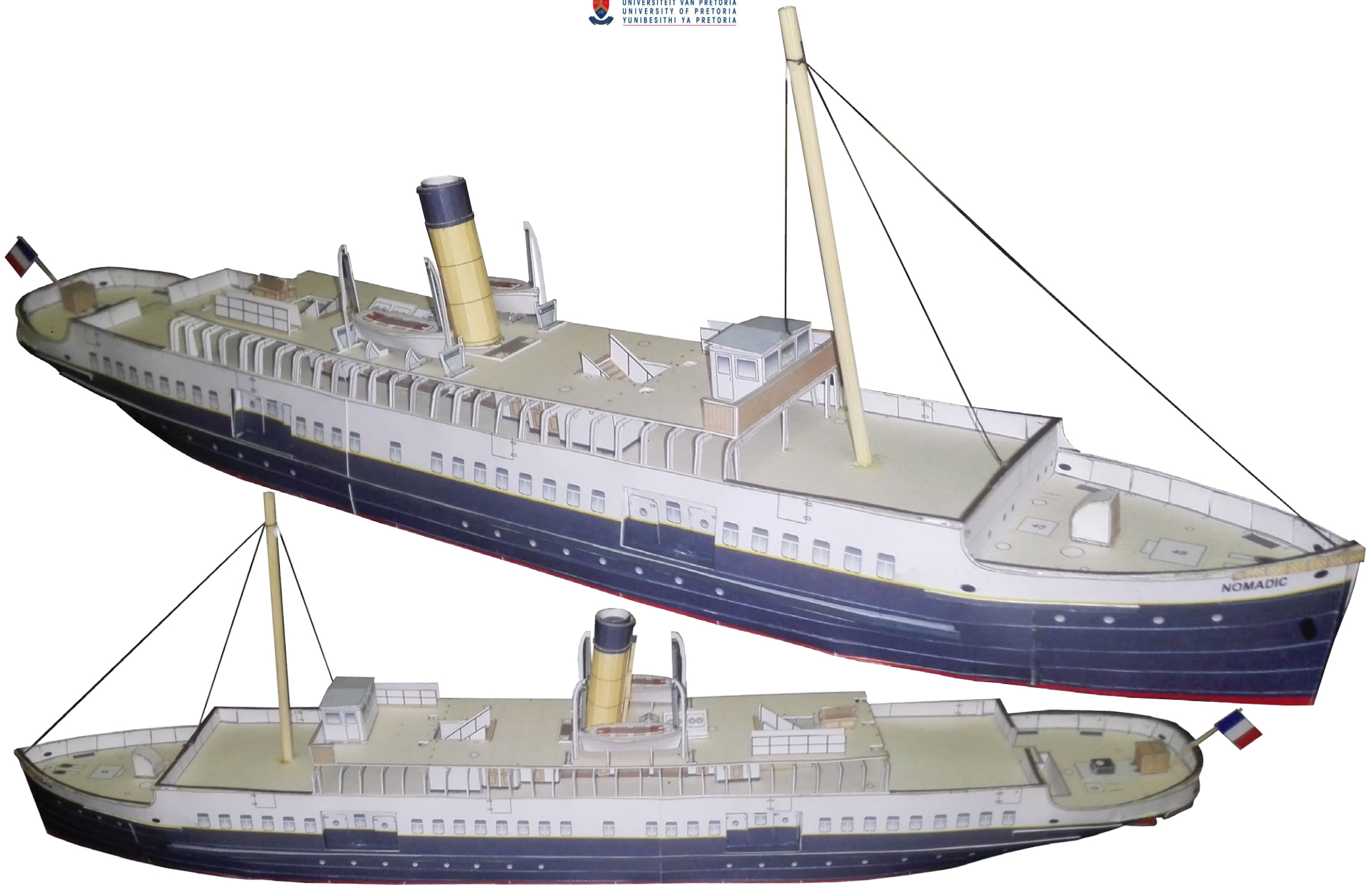

Figure 4.21. Model of Habitant (Author, 2016)

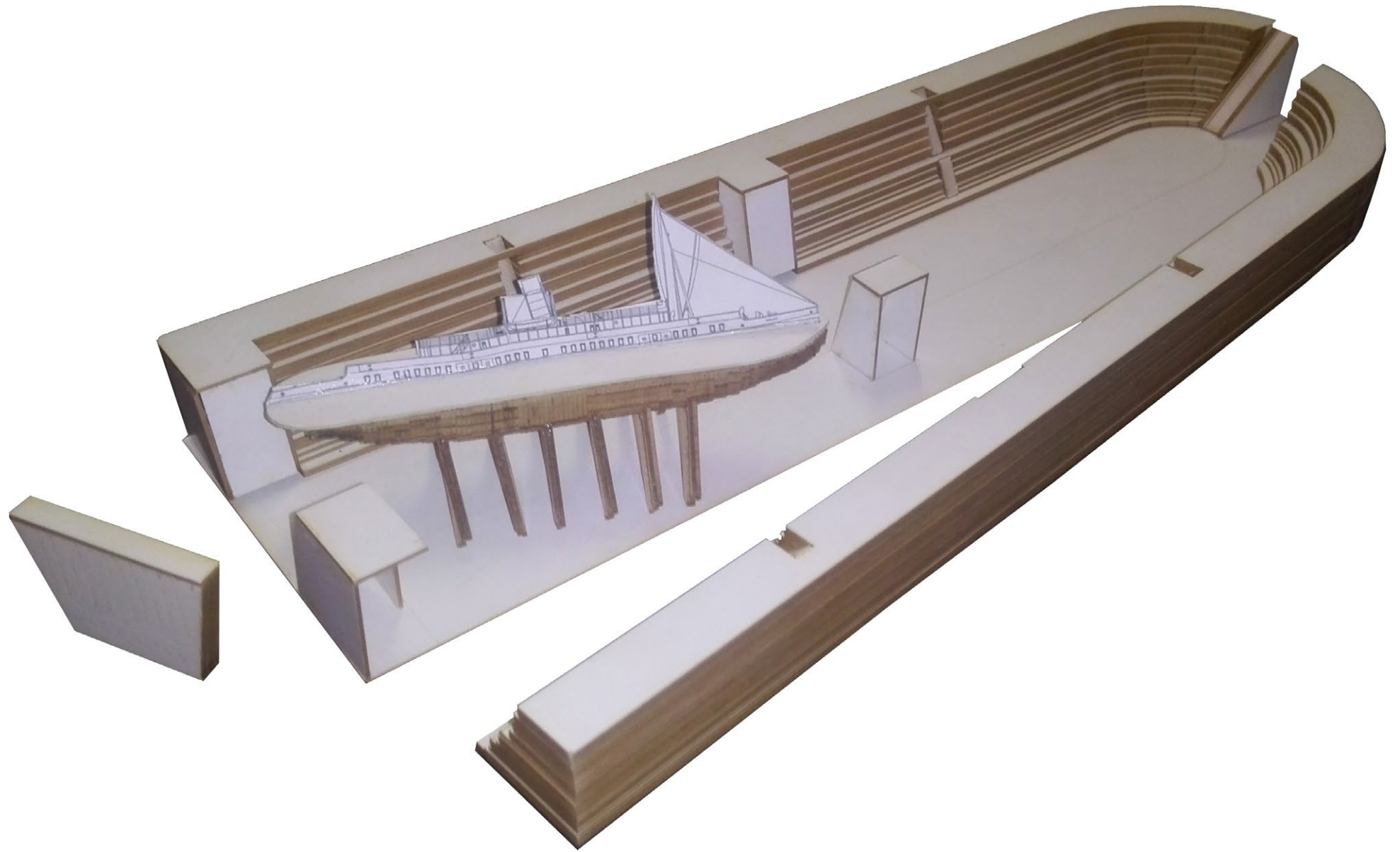

Figure 4.22. Deconstructed Model of Host (Author, 2016)

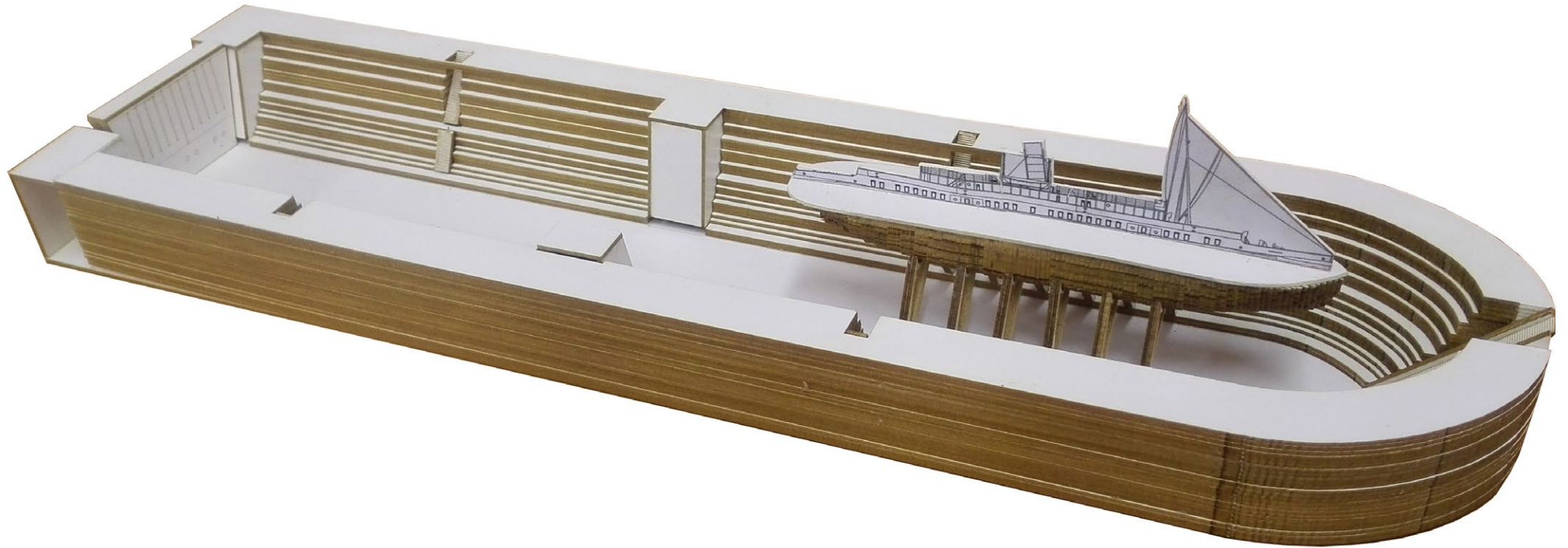

Figure 4.23. Model Depicting Proportional Differentiation of Proposed Connection (Author, 2016)

4.6 PLATFORM DEVELOPMENT

Having established a clear approach towards existing and proposed avenues of accessibility and permanent habitant-to-host joinery, the development of the **recommended elevated walkway** can be conceptualised (figure 4.24). In addition to the **provision of elevation** that permits **closer visual accessibility** to the underside of the ship's hull, this platform will admit **additional activity that ensures unremitting feasibility**.

A number of iterations are presented which factually illustrates the development of an **embedded multi-functional** platform that serve as an **outer, nested interior**.

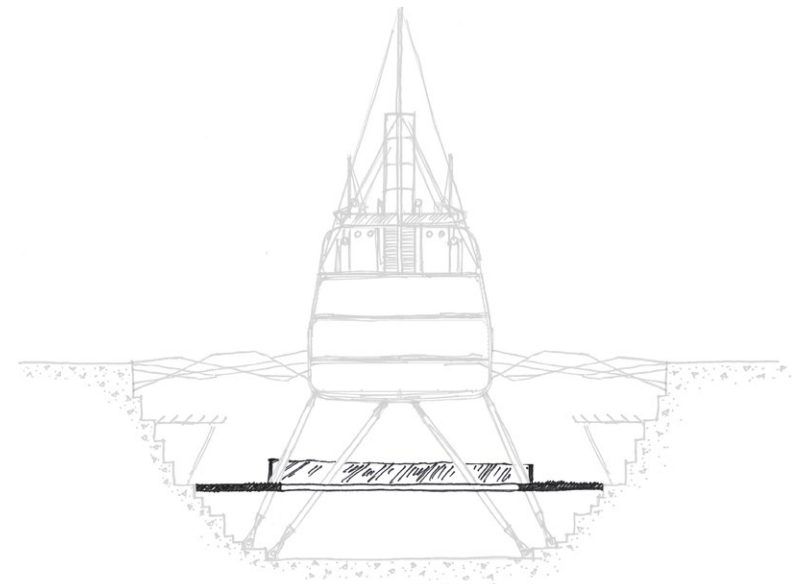

Figure 4.24. Platform Design (Author, 2016)

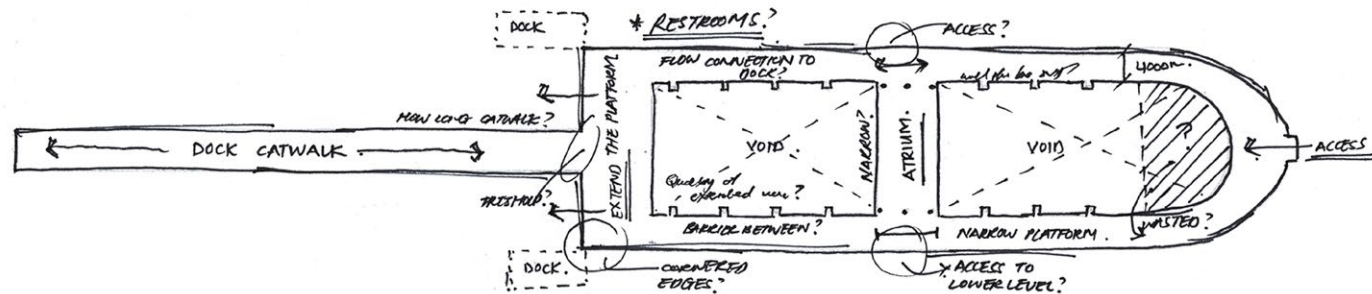
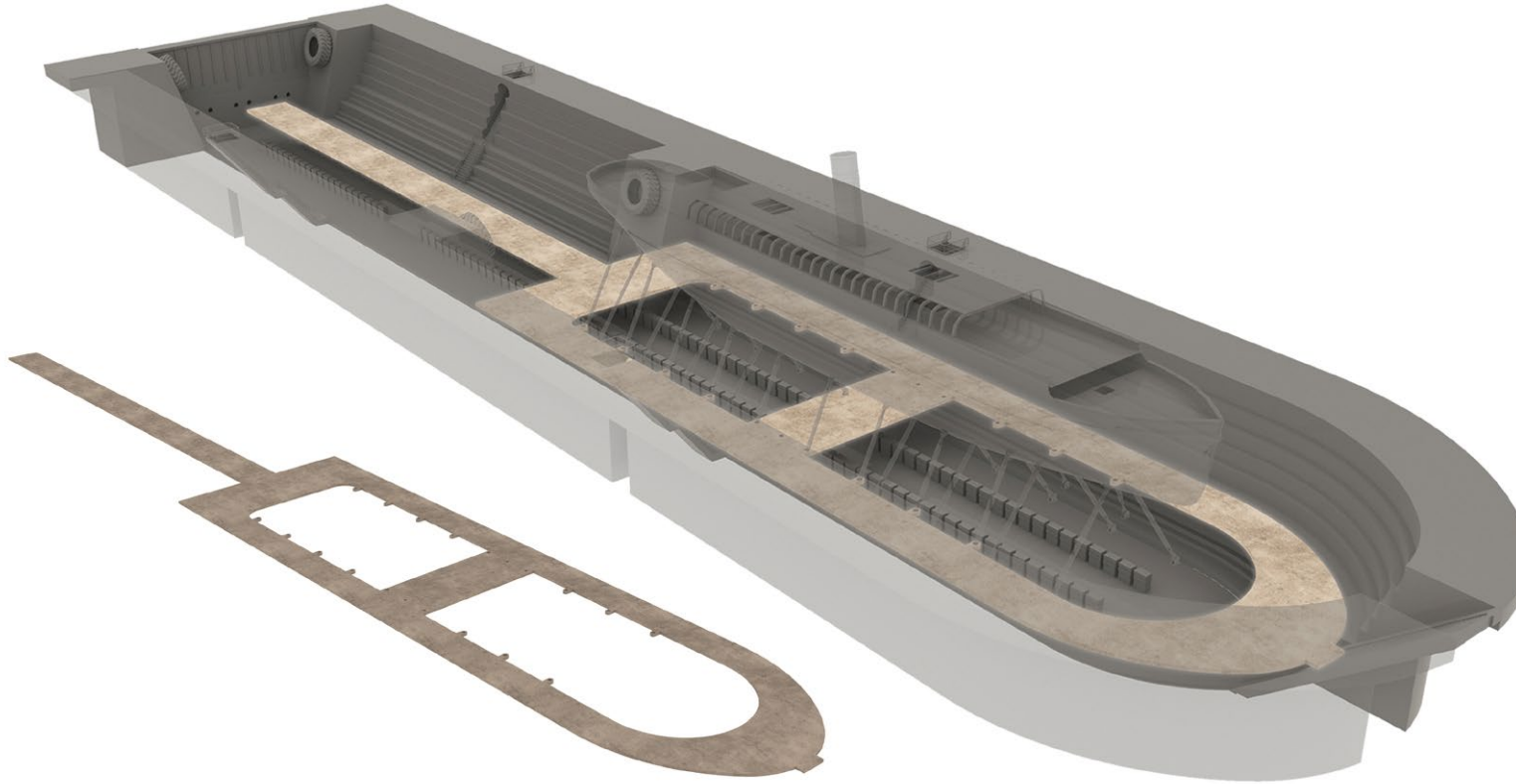

Figure 4.25. Platform Configuration 1 (Author, 2016)

- CONFIGURATION 1 -

The initial concept behind the main outline was to **ensure that the walkable area** be elevated in order to **permit partial accessibility to the existing dock below** and to raise walking level in order to have **closer perceptibility of the ship's hull**. Given that the ship will merely **occupy half of the dock**, the additional half will be converted into a **temporary dock aquarium**, allowing **possibility for extension**.

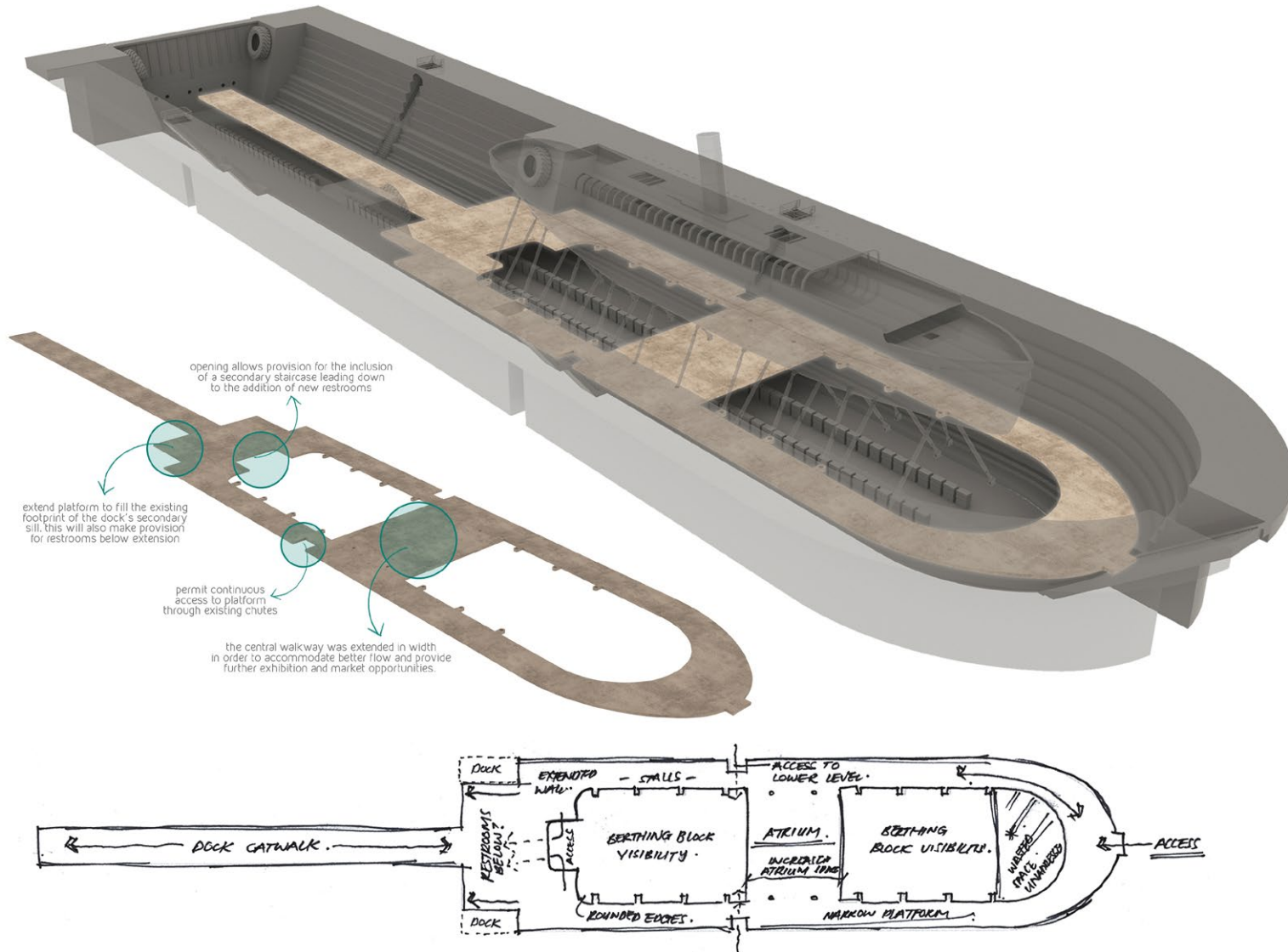

Figure 4.26. Platform Configuration 2 (Author, 2016)

- CONFIGURATION 2 -

The **revision of the overall shape** endorsed a second iteration. In order to fully utilise the existing space, the **platform was extended to fill the profile of the demolished secondary sill**. This extension made ideal **positioning for additional ablution facilities** thereunder. Added **cavities** were inserted on either sides of the platform to govern **admission through the existing chutes** to the dock below.

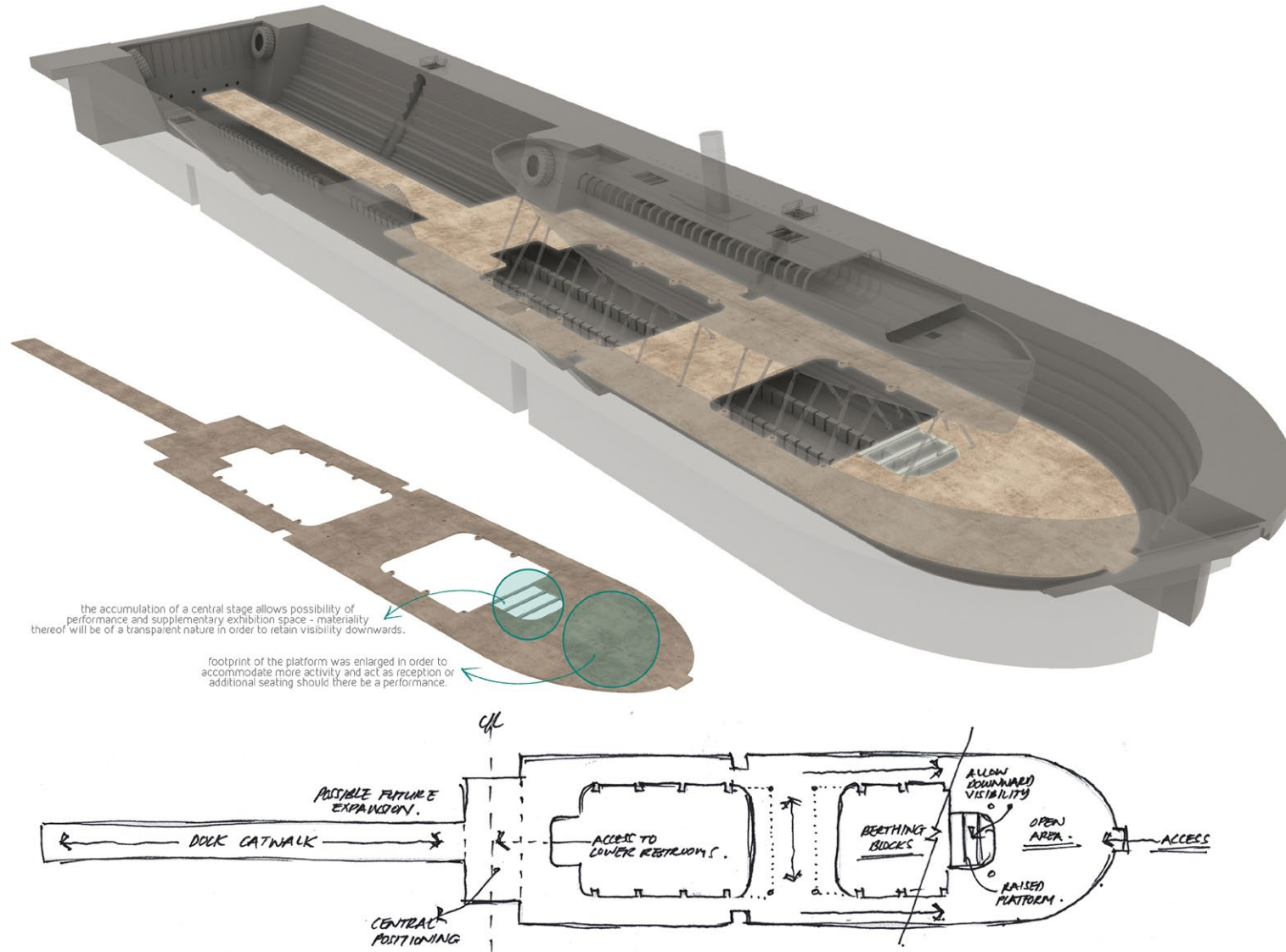

Figure 4.27. Platform Configuration 3 (Author, 2016)

- CONFIGURATION 3 -

The third revision was **relatively resolved in terms of accessibility**. The **postponement of the forward section of the platform** was instigated in order to allow **better use of space and greater potential for enlarged audiences**. Furthermore, a central stage was adjoined in order to provide a **flagrant performance space**, hence the utilisation of the **extended platform as concert seating**.

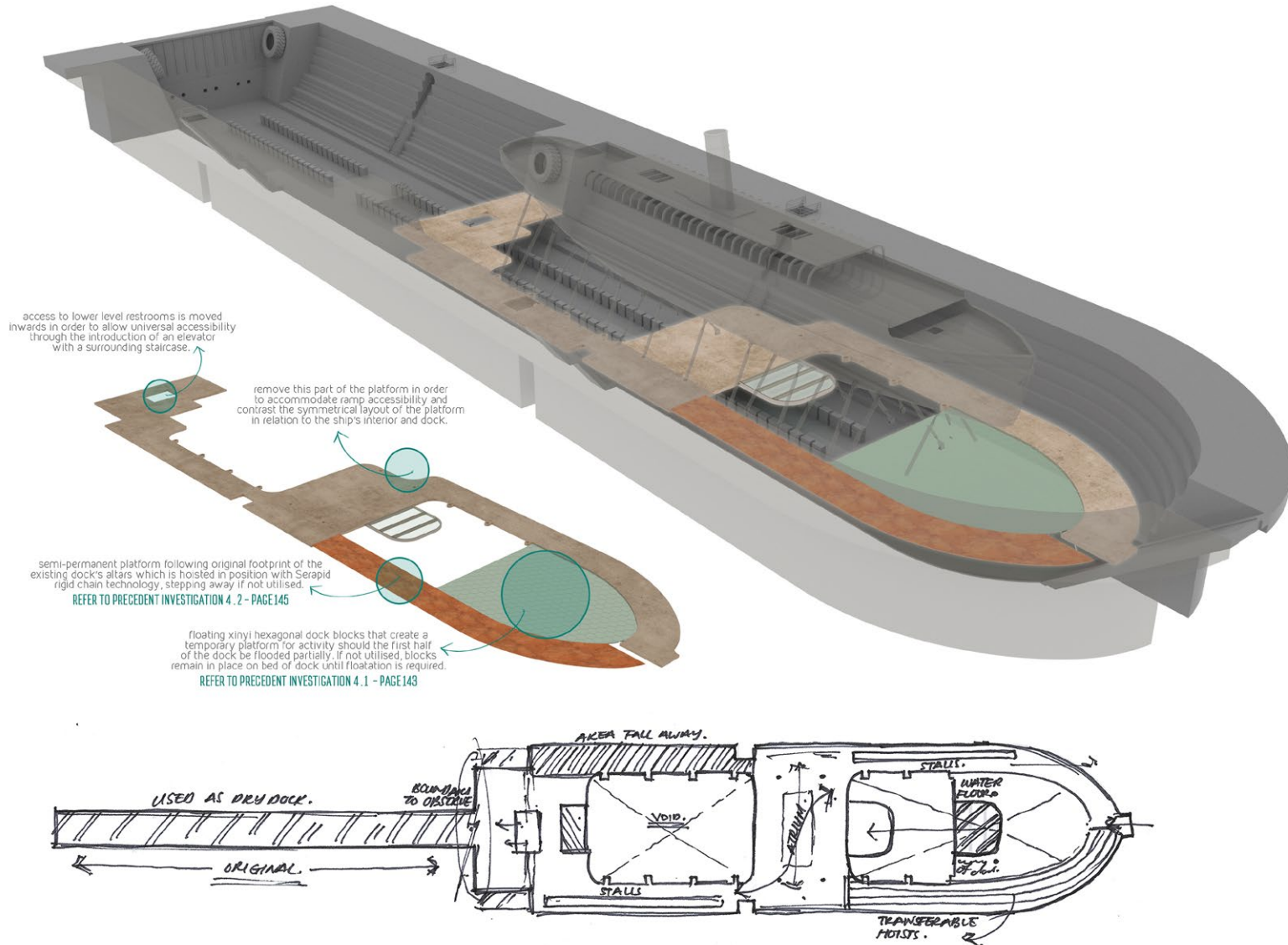

Figure 4.28. Platform Configuration 4 (Author, 2016)

- CONFIGURATION 4 -

Upon presentation of the third resolution, the **symmetrical and permanent nature of the announced platform was probed**. In order to **manipulate the use of space**, the introduction of **semi-permanent and temporary platforms** were introduced in order to provide **both intimacy and distance**, depending on what is required in terms of **scale and activity**.



Figure 4.29. The Floating Pier in Use (Volz, 2016)

PROJECT SYNOPSIS

Initially conceived in 1970, Christo and Jeanne-Claude reimagined Italy's Lake Iseo as a floating pier. As an extension of the street, the floating walkway connected Sulzano to Monte Isola to the island of San Paolo. The creation of a walkway, 3 kilometers in length and 16 meters in width, was assembled through the utilisation of a **modular floating dock system** consisting out of 220,000 **high-density polyethylene cubes**. In order to allow traction, prevent omission and linger united, the entire surface was covered in a bright yellow fabric. In addition to the aforementioned cognitive, this transferred the dull white blocks into a collective unit which contrasts beautifully against its nautical surrounding. **Undulated with the movement of the waves**, visitors relate the experience to **walking on water**. As this was a **temporary installation**, all components were removed and industrially recycled after the 16 days of exhibition (Claude, 2016).

PROJECT OBJECTIVES

- Through the extension of main streets on land, the connection of adjacent areas separated by water was to be connected.
- Construct a temporary installation that is discreet, **non-intrusive and environmentally friendly**. As this will be a walkway, the accommodation of large numbers **should not impair structural integrity**.

IMPLEMENTATION STRATEGIES

- To replicate the idea of walking on water, the addition of a similar **modular system** will be implemented in order to provide **additional and temporary platform** for intervention.
- If surplus space is required, the frontal half of the dock can be partially flooded, allowing elevation of the hexagonal blocks into place. Once drained, the blocks descend downwards back into place, following the outline of the original dock.
- Transparent materiality of the polyethylene cubes will allow **clear visibility of the original fabric** once recessed.



NAME OF PROJECT
FLOATING PIERS

LOCATION OF PROJECT
LAKE ISEO, ITALY

CHIEF DESIGNERS
CHRISTO & JEANNE-CLAUDE

DATE OF COMPLETION
2016



theory



materiality



design



programme

Figure 4.30. The Floating Piers (Volz, 2016)



Figure 4.31. The Pottor Rose Performace Hall in a Thrust Configuration (Baan, 2009)

PROJECT SYNOPSIS

As initial concept, the Dee and Charles Wylly Theatre was premeditated with the clear intent to reimagine conventional theater design. Forming part of the city's new AT&T Performing Arts Center, the Wylly will combine front-of-house and back-of-house areas above and beneath the auditorium, as opposed to conventional theaters where it is enveloped about. Defined by an **infinite variety of arrangements**, the vertical amassing of all facilities required for the functioning of a theatre in a single volume, permits completely **open or enclosed environments**. Utilising a state-of-the-art 'superfly' **hydraulic tower**, the unprecedented configuration of both seating and scenery arrangements is allowed. As a result, the preparation of a thrust, proscenium, arena, traverse, studio and flat floor arrangements can be set up in less than a day. Furthermore, being outlined by a glass façade, traditional perimeters are liberated through direct contact with its urban context.

PROJECT OBJECTIVES

- Stacking both front-of-house and back-of-house functions above and below the auditorium itself.
- Permit all seating and stages in the auditorium to be reconfigured timeously to suit different types of performance and rehearsal spaces.
- Allow visual accessibility for the surrounding context through the introduction of a glass envelope.

IMPLEMENTATION STRATEGIES

- In order to reconfigure the actual walkable footprint of the proposed semi-permanent platform, the utilisation of **similar hoisting technologies** are envisioned.
- Brief investigation of the actual **Syrapid® hydraulic system** will prove imperative when detailing and specifying load-bearing capacity.
- In addition to the implementation of a hoisted platform, **similar hydraulic possibilities** will be investigated during the design of applicable **market stalls**, which will be **permanently positioned on the proposed platform**.

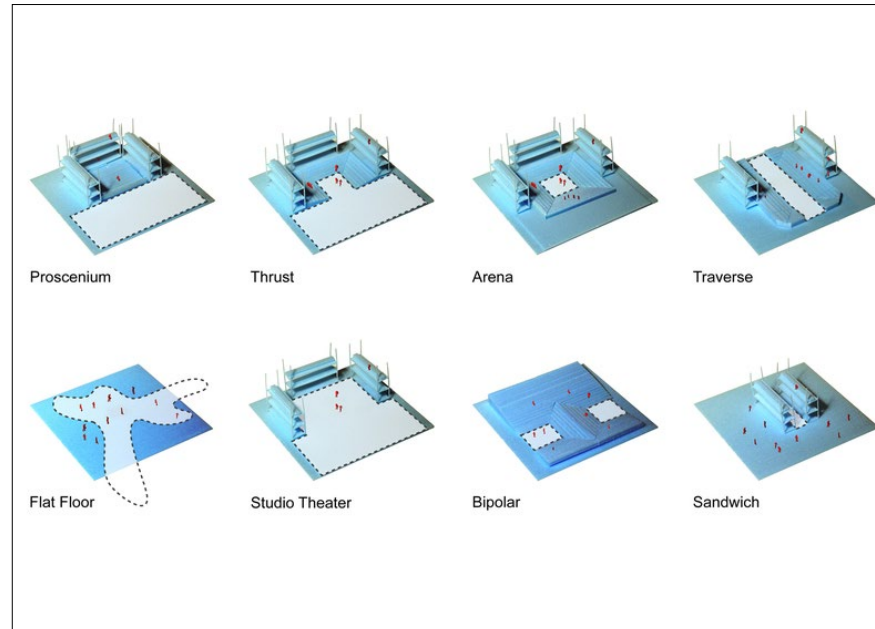

Figure 4.32. Configurations and Platform Hydraulics (Baan & Rex, 2016)

NAME OF PROJECT
DEE & CHARLES WYLLY THEATER

LOCATION OF PROJECT
DALLAS, UNITED STATES

CHIEF ARCHITECTS
REX | OMA

DATE OF COMPLETION
2009



theory



materiality



design



programme

- FINAL CONFIGURATION -

The final iteration is founded upon the fourth configuration. Keeping with the notion of **permanent and semi-permanent platforms**, the forward platforms were switched in order to **correlate better with the proposed stalls**. The **temporary platform was also eliminated** as it **convoluted the footprint** and its suggested **construction proved challenging due to the presence of the support armature**. Moreover, fixing the blocks to the bed of the dock would **encumber the existing fabric**. **Clear division** allowed for the frontal part of the dock to be **repurposed**, and the **latter half to continue serving its intended rationale as a dry dock** for small vessels requiring rudimentary maintenance. This educational and thought-provoking activity can be observed from the **proposed viewing deck**.

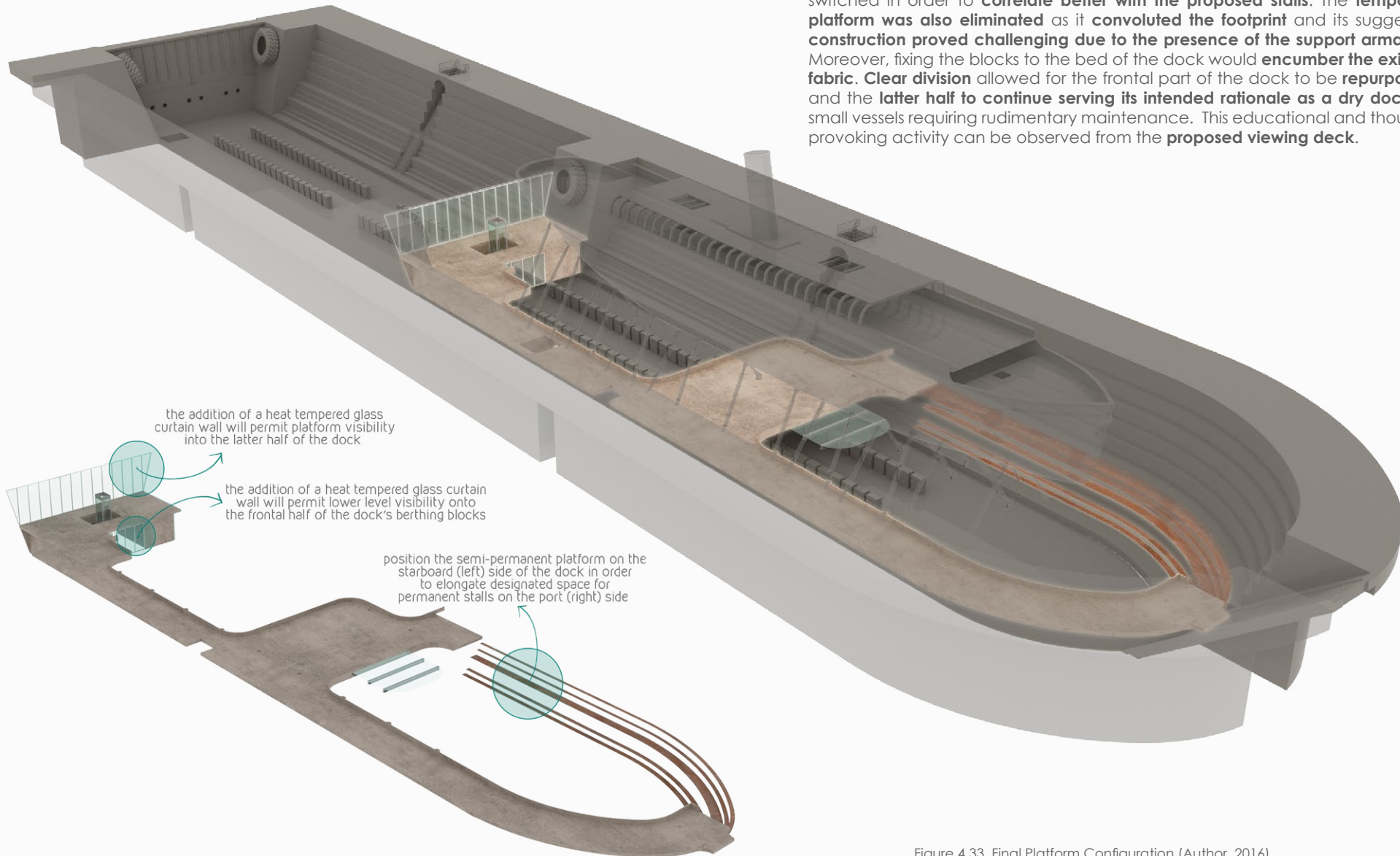

Figure 4.33. Final Platform Configuration (Author, 2016)

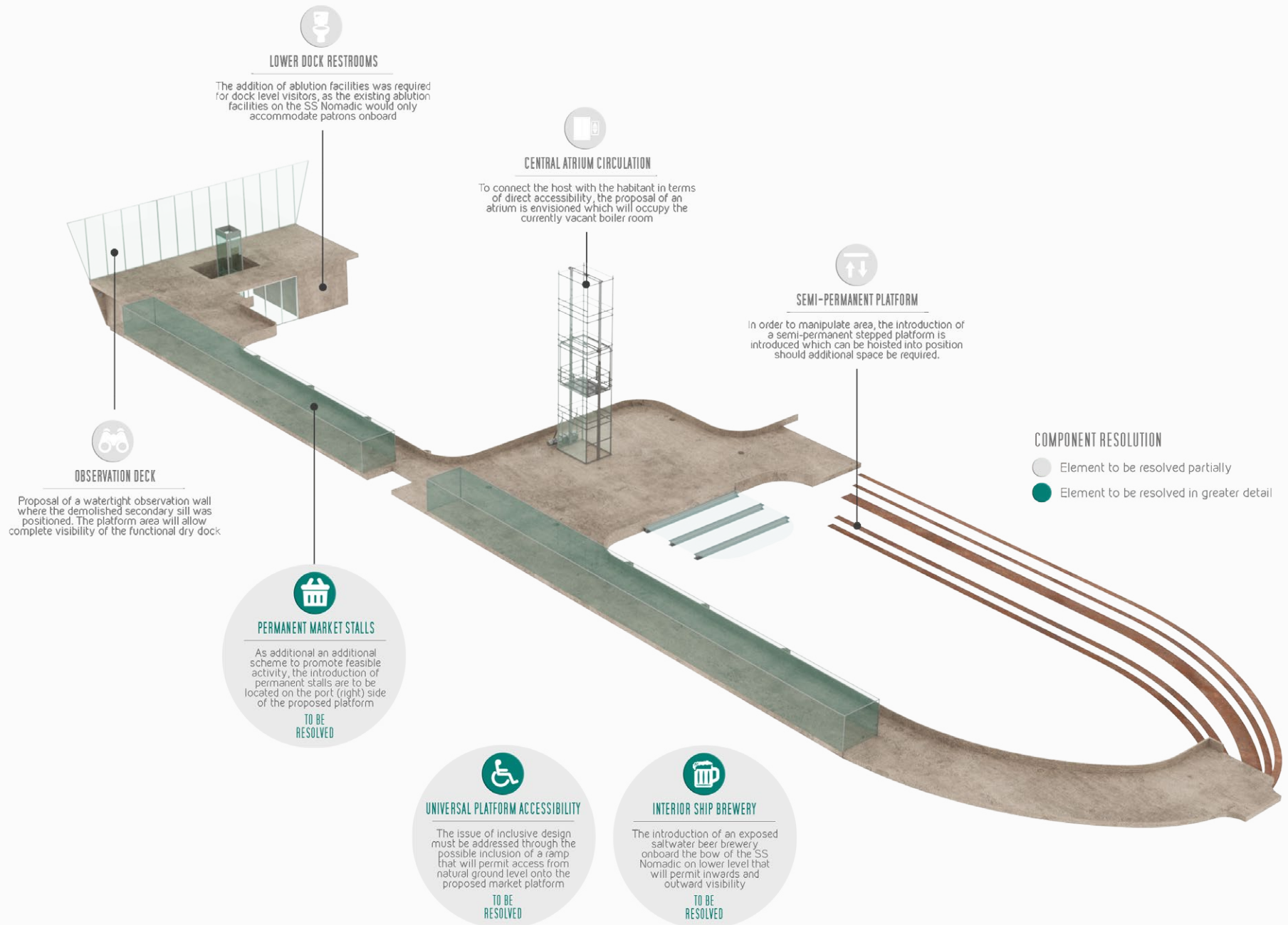

Figure 4.34. Dock Design Components (Author, 2016)

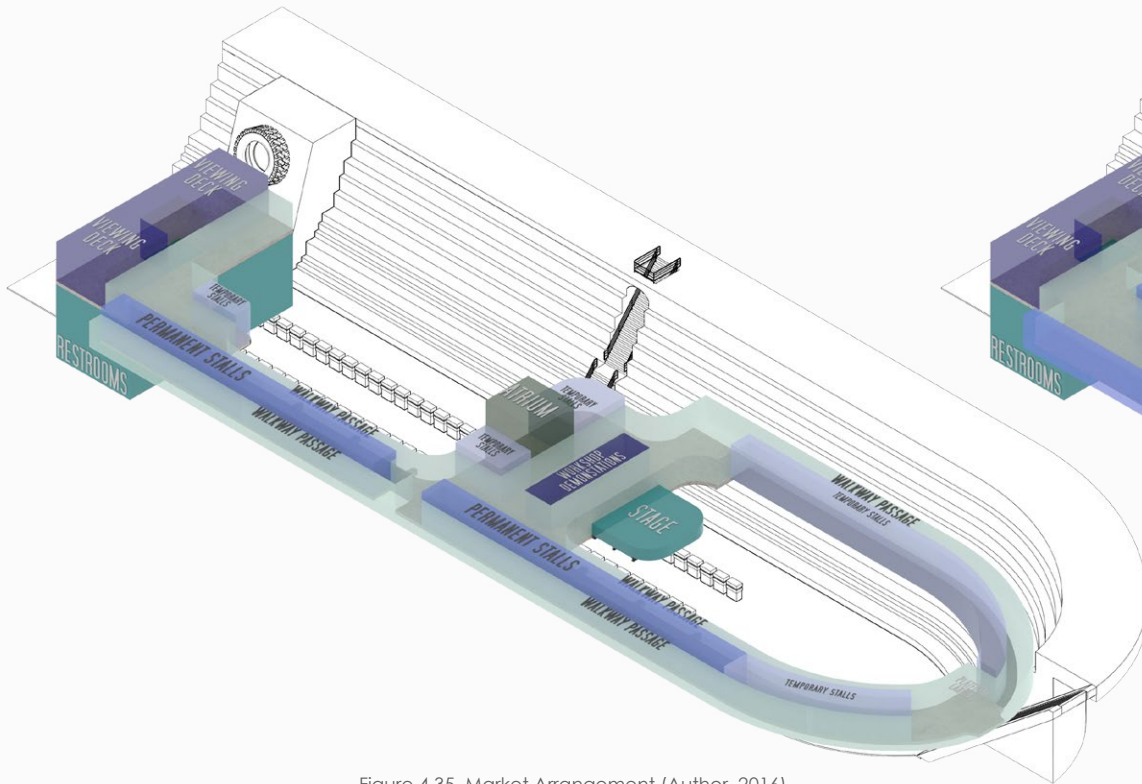

Figure 4.35. Market Arrangement (Author, 2016)



MARKET

The market/stall layout is the **secondary response pragmatically** and will receive additional resolution. In addition to the designated **permanent stalls**, temporary stands and feature workshop/demonstration areas are also available.

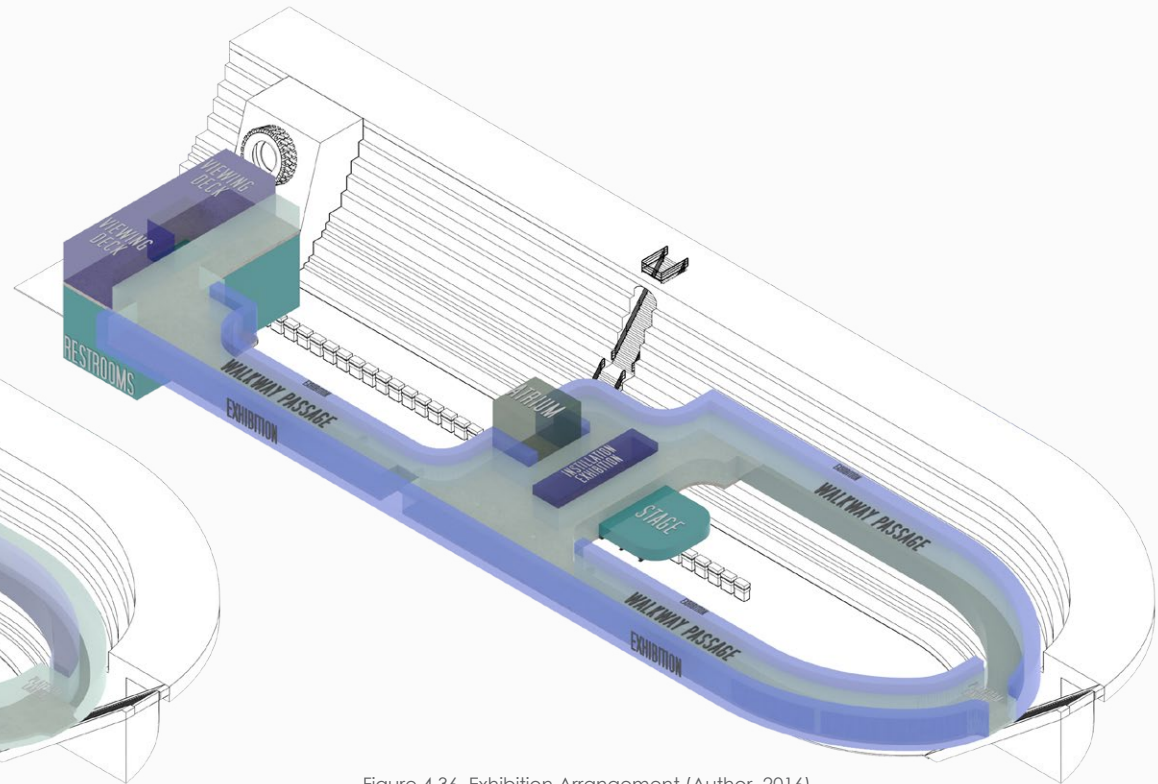

Figure 4.36. Exhibition Arrangement (Author, 2016)



EXHIBITION

In addition to being used as a market, the dock can also host exhibitions and act as **gallery space**. The dock will act as **ideal backdrop against current works of art**. A variation of work can be displayed, ranging from **canvas to temporary installations**.

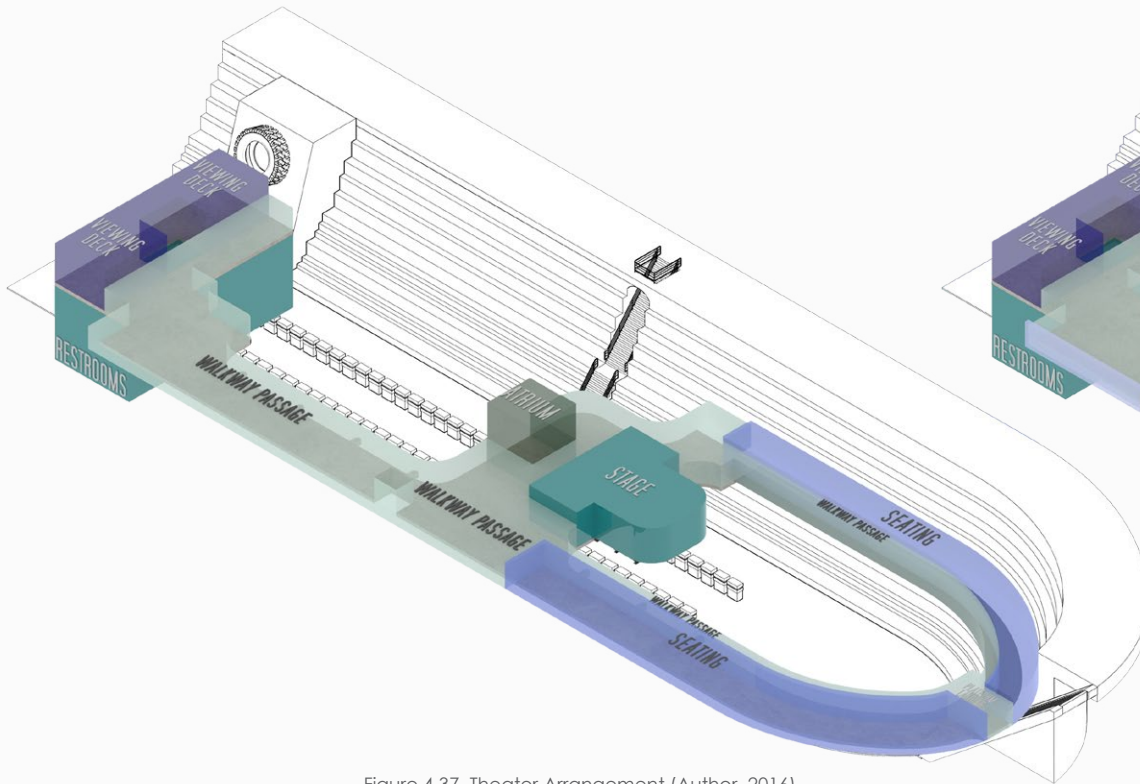

Figure 4.37. Theater Arrangement (Author, 2016)



THEATER

As a third possibility, the platform can be configured to host **theatrical activities**. Areas on adjacent sides of the designated stage area can be converted into **temporary seating** similar to that of an **amphitheatre**, with **frontal walkways to govern circulation**.

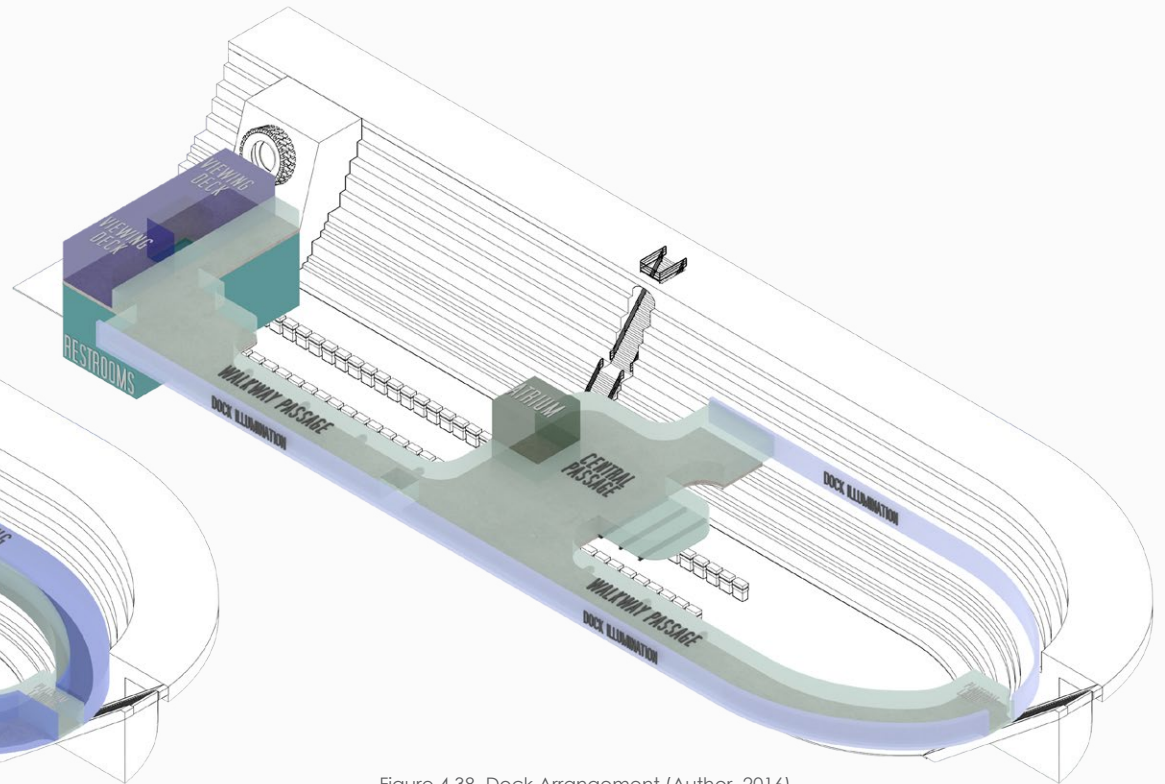

Figure 4.38. Dock Arrangement (Author, 2016)



DOCK

The final configuration showcases the possibility of space **merely functioning as a dock** when there is **no event taking place**. Illumination will direct emphasis towards the existing fabric and act as a **sculptural element**.

4.7

MIGRATION OF SHIP TYPOLOGIES

As a result of the proposed configuration and division of the dock into a **frontal market** and **aft functioning dry dock**, a display of vessels varying in **occupational status** will be observed. As mentioned in chapter one (refer to figure 1.3, page 18), the **lifecycle** of a ship is divided into five stages; **planning, ordering, ship building, ship operation and ship recycling**. As illustrated in figure 4.39, the **adaptive reuse** of the decommissioned SS Nomadic proposes a **fourth ship recycling alternative**, whereas any serviced vessel in the adjoining aft division of the functioning dock represents a **ship during operation**. The availability of **neighbouring harbors** will also display a ship in its **operational phase**, but as opposed to be serviced, these vessels are in **current use**. This combination of visual exposure to the **variety of vessel typologies actively assimilates the life cycle of a ship**.



SHIP RECYCLING

stage 5

fourth proposed alternative for decommissioned vessels



SHIP OPERATION

stage 4

vessels still in use, but requiring maintenance or repair



SHIP OPERATION

stage 4

vessels currently use primarily for recreational purposes



Figure 4.39. Migration in Ship Typologies (Author, 2016)

4.8

PERMANENT MARKET STALL DESIGN

As a resulting attribute due to the selection of a **definite form of the envisioned platform**, the design of additional elements for the outer interior can be conceptualised. Expending significant attention towards the **market arrangement scheme** (figure 4.35), the design of **permanent stalls** to be positioned as indicated on figure 4.41, will be resolved in greater detail. As a definite point of departure, it was established that the **stalls be fixed and modular in design**. This will ensure consistency, encourage proprietorship and evade any possibility of disrespecting the dock through aggressive market setups.

Based on the idea of having the **platform accessible to a variety of different schemes**, the notion of having stalls permanently fixed to the podium proved to be **perplexing in design**. Requiring joinery to the platform meant that the design was to be configured in such a fashion to **allow complete desertion when there is no active market**. Furthermore, the permanent nature of the envisioned stalls permits opportunity for **continuous product display** after hours. In addition to this principal criterion, possible **visual abstraction** caused by this market obstruction was to be restricted. As exemplified in figure 4.42, the placement of the stall was to be **located between two structures of historical significance**. The location thereof was not to **subtract from or obstruct, nor disappear amongst the vast existing fabric**. Furthermore, additional benchmarks were inaugurated to provide **framework and act as a tool of measuring amenability**. These principles include **visual discreetness, fixed temporality, adaptability, materiality, multi-functionality and constant exhibition** (refer to figure 4.43). The Gourmet Tea Shop will be investigated as precedent (page 155), with the only requirement pertaining to permanent exhibition not being met entirely.

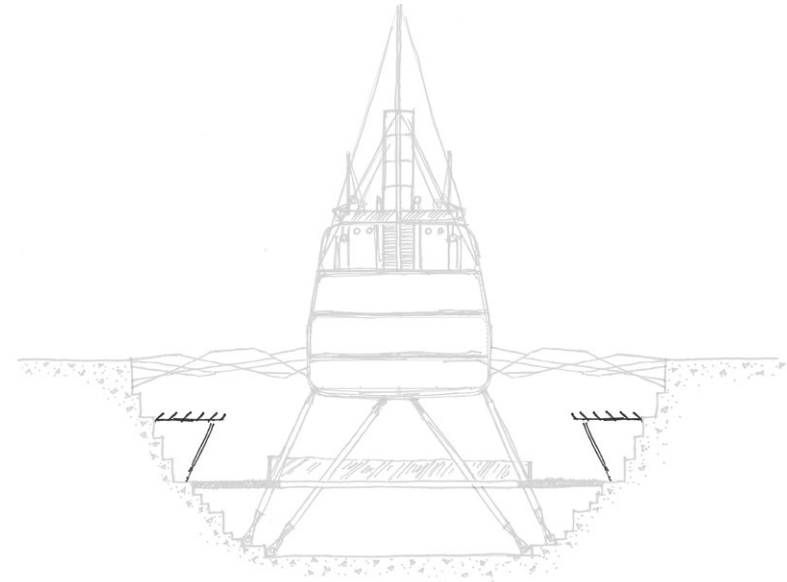

Figure 4.40. Market Stall Design (Author, 2016)

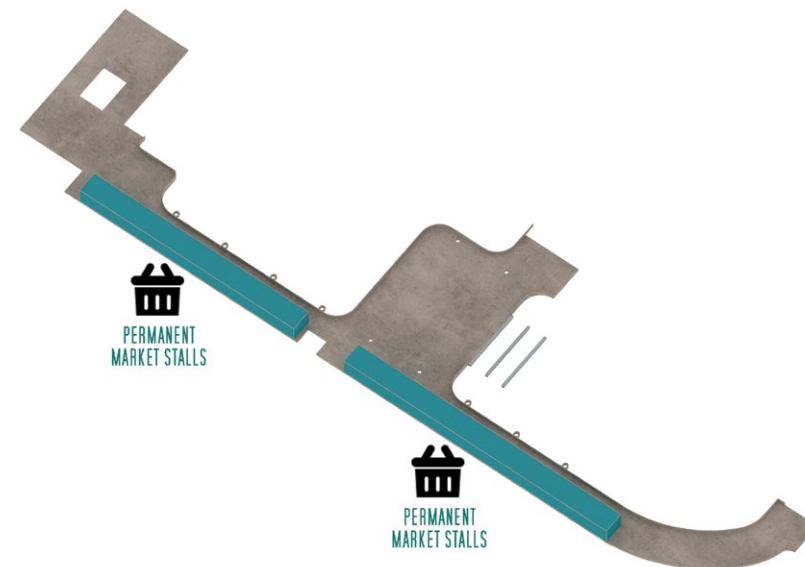

Figure 4.41. Permanent Stall Location on Proposed Platform (Author, 2016)

VISUAL ABSTRACTION

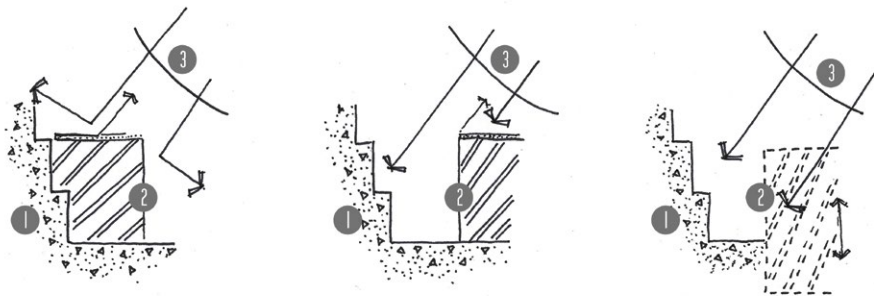

Figure 4.42. Stall Design Concept (Boat Smart, 2015)



CRITERIA ONE

VISUALLY DISCREET

The stall should not subtract from the current visual interest of the dock, and allow for transparency. Seamless introduction of market will allow for no intrusive field of range to occur, as the current materiality of both host (dock) and habitant (ship) must be highlighted.



CRITERIA TWO

FIXED TEMPORALITY

The stalls should be designed in such a fashion that it allows for permanent tenanship with a fixed layout that can be converted into other applications as programmatic response of dock changes. This is an essential principle that adds to the principle of adaptability.



CRITERIA THREE

ADAPTABILITY

The stalls should be designed in such a way that the layout is fixed, yet adaptable. Linking with criteria two, versatility in layout should be included in order to accommodate an array of craft objects to be displayed. Suit the needs of individual products - uniqueness.



CRITERIA FOUR

MATERIALITY

As one of the primary informant of this study, the selection of materials will be of primary concern. In addition to the choice of materials suitable for a coastal setting, the proposed materiality should contrast, yet conform in unity with the existing through the passing of time.



CRITERIA FIVE

MULTIFUNCTIONAL

As the stall with not always function as a market, it is essential that it should be able to cater multifunctional. Different interventions will allow for different utilisation - thus the need to adapt accordingly. A market by day, concert seating by night.



CRITERIA SIX

CONSTANT DISPLAY

Permanent opportunities for craft display should be allowed. The stalls should be designed in such a fashion that it allows for permanent tenanship with a fixed layout that can be converted into other applications as programmatic response of dock changes.

Figure 4.43. Permanent Stall Design Criteria (Author, 2016)



Figure 4.44. The Gourmet Tea Shop when Assembled (Chu, 2012)

PROJECT SYNOPSIS

As a flagship store for one of Brazil's most enjoyed hot beverage, the Gourmet Tea Shop was designed by architect Alan Chu. Working with a strict design manifesto which encompassed the rich history of this iconic brand, the choice in colour palate was derived from the packaging of the wide variety of organic tea blends available for purchase. All stores to follow would have a dedicated colour assigned to it as accent, depending on seasonality and the location. The counter of The Gourmet Tea slides forward from beneath a purple hatch, while shelves can be wheeled out from behind a grey panel and a cupboard emerges from behind a large brown door. Utilising plywood as materiality, the display is steady, durable and light of weight. The selection in material also permits informal maintenance and frequent replacement as stock alters. Complete assemblage allows for a dynamic design that caters for an ever evolving brand.

PROJECT OBJECTIVES

- Design an interior environment that is permanent, yet semi-transitory in nature.
- All fittings and material selection should be multi-functional and adaptable in nature, allowing display for a variety of stock and change in seasonality.
- Complete assemblage should be allowable after hours in order to permit additional activity within the surrounding area.

IMPLEMENTATION STRATEGIES

- The envisioned markets stalls will follow a similar typology in terms of modular and temporary design. As opposed to all elements folding away horizontally, the identified location only permits vertical assemblage.
- The selection of materials should be environmentally suitable.



NAME OF PROJECT
THE GOURMET TEA SHOP

LOCATION OF PROJECT
SAO PAULO, BRAZIL

CHIEF DESIGNER
ALAN CHU

DATE OF COMPLETION
2012



theory



materiality



design



programme

Figure 4.45. Configuration of Shop Dismantled and Assembled (Chu, 2012)

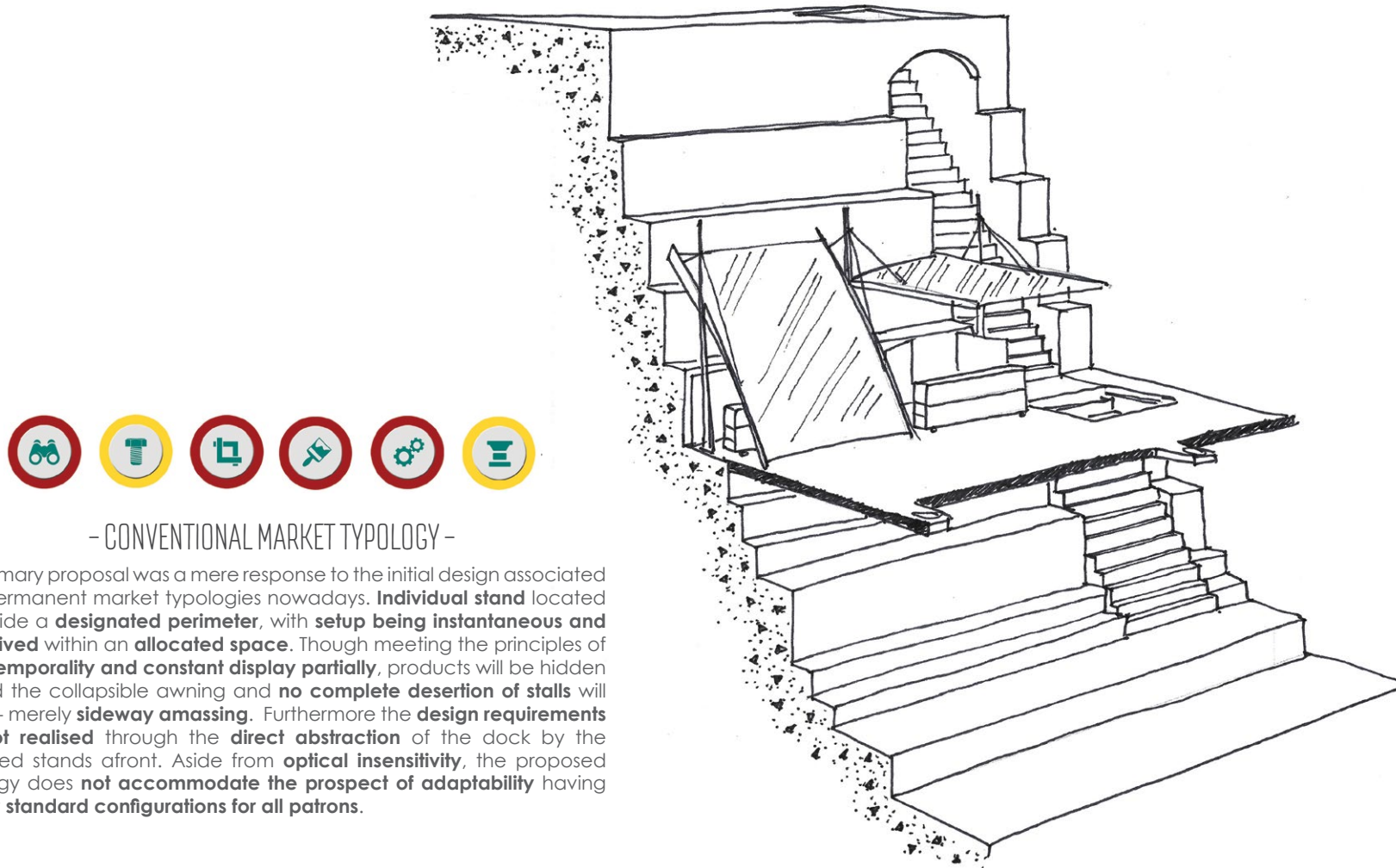

- CONVENTIONAL MARKET TYPOLOGY -

The primary proposal was a mere response to the initial design associated with permanent market typologies nowadays. **Individual stand** located alongside a **designated perimeter**, with **setup being instantaneous and conceived** within an **allocated space**. Though meeting the principles of **fixed temporality and constant display partially**, products will be hidden behind the collapsible awning and **no complete desertion of stalls** will occur - merely **sideway amassing**. Furthermore the **design requirements are not realised** through the **direct abstraction** of the dock by the enclosed stands afront. Aside from **optical insensitivity**, the proposed typology does **not accommodate the prospect of adaptability** having merely **standard configurations for all patrons**.

Figure 4.46. Conventional Market Typology (Author, 2016)

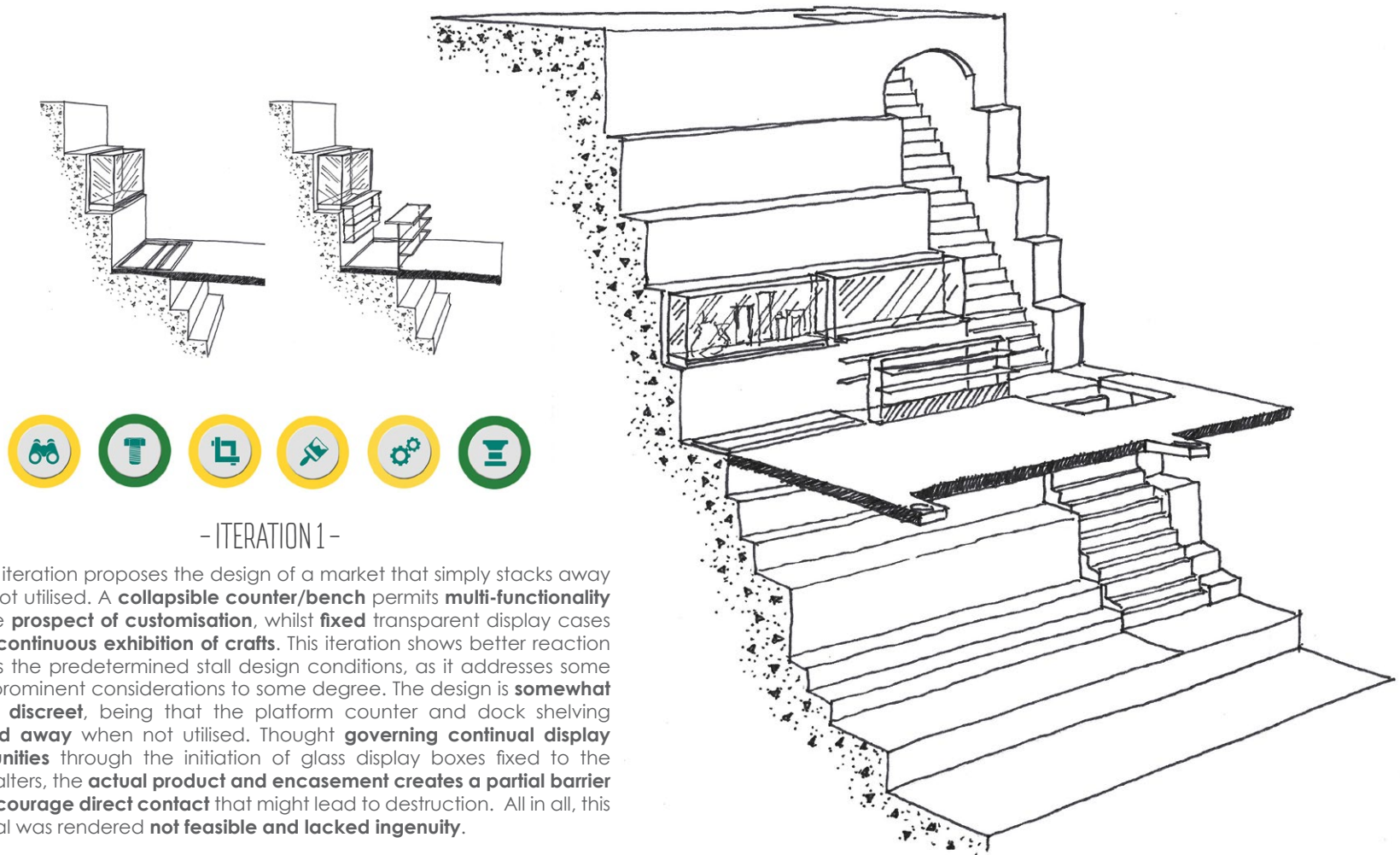

- ITERATION 1 -

The first iteration proposes the design of a market that simply stacks away when not utilised. A **collapsible counter/bench** permits **multi-functionality** and the **prospect of customisation**, whilst **fixed** transparent display cases permit **continuous exhibition of crafts**. This iteration shows better reaction towards the predetermined stall design conditions, as it addresses some of the prominent considerations to some degree. The design is **somewhat visually discreet**, being that the platform counter and dock shelving can **fold away** when not utilised. Thought **governing continual display opportunities** through the initiation of glass display boxes fixed to the dock's alters, the **actual product and encasement creates a partial barrier and encourage direct contact** that might lead to destruction. All in all, this proposal was rendered **not feasible and lacked ingenuity**.

Figure 4.47. Market Stall Iteration 1 (Author, 2016)

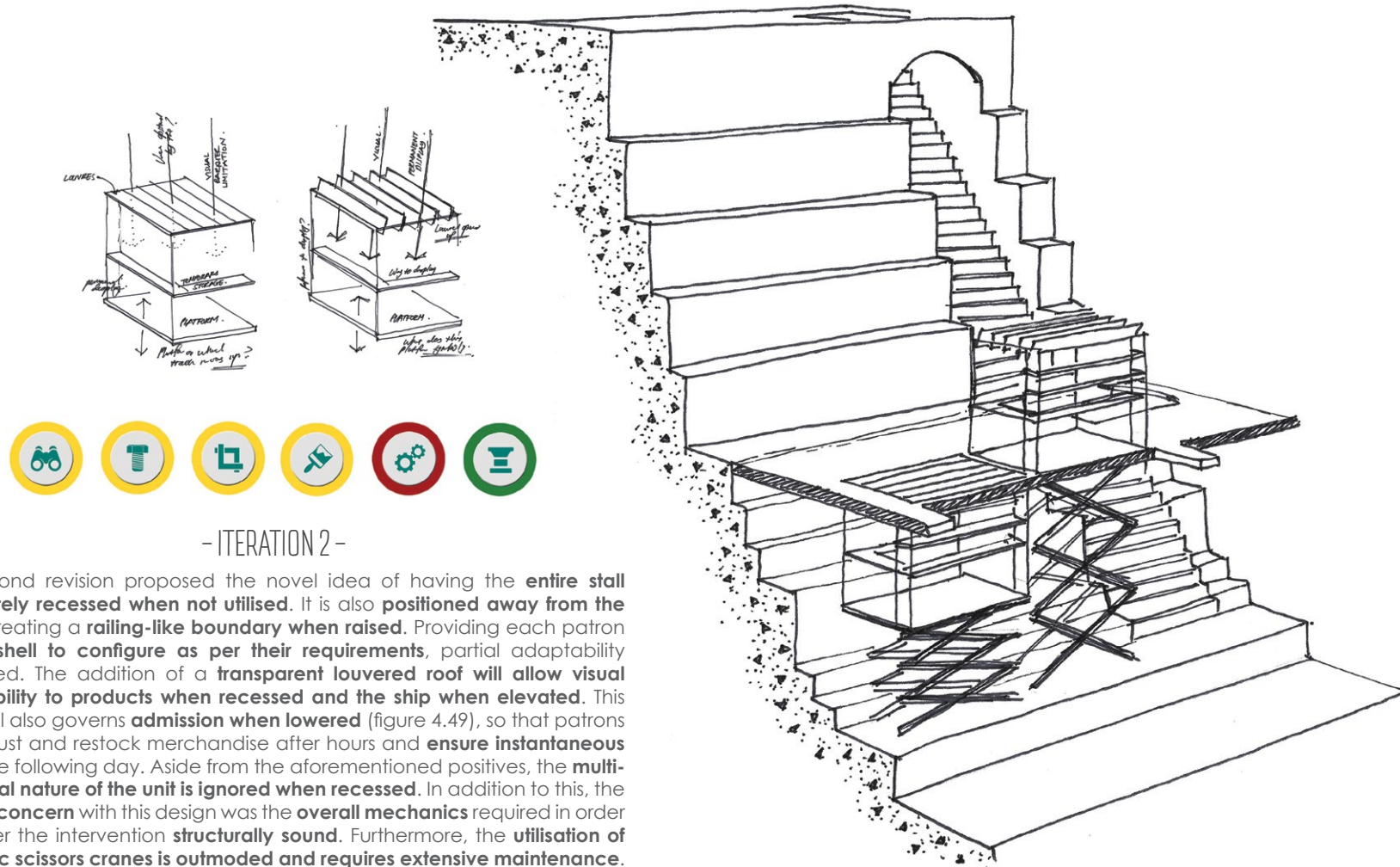

- ITERATION 2 -

The second revision proposed the novel idea of having the **entire stall completely recessed when not utilised**. It is also **positioned away from the dock**, creating a **railing-like boundary when raised**. Providing each patron with a **shell to configure as per their requirements**, partial adaptability is allowed. The addition of a **transparent louvered roof will allow visual accessibility to products when recessed and the ship when elevated**. This proposal also governs **admission when lowered** (figure 4.49), so that patrons can adjust and restock merchandise after hours and **ensure instantaneous setup** the following day. Aside from the aforementioned positives, the **multi-functional nature of the unit is ignored when recessed**. In addition to this, the **biggest concern** with this design was the **overall mechanics** required in order to render the intervention **structurally sound**. Furthermore, the **utilisation of hydraulic scissors cranes is outmoded and requires extensive maintenance**.

Figure 4.48. Market Stall Iteration 2 (Author, 2016)

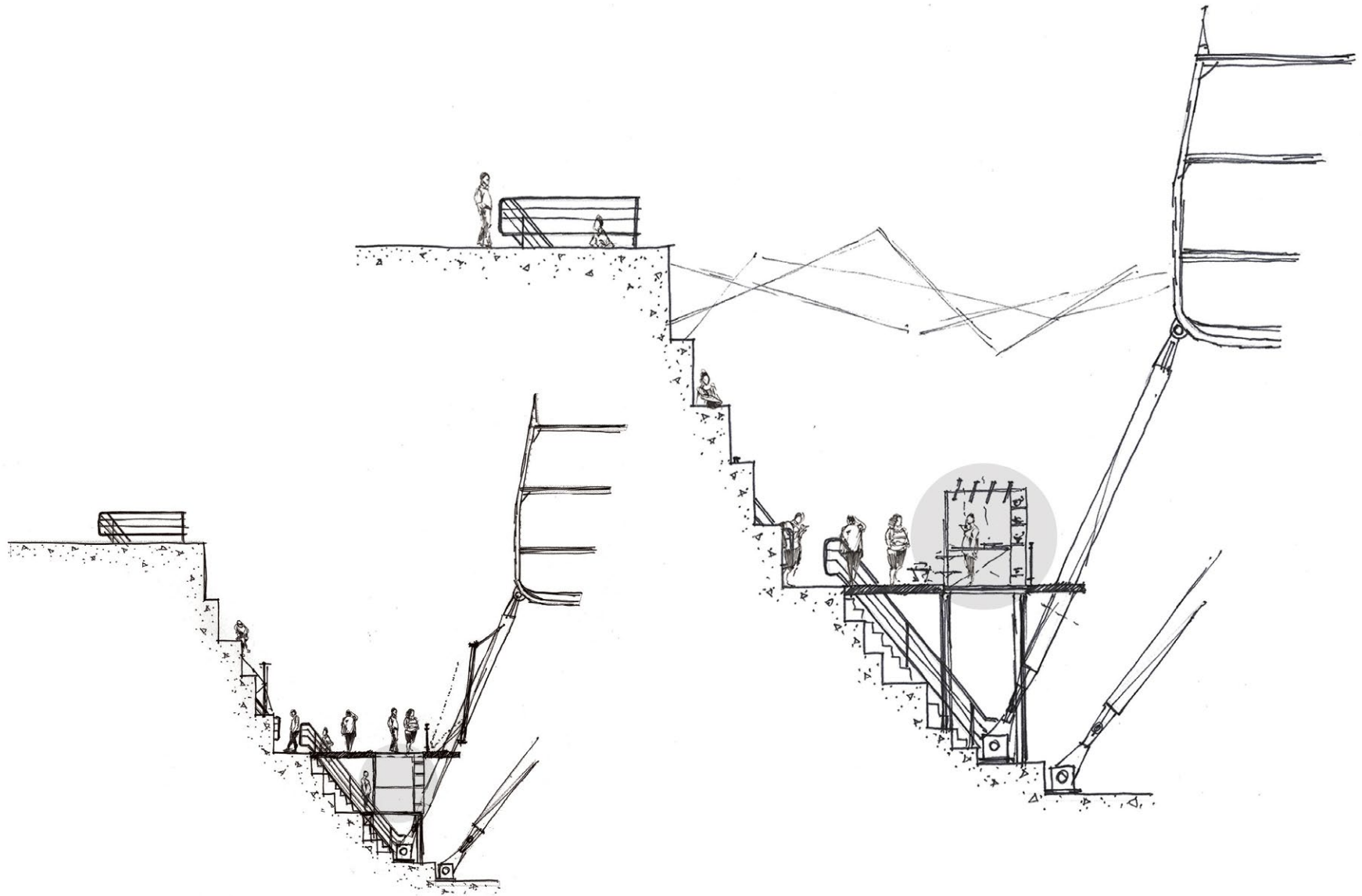

Figure 4.49. Iteration Below and Above Platform (Author, 2016)



Figure 4.50. Inspiration Palette Collection (Author, 2016)



- ITERATION 3 -

Reflecting on the said proposals, the third iteration provides a **combined revision**. Utilising the **pin point impression apparatus** (figure 4.50) as inspiration, the idea of **podiums as display**, which could be **recessed and raised individually**, was envisioned. The **central positioning** of the stall administers **all-round visibility and either side circulation**. As opposed to a central platform that was to be hoisted, **force is distributed evenly and direct load diluted through individual upheld**. As opposed to conventional hydraulics, the utilisation of **solar-powered electric actuators** will be used, which requires **less space, little maintenance and provide better structural support**. Patrons will have the opportunity to **configure** their platform with a **variety of podium types and arrangements** (refer to figure 4.53) that will be **preconfigured and elevated through central control when there is an active market**. The variety of configurations will permit the tubular podiums to be utilised as seating or tables when there is another event taking place.

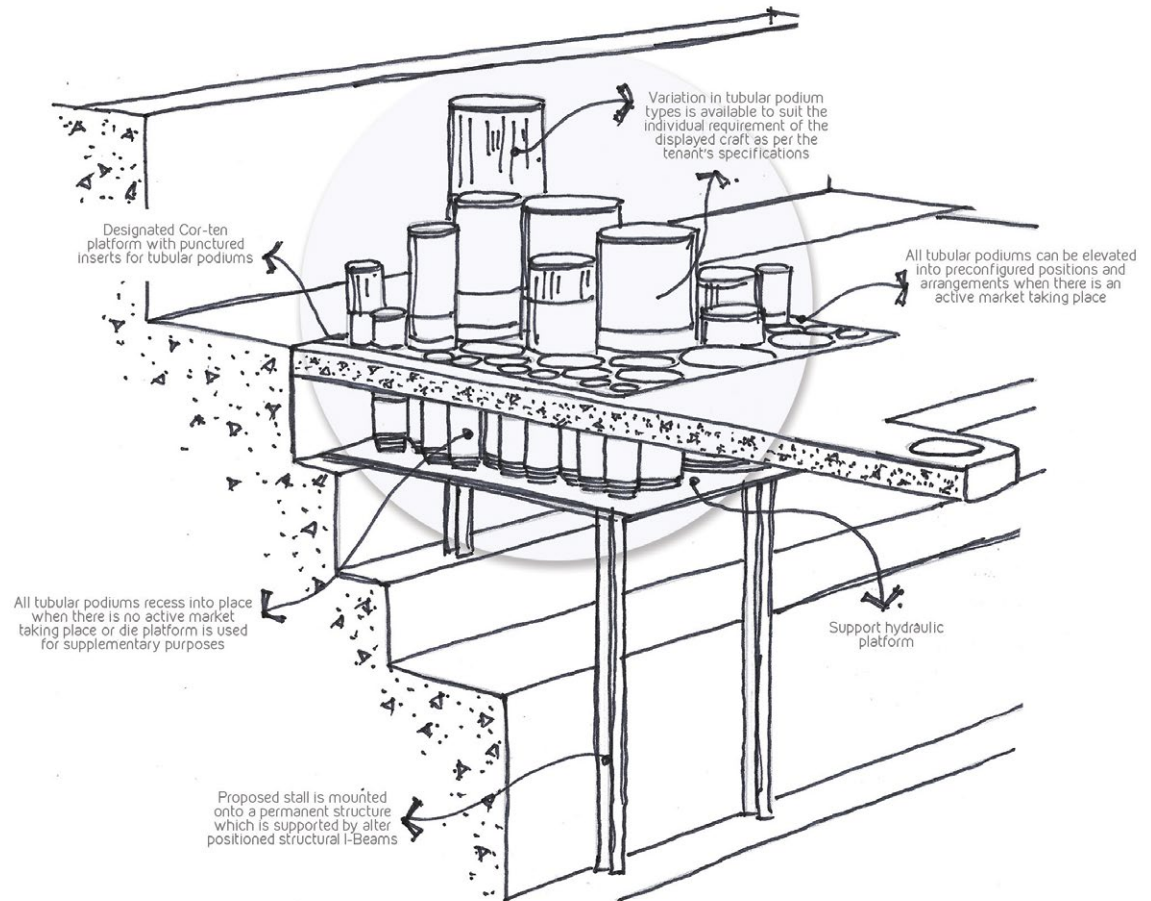

Figure 4.51. Market Stall Iteration 3 (Author, 2016)

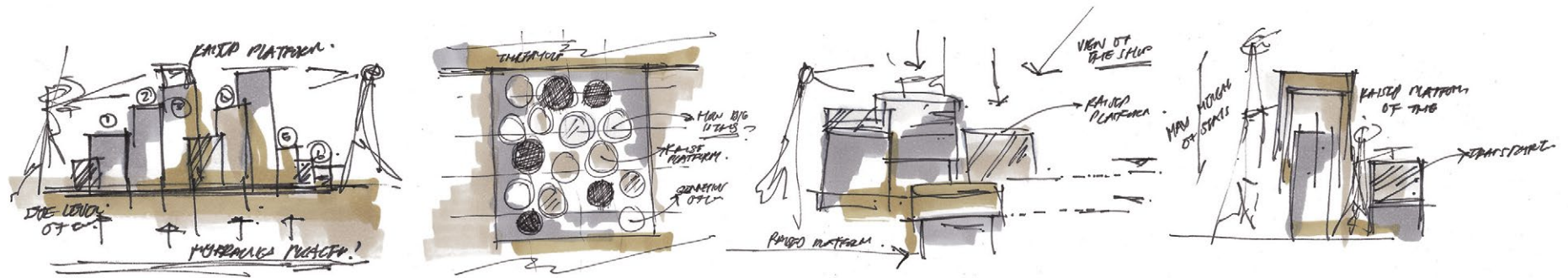

Figure 4.52. Conceptual Development of Iteration (Author, 2016)



Figure 4.53. Configuration Options (Author, 2016)



Figure 4.54. Inspiration Palette Collection (Author, 2016)



- FINAL STALL PROPOSAL -

The final iteration merely **amended the actual shape of the display podiums**. Through the conversion of circular to square podiums based on the above inspiration (figure 4.54), **waste of infill space is decreased** and the **actual display platform is increased**. Furthermore, modularity is correspondingly improved. With specific reference to figure 4.56, the provision of **various display types** permit a **wide array of display opportunities**. With the addition of a transparent compartment above, **protection** of expensive merchandise is governed when **elevated** and **continuous exhibition is provided when recessed**. As previously mentioned, this variety will license a **selection of configurations to suit the definite craft on display** (figure 4.57 - 4.59) and provide **additional usage for non-related occasions** (figure 4.60). In addition to the actual shape, **materiality is also improved**. This will be discussed momentarily in the technical chapter that follows (page 198). Though **highly novel and enthusiastic** in design, this stall typology is the only proposal that **meets all the predetermined requirements** - thus electing to implement it as a potential form of elucidation.

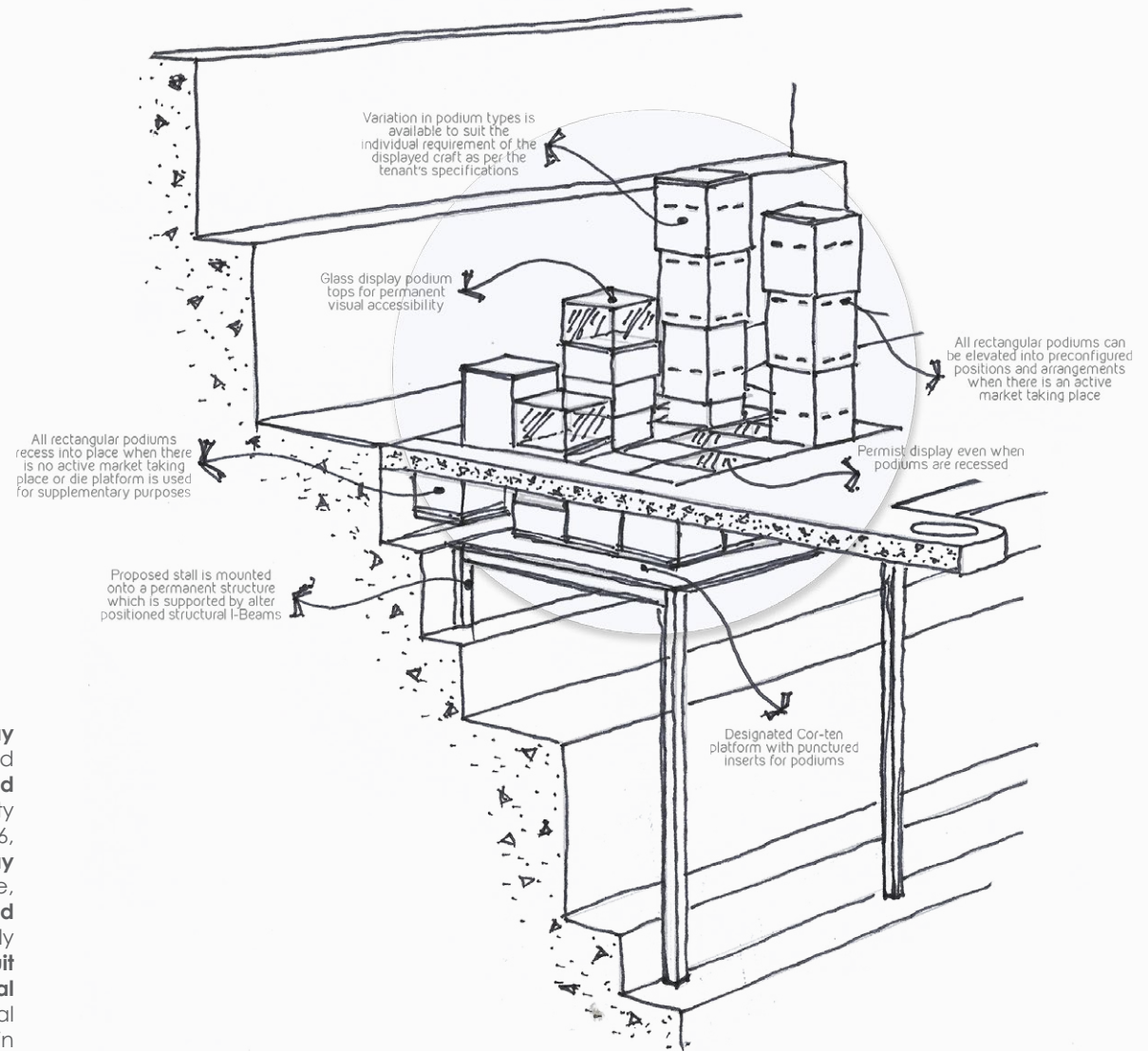

Figure 4.55. Final Stall Proposal (Author, 2016)

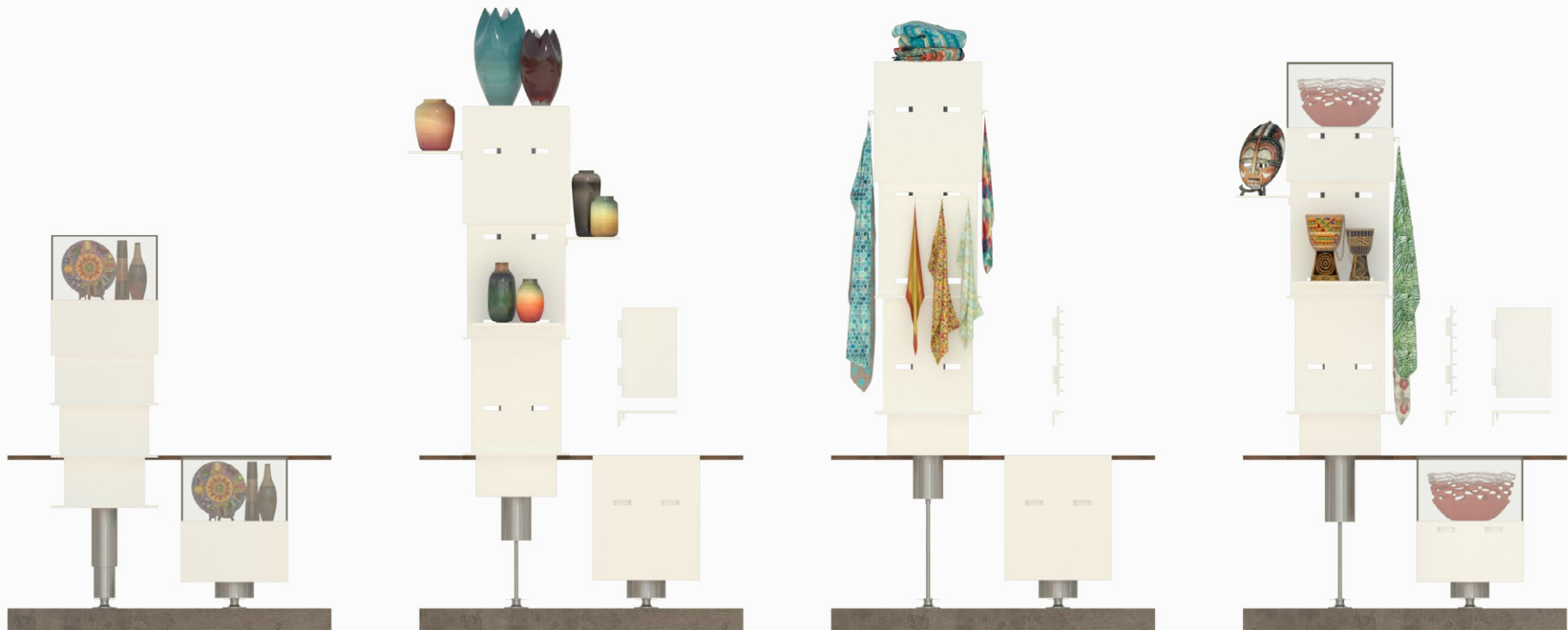

Figure 4.56. Configuration Options (Author, 2016)



Figure 4.57. Possible Arrangement 1 (Author, 2016)



Figure 4.58. Possible Arrangement 2 (Author, 2016)



Figure 4.59. Possible Arrangement 3 (Author, 2016)



Figure 4.60. Possible Arrangement 4 (Author, 2016)

4.9 CANOPY DESIGN

The **final component** of the envisioned **outer interior** that was to be addressed before the design of the inner interior could commence, is reserved for the addition of a **canopy that would enclose the frontal half of the dock**. The initial reasoning behind this was instigated by the Cutty Sark precedent and enthused by **geographical conditions on site**. The introduction of the canopy that **connects the host with the habitant would replicate the notion of water**, which as illustrated in figure 4.62, would be positioned in the location where **water would normally act as mediator** in a traditional dry dock. Using the work of Abdul Azri as inspiration (figure 4.63) the aesthetics of the canopy was **desired to be augmented**. Through these illustrated photographs, Azri wished to replicate the **current and hazardous conditions on a shipbreaking site**. His portrayal thereof influenced the **geometrical nature** of the canopy profoundly, romanticising the **force of the ocean and possible fate of all decommissioned vessels**.

As illustrated in figure 4.64, the development of possible solutions was investigated that would **correspond aesthetically and not hinder visibility**. The semi-finalised proposal (figure 4.65) never matured entirely due to a **change in approach** and question of true relevancy of this outer interior component. Ultimately, the complete enclosure of the dock was deemed **unnecessary**, as this would **isolate the dock from its surrounding** and **mere partial enclosure of certain areas was sufficient** against the elements. The later addition of a **scenic ramp** provided adequate enclosure and a way of **universal accessibility** (page 207).

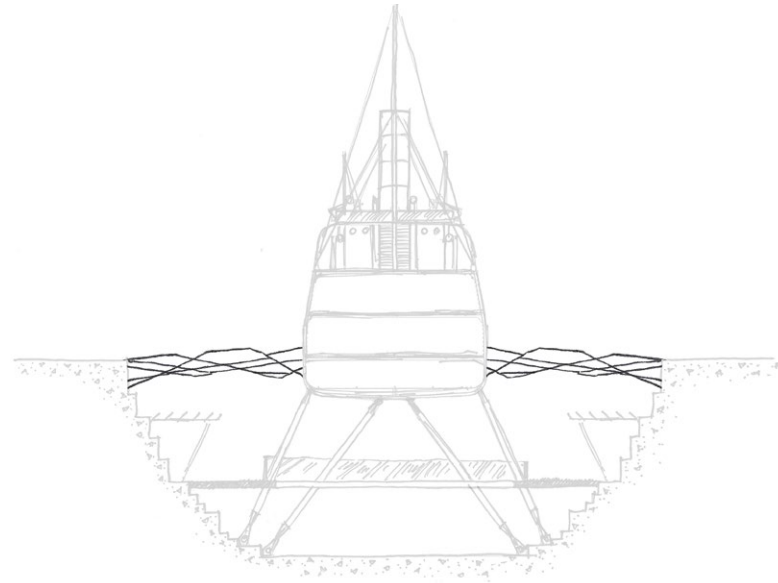

Figure 4.61. Canopy Design (Author, 2016)

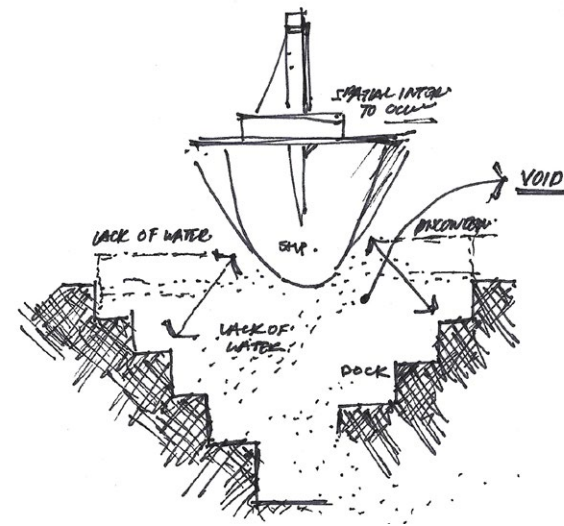

Figure 4.62. Canopy Mediation Between Host and Habitant (Author, 2016)

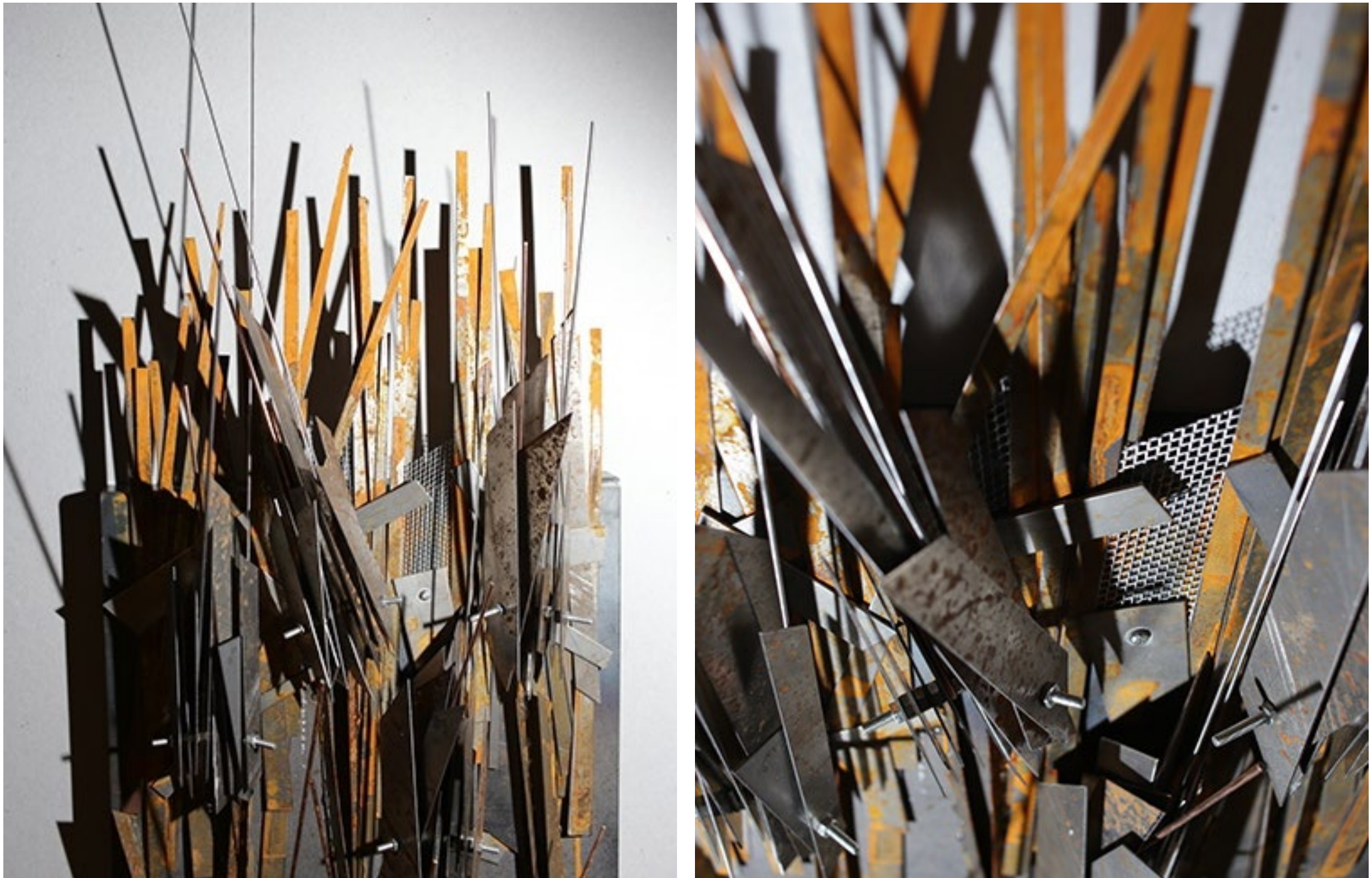

Figure 4.63. Figurative Representation of Conditions on a Ship Breaking Site (Azri, 2014)

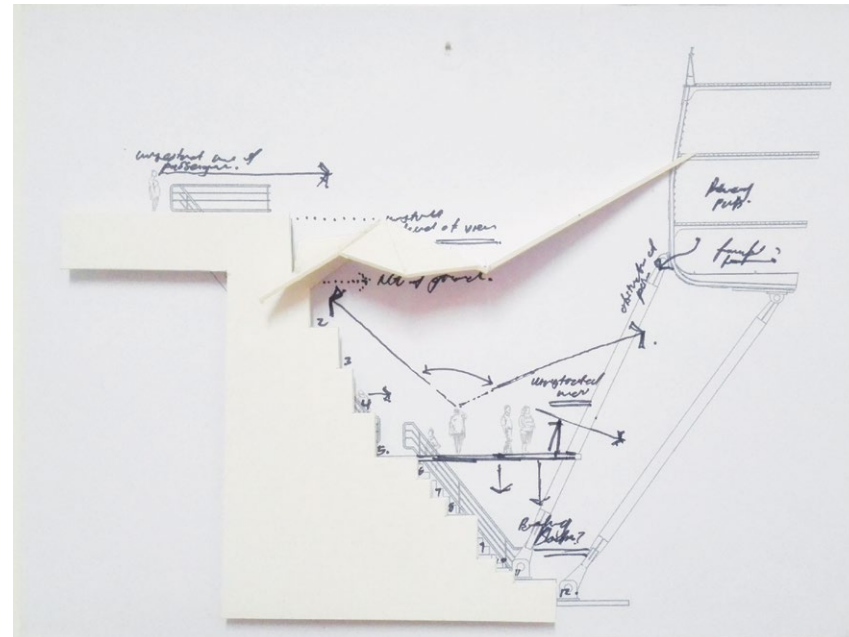
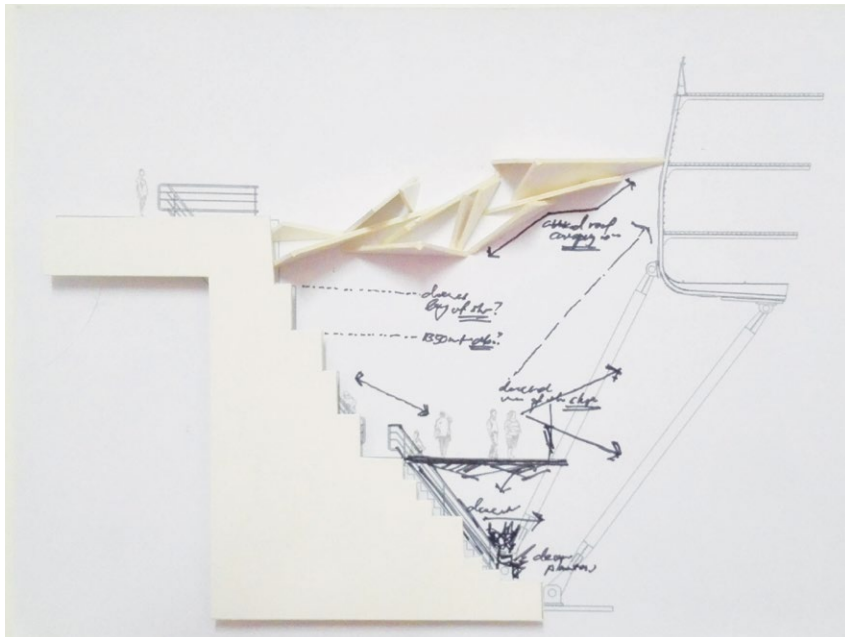
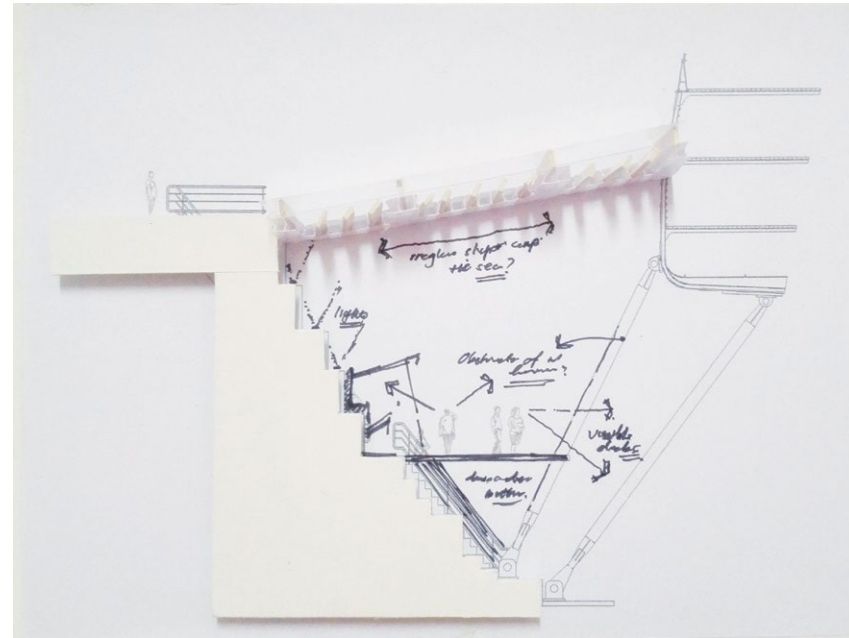
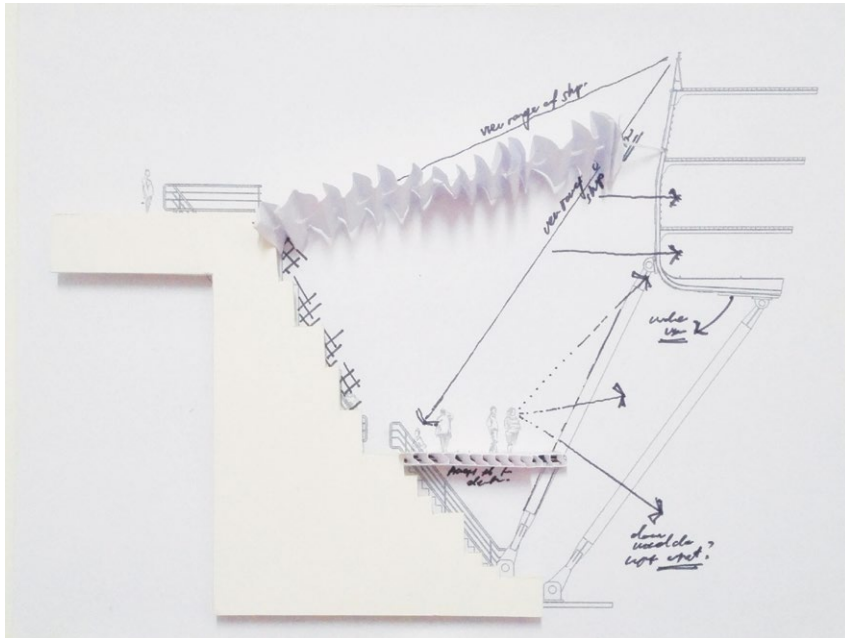

Figure 4.64. Canopy Maquette Development (Author, 2016)

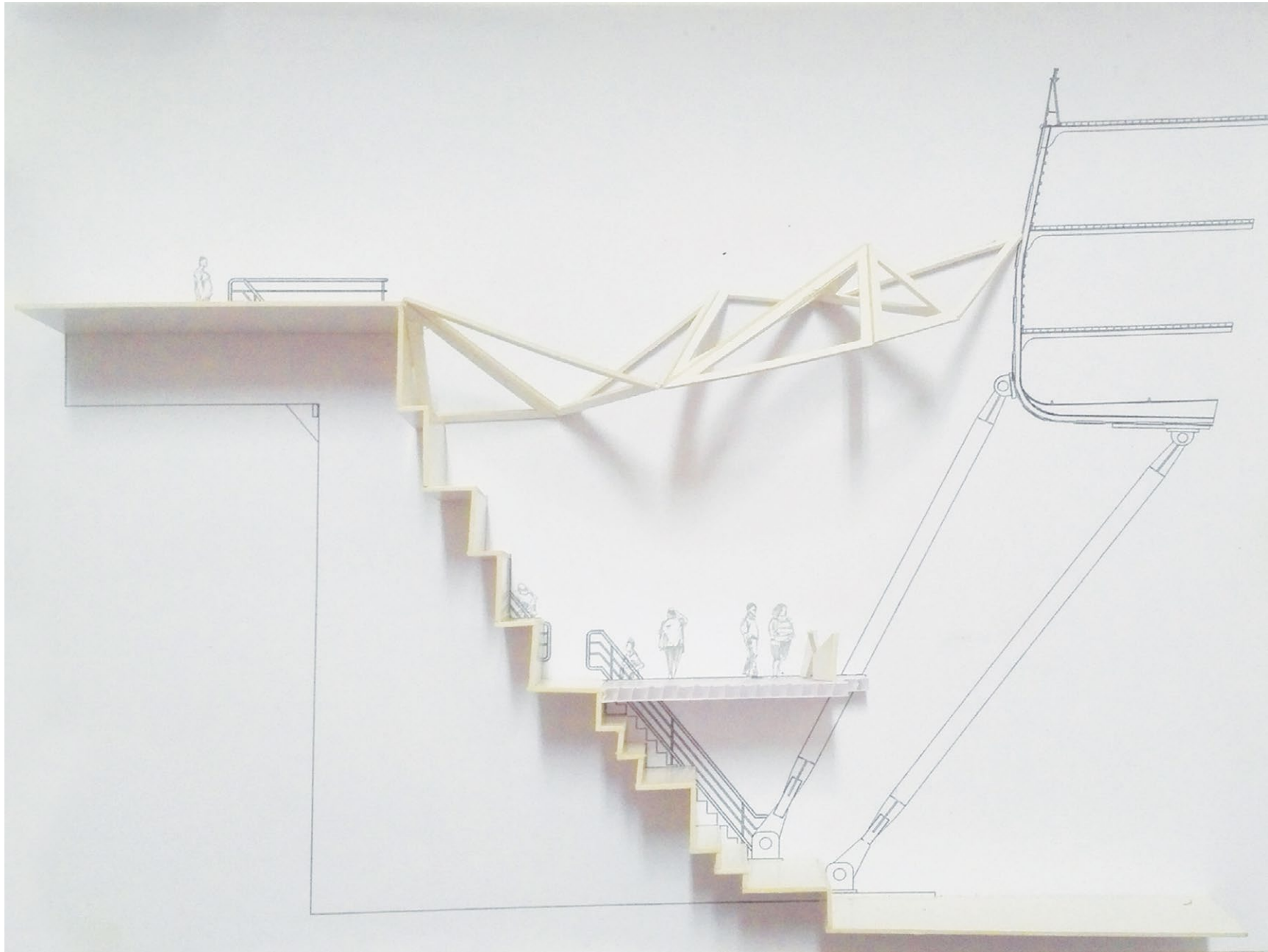

Figure 4.65. Semi-Finalised Canopy Maquette Proposal (Author, 2016)

4.10 BREWERY DESIGN

Diverting attention away from the outer interior and towards the **design of the inner interior**, the **ideal positioning** of the envisioned brewery onboard the SS Nomadic was to be determined. In appendage to the **actual production space** required for the brewing of this alcoholic beverage, the **addition of ample environments must be provided where the process can be observed and consumed**.

After thoughtful consideration, the design proposes the **brewery to be located in the bow (front)** section of the ship. As this portion of a ship customarily accommodates hefty machinery and a substantial amount of cargo, the **bow's frame is reinforced** and will thus be able to **board all associated fermentation equipment**. In addition to the assurance that the bow will be able to provide sufficient support, the **variety of interior conditions** associated with its relevant class will attest beneficial when investigating **materiality**.

Taking the abovementioned into cautious contemplation, the proposal of the brewery to be located on the **frontal lower decks** ascertained to be the most suitable possibility (refer to figure 4.67). This provides additional opportunity to establish a **visual link between the inner and outer interior**.

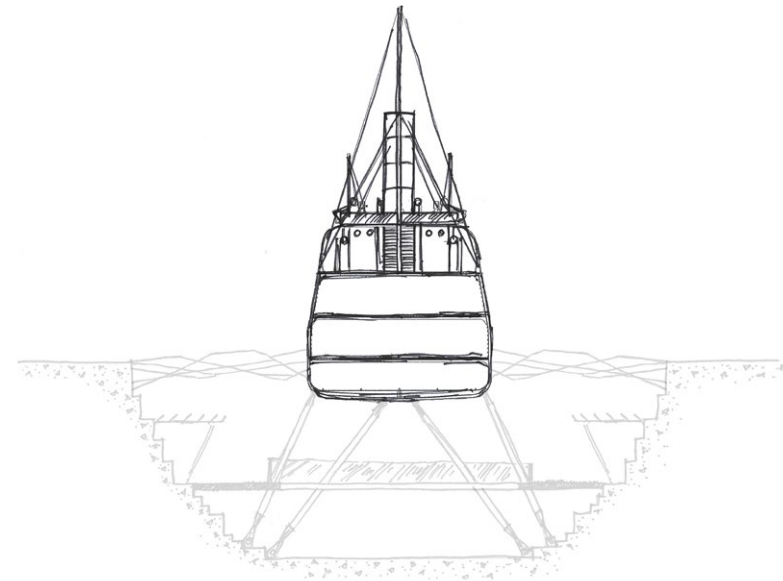

Figure 4.66. Inner Interior Brewery Design (Author, 2016)



Figure 4.67. Proposed Positioning of Brewery and Beer Cafe (Author, 2016)



Figure 4.68. First Class Lower Level Lounge (McDonald, 2013)

- FIRST CLASS LOWER LEVEL LOUNGE -

Smallest of the two lounges positioned at lower deck level, was the continuation of a lounge area for First Class passengers **forward of the boiler room**. Lit by **portholes** on either side and **accessed via stairs** down from the larger First Class lounge on the upper deck, it was designed to accommodate **lifebelt storage** at forward and aft ends and was **fitted with seats and tables**.



Figure 4.69. Lower Deck Spare Space (Sweeney, 2011)

- LOWER DECK HOLD AND SPARE SPACE -

This **large** spare space, **accessed from a hatch** on the forecastle deck, is located forward of the First Class lounge on the lower deck. Used for additional cargo, supplementary storage space is provided in the hold directly below. The main storage space is **connected to an additional hold** located beneath the First Class lounge on the lower deck, running the **entire length of the bow**.

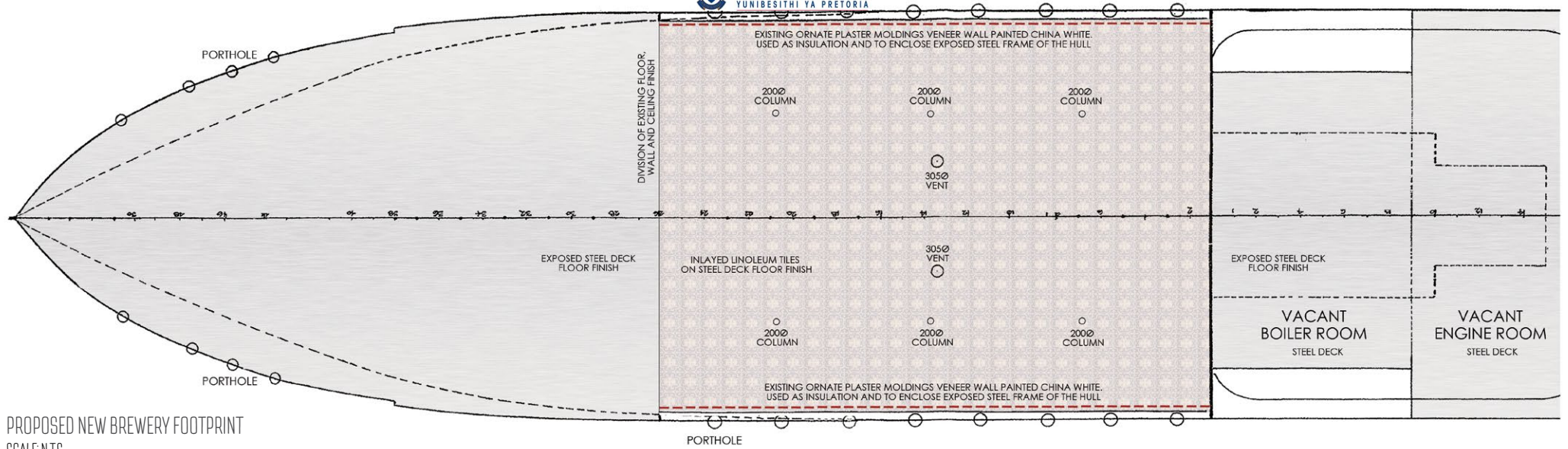

PROPOSED NEW BREWERY FOOTPRINT
SCALE: N.T.S

Figure 4.73. Proposed New Interior Footprint (Author, 2016)

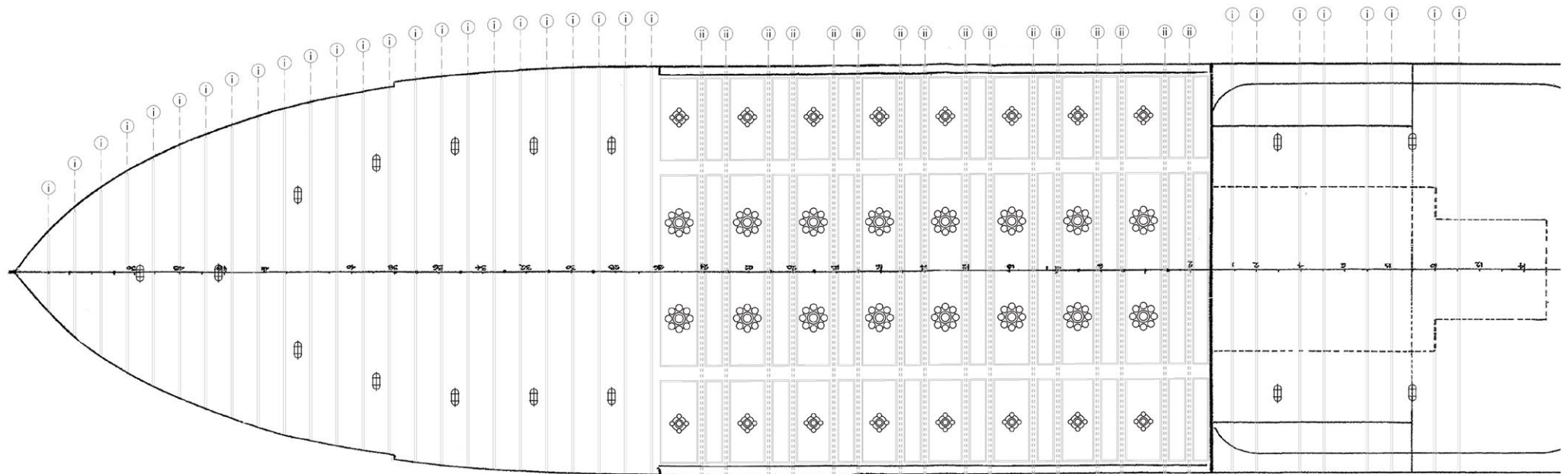

HULL FRAME LEGEND

- i EXPOSED MILD STEEL I-BEAM FRAME
CARGO, EXTRA, CREW AND BOILER SPACE
- ii PLASTER CLADDED MILD STEEL I-BEAM FRAME
FIRST CLASS LOUNGE AREA

ARTIFICIAL LIGHTING LEGEND

- i BRONZE OVAL BULKHEAD LAMP
CARGO, EXTRA, CREW AND BOILER SPACE
- ii BRONZE DECK HEAD LAMPS
FIRST CLASS LOUNGE AREA
- iii BRONZE GILT GLASS ELECTROLIER
FIRST CLASS LOUNGE AREA

FRAME AESTHETICS AND CEILING LAYOUT
SCALE: N.T.S

Figure 4.74. Frame Aesthetics and Ceiling Layout (Author, 2016)

DESIGN CONSIDERATIONS

- HULL AND FRAME PROFILES -

The SS Nomadic was built using traditional **open-floor flush-riveted steel** construction and employed similar **materials, techniques, and workforce** used to design all iconic **steel vessels of the Industrial Revolution** (Keyzar, 2009:129). Based on **typology and scale**, the hull was designed to be **round in shape** and comprised out of series of **uniformly spaced steel frames**. Bottom brackets and side deck beam knees were secured to every frame which was riveted at their lower end to the side plate of the double bottom and held in position at the top by a **steel ribband**.

The deck beams, which were **'cambered' or curved** in order to provide a run-off from the main deck, were bolted to the beam knees and held apart by additional **timber battens**. In total, the hull of SS Nomadic was constructed from **108 frames** (refer to figure 4.76) with most **varying in profile**. As illustrated in figure 4.75, the profiles on the right side are for the frames from the middle of the vessel to the stern, whilst those on the left are from the middle of the vessel to the bow.

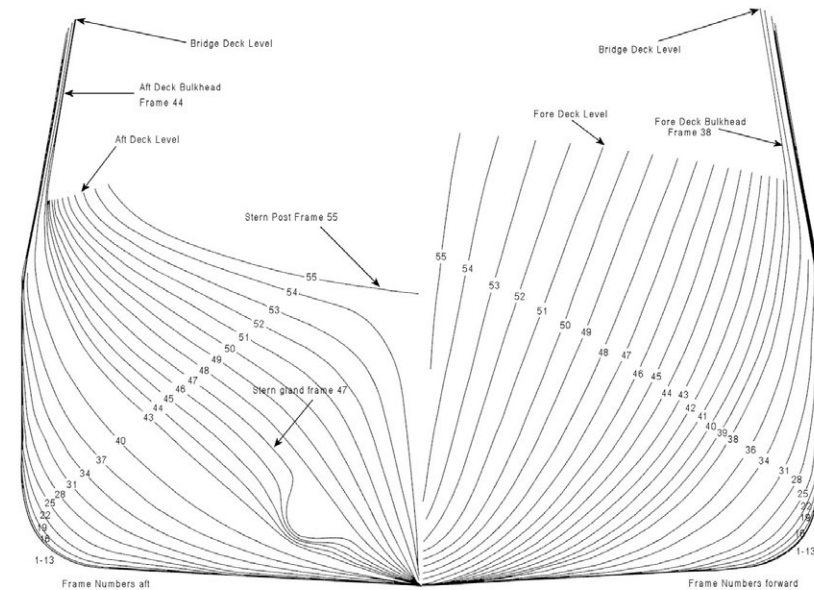

Figure 4.75. Frame Station Profile Guide of SS Nomadic (Pitchard, 2009)

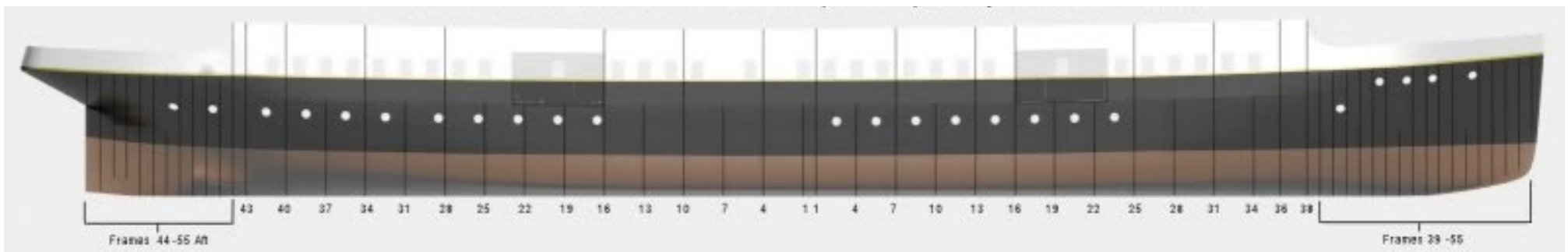

Figure 4.76. Frame Station Elevation Guide of SS Nomadic (Pitchard, 2009)

The complete assemblage of the frames permitted a **functional exterior profile and inimitably shaped interior**. Provided that the **brewery will be positioned in the bow**, distinct **rapid variation in frame profiles** can be noted instantaneously (refer to figure 4.77). The identification of **three distinct profiles** differing quite significantly in outline and scale were noted. Starting at the central boiler rooms and progressing forwards, the interior profile is **relatively uniform** (figure 4.78) and provides **ideal marine interior conditions**. Succeeding towards the bow, the U-shaped outline is bent upwards (figure 4.79), affording **sporadic spaces and decreasing the interior's clear width**. The final frame outline up to the bow's tip (figure 4.80) is **comparatively convex** and is normally **reserved for storage facilities, as the interior quality thereof is bantam**.

Subsequently, the brewing café will be positioned on the upper level where the frame profile is U-shaped. This will provide an **optimal interior environment and best utilisation of the acquired clear width of the space**. Furthermore, the brewing equipment will be positioned forwards in the **narrowly defined profiles**, utilising the **tapered doubles volumes where high levels of comfort are not required**.

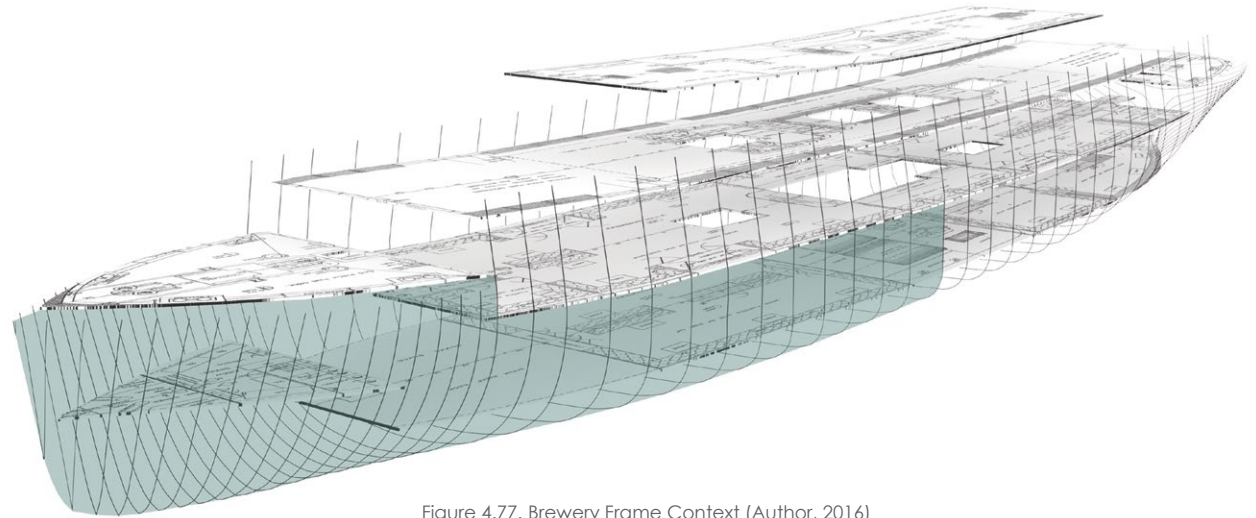

Figure 4.77. Brewery Frame Context (Author, 2016)



Figure 4.78. U-Shaped Frame Profile (Author, 2016)

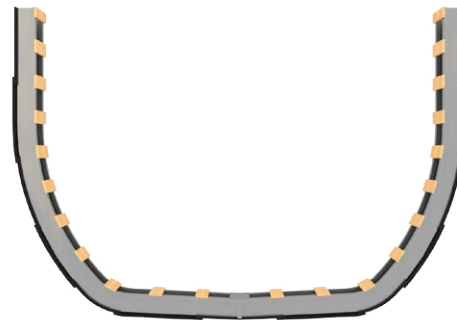

Figure 4.79. Upward Bent U-Shaped Frame Profile (Author, 2016)

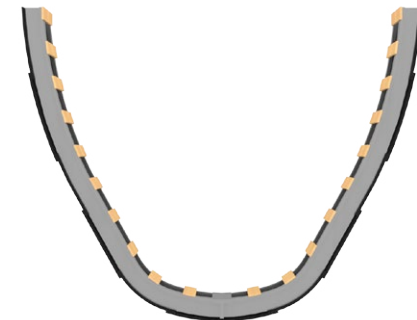

Figure 4.80. V-Shaped Frame Profile (Author, 2016)

- LAYERED HULL COMPOSITION -

Hosting **opportunity to perceptibly illustrate the vital process of layering**, the composition of the ship's hull will be used as design incentive. Upon dissection of the hull, one can clearly take note of **four distinct layers** (refer to figure 4.81 - 4.83). When combined, these **layers create a palimpsest in the form of a ship**. Dictated by locality and class, these layers are either **partially exposed or completely enclosed**. First and Second Class areas would normally be insulated with the fourth, **decorative layer**. This was to enhance **aesthetics and provide acoustic and thermal insulation**. Third Class and cargo areas are normally left **exposed**, with only the **two primary layers** (hull plates and steel frame) enclosing these spaces.

This **intricate composition** will host interesting design opportunity, as the **proposed brewery stretches over a variety of class fluctuating interiors**.



Figure 4.81. Permanent Stall Location on Proposed Platform (Author, 2016)

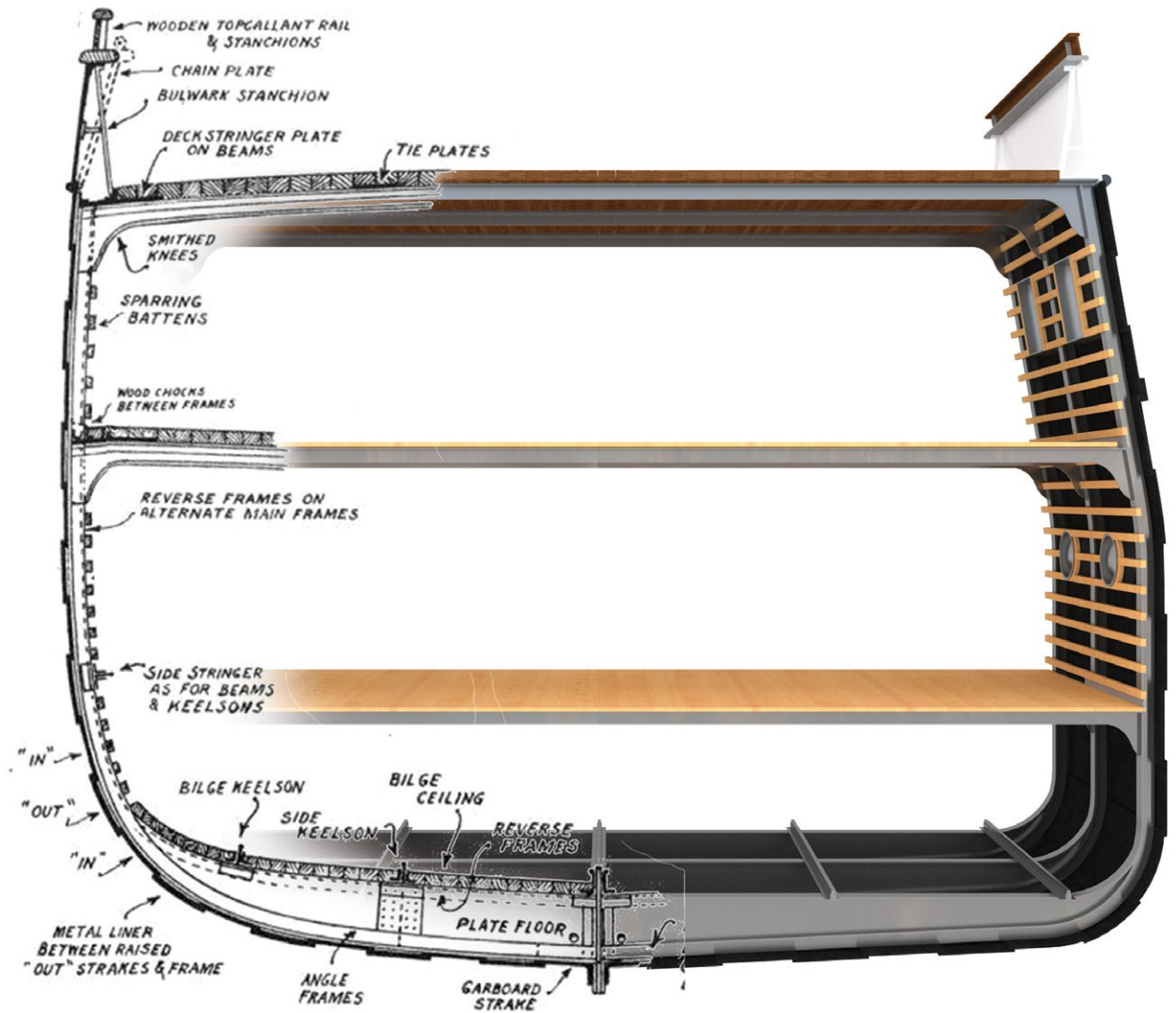
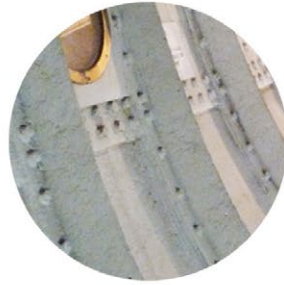

Figure 4.82. Permanent Stall Location on Proposed Platform (Author, 2016)



LAYER ONE
HULL

The initial outer layer that consists out of riveted steel plates configured in an overlaying fashion. This was an iconic feature for ships of the industrial revolution, and will prove vital when considering the portrayal thereof



LAYER TWO
FRAME

The second layer is reserved for the steel frame onto which keel plates are mounted. In addition to this, the frame also dictates the specific profile of the ship and forms the structural skeleton of the entire vessel.



LAYER THREE
BATTEN

The third layer consists out of a long flat strip of squared timber used to hold paneling in place or as a fastening against a wall. This molds the final interiority of a space and adorned in order to conceal honesty



LAYER FOUR
VENEER

The final layer is reserved for the purpose of ornamentation and forms the actual finish. This layer completely encloses structure, and creates a false façade that manipulates the visual aesthetics of the interior.



Figure 4.83. Permanent Stall Location on Proposed Platform (Author, 2016)

- EXISTING VENTILATION -

Aside from **natural ventilation** provided by the portholes when opened, **existing dorade apertures** provides **passive ventilation** into enclosed interiors below deck. As modern cruise liners utilise contemporary heating, ventilation and air conditioning (HVAC) systems, this form of passive ventilation is no longer utilised nowadays in naval design. **Positioned centrally** in the lower lounge area (refer to figure 4.84), two vents are directly connected to a rectangular timber case positioned on the flying bridge deck (figure 4.85). As illustrated in figure 4.86, this box is fitted with two freestanding interleaving vertical baffles that form a series of chambers. Facing forward, the horn shaped ventilation cowl **feeds cool air** into the case. Operating on the principle that air can pass relatively freely across the chambers, **rain and sea wash remains trapped in a successive chamber** which drains out through perforated openings (Brewer, 1994:75). As a result, **cool fresh air floods** the area connected to the secondary baffle, permitting each dorade vent to only feed one area in order to **assure pressure and adequate ventilation**.

Being that the vessel will be **stationary**, **inlet air will have to be amplified** in order to be of any significance. Furthermore, the vent is to be configured in such a fashion that the **incoming amount of air can be controlled**.

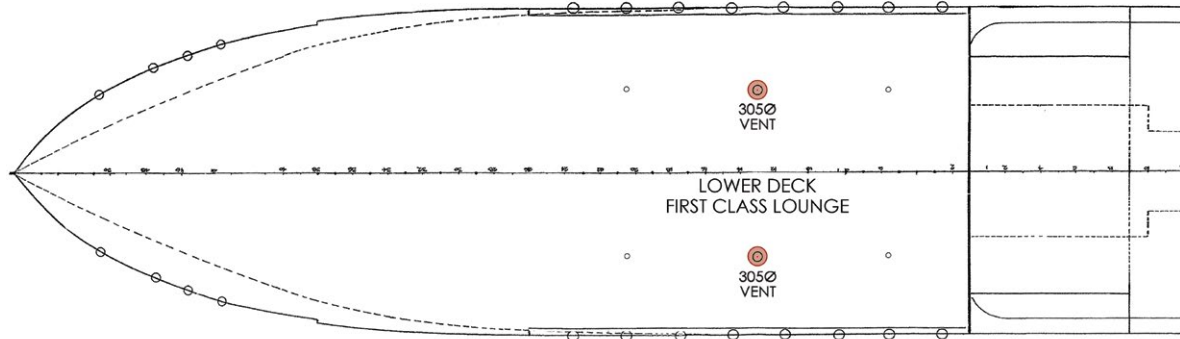

Figure 4.84. Locality of Existing Dorade Ventilation Shaft (Author, 2016)



Figure 4.85. Lower First Class Lounge Dorade Vent on Flying Bridge Deck (McDonald, 2013)

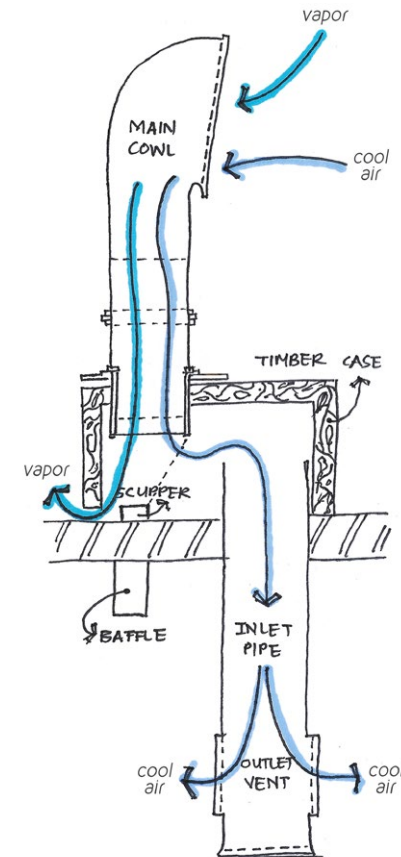

Figure 4.86. Diagrammatic Illustration of a Functioning Dorade Vent (Author, 2016)

- EXISTING LIGHTING -

Being located on the lower deck, the selected shell is subjected to **little natural light**. Other than **direct daylight provided by the 16 portholes of 450mm in diameter, all accompanying light is provided artificially**. Ample decorative light features provide abundant **general illumination**, replicating that of a **hotel's interior**. As maritime travel was generally regarded as being an arduous activity during the Industrial Revolution, **superior land-like comfort** was provided in order to compensate for the fact of being on water. Utilising **two distinct variations of light features**, deckhead lamps (figure 4.89) were positioned along the outer perimeter (overhead of former benches) and two rows of electrolier chandeliers (figure 4.90) positioned midway. The spare space and boiler room employed bulkhead lamps (figure 4.91) as a form of illumination.

As per **SANS 10114**, the luminous flux (lm) per square meter in areas where **visual tasks are only occasionally performed** must be above **150 lm**. As per calculation conducted in figure 4.88, it was determined that the current overall illumination levels of the existing First Class lower lounge area be considered **'moderately adequate, with room for improvement'**. As most decorative light fittings were **re-wired during restoration in 2012**, the usage of **incandescent light bulbs are employed**. This will however be refitted with light-emitting diode (LED) bulbs in order to **improve levels of illumination and lower electricity usage**.

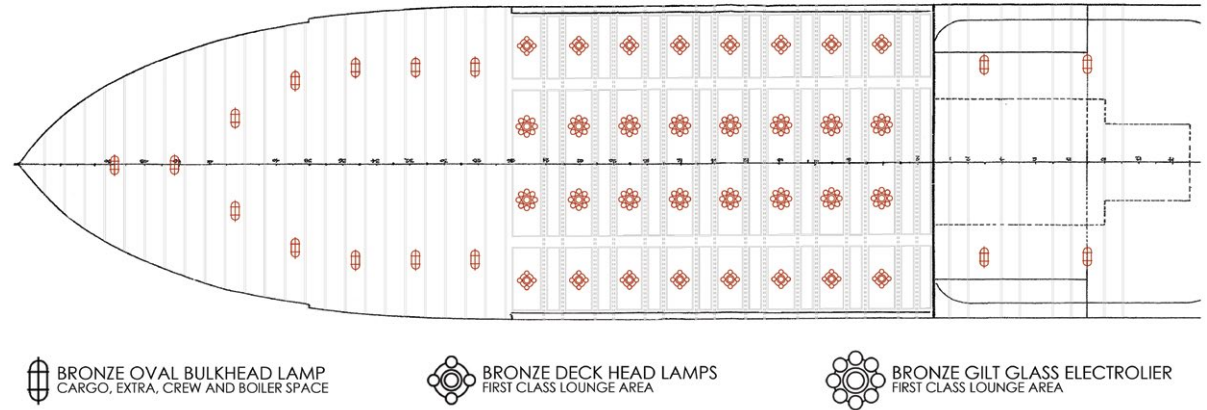

Figure 4.87. Locality of Existing Lighting (Author, 2016)



DECKHEAD LAMP

nickel-plated brass fittings with vented band and frosted cut glass shade

size
280 mm high

light source
incandescent light bulb warm white 40 W and 290 lm

total luminous flux
290 lm/m²

illumination ies map

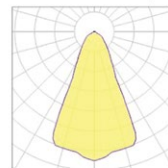

ELECTROLIER CHANDELIER

bronze gilt with glass beaded shade on wire frame with fittings for three lamps

size
300 x 300 mm

light source
incandescent light bulb warm white 40 W and 290 lm

total luminous flux
870 lm/m²

illumination ies map

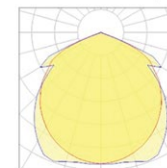

BULKHEAD LAMP

victorian flush frame lamp made from solid brass with a frosted glass shade

size
275 x 215 mm

light source
incandescent candle bulb warm white 60 W and 840 lm

total luminous flux
840 lm/m²

illumination ies map

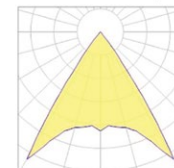

Figure 4.88. Current Lux Levels of Interior (Author, 2016)

Figure 4.89. Deckhead Lamp (Author, 2016)

Figure 4.90. Electrolier Light (Author, 2016)

Figure 4.91. Bulkhead Lamp (Author, 2016)

- EXISTING MATERIALITY -

The interior of the First Class areas onboard the SS Nomadic was designed according to the **Jacobean-style - elaborate and highly decorative** - similar to the interiors of her sister ship, the RMS Titanic. Following **strict conservation policies** under direct guidance of the Nomadic Preservation Society, the **interior was faithfully restored**. Having demolished the outer walls of the lower lounge, the **material honesty is exposed through the complete visibility** of the steel hull. This **resilient contrast will be celebrated** as design opportunity that tangibly illustrates the aforementioned theories. **Four distinct varieties of existing, material choices** were noted, as illustrated in figure 4.92.

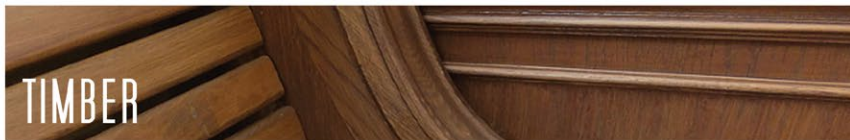

TIMBER

Fine English Oak inlaid with boxwood, ebony and satinwood cross-banding was used in all First Class lounge areas. This was sealed and polished with clear varnish in order to highlight contrasting colours and textures and outline actual originality. Furthermore, slatted oak was used for the bench seating, with elaborately carved armrests and fixed legs. Mahogany was used in all Second Class lounge areas.



LINOLEUM

All First and Second Class lounge areas were fitted with richly ornamented inlaid linoleum floor tiles. Retained on top of flushed steel decking and/or pinewood panels, this choice in material provided optimal durability (high traffic of passengers and their belongings) and easy maintenance. The tiles are bright rust red, dark grey and yellow cream in appearance, with a high gloss finish.



PLASTER

Apart from the decorative carving and Jesso plasterwork found on the walls, the ship's structure was clad with dove white painted Gypsyn plasterwork which operated as soft ceiling to conceal the steel frame. The craftsmanship remains exquisite with most original "boiseries" (elaborate carving, rosettes and molds) still present in a distinct symmetrical appearance.



STEEL

Completely contrasting the perceptible decorative materiality of the lounge area, mild steel is utilised for the hull plates and frame. The frame is either clad with decorative moldings to conceal it, painted white or remain exposed, depending on where it is employed. This material evokes the true honesty of industrially designed vessels, thus aspiring to celebrate it instead of mere concealment.

Figure 4.92. Existing Materiality of Brewery Interior (Author, 2016)



Figure 4.93. Inspiration Palette of Look and Feel (Author, 2016)

- ENVISIONED LOOK & FEEL -

The desired look and feel of the envisioned interior will comprise out of a **migration between contemporary and industrial design**. Utilising the basic **principles of design**, special attention will be directed towards the **selection, application and joining of all materials**. The overall approach to materiality will either **govern a material's fortification or degradation**. This methodology will not only be applied to all **newly introduced materials, but to all existing steel and concrete** as well. As illustrated in the aesthetical temper palette (figure 4.94 - 4.102), the **honesty of the selected materials will be celebrated**. This form of honesty will be accentuated through **protection, deterioration, concealment or exposure**, all **harmoniously employed to showcase the process of intentional layering**. A combination of **aged and novel techniques** will be exercised that either **contrast or migrate the new from the existing**. Moreover, supplementary inspiration was drawn from iconic elements associated with **nautical design**, and the progression thereof.

All in all, an **interior palimpsest** which tangibly illustrates the lapsing **effect of time and prospect of corrosion espousal** is envisaged.



Figure 4.94. Combined Materiality (Author, 2016)



Figure 4.95. Decay Concrete Lamp (Unknown, 2015)

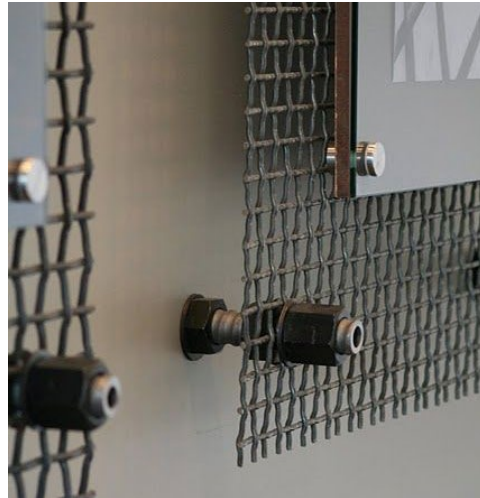

Figure 4.96. Metal Screens (Clemon, 2011)



Figure 4.97. Reclaimed Pendants (Hometalk, 2014)



Figure 4.98. Steel & Concrete (Shamia, 2015)



Figure 4.99. String Hexnut Bracelet (Unknown, 2011)



Figure 4.100. Rusted Chains (Unknown, 2014)



Figure 4.101. Molding and Casting (Lowe, 2012)



Figure 4.102. Warehouse 17C (Fernandez, 2006)

SPATIAL TRANSLATION

- PROPOSED UPPER LEVEL LAYOUT -

As illustrated in figure 4.103, the upper layout of the overall brewery follows a **distinctively symmetrical arrangement**. In contrast with the asymmetrical layout of the dock below, **naval architecture imposes an equally proportioned interior which uniformly distributes onboard weight and influence**. The novel introduction of a **central atrium space**, allows for the **inner interior to live out onto the outer interior**. Furthermore, the induction of an elevator permits **direct access** from the dock to the upper level of the brewery. Passing the point of sale, **repurposed bench seating** is provided along the outer perimeter of the enclosed interior. Modern raised seating **intermediates the original configuration** and allows for an extended, central clear width.

Sited on a **one-way tempered glass platform**, group seating (**adaptive reuse of aged anchor winches**) is imparted with **direct access to communal beer taps**, which is connected to the **beer keg tubes** below. The platform permits **downward visibility into the lower level brewery and dock**. Furthermore, inlaid gears figuratively **symbolise the initiation of ageing**, which is accentuated through the outer illuminated threshold that indicate a **change in materiality**.

Leading up to the bow of the ship, the actual **fermentation process is observable** through a profile-fitted **panoramic platform** that permits **continuous all-round visibility**. Faux oxidation creep up along the outer boundary of the raised walkway in order to **tangible exemplify the development of material degradation**. Ultimately, the **honest materiality of the habitant is celebrated** as one progresses through the space.

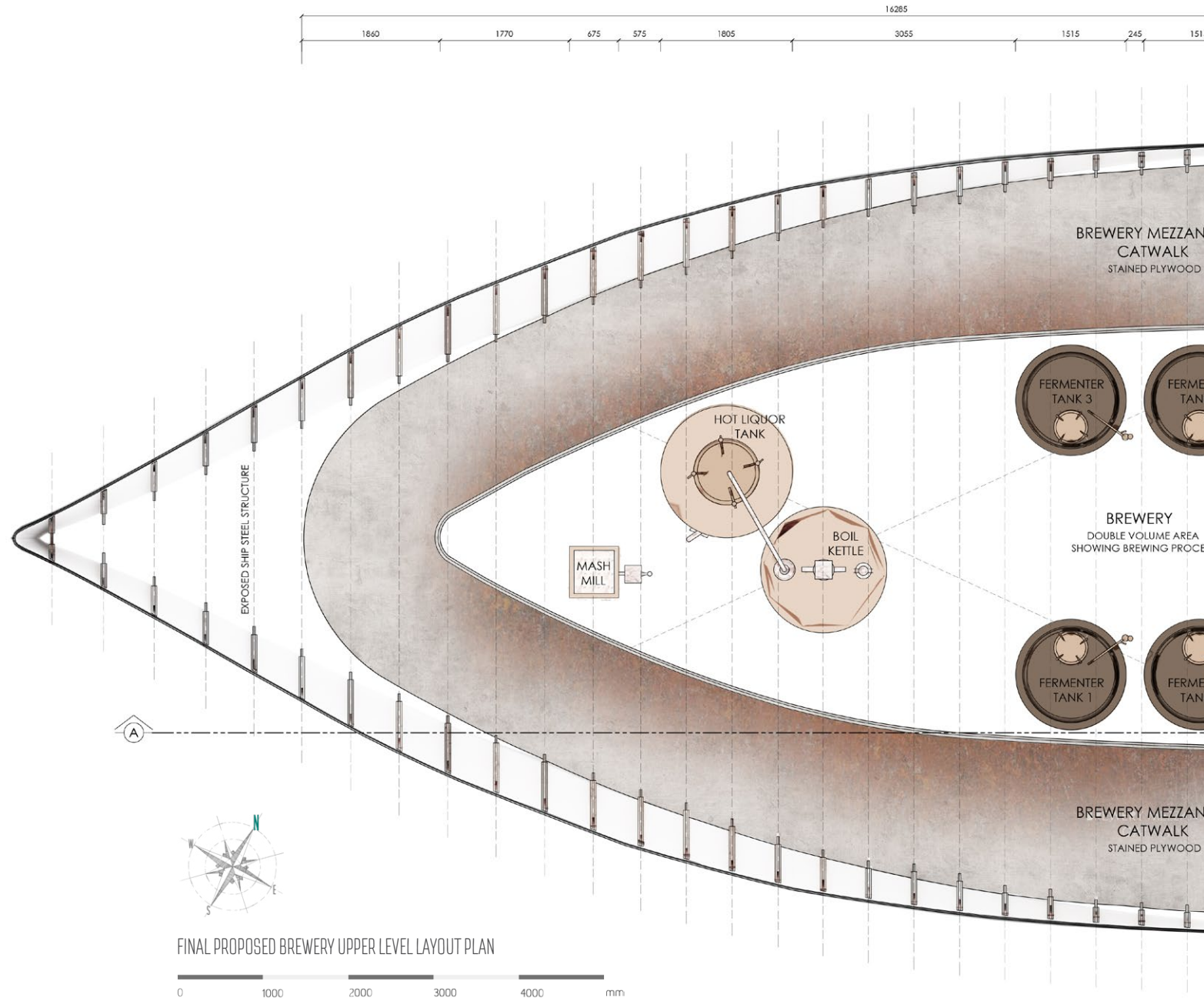

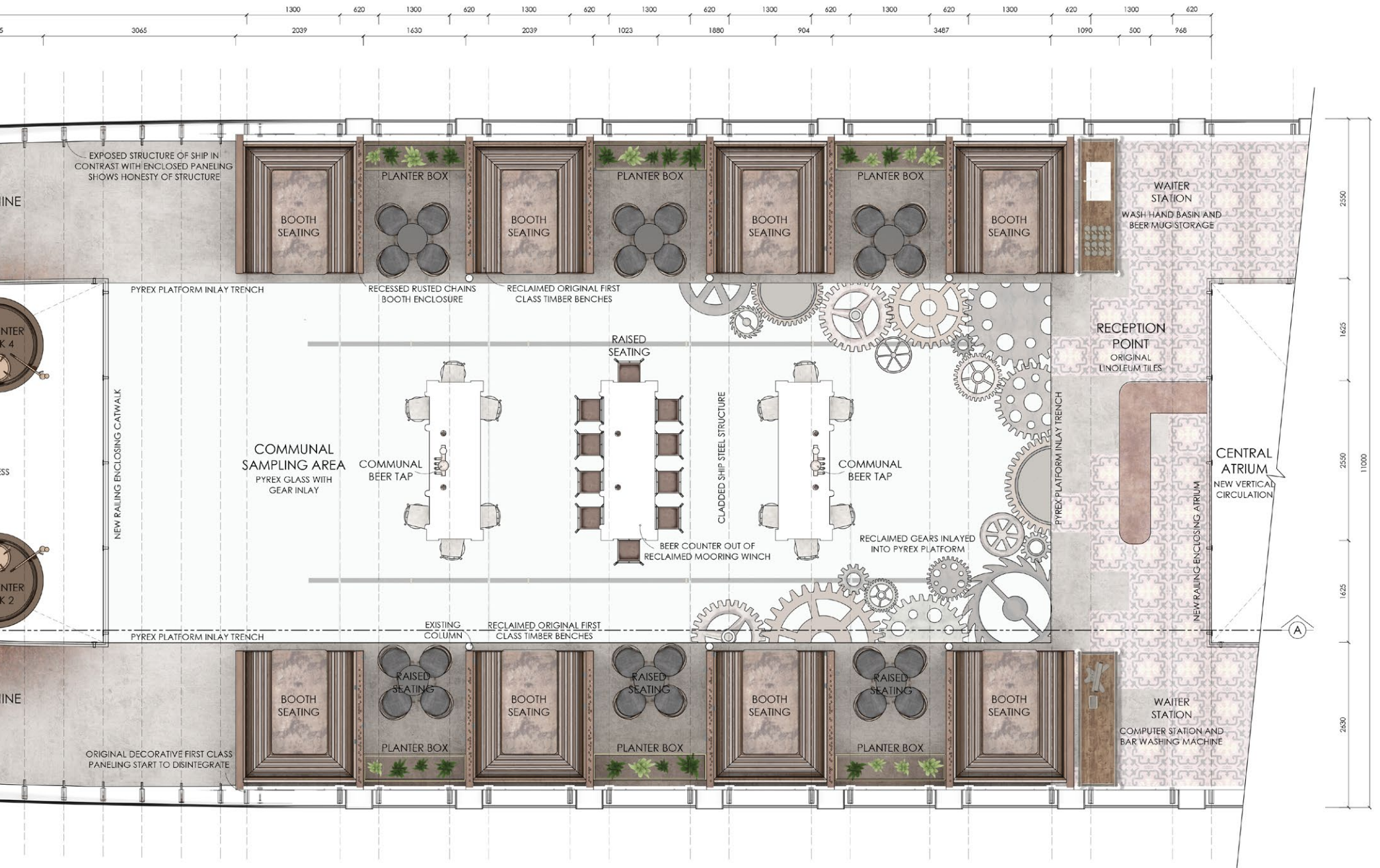

Figure 4.103. Proposed Upper Level Layout of Brewery (Author, 2016)



- PROPOSED LOWER LEVEL LAYOUT -

Correspondingly to the level above, a **symmetrical layout** is once again employed as per naval engineering guidelines (figure 4.104). Forward of the atrium, access to the **fermentation process and keging tubes** are permitted via **raised walkways**, as direct access onto the keel is not endorsed where **hull plates have been removed**. It was decided to replace a portion of the hull with transparent Pyrex plates in order to **govern direct visibility from dock level and improve natural lighting**. This was specifically employed in areas of low-maintenance and where downward force is limited - thus the beer keging tubes. The actual **fermentation process is positioned where the original steel hull remains intact**, as structural support will be required for **heavy equipment and direct accessibility**.

In addition to the availability of actual brewing equipment, the **existing water tanks** located on this level aft will be **utilised as reservoir which stores the potable saltwater** consumed during the production of **saltwater beer**. This will be further investigated in the technical chapter that follows.

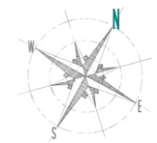
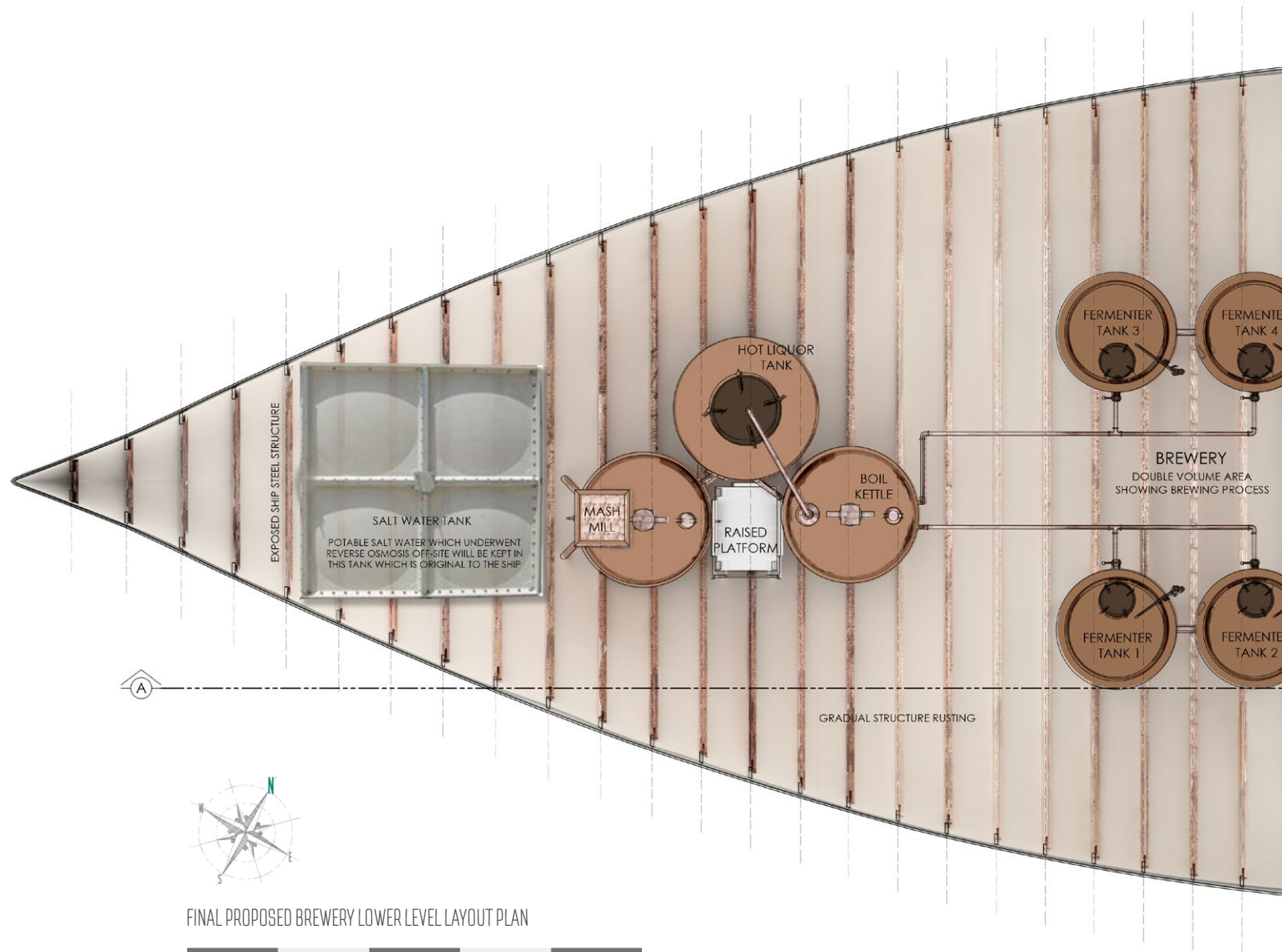

FINAL PROPOSED BREWERY LOWER LEVEL LAYOUT PLAN



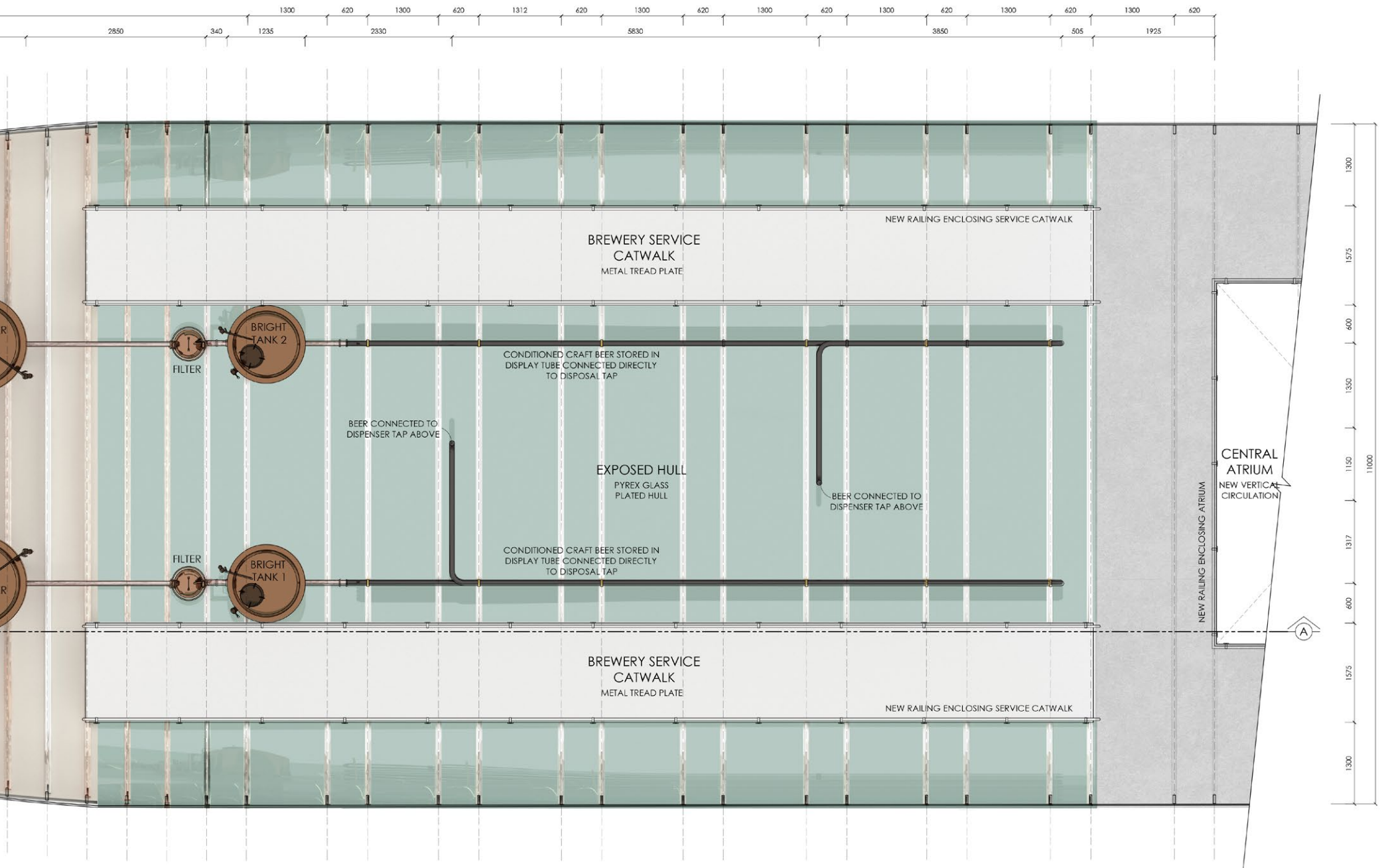
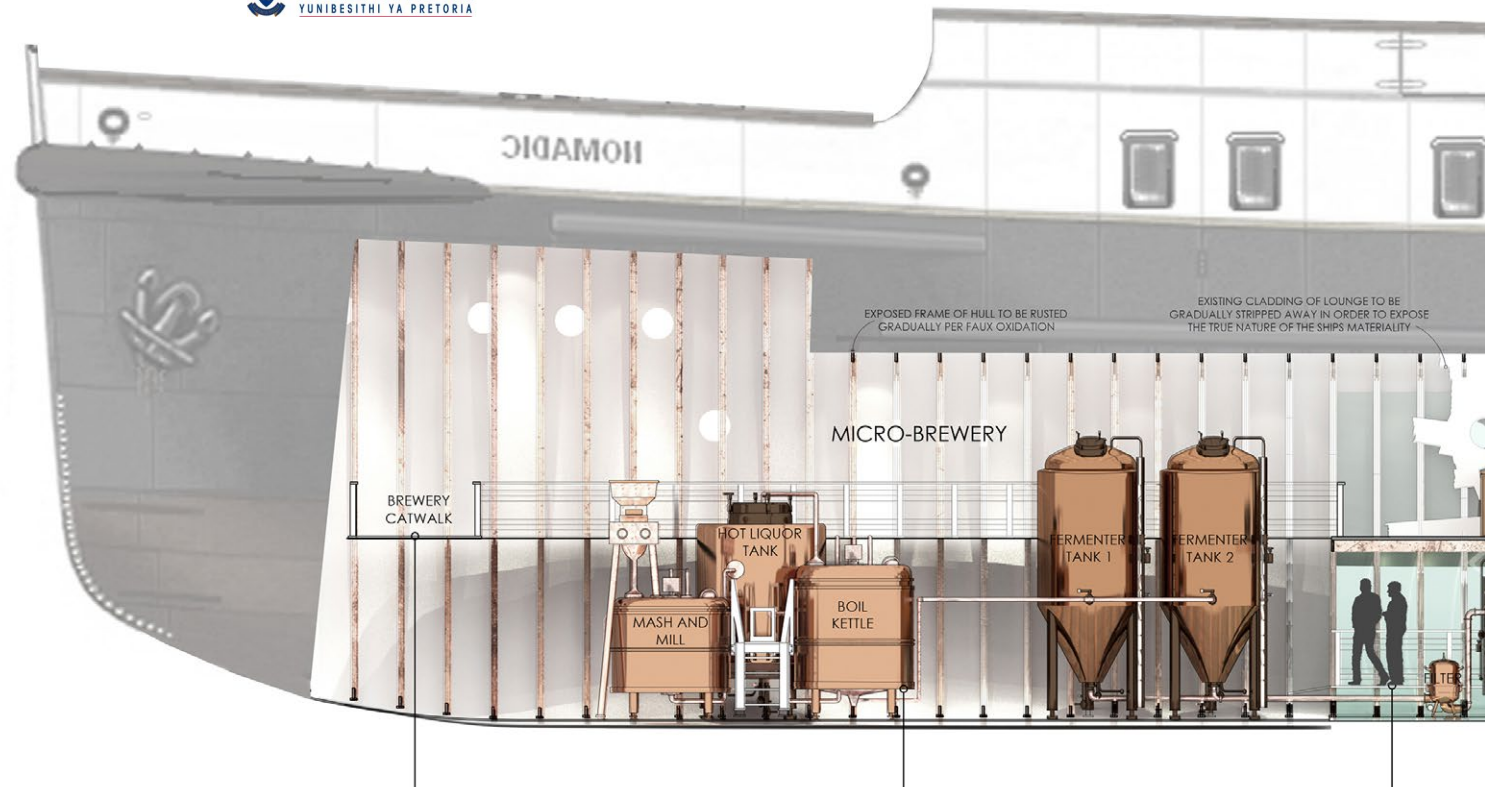

Figure 4.104. Proposed Lower Level Layout of Brewery (Author, 2016)

- PROPOSED SECTIONAL LAYOUT -

As illustrated sectionally (figure 105), the association of **various zones transpire either visually or through uniting constituents**. The upper and lower levels are allied though **direct accessibility of the showcased brewing progression**. This either occurs **visually** (transparent platform) or **palpably** (fermentation catwalk). Aside from optical and actual connectivity, **activities associated with the pragmatic response are concomitant**. This is exemplified through the communal **beer tapping system and atrium inclusion**. In addition to this internal connectivity, the **inner interior and outer interior is coupled**.

Furthermore, **honesty in the materiality** of the habitant is **celebrated and exposed** as one progresses through the bow. The corroded appearance of the frame is **intentionally** increased as it nears the initial brewing stages to **epitomise the course of degradation**. Additionally, all elaborate concealments and finishes (wall paneling, soft ceiling and linoleum flooring) are **gradually stripped away** in order to migrate, yet emphasise, the differentiation of new and existing materiality.



BREWERY CATWALK

THRESHOLD DIVIDING THE BEER CAFÉ WITH THE ACTUAL BREWERY. AN ELEVATED PLATFORM SUSPENDED OVER THE UPPER BOW OF THE SHIP FRAMES THE BREWERY. PANORAMIC APPROACHABILITY PROVIDES TRANSPARENT ACCESSIBILITY. THE CATWALK WILL FOLLOW THE PROFILE OF THE SHIP AND BE ATTACHED TO THE HULL FRAME.



MICRO-BREWERY

MICRO-BREWERY POSITIONED AT THE TIP OF THE BOW IN ORDER TO ENSURE SUFFICIENT SUPPORT AND ACCESSIBILITY. CAPABLE OF PRODUCING 30BBL OF SALTWATER BEER PER WEEK, THE PROCESS IS VISIBLE FROM START TO END. DOUBLE VOLUME ENABLED POSITIONING OF LARGE EQUIPMENT THOUGH PROVIDED HATCH OPENINGS.



MAINTENANCE CATWALK

IN ADDITION TO THE BREWERY CATWALK, OF AN ELEVATED WALKWAY IS PROVIDED TO ALLOW DIRECT ACCESS TO THE FRONT SECTION OF THE BREWERY. AS PART OF THE HULL WILL BE RUSTED PER FAUX PYREX PLATES, ACCESS THEREON WILL NOT BE HENCE THE INTRODUCTION OF AN ELEVATED



FINAL PROPOSED BREWERY SECTIONAL ELEVATION AA

0 1000 2000 3000 4000 mm

Figure 4.105. Sectional Elevation of Brewery (Author, 2016)

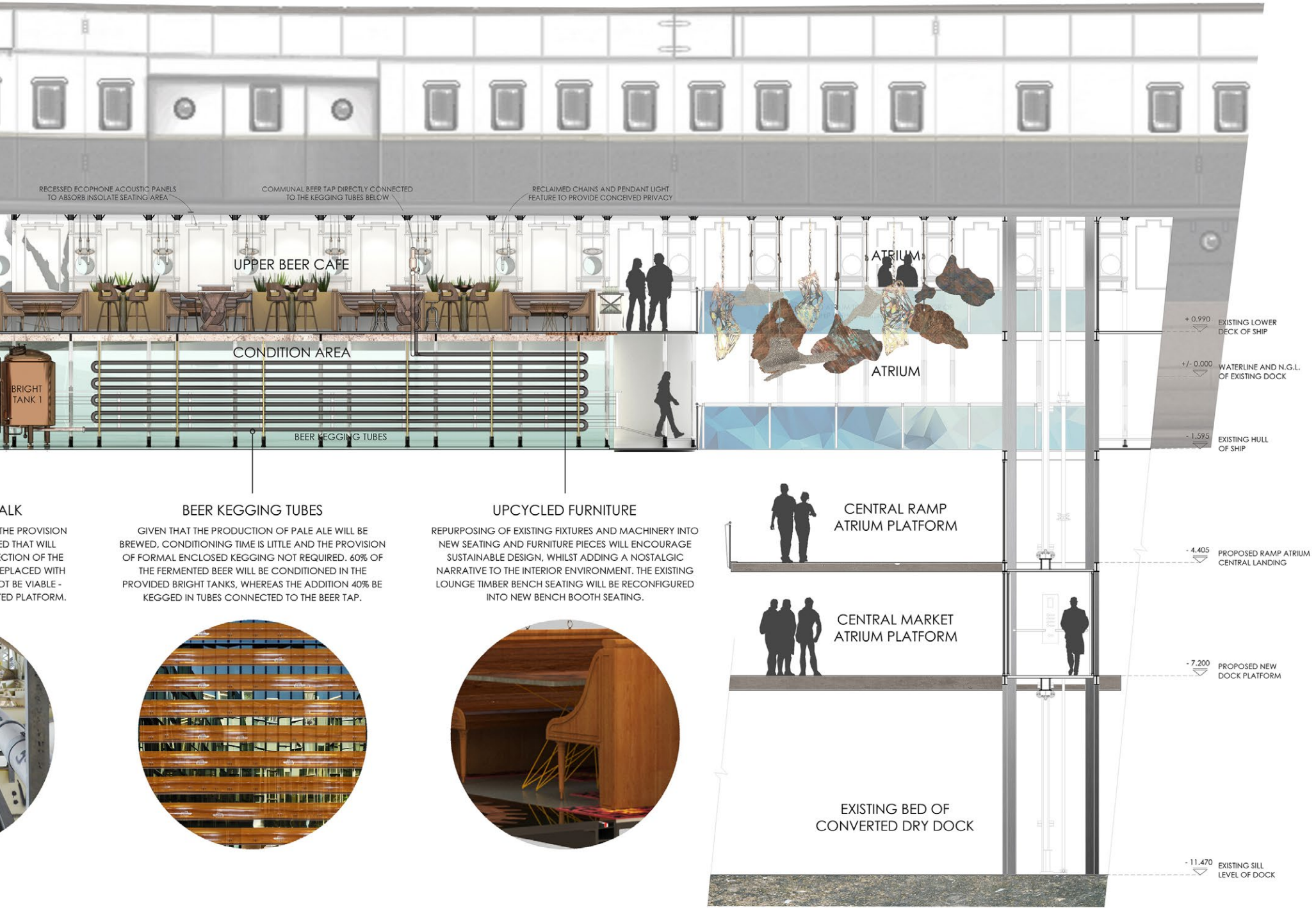

ALK

THE PROVISION
ED THAT WILL
CTION OF THE
EPLACED WITH
OT BE VIABLE -
ED PLATFORM.

BEER KEGGING TUBES

GIVEN THAT THE PRODUCTION OF PALE ALE WILL BE
BREWED, CONDITIONING TIME IS LITTLE AND THE PROVISION
OF FORMAL ENCLOSED KEGGING NOT REQUIRED. 60% OF
THE FERMENTED BEER WILL BE CONDITIONED IN THE
PROVIDED BRIGHT TANKS, WHEREAS THE ADDITION 40% BE
KEGGED IN TUBES CONNECTED TO THE BEER TAP.

UPCYCLED FURNITURE

REPURPOSING OF EXISTING FIXTURES AND MACHINERY INTO
NEW SEATING AND FURNITURE PIECES WILL ENCOURAGE
SUSTAINABLE DESIGN, WHILST ADDING A NOSTALGIC
NARRATIVE TO THE INTERIOR ENVIRONMENT. THE EXISTING
LOUNGE TIMBER BENCH SEATING WILL BE RECONFIGURED
INTO NEW BENCH BOOTH SEATING.





Figure 4.106. Existing Interior (Author, 2016)



Figure 4.107. Proposed Perspective of Brewery Interior (Author, 2016)



Figure 4.108. Lounge Arrangement Before (Author, 2016)



Figure 4.109. Designed Brewery Seating Area (Author, 2016)



Figure 4.110. Three Dimensional Section of Brewery (Author, 2016)

- FIXTURE & FURNITURE SPECIFICATION -



name
LOFT INDUSTRY HELIX PENDANT
suppliers
LED 7
finish & material
GALVANISED IRON & STAINED GLASS
dimensions
350mm L X 200mm W X 1000mm CORD
code
LED_LIHP002



name
CHAIN & TACCLE PENDANT
suppliers
CUSTOM DESIGNED
finish & material
POWDER COATED STEE, BRASS & GLASS
dimensions
400mm DIA X 1000mm CHAIN CORD
code
CUSTOM_01



name
TOLEDO BAR STOOL
suppliers
WAYLANDTS
finish & material
CHROME & ZEBRA FABRIC CORD
dimensions
115mm DIA X 2000mm CORD
code
LAMPCONT0601



name
TOLEDO BAR STOOL
suppliers
RED APPLE
finish & material
GALVANISED IRON & TIMBER SEAT
dimensions
500mm L X 500mm W X 1130mm H
code
VG-1160H



name
TOLIX BAR STOOL
suppliers
CHAIR CRAZY
finish & material
POWDER COATED STEEL & TIMBER SEAT
dimensions
500mm L X 500mm W X 1060mm H
code
T3513-30FBW



name
CECINA BAR STOOL
suppliers
BED, BATH & BEYOND
finish & material
WALNUT, LEATHER AND CHROME
dimensions
450mm L X 500mm W X 1100mm H
code
CEC-BS543



name
BELL TABLE
suppliers
WEYLANDTS
finish & material
ANTIQUED BRASS, ALUMINIUM & GLASS
dimensions
560mm L X 560mm W X 1250mm H
code
ACCIND1002



name
GORDON KERAMIK TABLE
suppliers
RED APPLE
finish & material
IRON & EMBOSSED LACQUERED STEEL
dimensions
1200mm L X 2000mm W X 750mm H
code
GKT-1200T



name
INDUSTRIAL STORAGE UNIT SERVER
suppliers
PEPPERMILL INTERIORS
finish & material
CAST IRON & PINE TIMBER
dimensions
530mm L X 1200mm W X 915mm H
code
SC677

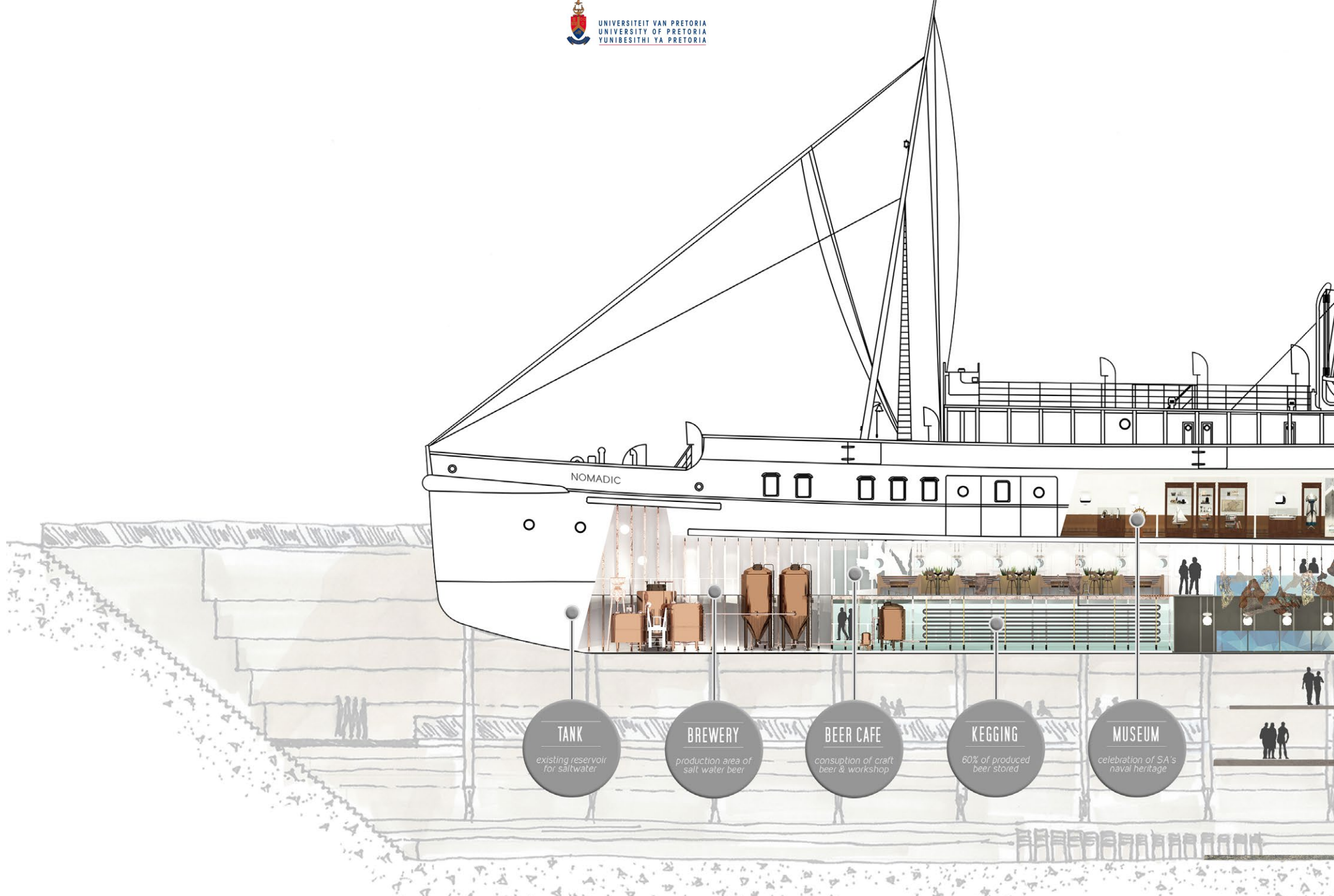
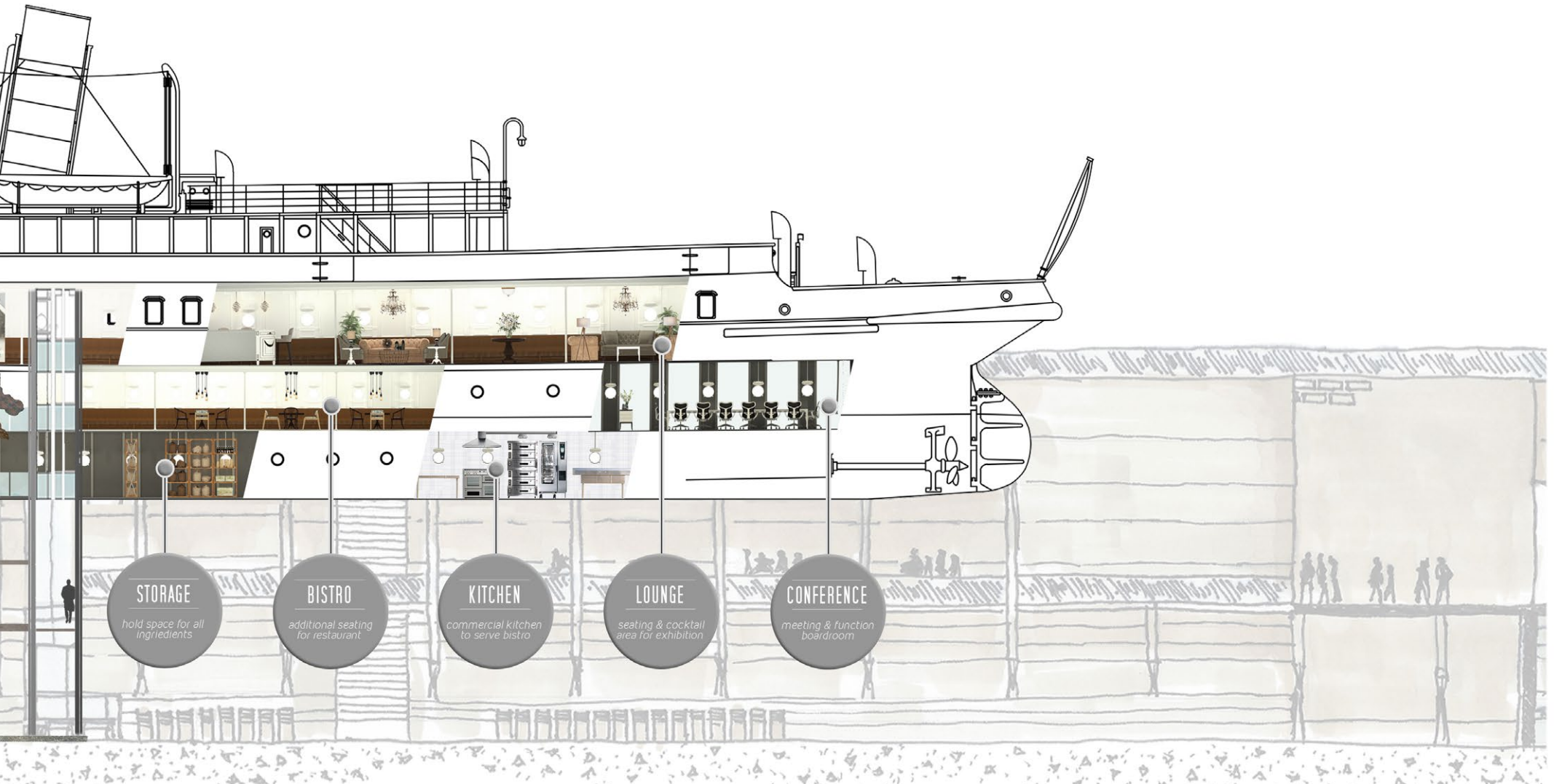

Figure 4.111. Sectional Arrangement of Ship (Author, 2016)



4.11 ATRIUM DESIGN

As a **concluding element**, the design of the **atrium** was **conceptualised**. As a way to **accentuate** the fact that this element will be responsible for the **actual connectivity of the inner and outer interior (host and habitant)**, **migration** was used as **concept** from which all design decisions branched. The central positioning of the elevator shaft hosted ideal opportunity to **substantially illustrate the symbiotic synthesis between steel and concrete**. The steel frame of the shaft is partially clad with **steel sinking from above and concrete rising from below**, centrally divided by glass (refer to figure 4.112). As the two materials near the divided glass, the **steel rusts and concrete weathers to factually illustrate the degradation of these materials**. **Structural integrity** is ensured through **steel reinforcement** that retains the material entirety in place. Additionally, the created interior atrium environment provides opportunity for **suspended accent lighting and coral rusticles**. This provides **additional illumination into the dock below** and some form of **acoustic insulation** from the void created (refer to figure 4.113).

To conclude, this chapter initiated the **conceptual development of the spatial intervention** proposed for both the **host and the habitant**. In order to evidently differentiate between the various proposed mechanisms of design, all mediations are classified as either contributing towards the **inner or outer interior** of the proposed intervention. In continuation, the design of the outer interior (platform, stalls and possible ramp) and inner interior (brewery) will be detailed through technical resolution.

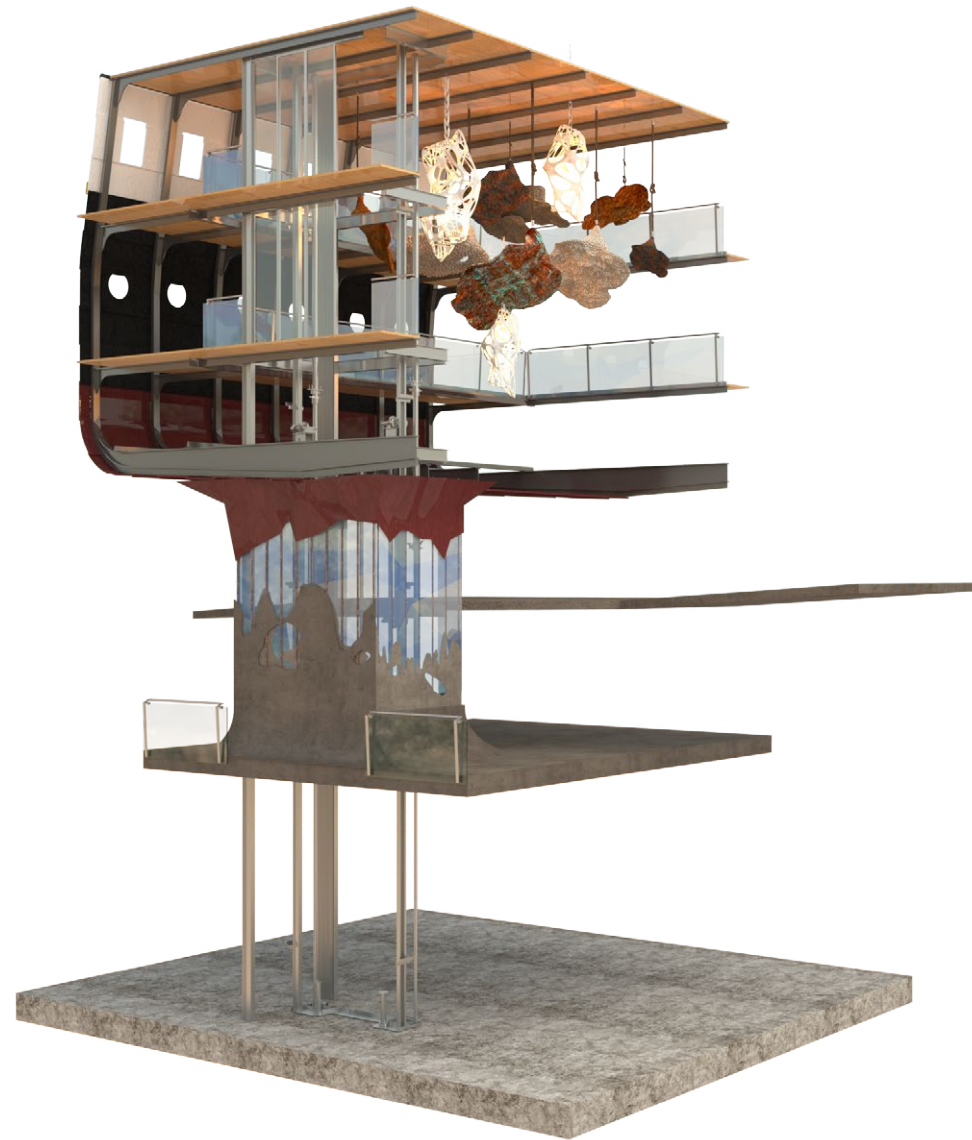

Figure 4.112. Atrium Design Proposal (Author, 2016)

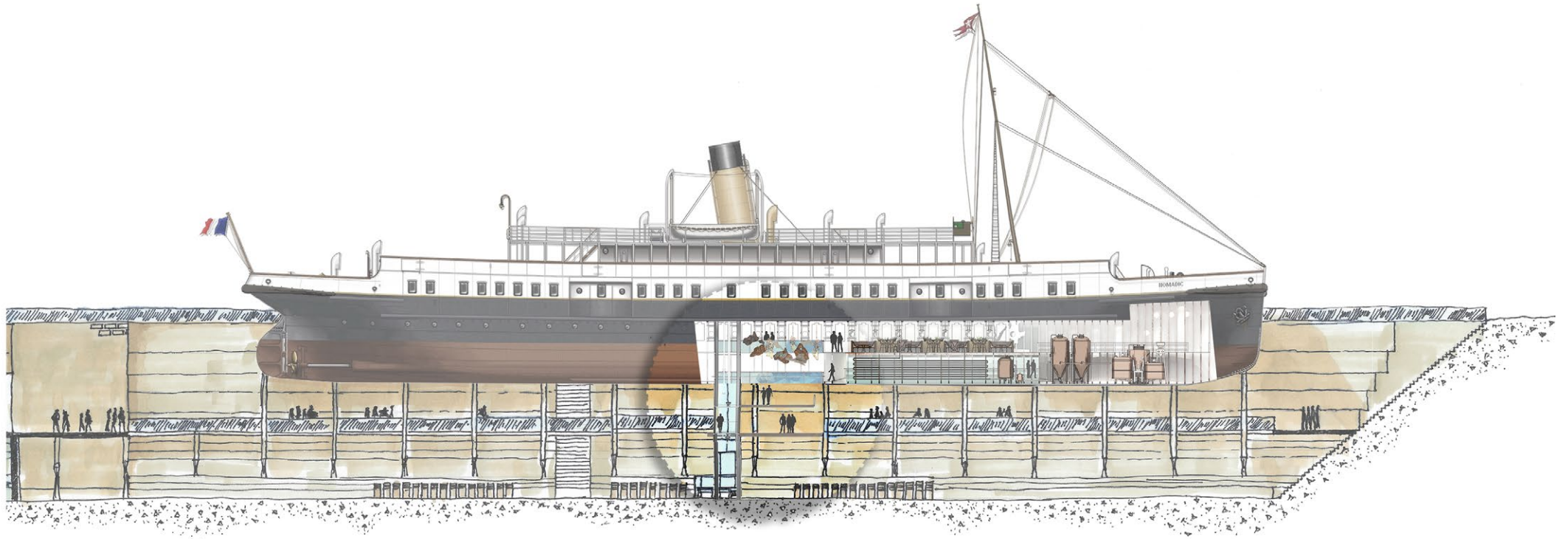

Figure 4.113. Proposed Atrium Introduction in Context (Author, 2016)