



Part 05. A Celebration of Diversity

The Design Discourse chapter identified two essential design tactics that emerged through the conceptual process and discussion that forms the basis for the technical resolution of the pavilion. Namely, the need to maintain a sense of connection between the different zones, while preserving the integrity of each of the four zone's individual experiences, and the use of contrasting materials and finishes. Combined, these two tactics express the brand essence of **"We Are Not Only & We have strong emotions"**.

The technical resolution has been divided into two sections. The first section deals with design elements and specification pertaining to the pavilion as a whole, while the second section presents detailed technical resolutions, following the approach of the Design Discourse chapter by handling each of the four experiential zones separately.

The resulting details will be discussed through an examination of the floor plans, elevations, sections, perspectives, and assembly drawings, (Figures 122 - 139).

9. TECHNICAL RESOLUTION

Both the development of the conceptual narrative as well as the form of the pavilion's interior needed to symbolically and actually engage in, or facilitate the renegotiation of our national identity and the coming together of our separate pasts.

The Technical Resolution chapter deals with the form of the pavilion's interior and the physical manifestations of the conceptual narrative.

9.1. FLOOR FINISHES PLAN

As discussed previously in the Design Discourse, the pavilion's floor plane is an integral part of the design's acoustic strategy. A soft and diffusive but hard wearing floor finish has been selected as part of a noise reduction rather than acoustic isolation approach. In addition to the technical specification of this finish which is applied across the pavilion, the details of changes in floor finishes that are used to highlight the focal points of each zone will be discussed, (Figure 122).

The Tactility Factory technical precedent is specifically selected for the technical resolution of the tactile wayfinding zones below the Petals of the *Reflection Well* [3] and the *Bobble heads* [3].

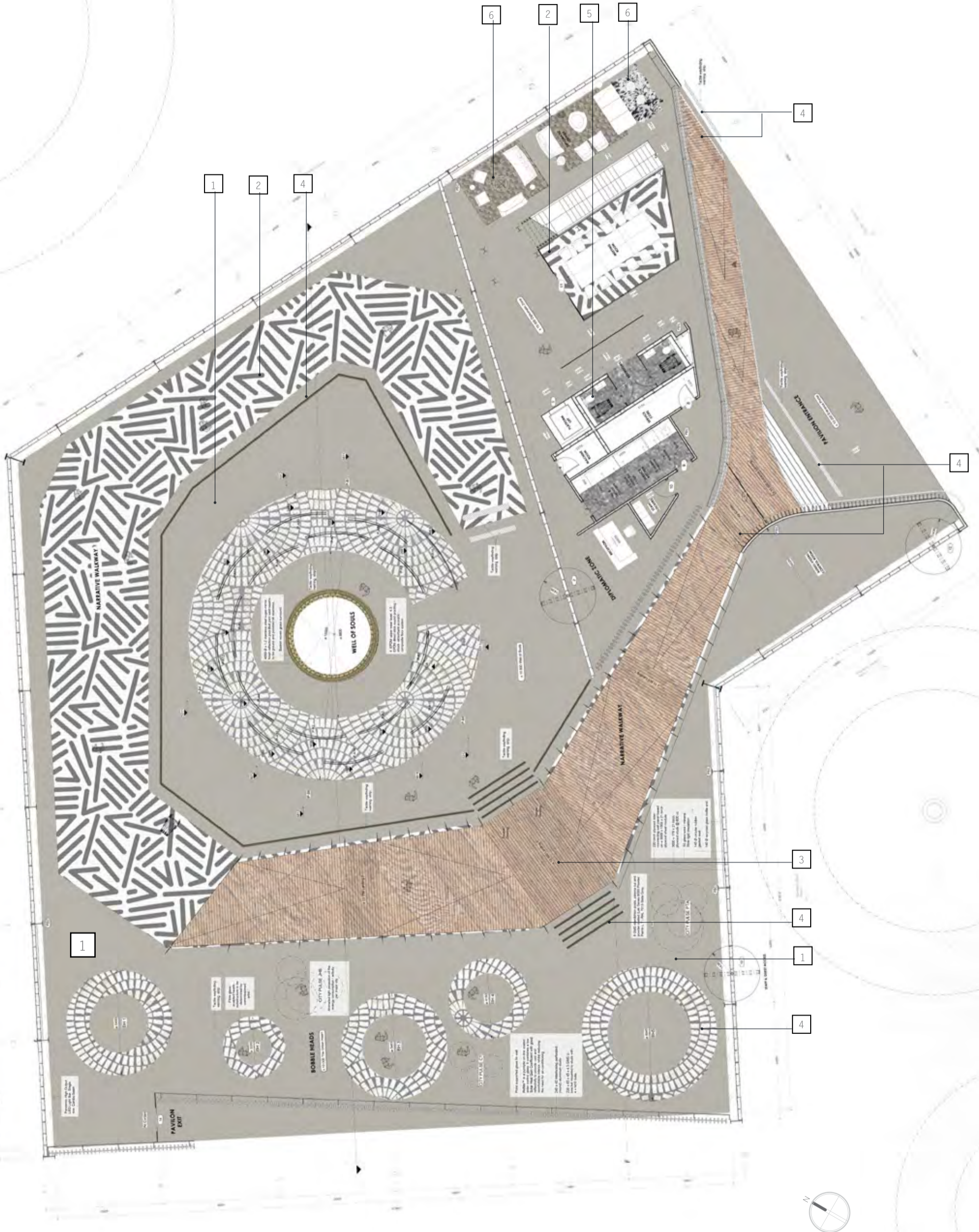



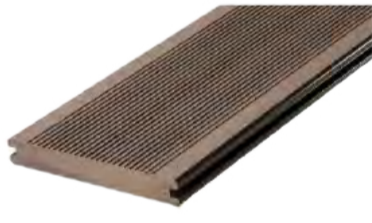



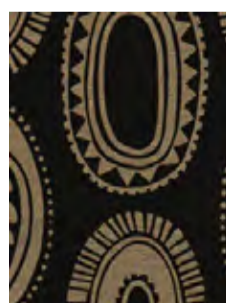











Figure 126: Floor Finishes Plan – Not to Scale
© University of Pretoria

9.1.1. Floor Finishes Schedule

Table 2: Floor Finishes Schedule

<p>General Floor Finish + Diplomatic Zone 1</p>  <p>Substrate: FFL Screed 4 EPDM upper wear layer, 4.5 EPDM direct stick sound proofing / shock-absorbent acoustic composite floor system (Melos)</p> <p>Finish: Special Colours [Slate Grey + Light Grey + Beige + Eggshell]</p> <p>Decal Beneath Walkway + Diplomatic Meeting Room 2</p>  <p>Substrate: 4 EPDM upper wear layer, 4.5 EPDM direct stick sound proofing / shock-absorbent acoustic composite floor system</p> <p>Finish: Melos Qualipur 7200, polyurethane two-component solvent-based line paint: Grey</p> <p>Walkway - Slope + Diplomatic First Floor 3</p>  <p>Aruna</p> <p>Recycled plastic composite decking</p> <p>Finish: Eva-tech : Summit Decking Profile -Aruna</p> <p>Walkway - Landings</p>  <p>Xavia</p> <p>Recycled plastic composite decking</p> <p>Finish: Eva-tech : Classic Decking Profile -Xava</p> <p>Tactile Wayfinding 4</p>  <p>Substrate: FFL Screed</p> <p>Finish: 15 concrete skin - Linen - Concrete . Fabrics by Design Team + Aluminium formable edge trim.</p>    <p>Warning Strips Reflection Well Bobble Heads</p>	<p>Diplomatic Restrooms & Service Kitchen 5</p>  <p>Substrate: 300 x 600 x 8mm Anti-Slip, Porcelain Preto Tiles</p> <p>Finish: Black matt riven, anti-slip surface.</p> <p>Diplomatic Seating 6</p>  <p>Substrate: 4 EPDM upper wear layer, 4.5 EPDM direct stick sound proofing / shock-absorbent acoustic composite floor system</p> <p>Finish: Rebtex Sisal Flooring - Heavy Boucle</p>  <p>Substrate: 4 EPDM upper wear layer, 4.5 EPDM direct stick sound proofing / shock-absorbent acoustic composite floor system</p> <p>Finish: Rebtex Sea Grass Flooring</p>  <p>Substrate: 4 EPDM upper wear layer, 4.5 EPDM direct stick sound proofing / shock-absorbent acoustic composite floor system</p> <p>Finish: Nguni Hide</p>
	<p>Eco Audit</p>      <p>EPMS FLOORING: Fulfil Austrian ISS Guideline</p>  <p>Composite Decking Climate change leadership awards Member of the Green Building Council ISO 9001 certification</p> <p>NATURAL FIBRES: 100% biodegradable. Its natural fibres are processed in an ecologically-sound manner and are free of pollutants.</p>



Renewable Resource



Downcycle



Recyclable



Biodegradable



Natural Material

9.1.1.1. Technical Precedent 1: Tactile Wayfinding



INFUSED CONCRETE®

4

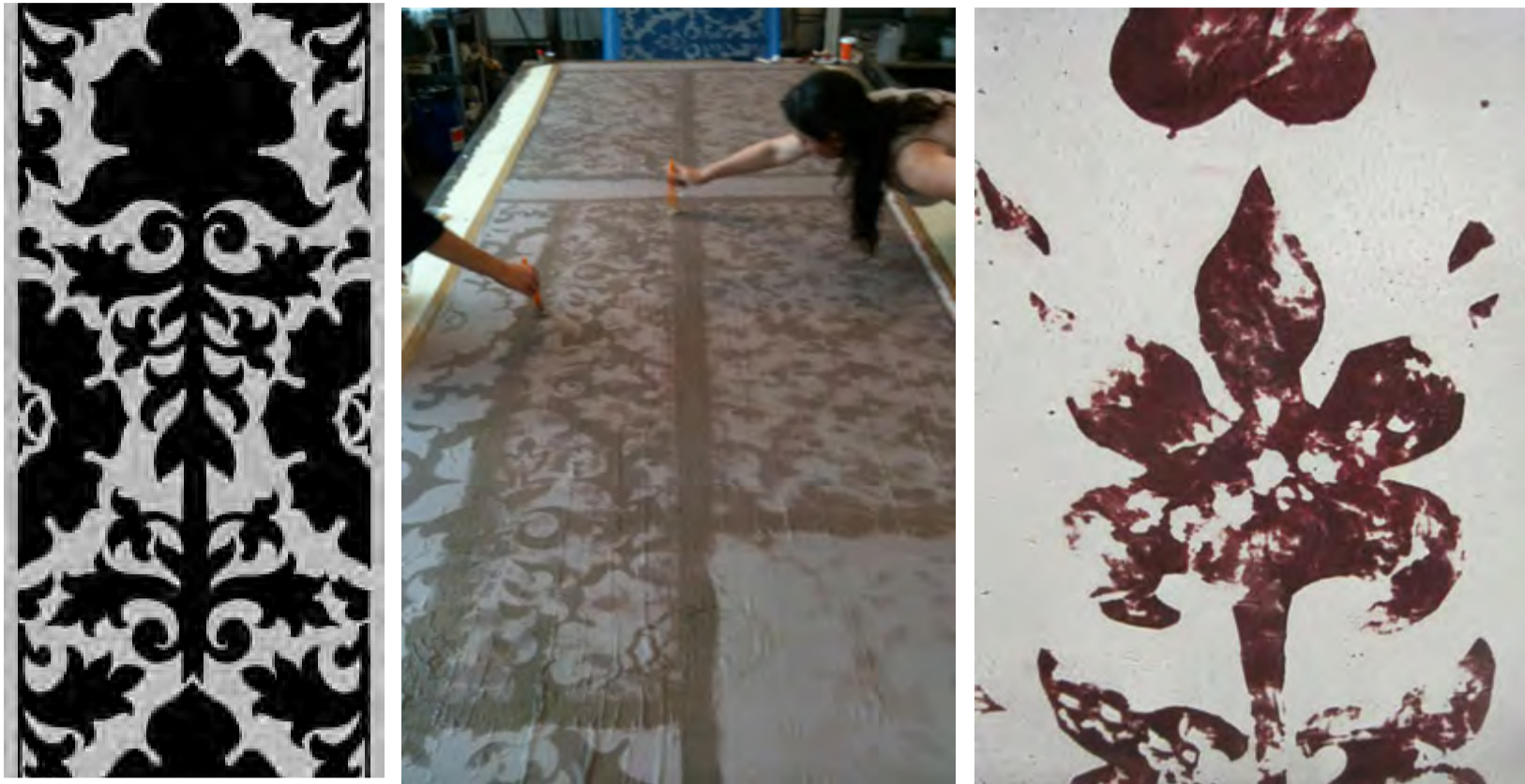

[1] Decorative form-work tile

[2] Embedding in progress

[3] End result

Figure 127: Making Infused Concrete

Tactility Factory (TF) creates bespoke concrete skins that permanently embed textiles into the surface of concrete. The technique used is a combination of silk-screening, woodblock printing and relief casting. The process involves filling the recesses of the form-work tile (section in white in Figure 123 - [1]) with the concrete and overlaying it with the selected fabric and fibre-glass reinforcement. The fabric and fibre-glass are then manually embedded into the concrete layer below, [2]. The end result is that the fabric is left exposed where-ever there is a raised section of the form-work, as can be seen when comparing image [1] and [3]. A concrete backing is then added to to finish the panel.

Quality, Durability and Maintenance.

TF skins are manufactured with a substrate layer of Glass Reinforced Concrete (GRC) that is high in tensile strength, therefore reducing the overall thickness and applied load on the building structure, (Tactility Factory 2010).

The surface of the concrete is treated with a stain resistant finish. The sealant contains organic solvents and is free of chlorinated hydrocarbons. The surface finish can be maintained regularly by light vacuum to remove surface dust. TF skins can be retreated with a clear sealant at a frequency that depends on the occupancy of the space.

Textiles need to be specifically selected, design and tested to ensure they can survive in the alkaline environment of the concrete, (Tactility Factory 2010), (Figure 124).

TF skins when integrated into other pre-cast concrete elements offer the opportunity to expose the surface of the concrete mass for thermal mass whilst still maintaining a strong visual effect. They additionally have a low embodied energy as the concrete is sourced locally.

TF skins also offer a positive acoustic profile for users, according to the manufactures, (Tactility Factory 2010).

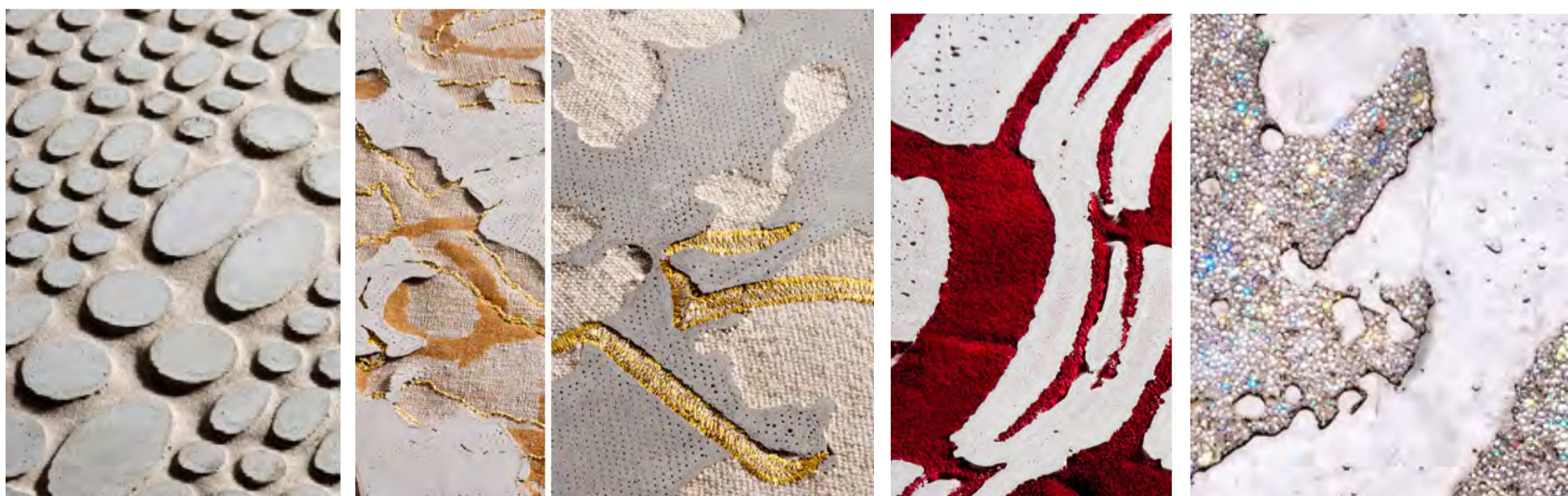

LINEN INFUSED CONCRETE®

LINEN STITCHED INFUSED CONCRETE®

VELVET INFUSED CONCRETE®







BEADED CRYSTAL INFUSED CONCRETE®



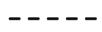

Figure 128: Type of Infused Concrete



9.2. ARTIFICIAL LIGHTING AND CEILING PLANS

Lighting Key:

- 1  Osram LIGHTIFY Flex RGBW with Osram LIGHTIFY Gateway for RGB colour control, 32.5m
- 2  LED Lighting SA High Bay Polycarbonate Dome LED fitting
- 3  LED Lighting SA Down Light Surface Mount Spot Tilt
- 4  LED Lighting SA Down Light Diffused
- 5  LED Lighting SA Down Light Surface Mounted Diffused Round
- 6  LED Lighting SA Down Light Surface Mounted Diffused Round
- 7  Haldane Martin - Fiela Arc Light / Heath Nash - Other Peoples Rubbish _ PLT LED Filament Type Tubular 6w 2200K

- 8  Custom Stamen Chandelier - PLT LED Filament Type Tubular 6w 2200K
- 9  Pandemic High Output LED Light Bar, Single row, Combo beam
- 10  LED Lighting SA LED linear rigid aluminum strip light
- 11  Low voltage tension wire system - Philips LED Spot 2 W GU10 cap 3000k

Eco Audit



LED Lighting technologies:

All artificial pavilion lighting supplied by LED lamps to reduce power consumption and heat gain.

Artificial lighting to be switched off during the day in zone with sufficient natural daylighting to reduce energy consumption of pavilion. (3-4 & Diplomatic FF).

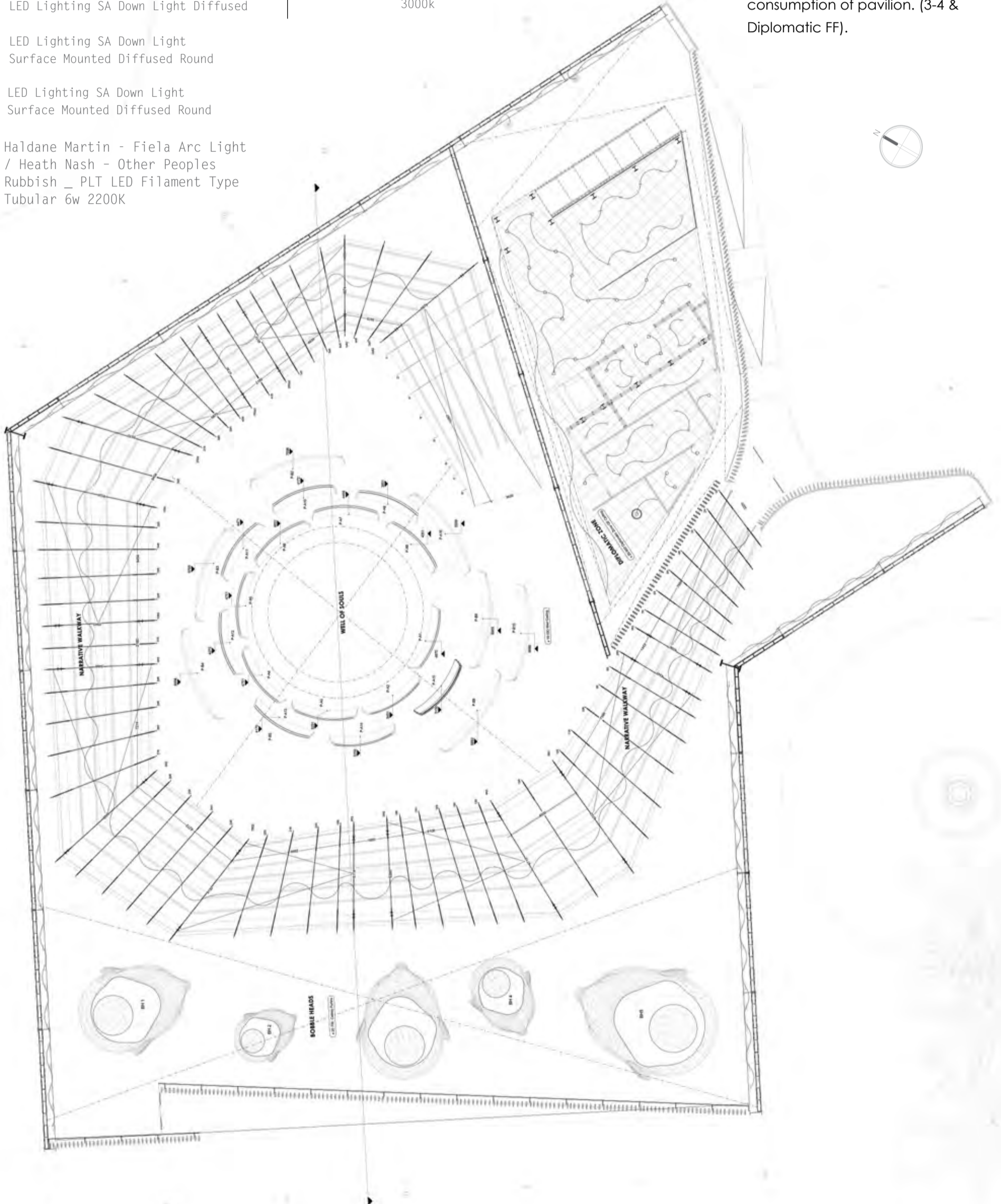







Figure 129: Artificial Lighting and Ceiling Plan GF _ Not to Scale



Ceiling Key:

-  50 mm extruded aluminum reflector light shelf
-  Existing soffit - 150 Insulated metal standing seam roof panel.
-  40 glass-wool acoustic panels
-  12.5 mm Plasterboard plastered flush and painted
-  12.5 mm flexible /curved lasterboard plastered flush and painted -
-  12.5 mm Gyprock Aquachek Plasterboard plastered flush and painted

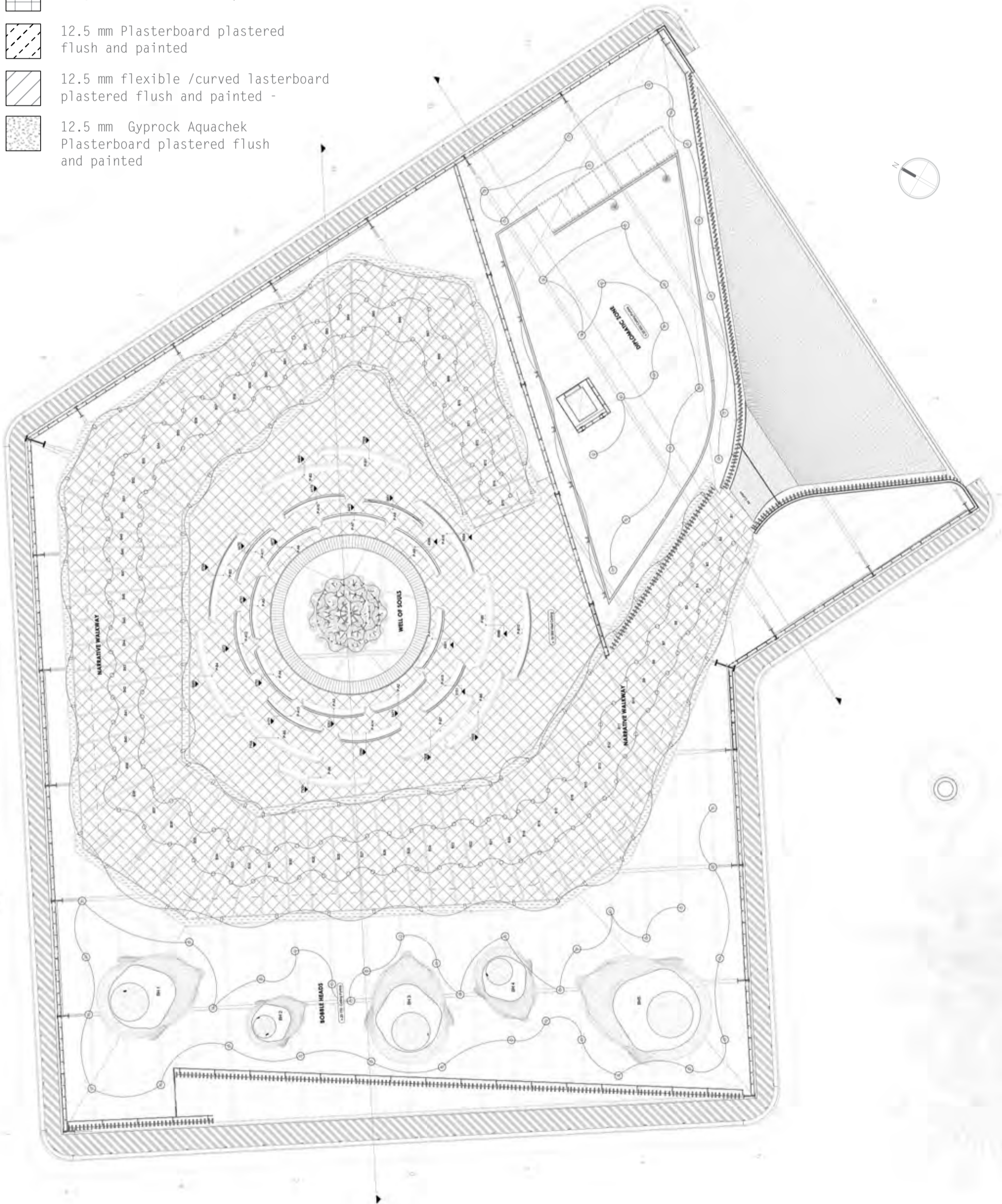
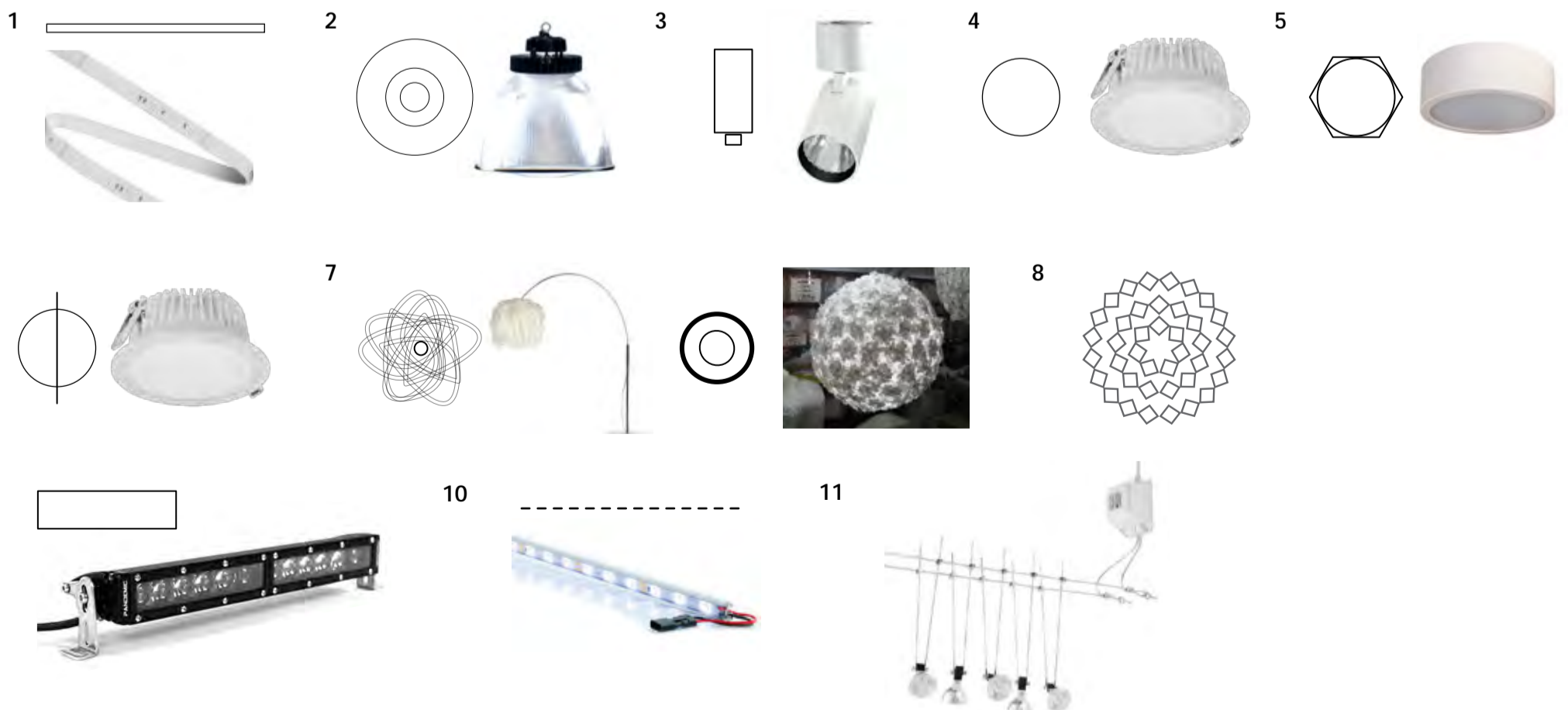

Figure 130: Artificial Lighting and Ceiling Plan FF _ Not to Scale

9.2.1. Lighting Specifications

Table 3: Lighting Specifications

	Luminaire spec.	Lamp spec.	Quantity (luminaire x lamp)	Luminous flux (lm/lamp)	Total load (W)	Total luminous flux (lm)	Efficacy (lm/W)	Dimmable ?
1	Osram LIGHTIFY Flex RGBW with Osram LIGHTIFY Gateway for RGB colour control, 32.5m	Osram 9 W per meter 2700k to 6500k adjustable RGB via LIGHTIFY	32.5mm LED spacing 32500 / 32.5 = 1000 (32.5m)	14	0.3 x 1000 = 300	14 x 1000 = 14000	14000 / 300 = 46.7	Yes + LIGHTIFY
2	LED Lighting SA High Bay Polycarbonate Dome LED fitting	Osram S8 LED 4.6W 4000k	50 x 1 = 50	610	50 x 4.6 = 230	50 x 610 = 30500	30500 / 230 = 132.61	Yes
3	LED Lighting SA Down Light Surface Mount Spot Tilt	Cree CXA 18W 4000k	80 x 1 = 80	1200	80 x 18 = 1440	80 x 1200 = 96000	96000 / 1440 = 66.7	Yes
4	LED Lighting SA Down Light Diffused	Osram Duris E5 16W 4000k	146 x 1 = 146	1222	146 x 16 = 2336	166 x 1222 = 178412	178412 / 2336 = 76.38	Yes
5	LED Lighting SA Down Light Surface Mounted Diffused Round	Osram Duris E5 6W 4000k	25 x 1 = 25	480	25 x 6 = 150	25 x 480 = 12000	12000 / 150 = 80	Yes
6	LED Lighting SA Down Light Surface Mounted Diffused Round	Osram Duris E5 11W 4000k	32 x 1 = 32	990	32 x 11 = 352	32 x 990 = 31680	31680 / 352 = 90	Yes
7	Haldane Martin - Fiela Arc Light (X4) Heath Nash – Other Peoples Rubbish (X1)	PLT LED Filament Type Tubular 6w 2200K	5 x 1 = 5	450	5 x 6 = 30	5 x 450 = 2250	2250 / 30 = 75	Yes
8	Custom Stamen Chandelier	PLT LED Filament Type Tubular 6w 2200K	47 x 1 = 47	450	47 x 6 = 282	47 x 450 = 21150	21150 / 282 = 75	Yes
9	Pandemic High Output LED Light Bar, Single row, Combo beam	Philips LED 7W with 4D PMMA Optics 6000k	12 x 119 = 1428	600	1428 x 7 = 9996	1428 x 600 = 856800	856800 / 9996 = 85.7	No
10	LED Lighting SA LED linear rigid aluminium strip light	Osram Duris E5 6.4W per meter 3000k	50mm LED spacing 97700 / 50 = 1954 (97.7m)	34	97.7 x 6.4 = 625,28	1954 x 34 = 66436	66436 / 625.28 = 106.25	Yes
11	Low voltage tension wire system	Philips LED Spot 2 W GU10 cap 3000k	98 x 1 = 98	130	98 x 2 = 196	98 x 130 = 12740	12740 / 196 = 65	Yes



9.2.2. Natural and artificial lighting comparison

Interior: Sun Only

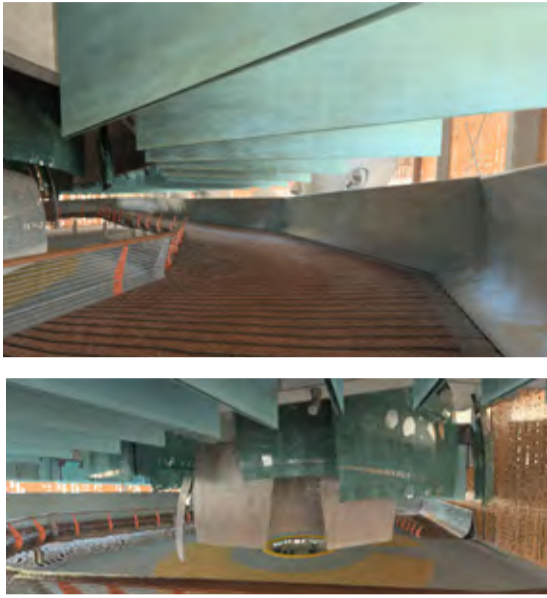

Interior: Sun & Artificial

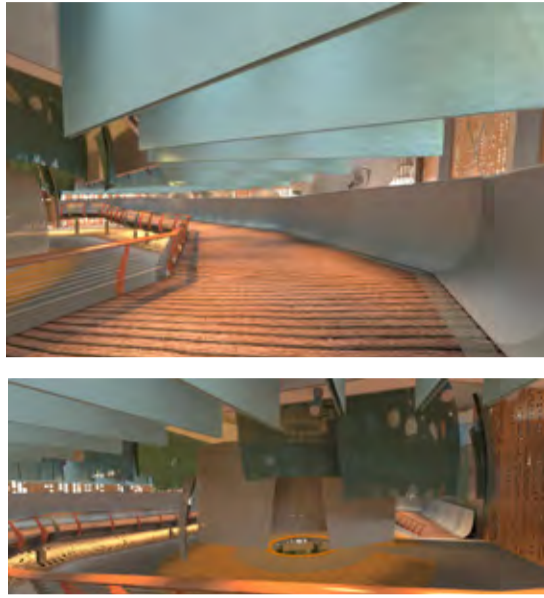

Interior: Luminance Study

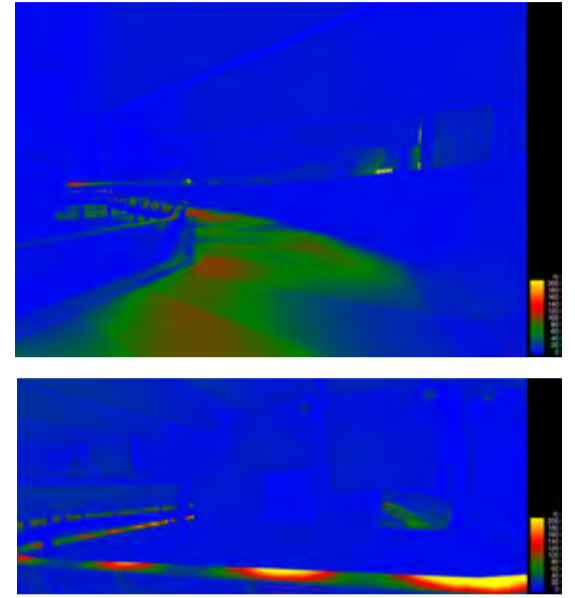

Lamps used in tests replaced with LED equivalents to reduce heat gain from artificial lighting sources 

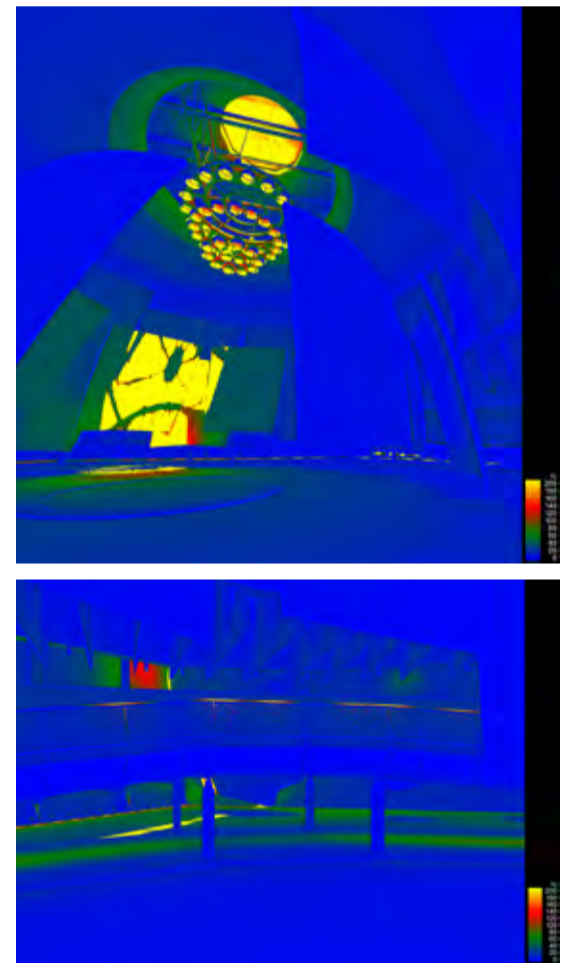
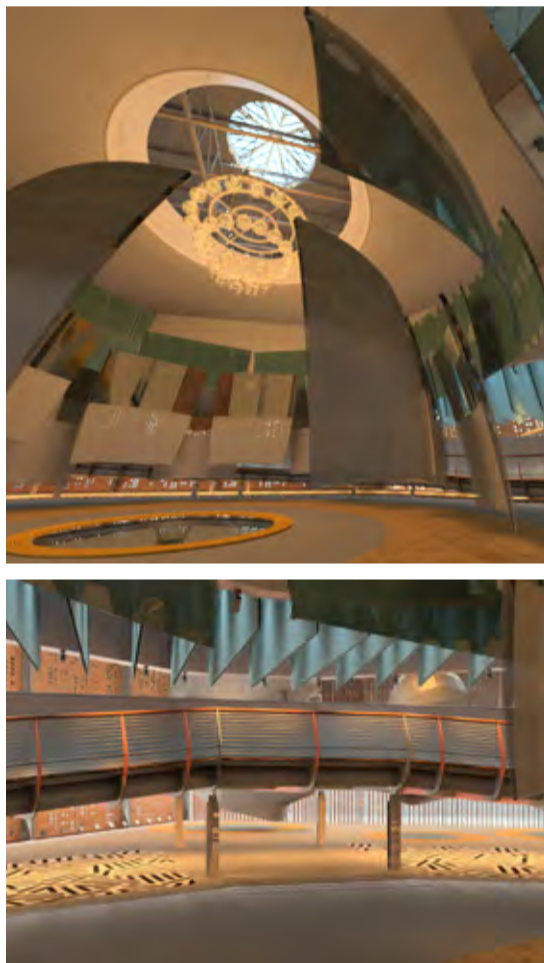
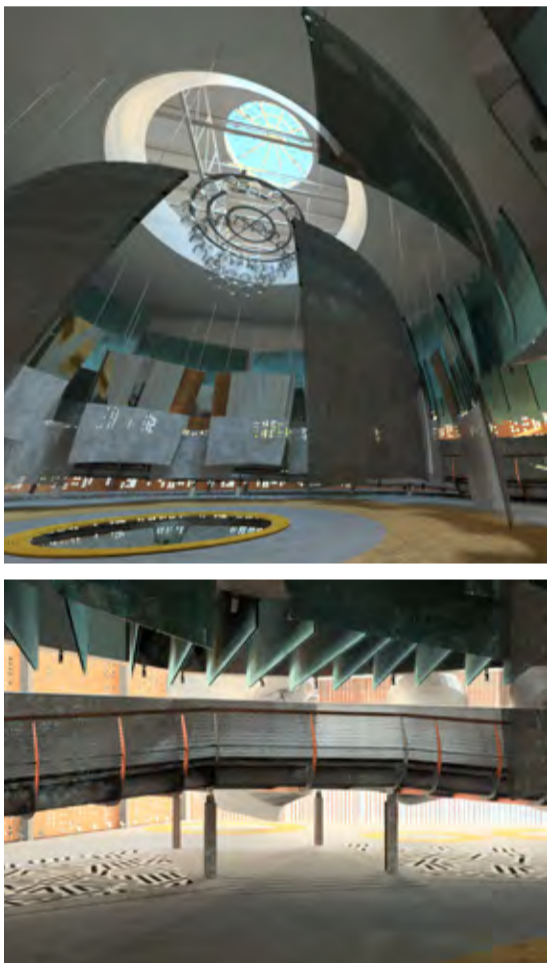

Fibre-optic light tubes explored to replace skylight to reduce heat gain. Skylight favoured as the **Symbolic Value** of the sun path and circadian rhythm it follows (Figure 88), is a priority over the **Utilitarian Need** within Zone 3 c.f. 7.3.3 

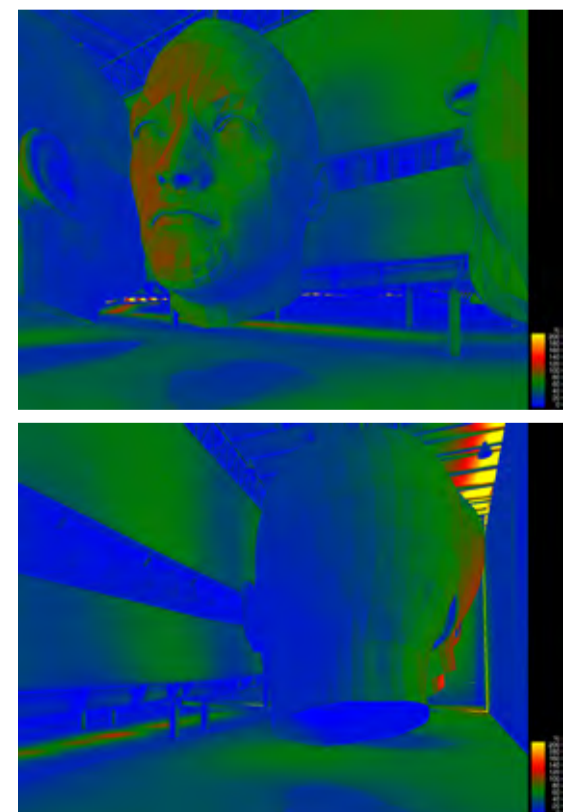
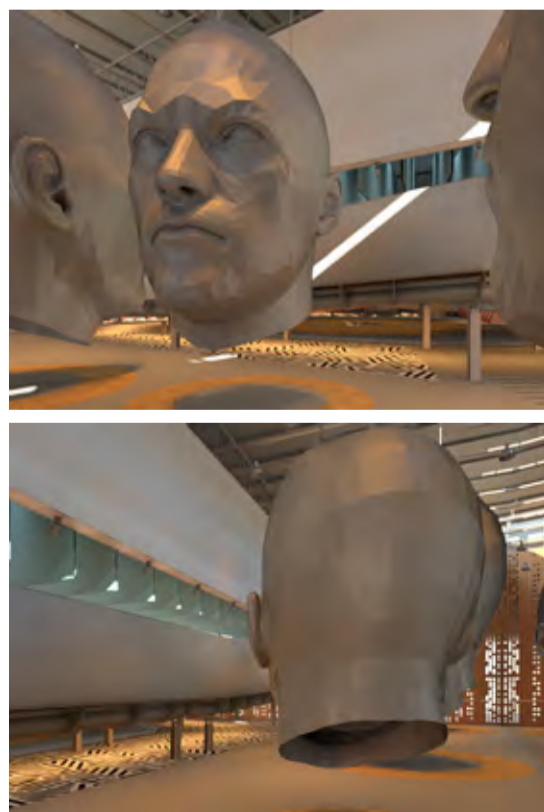
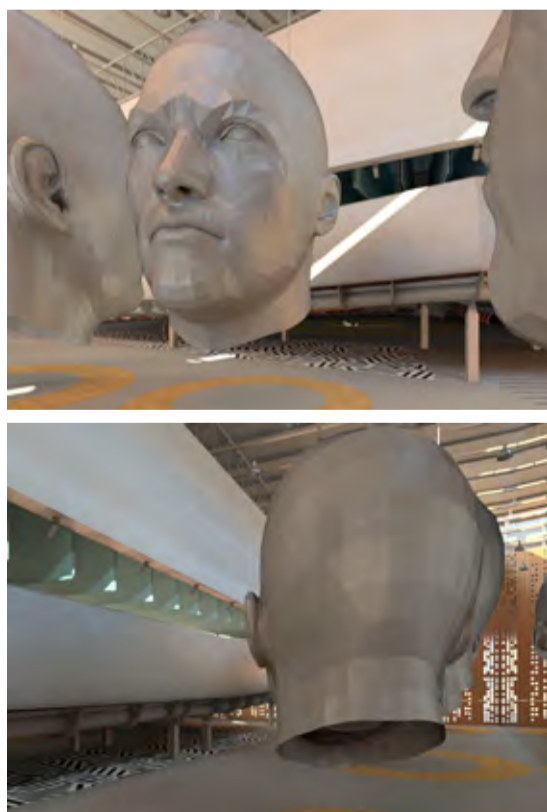

Figure 131: Comparative Assessment of Natural and Artificial Lighting Strategies
 © University of Pretoria

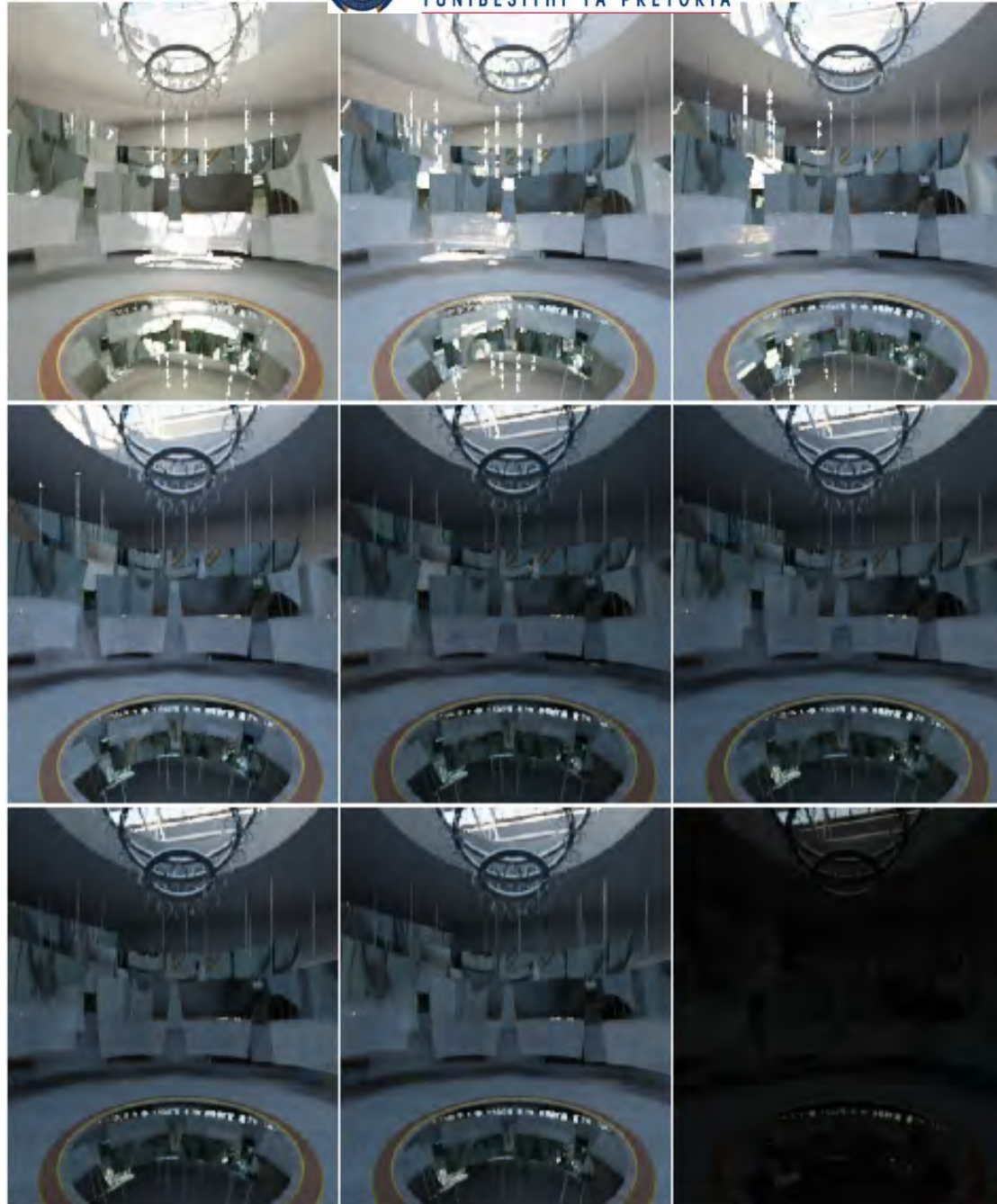

Figure 132: Reflection Well - Solar Study 12:00 -19:00

Please Note: Earlier study - Mirrored surface on back upper petal removed in final design. Mirrored surface remains on lower front petals

9.2.3. Approach to artificial lighting

A discrete approach was taken to the artificial lighting of the pavilion so as not to compete with the content on display. Consequently, minimalist luminaires have been selected and placed so as to be as invisible as possible.

With regards to the lighting of the individual zones, it is only necessary to light the *Wall Panels* [1] at night. These are lit from below by floor mounted spots along the periphery. The effect created is the inverse of the dot-matrix effect create by the sun during the day, (Figure 95), but on the outside not the inside of the pavilion. This reversal of spatial quality at night establishes the circadian rhythm that is reinforced by the *Reflection Well*, c.f 7.3.1. The illuminated pattern on the outside of the pavilion at night compliments the light displays on the shade panels that wrap the upper half of the pavilion.

A combination of side spots and down-lighters were used to create a dynamic illumination of the *Narrative Walkway* [2]. The combination allows the walkway to simultaneously have both an even spread of lighting with minimal pooling to aid visually impaired and/or signing visitors, while avoiding being over - lit and flattened, (Figure 129).

Low voltage tension wire lighting systems are positioned directly above the mural to ensure that it is well lit so that visitors can appreciate the intricacy and detail. (Not visible on earlier renders)

Additionally, an LED strip is located just on the inside of the floor rail of the mural (Detail 2), to avoid it shining directly into visitor's eyes. This acts as a visual warning in addition to the tactile wayfinding mounted in the floor alongside it.

The decorative floor decal directly underneath the walkway acts as a divider between Zones 3 and 4 while still maintaining the sense of connection across the pavilion, c.f. 8.2.1. This intangible boundary is enhanced by the LED strip lights mounted on the underside of each of the walkway ribs. The strips shine downwards to make the decal a striking focal point between the two zones, (Figures 131 -132).

The *Reflection Well* [3] is lit by both natural light coming in from the skylight and artificial lighting from the *Stamen Chandelier* during the day. The changing dynamic and animation of the well created by the sun's path throughout the day is visible in Figure 128. The combination of the two when seen from the walkway creates a dramatic pool which draws visitors to the centre, (Figure 130). The chandelier adds a warm overall tone to the well as a backdrop to the natural lighting effects.

In contrast, the outside ring of the well is not directly lit. This boundary space acts as the hallways and corridors in contemporary museums do, (Derne 2006:10). It is intended as a low intensity zone to balance out the stimulation levels within the pavilion and create a pause space for visitors. Seating is included in this area in corresponding locations to the seating on the walkway landings, (Figure 131).

The *Bobble Heads* [4] have been lit from above to mimic the sun rather than using floor mounted spots, (Figure 132). Faces lit from below can be read as sinister, and side long lighting will flatten the features.



Figure 133: Walkway Illumination (Natural & Artificial - whole pavilion)



Figure 134: Reflection Well Illumination (Natural & Artificial of well only - early render)

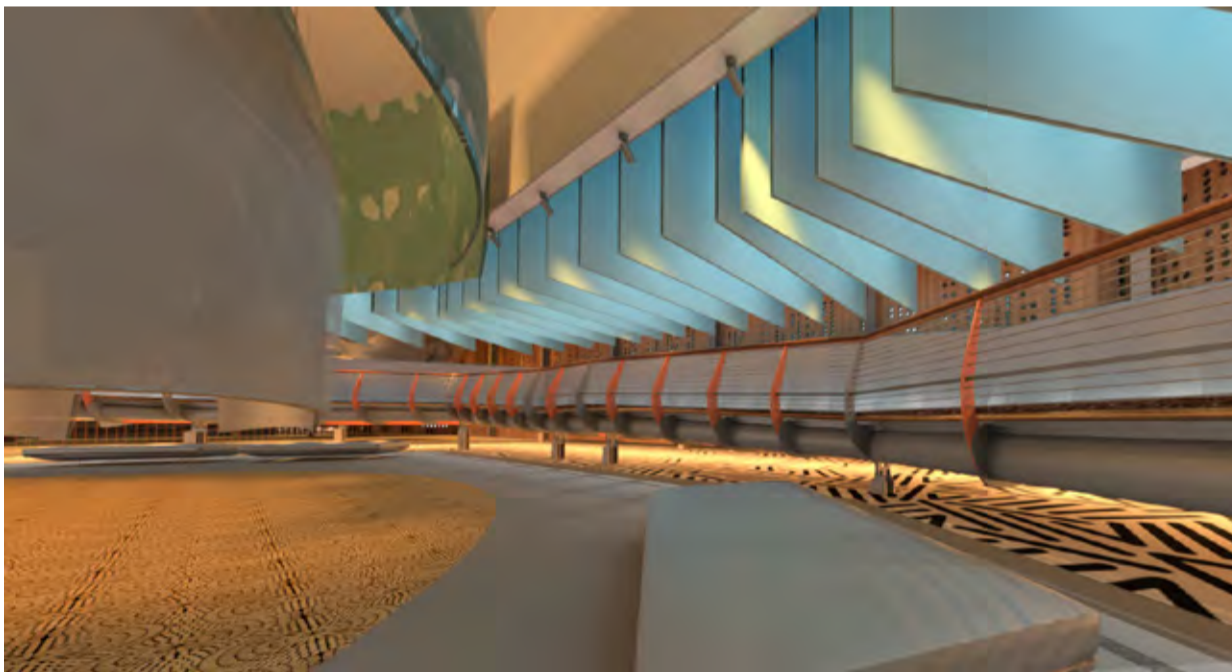

Figure 135: Well side - Low intensity boundary (Natural & Artificial - whole pavilion)

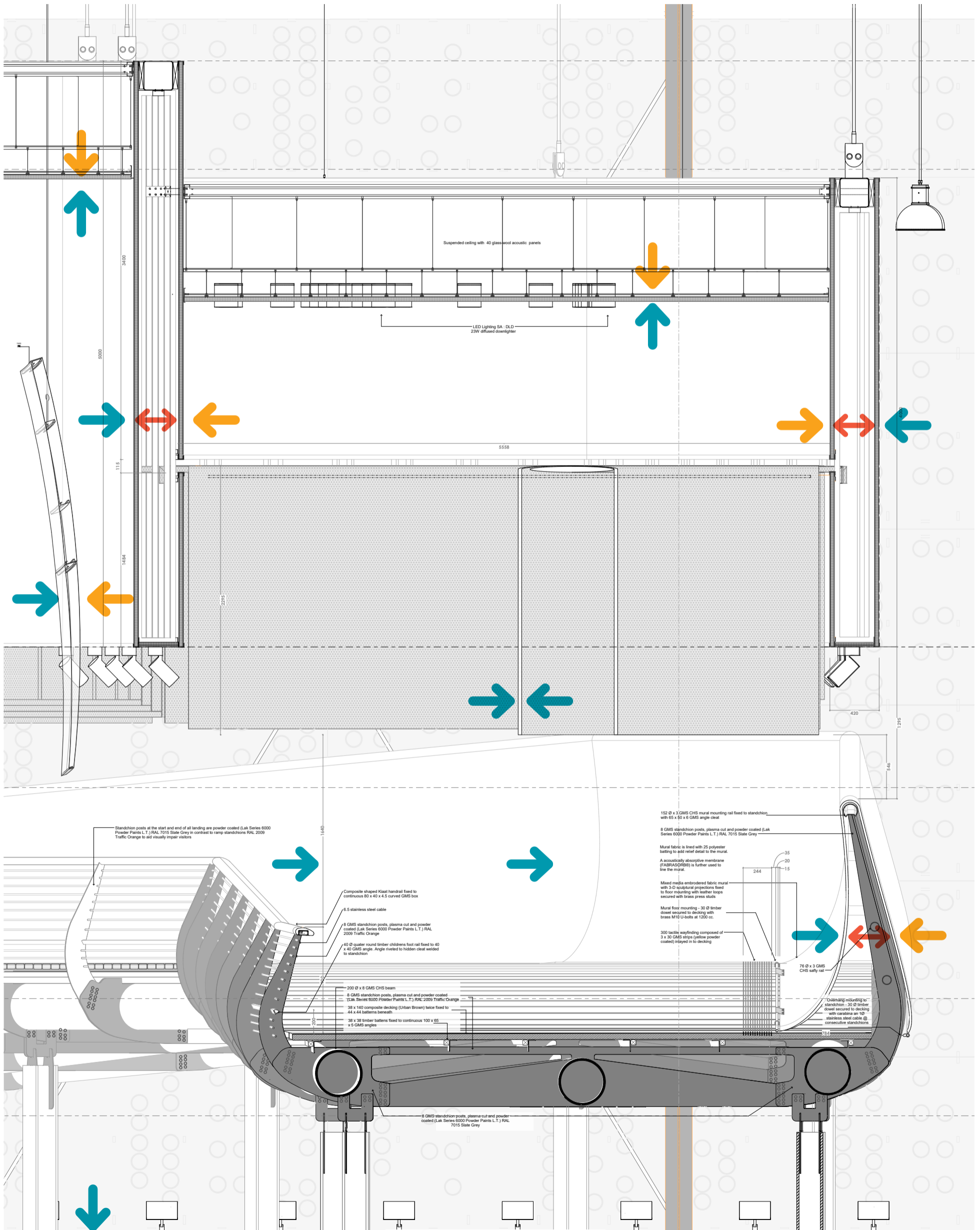

Figure 136: Bobble Head and walkway undercarriage lighting (Artificial only)

9.3. ACOUSTIC SUMMARY

The pavilion's acoustic strategy is based on maximising all acoustic surfaces by allowing the sound / noise to reach both sides of all acoustically absorptive materials. This is achieved by pairing acoustic layers and allowing for voids between them, this results in four acoustic layers per element in stead of just one if it were mounted against a wall. Thus reducing as much unwanted noise per surface as possible.

In order to support this strategy, EPDM with an acoustic underlay was selected for the general floor finish to reduce the noise generated by footfalls within the pavilion, and echoes as it is a diffusive surface. A similar strategy was applied to the walkway, specifically the insertion of rubber gasket strips between the decking planks and the structural skeleton to reduce noise being generated and transmitted via the walkway.



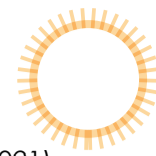

9.4. SUSTAINABILITY AND PASSIVE STRATEGIES.

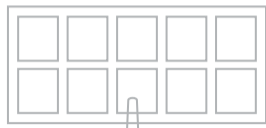

At least 50% of the expo sites' energy needs will be supplied with energy from renewable sources.

As part of this effort the expo park will feature its own photovoltaic farm on site.

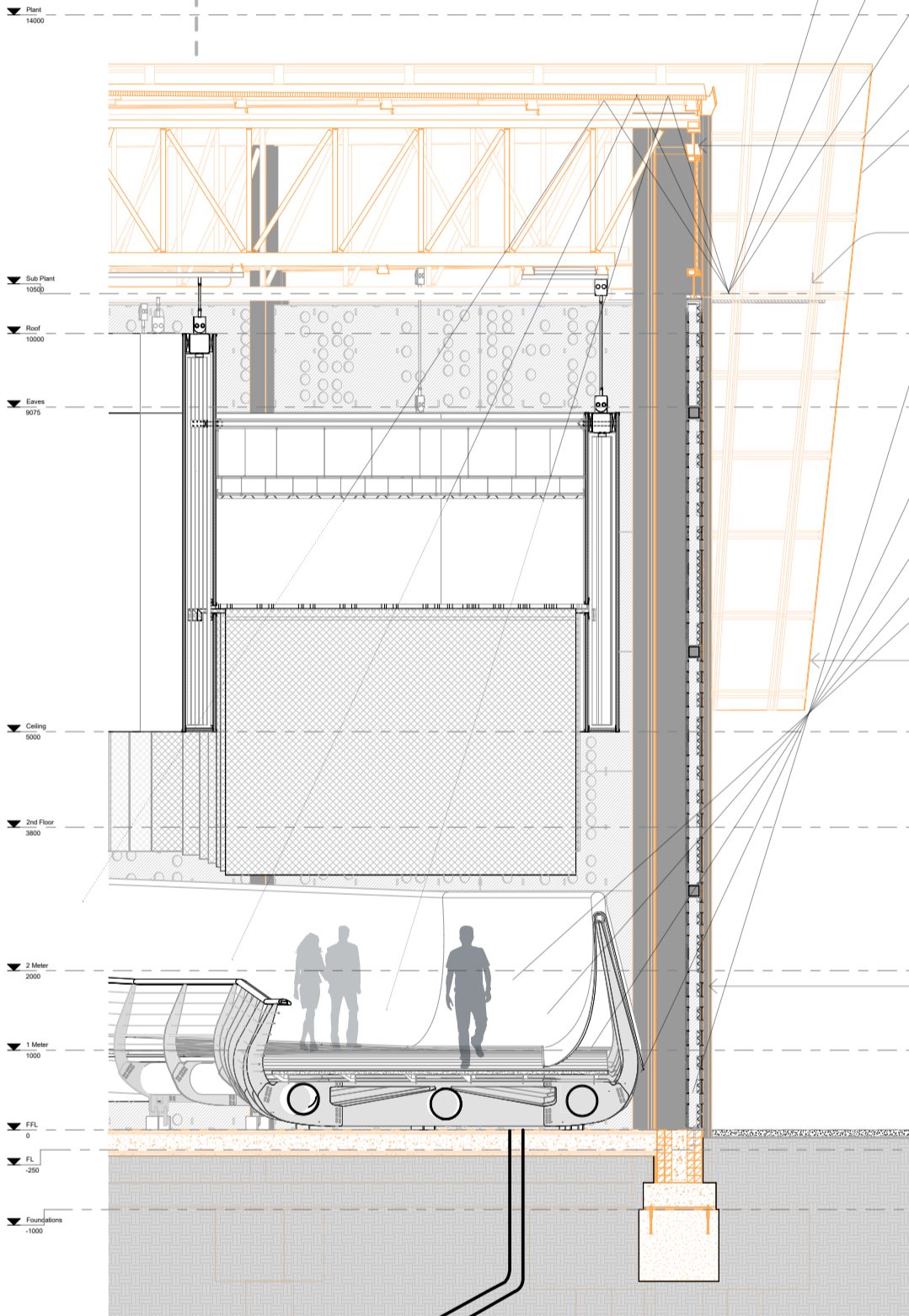
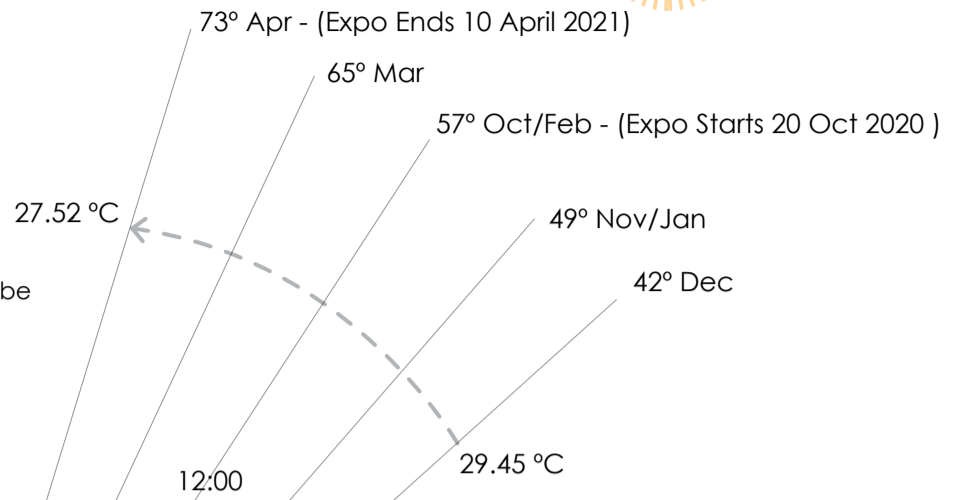

Clerestory windows to maximise natural lighting.

50 mm extruded aluminium reflector light shelf



SGM® Shade Mesh (fibreglass coated with Teflon® [PTFE]) provides shade while allowing air to pass through the openings in the membrane, providing high light transmission while supplying circulation of air.

These tensioned fabric screens wrapping the smaller pavilions within the Souqs will facilitate illuminated displays of lights and digital projections.(As per the Expo's vision, HOK 2016).

140 Ø recycled clear glass bottle end recessed into a 220 birch plywood inter-connecting wall panel based on a 3000 x 1500 x 21 birch plywood sheet module, with 50 glass-wool / mineral fibre rigid insulation.

Plywood was chosen for the outer walls as it has a lower heat gain capacity and transmission in comparison to glass and steel. This is supported by an air gap and insulation on the exterior facing side of the panel

The glass bottles allow for a good diffused quality of general lighting due to their even distribution across the façades. However, their small aperture prevents excessive heat gain.

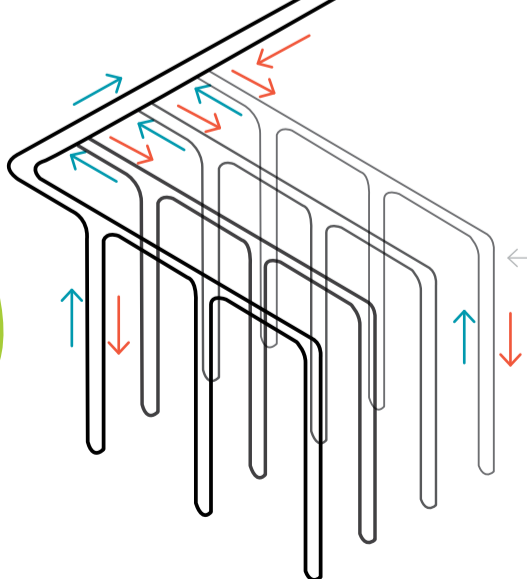

Vertical Closed Loop Geothermal Cooling to augment HVAC System

- Expo Rented Pavilion - Existing
- South African Pavilion Installation - New

Figure 138: Sustainable and passive strategies.

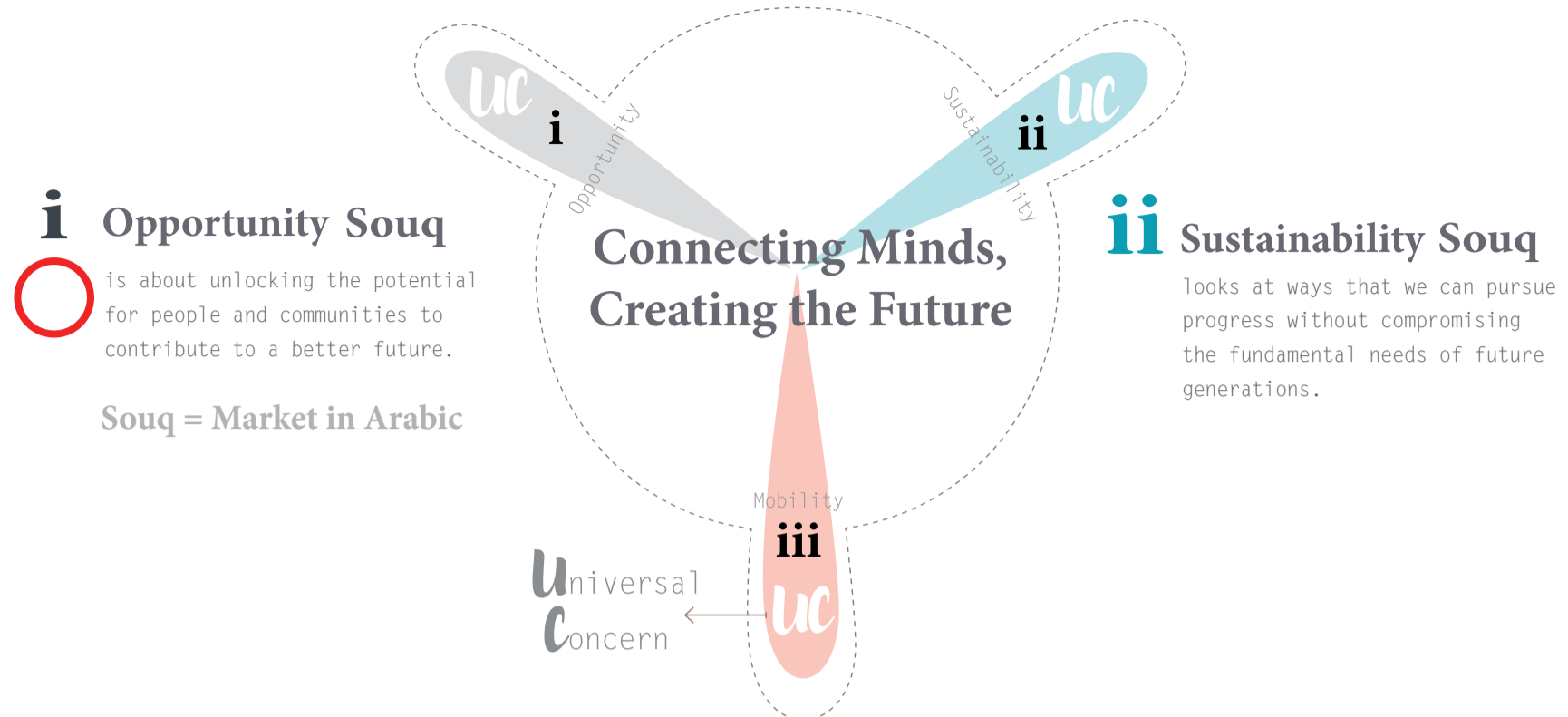

Figure 139: Expo theme requirements

The pavilion design includes several sustainable and passive features ranging from material selections to cooling and passive lighting. However, at this point it must be reiterated that the pavilion is located within the Opportunity Souq of the expo park not the Sustainability Souq. Hence, the pavilion has in addition to the alternative brand, focused on exploring and showcasing low-tech hand made alternatives and details as part of its response to the *Expo 2020* theme and *Universal Concern*. As this is where South Africa as a nation can make the biggest contribution, c.f 6.1. (Figure 135). Presenting a response to the theme is a vital part of any nation's participation in a *World Expo*. The design of the pavilion would have been substantially different if it had been located within the Sustainability Souq.

9.4.1. Energy and lighting

The Expo 2020 Dubai, UAE has set for itself the requirement that at least 50% of the expo sites' energy needs will be supplied with energy from renewable sources. As part of this effort the expo park will feature its own photovoltaic farm on site.

In-line with this energy conscious effort the South African pavilion's design included several passive lighting strategies; Firstly, clerestory windows with an attached exterior reflector light-shelf have been added to five of the six façades. Additionally, all clerestory windows are coated with a Low-E or similar Solar Control coatings. No clerestory has been implemented on the entrance facade as it receives the most direct sun for the longest period of time, without any shading measures, (Figure 136). The heat gain from this facade would be more detrimental than the lighting benefits.

The pavilion receives the most benefit from the clerestory windows on the North East, and North West façades as these are the two longest façades, and due to the pavilion's orientation they are also both shaded throughout the day. Consequently, the pavilion receives large amounts of indirect natural light without a significant amount of heat gain.

Due to the arrow head shape of the pavilion, the two façades; South and South West, which ought to be the most problematic in terms of heat gain are in fact the two shortest façades of the pavilion.

Therefore, their heat gain potential is greatly reduced. These façades are also shaded throughout the day by the shade mesh, surrounding buildings and by the Expo Shade Cones. This is evident in Solar Study in Figure 136.

Secondly, the pavilion receives natural light via the small apertures in the *Wall Panels [1]*. Heat gain resulting from these panels is limited by their base material (plywood), composite nature (insulation & air-gap) and the small size of the apertures, (Figure 134).

The extent of the natural light can be seen in the first column of images in Figure 127.

Lastly, LED Lighting has been specified throughout the pavilion to reduce energy consumption.

9.4.2. Cooling

Three passive cooling features have been added to the pavilion. The first being the shade mesh surrounding the upper half of the pavilion on five of the six side. This feature was included in the conceptual renders as part of the lighting display. However, no indication as to materiality was given. Based on material research SGM® Shade Mesh (fibreglass coated with Teflon® [PTFE]) has been specified as this mesh provides shade while allowing air to pass through the openings in the membrane, providing high light transmission while supplying circulation of air. This will prevent a 'hot air bubble' building up between the *Wall Panels [1]* and shade mesh beneath the light-shelf. Additionally, the high light transmission ensures that the effectiveness of the wall apertures are not significantly reduced.

The second passive cooling measure to be implemented is a Vertical Closed Loop Geothermal Cooling system to augment the HVAC System, (Figure 134). Due to the site's location in Dubai, mechanical ventilation could not be eliminated entirely, however the geothermal system acts as a primer to the HVAC, by preconditioning the air.

Lastly, slanted vertical fins have been added to the entrance facade (Figure 84), and vertical fins to the exit (Figure 85), as a solar control measure. The luminance studies in Figure 137, demonstrate the effects of these measures.

9.4.2.1. Solar Studies

Solar studies of the pavilion were conducted to determine problematic façades from a shading perspective. This information was used to determine which façades would benefit from additional solar control measures and on which façades passive features could be implemented.

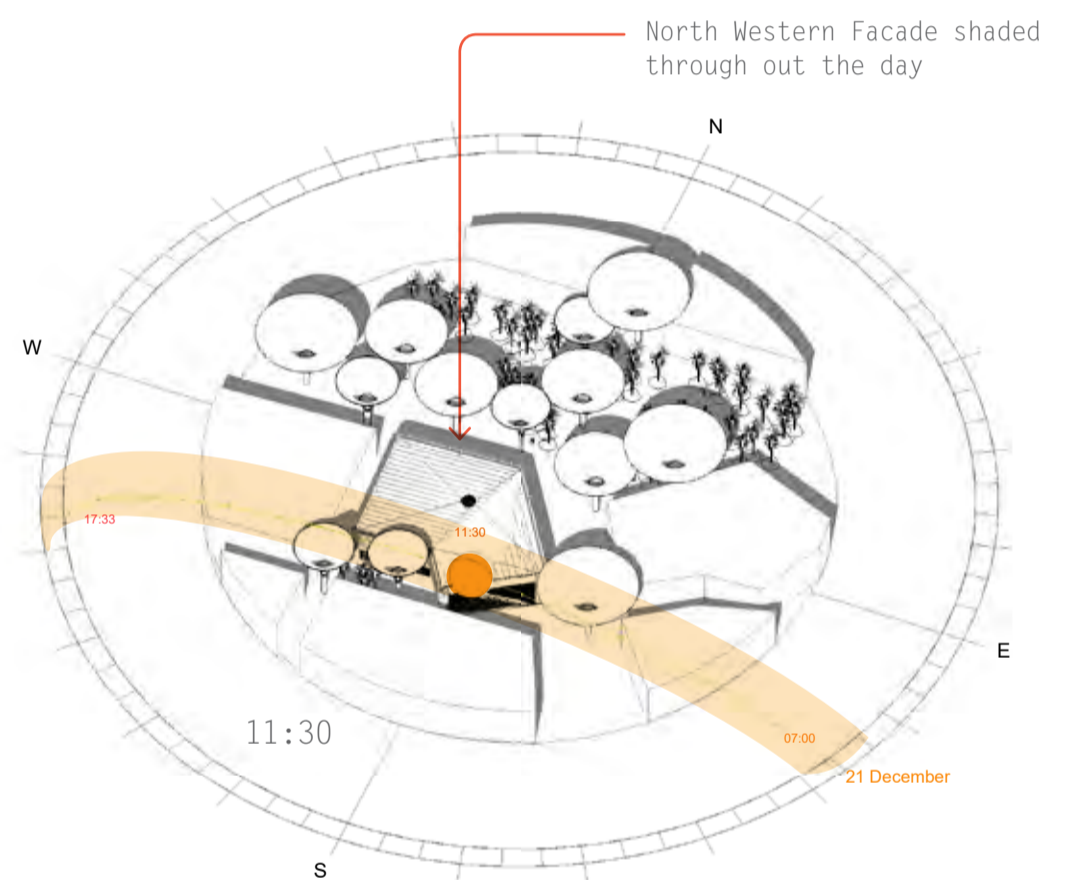
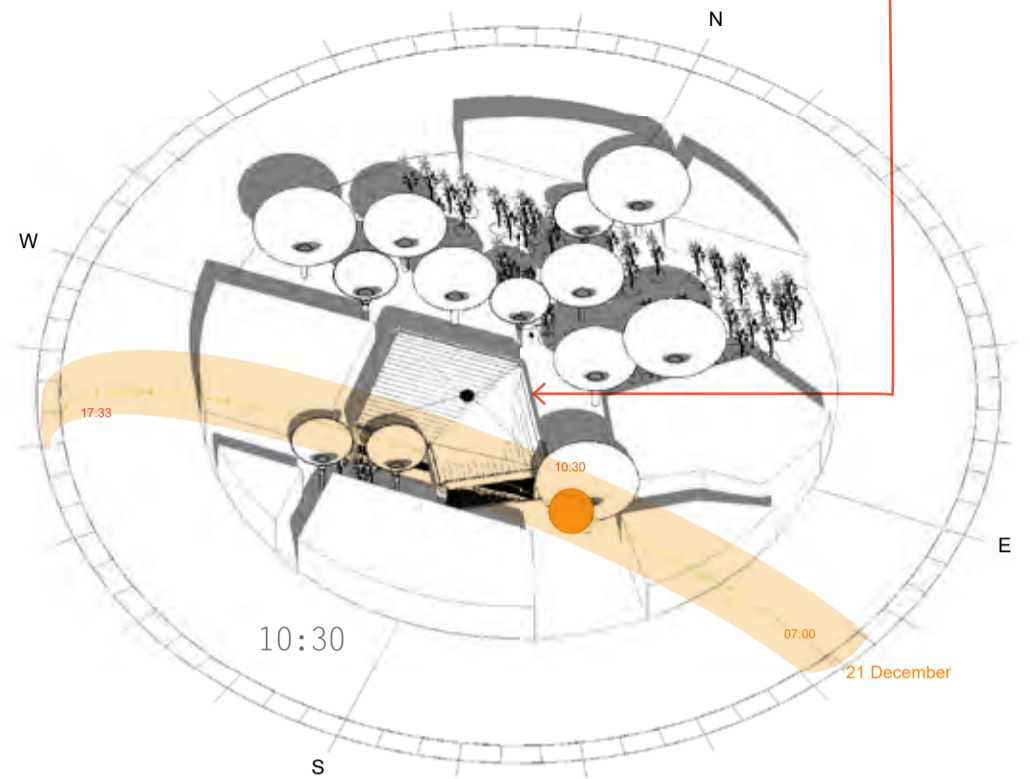
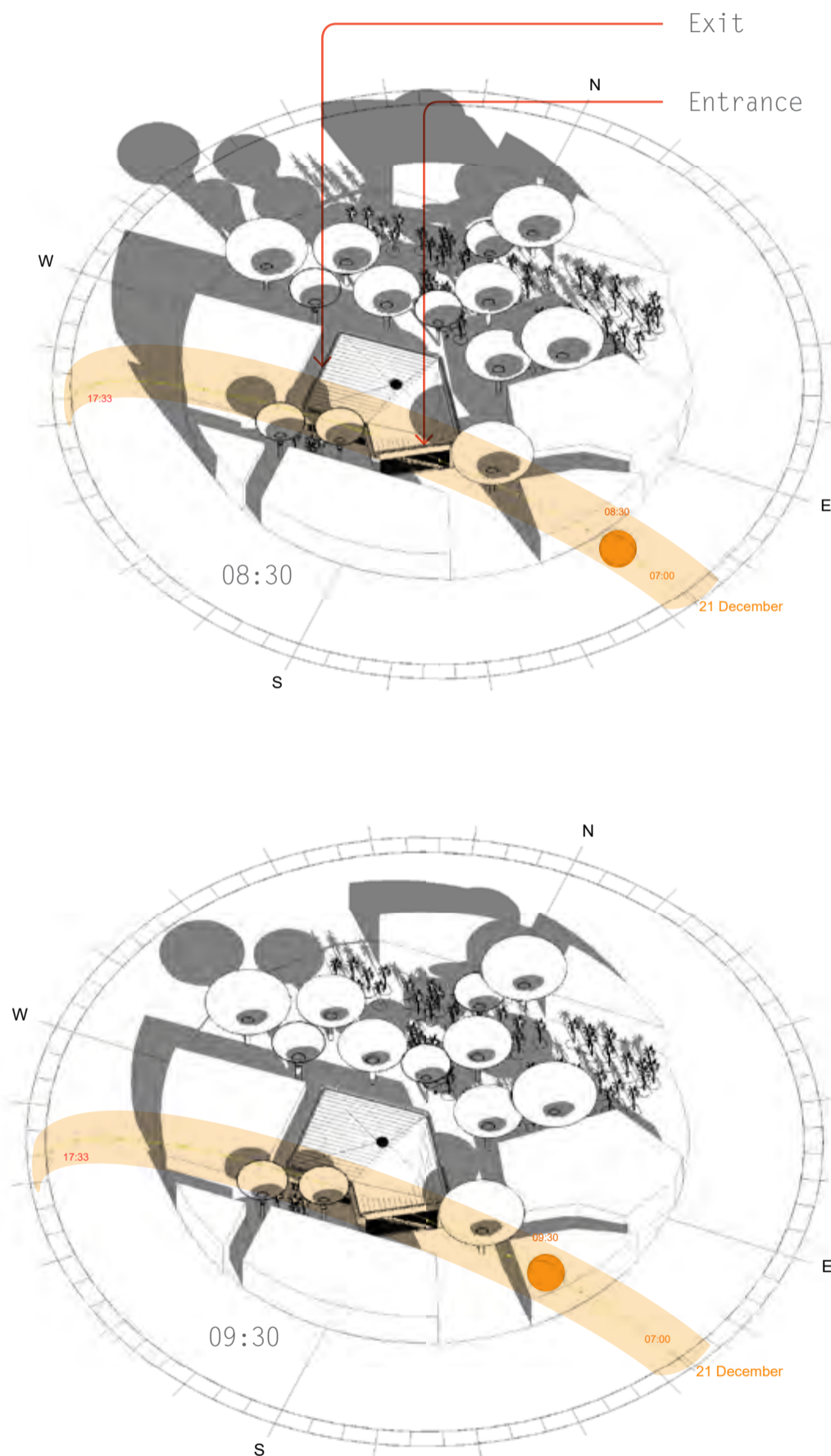

South Eastern facade directly lit throughout the morning, it is however partly shaded by adjacent buildings from 14:30 onwards

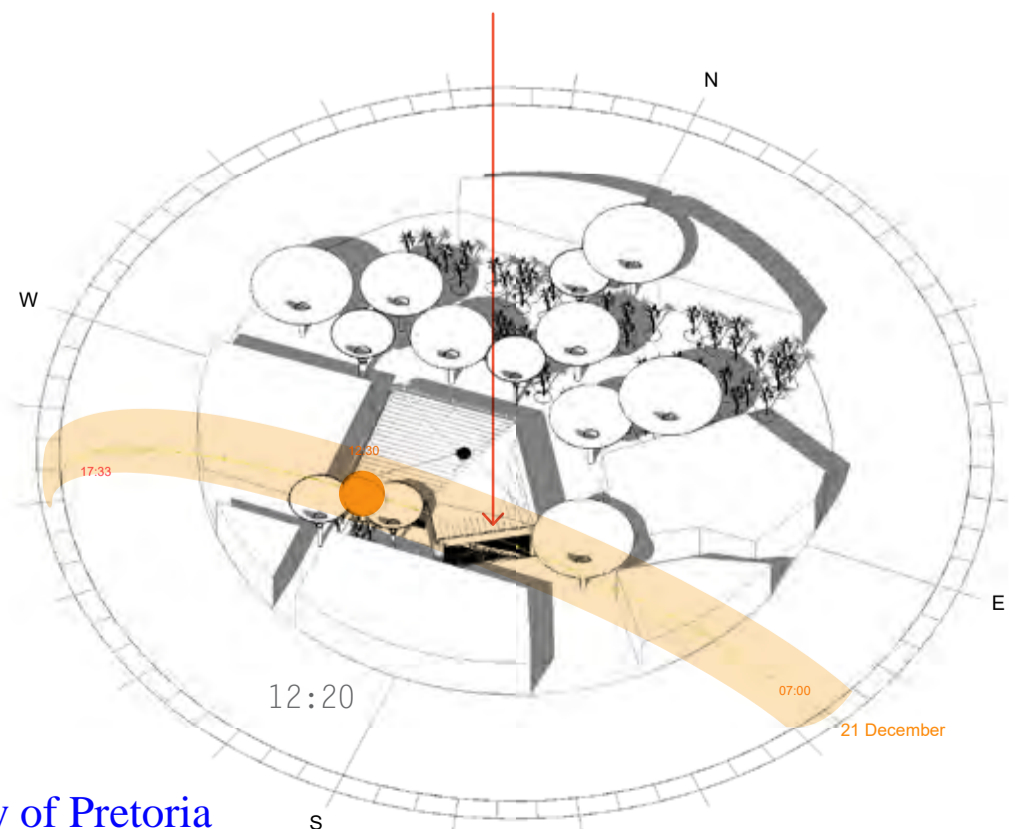
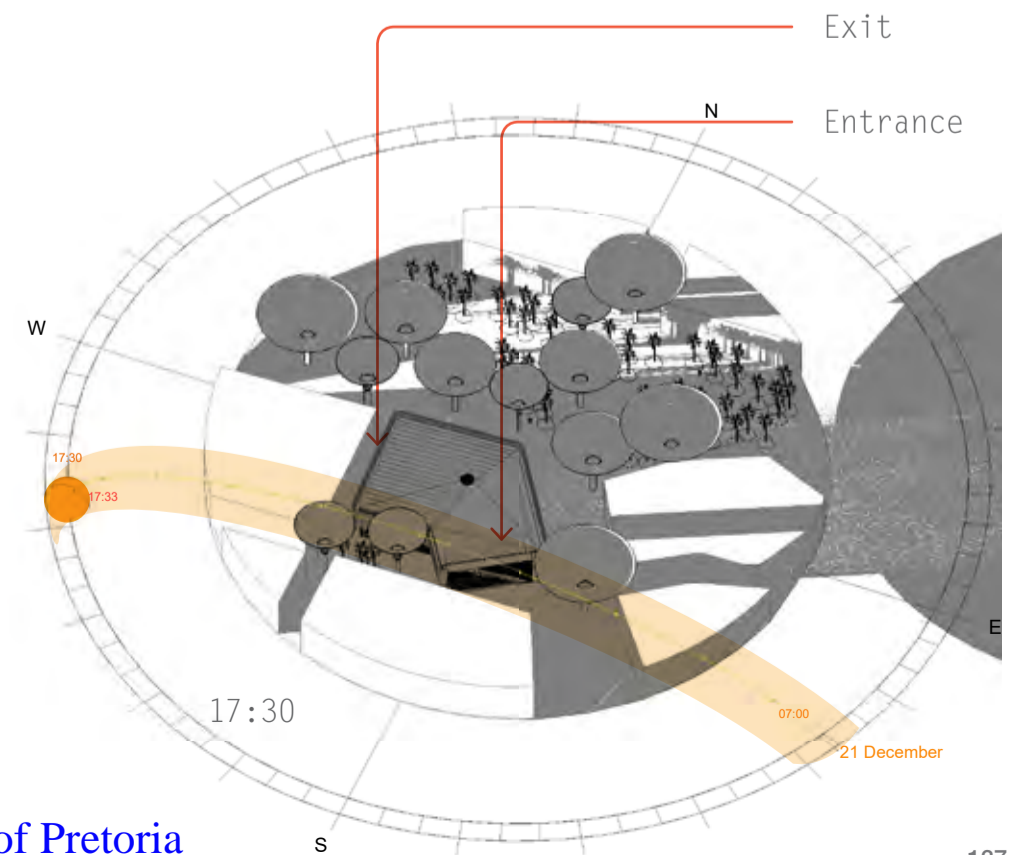
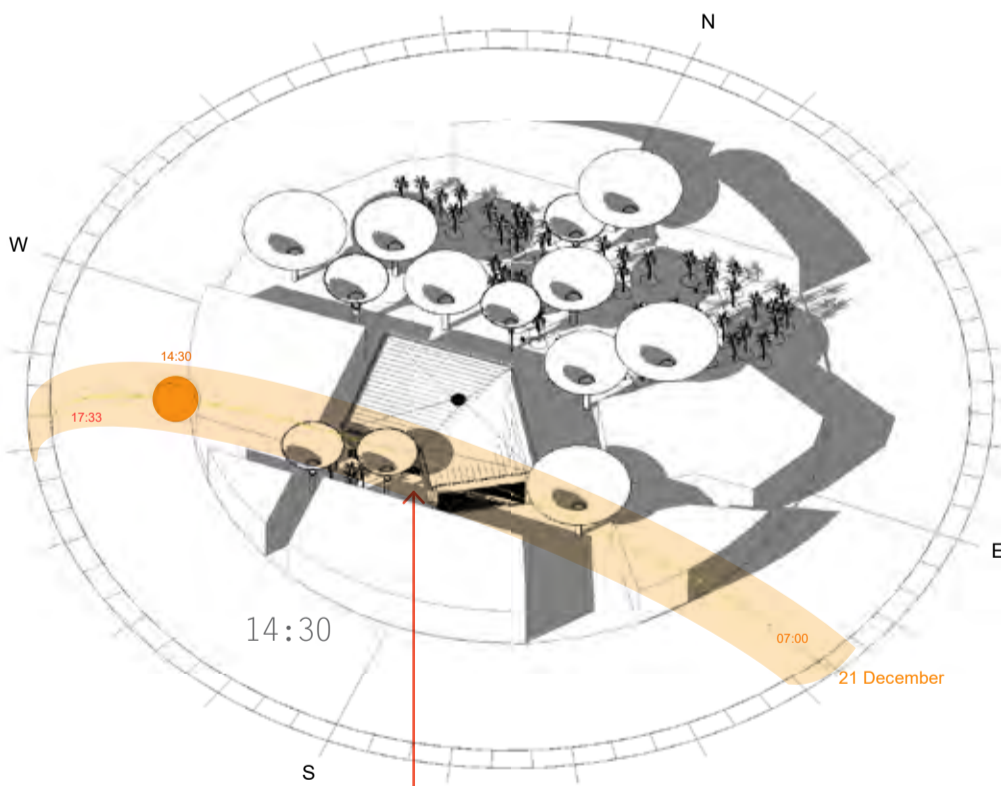
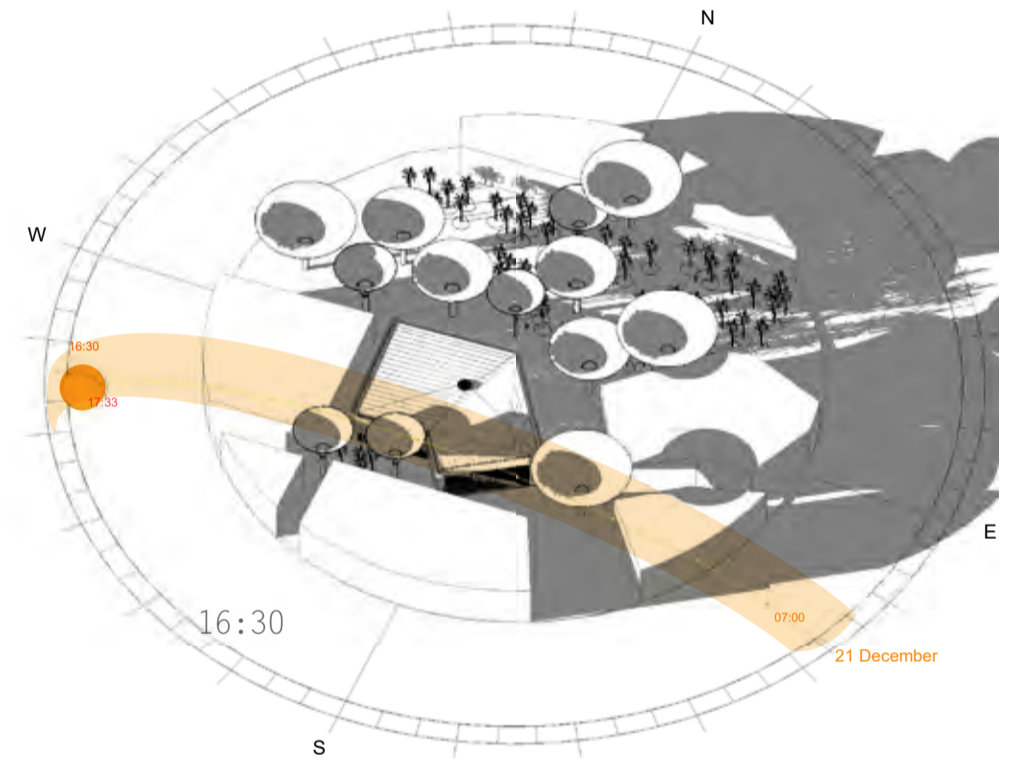
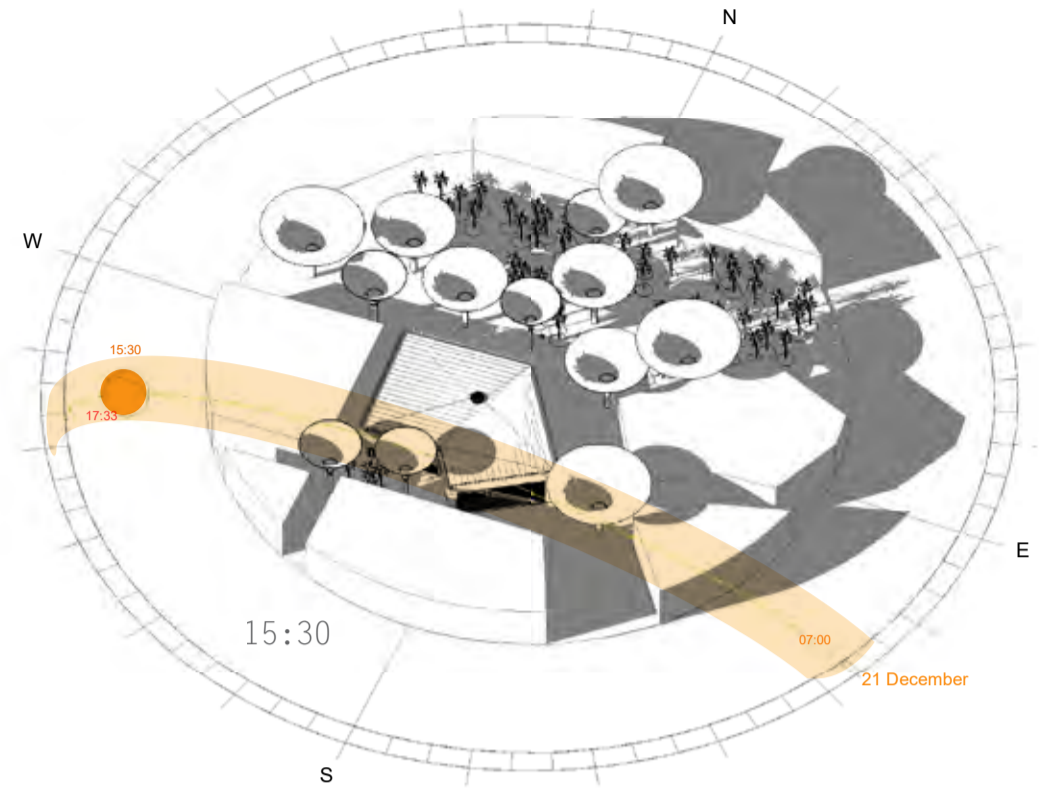
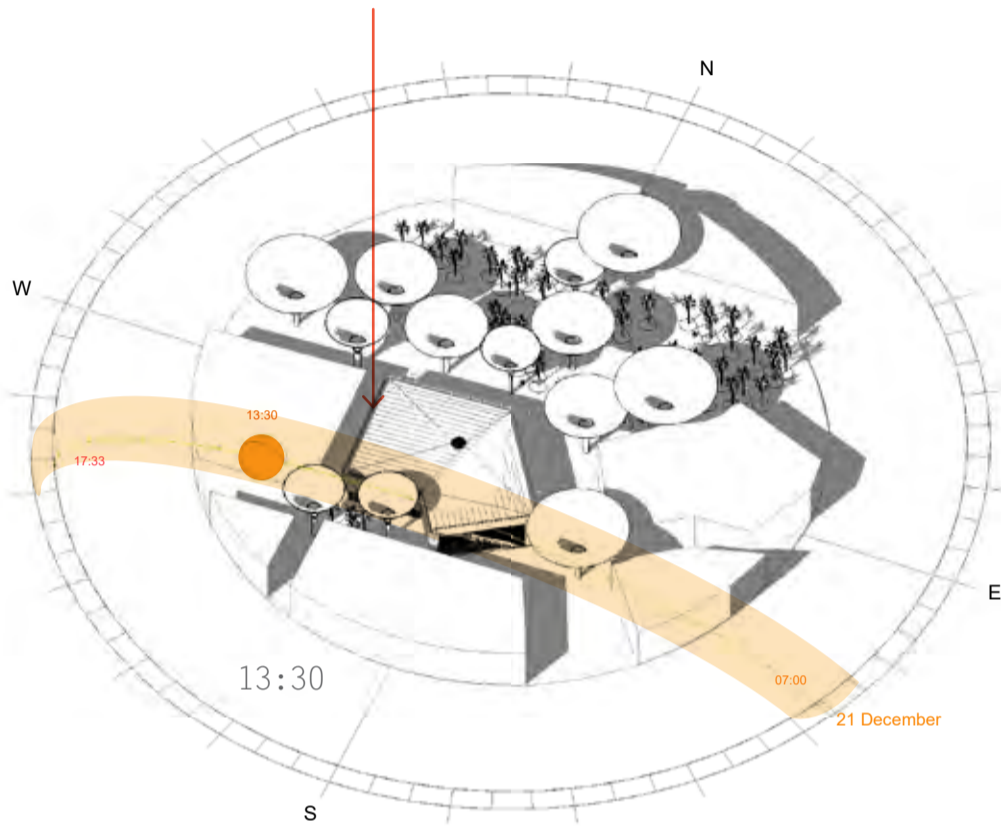

Figure 140: Climatic and site influences



Western Facade is directly lit from 12:30 onwards, it is however partly shade by the adjacent building from 14:30 onwards



South Western Facades directly lit from 10:30, however it is less problematic as it is partly shaded by 'cones'. These facades are additionally the shortest facades on the pavilion.

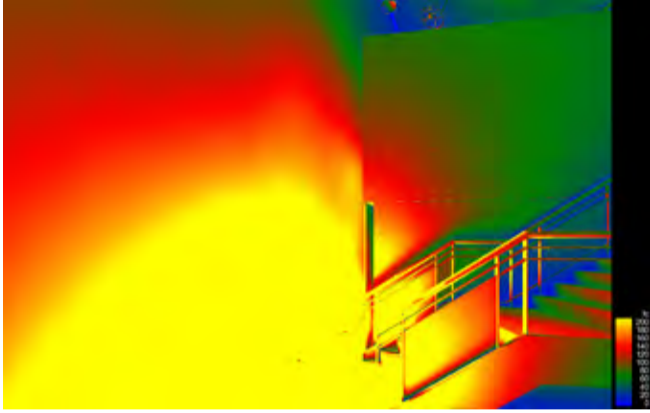
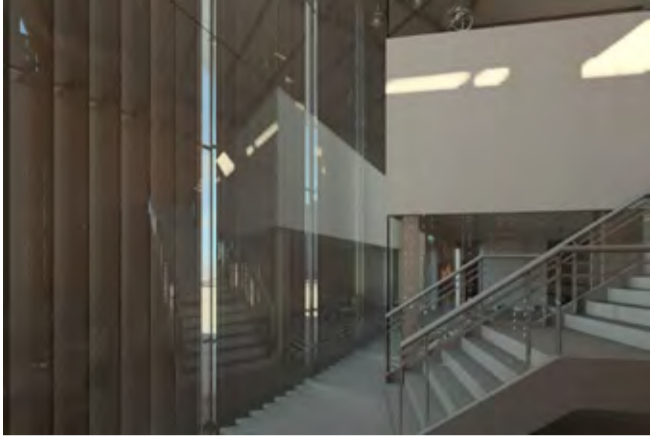

11:30
No Fins

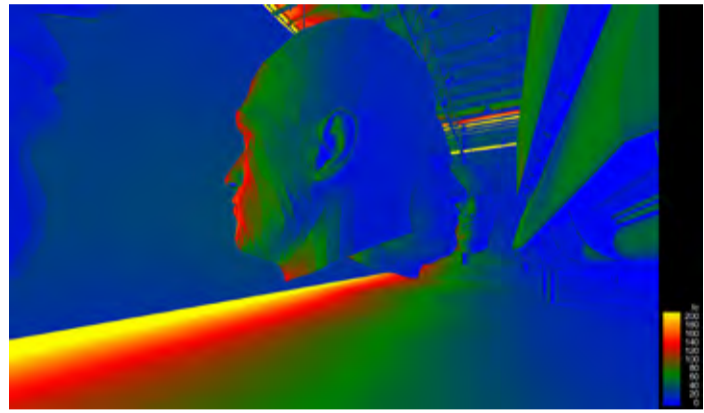

14:30
No Fins

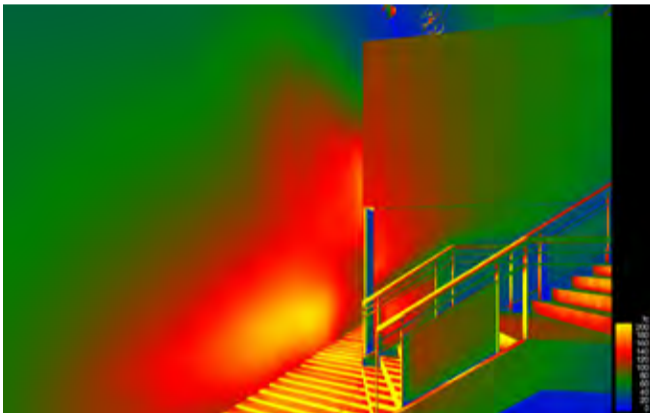

11:30
Fins
Added

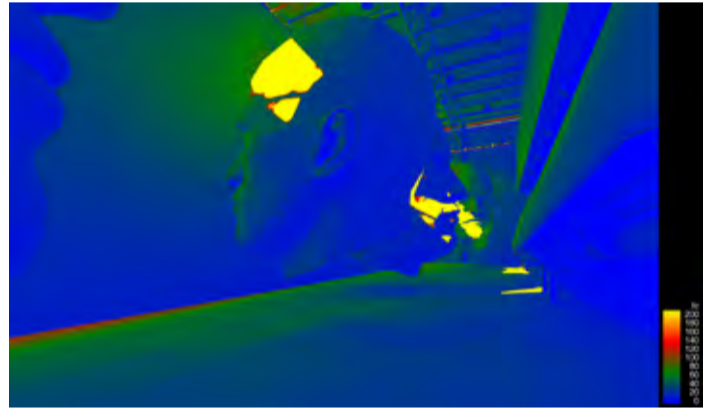

14:30
Fins
Added

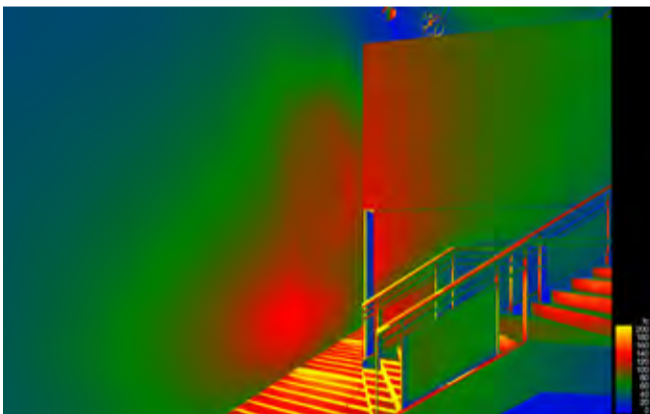

12:30
Fins
Added

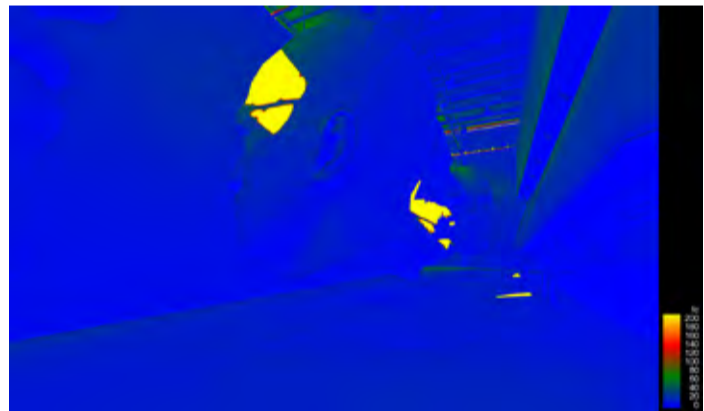

15:30
Fins
Added

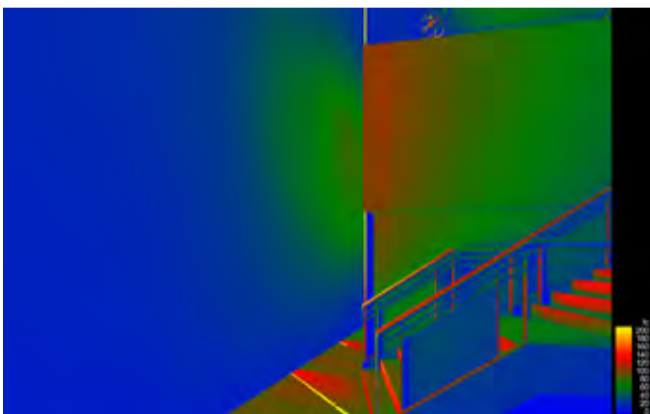

13:30
Fins
Added



11:30
Zone 4 Cool
through out
the morning

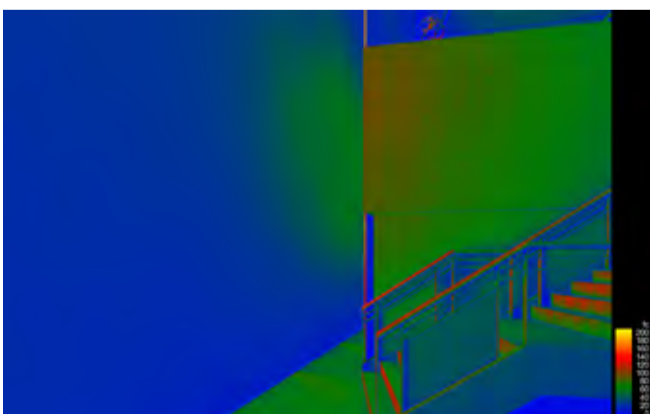

14:30
Fins
Added

Figure 141: Effects of Solar Fins

9.5. SBAT

Table 4: SBAT Assessment

SUSTAINABLE BUILDING ASSESSMENT TOOL RESIDENTIAL

1.04

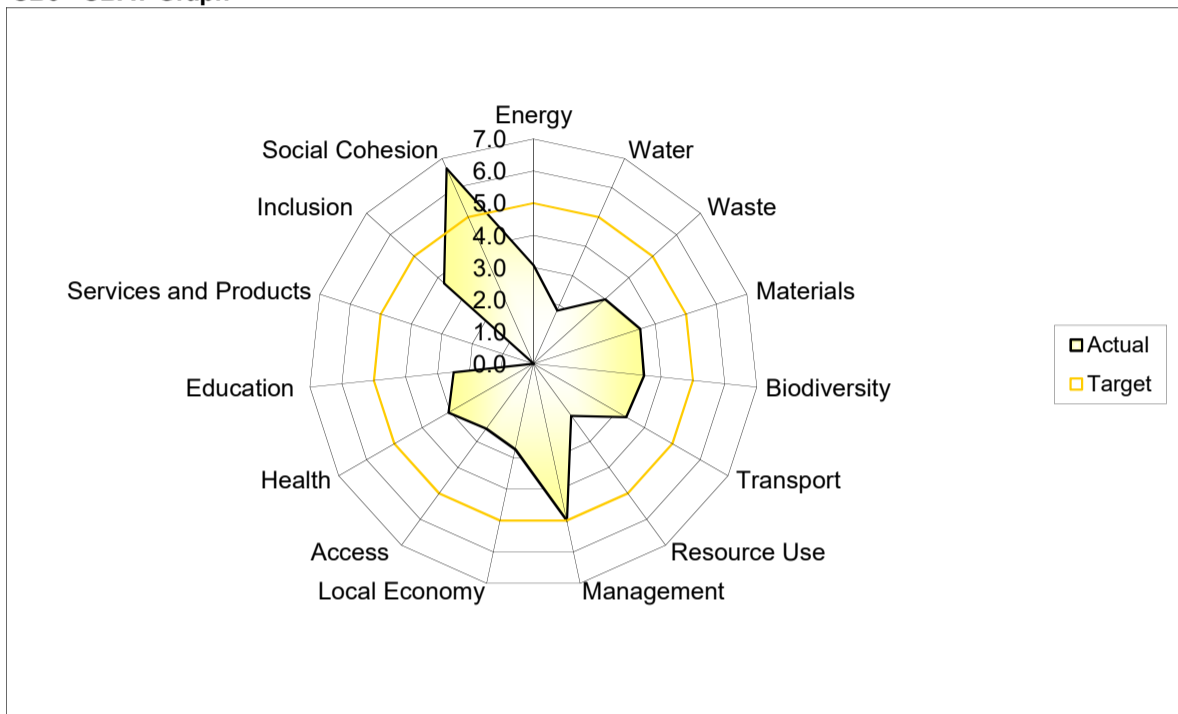
		Achieved
SB	SBAT REPORT	3.1
SB1	Project	
	South African Pavilion for the World Expo 2020, Dubai UAE	
SB2	Address	
	Dubai South District, [adjacent to Al Maktoum International Airport]	
SB3	SBAT Graph	
		
SB4	Environmental, Social and Economic Performance	Score
	Environmental	3.0
	Economic	3.1
	Social	3.2
	SBAT Rating	3.1
SB5	EF and HDI Factors	Score
	EF Factor	2.6
	HDI Factor	3.0
SB6	Targets	Percentage
	Environmental	59
	Economic	62
	Social	64

As the site is a new build, no comparison with the existing installation could be made.

Some targets; including Water, Biodiversity, Services and Products, could not be fully met due to the Expo location in Dubai and the location of the pavilion within a dedicated expo park. In other cases, such as the Local Sourcing and Materials, a decision was made to use international products based on their life-cycle assessments with regards to environmental impact of a product in comparison to locally available materials.

9.6. SERVICES

Occupation Classification: Mixed use - A1, C1, C2

A1_Entertainment and public assembly - 1person/1m²

C1_Exhibition hall - 1person/10 m²

C2_Museum (Art Gallery) - 1 person/20 m²

9.6.1. Services: Water & Sanitation

Services are located around the central service core and directly above it, (Figure 138). Pipes link to an existing sewage system located in the Underground Services network. The network is designed to service pavilions without impacting pedestrian movement on-site, c.f 5.3.5.

Plumbing Installation:

Plumbing and installation must be supervised by a qualified plumber.

HDPE sewers and drain pipes, and fittings:

High-density polyethylene sewers and drain pipes and fittings should comply with SANS 4427. Couplings must fit sockets with rubber seal rings. Sizes as specified are outside diameters. No bends and junctions allowed under floors and foundations.

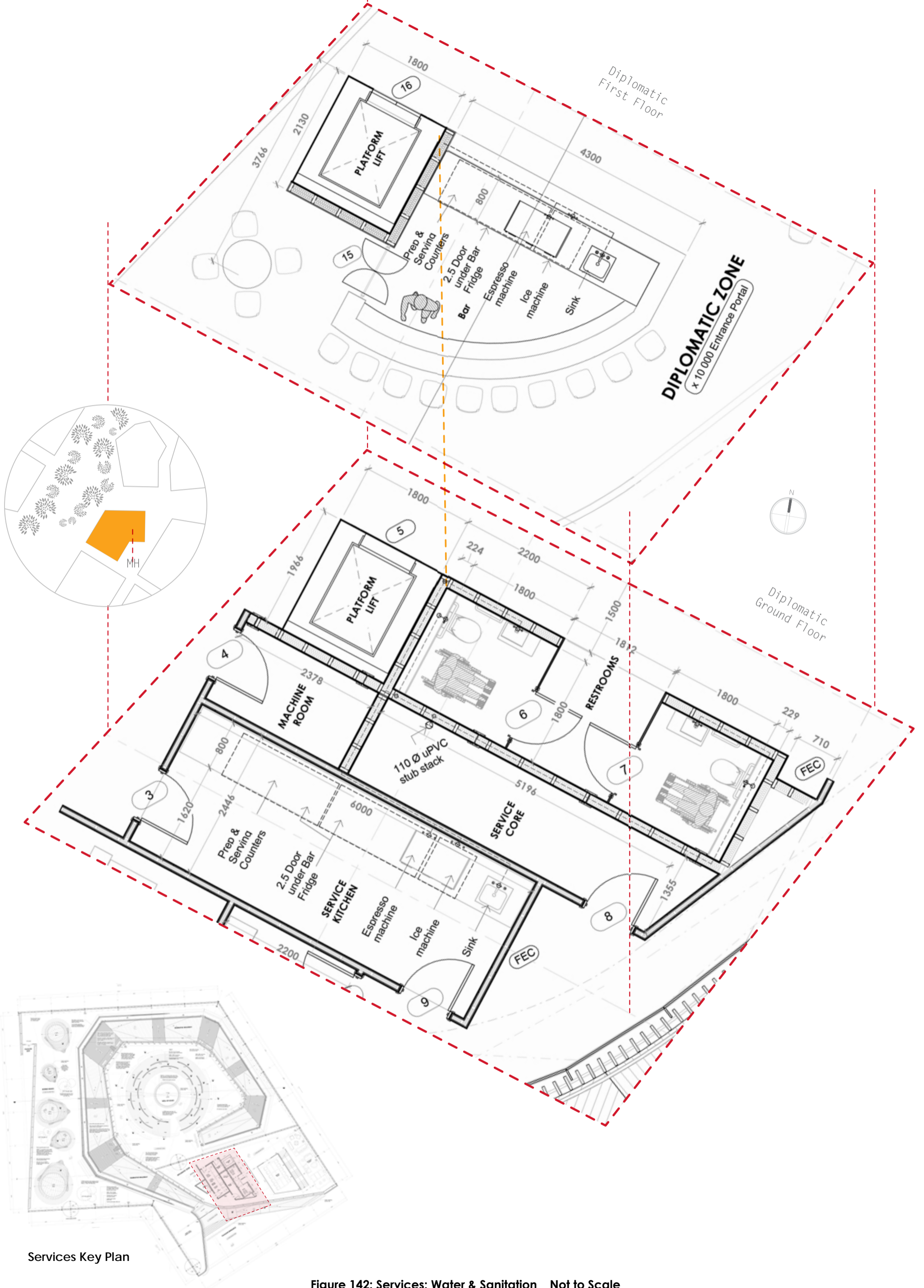

Figure 142: Services: Water & Sanitation _ Not to Scale



9.6.2. Services: Fire

A Rational Fire Design needs to be completed by a professional. In accordance with the NBR TT16 (SANS 10400), the travel distance to the nearest escape door may not exceed 45m, (Figure 139).





FIRE PROTECTION

Comply with SANS 10087-7

FIRE INSTALLATION

Comply with SANS 10400 Part W: Fire Installation.

Automatic sprinkler systems to comply with SANS 10287,
Automatic sprinkler installation for fire-fighting purposes (by Building Owner)

-  Exit routes from exhibition main floor
-  Exit routes from diplomatic zone
-  Fire Extinguisher Cabinet
-  Fire Hydrant

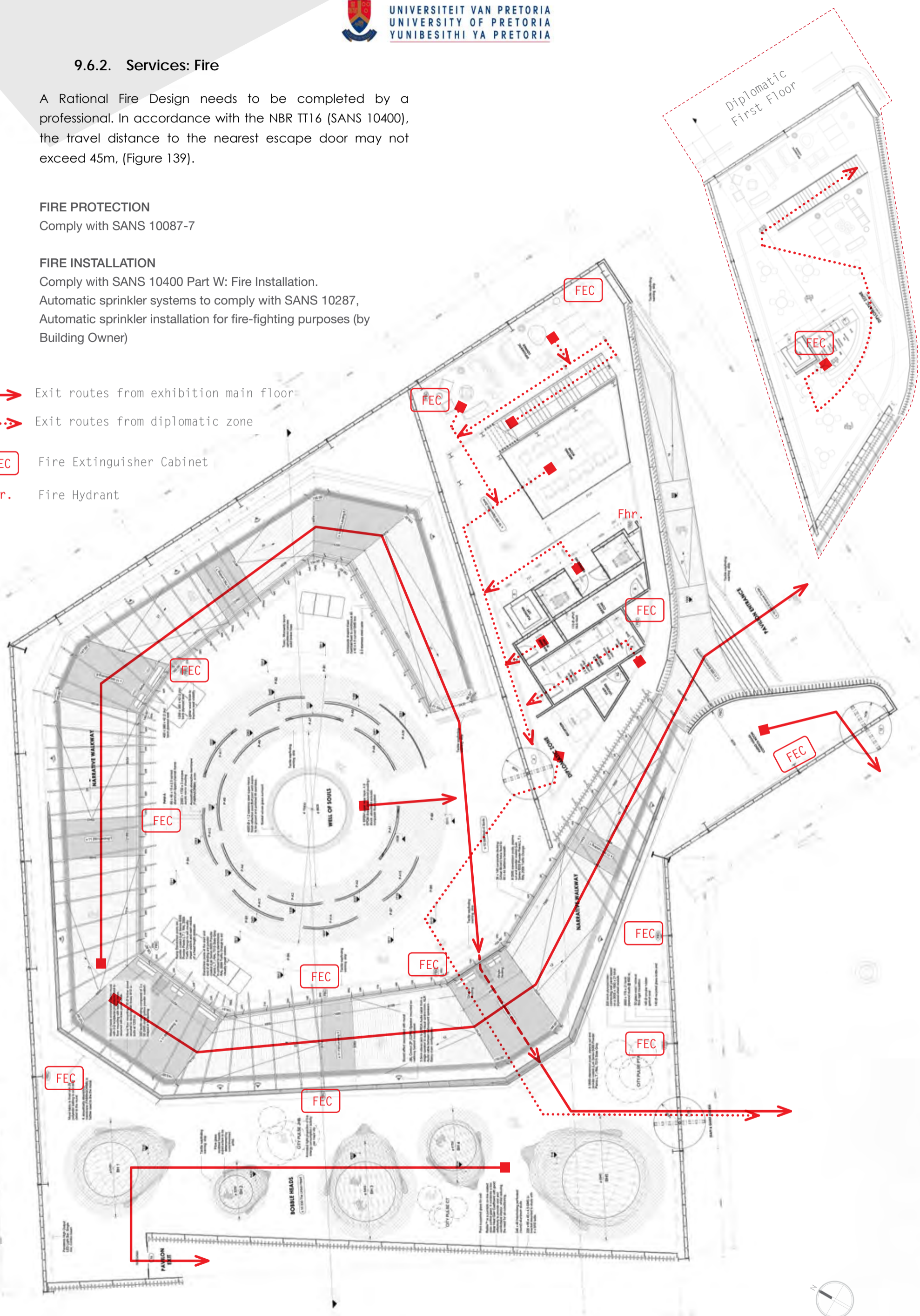
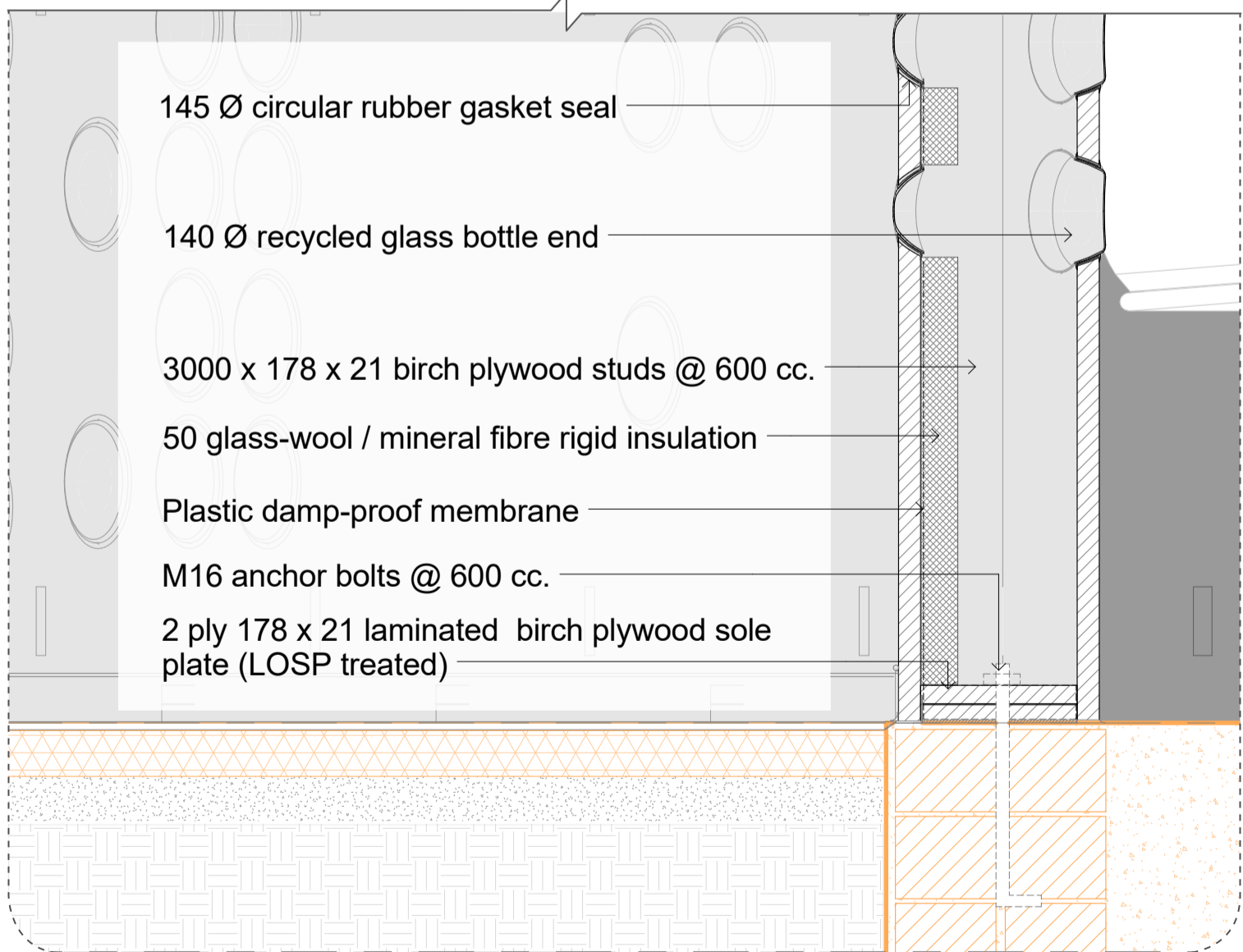
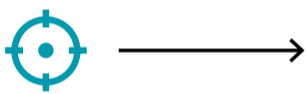
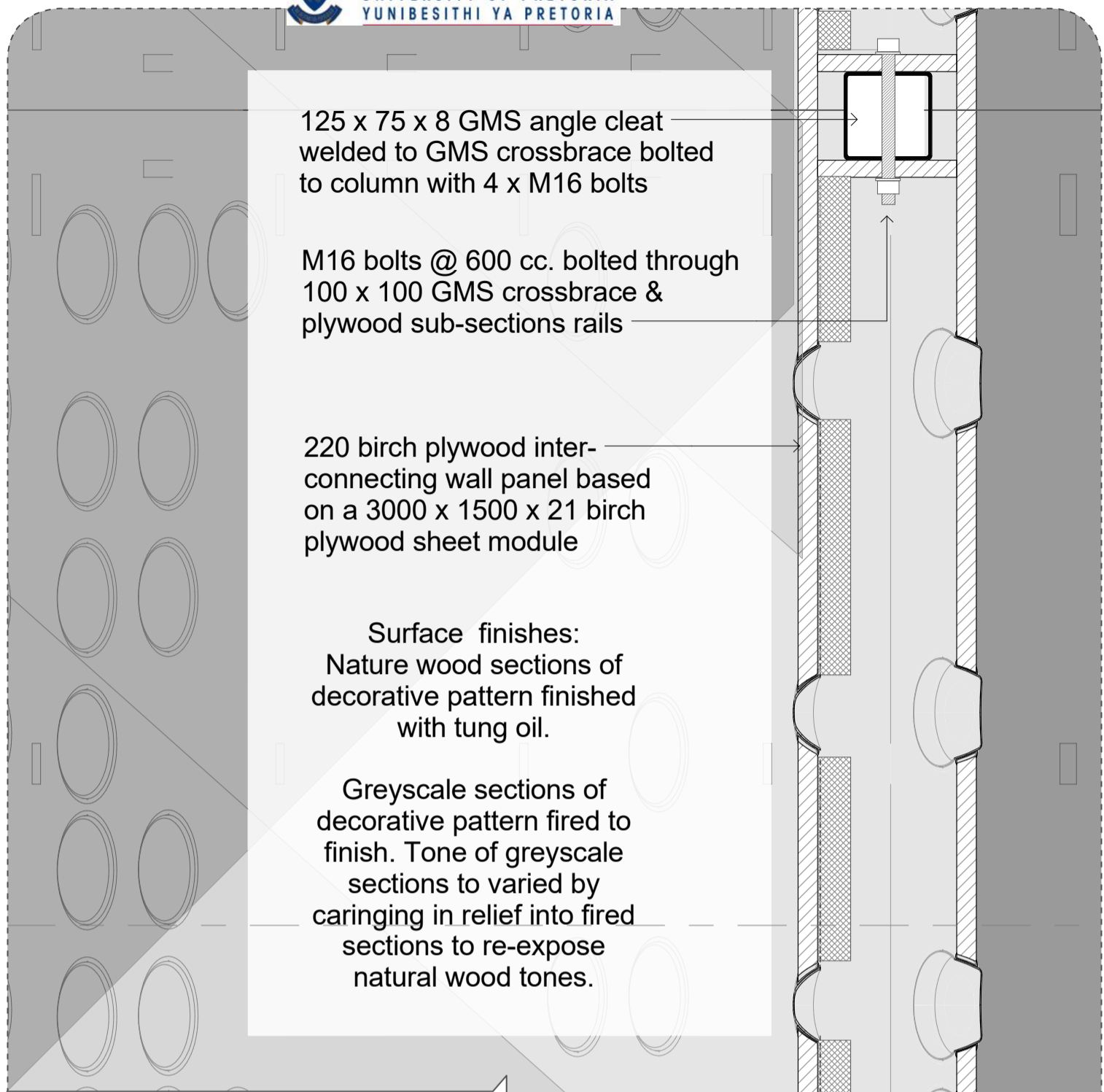

Figure 143: Narrative Routes & General Circulation Diagram _ Not to Scale
© University of Pretoria



SEE THROUGH OUR EYES _ Wall Panel Installation Detail
Not to Scale



Detail 2: Narrative Walkway



TO WALK A MILE IN OUR SHOES _
Overhead Carriage

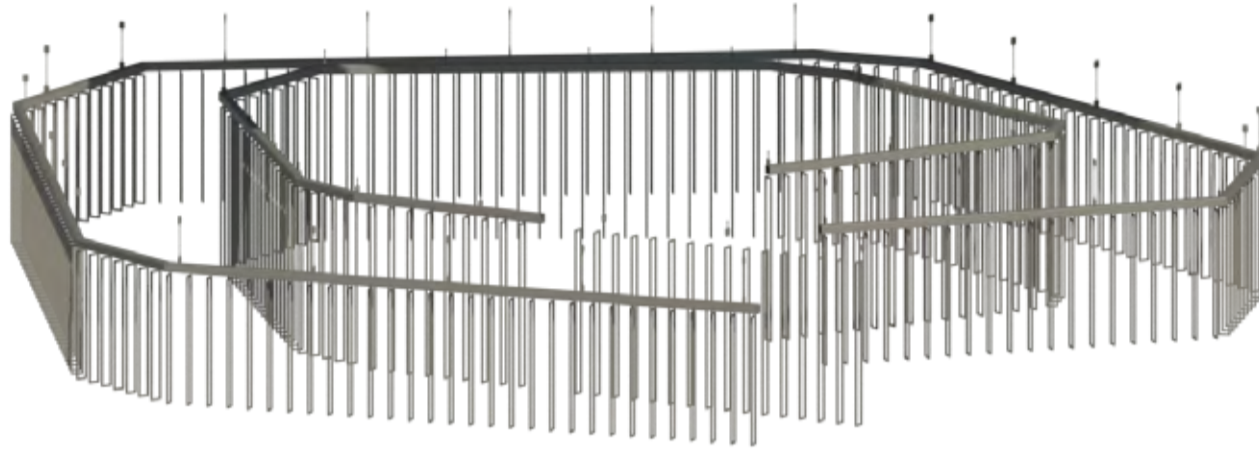
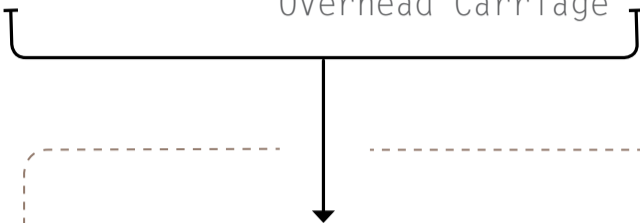

Overhead Frame



Acoustic Bulkhead

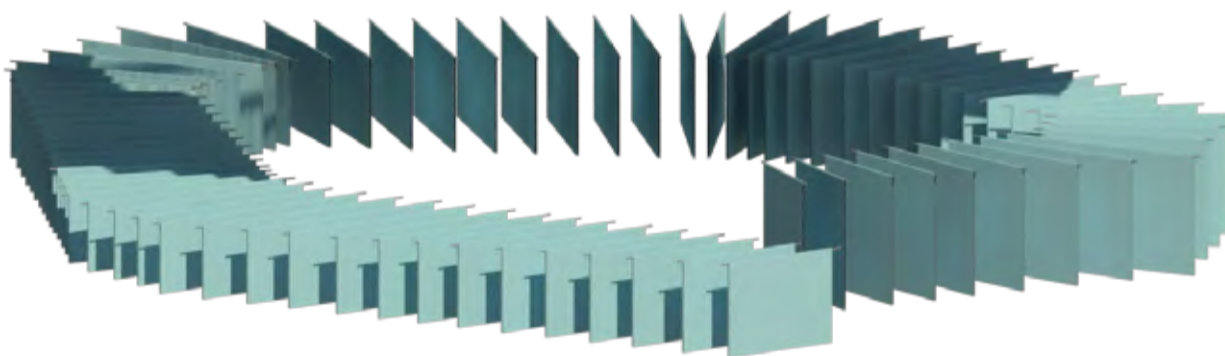

Acoustic Baffles



TO WALK A MILE IN OUR SHOES _
Narrative Walkway

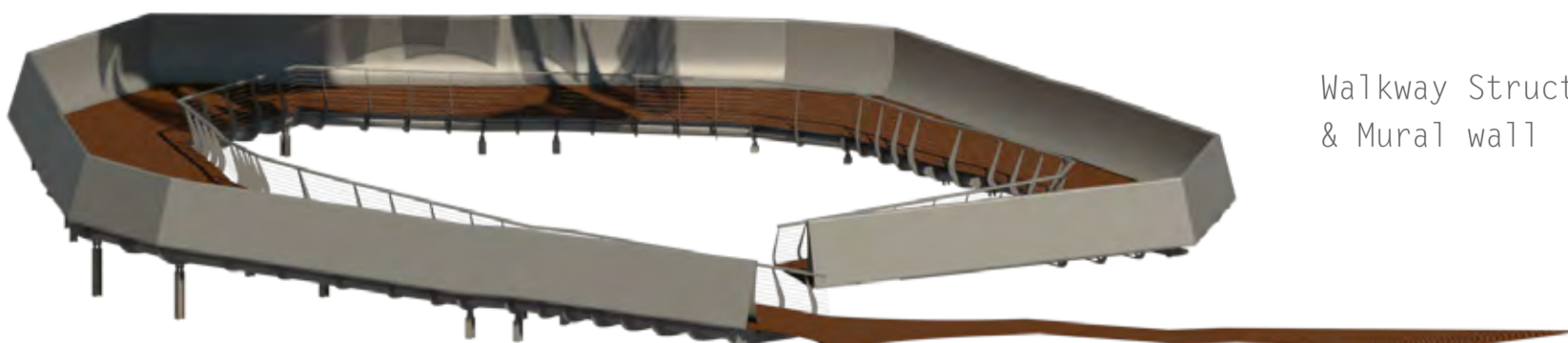

Walkway Structure
& Mural wall

Figure 145: Detail of Narrative Walkway
Over-carriage

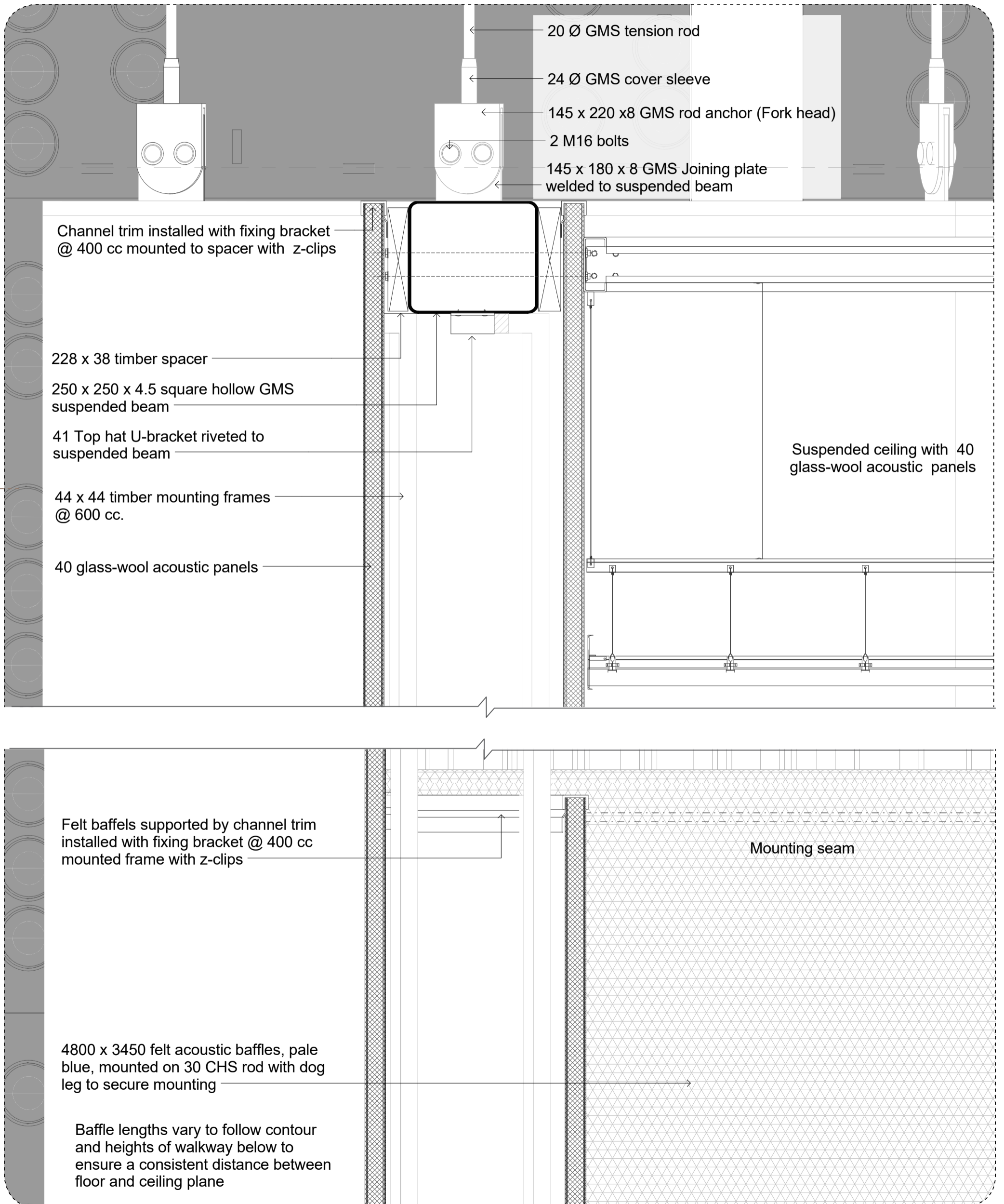



Detail 3 + 4 : Narrative Walkway



TO WALK A MILE IN OUR SHOES _
Narrative Walkway

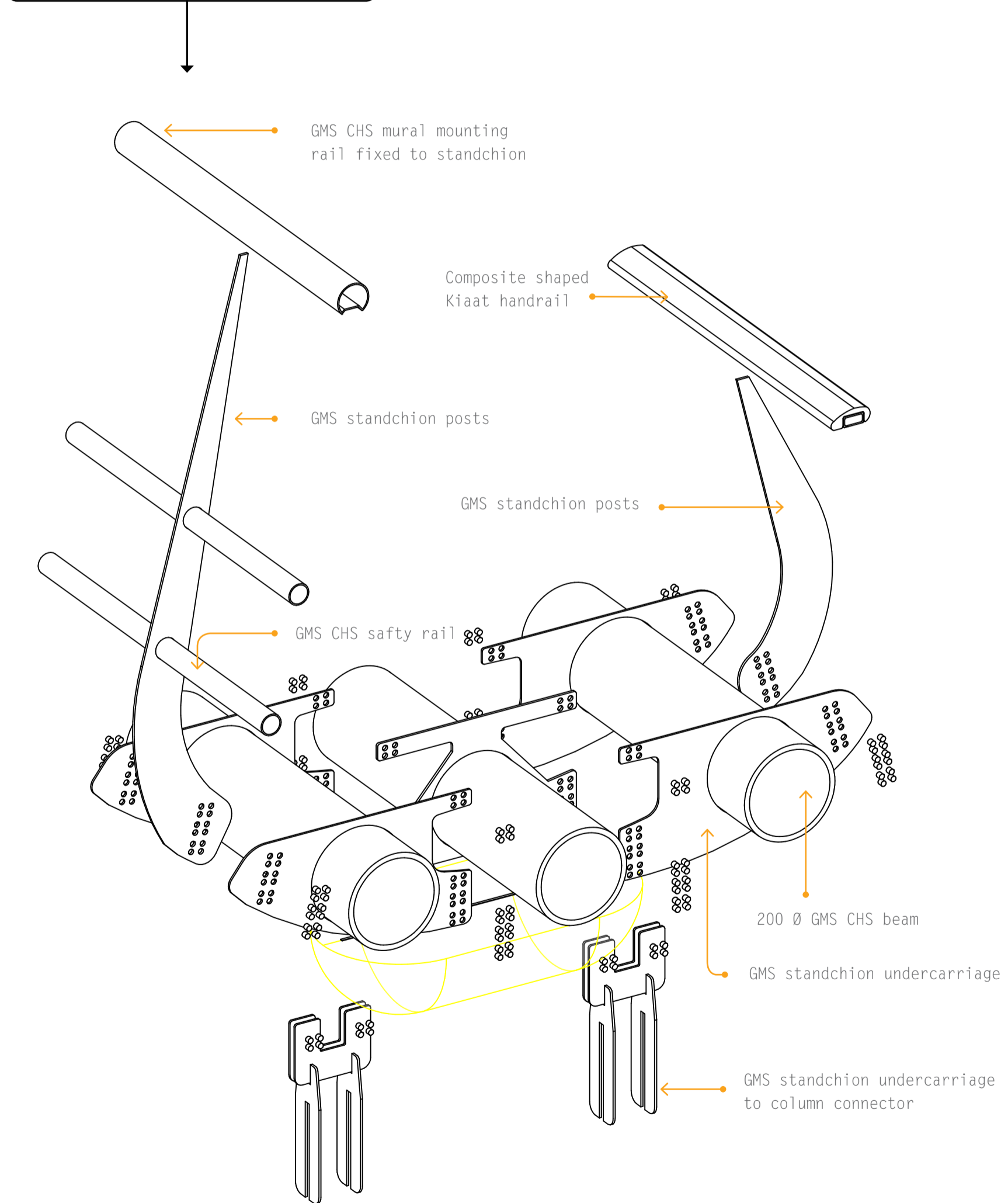
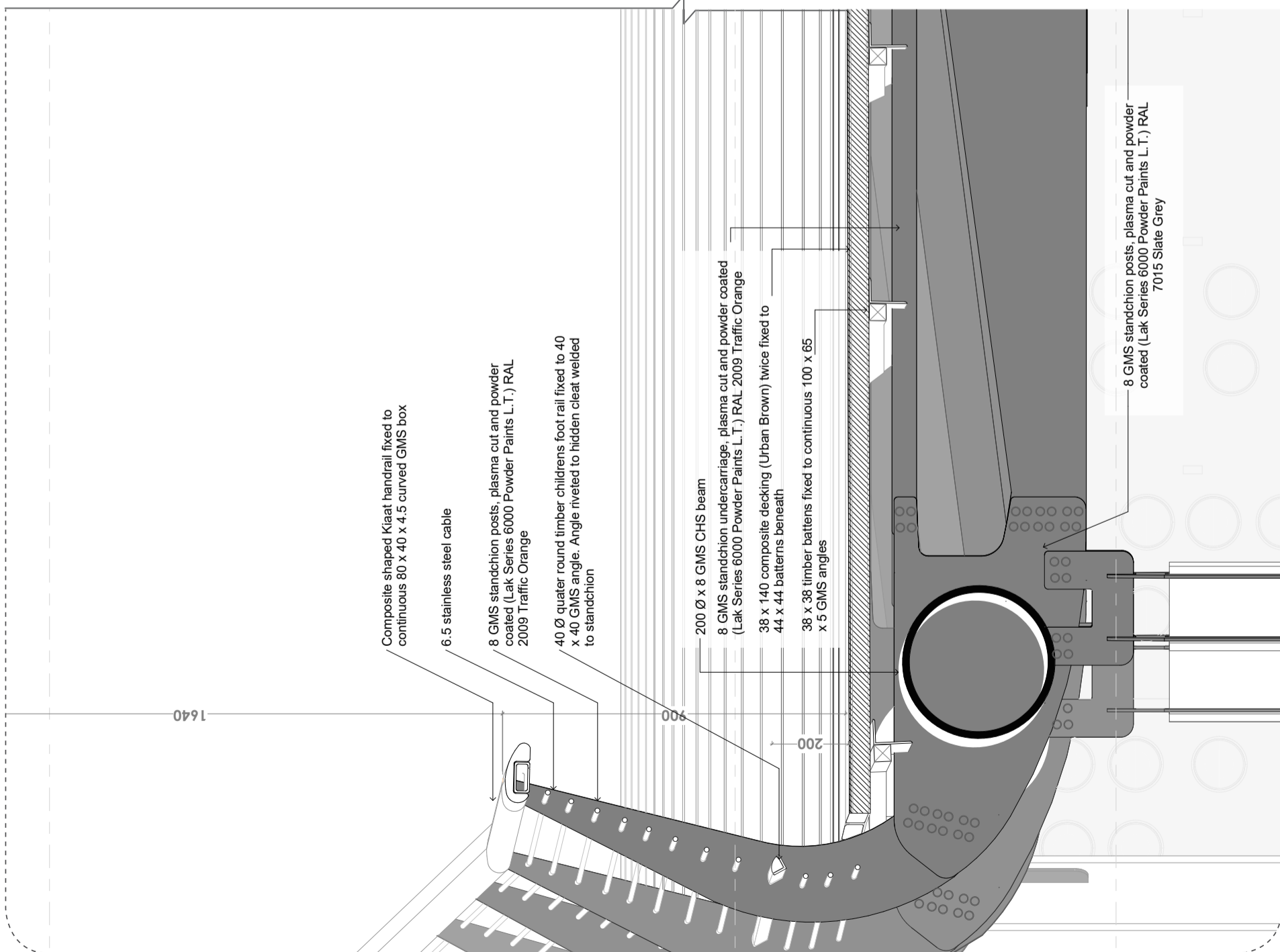
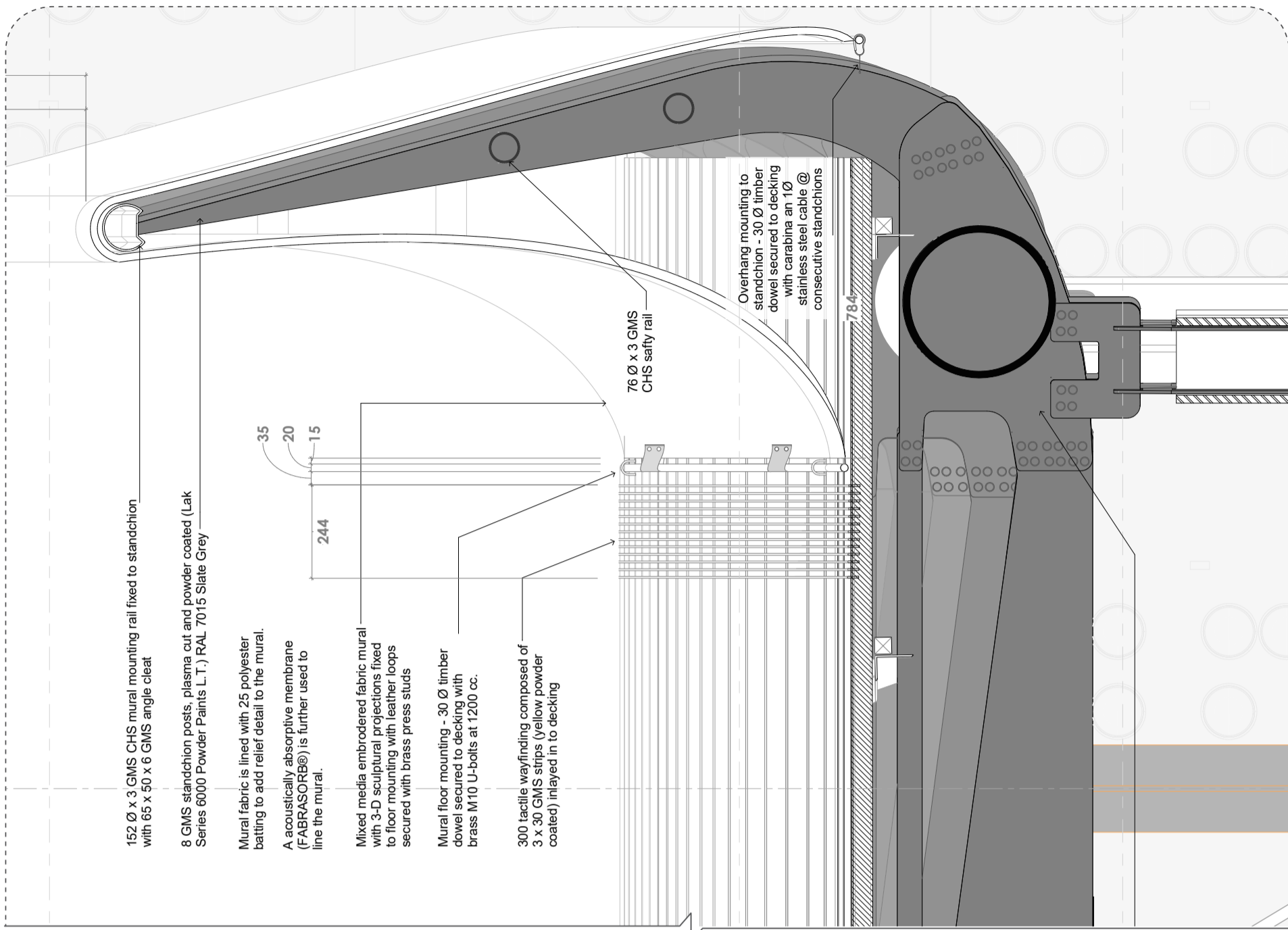

Figure 146: Walkway Supports Exploded Assembly

Figure 147: Detail of Narrative Walkway Mural Mounting





Detail 5: Reflection Pool



FEEL WITH OUR HEARTS_
Chandelier

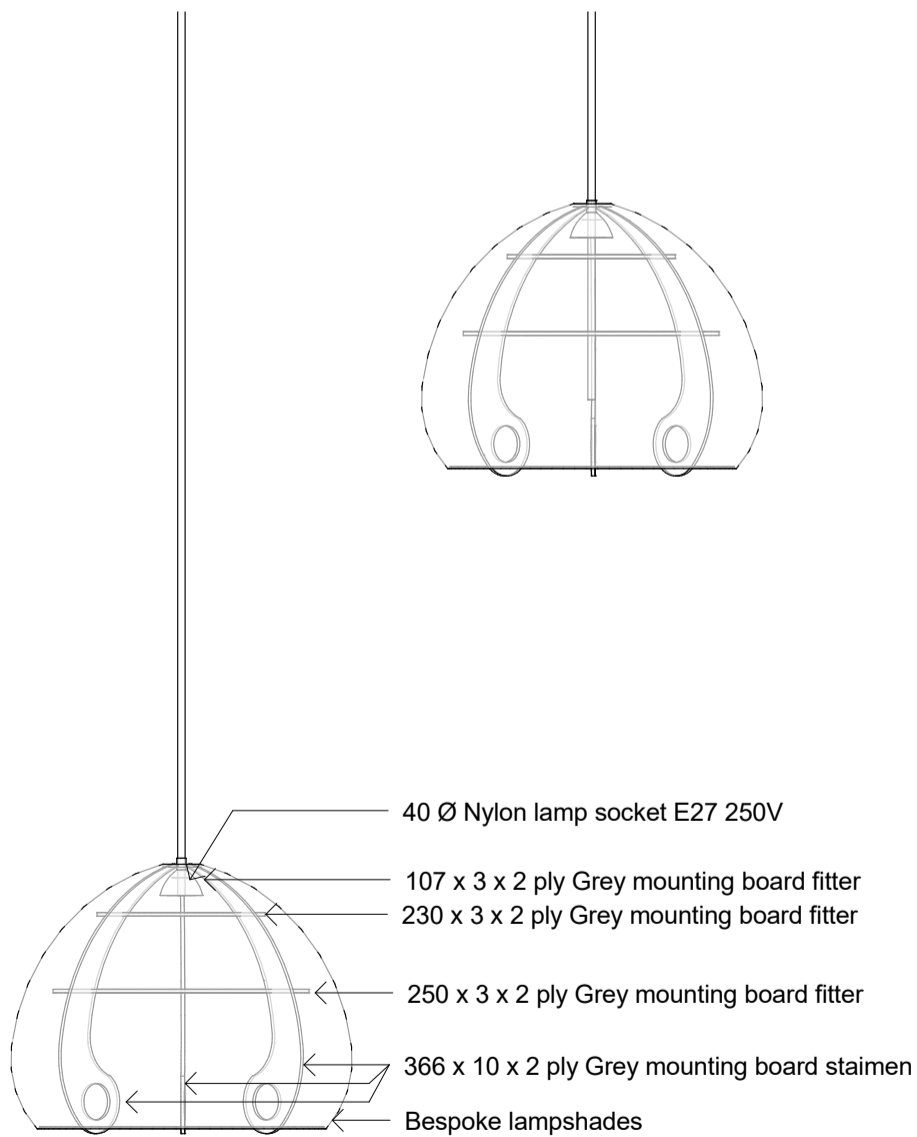
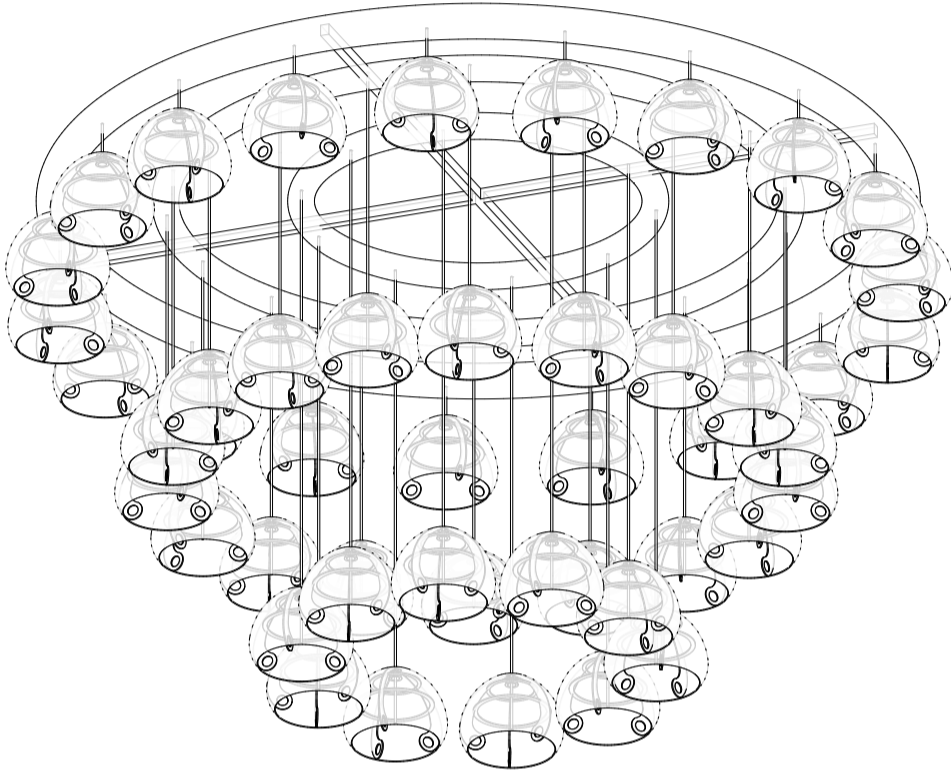
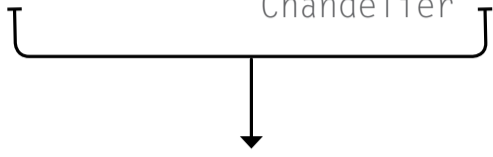
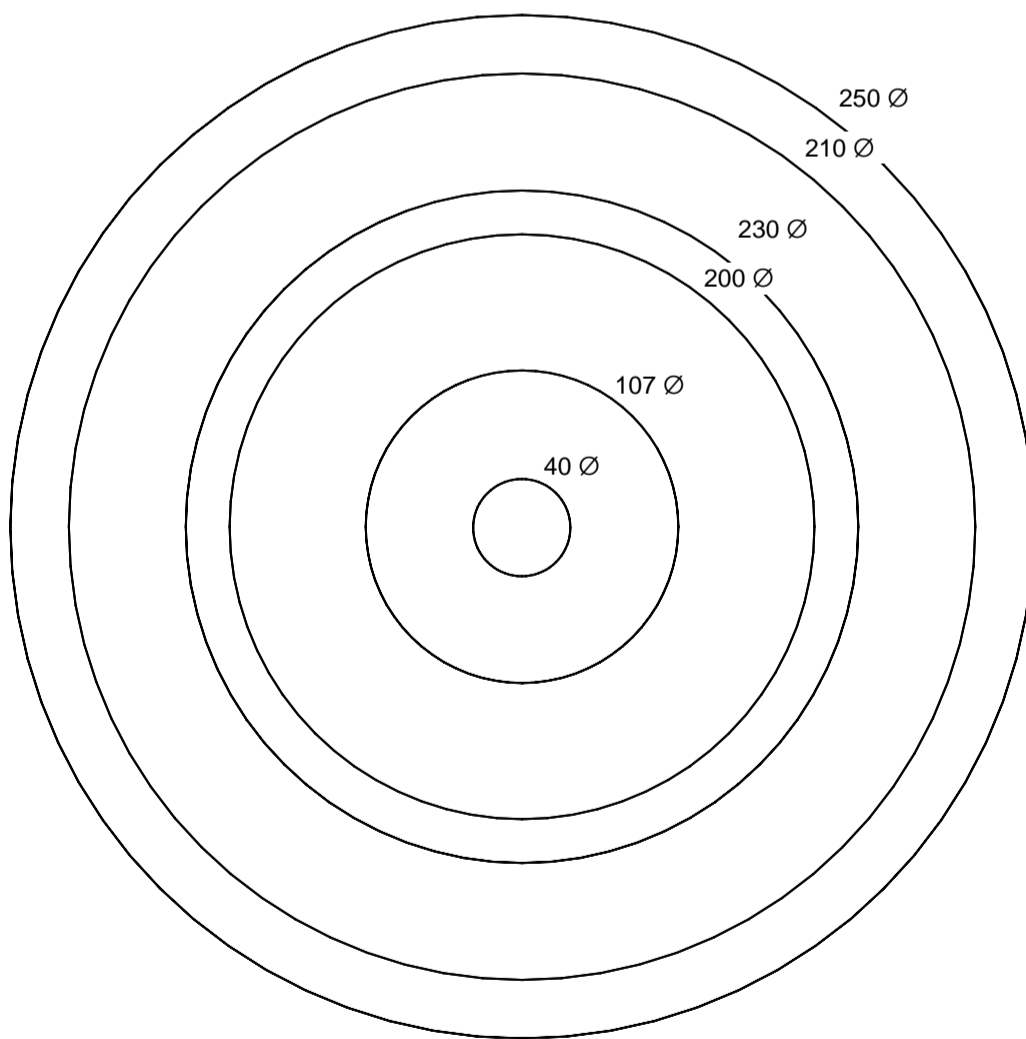
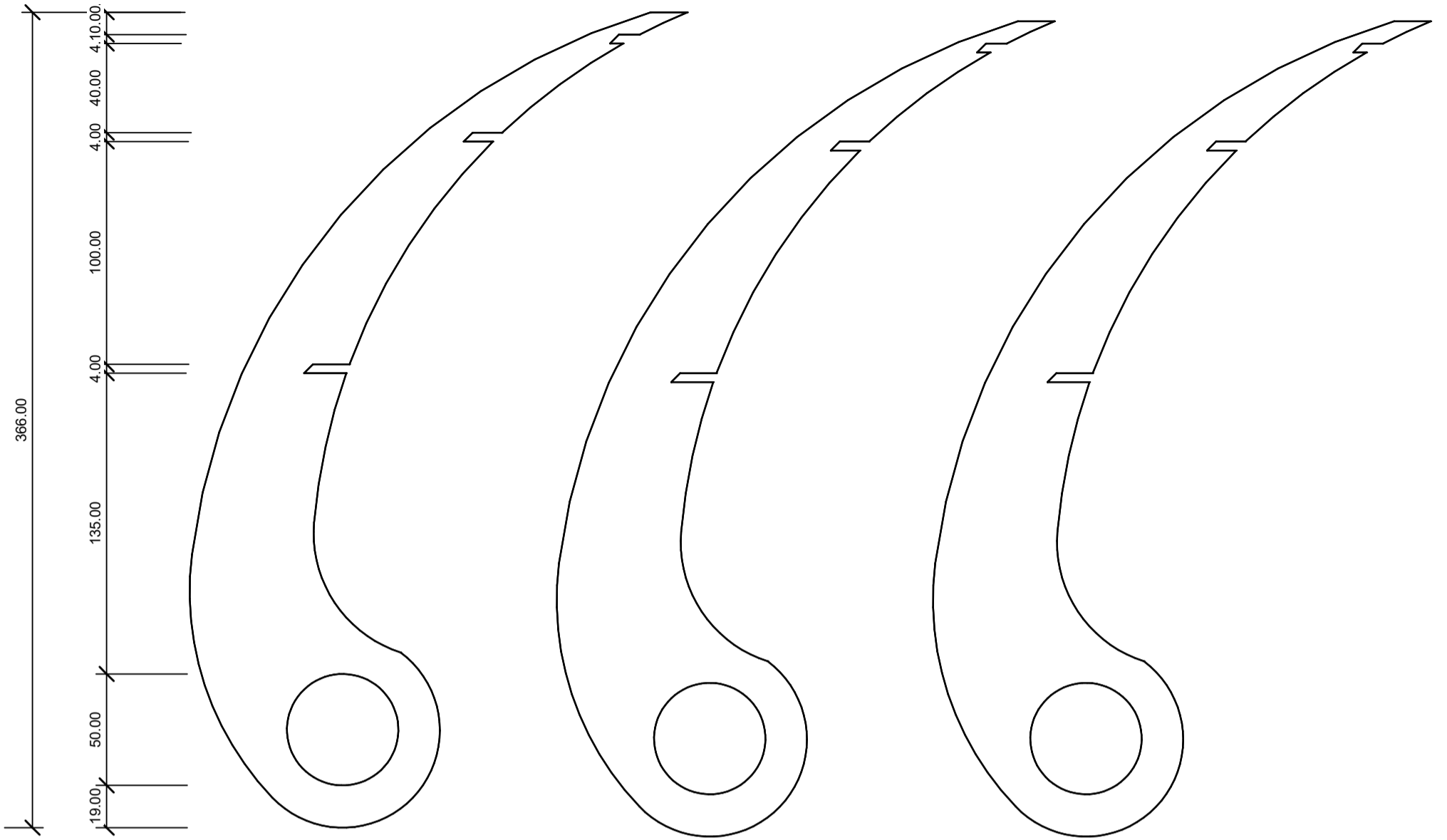

Figure 148: Detail of Reflection Pool Chandelier



9.8. MODELS & PROTOTYPES



Figure 149: Reflection Pool Chandelier Prototype



Figure 150: Wall Panel Prototype



Figure 151: Walk-way: Tactile Wayfinding Prototype



Figure 152: Exam: Prototypes



Figure 153: Exam: Building Model

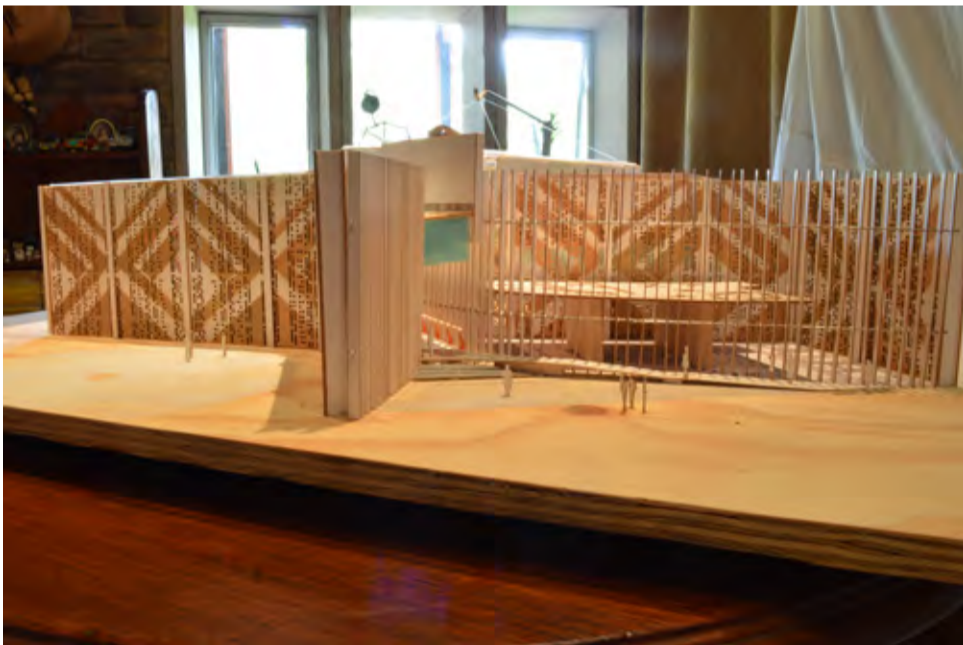

Figure 154-161: Exam: Building Model



10. CONCLUSION

10.1. SUMMARY OF FINDINGS

The western approach to nation branding is based on two critical assumptions; firstly, that modern nations are composed of homogeneous societies, and secondly, that these societies share a common culture.

It is here that the problem lies, for essentially South Africa is pluralistic. We are a multicultural nation. We do not have typical shared myths, historical memories and a mass public culture due to historic and more recent political struggles within our country.

Bhaba's (1994) theory of the 'Beyond' and his notions of Interstices and Cultural Hybridity as adjectives and means of complex cultural production, were used as the starting point in the distillation of an alternative multicultural South African identity. This identity needed to be complex rather than reductive, while still conveying a single, strong, clear, believable idea about what the country really is and what it stands for. The results of this process were then spatially transcribed into the design of South African pavilion at the Expo 2020, Dubai UAE. This spatial transcription needed to demonstrate that there was a different approach to the current brand washing tactic applied at previous expos.

The results and outcomes of South Africa's participation at Expo 2010, were also identified as providing a background and key informants to which to respond for the current study. In essence, in an attempt to produce a single, strong, clear believable idea about what South Africa is, following the Western approach, traditional and historic aspects of our collective heritage(s) were positions in opposition, and subservient to more modern and progressive aspects of our nations Collective National Identity (CNI).

10.2. CHAPTER SUMMARIES

Chapter Two established the alternative locations and forms that shared myths and memories (as the foundation for a nations CNI) may take. These new signs of identity are the result of the interstices of minority cultures which combine and influence each other to form new hybrid cultures. These new hybridities are at their essence often expressions of radical, unorthodox, unconventional and/or avant-garde Zeitgeists.

It is these new ideas of being that form the basis for an alternative national identity that is no longer unitary and reductive (shared), but rather complex and multiplicitous. The chapter concluded with an outline and description of the analytical procedures to be applied in the examination of the selected cultural hybridity.

While the application of the analytical method to the i-justi magazines, in Chapter Three, required some fine tuning to avoid the editors comments leading the results the overall procedure was successful. It allowed for the identification of dominant themes and their verification through a process making inferences and associations based on the life-world surrounding each idea. These themes were then further distilled by assessing the connections and oppositions between each theme to facilitate their eventual grouping into seven brand indications.

These indicators were then distilled one last time into the brand descriptor; We are not only & we have strong emotions. This brand essence was used to inform the design of the South African pavilion.

Chapter four addressed the concerns raised during the review of the South African Expo 2010 pavilion; specifically the positioning of the modern and the traditional in opposition to each other. Instead the intersection between the Modern and the Traditional was sought, via a comparative precedent study. The meeting point of the two was found in the concept of building with art. From this, two distinct approaches to the spatial translation of the seven key indicators was identified. These approaches involved the identification of the dominant need to be met by each element (Utilitarian or Symbolic), and the application of the associated technical strategy. The two strategies that emerged from the precedent study are either Handiwork/Craft (Utilitarian) or Fine Arts (Symbolic) approaches.

Together, Chapters 5 and 6 provided an understanding of the contextual framework within which the South African pavilion needed to function, at Expo 2020.

An important contextual development that has emerged in more recent years is the creation of a 'moment' by the participating countries through/in their pavilion. This 'moment' is meant to capture the essence of that country's culture, society and people, while expressing a particular message they want to project to the world.

Chapter 5 concluded with a contextual discussion of the upcoming World Expo 2020, Dubai, UAE. Details of the expo's masterplan and theme, which addresses a particular universal concern, were provided. Importantly, this theme must be addressed or responded to in some manner via the pavilion. This is in addition to the individual messages a country might want to express via their 'Moment'.

The most important aspect to understand from Chapter 6 is that expo's are typologically similar to contemporary museums, in that they function as 'interior' cities within cities.

The South African 'room' at the Expo 2020, is a rented 'box' in the Opportunity Souq, with a self-guided explorative exhibit format.

Chapter 7, established the reasoning behind the strategic approach taken by the proposed pavilion to focus on the promotion of the nation's People, Culture and Policies. These factors, combined with the seven indicators informed the pavilion concept: 'We are [in Full Colour]'.

Significantly, during the developmental process it emerged that it was necessary to shift away from viewing the pavilion as a single multi-layered exhibit. Instead the approach applied during the final design resolution was to handle each of the four experiential zones separately. The chapter concluded by providing a detailed summary of the various requirements that need to be met by each of the four zones in preparation for the technification of the design.

In Chapter 8's Design Discourse focus was placed on outlining how the multiplicitous character of our nation, as detailed by the seven design indicators of the alternative nation brand, was embodied in each of the four zones. Despite the chapter being divided into several separate sections, a common thread which speaks of the multiplicitous character of our nation can clearly be drawn through each section. This thread weaves both the narrative of our Collective National Identity and the key tenets of the Alternative Nation Brand into the design of the pavilion. Most notably, the importance of maintaining a sense of connection between the different zones, while preserving the integrity of each of the four zone's individual experiences, was highlighted.

This as a spatial tactic speaks most clearly of: "We Are Not Only". We are not only of the land or the city, and we understand that Ubuntu means: "I am because We Are". The second half of the brand descriptor: "& we have strong emotions", was brought to life throughout the pavilion via the contrasts in texture, material and finish. The combination of these two tactics serve to express the brand essence of: "We Are Not Only & We have strong emotions".

The technical resolution was divided into two sections. The first section deals with design elements and specification pertaining to the pavilion as a whole, while the second section presents detailed technical resolutions, following the approach of the Design Discourse chapter by handling each of the four experiential zones separately.

10.3. CONCLUSIONS

The method established to construct a complex rather than reductive identity proved successful. Viewing cultural construction through the lens of hybridity was an effective tool to re-frame the identity debate. However, as it was conducted on a small scale due to the constraints of the study the effectiveness of the protocol on alternative forms of hybrid cultures, such as Pantsula dancing or Zeff behaviours and culture, will need to be assessed. Perhaps criteria per hybridity 'genre' will need to be added to the method.

With regards to the spatial transcription of the brand values into spatial informants, the creation of the tactile objects to explore how the intangible brand values could be expressed tangibly was invaluable. These objects not only define the aesthetic of the pavilion but also help to establish the materiality and types of tectonic connections used later during the design and technical resolution of the pavilion. Additionally, through this integrated method an alternative to the brand washing approach was established.

Lastly, the research into and understanding of our nations' Collection National Identity tempered by an in-depth knowledge of the hybrid culture also prove extremely important in the development of the concept and narrative for the pavilion. Since, together they ensure that the 'Moment' created, was a single, strong, clear, believable idea about what the country really is and what it stands for.

The hybridity in this case can be understood as a filter through which the CNI and history surrounding it, could be critically assessed and questioned as the hybridity by default takes on the stance of the Punctum, while the CNI's takes on the stance of the Studium.

10.4. CONTRIBUTIONS

- The application of a hermeneutical, social visual semiotic and lexical method of analysis to examine interrelationships between the various levels of meaning present in the i-justi magazine series. The consequent distillation of the analysis into a new nation brand descriptor: We are not only & we have strong emotions.
- The design investigation and proposal contributes to the field of interior design through the presentation of an alternative to the typical industry approach, which is heavily dependent on development and application of a logo and associated graphics of a brand identity to the branding of space and place.

10.5. SUGGESTIONS FOR FURTHER RESEARCH

- The assessment and development of additional criteria and tools for the analysis of a diverse range of cultural hybrids. The development of a complete alternative nation brand for South Africa based on a complete set of cultural hybrids evident in our nation and the associated collateral.



11. SOURCES CONSULTED

- Anholt, S. 2005a. Some important distinctions in place branding. *Place Branding* 1(2):116-121.
- Anholt, S. 2005b. Nation brand as context and reputation. *Place Branding* 1(3):224-228.
- Anholt, S. 2006. The Anholt-GMI City Brands Index. How the world sees the world's cities. *Place Branding* 2(1):18-31.
- Anholt, S. 2007. Brand Africa. What is competitive identity? *African Analyst* 2(2):72-81.
- Anholt, S. 2008a. 'Nation Branding' in Asia. *Place Branding and Public Diplomacy* 4(4):265-269.
- Anholt, S. 2008b. Place branding: Is it marketing, or isn't it? *Place Branding and Public Diplomacy*. 4(1):1-6.
- Anholt, S. 2009. Branding places and nations, in *Brands and Branding*, edited by R Clifton. United States: Bloomberg Press: 206-216.
- Anholt-GfK 2013. NBI 2013 - Press release. [O] Available: <http://www.gfk.com/news-and-events/press-room/press-releases/pages/two-thirds-of-nations-experience-reputation-decline-in-2012-nation-brands-index.aspx>. Accessed 24 May 2014.
- Anholt-GfK Roper Nation Brand Index 2015_ South African results. [O]. Available: <http://www.brandsouthafrica.com/news/1289-south-african-nation-brand-amongst-top-50-most-globally-competitive-nations> Accessed 02 April 2016
- Austria Pavilion – Milan Expo 2015 / team.breathe.austria. 2015. [O]. Available: <http://www.archdaily.com/629540/austria-pavilion-nil-milan-expo-2015-team-breathe-austria/> Accessed: 17 August 2016.
- Baines, G. 1998. The rainbow nation? Identity and nation building in post-apartheid South Africa. *Mots Pluriel* 7, July:1-10.
- Bartholmé, RH & Melewar, TC. 2009. Adding new dimensions to corporate identity management and corporate communications: Exploring the sensory perspective. *The Marketing Review* 9(2):155-169.
- Beautiful Things™ - South African craft*. 2010. Shanghai. Departmental Press.
- Beiser, F.C. 1993. *The Cambridge companion to Heigel*. Cambridge University Press: Cambridge.
- Bhaba, HK. 1994. *The location of culture*. London: Routledge.
- BrandFinance Nation Brands 2015. [O]. Available: http://brandfinance.com/images/upload/brand_finance_nation_brands_report_2014_final_edition.pdf Accessed 18 April 2016.
- BrandSouthAfricaBlog. 2010. [O]. Available: <http://www.brandsouthafricablog.com/> Accessed 5 September 2010.
- BrandSouthAfrica.com. 2010. [O]. Available: <http://www.brandsouthafrica.com/> Accessed 13 September 2010.
- BrandSouthAfrica.com. 2011. South Africa at Expo 2010 Shanghai. [O]. Available: <http://www.brandsouthafrica.com/shanghai/> Accessed 09 March 2011
- BrandSouthAfrica.com. 2015. [O]. Available: <http://www.brandsouthafrica.com/news/789-brand-south-africa-launches-new-slogan> Accessed 4 November 2015.
- BrandSouthAfrica.com. 2016. [O]. Available: <http://www.brandsouthafrica.com/> Accessed 14 April 2016.
- Brazil Pavilion – Milan Expo 2015 / Studio Arthur Casas + Atelier Marko Brajovic. 2015. [O]. Available: <http://www.archdaily.com/628436/brazil-pavilion-nil-milan-expo-2015-studio-arthur-casas-atelier-marko-brajovic/> Accessed: 17 August 2016.
- Bureau International des Expositions (BIE). 2010. Official Site. [O]. Available: <http://www.bie-paris.org/site/> Accessed 21 February 2011.
- Bureau International des Expositions. 2016. Official Site. [O]. Available: <http://www.bie-paris.org/site/en/> Accessed 10 March 2016.
- Chandler, D 2007. *Semiotics: The Basics*. London: Routledge.
- Chattopadhyay, K. 1984. Crafts and the future. *India International Centre Quarterly* 11(4): 5-14
- Ching, F. D. K. 2007. *Architecture--form, space, & order* (3rd ed.). Hoboken, N.J.: John Wiley &.
- Crawford, A. 1997. Ideas and Objects: The Arts and Crafts Movement in Britain. *Design Issues* 13(1):15-26.
- Davenport, R & Saunders, C. 2000. *South Africa: A modern history*. London: Macmillan.
- Dernie, D. (2006). *Exhibition design*. London: Laurence King.
- Expo 2010 Shanghai China. 2010. [O]. Available: <http://en.expo2010.cn> Accessed 21 February 2011.
- Expo x Expos. 2010. [O]. Available: http://www.expoexpo.com/EXPO_x_EXPOS/Home.html Accessed 21 February 2011.
- Expo 2020 Dubai, UAE. 2016 [O]. Available: <https://expo2020dubai.ae/en/> Accessed: 02 February 2016.
- FutureBrand.2009. 2009 *Country brand index / executive summary*. Pdf.
- FutureBrand (2012). *Country Brand Index 2012-13*. Pdf.
- FutureBrand (2012). *Country Brand Index 2014-15*. [O]. Available: http://www.futurebrand.com/uploads/CBI-14_15-LR.pdf Accessed 7 April 2016.
- Gardiner, M. 1999. Bakhtin and the metaphors of perception. In Ian Heywood & Barry Sandywell (Eds.), *Interpreting visual culture: Explorations in the hermeneutics of the visual* (pp.57- 71). London: Routledge.

- Gaylard, J. 2004. The craft industry in South Africa: A review of ten years of democracy. *African Arts* 37(4): 26-29+94
- Groat, L. & Wang, D. 2013. *Architectural research methods*. Hoboken, NJ : Wiley.
- GfK Roper Public Affairs & Media. 2008. Anholt-GfK Roper Nation Brands IndexSM RankingGfKCustom Research North America, 2008.
- GfK Roper Public Affairs & Media. 2009. The Anholt-GfK Roper Nation Brands Index: 2009 Highlights Report, 2009.
- Heidegger, M. 1993. *Building, dwelling, Thinking. Basic Writings*. London: HarperCollins
- Heskett, J. 2001. Past, Present, and Future in Design for Industry. *Design Issues* 17(1):18-26
- HOK. 2016. A Sustainable Master Plan for Dubai's Winning World Expo 2020 Bid. [O]. Available: <http://www.hok.com/design/service/planning-urban-design/dubai-expo-2020-master-plan/> Accessed: 15 March 2016
- I-justi. 2016.[O]. Available: <http://www.ijusi.com/> Accessed 2 February 2016.
- Johnston, Y. 2010. Simon Anholt's view on Brand South Africa is, well, wrong. *The Daily Maverick*, 2 September:1.
- Jordana, S. 2010. UK Pavilion for Shanghai World Expo 2010 / Heatherwick Studio. [O]. Available: <http://www.archdaily.com/58591/uk-pavilion-for-shanghai-world-expo-2010-heatherwick-studio/> Accessed: 17 August 2016
- Kavaratzis, M. 2005b. Place branding: a review of trends and conceptual models. *The Marketing Review* 5(4):329-342.
- King, T.V. 2011. Examining the visual brand language used by Brand South Africa to communicate South African identity at the World Expo 2010. MA Dissertation, University of Pretoria, Pretoria.
- Kinsella, E.A. 2006. Hermeneutics and critical hermeneutics: Exploring possibilities within the art of interpretation. *Forum: Qualitative Social Research* 7(3) Art. 19.
- Kostelnick, C., & Hassett, M. 2003. *Shaping information: The rhetoric of visual conventions*. Carbondale: Southern Illinois University Press.
- Law-viljoen, B. 2008 (ed). *Art and Justice*. The Constitutional Court Trust and David Krut Publishing
- Margolin, V. 2005. A World History of Design and the History of the World. *Journal of Design History* 18(3): 235-243.
- McQuail, D. 2010. *McQuail's mass communication theory*. London: Sage.
- Moller, V. 2007. Quality of life in South Africa: The first ten years of democracy. *Social Indicators Research* 81(2): 181-201.
- Moller, V & Dickow, H. 2002. The role of quality of life surveys in managing change in democratic transitions: The South African case. *Social Indicators Research* 58(1-3):267-292.
- Moller, V, Dickow, H. & Harris, M. 1999. South Africa's "Rainbow People": National pride and happiness. *Social Indicators Research* 47(3):245-280.
- Maree, K (ed). 2010 *First steps in research*. Pretoria: Van Schaik.
- Muller, CFJ (ed.). 1981. *500 Years: A History of South Africa*. Pretoria: Academica.
- Nakamura, T. 2006. Innovation and Education of EXPO2005, Aichi, Japan. *International Exhibitions Bureau Bulletin* 2006:203-208.
- Narula, U. 2006. *Handbook of communications: Models, perspectives, strategies*. New Delhi: Atlantic.
- Nunn, C. 2009. Cedric Nunn Photography. [O]. Available: <http://www.cedricnunn.co.za/> Accessed: 23 July 2016.
- Oasys Innovations.2010. Oasys: strategic supplier for DIRCO at World Expo.[O]. Available: <http://www.bizcommunity.com/PressOffice/PressRelease.aspx?i=117078&ai=49308> Accessed 9 March 2011.
- Olins, W. 2000. Why companies and countries are taking on each other's roles. *Corporate Reputation Review* 3(3):254-265.
- Olins, W. 2002a. Brand the nation: The historical context. *Journal of Brand Management* 9(4/5):241-248.
- Olins, W. 2002b. Corporate Identity: the ultimate resource [O]. Available: <http://www.wallyolins.com/view.html> Accessed 21 July 2010.
- Olins, W. 2008. *Wally Olins: The brand handbook*. London: Thames & Hudson.
- Olins, W. & Olins, W. 2005. *The new guide to identity: How to create and sustain change through managing identity*. Gower: Design Council.
- Omar, YA. 2007. South Africa: Alive with possibility [O]. Available:http://www.oeronline.com/php/2007_oct/guesteditor.php Accessed 13 September 2010.
- Oxford Dictionary of English. 2005. Second edition. Oxford: Oxford University Press.
- Oxford English Dictionary (2016), Third edition. Online version (2016). [O]. Available: <http://www.oed.com/> Accessed 04 August 2016.
- Piat, C. 2003. A brief historical summary of the Convention. *International Exhibitions Bureau Bulletin* 2003-4:16-27.
- Proudly South African.2010. [O]. Available: <http://www.proudlysa.co.za/index.aspx> Accessed 23 July 2010.
- Robinson, J. 2003. Johannesburg's 1936 Empire Exhibition: Interaction, segregation and modernity in a South African city. *Journal of Southern African Studies* 29(3):759-789.
- Said, E. 1977. *Orientalism*. London: Penguin
- Scrase, J.T. 2003. Precarious Production: Globalisation and Artisan Labour in the Third World. *Third World Quarterly* 24 (3):449-461.

- Scelsa, J.A. 2014. Enfiladed Grids: The Museum as City. *Monu – Interior urbanism* 21(3)5-14.
- Smith, A.D. 1991. *National identity*. London: Penguin.
- South Africa. It's Possible. 2010. [O]. Available: <http://www.southafrica.net/sat/content/en/za/home>
Accessed 23 July 2010.
- South Africa. Alive with possibility. 2002. [O]. Available:http://www.safrica.info/what_happening/news/features/proudlysa.htm
Accessed 23 July 2010.
- South Africa: Alive with possibility. 2007. *Oman Economic Review*, 1 June.
- South African Government Information: About SA – South Africa's people. 2012. [O]. Available: <http://www.info.gov.za/aboutsa/people.htm>
Accessed 05 April 2012.
- Spencer, S. 2011. *Visual research methods in the social sciences : Awakening visions*. London: Routledge.
- Steeds, L. 2014. *Exhibition (Documents of contemporary art; Documents of contemporary art series)*. Cambridge, Massachusetts: The MIT Press.
- Stone, A. 2011. *The Edinburgh critical history of Nineteenth-century philosophy*. Edinburgh: Edinburgh University Press.
- Swift, A. 2006. Edification and Pleasure at International Expositions, 1851-2005. *International Exhibitions Bureau Bulletin* 2006:17-48.
- The International Marketing Council of South Africa. 2009. *Annual Report 2009, 2009*.
- The International Marketing Council of South Africa. 2010. *Clarification Briefing, 2010*.
- Van Leeuwen, T. & Jewitt, C. (2001). *Handbook of visual analysis*. London: SAGE.
- Walvis, T. 2004. Three eras of World Expositions: 1851–present. *Cosmopolite: Stardust World Expo & National Branding Newsletter*. Amsterdam: *Stardust New Ventures* 5(1):1-2.
- Welcome to South Africa in 2010 Shanghai EXPO! 2010. [O]. Available: <http://www.saexpo2010.com/english/index.html>
Accessed 5 September 2010.
- Wegelin, H. W. (2009). *Construction primer for Southern Africa* (1st ed.). Pretoria: Visual Books.
- Woodham, J. 1989. Images of Africa and the design at the British Empire Exhibition between the wars. *Journal of Design History* 2(1), Spring:15-33.
- Zhou, H. 2006. Education and Innovation of Expo 2010, Shanghai, China. *International Exhibitions Bureau Bulletin* 2006:223-225.



ADDENDUM 1

ADDENDUM 2

ADDENDUM 3





