



# *didactic* garden

our return to biophilia



# *didactic* ecology

*returning to biophilia*

Stephanie Kelly

Study Leader: Arthur Barker  
Course Co-ordinator: Arthur Barker

Submitted in fulfilment of part of the requirements of the degree MArch(Prof) in the  
Department of Architecture in the Faculty of Engineering, Built Environment and  
Information Technology and the University of Pretoria

Pretoria, Republic of South Africa 2016

Reggio Emilia Pre-primary School, Occupational Therapy and Community Sports and Culture Centre  
De Rapper Street Park, Sunnyside, Pretoria  
ELANDSPOORT 357-JR  
31 Borke Street, Pretoria, 0002  
25°45'4.97"S  
28°12'36.41"E

Magister of Architecture [Professional]  
Environmental Potential  
Regenerative Architecture | Biophilic Design | Didactic Landscape

Architectural Approach: The site was analysed in terms of potential didactic “garden” spaces as a new approach to early childhood development. An identity for each “garden” was derived from, firstly, the natural elements that already existed in each garden and secondly, how the importance of natural ecologies and systems can be taught through their rehabilitation and conservation. The architecture fills the role of the latter by facilitating the didactic rehabilitation, awareness and conservation of each garden space.

Stephanie Kelly, 2016

Department of Architecture  
University of Pretoria

In accordance with Regulation 4[e] of the General Regulations [G.57] for dissertations and thesis, I declare that this thesis, which is hereby submitted for the degree Master of Architecture [Professional] at the University of Pretoria, is my own work and has not previously been submitted by me for a degree at this or any other tertiary institution

I further state that no part of my thesis has already been, or currently being, submitted for any such degree, diploma or any other qualification.

I further declare that this thesis is substantially my own work. Where reference is made to the works of others, the extent to which that work has been used is indicated and fully acknowledged in the text and list of reference.

Stephanie Kelly

God's Garden

“THE Lord God planted a garden  
In the first white days of the world,  
And He set there an angel warden  
In a garment of light unfurled.

So near to the peace of Heaven,  
That the hawk might nest with the wren,  
For there in the cool of the even  
God walked with the first of men.

And I dream that these garden-closes  
With their shade and their sun-flecked sod  
And their lilies and bowers of roses,  
Were laid by the hand of God.

The kiss of the sun for pardon,  
The song of the birds for mirth,--  
One is nearer God's heart in a garden  
Than anywhere else on earth.

For He broke it for us in a garden  
Under the olive-trees  
Where the angel of strength was the warden  
And the soul of the world found ease.”

Dorothy Frances Gurney  
(Willis, 2006: 11)

Dedicated to my late grandmother, Daphne Kelly, whose poem, *God's Garden*, stood, engraved onto a stone, in *her* garden and inspired the essence of this dissertation.

Thank you

To Ryan, despite having your own architectural degree to complete, you have been my constant strength and sanity and I don't think any words could describe how much you have helped me these past five years.

Tegan, my sister and my best friend, for everything

Marguerite, for your encouragement and belief in me always

To my Parents and my Granny for always believing in me, and for all the encouraging phone calls and messages.

To Arthur, for your guidance, mentorship and encouragement

My Heavenly Father

*Didactic*

[di|dac|tic]

Adjective:

“Intended to teach, particularly in having moral instruction as an ulterior motive.”

(Oxford Dictionary 2016, sv didactic)

*Garden*

[gar|den]

Noun:

“A garden is a planned space, usually outdoors, set aside for the display, cultivation, and enjoyment of plants and other forms of nature. The garden can incorporate both natural and man-made materials.”

(Oxford Dictionary 2016, sv garden)

Verb:

“The activity of tending and cultivating a garden.”

(Oxford Dictionary 2016, sv garden)

*Didactic Garden*

“A planned space set aside for the display, cultivation, and enjoyment of plants and other forms of nature with the intention to teach moral instruction as an ulterior motive.”

*Biophilia*

[bio|phil|i|a]

Noun:

“an innate and genetically determined affinity of human beings with the natural world.”

(Oxford Dictionary 2016, sv biophilia)



## Abstract

Biophilia is a term that refers to man's love of other living things. However, over the last few hundred years, we have lost the love of nature. The urban built environment embodies the increasing disconnection between man and the natural world, with parks and natural resources showing signs of neglect and degradation.

In response to a regenerative approach to making architecture, the dissertation combines the theories of Stephen Kellert and Edward Wilson, in that our biophilic roots finds their extension in the form of an urban garden that aims to teach its users the importance of the conservation and protection of natural resources in our cities.

The design aims to re-stitch broken ecologies: The dwindling natural ecologies that exist in the urban environment as well as the barriers to people's cognitive development on a site riddled with infrastructural barriers preventing reconnection. It does so on a derelict park alongside the channelised Walkerspruit in Sunnyside, Pretoria.

## Vertaling

Die term Biophilia verwys na die mens se aangetrokkenheid na ander vorms van natuurlike lewe. Hierdie liefde van die natuur het egter gedurende die afgelope paar honderd jaar verlore geraak. Die oprigting van stedelike omgewings verteenwoordig 'n toenemende isolering van die mens vanaf die natuurlike wêreld. Hierdie tendens word getoonbeeld deur die verwaarlosing en degradering van parke en ander natuurlike bates.

Hierdie proefskrif is 'n respons waarin 'n regeneratiewe benadering tot argitektuur ondersoek word, deur van die teorie van Stephen Kellert en Edward Wilson te kombineer. Dit belig die wyse waarop ons biologiese wortels gegrond en verleng word in die stedelike tuin en lei die verbruiker tot kennis van die waarde van instandhouding en beskerming van ons natuurlike stedelike hulpbronne.

Die ontwerp van hierdie studie poog om afgetakelde ekologie te herstel. Die fokus is op die huidige afnemende natuurlike ekologie aanwesig in verstedelike omgewings asook belemmering wat die kognitiewe ontwikkeling van mense kortwiek, soos die teenwoordigheid van infrastruktuur wat herkonnesie met die natuur belemmer. Die studie is geplaas in 'n afgetakelde park langs die kanaal waarin die Walker spruit vloei, in Sunnyside, Pretoria.

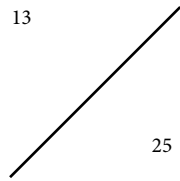

*Introduction*



1.1 Preface  
15  
1.2 Background: our return to biophilia  
16  
1.3 Problem Statement  
18  
1.4 The Urban Issue  
18  
1.5 Summary of Issues  
20  
1.6 Architectural Issue  
21  
1.7 Research Questions  
22  
1.8 Sub-questions  
22  
1.9 Research Methodology  
23  
1.10 Delimitations  
24  
1.11 Assumptions  
24  
1.12 Hypothesis  
25  
1.13 Objective  
25

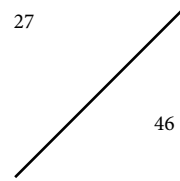

*Theory*



2.1 Introduction  
29  
2.2 The History of Biophilic Design and Ecological Design Principles  
30  
2.3 The dimensions, elements and attributes of biophilic design  
32  
2.4 The Biophilia of Water  
36  
2.5 Biophilia of Trees  
38  
2.6 The Biophilia of Children  
39  
2.7 The Barriers to Children's Biophilia  
39  
2.8 South African Examples of Biophilic Design  
41  
2.9 Water, Nature, Children and Architecture  
43

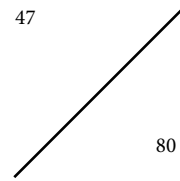

*Context*



3.1 Introduction  
49  
3.2 Pretoria's Riparian Network  
50  
3.3 The Didactic Garden: Group Urban Framework  
53  
3.4 The Didactic Garden: Physical Attributes  
57  
3.5 The Didactic Garden: Macro Vision  
60  
3.6 The Didactic Garden: Surrounding Fabric  
62  
3.7 The Didactic Garden: The Walkerspruit  
65  
3.8 The Didactic Garden: The Trees  
68  
3.9 The Didactic Garden: The Climate  
70  
3.10 The Didactic Garden: The Ground  
71  
3.11 The Didactic Garden: A Story of Place  
72  
3.12 The Didactic Garden: The Children  
74  
3.13 Theory related to site  
76  
3.14 Summary of Issues and Vision  
78

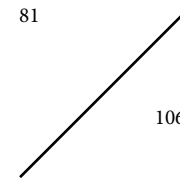

*Programme*



4.1 Introduction  
83  
4.2 Children's Spaces  
84  
4.3 Children's Developmental Needs  
86  
4.4 The School Building vs. The Third Teacher  
87  
4.5 The Reggio Child  
88  
4.6 The need for community space  
90  
4.7 Program Resolution  
91  
4.8 Cognitive: Reggio Emilia Classrooms and Administration  
93  
4.9 Physical Development: Kinetic Classrooms  
95  
4.10 School Atelier and Art and culture workshops and Play Court  
96  
4.11 Guidelines for the design of Early Childcare Facilities  
97  
4.12 Supporting Function: Occupational Therapy (Socio-emotional)  
101  
4.13 Summary  
103

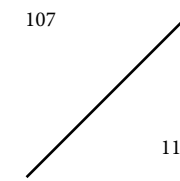

*Precedents*

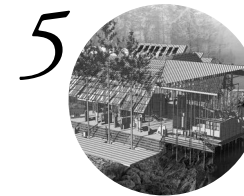

5.1 Introduction  
109  
5.2 Programmatic Precedent : SFU UniverCity Childcare  
110  
5.3 Design Precedent: Space As The Third Teacher  
112  
5.4 Site and Technical Precedent: Meet-se-a-Bophel Primary School  
114  
5.5 Summary  
116

119  
134  
*Concept development*

135  
174  
*Design development*

175  
205  
*Technical*

207  
210  
*Conclusion*

211  
248  
*Appendix*

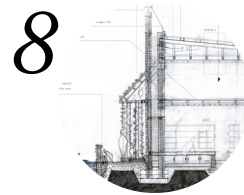
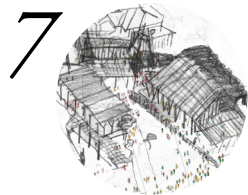

6.1 Introduction  
121  
6.2 Summary of issues, informants and  
intents  
122  
6.3 Conceptual resolution 1  
124  
6.4 Conceptual Resolution 2  
126  
6.5 Conceptual Resolution 3  
128  
6.6 Conceptual Resolution 4  
129  
6.7 Final Conceptual Resolution  
130  
6.8 Final Conceptual Resolution [Con-  
tinued]  
132

7.1 Introduction  
137  
7.2 Design Translation 1  
138  
7.3 Final Resolution of Translation 1  
144  
7.4 Design Translation 2  
147  
7.5 Development of Final Design Reso-  
lution  
149  
7.6 Development of the Section  
156  
7.7 Development of the route  
158  
7.8 Home-base Classroom development  
160  
7.9 Wet vs. Dry Spaces  
164  
7.10 Interior and Exterior Circulation  
165  
7.12 Kinetic Classrooms  
170  
7.13 Supporting Functions: Occupa-  
tional Therapy  
171  
7.14 Providing Security Without Creat-  
ing Barriers  
172

8.1 Introduction  
177  
8.2 Tectonic Concept  
178  
8.3 The Material Palette  
180  
8.4 Primary and secondary structure  
184  
8.5 The Joining of the Tree  
186  
8.6 The Section : Technical Exploration  
190  
8.7 The Water System: First resolution  
192  
8.8 The Water System: Water Budget  
194  
8.9 The Water System: Final Resolution  
195  
8.10 Passive Climate control and servic-  
es  
197  
8.11 Waste Management  
200  
8.12 Daylighting Iterations  
202  
8.13 SBAT  
204

9.1 Reconnecting child to nature  
208  
9.2 Biophilic Design = Restorative  
Design  
209

Appendix  
211  
References  
244  
List of Figures  
249





*introduction*

Chapter 1

Fig 1.1 No man ever steps in the same river twice. (dailygarlic.com. 2016)

“We cannot win this battle to save species  
and environments without forging an emotional bond  
between ourselves and nature as well -  
for we will not fight to save what we do not love.”  
(Gould, 1993: 39)

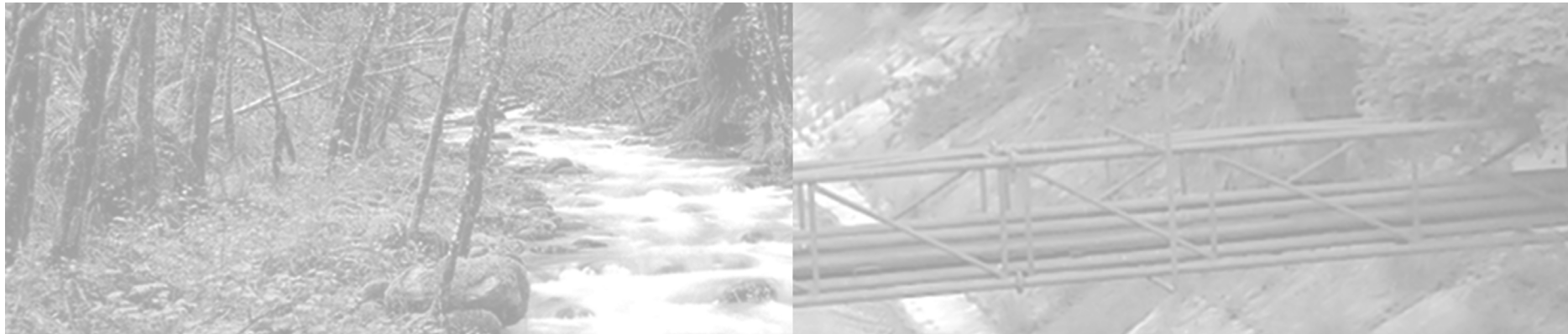

## 1.1 Preface

E. O. Wilson coined the term biophilia back in 1984 as the urge of man to affiliate with other forms of life. The term “biophilia” means “love of life or living systems.” It was first used by Erich Fromm (1964: 47) to describe a psychological orientation of being attracted to all that is alive and vital. Wilson uses the term in the same sense when he suggests that biophilia describes “the connections that human beings subconsciously seek with the rest of life” (Wilson, 1994: 350). He suggested the possibility that the deep attachments and connections humans have with other forms of life forms (and nature as a whole) are rooted in man’s biology.

Over the last few hundred years, however, there has been an ever increasing disconnection of humans from the natural environment (Maller, et al., 2005:48). But what does this mean? The **natural environment** or nature can be defined from many different angles, but for the purpose of this dissertation, nature refers to **natural ecosystems** or the dynamic complexities of plant, animal and micro-organism communities and their non-living environment interacting as a functional unit” (United Nations 1992: Article 2). The **disconnection** between man and nature refers to the **physical and metaphorical barriers** built between nature and man and therefore **interference and destruction** of the balance of natural ecosystems throughout history.

The aim of this dissertation is to depict how architecture can play a regenerative role in its environment through the re-stitching and rehabilitation of existing broken ecologies. This will be carried out by applying and critiquing the principles of biophilic design, through which the importance of these ecologies will be taught through their rehabilitation and conservation.

In Figure 1.2, the separation is seen between the natural river and what the river has become in our cities.

Fig 1.2: Natural River vs. Apies River Channel. (Author. 2016)

## 1.2 Background: our return to biophilia

The movement away from, and return to, ecological architectural design has been a journey extending across the last three centuries. However, the most significant paradigm shift has only recently occurred in the last fifty years with architectural theories and applications emphasising the importance of the interdependent relationship between humanity and nature. The theories of biophilic design are one of the latest theories that has emerged through the progressive furtherance of the sustainable architectural design movement.

The Enlightenment and the architectural project of rationalism brought with it feelings of domination over nature. Descartes (1637) advanced the philosophy that human minds and bodies were separate (Vinning, et al., 2008: 1). With the increasing focus on a scientific and empirical approach to nature came developments in science and technology. Many of these discoveries further enhanced people's abilities to control or transform nature into pristine gardens (Vinning, et al., 2008: 1). Later, the Industrial Revolution and Rapid City growth brought with it deforestation and large ecological destruction. Modernism and the International Style soon followed with design principles that promoted placelessness and designing a building on a clean site (Nesbitt, 1996: 468). (In Figure 1.4, the images show the movement away from nature in architecture)

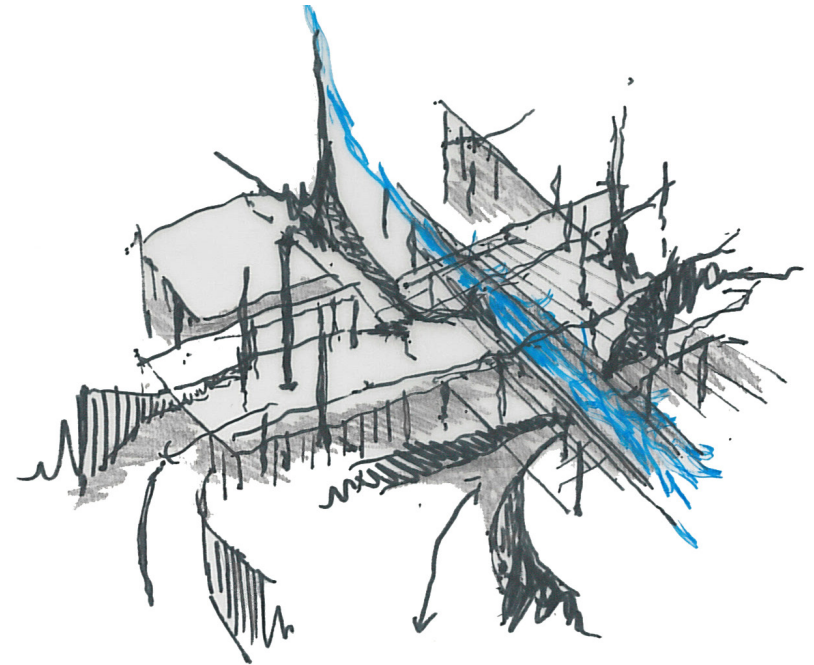
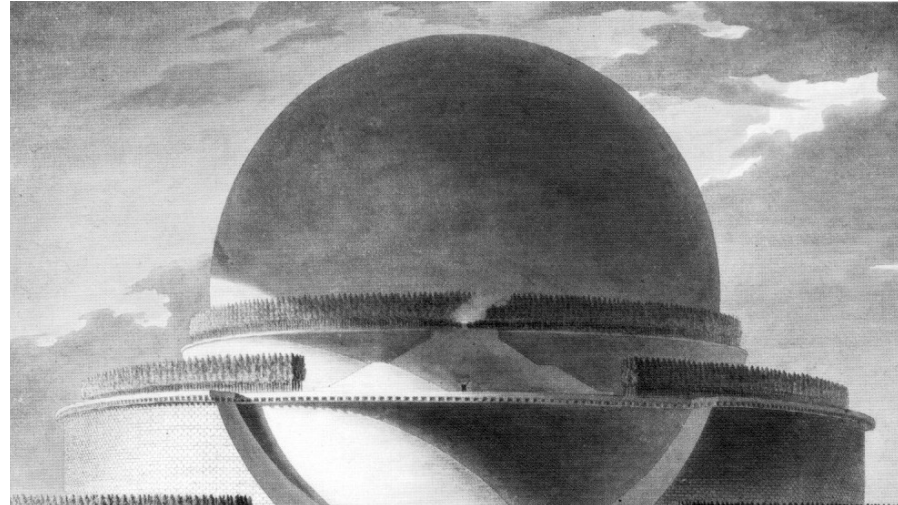

Fig 1.3: Drawing from conceptual development. (Author. March 2016)





1. Descartes. (www2.stetson.edu. 2016)



2. Architectural Rationalism.(doorofperception.com. 2014)



2. Palazzo della civiltà del lavoro. (www.flickr.com. 2011 )



3. Industrial Revolution (www.flickr.com. 2009)



4. The International Style. (http://www.3quarksdaily.com. 2005)



5. Statement Architecture. (en.wikiarquitectura.com. 2014)

Fig 1.4 Architecture and its movement away from nature. (Author. 2016)

### 1.3 Problem Statement

The concept of biophilic design arises from the increasing recognition that the human mind and body evolved in a sensory rich world, one that continues to be critical to people's health, productivity; emotional, intellectual, and even spiritual well-being. The development during the modern age of industry; artificial production, electronics and the city represent a small fraction of the history of human evolution. Humanity evolved in an adaptive response to natural conditions and stimuli, such as sunlight, weather, water, plants, animals, landscapes, and habitats, which continue to be essential environments for human development (Kellert, Heerwagen & Mador, 2008: 9).

Unfortunately, modern developments and technical accomplishments over the last few centuries have nurtured the idea that humans can transcend their natural heritage. This belief has encouraged a view of humanity as having escaped the order of natural ecosystems, with human progress and civilization measured by its capacity for **controlling** and altering the natural world (Kellert, Heerwagen & Mador, 2008: 10) As a result the remaining natural spaces in the urban environment show signs of degradation and neglect.

### 1.4 The Urban Issue

The Apies River and Walkerspruit within Pretoria embody broken ecologies and the control of natural systems. Historically, the river served as a natural representation of the Pretorian identity, where people used to spend Sunday afternoons along its banks, interacting with the animals and plants of the river (Van Der Waal Collection, 1989).

Today, however, the river has become a **barrier**. The Walkerspruit is an inaccessible engineered channel. No attention was paid to connecting the water to the urban context and no attention was given to the biophilic advantages humans have with water bodies and their ecosystems. The consequences thereof are still experienced today, as concerns regarding ecology and natural systems are being introduced in urban design strategies and architectural design (Jansen Van Vuuren, 2011).

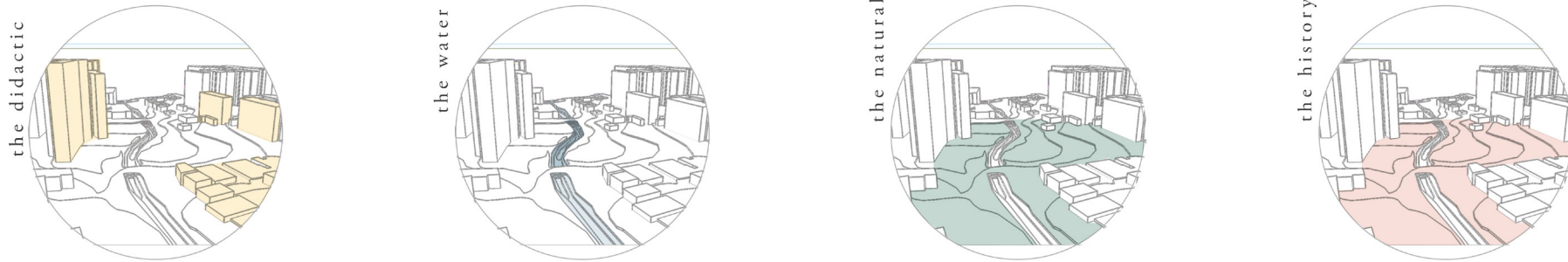

The modern age of urbanization has led the ever more increasing construction of barriers limiting man's access to natural spaces which prevents them from developing love and respect for the earth and its resources (Crain, 2003: 145). These barriers include the lack of direct experience and contact with natural materials and processes in early childhood when the sensory impact of these natural features is the fundamental mode of learning; the lack of use of living environments in schools where the young minds of children are most susceptible to the benefits of the natural world; and the lack of diverse and sustainable landscapes in residential suburbs where children live. Today, the built environment often creates barriers to children's independent mobility and therefore their experience of nature (Kellert, Heerwagen & Mador, 2008: 153-156).

Located along the Walkerspruit in Sunnyside, Pretoria, on the empty park space situated between Bourke and Leyds Street and North of De Rapper Street, the site holds four key informants, namely: the river or riparian element, the sparsely scattered trees on the site, the biophilic heritage of the site and lastly, the densely populated pre-primary schools surrounding the site. (Refer to Figure 1.5)



Fig 1.5: Site location and informants. (Author. 2016)

## 1.5 Summary of Issues

### Barriers

The vehicular roads between the schools and the site inhibit access to an open natural space alongside the Walkerspruit

### Broken Ecosystems

The natural site, as it is, shows signs of neglect and degradation, depicting how Pretoria and its engineered past have disregarded the need to integrate natural sites into the urban fabric.

### River serves as a barrier and safety hazard

The river serves as a barrier in itself as it proves inaccessible to children as well as unsafe.

### Schools ignore ecologies

Current early childhood development centres in the area ignore the potential of the open site as a vehicle for biophilic involvement.

### Dead zone

The space has become a lost space along the Walkerspruit, due to the nature of the area. The high rise flats and lack of safe green spaces for children result in a dead space. The large scale difference between buildings and ground leave it feeling lost and out of place

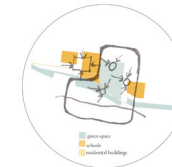

**School ignores ecologies**  
Current early childhood development centres in the area ignore the potential of the open site as a vehicle for biophilic involvement.



**Barriers**  
The vehicular road between the school and the site inhibits access to an open natural space alongside the Walkerspruit.



**Broken Ecosystems**  
The natural site, as it is, shows signs of neglect and degradation, depicting how Pretoria and its engineered past have disregarded the need to integrate natural sites into the urban fabric.

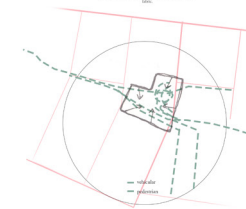

**Barriers**  
The vehicular road between the school and the site inhibits access to an open natural space alongside the Walkerspruit.

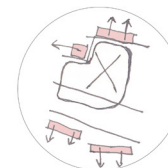

**Dead zone**  
The space has become a lost space along the Walkerspruit, due to the nature of the area. The high rise flats and lack of safe green spaces for children result in a dead space. The large scale difference between buildings and ground leave it feeling lost and out of place.



**Barriers**  
The river serves as a barrier and safety hazard. The river serves as a barrier in itself as it proves inaccessible to children as well as unsafe.

Fig 1.6: An example of Green Architecture. Bosco Verticale, Stefano Boeri.  
(Bosco Verticale. Techinsider. 2014 )



Fig 1.7: An example of Biophilic Design .Alvar Aalto's Villa Mairea in Noormarkku, Finland, 1939.  
(Villa Mairea. Ideasgn.com. 2013 )



## 1.6 Architectural Issue

In Architectural terms, humans, seeking shelter from the elements, were compelled to construct buildings and cities. Historically, the form of those structures arose from the materials and elements of their immediate environs (Kellert, Heerwagen & Mador, 2008: 59). Applying what was at hand to give structure to existence, people instinctively constructed places that provided the integral information, form, and meaning that their sense of well-being required (Kellert, Heerwagen & Mador, 2008: 60). Sustainability was an everyday ritual, giving back to the earth what we took from it. However, what happened to cause this slow progression of control and the building of barriers between natural ecologies and the built environment that has led to much of the architecture we experience today? An architecture that disregards the long-term potential of a interdependent relationship between humans and place.

The Green design movement focuses on increasing competence of the use of natural resources, removing discrepancies such as toxicity, and achieving sustainability through capable and disciplined practice (Refer to Figure 1.6). This is insufficient because it misses the potential that emerges out of the human presence on this planet: the possibility of organizing human activities so that they continuously feed and are fed by the living systems within which they occur (Mang & Reed, 2012: 26).

This is what Biophilic design aims to achieve: an interdependent, holistic relationship between humans and their environment, building within a culturally and ecologically relevant context, all basic to human health, productivity and well-being. These latter objectives are the essence of biophilic design. (Kellert, 2008: viii) (Refer to Figure 1.7)

The intention of the scheme is derived from two drivers: the theories of biophilic design, that state that “effective application of biophilic design must integrate two domains of health: children and planet” (Chawla, 2006: 57-78); as well as the key informants of the site which include the large amount of schools in the immediate area (Refer to Chapter 2). Children must spend enough time in naturally, healthy environments for biophilia to be instilled as a **lifelong affect**. Therefore, in order for biophilic design to become restorative, humanity’s biophilic afflictions need to be **taught** at a young age (i.e. A didactic biophilic design)

## 1.7 Research Questions

How can architecture help to rehabilitate and conserve dwindling natural ecosystems through education about the importance and fundamental value of their role in creating an ecological, healthy and regenerative environment in the urban context and therefore instil lifelong biophilia within its users?

## 1.8 Sub-questions

What can be done architecturally to rehabilitate the dwindling natural ecosystems in the urban environment and what role could these rehabilitated ecologies play in a regenerative city?

What relationship can building, as a catalyst of the didactic, have with the natural ecologies that exist, and through biophilic experiences, reconnect with the direct environment?

Is it possible for the inhabitants of this urban environment to contribute and build on these existing natural ecologies and repair broken ones?

Can the spatial and experiential attributes of natural ecologies act as drivers in the making of architecture that have spatial hierarchies, haptic experience, and didactic function?

Can architecture, while expressing sensitivity in the learning environments that exist, accommodate a new form of the didactic that address the gaps in the current methods of learning that do not completely assist in a child's full development?

## 1.9 Research Methodology

### 1.8.1 Literature

Theoretical desktop studies relating to concepts of biophilic design are investigated to further understand the meaning of man's love of other living systems and how this love can be exemplified to form a regenerative architecture.

### 1.8.2 Mapping

An in depth understanding of the site and mapping within the urban framework informed the development of a master-plan and group framework. This investigation will be conducted through in depth eco-mapping of the site alongside reinterpreting the existing ecosystems through the critique on Ken Yeang's 1995 book *Designing with Nature* (1995: 48). Yeang explores design through the both eye of an ecologist and an architect and focuses on diagrammatically analysing a site as an ecosystem in order to better understand how they interact with their immediate environment. Eco-mapping dealt with all environmental issues of the site including, ecologies, landforms, relationships on the site, circulation and movement patterns, existing vegetation and climatic conditions. This method is used to establish the site characteristics that led to the informants of a design approach.

There are four main informants that exist on site. These have been identified as the tree, the water or river, the existing schools and the biophilic memory of the site. Understanding where they exist, the biophilic attributes these informants possess, and the spatial qualities they possess will be investigated. The existing learning centres that exist around the site must be investigated in order to react and integrate a new didactic ecology on the site.

### 1.8.3 Applied Research

**Data:** Data is then summarised and applied to relevant aspects in order to complete the requirements for the design. The collection of site photos is essential in the study of site characteristics, scale, existing habitats and ecosystems and enables an appropriate design response.

**Analysis:** The relevant data collected is then turned into evidence that supports the intentions of the dissertation and its arrival at a relevant conclusion. The data is analysed to obtain the most relevant evidence relating to the outcome of the project. The data analysis is completed in computer investigations through the building of models and the delineation of presentation formants.

## 1.10 Delimitations

Delimitations: The aim of this dissertation is not to propose a new way of thinking about sustainability but to explore the use of current principles of biophilic design.

Biophilic design principles encompass an extremely wide field of sustainable design principles, ranging from biomimicry to the use of natural light. For the purpose of this dissertation, biophilic principles that relate to evolved human-nature relationships will be broadened upon.

The layout of the existing preschools alongside the site will be assumed according to their exterior as the aim of this project will only be to relate to the schools on a visual and circulatory level and not to carry out architectural alterations and additions to the physical buildings themselves.

## 1.11 Assumptions

It is assumed that the soil on site, which is excavated to create the bio-swimming pool and sunken playground courtyard is adequate for the use of berms or rammed earth as construction methods.

It is also assumed that occupants of the surrounding flats support the mini urban framework proposal of pedestrianising the motorways alongside the flats and that the relevant rezoning of the roads into public park spaces will be implemented.

Lastly, it is assumed that the Grade R building which is part of the Ring Ting Pre-primary school property will be demolished and its materials used in the proposed construction. The Grade R learners will be moved into the new classrooms of the proposed dissertation.





Fig 1.8: Author's conceptual interpretations of the didactic garden. (Author: 2016)

## 1.12 Hypothesis

It is proposed that humans can become more directly connected with their environment once more through an architecture which creates a synergy within its environment. Through the practise and application of biophilic design, the building will aid in creating a new ecology. An ecology that teaches and stirs an awareness of the users' biophilic heritage.

By facilitating a didactic space where users can experience and learn from their environment, through the design of an architecture that contributes to the development of young learners in a densely populated community, will ultimately establish an awareness of our place as humans within the greater natural ecosystem and foster lifelong regenerative thinking.

## 1.13 Objective

The project is intended to firstly reconnect a lost park space along the Walkerspruit in Sunnyside to the surrounding residential and school environment, which embodies the issues of industrial modernity where natural elements in the urban context are disregarded and neglected and the potential identity of place-based architecture is ignored. The proposed architecture, critical of the principles of biophilic design and appropriate within a culturally and ecologically relevant context, aims to facilitate a didactic landscape in which the importance of natural resources and natural parks will be taught to the children of the adjacent schools through the existing natural space's rehabilitation and conservation in the form of a new type of childhood development. This will foster emotional well-being and ultimately, a new regenerative philosophy to be instilled within the child to be carried with them throughout their lives and promote healthier cities in the future. In Figure 1.9, an initial conceptual collage was carried out to visually express the objectives and intentions of the scheme.





Fig 2.1: The Seven Sisters Oak Tree. [Kellert, 2008: 34]

“Humanity is exalted not because we are so far above other living creatures, but because knowing them well elevates the very concept of life.”

(Wilson, 1989: 22)

## 2.1 Introduction

This dissertation investigates the potential of architecture to restore man's biophilic nature in a world where built environments are increasingly creating barriers between man and the natural world by proposing a return to man's ecological and nature-connected existence. The concept of biophilia and the primary attributes of biophilic design are two relevant concepts of regenerative theory and will be discussed as starting points, followed by a critique the three fundamental aspects that form part of biophilic design and later how and in what context these fundamental theories can be practically applied. These elements include natural ecologies or systems, and the river or element of water, and biophilic child development.

## 2.2 The History of Biophilic Design and Ecological Design Principles

Biophilic Design is not only an ethical, ecological stance towards conserving earth's resources but phenomenological in that it regards one of the fundamental dimensions of biophilic design as buildings and landscapes that connect to the culture and ecology of a locality (Kellert, 2008: 6).

Since the dawn of modernity at the beginning of the 20th Century, there have been a number of architectural movements, contributing to the principles of biophilic design, that have contested how Modernism has contributed to the over exploitation of natural resources and the decline of place and meaning in the design of the built environment. Ian McHarg was one of the pioneers of ecological design, who recognised and “defined the problems of modern development and presented a methodology or process prescribing compatible solutions” (Palmer, 2000: 228-241). In his book “Design with Nature”, McHarg presented a system of guidelines where the layers of a site are analysed in order to generate a complete understanding of the qualitative attributes of a place. These layers include history, hydrology, topography, vegetation etc.

In 1974, Kenneth Frampton discusses a Martin Heidegger's paper, “Building, Dwelling, Thinking” where he emphasises how architects, at the time, were unable to create places connected to the identity of a locality. Two years later, Christian Norburg Schulz wrote the paper titled, “The Phenomenon of Place” where he also interprets Heidegger's essay. Edmund Husserl defines phenomenology as method that urges a return to things as opposed to abstractions and mental constructions (Nesbitt, 1996: 412). Schulz identifies phenomenology's potential in architecture as the ability to make the environment meaningful through the creation of specific places (Nesbitt, 1996: 412). This is where the ancient Roman idea of the *genius loci*, the spirit of a particular place is reintroduced. In 1983, Frampton offers an alternative, authentic architecture based on two essential aspects of architecture: an understanding of place, and tectonics. In the 1990's, Ken Yeang, one of the early pioneers of ecology-based green design and master planning wrote the book titled *Designing with nature* which proposes analysing a site in terms of an ecosystem. Other ethical standpoints in the 1990's include William McDonough's *Hannover Principles* which are a set of guidelines for sustainable design. Biophilic Design emerged as a result of all predeceasing theories and represents a combination of both ethical and phenomenological principles in an attempt to bring humanity back to nature through design.

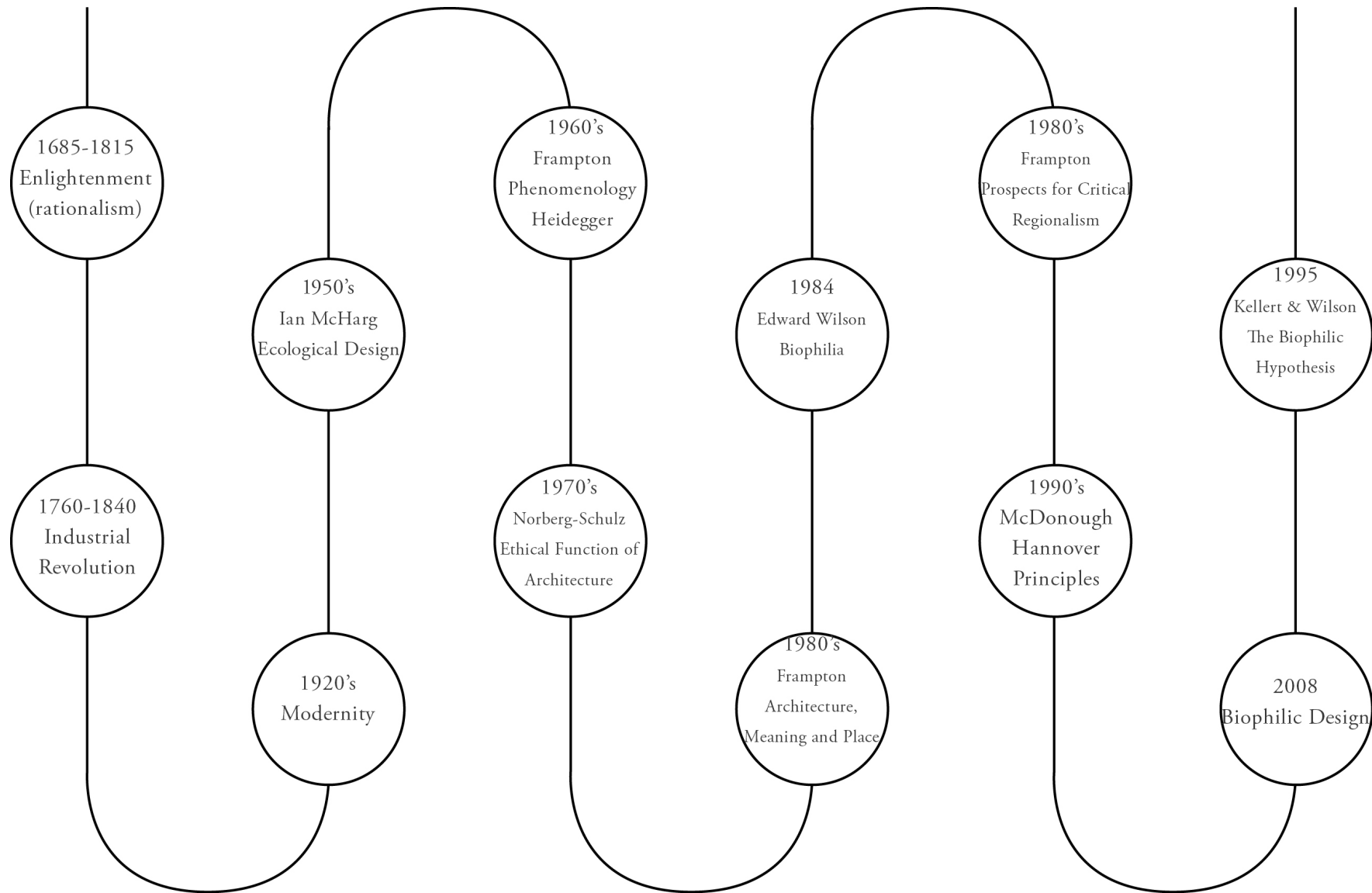

Fig 2.2: Author's interpretation of Architecture's return to biophilia. (Author. 2016)

## 2.3 The dimensions, elements and attributes of biophilic design

“Biophilia is the inherent human affinity to affiliate with natural systems and processes” (Wilson 1984, Kellert and Wilson 1993). Biophilic Design is the deliberate attempt to translate an understanding of biophilia into the design of the built environment. This biophilic tendency became biologically encoded because it proved instrumental in enhancing human physical, emotional, and intellectual well-being during the course of human evolution. People’s dependence on contact with nature reflects the reality of having evolved in a largely natural, not artificial or constructed, world. In other words the environment of human mind and body was a sensory world dominated by critical environmental features such as light, sound, odour, wind, weather, water, vegetation, animals, and landscapes.

Our biophilic needs is an adaptive product of human biology, and the satisfaction of our biophilic urges is related to human health, productivity and well-being. The findings by Stephen Kellert in 2005 are worth noting:

- Contact with nature has been linked to positive cognitive responses while completing tasks requiring concentration and memory.
- Healthy childhood development has been linked with contact with natural elements and landscapes

-Communities with higher-quality environments reveal more positive valuations of nature, superior quality of life, greater neighbourliness, and a stronger sense of place than communities of lower environment quality. These findings also occur in poor urban as well as more affluent and suburban neighbourhoods (Kellert 2008: 4).

According to Kellert (2008: 21-31) there are 70 physical attributes of biophilic design that can be applied to the built environment. These include two biophilic dimensions (Refer to Figure 2.3):

### 2.3.1 Organic or Naturalistic dimension:

Defined as “shapes and forms in the built environment that directly, indirectly or symbolically reflect the human affinity for nature” (Kellert 2008: 4). Direct experience refers to unstructured contact with the self-sustaining environment and indirect experience involves contact with nature that requires on-going human input to survive such as a potted plant. Symbolic contact requires no actual contact with real nature but rather the representation of the natural world through image.



### 2.3.2 Place-based or Vernacular dimension:

This dimension is defined as buildings and landscapes that connect to the culture and ecology of a locality or geographic area. This includes the *genius loci* or spirit of place emphasising how buildings and landscape of meaning to people become integral to their individual and collective identities.

Wendell Berry (1972: 68) remarked: “without a complex knowledge of one’s place on which such knowledge depends, it is inevitable that the place will be used carelessly and eventually destroyed”.

Today, despite the urge to travel around the globe, most people still retain a strong need for a place they can call “home”. This attachment to place remains a major reason why people assume responsibility and long-term care for the upkeep and preservation of buildings and landscapes. However, the built environment consists of an ever increasing dismemberment of connection to place and has unfortunately become a common characteristic of modern society (Kellert 2008: 6).

### 2.3.3 Summary of attributes

These two dimensions of biophilic design can be related to six biophilic design elements (Kellert 2008: 6)

- Environmental features
- Natural shapes and forms
- Natural patterns and processes
- Light and space
- Place-based relationships
- Evolved human-nature relationships

These six elements are then further elaborated on with each having several attributes, indicated in Fig 2.2.

<b>Environmental features</b>	<b>Natural shapes and forms</b>	<b>Natural patterns and processes</b>
Color	Botanical motifs	Sensory variability
Water	Tree and columnar supports	Information richness
Air	Animal (mainly vertebrate) motifs	Age, change, and the patina of time
Sunlight	Shells and spirals	Growth and efflorescence
Plants	Egg, oval, and tubular forms	Central focal point
Animals	Arches, vaults, domes	Patterned wholes
Natural materials	Shapes resisting straight lines and right angles	Bounded spaces
Views and vistas	Simulation of natural features	Transitional spaces
Façade greening	Biomorphy	Linked series and chains
Geology and landscape	Geomorphology	Integration of parts to wholes
Habitats and ecosystems	Biomimicry	Complementary contrasts
Fire		Dynamic balance and tension
		Fractals
		Hierarchically organized ratios and scales
<b>Light and space</b>	<b>Place-based relationships</b>	<b>Evolved human-nature relationships</b>
Natural light	Geographic connection to place	Prospect and refuge
Filtered and diffused light	Historic connection to place	Order and complexity
Light and shadow	Ecological connection to place	Curiosity and enticement
Reflected light	Cultural connection to place	Change and metamorphosis
Light pools	Indigenous materials	Security and protection
Warm light	Landscape orientation	Mastery and control
Light as shape and form	Landscape features that define building form	Affection and attachment
Spaciousness	Landscape ecology	Attraction and beauty
Spatial variability	Integration of culture and ecology	Exploration and discovery
Space as shape and form	Spirit of place	Information and cognition
Spatial harmony	Avoiding placelessness	Fear and awe
Inside-outside spaces		Reverence and spirituality

Fig 2.3 The table illustrates all 70 attributes of biophilic design in their various categories. (Kellert, Heerwagen & Mador, 2008: 15)

### 2.3.4 Choosing the appropriate attributes and elements

There are a wide range of dimensions, elements and attributes that make up biophilic design. The attributes have been explored in terms of what exists on site and the intentions of the dissertation. The four key informants on site have been identified as the element of **environmental features** such as water, light, and trees (Refer to page 17). What is intended are richer biophilic elements such as **human-nature evolved relationships** and **place-based relationships**.

Each environmental feature on site will therefore be explored in terms of how each feature can be re-appropriated biophilically through applied attributes, such as water and biophilia, the existing trees and interpreting them through biomimicry and lastly the child and how they are most cognitively stimulated through these biophilic applications.

Lastly, these attributes that can be applied according to each environmental feature will be related back to the intended elements such as place-based relationships and human-nature evolved relationships which are the intentions of the scheme. (Refer to Fig 2.4)

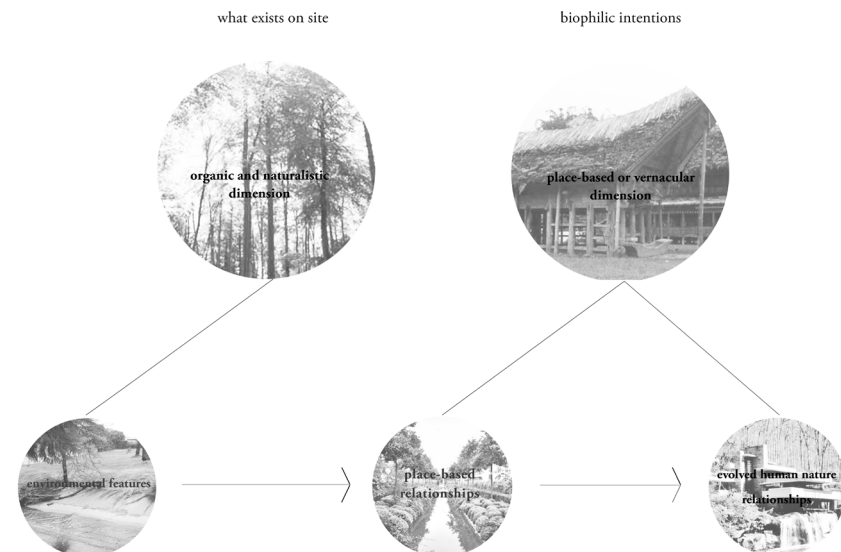

Fig 2.4 What exists and what is intended on the site according to the dimensions, elements and attributes of biophilic design (Author, 2016)



Fig 2.5: The channelised Walkerspruit.(Author, 2016)

## 2.4 The Biophilia of Water

“Water is the supreme sculptor of our environment” (Campbell, 1978: 9)

Water is in many ways the reticent component of our natural surroundings. Water covers 70 percent of the earth’s surface. Water is undoubtedly necessary for life and accompanies every instance of human habitation. It forms a major component of the cellular structure of organisms. According to Martin Mador (2008 : 60), water is the unifying element of nature, connecting all aspects of the landscape.

Kellert (1997: 42) (2005: 51-57) developed a framework that provides a comprehensive structure for enumerating our many attachments to water. The relevant relationships with water to this dissertation are highlighted below:

**Humanistic:** the ability of man to form a bond with this natural element, to value its existence, its significance in his sense of place, and its value as a life-giving element

**Aesthetic:** This includes all the aspects of water that are found appealing to our five senses.

**Moralistic:** the sense of valuing the gift of this resource; the obligation to preserve it; equitable sharing among human and non-human users

**Symbolic:** a brook communicating to us through the gurgling of its tumbling waters; the strength and power of the flow of a mighty river

**Scientific:** lessons of aquatic chemistry, ecology and biology

In Figure 2.5, the current condition of the Walkerspruit is shown, with most of it being channelised and disconnected from the surrounding fabric.



We began to see engineering as the only body of knowledge necessary for problem solving. (Kellert, 2008: 47) In the built environment at both large and intimate scales, roadblocks presented by the natural world to human ambition could simply be engineered over around, or through.

Most of nature, and especially water, fell victim to this "advance" of civilization. Water in nature is never linear. Water bodies always have curvilinear boundaries. Rivers, left to themselves, will develop a meandering, hairpin-dominated course. The engineered world, however, thinks in straight lines. Water, whether as fresh supply or wastewater, is universally contained in straight pipes. Many, many river courses have been straightened for the convenience of abutting landowners. In sum, over the past century, we have exercised our engineering prowess to defeat and devalue nature, and we have degraded our water resources rather than celebrating them. The biophilic opportunity of water has been ignored with some exceptions. Over the last 40 years, however, sustainable and environmentally friendly interventions have created opportunities to restore man's biophilic connection to water. (Kellert, 2008: 48)

In Texas, the Paseo del Rio river-front into an attractive destination for tourists and residents. Shops and restaurants line the San Antonio River. In New York, an extensive and coordinated effort is being made to rehabilitate the entire area along the Hudson and East Rivers (Kellert, 2008: 48).

Water can be seen as an animate, dynamic object with different physical characteristics depending on its speed, and the amount and type of light of its environment. The movement of water has very strong biophilic attraction (Refer to Figure 2.6) As a primary life-sustaining force, water's significance is dramatized by the addition of flora. Facultative wetland vegetation, riparian plantings, and immersed water-based plants such as water lilies combine with water to express strongly biophilic elements of life (Kellert, 2008: 49).

Fig 2.6: Pa Daet, Thailand. unpalsh.com. Photo: Keenan, A.

Fig 2.7 (left): The Seven Sisters Oak on Lake Pontchartrain has survived 1200 years due to its ability to withstand hurricane forces. (Kellert, 2008: 34)

Fig 2.8 (right): Eco-machines from John Todd Ecological Design, Inc. mimic the patterns of nature's water-purifying ecosystems to clean sewage to pure water (Kellert, 2008: 161)



## 2.5 Biophilia of Trees

“In an unscripted moment that happens all over the world, a child tosses a maple seed into the air, clapping with delight as it helicopters to the ground on its perfectly shaped wing. The maple samara plays gravity against a cushion of air, allowing the seeds of the next generation to escape their parent's shade. Like all good design, it never fails to inspire wonder, and, eventually, imitation” (Kellert, 2008: 27).

Biomimicry is the act of learning from nature, borrowing designs and strategies that have worked in place for billions of years. This conscious emulation of life's genius is a natural part of biophilia.

Vernacular architects, struck by the practical beauty all around them, may have learned mud-daubing from swallows and termites, weaving from birds and spiders, and masonry from caddis flies. It's only recently that we've turned a blind eye to nature's guidance, focusing instead on each other's latest fashion.

Biomimicry is not a style of building, nor is it an identifiable design product. It is rather, a design process—a way of seeking solutions—in which the designer defines a challenge functionally (flexibility, strength under tension, wind resistance, sound protection, cooling, warming, etc.), seeks out a local organism or ecosystem that is the champion of that function, and then begins a conversation.

This focus on function points to a key difference between buildings that mimic nature to "look as nature looks" for decorative or symbolic purposes and those that mimic nature to 'do as nature does" in order to enhance functional performance. “A building need not look exactly like a tree, but, as Frank Lloyd Wright reminded us, it should work like one” (Kellert, 2008: 29).

The two images above show how a tree, in nature, can be used as a model to create buildings that can withstand hurricane force while in Figure 2.9, eco-machines that mimic the water-purifying ecosystems found in nature are used to clean sewage. In terms of the trees that exist on site, biomimicry is seen as an appropriate element to mimic in terms of how trees bring the site back to human scale as well as the protective nature of trees and the mini-ecosystems they foster.

Fig 2.9 (left): The children of Ring Ting Pre-primary School in Sunnyside adjacent to the site. (Facebook/ Ring-Ting Pre Primary School & baby care. 2012)

Fig 2.10 (right): Children enjoying early morning exercise (Kellert, 2008: 159)



## 2.6 The Biophilia of Children

“Effective biophilic design must integrate two domains of health: children and planet” (Kellert, 2008: 155).

According to the latest research findings (Wells and Evans 2003; Wells 2000; Kua et al. 1998) children who are in direct exposure to nature experience a healthy, therapeutic effect on cognitive development and mental well-being. The research explores the physical design in improving the quality and quantity of contact with nature. It is evident that there is a paradigm shift in the way opportunities for children to explore nature are being created.

According to Chawla, children are born as “biophilic beings”, which means that an curiosity to explore and learn about how the natural world and its processes work is inherent to children’s biology. He states, ‘Effective biophilic design must integrate two domains of health: children and planet.’ In order for effective biophilic design to occur, children need to be a intricate part of it and must spend enough time in natural environments in order for biophilia to be installed as a lifelong effect. This will create a large community of biophilic citizens who love the earth so strongly they will do anything in their power to conserve and protect it (Chawla, 2006:57-78).

## 2.7 The Barriers to Children’s Biophilia

The modern age of urbanization has led the ever more increasing construction of barriers limiting man’s access to natural spaces which prevents them from developing love and respect for the earth and its resources (Crain, 2003: 145). These barriers include the lack of direct experience and contact with natural materials and processes in early childhood when the sensory impact of these natural features is the fundamental mode of learning; the lack of use of living environments in schools where the young minds of children are most susceptible to the benefits of the natural world; and the lack of diverse and sustainable landscapes in residential suburbs where children live. To increase the “activity friendliness” of urban neighbourhoods for children (de Vries et al. 2007: 35), enough structural urban design issues must be addressed such as high traffic roads and better designed pedestrian routes and park planning. Location of shared spaces between neighbourhoods and designating recreational facilities close to high density areas in order to increase walking for young people should also be incorporated in urban design strategies. In the images above, the children that exist on site are compared to the intended condition of their environment with complete immersion in nature.

Fig 2.11 (left): A group of toddlers play with fallen leaves, experience their sensory properties and explore their behaviour on the curved surface of a hollow log.



Fig 2.12 (right): Traffic-free urban trails and green-ways expose children to nature and help them learn the joy of bicycle riding at an early age.



### 2.7.1 Impact on cognitive development

According to a survey carried out in the UK by psychologist Michael Shayer involving 10000 11 – 12 year old children, many of them are falling behind in their cognitive and conceptual development due to an increase in video game culture and a decrease of experiential play (Crace, 2006: [sp]) A longitudinal study carried out by Wells in 2000 revealed that a statistically significant correlation between experiential play with views to nature and cognitive functioning. No doubt, full immersion of experiential play within natural surroundings will have a greater effect (Wells, 2000: 775-795).

Other beneficial factors of nature on the well-being of children include improvement in conditions of attention deficit disorders, child obesity, and improvement in mental, social and physical health including natural green spaces serving as immune system boosters.

In summary children are drawn to nature because it is pleasurable and gives them a sense of well-being, expansive freedom and agency and control over events. For children to reap the full benefits of being outdoors, engagement with nature must be available as an everyday ritual of life. In the images above, children are seen enjoying the many benefits that nature has to offer such as the sensory properties of a hollow log and green urban trails to help them learn how to ride a bike in a natural environment.



## 2.8 South African Examples of Biophilic Design

Although there are not very many explicit examples of biophilic design in South Africa, the Afrisam annual Awards which is an award which recognises buildings where design and sustainability go hand in hand, gives subtle examples of the positive impact biophilic design has on its users and the environment. The winners of this award goes to buildings that contribute to their surrounding community as well as reducing the impact on their environment by incorporating passive systems and regenerative design strategies (Afrisam.co.za. 2016).

One of the winners of the award was given to the design team of the Alexander Forbes building, designed by Paragon Architects, in Sandton, Johannesburg. Rain water is harvested, passive ventilation systems implemented and high performance glazing with louvres to shade from the afternoon sun are implemented into the building's design. These are sustainable principles but what makes this building biophilic is essentially its integration with natural elements into the spaces of the building which have proven to increase productivity and limit stress levels amongst its users.

There are two large atria which aims to maximise natural daylight penetration into the office spaces as well as to the ground below which was designed to become a natural park like environment with the inclusion of 6m high Ficus Benjamina trees sunken into the floor. The light sources are twelve giant 8.4m cones, which float above the atrium space like giant clouds. All of these principles incorporate biophilic principles such as biomimicry, the use of light and space, inside-outside spaces, the use of natural patterns and processes and many more.

In an interview with employees of Alexander Forbes conducted by the Afrisam awards, many expressed how they didn't even feel like they were at work because the building created such a beneficial and pleasant environment for them (Afrisam.co.za. 2016).

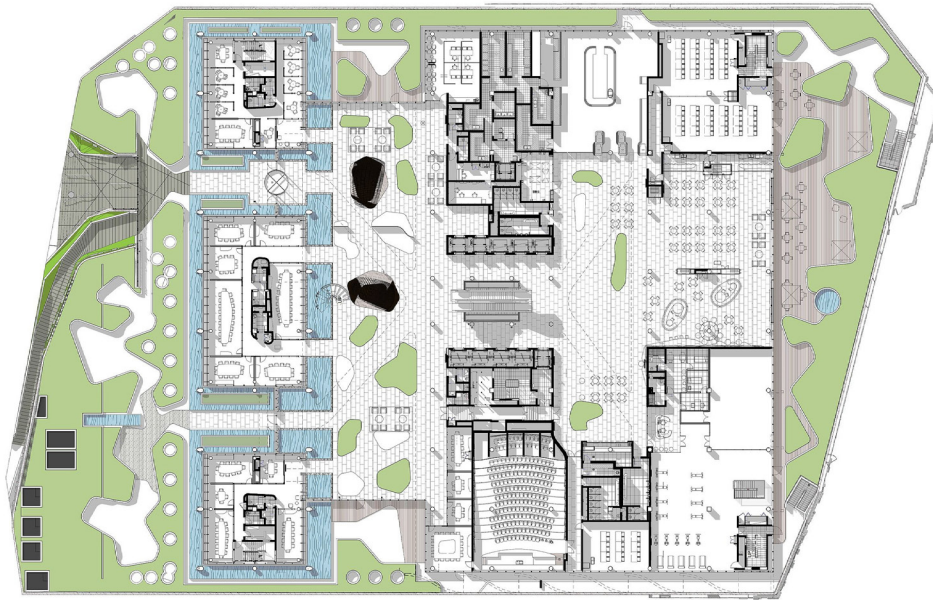

Fig 2.13 Ground floor plan (Arch Daily, 2012)

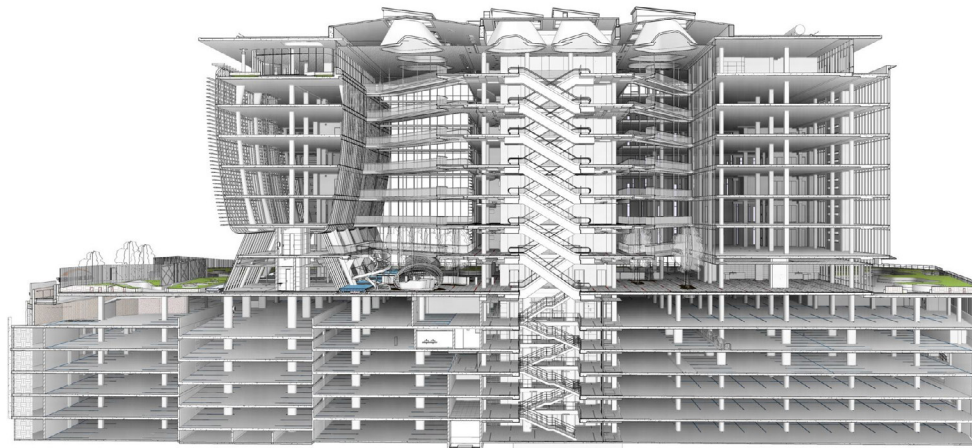

Fig 2.14 Section through atrium of building showing cloud like light sources (Arch Daily, 2012)



Fig 2.15 Image showing the trees in the designed park like ground floor. (Arch Daily, 2012)

## 2.9 Water, Nature, Children and Architecture

In the quest to answer the dissertation questions, of what relationship building should have with water, the child, and the natural systems that exist on site, and how biophilic experience can be enabled spatially, these different concepts of 'space' of firstly, water, the natural systems and the spatial perceptions of the child will be investigated in the architecture. For the water, space is seen as sculptor and unifier of all aspects of design (Kellert, 2008: 60). With regards to the biomimicry of natural systems, making of architecture is seen as a way to not only learn through the making of architecture what nature has to offer but also to pay homage and celebrate nature (Kellert, 2008: 164). The child, as biophilic beings, will learn through these principles, of the importance of natural systems, water and how they positively affect their environment.



Fig 2.16: A labyrinth at a primary school in the UK where children interact with nature and each other. (Kellert, 2008:170)

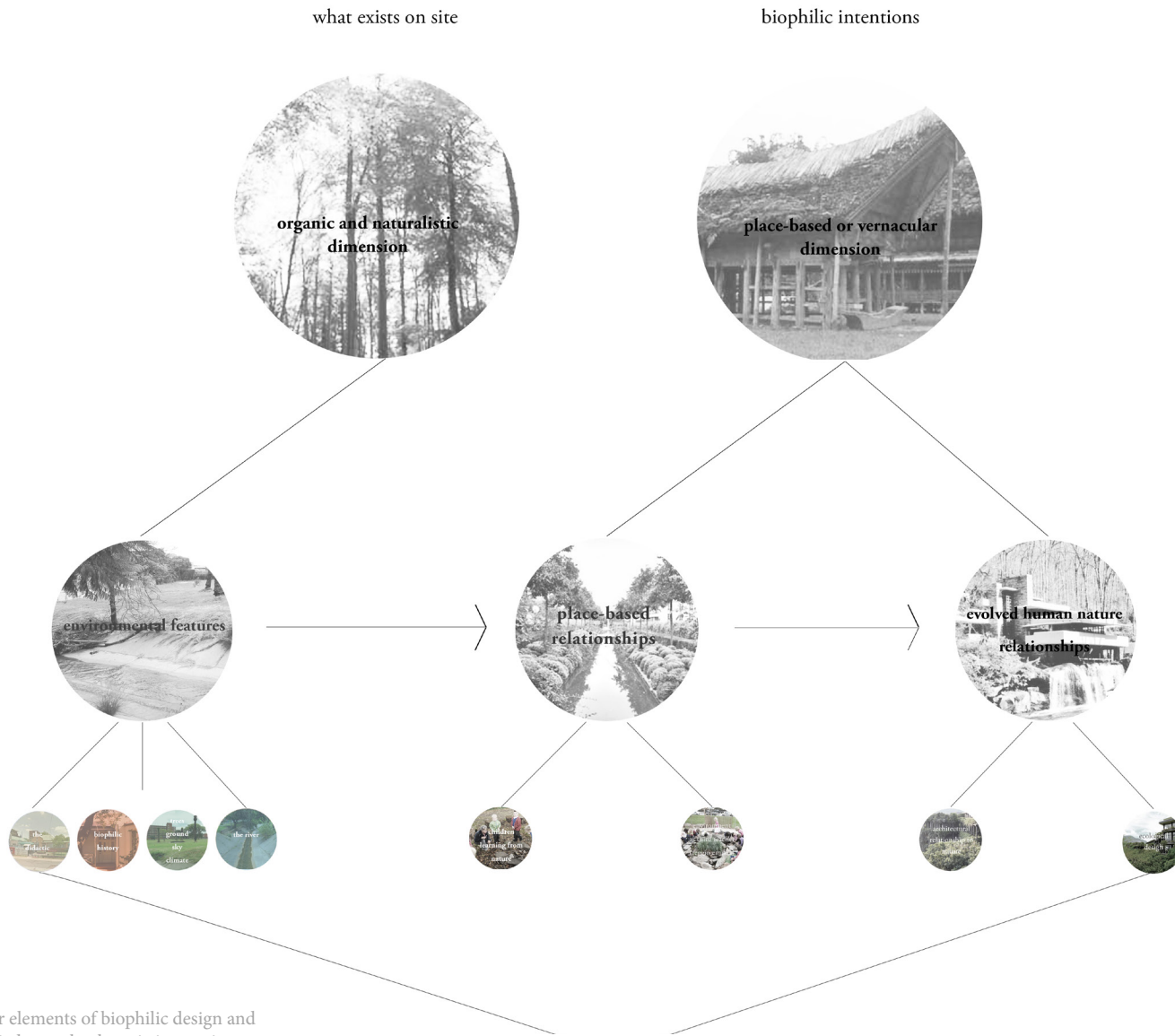

Fig 2.17 Diagram the richer elements of biophilic design and what attributes can be applied to make the existing environmental features richer (Author, 2016)







*context*

Chapter 3

Fig 3.1: Bourke Street Garden. [Author, 2016]

“Without a complex knowledge of one’s place on which such knowledge depends, it is inevitable that the place will be used carelessly and eventually destroyed.”  
(Wendell Berry 1972: 68)



### 3.1 Introduction

For the intentions of the dissertation to have effect, the best kind of site to select is one with evident barriers between man and the natural world and site which possesses opportunity for a didactic architecture through which man's biophilic origins could be restored. To the North of De Rapper Street, in Sunnyside, Pretoria lies an empty piece of ground, nestled between towering apartment blocks and the small urban river, the Walkerspruit. The once park, now dumping ground and storage space for various construction vehicles, has massive opportunity for didactic and ecological intervention and local community involvement. This chapter will highlight the importance of the place describing its current condition within the context of Sunnyside and the water networks of Pretoria and accentuating its potentials.

This dissertation also forms part of a group of six architecture students and one landscape architecture student working along the water systems within Pretoria. A collective vision was conceptualised and designed, and will be presented in this chapter as a response to the issues identified.

Lastly, the summary of informants will be related back to the principles of biophilic design in terms of what exists and what possible the biophilic intentions exist.



Fig 3.2: Aerial view of Site with initial program layout. (Author, 2016)

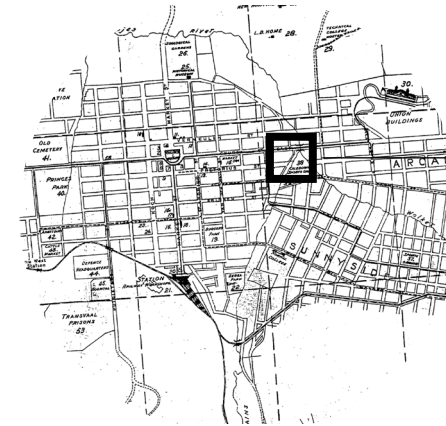

Fig 3.3 (right) Pretoria's development and shift in city grid due to the rivers. (University of Pretoria, Department of Architecture archives)

### 3.2 Pretoria's Riparian Network

One of the primary components that form part of Pretoria's development is water (Figure 3.3). Water was discovered in abundance in the form of dolomitic aquifers located at what is known today as Groenkloof nature reserve (Fig 3.6). The excess water not used for consumption from the two dolomite aquifers in Groenkloof flowed into the Apies River and continues to do so today. The other dolomitic aquifers, near Rietvlei dam were found to the south, known as Grootfontein and Sterkfontein (Fig 3.6). This water has been retained in large dams such as the Rietvlei and Hartebeespoort dams.

These aquifers form a vital part of Pretoria's heritage yet little understanding and appreciation of their significance as suppliers of water and symbols of Pretoria's identity exists among city dwellers. In addition the Apies and Walkerspruit Rivers embody broken ecologies and the control of natural systems due to their channelisation between 1910 and 1930 where a system of purely engineered concrete channels (refer to Figure 3.4 and 3.5) were built to divert the original course of the Apies in order to make way for urban development and to pass the water through the city as fast and efficiently as possible (Jansen Van Vuuren, 2016).

Spaces within the city facilitating holistic engagement with the water are few and far between. This is due to the impact the design of the channels have on the urban environment. They have a steep slope on either side, making them completely inaccessible and unsafe, especially for children, and no accommodation for vegetation or ecologies to develop alongside the channels has been made (Fig 3.7). As a result of the design of the channels, they have become forgotten, dirty, neglected barriers in a city that drastically requires urban renewal. The potential biophilic contributions of a water network in a city has been overlooked and engineered in a way that cuts the city in half, instead of connecting it. As concerns regarding ecology and natural systems are being introduced in urban design strategies and architectural design, Pretoria and its engineered past is experiencing negative effects in its much needed urban regeneration (Jansen Van Vuuren, 2016).

Fig 3.5 Cross-sections of the channels design.

(City of Tshwane Metropolitan Municipality, Department of Roads and Storm water, Pretoria. 2016)

Fig 3.6 Groenkloof and Grootfontein Springs respectively. (Grewar. 2014)

(Burger. 2014)

Fig 3.7 The current condition of the Walkerspruit channel (Author, 2016)

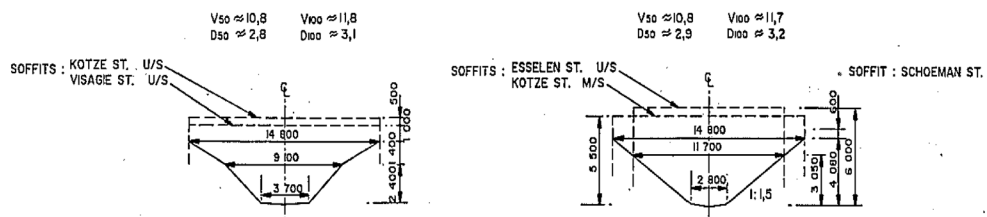
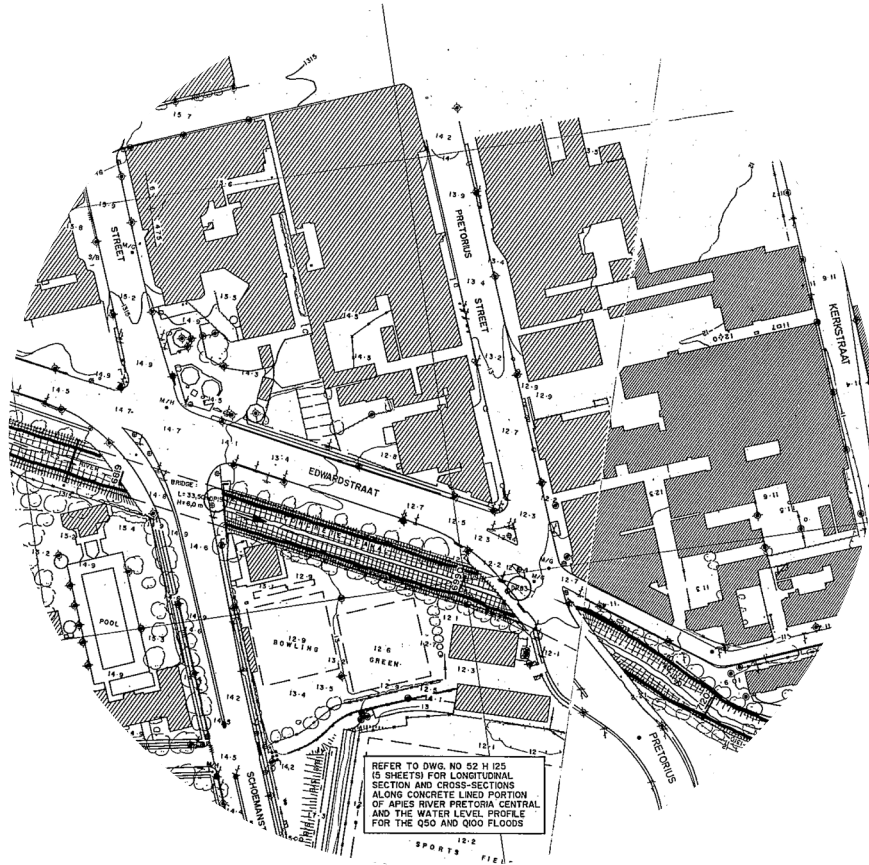

Fig 3.4 Engineering Drawings of the Apies River at Caledonian Sports Ground.  
(City of Tshwane Metropolitan Municipality, Department of Roads and Storm water, Pretoria. 2016)



Fig 3.8: Nolli map of water networks and surrounding urban fabric. [Author, 2016]

### 3.3 The Didactic Garden: Group Urban Framework

The group mapped all variables of the river space. These were everyday rituals along the river, which refers to how the water is used by different people along its edges; ecologies that still exist along the river; historical narratives; cross-sectional interfaces between river and city (fig 3.9); movement patterns alongside the river; ecologies that still exist and those that can be built upon.

The mapping concluded that the rivers act as barriers and dividers, not only between the urban fabric but between man and the natural world. Ecosystems are broken between the two ridges on the north and south sides of the city and therefore the services where humanity benefits in a multitude of ways from ecosystems are broken in the urban fabric . This is because the rivers serve as barriers, dead zones or lost spaces along the river edges, causing urban decay. Opportunities for intervention in these lost spaces were identified.

The aim of the vision was to build upon lost space along the river and use them to reconnect the broken river ecosystem as soon as it reaches the urban fabric. The redeveloped lost spaces will aim to foster public space adjacent and connected to the river, reconnect the water to the city of Pretoria to show its importance in everyday rituals, reconnect the ecological systems on the ridges that have been disconnected by the urban fabric and create an identity as a water city through celebration and awareness.

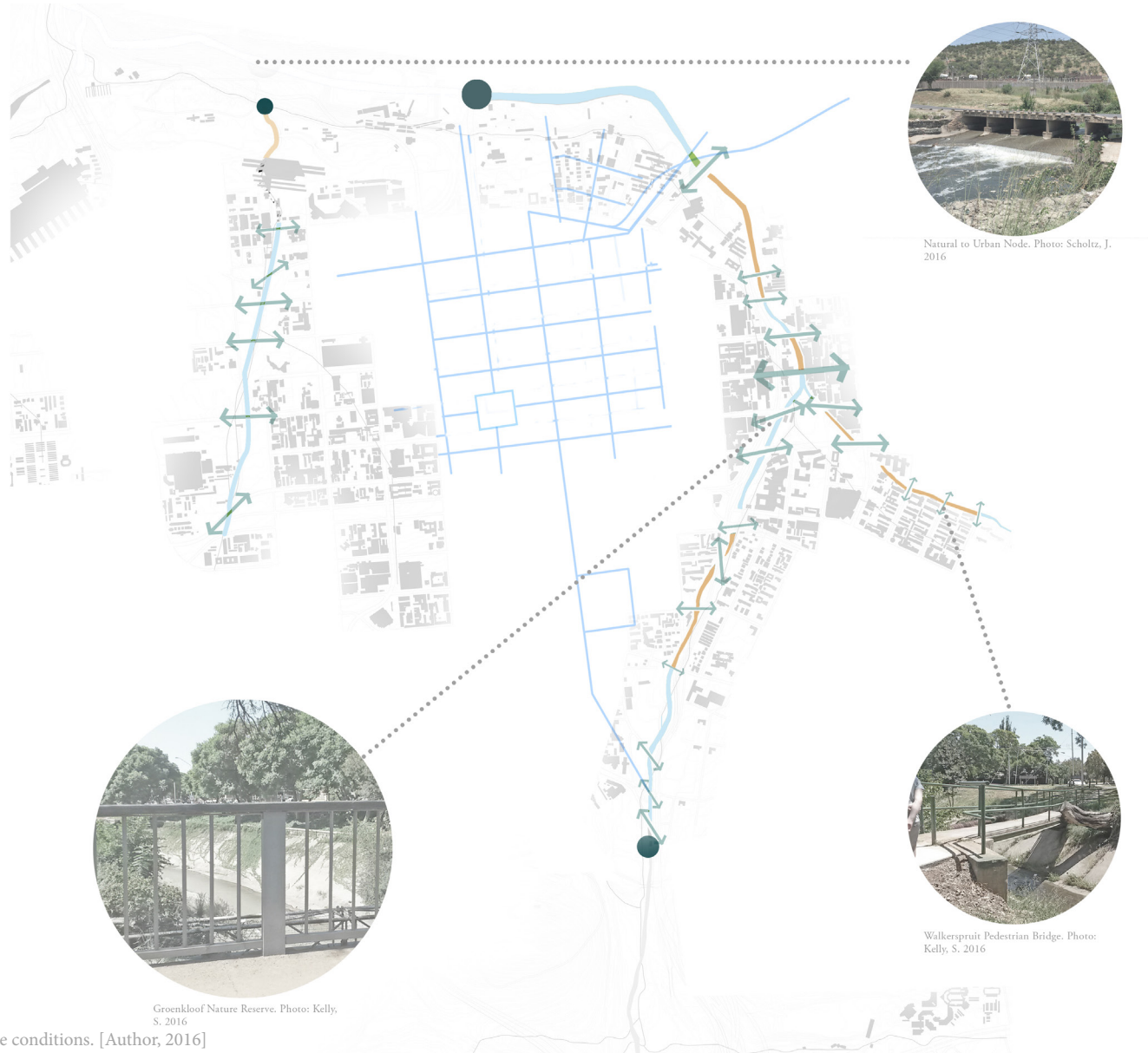

Fig 3.9 Mapping of river edge conditions. [Author, 2016]

Nodes of reconnection were identified along both the Apies River and Walkerspruit. These nodes were given specific identities according to their most apparent problems and appropriate resolutions with regards to the overall aim of the framework.

The chosen site, (indicated in Fig 3.10) is labelled “the didactic garden”. The aim of the vision for this node is to reconnect the lost park space along the Walkerspruit back to the identity of a natural river park as well as to reconnect the park to the existing schools situated on the western and eastern peripheries of the site.

The aim will be applied through, firstly, the identification of garden spaces from the analysis of the natural elements that still exist. These gardens will be the starting point of the identity of didacticism on the site. Secondly, a route that connects the existing schools on site is proposed. The relationship between the gardens and the route will facilitate the placement and essence of the architecture. Thirdly, it is proposed to introduce street parks along the roads around the site periphery. These minimise the issue that infrastructural barrier pose to children in urban environment that prevent them from accessing natural spaces.

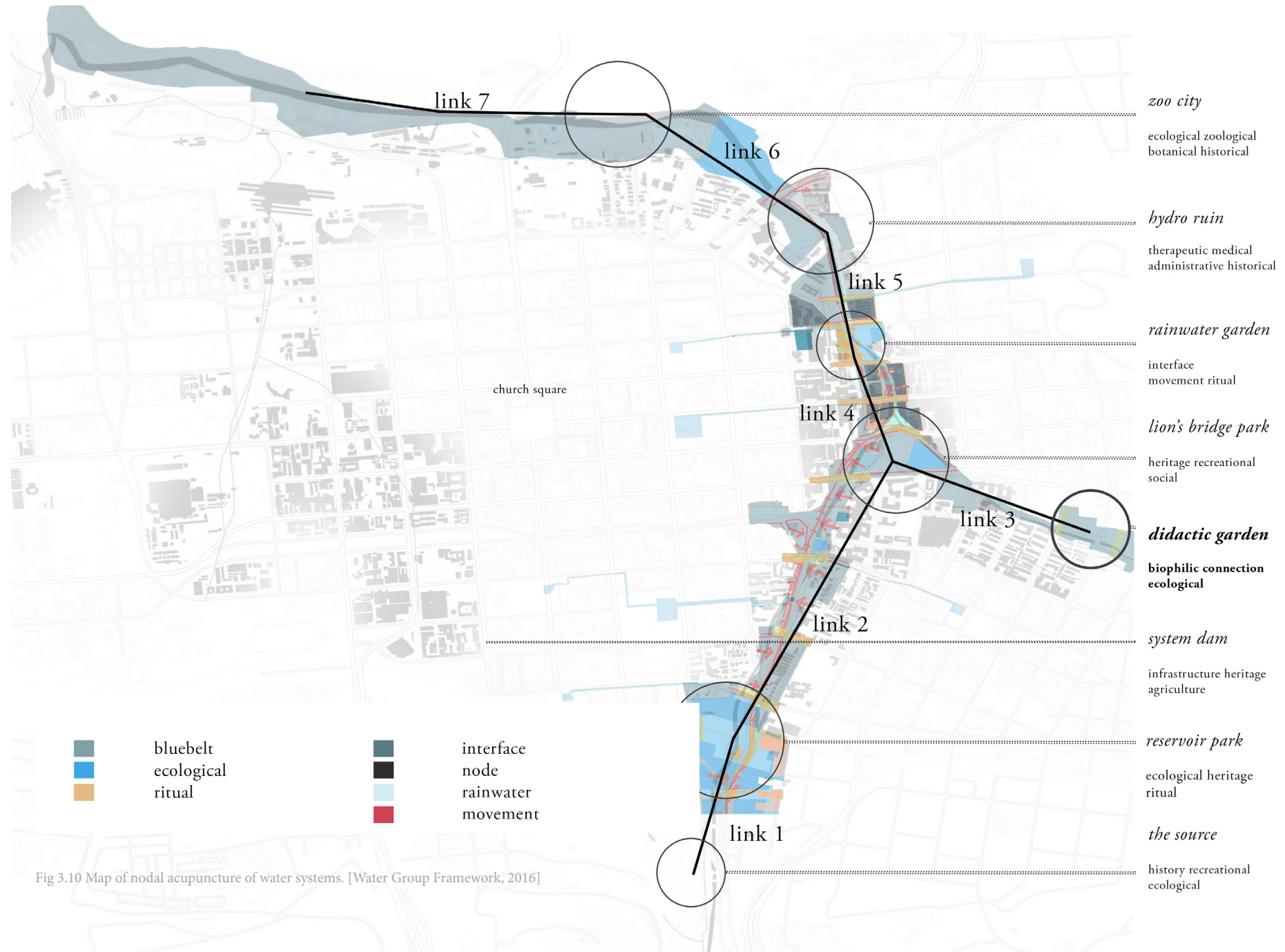

Fig 3.10 Map of nodal acupuncture of water systems. [Water Group Framework, 2016]



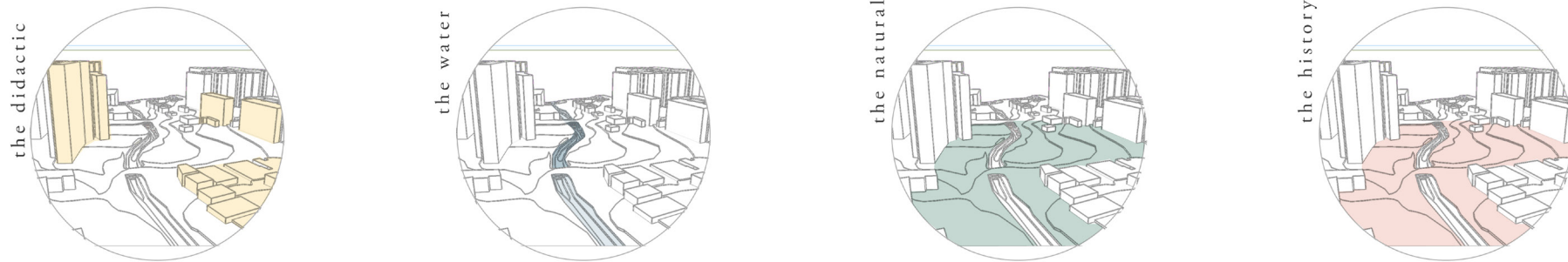

Fig 3.11 Primary attributes of site: the child, the river and the natural ground. [Author, 2016]

### 3.4 The Didactic Garden: Physical Attributes

The chosen site, in Sunnyside, between Bourke and Leyds Street is nestled between high rise apartment blocks and the small urban river known as the Walkerspruit. Bourke and Leyds streets are the north-south streets that serve as linkages to the primary east-west movement routes from Pretoria Central to Pretoria East. These streets are experienced as barriers to the site with most buildings turning away from the open land, creating negative or lost space as identified in the urban framework.

Currently, the site, owned by the City of Tshwane Metropolitan Municipality, serves as a place of shelter for homeless people, and a parking space for various construction vehicles. A distinct difference between high and low density housing within Sunnyside is also evident on its periphery. This reflects the economic and demographic division existing within the suburb. It is a divide which may be diminished by generating linear activity on a seam between neighbourhoods, connecting communities and suggested nodal interventions that occur along the water system framework.

The site holds four key informants, namely: the river or riparian element, the sparsely scattered trees on the site, the biophilic heritage of the site and lastly, the densely populated pre-primary schools surrounding the site. These will be the drivers to the mini vision for the site as well as the architectural response (refer to Fig 3.11)

Looking at the public and private spaces on site, the site has a public nature on its periphery and more private spaces moving towards its center. This is due to the fact that its edge condition is used by the public for small scale trade and pedestrian movement. There is one small path just south of the Walkerspruit, that acts as a movement route through the site, however, no path or connection to the river is evident on the northern side of the Spruit therefore creating a lost space along the river (refer to Fig 3.14). The vast difference in scale is also seen as an issue on the site where twenty storey apartment blocks look down on a ground scale park, creating a sense of scale imbalance. The existing scattered trees are the only element that helps return the site to human scale.



Fig 3.12: Site location and informants. (Author. 2016)



Fig 3.13 Fig ground map of site with context. Edited by Author (2016) from Google Earth (2016)

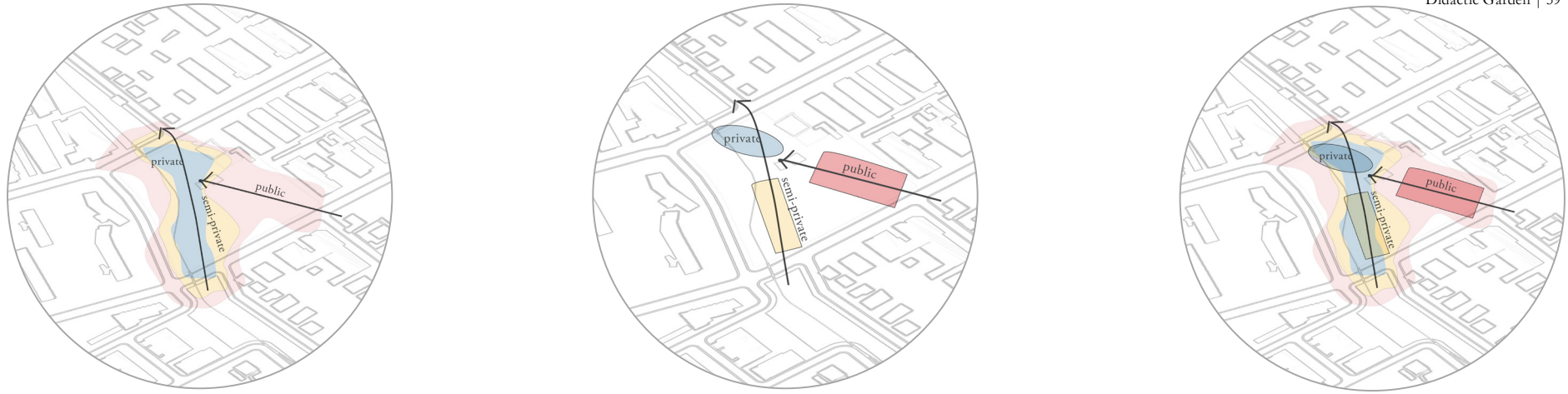

Fig 3.14 Physical nature of site according to public and private spaces. (Author, 2016)

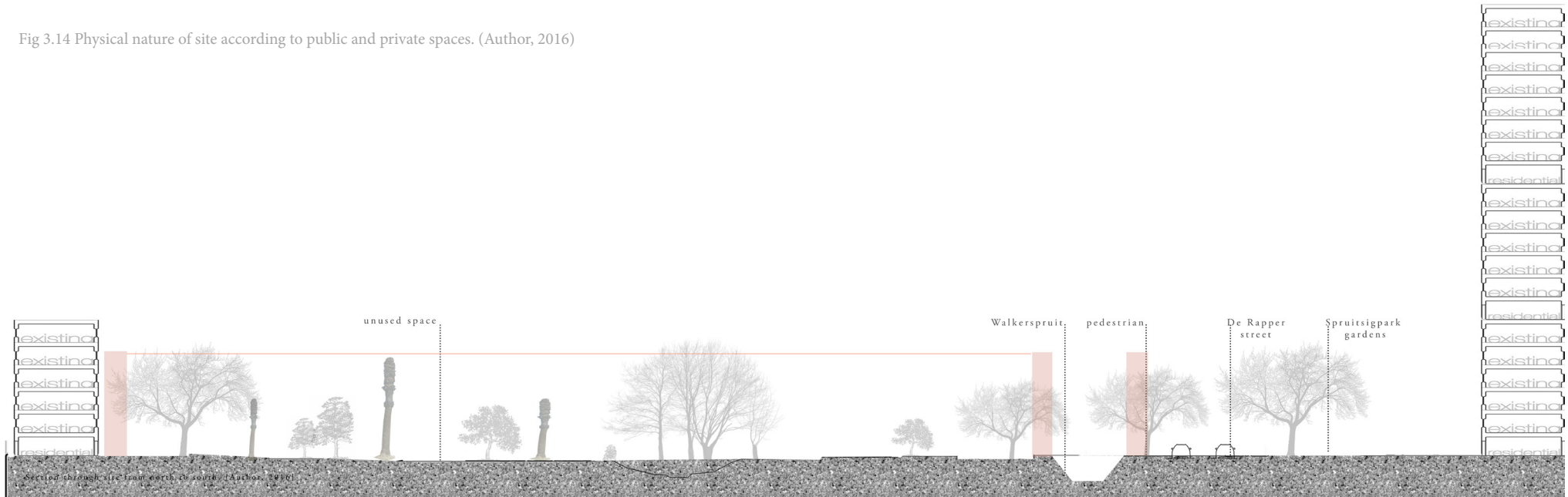

Fig 3.15 Section through site showing vast differences in scale between buildings and ground (Author, 2016)



### 3.5 The Didactic Garden: Macro Vision

The Sunnyside district, has since its densification in the 1960's, grown to become a vibrant, well functioning suburb within the city centre. Despite the recent movement of business and major commercial activities to the eastern peripheries, Sunnyside hosts a diversity of cultures, demographics and age groups. It is because of these features, that Sunnyside holds potential for urban renewal and further strategic development, such as facilities which promote community involvement. The residential characteristics of Sunnyside are however inadequately supported by few community facilities within the suburb.

Figure 3.13 shows that most vehicular thoroughfares occur along the east-west axis with the main north-south linkages being to other cities, rather than city streets. The two rectangles indicate the highest generators of commercial activity in the area. The four large circles indicate the main gateways into the city centre and the smaller dots indicate nodes of high activity and interaction (refer to Fig 3.17). It can be seen that Sunnyside, perhaps the most vibrant urban suburbs is well placed with a large degree of access to services and entertainment facilities. Its high density residential nature, provides an area with potential for urban development.

Fig 3.16 Visionary images of street parks along Bourke and Leyds Streets. (Author, 2016)

Private entertainment and commercial centres are found in Sunny Park on the western fringe of the suburb, and sports facilities are located along Kotze Street. Open public parks are scattered and for the amount of residential stock, limited. Day care can not always be afforded, so children are often left to care for themselves. It is difficult to control what these children do when unsupervised considering the degree of risk and exposure to criminal activity that they are exposed to (refer to Fig 3.18).

#### 2.5.1 From Streets to parks

In the suburbs, streets are lifeless. They are merely channels for vehicular movement. Cars dominate urban functions through the linkages created by these channels. The city is viewed through the car, resulting in high speed blurs, which supports an avoidance of physical interaction with the city and its natural elements [Koolhaas: 1252-3]. The lack of a coherent vision for Tshwane is aggravated by isolated developments and the ongoing eastern sprawl. Perhaps the answer to creating renewed interest in the city lies in small scale community initiatives that strive for the betterment of individuals as well as a re-adapting of particular streetscapes into park spaces that bridge between activities rather than creating barriers between them (refer to Fig 3.16).



Fig 3.17 Gateways, Nodes and activity and pedestrian movement. (Author, 2016)



Fig 3.18 Schools and green spaces. (Author, 2016)



Fig 3.19 Compilation of surrounding typologies. (Edited by Author (2016) from Google Earth (2016) and Peres, E. 2005)

### 3.6 The Didactic Garden: Surrounding Fabric

The adjacent urban fabric has a distinct character with most of the surrounding buildings built during the 1950's and 1960's composed of red brick, large balconied, multi-storey blocks. These red brick buildings form an integral part of the history of Pretorian Architecture (Fisher, le Roux and Mare, 1998: 123). According to the Burra Charter (1999: 1), 'places' of cultural significance enrich people's lives, often providing a deep and inspirational sense of connection to community and landscape, to the past and to lived experiences.'

Article 5.1 (Burra Charter, 1999:4) indicates that the "conservation' of a place should identify and take into account all aspects of cultural and natural significance without unwarranted emphasis on any one value at the expense of other. The site does not contain heritage value in itself but does contain natural value due to the potential the river and scattered trees pose to future ecological growth.

An appropriate response would be therefore to respond to this vernacular in a manner that blends with the brick textures at some points of the design but at the same time form contrasts to it to indicate the proposal of a new biophilic paradigm. This is in accordance with Article 22.1, 1997.7 of the Burra Charter which states, "New work, where new functions will be brought to the site, with the assurance that it does not distort or obscure the cultural significance of the place, or detract from its interpretation and appreciation." As well as Article 22,2, 1999:7, which states: " The new work should also be identifiable as such."

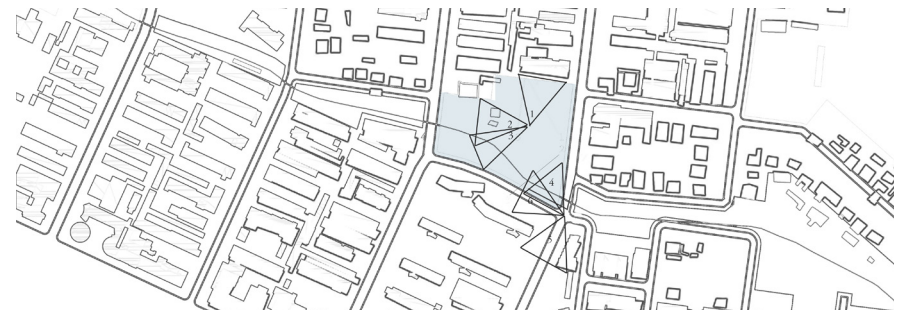



Fig 3.20 Current condition of river, looking West. (Author, October 2016)



Fig 3.21 Current condition of site, looking South. (Author, October 2016)

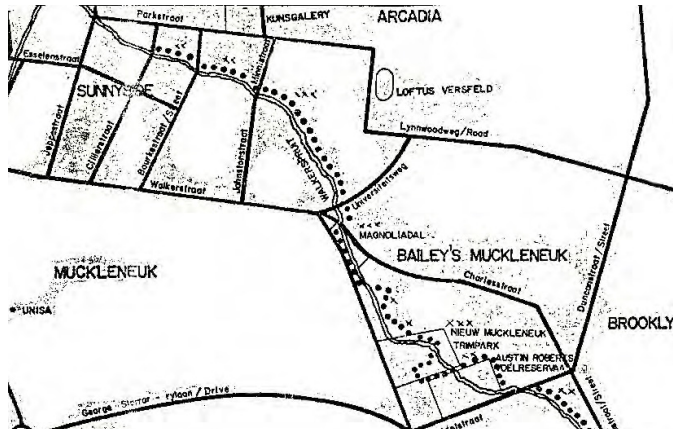

Fig 3.22 Current condition of site, looking North-West. (Author, October 2016)



Fig 3.23 Current condition of site, looking South-West. (Author, October 2016)





### 3.7 The Didactic Garden: The Walkerspruit

The group vision focused on the water systems in Pretoria and therefore incorporation of the Walkerspruit into the design is a key feature in the design of this node. In 1984, a pedestrian route was proposed along Walkerspruit, from its origin in Brooklyn up to its connection with the Apies River. It was aimed to cater for the rising population in Sunnyside-Arcadia area and at the same time create green space in the form of a meandering route along the river [Beeld, 1984: 12] [fig 3.24].

It is envisioned that this trail will be revived, from its soft, natural character in Magnolia Dell into the hard-edged urban channel cutting through Sunnyside to the Apies River. The Walkerspruit is a key movement corridor through this area. It currently functions as storm-water control in the city as well as movement corridor, linking various city blocks through the pedestrian route. However, large motorways such as Leyds Street serve as barriers to this route (refer to Fig 3.25).

The river and pathways form a sense of procession of east-west public movement. This creates opportunities for different spatial experiences to occur. The landscape and the connection to river should be considered as well as the technical aspects such as improved flooding control and natural methods of water purification. These include softening techniques to the flow of water, bioswales and riffles (refer to Fig 3.26).

Fig 3.24 Upgraded Walkerspruit trail [Beeld, 1984]

Fig 3.25 Different Angles of the Walkerspruit. Photo: Peres, E. 2005

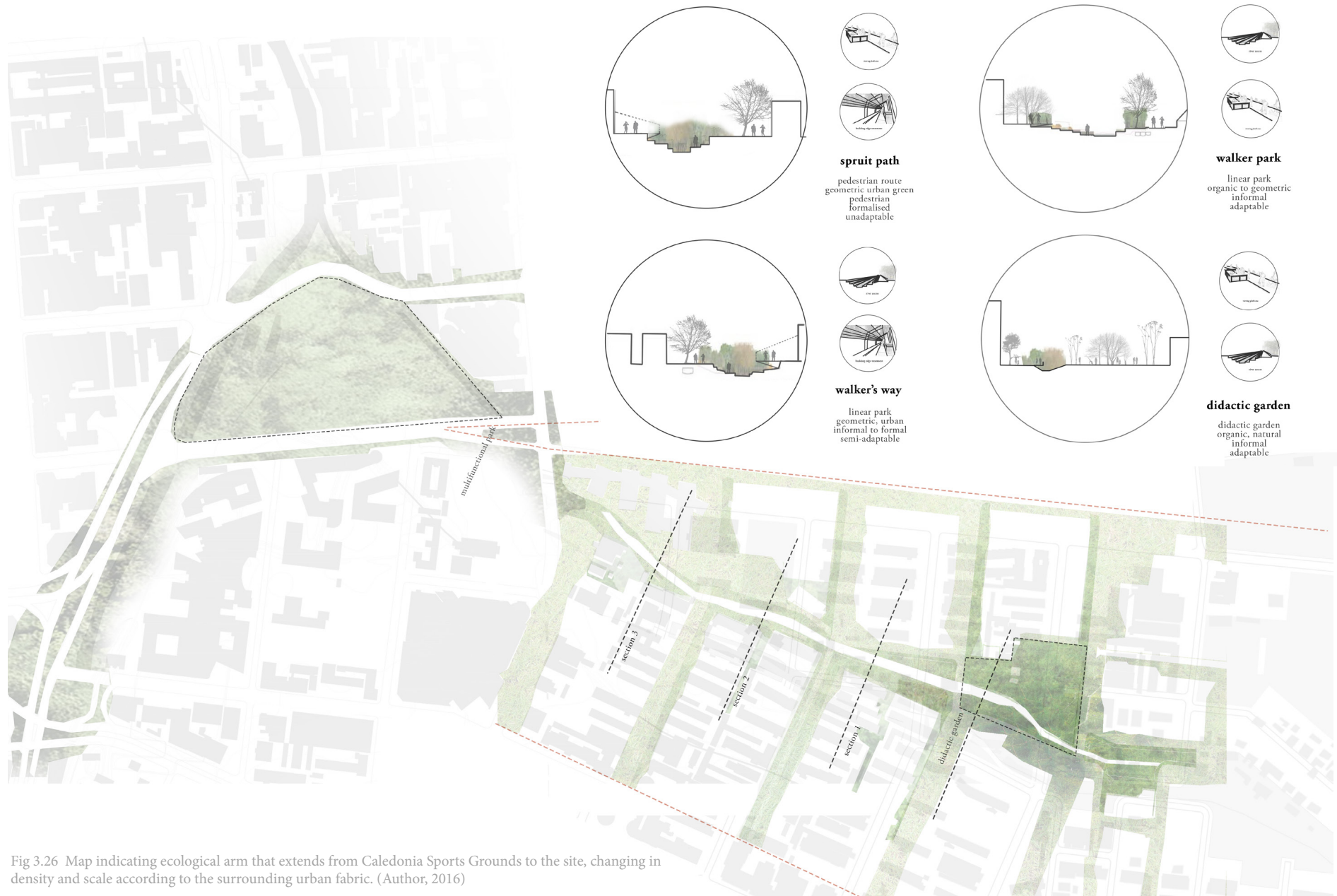
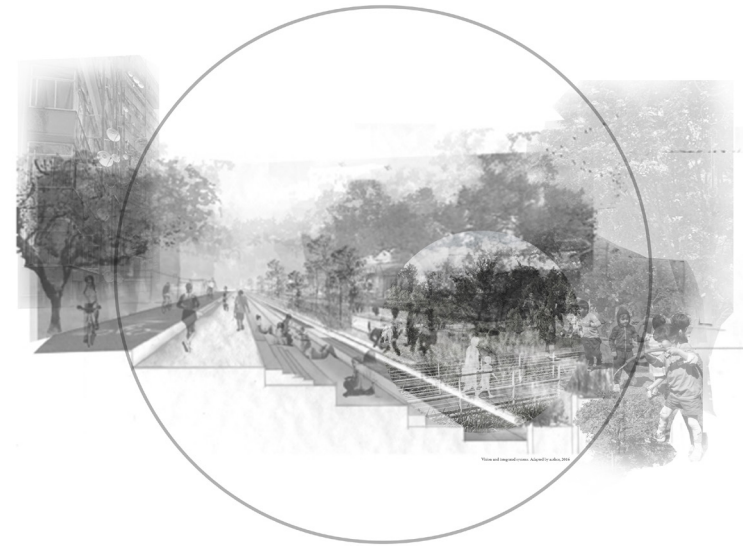
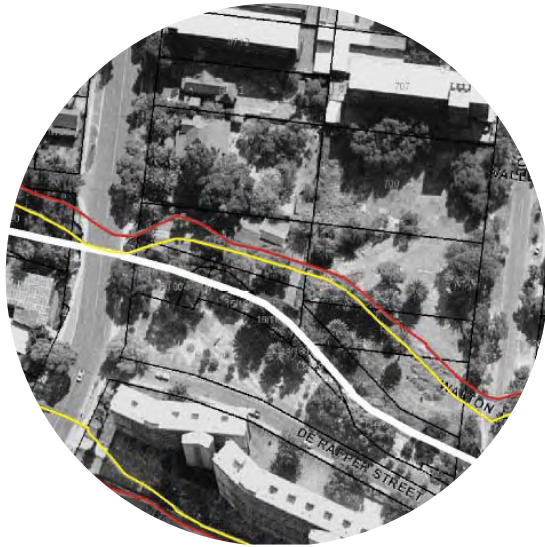

Fig 3.26 Map indicating ecological arm that extends from Caledonia Sports Grounds to the site, changing in density and scale according to the surrounding urban fabric. (Author, 2016)



Enhancing the quality of the Walkerspruit channel by applying softening techniques and spatial methods of connection will improve the environment however, still may affect drainage during peak flows and may worsen the effect of flooding. Design changes are therefore limited to the extent in which the channel banks can be widened to accommodate the 50 and 100 year flood lines and the minimum flow of 110 - 120 m<sup>3</sup>/s [SRK: 17].

Currently flooding is exacerbated by the limited sizes of the bridges on Bourke and Leyds Streets, resulting in a differential water capacity beneath the bridges, evident in a return flow of water over the bridges and erosion of the channel banks [Chunnett Fourie: 16]. After the severe 1996 floods, the following improvements were determined by the city engineers [SRK: 29] and are incorporated in the site design:

1. Widening of the channel
2. Using flood attenuation structures
3. Removing obstructions (such as trees which are too close to the channel)
4. Using indigenous vegetation
5. Not allowing any buildings below the 50 year flood line
6. Using erosion preventative measures

The maintenance of a safe environment around the channel should be considered and will be discussed further in the site vision. Safety is improved by providing adequate lighting, sufficient visibility and permeability. Passive surveillance should also be promoted by opening building façades towards the public spaces along the channel. Indigenous vegetation will be introduced along the stream to limit soil erosion and pedestrian priority will be emphasised.

Fig 3.27: The 50 and 100 year Walkerspruit flood-lines between Bourke and Cilliers street. [Tshwane City Engineer, 2005]

Fig 3.28: Initial vision of the river landscape, reconnecting to the surrounding fabric. [Author 2016]

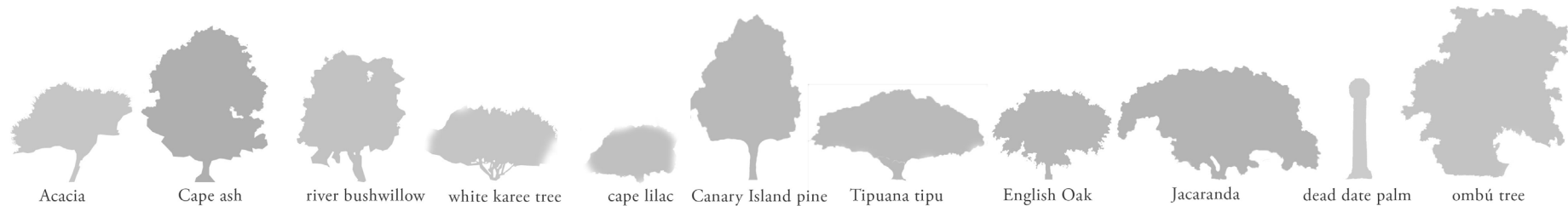

Fig 3.29: The profile of the trees on site, giving spatial qualities of each. (Author, 2016)

### 3.8 The Didactic Garden: The Trees

The trees on site consist of well established and healthy trees and some completely burnt by a fire, and have been incorporated into the design. The existing vegetation gives an established character to the site and provides the area with a neutral quality essential to the green spine formed by the Walkerspruit. These trees form one of the key informants of the design.

A range of different species of trees grow on site but the majority of trees is made up of Acacia and Canary Island Pine. The Pine trees are alien species and the well known Acacia tree is indigenous to South Africa and should be protected.

The Acacia tree has a large horizontally flat canopy with a medium sized trunk where the Canary Island Pine is a much larger tree with a more vertical canopy. The largest trees on site are the Rosewood trees and the acacia trees. On the eastern boundary there are quite a few English oak trees of medium size which serve as an edge condition along Bourke street. The position and species of each tree is indicated in Fig 3.30. The shape of each tree is shown in Fig 3.29, shedding light on the spatial qualities that each species of tree offers. Since the Acacia tree is the most common tree found on site as well as the fact that its indigenous, the spatial qualities of this tree will be taken further in design approaches.



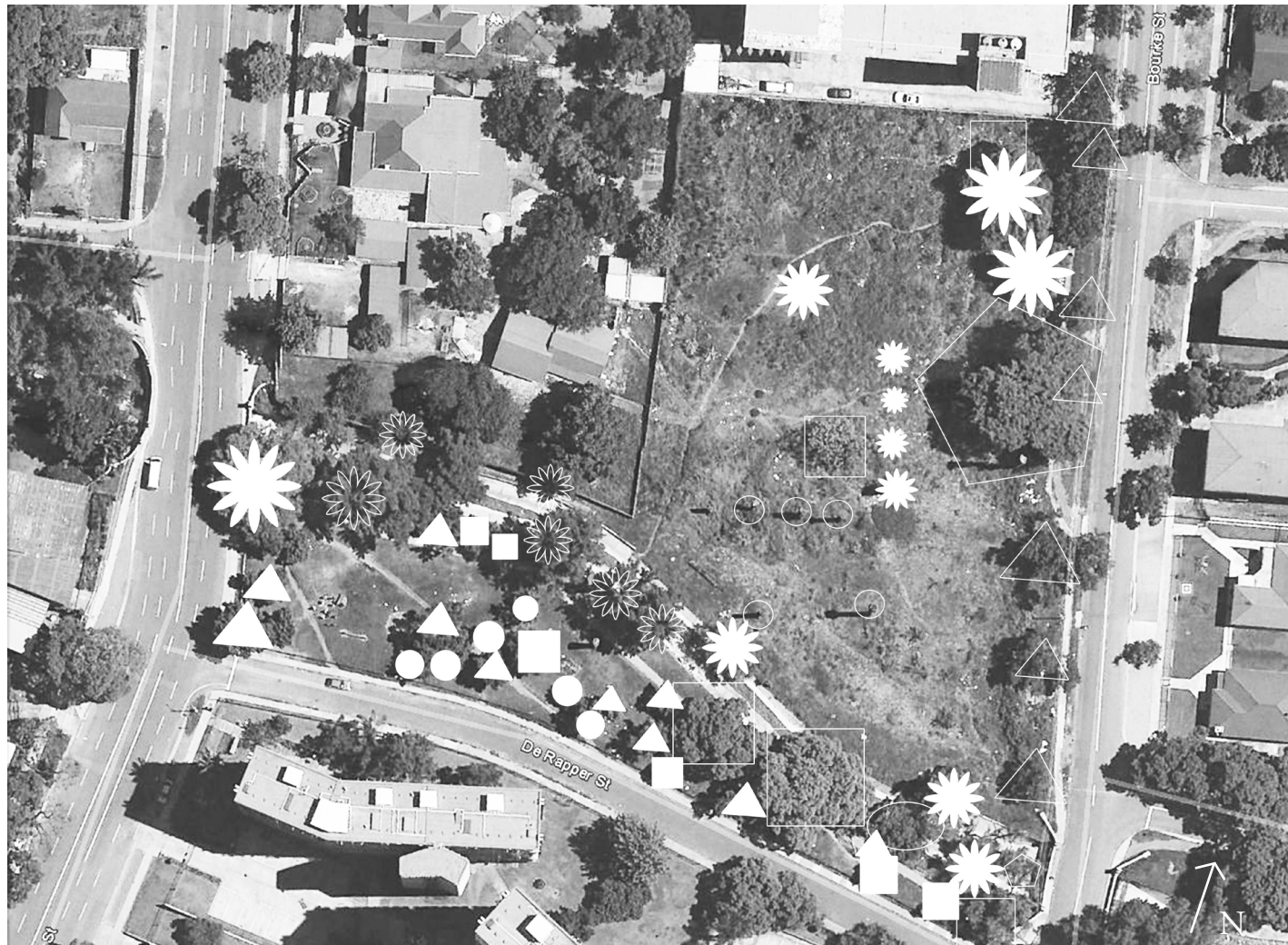

- Indigenous trees
- ☀ Senegalia karroo (Acacia)
  - Ekebergi capensis (Cape ash)
  - ▲ Combretum erythrophyllum (river bushwillow)
  - Sersea lancea (White Karee tree)
  - ◆ Ehretia rigida (Cape Lilac)
- Exotic Trees
- ☀ Pinus canariensis (Canary Island pine)
  - ◊ Tipuana tipu (Rosewood tree)
  - Jacaranda mimosifolia (Jacaranda tree)
  - △ Quercus robur (English Oak tree)
  - Phytolacca dioica (ombú tree)
  - Dead trunks of Phoenix canariensis (Canary Island date palm)

Fig 3.30: Mapping of different tree species on site. [Author, 2016]

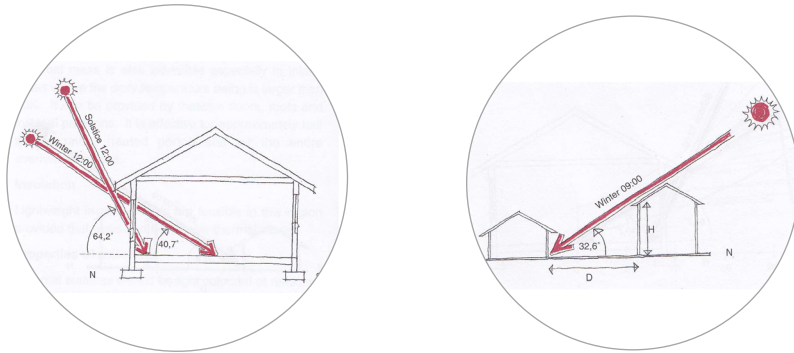

Fig 3.31: Solar access for building spacing. [Holm, D. 1996: 71]

Fig 3.32: Window height, overhang and positioning for Pretoria. [Holm, D. 1996: 72]

### 3.9 The Didactic Garden: The Climate

The city of Tshwane falls within the temperate eastern plateau and experiences an average summer rainfall that ranges from 125 to 375mm, most rain falling during isolated thunderstorms. The Winter rainfall averages between 62 and 250mm. The roof pitch and layout of the proposed building will affect the flow rate and direction of storm water during thunderstorms. Because of the frequent flooding of the Walkerspruit, attention to the runoff of this water on the site needs to be given. Rainwater may be stored in culverts, rainwater gardens or detention ponds and temporarily be allowed to permeate through the soil gradually. Daytime temperatures average 20-25 degrees Celsius and summer humidity is about 30%. Winter days are sunny and temperatures range between 10-15 degrees Celsius. In Summer, winds prevail from the North-East and in winter occur from the North-West. Sixty to eighty percent hours of daytime sunshine occur from the west during the afternoons.

The architectural implications of these climatic conditions result in designs with north-south orientated buildings and high thermal mass. Sun angles and their design implications are illustrated in Fig 3.31 and 3.32. A wind study and solar study on site is illustrated in Fig 3.33. The large scale of the buildings overlooking the site creates an overshadowed and colder northern boundary. The winds on site are affected by the tall buildings creating slight turbulence in the centre while the river embankment provides relief from humid conditions.

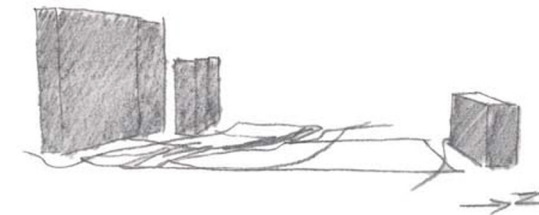

Solar study at 12:00 on 21 December

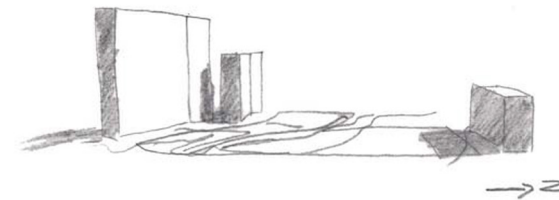

Solar study at 12:00 on 21 June

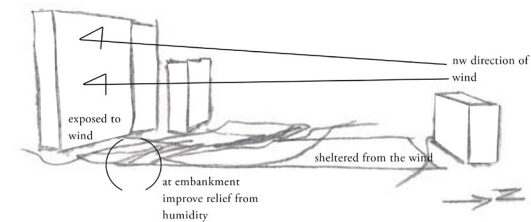
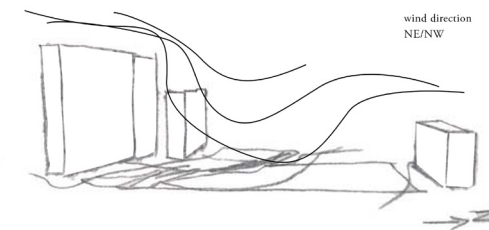

Fig 3.33: Site Wind and shadow Study. (Author, 2016)

### 3.10 The Didactic Garden: The Ground

**Geology:** The rock type mostly consists of shale which can be quite soft. Additional stabilising materials may have to be added to the foundations when structures are built upon it.

**Soil:** The soil on site is made up of hutton soils (34%) and avalon soil (22%). These soils are good for agriculture as they drain well. They do, however, have slight tendencies to erode.

**Topography:** The park has a gentle slope towards the south-west where it slopes towards the banks of the Walkerspruit. The banks themselves are unnaturally steep and mostly inaccessible to humans and children therefore serving as a barrier between the existing playground and the site (Meyer, 2011: 53).

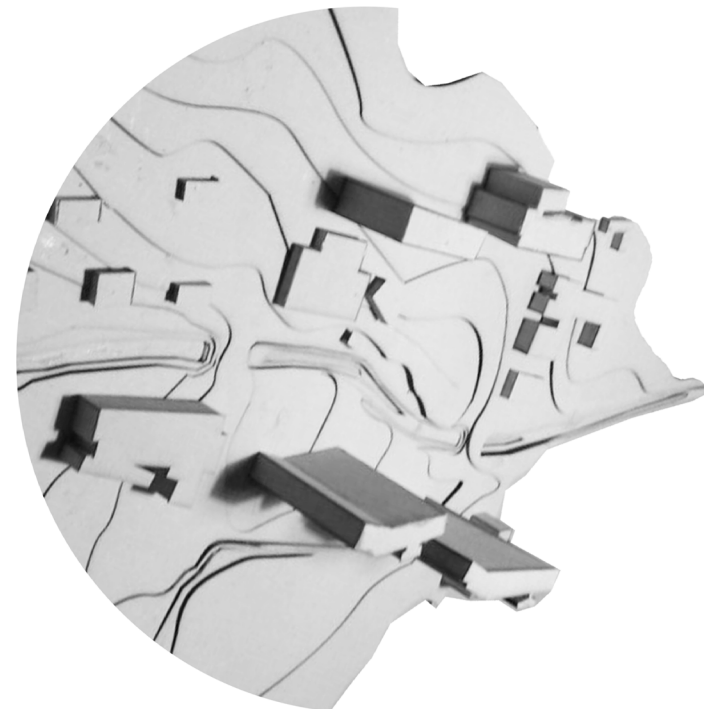
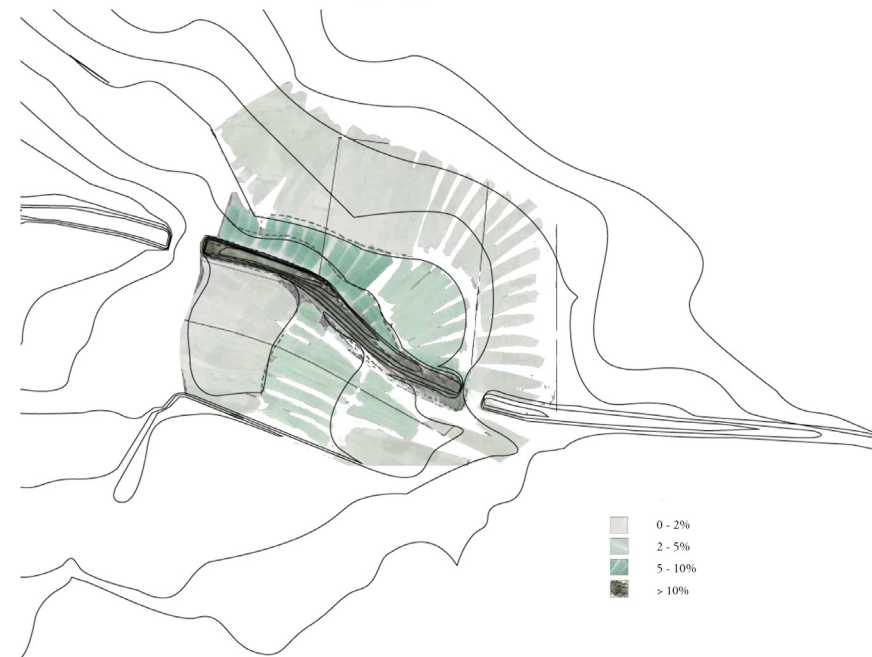

Fig 3.34: The slope of the site according to gradual or steel slopes [Author, 2016]

Fig 3.35: Contour Model of site [Author, 2016]

### 3.11 The Didactic Garden: A Story of Place

The site has little information regarding its history and past function, but according to early satellite imagery taken in the early 1990's, the area north of De Rapper street, always served as open park space, besides a single Victoria Household built between 1905 and 1906 and later demolished in the late 1980's. Its position is indicated in Fig 3.36. What is notable, however, regarding this household is its position in relation to river and the reason for its demolition.

According to researchers, the occupants of the house probably enjoyed peaceful afternoons spent on the veranda, overlooking the Walkerspruit and the house's garden.

It was a simple Victorian style home which was privately owned from construction until the year 1964 where city council bought the land and where it was later demolished. The research addressed possible methods of protection of the house's history regarding safeguarding some of the elements found in the house and displaying them in restaurants and museums at a later stage after demolition. None of this was carried out however, and no physical memory of the small house remains on site.

However this brings one back to the notable aspect of this house's memory – It served as a reminder of man's biophilic attraction to all that is living. In this case, the water running in the Walkerspruit served as the pleasing view and sound to which occupants enjoyed many afternoons listening to and looking at. The reason for its demolition to make way for a engineered barrier between man and the natural world is an example of the slow separation of these dimensions in the last century.

The intention would be to revive the biophilic spirit this site once possessed and bring the river, the land and man back together once more (Adapted from University of Pretoria, Department of Architecture, Bourkestraat 31 Archive. 1986).





Fig 3.36 1990 Satellite Imagery of Site and old photos of Victorian House that once occupied the site [University of Pretoria, Department of Architecture Archives, 1990]



Fig 3.37 Compilation of adjacent schools in the area. (Google Earth, 2016)

### 3.12 The Didactic Garden: The Children

The surrounding schools in the area consist of 3-6 year old children attending pre-primary school that aim to prepare them for primary school when they reach the age of seven through learning exercises such as writing and drawing. The type of pre-primary education is based on the mainstream approach which does not incorporate the surrounding natural environment as a facilitator of learning. Each school holds about 100 children and most don't have sufficient outdoor play areas for the children to play in.

It has been proven that green spaces in urban areas tend to pull residents outside their apartments, according to some environmental psychologists such as Coley, Kuo and Sullivan (1997:468). According to Coley (1997:469), children and the elderly living in low socio-economic status neighbourhoods such as Sunnyside would rather spend more time at home compared to people living in higher socio-economic neighbourhoods. Litter and filth in these low income neighbourhoods leads to further reason for children to stay indoors (Morrow, 2000:144-147)

Because of these factors, the neighbourhood itself becomes a barrier and do not want to move too far away from the vicinity of their homes. This makes the need for a safe space for children even more essential.

This environment is factored together with the fact that many children are falling behind in their cognitive and conceptual development due to an increase in video game culture and a decrease of experiential play, (Crace, 2006: sp). Because of this, there is an increasing need among South African children for occupational therapy (timeslive.. 2016). Seeing as the site contains such a great number of childcare facilities, the growing need for occupational therapy becomes even more crucial. There needs to be safe, appropriately programmed faculties implemented, that incorporate natural elements in the learning environment in order to address these issues.

The Ring Ting School situated on site will be primarily focused upon for the purposes of this dissertation and the children of the surrounding schools and children living in the adjacent apartments will be the secondary focus.

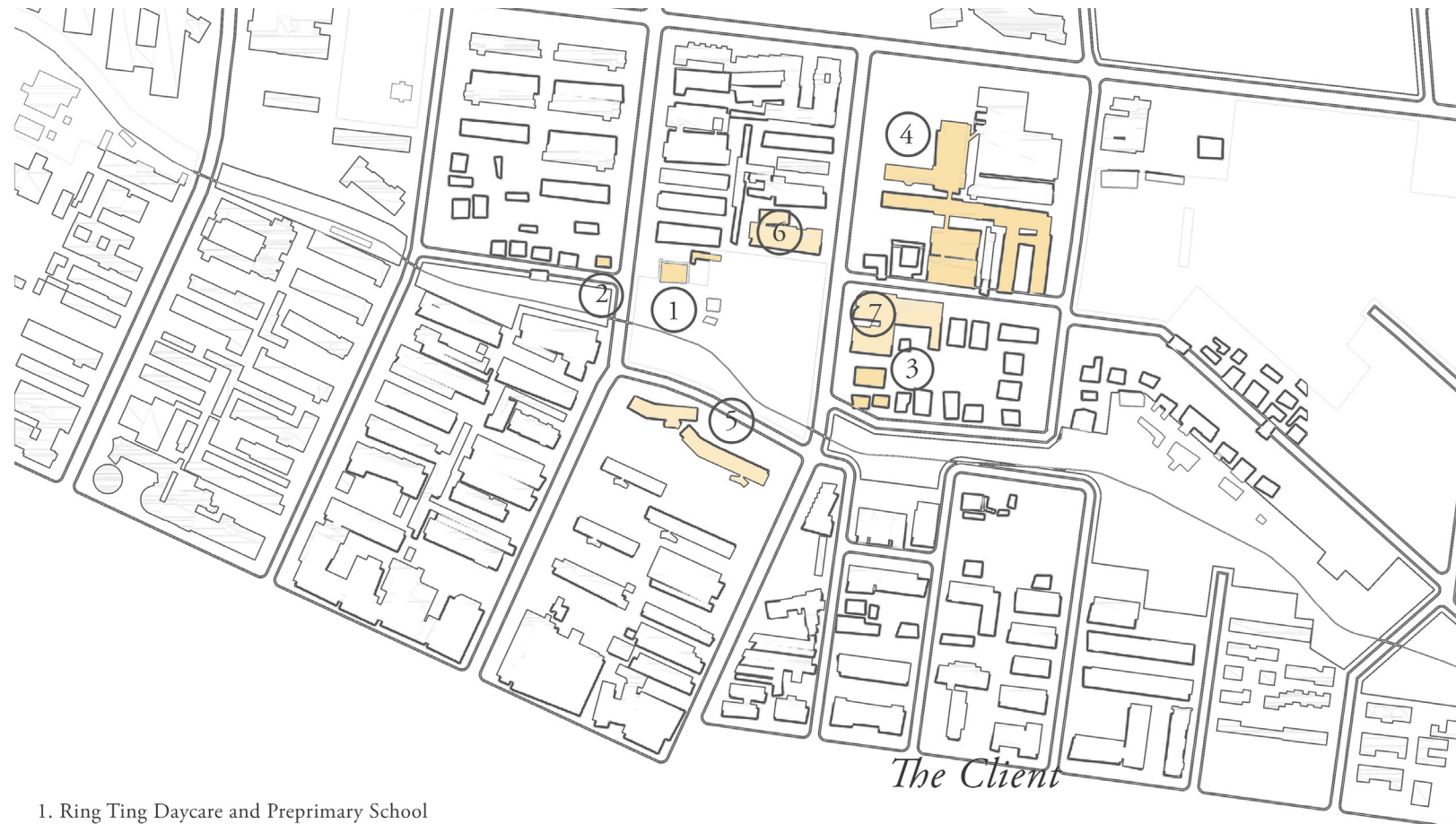

1. Ring Ting Daycare and Preprimary School
2. Sunnyside Orphanage Home
3. New Beginning Preprimary
4. Pretoria Technical Highschool
5. Spruitsig Park Apartments
6. Costando Apartments
7. Bourke Court Apartments

Fig 3.38 Map showing position of schools and apartments in relation to site. (Author, 2016)

### 3.13 Theory related to site

In Fig 3.39, the existing site condition and the intended site condition is related back to biophilic principles. Environmental features as they exist on site are seen as informants and opportunities to deepen into richer, more fulfilling principles and that is place-based relationships which mean landscape features defining building form and cultural, historic and ecological connection to place. The other more fulfilling principle is that of evolved human-nature relationships which develop into design principles such as prospect and refuge, order and complexity, curiosity and enticement.

he summary of biophilic intentions together with the site informants result in the formation of a culminating intent of a didactic landscape. In Fig 3.39 the image shows the theoretical and contextual intentions where the attributes of the natural environment that can be learnt by the child is shown. In Fig 3.40, the diagram shows what aspects of the existing landscape and ecologies can be learnt by the child.

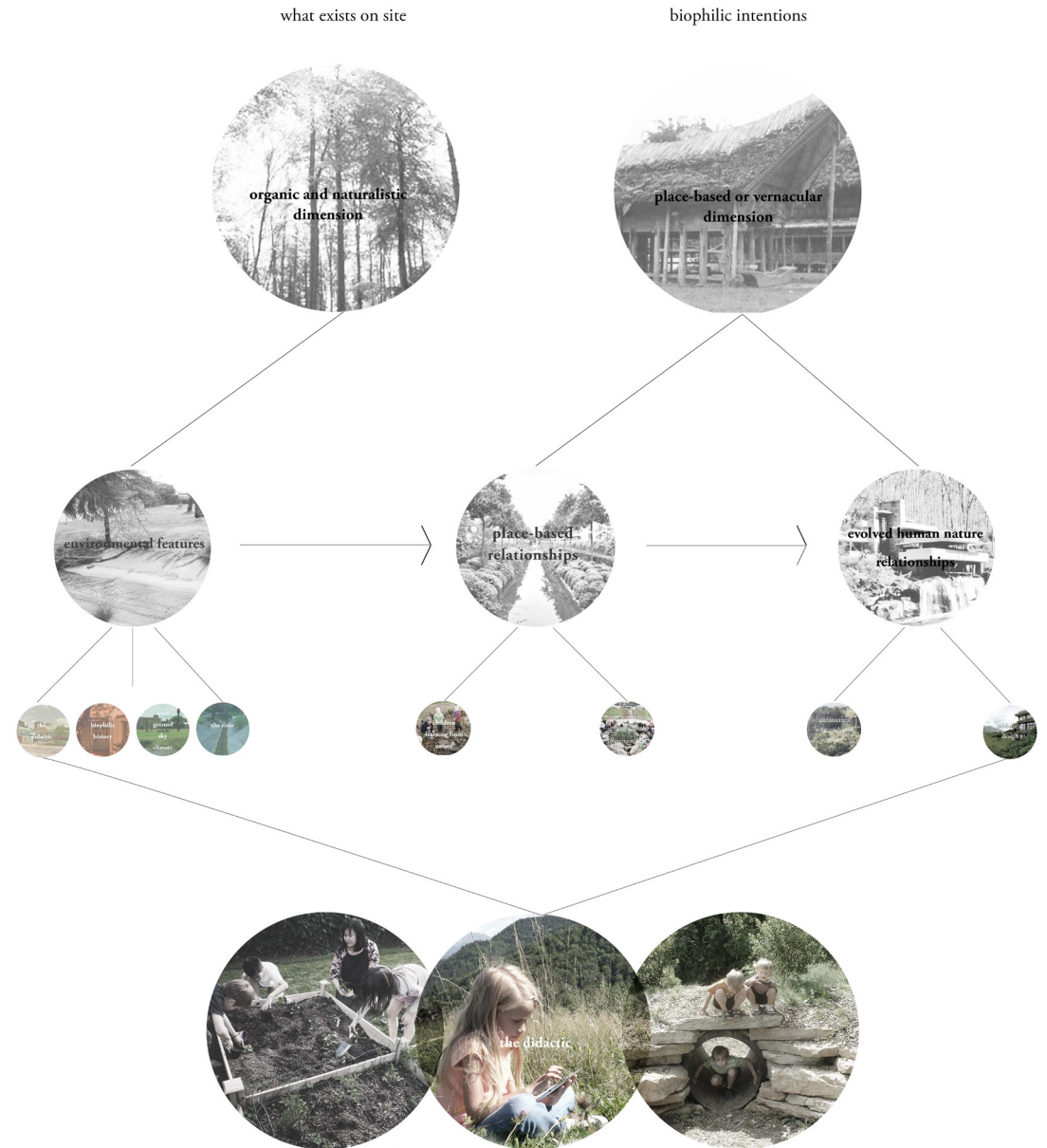

Fig 3.39: project's intentions as interpreted through the attributes of biophilic design. (Author. 2016)

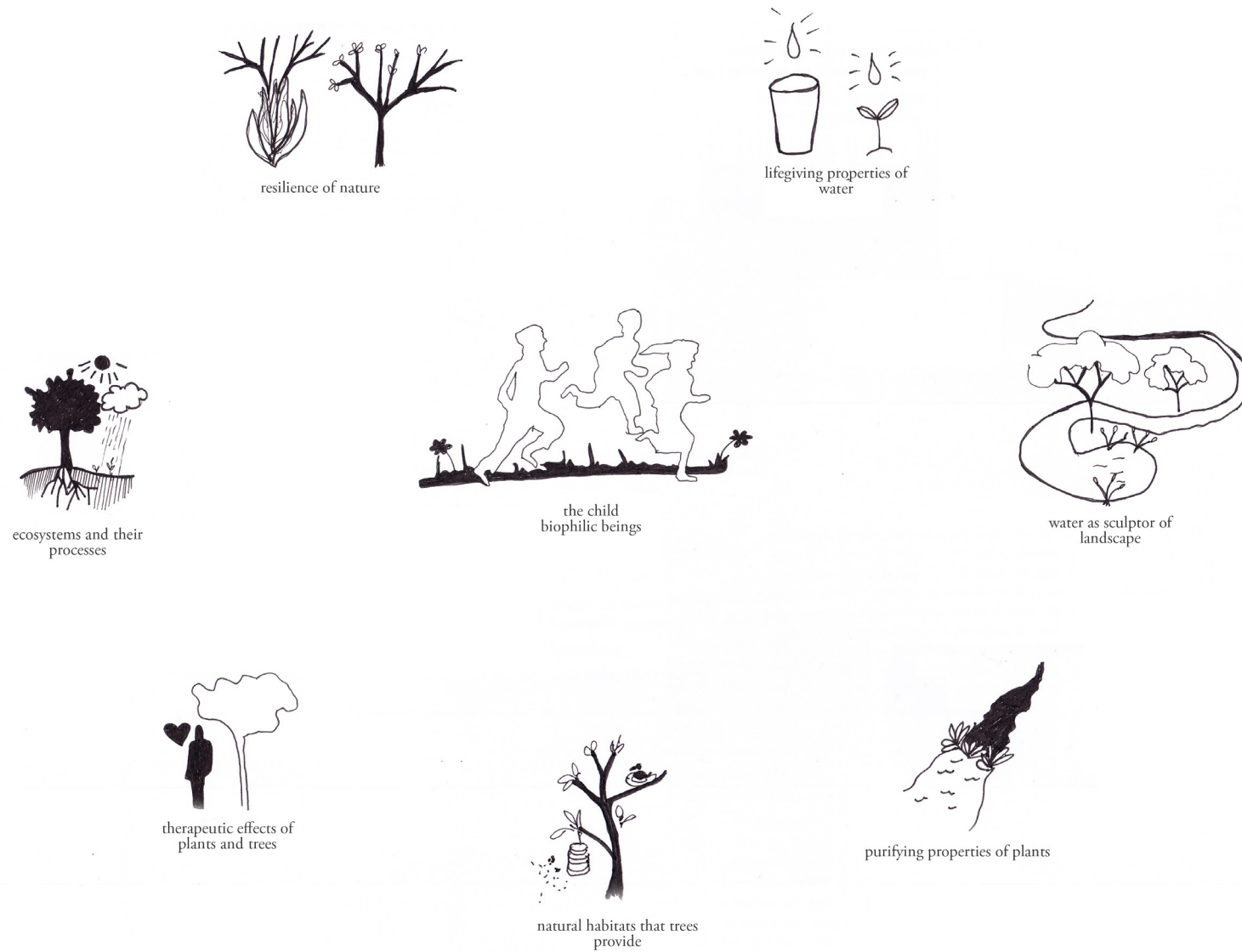

Fig 3.40 Diagram showing the different aspects of natural systems, and water that can be learnt on site. (Author, 2016)

### 3.14 Summary of Issues and Vision





<p><b>Barriers</b> The vehicular roads between the schools and the site inhibit access to an open natural space alongside the Walkerspruit</p>		<p><b>Links</b> The vehicular movement between the schools and the site will be softened and pedestrian movement prioritised with the creation of street parks.</p>
<p><b>Broken Ecosystems</b> The natural site, as it is, shows signs of neglect and degradation, depicting how Pretoria and its engineered past have disregarded the need to integrate natural sites into the urban fabric.</p>		<p><b>Connected Ecosystems</b> The natural site will be conserved and rehabilitated to become a renewed ecosystem</p>
<p><b>River serves as a barrier and safety hazard</b> The river serves as a barrier in itself as it proves inaccessible to children as well as unsafe.</p>		<p><b>River as integral part of new ecosystem</b> The river will become a didactic element in the landscape, and an integral part of the new ecosystem</p>
<p><b>Schools ignore ecologies</b> Current early childhood development centres in the area ignore the potential of the open site as a vehicle for biophilic involvement.</p>		<p><b>Schools involve ecologies</b> The vision proposes that the schools become integrally involved in the conservation and rehabilitation of the site in a didactic manner.</p>
<p><b>Dead zone</b> The space has become a lost space along the Walkerspruit, due to the nature of the area. The high rise flats and lack of safe green spaces for children result in a dead space. The large scale difference between buildings and ground leave it feeling lost and out of place</p>		<p><b>Vibrant, active space in community</b> It is proposed through the integration of didactic conservation and rehabilitation of the space, as well as the proposed new program, it will play a key role in the community as a space for ecological, social and cultural involvement from all individuals.</p>

Fig 3.41 Issues and vision diagrams (Author, 2016)







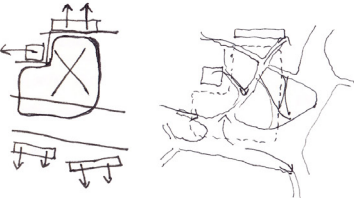

*program*  
Chapter 4

Fig 4.1: Children of Ring Ting Pre-primary. [Facebook.com, 2016]

“The social and cultural obstacles to good community design are closely related to the barriers that keep children from experiencing nature first-hand.”  
(Kellert, 2008: 207)

## 4.1 Introduction

As a result of the theoretical investigation, as well as looking at the key informants on site, the program aims to synthesize the research objectives into a unified whole: The lost space along the Walkerspruit, neglected and forgotten, with one of the key informants on site being the large amount of Pre-schools in the area with children mostly aged from 3-6 years; and lastly the investigation of the benefits of biophilic design in children's spaces. The culminating element is an approach first introduced in Italy after the second world war called Reggio Emilia Early Childhood Development. It is an approach similar to Montessori schooling but the primary focus revolves around the physical environment becoming a third teacher in the child's development.

It is proposed that the 50 children attending Grade R in the adjacent Ring Ting Pre-primary School as well as 100 additional children from the surrounding high density apartments, be relocated to new classrooms which introduces a new approach to early Childhood Development: Reggio Emilia. This approach will incorporate the landscape as the third teacher.

As a model, the Little Saints Pre-primary School at St Mary's School in Waverley, Johannesburg ([www.stmarysschool.co.za](http://www.stmarysschool.co.za)) serves as a guide to understanding the facilities of the school itself.

The site is very large, and in the context of Sunnyside requires multiple functions working cumulatively towards a common goal: The dissertation's intentions. In response to the issues raised in Chapter 3 as well as analysis in terms of the didactic landscape, an occupational therapy centre as well as a sports and cultural centre and cafe will support the Reggio classrooms. In addition, a vegetable garden and water garden that will support and rehabilitate the existing landscape is proposed.

Considering the size of the overall scheme, it has been decided, for the purposes of the dissertation, that only the classrooms be designed to a detailed level, with all other facilities proposed in terms of location and relationship to the rest of the site.

## 4.2 Children's Spaces

When designing for children, the scale of the environment around them should be kept in mind. Refer to Figure 4.2. For example large open spaces may seem large in an adult's eyes will look intimidating to a small child. A one meter wall can be perceived as low for an adult, yet a small child might not be able to see over it.

According to researchers Wendy Titman (1994: 49,59), small little nooks and crannies hidden under tree canopies as well high positions such as tree houses are attractive to children.

Figure 4.3 discusses the anthropometric design guidelines for children. Furniture and the design should correspond to these guidelines to a point but also create spaces that can be used by both children and adults alike and should therefore be as inclusive as possible.

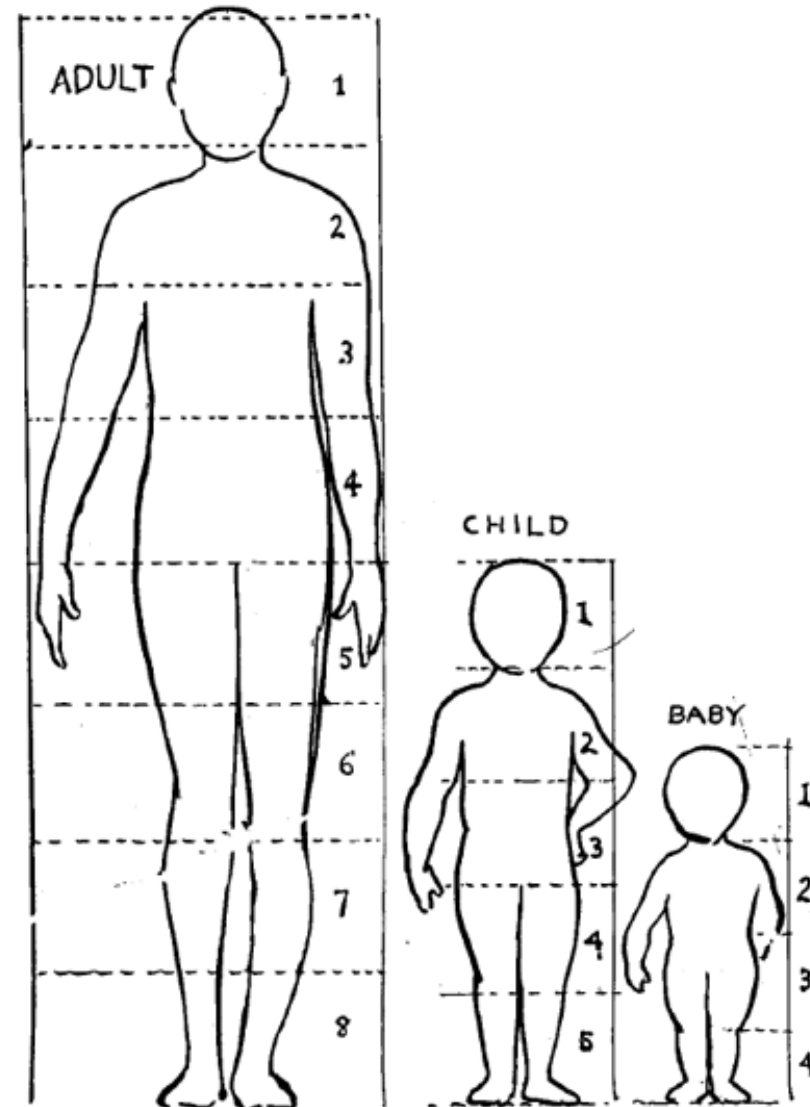

Figure 4.2 Scale differences between child and adult. (drawinghowtodraw.com)

## Anthropometrics For Children

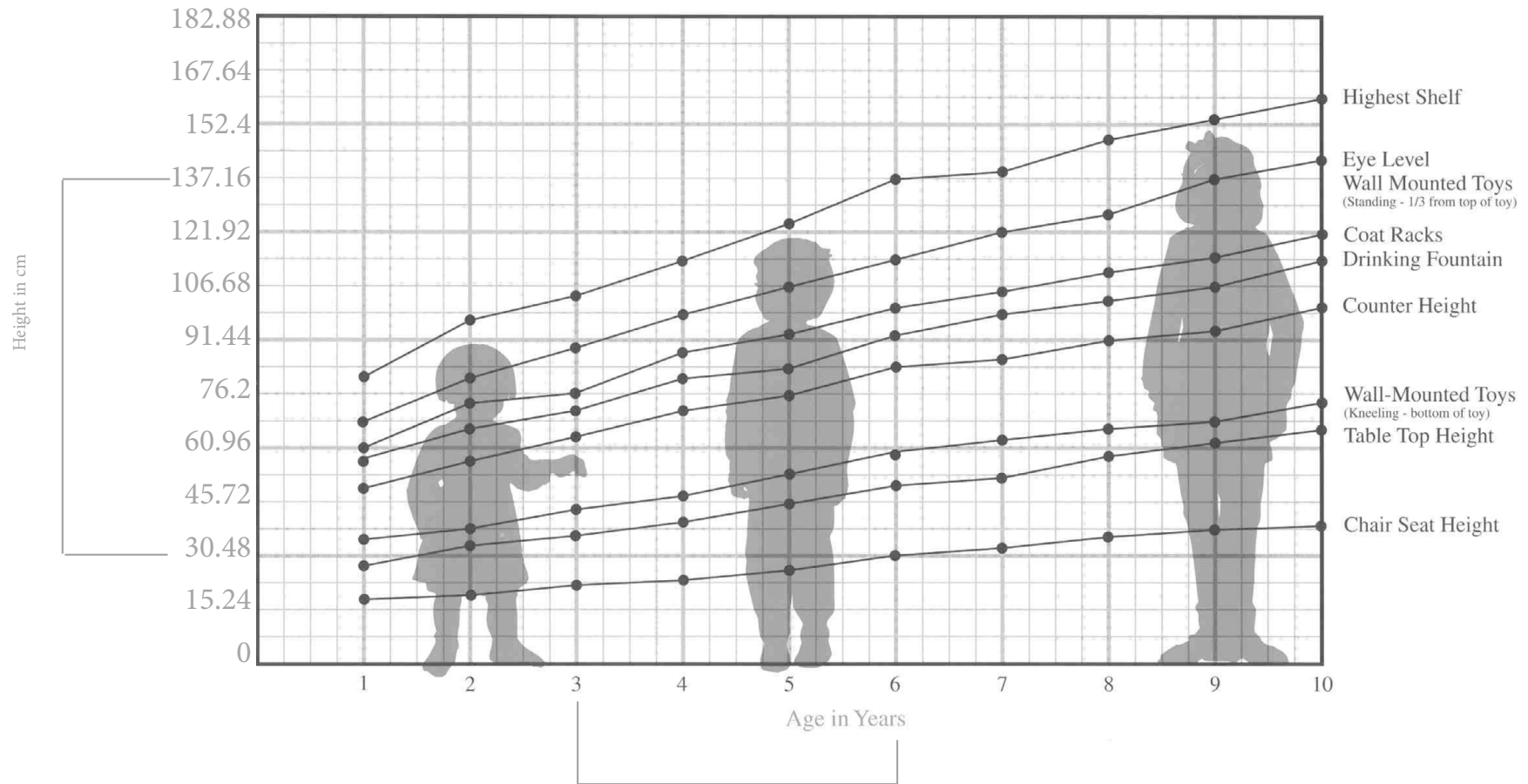

Fig 4.3 anthropometrics of a child (playscapes.com)



Fig 4.4 Needs of children in their cognitive, physical and emotional development. (Author, 2016, adapted from Berry, 2001)

### 4.3 Children's Developmental Needs

Figure 4.4 above discusses the developmental needs of children at different ages. These needs affect the design of spaces, for example, open space size, the physical qualities of the space and placement of objects. According to notable early childhood development theorists, the developmental needs of children are split up into three primary categories: Cognitive, Physical and Emotional development.

This also relates to the three different kinds of learners: visual (images), auditory (listening) learners and Kinesthetic (doing, touching) learners. This is the VAK model of early childhood development which uses the three main sensory receivers: Visual, Auditory, and Kinesthetic (movement) to determine the dominant learning style for each child. A child will learn more effectively through the dominant auditory receiver.

Another facet of children's development is through experiential and imaginative play. In this dissertation, learning through a didactic landscape, that stimulates children's biophilia resulting in positive cognitive development and well-being is the primary focus, however, one for one of the design approaches, experiential play is addressed as a resolution to finding the architectural language.

Experiential play is key in children's development because much of the child's development takes place outside the classroom. This can be also be interpreted as outdoor learning activities (Weaver, 2000: 12). Play allows children to learn things that nobody can teach them, discovering their place in the world, in relation to people, buildings and the course of time. Play is process-oriented, pleasurable, exploratory, self-initiated, and constitutes activities that are pursued for their own sake (Weaver, 2000: 12). Children aged from three to six years who take part in physical gross motor skill development activities surrounded by natural elements (such as trees, rocks, and large grass areas) develop these skills faster than children who learn in traditional playgrounds and indoors as discovered by architect and psychologist Nancy Wells (2000: 781).

According to child psychologists Kaduson and Schaefer (2006), the stimulation of the imagination through play has many benefits, where they can learn about suitable outcomes to real-life situations that they may have experienced. Abstract spaces can stimulate the child's imagination during play where the child will use archetypal elements to act out or process their emotion (Linden, 2003: 246). Landscape archetypes, such as a forest, river, or mountain, offers a non-prescriptive platform for the acting out of these stories, supporting and encouraging imaginative play in a natural setting.

Fig 4.5 Ring Ting Pre-primary School does not use the adjacent natural site to its full potential. (Google Earth, 2016)



#### 4.4 The School Building vs. The Third Teacher

Most school children grow up in institutions and almost three-quarters of preschool children with working parents spend many hours of each weekday in some form of childcare institution (Capizzano et al, 2000: 6-7).

Young children are spending the majority of their time with a different kind of family structure: biologically unrelated adults with similarly aged children in new, non-residential building forms (Kellert, 2008: 161). This is not necessarily a bad thing for child development as research has identified positive benefits (Palacio-Quintin 2000). The childcare centre may be regarded as a new form of community care. However, with exceptions, typically little attention is given to the learning potential of the physical environment—be it the actual spaces within the building's interior or the outdoor landscape (Kellert, 2008: 161).

Early childhood architecture, including landscape architecture, has extraordinary potential for igniting a lifelong positive engagement between the child and the environment. And yet, childcare centres not only ignore the advantages of this potential but barely meet basic functional requirements such as providing floor level windows, interior daylight penetration, and ample transitional threshold spaces between indoors and outdoors (Kellert, 2008: 161).

Outdoors, traditional playground equipment is typically provided rather than a dynamic, natural learning environment, which through play processes could offer new experiences each day instead of the repetition of static settings (Kellert, 2008: 161)

According to Kellert, (2008:167) green building design in schools needs to include another dimension, that is not only designing a sustainable school but a school that fully activates sustainable development practise as an educator especially in child care institutions where children can not only learn about the natural world and its conservation but also in and through its natural processes.

These dynamic settings where children interact with the natural environment via all their senses can stimulate not only increased cognitive development but develop new biophilic relations between children and nature. The Reggio approach to learning sees the physical environment as the third teacher in the child's education. Creating a Reggio centred learning environment will aim to resolve the issues faced in the current environment on site where the Ring Ting Pre-primary, specifically, does not involve the natural site alongside as potential for learning and playing in the natural environment (Figure 4,5). Therefore it is seen as an appropriate response to the biophilic theories, site-related issues and the issues of child development centres.

## 4.5 The Reggio Child

*“The child  
 is made of one hundred.  
 The child has  
 a hundred languages  
 a hundred hands  
 a hundred thoughts  
 a hundred ways of thinking  
 of playing, of speaking.  
 A hundred always a hundred...”*

Extract from the poem “No way. The hundred is there.” (Edwards et al., 1998: 3)

The hundred languages remind us that there are multiple ways of teaching and multiple ways of learning. Loris Malaguzzi was the founder of the Reggio Emilia approach to child development. The Reggio Emilia Approach is an innovative approach to early childhood education which values the child as *strong, capable and resilient*; rich with wonder and knowledge.

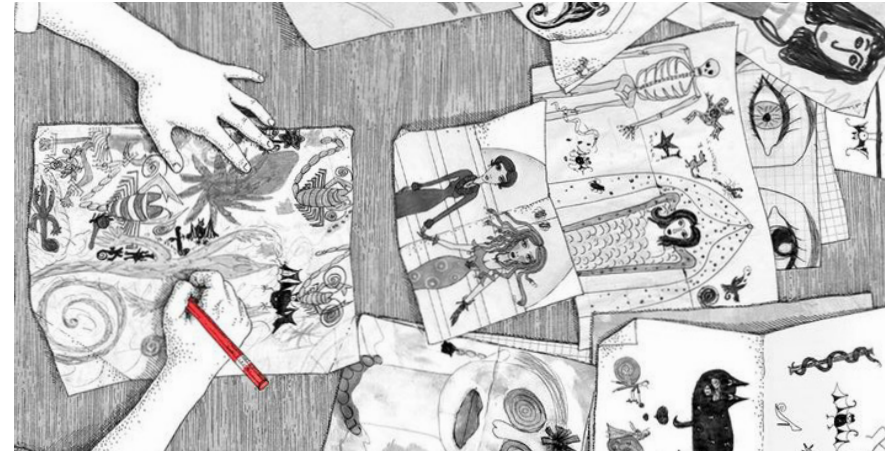

Fig 4.6 My Childhood - Sveta Dorosheva.(kireei.com. 2016)

The Reggio Emilia Approach originated in the town (and surrounding areas) of Reggio Emilia in Italy out of a movement towards progressive and cooperative early childhood education.

It is not a method but rather an approach. All schools and preschools (and home schools) are Reggio-inspired, using an adaptation of the approach specific to the needs of their community. No two Reggio-inspired communities should look the same, as the needs and interests of the children within each community will be different. The VAK method will be Reggio-inspired so all children can learn freely through their dominant sensory receivers.

### The Fundamental Principles of the Reggio approach

Children are capable of constructing their own learning; they are driven by their interests to understand and know more;

Children form an understanding of themselves and their place in the world through social interactions with others.

The teacher or adult is not the giver of knowledge but rather children search out the knowledge through their own investigations;



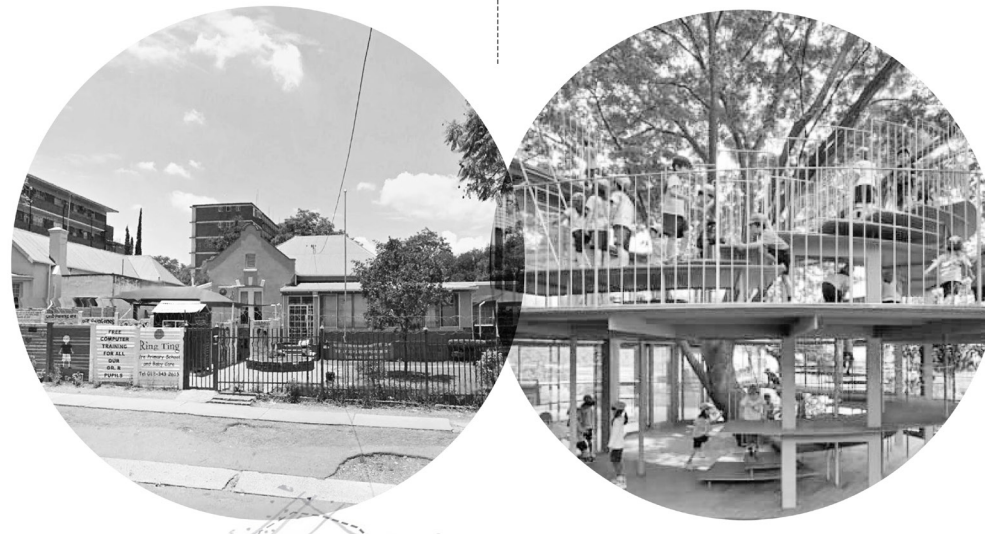

Children are communicators where the communication is a process, asking questions, and using language as play. Rather than the child asking a question and the adult offering the answers, the search is undertaken together.

The next principle of Reggio is that the environment is the third teacher. The environment is recognised for its potential to inspire children. An environment filled with natural light, order and beauty. Open spaces free from clutter, where every material is considered for its purpose, every corner is ever-evolving to encourage children to delve deeper and deeper into their interests. The space encourages collaboration, communication and exploration. The space respects children as capable by providing them with authentic materials & tools. The space is cared for by the children and the adults. The adult is a mentor and guide.

In Reggio-inspired environments, an emphasis is put on carefully displaying and documenting children's thoughts and progression of thinking; making their thoughts visible in many different ways: photographs, transcripts of children's thoughts and explanations, visual representations (drawings, sculptures etc.), all designed to show the child's learning process.

Another aspect of the Reggio-inspired approach is use of the atelier. The atelier is a studio/workshop filled with a varied of art materials. The space provides a means for children to explore and express their thoughts through the language of visual media. Experiences within the school atelier and the mini-atelier's in each classroom are provided and facilitated by the Atelierista (studio teacher with specialized training in expressive arts).

Lastly, children use many different ways to show their understanding and express their thoughts and creativity. The Reggio Emilia Approach emphasises hands-on discovery learning that allows the child to use all their senses and all their languages to learn. This includes, visual, auditory, smell, taste and kinaesthetic which refers to tactile, physical and emotional triggers to effective cognitive development (Cadwell, 2003:4-6). The two images above (Fig 4.7 and 4.8) respectively compare the differences between the mainstream classroom and a Reggio classroom.

Fig 4.7 Ring Ting Pre-School with little connection to the outdoors and sensory stimulation (Facebook. 2012)

Fig 4.8 A classroom connected to natural elements where the tree forms part of the child's education (tezuka-arch.com. 2016)

## 4.6 The need for community space

Due to the macro vision explored in Chapter 3, it is necessary to look at how the community of Sunnyside can make use of the space after-school hours as well as the children. Because of the analysis as well as the requirements of Reggio-inspired approach to learning, a multifunctional community intervention is proposed.

According to researchers, it has been found that natural green strips and parks in urban areas contribute a great deal towards residents' sense of community and social interaction with others (Kim & Kaplan, 2004; Kuo et al, 1998; Bixler & Floyd, 1997). Fostering a sense of community is vital as it will create a defensible space and a friendlier, safer environment, especially for children. This is true in a suburb such as Sunnyside where safety is a huge problem, where children live in isolated apartment flats and have no green space to play in.

The trees on site are sparse and the site itself is neglected. This fosters no sense of community in the area. Creating a space filled with natural trees and grass, together with benches and facilities that facilitate social engagement between residents is crucial in creating a sense of community in the suburb of Sunnyside. This will be carried out by creating a courtyard space that can be used by the community for sports and cultural events. Framing the courtyard, additional classrooms will be designed to be used by the community for events such as these. Access to the roof of these classrooms will be used for spectator seating areas. A cafeteria used by the school will be used by the community at these events to stimulate social engagement and a sense of community in a space designed for their children's positive development.

## 4.7 Program Resolution

In Figure 4.9 the three developmental needs as well as the three kinds of learners (Visual, Auditory and Kinesthetic), in conjunction with the investigations on the environment as a third teacher as well the Reggio Emilia approach are addressed through the resolution of three primary programs on site.

1. The Reggio Classrooms which will be the home base classrooms for the children
2. Kinetic Classrooms and outdoor play court, that deals with physical development
3. Occupational Therapy which deals with socio-emotional and development disabilities in children, preventing them from progressing in their education.

All three programs also address issues raised in Chapter 3 and Chapter 2 with regards to the community needs of Sunnyside as well as the developmental needs of the children in the many surrounding schools in the area.

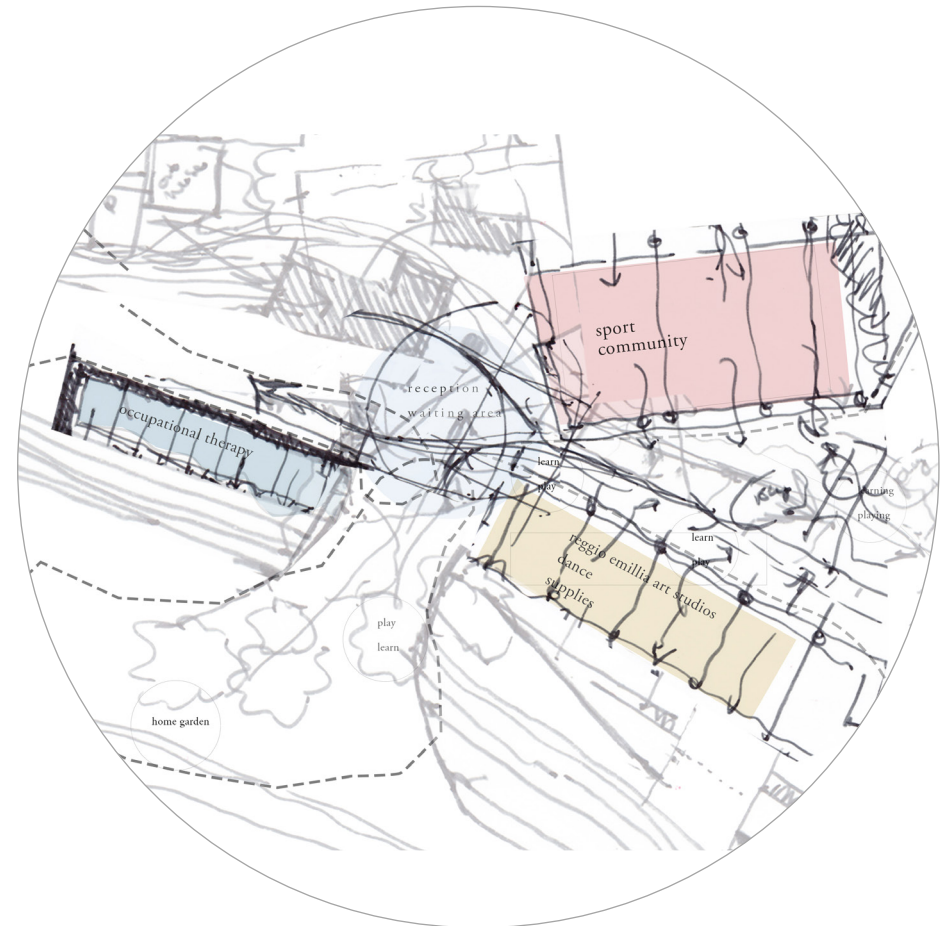

Fig 4.9 Initial Program layout on site, contain three primary programs (Author, 2016)

*The Resolution of three primary programs on site.*



socio-emotional

occupational therapy

deals with developmental setbacks in didactic community  
addresses issues in today's culture where outdoor play is limited



cognitive

reggio emillia home-baseclassrooms

the environment as third teacher  
approach to learning from nature  
biophilic in its nature



physical

kinetic classrooms and play court

addresses gross motor skills development in environment connected to nature

Fig 4.10 Needs of children in their cognitive, physical and emotional development (Author, 2016, adapted from Berry, 2001)



## 4.8 Cognitive: Reggio Emilia Classrooms and Administration

Classroom Users: Staff and 150 children

The Classrooms will accommodate 6 teachers and three assistants. The Classrooms will cater for 150 6 year old children (Visual, auditory and kinesthetic learners) . There will be 6 classrooms with around 25 children per classroom. The 150 children will consist of the 50 children already attending Grade R, as the existing Grade R at Ring Ting Pre-primary. The younger children at Ring Ting will remain in their existing classrooms. The existing Grade R classroom will be demolished to make way for the new classroom design as well create space for better linkages between the old and new school. The administration, staff members, cleaners, security and principal will be housed in an administration building connected to the classrooms on the north west corner. There will be 5 cleaners/maintenance workers, 3 admin staff, 1 secretary, 4 cooking staff, 3 security guards, and 1 principle and as well as staff lounge and kitchen accommodating for 9 teachers in total plus three admin staff and principle (6 teachers in these classrooms and 3 assistants). (Altogether 26 Staff excluding Occupational Therapists)

Fig 4.11 Central Piazza (Tarr, 2001: 35)

Classroom Function: Spaces and Requirements

All spaces are to be passively lit and ventilated as effectively as possible. Climate control should also be passive where applicable and all systems and services in the space will be didactically shown as far as possible in order to create a dynamic, didactic space where the children can learn from their environment. Specific Room Requirements are as follows:

Design Requirements

The classrooms are generally filled with indoor plants and vines, and awash with natural light. Classrooms open to a central piazza, kitchens are open to view, and access to the surrounding community is assured through wall-size windows, courtyards, and doors to the outside in each classroom. Entries capture the attention of both children and adults through the use of mirrors (on the walls, floors, and ceilings), photographs, and children's work accompanied by transcriptions of their discussions. These same features characterize classroom interiors, where displays of project work are interspersed with arrays of found objects and classroom materials. In each case, the environment informs and engages the viewer (Tarr, 2001: 33-35).

#### Entrance Lobby and Reception

The lobby should orientate and provide a datum point for the child and adult in relation to the school as a whole. A visitor should be introduced to the reception desk and orientated from there. The waiting area will include seating for 10 people, accommodating parents at the beginning of the year who are waiting to enrol their children. Two entrances will be provided.

#### Cafeteria

The cafeteria will accommodate about 50 children per seating. There will be two sit ins per day in order to feed the total 200 children in the school for lunch (150 children in the main classroom building and 50 in the existing Ring Ting). The kitchen will be visible from the seating area and some of the preparation of the food will be done by the children themselves in order for each process to become didactic. The kitchen will be staffed by four cooks and two cleaners. The cafeteria will be used after school hours by the community for sport and cultural events.

#### Administration and storage

There will two administration offices and one principle's office with a safe, teacher's lounge with attached kitchen, ablutions for 13 staff members and one sick room. These spaces will be accessed by staff only and will be situated on the first storey. There will be one toy library, two cleaner's storage room, one garden maintenance room, ablutions for 10 maintenance workers/cleaners and cleaner's lounge on the ground floor.

#### Classrooms:

Indoor Space: Indoor play area after cupboards and other furniture has been taken into account: 2m<sup>2</sup> per baby and 1.5m<sup>2</sup> per toddler

The minimum total classroom area to accommodate 30 children will be 1.5m<sup>2</sup> x 30 = 45m<sup>2</sup>. However, because the approach to Reggio Emilia requires free space for movement, the size of each classroom will be 9m x12m with a 3m high ceiling. (South Africa. Department of Social Development, 2006:45-47)

Each Classroom is to be accessed by an outdoor circulation route from a central courtyard or "piazza" space. Each will contain a central private space of 9m<sup>2</sup> used for private meetings between teacher and child or more focused group activities that need constant supervision or attention. Each will contain a mini-atelier to facilitate expressive learning through art. This will be carried out through the inclusion of shelving throughout the space to store the vast amount of materials needed. Shelving and furniture should be sized accordingly. (Refer to figure 4.3)

The activities that take place indoors will be dry activities that aren't relatively dirty. The schedule on page 80 will specify which activity will take place where. Activities that occur in this space include art related group activities, reading, fantasy play, exploration of nature, nap spaces and group meetings with the teacher. Therefore the classrooms each need a quite space for napping and reading, and a louder space with chair and table clusters as well as sufficient shelving to accommodate for small scale group and art activities.



## 4.9 Physical Development: Kinetic Classrooms

In order to address the developmental needs of the child with regards to gross motor skills and hand-eye coordination, three additional classrooms are proposed that attach to the administration building. These classrooms will primarily accommodate for physical gross motor skill activity. The intention is that this building is multifunctional and can either serve as three additional classrooms for gross motor activities or can open up to form an under cover assembly room. The classes can be used for after-school sports classes for young children in the area who attend neighbouring schools.

Fig 4.12 Design development perspective of kinetic play spaces (Author, 2016)

### Kinetic Classrooms Users:

Three classrooms will accommodate 25 children each, therefore 75 children will be accommodated in this building at one time. After-school classes of 75 children from neighbouring schools may use these facilities for extramural play gym activities.

### Kinetic Classrooms: Spaces and Requirements

The classrooms will satisfy the Department of Social Development regulations for daycare centres where a minimum of 1.5m<sup>2</sup> per child is required. Each classroom is to be accessed by an outdoor courtyard space or “piazza”. Each will contain a smaller private space of 9m<sup>2</sup> used for private meetings between teacher and child as required. The size of each classroom will be 96m<sup>2</sup>. Activities that occur in this space include gross motor group activities and any other activities that involve physical movement as well as short instructive meetings with the teacher. Therefore the classrooms each need open space with sprung floors to accommodate for the heavy movement that will occur in these classes.

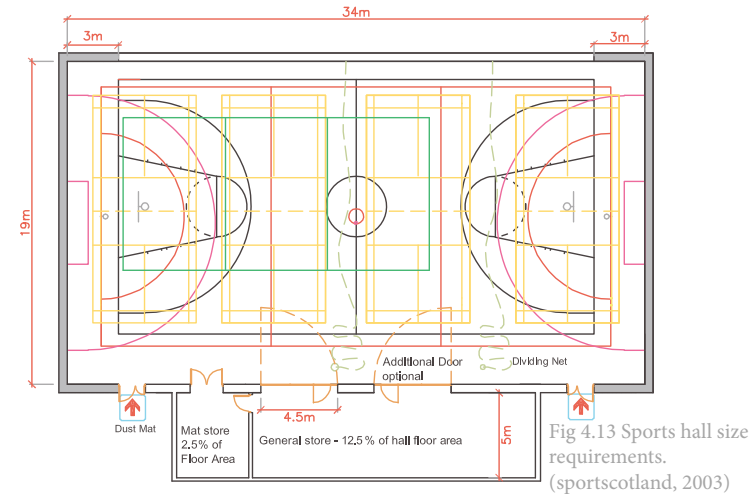

#### 4.10 School Atelier and Art and culture workshops and Play Court

On the northern boundary of the site, framing the play court, there will be three rooms designated as the school's atelier. These accommodate dirty or wet art related activities that cannot occur in the Reggio classrooms or kinetic. The activities will involve activities such as pottery, ceramic art and large scale painting. During after school hours, these can accommodate for cultural or art related activities, related to the community's needs at the given point in time.

The rooms will also be used on parent-child days to sell plants and fruits and vegetables grown on site. The nature of the spaces need to be easy to clean out with a hosepipe, for example and multifunctional and connected to the central play court.

The play court will be used by the children during formal recess. The school program allows for a free curriculum that the children regulate through their own discoveries, however, the court will be used for break times where they will eat their lunch in the cafeteria and sit outside and play in the court thereafter. Gross motor activities that require large spaces can spill out of the kinesthetic classrooms into the play court if required.

##### Play Court Users:

The play court will be used by the community after school hours for sport and cultural events. If required, larger activities carried out by the 75 children in the kinetic classrooms can spill out into the play court as well as after school classes.

##### Play Court: Spaces and Requirements

The play court will be sized according to the regulations regarding school sports halls where various forms of sports can be played. This is to accommodate for community sports events for specific types of sports namely: volleyball, basketball, 5-a-side, netball and badminton (Refer to Fig 4.13).

The surface of the court should be adaptable according to the various sports and activities that will occur upon it. Shading along a portion of the court is necessary as it will be used for lunchtime eating and resting areas.



## 4.11 Guidelines for the design of Early Childcare Facilities

In terms of the Department of Education guidelines relate to schools of children older than six years. The Department of Social Development, together with UNICEF have developed a set of design guidelines in terms of designing a pre-school for children of six years and younger.

### Minimum Standards:

“-The building must be clean and safe and protect young children from physical, social and emotional harm from themselves or others.

-All precautions must be taken to protect children and-teachers from fire or any other hazards

-The inside and outside spaces must be clean and safe. Each child must have at least 1,5m<sup>2</sup> of indoor space and 2m<sup>2</sup> of outdoor space.

-All equipment used must be clean and safe and appropriate in terms of the children’s development needs. The premises and equipment must be safe for young children, clean and well maintained. Children must have enough space to move around freely and explore the environment in safety. The premises should be bright and welcoming to children. Premises should be accessible to children with disabilities.

-The structure must be safe, weatherproof and well ventilated.

-The floor should be covered with material that is suitable for children to play and sit on. Walls and floors should be easy to clean.” (South Africa. Department of Social Development, 2006:45-47)

-There must be windows that give adequate light and, if possible, allow the children to see the outside world with a recommended lux level of 400 lux (South Africa. Department of Social Development, 2006:45-47).

“There should be separate areas that consist of an area for play activities, an area for taking care of sick children, and an area for food preparation. Fresh drinking water must be available for the children.

The play area for the children should be at least 1,5 m<sup>2</sup> per child.

Children with disabilities must have access to as many of the activities as possible.

- Where more than 50 children are enrolled for a full day, a separate office must be provided.

The office should be large enough to accommodate a sickbay for at least two children.

- Where more than 50 children are enrolled for a full day, provision must be made for a separate area where staff are able to rest and lock up their personal possessions.

- Where food is prepared on the premises, there must be an area for preparation, cooking and washing up” (South Africa. Department of Social Development, 2006:45-47).

### Outdoor Space Requirements

- “-The outdoor area must be fenced with a gate that children cannot open.
- Children should not be able to leave the premises alone.
- Strangers should not be able to enter the premises without the knowledge of the staff .
- Children need space to move and exercise to develop their gross motor skills. They need space to run freely and play with outdoor equipment.
- The outside area can consist of lawn, sand pits, shady areas and hard surfaces.
- Outside play equipment must be provided. This must be safe and not have sharp edges or pieces. No poisonous or harmful plants may be grown on the premises”  
(South Africa. Department of Social Development, 2006:45-47).

### Furniture requirements

- “-All furniture and equipment must be safe and in good repair.  
This means that, for example:
- Seating and working surfaces must be available.
- There must be enough age appropriate indoor as well as outdoor play equipment and toys, books and print material and other materials.
- There must be adequate storage space for indoor and outdoor equipment.
- Play apparatus must be safe so that children cannot be injured.
- Sufficient safe, clean and appropriate eating utensils must be provided.
- If there is a sand pit, it should be covered overnight so that animals cannot dirty it.
- If there is a swimming pool on the premises, the requirements of the local authority must be met.
- The swimming pool must be covered by a net and have a surrounding fence of sufficient height of no less than 1,2m and a lockable, self-latching gate”  
(South Africa. Department of Social Development, 2006:45-47).

#### Cafeteria requirements:

“Children must be protected from the dangers of hot liquids and food and from fire and other cooking fuels such as paraffin.

The kitchen area or separate kitchen must also:

- Be safe and clean;
- Have adequate washing up facilities and clean, drinkable water;
- Have hand washing facilities for staff ;
- Have adequate storage space;
- Have adequate lighting and ventilation;
- Have cooling facilities for the storage of perishable food;
- Have an adequate number of waste bins with tightly fitting lids;
- Have an adequate supply of water and cleaning agents for the cleaning of equipment and eating utensils.
- Cleaning agents must be kept in their original containers and out of the reach of children” (South Africa. Department of Social Development, 2006:45-47).

#### Toilet requirements

“Toilet facilities that are safe for children must be available.

- Toilet facilities must always be clean and safe.
- There must be somewhere for children to wash their hands.
- For older children (ages three to six years) one toilet and one hand washing facility must be provided for every 20 children, irrespective of gender.
- Doors on the children’s toilet facilities should not have locks.
- Facilities for the washing of children must be provided.
- Separate adult toilet and hand washing facilities must be provided for the staff in terms of the National Building Regulations.
- Provision must be made for the safe storage of anything that could harm children.
- Medicines, cleaning materials, cooking fluids (paraffin), sharp knives and kitchen utensils must be stored out of reach of children. Medicines and cleaning materials must be kept away from food”(South Africa. Department of Social Development, 2006:45-47).

## Activities taking place in each classroom

3-6 years

Open-8:00	Free Choice/Morning Group Welcome home-base classrooms) Children choose activities, multi-age collaboration
8:00-9:15	Outdoor Play/Gross Motor (4K begins @ 8:30 am) (outdoors and kinetic classrooms) Children select activities, explore nature
9:15-9:45	Breakfast, Bathroom (bathrooms, cafeteria, play court)
9:45-10:00	Morning Meeting and Group Time (home-base classrooms) Calendar, Share time, Stories, music
10:00-10:20	SMART Time (home-base and kinetic classrooms according to learners) Whole body development, fine and gross motor
10:20-11:20	Choice time (home-base classrooms) Activities may include centres, small group, etc. Active exploration and discovery
11:20-11:45	Story Time (4K ends – pick up at 11:40am) (home-base classrooms)
11:45-12:30	Lunch, Bathroom (bathrooms, cafeteria, play court)
12:30-1:30	Outdoor Play/Gross Motor (outdoors, kinetic classrooms, dirty classrooms) Children select activities, explore nature
1:30-2:00	Learning Activities (home-base classrooms) Various educational activities, story, group discussion
2:00-2:30	Rest/Quiet Activities (home-base classrooms) Children select fun quiet activities such as drawing, writing, books, etc. Time to calm our bodies
2:30-3:00	Snack, Bathroom (bathrooms, cafeteria, play court)
3:00-4:30	Free choice (home-base, kinetic, outdoors, dirty classrooms) Children select activities, discovery, exploration
4:30-5:00	Outdoor Play/Gross Motor (outdoors, kinetic classrooms, dirty classrooms) Children select activities, explore nature, join playhouse group
5:00-Close	End of Day Closings (home-base classrooms) Stories, quiet activities, multi-age collaboration

Fig 4.14 Schedule for Reggio-inspired child development, adapted from University Child Learning and Care Center (uwsp.edu. 2016).

Fig 4.15 Example of occupational therapy suite. (United Kingdom. Department of Health. 2013:33)

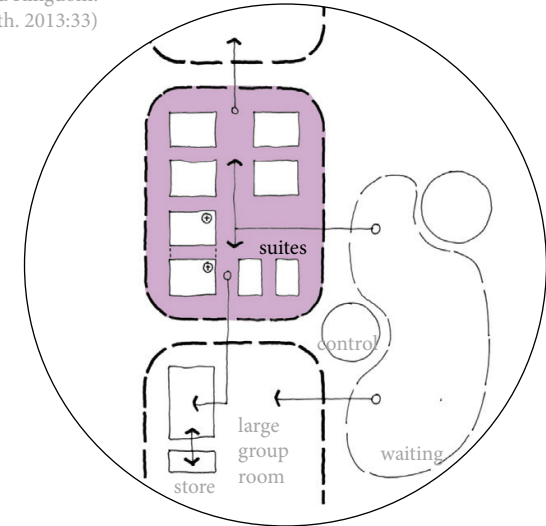

## 4.12 Supporting Function: Occupational Therapy (Socio-emotional)

Because of the nature of the site, as mentioned in Chapter 3, children are restricted to their home environment and parents are not able to supervise their children, when playing outdoors, from the apartment (Coley et al, 1997: 469).

This environment is factored together with the fact that many children are falling behind in their cognitive and conceptual development, as mentioned in Chapter 2, due to, firstly, an increase in video game culture and a decrease of experiential play immersed in nature (Crace, 2006).

Therefore, as a result of these issues, there is an increasing need among South African children for occupational therapy (timeslive. 2016). Seeing as the site contains such a great number of childcare facilities, the growing need for occupational therapy becomes even more crucial. As a supporting program to the existing Ring Ting Pre-primary, the new Reggio classrooms, as well as the neighbouring preschools, an occupational therapy suite that caters for 80 children in need of therapy will be introduced. The most western corner of the site was chosen as a good position for the occupational therapy suites as it was identified as the most private space on site (refer to Chapter 3) and at the same time, links to the neighbouring schools in the area.

Occupational Therapy Suites users:

80 children and 5 occupational therapists. The 80 child capacity will accommodate for a percentage of children of Ring Ting, the 150 children in the new Reggio classrooms as well as children from neighbouring schools in need of therapy. Sessions will be staggered and therefore a maximum of 30 children can be accommodated in the building at one time.

Occupational Therapy Function: Spaces and Requirements

Occupational therapists, require access to a range of different room types to enable them to see patients/ clients individually and/or in groups. Activity may be couch- or desk-based, or may require access to equipment (portable and fixed) and/ or open spaces. Interview rooms, with a clinical wash-hand basin, should be in a quiet location; group rooms for group discussions/counselling. Equipment will be brought into the room from an adjacent store for session use of the room. Small store for consumables and portable equipment and toys must be provided. According to Figure 4.9 , deemed to satisfy standards for a cluster of occupational therapy suites suggest 8m<sup>2</sup> for storage; 16m<sup>2</sup> for group consulting and 8m<sup>2</sup> for private interviews.

#### 4.13 Supporting Functions: Vegetable Garden, Wetland, Water Tanks

Other supporting functions include a vegetable garden, water garden and water tanks. The aim of these functions is to strengthen the didactic essence of the primary learning gardens while reacting appropriately to the context

The first of these is the garden of reuse, situated in the old playground of the Ring Ting pre-primary school. A vegetable garden that grows food to feed the new and existing school's children will be implemented into this space as well as small spaces to allow for the sorting of recycled materials used in the school. These will be attached to the existing school to emphasise that the existing school playground will be reused in a didactic way.

The second function is the water garden. The Water garden to establish a connection with the Walkerspruit and the identity of water on the site, however, the Spruit is unsafe for children because of the water's purity and the steep slopes of the channel. Therefore it was decided to incorporate a separate natural water system using water collected from rain water harvesting and clean it through passive methods, including a wetland and bio-pool. The garden will teach the children how water supports a multitude of ecosystems including plants and climate.

The third function, is the water tanks which will be suspended in two structural towers placed on either side of the entrance to the school. This not only creates an awareness of the supply of water amongst the staff and children but also creates an identity of the new school as a landmark in the community. The towers also resolve the large scale imbalance on the site between the high rise apartment bocks and the flat park space.

### 4.13 Summary

The overall programme for the scheme is large and multifaceted, but each part has a specific didactic purpose in the reconnection and rehabilitation of the site, as they contribute to each other's functions as well.

The placement of the programs were according to which parts of the site were more appropriate for the public and private nature of each of the programs. The western side of the site was most private and therefore proved appropriate for the occupational therapy, the northern east of the site had a semi-private nature to it and the southern part of the site had a semi-private nature to it. However, because the connection to water was identified as having highly didactic potential, the classrooms were placed alongside the river and the community elements were placed on the northern side, connecting to the street park condition with parking on the most eastern boundary, to the north.



Fig 4.16 Physical nature of site according to public and private spaces, and organic and urban nature of the site (Author, 2016)

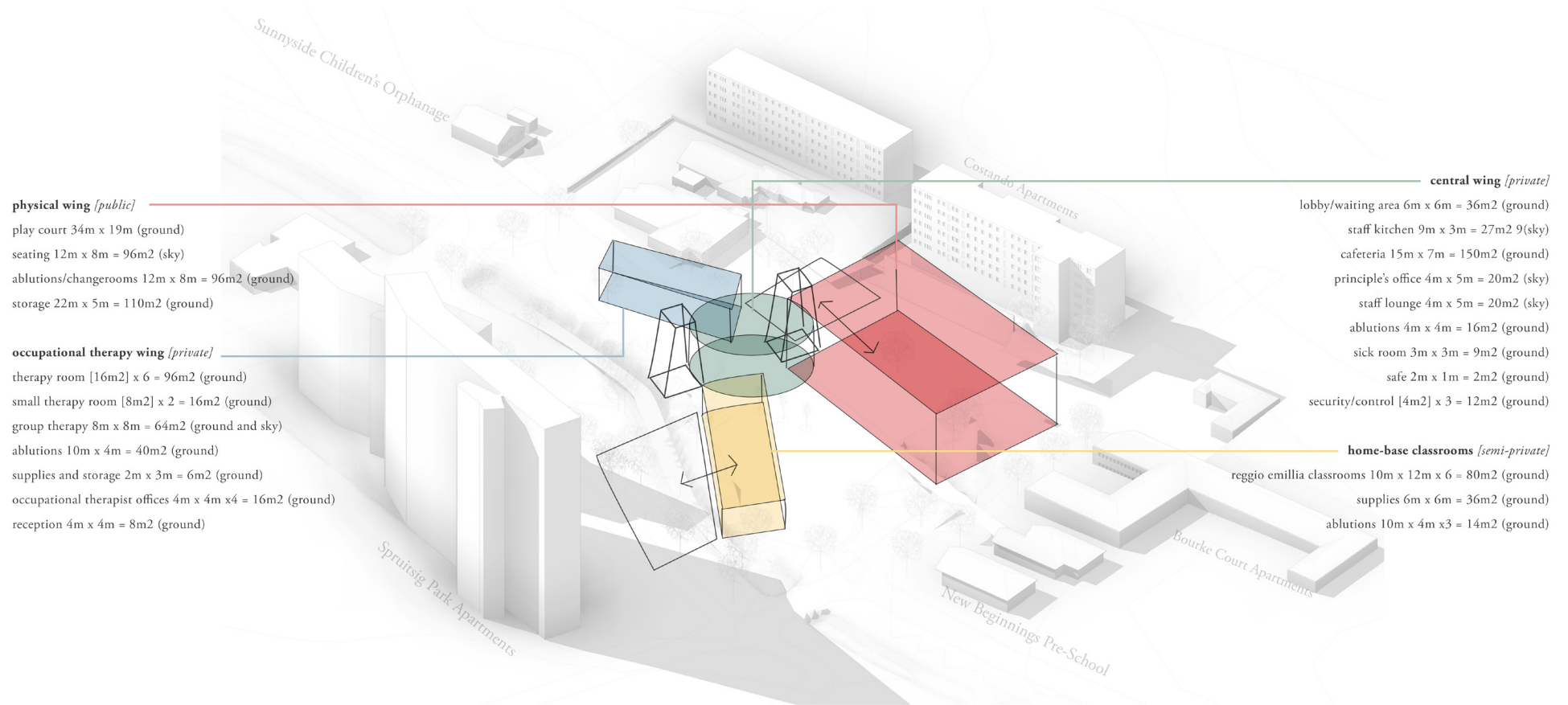

Fig 4.17 Program layout in context. (Author, 2016)



### occupational therapy

deals with developmental setbacks in didactic community  
addresses issues in today's culture where outdoor play is  
limited

#### Users:

(During and after hours):Sunnyside Orphanage  
Surrounding Residential Apartments  
New Beginnings Pre-School  
Ring Ting Pre-School

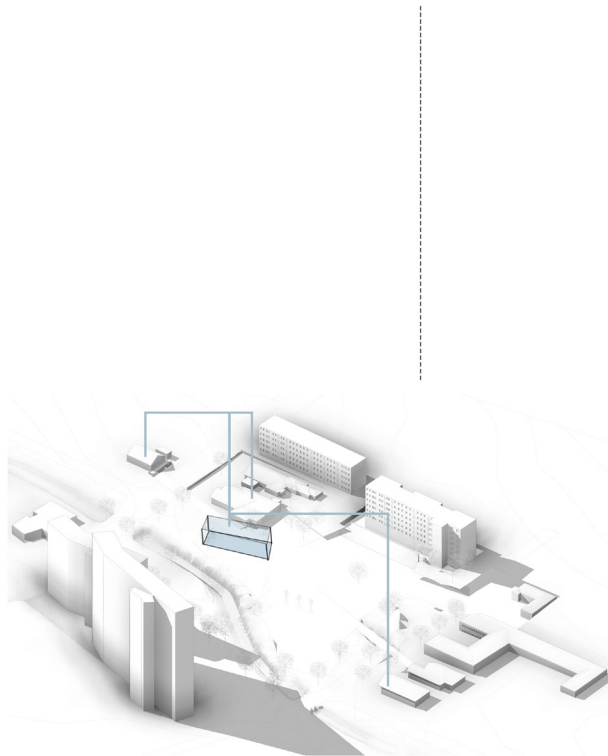

### reggio emillia home-baseclassrooms

the environment as third teacher  
approach to learning from nature  
biophilic in its nature

#### Users:

(School Hours):  
100 New Children from surrounding  
residential apartments  
50 Ring Ting Pre-School Grade R  
students

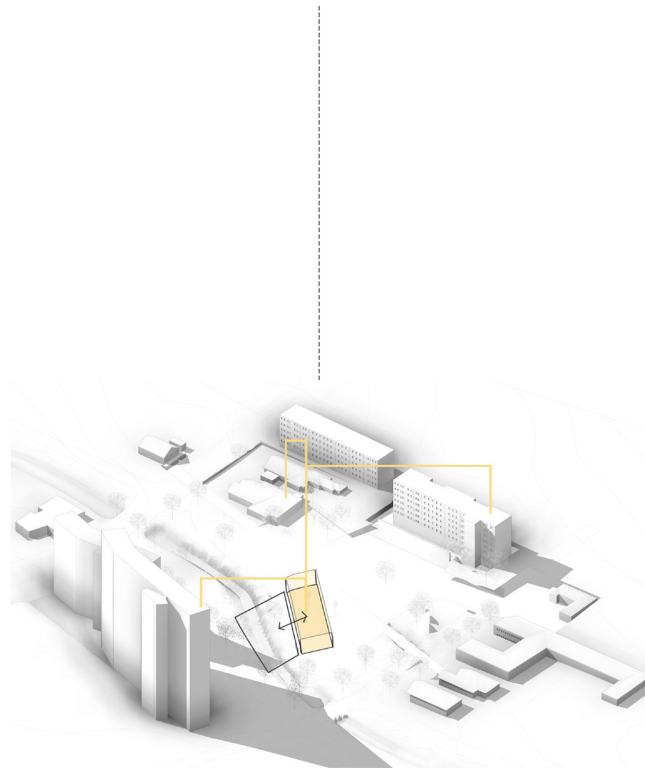

### kinetic classrooms and play court

addresses gross motor skills development in  
environment connected to nature

#### Users:

(School Hours):  
50 Ring Ting Pre-School Grade R students  
and 100 new children from surrounding  
residential apartments

#### (After Hours):

Sunnyside Orphanage  
New Beginnings Pre-School  
People from surrounding residential  
apartments

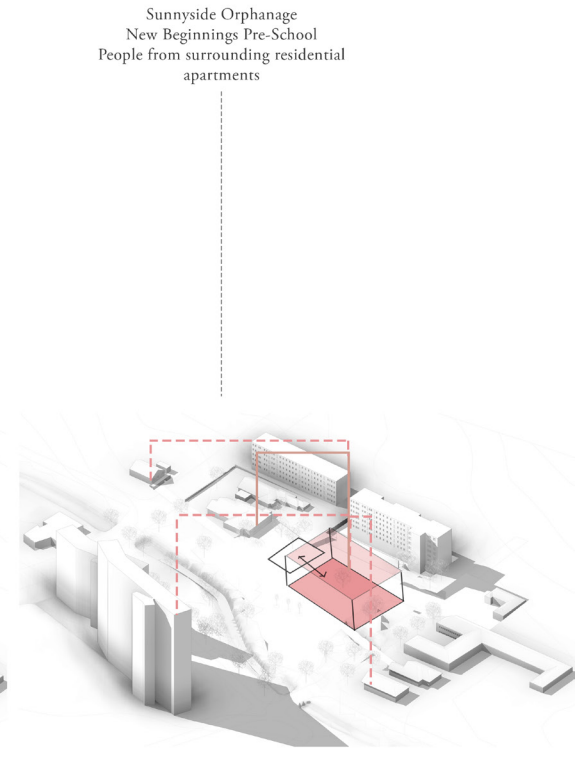

———— During School Hours  
- - - - - After School Hours

Fig 4.18 Program allocation. (Author, 2016)



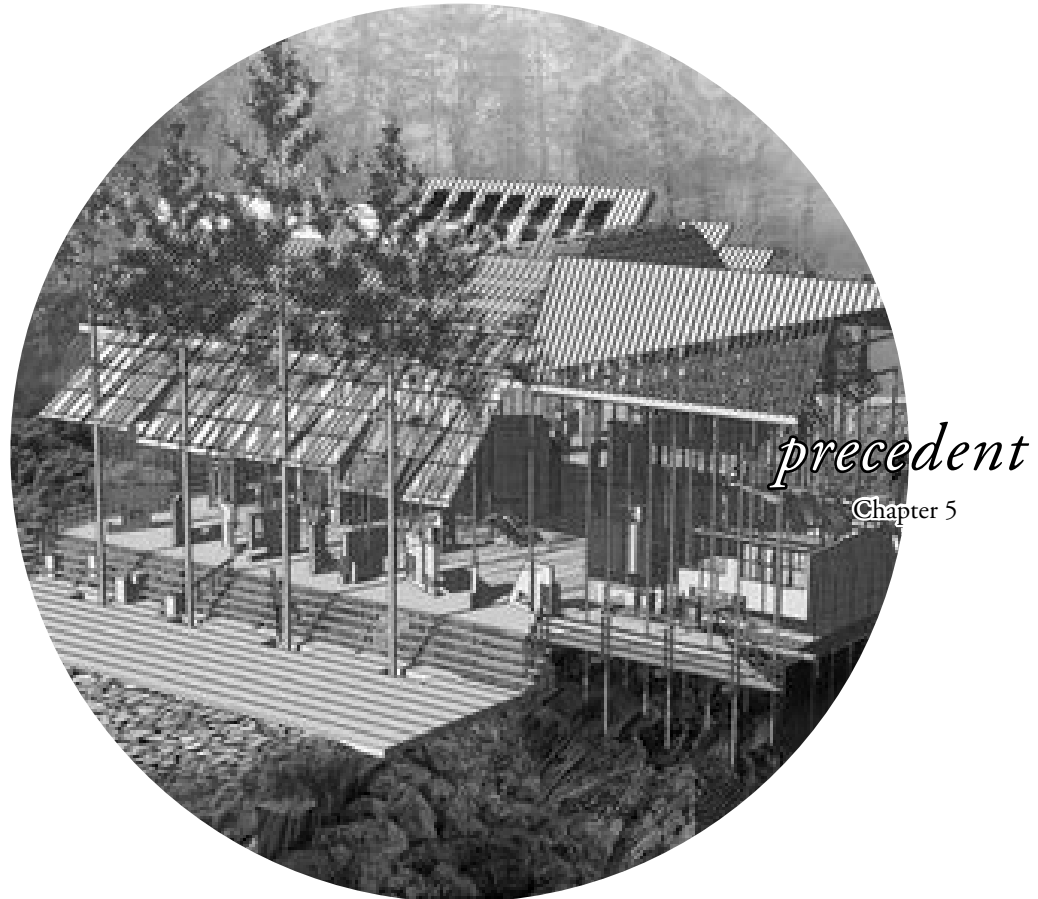

Fig 5.1: Design development sketches. [Author, 2016]

“It is through others that we develop into  
ourselves”  
(Vygotsky, 1981: 161)

## 5.1 Introduction

The following precedents were selected based on programmatic, design and character of the site. For each precedent the relevance to the project is discussed as well as each of their biophilic potential.

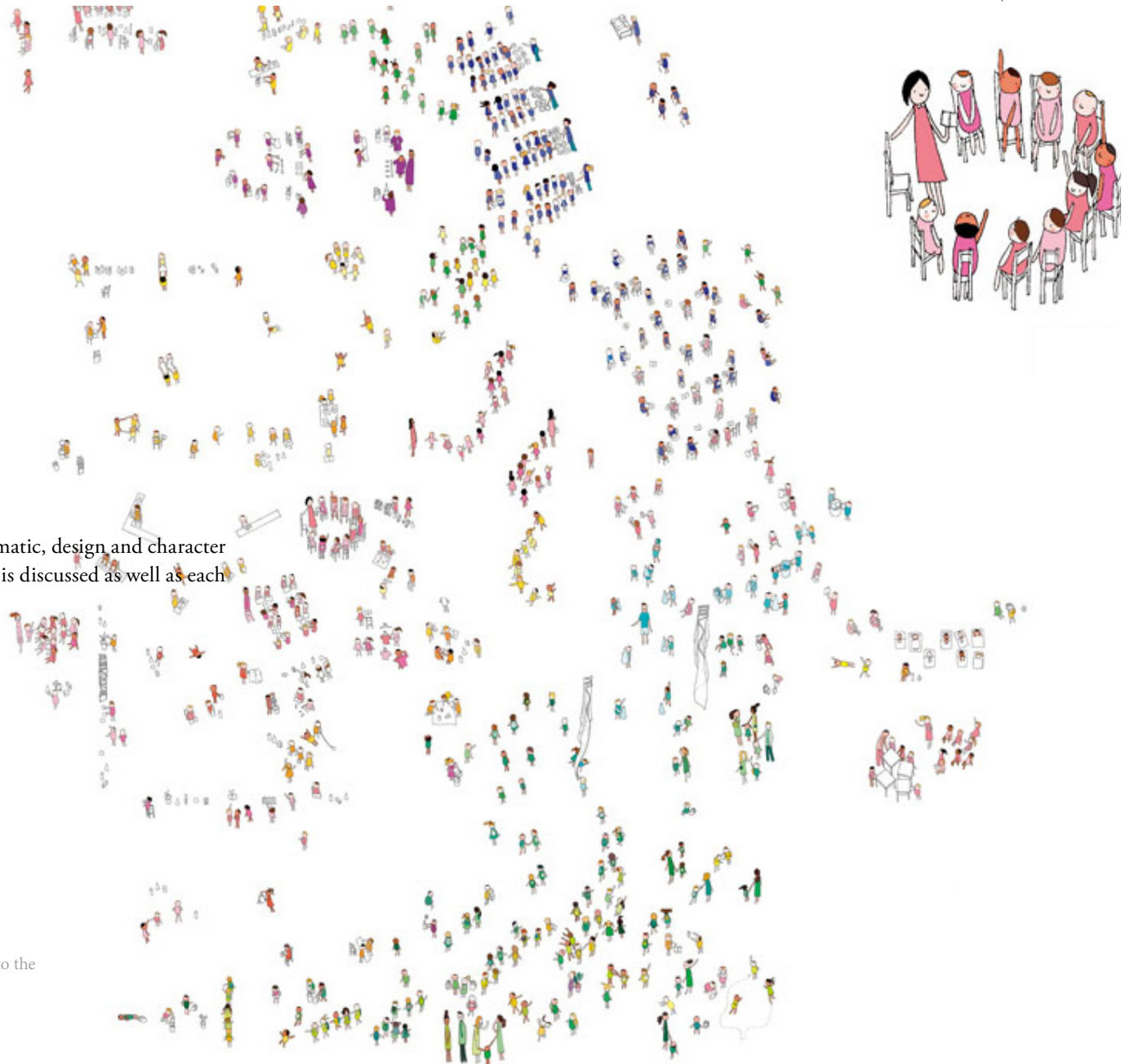

Fig 5.1 Drawings showing how activities of the children give meaning to the ambiguity of the spaces (presidentsmedals.com, 2015)

## 5.2 Programmatic Precedent : SFU UniverCity Childcare

Architects: HCMA

Location: Burnaby, BC, Canada

GroupArea: 530.0 sqm

Project: Year 2012

Photographs: Martin Tessler

The UniverCity Childcare is located in Simon Fraser University's high-density, sustainable community of UniverCity. The facility accommodates 50 children aged 3-5 years of age. The building is divided into two centres that accommodate 25 children each. The building also has shared "community" space used for social interaction between the two groups of children. In addition to 50 children and the 9 staff of the SFU Childcare society, academic research is accommodated for a live-in lab to observe early childhood education, first-hand (Arch Daily, 2013).

The building integrates a next-level green building framework together with the renowned Reggio Emilia early childhood pedagogy. As mentioned in Chapter 4, the Reggio approach is an educational programming model that is based on a deep respect for children's curiosity, their potential and their right to communicate through their "hundred languages". In addition because the environment is the "third teacher, curiosity and enticement are infused into the surfaces, materials and light quality of the preschool centres. The facility becomes a laboratory in itself for child-directed learning. Unique opportunities are provided throughout the facility to explore natural elements such as water, light, air, gravity, vegetation and seasonal changes (Arch Daily, 2013).

The building was built with almost no impact on existing natural ecosystems. Rainwater is collected on site to be used within the building. Any additional runoff will be filtrated on site and diverted to the community's rainwater treatment garden. The landscape plants required no irrigation after the initial establishment period. The building is net-zero energy, net-zero water with locally sourced materials (Arch Daily, 2013).

### Biophilic Potential

The potential of the project to connect the children to nature through their biophilic affections is prominent in the manner in which various biophilic principles have been applied. Curiosity and enticement which is applied through the use of materials and surfaces is a attribute of biophilic design that forms part of the element of evolved human-nature relationships. Place-based relationships are applied here due to the ecological connection to place through the use of natural elements to become "Third Teachers". Light and Space is an element of biophilic design which is applied throughout the classroom spaces. This is made up of attributes such as diffused light and inside-outside spaces which the school's design incorporates.

### Relevance

It is hard to argue how this project is not relevant to the dissertation as it incorporates a similar programmatic resolution, where natural elements are used as "third teachers" to the children's reggio-inspired early childhood pedagogy. It also placed ecological design as a priority at design stage, where multiple sustainable design applications are integrated within the building, perhaps forming additional "third teachers" in their function. Although biophilic theories weren't purposefully applied, many attributes are present throughout the building as a result of the Reggio-approach together with sustainable design. The site is much smaller than the chosen site of the dissertation, however, the principles remains the same of a community-based environment which the dissertation aims to achieve through appropriate programmatic solutions.



Fig 5.2 view of classroom spaces (Arch Daily, 2013)



Fig 5.3 view of pedagogic outdoor spaces (Arch Daily, 2013)



Fig 5.4 Rope nests forming tree-like structures (Arch Daily, 2013)

MAIN FLOOR

- 1 Ramp
- 2 Stone Steps
- 3 Log climber
- 4 Sand play
- 5 Slide
- 6 Lookout platform
- 7 Waterfall
- 8 SFU Research office
- 9 Community space
- 10 Covered outdoor play area
- 11 Activity room
- 12 Gross Motor nap room
- 13 Cubbies
- 14 Kitchen
- 15 Lobby

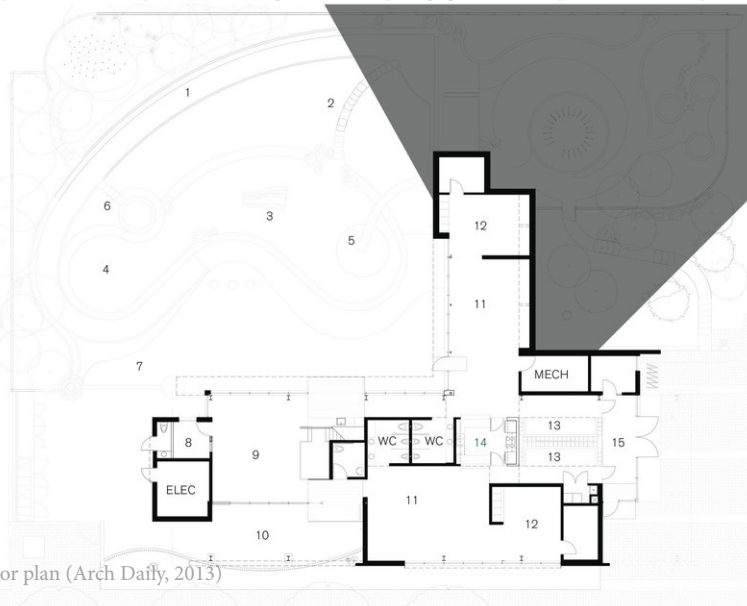

Fig 5.5 Mezzanine level floor plan (Arch Daily, 2013)

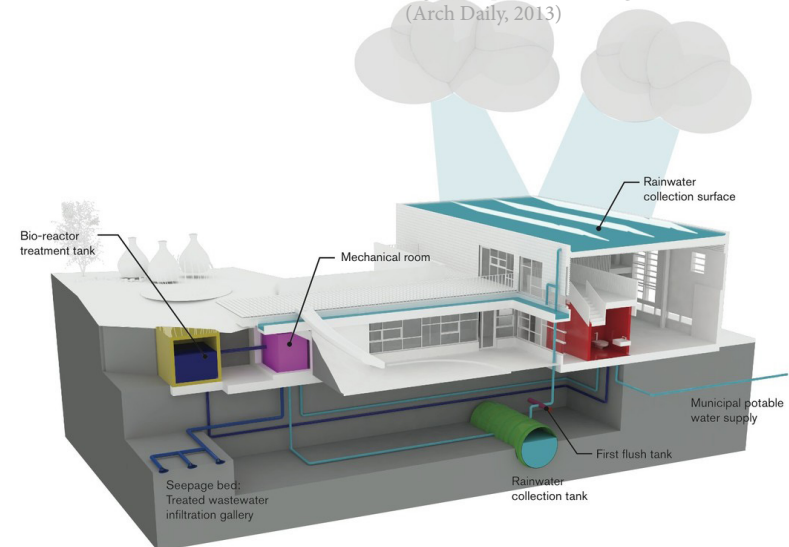

Fig 5.6 The sustainable energy and water system in the building (Arch Daily, 2013)

### 5.3 Design Precedent: Space As The Third Teacher

Student: Boon Yik Chung

School: The Bartlett School Of Architecture (UCL) London UK

Tutor:s Mr Rhys Cannon, Colin Herperger

Year: 2015

This project took a philosophical and theoretical approach to learning, in search of an alternative classroom typology for a Montessori school in Florida. Montessori is a similar approach to Reggio emilia whereby children learn through the environment, through auto-didactic toys and individual discovery. (The Presidents Medals, 2015)

Due to the independence children have in their learning process, the toys used in Montessori schools are minimalist and abstracted objects on which the child will place identity encouraging open-ended play. The research on the toys gave rise to the problems of contemporary classroom typologies which create sharp and unhelpful barriers between spaces, play and learning. According to the founder of the Montessori approach, 'Play is the work of a child' (The Presidents Medals, 2015)

This proposal permeates the architecture with the same notion of ambivalence and vagueness found in the toys. The classroom becomes a loosely defined space created by a collection of 'architectural suggestions' surrounding a core in which a learning group is based. Spaces are to be interpreted and negotiated; they are incomplete without the presence of the users. (The Presidents Medals, 2015)

'Children develop through interactions, first with lives - parents and teachers, then with their peers and ultimately with the environment,' (The Presidents Medals, 2015)

'Space is the third teacher.'

-Loris Malaguzzi

#### Biophilic Potential

In the same way the SFU Childcare Centre sparked curiosity and enticement through the nature of the spaces themselves, so are these classroom designed in this project, sparks curiosity and enticement through designed ambiguous spaces, designed to be interpreted and given meaning only once the child is present. The design of the building is culturally and ecologically rooted to place which forms part of the biophilic design element of human-nature evolved relationships. Analysing the classroom design, one can see light and space has become a prominent biophilic design feature with inside-outside spaces and spatial harmony becoming evident.

#### Relevance

This precedent is relevant to primarily the design of the project with regards to the classrooms where each classroom contains a "core" used for focused learning and where the rest of the classroom is given meaning by the activities that happen within them. Harsh barriers between space inhibiting children's freedom when it comes to learning from their environment have been limited and spatial freedom and freedom of Vermont are key factors in the dissertations classroom design approach. In terms of site, the classrooms are also placed alongside a body of water, creating opportunities for water to become a pedagogical element in the environment.





Fig 5.7 Aerial view of classrooms, also alongside a river (presidentsmedals.com, 2015)

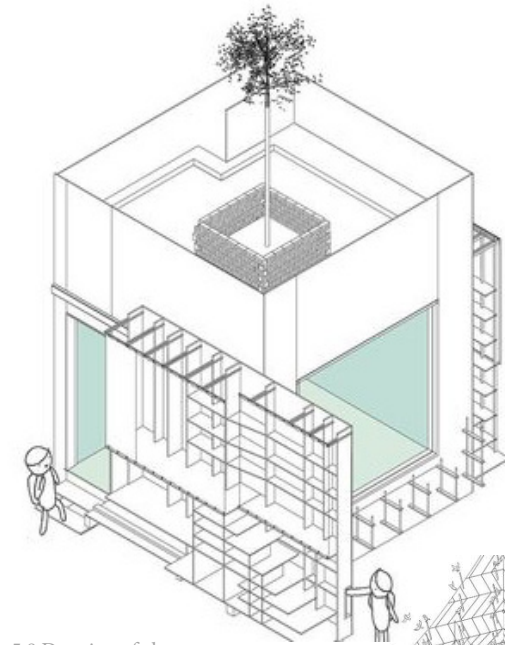

Fig 5.8 Drawing of classrooms cores, with usable shelving systems (presidentsmedals.com, 2015)



Fig 5.9 Drawings showing how activities of the children give meaning to the ambiguity of the spaces (presidentsmedals.com, 2015)



Fig 5.10 Classroom plan, showing cores, and the various child learning activities taking place (presidentsmedals.com, 2015)

## 5.4 Site and Technical Precedent: Meetse-a-Bophel Primary School

Project Name: Meetse-a-Bophel primary school

Architects: Humphries Jooste Architects

Year: 2011

For South African schools, the conception of ‘school as home’ is important especially in informal settlements. The architects, subscribing to Montessori’s view, equipped each classroom as a unit and a house in itself. In the same way that the Geschwister Scholl in Lunen is designed as a neighbourhood of classrooms, built to create continuity between home and work environments, the Meetse-a-Bophel primary school at Mamelodi, Tswane, is a new example of this radical, but very practical, approach to an architecture of necessity and empowerment (Raman, 2011: 12-15).

The school is arranged around three courts of triangular plan form. They converge at the nutrition centre, with covered outdoor and indoor seating areas for meals and a tuck shop. The centre is seen as the hierarchical element, where the children are ensured at least one square meal a day. The triangular form of the courtyard enables a north orientation to as many classrooms as possible. With the simplest of variations in roof section, glare-free lighting and effective cross ventilation is also achieved. Tunnel facilities are introduced, where fresh vegetables can be grown for the children by some thirty trained ladies from local communities (Raman, 2011: 12-15).

The school is constructed out of IPE portal frames bolted to raft foundations, considered suitable for all ground conditions, thus rendering the system used here applicable to a wide variety of contexts. The steel roof sheeting is fixed to top-hat steel section purlins. Cladding rails and the framework of partitions are also of steel and so are the insulated external claddings and the windows, which are powder-coated. Steel is used for furnishings such as tables, shelves and seating, too. The need for the existing school to function during construction meant that the work had to be phased. It took 13 months to complete the entire project – half the time that would be needed to build a school of this size using conventional means (Raman, 2011: 12-15).

### Biophilic Potential

This project revolves primarily around evolved human-nature relationships. The building connects to opportunities of natural lighting and making use of the land as a food source. The cultural connection to place is imminent in design a school that creates continuity between home and school environments. In terms of natural patterns and processes, an element of biophilic design, a central focus point is evident in the school’s plan where the hierarchy of the school is focused on the nutrition centre, aimed at providing at least one meal a day to the children. Also evident is the arrangement of plan which is the relation of parts to wholes, another attribute. The school is made up of parts that make up a whole in its shape and form.

### Relevance

In terms of relevance, the school aims to create a sense of community by providing spaces that can become the children’s second homes. In terms of its context, Sunnyside is similar in character to the qualities of Mamelodi where children depend on their school to provide them not only education but basic needs. The dissertation aims to fulfil these needs through the provision of food at the Cafeteria as well as creating a sense of community through the provision of facilities that encourage sport and cultural participation of individuals in the area. In terms of technical resolution, the structure is made up of portal frames, enabling easy and quick assembly, relating to the South African context.



1  
Fig 5.11 Northern entrance view (Raman, 2011: 12-15)



Fig 5.12 Plan of integrating parts to a whole, and central focus point (Raman, 2011: 12-15)



5  
Fig 5.13 Assembly court and classroom blocks (Raman, 2011: 12-15)

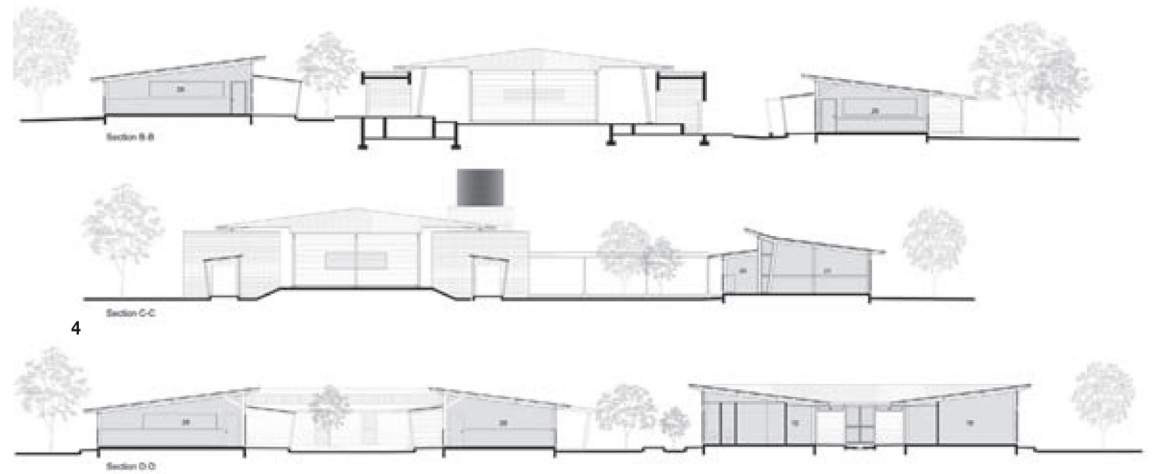

4  
Fig 5.14 Sections showing variations in the roofs and portal frame structure (Raman, 2011: 12-15)

## 5.5 Summary

As the most relevant precedent, the SFU Childcare Centre in how to respond to designing a new landscape in which it becomes a teacher in itself, making children aware of their changing environments and the need to conserve it. The Space as the Third Teacher gives clues to how to design a classroom where meaning to the spaces is given through the activities which take place within it. The Meetse-a-Bophel primary school indicates possibilities in how to construct a school in a harsh environment where the school becomes the children's second home.







Fig 6.1: Design development sketches. [Author, 2016]

“THE Lord God planted a garden  
In the first white days of the world,  
And He set there an angel warden  
In a garment of light unfurled.”

Dorothy Frances Gurney  
(Willis, 2006: 11)



## 6.1 Introduction

The design process of the scheme was marked by exploration and multiple iterations. It comprised of many exercises to try and establish a concept that would be a uniting element between theory, site and program, as well as a strong decision-making mechanism in producing architecture.

In an attempt to clearly communicate how the process unfolded, it is divided into 3 sections. These are represented by conceptual drawings that aim to resolve the overall strategy for the site, in terms of programmatic function, the route that links all learning elements together and the garden spaces.

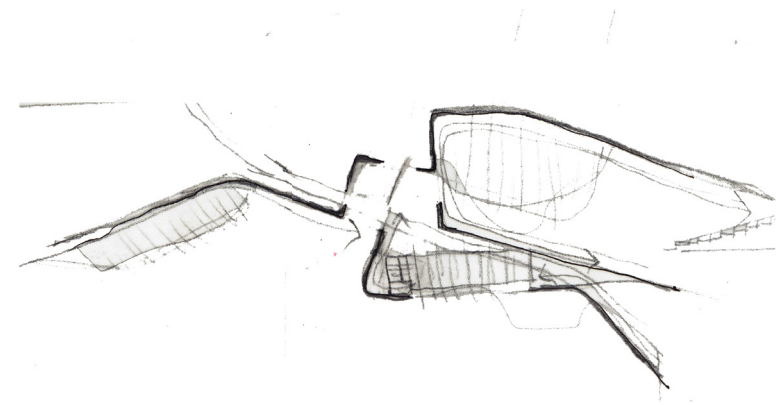

Fig 6.2 Initial design translation of conceptual resolution. (Author, 2016)

## 6.2 Summary of issues, informants and intents

The diagram on Page 119 (Fig 6.2) describes a summary of the issues identified on site, together with the informants and the intentions. The intentions are related to biophilic principles that are appropriate to all contextual factors and elements. These were seen as resolutions to the issues, using the informants as medium as well as starting points to the development of the concept and design.

In relation to the theories of biophilic design and the informants of site, the three primary elements were translated accordingly:

Water: sculptor and unifier of all aspects of landscape and building.

Natural Systems: the trees and the ground form the “teachers”. Biomimetics will be the approach at which building will be designed. This includes not only the preconceived idea of “what nature looks like” but also the systematic approach emphasising “what nature does”. The architectural significance of these will be expanded on in the Concept chapter.

The Child: Integration of cognitive development through the facilitation of experiential play taking place, immersed in natural surroundings. This will be expanded upon in the Programme chapter and the Concept chapter.

Fig 6.3 (opposite) Diagram summarising development of concept. (Author, 2016)

issues

informants

intentions

biophilic resolutions

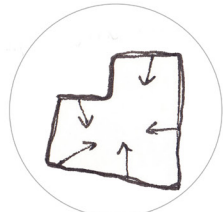

barriers

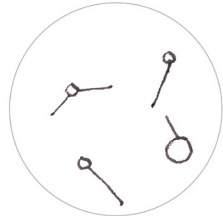

broken ecologies



river is barrier

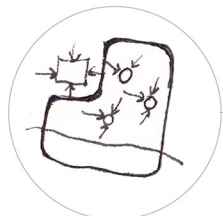

school ignores site



unsafe environment



the trees



the Walkerspruit



the neighbouring schools

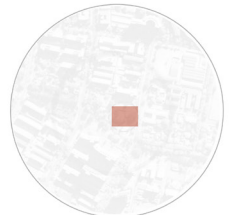

biophilic history

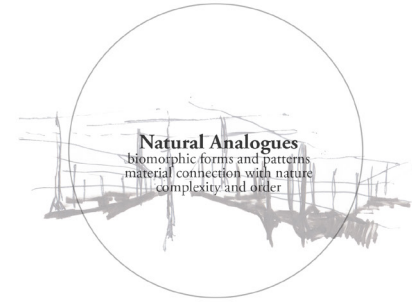
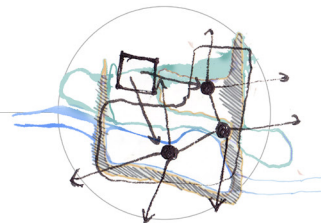
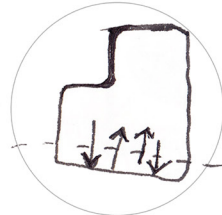
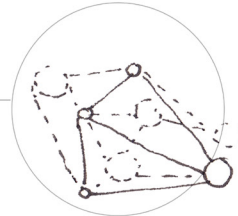

**Natural Analogues**  
biomorphic forms and patterns  
material connection with nature  
complexity and order



**Nature in the Space**  
visual connection to nature  
presence of water  
dynamic & diffuse light  
connection with natural systems



**Nature in the Space**  
visual connection to nature  
presence of water  
dynamic & diffuse light  
connection with natural systems



**Nature of the Space**  
prospect and refuge  
mystery and peril  
curiosity and excitement

## 6.3 Conceptual resolution 1

The first intention as shown in Figure 6.3, was to resolve the problem of barriers on site, by designing interesting spaces for children to learn about nature through observation and immersion. Diagrammatic solutions were explored to resolve these issues as well as to explore different possibilities of the type of architecture that was appropriate.

As Louis Kahn once said, “What does a brick want to be?”, the first approach was identifying what the *site* wanted to be, to identify a intuitive response to what the site needs in order to create spaces where children and adults will want to spend their time. In Fig 6.4 and Fig 6.5, these explorations are portrayed. The massive scale difference resulting in a lost space was the first identified issue and the trees on site and how they helped bring the site back to human scale was an approach. The biophilic principle of natural analogues was applied and resulted in diagrams that showed an architecture of canopies, columns and platforms that mimicked the nature of the tree and at the same time returned the site back to human scale.

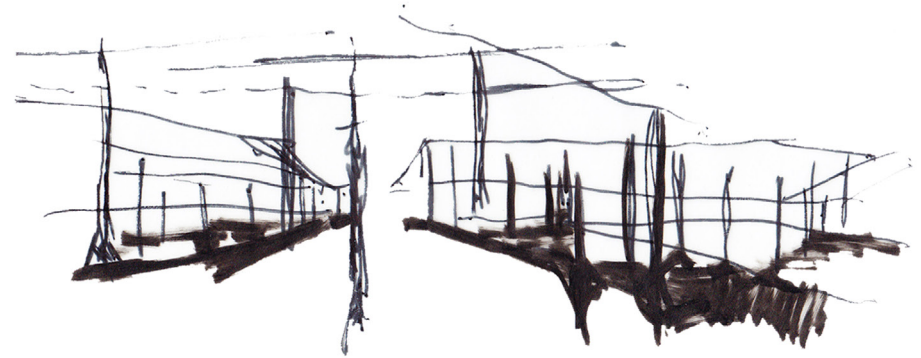

Fig 6.4 Diagram illustrating the analogue of the existing trees and how it returns the site back to human scale. (Author, March 2016)

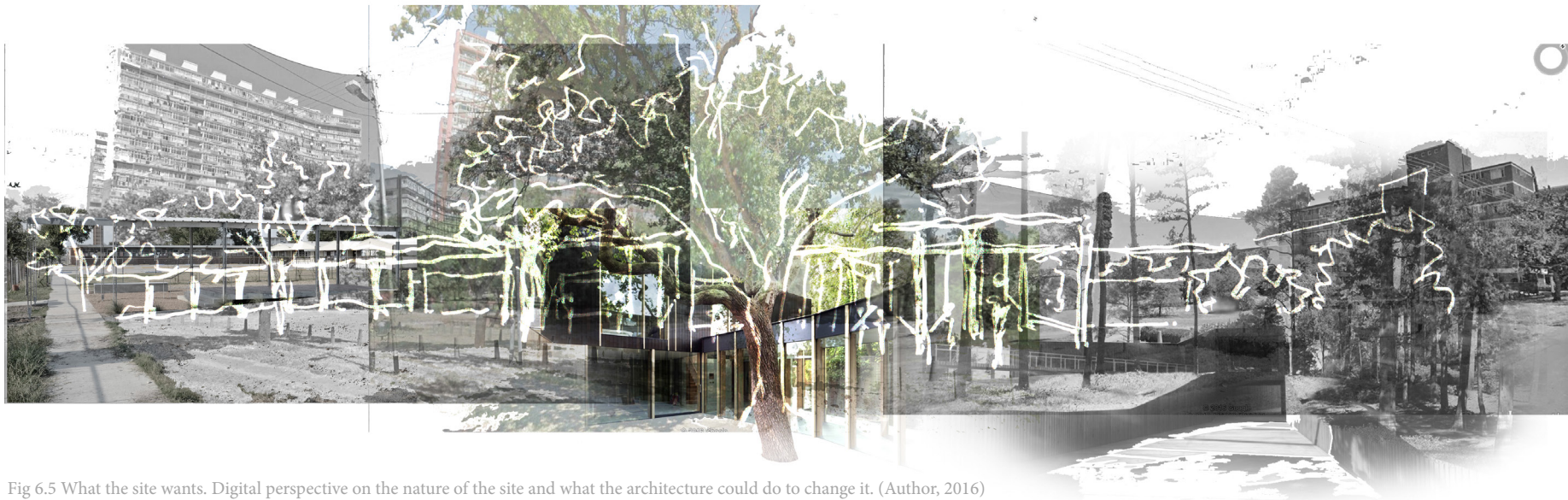

Fig 6.5 What the site wants. Digital perspective on the nature of the site and what the architecture could do to change it. (Author, 2016)

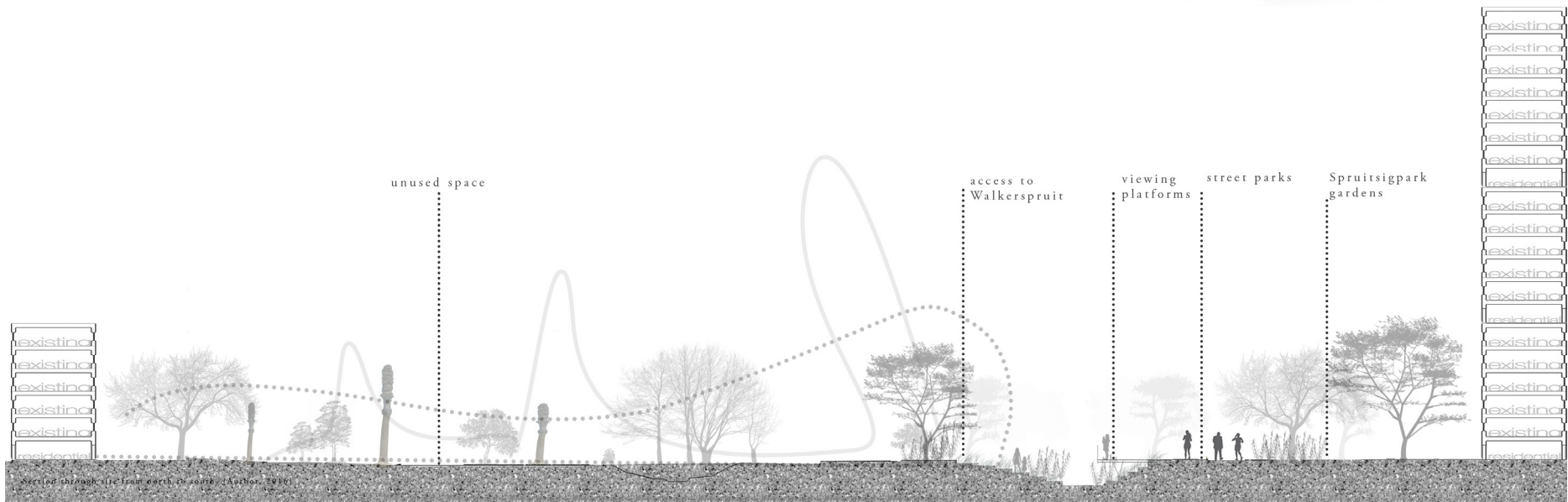

Fig 6.6 Section through site with conceptual diagram illustrating scale differentiations of the proposed design in order to create a sense of scale balance (Author, 2016)

## 6.4 Conceptual Resolution 2

The second intention as shown in Figure 6.2, was to rehabilitate the neglected ecologies and systems that exist on site as well as the river space that has become a barrier by, firstly recognizing the networks that do exist on site (as shown in Fig 6.7) and designing spaces that frame these existing ecologies. Diagrammatic explorations were carried out to show the water meandering through the site, and the architecture framing various spaces of importance. The findings of the nature of the architecture in resolution was 1 was carried forward to this development.

The approach investigated the various ecologies identified on site and where these networks met, spaces of learning could occur. In Figure 6.8, diagrams of these existing networks and how they converged and spread out, influenced the formation of the diagram in Fig 6.7. The diagram makes use of biophilic principles such as visual connections to nature, presence of water, and connections with natural systems.

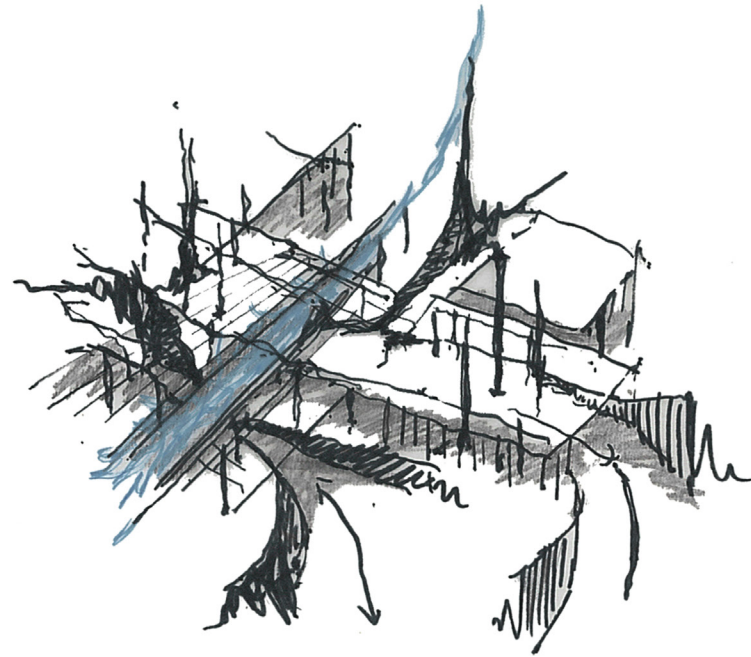

Fig 6.7 Diagram illustrating spaces of ecological potential being framed by the architecture (Author, March 2016)

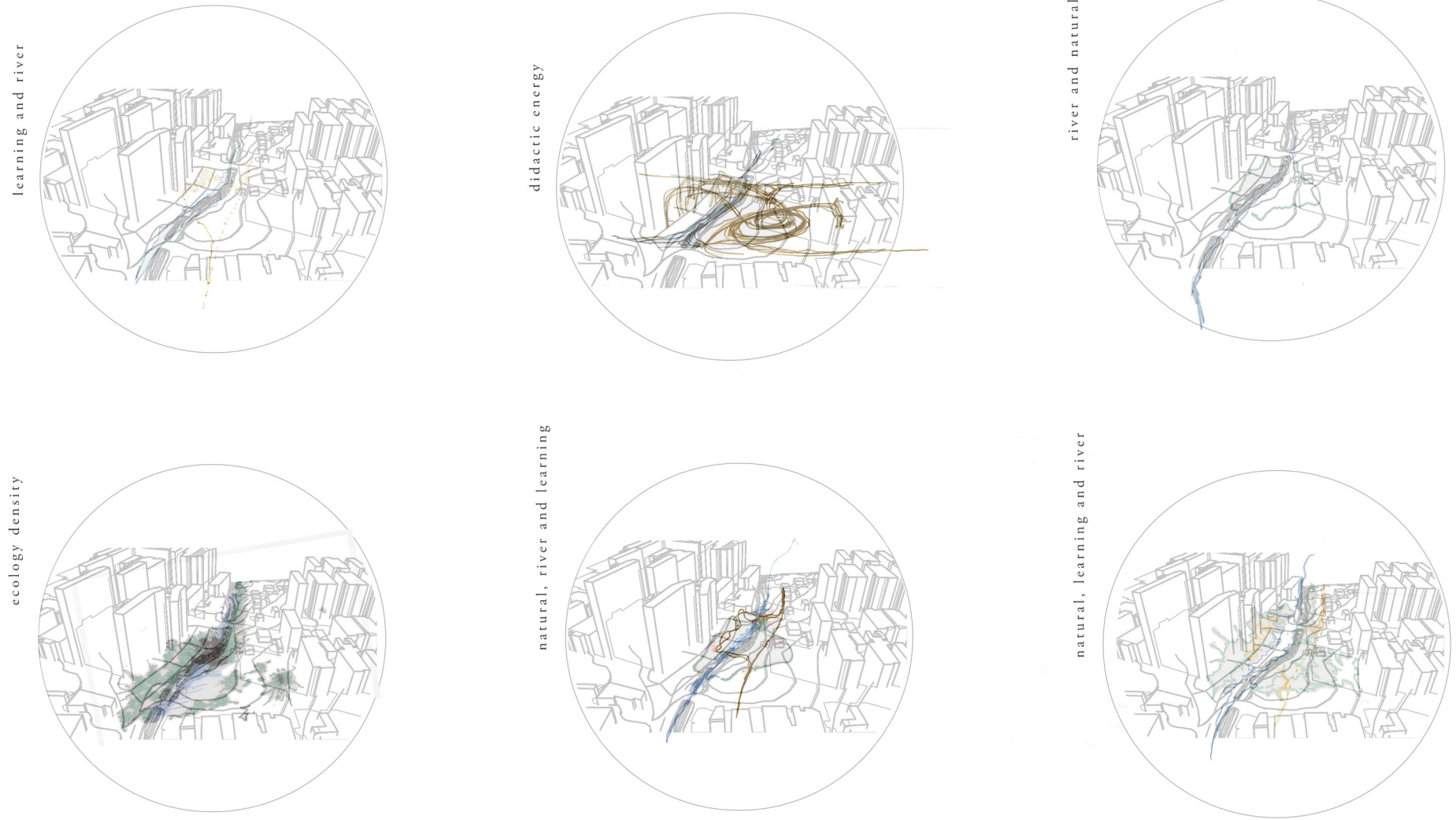
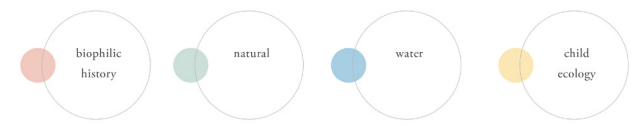

Fig 6.8 Diagrammatic exploration of the networks the four informants on site (Author, 2016)



### 6.5 Conceptual Resolution 3

The third intention as shown in figure 6.9 and 6.10 was to create a landscape that connects the learning institutions by a central route that meanders movement through the site and creating opportunity for spaces along the way that facilitate learning about the natural systems that exist on site. This was in order to resolve the issues such as the schools ignoring the latent potential of the empty site as well as the fact that the site had become a dead space because of the nature of the high-rise apartments. Diagrammatic explorations were carried out to show how space could be funnelled through from the east to the west, following the movement and flow of the river.

The diagrammatic exploration made use of biophilic principles such as prospect and refuge, curiosity and enticement and mystery and peril. These principles are juxtapositions between the nature of spaces. For example prospect and refuge relate to open spaces with views looking out to the horizons and prospect refers to protective spaces to shelter from the elements. The diagrams explore different possibilities between circulation routes of prospect and refuge spaces for classrooms and learning.

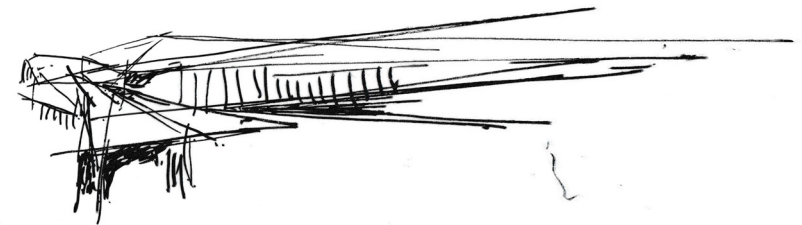
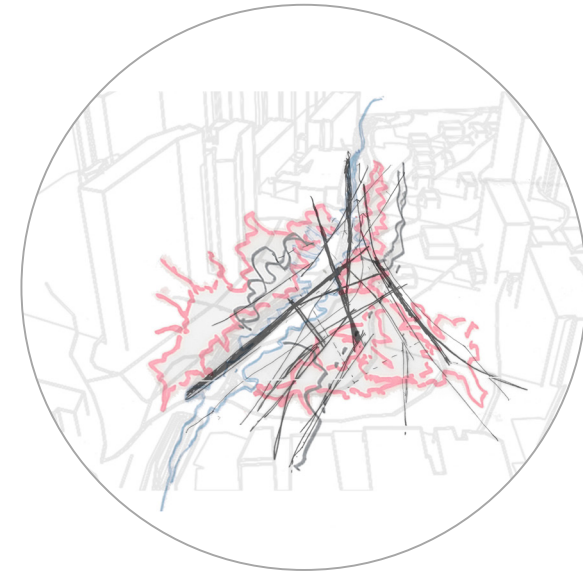
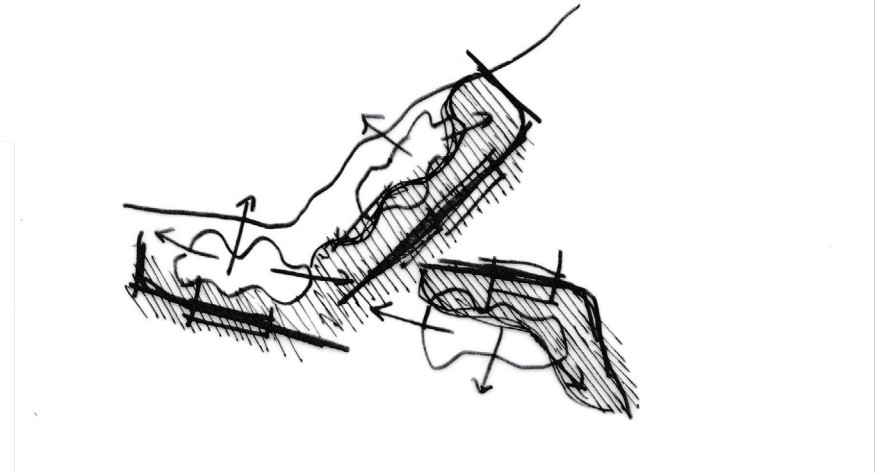

Fig 6.9 Diagram illustrating culminating environments, meandering movement through the site as well as creating spaces of refuge. (Author, 2016)

Fig 6.10 Progression of the exploration of how the program connects to the schools in the area (Author, 2016)





## 6.6 Conceptual Resolution 4

The fourth and final resolution was a combination of all three resolutions taking aspects from each of the preceding resolutions. The natural analogues of the tree, the framing and connection to natural systems of water and tree clusters and lastly the channelling of movement through the site as well as the linking of the different learning institutions through a movement pathway that breaks barriers and links existing childcare institutions.

What resulted was a meandering landscape, deeply connected to its context, a n architecture that sits within nature in various ways, framing ecologies that served as potential learning opportunities, and at the same time connecting the existing schools through a movement pathway. A plan of the resultant diagram is indicated in Figure 6.11 and a perspective thereof is depicted in Figure 6.12.



Fig 6.11 Plan view of final conceptual exploration. (Author, 2016)

Fig 6.12 Perspective of the final conceptual exploration. (Author, 2016)

## 6.7 Final Conceptual Resolution

Through the various investigations of where issues on site were resolved through the biophilic application of the informants (tree, water, child), the translation into a guiding concept formed. The final resolution was the use of the existing natural elements on site to become the “third teacher”. The tree, ground and sky became the teachers, and the child learnt about these elements through an architecture that mimicked the character of each through their physical attributes but also the way they work (natural analogues and biomimicry). This gave rise to the concept of a didactic garden or landscape where the children will learn about the various attributes of the environment around them, building a relationship of love and respect of natural systems (refer to figure 6.13).



Fig 6.13 Diagram of what elements of landscape the child can learn from , relating to site and theoretical investigation (Refer to Chapter 2) (Author, 2016)

## 6.8 Final Conceptual Resolution [Continued]

Translating these three aspects of concept into architecture, according to biophilic principles, are as follows:

**Water:** sculptor and unifier of all aspects of landscape and building. The water will form a sculpting, unifying path through the site, together with a linking walkway.

**Natural Systems:** the trees and the ground form the third teacher and will be framed, rehabilitated and protected through an architecture of biomimicry, ecological connection to place, landscape features that define building form, prospect and refuge and exploration and discovery which are all elements of biophilic design which relate to the two intended biophilic dimensions which are place-based relationships and human nature evolved relationships (Refer to Chapter 2)

**The Child:** Integration of cognitive development through the facilitation of learning taking place, immersed in natural surroundings. The learning will take place through the awareness and sensory stimulation that the landscape elements, as well as the architecture, will facilitate.



water as sculptor of



ecosystems and their processes



natural habitats that trees provide



therapeutic effects of plants and trees



the child biophilic beings

Fig 6.14 Water, the tree and the child design translations. (Author, 2016)





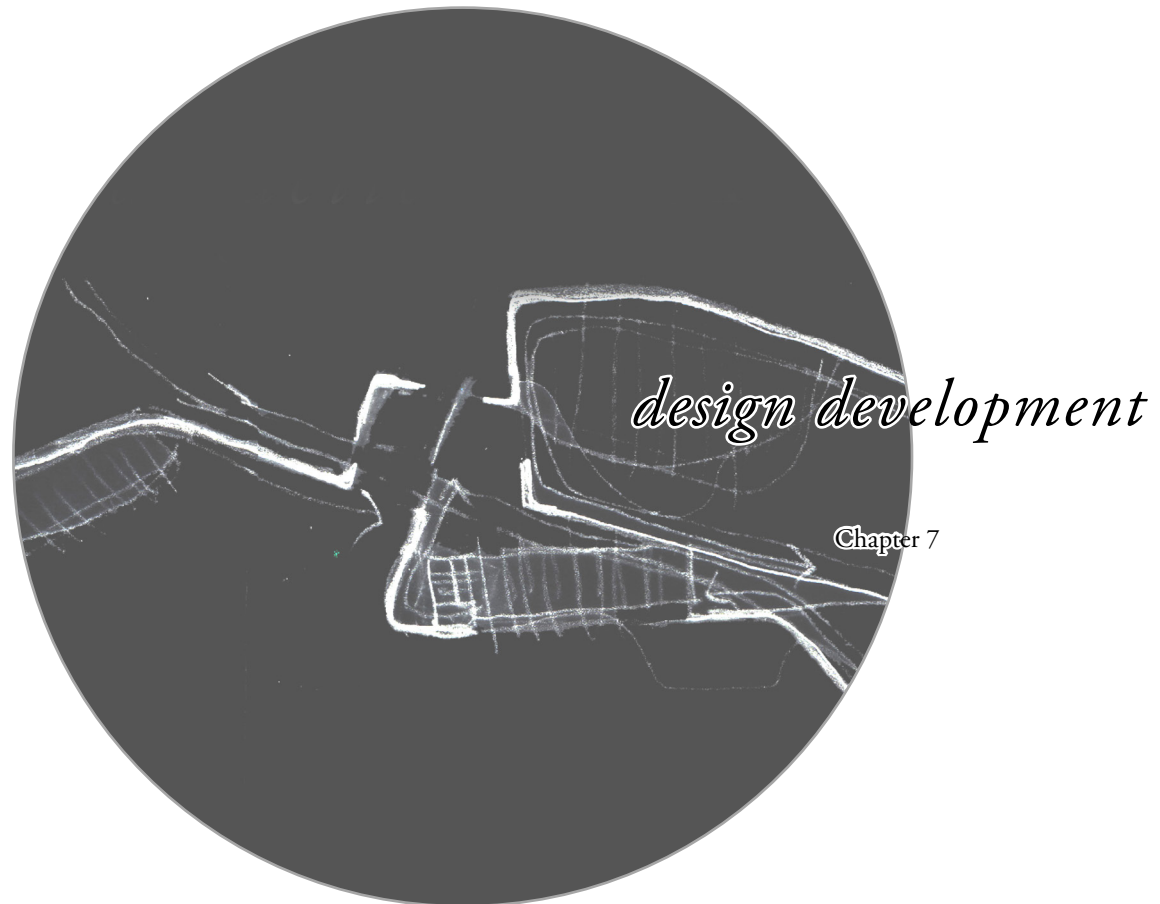

Fig 7.1: Design development sketches. [Author, 2016]

“And I dream that these garden-closes  
With their shade and their sun-flecked sod  
And their lilies and bowers of roses,  
Were laid by the hand of God.”

Dorothy Frances Gurney  
(Willis, 2006: 11)



## 7.1 Introduction

In the following chapter, the final conceptual resolution was translated into a more refined architecture in two different ways. First by taking the landscape elements that exist on site and forming an architecture that aims to re-appropriate them into non-prescriptive landscape elements that facilitate experiential play and the second translation which, instead of re-appropriating the landscape as separate elements, garden spaces of specific identities were identified and translated into architecture.

Each translation is critiqued in terms of the concept and a final design decision was made.

## 7.2 Design Translation 1

Water: sculptor and unifier of all aspects of landscape and building.

Natural Systems: the trees and the ground form non-prescriptive landscape elements that can be interpreted differently through the different scenarios created by children through experiential play.

The Child: Integration of cognitive development through the facilitation of experiential play taking place, immersed in natural surroundings. The learning will take place through play in the architecture that mimics the physical attributes and the functions that each landscape element plays in the larger ecosystem that makes up the site as well as creates sensory awareness of systems, physical characteristics and their place in a larger ecosystem of each landscape feature.

The Architecture: Through this conceptual approach, notional plans were explored, together with the initial placement of programs, as well as the design of the garden in order to develop spaces to facilitate learning. They are a further development of the fourth conceptual approach which combined the approaches of the other preceding conceptual diagrams. The central movement pathway remained key to the design of plan

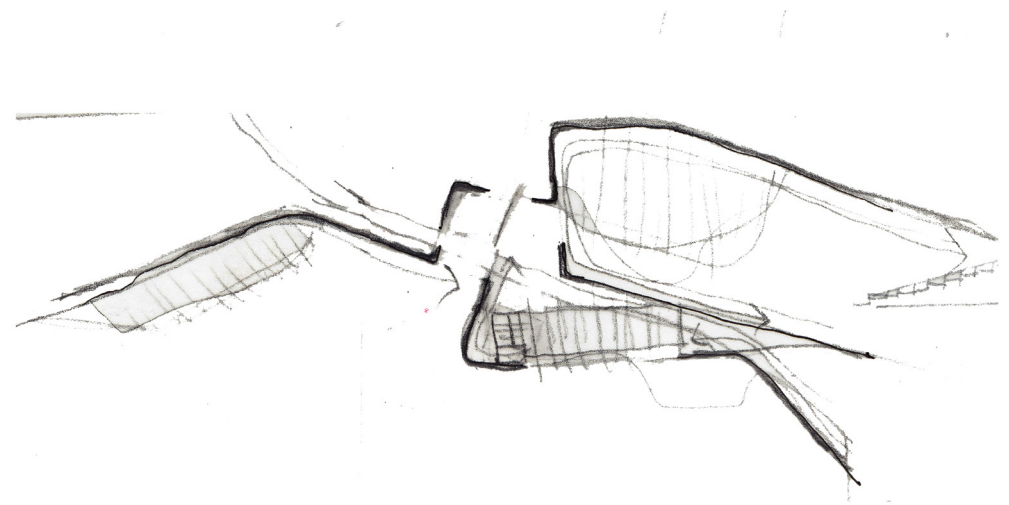

Fig 7.2 Development of plan (Author, 2016)

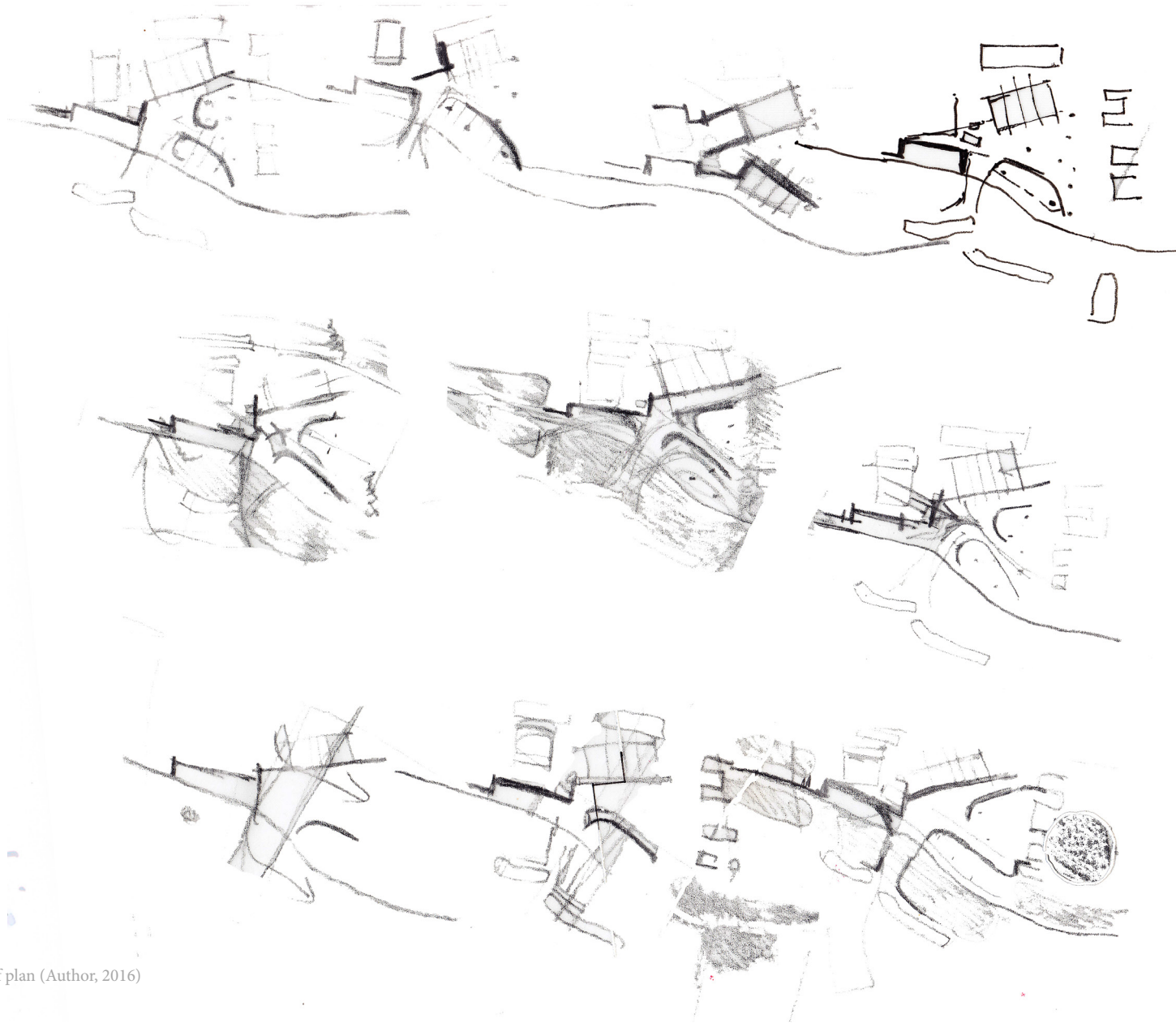

Fig 7.3 Development of plan (Author, 2016)

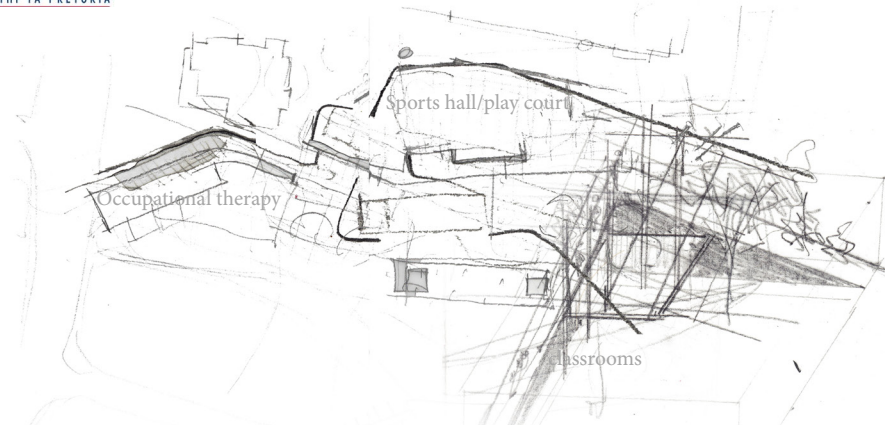

Fig 7.4 plan development, with sports hall becoming the dominant feature on site. (Author, 2016)

## 7.2.1 Architectural development

The four conceptual resolutions, developed the plan, section and garden further. The architecture began to form into stereotomic, guiding walls that meander through the landscape, forming alongside the central movement pathway. These were juxtaposed alongside spaces made up of light tectonic columns and light roofs, letting in natural light from high level windows. The Reggio Emilia classrooms sat as a light structure in the landscape, where the sports hall had a heavy backing towards the flats on the northern side, due to the corner being mostly cast in shadow. The occupational therapy suites, to the west, had a heavy wall to the rear, opening up towards the river to create private spaces for therapy and making use of the river as a therapeutic mechanism.

The play court, at the time, was in the form of a large sports hall with indoor seating and changing facilities below. It formed the largest space on site with a ramp that connected to the street park on the east. In Fig 6.14, the sports hall is seen on the top right of the image, connecting to the street condition. In Figure 6.15, the section of the sports hall alongside the classrooms is shown. In an earlier section, the basic principle of the architecture is explored, with lightweight towers resolving issues such as scale, as well as serving as didactic water tanks.

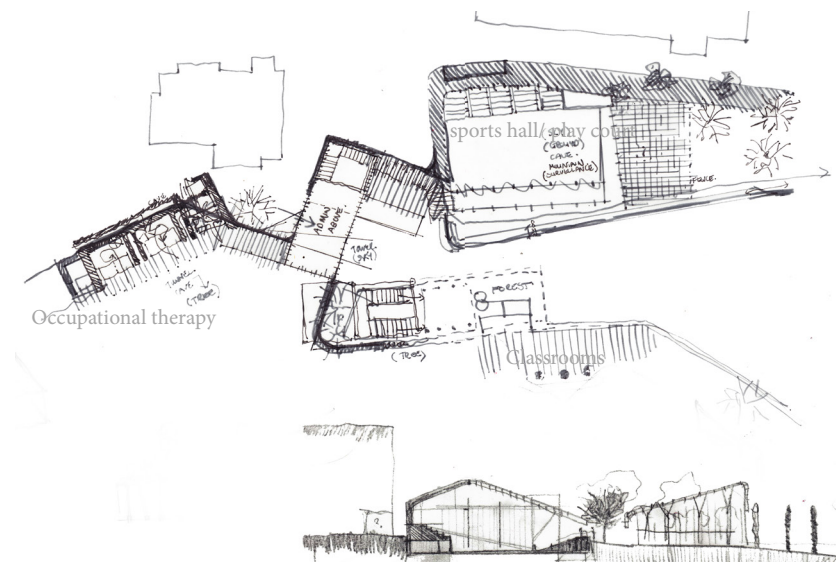
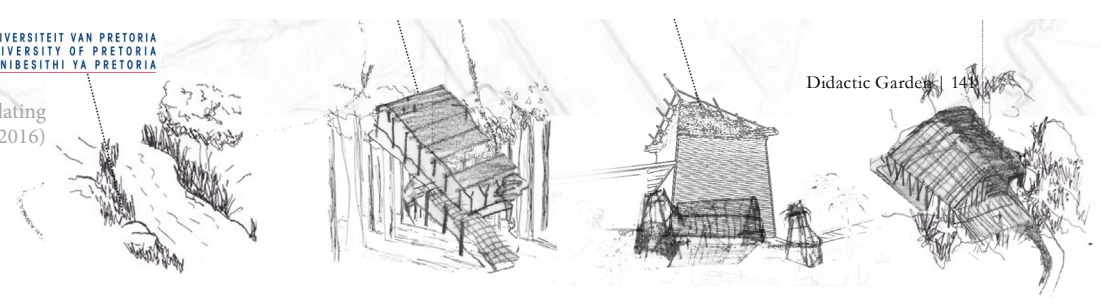

Fig 7.5 Section development, showing relationships between tectonic and stereotomic. (Author, 2016)

Fig 7.7 Archetypal landscape elements relating to architectural language (Author, 2016)



## 7.2.2 Typological development

Due to the investigations in Chapter 4, the benefits of abstract objects in the environment was identified as beneficial to children’s play as they form a non-prescriptive platform for children’s play to take place, offering an environment which stimulates cognitive development in children while at the same using the natural setting to ignite the child’s biophilia.

In an attempt to create a meaningful architectural language that is appropriate to children and the site, archetypal landscape objects that related to site conditions were identified as the forest, the cave, the river, the tower. In Fig 6.17 these archetypes are identified and translated into architectural form that mimic the physical attributes of each to stimulate imaginative play, and therefore learning, in and around the buildings. The physical and functional attributes of each were explored in terms of what the child can learn from each archetypal form.

Four key natural elements on site (namely the tree, the river, the sky and the ground) are related to the key informants on site as well as incorporating typological resolutions from the conceptual diagrams.

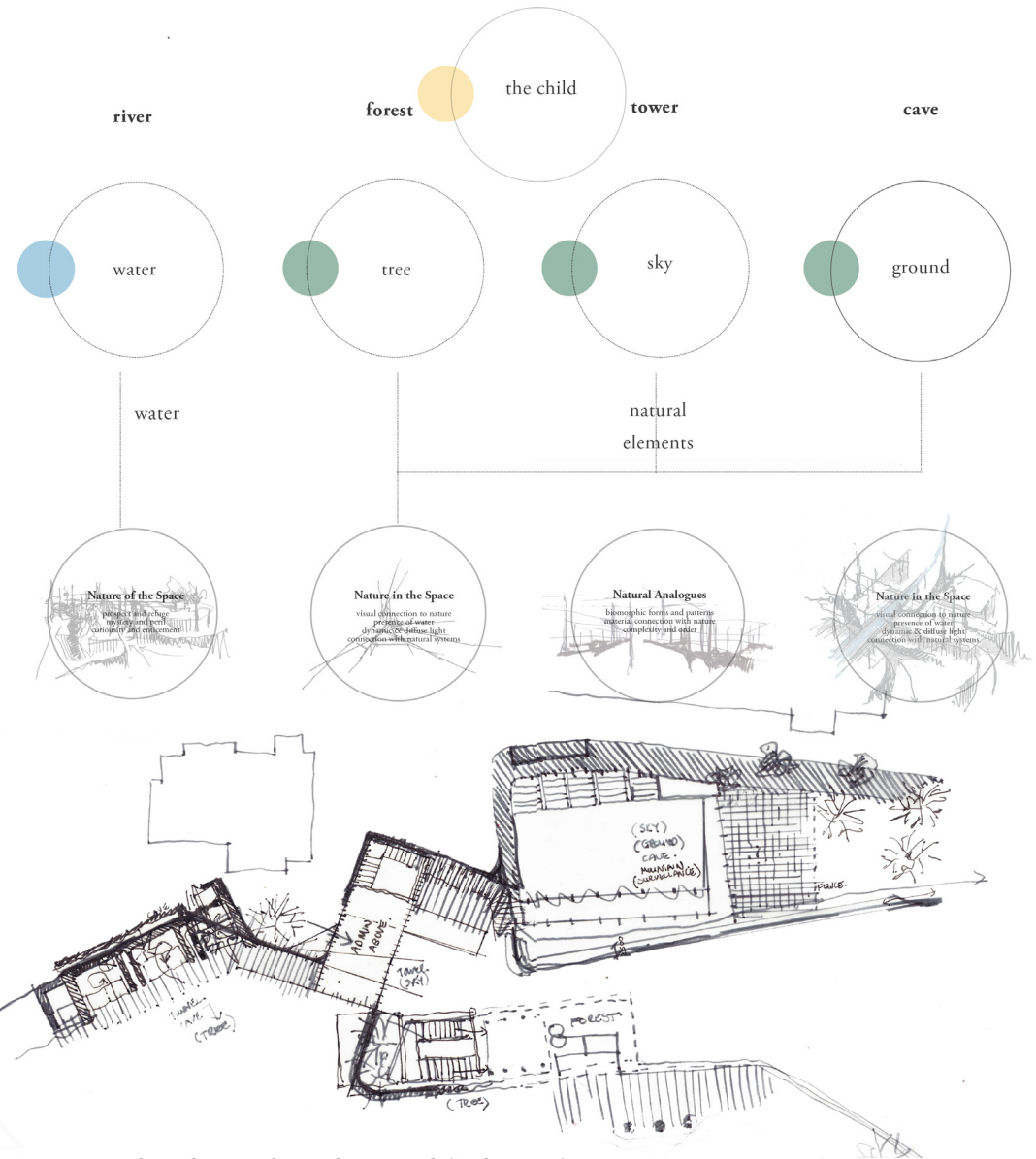
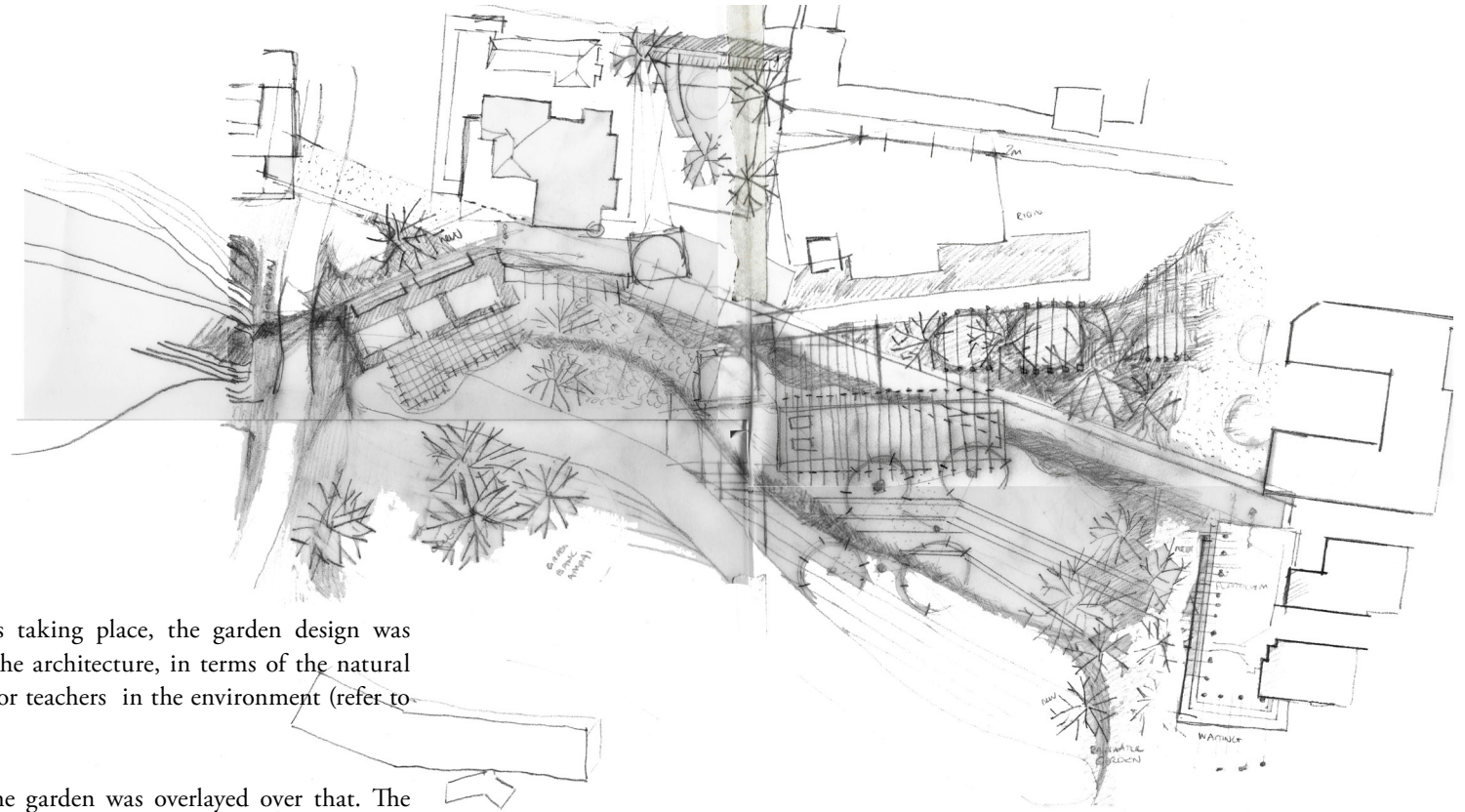

Fig 7.6 Resultant plan according to this approach (Author, 2016)



Fig 7.8 Resultant Aerial view of site (Author, 2016)



### 7.2.3 Garden development

While the design of the architecture was taking place, the garden design was concurrently being designed as a layer to the architecture, in terms of the natural elements of site becoming didactic entities or teachers in the environment (refer to figure 7.9).

The architecture was designed first and the garden was overlaid over that. The central movement pathway remained key to the ordering of the garden design. The result of this approach proved to be problematic due to the building becoming more of a sculpture in the landscape rather than part of the landscape, which were not the intentions, shown conceptually in Figure 6.11 in Chapter 6.

Fig 7.9 building outlines, guiding the garden design  
 (Author, May 2016)

### 7.3 Final Resolution of Translation 1

The following figures (fig 7.10 - 7.15) show the final resolution of translation 1 of the concept. The architecture resulted in a design that did not completely integrate itself with its landscape and became a sculptural form in the landscape, appearing to be placed on top of rather than part of the landscape. A different translation was needed to be investigated in order to create an architecture more connected to site and more didactic in essence.



Fig 7.10 Site plan (Author, June 2016)





Fig 7.11 Section bb through site (Author, June 2016)

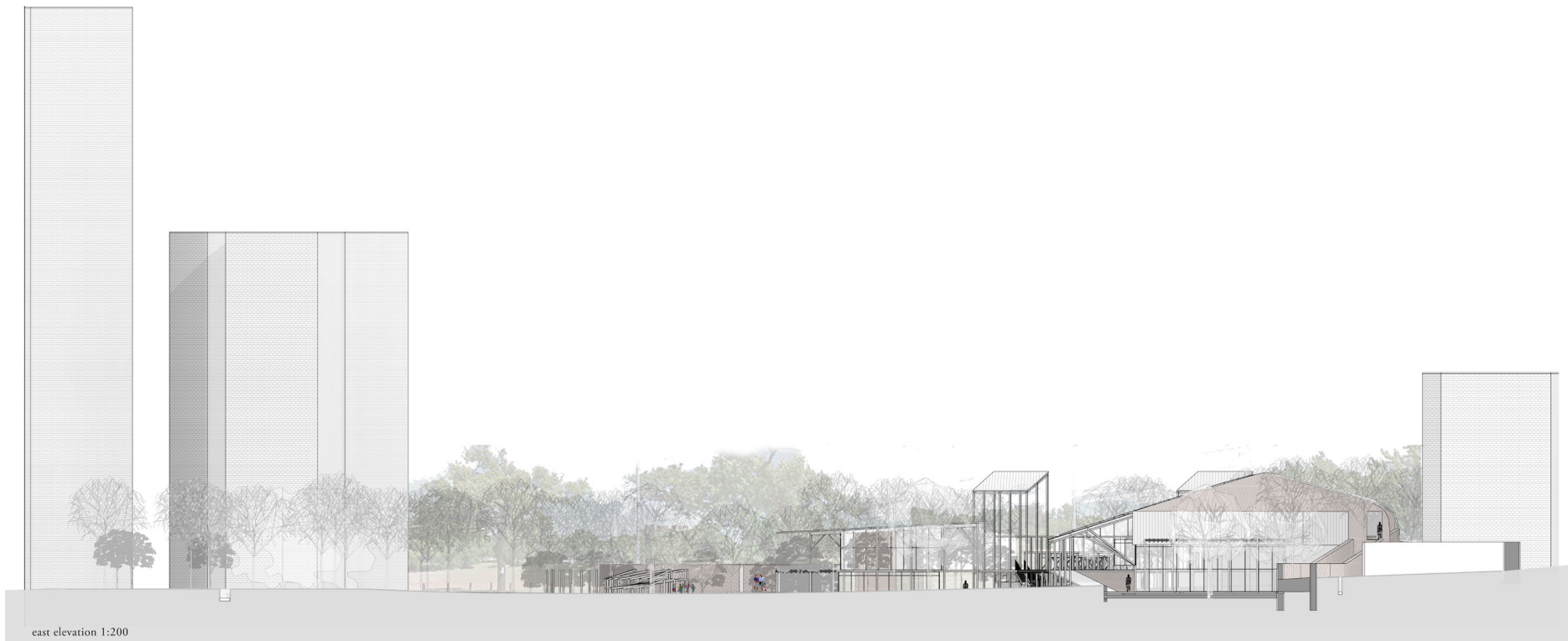

Fig 7.12 West elevation (Author, June 2016)

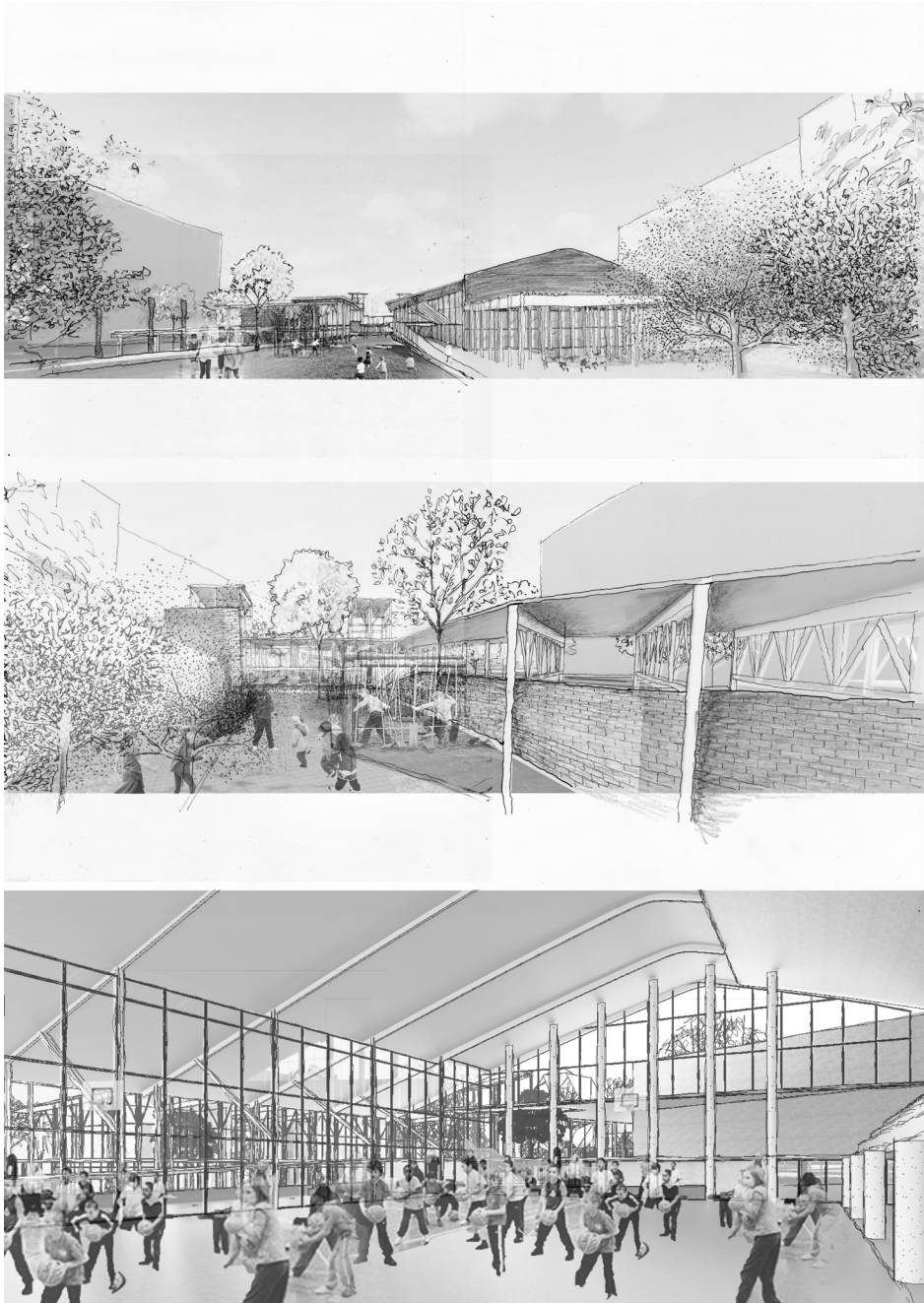

Fig 7.13 Perspectives of approach from street on east side, approach from western side and sports hall respectively (Author, June 2016)



Fig 7.14 Site perspective aerial view (Author, June 2016)

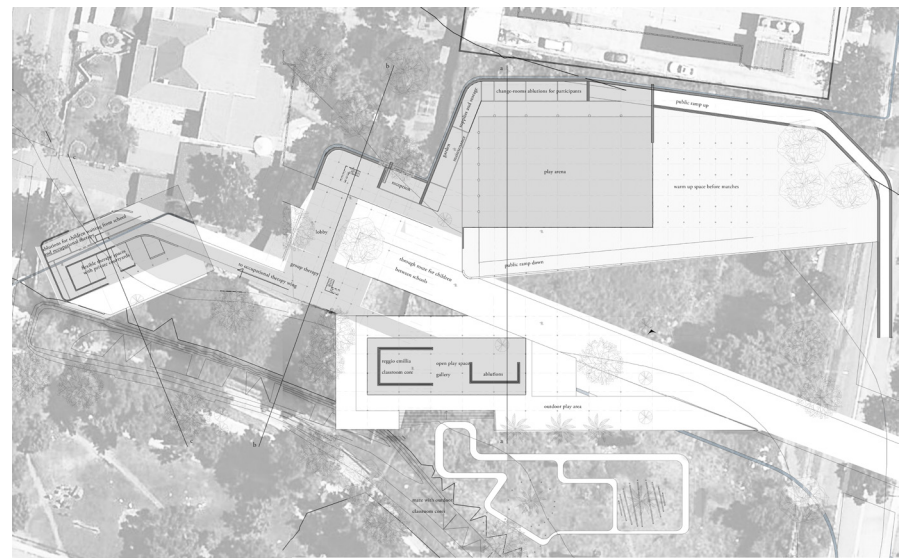

Fig 7.15 Ground floor plan (Author, June 2016)

## 7.4 Design Translation 2

In an attempt to connect the architecture to the site, the concept was translated through a different response. Instead of the building coming first and the garden being designed as an overlay to building, the garden spaces were identified first for their didactic potential with the building following suit.

The child and the spaces perceived by children was addressed through the investigation of the site in terms of potential didactic “garden” spaces. An identity for each “garden” was derived from, firstly, the natural elements that already existed in each garden and secondly, how the importance of natural ecologies and systems can be taught through their rehabilitation and conservation. The architecture fills the role of the latter by facilitating the didactic rehabilitation, awareness and conservation of each garden space. A central movement pathway that served as the linking element between the existing child institutions in the areas, was designed to serve two functions rather than simply circulation. It serves as a connection between the existing schools, a way in which physical barriers between child and nature is reconnected and secondly, it serves as an architectural ordering device which connects each garden while at the same time establishing control of form.

Each garden received an identity according to the nature of the garden space. The nature of the gardens gave rise to how and what activities of learning will take place in the architecture that framed and facilitated each garden.

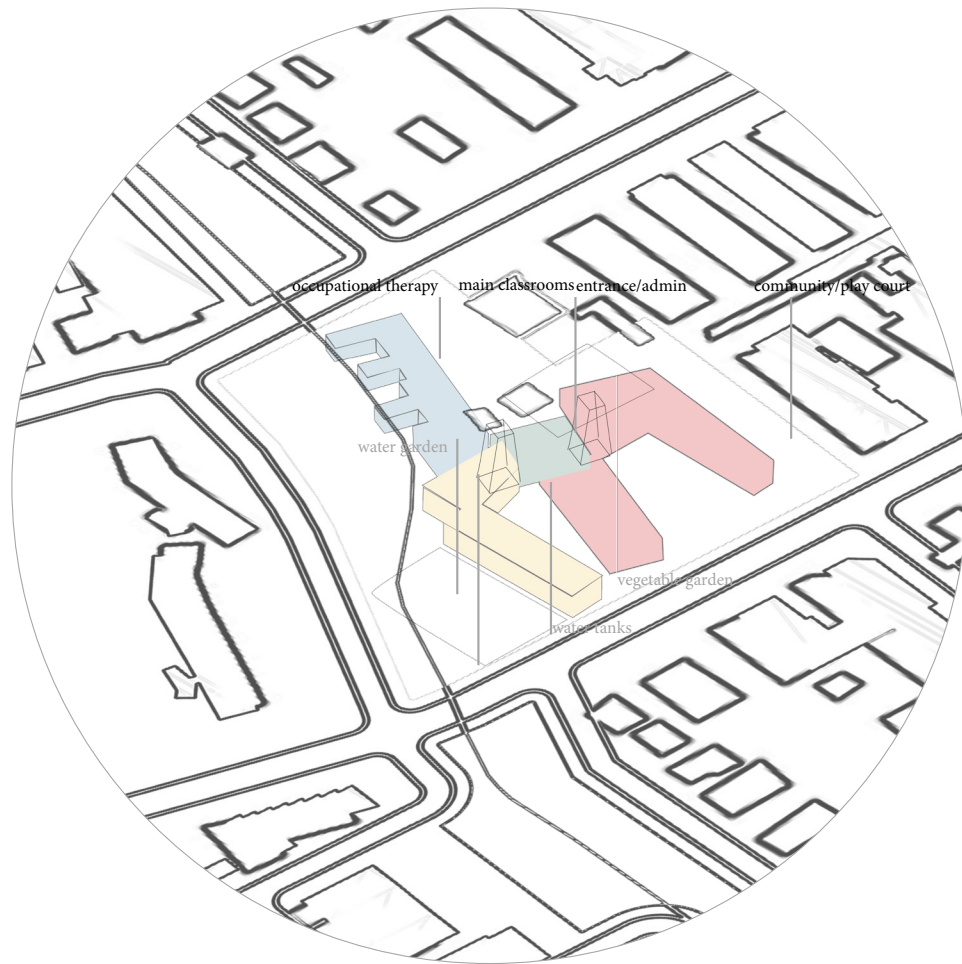

Fig 7.16 Development of program layout according to design translation (Author, 2016)

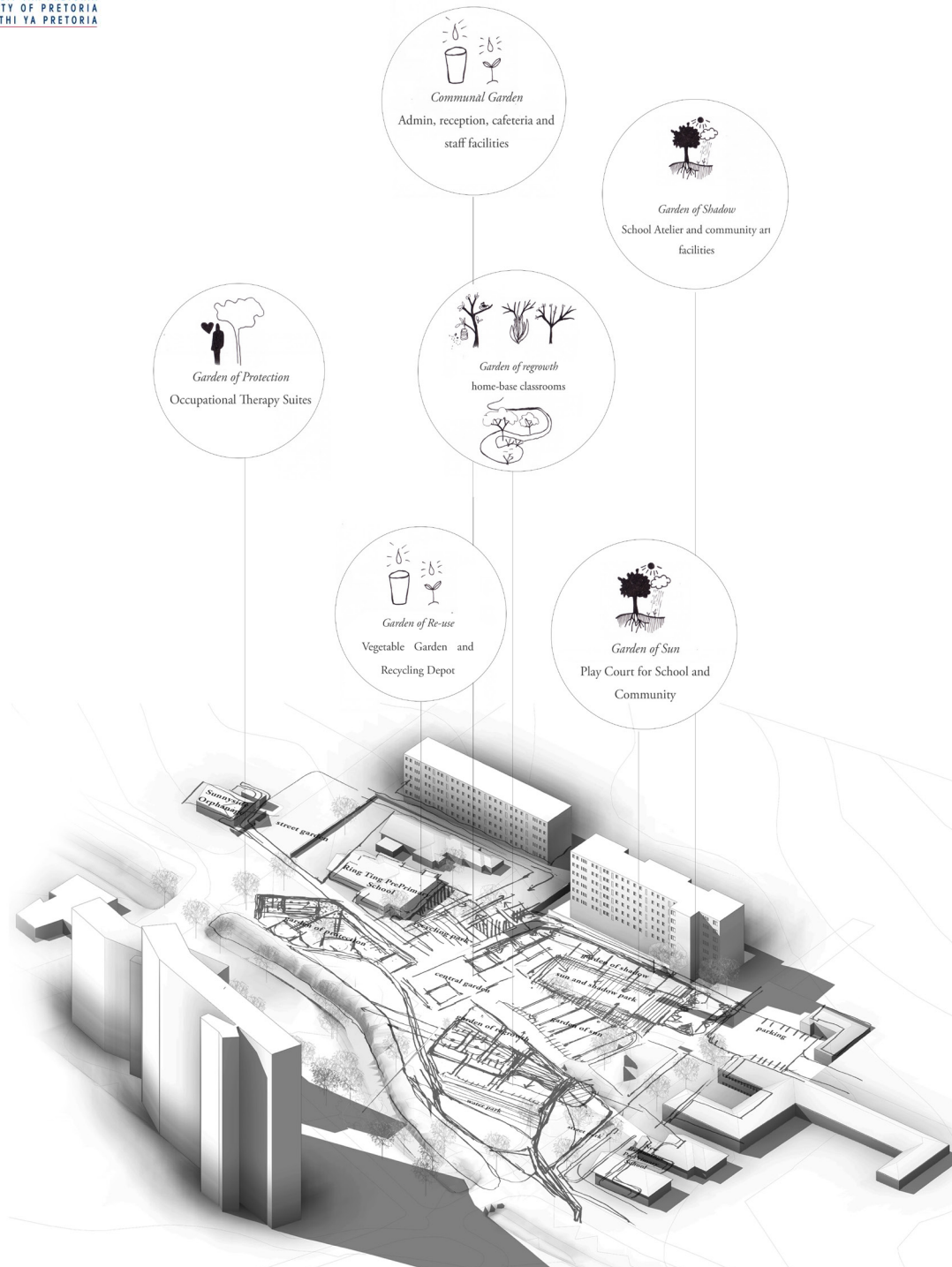

Fig 7.17 Identified gardens as the third teachers with the buildings facilitating learning (Author, August 2016)

## 7.5 Development of Final Design Resolution

Through the identification of each garden and the building which facilitates the learning of the nature of the garden, the language of the architecture needed refinement according to each garden's identity together with the linking pathway that offers views to the different didactic garden conditions.

The conceptual resolutions resulted in the design of the section following a combination between the biomimicry of the vertical and horizontal axis of the physical, emotional and functional aspects of the tree (Fig 7.18). This developed into a more refined 3D resolution to the scheme as well as answering the question: what is learnt in each garden and the biophilic approach to how it can be learnt (Fig 7.19). The tree is analysed in terms of tectonic and stereotomic relationships that are mimicked in the architecture. In section, the roots of the tree as well as thick trunks are identified as stereotomic elements as well as in plan, where the trunks and roots serve as service cores to the canopy or roof above, transporting minerals and water from the ground to its branches. The architecture will have stereotomic service cores serving the learning spaces juxtaposed to lighter, tectonic materials becoming dependent on these in terms of function and structural support.

*Concept gardens*

*What is learnt*

*How it is learnt*

*Vertical*

*Horizontal Axis*



The garden was identified due to three date palm trunks remaining after a fire. One of nature's wonders include the life that grows back after fire. The contrast between living and dead needs to be evident to show how new life can occur after death and how fostering the new life is crucial. Sensory and biophilic awareness of nature is established through site, touch, smell of plants, and the sound of water moving.

Together with the primary tectonic concept, the structure will foster the new life or regrowth through the incorporation of a planted shading system or living skin fixed to the facade of the building, where the plants are supported by an formally light steel beam system. The skin will puncture the interior as well as form shading on the outside. The aim is that the skin will be maintained by the children.

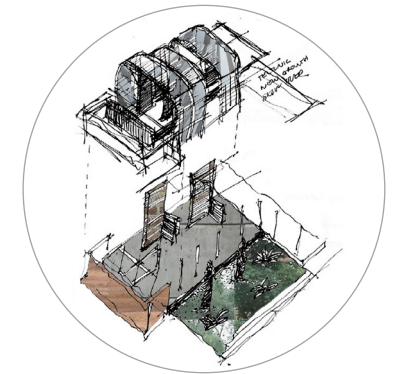
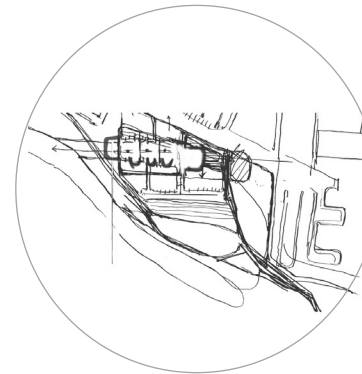

This garden aims to orientate the user, both child and staff, to the rest of the school by becoming a datum point of identification and control. What can be learnt through this garden is its centrality and communality. The services of the building are provided from this point and is made visible. Sensory and biophilic awareness is established through a central focus point on the site where the integration of parts to whole is gives a datum

Together with the primary tectonic concept, the structure will be heavy and grounded with two tall tectonic towers on either side serving a multitude of functions: first to hold the water tanks at pressure, then to contain circulation routes to the first floor, to become towers of identity and relation and lastly to balance the scale difference on the site by the alteration of scale between the towers and the rest

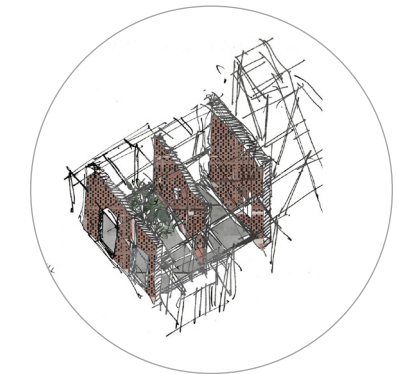
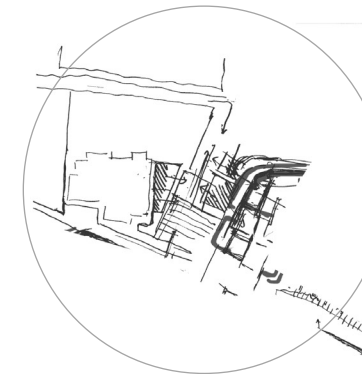
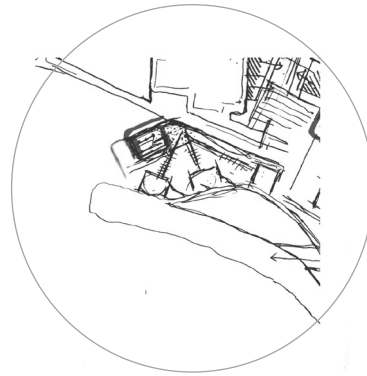
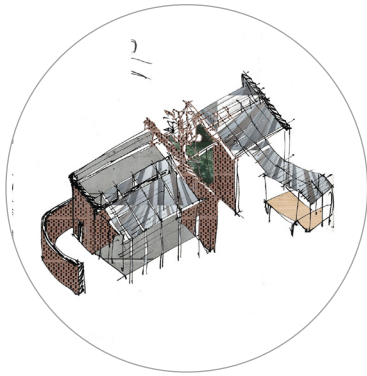
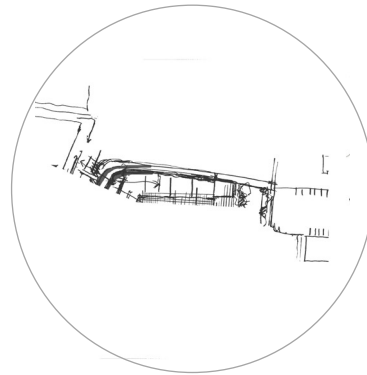
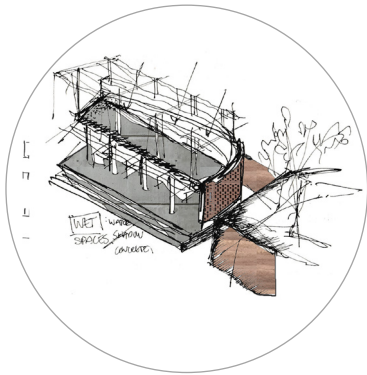

Fig7.18 Tectonic concept diagrams for each of the spaces



This garden aims to make the child aware of the protective nature of trees and how they allow you to breathe and relax. This was identified due to the protective nature of the cluster of trees situated here. The occupational therapy program allowed for the layout of the therapy rooms around clusters of trees so to create awareness of trees at the same time of positive therapy treatments. Biophilic principles include

Together with the primary tectonic concept, the structure will be heavily backed by a strong guiding wall and lighter elements or pods that branch off from this that sit in the landscape. The architecture aims to group therapy pods around trees so to create an awareness of the positive effects that trees have as well create a sense of prospect and refuge through the juxtapositions of stereotomic and tectonic.



The garden of shadow aims to teach how elements of the earth or ground can aid in growing new life. The garden is chosen due to the area on site cast in shadow of the neighbouring buildings. Therefore earthy, grounded activities will occur in this garden. Biophilic principles include prospect and refuge and landscape features defining building form.

Together with the primary tectonic concept, the structure will be predominantly stereotomic to mimic the shadow cast by the buildings as well as to allow dirty or wet activities to occur such as clay art and growing plants that like to shady conditions so as to clean out easily. A light steel structure will sit on the roof as

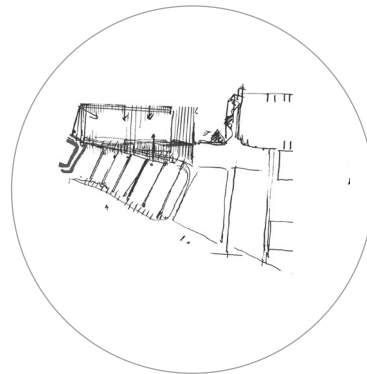
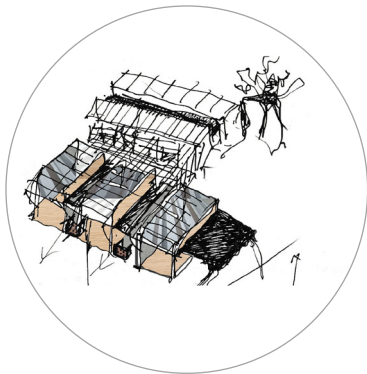

The garden of sun was identified due to the large area of ground almost always in sun. The movement of the sun throughout the seasons will be learnt in this garden and how the sun's movement will create an understanding and bring about biophilic connections. This deals with a multitude of biophilic principles such as ecological connection to place and landscape features and natural processes defining building form.

Together with the primary tectonic concept, the structure is an extension of a timber pergola system with timber beams and columns forming kinetic classrooms that each have timber screens that can be adjusted by the children themselves. This allows for direct engagement with the sun's movements.



*Concept gardens*

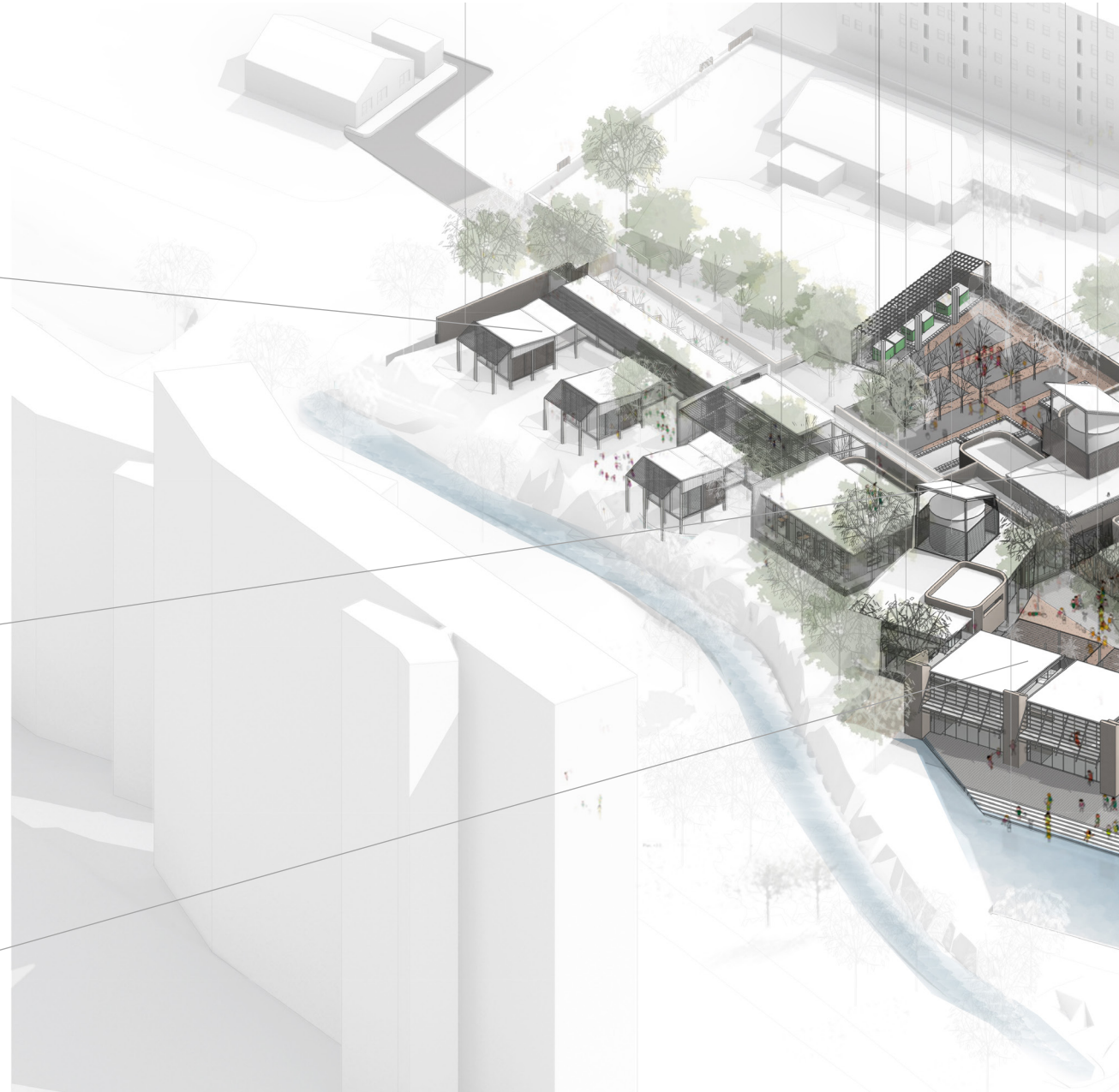



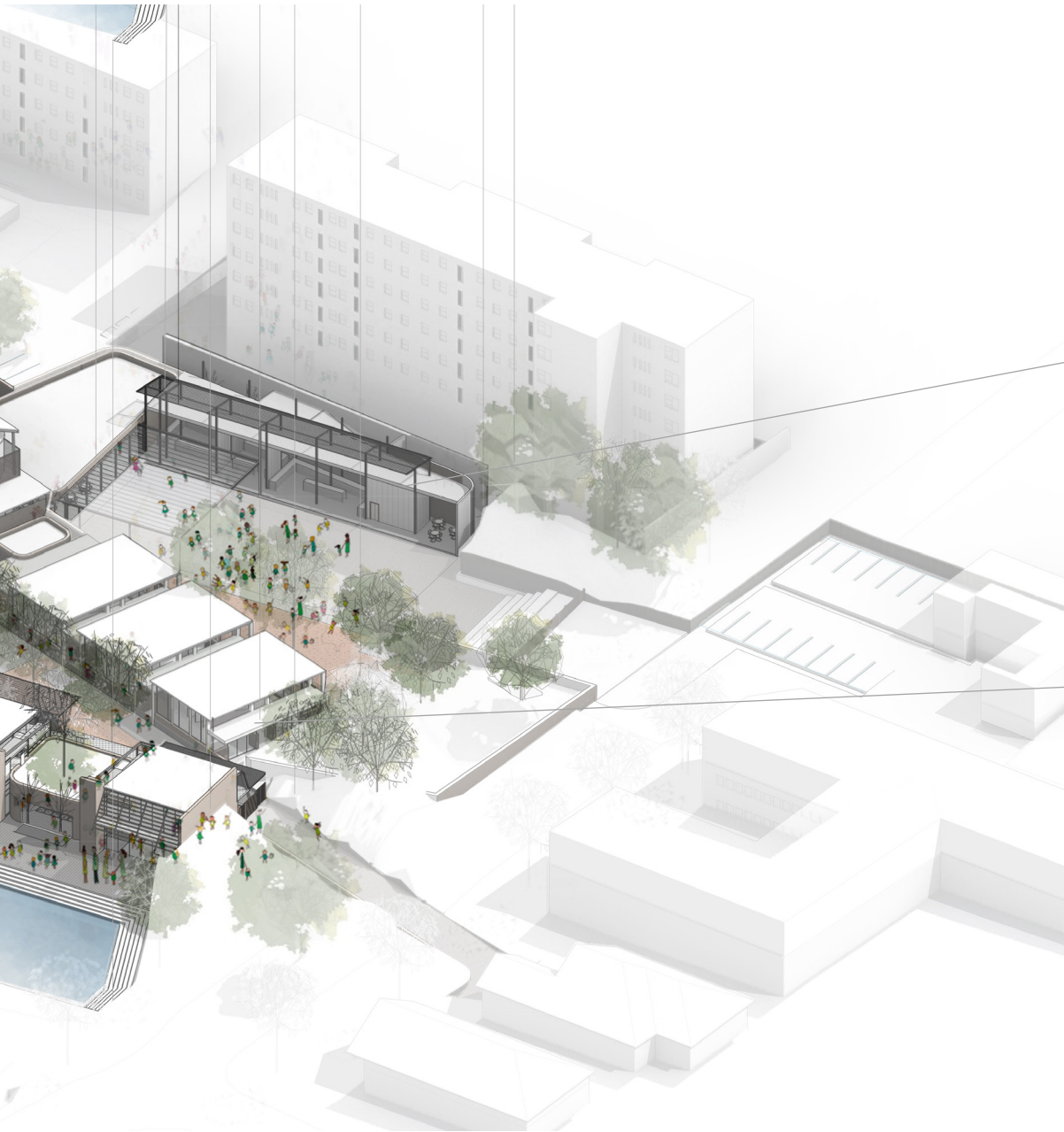

*Concept gardens*



*Garden of Shadow*

School Atelier and community art facilities



*Garden of Sun*

Play Court for School and Community

Fig 7.19 3D view of building indicating each garden and what is learnt in each and the biophilic approaches to methods of learning (Author, 2016)

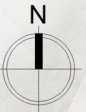
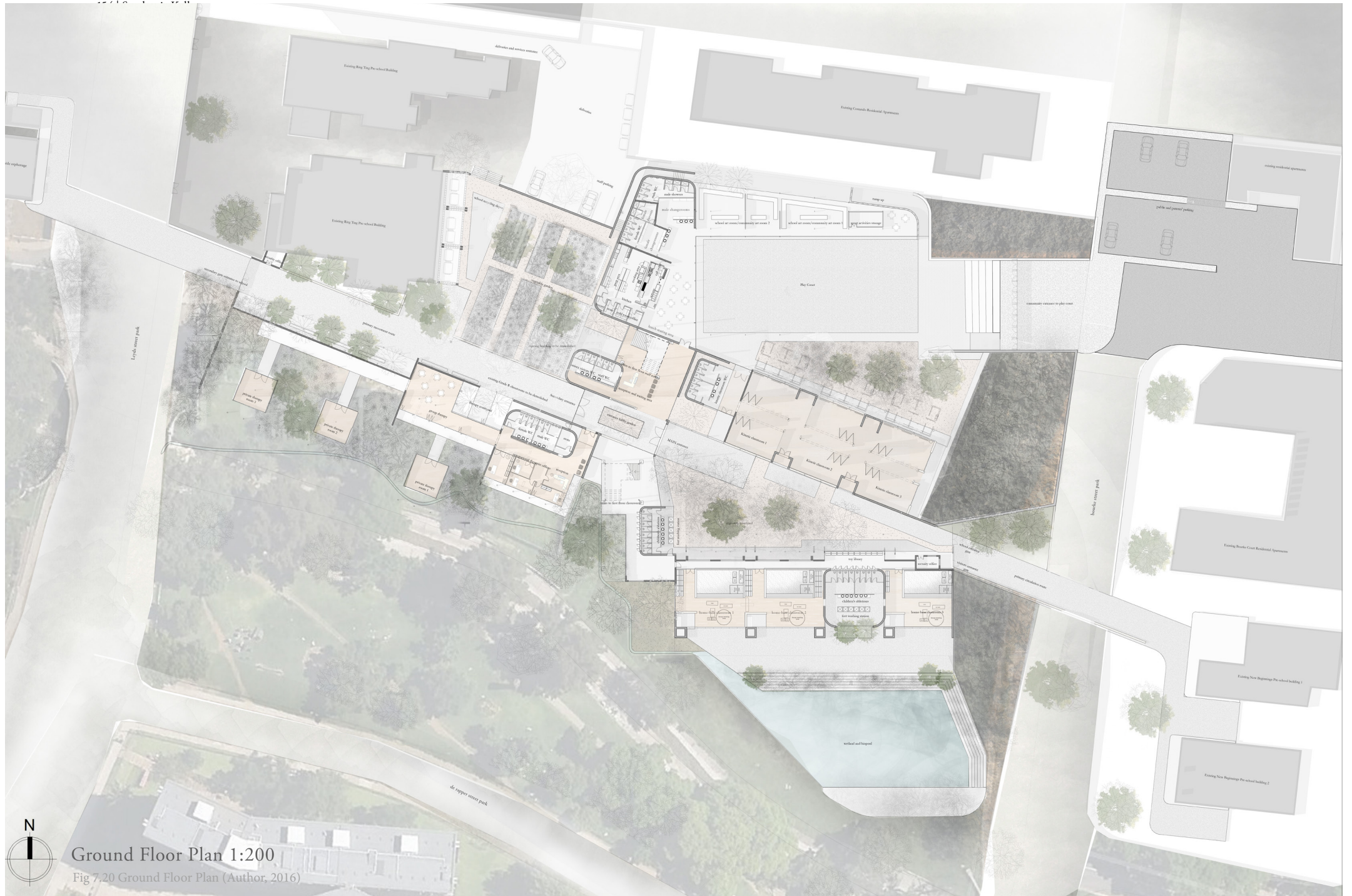

Ground Floor Plan 1:200

Fig 7.20 Ground Floor Plan (Author, 2016)



First Floor Plan 1:200  
 Fig 7.21 First Floor Plan (Author, 2016)

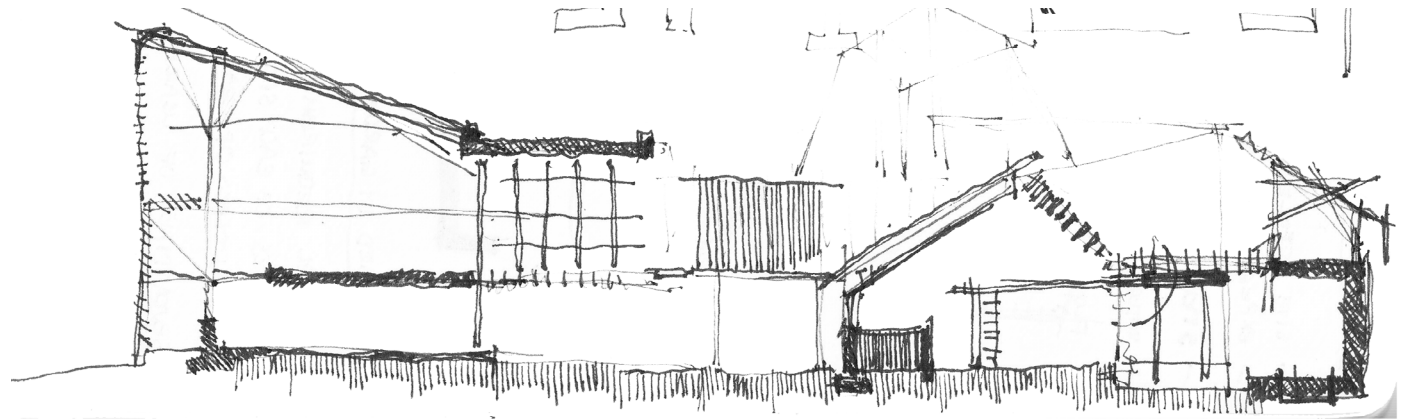

Fig 7.22 Initial design sketch of vertical axis resolution (Author, 2016)

## 7.6 Development of the Section

The vertical axis (or section) was developed according to how the architecture can facilitate the learning of each garden and how the learning of the garden can make the children aware of the benefits of nature through biophilic and/or sensory stimulation. In Figure 7.19 an in-depth exploration into each garden is carried out according to the biophilic/sensory qualities of each. The design translations and conceptual resolutions are all taken into account in this exploration. The exploration is also related to the specific aspects of the landscape that can be learnt by the “biophilic being” i.e. the child.

At first, the section was a simple angled roof that created a singular space that opened up towards the river. The large column that supported the roof has secondary supports to form the shape of a tree. The second level was proposed as a lighter timber suspended floor that sat separately from the primary envelop of the building (refer to Fig 7.22)

As the section developed, the structure slowly began to develop together with the design. The kinetic classrooms developed alongside the main classrooms (shown in Fig 7.23) as an extension of an outdoor pergola space, connected to the language of the play court. The shape of the towers as an element of identity for the school developed as steel framed structures with angulating columns supporting the tanks above.

In Fig 7.24, the section began to develop into the latest section resolution which is the incorporation of the solar stack as part of the stereotomic support for the roof as well as service core and the roof began to form a canopy like structure, branching off from the dominant stack. The kinetic classrooms became a flat roofed structure in order to not take away from the hierarchy of the main classrooms and also to form a more integrated extension of the outdoor play court, blurring the thresholds between inside and outside with pivoting doors that open up to the outside according to the season and time of day.

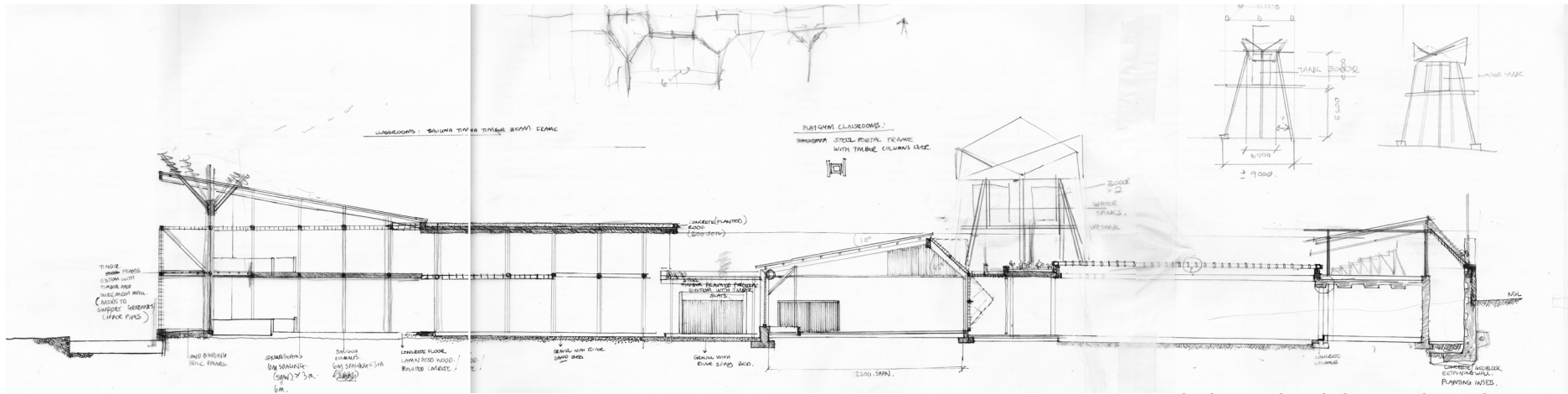

Fig 7.23 section development through classrooms, kinetic classrooms and atelier (Author, 2016)

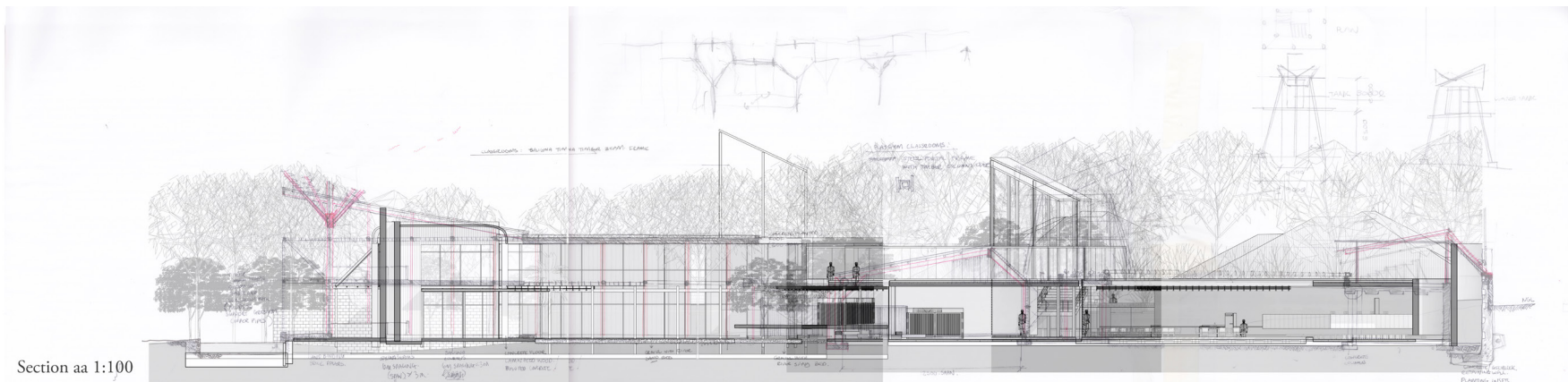

Fig 7.24 section development through classrooms, kinetic classrooms and atelier (Author, 2016)

## 7.7 Development of the route

The route serves as the linkage and ordering device to the different wings of the plan. It connects all the existing didactic elements together as well as the new. The route also aims to capture the biophilic qualities of each garden as the user moves through the site.

Walking along the route, from east to west, it begins at the New Beginnings pre-primary school. At first the route is more of a platform that attaches itself to the old school. This represents the old model of learning, disengaged from the surrounding environment. The platform slowly becomes steps that lead down to the paved pathway. As the user walks west, towards the new school, the topography on either side of the path begins to morph to becoming a gateway to the site, allowing only the pathway itself to cut through. The didactic gardens are hidden at first but as one moves through the site, the gardens open up and the essence of each becomes visible. When you reach the first garden (the garden of regrowth) the pathway's paved surface becomes gravel and grass, opening up and merging with a courtyard on the right. Three dead date palms stand tall in the centre of the courtyard with new classrooms framing the space and at the time, juxtaposed as their façades are shaded with a screen of living plants, currently being watered by the children. On the left hand side is the kinetic classrooms, with glimpses of children jumping through hoops and over

logs are caught through the open-able walls, some wide open to allow the cool breeze from the courtyard to filter through into the classrooms. Moving further along, the route is met with a folding glass door, that is the entrance of the school. Once inside, there are three medium sized leopard trees that look up to an open atrium with sunlight filtering through from above. The route moves outside again, through another smaller glass door and opens up to the left to an urban vegetable garden where children are seen planting carrots and spinach that will in a few months time be cooked and eaten for school lunch. The old Ring Ting pre-primary school is seen beyond the vegetable garden with small-scale brick shelters attached to its facade. There, one can see children helping the teacher to move plastic bottles to the one shelter and cardboard to the next all to be later recycled. On the right, benches are placed along a low wall running beneath a timber pergola. Beyond the low wall, to the left, one can see children taking part in occupational therapy sessions taking place underneath a cluster of trees as well as in small timber screened buildings scattered in the landscape. After taking a rest on the bench in the shade, one walks beyond the vegetable garden and small recycling depot, and catches a glimpse of the Sunnyside orphanage where children are gathering on a verandah platform that attaches to the building's facade, with steps leading down to the same pathway once more.

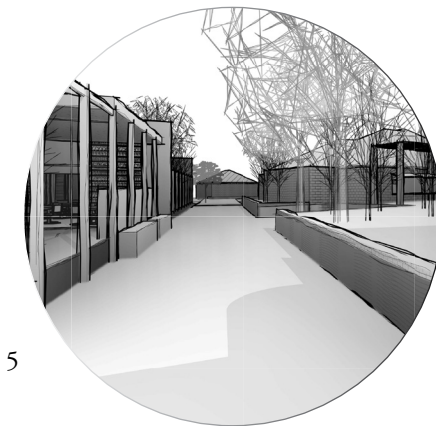
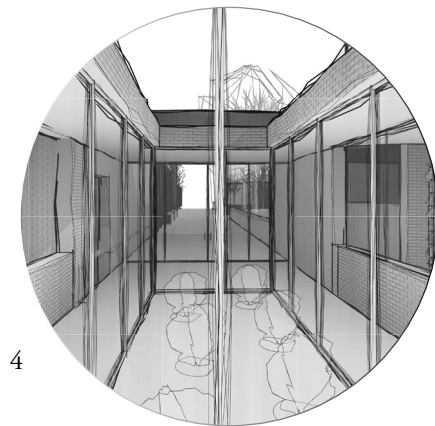
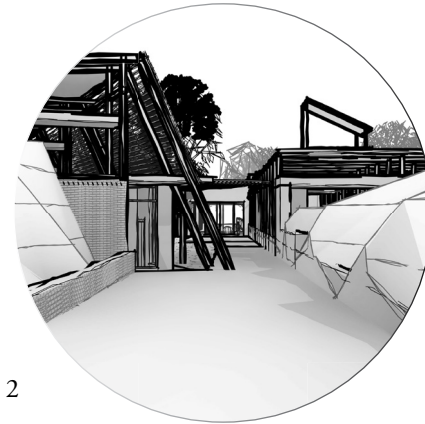
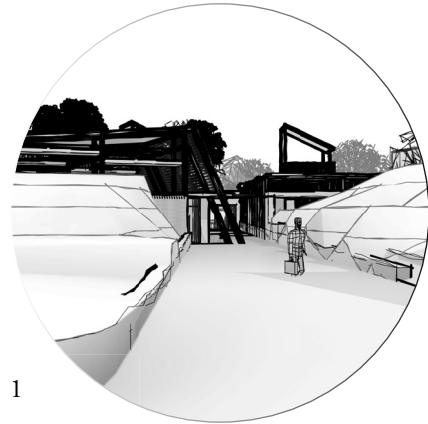

Fig 7.25 Route exploration (Author, 2016)

## 7.8 Home-base Classroom development

The exterior of the classrooms design was influenced by the identity of the garden that the classrooms frame. The garden of regrowth was centred around the classrooms having a living skin that becomes part of the building's facade as well as penetrate into the classrooms spaces. The roof canopy developed from pivoting roofs to a more integrated roof and skin system that fully incorporated the skin with the roof to emphasise the continuity of the roof as a canopy. The solar stack became not only a passive climate control mechanism but a design resolution in the modularity between each classroom, serving as the service core between each classroom space.

The interior of each classroom was dealt with according to the Reggio Emilia design guidelines which require classrooms awash with natural light as well as indoor plants and plenty of storage space for materials and display spaces for the children's art. With this in mind, as well as the exact activities that will take place in the classrooms according to the schedule (refer to Chapter 4), the classrooms were designed in terms of blurred thresholds between quiet and noisy spaces as well as between more private spaces and more public spaces to hold group activities such as painting and drawing (refer to Fig 7.29). The quiet, private spaces are designed for reading and nap times. This condition is evident in the home-base classrooms. Each classroom contains a service core that facilitates shelving for children's day bags, materials and books. The reading/napping space drops lower to create a separation between the loud activities and the quiet ones.

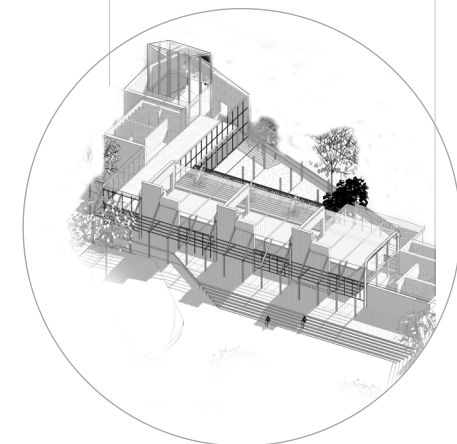
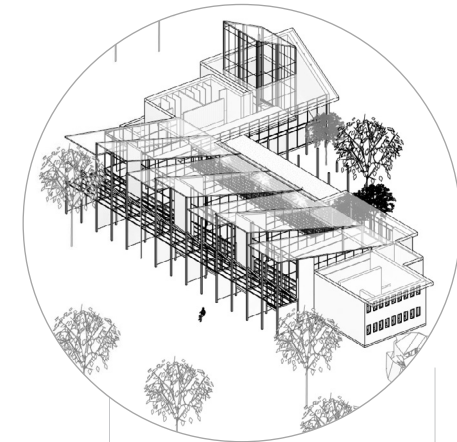
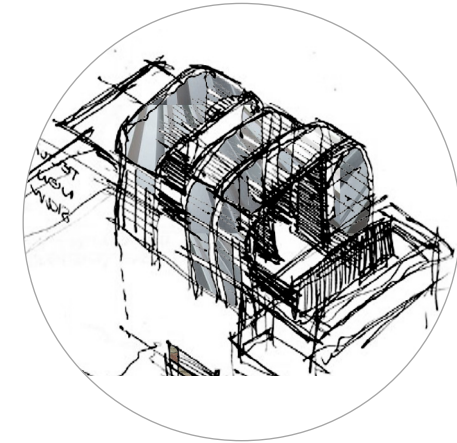

Fig 7.26 development of the classroom building from sketch phase to final design phase (Author, 2016)



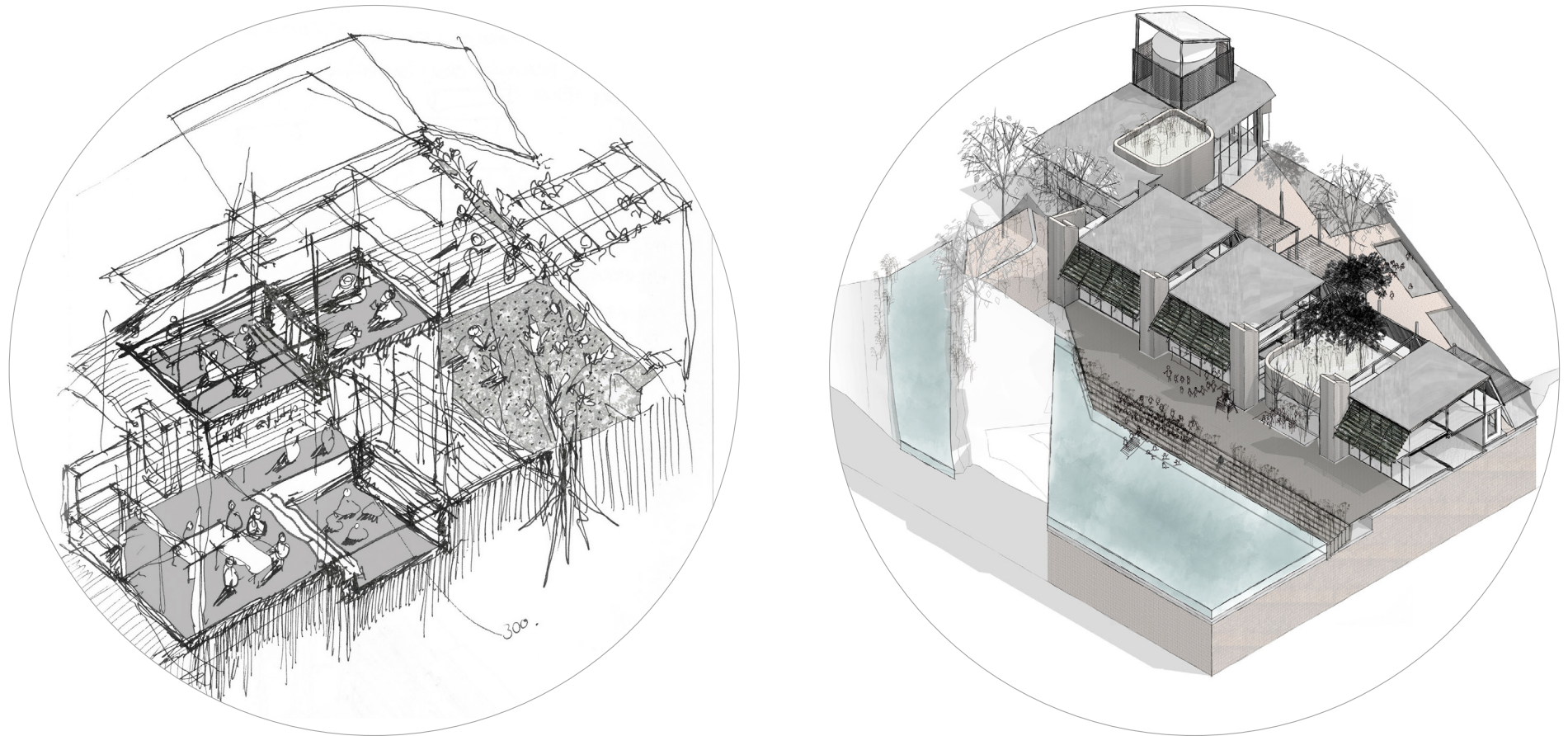

Fig 7.27 Final development of the classrooms and the activities that take place within them (Author, 2016)

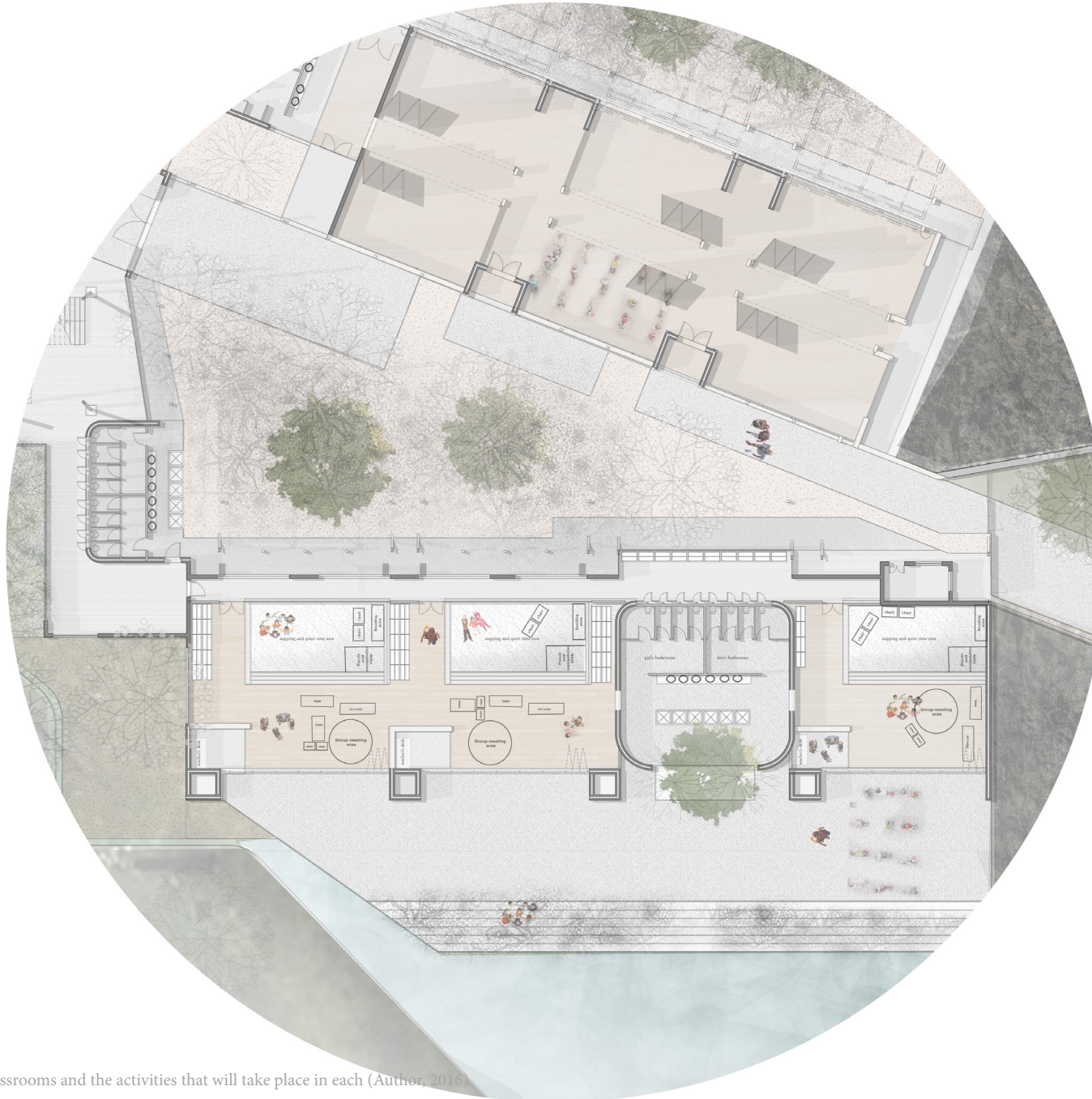

Fig 7.28 Zoomed in plan of classrooms and the activities that will take place in each (Author, 2016)

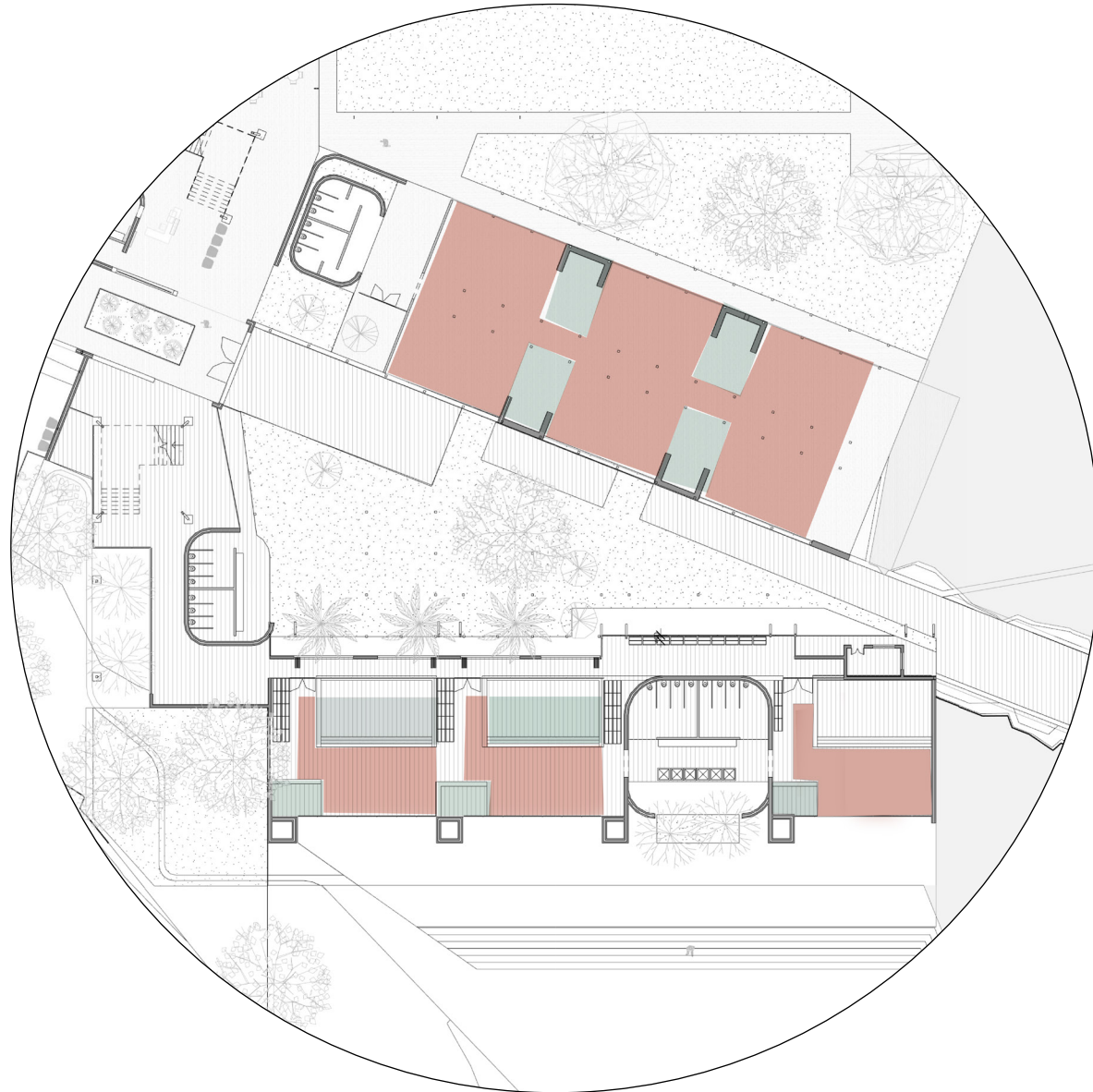

Fig 7.29 Diagram showing quiet(green) and noisy(red) spaces in the classrooms  
(Author, 2016)

## 7.9 Wet vs. Dry Spaces

The activities with regards to wet vs. dry activities were split between the schools main atelier and the water park outside the home-base classrooms becoming the wet spaces accommodating for activities that accommodate for easy cleaning of the children and the spaces after the activities have taken place. Attention to finishing materials needs to be given to ensure easy cleaning to take place such as self-levelling concrete screed for the main-atelier and brick paving for the water park (refer to Fig 7.30).

The wet and dry spaces were also placed according to the identity of the gardens. The wet spaces are placed firstly closest to the river as well as in the area on site cast in shadow. Both these spaces are dealing with wet spaces in different ways, one being water and the other being wet ground. Therefore the art activities taking place will consist of small scale clay pot making and large scale painting.

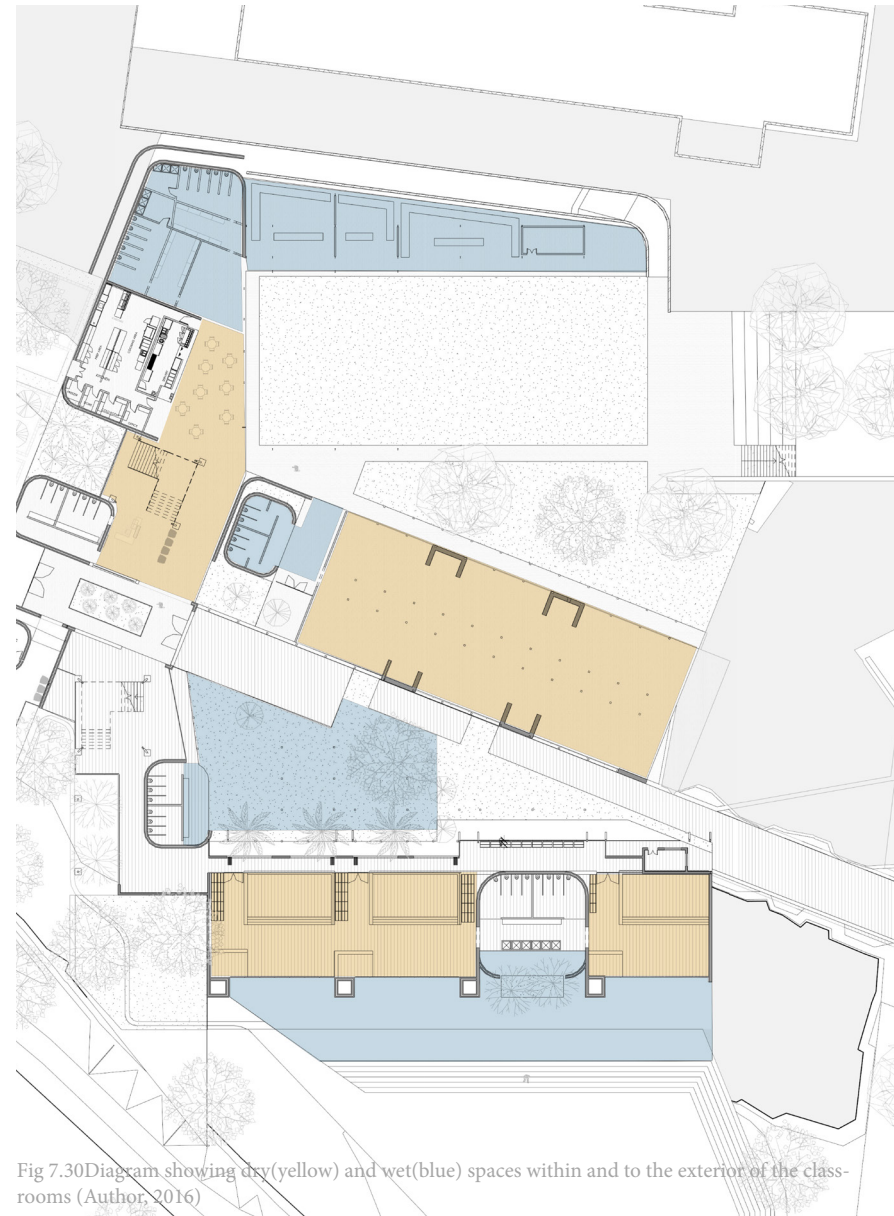

Fig 7.30 Diagram showing dry (yellow) and wet (blue) spaces within and to the exterior of the classrooms (Author, 2016)

## 7.10 Interior and Exterior Circulation

In terms of circulation, each classroom is accessible via the courtyard on the northern side, however, a undercover corridor is also provided and provides access to each classroom alongside the courtyard space to provide connection to natural spaces even in rainy weather (refer to Fig 7.31).

In the image, it can be seen that internal circulation is formalised while external circulation is a lot more haphazard and organic, showing how the planning of landscape planning allows for free movement while internal circulation frames the organic movement of the garden while guiding the user along a rigid path.



Fig 7.31 Diagram showing interior(blue) and yellow(exterior circulation routes and suggestive routes (Author, 2016)

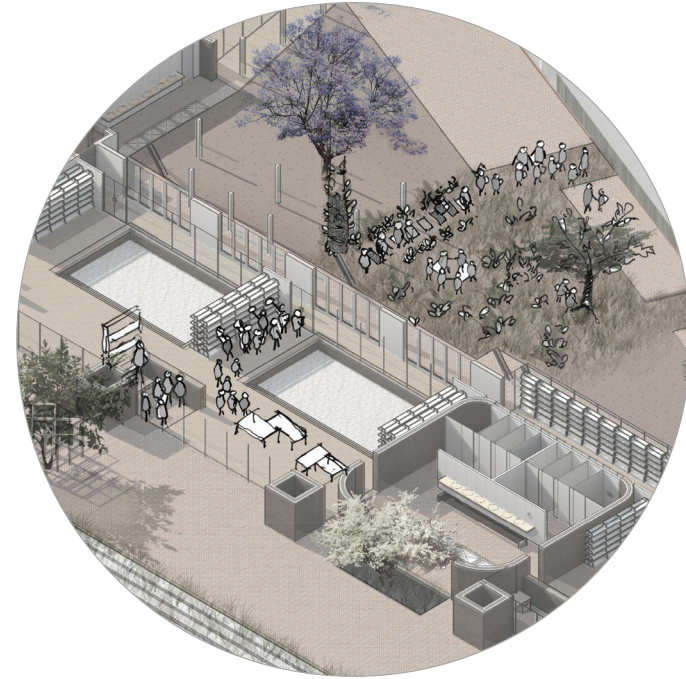

Fig 7.32 Daily Arrival (Author, 2016)

### 7.11 Daily Activities

The schedule of activities discussed in Chapter 4, is related to how these activities will occur in the building and garden spaces of the home base classrooms and the meaning these activities give to the nature of the spaces.

In the morning, the children arrive at school and are taken to the classrooms where they put their bags into the shelves and meet up with friends and greet the teacher (refer to Fig 7.32).

The second activity is gross motor activities that involve the children with the water element of the site where the children will be attending to the water plants, interacting with the bio-pool and attending to their plants on the shading system. The children will then file through to the foot washing area attached to the bathrooms and wash off before going back into the classrooms again (refer to Fig 7.33).

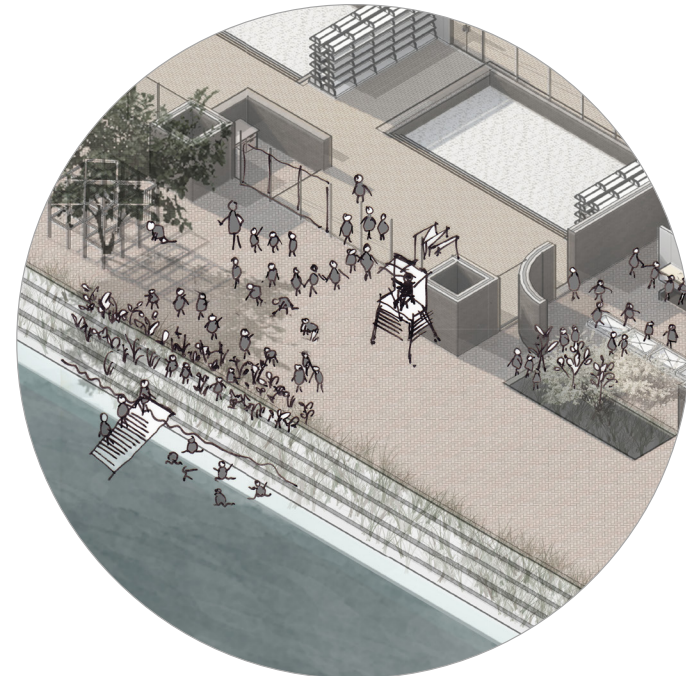

Fig 7.33 gross motor activities (Author, 2016)

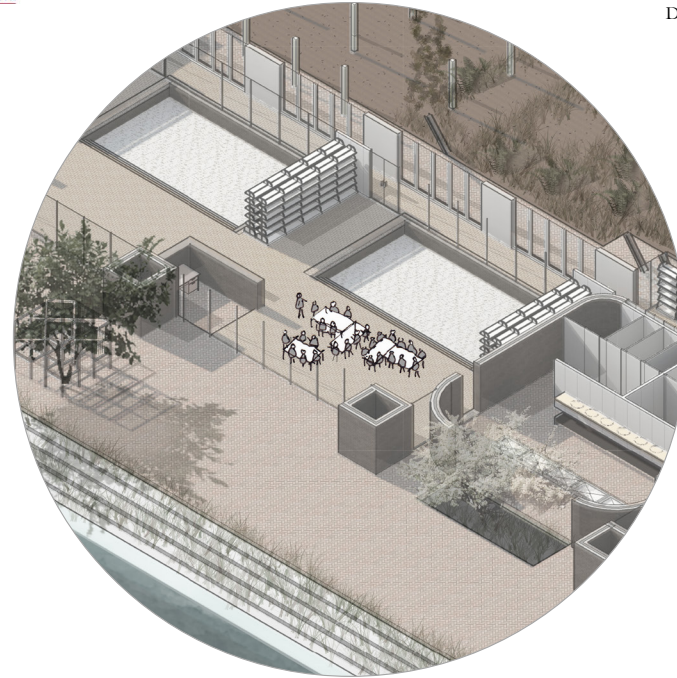

Fig 7.34 Group activities (Author, 2016)

After gross motor activities, the children take part in group activities facilitated by the teacher which involve drawing and writing while sitting down at large tables where the children use a multimedia of materials to express their understanding of different concepts (refer to Fig 7.34).

This is followed by SMART time where the children take part in activities in the courtyard that develop their cognitive skills. Bulbs are planted by each child, counting of fruits harvested is completed and maintenance and care of the shading skin system is carried out. Various outdoor cognitive activities take place in addition such as making art out of outdoor materials that help the children's thinking skills and understanding of concepts (refer to Fig 7.35)

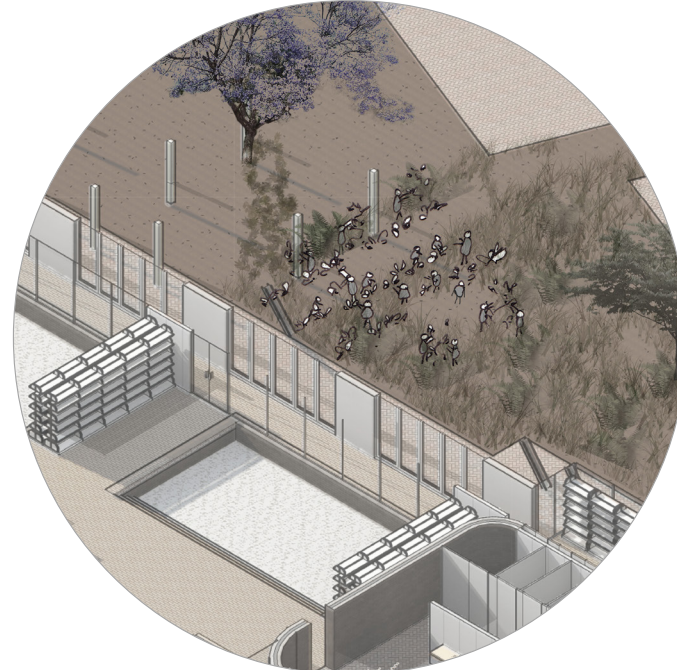

Fig 7.35 SMART time (Author, 2016)

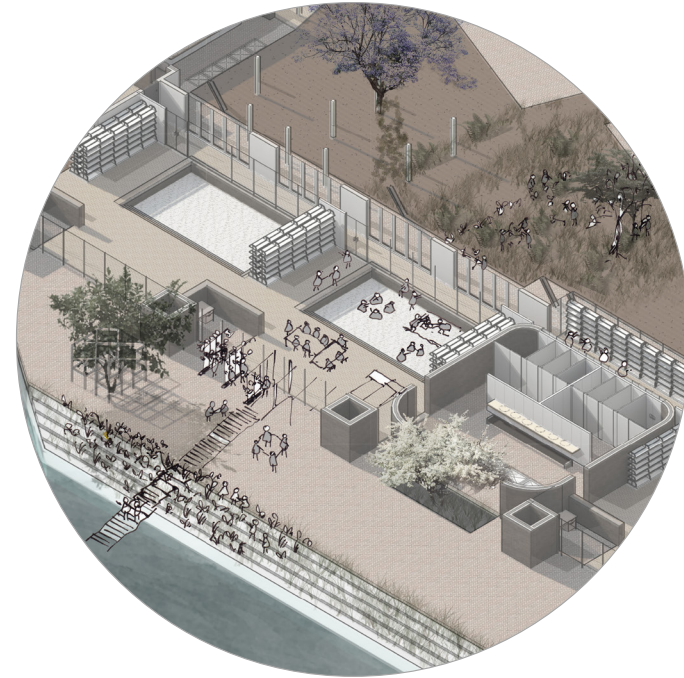

Fig 7.36 Whole body development. (Author, 2016)

Next is a the whole body development hour where children take part in various activities that develop their cognitive and gross motor skills. They use the various elements of the garden, classroom and water garden to develop these skills in the most appropriate way according to the learning method of each child. The visual learner will develop skills using drawing and painting while the kinesthetic learner will learn through attending to the living shading system or skin and watering and harvesting fruits in the courtyard (refer to Fig 7.36).

The whole body development hour is followed by story time where the children gather in the quiet nook and the teacher reads them a story. The quiet nook is at this time of day, shaded by the plant system in summer and letting in afternoon sun in winter, and so becomes the most comfortable spot to sit and read (refer to Fig 7.37).

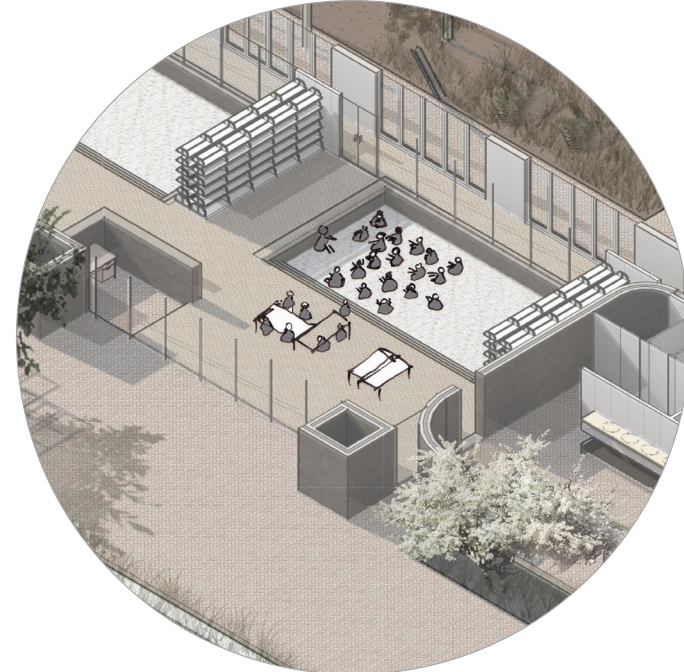

Fig 7.37 Story time (Author, 2016)



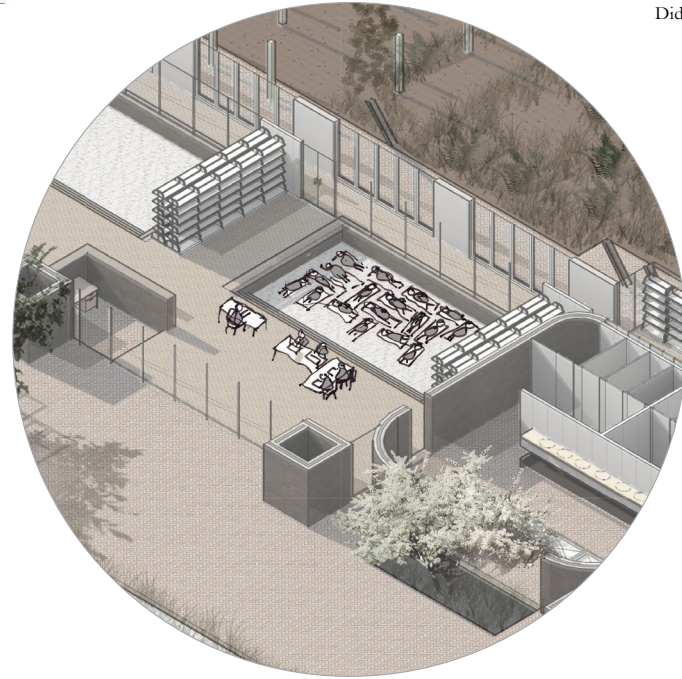

Fig 7.37 Quiet time. (Author, 2016)

Nap or quiet time follows suit with some children napping in the quiet nook and some drawing quietly alongside (refer to Fig 7.37).

Not long after this daily winding down, the children are picked up by their parents/guardians and they slowly disembark. The courtyard is filled with low sunlight and children can sit and wait under the trees to be picked up and have a last chat to their friends before home time (refer to Fig 7.38).

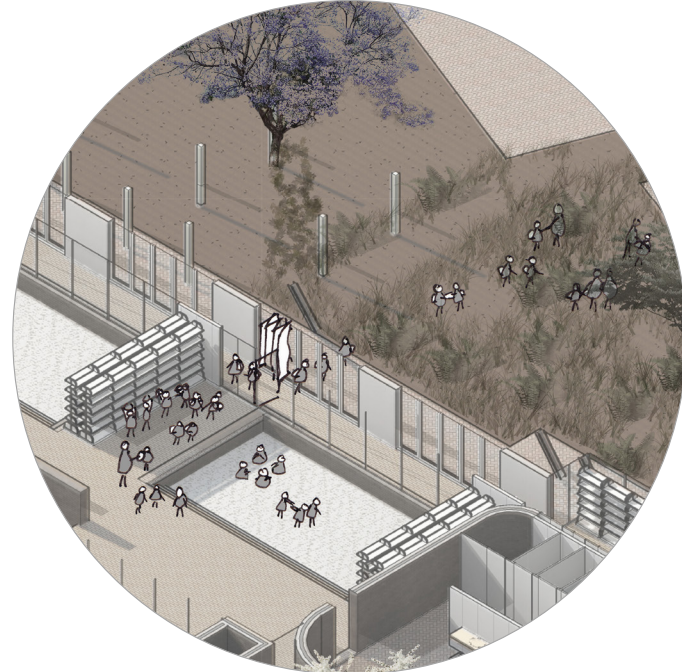

Fig 7.38 Home time (Author, 2016)



## 7.12 Kinetic Classrooms

As a supporting classroom, the kinetic classrooms address the need for open indoor play spaces for children to develop their gross motor skills. The kinetic Classrooms or Garden of Sun, relate to the identity of garden through movable pivoting doors that adjust according to the sun's movements. The building is kinetic itself as the doors open up to the play court and become an extension of the outdoor play space. In colder months, the doors can be closed up and outdoor activities can be moved indoors. All of these doors are operable by the children themselves in order to enable the building to become didactic.



Fig 7.39 Kinetic Classroom in plan and section , showing its connection to the outdoor play court (Author, 2016)

### 7.13 Supporting Functions: Occupational Therapy

The occupational therapy suites is planned as a progression from public to private. As one enters the suites through the main lobby of the school, one is guided towards a secondary reception as children outside the school will be attending occupational therapy sessions according to their level of developmental disability. The reception area is also closely situated to the occupational therapists' offices so parents and/or teachers can have meetings with the therapists and discuss the child's needs. In Fig 7.40, one can see that there are two types of therapy spaces. The one is group based therapy that takes place in an open plan room looking onto a courtyard. This group area then narrows to form a walkway with timber columns on either side with three private therapy pods leading off of the walkway where private one-on-one therapy sessions will occur. The association of trees with protection occurs here as children undergo helpful therapy.



Fig 7.40 Plan of occupational therapy suites (Author, 2016)

## 7.14 Providing Security Without Creating Barriers

Security is essential on site as the children need to be kept safe at all times from various risks such as the water hazard that the Walkerspruit poses. Sunnyside is also a low socio-economic neighbourhood and therefore protection from outsiders is necessary.

With regards to the water hazard berms are proposed all the edge where the river runs together with planted gabion walls to deter the children from nearing the water's edge. The berms will also address the flooding risk and decrease the flood plane to the river area and not into the site. In Fig 7.41, the security barriers are shown according to the different times of day. In Fig 7.42, the type of security barrier is shown.



Fig 7.41 security lines according to times of day (Author, 2016)



Fig 7.42 security types (Author, 2016)

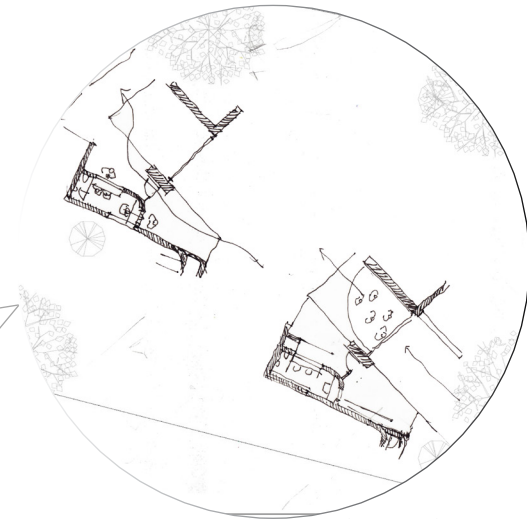

Fig 7.43 Security checkpoint alternating between school children and after hours. (Author, 2016)

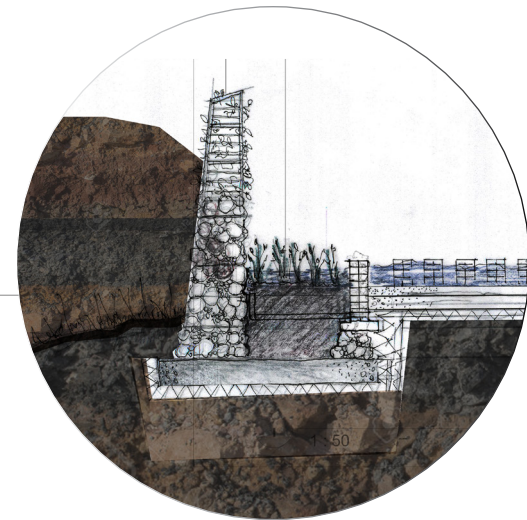

Fig 7.44 Gabion wall with berm in section (Author, 2016)



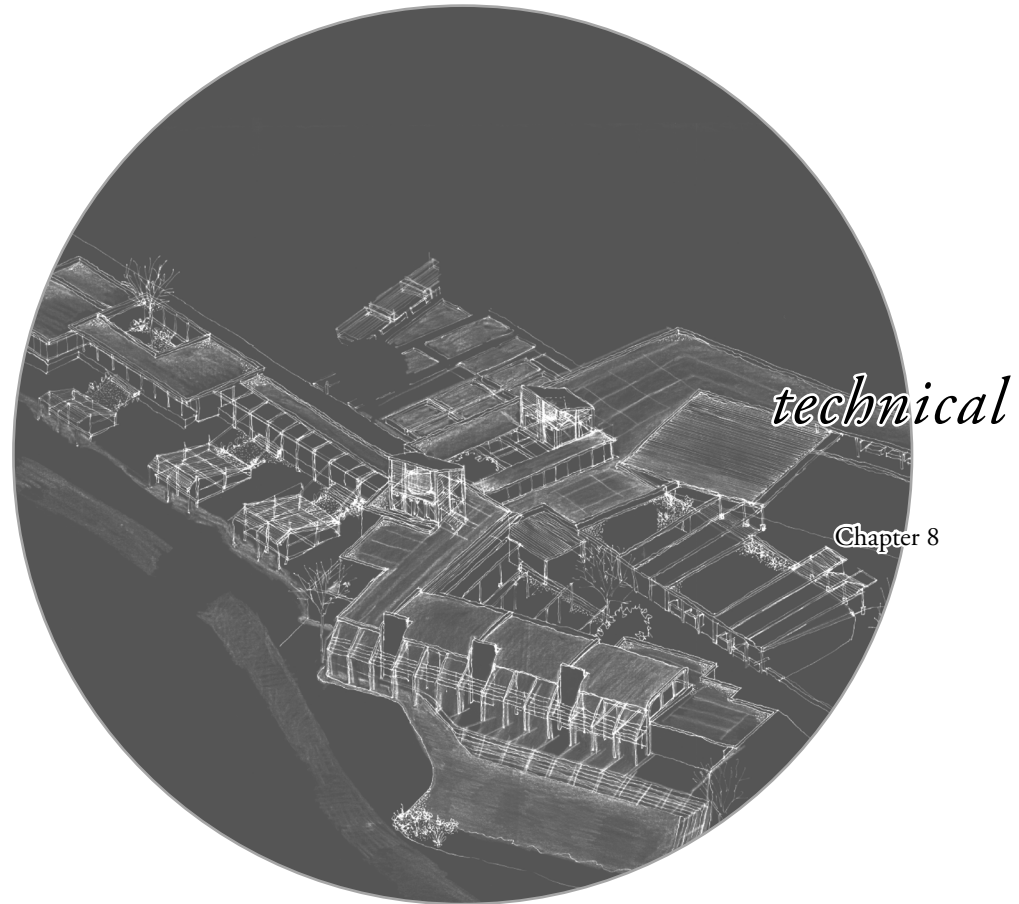

Fig 8.1 Technical development section. [Author, 2016]

“And I dream that these garden-closes  
With their shade and their sun-flecked sod  
And their lilies and bowers of roses,  
Were laid by the hand of God.”

Dorothy Frances Gurney  
(Willis, 2006: 11)



## 8.1 Introduction

The making of the building has become an extension of the dissertation intentions, the conceptual approach and design resolutions. This chapter will expand on these informants by discussing the technical concept, material palette, primary and secondary structure, and how the learning gardens come together in the aesthetics of joining focusing primarily on the home-base classrooms. Also discussed here are the solar stack and water system, together with how the building's interior climate is passively controlled.

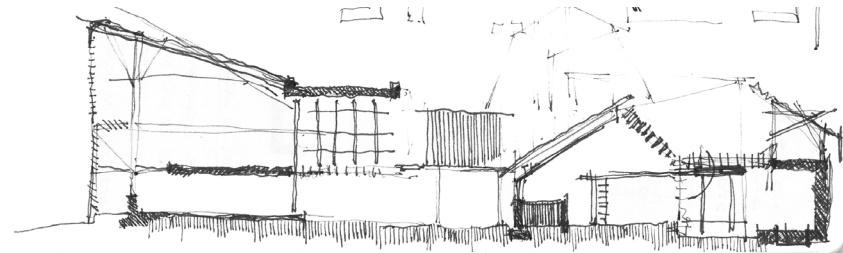

Fig 8.2 Diagram of tectonic resolution of classroom (Author, September 2016)

## 8.2 Tectonic Concept

The tectonic concept is a refinement of the design concept as an attempt to bring the conceptual intentions to a technical resolution. The stereotomic, the ground and the services (passive climate control and storage facilities), and the tectonic, the columns and vegetation was explored further in plan and section (fig 8.3 and 8.5), and an architectural language was developed that can be applied to every condition in the building. In detailing the section, it becomes important to express the definition of stereotomic and tectonic and qualities dependent on each other and this most apparent where the two meet. The focus, lies in the relationship between the characteristics of the existing garden and the tectonics of the architecture and how this relationship can facilitate learning. The primary tectonic concept is based on the biomimicry of the vertical and horizontal axis of the tree:

**Horizontal Axis:** The stereotomic, like the trunk of the tree, offers support as well as services to its branches. The plan is based on the relationship between learning spaces and service to learning showing the relationship between these. The placement of the serving and learning spaces are dependent on the nature of the garden. The services offered by these stereotomic trunk-like objects on plan relate to passive climate control and facilitation of storage space for the classroom's needs (Fig 8.3).

**Vertical Axis:** The vertical axis forms a primary structural system of stereotomic floors and trunks (service spaces); and branches (support columns) all supporting the roof canopies. The secondary structure is dependent on the nature of the garden and how and what type of learning takes place in each (Fig 8.3).

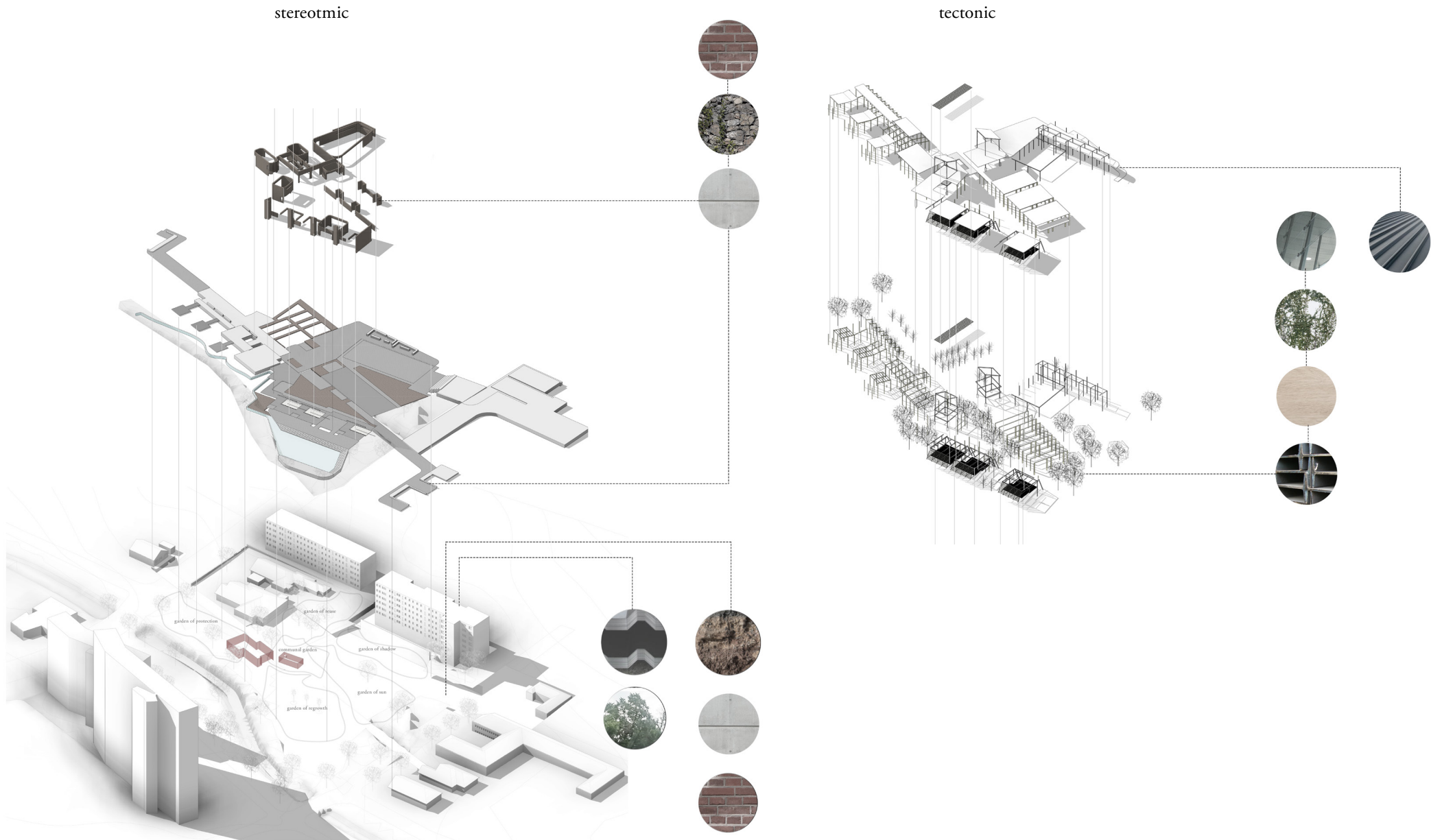

Fig 8.3 Diagrammatic representations of the stereotomic and tectonic concept (Author, November 2016)

### 8.3 The Material Palette

The definition of the material palette has been determined by the material qualities of the existing site, spatial requirements and conceptual intentions.

In the following pages, the material choices are explained in terms of what exists on site, the spatial requirements of the spaces and the conceptual intentions.

CONCRETE  
 Most of the surrounding fabric is of concrete and brick infill

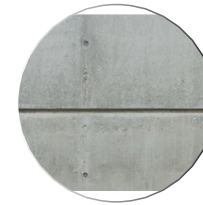

RED FACE BRICK  
 Most of the façades of the surrounding flats consist of red face-brick, reflecting Pretoria's brick-making heritage



SOIL  
 The soil on site is made up of shale rock closest to the river and avolon and hutton soils that are orange-brown in colour.



#### STEREOTOMIC QUALITIES ON SITE:

The predominant stereotomic material on site is the ground, which consists of mostly shale rock and avolon and hutton soils of a predominately orange brown colour. The site is relatively flat, however, and using a large amount of rammed earth would be ignoring the surrounding fabric. As mentioned in Chapter 3, the surrounding stereotomic fabric is made up of mostly red face-brick and concrete. Because the dissertation is adopting the principles of the Burra Charter, the design should blend in with its surroundings but also show that it is new in contrast to the existing. The stereotomic materials, as mentioned in 8.2 are related to spaces that become service cores, resembling “trunks” in their function as service cores in nature.



#### CONCRETE FLOOR SLABS

To create spaces with high thermal mass to prevent fluctuations in temperature throughout the year



#### RED FACE BRICKS

To blend with the surrounding fabric, red bricks will be used as facade infill in some areas as well where thermal massing in the façades are required



#### GABION WALLS

Where the earth is retained to create berms, gabion walls filled with rubble from site will be used. The cage will be made from 8x10 double twisted hexagonal woven galvanised steel wire mesh.

Fig 8.6 Material palette, stereotomic (Author, 2016)

### STEREOTOMIC SPATIAL REQUIREMENTS

In the classrooms, a comfortable temperature needs to be maintained throughout the year to aid in the children's concentration. A double skin with an air-gap and a single skinned brick walls that provide a large amount of thermal mass will be used in the façades at some points to provide a cooling in the classrooms as well as concrete floor slabs with high thermal mass to provide cooling from the ground. In winter, the concrete floor will act like a thermal battery, building heat in the morning and gradually releasing it late afternoon. Qualitatively, the texture of brick and gabion walls relates to the earth and ground and creates a haptic awareness of the materials of nature. The gabion walls will be used where there are retaining walls as well as for security purposes along the river periphery of the site.

### STEREOTOMIC: CONCEPTUAL INTENTIONS

Therefore, the predominant stereotomic material will be concrete, brick, and gabion walls as they relate to how the "tree" is deeply rooted within the ground and rises from it. The different stereotomic materials relate to the proximity of the tree to the ground, where the closest proximity to the ground is concrete and gabion walls (made up of brick and concrete rubble from the site and the demolished Grade R building, as well to support plant growth). The bricks are where the "tree" rises up from the ground and is becoming lighter, as it reaches to the sky.

#### IBR STEEL ROOFS

The surrounding learning institutions have IBR sheeting as roofing material



#### VEGETATION

A variety of tree species exist on site. The supports of trees are more durable where the canopies and leaves of trees change and grow over time.



### TECTONIC MATERIALS ON SITE

A range of different species of trees grow on site (refer to tree analysis in Chapter 3) but the majority of trees are Acacia and Canary Island Pine. The Pine trees are alien species and the well known Acacia tree is indigenous to South Africa and should be protected. Vegetation and tree canopies are light elements which change over time. Another tectonic aspect of the site is the steel IBR roof sheeting that covers most of the existing schools' roofs. Because of the trees on site, timber was seen as another appropriate tectonic material to be used as supports for outdoor pergola and shading systems.



#### TIMBER

Timber columns will be used as support systems in outdoor learning spaces as well as interior finishes to resemble the trees and vegetation on site.

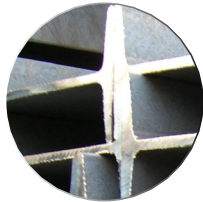

#### KLIP-LOK

Klip-Lok 700 roof sheeting will be used to relate to the steel roof sheeting of the existing fabric but it also creates a texture that relieves potential glare to the flats that look down on the building.



#### STRUCTURAL STEEL

a steel structure relates to the concept of lightness fixed to heaviness as well as serves as the new material introduced on site which is dependent on the natural, stereotomic materials

Fig 8.7 Material palette, tectonic (Lysacht, 2016)

## TECTONIC SPATIAL REQUIREMENTS

Internal spaces need to be well lit, especially in classrooms where a steady and well diffused 400 lux is required. The steel structures need to have adequate openings to allow the natural light into the spaces, however, attention needs to be given in allowing the inlet of natural light to be diffused. Shading systems and screens will be introduced to allow this to take place, as well as to create an awareness of the changing seasons with the use of planted shading systems with indigenous plants such as wild jasmine and geranium.

## TECTONIC: CONCEPTUAL INTENTIONS

An appropriate response to material is using steel which is faster to construct and longer lasting, together with Saligna timber columns and pergolas as a support system in outdoor spaces. These allow for the mimicry of the lightness of tree branches, coupled together with the use of dark grey painted Klip-Lok 700 roof sheeting adding texture to the roof plane and creating a lightness in the roof system, resembling the concept of the roof being a canopy over the spaces and functions below. The roof sheeting also relates to the metal sheeting used in the area. Saligna columns will be used in outdoor spaces for the support of treated Saligna pergolas. This is because the buildings become lighter (or more tectonic) around their peripheries relating to the concept of the tree. The first floor of the classrooms will be of Saligna timber members to support the intentions.

## 8.4 Primary and secondary structure

The technical concept, together with the material palette gave rise to how the structure will be put together. The primary structure will therefore be made up of concrete floors, brick and steel columns. The secondary structure becoming tectonic steel framing to support the primary.

### PRIMARY:

The primary structure consists of a thick concrete base with cast in-situ reinforced concrete foundations, coupled with a large 2x2m brick column reinforced with concrete set into the wall. The brick column is made up of one double skin layer of brick, a 50mm air-gap filled with concrete at the base and insulation at the top, creating a large amount of thermal mass necessary to form a solar stack to cool the space. Wherever retaining walls are required, brick walls and gabion walls are proposed reiterating the building's or "tree's" relationship to the ground. The gabion walls also support plant growth, which becomes a didactic element.

### SECONDARY:

A steel profile is fixed within the brick column and branches outwards, freeing itself from the brick column and grounding itself on the other end of the building with a concrete base. The profile is made up of hot rolled galvanised steel 203 x 102 x 25 taper flange I-section rafters at 10m spacing that meet the same size columns welded together and meeting the ground at a concrete base foundation. In the home-base classrooms, the portals are spaced every ten metres which relates to the classroom sizes of 10m x 12m. The portals are laterally supported by hot rolled galvanised steel 152x89x17 taper flange I-section rafters and cross braced with steel rods. Fixed to the top of the portal frame are 50x100x20x2 cold formed lipped channel steel purlins to which the Klip-lok 700 roof sheeting will be fixed. Saligna timber acoustic ceiling panels are fixed to the underside of the profile and suspended to a greater depth in the service cores to provide a plenum for electrical services

### TERTIARY:

In the garden of regrowth, the primary and secondary structure will foster the new life or regrowth through the incorporation of a planted shading system or skin, with the plants supported by a steel planted mesh fixed onto a lightweight steel beam system. The skin will puncture the interior as well as form shading on the outside. The aim is that the skin will be maintained by the children. This will form as a continuation of the roof canopy but with smaller sized steel members, where onto a planting mesh will be fixed to facilitate the growth of plants. Water pipes with perforations to allow for the outlet of water will be fixed to the steel members to water the plants as well to provide a level of evaporative cooling on the northern boundary of the classrooms.



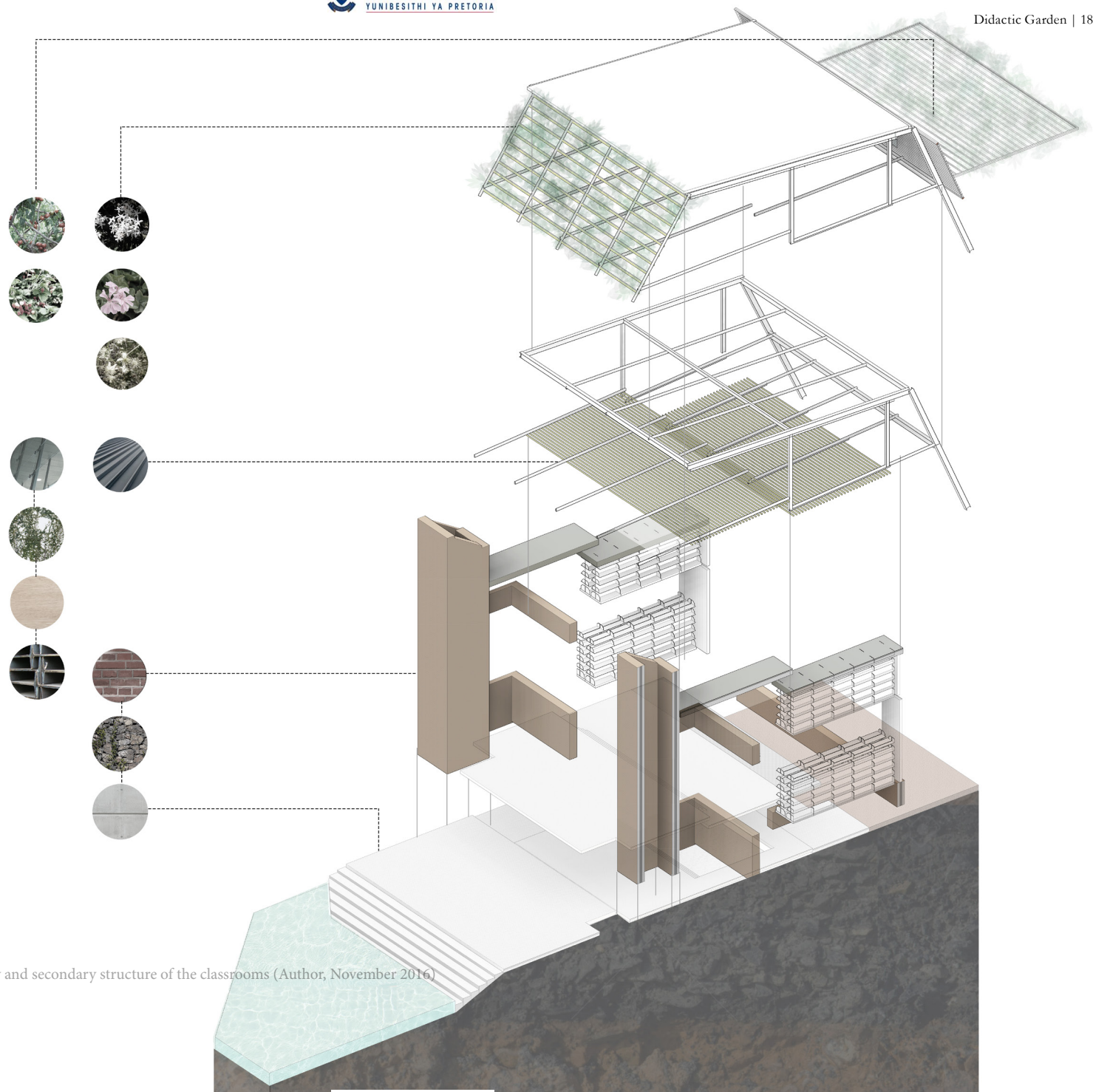

Fig 8.8 technical explosion showing primary and secondary structure of the classrooms (Author, November 2016)

## 8.5 The Joining of the Tree

Considering the material choices and conceptual intentions, the detailing of how these materials relate should be shown as separate entities that depend on the other for structural support and therefore although separate, form a sense of continuity. Just as the parts of the tree fulfil different functions and different aesthetic relationships, it remains one entity. The detailing of these should reflect that concept.

### THE BRANCHES

The intention of the tectonic is to have a light character but also a continuity in the way materials are joined. For the steel portal frame, the adequate depth for its span had to be identified in order to be self supporting the portal-like structure. Welded junctions gave a sense of continuity in the portal but also shows that they are different entities in material and function. The timber acoustic ceiling sits in line with the bottom flange of the I-section members but steps back at the prominent joining of the portal to show how the members are joined.

### THE TRUNKS AND ROOTS + THE BRANCHES

The heavy brick walls join to the tectonic steel elements through a concept of structural dependence and continuity, together with the juxtaposition of complete integration of the materials and partial separation. As the building leaves the ground, it is heavy, containing stereotomic elements and lighter elements integrated within the stereotomic. As the building or structure reaches the canopy, the portal frame separates itself from the heavy brick column and becomes the roof canopy. The roof structure supports the tertiary structure of the planted skin through a system of continuous beams that run in line with the suspended timber floor. Where the portal frame becomes the roof canopy, a small shaft of glass is placed between the brick column/stack and the roof sheeting together with a the slatted timber ceiling to emphasise where the two elements join as well as to highlight the dappled inlet of light that the roof canopy offers to the learning spaces

### THE TRUNKS

Where the brick wall meets the concrete floor, because of their different expansion and contraction rates therefore a shadow line is proposed along the skirting line to express the different materials but the skirting itself will be chamfered to express the continuity between them.

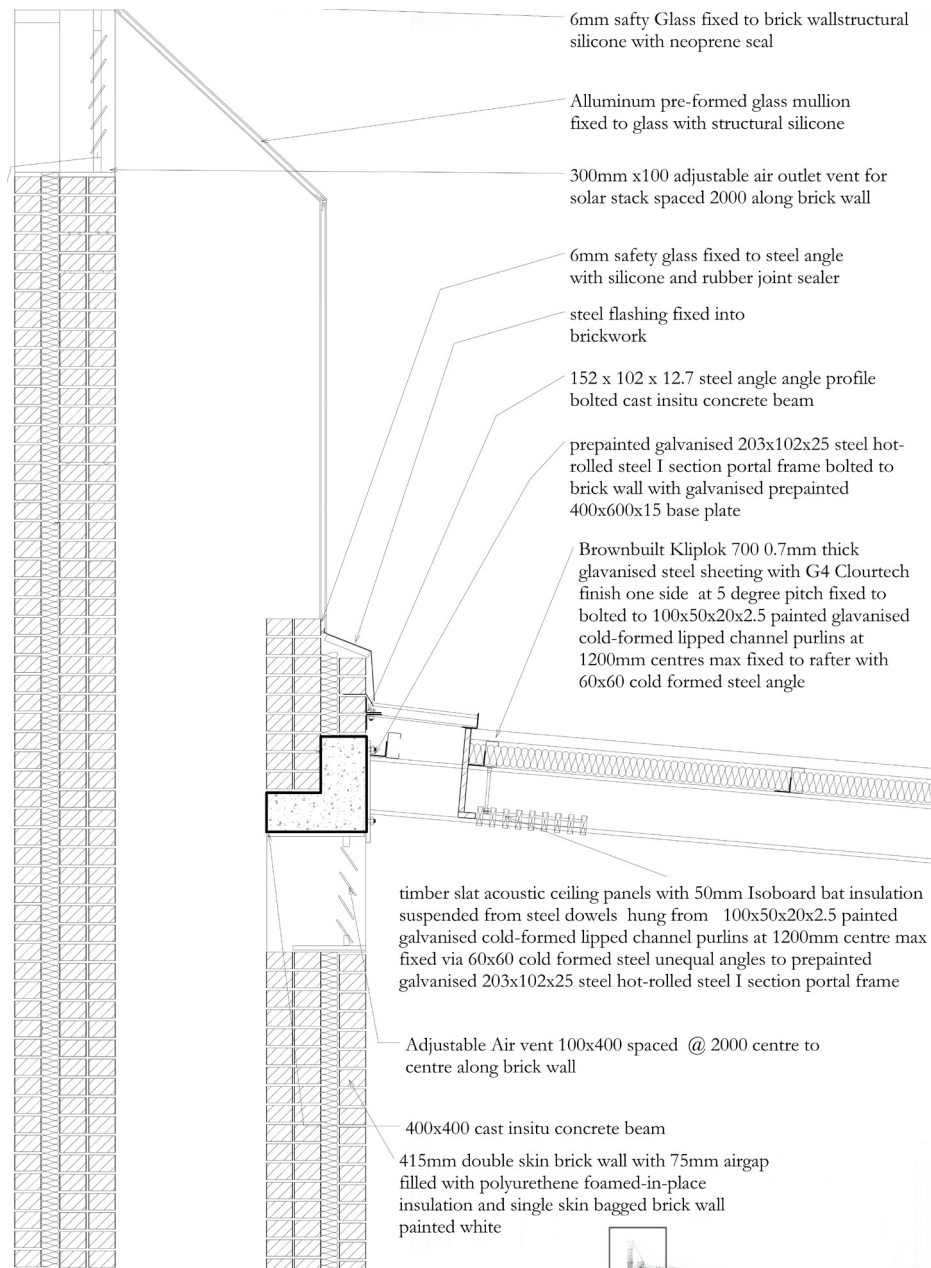

Fig 8.9 Detail showing how the concept influences the aesthetics of joining (Author, September 2016)

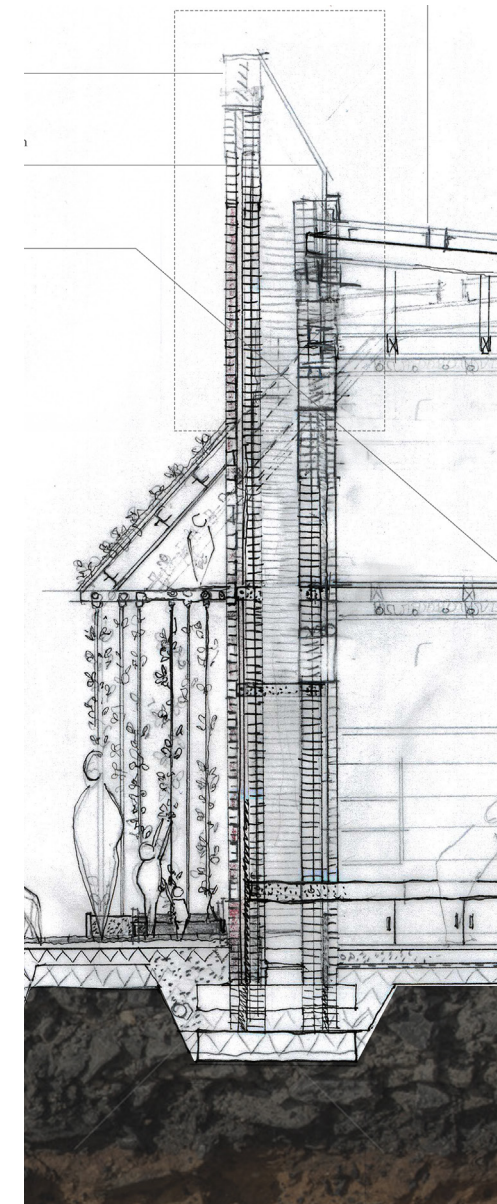
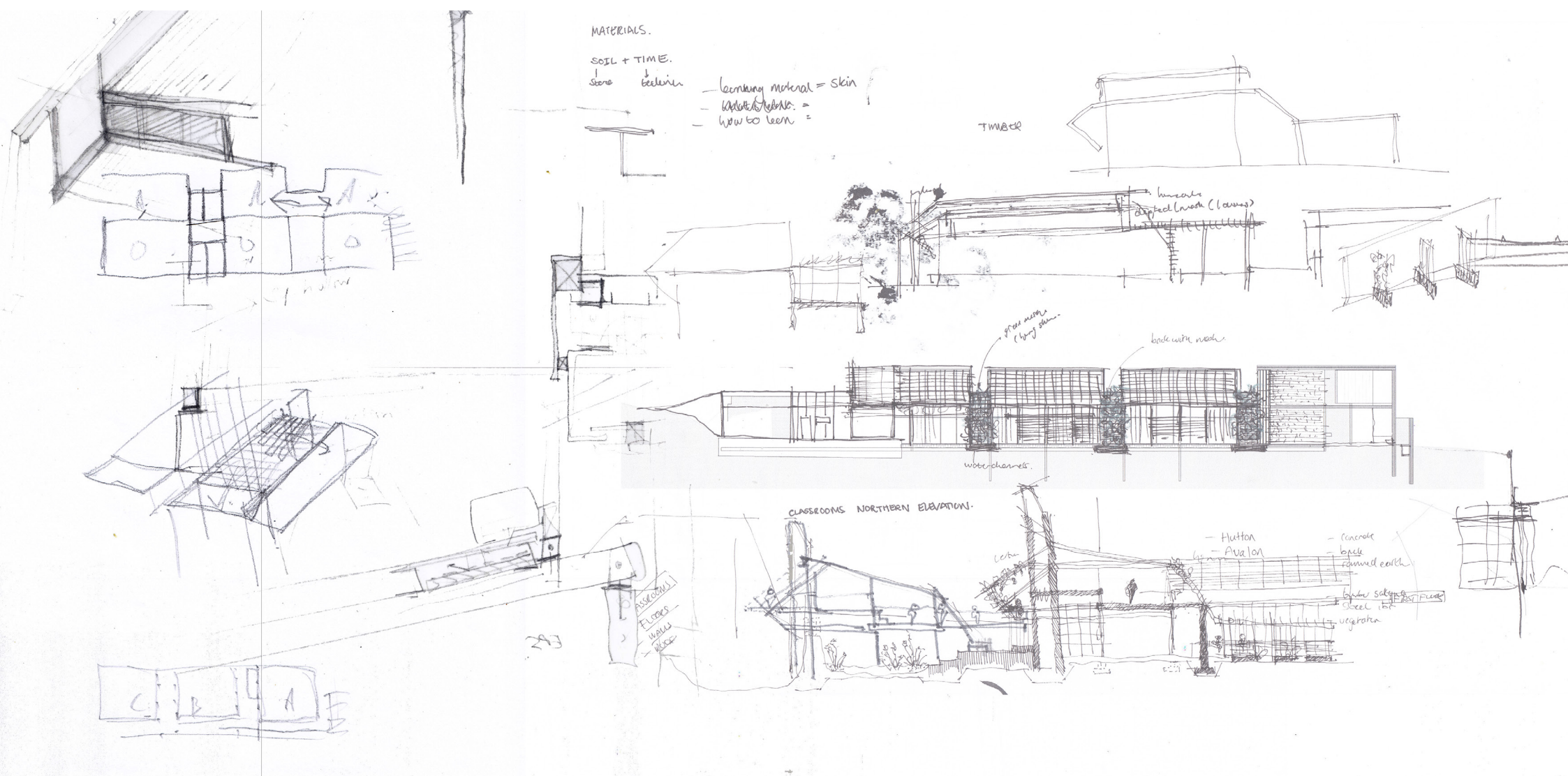

Fig 8.10 Section through solar stack and joining of portal frame (Author, 2016)



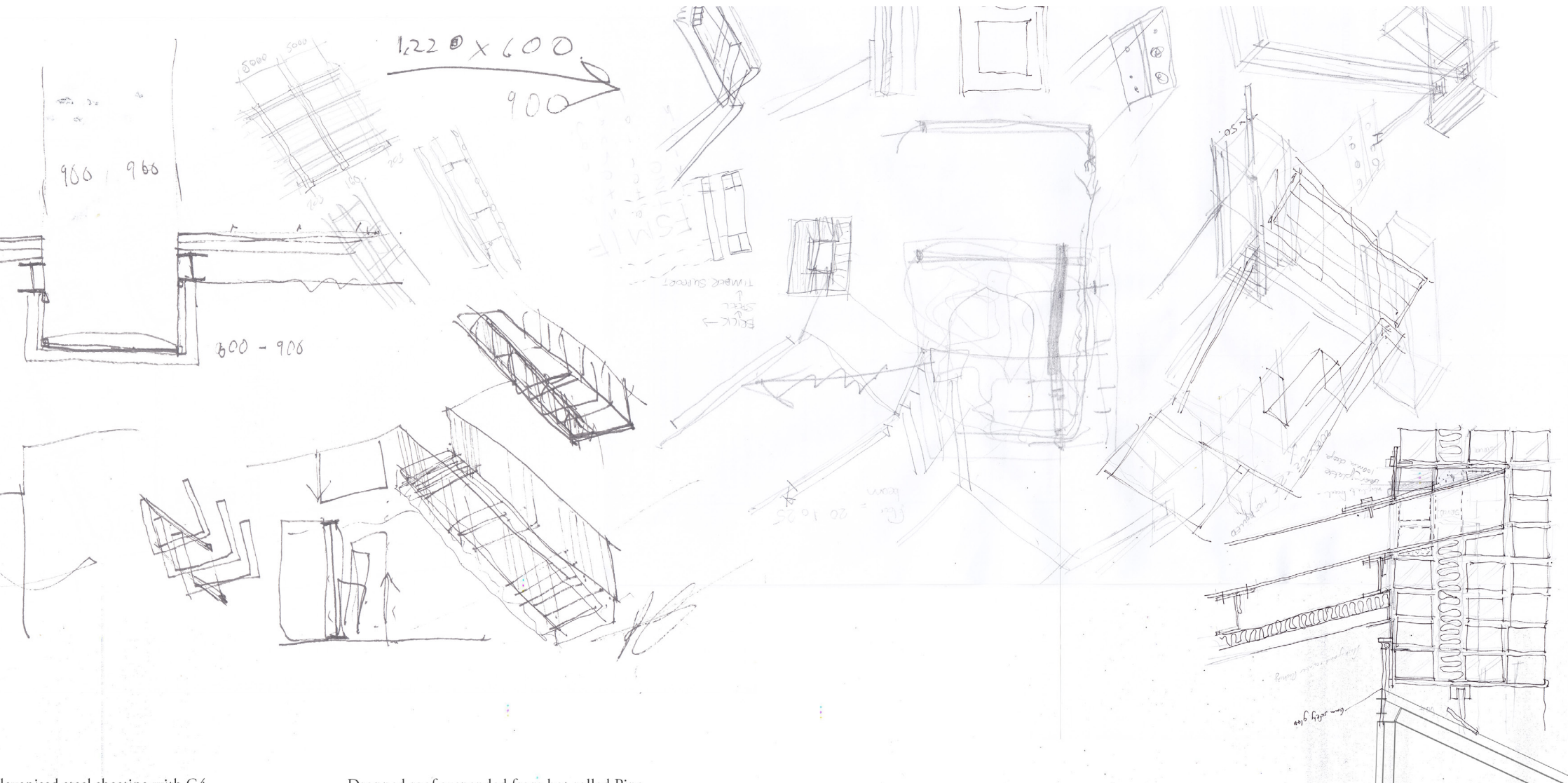
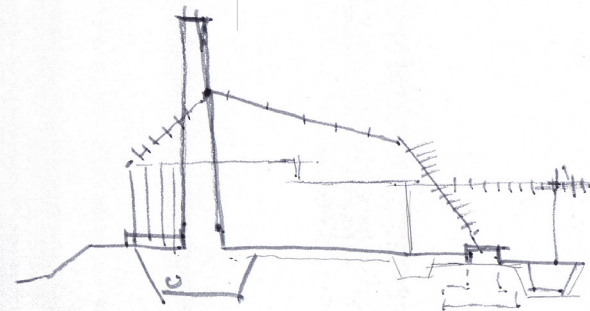

Fig 8.11 Technical Explorations (Author, 2016)

## 8.6 The Section : Technical Exploration

The Section under investigation is cut through the Reggio Emilia home-base classrooms and more specifically, the service core of the classroom which holds storage space for cupboards, display boards and locker shelves. The section displays the quiet and loud spaces by the differentiation between levels where the quiet space drops lower than ground level to create a sense of privacy for activities such as reading and napping. The more public spaces are on ground level with a higher ceiling level to facilitate group activities such as painting and writing. The second level of classrooms are also shown. The service core on the second level facilitates the dropped roof between classrooms to provide separation between classrooms, to hold the cupboards and shelves and also to allow for a modular design that can be adapted easily as well as providing children who live in the flats that overlook the area to identify their classroom from their flat, creating an identity of each classroom space. This modular spacing also incorporates the biophilic principle of integrated parts to whole where each classroom is a separate entity but forms part of the classroom structure.



Gabion walls to hold up artificial wetland made of brick and rubble from demolished Grade R building

Artificial wetland captures rainwater to send to underground water storage tanks to later be used within building.

Storm water channel directing excess flow away from building

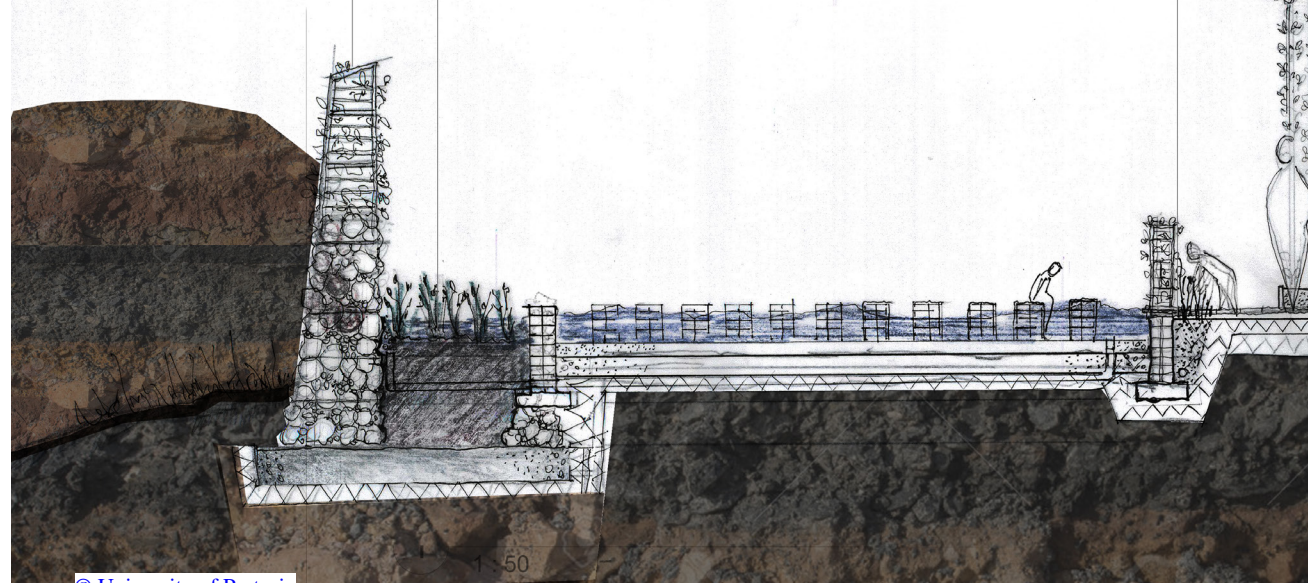

Aluminum framed 300x100 adjustable air outlet vent for solar stack

Aluminum pre-formed glass mullion fixed to glass with structural silicone

22 x 175 timber ceiling board supported on 38 x 114 joist

Brownbuilt Kliplok 700 0.7mm thick galvanised steel sheeting with G4 Clourtech finish one side at 5 degree pitch bolted to 100x50x20x2.5 painted galvanised cold-formed lipped channel purlins at 1200mm centres max fixed to rafter with 60x60 cold formed steel angle and fixed to 30mm Isoboard bat insulation according to engineers details

Dropped roof suspended from hot rolled Pine slatted ceiling boards suspended from 203x102x25 hot-rolled steel I-section rafters bolted to 100x100x3 cold formed square hollow section frame

galvanised steel planter mesh fixed to pre-painted galvanised 100x50x20 cold formed steel lipped c channels, bolted to pre-painted galvanised 203x102x25 hot-rolled steel I section portal

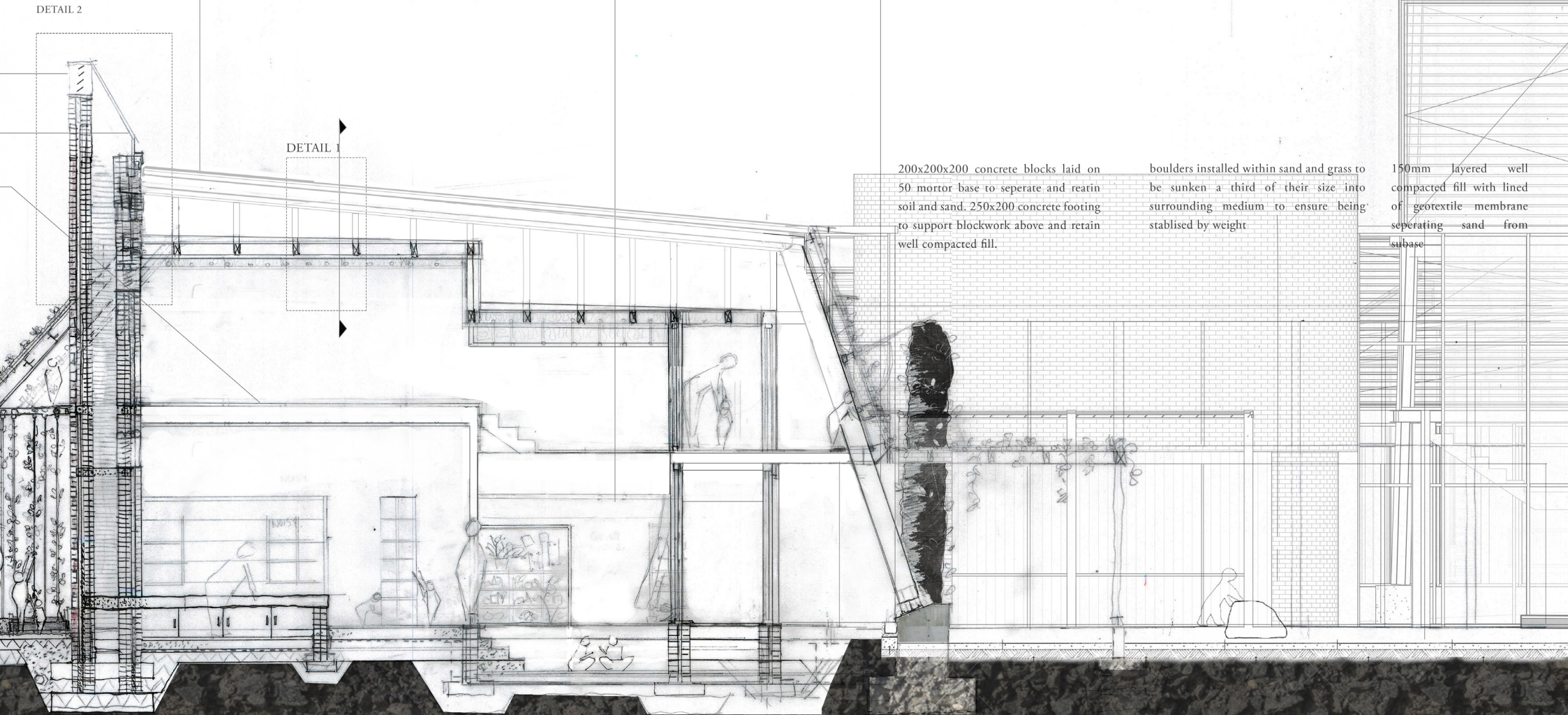

200x200x200 concrete blocks laid on 50 mortar base to separate and retain soil and sand. 250x200 concrete footing to support blockwork above and retain well compacted fill.

boulders installed within sand and grass to be sunken a third of their size into surrounding medium to ensure being stabilised by weight

150mm layered well compacted fill with lined of geotextile membrane separating sand from subbase

Fig 8.12 Section exploring technical concept and material joining (Author, 2016)

## 8.7 The Water System: First resolution

The programmatic functions as well as the presence of the Walkerspruit called for the integration of a water process into the children's education as well as in the design of landscape and the building. It was considered that the base flow from the Walkerspruit be diverted into a side-channel that meanders through the site, purified using the five-step filter system and led into a small wetland that will be maintained by the children, however, taking away from the walkerspruit proved inappropriate as the little ecological value it holds would run dry as its base flow was diverted.

In figure 8.10, a diagrammatic representation of this system is shown. Together with the side channel diversion, a rain water harvesting system was proposed where runoff from the roofs where diverted into small rainwater gardens at the base of the building and then pumped into a surge tank which is located in the central garden and thereafter pumped to water towers that hold the water needed to serve the building.

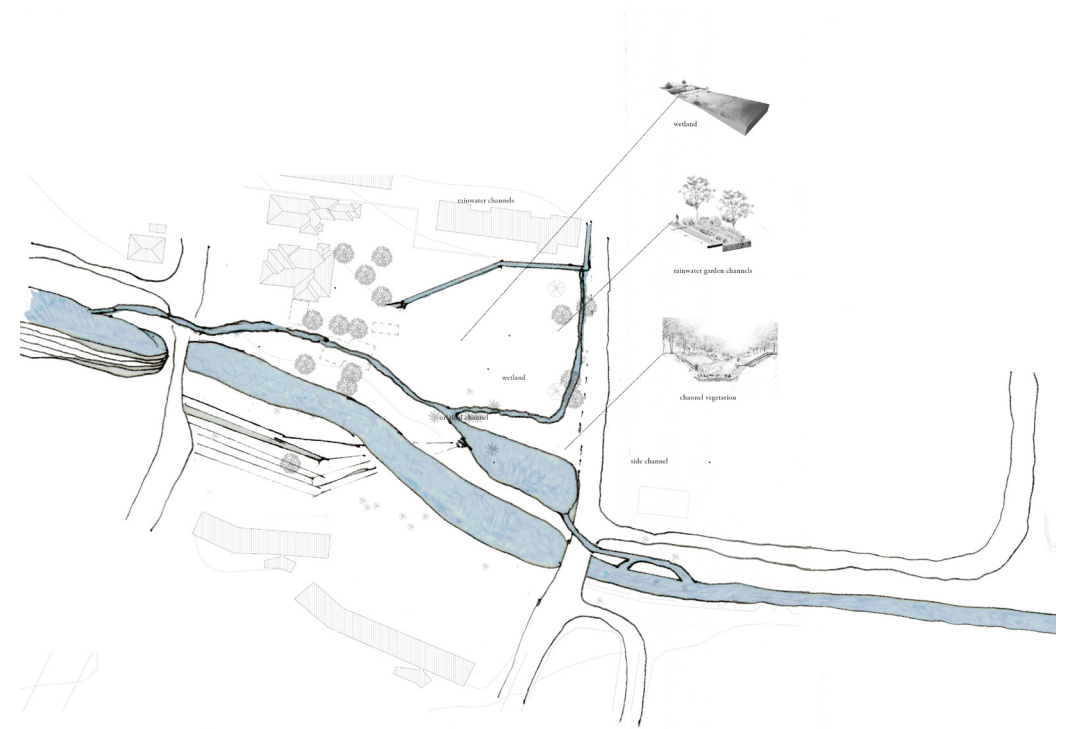

Fig 8.13 Diagram of proposed water system and its processes (Author, 2016)



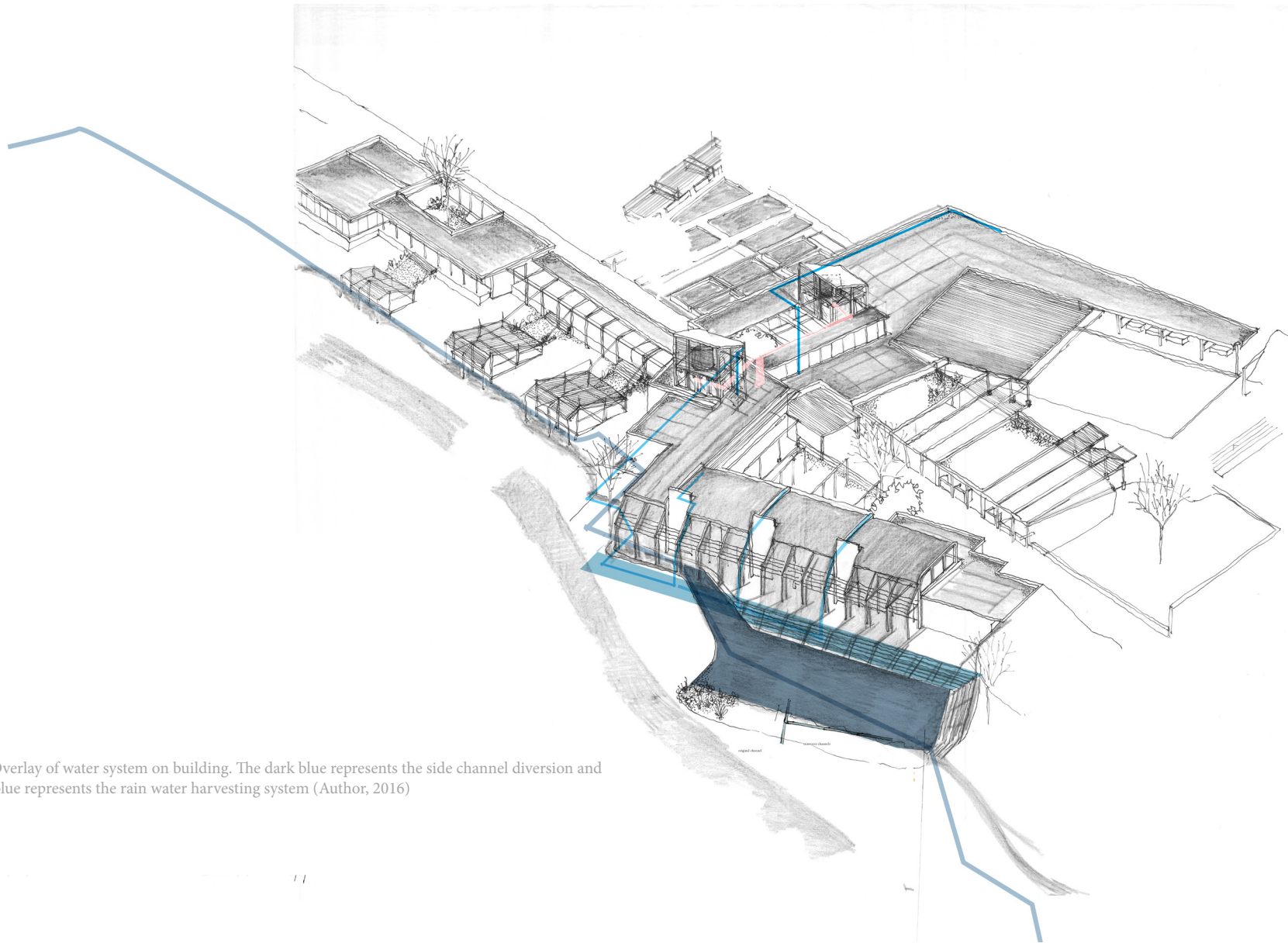

Fig 8.14 Overlay of water system on building. The dark blue represents the side channel diversion and the light blue represents the rain water harvesting system (Author, 2016)

## 8.8 The Water System: Water Budget

It was then proposed to integrate the rainwater system with the wetland and create a new ecosystem through the purification of the runoff of water from the roofs.

### WATER BUDGET

A water budget was calculated (refer to Appendix, Table 1) to establish the amount of water that can be collected from the rooftops and the thereafter the size of tank needed in order to support the water demand of the building and its users. It was originally proposed that composting toilets be used throughout the building to not only save water but also provide compost for the vegetable gardens and planted areas. However, they were identified as unhygienic in a school environment especially when dealing with young children. One set of composting toilets were proposed while the rest of the toilets were fed with grey-water by the other functions on site. Where there is not enough grey water, a municipal connection will have to be used.

## 8.9 The Water System: Final Resolution

Since the amount of water that can be stored in tanks far exceeds that which can be collected from the roof, it will be better to only collect a certain amount and let the rest either flow into a French drain or into the soil. The maximum amount of water that can be housed is 370m<sup>3</sup> or 370000 litres. Two 90m<sup>3</sup> tanks will be housed in the towers and 204m<sup>3</sup> will be housed in the form of three 68m<sup>3</sup> tanks, underground.

The rainwater runoff collection will be firstly, fed into a trash trap filter which deals with floating debris, thereafter a oil and sediment filter and then will be fed into a UV filter because the water cleaned by the wetland will be fed into a bio-pool which needs to be free of pathogens for the children to swim in. The water will be stored in underground tanks after going through this process. Thereafter, the water will be fed into a wetland and bio-pool to clear the water of nitrates and to provide nutrients to the plants of the wetland. Any pathogens that occur in the swimming area will be dealt with another UV filter to make the water potable. After this, the water will be pumped to a surge tank with pump to pump 180m<sup>3</sup> of water to the water towers and fed into the building where needed.

And of course, all will be made as visible as possible in order to create a didactic connection between the child and the water they use in order to create an awareness of the importance of water.

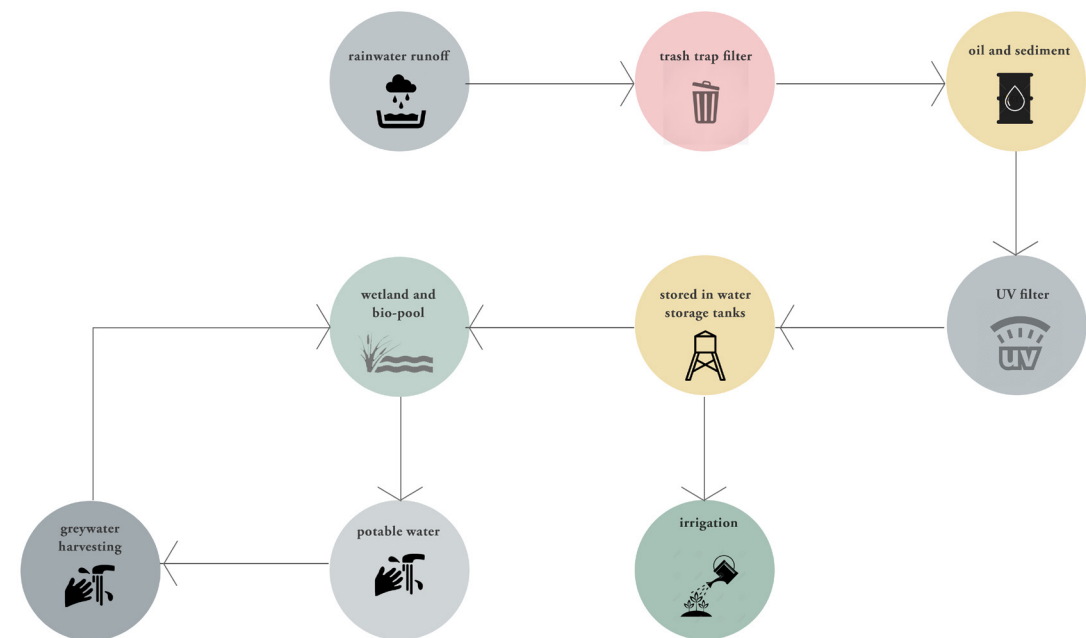

Fig 8.15 The water system (Author, 2016)

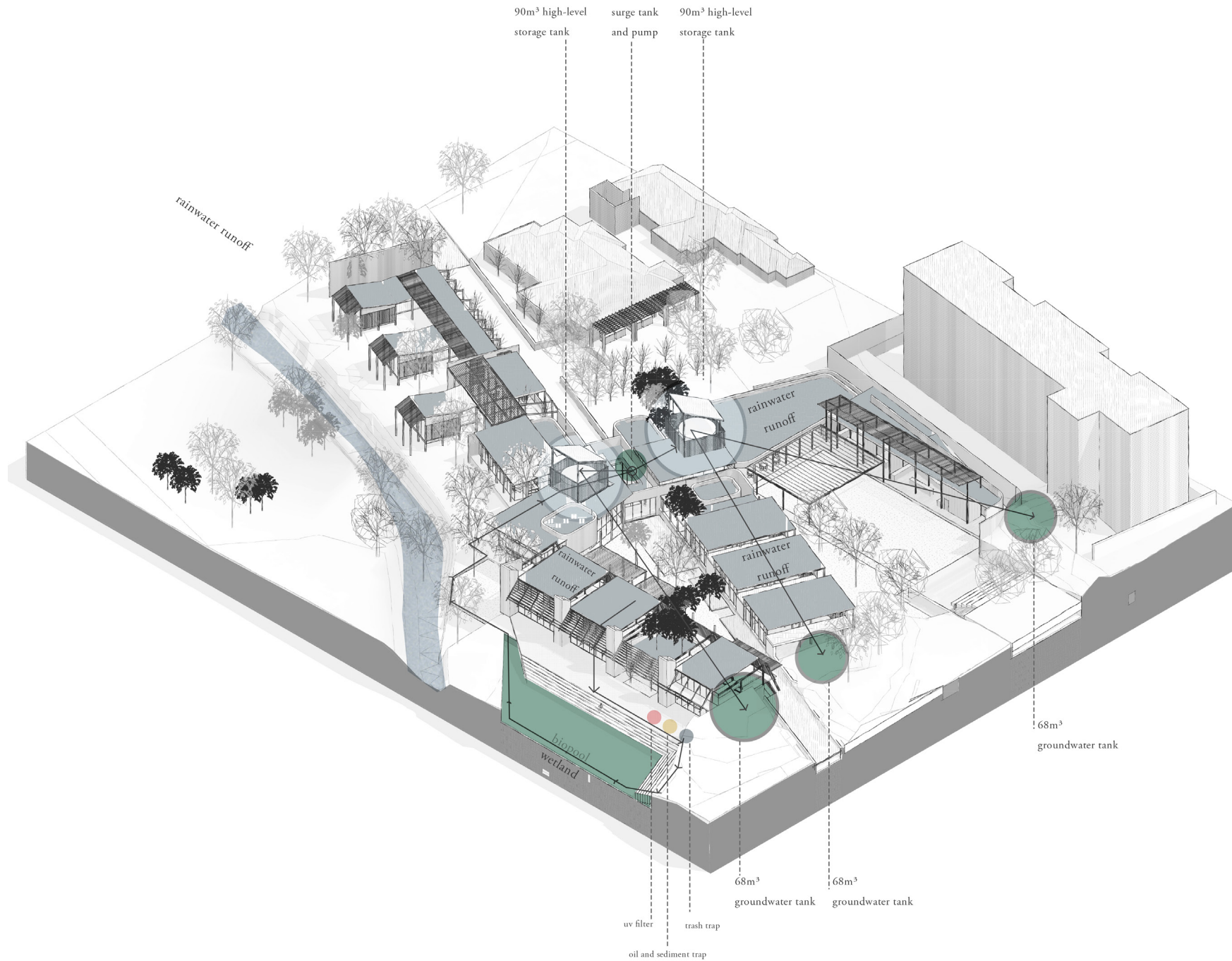

Fig 8.16 New water system showing process of rainwater collection, purification and reuse (Author, 2016)

## 8.10 Passive Climate control and services

8. There are three methods of passive climate control that will be incorporated within the home-base classrooms specifically.

This includes a solar stack which is shown (refer to Fig 8.9) in section, serving as the service core in the classrooms. The services it provides is cooling in summer and heating in winter of the classroom spaces as well as becoming a heavy backing for storage shelving and cupboards in the classrooms.

The second passive climate control is through the planted shading system or living skin which provides shading to the northern façades as well as deep set balconies which also allow access to the skin to be maintained by the children. The skin is designed to be essential to the climate control of the building, enabling a direct physical and sensory connection between natural systems and plants and the children that help them to survive. The use of the skin relates to the sun's angles throughout the seasons enabling sunlight to penetrate the building in summer to remain outdoors in summer and prohibited by the deciduous plants on the skin.

The third is the use of evaporative cooling which will be integrated onto the skin through water pipes that are fixed to its frame and will water the plants and at the time cool the building in summer.

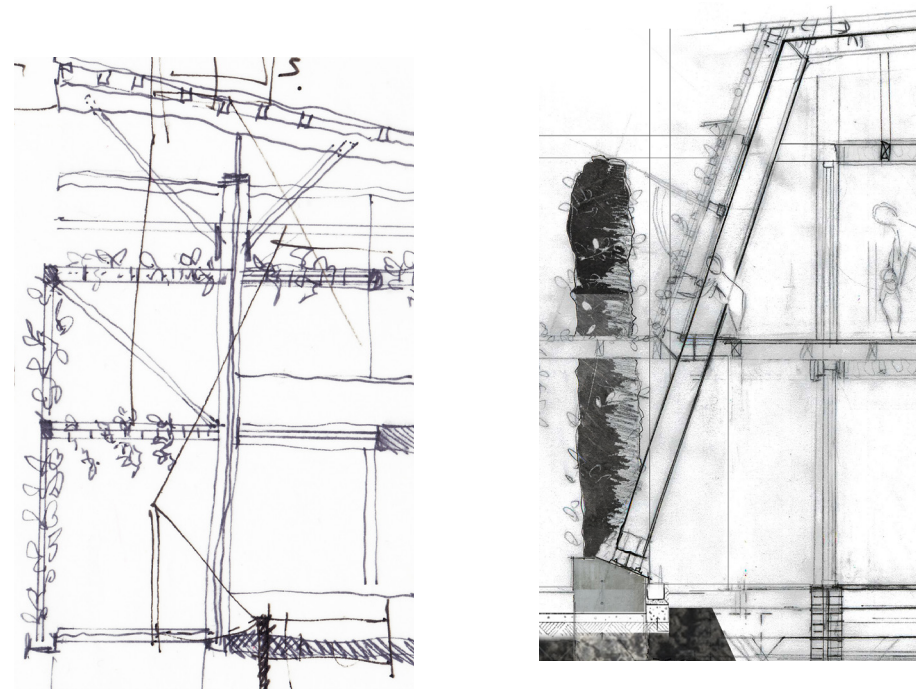

Fig 8.17 Development of living skin and how it punctures the building's facade (Author, 2016)



1. Strawberries (EzGro Garden, 2013)



3. Ivy-leaf geranium ( Net Plant Finder, 2016)

### 8.10.1 The Living Skin

The living skin will be made up of a steel beam system with a galvanised steel planting mesh fixed thereupon using cold formed lipped channels. The aim of the skin is to fulfil a multitude of functions including connection to identity of place as well as providing shading for the northern and southern façades as well as forming environmental teachers to the children, helping them learn about the upkeep and care of plants through spaces that are directly connected to their everyday classroom. The watering of the plants on the skin will also provide evaporative cooling to the building in summer months. In winter, to save water, plants will be watered less using hose-pipes.

The types of plants that will be grown on the skin include tomatoes and strawberries on the lower levels that will be directly accessed by the children. These are suitable as they are ground covers and provide fruit that can be picked and cared for by the children. In the higher levels that are less accessible, *Pelargonium peltatum* will be planted. It is commonly known as ivy-leaf geranium. It is indigenous to South Africa and is known for its pink flowers. It has also been categorized as one of least flammable plants and can be grown within a building protection zone. Other creepers that can be grown on the skin include wild jasmine which attracts a variety of birds and *Clematis brachiata*, commonly known as Traveller's Joy which is mostly found in Gauteng with attractive fragrant flowers that appear in summer months.



2. Vine Tomatoes (Grow It Organically, 2016)



4. Wild Jasmine (Florida friendly plants, 2010)



5. Clematis brachiata (wikipedia, 2014)

Fig 8.18 ground level plants (Author, 2016)

Fig 8.19 Higher level creepers (Author, 2016)

### Ventilation

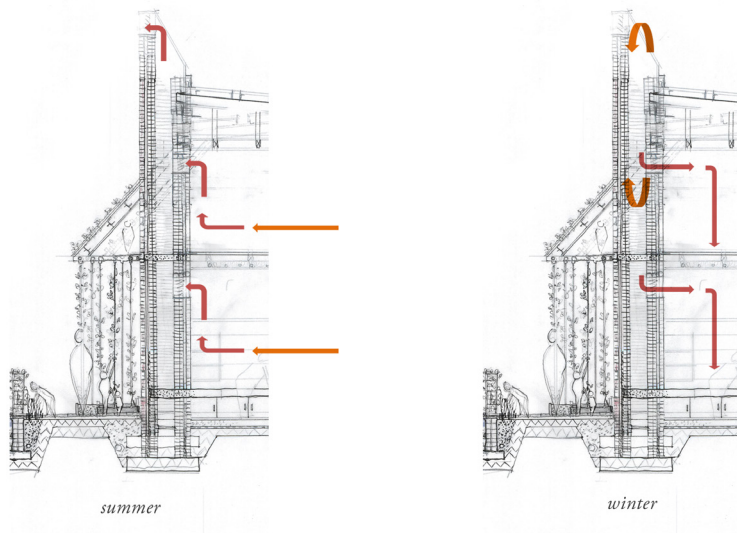

Fig 8.20 During summer months, the stack aims to cool the space through an updraught created by the form of the stack, the glass on top and the thermal mass and paint colour (Author, 2016).

### Daylighting

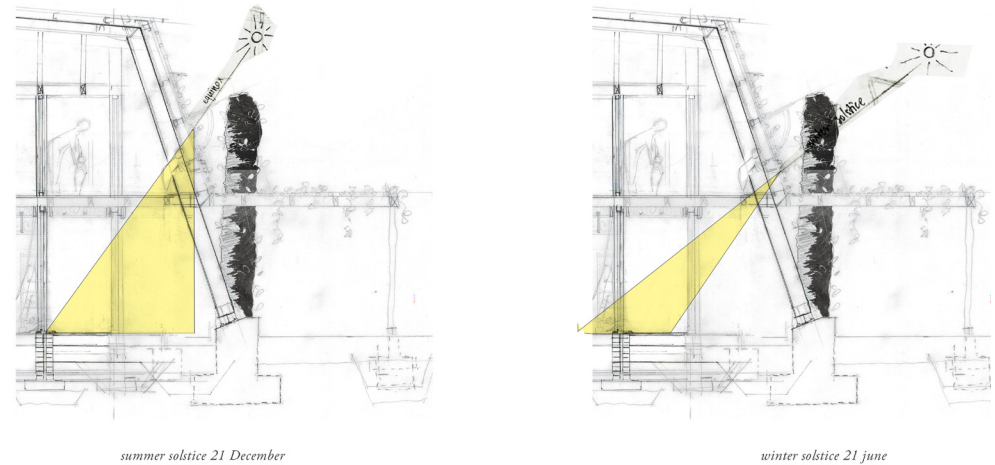

Fig 8.21 The pergola and deep set circulation corridor and balcony lets sun into the classrooms in winter and shades it in summer (Author, 2016).

## 8.11 Waste Management

With regards to the management of waste on site, the recycled and reused vegetable garden will be used for the creation of compost and the use of it for the vegetables to be used for cooking in the cafeteria. The compost created by the composting toilets on site will distributed to the planted areas on site to provide them with valuable nutrients where the organic waste of the kitchen will be distributed back into the vegetable garden. Paper, glass, cardboard and plastic will be sorted through in the recycle garden attached to the existing Ring Ting Pre-primary.

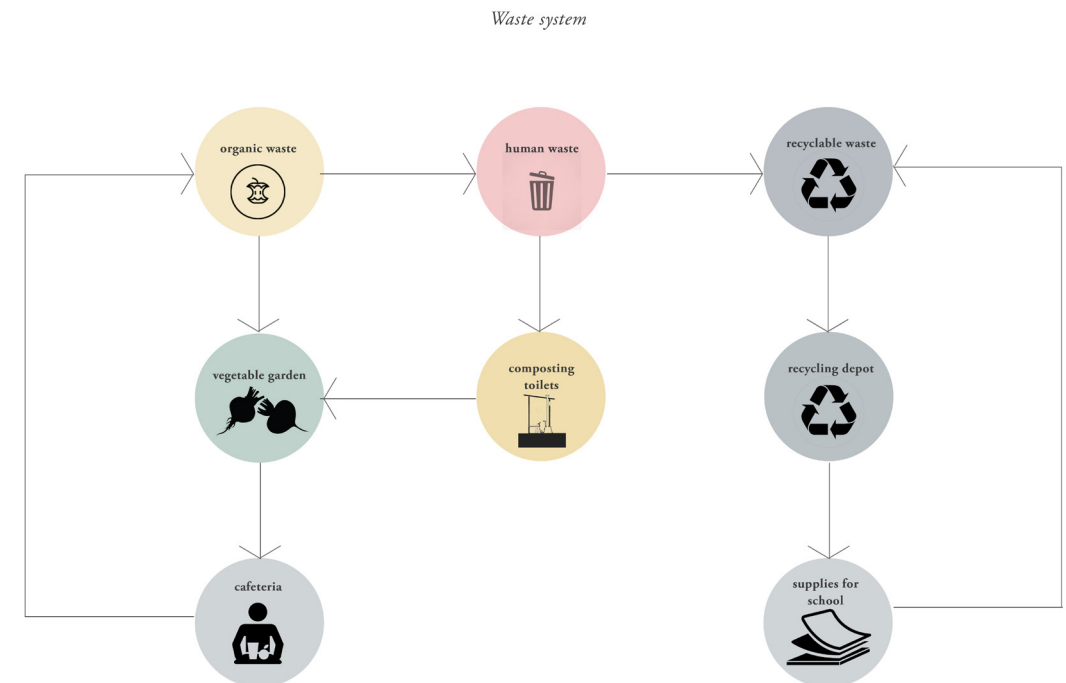

Fig 8.22 Waste management system. (Author, 2016)



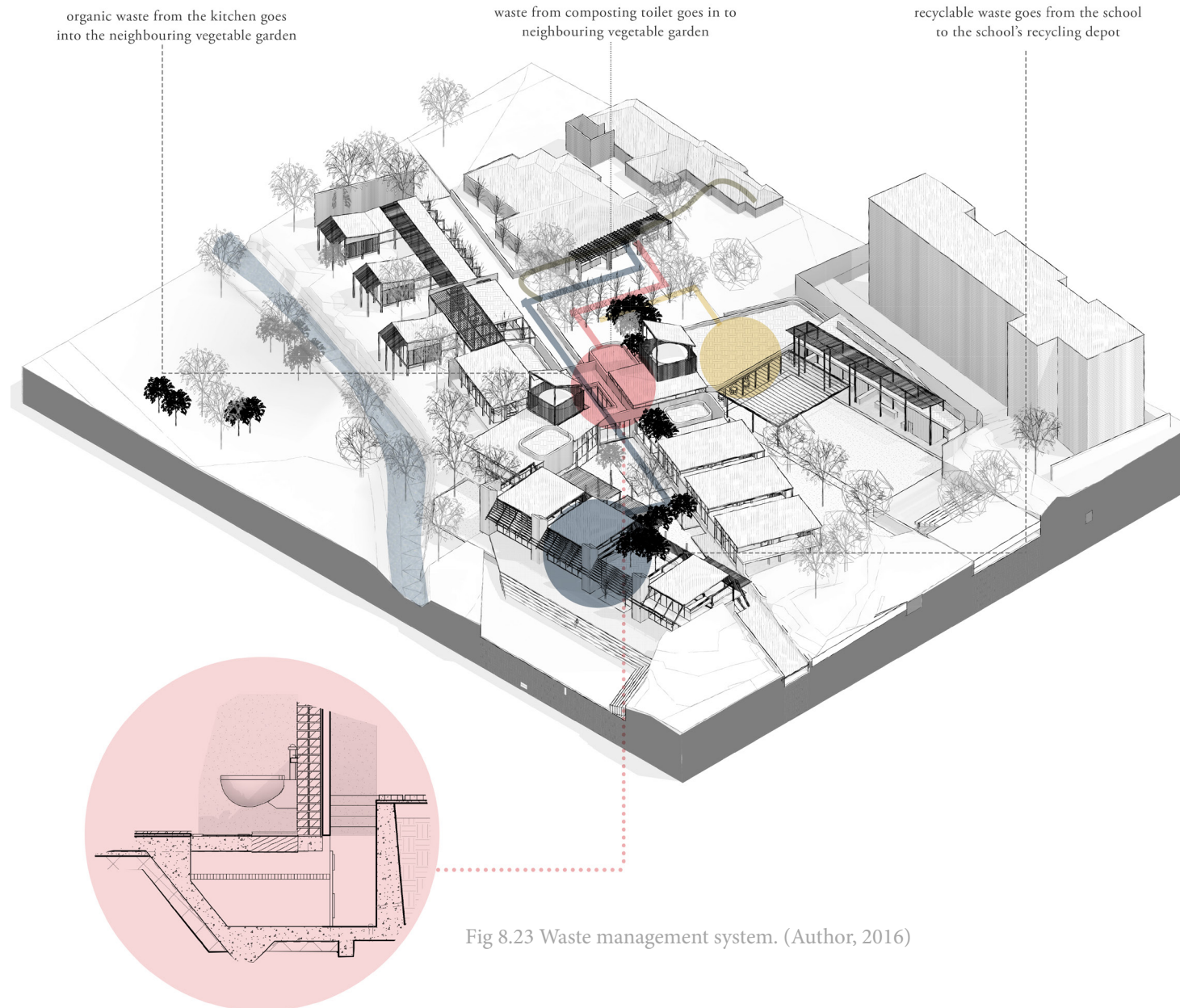

Fig 8.23 Waste management system. (Author, 2016)

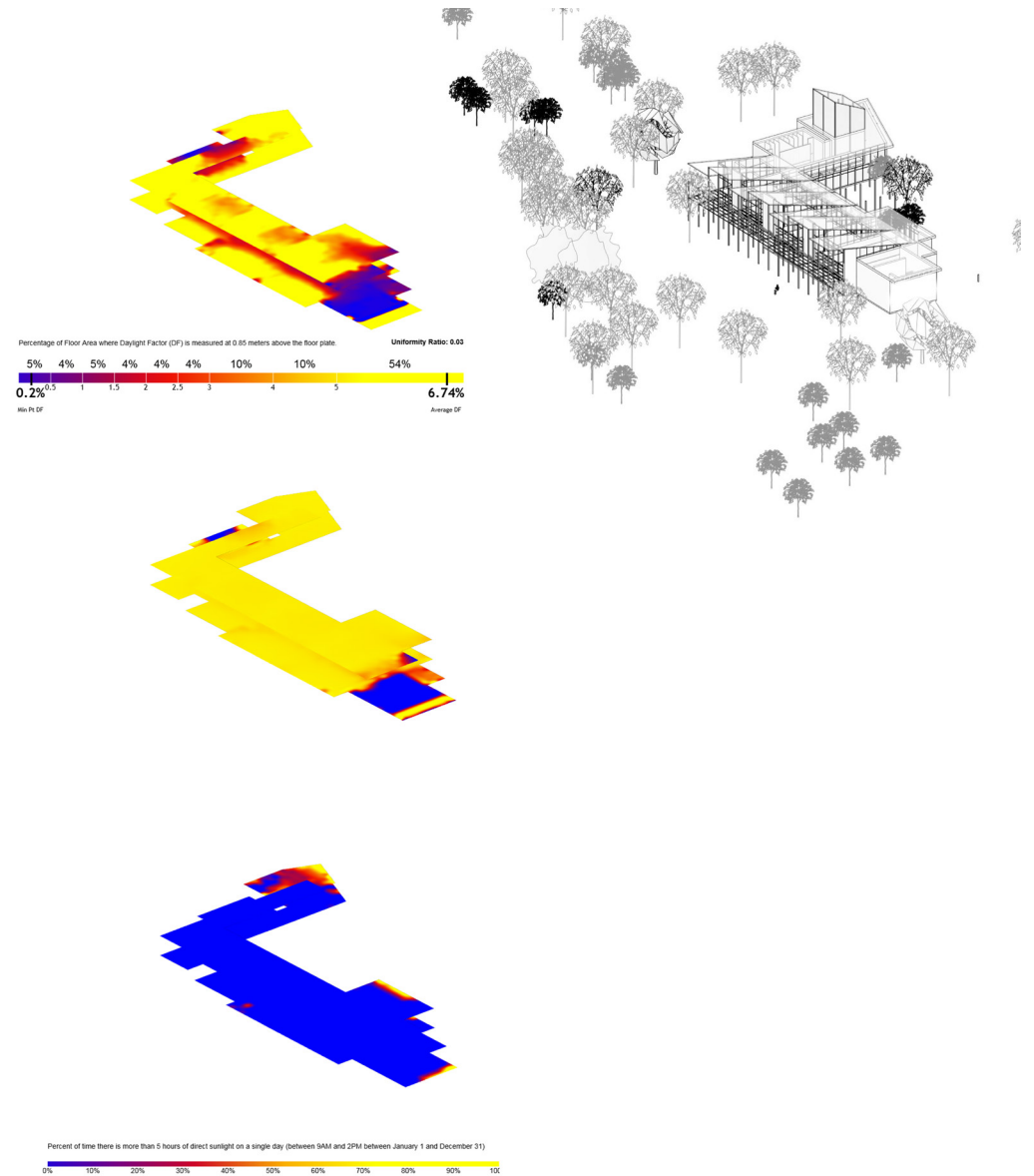

Fig 8.24 Base design daylighting analysis (Author, 2016)

## 8.12 Daylighting Iterations

Daylighting iterations were conducted on the home-base classrooms in order to establish a design resolution that enabled the classroom spaces to match up to the deemed to satisfy lux levels in school classrooms. According to the Department of Education in South Africa, the recommended artificial lux levels in classrooms, offices and libraries should be 200 lux and for art rooms such as Reggio Emilia home-based classrooms, the lux levels should be 300 lux (South Africa, Department of Education, 2012: 13). However, biophilically, the ideal would be to reach those levels using natural daylighting as far as possible and only artificial lighting where daylighting is not possible.

### 8.12.1 Base Design

The base design analysis was conducted at the stage where the classrooms had tilted roofs which allowed too much harsh sunlight into the classroom spaces and therefore proved that additional shading was necessary. The bathroom spaces also proved to be too dark and additional windows needed to be added. The results concluded that the majority of the spaces were over-lit with only the bathrooms being too dark.

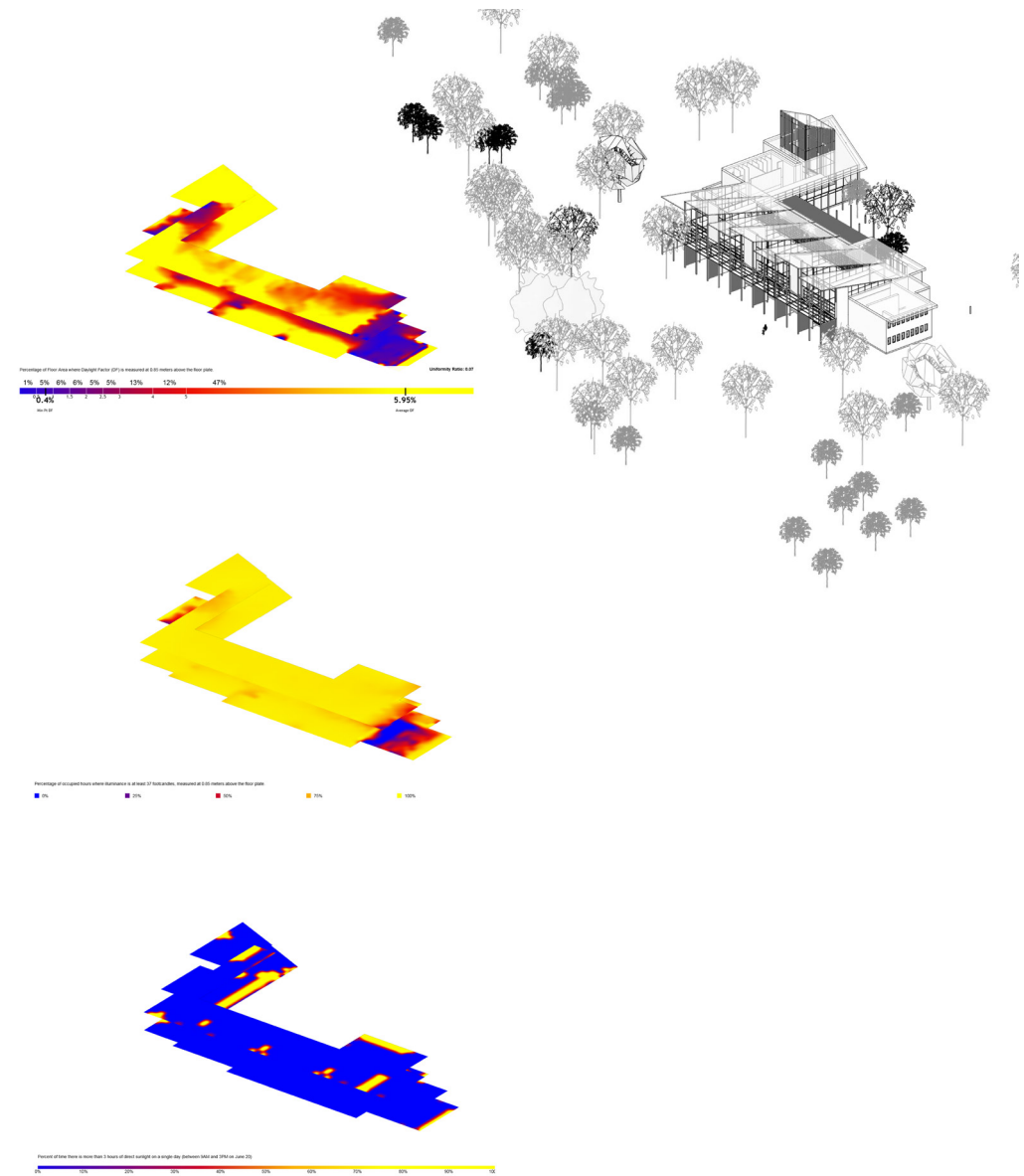

### 8.12.2 Iteration 1

The results from the base design analysis resulted in shading being added to the south facade as well as a pergola to the north of the building in the courtyard space. Small windows were added to the bathrooms. Shading was added to the circulation well. The changes seemed to have little effect on the overall result, however, and the tilted roofs were redesigned to reduce the direct sunlight inlet into the classroom spaces.

Fig 8.25 Iteration 1 daylighting analysis (Author, 2016)

### 8.13 SBAT

A Sustainable Building Assessment Tool (SBAT) study was completed in order to assess whether the design was sustainable in terms of Social, Economic and Environmental Factors. The Overall Score resulted in a good score with factors such as access to facilities rating the highest. Because of the fact that the classroom sizes are much larger than the deemed to satisfy guidelines, factors such as site and cost of building rated lower.

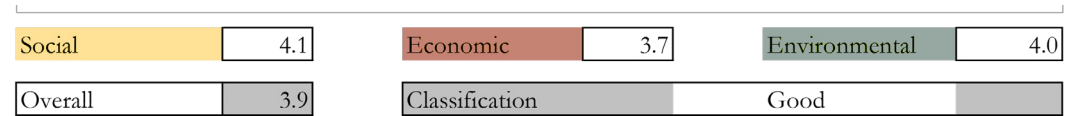
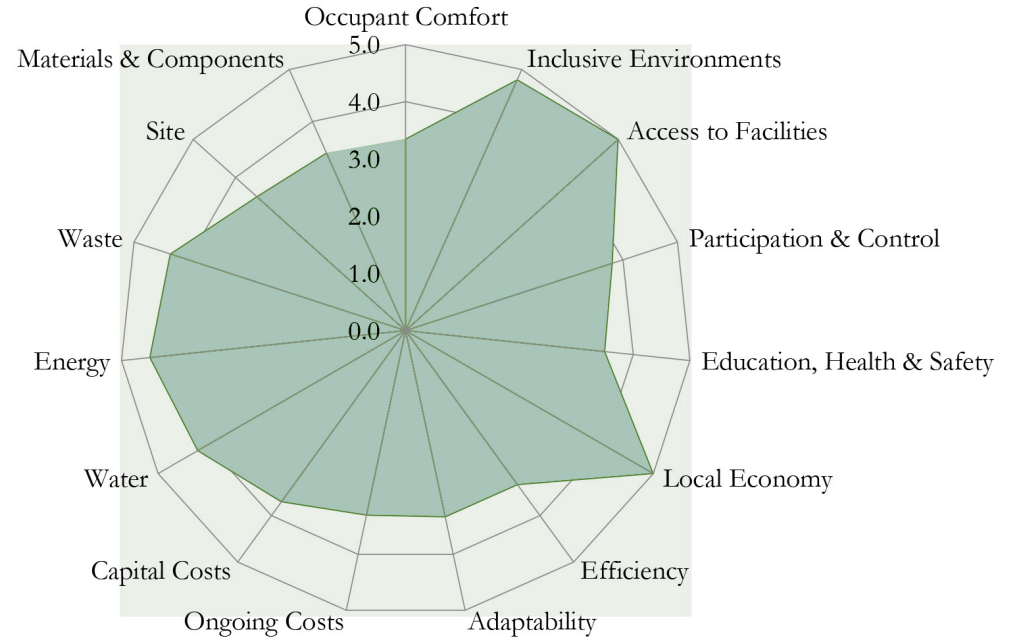

Fig 8.26 SBAT Graph and resultant score (Author, 2016)



“The kiss of the sun for pardon,  
The song of the birds for mirth,--  
One is nearer God’s heart in a garden  
Than anywhere else on earth.”

Dorothy Frances Gurney  
(Willis, 2006: 11)



*conclusion*

Chapter 9

Fig 9.1 View of linking pathway between schools. [Author, 2016]

## 9.1 Reconnecting child to nature

In the aim to address the disconnection between man and his environment, both physically and biophilically, the dissertation investigation came to the following conclusions:

### THE EXISTING GARDENS

By investigating the existing gardens in a biophilic manner, according to the features that exist on site and translating them into richer dimensions of biophilic design, the gardens play a role in healing the disconnection. They form catalysts in the installation of biophilia, showing that the existing natural site, neglected or not holds biophilic potential.

### THE PROGRAMME

Through the integration of the Reggio Emilia approach to learning where the environment becomes the third teacher, these gardens and their identity, be it negative, like the dead date palms after the fire, or positive, they both can become didactic, teaching children the importance of nature in their lives, on a day-to-day basis, completely sensually immersed in the physical, functional and emotional attributes of the environmental features.

### BUILDING

The concept of applying the principles of biophilic design such as biomimicry, prospect and refuge, curiosity and enticement, diffused light, landscape elements defining building form and the use of natural systems to passively control the climate of the spaces to the architecture, enables the building itself to not only facilitate learning of the existing gardens but becoming a teacher in itself. In this way, a new garden is formed that becomes didactic in its very essence.

### RELATIONSHIP

Through the relationship between existing gardens and the new garden (the building), a new relationship is formed between man and nature, creating not only an appreciation of natural systems but complete dependence. This enables a relationship between child and nature to form that will be carried with them for their entire lives, and hopefully, enable ecological cities to become essential to their very existence.



## 9.2 Biophilic Design = Restorative Design

The dissertation enables an evolved human-nature relationship to form as well as place-based relationships which are the intended biophilic dimensions of the dissertation through the integration of a multitude of biophilic principles, where the fundamental principles mentioned below:

Firstly, the biomimicry of natural systems was applied to the overall design of the building. This creates an awareness of the trees through the facilitation of the growth of new trees and the protection of old ones. This also relates to the ecological connection to place, creating a stronger identity in the community as a safe space for children. This also relates to the principle of using landscape features to define building form.

Cultural connection to place is addressed through the integration of outdoor sport facilitates and use of school rooms for community events that connect and revive a dead site into a rejuvenated space that will be giving back to the community for extended periods of time. The integration of the children into the site interweaves the youngest and most important members of the community in the most restorative manner: through education.

In terms of the intentions, most of the spaces designed for children, connect them to the aspects of site. In the classrooms of regrowth or the home-base classrooms, the first storey connects the children to the living skin where the ground floor connects them to the courtyard. In the occupational therapy suites, the connection to the river is evident with the therapy pods positioned in the landscape with the intention of associating therapy with the therapeutic effects of water and trees. In the garden of shadow, the biophilic connections are slightly lost and will hopefully be given meaning through the functions that take place within these spaces.

On the whole, the design fulfilled the original intentions of the scheme, apart from a few “gardens”, however, the interweaving of inside and outside spaces counteracts for the lost connections and contributes towards new ones between the child and the natural world.

“For He broke it for us in a garden  
Under the olive-trees  
Where the angel of strength was the warden  
And the soul of the world found ease.”

Dorothy Frances Gurney  
(Willis, 2006: 11)

*final presentation &  
appendix*

Chapter 10

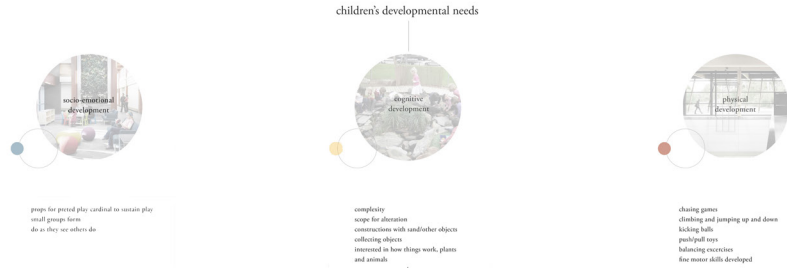

what exists vs programmatic intentions

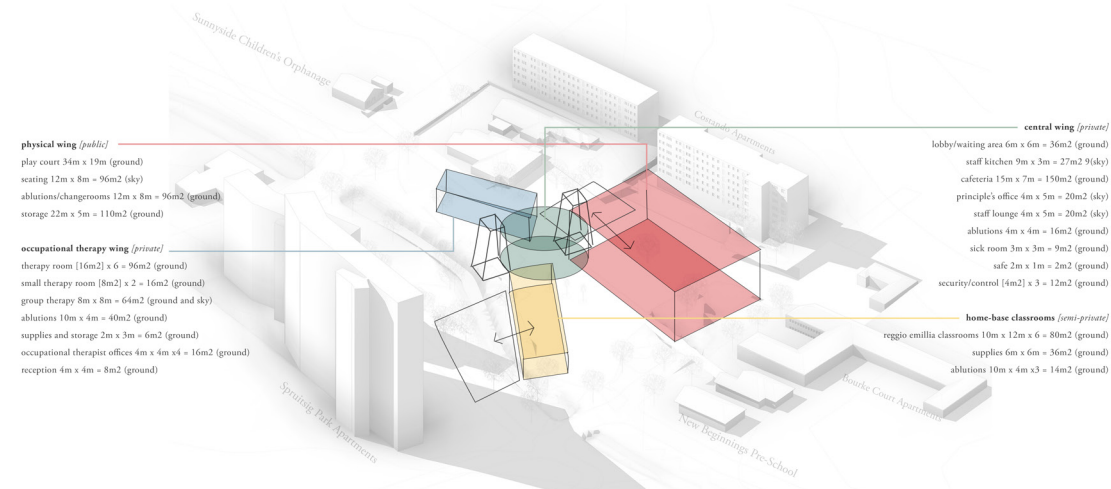

**Users:**  
(During and after hours): Sunnyside Orphanage, Surrounding Residential Apartments, New Beginnings Pre-School, Ring Ting Pre-School

**Users:**  
(School Hours):  
100 New Children from surrounding residential apartments  
50 Ring Ting Pre-School Grade R students

**Users:**  
(School Hours):  
50 Ring Ting Pre-School Grade R students and 100 new children from surrounding residential apartments  
(After Hours):  
Sunnyside Orphanage, New Beginnings Pre-School, People from surrounding residential apartments

The Resolution of three primary programs on site.

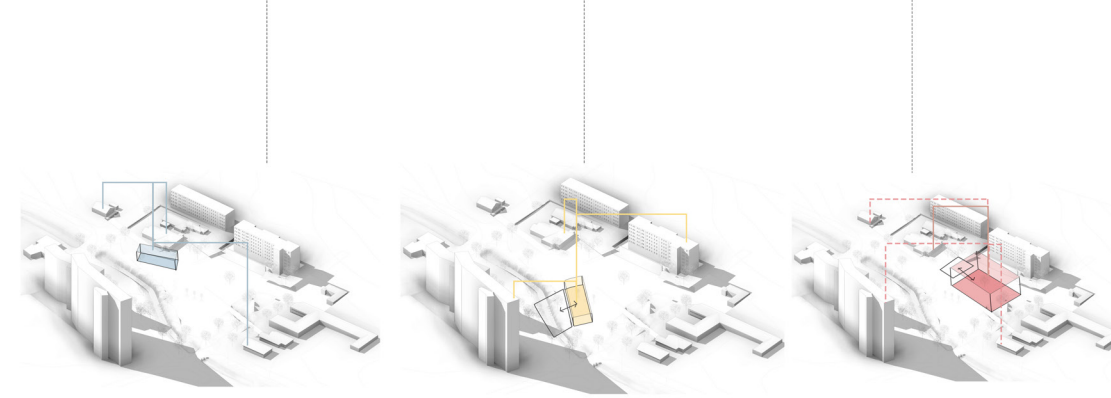
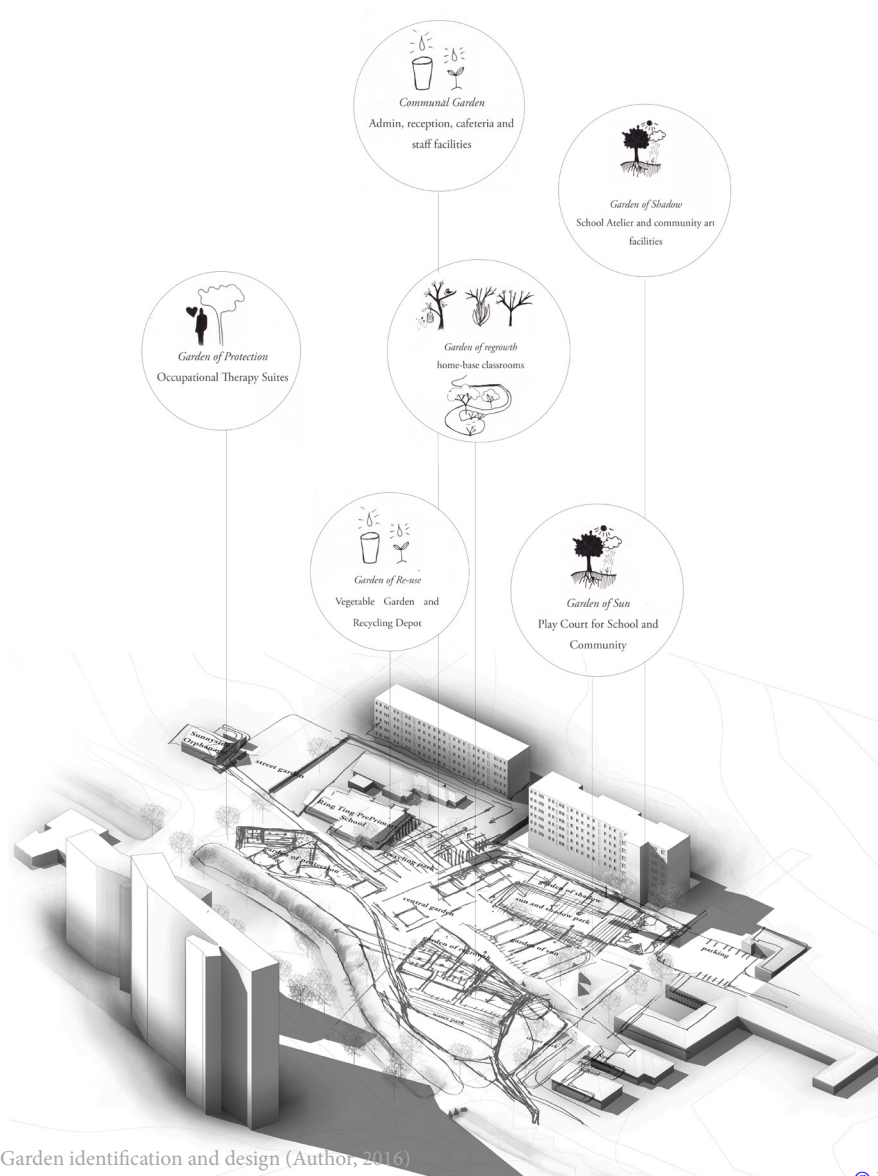

Fig 10.1 Programmatic Resolutions (Author, 2016)

garden identities

"Each space on site was identified as a garden and translated into a didactic concept through how and what can be learnt in each garden according to the identity it possesses."



**Communal Garden**  
Admin, reception, cafeteria and staff facilities

**Garden of Shadow**  
School Atelier and community art facilities

**Garden of Protection**  
Occupational Therapy Suites

**Garden of regrowth**  
home-base classrooms

**Garden of Re-use**  
Vegetable Garden and Recycling Depot

**Garden of Sun**  
Play Court for School and Community

This garden aims to make the adult users of the community aware of their own role in the status of the school. It is a learning space in the traditional sense of the word, but also a space for learning about the school's history and the role of the school in the community.

This garden aims to restore the sense of place and to create a sense of ownership in the school. It is a learning space in the traditional sense of the word, but also a space for learning about the school's history and the role of the school in the community.

This garden was identified as a green space in the school grounds. It is a learning space in the traditional sense of the word, but also a space for learning about the school's history and the role of the school in the community.

design translation

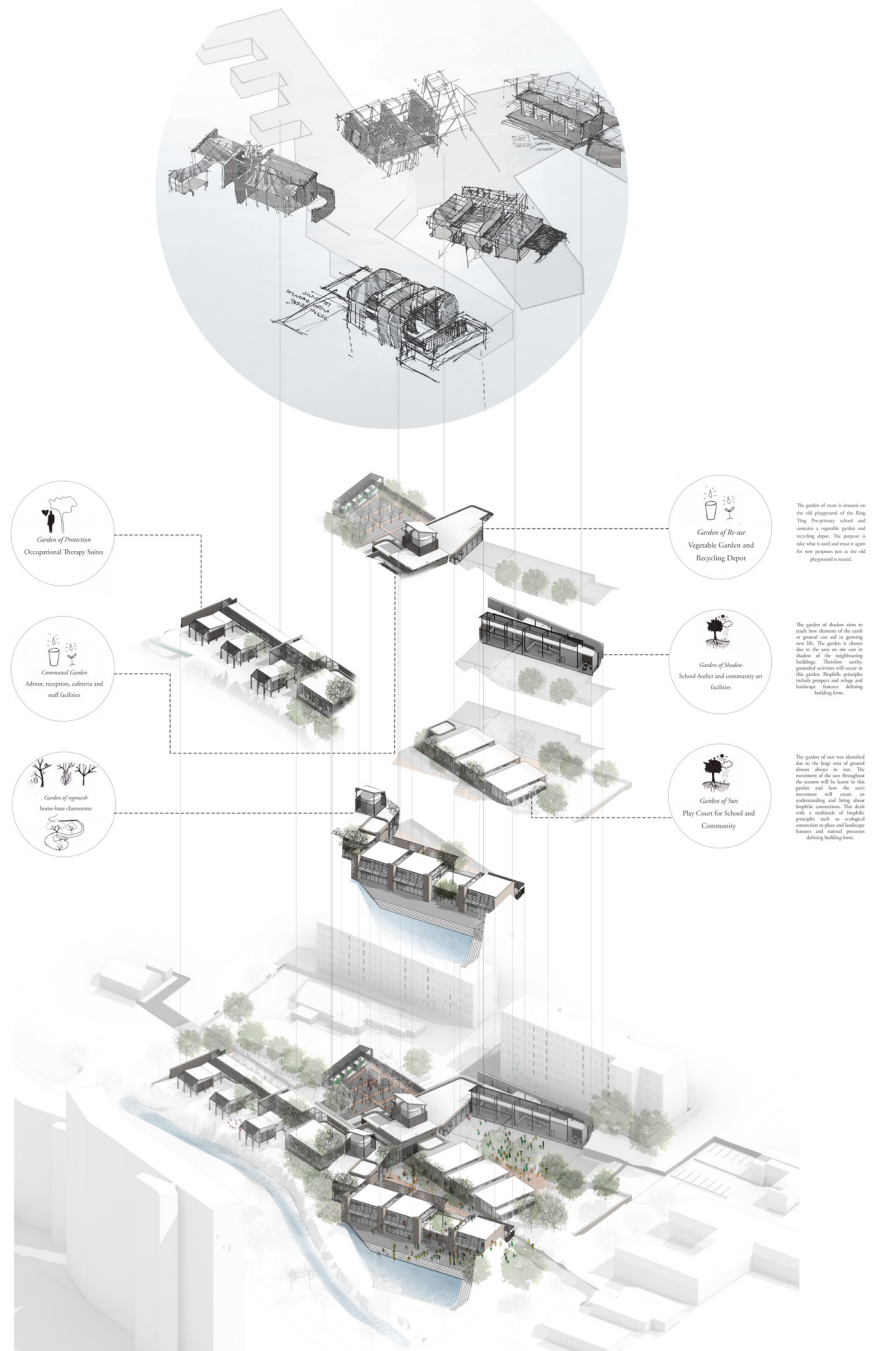

**Garden of Protection**  
Occupational Therapy Suites

**Communal Garden**  
Admin, reception, cafeteria and staff facilities

**Garden of regrowth**  
home-base classrooms

**Garden of Re-use**  
Vegetable Garden and Recycling Depot

**Garden of Shadow**  
School Atelier and community art facilities

**Garden of Sun**  
Play Court for School and Community

The garden of re-use is situated on the old playground of the King King Pharmacy school and contains a vegetable garden and recycling depot. The purpose is to take the school and reuse again for new purposes in the old playground's reuse.

The garden of shadow aims to make the children of the school aware of the school's history and the role of the school in the community. The garden is a learning space in the traditional sense of the word, but also a space for learning about the school's history and the role of the school in the community.

The garden of sun was identified as a green space in the school grounds. It is a learning space in the traditional sense of the word, but also a space for learning about the school's history and the role of the school in the community.

Fig 10.2 Garden identification and design (Author, 2016)

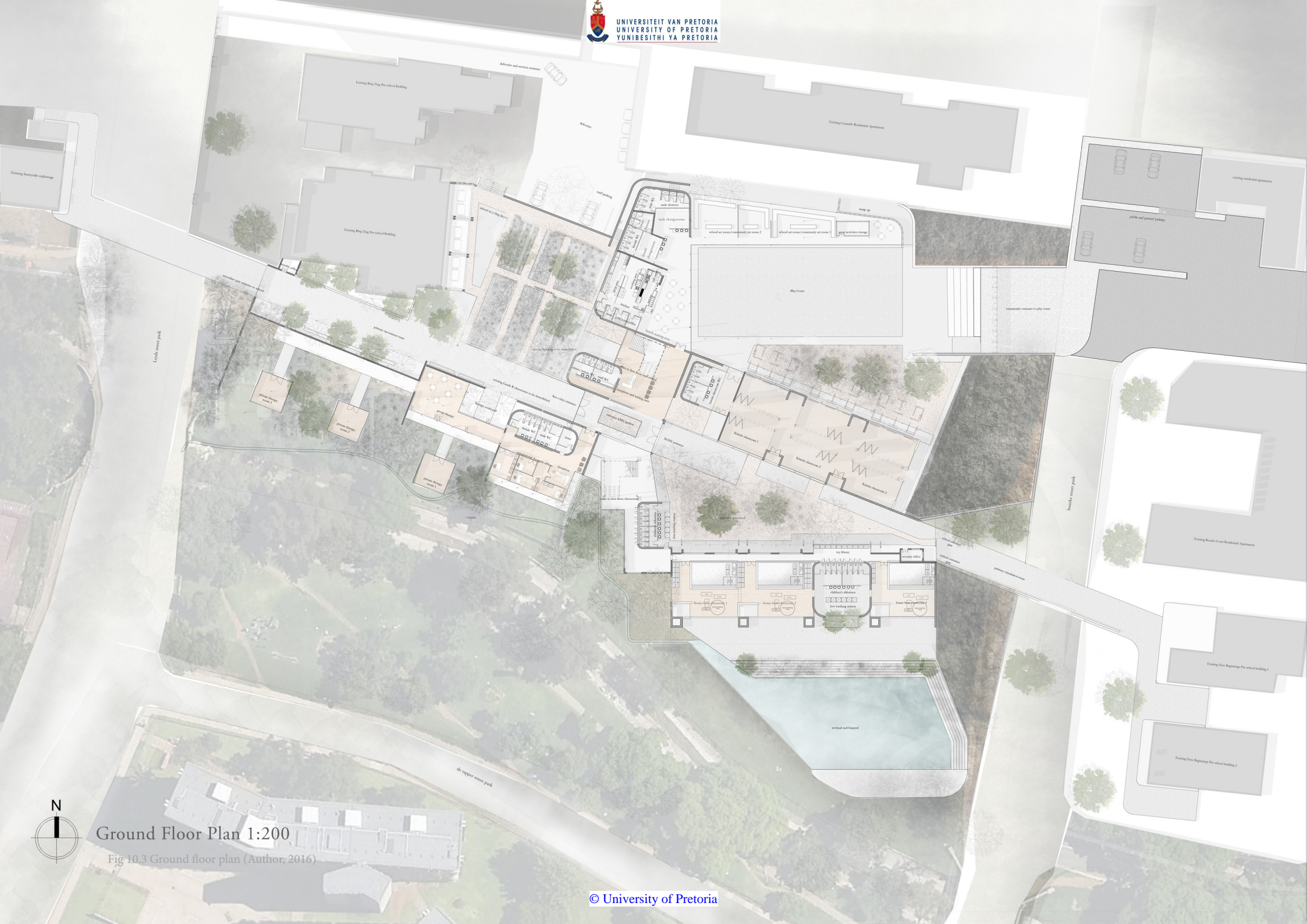

Ground Floor Plan 1:200

Fig 10.3 Ground floor plan (Author, 2016)

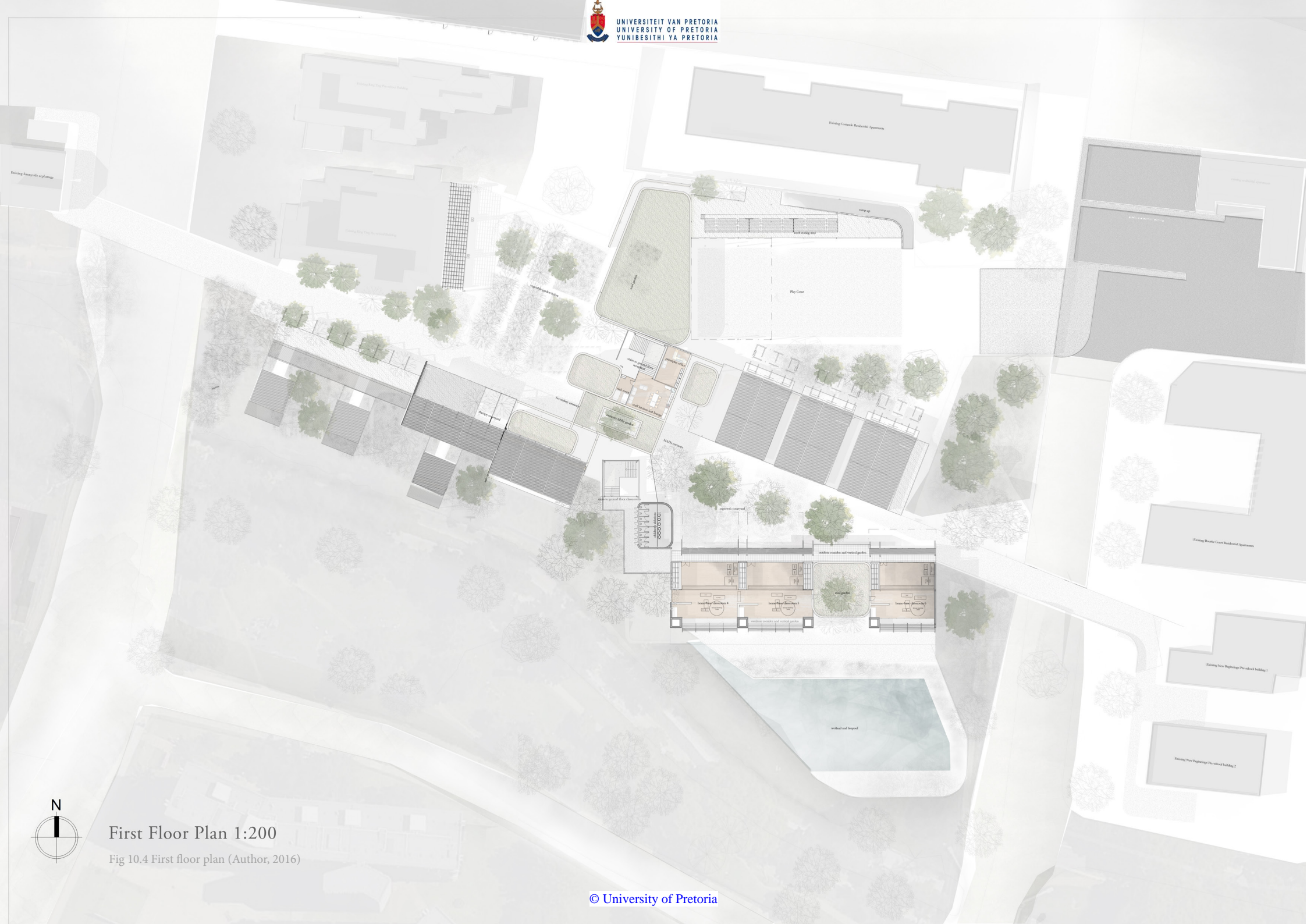

First Floor Plan 1:200

Fig 10.4 First floor plan (Author, 2016)

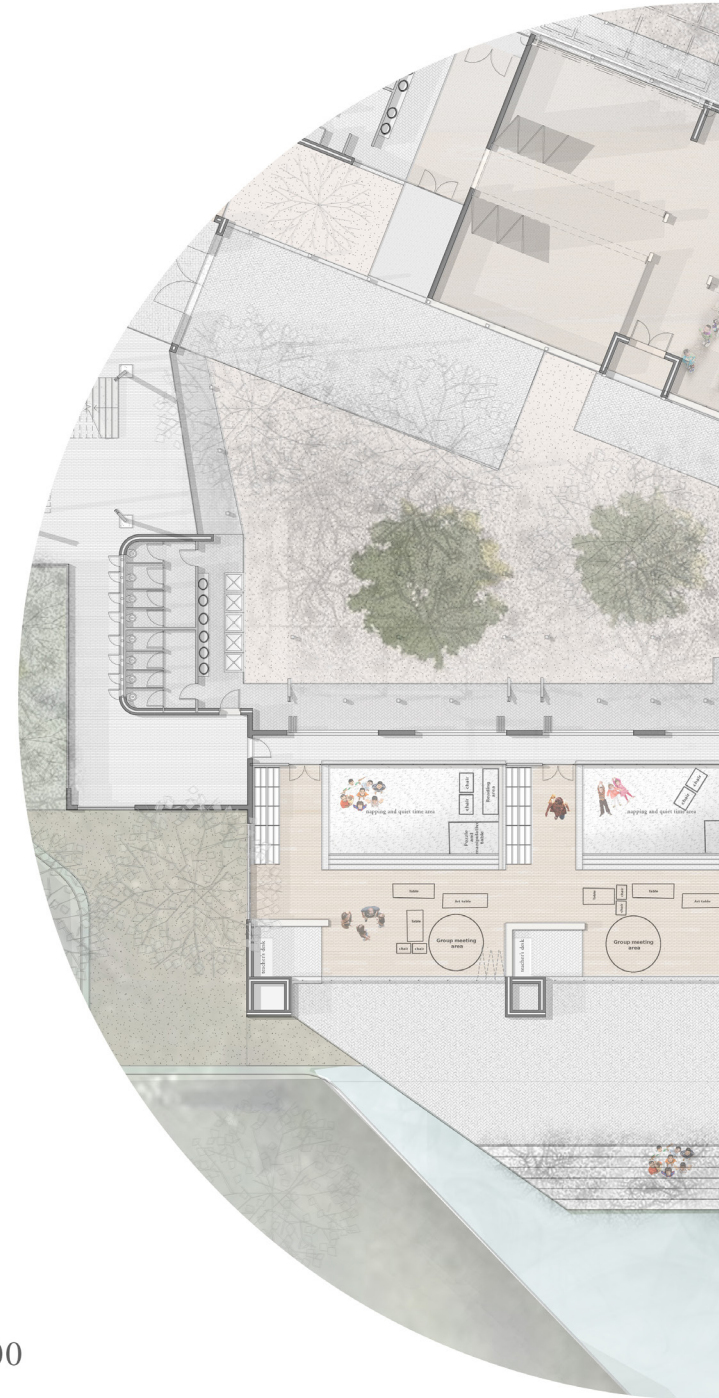
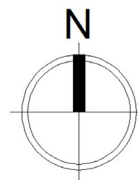
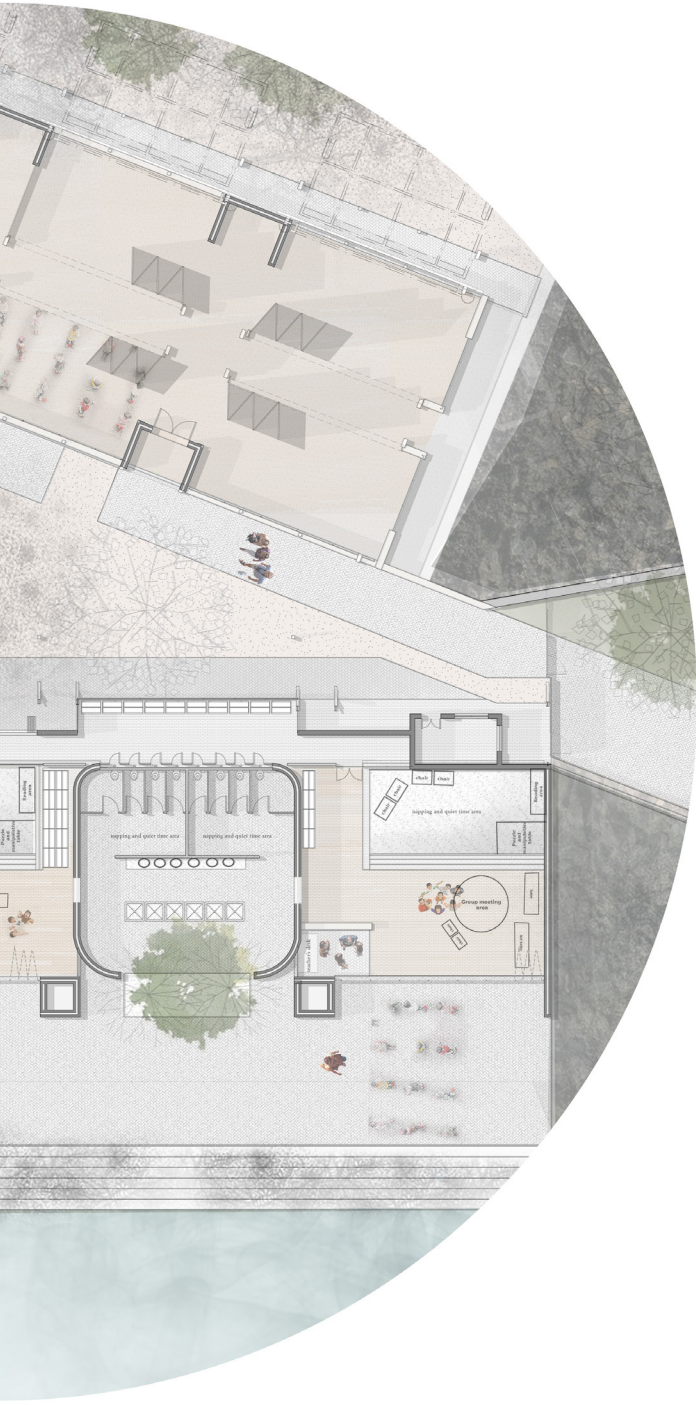

Fig 10.5 Ground floor classroom plan (Author, 2016)



Classroom Floor Plan 1:100





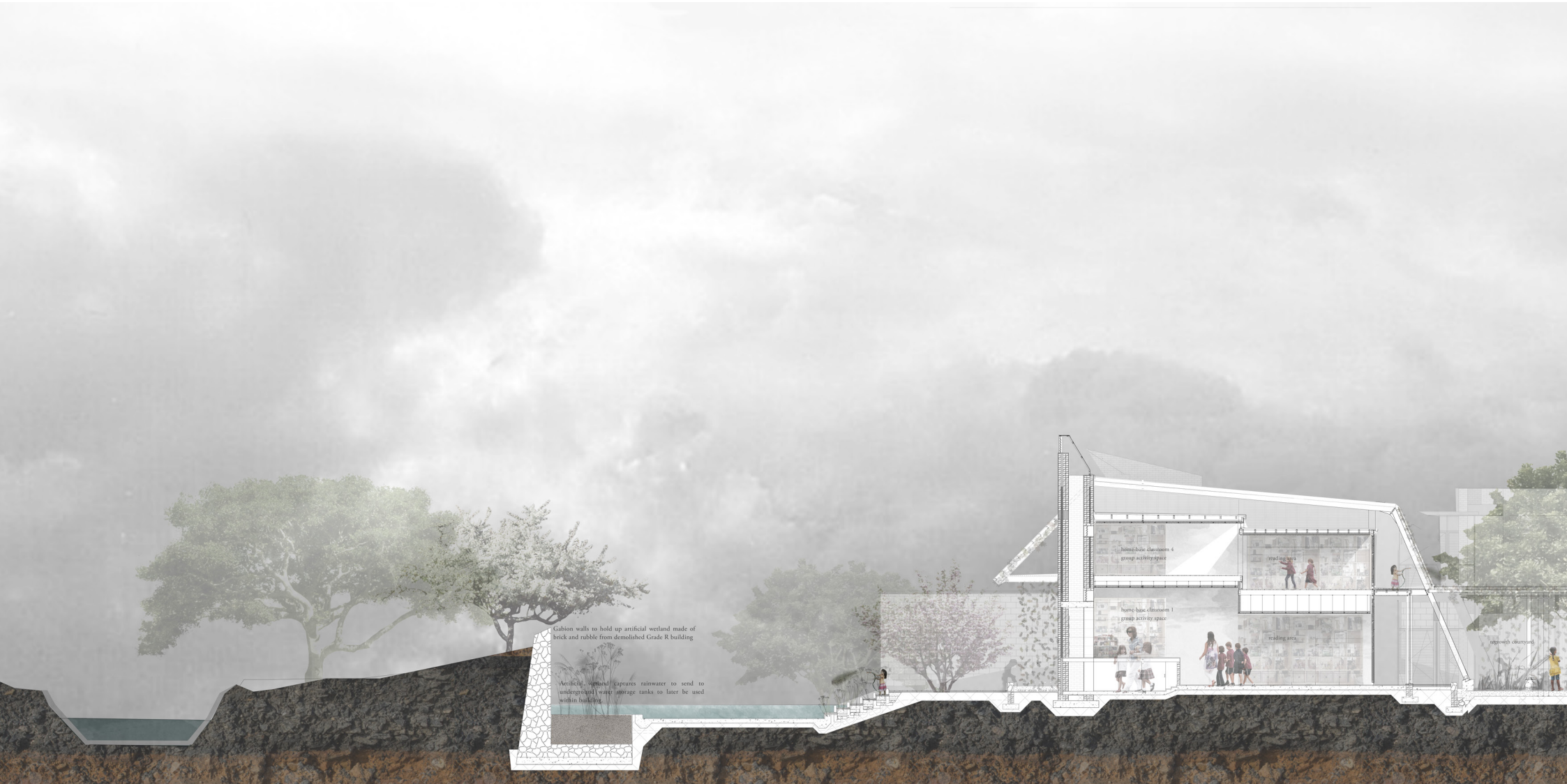

# south-north

Fig 10.6 south-north section(Author, 2016)

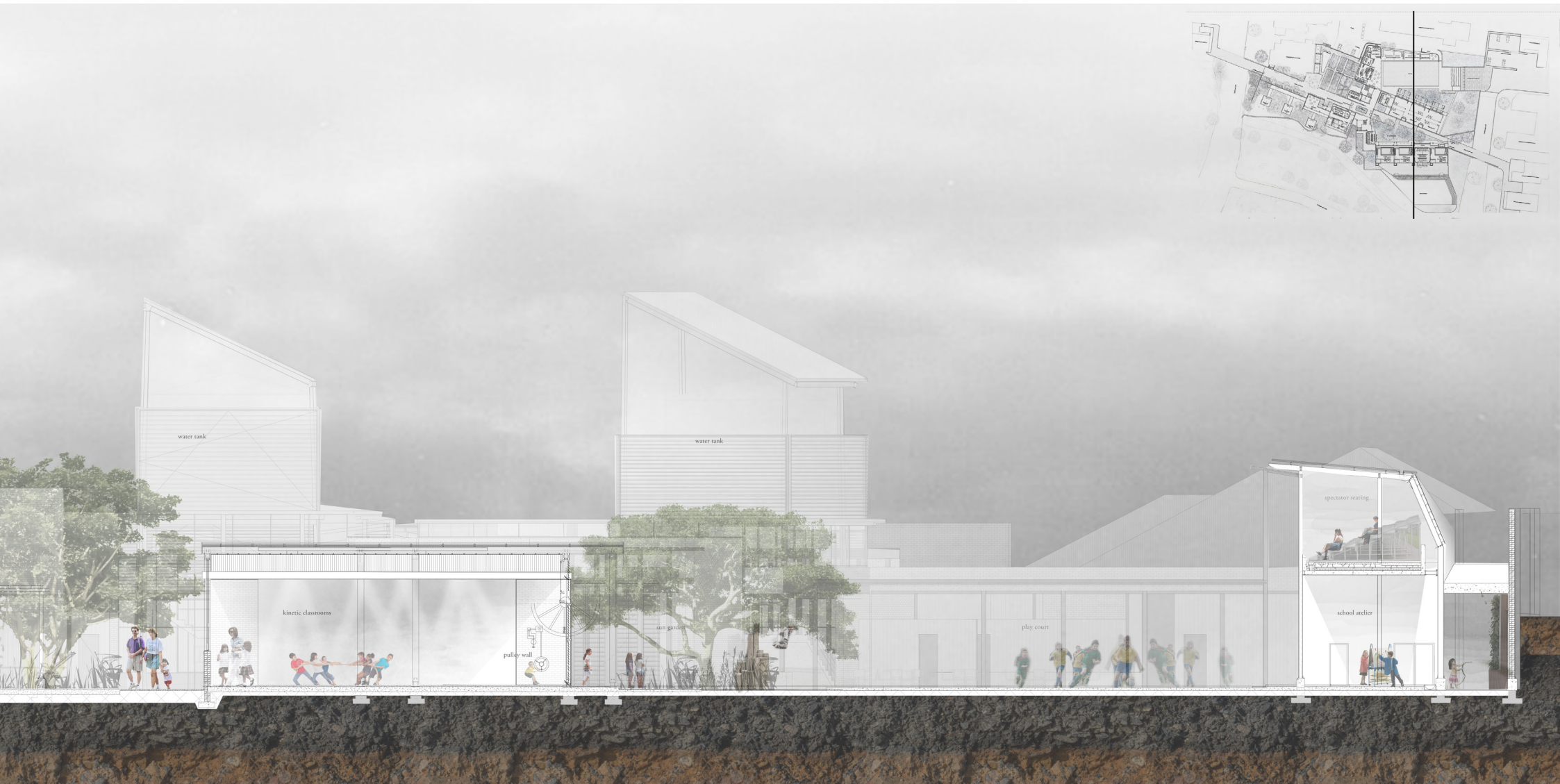

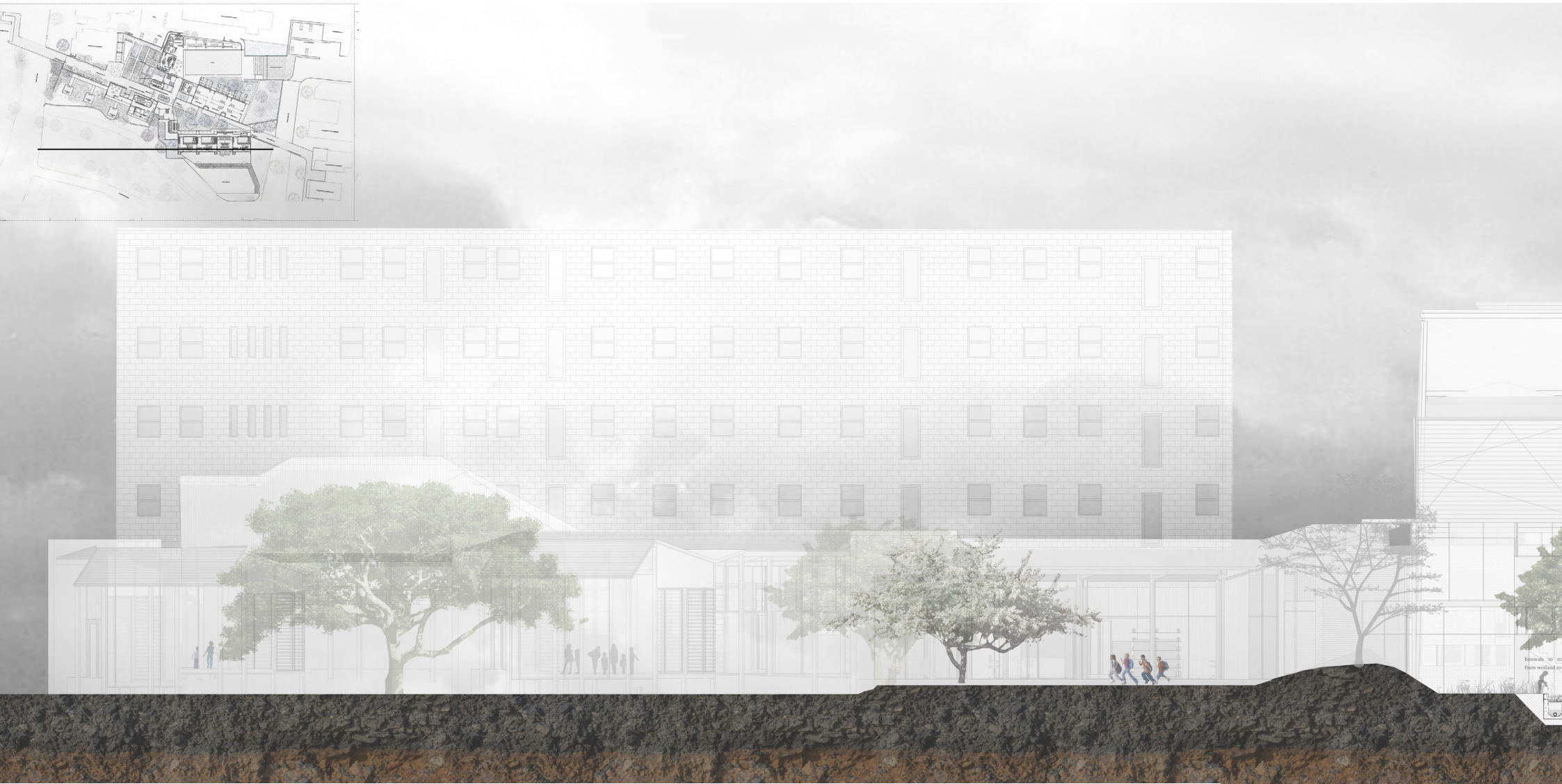
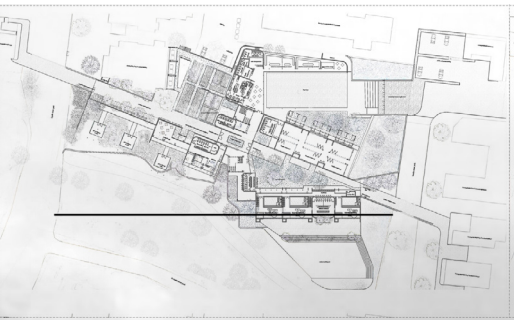

# west-east

Fig 10.7 west-east section(Author, 2016)



*tectonic concept*

The focus lies in the relationship between the characteristics of the existing garden and the tectonics of the architecture and how this relationship can facilitate learning. The primary tectonic concept is based on the biomimicry of the vertical and horizontal axis of the tree:

**Horizontal Axis:** The stereonomic, like the trunk of the tree, offers support as well as services to its branches. The plan is based on the relationship between learning spaces and service to learning showing the relationship between these. The placement of the serving and learning spaces are dependent on the nature of the garden.

**Vertical Axis:** The vertical axis forms a primary structural system of stereonomic floors and trunks (service spaces) and branches (support columns) all supporting the roof canopies. The secondary structure is dependent on the nature of the garden and how and what type of learning takes place in each.

**The Canopy:** The canopy or roofing system represents an overlay of protection over the functions and learning spaces. It is fragmented but in its language becomes an unified element over the site and building.

*material palette*

SYMBIOTIC QUALITIES ON SITE:

**SOIL:** The soil present on site is of shale rock and broken with a prominent reddish color.

**RED BRICK AND CONCRETE:** The surrounding fabric is mostly constructed from red brick and concrete finishes.

The predominant masonry material will be concrete and brick, however where the building is more part of the ground, gables walls will be used to blend with the ground material and support plant growth.

TECTONIC QUALITIES ON SITE:

**VEGETATION - TREE TRUNKS AND BRANCHES:** A variety of tree species exist on site. The majority of trees are more durable when the canopy of trees change and grow over time.

KEPLON™ TWO ROCKS

The surrounding learning structures have KEPLON™ creating an inert roofing language which was identified as an appropriate approach to the canopy of the tree and how the roof becomes the canopy over the learning that takes place.

TIMBER

Timber columns will be used as support systems to outdoor learning spaces as the structural system becomes part of a complete system, changing its condition from the indoor roof system.

An appropriate response to material is using steel which is faster to construct and being adaptive with vertical timber columns as support systems for a roof system. BRK roof sheeting will be used as it merges with the surrounding fabric of the existing children's centres as well as allows for the roof to become a canopy encompassing the learning spaces.

*classroom development*

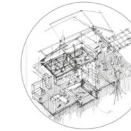
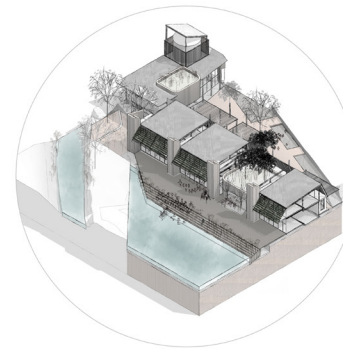

The exterior of the classrooms design was influenced by the identity of the garden that the classrooms frame. The garden of growth was centered around the classrooms having a living skin that becomes part of the building's facade as well as permeate into the classrooms spaces. The roof canopy developed from growing roofs to a more integrated roof and skin system that fully incorporated the skin with the roof to emphasize the continuity of the roof as a canopy. The solar stack became not only a passive climate control mechanism but a design resolution in the modularity between each classroom, serving as the service core between each classroom space.

The Roof (Canopy):

The roof canopy developed from growing roofs to a more integrated roof and skin system that fully incorporated the skin with the roof to emphasize the continuity of the roof as a canopy. The roof canopy is to enable activities below as a protective layer in the trunks and branches.

The Tectonic (The branches):

stereonomic trunks were juxtaposed alongside spaces made up of light concrete columns and light walls, being in natural light from high level windows, timber columns and vegetation. stereonomic learning depends on stereonomic in terms of function and structural support. stereonomic identity, some more aware became a recognizable element in the landscape.

The Stereonomic (The trunks):

relationship between learning spaces and service to learning. The placement of the serving and learning spaces are dependent on the nature of the garden. The services offered by these stereonomic made like objects on plan refer to passive climate control and facilitation of storage space for the classroom's needs as well as enhance facilities.

The Stereonomic (The Roots):

The base of the design establishes and defines the landscape to facilitate learning and create learning spaces through the incorporation of the roofed and water channel as well as the land forms.

The Identified Gardens (The roots):

The identified garden spaces are defined in the design and service mechanisms. These characteristics together with the primary design language determined the structural mechanisms.

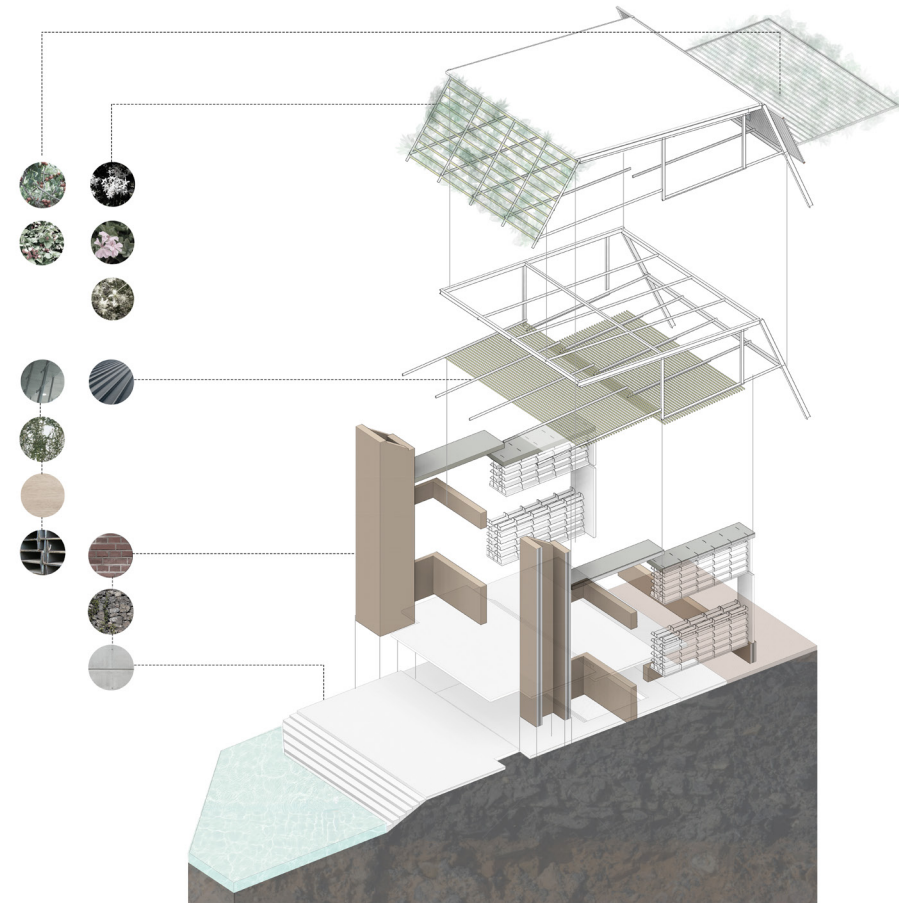
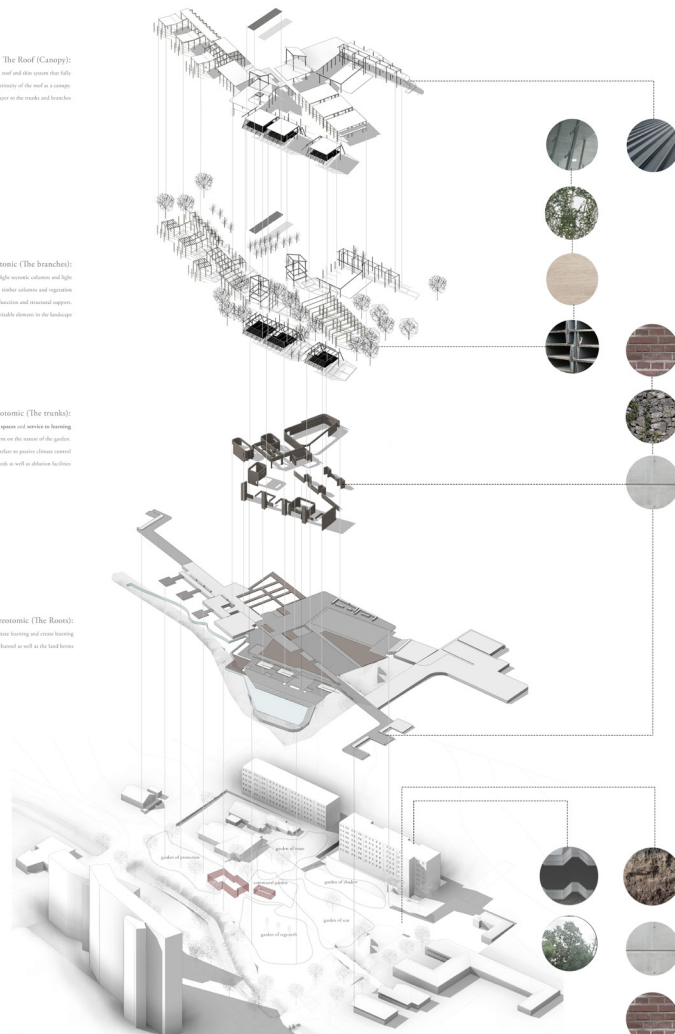
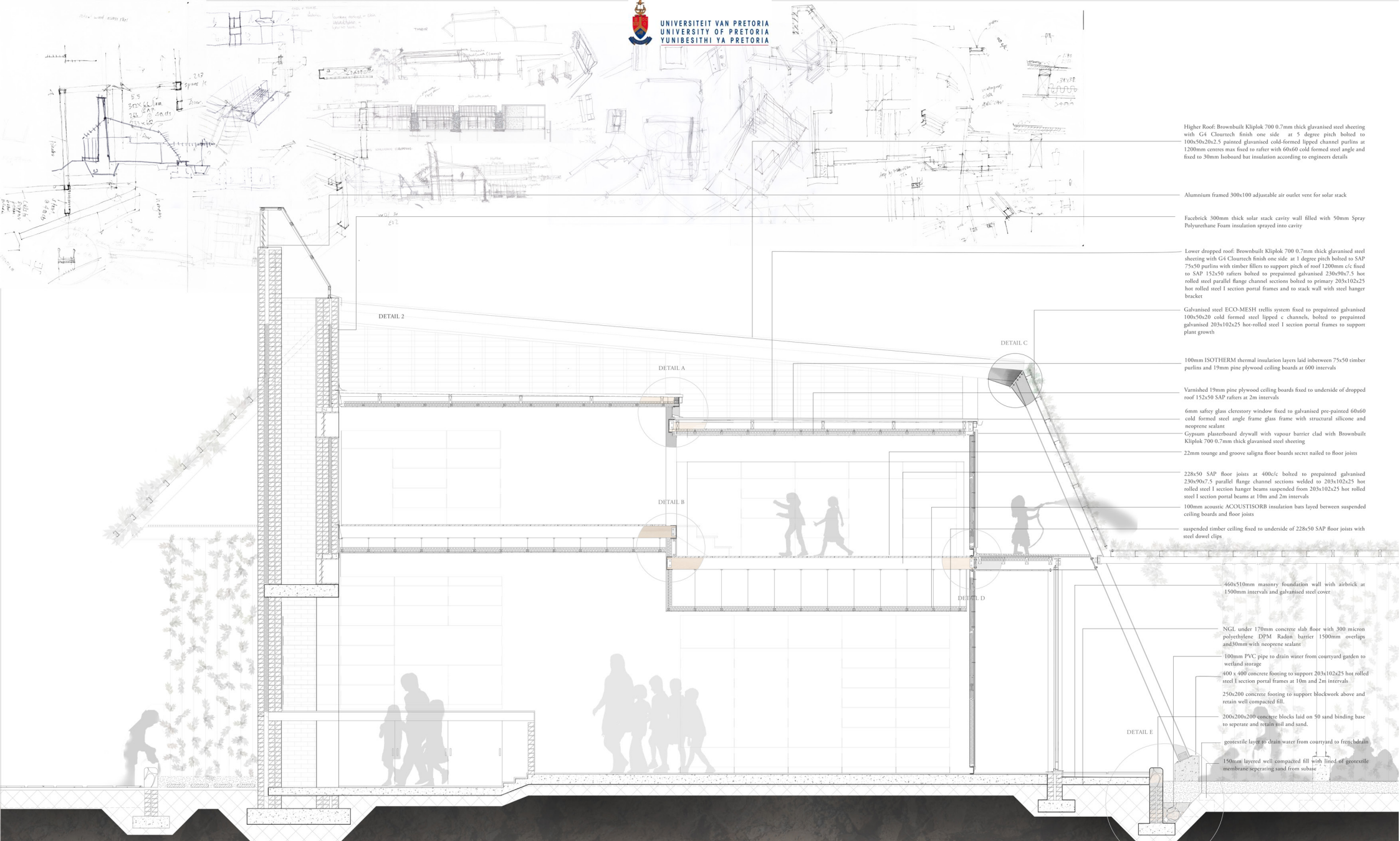

Fig 10.8 Technical axonometric explosions (Author, 2016)



Higher Roof: Brownbult Kliplok 700 0.7mm thick galvanised steel sheeting with G4 Cloutrtech finish one side at 5 degree pitch bolted to 100x50x20x2.5 painted galvanised cold-formed lipped channel purlins at 1200mm centres max fixed to rafters with 60x60 cold formed steel angle and fixed to 30mm looboard but insulation according to engineers details

Aluminium framed 300x100 adjustable air outlet vent for solar stack

Facebook 300mm thick solar stack cavity wall filled with 50mm Spray Polyurethane Foam insulation sprayed into cavity

Lower dropped roof: Brownbult Kliplok 700 0.7mm thick galvanised steel sheeting with G4 Cloutrtech finish one side at 1 degree pitch bolted to SAP 75x50 purlins with timber fillers to support pitch of roof 1200mm c/c fixed to SAP 152x50 rafters bolted to pre-painted galvanised 230x90x7.5 hot rolled steel parallel flange channel sections bolted to primary 203x102x25 hot rolled steel I section portal frames and to stack wall with steel hanger bracket

Galvanised steel ECO-MESH trellis system fixed to pre-painted galvanised 100x50x20 cold formed steel lipped c channels, bolted to pre-painted galvanised 203x102x25 hot-rolled steel I section portal frames to support plant growth

100mm ISOTHERM thermal insulation layers laid between 75x50 timber purlins and 19mm pine plywood ceiling boards at 600 intervals

Varnished 19mm pine plywood ceiling boards fixed to underside of dropped roof 152x50 SAP rafters at 2m intervals

6mm safety glass clerestory window fixed to galvanised pre-painted 60x60 cold formed steel angle frame glass frame with structural silicone and neoprene sealant  
Gypsum plasterboard drywall with vapour barrier clad with Brownbult Kliplok 700 0.7mm thick galvanised steel sheeting

22mm tongue and groove saligna floor boards secret nailed to floor joists

228x50 SAP floor joists at 400c/c bolted to pre-painted galvanised 230x90x7.5 parallel flange channel sections welded to 203x102x25 hot rolled steel I section hanger beams suspended from 203x102x25 hot rolled steel I section portal beams at 10m and 2m intervals

100mm acoustic ACOUSTISORB insulation bars layed between suspended ceiling boards and floor joists

suspended timber ceiling fixed to underside of 228x50 SAP floor joists with steel dowel clips

460x510mm masonry foundation wall with airbrick at 1500mm intervals and galvanised steel cover

NGL under 170mm concrete slab floor with 300 micron polyethylene DPM Radon barrier 1500mm overlaps and 30mm with neoprene sealant

100mm PVC pipe to drain water from courtyard garden to wetland storage

400 x 400 concrete footing to support 203x102x25 hot rolled steel I section portal frames at 10m and 2m intervals

250x200 concrete footing to support blockwork above and retain well compacted fill

200x200x200 concrete blocks laid on 50 sand binding base to separate and retain soil and sand

geotextile layer to drain water from courtyard to freyghdrain

150mm layered well compacted fill with lined of geotextile membrane separating sand from subsoil

1:20 Section

Fig 10.9 Final 1:20 Section (Author, 2016)

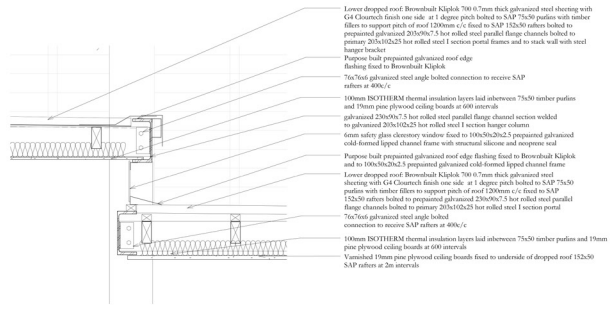

DETAIL A  
scale 1:10

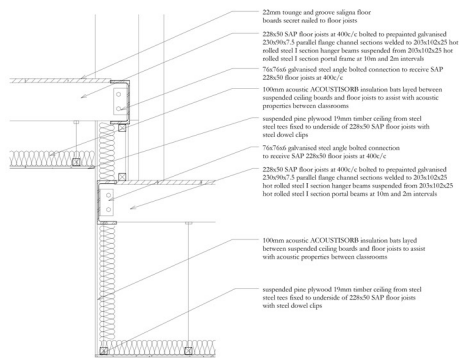

DETAIL B  
scale 1:10

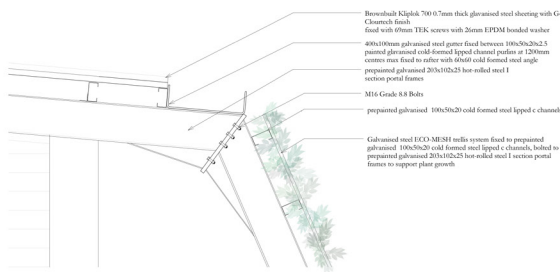

DETAIL C  
scale 1:10

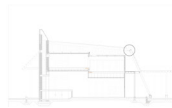
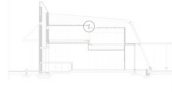
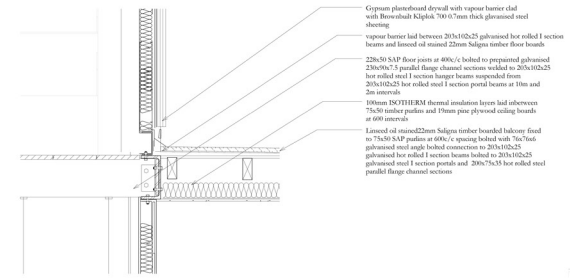
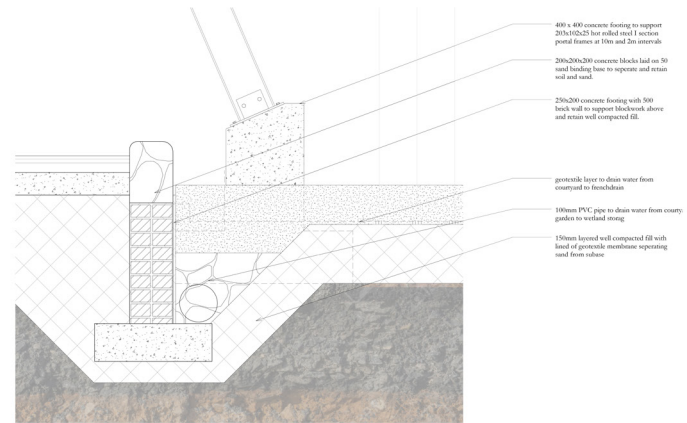

Fig 10.10 Details (Author, 2016)



DETAIL D  
scale 1:10



DETAIL E  
scale 1:10

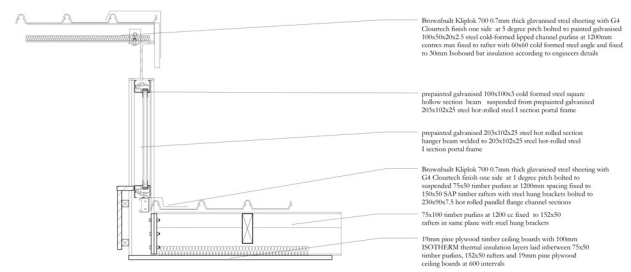

DETAIL F  
scale 1:10

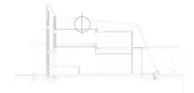
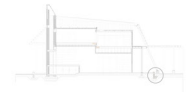
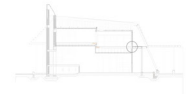



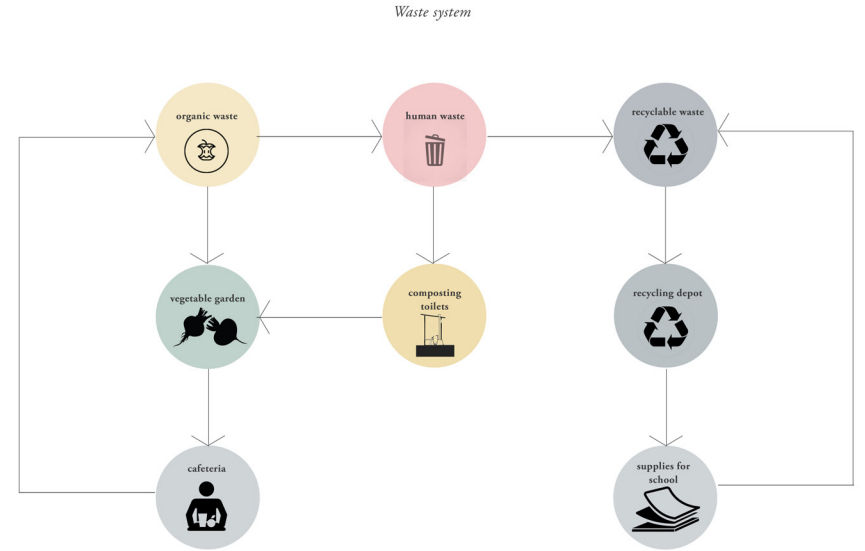
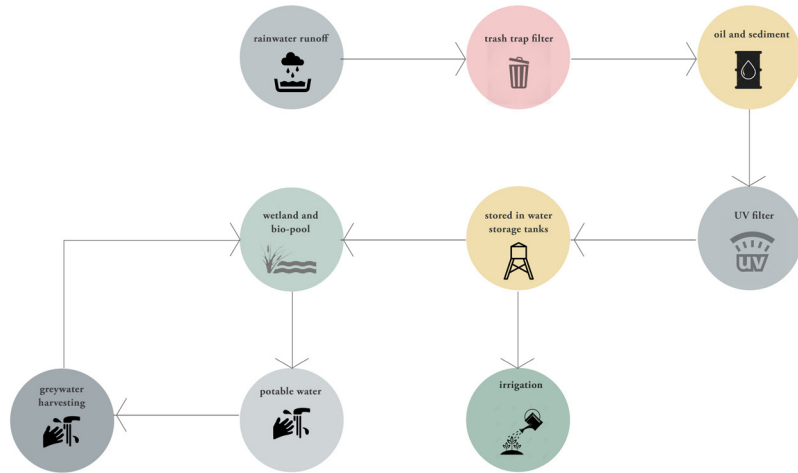

As a result of the investigation, a 500m<sup>3</sup> tank needs to be provided in order to support the demand. This is not possible due to space reasons, so 180m<sup>3</sup> will be stored in high level water towers.

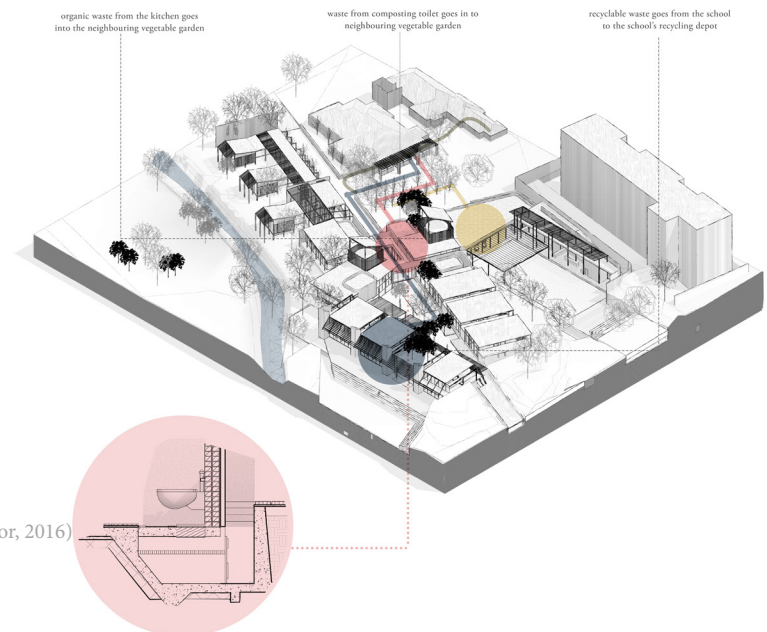
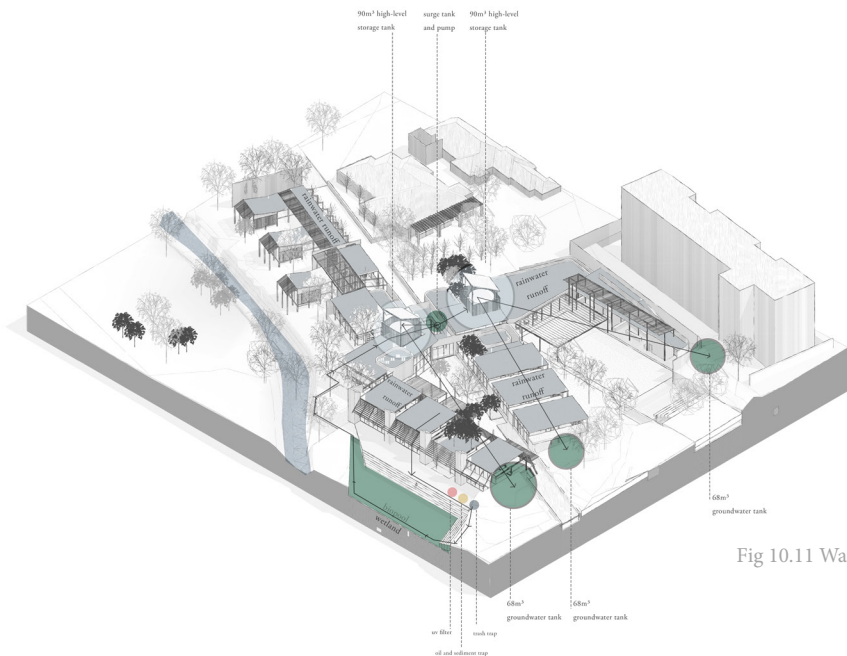
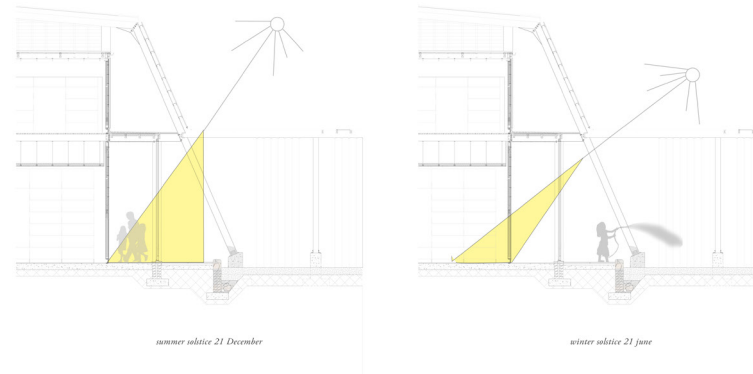
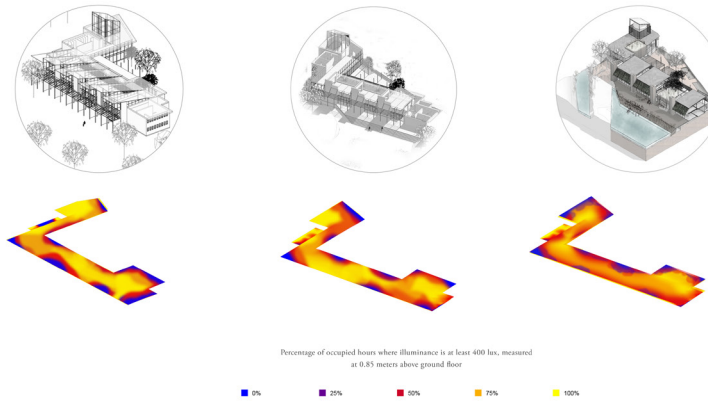

Fig 10.11 Water and Waste Passive Systems(Author, 2016)

Daylighting



The pergola and deep set circulation corridor and balcony lets sun into the classrooms in winter and shades it in summer



Ventilation

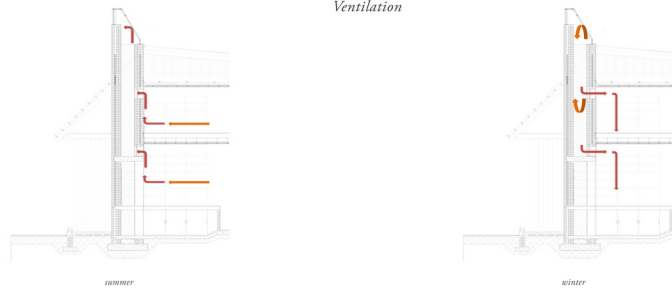

During summer months, the stack aims to cool the space through an updraught created by the form of the stack, the glass on top of the stack, the glass on top of the stack, the glass on top of the stack to mitigate heat

Fig 10.12 Daylighting Resolutions (Author, 2016)

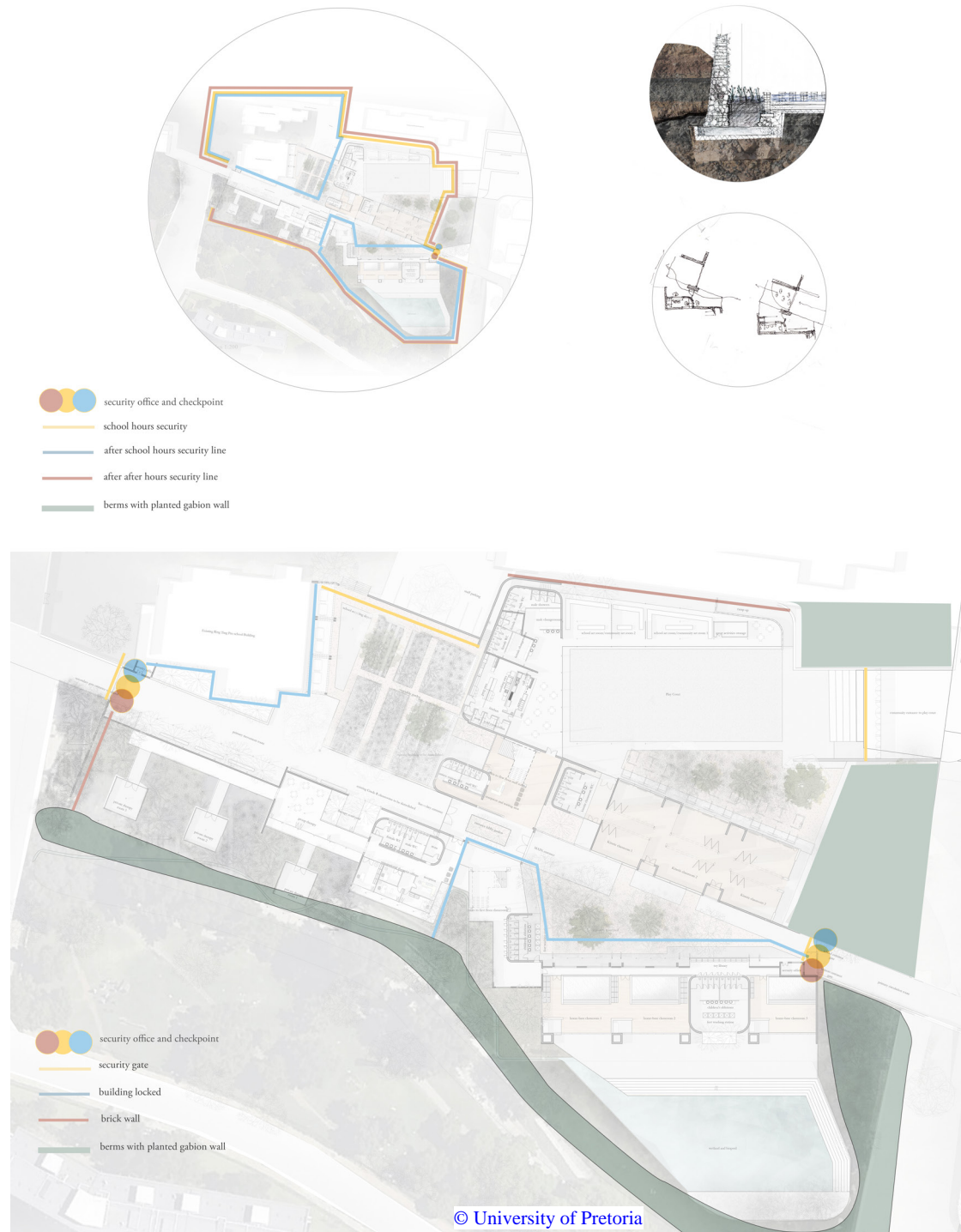

Fig 10.13 Child Safety Resolutions (Author, 2016)



Fig 10.14 Interior perspective of classrooms (Author, 2016)

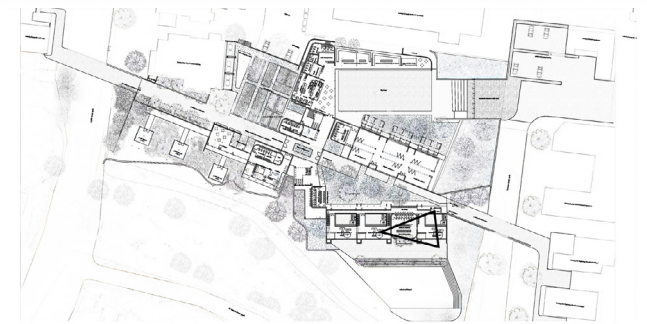



Fig 10.15 View over the Walkerspruit looking towards the classrooms and occupational therapy suites (Author, 2016)

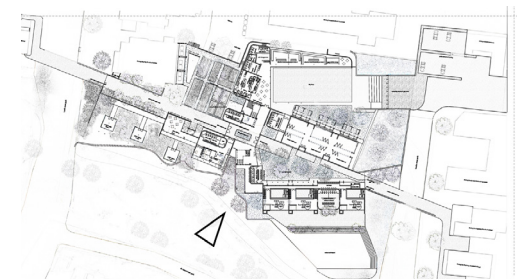
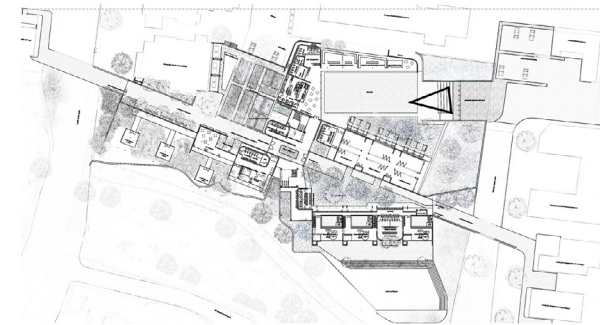



Fig 10.16 View of play court (Author, 2016)



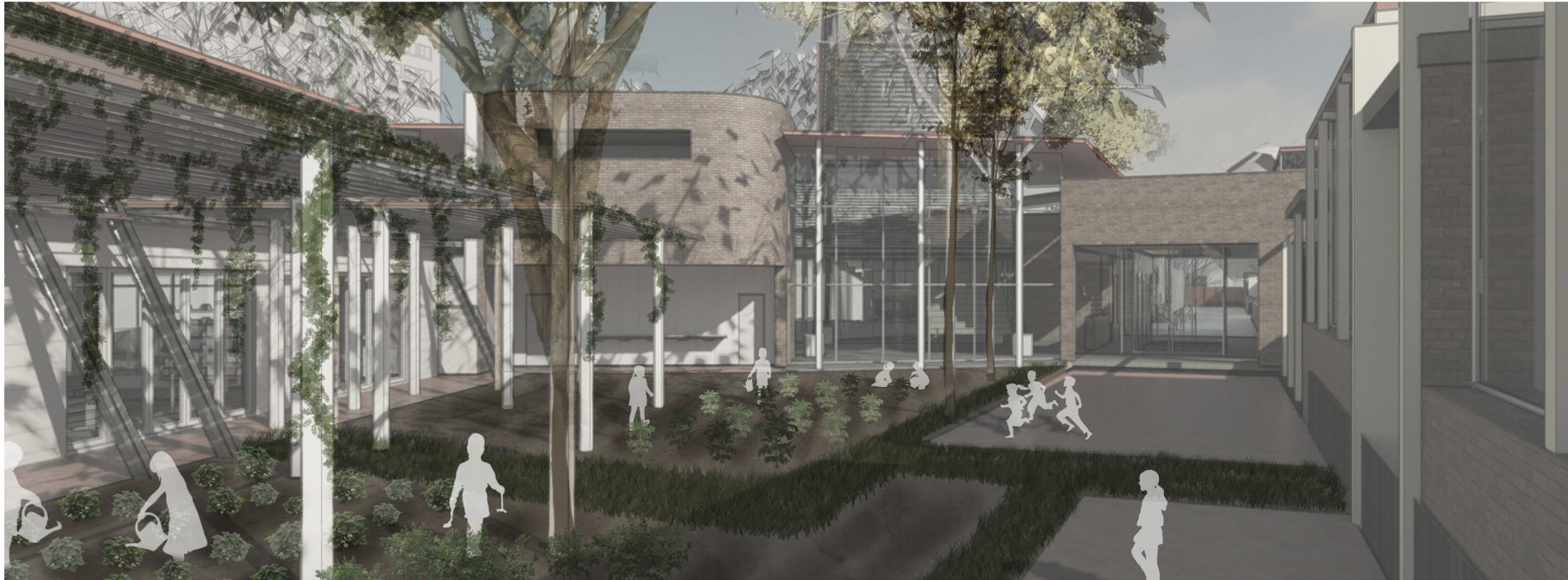
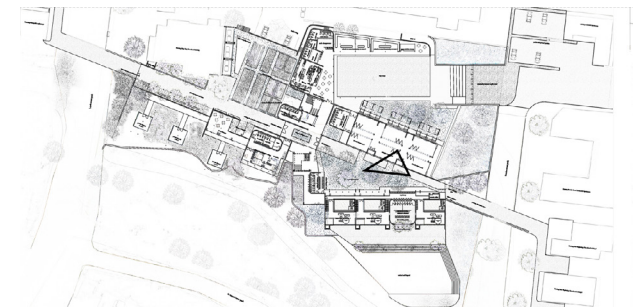

Fig 10.17 View of the garden of regrowth (Author, 2016)



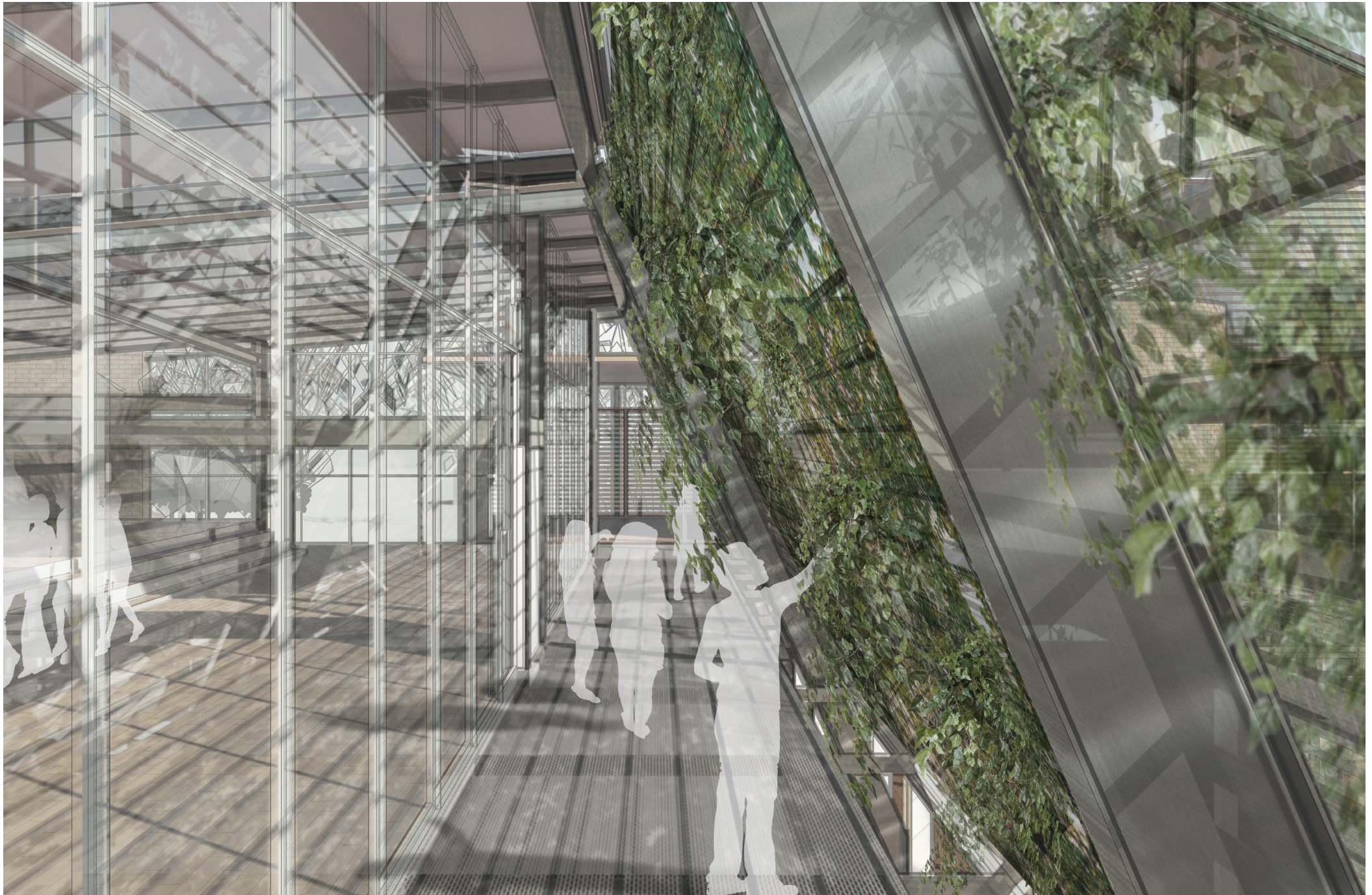

Fig 10.18 View of living skin and children maintaining it (Author, 2016)





Fig 10.19 View of the classroom threshold and bathroom entrance (Author, 2016)

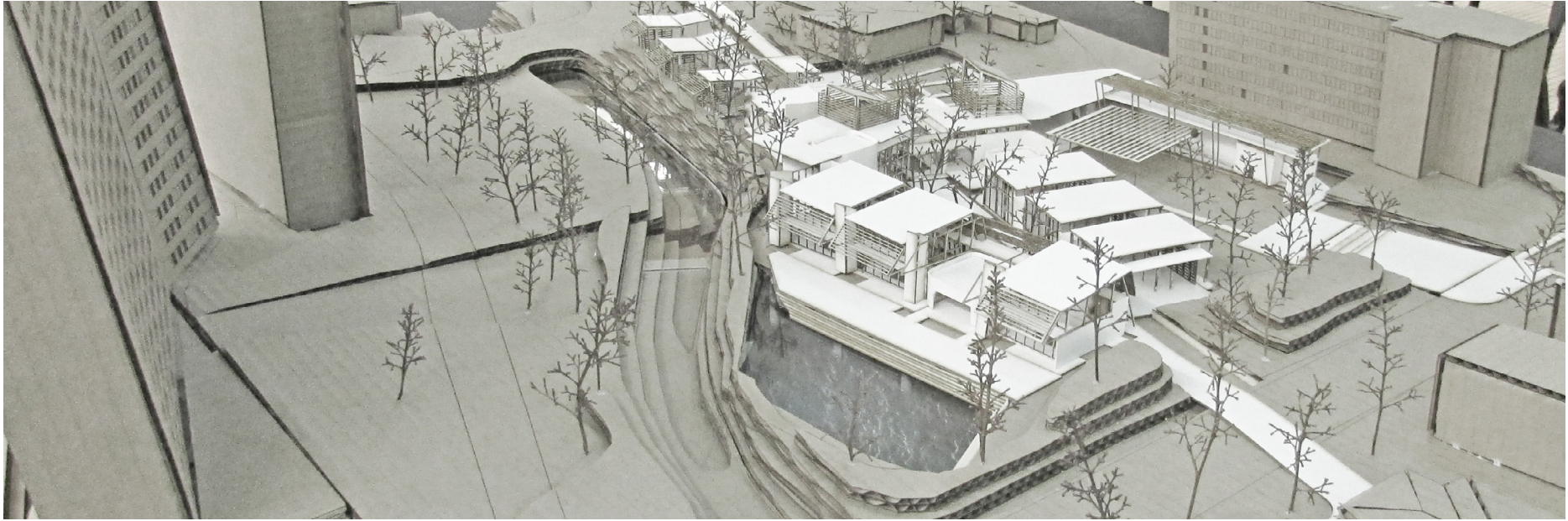

Fig 10.20 Final Model, overlooking home-base classrooms (Author, 2016)

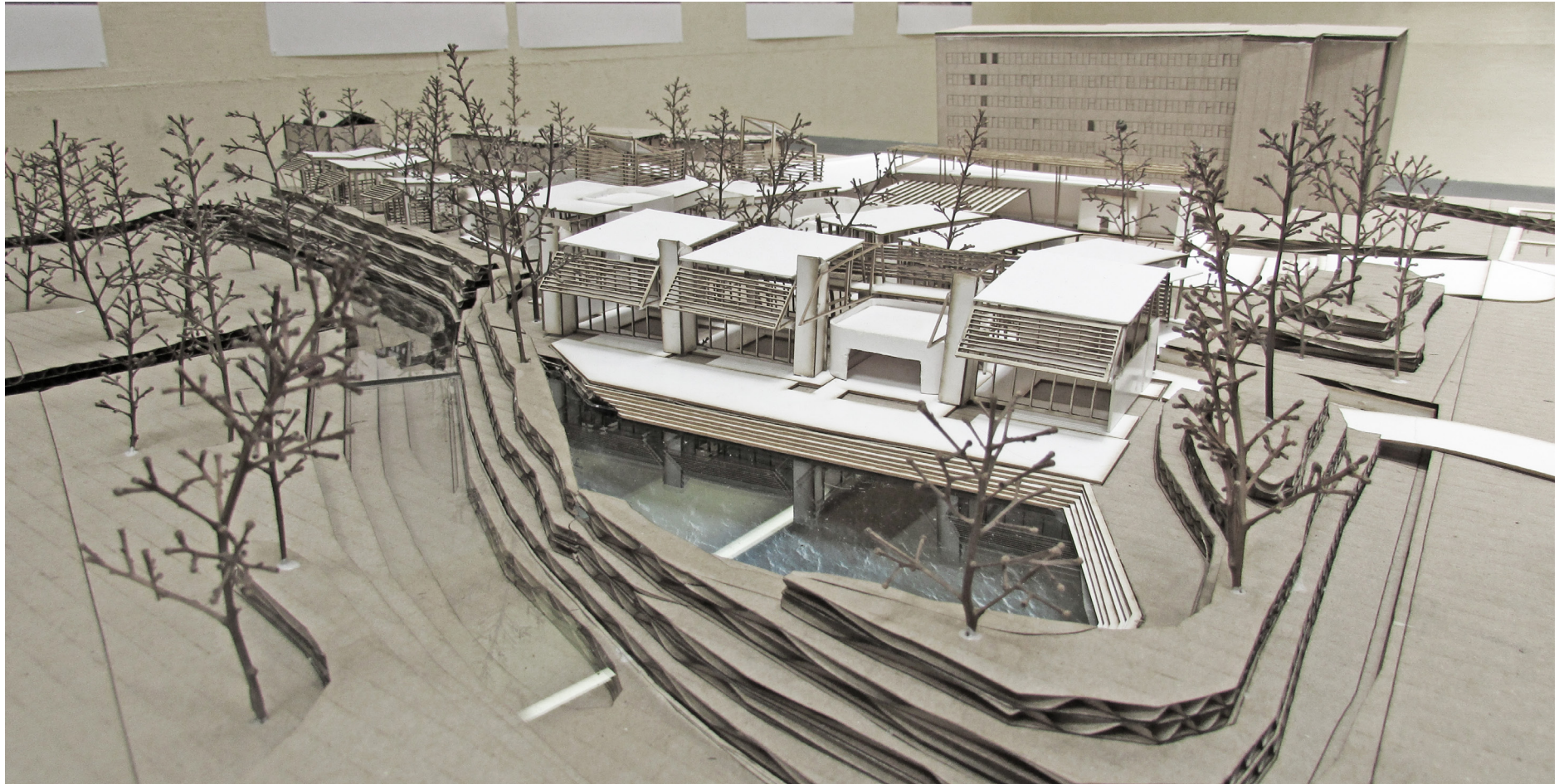

Fig 10.21 Final model, home-base classrooms and wetland and water park (Author, 2016)

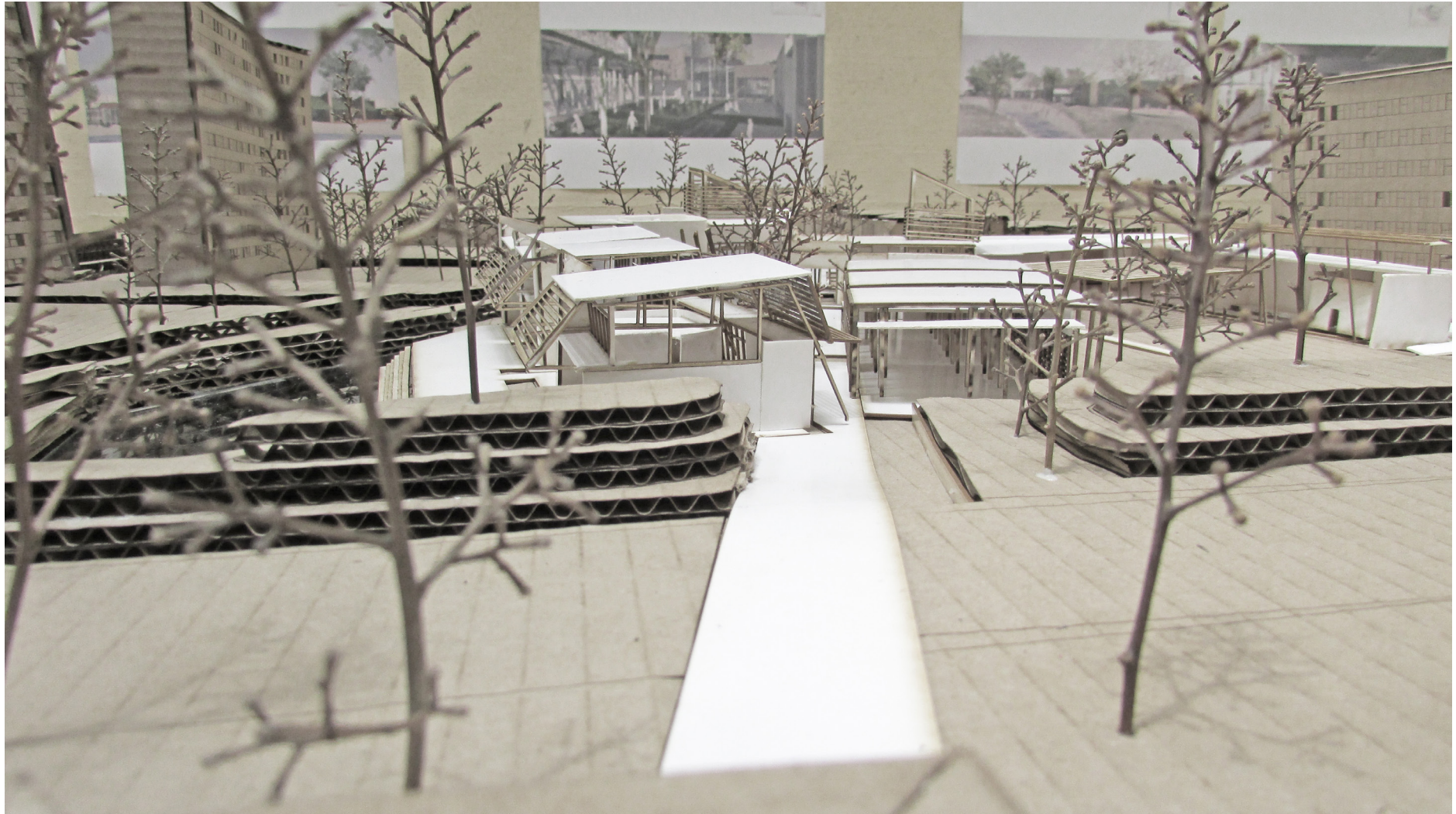

Fig 10.22 Final Model, en-route through school (Author, 2016)



Fig 10.23 Final Model, looking over Walkerspruit towards occupational therapy pods (Author, 2016)



Fig 10.24 Final Model, overlooking entire site towards the East (Author, 2016)



Fig 10.25 Final Model overlooking site towards the North (Author, 2016)



Fig 10.26 Final Presentation (Author, 2016)





Fig 10.27 Final Presentation (Author, 2016)

## Water Supply

### Rainwater yield calculation

Catchment surface

Roof

Area (m <sup>2</sup> )	Runoff coefficient weighted	Area of catchment weighted	
2671	0.9	2403.9	
		2403.9	

### Rainwater yield calculation

Ave. monthly precipitation	Area of catchment weighted	Rain yield (m <sup>3</sup> )	
January	0.136	2400	326.4
February	0.075	2400	180
March	0.082	2400	196.8
April	0.051	2400	122.4
May	0.013	2400	31.2
June	0.007	2400	16.8
July	0.003	2400	7.2
August	0.006	2400	14.4
September	0.022	2400	52.8
October	0.071	2400	170.4
November	0.098	2400	235.2
December	0.11	2400	264
Total	0.674	6480	1617.6

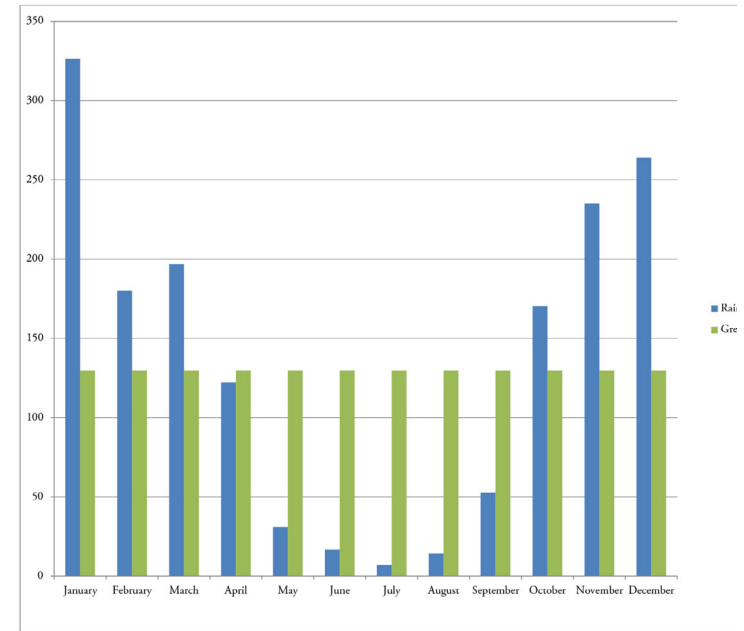

### Grey Water Harvisting

children and staff

662 Handwashing:spray taps	1	662
1 Clothes washing machine	4	4
52 Dishwashing machine	3	156
17 Shower	25	425
262 Drinking, food preparation and cooking	15	3930
		5177

visitors

150 Handwashing:spray taps	1	150
0 Clothes washing machine	25	0
3 Dishwashing machine	3	9
17 Shower	50	850
26 Drinking, food preparation and cooking	15	390
		1399

Total grey water back as yeild 6576

### Grey Water Harvisting

Month	Days/month	Working days/month	Water capita/Day	Water capita/month	Greywater Domestic Harvisting		
January	15	1399	21	5177	6576	129702	129
February	15	1399	21	5177	6576	129702	129
March	15	1399	21	5177	6576	129702	129
April	15	1399	21	5177	6576	129702	129
May	15	1399	21	5177	6576	129702	129
June	15	1399	21	5177	6576	129702	129
July	15	1399	21	5177	6576	129702	129
August	15	1399	21	5177	6576	129702	129
September	15	1399	21	5177	6576	129702	129

Table 10.1 Water Budget (Author, 2016)

October	15	1399	21	5177	6576	129702	129702
November	15	1399	21	5177	6576	129702	129702
December	15	1399	21	5177	6576	129702	129702
						1556424	1556424

### Water Demand

#### Irrigation Demand

Vegetable Garden Irrigation

Month	Planting Area (m <sup>2</sup> )	Irr. Depth/ month	Agricultural Land Irrigation demand (m <sup>3</sup> per month)	
January	500	0.12	60	
February	500	0.103	51.5	
March	500	0.101	50.5	
April	500	0.085	42.5	
May	500	0.085	42.5	
June	500	0.07	35	
July	500	0.06	30	
August	500	0.07	35	
September	500	0.1	50	
October	500	0.1	50	
November	500	0.115	57.5	
December	500	0.12	60	
		Total	564.5	

#### Irrigation Demand

Garden irrigation

Month	Planting Area (m <sup>2</sup> )	Irr. Depth/ month	Rehabilitated landscape demand (m <sup>3</sup> per month)	
January	600	0.09	54	
February	600	0.08	48	
March	600	0.07	42	
April	600	0.05	30	
May	600	0.04	24	
June	600	0.04	24	
July	600	0.04	24	
August	600	0.04	24	
September	600	0.07	42	
October	600	0.08	48	
November	600	0.08	48	
December	600	0.09	54	
		Total	462	

### TOTAL WATER DEMAND

Month	Days/month	total demand per month	Working days/month	Water capita/Day	Water capita/month	Domestic demand/month (
January	21	5192	15	674	5866	119142
February	21	5192	15	674	5866	119142
March	21	5192	15	674	5866	119142
April	21	5192	15	674	5866	119142
May	21	5192	15	674	5866	119142
June	21	5192	15	674	5866	119142
July	21	5192	15	674	5866	119142
August	21	5192	15	674	5866	119142
September	21	5192	15	674	5866	119142

#### Domestic Demand

##### Permanent Users

Children and Teachers	Appliances	Litres/day/person served	total demand per day
662	Handwashingspray taps		1
1	Clothes Washing		4
52	Dishwashing machine		3
17	Shower		25
3	WC flushing-urinals provided		5
262	Drinking, food preparation and cooking		15

##### Visitors

Public People	Appliances	Litres/day/person served	total demand per day
150	Handwashingspray taps		1
10	Urinal flushing 8h day		0
3	Dishwashing machine		3
5	Showers		25
26	Drinking, food preparation and cooking		15

Table 10.1 Water Budget (Author, 2016)

June	21	5177	20	674	5851	122197	122.197
July	21	5177	20	674	5851	122197	122.197
August	21	5177	20	674	5851	122197	122.197
September	21	5177	20	674	5851	122197	122.197
October	21	5177	20	674	5851	122197	122.197
November	21	5177	20	674	5851	122197	122.197

Water Budget							
Clean Water Demand Calculation		RAIN WATER & DEMAND					
	Rain water yield	Domestic demand/month (m3)		Leftover water in tank	year 1	year 2	year 3
January	326.4	122.197		204.203	204.203	355.439	
February	180	122.197		57.803	262.006	413.242	
March	196.8	122.197		74.603	336.609	487.845	
April	122.4	122.197		0.203	336.812	488.048	
May	31.2	122.197		-90.997	245.815	397.051	
June	16.8	122.197		-105.397	140.418	291.654	
July	7.2	122.197		-114.997	25.421	176.657	
August	14.4	122.197		-107.797	87.376	68.86	
September	22.8	122.197		-99.397	-101.723	-0.557	
October	170.4	122.197		48.203	-103.57	47.666	
November	235.2	122.197		113.003	9.433	160.669	
December	264	122.197		141.803	151.236	302.472	
Total	1617.6	1466.364		151.236			
Grey water demand							
	Greywater Domestic Harvesting/month (m3)	Garden demand	Vegetable Garden demand	grey water demand	Total demand of secondary water	left over water	
January	129.702	54	60	0.315	114.315	15.387	
February	129.702	48	51.5	0.315	99.815	29.887	
March	129.702	42	50.5	0.315	92.815	36.887	
April	129.702	30	42.5	0.315	72.815	62.887	
May	129.702	24	42.5	0.315	66.815	62.887	
June	129.702	24	35	0.315	59.315	70.387	
July	129.702	24	30	0.315	54.315	75.387	
August	129.702	24	35	0.315	59.315	70.387	
September	129.702	42	50	0.315	92.315	37.387	
October	129.702	48	50	0.315	98.315	31.387	
November	129.702	48	57.5	0.315	105.815	23.887	
December	129.702	54	60	0.315	114.315	15.387	

Table 10.1 Water Budget (Author, 2016)



## References

- Archdaily. 2013. *SFU UniverCity Childcare / HCMA*. <http://www.archdaily.com/390874/sfu-univercity-childcare-hcma> [3 September 2016]
- Beeld. 1984. “*Nou kan ‘n mens behoortlik wandel.*”
- Berry, P. 2001. *Playgrounds that work*. New South Wales: Pademelon Press.
- Berry, W. 1972. *A Continuous Harmony: essays Cultural and Agricultural*. New York: Harcourt.
- Bixler, R.D., and Floyd, M.F. 1997. *Nature is scary, disgusting and uncomfortable*. *Environment and Behaviour*, 29:443-467. [<http://0-find.galegroup.com.innopac.up.ac.za/>] [24 July 2011].
- Brown, G., Brown, B.B. and Perkins, D.D. 2004. *New Housing as Neighborhood Revitalization : Place Attachment and Confidence Among Residents*. *Environment and Behavior*, 36(6):749-775. [ONLINE] <http://eab.sagepub.com/content/36/6/749> [14 October 2016].
- Burns, G. W. 1998. *Nature-Guided Therapy—Brief Integrative Strategies for Health and Well-being*. Brunner/ Mazel, Philadelphia.
- Cadwell, L. B. 2003. *Bringing Learning to Life: The Reggio Approach to Early Childhood Education*. New York: Teacher’s College Press.
- Cadwell, L. B. 1997. *Bringing Reggio Emilia Home: An Innovative Approach to Early Childhood Education*. New York, NY: Teachers College Press
- Campbell, C. S. 1978. *Water in Landscape Architecture*. New York: Van Nostrand Reinhold.
- Capizzano, J., G. Adams, and F. Sonenstein. 2000. *Child Care Arrangements for Children Under Five: Variation Across States*. Washington, DC: The Urban Institute.
- Chawla, L. 2006. *Learning to Love the Natural World Enough to Protect It*. Barn.
- Coley, R.L., Kuo, F.E. And Sullivan, W.C. 1997. *Where does community grow: The social context created by nature in public housing*. *Environment and Behaviour*, 29(4): 468-495. <http://0-eab.sagepub.com.innopac.up.ac.za/content/29/4/468> [31 October 2016].
- Constantinidou, F. and Baker, S. (2002). *Stimulus modality and verbal learning performance in normal aging*. *Brain and Language*, 82(3), 296–311.
- Crace, J. 2006. “*Children Are Less Able Than They Used to Be.*” *Guardian*, January 24.
- Crain, W. 2003. *Reclaiming Childhood: Letting Children Be Children In Our Achievement-Orientated Society*. New York: Times Books/Henry Holt and Co.
- de Vries, S., I. Bakker, W. van Mechelen, and M. Hopmann-Rock. 2007. “*Determinants of Activity-Freindly Neighborhoods for Children: Results from the Space Study.*” *American Journal of Health Promotion* 21(4): 312-316
- Dudek, M. 2005. *Children’s Spaces*. Oxford: Architectural Press
- Edwards, C., Gandini, L. and Foreman, G. (eds) .1998. *The Hundred Languages of*

*Children: the Reggio Emilia approach to early childhood education*, 2nd edn. Norwood, NJ: Ablex.

-Fisher, R. C., le Roux, S., Mare, E. (eds.) 1998. *Architecture of the Transvaal*. University of South Africa: Pretoria

-Fourie, C. 1997. *Report on the January 1996 Flood in Pretoria*. Department of the City Engineer. City council of Pretoria.

-Fromm, Erich (1964). *The Heart of Man*. Harper & Row.

-Furnass, B. 1979. *Health values*. In: Messer, J. and Mosley, J. G. (eds) *The Value of National Parks to the Community: Values and Ways of Improving the Contribution of Australian National Parks to the Community*. University of Sydney, Australian Conservation Foundation.

-Glendinning, C. 1995. *Technology, trauma and the wild*. In Roszak, T., Gomes, M. E. and Kanner, A. D. (eds) *Eco psychology: Restoring the Earth, Healing the Mind*. Sierra Club Books, San Francisco

-Goodenough, E. 2003. *Secret spaces of childhood*. Michigan: University of Michigan.

-Gould, S. J. 1993. *Eight Little Piggies: Reflections in Natural History*. 1st Edition. W. W. Norton.

-Hurtwood, A. 1966. *New playgrounds*. London: Thames and Hudson.

-Hurtwood, A. 1969. *Planning for play*. London: Thames and Hudson.

-Jansen Van Vuuren, G. 2016. Interview with the engineer on 18 February 2016, City of Tshwane Metropolitan Municipality, Department of Roads and Storm water,

Pretoria.

-Kaduson, G.G. 2006. *Release play therapy for children with posttraumatic stress disorder*. In: Kaduson, H.G. & Schaefer, C.E. 2006.

-Katcher, A. and Beck, A. 1987. *Health and caring for living things*. *Anthrozoos*, 1, 175–183.

-Kellert, S. 2005. *Building for Life: Understanding and Designing the Human-Nature Connection*. Washington, DC: Island Press

-Kellert, S. R. 1997. *Kinship to Mastery: Biophilia in Human Evolution and Development*. Island Press, Washington, D.C.

-Kellert, S. R. and Wilson, E. O. (1993) *The Biophilia Hypothesis*. Shearwater Books/ Island Press, Washington, D.C.

-Kellert, S. R., Heerwagen, J., & Mador, M. 2008. *Biophilic design: The theory, science, and practice of bringing buildings to life*. Hoboken, N.J.: Wiley.

-Kim, J. and Kaplan, R. 2004. *Physical and psychological factors in sense of community : New urbanist Kentlands and nearby Orchard Village*. *Environment and Behavior*, 36: 313 <http://eab.sagepub.com/content/36/3/313> [1 November 2016].

-Koolhaas, R. 1995. *S M L XL*. New York: The Monticelli Press

-Kuo, F., M. Bacaicoa, and W. Sullivan. 1998. “*Transforming Inner-City Landscapes: Trees, Sense of Safety, and Preference*.” *Environment and Behavior* 30:28-59

-Kuo, F.E. and Taylor, A.F. 2004. *A potential natural treatment for attention-deficit/hyperactivity disorder: Evidence from a national study*. *American Journal of Public Health*, 94(9):1580-1586. <http://ajph.aphapublications.org/cgi/reprint/94/9/1580> [1

August 2016].

-Lambert, J. and Pearson, J. 1974. *Adventure playgrounds*. London: Penguin Books.

-Linden, J.H. 2003. *Playful metaphors*. American Journal of Clinical Hypnosis, 45(3):245-250. <http://www.asch.net/portals/0/journallibrary/articles/ajch-45/linden.pdf> [29 September 2016].

-Maller, C., Townsend, M., Pryor, A., Brown, D. & St Ledger, L. 2005. *Healthy Nature Healthy People: Contact with Nature as an Upstream Health Promotion Intervention for Populations*. Health Promotion International, 21(1). <http://heapro.oxfordjournals.org/content/21/1/45.full.pdf+html> [2 February 2016]

-Mallgrave, H. F. 2011. *An Introduction to Architectural Theory: 1968 to the Present*. Wiley-Blackwell, Malden

-Mang, P. and Reed, B. 2012. *Designing from place: a regenerative framework and methodology*. Building Research & Information, 40:1, 23-38

-McMichael, T. 2001. *Human frontiers, environments and disease. Past patterns, uncertain futures*. UK University Press, The Syndicate of the University of Cambridge, Cambridge.

-Merchant, C. 1996. *Reinventing Eden: Western culture as a recovery narrative*. In W. Cronon (ed.), *Uncommon Ground: Rethinking the Human Place in Nature*. W.W. Norton & Company, New York

-Meyer, E. 2011. *Playscape: A natural playground in the city*. Unpublished Masters Dissertation, University of Pretoria, Pretoria.

-Moore, R., and H. Wong. 1997. *Natural Learning: Creating Environments for Rediscovering Nature's Way of Teaching*. Berkeley, CA: MIG Communications

-Morrow, V. M., 2010. 'Dirty looks' and 'trampy places' in young people's accounts of community and neighbourhood: Implications for health inequalities. Critical Public Health, 10(2):141-152. <http://dx.doi.org/10.1080/713658244> [6 May 2016].

-Nasar, J. L. and Julian, D. A. 1995. *The psychological sense of community in the neighborhood*. Journal of the American Planning Association, 61(2):178-184. <http://dx.doi.org/10.1080/01944369508975631> [7 October 2016].

-Nesbitt, K. 1996. *Theorizing a New Agenda for Architecture. An Anthology of Architectural Theory 1965-1995*. New York: Princeton Architectural Press

-Noren-bjorn, E. 1982. *The impossible playground*. New York: Leisure Press.

-Orr, D. 1992. *Architecture as Pedagogy*. In *Reshaping the built environment*, edited by C. Kilbert. Washington, DC: Island Press.

-Oxford Dictionary. 2016. Sv 'didactic'. Oxford University Press

-Oxford Dictionary. 2016. Sv 'garden'. Oxford University Press

-Oxford Dictionary. 2016. Sv 'biophilia'. Oxford University Press

-Palacio-Quintin, E. 2000. "The Impact of Day Care on Child Development." ISUMA: Canadian Journal of Policy Research 1 (2)

-Palmer, J. A. (ed). 2000. *Fifty Key Thinkers on the Environment*. London: Routledge

-Peres, E. 2007. *Mindscape: A Centre for Creative Development in Sunnyside*. Unpublished Masters Dissertation, University of Pretoria. Pretoria.

-Presidents Medals. 2015. *Space as the Third Teacher: An Alternative Classroom Typology Promoting Creative Learning And Play*. <http://www.presidentsmedals.com/Entry-38471> [19 June 2016]

-Qvortrup, J., Bardy, M., Sgritta, G. and Wintersberger, H. (eds.) 1994. *Childhood Matters*. Vienna: European Centre.

-Raman, P.G. 2011. *Home away from home - School at Mamelodi*. Journal of the South African Institute of Architects, 49(3): 12-15



- Rourke, B., Ahmad S., Collins, D., Hayman-Abello, B., Hayman-Abello, S., and Warriner, E. (2002). *Child clinical/pediatric neuropsychology: some recent advances*. Annual Review of Psychology, 53, 309-339.
- Rupert Museum. 2016. *Pierneef*. <http://www.rupertmuseum.org/?m=5>. [28 February 2016].
- South Africa. Bureau of standards. 2012. The application of the national building regulations. Pretoria: government printer
- South Africa. Department of Social Development. 2006. *The Guidelines for Early Childhood Development Services*. Pretoria: Government Printer.
- SRK Consulting & MMM Consulting. 2002. *Integrated stormwater Management plan and prioritisation of upgrading projects along the Walkerspruit*. Greater Tshwane metropolitan municipality.
- Stats SA. 2010. *Mid-year population estimates, 2010*. Statistical release P0302. Pretoria : Statistics South Africa.
- Stilgoe, J. R. (2001) *Gone barefoot lately?*. American Journal of Preventative Medicine, 20.
- Tarr, P. 2001. *Aesthetic Codes in Early Childhood Classrooms: What Art Educators Can Learn from Reggio Emilia*. Art Education, 54 (3)
- The Burra Charter. 2013. *The Australia ICOMOS Charter for Places of Cultural Significance*. Australia: ICOMOS Inc.
- Unger, D.G. and Wandersman, A. 1985. *The importance of neighbors: the social, cognitive and affective components of neighbouring*. American Journal of Community Psychology, 13(2):139-169.
- United Nations Environment Programme. 2016. *Ecosystems*. <http://www.unep.org/dewa/assessments/ecosystems>. [07 March 2016]
- Van Der Merwe, T. 2013. The Garden Is Us. Unpublished Masters Dissertation, University of Pretoria, Pretoria.
- Van Der Waal Collection. 1989. *Pretoria as 'urbs quadrata'*. <http://repository.up.ac.za/handle/2263/22193>. [07 March 2016].
- Vining, J., Merrick, M. S., Price, E. A. 2008. *The Distinction between Humans and Nature: Human Perceptions of Connectedness to Nature and Elements of the Natural and Unnatural*. Human Ecology Review, 15(1). (eds) Short-term play therapy for children. New York: The Guilford Press.
- Vygotsky, L. 1987. *Collected works, Vol. 1. Problems of general psychology*. edited by R.W. Rieber, and A.S. Carton. New York: Plenum Press
- Weaver, L. 2000. *Learning Landscapes, Theoretical Issues and Design Considerations for the Development of Children's Educational Landscapes*. Unpublished ML (Prof) Thesis, Virginia Polytechnic Institute, Virginia.
- Wellhausen, K. 2002. *Outdoor play every day*. New York: Delmar.
- Wells, N. M., and W. Evans. 2003. "Nearly Nature: A Buffer of Life Stress Among Rural Children." Environment Behavior 35(3): 311-330
- Wells, N.M. 2000. "At Home with Nature. Effects of 'Greenness' on Children's Cognitive Functioning." Environment and Behavior 32(6): 775-795
- Willis, J.F. (ed). 2006. *Of Roses and Poets*, Volume 1. Washington: Xlibris Corporation
- Wilson, E. 1994. *The Diversity of Life*. New Ed Edition. Penguin Books Ltd.
- Wilson, E. O. 1984. *Biophilia: The human Bond with Other Species*. Cambridge, MA: Harvard University Press

-Unger, D.G. and Wandersman, A. 1985. The importance of neighbors: the social, cognitive and affective components of neighbouring. *American Journal of Community Psychology*, 13(2):139-169.

-Vygotsky, L. 1987. *Collected works, Vol. 1. Problems of general psychology.* edited by R.W. Rieber, and A.S. Carton. New York: Plenum Press

-Archdaily. 2013. SFU UniverCity Childcare / HCMA. <http://www.ArchDaily/390874/sfu-university-childcare-hcma> [Date accessed 3 September 2016]

-Presidents Medals. 2015. Space As The Third Teacher: An Alternative Classroom Typology Promoting Creative Learning And Play. <http://www.presidentsmedals.com/Entry-38471> [Date accessed 19 June 2016]

-Raman, P.G. 2011. Home away from home - School at Mamelodi. *Journal of the South African Institute of Architects*, 49(3): 12-15

# List of Figures

Fig 1.1 No man ever steps in the same river twice. (dailygarlic.com. 2016)	13
Fig 1.2: Natural River vs. Apies River Channel. (Author. 2016)	15
Fig 1.3: Drawing from conceptual development. (Author. March 2016)	16
Fig 1.4 Architecture and its movement away from nature. (Author. 2016)	17
Fig 1.5: Site location and informants. (Author. 2016)	19
Fig 1.6: An example of Green Architecture. Bosco Verticale, Stefano Boeri. (Bosco Verticale. Techinsider. 2014)	21
Fig 1.7: An example of Biophilic Design .Alvar Aalto's Villa Mairea in Noormarkku, Finland, 1939. (Villa Mairea. Ideasn.com. 2013)	21
Fig 1.8: Author's conceptual interpretations of the didactic garden. (Author. 2016)	25
Fig 2.1: The Seven Sisters Oak Tree. [Kellert, 2008: 34]	27
Fig 2.2: Author's interpretation of Architecture's return to biophilia. (Author. 2016)	31
Fig 2.3 The table illustrates all 70 attributes of biophilic design in their various categories. (Kellert, Heerwagen & Mador, 2008: 15)	34
Fig 2.4 What exists and what is intended on the site according to the dimensions, elements and attributes of biophilic design (Author, 2016)	35
Fig 2.5 The channelised Walkerspruit.(Author, 2016)	36
Fig 2.6: Pa Daet, Thailand. unpalsh.com. Photo: Keenan, A.	37
Fig 2.7 (left): The Seven Sisters Oak on Lake Pontchartrain has survived 1200 years due to its ability to withstand hurricane forces. (Kellert, 2008: 34)	38
Fig 2.8 (right): Eco-machines from John Todd Ecological Design, Inc. mimic the patterns of nature's water-purifying ecosystems to clean sewage to pure water (Kellert, 2008: 161)	38
Fig 2.9 (left): The children of Ring Ting Pre-primary School in Sunnyside adjacent to the site. (Facebook/ Ring-Ting Pre Primary School & baby care. 2012)	39
Fig 2.10 (right): Children enjoying early morning exercise (Kellert, 2008: 159)	39
Fig 2.11 (left): A group of toddlers play with fallen leaves, experience their sensory properties and explore their behaviour on the curved surface of a hollow log.	40
Fig 2.12 (right): Traffic-free urban trails and green-ways expose children to nature and help them learn the joy of bicycle riding at an early age.	40
Fig 2.13 Ground floor plan (Arch Daily. 2012)	42
Fig 2.14 Section through atrium of building showing cloud like light sources (Arch Daily. 2012)	42
Fig 2.15 Image showing the trees in the designed park like ground floor. (Arch Daily. 2012)	42
Fig 2.16 A labyrinth at a primary school in the UK where children interact with nature and each other. (Kellert, 2008:170)	43
Fig 2.17 Diagram the richer elements of biophilic design and what attributes can be applied to make the existing environmental features richer (Author, 2016)	44
Fig 3.1 Bourke Street Garden. [Author, 2016]	47
Fig 3.2 Aerial view of Site with initial program layout. (Author, 2016)	49

Fig 3.3 (right) Pretoria's development and shift in city grid due to the rivers. (University of Pretoria, Department of Architecture archives)	50
Fig 3.5 Cross-sections of the channels design. (City of Tshwane Metropolitan Municipality, Department of Roads and Storm water, Pretoria. 2016)	50
Fig 3.6 Groenkloof and Grootfontein Springs respectively. (Grewar. 2014) (Burger. 2014)	50
Fig 3.7 The current condition of the Walkerspruit channel (Author, 2016)	50
Fig 3.4 Engineering Drawings of the Apies River at Caledonian Sports Ground. (City of Tshwane Metropolitan Municipality, Department of Roads and Storm water, Pretoria. 2016)	51
Fig 3.8 Nolli map of water networks and surrounding urban fabric. [Author, 2016]	52
Fig 3.9 Mapping of river edge conditions. [Author, 2016]	54
Fig 3.10 Map of nodal acupuncture of water systems. [Water Group Framework, 2016]	56
Fig 3.11 Primary attributes of site: the child, the river and the natural ground. [Author, 2016]	57
Fig 3.12 Site location and informants. (Author. 2016)	58
Fig 3.13 Fig ground map of site with context. Edited by Author (2016) from Google Earth (2016)	58
Fig 3.14 Physical nature of site according to public and private spaces. (Author, 2016)	59
Fig 3.15 Section through site showing vast differences in scale between buildings and ground (Author, 2016)	59
Fig 3.16 Visionary images of street parks along Bourke and Leyds Streets. (Author, 2016)	60
Fig 3.17 Gateways, Nodes and activity and pedestrian movement. (Author, 2016)	61
Fig 3.18 Schools and green spaces. (Author, 2016)	61
Fig 3.19 Compilation of surrounding typologies. (Edited by Author (2016) from Google Earth (2016) and Peres, E. 2005)	62
Fig 3.20 Current condition of river, looking West. (Author, October 2016)	63
Fig 3.21 Current condition of site, looking South. (Author, October 2016)	63
Fig 3.22 Current condition of site, looking North-West. (Author, October 2016)	64
Fig 3.23 Current condition of site, looking South-West. (Author, October 2016)	64
Fig 3.24 Upgraded Walkerspruit trail [Beeld, 1984]	65
Fig 3.25 Different Angles of the Walkerspruit. Photo: Peres, E. 2005	65
Fig 3.26 Map indicating ecological arm that extends from Caledonia Sports Grounds to the site, changing in density and scale according to the surrounding urban fabric. (Author, 2016)	66
Fig 3.27 The 50 and 100 year Walkerspruit flood-lines between Bourke and Cilliers street. [Tshwane City Engineer, 2005]	67
Fig 3.28 Initial vision of the river landscape, reconnecting to the surrounding fabric. [Author 2016]	67
Fig 3.29 The profile of the trees on site, giving spatial qualities of each. (Author, 2016)	68
Fig 3.30 Mapping of different tree species on site. [Author, 2016]	69
Fig 3.31 Solar access for building spacing. [Holm, D. 1996: 71]	70
Fig 3.32 Window height, overhang and positioning for Pretoria. [Holm, D. 1996: 72]	70
Fig 3.33 Site Wind and shadow Study. (Author, 2016)	70
Fig 3.34 The slope of the site according to gradual or steel slopes [Author, 2016]	71
Fig 3.35 Contour Model of site [Author, 2016]	71
Fig 3.36 1990 Satellite Imagery of Site and old photos of Victorian House that once occupied the site [University of Pretoria, Department of Architecture Archives, 1990]	73
Fig 3.37 Compilation of adjacent schools in the area. (Google Earth, 2016)	74

Fig 3.38 Map showing position of schools and apartments in relation to site. (Author, 2016)	75
Fig 3.39 Project's intentions as interpreted through the attributes of biophilic design. (Author. 2016)	76
Fig 3.40 Diagram showing the different aspects of natural systems, and water that can be learnt on site. (Author, 2016)	77
Fig 3.41 Issues and vision diagrams (Author, 2016)	78
Fig 4.1: Children of Ring Ting Pre-primary. [Facebook.com, 2016]	81
Figure 4.2 Scale differences between child and adult. (drawinghowtodraw.com)	84
Fig 4.3 anthropometrics of a child (playscapes.com)	85
Fig 4.4 Needs of children in their cognitive, physical and emotional development. (Author, 2016, adapted from Berry, 2001)	86
Fig 4.5 Ring Ting Pre-primary School does not use the adjacent natural site to its full potential. (Google Earth, 2016)	87
Fig 4.6 My Childhood - Sveta Dorosheva.(kireei.com. 2016)	88
Fig 4.7 Ring Ting Pre-School with little connection to the outdoors and sensory stimulation (Facebook. 2012)	89
Fig 4.8 A classroom connected to natural elements where the tree forms part of the child's education (Tezuka-arch.com. 2016)	89
Fig 4.9 Initial Program layout on site, contain three primary programs (Author, 2016)	91
Fig 4.10 Needs of children in their cognitive, physical and emotional development (Author, 2016, adapted from Berry, 2001)	92
Fig 4.11 Central Piazza (Tarr, 2001: 35)	93
Fig 4.12 Design development perspective of kinetic play spaces (Author, 2016)	95
Fig 4.13 Sports hall size requirements (Sportscotland, 2003)	96
Fig 4.14 Schedule for reggio-inspired child development, adapted from University Child Learning and Care Centre (uwsp.edu. 2016).	100
Fig 4.15 Example of occupational therapy suite. (United Kingdom. Department of Health. 2013:33)	101
Fig 4.16 Physical nature of site according to public and private spaces, and organic and urban nature of the site (Author, 2016)	103
Fig 4.17 Program layout in context. (Author, 2016)	104
Fig 4.18 Program allocation. (Author, 2016)	105
Fig 5.1: Design development sketches. [Author, 2016]	107
Fig 5.1 Drawings showing how activities of the children give meaning to the ambiguity of the spaces (presidentsmedals.com, 2015)	109
Fig 5.2 view of classroom spaces (Arch Daily, 2013)	111
Fig 5.5 Mezzanine level floor plan (Arch Daily, 2013)	111
Fig 5.3 view of pedagogic outdoor spaces (Arch Daily, 2013)	111
Fig 5.6 The sustainable energy and water system in the building (Arch Daily, 2013)	111
Fig 5.4 Rope nests forming tree-like structures (Arch Daily, 2013)	111
Fig 5.7 Aerial view of classrooms, also alongside a river (presidentsmedals.com, 2015)	113
Fig 5.9 Drawings showing how activities of the children give meaning to the ambiguity of the spaces (presidentsmedals.com, 2015)	113
Fig 5.10 Classroom plan, showing cores, and the various child learning activities taking place (presidentsmedals.com, 2015)	113
Fig 5.8 Drawing of classrooms cores, with usable shelving systems (presidentsmedals.com, 2015)	113
Fig 5.11 Northern entrance view (Raman, 2011: 12-15)	115
Fig 5.13 Assembly court and classroom blocks (Raman, 2011: 12-15)	115

Fig 5.14 Sections showing variations in the roofs and portal frame structure (Raman, 2011: 12-15)	115
Fig 5.12 Plan of integrating parts to a whole, and central focus point (Raman, 2011: 12-15)	115
Fig 6.1: Design development sketches. [Author, 2016]	119
Fig 6.2 Initial design translation of conceptual resolution. (Author, 2016)	121
Fig 6.3 (opposite) Diagram summarising development of concept. (Author, 2016)	122
Fig 6.4 Diagram illustrating the analogue of the existing trees and how it returns the site back to human scale. (Author, March 2016)	124
Fig 6.5 What the site wants. Digital perspective on the nature of the site and what the architecture could do to change it. (Author, 2016)	125
Fig 6.6 Section through site with conceptual diagram illustrating scale differentiations of the proposed design in order to create a sense of scale balance (Author, 2016)	125
Fig 6.7 Diagram illustrating spaces of ecological potential being framed by the architecture (Author, March 2016)	126
Fig 6.8 Diagrammatic exploration of the networks the four informants on site (Author, 2016)	127
Fig 6.9 Diagram illustrating culminating environments, meandering movement through the site as well as creating spaces of refuge. (Author, 2016)	128
Fig 6.10 Progression of the exploration of how the program connects to the schools in the area (Author, 2016)	128
Fig 6.11 Plan view of final conceptual exploration. (Author, 2016)	129
Fig 6.12 Perspective of the final conceptual exploration. (Author, 2016)	129
Fig 6.13 Diagram of what elements of landscape the child can learn from , relating to site and theoretical investigation (Refer to Chapter 2) (Author, 2016)	131
Fig 6.14 Water, the tree and the child design translations. (Author, 2016)	132
Fig 7.1: Design development sketches. [Author, 2016]	135
Fig 7.2 Development of plan (Author, 2016)	138
Fig 7.3 Development of plan (Author, 2016)	139
Fig 7.4 plan development, with sports hall becoming the dominant feature on site. (Author, 2016)	140
Fig 7.5 Section development, showing relationships between tectonic and stereotomic. (Author, 2016)	140
Fig 7.7 Archetypal landscape elements relating to architectural language (Author, 2016)	141
Fig 7.6 Resultant plan according to this approach (Author, 2016)	141
Fig 7.8 Resultant Aerial view of site (Author, 2016)	142
Fig 7.9 building outlines, guiding the garden design (Author, May 2016)	143
Fig 7.10 Site plan (Author, June 2016)	144
Fig 7.11 Section bb through site (Author, June 2016)	145
Fig 7.12 West elevation (Author, June 2016)	145
Fig 7.13 Perspectives of approach from street on east side, approach from western side and sports hall respectively (Author, June 2016)	146
Fig 7.14 Site perspective aerial view (Author, June 2016)	146
Fig 7.15 Ground floor plan (Author, June 2016)	146
Fig 7.16 Development of program layout according to design translation (Author, 2016)	148
Fig 7.17 Identified gardens as the third teachers with the buildings facilitating learning (Author, August 2016)	148
Fig 7.18 Tectonic concept diagrams for each of the spaces	150
Fig 7.19 3D view of building indicating each garden and what is learnt in each and the biophilic approaches to methods of learning (Author, 2016)	153

Fig 7.20 Ground Floor Plan (Author, 2016) .....	154
Fig 7.21 First Floor Plan (Author, 2016) .....	155
Fig 7.22 Initial design sketch of vertical axis resolution (Author, 2016) .....	156
Fig 7.23 section development through classrooms, kinetic classrooms and atelier (Author, 2016) .....	157
Fig 7.24 section development through classrooms, kinetic classrooms and atelier (Author, 2016) .....	157
Fig 7.25 Route exploration (Author, 2016) .....	159
Fig 7.26 development of the classroom building from sketch phase to final design phase (Author, 2016) .....	160
Fig 7.27 Final development of the classrooms and the activities that take place within them (Author, 2016) .....	161
Fig 7.28 Zoomed in plan of classrooms and the activities that will take place in each (Author, 2016) .....	162
Fig 7.29 Diagram showing quiet(green) and noisy(red) spaces in the classrooms (Author, 2016) .....	163
Fig 7.30 Diagram showing dry(yellow) and wet(blue) spaces within and to the exterior of the classrooms (Author, 2016) .....	164
Fig 7.31 Diagram showing interior(blue) and yellow(exterior circulation routes and suggestive routes (Author, 2016) .....	165
Fig 7.33 Gross motor activities (Author, 2016) .....	166
Fig 7.32 Daily Arrival (Author, 2016) .....	166
Fig 7.34 Group activities (Author, 2016) .....	167
Fig 7.35 SMART time (Author, 2016) .....	167
Fig 7.37 Story time (Author, 2016) .....	168
Fig 7.36 Whole body development. (Author, 2016) .....	168
Fig 7.38 Home time (Author, 2016) .....	169
Fig 7.37 Quiet time. (Author, 2016) .....	169
Fig 7.39 Kinetic Classroom in plan and section , showing its connection to the outdoor play court (Author, 2016) .....	170
Fig 7.40 Plan of occupational therapy suits (Author, 2016) .....	171
Fig 7.41 security lines according to times of day (Author, 2016) .....	172
Fig 7.42 security types (Author, 2016) .....	173
Fig 7.43 Security checkpoint alternating between school children and after hours. (Author, 2016) .....	173
Fig 7.44 Gabion wall with berm in section (Author, 2016) .....	173
Fig 8.1 Technical development section. [Author, 2016] .....	175
Fig 8.2 Diagram of tectonic resolution of classroom (Author, September 2016) .....	177
Fig 8.3 Diagrammatic representations of the stereotomic and tectonic concept (Author, November2016) .....	179
Fig 8.6 Material palette, stereotomic (Author, 2016) .....	181
Fig 8.7 Material palette, tectonic (Lysacht, 2016) .....	183
Fig 8.8 technical explosion showing primary and secondary structure of the classrooms (Author, November 2016) .....	185
Fig 8.9 Detail showing how the concept influences the aesthetics of joining (Author, September 2016) .....	187
Fig 8.10 Section through solar stack and joining of portal frame (Author, 2016) .....	187
Fig 8.11 Technical Explorations (Author, 2016) .....	189

Fig 8.13 Diagram of proposed water system and its processes (Author, 2016)	192
Fig 8.14 Overlay of water system on building. The dark blue represents the side channel diversion and the light blue represents the rain water harvesting system (Author, 2016)	193
Fig 8.15 The water system (Author, 2016)	195
Fig 8.16 New water system showing process of rainwater collection, purification and reuse (Author, 2016)	196
Fig 8.17 Development of living skin and how it punctures the building's facade (Author, 2016)	197
Fig 8.18 ground level plants (Author, 2016)	198
Fig 8.19 higher level creepers (Author, 2016)	198
Fig 8.22 Waste management system. (Author, 2016)	200
Fig 8.23 Waste management system. (Author, 2016)	201
Fig 8.24 Base design daylighting analysis (Author, 2016)	202
Fig 8.25 Iteration 1 daylighting analysis (Author, 2016)	203
Fig 8.26 SBAT Graph and resultant score (Author, 2016)	204
Fig 9.1 View of linking pathway between schools. [Author, 2016]	207
Fig 10.1 - 10.27 (Author, 2016)	
Table 10.1 Water Budget (Author, 2016)	240
Table 10.1 Water Budget (Author, 2016)	241
Table 10.1 Water Budget (Author, 2016)	242