

# ASSESSING THE ROLL STABILITY OF HEAVY VEHICLES IN SOUTH AFRICA

R BENADE, R BERMAN\*, F KIENHÖFER\*\* and P NORDENGEN\*\*\*

CSIR Built Environment, P O Box 395, Pretoria, 0001  
Tel: 012 841-3409; Email: richardtbenade@gmail.com

\* CSIR Built Environment, P O Box 395, Pretoria, 0001  
Tel: 012 841-4986; Email: rberman@csir.co.za

\*\* University of the Witwatersrand, 1 Jan Smuts Avenue,  
Braamfontein 2000, Johannesburg,

Tel: 011 717-7320; Email: frank.kienhofer@wits.ac.za

\*\*\* CSIR Built Environment, P O Box 395, Pretoria, 0001  
Tel: 012 841-3945; Email: pnordengen@csir.co.za

## ABSTRACT

In South Africa there are approximately 12.5 truck-crash-related fatalities per 100 million kilometres travelled. This is between 4 and 10 times higher than a number of European countries such as Denmark, France, Germany and Switzerland and many of these crashes involve heavy vehicle rollover. The regulations in the National Road Traffic Act of South Africa that govern heavy vehicle design do not directly address the roll stability of heavy vehicles. The internationally accepted method of regulating roll stability is by means of a static rollover threshold (SRT) assessment or test, to determine the maximum lateral acceleration that a vehicle can withstand before rolling over. The SRT is determined by physical testing, or through multibody dynamics simulation; however, both of these approaches are costly and time-consuming. This paper considers various simplified tools to estimate the SRT of articulated heavy vehicles, and compares the results to SRT values determined using multibody dynamics simulation. The simplified tool as described by the New Zealand Land Transport Rule was identified as the most viable technique to potentially regulate the roll stability of heavy vehicles in South Africa.

# 1 INTRODUCTION

## 1.1 Background

For the past number of years, South Africa has recorded undesirable crash statistics when compared with other countries (OECD Publishing, 2011). Table 1-1 shows the results of an Organisation for Economic Co-operation and Development (OECD) study comparing the number of truck-crash-related fatalities per 100 million kilometres travelled for various countries. South Africa was found to have 12.5 fatalities per 100 million kilometres, over four times that of Denmark - the country with the second highest number of fatalities.

**Table 1-1 Truck crash statistics for various countries**  
(OECD Publishing, 2011)

Country	Fatalities per 100 million kilometres of truck travel	Year
South Africa	12.5	2005
Denmark	3	2004
France	2	2005
Canada	2	2005
Belgium	1.9	2005
Australia	1.7	2005
Great Britain	1.7	2005
Sweden	1.6	2005
United States	1.5	2005
Germany	1.5	2006
Switzerland	0.8	2005

Added to the benefit in reducing the loss of lives, proper regulation of heavy vehicles also plays a significant role in maintaining a healthy economy. Based on the 2013 State of Logistics survey (Council for Scientific and Industrial Research, 2013), logistics costs made up 12.4% of South Africa's gross domestic product, with 0.8% attributable to crashes as shown in Figure 1-1.

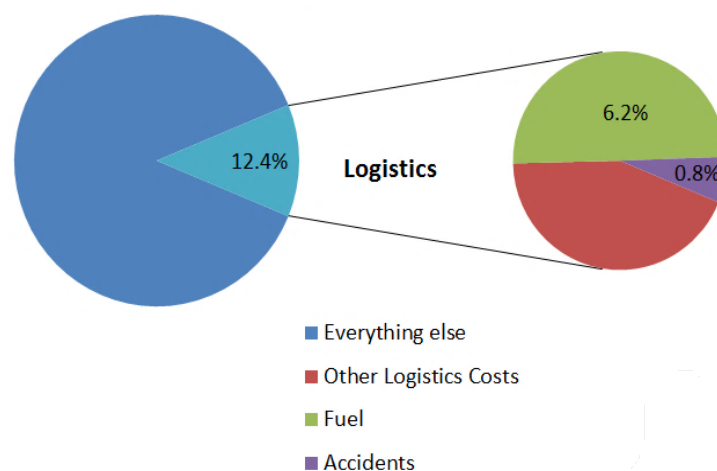
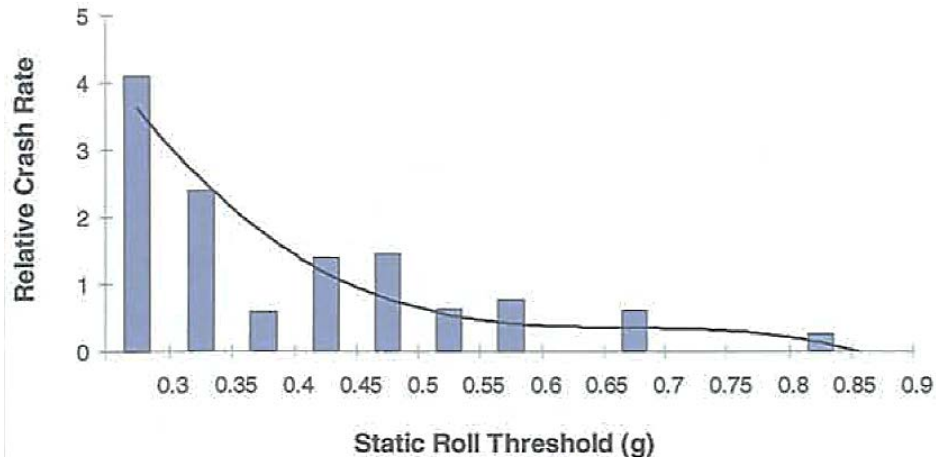

**Figure 1-1 Gross domestic product breakdown: SA 2013**  
(Berman and Benade, 2015)

Crashes often involve, or occur as result of heavy vehicle rollover. Rollover crashes generally cause greater damage and injury than other crash classes (Winkler, 2000). In December 2000, it was determined that each year over 15 000 rollovers of commercial trucks occurred in the US alone (Winkler, 2000). Rollover can typically be attributed to speeding, overloading, lack of maintenance and poor vehicle design. This paper focuses on identifying the most effective method to measure the roll stability of heavy vehicles; this is an important step in order to potentially directly regulate roll stability and thus reduce the occurrence of rollover due to poor vehicle design.

The internationally accepted method of regulating roll stability is by means of a static rollover threshold (SRT) test. The test determines the maximum lateral acceleration that a vehicle can withstand before rolling over. In South Africa, the National Road Traffic Act (NRTA) requires single-decker buses to have a minimum SRT of 0.53 g and double-decker buses (measured with the upper deck loaded) a minimum SRT of 0.42 g (Department of Roads and Transport, 1996). The test must be conducted using a tilt table. In South Africa, heavy vehicles other than buses are regulated only in terms of overall length, height, axle group mass and gross combination mass (GCM). The SRT performance measure is affected by suspension design, axle track width and centre of gravity (CoG) height. Thus the roll stability of buses is regulated using an expensive and time-consuming tilt table test and the roll stability of heavy vehicles other than buses is not regulated directly at all.

SRT is one of the most fundamental stability-related performance measures (Pont, Baas, Hutchinson and Kalasih, 2002). The probability of rollover occurring is related to the SRT performance of the respective vehicle. Figure 1-2 shows the relative crash rates for rollover and loss-of-control crashes involving heavy vehicles in New-Zealand in 1999 (Mueller, De Pont and Baas, 1999). As SRT increases, the crash involvement rate decreases. Vehicles with an SRT of less than 0.3 g generally have a three times higher risk of rolling over than the average vehicle. Furthermore, 15% of the vehicle fleet with an SRT below 0.35 g was involved in 40% of the rollover and loss-of-control crashes. As a result, all vehicle units of Class NC (heavy goods vehicle with a GCM of greater than 12 tonnes) or Class TD (heavy trailer with a GCM of greater than 10 tonnes (NZ Transport Agency, 2015)) in New-Zealand are currently required to comply with a minimum SRT of 0.35 g (New Zealand Government, 2014). This is in line with the Australian requirement of 0.35 g for performance-based standards vehicles (National Transport Commission, 2008).



**Figure 1-2 Relative crash rate versus SRT**  
(Pont et al., 2002)

SRT can be measured by means of a well-defined tilt-table procedure (SAE J2180). This procedure is traditionally carried out through expensive and time-consuming physical testing. A more cost-effective method is multibody dynamics simulation (MDS). Performed using software packages such as TruckSim® or TruckMaker®, MDS incorporates all the suspension properties of the vehicle. A tilt-table simulation is shown in Figure 1-3. By solving systems of multibody dynamic equations for small time steps, these software packages accurately predict the SRT of a vehicle. Apart from the expensive license fees, MDS also requires a detailed understanding of suspension characteristics and vehicle dynamics to conduct these simulations and interpret the results. Furthermore, the necessary suspension data is often a challenge to obtain.

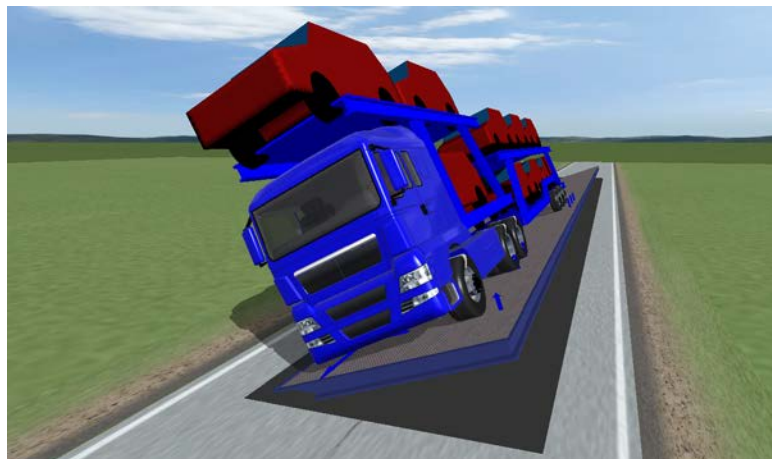

**Figure 1-3 Tilt table test performed on a commercial car-carrier using TruckSim®**

Both physical testing and MDS are expensive and time-consuming means of determining the SRT of a proposed vehicle. Enforcing a compulsory SRT assessment, based on either of these methods, is not viable in South Africa. However, a number of simplified approaches to predicting SRT have been developed over the years. These approaches are typically less accurate but offer a simplified approach without requiring costly hardware or computer software packages.

## 1.2 Aim

This paper considers various simplified tools to calculate the SRT of articulated heavy vehicles, and compares the results with a baseline MDS assessment with the aim of recommending an assessment tool that is simple to use but offers acceptable accuracy.

## 1.3 Scope

Five commercial car-carriers were considered for evaluating the SRT assessment tools. These incorporate a variety of hauling units, trailers and payloads.

## 2 SIMPLIFIED APPROACHES FOR PREDICTING SRT

The simplest approximation of predicting SRT as explained by Gillespie (1992) is as follows:

$$SRT = \frac{T}{2H} \quad (2-1)$$

where:

$T$  = track width (m)

$H$  = CoG height of entire vehicle including payload (m)

This method disregards the effects of deflection in the suspension and tyres. According to Gillespie, this method is a first-order estimate, and although it is a useful tool for comparing vehicle performance, it is not a good predictor of absolute SRT performance.

An improvement to Eq. (2-1) is an approximation developed by Elischer and Prem (1998), incorporating a factor,  $F$ , empirically derived to approximate the lateral shift of the sprung mass CoG as the body rolls. Elischer and Prem (1998) confirmed that this model was found to produce SRT results accurate to 7% for vehicles with a variety of load densities and configurations.

$$SRT = \frac{T}{2HF} \quad (2-2)$$

where:

$T$  = track width (m)

$H$  = CoG height of entire vehicle including payload (m)

$$F = 1 + \frac{W_p(H_p - H_e)}{H(W_e + W_p)}$$

where:

$W_p$  = payload mass (kg)

$W_e$  = empty vehicle mass (kg)

$H_p$  = height of CoG of payload (m)

$H_e$  = height of CoG of empty vehicle (m)

An even more detailed approximation is required by New Zealand’s Land Transport Rule (NZLTR, 2002). This method calculates the roll of the axle itself due to tyre compliance ( $\phi$ ), as well as the roll of the sprung mass relative to the axle due to suspension compliance ( $\theta$ ) as shown in Figure 2-1. Various physical suspension properties are incorporated into the model allowing for more accurate prediction.

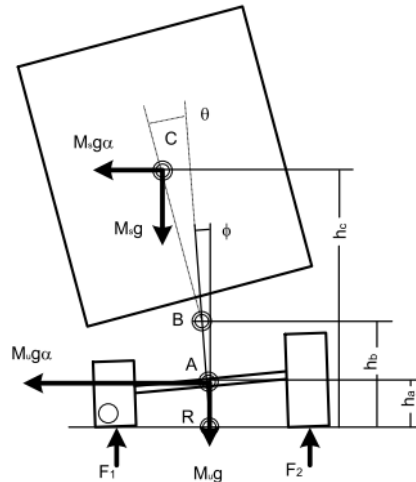

**Figure 2-1 Notation: land transport rule method**  
(New Zealand Government, 2014)

As per NZLTR “Case 1”, when there is zero lash SRT can be calculated as:

$$SRT = \frac{T}{2H} \left[ 1 - \frac{M_s^2 g (h_c - h_b)^2}{(k_r M H - M_s g (h_c - h_b) (M_s h_b + M_u h_a))} \right] - \frac{Mg}{k_r T} \quad (2-3)$$

where:

- $T$  = Wheel track width (m)
- $H$  = Overall CoG height (m) (not shown)
- $M_s$  = Sprung mass (kg)
- $h_c$  = Sprung mass CoG height from ground (m)
- $h_b$  = Roll centre height from ground (m)
- $k_r$  = Composite suspension roll stiffness (Nm/rad)
- $M$  = Total mass (kg)
- $M_u$  = Unsprung mass (kg)
- $h_a$  = Axle CoG height from ground (m)
- $k_t$  = Tyre stiffness (N/m)

Most steel suspensions have some form of lash, which occurs when the spring load changes from compression to tension and the axle experiences some resistance-free displacement before the spring is re-engaged as illustrated in Figure 2-2. This phenomenon has a detrimental effect on SRT performance.

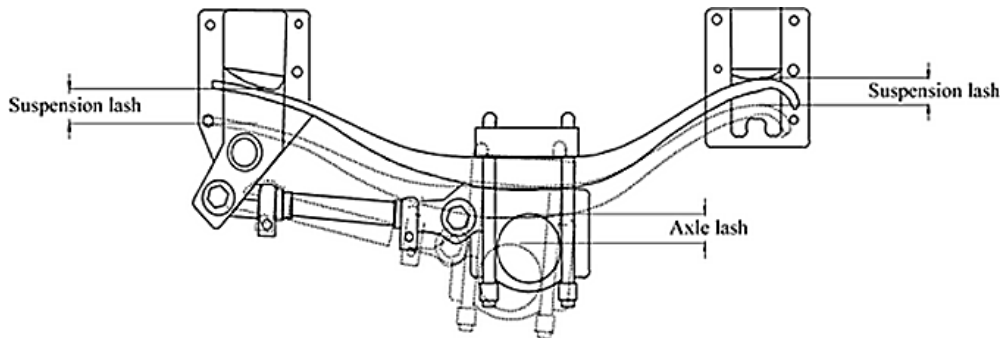

**Figure 2-2 Suspension and axle lash**  
(New Zealand Government, 2014)

The NZLTR “Case 2” incorporates the effect of lash under three potentially critical conditions. The conditions, together with the respective formulae for calculating *SRT* are:

Condition A: Lash is initiated

$$SRT = \frac{T}{2H} - \frac{M_s^2 g(h_c - h_b)}{k_s t MH} - \frac{2g(k_r MH - M_s g(h_c - h_b)(M_s h_b + M_u h_a))}{k_s t k_i T^2 (h_c - h_b)} \quad (2-4)$$

Condition B: Full extent of lash is applied

$$SRT = \frac{T}{2H} \left[ 1 - \frac{M_s^2 g(h_c - h_b)^2}{(k_r MH - M_s g(h_c - h_b)(M_s h_b + M_u h_a))} \right] - \frac{Mg}{k_i T} - \frac{M_s (h_c - h_b) l (k_r - k_{aux})}{t (k_r MH - M_s g(h_c - h_b)(M_s h_b + M_u h_a))} \quad (2-5)$$

Condition C: Lash is in the process of being applied (for suspensions with high auxiliary roll stiffness)

$$SRT = \frac{T}{2H} - \frac{Mg}{k_i T} - \frac{M_s^2 g(h_c - h_b)(T k_s t (h_c - h_b) - 2(k_r - k_{aux})H)}{2H k_s t (k_{aux} MH - M_s g(h_c - h_b)(M_s h_b + M_u h_a))} \quad (2-6)$$

where

$k_s$  = Spring stiffness (N/m)

$t$  = Suspension track (m)

$k_{aux}$  = Auxiliary roll stiffness (Nm/rad)

If the roll stiffness of individual axles in a vehicle unit differs substantially, it is possible that the wheel of a particular axle may lift off the table during the tilting procedure while the wheels of the remaining axles are still in contact with the table. This is particularly applicable to trucks (as opposed to trailers) as steering axles and drive axles typically have significantly different suspension characteristics. The NZLTR “Case 1” and NZLTR “Case 2” do not account for this. The NZLTR “Case 3” incorporates this effect, but with a significant increase in calculation complexity.

The method for calculating SRT in accordance with NZLTR “Case 3” now follows. Note that for this section, the subscript “front” refers to the steer axle and the subscript “rear” refers to the drive axle group and the subscript “gen” refers to the entire combination. In order to calculate SRT, Eqs. (2-7), (2-8) and (2-9) are to be solved simultaneously, at each of the critical points of the solution path.

$$\theta_{front} + \zeta_{front} + \varphi_{front} = \theta_{rear} + \zeta_{rear} + \varphi_{rear} = \theta_{gen} + \varphi_{gen} \quad (2-7)$$

Where

$\theta$  = Sprung mass roll angle (rad) as per Figure 2-1

$\varphi$  = Axle roll angle (rad) as per Figure 2-1

$\zeta$  = Suspension roll angle (rad) due to lash. For the lumped case this is included in

$\varphi_{gen}$

$$\left[ A_{front} \left( 1 - \frac{l}{MF_{front}} \right) - B_{front} \right] \varphi_{front} + A_{rear} \varphi_{rear} + (B_{front} - C_s)(\theta_{gen} + \varphi_{gen}) + D_{front} \zeta_{front} = - \left( 1 - \frac{l}{MF_{front}} \right) \frac{M_{tyre\_front}}{MHg} - \frac{M_{tyre\_rear}}{MHg} \quad (2-8)$$

$$A_{front} \varphi_{front} + \left[ A_{rear} \left( 1 - \frac{l}{MF_{rear}} \right) - B_{rear} \right] \varphi_{rear} + (B_{rear} - C_s)(\theta_{gen} + \varphi_{gen}) + D_{rear} \zeta_{rear} = - \frac{M_{tyre\_front}}{MHg} - \left( 1 - \frac{l}{MF_{rear}} \right) \frac{M_{tyre\_rear}}{MHg} \quad (2-9)$$

Where

$$A_{front} = \begin{cases} k_{t\_front} \frac{T_{front}^2}{2MHg} - MF_{front}, & \varphi_{front} \leq \frac{M_{front}g}{k_{t\_front}T_{front}} \\ -MF_{front}, & \varphi_{front} > \frac{M_{front}g}{k_{t\_front}T_{front}} \end{cases} \quad M_{tyre\_front} = \begin{cases} 0, & \varphi_{front} \leq \frac{M_{front}g}{k_{t\_front}T_{front}} \\ -\frac{M_{front}gT_{front}}{2}, & \varphi_{front} > \frac{M_{front}g}{k_{t\_front}T_{front}} \end{cases}$$

$$A_{rear} = \begin{cases} k_{t\_rear} \frac{T_{rear}^2}{2MHg} - MF_{rear}, & \varphi_{rear} \leq \frac{M_{rear}g}{k_{t\_rear}T_{rear}} \\ -MF_{rear}, & \varphi_{rear} > \frac{M_{rear}g}{k_{t\_rear}T_{rear}} \end{cases} \quad M_{tyre\_rear} = \begin{cases} 0, & \varphi_{rear} \leq \frac{M_{rear}g}{k_{t\_rear}T_{rear}} \\ -\frac{M_{rear}gT_{rear}}{2}, & \varphi_{rear} > \frac{M_{rear}g}{k_{t\_rear}T_{rear}} \end{cases}$$

$$B_{front} = \frac{k_{r\_front}}{MF_{front}MHg}, \quad B_{rear} = \frac{k_{r\_rear}}{MF_{rear}MHg}, \quad C_s = \frac{M_s(h_c - h_b)}{MH}$$

$$D_{front} = \frac{k_{aux\_front} - k_{r\_front}}{MF_{front}MHg}, \quad D_{rear} = \frac{k_{aux\_rear} - k_{r\_rear}}{MF_{rear}MHg}$$

$$MF_{front} = \frac{(M_{s\_front}h_{b\_front} + M_{u\_front}h_{a\_front})}{MH}$$

$$MF_{rear} = \frac{(M_{s\_rear}h_{b\_rear} + M_{u\_rear}h_{a\_rear})}{MH}$$

The SRT of all potentially critical conditions can subsequently be calculated as:

$$SRT = \left( k_{t\_front} \frac{T_{front}^2}{2MHg} - MF_{front} \right) \varphi_{front} + \left( k_{t\_rear} \frac{T_{rear}^2}{2MHg} - MF_{rear} \right) \varphi_{rear} - \frac{M_s(h_c - h_b)}{MH} (\theta_{gen} + \varphi_{gen}) \quad (2-10)$$

The highest value of SRT calculated this way indicates the vehicle unit's overall SRT.



### 3 METHOD

The full design specifications of five commercial car-carriers were obtained from the relevant OEMs. These vehicles represent a variety of hauling unit manufacturers (Mercedes Benz, Scania and Volvo), trailer manufacturers (Lohr, Rolfo and Unipower) and payload configurations. The SRT performance of these vehicles was assessed using MDS (TruckSim<sup>®</sup>) as a baseline and then re-assessed using each of the simplified tools as discussed in Section 2. The relative accuracy of each method was then calculated.

### 4 RESULTS

Assessing the trucks using the methods of Gillespie, Elischer & Prem, NZLTR “Case1” and NZLTR “Case2” required some assumptions to be made to arrive at an effective suspension i.e. combining the front and rear suspensions of the truck. The axle track width, for example, was taken as the average of the front and rear suspensions, weighted by the axle group load. Similar assumptions were made for spring track and roll centre heights. Stiffness features were summed as these function in parallel. For NZLTR “Case3”, the front and rear suspension characteristics are required to be specified separately, however again the concept of averaging was applied in combining the drive and tag axles where non-identical.

As expected, when compared with the TruckSim<sup>®</sup> vehicle unit results as a baseline, the method of Gillespie did not provide accurate results, with an average absolute error of 40.5% for trucks and 18.5% for trailers as shown in Table 4-1. The method of Elischer & Prem provided more accurate results, especially considering the simplicity of the model with an average absolute error of 7.4% for trucks and 11.4% for trailers. With the truck assessments, NZLTR “Case1” proved to be less accurate than Elischer & Prem’s method, with an absolute average error of 14.5%. NZLTR “Case2” was only applicable to the third truck, the Volvo FM400, which showed a 1.15% error. The remainder of the trucks experienced wheel lift-off before lash could occur and were thus not assessed using NZLTR “Case2”. The reason for this is the high auxiliary roll stiffness of the respective trucks’ averaged suspensions. When using NZLTR “Case3”, the individual axle group characteristics were incorporated allowing an improved accuracy of 4.66%. No NZLTR “Case3” solution was found for the two Volvo trucks. In the case of the trailer assessments, the NZLTR “Case1” provided excellent accuracy with an average absolute error of 0.82%. Once again lash was also not achieved due to the high auxiliary roll stiffness of the trailer axles.

**Table 4-1 SRT performance using various predictor tools**

SRT Model	SRT (g)					Average absolute error	Maximum absolute error
	Comb1	Comb2	Comb3	Comb4	Comb5		
Entire combination							
TruckSim	0.375	0.387	0.446	0.391	0.369		
Truck							
TruckSim	0.375	0.384	0.428	0.393	0.363		
Gillespie (Averaged)	0.528	0.542	0.564	0.552	0.538		
Elischer & Prem (Averaged)	0.397	0.405	0.430	0.427	0.422		
NZLTR "Case 1" (Averaged)	0.418	0.448	0.436	0.443	0.470		
NZLTR "Case 2" (Averaged)	N/A	N/A	0.432	N/A	N/A		
NZLTR "Case 3"	0.397			0.412	0.352		
Trailer							
TruckSim	0.439	0.446	0.484	0.468	0.475		
Gillespie	0.504	0.511	0.585	0.570	0.572		
Elischer & Prem	0.373	0.376	0.440	0.434	0.428		
NZLTR "Case 1"	0.446	0.453	0.482	0.468	0.472		
<i>Percentage error w.r.t vehicle unit's TruckSim SRT performance</i>							
Truck							
Gillespie	40.9%	41.2%	31.8%	40.6%	48.1%	40.5%	48.1%
Elischer & Prem	6.0%	5.4%	0.7%	8.6%	16.2%	7.4%	16.2%
NZLTR "Case 1"	11.4%	16.7%	2.0%	12.9%	29.3%	14.5%	29.3%
NZLTR "Case 2"	N/A	N/A	1.1%	N/A	N/A	1.1%	1.1%
NZLTR "Case 3"	6.0%	N/A	N/A	5.0%	-3.0%	4.7%	6.0%
Trailer							
Gillespie	14.8%	14.5%	20.9%	21.7%	20.4%	18.5%	21.7%
Elischer & Prem	-15.1%	-15.8%	-9.0%	-7.3%	-9.9%	11.4%	15.8%
NZLTR "Case 1"	1.7%	1.4%	-0.4%	0.0%	-0.6%	0.8%	1.7%

The approach of the NZLTR was found to provide the best correlation with the TruckSim® results. This is likely due to the fact that the NZLTR approach incorporates customised suspension characteristics, such as spring stiffness, auxiliary roll stiffness, tyres stiffness and lash, allowing for improved prediction accuracy.

## **5 CONCLUSION**

When assessing the SRT of trailers, “case 1” of the NZLTR was identified as the most accurate method, however if lash occurs, “case 2” would be the preferred method as stipulated in the NZLTR. Because of their non-identical front/rear suspension characteristics, trucks should be assessed using “case 3” of the NZLTR. Following this approach, we observed very accurate prediction with an average absolute error of 4.7% for trucks and 0.8% for trailers. The maximum absolute error of 6% for the truck and 1.7% for the trailer can also be considered acceptable.

## **6 RECOMMENDATIONS**

The NZLTR method for calculating SRT specifies various default suspension parameters such as typical spring stiffness, suspension track width, composite roll stiffness, axle lash and roll centre height for generic steer, steel and air suspensions. The values of these properties were sourced from the relevant OEMs for the SRT assessments. As this information is generally time-consuming to gather from OEMs, it is recommended to investigate assessing the impact of using the generic NZLTR suspension characteristics. If these generic characteristics provide acceptable results, it would streamline the assessment process significantly.

A further, even more simplified method of predicting SRT may be possible by using a data-driven machine learning approach. The work of Berman et al. (2015) proves that this is possible for the low-speed performance-based standards and hence likely possible for predicting SRT. Sufficient learning data could be created by assessing the SRT of a wide variety of suspension, payload and vehicle configurations from which the machine learning model could be trained and thus offer a new data-driven model for predicting SRT. A sensitivity analysis, similar to the work of Benade et al. (2015), may also be required in order to select the applicable machine learning algorithm to predict SRT.

## **7 ACKNOWLEDGEMENTS AND LIABILITY DECLARATION**

This work is based on the research supported in part by the National Research Foundation of South Africa (TP1207173267 Designing Safer, More Productive Trucks Using PBS). The authors gratefully acknowledge the generous support of this research from Unipower (Natal), Lohr Transport Solutions ZA, Rolfo South Africa, Volvo South Africa, Scania South Africa and Mercedes-Benz South Africa. Without the support of these industry partners this research would not have been possible. The grant holder acknowledges that opinions, findings and conclusions or recommendations expressed in any publication generated by the NRF supported research are that of the authors, and that the NRF accepts no liability whatsoever in this regard.

## REFERENCES

Benade, R., Kienhöfer, F., Berman, R. and Nordengen, P.A., 2015. A Pro-Forma Design for Car-Carriers : Low-Speed Performance-Based Standards. In: *South African Transport Conference*. Pretoria: SATC, pp.253–265.

Berman, R. and Benade, R., 2015. Performance-Based Standards: A Sustainable Solution for Transportation in South Africa. Pretoria: SASBE.

Berman, R., Benade, R. and Rosman, B., 2015. Autonomous Prediction of Performance-based Standards for Heavy Vehicles. Port Elizabeth: PRASA-RobMech.

Council for Scientific and Industrial Research, 2013. *10th Annual State of Logistics Survey for South Africa*. 10th ed. Pretoria: CSIR.

Department of Roads and Transport, 1996. *Overview of the South African Mechanistic Pa*. Republic of South Africa.

Elischer, M. and Prem, H., 1998. Stability of Over-Height Low-Density Freight Vehicles and Its Prediction. In: *5th International Symposium on Heavy Vehicle Weights and Dimensions*. Queensland, pp.147–160.

Gillespie, T.D., 1992. *Fundamentals of Vehicle Dynamics*. Society of Automotive Engineers.

Mueller, T., De Pont, J. and Baas, P., 1999. *Heavy Vehicle Stability Versus Crash Rates*.

National Transport Commission, 2008. *Performance Based Standards Scheme – The Standards and Vehicle Assessment Rules*. Melbourne.

New Zealand Government, 2014. *Land Transport Rule : Vehicle Dimensions and Mass 2002*. New Zealand.

NZ Transport Agency, 2015. *Vehicle Classes*. [online] Available at: <<https://www.nzta.govt.nz/vehicles/vehicle-types/vehicle-classes-and-standards/vehicle-classes/#NC>>.

OECD Publishing, 2011. *Moving Freight with Better Trucks: Improving Safety, Productivity and Sustainability*. *International Transport Forum*.

Pont, J. De, Baas, P., Hutchinson, D. and Kalasih, D., 2002. Including Performance Measures in Dimensions and Mass Regulations. In: *7th International Symposium on Heavy Vehicle Weights and Dimensions*. Delft, pp.349–358.

Winkler, C., 2000. Rollover of Heavy Commercial Vehicles. *UMTRI Research Review*, 31(4), pp.1–20.