

## DEVELOPING NEW PHASE CHANGE MATERIAL COMPONENTS TO IMPROVE ENERGY SAVINGS AND COMFORT IN BUILDINGS

Bontemps A.<sup>a</sup>, Royon L.<sup>b\*</sup>

\* Author for correspondence

<sup>a</sup> LEGI, Université Joseph Fourier, Grenoble, France

<sup>b</sup> Laboratoire M.S.C, Université Paris Denis Diderot, Paris, France

E-mail: laurent.royon@univ-paris-diderot.fr

### ABSTRACT

In many regions, it is sometimes difficult to reach acceptable thermal comfort without continuous energy consumption for Heating, Ventilating and Air-Conditioning (HVAC) inside buildings. This paper describes some strategies and some technologies to naturally improve comfort without or with reduced air-conditioning. These strategies are based on using Phase Change Materials (PCM) incorporated in building structures. The PCMs used in this study are described and characterized and a new composite material (polymer/PCM) is proposed. Among the several types of structures that have been studied, a brick filled with this new material has been chosen. The responses to temperature and heat flux variations have been studied. It is shown that the brick thermal inertia is strongly increased and that this construction component presents no PCM leaks.

### INTRODUCTION

To conserve energy and reduce GHG effects, it has become necessary to seek effective means of reducing peaks in power consumption. However, reducing power consumption can affect thermal comfort in buildings. The development of improved means to manage power consumption and to insure comfortable indoor conditions at the same time is a challenge for the next years, along with the integration of these new solutions in a sustainable architecture which consider the effects on people and the environment.

One way to reduce energy consumption is to use large thermal storage devices, especially in climates where daily temperature variations require both heating and cooling over the same 24 hour period. It is the case in many desert or semi-desert regions, where a very large range of daily temperature can be observed between nights and days for given seasons. Buildings designed

to make use of thermal storage include systems which increase their thermal mass. These systems may be used for storage only, or may serve both as storage and as structural elements.

A significant building thermal capacity should contribute in stabilizing the large daily temperature fluctuations and should increase the lag time between the external and internal temperature peaks. Massive construction materials, such as stone, have long been used for this purpose. However, lighter thermal storage materials would be more attractive to consumers. In this objective, Phase Change Materials (PCMs) can be used for thermal storage. Ideally, such materials should be incorporated inside building components. However this technique had limited success because it is difficult to incorporate these materials into existing building substances. The utilization of Phase Change Materials in active and passive cooling/heating of buildings has been a major research topic for the last three decades. Many papers have been published on this subject and their main results can be found in recent reviews (Zalba *et al.*, 2003, Khudair & Farid, 2004; Tyagi & Buddhi, 2007).

The incorporation in construction elements has been carried out in several ways including (i) direct incorporation or impregnation of the construction material, (ii) incorporation of PCM capsules in building components, (iii) manufacturing new panels with PCMs to replace classic wallboards, and (iv) incorporation in a heat exchanger plate to improve performance of a HVAC system.

### NOMENCLATURE

$\Phi$	[W/m <sup>2</sup> ]	Heat flux
$T$	[K, °C]	Temperature

Subscripts

$s$	out
$e$	in

Many researchers have worked on impregnation of plasterboard or concrete with PCMs (Salyer *et al.*, 1985; Shapiro *et al.*, 1987; Babich *et al.*, 1994; Banu *et al.*, 1998) in order to store / release the energy coming from solar or internal sources. However, this technique can induce several problems. One of them is PCM migration through the walls and subsequent leakage when the PCM is in liquid state. To overcome this problem two types of solutions are proposed: (i) incorporation of PCMs in micro- or macro-capsules (ii) realization of a composite material by embedding paraffin in a matrix. Hawes *et al.*(1993) have considered several means of PCM incorporation, and they have concluded that the PCM must be encapsulated. So, PCMs can be packaged inside containers of 1 cm<sup>3</sup> to few dm<sup>3</sup> (as manufactured by Cristopia) or a plastic panel can be directly filled with PCMs (Ahmad *et al.*, 2006).

A recent process is microencapsulation. Paraffin can be incorporated inside a polymer solid shell whose diameter is varied from 1 to 100 µm. The resulting product appears as dry powder or as emulsion which can be applied in building materials (Jahns, 1999). Recently, Cabeza (2007) has worked on the introduction of a microencapsulated PCM into concrete walls. The PCM melting temperature was 26°C and its latent heat 110 kJ/kg. This experiment, located at Lleida in Spain, consisted in two test-cells and it has been shown that the indoor and wall surface temperatures were reduced. The author observed that the introduction of microcapsules in concrete did not alter its mechanical properties.

As the thermal conductivity of PCMs is not large enough, a strategy to increase it could be to form a composite with highly conducting materials. Such an approach has been presented in several publications (Melhing *et al.*, 1999; Py *et al.*, 2001). In this communication, we present several applications of a new material which can be used in several ways such as (i) incorporation in a brick to build a wall, (ii) incorporation in a panel to make a light wallboard, (iii) incorporation in a heat exchanger plate to improve performance of a HVAC system. After reviewing the different uses of several PCMs, we will present results obtained in our laboratories. The studies allowed us:

- to measure thermal properties of materials and associated components (Heat capacity, Latent heat, Thermal conductivity)
- to measure the thermal response of a brick and of a panel with prescribed periodic boundary conditions in order to evaluate their capability in reducing energy consumption.

## PHASE CHANGE MATERIALS AND PREVIOUS STUDIES

### Criteria for choosing PCMs

Several criteria have to be fulfilled by PCMs to be of interest.

They are summarized in the following table:

- thermodynamical criteria:

Phase change temperature adapted to applications

High latent heat of fusion

High sensible heat to provide additional heat storage

No subcooling during freezing

- heat transport properties :

High thermal conductivity to diminish temperature gradients required to charging and discharging the material

- mechanical properties:

Small volume change during phase transition

- chemical properties:

Chemical stability

Chemical compatibility with construction materials

Non-flammable and non-explosive

Non-toxic or poisonous

- economical properties:

Available in large quantities

Cheap

It is difficult to find a material capable to satisfy all these criteria. Moreover, the chosen PCM must be conditioned in a manner that avoids leaks and contacts with the environment.

The adopted strategy was the following:

- to choose PCMs allowing a comfort temperature about 23 °C,
- to measure their thermophysical properties (thermal conductivity and specific heat capacity)
- to choose a mode of packaging and eventually to build a construction component or a wallboard
- to measure the response of the construction component or the wallboard to temperature variations.

In an attempt to fulfil most of the above criteria, several ways have been followed :

- filling liquidtight panels with PCMs,
- using PCMs incorporated inside granulates or microcapsules,
- manufacturing a composite material.

### Previous studies

#### Panels filled with PCM

To reach a comfort temperature of about 23 °C, three types of PCMs have been tested (PolyEthyleneGlycol 600, Fatty acid mixture, Paraffins) to fill PVC and polycarbonate panels used as wallboards (Figure 1)

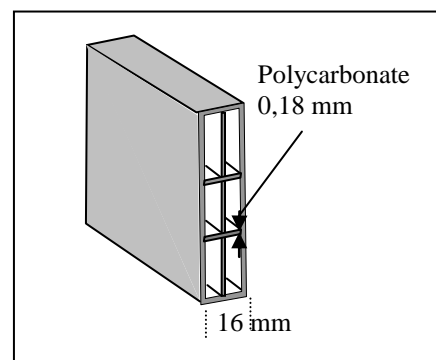

(a)

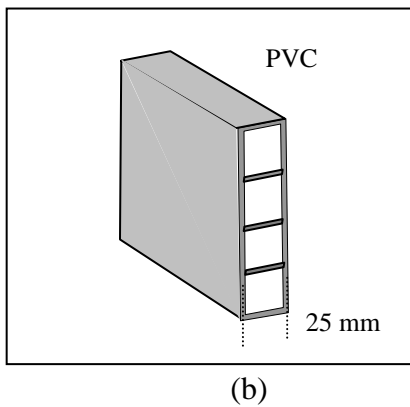

**Figure 1:** Structure of tested panels: (a) polycarbonate and (b) PVC panel.

To study the panel performances, a linear or a periodic variation of temperature was imposed on one side of the panels, while flux and temperature were measured on the other side.

Obtained results are reminded and can be summarized as following (Ahmad *et al.*, 2006):

- An appreciable attenuation of temperature amplitude has been observed on the opposite side
- Due to low thermal conductivity of used PCMs a strong superheating was observed whilst one part is not completely molten
- In some cases, wall cracks occurred and the liquid PCM flowed outside the panel.

#### PCM embedded in granulates

To avoid liquid leaks, use of granulates as means of packaging PCMs was tested. Samples constituted by a mixture of granulate (from Rubitherm) containing a PCM (paraffin) and gypsum have been realized with a phase change temperature of 26 °C (Ahmad *et al.*, 2006).

It has been observed that the presence of granulates incorporating a PCM in the wallboard does not bring a significant improvement in the attenuation of the amplitude of the temperature oscillations compared to the use of an insulating material. However, the amount of PCM available for efficient heat storage was rather small and should be increased. If done, the thickness of the wallboard would have been increased too much and the advantage of a light envelope would have been lost. Another difficulty appeared when using such samples, their durability due to the effusion of paraffin through granulates. So, other types of encapsulation were tested.

#### Microencapsulation

Microencapsulation is known to be an efficient way to avoid liquid leaks. Microcapsules of paraffin (Melting temperature 28 °C) have been tested in order to be included in plasterwalls. The first task was to measure the equivalent specific heat capacity and phase change temperatures by Differential Scanning Calorimetry (DSC).

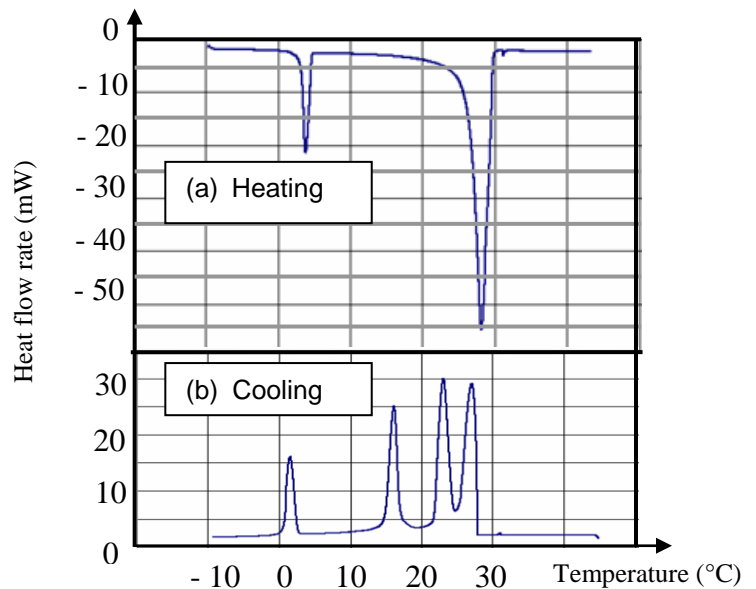

**Figure 2:** DSC thermograms showing the occurrence of solid – liquid phase transitions of microencapsulated paraffin: (a) sample heating, (b) sample cooling.

On figure 2 are presented typical curves obtained by DSC with a Setaram microcalorimeter when microcapsules are heated (Figure 2(a)) and cooled (Figure 2(b)) at a constant rate of 0.1 °C/min. The curves show the difference in the amount of heat required to increase or decrease the temperature of the sample compared to a reference as a function of temperature. The horizontal axis indicates temperature, and the vertical axis indicates heat flow rate. Peaks indicate the phase change temperature zones and correspond to an endothermal process for heating and exothermal process for cooling. For the heating process one peak is observed near the expected fusion temperature. The peak area allows us to determine the latent heat. Another peak is seen near 0°C probably due to presence of residual water. Several peaks are seen in the cooling process which indicate presence of residual water and a probable subcooling due to the small dimension of the microcapsules. This mode of packaging has been used by several authors, but in our case, due to the occurrence of several peaks during the cooling process, we have preferred the use of paraffin composite material as described in the following section.

## THE NEW POLYMER – PARAFFIN COMPOSITE MATERIAL

### Material preparation

The basic idea is to prepare the Phase Change Material (PCM) by mixing at high temperature (> 100 °C) the paraffin which serves as a latent heat storage material and a styrene-butadiene-styrene (SEBS) block copolymer-polymer leading to a matrix acting as a supporting material. The paraffin is a commercial grade wax obtained from petroleum distillation. This fusible material used here is a combination of (CH<sub>2</sub>)<sub>12</sub>,

(CH<sub>2</sub>)<sub>13</sub>, (CH<sub>2</sub>)<sub>14</sub>, and (CH<sub>2</sub>)<sub>15</sub>. With a polymer mass weight of 25%, no liquid leakage during its solid-liquid phase change is observed. The PCM mass density is respectively 840 kg/m<sup>3</sup> at  $T = 5\text{ }^{\circ}\text{C}$  and 771 kg/m<sup>3</sup> at  $T = 20\text{ }^{\circ}\text{C}$ .

Thermal properties of the commercial blended paraffin and PCM samples such as phase change enthalpy, specific heat and phase change temperature were measured by using DSC method applied with Mettler Toledo Co instrument through a thermal cycle of cooling-to-heating. Samples of 2 to 8 mg in aluminium pans (hermetically sealed before being placed in the calorimeter) were used and scans were recorded at a heating and cooling rate of 1°C/min with a deionized water pan as reference. The DSC thermal analyses are performed from 50 °C to -20 °C and then from -20 °C to 50 °C.

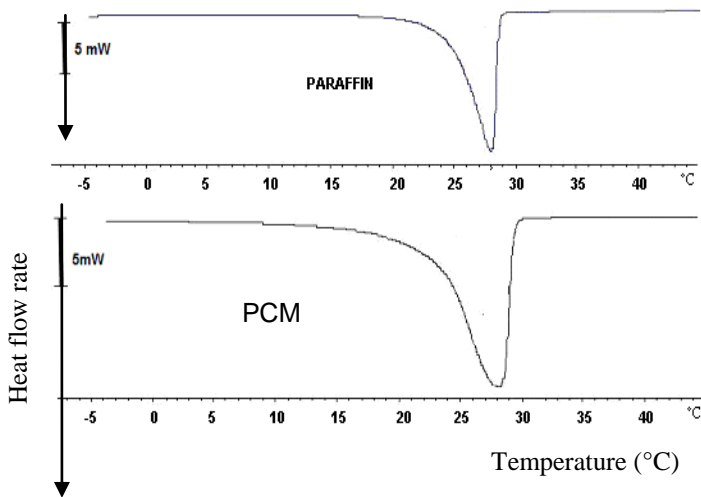
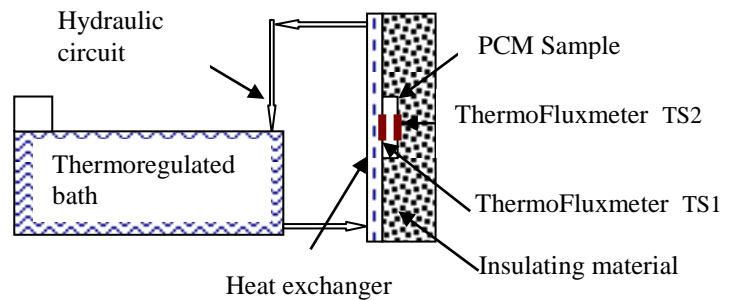

**Figure 3:** DSC thermograms of the paraffin and the PCM - polymer composite.

The figure 3 shows a typical DSC thermogram of the paraffin used in the preparation of the composite PCM. One can observe that the melting phase appears within a large range of temperature because of the composition of the paraffin. This result is in agreement with the study of He *et al.* (2004) who have shown that paraffin mixtures melt and freeze within a temperature range and not at a constant temperature. An extrapolated peak onset temperature  $T_m$  can be obtained by drawing a line at the point of maximum slope of the leading edge of the regarded DSC peak and extrapolating the base line on the same side as the leading edge of the peak. This temperature is often recommended when reporting the melting and crystallisation peak characteristics. For the paraffin,  $T_m$  is estimated to 27.4°C. The specific enthalpy, calculated as the total area under the peaks of solid-liquid transition by numerical integration, is for the paraffin 165 kJ/kg. For PCM particle including 80 wt % paraffin, the thermogram is broader than that of the paraffin. This result is due to the presence of the polymer. The fusion specific enthalpy of the composite material is 115 kJ/kg.

### Thermal response of the PCM-polymer composite material

Schematic of the experimental set up is presented in figure 4. Water feeds a plate heat exchanger which imposes its temperature to a sample of PCM placed inside insulating foam. The temperature of the water flow is controlled through a thermoregulated bath. The water velocity is large enough so that no temperature difference can be observed between inlet and outlet.



**Figure 4:** Schematic drawing of the experimental set-up to study the thermal response of the PCM – polymer composite.

Temperatures together with heat fluxes are measured on both sides of the composite material sample (Thermofluxmeters TS1, on front side, and TS2 on back side, measuring temperatures and heat fluxes, from Captec).

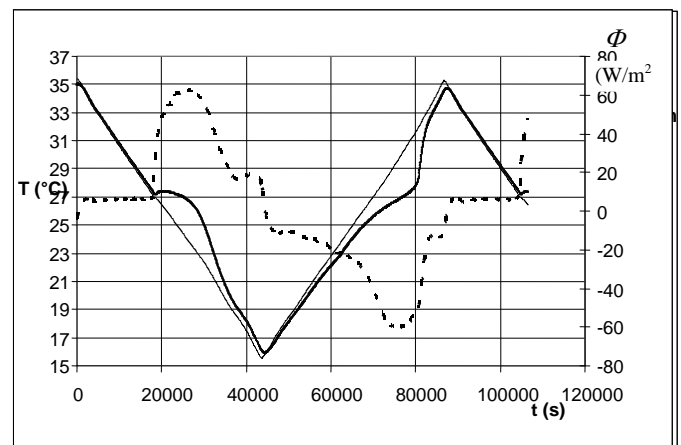

**Figure 5:** Temperature profiles and heat flux variations for test cycles of PCM-polymer composite material.

In Figure 5, the temperature variations measured at both sides of the composite material sample are presented. A cyclic temperature variation is imposed on the front side of the sample (thin full line). Temperature variation is linear during heating and cooling and its period is 24 hours. The temperature on the back side (thick full line) shows a characteristic “flattening” due to phase-change both during cooling and heating. During cooling a slight subcooling phenomenon is also apparent. A strong increase in heat flux (dotted line) is observed at the phase-change occurrence.

By integrating the heat flux curves, the heat stored and released by the material is evaluated as 127 kJ/kg for crystallisation and 133 kJ/kg for fusion in agreement with values obtained by DSC.

During these cycles no leaks were observed when paraffin was in liquid state.

## BRICKS FILLED WITH PCM-POLYMER COMPOSITE: FABRICATION AND TESTS

### Fabrication method

A paraffin-polymer mixture was introduced during its preparation inside cavities of commercial hollow bricks whose dimensions are 11cm x 21.5 cm x 15 cm. Each cavity is a parallelepiped which has a section of 2.5 cm x 2.5 cm and a height of 15cm. Figure 6 presents a picture of two bricks which have been tested: Cavities of the brick on the left hand side are filled by the composite material, the ones of the brick on the right hand side are empty. The volume proportion of composite material is 26 %.



**Figure 6:** Picture of tested bricks. Right: hollow brick. Left: brick filled with the PCM – polymer composite. Experimental set-up and procedure

In order to show the efficiency of this PCM, we have made a comparative measurement in two test cells. An experimental device has been developed to apply identical temperature variation to the bricks with and without PCM (Figure 7). The front side temperature ( $T_1$ ) is imposed by the plate heat exchanger. The opposite side is adjacent to a room in which temperature  $T_4$  is kept constant. Temperature at the internal surface of a brick cavity is also measured. Temperatures  $T_2$  and  $T_4$  are measured by type K thermocouples. Temperature  $T_1$  and  $T_3$  are measured together with surface heat fluxes,  $\phi_e$  and  $\phi_s$  (Figure 7).

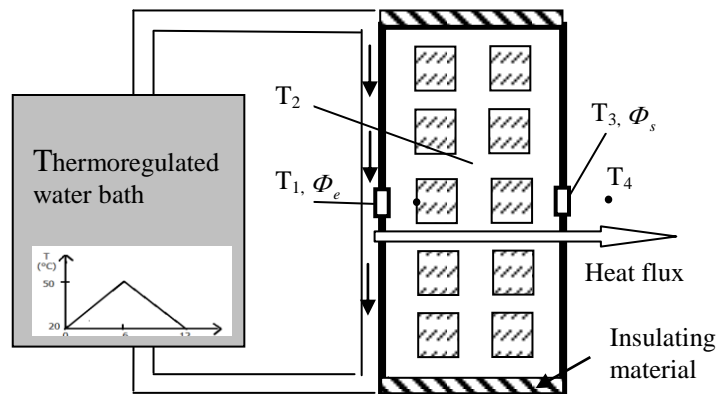

**Figure 7:** Experimental set-up to test thermal response of bricks.

Figure 8 present the imposed temperature variation on one side of the brick. It comprises a linear increase of temperature from 21°C to 46 °C during 12 h followed by a decrease of temperature from 46 °C to 21°C during 12 hours. The other side is in contact with the room atmosphere stabilized at nearly 21 °C.

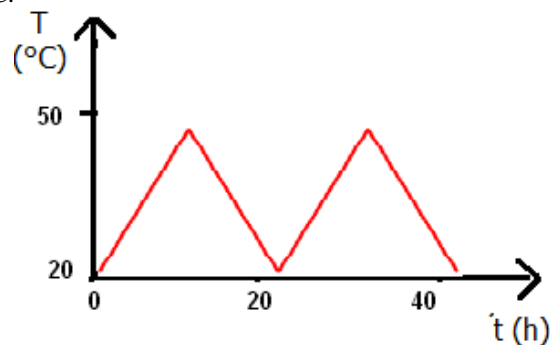

**Figure 8:** Variation of the imposed temperature  $T_1$  as a function of time.

### Results and discussion

Figure 9 shows temperature variations ( $T_1$ ,  $T_3$ ) during two periods. One can observe for the brick filled with PCM, a slope modification for the variation of  $T_3$  at about 26°C which corresponds to the fusion temperature of paraffin. The comparison of the thermal behavior of the two bricks show that the variation of surface temperature of the brick containing the composite material kept always lower than that of the hollow brick.

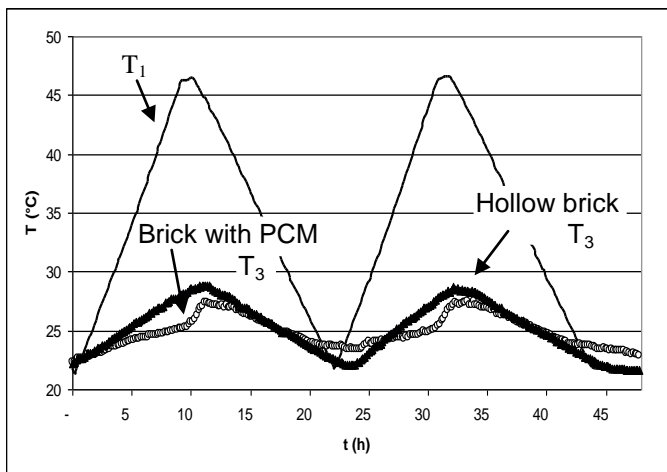

**Figure 9:** Temperature variations as a function of time:  $T_1$ : Imposed temperature on the front side.  $T_3$ : Surface temperature at the back side.

This experiment clearly shows the PCM role on brick thermal inertia: The brick with PCM inside reaches its limiting temperature more slowly than the hollow brick. On the back side the temperature level reached after 12 hours is lower if the brick contains the composite material.

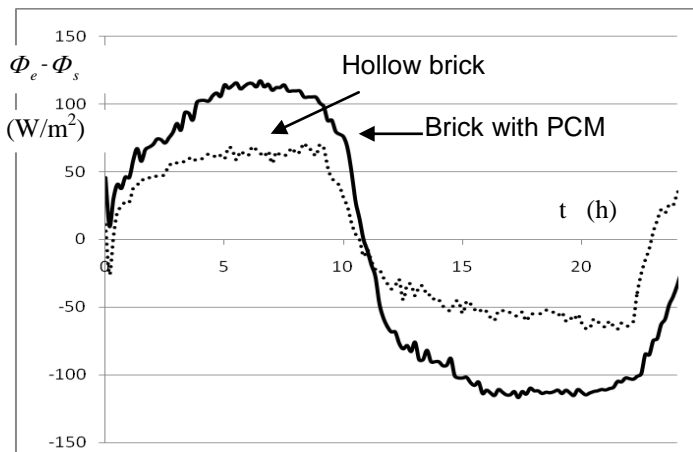

**Figure 10:** Heat flux variation  $\Phi_e - \Phi_s$  as a function of time.

In figure 10 are presented heat flux variations  $\Delta\Phi = \Phi_e - \Phi_s$  as a function of time in order to appreciate the heat storage in the brick. If  $\Delta\Phi = \Phi_e - \Phi_s$  is positive, the heat storage takes place and conversely, if  $\Delta\Phi$  is negative. One can note that heat flux variations  $\Delta\Phi$  of the brick filled with PCM is higher than the variation  $\Delta\Phi$  of the hollow brick. The difference between the  $\Delta\Phi$  heat fluxes of the two bricks allows us to calculate, by integration, the heat stored by the composite phase change material.

For this experiment, about 58kJ have been stored in the composite material, corresponding to 51 % of the available latent heat. This discrepancy can be explained both by volume changes of paraffin (edge effect), the lateral heat losses and errors related to measurements.

If we compare our experiment with a real case in which a solar flux is applied on the front side (external side) of a brick wall, the temperature on the opposite side (internal side) would be lower if the bricks are filled with a PCM-polymer composite.

## CONCLUSION

Use of renewable energy sources such as solar heating, night air cooling, etc. for indoor air conditioning needs for an adequate choice of construction materials. The works presented here aim at describing some ways to obtain passive regulation of indoor temperature by artificially augmenting the heat capacity of materials. This can be done by incorporating phase-change materials inside building elements.

One of the practical problems when using PCMs is to avoid leaks when they are in the liquid state. Then, PCM packaging is a question of utmost importance. Several types of packaging have been tested, panels and microcapsules. The retained solutions are the use of a PCM-polymer composite and its incorporation in the cavities of bricks. The chosen PCM was Paraffin whose melting temperature is about 27 °C. Physical properties (thermal conductivity, specific heat capacity) of the composite material have been measured and its latent heat was found to be 133 kJ/kg. Preliminary tests have shown that PCM remained incorporated in the polymer matrix by capillarity when in liquid state.

Several tests have been carried out to find the thermal response of the composite alone and of bricks when a temperature variation was imposed on one side. Obtained results show that the temperature reached on the other side is lower with a brick filled with a composite than with a hollow brick. If a wall is built with such bricks, it could store solar energy to avoid large increase of indoor temperature during the day and release it during the night. Several walls have been built with PCM bricks to study their behaviour in real climatic conditions. This is the next step of this study.

## REFERENCES

- Ahmad, M., Bontemps, A., Sallée, H., Quenard, D., (2006), Experimental investigation and computer simulation of thermal behaviour of wallboards containing a Phase Change Material (PCM) for the light envelope of buildings, *Energy and Buildings*, 38(4), 357-366.
- Babich, M.W., Benrashid, R., Mounts, R.D., (1994), DSC studies of energy storage materials. Part 3.: Thermal and flammability studies, *Thermochemica acta*, 243, 1994, 193 – 200.

Banu, D., Feldman, D., Haghghat, F., Paris, J., Hawes, D., (1998), Energy storing wallboards: flammability tests, *Journal of Materials and Civil Engineering*, 10, 98 – 105.

Cabeza, L.F. Castellón, C., Nogués, M., Medrano, M., Leppers, R., Zubillaga, O., (2007), Use of microencapsulated PCM in concrete walls for energy savings, *Energy and Buildings*, 39(2), 113-119.

Hawes, D.W., Feldman, D., Banu, D., (1993), Latent heat storage in building materials. *Energy and Buildings*, 20 (1) 77-86

He, B., Martin, V., Setterwall, F., (2004), Phase transition temperature ranges and storage density of paraffin wax phase change materials, *Energy*, 29, 1785 – 1804.

Jahns, E., (1999), Microencapsulated phase change materials, Proceedings of the 4th workshop of IEA ECES IA Annex 10, Bendiktbeuern, Germany.

Khudair, A.M., Farid, M.M., (2004), A review on energy conservation in building applications with thermal storage by latent heat using phase change materials, *Energy Conversion and Management*, 45, 263 – 275.

Lai, C., Chiang, C., (2006), How phase change materials affect thermal performance: hollow bricks, *Building Research & Information*, 34 (2), 118 – 130.

Melhing, H., Hiebler, S., Ziegler, F., (1999), Latent heat storage using a PCM-graphite composite material: advantages and potential applications, Proceedings of the 4th workshop of IEA ECES IA Annex 10, Bendiktbeuern, Germany.

Py, X., Olives, R., Mauran, S., Paraffin/porous-graphite-matrix composite as a high and constant power thermal storage material, *Int. J. Heat Mass Transfer*, 44, 2727 – 2737.

Salyer, I.O., Sircar, Chartoff, R.P., Miller, D.E., (1985), Advanced phase change materials for passive solar storage applications, in *Proceedings of the 20 th Intersociety Energy Conversion Engineering Conference*, Warrendale, Pa, USA, 699 – 709.

Shapiro, M., Feldman, D., Hawes, D., Banu, D., (1987), PCM thermal storage in drywall using organic phase change material, *Passive Solar Journal*, 4, 419 – 438.

Tyagi, V.V., Buddhi, D., (2007), PCM thermal storage in buildings: A state of art, *Renewable & Sustainable Energy Reviews*, 11, 1146 – 1166.

Xu, X., Zhang, Y., Lin, K., Di, H., Yang, R., (2008), Modeling and simulation of shape-stabilized phase change material floor used in passive solar buildings, *Energy & buildings*, 37, (10), 1084-109.