

## USING LIQUID AIR AS A WAY TO STORE ENERGY

Ameel B. and De Paep M. \*

\*Author for correspondence

Department of Flow, Heat and Combustion Mechanics,

GhentUniversity - UGent,

St-Pietersnieuwstraat 41, Gent,

Belgium,

E-mail: michel.depaepe

### ABSTRACT

Energy storage is becoming an issue in a world where renewable energy will probably be the major way of energy production.

Liquefaction of gasses in order to store the liquid is being looked at. This liquid can then be expanded in a Rankine cycle in order to recover the energy. If waste heat is used as input for the boiler, this can be an interesting technology to raise energy efficiency in industry.

In this paper an analysis is made of the efficiency of storing liquefied air. Starting from the thermodynamics of the basic cycle, more complex combined cycles are studied.

It is clear the ideal cycles have a good efficiency. Taking real expander efficiencies into account reduces the output a lot. Using combined cycles for liquefaction and energy production do not raise efficiency in a significant way.

Conversion efficiencies are in the order of 20 to 50% , making these cycles comparable to hydrogen storage and compressed air storage.

### INTRODUCTION

In the near future a lot of fossil fuel electricity production is to be replaced by renewable energy sources, such as solar and wind power [1]. EU is aiming at meeting 20% of its energy needs from renewable sources [2].

In most countries electricity production is mainly centralized. Load levelling is based on prediction of daily and seasonal needs. When the production has to be augmented, hydraulic storage (water in dams) or chemical storage in fossil fuels (gas turbines eg) are in essence used for capacity variation.

However renewable energy sources, in particular wind and solar, are intermittent and they often do not match the electricity demands. Due to the strong fluctuation in the production-demand balance when renewable sources will be introduced on a larger scale, more attention is paid to storing energy. The aim is to generate electricity when possible, and convert it into a storable energy form if the demand is lower.

When demand goes up and not enough electricity is generated by power plants connected to the grid energy is taken from the storage. Several levels (power and applicability) and strategies for storage are under study [3].

A first possibility is storing electricity in capacitors or via magnets (SMES) [4]. A second method is to convert electricity to chemical or mechanical energy (as sodium sulphur batteries, fly wheels). All these technologies are in the relatively small power range (less than 100 MW)

Larger scale facilities are needed when renewables are introduced on a large scale into the grid [5]. Classically, pumped hydro storage is used for large capacity and is cheap per MWh stored [4]. In most developed countries the capacity for using large water reservoirs is mostly taken. Compressed air storage (CAES) is under study and is now implemented in a few plants [6]. Several configurations are under development, but these systems need underground storage capacity and are thus limited in use due to geological constraints. In Figure 1 an overview of storage systems, their capacity and their typical time response is given.

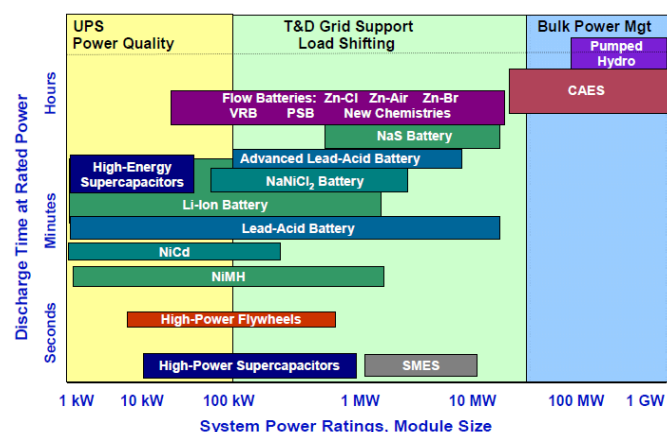

Figure 1 Storage technologies overview according to EPRI [4].

In the EPRI study no mention is made of hydrogen production through electrolysis [7]. The hydrogen can be transformed back to electricity by either combustion in a gas turbine or gas engine or in the near future a fuel cell. Hydrogen electrolysis could be done on a large scale. Hydrogen is a gas that can be relatively easily stored and transported. Also this energy carrier has the potential of being used as fuel for transport and stationary energy production.

Next to hydrogen, storage of energy in liquefied gases is thought of, but again not mentioned by EPRI. Here the high energy density of liquefied gases is a clear advantage. There is a high amount of exergy available in these liquids, allowing for an efficient expansion through Rankine cycles [8, 9].

In [8] several cycle layouts are presented and analysed under ideal and reversible conditions. Also a patent was filed [10]. In these studies the effects of real system components clearly led to estimations of the potential of these cycles which are not realistic.

In this paper a thermodynamic analysis of these cycles is made, based on realistic assumptions.

## NOMENCLATURE

$A$	$m^2$	Heat transfer area
$C_p$	$J/kgK$	Thermal capacity
$h$	$J/kg$	Enthalpy
$k$	$W/m^2K$	Heat transfer coefficient
$\dot{m}$	$Kg/s$	Mass flow rate
$P$	$Pa$	Pressure
$Q$	$W$	Heat
$T$	$K$	Temperature
$W$	$[J/kg]$	Specific Work
$x$	-	Ratio of fresh air intake rate to liquefied air flow rate in the Rankine cycle
$y$	-	The fraction of fresh air that is liquefied

### Special characters

$\eta$	$[-]$	Efficiency
$\epsilon$	$[-]$	Heat Exchanger Effectiveness

### Subscripts

<i>Air</i>	Of fresh air
<i>Boiler</i>	Boiler
<i>Compressor</i>	Compressor
<i>Conversion</i>	Of the reconversion of energy
<i>Liquefaction</i>	Of the liquefaction process
<i>Liquid</i>	Of the liquefied air
<i>max</i>	Theoretical maximum
<i>Pump</i>	Pump
<i>Rankine</i>	Of the Rankine cycle
<i>Recovery</i>	Related to the energy needed for liquifaction
<i>Turbine</i>	Turbine
<i>s</i>	isentropic
<i>Vapor</i>	Of the saturated vapour
<i>1</i>	Inlet flow
<i>2</i>	Outlet flow

## DIRECT EXPANSION OF LIQUID AIR

### Potential of the Rankine cycle

Liquid air can be converted into work using a simple Rankine cycle (as shown in Figure 2). In this cycle the liquid air is compressed, and then heated, before going to a turbine. If liquid air is heated at low pressure, it will evaporate into a gas.

If the pressure after the pump is above the critical point of air (132,41K, 38.836 bar), the fluid will be supercritical in the heater and the turbine.

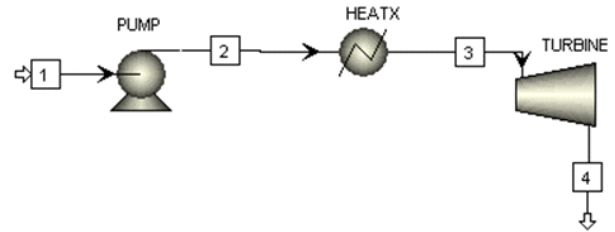

**Figure 2** Rankine cycle for direct expansion of liquid air

Liquid air contains a fairly large amount of exergy that can be converted into power. In Figure 3 the exergy content is given of saturated liquid air at 1 bar starting at 78K and being heated to a higher temperature. Clearly the exergy drop due to evaporation (at constant  $T=78K$ ) is very high. At the reference temperature of 298.15 K, the exergy drops to 0 and rises afterwards.

When the liquid air is isentropically compressed to a higher pressure, the evaporation takes place at a higher temperature (in Figure 3 10 bar, above 200 K). The corresponding exergy loss during evaporation is also smaller.

For the supercritical pressures no phase change occurs and the exergy is clearly higher (Figure 3 : 100 and 300 bar). Expanding this liquid will gain much more work.

The compression of the liquid air also takes some work, which reduces the net work produced by the cycle. In Figure 3. The dotted lines show the exergy available at the inlet of the turbine, minus the exergy added by the pump. This illustrates that the increase of the heat exchanger outlet exergy is to be attributed to the smaller exergy loss in the heat exchanger and not to the compression work. Using a Rankine cycle and going supercritical is thus an interesting technique.

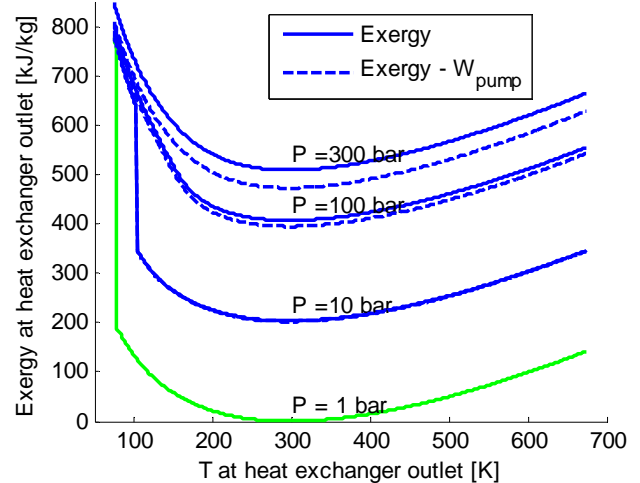

**Figure 3** Exergy of liquid air

### Energy production with the Rankine cycle

In order to evaporate the air in the Rankine cycle heat input in the boiler is needed. This leads to the definition of the cycle efficiency:

$$\eta_{rankine} = \frac{W_{turbine} - W_{pump}}{Q_{boiler}} = \frac{W_{net}}{Q_{boiler}} \quad (1)$$

Figure 4 shows that the efficiency for isentropic expansion is lower than for isothermal expansion in Figure 5. Isothermal expansion raises the average temperature at which heat is added, which improves the efficiency. However, it also increases the average temperature at which heat is rejected in the condenser, which is detrimental to the efficiency. Due to the low average condenser temperature this latter effect dominates. The efficiency of the Rankine cycle can reach up to just above 60%. Raising the temperature after the boiler has a positive influence on efficiency.

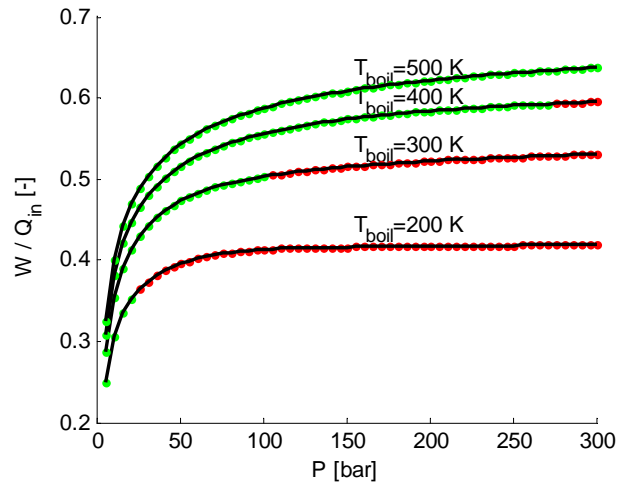

Figure 4 Rankine cycle efficiency for isentropic expansion

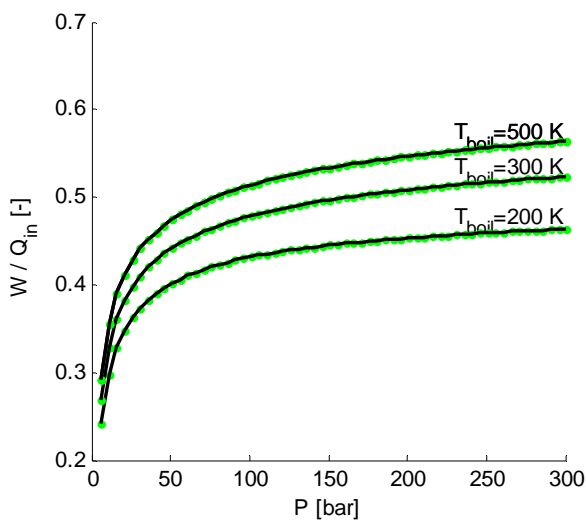

Figure 5 Rankine cycle efficiency for isothermal expansion

### Exergy conversion with the Rankine cycle

As liquid air has to be produced out of atmospheric air, the energy cost of liquefaction is not unimportant. Liquefaction is currently done in efficient plants, where about 1080 kJ of energy for each liquefied kg is needed [11].

In this paper the recovery efficiency is defined as the ratio of the net produced work to the exergy available in the liquefied air:

$$\eta_{recovery} = \frac{W_{turbine} - W_{pump}}{\text{Exergy of liquefied air}} \quad (2)$$

This parameter is 1 if all the energy of the liquefaction process is recovered after storage.

In a liquefaction process the cycle efficiency is defined as the ratio of the exergy of the liquefied product to the work needed to produce it [12]:

$$\eta_{liquefaction} = \frac{\text{Exergy of liquefied air}}{W_{liquefaction}} \quad (3)$$

The efficiency of the storage system is thus given by the storage efficiency, giving the ratio of the energy needed for air liquefaction to the net energy produced :

$$\begin{aligned} \eta_{storage} &= \frac{W_{net}}{W_{liquefaction}} \\ &= \frac{W_{net}}{\text{Exergy of liquefied air}} \frac{\text{Exergy of liquefied air}}{W_{liquefaction}} \quad (4) \\ &= \eta_{recovery} \eta_{liquefaction} \end{aligned}$$

The pump is assumed to be isentropic and for the turbine two cases are looked into: isentropic expansion and isothermal reversible expansion. No reheating is used.

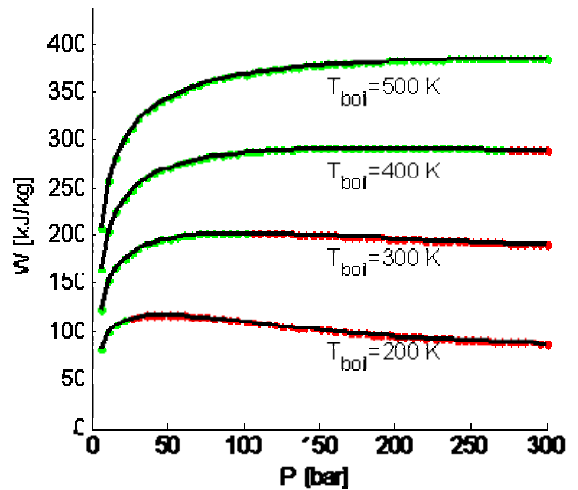

Figure 6 Net specific power produced for the Rankine cycle with isentropic expansion

In Figure 6 the net produced specific work is given for the Rankine cycle with isentropic expansion. Raising the boiler exit temperature raises the work output. For pressure there is for

each temperature a clear maximum. The maximum storage efficiency is about 30% if 1080 kJ/kg is used as the reference work needed for liquefaction.

For isothermal expansion (Figure 7) the produced work can be much higher. In this case the work goes up with pressure and temperature. The storage efficiency of the cycle is maximally about 60%. During isothermal expansion heat is transferred to the air.

This limited analysis shows that even with isothermal expansion the work needed for liquefaction is still a lot more than the energy recovered out of the expansion of the liquefied air. So, suggestions of combining liquefaction with expansion (and using heat recovery between the cycles), are made by different authors [10, 13].

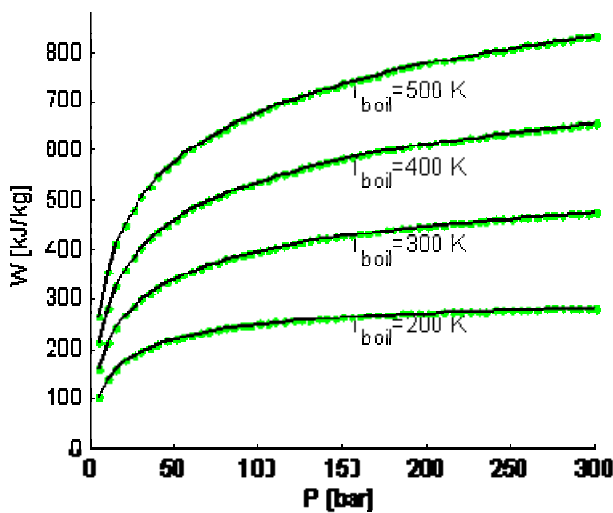

Figure 7 Net specific power produced for the Rankine cycle with near isothermal expansion

### COMBINED RANKINE AND LIQUEFACTION CYCLES

A possible combination of in essence a Linde-process with a Rankine cycle is given in [10] and in Figure 11.

From a cryogenic storage tank (5) liquid air I pressurized. This air is heated in a recovery heat exchanger (7-8) and in a heater using externally provided heat (8-9). Then the air is expanded over a turbine (9-10). This is in essence the classical Rankine cycle.

The second mass flow is fresh air being taken in, and being liquefied (Linde process) [12]. This air is first compressed (1). The air is then cooled down in Heat Exchangers 1 and 2, transferring heat to the (liquefied) air in the other cycle. After throttling this cooled down air is brought in the liquid/gas region of air (below critical point) and then separated. The saturated gas flow is evacuated in (6) and cools down the fresh air. An additional liquid air feed is added, because in most operational point not enough liquid air is produced to balance the cycle. In Figure 9 a T-s diagram is given of the combined cycle. The work produced in the Rankine cycle does not depend on the energy input through the liquefaction process. The

liquefaction only slightly differs from the classical Linde process, as now also liquefied air is used for cooling down fresh air before expansion. For liquefaction some of the exergy loss of the Rankine cycle is thus used.

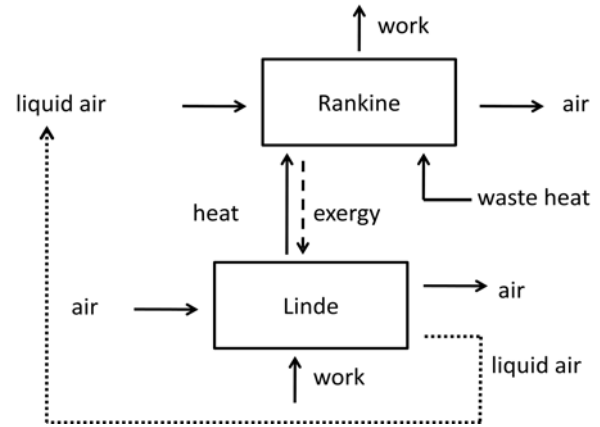

Figure 8 Exergy transfer between Rankine – liquefaction cycle

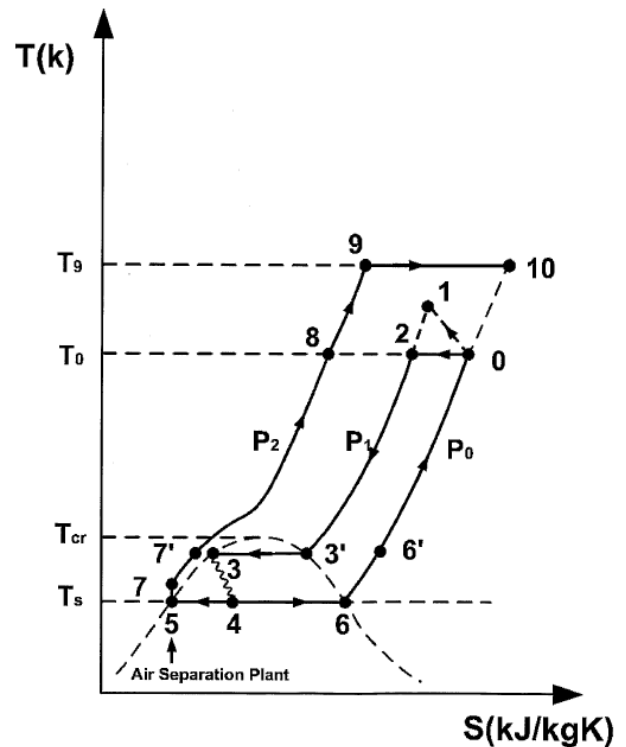

Figure 9 T-s diagram of Combined Rankine – liquefaction cycle [10]

Neglecting the exergy of the heat input in compressor, turbine and heat exchangers, the exergetic efficiency of the Rankine cycle is defined as

$$\eta_{recovery} = \frac{W_{turbine} - W_{pump}}{\text{Exergy of liquefied air}} = \frac{W_{net}}{\text{Exergy of liquefied air}} \quad (5)$$

The liquefaction efficiency is defined as

$$\eta_{liquefaction} = \frac{\text{Exergy of liquified air}}{W_{liquefaction}} \quad (6)$$

The combined cycle also produces liquid air. To produce this amount of liquid air, some compressor work  $W_c$  is needed. For the combined cycle the efficiency is thus given by :

$$\eta_{combined} = \frac{W_{turbine} - W_{pump} - W_{compressor}}{(1 - xy)W_{liquefaction}} \quad (7)$$

Where  $y$  is the fraction of fresh air that is liquefied and  $x$  is the ratio of fresh air supplied to the compressor to the air flow rate in the turbine.

The additional delivered work compared to the Rankine cycle, combining eq (5) and (7).

$$W_{add} = \frac{\eta_{liquefaction} \eta_{cycle} \text{Exergy of liquified air} - W_c}{1 - \eta_{liquefaction}} \quad (8)$$

This expression shows that for constant compressor work and constant production of liquid air, the combined cycle performs better with respect to the Rankine cycle as the exergetic efficiency of the Rankine cycle is better. When the work obtained by expanding the produced liquid air becomes equal to the compressor work required to produce this air, the combined cycle performance is equal to the Rankine cycle performance.

For a standalone isothermal Rankine cycle, e.g. working at between 1 bar and 100 bar at 400K, the exergy loss due to heat transfer is equal to 352 kJ/kg.

The combined cycle recovers 180.4 kJ/kg while the rest is destroyed during the transfer process. For these conditions about half of the exergy loss during heating of the simple Rankine cycle can be recovered in the Linde cycle, as is illustrated in Figure 10.

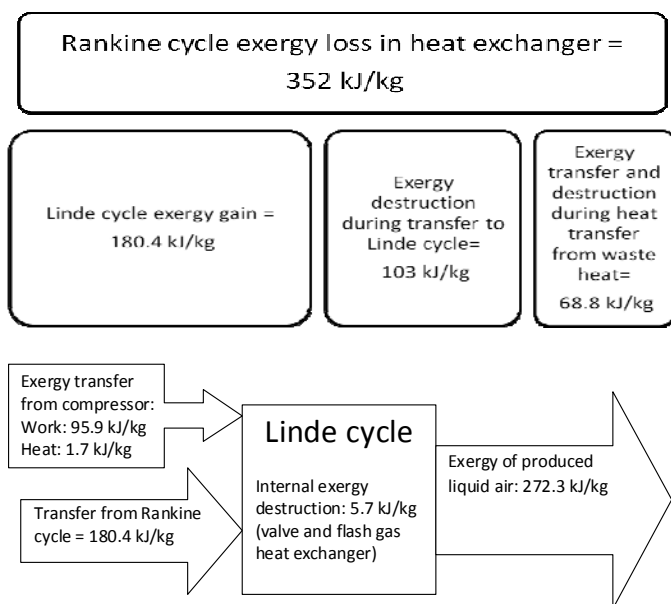

**Figure 10** Combined Rankine – liquefaction cycle, exergy recovery, example

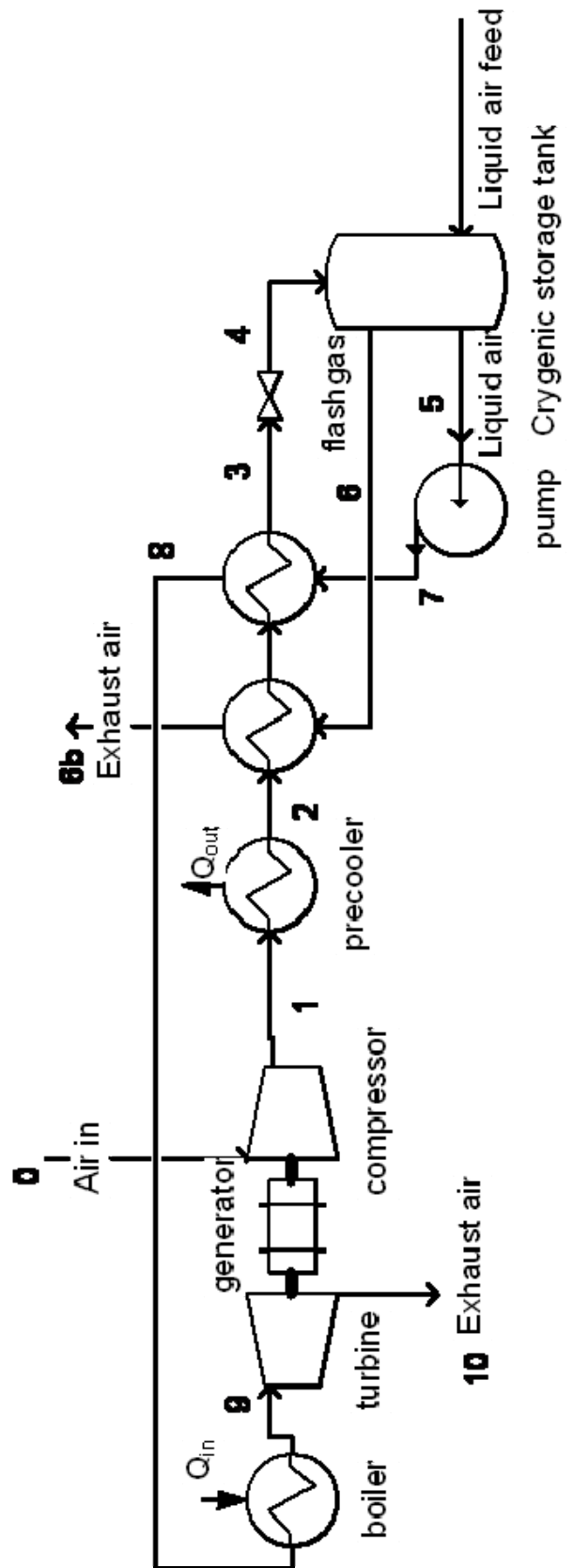

**Figure 11** Combined Rankine – liquefaction cycle

## COMBINED RANKINE AND LIQUEFICATION CYCLE MODEL

### Compressor

The compressor is modelled by an isentropic efficiency :

$$h_2 = h_1 + \frac{h_{2s} - h_1}{\eta_s} \quad (9)$$

### Turbine

For the turbine also an isentropic efficiency is used :

$$h_2 = h_1 + \eta_s (h_{2s} - h_1) \quad (10)$$

### Expansion valve

Throttling is given by :  $h_2 = h_1$  (11)

### Heat exchanger with two flows

The heat exchanger is modelled by the introduction of the effectiveness:

$$\varepsilon = \frac{Q}{Q_{max}} \quad (12)$$

With

$$Q_{max} = \min(\dot{m}_1 \Delta h_1, \dot{m}_2 \Delta h_2) \quad (13)$$

$$\Delta h_i = h_i^{in} - h_i^{out} (p_i, T_i) \quad (14)$$

### Heater

In the heater model the heat is determined to reach the desired exit entrance temperature for the turbine.

### Separator

The fluid in the separator is saturated at the atmospheric pressure. The flow rates of liquid and gaseous phase are given by :

$$\dot{m}_{vapor} = x \dot{m}_{air} \quad \dot{m}_{comp} = \dot{m}_{in} \cdot x_{in} \quad (15)$$

$$\dot{m}_{liquid} = (1 - x) \dot{m}_{air} \quad (16)$$

## SIMULATION RESULTS FOR IDEAL CYCLES

Cycle simulations were done with compression in the compressor to 20 bar, Rankine cycle working at 100 bar and superheating till 400 K. Compression was assumed to be isothermal, and the expansion is isothermal or isentropic. The heat exchanger effectiveness was set to 100 % and in a second analysis to 85%. This resulted in the T-S diagram given in Figure 12.

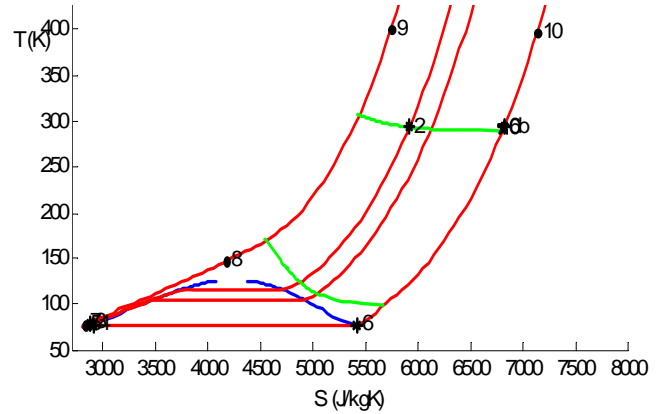

**Figure 12** T-s diagram of cycle simulations with  $\varepsilon=100\%$

The ratio (x) of the mass flow rate of the fresh air taken by the compressor to the mass flow rate of liquefied air taken by the turbine was varied in order to find the maximum efficiency of the cycle (see equation 7).

At low mass flow rates the fresh air after compression can be cooled in the heat exchangers to the temperature of liquefied air (if  $\varepsilon = 100\%$ ), or near to it ( $\varepsilon = 85\%$ ). As long as this is the case the liquefaction fraction y is fairly constant, about 95%. Raising mass flow rate under this condition, results in the production of more liquefied air. Work in the compressor and the turbine is linearly related to the flow rate. As this liquefied air can produce more work in the turbine compared to the work needed in the compressor, the net produced work will go up with raising x.

At a certain moment raising x will result in no longer cooling down the fresh air sufficiently, i.e. close to the saturation temperature. From that point on, the production of liquefied air goes down, resulting in a net power loss. So an optimum x exists.

**Table 1** Simulation results

	Isothermal expansion	Isentropic expansion
$\varepsilon = 100\%$	$\eta = 63.7\%$ $W = 693 \text{ kJ/kg}$ $x = 36.8\%$ $y = 97\%$	$\eta = 27.7\%$ $W = 299 \text{ kJ/kg}$ $x = 36.8\%$ $y = 97\%$
$\varepsilon = 85\%$	$\eta = 55.0\%$ $W = 596 \text{ kJ/kg}$ $x = 36.8\%$ $y = 70.0\%$	$\eta = 26.6\%$ $W = 287.2 \text{ kJ/kg}$ $x = 0$ $y = -$
Simple Rankine cycle	$\eta = 50\%$ $W = 538.4 \text{ kJ/kg}$	$\eta = 26.6\%$ $W = 287 \text{ kJ/kg}$

In Table 1 the results are given. A stand alone Rankine cycle at 100 bar and 400 K, with isothermal expansion would yield 542 kJ/kg work. This is a recovery efficiency of 50 %. The combined cycle with 85% heat exchangers effectiveness is only gaining 5 % points in efficiency. In the simple Rankine cycle



the exergy destruction/losses through heat transfer is 352 kJ/kg. In the combined cycle 229.3 kJ/kg of exergy can be transferred to the liquefaction process for  $\epsilon=100\%$ . The combined cycle can produce liquefied air at a cost of compression work of 103.5 kJ/kg, while otherwise this work input would be 281 kJ/kg, a net gain of 177.5 kJ/kg.

For an isentropic expansion the cycle efficiency goes down. For a heat exchanger effectiveness of 85% the optimum mass flow rate of fresh air was found to be 0. No gain can be made compared to the simple Rankine cycle. With perfect heat exchangers this gain is only 1% points at 20 bar.

If the work produced out of liquefied air goes down, the relative importance of producing liquid air by the cycle itself goes down. If this liquefaction process and the heat recovery between the cycles is less efficient, there is a point where the gains of producing liquefied air are 0.

For the mass fraction of compressed air  $x$  low enough, the heat capacity of the fresh compressed air stream limits the amount of transferred heat per unit of mass. The pinch point is at the heat exchanger exit, the compressed air exists subcooled (Figure 13 (a))

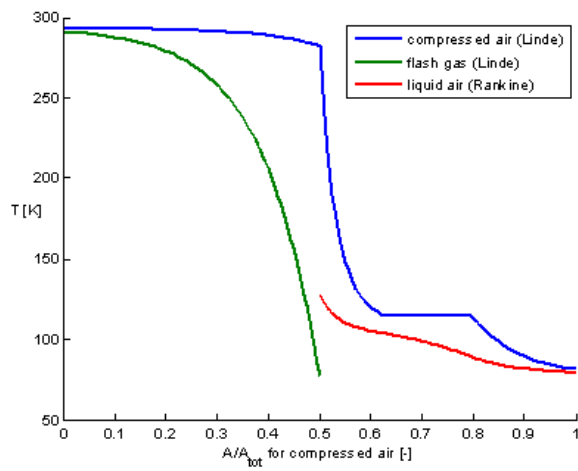

(a)

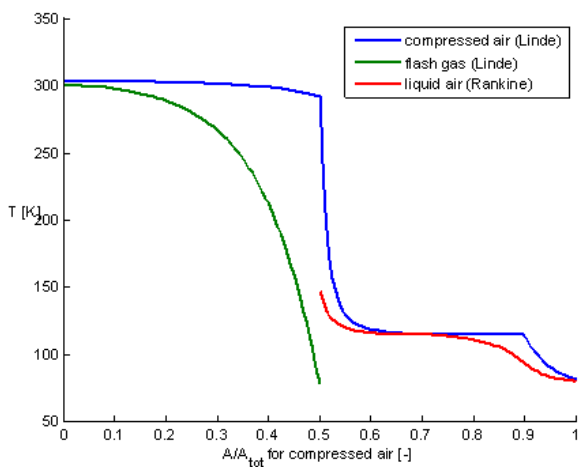

(b)

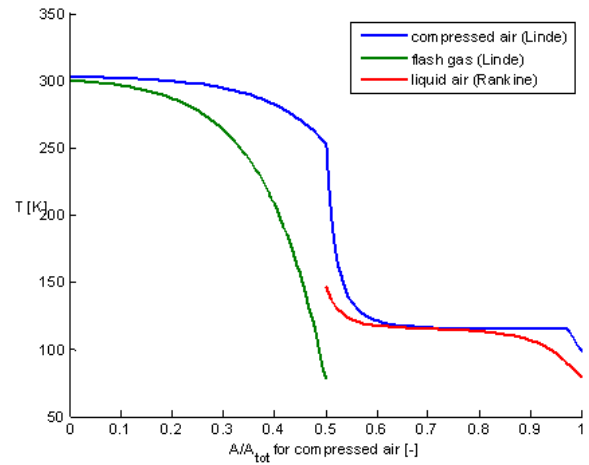

(c)

**Figure 13** Temperature profiles through the heat exchangers

When  $x$  is increased, more heat is transferred. This is visible in the exit temperature of the liquid air stream, which has a constant mass flow rate. A higher exit temperature at constant mass flow corresponds to a larger amount of heat transferred. This means the temperature profile of the liquid air stream approaches the temperature profile of the compressed air stream (Figure 13 (b)). When a critical  $x$  is reached, the two temperature profiles touch in a pinch point, due to the saturation temperature plateau of the compressed air stream. Since the outlet condition remains constant, the amount of heat transferred per unit mass is also constant.

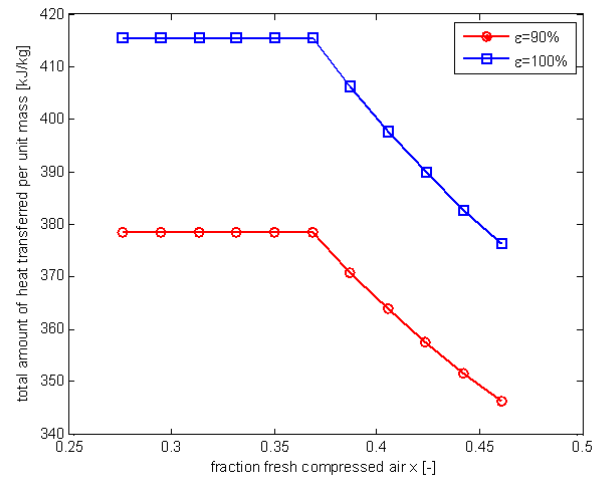

**Figure 14** Heat transferred between the cycles for different heat exchangers effectiveness

When  $x$  is further increased, the total transferred amount of heat transferred to the liquid air of the Rankine cycle is approximately constant, limited by the pinch point. The location of the pinchpoint in the interior of the heat exchanger moves in function of  $x$ , and a change in  $x$  also has a

consequence for the entrance temperature of the compressed air stream when it comes into thermal contact with the liquid air stream. This change in  $x$  also affects the heat transferred to the flash gas. These three effects cause further variations in total transferred heat in function of  $x$ . Still, the total transferred heat per unit of mass decreases, which means increased exit enthalpy for the compressed air stream. The heat exchanger exit is no longer a pinch point (Figure 13 (c)).

This behaviour of the heat exchanger has direct ramifications on the produced quantity of liquid air (Figure 14). As the exit enthalpy of the compressed air stream increases, the vapor fraction after expansion also increases. This corresponds to a smaller liquefied fraction of the compressed air stream. As  $x$  increases, this fraction  $y$  decreases. However, the total amount of produced liquid air as a fraction of the Rankine cycle mass flow is equal to the product of  $x$  and  $y$ .

The vapour fraction  $y$  is equal to

$$y = \frac{(h_3 - h_f(1 \text{ bar}))}{h_g(1 \text{ bar}) - h_f(1 \text{ bar})}$$

Here  $h_3$  is the exit enthalpy after both heat exchangers.

$$h_3 = h_2 - \frac{Q_{\text{tot}}}{\dot{m}_{\text{compressed air}}}$$

As long as the total removed heat per unit mass is constant, the exit enthalpy is constant. This means the fraction  $y$  is constant, and hence the total fraction of produced air varies linearly with  $x$ . When the critical value of  $x$  is reached, the total heat transfer per unit mass decreases almost linearly with  $x$ . This means  $y$  will also approximately linearly decrease with  $x$ , so the total produced liquid fraction will be approximately constant.

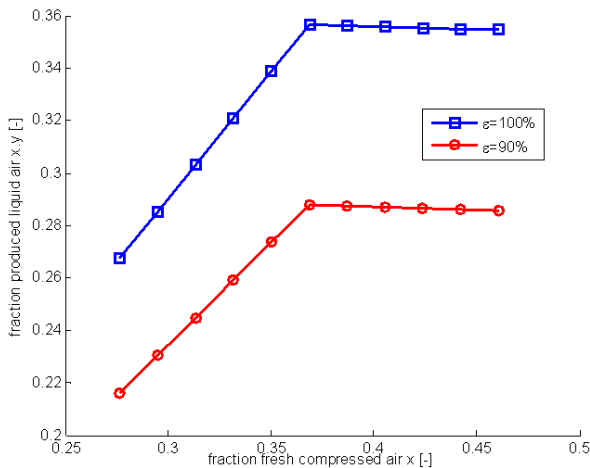

Figure 15 Relation between produced liquid air and delivered fresh

For a smaller than unity heat exchanger effectiveness, the actual heat transferred is a fraction of the maximal possible heat transfer. Apparently, the inlet condition of the compressed air

when it comes into thermal contact with the liquid air is not important for the critical value of  $x$ . This is because the internal pinch point is determined by the temperature profile of the liquid air stream and the saturation temperature of the compressed air. The inlet conditions of the compressed air stream only affect the temperature profile of the liquid air stream for the area where the compressed air stream is still single phase. The critical  $x$  is hence independent of the inlet conditions after heat exchange with the flash gas stream, and hence independent of the heat exchanger effectiveness.

To conclude, for pressure levels where the total heat transfer is limited by the internal pinch point, the total fraction of produced liquid air increases with  $x$  up until a critical value, and then remains approximately constant. This is valid for all values of the heat exchanger effectiveness, and this critical value of  $x$  is independent of the heat exchanger effectiveness.

The additional work compared to the Rankine cycle is given in (8). The optimal  $x$  is 0 if the numerator is negative. The Rankine cycle performs better than the combined cycle. If the numerator is positive, it increases with  $x$ . The denominator decreases with  $x$ , as long as  $x$  is below the critical value. When the critical value is surpassed, more compression work is needed due to the increased mass flow, even though the total fraction of produced air remains constant. From this analysis it is clear that the optimal  $x$  will be equal to the critical  $x$ .

This optimal value of  $x$  is caused by the internal heat exchanger pinchpoint. It is determined only by the liquid air condition after compression by the pump and by the saturation temperature of the fresh compressed air stream.

## PARAMETER ANALYSIS OF THE IDEAL CYCLES

In this part of the paper the effect of varying the operational conditions of the liquefaction process is studied. The Rankine cycle works again with isothermal expansion at 100 bar and 400 K, producing 542 kJ/kg .

### Compressor pressure, isothermal compression

For isothermal compression the cycle efficiency and net power output go up with compression ratio of the fresh air compressor as shown in Figure 16 and Figure 17. For lower heat exchanger effectiveness the net work output gain with compression pressure is lower.

The compressed air is cooled down in the second heat exchanger, transferring heat to the liquefied air of the Rankine cycle. In Figure 13 the temperature profiles of these two flows are shown for different cases. The heat transfer is limited by the saturation temperature of the compressed air (pinch point). If exit temperature of the liquid air is higher, more heat can be absorbed from the liquefaction process, resulting in more exergy transfer to the Linde cycle. This results in more liquid air production.

If the saturation temperature of the fresh air goes up (by raising the pressure of the air), the heat transfer from the liquefaction process goes up, resulting in more liquid air production. This effect is non-linear as the pinch point position moves inside the heat exchanger.

Note that the compression work goes up with compression ratio. The optimal point may thus no longer be with the



maximum amount of fresh air, in case the compression work goes up more rapidly than the liquid air production goes up.

Finally the work delivered by the Rankine cycle has to be considered. In eq. (8) the difference is made between work delivered and work needed by the compressor. If the work of the Rankine cycle is low, the work raise of the compressor is of more importance.

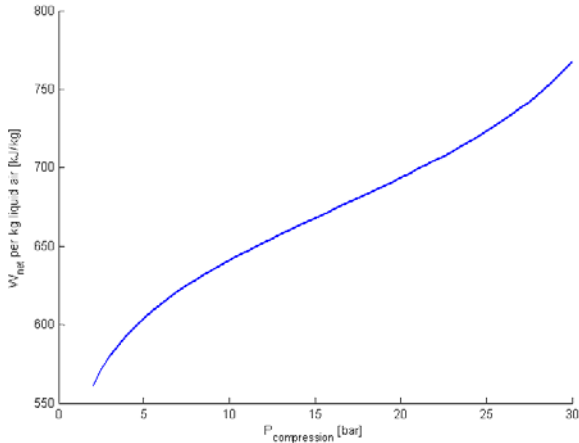

**Figure 16** Net work output for  $\epsilon = 100 \%$ , isothermal compression

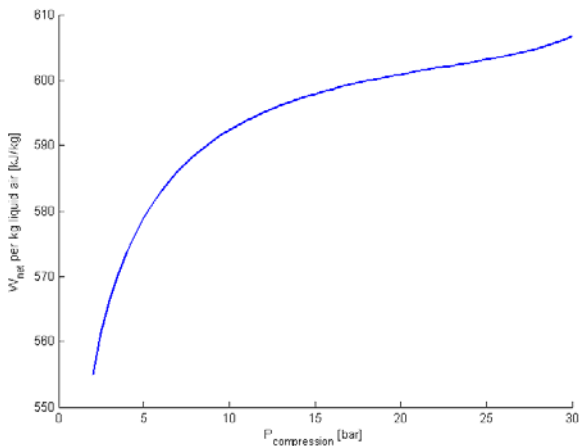

**Figure 17** Net work output for  $\epsilon = 85 \%$ , isothermal compression

### Compressor pressure, isentropic compression and adiabatic compression

For isentropic compression more energy is needed than for isothermal compression. Work also goes up more rapidly with compression pressure. In Figure 18 a clear optimum compression ratio can be seen. Net work output is also always lower than for isothermal compression.

Raising the temperature of the Rankine cycle gives higher net work output, but the maximum occurs now at higher

pressure. This is because the work output van de Rankine cycle is higher at higher temperatures, and so higher compression work is allowed.

Calculating the compression with an isentropic efficiency (here 88%) reduces the net work output even more and brings the optimum compression ratio down. With an isentropic efficiency of 88%, the net work output of the combined cycle is equal to the output of the Rankine cycle (542 kJ/kg) at about 26 bar. From then on, the mass flow rate of fresh air is 0 and the work output is independent of the compression ratio.

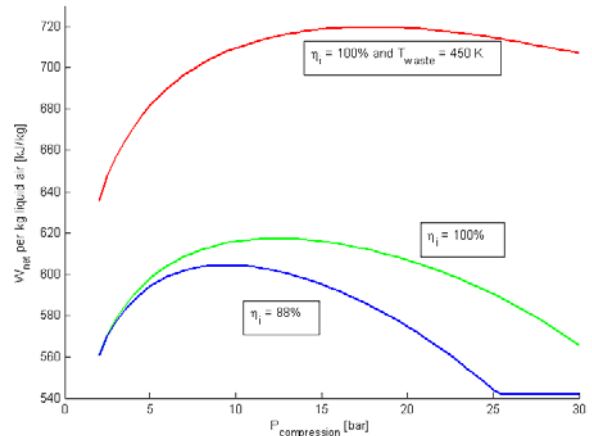

**Figure 18** Net work output isentropic compression

### Cycle with 'realistic' parameter assumptions

A final analysis is made with more realistic cycle settings:

- Rankine cycle at 100 bar, 1 reheat at 10 bar
- Heat exchanger effectiveness of 90%
- Turbine and pump an isentropic efficiency of 86%

The pressure at the exit of the compressor is varied from 2 to 20 bar and the heating temperature in the Rankine cycle from 400 to 800 K.

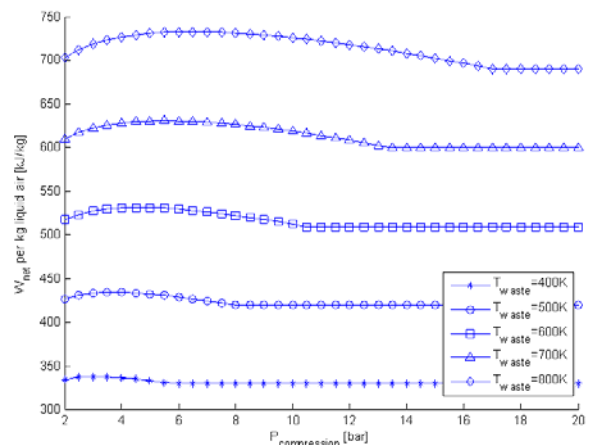

**Figure 19** Net work output for non-ideal cycle

Figure 18 shows that for each temperature there is a optimum pressure. This pressure is relatively low, because the Rankine

cycle has a lower power output. Once the work output stops going down, fresh air intake reaches 0. This is the work output of the simple Rankine cycle. Combined cycle work output is not much better (< 10% points). Even at 800K the efficiency of the cycle is only 70%.

## COMBINED CYCLE FOR LIQUEFACTION

In principle the combined cycle could also be used to produce liquid air, by not feeding any liquid air to the Rankine cycle. However, from Figure 18 and Figure 19 is apparent that the optimal pressure for the Linde part of the combined cycle is quite low, in the order of 10 bar. For these pressures the Linde cycle for producing liquid air is not feasible [12].

## CONCLUSION

Energy storage through liquefaction of air seems to be an interesting option in a world with a larger share of renewable energy production.

Several cycles have been proposed to do this with waste heat. A combined cycle was patented.

Thermodynamic analysis shows that the performance of the ideal cycle is not high. If liquefied air is stored, the energy can only be recovered with an efficiency of 50% in a Rankine cycle and with 64% in a combined cycle.

The cycle is very sensitive to the heat exchanger effectiveness and the efficiency of the compressor and turbine.

In case of a combined cycle with isothermal compression and expansion 70 % can be reached.

## REFERENCES

- [1] A. F. Ghoniem, "Needs, resources and climate change: Clean and efficient conversion technologies," *Progress in Energy and Combustion Science*, vol. 37, pp. 15-51, Feb 2011.
- [2] EU, "EU Climate and Energy package," [http://ec.europa.eu/climateaction/docs/climate-energy\\_summary\\_en.pdf](http://ec.europa.eu/climateaction/docs/climate-energy_summary_en.pdf), 2008.
- [3] H. Ibrahim, A. Ilinca, and J. Perron, "Energy storage systems - Characteristics and comparisons," *Renewable & Sustainable Energy Reviews*, vol. 12, pp. 1221-1250, Jun 2008.
- [4] E. E. P. R. Institute, "Electricity Energy Storage Technology Options A White Paper Primer on Applications, Costs and Benefits," *1020676 Final Report, December 2010*, 2010.
- [5] H. S. Chen, T. N. Cong, W. Yang, C. Q. Tan, Y. L. Li, and Y. L. Ding, "Progress in electrical energy storage system: A critical review," *Progress in Natural Science*, vol. 19, pp. 291-312, Mar 2009.
- [6] E.-E. P. R. Institute, "EPRI Energy Storage Handbook," 2002.
- [7] J. Brouwer, "On the role of fuel cells and hydrogen in a more sustainable and renewable energy future," *Current Applied Physics*, vol. 10, pp. S9-S17, Mar 2010.
- [8] Y. L. Li, H. S. Chen, and Y. L. Ding, "Fundamentals and applications of cryogen as a thermal energy carrier: A critical assessment," *International Journal of Thermal Sciences*, vol. 49, pp. 941-949, Jun 2010.
- [9] Y. L. Li, H. S. Chen, X. J. Zhang, C. Q. Tan, and Y. L. Ding, "Renewable energy carriers: Hydrogen or liquid air/nitrogen?," *Applied Thermal Engineering*, vol. 30, pp. 1985-1990, Oct 2010.
- [10] Y. D. H. Chen, T. Peters, F. Berger, . "A method of storing energy and a cryogenic energy storage system," *US patent*, 2007.
- [11] W. F. Castle, "Air separation and liquefaction: recent developments and prospects for the beginning of the new millennium," *International Journal of Refrigeration-Revue Internationale Du Froid*, vol. 25, pp. 158-172, Jan 2002.
- [12] G. Venkatarathnam, *Cryogenic Mixed Refrigerant Processes*, 2008.
- [13] J. Szargut and I. Szczygiel, "Utilization of the cryogenic exergy of liquid natural gas (LNG) for the production of electricity," *Energy*, vol. 34, pp. 827-837, Jul 2009.