

# REMANUFACTORY

THE TYPOLOGICAL INHERITANCE OF INDUSTRIAL ARCHITECTURE IN THE AGE OF DIGITAL CONSUMPTION

Claudia Filipe

Study Leader: Gary White  
Studio Co-ordinator : Arthur Barker

Submitted in partial fulfilment of the requirements for MArch( Professional) in the Faculty of Engineering, Built Environment and Information Technology at the University of Pretoria

## For my family

With appreciation and thanks to Dayle  
Shand, Gary White, Jacqueline Cuyler, Jhono  
Bennett, Isabel de Gouveia, Catherine Deacon  
Dominique Visser, Tom Nomico and Carin  
Combrinck.



# 00 ABSTRACT |

The dissertation investigates the design of an **electronic-waste material recovery facility** in the north western precinct of the inner city of Tshwane.

It aims to explore the re-configuration of the industrial typology within a contemporary network society, and make apparent it's changing role and form, influenced by a globalized industrial paradigm that is increasingly decentralized, immaterial and knowledge intensive.

It suggests a hybridity of type and process, where value in terms of the local and the material is investigated as an expression of the new industrial ethos of innovation, information access, collaboration and transparency.

# CONTENTS |

## PART 1

### PROBLEM EXPLORATION

#### 01 INTRODUCTION

- 1.1 POINT OF DEPARTURE
- 1.2 PROBLEM STATEMENT
- 1.3 HYPOTHESIS
- 1.4 RESEARCH METHODOLOGY
- 1.5 RESEARCH QUESTIONS
- 1.6 AIMS AND OBJECTIVES

#### 02 BACKGROUND

- 2.1 NEW INDUSTRIAL ETHOS
- 2.2 INDUSTRIAL URBAN INHERITANCE
- 2.3 THE INFORMATION AGE
- 2.4 A CHANGE IN VALUES
- 2.5 THE INERT URBAN OBJECT
- 2.6 CONCLUSION

#### 03 THEORY

- 3.1 A THEORETICAL SHIFT
- 3.2 ARCHITECTURE AND TECHNOLOGY
- 3.3 RECOMBINANT TYPES
- 3.4 ARCHITECTURE OF THE GLOCAL CONDITION

#### 04 CONTEXT

- 4.1 AN URBAN VOID
- 4.2 URBAN ANALYSIS
- 4.3 SOCIO-SPATIAL CONTEXT
- 4.4 CONTEXTUAL MAPPING
- 4.5 INDUSTRY AND URBAN POTENTIALS
- 4.6 PRECINCT FRAMEWORK
- 4.7 SITE INTRODUCTION

# PART 2

## DESIGN DEVELOPMENT

### 05 PROGRAMME

- 5.1 PROGRAMME REASONING
- 5.2 E-WASTE PROCESS
- 5.3 PIXELLATING THE PROCESS
- 5.4 PROCESS DIAGRAM
- 5.5 A GLOCAL PROGRAMME

### 06 PRECEDENT

- 6.1 INFORMATION AGE
- 6.2 INDUSTRIAL TRANSPARENCY
- 6.3 CO-WORKING SPACE
- 6.4 E-WASTE PROCESS

### 07 CONCEPT AND DESIGN DEVELOPMENT

- 7.1 CONCEPT
- 7.2 PROCESS REQUIREMENTS
- 7.3 DESIGN ITERATIONS
- 7.4 CONCEPT AND DESIGN DEV.1

- 7.5 CONCEPT AND DESIGN DEVELOPMENT 2
- 7.6 CONCEPT AND DESIGN DEVELOPMENT 3
- 7.7 INTERFACING A GLOCAL CONDITION
- 7.8 LAYERED SKIN
- 7.9 LIGHT AS MATERIAL
- 7.10 FINAL LAYOUT
- 7.11 SECTIONAL DEVELOPMENT
- 7.12 MASS AND FORM

### 08 TECHNICAL INVESTIGATION

- 8.1 TECHNICAL CONCEPT AND APPROACH
- 8.2 STRUCTURE
- 8.3 ENVIRONMENTAL

### 09 CONCLUSION

### 10 APPENDICES REFERENCES

CONTEMPORARY  
RELEVANCE +  
TYPE +  
THEORY +  
CONTEXT +

# PART 1

## DEFINING A PROBLEM

The first part of the dissertation describes the inception and development of the architectural brief, its contemporary relevance within the real world context, and its architectural impact on the industrial typology. It uses both an analytical and qualitative research method to inform the proposed design strategy.

# 01. INTRODUCTION



## 1.1 | POINT OF DEPARTURE

The dissertation is inspired by the post industrial landscapes of the former Witwatersrand mining belt and its spaces of capitalist consumption.

South Africa's economy was once largely based on primary industrial activity<sup>1</sup>. The spaces produced by its capitalism have resulted in an urban industrial inheritance of a "Shrinking City<sup>2</sup>", while simultaneously leaving a strong architectural and cultural inheritance.

The de-industrialization of these local towns and cities, becomes a lens for examining the value and role of the architectural products of industry today.

Industry is moving towards a more knowledge intensive cognitive economy<sup>4</sup> in parallel with a growing informal or micro industry sector, effecting both ways of manufacturing and spaces of production.

Should today's spaces of industry, suddenly de-industrialize, what would be the industrial architectural inheritance and value, if any, of a culture of immateriality, consumption and mobility?

|1| **PRIMARY INDUSTRY**  
INDUSTRY INVOLVED WITH THE EXTRACTION AND PROCESSING OF MINERALS FROM THE EARTH SUCH AS MINING.

|2| **SHRINKING CITIES**  
A TERM COINED BY X TO DESCRIBE CITIES WITH RAPID OUT MIGRATION AND SPRAWL, FOLLOWING DE INDUSTRIALIZATION, IN THE CASE OF SOUTH AFRICA.

|4| **COGNITIVE ECONOMY**  
A TERM COINED BY X TO DESCRIBE CITIES WITH RAPID OUT MIGRATION AND SPRAWL, FOLLOWING DE INDUSTRIALIZATION, IN THE CASE OF SOUTH AFRICA.



FIG. 1.1.1. COLLAGE BY X THOR (2012)



PRIMARY INDUSTRY

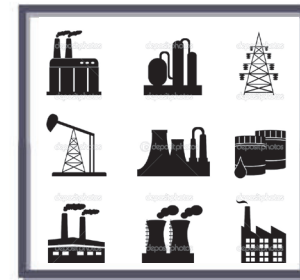
SECONDARY INDUSTRY

POWERVERSION  
MINING AGRICULTURE

PROCESSING  
MANUFACTURING



500x MSQ



10x MSQ



# SHRINKING PRODUCTIVE SPACE and INDUSTRY CHANGE

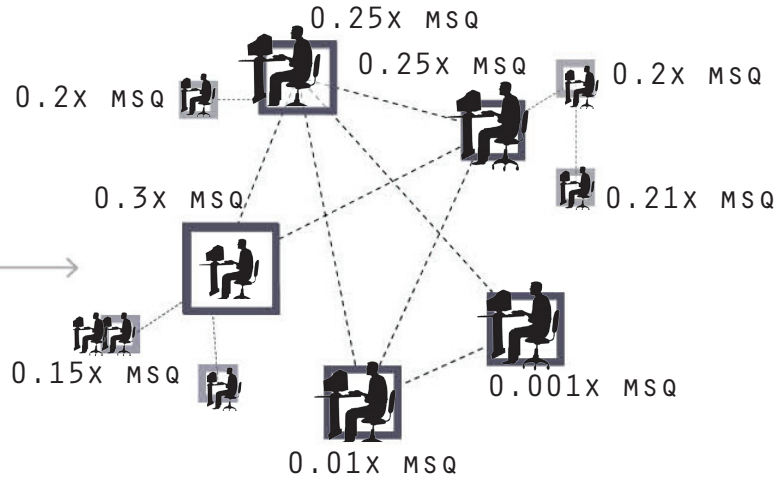
TERTIARY INDUSTRY

STORAGE  
SERVICES



X MSQ

QUARTERNARY INDUSTRY



INFORMATION

BETWEEN THE MATERIAL AND  
IMMATERIAL



FIG. 4. 4.

FIG.1 2 SHRINKING SPACE  
AND INDUSTRY CHANGES.  
AUTHOR 2012.

ADAPTED FROM MULTIPLE  
SOURCE. (SEE FIG.LIST)

## 1.2 | PROBLEM STATEMENT

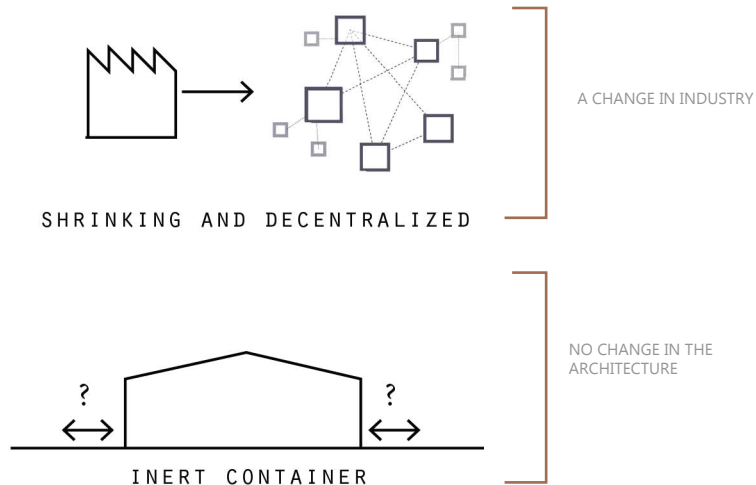
The architectural expression of the spaces of industry remain static and inert to their urban environments, in spite of the dynamic shifts in production modes, an emerging digital economy, and contemporary social and environmental values.

The role of the factory is changing and an expression of the new industrial ethos is investigated through the following problems:

A| The urban and architectural problem\_ the inert industrial object

B| A social problem\_ the disparities and opportunities generated by the Information Economy.

C| A cultural problem\_ Value of the material (the consumption patterns of global society) and immaterial ( local cultural value or significance within a particular context .)



THE LIGHT INDUSTRIAL  
ARCHITECTURE OF  
POST-INDUSTRIAL  
SHRINKING CITIES<sub>[1]</sub> AND  
AGGLOMERATIONS HAVE  
LITTLE INHERITANCE  
VALUE AND POOR URBAN  
QUALITY

Fig1.3.ARCHITECTURAL AND URBAN PROBLEM(AUTHOR 2012)

### 1.3 | HYPOTHESIS

It is proposed that an appropriate re-configuration and expression of the industrial typology in the “network society” is generated by the interfacing between the local and the global. It is in an enduring dialogue with its urban environment that spaces of industry can be of significance and value (social, cultural, economic) to the social contexts in which they are placed.

### 1.5 | RESEARCH QUESTIONS

1| Investigating the isolated nature of industrial space the dissertation questions the possibility and practical application of a durable civic or public element in a productive type|1|

2| Can the industrial type be reprogrammed and its spatial relationships challenged to integrate into existing contexts?|2|

3| What is the architectural expression and future heritage-value of industrial space and process in the age of digital consumption and to what extent is it influenced by the local?

3| How has the concept of value changed in industry, and the socio-cultural environment, on a local and global scale and what is the architectural and programmatic expression of that value?

4| What is the role of the temporary and the permanent in a digital economy of constant technological shrinkage and inevitable de-industrialization?

### 1.4 | RESEARCH METHODOLOGY

Data was obtained through both qualitative and analytical methods. The proposal made use of qualitative methods to investigate the social context and user needs and analytical methods informed by precedent study.

### 1.6 | AIMS AND OBJECTIVES

The study aims to make apparent the changing role and form of industrial space within urban environments in a dynamically changing global and local context, driven by the idea of value, transparency and collaboration.

The objective therefore is the re-configuration and spatial design of an industrial typology which:

- A. Plays an active and enduring urban role in its context
- C. Is an appropriate expression of the contemporary industrial ethos of the network.
- D. Generates value in process, product and its environment( ecological,social cultural), contemporarily and with time.
- E. Is shaped by both its local and global conditions and the interfacing between the two

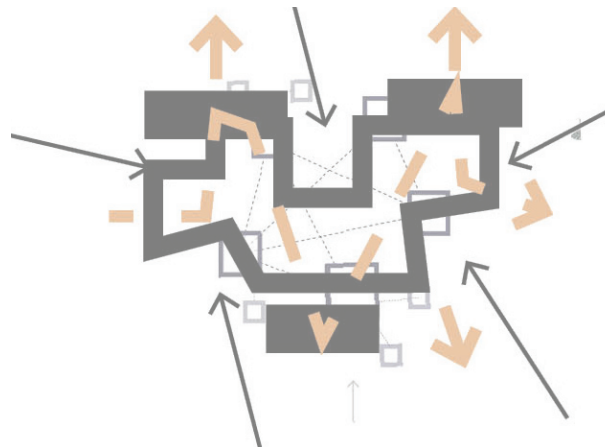


FIG.1.4

FIG 1.4.DIAGRAM  
INDICATING ARCHITECTURAL  
APPROACH.(AUTHOR 2012)

## 1.7 DELIMITATIONS

The investigation of the potentials of an alternative industrial space will not include adaptive reuse of an existing industrial site for the following reasons

A. The dissertation aims to investigate the role of industrial space in an active urban environments as a result of the decentralized potentials of the Information Age.

B. It tests the changing form and typological recombination of industrial space to serve a new purpose within a particular context.

The study of adaptive reuse of existing industrial buildings however reveals a condition of incubation, which will be used as a generator for design.

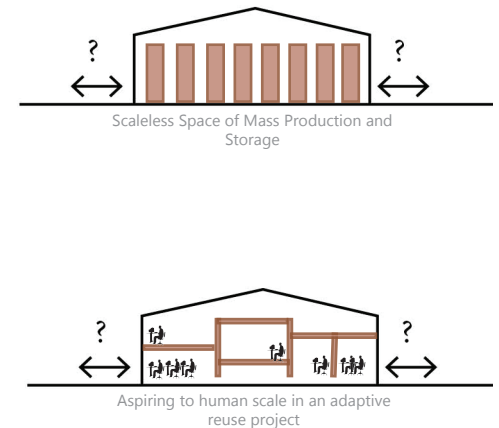


FIG.1.5.ADAPTIVE RE-USE OF LARGE SCALE INDUSTRIAL ARCHITECTURE(AUTHOR 2012)

## 1.8 | PROGRAMME

The programme is an electronics waste material recovery facility with a public interface which allows access to information and the use of information technology.

## 1.9 | CLIENT

The proposed client is a partnership between the E-waste Association of South Africa (EWASA) the Marabastad Community Development Forum and the Department of Social Development.

## 1.10 | LOCATION

The proposal is located on the corner of Eskia Mphahlele Street (formerly DF Malan Drive) and Johannes Rhamakoase Street (formerly Proes Street) within the North Western Precinct of Pretoria Innercity. The particular site adjacent to an existing skills training centre and cultural heritage site and a recycling crafts industry.

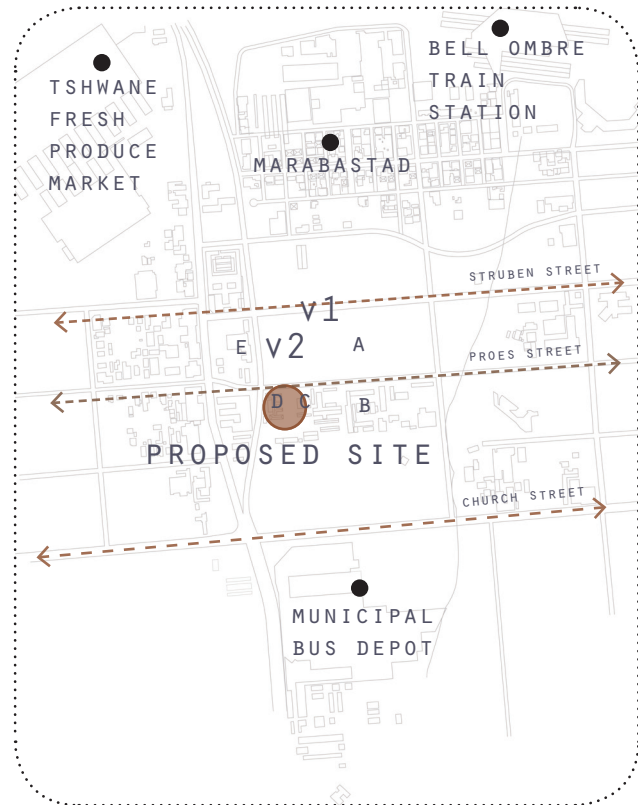


FIG 1.6

FIG 1.6. LOCALITY PLAN  
(AUTHOR 2012)



# 02 . BACKGROUND |

## 2.1 A NEW INDUSTRIAL ETHOS

The industrial building as a productive space and type is faced with significant changes in industry, energy, resources and programme as the economy progresses to an informational one and the micro-industry's role increases.

A contemporary surge for regional productivity, sustainability and flexible modes of production make existing industrial development models questionable in terms of their urban spatial impact, scale, social effects and resource consumption.

The physical built environment in which architecture finds its expression is rapidly changing, mutating and recombining, as a result of this transition in industry, described as the Third Industrial Revolution.

It is proposed that the industrial building type presents itself as an ideal vehicle for the testing of these new social, cultural and economic changes.

It embodies the expression of the process, is at the heart of resource consumption and energy generation, and conveys the extent of a social conscience in parallel with profit margins.

THE THIRD INDUSTRIAL  
REVOLUTION the merging  
of internet technology  
and renewable energies  
to create a powerful new  
infrastructure.

## 2.2 | INDUSTRIAL URBAN PATTERNS

The “Post -Industrial” is a term coined by sociologist Daniel Bell in 1976 , which predicted the informational economy , where trade in services and information supersede the manufacturing of goods.( Bell 1976 ).

The post-industrial presents a condition of plurality where the previous manufacturing paradigm is layered with the new industrial paradigm of the information age. ( Bell 1976)

### 2.2.1 | A PREVIOUS PARADIGM

The spatial implications of the decline of large manufacturing industries generated by Fordism<sup>6</sup> can be observed with the abandoned industrial infrastructure, lost space and outmigration of previously industrialized areas.

Phillip Oswalt ,theorist , architect and editor of the *Shrinking Cities Project* ( Oswalt 2008:4 ), conducted a global study of major cities to investigate the urban influences that create these post-industrial sprawling cities. Four processes were investigated.

De-industrialization and sub-urbanization of the four processes were studied in the cities of Detroit Michigan and Manchester in the UK. The former, a renowned motor industry, the latter a textile industry.

By examining density maps of these cities and their erased urban fabric in figure ground analysis, Brent D Ryan (2008), an urban researcher , was able to conclude (in the case of Detroit), that two major changes influenced the condition of the current urban fabric.

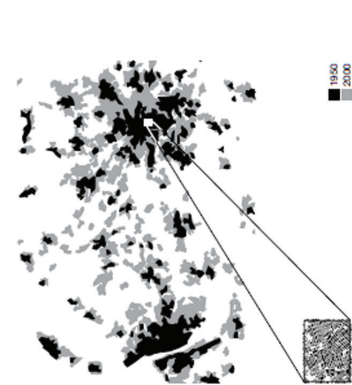
The first was the process of industrialization , which transformed small scale urban fabric into large scale super blocks. The second, the subsequent de-industrialization of the city, resulting in infrastructure decline ,abandonment and eventual mass demolition to accommodate large scale master planned regeneration schemes( Ryan 2008 : 9).

The density maps, of the former productive industrial cities illustrate the sprawling of the city from its core, with reduced legibility and street frontage .This urban industrial product is referred to as urban shrinkage.

Within the context of the dissertation the international examples serves to illustrate the spatial impacts (urban inheritance) of the social and economical forces generated by the presence of the previous industrial paradigm and its urban patterns.

FIG 2.1. (OPPOSITE)  
SHRINKING CITIES JAPAN.  
(OSWALT 2008). EXCERPT  
FROM THE SHRINKING CITIES  
PROJECT. INDICATING THE  
URBAN CONDITION OF THE  
POSTINDUSTRIAL

MANCHESTER/LIVERPOOL



FINE GRAIN URBAN FABRIC



LARGE SCALE AND  
FRAGMENTED



DECLINE AND DEMOLITION



ISOLATED LARGE SCALE DEVELOPMENT



DETROIT MICHIGAN



FIG 2.1.1

**TECHNOPOLE<sup>4</sup>**

"VARIOUS DELIBERATE ATTEMPTS TO PLAN AND PROMOTE, WITHIN ONE CONCENTRATED AREA, TECHNOLOGICALLY, INNOVATIVE, INDUSTRIAL RELATED PRODUCTION: TECHNOLOGY PARKS, SCIENCE CITIES, ... AND THE LIKE."  
(CASTELLS 1994:8)

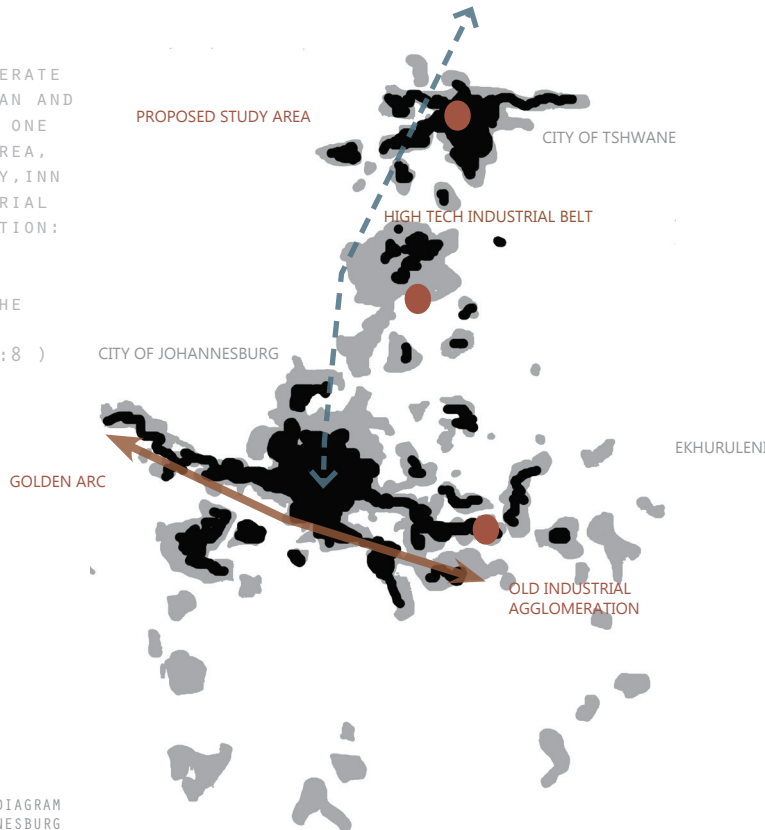


FIG.2.2.DENSITY DIAGRAM INDICATING JOHANNESBURG AND TSHWANE.(AUTHOR 2012)  
ADAPTED FROM JOHANNESBURG\_77.(WWW.MANDYFEHR8.TRIPOD.COM.ND)

## 2.2.2 | THE LOCAL POST-INDUSTRIAL URBAN CONDITION

Adapting the *Shrinking Cities*'(2008) method of analysis of the industrial city, the density map of Pretoria and Johannesburg illustrate the growth of one megacity, along the proposed "technological corridor" of the N1 highway.

A figure-ground analysis of Johannesburg's old and biggest industrial and manufacturing agglomeration along the "Golden Arc" (Fig 2.4), illustrates the lack of civic character and legibility within large scale urban fabric.

Currently a portion of the high- tech industrial corridor along the N1 highway ( Fig 2.5 ), illustrates recent trends for the development of "technopoles"<sup>4</sup>, and industrial parks as the emerging spaces of an innovation based industry.

The proposal suggests that the urban condition of productive space both in the previous paradigm and emergent industry does not address or play an active role in it's urban setting. The former, in its large scale privatization, and the latter in an isolated campus typology.

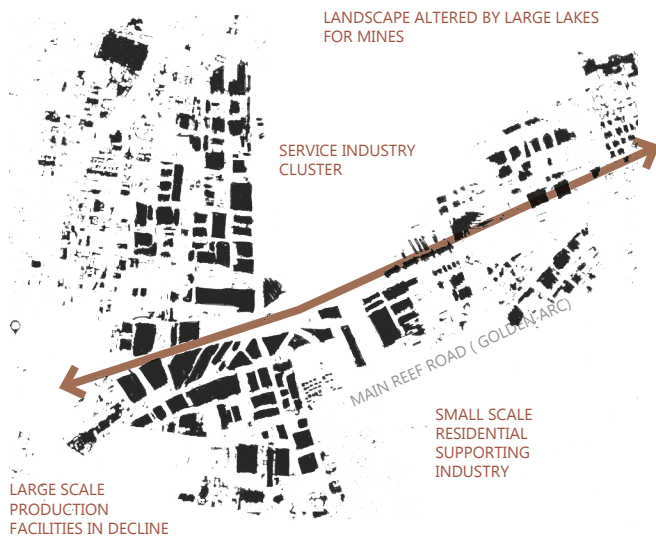


FIG.2.3 FIGURE GROUND ANALYSIS OF EAST RAND INDUSTRIAL AGGLOMERATION (AUTHOR 2012)

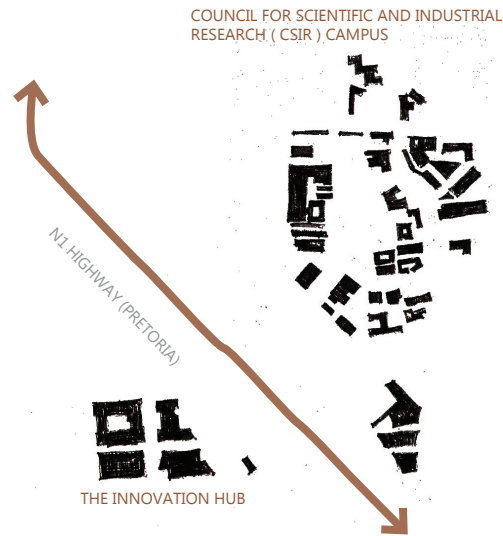
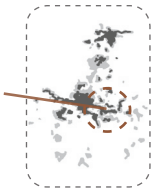


FIG.2.4.FIGURE GROUND ANALYSIS OF TECHNOPOLE CLUSTER, PRETORIA, SOUTH AFRICA.(AUTHOR 2012)

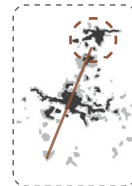
“GROWTH IN ONE AREA MEANS SHRINKAGE AND DECLINE IN ANOTHER”

Oswalt (2008) on Shrinking Cities



SHRINKAGE AND DECLINE(2012)\FIGURE GROUND ANALYSIS OF MAJOR INDUSTRIAL AGGLOMERATION IN THE EAST RAND ALONG MAIN REEF ROAD ILLUSTRATING THE LARGE SCALE INDUSTRIAL FABRIC AND URBAN FRAGMENTATION.

Fig.2.3



GROWTH AND DEVELOPMENT(2012)|THE DENSITY DIAGRAM INDICATES A TECHNOPOLE, AS DESCRIBED BY CASTELLS ADJACENT TO A MOBILITY SPINE (HIGHWAY).

Fig.2.4

## 2.3 | THE INFORMATION AGE

The information economy marks a transition of value in business, from goods to services, and research and development activities that foster innovation in the other sectors of the economy, such as manufacturing.

Manuel Castell's remarked in *The Network Society* (1996:30), that information is to this revolution, what energy was to previous revolutions. "The "new industrial space"( Castell's 1996 : 417) will be "organized around flows of information that bring together and separate at the same time ( Castell's 1996; 424 )

The implications of that statement are finding relevance in the changing attributes of industry, and the emergence of technopoles today.

### 2.3.1 TRANSPARENCY, COLLABORATION AND THE NETWORK

Jeff Jarvis, a journalist, verbalises in *What would Google do?*(2009), the impacts of the information age in industry and business.

Using Google as a precedent, he illustrates a transition in industry in which growth and success can be attributed to a new public nature, transparency and linking into a network, of collaboration and conversation.(Jarvis 2009

:55)

### 2.3.2 SMALLER IS BETTER

"The new economy is a small one. A tiny start start-up can become a manufacturing company using somebody else's factory and distribution while selling to a world-wide market that can find its products via Google". (Jarvis:2009:54). The "democratization of computers"( Boutang 2001 : 76), has resulted in reduced start up costs of micro, small and medium enterprises, and a rise of flexible niche industries.

### 2.3.3 THE CLOUD, PLUG POINTS AND WIFI

Similarly technology, is physically reducing in size, becoming smarter and smaller, as time passes on.

Cloud computing, offers a virtual collaborative environment where processing power is shared in an immaterial context: a shared resource, reducing unnecessary capital costs and infrastructure, but also potentially contributing to the cloud. The internet and digital production, results in an office being defined by the availability of network and power. (Fig Ref)

### 2.3.4 THE DIVISION OF LABOUR

8 DIGITAL DIVIDE  
PERCEIVED GAP BETWEEN  
THOSE THAT HAVE ACCESS TO  
THE LATEST TECHNOLOGIES  
AND THOSE WHO DO NOT" ( COMPAINÉ (2001 :198)





FIG.2.5



FIG 2.6

FIG.2.5. GOOGLE NETWORKING EVENT SHARING IDEAS (WWW.BUSINESSBECAUSE.COM)

FIG.2.6. THE SHARED VIRTUAL RESOURCE OF CLOUD COMPUTING. (WWW.DYNAMIC-METHODS.COM.N.D)



FIG-2.7 TRUTH CAFE ( 2013)

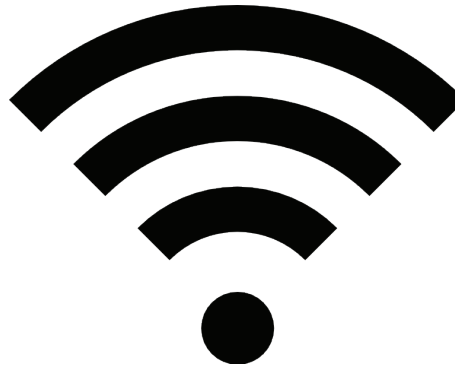


FIG2.8

FIG.2.7 TRUTH CAFE CAPE TOWN. FREE WIFI, LARGE TABLES AND CHARGING SPACE FOR LAPTOPS AND MOBILE DEVICES. ( HALDARE 2013)

FIG.2.8. WIFI AS NEW ACTIVATORS OF SOCIAL SPACE



### 2.3.5 SMART INDUSTRIES

Simon Roberts a South African chief economist defines smart industry as “any industry where the application of technology is important for production, and where firm performance depends on the on going development of production capabilities ( Roberts 2006: 86). Roberts states that “all industries are potentially smart”(2006:77).

Therefore, technological upgrading of existing industries has the potential to be “smart”, and link into the “space of flows.”

### 2.3.6 INDUSTRIAL DISTRICTS AND INNOVATION SYSTEMS

Industrial districts are characterised by the “concentration of specialized industries in particular localities.”( Alberti(2000:2) citing Marshall 1922) .It is a bottom up industrialization model that is strongly socially embedded.

With the fall of the Fordist model of production, the industrial district model of local industry presented a resilient typology to massive economic change.( Alberti 2000)

Lynn Mytelka( 2000 : 35),an economist studies the transition from industrial clusters to innovation systems. The author attributes this to an increasing knowledge intensity of production and global innovation based competition.

The studies reveal the lack of constructed technopoles’ and industrial parks’ potential to create innovative systems, because of the lack of interaction, of different actors at all levels in industry.

Similarly informal clusters, while possessing potential, are fragile through lack of infrastructure, training and information access to support the research and development needed for an innovation system and dynamic growth ( Mytelka 2000)

In a discussion of “The Digital Divide”, Compaine ( 2000; 198 ) describes access to information technology as access to the tools of learning and prosperity.

This view is supported by Boutang (2001;79), who states that in order to learn , innovate and transform material in the emerging paradigm, one must have hardware, software,wetware(human thinking) and netware, working in collaboration.

### 2.3.7 “COMPUTER VILLAGE”, LAGOS, NIGERIA

Computer Village, in Lagos Nigeria is a popular case study illustrating the growing importance of information and communications technologies within the informal sector, and an example of a locally embedded and bottom up innovation system ( Mytelka 2000 : 37 )

Situated in the Ikeja district , the precinct is famous for the clustering of small enterprises dealing with the sales and repair of new and second hand technology. The result is a dynamic market environment, activating the street.

AN INNOVATION SYSTEM  
IS THE INTERACTION  
PROCESS BETWEEN A  
NETWORK OF FIRMS

(MYTELKA 2000)



FIG.2.9

FIG 2.9.COMPUTER VIL-  
LAGE NIGERIA.WILL  
CONNOR 2009.(WWW.NIGE-  
RIAVILLAGESQUARE.COM)



FIG 2.8

FIG 2.10.  
COMPUTER VILLAGE  
IKEJA, LAGOS, NIGERIA.  
BUSTLING INFORMAL MOBILE  
AND COMPUTER CLUSTER.  
(HTTP://JIDEODUKOYA.COM)

## 2.4 | A CHANGE IN VALUES

### 2.4.1 CONSUMPTION PATTERNS AND CHANGE

Mitchell, J(1995:5) describes the consumption patterns of the electronic information age as a “darwinian environment”, where the aspiration for the new and better, means that “superseded carcasses” ( Mitchel 1995:5 ) unable to adapt are thrown away. Mobs ( 2010 :11 ) describes it as a “culture of obsolescence.”

Parallels in the built environment can be observed in the manner in which the post-industrial shift in economy resulted in large scale urban blight and decline and the urban environment a means of expediency.( Gissen 2010:1 )

However, in the light of sustainability concerns and an emerging “green economy” (UNEP n.d) there is a global questioning of value, and the reassigning of value to materials, processes and objects previously deemed as waste.

### 2.4.2 VALUE IN INDUSTRY

In industry the concept of “value-adding sectors” are those which have high growth multipliers and high employment rates.( IPAP 2010). The Department of Trade and Industry describes these value-adding industries as the “manufacturing industries of the green economy.”(

IPAP 2010).

In terms of process, there has been a shift from mass production to lean manufacturing and manual value adding processes , which aim at reducing material usage and increasing skills based tasks.

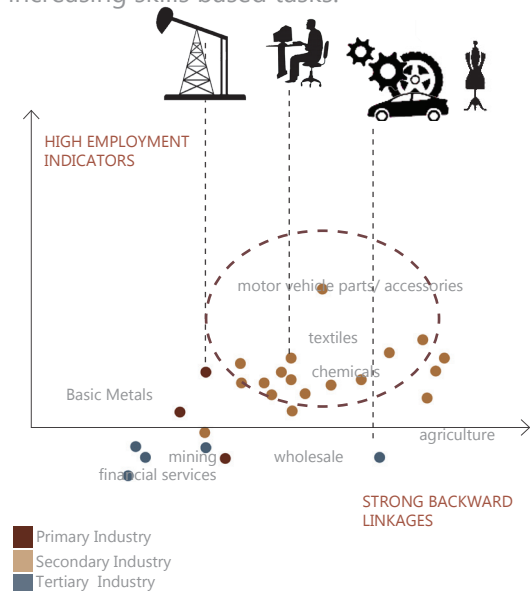


FIG 2.11. GRAPHIC ILLUSTRATION OF VALUE-ADDING INDUSTRIAL SECTORS. ( AUTHOR 2012)

ADAPTED FROM ( IPAP 2010:10)

FIG 2.11

### 2.4.3 VALUE PRODUCING NEW TYPES

Interest in new industries ,processes and the value of information has generated architectural needs for appropriate productive types to process and store valuable materials and information with an energy efficient concern.

The energy demands of data centres have generated innovative green technologies in energy production and resource use,due to there high heating and cooling loads. Essentially a storage warehouse, this emerging type is inert to the urban environment.(Fig 2.9 )

Recycling Centres have the potential for greater public interaction since the process often involves the consumption items of public use. Locally the industry interface is yet to be developed.

World wide the landscape is changing as solar and wind generating technologies, create a new landscape of harvesting, and new autonomous objects, which speak of an energy of a different kind to a previous oil rich society.

The dissertation suggests that these changes represent a global change in values , but as autonomous objects contribute little to the local social and place value.



FIG.2.12

FIG 2.12. PROPOSED FACEBOOK, LULEA SERVER FARM. (WWW.DATACENTERKNOWLEDGE.COM)



FIG.2.13

FIG 2.13. MAAG RECYCLING IN WINTERTHUR 2006, SWITZERLAND BY OPEN OPERATING SYSTEM (HTTP://WWW.ARCHIDOSE.ORG)



FIG.2.14

FIG 2.14 STORAGE TANKS OF A BIOGAS PLANT (WWW.DIYTRADE.COM)

## 2.5 | THE INERT URBAN OBJECT

In the midst of the global shift in the productive environment, local industrial architecture comprising the urban fabric of the post-industrial condition, appears inert, and isolated, both within the previous industrial paradigm and the current.(Fig 2.6 and 2.7).

The discussion of innovation systems, and industrial clusters proposes an alternative spatial condition, which suggests that in spite of the de-materialization and network nature of the information economy, spatial proximity fosters innovation.

Currently small to medium enterprise service industries and processing facilities within the previous capitalist industrial agglomerations ,lie between derelict and vacant property, operating in isolation.(Fig 2.8)

The innovation hub is South Africa's first technopole intended on facilitating an environment of collaboration and exchange between entrepreneurs and established business, through an office park, networking centre and large public square.

However, isolated from the activity of the city environment, the public space again appears too large in scale ,and office blocks independent and disconnected.

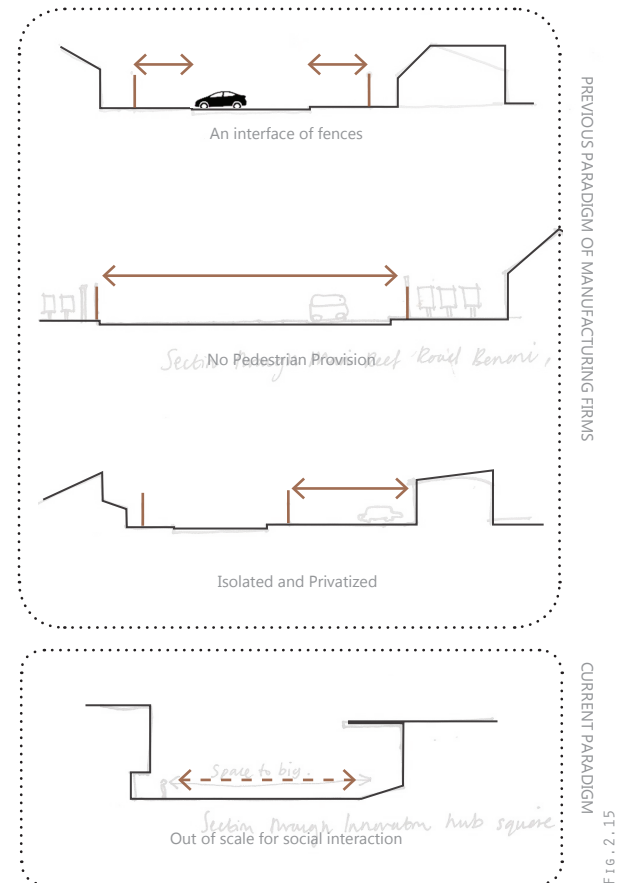


FIG.2.15. ANALYTICAL DIAGRAM OF LIGHT INDUSTRIAL ARCHITECTURES RELATIONSHIP TO THE URBAN ENVIRONMENT(AUTHOR 2012)

FIG.2.16.GRAPHIC COLLAGE OF INERT INDUSTRIAL CONTAINERS OF THE EAST RAND. ( AUTHOR 2012)

FIG.2.17.PUBLIC SQUARE BETWEEN ENTERPRISE BUILDING AND RECEPTION. INNOVATION HUB,LYNWOOD PRETORIA.(AUTHOR 2012)



NO DIFFERENCE

STREETScape PREVIOUS PARADIGM OF MANUFACTURING FIRMS



STREETScape CURRENT PARADIGM OF INDUSTRIAL PARKS



Fig. 2.16

“A RAPIDLY EXPANDING ECONOMY THAT TRANSFORMED NATURE INTO A RESOURCE, URBAN SPACE INTO INVESTMENTS AND IDEAS INTO CONSUMERIST SPECTACLE.”

David Gissen (2010;10)  
on capitalism

Fig. 2.17



## 2.6 | CONCLUSION

The background study elaborates on the problems and themes that are architecturally explored. Its intentions were to provide adequate reasoning for the hypothesis and discuss its importance .

The proposal challenges the locale of manufacturing facilities and innovation clusters, and their relationship within the urban environment. The impacts of information technology and its decentralized character demonstrate a possible shift in the form and role of industrial facilities, from a privatized initiative to a shared resource. The shifts in value , and an awakened awareness of global consumption patterns, has directed industry towards value-adding processes, which increase employment rates, are resource efficient ,not capital intensive, and therefore intrinsically flexible.

The new industrial ethos is one of collaboration, transparency and innovation. The patterns of industrial clusters transmuting into innovation systems suggest that even in a global context of the decentralized and mobile, physical place and geographical proximity are still crucial, if not pre-conditions for a stable bottom up innnovation system.

Architecture has a role to play both in the support and expression of “glocally” embedded systems.

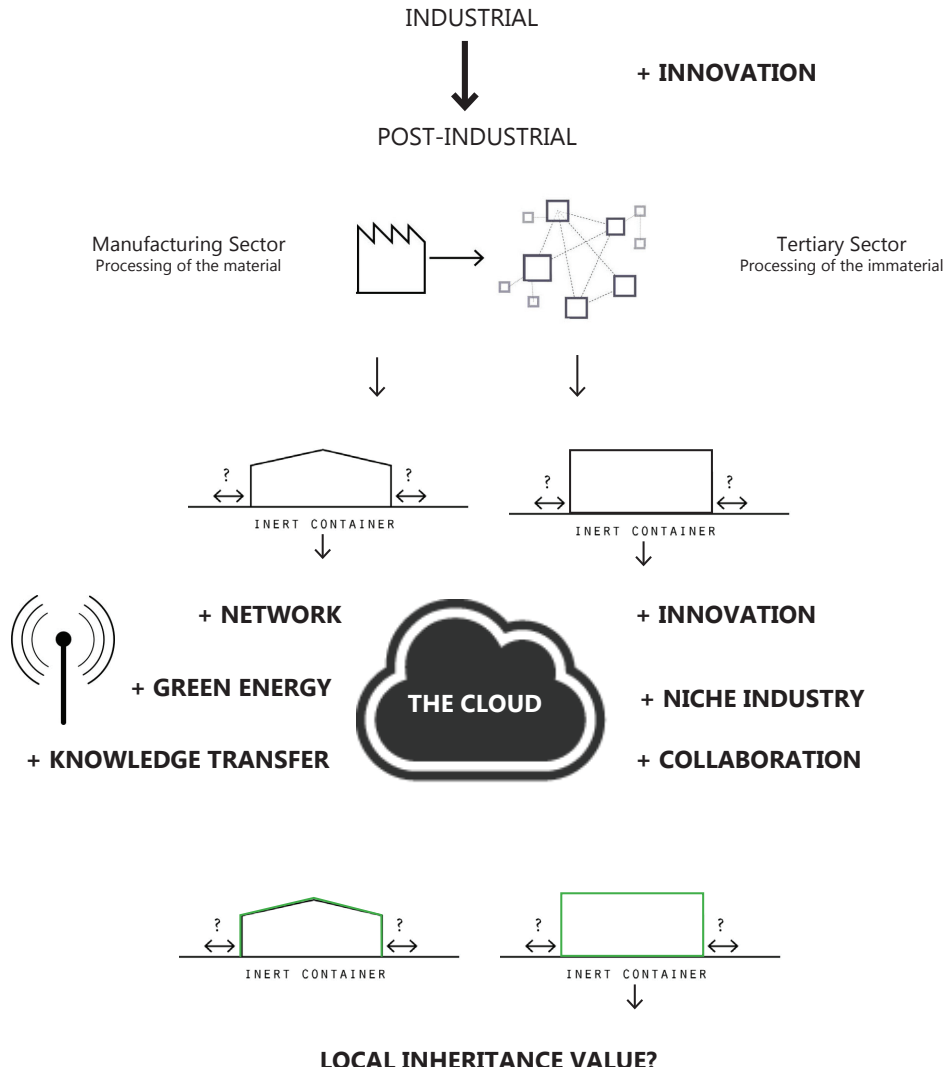


FIG.2.18

FIG.2.18. GRAPHIC SUMMARY OF PLACING THE PROBLEM STATEMENT IN CONTEXT. (AUTHOR 2012)



# 03. THEORY |

## 3.1 A THEORETICAL SHIFT

The concept of “value-adding” within the digital industrial ethos, is yet to find an appropriate expression in an industrial architecture. Contemporary architectural thinking and conceptualizing of space is in a state of transition, adapting to changes and a re-configuration of space in response to the current technological shift.

A dialogue between the permanent and the temporary, past and present, the local and the global, the digital and the material , has generated a new expression of architecture and its relationship to it’s urban environment in a multivalent and complex way.

The theoretical discourse investigates the value and influence of this multivalent character within the architecture of industry, and its potential to interface and support locally embedded systems.

## 3.2 | ARCHITECTURE AND TECHNOLOGY

Castells states that “if the space of flows is truly the dominant spatial form of the network society, architecture and design are likely to be rectified in their form, function, process and value, in coming years.” (Castells;1996:448).

The space of flows is a term coined by Castells, describing an a-spatial or non place condition generated by the network, allowing for the continual flow of goods, information and people.

### 3.2.1 ARCHITECTURAL RESPONSES TO TECHNOLOGY

Previous architectural responses to the space of continual flows and rapid technological change, envision space as fluid and mobile and structure as the facilitator of the flow of things.

Cedric Price ,an author of Archigram, inspired by technological innovation and consumerism of the 1960’s believed that “buildings were catalysts or enabling mechanisms, which facilitate and encourage social and spatial interaction.”( Spiller 2002:84 ).

The flexible containers of the Hi-Tech movement and metaphorical explorations of the rise of software systems, where “content is king”, moved from a “inside out”public

interaction with the city, to a “flattened” experience of the hyper surface to accommodate the accelerated pace of change.( Puglisi 1999:15)

Castells cites Buiki 1972 that “ there is no simple, direct interpretation of the formal expression of social values”, but “ there has always been a strong, semi-conscious connection between what society ( in its diversity) was saying and what architects wanted to say.” ( Castells:1996:449).

However, ( Horan: 2002; 5) argues that the social use of “unplugged settings”, referring to physical place, indicates the “enduring socio-cultural value of material spaces of interaction, and that it is within context and communities that value is assigned over time.

Castells, Horan, Mitchell and Nagashima(1999) argue that the architecture of the future is not a digital aesthetic, but an interfacing between a space of flows( the global ) and the space of place( the local).

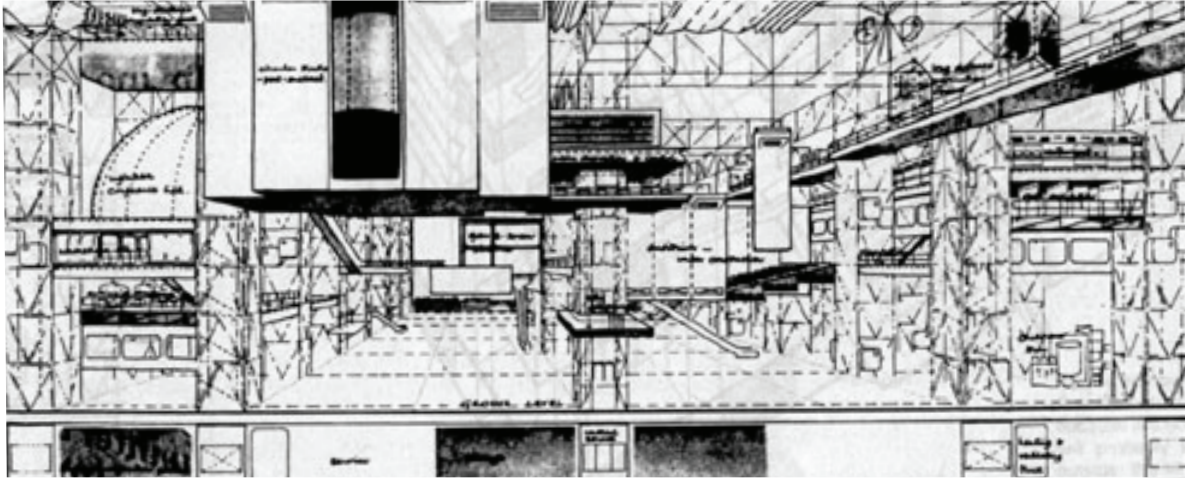


FIG. 3.1

FIG 3.1. *THE FUN PALACE* 1961, CEDRIC PRICE. AN INTERACTIVE PUBLIC ENVIRONMENT AND PRECEDENT TO THE GEORGIU POMPIDOU CENTRE, PARIS. (WWW.THERESPONSIVECITY.ORG)

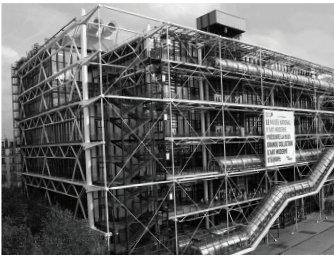


FIG. 3.2

FIG 3.2. CENTRE GEORGIU POMPIDOU. RICHARD ROGERS AND RENZO PIANO. 1976. DESIGNED AS A FLEXIBLE CONTAINER FACILITATING COMMUNICATION. (WWW.MONSIEURMAMAN.WORDPRESS.COM)

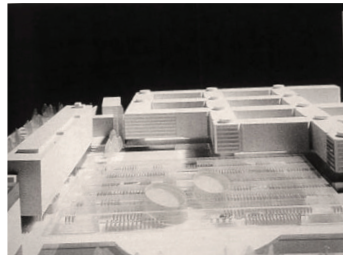


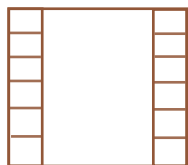
FIG. 3.3

FIG 3.3. DESIGN PROPOSAL FOR THE NEW NATIONAL LIBRARY, PARIS. TOYO ITO. 1991. (PUGLISI 1999:15)

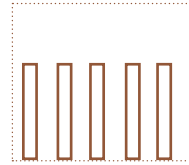


FIG. 3.4

FIG 3.4. SYNCHROTRON CENTER FOR SCIENCE, AUSTRALIA. BATES 2012. A RESEARCH FACILITY THAT USES LIGHT AS A MATERIAL AND INTERFACE. (WWW.BATESSMART.COM.AU)



Heroic Structure and Flexible Container



Transparent Container "Content is King"



Interactive Interface? Material as Fluid

FIG. 3.5

FIG 3.5. DIAGRAM ILLUSTRATING DIFFERING CONDITIONS OF INTERACTIVITY, MATERIALITY AND TRANSPARENCY IN ARCHITECTURE OF THE INFORMATION AGE. (AUTHOR 2012)

## 3.3 | RECOMBINING TYPES

The contemporary relevance of typological studies in architecture, are evidenced by the dramatic change in social structure, technology, time and immateriality of the network society.

### 3.3.1 DEFINING A TYPE

Both Raphael Moneo in 1976 and recently Lee and Jacoby (2010), cite a definition of type by Nicholas-Louis Durand (1825), in an introduction to their theoretical discourse.

Durand stated that “new types develop in response to the requirements of a changing society and urban conditions, whereby the typological diagrams are adapted to the constraints of the specific site.”

Structuralist thinker John Habraken interprets type and its emergence as “socially embedded,” the act of inhabitation re-affirms type through daily interaction, just as continuity and repetition over time reinforce the type (1998: 95).

A type can be described by various systems and observed patterns, which contain typological parts which constitute the spatial language. (Fig 3.6)

### 3.3.2 RAPHAEL MONEO ON TYPOLOGY

Raphael Moneo’s theory on type is that it “implies the idea of change and transformation”. The type is the “act of the grouping of things.” (Moneo 1976: 15)

For Moneo the type presented the opportunity for architecture to confront its past and future by not being a replicable spatial diagram of typically grouped parts but constantly changing, gradually fading out obsolescence and responding to social and technological change. It has a history. (Moneo 1976)

The particular significance of these theoretical positions on type, particularly Durand (1825), is that type, and the urban artefact or inextricably tied to its socio-cultural context.

### 3.3.3 TYPE IN THE DIGITAL AGE

Mitchell (1995 :47) states that “The solvent of digital information decomposes traditional building types. one by one, the familiar forms vanish. Then the residue of recombinant fragments yields up mutants.”

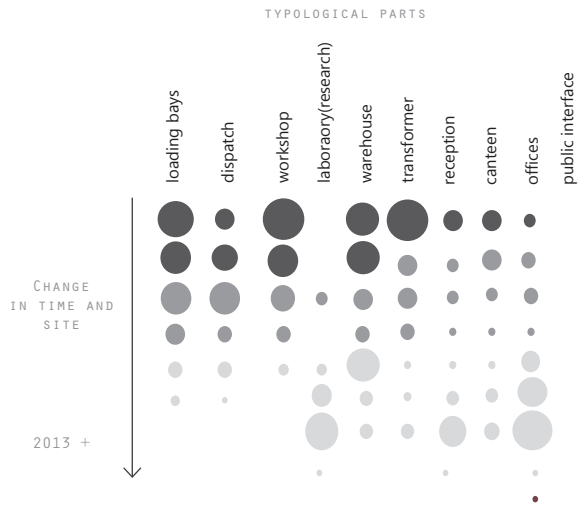


FIG 3.6

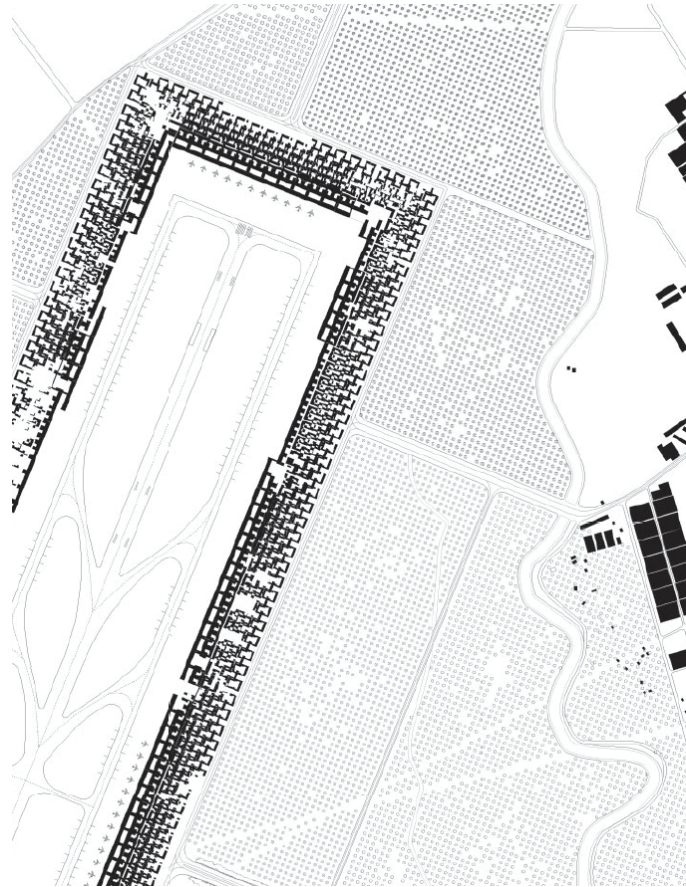


FIG 3.6. TRADITIONAL VARIATIONS OF THE TYPE. (AUTHOR 2012)

FIG 3.7. THE ADJACENT THESIS PROJECT ILLUSTRATES A NEW EXPRESSION OF A SPATIAL CONTAINER. THE GLOBAL TYPOLOGY OF AN AIRPORT, IS ENCLOSED BY A TRADITIONAL BUILDING TYPOLOGY OF THE COURTYARD HOUSE, ARRANGED AS A MULTIPLICITY OF SMALLER ELEMENTS AND COMPONENTS THAT INTEGRATE INTO THE SURROUNDING CONTEXT. (LIU 2008 IN AD 2010:88)

## 3.4 | ARCHITECTURE OF THE GLOCAL CONDITION

### 3.4.2 INTERFACING THE GLOCAL

Horan states that the value of the architecture of the information age, is the interfacing and interaction of inverses that “engages a spectrum of participants. ( Horan 2002 : 22).

This presents a glocal condition which refers to the “co-presence of both the local and the global (Robertson. s.a), and a multivalent or plural condition of value,time and space.

Architecture has the potential to negotiate the divide between plugged and unplugged settings,producing new types of social spaces and programmes, and diverse hybrids.

Theoretical investigations of the architectural type indicate that the transformation of the type is not an isolated technological event. It implies a reference and memory to the past, that finds value in the local social environment.

Peter Rowe in Civic Realism States that civic realist places “contain a pluralism of attitudes with a sense of common accord, they are adaptive support everyday life, and allow for group and individual expression. ( Rowe 1982 )

### 3.4.1 REMANUFACTORY

Flexible industrial space requires a re configuration of its typological components.

This recombination will be a mutation that describes a “glocal condition”, an alternative interface that engages with the city. It should possess both the temporary qualities of the technological revolution, and a permanence of place,through an integration with its urban environment.

Nagashima(1999:5) states that within the current Information Age, the concept of social and cultural value in the urban environment can be reinstated, as capitalism moves to the realm of the virtual.

The “real time places of exchange”(social spaces ) provide the spatial conditions necessary for an innovation based industry, where spatial proximity, creates a collaborative environment of learning by doing and observation

A cross pollination of form,material space and programme has the potential to transform the generic inert object of the industrial container into an enduring civic resource and element, particular and unique within it’s context.

THE INTERFACING BETWEEN A GLOCAL CONDITION

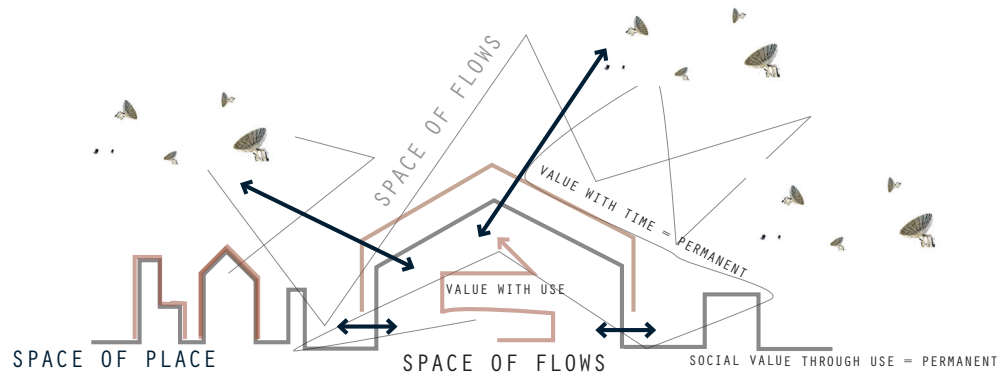


FIG.3.8. THEORETICAL AIMS AND POSITIONS OF AUTHOR, LINKING CONCEPTS OF TIME, VALUE AND SOCIAL SPACE AS A GENERATOR FOR DESIGN (AUTHOR 2012)



# 04 . CONTEXT |

## 4.1 AN URBAN VOID

### 4.1.1| INTRODUCTION TO STUDY AREA

The chosen study area is the Northwestern precinct of the innercity of Tshwane ( Pretoria). It is bordered by the major arterial of DF Malan to the West, and the Steenhovenspruit to the East. Its northern border defined by the rail, and its southern border defined by Skinner Street.

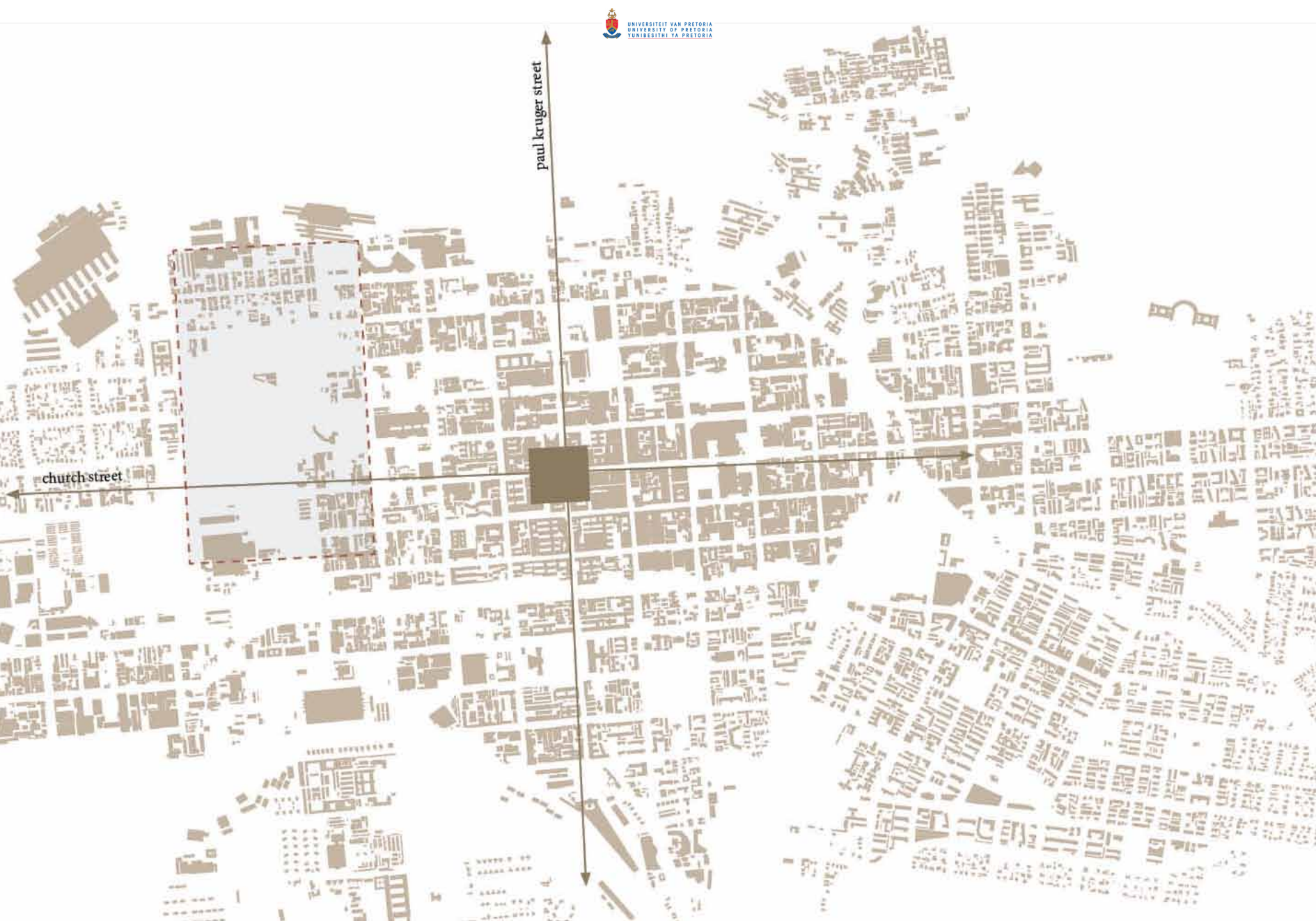
The area is characterised as an apparent urban void, of sparse haphazard development, vacant land,superblocks and scattered municipal functions, where foreign nationals find refuge and employment, and an informal economy flourishes.



FIG 4.1. LOCALITY PLAN OF  
SELECTED STUDIED AREA.  
(AUTHOR 2012)

ADAPTED FROM PIENAAR.N.D





## 4.2 URBAN ANALYSIS

### 4.2.1 APPROACH

The group urban analysis investigates the city in terms of the fixed and the fluid, or the formal and informal.

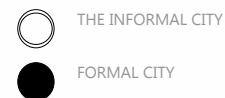
Like most African cities Tshwane is both a formal and informal city. Post capitalist space, the street edge and the reinterpretation and appropriation of vacant pieces of land and empty buildings provide the temporary and territorial spaces for a new economy.

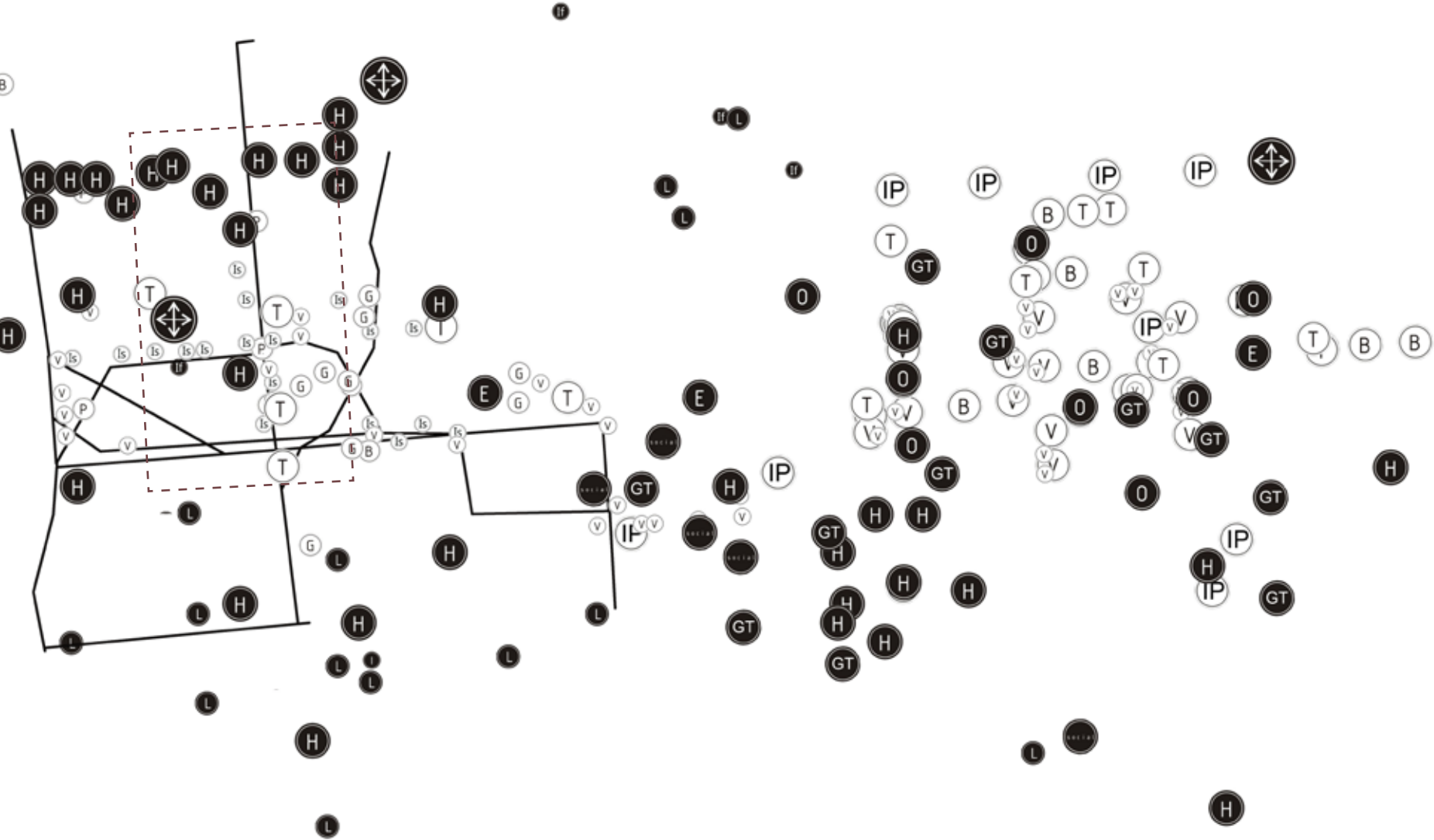
The adjacent diagram maps the city of Pretoria, on an abstract level to make more apparent the relationship between the built city and informal activity, the density of activities based on the proximity of formal facilities, and its relationship to dominant movement patterns within the city.

See appendices 1-5 for group urban mapping and conclusions

FIG.4.2 PRETORIAS NETWORK OF PLACES. THE DIAGRAM ILLUSTRATES THE CITY OF TSHWANE AS A PATTERN OF PLACES AND TRAJECTORIES BETWEEN THINGS. (AUTHOR 2012)

ADAPTED FROM GROUP ANALYSIS. (COMINS ET AL 2012)





## 4.3 SOCIO-SPATIAL CONTEXT

### 4.3.1 | INTRODUCTION

Marabastad is a bustling commercial centre to the north of the proposed site. Historically a location for africans( Friedman 1994 : ), its informal activities make use of sidewalks and pedestrian movement between its major transport interchanges. The small scale fabric of the precinct fosters a social environment of engagement and casual conversation.

Contrasting the fine grain of Marabastad, the vast open ground of a demolished bus depot and municipal compound and stables, provides an arena for the hosting of various temporary events. The purpose of the contextual study is to investigate how local circumstances can influence the architecture of a global type.

### 4.3.2 | HISTORICAL DEVELOPMENT

The relevance of Marabastad's historical development is that the area had always been intended as an isolated buffer strip, between the development in Pretoria west and Pretoria East. Its emergence was from the start a temporary location for the racially segregated and its erasure was a result of political ideals and modern utopian visions.

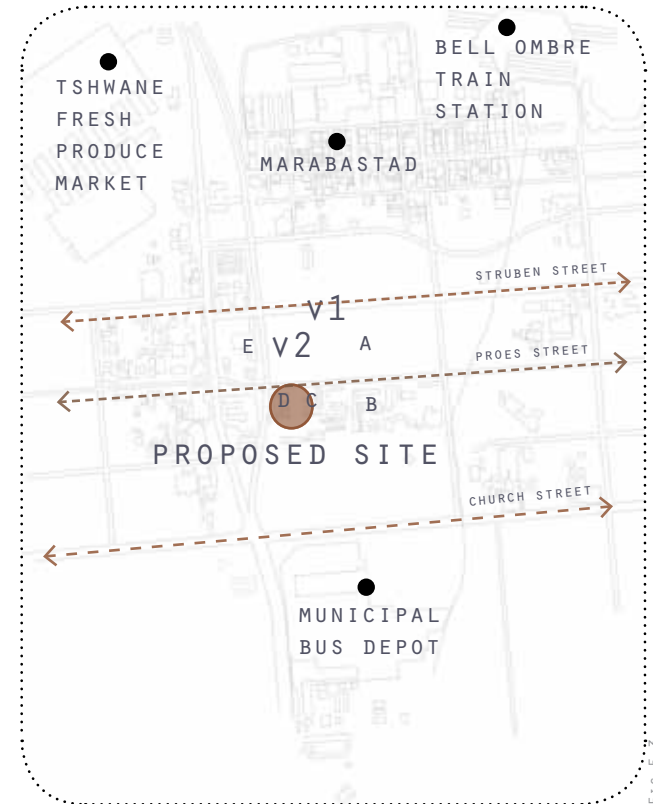


FIG 4.3

FIG 4.3. SITE LOCALITY MAP ( AUTHOR 2012)

FIG 4.4. (OPPOSITE). PANORAMIC VIEW OF PROPOSED STUDY AREA. INDICATING VACANT LAND. ( AUTHOR 2012)

FIG 4.5. (OPPOSITE) LORENTZ STREET INFORMAL MARKET AND HOME AFFAIRS IMMIGRATION BUILDING, ESKIA MPHAPHELE STREET. MARABASTAD. (AUTHOR 2012)







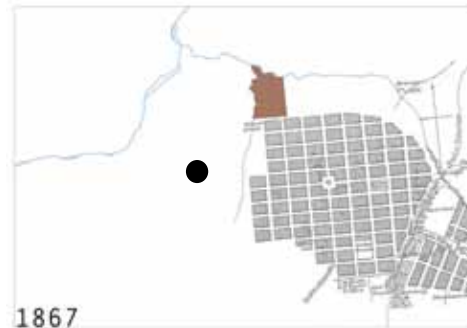
FIG 4.6. PEDESTRIAN STREET  
IN MARABASTAD WITH  
INFORMAL ACTIVITIES.  
( AUTHOR 2012)





FIG 4.7. IMAGE FROM  
MARABASTAD LOOKING EAST  
( AUTHOR 2012)

“.....DESPITE ALL ATTEMPTS TO DESTROYING IT, MARABASTAD HAS REMAINED A PLACE OF SURVIVAL “ (FRIEDMAN 1994)



1867

01 | SKOOL PLAATS IS A PERMANENT COMMUNITY WHERE CHRISTIAN CONVERTS WERE EDUCATED, COULD BUILD A PERMENT HOME, AND USE THE LAND FOR SMALL AGRICULTURAL PRACTICES.



1888

02 | OLD MARABASTAD NAMED AFTER CHIEF MARABA AN ADVISOR TO THE COUNCIL. AN AFRICAN LOCATION WEDGED BETWEEN THE APIES RIVER, STEENHOVEN SPRUIT AND THE ROAD TO DASPOORT TO THE SOUTH. THE SETTLEMENT ALSO TOOK ON A PERMANENT CHARACTER. TO THE SOUTH



1925

05 | MUNICIPAL COMPOUND IS BUILT ON PROES STREET TO HOUSE WORKERS ACCORDING TO THE NATIVE URBAN AREAS ACT OF 1923



1947

06 | IN TOWN IS ESTABLISHED AS A TEMPORARY HOUSING LOACTION DUE TO OVERCROWDING IN THE COMPOUND. RESIDENTS OF MARABSTAD ARE FORCED TO RELOCATE TO ATTRIDGEVILLE

FIG 4.8. HISTORICAL DEVELOPMENT OF MARABASTAD AND SURROUNDS (AUTHOR 2012)

FIG 4.9 AERIAL PHOTOGRAPH OF STUDY AREA. 1947. ( DEPARTMENT OF RURAL DEVELOPMENT)



1892

02 | PRETORIA WEST RESIDENTIAL IS DELIBERATELY SEPARATED FROM A GROWING MARABSTAD WITH VON WELIGH ROAD. THE ASIATIC BAZAAR IS ESTABLISHED SOUTH OF MARABSTAD



1910

04 | DENSE MILITARY HOUSING TO THE EAST OF THE STEENHOVEN SPRUIT. MUNICIPAL SEWER WORKS DISPLACE MARABSTAD AND NEW MARABSTAD IS LOCATED TO THE SOUTH ABOVE THE ASIATIC BAZAAR.



1976

07 | A 1967 FREEWAY PLAN SEES THE DEMOLITION OF A PORTIO OF THE ASIATIC BAZAAR AND MUNICIPAL COMPOUND. THE GOEDEHOOP HOUSING SCHEMES OF KRUGER PARK AND SCHUBART PARK, ARE PART OF A MODERNIST SCHEME MASS HOUSING SCHEME.



2012

06 | THE STUDY AREA TODAY

FIG 4.8

FIG 4.9



1947

### 4.3.3 | ARCHITECTURAL AND URBAN CHARACTER

The architectural value of the Marabastad area has been studied and documented by Le Roux (1991) and the Tayob et al (1998). Most of the original urban fabric of the former mixed use residential area has been demolished but what remains is of a human scale and “pedestrian friendly character” (Tayob et al 1998:66), particularly in Boom Street.

The buildings of the former Asiatic Bazaar range from one to two storeys in height with simple pitched roof construction and of an arcade typology. Between the permanence of the remaining fabric temporary structures on sidewalks provide alternative spaces for North South orientated pedestrian streets lend permeability.

This condition changes to the south as large vacant lots exist and interrupted by isolated face brick buildings, and monolithic housing towers in the back ground



FIG. 5.10



FIG 5.11

FIG 4.10. PEDESTRIAN STREET WITH INFORMAL VENDORS (AUTHOR 2012)

FIG 4.11. UNUSED VENDING STALLS WHERE THERE IS LITTLE PEDESTRIAN MOVEMENT (AUTHOR 2012)



#### 4.5.4 | ECONOMIC ACTIVITY

The majority of economic activity varies from small owned retail business and informal trading in clothing, cell phones, by-products, consumer electronics and fresh produce.

Mainly of an entrepreneurial nature the small and micro enterprises practice in small shops, the pavement area of arcades, temporary structures and small spaces of abandoned and government owned buildings incubating small production and recycling companies



FIG 4.13

FIG 4.14



FIG 4.12



FIG 4.15

FIG 4.12.COMMUTERS AND VENDORS AT PUTCO BUS STATION (AUTHOR 2012)

FIG 4.13.PROCESSING OF ANIMAL BY PRODUCTS ON MAJOR PEDESTRIAN ROUTE(AUTHOR 2012)

FIG 4.14.RECYCLING OF PACKAGING INTO BASKETS AT NGEZANDLA ZETHU CRAFT AND EARTH CENTRE.(AUTHOR 2012)

FIG 4.15.TEMPORARY HOUSING MADE OF STOCK (SLABBERT 2012)

## 4.4 CONTEXTUAL MAPPING

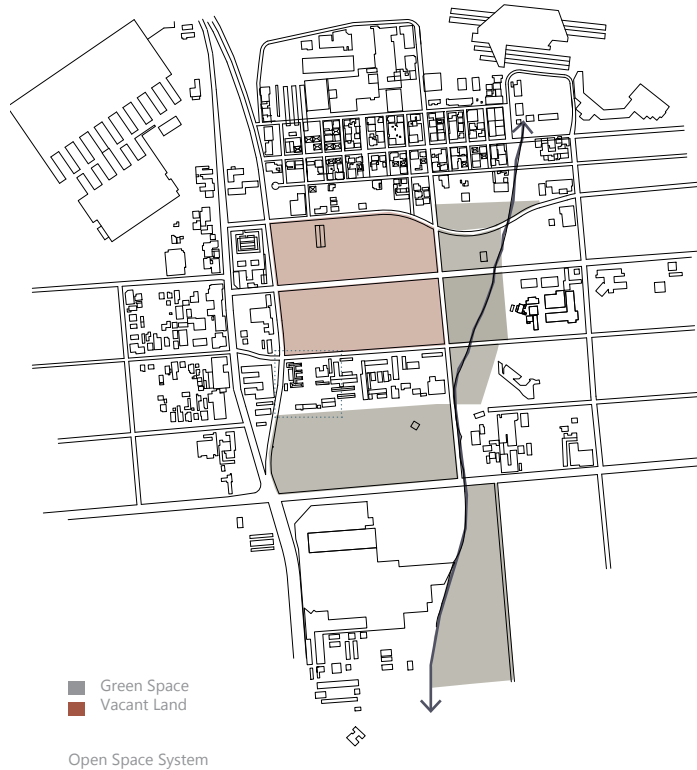


FIG 4.10. PEDESTRIAN STREET WITH INFORMAL VENDORS (AUTHOR 2012)

FIG 4.11. UNUSED VENDING STALLS WHERE THERE IS LITTLE PEDESTRIAN MOVEMENT (AUTHOR 2012)



FIG 2.16

FIG 2.17 (AUTHOR 2012)

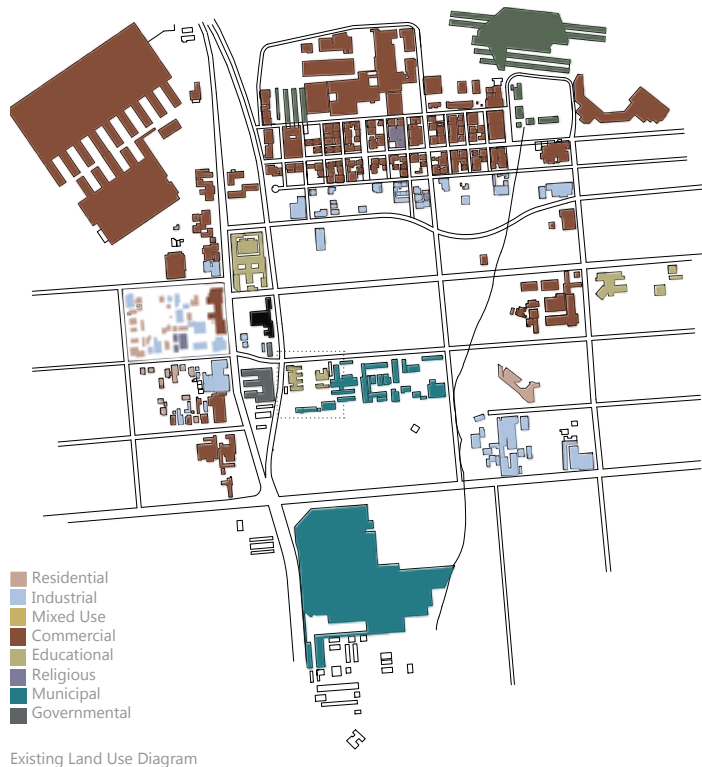


FIG 4.18(AUTHOR 2012)

#### 4.4.1. FRAGMENTED URBAN STRUCTURE

The haphazard urban structuring of the area has resulted in a fragmented and disconnected open space system and urban fabric.

The healthy small grained urban fabric to the north and west is strongly contrasted by and spatially segregated by large scale blocks with inert edge definition, while the demolition of a former residential area, has significantly contributed to the monofunctional nature of the study area

The existing land-use of the formerly mixed use area, is predominantly retail. The Aziz Tayob Framework attributes this change to the removal of a residential component and its associated community facilities. (Tayob et al:1998;90)

The presence of civic or public service spaces is lacking, however where it does exist, the value of the public space in front of the civic building generates activity and gathering, as evidenced by the Marabastad Refugee Home Affairs. ( Fig 4.18)



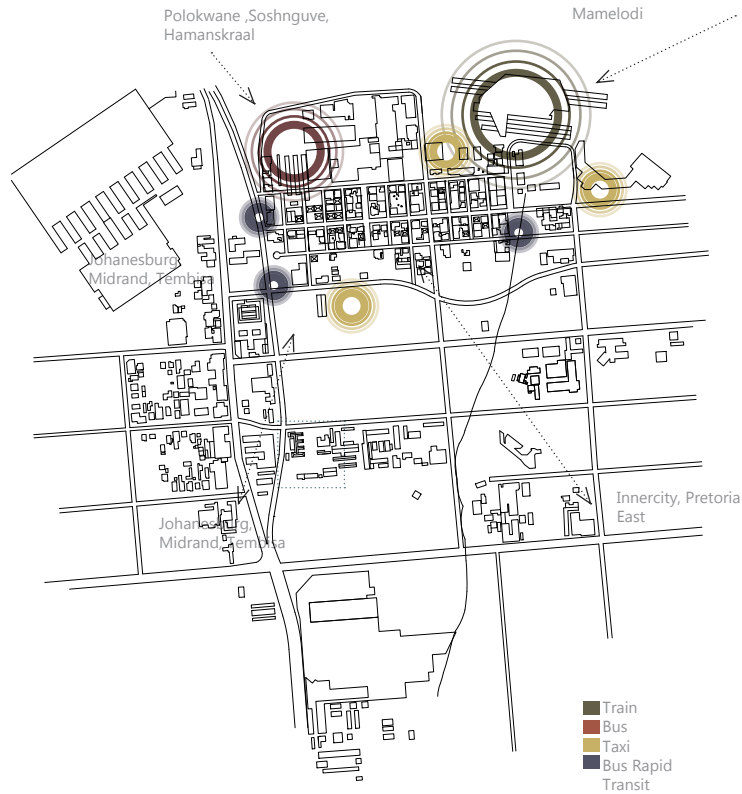




FIG 4\_18 LORENTZ STREET WAITING EDT. JPG(AUTHOR 2012)

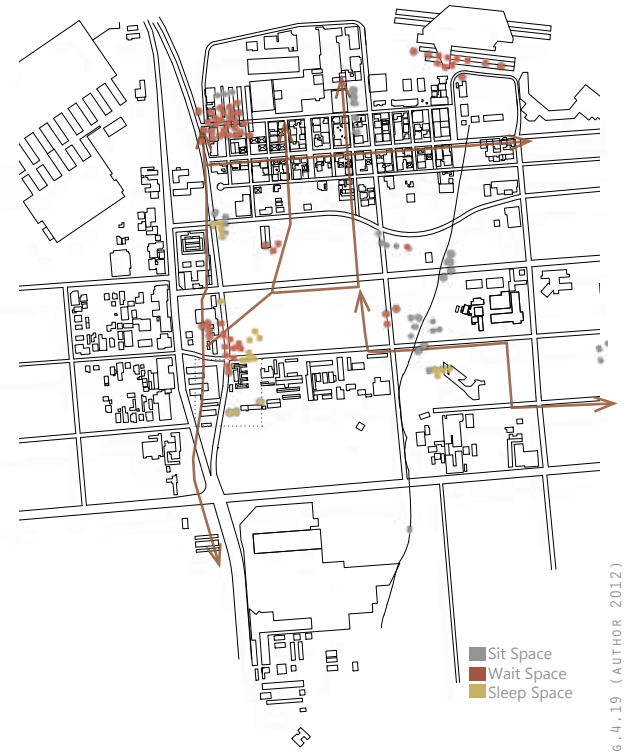


INSTANT MARKET | DURING WEEKDAYS THE WESTERN PORTION OF THE STUDY AREA BECOMES AN ANIMATED WAITING SPACE, AS FOREIGN NATIONALS WAIT OUTSIDE THE HOME AFFAIRS OFFICE, PRODUCING INSTANT AND TEMPORARY MARKETS.



Major Transport Routes and Interchanges

FIG 4.19 (AUTHOR 2012)

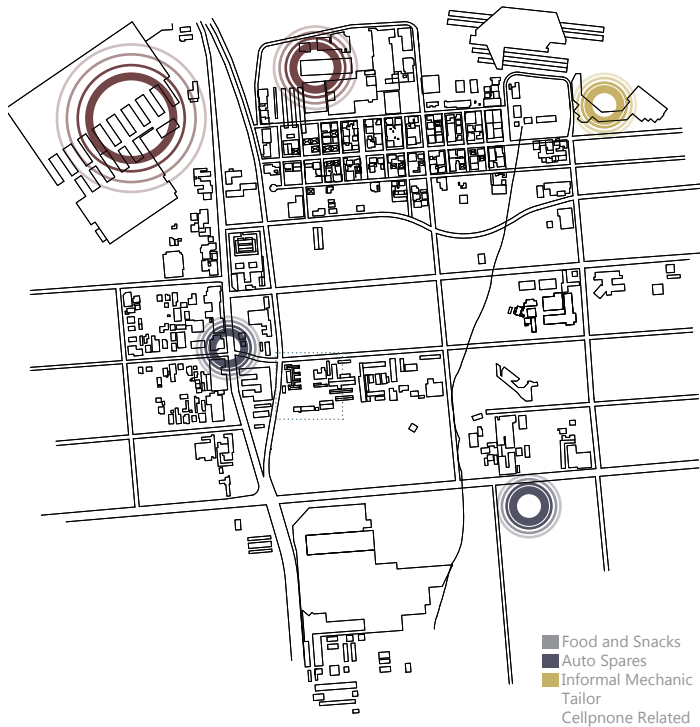


Pedestrian Routes and Concentrations of People

FIG.4.19 (AUTHOR 2012)

#### 4.4.2. MAJOR COLLECTOR AND DISTRIBUTOR

The close proximity of the Belle Ombre Train Station ,various intercity bus services, taxi networks and Tshwane Fresh Produce Market , makes the study area a major gateway in and out of the city along the DF Malan Drive, resulting in a zone of convergence of pedestrians commuters and informal traders moving between sources of stock and and sites of retail, positioned along major pedestrian routes.



Informal Vendors and Service Providers and Stock Sources

FIG-4.20.( AUTHOR 2012)

## 4.5 LOCAL INDUSTRY AND URBAN POTENTIALS

Within the industrial theme of the dissertation, a mapping of industrial activity within the study area was examined to analyse the nature of production in the area, and how a new productive industry could complement and strengthen current activities.

The mapping of industry in the precinct and its edges, shows a strong industrial presence in Pretoria West, mainly consisting of light Industrial activities related to auto services and scrap metal dealing. The nature of material recovery industries extends into the study area, where a strong recycling culture exists. Discarded packaging, electronics, second hand clothing, animal by-products, scrap metals and auto spares are recovered recycled, up cycled, remanufactured and reprocessed into second life items for retail.

To the east of the site industry consists mainly of corporate activities, and ground floor retail, where the production and flow of information dominates.

The sectorial mapping of industry in the study area, indicates the strong role that the informal sector (micro-enterprises) plays in the material recovery industry.

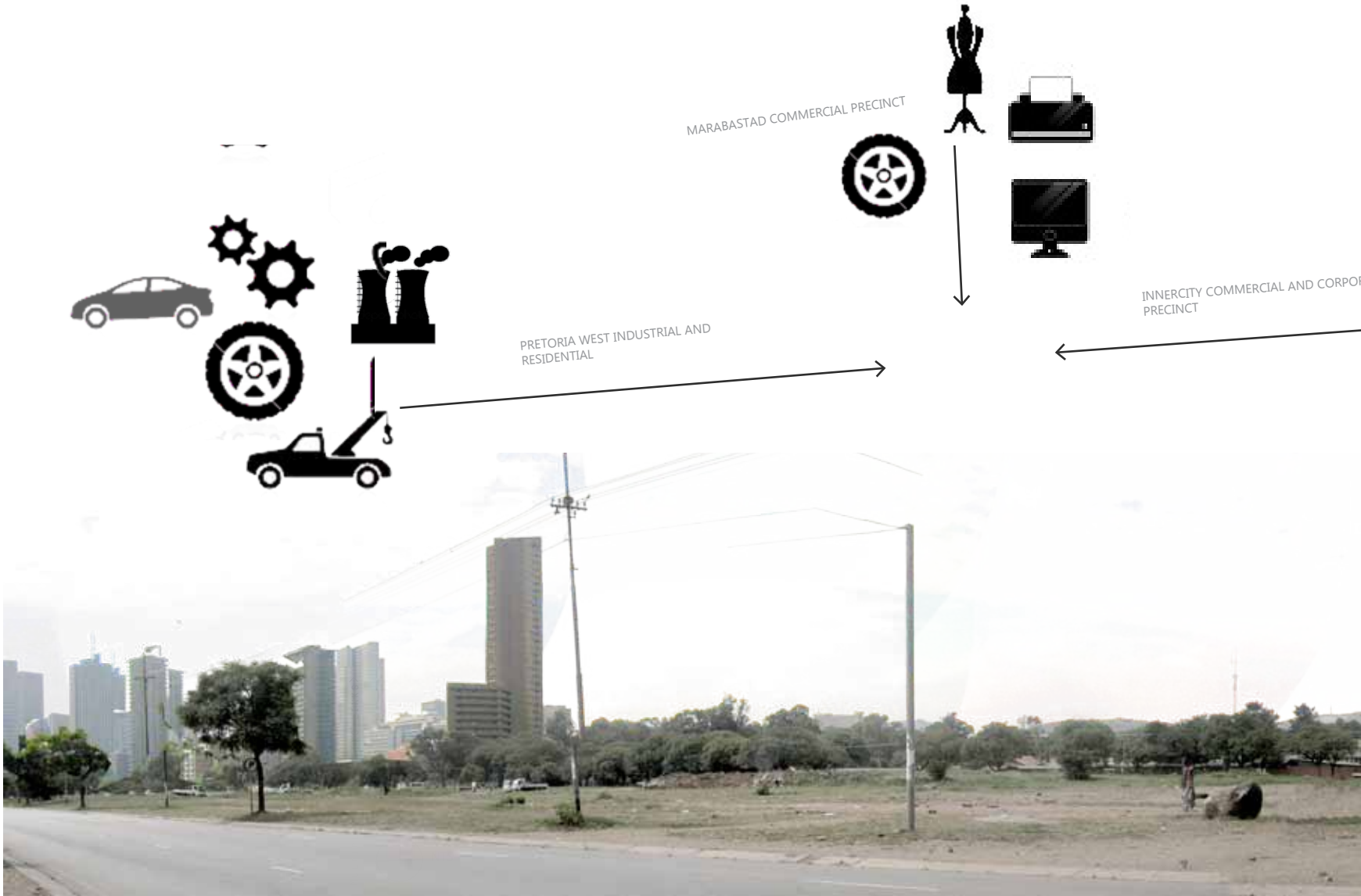


FIG 5.21

FIG 4.23. MAPPING  
INDICATING THE PRESENCE  
OF A DOMINANT RETAIL  
INDUSTRY. (AUTHOR 2012)



FIG 4.24. THE PRESENCE OF LOCAL RECYCLING AND REUSE. (AUTHOR 2012)





## URBAN POTENTIAL

The site's urban potential as a space of reconvergence and spatial connection exists, bringing together the activities in Pretoria West with the activities in Pretoria Inncity east through a common industry



FIG 5.25

## 4.6 PRECINCT FRAMEWORK

### 4.6.1 MARABASTAD AZIZ TAYOB FRAMEWORK.

Aziz Tayob Integrated Spatial Development Framework (1998) is a focused urban design proposal for the Northwestern Precinct of the city described as a “Strategic Area of Development.”

The intention of the framework is to integrate Marabastad into the surrounding urban fabric and address community needs through new proposals in the area, while being sensitive to the historical context.(Tayob 1998:155).

### 4.6.2 PIXELLATE\_ A PROPOSED URBAN FRAMEWORK

The proposal for the dissertation works within the the Aziz Tayob Framework ideals, with additional layering and interpretation, based on the current contextual analysis.

The analysis reveals the removal of communal facilities, residential component and a diversity of land uses within the area. The large scale urban blocks are in strong contrast to an adjacent fine grain fabric, isolated buildings incubate small micro industries, with a poor surrounding urban character to support collaboration and retail activities.

Based on the principals of emergent urbanism , the proposed mixed use zoning is extended towards the south as a metaskin integrating Marabastad with the surrounding context and promoting small to medium enterprises and small businesses, while increasing permeability.

### 4.6.3. FRAMEWORK OBJECTIVES

The objectives of the proposed framework are two:

- A. Integrate The Northwestern Precinct with the surrounding urban fabric through “pixellating” super blocks to encourage a fine grained mixed use character and permeable pedestrian network
- B. Reintroduce a network of public spaces and resource sites within the area of varying character
- C. Propose the insertion of additional civic and communal facilities in strategic areas
- D. Zoning\_ Zoning mixed use character , to include provision for small to medium scale productive enterprises, with a residential component.

FIG 4.25.(PREVIOUS) URBAN POTENTIAL. AUTHOR 2012

SOURCE IMAGES: SEE FIG LIST

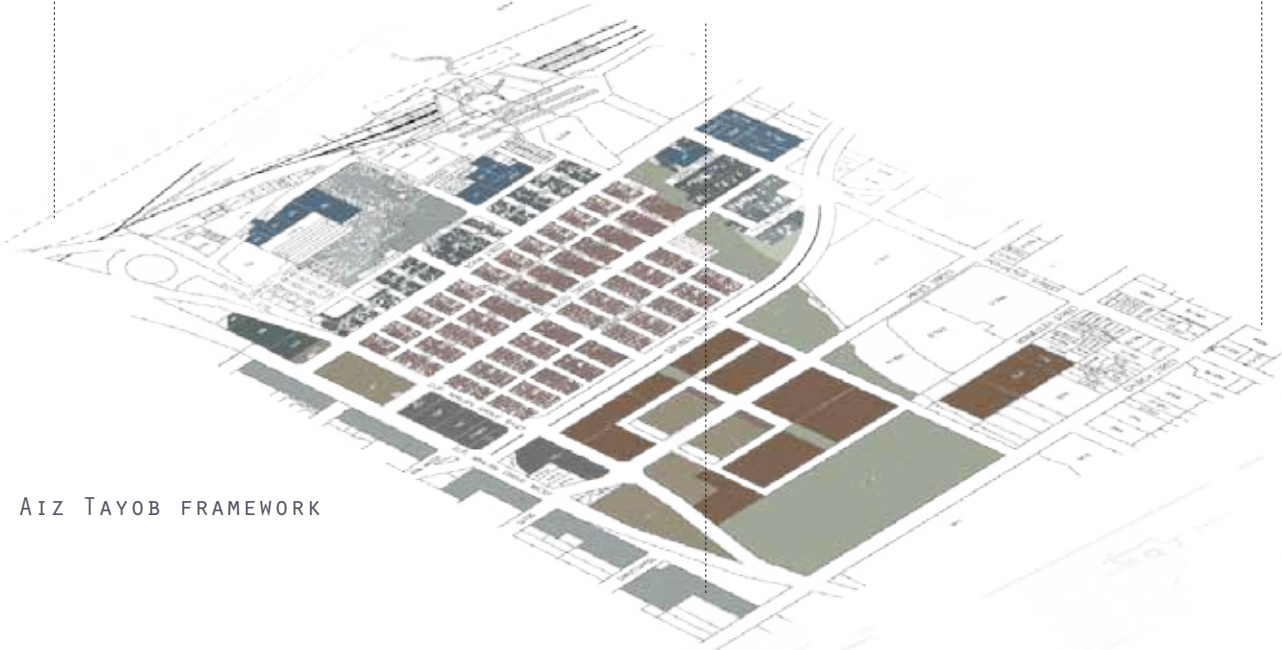
FIG 4.26.(OPPOSITE) EXISTING AZIZ TAYOB FRAMEWORK AND PIXELLATE FRAMEWORK (AUTHOR 2012)

ADAPTED FROM ( AZIZ TAYOB:1998:PG)





PIXELLATE\_ PROPOSED  
URBAN STRATEGY



AIZ TAYOB FRAMEWORK

- proposed public squares
- proposed pedestrian boulevard
- proposed residential mixed use
- proposed residential industrial mixed use
- proposed agricultural mixed use
- proposed agricultural mixed use
- proposed community agricultural plots
- proposed
- proposed community resource site
  
- Land Reclamation Housing
- proposed mixed use
- proposed civic or communal facilities
- proposed residential

## 4.7 SITE INTRODUCTION

### 4.7.1 | LOCALITY

The proposed site comprises a portion of the Municipal Maintenance workshops, the Self Help Skills Training Centre, occupying the former Pass Detention Facility, and the Ngezandla Zethu Earth Centre, occupying a former clinic.

Bordered by Proes Street to the north and the vacant city block and DF Malan Street to the East.

Heroes Acre Cemetery forms the southern border to the site, and as a historically significant space to the city needs to be dealt with in an adequate manner.

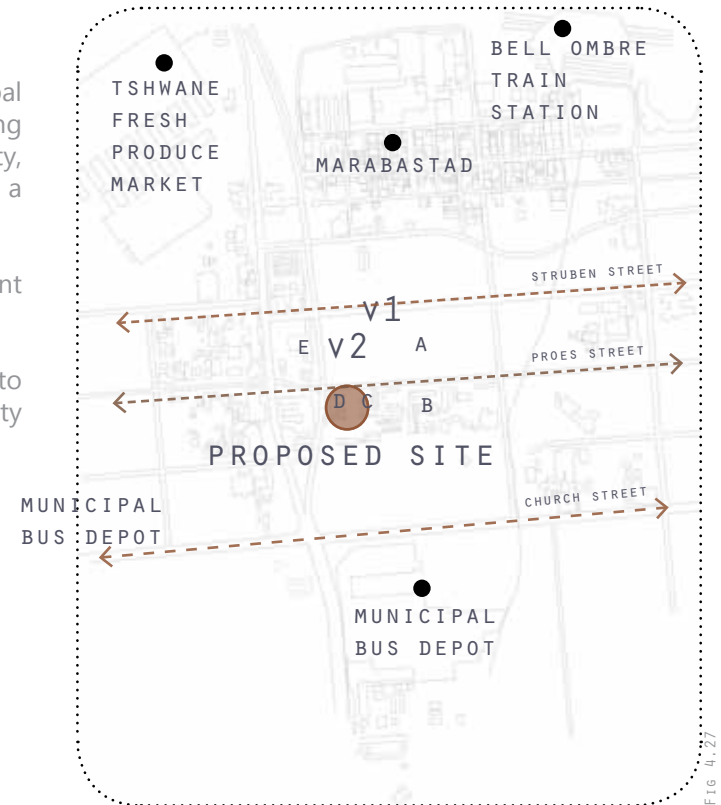
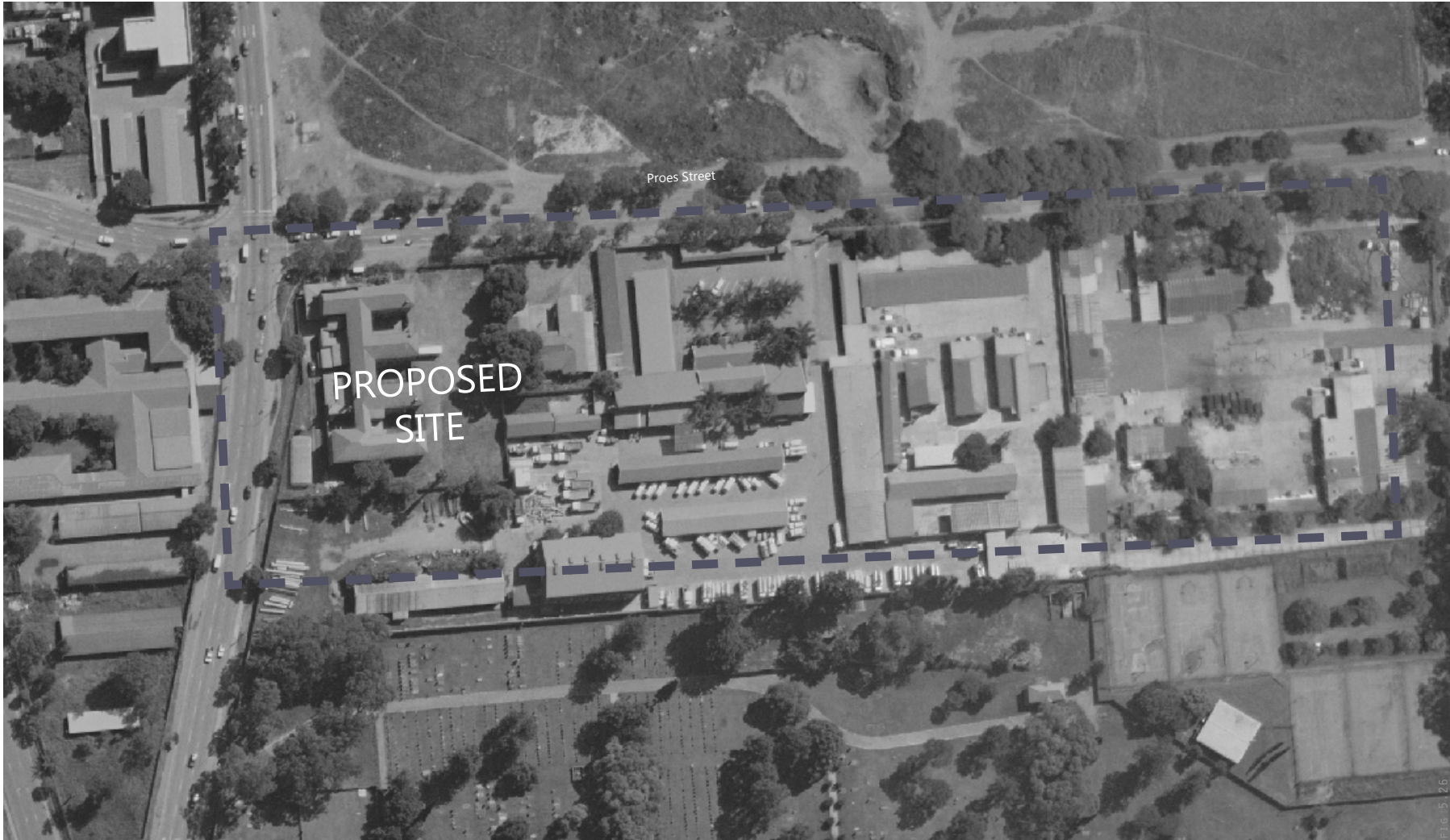


FIG 4.27. LOCALITY MAP  
(AUTHOR 2012)

FIG 4.28. STUDY AREA.  
(AUTHOR 2012)



## 4.8 SITE ANALYSIS

### 4.8.1 | SITE HISTORY

The proposed site was previously part of workers temporary housing of the municipal compound on the opposite side of Proes Street, called "Tin Town", during the 1940's( Friedman:1999).

It was during this time that the Pass Laws governing the movement of African workers in urban areas was passed, and the Native Reception Depot and Pass detention centre was built at this location.

The purpose of the Depot was a first point of entry for migrant workers from surrounding areas seeking work in Pretoria. People were processed into the system and issued with passes. The building also functioned as a temporary detention facility for people found without passes and in the city outside of business hours.

The Old Native Reception Depot and an adjacent clinic building are both protected by the NHRA act of 1999, the former a provincial heritage resource.

Today the Old Native Depot houses a skills training centre while the clinic is a small business incubator, recycling and crafts industry.

FIG.4.30.AERIAL PHOTO OF STUDY AREA INDICATING THE MUNICIPAL COMPOUND, PASS DETENTION CENTRE, AND "TIN TOWN" (FRIEDMAN.N.D)

ADAPTED FROM AERIAL PHOTO 1947 (DRD N.D)



FIG.4.30





FIG 4.31-EXISTING SITE (  
AUTHOR 2012)



FIG 4.32-NGEZANDLAZETHUELEVATIONS.JPG  
AUTHOR 2012



FIG 4.33 NGEZANDLA ZATHU EDGE.JPG  
AUTHOR 2012

EXISTING SITE  
CONDITION | THE  
ADJACENT IMAGES  
ILLUSTRATE THE  
DISCONNECTED NATURE  
OF THE SITE AND ITS  
SOCIAL PROGRAMMES  
AMONGST A STORAGE  
YARD.

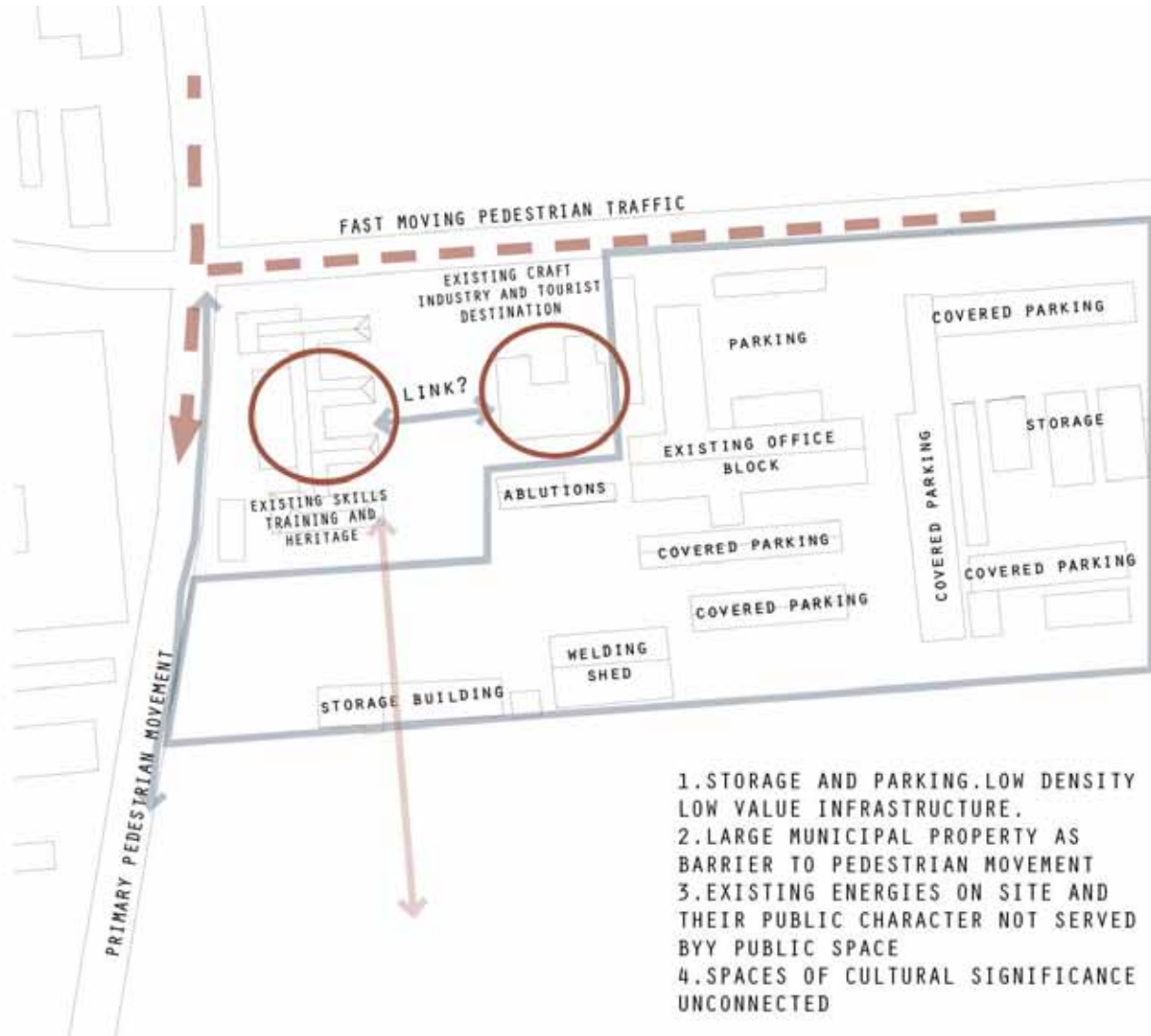


FIG. 4.34. OPPURTUNITY ANALYSIS. ( AUTHOR 2012)

FIG. 4.34.

## SITE PROBLEMS

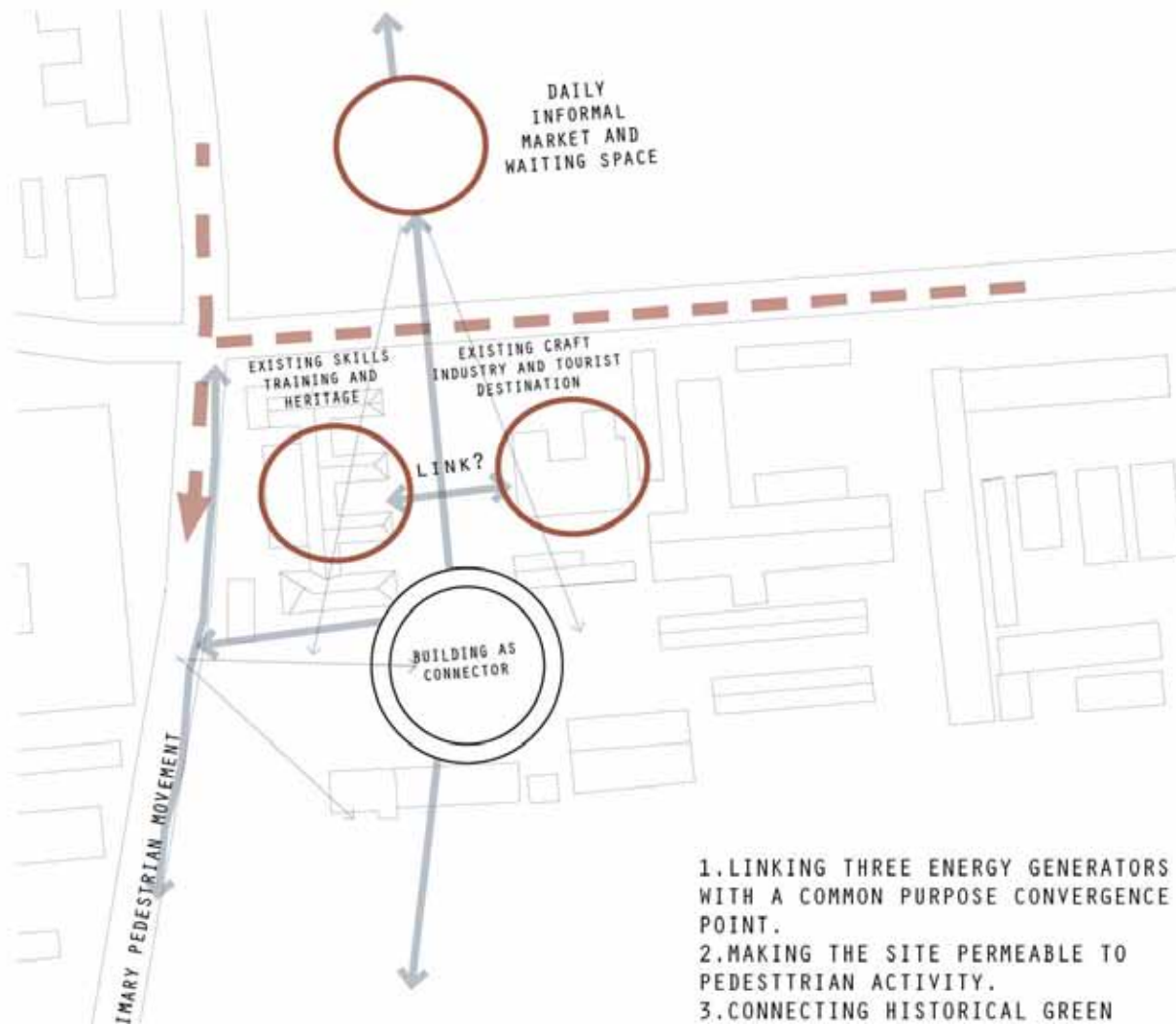


FIG 4.35. PROBLEM ANALYSIS AUTHOR (2012)

## 4.9 EXISTING ARCHITECTURE AND USE

### 4.9.1 | THE OLD NATIVE DEPOT BUILDING

The building is of an introverted nature where courtyards are walled off and divorced from its context and small high placed windows allow little interaction and views to the outside.

The courtyard typology, service and circulation spine create a robust structure that allows for a change of use and different programming of workshop spaces.

The stereotomic structure of the building comprises of a load-bearing brick structure with intricate flemish bond detailing and corbelling that contributes to the buildings significance. Smaller service spaces plug in to the main structure of the building.

A veranda on the outside of the building provides an additional space for instruction, and repose.

The problems experienced by the buildings users are the old services and the difficulty in upgrading the electricity and water reticulation to meet changing programmes, from residential, to computational, cullinary and workshop activities.

FIG.4 .36. THE SELF HELP SKILLS TRAINING CENTRE LOOKING NORTH. (AUTHOR 2012)



FIG.4 .33





FIG. 5.34



FIG. 5.35



FIG. 5.36



FIG. 5.37

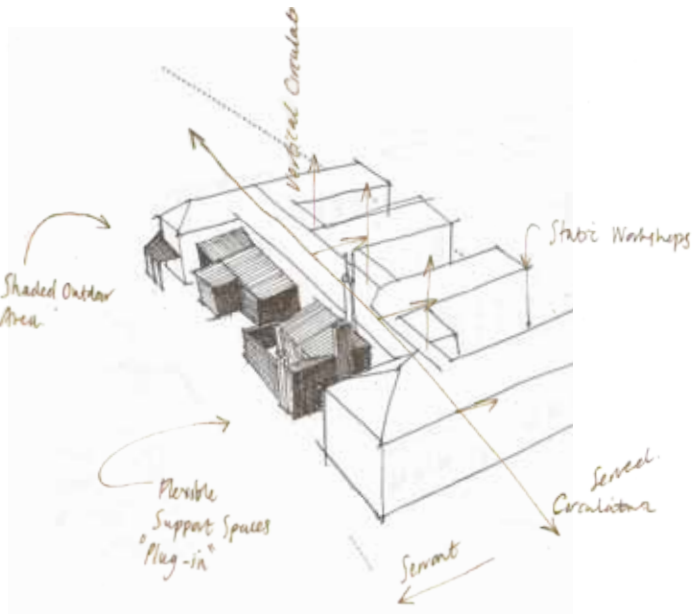


FIG. 4.38

FIG. 4.37 IMAGE ILLUSTRATING THE VERTICAL EXPRESSION OF CHIMNEYS ( AUTHOR 2012)

FIG. 4.38 MATERIALITY OF ROOF ( AUTHOR 2012)

FIG. 4.39 LIGHTWEIGHT OUTDOOR SPACE MEETING HEAVY BRICKWORK (AUTHOR 2012)

FIG. 4.40 IMAGE INDICATING FACE BRICK WORK ( AUTHOR 2012)

FIG. 4.41 ANALYSIS OF COMPOSITIONAL ELEMENTS AND SERVICES TREATMENT (AUTHOR 2012)

#### 4.9.2 | CURRENT USE

The Self- Help Skills Training Centre is a an NGO organization that aims at training vulnerable target groups with skills adequate to enter the job market, based on industry demand. Since 1995 the organization has been using the premises of the Old Native Depot , to house training workshops classes and examination venues rented out to other institutions. The first floor acts as staff accommodation and temporary housing for recruits from informal settlements from around Pretoria. In that regard the building still functions as a point of entry into the city for job seekers.

#### 4.9.3 PROBLEMS AND POTENTIALS

The building lacks ample space for meetings and exhibition. Despite the inherent flexibility of the layout, the old electrical and services are difficult to access and change.



FIG 4.42. SIGNAGE OF SKILLS TRAINING CENTRE (AUTHOR ET AL)

FIG 5.38



FIG 5.39



FIG 5.40



FIG 5.41

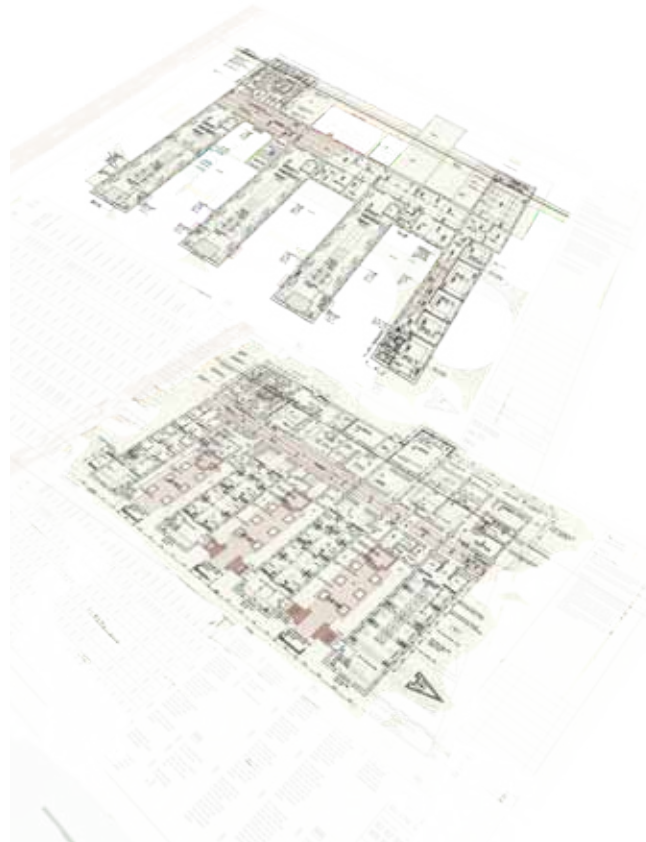


FIG 5.42

FIG 4.43 PAINTING  
WORKSHOP TEACHING BASIC  
ARTISANS SKILLS  
(AUTHOR 2012)

FIG 4.44 CLASSROOM  
(AUTHOR 2012)

FIG 4.45 RECREATIONAL  
ROOM OF SLEEPING QUARTERS  
(AUTHOR 2012)

FIG 4.46 PLANS OF THE  
SHSTC C.1994. STUDENT  
WORK (UP C.1994)

#### 4.9.4 | THE NGEZANDLA ZETHU CRAFT CENTRE

The Ngezandla Zethu Earth Centre is a Recycling and Crafts Industry, making use of an old clinic that was once part of the municipal compound. The mixed use centre accommodates artists in residences and small businesses.

The organization strongly believes in the preservation of the craft as an indigenous and legitimate industry, though it struggles in competition with chinese imports

Programmes include fashion design workshops, remanufacturing of old clothes, sleeping areas for crafters, woodworking business, beading, an outdoor sculpture workshop for recycled materials and a retail component for tourists. The centre is a strong tourist attraction.

#### 4.9.5 | POTENTIAL

The technological upgrading of the craft industry through training in new tooling for cutting and processing of material can create greater income, by saving time.

The presence of a craft industry invites architectural dialogue between the digitally produced and the hand made.



FIG 4.47. THE NGEZANDLA  
ZETHU CRAFT CENTRE  
(AUTHOR 2012)

FIG 4.47





FIG 4.48



FIG 4.49



FIG 4.50



FIG 4.51

FIG 4.47. SMALL START UP FASHION DESIGN AND CORPORATE GIFT COMPANY MAKING USE OF ONE OF THE ROOMS IN THE CLINIC. (AUTHOR 2012)

FIG 4.49. THREE CRAFTERS WORK IN AN OUTDOOR WORKSHOP MAKING SCULPTURE AND ACCESSORIES FROM RECYCLED PLASTIC. (AUTHOR 2012)

FIG 4.50. CARPENTRY BUSINESS SPECIALIZING IN THE PRODUCTION OF TROPHYS. (AUTHOR 2012)

FIG 4.51. SMALL FASHION AND HOME ACCESSORIES WORKSHOP (AUTHOR 2012)

## 4.10 SITE DEVELOPMENT CONCEPT

### 4.10.1 EXTRAVERT AND COLLABORATE

The concept for the development of the site is to create a place of flows and real time exchange between the skills training centre, craft centre and the proposed intervention along a common interest and layering of a technological upgrading.

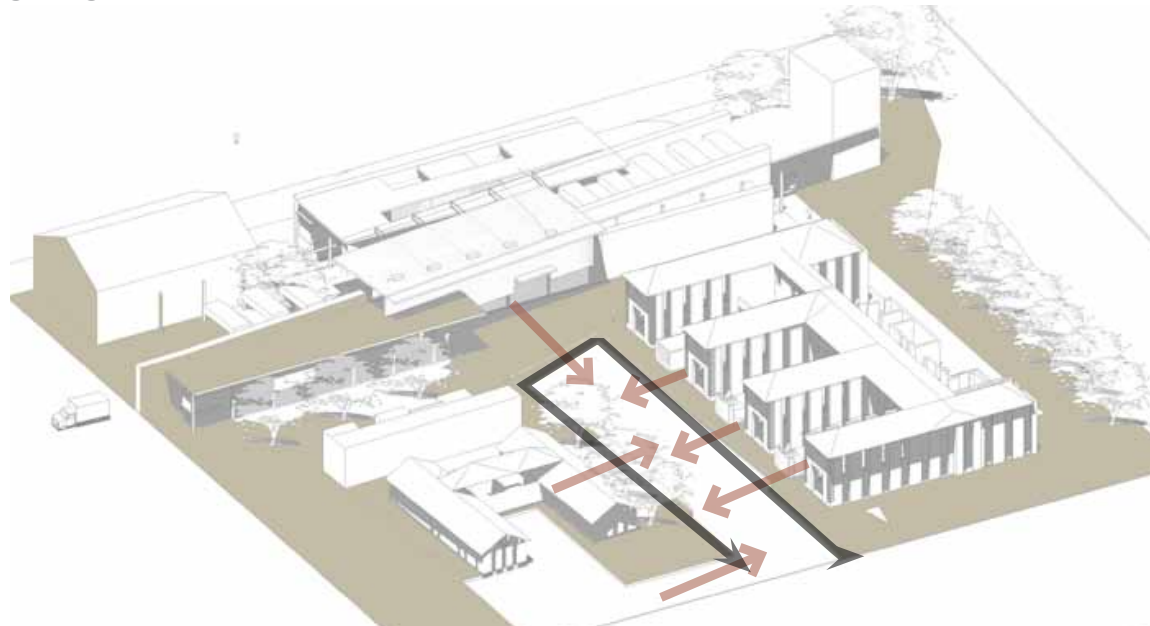


FIG 4.52 SITE DEVELOPMENT  
CONCEPT ( AUTHOR 2012)

FIG 5.53

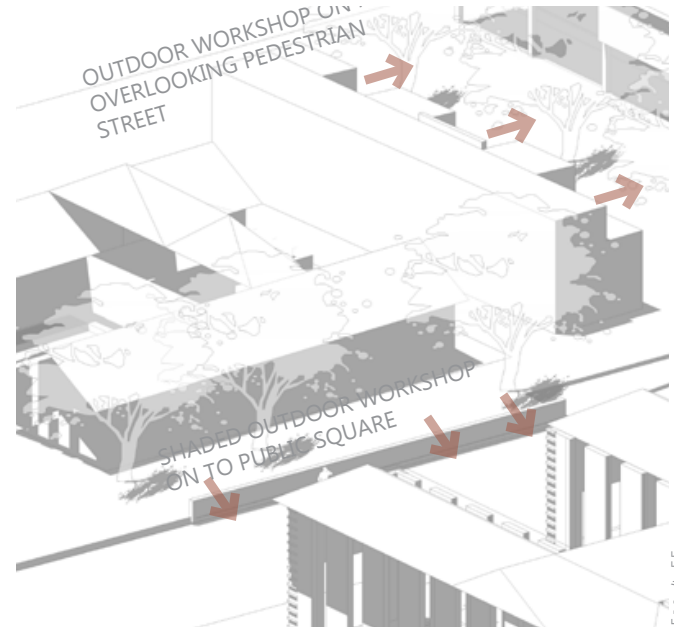
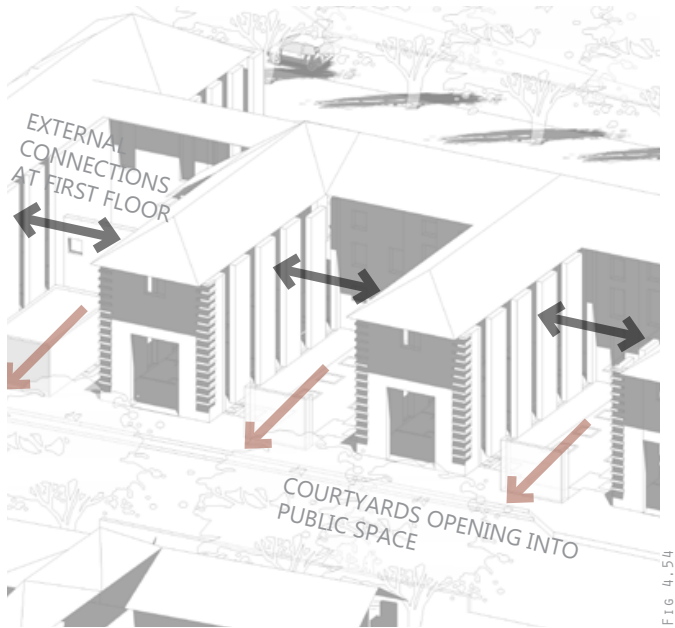


FIG 4.54 STRATEGY FOR SELF HELP SKILLS TRAINING CENTRE EXTRAVERSION OF THE FORMER PASS DETENTION FACILITY SO THAT IT ENGAGES WITH ITS URBAN ENVIRONMENT( AUTHOR 2012)

FIG 4.55. STRATEGY FOR THE CRAFT AND RECYCLING CENTRE( AUTHOR 2012)



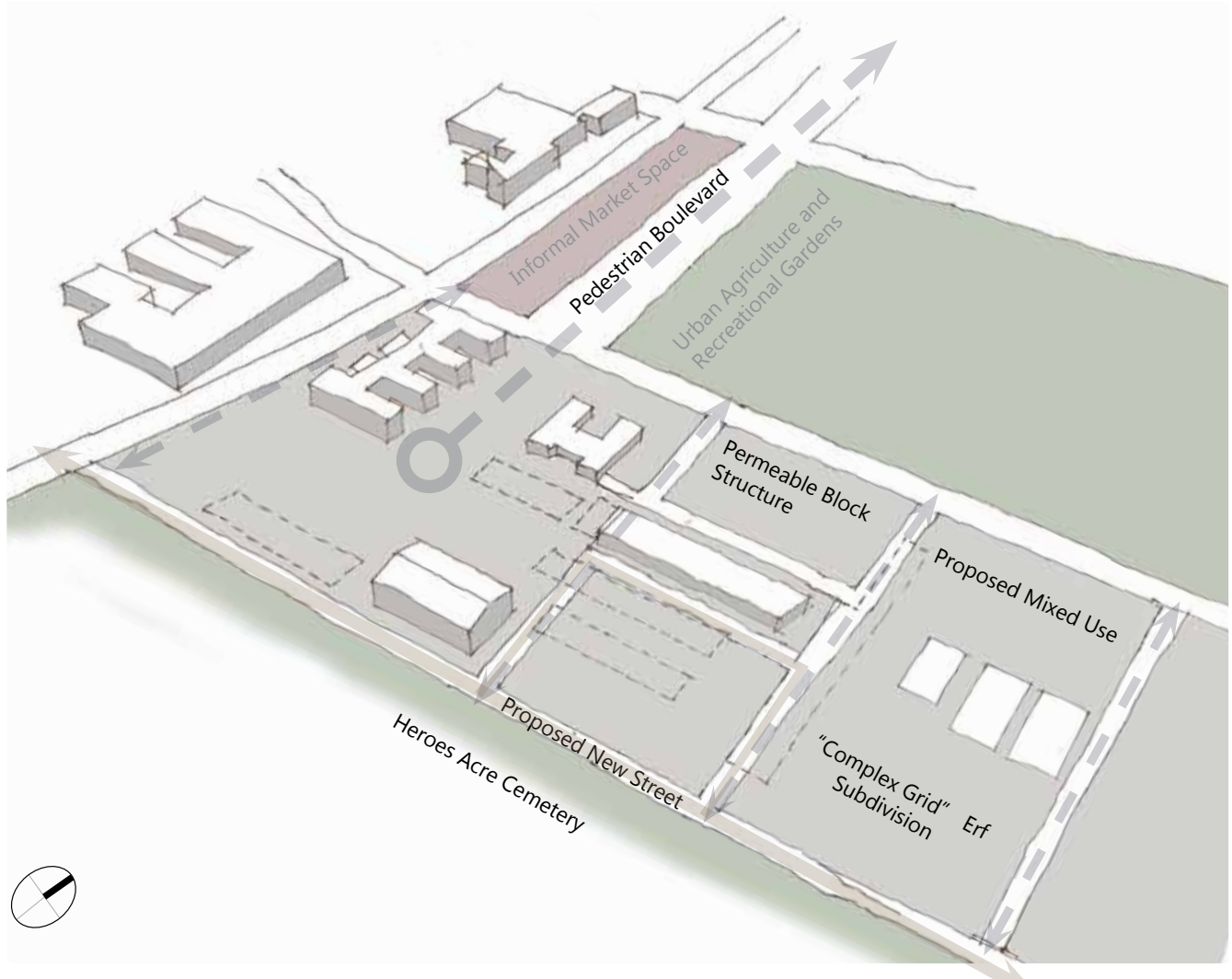


FIG 4.56. CONCEPTUAL SITE DEVELOPMENT 1 (AUTHOR 2012)

FIG 5.56

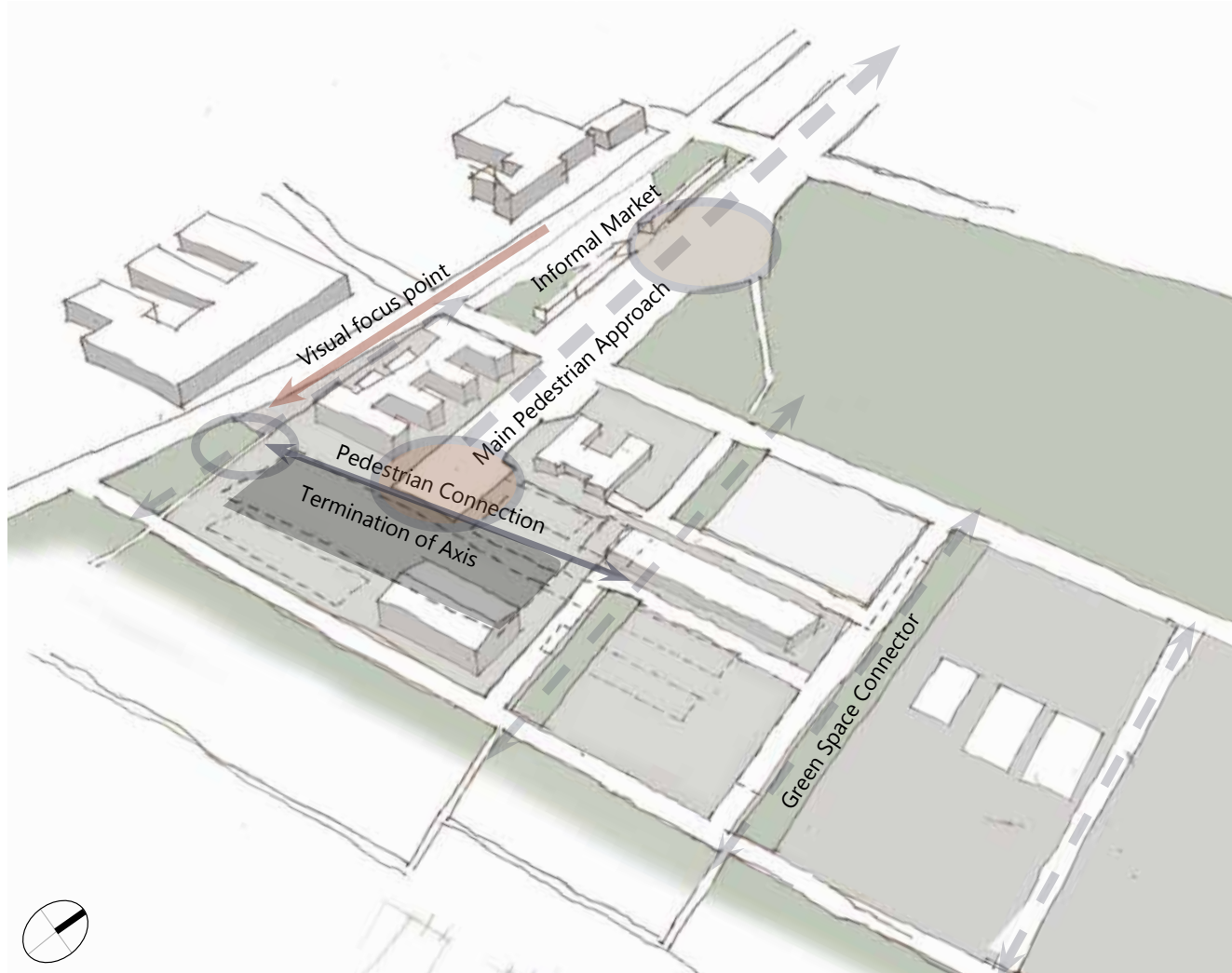


FIG 4.57 CONCEPTUAL SITE  
DEVELOPMENT 2  
FIG 5.57 (AUTHOR 2012)

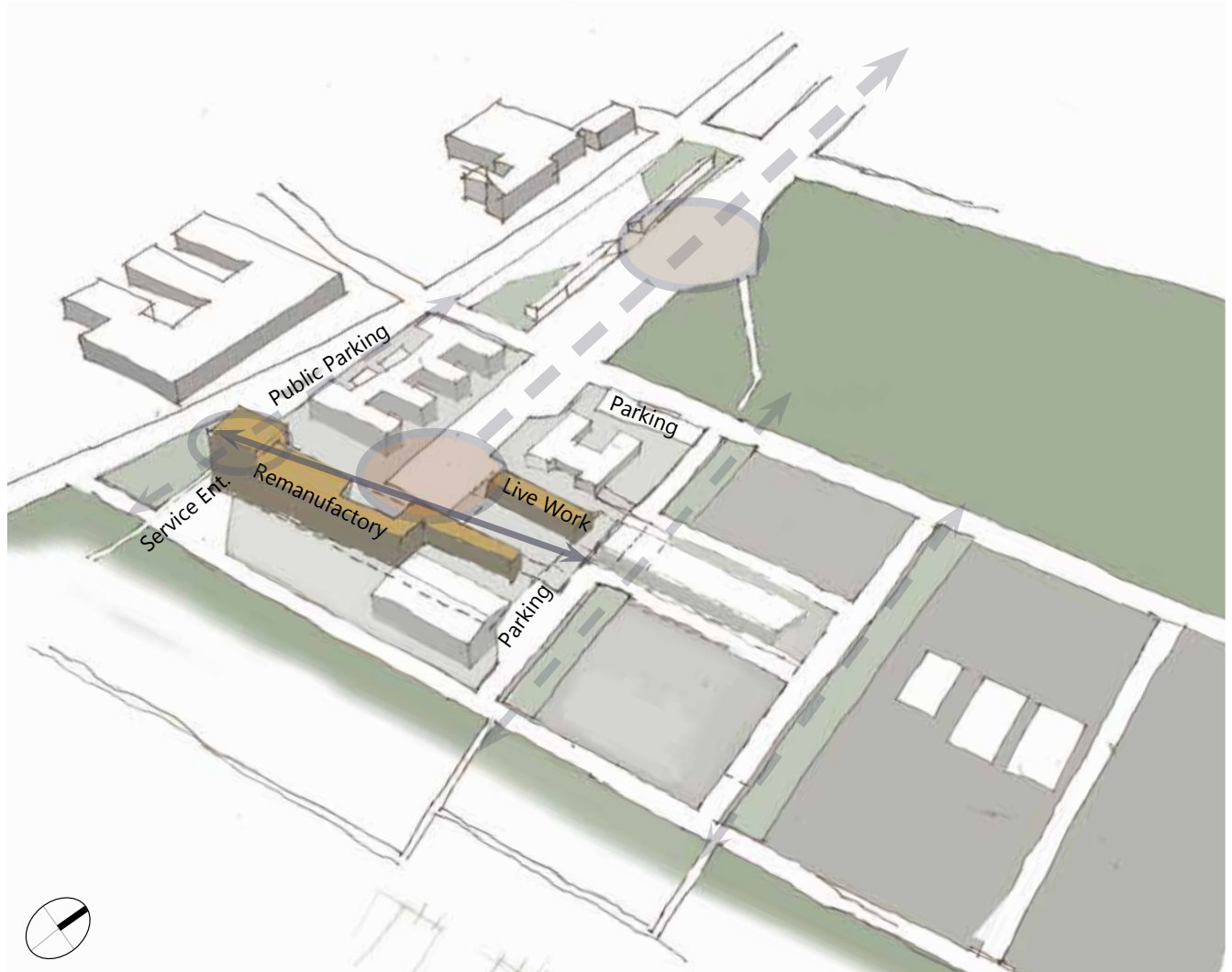


FIG 4.58 CONCEPTUAL SITE  
DEVELOPMENT 3  
(AUTHOR 2012)

[contemporary relevance]

CONSUMPTION MICRO INDUSTRY ICT  
REVOLUTION SPRAWL DIGITAL DIVIDE +

[type]

INERT SHRINKING LARGE SCALE  
TEMPORARY GLOBAL

+

[context]

TERRITORIAL HUMAN SCALE RECYCLING CULTURE ON  
STREET INNOVATION SMALL BUSINESSES SHARED  
SPACE STEREOTOMIC STATIC EDGE INHABITING THE  
SKIN

+

[theory]

SPACE OF FLOWS TRANSPARENCY COLLABORATION  
PLACE IMMATERIAL NEW FLATNESS PLACES OF  
REAL TIME EXCHANGE INHERITANCE VALUE

## PART 2

### DESIGN DEVELOPMENT

The themes and problems identified in Part 1 were used to determine an appropriate programme, and design solution. The synthesis of the theoretical investigation suggested that the selected programme was to take into account the existence of a local industry, should respond programmatically and architecturally to the activities that are currently taking place on site, and deal with the collateral damage of the digital age of consumption.

# 05 . PROGRAMME |

## 5.1 | PROGRAMME REASONING

The primary industrial programme is an electronics waste material recovery facility. The material processing facility is concerned with the collection, dismantling and recovery of materials and secondary raw materials for reuse.

The selected programme is a theoretical response to the social, spatial, and environmental impacts of the information age. Contextually the re-processing facility, responds to existing recycling, productive and commercial activities.

### 5.1.1 | A LOCALLY EMBEDDED INDUSTRY

The strong recycling culture of the Marabastad commercial precinct and the light industrial activities to the west of the site reprocess discarded materials into goods with value.

Beyond plastics, cardboards and second hand clothing, local reuse and recycling is extending to include e-waste. Concealed within the more formal spaces of shops and workshops, the value of information technology is prevalent.

Many small businesses and entrepreneurs within the study area deal with the service and sale of new, obsolete

and second hand electronic products or components. The presence of an e-waste processing facility, will be able to support the existing local industry and retail activities, providing a resource site for small business development, raw materials, training and access to information.

### 5.1.2 | E-WASTE SOURCES AND NETWORKING POTENTIAL

The sources of electronic waste is in close proximity to the commercial and corporate centre of the city. Businesses replace their information technology equipment on an average of 5 years ( Personal Communication Business Connexion 2012)

Its position near a major access route in and out of the city, presents the opportunity to capture domestic markets.

The interaction of these multiple stakeholders present an opportunity for a local productive network ( Fig 5.1)

FIG 5.1 NETWORKING  
POTENTIAL OF SITE AND  
SELECTED PROGRAMME  
(AUTHOR 2012)



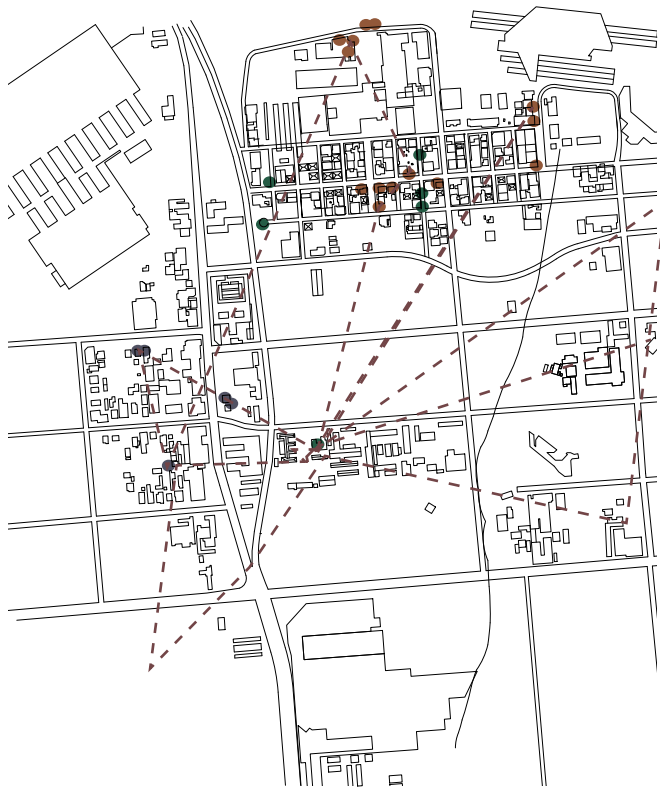


FIG 5.1.

- SCRAP METAL DEALERS
- LOCAL RECYCLING
- SALE AND SERVICES OF SECOND HAND ELECTRONICS



FIG 5.2



FIG 5.3

FIG 5.2 REPAIR OF MOBILE DEVICES ON MAJOR PEDESTRIAN ROUTE ( SLABBERT 2012)

FIG 5.3 INNOVATIVE GEYSERS( SLABBERT 2012)



FIG. 5.4

FIG 5.4 | A LOCAL SHOP THAT SPECIALIZES IN THE SALE OF OBSOLETE CONSUMER ELECTRONICS THAT NEVER REACHED THE MARKET. (AUTHOR 2012)



FIG. 5.5

FIG 5.5 | A LOCAL COMPUTER SHOP SELLING SECOND HAND TECHNOLOGY DAILY PLACES UNRECOVERABLE ELECTRONICS OUTSIDE, TO BE TAKEN BY THE PUBLIC. (AUTHOR 2012)



FIG. 5.6

FIG 5.6 | A LOCAL ELECTRONICS SHOP SPECIALIZING IN SPARE PARTS AND SERVICING (AUTHOR ET AL. 2012)



FIG. 5.7

FIG 5.7 | DISCARDED CELLULAR PHONE FOUND ON SITE. (AUTHOR 2012)



FIG 5.8



FIG 5.9

“...THE INFORMATION ECOSYSTEM IS A FEROCIOUSLY DARWINIAN PLACE THAT PRODUCES ENDLESS MUTATIONS AND QUICKLY WEEDS OUT THOSE NO LONGER ABLE TO ADAPT AND COMPETE.”

(MITCHELL 1996;5)

FIG 5.8|A LOCAL ELECTRONICS SHOP SELLING NEW RECOVERED TECHNOLOGY FROM IT COMPANIES (AUTHOR 2012)

FIG 5.9|AN INFORMAL WORKSHOP (AUTHOR ET AL. 2012)

LOCAL E-BUSINESSES | MANY FORMAL BUSINESSES WITHIN MARABASTAD TRADE IN SECOND HAND AND OBSOLETE ELECTRONICS AND COMPONENTS. EVEN BROKEN ELECTRONICS FIND A MARKET AND ARE TAKEN FROM PAVEMENT EDGES AND REUSED

### 6.1.3 A GLOBAL CONSUMPTIVE PROBLEM

The significance of the proposed programme becomes evident on a global scale. UNEP (2009:55) reports suggest that a total of 40 million tonnes are added globally each year.

E-waste is becoming South Africa's fastest growing waste stream, projected to increase by 400% in the next ten years. (UNEP 2008). In an industry whose value is placed in the processing of information, companies upgrade computers on a yearly basis as the hardware is unable to adapt to new software that ensures that they are able to compete. The rate of consumption of electronic devices is also accelerated by its design, which doesn't encourage disassembly.

A life cycle assessment of electronic products, indicate their relatively short life spans as technology is continuously updating and becoming obsolete. E-waste has been described as the collateral damage of the ICT Revolution, contributing 17 % of landfill content and classified as hazardous waste when improperly discarded. (UNEP 2008).

The carbon footprint contributes 2% of global Carbon emissions ( Gartner, Finlay 2010) and is estimated to quadruple by the year 2020. ( Boccaletti, Finlay 2010).

E-waste includes white goods, consumer electronics and information technology. Many countries do not have the facilities to deal with the toxic elements of this electronic waste, and lack of legislation allows the illegal dumping of these toxic elements into the environment.

The global response has been the initiation of legislation concerning e-waste management strategies , increased awareness programmes and the development of a global network for the processing of various fractions of e-waste.

Additionally electronics make use of many recyclable high value and precious metals, such as gold which is lost through discarding and improper extraction techniques ( UNEP 2008).

FIG 5.10 GLOBAL ELECTRONICS MANUFACTURING NETWORK INDICATING THE CARITY OF SOURCES OF MATERIAL AND THE DIVISION OF LABOUR

# Global electronics Manufacturing Network

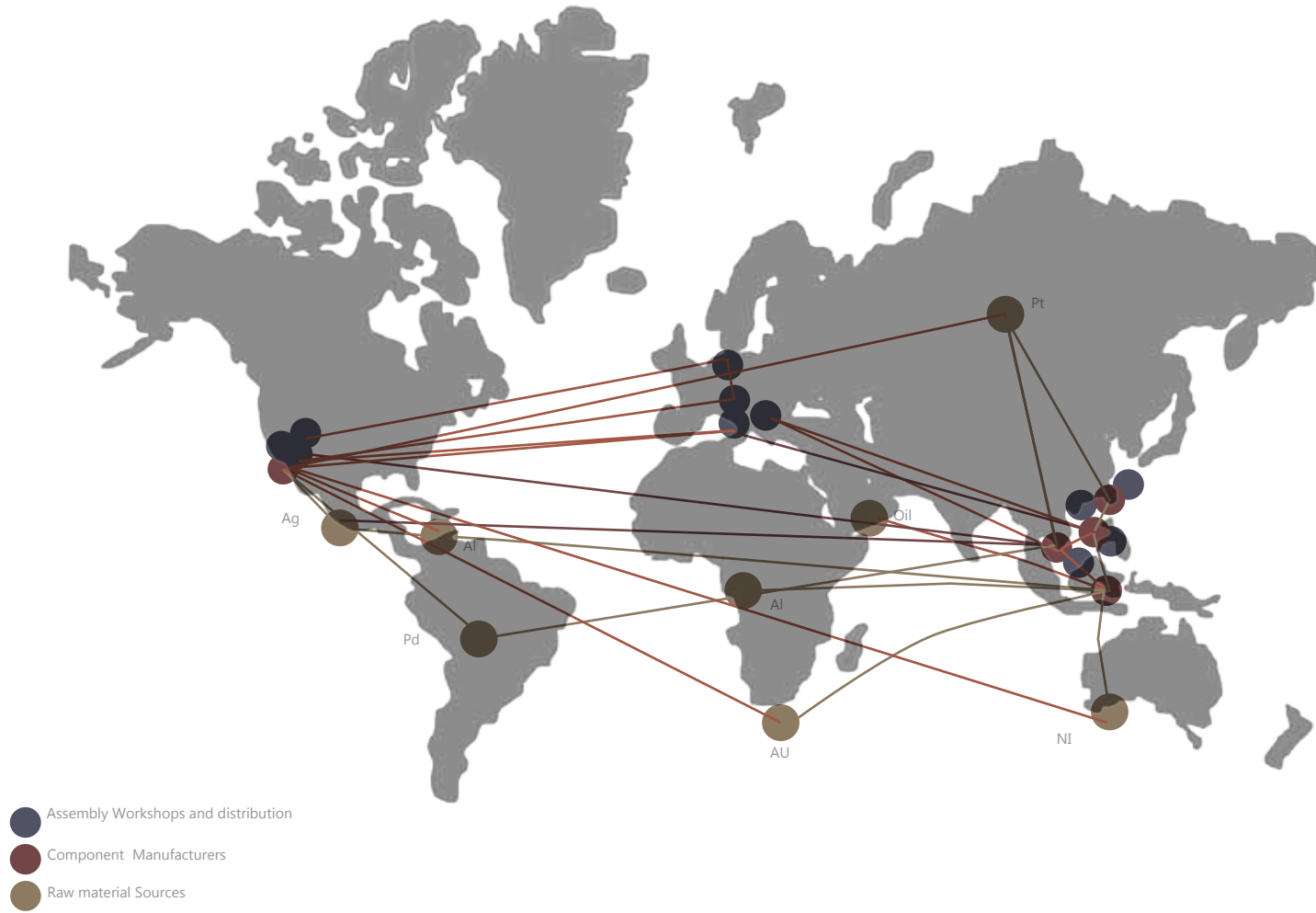


FIG 5.10



## Global Electronics Waste Streams



FIG 5.11 GLOBAL ELECTRONICS WASTE STREAM (AUTHOR 2012)

FIG 5.11

### 6.1.4 | E-WASTE AND THE INFORMAL SECTOR

The informal recycling of e-waste presents both an opportunity and a problem. The improper handling of electronics which contain toxic elements, is dangerous for both the environment and the people who handle them. As an uncontrolled and un-monitored process , informal e-cycling contributes to pollution, health risk and exploitation. (EWASA 2008)

Developing countries worldwide are experiencing the problems associated with this informal **urban mining** practice, where dangerous toxins are leached into the environment and carcinogens inhaled with the burning of plastics and the dangerous electrochemical processes used to extract precious metals from printed circuit boards, as observed in China, India and Lagos, Nigeria.

From a positive point of view the informal dismantling and refurbishment of electronic waste, has created entrepreneurial opportunities, increased access to information technology to those which cannot afford it, and job creation. The “Computer Village” in Lagos demonstrates this growing market.



FIG 6.12

FIG 5.12 BURNING OF E-WASTE IN ACRA, GHANA (WWW.NATIONAL GEOGRAPHIC .COM 2012)



FIG 6.13

FIG 5.13 INFORMAL COLLECTION OF E-WSATE FOR COPPER STRIPPING ( WWW.EPA.GOV 2011)



### 5.1.5 | ECONOMIC AND SOCIAL POTENTIAL FOR SOUTH AFRICA

According to the 2009 UNEP Report on *Sustainable Innovation and Technology Transfer in Industrial Sectors* South Africa has the potential in becoming an innovation hub within the e-cycling industry, since its much smaller economy improves faster in awareness and competence. ( UNEP 2009:vii)

E-waste can become a resource for economic and social development. An E-waste Assessment Report on South Africa( Finaly and Liechti 2008) illustrates that manual dismantling of e-waste is a value adding process that

- A. Creates wage oppurtunities
- B. Recovers high value components
- C. Allows for a more efficient recovery of metals
- D. Eliminates exposure to dangerous substances in processing
- E. Creates markets for processed fractions
- F. Supports small business start up
- G. And encourages technology transfer.

FIG 5.14 MARKET VALUE OF MATERIALS BASED ON PERCENTAGE COMPOSITION. ( CSR BRAKPAN: 2012)

FIG 5.15. MONETARY VALUE PER KG OF MATERIAL SEPERATED, BASED ON MARKET VALUES OF MATERIALS MAY 2012. ( CSR BRAKPAN: 2012)



FIG 5.14

FIG 5.15

### 5.1.6 THE LOCAL E-WASTE NETWORK

The processing of e-waste is a multiple stakeholder process, governed by recent legislation and non-statutory bodies.

The various actors involved in the process vary from refurbishers, dismantlers and downstream recyclers. The breaking down of the e-waste process into its different stages allows opportunity for both small and big businesses to exist within a collaborative network. ( Fig 5 .17)

The E-waste Association of South Africa, is the regulatory body for the management and processing of e-waste, allowing an “elegant organization” of and interaction between the various collectors, recyclers, refurbishers and secondary processors in industry.

It is proposed that the network nature of the industry can form the user base for the proposed design intervention, and as a result an new agglomeration or innovation system that can serve a civic function.

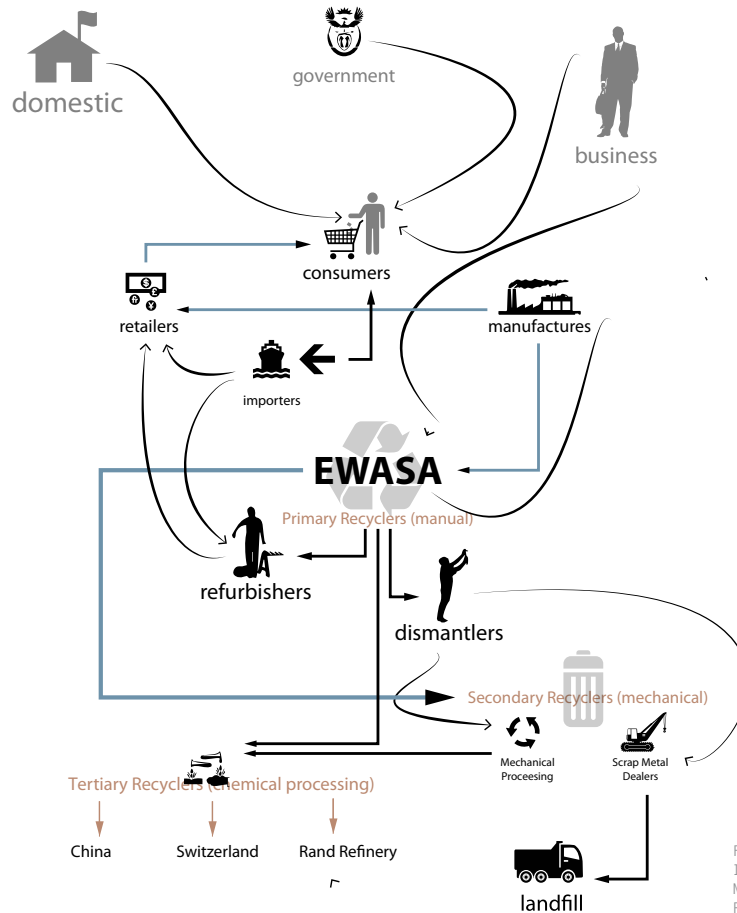


FIG 5.16. DIAGRAM INDICATING THE NETWORK NATURE OF E-WASTE PROCESSING IN SOUTH AFRICA ( AUTHOR 2012)

## 5.2 | E-WASTE PROCESS

### 5.2.1 | PROCESS DIAGRAM

Similar to all industrial processes the e-waste process makes use of a linear production line of inputs and outputs. A generic production diagram indicates the main stages of the recycling and refurbishment processes and their sub-processes. (Fig 5.19). The variation of the production diagram between mechanically and manually processed material, indicates a difference in value assigned to the by-products and products of the process.

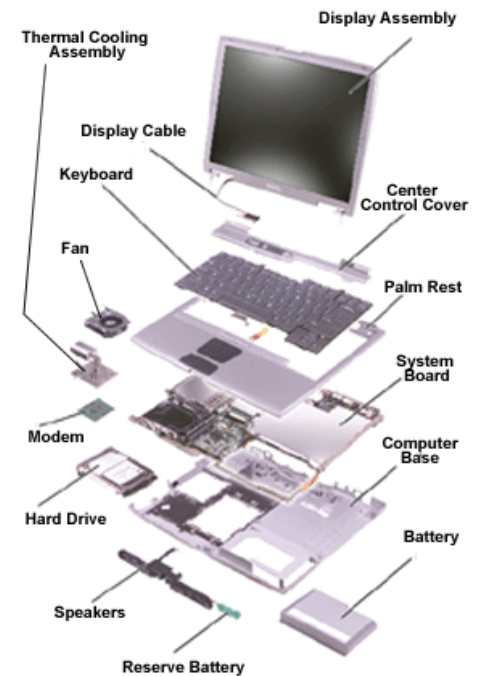


FIG 5.17 | RECOVERABLE COMPONENTS OF COMPUTERS  
( WWW.PROPROFS.COM )

FIG 6.18

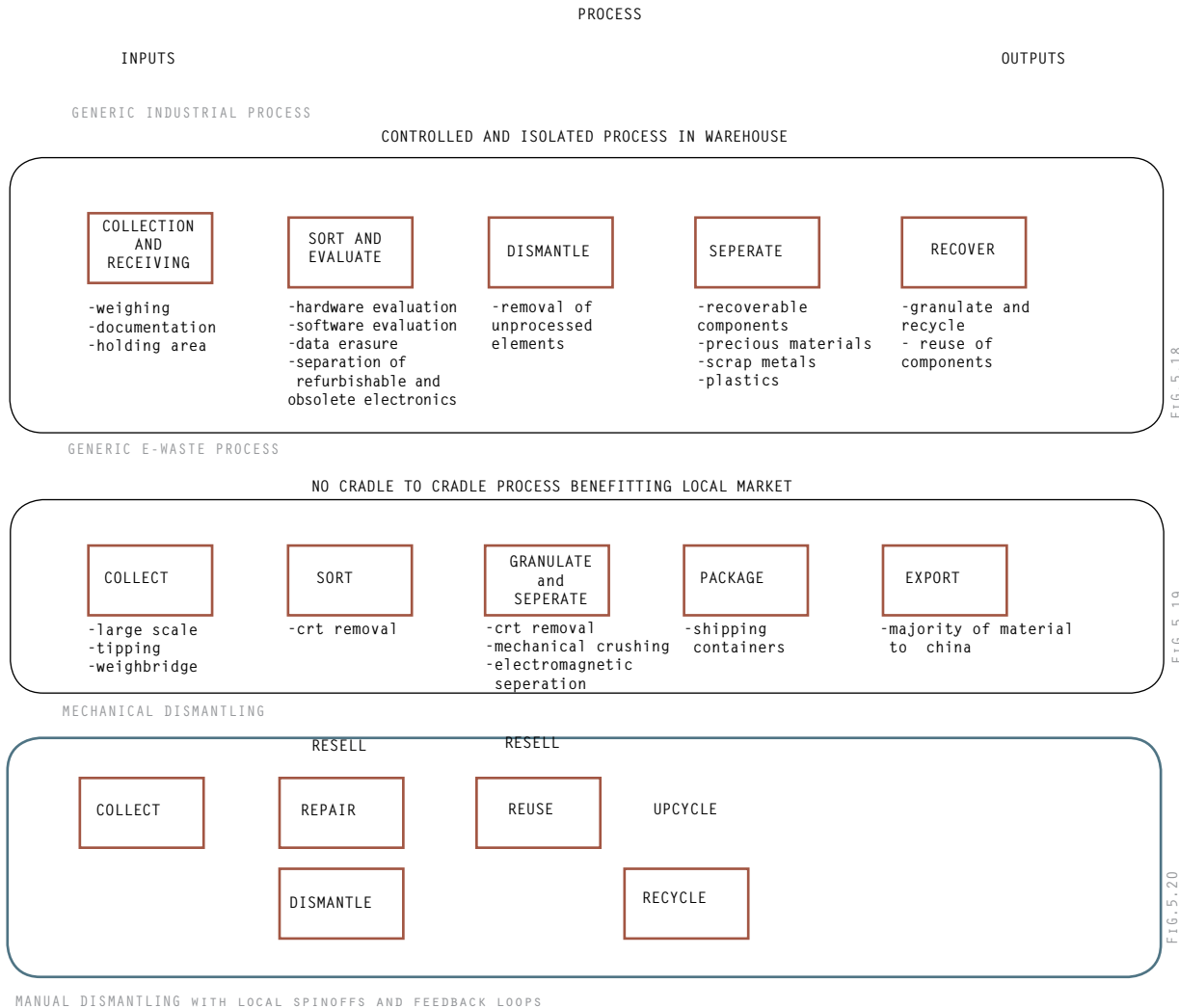


FIG.5.18

FIG.5.19

FIG.5.20

FIG 5.18|CRADLE TO CRADLE EEE MANAGEMENT SYSTEM. INDICATING THE VALUE OF THE PROCESS( WWW.URBANMINING.ORG)

FIG 5.19|EXTRAPOLATION OF CRADLE TO CRADLE MANAGEMENT SYSTEM, ILLUSTRATING THE VALUE ADDED PROCESS OF MANUAL PROCESSING.( AUTHOR 2012)

FIG 5.20|EXTRAPOLATION OF MECHANICAL PROCESS INDICATING A CONTROLLED AND TOXIC PROCESS WITH MATERIAL LOST TO INTERNATIONAL MARKETS. ( AUTHOR 2012)

MANUAL DISMANTLING WITH LOCAL SPINOFFS AND FEEDBACK LOOPS

### 5.2.2 | MECHANIZED PROCESSING OF E-WASTE

Mechanized material processing facilities, make use of crushing and granulation of e-waste, from the start of the process before material is separated. The material handling system often includes the tipping of containers, resulting in damage to the toxic elements of the electronics, creating a dangerous working environment for the workers and no opportunity for the reuse of components in their original state. This is contrary to the cradle to cradle recycling process which promotes first reduction, then re-use, and finally recycle.



FIG. 5.21

### 5.2.3 | MANUAL PROCESSING OF E-WASTE

Manual dismantling of e-waste is a value adding process that separates materials more efficiently and allows for the recovery and reuse of components in their original state. The manual removal of toxic and lead containing elements such as cathode ray tubes, and batteries, prevents leaching into the environment, and controlled processing.

The working environment, is low risk for workers, requiring only basic protective equipment, as opposed to the use of masks in a controlled mechanical process.



FIG. 5.22

FIG 5.21 | THE MANUAL DISMANTLING OF ELECTRICAL EQUIPMENT, WHERE THE WORKING ENVIRONMENT IS SAFER AND MORE HUMANE. ( DESCO ELECTRONIC RECYCLERS 2012)

FIG 5. 22 | THE MECHANICAL DISMANTLING PROCESS, REQUIRING MASKS, AND WATERING DOWN OF SHREDDED FRACTIONS TO REDUCE TOXIC CHEMICALS RELEASED INTO THE WORKING ENVIRONMENT ( DESCO ELECTRONIC RECYCLERS 2012)

### 5.3.3 | TYPICAL PLANT LAYOUT AND WORKING ENVIRONMENTS

As a result of this network setting a typical plant layout for an e-waste processing or material recovery facility is still in its infancy, as the industry emerges and demand grows. Plants range in size from 335msq to 10000 msq, from adaptive reuse of small spaces, to large warehouse buildings, and from manual processing to mechanical processing.

The common element between these facilities, is an introverted nature, which does not create public awareness of the existence of such facilities.

The adjacent images illustrate the varying scale and layout of e-processing facilities, that accommodate the entire process or just elements of the process.

The design proposal investigates the re-configuration of the typological parts of an e-waste facility, that responds to and is integrated in to the social life of it's context.



FIG 5.23

FIG 5.23 | EXAMPLE OF FITTING OUT A RECYCLING AREA  
( VARIN, B & ROINAT, P 2008

## 5.3 | PIXELLATING THE PROCESS

The dissertation will focus on the design of a manual dismantling and refurbishing material recovery facility, with a public and semi public component.

The intention will be to reduce the inactive warehouse container, by reducing the size of the administrative and controlled area to the minimum to which is necessary, which includes goods receiving, data erasure, and dispatch.

The proposed facility will co-ordinate the material flow of independent workshops.

Mechanical processing of material fractions will not be included within the proposal, for health reasons, zoning reasons and the existing socioeconomic context.

A simplified flow diagram which follows illustrates the production diagram that will be used to generate the design.

FIG 5.24 | INTERIOR OF COLLECTION FACILITY OF LOWER EAST SIDE ECOLOGY CENTRE NEW YORK. CAPACITY 30000 LBS /MONTH (WWW. INHABITAT.COM 2011)

FIG 5.25 | EXTERIOR OF COLLECTION FACILITY OF LOWER EAST SIDE ECOLOGY CENTRE NEW YORK. CAPACITY 30000 LBS /MONTH (GOOGLEMAPS 2012)

FIG 5.26 | AERIAL VIEW OF LARGE E-WASTE PROCESSING FACILITY IN KEMPTON PARK, JOHANNESBURG. (DESCO ELECTRONIC RECYCLERS 2012)



FIG 5.24



FIG 5.25



FIG 5.26





LARGE INERT WAREHOUSE BUILDING HOUSING THE PROCESS

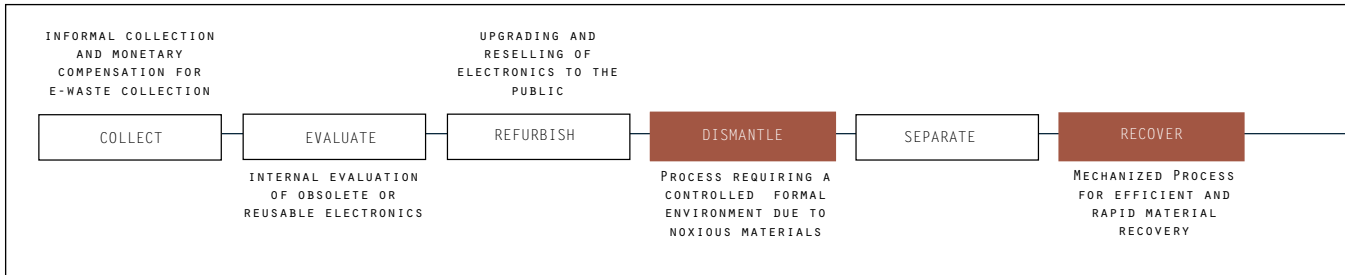


FIG. 5.27



REDUCED CONTROL FORM ORGANIZING THE INTERACTION OF DIFFERENT ACTORS

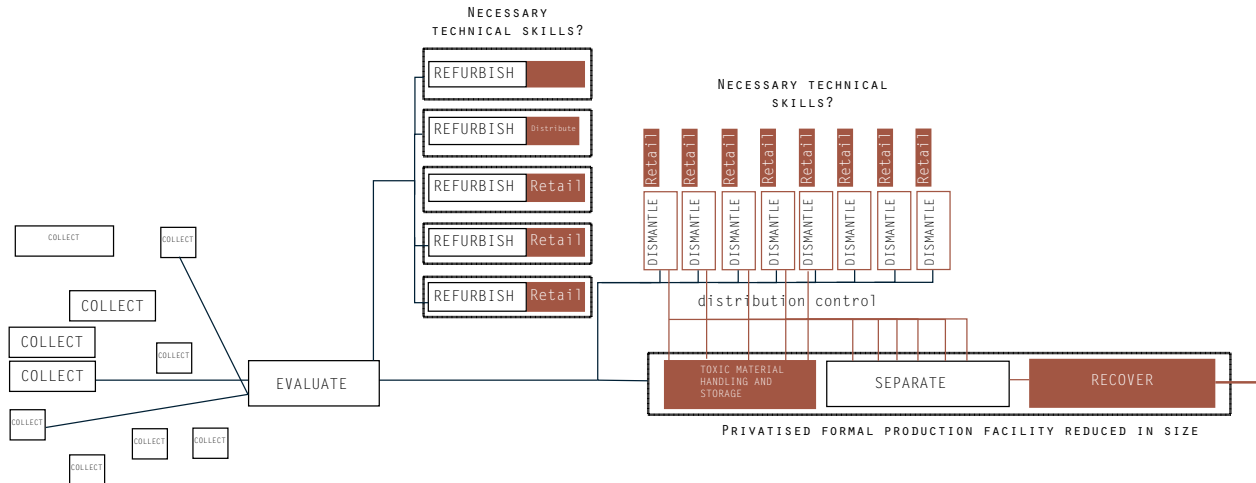


FIG. 5.28

FIG 5.27 | DIAGRAM INDICATING THE PROCESS THAT IS USUALLY CONTAINED WITHIN AN ANONYMOUS BUILDING ENVELOPE. (AUTHOR 2012)

FIG 5.28 | DIAGRAM INDICATING THE CONCEPTUAL INTENTION OF THE PROGRAMMING BY INCLUDING MULTIPLE PARTICIPANTS AS A MEANS OF SOCIALLY ACTIVATING THE PROGRAMME. (AUTHOR 2012)

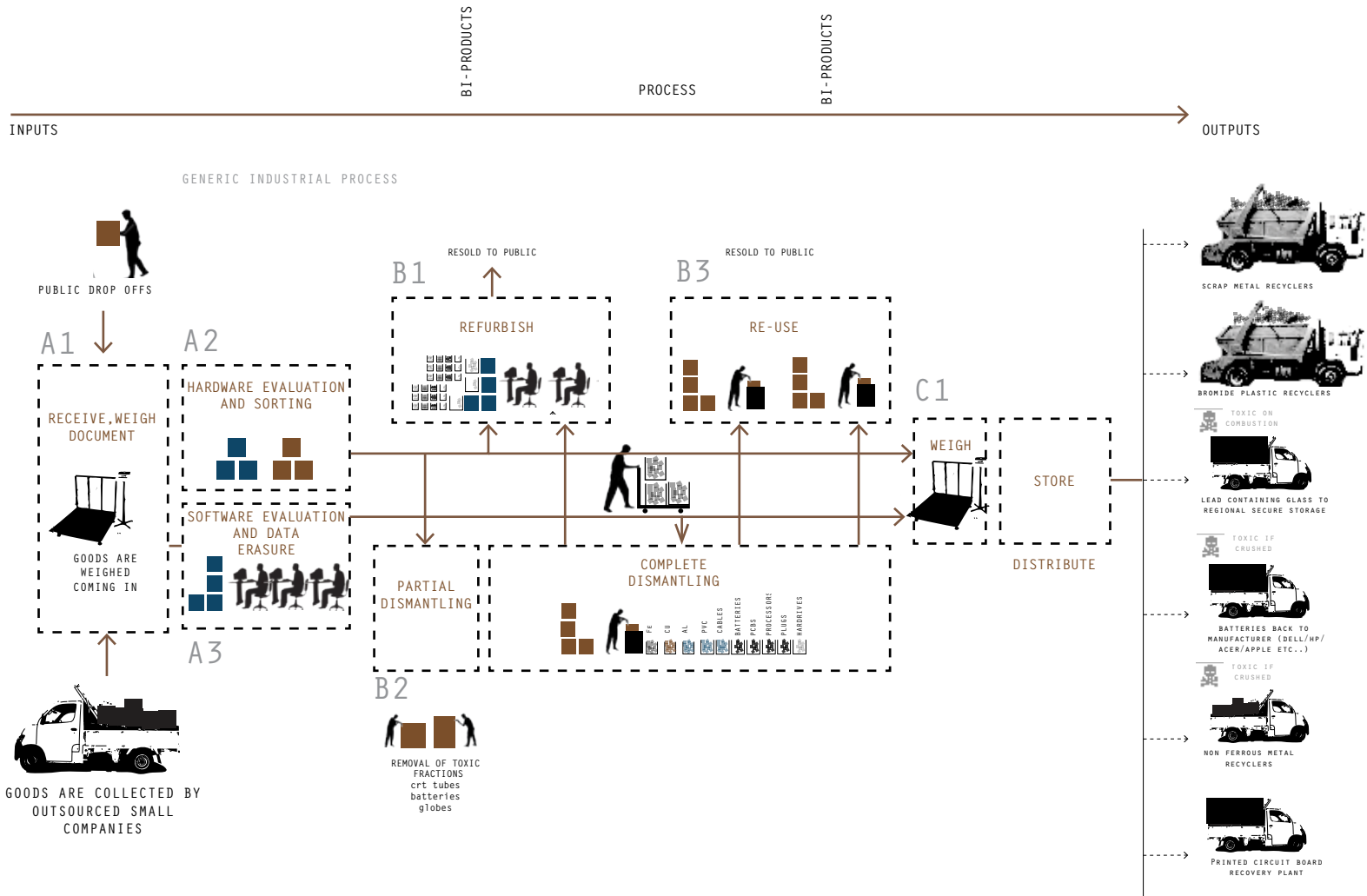


FIG 5.29 PROCESS DIAGRAM 2012)

## 5.3 | PROCESS DIAGRAM

### A1 GOODS RECEIVING

RISKS MEDIUM FIRE RISK  
NEEDS SECURE STORAGE  
MATERIALS FULL COMPONENTS  
FLOWRATE 15 UNITS/HR/PERSON

### A2 HARDWARE EVALUATION

RISKS LOW RISK  
NEEDS PLUG POINTS  
MATERIALS FULL COMPONENTS  
FLOWRATE 15 UNITS/HR/PERSON

### A3 SOFTWARE EVALUATION AND DATA ERASURE

RISKS LOW  
NEEDS SECURE COMPUTER LAB  
MATERIALS DATA CONTAINING DEVICES  
FLOWRATE 1 UNIT/HR

### B1 REFURBISHMENT

RISKS LOW  
NEEDS RETAIL INTERFACE SECURE.STORAGE.CLEANING  
MATERIALS-COMPONENTS.MONITORS PCS,  
LAPTOPS,PRINTERS

### B2 DISMANTLING

RISKS MEDIUM  
NEEDS PROTECTIVE EQUIPMENT,TOXIC MATERIAL STORE  
MATERIALS PRECIOUS  
FLOWRATE 9 UNITS/HR/PERSON

### B3 UPCYCLING

RISKS LOW  
NEEDS ACCESS TO MATERIALS RETAIL INTERFACE  
MATERIALS RECLAIMED SMALL COMPONENTS  
FLOWRATE N/A

### 5.3.1 | FUNCTIONAL PROCESS DIAGRAM

The E-waste recycling process consists of two major divisions, dismantling and material recovery and secondly refurbishment and component recovery. The adjacent diagram illustrates a simplified workflow of the process. It illustrates the non-linear nature and feedback loops inherent in the process, which need to be translated spatially in an “elegant organization”, to increase productivity by facilitating the seamless flow of materials.

## 5.4 | A GLOCAL PROGRAMME

PROCESSING FACILITY ACCOMMODATION SCHEDULE	INTERFACING CONDITION	LOCAL AND MICRO-INDUSTRY NEEDS
EWASA ADMINISTRATION	PUBLIC AND VISITOR ENTRANCE	UPGRADING OF EXISTING INFORMAL RECYCLING NETWORK
STAFF FACILITIES	VIEW OUT	MICRO-INDUSTRY SUPPORT
GOODS RECEIVING HOLDING AREA AND LOADING BAYS	PUBLIC CLEAN AND DIRTY DROP OFF	WIFI CAFE
DIAGNOSTICS	RETAIL AND SERVICE CENTRE INTERFACE	- ACCESS TO NETWORK - ACCESS TO HARDWARE - ACCESS TO NETWORK AND MEETING SPACE
REFURBISHMENT WORKSHOP	VIEW IN NETWORKING SPACE SEMINAR SPACE	- STUDY CENTRE FOR SKILLS TRAINING CENTRE
DISMANTLING WORKSHOP	RETAIL AND SERVICE CENTRE INTERFACE	PUBLIC COMPUTER
UPCYCLING WORKSHOP	VIEW OUT	
RESEARCH AND DEVELOPMENT		
STORAGE AND DISPATCH		

FIG 5.30 | TABLE INDICATING THE VARIOUS PROGRAMME ELEMENT INTERFACE WITH A LOCAL CONDITION (AUTHOR 2013)

FIG.5.30. TABLE INDICATING PROGRAMME INTERFACING

## 07 | CONCLUSION

The benefit of a public interface is the generation of a local market and increased public awareness, ultimately increasing material flow.

The selected programmes are aimed at generating self capacity for smaller companies and individuals, through a shared resource

The concept of “plug-ins” was applied in the generation of the programme. Plug-ins in computational terms refer to programmes or components that add value or gain value from and to a process, in a multidirectional flow ( Fig 5.30 ). A conversation between the various programme elements act as value adding and value taking elements.

The facility therefore acts as a shared civic resource.

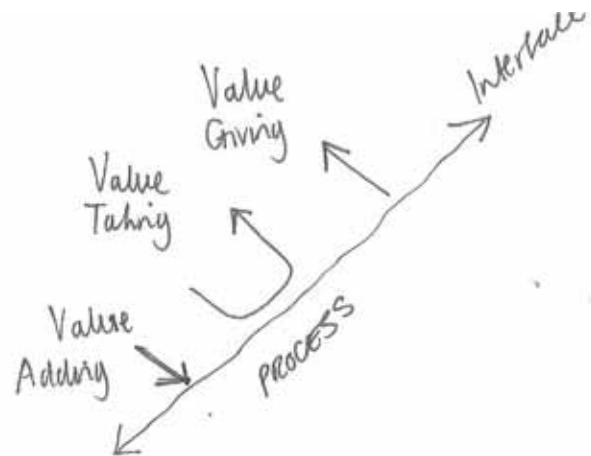


FIG.5.31. ( AUTHOR 2012)

FIG 5.31|DIAGRAM  
INDICATING THE CONCEPT OF  
PLUG INS ( AUTHOR 2012)

# 06 . PRECEDENT STUDIES |

TYPE: DESIGN + TECHNICAL+ THEORETICAL

## 6.1 INFORMATION AGE

### 6.1.1 NATIONAL LIBRARY PROPOSAL 1992

TOYO ITO  
PROGRAMME: LIBRARY

Toyo Ito's National Library in Paris 1992, is conceptualized as a transparent spatial container, where the content supercedes the container. It expresses the immateriality as an architectural expression of the electronic age and its space of flows. The spatial organization consists of rows of contained spaces alternating between service courtyards. The services from a horizontal rhizome throughout the structure and elliptical forms interrupt the flow signifying a " convergence of energy (Puglisi 1999) The skin becomes a transparent surface that is subordinate to the content.

#### DESIGN APPLICATION:

The theoretical position of content superceding the container, is challenged in the dissertation by examining the value of the envelope condition in relationship to a specific site. The use of transparent material, as a waterproofing solution, and treatment of horizontal and flexible services are explored.

FIG 6.1 | EXTERIOR OF  
COLLECTION FACILITY OF  
LOWER EAST SIDE ECOLOGY  
CENTRE NEW YORK. CAPACITY  
30000 LBS /MONTH





FIG. 6.1. PUGLISI 1999 : 55



FIG. 6.2 PUGLISI 1999:55



FIG 6.3. PUGLISI 1999:56

FIG 6.1-6.3|Toyo Ito  
SUBMISSION FOR NEW  
NATIONAL LIBRARY IN PARIS  
( PUGLISI 1999 : 55)

## 6.1.2 POMPIDOU CENTRE, PARIS

RICHARD ROGERS AND RENZO PIANO  
PROGRAMME:

The Centre Pompidou is a built expression of a strong archigram influence, during the late 1980's. The architects describe the project intention as creating a "flexible container" ([www.rsh-p.com/@](http://www.rsh-p.com/@) 2010). This was achieved through the peripheral treatment of the services and articulation of the skin, structure and technology.

The building was intended to be a "dynamic communications centre" ([www.rsh-p.com/@](http://www.rsh-p.com/@) 2010), a hybrid between a communications centre and civic building. The superstructure is industrial in its expression of its bracing and external expression of vertical movement.

DESIGN APPLICATION:

The notion of transparency through structural expression relates to a more "machine oriented" expression of the digital age, compared Toyo ito's surfaces. The shed architecture creates a deep and habitable skin. The incubation of smaller spaces within a larger volume is of importance. The treatment of services and circulation. Its relationship to public space.



FIG. 6.4 | WWW.RSH\_P.COM 2010



FIG. 6.5 | WWW.RSH\_P.COM 2010

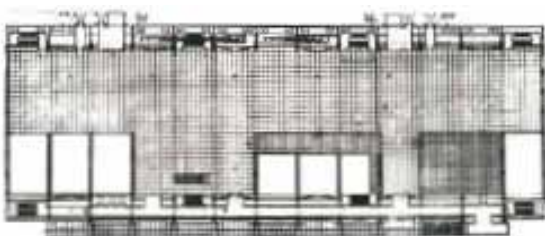


FIG. 6.6 | WWW.RSH\_P.

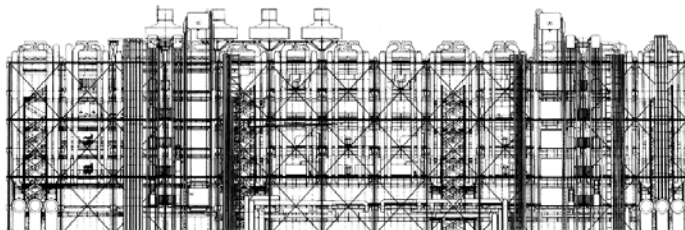


FIG. 6.7 | WWW.RSH\_P.

FIG 6.4-6.7 | CENTRE GEORGE  
POMIDOU. RENZO PIANO AND  
RICHARD ROGERS.  
( WWW.RSH\_P.COM )

TYPE: DESIGN + THEORETICAL

## 6.2 INDUSTRIAL TRANSPARENCY

### 6.2.1 VW TRANSPARENT FACTORY , DRESDEN

GUNTER HENN 2002

PROGRAMME: Vehicle Assembly Plant

#### DESIGN RELEVANCE

The VW Factory demonstrates a transformation of industrial production in the information age. The production process at the assembly plant becomes completely transparent to the public. Components are delivered into factory through specialized trams that run through the city, and create interest. Prospective buyers can walk into the production space, observe the assembly and make user specified choices.

The theme of transparency explored through surface and public interface relationships and the expression of movement within the building and with in the urban context.

The skin takes on the character of high tech transparency, where the assembled vehicles are visible from the outside, in a "storage silo" (Fig Ref). The factory resembles a building of a civic nature where the public is welcomed into the production space.

The roof and floor space of the factory becomes an electronic plug in surface, making floor spaces incredibly flexible. An electromagnetic circuitry in the floor moves kits of parts to various workstations.



6.8



6.9



6.10

FIG 6.8|TRAM SYSTEM FOR DELIVERY OF PARTS TO FACTORY. (WWW. EXAMINER.COM)

FIG 6.9|VEHICLE STORAGE SILO.( WITMAN 2002 IN WWW. AUTO-INTELNEWS.COM)

FIG 6.10|MODEL OF VW TRANSPARENT FACTORY(VOLKSWAGEN 2002 IN WWW.NOTCOT.ORG)

TYPE: THEORETICAL + PROGRAMMATIC (LEARNING FROM ADAPTIVE REUSE)

## 6.3 CO-WORKING SPACE

### 6.3.1 PIET HEIN EEK FACTORY, EINDHOVEN

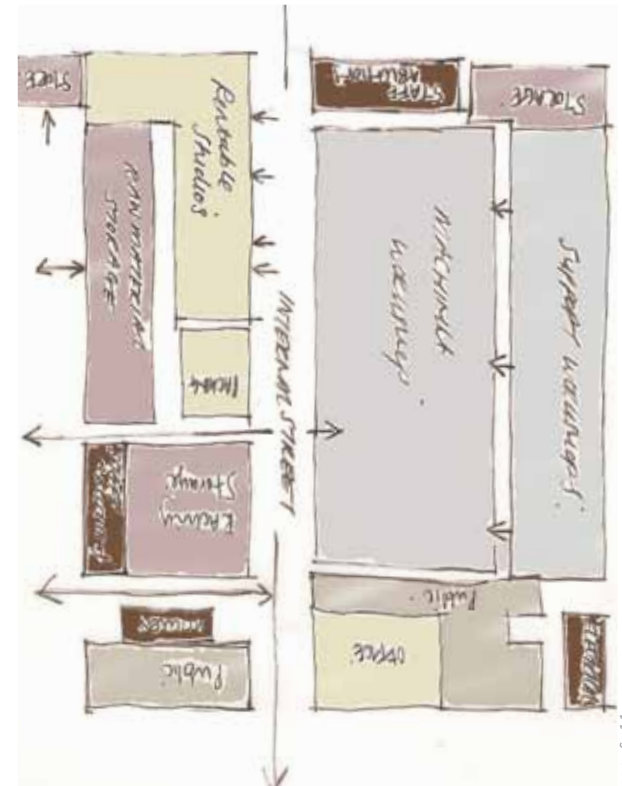
PIET HEIN EEK  
PROGRAMME: CO-WORKING PRODUCTIVE SPACE

Piet Hein Eek is an architectural and Recycled Wood Furniture Company that relocated their premises into an abandoned Phillips Ceramic Factory in an old industrial area. Design Sales and distribution take place within the enclosure of the large factory envelope. The precedent illustrates the transformation of spaces of mass production into a space that incubates small businesses and production processes.

Many small businesses make use of the same canteen facilities, shared shop and showroom, and shared workshops. Multiple loading bays and entrances exist for different users while the primary process uses only a portion of the buildings area. The result is a production building of mixed use character

#### DESIGN APPLICATION:

The functional co-ordination of multiple tenants and shared facilities and services, including loading bays, and public interface.



ANALYTICAL DIAGRAM OF FACTORY LAYOUT

FIG 6.11



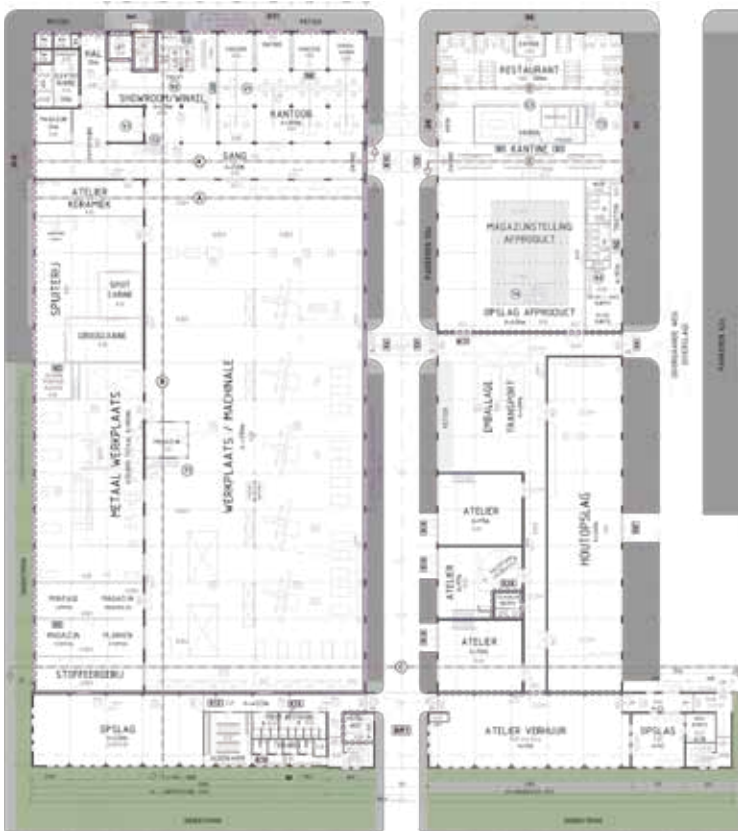


FIG. 6.12



FIG. 6.13

FIG 6.11 | ANALYTICAL  
DIAGRAM ( OPPOSITE )  
( AUTHOR 2012 )

FIG 6.12 | GROUND FLOOR PLAN  
PIET HEINEEK FACTORY.  
( HEINEEK 2010 : 4 )



FIG. 6.14

FIG 6.13 | VIEW OF OPEN PLAN  
WORKSHOP  
( WWW.PIETHEINEEK.NL/EN )

FIG 6.14 | MOVEMENT BETWEEN  
STORAGE AND PRODUCTION.  
( WWW.PIETHEINEEK.NL/EN )

## 6.3.2 GOOGLE CAMPUS LONDON

JUMP STUDIOS

PROGRAMME: ENTREPRENEUR CO-WORKING SPACE

The design is an adaptive reuse of a existing building. The project intention is to create cheap co-working space for small start ups.

Programmes Accommodated:

- 1.Seminar Rooms
- 2.Skype Pods
- 3.Auditorium
- 4.Meeting Rooms
5. Open plan Working Areas
- 6.Networking Event Space
- 7.Cafe

DESIGN APPLICATION:

The creation of human scaled spaces of interaction and collaboration. Small spaces within small mobile units. In expensive materials are used to provide the basic functional requirements for production. Incubation of small businesses in a larger building.



FIG 6.16 JUMP STUDIOS 2011



FIG 6.17 JUMP STUDIOS 2011



FIG 6.18 JUMP STUDIOS 2011

FIG 6.16 | OPEN PLAN CO-WORKING SPACE ( JUMP STUDIOS 2011 IN WWW. ARCHDAILY.COM)

FIG 6.17 | CONTAINERS AS SERVICE AREAS. ( JUMP STUDIOS 2011 IN WWW. ARCHDAILY.COM)

FIG 6.18 | GOOGLE CAMPUS FLOOR PLANS . (JUMP STUDIOS 2011 IN WWW. ARCHDAILY.COM)

TYPE: PROGRAMMATIC

## 6.4 E-WASTE PROCESS

### 6.4.1 | E-WASTE ALLIANCE MATERIAL RECOVERY FACILITY, CAPETOWN. 2008

ARCHITECT  
PROGRAMME: E-WASTE MATERIAL RECOVERY

The project intention was to “test the feasibility of a value-adding local e-waste management system.” (Empa/ Switzerland:2008), provide basic training and become a replicable prototype for an emerging industry. The main process comprises the manual dismantling, testing and refurbishment of electronics, with an additional waste to art component.

Plant Size\_335MSQ  
Annual Capacity\_150t/Annum  
Staff\_20

#### PLANT LAYOUT

The plant makes use of a rentable workshop, divided into three main production areas

A | Testing and Refurbishing 80 msq  
B | Dismantling 120msq  
C | Waste to Art.60 msq

#### LESSONS AND DESIGN APPLICATION

A| the eventual layout of the plant separated the refurbishment from the dismantling process

B| the inclusion of the waste to art facility was unsustainable, since there was no access to a local market and the craft was too specialized.

C| The required space for one person to work effectively on dismantling is 25msq.

D| High Rental costs of the property consumed a majority of the income.



FIG. 6.19. SHLEUP, ET AL. 2008



FIG. 6.20. SHLEUP, ET AL. 2008



FIG. 6.21. SHLEUP, ET AL. 2008



FIG. 6.22. SHLEUP, ET AL. 2008

## 6.4.2 | COMPUTER SCRAP RECYCLING BRAKPAN SOUTH AFRICA

ADAPTIVE REUSE OF RESIDENTIAL PROPERTY  
PROGRAMME: MANUAL E-WASTE RECOVERY FACILITY

The Computer Scrap Recycling Company is an EWASA accredited e-waste reclaiming and recycling facility and drop off and buy back centre.

### PROGRAMMES

Repair Centre  
Second -Life Goods Retail  
Diagnostics Testing and Refurbishing  
Proposed Computer Skills Training Centre  
Independent Dismantling Workshops

PLANT SIZE\_+-2000 msq  
ANNUAL CAPACITY\_100 Tonnes  
STAFF\_12

### PLANT LAYOUT

The general layout of the material processing facility, is largely a result of an adaptive reuse of an old residential building. The facility has a street edge and public retail interface, with production activities happening towards the back of the site. Its main Areas

A|Dismantling Workshops  
B|Testing and Refurbishing  
C|Retail  
D|Storage

### DESIGN APPLICATION

A|the facility benefits from a mixed use programme of retail training and processing,since it encourages public interaction.

B| the public interface is to its advantage as it creates greater awareness of its products and services, by being located where the market exists.

C| Dismantlers have individual workshops

D| A central storage space provides secure storage of dismantled material and easy access to recovered components for refurbishment.





FIG. 6.23



FIG. 6.24



FIG. 6.25

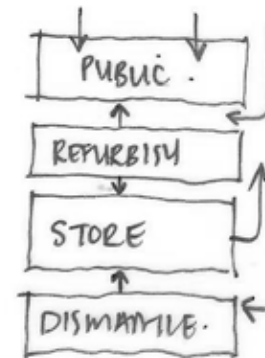
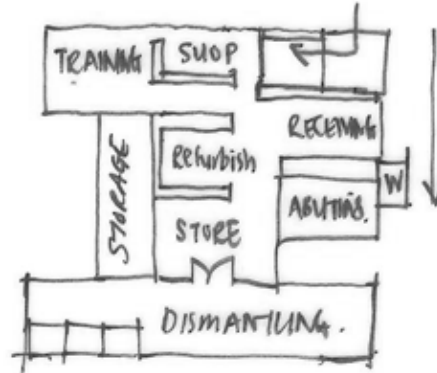
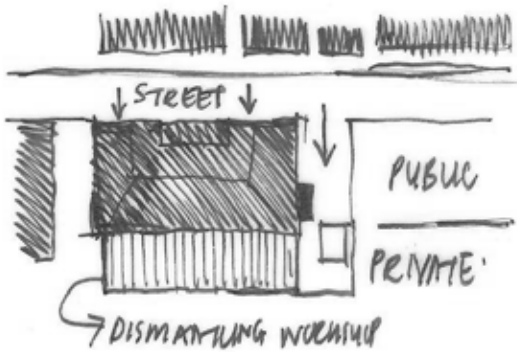


FIG. 6.26

FIG 6.23 | MANUAL DISMANTLING BAYS AT THE CSR. ( AUTHOR 2012)

FIG 6.24 | WEIGH STATION. ( AUTHOR 2012)

FIG 6.25 | REFURBISHMENT WORKSTATION ( AUTHOR 2012)

FIG 6.26 | ANALYTICAL DIAGRAMS OF PROCESSING FACILITY ( AUTHOR 2012)



# 07. CONCEPT AND DESIGN DEVELOPMENT |

# 7.1 CONCEPT

## 7.1.1 | A RECOMBINANT FACTORY

The spatial design concept investigates the re configuration of the inert industrial building. Inspired by the anonymity of the process contained, flatness of edges ,thresholds and the shrinking of the productive space, which have parallels with electronic devices.

The design approach aims to increase transparency, public spatial thresholds to expose the process, and enclose a a real time place of exchange by mutation of the global type to a place specific solution. In an attempt to create balance between the global "space of flows" and the local "space of place."

The concept addresses the previously stated problems of the inert urban object, the social and spatial impacts of the ICT revolution within the global and local context, and the questioning of value in terms of form, material and process.



FIG.7.1 cONCEPT. ( AUTHOR 2012)

FIG 7.2 |GRAPHIC ILLUSTRATING COMPLEXITY BENEATH AN INERT SKIN.( AUTHOR 2012)

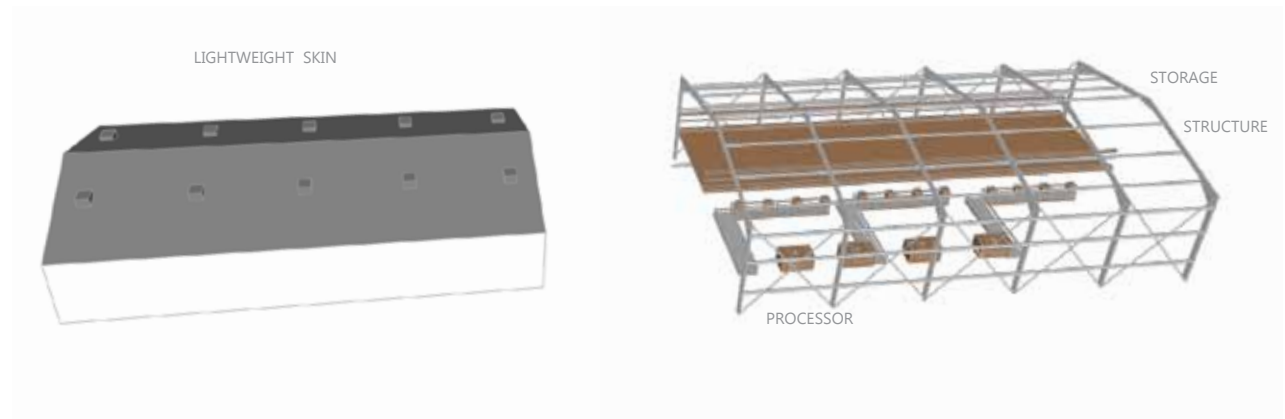
ADAPTED FROM

FIG 7.3 |GRAPHIC ILLUSTRATING COMPLEXITY BENEATH THE SKIN OF AN INERT STORAGE FACILITY ( AUTHOR 2012)

AN ANONYMOUS  
CONTAINER THAT  
EXPRESSES  
NOTHING OF ITS  
WORKING BEYOND  
ITS DIGITAL  
INTERFACE



AN ANONYMOUS  
CONTAINER THAT  
EXPRESSES  
NOTHING OF ITS  
PROCESS BEYOND  
A SURFACE  
AESTHETIC



## 7.1.2 | POSSIBLE DESIGN LANGUAGE FOR CONTAINER INTERFACE



**|1| THE EXISTING ENVELOPE CONDITION**  
THE CONCEPT MODEL EXPLORES THE HARD EDGES OF EXISTING AND UNRESPONSIVE EDGES OF WAREHOUSE ARCHITECTURE. THIS ANALYSIS APPLIES BOTH TO THE BUILT ENVIRONMENT AND THE CONTAINERS OF THE ELECTRONIC PROCESS



FIG. 7.4. INERT. (AUTHOR 2012)

**|3| A NEW FLATNESS**  
INSPIRED BY THE DIGITAL INTERFACE, THE SPACE IS DEFINED BY A SERIES OF LAYERED SKINS AND MULTIPLE THRESHOLDS

FIG.7.5. NEW FLATNESS. ( AUTHOR 2012)

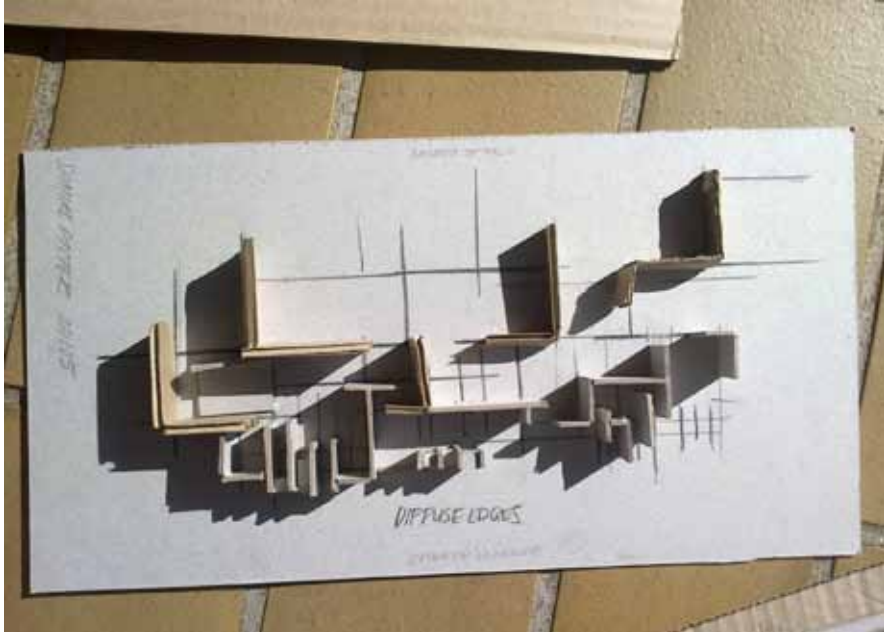


FIG.7.6 DEEP THRESHOLD AND LAYERED INTERFACES. AUTHOR 2012

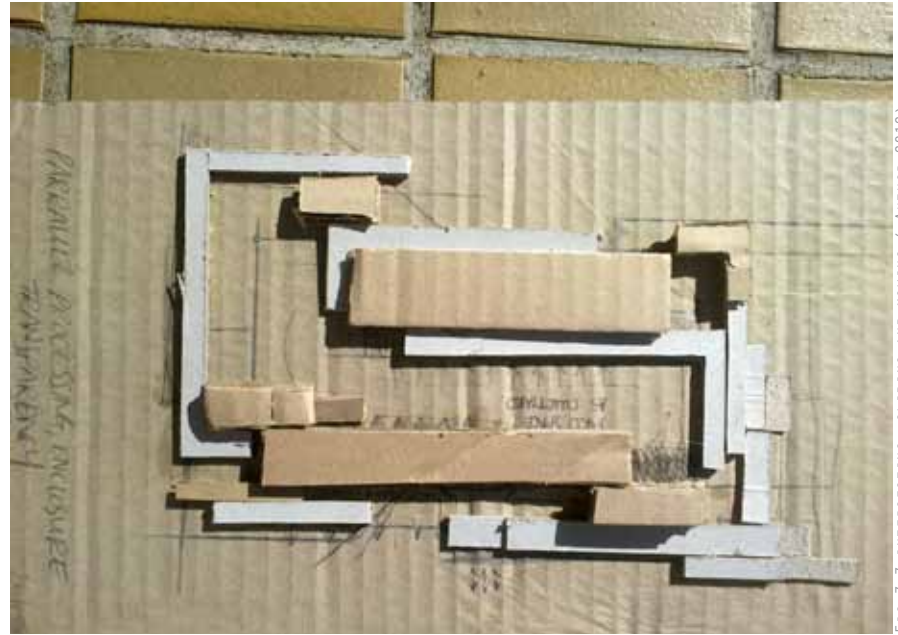


FIG.7.7 INTERSECTING, SLIDING AND MOVING ( AUTHOR 2012)

|3| DIFFUSING THE EDGES.FROM CONTAINER TO SPATIAL FILTER  
AS A CONTROL FORM , THE SKIN IS INTERPRETED AS A SPATIAL FILTER OF GOODS, PRODUCTS AND INFORMATION

|4| ALTERNATIVE OPTION TO THE CONTAINER  
AN RECOMBINANT AGGLOMERATION OF FRAGMENTED BODIES OR ACTORS ENCLOSING A COMMON SPACE OF FLOWS, WHILE INSINUATING MOVEMENT.

## 7.2 PROCESS REQUIREMENTS

The material flow diagram was used to calculate the plant capacity and functional sizing of the facility.

Sizing was calculated based on research values on the MRF Pilot Project (previous precedent study) and estimated work rates to determine adequate sizing for each phase.

The initial space allocation indicates that the primary process is the dismantling workshops.

### 02 | PLANT CAPACITY AND SIZING

A manually operated medium sized material recovery facility has an average capacity of 150 tonnes per annum (HP Report 2008). Assuming the 200% increase as suggested by (UNEP 2008) in the next ten years, the working capacity of the plant will be assumed to be 300 tonnes/annum.

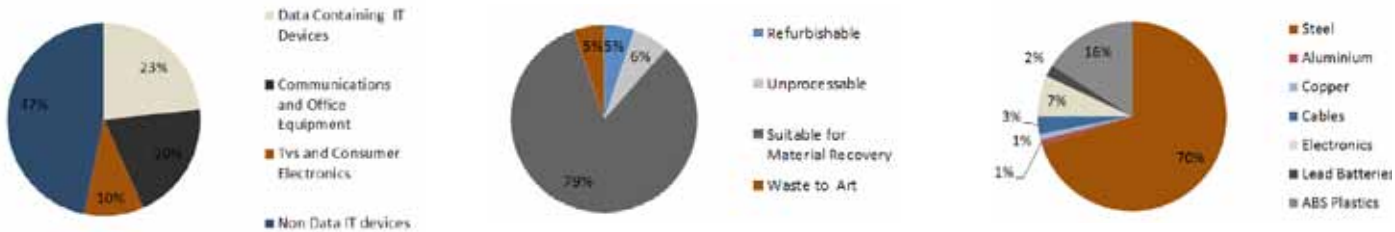
This equates to 25 tonnes/month of which 18.25 tonnes is dismantled. The average monthly capacity of one dismantler is 2t/month and a working area of approximately 25msq (HP Report 2008). Therefore 12.5 dismantlers, and total of 300 msq will be necessary for the plant to operate efficiently. Similar methods were

utilized to calculate the sizing of the remainder of the facility.

### USER

The processing facility will be utilized by :

- A. E-waste Association Process Administration
- B. Public and Visitors for drop offs and use of public components
- C. Informal Collectors and Local Business
- D. Dismantlers
- E. Refurbishers
- E. Research and Development Staff
- F. Goods Receiving and Sorting Staff
- G. DownStream Recyclers for Collections
- H. Upcycling Artists and Innovators



General Area	Asumed Area	Process Rate/Person	No of Employees
<b>Ewasa_Goods Receiving and Cataloguing</b>			
Loading Bay for 1 tonne trucks and vans	21 msq	50 units/hr	
Loading and Sorting Platform workshop	90 msq	15 units/hr/	4
Public Drop Off and Certification Office and Control Office	6msq	1.25units/hr	1
<b>Data Erasure Lab</b>	20msq	1.5 units/hour	1
Assessment and Plug in Test Area	7msq	30 units/hour x 0.25msq	1
Photography and Cataloguing Area	6 msq	15 units/hr	2
Secure Holding Area Preprocessing	90 msq	20 % annual tonnage	
<b>Ewasa_Regional Managers Offices</b>	60 msq	ancillary	6
Ablutions	20msq	ancillary	1
Staff Lounge	100msq		
<b>Dismantling</b>	425msq	9 units/ hr	12
Workshop Managers Office	6msq	ancillary	1
Ladies Ablutions and Changing Rooms	12 msq	ancillary	
Mens Ablutions and Changing Rooms	12msq	ancillary	
<b>Dispatch and Secondary Raw Material Storage</b>			
Weighing and Cataloguing Station ( In)	5msq	9 units/ hr	1
Store Managers Office	5msq		
Store (Monthly Capacity )	72 msq	Monthly holding capacity	
<b>Refurbishment</b>			
Refurbishment Workshop	100 msq	1.5 units/day	4
<b>Upcycle Workshop</b>			
Individual Storage and Work Areas	100msq	1.5 units/day	2
			5
<b>Research and Development</b>	72msq		

FIG. PLANT SIZING - PNG (AUTHOR 2012)

FIG 7.8 | ACCOMADATION SCHEDULE AND PLANT CAPACITY (AUTHOR 2012)



## 7.3 DESIGN ITERATIONS

### 7.31 | DESIGN ITERATIONS

The design iterations which follow, illustrate a process of enquiry into

- A| A design language which is an appropriate expression for the intended programme and context
- B| A configuration of typological parts which express a change in industrial organization
- C| The relationship between the proposed facility and its context.

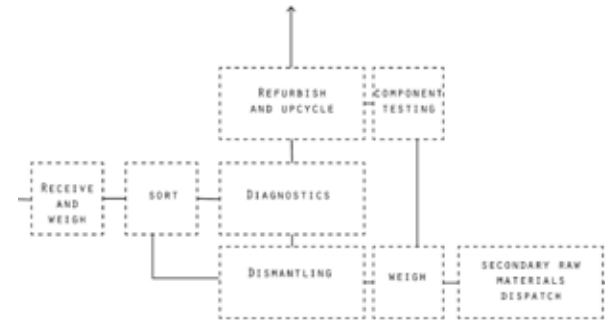
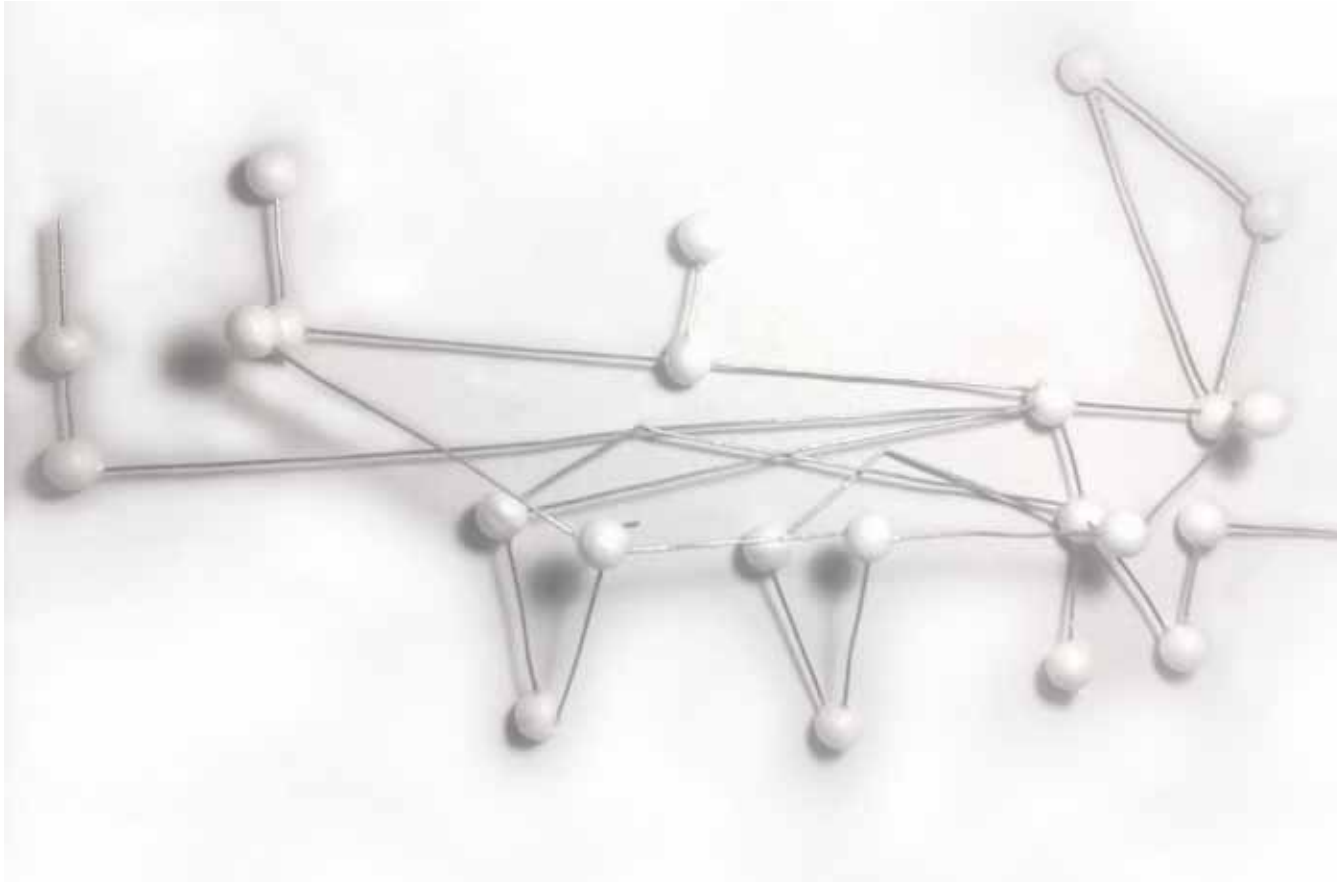


FIG. 9. SIMPLIFIED FLOW DIAGRAM. JPGAUTHOR(2012)

“ the greatest technological breakthrough of modern electronics has been the ability of a simple programmable device to perform a wide variety of different functions. This is the true meaning of convergence.”  
( Mobs 2012:9)



OP

FIG 7.10

FIG 7.10 | ABSTRACT MODEL REPRESENTING THE FLOWS AND NODES WITHIN THE SPACE. REFURBISHMENT WORKSHOPS AND DISMANTLING WORKSHOPS INTERCEPTING FLOW ALONG A PRIMARY CIRCULATION CORRIDOR, REPRESENTED BY THE CROSS-OVERS AND COLLISIONS BETWEEN DIFFERENT ACTORS (AUTHOR 2012)

## 7.4 CONCEPT DEVELOPMENT 1

### 7.5 | SPATIAL FILTER

The processing plant was conceptualized as a spatial filter with organized courtyard connections between a skin for the remanufacturing of electronics and a skin for the dismantling of electronics.

The illustrations illustrate the manipulation of a design language in both plan and section as an abstract exploration of transparency, the container and the contained.



FIG 7.11 | SPATIAL CONCEPT  
ORGANIZING PROCESS  
(AUTHOR 2012)

FIG. 7.11.



INSIDE THE CONTAINER



DETAIL OF LAMP MATERIALS TOP FLOOR BOARDING



FIG. 7.12

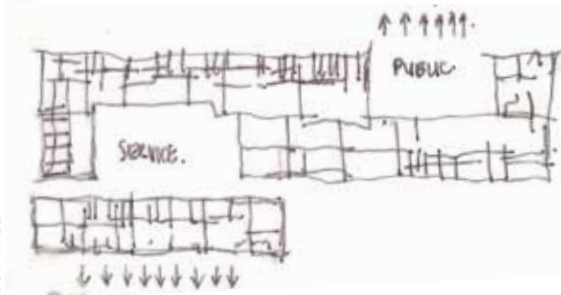
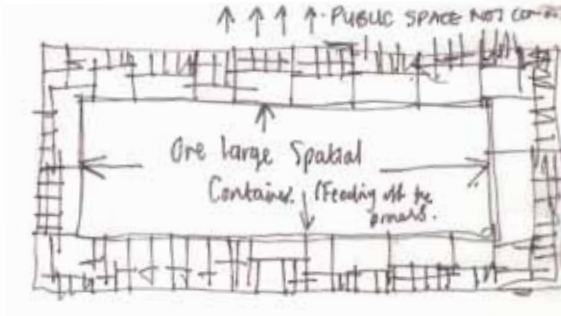


FIG. 7.13

FIG 7.12 | SPATIAL CONCEPT ORGANIZING PROCESS IN SECTION (AUTHOR 2012)

FIG 7.13 | EARLY CONCEPT DIAGRAM EXPLORING FORM AND RELATIONSHIP TO PUBLIC SPACE, POSITIVE AND NEGATIVE SPACE CREATION (AUTHOR 2012)

## 7.5 CONCEPT DEVELOPMENT 2

### 7.5.1 | POINTS OF RECONVERGENCE. URBAN CLUSTER

An early development of the first partii diagram considered the intervention as a container of flows.

Strongly influenced by Castells theory of a space of flows. A central void where the movement of goods people and information was conceptualized. The skin of the container becomes a thickened deep skin of production.

The form of an inanimate cube was challenged by suggesting the sliding of the skin in defining positive public space both internally and externally, and making the process visually accessible.

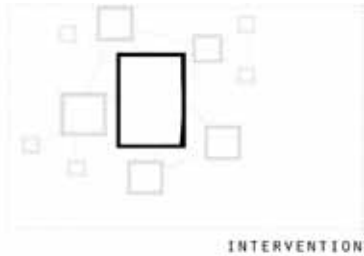
The conceptual layout generated from this approach was not grounded by its context or the functional prerequisite that defines industrial architecture.

The conclusion reached during this exploration was that the interface, scale form and materiality of the architecture needed to be generated from the context.

FIG 7.14\_7.18.  
CONCEPTUAL MODELS  
INVESTIGATING HIERACHY  
BETWEEN DIFFERENT  
ELEMENTS WITHIN CONTEXT.  
( AUTHOR 2012)



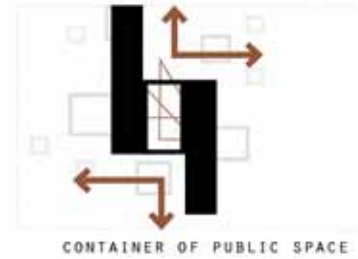
FIG.7.14



THE PROPOSED INTERVENTION SUGGESTED THAT EXISTING INDUSTRIAL ARCHITECTURE IS AN ANONYMOUS CONTAINER OF ANONYMOUS PROCESSES. THE PROPOSED INTERVENTION WOULD REINTERPRET THE FLATNESS PRESENTED BY THE INANIMATE SKIN



THE PROPOSED CONTAINER CONTAINING THE SPACE OF FLOWS SHARED SPACE.



THE PROPOSED CONTAINER WOULD NOT ONLY CONTAIN THE SPACE OF FLOWS IN TERMS OF EXCHANGES OF PEOPLE GOODS AND INFORMATION, BUT THE MUTATION OF THE "CUBE" WOULD CONTAIN POSITIVE PUBLIC SPACE. THE PROCESS IS NOW RELEGATED TO THE SKIN AS A THICKENED THRESHOLD BETWEEN A SHARED SPACE.

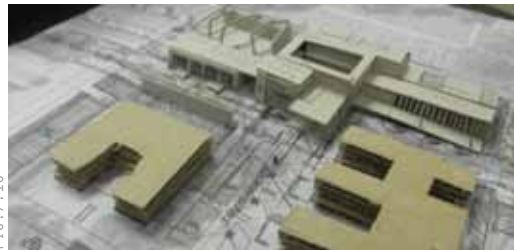


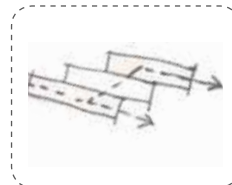


FIG. 7.18



FIG. 7.19

ARCHITECTURE OF TRANSPARENCY AND DYNAMISM. THE INTENTION OF THE ITERATION WAS TO MAKE THE RELATIONSHIP BETWEEN THE PUBLIC REMANUFACTURING AND DISMANTLING A SHARED AND OVERLAPPING SPACE. THIS RESULTED IN A COMPLICATED SECTION, AND IMPRACTICAL PRODUCTION PROCESS



THE ARCHITECTURE OF TRANSPARENCY AND DEEP THRESHOLDS. THE ORIENTATION OF THE WORKSHOPS ARE ROTATED TO ALLOW VARIETY IN THE STREET EDGE AND COURTYARDS. CIRCULATION IS STILL UNNECESSARILY COMPLICATED.

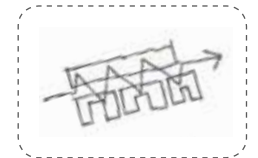


FIG 7.18-21.  
CONCEPTUAL MODELS  
INVESTIGATING HIERACHY  
BETWEEN DIFFERENT  
ELEMENTS WITHIN CONTEXT.  
( AUTHOR 2012)



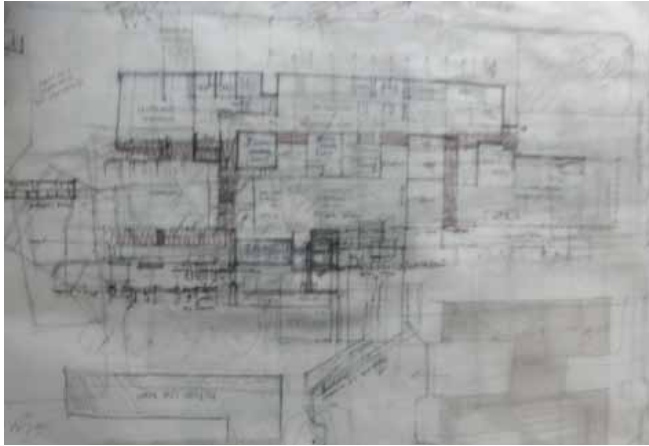


FIG.7.20

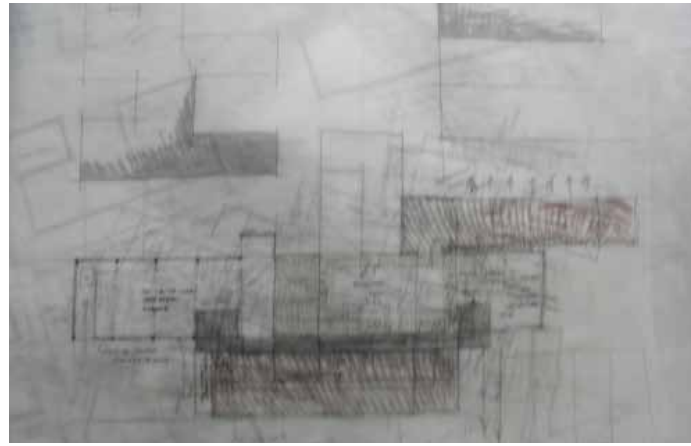
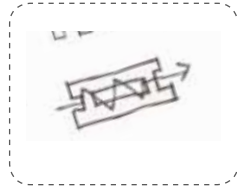
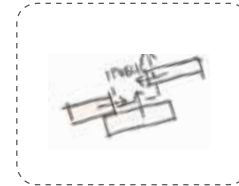


FIG.7.21

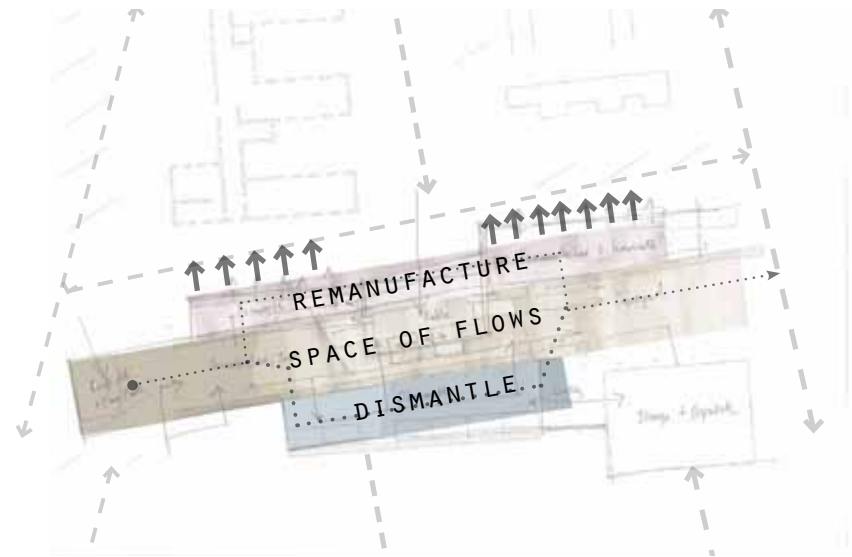
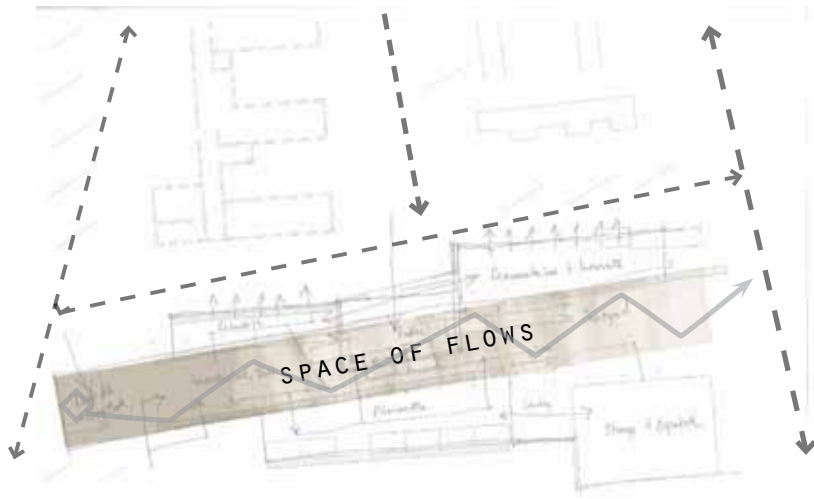
THE REFURBISHMENT AND UPCYCLING  
FACTORY MASS IS SEPERATED BY  
THE SPACE OF FLOWS FROM THE  
DISMANTLING MASS TO THE SOUTH.  
CIRCULATION IS IMPRACTICAL, AN  
ORDER DIFFICULT TO ACHIEVE.

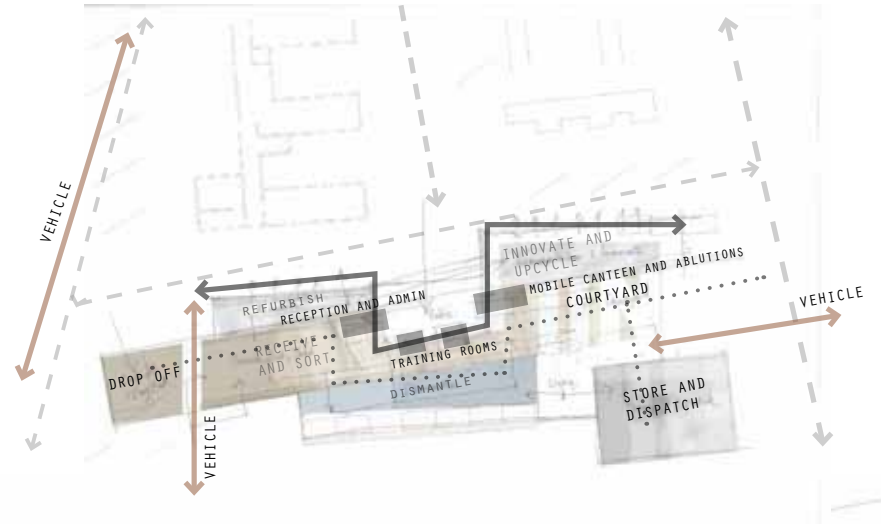
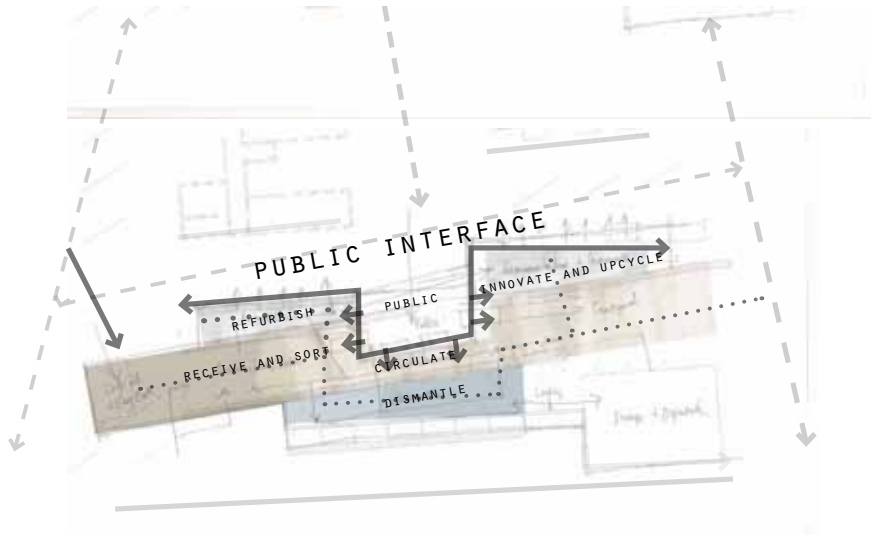


THE SHIFTING OF THE CONTAINER,  
WITH A PUBLIC CANTEEN AND EVENT  
SPACE THAT INTERCEPTS THE PROCESS,  
AND WHOSE SHIFTED FORM ATTEMPTED  
TO DEFINE POSITIVE PUBLIC SPACE.



## 7.6 CONCEPT DEVELOPMENT 3





### 7.6.1 | FINAL SPATIAL CONCEPT

The final conceptual exploration resulted in a linear layout as a result of the production process of inputs and outputs and the existing linear geometry on site.

Previous explorations attempted to over complicate and interrupt the production process, as a complex network, of angular geometry, with interfaces within the same plane, which did not respond to place.

The true form of industrial space is the elegant organization of different bodies and it is this concept, that resulted in the final design layout.

In plan and section, the conceptual layout consists of the three primary workshops which “plug in to” a central circulation and service spine.: dismantling, refurbishment and upcycling. The circulation spine divides the processing facility into clean and dirty processes, public and private, and allows for the feedback loops within the process

A public “workshop” interrupts the processing facility and terminates the square inviting visitors in, where the industrial mezzanine becomes a point of passive observation and interaction through adjacency.



FIG. 7.23



FIG. 7.24

FIG 7.22  
PREVIOUS PAGE.FINAL  
CONCEPT DIAGRAM  
( AUTHOR 2012)

FIG 7.23\_7.24  
CONCEPTUAL VIEWS OF  
THE VISITORS CENTRE  
TERMINATING THE PUBLIC  
SQUARE ( AUTHOR 2012)

The first floor mezzanine is interrupted into three separate systems: The facility administration offices, public co-working space and research and development lab ,connecting public and private with threshold balconies for casual conversation and interaction. The spatial arrangement allows views of the process, and is congruent with the original abstract concept of a recombinant container.

The horizontal and vertical surfaces become a layered smart skin, and a collaborative system of components

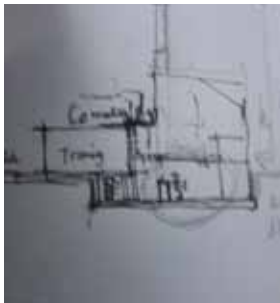


FIG. 7.25



FIG. 7.26

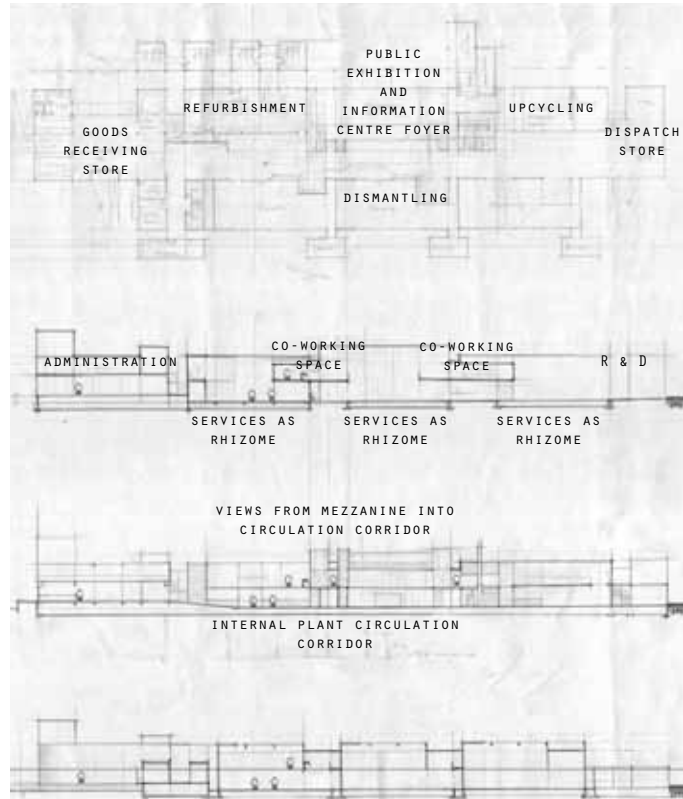


FIG. 7.27

FIG 7.25-7.26  
PLUG INS AND COMPONENTS  
( AUTHOR 2012)

FIG 7.27  
CONCEPT INSECTION  
( AUTHOR 2012)

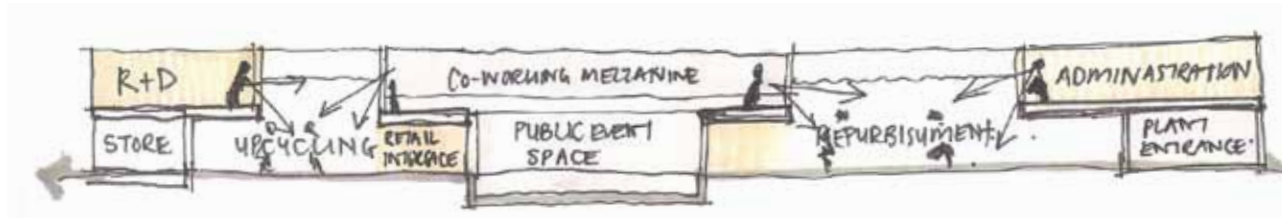
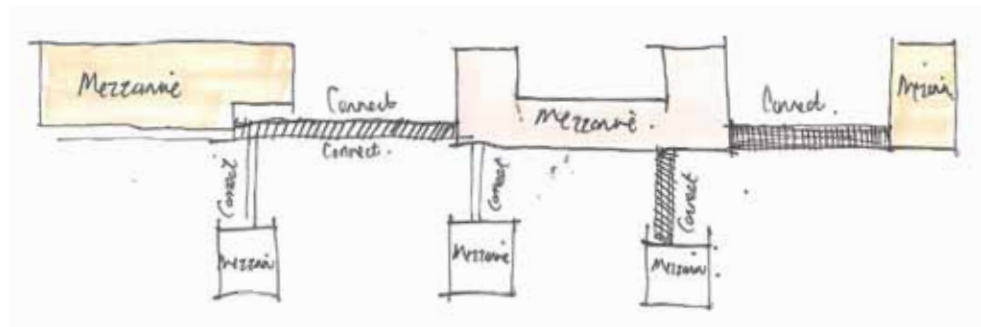
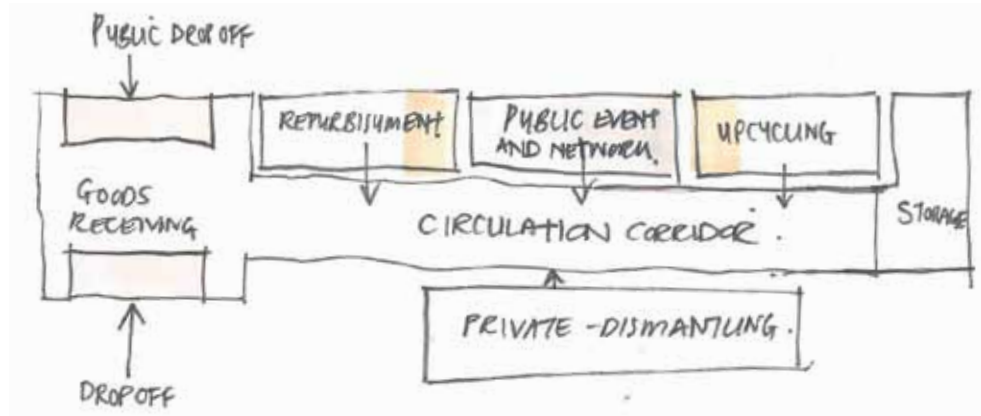


FIG 7.28  
DIAGRAMMATIC EXPLORATIONS  
IN PLAN, SECTION AND  
ELEVATION ( AUTHOR 2012)

FIG.013 .JPG (.  
DATE)



FIG 7.29-7.31  
THREE DIMENSIONAL  
EXPLORATION OF CONCEPT  
INVESTIGATING THE CIVIC  
INTERUPTION( AUTHOR 2012)



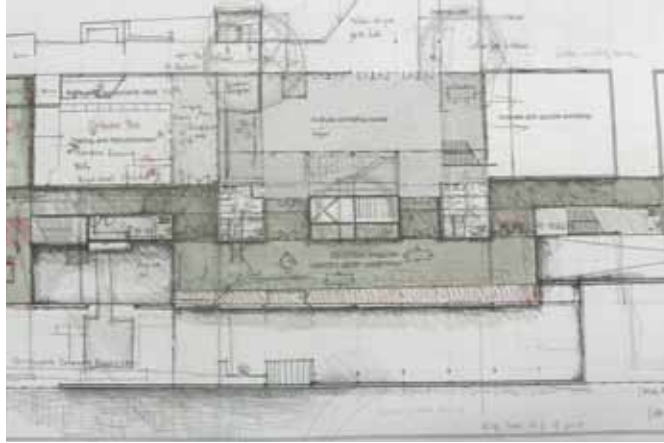


FIG. PA250043.JPG (, DATE)

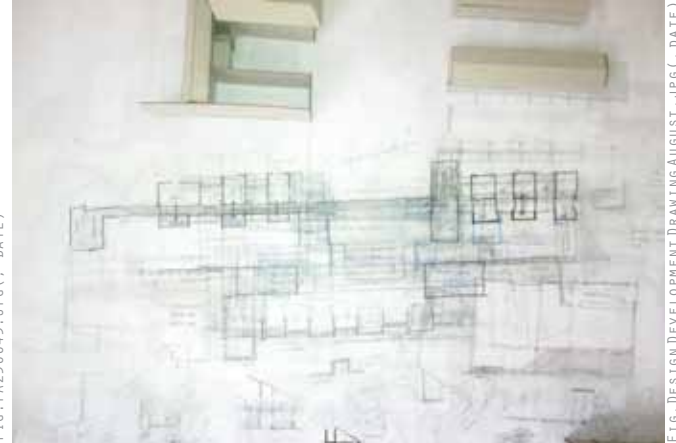
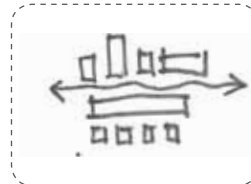


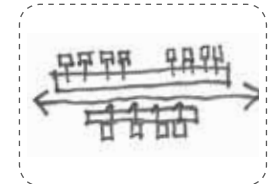
FIG. DESIGN DEVELOPMENT DRAWING AUGUST . JPG (, DATE)

FIG 7.31-34  
CONCEPTUAL MODELS  
INVESTIGATING HIERARCHY  
BETWEEN DIFFERENT  
ELEMENTS WITHIN CONTEXT.  
( AUTHOR 2012)

PRIMARY INDUSTRIAL CIRCULATION  
INTRUPTED BY PUBLIC COMPONENT AND  
IS IMPRACTICAL.



THE PLUG-INS AND SUPPORT  
STRUCTURE. INSPIRED BY THE  
THOUGHTS OF ARCHIGRAM, THE  
FACILITY WAS AS A PERMANENT  
CIRCULATION AND SERVICE CORE WITH  
MOBILE PLUG INS WHICH DESCRIBED  
THE LOCAL CONDITION



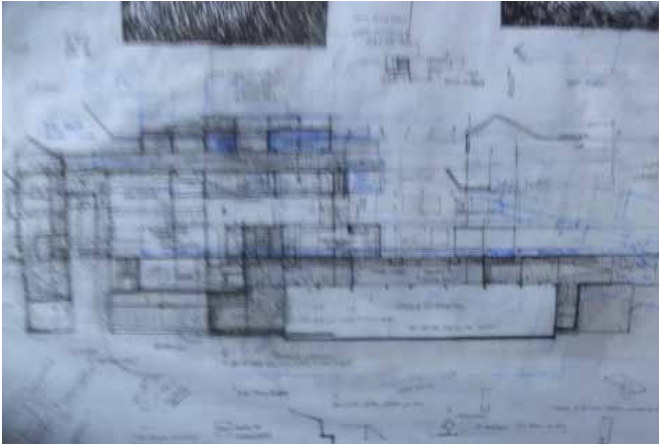


FIG. P9290480.JPG (, DATE)

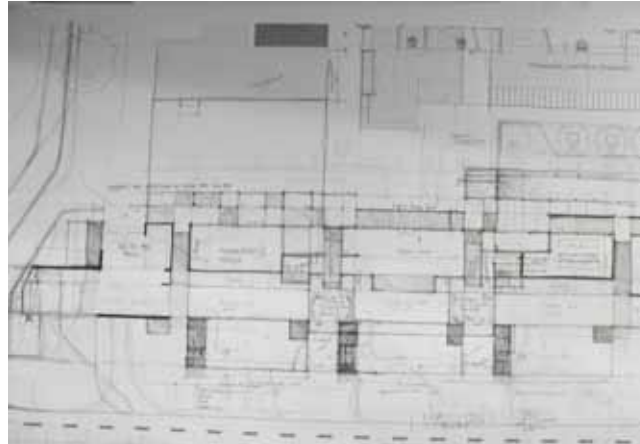
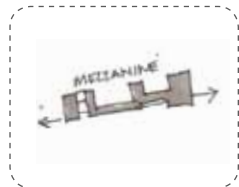


FIG. PA250054.JPG (, DATE)

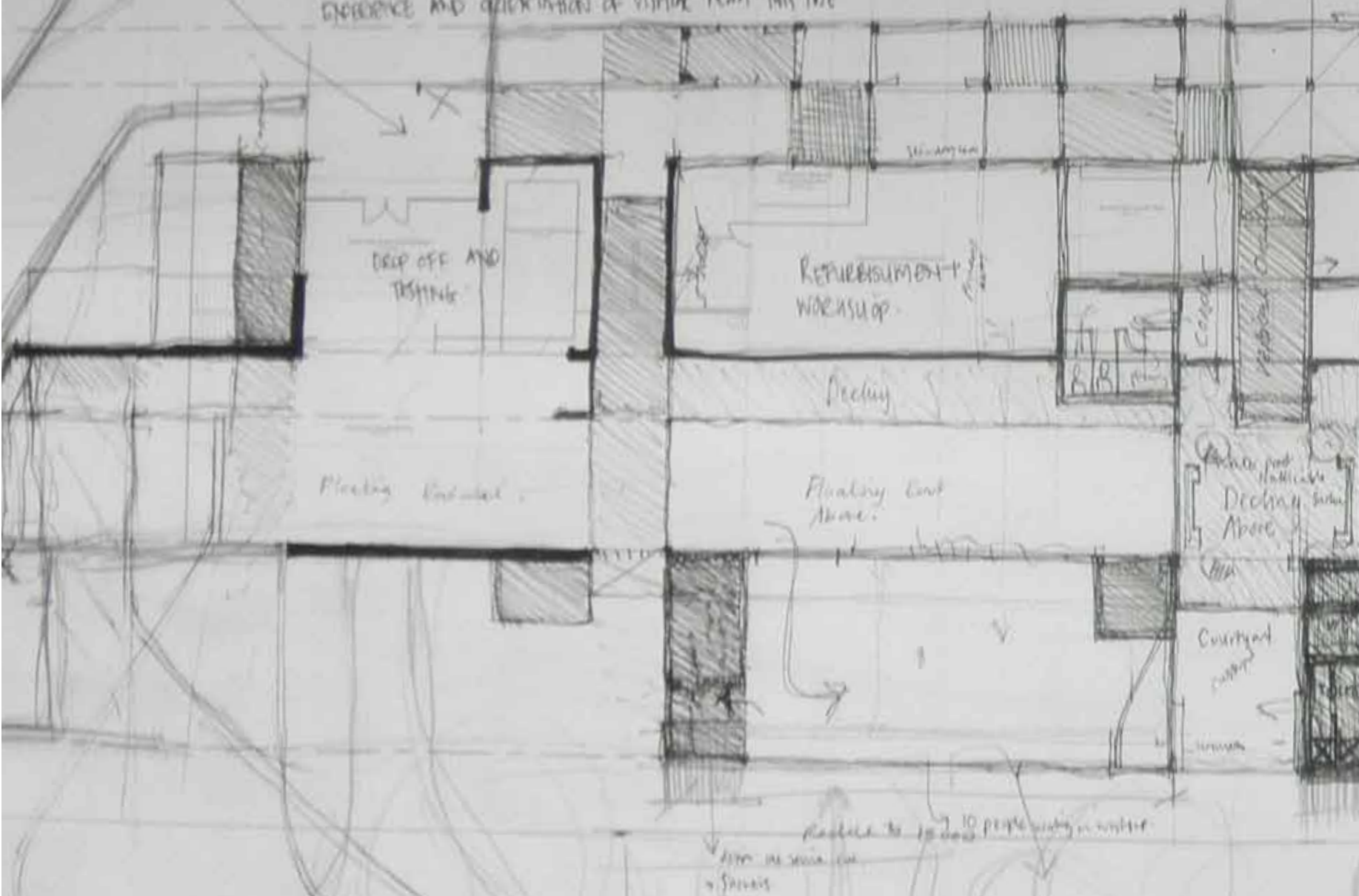
THE SPACE OF FLOWS BECOMES A PART OF A CO-WORKING ENVIRONMENT, WHERE A MEZZANINE BECOMES A PUBLIC POINT OF OBSERVATION AND LEARNING, PUNCHING THROUGH THE THREE PRIMARY WORKSHOPS OF REFURBISHMENT, UP CYCLING AND INNOVATION AND CRAFT.



DIFFUSE EDGES INTEGRATING INTO CONTEXT. THE DESIGN INTENTION FOCUSED ON THE LAYERING OF THRESHOLDS TO CREATE A HUMAN SCALE RELATIONSHIP WITH THE CONCEPT, ABSTRACTLY SUPPORTING PIXELLATION.

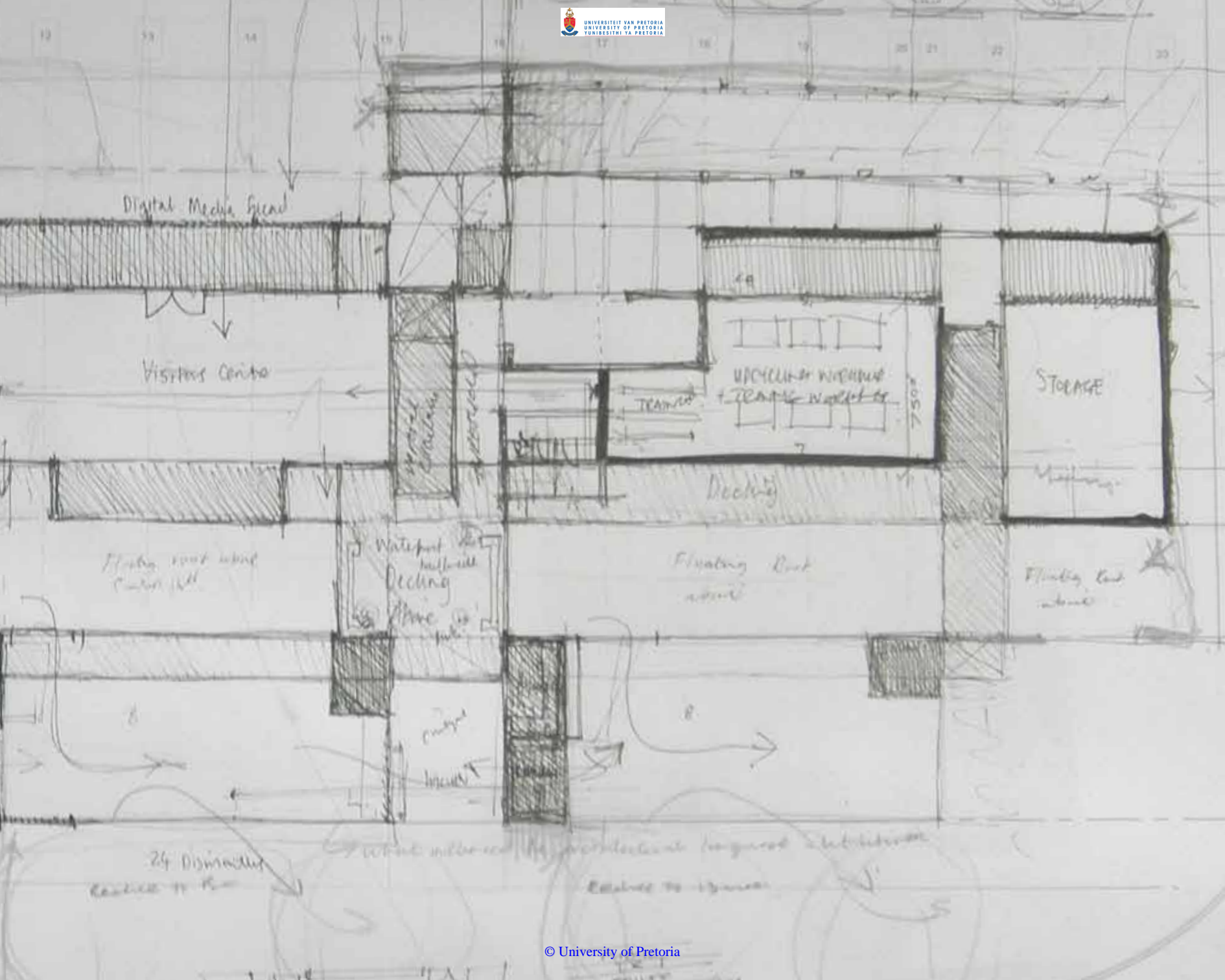


EXPERIENCE AND ORIENTATION OF VISITOR FROM THIS SIDE



Ramp to 1st floor 10 people sitting in waiting

from the main car  
- stairs  
- lifts  
- ramp to level



## 7.7 INTERFACING A GLOCAL CONDITION

### 7.1 | APPROACH TO EXISTING HERITAGE OBJECT

The Old Native Building is of cultural significance, and the english bond brickwork is it's most significant architectural feature. The enclosed nature of it's building envelope however does not converse with the site,yet its programme and social function do.

Later iterations of the plan use the 6m proportioning of the courtyard building to generate a rhythm, that suggests that the proposed facility is an addition and support to the existing and dynamic energy on site.

The heritage precedent, adjacent has similar aspects to the existing Old Native Depot on site. Designed by Exit Architects the Civic Centre in Palencia, is a conversion of an old prison.

The additions and re-cladding of the building follows a contemporary argument where wall and roof plane form a continous skin, light as a material opens up the facility but at the same time gives emphasis to the rich brick detailing that make the building significant.



FIG. 7.36



FIG. 37

FIG 7.35  
PREVIOUS PAGE.  
DEVELOPMENT OF PLAN  
( AUTHOR 2012)

FIG 7.36  
SHTC IN CONTEXT  
( AUTHOR 2012)

FIG 7.37  
CIVIC CENTRE PALENCIA  
(GUERRA 2010)



Similar alterations are proposed for the existing heritage building. The existing building acts as a generator for design, by

- A. Providing a proportional module to which the facility can relate
- B. Introducing a “pitched roof” language which must be responded to
- C. Allowing conversation of materials and construction technology, between old and new and a hybrid condition between the two.

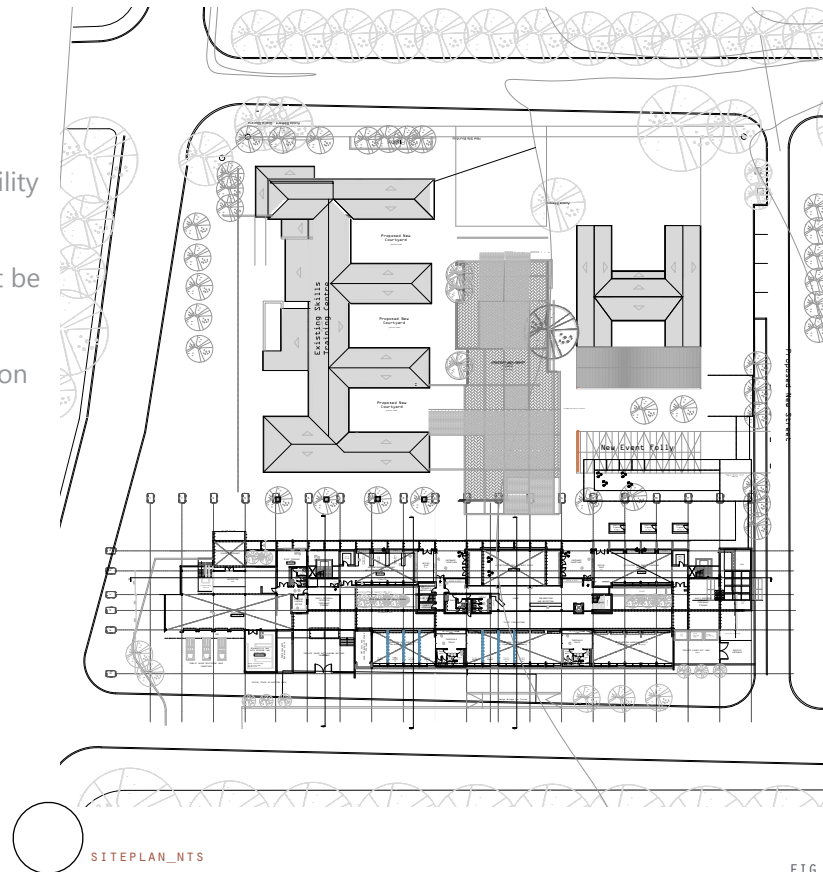


FIG 7.38  
REVISED SITE DEVELOPMENT  
PLAN ( AUTHOR 2012)

## 7.8 LAYERED SKIN

### 7.8.1 APPROACH TO EXISTING MATERIALS

The proposed intervention converses with the site through a collaborative layer of skins.

The strong horizontal, load bearing structure and division of roof and wall plane in the existing is challenged within the new facility, as load bearing structure, becomes skeletal, the skin layered and wall and roof plane appear continuous and fluid.

The intention of the layered skin aims to create shaded deep edges encouraging the public to occupy and experience structure as an interior condition, . The shaded structure becomes a cantilevered arcade, defining shop fronts and display windows and a public circulation route between the plant entrance and the public event space, making quiet reference to the arcade typology typical of the Marabastad precinct. ( Fig

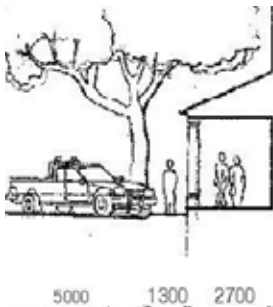


FIG. 7.39 BOOM STREET ARCADE. (TAYOB ET AL 1998)

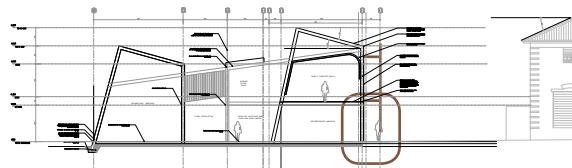


FIG. 7.40



FIG. 7.41 SHADED SKIN.JPG (, AUTHOR 2012)





PROFILED SHEETING AS SURFACE



PLASTERED DIVISION BETWEEN MASONRY AND WALL AND ROOF



CRAFT AS SURFACE APPLIED

SMART MATERIALS

SOLAR SHADING AND CRAFTED PATTERNED FACADE

MEDIA FACADE. FLUID SURFACES. CHANGING SKIN

TRANSPARENCY GLASS AS VERTICAL SKIN

INTERFACE



COLLABORATE

COLLABORATE

INTERFACE

RECYCLED MATERIALS

DECORATIVE HEADER BOND

REFERENCE TO HERITAGE: SHEETING AS ROOF AND WALL, MASONRY AS LOW INFILL PANEL

EXISTING. SKIN AS LOAD BEARING STRUCTURE HORIZONTAL DIVISION BETWEEN MATERIALS

PROPOSED LAYERED SKIN. MASONRY AS INFILL. MEETING BETWEEN MASONRY AND CLADDING EMPHASIZED

FIG. 7.41 HERITAGE APPROACH (AUTHOR 2012)

## 7.9 LIGHT AS MATERIAL

### 7.9.1 FLUID SURFACES

The design investigates the use of light as a material in activating public space in the evenings, where podcasts, movies and similar broadcasts activate the square, at night and during the day. The use of light also generates the opportunity for increased legibility between public and private.

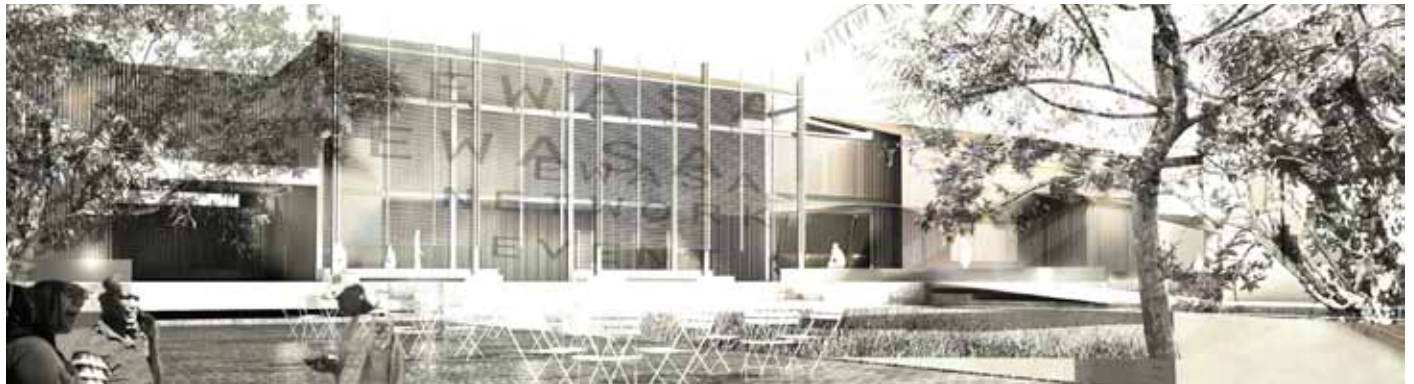
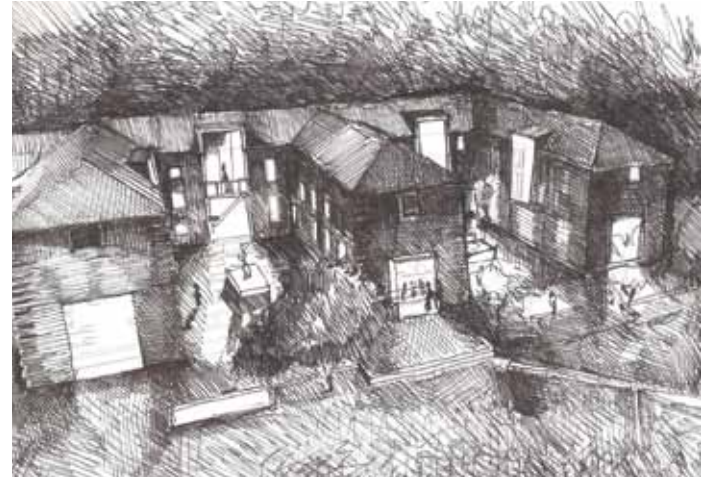


FIG 7.42  
NIGHT VIEW OF HERITAGE  
BUILDING ( AUTHOR 2012)

FIG 7.43  
DAY VIEW OF MEDIA FACADE  
(AUTHOR 2012)

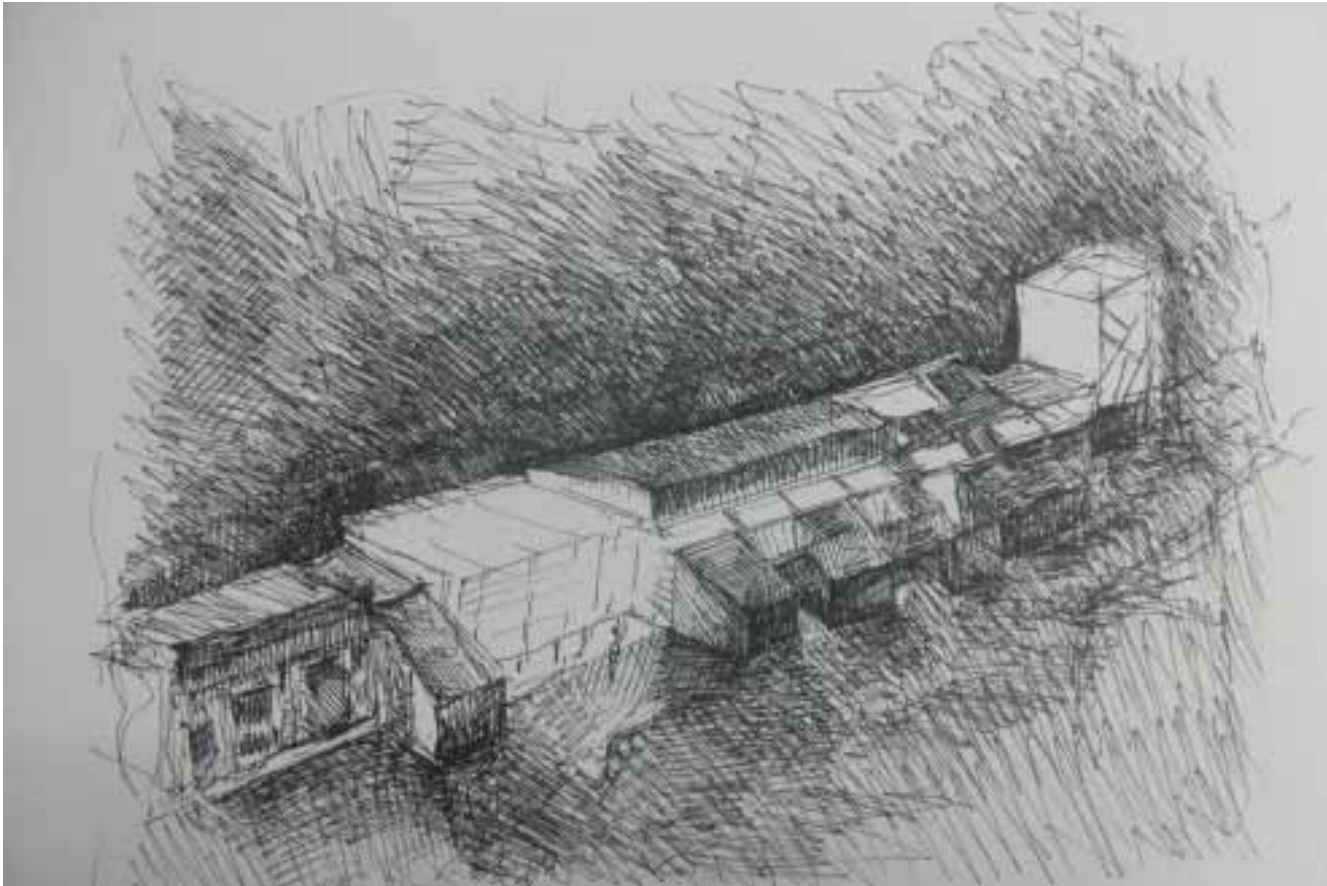


FIG 7.44  
CONCEPTUAL EXPLORATION  
OF LIGHT  
(AUTHOR 2012)

## 7.10 FINAL LAYOUT

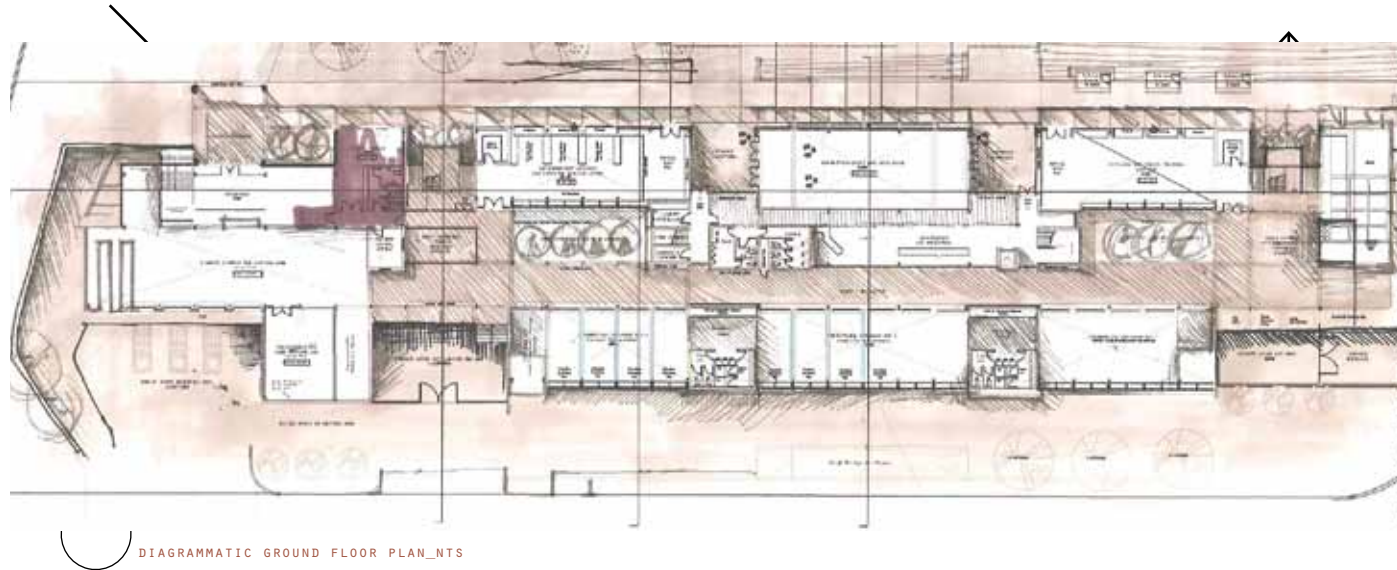


FIG.7.15. FINAL LAYOUT. (AUTHOR 2012)

DIAGRAMMATIC GROUND FLOOR PLAN\_ANTS

- |   |                                       |  |  |
|---|---------------------------------------|--|--|
| 1 COVERED PLANT ENTRANCE                      | 11 PUBLIC EXHIBITION AND WIFI SPACE   | 21 GOODS RECEIVING DOCUMENTING AND SORTING                     | 28 PEDESTRIAN PATH AND VIEW INTO WORKSHOPS |
| 2 PLANT VISITORS ENTRANCE AND PUBLIC DROP-OFF | 12 UPCYCLING WORKSHOP                 | 22 SOFTWARE EVALUATION AND DATA ERASURE LAB                    |  |
| 3 COVERED WALKWAY                             | 13 FIRE ESCAPE                        | 23 PEDESTRIAN CONNECTION BETWEEN GOODS RECEIVING AND RECEPTION |  |
| 4 E-POD INFORMAL SERVICE KIOSKS               | 14 SECURITY SURVEILLANCE              | 24 GOODS RECEIVING YARD  |  |
| 5 STAFF LOUNGE                                | 15 PUBLIC ABLUTIONS                   | 25 PALLET STORAGE AND DISPATCH YARD FOR TOXIC ELEMENTS         |  |
| 6 STORAGE/SERVER ROOM/SERVICE CORE            | 16 LOBBY                              | 26 GOODS OUT LOADING AREA                                      |  |
| 7 MATERIAL DISPATCH HOLDING AREA              | 17 PUBLIC CIRCULATION                 | 27 SKIP STORAGE  |  |
| 8 SECURE STORAGE                              | 18 OPEN COURTYARD AND RAIN GARDEN     |  |  |
| 9 REFURBISHMENT WORKSHOP                      | 19 DISMANTLING WORKSHOP               |  |  |
| 10 RETAIL INTERFACE                           | 20 COVERED PLANT CIRCULATION CORRIDOR |  |  |

- PUBLIC CIRCULATION
- PRIVATE CIRCULATION
- MATERIAL CIRCULATION



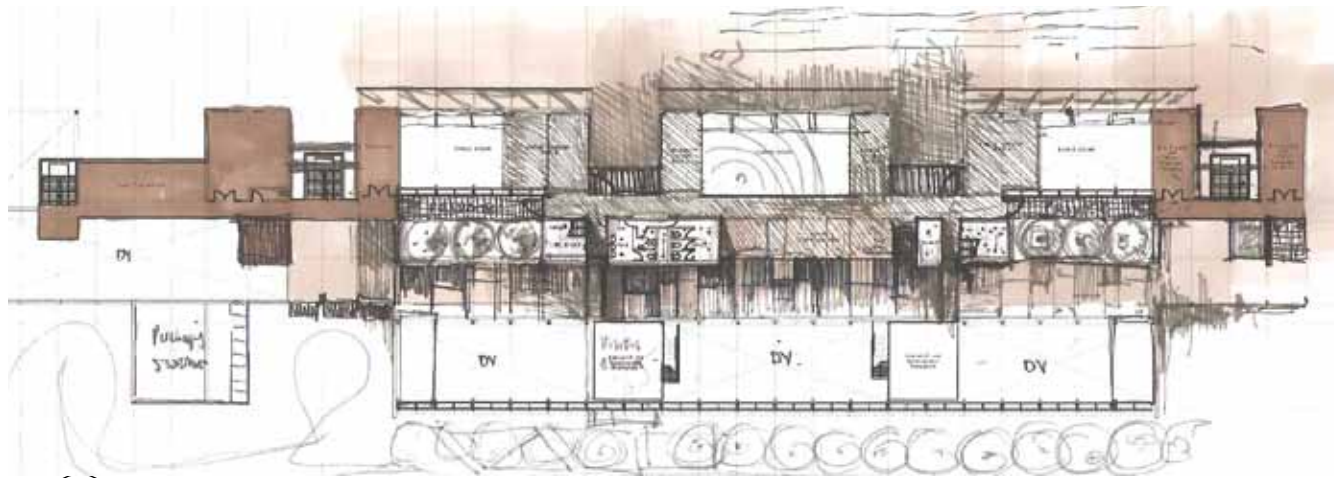


FIG.7.45 FINAL LAYOUT 2. ( AUTHOR 2012)



DIAGRAMMATIC MEZZANINE/ FIRST FLOOR PLAN\_NTS

- |                                     |                                   |
|-------------------------------------|-----------------------------------|
| 1 PUBLIC VIEWING PLATFORM           | 11 WALKWAY CONNECTION             |
| 2 RECEPTION AND WAITING AREA        | 12 PRIVATE VERTICAL CIRCULATION   |
| 3 ADMINISTRATION                    | 13 RESEARCH AND DEVELOPMENT LAB   |
| 4 BOARDROOM                         | 14 MULTIPURPOSE MEZZANINE/STORAGE |
| 5 PUBLIC COMPUTER ROOM<br>MEZZANINE | 15 SWIPE CARD ACCESS              |
| 6 FIRE ESCAPE ROUTE                 |                                   |
| 7 ABLUTION AND SERVICE CORE         |                                   |
| 8 SEMINAR ROOM MEZZANINE            |                                   |
| 9 CO-WORKING SPACE                  |                                   |
| 10 PUBLIC VERTICAL CIRCULATION      |                                   |
| 11 WALKWAY CONNECTION               |                                   |
| 12 PRIVATE VERTICAL CIRCULATION     |                                   |
| 13 RESEARCH AND DEVELOPMENT LAB     |                                   |
| 14 MULTIPURPOSE MEZZANINE/STORAGE   |                                   |

- |         |                      |
|---------|----------------------|
| ——      | PUBLIC CIRCULATION   |
| - - - - | PRIVATE CIRCULATION  |
| •••••   | MATERIAL CIRCULATION |
| - - - - | GUIDED FACILITY TOUR |

## 7.11 SECTIONAL DEVELOPMENT

The development of the section was centred around the idea of multiple thresholds and overlapping territories, and with a dialogue with the context.



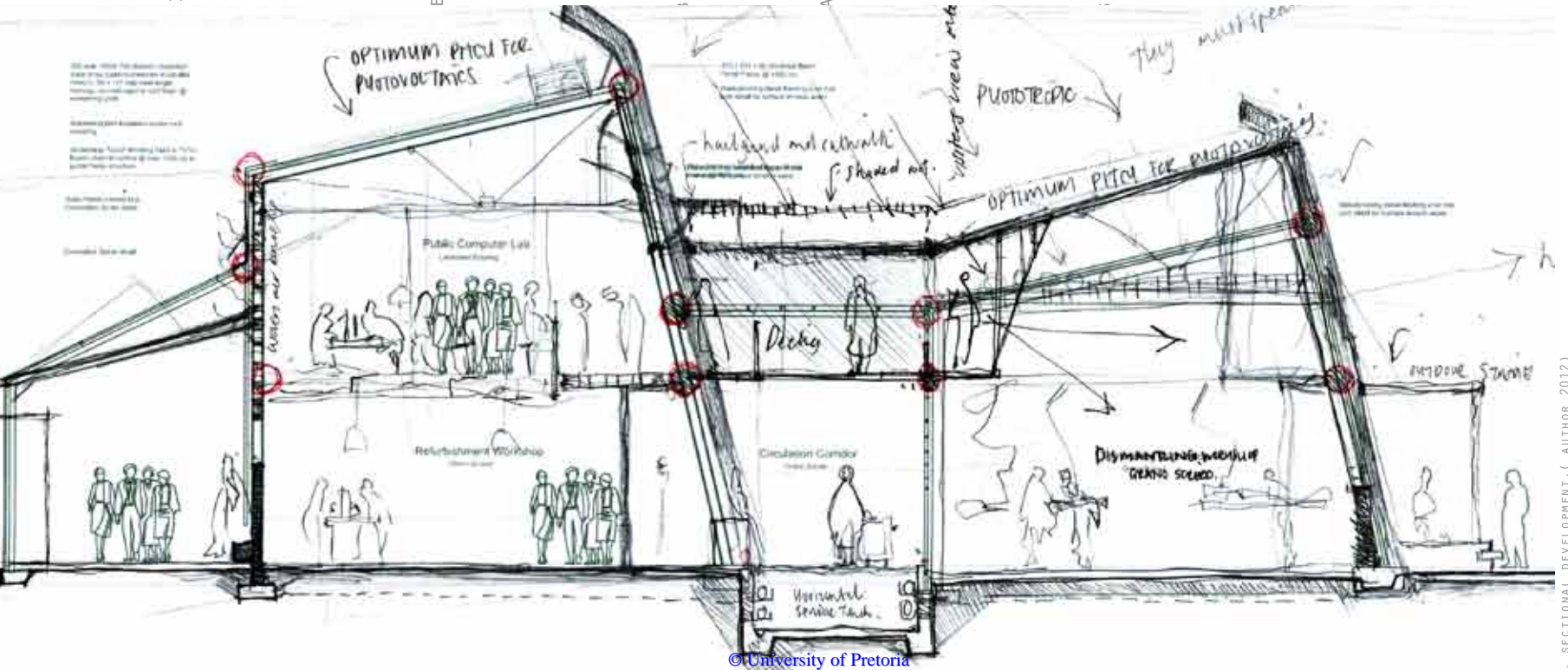
IC CIRCULATION

EFURBISHMENT SKIN

BALCONY CIRCULATION

AL CIRCULATION

IMANTLING WORKSHOP





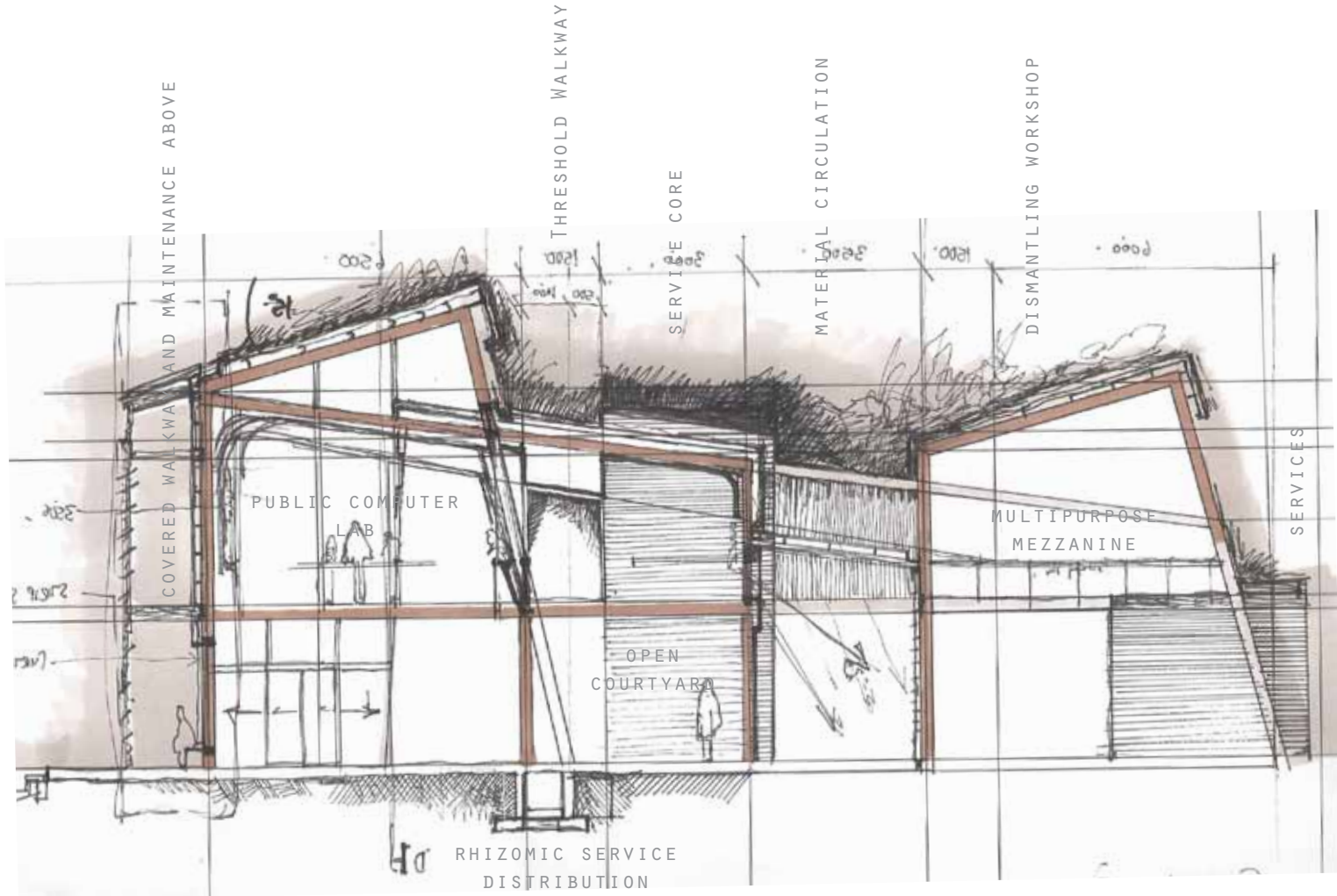


FIG 7.49  
INTERSECTING OF THREE  
BODIES AS PRIMARY  
MASSING GENERATOR  
( AUTHOR 2012)





FIG 7.50-7.54  
REVISED CONCEPT MODEL  
AND SITE DEVELOPMENT  
PLAN( AUTHOR 2012)

## 7.12 MASS AND FORM

A three dimensional exploration concluded in a realization that three primary elements form the massing and form of the processing facility.

- A. The Remanufacturing Upcycling and Public Workshop
- B. The Dismantling workshops
- C. The supporting circulation and service spine

In section this relationship between two permanent masses and their connection became the collision between three masses. The mass model below was refined through a technical investigation.

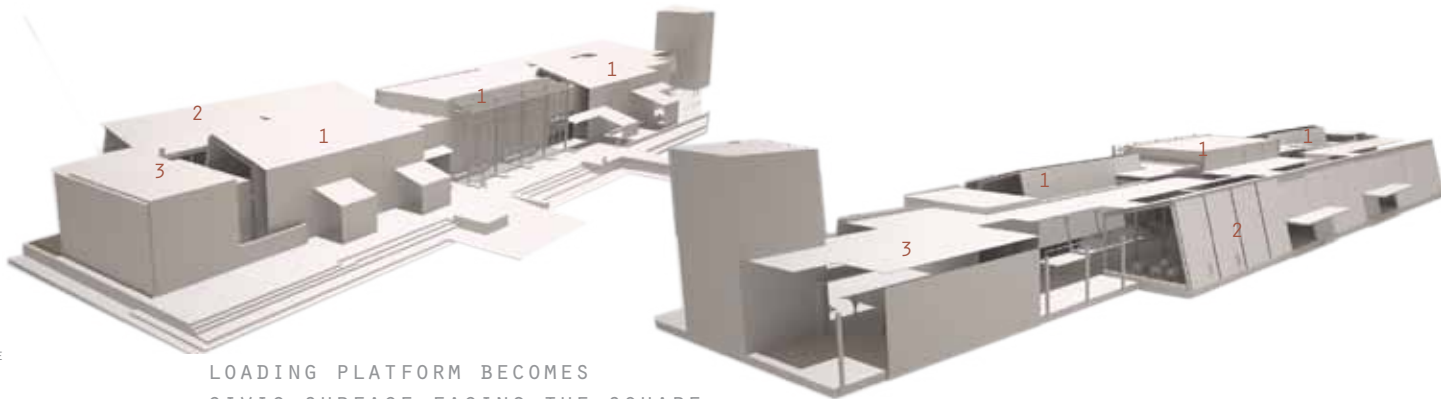


FIG 7.55-56  
INTERSECTING OF THREE  
BODIES AS PRIMARY  
MASSING GENERATOR  
( AUTHOR 2012)

LOADING PLATFORM BECOMES  
CIVIC SURFACE FACING THE SQUARE



FIG 7.57  
EARLY CONCEPTUAL VIEW  
OF CIRCULATION CORRIDOR  
( AUTHOR 2012)

FIG 7.58  
EARLY CONCEPTUAL VIEW  
OF DISMANTLING WORKSHOP  
( AUTHOR 2012)

# 08 . TECHNICAL INVESTIGATION |

# 8.1 | TECHNICAL CONCEPT AND DESIGN PRINCIPLES

## 8.1.1 | APPROACH

The technical concept explores the theme of collaboration and conversation between

- A. The local and the global
- B. The permanent and the temporary
- D. The container and the contained
- E. Extraversion and transparency
- F. The interfacing condition

Urban designer, Aditya Vipparti (2011), proposes a parasitic design methodology in response to the contemporary network society and applicable at all scales within the design process. ( Fig 8.2 ).

As a simple diagram, it suggests the inclusion of static functions, located within a fixed and transformable framework respectively. The intention is to generate a robust structure that would allow "adaptation by reuse" as well as "addition to the existing static systems." (Vipparti 2011;285).

A similar approach is used within the structural composition of the processing facility, in response to the recycling process, and a theoretical discourse which describes value through use and integration within a local context.

The waste hierarchy suggests, first to reduce, then reuse, and finally recycle. The technical resolution of the structure should therefore, allow for design-for-disassembly, in the event that the facility no longer has use or value in time, but also design-for-reuse and mutation, if it's value within the local context becomes permanent, and needs change.

Steel was selected as the main structural member as it possesses qualities of both permanence and transience : congruent with the design intent.

Deplazes (2009 :114), describes steel as the "child of the industrial revolution", that introduced a "hybrid form in which the partner material was no longer "only " an infill without a structural function...but rather ,in mutual dependency, becomes an integral component of the load bearing construction."

The author refers to composite construction, where "steel continues to provide a frame of columns and beams but the stability is achieved only through composite action with the concrete. In this volatile relationship the two materials complement each other." and highlights the emergence of an "impure form of construction." ( Deplazes ( 2009 : 114 ).

FIG 8.1  
THEORETICAL INVESTIGATION  
OF STRUCTURE AND SKIN  
INFLUENCED BY TECHNOLOGY  
( AUTHOR 2013)  
FIG 8.1  
VIPARTI'S PARASITIC  
SPATIAL SYSTEM FOR THE  
NETWORK SOCIETY  
( VIPARTI 2010:285)  
FIG 8.2  
CONCEPTUAL LAYERED  
STRUCTURAL APPROACH  
(AUTHOR 2012)



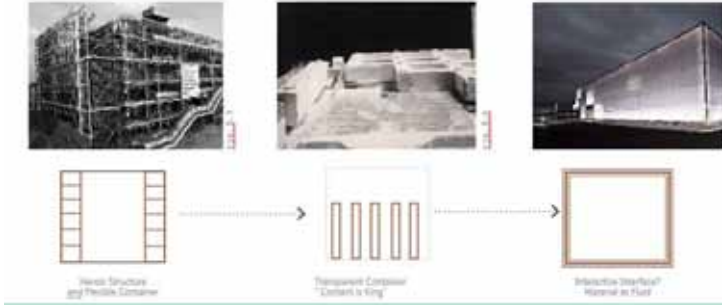


FIG. 8.1 TECHNOLOGIC EXPRESSION INFLUENCED BY TECHNOLOGY (AUTHOR 2012)

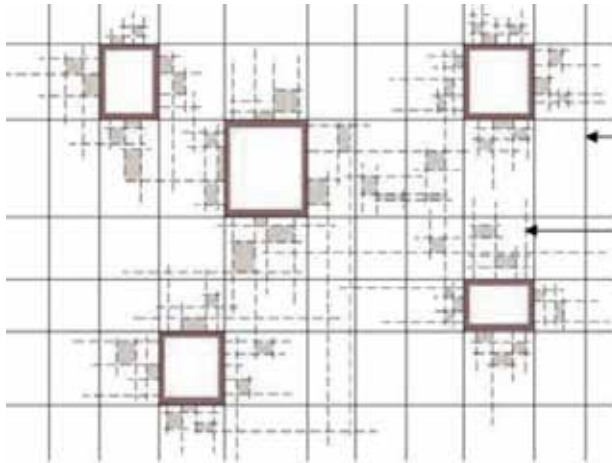
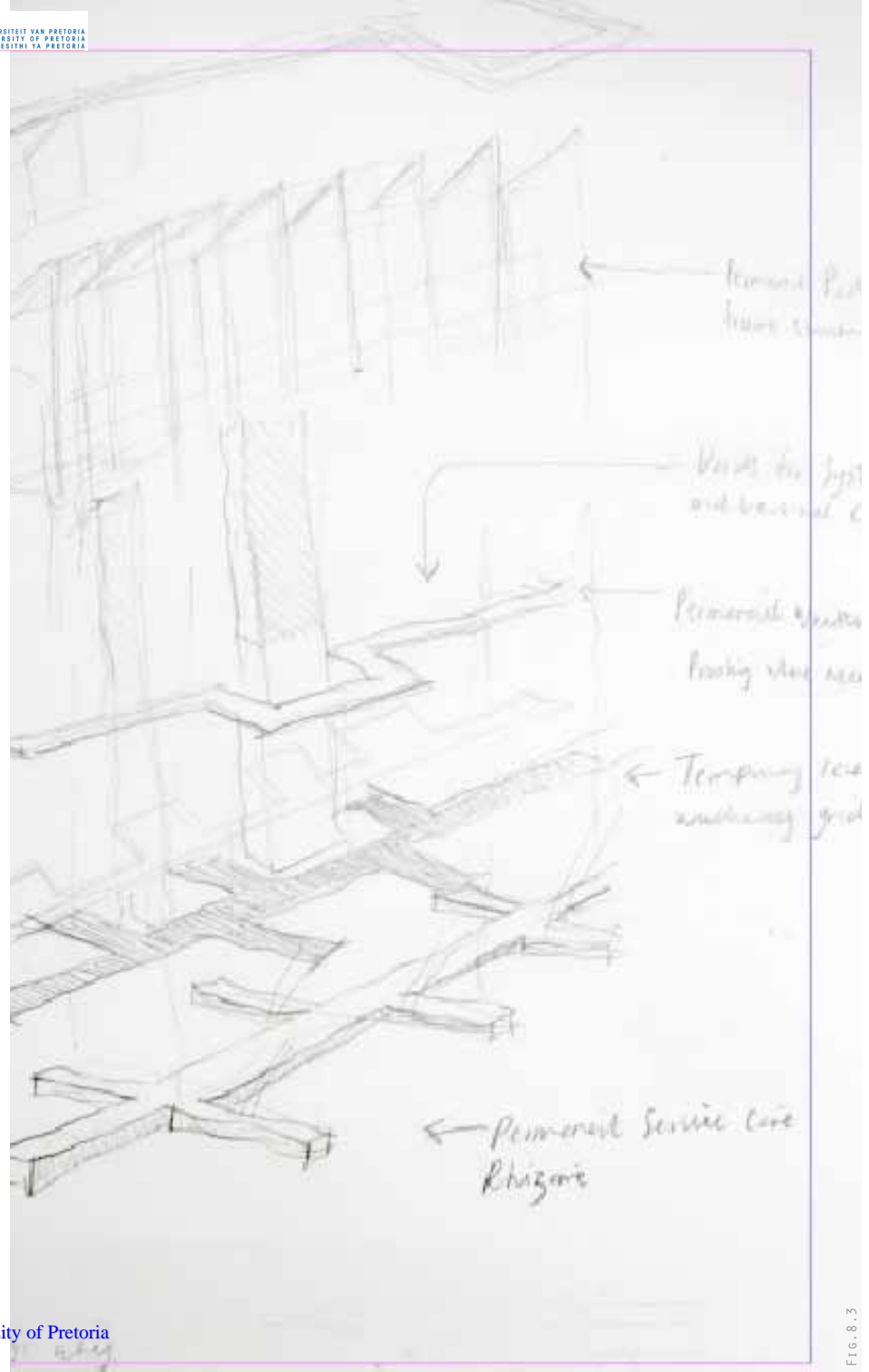


FIG. 8.2 VISPARTI'S PARASITIC SPATIAL SYSTEM (VISPARTI 2010)



## 8.2 | STRUCTURE

### 8.2.1 | STRUCTURAL PRECEDENT 1

The Paykar Bonyon Panel Factory in Iran, by ARUD Office, is a prefabricated factory system, consisting of intersecting framed members, resting on reinforced concrete pad foundations.

Load bearing columns are centred at the point of intersection. Every second bay is cross-braced, and infill framework supports openings and cladding. ( Fig 8.4-8.5)

### 8.2.2 | STRUCTURAL PRECEDENT 2

The Swiss School for Engineering, is primarily a timber structure, in which service cores of reinforced concrete protrude through the roof. The service cores provide a rigid bracing for the filigree construction, while simultaneously generating the conditions necessary to comply with fire safety requirements, and logical ordering of the ablutions.

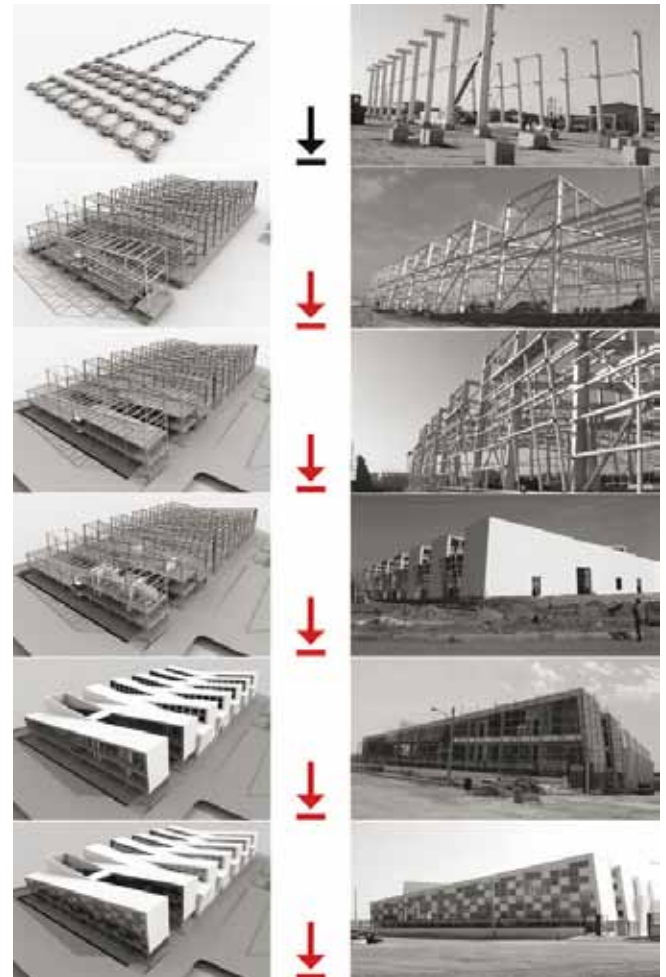


FIG. 8.4

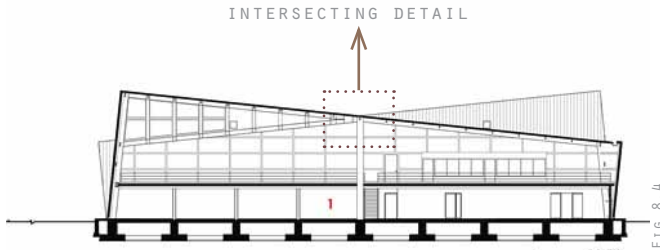


FIG 8.4

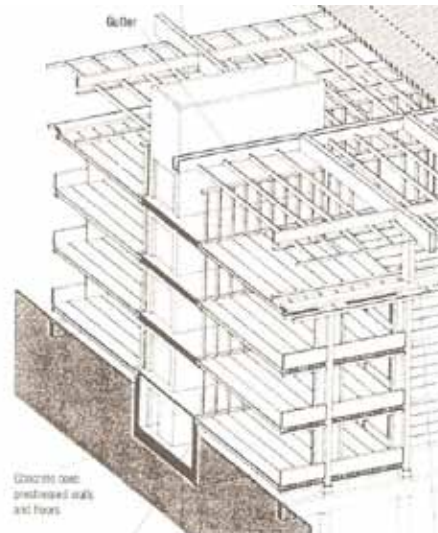


FIG. 8.7

FIG 8.4  
STRUCTURAL DEVELOPMENT  
OF PANEL FACTORY ( ARUD  
2011).WWW.OPENBUILDING.  
COM

FIG 8.5  
INTERSECTING OF FRAMING ( ARUD 2011).  
WWW.OPENBUILDING.COM

FIG 8.6  
ROOF STRIATIONS AND  
WATERPROOFING (ARUD 2011).  
WWW.OPENBUILDING.COM

FIG 8.7  
SERVICE CORE MODEL  
(DEPLAZES 2009 : 400)

FIG 8.8  
SERVICE CORE MODEL  
(DEPLAZES 2009 : 400)



FIG. 8.6

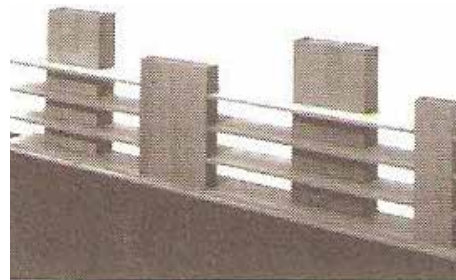
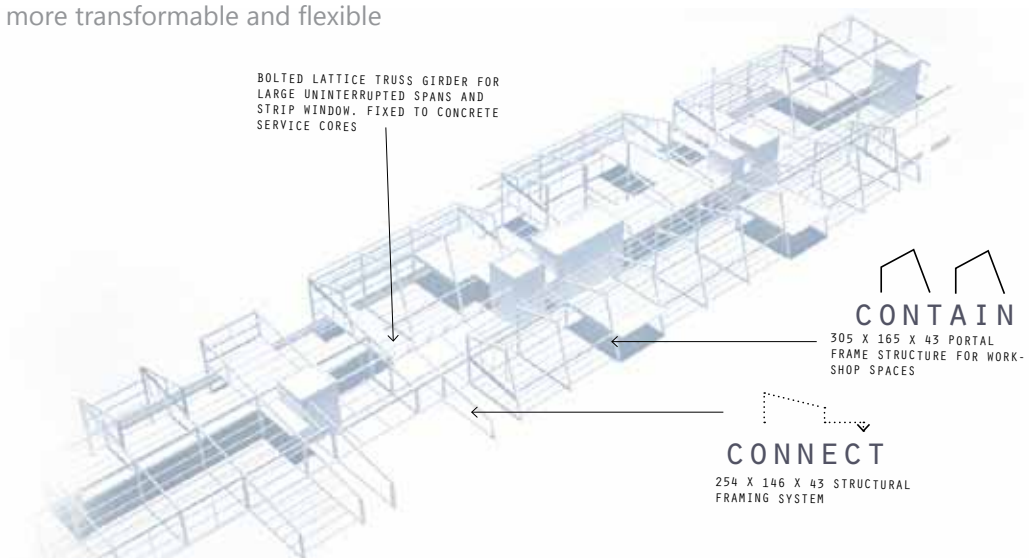


FIG. 8.8

### 8.2.3 | PRIMARY STRUCTURE

The structure consists of a plinth and a series of independent steel framed workshops forming the fixed boundaries to the processing facility, and defining a central circulation corridor. These portal frames act as the containing elements of the structure (Fig 8.8).

The workshops are connected via a secondary frame structure extending from the workshop buildings. These function as a connecting element within the design, and a more transformable and flexible framework.

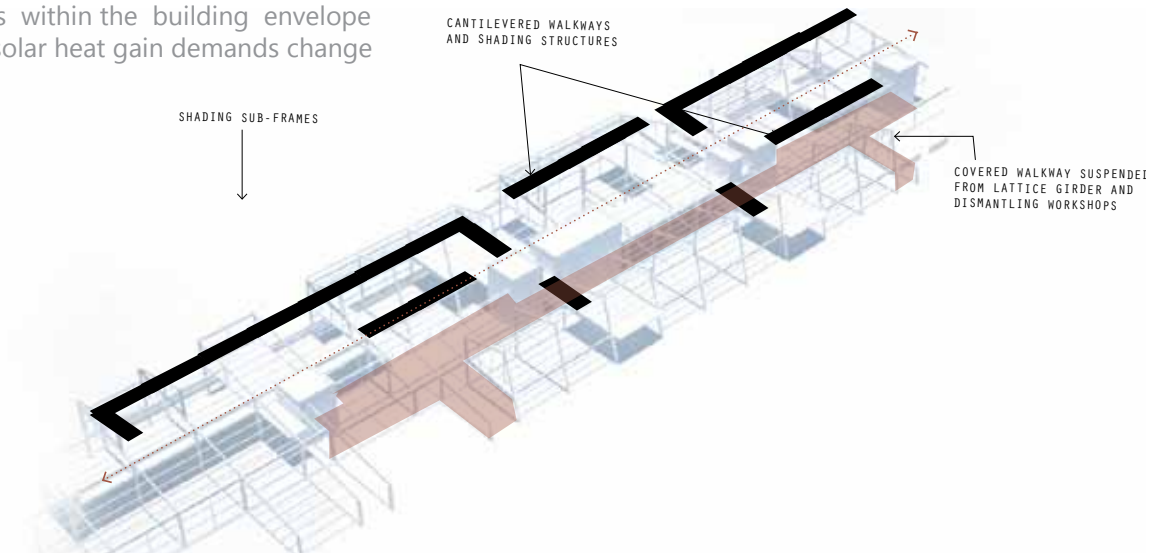




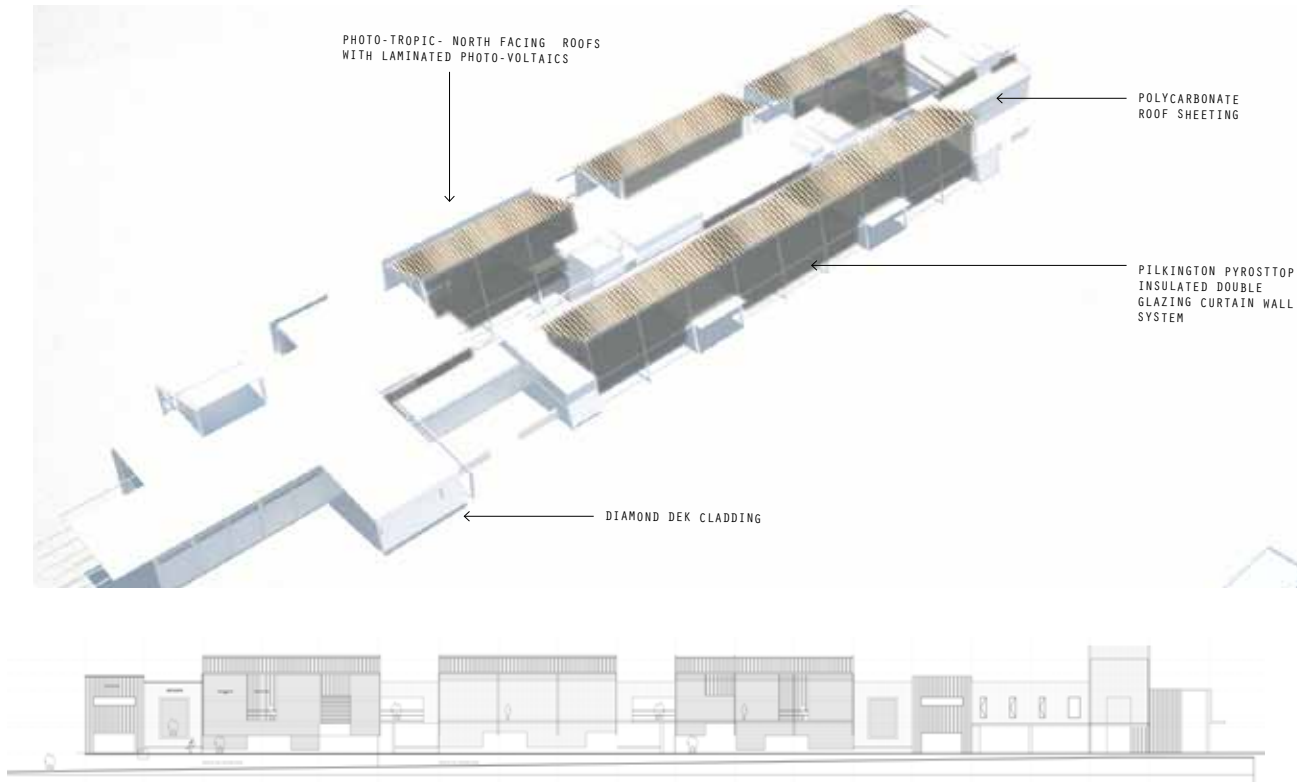
### 8.2.4 | TERTIARY STRUCTURE

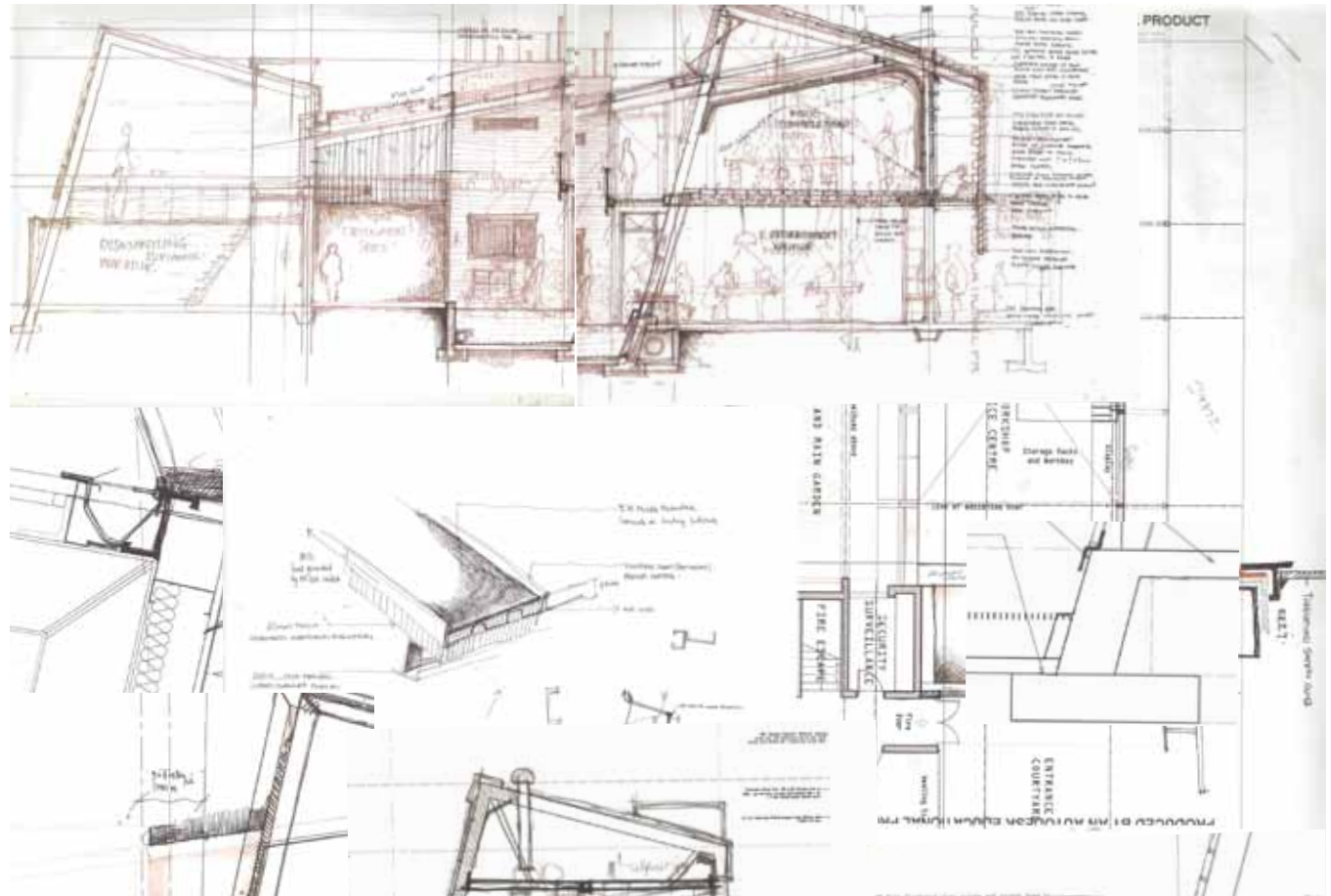
The shading structure forms a tertiary system, that explores the theoretical premise of surface as influenced by current technology.

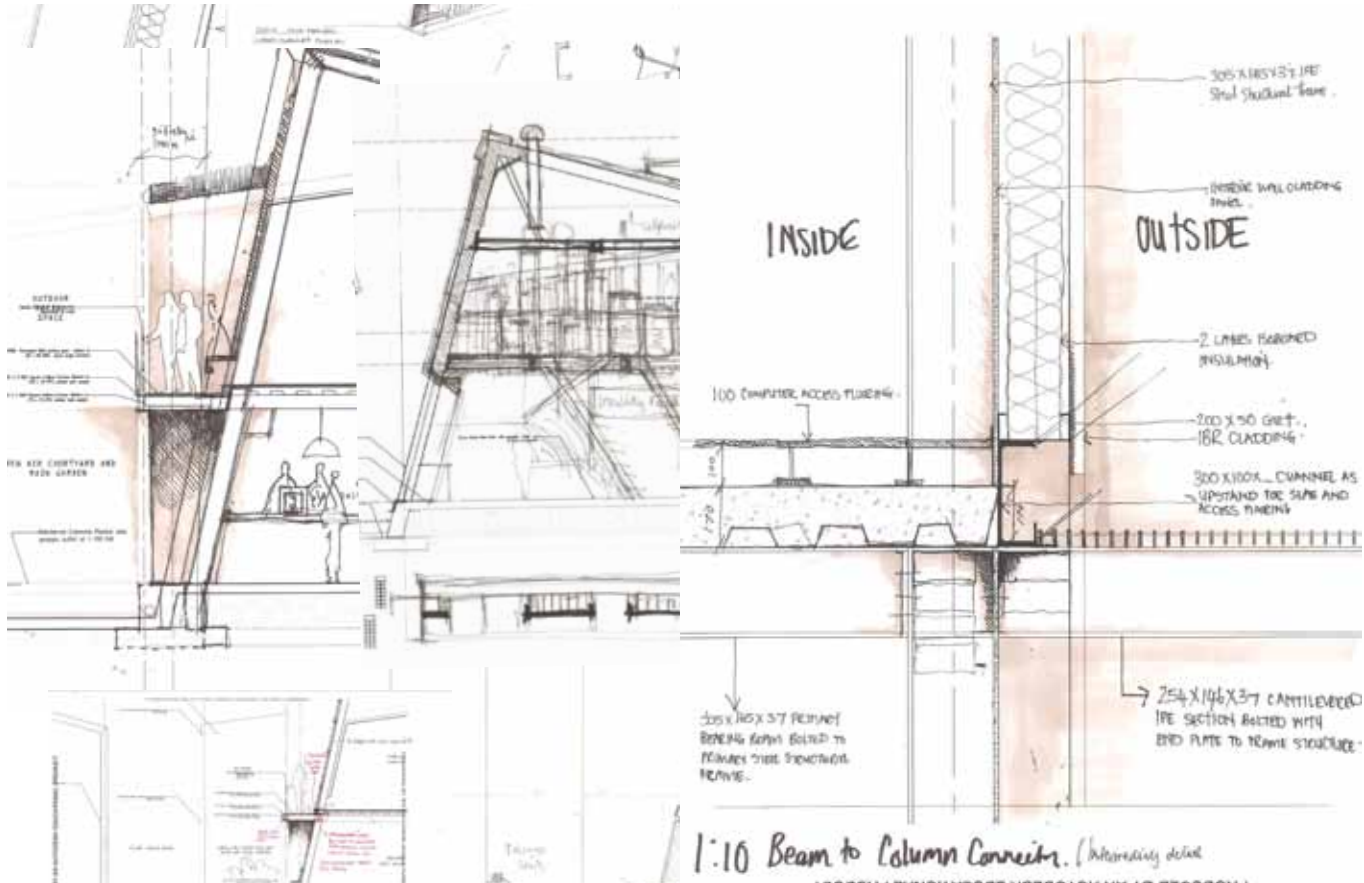
Cladding panels and maintenance catwalks brace the shading structure, and allow for an adaptable system, that can be added or removed in bays of 3000 increments as openings within the building envelope change overtime, and solar heat gain demands change from indirect to direct.











## 8.25 | SMART SKIN

### PRODUCTION FACILITY

In order to differentiate between the public exhibition workshop and those of the processing facility, different smart skins are utilized.

The tertiary shading structure is a hybrid between a horizontal shading structure and a LED media facade, producing a fluid surface. Louvre LED ([www.louvreled.com](http://www.louvreled.com)) produces a louvre system, of a variety of materials, with led lights embedded. The spacing of 125mm allows for a 64 pixel resolution at a viewing distance of 30m. This will be most effective at night.

Since the louvre can be a variety of materials composite recycled plastic and wood fibre planks by Eva Tech are proposed as the louvre system, in which the LEDs are to be embedded. A different colour range is proposed to add visual interest to the facade and generate pattern.



FIG. LEDTIMBERLOUVRE2.JPG (WWW.LOUVRELED.COM)

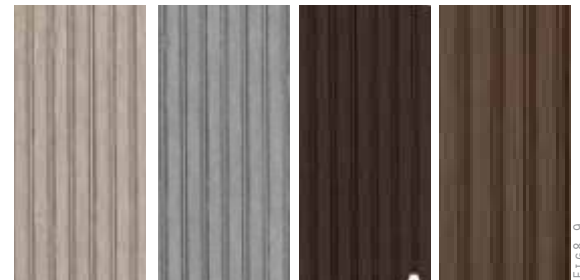


FIG.8.9

FIG 8.8  
DETAIL OF COMPOSITE LED  
LOUVRE (WWW.LOUVRELED.COM)

FIG 8.9-8.10  
EVATECH COLOURS AND  
PLANKS (WWW.EVA-LAST.COM)



FIG.8.10

## PUBLIC EXHIBITION FOYER AND PLANT ENTRANCE

The public exhibition foyer will make use of GKD media mesh, with a 40mm spacing producing a high resolution image for podcasts and event screenings during the day and the night.

The stainless steel mesh will be fixed to a subframe bolted with angle cleats to the cantilever walkways, and above window openings

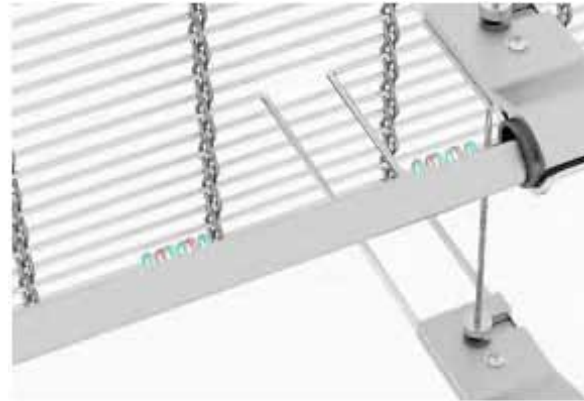


FIG 8.11  
GKD MEDIA MESH DETAIL  
(WWW.GKD.COM)

FIG 8.12  
MEDIA FACADE AT NIGHT  
(AUTHOR 2013)

## 8.03 | ENVIRONMENTAL

### 8.3.1 | ENERGY

The plugloads electrical devices used within the processing facility was calculated to be 277KW hrs per day, ( See Addendum C ).The efficiency of photovoltaics is 12- 16%( Weller et al: 2010), which is increasing with new technology, and gradually reducing in cost.

The proposal suggests that the cost of the photovoltaic system is mitigated through funding from the Department of Social Development ,as a pilot project, operated tested and maintained by the tenants of the building. In that manner, the architectural expression of the placeless solar panel , can be integrated into the design language of the building, and its active urban skin.

Flexible Thin Film Photovoltaics contain no glass, and therefore are unbreakable, cheaper and lose less efficiencies with an increase in temperature ( Kwak & Grandzik :2007:194).They also allow greater opportunity for Building Integrated solutions and bending.

Required Roof Area=  $C/3.3$   
where C , is the desired output in watts and 3,3 Referring to a 12% module efficiency.

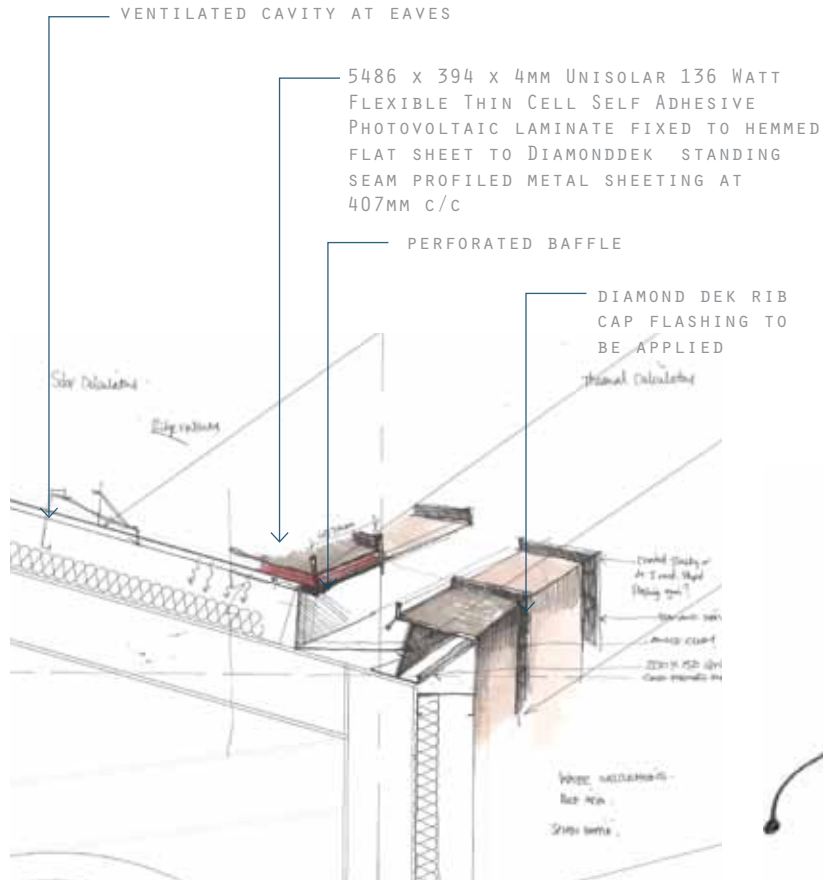
According to Kwak & Grandzik (2007:194) it is acceptable to design a system based on providing 40% of the overall plugloads

The total north facing roof area totals 594msq, resulting in a 20% reduction in plug loads within the facility, the adhesive panels can be easily be replaced with newer more efficient technology overtime.

The system is a grid connected system therefore the optimum orientation is latitude -10 degrees (REF) which for Pretoria is 25 degrees - 10 = 15 degrees.

A ventilated cavity detail, can increase the efficiency of a module by decreasing temperature and be integrated into the ventilation strategy of the facility.





CONCEPTUAL DETAIL OF GUTTER IN CONJUNCTION WITH SOLAR PANEL LAMINATE



UNISOLAR FLEXIBLE PV LAMINATE. CABLES ARE CONCEALED BENEATH RIDGE CAP FLASHING

FIG. 8.14 WWW.UNI-SOLAR.COM

FIG 8.13  
CONCEPTUAL GUTTER AND LAMINATE DETAIL  
( AUTHOR 2013)

### 8.3.2 | HEATING COOLING AND VENTILATION SYSTEM

The environmental concept attempts to form a collaborative whole, between various systems.

The ventilation concept makes use of the displacement concept and high ceiling volumes and cross ventilation.

In order for stack ventilation to be effective, the stack should be twice the height of the space ventilated. Roof Ventilators and operable Louvres pull air out through the building and introduce cool air into the service ducts.

The thermal insulation and bi-product heat of the photovoltaic system of the roof envelope in winter prevents heat losses, and in summer prevents heat gains. This is mutually beneficial since a temperature rise of reduces photovoltaic efficiency

In summary. passive strategies include solar shading to reduce solar gain, stack ventilation using temperature and pressure differentials, thorough insulation of the building envelope and natural daylight.

Active strategies include the roof extractors and photovoltaic system

### 8.3.3 RAINWATER

According to the rainwater calculations there is a surplus , where the seasonal demand for the flushing of toilets is stored. overflow water is diverted into a bio-swale or rain garden within the production facility, providing visual relief and transpiration effects with the courtyard

### 8.3.4 FIRE

The adjacency of multiple occupancies within the proposal, resulted in a brief investigation of fire compliance. Furthermore the implication of an isolated public component resulted in the consolidation of services and a central escape route discharging directly out of the building. Separate fire escapes are provided for the processing facility.

Safety distances and occupancy separating elements were investigated conceptually in section, where medium risk industrial storage is presents affecting material choice.

1 SOUTH FACING WORKSHOP WINDOWS, PROVIDE ADEQUATE DIFFUSE LIGHTING. PILKINGTON PYROSTOP LAMINATED DOUBLE GLAZED WINDOW SYSTEM THERMALLY PROTECTS THE BUILDING ENVELOPE AND ASSISTS IN ACOUSTIC ISOLATION

2 INDIRECT PASSIVE DOWN DRAFT COOLING TOWER IN SERVICE CORE USING THERMAL MASS AS HEAT EXCHANGER

3 RAIN GARDEN PLANTED WITH DROUGHT RESISTENT PLANTS AS OVERFLOW STORMWATER CATCHMENT DRAINING INTO GEOPIPE. TRANSPIRATION ASSISTING WITH COURTYARD

4 STACK EFFECT AND DISPLACEMENT PRINCIPLE. EFFECTIVE FOR 2H THE SPACE VENTILATED

5 FLEXIBLE SOLAR SHADING SCREEN PREVENTING DIRECT HEAT GAINS INTO SPACE

6 WASTE HEAT GENERATED BY PHOTOVOLTAIC SYSTEM CAN PREHEAT SPACES DURING WINTER

6 SMART FLOORS. COMPOSITE FLOORS WITH HORIZONTAL SERVICE DISTRIBUTION

7 POROUS CIRCULATION CORRIDOR ALLOWS FOR CROSS VENTILATION

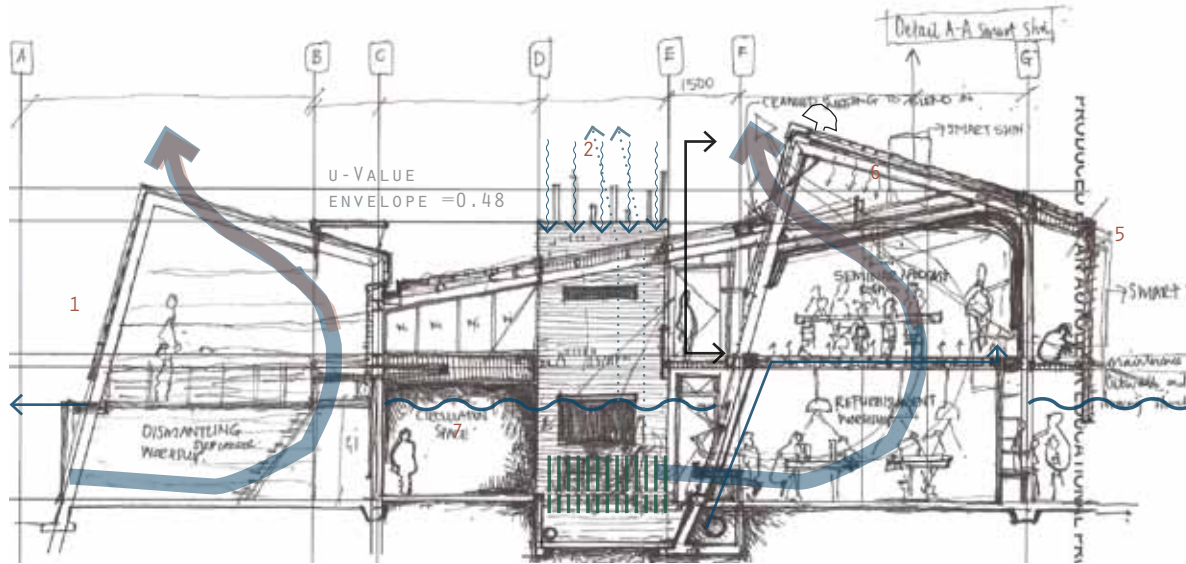


FIG 8.15

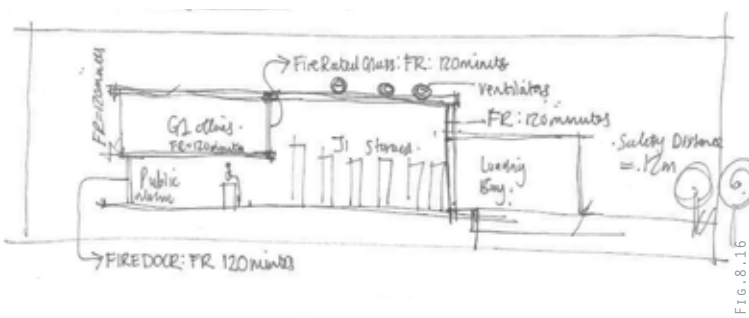


FIG.8.16

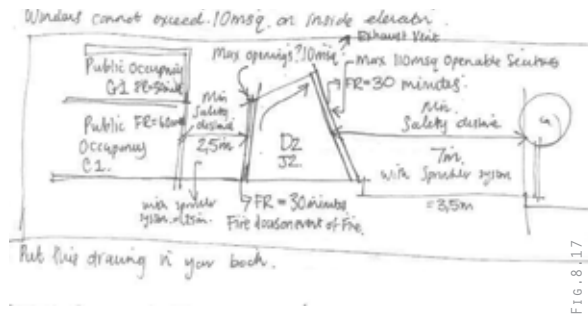


FIG.8.17

FIG 8.15 ENVIRONMENTAL SYSTEM APPROACH ( AUTHOR 2013)

FIG 8.16 FIRE TREATMENT FOR GOODS RECEIVING STORAGE ( AUTHOR 2013)

FIG 8.17 FIRE TREATMENT BETWEEN PUBLIC COMPONENT AND DISSASSEMBLY ( AUTHOR 2013)

# 09 . C O N C L U S I O N |

## 9.1 | CONCLUSION

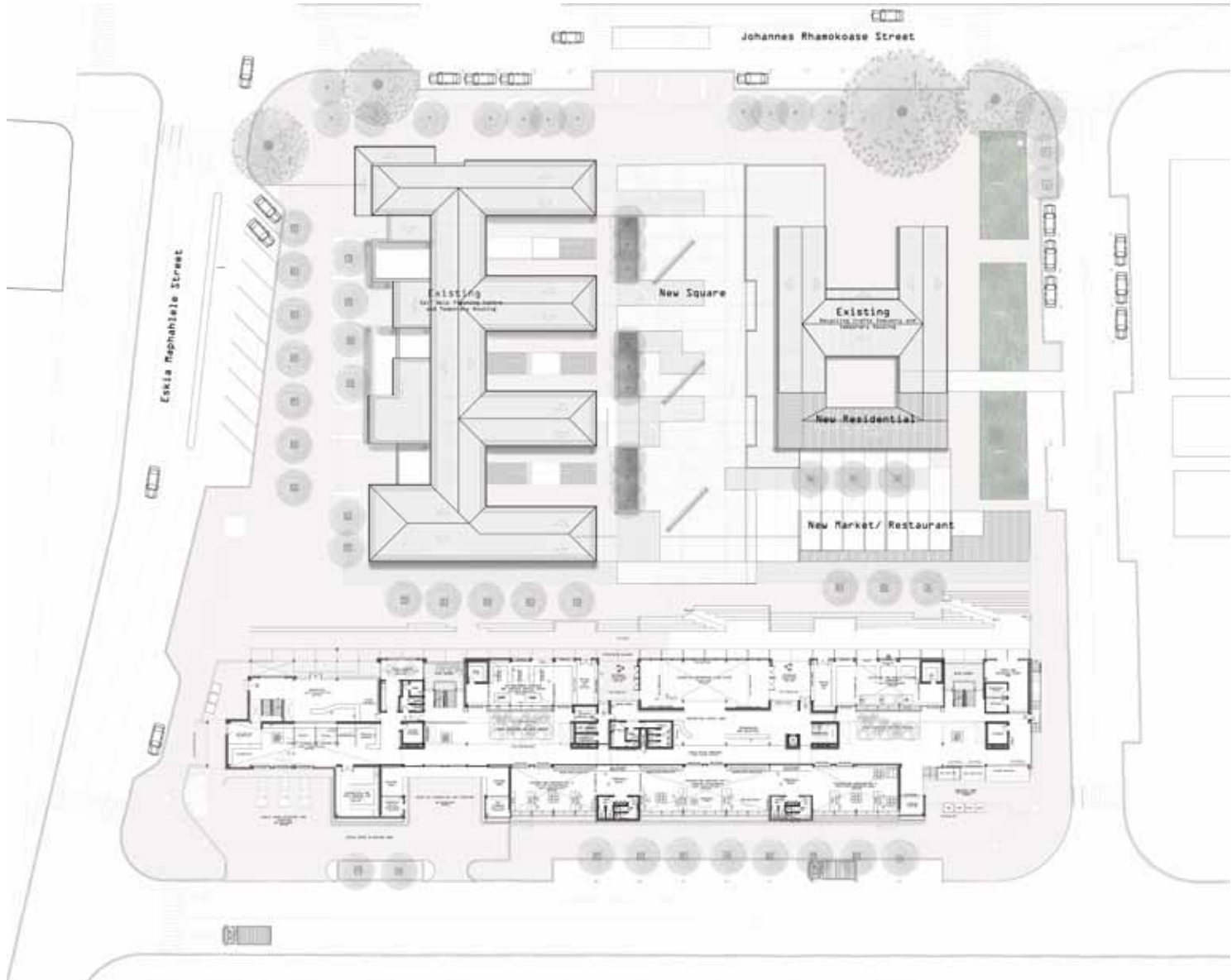
The design resolution which follows serves as a conclusion to the original hypothesis.

The investigation of the potential mutation of the architecture of industry, in light of a contemporary industrial ethos centred around the “ network society” ( Castells: 1994) resulted in the design of a hybrid or multivalent typology in which:

- A. programme was derived by both a global and local need and the negotiation between the two.
- B. a condition of plurality and multiple interpretations of value is generated , where a production facility can act as durable civic resource and simultaneously an architectural expression of a global value-adding process.
- C. form is generated by the linear nature of the industrial process, and is a recombinant mutant of process optimization decisions, environmental concerns and reference to local heritage and space making.



○ URBAN STRATEGY



○ SITE PLAN

NTS

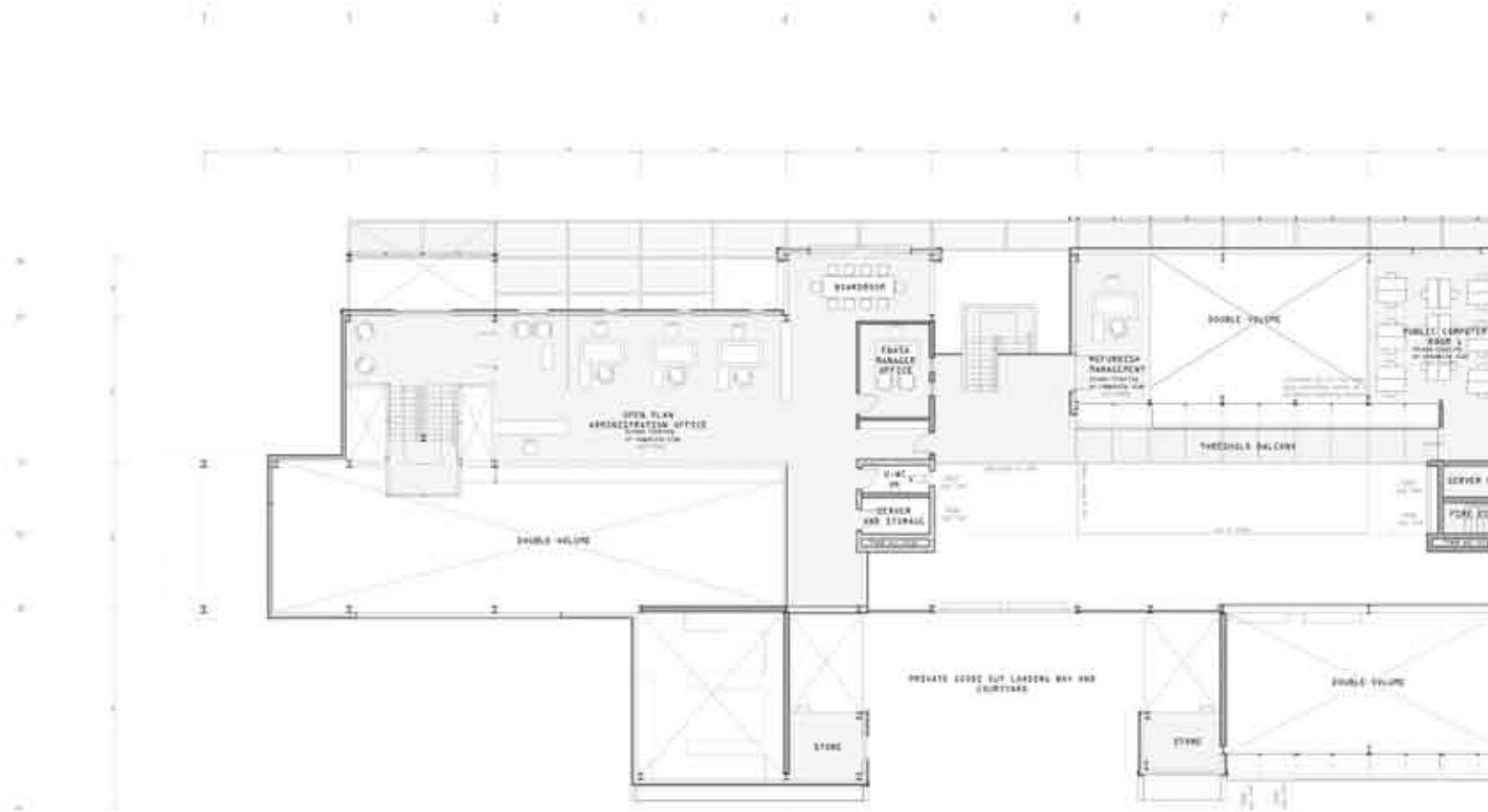




○ GROUND FLOOR PLAN

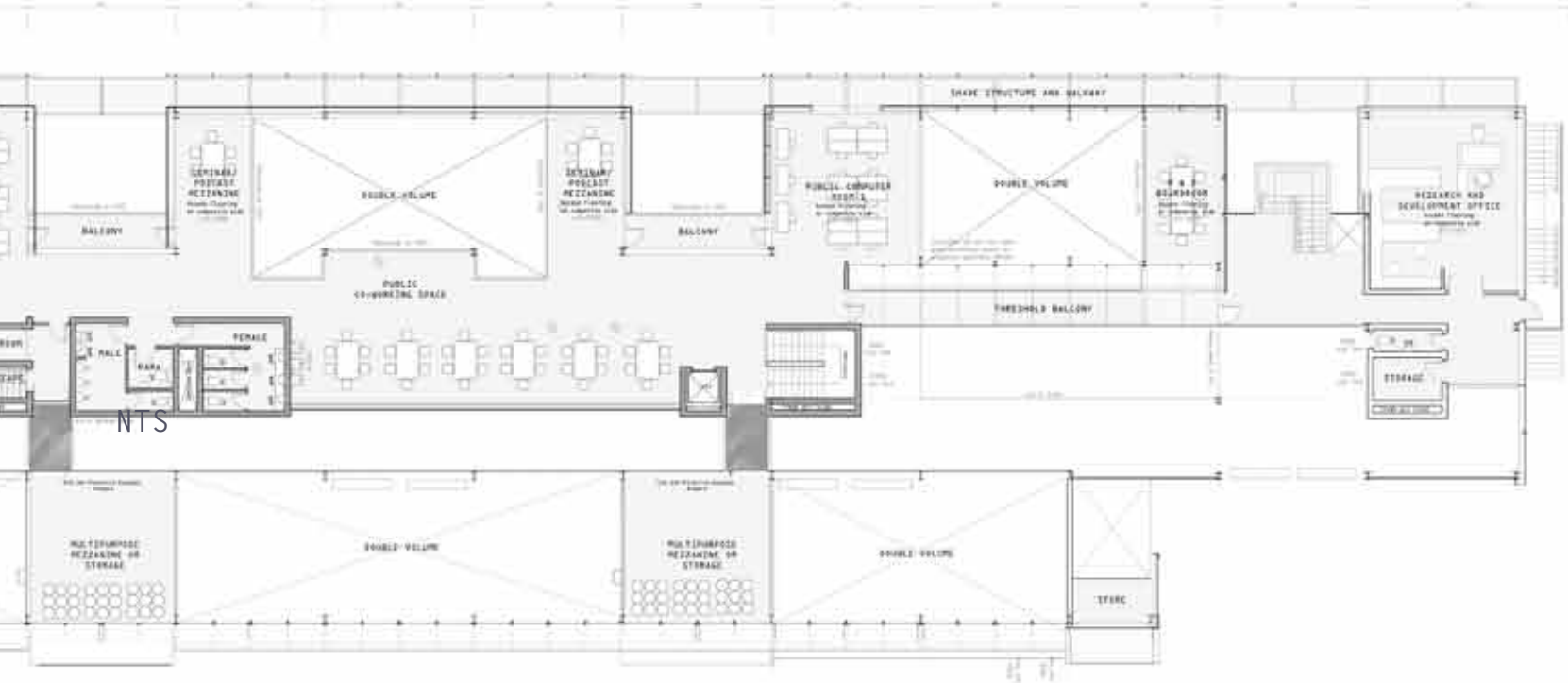
NTS

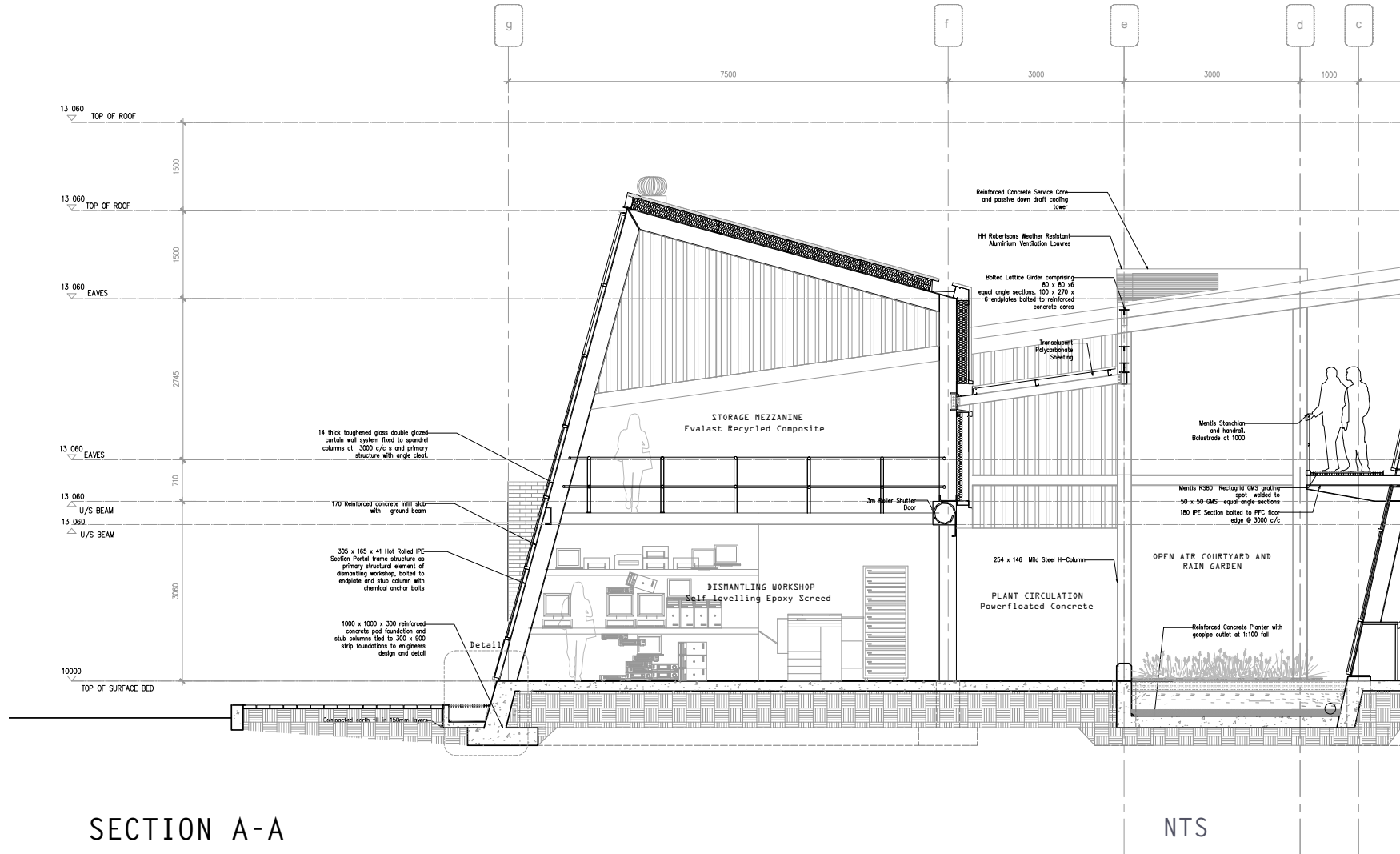


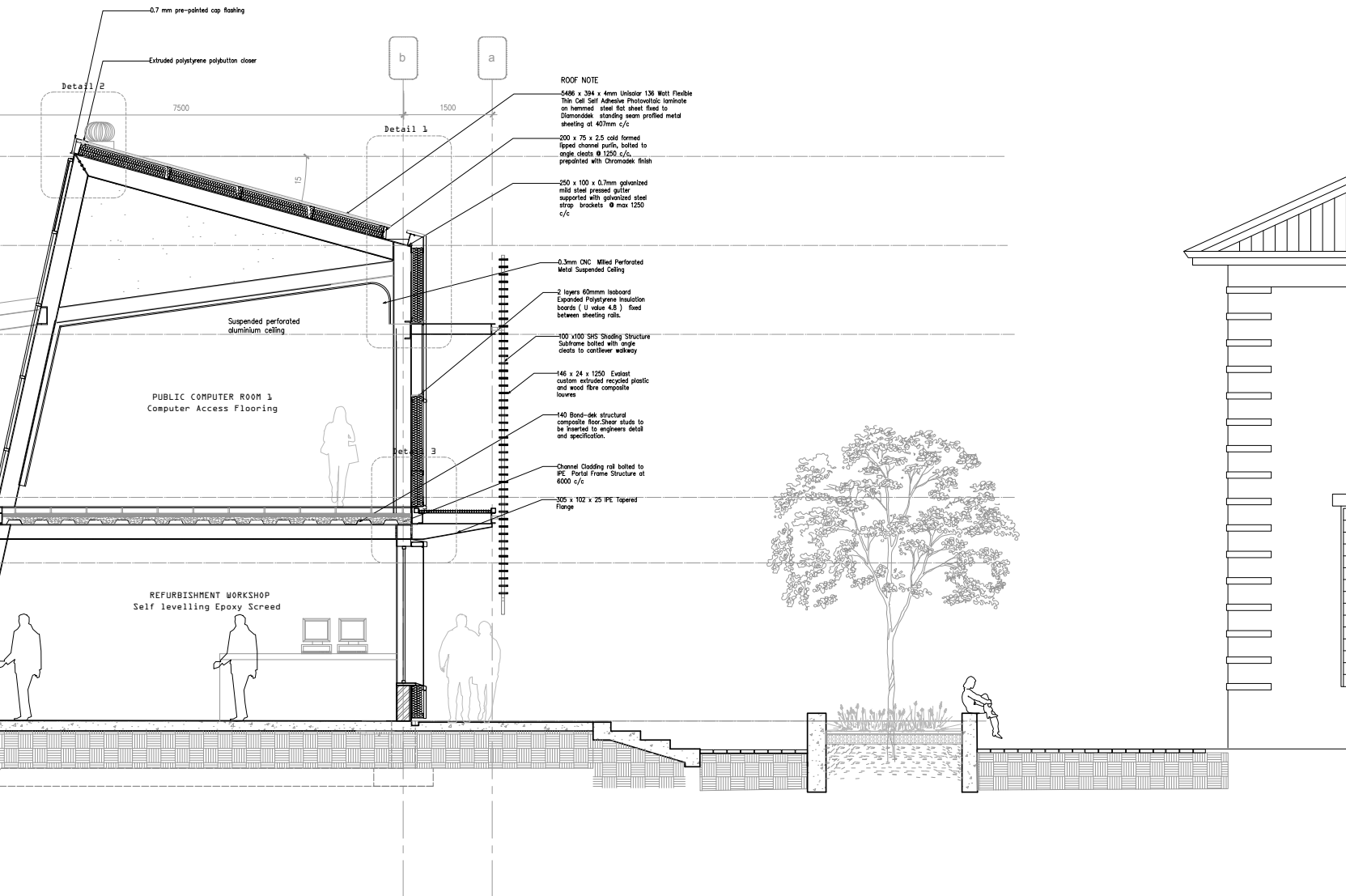


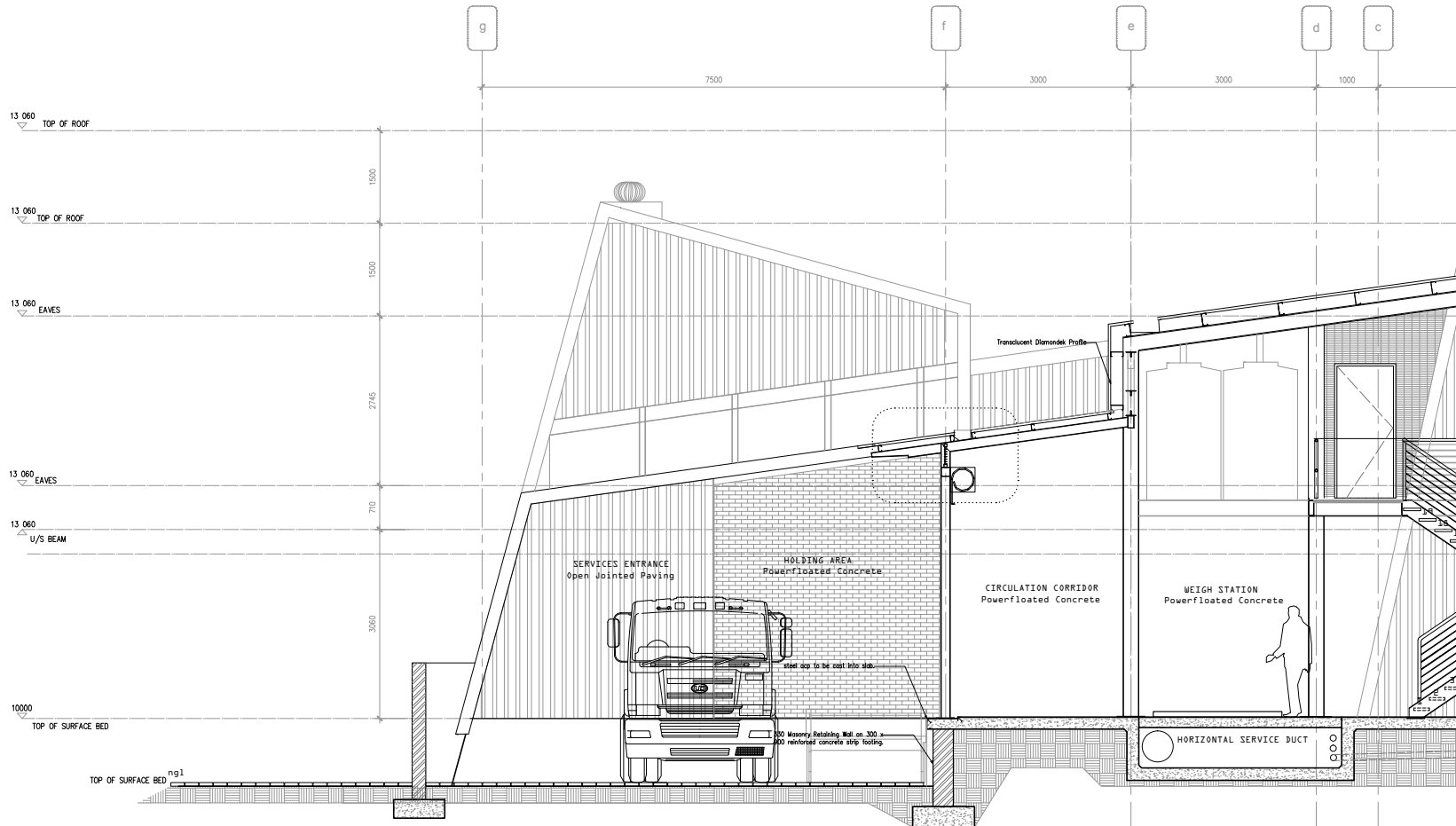
○ FIRST FLOOR PLAN

NTS





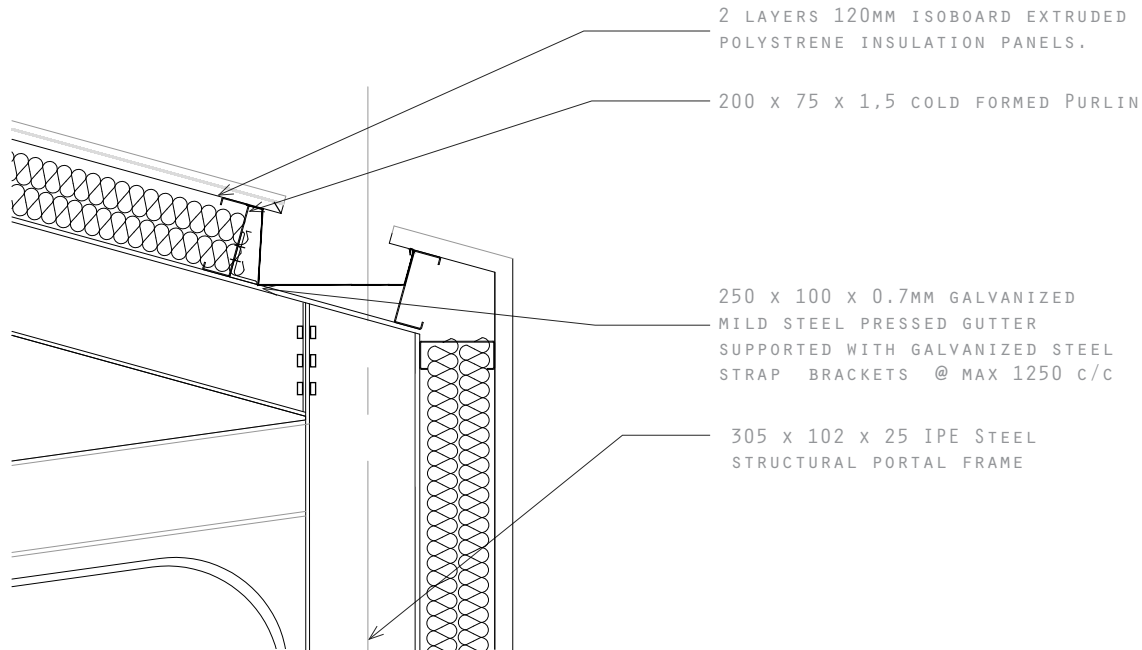




SECTION B-B\_

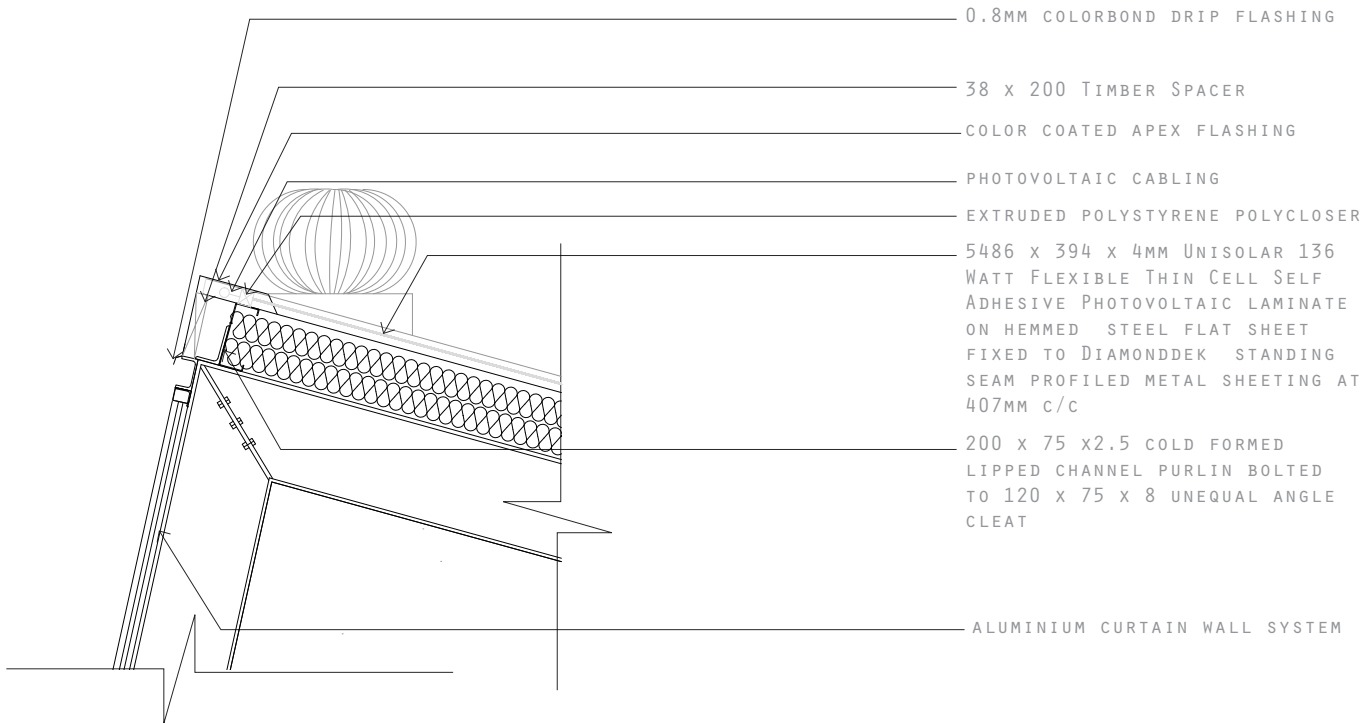
NTS





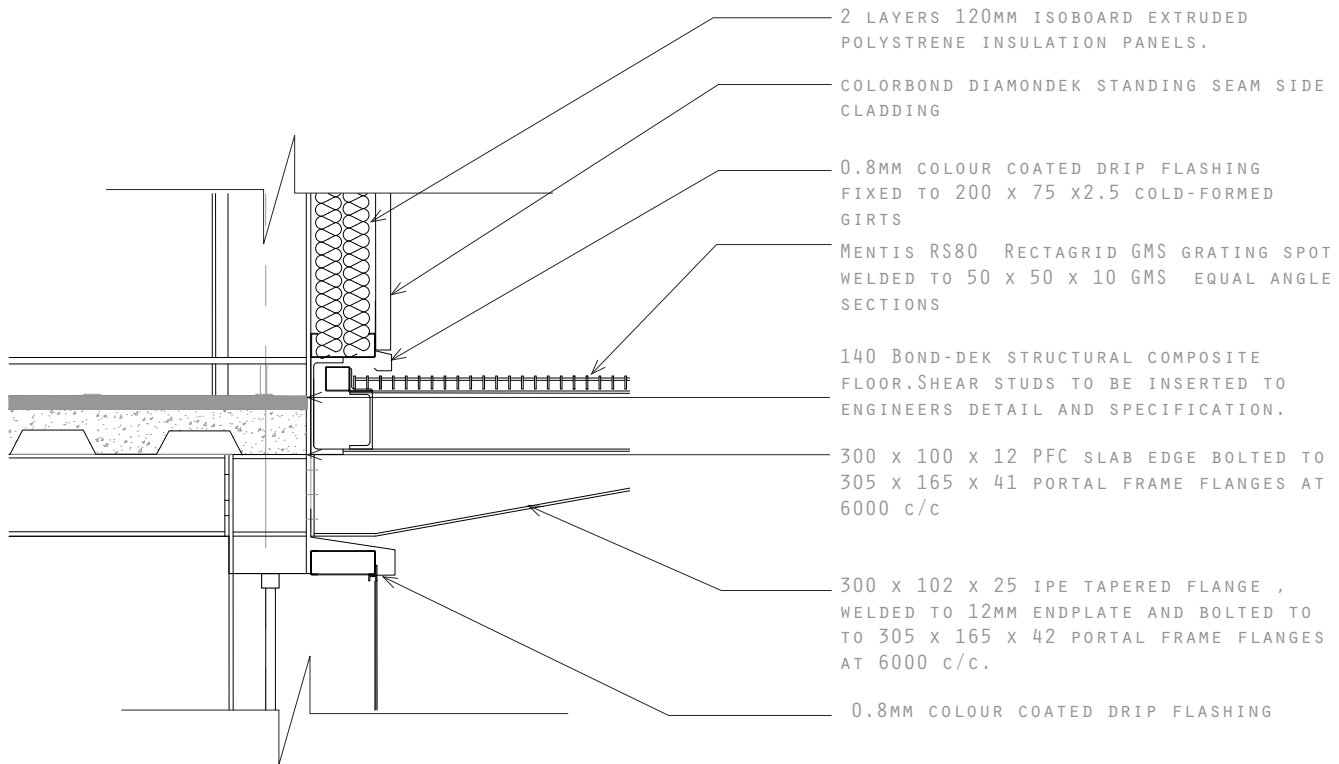
DETAIL 1\_ CONCEALED GUTTER

NTS



DETAIL 2\_ ROOF APEX

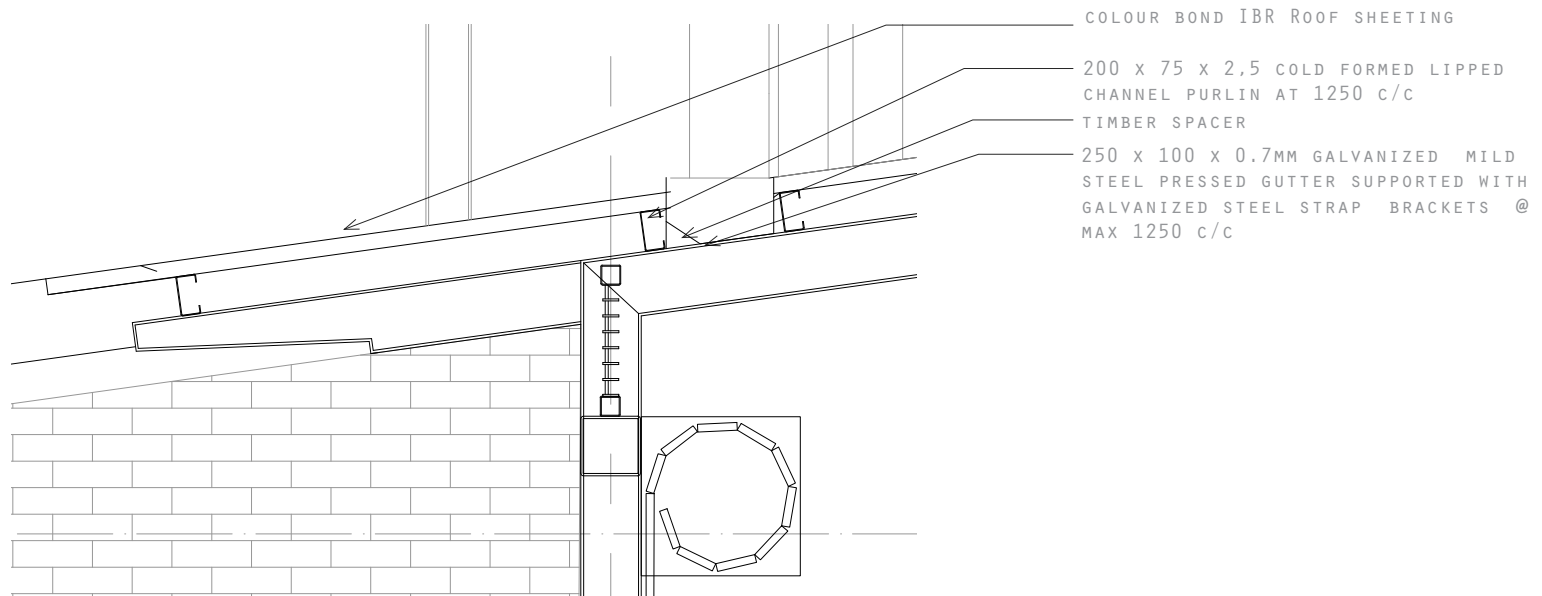
NTS



DETAIL 3\_ INTERMEDIARY FLOOR WALL CONNECTION

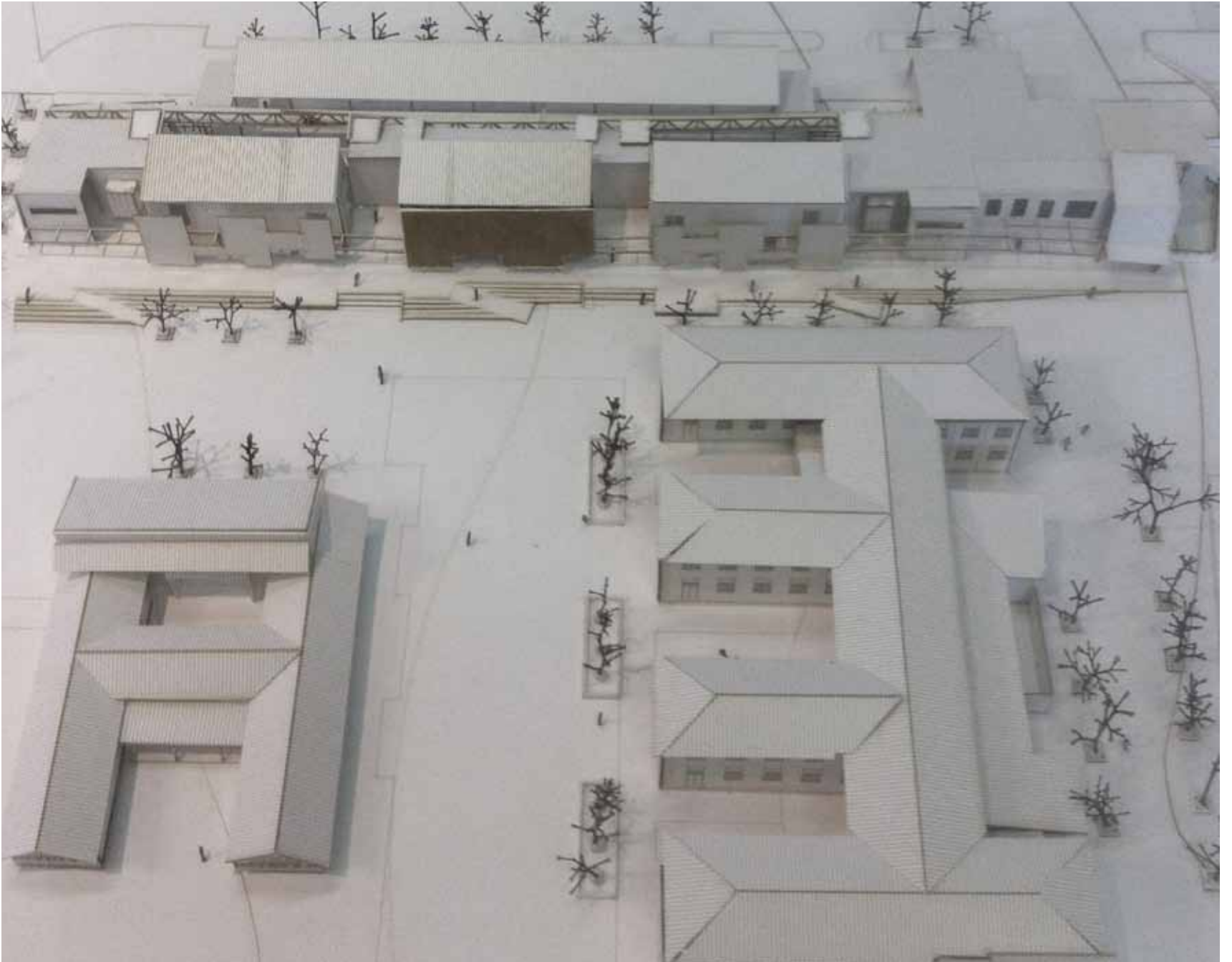
NTS

NTS



DETAIL 4\_ LOADING BAY ROOF

NTS





# 10. REFERENCES AND APPENDICES |



### Addendum C: daily Plug load Calculation for Processing Facility

Zone	Equipment	no	Operation Hrs	Wattage	Watt hrs/day
Diagnostics	Monitors ( Testing )	10	8	150	12000
	Computers ( Erasing )	10	8	120	9600
Adminastration Offices and Reception, Boardroom	Computers	4	8	120	3840
	Server Room	1	24	1000	24000
	Laptops	3	8	50	1200
Public Co-Working Space	Laptops	30	5	50	7500
	Public Printers	2	16	70	2240
	Public Photocopiers	2	5	200	2000
Public Computer Room 1 and 2	Computers	40	16	120	76800
Seminar Rooms 1 and 2	Monitors or Projector	1	2	30	60
	Laptops	8	2	50	800
Research and development	Laptops	10	12	50	6000
	Server Room	1	24	1000	24000
	Computers	3	8	120	2880
Refurbishment Workshop	Drills and other hand tools	5	8	360	14400
	Computers	4			0
Upcycling and Public Training Workshop	Computers	2	8	120	1920
	CNC Machines	1	1	1000	1000
	Rapid Prototyping Machines	1	1	1000	1000
Dismantling Shop					0
	Power Tools General	30	8	360	86400
					<b>277640</b>
<b>Total</b>					<b>277 KW HRS</b>

*\*Estimated plug loads per equipment sourced from Kwak, A & Grandvik, W(2007:194)*

## LIST OF REFERENCES

- Alberti, F ( 2002). The Concept of Industrial District: Main Contributions. Conference proceedings at [www.insme.org/files/922](http://www.insme.org/files/922)
- Aziz Tayob Architects (1998). Integrated Urban Design Framework for Marabastad. Tshwane Metropolitan Municipality: Tshwane.
- Bell, D ( 1976). *The Coming of the Post Industrial Society: A Venture in Social Forecasting*. USA. Basic Books
- Boutang, Y (2001) A Mutation of Political Economy as a Whole, in *Mutations*, Boeri et al. ACTAR.
- Buchanan, P. (1995). *Renzo Piano Building Workshop: complete works*. London, Phaidon Press.
- Castells, M and Hall, P. 1994. *Technopoles of the World*. The making of 21st Century Industrial Complexes. USA: Routledge
- Castells, M. (1996). *The Rise of the Network Society*. 2nd Edition. Malden, Mass, Blackwell Publishers.
- Compaine, MB ( 2001). *The Digital Divide, Facing a Crisis or creating a Myth* ( Preface) . USA: MIT
- Dezplazes, A (Ed). 2009. Constructing Architecture : Materials processes and Structures Handbook. 2nd Edition . Birkhauser, Berlin
- Dunn, H ( 2010). The Carbon Footprint of ICTS. In Introduction in Finlay, A. Ed. (2010). *Global Information Society Watch 2010*. Switzerland: APC and HIVOS. Pg 15-16
- Eisenman, P (1982) Introduction. In Rossi, A. (1982). *The architecture of the city*. Cambridge, Mass, MIT Press.
- Eek, P.H ( 2010) Piet Hein Eek: New Premises. S.I.S.n
- Ewasa. (2009 ). Technical Guidelines on the Recycling of Electrical and Electronic Appliances. S.I. S.n
- Friedman, M. (1990). "Tshaya! He has our money!": The Uprising of the Municipal compound workers in Marabastad, 1942. Wits. *History Workshop Conference 1990*. Johannesburg, 1990, Wits :Johannesburg. Available at: <http://wiredspace.wits.ac.za/bitstream/handle/10539/7813/HWS-126.pdf?sequence=1> [17 July 2012]
- Friedman, M. (1994). *A History of Africans in Pretoria with Special Reference to Marabastad, 1902-1923*. Pretoria :University of South Africa
- Habraken, N. J., & Teicher, J. (1998). *The structure of the ordinary: form and control in the built environment*. Cambridge, Mass, MIT Press.
- Horan, T.A. (2000). *Digital Places Building our City of Bits*. Washington DC : ULI- the Urban Land Institute
- ICOMOS., & International Council on Monuments and Sites. (2000). *The Burra Charter: the Australia ICOMOS charter for places of cultural significance 1999* : with associated guidelines and code on the ethics of co-existence. Burwood, Vic, Australia ICOMOS.
- Jarvis, J. (2009). *What would Google do?* New York, NY, Harper Collins.
- Kwak, A and Grondzik B. (2007). The Green Studio handbook: Environmental Strategies for schematic design. Elsevier. London.
- Mitchell, J ( 1996). *Space Place and the Infobahn*. 2nd Edition. USA : Massachusetts Institute of Technology
- Lee & Jacoby (2011). Typological Urbanism and the Idea of the City. *Architectural Design*. 209, Jan/Feb 2011, pg 15-23. Available at : [http://0-onlinelibrary.wiley.com/innopac.up.ac.za/journal/10.1002/\(ISSN\)1554-2769/issues?year=2011](http://0-onlinelibrary.wiley.com/innopac.up.ac.za/journal/10.1002/(ISSN)1554-2769/issues?year=2011) [13 May 2012]
- Mobbs, P. (2010). Introduction in Finlay, A. Ed. (2010). *Global Information Society*

- Watch 2010*. Switzerland: APC and HIVOS pg 9-11
- Le Roux, S.W.(1991). *Marabastad of die Asiatiese Bazaar:Geboue en Plekke van Belang*.Schalk Le Roux Uys Kruger Architects.
- Lombard, R & Widmer, R. (2005).E-waste Assessment in South Africa: A case study of the Gauteng Province. St Gallen. Switzerland :EMPA. Available at : [http://ewasteguide.info/Widmer\\_2005\\_Empa](http://ewasteguide.info/Widmer_2005_Empa) [ 11 July 2012 ]
- Moneo, Raphael (1978). *On Typology*, Oppositions 14, MIT press, 1978, 22-45. Available at :
- Mytelka, L(2000). From Industrial Clusters to Innovation Systems in Innovation Systems in Africa.
- Nagashima.K. (1999). Glocal Approach Toward Architecture of the Future. In: *Union Internationale des Architectes*, XX UIA Beijing Conference. Japan, 1999, Union Internationale des Architectes and Japan Institute of Architects: Japan.
- Oswalt , P.Ed.(2005). *Shrinking Cities: International Research*. Vol 1,Hatje Cantz Verlag, Germany
- Pevsner, N. (1976). *A History of Building Types*. Princeton, N.J., Princeton University Press
- Puglisi, L.( 1999).*Hyperarchitecture: Spaces in the Electronic Age*. Berlin. Birkhauser
- Robert, S (2006). Smart Industries: The importance of Technology and research and development for industry performance in *Trade and Industry Monitor* (Gavera, L Ed) 2008 accessed online at [www.tips.org.za/monitor](http://www.tips.org.za/monitor) [3 June 2012]
- Rogers. (2010). Centre Pompidou. S.i.s.n. Available at [www.rsh-p.com](http://www.rsh-p.com) [ 5 July 2012]
- Roinat, P & Varin, B. (2008). *Entrepreneurs' Guide to Computer Recycling : Volume 1. Basics for Starting up a Computer Recycling Business in Emerging Markets*, TIC ETHIC SARL : CreDEX
- Rowe P. (1982). *Civic Realism* Cambridge, Mass, MIT Press.
- Ryan,BD ( 2008). The Restructuring of Detroit: City Block Form Change in a Shrinking City, 1900-2000, *Urban Design International*,00, 1-13. Palgrave Macmillan Ltd. Available online at :<http://www.palgrave-journals.com/udi/journal/v13/n3/abs/udi200821a.html> [ 10 January 2012]
- Spiller, N (Ed).(2002). *Cyber-Reader: Critical Writings for the digital era*..London. Phaidon Press Limited
- Scleup et al. (2008). A Material Recovery Facility in Capetown, South Africa, as a replicable concept for sustainable e-waste management and Recycling in Developing Countries. *2008 Global Symposium on Recycling, Waste Treatment and Clean Technology*,2008, Mexico,Empa: Switzerland. Available at: [http://ewasteguide.info/2008\\_Schluemp\\_REWAS](http://ewasteguide.info/2008_Schluemp_REWAS) [ 17 July 2012]
- UNEP (2009 ). *Recycling- From E-waste to Resources in Sustainable Innovation and Technology Transfer Industrial Sector Studies* . United Nations University. S.I
- Vipparti, A (2010). "Adapting to a Culture of Transience- A design Methodology for the 21st Century. Conference proceedings *Architecture in the Fourth Dimension*,Nov 15-17 2011, Boston, Berkley

# LIST OF FIGURES

## CHAPTER 1

Fig. 1.1. Collage.author (2012)  
Adapted from Motorcity Industrial Park Detroit s.a, <<http://www.drpinna.com/empty-city-streets-now-detroit-17347/motorcity-industrial/park>> . [ Accessed 14 March 2012 ] ; Author 2010. Petrol Station; Heger, J, s.a. A Gold Mine Headgear in Johannesburg South Africa, digital image, [http://www.environmentmagazine.org/Archives/Back%2FIssues/2012/March-April-sustainable\\_full.html](http://www.environmentmagazine.org/Archives/Back%2FIssues/2012/March-April-sustainable_full.html), [Accessed 3 May 2012 ]

Fig 1.2. Shrinking space and industry changes. Author 2012  
Adapted from 1: Heger, J, s.a. A Gold Mine Headgear in Johannesburg South Africa, digital image, [http://www.environmentmagazine.org/Archives/Back%2FIssues/2012/March-April-sustainable\\_full.html](http://www.environmentmagazine.org/Archives/Back%2FIssues/2012/March-April-sustainable_full.html), [Accessed 3 May 2012 ] 2: Motorcity Industrial Park Detroit s.a, <<http://www.drpinna.com/empty-city-streets-now-detroit-17347/motorcity-industrial/park>> . [ Accessed 14 March 2012 ] ; Author 2010. Petrol Station, Author 2010. Nancefield Industrial ; The Forum Turbine Hall Conference Venue.< <http://www.conferencevenues.co.za/gjhb-forumturbine.html>> [ Accessed 14 May 2012 ], 7000T Biodiesel Plant-7000T /Year. <[http://www.diytrade.com/china/pd/1773932/700T\\_Biodiesel\\_Plant\\_html#\\_normal\\_jpg](http://www.diytrade.com/china/pd/1773932/700T_Biodiesel_Plant_html#_normal_jpg)>. [ Accessed 10 August 2012 ]

Fig.1.3.Architectural and Urban Problem. Author 2012

Fig.1.4.Diagram indicating architectural approach. Author 2012

Fig.1.5.adaptive Reuse of large Scale Industrial Architecture. Author 2012

Fig 1.6. locality plan. Author 2012

## CHAPTER 2

Fig.2.1.Excerpt from the shrinking cities Project. Oswald,P ( Ed). 2008,. *Unknown* in Shrinking Cities Japan. Vol 1,pg 7, <<http://www.shrinkingcities.org>> . [ Accessed 30 November 2011 ]

Fig.2.2.Density Diagram Indicating Johannesburg and Tshwane. Author 2012. Adapted from Fehr, M. s.a . Johannesburg\_77.<<http://mandyfehr8.tripod.com.nd>>.[ Accessed 15 May 2012 ]

Fig.2.3.Shrinkage and Decline. author 2012

Fig.2.4.Growth and development. Author 2012

Fig.2.5. Google Networking Event Sharing ideas.sn. < <http://businessbecause.com>> [ Accessed 13 March 2013 ]

Fig.2.6.Cloud Computing. Available at: < [www.dynamic-methods.com\\_nd](http://www.dynamic-methods.com_nd)> . [ Accessed 13 March 2013 ]

Fig.2.7.TruthCafe.Haldane,M. 2013. Available at <[http://static.dezeen.com/uploads/2013/02/dezeen\\_Truth-Coffee-by-Haldane-Martin\\_ss\\_8.jpg](http://static.dezeen.com/uploads/2013/02/dezeen_Truth-Coffee-by-Haldane-Martin_ss_8.jpg)> [ Accessed 13 March 2013 ]

Fig 2.8. Wifi as New Activators of Social Space

Fig 2.9.Computer Village Nigeria. Connor, W. 2009. Computer Village, digital image, <<http://nigeriavillagesquare.com>> . [ Accessed 18 September 2012 ]

Fig 2.10. Bustling Informal mobile and computer centre. Available at : Sn. < <http://jideodukuya.com>> [Accessed 13 March 2013 ]

Fig 2.11. Graphic illustration of Value-Adding Industrial Sectors. Author 2012. Adapted from [IPAP 2010 : 10], Department of Trade and Industry South Africa,< [http://www.thedti.gov.za/industrial\\_development/research.jsp](http://www.thedti.gov.za/industrial_development/research.jsp)> .[Accessed 30 November 2011 ]

Fig 2.12. Proposed Facebook Lulea Server farm.([www.datacenterknowledge.com](http://www.datacenterknowledge.com)). [Accessed February 2012 ]

2.13.Maas recycling in winterhuur farm.< <http://www.archidose.org>> . [ Accessed 13 March 2013 ]

2.14.storage tanks of biogas plant. 7000T Biodiesel Plant-7000T /Year. <[http://www.diytrade.com/china/pd/1773932/700T\\_Biodiesel\\_Plant\\_html#\\_normal\\_jpg](http://www.diytrade.com/china/pd/1773932/700T_Biodiesel_Plant_html#_normal_jpg). [ Accessed 10 August 2012 ]

Fig.2.15. analytical diagram of light industrial architectures relationship to the urban environment. author 2012

Fig.2.16. Graphic collage of inert industrial containers of the east rand. ( author 2012)

Fig.2.17.Public square between enterprise building and reception.innovation hub,lynwood pretoria.AUTHOR 2012

Fig.2.18. Graphic summary of placing the problem statement in context. ( Author 2012)392

#### CHAPTER 3

Fig 3.1. Graphic collage illustrating theoretical shift in architecture. (Author 2012)

Fig 3.2. *The fun palace 1961*. cedric price.An interactive public environment and precedent to the georgiou pompidou centre,paris.[Online]<[www.theresponsivecity.com](http://www.theresponsivecity.com)>. [accessed 5 september 2012]

Fig 3.3.centre Georgiou Pompidou. Richard rogers and renzo piano. 1976. Designed as a Flexible container facilitating communication. ([www.monsieurmaman.wordpress.com](http://www.monsieurmaman.wordpress.com))

Fig 3.4. design proposal for the new national library, paris.toyo ito. 1991.(puglisi 1999:15)

Fig 3.5. Synchrotron Center for Science. Australia. Bates 2012. Available at: <[www.batesmart.com.au](http://www.batesmart.com.au)>

Fig 3.6. Diagram Illustrating Different Conditions of Materiality, Transparency and Interactivity. Author 2012. Adapted from

Fig 3.7 . Recombinant Type. Liu 2008. pg 33 in Lee & Jacoby (2011). Typological Urbanism and the Idea of the City. *Architectural Design*. 209, Jan/Feb 2011,pg 15-23. Available at : [http://0-onlinelibrary.wiley.com/innopac.up.ac.za/journal/10.1002/\(ISSN\)1554-2769/issues?year=2011](http://0-onlinelibrary.wiley.com/innopac.up.ac.za/journal/10.1002/(ISSN)1554-2769/issues?year=2011) [13 May 2012]

Fig.3.8. Theoretical aims and Positions. ( Author 2012 )

#### CHAPTER 4

Fig 4.1. Locality Plan of Selected Studied Area.(Author 2012). Adapted from Pienaar.n.d

Fig.4.2. Pretorias Network. Author 2012. Adapted from Comins, D et al.2012. Group Framework.

Fig 4.6. Pedestrian Street in Marabastad with Informal Activities. Author 2012

Fig 4.7. Image from Marabastad looking East . Author 2012

Fig 4.8. Historical Development of Marabastad and Surrounds. Author 2012.

Fig 4.9 Aerial photograph of study area. 1947. Available at : < <http://ruraldevelopment.gov.za> > on request.

Fig 4.10.Pedestrian Street with Informal Vendors . Author 2012.

Fig 4.11.Unused Vending Stalls. Author 2012

Fig 4.12. Commuters and Vendors at Putco Bus Station . Author 2012

Fig 4.13.Processing of Animal By Products on Major Pedestrian Route. Author 2012

Fig 4.14. Recycling of Packaging into Baskets at ngezandla zethu craft and earth centre.. Author 2012

Fig 4.15. Temporary Housing made of Stock Slabbert, P 2012.

- 4.16. Pedestrian Streets with Informal Vendors. Author 2012
- 4.17. Edge Conditions. Author 2012
- 4.18. Existing Land Use Diagram. Author 2012
- 4.19 Lorentz Street Waiting. Author 2012
- Fig.4.20. Major Transport Routes and Interchanges. Author 2012
- Fig 4.21. Pedestrian Routes and Concentration of People. Author 2012
- Fig 4.22. Informal Service Providers, Vendors and Stock Sources. Author 2012
- Fig 4.23 Urban Potential. Author 2012
- Fig 4.25.Existing Aziz Tayob Framework Tayob et al 1998.
- Fig 4.26 Framework. Author 2012 Adapted from ( Tayob et al :1998;pg)
- Fig 5.27.Locality Map. Author 2013  
Fig 4.29 Study Area. Author 2012
- Fig.4.30.Aerial photo of study area indicating the municipal compound, pass detention centre, and "tin town" Aadapted from aerial photo 1947 (drd n.d)
- Fig 4.31 .Existing Site. Author 2012
- Fig 4.32 Ngezandla Zethu Elevations. Author 2012
- Fig 4.33 Ngezandla Zethu Edge.jpg. Author 2012
- Fig.4.34.oppurtunity analysis.author 2012
- fig 4.35. Problem analysis author .2012.
- Fig.4.36 The Self help skills training centre looking north. Author 2012
- Fig.4 .37 Image illustrating the vertical expression of chimneys . Author 2012
- Fig 4.38. Materiality of Roof. Author 2012
- Fig 4.39. Lightweight Conctruction . Author 2012.
- Fig 4.40. Image Indicating Facebrick work Author 2012
- Fig 4.41. Analysis of Compositional Elements and Service Treatment
- Fig 4.42 Signage of Skills Training Centre. Author 2012.
- Fig 4.43.Classroom (Author 2012)
- Fig 4.44. Painting Workshop Teaching Basic Artisan Skills. Author 2012
- Fig 4.45. Recreational Room of Sleeping Quarters. Author 2012
- Fig 4.46.Plans of the SHSTC c.1994.
- University of Pretoria. c 1994. Student Work. Department of Architecture Archives,Univeristy of Pretoria
- Fig 4.47 The Ngezandla Zethu Craft Centre. Author 2012
- Fig 4.48 Small Start Up Industry- Fashion. Author 2012
- Fig 4.49 Three Crafters in Outdoor Workshop. Author 2012
- Fig 4.50 Carpentry Business Specializing in the Production of Trophys. Author 2012
- Fig.4.51. Small Garment Construction Workshop. Author 2012
- Fig.4.52 Site development Concept . Author 2012
- Fig 4.53 Strategy for Selfhelp Skills Training Centre.AUthor 2012
- Fig 4.54 Strategy for the Craft and Recycling Centre. Author 2012
- Fig 4.55 Conceptual Site Development 1 . Author 2012
- Fig 4.56 Conceptual Site Development 2. Author 2012
- Fig 4.57.Conceptual Site Dvelopment 3. Author 2012

CHAPTER 5

Fig 5.1 Networking Potential of site and selected programme. Author 2012

Fig 5.2 Repair of Mobile Devices. Slabbert 2012

Fig 5.3 Innovative geysers. Slabbert 2012

Fig 5.4 Local Shop Specializing in Sale of Obsolete electronics. Author 2012

Fig 5.5 Local Computer Shop Selling Second Hand electronics. Author 2012

Fig 5.6. Local Electronics Shop Specializing in Spares. author 2012

Fig 5.7. Discarded cellphone. Author 2012

Fig 5.8. Local shop Selling recovered electronics. Author 2012

Fig 5.9 An informal workshop. Author 2012

Fig 5.10 Global electronics Manufacturing Network. Author 2012

Fig 5.11 Global electronics Waste Stream. Author 2012

Fig 5.12 Burning of Ewaste on Accra. Essick, P 2002. Available; < <https://www.google.co.za/url?sa=i&rct=j&q=&esrc=s&source=images&cd=&cad=rja&docid=n2Un5-m1IWlxXM&tbnid=z3TW6LKHAb6rpM:&ved=0CAUQjRw&url=http%3A%2F%2Fngm.nationalgeographic.com%2F2008%2F01%2Fhigh-tech-trash%2Fcarroll-text&ei=clfkUYKTBInT0QW8oYDwBg&bvm=bv.48340889,d.ZGU&psig=AFQjCNGSI2hOChpUlu8NORyuXzU8h7yfo g&ust=1372301547159600> > [Accessed 10 August 2012 ]

Fig 5.13 Informal collection of W-waste for Copper Stipping. Essick P. 2002. Available : < <http://ngm.nationalgeographic.com/2008/01/high-tech-trash/carroll-text> > [Accessed 10 August 2012]

Fig 5.14 Market Value of Materials. Author 2012. Adapted from values CSR Brakpan 2012

Fig 5.15. Monetary Value per Kg Material. Author 2012

Fig 5.16 Ewasa Network. author 2012

Fig 5.17 Recoverable Components. Available: < [www.proprofs.com](http://www.proprofs.com) > [Accessed 31 January 2013]

Fig 5.18 Cradle to Cradle eee management. Author 2012. Adapted from < [www.urbanmining.org](http://www.urbanmining.org) > [ accessed May 2012 ]

Fig 5.19. Extrapolation of Cradle to grave System. Author 2012

Fig 5.20 Extrapolation of Mechanical Process. Author 2012

Fig 5.21. The Manual Dismantling of electrical equipment. Desco 2012. Available: < [www.descorecyclers.com](http://www.descorecyclers.com) > . [Accessed 10 August 2012]

Fig 5.22 The mechanical dismantling process. Desco 2012. Available: < [www.descorecyclers.com](http://www.descorecyclers.com) > . [Accessed 10 August 2012]

Fig 5.23 Example of fitting out a recycling area. Carin, B & Roinat, P 2008 pg 5

Fig 5.24 Interior of Collection Facility Lower east Side ecology centre. Available at < [www.inhabitat.com](http://www.inhabitat.com) > [accessed 10 August 2012]

Fig 5.26 Aerial View Deso Recyclers. Desco 2012. Available: < [www.descorecyclers.com](http://www.descorecyclers.com) > . [Accessed 10 August 2012]

Fig 5.27 Pixelating the process. Author 2012

Fig 5.28 Diagram Indicating the Process. Author 2012

Fig 5.29 Process Diagram. Author 2012

Fig 5.30 Table indicating Programme elements. Author 2012

Fig 5.31 Diagram Indicating the Concept of Plug-Ins. Author 2012

chapter 6

Fug 6.1 Toyo Ito New National Library Submission. Puglisi, L .( 1999).pg 55 *Hyperarchitecture: Spaces in the Electronic Age*. Berlin. Birkhauser

Fig 6.2 Perspective Toyo Ito Submission. Puglisi, L .( 1999).pg 55 *Hyperarchitecture: Spaces in the Electronic Age*. Berlin. Birkhauser



Fig 6.3 Section toyo Ito Submission. Puglisi, L. (1999), pg 55 *Hyperarchitecture: Spaces in the Electronic Age*. Berlin. Birkhauser.

Fig 6.4 .Centre Georgiou Pompidou. Richard rogers and renzo piano. 1976. Available at <[www.monsieurmaman.wordpress.com](http://www.monsieurmaman.wordpress.com)> [ Accessed 5 July 2012 ]

Fig 6.5 Plan Centre George Pompidou. Rogers and Piano. Available at < Rogers. (2010). Centre Pompidou. S.i.s.n. Available at [www.rsh-p.com](http://www.rsh-p.com) [ 5 July 2012]

Fig 6.6 Plan Centre George Pompidou. Rogers and Piano. Available at < Rogers. (2010). Centre Pompidou. S.i.s.n. Available at [www.rsh-p.com](http://www.rsh-p.com) [ 5 July 2012]

Fig 6.7 Plan Centre George Pompidou. Rogers and Piano. Available at < Rogers. (2010). Centre Pompidou. S.i.s.n. Available at [www.rsh-p.com](http://www.rsh-p.com) [ 5 July 2012]

Fig 6.8 Elevation Centre Pompidou. Rogers and Piano. Available at < Rogers. (2010). Centre Pompidou. S.i.s.n. Available at [www.rsh-p.com](http://www.rsh-p.com) [ 5 July 2012]

Fig 6.9 Tram system for delivery of parts to factory. Available at <[WWW.EXAMINER.COM](http://WWW.EXAMINER.COM)> [ Accessed 11 September 2012]

FIG 6.9|VEHICLE STORAGE SILO.( WITMAN

2002 IN [WWW.AUTO-INTELNEWS.COM](http://WWW.AUTO-INTELNEWS.COM))

FIG 6.10|model of vw transparent factory(vOLKSWAGEN 2002 IN [WWW.NOTCOT.ORG](http://WWW.NOTCOT.ORG))