

6.1 De-Structuring

STRUCTURE VS. ORNAMENT
QUESTIONING THE FOUNDATIONS

De-structuring

Technical Inquiry

The Architecture

RADICAL TECTONICS

The Structure

STEEL

CONCRETE

FIRE STRATEGY

CONSTRUCTION

Steel Construction

Concrete Construction

Detail

The Services

VENTILATION

ORIENTATION

SOLAR CONTROL

The northeastern aspect of the building

The southwestern aspect of the building

NATURAL LIGHT

ACOUSTICS

RAINWATER DRAINAGE

Drawings

1.1
Technologies of De-
Familiarisation

2.1
Events: the Turning Point

3.1
Crossprogramming

4.1
Superimposition

5.1
The Mediated
Metropolitan Shock

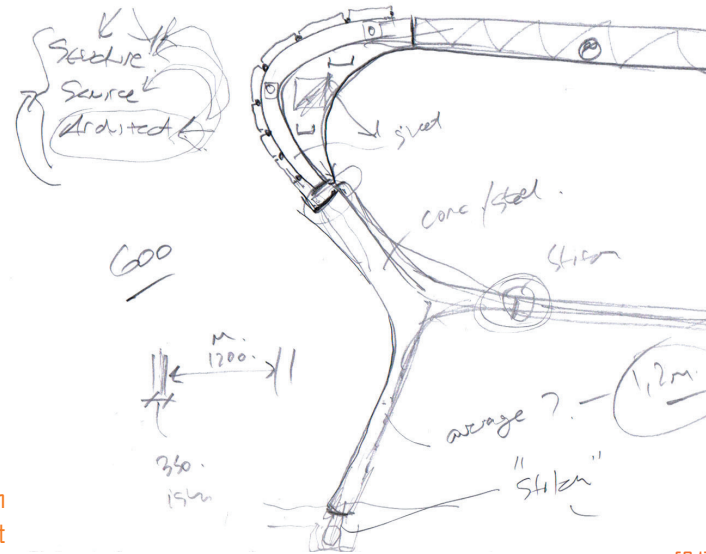

[6.1]

Concept 6: De-structuring

There is a long-standing debate about structure vs. ornament; we are all too familiar with Viennese architect Adolf Loos's controversial essay 'Ornament and crime' 1908: "He who hides any part of the framework not only deprives architecture of its sole legitimacy but also strips from it its most beautiful ornament. He who hides a column makes a blunder, he who makes a fake column commits a crime." (Perret 1952:34-35). Tschumi (1997:16) advocates that the altered relationship between structure vs. ornament / structure vs. image / structure vs. skin leads to the weakening of architecture. Ornament is meant to be additive; it must not challenge nor weaken the structure.

STRUCTURE VS.
ORNAMENT

Today the structure often remains the same on a repetitive neutralised grid, where the majority of construction is quite simply a basic frame of wood, steel or concrete. The decisions on the type of construction and other important decisions about the structure are generally left to engineers and economists instead of the architect. This leads Tschumi to the conclusion that the architect is not meant to question the structure. There are so many parties and issues involved in commercial structures that influence the decisions made towards the structure (Tschumi 1997: 17).

QUESTIONING THE
FOUNDATIONS

In comparison to science or philosophy, architecture rarely questions its foundations. Architects often hand over the design to have the structure designed as if it were separated from the architectural language and the remainder of the building.

Construction has played a phenomenological role in Sverre Fehn's architecture, in his book 'The Thought of Construction', published in 1983 we find the following reflection on the expressive range of constructional form:

'The use of a given material should never happen by choice of calculation, but only through intuition and desire. For the young architect each material is a measurement of strength. To apply the material to its ultimate capacity is natural for youth. The expression of this inherent force compliments a natural vitality. The material's sensation carries its conviction and the energy of youth attains structural perfection. With time, certain architects will accept age as a tiredness which has a beauty of its own, allowing raw material a dimension of life and wisdom. The acquiescence of age is a recognition of maturity, a sign of personal growth. It is a generosity transcended through simplicity' (Frampton 1996:358-359).

Philosophers such as Hegel, Heidegger, Norberg-Schulz, Derrida and Nietzsche have entered the realm of architecture querying various aspects left unquestioned by architects. Contemporary philosophy has touched upon the relationship between frame and image, where the frame is seen as the structure and the image as the ornament (Tschumi 1997:17). Tschumi further mentions Jacques Derrida's Pereragon where the question of frame and image is set as a theme. This might be applied to multiple disciplines although Tschumi defends that 'frame and structure traditionally perform the same function of holding it together'.

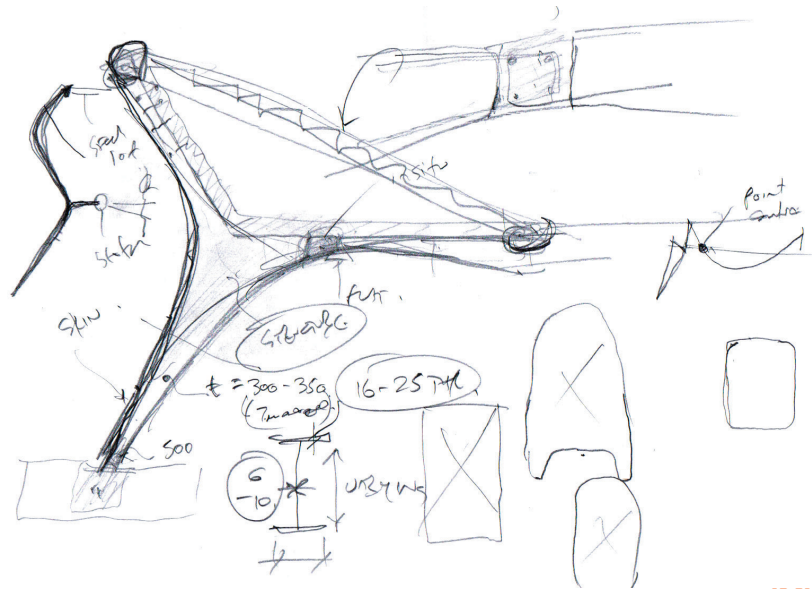

[6.2]

De-structuring Technical Inquiry

The technical inquiry aspires to bridge the gap of communication between the building and the structure. The technical aspects of the building were approached with the knowledge that the design of any building is made up of three different aspects: the architecture, the structure and the services. There has to be a continuous loop of communication between the three aspects, enabling them to realise the concept. It is quite possible for the structure or the services of the building to ruin the architectural concept; and in turn it is also possible to spoil a beautiful structure with bad architecture.

The Architecture RADICAL TECTONICS

Research was done on tectonics and the poetics of structure/construction, in the hope of achieving clarity on the world of innovative structure. In the book *Studies in Tectonic Culture: The poetics of construction in Nineteenth and Twentieth Century Architecture*. 1996. by Kenneth Frampton the title recalls that architecture was once rendered as a more substantial art. It is refreshing to be reminded that architecture can be evaluated by an entirely different set of criteria, involving the appreciation of craft and an expressive emphasis on what Frampton terms its tectonic and tactile dimension (Frampton 1996: x-xi).

Tectonic suggests a preoccupation with materiality and a championing of craft that respect the trace of the hand and the expressive potential of construction. The term tectonic has been misused by applying it to denote the undermining rather than the fusion of art and technique. The term radical

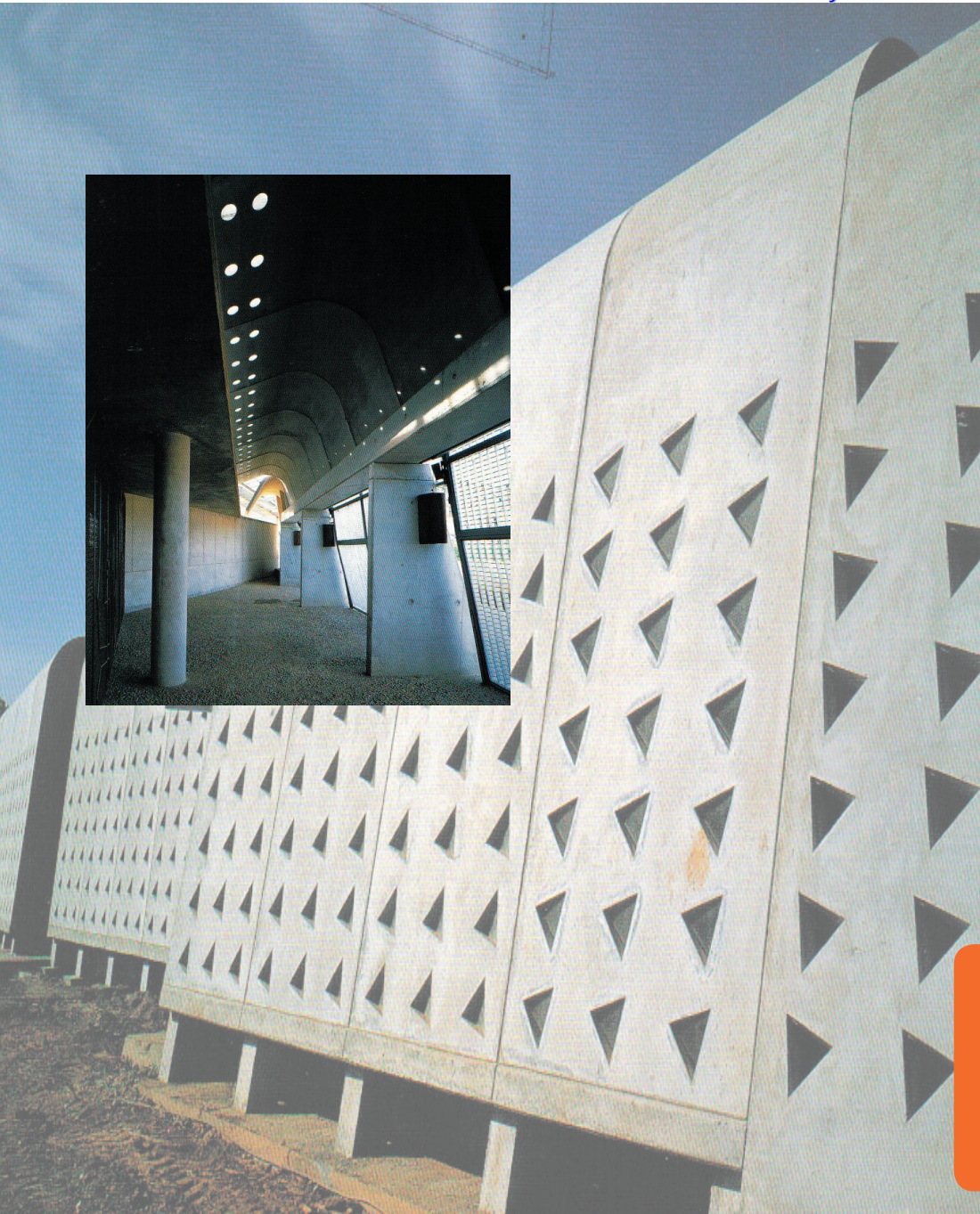

6.3 Igualada Cemetery
Park, Barcelona. Designed
by Enric Miralles and
Carme Pinos

tectonic is used when architects make an effort to restore this delicate balance. A few architects have explored ways in which construction can reach beyond the pragmatic. According to Le Cuyter (2001: 16) the term radical tectonic is not a style but a sensibility, a way of working with many possible manifestations. The radical tectonic finds its expression in the physical and material attributes of construction. Frame and skin become highly articulated, that enhance the experience of space.

The work of Enric Miralles [fig. \[6.3\]](#) was chosen as precedent for the clear way in which it embodies particular tectonic issues, demonstrating the continuity of ideas from project to project, and how the ideas develop and change. The ideas that have inspired the designer include: rejecting the ideal for the real, the idealised conjunction of form and program is rejected and the buildings are reconfigured to reflect the reality of changing technologies, evolving social patterns and the increasingly hybrid character of institutions and simple rational geometries are replaced by complex, variable and non-rational systems, (Le Cuyter 2001:16)

Tectonic: Annette Le Cuyter gives a formal definition of the term in her book *Radical Tectonics*, 2001. The word tectonic is derived from the Greek word tekton, meaning carpenter or builder. It signifies the fusion of technique with art, of construction with poetry (Le Cuyter 2001:15). In a 1973 essay entitled 'Structure, Construction and Tectonics,' Eduard Sekler defined tectonic as a certain expressivity arising from the

static resistance of constructional form in such a way that the resultant expression could not be accounted for in terms of structure and construction alone (Frampton 1996:19).

The Structure The structure of the building is of primary concern in the dissertation. Students often rely on working with familiar materials and construction methods. If we are to be the next generation of practising architects, we might as well dive in and try our hand at designing the language of the structure of the building.

An investigation of the structure was done to enable the designer to have a better concept of the building and the tectonics involved. Santiago Calatrava [6.4] and the world of steel construction remain a mystery to most of us, in terms of the knowledge system necessary to design such leaping structural elements. The majority of architects rely on a simple rectangular/linear weight distribution system. Few architects have stepped into the unknown of questioning why a vertical weight bearing system is used when structures are not bound to it by nature. Architects and engineers have separate comprehension systems and neither have the knowledge to intrude on the other's terrain. If architects knew more about the physics involved in the structures, far more than learnt in schools of architecture, they would perhaps pursue better structures.

The structural design exploits the expressive potential of the structural elements, it becomes the ornament – through beauty and honesty of construction. This ornament is not additive but incorporated into the design so that the structure falls into harmony with the building as a whole. Ornament (image) will not challenge or weaken the structure (frame).

The conceptual design of the steel structure was done during the early stages of the project, with the preoccupation of arriving at a design that has certain tectonic qualities. A structural engineer fig. [6.3] was consulted at a later stage and shared insight into the possibilities and constraints of the structure of the building. The structural design has evolved to the final product through a process of intensive refinement of the structural members.

A decision had to be made whether the structural components

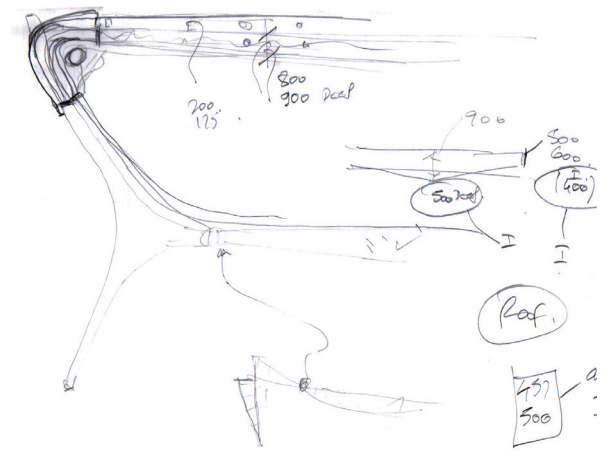

[6.2]



6.4 Left: Santiago Calatrava's Oriente Station, Lisbon, Portugal

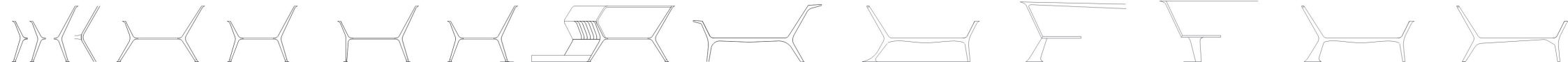

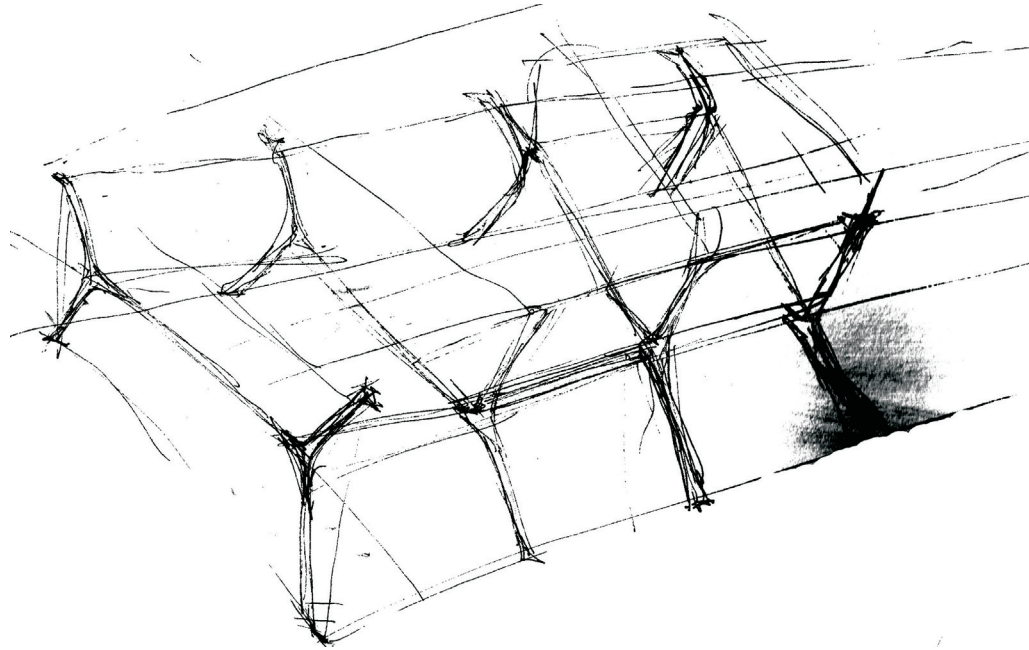

6.5 **Right:** Conceptual
Layout of Steel Frames

6.6 **Bottom:** Design
Development of the
Structural Steel Frames

were to be made of steel or concrete. The properties of the various materials would have had varying effects on the dimensions and the shape of the structural elements. The decision was made to use both steel and concrete. The steel is used for the main structural frame and the concrete for the extruded shape of the first floor, exploiting the plasticity of the material. The materials used in the building are rich and varied and were selected for their inherent qualities as much as their economy or utility.

The structural system **fig. [6.6 & 6.7]** of the building consists of 18 steel frames functioning as supports for the extruded concrete shape of the first floor. It is not necessary for bracing between the frames, other than during the construction phase, as the concrete shell on the inside of the frames provide sufficient rigidity. The intention of the structural design is to expose the steel frames to the extent that their function can be read by the user.

[6.5]



[6.6]

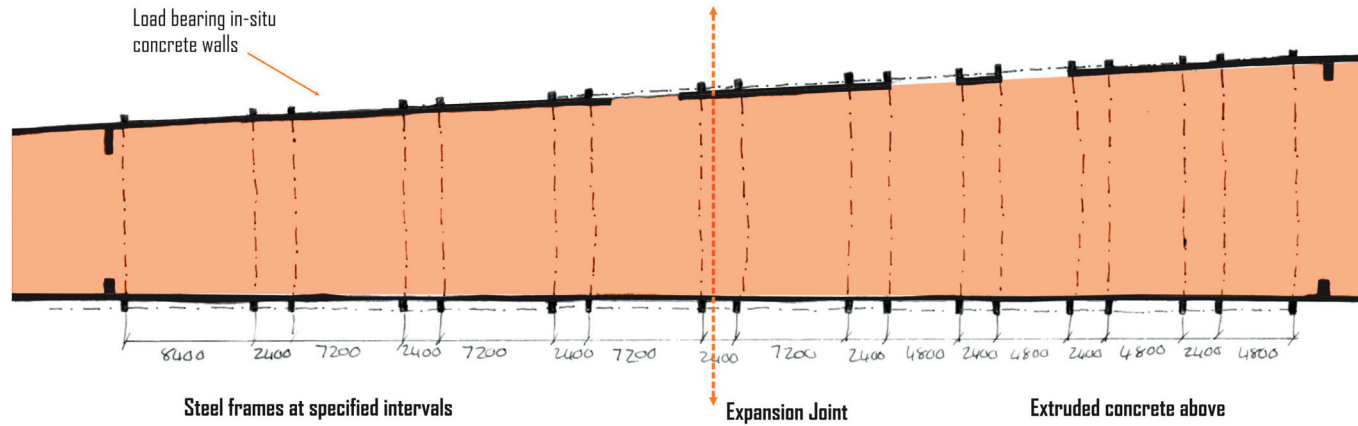

6.6 & 6.7 Left: Structure of the Building on Ground and First Floor Plans

6.8 Below: Final Ground and First Floor Plans

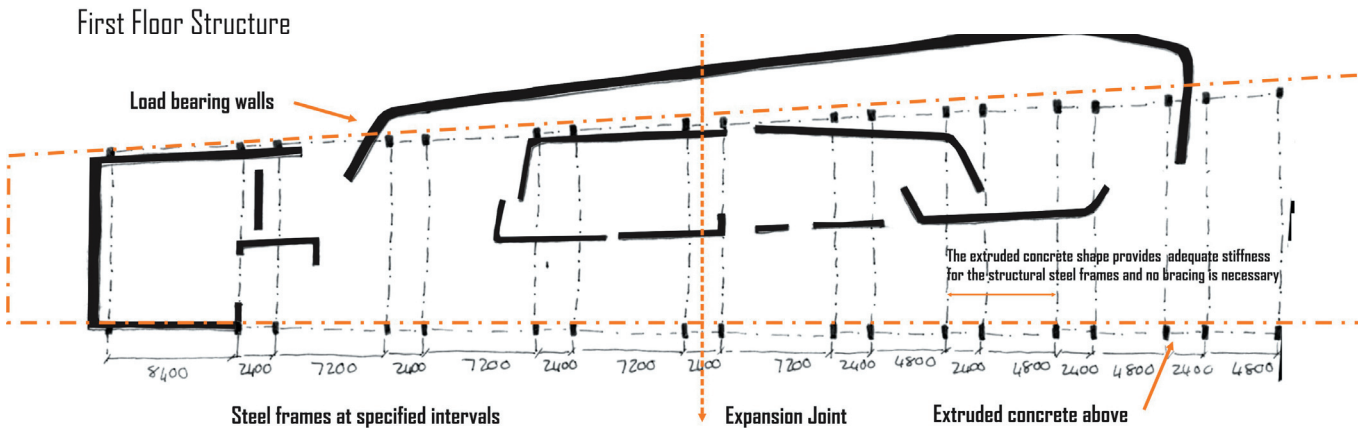

Ground Floor Structure

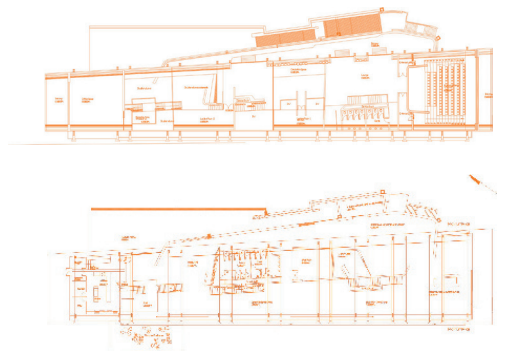

6.9 Section Illustrating the Structure vs. Open Space of the Building

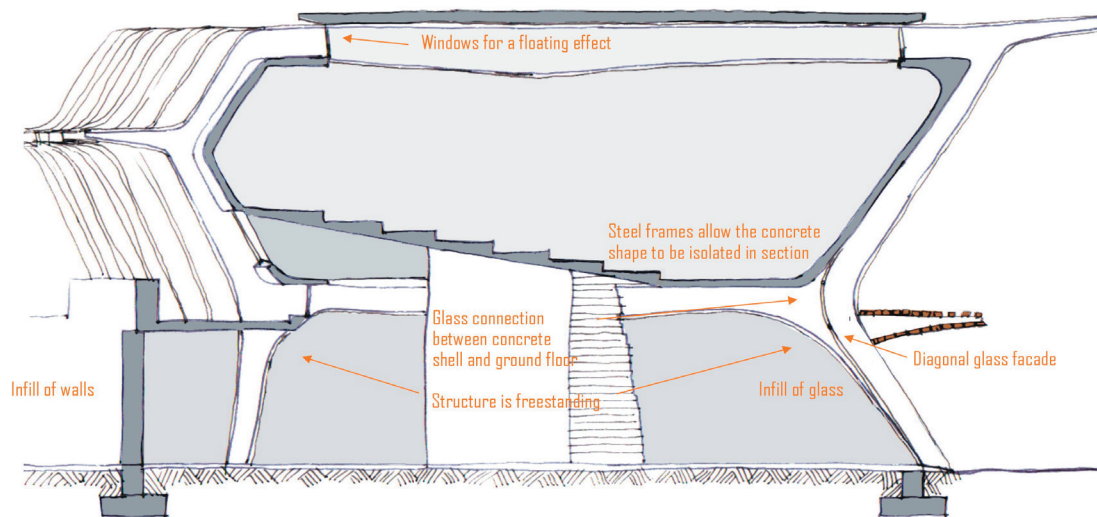

Firstly, the function of the frames is enforced by allowing the ground floor to become an infill of walls and glass facades that only bear their own weight [fig. \[6.9\]](#). The connection between the ground floor walls and the first floor slab was mainly made by using windows. This permits a floating effect, revealing that the walls below are not load-bearing. This concept is also applied in the south-western street façade's diagonally angled panes of glass and sliding doors. This moves away from a linear load-bearing system where glass reads as a structural element. Jørn Utzon applies the same principle in the Sydney Opera House [\[6.11\]](#) where he tries to avoid vertical panes of glass (Frampton 1996: 283). In Santiago Calatrava's Sondica Airport [\[6.10\]](#), Bilbao and his Milwaukee Art Museum [\[6.12\]](#), Wisconsin we find the same situation.

Secondly, the functions of the structural steel frames are exposed to the user by the spacing between the columns [fig. \[6.13\]](#). From the main facade, a person cannot perceive the depth of the building. The structural frames are placed in relation to the increasing depth of the building towards the south-western side. The closer the frames are spaced, the greater the depth of the building. On the main road façade there is consequently an increase of steel structures from the left to the right. This aspect relates closely to the dynamic nature of the building and the sporting function. As pedestrians walk past the building, the frames contribute to a sense of acceleration

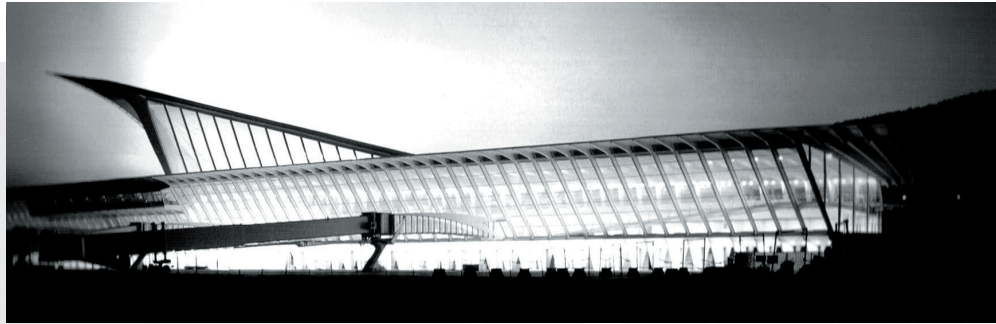

[6.10]
[6.11]

[6.12]

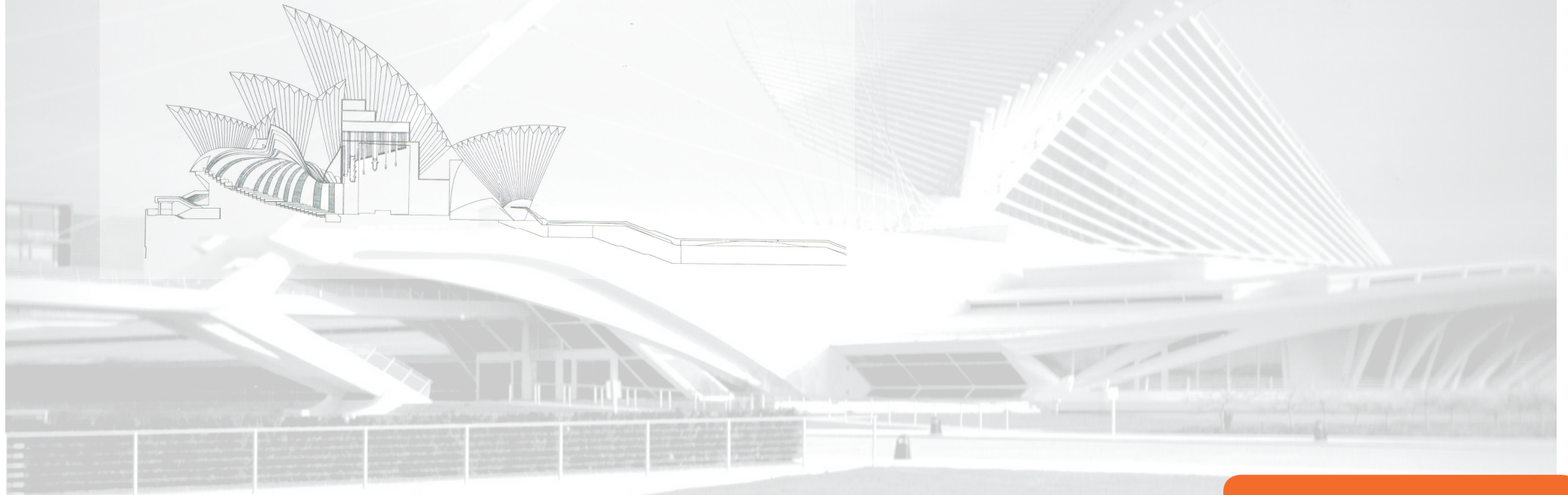

6.10 Sondica Airport, Bilbao, by Santiago Calatrava
6.11 Sydney Opera House Designed by Jørn Utzon
6.12 **Watermark:** Milwaukee Art Museum, by Santiago Calatrava

from north to the south, revealing the sports grounds at the end of the walkway.

The main structural members of the frame are to be made of grade 300W hot rolled weldable structural steel to comply with SABS 1431. Each steel frame is galvanised to comply with SABS 763 to specified thickness after which the frame is to be primed and painted charcoal.

The decision to use steel is based on various factors including:

Positive attributes of steel:

Economic aspects: Steel is affordable, and has a low initial energy cost.

Physical aspects: steel is structurally efficient for the desired craftsmanship.

Aesthetic considerations: steel is aesthetically pleasing and elegant for the desired tectonic aspects.

Negative attributes of steel:

Steel buckles under extreme heat (± 500 °C) and the building can collapse.

Steel must be made fire proof when the building has two or more storeys. The fireproofing paint (intumescent coating) gives an unsightly finish to steel.

Concrete on the other hand was chosen for its high mass that attributes to good thermal insulation and sound isolation necessary for the auditoriums and lecture rooms. **CONCRETE**

The aesthetic and expressive potential of the building is dependent on the steel. Fireproofing paint gives an undesired finish to steel. According to NBR TT7 (SABS 0400) unprotected steel is allowed in double storey buildings that are used for the purpose of lectures/ auditoriums and offices, where the floor on the second floor is made of concrete and the height of the building does exceed 15 meters. The main administration building falls within the regulations as it is a two storey structure and a maximum of 10 meters high. **FIRE STRATEGY**

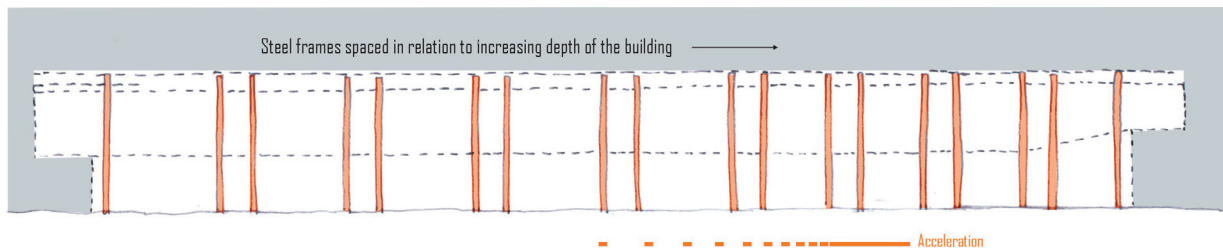

6.13 Rhythm of the Structural Frames

A rational fire design will have to be done by a professional. The steel structure of the building is in fact an 'exoskeleton', which will keep the steel cooler for longer if the building catches fire. This will allow sufficient time for the occupants the escape via the various fire escape routes. The entire building will comply with the standard building regulations, having a sufficient sprinkler system and fire fighting devices in place. Each of the 3 formal facilities on the first floor has 3 possible escape routes out of the building fig. [6.14]. The concrete structure is deemed to provide sufficient fire resistance, according to the regulations.

CONSTRUCTION
Steel Construction

The steel frame is constructed in four parts [6.15]. Each part consists out of 2 x 25 mm flat grade 300W hot rolled steel sheets and 350 mm flanges that are welded to the sheets. The four parts are dipped in galvanising, primed and painted after which they are assembled on site using the steel end plates, as detailed.

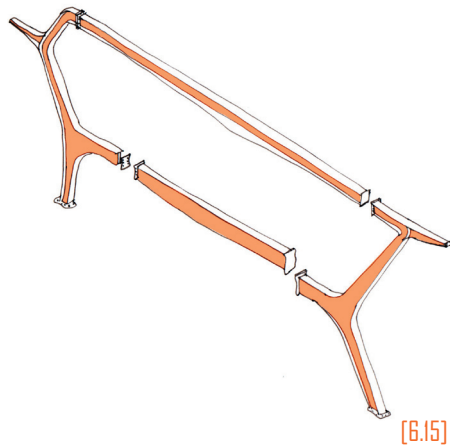

6.15 The Four Components of a Single Structural Steel Frame

6.16 A 2500mm Portion of the In-Situ Concrete Between two Construction Joints

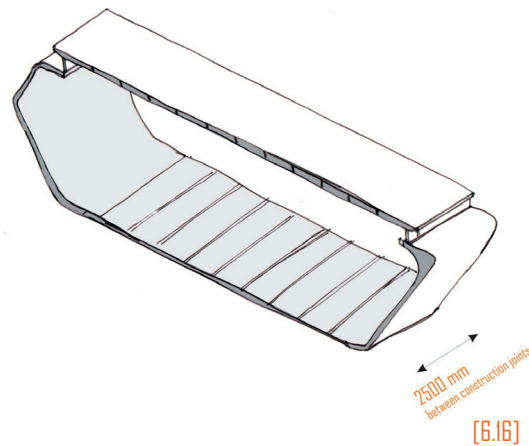

2500 mm between construction joints [6.16]

6.14 Diagram indicating the Fire Escapes From the Building

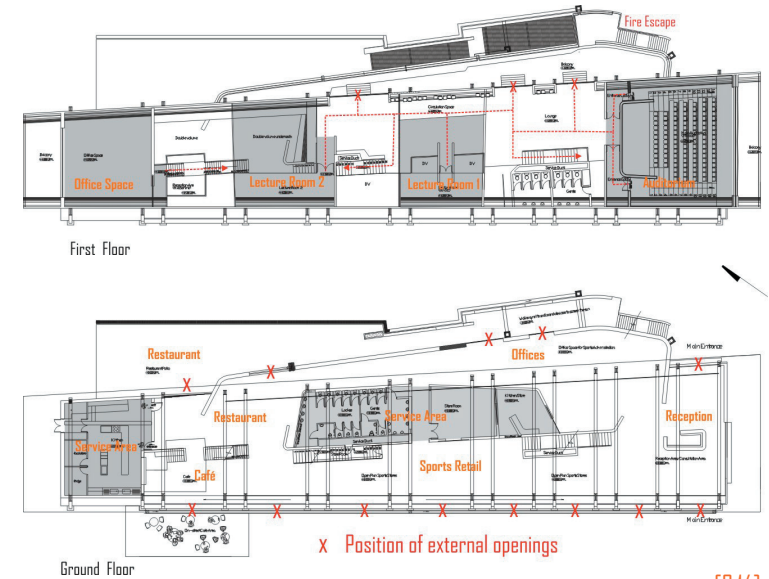

[6.14]

x Position of external openings

6.17 An Isometric Sketch of the Concrete and Steel Structural Components of the Building

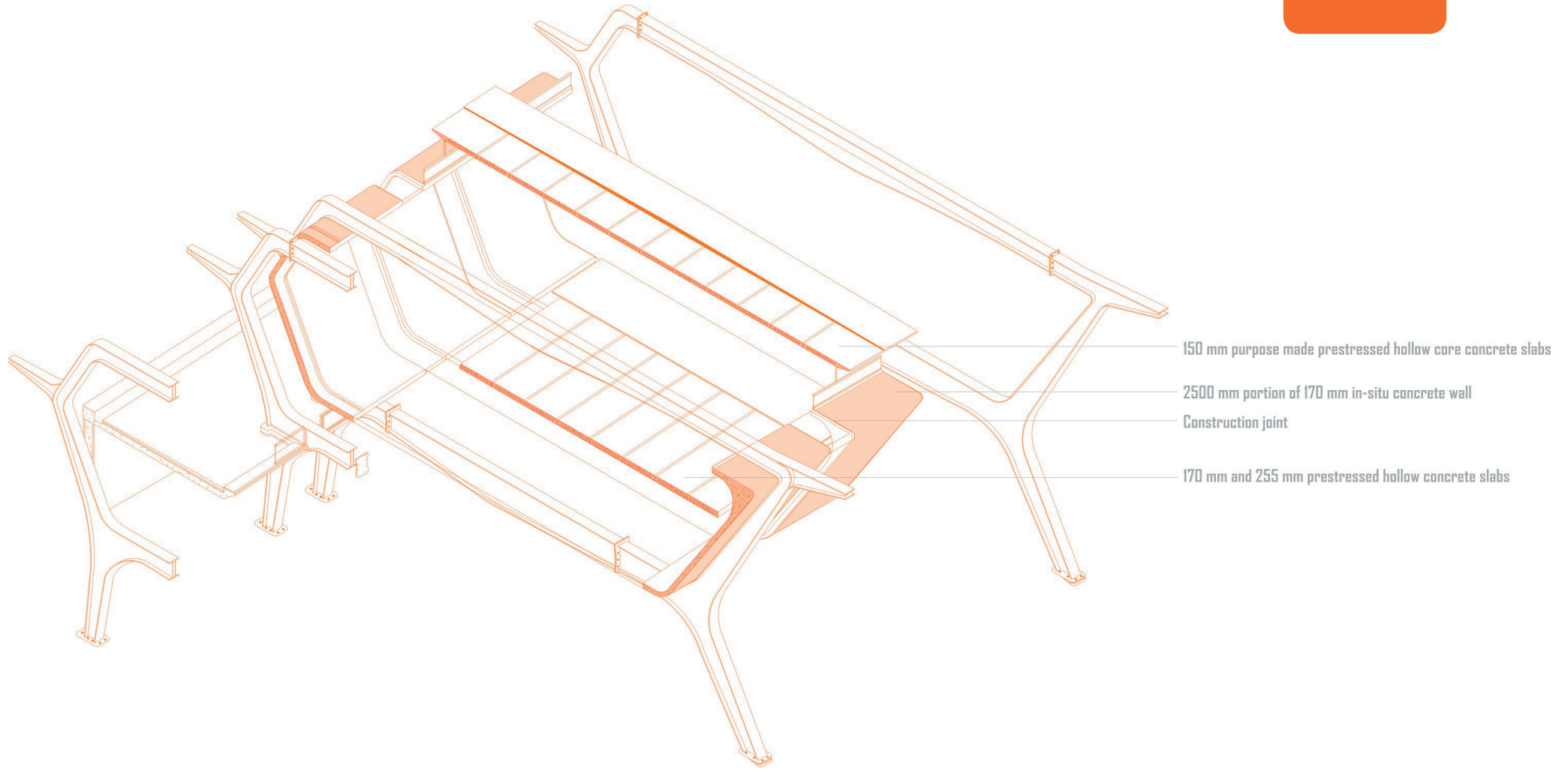

The end plates [6.18] are welded to the section and both end plates bolted together. The steel frames are held in place during construction by temporary bracing that is later removed after the concrete has been cast. The steel frames will have piled foundations as detailed according to the engineer. All down pipes are built into the frame as discussed under drainage.

Concrete Construction The building consists of various concrete products [6.16]. The roof is made of 150 mm purpose made prestressed hollow core concrete slabs, with appropriate waterproofing as detailed. The first floor slab is also made of 170 mm and 255 mm prestressed hollow concrete slabs as detailed. The walls of the first floor are comprised of 170 mm off-shutter concrete to a smooth finish. The concrete will be cast in 2500 mm portions with steel formwork. The construction joints, expansion joints and tie bars are positioned as detailed, and will be adapted on site according to ease of construction. The 2500 mm portions will be separated by construction joints and sealed after curing. The south-eastern end of the building, where the auditorium is located, will have separate custom made formwork as it is not part of the continuous extruded shape.

Detail The various materials used in the building attribute sensory qualities to certain spaces within the building. The importance of the physical suggests a preoccupation with construction detail as a vehicle for expression. The complex range of spaces, language and material used in the building necessitates

a vast number of details. It became apparent throughout the design and refinement of the building that the recurring theme throughout the building is that of endlessness, seamlessness, infinity and undistinguished repetition. This theme is linked to the investigation of deconstruction theory of the 'in between' where one element (of any dualism) cannot be isolated from the other. The same theme is carried through to the shape of the walls in section and on plan, the walls are suggestions of completed shapes that signifies infinity. The recurring theme of endlessness is neatly tied-up in the detailing:

A patent and designed safety glass system is used for the majority of the balustrades. The idea of glass originated from the concept of being able to experience the structure and the spaces without any obstructions. There are glass balustrades within the building on the main two staircases that are fixed 300 mm below the tread. The smaller staircase leading to the mezzanine level has a safety glass balustrade that cuts into the steel staircase. On the first floor the glass allows the unobstructed views towards the river, it is hard to tell where the barrier is as there seems to be none. Rem Koolhaas uses a similar clear glass for the balustrades in Casa da Música, Porto.

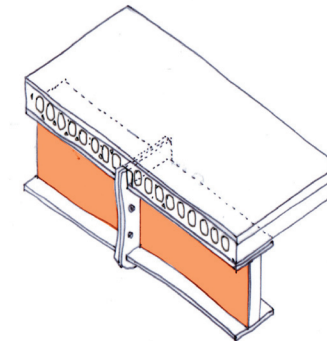
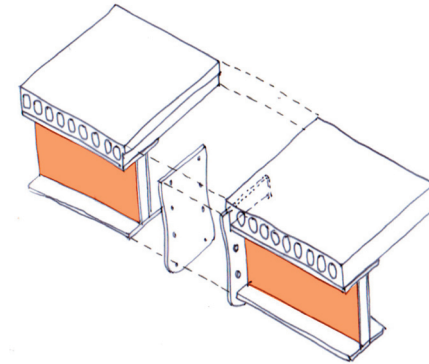

[6.18]

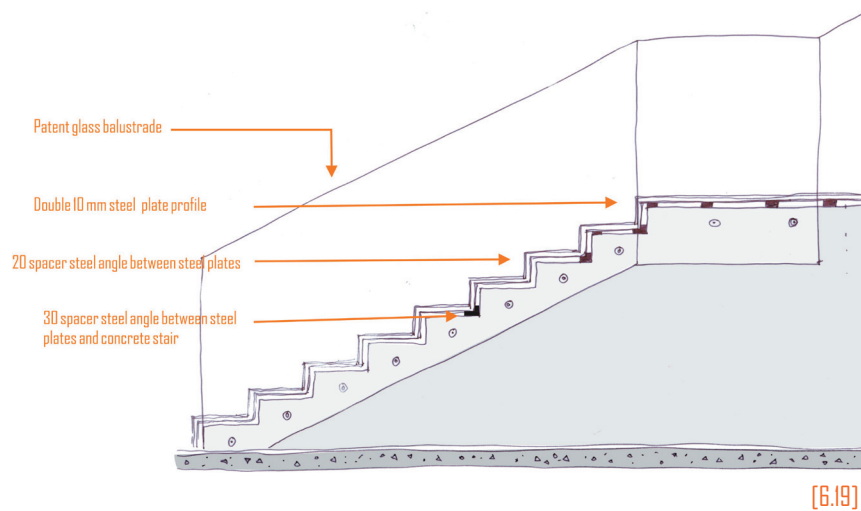

The internal staircases are made of steel sheets that appear seamless. The steel hovers over the concrete, creating a synthesis where the two main structural materials of the building meet. The staircases on the main balcony are also made of seamless steel sheets that have been bent to shape and remains a light structure that does not compete with the concrete mass.

The floor finishes on the heaviest trafficable areas are seamless epoxy mortar. The areas that have less traffic is finished with bent plywood, to a seamless finish. The majority of the wall covering in the lecture rooms is finished with perforated plywood with absorptive material behind, to attain acoustic properties.

6.19 Sketch of the Glass Balustrade on the Main Staircase

6.19a The Safety Glass Balustrades on the Stairs Leading to the Entrance of Casa Da Musica, by Rem Koolhaas (OMA)



The Services

Louis Kahn on services:

" I don't like pipes, I don't like ducts. I hate them really thoroughly, but because I hate them thoroughly, I feel they have to be given their place. If I just hated them and took no care, I think they would invade the building and completely destroy it." (Frampton 1996: 217)

The design was refined several times from the concept design to the final product. The most important decisions were made on the basis of ensuring services that work as best they could without cluttering the spaces in between. Various precedents were investigated where the perimeter walls of the buildings are not vertical. Rem Koolhaas's (OMA) 'Casa da Música' in Porto uses an inner core as a service area, and the remainder of the functions arranged around the core. The conclusion was drawn that by organising the services in a central part of the ground floor, the exterior walls and columns are liberated to be experienced.

After the positioning of the services were resolved the remainder of the building seemed to function better fig. [6.23 & 6.24]. The services in the building were regarded as design opportunities rather than constraints.



[6.20]

6.20 Above: Rem Koolhaas's (OMA) Casa Da Musica, Porto

6.21 Top Right: Ground Floor Plan with Service Core Indicated

6.22 Far right: South - East Section

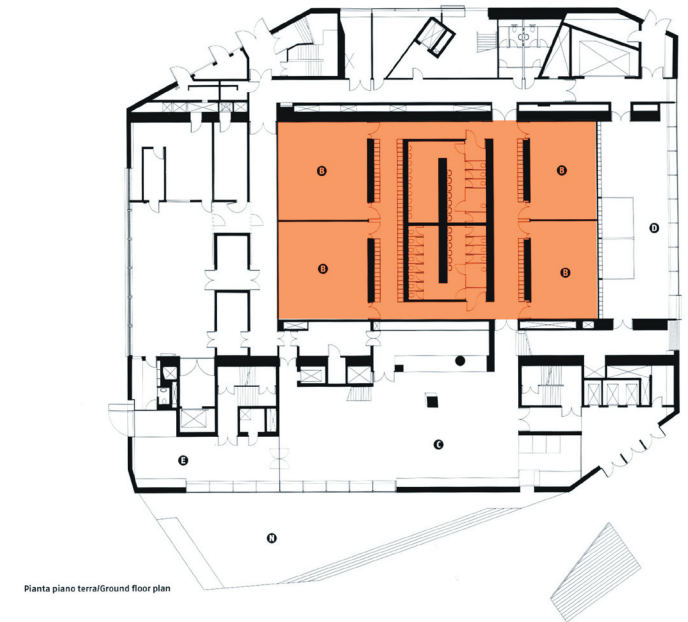

Pianta piano terra/Ground floor plan

[6.21]

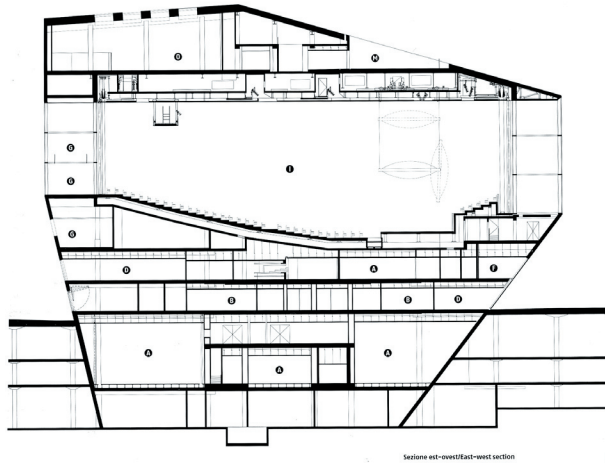

- A. Sala prove/Rehearsal rooms
- B. Camere/Changing rooms
- C. Ristorante musicisti/Musician's restaurant
- D. Uffici/Offices
- E. Ingresso musicisti/Musician's entrance
- F. Sala collettori/Salet rooms
- G. Foyer
- H. Biglietteria e guardaroba/ticket office and cloakrooms
- I. Auditorium principale/large auditorium
- J. Ingresso principale/Public entrance
- K. Piccolo auditorium/Small auditorium
- L. Sale per corsi/Educational rooms
- M. Terrazzo/Terrace
- N. Sala principale/main stairway
- O. Ristorante/Restaurant

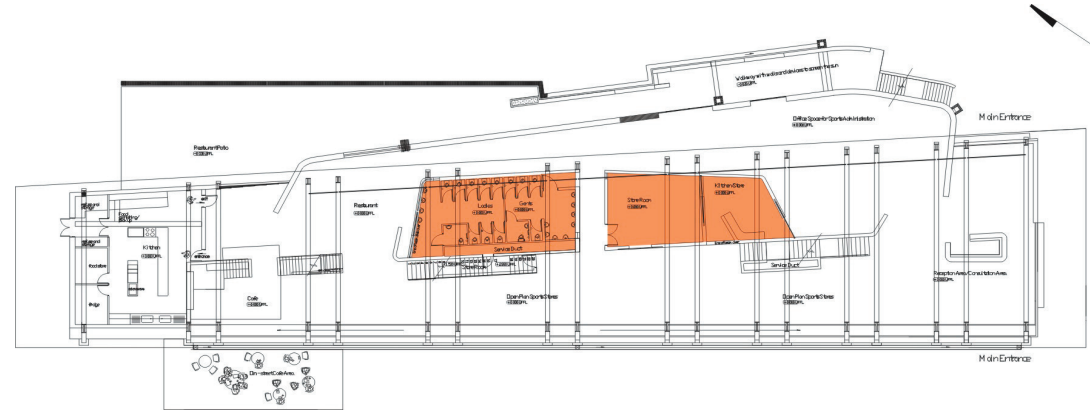

[6.22]

6.23 Bottom Right: initial Ground Floor Plan with Services Indicated

6.24 Above Right: Ground Floor Plan with Centralised Service Core



The areas allocated for the toilets are exploited to be interesting experiential spaces. A roof light illuminates the first floor toilets, washing walls with light fig. [6.25]. On the ground floor the toilets are set back and light enters through top windows that are placed just below the concrete slab of the first floor.

VENTILATION

The nature of the building does not lend itself to rely solely on passive ventilation systems. The formal parts of the building (the auditorium, lecture halls and offices) need mechanical ventilation to achieve optimum human comfort levels. A deliberate attempt was made to reduce the demand on the mechanical ventilation system and to save energy. Principles that are applied include:

1. high thermal mass provided by the concrete roof and walls and brick walls- taking advantage of the fly wheel effect.
2. using a light colour concrete for exterior walls of the building. The light colour of the concrete will reflect solar heat instead of gaining heat through absorption.
3. minimising glazed surfaces on the western and eastern sides of the building, to reduce solar heat gain or heat loss. The two longitudinal sides of the building mainly face northeast and southwest. The building exploits the warmth of the northern sunlight and the light from the south.

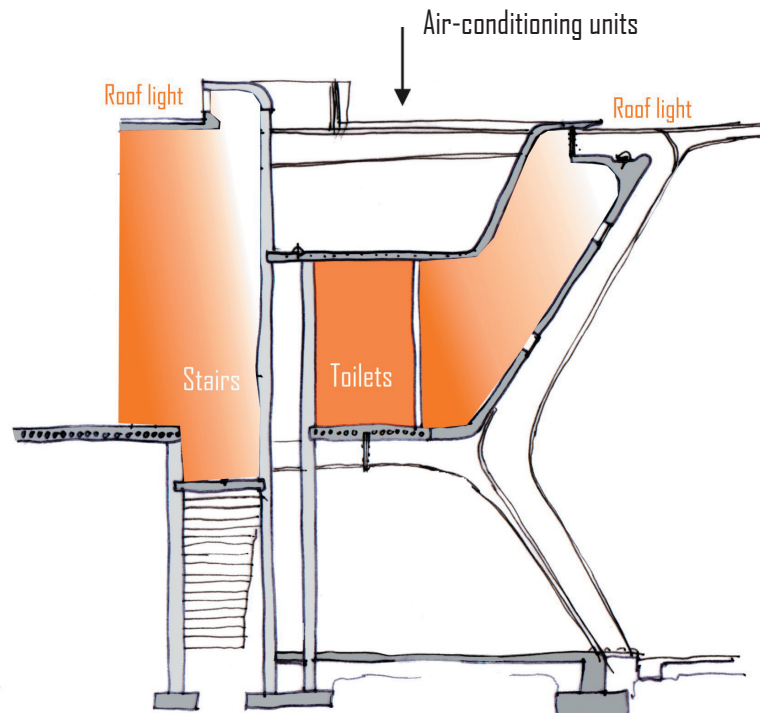

6.25 Partial Cross Section Indicating Roof Lights, and Services.

6.26 Cross Section
Illustrating the Airflow
through the Building

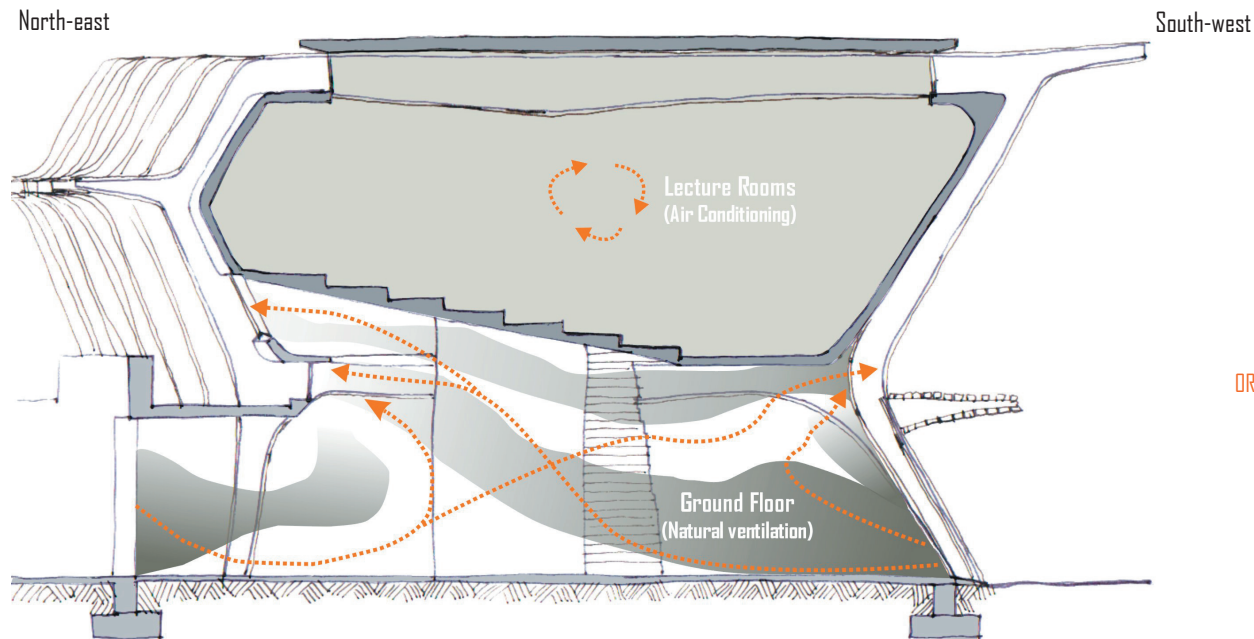

The ground floor is naturally ventilated. Air flows in through the sliding doors on the north-eastern and south-western façade; and exits through the windows placed under the concrete slab. The sliding doors on the main road have louvres above the sliding doors. The sliding doors can be opened whilst the security screens are in place to allow air to enter. Provision is made to mechanically ventilate the whole building, if the need arises. It is possible to extend the system to service the ground floor.

The majority of the first floor is mechanically ventilated. These areas include the auditorium, two lecture rooms and the office space. The circulation space and the lounge are ventilated by using natural or mechanical ventilation. The air-conditioning consists of a condenser and split units located above the toilets on the first floor, with additional space above the auditorium.

See diagram [6.26] for passive airflow through the building.

ORIENTATION The orientation of the building is typical of the majority of the buildings located on the main road of Rainbow Junction. The main road is to be defined by building to the build-to lines set out in the framework. The building cannot be orientated in the other, more favourable direction, as it will invade the public green space that has been created by placing the buildings on the periphery. A sensible design and the exploitation of the northern and southern aspects of the building overcame the orientation of the building.

SOLAR CONTROL
Northeastern
aspect of the
building

The ground floor office space is extended through the balcony on the first floor. This area has been allocated for offices and as a result the space needs to achieve good human comfort in order to be productive. The exterior wall is set at an angle (the new angle is north with a slight easterly aspect) to take advantage of indirect heat gain from the north. Direct solar heat gain is eliminated from the east through the use of a steel mesh screened walkway and fire escape. The door openings have been kept to a minimum and sun angles were used to eliminate eastern heat gain by means of direct sunlight. On the first floor balcony, there are shading devices that are designed to fit onto the protruding steel structure to shade the balcony. The openings that lead onto the balcony are cut back into the building, to allow for shading by the structure of the building.

6.27 Ground Floor Plan Illustrating the Morning Easterly Sun and the Management thereof

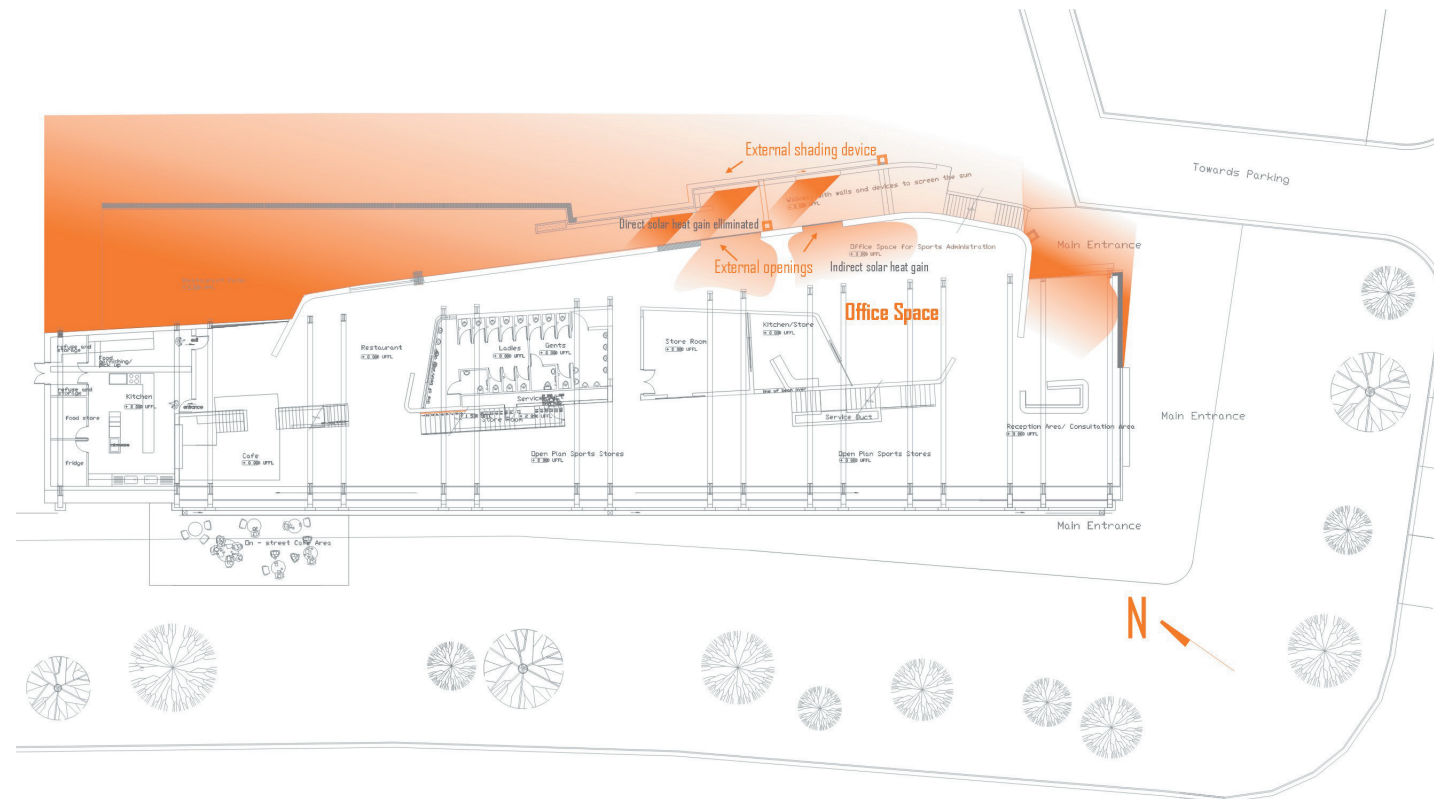

Southwestern aspect of the building

The openings on the eastern and western sides of the building in general are kept to a minimum and are shaded when exposed. The street façade has security/sun screens in front of the sliding doors and windows. These screens can be locked while the doors remain open, allowing air to pass through. The screens can open to act as a canopy over the entrance for sun shading or to shed rainwater.

NATURAL LIGHT

A third of the functions in the building require mechanical ventilation. The offices on the ground floor and first floor are aimed at achieving optimum levels of human comfort regarding illumination and thermal comfort.

Natural light on the ground floor enters through window openings under the roof slab and the windows on the street façade [fig. \[6.27\]](#). The southern facade of the building has glass walls on the first (auditorium) and ground floors to allow optimum southern light. The light that enters the auditorium is controlled specially designed curtain with the dual purpose of illuminating sunlight and absorbing sound. In addition to the door openings, natural light channels in to illuminate the first floor through the window openings between the roof and the concrete wall and the roof lights. These windows eliminate direct solar heat gain, through the design and placement of the windows. The first floor office on the northwestern façade ensures that natural light enter the space.

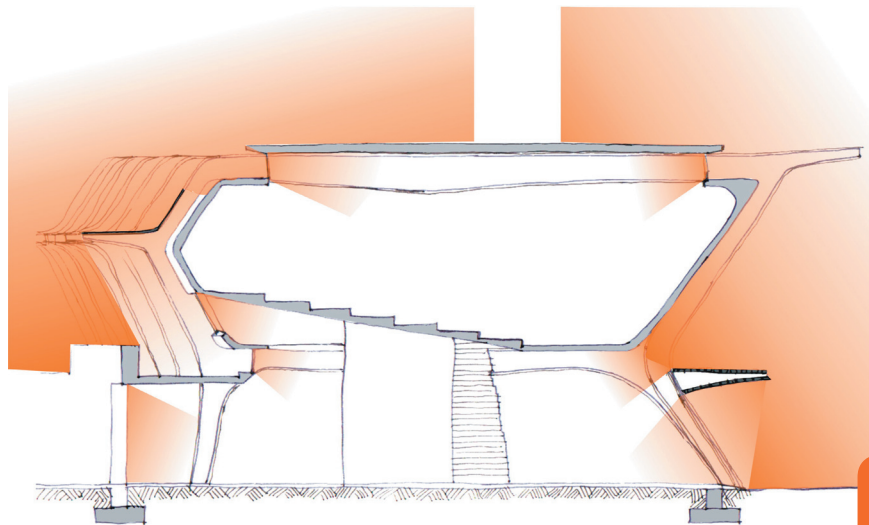

6.28 Cross Sectional Diagram Illustrating the Management of the Eastern and Westerly Sun Aspect

Pedestrian Walkway and Parking

ACOUSTICS

Due to the building's location next to the main road, it is subject to high levels of noise pollution. The concrete mass provides the formal spaces of the building, with appropriate acoustic isolation. There are few windows located on the first floor and these are not in the direct sound path of the noise generated by the street. The auditorium along with the lecture rooms are fitted to allow for optimum acoustic performance.

Standing waves between parallel walls may cause the enhancement of certain frequencies. This is undesirable, as optimum sound produces the same amount of enhancement across all frequencies. To avoid this, the auditorium and lecture rooms have non-parallel walls along the sides so that the standing waves are not trapped. Contents of the rooms affect the amount of absorption and in turn the reverberation time, for this reason the auditorium and lecture room have seats that act as sound absorbers for shorter reverberation (speech).

In the auditorium and the lecture rooms, the speaker in front produces the sound and for good hearing, in a direct sound path; all the listeners sit on stepped seats within eyesight of the speaker. For excellent sound enhancement, the ceiling and side walls of the rooms are finished with plywood panels that reflect and disperse sound. The plywood panels have absorptive material at the back of the panels to absorb background noise.

The floor and the ceiling are parallel where the speaker stands and flutter echoes will occur between the two surfaces. The

speaker will hear himself and tone down his voice but not heard at the back of the room. An additional sounding board suspends above the speaker to reflect sound where it is desired. The back wall of an auditorium and lecture rooms is to be absorbent along with a third of the ceiling. The back wall of the auditorium is made of panels that are placed out of the parallel plain of the front wall, and has a purpose designed acoustic curtain in front of the glass. Both lecture rooms have absorptive panels on the back wall, consisting of plywood panels with 6mm drilled holes, to allow the sound through to the absorbing material behind the panels. The entrance lobby of the auditorium functions as a sound isolation room, that is entirely finished with absorbing panels.

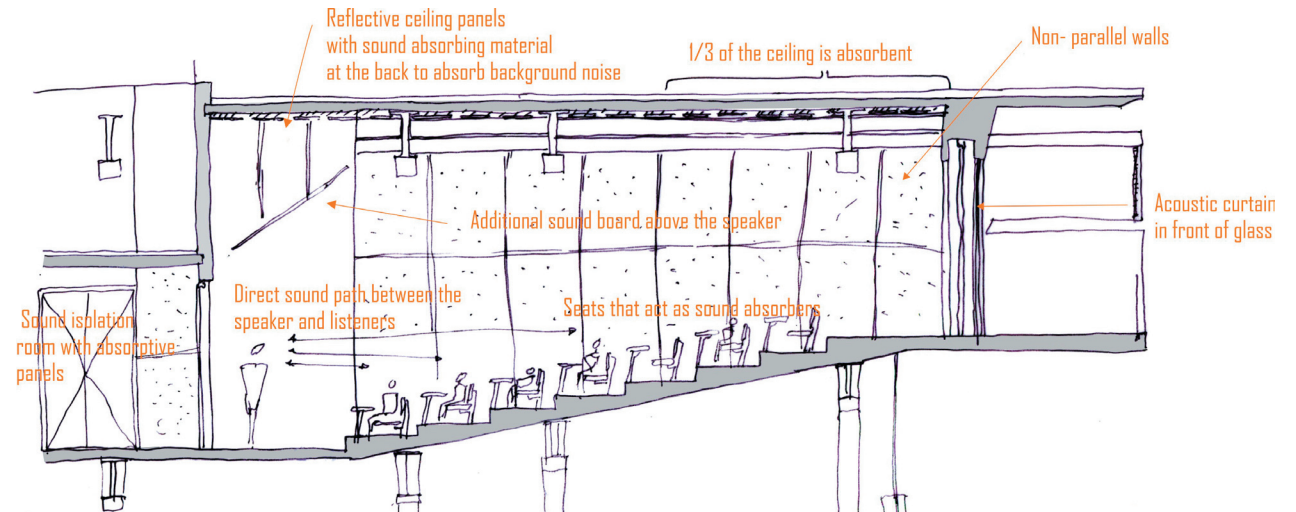

6.29 A Diagram of the Acoustics for the Auditorium

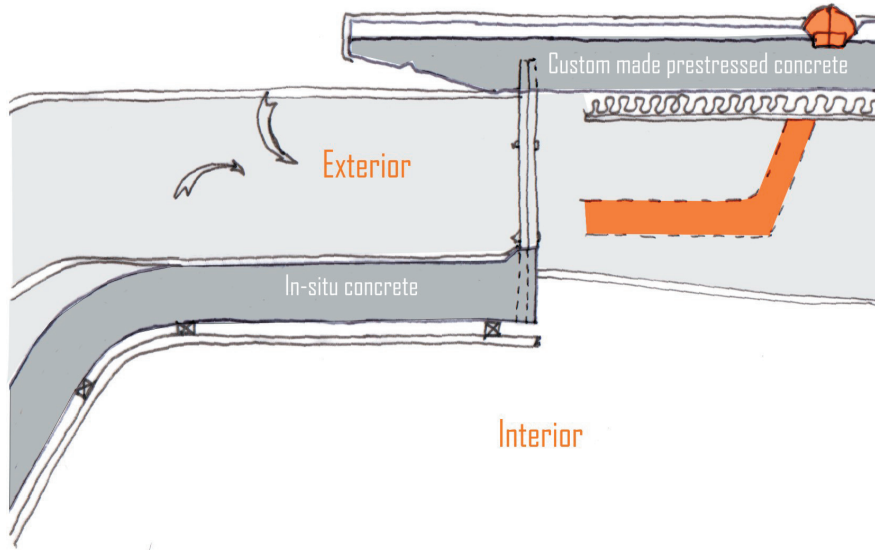

6.30 Rainwater Drainage from the Roof
6.31 Roof plan indicating the Water Outlets

RAINWATER DRAINAGE

The majority of the drainage surface of the roof consists of 1145 m² of 150 mm purpose-made prestressed hollow core concrete slabs. The cement screed and waterproofing is laid to fall and roof is drained by cast iron rainwater outlets cast into the slabs, with 80 dia. mild steel galvanised down pipes placed in the columns. The waterproofing on the roof will be modified bitumen sheeting, consisting of a polyester core impregnated with polymer-modified bitumen, of type APP (atactic polypropylene) wax modified bitumen membrane. The rainwater collected from the roof drains into a 340mm storm water channel that runs on the pavement past the building and leads to the underground storm water harvesting system. The harvested rainwater forms part of the major storm water management system of Rainbow Junction and the Apies River Urban Design Framework. The rainwater is re-used within the precinct.

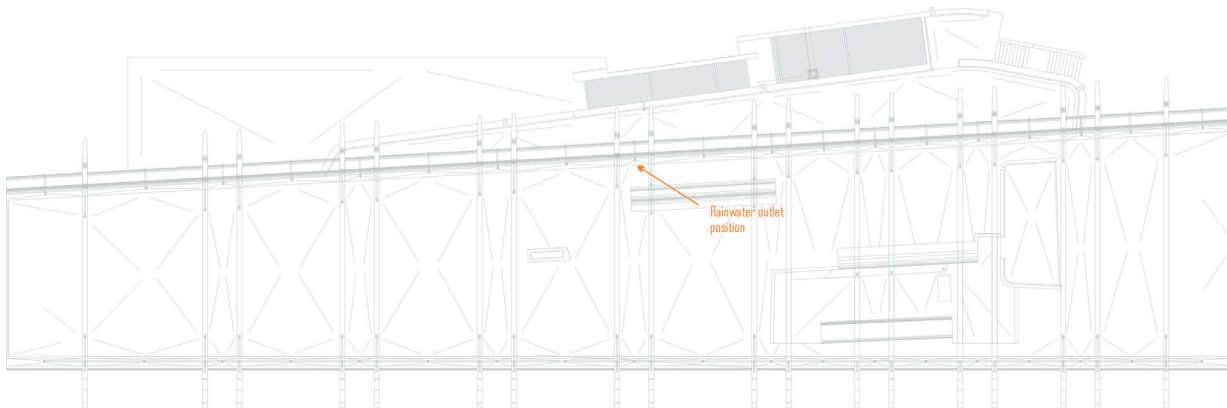

[6.28]