



Figure 159.
Tailor

Technical report

chapter

8

TECHNICAL REPORT

TECHNICAL EXPLORATION

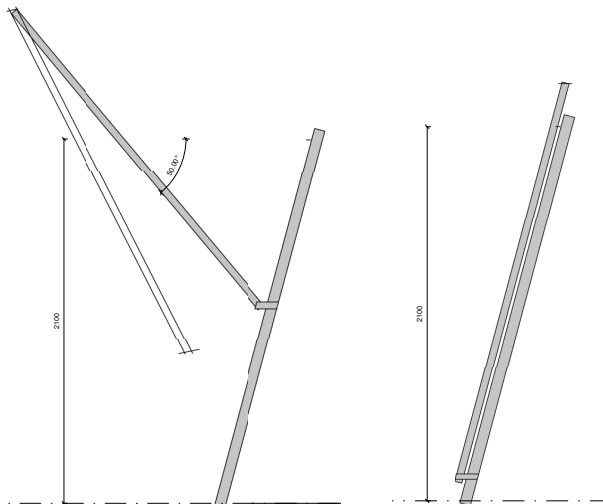
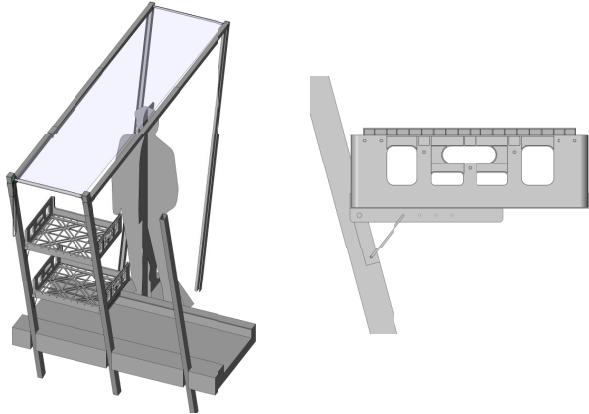
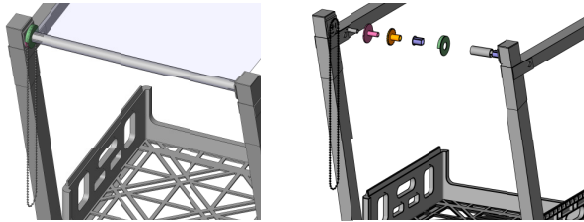

Figure 160.
Initial exploration of the high order trader post element

A space with its own rhythms needs to act and react in response to habitation. The post elements must also be able to do so. In initial design and technical explorations, a roll up element and long elements were used. These long elements were not easily carried by a single person and did not allow for a variety of configurations.

The rollup mechanism was also problematic in that if a single component were to break, the entire system would not work.

Reducing the length of the segments allowed for a wider range of possibilities. The following images show the possible configurations when using shorter segments for the post elements.

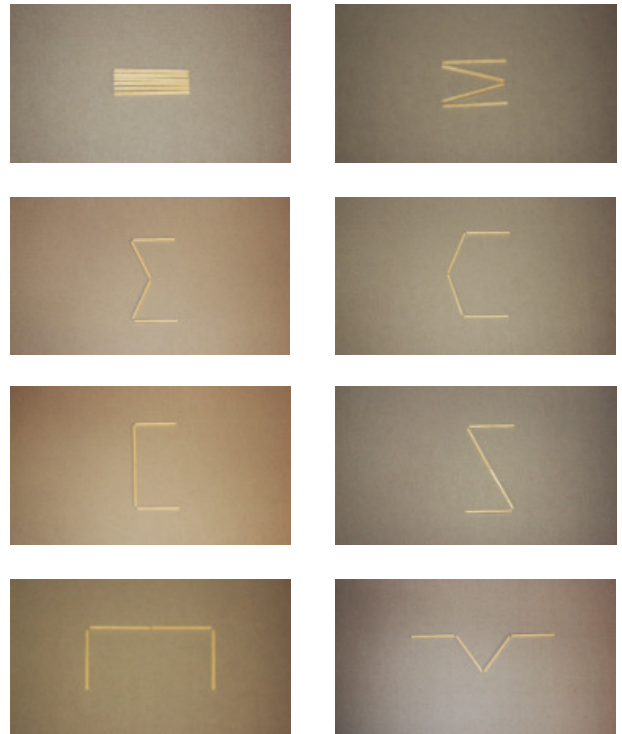

Figure 161.
Exploring possibilities of the post using shorter extrusions

The majority of elements in the proposed intervention are interchangeable and are repeatedly joined and rejoined. They are portable and used in a variety of applications thus, it was important that they be:

LIGHT, DURABLE, WEATHER RESISTANT, IMPACT RESISTANT

Figure 162.

Aluminium multi-purpose folding ladder

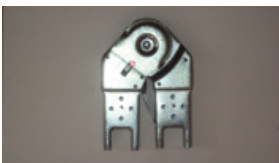

POST ELEMENTS

The characteristics of the following elements will be explored and compared for use as post elements.

POLYMER, METAL, POLYMER COMPOSITE, POLYMER METAL COMPOSITE PANELING

1. POLYMER

Polymer fibers are strong and stiff because during the drawing process, polymer chains are orientated along the fibre axis. The strongest polymers are polypropylene, polyethylene and aramid. The strength of these materials relative to their weight exceeds that of steel. Polymers are easily moulded to achieve complex shapes. They allow cheap manufacture of integrated components that in other materials can only be built up by expensive assembly methods and made from many parts (Ashby & Johnson 2001:180).

The following are some of the attributes of polymers:

- cheap to buy and shape
- light and flexible
- colour and freedom of shape allows flexible design
- thermoplastic polymers are recyclable and most are non toxic
- properties change rapidly even at room temperature and many creep under load, they sometimes become very brittle in very cold temperatures
- Polymers are sensitive to UV radiation thus requiring special protection
- Polymers with higher thermal stability, stiffness, strength and toughness are constantly under development (Ashby & Johnson 2001:180-181).

Polymers consist of three subgroups: thermoplastics, thermosets and elastomers. Thermoplastics and thermosets are the only two relevant to this exploration of possible materials to use for as post elements because elastomers are elastic and expand substantially in warm environments (Ashby & Johnson 2001:211)

Figure 163.

Stainless steel positive locking hinge from SA Ladder

a. Thermoplastics

Can be moulded into complex shapes

- Sensitivity to sunlight decreased by adding UV filters
- Flammability decreased by adding flame retardants
- Shrinkage increases with wall thickness and decreases with higher moulding pressures
- Most thermoplastics can be recycled.

(Ashby & Johnson 2002:177-178)

b. Thermosets

- Once shaped thermosets cannot be reshaped.
- They have greater dimensional stability than thermoplastics.
- They are highly resistant to temperature changes resulting in little to no creep
- The fluidity of some thermosets before moulding allows them to take up fine detail, and to penetrate between fibres to create composites
- Most thermosets cannot be recycled because they cannot be moulded and reshaped (Ashby & Johnson 2002:178).

2. POLYMER COMPOSITES

- Very stiff and strong and are usually made of continuous fibres (glass, carbon or Kevlar, an aramid) and flexible textile reinforcing fibres embedded in a thermosetting resin (polyester/epoxy)
- Fibers carry the mechanical loads, whilst the matrix material transmits loads to the fibres and provides ductility and toughness whilst protecting fibres from dangers caused by handling or the environment.
- The strength of a composite is increased by raising the fibre-resin ratio, and orientating the fibres parallel to the loading direction
- The pultrusion process which is used to make continuous shapes of constant length and cross section, compacts the material components, making the material stronger, more rigid and resistant to wear and tear (Ashby & Johnson 2002:182-183)

CONCLUSION

Polymers are not a viable choice for use as the post elements because they are all vulnerable to damage such as creep and chemical deterioration caused by UV radiation. This is a very unfavourable property for the post elements which need to be extruded hollow sections that can be reused. It is essential that dimensional stability be maintained in the post elements because these elements function as structural elements in higher order trader types (Type 1-3).

3. METALS:

- Stiff
- Strong and tough
- Primary production is energy intensive, aluminium requires twice as much energy per unit weight than polymers.
- Metals can be recycled, and the energy required to do so is much less than that required for primary production.
- Some are toxic, particularly the heavy metals (Ashby & Johnson 2002:184)

4. POLYMER METAL COMPOSITE - ALUPANEL

Alupanel is a composite panel which consists of a 0,3mm aluminium sheet on either side of a polyethylene core. It is a prefinished, premade product that requires no decoration. Its applications include:

- Sign Making and Out of home media
- Shop fitting and Design
- Manufacture of point of sale displays
- Trade stands and designs
- Transport
- Partitioning, Wall Linings and Suspended Ceilings
- Industrial Applications

Some of the advantages of Alupanel include (Multipanel UK LTD. 2007):

- no colour fade in comparison to some plastic products
- dimensionally stable and does not expand and contract under extreme temperature
- a wide range of colours and finishes are available
- rigid and lightweight
- five year product guarantee
- smooth flat surface
- easily cut, folded and formed
- can be finished in a variety of ways, including the application of vinyl, screen printing, digital printing as well as paint

CONCLUSION

Alupanel has some disadvantages in that the components are put together with adhesive. Therefore it is not likely that this product will be able maintain its appearance with constant abrasion, impact, assembly and disassembly in the street trading environment. This may be challenging in the long term as the trader's components are subject to constant use and must be hardwearing and durable.

The following table is a comparison of the rigidity vs weight of the traditionally used structural materials, steel and aluminium with polymer composite fibreglass.

Based on the material exploration conducted, it seems that polymer composite fibreglass compares favourably with metals which are usually selected for use as structural components due their rigidity and durability. However fibreglass has a slightly more favourable strength to weight ratio. The following is a comparison of the material characteristics of fibreglass vs traditional structural materials (aluminium and steel).

Fibreglass vs traditional materials			
	Fibreglass	Aluminium	Steel
Corrosion resistance	High	Medium	Low
Strength	High	High	High
Weight	Low	Low	High
Electrical Conductivity	Low	High	High
Thermal conductivity	Very low	High	High
EM/RFI Transparency	Yes	No	No
Ease of Fabrication	Easy	Moderate	Easy
Life cycle cost	Low	Moderate	Moderate
Environmental impact	Low	High	High

Table A. Fibreglass vs traditional materials

CORROSION RESISTANCE

FIBREGLASS

- Fibreglass is corrosion resistant to a broad range of chemicals.
- In applications where metals corrode, fibreglass products endure a long life span with very little maintenance.

STEEL

- Steel is subject to oxidation and corrosion and requires painting or galvanizing for many applications.

ALUMINIUM

- Can cause galvanic corrosion particularly when steel connections are used in the presence of water.
- Corrosion resistance for aluminium is increased by anodizing or application of coatings.

STRENGTH

FIBREGLASS

- Pultruded fibreglass structural shapes have a strength-to-weight ratio, greater than that of steel in the lengthwise direction
- These pultruded fibreglass shapes do not permanently deform under impact.

STEEL

- Being a homogeneous material, it can deform permanently under impact.

ALUMINIUM

- Being a homogeneous material, it can deform permanently under impact.

WEIGHT

FIBREGLASS

- It is light weight - on an equal volume basis, pultruded fibreglass weighs only 25% of the weight of steel and 70% of the weight of aluminium.

STEEL

- Steel components are heavier than Fibreglass and Aluminium.

ALUMINIUM

- Aluminium is lighter than steel but it heavier than Fibreglass.

ELECTRICAL CONDUCTIVITY

FIBREGLASS

- Has low electrical conductivity

STEEL

- Steel conducts electricity and can be a potential shock hazard during cold dry winter months

ALUMINIUM

- Aluminium conducts electricity and can be a potential shock hazard during cold dry winter months

THERMAL CONDUCTIVITY

FIBREGLASS

- Fibreglass has low thermal conductivity; this can be a safety feature. For example, if one part of a fiberglass structure is extremely hot, individuals who touch the structure away from the heat source will not get burned. It will not gain heat in extremely hot temperatures.

STEEL

- Steel is thermally conductive.

ALUMINIUM

- Aluminium is thermally conductive.

EASE OF FABRICATION

FIBREGLASS

- Fibreglass can be fabricated in a non specialized environment using simple carpenter tools with carbide or diamond tip blades
- torches and welding equipment are not required

STEEL

- Steel fabrication requires cutting torches

ALUMINIUM

- Aluminium fabrication requires more skilled workers than those required to fabricate Fibreglass or aluminium

LIFE CYCLE COST

FIBREGLASS

- Fibreglass has a long life expectancy that is virtually maintenance free.
- The pigments added to the resin provide colour throughout lifespan requiring no painting maintenance.

STEEL

- Lower initial cost however maintenance costs lead to higher lifecycle costs.

ALUMINIUM

- Has a low initial cost because tooling is relatively inexpensive compared to fibreglass and steel

ENVIRONMENTAL IMPACT

FIBREGLASS

- Compared to steel and aluminium, the manufacture of fibreglass produces fewer air and water emissions, consumes less energy and emits less greenhouse gas.
- Producing fibreglass products results in a lower environmental impact than the production of steel or aluminium.

STEEL

- The production of steel consumes more energy and produces more greenhouse effects than the production of fibreglass

ALUMINIUM

- The production of aluminium consumes more energy and produces more greenhouse effects than fibreglass

CONCLUSION

The comparative study between fibreglass, steel and aluminium revealed fibreglass as a more favourable material for use as post elements. Compared to steel and aluminium it is a lighter more environmentally friendly material. Its impact resistant properties make it favourable to use for both low and high order trader types. The ease of fabrication means that components will be able to be cut to accommodate to traders needs, enabling them to create new instances within the system. Its excellent durability properties make it ideal for use within the system. The same components can be sold and resold to individual traders as traders move into and through the system.

INFILL TRAYS

The infill trays are used between the post elements for each of the trading unit types. They may act as shading, display trays and can be printed on for branding and advertising.

They are multifunctional elements that can be made from a variety of materials depending on financial constraints, private sector sponsorship as well as the precinct identity. In this instance, they are made from perforated steel mesh and polyethylene.

Perforated steel mesh - provides a usefull surface that can have hooks put onto it for the display of goods.

Polyethylene – is made by a process that is relatively energy efficient compared to other polymers. It is inert chemically inert and easy and cheap to mould and fabricate. Because it is chemically inert, it is commonly used for food and packaging but is also used for street bollards and beer crates. It as an FDA approved nontoxic material that can be produced from renewable resources. It is easily recycled of it is not contaminated. Being a thermoplastic it can be remoulded into new shapes for reuse (Ashby &.Johnson 2002:188)

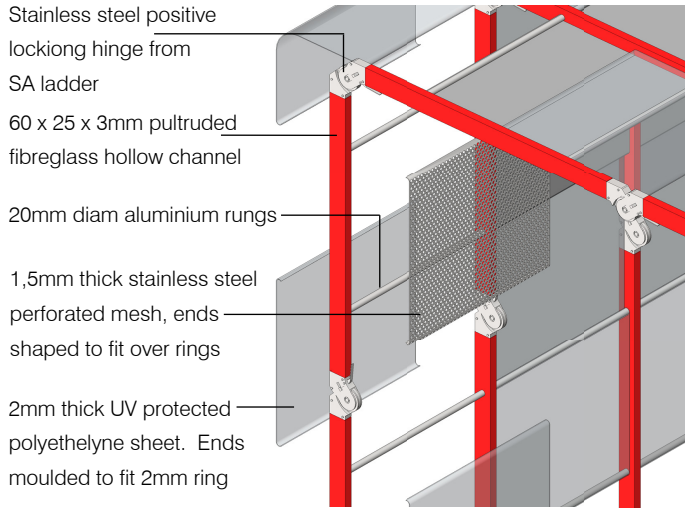

Figure 164.
Detail of high order trader form and components

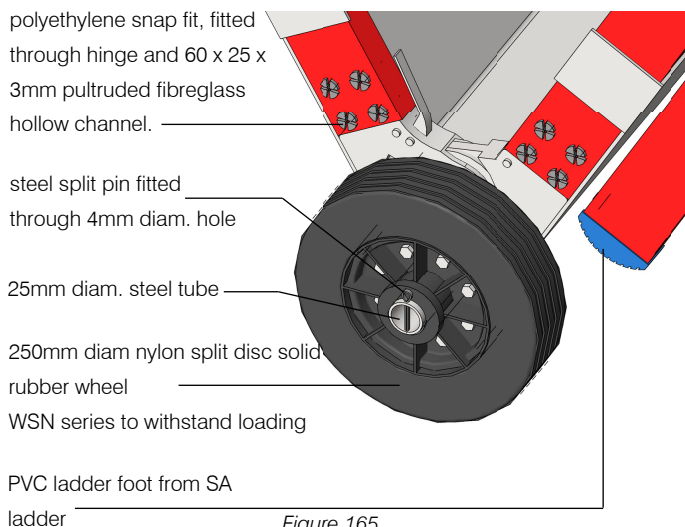
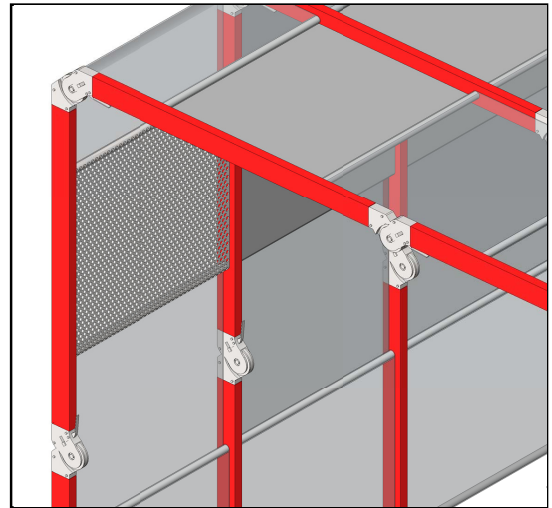

Figure 165.
Detail of high order trader form acting as a wheelbarrow

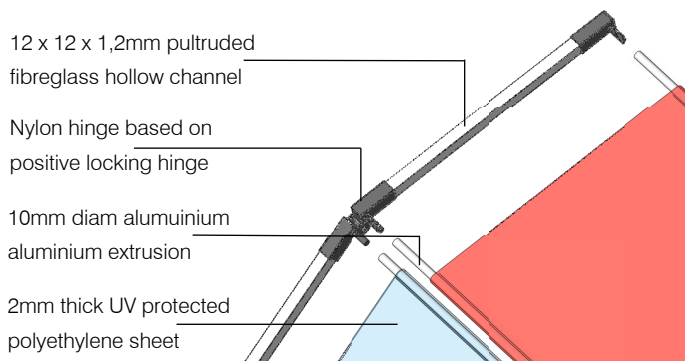
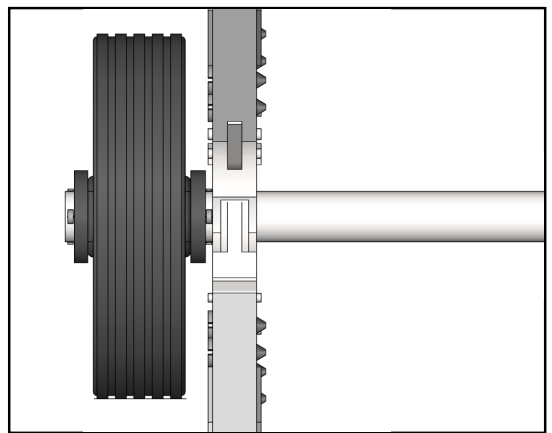

Figure 166.
Detail of Type 1 shading structure

