



# wood for the trees

A temporary theatre for the performance of '*Circles in a Forest*'

Submitted in partial fulfilment of the requirements for the degree of Magister of Interior Architecture (professional) in the faculty of Engineering, Built Environment and information Technology.  
University of Pretoria  
November 2010

Study Leader: Barbara Jekot  
Co-Study Leader: Elana van der Watt  
Studio Master: Arthur Barker





# TABLE OF CONTENTS

001. ACKNOWLEDGEMENTS  
 002. ABSTRACT  
 003. LIST OF FIGURES

004  
 005  
 006

<b>01</b>	<b>INTRODUCTION</b>	<b>013 - 015</b>
<b>02</b>	<b>THEORETICAL APPROACH</b>	<b>017 - 031</b>
<b>03</b>	<b>FRAMEWORK</b>	<b>033 - 041</b>
<b>04</b>	<b>PHYSICAL CONTEXT</b>	<b>043 - 069</b>
<b>05</b>	<b>TEXT ANALYSIS OF 'CIRCLES IN A FOREST'</b>	<b>071 - 089</b>
<b>06</b>	<b>PRECEDENT STUDIES</b>	<b>091 - 099</b>
<b>07</b>	<b>CONCEPT DEVELOPMENT</b>	<b>101 - 121</b>
<b>08</b>	<b>DESIGN &amp; TECHNICAL RESOLUTION</b>	<b>123 - 189</b>

004 CONCLUSION

190

005 LIST OF REFERENCES

192



1.1 OUTLINE 1.2 ARCHITECTURAL ISSUE 1.3 DESIGN INTENSION 1.4 INTERIOR ARCHITECTURE 1.5 METHODOLOGY

2.1 TENSION: TEMPORARY VERSUS PERMANENT 2.2 FORMS OF TEMPORALITY 2.3 EXAMPLES OF TEMPORARY ARCHITECTURE 2.4 DELIGHT 2.5 THE IMPORTANCE OF TEMPORARY ARCHITECTURE 2.6 THE TEMPORARY USE OF VACANT SPACE 2.7 ARCHITECTURE AS EVENT & EXPERIENCE 2.8 CASE STUDY

3.1 GROUP FRAMEWORK\_ PRETORIA PLUGIN CITY 3.2 PHASE 4 PRETORIA PLUGIN FESTIVAL 3.3 HOW DOES THE TEMPORARY THEATRE FIT INTO THE FESTIVAL FRAMEWORK?

4.1 SITE 4.2 HISTORY CONTEXT OF THE SITE 4.3 RELATIONSHIP WITH OTHER EXISTING STRUCTURES  
4.4 HOST BUILDING \_ANALYSIS & APPROACH 4.5 STRUCTURE 4.6 ACCESS, VERTICAL CIRCULATION & ABLUTION FACILITIES 4.7 FOCUS AREA

5.1 UNIVERSAL STORY 5.2 THE MAIN THEME 5.3 OTHER THEMES 5.4 MILIEU (ENVIRONMENT) 5.5 CHARACTERS  
5.6 NARRATION & STORY TELLING 5.8 STORYBOARD

6.1 TEMPORARY THEATRES 6.2 TYPICAL THEATRES 6.3 ADAPTIVE REUSE THEATRE

7.1 CONCEPT 7.2 TRADITIONAL STAGE FORMS 7.3 FICTIONAL SPACE IN REAL SPACE 7.4 ACCESS RAMP 7.5 THRESHOLD STAGE MOOD BOARD 7.6 FOREST STAGE MOOD BOARD  
7.7 MILLWOOD STAGE MOOD BOARD 7.8 VILLAGE STAGE MOOD BOARD 7.9 THRESHOLD STAGE CONCEPT SKETCH 7.10 FOREST STAGE CONCEPT SKETCH 7.11 MILLWOOD STAGE CONCEPT SKETCH 7.12 VILLAGE STAGE CONCEPT SKETCH

8.1 TYPICAL SET CONSTRUCTION 8.2 MATERIALS 8.3 FLOOR PLANS 8.4 ACCESS RAMP 8.5 FOYER, SCREEN & COUNTER 8.6 LIGHTING 8.7 SECTIONS 8.8 INTERIOR PERSPECTIVES  
8.10 ACOUSTICS 8.11 SEATING \_ CARDBOARD DRUM SWIVEL CHAIR 8.12 FIRE SAFETY



## 001. THANK YOU

**Barbara** for remaining calm and believing that I could do this. It was great getting to know you

**Elana** for being available for inspiring chats

**Arthur** for giving me method & direction in my madness

**Nico, Karlien & Studio folk** you are Boukunde

**Spiro** for advice & being the reality & brawn to my brain

**Annalie, Gerhard, Ouma, Oupa, Marietjie, Carien, Anneke, Suné & Rossen** for sanity, patience, motivation, food, all your help & so much love

**Pa** for perseverance

**Ma** *All the above and more - Ma is my rots*





## 002. ABSTRACT

In the world of architecture a field of **tension** exist between **permanence** and **temporality**. The aim of this study was to explore the **possibilities** residing within this duality. During the urban investigation conducted in the Pretoria CBD, scars of **vacant space** were found that exposed the possibility of **temporarily utilizing** these empty spaces. In general vacant spaces tend to become **unsafe, degraded** and **illegally occupied**. If these vacant spaces could be **temporarily reused** it would **benefit** the owners, users and community at large.

The **binding workshop** of The Government Printing Works on Vermeulen Street just west of Church Square is in the process of being **relocated** and no planned future use is evident. The investigation proposes that the workshop be adapted to accommodate a **temporary performance space**. Through the process of matching a vacant permanent space with a temporary program their **interdependence** became evident resulting in an approach towards a **mutuality beneficial symbiosis** between the temporary and the permanent. The **permanent host** will benefit the **temporary guest** by providing **shelter, safety** and **physical support**. The **temporary guest** will benefit the permanent host by giving it **life, activity** and the opportunity to contribute to its local context. The temporary program will **preserve** the existing host and **protect** it from deterioration.

**Production design** as an inherently, temporary form of space creation was selected as the **medium** for this investigation. Performance space positions architecture within the realm of temporary **experience** and lasting **memory**. **Circles in a Forest** are the **inspiration** behind the design of the temporary performance space. This novel by author Dalene Matthee speaks of a segment in the **history** of South Africa, but also tells a **universal story**; that serves as a **warning** against the **exploitation** of people and natural **resources**.

The design focused on creating **layers** of permanence and temporality dependant on each other. As these layers are **peeled** away the space can be **reinterpreted** and adapted for **other** performances and programmes.

**temporary**

**permanent**

**tension**

**symbiosis**

**theatre**

**stage production**

**narrative**

**reuse**

**recycle**

**vacant**



## 003. LIST OF FIGURES

Figure 01. Artist impression of Calvino's Sophronia (Jong, 2007)	11
Figure 02. Digital collage depicting architectural issue (Flicker, 2009).	12
Figure 03. Illustration of the symbiotic relationship between the temporary and the permanent (Banks, 2008).	16
Figure 04. Human scale stand (Design Week, 2009).	20
Figure 05. Abandoned industrial space (Summers, 2009).	20
Figure 06. Softwall (Molo Design, 2010).	20
Figure 07. We Can Xalant/ Mobile constructions (Muns, 2009).	20
Figure 08. Burning Man Festival (Fairs, 2007).	20
Figure 09. Open Burble (Fuller & Haque, 2009).	20
Figure 10. Canary Wharf Terrace Canopy (Architen Landrell, 2010).	21
Figure 11. Back Side Flip 360° (Fairs, 2008).	21
Figure 12. The Port Eliot Lit Fest (Bradshaw & Campbell, 2010)	21
Figure 13. Krzysztof Wodiczko projection in Tijuana, Mexico (Flicker, 2004).	21
Figure 14. Vertical Garden (Ping mag, 2006).	21
Figure 15. Video Ice Hotel (Bulletin Solutions, 2010).	21
Figure 16. Exterior view of Urban (Schwiontek, 2008).	22
Figure 17. Exterior view of Kubik (Schwiontek, 2008).	22
Figure 18. Exterior view of Kunsthülle LPL (Schwiontek, 2008)	22
Figure 19. Urban mini-golf temporary transformation (Cave, 2008).	25
Figure 20. Reclaiming land with yellow beach towels (Cave, 2008).	25
Figure 21. Rundown storefront that once was a CoraMart (Heavilin, 2009).	27
Figure 22. Temporary art space (Bradshaw et al. 2010).	27
Figure 23. Palio dinner in Siena (Baunach, 2009)	28
Figure 24. Building containing the Théâtre de l'Espace designed by Paul Tournon for the Exposition Internationale des Arts et Metiers, Paris, 1937 (Read, 2006).	31
Figure 25. Left: Plan, Section and Elevation drawn by Edouard Autant (Read, 2006).	31
Figure 26. View from stage showing scenery panels overlapping windows above the heads of actors (Read, 2006).	31
Figure 27. Cross-section based on Autant's sketches and photos of the built hall (Read, 2006).	31
Figure 28. Interior based on Edouard Autant's plan and section. Tilted mirrors reflect action behind spectators (Read, 2006).	31
Figure 29. Digital collage for framework (Pretoria PlugIn City group, 2010).	32
Figure 30. Boundaries of the framework investigation (Pretoria PlugIn City group, 2010).	34
Figure 31. Diagram explaining the theoretical approach of the framework (Pretoria PlugIn City group, 2010).	35
Figure 32. Diagrammatic maps showing framework intensions & phasing (Pretoria PlugIn City group, 2010).	36
Figure 33. Diagram showing the proposed site in relation to Church Square and other points of interest (Author, 2010).	39
Figure 34. Map showing existing point of interest, museums & theatre buildings (Pretoria PlugIn City group, 2010).	40
Figure 35. Map showing festival routes, group sites and proposed uses of existing buildings and spaces during the festival (Pretoria PlugIn City group, 2010).	41
Figure 36. View of the site from across the street on the corner of Vermeulen- & Bosman Street (Author, 2010).	43
Figure 37. Gauteng within the context of Africa & South Africa (Author, 2010).	44
Figure 38. Figure 51. Figure 04 Impressions of Pretoria (Author, 2010).	44
Figure 39. Pretoria within the context of Gauteng (Author, 2010).	45
Figure 40. Perspective of the Government Printing Works (Author, 2010).	45
Figure 41. Location of the Government Printing Works within the Pretoria CBD (Author, 2010).	45
Figure 42. Location of the binding workshop in the contexts of The Government Printing Works (Geography department, UP, 2010).	45
Figure 43. Perspective showing the binding workshop & The Government Printing Works (Author, 2010).	45
Figure 44. Map showing parking, schools, pedestrian activity and BRT route (Author, 2010).	46
Figure 45. Map showing the site in relation to the Pretoria Plug In Festival routes and points of interest (Author, 2010).	47
Figure 46. Map showing land usage of property surrounding the site (Author, 2010).	48
Figure 47. Digital collage showing impressions of the site and its surrounds (Author, 2010).	49
Figure 48. Aerial photo showing the site in relation to other existing structures (Geography department, UP, 2010).	52
Figure 49. Other existing structures and facilities (Author, 2010).	53
Figure 50. Views of the street edge and Jacaranda trees (Author, 2010).	53
Figure 51. Interior view of the host building (Author, 2010).	54
Figure 52. Perspective of the host building, cardboard model (Author, 2010).	56
Figure 53. Exterior views of the host building (Author, 2010).	57



Figure 54. Cardboard model of the host building showing exterior dimensions (Author, 2010).	58
Figure 55. Perspective of the ground floor (Author, 2010).	59
Figure 56. Perspective of the first floor with trusses (Author, 2010).	59
Figure 57. Perspective of the first floor without trusses (Author, 2010).	59
Figure 58. Structure (Author, 2010).	59
Figure 59. Column & truss spacing (Author, 2010).	59
Figure 60. Ground floor plan of existing building showing access & ablution facilities (Author, 2010).	60
Figure 61. View of the entrance (Author, 2010).	60
Figure 62. View of service access in the western facade (Author, 2010).	60
Figure 63. View of the female ablution facilities; 9 wc's, 6 showers & 5 basins (Author, 2010).	61
Figure 64. View of the staircase leading to the first floor (Author, 2010).	61
Figure 65. Exterior view of the hoist going up to the first floor (Author, 2010).	61
Figure 66. View of the access door from the staircase to the first floor (Author, 2010).	61
Figure 67. Interior view of the hoist from the first floor (Author, 2010).	61
Figure 68. View of the secondary entrance to the first floor from adjacent buildings (Author, 2010).	60
Figure 69. Ground floor plan of existing building showing access & ablution facilities (Author, 2010).	61
Figure 70. First floor plan indicating the focus area of the study (Author, 2010).	62
Figure 71. View of the south facade indicating the focus area of the study (Author, 2010).	62
Figure 72. Typical section indicating the focus area of the study (Author, 2010).	62
Figure 73. Figure 38 Cardboard model indicating the focus area of the study (Author, 2010).	62
Figure 74. Interior view of cardboard model showing natural light effect (Author, 2010).	63
Figure 75. Interior view A (Author, 2010).	64
Figure 76. Steel frame windows in South Facade (Author, 2010).	65
Figure 77. Wall thickness seen through the opening for hoist (Author, 2010).	65
Figure 78. Plan showing view A, 1-3 (Author, 2010).	65
Figure 79. Steel truss supported by column. Note the water pipe, electrical cables and sprinkler system supported by the truss structure (Author, 2010).	65
Figure 80. Interior view B (Author, 2010).	66
Figure 81. Stacks of paper on wooden pallets (Author, 2010).	67
Figure 82. Old printing equipment (Author, 2010).	67
Figure 83. Plan showing view B, 1-3 (Author, 2010).	67
Figure 84. Existing electrical fans (Author, 2010).	67
Figure 85. Interior view C (Author, 2010).	68
Figure 86. Existing ventilation system (Author, 2010).	69
Figure 87. Hoist and opening through western facade (Author, 2010).	69
Figure 88. Plan showing view C, 1-3 (Author, 2010).	69
Figure 89. Existing sink, provided with hot and cold running water (Author, 2010).	69
Figure 90. Maska's house (Author, 2010).	78
Figure 91. Saul walking into the forest (Author, 2010).	78
Figure 92. Saul & Joram talking about the gallowhead (Author, 2010).	79
Figure 93. Going to the village (Author, 2010).	79
Figure 94. Mac Donald's wood yard & shed (Author, 2010).	80
Figure 95. Saul & Kate meet at the wood yard (Author, 2010).	80
Figure 96. Knysna Village (Author, 2010).	81
Figure 97. Felling of the Kalander tree (Author, 2010).	82
Figure 98. Saul leaving his father (Author, 2010).	83
Figure 99. Saul at the wood yard to work for Mac Donald (Author, 2010).	83
Figure 100. Saul panning gold with the prospectors (Author, 2010).	84
Figure 101. Saul panning independently (Author, 2010).	84
Figure 102. Maska telling Saul his father died (Author, 2010).	84
Figure 103. Saul runs into Old Foot (Author, 2010).	85
Figure 104. Kate shows up in Millwood (gold town) (Author, 2010).	85
Figure 105. Saul runs into Old Foot (Author, 2010).	86
Figure 106. Mac Donald refusing to buy Joseph's wood (Author, 2010).	86
Figure 107. Saul on board the Pictor (Author, 2010).	86
Figure 108. Saul trekking Old Foot in circles thought the forest (Author, 2010).	87
Figure 109. Old foot gets shot (Author, 2010).	88
Figure 110. Saul & Kate decides to stay in the forest. (Author, 2010).	89
Figure 111. Stage door of the Pretoria State Theatre's Opera stage (Author, 2010).	90
Figure 112. Exterior view of the Pop-Up Theatre (De Boer, 2009).	92



Figure 113. Interior view of the Puppet Theatre (Bellostes, 2008).	92
Figure 114. Adaptation of Gainsborough studios (Tompkins, 2010).	93
Figure 115. Interior views of The Almeida Theatre (Tompkins, 2010).	93
Figure 116. Section through The Almeida Theatre. (Tompkins, 2010).	93
Figure 117. Internal illumination contrasting the gritty industrial shell (Arquitectura de Interiores, 2008).	94
Figure 118. The found space before and after. No sign of the theatre's presence remained (Arquitectura de Interiores, 2008).	94
Figure 119. Eight volunteers assembling the media wall (Arquitectura de Interiores, 2008).	94
Figure 120. Four steel columns of the industrial warehouse framed the temporary stage (Arquitectura de Interiores, 2008).	95
Figure 121. The visqueen cladding of the "media wall" reveals the skeletal scaffold structure (Arquitectura de Interiores, 2008).	95
Figure 122. Layout of the theatre and the media wall construction (Arquitectura de Interiores, 2008).	95
Figure 123. TBA (Time Based Art) festival poster	95
Figure 124. Plastic buckets, medium-density fiberboard and borrowed carpet tiles create bench seating with a raked backrest (Arquitectura de Interiores, 2008)	95
Figure 125. Exterior gathering space & entrance of the Lier (Author, 2010).	96
Figure 126. Foyer of the Lier (Author, 2010).	96
Figure 127. Views of the audience, control box & stage (Author, 2010).	96
Figure 128. Views of the rehearsal space & change room (Author, 2010).	96
Figure 129. Views of the change room & backstage passage to stage (Author, 2010), ment in the control box (Author, 2010).	96
Figure 130. Luminaires fixed to existing trusses & lighting equipment in the control box (Author, 2010).	96
Figure 131. Exterior gathering space & entrance of the Masker (Author, 2010).	97
Figure 132. Foyer of the Masker (Author, 2010).	97
Figure 133. Raked audience seating (Author, 2010).	97
Figure 134. Pulleys of the fly system & view of the change room (Author, 2010).	97
Figure 135. Exterior gathering space & entrance of the Market Theatre (Author, 2010).	98
Figure 136. Foyer of the Market Theatre (Author, 2010).	98
Figure 137. Banners in the foyer, advertising the shows (Author, 2010).	98
Figure 138. Interior view of the Laager Theatre showing stage & seating (Author, 2010).	99
Figure 139. Interior view of the Barney Simon Theatre showing stage & seating (Author, 2010).	99
Figure 140. Interior view of the Main Theatre showing stage & seating (Author, 2010).	99
Figure 141. Scaffold lighting system & control box of the Laager Theatre (Author, 2010).	99
Figure 142. Control box of the Main Theatre (Author, 2010).	99
Figure 143. Lighting system in the Main Theatre fixed to the existing roof structure (Author, 2010).	99
Figure 144. Cardboard sign (Camp Photoshop, 2009).	100
Figure 145. Diagram illustrating the symbiosis between the permanent host (existing) & the temporary guest (new) (Author, 2010).	102
Figure 146. Diagrams illustrating layers of temporality (Moring, 2010).	103
Figure 147. Diagrams illustrating strategies of reuse (Author, 2010).	104
Figure 148. Diagrams illustrating traditional stage forms (Author, 2010).	105
Figure 149. Figure 267. Figure 15 & 16 Diagrams illustrating spatial programming (Author, 2010).	106
Figure 150. Diagrams illustrating possible alternative arrangements (Author, 2010).	107
Figure 151. Diagrams illustrating permanent host and temporary insertion (Author, 2010).	108
Figure 152. Floor plan of Temporary Theatre 1:500 (Author, 2010)	108
Figure 153. Floor plan of Temporary Theatre not to scale (Author, 2010)	109
Figure 154. (Domanovic et al. 2010).	110
Figure 155. (Author, 2010).	110
Figure 156. (Omara, 2007).	110
Figure 157. (Beginbeing, 2009).	110
Figure 158. (Barros & Pereira, 2010).	111
Figure 159. (Vyzoviti, 2005).	111
Figure 160. Concept model, June (Author, 2010).	111
Figure 161. Concept sketches (Author, 2010).	111
Figure 162. Exterior perspectives of the scaffold ramp (Author, 2010).	112
Figure 163. South facade showing scaffold ramp with trees, not to scale (Author, 2010)	113
Figure 164. Threshold stage mood board (Author, 2010).	114
Figure 165. Forest stage mood board (Author, 2010).	115
Figure 166. Millwood stage mood board (Author, 2010).	116
Figure 167. Village stage mood board (Author, 2010).	117
Figure 168. Interior view of the Threshold stage (Author, 2010)	118
Figure 169. Interior view of the Temporary Theatre showing the Forest, Millwood & Village stage (Author, 2010)	119
Figure 170. Interior view of the Millwood stage (Author, 2010)	120
Figure 171. Interior view of the Village stage (Author, 2010)	121



Figure 172. Follow spot effect 2 kW (McGill, 2007).	123
Figure 173. Construction of a rostra, Pretoria State Theatre (Author, 2010).	125
Figure 174. Frames used for the painting canvas backdrops, Pretoria State Theatre (Author, 2010).	125
Figure 175. Canvas cyclorama suspended with cables, Johannesburg Theatre (Author, 2010).	125
Figure 176. Construction of steel frame, Johannesburg Theatre (Author, 2010).	125
Figure 177. Local material inspiration (Author, 2010).	128
Figure 178. Wooden pallets used for raked seating (Michler, 2010).	129
Figure 179. Stacked cardboard tubes creating a wall (Heaney, 2005).	129
Figure 180. Stacked cardboard tubes creating a room (Ohr, 2007).	129
Figure 181. Stacked cardboard boxes creating an entrance ((Fairs, 2008).	129
Figure 182. Stacked cardboard sheets creating an enclosed sound box (The Cool Hunter, 2007).	129
Figure 183. Ground floor plan showing proposed access ramp (Author, 2010)	130
Figure 184. First floor plan showing Temporary Theatre insertion (Author, 2010)	131
Figure 185. Section through scaffold ramp (Author, 2010)	132
Figure 186. Diagrams illustrating how KwikAz clips work (Scaffold Industry Association, 2010)	133
Figure 187. Example of new sliding door to be fitted in two existing window openings after windows have been removed (Marathondoor, 2010)	133
Figure 188. South facade (Author, 2010)	133
Figure 189. Perspective of space underneath the access ramp showing the secondary entrance, shade cloth wrapping & ticket sales counter (Author, 2010)	134
Figure 190. Perspective of access ramp showing the first pause point	135
Figure 191. Perspective showing seating underneath the ramp, advertisement boards & covered space to be appropriated by informal traders (Author, 2010)	135
Figure 192. Interior perspective of foyer space (Author, 2010)	136
Figure 193. Details of ticket & information counter (Author, 2010)	138
Figure 194. Section through refreshment counter (Author, 2010)	139
Figure 195. 1:20 Model illustrating tree shaped X-board screen supports, perforated & covered with grey felt (Author, 2010).	140
Figure 196. 1:1 Prototype of cardboard tube building blocks (Author, 2010)	140
Figure 197. Prototype showing how tubes are joined to form a screen (Author, 2010).	140
Figure 198. 1:20 model of tickets & info counter (Author, 2010).	140
Figure 199. Prototype showing light application of blocks & examples of felt & acrylic disc covers (Author, 2010).	141
Figure 200. Model illustrating lighting effect of layers of open cell X-board & acrylic sheet lit from behind with a CFL (Author, 2010).	141
Figure 201. Existing fluorescent lighting (Author, 2010).	143
Figure 202. Figure 555, Figure Fluorescent lamps (Osram, 2010, 3).	143
Figure 203. GM 48 x 2 kW Dimmer (Author, 2010).	144
Figure 204. 5m Z-Line truss (Dance South Florida, 2010).	144
Figure 205. Parcan (Par 64) 1 kW (Mellor, 2009).	144
Figure 206. Profile 1 kW (Livelite, 2010).	144
Figure 207. Follow spot 2 kW (Arts Council of Northern Ireland, 2010).	144
Figure 208. Floodlight temporarily attached to Z-Line truss (Author, 2010).	145
Figure 209. Floodlight effect 2 kW (Berne, 2010).	145
Figure 210. Follow spot effect 2 kW (McGill, 2007).	145
Figure 211. Gobo effect 2 kW (WeddingWire, 2010).	144
Figure 212. Profile spot effect 2 kW (Mellor, 2008).	145
Figure 213. Lighting plan (Author, 2010).	145
Figure 214. Aluminium gobo (West Bay Opera, 2006).	148
Figure 215. Cardboard drum found on site and cut into discs (Author, 2010).	148
Figure 216. Acrylic disc with lazar cut pattern (Author, 2010).	148
Figure 217. Gobo inserted in the focal plane of a luminaire (GoboMan, 2010).	148
Figure 218. Gobo inserted in the focal plane of a luminaire (Merrell, 2009)	148
Figure 219. Insert acrylic disc into the drum (Author, 2010).	149
Figure 220. Elevation of hanging diffusers (Author, 2010).	149
Figure 221. Lighting effect of diffusers (Author, 2010).	149
Figure 222. 1:1 Prototype of cardboard drum diffuser (Author, 2010)	150
Figure 223. Details of cardboard drum diffuser (Author, 2010)	150
Figure 224. Interior perspective showing diffusers & drinks tables from cardboard drums (Author, 2010)	151
Figure 225. Photo's showing diffuser assembly (Author, 2010)	151
Figure 226. Section A-A showing Threshold stage & adjustable screens with forest projection (Author, 2010)	153
Figure 227. Section A-A showing Threshold stage with adjustable screens & changing projections to show destruction, 1:200 (Author, 2010)	154
Figure 228. Section A-A projections depicting Maska's spiritual forest, not to scale (Author, 2010)	155
Figure 229. Curtain screens with lighting (Author, 2010)	155
Figure 230. Section B-B showing the ceiling panels & the audience caught between the Forest & the Village stage (Author, 2010)	156



Figure 231. Forest stage with Kalander tree during the day (Author, 2010)	158
Figure 232. Forest stage with Kalander tree during the night (Author, 2010)	159
Figure 233. Perspectives of the Threshold stage showing destruction (Author, 2010)	160
Figure 234. Concept model for 'Living tree costume' (Author, 2010)	160
Figure 235. Interior perspective showing Millwood stage & audience seating between Forest & Village stage (Author, 2010)	161
Figure 236. Interior elevation of the Village stage (Author, 2010)	163
Figure 237. Detailing & assembly of the Kalander tree (Author, 2010)	165
Figure 238. Joining of cardboard tubes to create branches (Author, 2010)	166
Figure 239. 1:1 Prototype to show assembly & disassembly of the Kalander tree (Author, 2010)	166
Figure 240. Felling of the Kalander tree (Author, 2010)	167
Figure 241. Live size model experimenting with the acoustic panel system (Author, 2010)	168
Figure 242. Determining the reflection angles of the acoustic panels (Author, 2010)	171
Figure 243. Table showing the sound absorption coefficient values of existing materials (Author, 2010)	171
Figure 244. Live size model installation testing the acoustic panel system (Author, 2010)	173
Figure 245. Sound reflection of convex surfaces (Acoustics.com, 2004).	174
Figure 246. Sound reflection of flat surfaces (Acoustics.com, 2004).	174
Figure 247. Sound reflection of concave surfaces (Acoustics.com, 2004).	174
Figure 248. The set for a dance called "California." Polycarbonate panels are joined with plastic zip ties and suspended above the stage with cables (Cramer, 2004).	174
Figure 249. A focal point for Mash-Up!, an eight-week-long series of experimental events and performances (Ferrara, 2005).	174
Figure 250. 1:20 Model illustrating acrylic materiality of ceiling panels (Author, 2010).	174
Figure 251. Assembly of the model testing the acoustic panel system (Author, 2010)	175
Figure 252. Plan view of acoustic panel model (Author, 2010)	176
Figure 253. Ceiling plan showing sound reflecting acoustic panels (Author, 2010)	177
Figure 254. Concept sketches of acoustic panels (Author, 2010)	177
Figure 255. Detail showing the suspension of the acoustic panel system (Author, 2010)	178
Figure 256. Cable ties (Author, 2010)	179
Figure 257. Diagram illustrating how a looping gripper works (Cable grippers, 2010)	179
Figure 258. View from above ceiling model showing shadows created on the floor surface underneath (Cable grippers, 2010)	179
Figure 260. Elevation of swivel chair (Author, 2010)	180
Figure 259. Plan of swivel chair (Author, 2010)	180
Figure 261. Cardboard drum available on the site (Author, 2010)	180
Figure 262. Chair profile cut from tube resulting in two identical pieces that fit onto each other (Author, 2010)	180
Figure 263. Two 38x114mm pieces of timber are cut to 600mm lengths... (Author, 2010).	181
Figure 264. The wood members are fixed to the base of the drum with wood screws and washers... (Author, 2010).	183
Figure 265. Sheets of cardboard was cut according to the chair profile and stacked next to each other inside the chair to create a seating surface. (Author, 2010).	183
Figure 266. Detailing of cardboard swivel chair (Author, 2010)	185
Figure 267. 1:1 Prototype of cardboard swivel chair with upholstered covering (Author, 2010)	185
Figure 268. Existing fire escapes routes (Author, 2010).	186
Figure 269. Signposting for escape routes & equipment (Author, 2010).	187
Figure 270. Discharge spaces emergency routes (Author, 2010).	187
Figure 271. Fire-fighting equipment (Author, 2010).	188



*“The city of Sophronia is made up of two half-cities. In one there is the great roller coaster with its steep humps, the carousel with its chain spokes, the Ferris wheel of spinning cages, the death-ride with crouching motorcyclists, the big top with the clump of trapezes hanging in the middle. The other half-city is of stone and marble and cement, with the bank, the factories, the palaces, the slaughterhouse, the school, and all the rest. One of the half-cities is permanent, the other is temporary, and when the period of its sojourn is over, they uproot it, dismantle it, and take it off, transplanting it to the vacant lots of another half-city.”*

*“And so every year the day comes when the workmen remove the marble pediments, lower the stone walls, the cement pylons, take down the Ministry, the monument, the docks, the petroleum refinery, the hospital, load them on trailers, to follow from stand to stand their annual itinerary. Here remains the half-Sophronia of the shooting-galleries and the carousels, the shout suspended from the cart of the headlong roller coaster, and it begins to count the months, the days it must wait before the caravan returns and a complete life can begin again.”*

*From 'Invisible Cities' by Italo Calvino in (Groak, 1992, 59)*



Figure 01. Artist impression of Calvino's Sophronia (Jong, 2007)



Figure 02. Digital collage depicting architectural issue (Flicker, 2009).



# 01. INTRODUCTION

## 1.1 OUTLINE

The dissertation suggests a mutually beneficial relationship between what is considered as temporary and permanent architecture. To illustrate this mutualism the study focus on the temporary use of vacant, permanent space and the inter-dependance of layers that vary between permanent and temporary. The role of small scale temporary architecture and the temporary use of vacant space in an urban context are explored (Figure 1).

Temporary design practices exist on the fringe of architecture and are therefore ideally positioned to offer an “outsider’s perspective” and explore current practices and theory. It contests the preoccupation of architecture as being permanent in order to reaffirm architecture as not just form and function but as experience.

The vacated, binding workshop of The Government Printing Works in the Pretoria CBD, is temporarily adapted into a theatre for the estimated time of three to five years. The temporary theatre is designed to host the performance of ‘*Circles in a Forest*’ by Dalene Matthee. The theatre itself becomes the set and experience of the text. The design allows the theatre to be reinterpreted and altered to the needs of other production via lighting, projections, props, and detail elements.

## 1.2 ARCHITECTURAL ISSUE

In a time where the socio-cultural, economic and ethical impact of thoughtless large scale permanent developments are frequently under question while existing structures stand empty, could small scale temporary architecture contribute towards change and meaningful experiences?

### Delight

- Architecture neglects delight, experience, imagination, fantasy, tension, temporality and experimentation
- The inner city of Pretoria lacks recreational facilities and activities

### Tension

- In the urban context of Pretoria there is tension between permanence and impermanence not being addressed by design practices (Figure 02)

### Use

- Vacant, abandoned and forgotten inner city space becomes dangerous, derelict and is eventually lost to the public due to disuse or illegal use

### Research questions

- What is permanent and temporary architecture?
- What is the relationship between temporary and permanent design?
- What is the role and importance of temporary design?
- What is the importance of spatial experience, memory and recreational spaces?
- Can vacant space be used and programmed temporarily?

## 1.3 DESIGN INTENSION

The architectural intention is to investigate temporary design as a catalyst in an urban context to activate under utilized or vacant space and to experiment with programming, spatial experience, and technology.

*The Temporary Theatre* endeavours to explore the possibilities of programming and occupying a vacant space temporarily. For the purpose of this thesis scenographic design was chosen as medium, as set construction is generally accepted as a temporary form of space creation and has the design of an emotively communicating space at its core.

*The Temporary Theatre* addresses the inaccessibility and separation of art from the public realm, as well as the tension between opposites. Ultimately a recreational attraction will be created, providing opportunity for social and cultural interaction in the city of Pretoria.

- **Symbiosis** (mutualism): Interdependent layers of temporary and permanent architecture
- **Catalyst:** temporary insertion towards positive change
- Temporary architecture facilitating **experiment and experience**

“Architecture is about space and about the events that take place in that space”  
 (Tschumi, 2000, 12).

## I.4 INTERIOR ARCHITECTURE I.5 METHODOLOGY

Interior design encompasses more temporary forms of architecture. It is the author's belief that interior architecture can play a vital role in rediscovering the opportunities of temporary construction and permanent infrastructure. These forms of design generally have a shorter life-span, are more mutable and have greater potential for change; therefore it is ideally positioned to explore the unpredictable, experimental and experiential opportunities of temporary construction.

“By their nature, temporary constructions dispute the dominant role of Architecture as lasting and providing permanent solutions” says Lévesque (2007,1). Temporary architecture allows for the testing of new possibilities in construction and spatial experience because of its smaller scale, shorter time frame and freedom to exist on sites inaccessible to permanent architecture. The interior architect could play the role of the “practitioner researcher” (Groak, 1992, 180-183).

We are surrounded by three skins that vary in terms of permanence - our own, the clothes we layer ourselves with, and the skin of the building (Ferreira, 2004, 46). This thesis suggests that interior architecture should boldly claim an intermediate, softer place between our bodies and the skin of a building and celebrate its function as a user-interface, creating the experience between individual and environment.

### Grounded theory

The research approach for this dissertation borrows aspects of “grounded theory”. This method recognises and combines the use of various sources for generating research material and data and, as explained by Knight and Ruddock (2008, 87), it relates to the design process. Grounded theory includes the following:

#### Case studies

Case studies provide different perspectives and link closely with reality. A cross-sectional case study approach was used. This approach captures a situation at a moment in time and supports the use of multiple case studies. This method is less time consuming than a longitudinal case study, which follows a specific case over a period of time (Knight & Ruddock, 2008, 93).

#### Formal theory

According to Knight & Ruddock (2008, 87) it is unlikely for a new theory to be built from first base and that new theory should be built on an existing theory in order to make improvements. Theory is generated from a combination of literature, observations, common sense and experience. The use of literature is important as it allows researchers to build their case through supporting evidence.

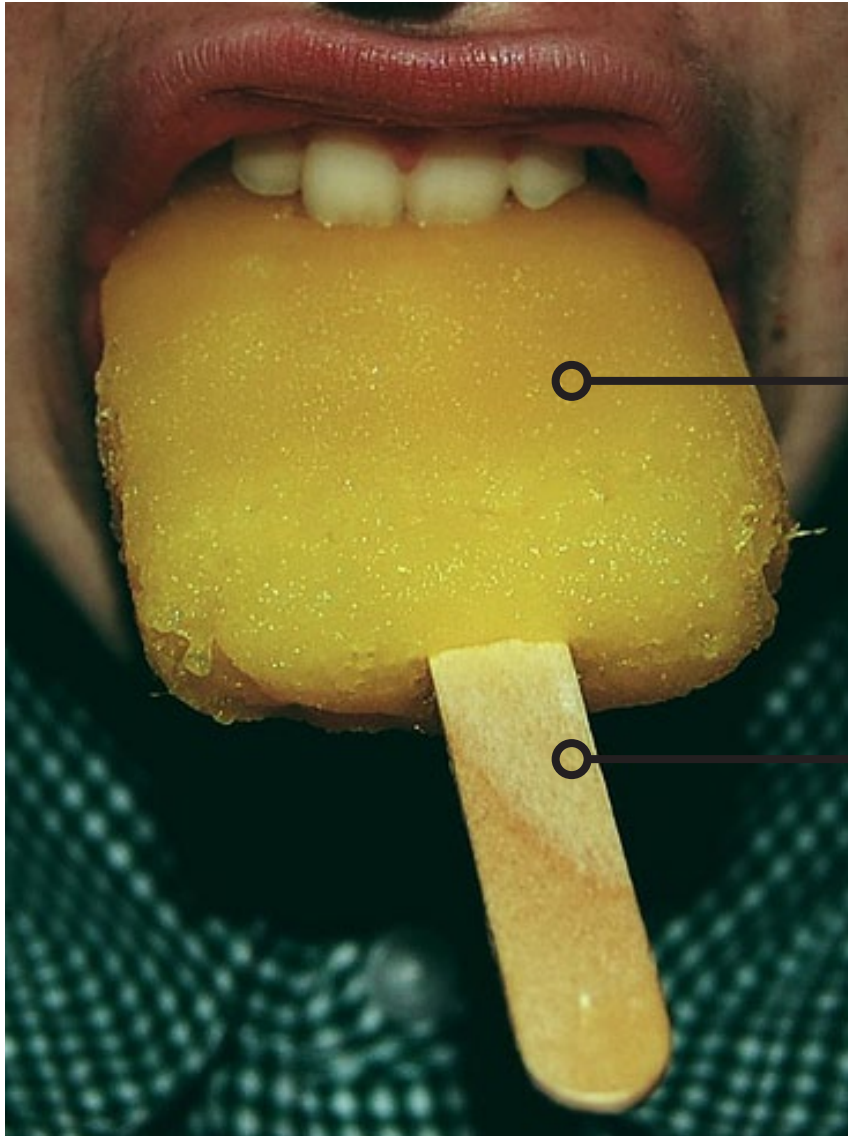

*temporary*

*permanent*

Figure 03. Illustration of the symbiotic relationship between the temporary and the permanent (Banks, 2008).

## 02. THEORETICAL APPROACH

## 2.1 TENSION: PERMANENT VERSUS TEMPORARY

“All art is perishable” (Harbison, 1991, 13)

Within the discipline of architecture there exists paradox, duality and tension. The area of investigation lies between permanence and temporality. This tension cannot be easily resolved, if ever. It's doubtful that there exists an ultimate, or extreme form of temporality or permanence. There is, however a spectrum that exists in-between and is evident in architecture.

The relationship between temporary and permanent structures is a relationship of complementary influence. The tipping of the scale between the two depends largely on ones perception, interpretation and experience.

Agreeing that this tension is relative and intuitive, there are certain practices and forms of architecture that are generally considered to be of a more permanent or temporary nature and this will be the focal point of the study (Figure 03).

*Fernández-Galiano observes: “Architecture involves an uncertain mix of solid reality and pale shadow.” (Touw, 2006, 7)*

*“Entities existing in the physical world and those that live only in the minds of human beings both have durability. But the two obey quite different rules, and the destiny of objects made of resistant matter varies from that of their counterparts in memory.” Rudolf Arnheim (Touw, 2006, 7).*

### 2.1.1 Permanent

A) adjective [adaptation of Latin *permanent-em*, present participle of *permanere*; to stay to the end, that B) remains fixed, motionless (Touw, 2006, 24).

‘Permanent’ is defined in the Oxford English Dictionary as “continuing or designed to continue indefinitely without change” (Touw, 2006, 23).

### 2.1.2 Permanence & Perception

By definition, architecture is meant to be permanent, to serve a practical and aesthetic purpose over an indefinite period of time (Chabrowe, 1974, 38). Formally, the concept is introduced into architectural discourse in Vitruvius’ *Ten Books of Architecture* as ‘firmitas’ and refers to the “ability of a building to endure, based on its own material strength and soundness of construction; often defying both nature’s and time’s deteriorating effects” (Touw, 2006, 28).

Embedded in the word ‘permanence’, is an understanding of both “time” and “matter”. This understanding is dependent on, and affected by cultural and scientific insights. “And it is, therefore, inevitable that changes in our definitions of “time” and “matter” will also compel us to rethink the concept of permanence” Shadi Nazarian (Touw, 2006, 7)

In contemporary society, permanence is generally perceived as an absolute concept. This causes confusion because we “permanence” to describe things we perceive from a relative perspective. Keeping this in mind and seeing permanence as both absolute and the relative, avoids conflict (Touw, 2006, 8).

“If left to itself or discarded from the human world, the chair will again become wood, and the wood will decay and return to the soil from which the tree sprang” (Touw, 2006, 10). In this sense, then, permanence might be thought of, or measured, as the interval between successive cycles – the longer the interval, the more permanent or durable is the object.

### 2.1.3 Defining temporary architecture

Temporary construction is something that is already present, and plays an important role in the socio-cultural and economical context of Pretoria; beginning from the time when farmers set up camp in Pretoria to buy supplies and have communion until today when street vendors commute to the city to put up their various stalls to sell cigarettes, sweets and fruit. Temporary construction also plays an important role in architecture and design, for example: the form, work and scaffolding used during construction and maintenance of permanent buildings as well as the temporary structures used for events and exhibitions.

## 2.1.4 Types of temporary uses and structures already present in the Pretoria CBD

- Fairs and festivals
- Sporting events
- Art installations
- Exhibitions
- Live performances
- Performance stages and sets
- Film sets
- Shop fittings
- Food vendors
- Events (demonstrations, promotions & marketing)
- Micro-enterprise developments
- Markets
- Mobile public outreach centres

The SANS 0400-1990 (18) defines a ‘temporary building’ as any building that is so declared by the owner and that is being used or is to be used for a specified purpose for a specified limited period of time, but does not include a builders shed.

“Temporary architecture can range from a one-time educational event to a month-long art installation to mobile architecture that is designed to be portable but may stay on one site for several years.” (Dann et al. 2009, 3)

“Temporary architecture, to me, is simply the space created and removed over a short period of time, like for an event.” (Baunach, 2009)

## 2.1.5 Temporary design through history

Temporary architecture serves a different purpose from permanent architecture and has been flourishing for over 100 years. Throughout history its essential function has been to stand as an advertisement, conveying a political, social or commercial message. Once the occasion for the message had passed, so did the architectural messenger. The history of temporary architecture goes back to antiquity (Chabrowe, 1974, 385).

### Hellenic times

The first main visual records of temporary structures were coins

### Middle Ages

Scarcely any records

### Early Renaissance

As coherent history emerged, temporary structures became a distinct genre

### Baroque

This genre reached a peak

### Early Renaissance & Baroque

- Public celebrations and mourning
- Decorative edifices, wooden scaffold faced by stucco and canvas
- Incorporated into elaborate ceremonial events
- Commemorated in pamphlets that contained engravings and descriptions of the structures along with accounts of the events and their participants

### Mid-nineteenth century

Declined to the point of dying out but gave way to an industrial equivalent (Chabrowe, 1974, 386)

The **Industrial Revolution** accompanied by urbanization and the mechanization of labour, freed individuals from toil and resulted in the need for new and different forms of architecture and experiences.

**Today** the industrial era is giving way to a technologically inspired and knowledge-based society in which definitions of concepts like ‘temporality’ and ‘permanence’ are again being redefined (Edginton & Chen, 2008, 1-6). Architects are again fascinated by the idea of temporality, to a degree not seen since the nineteen- sixties and -seventies, when experimental design teams explored what Peter Cook, a member of London’s Archigram, called “expendability” and “throw-away architecture” (Hawthorne, 2008)

## 2.1.6 Intention

A clue towards defining temporary and permanent architecture can be found in the intention. Compare a structure, built with the knowledge that it will be erased soon after planning and expecting its demise; to a structure built with the intention that it should last indefinitely. Sometimes, when structures outlast their expectations, continue to be used or become socially or culturally important. That which was intended to be temporary, cross over to permanence. Examples are; the Eiffel Tower built in 1889 which was intended only as a temporary demonstration piece as the entrance arch to The World Fair and the outdoor Delacorte Theatre in Central Park, New York which was originally built as a temporary structure in 1962 (Groak, 1992, 70).



## 2.2 FORMS OF TEMPORALITY

### Temporary & Changeable Use

These are: permanent structures of which the use or program change over time. Certain permanent structures are not used continually or the use changes. In the realm of architecture a permanent structure does not guarantee that it will be permanently occupied.

Examples are: theatres, holiday homes, expo-, event- and exhibition centres, as well as vacant or abandoned spaces.



Figure 04. Human scale stand (Design Week, 2009).



Figure 05. Abandoned industrial space (Summers, 2009).

### Temporary & Different Location

These are: nomadic or mobile structures that can be dismantled, relocated and re-assembled; movable, foldable and collapsible architecture or furniture.

Examples are: tents, caravans, travelling carnivals and shows, installations, exhibitions, form work, scaffolding and camping chairs.



Figure 06. Softwall (Molo Design, 2010).



Figure 07. We Can Xalant/ Mobile constructions (Muns, 2009).

### Temporary & Once-off Existence

These are: once-off disposable structures that will be thrown away or cease to exist. Structures that are constructed with the intention of being de-constructed never to be assembled again.

Examples are: once-off events, pavilions, promotions, launches, exhibitions, insertions, sets, decor and installations.



Figure 08. Burning Man Festival (Fairs, 2007).



Figure 09. Open Burble (Fuller & Haque, 2009).



## Temporary Materiality

These are: structures with a transient material quality: structures composed of materials that can easily break or degrade; disposable & recyclable materials; non-durable, light, translucent or thin materials; materials culturally associated with temporality.

Examples are: paper, cardboard, reeds, thatch, fabrics, canvas, tensile structures, glass, ice, wood, water, light and corrugated cardboard.



Figure 10. Canary Wharf Terrace Canopy (Architen Landrell, 2010).



Figure 11. Back Side Flip 360° (Fairs, 2008).

## Events

These are: structures that last as long as the experience they facilitate and space that is temporarily appropriated to accommodate an event or happening.

In this case the focus is on the experience that only lasts temporarily but creates a lasting memory.

Examples are: promotions, festivals, performances digital media such as film projections and virtual space.



Figure 12. The Port Eliot Lit Fest (Bradshaw & Campbell, 2010)



Figure 13. Krzysztof Wodiczko projection in Tijuana, Mexico (Flicker, 2004).

## Temporary phase or position

These are: structures that grow, age, change form, composition, state or position. Structures that are intended to decay, change or evolve over time

Examples are: adjustable architecture, flexible space, open building systems, ice structures, plants, corroding metals.



Figure 14. Vertical Garden (Ping mag, 2006).



Figure 15. Video Ice Hotel (Bulletin Solutions, 2010).

## 2.3 EXAMPLES OF TEMPORARY ARCHITECTURE

### Urban Switch

This was a two-storey, 12 m high, temporary information pavilion by Modulatorbeat, for the sculpture projects Münster 2007 exhibition. It had a gold-coloured exterior shell of perforated copper sheets in response to the Silberne Frequenz (i.e. Silvery Frequency), a light installation by Otto Piene, on the facade of the adjacent building. Illuminated from the inside at night, the interplay with the Silberne Frequenz installation created a particularly unique atmosphere. Acting as an “urban switch”, a moving part of the pavilion was able to re-route pedestrian and bicycle traffic on the square, thus also transforming the use and perception of this public space ( Schwiontek, 2008).



Figure 16. Exterior view of Urban ( Schwiontek, 2008).

### Kubik,

Temporary buildings are often minimalistic; stripped to their bare essentials (Modulatorbeat, 2006). For three months, an empty plot of land in Berlin was transformed by constructing a temporary night club out of 144 plastic water tanks, normally used in industry. They were joined together by a simple system of metal bars and Euro Pallets, a 150 watt bulb was placed in each canister and wrapped in heat-resistant coloured film. Kubik has since been on tour in other cities like Barcelona and Lisbon ( Schwiontek, 2008).



Figure 17. Exterior view of Kubik (Schwiontek, 2008).

### Kunsthülle LPL

This provided a temporary venue for the Liverpool Biennial 2006 by OSA architects. The quality of temporary architecture is also determined by the aesthetic impact of the realized concepts. On the flat roof of a disused factory, a simple steel construction was covered with PVC strips that stretched down to the ground. On the roof itself, a second inner shell, made of red PVC strips formed the actual venue. The PVC curtain of this two-layer facade allowed light and visitors to pass through ( Schwiontek, 2008).



Figure 18. Exterior view of Kunsthülle LPL (Schwiontek, 2008)

## 2.4 DELIGHT

### 2.4.1 The importance of recreational spaces and activities in an urban environment

As previously discussed, for several centuries, temporary construction has been, and still is associated with festivals and other forms of public, urban recreational and cultural activities.

Recreation is an expression of individual interest, often reflecting broader social and cultural values, and can serve as a wellspring for the generation of new creative perspectives for cities. As such, recreation is an optimal medium for transformation (Edginton & Chen, 2008, 1-6)

In the development of modern society, we can observe a few changes. One of these changes is the increase of mobility of mankind, the increase of speed in general and the progress in telecommunications. We can observe an increase of free-lance specialists, who work as teams and project-oriented for a specific and relatively short time, often on different locations; "The Nomads of the 21st Century". Isolation, a decreasing social life and alienation, is already manifesting itself for the pioneers (Horsmans, 1996).

"Rapid changes in society have resulted in a very dynamic, fluid environment that demands from individuals and societies the ability to engage in the process of transformation", says Edginton & Chen (2008, 1-6). To transform or change, one must be free or unencumbered from the constraints that are imposed in seeking a new way of being. Leisure provides an optimal oppor-

tunity for such transformation or change. Changes in society also create needs for new and different forms of leisure amenities and experiences. Recreation has the potential for improving, nourishing and sustaining individuals as well as cities because it:

- Enhances the livability of communities which has become a central theme in the promotion of cities in order to attract businesses. A livability approach focuses on creating leisure-oriented social and physical environments
- Provides an optimal environment for individuals to seek new experiences, to experiment and to learn and grow anew.
- Creates opportunities for professionals to gain new knowledge, skills, attitudes and values
- When applied to the workplace, environments can be designed in such a way as to promote a more creative, playful, and open social and physical environment

(Edginton & Chen, 2008, 1-6).

In the chapter 'The Carnivalization of the World' Parker (2003, 140) discusses the Rio Carnival in Brazil and points out that the carnival has changed and grown over time in response to the specific circumstances of Brazilian life. "The carnival itself has been "Brazilianized" and has itself become a kind of metaphor with its own highly complicated set of meanings" (Parker, 2003, 140).

Hawthorne (2008) uses the example of Los Angeles as a city that has a long history of what he calls vernacular temporality; rows of taco trucks and party tents during Oscar week and thousands of people drive into the desert to take in the pop-up urbanism of the annual Coachella and Burning Man festivals.

*"This linear trajectory of ones life is interrupted each year by the cyclical rhythm of the seasons, by the time outside time, when the world of established order and daily life dissolves , giving way to a world of play , in which all hierarchical structures are overturned and the fundamental equality of all human beings is proclaimed."*  
 (Parker, 2003, 141)

*"(As such) public festivities were intimately linked to improvisation: the magic created in the imperfect was what carried the essence of the event, for in the unfinished, one can imagine new realities; they allowed to test and develop construction hypothesis and new forms."*  
 (Lévesque, 2007)

## 2.5 THE IMPORTANCE OF TEMPORARY ARCHITECTURE

*“...temporary structures are valuable not despite but because of their fleeting, popular character.” (Chabrowe, 1974, p.391)*

*“We are in need of a new approach where variability in space, time and shape, flexibility and portability are the main characteristics. Where conventional urbanism is based on two dimensional planning of functions and building architecture, that lasts forever, we now need an urbanism that introduces time as a parameter.” (Horsmans, 1996)*

### 2.5.1 Economical climate

Currently the economic impacts of large-scale developments are being questioned. Lévesque (2007) is of opinion that small-scale temporary architecture has the liberty to explore and test larger themes through direct engagement with their site and their audience “Indeterminability emerges in the meeting of experience, time and context; the outcome of this conflation is impossible to predict” Lévesque (2007). Temporary architecture is an intervention which unveils unpredictable, experimental and educational opportunities. She also explains that impermanence superimposes an alternative reality by changing the time of experience (Lévesque 2007). As Perez-Gomez noted “festival time was obviously different from normal time. It dislocated and relocated human temporality, without resorting to banal linear time or a simple return of the same” (Lévesque, 2007). Once again, according to Lévesque (2007) ‘As such, public festivities were intimately linked to improvisation: the magic created in the imperfect was what carried the essence of the event, for in the unfinished, one can imagine new realities; they allowed to test and develop construction hypothesis and new forms’.

### 2.5.2 Reusing and recycling

We live in times where dwindling resources, pressing environmental problems and sustainability play an important role in the future of architecture. “Though it may sound paradoxical at first, this is precisely where we see great potential for temporary buildings and installations”, says Oliver Langbein from OSA (Office for Subversive Architecture) a network of eight architects and town planners who studied together in Darmstadt and now work in eight cities in five European countries. Langbein explains that “Experience shows that plans for the future are often very unreliable and that some buildings become obsolete much more quickly than originally expected”. The key to sustainable planning, he believes, is to develop a solution which is appropriate to the particular space: “It may prove more sustainable to first use a temporary installation to identify a location’s potential rather than designing a particularly eco-friendly building.” (Cave, 2008)

### 2.5.3 Collaboration

An integral part of temporary construction is, in many cases, a dialogue with local players. Oliver Langbein explains: “By incorporating their background knowledge into the work process, alternative concepts can emerge and planning errors can be avoided.” (Cave, 2008) The boundaries between architecture, art, design and social intervention become blurred. “The open links to other disciplines are simply more diverse with temporary concepts than is the case in classical building projects”, says Oliver Langbein, while Jan Kampshoff from Modulorbeat stresses: “All these categories are relevant to us, and it makes little difference whether

our work is then dubbed art, architecture, design or whatever.” (Cave, 2008)

## 2.5.4 The temporary as catalyst ground for experiment, facilitating change in the permanent

The temporary intervention could make suggestions towards ways in which the building could be permanently altered or re-used.

“Temporary projects are a bit like an **urban laboratory**”, says Jan Kampshoff from Modulorbeat (a firm of urbanists and planners in Münster): “What is fascinating about this type of work is that we can use the projects to transform, improve, disrupt, ignore or reinterpret spaces for a short period of time. The projects may disappear, but the spaces are never the same again.” Temporary buildings also have the advantage that they can often be erected **more quickly** than conventional buildings based on light and inexpensive materials and inventive and logical assembly”. (Cave, 2008).

An interdisciplinary workshop was ran by Oliver Langbein and Britta Eiermann during the Darmstadt Summer of Architecture 2008. Inspired by the question “Who does public space belong to?”, the workshop examined the scope for young people to make active use of urban spaces. Together with university and school students, the architects devised temporary transformations. They transformed lonely park benches into lounges and played urban mini golf in empty water basins and through old drainpipes and gutters (Figure 19). For their Landgewinnung (i.e. land reclamation) event they used large yellow towels to occupy public

spaces and bus stops like only the Germans can (Figure 20). One thing that does become clear is that the experimental character of temporary works allows provocative architectural statements and a new perception of squares, public spaces and parks.



Figure 19. Urban mini-golf temporary transformation (Cave, 2008).



Figure 20. Reclaiming land with yellow beach towels (Cave, 2008 ).



## 2.6 THE TEMPORARY USE OF VACANT SPACE

In the CBD of Pretoria, vacant spaces are seen as dangerous and to be avoided. These spaces are then illegally occupied. Eviction usually causes great distress to the owners, occupants and the surrounding community. Property also gets damaged when lying vacant for too long. Vacant spaces also have an adverse effect on the property value in an area (Figure 21). For these reasons the temporary use of vacant space is worth exploring.

During 2009 the Central Eastside Industrial Council of Portland Oregon in collaboration with Portland State University did research on this subject and identified benefits that temporary projects offer to property owners, space users and the community.

### 2.6.1 For property owners temporary projects can:

- Maintain the commercial viability for a property or area
- Demonstrate a viable, active use of a space to potential permanent tenants and attract people to the site, increasing exposure and interest
- Improve the space if users do painting or other finishing work—increasing its value
- Generate revenue.
- Prove the viability for permanent use
- Put the property “on the map” and boost the image of the property and the owner
- Help maintain and develop good relationships with neighbouring owners and the community
- Enable owners to be involved in uplifting their community by fostering creative activity and start-

up businesses

### 2.6.2 For property users temporary projects can:

- Test out a neighbourhood before making permanent commitments
- Offer a low-budget way to demonstrate property viability
- Allow existing businesses and community groups to expand their workshops, stores, or office space for special events, seasonal activities, or short-term projects
- House temporary events in unconventional locations
- Give artists and businesses exposure to new customers and spaces
- Provide venues for displays of art in storefronts (Figure 22)
- Provide locations for entrepreneurs to try out ideas and experiment with a low budget

### 2.6.3 For communities temporary projects can:

- Keep a business district active and attractive
- Prevent property from becoming an eyesore and reveal new possibilities for vacant spaces
- Activate and enliven dead or awkward spaces, such as publicly-owned pieces of land near highways and rail lines, walls and rooftops, or unused portions of occupied buildings
- Demonstrating possible uses for a space that is currently empty
- Spark more ideas and build a vision of could be

*“Sometimes the spaces act as laboratories for the future city.  
Sometimes the uses act as catalysts for (re)development.  
Sometimes they make money.  
Sometimes they are just fun.”*  
(Dann et al. 2009, 2)



Figure 21. Rundown storefront that once was a CoraMart (Heavilin, 2009).

Figure 22. Temporary art space (Bradshaw et al. 2010).

## 2.7 ARCHITECTURE AS EVENT & EXPERIENCE

Spatial, social and cultural experience

**Event = people + activity + space =  
architecture**

According to Tschumi (1977) the difference between architecture and art lies in “the experience of the moving body in space.” He sees the exclusion of the body and its experience from discourse as resulting in a reductive and formalist interpretation of architecture. According to him architecture should be seen as “...an interaction of space and events” instead of an object, as a “human activity or open-ended text” (Tschumi, 1981). Tschumi’s writing focuses on themes of transgression, limits and excess. He also places emphasis on the event and the experience of pleasure as being orchestrated by architectural space (Nesbitt, 1996).

He concentrates on the senses and the exhilarating differences and dialectics in the experience of space. He sees architecture as a pleasure of the mind rather than a thing of the mind. Architecture depends on imagination, sensual experience as well as rational concepts. In his explanation of fragments he refers to ‘desire’ as the movement between opposing fragments; the real and the virtual, memory and fantasy, presence and absence.

“Architecture is architecture because it sets in motion the operations of seduction and the unconscious.” (Nesbitt, 1996, pp.530-540).

Events are temporary by nature. In order to accommodate events, space is often created and removed over a short period of time. During an event a space can

make you feel special in the moment when, normally, you would not consider that space as being special (Baunach, 2009).

### 2.7.1 Palio dinner

An example of this is a Palio dinner. The Palio is an annual horse race in Siena that pits neighbourhoods against each other. Before the race, a big dinner is held in each street and neighbours come out to eat. At the head of the table is the horse, the guest of honour.

This event transforms a city street into a dining room for thousands. Although Siena has a natural and man-made beauty, Baunach (2009) would argue that the temporal experience of the dinner is the basis for falling in love with the city of Siena. The event is fleeting but it is this intense memory of civic transformation that truly creates the lasting impression of the city rather than its day to day stasis (Figure 23).

Temporary architecture also helps resolve what is really important for inhabitation, says Baunach (2009). The importance of space lies in the architectural experience augmented by its static form and aesthetics which is based more on a memory of a space at that moment.



Figure 23. Palio dinner in Siena (Baunach, 2009)



## 2.7.2 Theatre & Temporality

Temporary structures have customarily been associated with the theatre. But while they shared the transient nature of the stage sets, they were always three-dimensional. A temporary structure constituted a volume of mass and usually enclosed space. The stage set was primarily two-dimensional and only simulated mass (Chabrowe, 1974, p.386).

In commenting on his set design for Richard Wagner's 'Tristan and Isolde', Daniel Libeskind says that: "the difference between architecture and theatre is that in theater everything is built to disappear...made with paper glue and light materials."

He continues to explain how powerful the impermanent can be, because it creates memory and emotions which remain in the hearts and minds of the audience and that this is what architecture and theatre have in common (Libeskind, 2009). Places where collective and public cultural activity occur have an important and lasting influence (aesthetic, social, economical and symbolic) on the form and function of cities (Groak, 1992).

## 2.7.3 Environmental Theatre

"In 1916, poet Guillaume Apollinaire imagined a theatrical performance like a festival or market day in a public plaza. Apollinaire's vision of a multifaceted performance on a stage surrounding the audience was developed by modern directors in the 1920s and 30s as "environmental theatre." Apollinaire argued that art, theatre and architecture should neither mirror nature, nor construct an ideal, but draw back the veil of the ordinary by juxtaposing images that open viewers' imaginations" (Read, 2006, 8).

Walter Gropius and El Lissitzky were respectively approached to design environmental theatres that would engulf the audience spatially, erasing theatrical distance. Bringing audience and actors into the same space challenged the boundary between fiction, reality and constructed plays, not as fantasy, but as meaningful stories that have a real effect in the world (Read, 2006, 8).

During the same time Erwin Piscator in Germany and Vsevolod Meyerhold in Russia led a movement to do away with the box stage, to cross the proscenium arch and to bring performances into the hall with the audience (Read, 2006, 8).

## 2.7.4 Theatre as Experiment

"Theatre is perhaps architecture's most powerful ally in exploring the social impact of design: how space shapes actions and relationships. Theatre offers a manipulable realm of make-believe that can reflect on real situations, characters and places. In this protected field of play an architect and director may set up situations that actors explore emotionally in movement and gesture. In this sense, theatre demonstrates architecture, playing on exactly the issues of interpersonal relationships in space that architects engage with most pointedly in designing buildings, public space and urban life." (Read, 2006, 2).

"Through theatre, a designer may explore physical and social space in real time, at a real scale and with real people." (Read, 2006, 2).

Performances were to absorb spectators in a complete experience of action in space. Autant and Lara saw architecture neither as an art of composition nor as engineering, but as a performing art. In the experimental realm of theatre, actors and spectators could test the space poetically in performance (Read, 2006, 3).

## 2.8 CASE STUDY \_ THE DESIGN OF THE THÉÂTRE DE L'ESPACE

In 1937, Autant built the Théâtre de l'Espace (Theatre of Space) performance hall within a larger structure designed by Paul Tournon for the Paris International Exposition, which stood for one year (Figure 24) (Read, 2006, 3).

The theatre comprised a 50m long rectangular hall. The audience was accommodated in a smaller rectangular pit at the centre, surrounded on three sides by a fixed, raised stage. Small stage spaces were also placed in between the audience. This created two levels of performance space; one close-up and one seen from further away. On the upper surrounding stage, three scenes appeared: one beyond the facing audience, a second scene to the side requiring spectators to turn and a third going on behind them. (Read, 2006, 6).

The exterior walls of the hall were pierced with glazed doors and windows that reached from the floor of the stage to a high ceiling to create a 'transparent atmospheric band, continuous with the outside' (Read, 2006, 5). Panels of scenery were hung in front of the windows yet they never entirely obscured a view to the outside. Actors on the panoramic stage would perform with scenery above them as well as a view through the windows to trees and sky beyond. This juxtaposition read simultaneously as flat paint and as illusory space (Read, 2006, 8). Most of the roof was a skylight that could be opened completely in good weather, releasing the hall to the sky (Figure 26) (Read, 2006, 4).

The slope of the stage floor on the upper levels created traditional up-stage and down-stage positions but because it followed the line of sight the audience could not see the floor and, as a result, it would be difficult to read depth (Figure 27). Together with the bright light from the windows behind, actors would seem two-

dimensional and as if they were floating in weightless silhouette, their faces invisible (Read, 2006, 7).

The skylight lit the actors from above and made them appear close up when surrounded by the audience. This proximity and consistent shadow emphasized their physical presence and allowed the audience to see their movements in three-dimensional detail. The seating configuration placed both actors and members of the audience opposite each other with pieces of performance in-between. This meant that they were integrated into the performance and could see each others' reactions (Read, 2006, 6).

Théâtre de l'Espace played on the boundary between the theatre and the city, constructing a fictional scene within a real place. While the narrative of the script invoked a fictional elsewhere, a view of the Parisian landscape was maintained juxtaposed with scenery. This recalled ancient epic dramas staged outside in natural landscapes or city squares.

Autant included a large screen on the building façade so that performances which were in progress inside, could be projected into the city (Read, 2006, 10). "... rubbing the story against reality, placing spectators both there and here, inviting them to speculate in between" (Read, 2006, 7)

The architecture of the Théâtre de l'Espace might be read as a demonstration – a testing ground – for modernity that stands opposed to both traditional theatres and urban spaces (Read, 2006, 9).

Autant applied visual techniques used in modern cin-

ema to the design of the theatre. The surrounding stage functioned like a panorama that the audience could scan like a camera, filming a landscape. Similarly the audience could follow a character moving between scenes like a cinematic tracking shot (Read, 2006, 10).

The Théâtre de l'Espace identified two experiences familiar in the structure of public, urban life and performances that are representative of public life (Read, 2006, 13). Distant scenes on the upper level surrounding the audience evoked one's view of the lives of others, which often appear scenographic and well-ordered (Read, 2006, 9). The scenes on the lower stages unfolded unpredictably and like spontaneous events in one's own life and modelled the casual, more private interactions of the city (Read, 2006, 11). The two areas remained linked and could affect each other. The boundaries between were "permeable enough for drama in motion" to cross from one to the other, defining moments of particular intensity when characters step from one into the other (Figure 28) (Read, 2006, 10).

Through theatre, Autant and Lara investigated architecture not as form but as action, a practice particularly relevant to design in cities (Read, 2006, 1).



Figure 24. Building containing the Théâtre de l'Espace designed by Paul Tournon for the Exposition International des Arts et Metiers, Paris, 1937 (Read, 2006).

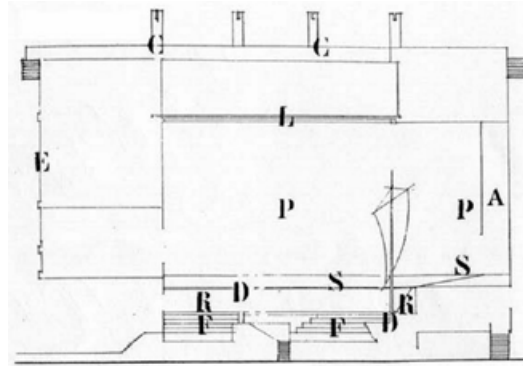
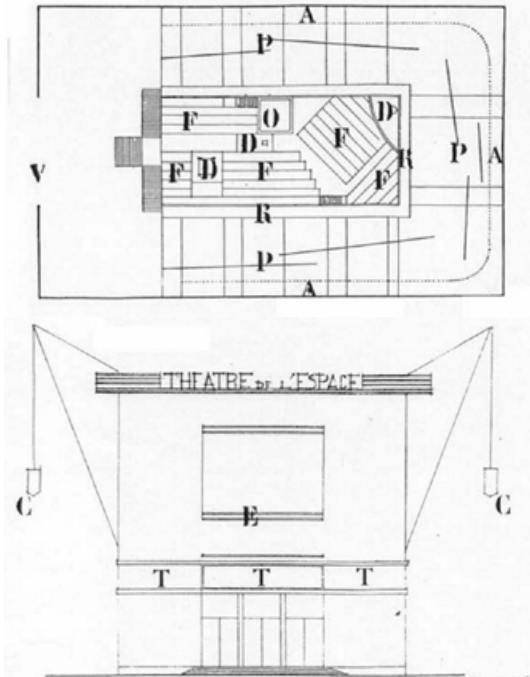

Figure 25. Left: Plan, Section and Elevation drawn by Edouard Autant (Read, 2006).

- A - Transparent Atmospheric Band (open to fresh air)
- C - Counterweights for moveable ceiling
- D - Scenery (Improvised)
- E - Closed-circuit television screen showing performances in progress
- F - Seating for Audience
- L - Moveable Ceiling (Fresh air and weather protection)
- O - Orchestra funnel
- P - Panoramic Stage
- R - Mirrors
- V - Entry Hall
- T - Advertising Posters



Figure 26. View from stage showing scenery panels overlapping windows above the heads of actors. Retractable ceiling and skylights flood theatre with sunlight during the day and frame view of heavens at night. Layered scenes, views and light proposed spatial experience of a modern public plaza (Read, 2006).

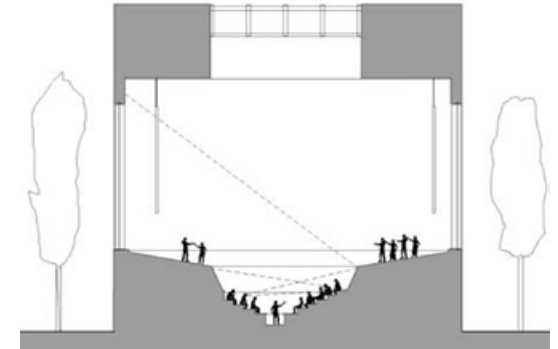

Figure 27. Cross-section based on Autant's sketches and photos of the built hall. Actors perform at the lowest level between sections of spectators and on the upper surrounding stage (Read, 2006).



Figure 28. Interior based on Edouard Autant's plan and section. Actors play improvised scenes in lower area between audience bleachers and choreographed drama on upper surrounding stage. Tilted mirrors reflect action behind spectators (Read, 2006).



# whole

existing fabric and  
digital environment



Figure 29. Digital collage for framework (Pretoria PlugIn City group, 2010).

## 03. FRAMEWORK

## 3.1 GROUP FRAMEWORK\_ PRETORIA PLUGIN CITY

[COLLECTING FRACTIONS OF THE WHOLE]

### 3.1.1 Vision

- **Celebrate** the unique and multiple layers and characteristics of Pretoria's inner city
- **Build** on and promote the existing urban fabric
- **Promote** Pretoria's inner city as a stimulating energetic environment.

### 3.1.2 Identity

- Create local and regional identity in the inner city through creating a distinct brand identity for specific **nodes** and **strips**.
- Employ furniture, finishes, tectonics and existing fabric to reinforce and maintain strip (street) **identity**.
- Use markers to increase **legibility** of programmes, features and districts

*'It is better to think of an aggregation of small and even contradictory set pieces (almost like the products of different regimes) than to entertain fantasies about total and faultless solutions which the conditions of politics can only abort.'*

(Rowe & Koetter, 1996, 279)

### 3.1.3 Connect

- Promote **connections** between the CBD and bordering regions
- Promote inter connectivity within the CBD by **linking** open spaces and defining and developing social and cultural **nodes**
- Introduce people to the area identity by using **thresholds** as introductory points at specific entrances where people can "read" the city

- Preserve and promote **existing green and recreational public spaces** while creating new public recreational spaces and programmes in under utilized areas and where pedestrian activity is needed
- Formalise pedestrian routes between established nodes and engage with the existing landscape to form greenbelts along **pedestrian routes**; creating places of **rest** and **interest** to encourage pedestrians to **linger**

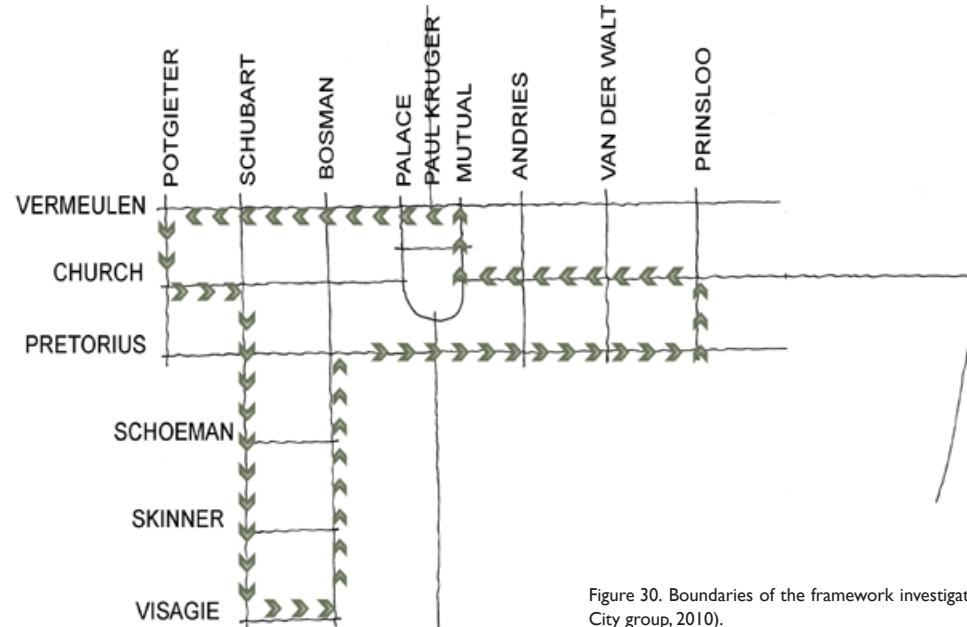

Figure 30. Boundaries of the framework investigation (Pretoria Plugin City group, 2010).



### 3.1.4 Collage city [Colin Rowe and Fred Koetter]

'Collage city' is a theoretical approach that recognises the city as a **composition of individual fragments** and allow **contradictions to coexist**. Collage is used to identify the problem of composite presence in the city. This theory criticises utopian and totalitarian reasoning and promotes an urbanism that allows for **change**.

The intention and application of this method is to use the existing, as a point of departure, and then initiate focussed, **site specific** (fragments) interventions with a common vision.

Each intervention functions as a catalyst on its own, creating points of rejuvenation throughout the city that circles out and in turn sparks future initiatives. When the **interventions** are viewed on a larger **scale**, a **collage** is created, revealing the **diverse** and **pluralistic** character of Pretoria's inner city.

*'A method of paying attention to the leftovers...of preserving their integrity and equipping them with dignity, of compounding matter of factness and cerebrality, a convention and a breach of convention.'*

(Rowe & Koetter, 1996, 288)

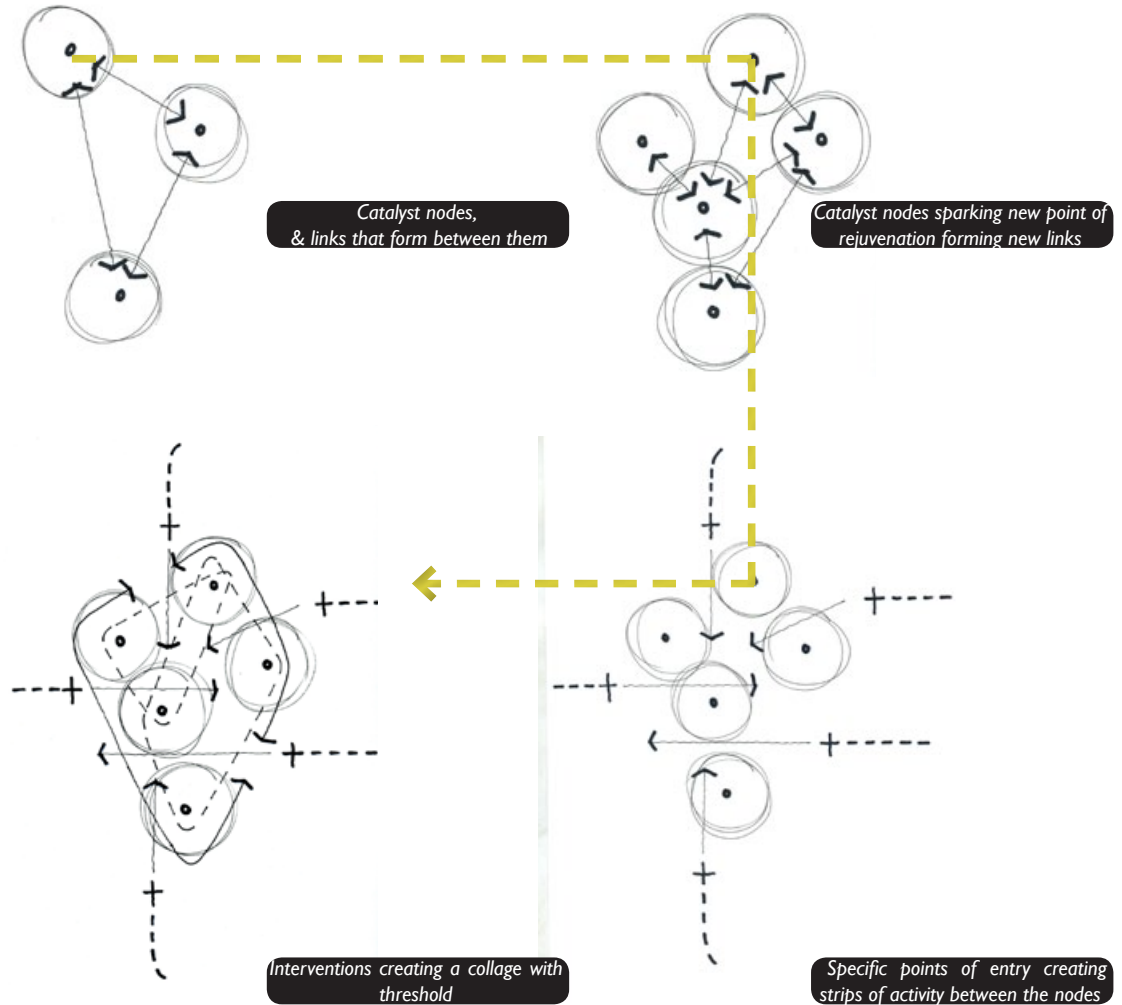

Figure 31. Diagram explaining the theoretical approach of the framework (Pretoria PlugIn City group, 2010).

### 3.1.5 Phasing

**Phase 1: Public nodes, recreation & links**  
Create public recreational programmes and events and provide links to unite the layers of activity.



#### Phase 2: Strip Strategy

Reinforcing and maintaining strip (street) identity with street furniture, finishes and building tectonics and create a brand identity for specific nodes and strips.



#### Phase 3: Thresholds

Create well defined thresholds at specific entrance points where people can “read” the city.

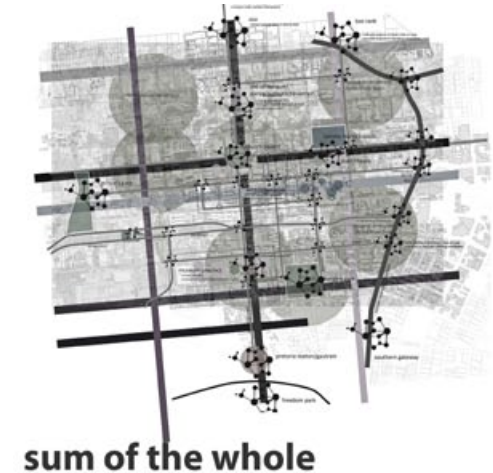

collecting **fractions** of the whole



Figure 32. Diagrammatic maps showing framework intensions & phasing (Pretoria PlugIn City group, 2010).



## 3.2 PHASE 4 PRETORIA **PLUGIN** FESTIVAL

### 3.2.1 Proposal

The aim of phase four of the framework is to **celebrate** the city. For this purpose the framework proposes a cultural festival in the **inner city**. According to research an annual festival called the Jacaranda Festival was held on Church Square during the nineties. Building on this **heritage** the framework proposes a new cultural festival called the **Pretoria PlugIn Festival** with **Church Square** at its centre.

### 3.2.2 Existing Jacaranda festival

During 2010, the Jacaranda Festival was held again for the first time in years.

The 2010 festival took place on a 50 000 square metre terrain next to the Zambezi Mall in Derdepoort, a northern suburb of Pretoria. Events included live music, acting performances and art exhibitions.

#### Criticism

- **Isolated** location: removed from the city centre
- **Inaccessible**: not in close proximity to major existing taxis and bus stops. Removed from the main public transport network of the inner city.
- **Exclusive** target market in terms of entertainment
- The programme doesn't promote up-and-coming artists – almost exclusively well-known artists

### 3.2.3 Perceptions about Festivals in South Africa

Judging from personal experience and asking peoples' opinions the following are some observations and assumptions:

- The major, well-known arts festivals in South Africa are held in smaller cities or towns
- The target market of these festivals is limited and generally feature more commercial performances. These festivals tend to exclude experimental, amateur performances and up-and-coming artists
- Other festivals are centred around a specific consumer or fresh product or a specific art form (wine, comedy, jazz, dance).
- Each year more people flock to festivals as they grow in popularity
- Festivals create economic opportunities
- People see festivals as a form of cultural expression
- People attend festivals specifically for its social aspects

*'As embassy capital we want to expose citizens of Pretoria and people from across South Africa to the rich diversity of cultures in Pretoria. We want to improve awareness among all people, of the important role the arts play in a multi-cultural South African society.'*

*(Jacaranda National Arts Festival, 2010)*

### 3.2.4 Intention

The intention of the festival is not to entirely replace the Jacaranda Festival but rather to incorporate or supplement it. The PlugIn Festival agrees with the Jacaranda Festival's mission statement but suggests some changes and adaptations to the way it is executed.

### 3.2.5 Location

The intention is to change the location of the entire festival or, at least a fringe component, to the Pretoria CBD. This location has historic importance, since Church Square used to be the centre of this festival. This will give people the opportunity to experience the inner city of Pretoria, rich in cultural and historic value. While providing public spaces and venues, the inner city will benefit from the rejuvenating social and economic boosts of a festival.

### 3.2.6 Accessibility

Church Square is close to BRT stops, taxi ranks and parkades that can accommodate a hop-off and walk network. The boundaries of the festival were determined by measuring walking distances from Church Square and the existing points of interest surrounding the square.

### 3.2.7 Target market

The location implies a different collection of people. The festival should, therefore, appeal to art lovers of different ages, races & genders, as well as renew interest in culture and the city. The intention is that the festival will attract a local, as well as an international market. The city of Pretoria, with its many embassies, is the perfect location for contributing an international element to the festival. The event historically featured international performances. The festival will allow room for a larger alternative, experimental and amateur segment.

### 3.2.8 Vision

- To promote the urban context; giving a new angle to South African festivals as we know them
- To create an urban event, annual ritual and tourist attraction in Pretoria
- Make it a more accessible and inclusive event
- To create a local and regional identity in the city, thus promoting Pretoria
- To connect people with the city - giving them a reason to visit the city
- Community focus, giving a platform to local artists & performers
- To generate an income for the inner city
- To create a framework for collaboration & skills transfer, sparking future incentives and creating a community legacy

### 3.2.9 Attractions

#### Culture and education

- Theme walks
- Artist & community craft workshops
- Schools & educational institutions; competitions & involvement of surrounding schools, TUKS and TUT's music, drama and arts departments

#### Additional categories & activities

- Digital art
- Animation
- Film
- Experimental & recycled media
- Photography
- Performance art
- Architectural & industrial design
- Fashion & textile design
- Location-specific art
- Museum/cultural walks
- Public - artist workshops
- Installation art

### 3.2.10 Time

The PlugIn Festival will be held for a week during the April school holidays. At this time of year the chances of rain are less and the weather in Pretoria is still pleasant. Events will also be scheduled for the evenings in order to attract people to the city, thus promoting it as a 24-hour zone, which will improve safety.

## 3.3 HOW DOES THE TEMPORARY THEATRE FIT INTO THE FESTIVAL FRAMEWORK?

### 3.3.1 Location

The site is located within easy walking distance of Church Square and falls within the festival boundaries.

### 3.3.2 Program

The building will function as a performance venue for the festival. The festival will be an annual city event and thus the building could be used on a yearly basis for this purpose. During and after the festival, The Temporary Theatre will act as a fringe venue to the State Theatre, located nearby. The Temporary Theatre will focus on more alternative and experimental theatre pieces, specifically supporting youth, community and other amateur stage productions.

### 3.3.3 Experience

As identified by the framework, the inner city lacks leisure and public recreation activities. Recreational events, such as festivals, are an economic, cultural and social boost for cities and can play a positive role in establishing a city's identity and regenerating the cities, as can be seen from examples of local and international cities such as Grahamstown, Potchefstroom, Rio de Janeiro and Edinburgh.

The temporary programme within the framework of a festival allows for repetition. The temporary structure should aim to leave small, permanent and positive traces. These small improvements, in turn, will spark greater change and renewal.

### 3.3.4 Location

The site is located within easy walking distance of Church Square and falls within the festival boundaries.

### 3.3.5 Use

As the framework proposes an existing building was utilized to accommodate The Temporary Theatre.

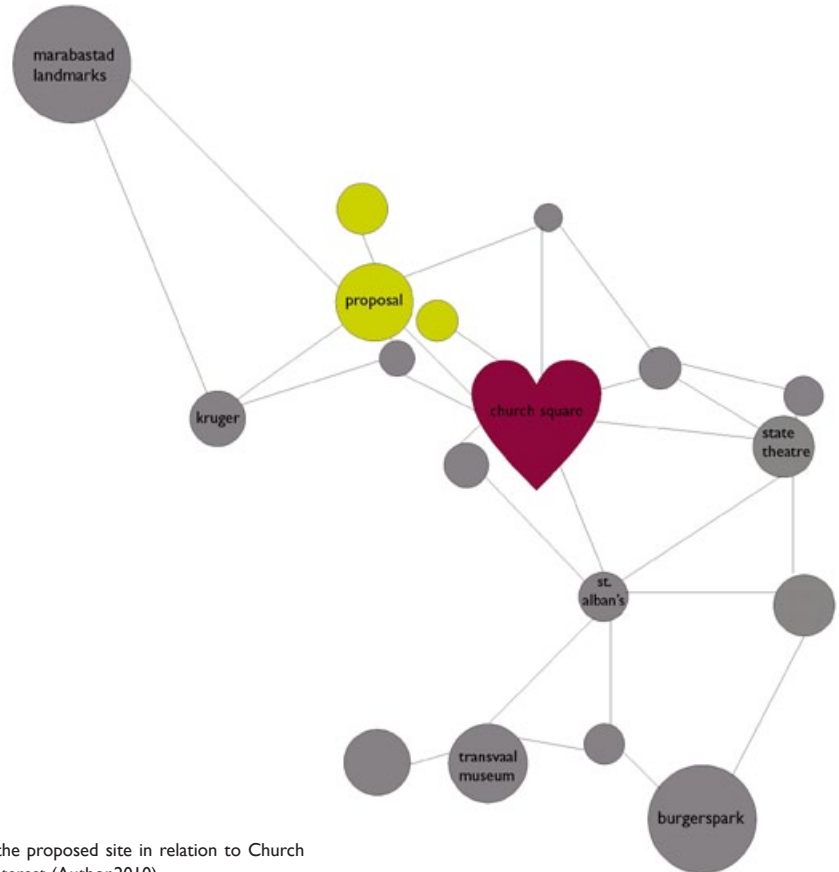

Figure 33. Diagram showing the proposed site in relation to Church Square and other points of interest (Author,2010).

## Existing point of interest, museums & theatre buildings



- 1 - Miriammen Temple
- 2 - Kruger House Museum
- 3 - Paul Kruger's Church
- 4 - Groote Kerk
- 5 - Palace of Justice
- 6 - Church Square + P. K Statue
- 7 - Old Raadsaal
- 8 - Tshwane Market
- 9 - Mosque
- 10 - St. Alban's Cathedral
- 11 - State Model School Museum
- 12 - Burger's Park + T.F Burgers Statue
- 13 - Museum of Science and Technology
- 14 - Transvaal Museum + Geological Survey
- 15 - City Hall + Pretorius Square
- 16 - African Window Cultural History Museum
- 17 - State theatre
- 18 - Capital theatre
- 19 - Small theatre
- 20 - Breytenbach theatre









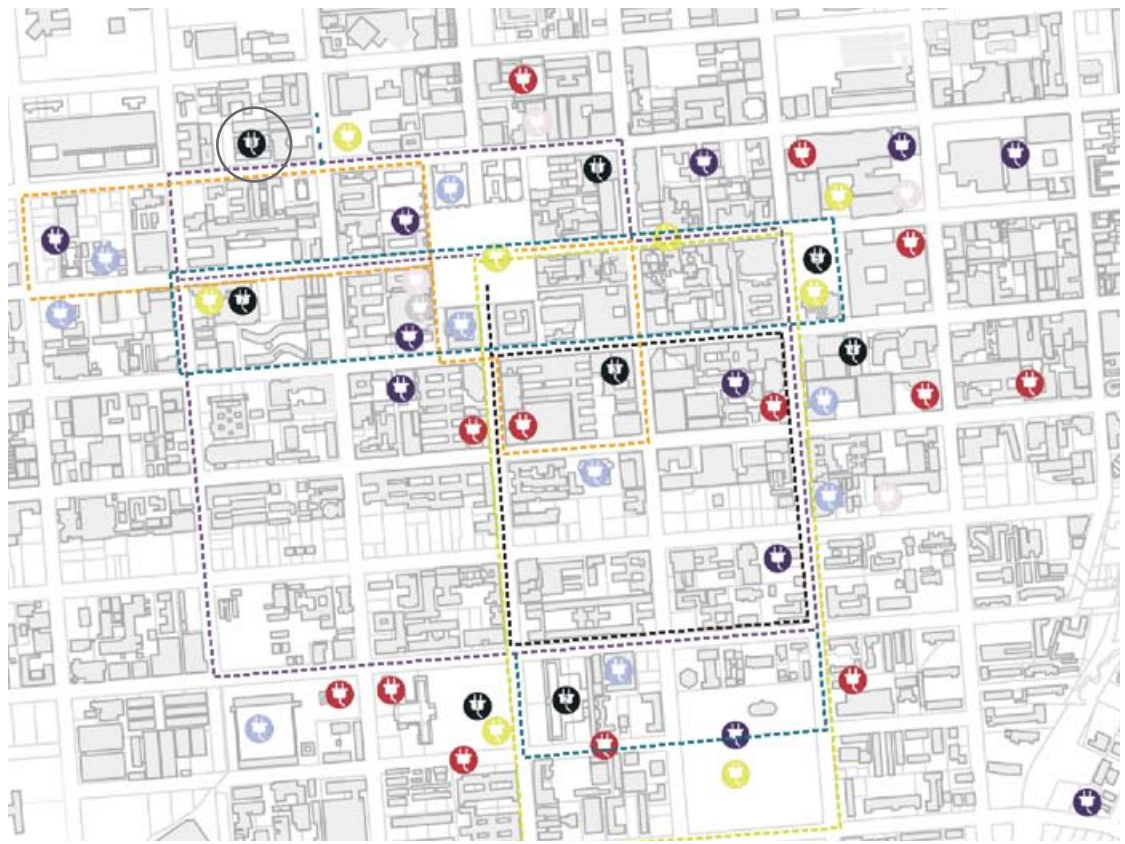





Figure 34. Map showing existing point of interest, museums & theatre buildings (Pretoria PlugIn City group, 2010).





# Pretoria **PLUGIN** festival



-  Venue
-  Attraction
-  Information
-  Refreshment
-  Market
-  Parking
-  Radhia
-  Olga-Marie
-  Grant
-  Andreas
-  Sune
-  Collin
-  Nadia
-  Janri





-  Conservation route
-  Culture route
-  Market route
-  Parks & public open space route
-  Knowledge route

Figure 35. Map showing festival routes, group sites and proposed uses of existing buildings and spaces during the festival (Pretoria PlugIn City group, 2010).





## 04. PHYSICAL CONTEXT

Figure 36. View of the site from across the street on the corner of Vermeulen- & Bosman Street (Author, 2010).



Founded in 1855 Pretoria has mostly developed along an east west axis in response to the restrictions posed by the topography of the terrain. This part of the city has a logical grid-based layout with Church Square still at its centre.

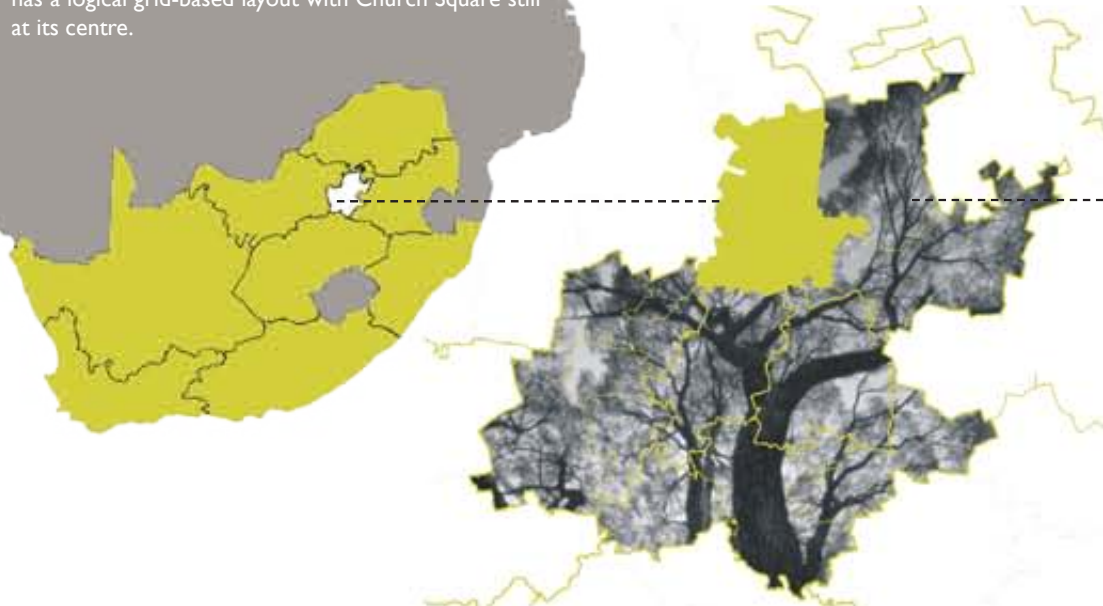

Figure 37. Gauteng within the context of Africa & South Africa (Author, 2010).

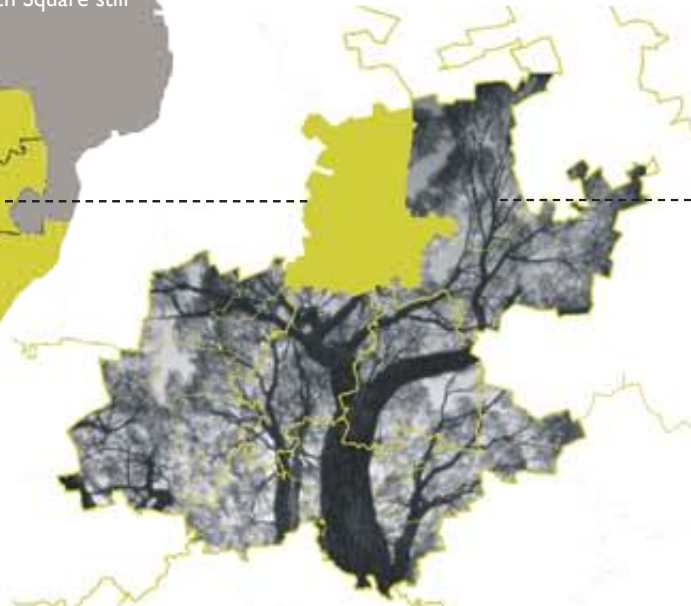

Figure 39. Pretoria within the context of Gauteng (Author, 2010).

The capital city of Pretoria is regarded as the core city of the multi- nodal municipal ward of Tshwane. The Central Business District of Pretoria lies between the borders of D.F Malan Drive to the west, Nelson Mandela Drive to the east, the Pretoria Railway Station to the south and Boom Street to the north.



Figure 38. Figure 51. Figure 04 Impressions of Pretoria (Author, 2010).



## 4.1 SITE

The bookbinding workshop of the Government Printing Works  
Bosmanstraat 148, erf 1/218-222



*Relationship to the inner city*

Figure 41. Location of the Government Printing Works within the Pretoria CBD (Author, 2010).

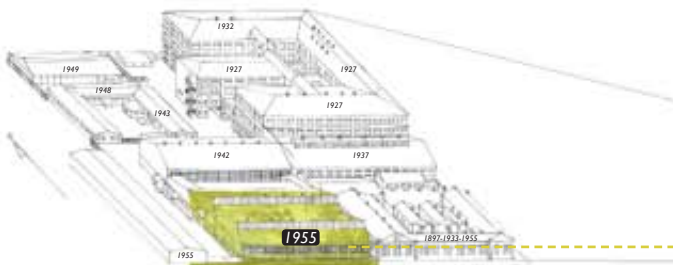

Figure 40. Perspective of the Government Printing Works (Author, 2010).

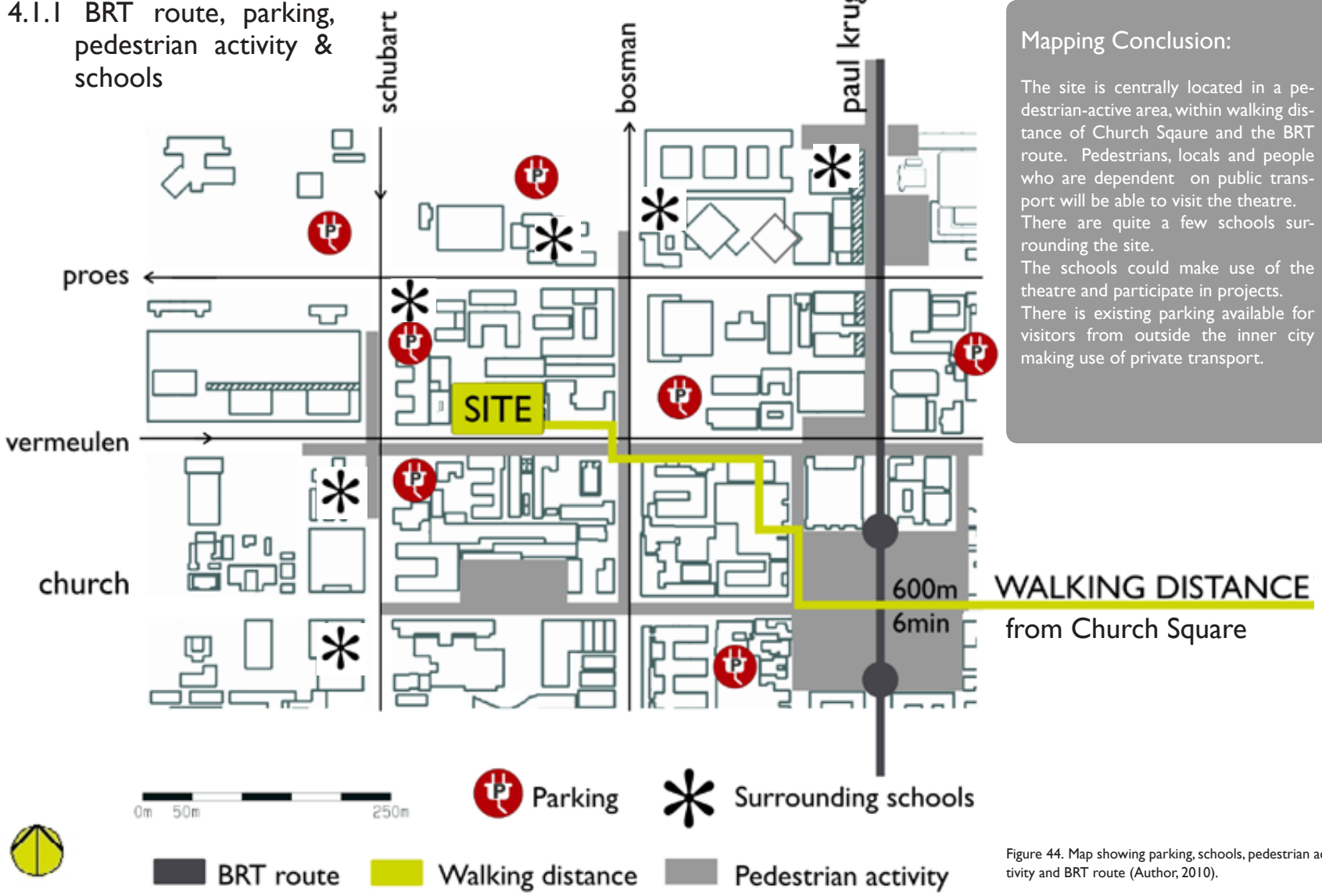

Figure 42. Location of the binding workshop in the contexts of The Government Printing Works (Geography department, UP, 2010).



Figure 43. Perspective showing the binding workshop & The Government Printing Works (Author, 2010).

### 4.1.1 BRT route, parking, pedestrian activity & schools



**Mapping Conclusion:**

The site is centrally located in a pedestrian-active area, within walking distance of Church Square and the BRT route. Pedestrians, locals and people who are dependent on public transport will be able to visit the theatre. There are quite a few schools surrounding the site. The schools could make use of the theatre and participate in projects. There is existing parking available for visitors from outside the inner city making use of private transport.

**600m  
6min**  
**WALKING DISTANCE**  
from Church Square

Figure 44. Map showing parking, schools, pedestrian activity and BRT route (Author, 2010).

### 4.1.2 Pretoria Plug In Festival routes & points of interest

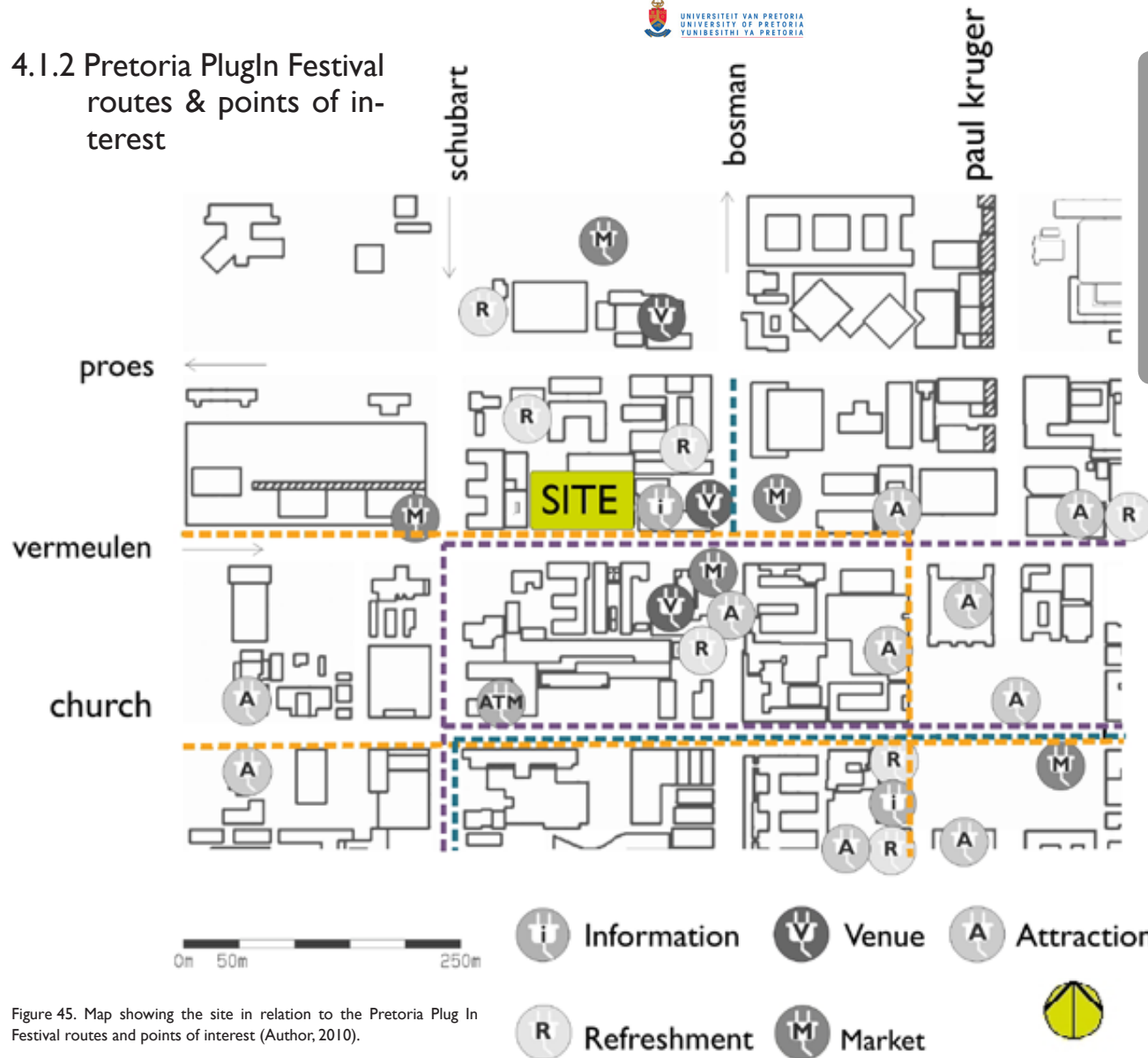

**Mapping Conclusion:**

The site is located within the boundaries of the proposed festival and in close proximity to new and existing points of interest.

The theatre will contribute to, and benefit from, the festival activities.

Figure 45. Map showing the site in relation to the Pretoria Plug In Festival routes and points of interest (Author, 2010).

### 4.1.3 Current land usage of property around the site

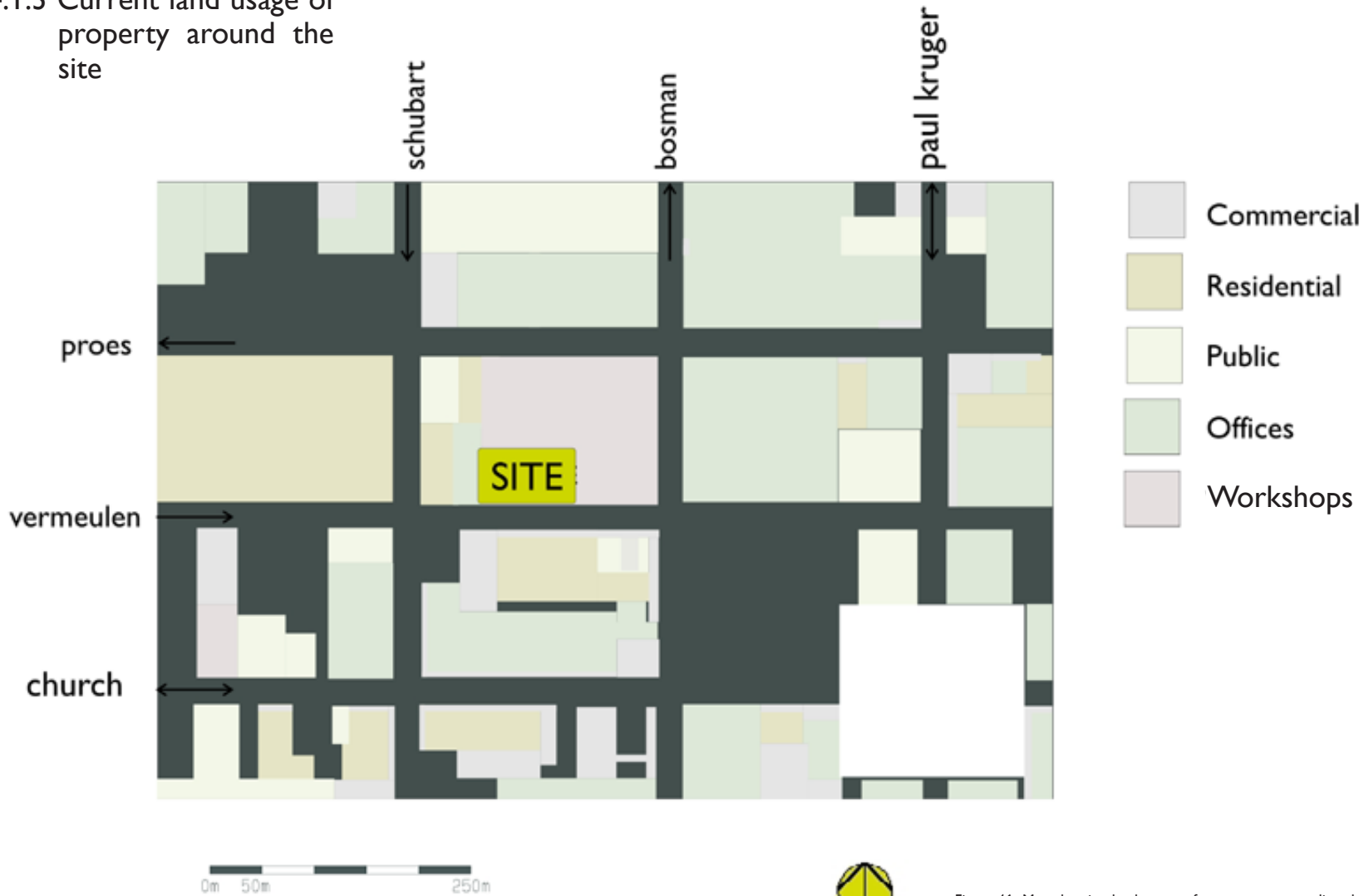

Figure 46. Map showing land usage of property surrounding the site (Author; 2010).





Figure 47. Digital collage showing impressions of the site and its surrounds (Author, 2010).

## 4.2 HISTORY CONTEXT OF THE SITE

Seen in isolation, the building that houses the book-binding workshop could be considered unimportant. The building's historical importance lies in the fact that it is part of a larger whole; the Government Printing Works, and therefore related to its development and associations.

Over the years the Printing Works printed, among other things, the SA Railway timetables, voters' lists, ballot papers, maps, cigarette excise duty labels, Union Government Gazettes, Matric exam papers, ID and passport documents.

The original printing works occupied a site in Church Street which were subsequently occupied by the State Library and later became the first home of the South African Reserve Bank.

Similarities found in comparing the Old Printing Press (Staatsdrukkerij, 1895) with the current binding workshop (1955) led the author to believe that the original printing press influenced the design of the binding workshop. In the light of available literature the following aspects could have been influential:

- Little detail, limited to the street facing facades (Minnaar, 2000, 68-75)
- Corner entrances unlike the central entrances of other government buildings of the time
- Other entrances are placed at the most useful positions for public access and workers entering from the street

**Architect:** Sytse Worpes Wierda (Government Engineer and Architect of the ZAR 1877 – 1899)

### 4.2.1 Wierda's point of approach:

Functional, utility and industrial architecture can still make a positive contribution to the image of the city through following the same city building principles of, for example, edgebuilding (randbebouing) and through using the same building materials (Minnaar, 2000, 68-75).

Commonalities between these types of buildings are also evident in the binding workshop:

- A basic system of links and integration
- Materials chosen according to local availability – red brick, sandstone, painted corrugated iron roof sheeting and wooden doors
- Ventilators and volumetric interpretations of facades.
- Placement of buildings to face the street or square.
- Autonomous buildings, proud and steadfast with a clear outline

### 4.2.2 Basic heritage evaluation adapted from Le Roux (1993,57)

*A: Architectonic or style importance*

*C: Contextual importance in relation to the street or as part of a group*

*D: Designer of importance*

*E: Economic and reuse potential*

*H: Historical importance due to association with a person, group or event or by age (Older than 50 years)*

*L: Landmark, visually or within community sentiment*

*P: Physical condition*

*T: Typological importance*



### Elements with historical importance Industrial heritage

- Ventilators
- Red face brick
- Jagged roof profile
- Clerestory windows
- Corrugated iron roof sheeting



1887

The Transvaal government purchased the printing plant and gave Jan Cilliers the order to establish a

## Government Printing Works.

1892

**Nationalized** and established as a state printing press by old president Paul Kruger

1875

President appointed the stamp commission

1877

British occupation – stamps displayed the **British queen's head**

1895

Department of **Public Works** were placed in charge and moved the Printing Works to a **new red-brick building on the corner of Vermeulen and Kock Street** (now Bosman)

1899 – 1902

During the **Anglo-Boer War** the **Printing Works** closed.

Government printing was made possible by establishing a **mobile plant** on a train that ran between Pretoria and Delagoa Bay.

Towards the end of the war the **Printing Works re-opened** with an entirely new staff, engaged by Lord Milner, the High Commissioner in Durban

1901

The bust of the President appeared on stamps.

Up to 1901 **only hand composition** and ordinary letterpress machine minding and bookbinding were in operation.

1926

The red-brick building got too small and the staff and equipment moved to a **new and commodious building** on an adjoining site valued at £350 000 and occupied more than 700000 square feet in 1955

1955

The quartermaster of the **South African Police** occupies the **red brick building**.

Greatly **modernized** by the installation of new machinery. Original value of equipment – £500 000  
350000 copies of the Transvaal telephone directory consumes more than **450 tons of paper**

## 4.3 RELATIONSHIP WITH OTHER EXISTING STRUCTURES

### LONG-TERM INFLUENCE OF THE TEMPORARY THEATRE

Activating under-utilized space  
 Reclaiming lost space  
 Learning through experimenting:  
 -facilitate temporality & recycling  
 -programming, construction & materials  
 Learning through repetition  
 Testing of theory

ARCHITECTURAL

Cultural education  
 Sparking interest in culture  
 Exposure to cultural activities  
 Promoting art & culture in the public realm

CULTURAL

Workshops & training  
 Skills transfer  
 Job creation  
 Income generation  
 Cyclical - lasting benefits

ECONOMICAL

People getting together to work & play  
 Promotes community identity  
 Community events during the festival  
 - common design language/character  
 - create a local brand  
 Establishing a community facility

SOCIAL

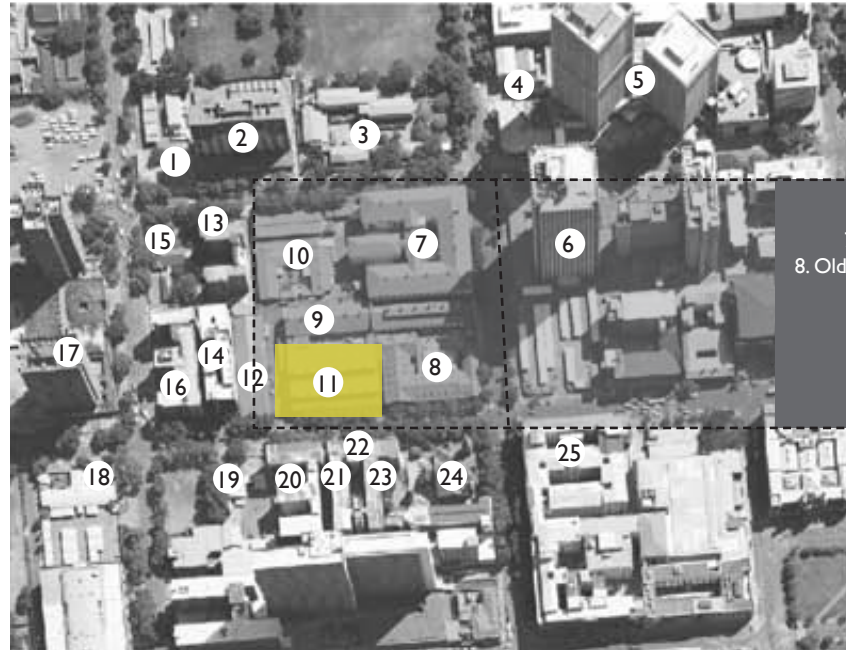

1. Engen Garage & sports bar
2. Batho Pele house
3. Eendraght Primary School
4. Primary School
5. Telkom Tower
6. Telkom Tower South

7. Press: workshops, offices & cafeteria
8. Old government publishing house & press
9. Paper recycling
10. Workshops, storage & offices
11. Lithography & binding
12. Parking

13. House Davidtz Old Age Home
14. City Forum - offices
15. Pennies Primary School
16. Vergesig - apartment block
17. Schubart Park
18. Nursery school
19. Van Zyl's Fitment Centre
20. Social housing
21. Social housing
22. Retail on street level
23. Social housing
24. Groote Kerk
25. Old Department of Public Works

Figure 48. Aerial photo graph showing the site in relation to other existing structures (Geography department, UP, 2010).





Figure 49. Other existing structures and facilities (Author, 2010).

### 4.3.1 Natural elements

The most prominent natural element on the site are the large Jacaranda trees lining Vermeulen Street parallel to the south facade of the building. There are six big trees at regular intervals towering up to the top of the roof and shading the building.

### 4.3.2 Street edge

The south facade is the only street edge of the building. The column, slab and infill composition are visible on this facade. Large steel frame windows are elevated from the street restricting any view into the building from outside. The incline of the sidewalk decreases towards the west. Although the edge of the building is completely closed off from the street, the trees provide a pleasantly shaded walkway along it. Pedestrians frequent this street judging by the palimpsest of posters and flyers against the edge of the building.



Figure 50. Views of the street edge and Jacaranda trees (Author, 2010).

### 4.3.3 Existing community facilities that could contribute to, or benefit from the re-use of the site as a temporary theatre

#### **Schools:**

**Festival:** community participation, fund-raising & showcasing talents  
**After:** upgrading facilities + new venue = fund-raising, recitals, exhibitions, skills training, workshops, functions & performances

#### **Groote kerk (church):**

**Festival:** Music & Choir performances, guest speakers fund-raising, youth involvement  
**After:** Youth facility, Venue for Christmas play in collaboration with Huis Davidtz

#### **Residential component:**

**Festival:** community building, workshops & on-the-job skills training needed for festival  
**After:** community venue, continued workshops & training, job creation - residents become the staff/workforce

#### **Huis Davidtz Old Age Home:**

**Festival:** Tea garden, venue, craft workshops & market  
Creating awareness  
**After:** continued workshops, training, new venue for events, community involvement  
job creation - admin & maintenance

## 4.4 HOST BUILDING -ANALYSIS & APPROACH

### 4.4.1 Temporary use of found space

While this study was conducted (2010) the Government Printing Works in central Pretoria occupied the largest part of the block between Proes, Vermeulen, Shubart, and Bosman Street. At the time the relocation of this state facility, to the corner of Proes and Paul Kruger Street, two blocks to the east, was already underway and intended for completion by 2013 Reynhard.

Since 1970 a series of productions by Peter Brook experimented with performing in a variety of found spaces. In the context of this study 'found space' refers to existing spaces that had not been designed for theatrical performances but can, nevertheless, be converted into theatres with surprising success. Usually these performances also have the support of a community, relieved that a use has been found for an empty or precious old building. Little, or nothing, would otherwise be done to these spaces (Mackintosh, 1993, 83).

#### Examples

- Roundhouse – A circular 19th century steam engine shed in London
- Joseph Papp public theatre – Library in New York
- Schechner's performing arts garage – Garage in New York
- Mnouchkine's Cartoucherie de Vincenne – an old ammunition factory outside Paris (Mackintosh, 1993, 86)

Traditionally theatre stages are neutral, black boxes suspended in space. Designed specifically to host different productions, the black box theatre relies on function and performance rather than on spatial experience. This type of theatre is referred to as a 'black box' because it is typically a dark rectangular volume with no reference to the external environment. Although the size and the technical capability of a black box theatre impose some constraints on the director and designers, in effect they work on a blank canvas.

In 1989 Ariane Mnouchkine made the case for 'found space'. The development of this concept emphasised the fact that existing buildings and spaces have existing character, experiential qualities and dramatic potential. The found space (permanent) functions as a sacrificial backdrop to the performance (temporary) and becomes a theatre building in its own right. In turn the design and experience of the performance are directed and influenced by the existing space. This means that existing spaces other than traditional theatres has the potential to become a theatre.

*"Theatre is the place where fiction and reality come together to promote each other. Real and unreal exist in tension; two opposites manifested at the same time and never fully one or the other. The potentials of space for performance are necessarily spaces where the reality and illusion are both a simulation of the material world but also real"* (Oddey & White, 2006: 15)

Found space is the opposite of the black box theatre, the famous multi-purpose technical box which in fact bristles with limitations (Mackintosh, 1993, 86)

The architecture of theatre space has both a physical and metaphysical function.

Years ago directors were saying: "Give us a neutral space and we'll handle the rest. I'm not sure if they would still say the same thing today. I say an empty space but an inspiring empty space that can be filled with images." Existing space will also have its own ghosts from the past; memories, associations and meaning. (Mackintosh, 1993, 86)

According to Mackintosh (1993, 86) this unconventional preference for space that is not purpose-made might seem incomprehensible to architects. Actors, designers and directors however have the opportunity to comprehend immediately the practical and poetic dimension of an existing space; becoming aware of its character and dramatic potential.

A performance in a found space clearly advertises that the theatre played here is going to be a different experience from theatre played in a traditional theatre building. The audience will have a heightened sense of expectation and as a result take greater notice of the architectural quality of the space.

*"The audience gets a buzz from the feeling that the players have come to town and taken over this particular structure."* (Mackintosh, 1993, 86)

Figure 51. Interior view of the host building (Author, 2010).





*“For us La Cartoucherie is almost the ideal place. Of course the ceiling is rather low and the truss rods sometimes get in our way, but it is a house, a theatre, a large gracefully shaped umbrella made out of solid material that can be sculpted, painted, arranged and veneered.”*  
Ariane Mnouchkine (Cited in Mackintosh, 1993, p.86)

## 4.4.2 Reasons for choosing this site

- It falls within the Pretoria PlugIn Festival boundaries
- The site is within walking distance of Church Square
- Currently, The Government Printing Works is in the process of being relocated and is expected to remain empty for three to five years
- There is active pedestrian traffic along Vermeulen Street as suggested by the palimpsest of posters and flyers against the southern facade
- Vermeulen is a pleasant tree-lined street that can be incorporated into the design
- Natural southern light from clerestory windows can be employed
- The site is accessible for pedestrians and vehicles
- The existing hoist, and a large opening, allow for equipment and scenery to be lifted into the space.
- The industrial-capacity concrete floor slab and beams can carry an audience as confirmed by engineer
- The building contains a large double-volume space with minimal obstructions
- This building is part of a larger building complex that can contribute to, and benefit from, this intervention.

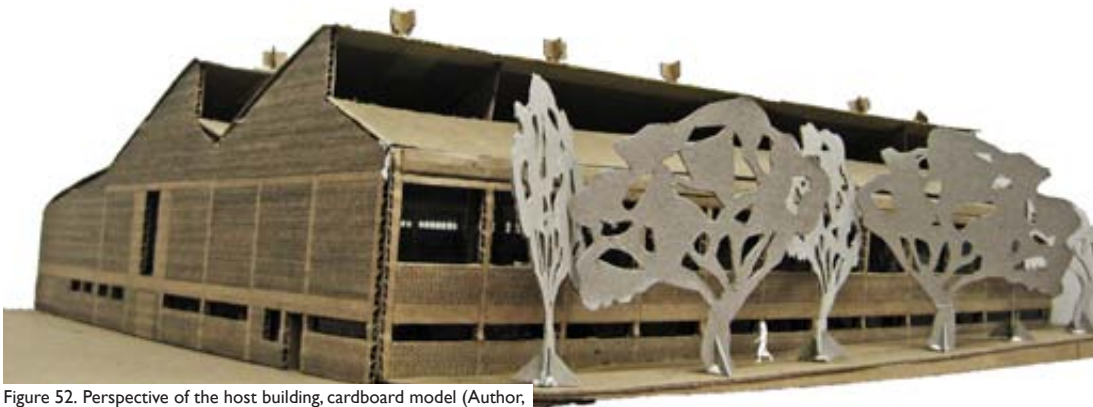

Figure 52. Perspective of the host building, cardboard model (Author, 2010).



Figure 53. Exterior views of the host-building (Author, 2010).



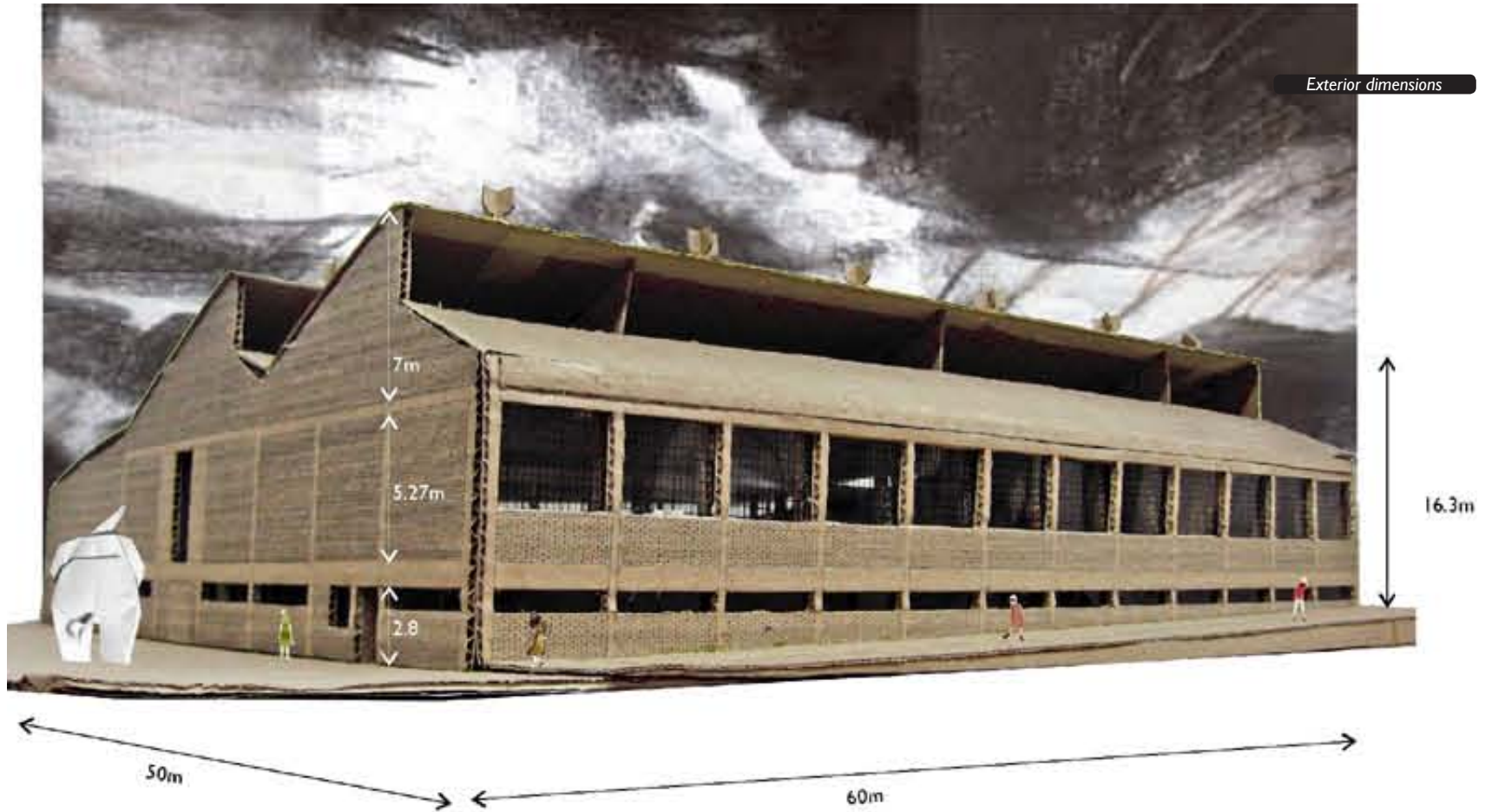

Figure 54. Cardboard model of the host building showing exterior dimensions (Author, 2010).



## 4.5 STRUCTURE

*“Interior architecture is the spatial manipulation of an existing building whilst engaging with its structural DNA, history, context, orientation and proposed program.”  
(Gigli, 2007, 34)*

The structure of the existing building is composed of a concrete column and beam-system with a 340mm thick concrete floor-slab and brickwork infill. The roof is supported by 40x40x5mm angle iron trusses bolted together and spaced at 4945mm centres. The trusses are supported by the 345x460mm columns also spaced at 4945mm.

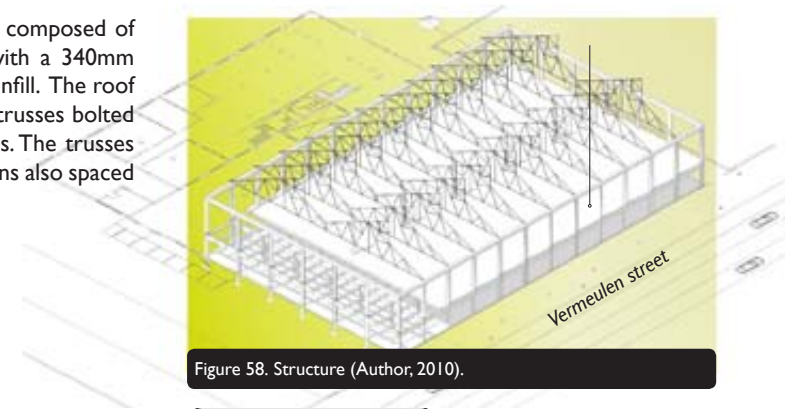
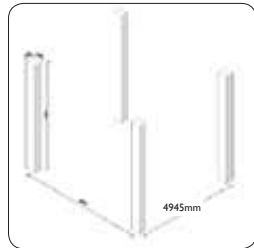
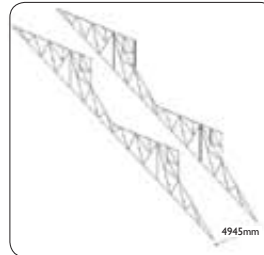

Figure 58. Structure (Author, 2010).



Interior dimensions

$l=59310\text{mm}$   
 $w=35880\text{mm}$   
 $h=6120\text{mm}$



Interior dimensions

$l=59310\text{mm}$      $l=59310\text{mm}$   
 $w=14260\text{mm}$      $w=35880\text{mm}$   
 $h=5270\text{mm}$      $h=6120\text{mm}$

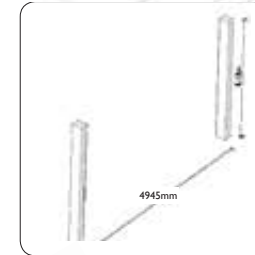

Figure 59. Column & truss spacing (Author, 2010).



Figure 55. Perspective of the ground floor (Author, 2010).



Figure 56. Perspective of the first floor with trusses (Author, 2010).

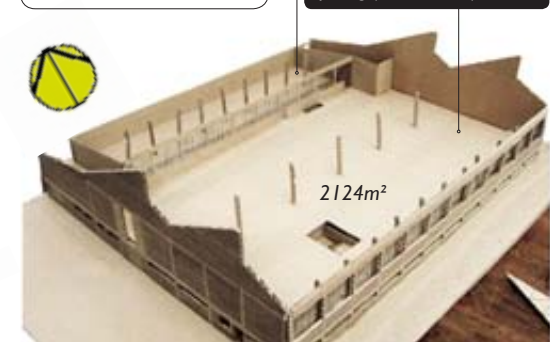

Figure 57. Perspective of the first floor without trusses (Author, 2010).

# 4.6 ACCESS, VERTICAL CIRCULATION & ABLUTION FACILITIES

## Ground floor-lithography workshop

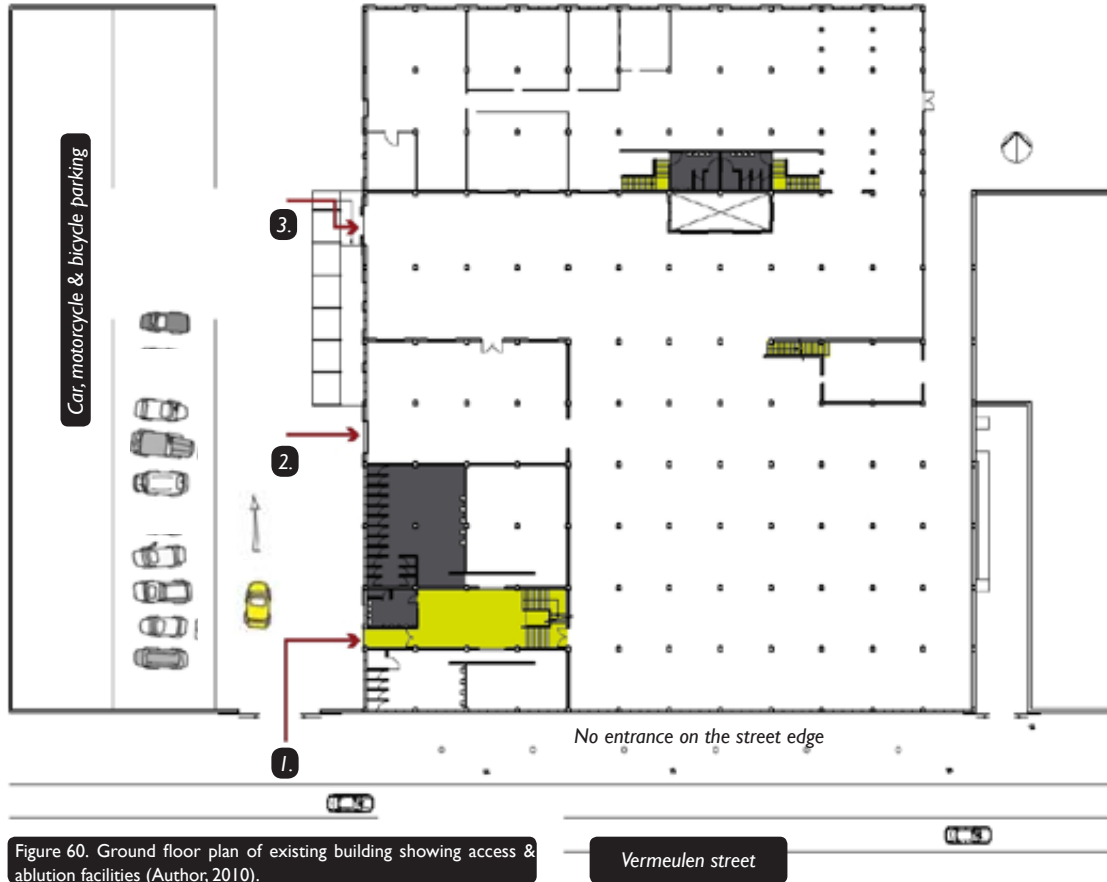

Figure 60. Ground floor plan of existing building showing access & ablution facilities (Author, 2010).

Existing vertical circulation

Existing ablution facilities

Main existing entrances & exits



Figure 61. View of the entrance (Author, 2010).



Figure 62. View of service access in the western facade (Author, 2010).



Figure 63. View of the female ablution facilities; 9 wc's, 6 showers & 5 basins (Author, 2010).

## First floor-binding workshop

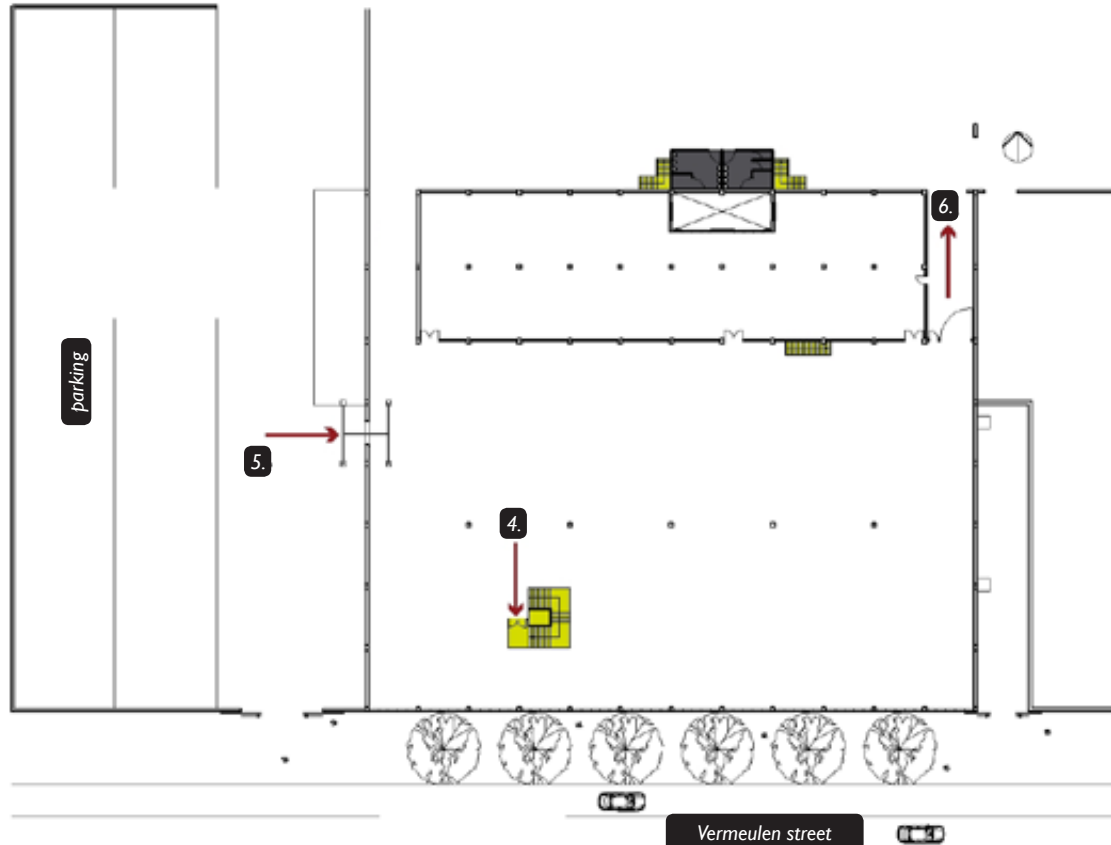

Figure 69. Ground floor plan of existing building showing access & ablution facilities (Author, 2010).

Existing vertical circulation

Existing ablution facilities



Figure 64. View of the staircase leading to the first floor (Author, 2010).



Figure 65. Exterior view of the door going up to the first floor (Author, 2010).

Figure 66. View of the access hoist going up to the first floor (Author, 2010).

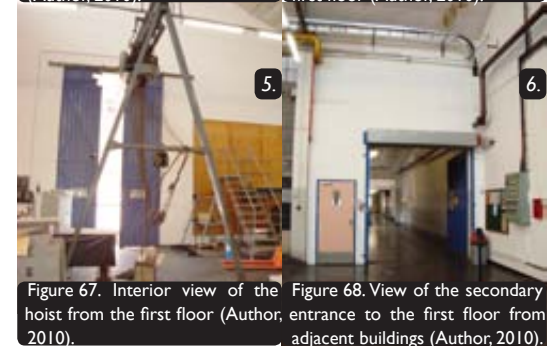

Figure 67. Interior view of the hoist from the first floor (Author, 2010).

Figure 68. View of the secondary hoist from the first floor (Author, 2010).

→ Main existing entrances & exits

## 4.7 FOCUS AREA

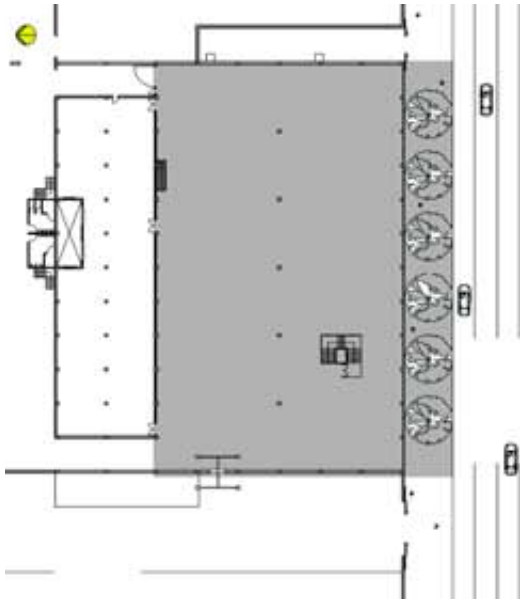

Figure 70. First floor plan indicating the focus area of the study (Author,2010).



Figure 71. View of the south facade indicating the focus area of the study (Author,2010).

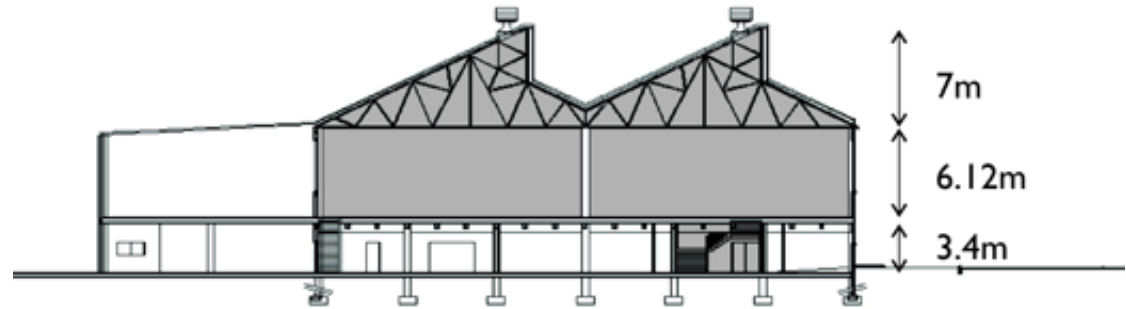

Figure 72. Typical section indicating the focus area of the study (Author,2010).

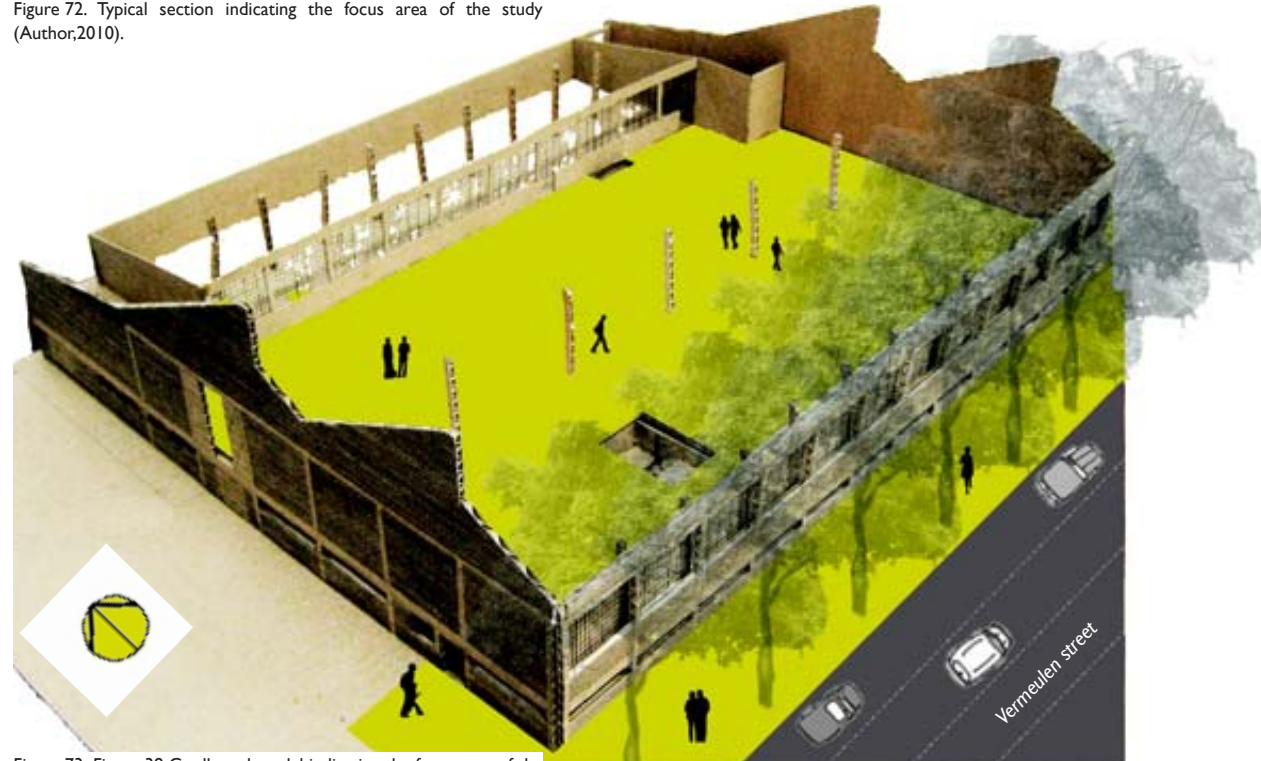

Figure 73. Figure 38 Cardboard model indicating the focus area of the study (Author,2010).





*Factories often make great theatres because they have been built to house creations, productions, works, inventions and explosions.”*

*Ariane Mnouchkine (Cited in Mackintosh,*

*1993, 86)*

Figure 74. Interior view of cardboard model showing natural light effect (Author,2010).



Figure 75. Interior view A (Author,2010).



Figure 76. Steel frame windows in South Facade (Author,2010).

1.

## VIEW A



Figure 77. Wall thickness seen through the opening for hoist (Author,2010).

2.

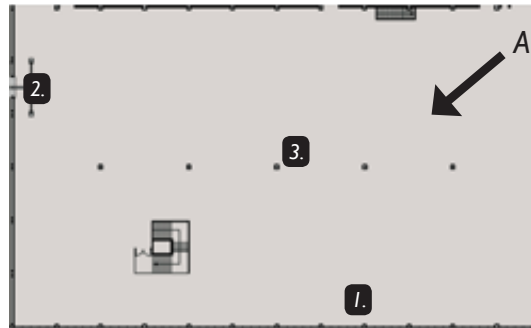

Figure 78. Plan showing view A, 1-3 (Author,2010).



Figure 79. Steel truss supported by column. Note the water pipe, electrical cables and sprinkler system supported by the truss structure (Author,2010).

3.





Figure 80. Interior view B (Author,2010).



## VIEW B

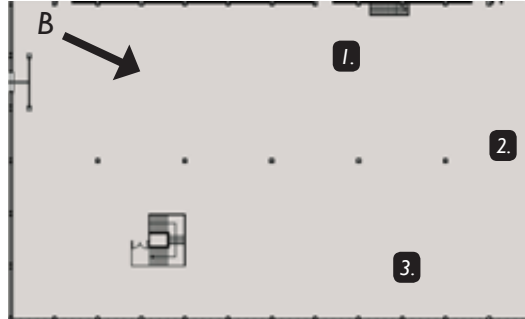

Figure 83. Plan showing view B, 1-3 (Author,2010).



Figure 84. Existing electrical fans (Author,2010).





Figure 85. Interior view C (Author, 2010).





Figure 86. Existing ventilation system (Author, 2010).

## VIEW C



Figure 87. Hoist and opening through western facade (Author, 2010).

1.



2.



3.

Figure 88. Plan showing view C, 1-3 (Author, 2010).

Figure 89. Existing sink, provided with hot and cold running water (Author, 2010).

## SYNOPSIS

*Set in the late nineteenth century, Knysna Forest is home to wild elephants and the fiercely independent families of woodcutters, who have coexisted warily but, for the most part peacefully, for generations. Now their future, and the destiny of the forest itself, is threatened by the exploitative greed of the timber merchants and ivory hunters, and the rumours of gold in the far reaches of the Forest's rivers.*

*Saul Barnard, son of woodcutter Joram Barnard, stands on the deck of the ship called the 'Pictor'. There is urgency in him. Once they have set sail he would be free of everything he had once cared for; the forest, Kate, Old Foot. Behind him, 29 years would die. While still in the harbour the wrinkled Outiniqua – Maska-brought him the news that his brother's son had been gored by an elephant – Old Foot- and that Fred Terblans was going to shoot him. A special relationship existed between Saul and Old foot. He felt that he owed it to Old Foot to save him – the king of elephants – from the humiliation of falling to Terblanche's gun. If someone had to do it, it would have to be him. So with four days left before the ship would sail, Saul left the ship, borrowed a gun from Maska and headed back into the forest to look for his animal brother.*

*As Saul walked into the forest, it felt as if he was walking backwards into himself. He relives his past. He again remembers being fourteen; butchering the Gallhead, the cutting of the Kalandar, his experiences with Old Foot, Kate, the woodcutters and the wood buyer, Mac Donald, the discovery of Millwood and his years as a gold-digger. At the end, he has to face his fears, the forest, Kate, Old Foot... and come to terms with his past.*



## 05.TEXT ANALYSIS OF '*CIRCLES IN A FOREST*'

## 5.1 UNIVERSAL STORY

‘Circles in a forest’ were chosen as text for this study as it is both a **South African** and a universal story. In South Africa it is generally wellknown and prescribed for high school language subjects. It presents a segment from the country’s industrial development and gives insight into the **history** of South Africa.

It tackles the ever relevant issue of man’s careless and **greed**-driven **destruction** of natural resources without considering future generations. Jooste, (1986, 3) describes ‘Circles in a Forest’ as a **timeless** story, so **human** that anyone can relate to it. It is a story about Man’s search for worth and **dignity**. It tells about the division between classes and the struggle towards social and economic justice and **equality**. ‘Circles in a Forest’ is also a story of **hope** and the **triumph** of an individual in the face of adversity.

‘Kringe in ‘n Bos’ has been **translated** into English, Portuguese, Dutch, French, Icelandic, Spanish, Hebrew, German, Swedish, Italian, Finnish and Norwegian. It is also available in Braille and on cassette for the visually impaired. Philo Pieterse Productions produced ‘Circles in a Forest’ as a feature film and the stage adaptation of ‘Kringe in ‘n Bos’ was done by Peet van Rensburg.

### 5.1.1 Relevant Issues

- Relationship between Man and his environment
- Natural resource dependency, exploitation, destruction & protection
- Discrimination, class struggle for social & economic equality
- Eco-fable relevant to architecture

## 5.2 THE MAIN THEME

### 5.2.1 The obliteration of nature

The destruction of the **Knysna Forest** and its **elephants** is one of the main themes of ‘Circles in a Forest’. Tracing history it is true that the demand for **wood** during the discovery of **gold** and **diamonds** in the 19th century contributed to the **demise** of parts of the Knysna Forest.

*“Where Harrison or his men stopped them today, they felled tomorrow because the Government were putting pressure from the west for more and more wood for railway lines, wood for jetties, wood for harbours, wood for the mines, wood for making wagons that had to take man and his possessions north! Wood for tables, wood for chairs and cupboards and beds! Wood! Wood! Wood!”* ( Matthee, 1984, 109).

To the woodcutters, the forest was **home**. They believed it belonged to them and that they could **fell trees** and **shoot elephants** as they wished. Any attempt at nature **conservation** was met with severe **resistance**.

*“Everybody was shooting, everybody was felling. Harrison’s control was not strict enough; where he warned them off today, they cut open the roof of the forest that should have protected the seedlings tomorrow. Or they shot the cows that should have calved in the spring. Harrison says, the way they’re felling now, there will be little more than fifty years left for the forest...How long for the elephants.”* (Matthee, 1984, 109).

## 5.3 OTHER THEMES

### 5.3.1 Liberation & boundaries

*“At the age of 29 Saul Barnard had just one overwhelming need – to be free!  
He wanted to be free of everything he had once cared for: the forest, the people of the forest, the things of the forest, Kate, Old Foot”* (Matthee, 1984, 13).

### 5.3.2 The truth versus the lie

*“To believe a lie is to betray yourself.To walk past the truth because the path of the untruth is well trodden is just the same. Let him then be guilty of everything, but not that!”* (Matthee, 1984, 63).

### 5.3.3 The bond between human and nature (animal)

*“...every time something happens, I find him somewhere in my way.The first time was when my mother died. In between, every time I’ve been in trouble.”*

*“Then it is so”, he whispered in awe.  
“Old Foot is watching you...”*

*“You are the brother of the noblest Bigfoot that ever walked this Forest”* (Matthee, 1984, 242).

### 5.3.4 Circles ( circle of life)

Life is a **crooked circle**: *“the woodcutter killed the forest; the wood-buyer killed the woodcutter. Round and round you walked the crooked circle year in year out.The wood-buyer got richer and richer while the hands that held the axes had*

## 5.4 MILIEU (ENVIRONMENT)

### 5.4.1 The forest

#### Muffled, subdued, still, peaceful, dark

The forest is a **unifying** element that has a life-presence and becomes an **antagonist** in the story. The experience of the forest makes a strong onslaught on the **senses** and its **impenetrable** terrain is often made worse by natural elements such as **rain** and **mist**. Jooste, (1986, 3) describes the forest as having a unique, **secretive and mystic beauty**.

*“Maska, you used to tell us that the spirits live in the trees”* (1986, 240)

At the beginning of the 1800's the Knysna Forest was tremendous and **dense**. The Great Lourie, the Blue buck and the Kalander (Outeniqua yellowwood tree) are icons of the forest.

*“...lay like a thick black wall around big island”* (Matthee, 1984, 27)

*“He would hide in the forest so that nobody would ever find him. Surely God could not have seen down into the forest from up in the sky, even the sun has to struggle to shine to the ground. Only specks of sunlight got through that roof of the tree tops”* (Matthee, 1984, 47)

#### The forest was home to the woodcutters and their families

*“By the time it was dark they were back in the forest. It was like a thick blanket closing around your body, warming you*

*no defence and neither had the forest”* (Matthee, 1984, 108-109).

*“Elephants have this primeval self-defence tactic to find out whether someone was following him or not. They walked in circles “round and round and round. At some time the elephant must catch up from behind”* (Matthee, 1984, 183)

*“Saul walks a circle back into his past. “Saul Barnard walks into the forest and it feels like walking backwards into himself”* (Matthee, 1984, 1)

### 5.3.5 Superstitions & myths

Uttering the word ‘elephant’ was forbidden. *“You never say their name in the forest! They will hear you and think you are calling them. You called them ‘bigfeet’ or ‘thicklegs’ or Old people but never by their name”* (Matthee, 1984, 20)

*“...the grown-ups taught you another thing about the blue buck: they were different from all the other buck in the forest because their gall was in their heads”* (Matthee, 1984, 20)

This belief left Saul feeling uneasy. He looked for the gall in its head but found it in its usual place. *“Either the grown-ups had deliberately lied to him or they believed the lie themselves”* (Matthee, 1984, 40)

*against the cold,”* (Matthee, 1984, 61)

*“They came to know the shrubs of the underbrush: which were medicine and which were not; which berries you could eat and which not.”* (Matthee, 1984, 18)

#### The gold diggers were afraid of the forest

Patterson: *“I’m suffocating! This place is too close round me”* (Matthee, 1984, 147)

*“It’s this forest that’s got us confused. It’s killing us. It’s different for you...you don’t hate the forest as we do.”* (Matthee, 1984, 233)

*“There were times when he really felt sorry for Patteson. It was the first time in his life that he had come across a man who feared the Forest like death itself”* (Matthee, 1984, 149)

### 5.4.2 The woodcutters’ houses

*“In some places there were natural openings in the forest like Big Island and there you could find 3-4 families living in makeshift homes of wood and corrugated iron sheets... The grey timber walls are parched like deadwood, the roof sagging to the one side”* (Matthee, 1984, 63)

*“Woodcutters never made wonderful houses; when the forest became thinned out around them, they just moved to another clearing in the forest. Their houses like most had only two rooms. Old Anro had made himself a lean-to against the outside wall”* (Matthee, 1984, 26). While cutting they lived in an almost **nomadic** fashion – moving from tree to tree. They built a shelter and a workplace



where they were cutting. Here they stayed until the wood was ready to be taken to town.

### 5.4.3 Cripple Bush

*“...where diggers’ axes had hacked out everything to make space for the tents and houses, and to provide firewood.”* (Matthee, 1984, 109)

### 5.4.4 Old Foot

*“The great terror that walked the forest: the elephant”* (Matthee, 1984, 20)

*“Where the huge thick tusks bulged from their sockets at the side of his head, they were smooth like butter and yellow. The lower part right down to the rounded tip was stained greenish black at least a hundred pounds of ivory on each side of his head. Under the eye a wet patch stained the rough wrinkled skin dark.”* (Matthee, 1984, 29&30)

*“Something indescribably majestic about him...”* (Matthee, 1984, 30)

### 5.4.5 Kalander

*“...enormous”*

*“Standing with his feet almost in the water of the Homtini... The most beautiful... Towering above all other trees. Giant roots anchored it to the ground like giant arms. Grey bark hung like dry strips of skin”*

*“The old man’s beard, moss in its branches hung like thin green hair, waving eerily in the wind.”* (Matthee, 1984, 74)

### 5.4.6 Going to the village

Saul was 14 years old when he first saw Knysna village.

*“And nobody ever told him that the village was not in the forest.”* (Matthee, 1984, 53)

*“They came out of the forest on the eastern side of the town. One moment the forest was still around and above them, the next moment it started thinning out, getting lighter...more sun and then suddenly the world was lying open. Naked. Like someone without a hat. Without a roof. He wanted to turn round and run back to the shady shelter of the forest. The sun was hurting his eyes.”* (Matthee, 1984, 54)

### 5.4.7 Knysna Town

*“He stayed behind the wagon when they came to the first houses. Far apart to start with. Then closer together. Square and white, their roofs neatly made of thatch; on top of some houses, another house, with windows and all, was built. The gardens were lush and came right up to the street; there were flowers growing in them that he did not know existed. And the fear that was in him was not the same fear as for bigfeet, it was different, he was surrounded by it, he was in it.”* (Matthee, 1984, 55)

### 5.4.8 Mac Donald’s wood yard and shed

*“...enormous. Wood was stacked up everywhere, wood wherever you looked! Mountains of wood. Next to a large shed men were loading some of the wood on other wagons...”* (Matthee, 1984, 56)

### 5.4.9 The Pictor

*“450 ton, three masted barque, sails furled, was lying on the starboard side of the wooden jetty”* (Matthee, 1984, 11)



## 5.5 CHARACTERS

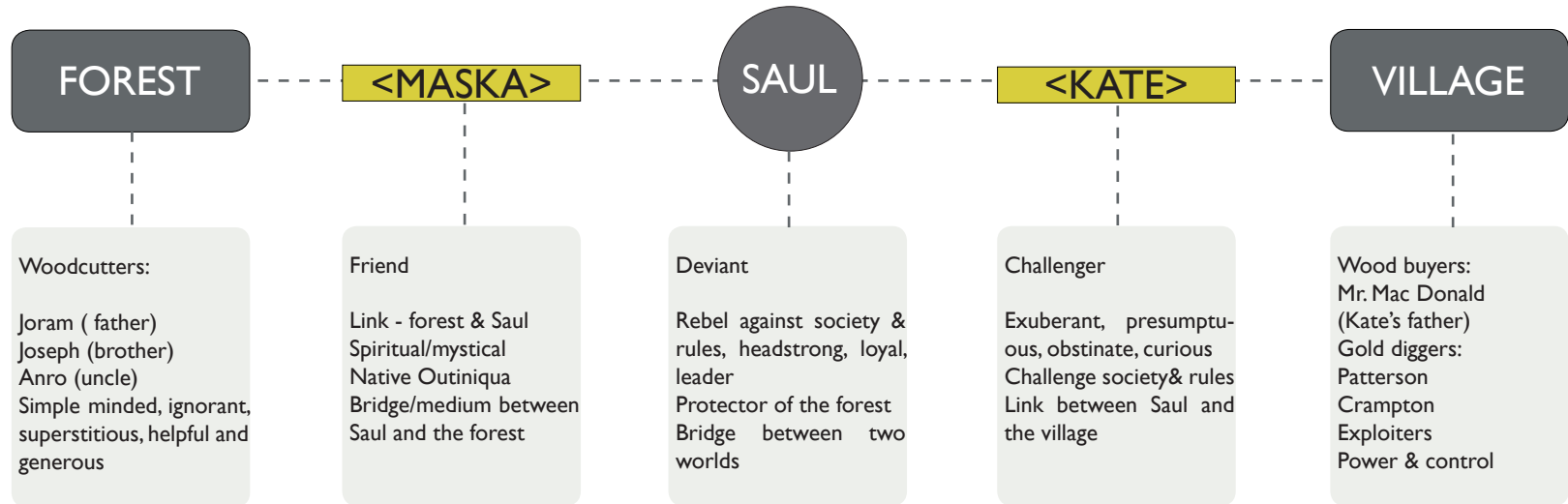

## 5.6 NARRATION & STORY TELLING

The story is told by a narrator in the third person but through the eyes of Saul. This allows the audience to associate and sympathize with Saul. The non-chronological order of the events and the story-line that weaves between the past and the present gives the audience the opportunity to discover the story.

“Wherever there are people, the world over, there are tales...” (Savory, 1982, 171)

The stories of a 'People' is very much part of its life. Fables are told for the purpose of enforcing, or supporting, some point of family discipline, tribal custom or life-lesson. These rely on make-belief and elements of fantasy for their popularity – called magic realism (Gordon, 1995, 9). They uphold conduct that benefits society, individual character and the welfare of the community. They gain a great deal of their power from their skilful exploitation of language (Savory, 1982, 9).

This powerful tradition of the spoken word is called the oral tradition, and Africa is world famous for its rich storehouse of literature composed and handed down in this way (Gordon, 1995, 5).

## 5.7 STORYLINE\_NOT CHRONOLOGICAL\_BETWEEN PAST & PRESENT, FOREST & VILLAGE

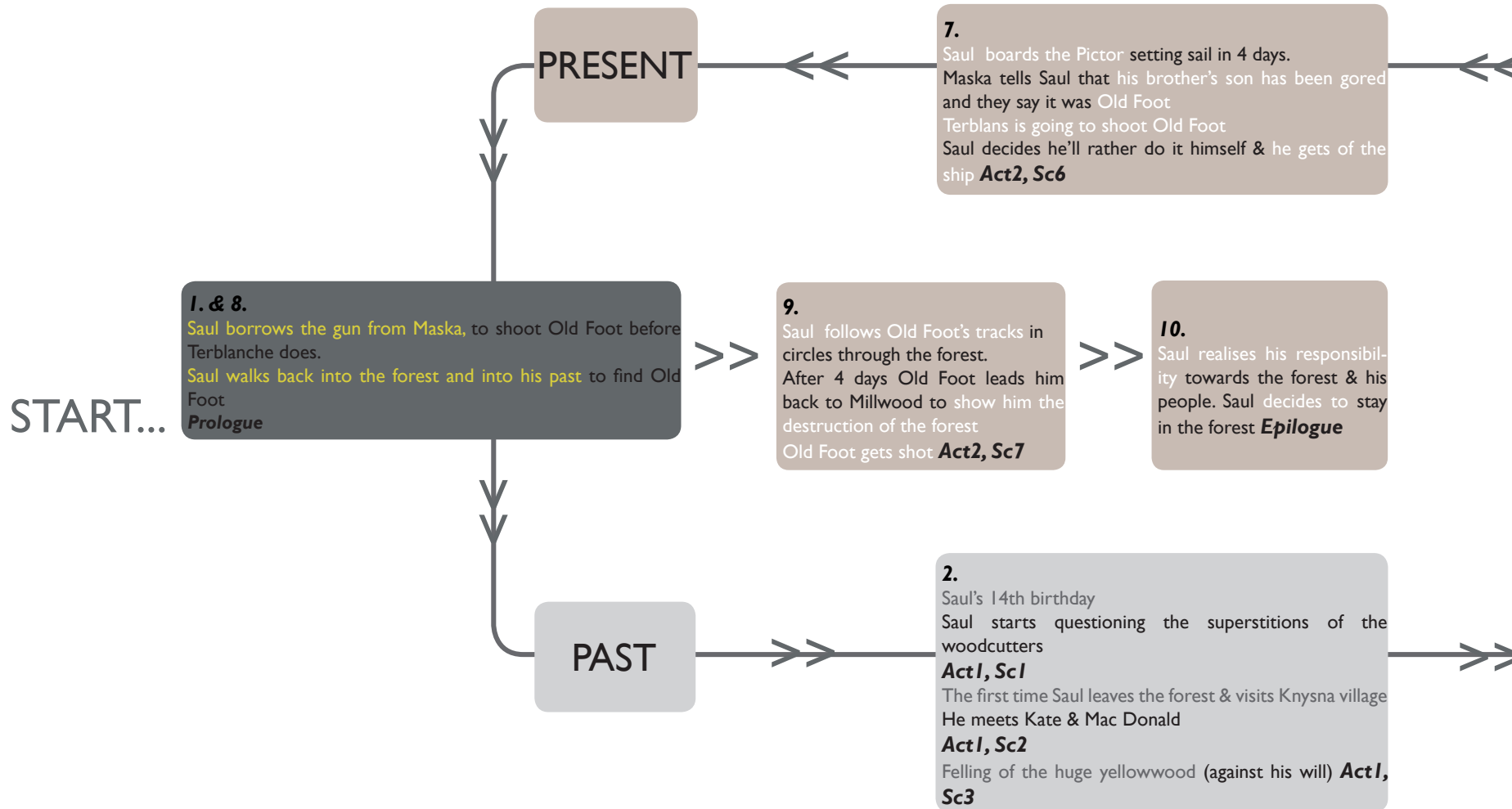

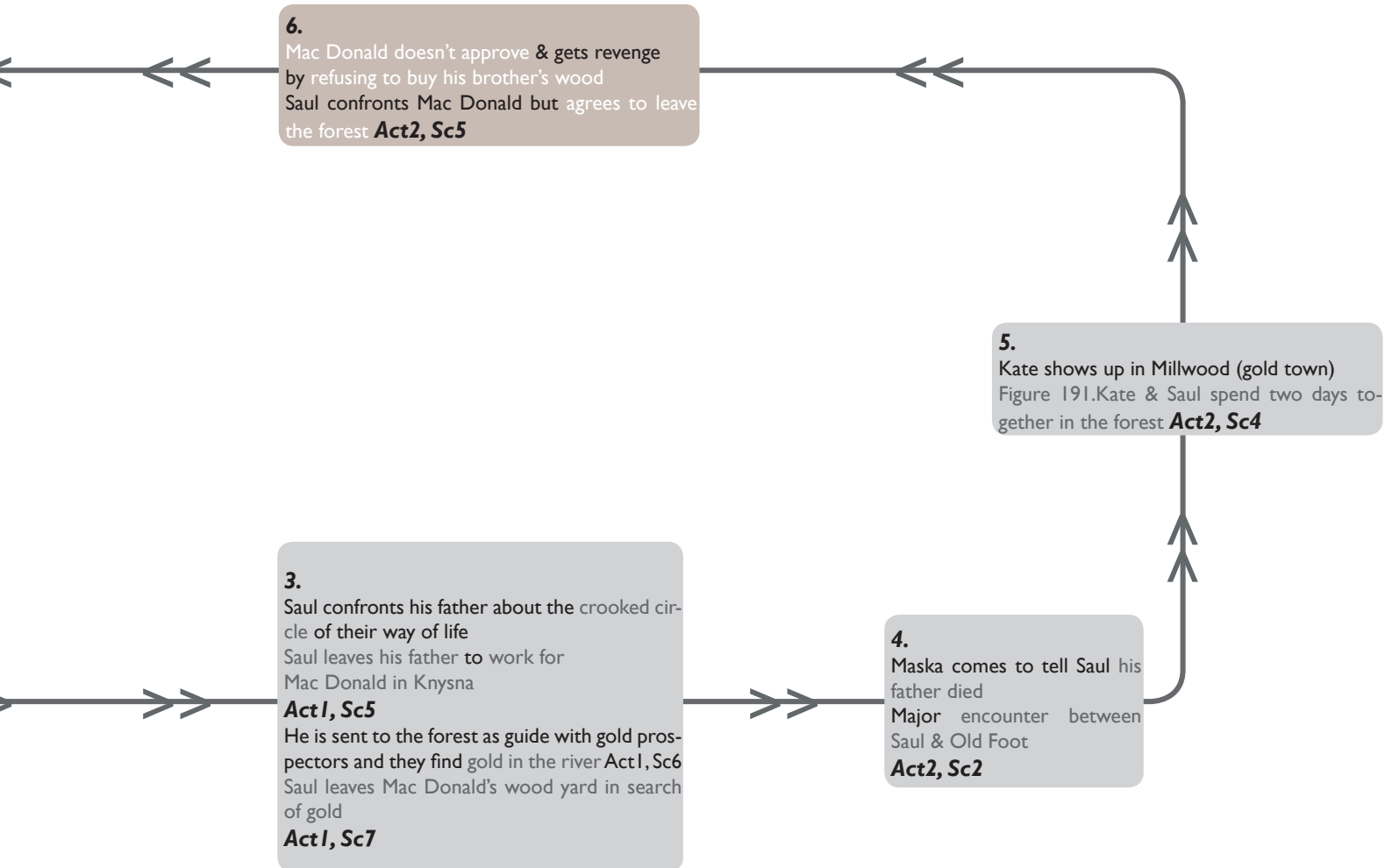

## 5.8 STORYBOARD

### 5.7.1 PROLOGUE

#### Key events

Saul borrows the gun from Maska, to shoot Old Foot before Terblanche does Saul walks back into the forest and into his past to find Old Foot

#### Setting

Maska's scanty wooden house in a clearing in the forest  
 Maska is sitting by a small fire on one side of the stage  
 Saul walks up to him

#### Mood

Mystic and spiritual, then panic and urgency,

#### Lighting

Cool, soft and dappled with fine bright rays of violet & white light  
 Gets more dappled & darker as Saul walks deeper into the forest  
 Spotlight on Saul

#### Sound Effects

Birds and other forest sounds  
 Footsteps - walking on stones  
 Sound gets softer as Saul walks deeper into the forest  
 Smoke effect at Maska's house

Figure 90. Maska's house (Author,2010).



Figure 91. Saul walking into the forest (Author,2010).





## 5.7.2 ACT I SCENE 1

### **Key events**

Saul's 14th birthday.

Saul starts questioning the superstitions of the woodcutters

### **Setting**

Cutting shelter.

Joram & Anro on stage. Saul comes in with food in his hands.

### **Mood**

Celebratory , playful, confusion defiance, unease

### **Lighting**

Warm, dappled, scattered white, sharp rays

### **Sound & Effects**

Bird sounds, fire, chopping of tree

## 5.7.3 ACT I SCENE 2

### **Key events**

The first time Saul leaves the forest to go to Knysna

### **Setting**

Traveling through the forest with the wagon

### **Mood**

Curiosity, excitement

### **Lighting**

Gets whiter & brighter as they walk out of the forest

### **Sound & Effects**

Forest sounds fade as they go further out of the forest

Figure 92. Saul & Joram talking about the Gallhead (Author,2010).



Figure 93. Going to the village (Author,2010).

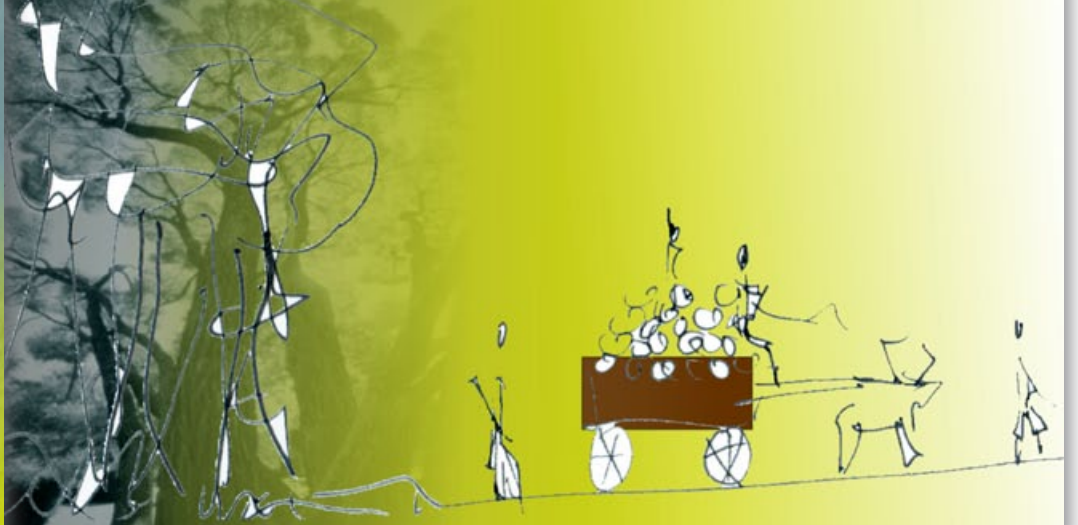

## 5.7.3 ACT I SCENE 2

### Key events

Saul meets Kate & Mac Donald for the first time

### Setting

Knysna town

Mac Donald's wood yard & shed

### Mood

Exploitation, intimidation & fear

### Lighting

Harsh, bright, white & blue

### Sound & Effects

Foghorn, distant waves, yard sounds, school bell & children.

### Lighting

Light: softer, violet spot on Saul & Kate.

Figure 94. Mac Donald's wood yard & shed (Author,2010).

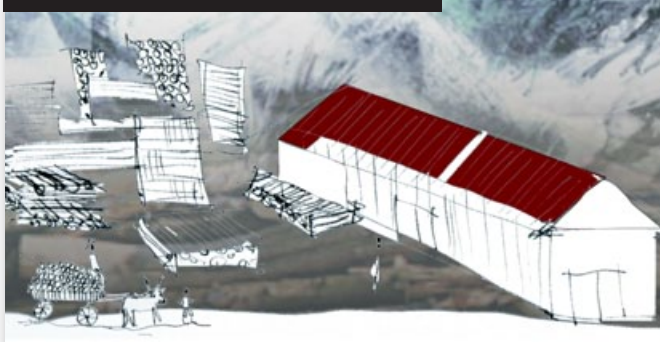

Figure 95. Saul & Kate meet at the wood yard (Author,2010).





Figure 96. Knysna Village (Author,2010).





Figure 97. Felling of the Kalandar tree (Author,2010).

## 5.7.4 ACT I SCENE 3

### **Key events**

Felling of the huge yellowwood against Saul's will  
 Saul raises his concern – that the tree feels  
 Joram forces Saul to help cut down the tree  
 The tree falls.  
 They see signs of Old Foot's presence

### **Setting**

Forest, walking through the under bush, big Kalandar tree, cutting shelter  
 Night & daybreak

### **Mood**

Anticipation, amazement, frustration, helplessness, anger & despair

### **Lighting**

Warm amber & green, scattered white rays, dappled effect  
 Fades and gets bluer and darker to show the day passing and turning into night  
 Spot on tree

### **Sound Effects**

Forest sounds, footsteps walking on forest floor, chopping of the tree, tree crashing to the ground.

## 5.7.5 ACT I SCENE 5

### **Key events**

Saul confronts his father about the crooked circle of their way of life and the destruction of the forest  
Saul leaves his father to work for Mac Donald in Knysna  
Anro walks into Old Foot

### **Setting**

Another cutting shelter

### **Mood**

Conflict, tension & anger

### **Lighting**

Dim, somber blue, grey and green with scattered white rays creating a dappled effect

### **Sound Effects**

The far off sound of trees being felled and falling to the ground

### **Lighting**

Harsh, bright, white & blue

### **Sound & Effects**

Foghorn, distant waves & yard sounds

Figure 98. Saul leaving his father (Author,2010).



Figure 99. Saul at the wood yard to work for Mac Donald (Author,2010).





## 5.7.6 ACT 1 SCENE 6

### Key events

Saul is sent to the forest as a guide for gold prospectors. They find gold in the river

### Setting

Knysna town, Mac Donald 's wood yard and a stream in the forest

### Mood

Curiosity & suspense

### Lighting

Village - harsh, bright, blue & white

Forest - dappled blue, amber and white

### Sound Effects

Village - Foghorn, waves, yard sounds

Forest - Birds & other forest sounds

Flowing water



Figure 100. Saul panning gold with the prospectors (Author,2010).

## 5.7.7 ACT 1 SCENE 7

### Key events

Saul leaves Mac Donald's wood yard in search of gold

### Setting

Knysna town, Mac Donald 's wood yard and a stream in the forest

### Mood

Defiance, adventure, and excitement

### Lighting

Village - harsh, bright, blue & white

Forest - dappled blue, amber and white

### Sound Effects

Village - Foghorn, waves, yard sounds

Forest - Birds & other forest sounds

Flowing water



Figure 101. Saul panning independently (Author,2010).

## 5.7.8 ACT 2 SCENE 2

### Key events

Maska comes to tell Saul his father has died

Saul comes across Oldfoot in the forest

### Setting

A stream in the forest

### Mood

Sorrowfull & solemn, owe & wonder

### Lighting

Village - harsh, bright, blue & white

Forest - dappled blue ,amber and white

Gradually becomes darker & down lighting create somber shadows

Broad ray of light on Oldfoot

### Sound & Effects

Forest - Birds & other forest sounds.

Flowing water



Figure 102. Maska telling Saul his father died (Author,2010).



Figure 103. Saul runs into Old Foot (Author,2010).

### 5.7.9 ACT 2 SCENE 3

#### **Key events**

Saul and Kate walks into each other in Millwood (gold town), She confronts him about being swept up in the gold rush and so contributing to the destruction of the forest

#### **Setting**

Millwood (gold town)

#### **Mood**

Unease, confrontation & frustration

#### **Lighting**

Village - harsh, bright, white & blue

Forest - dappled green, amber and white rays

#### **Sound Effects**

none



Figure 104. Kate shows up in Millwood (gold town) (Author,2010).

## 5.7.10 ACT 2 SCENE 4

**Key events**

Kate asks Saul to show her the forest as he sees it. They spend two days in the forest

**Setting**

Forest

**Mood**

Surreal & dreamlike

**Lighting**

Soft, dappled violet, amber & green – spot on Saul & Kate

**Sound Effects**

Birds & other forest sounds



Figure 105. Saul runs into Old Foot (Author,2010).

## 5.7.11 ACT 2 SCENE 5

**Key events**

Mac Donald doesn't approve of their friendship. He gets revenge by refusing to buy Joseph's, Saul's brother's, wood. Saul confronts Mac Donald but eventually he agrees to leave the forest

**Setting**

Mac Donald's wood yard

**Mood**

Tension, confrontation & anger

**Lighting**

harsh & bright, white & blue, red spot on Mac Donald

**Sound & Effects**

Foghorn, distant waves & yard sounds



Figure 106. Mac Donald refusing to buy Joseph's wood (Author,2010).

## 5.7.11 ACT 2 SCENE 6

**Key events**

Saul boards the 'Pictor', about to set sail in 4 days. Maska comes to tell him that his brother's son has been gored. They blame Old Foot and Terblanche is going to shoot the elephant. Saul decides he'll rather do it himself and gets off the ship

**Setting**

The deck of the Pictor

**Mood**

Serious, unsure & urgent

**Lighting**

Harsh & bright, white & blue

**Sound & Effects**

Foghorn, waves & seagulls



Figure 107. Saul on board the Pictor (Author,2010).



## 5.7.12 ACT 2 SCENE 7

Saul follows Old Foot's tracks in circles through the forest.

After 4 days Old Foot leads him back to Millwood and shows him the destruction of the forest.



Figure 108. Saul trekking Old Foot in circles through the forest (Author, 2010).



### 5.7.13 ACT 2 SCENE 7

Old Foot gets shot by one of the gold diggers.

Figure 109. Old foot gets shot (Author,2010).





Figure 110. Saul & Kate decides to stay in the forest. (Author,2010).

## EPILOGUE

Saul realises his responsibility towards the forest & his people.

Saul decide to stay in the forest.



Figure 111. Stage door of the Pretoria State Theatre's Opera stage (Author,2010).

## 06. PRECEDENT STUDIES

## 6.1 TEMPORARY THEATRES

### 6.1.1 Pop-Up Theatre

Hessisches Staatstheater  
 Darmstadt., Germany  
 Convertible City  
 2005

While the original theatre designed in 1972 by Rudolf Prange was being reconstructed, the **parking lot** beneath it was used as a **temporary performing space**. The new structure was inserted where the driveway divides into multiple lanes in front of the entrance of the parking lot.

The space accommodates all of the functions needed to run a studio theatre and includes a canteen, storage rooms and access to the new two-storey high foyer of the main building above.

“Very interesting is the **renewed atmosphere** that is created by the **temporary transformation**. Both friendly and inspiring.” (De Boer, 2009).

*This Precedent illustrates that a temporary insertion can enable a building to stay in use while it is being renovated.*



Figure 112. Exterior view of the Pop-Up Theatre (De Boer, 2009).

### 6.1.2 Puppet Theatre

Carpenter Centre for the Visual Arts  
 Harvard University, Massachusetts  
 Pierre Huyghe & Michael Meredith  
 2004

The only major **Le Corbusier-designed building** in North America is The Carpenter Centre for the Visual Arts at Harvard University in Cambridge, Massachusetts. A **temporary puppet theatre** was constructed within its sunken courtyard in **celebration** of its 40th anniversary.

With the help of computer technology and students, conceptual artist Pierre Huyghe and Harvard assistant professor of architecture, Michael Meredith, **collaborated** on the structure. 2,000 bolts were used to form a rigid frame that held together 500 white polycarbonate panels covered in real moss. “Metaphorical identities included an egg, a seed, a tumour, an alien spacecraft, and Le Corbusier’s brain.” (Bellostes, 2008).



*This precedent illustrates how a temporary insertion can be used to celebrate a permanent building.*

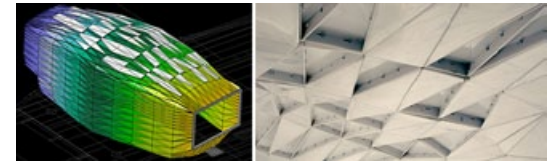

Figure 113. Interior view of the Puppet Theatre (Bellostes, 2008).



### 6.1.3 Almeida at Gainsborough Studios

The Almeida Theatre  
Shoreditch, London  
Haworth Tompkins  
2000

#### Materials:

- Turf
- Painted steel
- Reclaimed timber
- Painted scaffold tube
- Recycled theatre seats

Value: £750,000

During renovations The Almeida employed a series of **temporary venues** and staged **once-off shows** to maintain its presence. The coal-fired power station, a huge **19th century industrial structure** that was used to support the Metropolitan railway, was converted into film studios in 1919. By 1999 partial demolition and **conversion to apartments** were scheduled for the now derelict building.

At the time, The Almeida Theatre was looking for a temporary venue for the staging of Richard II and Coriolanus; two large-scale productions. The theatre negotiated a **one-year-lease** from the developer and Haworth Tompkins did the conversions for as low-cost as possible.

The original volume, of over 25m high, was restored by demolishing an intermediate floor (Figure 114).

The remainder of the building was treated as **'found' material** and contained the foyers and bars. Original openings were retained for scenic effect. **Scaffold staircases, ramps and simple cut openings** were inserted to **comply with the complex fire escape and circulation requirements** for an audience of 900.

A simple scaffold seating system created a large courtyard auditorium on three levels (Figure 116) and **basic soundproofing was installed**. After playing to full houses throughout the summer of 2000, the venue closed at the end of the season and has now been **demolished , as planned** (Tompkins, 2010).

*This precedent demonstrates how an old building can be temporarily adapted into a theatre that complies with safety requirements.*



Figure 114. Adaptation of Gainsborough studios (Tompkins, 2010).



Figure 115. Interior views of The Almeida Theatre (Tompkins, 2010).

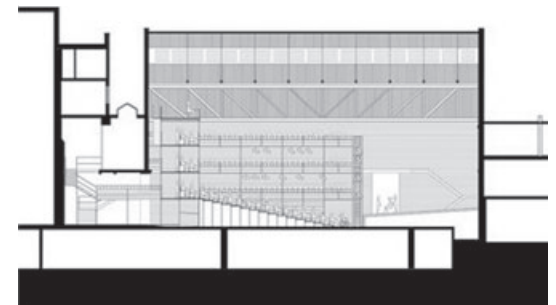

Figure 116. Section through The Almeida Theatre. (Tompkins, 2010).

## 6.1.4 Ten-day Theatre

Institute for Contemporary Arts (PICA)  
 TBA (time based art) festival, Portland,  
 Oregon  
 BOORA Architects  
 2004

### Materials:

- Pegboard
- Scaffold structure
- Visqueen
- Plastic buckets
- MDF board
- Recycled carpet tiles

Value: \$10 000

Eight **volunteer architects** turned a **vacant warehouse** into a **ten-day temporary theatre** for the TBA (Time Based Art) **festival** (Figure 123), Portland Institute of Contemporary Art's annual 10-day international arts festival (Figure 119). The **budget was small** and **materials** had to be undamaged and **re-usable** afterwards.

"It's always fun when a team of architects gets the opportunity to roll up their sleeves and engage in making something directly, not having products be confined to paper and scale models." (Architecture Week, 2005)

The **structural grid** of the building **informed** the diagram of the theatre (Figure 117). One of the structural bays provided sufficient clear space for the stage.

Around this stage, seating was positioned in the bays of the grid (Figure 124). Existing offices lining one wall were used as back-of-house support spaces. The positioning of the theatre in the warehouse reserved a large area of remaining space for the cabaret, bar and café (Figure 121).

A **scaffold** "media wall" differentiates the theatre volume from the surrounding volume of the warehouse. It partially bisects the warehouse, creating the **envelope** that **encloses** the theatre. The media wall's interior and exterior are clad in pegboard and visqueen and illuminated from within, creating a glowing volume of light contained within a gritty industrial shell (Figure 118).

Pegboard, suspended from a swinging crane, creates a hanging entry marquee. A portal in the media wall with a projecting canopy forms the entrance. **Technical equipment**, transformers and cabling are **concealed** within the media wall. An elevated control room serves both the theatre and the cabaret stage. Benches, on a raked scaffold substructure was assembled from five gallon plastic buckets, MDF board and recycled carpet tiles (Figure 120 & 122) (Arquitectura de Interiores, 2008).



Figure 117. Internal illumination contrasting the gritty industrial shell (Arquitectura de Interiores, 2008).



Figure 118. The found space before and after. No sign of the theatre's presence remained (Arquitectura de Interiores, 2008).

*This precedent illustrates how a vacant space can be temporarily activated to create a performance venue during a festival and then be returned completely to its former state leaving only the memory behind.*



Figure 119. Eight volunteers assembling the media wall (Arquitectura de Interiores, 2008).



Figure 120. Four steel columns of the industrial warehouse framed the temporary stage (Arquitectura de Interiores, 2008).

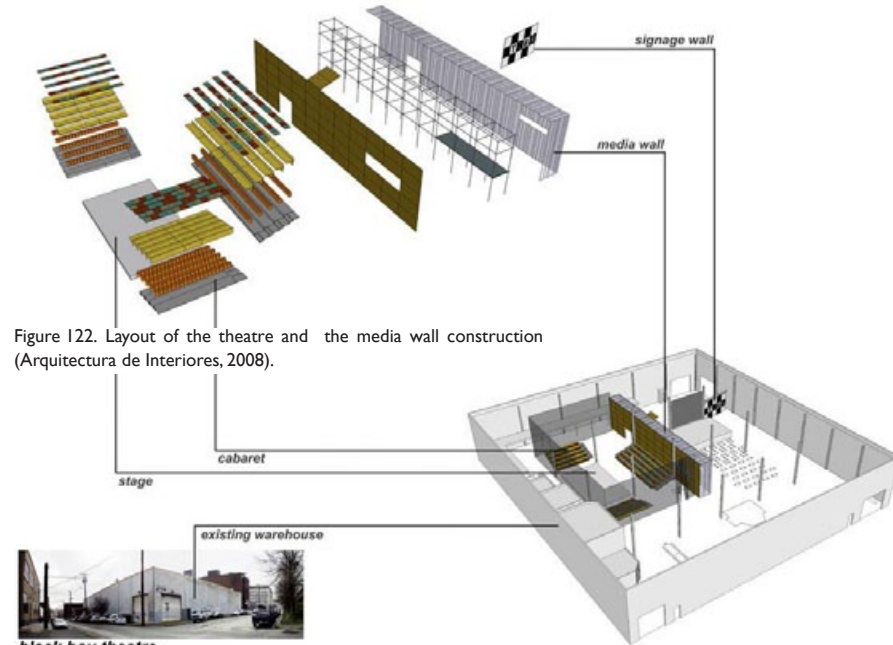

Figure 122. Layout of the theatre and the media wall construction (Arquitectura de Interiores, 2008).



Figure 121. The visqueen cladding of the “media wall” reveals the skeletal scaffold structure (Arquitectura de Interiores, 2008).



Figure 123. TBA (Time Based Art) festival poster



Figure 124. Plastic buckets, medium-density fiberboard and borrowed carpet tiles create bench seating with a raked backrest (Arquitectura de Interiores, 2008)



## 6.2 TYPICAL THEATRES

### 6.2.1 Lier Theatre - UP Campus

#### Description

Simple orange face-brick building, corrugated steel roof and exposed wooden trusses 3.5m above the finished floor level. Medium sized, black box theatre for intimate productions.

#### Exterior & entrance



Figure 125. Exterior gathering space & entrance of the Lier (Author, 2010).

Trees, planters and concrete benches along pathways separate the building from the parking area and create an outdoor waiting area.

#### Foyer

Service counter, sink, bar fringe, freezer, kettle and cupboards. Ablution facilities; one male and one female wc. A black pin-up board. Recessed, ceiling down lighters.



Figure 126. Foyer of the Lier (Author, 2010).

#### Seating capacity 80

#### Audience

Entrance from the side. One door between the stage and the raked seating. Stackable upholstered chairs staggered on 6 levels of rostra.

#### Stage

Proscenium stage on ground level, 8.4m wide and 7m deep play area. The stage is on ground level.



Figure 127. Views of the audience, control box & stage (Author, 2010).

Floor surface of boards nailed together. Boards can be painted and re-painted. No fly tower; scenery is supported by the floor surface or hung from the trusses. A backstage double door provides access for scenery.



Figure 128. Views of the rehearsal space & change room (Author, 2010).

#### Backstage

A long narrow rehearsal space called 'The Bok'; perpendicularly attached to the main theatre building with backstage access to the dressing room. One dressing room with lit mirrors and worktops divided into two areas by a curtain. Separate male and female ablution facilities with one wc, wash hand-basin and shower each. Backstage access to the stage via a passage, lit with blue lights that won't spill onto the stage.

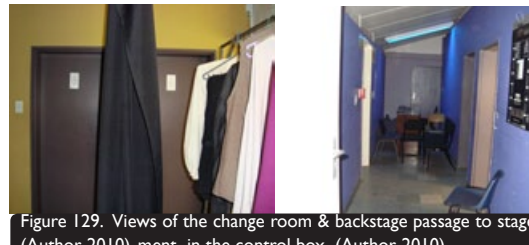

Figure 129. Views of the change room & backstage passage to stage (Author, 2010). ment in the control box (Author, 2010).

#### Technical aspects

A 3x1.5m control box on the highest rostra behind the audience is used to operate the sound system, lighting and special effects. The control desk houses the necessary electronic equipment; a computer to programme lighting sequences, a CD player and communication devices. Luminaries for effect and functional lighting are hung from the exposed wooden roof trusses.

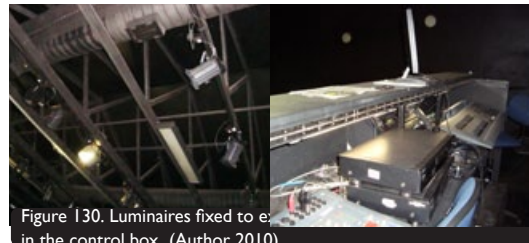

Figure 130. Luminaires fixed to exposed wooden roof trusses in the control box (Author, 2010).



## 6.2.2 Masker Theatre - UP Campus

### Description

Converted from an old school hall, the Masker dates back to the 1970's. The building consists of a concrete frame with orange-brick infill and a corrugated steel, pitched roof with a three-storey high apex. Steel-framed windows were painted black to create the necessary level of darkness inside.

### Exterior & entrance

Brick paving, walkways, some trees, planters and concrete seating, separate the entrance from the parking and create a gathering space. Although notice boards are placed along the walkways, posters are stuck onto the theatre door and front facade (Figure 133).

### Foyer

Separated from the theatre auditorium by a purple velvet curtain which also functions as an acoustic absorber behind the audience. A simple service counter is located close to the entrance door. Ablution facilities can be accessed from the foyer (Figure 131).



Figure 131. Exterior gathering space & entrance of the Masker (Author, 2010).

Seating capacity: 117

### Audience

Loose chairs are placed on a series of raked rostra that can be altered to allow different seating arrangements. Additional seating is provided on a mezzanine level above the foyer.

### Stage

A typical 9m x 7m wooden school hall proscenium stage raised 800mm above the ground floor level. Dark fabric curtain wings.



Figure 132. Foyer of the Masker (Author, 2010).

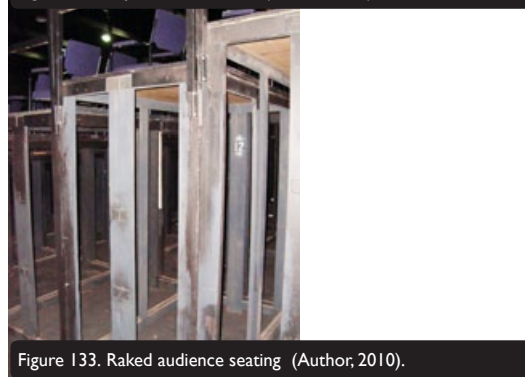

Figure 133. Raked audience seating (Author, 2010).

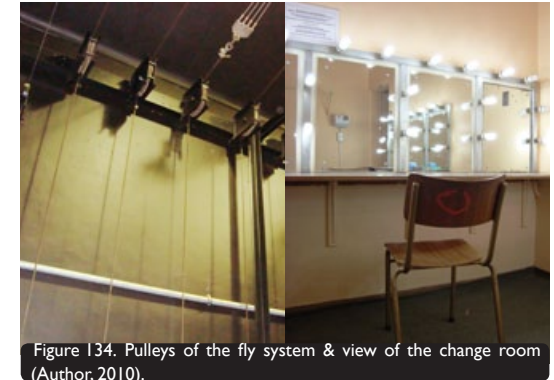

Figure 134. Pulleys of the fly system & view of the change room (Author, 2010).

### Backstage

Four change rooms with lit dressing tables; wc's, basins and showers located behind the stage with backstage access to the stage.

### Technical aspects

6m above the ground level are six parallel rigs onto which luminaries are fixed. The control desk is situated towards the front on the mezzanine level,.

## 6.3 ADAPTIVE RE USE THEATRE

### 6.3.1 Market Theatre - Johannesburg

#### Description

In 1976 Johannesburg's Indian Fruit Market was converted into the Market Theatre; internationally renowned as South Africa's "Theatre of the Struggle". In a post-apartheid South Africa the theatre aims to encourage new dramatic writing. The complex spans 36 meters and the roof of this vast Edwardian market hall is 200m in length. Metal trusses and other components were manufactured in Glasgow in 1922, shipped to South Africa and assembled here.

#### Exterior & entrance

The main entrance to the Market Theatre complex is the grand Edwardian facade in Wolhuter Street, which has three arched windows, flanked by twin domed towers (Figure 135).

#### Rental

The theatre and other spaces are available for rent and can be used for exhibitions, conferences and launches.



Figure 135. Exterior gathering space & entrance of the Market Theatre (Author, 2010).

#### Foyer

The entrance hallway is defined by a series of arches and concrete columns, a row of pendant luminaries and banners (Figure 136 & 137). The ticket office is situated to the right of the entrance. Niche-like rooms branch out of the hallway creating seating and gathering spaces. A flight of stairs leads up to a second foyer with a small bar.

#### Audience

The temporary, *ad-hoc* character, usually restricted to the stage, is brought into the auditorium space through the nature of the conversion. Existing services are exposed; brick walls are left bare and some of the vendors' signs still hang from the gallery. Loose rows of upholstered auditorium chairs or benches are packed onto raked rostra.

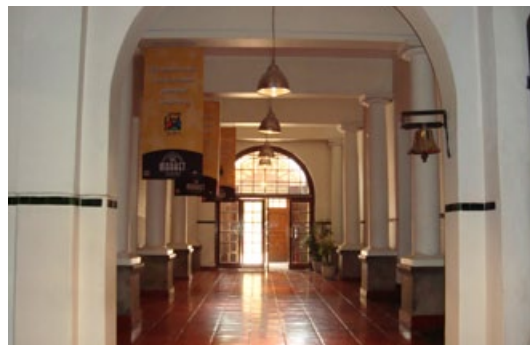

Figure 136. Foyer of the Market Theatre (Author, 2010).

#### Stage

The Market Theatre consists of three theatres; the Main Theatre, the Barney Simon Theatre and the Laager Theatre. All three are open stages with seating on three sides. The stage floor of the Laager Theatre is on the ground level; the stage of the Barney Simon Theatre is raised one step and the circular stage of the Main Theatre is raised about 900mm from the ground level (see next page).

#### Technical aspects

Control desks and technical equipment were handled in a makeshift fashion and traditional theatre conventions adapted to overcome the limitations presented by the existing spaces. For example, the placement of the control desk to the side in the Laager Theatre (see next page).



Figure 137. Banners in the foyer, advertising the shows (Author, 2010).

### **Laager Theatre**

Seating capacity: 100-120  
Rental: R8 500 (+ 5% of door income)



Figure 138. Interior view of the Laager Theatre showing stage & seating (Author, 2010).



Figure 141. Scaffold lighting system & control box of the Laager Theatre (Author, 2010).

### **Barney Simon Theatre**

Seating capacity: 100-120  
Rental: R8 500 (+ 5% of door income)  
• Laager Theatre:



Figure 139. Interior view of the Barney Simon Theatre showing stage & seating (Author, 2010).



Figure 142. Control box of the Main Theatre (Author, 2010).

### **Main Theatre**

Seating capacity: 387  
Rental per week: R25 000 (+ 5% of door income)



Figure 140. Interior view of the Main Theatre showing stage & seating (Author, 2010).



Figure 143. Lighting system in the Main Theatre fixed to the existing roof structure (Author, 2010).





Figure 144. Cardboard sign (Camp Photoshop, 2009).



## 07. CONCEPT DEVELOPMENT

## 7.1 CONCEPT

### 7.1.1 Symbiosis between temporary and permanent architecture

In 1879 German botanist Heinrich Anton de Bary coined the term symbiosis as “the living together of unlike organisms.” (Hartnett, 2010).

#### **Mutualism**

Beneficial to both interacting species.

#### **Endo-symbiosis**

One partner lives inside the other

#### **Ecto-symbiosis**

One organism lives on another

#### Symbiosis

–Dynamic, organic, growth, change, temporality

–Coexistence & tension– man/nature, permanent/temporary

\_Arbour motif (text, prominent natural feature on the site, paper, books - stories, & press)

The theatre (temporary guest) moves into the existing building (permanent host) and together they accommodate an event. In the process, both the permanent host and the temporary insertion benefits (Figure 145).

While occupied by the temporary, the existing space will be activated, gain social and cultural importance and learn from the experimental symbiotic relationship.

After the performance moves out, the permanent host will be free to accommodate other temporary (guest) programmes using this one as an example. In this way the existing space that would have stood empty will be

able to continually contribute to and interact with, its urban environment in an ever-changing way and provide meaningful spatial experiences.

In return the host will sheltered and protect the temporary insertion. The existing structure will provide physical support while the existing services like water and electricity will sustain the needs and requirements of the temporary insertion.

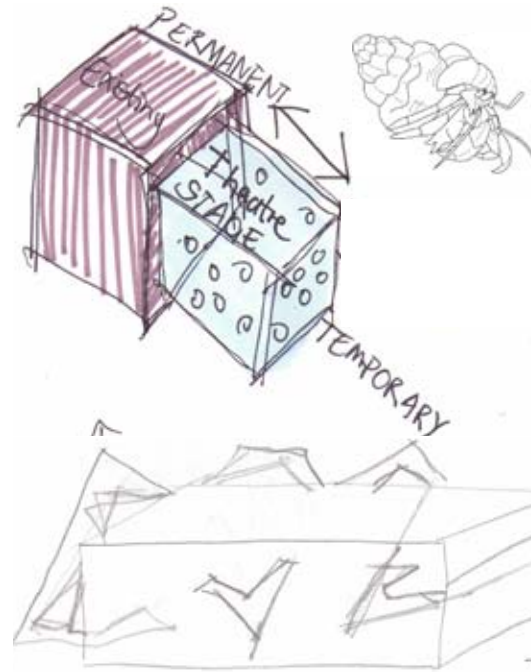

Figure 145. Diagram illustrating the symbiosis between the permanent host (existing) & the temporary guest (new) (Author, 2010).

“They came to know the shrubs of the underbrush: which were medicine and which were not; which berries you could eat and which not.”

(Matthee, 1984, 18)

## 7.1.2 Layers of temporality

Within the spectrum between the temporary and the permanent there are layers varying from more permanent to more temporary. The same can be applied to nature in the case of symbiotic relationships and in the world of theatre.

The study applied the following layers of temporality to the design of the Temporary Theatre within the Permanent host building. Where the most permanent layer will remain the longest and the most temporary will fluctuate the most.

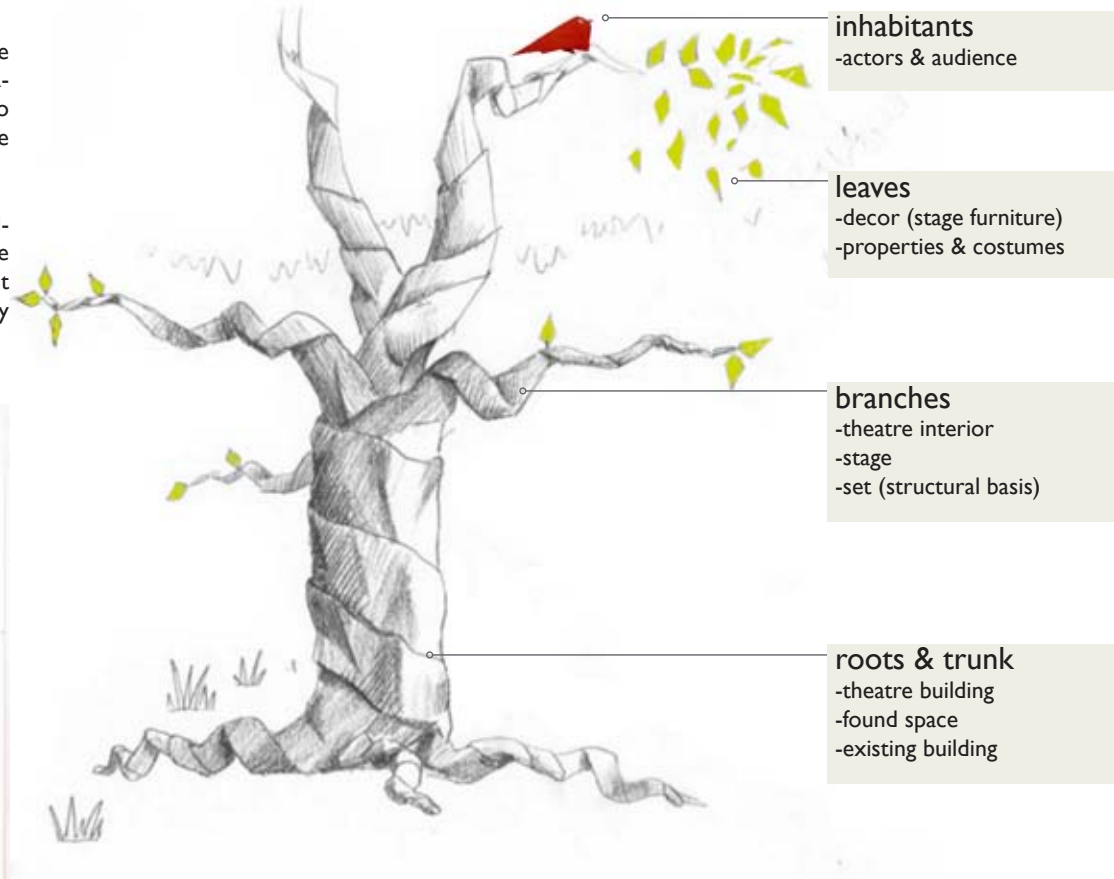
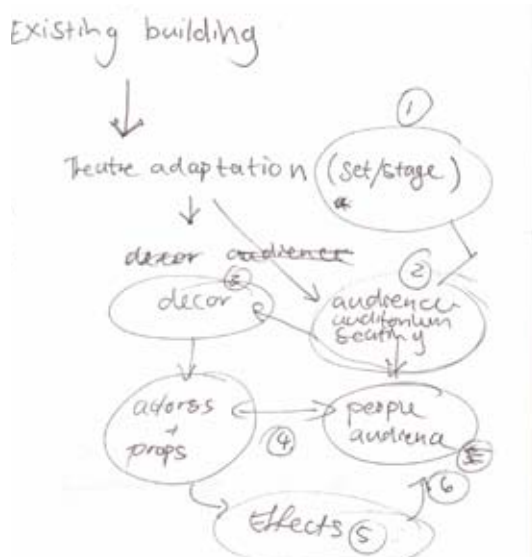

**TREE OF TEMPORALITY**

Figure 146. Diagrams illustrating layers of temporality (Moring, 2010).

### 7.1.3 Recycling the permanent building by temporary insertion

In dealing with existing buildings Gigli et al (2007, 35) identified three types of strategies according to the intimacy of the relationship between the existing and the new.

#### Intervention

When the existing is so transformed that it can no longer viably exist independently, and the nature of the re-modelling is such that the old and new are completely intertwined. **Most permanent**

#### Installation

The existing, and the new, exist independently. The new elements are placed within the boundaries of the building. The design or the grouping, of these elements may be influenced by the existing, but the fit is not exact and, should the elements be removed, then the building would revert to its original state.

**Most temporary**

#### Insertion

If a new autonomous element, the dimensions of which are largely dictated by those of the existing, that is, it is built to fit, is placed in the confines of the existing. **Between temporary and permanent**

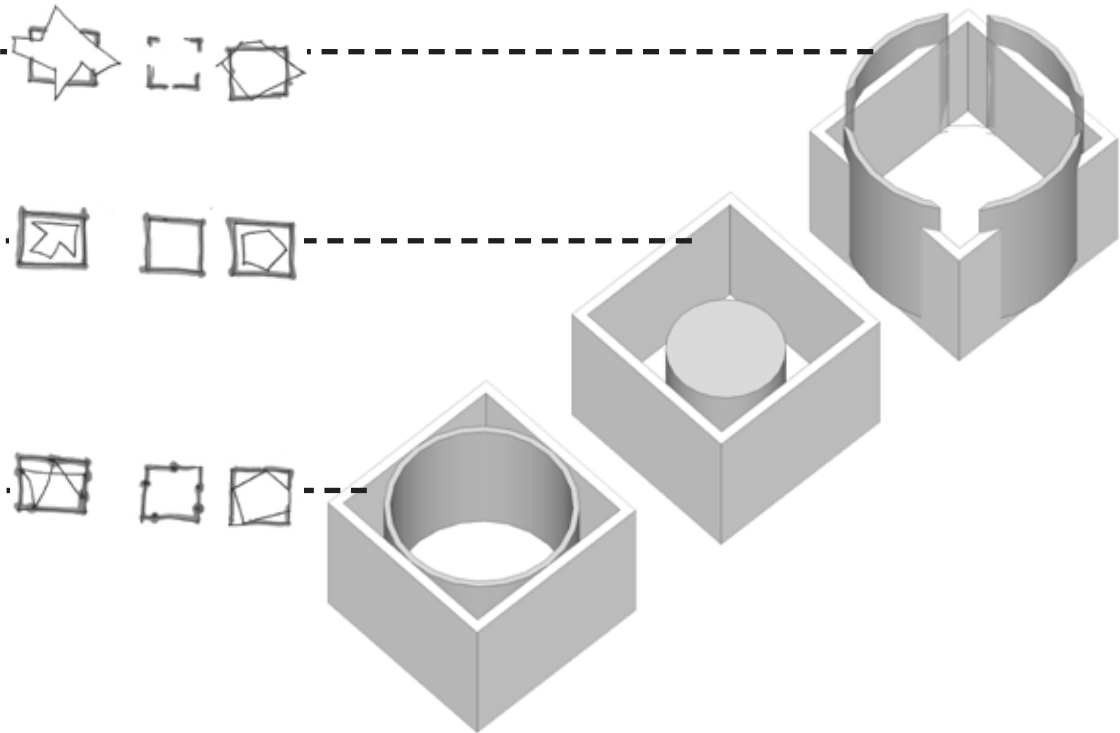
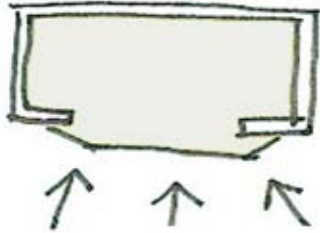

Figure 147. Diagrams illustrating strategies of reuse (Author, 2010).



## 7.2 TRADITIONAL STAGE FORMS

### Proscenium stages



In this conventional arrangement the audience sits facing the stage on one side and views actors on stage through an opening framed by a decorative arch separating the stage from the auditorium. (Pecktal, 1975, 13)

### Open stages

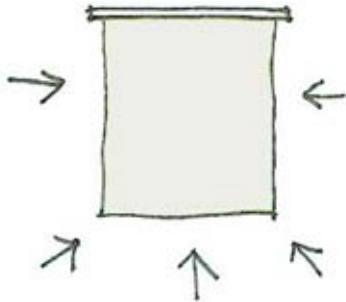

This arrangement allows half- or three-quarter round seating. The Stage may be circular, semicircular, square, rectangular or otherwise angular. An intimate relationship is created between the audience and the actors (Pecktal, 1975, 13).

### Theatre in the round (arena stage)

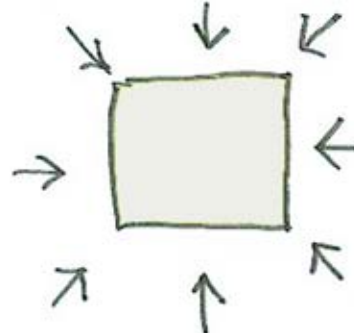

The audience, seated all round the acting area are closer to the action than in a proscenium theatre. Large scenic structures and flown scenery are limited and emphasis is placed on level differences, the floor and furniture. People must be able to see over or through the largest object and not be separated from the action behind it. The entrance gangways can also be used as part of the stage.

### Thrust stages

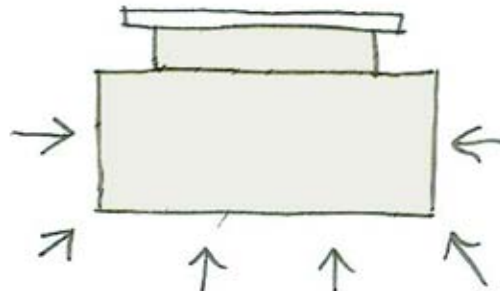

This is a proscenium stage with an extended apron. A stage, attached to a rear acting area extends into the audience. It functions effectively as theatre in the round but is more theatrical, allows for more exaggerated design and has a scenic background. The design challenge is to disguise any division through use of colour, shape and, or texture. Actors should be given immediate forward access to the thrust as directly as possible.

### Traverse stages

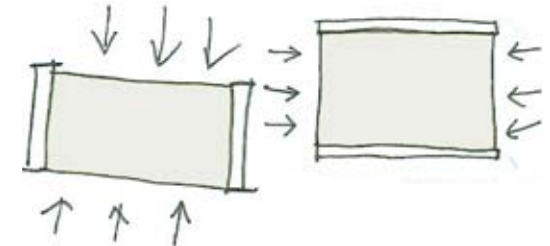

These stages although rarer than the others allow imaginative scenic images at either end of the acting area. Very similar to theatre in the round with the focus on the floor. The audience is placed in two blocks facing each other. The design must create a shared environment that becomes the theatrical bond between the audience and the actors.

### Flexible theatres

Designed to be adaptable to several different shapes. Allow the production team to decide which is most appropriate according to the play and other practicalities.

Figure 148. Diagrams illustrating traditional stage forms (Author, 2010).

# 7.3 FICTIONAL SPACE IN REAL SPACE

## 7.3.1 Spatial programming informed by the text

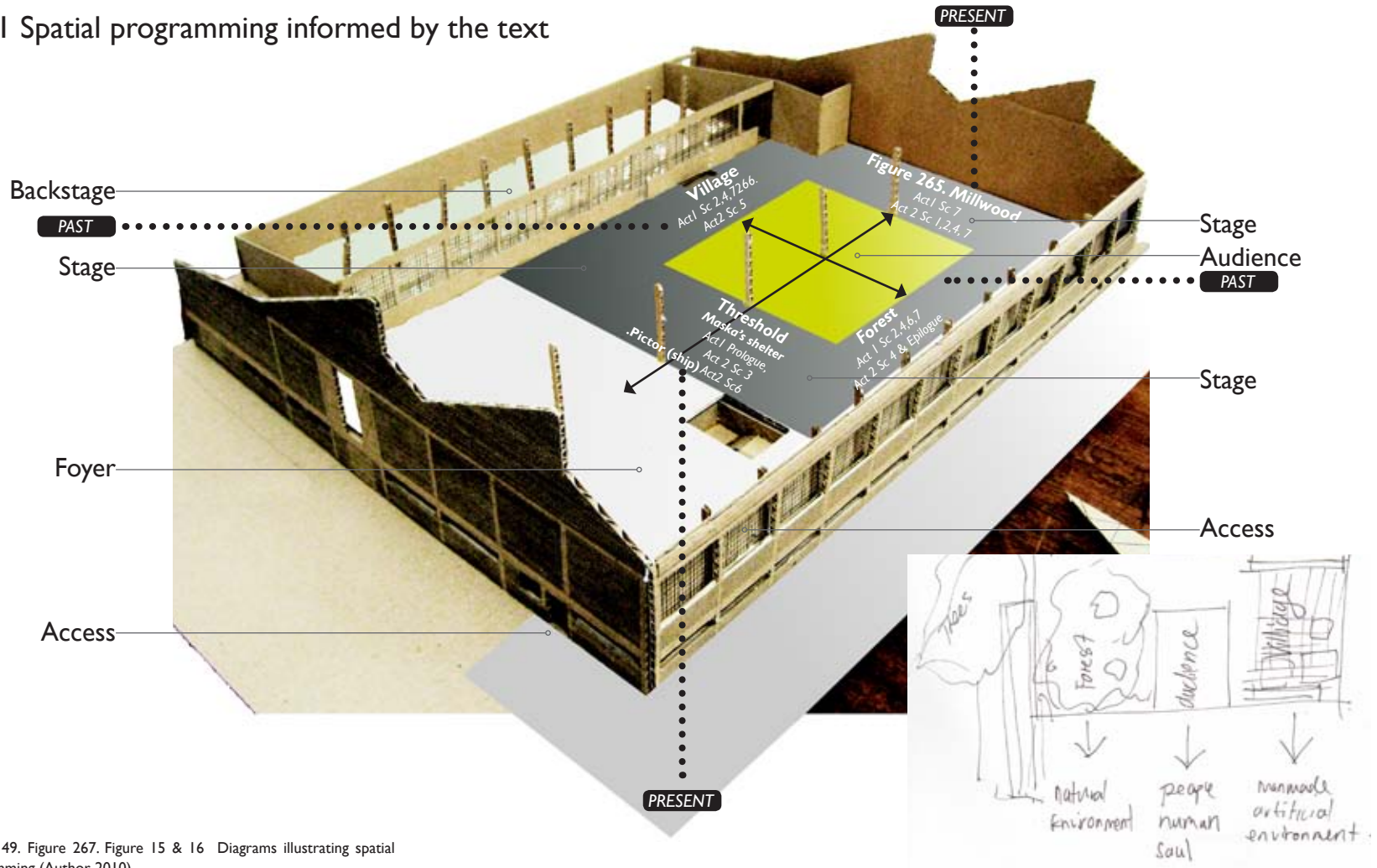

Figure 149. Figure 267. Figure 15 & 16 Diagrams illustrating spatial programming (Author, 2010).

As discussed in the analysis of 'Circles in a Forest' circles in a prominent theme in the text. The story line also jumps back and forth between the past and the present.

The audience is still in the foyer. The sounds of the foghorn and seagulls draw their attention. The light changes to that of Maska's shelter and a voice recording of important lines starts playing in Afrikaans:

Die lewe is 'n skewe kring, Saul, die lewe is 'n skewe kring!  
Die bloubokkie se gal sit nie in sy kop nie.

The actors come onto the Threshold stage and the play begins. At the end of the prologue scene the narrator says: **"Saul Barnard walks into the forest and it feels like walking backwards into himself"** (Matthee, 1984, 1). With this the actors turn open the screens and walk into the forest. As the actors walk in the audience follow them and take their seats. The spotlight indicates the passages and the seating. Scene 1 begins...

As the play progresses the actors move along the passages, through the audience to the different stages for certain scenes. The audience will naturally follow their movement visually. Rotating chairs allow to the audience to also follow their movements physically. The audience becomes aware of the fact that man like the characters are caught between these two world; that of the forest (nature) and that of the village (man-made).

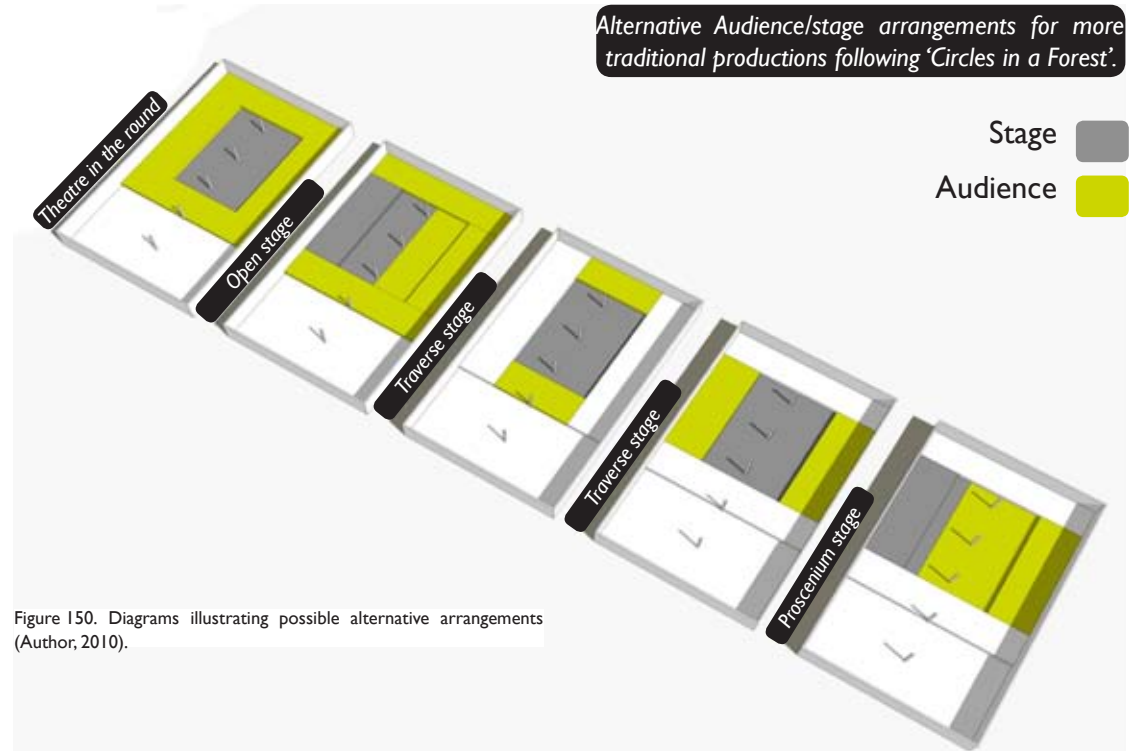

Figure 150. Diagrams illustrating possible alternative arrangements (Author, 2010).

*"Round and round you walked the crooked circle year in year out." (Matthee, 1984, 108-109)*

*"In some places there were natural openings in the forest like Big Island and there you could find 3-4 families living in makeshift homes..." (Matthee, 1984, 26)*

*"They walked in circles "round and round and round. At some time the elephant must catch up from behind" (Matthee, 1984, 183)*

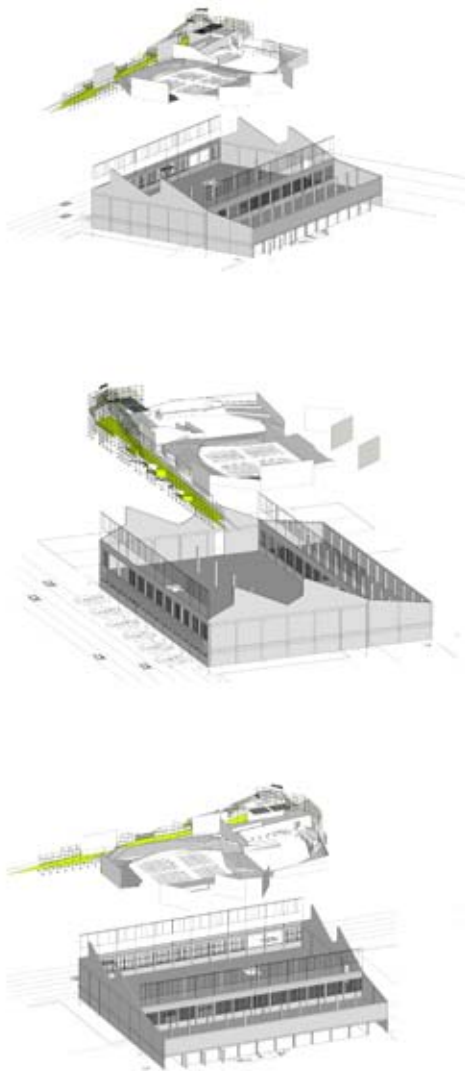

Figure 151. Diagrams illustrating permanent host and temporary insertion (Author, 2010).

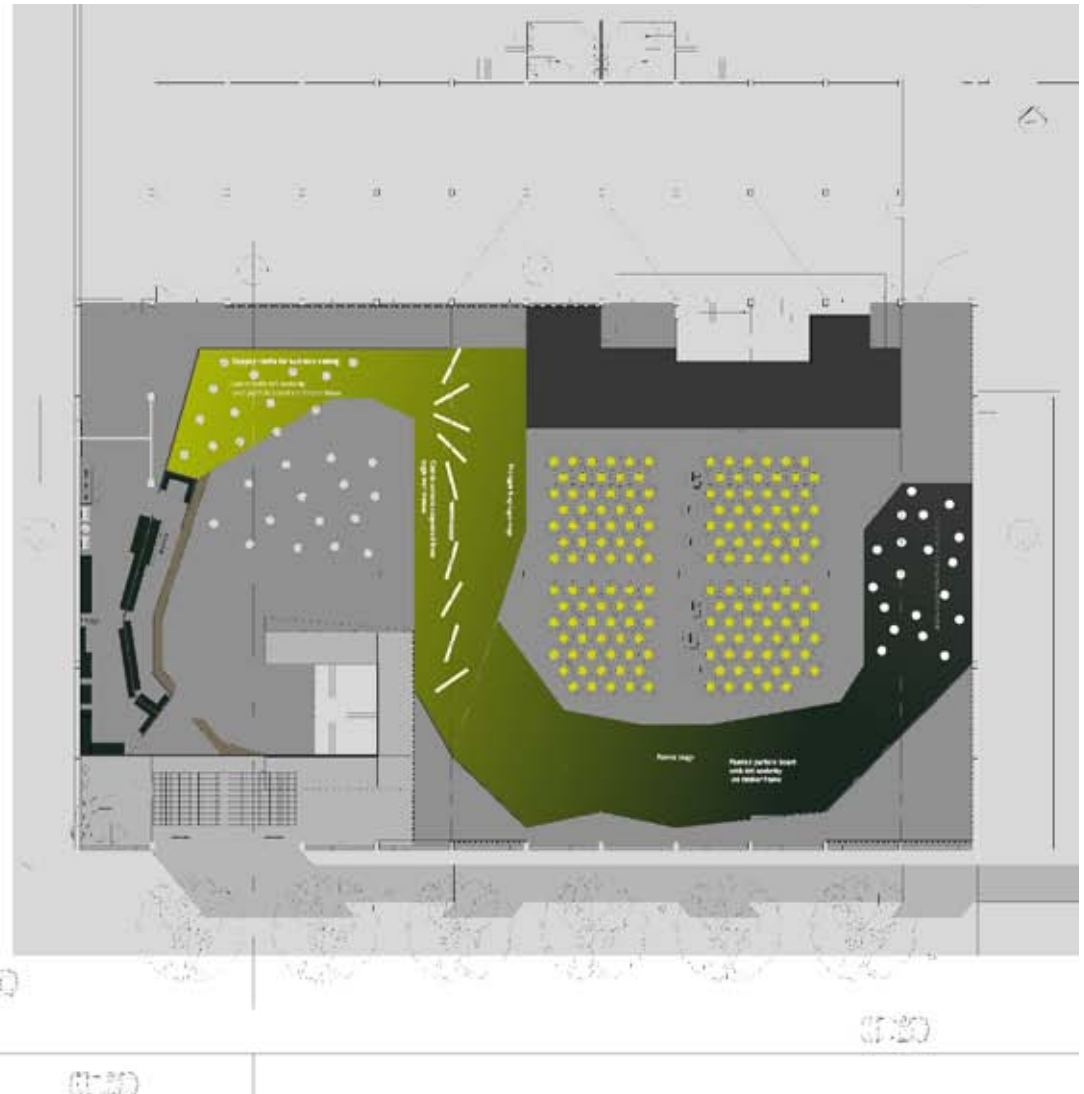

Figure 152. Floor plan of Temporary Theatre 1:500 (Author, 2010)





Figure 153. Floor plan of Temporary Theatre not to scale (Author, 2010)



## 7.4 PROPOSED ACCESS RAMP

The host space of the Temporary Theatre have no direct access to the outside. The two points of access first lead through other parts of the building. There is also no accessible access to this space. The facade with most contact to the exterior is the southern facade. This is also the facade parallel to Vermeulen Street with the most pedestrian activity. As stated previously this facade is already used as an informal advertisement board as can be seen by the palimpsest of posters.

As part of the design a new, accessible point of entry along this facade is proposed. A ramp supported by a scaffold structure and with a shade net covering and leading directly into the theatre space was chosen for this purpose. The ramp function as a strong visual element drawing attention and advertising the Temporary Theatre to passers by. Like a giant root the ramp attach the Temporary Theatre to the ground and draw people from the sidewalk directly into the theatre space, giving it life. The experience will already begin as people ascend on the ramp exporting them from the real world of the city to the fantasy world of the.

Visitors will feel the rough texture of the oriented strand board under their feet and become aware of the shade net covering with scattered openings over their heads closing around them progressively as they ascend further up the ramp creating a luminous green glow.

The scaffold structure will become a canvas to be filled in with billboards, production posters and community art works. The sheltered space underneath the ramp will become a host for informal traders, a resting place for tired pedestrians or a meeting place for friends.

Ramp inspiration

April concept sketches

Figure 154.  
(Domanovic et al., 2010).



Figure 155. (Author, 2010).



Figure 156. (Omara, 2007).



Figure 157. (Beginberg, 2009).

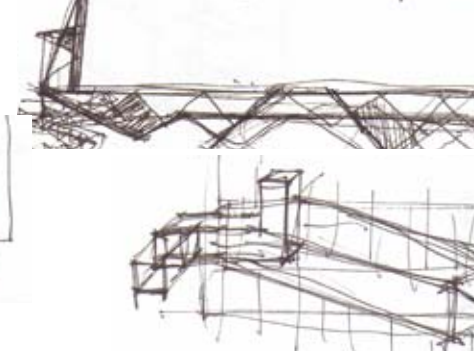
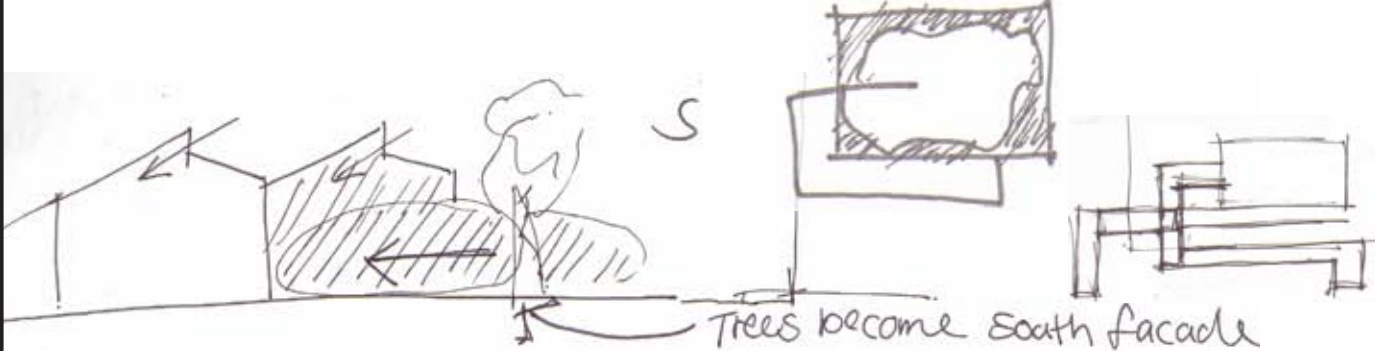
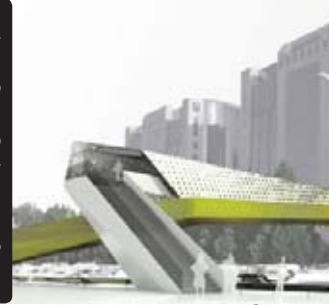

Scaffold structures are strongly associated with temporality. They are expected to be disassembled and re-located and designed for that purpose. The framework and infill construction of the ramp will support the concept of symbiosis. Compared to the light, translucent and fluid character of the shade netting, the hard, rectilinear metal scaffolding become the permanent layer and the shade netting the temporary layer dependant on the structural support of the scaffolding. The same apply to the board infill of the sides of the ramp.

The ramp itself can also be reinterpreted and repainted according to the current production being shown, adding another layer of temporality.



Figure 158. (Barros & Pereira, 2010).



Figure 159. (Vyzoviti, 2005).

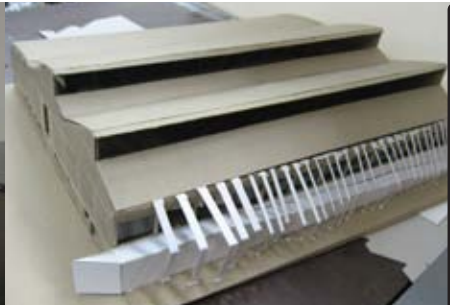
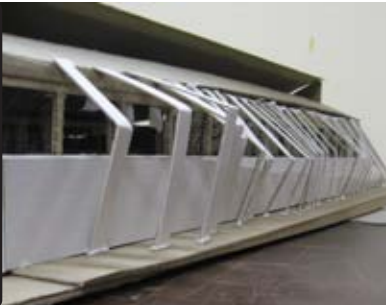
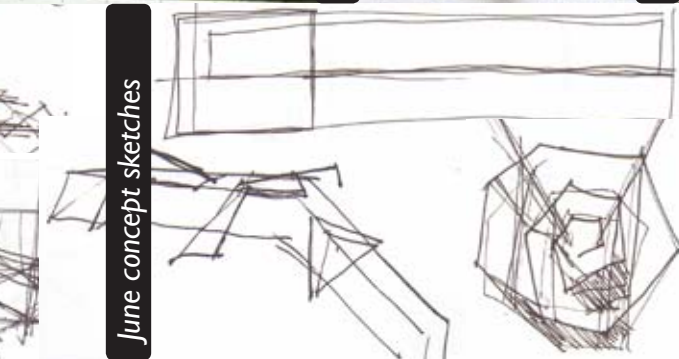

Figure 160. Concept model, June (Author, 2010).



June concept sketches

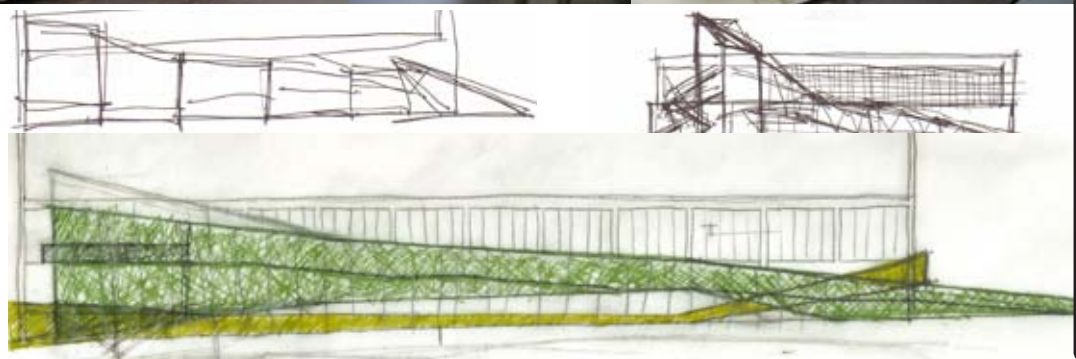

Figure 161. Concepts sketches (Author, 2010).



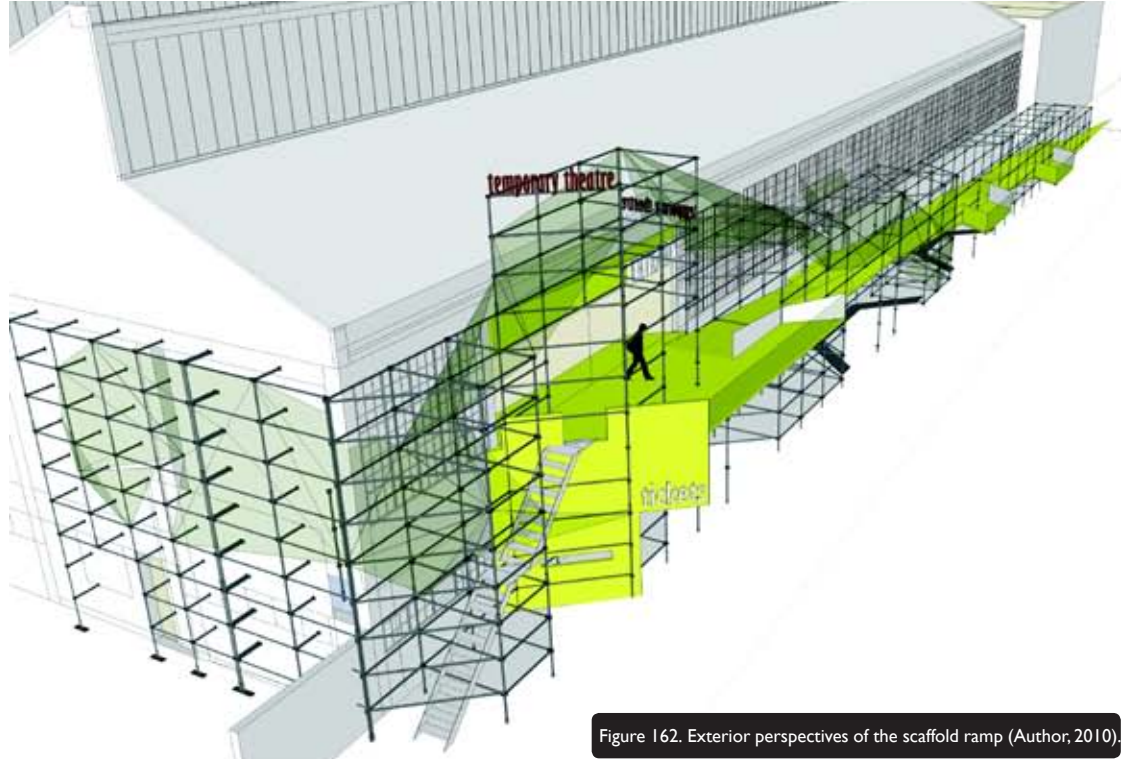
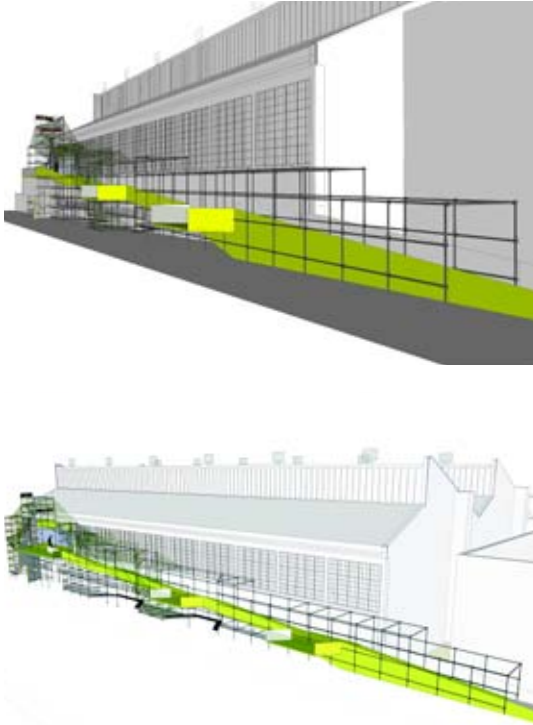

Figure 162. Exterior perspectives of the scaffold ramp (Author, 2010).



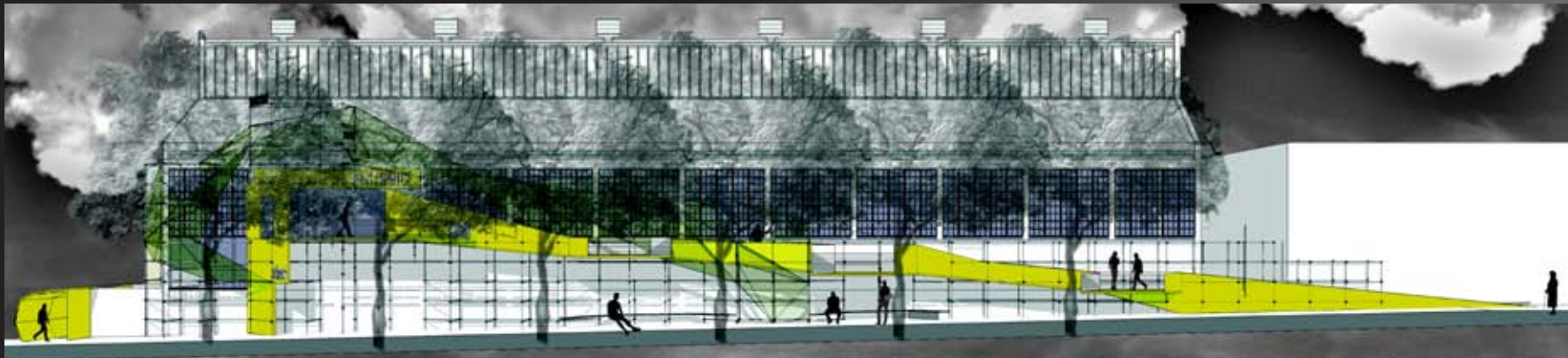

Figure 163. South facade showing scaffold ramp with trees, not to scale (Author, 2010)

# 7.5 THRESHOLD STAGE MOOD BOARD



*“Maska, you used to tell us that the spirits live in the trees” (1986, 240)*

- Mystical
- Spiritual
- Free
- Foggy
- Smoky
- Transient



(Receveur, 2010)

(Kingsley, 2009)

(Ruzza, 2006)

(Hiemstra-van der Horst, 2010)

(Ruzza, 1991)

(Deviant Art, 2009)

(Nature Maker, 1998)

Figure 164. Threshold stage mood board (Author, 2010).



## 7.6 FOREST STAGE MOOD BOARD

(Barros & Pereira, 2010)

(Química visual, 2010)

(Flicker, 2005)

Enclosed

Covered

Dense

Dappled

Impenetrable

(Ruzza, 1991)

(Goethe-institut, 2010)

*"He would hide in the forest so that nobody would ever find him. Surely God could not have seen down into the forest from up in the sky, even the sun has to struggle to shine to the ground. Only specks of sunlight got through that roof of the tree tops"*  
(Matthee, 1984, 47)

(Manferdini 2008)

(Saraceno, 2009)

Figure 165. Forest stage mood board (Author, 2010).

(Taller, 2009)

(Rothstein, 2010)

(Knowlesystem, 2007)

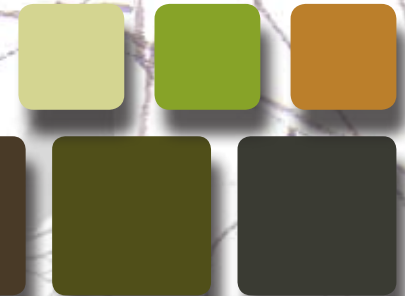



## 7.7 MILLWOOD STAGE MOOD BOARD

Destruction

Greed

Exploitation

Death

Scarring

*"...where diggers' axes had hacked out everything to make space for the tents and houses, and to provide firewood."*

(Szukalski, 2008)

(Lehr, 2008)

(Turto, 2010)

(Smithee, 2009)

(Willhelm, 2007)

(Ruzza, 1991)

(Whittaker, 2008)

(Nettler, 2010)

(Electrosonic, 2010)

Figure 166. Millwood stage mood board (Author, 2010).



## 7.8 THE VILLAGE STAGE MOOD BOARD

Open

Exposed

Bare

Inequality

Oppression



(Lambie, 2007)



(Fopple, 2010)

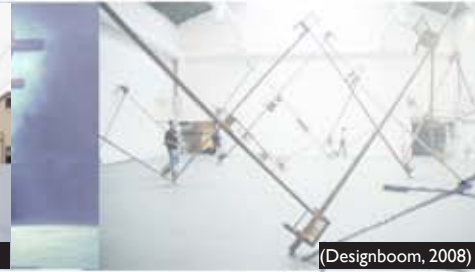

(Designboom, 2008)



*They came out of the forest on the eastern side of the town. One moment the forest was still around and above them, the next moment it started thinning out, getting lighter... more sun and then suddenly the world was lying open. Naked. Like someone without a hat. Without a roof. He wanted to turn round and run back to the shady shelter of the forest. The sun was hurting his eyes.” (Matthee, 1984, 54)*

*“...enormous. Wood was stacked up everywhere, wood wherever you looked! Mountains of wood. Next to a large shed men were loading some of the wood on other wagons...” (Matthee, 1984, 56)*

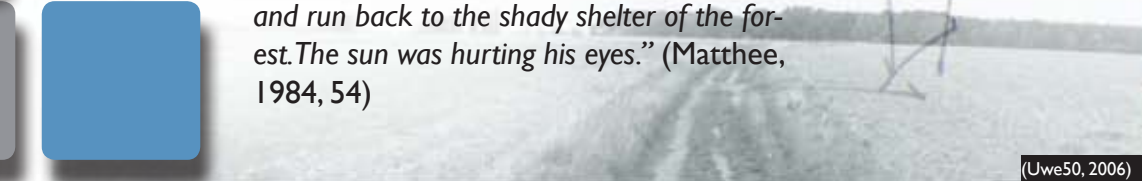
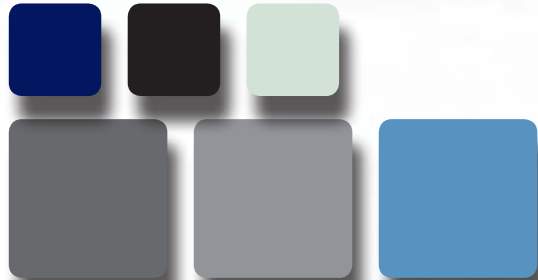

(Uwe50, 2006)



(Ruzza, 2006)



(Jewell, 2010)



(Del Signore, 2007)



(Fopple, 2010)

Figure 167. Village stage mood board (Author, 2010).



(Fopple, 2010)



(LaFarge, 2008)

## 7.9 THRESHOLD STAGE CONCEPT SKETCH



Figure 168. Interior view of the Threshold stage (Author, 2010)



## 7.10 FOREST STAGE CONCEPT SKETCH



Figure 169. Interior view of the Temporary Theatre showing the Forest, Millwood & Village stage (Author, 2010)

## 7.11 MILLWOOD STAGE CONCEPT SKETCH



Figure 170. Interior view of the Millwood stage (Author, 2010)



## 7.12 VILLAGE STAGE CONCEPT SKETCH

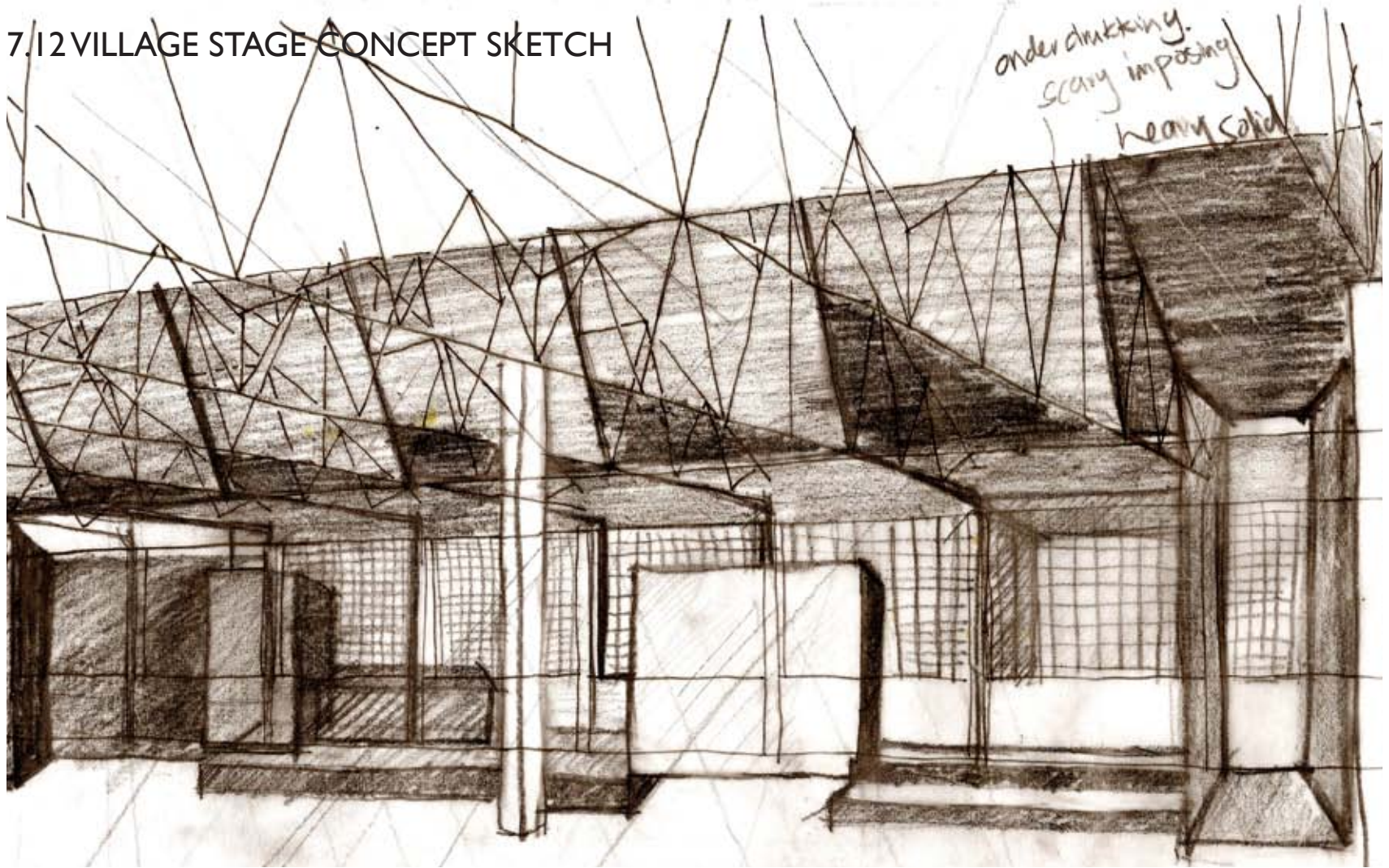

Figure 171. Interior view of the Village stage (Author, 2010)



## 08. DESIGN & TECHNICAL RESOLUTION

Figure 172. Follow spot effect 2 kW  
(McGill, 2007).

## 8.1 TYPICAL SET CONSTRUCTION

The list of materials used in the construction of scenery is endless. New innovations, materials and applications are constantly introduced to the theatre. There are however certain materials that are considered to be standard, widely used, traditional stage materials. Parker & Smith (1974, 164) classify these materials as follows.

### 8.1.1 Structural materials

#### *Timber*

Timber is the most common framing and structural material. Timber used for scenery must be lightweight, straight, strong and cheap. In South Africa clear pine provides the best combination. Clear SA pine is preferred because it has few knots that cause weak spots in the wood that tend to split. Wood is combustible and must be protected with paint, varnish or fire and water resistant agents. Timber is recyclable and reusable.

#### *Metal*

Hollow, square and angle iron sections are used for the structural frames of platforms and panel scenery and to support standing scenery. Malleable iron pipes is used for battens to support hanging scenery, as a weight or bottom batten for a drop; for lighting booms and as structural elements (Parker & Smith, 1974, 168).

### 8.1.2 Cover stock

The material used to cover the structural frame of scenery is called cover stock. Depending on the use fabric or a hard surface material can be used.

#### *Covering Fabrics (soft Scenery)*

Structural frames are traditionally covered with canvas although any fabric can be used as covering. Fabrics like gauzes (scrimps), vision, square or sharks tooth mesh, Holt (1988, 33) and Hessian are often used to create textured or lighting effects. In South Africa unbleached Calico is most often used as a substitute because it is lighter, cheaper and more readily available. Fabric covering is fireproofed and sewn to size. A thin mixture of water and PVA paint is used to prepare the surface before it gets painted.

#### *Hard surfaces*

If the surface is such that it has to be walked on or withstand active handling, the frame is covered with a harder surface. Plywood is most commonly used because it is lightweight yet strong enough to supply a hard surface with a minimum of framing. Laminated wood is sometimes used as a substitute. Masonite, a very hard surface of compressed wood pulp, is also commonly used as a floor covering. Thin plywood is mainly used for platform tops. Double faced corrugated cardboard is an inexpensive hard surface covering (Parker & Smith, 1974, 170).

### 8.1.3 Hardware

#### *Joining hardware*

Joining hardware includes nails, screws, tacks, staples, and bolts used for joining wood or metal.

#### *Stage hardware*

Stage hardware refer to hardware made especially for the stage and designed to brace, stiffen, rig flying scenery and temporarily join units of scenery (Parker & Smith, 1974, 172).

### 8.1.4 Rope, cable, and chains

#### *Cotton braid rope*

This type of rope is used for lightweight rigging and as a trick line to trigger a mechanical effect from an offstage position.

#### *Manila rope*

Stranded manila rope is used for heave rigging.

#### *Cable*

Cable is used to hang scenery when the supporting wire will be in view. Cables are very strong for its small diameter and can support a heavy piece of scenery without being too prominent.

#### *Chain:*

in theatre chains are used for special rigging and as weights for draperies.



## 8.1.5 Structural materials

### *Timber*

Timber is the most common framing and structural material. Timber used for scenery must be lightweight, straight, strong and cheap. In South Africa clear pine provides the best combination. Clear SA pine is preferred because it has few knots that cause weak spots in the wood that tend to split. Wood is combustible and must be protected with paint, varnish or fire and water resistant agents. Timber is recyclable and reusable.

### *Metal*

Hollow, square and angle iron sections are used for the structural frames of platforms and panel scenery and to support standing scenery. Malleable iron pipes is used for battens to support hanging scenery, as a weight or bottom batten for a drop; for lighting booms and as structural elements (Parker & Smith, 1974, 168).

### *Chain:*

in theatre chains are used for special rigging and as weights for draperies.

## 8.1.6 Free forms

Depending on the form, irregular three-dimensional pieces of scenery are created by constructing a framework from a structural material such as timber or metal. Contour pieces are often cut across the shortest dimension, fixed to a base shape and stiffened with cross bracing. The frame is wrapped in chicken wire so that it adapts to the shape of the frame. The final surface is then applied to the chicken wire. Usually unbleached Calico is dyed with a base colour, dipped in a water-and-wood glue mixture, tacked to the frame and allowed to dry. Once dry effect painting and texturing (saw dust) are applied. Free forms are also frequently made from fibreglass, polystyrene or polyurethane which is undesirable unless reused, because they are environmentally unfriendly. These pieces are lightweight, inexpensive and sturdy (Parker & Smith, 1974, 204).



Figure 176. Construction of steel frame, Johannesburg Theatre (Author, 2010).



Figure 173. Construction of a rostra, Pretoria State Theatre (Author, 2010).



Figure 174. Frames used for the painting canvas backdrops, Pretoria State Theatre (Author, 2010).



Figure 175. Canvas cyclorama suspended with cables, Johannesburg Theatre (Author, 2010).

## 8.2 MATERIALS

### 8.2.1 Approach

*“A seamless package is frustratingly daunting. However, a broken system is usually one that attracts the most attention... breaks enable one to understand better how something should or could work.”*  
 (Fuller & Haque, 2009)

When encouraging the reuse and re-purposing of buildings and materials Fuller & Haque, (2009) recommend the use of what they call “pre-broken” materials and buildings.

The fabric of the existing building could be considered as pre-broken. It is a utility industrial building that speaks of creating rather than an intimidating, pristine or precious building.

Pre-broken materials are materials that are discarded, unused, readily decomposed and are interrogate-able or hack-able. Because these materials aren't expected to last they encourage reuse and re-purposing and enable people to experiment and participate. Building with these materials requires constant innovation, replenishment and reconstruction and emphasises the ephemerality of architectural constructs, says Fuller & Haque, (2009).

### 8.2.2 Temporality

Materials chosen for this design were chosen based on their temporality or ephemeral feel. The inserted space is of a temporary nature and therefore the materials should speak of the transient nature of the design. Materials perceived as temporary materials will be easily distinguishable from the permanent fabric of the existing building and reinforce the concept of symbiosis between the temporary and permanent elements.

Materials already used in a temporary fashion in the Pretoria CBD were observed during the framework investigation and informed material choices.

Greef (2005, 3-6) is of opinion that South Africans reject the notion of temporary and reused materials mainly because of the perceived stigma of inferiority. By using these kind of materials in an innovative and fun way could greatly improve the public's perception and open them up to the idea. It also gives designers the opportunity to experiment with and test the use of these materials.

### 8.2.3 Availability & sustainability

Material was selected based on whether they could be sourced locally. Using available materials from the site and surrounding area are cheaper and faster. The embodied energy will also be less that if materials had to be transported over great distances. The local community could the also benefit and be involved in the collecting of materials.

## 8.2.4 Floor covering

### Interlocking, recycled rubber floor tiles qualify as a green product.

# Rubber tiles usually comes in square sizes from 300-500mm, it is a bit easier to install and can easily be mixed to create patterns. A tile can be replaced if needed.

# Sheets: Rubber sheets are better protected against moisture and water damage due to less seams than tiles.

\* Glued: The rubber tile or sheet gets glued to the sub-floor.

\* Interlock: The rubber tiles are manufactured with a locking system.

#### Pattern Options

\* Plain: Available in both tiles or sheets this floor has a smooth surface.

Recycled rubber flooring is suitable for indoor and outdoor use. It has outstanding slip-resistance, low VOC emissions, provides cushioned resilience and is very durable, stain resistant and has constant colour. (ECOsurfaces, 2005).

Installation and maintenance are relatively easy. Rubber flooring is generally considered a low-impact, environmentally friendly building material. Flooring that contains recycled rubber is a cheaper and more durable choice than synthetic or virgin rubber says TVE (2002). The energy required to process the used tyres and chemicals is lower than that used to produce other resilient flooring says ECOsurfaces (2005).

Additional recycling benefits can be realized if rubber flooring is installed without adhesive. The environmental impact of manufacturing the adhesive is eliminated and the air quality of the area where the adhesive would have been used is improved. Rubber tiles are flammable but they are 100% recyclable.

### Carpet

Styles Loop Pile: The loop pile carpet is an great all rounder both for residential and commercial use. This is due to the fairly low pile and tight weave which makes for easy cleaning and is also available in a wide range of colour combinations.

Dark colours: Deep colours create a cosier feeling in rooms, as well as disguising dirt and stains better than lighter shades. Dust and lint will show up more on darker colours, making a darker palette ideal for rooms that have high use.

This is a crucial part of the installation and serves a variety of purposes. Underlay or under felt drastically lengthens the life of your carpet and serves as a shock absorber, reducing the strain of impact on your carpet, this will also reduce pile crushing. Protecting your carpets backing from rubbing on the sub-floor is also an important function while allowing for airflow beneath your carpet. Sound and heat insulation are also added benefits.

Always use a good quality underlay, in South Africa the most common and cost effective underlay is the fibre underfelts which are classified in ranges by the gram per m<sup>2</sup> of the underlay. The minimum recommended is the 800gsm but we recommend you ask your supplier

for the 1000gms under felt which is most commonly used.

#### Carpet Pile Fibres

Blends: It is a popular practice to blend the above fibre types in order to use the best properties from each and also to reduce the cost of the more expensive fibre types like wool.

Polyester: Polyester is available in vibrant colours and has similar properties to Nylon, non-allergenic, moisture and wear resistant properties, high resistance to staining, does not fade easily and is also permanently anti-static, but lacks the same degree of durability.

**Wool:** Unique, Natural, Soft, Luxurious and more, guarantees an exceptional experience. Wool also naturally has excellent properties like, water repellent, flame resistant, resistant to crushing, extremely durable and naturally antistatic, which improves soil resistance and ease of maintenance. Wool also has good sound and thermal insulation properties and gives unsurpassed comfort underfoot. This premium fibre is in a class of its own, as its price will reflect.

## 8.2.5 Temporary local materials

cardboard boxes



wood pallets



recycled wood



plastic cold drink crates



shopping centre trolleys



printed vinyl billboards



scaffolding & shade net



Figure 177. Local material inspiration (Author, 2010).



## 8.2.6 Temporary materials on site & application examples

cardboard tubes



Figure 178. Wooden pallets used for raked seating (Michler, 2010).



cardboard drums



Figure 179. Stacked cardboard tubes creating a wall (Heaney, 2005).



wood crates



Figure 180. Stacked cardboard tubes creating a room (Ohrt, 2007).



cardboard boxes



Figure 181. Stacked cardboard boxes creating an entrance (Fairs, 2008).



paper



Figure 182. Stacked cardboard sheets creating an enclosed sound box (The Cool Hunter, 2007).



wood pallets

cardboard sheets

# 8.3 FLOOR PLANS

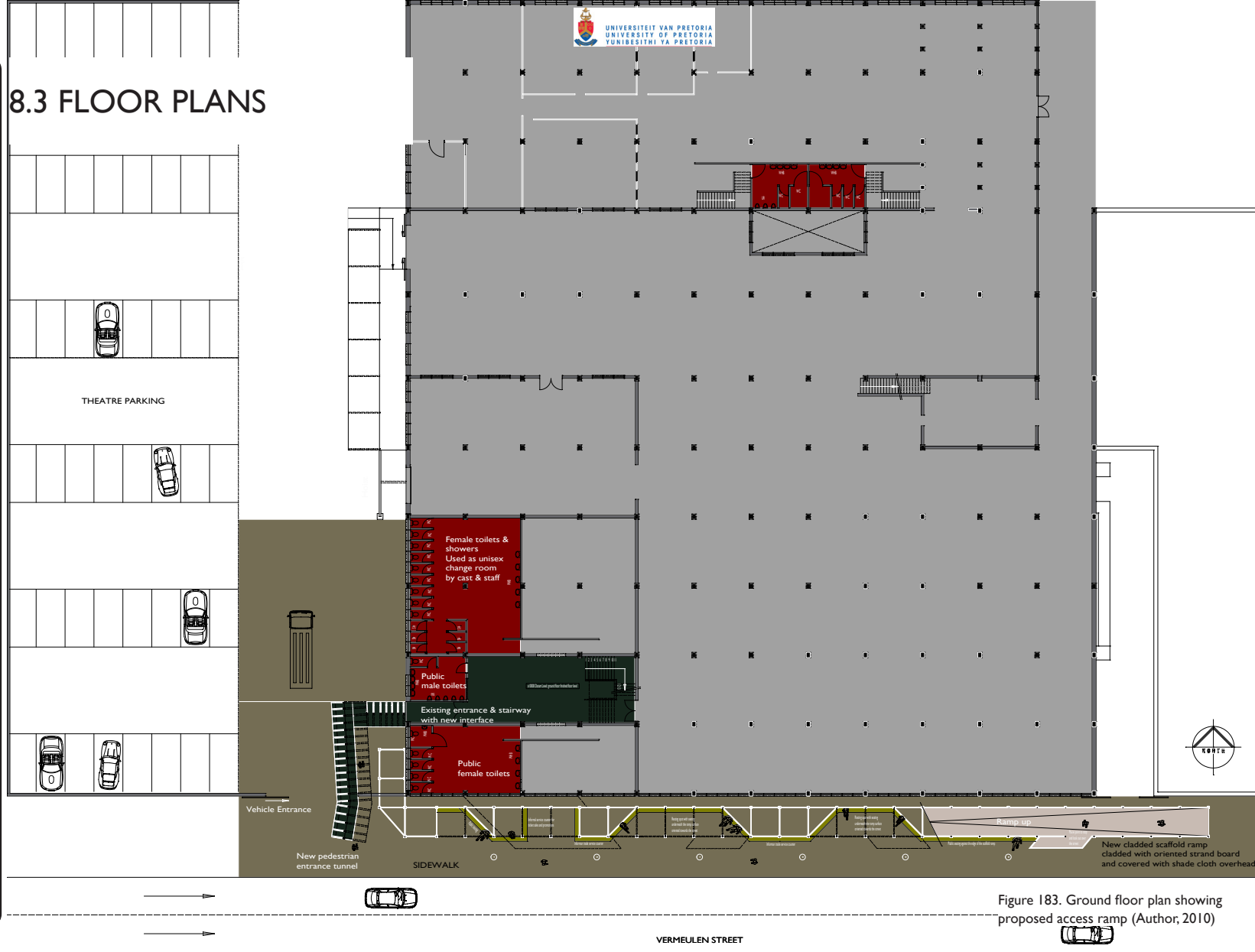

Figure 183. Ground floor plan showing proposed access ramp (Author, 2010)

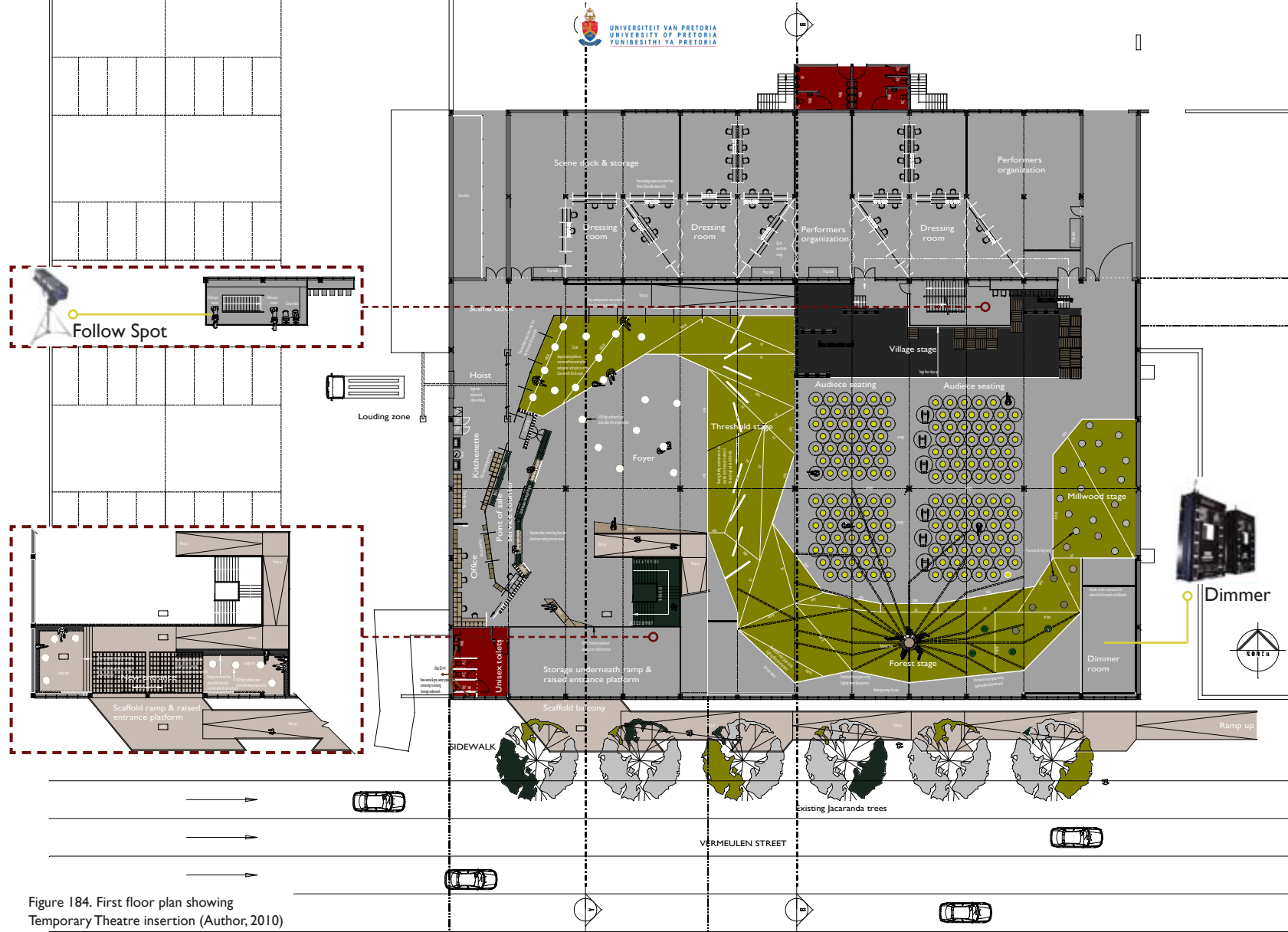
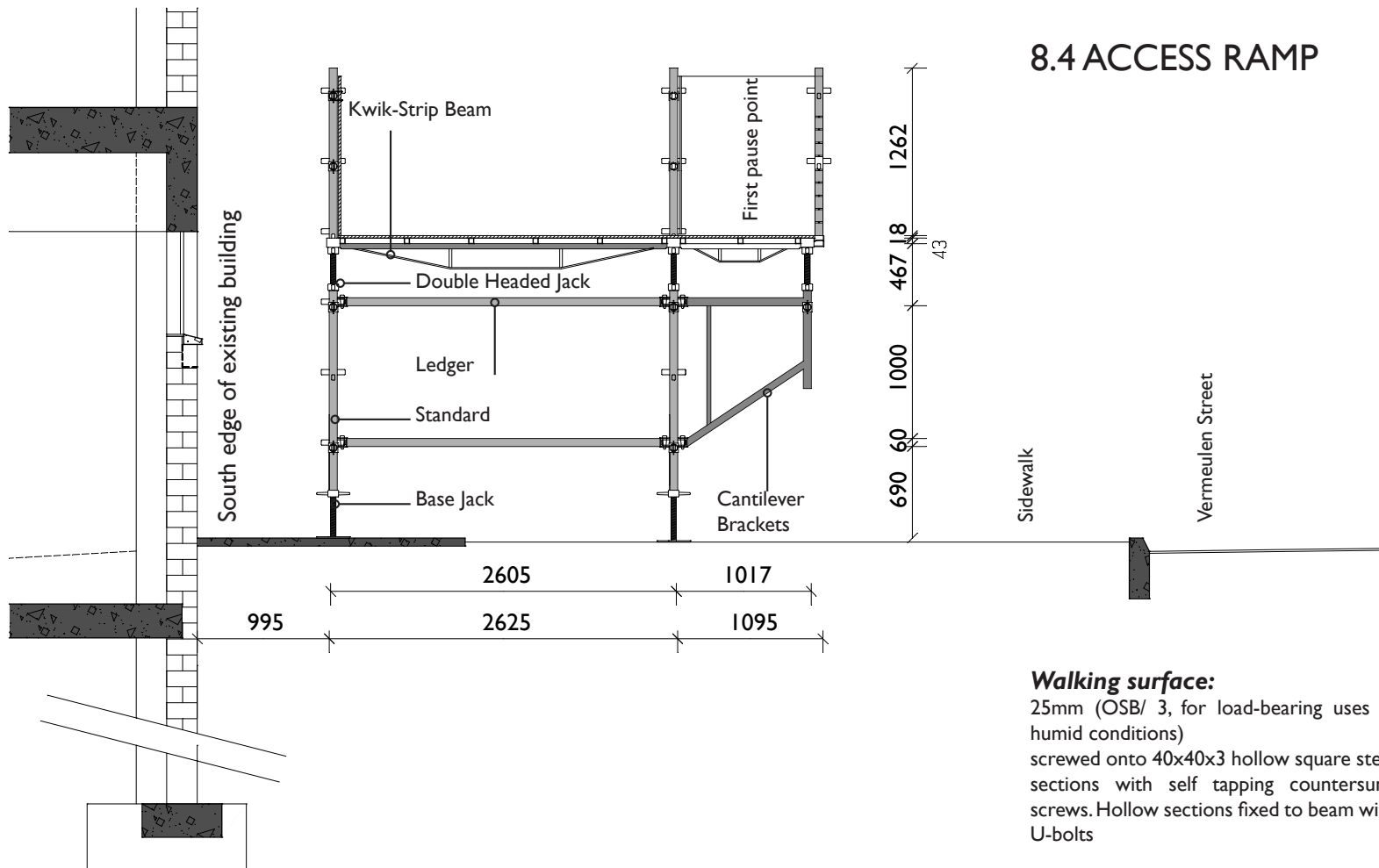

Figure 184. First floor plan showing Temporary Theatre insertion (Author, 2010)



## 8.4.1 SECTION THROUGH SCAFFOLD RAMP

1:50

Figure 185. Section through scaffold ramp  
 (Author, 2010)



# KwikAz clips

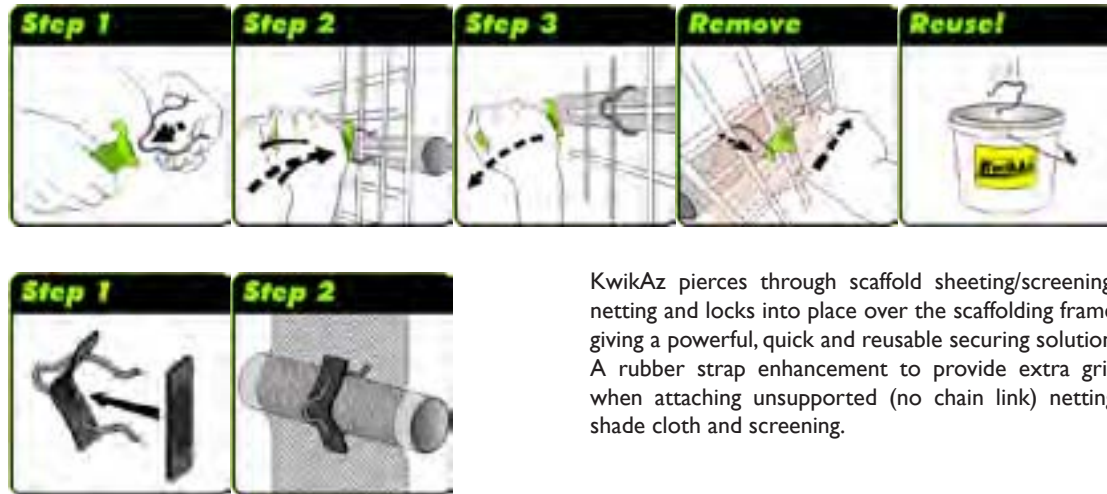

KwikAz pierces through scaffold sheeting/screening/netting and locks into place over the scaffolding frame, giving a powerful, quick and reusable securing solution. A rubber strap enhancement to provide extra grip when attaching unsupported (no chain link) netting, shade cloth and screening.



Figure 187. Example of new sliding door to be fitted in two existing window openings after windows have been removed (Marathondoors, 2010)

Figure 186. Diagrams illustrating how KwikAz clips work (Scaffold Industry Association, 2010)



Figure 188. South facade (Author, 2010)

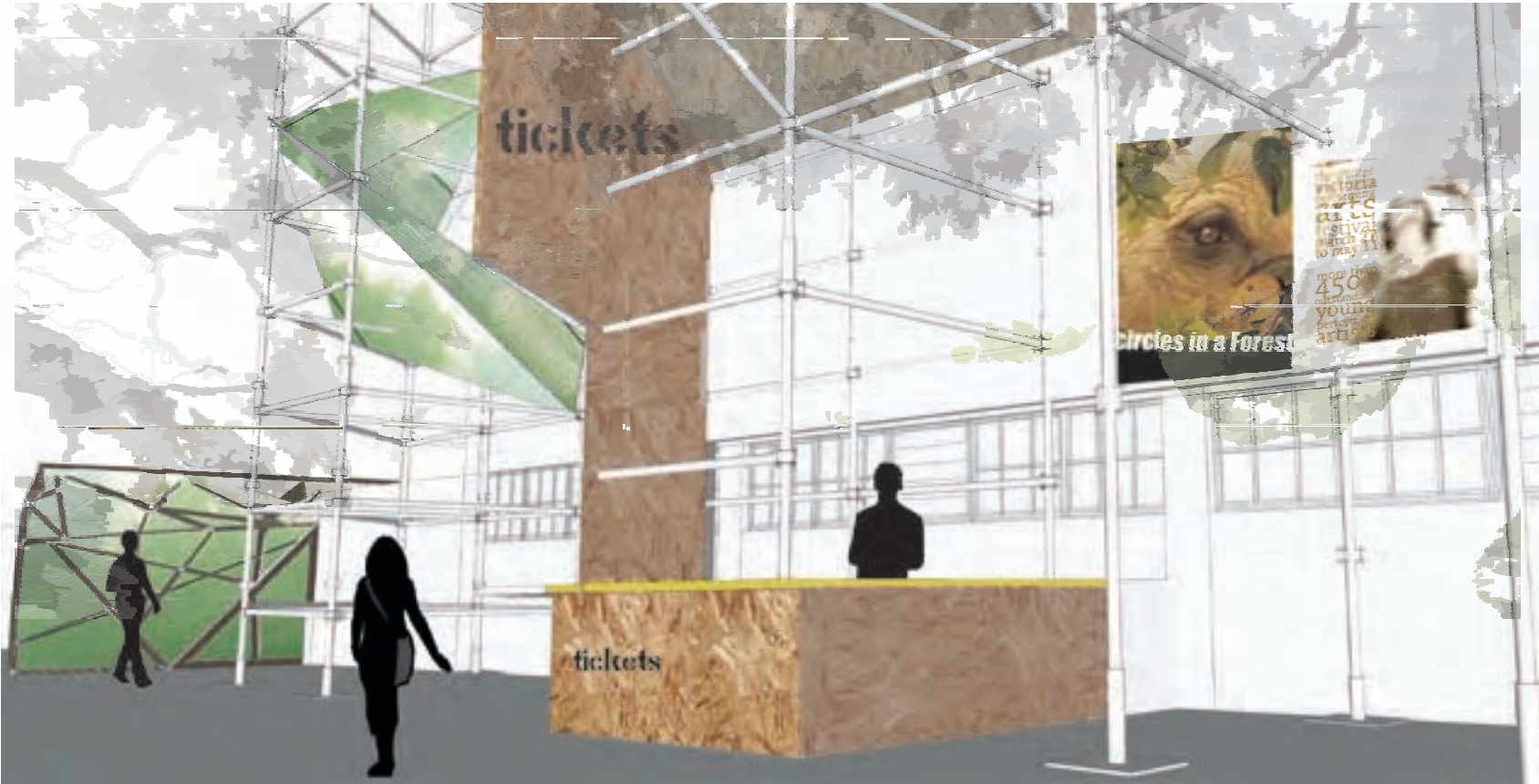

Figure 189. Perspective of space underneath the access ramp showing the secondary entrance, shade cloth wrapping & ticket sales counter (Author, 2010)

### 8.4.3 PERSPECTIVES OF STREET INTERFACE & RAMP

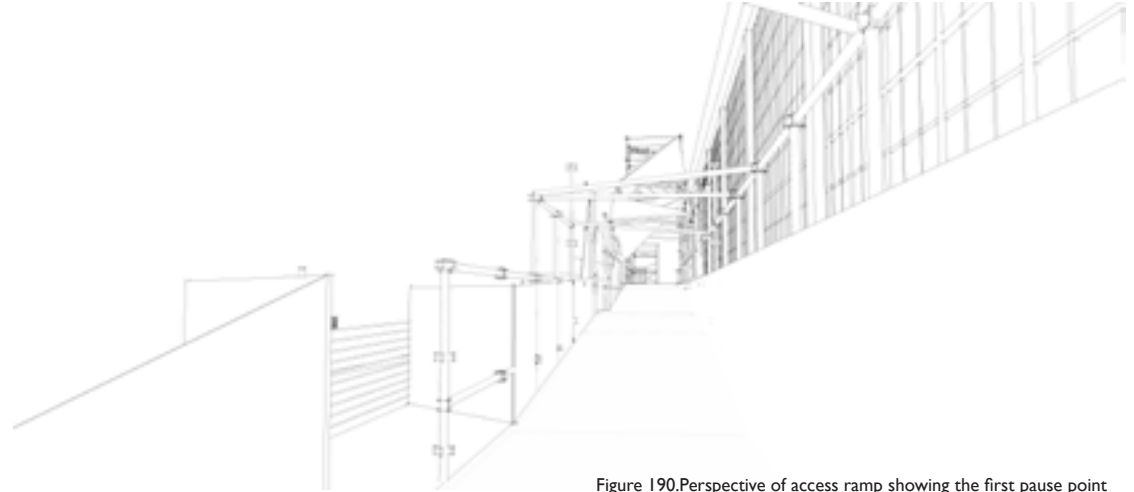
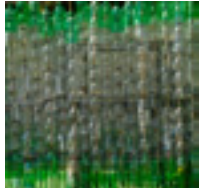

Figure 190. Perspective of access ramp showing the first pause point



Figure 191. Perspective showing seating underneath the ramp, advertisement boards & covered space to be appropriated by informal traders (Author ,2010)



Recycled plastic cold drink bottles strung together with wire rope and hung from the existing trusses.



Scaffold interior entrance ramp structure clad with 10mm oriented strand board, finished with clear varnish.



270x270x270 mm Building blocs constructed from nine pieces of 75ø cardboard tubes, cut to size and fixed together with clear silicon in 270x270x270 cubes. Cubes are fixed to each other with 4ø threaded rod through corresponding pre-drilled holes.



Lit lettering created by fixing a compact fluorescent lamp inside selected tubes. The open ends of the tube are covered with a disc of white translucent acrylic sheet cut to size. Different coloured lamps will provide additional possibilities.

## 8.5 FOYER, SCREEN & COUNTER

### 8.5.1 PERSPECTIVE VIEW AS SEEN BY VISITORS ENTERING THE FOYER SPACE FROM THE STAIRS OR THE RAMP



Recycled rubber interlocking floor tiles over the existing concrete floor.



75ø Cardboard tubes fixed together with clear silicon in 270x270x270 cubes. Cubes are fixed to each other with 4ø threaded rod.



16mm Thick layers of acrylic sheet inserted between layers of X-board to transmit light from mini fluorescent tubes fixed to the inside of the crates with cable ties.

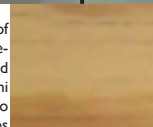

10 mm Plywood Curved over X-board at seating and service areas.

Figure 192. Interior perspective of foyer space (Author, 2010)



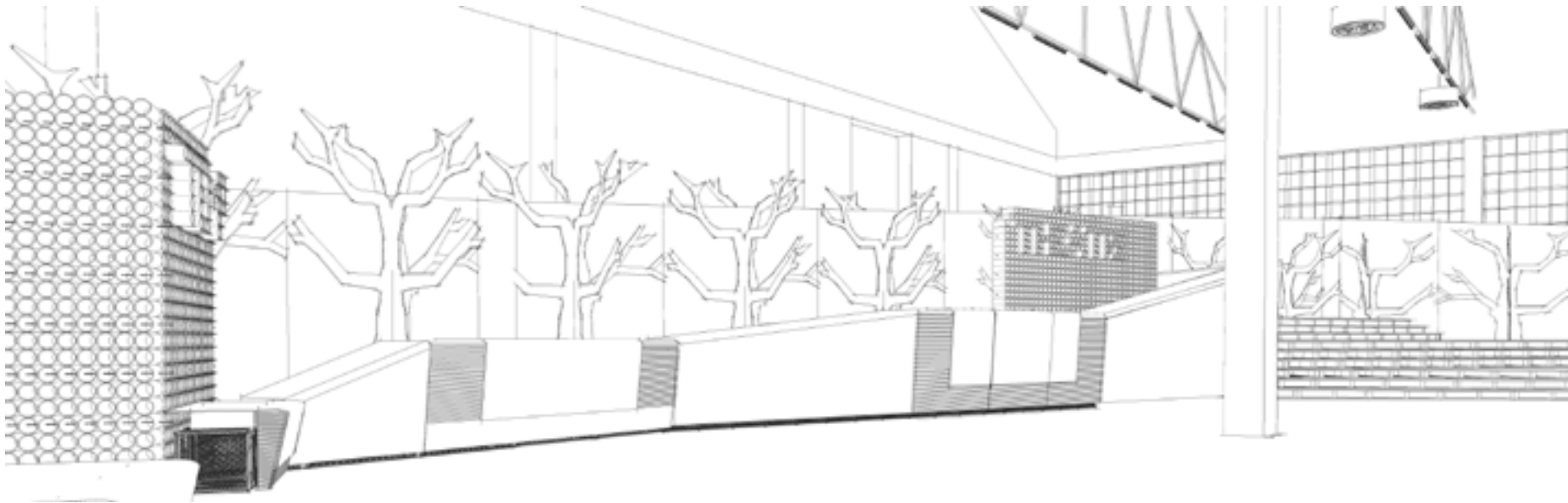

**8.5.2 PERSPECTIVES OF TREE SCREEN, TERRACED PALLET SEATING & SERVICE COUNTER**

8.5.3 DETAILING OF TICKET & INFO COUNTER

1:50

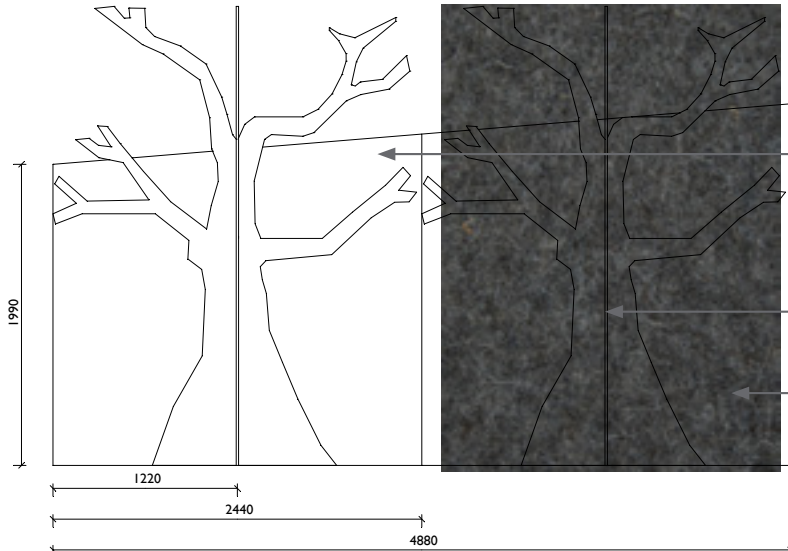

16 mm Closed cell X-Board screens, 2440mm wide each (standard sheet sizes)

16 mm Closed cell X-Board tree cut-outs to form perpendicular supports

Holes are drilled into the X-Board tree shapes. The perforated shapes are then covered with 10mm grey felt to increase sound absorption

Elevation of Tree screens separating service spaces from front of house 1:50

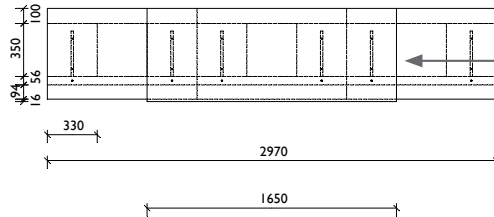

Segment of service counter consists of three 990mm long units

Plan of ticket & information counter 1:50

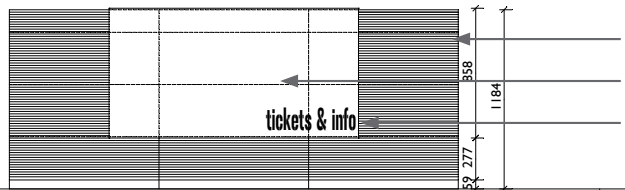

16 mm Open cell X-Board off-cuts stacked with edges exposed in elevation.  
90 Degree curved plywood to be primed and painted. Lettering painted on with stencil

Front elevation of ticket & information counter 1:50



10 mm thick, curved plywood fixed to stack of X-board with 6ø threaded rod strung through corresponding pre-drilled holes in the plywood and layers of X-board. Rod secured with a 6ø nut & washer at the top & the bottom.

Figure 193. Details of ticket & information counter (Author; 2010)

8.5.4 SECTION THROUGH REFRESHMENT COUNTER 1:25

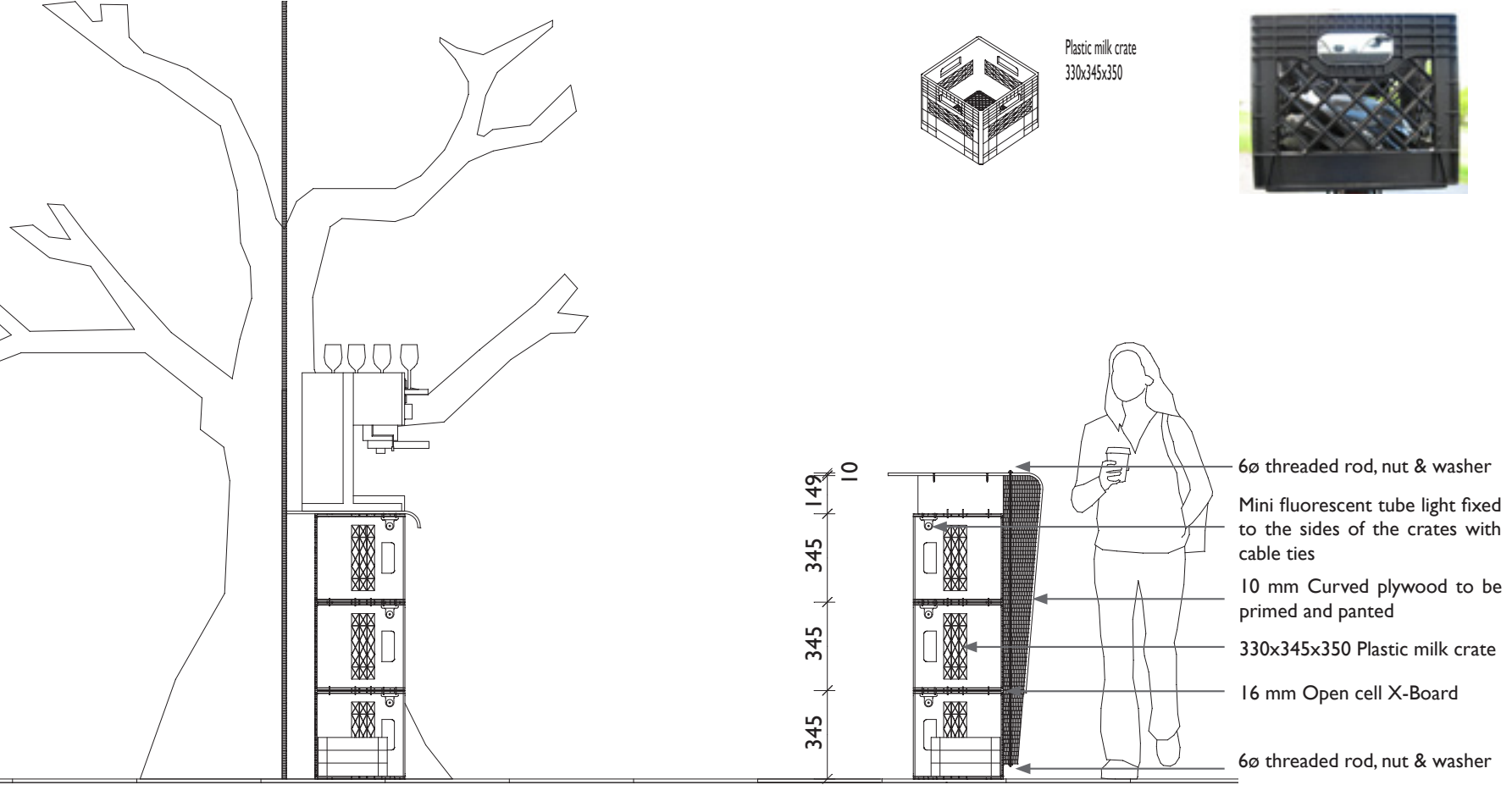

Figure 194. Section through refreshment counter (Author, 2010)

Figure 195. 1:20 Model illustrating tree shaped X-board screen supports, perforated & covered with grey felt (Author, 2010).



Figure 196. 1:1 Prototype of cardboard tube building blocks (Author, 2010)



The tube can be filled with fibre glass or any re-used material with good sound absorption qualities and the open ends covered with a disc made of metal mesh with a layer of felt glued to it.

4ø Threaded rod connector stretching the 74ø diameter of the tube and held in place by the thickness of the cardboard wall of the tube through two corresponding holes.



Figure 197. Prototype showing how tubes are joined to form a screen (Author, 2010).

Figure 198. 1:20 model of tickets & info counter (Author, 2010).

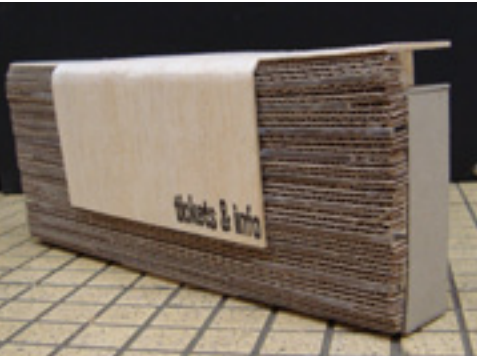

The building blocks are modular, each with two rods, one to the top(bottom) and one to the side and two holes one to the top(bottom) and one to the side. This allows the blocks to be stacked and joined in various configurations





Figure 199. Prototype showing light application of blocks & examples of felt & acrylic disc covers (Author, 2010).



Figure 200. Model illustrating lighting effect of layers of open cell X-board & acrylic sheet lit from behind with a CFL (Author, 2010).



## 8.6 LIGHTING

### 8.6.1 Existing lighting

The existing building is currently provided with 220 luminaires each with two fluorescent tube lamps. In total there are 440 lamps. Assuming that these lamps are basic T8, 58W lamps they add up to 25.5 KW

Fluorescent tube lights are discharge lamps that produce light through electric discharge when a current passes through an inert gas. These lamps use 5 times less electricity than a tungsten lamp, produce less heat and have a longer life. The light quality of these lamps is generally harsh and flat. Softer colours are available; Neon for example produces a warm red colour. Fluorescent light is diffuse and cannot be directed. These lamps can only be dimmed with an electronic dimmer. Fluorescent tube lights are mainly used for general lighting.

### 8.6.2 Replacement lamps

Luminous intensity of source = candela (cd)

Luminous flux = lumen (lm)

Illuminance (Lux) = lumen/m<sup>2</sup> = lux (lx) lx = lm/m<sup>2</sup>

On April 13, 2010 as part of the implementation measure for EU ordinance 245/2009, there will be an incremental phasing-out of products used mainly in street, industry and office lighting, namely inefficient fluorescent lamps as well as control gear and luminaires for fluorescent lamps and high-intensity discharge lamps.

The Temporary Theatre will replace these lamps with **OSRAM LUMILUX® Cool Daylight** fluorescent

lamps that have a longer service life that allows longer replacement intervals and therefore lower maintenance costs. It is also more ecologically friendly as a result of greatly reduced mercury content and full recyclability (Osram, 2010, 3).

### 8.6.3 Calculations

The recommended value of 50 Lux for the new occupancy class (A2: Theatrical and indoor sport) is much less than the 700 Lux recommended for the current occupancy class (D1: High-risk industrial). This means that the replacement lamps can have a lower Watt value. Alternatively fewer lamps can be used to achieve the necessary Lux value. Using fewer lamps will be more cost effective and when the theatre is used for other purposes more lamps can be added to suit the specific lux requirements. As a result electricity will be saved (SANS 204-2:2008).

Luminous intensity of source = candela (cd)

Luminous flux = lumen (lm)

Illuminance (Lux) = lumen/m<sup>2</sup> = lux (lx) lx = lm/m<sup>2</sup>

#### Existing D1 occupancy

Lux = lm/m<sup>2</sup>

700Lux = lm/2124m<sup>2</sup>

lm = 700x2124 = 1486800 lm

Basic T8, 58W = 5200lm

1486800/5200 = 285.9

**286 lamps needed**

Even if calculated for occupancy D1 which has the highest Lux requirement the 420 lamps are excessive.

#### New A2 occupancy

50Lux = lm/2124m<sup>2</sup>

lm = 50x2124 = 106200 lm

OSRAM LUMILUX® T8 = 5200lm

106200lm/5200lm = 20.42

**21 OSRAM LUMILUX® T8 lamps will be needed for the temporary theatre.**

#### Other possible occupancies

A1: Entertainment and public assembly: 50 Lux

A3: Place of instruction: 100 Lux

A4: Worship: 100Lux

B3: Low-risk commercial:

C1: Exhibition Halls: 300 Lux

C2: Museums: 300Lux

300Lux = lm/2124m<sup>2</sup>

lm = 300x2124 = 637200 lm

637200/5200lm = 122.54

**A maximum of 123 OSRAM LUMILUX® T8 lamps will be needed for alternative occupancies which is still less than the 440 fluorescent lamps currently in use.**

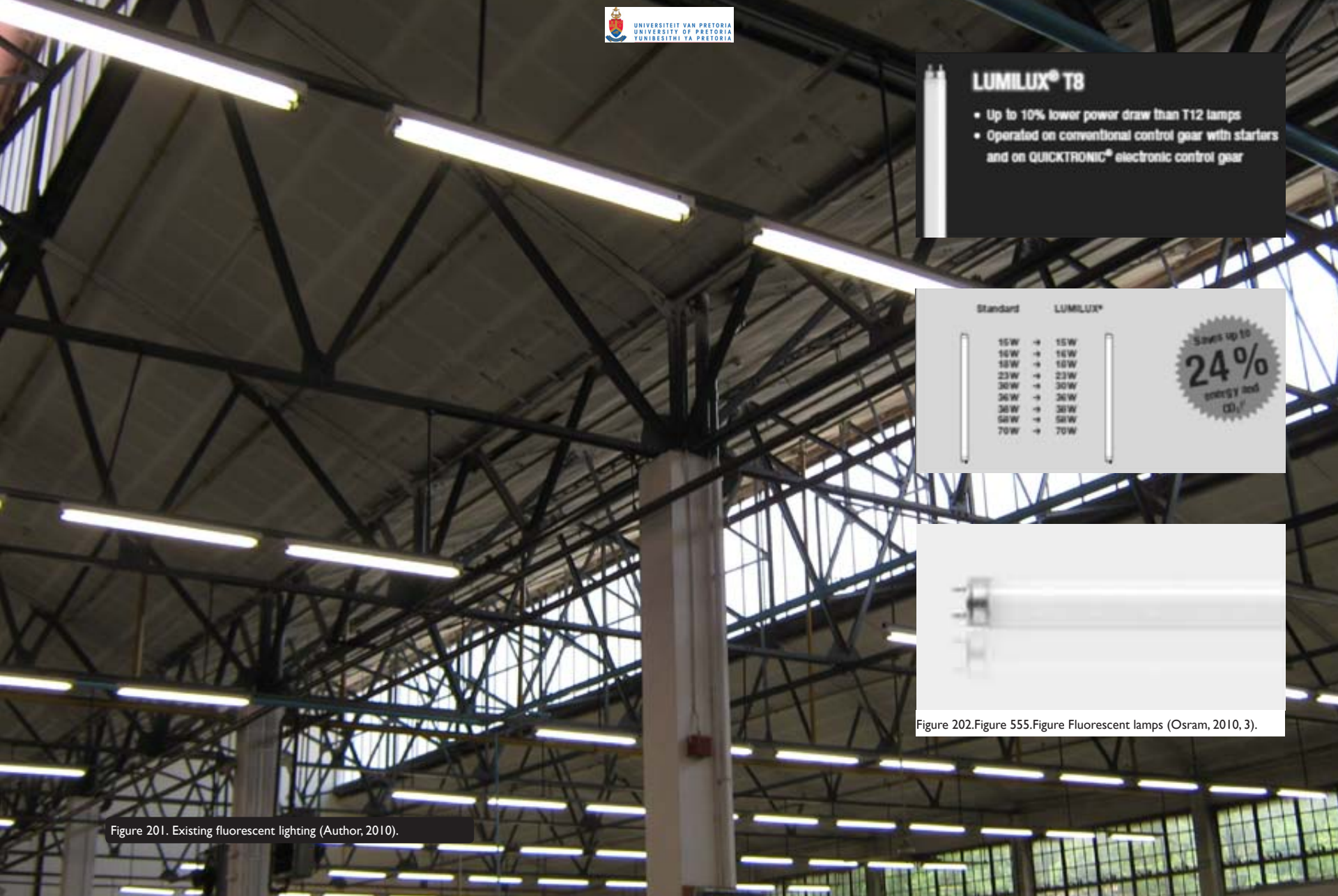

## LUMILUX® T8

- Up to 10% lower power draw than T12 lamps
- Operated on conventional control gear with starters and on QUICKTRONIC® electronic control gear

Standard		LUMILUX®
15W	→	15W
16W	→	16W
18W	→	18W
23W	→	23W
30W	→	30W
36W	→	36W
36W	→	36W
54W	→	54W
70W	→	70W

Saves up to  
**24%**  
energy and  
CO<sub>2</sub>

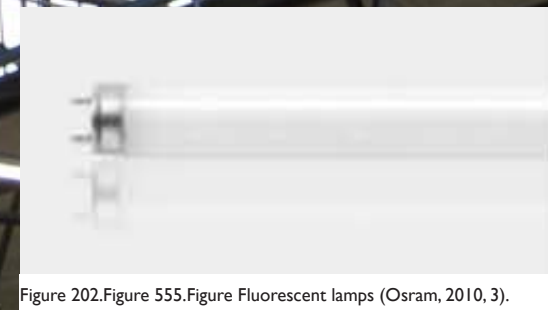

Figure 202. Figure 555. Figure Fluorescent lamps (Osram, 2010, 3).

Figure 201. Existing fluorescent lighting (Author, 2010).



## 8.6.4 Stage lighting Instruments

### Dimmers

External dimmers are relied on to control the lighting level of lights that have no built-in electronics or dimming (Cadena, 2006, 49).



Figure 203. GM 48 x 2 kW Dimmer (Author, 2010).



Figure 204. 5m Z-Line truss (Dance South Florida, 2010).

### Rigging Systems

A rigging system is used to provide a safe and convenient structure on which to hang production equipment such as lighting, sound, video, and scenic elements (Cadena, 2006, 36).

### Floodlights

PAR lights (parabolic aluminized reflector) come in varying diameters and are used to light scenes, as top lights, and for special effects. The wide unfocused beam produces an intense oval pool of light with soft edges. An adjustable knob allows the lamp unit to be rotated within its casing, changing the orientation of the oval. The colour and intensity can be altered.

### Profile Spot Fixtures

A profile spot luminaire is a hard-edge fixture that can project an image by using a gobo. The beam can be focused and controlled. It is used to light the faces of actors, to control light spill or to project scenery or graphic images (Cadena, 2006, 373).

### Follow Spots

Follow spots are used to emphasize a moving actor by increasing the brightness of the light on him over the general intensity of the stage lights. The movement of the actor is followed by a single, freely mounted spotlight. In straight drama soft edge follow spots with reduced intensity are used so that the audience doesn't notice it and only feels the effect (Parker & Smith, 1974, 368).



Figure 208. Floodlight temporarily attached to Z-Line truss (Author, 2010).



Figure 205. Parcan (Par 64) 1 kW (Mellor, 2009).



Figure 206. Profile 1 kW (Livelite, 2010).



Figure 207. Follow spot 2 kW (Arts Council of Northern Ireland, 2010).



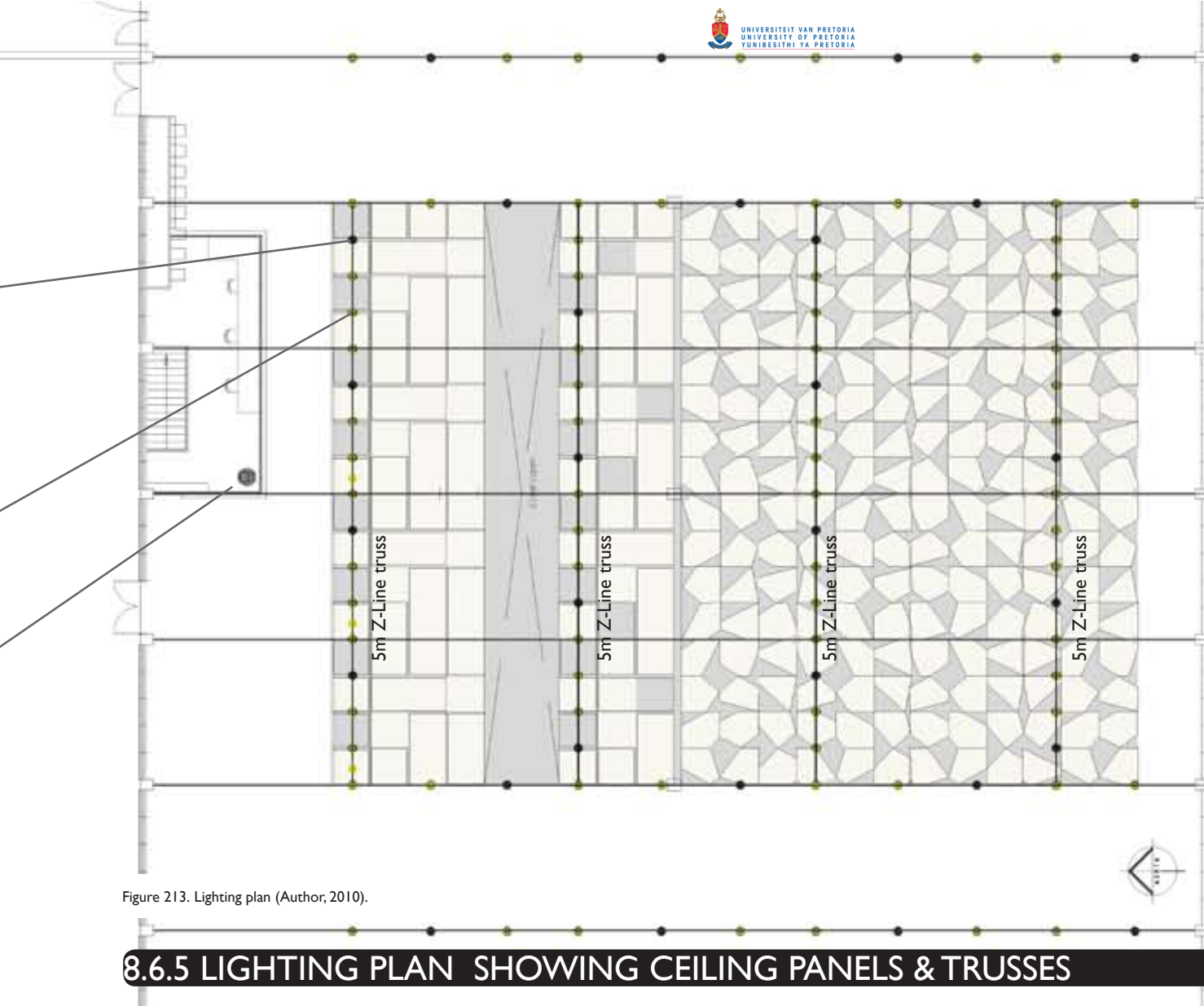

Figure 213. Lighting plan (Author, 2010).

## 8.6.5 LIGHTING PLAN SHOWING CEILING PANELS & TRUSSES



Figure 209. Floodlight effect 2 kW (Berne, 2010).



Figure 210. Follow spot effect 2 kW (McGill, 2007).



Figure 211. Gobo effect 2 kW (WeddingWire, 2010).



Figure 212. Profile spot effect 2 kW (Mellor, 2008).

NOT TO SCALE

## 8.6.6 Light & Colour

### Colour experience

The expressive content of a colour can stimulate, relax or depress the feelings of the viewer. Reds quicken the heartbeat, greens are restful, and neutral hues can be depressing. The impression is registered in terms of colour and brightness. The experience of colour is a physiological, intellectual and emotional process. Tradition and personal frame of reference can also condition an emotional response (Parker & Smith,235).

The six basic spectrum hues can be described in terms of their emotional response:

**Yellow:** Radiant, light giving, golden, saintly; in light values near white, virginal.

**Orange:** Festive, earthly, peasant colours, warmth, neutral shades, nature in the fall.

**Red:** Danger, active, passionate, full of inner warmth, fiery, strong, forceful, anger war.

**Violet:** Royal, piety, deeper shades, shadows, terror, chaos, a reddening colour.

**Blue:** Passive, receding, restraint, detached, deep, cold, purity, icy tints.

**Green:** Tranquillity, compassion, restfulness, nature in the spring and summer.

**Black:** Evil, dominance

### Coloured light and the actor

Startling colours will be avoided for the acting areas as it will adversely effect the faces and costumes of the actors. Often the acting area is lit with tints of pink and amber that is flattering to the faces of the actors but deadly to green materials. For the forest stage shades of green will be used in the scenery. These acting areas will be lit with clear light which appears warm when used in conjunction with cool colours on stage such as green.

Green light has limited use on the acting areas of the stage. Green adversely effects the human face; cheeks and lips appears muddy, blond and reddish hair look dead and any blemish becomes grotesque. Green light will only be used on the acting area of the destruction stage where a distorted effect is desired.

Green light will be used on the transitional scenery between the threshold and the forest and the forest and the destruction stage. On scenery green light is especially enriching (Parker & Smith,394).

### Coloured light and the scenery

The lighting should enhance the scenery. Only tints of light will be used. Strong colours tire the audience and tend to distort the colours of the scenery. Light intensifies, brightens and makes the colour of paint appear lighter. The colour of scenery was chosen a shade or two darker than the desired colour.

On the background stronger colours can be used to

show the time of day, weather conditions and other effects. Delicate and precise shadings require different colours to be blended in stead of using a single colour medium (Parker & Smith,395).

### Colour media

A gel or gelatin is the most typically used because the sheets are very thin, the colour range is extensive and it is the cheapest. The plastic like coloured sheet is bought and cut into the desired sizes and placed in the colour frame of a luminaire. They have to be replaced quite often but can last up to two years (Parker & Smith,395).

## 8.6.7 Light as scenery

The most familiar form of light as scenery is projected imagery and live footage. However curtains and columns of light are also included in this definition.

At this point in time the use of projections have developed past a sensational novelty and extreme experimentation. Now designers can draw from previous crude and successful examples and apply projections more effectively, economical and subtly in order for it to be a supporting element rather than overwhelming and distracting.

For the purpose of this study projections will be employer as it embodies the concept of symbiosis between the temporary (ephemeral projected light image) and the permanent (tangible object, surface or plane projected on).

Projections will be used to reinforce the setting or milieu and to incorporate the original culturally idiosyncratic text into the space.

Because of the temporality of light and projections it is more flexible, multi- functional and sustainable. Although the equipment necessary are currently expensive and rely on electricity creating and projecting an image is quicker and less resource and labour intensive.

Projections are usually applied to the background; not as a substitute realistic background but as a medium of its own and best expressed in abstract or thematic terms becoming an additional actor.

Projection= light source + medium (slide/electronic) +

image+surface (called the screen but can be anything)  
Projection equipment can be placed in front of an opaque screen or behind a translucent screen normally used for shadow projection (Parker & Smith,440).

### Tips for a clear image

- Use dark colours in your setting.
- Keep reflective surfaces on the floor to a minimum
- Baffle reflected light from the stage with a black gauze in front of the screen. This is especially useful in back projection.
- Light actors from the side reducing damaging front light.
- Give the screen a black border to sharpen the projected image by contrast.

## 8.6.8 New temporary diffusers

The thesis investigates the temporary reuse of an existing building by means of insertion. The intention is to avoid too much major permanent changes and to utilize as much of what is existing as possible. To support this intention the design decision was made to use the existing lighting fixtures. As mentioned fluorescent light is mainly used for functional lighting. To create a more intimate theatre atmosphere that is in keeping with the text new, designed temporary diffusers will be suspended from the horizontal members of the existing angle iron trusses so that it hangs underneath the fluorescent tubes at varying distances.

The design of the diffusers is inspired by the way gobos work. A gobo, also known as a break up pattern is a mask used to create patterns, shapes or dappled light effects on the stage. A shape is cut into a disc of aluminium, stainless steel, or glass that is inserted in the focal plane of a luminaire. Gobos come in many shapes, but often include leaves, waves, stars or similar patterns (Cadena, 2006, 254).

The diffusers will be made from cardboard drums cut across the width into two cylinders of varying length. A circular disc of translucent acrylic sheet, cut to size is then loosely placed inside the drum. The metal reinforced edges of the drum have a smaller diameter than the rest of the drum. After the drum is cut there will be two cylinder pieces with one metal edge each. The diffuser will be suspended with the metal edge to the bottom so that the acrylic sheet will be held by the smaller diameter of the drum. Before installation, twig and leaf shapes are laser cut out of the acrylic discs. Shades of green and yellow acrylic will be used for the discs.



Figure 214. Aluminium gobo (West Bay Opera, 2006).



Figure 217. Gobo inserted in the focal plane of a luminaire (GoboMan, 2010).



Figure 218. Gobo inserted in the focal plane of a luminaire (Merrell, 2009)



Figure 216. Acrylic disc with laser cut pattern (Author, 2010).



Figure 215. Cardboard drum found on site and cut into discs (Author, 2010).



"Of the original phenomena, light is the most enthralling.  
Leonardo da Vinci" (Cadena, 2006, 213)

Green lights distorts the human face while warm yellow livens the face creating a visible duality and separation among the audience



Figure 219. Insert acrylic disc into the drum (Author, 2010).

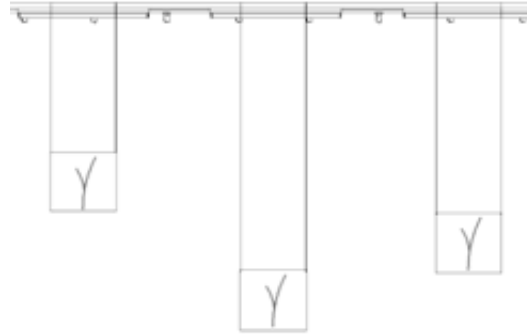

Figure 220. Elevation of hanging diffusers (Author, 2010).

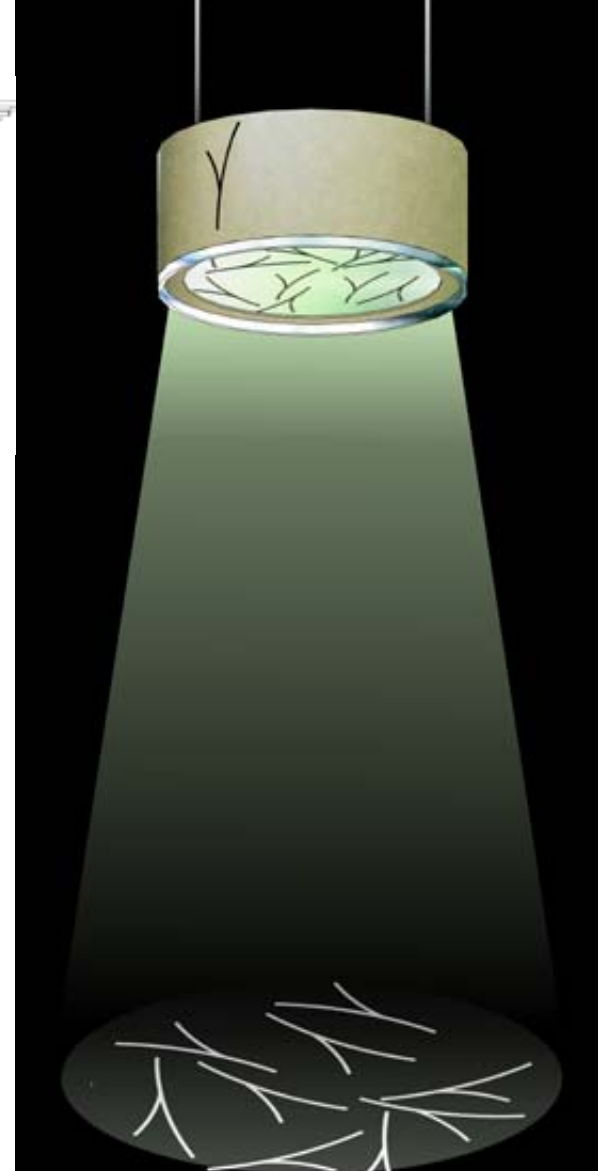

Figure 221. Lighting effect of diffusers (Author, 2010).

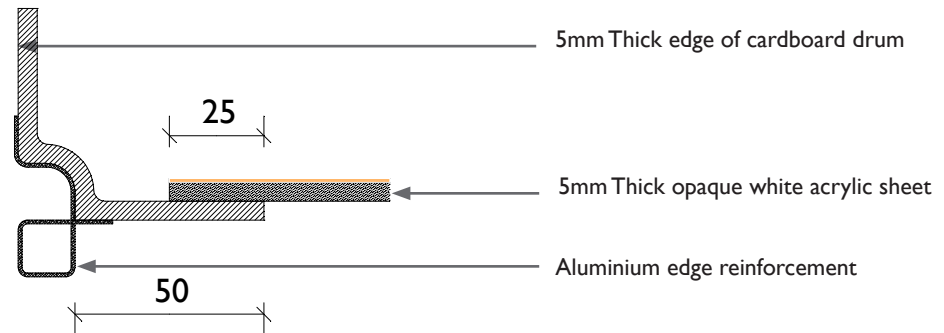
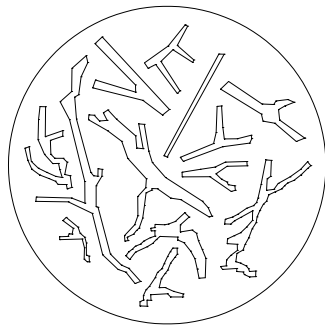
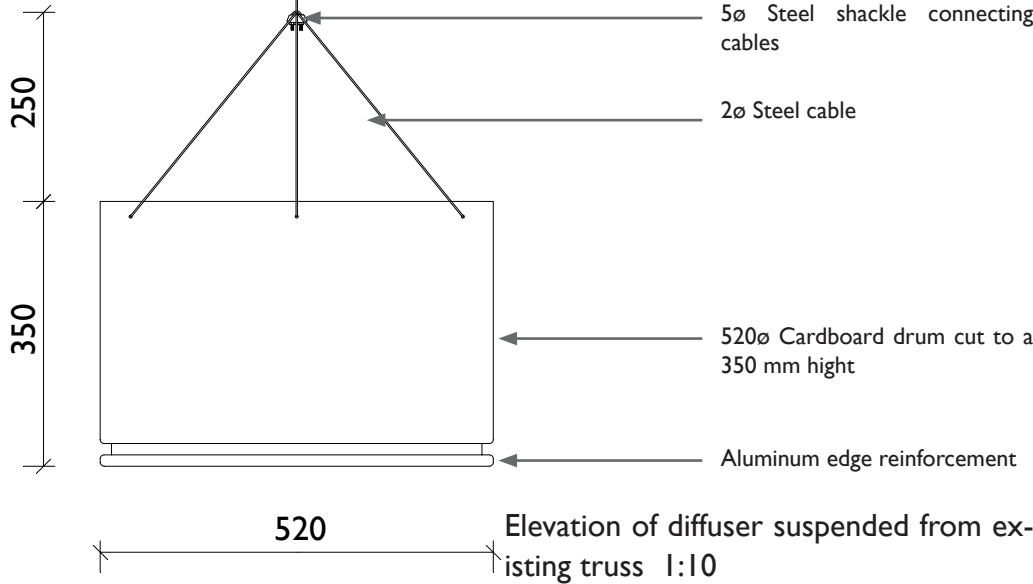

Figure 222. 1:1 Prototype of cardboard drum diffuser (Author, 2010)

Figure 223. Details of cardboard drum diffuser (Author, 2010)

Plan of acrylic sheet "gobo" insertion 1:10

Section through the edge of the diffuser 1:2



Cables united and tied together with a 5ø steel shackle

Three 4ø holes drilled 20mm away from the edge of the drum  
2ø Steel cable looped through

420ø round acrylic disk with twig pattern laser cut before assembly

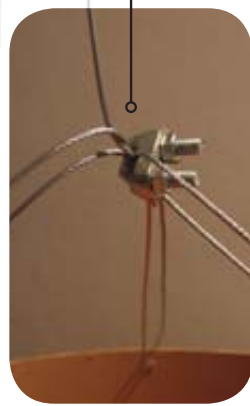
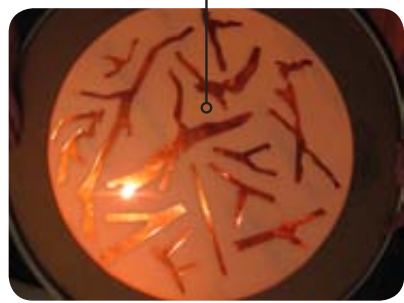

Figure 225. Photo's showing diffuser assembly (Author, 2010)

Figure 224. Interior perspective showing diffusers & drinks tables from cardboard drums (Author, 2010)

# 8.7 SECTIONS







Figure 226. Section A-A showing Threshold stage & adjustable screens with forest projection (Author, 2010)

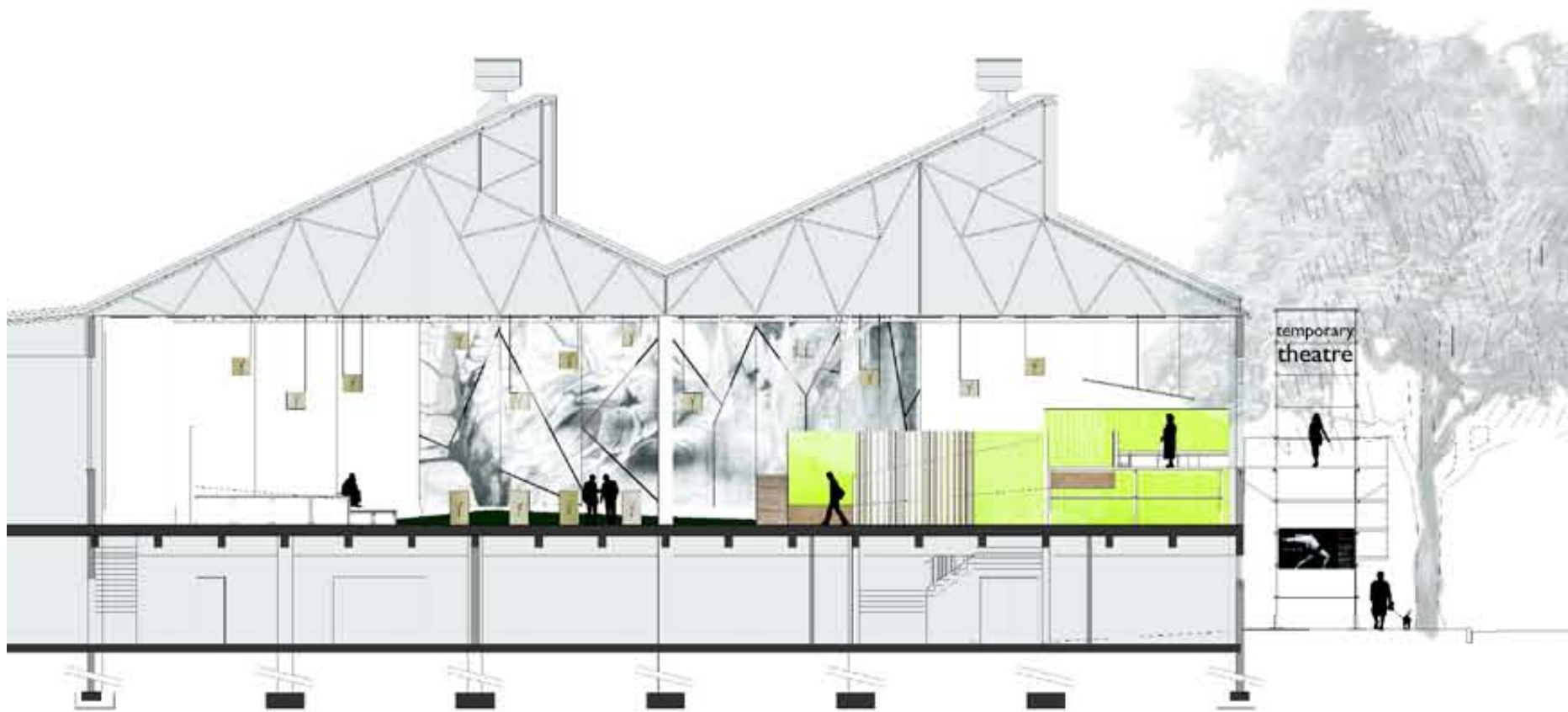

Figure 227. Section A-A showing Threshold stage with adjustable screens & changing projections to show destruction, 1:200 (Author, 2010)

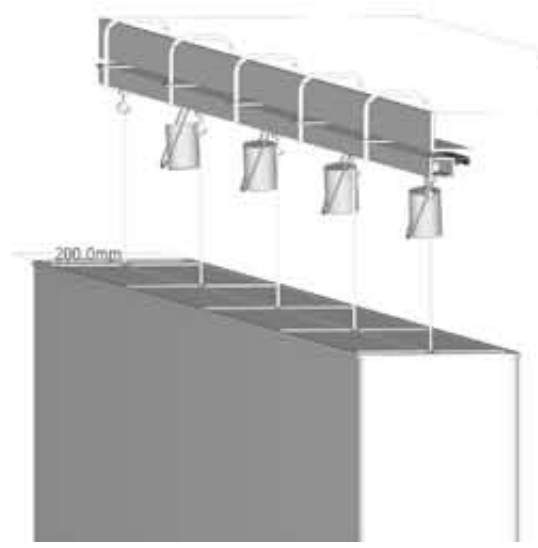

Figure 228. Curtain screens with lighting (Author, 2010)

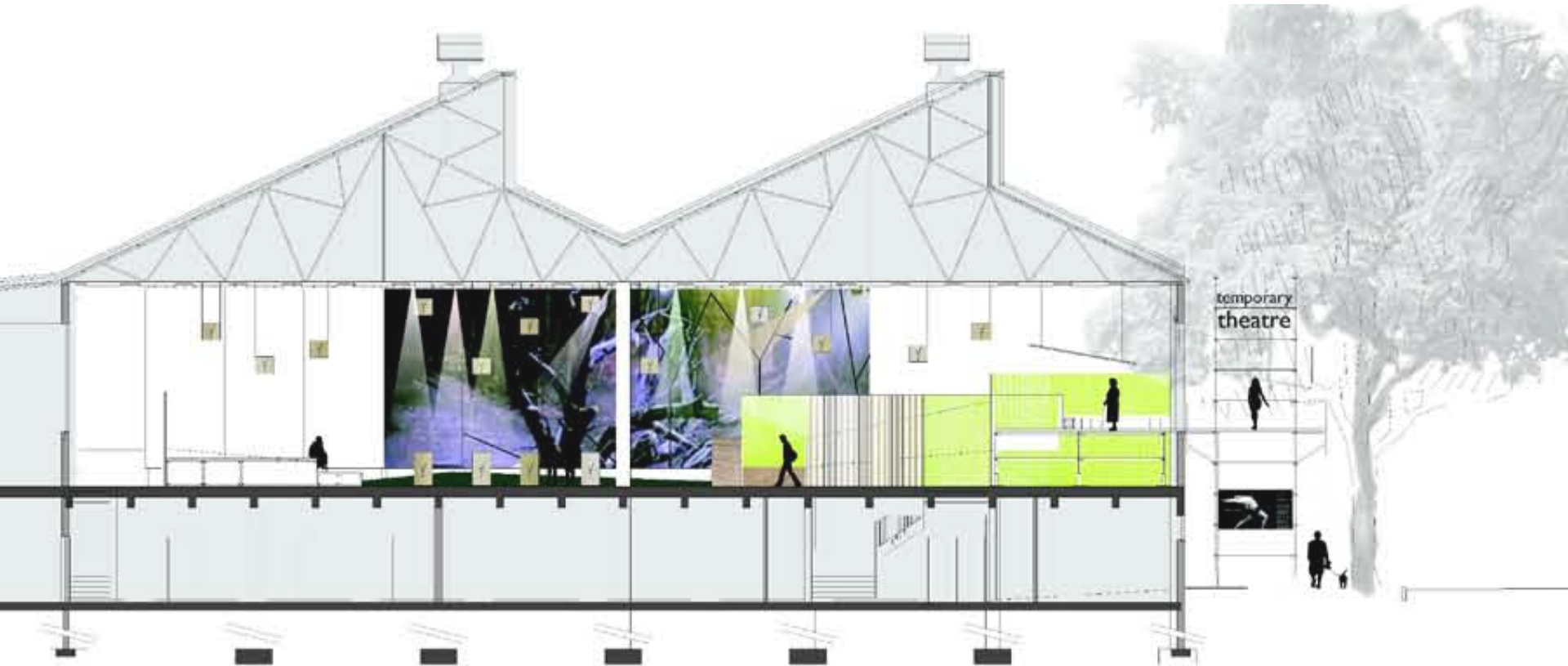

Figure 229. Section A-A projections depicting Maska's spiritual forest, 1:200 (Author, 2010)



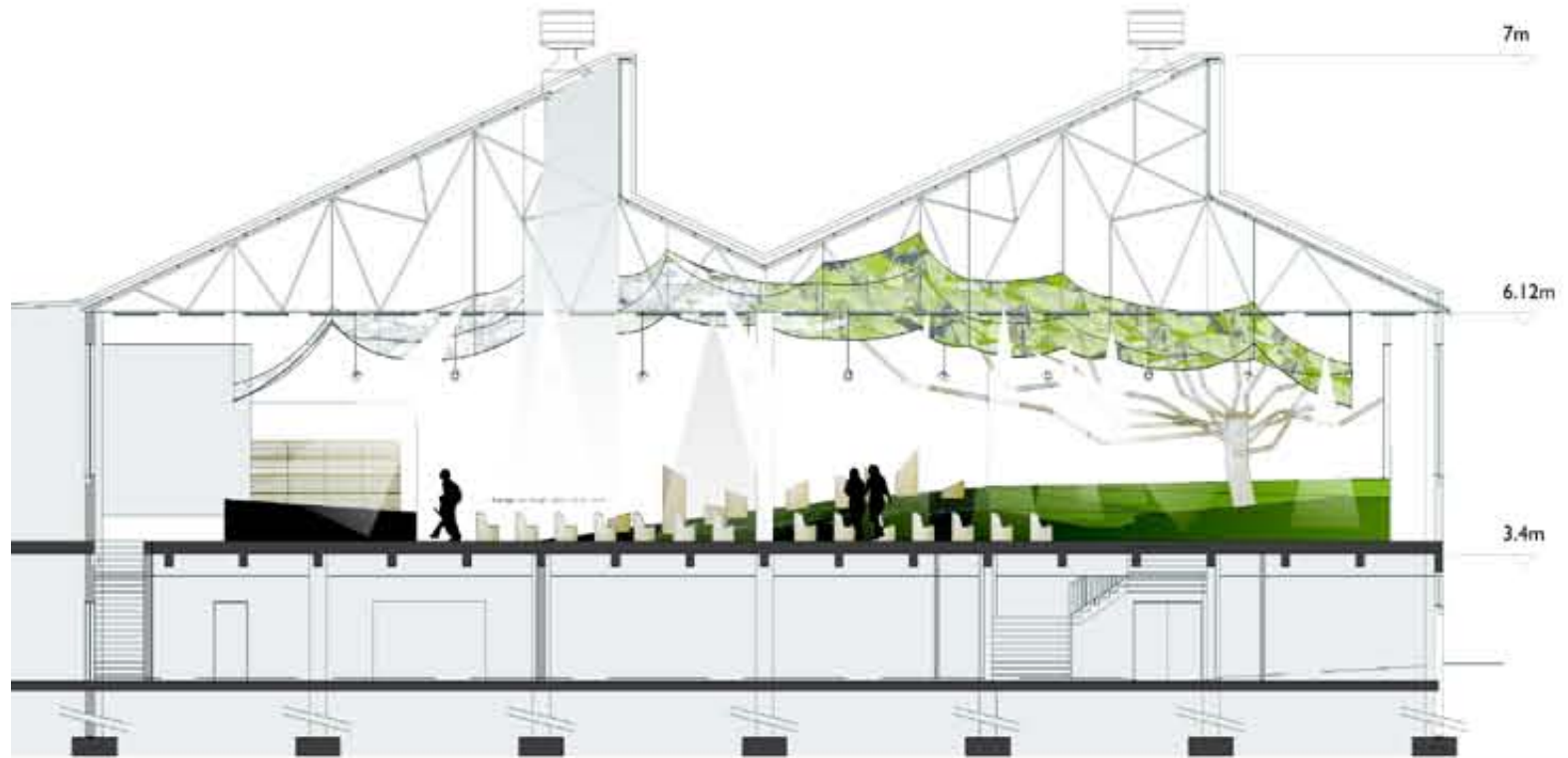

Figure 230. Section B-B showing the ceiling panels & the audience caught between the Forest & the Village stage (Author, 2010)

## 8.8 INTERIOR PERSPECTIVES

*“Maska, you used to tell us that the spirits live in the trees” (1986, 240)*

*“He would hide in the forest so that nobody would ever find him. Surely God could not have seen down into the forest from up in the sky, even the sun has to struggle to shine to the ground. Only specks of sunlight got through that roof of the tree tops” (Mathee, 1984, 47)*

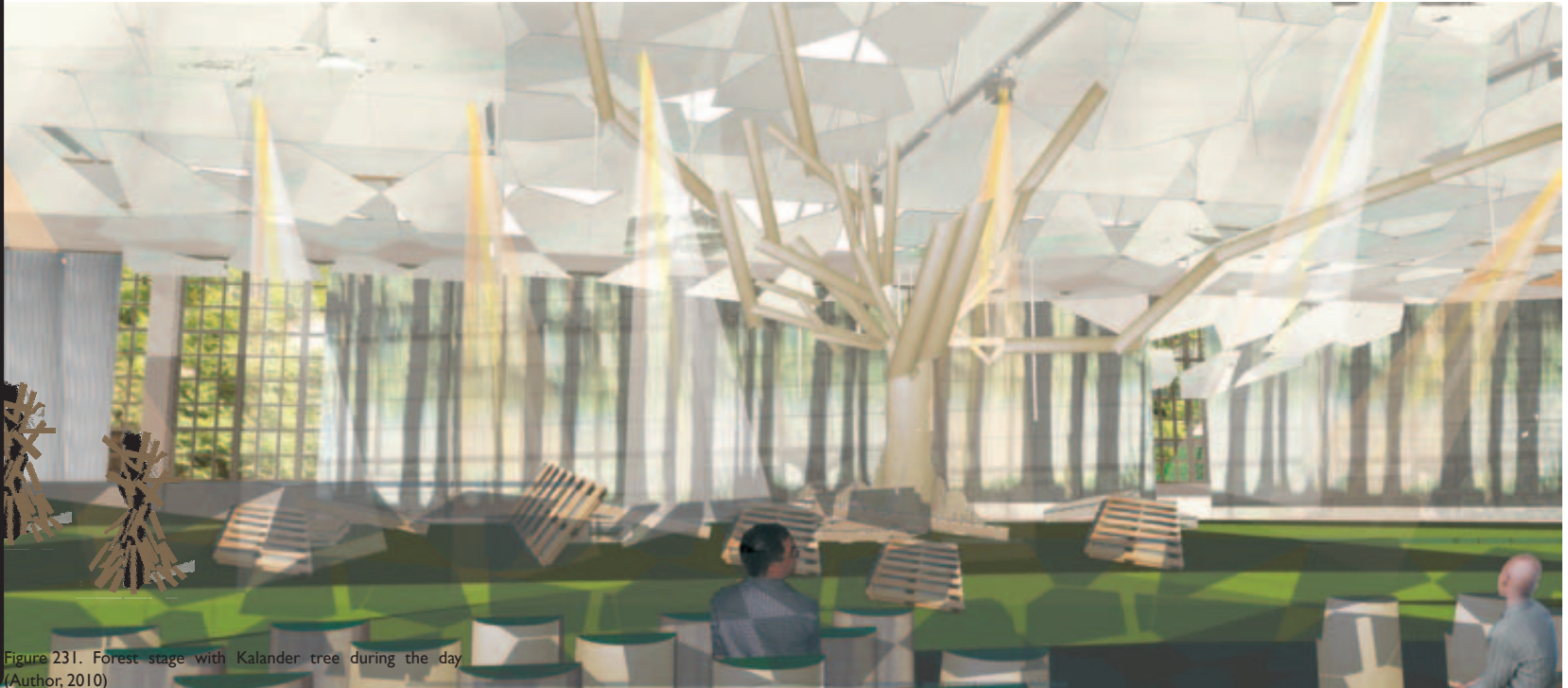

Figure 231. Forest stage with Kalandar tree during the day  
(Author, 2010)

*“By the time it was dark they were back in the forest. It was like a thick blanket closing around your body, warming you against the cold,” (Matthee, 1984, 61)*

*“They came to know the shrubs of the underbrush: which were medicine and which were not; which berries you could eat and which not.” (Matthee, 1984, 18)*

8.8.2 FOREST STAGE AT NIGHT WITH ARTIFICIAL LIGHT

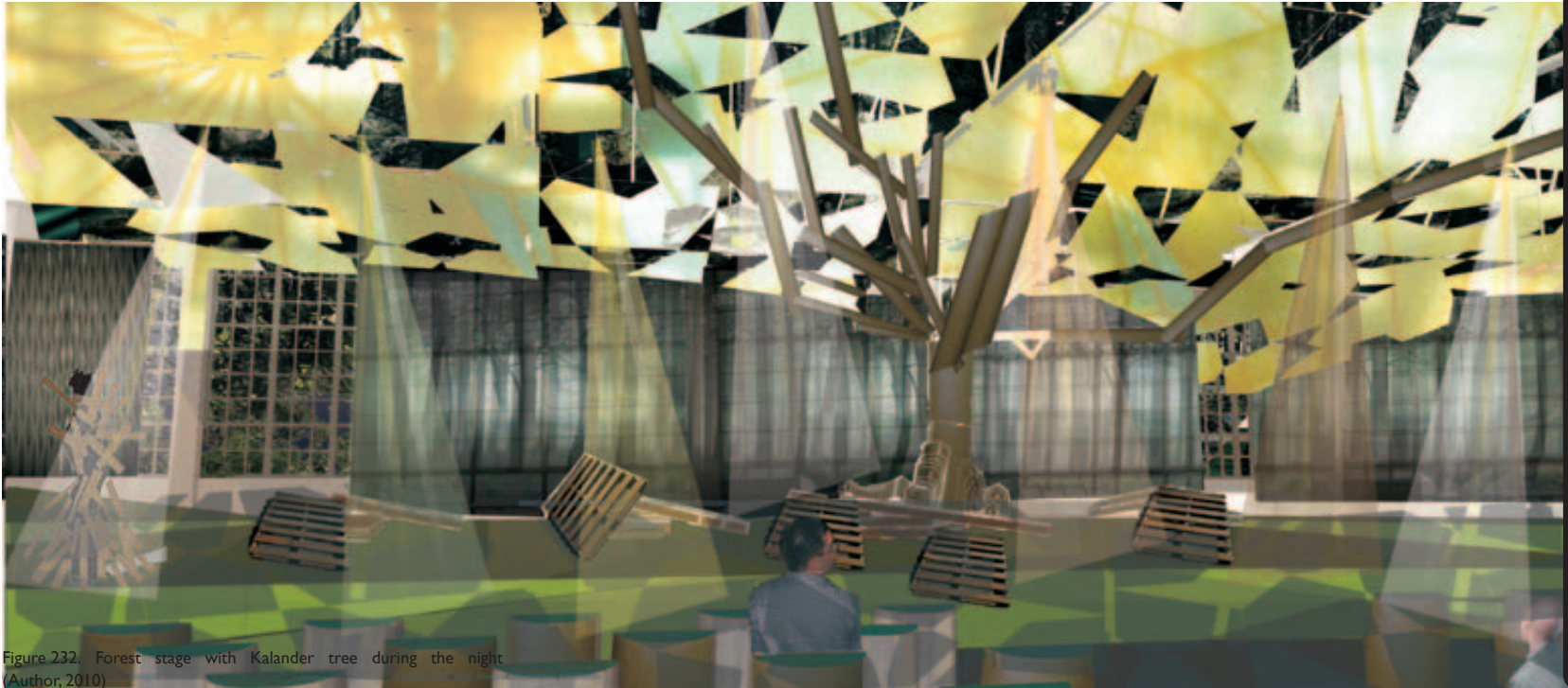

Figure 232. Forest stage with Kalander tree during the night (Author, 2010)





At the beginning of the play 'living trees' (extra's in costume) are standing inside the cardboard drum tree stumps

As the play progress they gradually exit the stage leaving the red painted stumps exposed to depict the gradual destruction of the forest

*"Where Harrison or his men stopped them today, they felled tomorrow because the Government were putting pressure from the west for more and more wood for railway lines, wood for jetties, wood for harbours, wood for the mines, wood for making wagons that had to take man and his possessions north! Wood for tables, wood for chairs and cupboards and beds! Wood! Wood! Wood!" (Matthee, 1984, 109).*

*"...where diggers' axes had hacked out everything to make space for the tents and houses, and to provide firewood."  
(Matthee, 1984, 109)*

Saul follows old foot in circles through the forest. Eventually Oldfoot leads him to Millwood to show him the destruction. This is also where Oldfoot gets shot by a gold prospector

Figure 233. Perspectives of the Threshold stage showing destruction (Author, 2010)



*"Everybody was shooting, everybody was felling. Harrison's control was not strict enough; where he warned them off today, they cut open the roof of the forest that should have protected the seedlings tomorrow. Or they shot the cows that should have calved in the spring. Harrison says, the way they're felling now, there will be little more than fifty years left for the forest...How long for the elephants."(Matthee, 1984, 109).*

Figure 234. Concept model for 'Living tree costume' (Author, 2010)



*And nobody ever told him that the village was not in the forest.” (Mathee, 1984, 53)*

*“They came out of the forest on the eastern side of the town. One moment the forest was still around and above them, the next moment it started thinning out, getting lighter...more sun and then suddenly the world was lying open. Naked. Like someone without a hat. Without a roof. He wanted to turn round and run back to the shady shelter of the forest. The sun was hurting his eyes.” (Mathee, 1984, 54)*

Villagers “traveling” through the audience from the Forest stage to the Village stage to sell the “chopped wood”



Figure 235. Interior perspective showing Millwood stage & audience seating between Forest & Village stage. (Author, 2010)

*“He stayed behind the wagon when they came to the first houses. Far apart to start with. Then closer together. Square and white, their roofs neatly made of thatch. And the fear that was in him was not the same fear as for bigfeet, it was different, he was surrounded by it, he was in it.” (Matthee, 1984, 55)*  
*“...enormous. Wood was stacked up everywhere, wood wherever you looked! Mountains of wood. Next to a large shed men were loading some of the wood on other wagons...” (Matthee, 1984, 56)*



## 8.8.5 WOOD BEING PROCESSED IN THE VILLAGE



Figure 236. Interior elevation of the Village stage (Author, 2010)

# 8.9 KALANDER TREE DETAIL

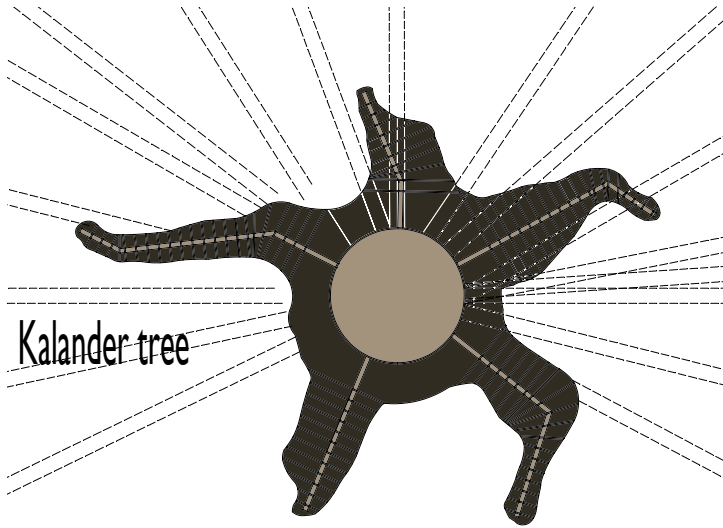

Plan of Kalander tree 1:50



Base of Kalander tree cut from 16mm X-board

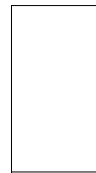

1100mm High, 590 ø,  
cardboard drums placed  
in the centre of the root  
construction  
1:50

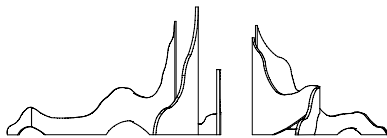
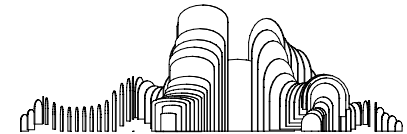

Vertical root profile shapes cut from 16mm X-board  
and fixed perpendicular to the base with wood screws  
,from underneath the base, in a radial fashion  
1:50

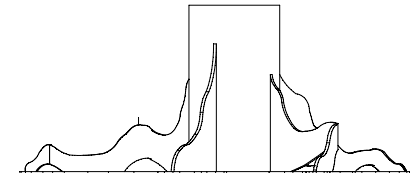
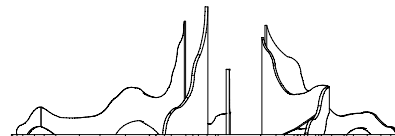
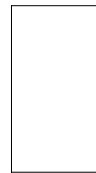



“...enormous”  
 “Standing with his feet almost in the water of the Homtini...The most beautiful...Towering above all other trees. Giant roots anchored it to the ground like giant arms. Grey bark hung like dry strips of skin”  
 “The old man’s beard, moss in its branches hung like thin green hair, waving eerily in the wind.” (Mathee, 1984, 74)  
 ... something tells me that tree is alive! If he was dead he could not have grown and if you live, you can feel and if you feel you’ll be afraid to go dead”

Figure 237. Detailing & assembly of the Kalander tree (Author, 2010)

Perpendicular bracing from corrugated cardboard sheets cut to root section profiles and slotted over vertical element provide thickness to the roots  
 1:50

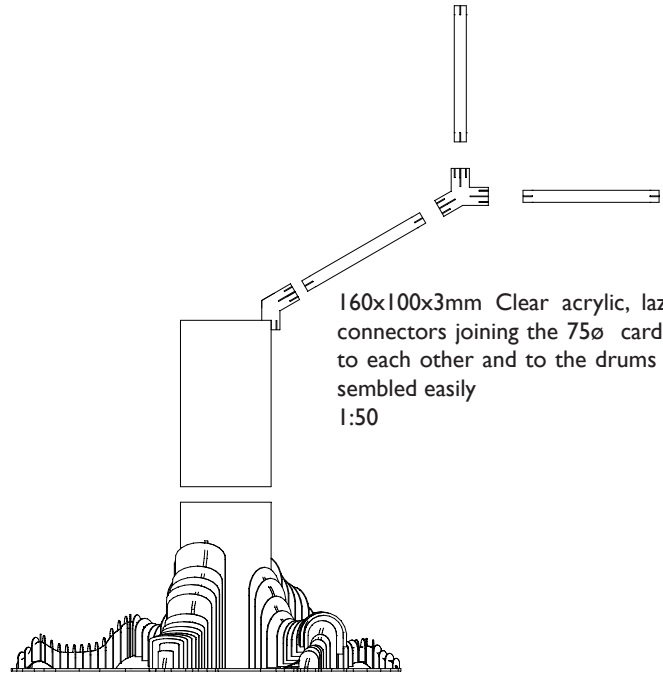
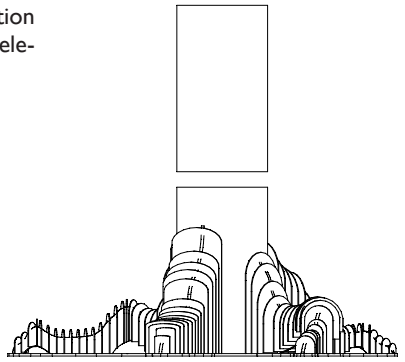
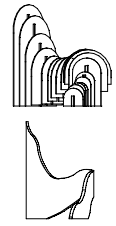

160x100x3mm Clear acrylic, lazer cut slot connectors joining the 75ø cardboard tubes to each other and to the drums to be disassembled easily  
 1:50

160x100x3mm Clear acrylic connectors  
 joining the 75 $\phi$  cardboard tubes together  
 1:20

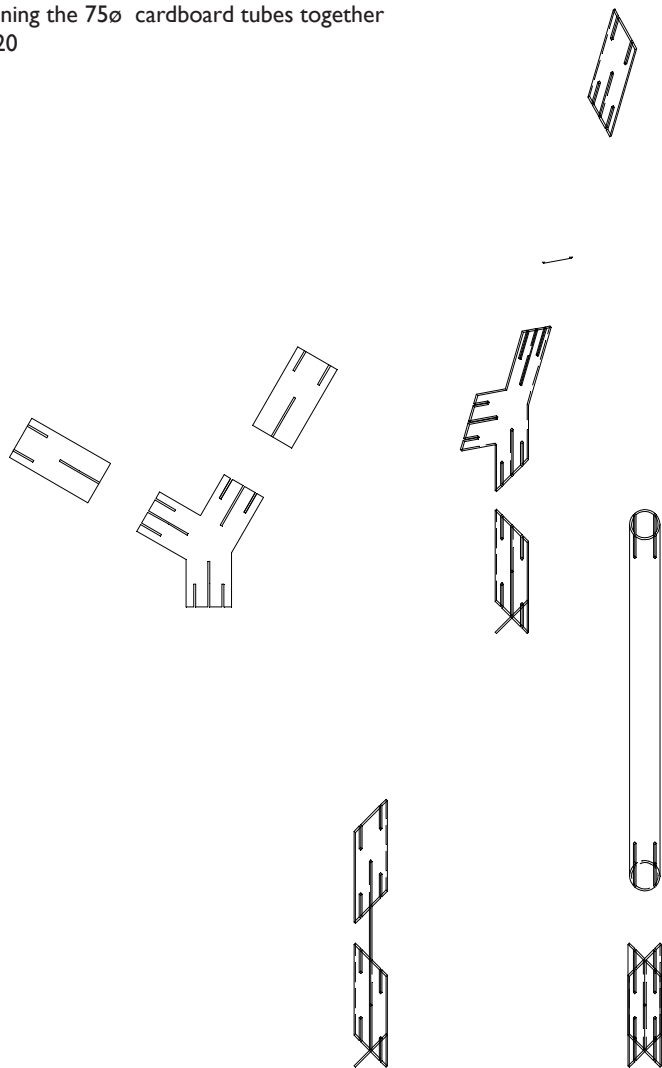

Figure 238. Joining of cardboard tubes to create branches (Author, 2010)

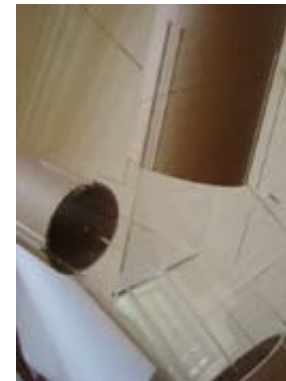

Figure 239. 1:1 Prototype to show assembly & disassembly of the Kalandar tree (Author, 2010)

When the Kalander tree is felled and during the course of the play the Kalander tree is disassembled and transported to the Village stage where the “wood” is sold

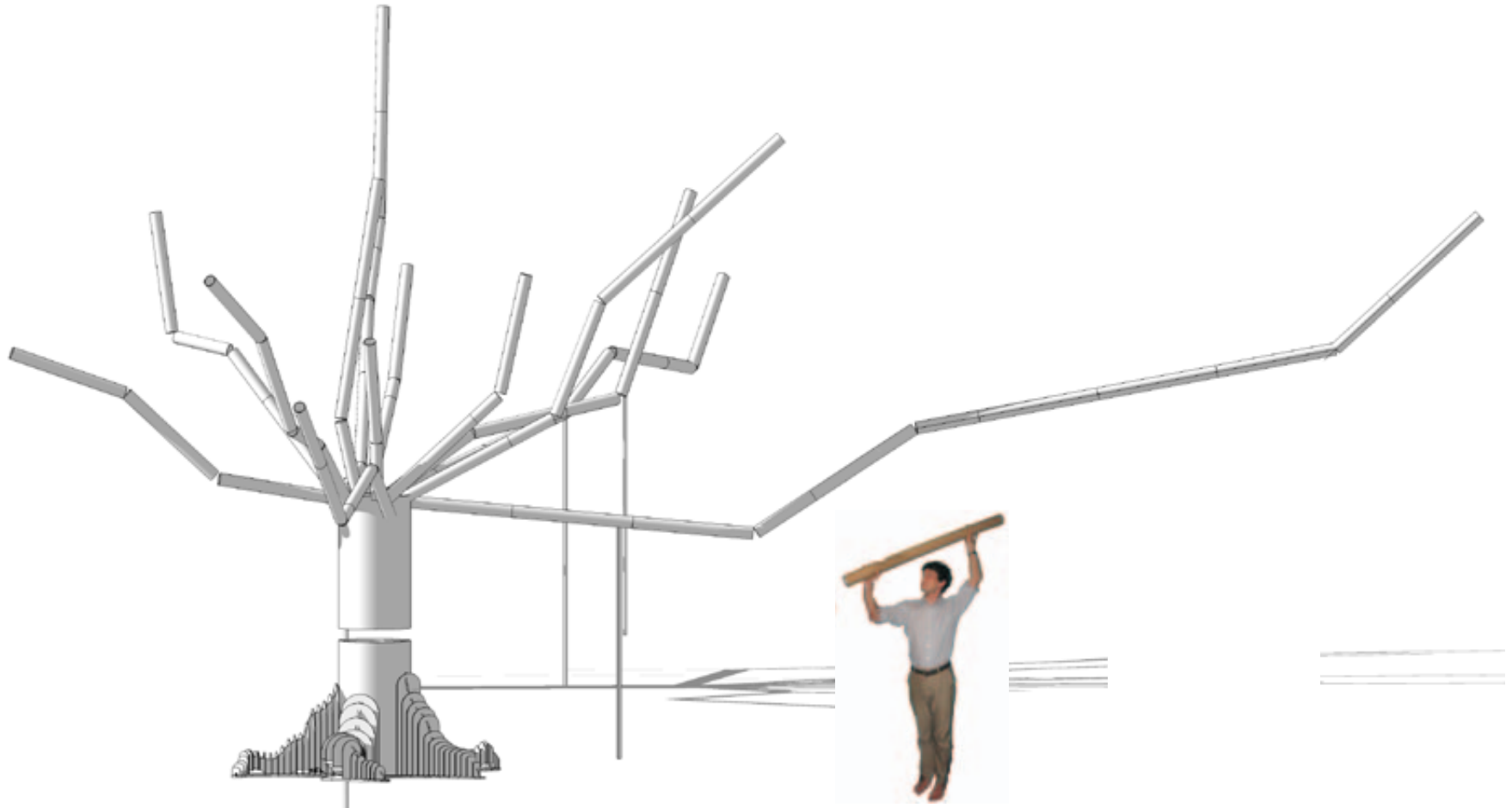

Figure 240. Felling of the Kalander tree (Author, 2010)

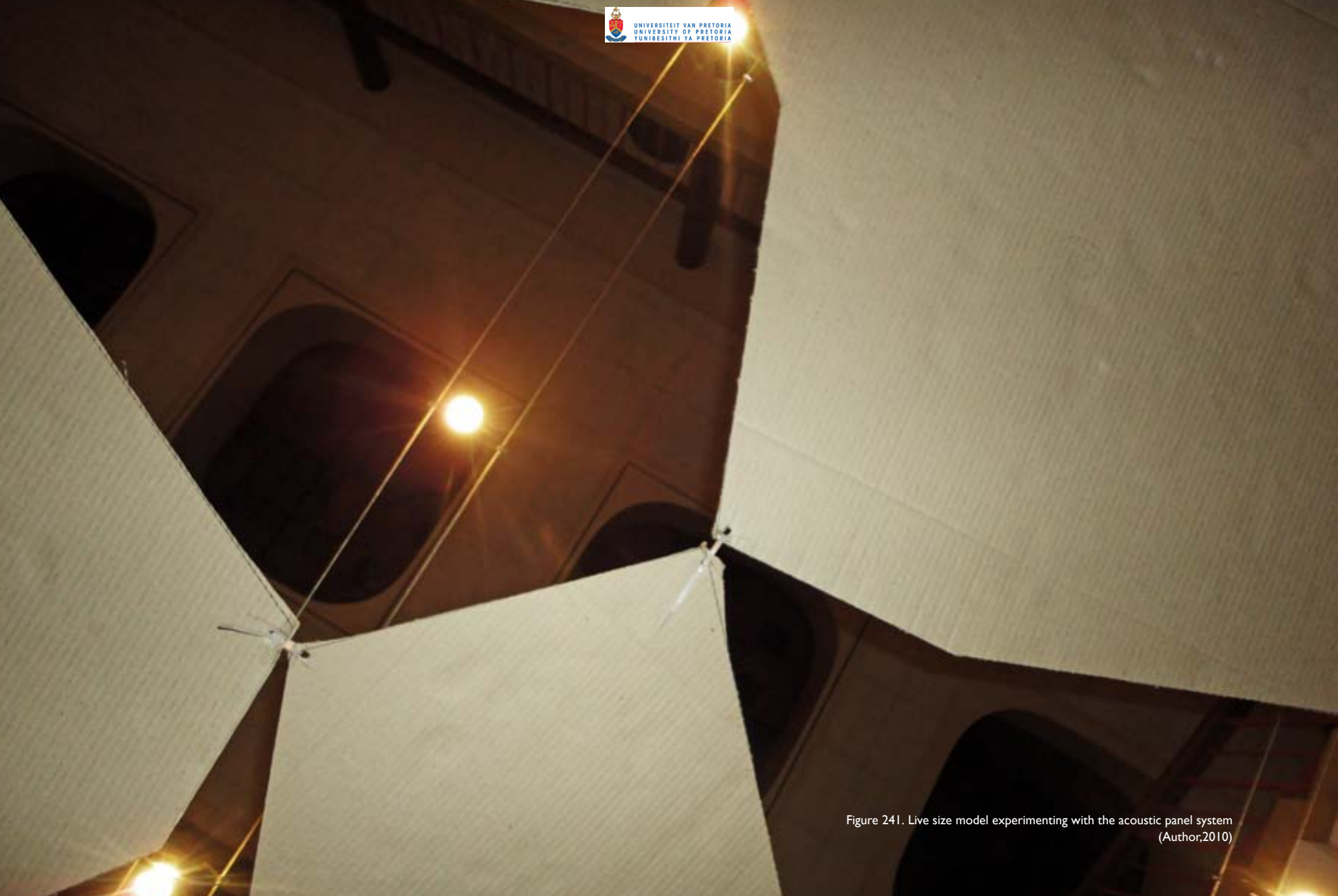

Figure 241. Live size model experimenting with the acoustic panel system  
(Author,2010)



*“By the time it was dark they were back in the forest. It was like a thick blanket closing around your body, warming you against the cold,”  
(Matthee, 1984, 61)*

## 8.10 ACOUSTICS

Theatres used for drama depend on good speech intelligibility and acoustic intimacy around the audience. The affects of sound occur in two ways; the quality of generated sound that the audience wants to hear and annoyance with unwanted sound (noise).

### 8.10.1 Existing building

When using an existing building not designed as a theatre there will be shortcomings regarding acoustics. Sensitive spaces may be located adjacent to a noise source for example a busy road, or the building might have poor sound insulation. The Temporary Theatre is located parallel to Vermeulen Street which is quite busy during the day but much quieter during the night. Some of the noise disturbance is alleviated by positioning the theatre space on the first floor and the useful mass provided by the heavy traditional brick construction (Lord & Templeton, 1986, 41).

“Subjectively people will be more tolerant of prevailing acoustical conditions in an existing building than in a new one, and there may be more tendencies to have to compromise standards where existing fabric is dealt with. It may be more cost effective to employ corrective measures like sound reinforcement rather than drastically modifying a sound fabric” (Lord & Templeton, 1986, 41).

This statement supports the intention of the study to utilize the existing and avoid drastic permanent changes.

### 8.10.2 Reverberation time

For the audibility of speech clarity is a prime requirement. To achieve this, the audience must receive strong sound reflections immediately after the direct sound. For clear speech in a theatre, the desired reverberation time is between 1.0 s and 1.5s (Spring, 1999, 2).

“The reverberation time is defined as the time taken for an interrupted sound to fall in level by 60 dB. The reverberation time is probably the most significant measurable factor determining the acoustical character of a room”

### 8.10.3 Existing acoustic character

#### Reverberation time calculations

Room dimensions: 59m x 36m x 9.17m = 19470m<sup>3</sup>

Wall surface area:

631 + 111.656(2) = 854.312m<sup>2</sup> (bricks - plastered)

197 + 164.22 + 413 = 774.22m<sup>2</sup> (windows)

108m<sup>2</sup> (concrete – plastered)

Floor surface area:

2124m<sup>2</sup>

Ceiling surface area:

885+767+236 +413 = 2300m<sup>2</sup>

Total absorption for 125Hz

=646.76 m<sup>2</sup>

With people = 946.76 m<sup>2</sup>

Reverberation time (RT60)

RT60=0.161(V/A)

RT60=0.161(19470 m<sup>3</sup>/646.76 m<sup>2</sup>)

RT60=4.84 sec. with people - 3.31sec

4.84=0.161(19470 m<sup>3</sup>/A)

4.848=3134.67

A must be 2089.78

Critical distance D<sub>c</sub>

D<sub>c</sub> = 0.057. √V/RT60

= 0.057. √ 19470 m<sup>3</sup>/ 3.31

= 0.057. √ 5882, 2

= 0.057x76.7

= 4.4m

Existing acoustics

Floors	125Hz	250Hz	500Hz	1000Hz	2000Hz	4000Hz
Concrete	.01	.01	.015	.02	.02	.02
2124m <sup>2</sup>	21.24 m <sup>2</sup>	21.24 m <sup>2</sup>	31.86 m <sup>2</sup>	42.48 m <sup>2</sup>	42.48 m <sup>2</sup>	42.48 m <sup>2</sup>
Walls	125Hz	250Hz	500Hz	1000Hz	2000Hz	4000Hz
Plaster on masonry	0.01	0.02	0.02	0.03	0.04	0.05
854m <sup>2</sup>	8.54 m <sup>2</sup>	17.1 m <sup>2</sup>	17.1 m <sup>2</sup>	25.62 m <sup>2</sup>	34.16 m <sup>2</sup>	42.7 m <sup>2</sup>
Concrete (sealed or painted)	0.01	0.01	0.02	0.02	0.02	0.02
108m <sup>2</sup>	1.08 m <sup>2</sup>	1.08 m <sup>2</sup>	2.16 m <sup>2</sup>	2.16 m <sup>2</sup>	2.16 m <sup>2</sup>	2.16 m <sup>2</sup>
Windows	125Hz	250Hz	500Hz	1000Hz	2000Hz	4000Hz
Ordinary glass in steel frame	.35	.25	.18	.12	.07	.04
774m <sup>2</sup>	270.9 m <sup>2</sup>	193.5 m <sup>2</sup>	139.32 m <sup>2</sup>	92.88 m <sup>2</sup>	54.18 m <sup>2</sup>	30.96 m <sup>2</sup>
Ceilings	125Hz	250Hz	500Hz	1000Hz	2000Hz	4000Hz
Plasterboard 12mm in suspended ceiling grid	0.15	0.11	0.04	0.04	0.07	0.08
2300m <sup>2</sup>	345 m <sup>2</sup>	253 m <sup>2</sup>	92 m <sup>2</sup>	92 m <sup>2</sup>	161 m <sup>2</sup>	184 m <sup>2</sup>
People	125Hz	250Hz	500Hz	1000Hz	2000Hz	4000Hz
Highschool	2	3	4	5	5	4
150	300 m <sup>2</sup>	450 m <sup>2</sup>	600 m <sup>2</sup>	750 m <sup>2</sup>	750 m <sup>2</sup>	600 m <sup>2</sup>

Figure 243. Table showing the sound absorption coefficient values of existing materials (Author,2010)

Sound absorption coefficient values of existing materials



Figure 242. Determining the reflection angles of the acoustic panels (Author,2010)

Distributing sound; Angle of incidence = Angle of reflection

## Problem: Noise

### Possible cause

The most important kind of external noise affecting buildings is transport noise from road traffic, aircraft and railways (Appleton & Aveline, 1999, 4). The windows are usually the weakest part of the envelope where sound insulation is concerned.

Larger rooms with large reflective surfaces can cause echoes and excessive reverberation (Lord & Templeton, 1986, 42).

### Possible solution

Screen or add absorption (Lord & Templeton, 1986, 43). Noise level can be reduced by lining the room surfaces with an efficient acoustical absorbent material (Spring, 1999, 3)

For speech the wall behind the audience must be absorptive and the surfaces behind the actors should be reflective (Appleton & Aveline, 1999, 4). In the case of the Temporary Theatre the walls behind the audience is also the wall behind the actors. From the calculations it is clear that more absorptive material is necessary. Absorptive material will be applied to available surfaces in the form of carpets felts and fabric. The largest floor surface will be covered in rubber tiles. Rubber is a resilient material which will act as an absorber because the interlocking tiles are placed on the concrete floor and not fixed to it with a rigid connection.

Because the theatre has large standard steel frame windows with opening sections it will be a futile exercise to try and insulate the space. The design will aim to

reduce the noise level by placing barriers that intercept the line-of-sight between a sound source (the street) and the audience. As a rough guide, screen-type barriers 1 to 4 m high and mass about 10 kg/m<sup>2</sup> can give transmission losses of 5 to 20 dB (Spring, 1999, 6).

## Problem: Poor reception at rear

### Possible cause

Lack of useful reinforcement of sound source (Lord & Templeton, 1986, 43).

Normal conversation is audible over a distance of up to 10m. Raised conversation is audible up to 24m (Lord & Templeton, 1986, 29).

The volume and quality of the unamplified sound is dependent on the volume, shape, size and internal finishes of the auditorium, and on its resultant reverberation time (Appleton & Aveline, 1999, 4).

### Possible solution

Add reflective surfaces. Flat surfaces is effective in distributing sound but easily cause a “flutter echo” or “standing wave”. Reflective Concave surfaces concentrate sound in some places causing deficiencies of the reflected sound in certain places called dead spots (Lord & Templeton, 1986, 42). Convex surfaces are the best surfaces for distributing sound. They provide a wide-spread of reflected sound. Reflections can be controlled by irregularities such as columns and trusses or through the use of absorptive materials (Acoustics.com, 2004).

## 8.10.4 New temporary, sound reflective ceiling panels

The ceiling suspended at calculated angles will reflect and disperse sound into the audience to reinforce the sound and make sure that desired sound is audible. The reflective ceiling panels will be suspended from the existing steel trusses with adjustable cables at the corners. The panels will be made of white, translucent acrylic sheets cut into irregular (forest) and regular shapes (village) and tied together with cable ties through pre-drilled holes. The ceiling will cover the audience and progress from irregular to regular. Assemble will be done on the floor surface below and then hoisted into place. The resilience of the suspended acrylic sheets together with gravity will cause the sheets to sag in the middle forming convex surfaces that will reflect and disperse the sound. The resilience of the sheet is inhibited by the convex shape it takes on and thus loses its absorptive qualities.





Figure 244. Live size model installation testing the acoustic panel system (Author,2010)

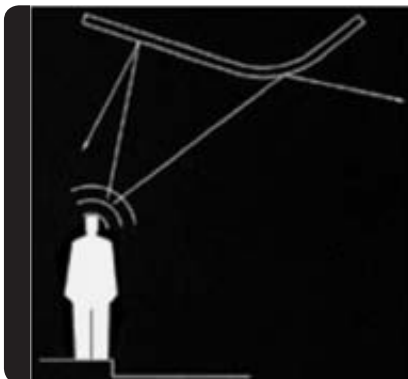

Figure 245. Figure Sound reflection of convex surfaces (Acoustics.com, 2004).

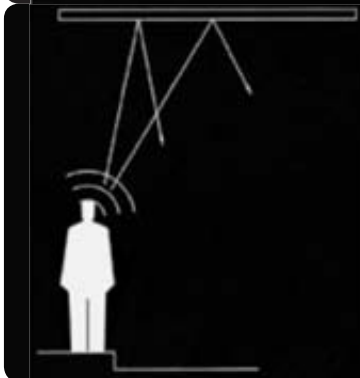

Figure 246. Figure Sound reflection of flat surfaces (Acoustics.com, 2004).

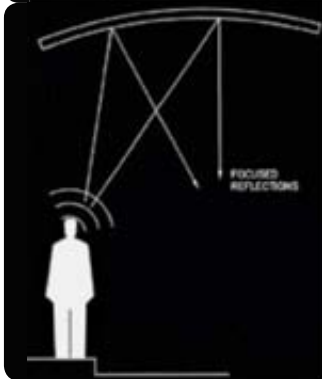

Figure 247. Figure Sound reflection of concave surfaces (Acoustics.com, 2004).

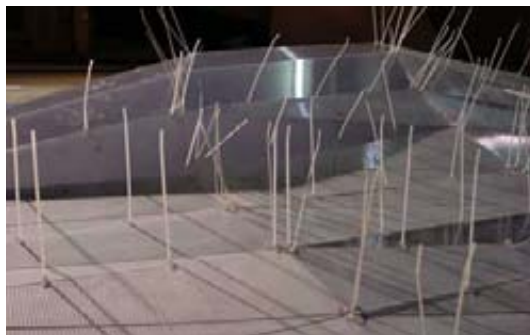

Figure 248. The set for a dance called "California." Polycarbonate panels are joined with plastic zip ties and suspended above the stage with cables (Cramer, 2004).



Figure 249. A focal point for Mash-Up!, an eight-week-long series of experimental events and performances (Ferrara, 2005).



Figure 250. Figure 1:20 Model illustrating acrylic materiality of ceiling panels (Author, 2010).

## 8.10.5 Configuration & assembly

*Marking the dimensions of on the floor.*

*Filling the marked area with cardboard.  
Tracing and cutting out the shapes.*

*Marking holes in the corners.  
Tying pieces together with cable ties.  
Attaching strings of fishing line from the  
cable ties to the outside.*

*Lifting and suspending the panel from  
existing hooks and ballustrades.*

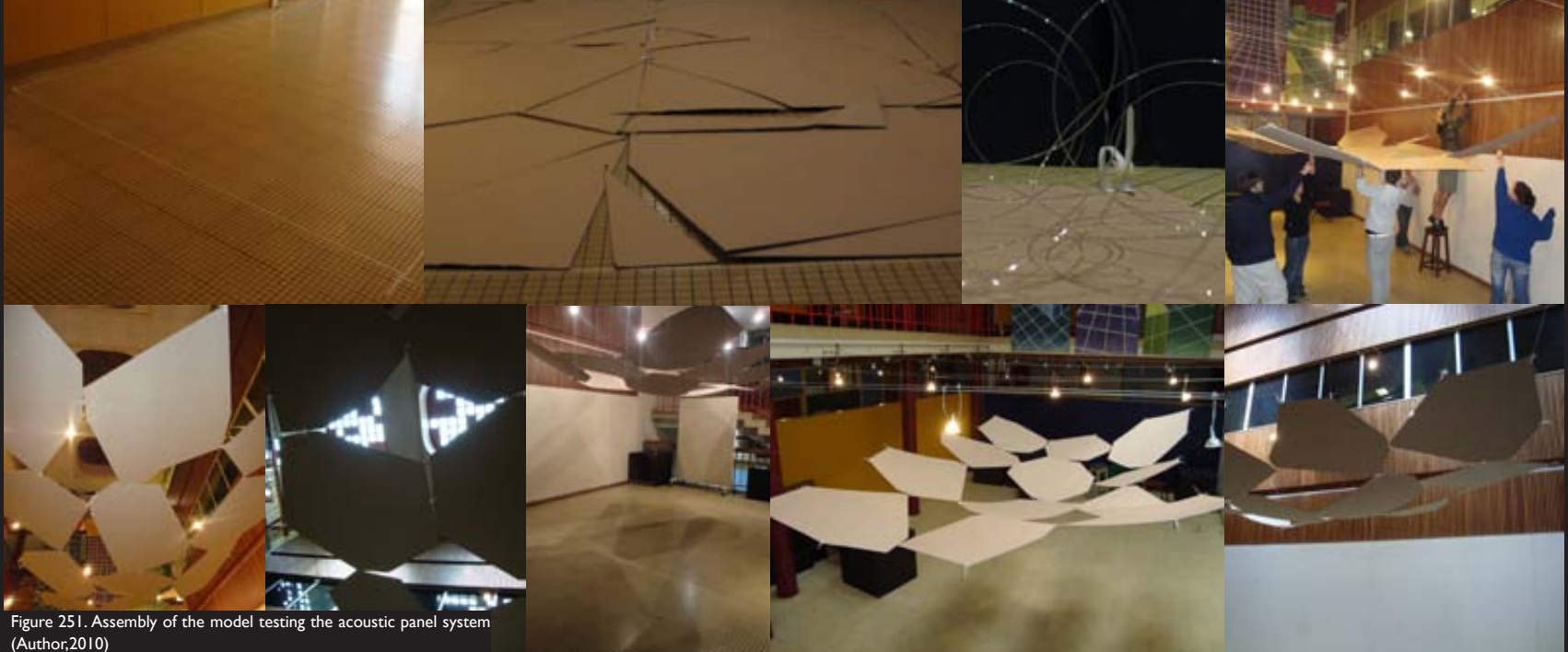

Figure 251. Assembly of the model testing the acoustic panel system  
(Author,2010)





Figure Forest ceiling panel plan Village ceiling panel plan  
(Author, 2010)

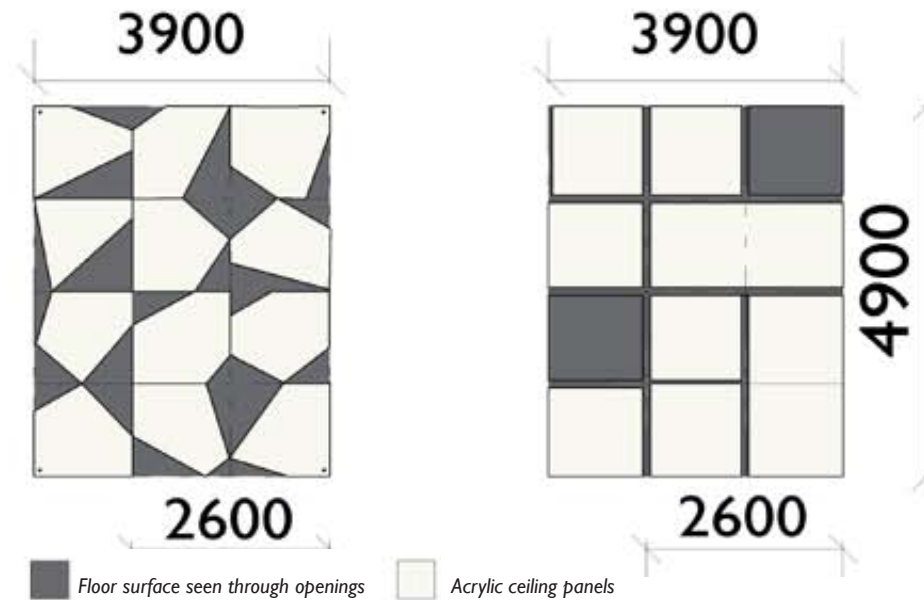
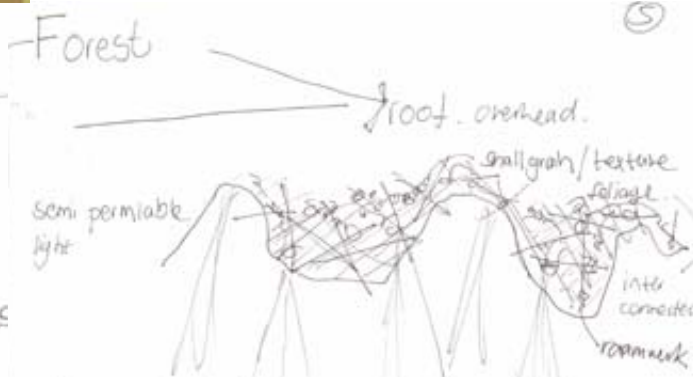
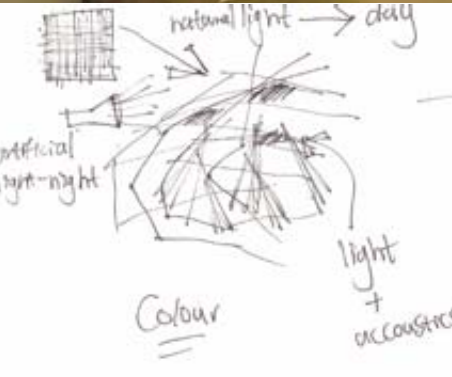
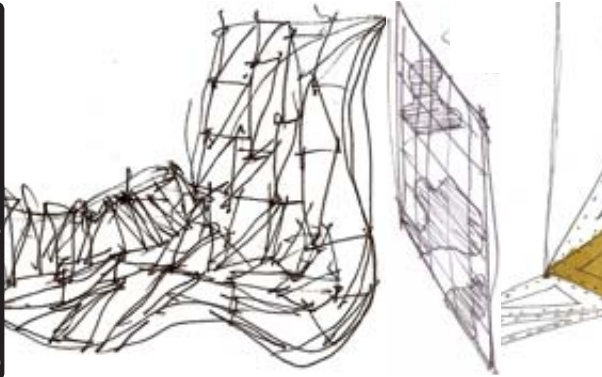

Figure 252. Plan view of acoustic panel model (Author,2010)

April concept sketches



June concept sketches





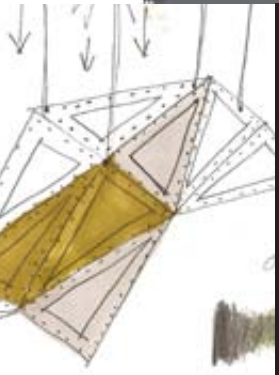

Figure 254. Concept sketches of acoustic panels (Author, 2010)

Figure 253. Ceiling plan showing sound reflecting acoustic panels (Author, 2010)



## Adjustable suspension of the ceiling panels from the existing angle section steel trusses 1:10

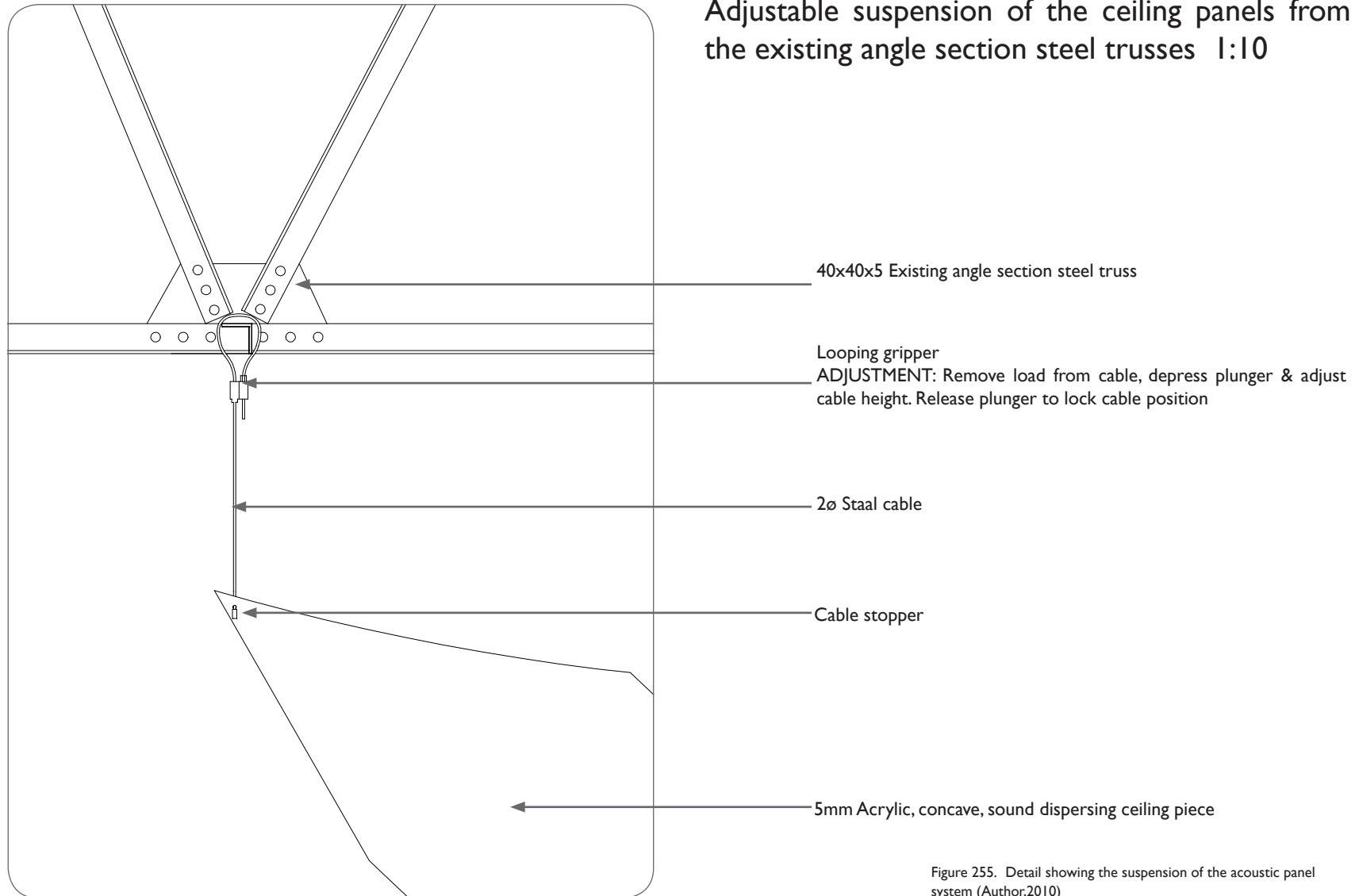
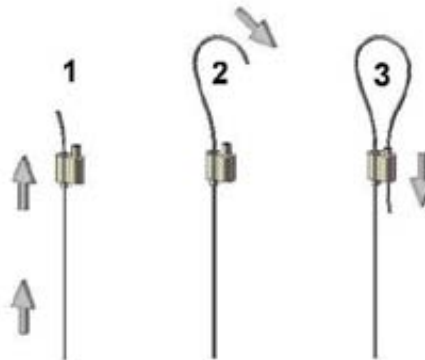

Figure 255. Detail showing the suspension of the acoustic panel system (Author,2010)



Cable ties used to join the 12 individual pieces of each panel

Figure 256. Cable ties (Author,2010)



STEP 1: Insert cable into looping gripper  
STEP 2: Pass cable through or around anchor point  
STEP 3: Insert cable back into

Figure 257. Diagram illustrating how a looping gripper works (Cable grippers,2010)

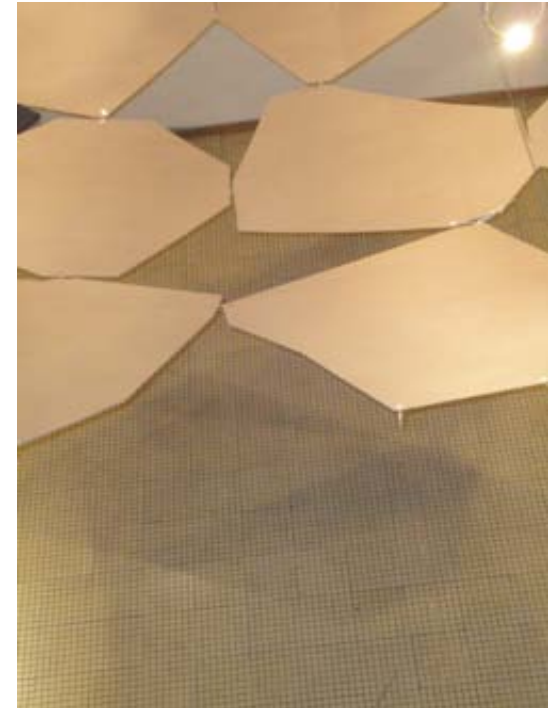
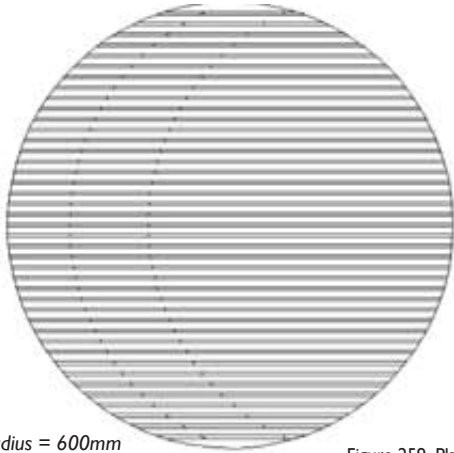

Figure 258. View from above ceiling model showing shadows created on the floor surface underneath (Cable grippers,2010)

# 8.1 | SEATING \_ CARDBOARD DRUM SWIVEL CHAIR



Radius = 600mm

Figure 259. Plan of swivel chair (Author,2010)

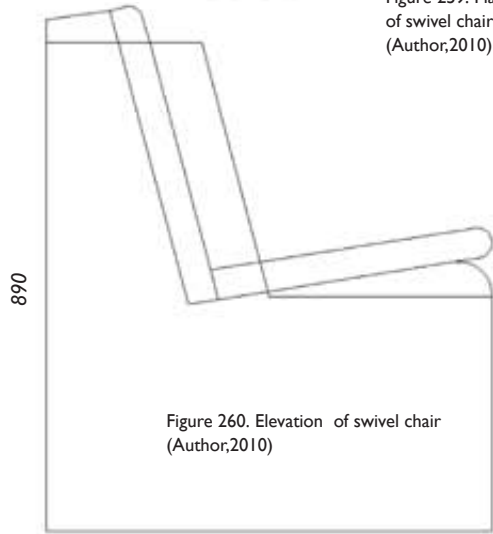

Figure 260. Elevation of swivel chair (Author,2010)

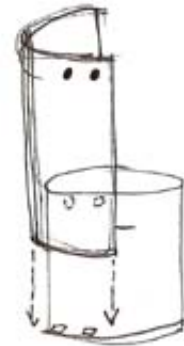
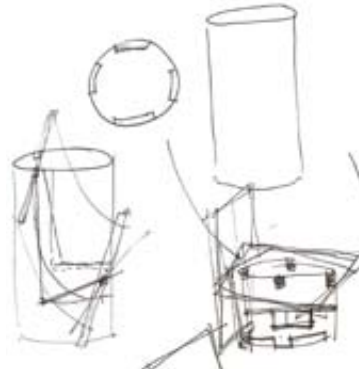

Figure 261. Cardboard drum available on the site (Author,2010)



Figure 262. Chair profile cut from tube resulting in two identical pieces that fit onto each other (Author,2010)

June concept sketches





360 degree rotating chair



Figure 263. Two 38x114mm pieces of timber are cut to 600mm lengths. The ends are rounded and a slot is cut in each end for a casters to fit through. The two pieces are fixed together with a shiplap joint and secured with wood-glue and wood-screws .A caster is placed in each slot and fixed to the wood with wood-screws. Matching holes are cut in the base of the drum to accommodate the casters. The assembly is placed in the bottom of the drum (Author,2010).

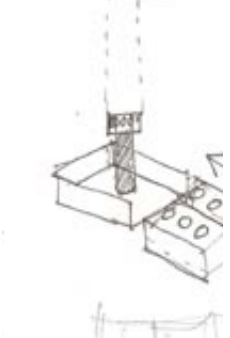
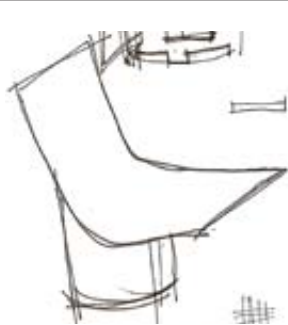

The chair will be manufactured on site from the cardboard drums in which printer toner is packaged and delivered. The profile that is being cut out will allow two chairs to be made from one 1100mm high, 600dia. drum. The sharp edged angular profile will also resemble the stumps of cut down trees. The casters that cant swivel themselves are attached in such a way that the chair can only rotate and not move back and forth easily to help keep the chairs in place and avoid distraction.

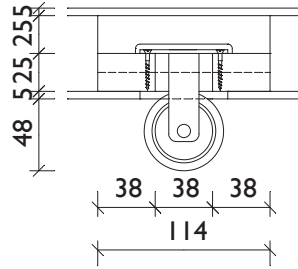

Figure 264. The wood members are fixed to the base of the drum with wood screws and washers. Four pieces of timber are cut to size and a groove is made in each, to fit over the connections of the casters. These pieces are then fixed over the casters and screwed to the wood underneath. This is done to secure the casters in place (Author,2010).



Figure 265. Sheets of cardboard was cut according to the chair profile and stacked next to each other inside the chair to create a seating surface. A 450 x 1000 mm rubber mat is woven from 40mm wide strips of the inner tube of a vehicle tyre. A 400 x 950 x 40 mm piece of foam is covered with a felt cover that can be removed and washed. The covered foam is attached to the rubber mat by pressed-it clips. The 'pillow' is then placed onto the seating surface of the chair to increase comfort & acoustic absorption. The pillow itself can also be used as temporary movable seating with the rubber mat as durable substrate providing a non-slip grip (Author,2010).





← Castor screwed onto the 25mmx114mm plywood cross support into which a slot is cut for the castor to fit through

Detail of castor connection 1:5

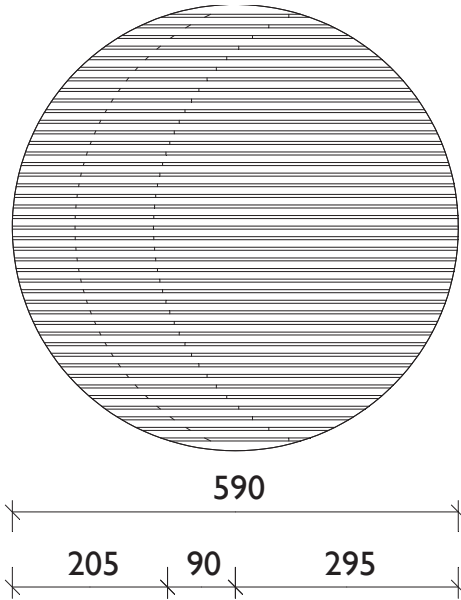

Plan of cardboard swivel chair 1:10

Figure 266. Detailing of cardboard swivel chair (Author, 2010)

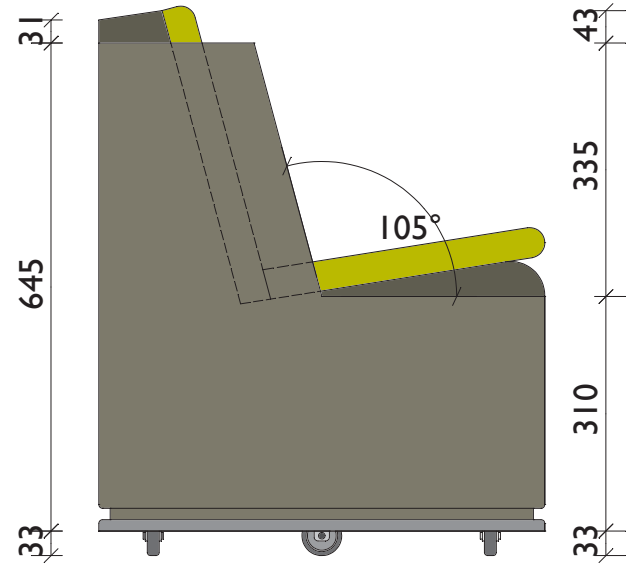

Elevation of cardboard swivel chair 1:10





Figure 267. 1:1 Prototype of cardboard swivel chair with upholstered covering (Author, 2010)

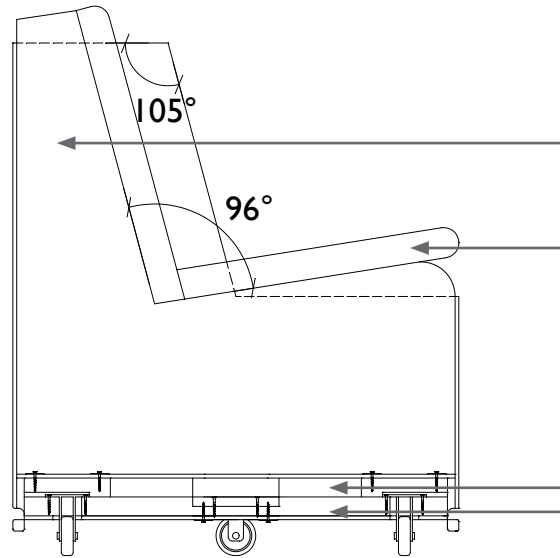

590ø Cardboard drum cut to specifications

1000mm x 400mm Upholstered covering made from recycled rubber, foam and felt

5mm Masonite coveringbase, screwed onto 25mm plywood over castor  
Caster screwed onto a 25mmx14mm plywood cross support into which a slot is cut for the castor to fit through

Longitudinal section through cardboard swivel chair 1:10

## 8.12 FIRE SAFETY

### General requirements according to SANS 0400 Part T

### Compliance of the Temporary Theatre

Escape routes & doors	Escape routes & doors
<ul style="list-style-type: none"> <li>45 Maximum travel distances to nearest escape door</li> </ul>	<ul style="list-style-type: none"> <li>The length of the building exceeds 45m and therefore a minimum of two escape routes have been provided in the initial design. The added ramp entrance will further ease evacuation.</li> </ul>
<ul style="list-style-type: none"> <li>Exit door shall open in the direction of travel along the escape route</li> </ul>	<ul style="list-style-type: none"> <li>All of the existing exit doors already open in the direction of travel. The new door that exit to the ramp is a sliding door.</li> </ul>
<ul style="list-style-type: none"> <li>Walls of corridors forming part of an escape route must be constructed of non-combustible materials</li> </ul>	<ul style="list-style-type: none"> <li>The existing walls of corridors forming part of an escape route are constructed of non-combustible materials</li> </ul>
<ul style="list-style-type: none"> <li>The floor of any escape route must have a slip resistant surface.</li> </ul>	<ul style="list-style-type: none"> <li>The existing concrete floor screed will be covered in rubber tiles that increase the slip resistance of the interior floor surface and varnished OSB board will be used for the surface of the interior and exterior ramp.</li> </ul>
<ul style="list-style-type: none"> <li>The maximum number of people per escape route is 190.</li> <li>Escape routes for 190 people must have a minimum width of 1800mm.</li> </ul>	<ul style="list-style-type: none"> <li>The existing escape routes are 2900mm (exit 6) and 2185mm (exit 4). The planned occupancy for the Temporary Theatre is 150 patrons and shouldn't exceed 200 including staff. The existing escape routes are thus sufficient. The new exit via a 2150mm wide scaffold ramp will provide an accessible fire escape.</li> </ul>
<ul style="list-style-type: none"> <li>Rooms with a population of more than 25 must have at least 2 exit doors opening in the direction of travel along the escape route and with an aggregate width not less than the required width for the escape route.</li> </ul>	<ul style="list-style-type: none"> <li>There are two existing exit doors. A third one will be provided for the ramp exit.</li> </ul>
<ul style="list-style-type: none"> <li>Emergency routes shall discharge at ground level directly to a street or public place or to an approved open air space leading to a street or public place.</li> </ul>	<ul style="list-style-type: none"> <li>The existing stairway forms part of an emergency route. It has handrails on each side throughout its length and discharge into a corridor that is part of the route and then into an open space. The ramp discharges into the street.</li> </ul>



Figure 268. Existing fire escapes routes (Author, 2010).

General requirements according to SANS 0400 Part T

Compliance of the Temporary Theatre

Markings, signposting & Emergency lighting	Markings, signposting & Emergency lighting
<ul style="list-style-type: none"> <li>Emergency routes shall be clearly marked and signposted to indicate the direction to be travelled in the case of emergency.</li> </ul>	<ul style="list-style-type: none"> <li>The Temporary theatre will be entirely non-smoking and “No smoking” signs of approved size shall be prominently displayed.</li> </ul>
<ul style="list-style-type: none"> <li>Emergency routes must be provided with artificial lighting and when the building is occupied there must be a minimum illuminance of 50 lux on a horizontal plane 100 mm above the floor.</li> </ul>	<ul style="list-style-type: none"> <li>The existing exit routes already comply. The new exit route will be provided with such lighting.</li> </ul>



Figure 269. Signposting for escape routes & equipment (Author, 2010).



Figure 270. Discharge spaces emergency routes (Author, 2010).

## Occupancy specific requirements requirements according to SANS 0400 Part T

## Compliance of the Temporary Theatre

Escape routes	Escape routes
<ul style="list-style-type: none"> <li>Aisles must have a minimum clear width of 1100mm and allow unobstructed movement to the escape routes.</li> <li>Distance from the front edge of any seat to the front edge of the seat immediately in front of, or behind must be a minimum of 675 mm.</li> </ul>	<ul style="list-style-type: none"> <li>The width of the aisles between the chairs is 1800mm to allow actors to move and perform along them.</li> <li>To allow the chairs to rotate 360 degrees and for people to have enough legroom the seats are spaced 841mm away from each other which is further than in a typical theatre. As a result there is ample space between the seats.</li> </ul>
Fire-fighting equipment	Fire-fighting equipment
<ul style="list-style-type: none"> <li>Fire hydrants One per 1 000 m<sup>2</sup> or part thereof</li> <li>Portable extinguishers Occupation A2: 1 per 200m<sup>2</sup> Occupation D2: 1 per 100m<sup>2</sup> (Previous occupation: D2 Moderate risk industrial)</li> <li>Hose reels Any building of two or more storeys in height or in any single storey building of more than 250 m<sup>2</sup> in floor area must have hose reels at a rate of 1 for every 500 m<sup>2</sup></li> <li>Sprinkler system</li> </ul>	<ul style="list-style-type: none"> <li>For occupation A2 fire hydrants aren't required. The fire hydrants required for the previous occupation will be an added benefit.</li> <li>In accordance with its previous occupation the space has more portable extinguishers with bigger capacities than needed for the new occupation.</li> <li>There are already enough fire hydrants provided for the existing buildings floor area of 2972m<sup>2</sup> (3000m<sup>2</sup>/500m<sup>2</sup> =6)</li> <li>For occupation A2 without a fly tower a sprinkler system isn't required. The existing building does have a sprinkler system that will provide extra safety in the case of fire.</li> </ul>



Figure 271. Fire-fighting equipment (Author, 2010).



## Occupancy specific requirements according to SANS 0400 Part T

### Compliance of the Temporary Theatre

Escape routes & doors	Markings, signposting & Emergency lighting
<ul style="list-style-type: none"> <li>45 Maximum travel distances to nearest escape door</li> </ul>	
<ul style="list-style-type: none"> <li>Exit door shall open in the direction of travel along the escape route</li> </ul>	<ul style="list-style-type: none"> <li>The Temporary theatre will be entirely non-smoking and "No smoking" signs of approved size shall be prominently displayed.</li> </ul>
<ul style="list-style-type: none"> <li>Walls of corridors forming part of an escape route must be constructed of non-combustible materials</li> <li>The floor of any escape route must have a slip resistant surface.</li> </ul>	<ul style="list-style-type: none"> <li>Such signage is not provided in the existing building and will be added in order to comply with the requirements. The possibility of battery powered devices will be investigated.</li> </ul>
<ul style="list-style-type: none"> <li>The maximum number of people per escape route is 190.</li> <li>Escape routes for 190 people must have a minimum width of 1800mm.</li> </ul>	<ul style="list-style-type: none"> <li>The existing building wasn't intended for use during the night and therefore new emergency lighting independent of the normal mains supply will be installed.</li> </ul>

### Rules that don't apply

Sub rules TT49.2, TT49.4, TT49.5 and TT49.6 don't apply in the case of places used solely for amateur productions or stages without a fly gallery. The Temporary theatre will mainly be used for amateur productions and won't have a fly tower. This provides certain design advantages: the existing separation or lack thereof between the audience and the stage and the stage and the dressing rooms is allowed. Fire shutters aren't required, the stage floor may be of timber, an automated roof ventilation system, communication and alarm systems aren't needed and the dressing rooms don't need direct access to an emergency route. Any Decorative material, wall, partition, horizontal slab and ceiling don't have to be of a non-combustible material.

- Rooms with a population of more than 25 must have at least 2 exit doors opening in the direction of travel along the escape route and with an aggregate width not less than the required width for the escape route.
- Emergency routes shall discharge at ground level directly to a street or public place or to an approved open air space leading to a street or public place.

## 004. CONCLUSION

The initial aim of investigating the role of temporary architecture and the relationship between perceived temporary and permanent architecture became more clear and focused as the research and design process progressed through the course of the academic year.

The design investigation emphasized the experimental and role of temporary architecture. Temporary architecture are generally less intimidating, of a smaller scale, involve easily workable materials and can therefore be produced quicker. This quality proved important in building models and prototypes for the design

The concept of a mutually beneficial, symbiotic relationship and the hierarchical layering of temporality and permanence that emerged together with the text requirements were the drivers that guided the design process.

This conceptual approach can be seen in the design in the following examples.

The insertion of the Temporary Theatre (guest) as a whole into the existing permanent structure (host) depend on and benefit each other. The existing space restrictions determined the space created by the insertion although to permanent attachments were made except for the two window panels that were removed and replaced with permanent sliding doors. This is the permanent sacrifice of the existing building for the Temporary Theatre but will benefit the existing building after the insertion has been removed.

The new temporary access ramp will attract attention to the building and will provide easy and visible access.

Drawing people directly of the street into the theatre like a root drawing water from the ground the ramp will give life to the theatre. The public interface and the shaded space created underneath the ramp will become a host to be appropriated for social interaction and informal trade.

The scaffolding structure of the ramp will be the most permanent layer supported by the ground of the sidewalk and in turn supporting the oriented strand board cladding and the shade cloth which is the more temporary layers. The most temporary layers will be the varnish finish of the OSB, advertisements and poster and finally the human activity.

The X-board screens in the foyer are constructed from two interdependent parts; the sloped screens obstructing the view to the back of house spaces and the tree cutouts providing perpendicular support. The screens are supported by the existing floor and intern supports the felt covering.

The cardboard drum light diffusers are dependant on the existing trusses (most permanent) from which they are suspended. The acrylic 'gobo' discs are supported by the cardboard drums and the coloured gels (more temporary) lie on the acrylic discs. The light that is diffused form the most temporary layer.

The screens that divide the foyer space from the auditorium space swivels and slides on a track that are temporarily fixed to the trusses and consists of a frame covered with canvas. The more temporary canvas creates a substrate for paint, lighting effects and projections which are the most temporary layer.

The ceiling panels are also temporarily suspended from the existing trusses. The white translucent acrylic panels are a neutral base for lighting effects and projections (most temporary) The panels can be removed, broken up into individual pieces, stacked and relocated.

The cardboard swivel chair (supported by the floor) is constructed from a cardboard drum that houses the cardboard sheet cutouts that creates a seating surface onto which the pillow is placed. The pillow itself is made from a rubber weaved mat (two interdependent elements) and a piece of foam with a felt cover. The most temporary layers are the felt cover that can be removed and washed changed and the person sitting on the chair.

The examples illustrate how the design was driven be the concept and supports the argument that the temporary and the permanent are layered and interdependent, benefitting instead of opposing each other.



## 005. LIST OF REFERENCES

- Acoustics.com, 2004, *Acoustic reflections*, Acoustics.com, viewed 5 September, 2010, <<http://www.acoustics.com/>>.
- Anderson, R 2010, *Delacorte Theater in Central Park*, Greensward Group, viewed 29 April 2010, <<http://www.centralpark.com/pages/attractions/delacorte-theatre.html>>.
- Appleton, I & Aveline, J 1999, 'Auditoria', in Adler, D, *Metric Handbook*, Sound: Planning and Design Data, Reed Educational and Professional Publishing Ltd, Great Britain.
- Architecture Week 2005, *Ten Day Theatre*, Architecture Week, viewed 29 July, 2010, <[http://www.architectureweek.com/2005/0202/building\\_2-1.html](http://www.architectureweek.com/2005/0202/building_2-1.html)>.
- Architen Landrell, 2010, *Canary Wharf Terrace Canopy*, Architen Landrell, viewed 20 October, 2010, <<http://www.architen.com/projects/canary-wharf-terrace-canopy>>.
- Arquitectura de Interiores 2008, *2004 TBA Festival Temporary Theater*, Arquitectura de Interiores, viewed 29 July, 2010, <<http://universointeriores.blogspot.com/2008/11/2004-tba-festival-temporary-theater.html>>.
- Banks, L 2008, *Ice Lolly*, Yahoo! Inc, viewed 20 October, 2010, <<http://www.flickr.com/photos/louiebanks/3016503261/>>.
- Barros, T & Pereira, J 2010, *Cross-wind bridge*, Designboom, viewed 22 October, 2010, <<http://www.designboom.com/weblog/cat/8/view/7974/tiago-barros-jorge-pereira-cross-wind-bridge.html>>.
- Baunach, BT, 2009, *Temporary Architecture: A Palio Dinner*, WordPress, viewed 21, April, 2010, <<http://designcrack.com/v2/2009/09/29/temporary-architecture-a-palio-dinner/>>.
- Beginbeing, 2009, *Rojkind Arquitectos*, Beginbeing, viewed 21 October, 2010, <<http://www.beginbeing.com/2009/12/rojkind-arquitectos.html>>.
- Bellostes, J 2008, *Puppet Theater at Harvard's Carpenter Center*, CubeMe, viewed 26 March, 2010, <<http://cubeme.com/blog/2009/07/07/puppet-theater-at-harvards-carpenter-center/>>
- Bellostes, J 2009, *Teatro de marionetas – puppet theater temporary*, Worldpress, viewed 24 September, 2010, <<http://blog.bellostes.com/?p=2945>>.
- Berne, K 2010, *The Caucasian Chalk Circle*, viewed 28 October, 2010, <<http://blog.kevinberne.com/>>.
- Bradshaw, A, Milner, B, Senior, T, Boniface, K & Boniface, G 2010, *Temporary art space*, viewed 20 October, 2010, <<http://www.temporaryartspace.co.uk/>>.
- Bradshaw, B & Campbell, F 2010, *Port eliot: the best festival you have never heard of*, Grazia magazine, UK, viewed 20 October, 2010, <<http://fashioneditoratlarge.blogspot.com/2010/07/port-eliot-best-festival-you-have-never.html>>.
- Bulletin Solutions, 2010, *Video Ice Hotel*, Bulletin Solutions, Inc., viewed 20 October, 2010, <<http://www.uevf.net/forum/showthread.php?t=4126&pagenumber=>>>.
- Buyers Packaging, 2008, *Shipping Products - Cardboard sheets*, Buyers Packaging Group Ltd. ,viewed 27 October, 2010, <<http://www.buyerspackaging.com/Shipping/CardboardSheets.html>>.
- Cablegrippers, 2010, *Cable Hardware*, viewed 01 December, 2010, <<http://www.cablegrippers.com/accessories-cable-hardware.html>>
- Cadena, R 2006, *Automated lighting: The Art and Science of Moving Light in Theatre, Live performance, Broadcast, And Entertainment*, Elsevier, China.



- CampPhotoshop, 2009, *FREE Cardboard Sign PSD*, Creative Partners LLC, viewed 27 October, 2010, <<http://www.campphotoshop.com/How-to-create-a-cardboard-box-sign-written-with-a-marker>>.
- Cave, C 2008, *City of the Future*, Goethe-Institut viewed 21 April, 2010, <<http://www.goethe.de/KUE/arc/dos/dos/sls/sdz/enindex.htm>>.
- Chabrowe, B 1974, 'On the Significance of Temporary Architecture', *The Burlington Magazine*, Vol. 116, No. 856, pp. 385-391, viewed 27 April 2010, <<http://www.jstor.org/stable/877732>>.
- Chen, P & Edginton, C. R 2008, *Leisure as Transformation*, Sagamore Publishing, USA
- Cramer, N 2004, *California, Architettura*, viewed 28 October, 2010, <<http://architettura.supereva.com/architettura/20040228/index.htm>>.
- Dance South Florida, 2010, *Stage Lighting Rental*, viewed 28 October, 2010, <<http://www.dancesouthflorida.com/event-lighting/event-lighting-boca-raton-west-palm.html>>.
- Dann, B, Meier, B, Rice, E, Somerfield, B 2009, *No Vacancy: A Guide to Creating Temporary Projects in the Central Eastside Industrial District*, LocusLab, viewed on 29 April, 2010, <<http://novacancyproject.wordpress.com/2009/02/18/hello-world/>>.
- De Boer, J 2009, *The Pop-Up City*, viewed 26 March, 2010, <[popupcity.net/2009/06/darmstadts-pop-up-theatre/](http://popupcity.net/2009/06/darmstadts-pop-up-theatre/)>
- Del Signore, J 2007, *Saint Joan of the Stockyards*, viewed, Gothamist LLC., viewed 27 October, 2010, <[http://gothamist.com/2007/06/24/opinionist\\_sain.php](http://gothamist.com/2007/06/24/opinionist_sain.php)>.
- Design Week, 2009, *Design Week Awards 2009 Category: Temporary Exhibition Design*, viewed 29 April, 2010, <<http://awards.designweek.co.uk/dw/2009/category/temporary-exhibition-design/humanscale-stand/humanscale-stand.php>>.
- Designboom, 2008, *Venice Architecture Biennale 08*, Designboom, viewed 27 October, 2010, <<http://www.designboom.com/weblog/cat/9/view/3933/venice-architecture-biennale-08-herzog-de-meuron-and-ai-weiwei.html>>.
- Deviant Art, 2009, *Rainbow smoke*, viewed 22 October, 2010, <<http://k113.deviantart.com/art/Moar-Rainbow-Smoke-146102327>>.
- Domanovic, A, Laric, O, Priglinger, C & Schnitzer, G & 2006, *There Will Be No Miracles Here*, Vvork, viewed 21 October, 2010, <<http://www.vvork.com/?m=200710>>.
- Driscoll, M 2010, *TBA: 10 Visual Arts Picks*, Portland Art, viewed 23 September, 2010 <[http://www.portlandart.net/archives/openings\\_events/index.html](http://www.portlandart.net/archives/openings_events/index.html)>
- Electrosonic, 2010*, Electrosonic at the Scotch Whisky Experience, *Electrosonic*, viewed 24 October, 2010, <<http://www.electrosonic.com/solutions/projects/electrosonic-scotch-whisky-experience>>.
- Etchells, T 1999, *Certain Fragments: Contemporary Performance and Forced Entertainment*, Routledge, Oxon
- Fairs, M 2007, *Burning Man*, Barcelon Institute of architecture, viewed 29 April, 2010, <<http://www.dezeen.com/category/all/featured-designer-arne-quinze/page/2/>>.
- Fairs, M 2008, *Back Side Flip 360°*, Barcelon Institute of architecture, viewed 29 April, 2010, <<http://www.dezeen.com/2008/09/19/back-side-flip-360%C2%B0-by-o-s-architectes/>>.
- Ferrara, A 2005, *Nubik, Architettura*, viewed 28 October, 2010, <<http://architettura.supereva.com/architettura/20050329/index.htm>>.

- Flicker, 2004, *Krzysztof Wodiczko From the projection in Tijuana, Mexico*, Yahoo! Inc., viewed 20 October, 2010, <<http://www.flickr.com/photos/56125256@N00/2833260848/>>.
- Flicker, 2005, *Moon silhouetted trees mosaic*, viewed 22 October, 2010, <<http://www.flickr.com/photos/kikisdad/112768534/in/faves-lanerd/>>
- Flicker, 2009, *German Creepy Dolls in 1950s Test Tubes*, Yahoo! Inc, viewed 20 October, 2010, <<http://www.flickr.com/photos/23303492@N06/3730384260/>>.
- Floors online, 1999, Floors online, viewed 7 October, 2010, <<http://www.floorsonline.co.za/carpet-choices/>>.
- Floors online, 1999, Floors online, viewed 7 October, 2010, <<http://www.floorsonline.co.za/rubber-choices/>>.
- Fopple, 2010, *Ultra Minimalist Luxury Urban House in Japan by Datar*, viewed 27 October, 2010, <<http://www.fopple.com/ultra-minimalist-luxury-urban-house-in-japan-by-datar/>>.
- Freenet Africa, 2010, Unemployment rate remains virtually unchanged, *Freenet Africa current affairs journal*, viewed 09 April, 2010, <<http://freenetafrica.com/node/1186>>.
- Fuller, M & Haque, U 2009, *Urban Versioning System 1.0.1*, boiteaoutils: architecture early warning radar, viewed 13 November, 2009, <<http://boiteaoutils.blogspot.com/2009/01/usman-haque-and-granularity.html>>.
- Gigli, J ed.... [et al.] 2007, *Thinking inside the box: a reader in interior design for the 21st century*; Middlesex University Press, London.
- GoboMan, 2010, *LED Gobo Projector*, viewed 28 October, 2010, <<http://goboman.blogspot.com/2010/04/goboman-launches-led-gobo-projector.html>>.
- Goethe-institut, 2010, *Maybe forever*, viewed 22 October, 2010, <[http://www.malthousetheatre.com.au/page/MAYBE\\_FOREVER](http://www.malthousetheatre.com.au/page/MAYBE_FOREVER)>
- Gordon, I 1995, *Looking for a rain god and other short stories from Africa*, Macmillan, London.
- Groak, S 1992, *The Idea of Building: Thought and action in the design and production of buildings*, Spon Press, London.
- Hartnett, DC 2010, *Symbiosis*, Biology Reference, viewed 2 October, 2010 <<http://www.biologyreference.com/Se-T/Symbiosis.html>>.
- Haus Elise, 2009, *Camper store in Malmö by TAF*, Barcelona institute of architecture, viewed 9 April, 2010, <<http://www.dezeen.com/2009/12/21/camper-store-in-malmo-by-taf/>>.
- Hawthorne, C 2008, *Temporary Architecture*, WordPress, viewed 21 April, 2010, <<http://slowpainting.wordpress.com/2008/04/21/temporary-architecture/>>.
- Heavilin, S 2009, *Former VideoLand Space For Rent*, viewed 20 October, 2010, <[http://coronadocommonsense.typepad.com/coronado\\_common\\_sense/2009/10/former-videoland-space-for-rent.html](http://coronadocommonsense.typepad.com/coronado_common_sense/2009/10/former-videoland-space-for-rent.html)>.
- Herbert, 2007, *Sportplaza Mercator, Amsterda*, SkyScraperLife, viewed 29 April, 2010, <<http://www.skyscraperlife.com/low-rise-architecture/9631-innovative-architecture-holland.html>>.

Hiemstra-van der Horst, J 2010, Shadows, viewed 22 October, 2010, <file:///C:/laptop%202010/Architecture I/Masters%20Oct2/Research/Plays%20&%20trees/Tree%20pics/mwpt8.htm>.

Historical Stock Photos, 1938, Children Playing Tug of War at Recess on a Playground, Historical Stock Photos, viewed 20 October, 2010, <http://www.historicalstockphotos.com/details/photo/2459\_children\_playing\_tug\_of\_war\_at\_recess\_on\_a\_playground.htm>.

Holt, M 1988, Stage design and properties, Phaidon, Oxford.

Homann, G (ed.) 2009, At this stage: plays from post apartheid South Africa, Wits University Press, Johannesburg.

Horsmans, Y 1996, Project: (Con)Temporary Architecture, viewed 30 April 2010, <www.archyves.com/portfolio/2Inomad.doc>.

Idee, I 2008, *Projektpilot*, viewed 27 October, 2010, <http://www.projekt-pilot.de/en/archive/database/projektpilot-gmbh-2008-trade-fair-exhibition-euroshop-euroshop-1.html>.

Jacaranda National Arts Festival, 2010, Standard Bank, viewed 8 August, 2010, <http://english.jacarandakunstefees.co.za/>.

Jaye, MC & Watts, A (eds) 1980, *Literature and the urban experience: essays on the city and literature*, Rutgers university press, New Jersey.

Jewell, K 2010, *Pictures of Sproxton and the surrounding area*, Geograph, viewed 27 October, 2010, <http://www.yourlocalweb.co.uk/leicestershire/sproxton/pictures/>.

Jong, J 2007, *Sophronia*, Yahoo! Inc, viewed 20 October, 2010, <http://www.flickr.com/photos/janicejs/2119083435/>.

Kingsley, M 2009, *The Agony of DeFeet*, Speak Up, viewed 22 October, 2010, <http://www.underconsideration.com/speakup/archives/002067.html>.

Knowlesystem, 2007, *Folding an architecture*, WordPress, viewed 22 October, 2010, <http://knowlesystem.files.wordpress.com/2007/10/emergent.jpg>.

LaFarge, A 2008, *Playing the Rapture*, viewed 27 October, 2010, <http://www.forger.com/set.html>.

Lambie, J 2007, *Mental Oyster*, Vvork, viewed 26 October 2010, <http://www.vvork.com/?m=200709>.

Lehr, D 2008, *Can the conservative movement be saved from itself?*, News channel 9, viewed 25 October, 2010, <http://vote08.freedomblogging.com/category/essential-reads/>.

Lévesque, c 2007, *'reconciling poetics and ethics in architecture abstract'*, in the history and theory of architecture program: proceedings of the reconciling poetics and ethics in architecture conference, montréal, 13 -15 September 2007, McGill university school of architecture, Montréal.

Libeskind, D 2009, *The difference between architecture and theatre*, All about Jewish Theatre, viewed on 14 October, 2009, <http://www.jewishtheatre.com/visitor/article\_list.aspx?articleGroupID=74>.

- Livelite, 2010, *Profile Spots*, Livelite Lighting Hire & Sales Ltd, viewed 28 October, 2010, <[http://www.livelite.co.uk/shop/index.php?cPath=43\\_51](http://www.livelite.co.uk/shop/index.php?cPath=43_51)>.
- Lord, P & Templeton, D 1986, *The architecture of sound: Designing places of assembly*, The Architectural Press, London.
- Manferdini, E 2008, *Works in progress*, Italian Cultural Institute of Los Angeles, viewed 22 October, 2010, <[http://www.iicbelgrado.esteri.it/IIC\\_LosAngeles/webform/SchedaEvento.aspx?id=218](http://www.iicbelgrado.esteri.it/IIC_LosAngeles/webform/SchedaEvento.aspx?id=218)>.
- McGill, S 2007, *Richard Stockton Rand*, viewed 28 October, 2010, <<http://www.richrand.com/actor.php>>.
- Mellor, D 2008, *Lighting design — an overview*, SOS Publications Group, viewed 28 October, 2010, <<http://www.performing-musician.com/pm/nov08/articles/spgltl.htm>>.
- Mellor, D 2009, *Lighting a band*, SOS Publications Group, viewed 28 October, 2010, <<http://www.performing-musician.com/pm/apr09/articles/spgltl.htm>>.
- Merrell, D 2009, *Trends: A New Meaning for “Corporate Merger”*, Designdawgs, viewed 28 October, 2010, <[http://www.designdawgs.net/2009\\_06\\_01\\_archive.html](http://www.designdawgs.net/2009_06_01_archive.html)>.
- Michler, A 2010, *Be Palett: A Pavilion Of Pallets Provide Pupils With a Place to Relax*, Inhabitat, viewed 27 October, 2010, <<http://inhabitat.com/2010/07/09/be-palett%C3%B8-a-pavilion-of-pallets-provide-pupils-a-place-to-relax/>>.
- Minnaar, E 2000, 'Grondleggende argitekte van die Departement Openbare Werke in Transvaal tot 1910, hul werk en invloed' PhD thesis, University of Pretoria.
- Molo Design, 2010, *Softwall modular system - LED lighting*, Molo Design, viewed 29 April, 2010, <[http://www.molodesign.com/products/softwall\\_softblock\\_modular\\_system\\_led\\_lighting](http://www.molodesign.com/products/softwall_softblock_modular_system_led_lighting)>.
- Moring, G 2010, *Paper tree*, viewed 21 October, 2010, <<http://gmoring.com/animation.php>>.
- Muns, S 2009, *We can xalant*, viewed 29 April, 2010, <<http://wecanxalant.blogspot.com/>>.
- Nature Maker, 1998, *Oak Root Ball*, viewed 22 October, 2010, <<http://www.naturemaker.com/portfolio-heritage.php>>.
- Nettler, LK 2010, *Charcoal*, viewed 25 October, 2010, <<http://www.lydiakannettler.com/index.htm>>.
- Ohrt, D 2007, *How to make a bedroom out of cardboard*, Brandflakes for Breakfast, viewed 27 October, 2010, <<http://www.brandflakesforbreakfast.com/2007/03/how-to-make-bedroom-out-of-cardboard.html>>.
- Omara, K 2007, *Tunnel House*, Designverb, viewed 21 October, 2010, <<http://www.designverb.com/2007/06/11/tunnel-house/>>.
- Osram 2010, *Better light –in every respect*, Osram, viewed 8 October, 2010, <[www.osram.com/change-now](http://www.osram.com/change-now)>.
- Parker, R 2003, 'The Carnivalization of the World' in Gutmann, MC, Matos Rodríguez, FV, Stephen, L, Zavella, P (eds), *Perspectives on Las Américas: A Reader in Culture, History, & Representation*, Blackwell Publishers, USA



Parker,WO, Smith, HK 1974, *Scene design and stage lighting*, Holt, Rinehart and Winston Inc., USA

Pecktal, L 1975, *Designing and Painting for the Theatre*, Holt, Rinehart and Winston, USA

Ping mag, 2006, *Vertical Garden:The art of organic architecture*, viewed 20 October, 2010, <<http://pingmag.jp/2006/12/08/vertical-garden-the-art-of-organic-architecture/>>.

Quimica visual, 2010, *One Day At A Time*, viewed 22 October, 2010, <<file:///C:/laptop%202010/Architecture1/Masters%20Oct2/Research/Plays%20%20trees/Tree%20pics/trees5.htm>>.

Read, G 2006, 'Theater of Public Space: Architectural Experimentation in the Théâtre de l'espace (Theater of Space), Paris 1937', *Journal of Architectural Education*, vol.58, no.4, pp.53-62

Receveur, J 2010, *Junk Theory*, viewed 22 October, 2010, <[http://lifeisbeautiful-jules.blogspot.com/2010\\_03\\_01\\_archive.html](http://lifeisbeautiful-jules.blogspot.com/2010_03_01_archive.html)>.

Rothstein, A 2010, *Today we tube*, Blogspot, viewed 25 October, 2010, <<http://interdome.blogspot.com/>>.

Ruzza, L 1991, *Don Giovanni*, Openlabcompany, viewed 22 October, 2010, <<http://www.openlabcompany.com/00setdesign.htm>>.

Ruzza, L 2006, *Il flauto magico*, Openlabcompany, viewed 22 October, 2010, <<http://www.openlabcompany.com/00setdesign.htm>>.

Ruzza, L 2006, *Il flauto magico*, Openlabcompany, viewed 22 October, 2010, <<http://www.openlabcompany.com/00setdesign.htm>>.

Saraceno, T 2009, *Floating museum*, The Functionality, viewed 24 October, 2010, <<http://www.thefunctionality.com/blog/?currentPage=4>>.

Savory, P 1982, *African fireside tales*, Howard Timmins, Cape Town.

Scaffold Industry Association, 2010, *How KwikAz Works*, MASS Electronics, viewed 03 December, 2010, <<http://www.kwikaz.com/howitworks.aspx>>

Schwiontek, E 2008, *Urban Laboratory: temporary Architecture*, Goethe-Institut, viewed 21 April, 2010, <<http://www.goethe.de/KUE/arc/dos/dos/sls/sdz/enindex.htm>>.

Smithee, A 2009, *Rain Forest Facts*, Blogspot, viewed 24 October, 2010, <<http://autoacneproductions.blogspot.com/2009/02/rain-forest-facts.html>>.

Spotlight, 2010, *Followspot*, ArchiExpo, viewed 28 October, 2010, <<http://www.archiexpo.com/prod/spotlight/followspot-br-halogen-lamp-56998-149064.html>>.

Spring, N 1999, 'Sound', in Adler, D, *Metric Handbook*, Sound: Planning and Design Data, Reed Educational and Professional Publishing Ltd, Great Britain.

Summers, J 2009, *What happens when a tenant abandons an industrial space?*, Sotheby's, viewed 20 October, 2010, <<http://www.socalindustrialrealestateblog.com/?cat=13>>.

Szukalski, T 2008, *Old coal mine shaft*, viewed 24 October, 2010, <[http://www.digital-photo.com.au/v/Landscapes/Old-coal-mine-shaft\\_MG\\_7499\\_500\\_501-Edit.jpg.html](http://www.digital-photo.com.au/v/Landscapes/Old-coal-mine-shaft_MG_7499_500_501-Edit.jpg.html)>.

Taller 9, 2009, *Folding Architecture*, viewed 22 October, 2010, <<http://blog.pucp.edu.pe/item/53589/folding-architecture>>

The Cool Hunter, 2007, *Cardboard Sound Box (A place for listening)*, The Cool Hunter, viewed 27 October, 2010, <<http://www.thecoolhunter.net/article/detail/967/cardboard-sound-box-a-place-for-listening>>.

The Council of the South African Bureau of Standards 1990, *Code of practice for the application of the building regulations*, 004, The Council of the South African Bureau of Standards, RSA

Tompkins, H 2010 , *Almeida at Gainsborough studios*, viewed 29 April, 2010, < <http://www.haworthtompkins.com/gainsboro>>

Touw, K 2006, '*Firmitas re-visited: Permanence in Contemporary Architecture*', Master of Architecture, University of Waterloo.

Turto, L 2010, *The Sacred Realm of the Forest Elf*, Red Bubble, viewed 24 October, 2010, <<http://www.redbubble.com/people/artworksry/art/3459400-4-lea-turto-the-sacred-realm-of-the-forest-elf>>.

Uwe50, 2006, *Clouds in black & white*, American Greetings, viewed 27 October, 2010, <<http://entertainment.webshots.com/photo/2978332530082802719XbpNkV>>.

Vyzoviti, S 2005, *Folding Architecture: Spatial, Structural And Organization Diagrams*, Gingko Press, USA.

WeddingWire, 2010, Chicago lighting design, viewed 28 October, 2010, <<http://www.weddingwire.com/biz/chicago-lighting-design-oswego/faq/d7a98d170074935b.html>>.

West Bay Opera, 2006 *Manon Lescaut*, West Bay Opera, viewed 28 October, 2010, <<http://westbayopera.net/CrewView/graphics/Gobo.jpg>>.

Whittaker, J 2008, *Amazing new play area in the Parc de Belleville*, Blogspot, viewed 24 October, 2010, <<http://www.jasonw.eu/2008/08/new-play-area-in-parc-de-belleville.html>>.

Willhelm, B 2007, *Embrouillamini*, Blogspot, viewed 24 October, 2010, <[http://embrouillamini.blogspot.com/2007\\_10\\_01\\_archive.html](http://embrouillamini.blogspot.com/2007_10_01_archive.html)>.

WordQ 2010, *Gobo (lighting) – Definition*, WordIQ, viewed 10 August, 2010, <[http://www.wordiq.com/definition/Stage\\_lighting](http://www.wordiq.com/definition/Stage_lighting)>.