

*re:fresh\**



UNIVERSITEIT VAN PRETORIA  
UNIVERSITY OF PRETORIA  
YUNIBESITHI YA PRETORIA

# *re:refresh\**

refreshment and retail strategy for Gautrain stations

Elize Venter

Submitted in partial fulfilment of the requirements for the degree of Master in Interior Architecture (Professional) in the Department of Architecture, in the Faculty of Engineering, Built Environment and Information Technology, University of Pretoria

Study Leader: Barbara Jekot  
Mentor: Catherine Karusseit

Course coordinator: Jacques Laubscher

November 2009

© University of Pretoria



UNIVERSITEIT VAN PRETORIA  
UNIVERSITY OF PRETORIA  
YUNIBESITHI YA PRETORIA

# Contents

<b>Chapter 1 Introduction</b>	
1.1 Overview	1
1.2. Historical precedents for transport in Gauteng	6
1.3 The post-apartheid city	10
1.4 Gautrain rapid rail link	11
1.5 Summary	14
<b>Chapter 2 Problem Statement</b>	
2.1 Problem statement	17
2.2 Aims	17
2.3 Subproblems	18
2.4 Assumptions	19
2.5 Delimitations	19
2.6 Client	19
2.7 Users	20
2.8 Importance of the study	21
2.9 Research methodology	21
2.10 The role of the Interior Architect	22
<b>Chapter 3 Context Analysis</b>	
3.1 Overview	25
3.2 Gautrain System Identity	26
3.3 Site location	42
3.4 Transport routes	47
3.5 Station precinct	48
3.6 Summary	59
<b>Chapter 4 Philosophy and design approach</b>	
4.1 Macro scale - Railways as public meeting places	63
4.2 Medium scale - Tectonics	68
4.3 Micro scale - Performance criteria	69
<b>Chapter 5 re:refresh* strategy</b>	
5.1 Phased deployment	79
5.2 Station specific strategies	86

Chapter 6 Concept	
6.1 Overview	91
6.2 Branding	98
Chapter 7 Design development	
7.1 Precedent studies	101
7.2 Conceptual expression	108
7.3 Factors to consider	112
7.4 Security	131
7.5 Storage	131
7.6 Potential future configuration	133
7.7 Materials and jointing	134
7.8 Conclusion	142
Chapter 8 Technical resolution	145
Appendices	185
Appendix 1 Theory matrix	185
Appendix 2 Urban framework	191
Appendix 3 Calculations	203
Appendix 4 Sample board	209
List of references	213



# List of Figures

<b>Fig. 1</b> Aerial photograph of South Africa (Google Earth 2009: [sp])	5
<b>Fig. 2</b> Map of Tshwane, Gauteng (City of Tshwane: Cartography 2008:[sp])	5
<b>Fig. 3</b> Areas for development as Metropolitan Activity Nodes as indicated in the City of Tshwane Spatial Development Strategy, 2010 and beyond, one of which is the proposed investigation site, Hatfield (2007:17)	5
<b>Fig. 4</b> Calendar advertising the coach service owned and run by George Heys, 1892 (Allen 1971:72)	6
<b>Fig. 5</b> George Heys' stage coach with horses (Allen 1971:68)	6
<b>Fig. 6</b> The arrival of the first train at Pretoria station on 1 January 1893, not from Delagoa Bay, but from the Vaal River (De Jong e.a. 1988:160)	6
<b>Fig. 7</b> Covered platform at Johannesburg's Park station showing ticket kiosk and luggage room in 1898 (De Jong 1988:92)	7
<b>Fig. 8</b> Horse drawn tram in front of TW Beckett's store on the corner of Church and van der Walt streets in Pretoria in 1919	7
<b>Fig. 9</b> Electric tram at Pretoria Station, 1910.	7
<b>Fig. 10</b> Relief of congested roadways, such this crossing of Duncan and Schoeman roads in Hatfield, is one of the reasons for the implementation of the Gautrain Rapid Rail Link.	10
<b>Fig. 11</b> Gautrain carriages in South Africa on a test run and the interiors, showing high visibility grab rails	12
<b>Fig. 12</b> The GRRL would be operating an electronic ticketing and barrier system.	12
<b>Fig. 13</b> Gautrain route alignment and stations (Gautrain Rapid Rail Link 2009:[sp])	13
<b>Fig. 14</b> Excerpt from Plan of Centurion Gautrain station plans and digital design images showing no refreshment facilities (Presentation To Hatfield Stakeholders: 2007:[sp])	14
<b>Fig. 15</b> Design images of Pretoria Gautrain station showing no refreshment facilities (Presentation To Hatfield Stakeholders: 2007:[sp]).	15
<b>Fig. 16</b> Bombela contractual structure	22
<b>Fig. 17</b> Visual representation of Gautrain system identity	29
<b>Fig. 18</b> GSI basic external station finishes	30
<b>Fig. 19</b> Civil structures, pylons and viaduct barriers incorporate motifs abstracted from local cultural elements	30
<b>Fig. 20</b> Viaduct piers exhibiting influences of both the tree motif as well as local arts and crafts.	31
<b>Fig. 21</b> Signage and wayfinding	32
<b>Fig. 22</b> Various external and interior material and detail sample mock-ups at the Bombela offices would offer a better understanding of the Gautrain aesthetic.	32
<b>Fig. 23</b> The diagram illustrates the target market of the GRRL in terms of current method of transport	37
<b>Fig. 24</b> Gautrain users' needs illustration	39
<b>Fig. 25</b> Nollie map of Pretoria with Hatfield area outlined in red.	42
<b>Fig. 26</b> The Hartbeesspruit Metrorail station has the potential to connect the Hatfield Gautrain station to the Tshwane Ring Rail system.	47
<b>Fig. 27</b> Feeder and distribution route bus.	47
<b>Fig. 28</b> Feeder and distribution bus routes from Hatfield GRRL station give an indication of the catchment area for the Hatfield GRRL (Gautrain Rapid Rail Link 2009: [sp])	48
<b>Fig. 29</b> Transport routes in Pretoria indicate the interlink between the GRRL and Metrorail and proximity of other transport modes	48
<b>Fig. 30</b> Pedestrians and cyclists in Duncan Rd.	50
<b>Fig. 31</b> Proposed bus routes (Bombela CJV 2007:[sp])	50
<b>Fig. 32</b> Proposed pedestrian (orange) and bicycle (red) routes. Important nodes indicated by the	



circles (Bombela CJV 2007:[sp])	50
<b>Fig. 33</b> Hatfield site erven, land use and municipal sewer connection	52
<b>Fig. 34</b> Contours on figure ground background (1m interval contours) (Gautrain Rapid Rail Link 2009: [sp])	52
<b>Fig. 35</b> Informal trade at Hartbeesspruit Metrorail station.	54
<b>Fig. 36</b> Newspaper sellers at the corner of Duncan and Schoeman streets	54
<b>Fig. 37</b> Dwelling house converted to offices	54
<b>Fig. 38</b> High density residential development in Schoeman street, within 100m of the station	54
<b>Fig. 39</b> Multi-storey office park opposite Hatfield GRRL station in Grosvenor st.	54
<b>Fig. 40</b> Motor dealership on the corner of Duncan and Schoeman streets	54
<b>Fig. 41</b> Example of Transvaal School of architecture in the old Hatfield Primary School (1916) Grosvenor St.	54
<b>Fig. 42</b> Duncan Rd.	54
<b>Fig. 43</b> Climatic data for Pretoria (Holm 1996: 70)	56
<b>Fig. 44</b> Summer wind directions (Holm 1996: 72)	56
<b>Fig. 45</b> Winter wind directions (Holm 1996: 72)	56
<b>Fig. 46</b> Summer sun angles on site (Holm 1996: 70)	59
<b>Fig. 47</b> Winter sun angles on site (Holm 1996: 72)	59
<b>Fig. 48</b> Possible noise & air pollution sources from the parking garage and trains	59
<b>Fig. 49</b> Place diagram indicating key attributes of successful places in inner ring, middle ring intangible qualities and in the outer ring	66
<b>Fig. 50</b> Diagram illustrating the retail deployment strategy over a period of time	80
<b>Fig. 51</b> Identification of the main vehicular and pedestrian traffic routes could help identify the optimum location for the re:fresh interventions at the Gautrain stations	84
<b>Fig. 52</b> In Hatfield, the station parking closest to the glazed pedestrian bridge into the station had been identified as a good location for re:fresh L in future and the station lobby for the re: fresh M kiosks	84
<b>Fig. 53</b> Concept sketch plan potential future parking area for re:fresh L.	84
<b>Fig. 54</b> Breakdown of the different phases of the product lifecycle specific to re:fresh brand	87
<b>Fig. 55</b> Various views of the basic kiosk unit	115
<b>Fig. 56</b> Figure sequence outlining the assembly of a single re:fresh kiosk on site	117

## **Abbreviations**

GRRL - Gautrain Rapid Rail Link

BRT - Bus Rapid Transit

SARCC - South African Rail Commuter Corporation

PRASA - Passenger Rail Association of South Africa

COTMM - City of Tshwane Metropolitan Municipality

GTIA - Gautrain Transport Infrastructure Act

GSI - Gautrain System Identity





**Pretoria**





# Chapter 1

## Introduction

### 1.1 Overview

Public transport in South Africa is generally under-utilised and if used it serves mostly lower income users. It is believed that the public-private **Gautrain Rapid Rail Link** enterprise could correct this imbalance through a quick, reliable connection between Tshwane and Johannesburg. This proposal presents an opportunity for design interventions in the field of human interaction and reinforcement of place within the environment of transport facilities.

The focus of this study is the provision of **refreshment, retail and supporting facilities** at Gautrain stations. This forms part of an overarching strategy called *re: fresh\** for the deployment of refreshment, retail and supporting facilities at stations. For the purposes of this thesis, the concept of **refreshment** focuses on the aspects of bodily / physiological and mental refreshment, whether this be through sale of beverages and snacks or distribution and availability of information, news and mental stimulation through design. The *re: fresh\** strategy is explored in more detail through the design of a multifunctional **kiosk** for medium term deployment at any of the Gautrain stations.

Important factors in this scheme is the identifying of the most popular refreshment and ancillary facilities at other similar train stations as well as the integration of such facilities into the existing Gautrain system identity.



The design approach is formulated on the three levels of scale:

- \* **macro**, or neighbourhood to building interior scale, with the focus on the **creation of places** and the idea of the railway station as public meeting place
- \* **medium**, or unit scale, informed by the importance of **tectonic** expression in interior architecture
- \* **micro**, or unit & details scale informed by various factors relating to **cost** and **sustainability**.

The aim is to contribute to the understanding of user needs in terms of refreshment, retail and ancillary behaviours (e.g. access to info) at transport interchanges. It would also suggest a strategy on management and operations level for the phased implementation of various retail and refreshment interventions at small, medium and large scale. In this manner the thesis would make a contribution to the field of the environment and cultural landscapes as applicable to the discipline of interior architecture.

For the purpose of this thesis the following assumptions are made:

The Gautrain project, currently in the construction phase will be completed.

The projected usage figures of the Gautrain Rapid Rail will be realised, making the *re:refresh\** strategy feasible.

Within the scale of the Gautrain Rapid Rail Link, the scope of this investigation is limited to a 300 meter radius, or approximately five minute walking distance, around the **Hatfield Gautrain station**. The Hatfield station building interior will form the backdrop of an in depth design development of the *re:refresh\** intervention.

**Chapter 1** serves as introduction and highlights local historical transport precedents and an introduction to the recent Gautrain development.

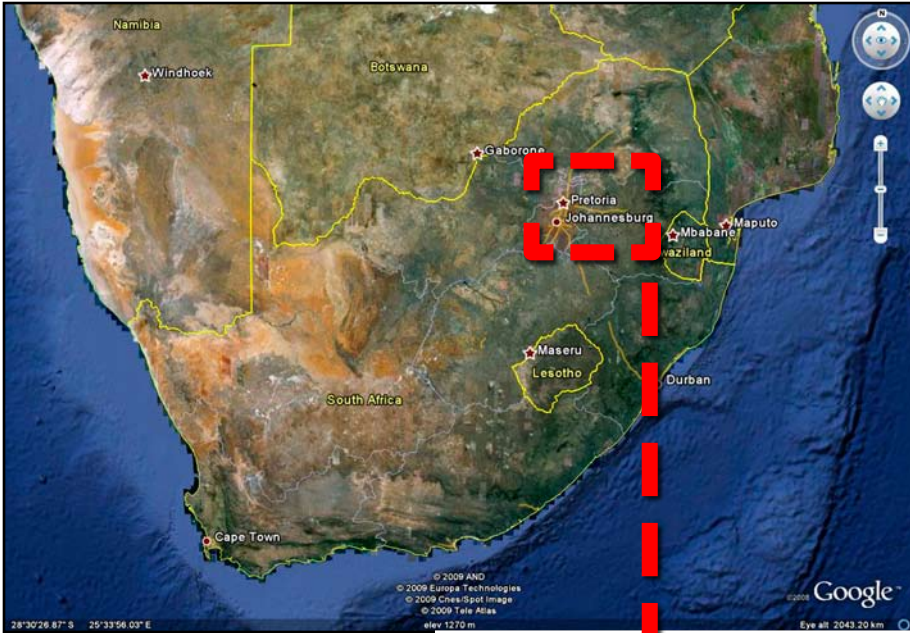
**Chapter 2** sets the problem statement and hypothesis.

The Gautrain organisational and design context as well as the site characteristics are analysed in **Chapter 3**.

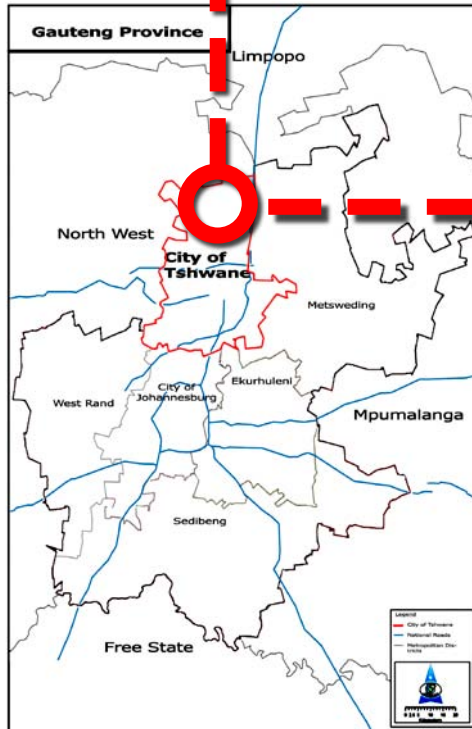
**Chapter 4** sees the formulation of a philosophy and design approach for *re:refresh\** on three levels of scale.

The *re:refresh\** strategy for the phased deployment of refreshment, retail and supporting facilities occurs in **Chapter 5**.

**Chapter 6** and **7** illustrate the concept and design development respectively, while technical resolution is contained in **Chapter 8**.

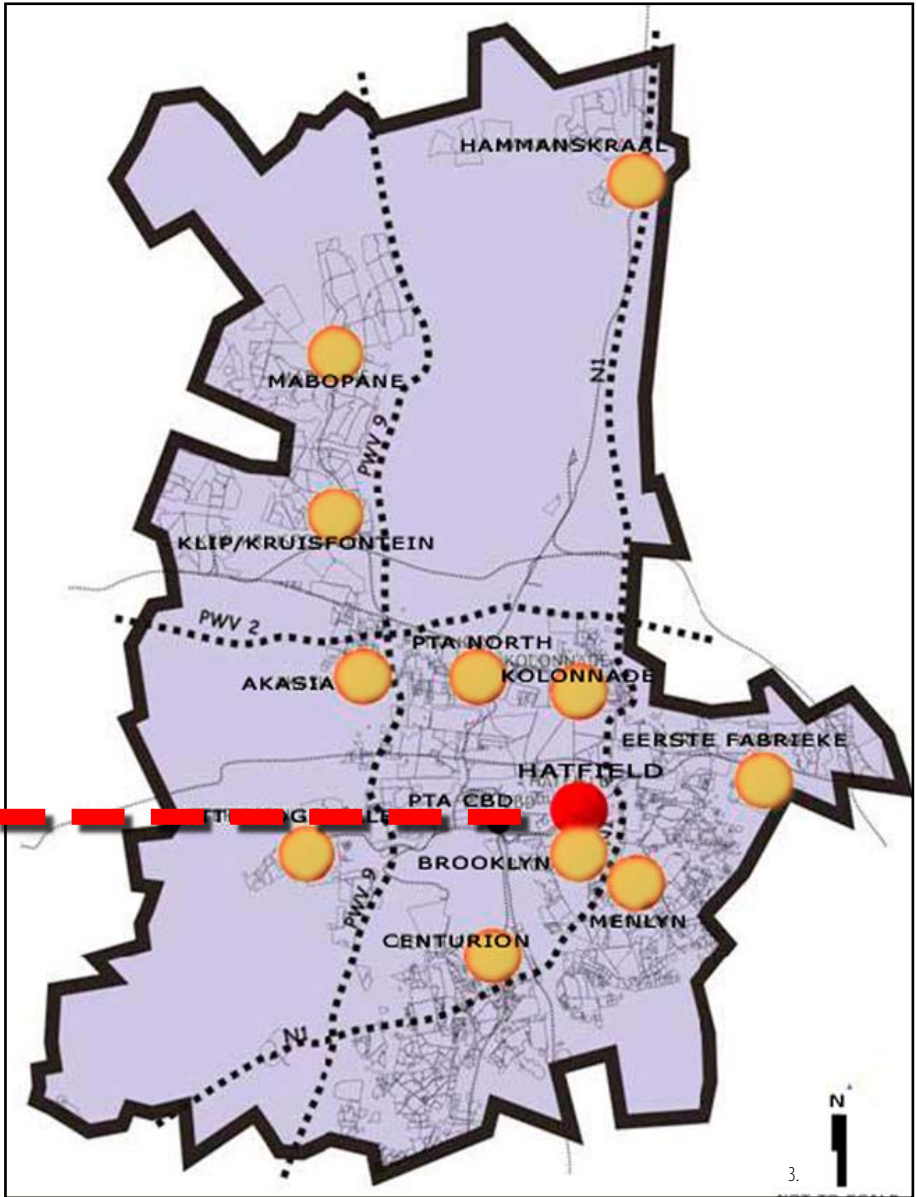


1.



*site location in Gauteng*





1. Aerial photograph of South Africa (Google Earth 2009: [sp])
2. Map of Tshwane, Gauteng (City of Tshwane: Cartography 2008:[sp])
3. Areas for development as Metropolitan Activity Nodes as indicated in the City of Tshwane Spatial Development Strategy. 2010 and beyond, one of which is the proposed investigation site (City of Tshwane: 2007:17)





4.



5.



6.

4. Calender advertising the coach service owned and run by George Heys, 1892 (Allen 1971:72)
5. George Heys' stage coach with horses (Allen 1971:68)
6. The arrival of the first train at Pretoria station on 1 January 1893, not from Delagoa Bay, but from the Vaal River (De Jong e.a. 1988:160)

## 1.2. Historical precedents for transport in Gauteng

It was around the 1870's that the first refreshment facilities at a railway station was provided on the Cape railway line at **Matjiesfontein** by Scotsman and founder of the station, James Logan. As the station was a crucial watering point for then steam engines travelling between Cape Town and Kimberley, all trains stopped there. This made it the ideal place for a **restaurant** on the station platform, as the trains had no dining cars as of yet (Ash 1998:66).

The first **"express coach"** services from Pretoria were established around late 1882 or early 1883 by merchant and concessionaire George Heys (Allen 1971:69). This route connected Pretoria to four major destinations:

- \* Charlestown towards Durban
- \* Kimberly and the start of the Cape railway
- \* Barberton with branches to Lydenburg and Pilgrim's Rest to serve the Eastern goldfields
- \* Pietersburg to accommodate Northern Transvaal trade. (ibid).

The speedy 24-hour travel, achieved by changing horses every ten to fifteen miles. This assured that George Heys was awarded the contract for mail delivery between Pretoria and Kimberley (the last station on the railway line from Cape Town at that time) in 1888. Later on passengers were also transported. This service was gradually replaced from early 1893 to 1905 as the existing railways were extended through Bloemfontein to Pretoria to connect it to Johannesburg and the Cape (Allen 1971:128).

The completion of the **NZASM** (Nederlands Zuid-Afrikaansche Spoorweg Maatschappij) railway connecting Pretoria with Delagoa Bay in the east in November 1894, and linking with the existing Cape and Natal railways to the south and south east marked the end of Heys' coach service and the start of fast, more comfortable travel across South Africa.

NZASM railways stations were typically **utilitarian** and ranged from simple corrugated iron shacks to grander red brick and dressed stone buildings (De Jong 1988:81-88). Most stations had, besides necessary ticket offices, baggage rooms and staff accommodation, only a **waiting room** for passengers. There is mention of a kitchen and restaurant at Elandsfontein station, but it is not clear whether this was for staff or passengers (De Jong 1988:91).

Stations were typically part of official buildings such as magistrate's courts and post offices **combined** under one roof (De Jong 1988:81). Schools were also often found in close vicinity to some stations, such as today's Jeppe station.

To accommodate weary travelers at the Pretoria station, the **Victoria Hotel**, known then as the Hollandia Hotel, in Scheiding Street, opposite the Pretoria main rail station, first opened its doors in 1896 (Allen 1971:128).

For about thirty years, the ground floor **shops** along Scheiding Street opposite Pretoria station housed a **men's outfitters** and **barber shop** before these made way for the hotel **lounge** (Allen 1971:130). The owner of the land, T.W. Beckett, leased it to Jacob Joffe on condition that he builds a hotel on it (Allen 1971:128)

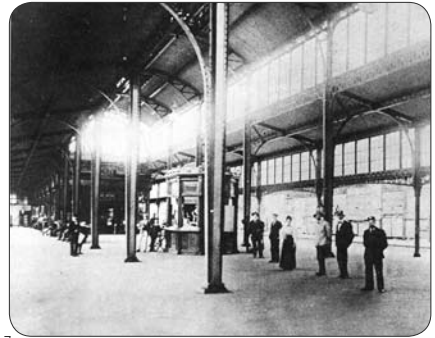
English trader TW Beckett greatly profited, not only from his shops, such as TW Beckett & Co on the corner of Church and van der Walt streets, but also from supplying tools for the construction of the NZASM railway line from Delagoa Bay to Pretoria. (Allen 1971:139). His business grew rapidly, opening more shops over Transvaal and London, supported in part by the drive for expansion and faster transport connections in the Transvaal.

The year 1896 saw the first recorded use of **horse-drawn trams** in Pretoria, adopted as public transport in 1904 (Pretoria 150 2005: 30).

In 1897 the first **motor** vehicle in South Africa is publicly displayed in Berea Park (Pretoria 150 2005: 25).

**Electric trams** were first used in Pretoria in 1910. These were supplemented by **double height buses** in 1935 and **trolley buses** in 1938, by which they were ultimately replaced in 1939 (Pretoria 150 2005: 44-45).

Pretoria has since the earliest days had a history of public transport, with modes ranging from stage coach, rail, tram and bus. In contrast, over half of modern day transport in Gauteng occurs by means of private motorized transport (City Of Tshwane Integrated Transport Plan 2006: 3-21).



7.



8.



9.

7. Covered platform at Johannesburg's Park station showing ticket kiosk and luggage room in 1898 (De Jong 1988:92)

8. Horse drawn tram in front of TW Beckett's store on the corner of Church and van der Walt streets in Pretoria in 1919

9. Electric tram at Pretoria Station, 1910.





Matjiesfontein railway station refreshment facilities (restaurant) established on Cape lines

1882 - 1905. George Heys express coach service established  
 1894. Completion of NZASM railway line from Pretoria to Delagoa Bay // Lourenço Marques  
 1896. Victoria Hotel at Pretoria Station opened  
 1897. First private motor vehicle displayed in Pretoria

1860

1860. Pretoria proclaimed as capital of the ZAR and seat of the "Volksraad"  
 1877. Annexation of Pretoria by British forces

1880

1899. 12 October. Second Anglo-Boer War declared  
 1900. 29th May. Pretoria peacefully surrendered to British forces  
 1902. Hillcrest laid out  
 1905. Hatfield laid out by W.R. Lanham  
 1910. Transvaal University Kollege (TUK) established

1900

[De Jong 1988] [Laubscher 1992:1-3, 12] [Lombaard 2005: various] [Spoornet 2006]



1910. Electric trams used in Pretoria

1935. Double height buses used in Pretoria  
1938. Trolley buses used in Pretoria



1958. First diesel electric locomotive arrives in SA

1983. Belle Ombre - Mabopane commuter railway in Pretoria completed  
1997. Metrorail created as division of Transnet for commuter services

2000. Gautrain project announced by Gauteng Provincial Government  
2005. Bombela announced as preferred bidder  
2006. September. Gautrain construction commences



1916. Hatfield / Hillcrest officially part of Pretoria  
Named Hatfield in honour of 2nd Earl of Selbourne, British Governor of Transvaal from 1905. Hatfield was the name of his property in England  
1927. Natal Immorality Act makes it illegal to marry a person of a different race  
1930. University of Pretoria established from TUK  
1939. Atteridgeville proclaimed as black residential area

1945. Native Urban Areas Act 25 of 1945 decrees that black people may not be present in white areas for longer than 72 h. Pass system established  
1959. UP Sports grounds LC de Villiers set into use.  
1961. Republic of South Africa. CR Swart as first president

1985. PW Botha's Rubicon speech  
1986. Pass laws abolished  
1990. ANC unbanned. 12th February Nelson Mandela released from prison  
1994. Democratic elections. Nelson Mandela elected president

2000. Gautrain project announced by Gauteng Provincial Government  
2005. Bombela announced as preferred bidder  
2006. September. Gautrain construction commences

*timeline*

Indicates major historical events in South Africa and Gauteng, as well as illustrating important transport and related passenger facilities highlights





10.

10. Relief of congested roadways, such this crossing of Duncan and Schoeman roads in Hatfield, is one of the reasons for the implemented Rail Link.

### 1.3 The post-apartheid city

Even before Dr. H.F. Verwoerd came into power in 1958, previous land and settlement policies in apartheid cities like Pretoria had pushed black populations out of the cities and into the urban peripheries (Chipkin 1998:160). Here they were isolated from the city centres, advanced infrastructure and opportunities provided by the cities, leading to large pockets of peri-urban **underdevelopment** (ibid).

A series of new towns were established in the urban periphery of Pretoria to consolidate population in the underdeveloped areas (Chipkin 1998:163). Examples of such towns are Temba at Hammanskraal, started in the 1950's which had an express rail service to Pretoria; Ga-Rankuwa, Mabopane and Soshanguve (ibid).

Limited job opportunities existed in these border towns, despite the establishment of nearby industrial centres such as Rosslyn (Chipkin 1998:163).

The new towns were described as the "commuting hinterland" by urban geographers Hattingh and Horn in 1991, and were characterized by long and uncomfortable commutes into the city (Chipkin 1998:163). In 1983 it was recorded that 400 000 Africans were commuting to Pretoria city core of which 40% came from Mamelodi and Atteridgeville and 60% from outside Pretoria (ibid).

The doctrine of apartheid had a far-reaching effect on the spatial quality of South African cities. It created a **spatial duality**, an imbalance in the allocation of urban space and access to the opportunities and infrastructure of cities. Contemporary urban spatial development frameworks in part attempt to **rectify** this imbalance. Interventions are suggested in various sectors, such as in the:

- a) **economic** sector by encouraging development in previously underdeveloped peri-urban areas (City Of Tshwane Integrated Transport Plan 2006: 2-2, 2-3),
- b) **political** sector by unifying the areas under the auspices of the Tshwane Metropolitan Council, and
- c) **spatially** by espousing sustainable urban development practices to revitalize the inner city center, such as mixing uses, densification, compaction and development and promotion of **public transport** systems (City Of Tshwane Integrated Transport Plan 2006: 2-3).

Public transport in Tshwane is not being optimally utilized. The majority of **private car owners** reside in the

more affluent Pretoria Eastern suburbs, with lowest number of car owners residing in the outlying townships of Temba, Winterveld, Mabopane and Garankuwa (City Of Tshwane Integrated Transport Plan 2006 – 2011:3-15).

These areas are also the areas of some of the lowest income groups in Tshwane (ibid.). Since the majority of job opportunities lie in the inner city core (City Of Tshwane Integrated Transport Plan 2006: 3-14), this makes the **lower income groups** the most likely and most needful of **public transport**. Public transport has become the domain of the disenfranchised. Considering the incidences of bad driving and intimidation by taxis (Addison 2002: 225) and crime and passengers' fear for safety on buses, trains and taxis (City Of Tshwane Integrated Transport Plan 2006: 3-23) it is no wonder anyone who is able to, will utilise private motorized transport.

However, private transport does not come without **costs**. There are some serious environmental, social and economic drawbacks. Noise & air pollution affect cities and natural environments. Freeways cut through the landscape like dark scars. Vast amounts of energy are expended in transit.

Personal energy is also expended by travelers trying to get from point A to point B. Traffic congestion increases personal time spent on the road and away from families, and is generally unpleasant. Society suffers from the effects of pollution, loss of privacy, expense of providing new roads and parking, accidents and death. Costs for goods on roads increase as the delivery time increases (Lynch 1981: 193-194).

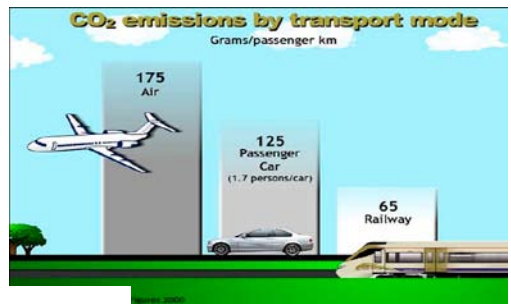
There seems to be a need for the increased use of public transport. The image, comfort and safety of public transport and associated facilities are an area of concern. The idea that public transport is the domain of the peri-urban poor needs to be challenged in order to improve sustainable public transport use.

## 1.4 Gautrain rapid rail link

### 1.4.1 Brief description and route

The Gautrain Rapid Rail Link (GRRL) is a local government intervention to address the public transport condition as described in section 1.3. It is a state-of-the-art rapid rail network planned in Gauteng. Upon completion it will link Tshwane, Johannesburg and OR Tambo, between the ten planned stations (Gautrain Rapid Rail Link 2009:[spj]).

Comparison of CO<sub>2</sub> emissions by transport mode (Andrew 2009:10)





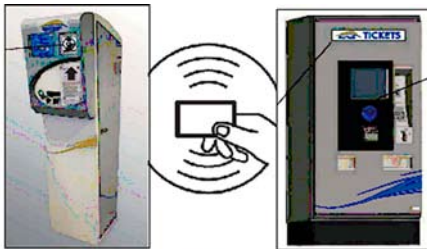
The project is a **public-private partnership** between the Gauteng Provincial Government (GPG) and Bombela Concessions Company (Gautrain Rapid Rail Link 2009:[sp]).

At speeds of **160 – 180km/h** the journey time from Hatfield station to Park station is estimated at **40 minutes**. Sandton to OR Tambo Airport should take 15 minutes. Four four-car sets (450 passengers) of Bombardier's tried and tested **Electrostar** range of vehicles will be supplied initially, later to be increased to eight. The service will run at least from 5:30 to 20:30, seven days a week (Andrew 2009:9).



At peak times there will be a service **every twelve minutes**, whilst off-peak hours the service runs **every twenty to thirty minutes** (Gautrain Rapid Rail Link 2009:[sp]).

Gautrain **fares** have been determined in relation to existing taxi fares, bus fares and private transport costs. The fares, yet to be specified, will be less than the cost of using a car, but more than existing rail and taxi fares, as the new train will offer a higher quality service (ibid.). Airport passengers' fare will be higher than the fares charged on other services. (ibid.).



The project also includes the implementation of dedicated **bus feeder routes** to and from the stations (Gautrain Rapid Rail Link 2009:[sp]). It is directed mainly at users of **low to middle income** who may or may not own cars and need to commute regularly between Tshwane and Johannesburg (ibid.).

The vision of the GRRL is to provide an international standard transport service with safety, reliability, predictability and comfort being paramount. It is envisaged that the Gautrain Rapid Rail Link will provide a cost effective, efficient and **sustainable** alternative to private vehicle commuting and relieve traffic congestion, especially on the freeway between Tshwane and Johannesburg (ibid.).



The main aim of the GRRL project is **improving** public transport in order to enhance and support economic growth and stimulate job creation and economic opportunities in Gauteng. This aim is in line with the objectives of the *Integrated Development Plan 2006-2010*, the *Tshwane Growth and Development Strategy Final Draft 2006*, and the *City of Tshwane Integrated Transport Plan 2006-2011*.

The Gautrain System Identity (GSI) is a broad spectrum

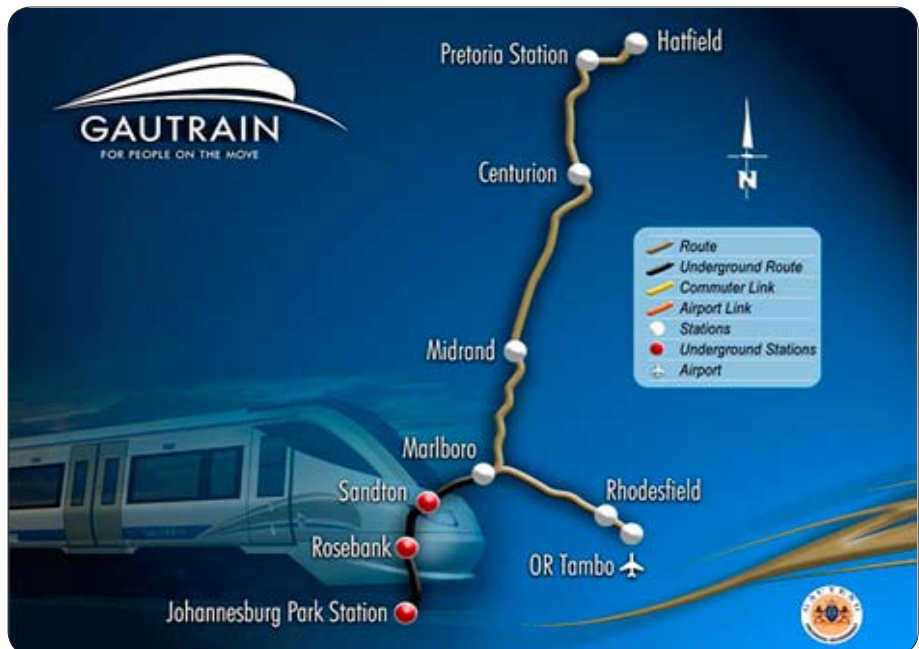
11. Gautrain carriages in South Africa on a test run and the interiors, showing high visibility grab rails

12. The GRRL would be operating an electronic ticket

standard of design, developed by Bombela designers and Gautrain Architects Joint Venture (GAJV). It is to be applied to all GRRL stations, with subset of the GSI at each station responding to local context. In general it amounts to the branding of the GRRL and aids legibility and customer identification with the GRRL (Steer 2009:[sp]).

The proposed site for the investigation of retail and refreshment facilities is the Hatfield Gautrain station. Located within the existing Hatfield business node, the Hatfield Gautrain station is the last on the north-south line of the Gautrain rail system.

From perusing the Gautrain stations plans it would seem that no refreshment or retail facilities are provided. Bombela have indicated approval for future appropriation of portions of the parking allocation for such facilities.



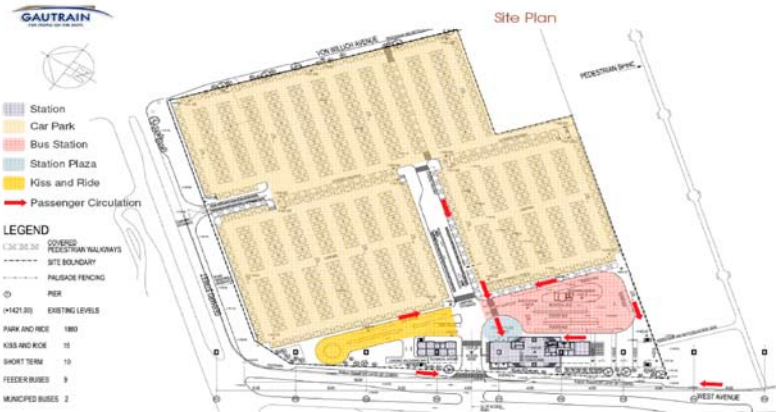
13. Gautrain route alignment and stati



## 1.5 Summary

From a historical perspective the presence and use of public transport has always been evident in Pretoria. The current transport condition is one of large-scale private vehicle use and congested roads, as well as the accompanying environmental and social disadvantages.

If fully realised, it is believed the Gautrain will reinvigorate the city centres of Tshwane and Johannesburg as well as providing a fast, efficient, predictable link between the two cities. However, it would seem that opportunities for refreshment and retail facilities in the stations have been overlooked. It is believed that the GRRL system would benefit from the investigation of and implementation of the *fresh\** intervention in this regard. Provision for bodily and mental refreshment would contribute to the establishment of the railway stations as places by the creation of small “nodes of choice” contributing to the sense of place inside the stations. It would also contribute to customer satisfaction and identification with the GRRL system as a whole.



14. Excerpt from Plan of Centurion Gautrain station plans and digital design images showing no refreshment facilities (Presentation To Hatfield Stakeholders: 2007:[sp])



15. Design images of Pretoria Gautrain station showing no refreshment facilities (Presentation To Hatfield Stakeholders: 2007:;sp).





2



UNIVERSITEIT VAN PRETORIA  
UNIVERSITY OF PRETORIA  
YUNIBESITHI YA PRETORIA

# Chapter 2

## Problem Statement

### 2.1 Problem statement

The problem, as identified in Chapter 1 is insufficient provision for the **refreshment and retail wants and needs of users** of the Gautrain Rapid Rail Link. It is believed that there are opportunities for the **formal** retail and refreshment sector in the station environments. Many local and international examples had been examined where retail and refreshment facilities are encountered side by side at station and termini, such as Grand Central terminal in New York . The current GRRL proposals do not include any infrastructure for such facilities. The thesis would suggest a solution to this problem.

The manner in which the *re:refresh\** intervention responds to the Gautrain system identity and philosophy would be an important part of the investigation for the design of the system.

As mentioned in the introduction the idea of **refreshment** focuses on the aspects of **bodily** / physiological and **mental** refreshment. This would include both sustenance (food, beverages) and the mental stimulation and expansion of knowledge offered by reading of newspapers, magazines, etc, purchased at the station. This also would not exclude other forms of retailing, such as gifts, clothing, accessories (hats, scarves, gloves) and other impulse buying behaviour (sweets, cool drinks, cigarettes).

### 2.2 Aims

The aim of the thesis is to formulate the *re:refresh\** yment of **refreshment, retail and**



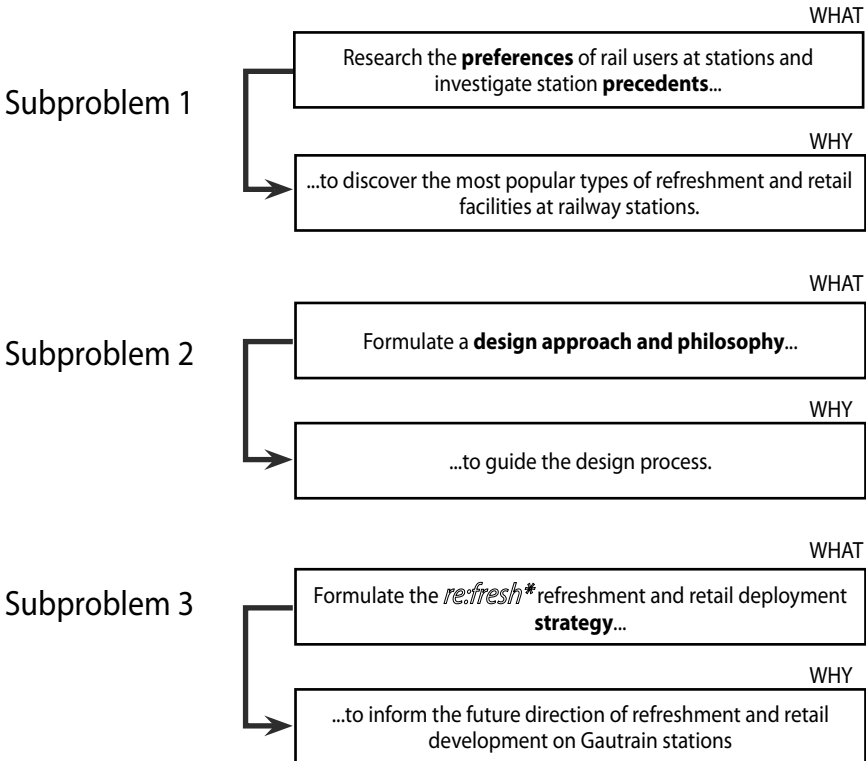


**supporting facilities** as transition between the current situation and the end result of integrated retail and refreshment facilities that respond to user desires and context.

A part of this strategy should be tested and demonstrated in designed form in the context of the **Hatfield Gautrain station**. This framework will contribute to the study and facilitation of user refreshment and retail preferences at intermodal transport facilities in the field of the environment and cultural landscapes.

### 2.3 Subproblems

The problem statement could be broken up into three subproblems presented in the diagram.





## Precedent //

Grand Central Terminal, NY, USA

Grand Central terminal has become a **destination** - not just for transport, but also for the five exquisite restaurants and cocktail bars, including the world famous **Oyster Bar**, twenty casual international eateries, **gourmet foods** from the Grand Central Market and the fifty unique **specialty shops** throughout the concourses

(Grand Central terminal 2009:[sp]).



## 2.4 Assumptions

For the purpose of this thesis the following is assumed:

- \* The Gautrain project, currently in the construction phase, will be completed as per plans available in the first six months of the year.
- \* Although the Gautrain stations are currently in the construction phase, they will be **regarded as complete** as per drawings provided by Bombela.
- \* The projected usage figures of the Gautrain Rapid Rail will be realised. In other words, the Gautrain project in its entirety will be deemed financially **feasible** with large enough numbers of users to make ancillary refreshment and retail facilities a viable option, at least at first.

## 2.5 Delimitations

Given the scale of the Gautrain Rapid Rail Link and due to time constraints, the scope of this investigation has been limited to a 300m radius around the Hatfield Gautrain stations. The Hatfield station precinct will form the backdrop of an in-depth design development applying and testing the spatial framework for refreshment facilities.

The focus of the study is mainly the interpretation of qualitative data (as explained in 2.9). Because qualitative studies generally require considerable planning, preparation and time, the qualitative data collection in this study will employ the case study method where the study of one or a few precedents can enhance understanding and inform practice for similar situations (Leedy 2005: 135). The time allocated to the study will not allow for detailed ethnographic or phenomenological research methods.

## 2.6 Client

The proposed client is the main Gautrain concessionaire, **Bombela Concession Company (Bombela)** (Gautrain Rapid Rail Link 2009: [sp]). The GRRL is operated and run by Bombela. The system and associated properties (stations) is also owned by the company for the first fifteen years of operation. Thereafter the assets will be expropriated by the Gauteng Provincial Government (Otto 2009:[sp]).

Thus far, proposals for small kiosks inside the stations have been postponed for future decision once the rail and stations are complete. They are, however, aware of the potential financial benefits indicated by such a venture, as well as improved Gautrain brand identification and customer satisfaction. Current provision for retail

# Gautrain Stakeholders



Gauteng Provincial Government  
Client



Bombela Concessions Company  
Manage concession  
Operate, run, part-finance GRRL



Murray & Roberts  
Engineering & construction  
Bombela shareholder



Strategic Partners Group (SPG)  
BEE shareholder in Bombela



Bombardier UK  
Railway design & manufacture  
Bombela shareholder



Bouygues Travaux Publics  
Civil Engineering & construction  
Bombela shareholder  
(Gautrain Rapid Rail Link 2009:[sp]).

include:

- \* discouragement of intensive cooking activities inside station buildings themselves,
- \* potential deployment of small 5m<sup>2</sup> kiosks e.g. newspaper kiosks inside stations,
- \* potentially appropriating a portion of the ground floor parking allocation for the facilitation of refreshment and retail facilities, and
- \* future expansion of such facilities.

Since the station buildings are assumed to be complete (see Assumptions 2.4), it is important to preserve the original structure as far as feasible, as the existing structure represents a significant financial investment. It is proposed to only add to the existing structure and only replace or amend where an alternative design option would prove unfeasible or impractical.

## 2.7 Users

The proposal is aimed at **commuters** using the Gautrain system. The GRRL itself is aimed mainly at commercially active people needing to commute between Johannesburg, Tshwane and OR Tambo Airport. The two most important target market segments are existing private vehicle **commuters** (including public transport users 'upgrading' from the traditional metrorail, taxi's and buses) and **airport passengers** including foreign tourists (Gautrain Rapid Rail Link 2009:[sp]).

The relief of traffic congestion on freeways such as Ben Schoeman between Johannesburg and Tshwane is one of the major objectives of Bombela's Gautrain proposal as well as that of local government development plans, hence the focus on existing motorists (ibid).

Forecasts indicate approximately 100,000 passengers would use the GRRL per day (ibid.). With an expected annual growth of 4.8%, more than **120,000** passengers would be using the GRRL per day by 2010 (ibid.).

It is assumed for the purposes of this thesis that tourists from OR Tambo International Airport would do the bulk of souvenir and arts and crafts purchases at tourist attractions, such as the Union Buildings, and not at stations such as Hatfield. The focus of the investigation is not on the tourist and arts and crafts industry, but rather on provision for commuters.



## 2.8 Importance of the study

This study investigates the factors influencing the strategy for the implementation of refreshment and retail facilities at the Gautrain stations from an organisational and design viewpoint. This could potentially be extended to other SARCC commuter rail stations, but should be investigated in a different study. During the course of this study, the refreshment and retail facilities associated with train stations would be analysed and applied in a way that will improve the experiential quality of the public context in which it appears.

This proposal presents an opportunity for design interventions in the field of human interaction interior space and the reinforcement of place within the environment of transport facilities.

## 2.9 Research methodology

The ideal research approach for this thesis is a **mixed-method** design (Leedy 2005: 97). This consists of a combination of **qualitative** and **quantitative** approaches to the research problem (ibid).

The mixed-method approach is holistic, subjective, and emergent, with methods, categories or variables “emerging” as the study proceeds (Leedy 2005: 95). Data collection would consist of personal field **observations**, confirmed by direct questioning or interviews, as well as the extensive use of photographs, drawings and sketches. This data would then be interpreted by searching for common **themes** and categories (Leedy 2005: 96).

A **needs assessment** could also be used employed to draw out information. It would provide a framework to prioritise people’s needs and raise their awareness of related issues (World Bank 2009:10).

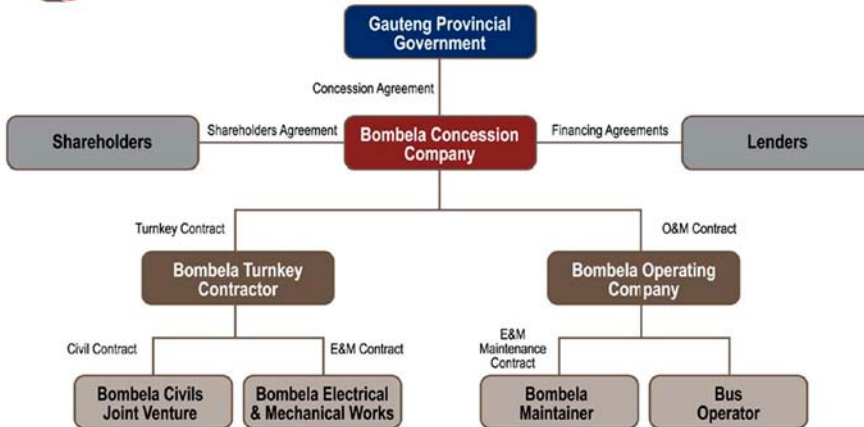
Another method to ascertain people’s preferences is **preference ranking** or direct matrix ranking. This exercise requires participants to list things they do and do not like about a class of objects, e.g. available retail facilities (World Bank 2009:13).

The needs assessment and preference ranking mentioned is a method of surveying that would ideally be conducted as market research. The subjects would have to be Gautrain users. Since the GRRL is not operational yet, these methods could not be used at present.

**Quantitative** analyses should be applied where possible to increase the universality of the conclusion, since purely qualitative studies are often very context-bound (Leedy 2005: 97).

Where possible, qualitative and quantitative data will be used to reach the same conclusion in order to ensure that the study maintains its internal validity. The internal validity of a study refers to the extent to which the conclusions could be logically drawn from the data presented (ibid).

## Bombela Contractual Structure



16. Bombela contractual structure

Due to the time constraints posed by the study time frame, not all of the above research methods would be employed. They are an example of what should be done in an ideal situation. The research for the proposed study would include a limited amount of field observations and semi-structured interviews, photographs and observations. This would be supported by analyses of relevant precedents. Contextual background would be provided by desk review or secondary data review, consisting of information gathered from theses, dissertations, census data, maps, etc (World Bank 2009:16).

### 2.10 The role of the Interior Architect

There is a growing body of contemporary theorists offering new insights into the role of interior architecture within the built environment. A few themes that are common to the fields of Architecture and interior architecture have been identified:

- \* Design as enhancing the quality of life
- \* Design as the agent for democracy and design humanism (designing with equity of access and promotion of cultural and social values in mind) (Bonsiepe 2006:30)
- \* Design as the agent for social and environmental development

Havenhand (2004: 36) suggests an approach to interior architecture that regards it not as supplemental and inferior to architecture, but a field in its own right. This relates to the distribution of design – of where the discipline of interior architecture fits into the design process along with Architects, Landscape Architects and other design team members. The thinking is that, whereas architects are required to have a broad spectrum of knowledge across the entire design process, interior architects are free to focus on the field of interior space and objects and provide a depth of knowledge in that field (König, R. 2009). In this manner, interior architects could be superficially compared to engineers, who might not be knowledgeable about the entire spectrum of design decisions in a building project, but have great depth of knowledge in the specific focus area of engineering.

The idea of distributed design also asks the question of where the designer relinquishes creative control

and allows the users to inhabit, use and adapt the space to achieve the best fit possible. As described in Chapter 5, the allowance for future adaptation and accommodation of user preferences is highly prioritised as an embodiment of democratic design principles as well as sustainable practice.

A strong common thread in contemporary literature is the discipline's focus on humanism and the importance of designing to human scale and the body as an important interface in informing a person's sense of place. This is especially important in interior architecture. Broadly speaking the discipline of interior architecture is focused on the interaction between user, space and object. Kurtich and Eakin (1992: 3) sum it up: "Interior Architecture is the holistic creation, development, and completion of *space for human use*" [emphasis added].



3



UNIVERSITEIT VAN PRETORIA  
UNIVERSITY OF PRETORIA  
YUNIBESITHI YA PRETORIA

# Chapter 3

## Context Analysis

### 3.1 Overview

Before proceeding into detail design, it is necessary to analyse the **site**. This consists of analysing site location, physical conditions, climate, transport routes, land use, built character around site and town council planning schemes, as well as requirements of the client and users. This is important in this study, since the Gautrain Hatfield station is not complete yet, even though it is assumed, from a design point of view, that they are.

The chapter leads with a detailed description of the **Gautrain system identity**, the existing system of motifs, finishes and construction details Bombela have included as part of the station design guidelines. It is necessary to explore the aesthetic guidelines within which the design and strategy are metaphysically located, even if the aesthetic response for refreshment and retail facilities might differentiate from the original GSI guidelines.

The proposed **users** of the system are also investigated before moving on to the site investigation of the focus site, Hatfield Gautrain station.



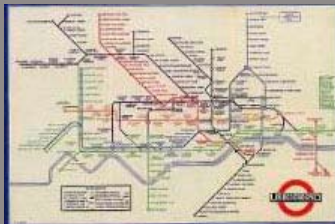


## System Identity

The concept of a “system identity” stems from the London underground system, first initiated with a corporate design in 1916 and developed from there.



Roundel logo, Frank Pick, 1918



Tube map, Henry Beck 1933

[GAJV 2008:5]

## 3.2 Gautrain System Identity

### 3.2.1 Scope

Part of the Master Architect’s role on the GRRL project is to establish generic, system-wide details and standards for the GRRL system identity (GAJV 2008:3). Together these constitute the Gautrain System Identity Design Manual. (GAJV 2008:6). The different work packages and more detailed, site-specific station design packages are to be checked by the Master Architect for compliance with the generic GRRL system identity (GAJV 2008:3).

The generic, linewise concepts inform:

- \* Linewise station identity
- \* Entrances and external elevations
- \* Finishes, materials and colours
- \* Fencing, gates and other security features
- \* Landscaping
- \* Bus stops
- \* Viaducts, bridges and portals

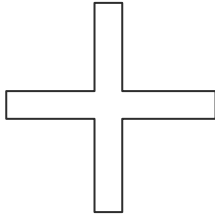
Generic details had been designed for:

- \* Lifts and escalators
- \* Stairs
- \* Handrails and barriers
- \* Doors and ironmongery
- \* Information systems
- \* Advertising
- \* Carpentry and joinery
- \* Acoustic treatments
- \* Suspended ceilings
- \* External cladding and glazing systems
- \* Sanitary fittings and accessories
- \* Specification for finishes and materials
- \* Station furniture - public and ROA

Detail drawings include those for the:

- \* Ticket office
- \* Station office

## System Identity



- + Create customer affinity
- + lower lifecycle & maintenance costs due to standardisation
- + ease of use & legibility
- + accessibility

[GAJV 2008:7]



**The object of these guidelines and standards is not to create an authoritarian approach, but rather a framework to orientate and guide designers...**

**...each designer brings their own creative contribution to an evolving unified design. In this way the operator can manage the lifecycle of the system in a cost effective and design managed way**



[GAJV 2008:7]

- \* Vending machine enclosures
- \* Lift cars
- \* Station furniture and components
- \* Signage (excluding statutory)

(ibid.)

At the time of research, the Hatfield specific identity had not been available. Therefore, the research regarding GSI had to be limited to the generic GRRL system identity.



### 3.2.2 GSI Philosophy

The Gautrain system identity is an expression of technological achievement infused with **African metaphor**. Because of the cultural diversity inherent in South Africa and Gauteng, it would seem the African metaphors were chosen for their non-denominationality and a-culturalness. They relate to human activity and landscape, rather than embody any one culture.

One of the central concepts of the GSI is the **acacia tree** and idea of trees as places of pause along pathways, providing shelter from the African sun and a place for **rest, meeting, trade and worship** (GAJV 2008:9).

The train system was conceived of as a **journey** through a rural landscape, interspersed by meeting and rest nodes, marked by a lone **acacia tree** (figure XX) (GAJV 2008:10). So the railway lines are envisioned as pathways enabling the journey and stations as meeting places along the pathways. Thus, stations become conceptual "meeting place trees".

### 3.2.3. GSI concepts

Gautrain stations need to express the Gautrain brand. To this effect, certain elements are required to become recognisable as part of the Gautrain brand (GAJV 2008:11-12). These elements are derived from the GSI philosophy.

## Tree structure

The internal columns in Gautrain stations resemble the trunk and branches of the acacia tree, holding up the ...

## Wave structure

roofs,  
derived from the umbrella shaped canopy of the acacia tree.

## Transparency

is incorporated into the design in aid of legibility in above ground stations and where possible, below ground stations, since stations are conceived of as **meeting places**. The underlying metaphor is complemented by technological consideration bringing the Gautrain system in line with international precedents. For example, while transparent elements allow sunlight in, elements allowing energy efficiency are built in elsewhere (GAJV 2008:12).

## Micro & macro regional influences

Various local influences are incorporated at individual stations in order to anchor the stations in the local contexts and create regional public affinity and identification with the Gautrain system (GAJV 2008:12).

☞ **The tree is a most significant element in the African landscape,**

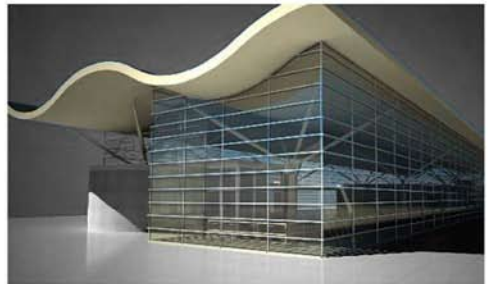
**The tree is an icon to the sub-Saharan environment**

**The tree is a focus to a way of life** ☞

[GAJV 2008:9]



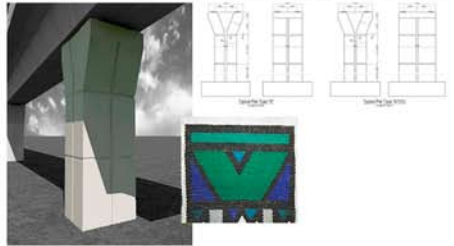
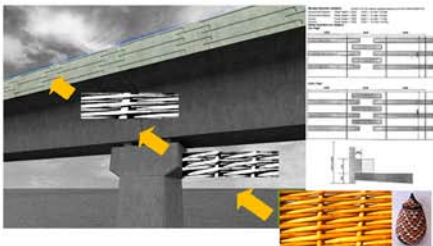
**A  
c  
c  
i  
a**



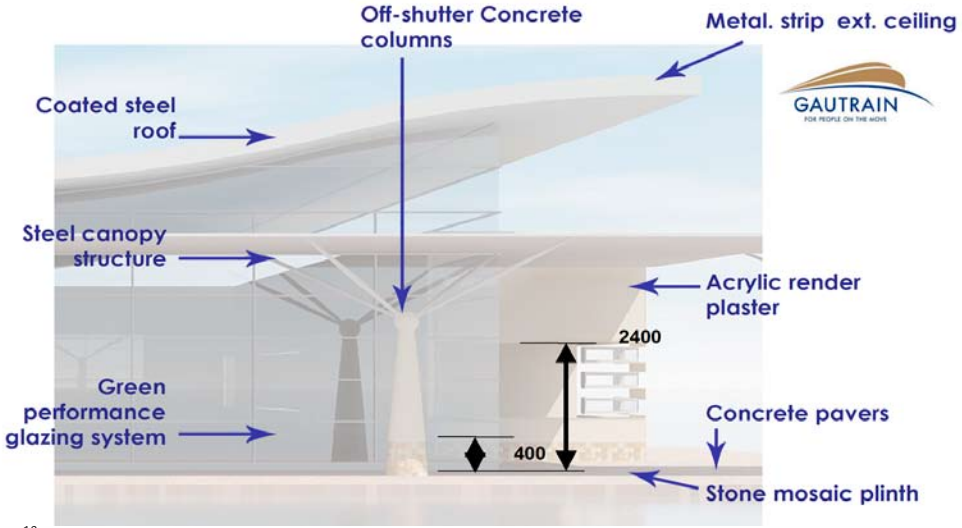
**Wave**

*Transparency*

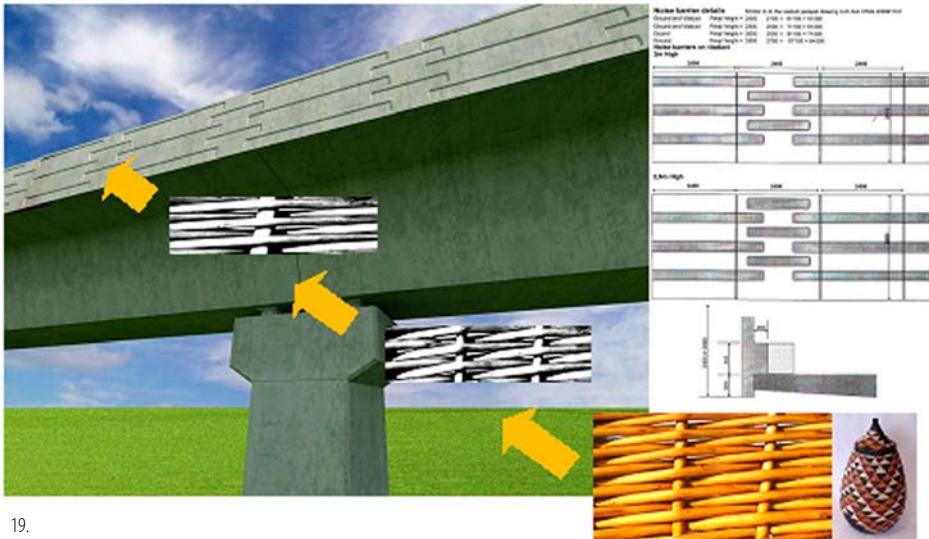
**Regional  
influences**



This ensures unique, vibrant stations, while still maintaining the over arching Gautrain system identity and recognisability (ibid.).



18.



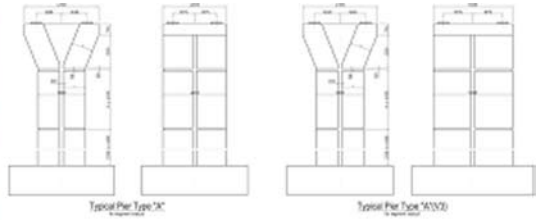
19.

18. GSI basic external station finishes

19. Civil structures, pylons and viaduct barriers incorporate motifs abstracted from local cultural elements



20..



20. Viaduct piers exhibiting influences of both the tree motif as well as local arts and crafts.



21.



21. Signage and wayfinding

22. Various external and interior material and detail sample mock-ups at the Bombela offices would offer a better understanding of the Gautrain aesthetic.

# EXTERIOR

## paving



square concrete  
cobble in colour  
charcoal and tan



brick pavers in herringbone pattern



sandstone listello to plinth



## glazing



silver PPC Aluminium glazing frames



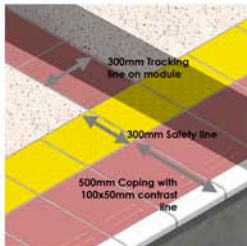
## canopy



Silver PPC steel sections, and clear polycarbonate



## platform





# SANITARYWARE

## *wc's & urinals*



*Wall hung Wc*



*wall hung disabled WC*



*urinal  
and flush plates*



## *wash hand basins and taps*



*wall hung WHB with  
lever mixer taps*



*sensor operated vandal  
proof tap*



## *hand drier*



*electric hot  
stainless steel*



## *stairs and balustrade*



*grey painted GM steel balustrade with stainless steel handrail at high low heights*



*contrasting colour nosing for visibility, return on handrail for accessibility, grip tread*

## *doors and ironmongery*



*wooden doors with brushed stainless steel ironmongery and double rebate door detail*



*brushed stainless steel ironmongery with disabled accessible latch (top)*

## *seating fixed*



*profiled concrete bench, painted chalk white with polished ceramic tile skirting*

# INTERIOR

## floor



*terrazzo tiles in*



*cream with*



*grey border tile*



*black granite tiles, structured finish and polished finish*



## wall



*terrazzo effect tiles in*



*grey variegated*



*soft mocha and white*

## columns

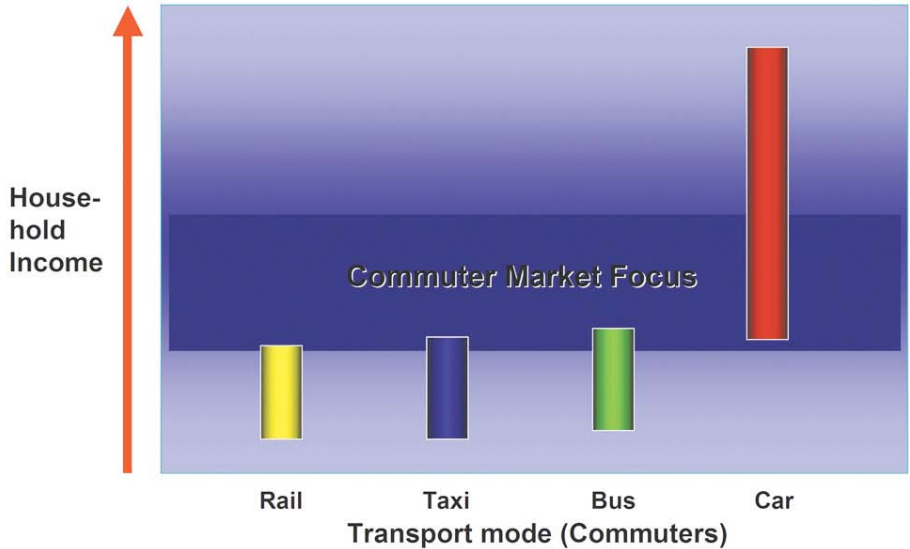


*polished black granite skirting tiles, painted grey, steelwork painted white*



### 3.2.8 Gautrain users

As mentioned in Chapter 1, the GRRL is directed mainly at users of low to middle income who may or may not own cars and need to commute regularly between Tshwane and Johannesburg (ibid.). This group also includes public transport users who have either bought a first family car or are 'upgrading' from traditional public transport because of increased salary levels.



23. The diagram illustrates the target market of the GRRL in terms of current method of transport



## *Precedent //*

### *Liverpool Street Station, London*

Liverpool Street Station, refurbished in and opened in 1992, has many retail and refreshment facilities. These include:

- Accessory / jewellery stores
- Food market (Marks & Spencer)
- Take-away venues and quick service restaurants
- News agents and newsstands
- Gift shops
- Convenience stores.

The public station concourse also contains a variety of services both expected and ancillary to its function as a transport interchange with local, long-distance and express rail, bus and Underground services. Services include:

- Tickets and information
- Telephones
- Taxis
- Buses
- Toilets and baby changing
- British Transport Police
- First aid
- Additional assistance
- Trolleys
- Cash and Bureau de Change
- Post Office
- Left luggage
- Photo booths
- Lost property
- WiFi Coverage

[Network rail 2009:[sp]]



## *Precedent //*

### *Pretoria Station, Pretoria*

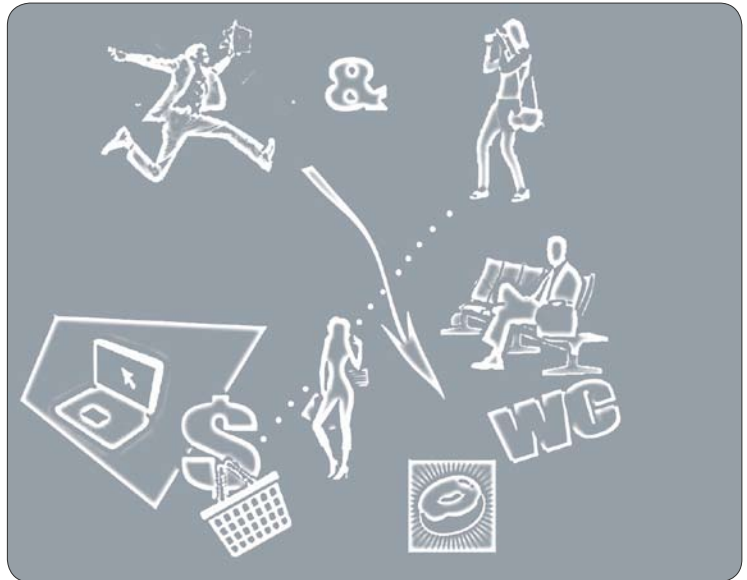
Pretoria station is one of the main South African Rail Commuter Corporation (SARCC) Metrorail stations for the city of Tshwane. There are various services and retail facilities incorporated in the main building as well as outside.

Inside the terminal building in the unpaid area are:

- ticket kiosks,
- male and female toilets a
- restaurant and small café, and a
- small convenience shop selling snacks, drinks and cigarettes.

Outside off the parking area and along Scheiding St. a bustling semi-formal market sells variety of consumer goods, fast food, snacks, cool drinks and services, such as cheap telephone stalls.





24. Gautrain users' needs illustration

According to Lynch (1981) people in an urban setting require **access** to other people, **activities, resources, places** (shelters, open spaces, symbolic, natural etc.) and **information**.

This theory is supported by the investigation of the range of services, retail and refreshment services provided in other train stations such as Liverpool Street station in London and Pretoria station. The facilities could be grouped in five basic categories:

Administrative - Ticketing, offices, security etc.

Shops - food, items and luxury goods

Eating & drinking - coffee bars, snack bars, take-aways, restaurants

Services -hairdressers, shoe shine, or repair, luggage storage, ATM's and Bureau de Change

Ablution facilities.

From this, five **common station activities** that could be applied to the GRRL stations could be identified:

EAT (coffee, cool drinks, snacks, sandwiches, paninis, fruit)

PAUSE (SIT / WAIT / READ)

SHOP (BUY curios, papers, magazines, small convenience items, hats, scarves, gloves, gifts, cigarettes, etc.)

ACCESS INFORMATION

ABLUTION

The ablution function is already available at all stations to regular and disabled users, mostly from the paid concourse, beyond the ticket barriers. Therefore, the ablution function should not be addressed as part of this study, except for being conceptually explored as part of larger scale facilities removed from the con-

courses or station building.

An important factor in whether or not refreshment facilities will be used at Gautrain stations is the **time** available to the users. The minimum frequency of trains between Johannesburg and Tshwane will be five trains per hour, meaning that there will be a train every twelve minutes. During off-peak hours, the service is reduced to three trains per hour, making it one train every twenty minutes (Gautrain Rapid Rail Link 2009:[sp]).


Twenty minutes would seem a long time to wait on a train platform, but is ample time to buy a take-away coffee, newspaper and sit and read a while.

Action	Estimated time
Select paper	30 seconds
Queue & pay	30 seconds – 3 minutes
Walking time	30 sec – 1.5 minutes
Queue for coffee	10 sec – 3 minutes
Order coffee & pay	30 seconds
Wait for order	2 minutes
Customise beverage	1 minute
Access Wi-Fi network Check email	10 minutes
<b>Total</b>	15min 10 sec – 21.5 minutes

These values are estimates based on observation and timing of service at a take-away coffee shop on University of Pretoria campus as well as being based on personal experience. Duration also depends on proximity of services to each other and length of queues

Other users could include passersby and workers in or around the Hatfield area.

Activities	Use by commuters and tourists	Types of facilities
EAT	•	coffee take away, snack kiosk, sandwich bar panini bar cool drinks food, snacks and drinks vending machines
SHOP	•	arts & crafts / souvenirs / local crafts newsagents (newsprint & magazines) impulse buy convenience items (tissues, pens, cellphone air-time, cigarettes) seasonal - hats, scarves, gloves, sunglasses photo booths
PAUSE	•	SIT / WAIT / READ public seating small 2 person chill rooms news or local information on LCD flat screen TV's left luggage facility
ACCESS INFO	•	station wide Wi-Fi for internet / email access to wireless devices public LCD flat screen TV's set to news channels touch screen local and tourist information kiosks Internet access terminals (pre-paid or coin operated, supervised) ATM's public telephones DVD rental vending machines
ABLUTION	•	public toilet facilities public disabled WC facilities baby change room
Individual actors	Mid-to low income car users Higher income public transport users / one car families International or South African tourists from other regions	
Activities / Importance	Support public transport venture Support local job creation Support tourist industry	

 Area for further investigation



25. Nolli map of Pretoria with Hatfield area outlined in red.

### 3.3 Site location

This study focuses on the Gautrain station located in **Hatfield**. Other stations, such as Pretoria and Belle Ombre in Pretoria had been investigated as potential sites for the thesis, but at Hatfield, the lack of retail and refreshment facilities adjacent to the GRRL station was especially dire.

Hatfield was chosen as the last stop on the Gautrain for its proximity to a number of services and facilities, such as:

- \* the N4 and N1 freeways, major arterial roads into the Tshwane Central Business District (CBD),
- \* existing Hatfield business, office and retail node,
- \* Innovation Hub,
- \* University of Pretoria (UP) sports grounds, high Performance Sports Centre and campus,
- \* Loftus Stadium,
- \* embassies and diplomatic missions,
- \* Brooklyn Mall retail facilities (10 minute drive),
- \* Academic institutions other than UP including Boys' High School, Pretoria High School for Girls, Afrikaans Meisies Hoër, Afrikaanse Hoër Seunskool as well other private schools and colleges (Gautrain Rapid Rail Link 2009:[sp]).

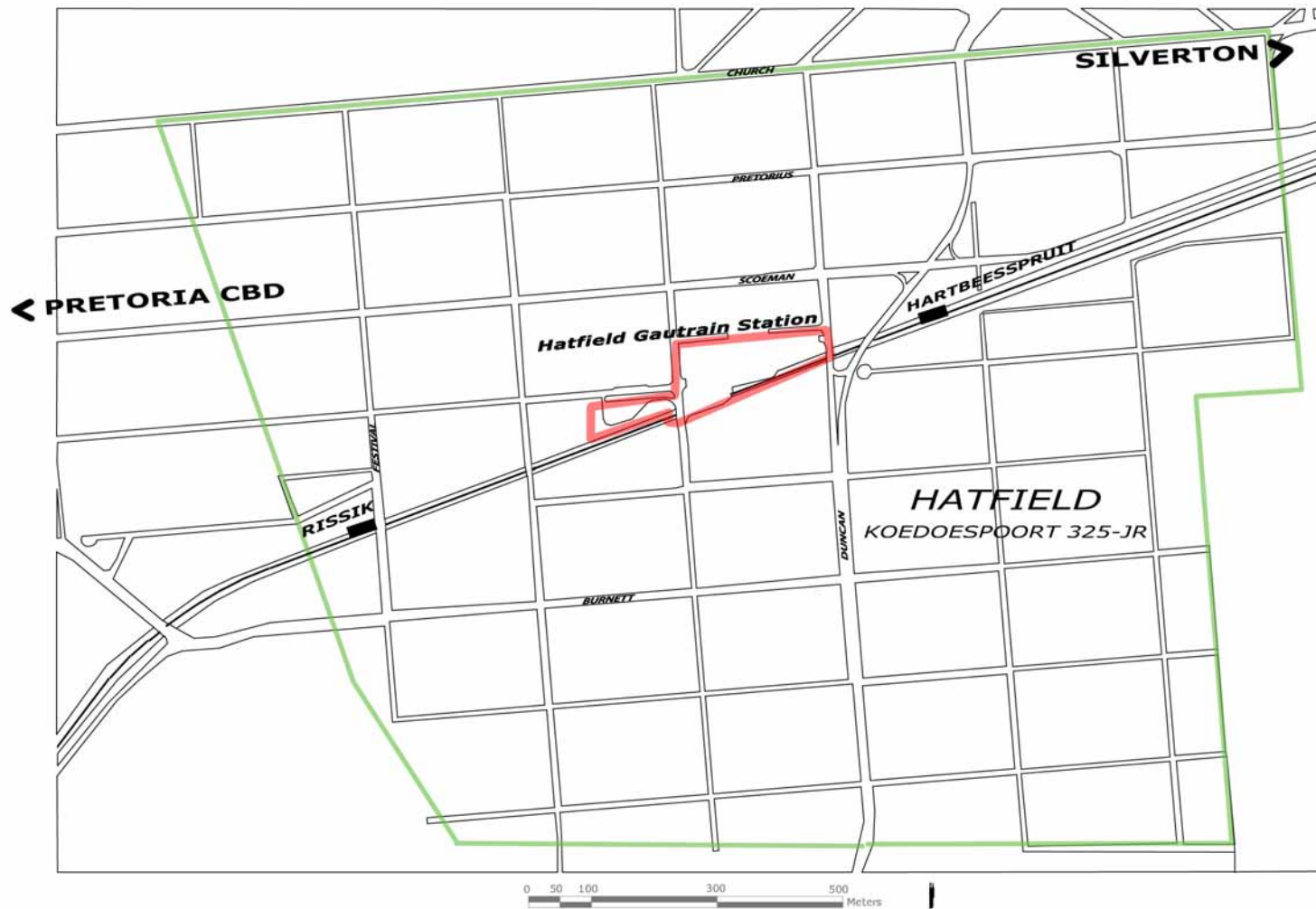
As such the Hatfield Gautrain station area has potential for **supporting** the GRRL station at Hatfield. The station should in turn be regarded as a catalyst for further development in the Hatfield area.

The site location within the Hatfield context is indicated in the figures on the next pages.

The appearance and layout of the Hatfield GRRL station is illustrated on the pages following.

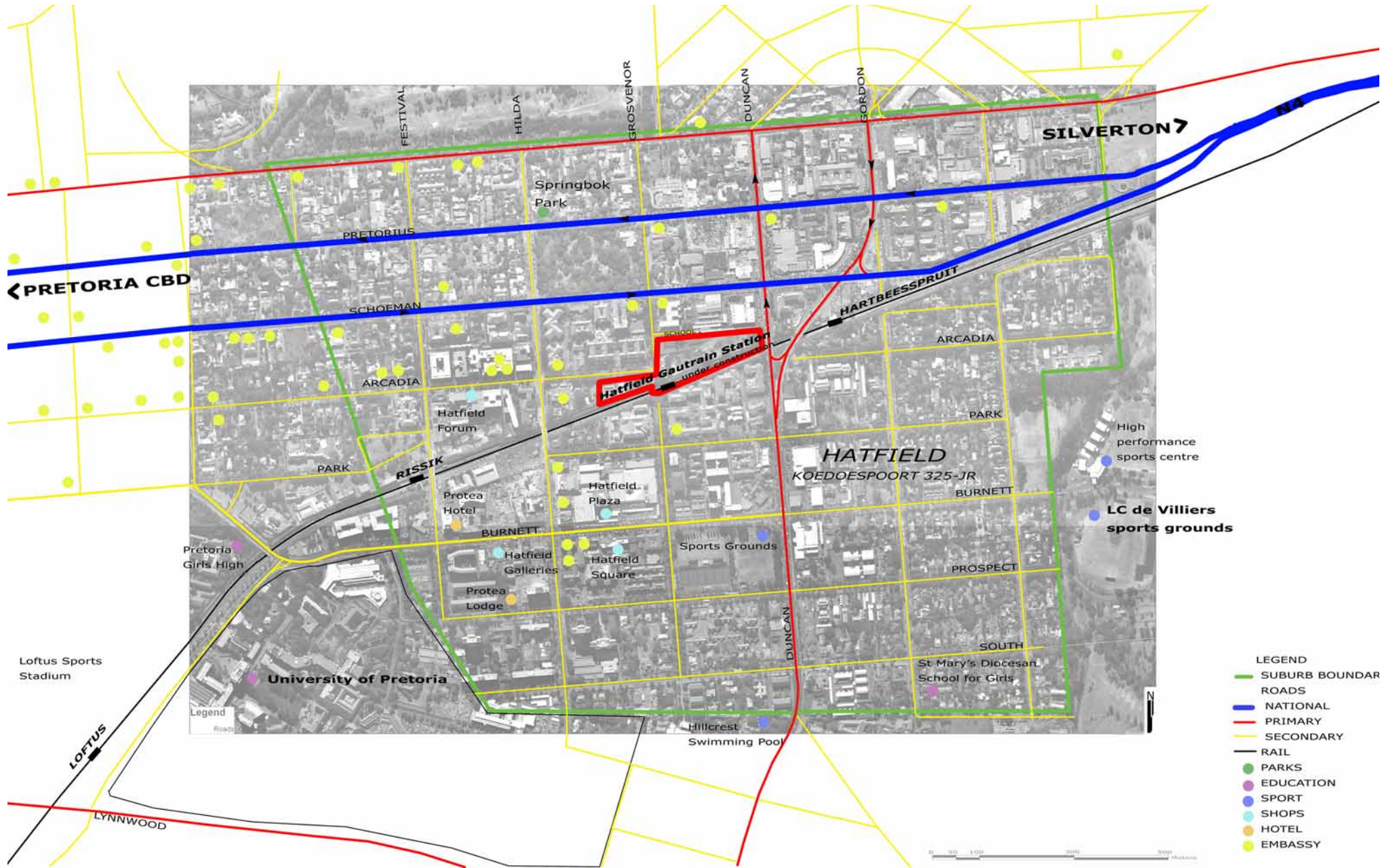


25...

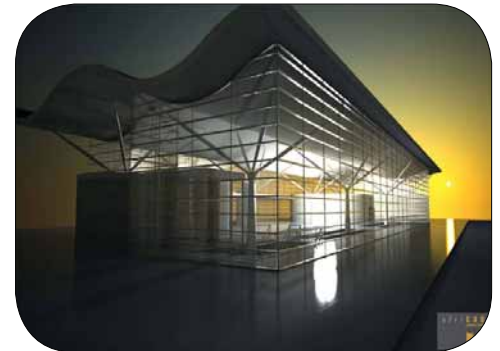


## *Site location in Hatfield*

The site is located on the outskirts of the city centre and located on the SARCC railway line between two Metrorail stations



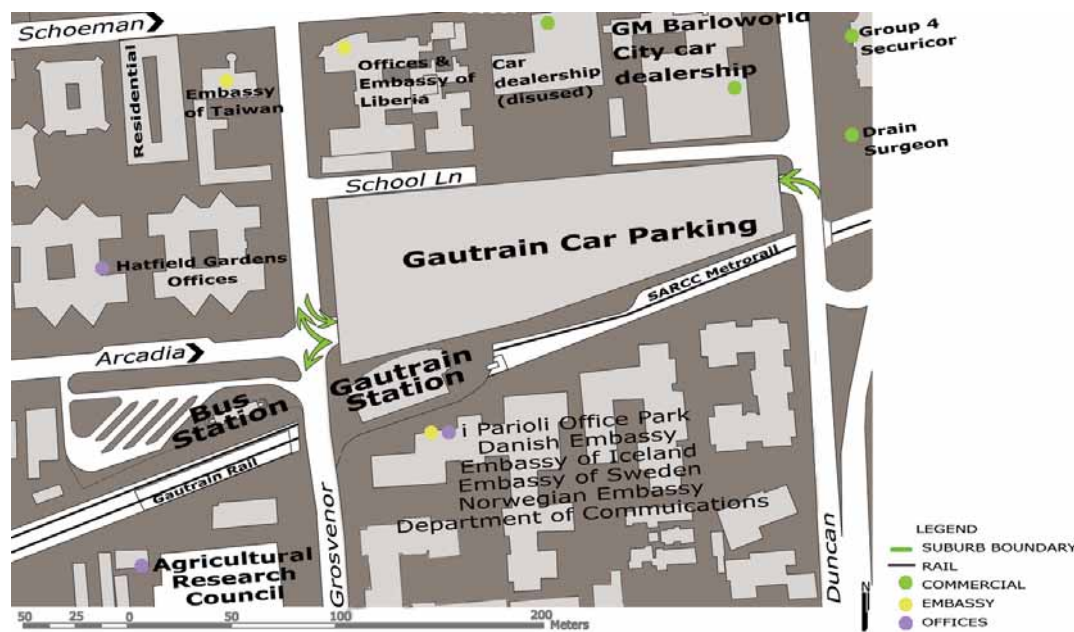
*Site location in Hatfield*

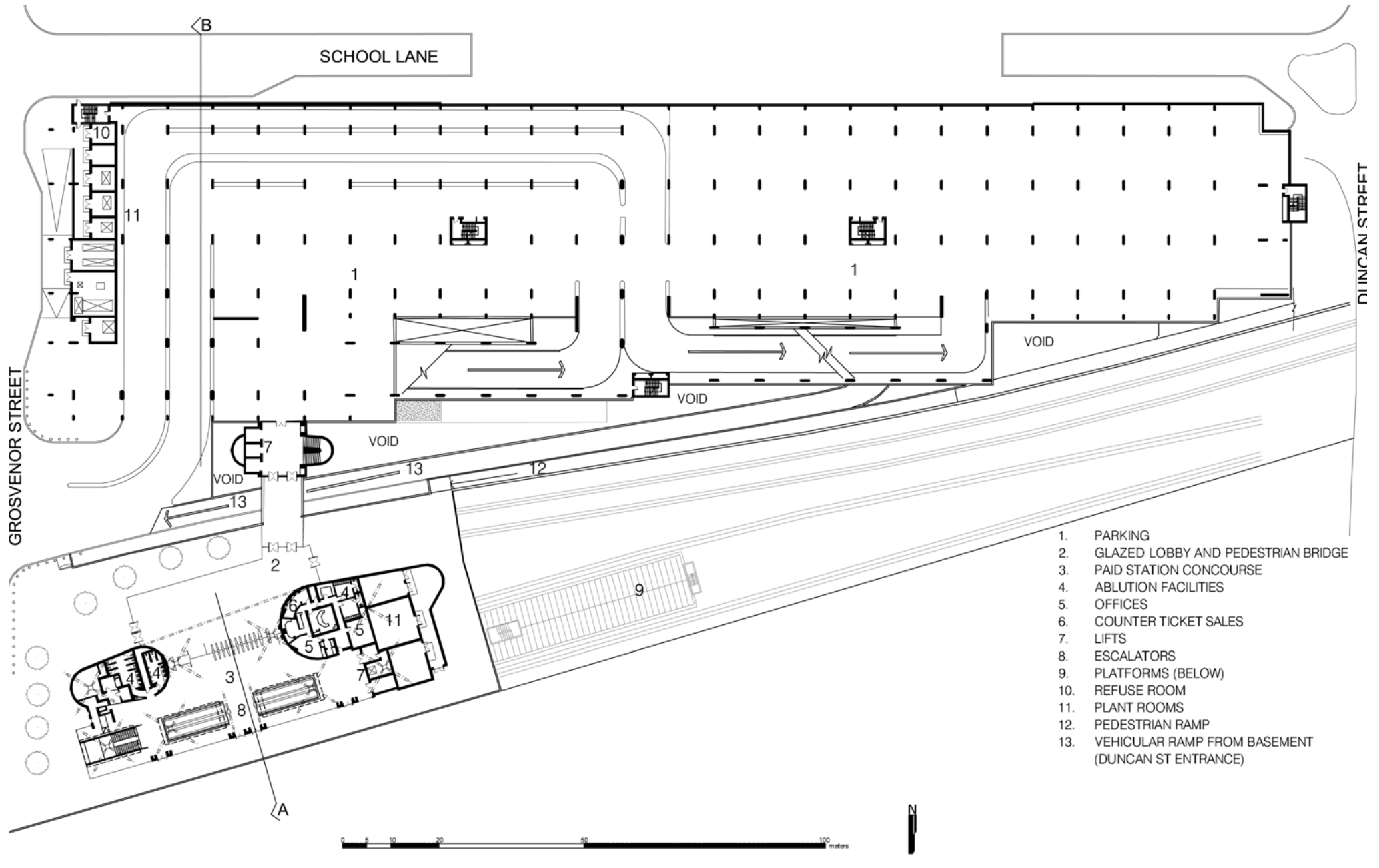


*Figure ground site map*

*artist's impressions*

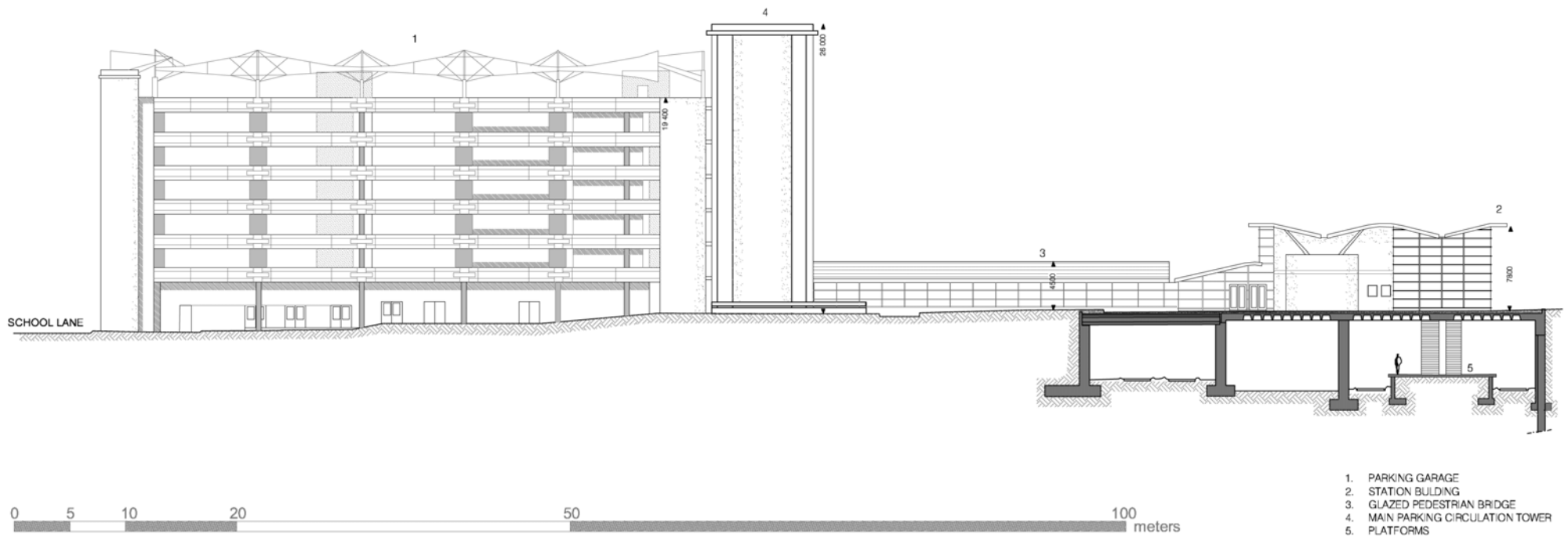
The immediate station surrounds supports mainly office, commercial (motor showrooms and some residential and retail uses



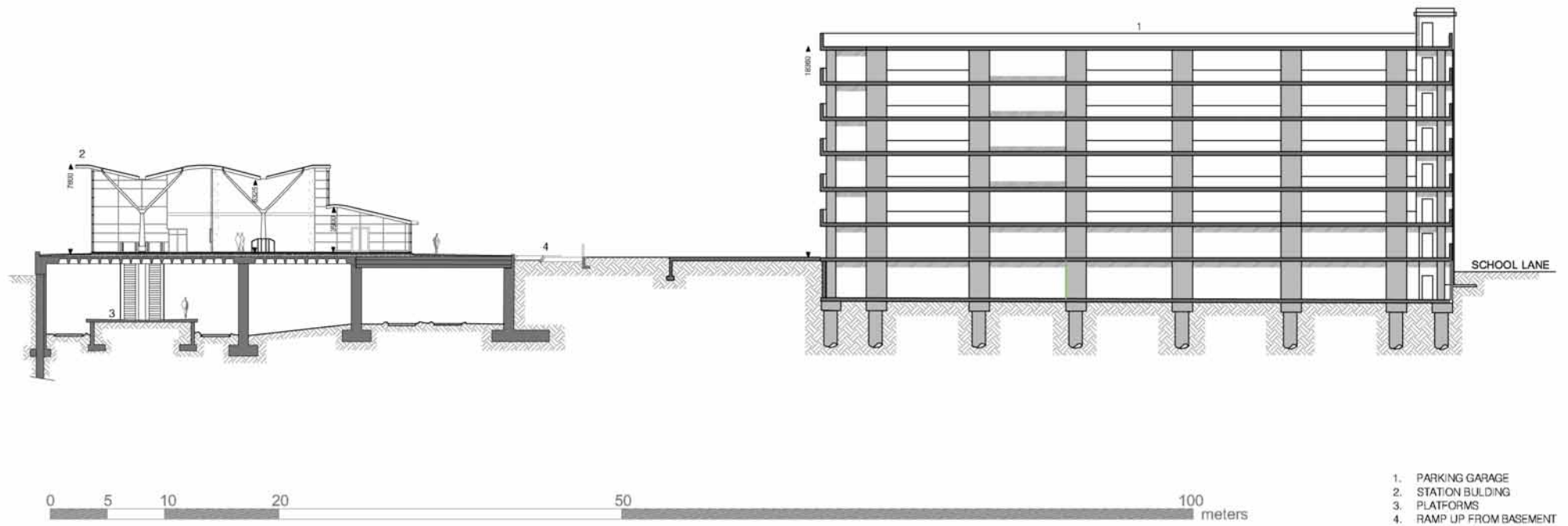


1. PARKING
2. GLAZED LOBBY AND PEDESTRIAN BRIDGE
3. PAID STATION CONCOURSE
4. ABLUTION FACILITIES
5. OFFICES
6. COUNTER TICKET SALES
7. LIFTS
8. ESCALATORS
9. PLATFORMS (BELOW)
10. REFUSE ROOM
11. PLANT ROOMS
12. PEDESTRIAN RAMP
13. VEHICULAR RAMP FROM BASEMENT (DUNCAN ST ENTRANCE)

*Gautrain Hatfield site layout*



*Western  
section / elevation*



*Section A-B*



26.

## Bus feeder & distribution system fast facts

36 Bus routes serving 9 stations

125 Gautrain Buses at start-up

430 kms of routes with bus stops every 500 metres

26 000 kilometers of bus service per day

High quality buses : low floor, air conditioned, fully accessible

Safety and security enhanced through radio communication and satellite tracking of vehicles

Buses availability : 99%

Buses punctuality : 95%

27.

[Andrew 2009:14]



26. The Hartbeespoort Metrorail station has the potential to connect the Hatfield Gautrain station to the Tshwane Ring Rail system.

27. Feeder and distribution route bus.

### 3.4 Transport routes

The Hatfield GRRL station was designed as a **multi-modal interchange**. Figure 29 shows how the Hatfield station fits in the Pretoria-wide transport network, highlighting the Gautrain route, SARCC Metrorail and nearby bus rapid transit (BRT) routes.

Within the station precinct the station is meant to allow easy pedestrian movement between the station and various modes of transport and Hatfield centre. A pedestrian walkway links the station to the nearby **Hartbeespoort SARCC station**. A planned pedestrian walkway alongside the railway reserve will link Hartbeespoort station through the Gautrain station, to Risik station (Hatfield Station development Framework 2003:24). A **bus terminus** is provided to the west of the station across Grosvenor street. The GRRL Hatfield station will, upon commissioning, be serviced by dedicated **bus feeder and distribution** routes.

#### a. SARCC

The SARCC (PRASA) rail runs alongside the Gautrain tracks. It provides commuter rail services between Mamelodi and Pretoria City centre and could link the station with the Metrorail and Pretoria Ring Rail system.

#### b. Gautrain bus feeder and distribution routes

The Hatfield station will, upon completion, be serviced by dedicated bus feeder and distribution routes, connecting it to Brooklyn, Lynnwood, Arcadia, Waverley and Faerie Glen (figure 28). A further route along Lynnwood road is being considered. It is envisioned that commuters to Hatfield station will walk to their onward destination or make use of the BRT, buses or taxi's.

#### c. BRT

The Bus Rapid Transit system is a system that has been fast-tracked by the Gauteng Government in order to provide a high quality bus service in time for the FIFA World Cup, to be hosted in South Africa in 2010. The system will provide fast, efficient, clean and safe bus service in Pretoria city centre. The closest BRT routes to the Hatfield station are in Church St, three blocks north of the Hatfield station and Loftus SARCC station and Lynnwood road.

#### d. Bus and taxi

Metro buses and taxi's provide a more localised service in the station precinct. However, these will need up-



grading and regularisation (taxi's) before meeting the standards of the majority of GRRL users.

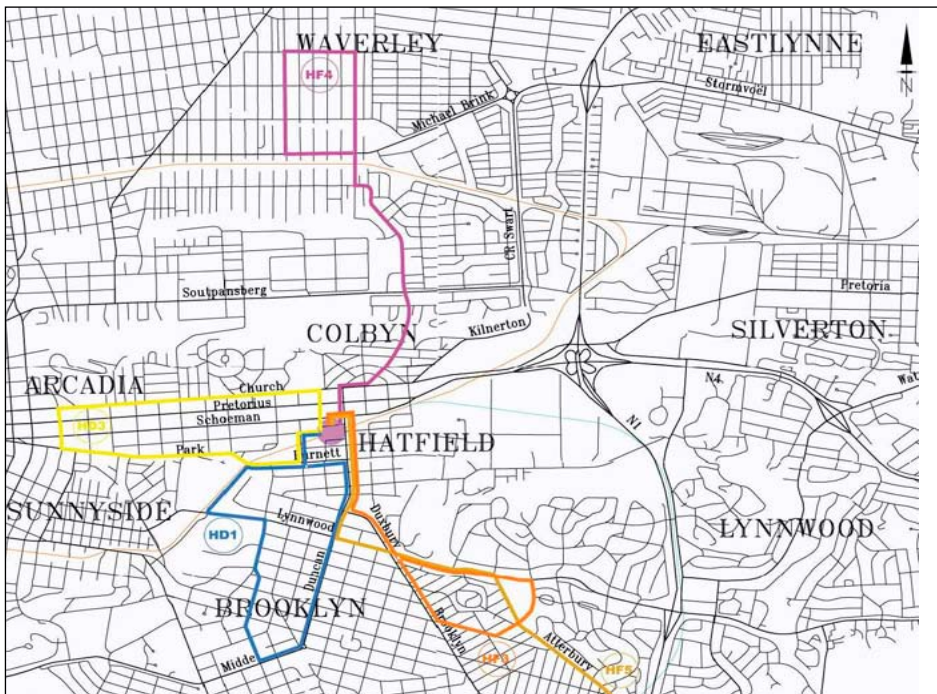
### 3.5 Station precinct

For the purposes of this study the station precinct incorporates an area within a 300m radius from the station building.

The erven constituting the site are still regarded as unconsolidated according to COTMM Planning division. The consolidation of the erven will be taken care of at the time of expropriation of the site by the Gauteng Provincial Government (see section 3.5.2 and 3.5.3 in this chapter).

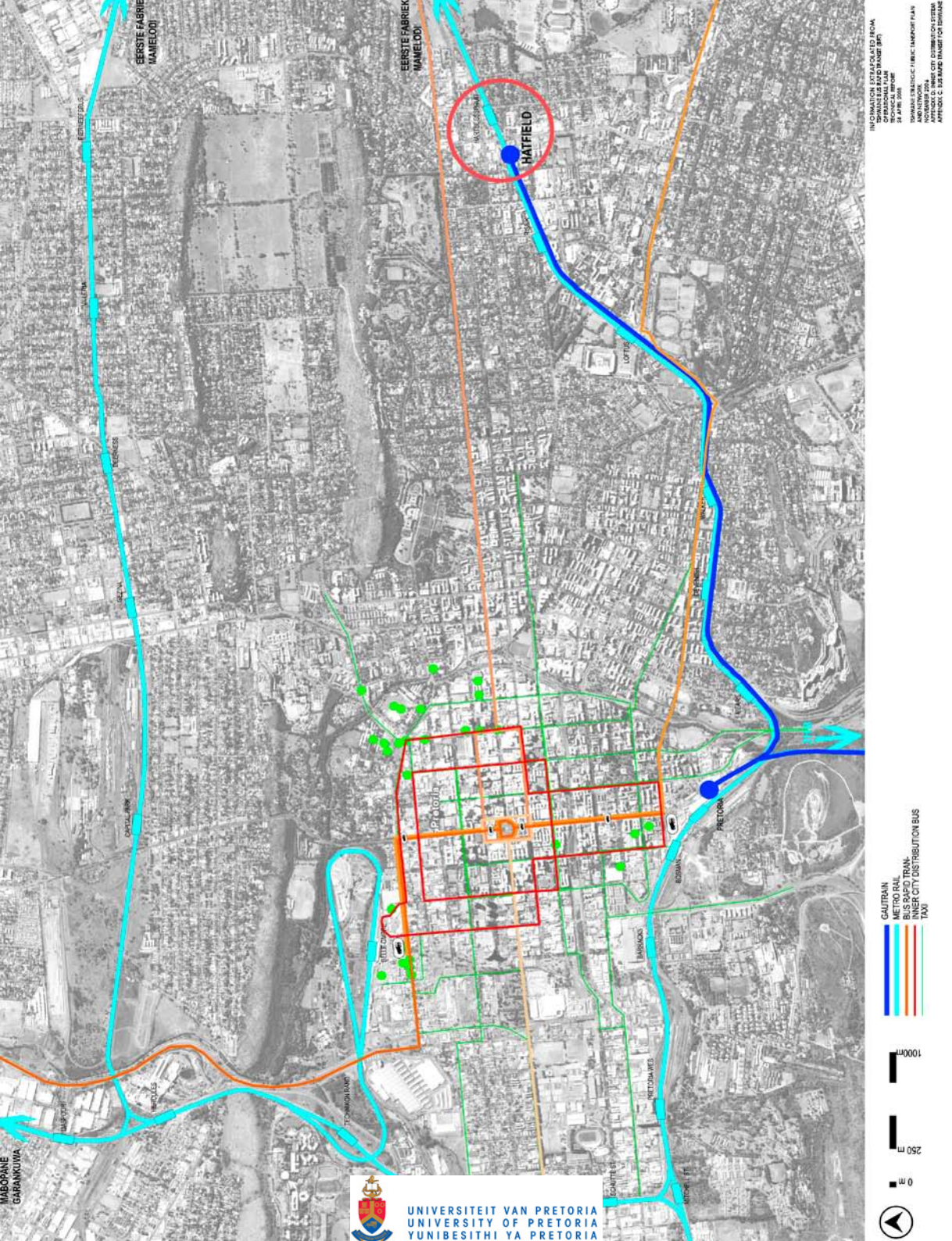
The contours on site are mostly fairly level, with a gentle slope towards the northeast corner of the site. The steep cut slopes within the railway reserve drops the ground level by approximately 5 meters to the railway tracks.

28.



28. Feeder and distribution bus routes from Hatfield GRRL station give an indication of the catchment area for the Hatfield GRRRL (Gautrain Rapid Rail Link 2009: [sp])

29. Transport routes in Pretoria indicate the interlink between the GRRL and Metrorail and proximity of other transport modes



BERSTE FABRIEK  
(MAMELOO)

BERSTE FABRIEK  
(MAMELOO)

RAIFIELD

MORITZBURG

MORITZBURG

PRAETORIUM

PRETORIA

INFORMATION EXTRACTED FROM:  
 METRO RAIL (MTR) (MTR) (MTR)  
 OPERATIONAL PLAN  
 2014/15  
 28 APRIL 2014  
 DORLANDS  
 METRO RAIL (MTR) (MTR) (MTR)  
 OPERATIONAL PLAN  
 2014/15  
 28 APRIL 2014

- GAUTRAIN
- METRO RAIL
- BUS RAPID TRANSIT
- UNIVERSITY CITY DISTRIBUTION BUS
- TAXI

1000m

250 m

0 m



UNIVERSITEIT VAN PRETORIA  
 UNIVERSITY OF PRETORIA  
 YUNIBESITHI YA PRETORIA

MABOPANE  
 GARANKUWA

PETREUS DR.

VALUEN

BERGENSS

GRUEN

GRUEN

GRUEN

GRUEN

GRUEN

GRUEN

GRUEN

GRUEN

GRUEN

GRUEN

GRUEN

GRUEN

GRUEN

GRUEN

GRUEN

GRUEN

GRUEN

GRUEN

GRUEN

GRUEN

GRUEN

GRUEN

GRUEN

GRUEN

GRUEN

GRUEN

GRUEN

GRUEN

GRUEN

GRUEN

GRUEN

GRUEN

GRUEN

GRUEN

GRUEN

GRUEN

GRUEN

GRUEN

GRUEN

GRUEN

GRUEN

GRUEN

GRUEN

GRUEN

GRUEN

GRUEN

GRUEN

GRUEN

GRUEN

GRUEN

GRUEN

GRUEN

GRUEN

GRUEN

GRUEN

GRUEN

GRUEN

GRUEN

GRUEN

GRUEN

GRUEN

GRUEN

GRUEN

GRUEN

GRUEN

GRUEN

GRUEN

GRUEN

GRUEN

GRUEN

GRUEN

GRUEN

GRUEN

GRUEN

GRUEN

GRUEN

GRUEN

GRUEN

GRUEN

GRUEN

GRUEN

GRUEN

GRUEN

GRUEN

GRUEN

GRUEN

GRUEN

GRUEN

GRUEN

GRUEN

GRUEN

GRUEN

GRUEN

GRUEN

GRUEN

GRUEN

GRUEN

GRUEN

GRUEN

GRUEN

GRUEN

GRUEN

GRUEN

GRUEN

GRUEN

GRUEN

GRUEN

GRUEN

GRUEN

GRUEN

GRUEN

GRUEN

GRUEN

GRUEN

GRUEN

GRUEN

GRUEN

GRUEN

GRUEN

GRUEN

GRUEN

GRUEN

GRUEN

GRUEN

GRUEN

GRUEN

GRUEN

GRUEN

GRUEN

GRUEN

GRUEN

GRUEN

GRUEN

GRUEN

GRUEN

GRUEN

GRUEN

GRUEN

GRUEN

GRUEN

GRUEN

GRUEN

GRUEN

GRUEN

GRUEN

GRUEN

GRUEN

GRUEN

GRUEN

GRUEN

GRUEN

GRUEN

GRUEN

GRUEN

GRUEN

GRUEN

GRUEN

GRUEN

GRUEN

GRUEN

GRUEN

GRUEN

GRUEN

GRUEN

GRUEN

GRUEN

GRUEN

GRUEN

GRUEN

GRUEN

GRUEN

GRUEN

GRUEN

GRUEN

GRUEN

GRUEN

GRUEN

GRUEN

GRUEN

GRUEN

GRUEN

GRUEN

GRUEN

GRUEN

GRUEN

GRUEN

GRUEN

GRUEN

GRUEN

GRUEN

GRUEN

GRUEN

GRUEN

GRUEN

GRUEN

GRUEN

GRUEN

GRUEN

GRUEN

GRUEN

GRUEN

GRUEN

GRUEN

GRUEN

GRUEN

GRUEN

GRUEN

GRUEN

GRUEN

GRUEN

GRUEN

GRUEN

GRUEN

GRUEN

GRUEN

GRUEN

GRUEN

GRUEN

GRUEN

GRUEN

GRUEN

GRUEN

GRUEN

GRUEN

GRUEN

GRUEN

GRUEN

GRUEN

GRUEN

GRUEN

GRUEN

GRUEN

GRUEN

GRUEN

GRUEN

GRUEN

GRUEN

GRUEN

GRUEN

GRUEN

GRUEN

GRUEN

GRUEN

GRUEN

GRUEN

GRUEN

GRUEN

GRUEN

GRUEN

GRUEN

GRUEN

GRUEN

GRUEN

GRUEN

GRUEN

GRUEN

GRUEN

GRUEN

GRUEN

GRUEN

GRUEN

GRUEN

GRUEN

GRUEN

GRUEN

GRUEN

GRUEN

GRUEN

GRUEN

GRUEN

GRUEN

GRUEN

GRUEN

GRUEN

GRUEN

GRUEN

GRUEN

GRUEN

GRUEN

GRUEN

GRUEN

GRUEN

GRUEN</

### 3.5.1 Precinct transport routes

Since the station is not complete as yet, the only data available on transport routes in the area is from a study undertaken by Bombela, based on a traffic impact analysis. According to this study the station building will generate 3035 PCU (Passenger car units) or trips per day (Hatfield Station development Framework 2003:24). The current road network in Hatfield would be grid locked by this influx of traffic. A new one-way system and a programme of road upgrading has recently been implemented by COTMM to accommodate these estimated values.

Bus, taxi and vehicular traffic will follow a basic route as indicated in figure 31, entering the parking garage from Grosvenor or Duncan Rd (Bombela CJV 2007:[sp]).

There is provision for “kiss and ride” or drop-off bays in the basement, where motor vehicles and taxi’s may halt to off load passengers.

### 3.5.2 Pedestrian movement

Currently, pedestrian movement occurs mainly in a north-south direction to and from Hatfield and Hartbeesspruit station. This movement will not be impeded by the new development. The east-west link between the Gautrain station and Hartbeesspruit and Rissik station will be improved and celebrated in the Gautrain station precinct development plan (Hatfield Station development Framework 2003:25).

Figure 32 indicates the predicted pedestrian and bicycle movement and emphasises the important **nodes** around the station. The **Grosvenor/Arcadia St intersection** is an especially important node in the pedestrian movement patterns and is the focus of the study site (Bombela CJV 2007:[sp]).

It is very important, in this plan, that pedestrian movement be easy and safe. Thus, the extension of Grosvenor road over the railway, which is located below ground level, provides an opportunity to create a pedestrian friendly zone along Grosvenor St, linking Hatfield, the station as well as reestablishing a link between the two green open spaces along Schoeman (Springbok Park) and Burnett (green open space and bowls club).

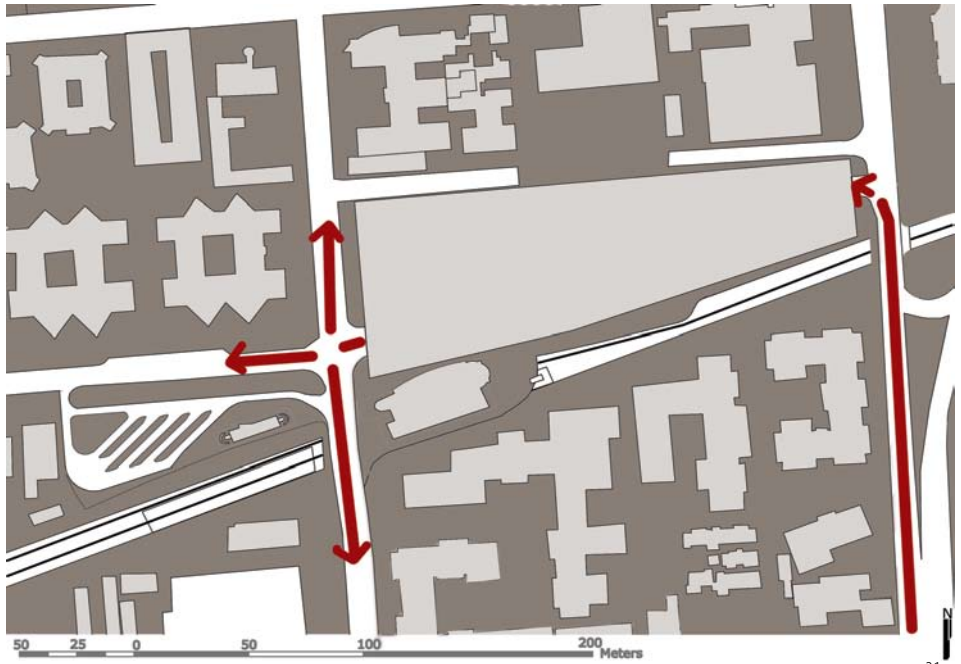
30.



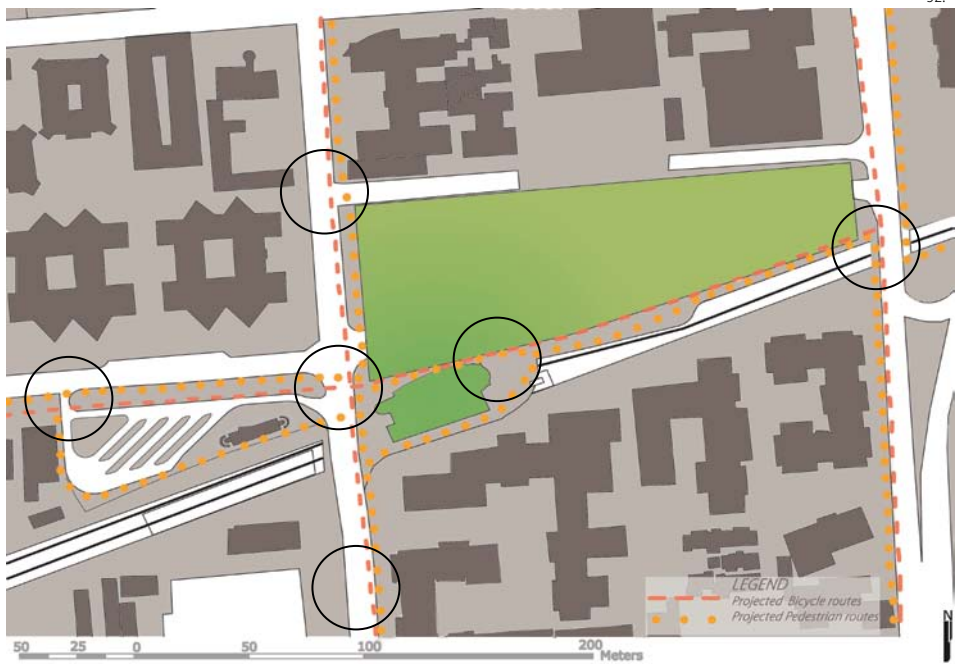
30. Pedestrians and cyclists in Duncan Rd.

31. Proposed bus routes (Bombela CJV 2007:[sp])

32. Proposed pedestrian (orange) and bicycle (red) routes. Important nodes indicated by the circles (Bombela CJV 2007:[sp])



31.



32.



### 3.5.3 Land use

According to a density study undertaken by Bombela the land use in the station precinct is mainly **office**, followed by **residential** and only 7% **retail** (Hatfield Station development Framework 2003:11). Their proposal includes providing a higher density residential component to support the station and ameliorate the seasonal nature of occupation in Hatfield due to the high number of student tenants.

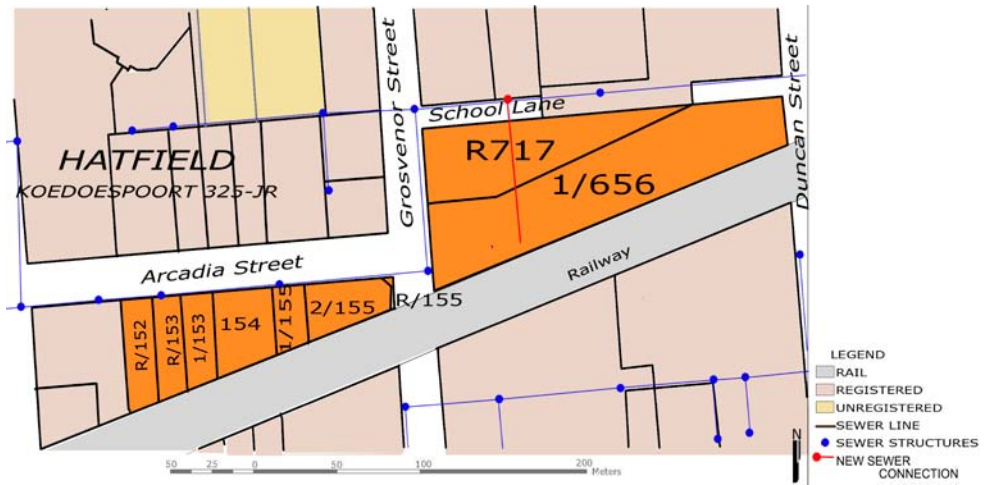
The station site itself is covered by the provisions of the Gautrain Transport Infrastructure Act (GTIA). This legislation sets guidelines for the Gautrain development including land proclamation and expropriation and construction for the rail reserve (route) and stations. According to the agreement with Bombela the Gauteng Provincial Government would be part subsidising the running costs of the GRRL for the first seven years of operation (Steer 2009). After 15 years of operation the stations, reserves and associated sites would be expropriated by the GPG.

At present it is still zoned as vacant /residential 3 . After expropriation any stations not previously zoned for railway land use will automatically be zoned as such (Steer 2009:[sp]).

Currently the preparation of food is not allowed on Gautrain stations. However, designs for kiosks for coffee, snacks, papers, etc., had been proposed by the project architects, Gautrain Architects Joint Venture (GAJV). The decision on these had been postponed to future date when the GRRL stations had been completed and usage figures would be more certain.

33. Hatfield site erven, land use and municipal sewer connection

34. Contours on figure ground background (1m interval contours)  
(Gautrain Rapid Rail Link 2009: [sp])



33.



- 35. Informal trade at Hartbeesspruit Metrorail station.
- 36. Newspaper sellers at the corner of Duncan and Schoeman streets
- 37. Dwelling house converted to offices
- 38. High density residential development in Schoeman street, within 100m of the station
- 39. Multi-storey office park opposite Hatfield GRRL station in Grosvenor st.
- 40. Motor dealership on the corner of Duncan and Schoeman streets
- 41. Example of Transvaal School of architecture in the old Hatfield Primary School (1916)
- 42. Grosvenor St.
- 43. Duncan Rd.

### 3.5.4 Building typology / visual character

The building typology of the precinct is mainly multi storey offices blocks (fig. 39), motor showrooms (fig. 40, 41), single dwelling to offices conversions (fig. 37) and a few high density residential buildings (fig. 38). The red brick Hatfield Primary School (1916) on the corner of Duncan and Schoeman streets (fig. 41), now used as motor showroom offices, is an example of the early Transvaal School of Architecture.

**Streets** are mostly treed with wide concrete pavements and have a largely residential feel (fig. 42). The busier streets (fig. 43, Duncan Rd.) are vehicular in character and largely deserted by pedestrians. Currently, the only **daytime users** in the station precinct are informal vendors at Hartbeesspruit SARCC station (fig. 35), newspaper vendors at intersections during morning and afternoon rush hours (fig. 36) and informal cardboard collectors.



35.



36.

39.



41.

40.



42.

37.



38.



43.





### 3.5.5 Climatic factors

Tshwane receives only medium amounts of rain and is fairly wind still. Nevertheless, consideration must be given to some screening from north western and south eastern winter **winds**.

Due to the site location in the shade of the parking garage, the proposed site would not be exposed to a lot of direct **sunlight**.

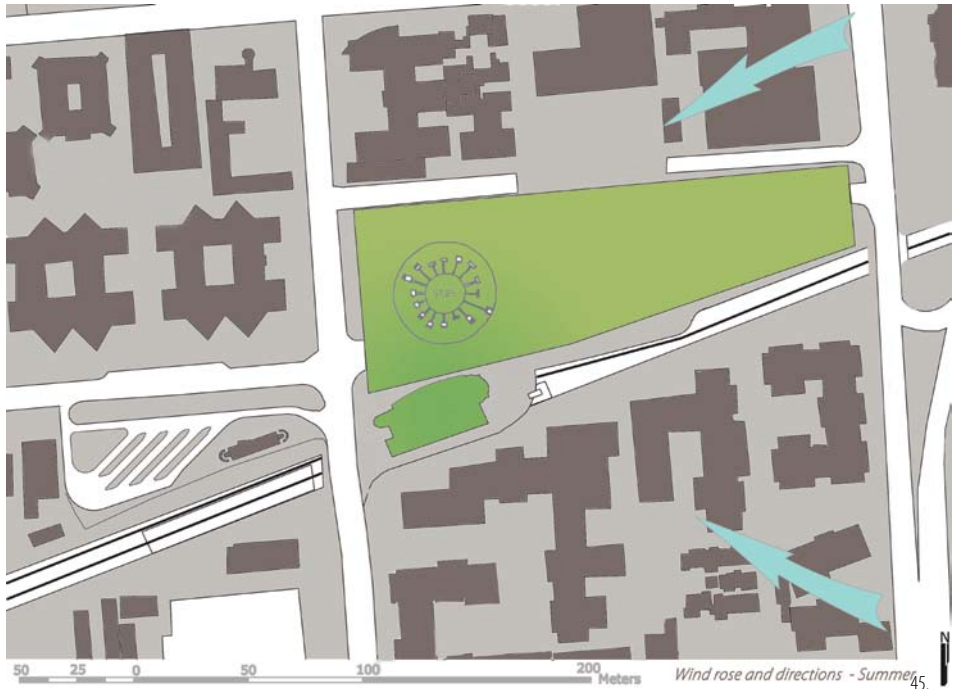
44.

Jan	Jan	Feb	Mar	Apr	May	Jun	Jul	Aug	Sep	Oct	Nov	Dec	Ave
Maximum average monthly temperature (°c)	28,6	28	27	24,1	21,9	19,1	19,6	22,2	25,5	26,6	27,1	28	24,81
Minimum average monthly temperature (°c)	17,4	17,2	16	12,2	7,8	4,5	4,5	7,6	11,7	14,2	15,7	16,8	12,13
Average monthly amplitude (K)	11,2	10,8	11	11,9	14,1	14,6	15,1	14,6	13,8	12,4	11,4	11,2	12,68
Average monthly relative humidity (%)	58,0	59,5	60,0	59,5	55,0	53,0	50,0	46,0	45,0	49,5	54,0	56,5	53,83
Average monthly rainfall (mm)	136	75	82	51	13	7	3	6	22	71	98	110	56,17
Rham 72	74	76	78	76	75	71	64	61	64	68	70	75	70,75
Rhpm 44	45	44	41	34	31	29	28	29	35	40	43	44	36,92

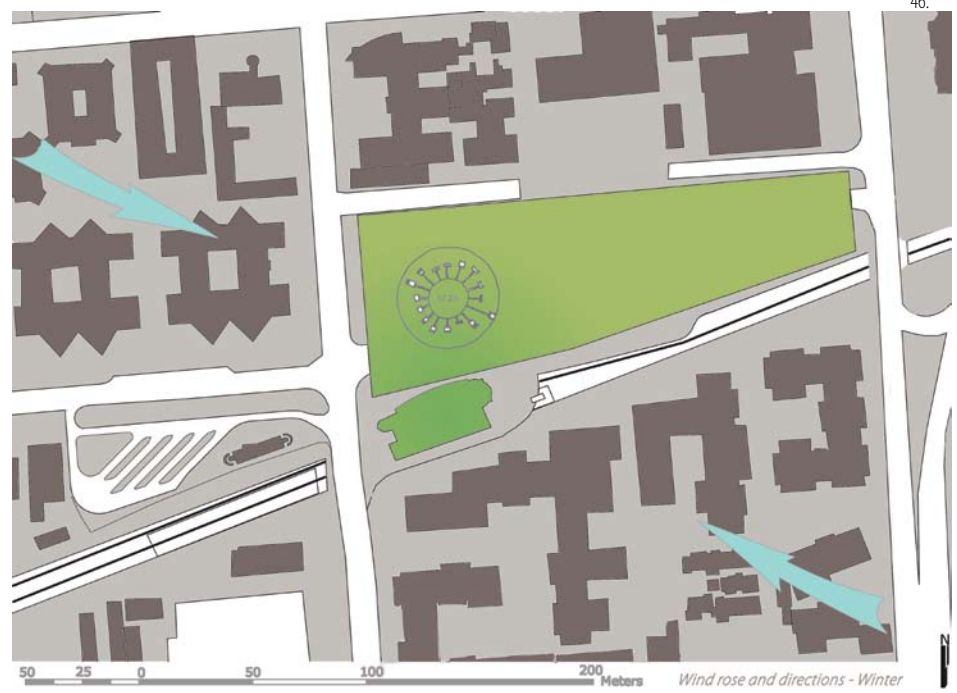
44. Climatic data for Pretoria (Holm 1996: 70)

45. Summer wind directions (Holm 1996: 72)

46. Winter wind directions (Holm 1996: 72)

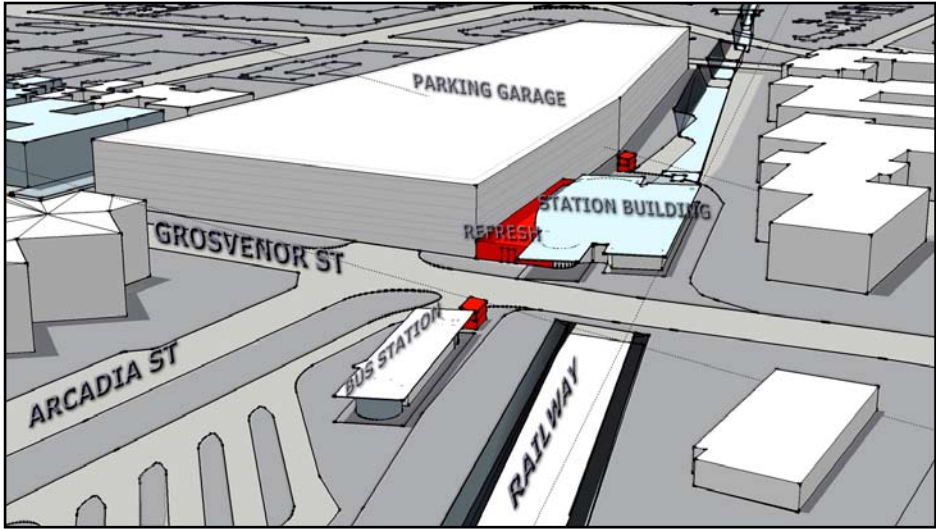


45.



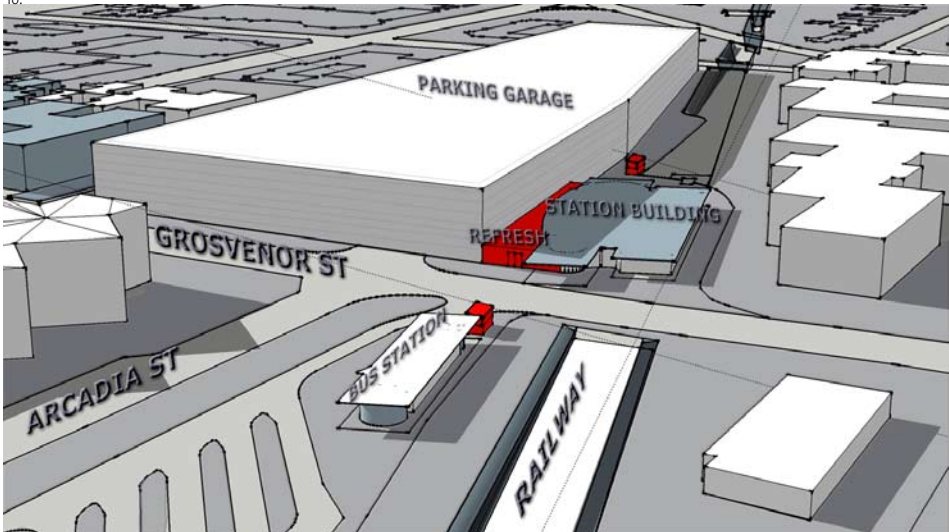
46.





47.

48.



- 47. Summer sun angles on site (Holm 1996: 70)
- 48. Winter sun angles on site (Holm 1996: 72)
- 49. Possible noise & air pollution sources from the parking garage and trains

### 3.5.6 Auditory amenity

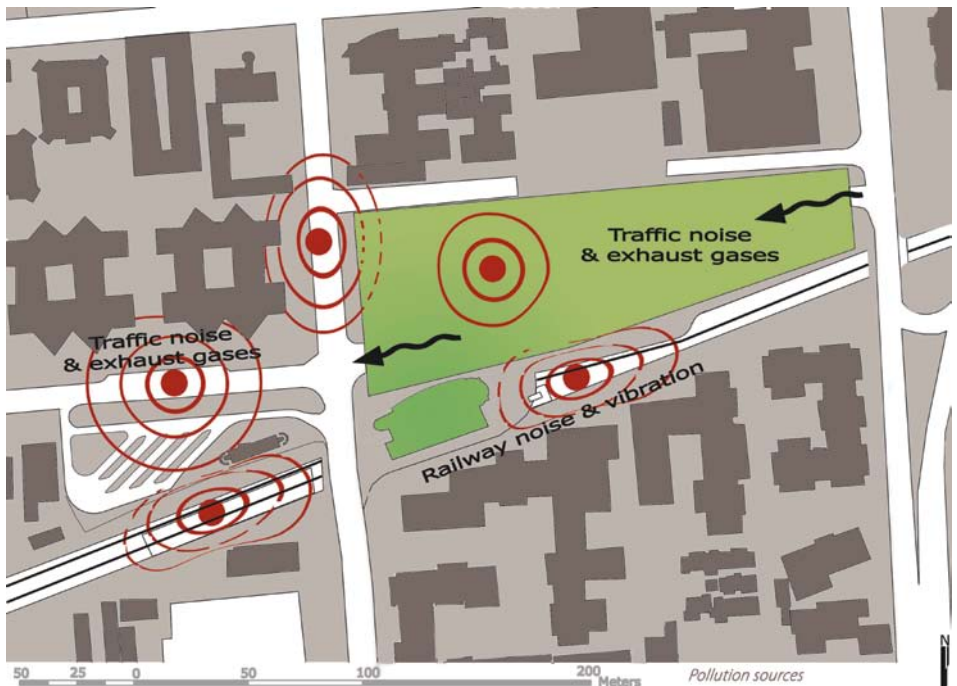
Noise pollution could impact the station from the parking garage as well as the railway line. The effect is reduced by the glazed walkway and two door sets between the ground floor parking garage and station unpaid concourse. The impact of noise from the railway is ameliorated by not having high speed through trains and the railway being located in a cutting 6 meters below ground level.

Air pollution from airborne dust and exhaust gases from increased rail and vehicular traffic is a possibility. However, at present it is impossible to quantify the impact this would have on the environmental health of the area.

### 3.6 Summary

The analysis of the Gautrain system identity has revealed the **Acacia tree** to be the most important concept. An extensive range of finishes and details had been produced. It is suggested that any new interven-

49.



tion in the station environment not slavishly follow the GSI. The GSI should act as a framework or set of guidelines to **orientate** the designer, rather than a set of authoritarian rules. Any new intervention in the station spaces should be visible as something new to set it **apart** from the original build. That being said, new interventions should continue the common thread from the GSI, something to **connect** it to the station context.

Since the acacia tree is such a major part of the GSI, it would seem that this would be a suitable concept to **appropriate** and **reinterpret** in the *re:refresh\** system. Working with the idea of the station (or kiosks for example) as an embodiment of the "treeness" and the idea of the acacia as **meeting** and **trading** place would provide the golden thread connecting the original station with the new refreshment and retail designs.

In terms of functional aspects of the *re:refresh\** the conclusion had been that, in addition to the primary function, five basic **activities** mostly occur at train stations:

EAT

SHOP

PAUSE

ACCESS INFO

ABLUTION

The ablution facilities are already provided at all Gautrain stations. The remainder of the functions would be included in the *re:refresh\** strategy (Chapter 5)

The designs for use inside the stations are not influenced by the physical site context as much as if it were an exterior, new building.

The pedestrian and vehicular **nodes** at the station are important indicators of where the best location with the most significance and foot traffic would be for kiosks. In the Hatfield scenario this would be inside the station unpaid concourse (giving access to non-ticket holders and the public as well), at the northern, north eastern and north western entrances to the station.

Of greater importance than the surrounding physical site characteristics is the **GSI**, the look and feel and details and finishes associated with the GRRL. Station design, ceiling height, wall and floor finishes (grey and cream terrazzo with soft mocha and cream and variegated grey gloss ceramic wall tiles) would also be important informers of the *re:refresh\** design.

An important point from the management position is the **public-private** contract. As mentioned in Chapter 2, Bombela part owns and finances and operates the GRRL for the first fifteen years since commission of the system. The Gauteng Provincial Government is part **subsidising** the GRRL for the first seven years of operation. After fifteen years the stations are to be **expropriated** by the GPG. At that time the land use would, if not already zoned as such, be changed to *railway use* by the GPG.



4



UNIVERSITEIT VAN PRETORIA  
UNIVERSITY OF PRETORIA  
YUNIBESITHI YA PRETORIA

# Chapter 4

## *Philosophy and design approach*

creating places

### 4.1 Macro scale - Railways as public meeting places

The theoretical tools applied to the study can be divided into three levels of scale.

**macro //**

**neighbourhood to building  
interior scale**

**medium //**

**unit scale**

**micro //**

**unit & details scale.**

Carmona, Heath, Tiesdell and Oc (2003) argue for a conception of urban design as needing to be primarily for and about **people** and stress the importance of **creating "places"**. An important quality of urban design is its functioning across different levels of **scale**. Christopher Alexander's Pattern Language is a good example of urban design ranging from the scale of city and surrounds down to the scale of the interior.

Bob Jarvis (1980) distinguished between two **traditions in urban design** namely the 'visual-artistic tradition' and the 'social usage tradition'. Over the last twenty years of the 20th century these had been condensed into the 'making places' tradition (Carmona 2003:6-8).



## Visual-artistic tradition

A product-oriented approach to urban design focusing on the visual qualities and aesthetic experience of urban spaces rather than cultural, social, economic political and spatial factors.

## Social usage tradition

Social usage tradition emphasised the way people use and occupy a space. It encompasses issues of perception and sense of place. Kevin Lynch and Jane Jacobs are key proponents of this approach to urban design. Lynch attempted to shift the urban paradigm in favour of appreciation and enjoyment of urban space as commonplace instead of elitist. Jane Jacobs highlighted sociofunctional aspects of sidewalks, streets and parks as containers of human activity and places of social interaction.

## Making places tradition

The dominant tradition in urban design today is that of making places for people. It is concerned with the city as both an aesthetic entity and a container for human behaviours. It focuses on diversity, activity in order to create successful public places and how well the environment supports the functions and activities that take place.

Kevin Lynch (1981) identified five key performance dimensions that need consideration for the design of "good" urban spaces:

1. **Vitality**, the degree to which places support life, biological functions and the capabilities of people.
2. **Sense**, the degree to which users can recognise and distinguish a space due to its unique temporal and physical milieu.
3. **Fit**, the degree to which a place accommodates and enables human cultural and social behaviour.
4. **Access**, the ability of people to reach other people, activities, resources, places (shelters, open spaces, natural/ symbolic spaces) and information.
5. **Control**, degree to which users of a space create and manage access to a place.

He also mentions two metadimensions: **efficiency** or the cost of achieving a degree of vitality, sense, fit, access and control and **justice** or who is getting how much of it.

**Sense of place** is particularly important in urban design especially in terms of *genius loci* or spirit of the place (Porter 2004:88). The shift of focus from the quantitative to the qualitative in architectural theory was awakened in 1979 by Christian Norberg-Schultz publishing his book, *Genius Loci: towards a phenomenology of architecture*. Today it encompasses any quality denoting the essence or experience of a place.

General consensus is that the creation of place hinges on three factors:

**activity**, land use, traffic flow, trade, behaviours

**physical setting**, built form, access and permeability, furniture

**meaning**, legibility, culture-historical associations, qualitative experience (Carmona 2003:98-99)

Lynch (1981) defines the identity of a place as the physical or experiential qualities which allows users to recognise and distinguish it from neighbouring spaces or places (create meaning). He suggests this may be accomplished through the incorporation of **sensory** and **temporal** characteristics unique to the place. Kurtich and Eakin (1993) also argue for the incorporation of temporal aspects into space (open or interior). This causes a heightening of users' awareness and thus the experiential qualities of a space resulting in the creation of place.

Jacobs (1961) stresses the formal and informal communal **activities** taking place in a **physical setting** (pavements, parks) as the prime creators of **meaning** and place.



The typical activities taking place inside stations have already been identified in Chapter 3. To recap, the simplified ancillary activities that should be accommodated in the stations are EAT, SHOP, ACCESS INFO and PAUSE.

Manuel Castells (1989) is of the opinion that the current restructuring of urban form is as a result of the transition from and industrial era (pre-1970) to an **informational era** (Carmona 2003:32). Over the past forty years the increasing speed of **electronic communication**, transportation and the pressures of **globalisation** have decreased the significance of place (Carmona 2003:20). While physical experience of a place remains important, increasing significance of electronic communications could mean that future cities are aspatial and ageographic, with the Internet being everywhere and nowhere.

Three interrelated processes need to be considered in order to avoid the threat of “**placelessness**” in the contemporary urban condition (Carmona 2003:101).

## Globalisation

The world is becoming more connected. Improved physical and electronic communication are shortening the distances that separates us, creating “global space”. The process of globalisation is leading to increasing homogenisation and loss of meaning in places. There is a tension in urban places between the celebration of the global and the support and enhancement of the local context in which the place is rooted. The danger is that of losing the local cultural and historical meaning in favour of the standardising, commercialising global culture.



## Mass culture

With globalisation comes mass culture pandering to the mass market with processes of mass production and mass media stifling or even eroding local “authentic” culture. Uniform products and places are created for people instead of being designed and created by them, overriding the local authentic in favour of the commercial.

## Loss of attachment to territory

Increasingly places are created that make people feel they do not belong and consequently these environments are not cared for by its users. An increasingly mobile and transient society has increased the loss environments people care about. Communities are increasingly interest- bound rather than place-bound.

The objective of an urban framework for the Gautrain stations is the creation and strengthening the sense of place in the Gautrain stations to counter the effects of the information age, globalisation and mass culture. The Gautrain system identity already accommodates the inclusion of local myths and concepts including a nod to local African arts and crafts as translated into concrete balustrade patterns and viaduct pylons. The Hatfield area urban framework has been re-evaluated in light of the importance of the creation of place in appendix 1.

On the scale of building interior and the immediate surrounds the *re:fresh\** intervention is intended to increase the levels of activities and vitality in stations. The aim is to establish the Gautrain stations not only as transport interchanges, but also as public meeting places. The design approach informs a design that contributes to and supports the place making paradigm already implemented by Gautrain architects at the larger scales of urban and architectural design.

### 4.1.1 Design guidelines for macro scale

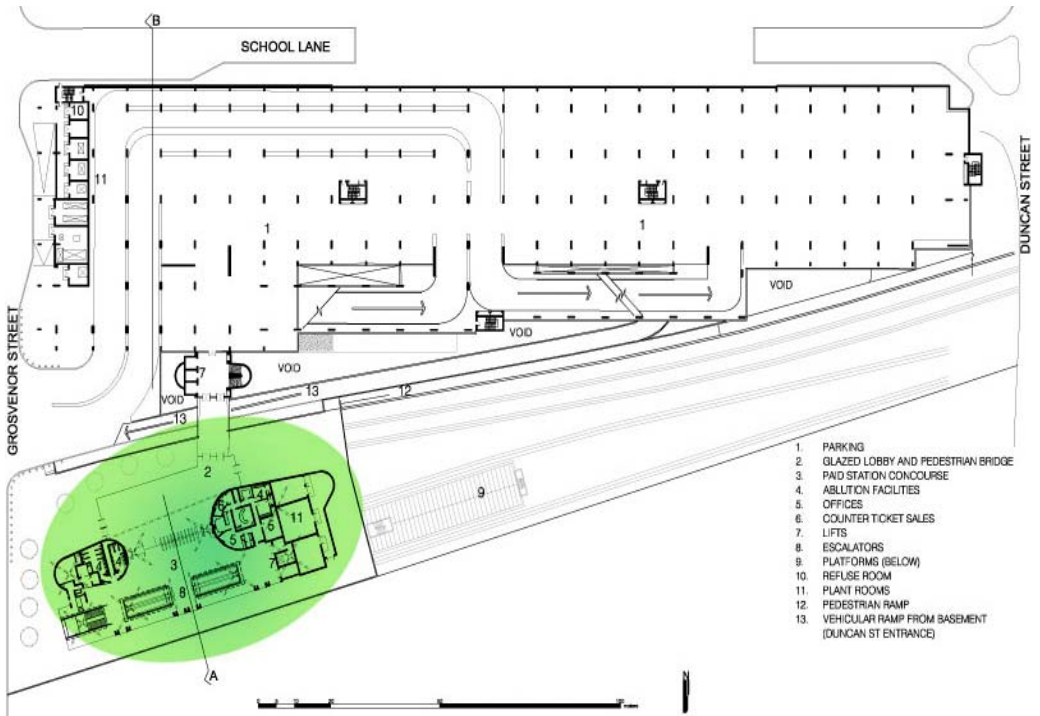
The following guidelines take their cue from the place diagram regarding key attributes of successful places

(Project for public spaces: 2009) as well as being extrapolated from the urban qualities guidelines in appendix 1. The guidelines inform about desirable qualities of urban spaces from a variety of architectural theorists.

1. Create public meeting places, with space for casual social interaction.
2. Create a sense of place, by increasing legibility and incorporating unique temporal and spatial elements.
3. Incorporate a temporal dimension, indication of passage of time and space to heighten awareness and experiential qualities. (e.g. use of wood, temporary materials, design for transience)
4. Provide access to opportunities and services, including the secondary functions identified in Chapter 3, EAT SHOP, PAUSE, ACCESS INFO.
5. Enable choice of activity (e.g. more secondary activities ,shop, eat, access info available in public station building, serving the station precinct).
6. Provide complexity and diversity in terms of activities and scales.
7. Mix levels of intensity and exposure from very intensive and exposed to less intensive and more private.
8. Mix secondary and primary functions, including the secondary functions identified in Chapter 3, EAT SHOP, PAUSE, ACCESS INFO.
9. Design to allow for manipulability (small changes to present use) and resilience (able to return to original state).
10. Increase future adaptability.

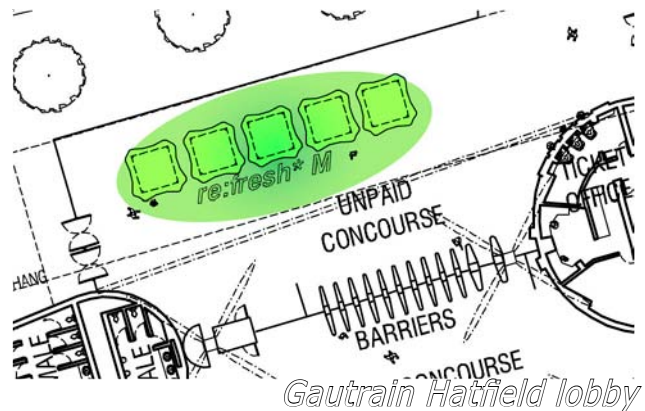


50. Place diagram indicating key attributes of successful places in inner ring, middle ring intangible qualities and in the outer ring



*Gautrain Hatfield site layout*

creating places



*Gautrain Hatfield lobby*

not to scale



## 4.2 Medium scale - Tectonics

### the poetics of construction

Kenneth Frampton defines the **tectonic** as the poetics of construction or the art of joinings (Frampton 1995: 2). It comes from the Greek *tekton*, carpenter or builder, from which *architekton* or master builder would later be derived (Frampton 1995: 2-4). Frampton claims the legitimacy of modern architecture derives from the interplay between *topos* (site), *typos* (type) and *tectonics*.

Gottfried Semper's *Die vier Elemente der Baukunst (four elements of architecture, 1851)* defines tectonics as the lightweight structural frame reaching to the sky in opposition to the **stereotomics** of the earthwork, heavy elements piled up to create mass and volume (Frampton 1995:5).

Semper also described the historic differentiation of one material to another with similar tectonic qualities, such as wood to woven materials and tensile structures and earthwork to bricks and mortar and later concrete. His *Stoffwechseltheorie* pointed out occasional **transpositions of materials** in cultural history, for example Greek temples where stone was cut in such a way as to embody the traditional wood constructional details (Frampton 1995:5-6). The embodiment of the architectonic attributes of one material in another is seen as a continuation of cultural history, but also of the culture of craft in construction.

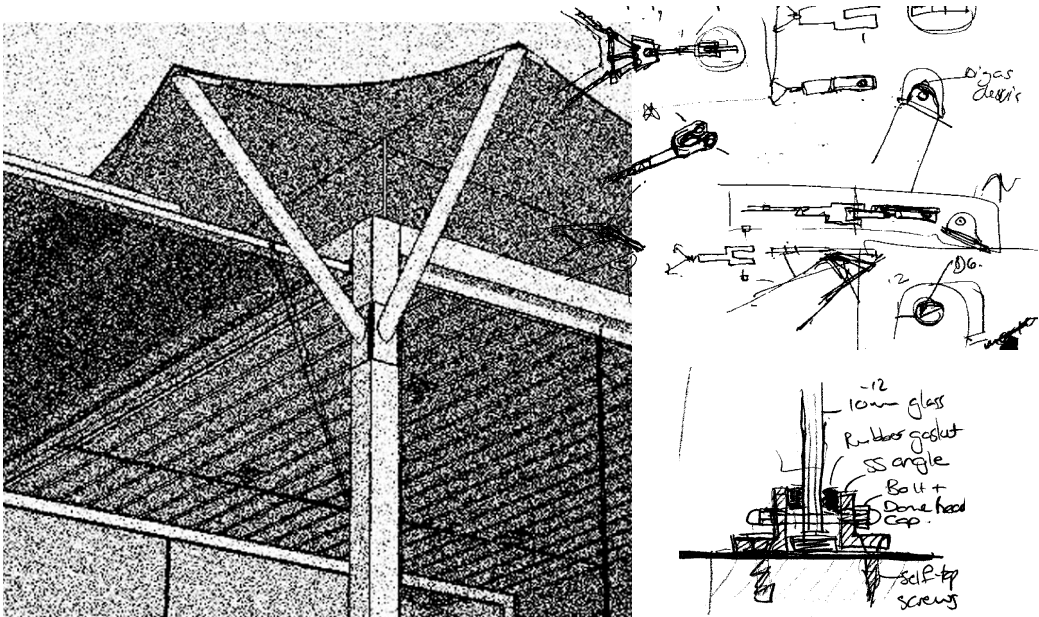
The tectonic is regarded as an antidote to the primacy of the creation of three-dimensional space in architecture to the detriment of tectonic expression, a view increasingly espoused since the end of the nineteenth century (Frampton 1995:1). Modern approaches have ranged from the suppression of tectonics in favour of iconography and scenography of the Postmodern to the extreme tectonic expression of Santiago Calatrava.

The increased technological character of contemporary building has seen the escalation of the level of complexity in building, precluding any one practitioner personally overseeing every aspect of construction. The concern is that architects and associated designers are losing control over constructional craft, hence the call to a return to constructional craftsmanship, even if only to ensure the various practitioners on a project design to a **tectonic paradigm** (Frampton 1995:386).

While tectonic expression is not mentioned as part of the Gautrain design philosophy there are visible signs evident in the station designs, such as the treelike columns, balustrades and aluminium glazing. No doubt it may have been more of a background influence to designers. The tree motif, an important part of the GSI, could be seen as a natural expression of the tectonic. Structural trunk and branches contain the means of providing nutrients and water to the photosynthesising leaves, supported so as to optimally absorb energy from the sun. The beginnings of tectonic expression and transposition of wood to steel as evident from the steel column design strengthen the idea of the tectonic in the Gautrain designs. It would seem fitting that with a tree concept as well as a subliminal tectonic design paradigm, the art of the tectonic and focus on the joint in the spirit of Carlo Scarpa also be incorporated into the *re:fresh\** design toolkit.

#### 4.2.1 Guidelines for the design approach

1. Work within the "materiality" of materials to find the construction method most suitable (or true) to the material, or how the material wants to be joined
2. Design lightweight tectonically expressive structure (to evoke the tectonic expression of a tree and link with the tectonic elements already inherent in the Gautrain station designs)
3. Focus on tectonic expression and articulation of joints and connections between materials
4. Make use of material transpositions as tectonic expression and highlighting of material qualities and properties



### 4.3 Micro scale - Performance criteria

At the detail design level the design is influenced by the cost related to the manufacture of the units, the degree of transience of the units, ease of assembly and issues related to sustainability and future use of the unit. These factors are illustrated with examples and precedents.

#### 4.3.1. Cost factors

##### \* Standardisation

**Standardisation** of the kiosk components into a system allows for a greater degree of **cost control** for the manufacturer / contractor. This does not mean that all the elements have to be combined into factory assembled components e.g. an entire wall component. Considering the location of the kiosks in different Gautrain stations it is actually preferable to employ a system that can be brought to site in **smaller parts** in order to allow easy access into the station concourses. The standardisation also allows **easy and fast assembly** and **future disassembly** by a contractor familiar with the system.

The standardisation of the units has a number of advantages:

1. Shorter production time means greater savings
2. Increased quality control in factory
3. Easy delivery and assembly on site

##### \* Degree of transience

The *refresh*\* kiosks are intended for use as an interim level between deployment of vending machines and more permanent facilities (Chapter 5). They would ideally be used for 3-10 years. This requires, at design level a balance between the qualities of **transience and permanence**. The units need to be, in terms of materials, **durable** enough to withstand wear and tear of use in a public place and maintain an acceptable standard of finish.

# Standardisation //



## BoKlok kit houses

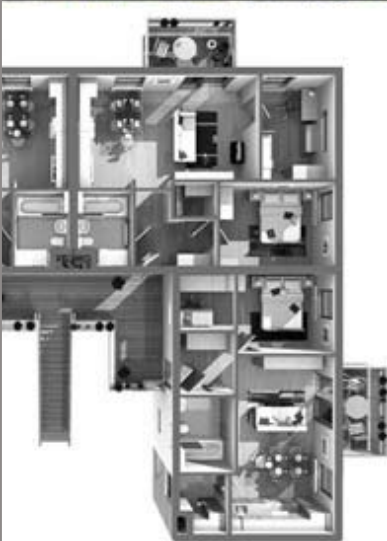
Sweden, Norway, Finland, Denmark, UK.

IKEA

Designed by Swedish flatpack furniture giant, IKEA the BoKlok house offers affordable, stylish living. Unlike other IKEA products, these houses or flats are not bought in IKEA stores. The walls and floors are factory manufactured as closed panels or cassettes and then assembled on site by a local approved builder. Walls come finished with service conduits, windows and doors. Roofs are assembled on site and craned into position. The interior fitting are all manufactured by IKEA.

Home buyers may customise their flat with a variety of external finishes and colours and the interior layout allows a measure of flexibility in space organisation.

[Home Architects 2008: 2-3]



**FACTORY MANUFACTURED = REDUCES COSTS  
= ENSURES QUALITY**



UNIVERSITEIT VAN PRETORIA  
UNIVERSITY OF PRETORIA  
YUNIBESITHI YA PRETORIA

# Standardisation //

## Cellophane House

MoMA exhibition. Home Delivery: Fabricating the modern dwelling. New York, July 2008

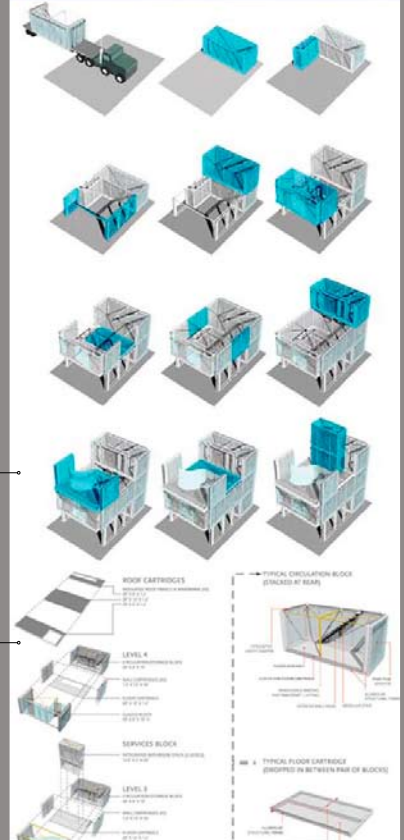
Kieran Timberlake Associates

Part of the MoMA exhibition was the exploration of the modern prefabricated house. Cellophane house is a four-storey single family home comprised of factory made components assembled onto a structural aluminium frame. The use of components allows the materials to retain their discrete identities, while allowing for future disassembly and recycling instead of demolition. The "kit of parts" nature of the house is a low-cost and sustainable housing option. Personal taste and budget are accommodated in a range of choices regarding material, texture and colour. Ultimately this project merely provides a framework for designers or clients to customise to their tastes. This fits the architects' view of the role of the architect not as the reinventors of infrastructure, but as the procurers and editors of materials from the vast pool of building materials available.

[MoMA 2008: sp]

Site assembled components

Cassettes with integrated services



**COMPONENTS ALLOW FUTURE  
DISASSEMBLY  
= SUSTAINABILITY**

# Adaptability //



## **Bradbury street community workshops / market stalls**

Dalston, London, 1999

Hawkins/Brown

The Bradbury street market stalls formed part of the second phase of an urban regeneration project in the East London borough of Dalston. The market stalls are permanent, lockable stalls for small businesses, facing a car park. The stalls are robustly designed from robust, durable materials with simple details. With a back-to-back layout, tenants are offered the possibility of renting or buying a neighbouring stall in order to expand their business. The robust nature of the stalls allows for easy refurbishing, repair and customising of individual stalls.

[Hardingham 2002: 232-235]

## ROBUSTNESS

## DESIGN FOR EXPANSION / ADDITION



UNIVERSITEIT VAN PRETORIA  
UNIVERSITY OF PRETORIA  
YUNIBESITHI YA PRETORIA



# Adaptability //

## Paper temporary studio

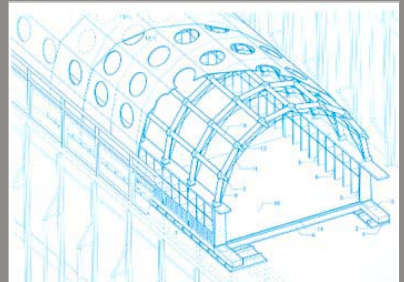
6th Floor Terrace, Centre Georges Pompidou, Paris, 2004

Shigeru Ban Architects

After winning the competition to design the Centre Pompidou's new facility in Metz, architect Shigeru Ban received permission to construct a temporary studio on top of the Piano & Rogers landmark. Arches constructed from cardboard tubes with timber block connectors and steel stiffeners created the roof. This was then clad with wood panels and PTFE (poly tetra fluoro ethylene) and PVC membranes. The interior was finished with timber decking, carpet tiles and Vitra furniture. Structural bookshelves support the arched roof.

In order to discharge their duties competently, this structure would have had to allow a feeling of substantialness and required services such as power and telecommunications. Yet, since this was a transient structure, it would have been important that no trace of the building remain once dismantled and no damage be caused the Centre Pompidou building surface. This balance between transience and permanence is a fine line and would require a lot of design consideration.

[Jodidio 2006: 78-81]



## TRANSIENT PRESENCE

# Permanence vs Transience //

## Kiosks

Various

Looking at the samples of various kiosk types represented here, it is possible to distinguish two important factors in kiosk design, namely:

- \* the level of transience or how temporary or permanent the kiosk is, and
- \* size.

The kiosk's transience could be equated to how easy it would be to move, remove or disassemble without causing major disruption and damage to the immediate environment. The small paper, drinks, info kiosks at top would rate more transient than the platform-side built-in kiosk at bottom.

It is interesting to note that the level of transience does not necessarily correspond to the size of the kiosk. The more permanent kiosk at bottom is almost half the size of the Panini Pronto Kiosk second from top. Therefore, a small kiosk footprint does not automatically make it more transient

[Comet Catering Equipment Company (Ltd) 2006: sp]



[displays4media.com] 25 July 09



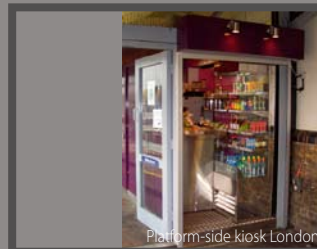
Panini Pronto, Excel, London



West Cornwall Pasty Company, Gatwick Airport London



Fuel Juice Bar, Birmingham



Platform-side kiosk London

TRANSIENT



PERMANENT

### 4.3.2 Sustainability factors

Stuart Walker (2006:114-118) set out to compile a list of the aesthetic identifiers of unsustainable contemporary product design. The following is a simplified version of his aesthetic typology of unsustainability. These aesthetic identifiers should be avoided or limited when producing the *refresh*\* design products.

Aesthetic identifier	Description	Relationship to unsustainable practices
Culturally neutral or bland	A result of mass production for global consumption. Cultural and regional distinctiveness is absented in favour of homogenised aesthetics suitable to mass market.	Designs with such aesthetic neutrality fail to consider or respond to the local context or place and fall within unsustainable practices.
Pristine polished and fragile	The production of flawless forms and surfaces is usually driven by capital and energy intensive production methods using non-recyclable, non-renewable resources.	With everyday use "perfect" products and surfaces quickly deteriorate in appearance leading to consumer dissatisfaction and premature disposal. The quality of finish increases the amount of packaging required for delivery. This practice increases waste generation.
Concealing and disguising	The exterior of a product or component is perceived as an "envelope" or casing. It is usually a moulded or press-formed shell with little relevance to functions of the interior workings or services it conceals.	This is a barrier to product comprehension. It prevents identification and engagement with the design products. It hampers product repair and maintenance, shortening the component life span.
Cold or remote	Materials are unfamiliar and remote in terms of users' understanding.	This is also a barrier to product comprehension. This quality can decrease one's ease or comfort with a design product and decrease the values attached to it. This lack of regard increases disposability and detracts from user identification with a design product.
Curved rounded and smooth	Many contemporary designs include curved forms, often made of plastic, that can be readily injection-moulded. Hard edges are eliminated and forms become smoothed.	This "moulded" aesthetic is indicative of energy and resource-intensive processes that are environmentally damaging and frequently socially problematic. Manufacture often occurs in low-wage economies with poor worker conditions and lax environmental policies. This characteristic could be indicative of environmentally and socially unsustainable practices.
Fashionable or showy	Designs pandering to short-lived trends, colours, patterns quickly lose their fashionability.	Quickly outdated designs cause premature "aesthetic obsolescence", waste and consumption and user dissatisfaction.
Complete and inviolable	This aesthetic quality is a result of overall presentation of a design in terms of sophisticated forms, finishes, materials.	Most products demand passive acceptance by users. Nothing can be contributed by the user. The user can not truly care for it without being able to engage with, maintain or repair it. This can again lead to lack of valuing and premature disposal.

#### \* Adaptability

The standardised nature of the units does not mean that they should all look alike. Like the approach followed by the designer participating in the MOMA housing exhibition (Cellophane House), it is possible to include **randomness**, **choice** and the resulting **diversity** in a modular building design.

It is also important, in view of the proposed formal traders plying trades as diverse as take-away coffee bars, convenience shops, gift stalls and newspaper kiosks, that the basic unit be adaptable to various uses if rented to a different tenant. As the tenant or function of the unit may change over **time** would depend on

the use of the unit and the influence of the users.

The adaptability of the unit increases its **sustainability** in terms of future **use, re-use or adaptation** as seen in the previous table. Not only that, it provides **choices** to the future tenants, allowing them to expand a thriving business without having to relocate or having to reinvest their capital outlay.

Osman and Königk (2008:115-116) argue that the ability of the built environment to be continuously adapted and transformed is particularly relevant to issues of accessibility and affordability in South Africa. This related to idea of **Open Building**, or the ability (and flexibility) of the built environment to be adapted and accommodate change. Even though their study related urban housing and community facilities, it would be able to be applied to smaller interior architectural retail and refreshment facilities within the South African context. The adaptability of the *re:refresh\** units over time would spell the success of the project.

Adaptability requires not only a durable construction and material application, but also a **robustness** of design and detail in order to ensure the longevity and reparability of the units.

#### 4.3.3 Guidelines for the design approach

1. Design for easy manufacture and site assembly
2. Manufacture factory finished components where feasible (e.g. pre plumbed wall panels)
3. Keep components small enough to allow easy delivery and access onto station concourses (door sizes are limiters)
4. Design for easy future disassembly without deleterious effects to the materials / elements joined together
5. Design for minimum damage to existing station floor and wall finishes upon future disassembly
6. Balance visual and perceptual presence of the units with their level of relevant transience
7. Material cost needs to be low enough for level of transience as well as sustainable where possible
8. Materials and joints need to allow for future adaptability, expansion / addition, disassembly and repair
9. Materials need to be durable enough for heavy public use
10. Joints need to be simple and robust





5



UNIVERSITEIT VAN PRETORIA  
UNIVERSITY OF PRETORIA  
YUNIBESITHI YA PRETORIA

# Chapter 5

## *re:refresh\** strategy

### 5.1 Phased deployment

From the design philosophy discussed in the previous chapter, it is apparent that the design approach requires an overall strategy for the deployment of retail and refreshment facilities at Gautrain stations.

The *re:refresh\** strategy encompasses the retail and refreshment facilities as previously discussed as well as being used to refer to the actual designs for each of the stages.

The aim of the *re:refresh\** strategy is the furthering of the design approach regarding the creation of public meeting places at stations, improving the experience of the sense of place. On a pragmatic level it is meant to provide a framework for the systematic deployment of retail and refreshment facilities, as well as prescribe the type of facilities and scale of facilities deployment at Gautrain stations.

The strategy could be divided into three phases. These relate to the scale of the intervention but also corresponds to an element of timing. Each is programmed for deployment at and operation across different time scales. They are as follows:

### *refresh*\* **S** Small

Provision of vending machines, ATM's, public seating (PAUSE function), legible timetables, station information and local and tourist information (ACCESS INFO activity).

Located inside stations and on platforms.

### *refresh*\* **M** Medium

Provision of semi-permanent (3-10 years) kiosks for SHOP and EAT activities.

No cooking activities allowed by Bombela inside stations. Pre-packaged snacks and pre-prepared foods need to be made off-site and delivered to site daily or every couple of days depending on sales.

Located inside stations on paid concourses, not on platforms.

### *refresh*\* **L** Large

Provision of larger scale retail and refreshment facilities SHOP, EAT, INFO, PAUSE, ABLUTION activities.

Located in parts of parking areas or garages where feasible. Bombela has made an allowance that a part of the parking area may be used for retail and refreshment purposes in future.

The strategy would be implemented over a number of years as indicated in the deployment strategy diagram. Each intervention would be allowed a reasonable amount of time for users to become familiarised with them and usage figures to settle after the initial novelty has worn off. After a certain period of time, Bombela management would, at a station by station basis, evaluate the success or failure of each intervention. The purpose is to ascertain:

- \* whether commuters are using the facilities,
- \* whether more of the same facilities are needed, whether different types of facilities, retail are required,
- \* whether the next level of retail facilities are warranted or whether the local market is saturated.

**Management** of the retail and refreshment facilities would be handled by a new division of Bombela Operations Company, a subsidiary of Bombela Concessions Company, as mentioned in Chapter 2.

After 15 years the stations and associated facilities are to be **expropriated** by the **Gauteng Provincial Government**. It would be up to the GPG to then consider the success and continued operation of the retail facilities or dismantling and disposal of the facilities.



# retail deployment strategy

years since  
commissioning of  
stations

Duration

re:refresh\* S

0-1 5 yrs min

vending machines  
ATM's

re:refresh\* M

1-2 3-10 yrs

kiosks

re:refresh\* L

2.5 20+ yrs

are kiosks profitable?

no

yes

provide additional permanent yet  
demountable facilities  
[convenience shop or number of  
different shops]

are permanent facilities  
profitable?

no

yes

Provide additions or subdivide  
existing into number of divergent  
functions

5

15

at expropriation, is GPG willing to  
continue retail functions?

no

yes

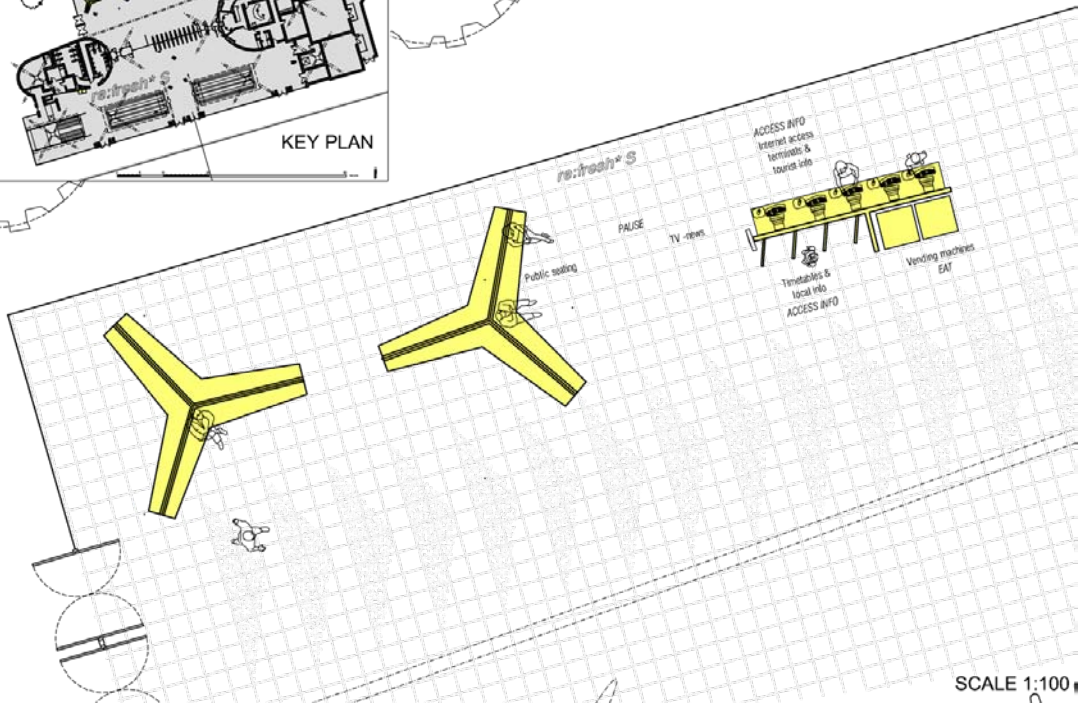
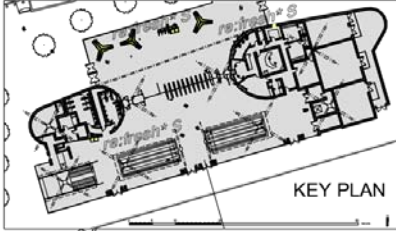
Retain, possibly expand.

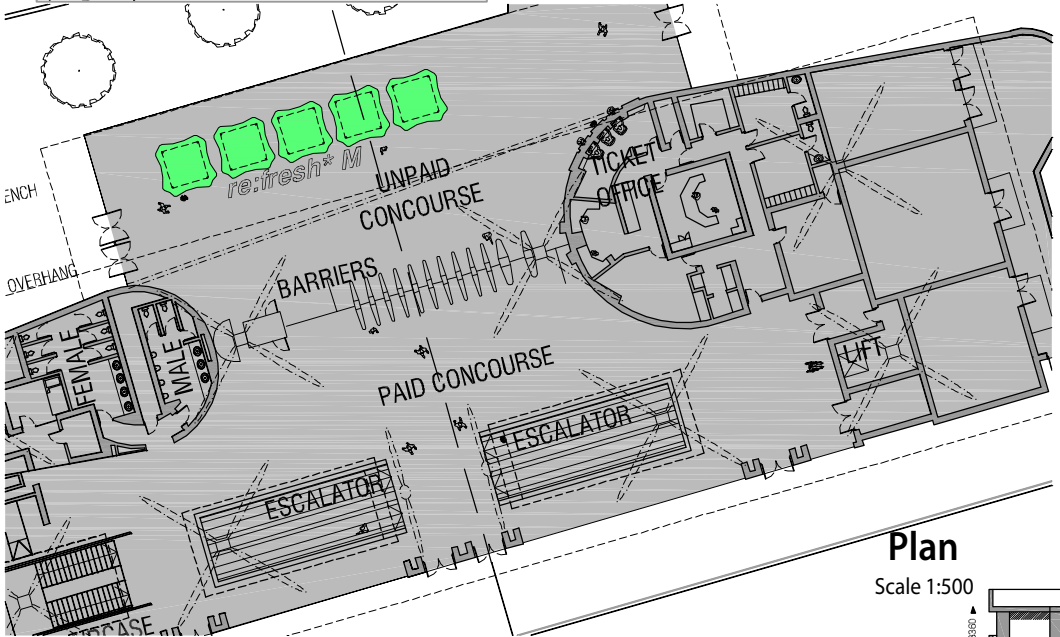
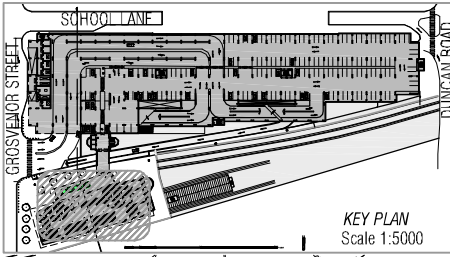
Disposal

X

DEMOUNT

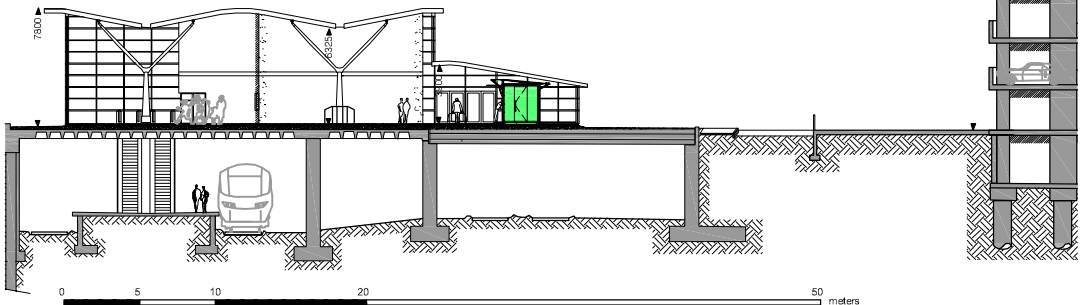






Plan

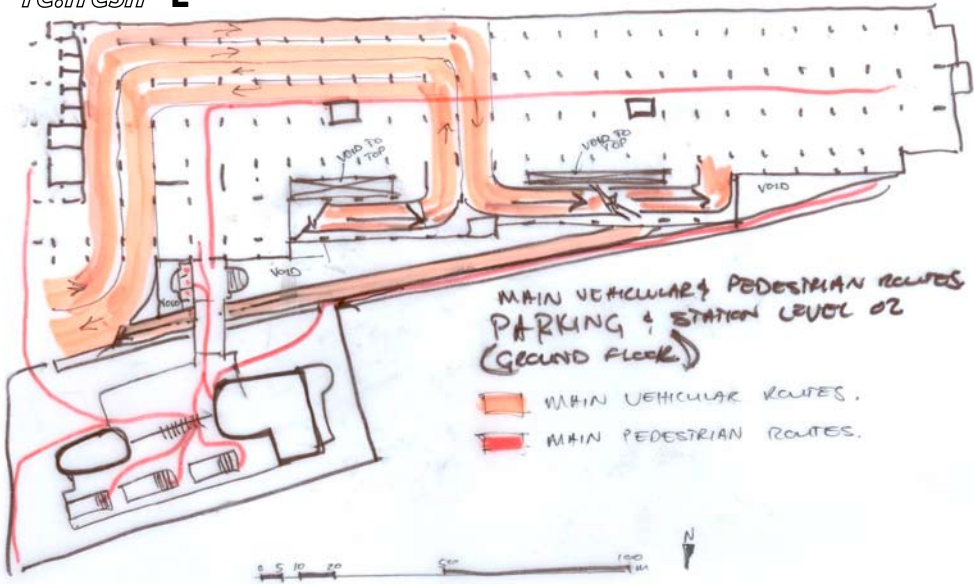
Scale 1:500



Section A-A

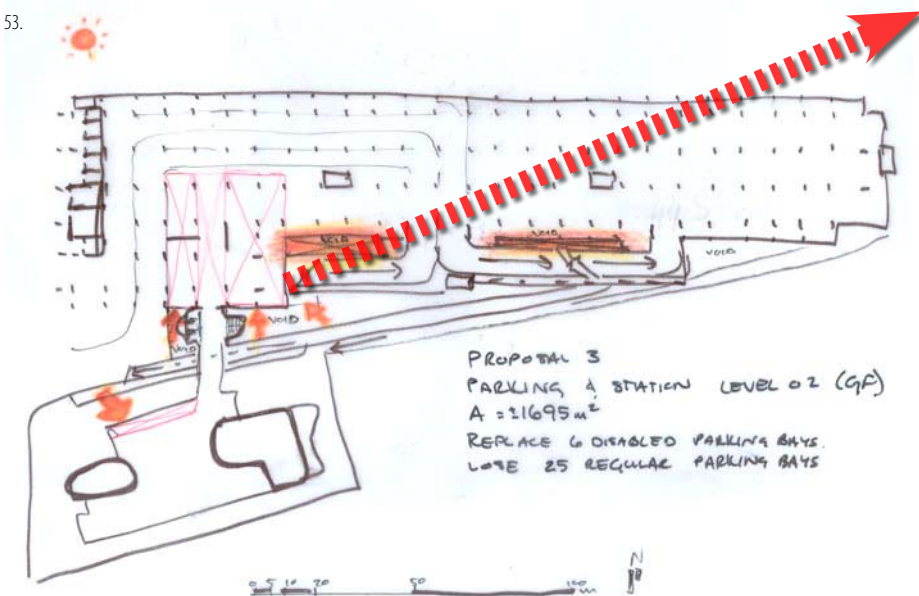
Scale 1:500





52.

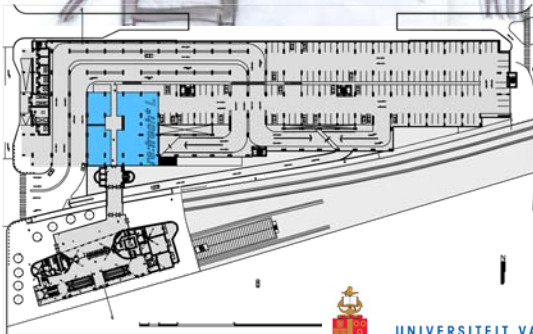
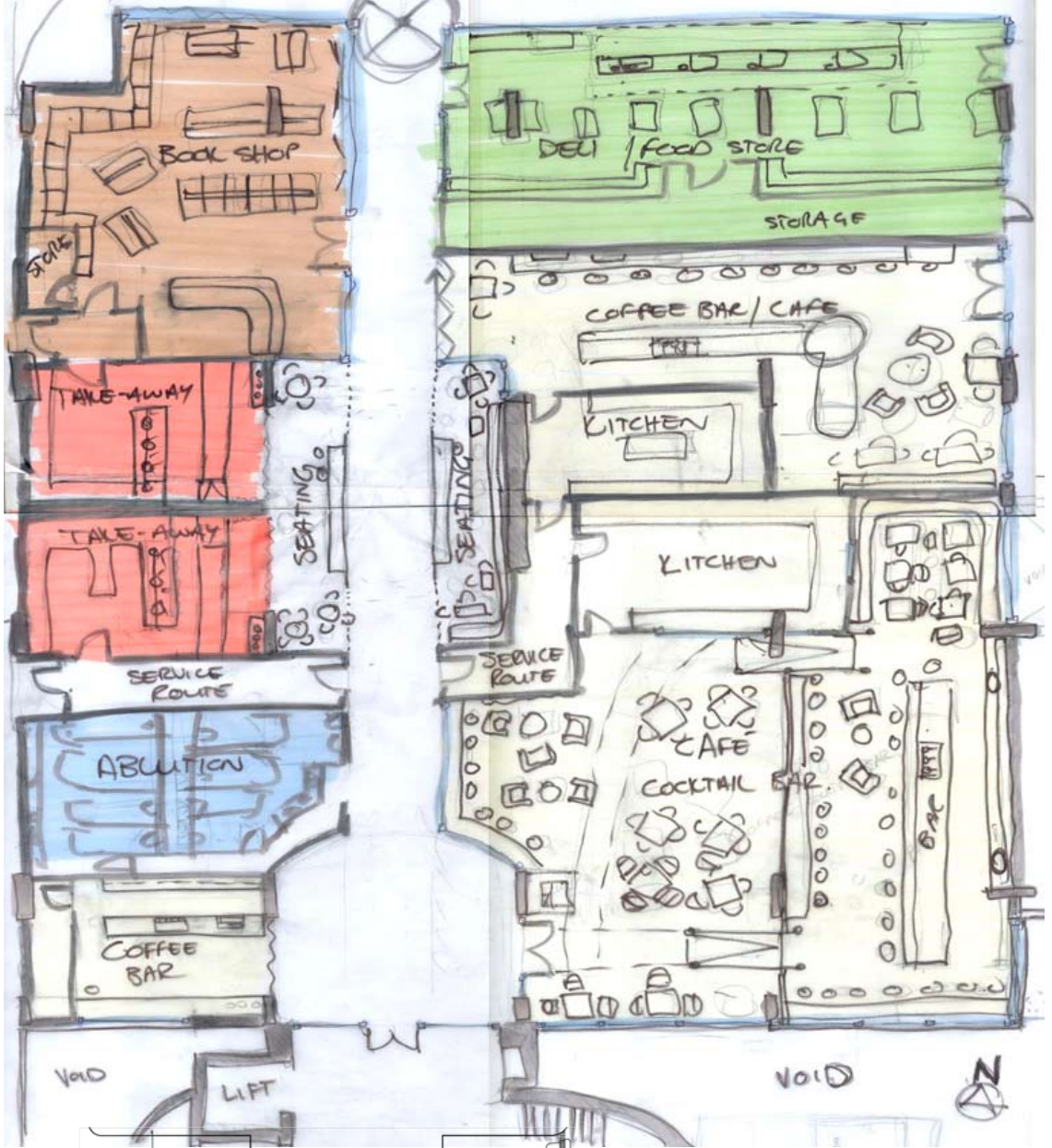
53.



52. Identification of the main vehicular and pedestrian traffic routes could help identify the optimum location for the re:refresh interventions at the Gautrain stations

53. In Hatfield, the station parking closest to the glazed pedestrian bridge into the station had been identified as a good location for re:refresh L in future and the station lobby for the re:refresh M kiosks

54. Concept sketch plan potential future parking area for re:refresh L.



## Product Lifecycle

Regarding the entire *refresh\** intervention as design product, it would be helpful to conceptualise it in terms of the **eight phases** of the *refresh\** **product lifecycle** (Burke 2007:40-53). These are contained in diagram form as applied to this project. The operation phase as well as expansion and upgrade phases are repeated for each new phase of *refresh\**. Each phase, *refresh\****S**, *refresh\****M** or *refresh\****L** is regarded as an embedded mini-project in the duration of the product lifecycle and consists of each of the four phases of the project lifecycle.

### 1. Pre-project phase

Projects evolve from the market and work environment of the Bombela company, namely the transport sector and user needs at stations as identified in this study.

### Project lifecycle

Most projects pass through a **four phase lifecycle**:

**2. Concept and initiation phase:** Starts by establishing a need or opportunity for the product facility or service and feasibility is investigated.

**3. Design and development phase:** Guidelines of the feasibility study are used to design the product, outline the build-method and develop detailed plans for making or implementation of the product.

**4. Implementation or construction phase:** Implementation proceeds as per baseline plan developed in previous phase.

**5. Commissioning and handover phase:** Completion as per plans is confirmed and terminates the project.

### 6. Operation phase

This includes handover, maintenance, upgrade and expansion and disposal.

### 7. Upgrade and expansion phase

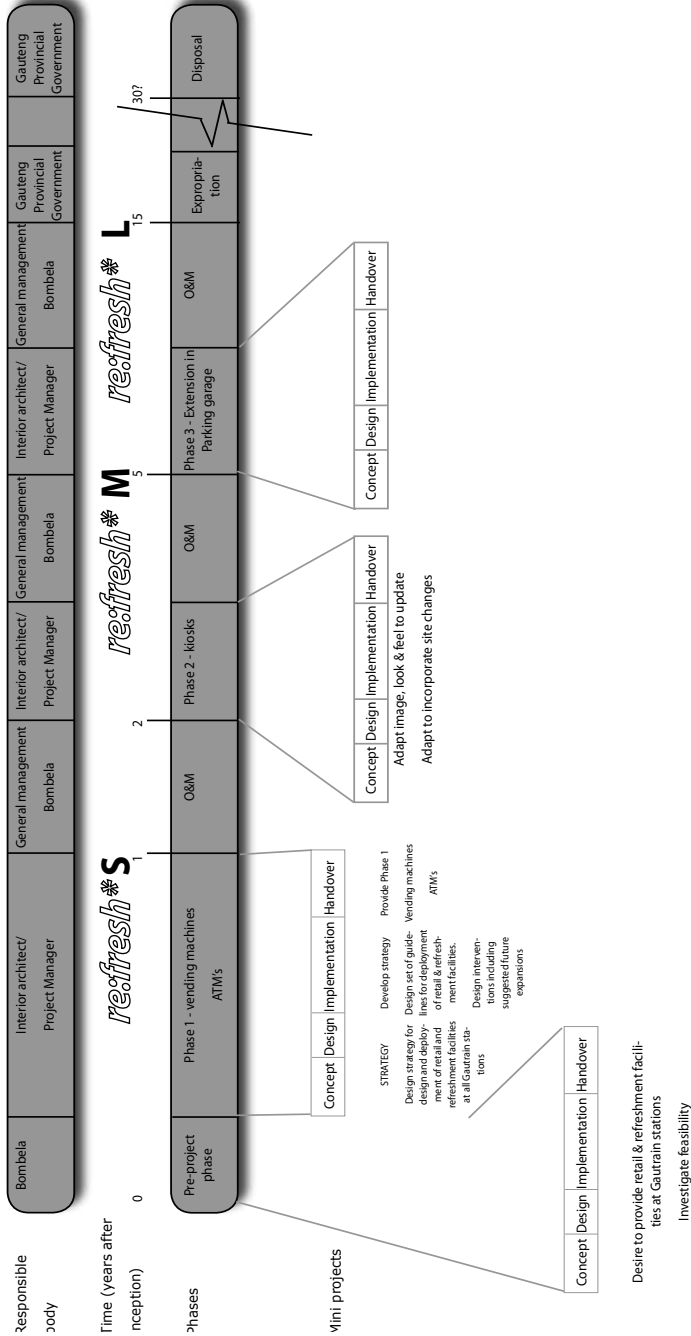
Also called *half-life refit*. At some point a major upgrade, refit or expansion would be required to help keep the facilities running efficiently and competitively. New technology, competition, market requirements and rules and regulations are all factors influencing this phase. *refresh\****M** and *refresh\****L** are examples of what is essentially an expansion of existing facilities in response to changing market conditions or market demand. Each of these phases will follow the project lifecycle pattern of concept and initiation, design and development, construction and commissioning as mini projects embedded in the overarching product lifecycle.

### 8. Decommission and disposal

The impact of the disposal of the products had been considered in terms of environmental concerns. The products would have to be able to be relatively easily dismantled and recycled, reused or safely disposed of.

## 5.2 Station specific strategies

The concept of **micromarketing** is of particular importance with regards to the types of facilities deployed at different stations. It is generally applied to large chain stores and franchises (like supermarkets) customising the merchandise to **suit the preferences of the neighbourhood**. Neighbourhood demographics are matched to product demand. Another factor influencing the merchandise makeup is **what is available in**



*Product Lifecycle*



**the area** surrounding the shop (Dunne & Lusch 2008:78).

This could be applied to the Gautrain stations, viewing the overall management of the retail and refreshment facilities in all the stations as the franchise, and the collective retailing at each station as the franchisee or “neighbourhood store”. Instead of tailoring the merchandise in a shop, the type of kiosks and shops deployed would be influenced. Therefore there may be certain types of functions more suitable to one station, that would be less successful at the next. This is not intended as a rigid system of rules, but merely as a guideline. If a kiosk or shop lessee feels they could run a successful shop at a certain station, they should be allowed to do so.







UNIVERSITEIT VAN PRETORIA  
UNIVERSITY OF PRETORIA  
YUNIBESITHI YA PRETORIA

6



# Chapter 6

## Concept

### 6.1 Overview

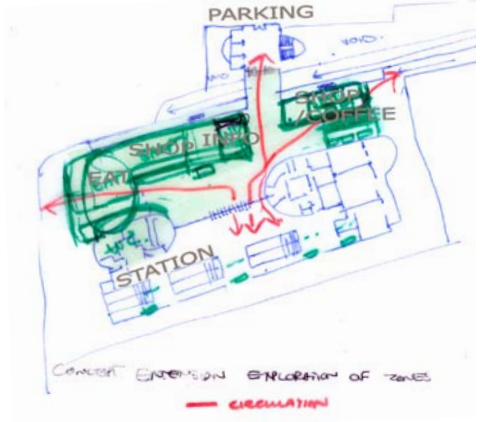
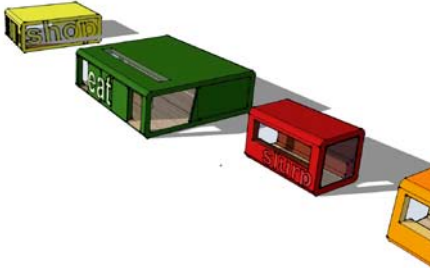
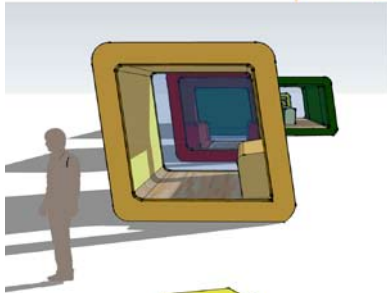
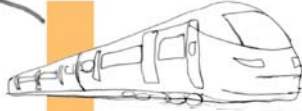
The current chapter is a summation of the three main concepts considered and explored in sequence. The aim is to clarify some of the design decisions made in the final design by illustrating the lessons learnt from each concept exploration. Each concept is briefly illustrated in terms of

Concept

Location & deployment

Most important qualities / criteria

Lessons learnt



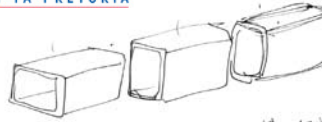
### CONCEPT

Train carriages

Curvilinear shape denotes speed and motion

### LOCATION & DEPLOYMENT

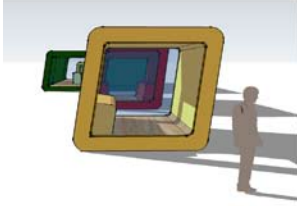
- \* Inside and outside stations
- \* Outside stations with high level roof covering to create artificial arcade
- \* Deployed at Gautrain stations and at other railway stations or retail platforms. New business opportunity for unit manufacturer



Units fitting together like train carriages.



Elements within help structure on ground security & shade

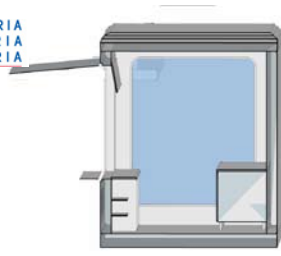
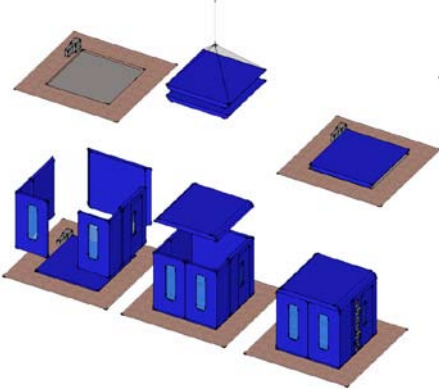


### IMPORTANT QUALITIES/ CRITERIA

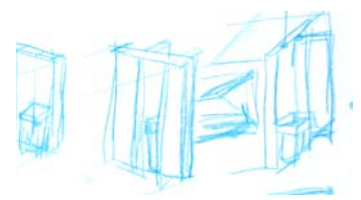
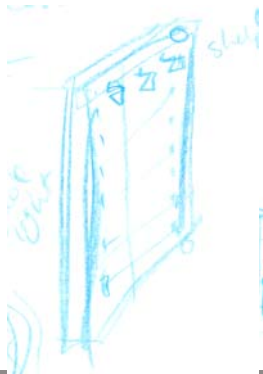
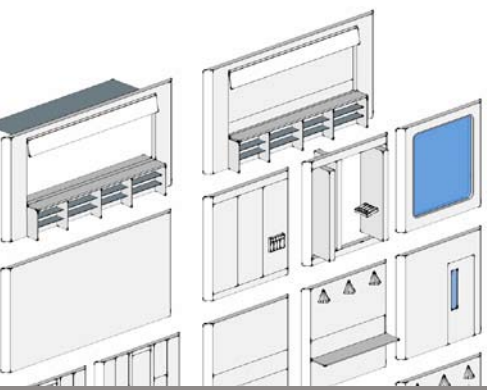
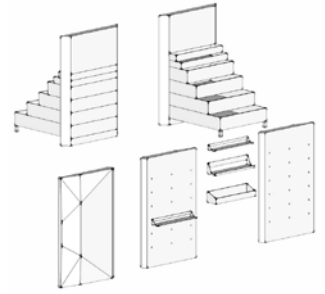
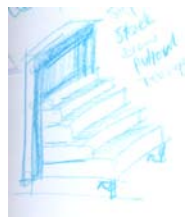
- \* Three types defined by different sizes
- \* Robustness
- \* Connectivity /Accretion

### LESSONS

- \* Curvilinear shape not as sustainable as a rectilinear shape (see 4.3.2)
- \* Shape not in feeling with local African context



Kit of parts  
Standardisation



**CONCEPT**

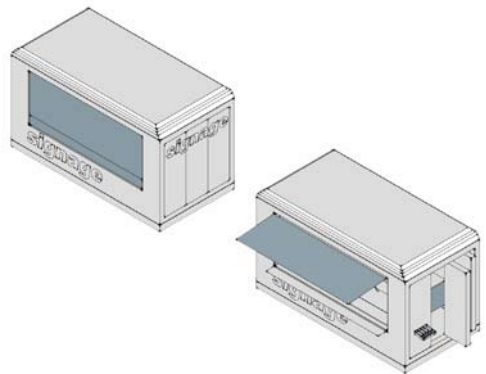
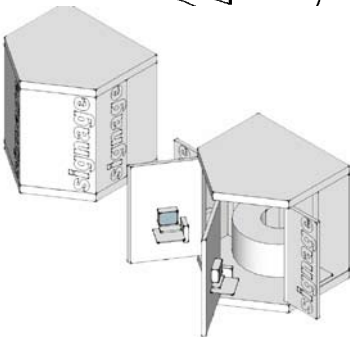
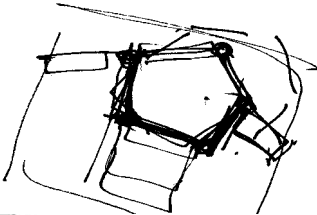
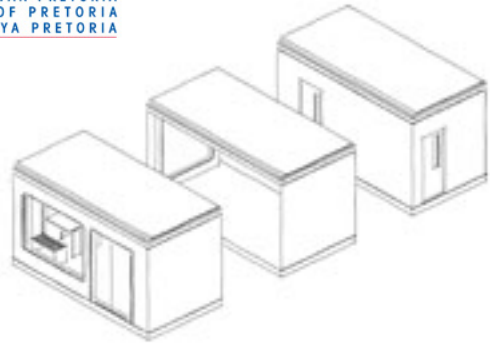
"Train cars" differentiated into five different types

5 types combined from a kit of parts:

1. Coffee - coffee bar, combined into small cafe bar
2. iSpace - computer / internet terminals in kiosk
3. Bloom - florist
4. Paper - Newsagent, convenience shop, snacks and drinks not prepared onsite
5. Pause - small waiting room / TV lounge/ chill space

**LOCATION & DEPLOYMENT**

- \* Inside and outside stations
- \* Deployed at Gautrain stations and at other railway stations or retail platforms. New business opportunity for unit manufacturer
- \* Mix of pods deployed at each station
- \* Tenants/ owners can extend pods in future by replacing and adding structural cartridges



differentiate functions by different shapes

### IMPORTANT QUALITIES/ CRITERIA

- \* Five types differentiated by different functions accommodated
- \* Standardisation
- \* Kit of parts - Unit assembled from selectively interchangeable structural wall, floor and ceiling cartridges
- \* Robustness & durability

### LESSONS

- \* Scheme is not identifiable as part of Gautrain system identity
- \* Scheme is too generic due to design for pod deployment at non-Gautrain stations as part of new local manufacturing business
- \* Too many different parts system becomes too complex and costly for 10 Gautrain stations
- \* Shape not in feeling with local African context



cross beams  
timber structure  
frameless glazing



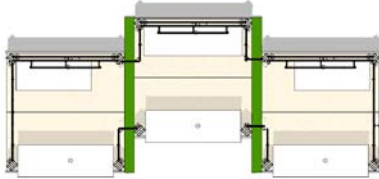
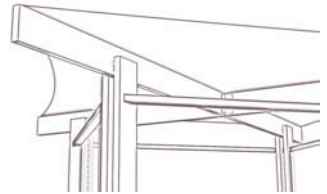
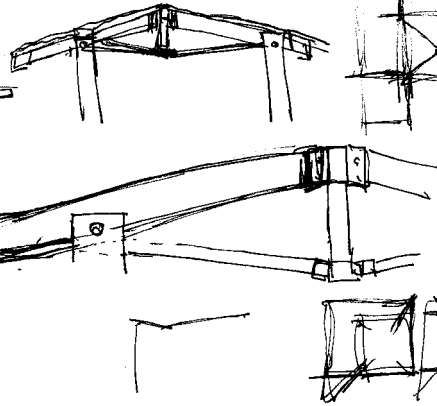
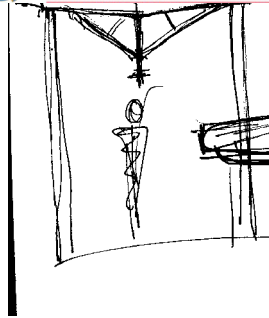
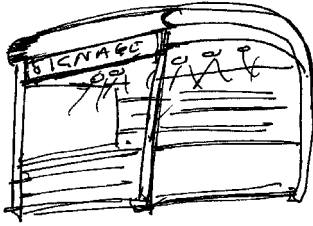
**CONCEPT**

Acacia tree  
... as a meeting place  
...place of trade  
Concept appropriated from GSI and reinterpreted

**LOCATION & DEPLOYMENT**

- \* Inside stations
- \* Deployed at Gautrain stations only
- \* One multifunctional unit
- \* 5-6 units at each location





**IMPORTANT QUALITIES/ CRITERIA**

- \* Impulse buy types of retail (SHOP)
- \* Lessees can extend units in future by adding more units, connected by a filler piece
- \* Kit of parts - Unit assembled from system of standard components
- \* Robustness & durability

**LESSONS**

- \* Kit of parts does not have to be large ready made wall, floor and ceiling components, should be system of smaller, separate elements and components
- \* Separate elements would be easier to get into station
- \* Tree concept links design with local natural context



The original two concepts had been fairly well developed before the decision was made to incorporate the acacia theme from the Gautrain system identity. The basic box shape from the first concepts was then developed in tandem with the new tree concept. The shape was also retained because of its robustness, ease of manufacturing, lowering costs and possibility for standardisation. The design development is contained in the next chapter.

## 6.2 Branding

A good brand should instantly sum up

- \* who you are
- \* what you do, and
- \* why it matters.

(Branding open lecture: 2009:[sp])

The concept of the *re:fresh\** brand is illustrated in the mood board at right. These images are not to be confused with the types of foodstuffs and products to be sold at the station. Rather, they depict the idea behind the concept of *re:fresh\**, being that of mental and bodily refreshment. The images evoke the emotional response to the intervention on a human interaction and experiential scale.

The colour green is extensively used, conjuring images of freshness, new life, nature and the fresh smell of a new-mown lawn.

The other citrus colours connote similar images of freshness and cleanliness, the smell of fresh citrus and bright, sunny, welcoming colours.

The water is included as a reminder of bodily refreshment and sustenance, being necessary for the human physiological processes.

Coffee is included as reminder of both physical and indirectly mental stimulation.

The bright splash of raspberry colour introduces a strong contrast with the yellow and green colours. Contrast is a time-honoured way to heighten user / viewer arousal and mental stimulation, aiding in the user's engagement with a design.



UNIVERSITEIT VAN PRETORIA  
UNIVERSITY OF PRETORIA  
YUNIBESITHI YA PRETORIA



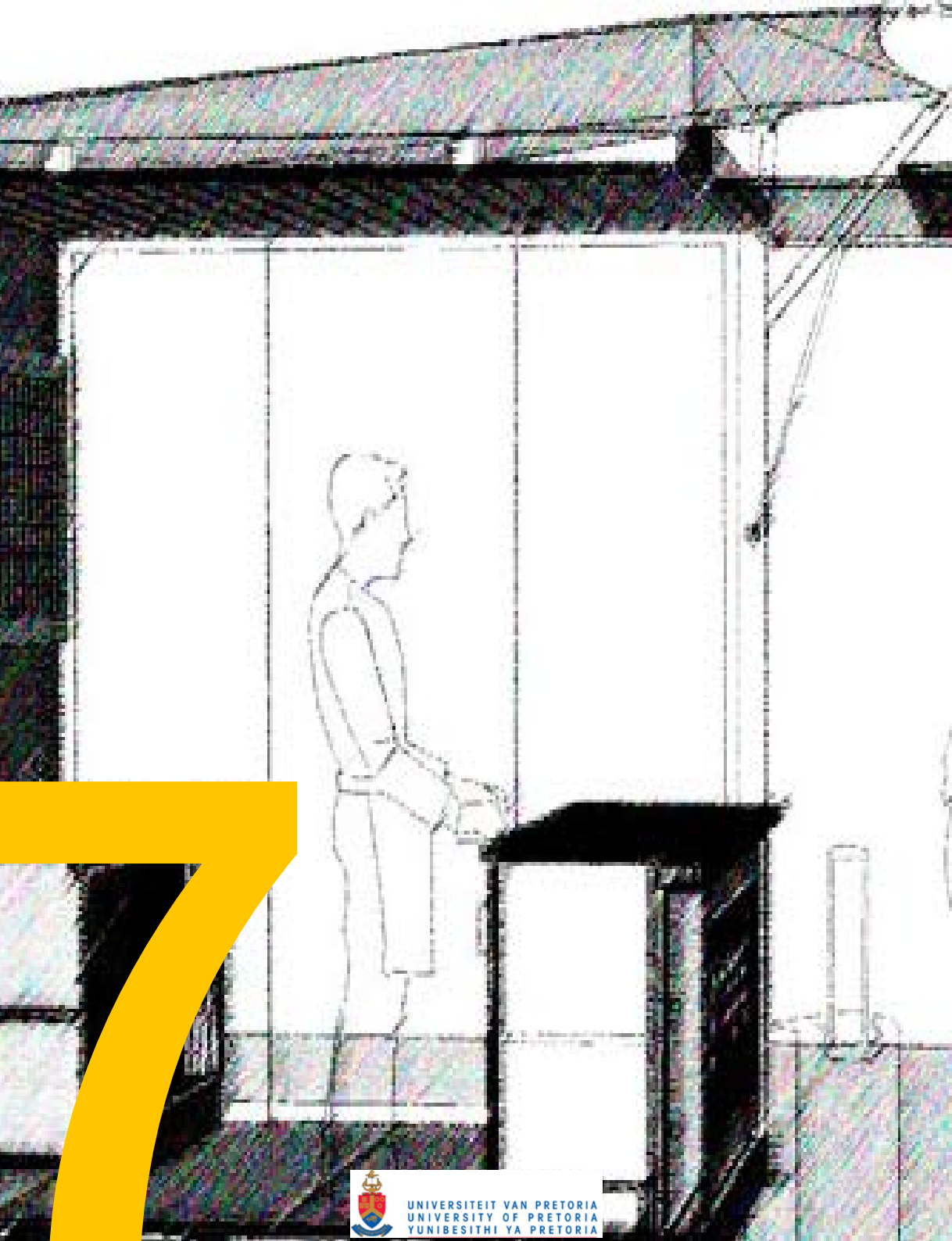
pause pause pause pause



pause pause pause pause



teateateateate



UNIVERSITEIT VAN PRETORIA  
UNIVERSITY OF PRETORIA  
YUNIBESITHI YA PRETORIA

# Chapter 7

## *Design development*

### 7.1 Precedent studies

As part of the design development various kiosk and small buildings, bus stops etc. had been critiqued. The evaluation was undergone on the basis of pro's and con's of aesthetic, function, philosophy, practicality, security, suitability to environment and approach to space, as and if it applies to each precedent. Not all of the precedents yielded useful responses in each of the categories. The most salient critiques and observations are represented in the next few pages.



# Precedents // kiosks & small buildings



## Description

### Temporary Buckingham Palace ticket kiosk, London

**Michael Hopkins & Partners, 1994**

Kiosk for tickets to Buckingham Palace in August and September.

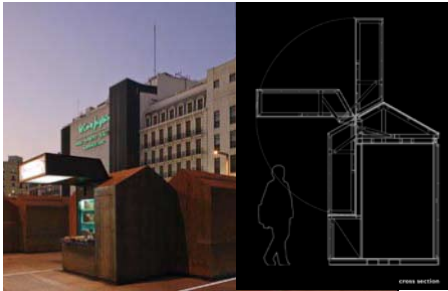
Demountable, storable structure that could be used for 5 years.

Prefabricated timber cabin in two parts on wheels with timber deck on adjustable feet.

Tensile fabric canopy supported by timber beams bolted together and attached to cabin with steel plates.

Vertical tensile cables tied to concrete blocks in the ground.

[Hardingham 2002:76]



### Kiosk M. Poli, Madrid,

**Brut Deluxe, 2006**

Based on the Monopoly board game house tokens.

For temporary street markets.

Creates a temporary mini streetscape.

When closed the kiosk has an archetypal house shape. This perception is heightened when the kiosk is opened fully, forming an oversized chimney.

The opening section can be backlit for advertisement, lighting or just attracting attention.

[Architectural Review 2008:sp]



### Paperhouse newspaper kiosk, Kensington & Chelsea, London,

**Heatherwick Studios, 2009**

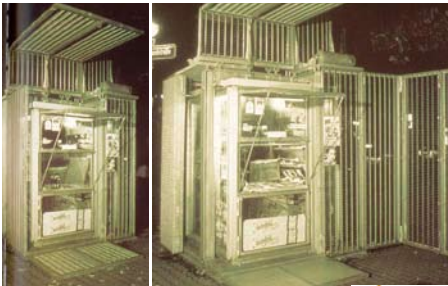
No flat surfaces inviting graffiti.

Allows vendors easier opening and setting up.

Kiosks open by rotating front panels which also allow for more ergonomic magazine display areas.

Steel frame clad with wood internally and patinated brass externally. An upper band of toughened glazing allows natural lighting during the day and shines out from it at night.

[Etherington 2009: sp]



### Newspaper kiosk, Frankfurt, Germany,

**Jörg Joppien**

Glass cube covered with movable steel panels for security while maintaining pleasing aesthetic.

Temporary structure.

Panels fold away to minimise intrusion on transparency of structure.

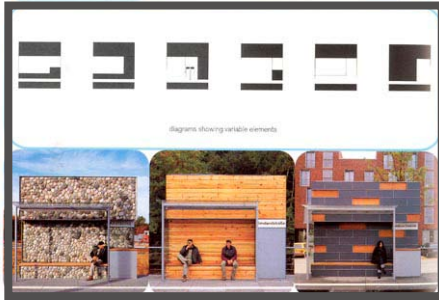
L-shaped, roof-anchored grid swings up to give the kiosk a distinctive profile.

Cantilevered overhang provides protection for customers and outside display racks.

+	-	<i>re:refresh</i> <sup>®</sup> application
<p><b>Tectonic</b> expression contrasting with stereotomic box.</p> <p>An area of <b>intermediate space</b> is created between the ticket windows and the public space by the wooden deck and overhanging tensile fabric roof.</p>		<p>Structural concept for structural frame, translated into steel to enable the use of slimmer components.</p> <p>Provide transition zone between public and kiosk interface.</p>
<p><b>Witty</b> play on Monopoly board game houses .</p> <p>Use of <b>archetypal</b> house shape creates interest to perceiver.</p> <p>Flip up cantilever canopy creates <b>intimate</b> space in front of kiosk, also doubles as lighting and backlighting for advertising.</p> <p>Units <b>secure</b> when closed.</p>	<p>Translation from concept a bit too direct.</p>	<p>Use of hinged flip-up canopy for security and advertisement / aesthetic at night.</p>
<p>Unit <b>secure</b> when closed.</p> <p>Kiosk doubles as public <b>art</b>.</p> <p>Sliding doors form shelves on inside, reduces amount of stock packed out every day.</p> <p>Band of toughened glass allows natural <b>daylighting</b>.</p>	<p>Form is somewhat arbitrary.</p> <p>Inviolable whole means difficult disassembly at end of product life.</p> <p>Difficult to customise, make your own.</p>	<p>Limit amount of stock to be unpacked each day.</p>
<p>Unit <b>secure</b> in outside location.</p> <p>Unit unfolds to form <b>canopy</b> and <b>threshold</b> to differentiate front of kiosk from public space.</p> <p>Glazed sides allow 24h <b>display</b> of goods.</p> <p>Hinged side panels allow different spatial <b>configurations</b> for effect or display.</p>	<p>Closed kiosk looks unfriendly.</p>	<p>Provide "threshold" between public and kiosk interface.</p>



# Precedents // kiosks & small buildings



## Description

### Tram stations, Hanover, Germany,

#### Despang Architekten, 2000

Thirteen tram platforms were designed for a new urban light railway, to coincide with Expo 2000.

Kit of parts consisting of rectangular blocks.

Block elements variable, different combinations of same elements were made possible.

Cladding could be tailored to respond to different contexts of the tram stops, e.g. use of brick facing in neighbourhood with predominantly brick houses, other materials used were glass, concrete, larch strips, pre-patinated copper and stainless steel mesh.

[Richardson 2001:114-117]



### Design cafe verandah, Hatfield, Pretoria

#### +27 Architects

Outdoor covered verandah as part of design shop and cafe.

Steel frame structure clad with fibre cement panels.

Floor finish is painted OSB, cost effective, durable, moisture resistant.

Transient structure which looks permanent (development owner wanted verandah to be temporary, easy to dismantle).

[author 2009]



### Bus shelter, Innovation Hub, Pretoria, 2009

Bus shelter outside Innovation Hub entrance gates.

Planar structure gets delicate treatment with finely corrugated steel cladding and patterned, punched steel bench.



### Fuel juice bar, Birmingham, UK

#### Comet Catering Equipment Company Ltd, 2006

Located in busy shopping centre.

Island type layout.

Safety glazing around sides prevent unauthorised access during day-time use and ensure hygiene (no sneezing on fresh produce).

[Comet Catering 2006:(sp)]



+	-	<i>re:refresh</i> * application
<p>Unified system with interchangeable components and makes each station unique.</p> <p>Materials anchor stations in local contexts and make each unique.</p>		<p>Provide elements or components (cladding / signage) unique to each station in aid of legibility.</p>
<p>Balance between stereotomic and tectonic expression.</p>		<p>Floor construction.</p>
<p>Delicacy of cladding finish and pattern.</p>		<p>Subtle pattern can soften large expanses of the same material.</p>
<p>Location ensures wider exposure to possible clients.</p> <p>Open to all sides makes display of goods and theatre of juice preparation.</p>	<p>Openness necessitates excessive packing up and night- time storage.</p> <p>Security weak, high likelihood of vandalism, possibly ameliorated by shopping mall security.</p>	<p>Front and sides being open draws attention, affords of a view of what's happening inside, while still remaining secure.</p> <p>Preparation and serving becomes theatre.</p>



# Precedents // kiosks & small buildings



## Description

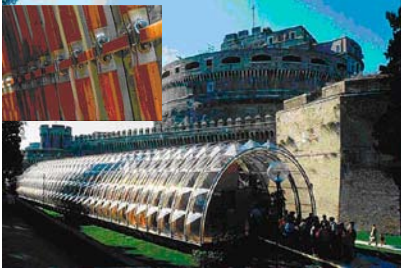
**West Cornwall Pasty kiosk, Gatwick Airport, London**

**Comet Catering Equipment Company Ltd, 2006**

Kiosk for pie makers franchise.

Located at busy airport close to entrance to train platforms.

[Comet Catering 2006:sp]



**IBM travelling exhibition,**

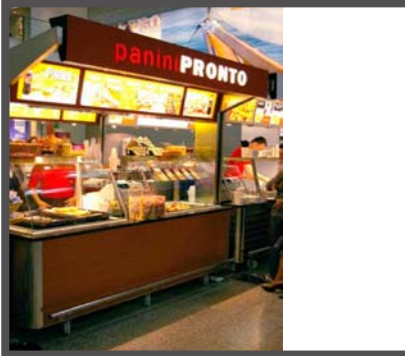
**Renzo Piano, 1986**

Temporary exhibition building for IBM on the future of information technology.

48m length, 12m width, 6 m height.

Constructed from 34 arches each consisting of 6 pyramidal polycarbonate elements in laminated wood and cast aluminium.

Each arch consists of two arches joined to floor/ platform and at the top.



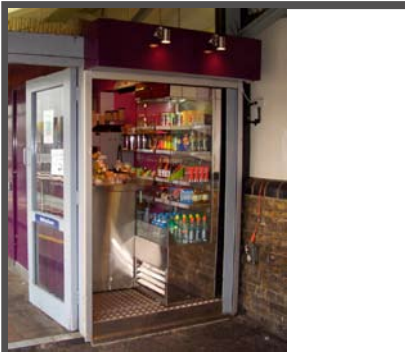
**Panini Pronto kiosk, Excel, London**

**Comet Catering Equipment Company Ltd, 2005**

Snacks and hot and cold drinks.

Paninis & hot snacks, require grill and microwave at least.

[Comet Catering 2006:sp]



**Espress Organics kiosk, Seven Sisters station, London**

**Comet Catering Equipment Company Ltd, 2005**

Small, built-in kiosk next to enclosed waiting room on train platform.

[Comet Catering 2006:sp]

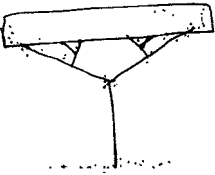
+	-	<i>re:refresh*</i> application
<p>Attractive yet secure kiosk.</p> <p>Durable materials employed.</p> <p>Whole kiosk becomes display area.</p> <p>Traditional values expressed.</p>	<p>High counter with small overhang excludes disabled users.</p> <p>Stereotomic expression seems clumsy.</p> <p>Rounded corner glazing means more expensive repairs.</p>	<p>Glazing on the sides of the kiosks would allow views to the inside.</p> <p>Draws customer attention.</p> <p>Serving as theatre.</p>
<p>Demountable components allow for easy disassembly and flat packing for transport.</p> <p>Use of durable metal joints with wood struts ensure ease of demountability and preserves appearance.</p>		<p>Use small components with durable / robust joints make the structure easily demountable in future, yet structurally sound.</p>
<p>Menu display backlit for attracting attention and visibility.</p>	<p>Open nature of this kiosk requires a secure environment or security.</p> <p>Kiosk is not securable.</p>	<p>Allow for backlighting of menu displays at front of kiosk and back wall (provide power and wiring or provide for potential of future wiring, e.g. PVC conduit and extra MCB's on distribution boards).</p> <p>Point of sale (POS) at front (customer interface, preparation at back (for the sake of appearance, hygiene and safety).</p>
<p>Optimal size for server and one patron at a time.</p> <p>Optimal size for quick service.</p> <p>Lower rent than unit which allows many clients at one.</p>	<p>Kiosk looks squeezed in.</p> <p>Difficulty with deliveries due to narrow entrance.</p> <p>Difficulty at rush hour due to narrow entrance.</p>	<p>Utilise space optimally (small spaces can work).</p>



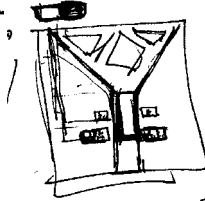
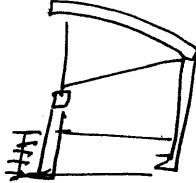
## 7.2 Conceptual expression

The **Acacia tree** as **meeting and trading place** and marker of route intersections is central to the Gautrain design philosophy. This theme was picked to form the main concept of the *re:refresh\** kiosks and to **conceptually link** the *re:refresh\** kiosks with the overarching Gautrain design and philosophy and **anchor** it in the Gautrain context.

### *"Treeness"*



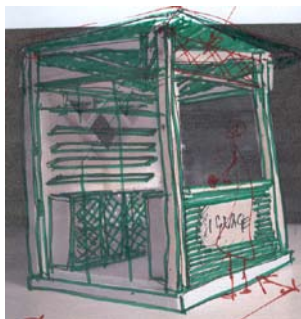
...tree shape embodied in three dimensional space...

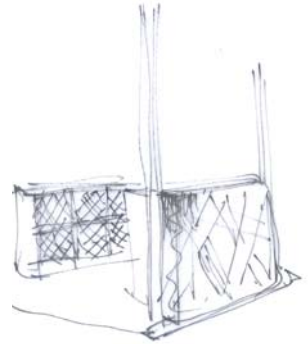


...a forest of trees swaying in the wind...



Exploration of tree concept overlaid over original box shaped concepts (which is important to meet the standardisation theory)

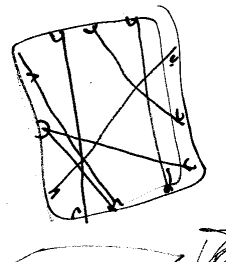




Use of natural colours and textures

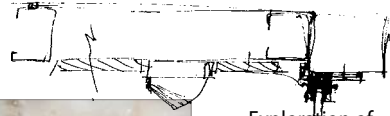


Application of the random criss-cross pattern to the back counter doors and lightbox

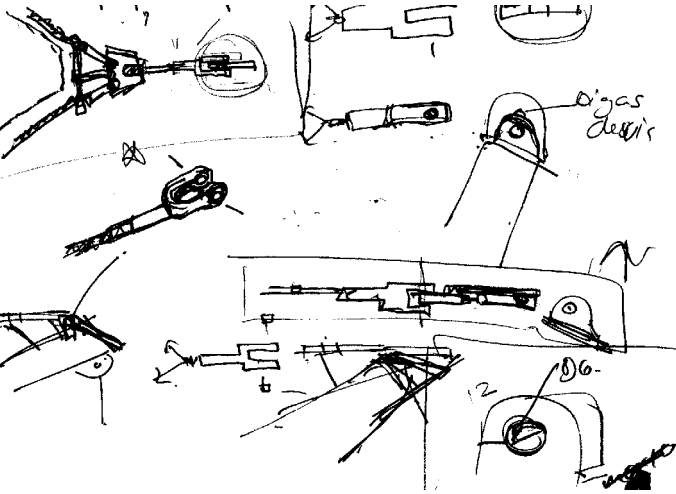


## Tectonics & joint consideration

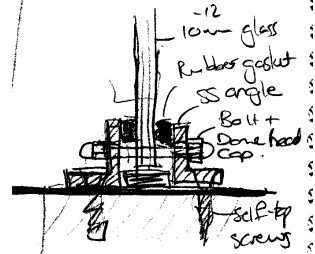
Use of Surinno solid surface, which resembles OSB texture. The fixing of the solid surface is similar to how a panel of OSB would be fixed, linking back to Semper's *Stoffwechseltheorie*. The play on the similarities between the two materials adjacent to each other also supports this theory.



Exploration of ceiling & lighting detail



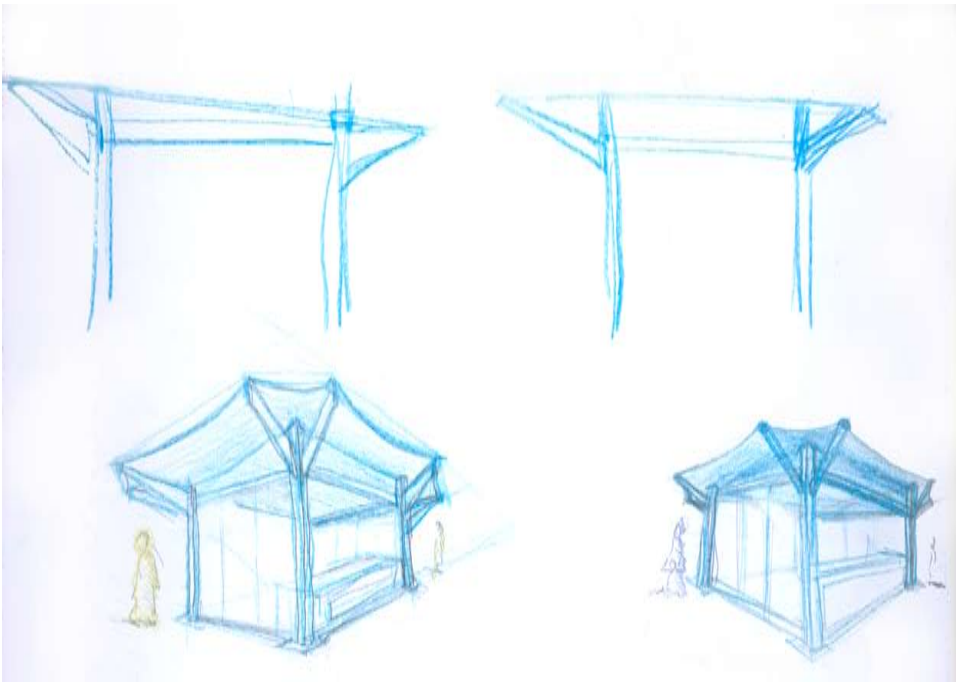
Exploration of tensile fabric roof rigging details



Exploration of glazing detail

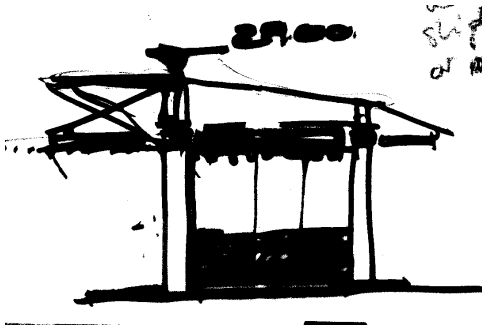


Rectangular steel structural frame with bolt-on corner posts for tensile fabric fixing

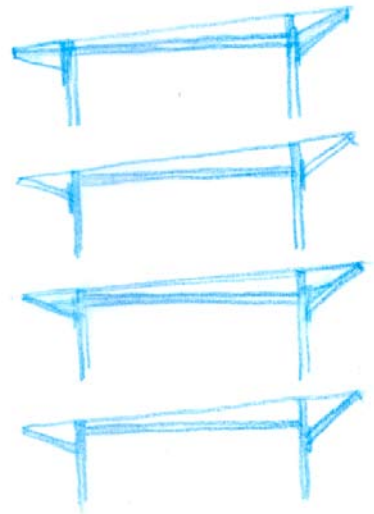


flat steel corner posts

vs  
circular section  
corner posts



Exploration of roof shape



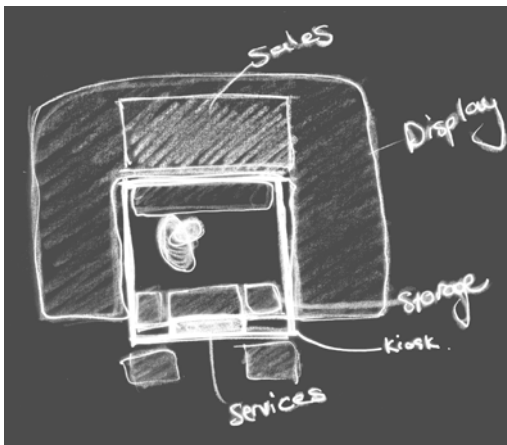
## 7.3 Factors to consider

### 7.3.1 Different functions

Based on the most common types of trade as investigated in Chapter 3 the types of functions *refresh\** could be adapted to include the following:

EAT: coffee, snacks (prepared off site)

SHOP: convenience, newsagents (papers, magazines), gifts, accessories. The various requirements and what is provided in the kiosk design is tabulated at right.



activity zones



	Requires	Provide
<b>EAT</b> Coffee	Counter space for coffee machine Under counter fridge Microwave oven Water supply Drainage Under counter water heater Wash up facilities / sink, dishwasher Storage	Counter top at front and back Adjust back counter length Counter top at back Supply to central point by Bombela Supply to central point by Bombela Back cupboard, conceal Back cupboard top, adjust cupboard length Cupboard at front and back, on-site / off-site
Snacks	Counter space for coffee machine and grill Under counter fridge Microwave oven Water supply Drainage Under counter water heater Wash up facilities / sink, dishwasher Storage	Counter top at front and back Adjust back counter length Counter top at back Supply to central point by Bombela Supply to central point by Bombela Back cupboard, conceal Back cupboard top, adjust cupboard length Cupboard at front and back, on-site / off-site
<b>SHOP</b> Convenience	Display bulk items Display small / specialty items Advertising Point of sale space Storage	Back cupboard, gridwall display Gridwall panels Wire & acrylic window display Front counter Cupboard at front and back, on-site / off-site
Newsagents	Display bulk items Display small / specialty items Advertising Point of sale space Storage	Back cupboard, gridwall display Gridwall panels, wire & acrylic window display Wire & acrylic window display Front counter Cupboard at front and back
Gifts	Display bulk items Display small / specialty items Advertising Point of sale space Storage	Back cupboard, gridwall display Gridwall panels, wire & acrylic window display Wire & acrylic window display Front counter Cupboard at front and back
Accessories / gifts / souvenirs	Display bulk items Display small / specialty items Advertising Point of sale space Storage	Back cupboard, gridwall display Gridwall panels, wire & acrylic window display Wire & acrylic window display Front counter Cupboard at front and back

## Section /perspective from right side

The cantilevered canopy separates public space from the more intimate "meeting place" in front of the kiosk





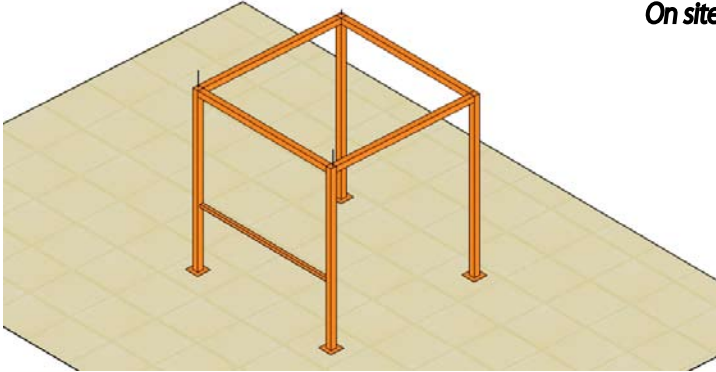
The modular nature of the components means the glazed door could be switched to the other side for access from the right



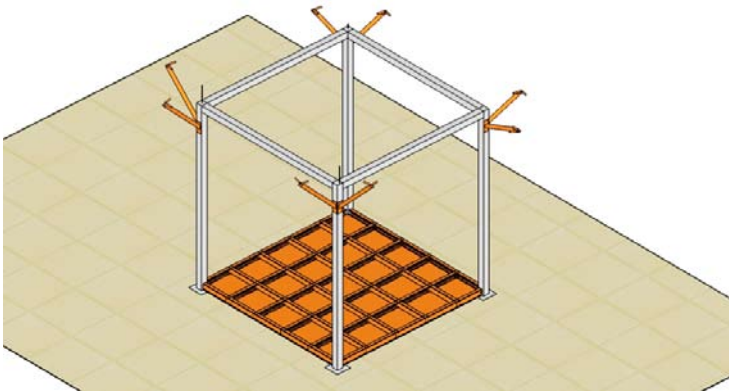
57. Various views of the basic kiosk unit



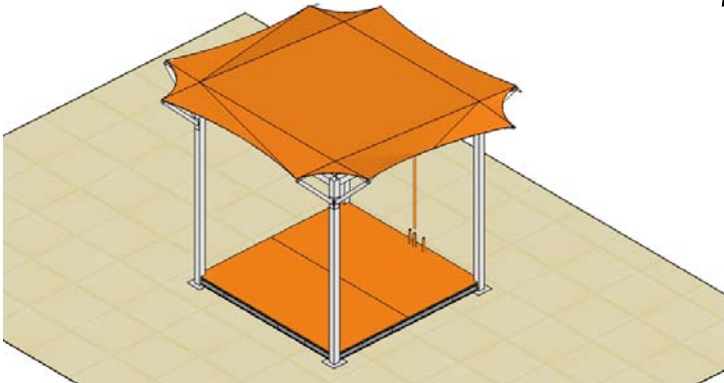
*On site assembly sequence*



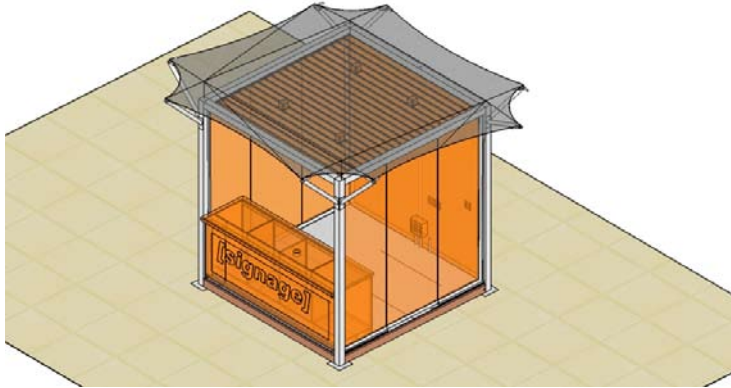
**Structural steel frame**



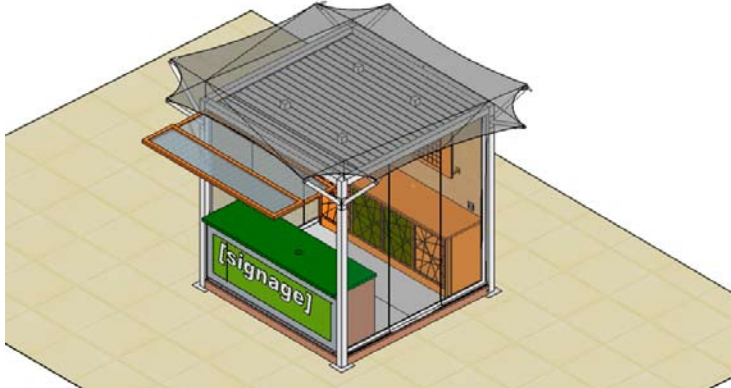
**Steel floor grid and detachable masts for tensile roof**



**OSB floor finish and tensile roof, services, PVC conduits**



**Infill**  
**wall cladding, glazing, front counter**



**Cantilever canopy, back counter,**  
**display panel**

56. Figure sequence outlining the assembly of a single re:fresh kiosk on site

# Model exploration



View from front left side      Steel column & masts

View from back right side



Underside of canopy and ceiling



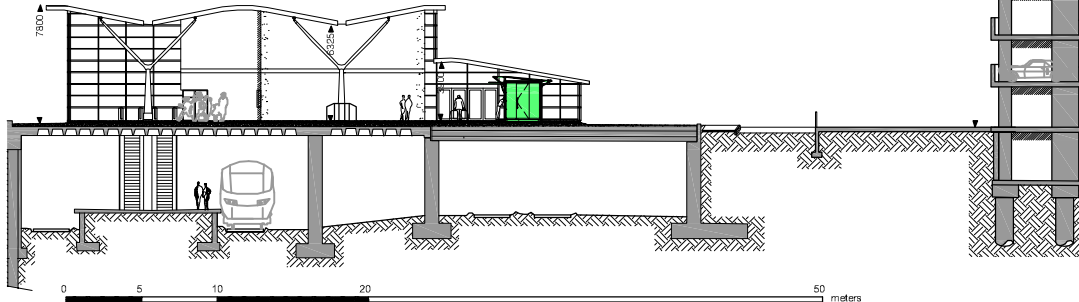
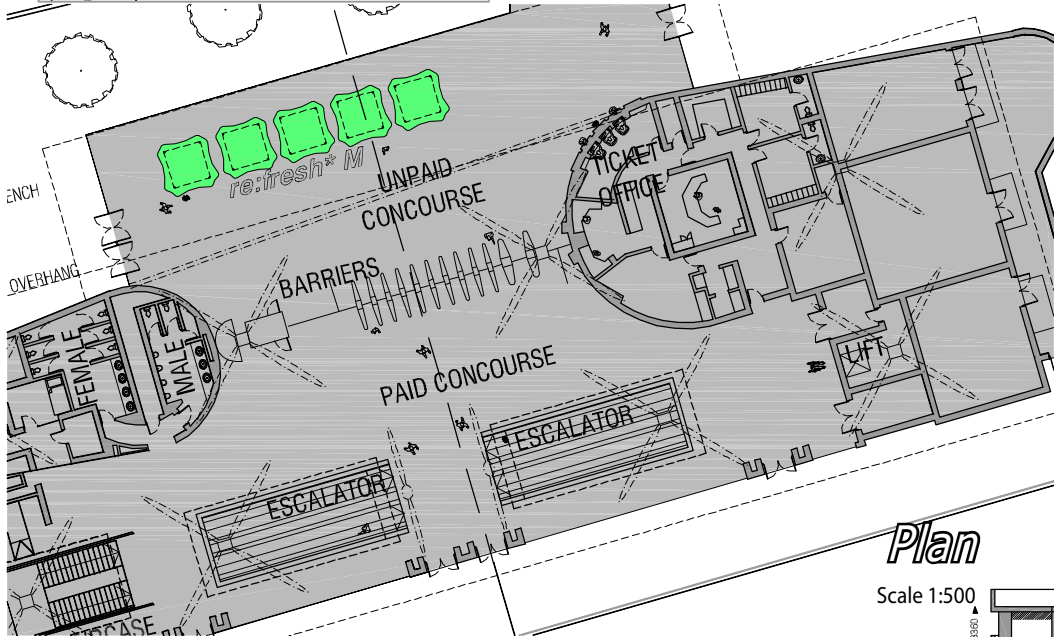
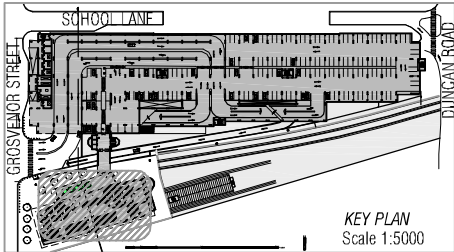


Interior view showing back wall, display unit and ceiling  
View through glazing to back wall & storage/ display counter



# Kiosk location in Hatfield station

The kiosk is located in the public, unpaid concourse of the station





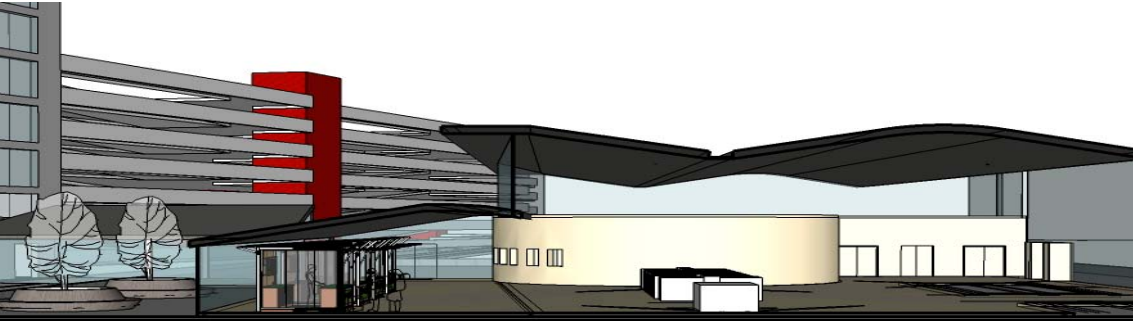
*Hatfield station lobby (unpaid concourse)*



*Location at Hatfield station*



*Hatfield station from the west (Grosvenor St.)*



*Section showing kiosks in entrance lobby*



*Section through station*



*The kiosks inside the Hatfield station located in the public, unpaid concourse provides an intermediate space between open public space, and station public space*





## Newspaper kiosk

### Section /perspective from left side

A3 clear perspex pockets on tensioned suspended wire rope display

Additional display stands

Back cupboard doors with wire as goods display

Section view of back wall





## Take-away coffee kiosk

### Section /perspective from left side

Fit out with tenant supplied catering equipment

Warm counter top display

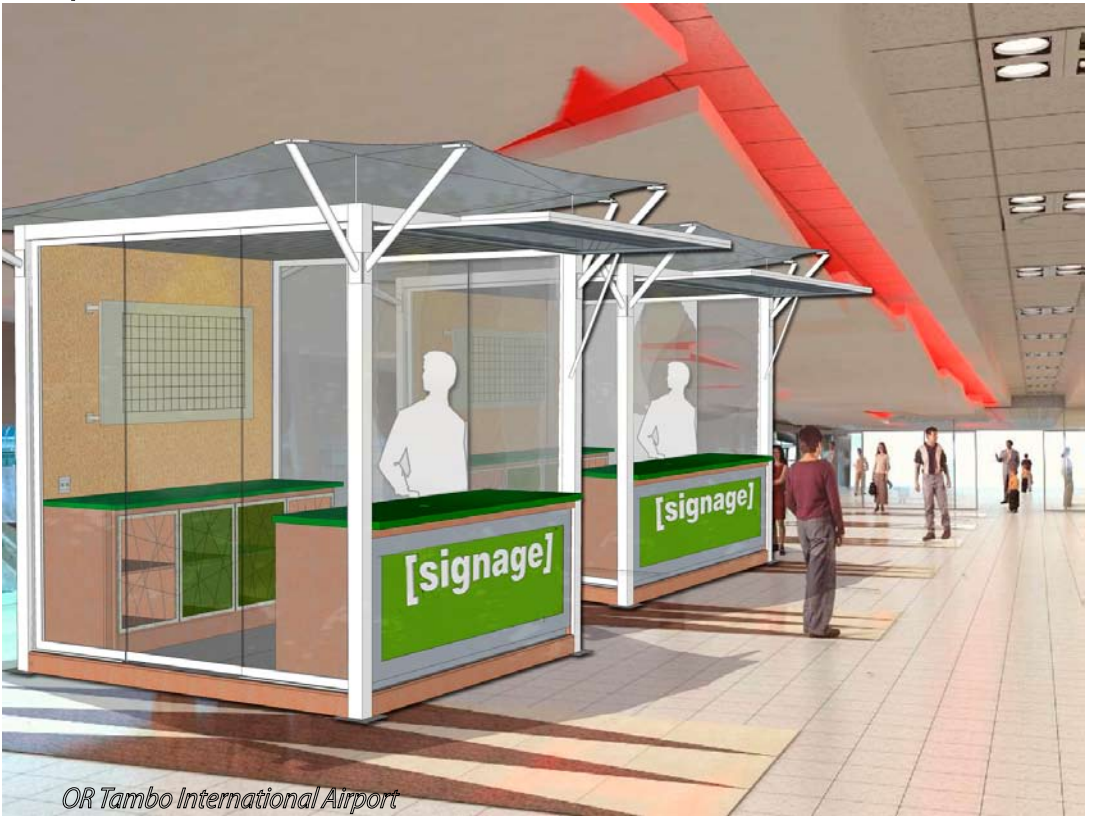
Water and drainage provided

Menu sign suspended from steel beams above ceiling

Section view of back wall



# Impression of kiosks at GRRL stations



*OR Tambo International Airport*



*Centurion station*



### 7.3.2 Services

Due to the variety in GRRL sites, it is only possible to suggest a strategy in terms of services, as follows:

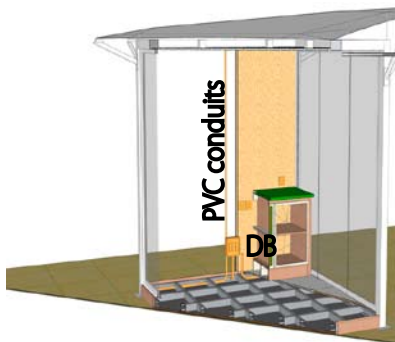
- \* Locate kiosks over void & perforate slab to access services zone underneath
- \* Alternatively locate kiosk close to existing service connections
- \* Service connections to be provided for by Bombela
- \* Access services above suspended ceiling from underneath (dropdown into kiosk wall)

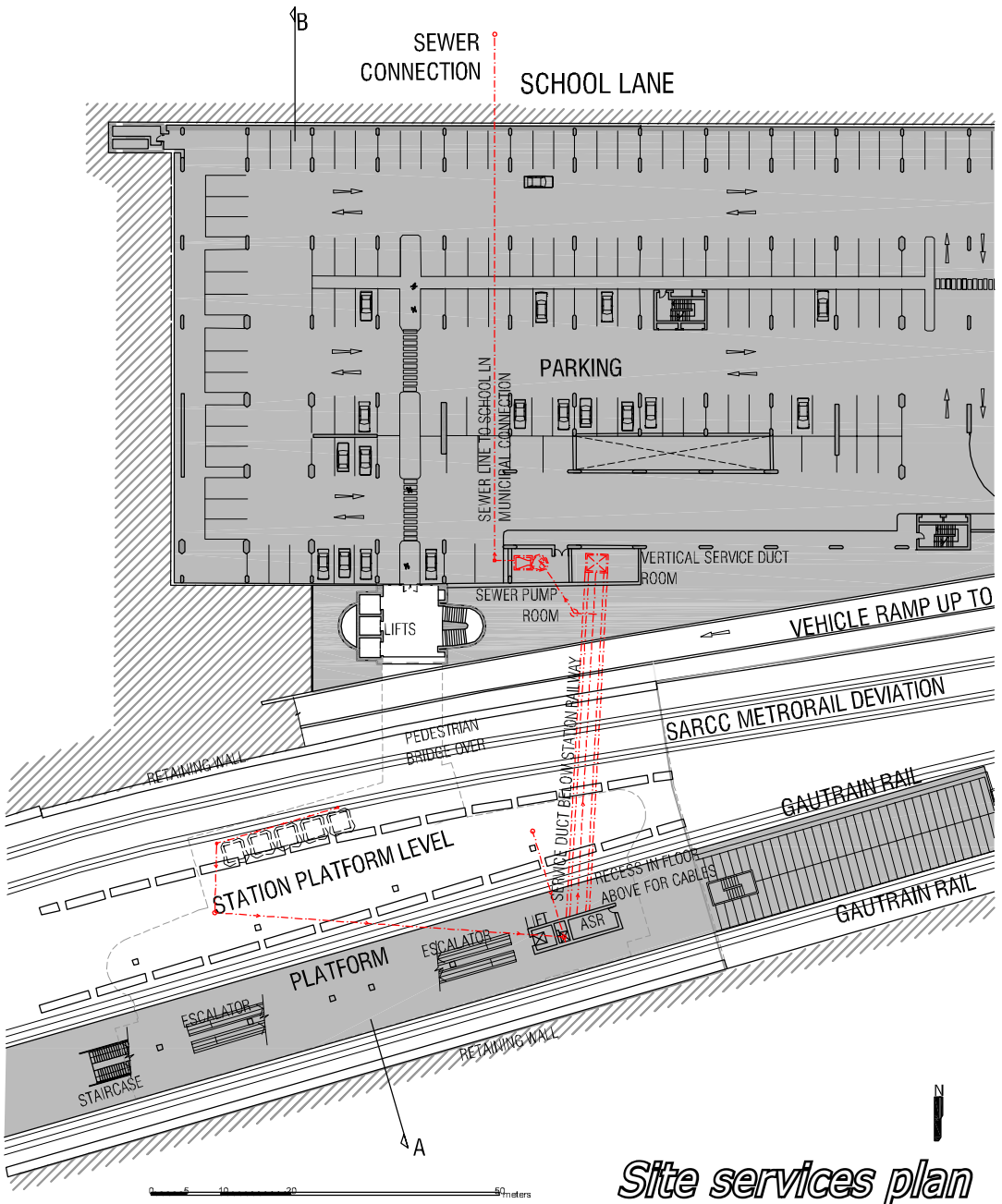
Power, water and drainage are to be provided from the nearest connection point and would have to be provided by Bombela. This might necessitate some excavation and consequent damage to existing station floor finishes. Where walls are damaged they should be repaired and made good. The finish would probably never be satisfactorily matched to existing terrazzo. Therefore, floor damage where shallow trenches are dug would be repaired with stainless steel access tread plates to ensure access for maintenance.

Overhead **cable trays** could also be employed to supply power from above the unit. Each unit is provided with four power supply PVC conduits so mains power could be supplied from sides, back, or top. The side conduits also allow for future connection to B unit extensions.

The same goes for water supply and drainage.

It is suggested that Bombela provide a suitable length of cable or pipe to the optimum location for kiosks into which the individual tenants could, if necessary arrange connections, done with the approval of Bombela by approved contractors. Another system, that could be employed with reference to drainage is a manifold system. This is utilised in pod construction projects where bathrooms or kitchens are manufactured off site and craned into position on site with fully finished interiors. The pods are then connected to power, water, drainage and HVAC systems from connections blocks on the exterior of the pod, which later becomes part of a service duct usually accessed off of a corridor (in the case of hotels or group accommodation for example).





# Site services plan

Basement & platform level

Scale 1:200

### 7.3.3 Communications

It is proposed that voice and data connections be handled **wirelessly**. With a VOIP (voice over internet protocol) phone system the connection would be handled by wireless internet connection. VOIP phone handsets use an internet connection instead of regular data cables for users to make calls. This system would be administrated by Bombela per station.

Tenants would need to subscribe to the system in order to connect to the secure wireless account. The same internet connection would serve the pdx (credit card) machines for card transactions.

The basic strategy could be summed up as follows:

- \* Provide WiFi (wireless internet connection) for voice and data.
- \* Provide VOIP phones (voice over internet protocol).
- \* WiFi would also be available stationwide for e-mail and internet access to commuters

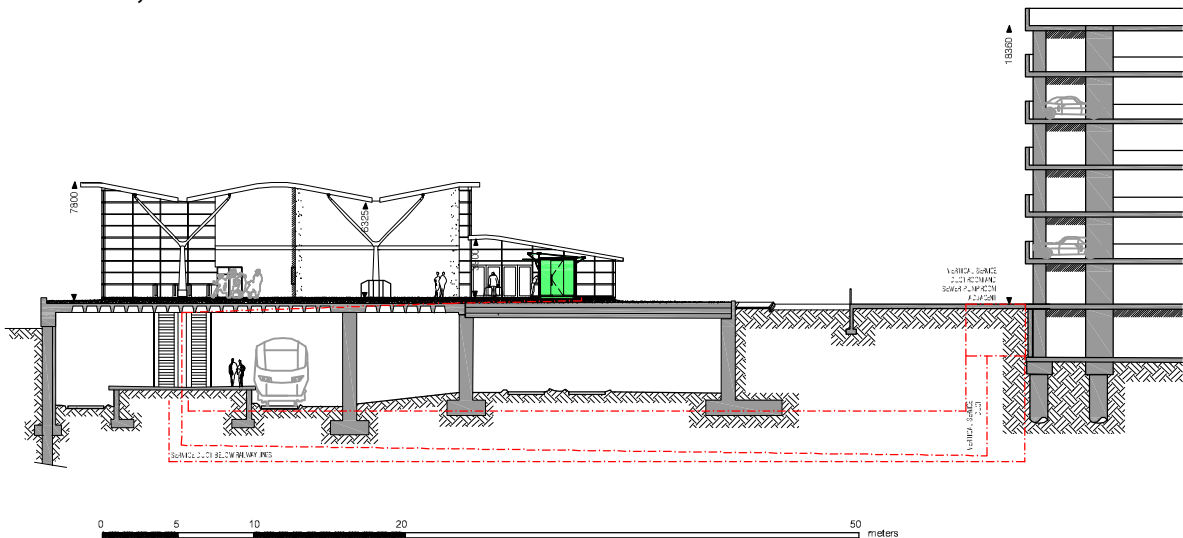
### 7.4 Security

The unit sides are **laminated safety glazing**, guarding against accidental impact, but also acts of petty vandalism.

For temporary day and night-time security the front of the unit is easily lockable by means of a hinged gas lifted screen / **canopy**. The cantilevered canopy also extends the space associated with the kiosk, distinguishing it from the surrounding public space and creating a more **intimate** trading platform.

### 7.5 Storage

Storage occurs in the front and back **cupboards** inside the unit. Large volume storage occurs off-site or in hired storage space in the station proper. Due to Bombela's provision that no cooking activities occur inside the station buildings, food and snacks vendors would have to produce food off site and have it delivered to site daily or every few days.

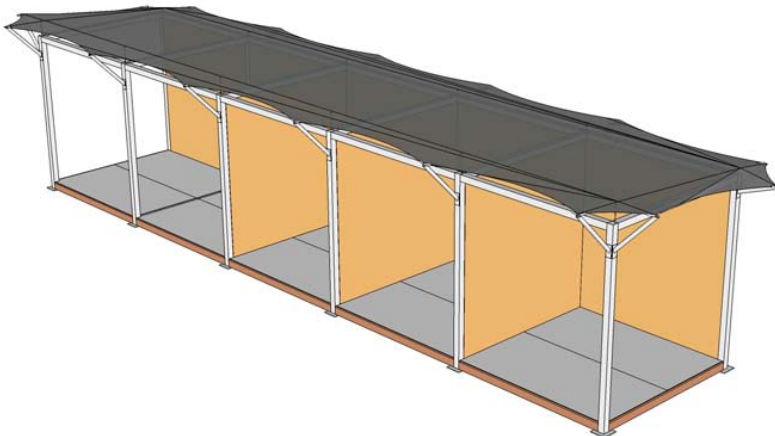


*Services section A-A*

Scale 1:200



Perspective



Isometric projection showing layout possibilities of pavilion

## 7.6 Potential future configuration

Due to the adaptability of the kiosk, there is an option to create a pavilion version, combining kiosks into a row. This is meant only as a suggestion, and has not been fully technically resolved.

A pavilion would offer two important benefits:

- \* Easier and more cost effective services reticulation
- \* Stronger sense of place due to concentration of kiosks.

In order to attach kiosks next to each other with just one steel column in between, one corner mast would need to be unbolted and the redundant glazing on each unit replaced with an OSB partition wall. The tensile roof would need to be replaced with a larger roof covering the entire row.

This option enables more tenant choice as two or more units could be combined under one tenancy to create a small bar or cafe. This would be a further increment towards the implementation of *re:fresh\* L*, according to the *re:fresh\** deployment strategy in Chapter 5

Because of the design of the kiosks to be adaptable, the infill components (walls, doors), would be regarded as a kit of parts, with new ones needing to be designed to fit the new layout. In particular this applies to the central units, where an infill unit with an adapted counter and front access door would be manufactured.

With the reorganisation and adaptation, any changes in the service counters would be accommodated due to the modularity of the units.



## 7.7 Materials and jointing

Material selection and jointing was based on the medium (tectonic) and micro level design guidelines mentioned in Chapter 4:

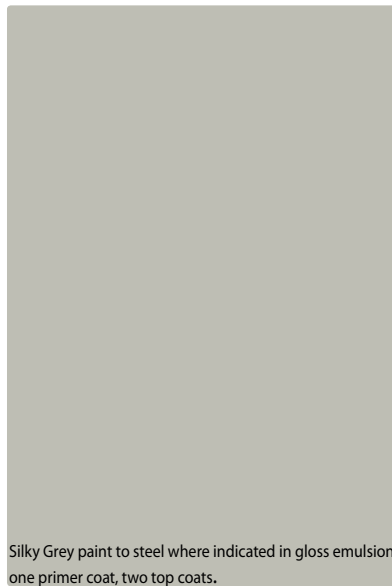
Joints and materials need to be **robust** enough to be easily repaired or altered, The **cost** of materials and manufacture need to be low enough to make the investment feasible to Bombela as lessees as well as for the tenants. A high manufacture cost would imply high **rental fees**. The higher the cost, the higher the turnover generated would need to be. For small kiosks moving relatively small amounts of stock, the rental would need to be fairly low. For example, kiosks in Menlyn Park shopping Centre amount to approximately R12,000 per month. The tenants would have had to weigh the rental fee against the forecast likelihood of and amount of custom they could expect.

The visual and tactile aesthetic needs to reflect and support the chosen **tree** concept. Materials such as the oriented strand board (OSB) had been selected because of the texture reminiscent to wood without having to be a carefully finished grained wood. The **translation** of the tree concept to product therefore attains a higher level of conceptual expression. Gottfried Semper's *Stoffwechseltheorie* had been put to good use as part of the paradigm of tectonic expression espoused in this study. The finish of the solid surface display system to the back wall had been selected to resemble the "grain" of the strands of the OSB.

The qualities and characteristics of the main materials used should be discussed.



Primary Green Formica laminate to counter top



Silky Grey paint to steel where indicated in gloss emulsion, one primer coat, two top coats.

# Material //

# Oriented strand board (OSB)

**Where applied:**

Floor finish  
Back wall finish, inside and outside

**Fixing:**

Countersunk wood screws

**Surface treatment:**

Floor - Satin finish white floor paint  
Wall - satin finish polyurethane varnish

**Properties:**

Made from softwood strands approximately 75mm long placed in layers in different directions and compressed with exterior grade water resistant resins.  
Moderately water resistant  
Environmentally sound use of normally discarded scraps of wood.  
Cheaper than plywood  
Good strength in both directions.  
Uniform, decorative appearance.  
Suitable for sheathing, flooring and decorative panels.

**Size:**

18mm thick for flooring (see appendix 3).  
15mm thick for back wall.  
Sheet size 2500 x 1250mm (from PG Bison).  
Cut one sheet in half for one kiosk unit floor

**Reason for selection:**

Aesthetic - strands of wood bring texture and movement and suit the tree concept.

# Material //

# Saligna wood (*Eucalyptus*)



**Where applied:** Ceiling slats  
Supawood veneer to storage counters  
External skirting boards

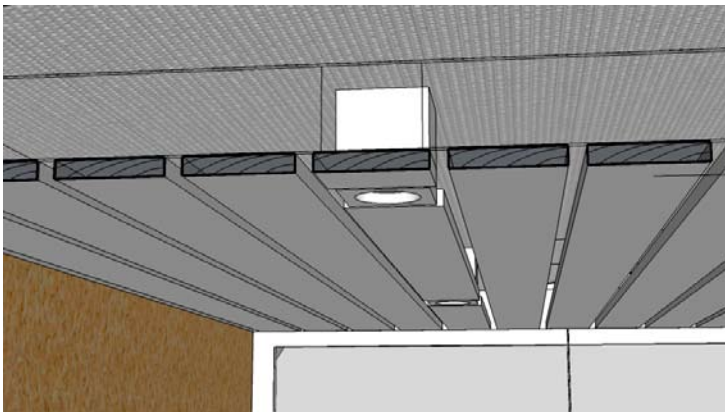
**Fixing:** Countersunk wood screws

**Surface treatment:** Satin finish polyurethane varnish

**Properties:** Fairly heavy wood (approx. 920 kg/m<sup>3</sup>).  
Fairly hard  
Coarse, even grain, reasonably easy to work.  
Moderately durable.  
Use in construction, flooring (light domestic) weather-boards, boat-building fencing and plywood (veneer needs careful drying)  
Generally pale straw coloured wood, occasional pinkish or red hues

**Size:** Standard timber size 100 x 19mm is reduced to 94 x 16mm when planed as used in ceiling.

**Reason for selection:** Relatively inexpensive locally grown timber, good appearance and durability





## Material //

## Surinno solid surface



**Where applied:**

Gridwall display unit

**Fixing:**

Anchor bolt fixed to 25x25mm rectangular steel frame, which is in turn bolted to steel angle brackets fixed through OSB into metal studs in back wall.

**Surface finish:**

Semi-matt

**Properties:**

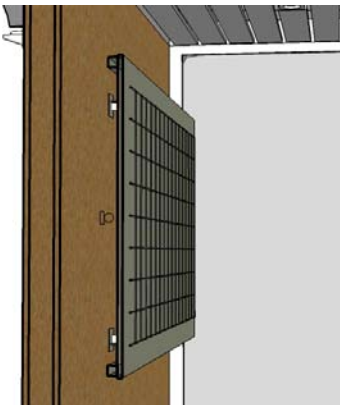
Manufactured from acrylic, modified polyester resin and mineral fillers, mainly Aluminium Hydroxide (ATH). Suitable for vertical and horizontal applications (12mm standard thickness)  
Non-porous  
Consistent finish throughout due to manufacturing process, making it easily to lightly sand and polish out scratches and damaged areas.  
Heat and stain resistant  
Durable  
Low maintenance  
Scratch resistant  
Hygienic, due to non-porosity, stains are not absorbed, leaving no substrate for microbial action. Fabrication technology can achieve seamless joints, reducing potential for microbial growth.

**Size:**

3050 x 765 x 12mm (from PG Bison)  
Half sheet used per kiosk for cost saving - determines display size in interrelation with gridwall sizes

**Reason for selection:**

Aesthetic. When backlit, the pattern of the solid surface resembles the OSB surface. This play on material characteristics lends depth to the scheme and links to the idea of Stoffwechseltheorie as part of tectonic expression.  
Surface is fairly translucent, and achieves attractive and attention focusing glow on display / menu area.



# Material //

# Satine 5500 tensile fabric



**Where applied:** Roof

**Fixing:** Tensioned stainless steel wire fixed with NF Inox anchoring / rigging system.

**Surface treatment:** Factory applied PVC coating

**Properties:** Weight 535 g/m<sup>2</sup>  
Heavy weight PVC coated glass based mesh fabric, RF welded or stitched in zig zag pattern.  
Used for internal structures, including ceilings and screens.  
Fire rated to BS 476 Pt 6 & 7. Class O M1, B1.  
Can be printed.

**Reason for selection:** Filtered light quality similar to tree canopy and extension beyond kiosk creates intermediate public space.  
Light, airy feel desirable.



# Canopy / screen // Specimesh, twin -walled polycarbonate



**Where applied:** Cantilevered front canopy / lockable security screen

**Fixing:** Bolted into steel frame (see technical)

**Surface finish:** White polyester powder coated

**Properties:** Relatively inexpensive versatile precision mesh product. Available in a wide variety of aperture and wire diameters. Flush-cut all round (no sharp edges). Ease of installation when welding and framing. Easy to profile.

**Size:** 2400 x 1200 x 3mm (selected for this application)  
100 x 50mm mesh aperture

**Reason for selection:** Security to front screen, closed and locked at night. Appearance, colour and pattern.

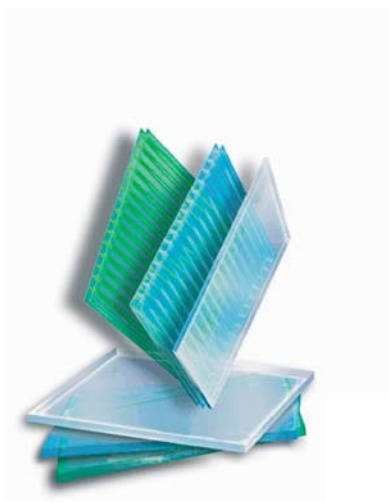
**Where applied:** Cantilevered front canopy / lockable security screen

**Fixing:** Bolted into steel frame (see technical)

**Surface finish:** Frosted (clear)

**Properties:** High impact strength (up to 80 times stronger than glass.)  
Fireproof  
Variety of colours.  
UV protective coating- normally used as light duty roofing.

**Size:** Maximum width 1200mm, 4mm thickness



# Product //

# Gridwall display system



**Where applied:**

To Surinno backlit display

**Fixing:**

Steel brackets anchor fixed through solid surface

**Size:**

750 x 1220 x 3mm.  
75 x 75mm mesh apertures

**Accessories:**

Variety of proprietary, commercially available hooks, shelves, angled shelves, shelf brackets, baskets, clothes rails etc.

**Reason for selection:**

Readily available (supplied locally e.g. from Cyntron Wire products or online ordering)  
Relatively cheap.  
Commercially available and adaptable, highly customisable system.

CHROME-BLACK-WHITE				GRID ACCESSORIES		50
GRID FACE-OUT HARDWARE (CHROME-BLACK-WHITE)						
7 BALL MATERIAL	8 BALL MATERIAL	1/2 STRAIGHT ARM	1/2 CAPPED HOOK	WIRE HOOK		
PNR75	PNR80	PNR12	PNR13	PNR14		
GRID BRACKETS (CHROME-BLACK-WHITE)						
STANDARD BRACKET	SHelf BRACKET	ALTERNATE SHelf BRACKET	ALTERNATE SCRAMBLER			
PNR15 (1/2 LONG)	PNR16 (1/2 LONG)	PNR17 (1/2 LONG)	PNR18 (1/2 LONG)			
GRID SHELVES (CHROME-BLACK-WHITE)						
STRAIGHT SHELF	SLANT SHELF	STRAIGHT BASKET	TRIANGULAR BASKET	STRAIGHT SHELF W/ UP		
PNR19 (1/2)	PNR20 (1/2)	PNR21 (1/2)	PNR22 (1/2)	PNR23 (1/2)		
SPECIAL GRID BASKETS			GRID ACCESSORY DISPLAYS			
			TEE ON SHELF DISPLAY	SHelf DISPLAY	WIRE SHelf ARM	
			PNR24	PNR25	PNR26	
			SPECIAL GRID BASKETS			



from Spazio lighting



**Where applied**

Adjustable ceiling down light

**Size:**

82.5 x 82.5 x 90mm height

**Specifications:**

220V,  
Halogen lamp 50W / GU10  
IP 20  
Aluminium body and base.  
Surface mounted  
Adjusts and rotates

**Finish**

Aluminium

**Reason for selection:**

Fits flush with timber ceiling slats.  
Adjustable to adapt to changing displays or focus / activity areas.  
Suitable light levels for retail environment.

# Fluorescent tube lamp



**Where applied**

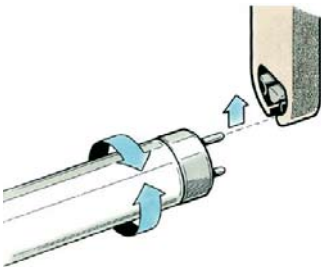
Display board  
Front light box / signage

**Size:**

26mm dia, 600mm length  
18W

**Specifications:**

Appropriate lamp holders / ballast to be provided, two areas to be switched separately to light switch



## 7.8 Conclusion

During the course of this study, **refreshment, retail and supporting facilities** at transport interchanges had been thoroughly investigated. Through observation and precedent studies the five most important activities at train stations had been condensed as follows:

- \* EAT
- \* SHOP
- \* ACCESS INFO
- \* WAIT
- \* and ABLUTION.

Ablution facilities had already been provided at GRRL stations. However, **refreshment, retail and supporting facilities** had not. It had been established that Bombela was aware of the potential financial benefits of such facilities, but at the time of study, no serious proposals had been made in this regard.

This potential for intervention had been explored and researched and the *refresh\** strategy for deployment of retail and associated facilities had been developed. The strategy outlines three levels of intervention, *refresh\*S*, *refresh\*M* and *refresh\*L*, differentiated by means of scale, as well as time frame and duration. The scales range from small through medium and large, and duration from short to long term. A phased deployment of retail and refreshment facilities had been suggested, including the 5 station activities as identified, at the different levels. This strategy not only takes into account the needs of station users, but also the actions required by management and the operation and lifecycle of the *refresh\** intervention.

The complex design approach had also been formulated on the three levels of scale:

- \* **macro**, or neighbourhood to building interior scale, focused on the **creation of places** and the railway station as public meeting place. This was embodied in the design and the ancillary function of the kiosks of *refresh\*M* as places within a place. An intermediate place between public space and a more intimate, ephemeral meeting and trading place had been created.
- \* **medium**, or unit scale, informed by the importance of **tectonic** expression in interior architecture. This had been further explored in a detailed technical resolution. Importance had been placed on the details of construction and material selection.
- \* **micro**, or unit & details scale informed by various factors relating to **cost** and **sustainability**. The characteristics of adaptability and providing choice to tenants had been incorporated in flexible technical design details and modularity to enable adaptation, ease of demounting at the end of the product lifecycle and potential for reuse elsewhere. Providing tenants with choice and not imposing an inflexible design on them, created a more approachable and customisable design would heighten end user affinity for the design product. The adaptability of the kiosks also increased the sustainability of the design by making it easier to repair and maintain.

The standardisation of the kiosks, while seemingly in opposition to the principles of sustainability, would allow for fast and less messy installation, saving on time and project costs.

Materials had been chosen for cost effectiveness, except where the additional cost had been deemed justified to achieve a certain aesthetic or technical requirement, such as the choice of the Surinno solid surface as part of a display design.

The design of the unit had to be carefully balanced between the cost relative to the product lifecycle, the expected level of transience, the standard of design at GRRL stations and the Gautrain system identity. As such the kiosk design represents a careful balancing act, taking into account various factors, and embodying various theoretical discourses.

This study had provided valuable information to the field of interior architecture on user needs at transport interchanges, as well as design as a tightrope act, balancing the needs of users with those of clients, costs with aesthetics and theoretical discourse with everyday practicalities.



8

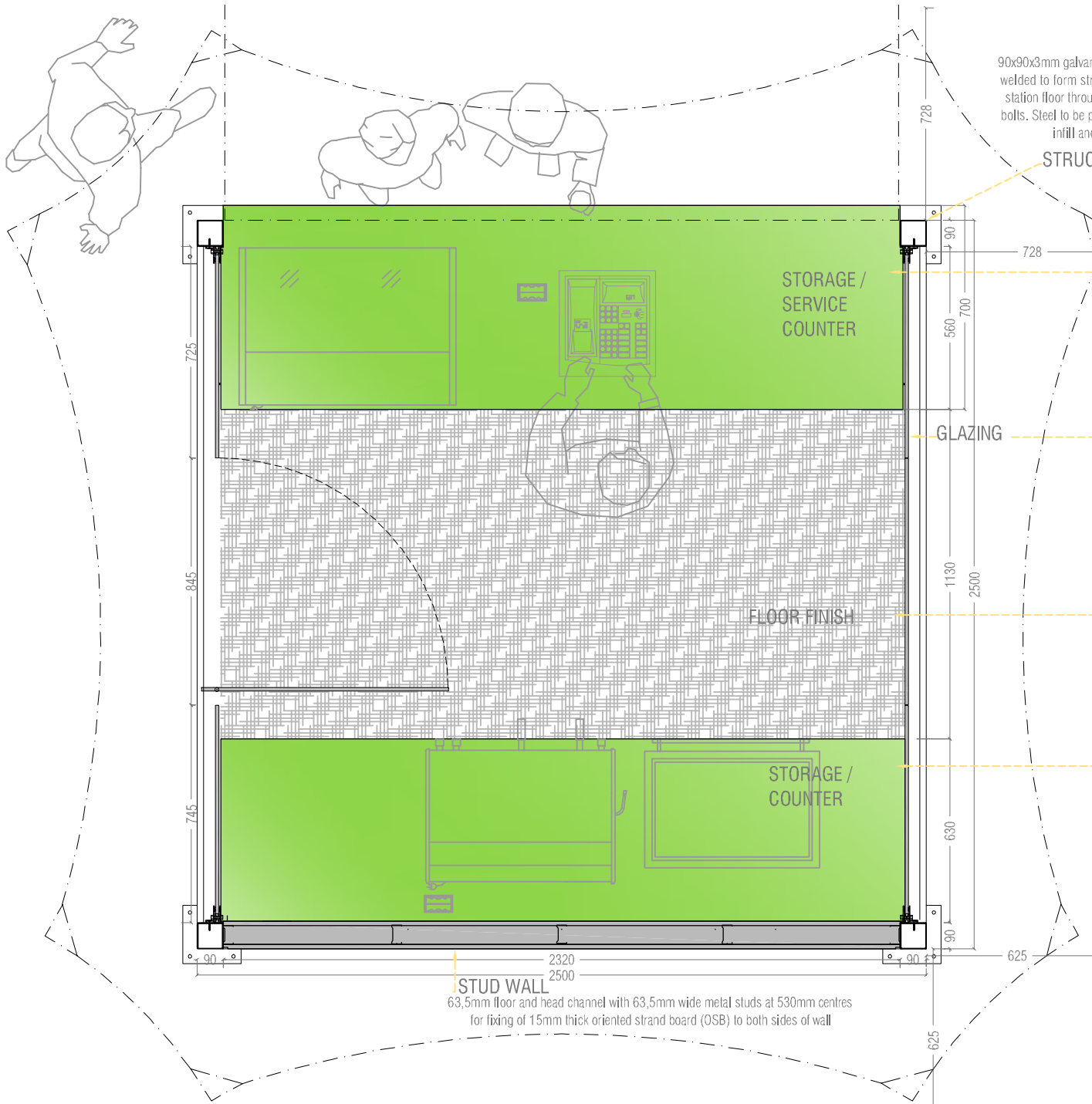


UNIVERSITEIT VAN PRETORIA  
UNIVERSITY OF PRETORIA  
YUNIBESITHI YA PRETORIA



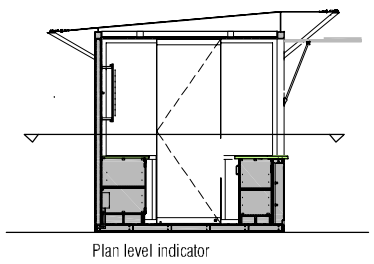
# *Chapter 8*

## *Technical resolution*



90x90x3mm galvanised mild steel cold rolled square tubes welded to form structural frame, corner columns bolted to station floor through square base plate with 4 no. anchor bolts. Steel to be primed and painted dark grey. Holes for infill and roof masts to be pre-drilled.

**STRUCTURAL STEEL FRAME**



Okoume wood veneer storage and service counter with counter top in "Primary Green" Formica laminate with lightbox for signage to front in 4mm cast acrylic with adhesive vinyl decorative transfer for tenant signage (solid lettering, plastic, stainless steel or vinyl). 2 no. double sockets under counter with cable outlet in work top.

**GLAZING**

12mm laminated safety glazing to comply with SANS 50572 as relates to human contact, fixed in stainless steel profile frame through fixed with M7 hexagon bolts with suitable rubber washer at 560mm centres vertically and 610mm centres horizontally

**FLOOR FINISH**

18mm thick oriented strand board (OSB) floor finish painted one layer white floor paint to allow retention of OSB surface texture, fixed to steel substructure with self tapping screw, holes in OSB to be filled with wood filler and leveled prior to painting

**STORAGE / COUNTER**

Okoume veneer storage and occasional display cupboards or preparation counter with counter top in "Primary Green" Formica laminate with feature doors in green cast acrylic with adhesive vinyl transfer or customisable stainless steel wire pattern in steel frames

**STUD WALL**  
63,5mm floor and head channel with 63,5mm wide metal studs at 530mm centres for fixing of 15mm thick oriented strand board (OSB) to both sides of wall

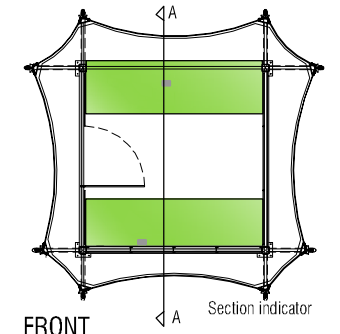
Satine 5500 fire retardant fibreglass tensile fabric with 6mm stainless steel catenary rope in RF welded catenary pocket (perimeter seams) attached to ends of steel masts by stainless steel clevis, connector plate and threaded clevis. Fabric tensioned to manufacturer's specifications on site

**TENSILE FABRIC**

16mm Saligna timber ceiling slats screw fixed to steel lipped channels, satin varnish finish. Two slats to either side of light fittings remain removable for maintenance. 15mm offset between slats with 22mm shadow gap to perimeter of ceiling.

90x90x3mm galvanised mild steel cold rolled square tubes welded to form structural frame, corner columns bolted to station floor through square base plate with 4 no. anchor bolts. Steel to be primed and painted dark grey. Holes for infill and roof masts to be pre-drilled.

50mm dia, 3mm thick steel circular section for tensile fabric roof rigging, closed at top and welded to base plate at bottom, painted Silky Grey,



**STRUCTURAL STEEL FRAME**

**STEEL MASTS**

BACK

FRONT

**FOLD UP HINGED SECURITY SCREEN**

25mm gas spring assisted cantilevered canopy / shutter with stainless steel frame, with white polyester powder coated Specimesh steel mesh to inside and 4mm twin walled polycarbonate sheet outer layer with "tree" motif adhesive vinyl transfer.

**DISPLAY**  
12mm thick Surinno solid surface resin composite in colour Alabaster supporting proprietary chromed wire gridwall display system from Cynton Wire Products fixed back to wall with galvanised mild steel angle brackets fixed into metal wall studs or battens between studs for support.

**WALL FINISH**  
15mm thick oriented strand board (OSB) semi-gloss varnished to inside and outside of kiosk, fixed to metal furring studs with self tapping screws, holes to be filled with wood filler in colour to match board and leveled prior to varnishing

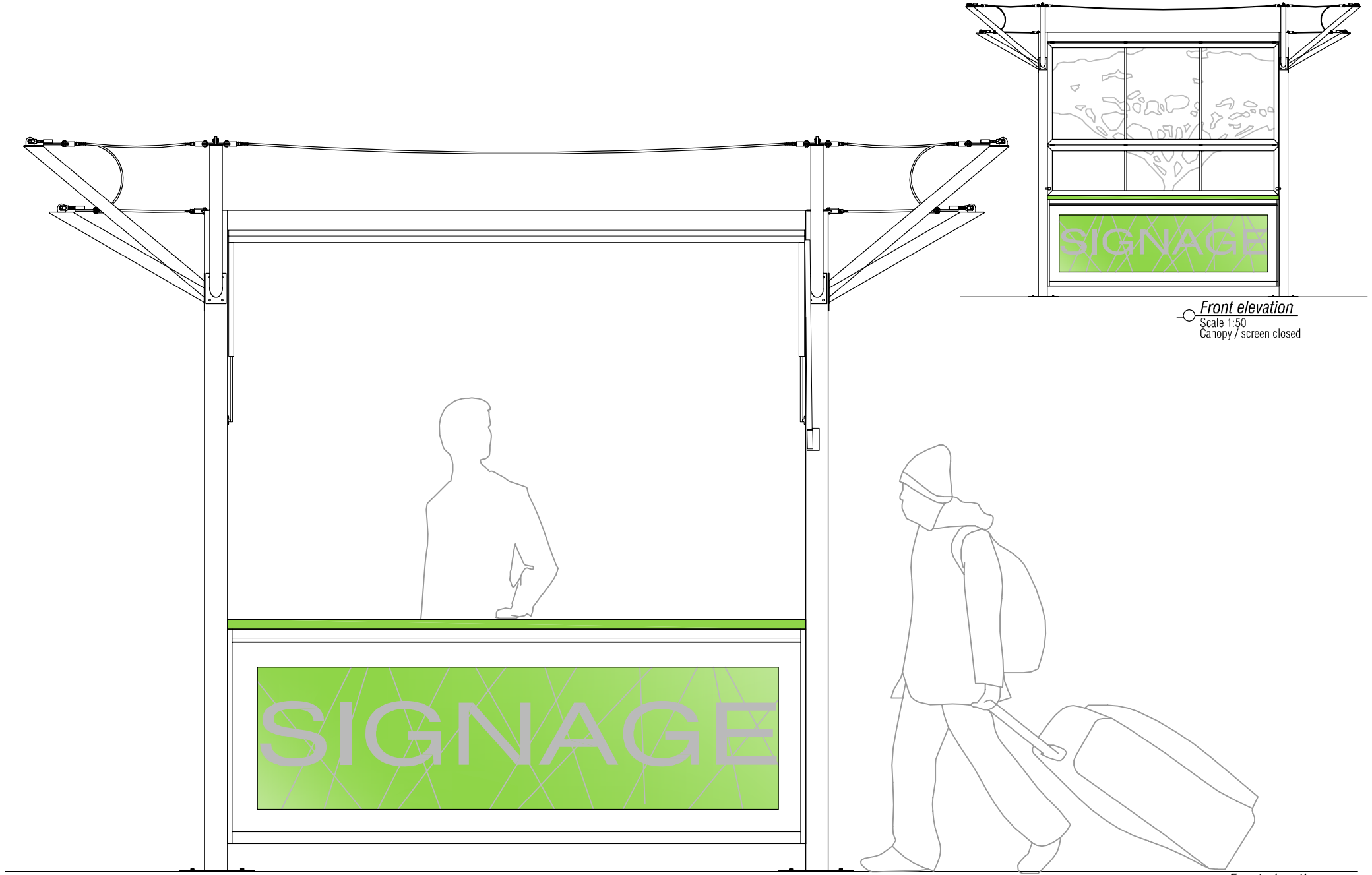
**ELECTRICAL**  
Distribution board with minimum 3 no. micro circuit breakers (MCB's) and earth leakage test switch to engineer's specification. Provide 2 no double sockets at under counter level (with cable outlet in worktop) to front and back counters and 3 gang light switch. 4 no integrated PVC conduits allow for wiring from station mains power from kiosk sides, back or top (for supply from overhead cable tray)

18mm thick oriented strand board (OSB) floor finish painted one layer white floor paint to allow retention of OSB surface texture, fixed to steel substructure with self tapping screw, holes in OSB to be filled with wood filler and leveled prior to painting

**FLOOR STRUCTURE**

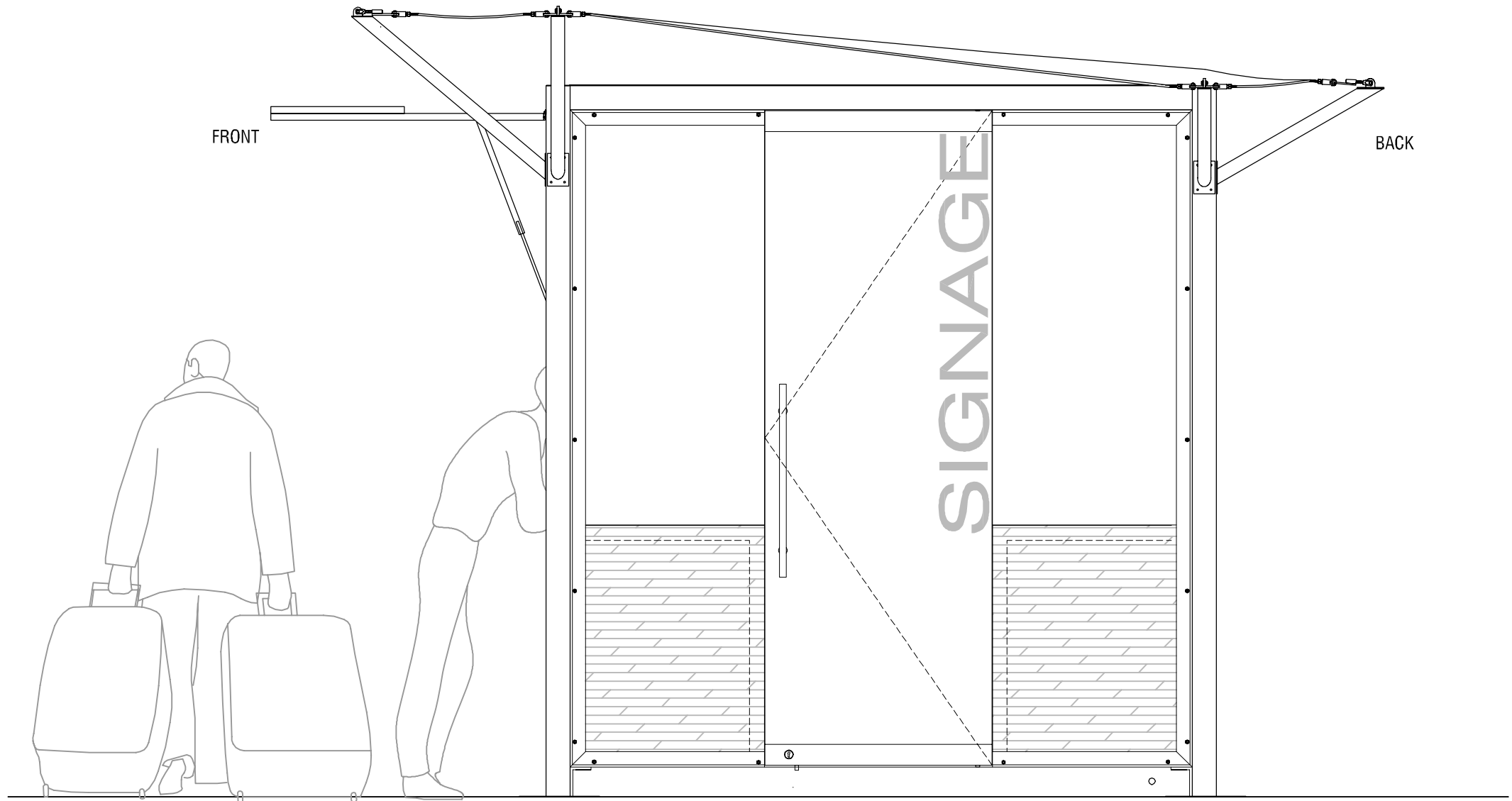
75x50x20x2mm deck of Clotan galvanised mild steel lipped channel grid at 445mm centres, with channels pre-punched to allow fixing with self-tapping screws, bolted to corner columns. Openings for PVC conduit pre-cored. 915x915x20mm thick protective neoprene rubber underlay sheets cut to size with adhesive backing fixed to substrate flooring (ceramic tiles / terrazzo)

**Section A-A**  
Scale 1:20

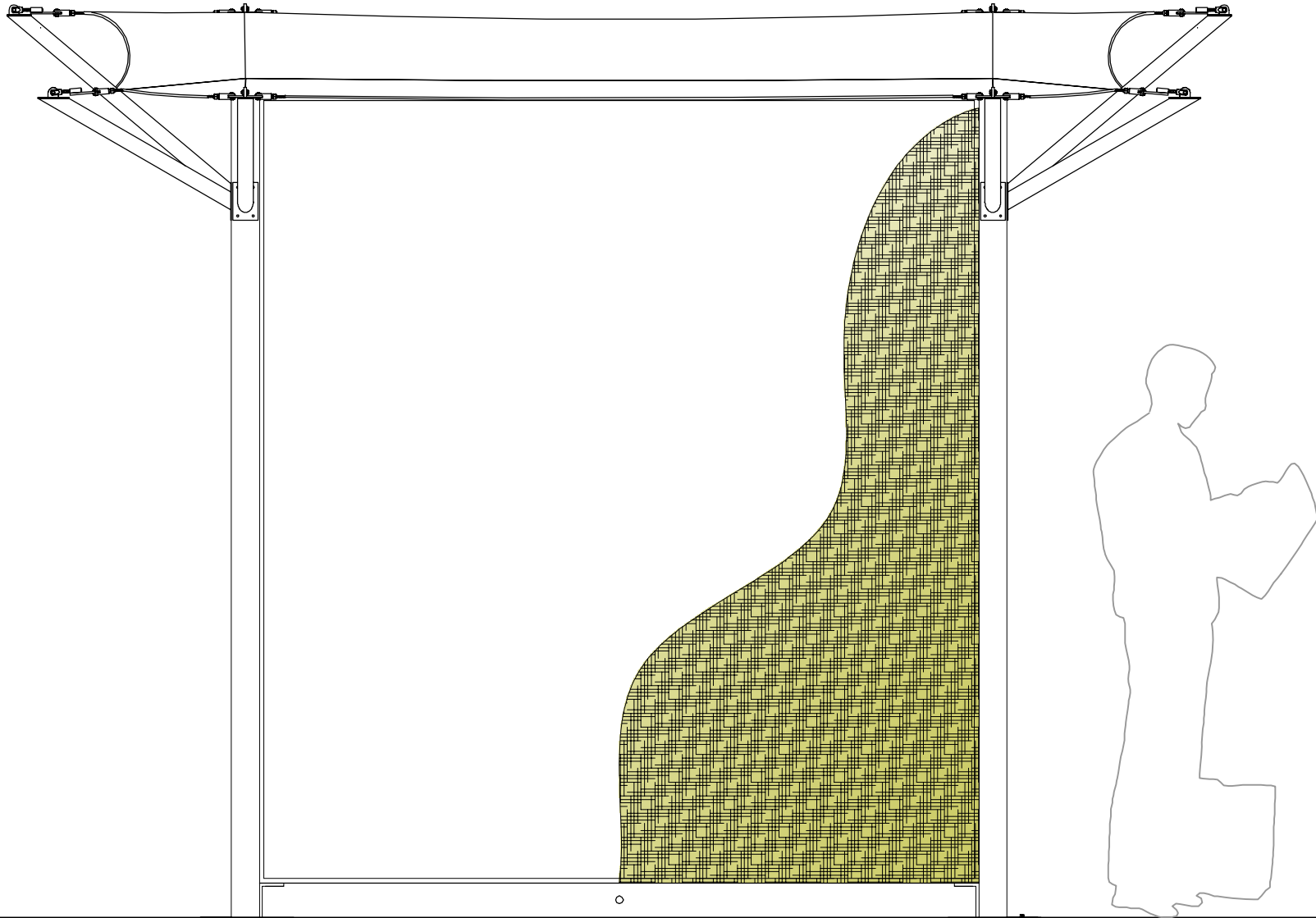


○ *Front elevation*  
Scale 1:50  
Canopy / screen closed

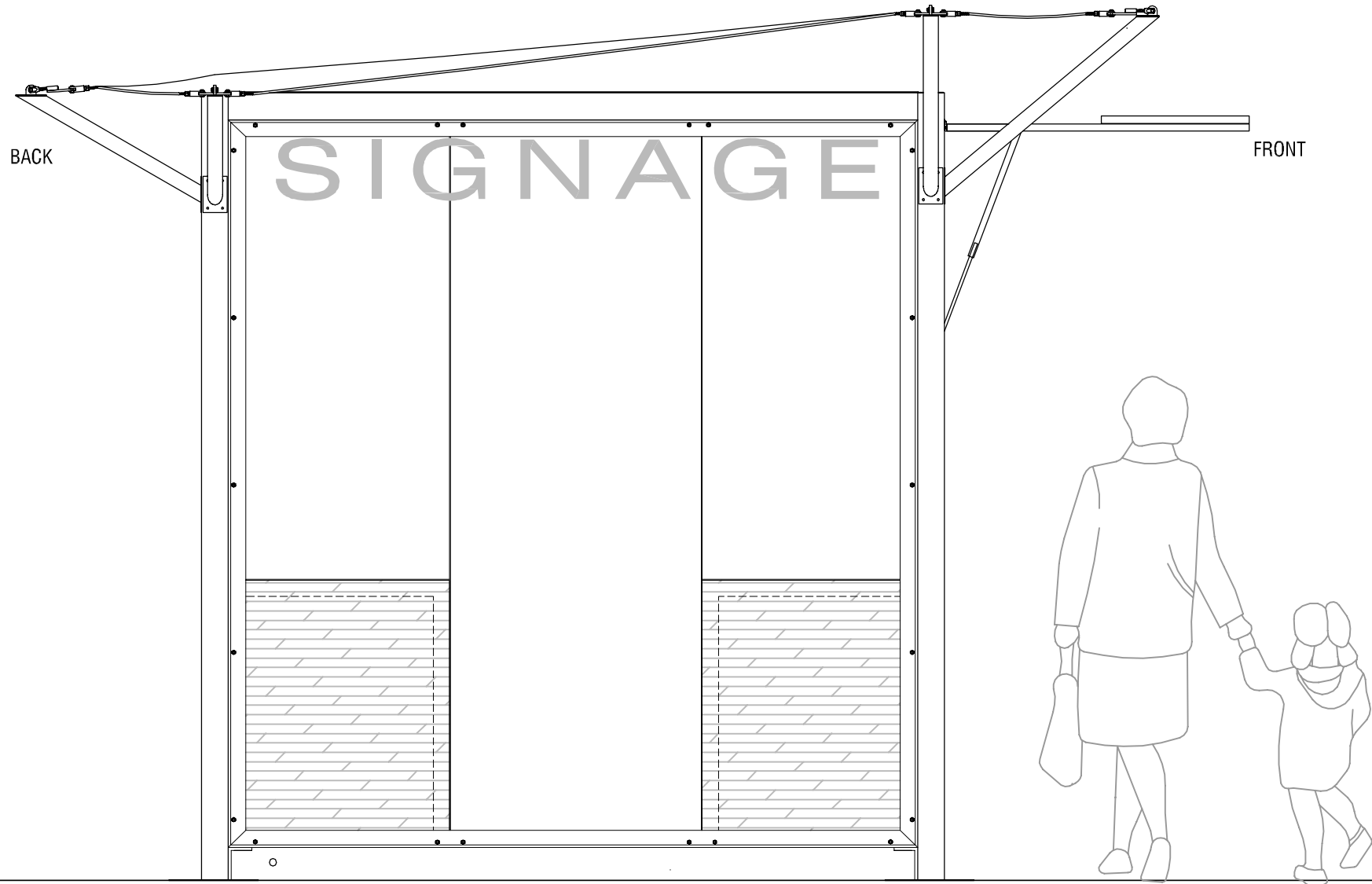
○ *Front elevation*  
Scale 1:20



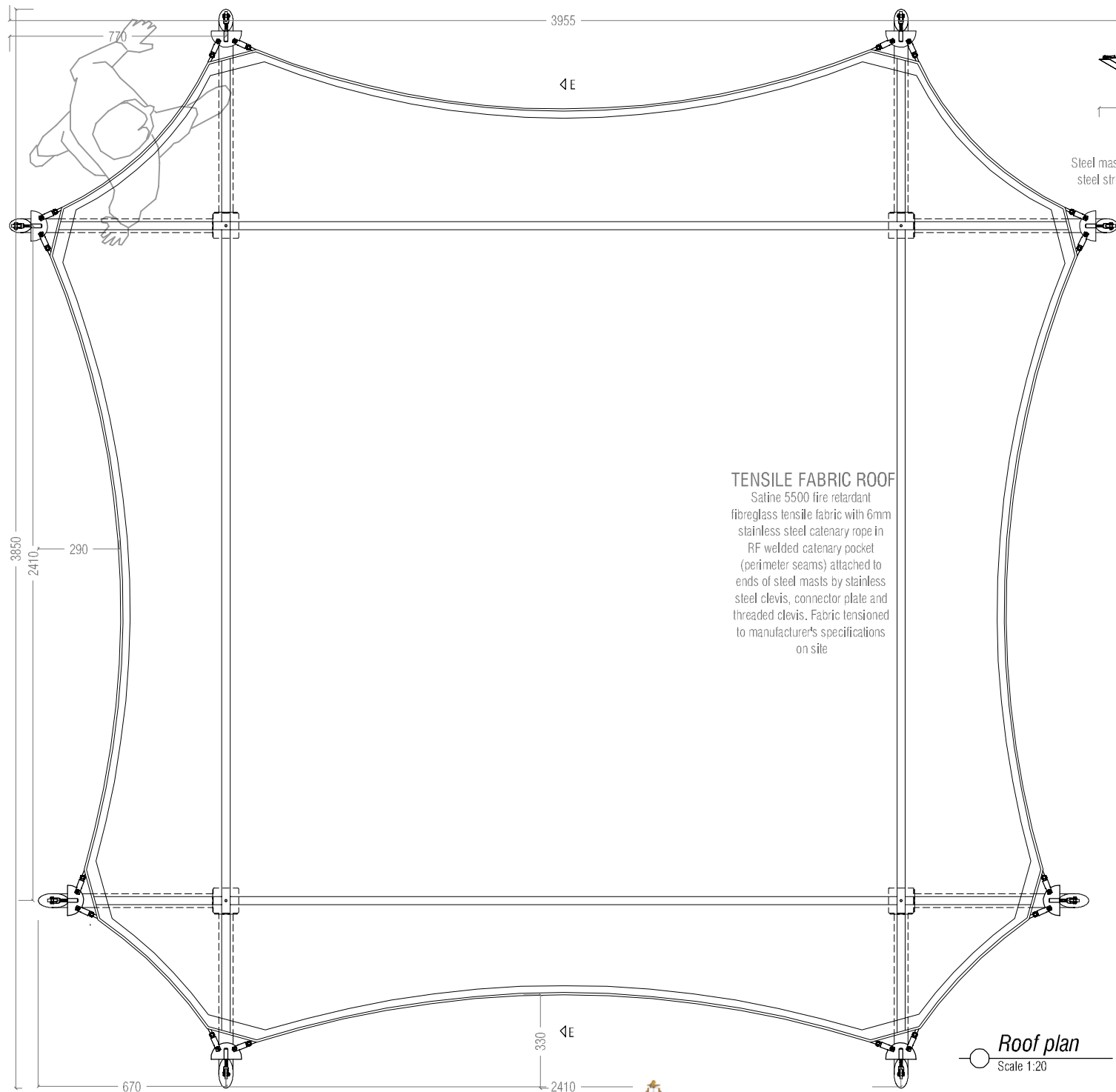
Left elevation  
Scale 1:20



○ *Back elevation*  
Scale 1:20



*Right elevation*  
Scale 1:20

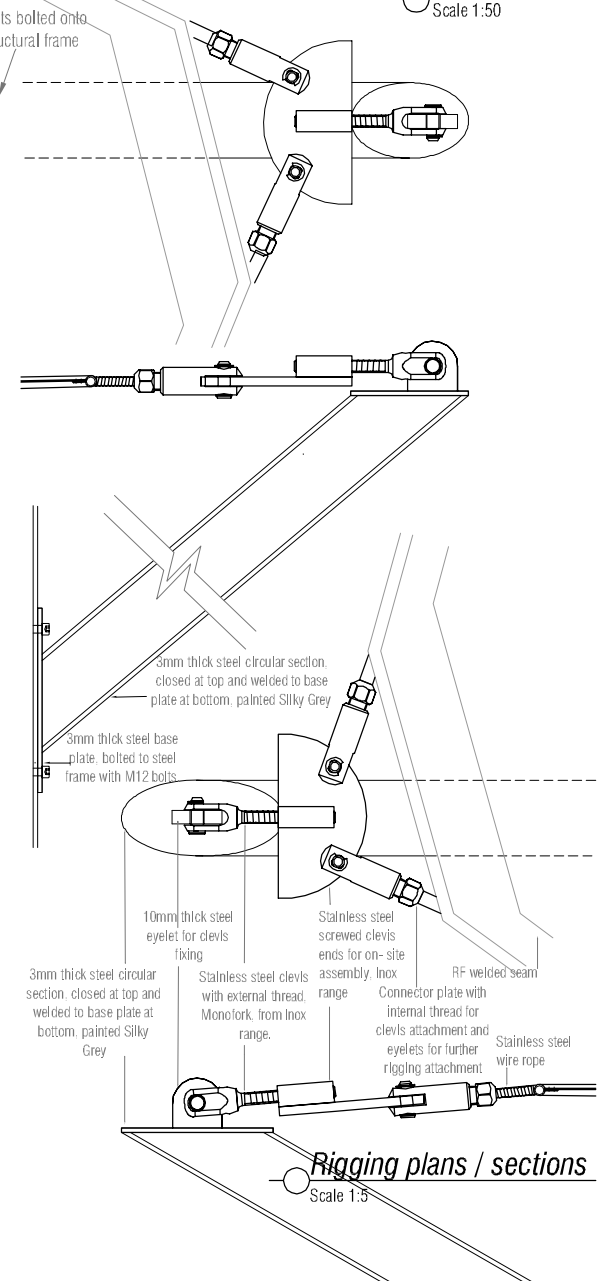


**TENSILE FABRIC ROOF**

Satine 5500 fire retardant fibreglass tensile fabric with 6mm stainless steel catenary rope in RF welded catenary pocket (perimeter seams) attached to ends of steel masts by stainless steel clevis, connector plate and threaded clevis. Fabric tensioned to manufacturer's specifications on site

Steel masts bolted onto steel structural frame

Section E-E  
Scale 1:50



**Roof plan**

Scale 1:20

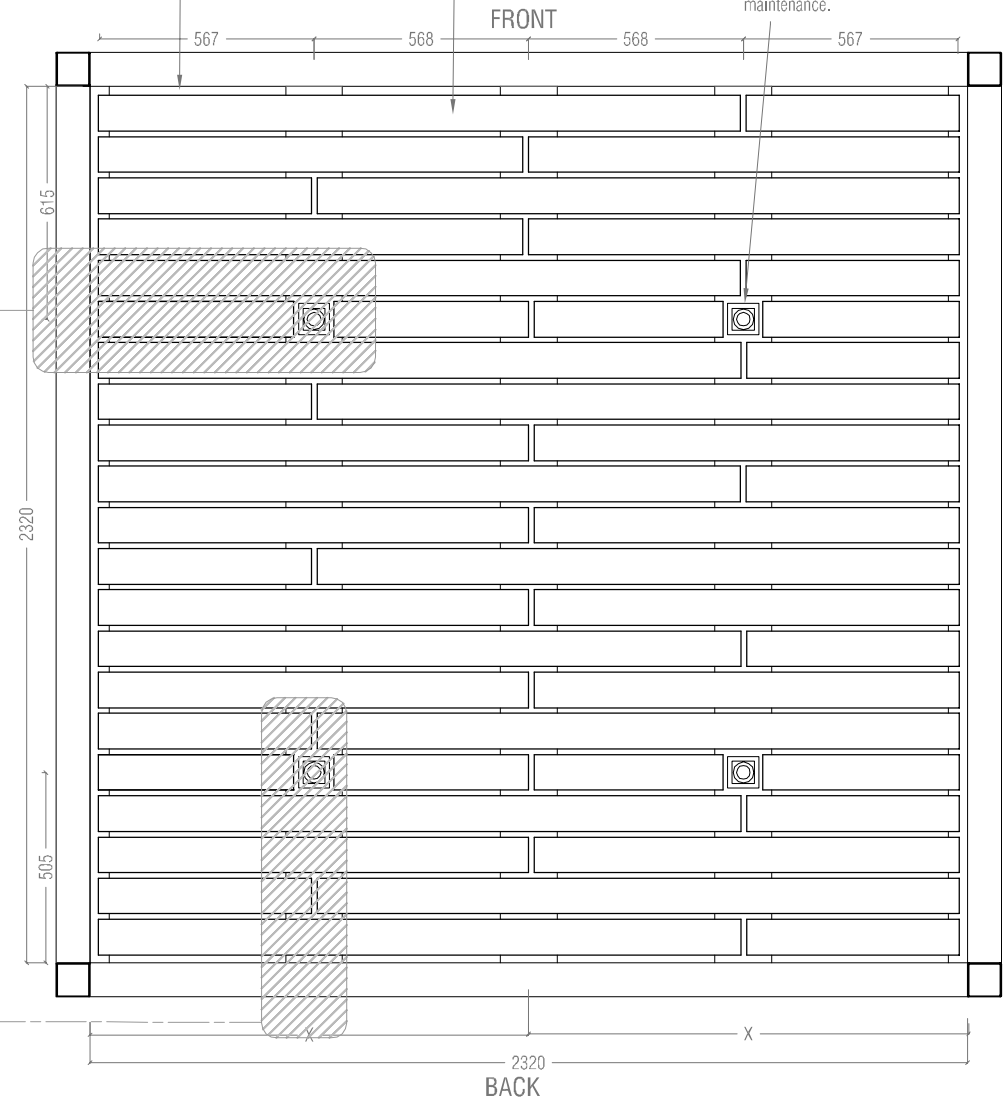
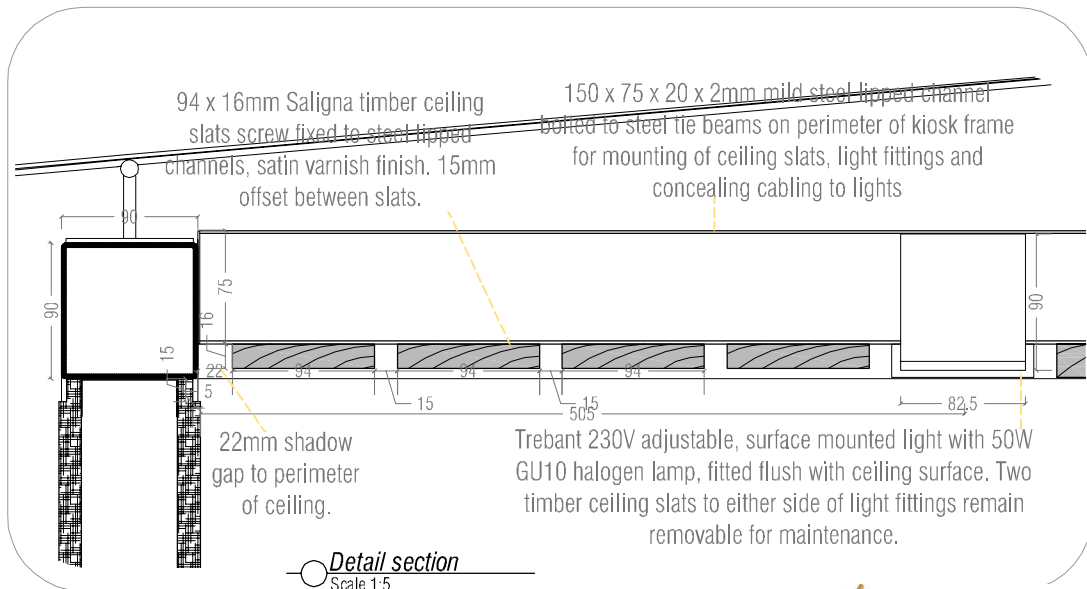
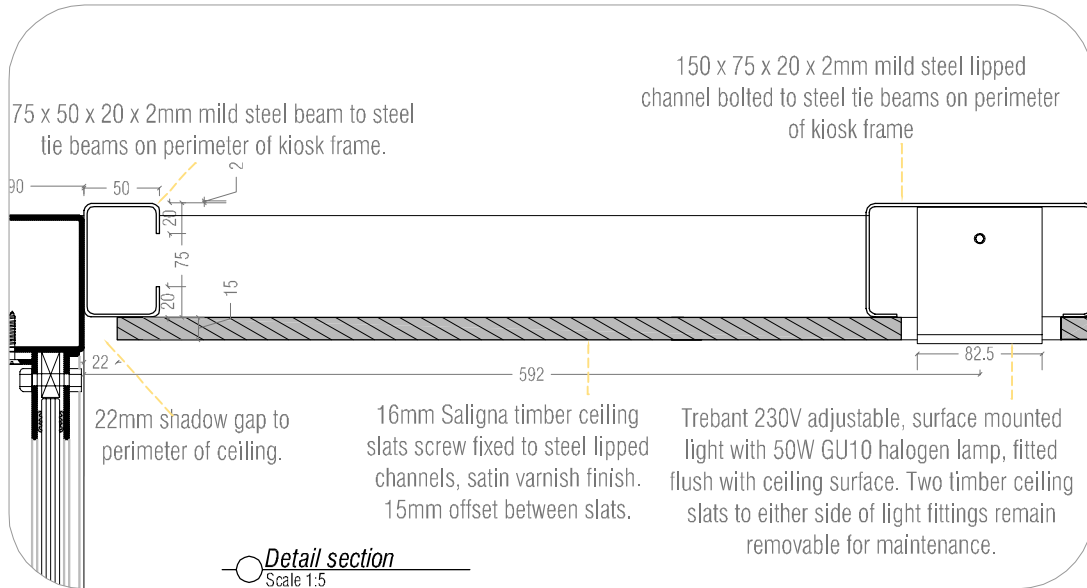




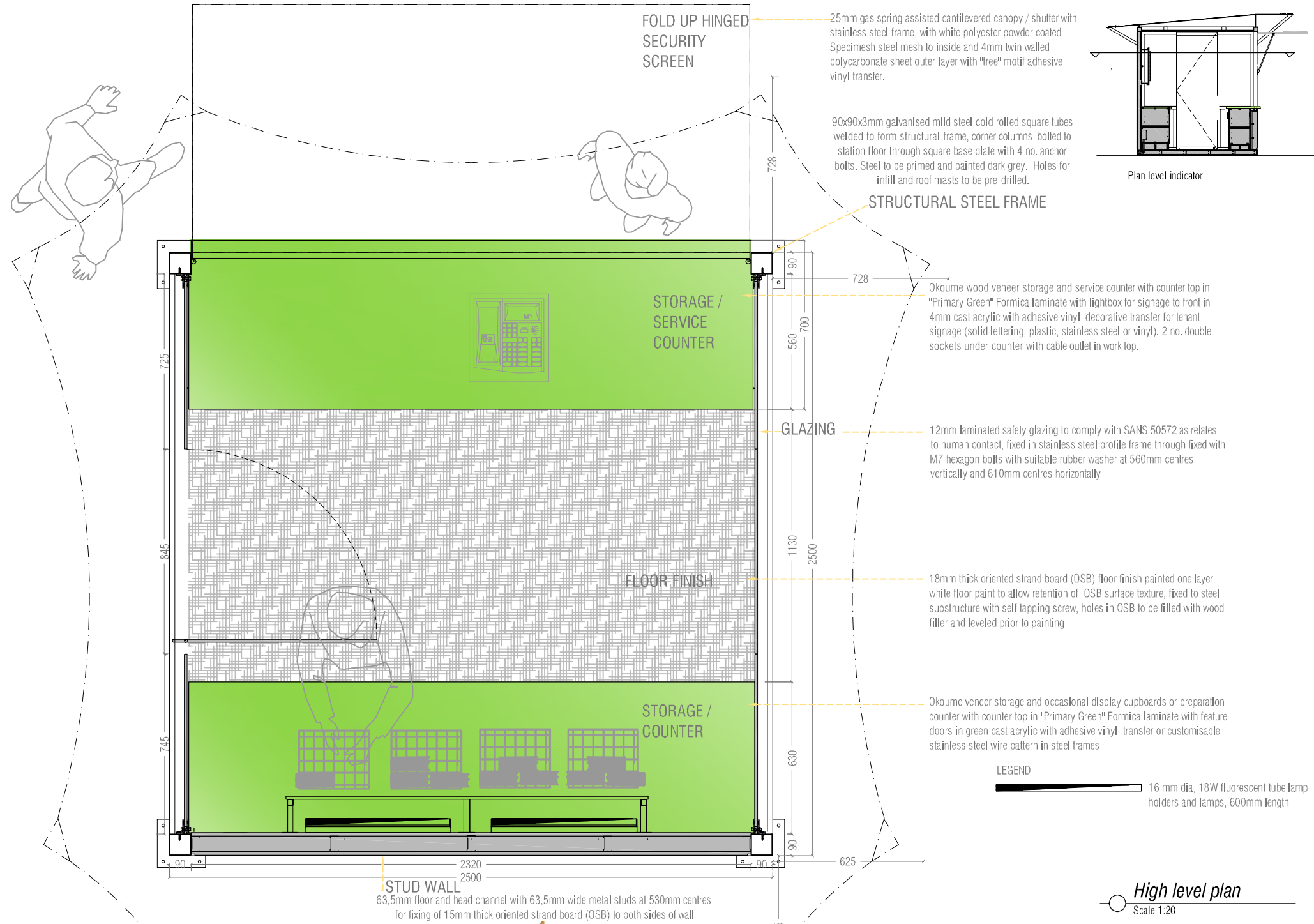
16mm Saligna timber ceiling slats screw fixed to steel lipped channels, satin varnish finish. 15mm offset between slats.



Trebant 230V adjustable, surface mounted light with 50W GU10 halogen lamp, fitted flush with ceiling surface. Two timber ceiling slats to either side of light fittings remain removable for maintenance.



**Reflected ceiling plan**  
Scale 1:20



FOLD UP HINGED SECURITY SCREEN

25mm gas spring assisted cantilevered canopy / shutter with stainless steel frame, with white polyester powder coated Specimesh steel mesh to inside and 4mm twin walled polycarbonate sheet outer layer with "tree" motif adhesive vinyl transfer.

90x90x3mm galvanised mild steel cold rolled square tubes welded to form structural frame, corner columns bolted to station floor through square base plate with 4 no. anchor bolts. Steel to be primed and painted dark grey. Holes for infill and roof masts to be pre-drilled.

STRUCTURAL STEEL FRAME

STORAGE / SERVICE COUNTER

Okoume wood veneer storage and service counter with counter top in "Primary Green" Formica laminate with lightbox for signage to front in 4mm cast acrylic with adhesive vinyl decorative transfer for tenant signage (solid lettering, plastic, stainless steel or vinyl). 2 no. double sockets under counter with cable outlet in work top.

GLAZING

12mm laminated safety glazing to comply with SANS 50572 as relates to human contact, fixed in stainless steel profile frame through fixed with M7 hexagon bolts with suitable rubber washer at 560mm centres vertically and 610mm centres horizontally

FLOOR FINISH

18mm thick oriented strand board (OSB) floor finish painted one layer white floor paint to allow retention of OSB surface texture, fixed to steel substructure with self tapping screw, holes in OSB to be filled with wood filler and leveled prior to painting

STORAGE / COUNTER

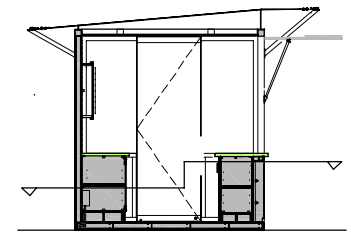
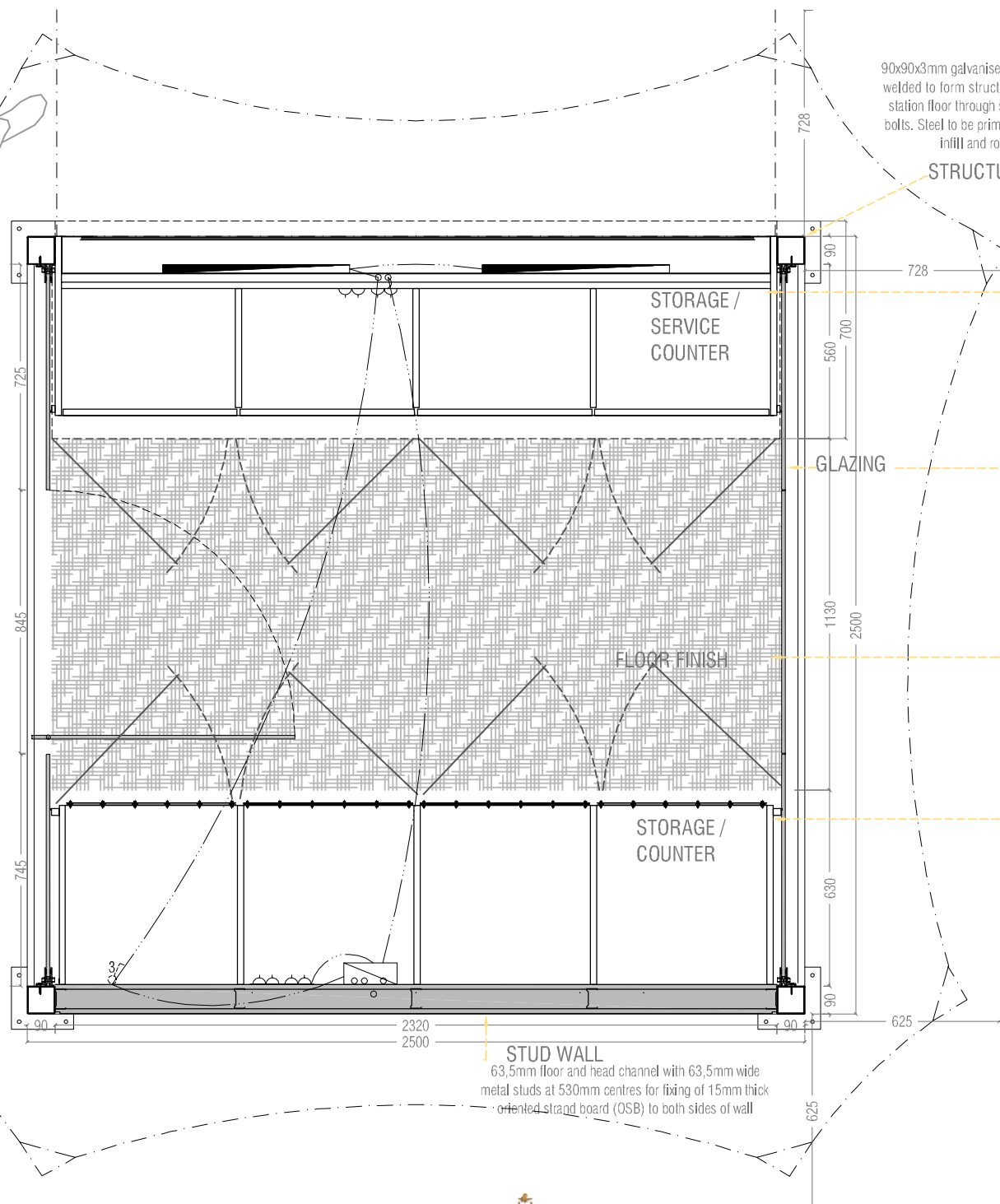
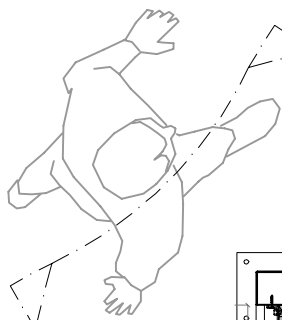
Okoume veneer storage and occasional display cupboards or preparation counter with counter top in "Primary Green" Formica laminate with feature doors in green cast acrylic with adhesive vinyl transfer or customisable stainless steel wire pattern in steel frames

LEGEND

16 mm dia, 18W fluorescent tube lamp holders and lamps, 600mm length

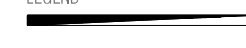




STUD WALL  
63,5mm floor and head channel with 63,5mm wide metal studs at 530mm centres for fixing of 15mm thick oriented strand board (OSB) to both sides of wall

High level plan  
Scale 1:20

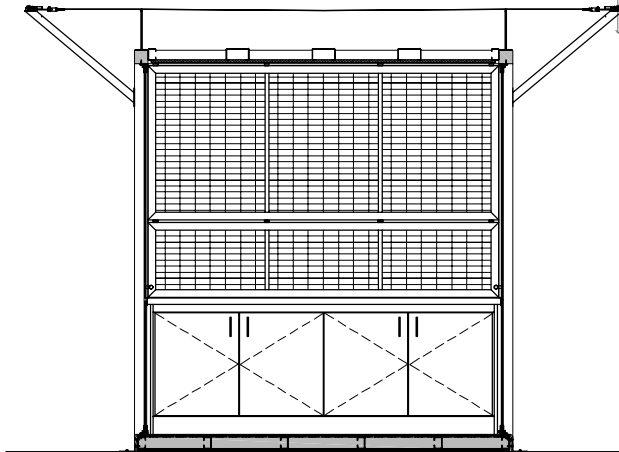
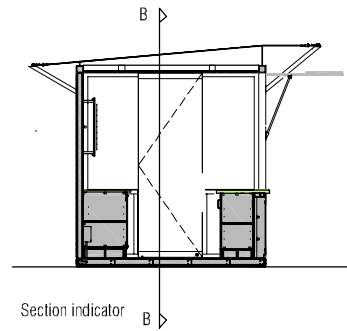


Plan level indicator

**LEGEND**

-  16 mm dia, 18W fluorescent tube lamp holders and lamps, 600mm length
-  Distribution board with minimum 3 no. micro circuit breakers (MCBs) and earth leakage test switch
-  Double socket under counter top level
-  3 gang light switch above counter top level
-  PVC conduit for electrical wiring

**Under counter plan**  
Scale 1:20



**Section B-B**  
Scale 1:20  
Screen closed

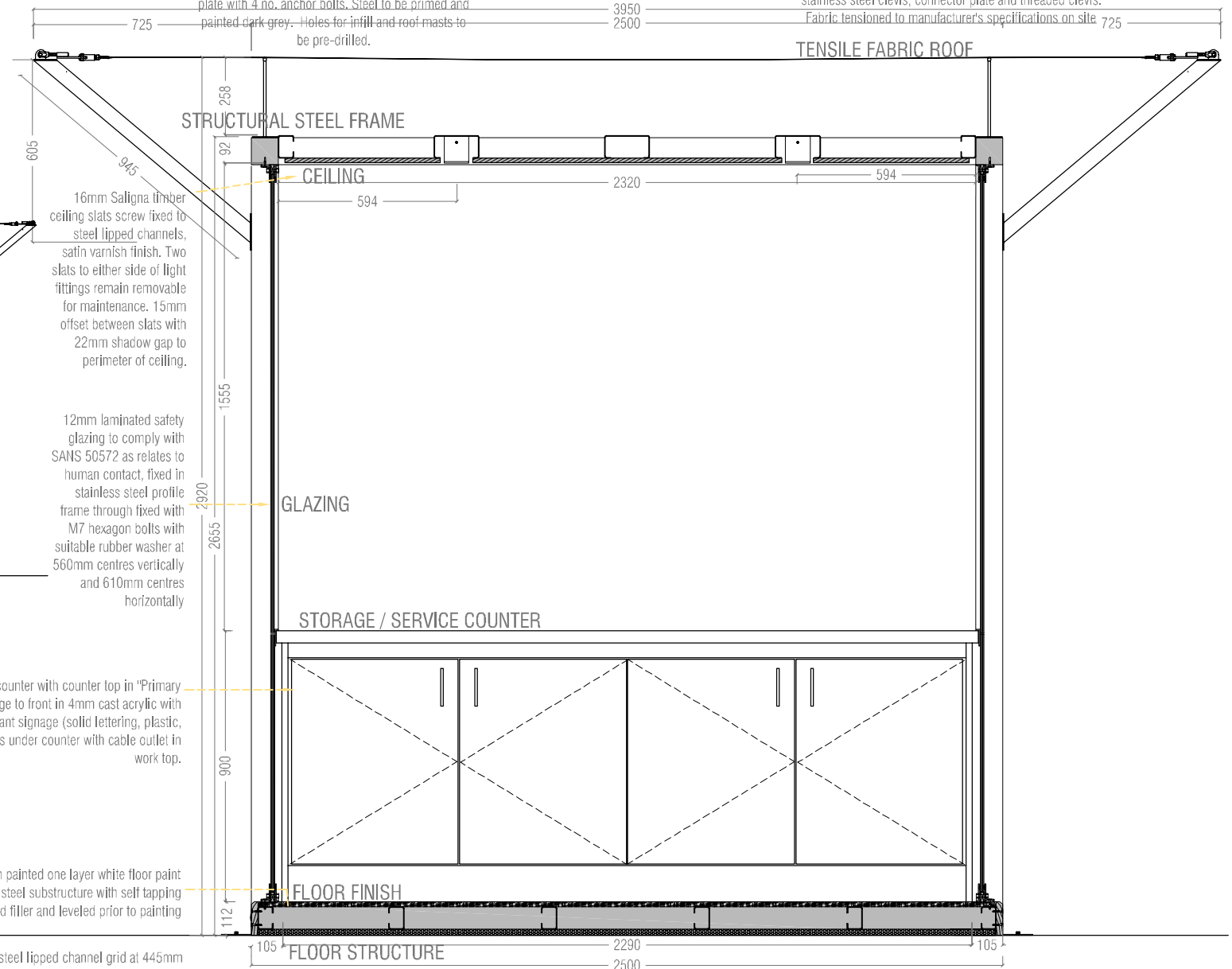
Okoume wood veneer storage and service counter with counter top in "Primary Green" Formica laminate with lightbox for signage to front in 4mm cast acrylic with adhesive vinyl decorative transfer for tenant signage (solid lettering, plastic, stainless steel or vinyl). 2 no. double sockets under counter with cable outlet in work top.

18mm thick oriented strand board (OSB) floor finish painted one layer white floor paint to allow retention of OSB surface texture, fixed to steel substructure with self tapping screw, holes in OSB to be filled with wood filler and leveled prior to painting

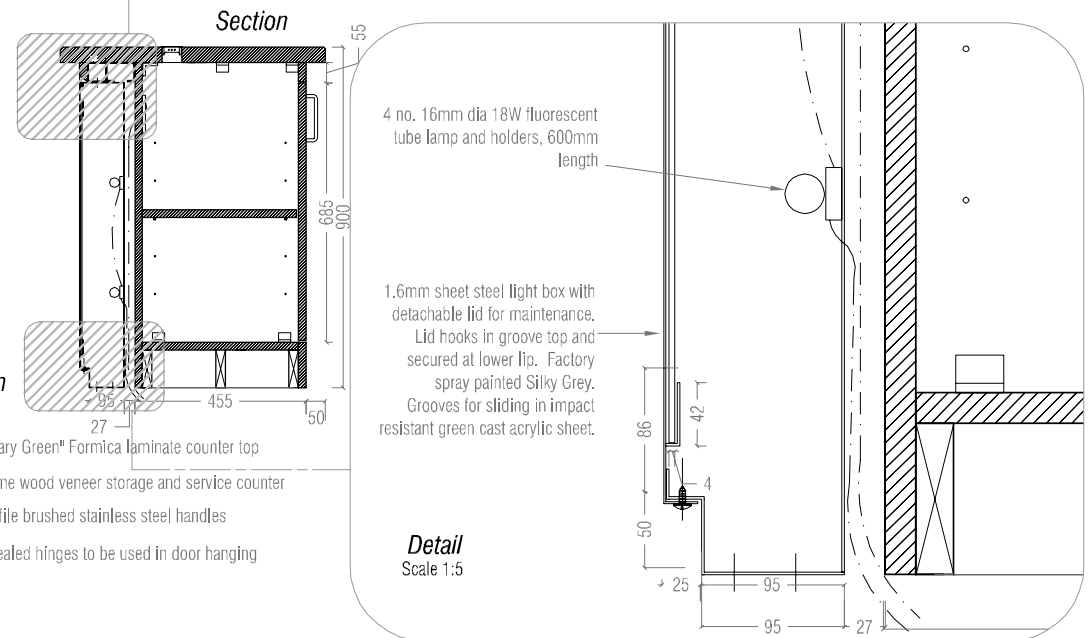
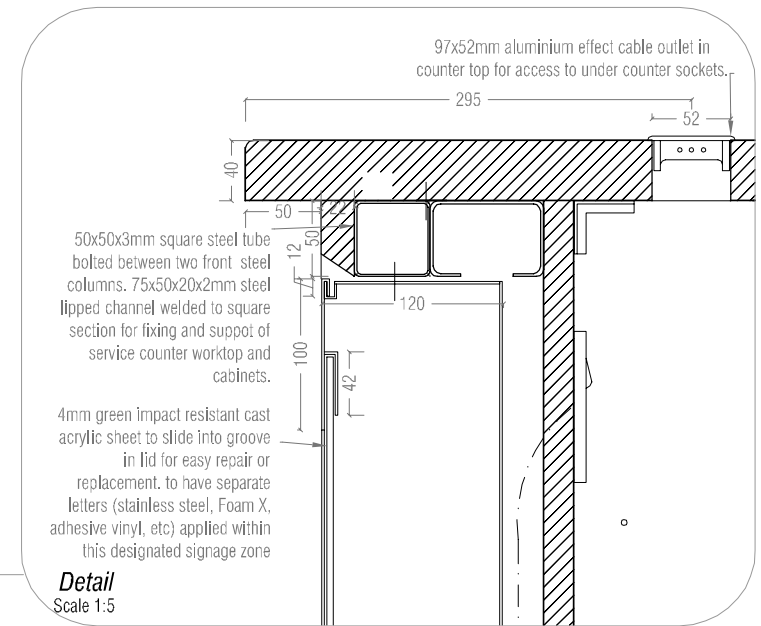
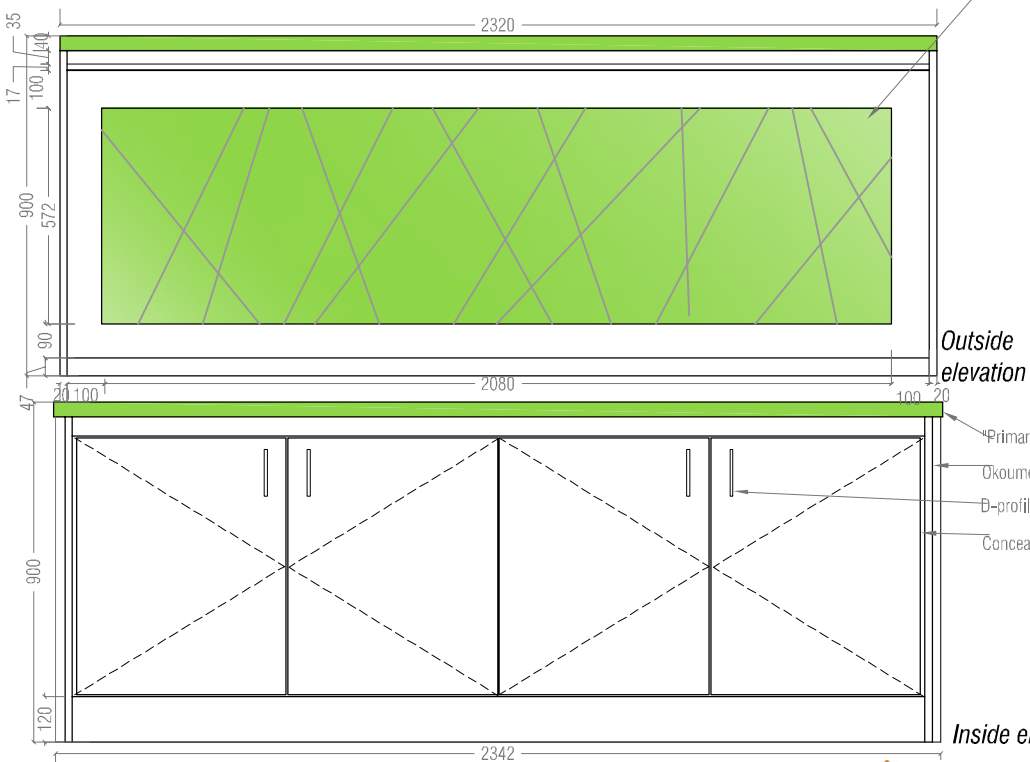
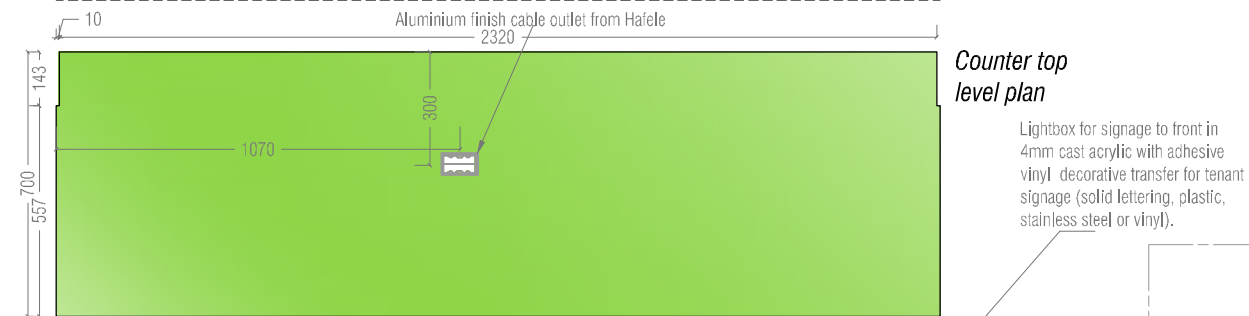
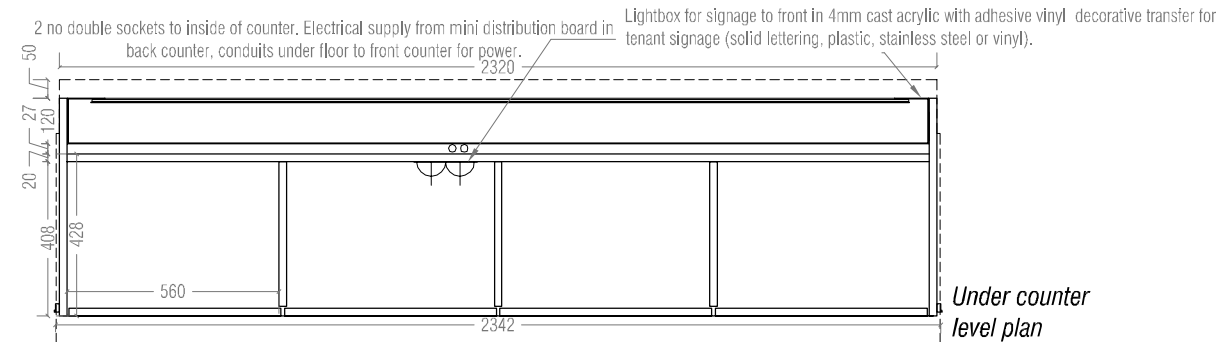
75x50x20x2mm deck of Clotan galvanised mild steel lipped channel grid at 445mm centres, with channels pre-punched to allow fixing with self-tapping screws, bolted to corner columns. Openings for PVC conduit pre-cored. 915x915x20mm thick protective neoprene rubber underlay sheets cut to size with adhesive backing fixed to substrate flooring (ceramic tiles / terrazzo)

90x90x3mm galvanised mild steel cold rolled square tubes welded to form structural frame, corner columns bolted to station floor through square base plate with 4 no. anchor bolts. Steel to be primed and painted dark grey. Holes for infill and roof masts to be pre-drilled.

Satine 5500 fire retardant fibreglass tensile fabric with 6mm stainless steel catenary rope in RF welded catenary pocket (perimeter seams) attached to ends of steel masts by stainless steel clevis, connector plate and threaded clevis. Fabric tensioned to manufacturer's specifications on site

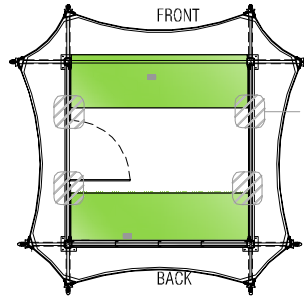
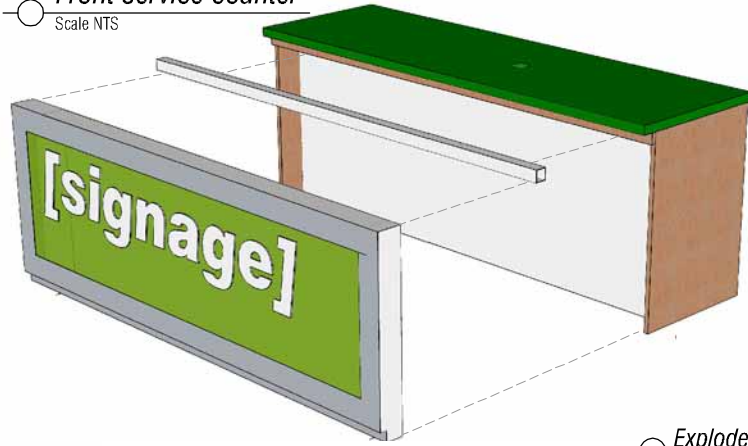


**Section B-B**  
Scale 1:20



**Front service counter**  
Scale 1:20

Front service counter  
Scale NTS

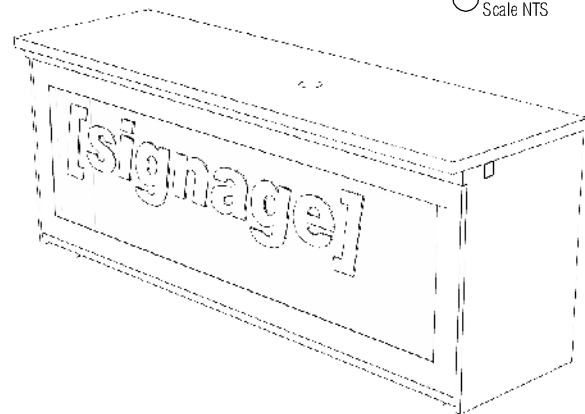


KEY PLAN  
Scale 1:100

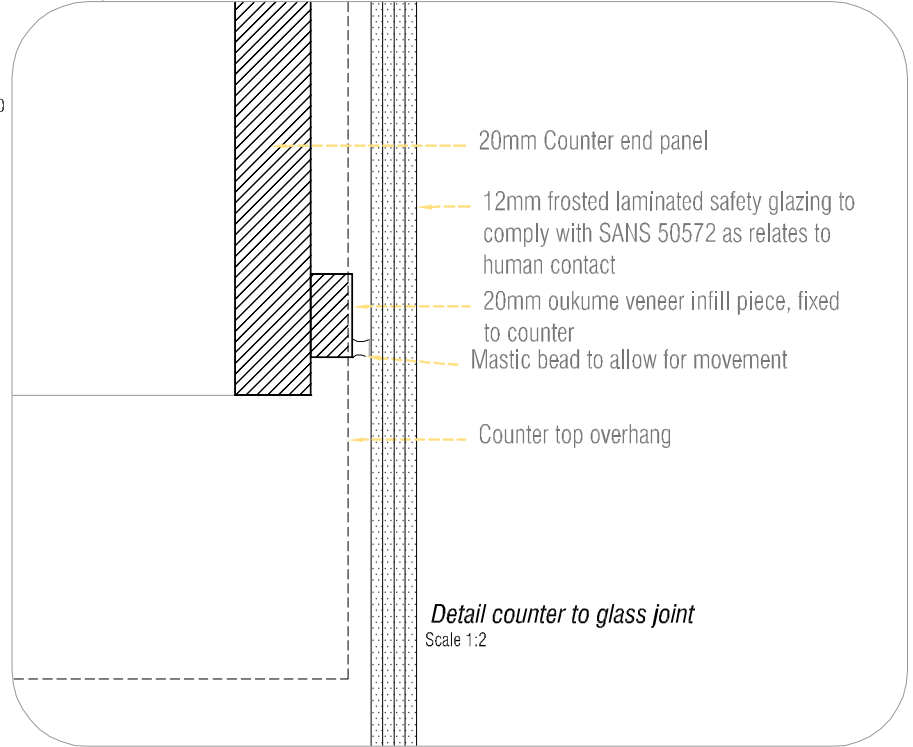
Alternative to lightbox, commercially available magazine gondola to exterior of front counter



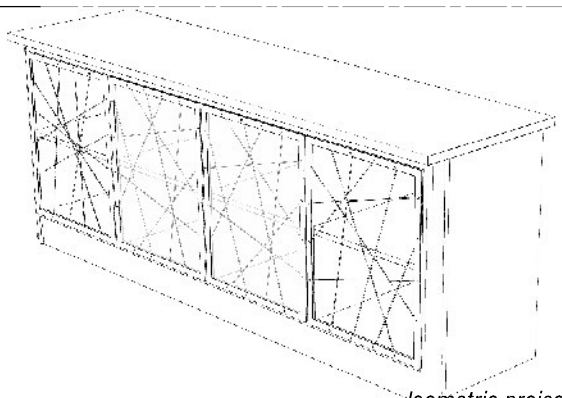
Exploded isometric projection  
Scale NTS



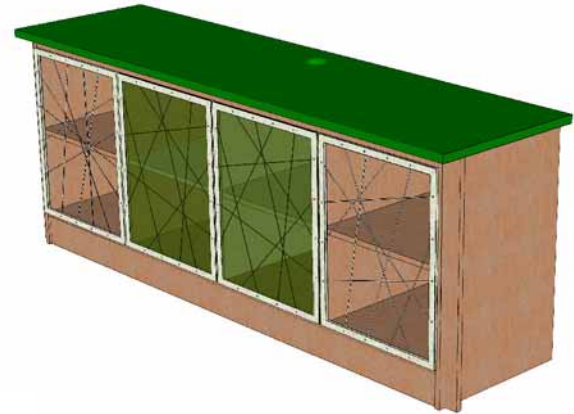
Isometric projection  
Scale NTS

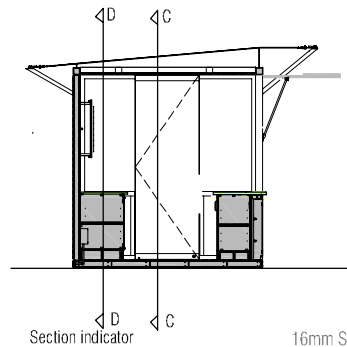


Back counter  
Scale NTS

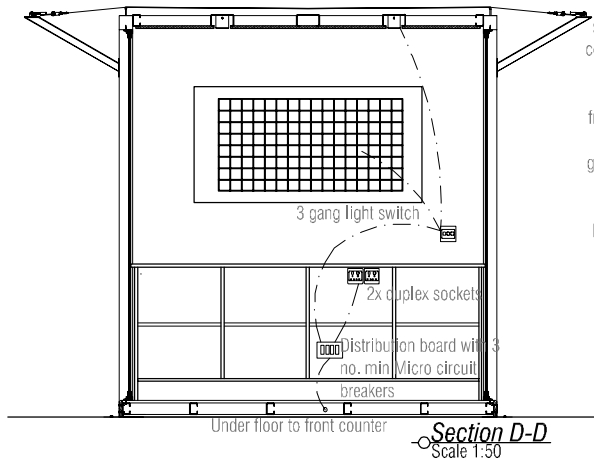


Isometric projection  
Scale NTS





16mm Saligna timber ceiling slats screw fixed to steel lipped channels, satin varnish finish. Two slats to either side of light fittings remain removable for maintenance. 15mm offset between slats with 22mm shadow gap to perimeter of ceiling.



12mm thick Surinno solid surface resin composite in colour Alabaster supporting proprietary chromed wire gridwall display system from Cyntron Wire Products fixed back to wall with galvanised mild steel angle brackets fixed into metal wall studs or battens between studs for support.

15mm thick oriented strand board (OSB) semi-gloss varnished to inside and outside of kiosk, fixed to metal furring studs with self tapping screws, holes to be filled with wood filler in colour to match board and leveled prior to varnishing

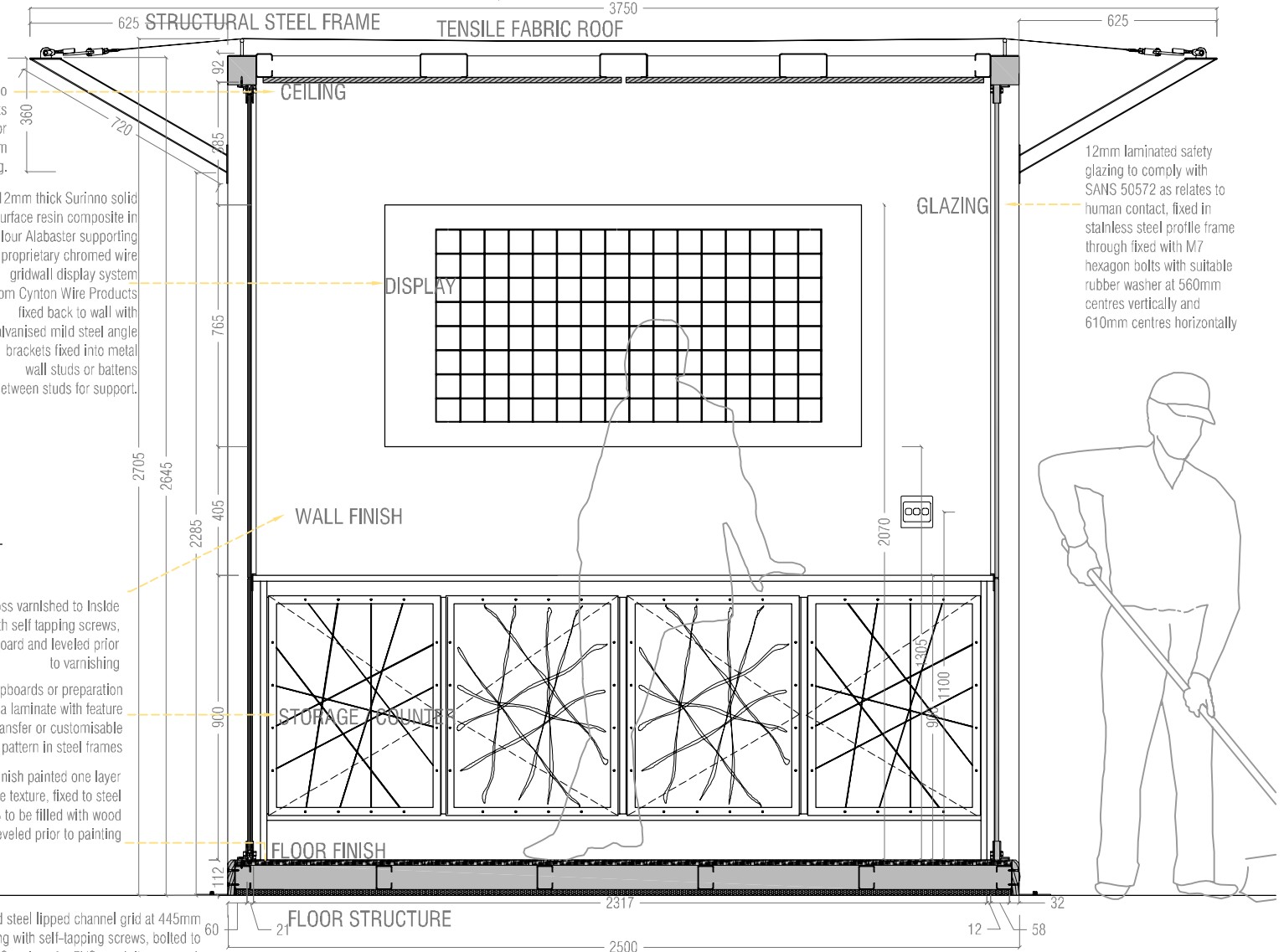
Okoume veneer storage and occasional display cupboards or preparation counter with counter top in "Primary Green" Formica laminate with feature doors in green cast acrylic with adhesive vinyl transfer or customisable stainless steel wire pattern in steel frames

18mm thick oriented strand board (OSB) floor finish painted one layer white floor paint to allow retention of OSB surface texture, fixed to steel substructure with self tapping screw, holes in OSB to be filled with wood filler and leveled prior to painting

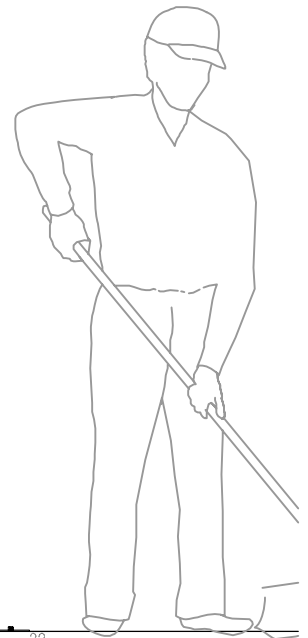
75x50x20x2mm deck of Clotan galvanised mild steel lipped channel grid at 445mm centres, with channels pre-punched to allow fixing with self-tapping screws, bolted to corner columns. Openings for PVC conduit pre-cored. 915x915x20mm thick protective neoprene rubber underlay sheets cut to size with adhesive backing fixed to substrate flooring (ceramic tiles / terrazzo)

90x90x3mm galvanised mild steel cold rolled square tubes welded to form structural frame, corner columns bolted to station floor through square base plate with 4 no. anchor bolts. Steel to be primed and painted dark grey. Holes for infill and roof masts to be pre-drilled.

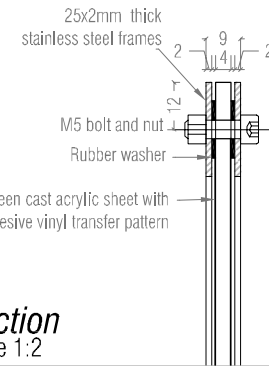
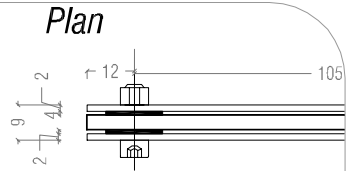
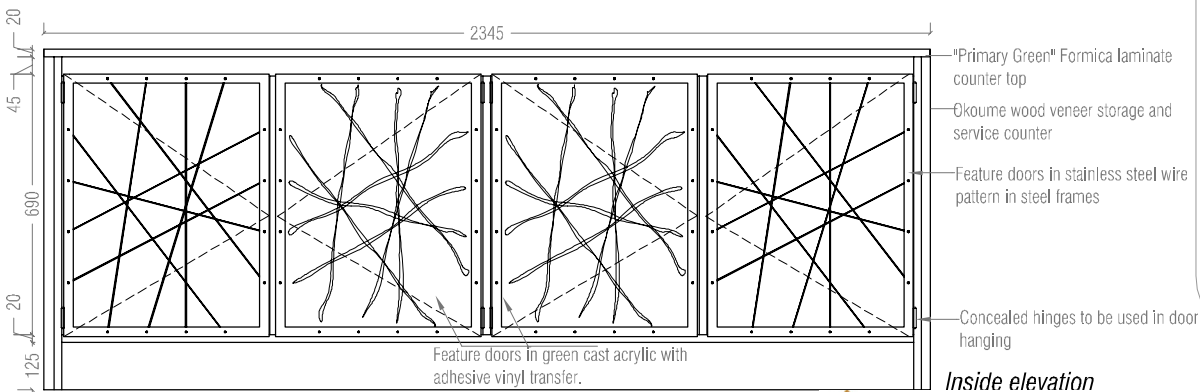
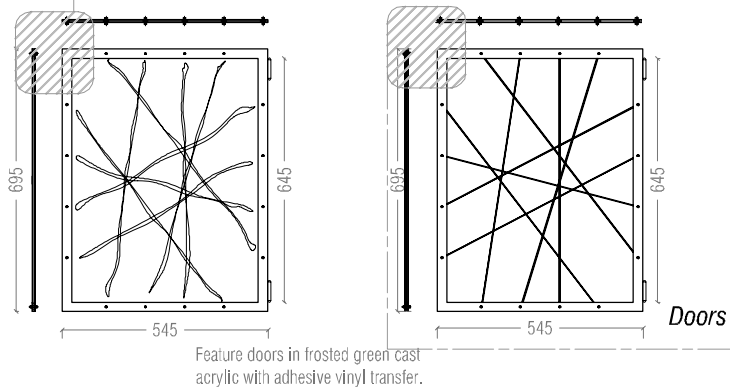
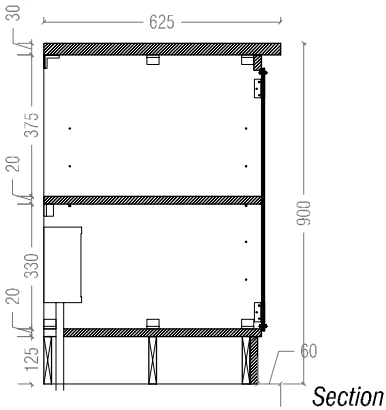
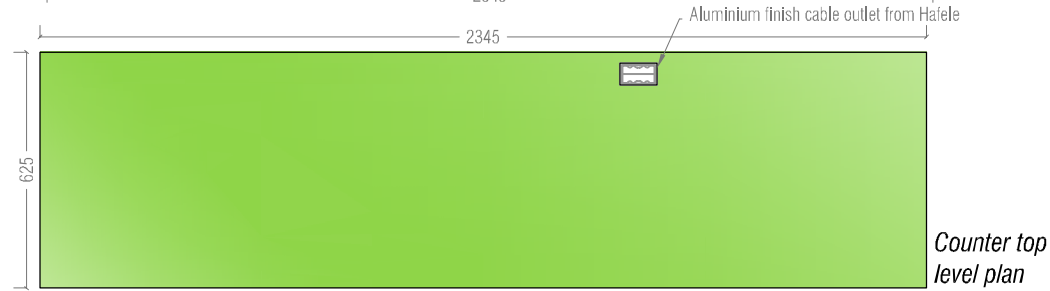
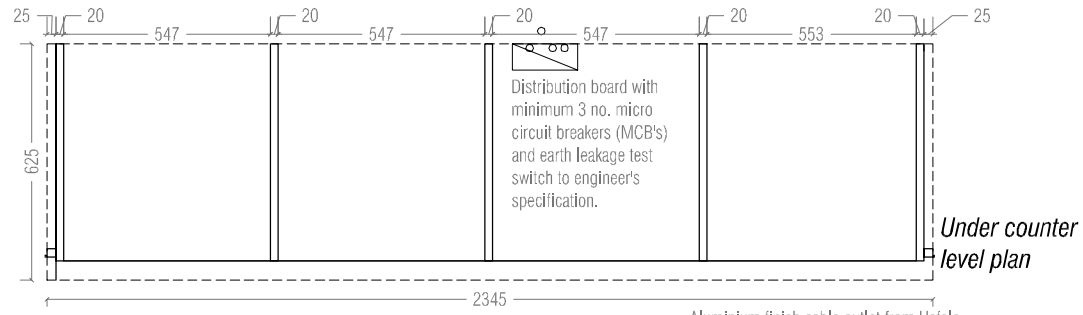
Satine 5500 fire retardant fibreglass tensile fabric with 6mm stainless steel catenary rope in RF welded catenary pocket (perimeter seams) attached to ends of steel masts by stainless steel clevis, connector plate and threaded clevis. Fabric tensioned to manufacturer's specifications on site



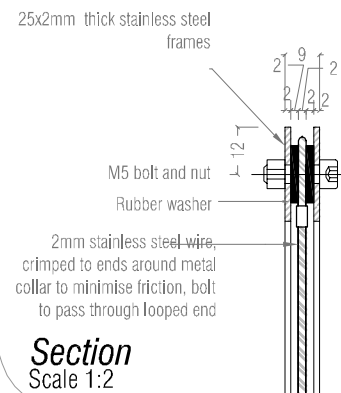
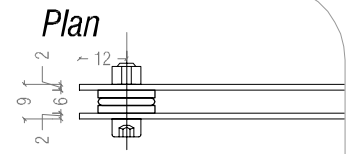
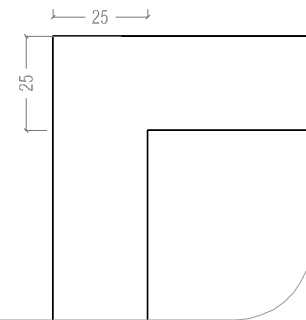
12mm laminated safety glazing to comply with SANS 50572 as relates to human contact, fixed in stainless steel profile frame through fixed with M7 hexagon bolts with suitable rubber washer at 560mm centres vertically and 610mm centres horizontally



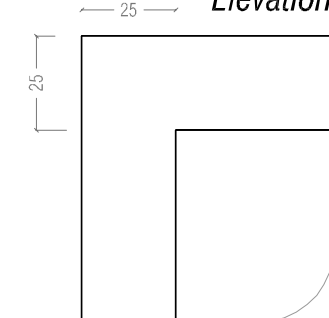
Section C-C  
Scale 1:20



**Elevation**

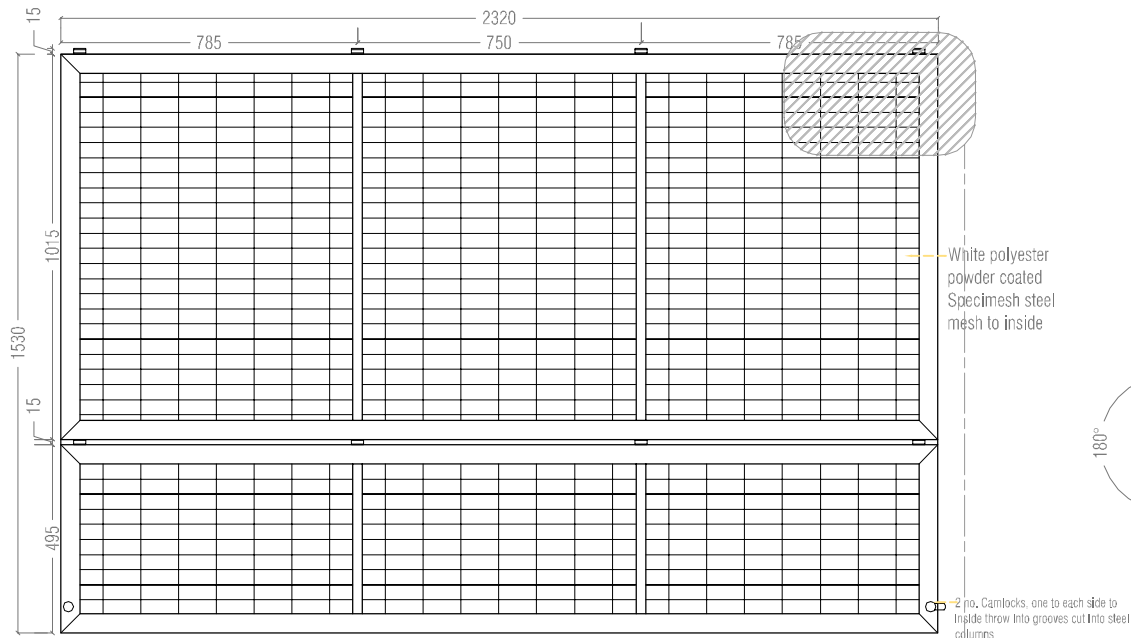


**Elevation**

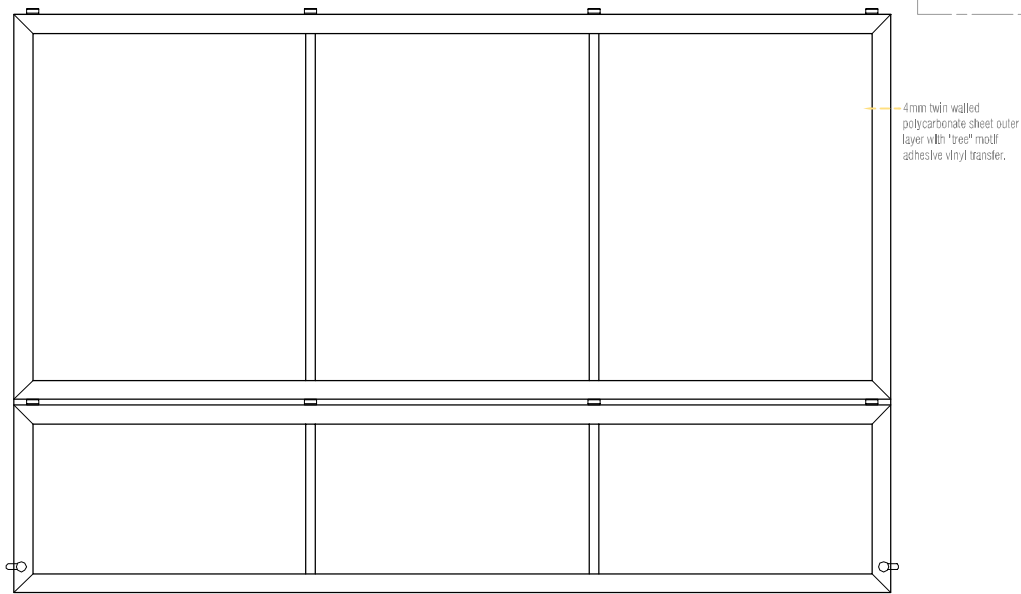


**Back storage counter**  
Scale 1:20





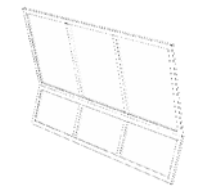
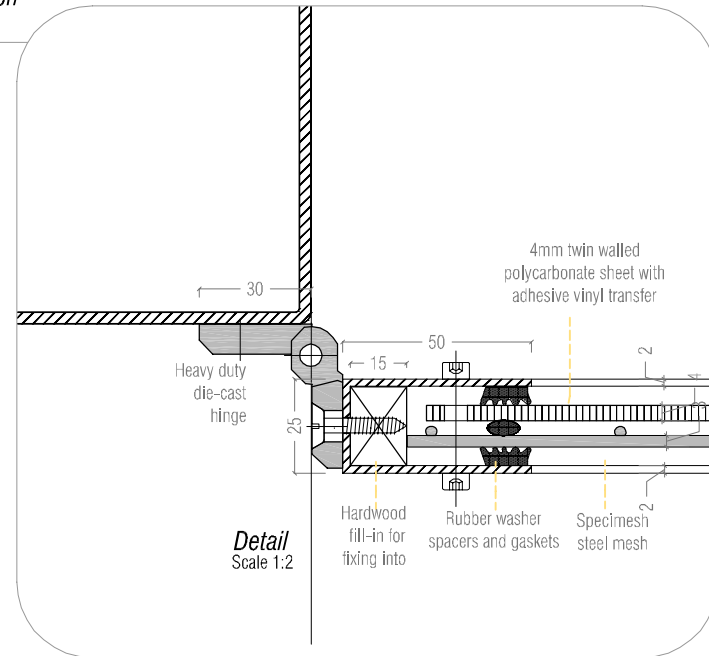
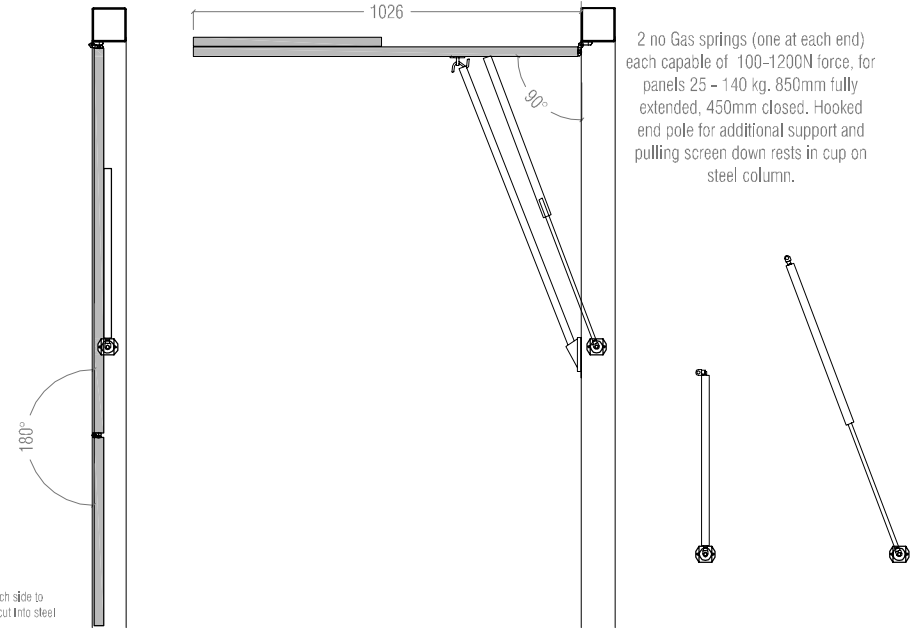
Inside elevation



Outside elevation



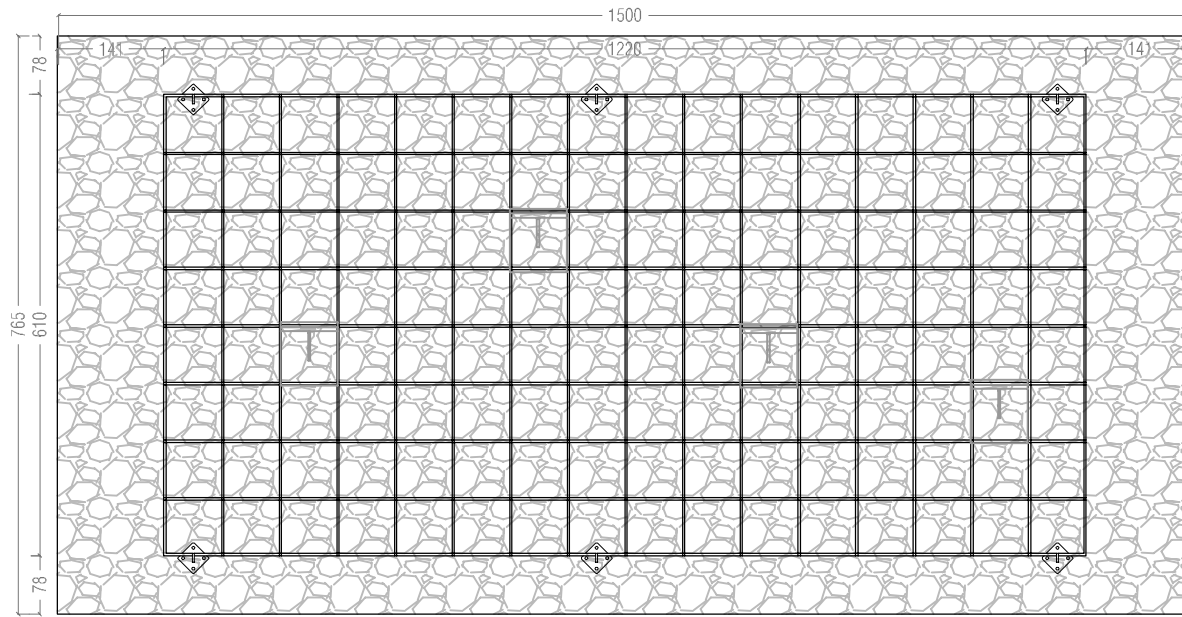
Plan



Isometric projection Scale NTS

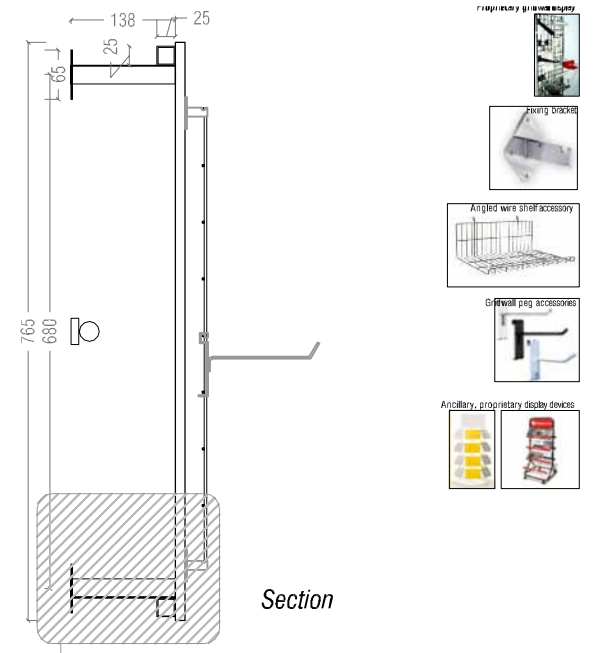


Canopy / screen Scale 1:20

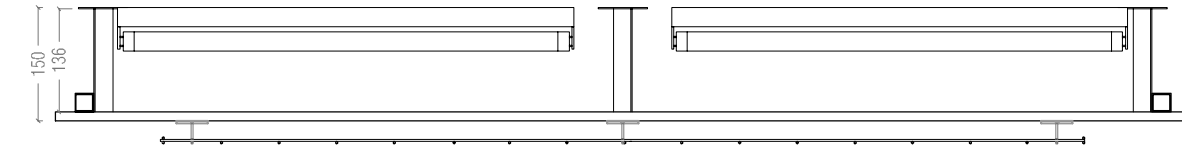


**Elevation**

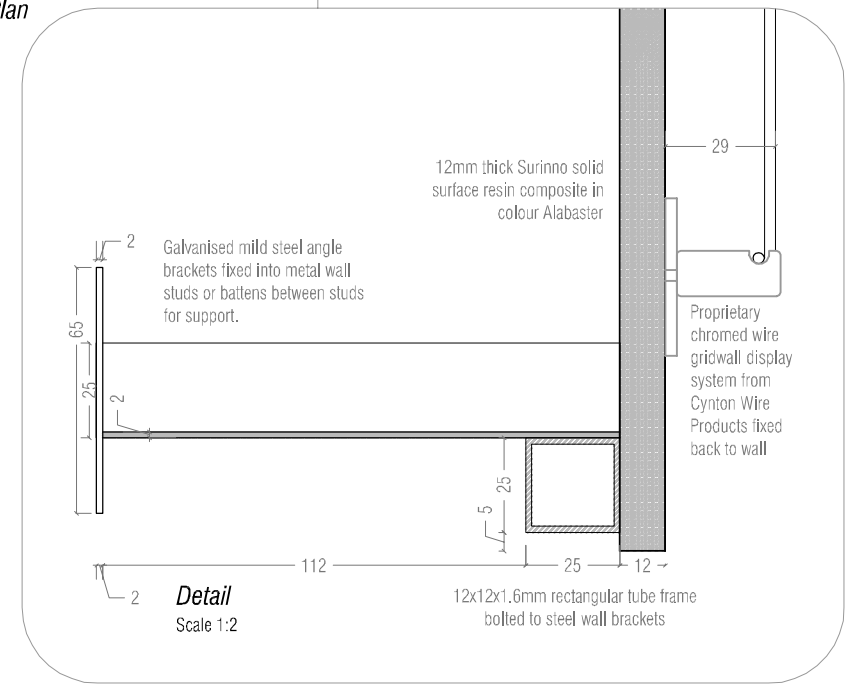
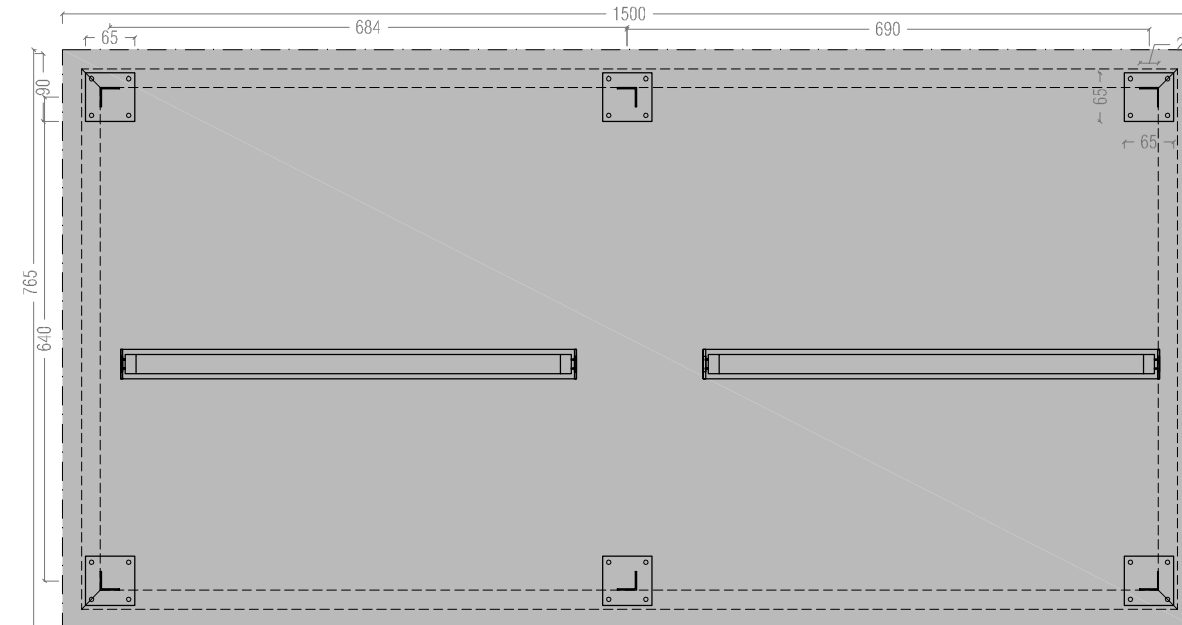
12mm thick Surinno solid surface resin composite in colour Alabaster supporting proprietary chromed wire gridwall display system from Cyntron Wire Products fixed back to wall with galvanised mild steel angle brackets fixed into metal wall studs or battens between studs for support.



**Section**



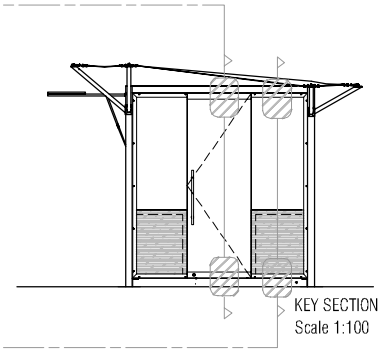
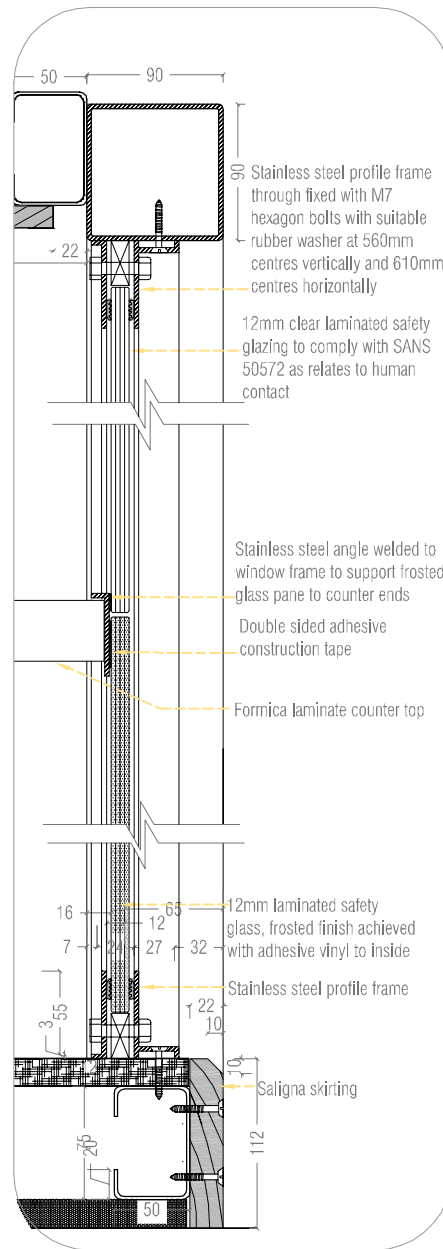
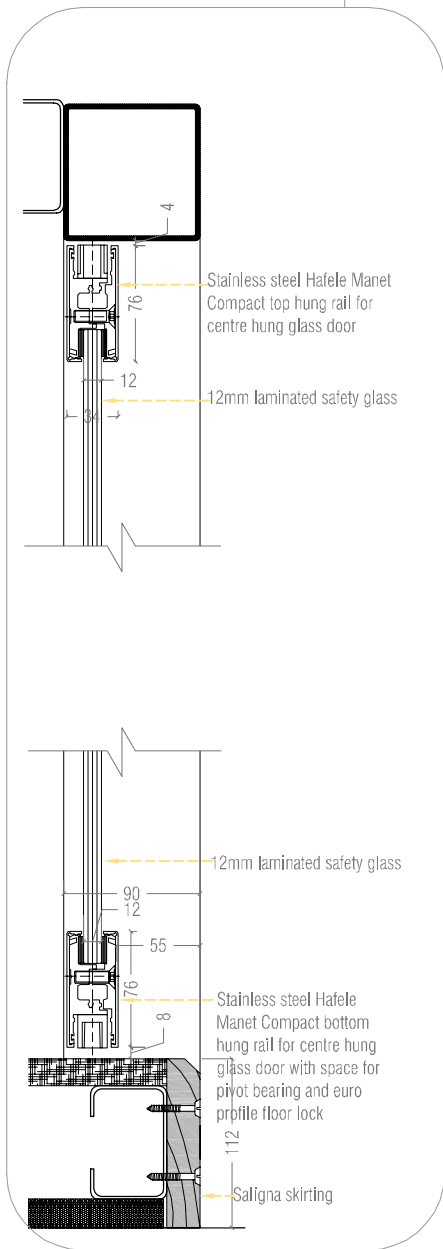
**Plan**



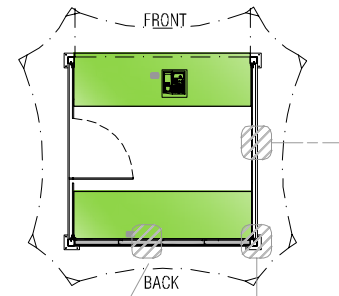
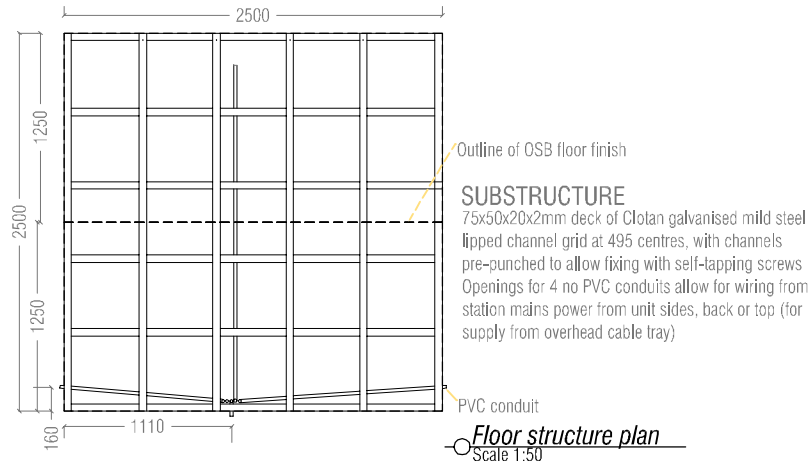
**Detail**  
Scale 1:2

**Section Elevation (brackets)**

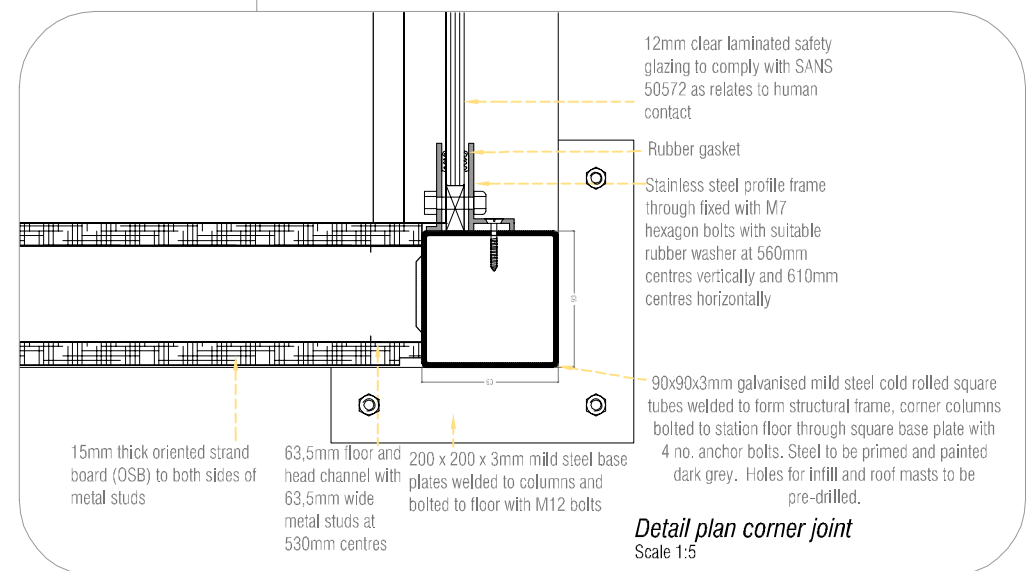
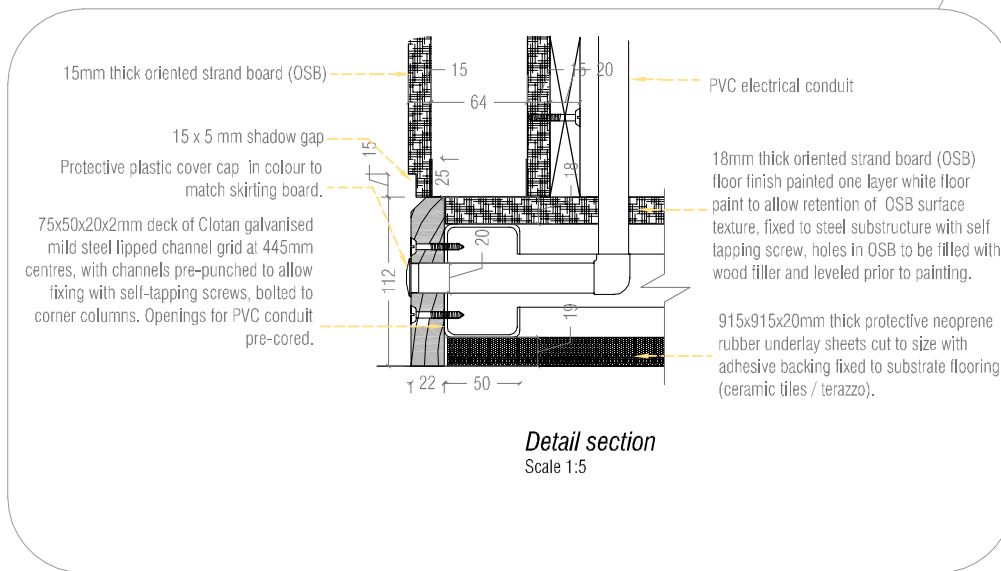
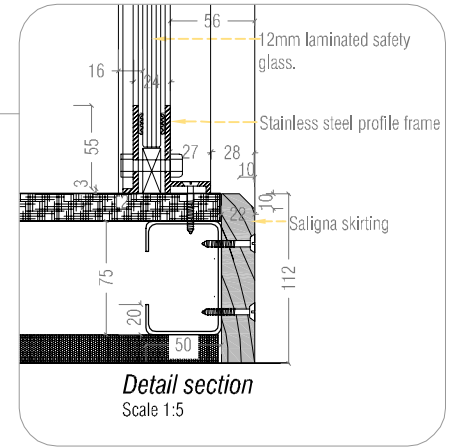
**Display grid**  
Scale 1:5



Glazing & door details  
Scale 1:5



KEY PLAN  
Scale 1:100



**Floor details**  
Scale: various

# List of references

## Books

- ADDISON, C. 2002. *Autopia: Cars and culture*. Edited by P. Wollen, J. Kerr. London: Reaktion Books. P. 219-226.
- ALLEN, V. 1971. *Kruger's Pretoria: buildings and personalities of the city in the nineteenth century*. Cape Town: Balkema,
- ASH, P. 1998. *South Africa by rail*. Chalfont St Peter, UK : Bradt Publications.
- BURKE, R. 2007. *Project Management techniques*. Burke publishing.
- CARMONA, M., HEATH, T., OC, T., TIESDELL, S. 2003. *Public places - urban spaces: the dimensions of urban design*. Oxford: Architectural Press
- CHIPKIN, C. 1998. *Architecture of the Transvaal*. Edited by R. Fisher, S. le Roux, E. Mare. Pretoria: University of South Africa
- DE JONG, R.C., VAN DER WAAL, G.M., HEYDENRYCH, D.H. 1988. *NZASM 100: The buildings, steam engines and structures of the Netherlands South African Railway Company*. Pretoria: Chris van Rensburg Publications.
- DEWAR, D., UYTENBOGAARDT, R.S. 1991. *South African Cities: a manifesto for change*. Cape Town: Mills Litho
- DUNNE, P.M., LUSCH, R.F. 2008. *Retailing*. International student edition. 6th Edition. Ohio: Thomson South-Western
- FRAMPTON, K. 1995. *Studies in tectonic culture: the poetics of construction in nineteenth and twentieth century architecture*. London: MIT.
- HARDINGHAM, S. 2002. *London: a guide to recent architecture*. London: Batsford
- HOLM, D. 1996. *Manual for energy conscious design*. Pretoria: Directorate for development: Department of minerals and energy.
- JACOBS, J. 1961. *The death and life of American cities: The failure of town planning*. Middlessex, England: Penguin Books
- JODIDIO, P. 2006. *Architecture now! 4*. Cologne: Taschen.
- KURTICH, J., EAKIN, G. 1993. *Interior architecture*. New York: Van Nostrand Reinhold.



- LAUBSCHER, H.P. 1992. *Die verhaal van Hatfield / Hillcrest*. Pretoria: Pretoria Historica Publishers.
- LEEDY, P. 2005. *Practical research: planning and design*. 8th Ed. New Jersey: Prentice Hall
- LYNCH, K. 1981. *Good city form*. Cambridge, Mass: MIT
- PORTER, T. 2004. *Archispeak: an illustrated guide to architectural terms*. Oxon: Spon Press.
- Pretoria (1855-1955): History of the city of Pretoria*. Edited by Engelbrecht, S.P., Agar-Hamilton, J.A.I., Pelzer, A.N., Behrens, H.P.H. 1955. Pretoria: Council of Pretoria
- Pretoria 150: 'n Geskiedenis*. Edited by Lombaard, A., Green, F., Pretorius, J. 2005. Pretoria: Olimpiade Uitgewers.
- RICHARDSON, P. 2001. *XS: Big ideas, small buildings*. London: Thames & Hudson
- WALKER, S. 2006. *Sustainable by design: explorations in theory and practice*. London: Earthscan.

## Journals

- BARAC, M. 2007. *Public Space Project, Philippi, Cape Town*. The Architectural Review. June 2007, Volume CCXXI, no. 132, p. 64-65.
- BONSIEPE, G. 2006. *Design and democracy*. Design Issues. Spring 2006, Volume 22, no. 2, p 27-34.
- HAVENHAND, L.K. 2004. *A View from the Margin: Interior Design*. Design Issues, Fall 2004, Vol 20 Issue 4, p32-42

## Theses

- BINDER, M. 2003. *Adaptive reuse and sustainable design: a holistic approach for abandoned industrial buildings*. MArch thesis. University of Cincinnati.
- DU PLESSIS, A. 2003. *Gautrain Station, Hatfield*. M(Arch) thesis. University of Pretoria
- GROBLER, J. 2003. *Hatfield Gautrainstasie*. M(Arch) thesis. University of Pretoria
- LE ROUX, J.C. 2008. *Transforming public space*. M(Arch) thesis. University of Pretoria
- VAN DER WATH, E. 2008. *Recover*. MInt(Prof) thesis. University of Pretoria

## Internet

2008. *Gautrain Image Gallery*. Available at [http://www.gautrain.co.za/img\\_gal/](http://www.gautrain.co.za/img_gal/). Accessed on 12 February 2009.
- ARCHITECTURAL REVIEW. 2009. *Awards for Emerging Architecture: 2008*. Available at <http://www.architecturalreviewawards.com/>. Accessed on 15 June 2009.
- CITY OF TSHWANE METROPOLITAN MUNICIPALITY. 2006. *City Of Tshwane Integrated Transport Plan 2006-2011*. Available at [www.tshwane.gov.za/idp.cfm](http://www.tshwane.gov.za/idp.cfm). Accessed on 12 February 2009
- CITY OF TSHWANE METROPOLITAN MUNICIPALITY. 2006. *Tshwane Growth and Development Strategy Final Draft 2006*. Available at [www.tshwane.gov.za](http://www.tshwane.gov.za). Accessed on 12 February 2009
- CITY OF TSHWANE METROPOLITAN MUNICIPALITY. 2007. *City of Tshwane Spatial Development Strategy 2010 and beyond*. Available at <http://www.tshwane.gov.za/documents/cityplanning/SpatialDevelopment-2010beyond.pdf>. Accessed 12 Feb 2009.
- CITY OF TSHWANE METROPOLITAN MUNICIPALITY: CARTOGRAPHY, GEOMATICS. 2008. *Gauteng\_Province\_A4.mxd*. Available at [http://www.tshwane.gov.za/streetmaps/Gauteng\\_Province\\_A4.pdf](http://www.tshwane.gov.za/streetmaps/Gauteng_Province_A4.pdf). Accessed on 30



March 2009.

COMET CATERING EQUIPMENT COMPANY (LTD.). 2006. Available at <http://www.cometcatering.com/commercial.html>. Accessed on 25 July 2009.

ETHERINGTON, R. 2009. Dezeen: Design magazine: *Paperhouse by Heatherwick Studio*. Available at [www.dezeen.com/wp-content/uploads/2009/08/paperhouse-by-heatherwick-studio-1.jpg](http://www.dezeen.com/wp-content/uploads/2009/08/paperhouse-by-heatherwick-studio-1.jpg). Accessed on 28 August 2009.

Google Earth. 2009. *Aerial photo of South Africa*. <http://earth.google.com/>. Accessed on 30 March 2009

*Grand Central terminal*. 2009. <http://grandcentralterminal.com/info/heartofnyc.fcm>. Accessed on 26 April 2009

HOME ARCHITECTS. 2008. *UK specification: BoKlok apartments*. Available at <http://livesmarthome.com/livesmart/downloads/pdf/boklok%20visual%20spec%20-%20gen1%20apartments.pdf>. Accessed on 8 June 2009.

MOMA. 2008. *Home Delivery: Fabricating the Modern Dwelling*. Available at <http://www.momahomedelivery.org>. Accessed on 17 June 2009.

NETWORK RAIL. 2009. *Liverpool Street Station guide*. Available at [http://www.networkrail.co.uk/documents/For%20Passengers/Station%20Maps/4512\\_Liverpool%20Street%20Station%20Map.pdf](http://www.networkrail.co.uk/documents/For%20Passengers/Station%20Maps/4512_Liverpool%20Street%20Station%20Map.pdf). Accessed on 30 March 2009.

PROJECT FOR PUBLIC SPACES. 2009. *What is placemaking?* Available at [www.pps.org/info/bulletin/what\\_is\\_placemaking](http://www.pps.org/info/bulletin/what_is_placemaking). Accessed on 5 October 2009

SPOORNET. 2006. *The Spoornet Heritage*. Available at <http://www.spoornet.co.za/SpoornetWebContent-SAP/html/about/history.htm>. Accessed on 16 October 2009.

## Other

2009. *Branding open lecture*. 28.04.2009. University of Pretoria, Pretoria.

ANDREW, C. 2009. *Gautrain Progress Update for The Old Edwardian Society 15 May 2009*. Received 30 July 2009. pdf file.

BOMBELA CJV. 2007. *Presentation to stakeholders: Tshwane stations*. Powerpoint presentation. Date: 01.03.2007

BOMBELA. 2009. *Gautrain: Detailed Landscape Design Forum: Pretoria – Hatfield section & University Road palm trees*. Bombela: Johannesburg

GAJV. 2008. *Architectural Guideline: Specification: revision 3*. 20 June 2008. pdf document.

KÖNIGK, R. 2009. Interview. 18.03.2009. University of Pretoria, Pretoria

OSMAN, A.O.S., KÖNIGK, R. 2008. *Educating for flexibility: housing and urban environments in South Africa*. Proceedings of an international joint conference held by CIB W104 - Open Building Implementation and CIBW110 - Informal settlements and affordable housing: Education for an Open Architecture. Edited by Stephen Kendall. Ball State University, pp 112 - 119.

OTTO, N. 2009. Personal email. (22 April 2009).

STEER, T. 2009. Interview. 23.04.2009. University of Pretoria, Pretoria.

WORLD BANK PARTICIPATION SOURCEBOOK. 2009. *Methods*. pdf document.

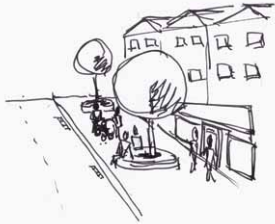


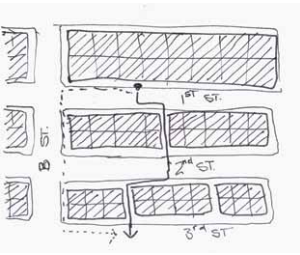






# *Appendices*

## *Appendix 1 Theory matrix*





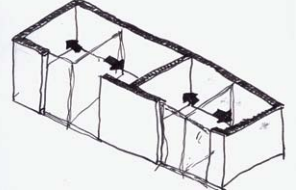


URBAN QUALITIES: IDENTIFICATION OF THEMES							
Source	Sense of place	Access	Control & Safety	Mixed use	Scale & fit	Legibility	Adaptability
Lynch 1981 Good city form	Unique sensory & temporal characteristics of a space allows user to recognize and distinguish it and create a "place"	People require access to other people, activities, resources, places (shelters, open spaces, symbolic, natural etc), information.	Those who use wield control over a space must do it with: * Responsibility, and * certainty (people understand system and feel secure)		Spatial & temporal patterns should enable competent execution of customary behaviours e.g. movement, social interaction	Ease of orientation in space and time provides greater legibility	Two dimensions important for adaptability: Manipulability (small changes to present use) and resilience (reversible) for undoing previous adaptations
		Important subdimensions of access: 1. require diversity of things accessed 2. Require equity of access 3. Control of access system, necessary to enforce basic social control	Controlling boundaries can be physical or symbolic		Fit relates to culture and behaviours within culture –clashes between different actions can be overcome by compartmenting –= providing overlapping spaces for different behaviours, within control system		
			Compartmentation – small areas of control		Design elements should relate to human scale		
			Tolerance of diversity important		Better fit is achieved if user controls some or all of space		
Dewar, D & Uytendogaardt, R.S 1991 SA cities: a manifesto for change	Expressing community identity spatially allows social ties to be made in community (p.21)	Providing freedom to act, WITHIN constraints / structure enables release of energy & constructive action)	Constraints are necessary for creation of realistic choices, choices lead to individual freedom (p23)	Need for diverse activities & specialization over relatively small (walking) distances (needs high level of support)	Spaces need to enable activities	Community identity in spatial form increases legibility	Generality of plan allows future reinterpretation of plans
		Equity essential - easy access by majority to opportunities presented	Constraints offer coherence and continuity (p24.)	Densified urban environment good for mixed use scheme, as these work better at a pedestrian scale = short walking distances.	Create places for social interaction & innovation		
		Choice important			Densification on urban level works better at pedestrian scale, small businesses are well supported on foot, greater diversity allowed		
Kurtich & Eakin 1993 Interior Architecture	Incorporation of temporal aspects into three dimensional space enhances experiential qualities of space						
Jacobs 1961 The death and life of American cities	Pavement and neighbourhood amenities as communal meeting place (p 66 & 82) Can experience public contact with no private commitments	Short, permeable city block, decrease walking distance between attractions (p161), promote mingling of people, commerce and activity (p.192)	Residents are natural proprietors (eyes on the street). Continuous 24 h use results in safer streets (p.45).	Diversity generates diversity (retail, commercial), but needs enough local population to support the diversity of uses (p161)	Street & pavement scale for public interactions	Visual interruptions of long streets increases legibility of street (p397)	
			Clear demarcation between public and private space (p 45)	Ideally 2 or more primary functions (office, retail, something that draws people), busy at different times of day. (p162)		People use landmarks to orientate themselves in a space (p.397)	
			Create attractions to draw people through spaces not regularly used (p46)	Mix secondary functions with primary to serve people drawn by primary functions & support secondary functions (p174)		Emphasising a space's diversity & difference from adjacent ones increases legibility and recognition (p399)	
			Lively activity attracts watchers who act as part-time proprietors (p 47)	Provide attractions not found nearby will draw people (p172)			
			Allow Neighbourhood self-governance, limit institutional control				

Performance criteria	Ideals	Illustration
<b>1. Sense of place</b>	Incorporate temporal dimension into three dimensional space to increase recognition & experiential qualities of space and creates "place"	
	Express community identity to enable more social ties	
	Create public meeting places pavement / local shops for informal communal interaction	
<b>2. Access &amp; permeability</b>	People require access to other people, activities, resources, and information.	
	Enable easy access and choice / diversity	
	Create permeable city blocks / streets to lessen walking distances, increase activity	
	Provide structured access (control) for constructive activity & energy	

Performance criteria	Ideals	Illustration
<b>3. Control</b>	Control offers realistic choices, coherence & continuity	
	Diversity must be tolerated	
	Control of boundaries between public and private can be physical or symbolic and is most effective if spaces are compartmentalized as small areas of control	
	For safety, lively activities attract watchers who act as part-time proprietors and 24h use ensures safer environments.	
	Limit institutional control, neighbourhood or business district self-governance allows people to take charge of "their" space	
<b>4. Contextual dialogue</b>	Overlap conditions and activities to provide vital complexity & diversity	
	Balance society & cosmos, and society & nature	
	Include mix of levels of intensity & exposure from very intensive & exposed to quiet and private	
<b>5. Mixed use</b>	Provide diverse activities & specialization over relatively small (walking) distances.	
	Mix secondary functions (shops, eateries) with primary functions (railway, offices) to serve people drawn by primary functions & support secondary functions	
	Provide attractions not found nearby to draw people	



Performance criteria	Ideals	Illustration
<p><b>6. Scale &amp; fit</b></p>	<p>Spaces need to enable competent execution of activities in terms of</p> <p>a. human scale and</p>	
	<p>b. enabling of culturally linked behaviours</p>	
<p><b>7. Legibility</b></p>	<p>Use landmarks or expression of community identity to enable people to orientate themselves easily and increase legibility</p>	
	<p>Emphasise difference and diversity of a space compared to others nearby to increase legibility and recognition</p>	
<p><b>8. Adaptability</b></p>	<p>Design to allow for manipulability (small changes to present use) and resilience (reversibility) for undoing previous adaptations</p>	
	<p>Allow generality of plan and standardization to increase future adaptability</p>	



# Appendix 2

## Urban framework

### 1. Urban framework

The main aim of investigating the existing urban frameworks proposed for the Hatfield area is to analyse the Hatfield context site in terms of current proposals such as the Gautrain project, *Hatfield station development framework* and the *City of Tshwane Spatial Development Strategy 2010 and beyond*, discussed briefly in the next section.

### 2. City of Tshwane Spatial Development Strategy 2010 and beyond

The Hatfield precinct is identified in the strategy as an area in which economic activity needs to be **strengthened**. Three types of economic development areas are identified, namely:

- Metropolitan Activity Nodes
- Development Corridors
- Specialised Activity Areas

Hatfield is identified as a potential **metropolitan node** and a **specialized Activity** area. This is due to the Education and Research Hub and the proximity of various academic institutions including the University of Pretoria and the Innovation Hub (see below).

Metropolitan Activity Nodes are major urban **centres of activity**, characterised by **mixed** land uses such as commercial, residential, social and cultural.

These areas should as far as possible be physically and functionally integrated with major transport infrastructure in the area. These areas are further characterised by:

- High intensity and high density mixed land use;
- Highest level of accessibility;
- 24 hour activity;
- Well defined public spaces;
- Pedestrian friendly environments; and
- Public transport facilities and activities.



The focus of the development strategy around the Hatfield Gautrain station involves the redevelopment of the existing business node to **align** with the **Gautrain** development, **pedestrianisation** and integration with existing and proposed dedicated **public transport** facilities (City of Tshwane Spatial Development Strategy, 2010 and beyond. 2007:17)

The Innovation Hub is a Blue IQ project undertaken with the Gauteng Provincial Government to partially achieve the goals set out in the Gauteng Growth & Development Strategy. The main aims of the latter strategy is to develop Tshwane as a Smart Province and investing in the knowledge and innovation economy sectors (Blue IQ 2009:[sp])

This cluster of innovation businesses is located in a business complex to the east of the N1 highway bordering the University of Pretoria experimental farm which is in turn located just east of Hatfield.

The project has a number of strategic objectives:

- \* Support entrepreneurship
- \* Increase local technological development to bridge the “commercialization chasm”
- \* Create a centre for innovation knowledge and practical experience in support of the Provincial knowledge economy initiatives
- \* Sustain economic growth by yielding more knowledge workers in innovative businesses
- \* Create a Smart Province and develop high tech businesses in Gauteng.

The proximity of the Innovation Hub contributed to the perceived need for a Gautrain station in Hatfield.

### 3. Development framework for the Hatfield station functional area, 2003

This development framework was initiated in order to coordinate the Station Functional guidelines prepared by the Gautrain team with other COTMM design proposals in the area. It has been adopted almost wholesale for the purposes of this study. Since the focus of the study is at a relatively small scale, and due to time constraints, the development of a new urban framework was not deemed essential. An abbreviated version of this framework is included here to demonstrate cognizance of the larger scale of urban development schemes, with a few alterations in line with the design philosophy and approach as outlined in Chapter 4.

#### Vision

The vision for Hatfield Station is to create a **pedestrian friendly** environment where all major destinations are connected via pedestrian routes. Security, general appearance and marketing are also important issues to be considered. The Hatfield Station area should:

- \* become a **tourist** destination for local and foreign visitors, incorporating entertainment, educational and sports facilities.
- \* support and extend **pedestrian** movement
- \* support residential **densification**
- \* encourage more **permanent** residents to combat the seasonal nature of student occupation
- \* encourage **integration** of the station with surrounding land uses
- \* make provision for the pedestrian **linkages** of the Gautrain station with existing SARCC stations, Hartbeespoort and Rissik.

To this should be added:



- \* Focus on the creation of place inside the station and in station vicinity.
- \* Care should be taken to incorporate local and/ or cultural references to enable community identification with the place. With an international standard system such as the Gautrain the pressures of globalisation and mass culture could stifle local authentic influences.

### Short term objectives

In the short term, these objectives focus mostly on **pedestrian movement** and improvement of pedestrian routes.

- \* Implement generous sidewalks
- \* Ensure appropriate signage for wayfinding
- \* Increase permeability due to large city blocks
- \* Ensure adequate lighting and safety along pedestrian routes
- \* Guide development to enhance public realm along pedestrian routes
- \* Guide or restrict informal development along pedestrian routes
- \* Allocate space and coordinate interaction at modal transfer points
- \* Ensure road improvements consider pedestrian movement
- \* Ensure legibility in urban form

### Medium term objectives

These objectives focus on change of and management of land use in surrounding area.

- \* Develop and monitor the potential spatial structure
- \* Determine hard and soft fabric to determine the limits of intervention
- \* Promote mixed-use development
- \* Implement a City Improvement District (CID) to ensure clean and safe environments
- \* Ensure appropriate interface rules between different land uses
- \* Promote linkages through existing developments

## Context

The following context analysis includes only information not already contained in Chapter 3.

### Functional area (see map)

The functional area is defined by Church Street in the north, Hill street to the west, Lynnwood Road to the south and the border of LC de Villiers University sports grounds to the east.

It encapsulates a range of land uses including a large retail node (along Burnett St), offices located in office buildings and converted dwelling houses, residential areas (mainly low density), student accommodation to the south and the educational precinct of the University of Pretoria.

There are a number of important facilities in and around the Hatfield station functional area where **linkages** should be encouraged and facilitated:

- \* The Innovation Hub located on a portion of the University of Pretoria experimental farm
- \* The university of Pretoria campus and sports grounds (LC de Villiers)
- \* Securicor Loftus stadium
- \* Brooklyn business node, including Brooklyn Mall
- \* Hatfield retail node (Hatfield Plaza, Hatfield Square and retail along Burnett st)
- \* Business / office zone to the north and north-east of the station.

### Land use

Land uses trends in the different areas within the functional area were identified

#### Hatfield Village

- \* Low density **residential**
- \* Limited **medium density** (20units/ha and more) residential
- \* **Student** flats and communes
- \* **Offices** in converted dwelling houses along Glynn and Burnett streets are the second largest land use in the area
- \* **retail** facilities and higher order **offices** close to Duncan Road

#### Hatfield south

- \* Retail facilities on ground floor within respective land parcels are not clearly **linked** via pedestrian walkways
- \* **offices** as well as student **accommodation** are situated in medium high buildings with retail and/or entertainment and/or restaurants on ground floor
- \* Duncan road includes a large number of **motor** related developments while land use to the west of the retail node focuses on **apartment** buildings / residential
- \* The area in proximity to the railway line north of the retail node has not been extensively developed and no linkage to this area is evident
- \* Although limited informal trade is located in this area and the area is demarcated as a controlled trade area, this is not being managed properly.





Hatfield north

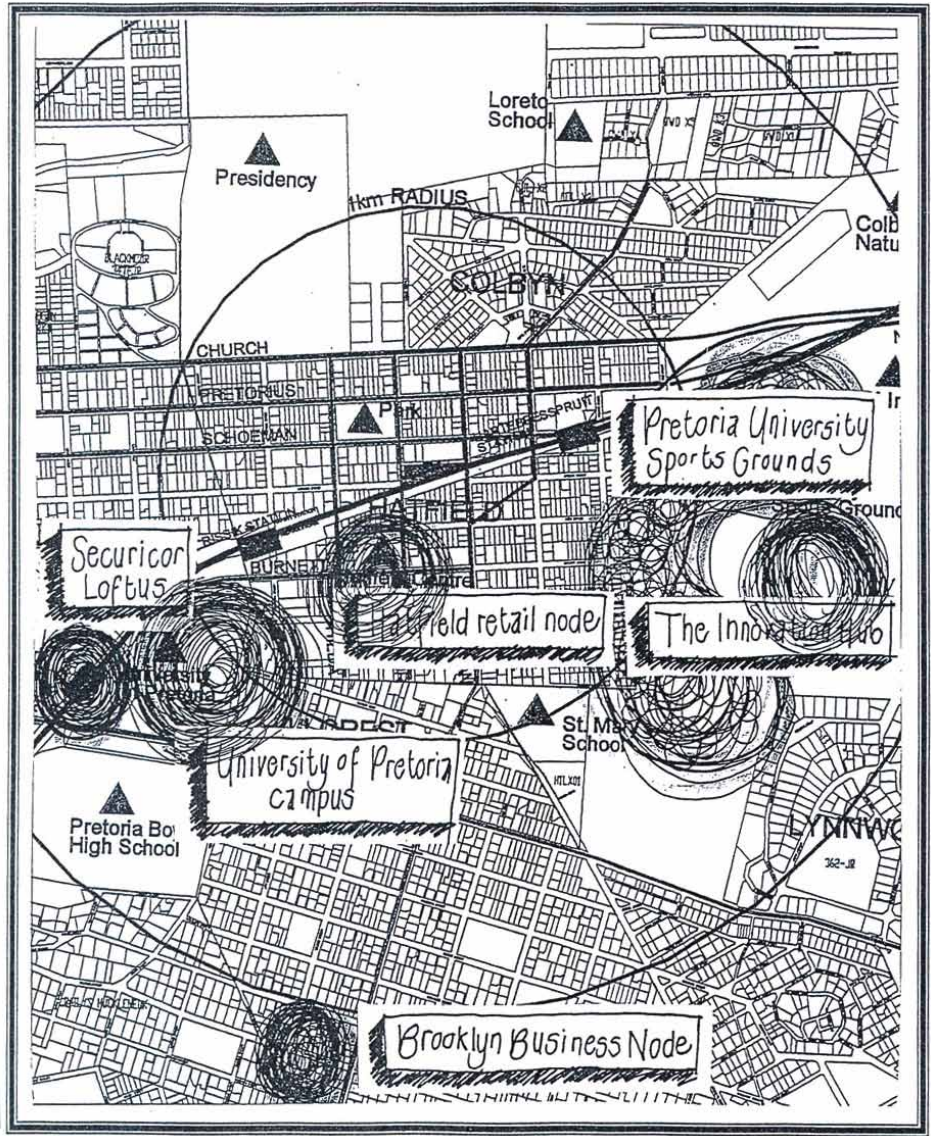
- \* **Offices** (blocks, dwelling type offices, embassies)
- \* Limited **residential** component except for Arcadia st west

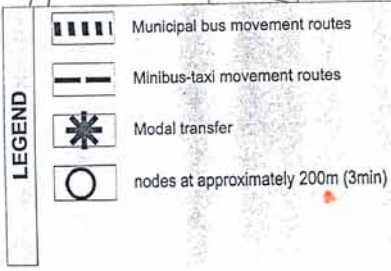
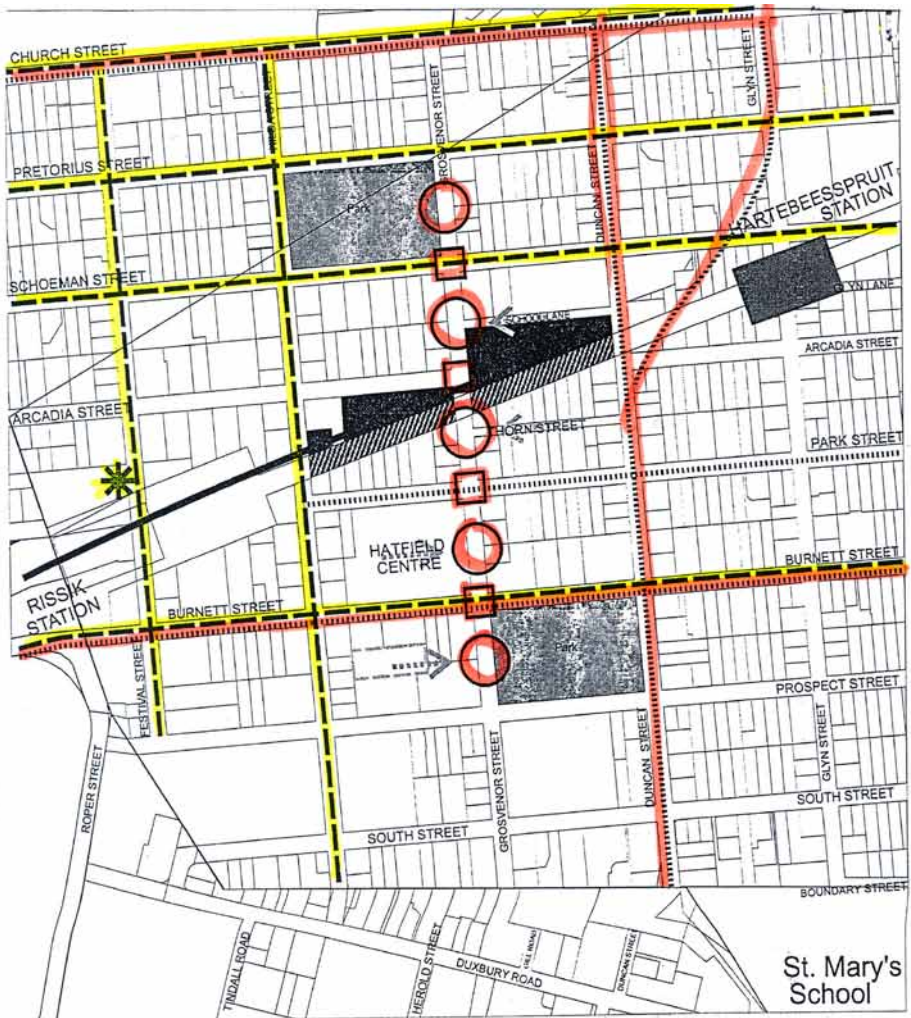
Table 4.2: Density Proposals for 100 ha around Hatfield Station

LAND USE	STATUS QUO			QUANTIFIED FUTURE SCENARIO					
	Total area (m <sup>2</sup> )	Current mix (%)	Average height	Future bulk area (m <sup>2</sup> )	Future mix (%)	Required bulk (m <sup>2</sup> )	Desired height (storeys)	Desired coverage (%)	Required area (m <sup>2</sup> )
Residential	94,337	17.7	2.4	250,000	29	155,663	4	50	77,832
Offices	267,130	50.3	4	300,000	34	32,870	4	60	13,696
Retail	50,817	9.6	1.7	80,000	9	29,183	1	60	48,638
Industry	0	0.0	-	0	0	0	-	-	-
Community Fac	17,876	3.4	1	25,000	3	7,124	1	50	14,248
Recreation / Parks	60,073	11.3	1	100,000	11	39,927	-	-	39,927
Hotel / Conference	11,616	2.2	1	40,000	5	28,384	4	60	11,827
Transport / Parking	3,142	0.6	1	80,000	9	76,858	3	80	32,024
Vacant	26,534	5.0	0	0	0	0	-	-	-
<b>TOTAL</b>	<b>531,525</b>	<b>100</b>	<b>-</b>	<b>875,000</b>	<b>100</b>	<b>370,009</b>	<b>-</b>	<b>-</b>	<b>238,192</b>

Source: Primary project research







**movement system/ pedestrian linkages**

0 100 SCALE



## SWOT analysis

### Strengths

- \* **Diversity** of land use that creates a variety of opportunities
- \* Possible **linkage** with Hatfield retail area and University educational precinct to strengthen the node and station use
- \* Links with **diplomatic** organisations and embassies
- \* proximity to **tourist** destinations
- \* Linear **pedestrianisation** and access to development along the railway line, connecting Loftus station, Rissik station, proposed Gautrain station and Hartbeesspruit station

### Weaknesses

- \* Development has generally been **low to medium density** (e.g. motor showrooms which de-densify concentrations)

### Opportunities

- \* **Linking** the Gautrain station with the Hartbeesspruit SARCC station as part of the Tshwane ring rail system and proposed extension of the Hatfield retail area

### Threats

- \* Increased **traffic congestion** would make the station less accessible

## Development framework concept

The urban design concept is based on the short and medium objectives as well as the vision for the Hatfield station area.

The Gautrain station is regarded as a catalyst for spatial restructuring. The focus is on improving access, linkage and mixed use in the node.

Spatial articulation should be improved by celebrating nodes at pedestrian and vehicular traffic intersections and along routes, ideally at 3 minute walking distances (200m).

Permeability should be enhanced in light of the fairly rigid, large block nature of the urban fabric. Mid-block pedestrian linkages should be encouraged.

The linkage of Grosvenor street across the railway cutting provides an opportunity to reduce the scale of the super block defined by Burnett, Schoeman, Hilda and Duncan streets. Although this linkage is mainly for improved vehicular access, there is an opportunity for a strong pedestrian oriented linkage. This has a logical extension to the two north and south urban parks.

## Development framework guidelines

The framework aims to improve pedestrian accessibility, spatial articulation, increased density and a stronger identity for the area.

- \* Land use changes are crucial for densification as there is little vacant land available
- \* Two urban spaces should be connected via Grosvenor street and the planned bridge across the railway cutting to increase legibility and symbolic character of the area
- \* Support the Grosvenor link with east-west pedestrian walkways to ensure a multidirectional linkage. This may be reinforced by the integration of Hatfield Plaza as a mid-block linkage into the station



**area**

- \* **The Hartbeesspruit station is currently isolated from the Hatfield core area. The linkage of this station and the Gautrain station should be a priority.**

To this could be added conclusions on macro scale from Chapter 4:

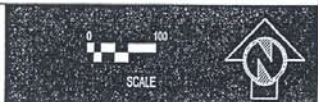
- \* Support the creation of place and the node at the Grosvenor / Arcadia st. intersection with a vibrant and user-oriented refreshment and retail node at the station
- \* Provide a greater mix of uses and more intensity of use within the station, linked to the Grosvenor / Arcadia st. intersection node.
- \* Create public meeting places (within the station as public space as well), with space for casual social interaction.
- \* Provide access to opportunities and services where these might be in short supply, including the secondary functions identified in Chapter 3, EAT SHOP, PAUSE, ACCESS INFO.
- \* Provide complexity and diversity in terms of activities and scales from larger scale outdoor activities to smaller scale indoor activities (re:refresh)
- \* Mix levels intensity and exposure from very intensive and exposed (e.g. public space, outside and inside station, train platforms, transport interchange) to less intensive and more private (e.g. kiosk interface inside stations).
- \* Mix secondary and primary functions, including the secondary functions identified in Chapter 3, EAT SHOP, PAUSE, ACCESS INFO.





<b>LEGEND</b>		Pedestrian link		Pedestrian development interface		Residential densification
		Mid-block pedestrian access		Commercial edge interface		Buffer zone/office interface
		Proposed bridge over road		Urban square		Interface with building
		Landmark opportunity		300m radius walking distance		Existing building
		Open space to protect		Main vehicular route		

**urban design framework**





UNIVERSITEIT VAN PRETORIA  
UNIVERSITY OF PRETORIA  
YUNIBESITHI YA PRETORIA

## *Appendix 3 Calculations*





## Horizontal beam and deck elements

Floor material :Oriented strand board

Closest type of element is plywood floor decking.

To get depth range:

Typical depths  $d$  (mm) 12-30    Typical spans  $L$  (m) 0.3-0.9    Typical  $L/d$ 30-40

Depth 18mm

$L/d = 30-40$

$L = 30d$

$L = 30(18)$

$L_{min} = 540\text{mm min span}$

Depth 18mm

$L/d = 30-40$

$L = 40d$

$L = 40(18)$

$L_{max} = 720\text{mm max span}$

To get depth assume span 600mm

$D = L/30$

$D = 600/30$

$D_{max} = 20\text{mm}$

To get depth assume span 600mm

$D = L/40$

$D = 600/40$

$D_{min} = 15\text{mm}$

## Vertical support elements:

Steel

RHS column

Height 2,9m

Typical heights single storey 2-8m

Span values  $h/d = 20-35$

Critical factors for sizing



Buckling  $h/d > 20$

Buckling and compression  $h < 20$

H/d between lateral supports at 20

$$X = h/d$$

$$20 = 2.9 / d$$

$$d = 2.9/20$$

$$d = 0.145$$

$$145\text{mm}$$

$$h/d =$$

$$S_{\text{max}} = h/d$$

$$35 = 2.9 / d$$

$$d = 2.9/35$$

$$d = 0.082$$

$$d = 82\text{mm}$$

(Orton)

### Gas Spring calculation:

Weight of 25x25x3mm angle iron frame at approx 1,11kg/m:

Total length: 15,34kg

Weight= 17kg

Weight of steel grid at approx 1,1kg/m<sup>2</sup>

Area : 3,53m<sup>2</sup>

W = 3,8kg

Weight of cast acrylic at 1190kg/m<sup>3</sup>

Thickness 4mm

volume approx= 0.0141

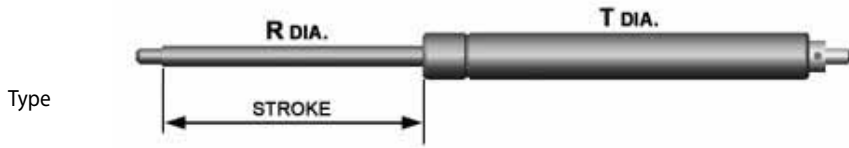
$$x \text{ kg/ m}^3 = 1190$$

$$x / 0.0141 = 1190$$

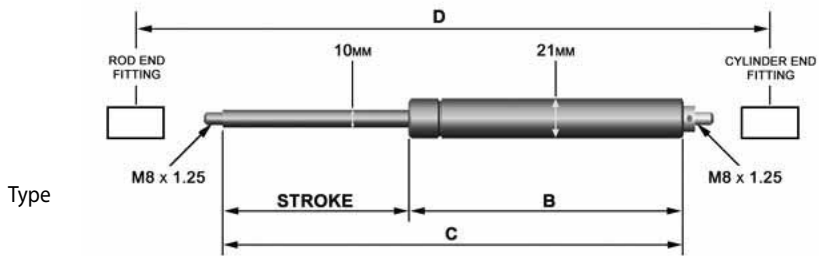
$$x = 16 \text{ kg}$$



Total screen weight = 17 + 3.8 + 16 = 36,8kg



Type					
SS-SD01	6	15	60 - 200	1 - 10	30 - 400N
SS-SD02	8	18	100 - 250	6 - 35	75 - 650N
SS-SD03	10	23	100 - 400	<b>25 - 140</b>	100 - 1200N



Type			
SDSS-03-100	100	150	250
SDSS-03-150	150	200	350
SDSS-03-200	200	250	450
SDSS-03-250	250	300	550
SDSS-03-300	300	350	650
SDSS-03-400	<b>400</b>	<b>450</b>	<b>850</b>



*Appendix 4*  
*Sample board*





UNIVERSITEIT VAN PRETORIA  
UNIVERSITY OF PRETORIA  
YUNIBESITHI YA PRETORIA

# Security screen /

## canopy Twin walled polycarbonate

**Where applied:** Cantilevered front canopy, lockable security screen.

**Fixing:** Bolted into steel frame (see technical).

**Surface finish:** Frosted (clear).

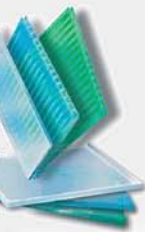
**Properties:** High impact strength (up to 80 times stronger than glass).

**Fireproof**

**Variety of colours**

**UV protective coating** - normally used as light filter.

**Size:** Maximum width 1200mm, 4mm thickness



## Specimesh

white polyester powder coated steel mesh bolted into steel frame.

**Where applied:** Cantilevered front canopy / lockable security screen.

**Fixing:** Bolted into steel frame (see technical).

**Surface finish:** White polyester powder coated.

**Properties:** Relatively inexpensive versatile mesh product.

Available in a wide variety of aperture and wire diameters.

Flush-cut all round (no sharp edges).

Ease of installation when welding and framing.

Easy to profile.

**Size:** 2400 x 1200 x 3mm (selected for this application)

100 x 50mm mesh aperture

**Reason for selection:** Security to front screen, closed and locked at night, Appearance, colour and pattern.



# Lighting



26mm dia 600mm fluorescent tube lamps.

**Where applied:** Display board

**Front light box / signage**

**Size:** 26mm dia - 600mm length, 18W

**Specifications:** Appropriate lamp holders / ballast to be provided, two areas to be switched separately to light switch

**Trebrant** 230V, GU10 (50W) halogen lamp, surface mounted, adjustable ceiling down light.

**Size:** 82.5 x 82.5 x 90mm height

**Specifications:** 220V, Halogen lamp 50W / GU10, IP 20

Aluminium body and base.

Surface mounted

Adjusts and rotates

**Finish:** Aluminium

**Reason for selection:** Fits flush with timber ceiling slats. Adjustable to adapt to changing displays or focus / activity areas. Suitable light levels for retail environment.



# Ceiling slats

## Saligna (Eucalyptus)

**Where applied:** Ceiling slats

External skirting boards

**Fixing:** Countersunk wood screws

**Surface treatment:** Satin finish polyurethane varnish

**Properties:** Fairly heavy wood (approx. 920 kg/m<sup>3</sup>).

Fairly hard

Coarse, even grain, reasonably easy to work.

Moderately durable.

Used in construction, flooring (light domestic), weather-board boat-building, fencing and plywood (veneer needs careful drying)

Generally pale straw coloured wood, occasional pinkish or red hues

**Size:** Standard timber size 19 x 100mm is reduced to 16 x 94mm when planed as used in ceiling.

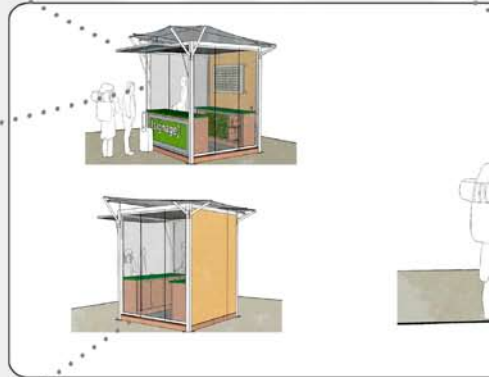
**Reason for selection:** Relatively inexpensive locally grown timber good appearance and durability



# Steel structural frame

Galvanised mild steel, painted

**Surface treatment:** One coat metal primer, two coats gloss finish emulsion in colour Silky grey.



# Storage cupboards

Okoume veneer

similar in appearance to Saligna

**Where applied:** Front and back service counter and storage counter.

**Fixing:** Wood screws, knockdown kitchen cupboard fittings. Concealed hinges to front counter and 180 degree butt hinges to back storage counter.

**Surface treatment:** Satin finish polyurethane varnish.



# Floor finish

OSB painted white

**Surface treatment:** White floor paint, satin finish.



## Tensile Fabric

### Satine 5500 PVC coated glass fibre mesh

Where applied: Roof

Fixing: Tensioned stainless steel wire fixed with NF Inox anchoring / rigging system.

Surface treatment: Factory applied PVC coating

Properties: Weight 535 g/m<sup>2</sup>

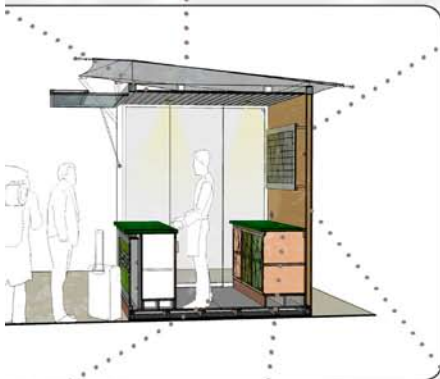
Heavy weight PVC coated glass based mesh fabric, RF welded or stitched in zig zag pattern. Used for internal structures, including ceilings and screens.

Fire rated to BS 476 Pt 6 & 7, Class Q M1, B1. Can be printed.

Reason for selection: Filtered light quality similar to tree canopy and extension beyond kiosk creates intermediate public space. Light, airy feel desirable.



Stainless steel threaded end clevis, part of tensile fabric roof rigging



## Counter tops

Formica laminate  
Colour: Primary Green



UNIVERSITEIT VAN PRETORIA  
UNIVERSITY OF PRETORIA  
YUNIBESITHI YA PRETORIA

## Steel Gridwall

Where applied: To Surinno backlit display

Fixing: Steel brackets anchor fixed through solid surface

Size: 750 x 1220 x 3mm. 75 x 75mm mesh apertures

Accessories: Variety of proprietary, commercially available hooks, shelves, angled shelves, shelf brackets, baskets, clothes rails etc.

Reason for selection: Readily available (supplied locally e.g. from Cyntron Wire products or online ordering) Relatively cheap.

Commercially available and adaptable, highly customisable system.



Fixing bracket



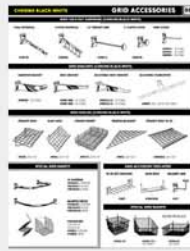
Metal gridwall interchangeable display accessories



Gridwall pegs



Gridwall angled wire shelf



## Display board

Surinno solid surface in

colour Alabaster.

Proprietary metal gridwall display bolted to solid surface backing

Where applied: Gridwall display unit

Fixing: Anchor bolt fixed to 25x25mm rectangular steel frame, which is in turn bolted to steel angle brackets fixed through OSB into metal studs in back wall.

Surface finish: Semi-matt

Properties: Manufactured from acrylic, modified polyester resin and mineral fillers, mainly Aluminium Hydroxide (ATH). Suitable for vertical and horizontal applications (12mm standard thickness)

Non-porous. Consistent finish throughout due to manufacturing process, making it easily to lightly sand and polish out scratches and damaged areas.

Heat and stain resistant. Durable.

Low maintenance. Scratch resistant.

Hygienic, due to non-porosity, stains are not absorbed, leaving no substrate for microbial action. Fabrication technology can achieve seamless joints, reducing potential for microbial growth.

Size: 3050 x 765 x 12mm (from PG Bison) Half sheet used per kiosk for cost saving - determines display size in interrelation with gridwall sizes

Reason for selection: Aesthetic. When backlit, the pattern of the solid surface resembles the OSB surface. This play on material characteristics lends depth to the scheme and links to the idea of Stoffwechseltheorie as part of tectonic expression.

Surface is fairly translucent, and achieves attractive and attention focusing glow on display / menu area.



## Wall cladding

OSB satin varnished

Where applied: Back wall finish, inside and outside.

Fixing: Countersunk wood screws  
Surface treatment: Wall - satin finish polyurethane varnish

Properties: Made from softwood strands approximately 75mm long placed in layers in different directions and compressed with exterior grade water resistant resins. Moderately water resistant.

Environmentally sound use of normally discarded scraps of wood. Cheaper than plywood.

Good strength in both directions. Uniform, decorative appearance. Suitable for sheathing, flooring and decorative panels.

Size: 18mm thick for flooring (see appendix 3). 15mm thick for back wall. Sheet size 2500 x 2500mm (from PG Bison). Cut one sheet in half for one kiosk unit floor.

Reason for selection: Aesthetic - strands of wood bring texture and movement and suit the tree concept.

