

the 4th wall

BREAKING DOWN THE BOUNDARIES OF AN EXISTING PUBLIC SPACE IN PRETORIA

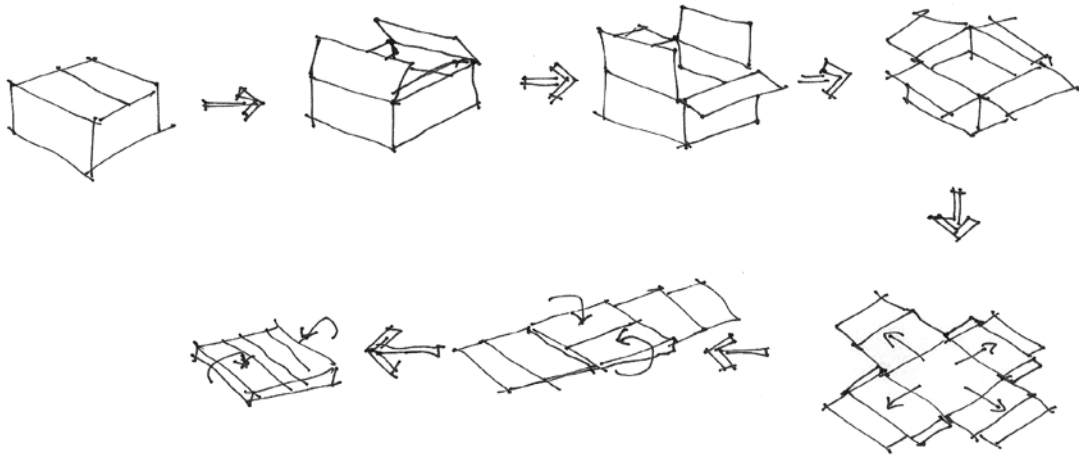

By Lizelle Cloete

Study leader: Gary White

Course co-ordinator: Jacques Laubscher

Submitted as part of the requirements of the degree of Magister in Architecture [Professional] in the Faculty of Engineering, Built Environment and Information Technology, University of Pretoria. 2009.

To those who advised, inspired, supported, consoled, endured, remembered, loved and listened

THANK YOU

the fourth wall. *phrase (breaking down the fourth wall)* **1.** Theatrical term describing the imaginary line separating the audience from the stage. **2.** The imaginary wall through which the audience views the action of a play. When this boundary is broken (e.g. when the audience is directly addressed), it is called “breaking the fourth wall”.

ABSTRACT

This thesis deals with the regeneration of an existing public square in Pretoria, formerly known as Strijdom Square. The document considers contemporary anthropological and urban design theory of good public spaces and argues that the presence of people is the key determinant in success of public space. The hypothesis argues that public spaces should be designed to draw human activity and accommodate basic human needs and wants including comfort, security and activity.

The thesis proposes breaking the *fourth wall* of the State Theatre through the insertion of a filter building between the theatre and the public square. The proposed design celebrates the performing arts and aims to educate the public about the arts by providing opportunity to experience the magic of the theatre in everyday life. The architecture becomes a filter on every level, allowing visual and physical connections to the theatre and aims to make the theatre more accessible to all.

CONTENTS

01_ INTRODUCTION	II
02_ CONTEXT	3
03_ CITY SQUARE	32
04_ URBAN THEATRE	46
05_ CONCEPT + BRIEF	56
06_ PRECEDENT STUDIES	60
07_ DESIGN DEVELOPMENT	69
08_ TECHNICAL INVESTIGATION	99
09_ CONCLUSION	120
10_ DOCUMENTATION	122

APPENDICES

LIST OF FIGURES

REFERENCES