

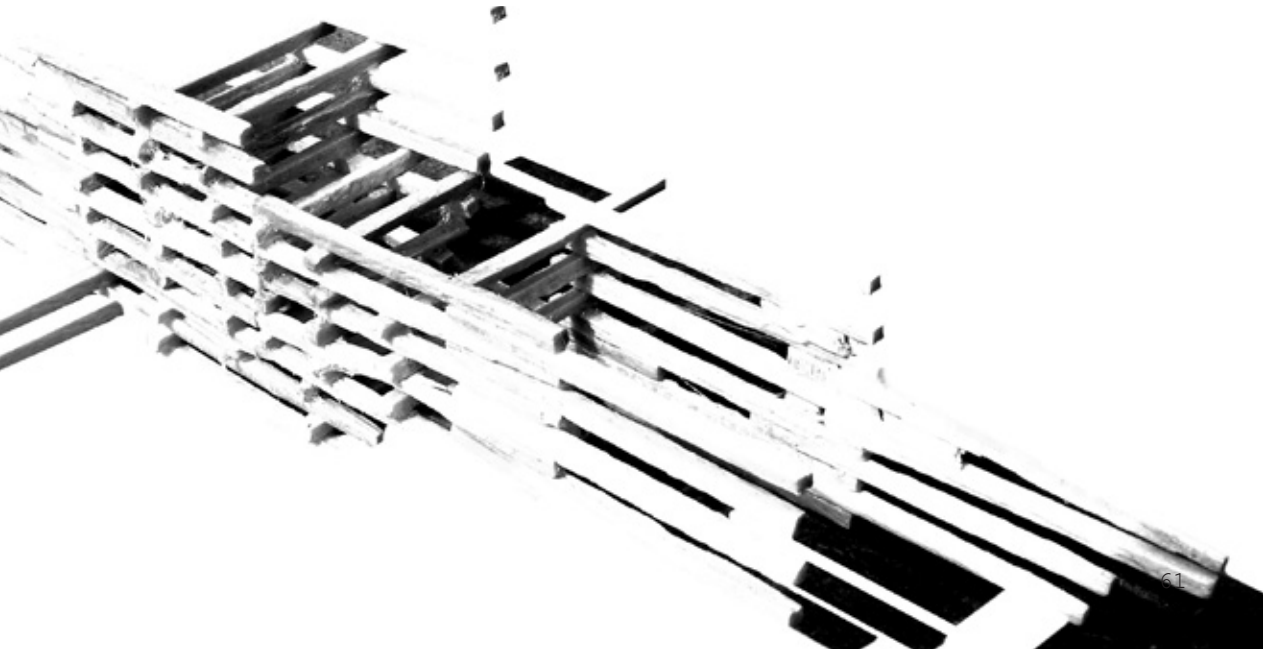
04. Technical development

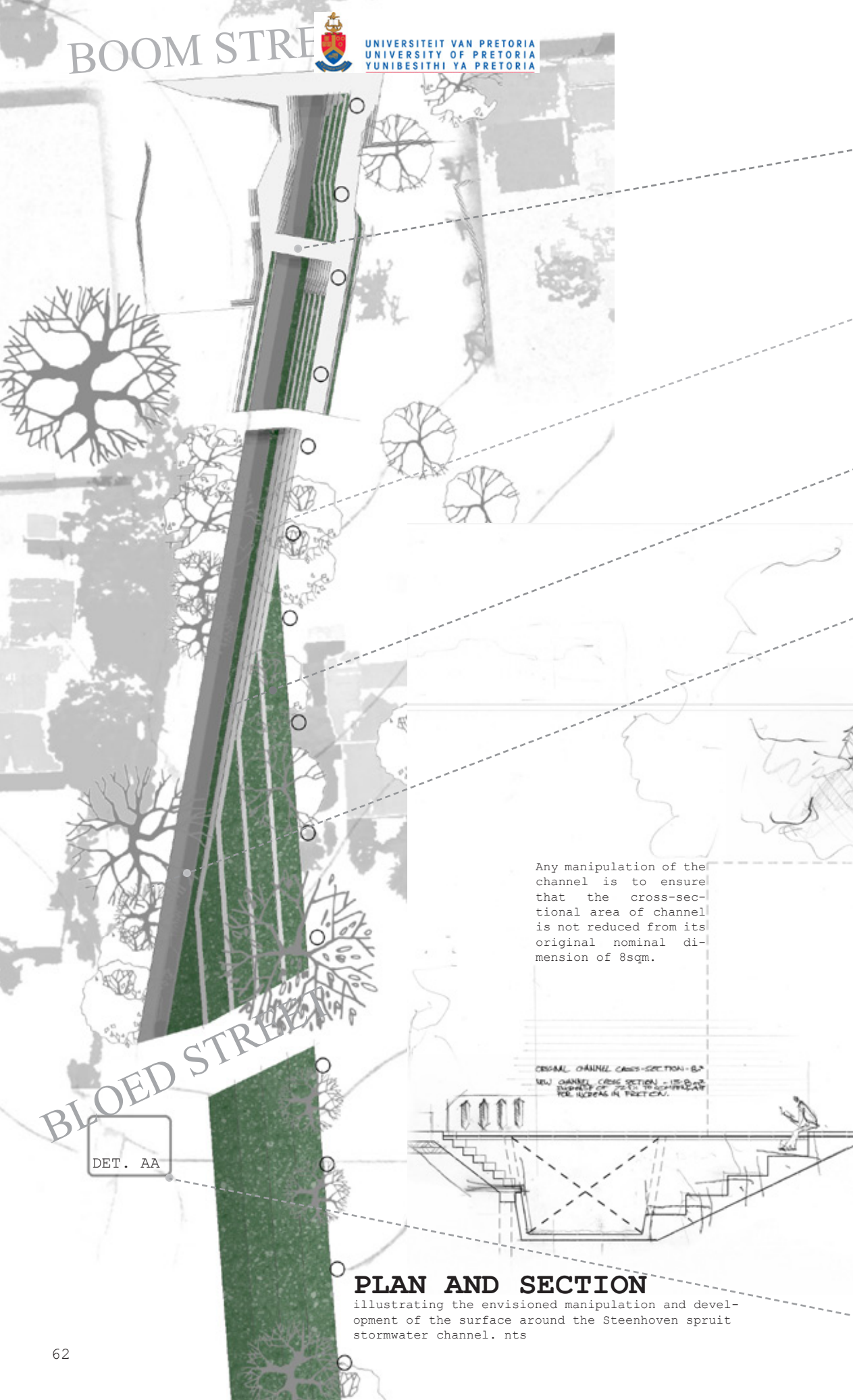


Figure 64. Photograph of concept model, illustrative of an approach to technical resolution as a continuation of the design process.



The design concept manifests in three overlapping components, namely the surface, the shelter and their servicing infrastructure. These distinct components, rooted in their separate requirements and conditions, combine to generate the design. As such, each is investigated and technically discussed in principle, prior to their combination into realized form.





Any manipulation of the channel is to ensure that the cross-sectional area of channel is not reduced from its original nominal dimension of 8sqm.

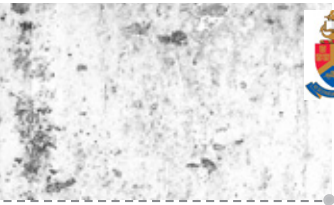
ORIGINAL CHANNEL CROSS-SECTION - 8.2
NEW CHANNEL CROSS SECTION - 11.5 (2.3m² INCREASE OF 28.1% TO COMPENSATE FOR INCREASE IN FRICTION)

BLOED STREET

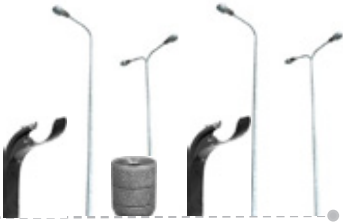
DET. AA

PLAN AND SECTION

illustrating the envisioned manipulation and development of the surface around the Steenhoven spruit stormwater channel. nts



lines the channel walls, giving way to green areas.



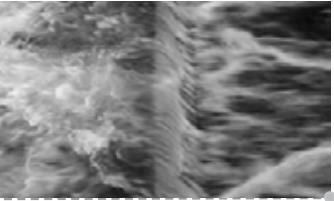
Services provided along the channel edge include water fountains, lights and rubbish bins.

Surface

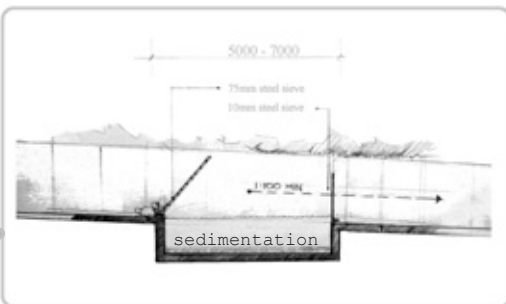
The manipulation of the urban surface aims to celebrate the experiential potential of infrastructure. Exemplified by the storm water channel being reestablished as natural entity while retaining its ability to function as a conduit of storm water.



Public seating, both in terms of the surface and benches are provided.



Materiality:
Water flowing down the channel becomes animated, creating white noise while celebrating water visually.



Detail AA, nts.
Debris traps to be placed at intervals along the channel development. Ensuring high visual quality of water throughout.

Figure 65.
Site plan and channel section. nts.





Figure 66. (opposite)
Site plan.

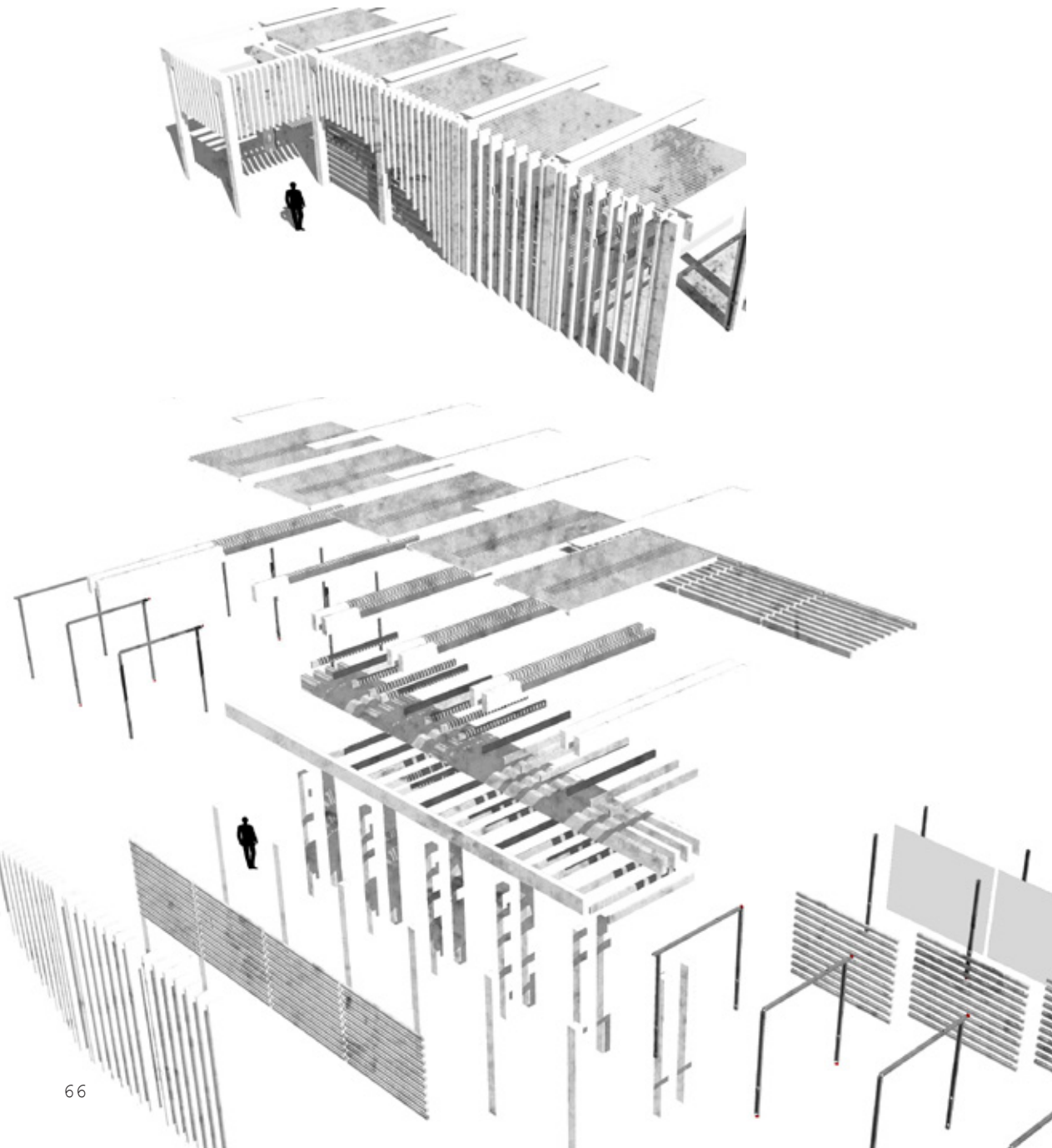
Figure 67. Conceptual
sketch of bathhouse
and manipulated ground-
plane, as experienced
from the south.

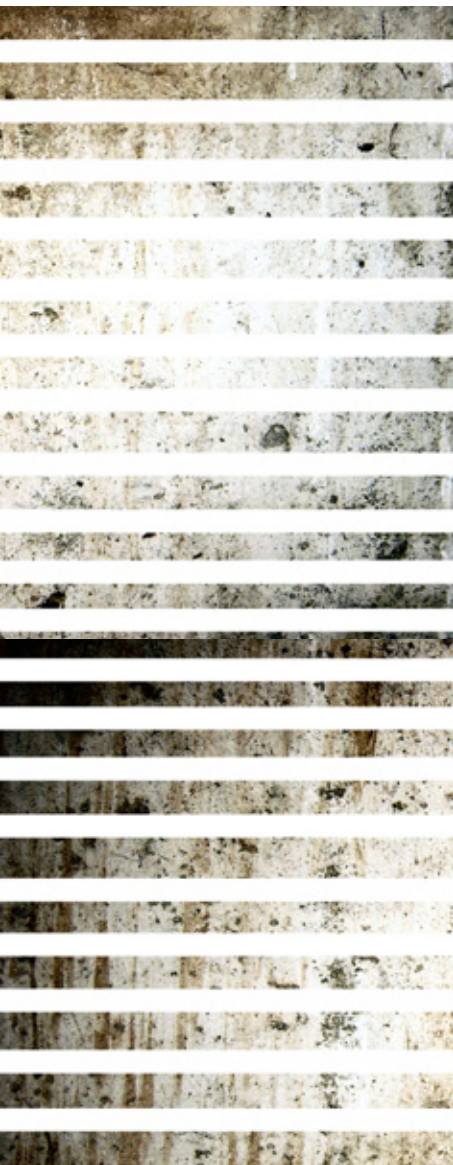


Figure 68. (opposite bottom)
Diagram illustrating the pre-
stressed, precast concrete
process.

Figure 69. (opposite top)
Materiality: Concrete

Figure 70. A model of part
of the shelter, composed and
exploded, illustrating the manner
in which the components of the
shelter combine. The composed
model illustrates the system ma-
nipulated to provide legibility,
an entrance is defined.





Shelter

The shelter consists of several parts: the structural matrix, a louvred roof, glazing and a system of steel frames for fittings. These components combine to form the superstructure of the building. The inherent properties of the shelter concept is manipulated in service of programme requirements.

Structure

The structural system employed to realize the design is intended to act as a fundamental part of the experience. The structure directly results in the building, acting as structure and shelter simultaneously. Understood as a weaving of modular, precast and prestressed concrete structural components, a three-dimensional matrix of interrelated parts combine to form the building. This interrelated nature ensures structural stability of the system through lateral bracing throughout. Concrete, precast and in-situ, fulfils many of the requirements of programme and structure. Concrete is durable and robust, intended to resist any physical abuse to which the building might be subject to. Concrete resists weathering, while maintaining structural integrity, vital when considering the presence of moisture implied by the programme. Finally, the physical mass of concrete allows for a measure of thermal comfort control through mass dampening of exterior temperature fluctuations.

Large structural prestressed concrete components are premanufactured off site to ensure quality control and structural integrity. These components are not small enough to be manufactured locally and are transported to be assembled on site. Smaller prestressed concrete elements are to be manufactured on site or within Marabastad using a robust process of prestressed manufacture (Figure 67). The intent is to establish a local industry and skills and production. The principles of precast concrete manufacture can be applied to the proposed densification and development of Marabastad in the near future. This proposed process consists of (Bruggeling et al, 1991: 5-6):

- Cleaning moulds
- Pretensioning, laying of reinforcing steel
- Concreting, vibrating, compacting
- Finishing
- Curing
- Prestressing by detensioning the moulds
- Cutting of protruding prestressing steel
- Demoulding and storage.

The intent is to expand the social potential of the bathhouse by capitalizing on the construction process.

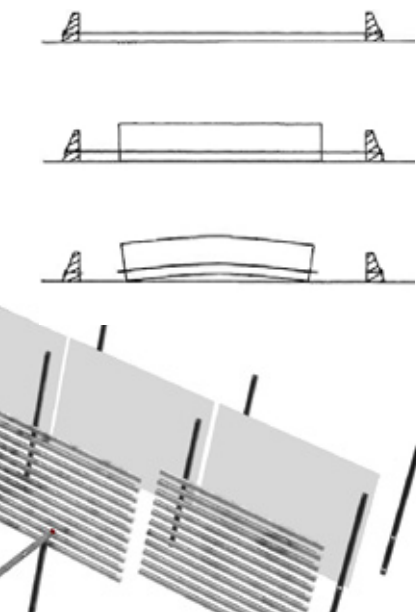
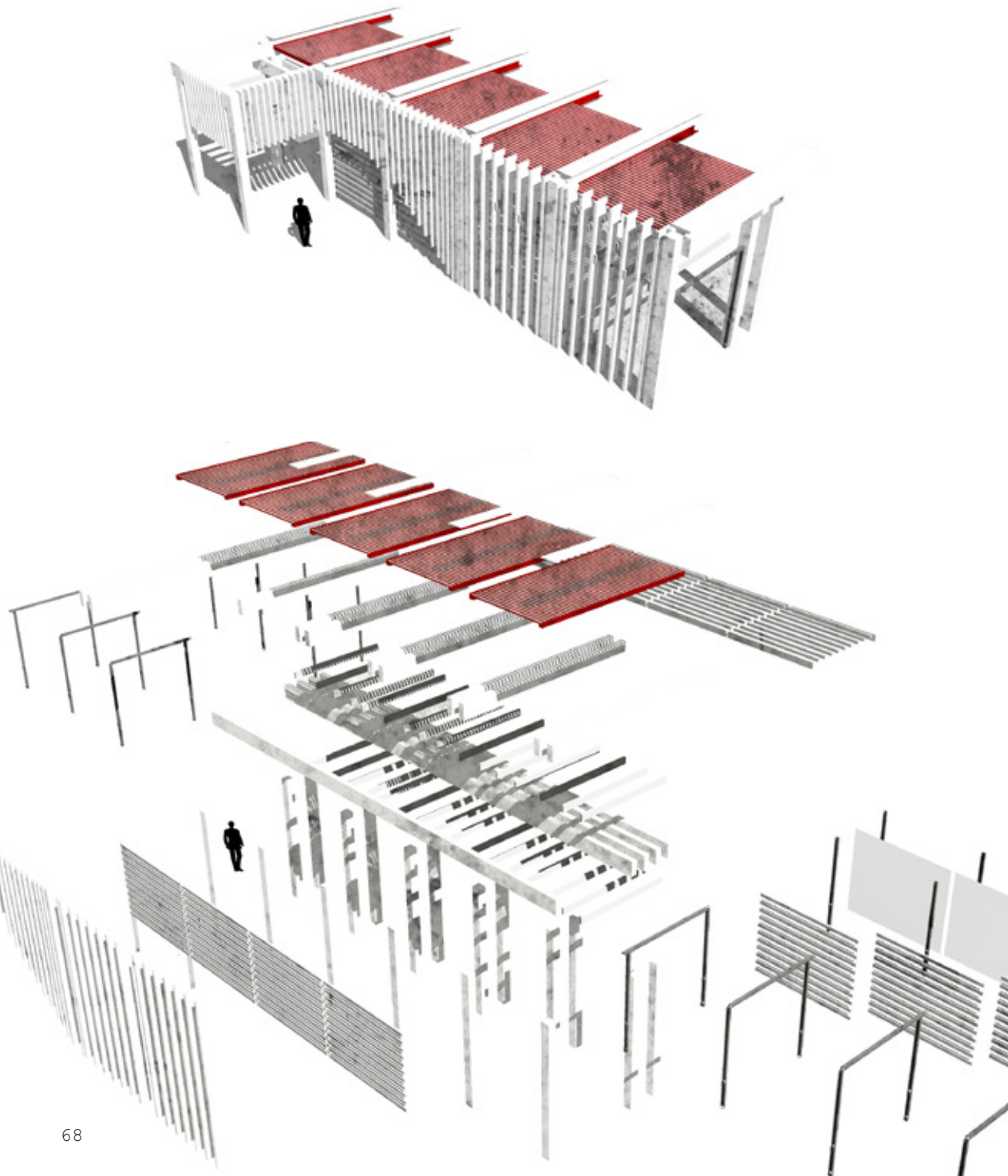


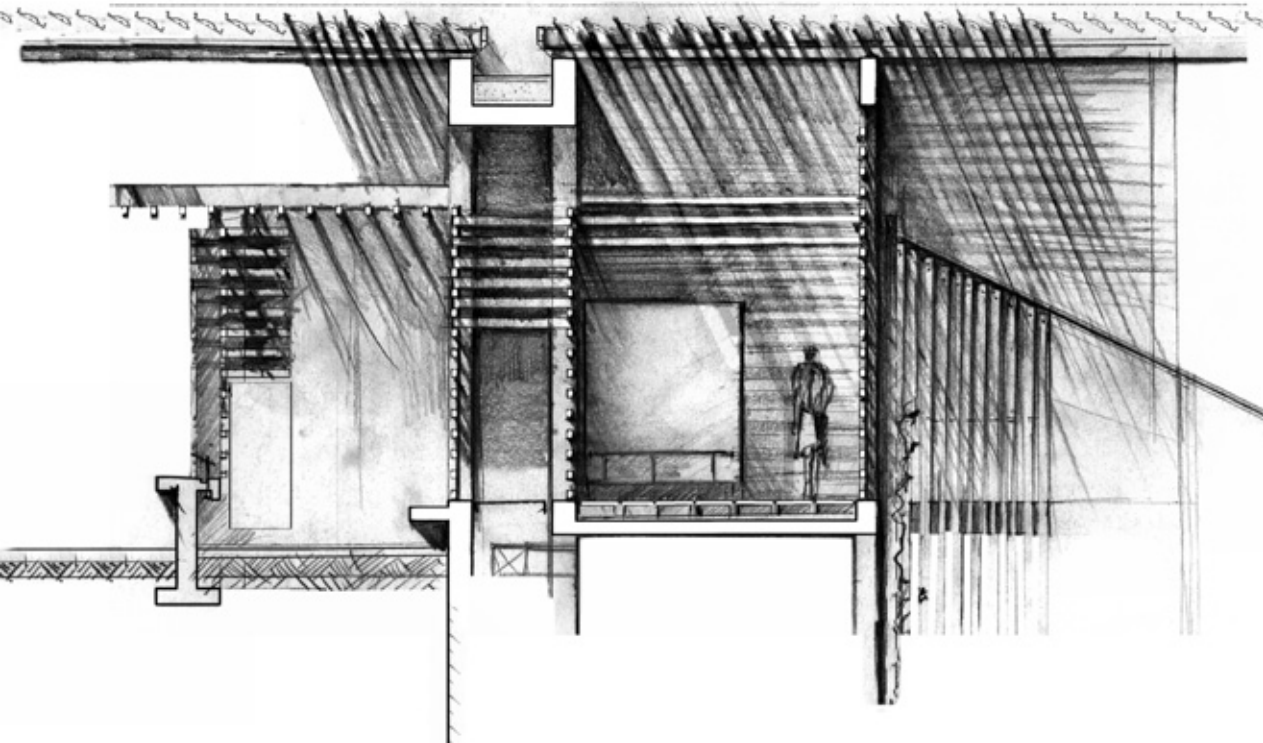


Figure 71. (opposite top). An exploration of the spatial implication of the chosen roof system.

Figure 72. (opposite bottom). The louvred translucent opening roof system in detail, indicating automated motor to be connected with solar and rain sensors.

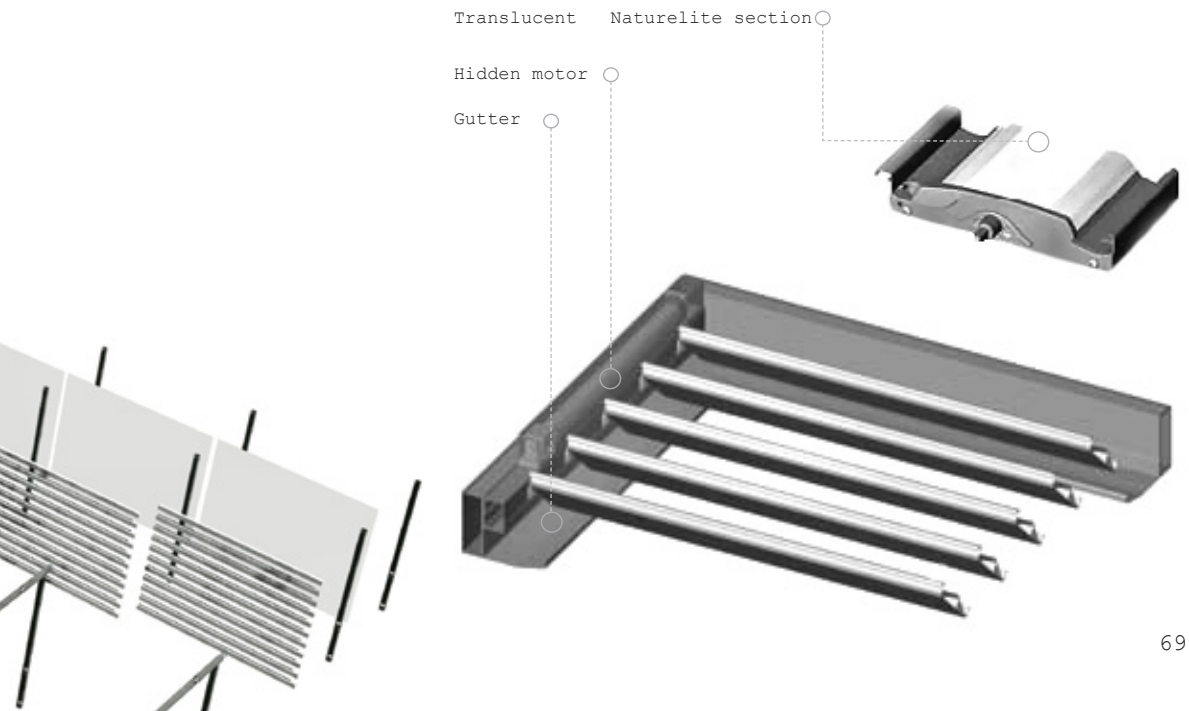
Figure 73. (below). Composed and exploded diagram illustrating the roof system relative to the rest of the shelter construction.

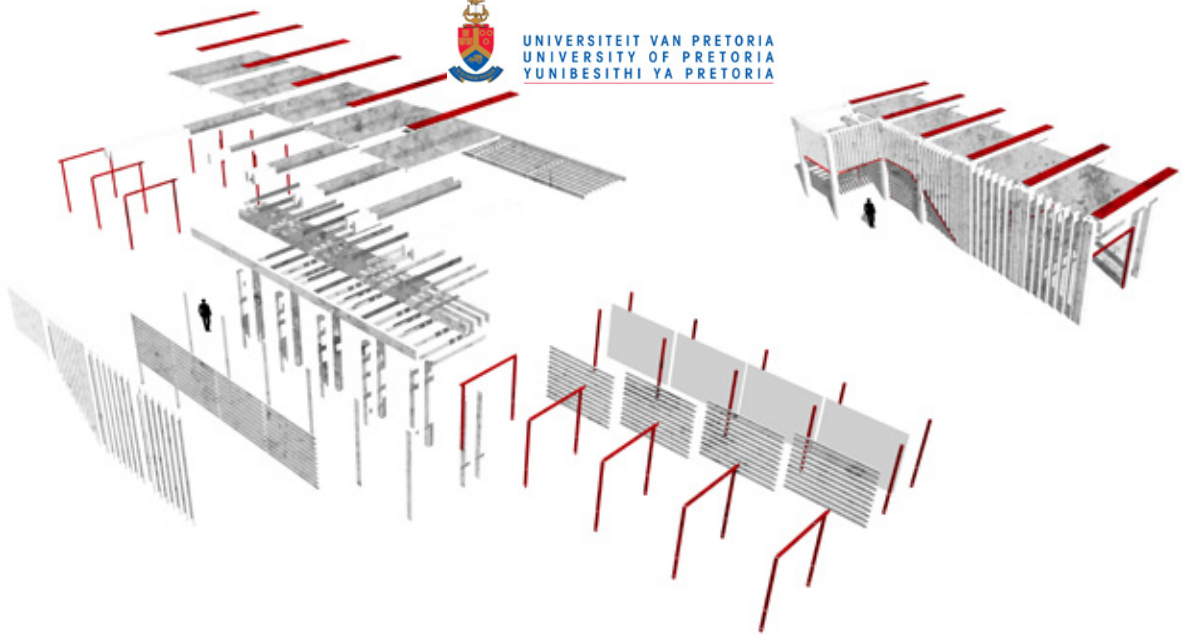




Louvered roof

A premanufactured aluminium opening louvre roof system is proposed. The louvres close and interlock, creating a weatherproof roof. When closed, a translucent UV treated Naturelite panel in the louvre admits light through. The louvres have a 180 degree range of motion, managed through a hidden motorized pivot system, this motor can be connected to a sun and rain sensor and be fully automated (LouvreTec, 2009:9). The lightweight aluminium louvres resist heat gain, while shading or exposing the concrete mass from and to the sun.





Non-structural support system

The intent of the steel infill is to act as a system for housing various necessary fittings, while acting as a finish and support to the concrete construction. Glazing frames are connected to the steel support structure, setting these back from the concrete shelter. Lights, ducts and various other services and pipes are fixed to the fine grain steel structure, ensuring access to and adaptability of these systems. Steel construction is shop welded and galvanized before assembly on site to ensure corrosion protection.

Figure 74. (top)
Composed and exploded diagram illustrating the steel support system relative to the rest of the shelter construction.

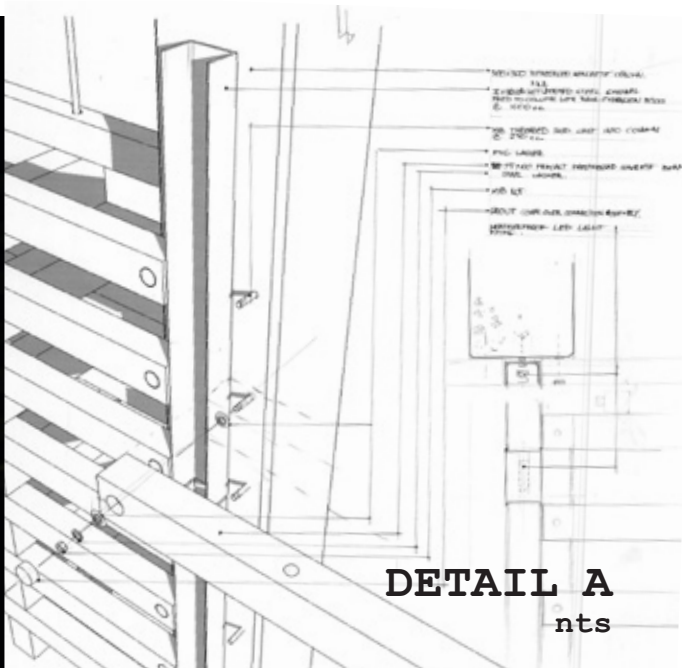
Figure 75. (opposite top)
Composed and exploded diagram illustrating glazing relative to the rest of the shelter construction.

Figure 76. (below left)
Render of LED Light fitting in steel supports

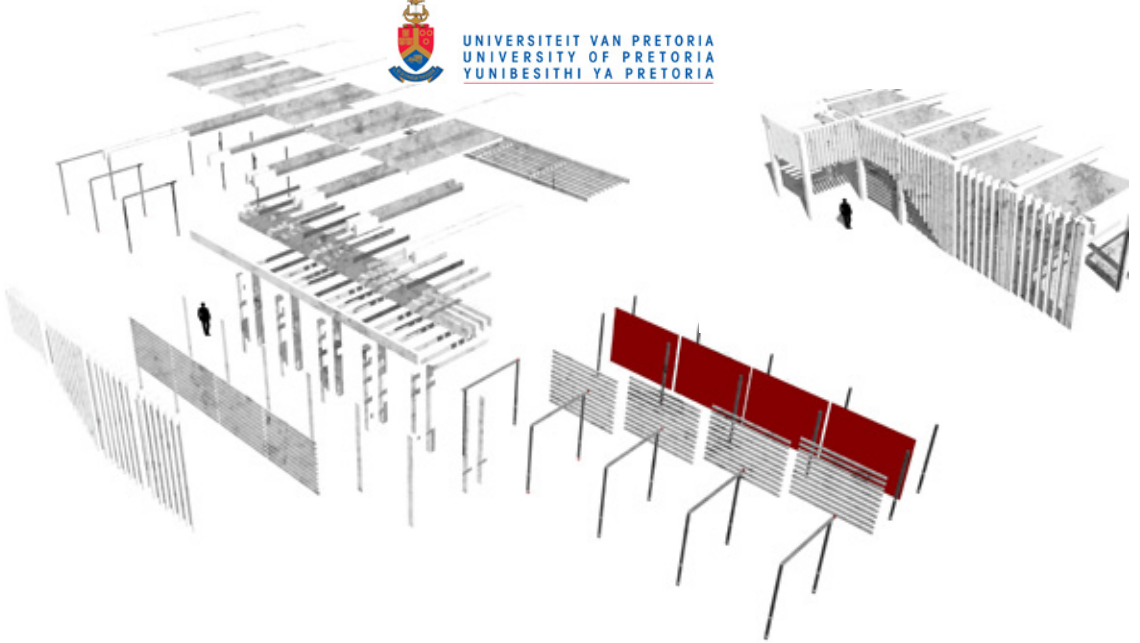
Figure 77. (below)
Detail A. Horizontal precast beam to in-situ column connection

Figure 78. (opposite left)
Detail B. Shadowline parallel to steps in concrete, created by steel support system

Figure 79. (opposite right)
Heavy duty precast concrete palisade fencing as a construction precedent

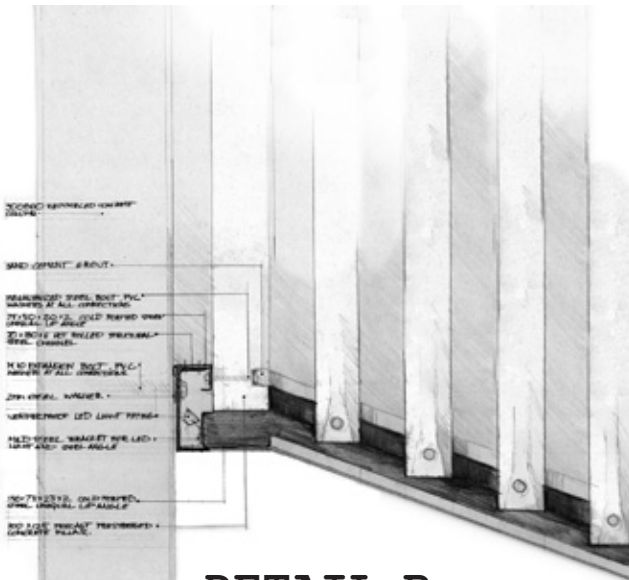
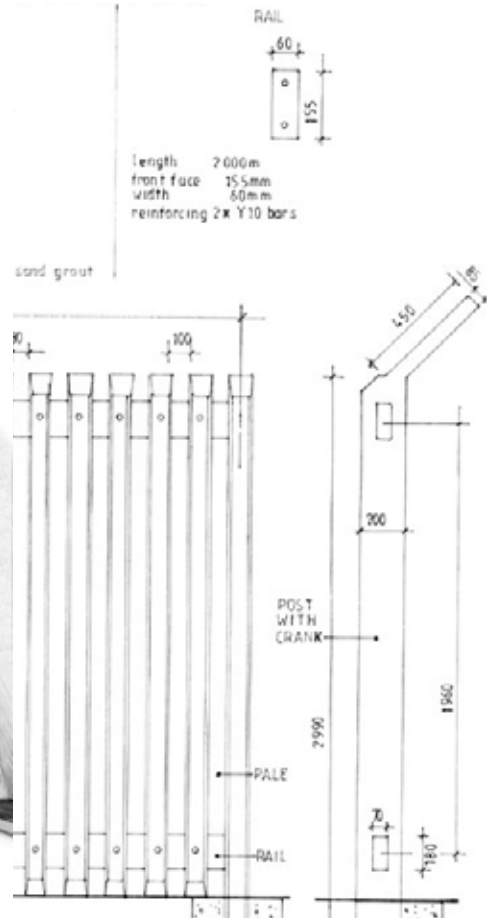


DETAIL A
nts



Glazing

Areas where complete weatherproofing is required will have a layer of glazing as part of the shelter composition. These areas include offices, laundry, store rooms etc. This glazing layer further allows for a measure of control over the ventilation of the building. Control allows for the efficient use of the concrete as thermal mass, by allowing the building to ventilate during summer nights, cooling the shelter, or preventing ventilation during winter nights, retaining heat build-up from the day.



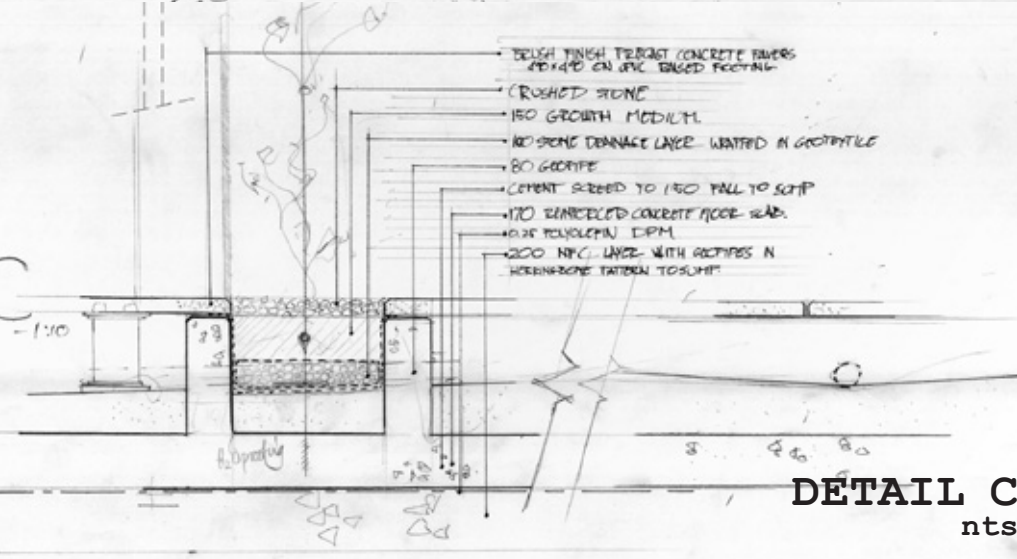
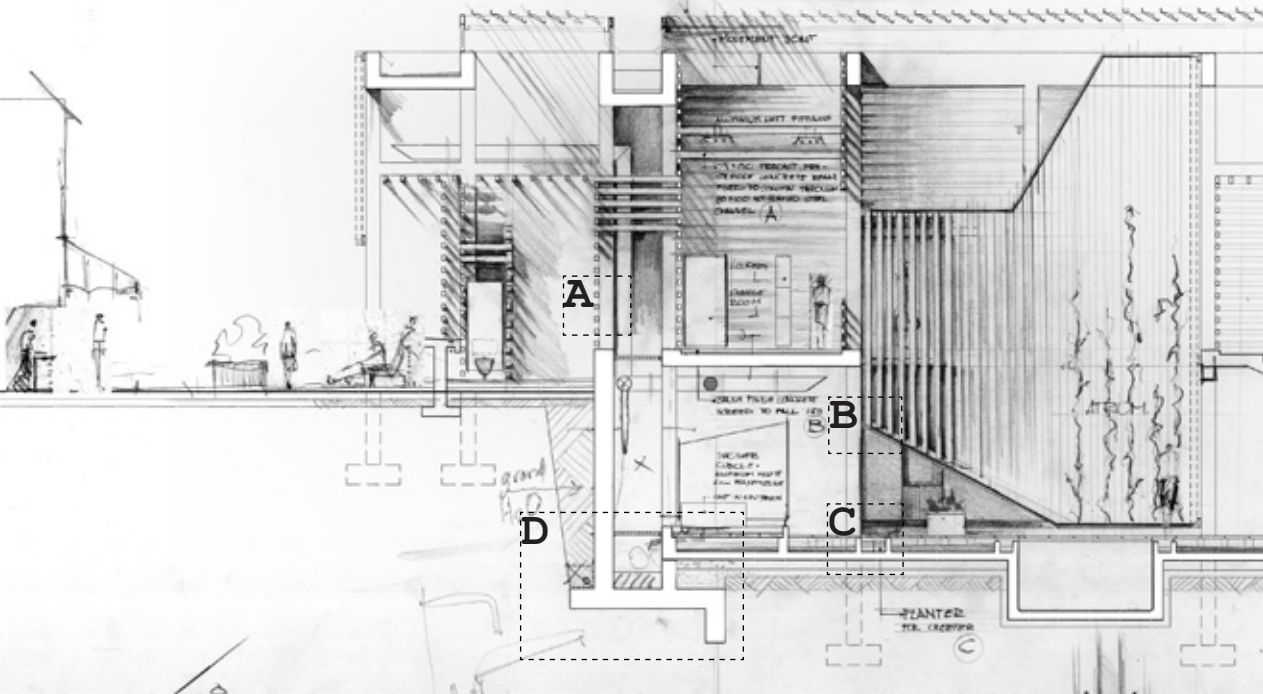
- WOODEN SUPPORT FOR THE RAIL
- SAND JOINT @ BUTT
- REINFORCED CONCRETE WITH PVC COVERED AT ALL CORNERS
- ZINC PLATE GILD RAISED OVER JOINT @ BUTT
- ZINC PLATE WELDED TO RAISED OVER JOINT CHANNEL
- WOOD FRAMING WITH PVC COVERED AT ALL CORNERS
- ZINC PLATE WELDED
- REINFORCED CONCRETE WITH PVC COVERED AT ALL CORNERS
- WOOD JOINT WELDED TO RAIL
- WOOD JOINT WELDED TO RAIL
- WOOD JOINT WELDED TO RAIL
- WOOD JOINT WELDED TO RAIL
- WOOD JOINT WELDED TO RAIL

DETAIL B
nts



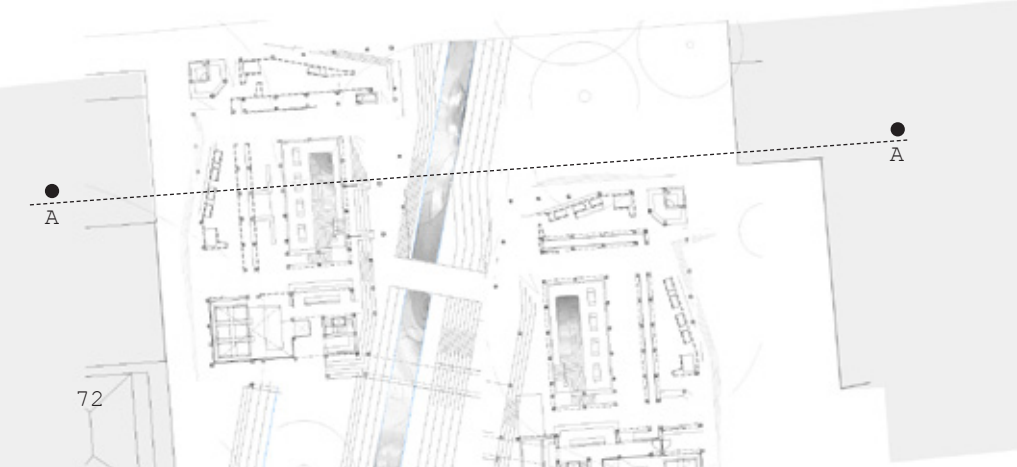
CONCRETE GUTTER:
 NET AREA: 817.5 m²
 @ 1000 mm @ 100 mm fall
 = 817.5 m²
 F: 104.5 mm dia.
 T: 4.75 mm @ 1000 mm.
 GUTTER: 1000 mm dia.
 @ 1000 mm @ 100 mm fall
 = 1000 m²
 @ 1000 mm @ 100 mm fall
 = 1000 m²
 @ 1000 mm @ 100 mm fall
 = 1000 m²
 @ 1000 mm @ 100 mm fall
 = 1000 m²

RESISTANCE TO PLAIN LOOSE ROOF
 WITH TRANSPARENT PAPER IN PAINTED
 PLAIN FINISH TO GIVE PLATE BE SECURE
 TO BE KEPT ON CASE WITH DOWN



DETAIL C
nts

BOOM STREET



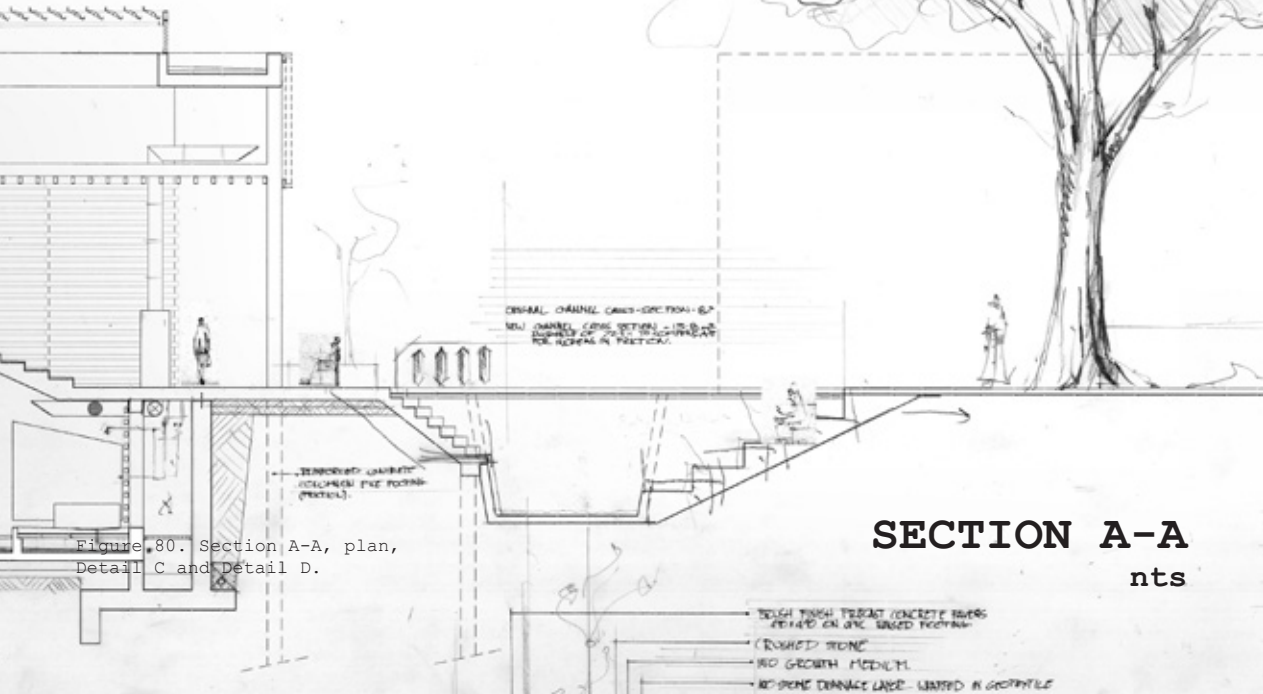


Figure 80. Section A-A, plan, Detail C and Detail D.

Figure 81. 'Vitrex' type 116 18.5mm enamelled steel composite panels to be used in toilet and shower cubicles. Installed on raised stainless steel footings.

Figure 82. Non-skid, fungicide treated, draining, replaceable vinyl tiles placed in recess as shower floor.

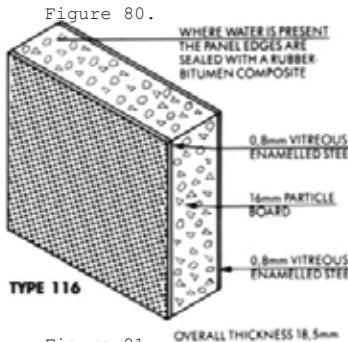
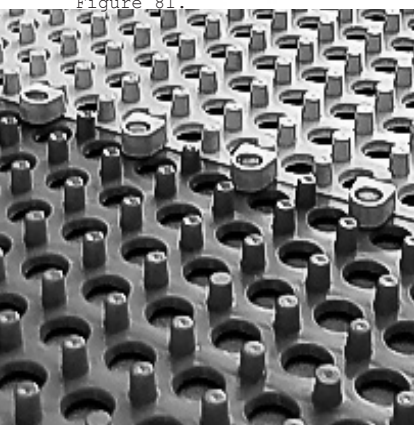


Figure 81.



CAST IN SITU CONCRETE FINISH, TREATED WITH TERRAZO FUNGICIDE.

25x100 TERRAZO TERRAZO CONCRETE FINISH TREATED WITH TERRAZO FUNGICIDE.

PROVIDE SLIP-RESISTANT, MICROBICIDAL RESISTANT FLOOR MATS PLACED IN GROOVES, GREYS.

ROUGH FAUCH TERRAZO (CONCRETE FINISH) FINISH ON JMC SAVED FOOTING.

200 PVC DRAINAGE TYPE CONCRETE SLEEDS TO 1:50 FALL TO SUMP.

100 REINFORCED CONCRETE FLOOR SLAB.

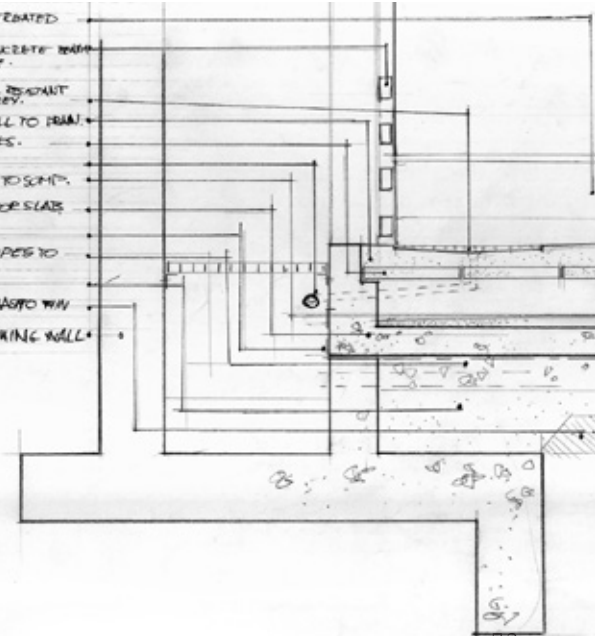
0.25 POLYETHYLENE DPM.

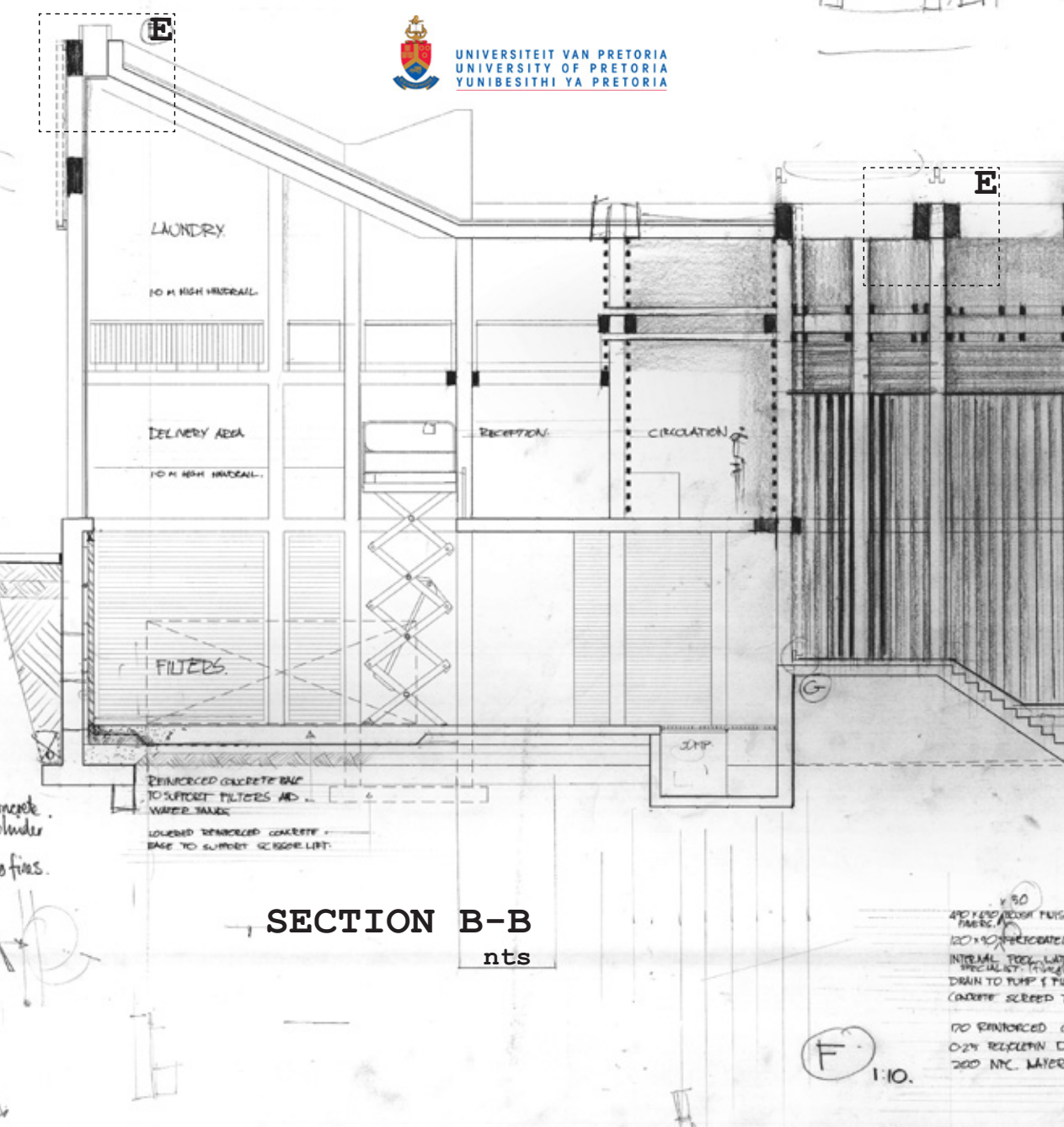
200 NTC LAYER WITH 600x120x10 SUMP.

150 BLENDED LAYER.

FILL COMPACTED TO 95% MCD-AGGREGATE WITH LAYERS MAX 150mm.

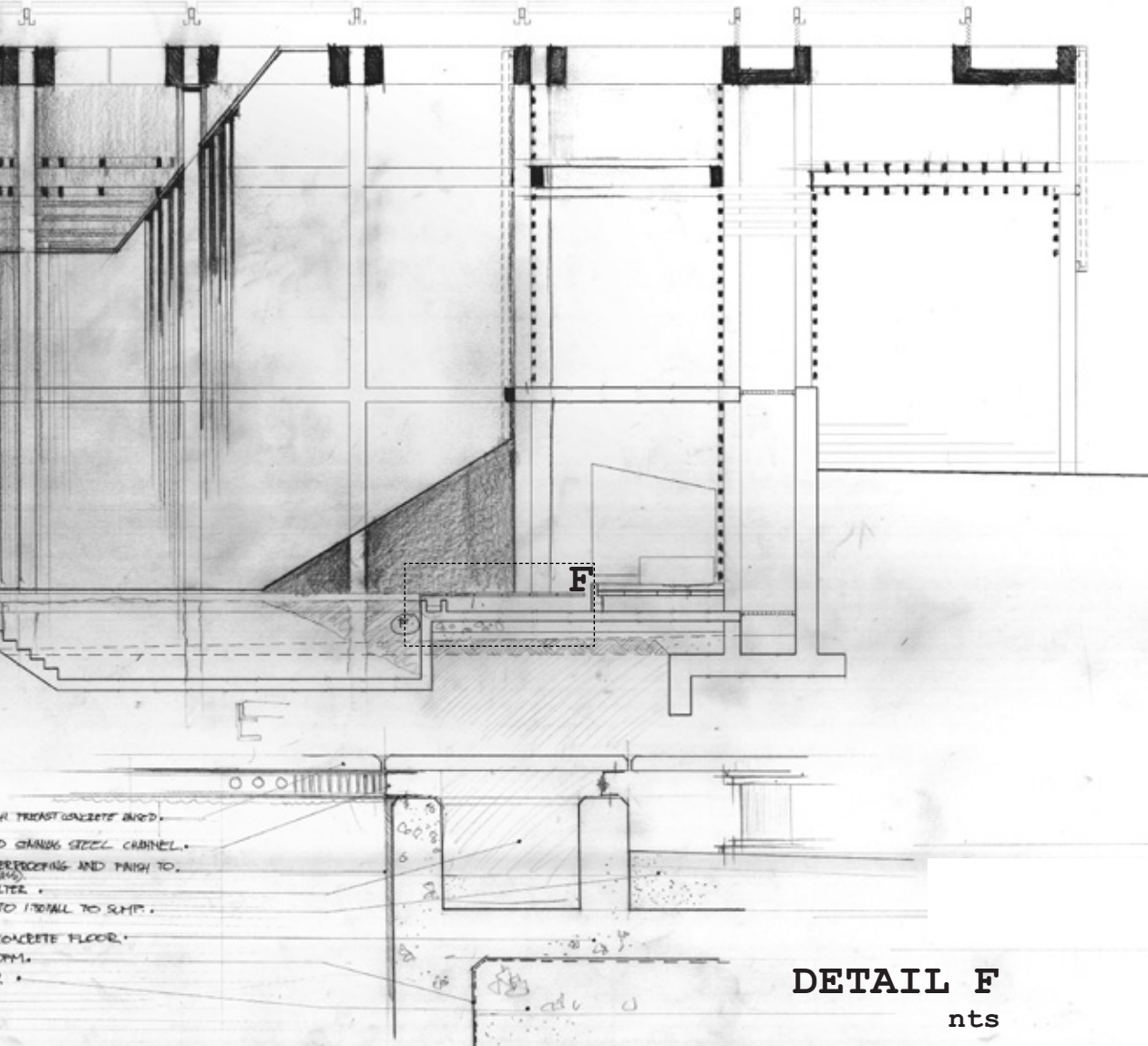
REINFORCED CONCRETE RETAINING WALL.





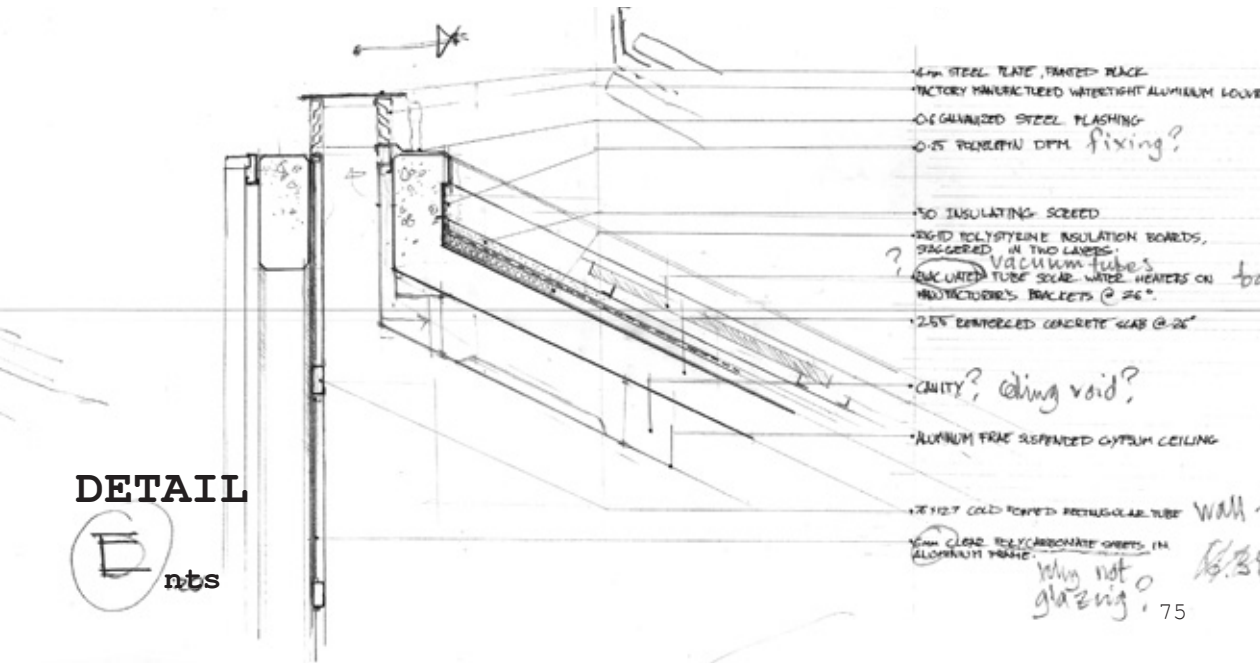


1/2" x 1/2" GOLD FINISHED RECTANGULAR TUBE Wall thickness
1/4" CLEAR POLYCARBONATE SHEETS IN ALUMINUM FRAMES
Why not glazing?
18.38



DETAIL F
nts

Figure 83. Section B-B, plan, Detail E and Detail F.



DETAIL E
nts

1/4" STEEL PLATE, PAINTED BLACK
FACTORY MANUFACTURED WHERETIGHT ALUMINUM LOUVER
0/6 GALVANIZED STEEL FLASHING
0/25 POLYURETHAN DPM fixing?
50 INSULATING SCREED
RIGID POLYSTYRENE INSULATION BOARDS, BRAGGERAD IN TWO LAYERS
VACUUM TUBES
EVACUATED TUBE SOLAR WATER HEATERS ON MANUFACTURER'S BRACKETS @ 26"
25% REINFORCED CONCRETE SLAB @ 26"
Cavity? ceiling void?
ALUMINUM FRAME REFINISHED GYPSUM CEILING
1/2" x 1/2" GOLD FINISHED RECTANGULAR TUBE Wall thickness
1/4" CLEAR POLYCARBONATE SHEETS IN ALUMINUM FRAMES
Why not glazing?
18.38

Services

Servicing of the building refers to the systems and methods employed to manage the functional requirements of the programme. These include ventilation, thermal comfort and climate control, water management, drainage, and circulation of people and goods. As previously discussed in design development, the intent is to use the service areas as shelter for the private nature of the programme. The result is the use of courtyards framed by service corridors. These corridors are rooted in the service, staff, and administrative areas of the building.

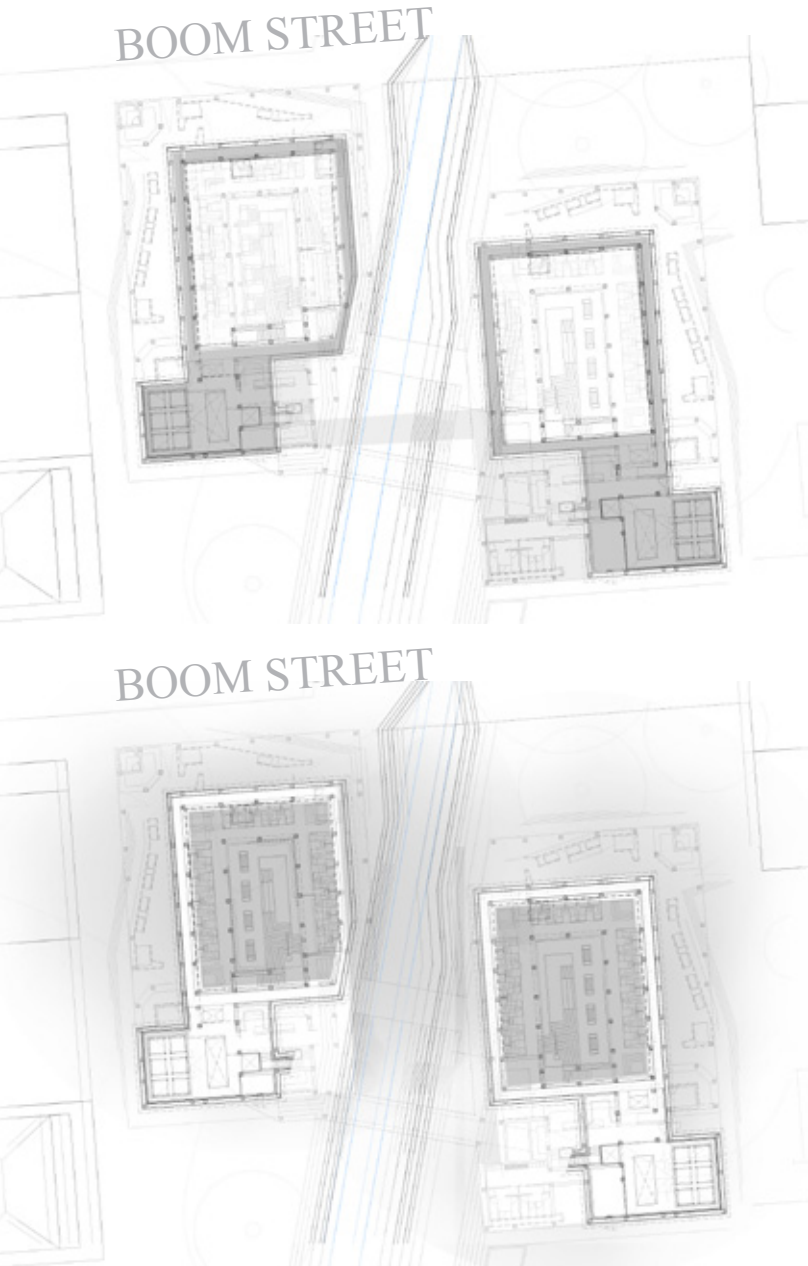


Figure 84. Diagram illustrating servicing strategy, particularly the relationship between service (top) and serviced areas. The loop of service corridors allows for a private internal courtyard, while being able to service the surrounding area.

Figure 85. (opposite) Conceptual circulation diagram.

Circulation

Circulation refers to the manner in which the shelter is used, by people and services. Movement of people differs depending on the reason for entering the facility. A pedestrian walking to the CBD can move through the building without being physically impeded. The manner in which a person moves through the building becomes a social act sensitive to gender. While free physical movement is encouraged to prevent isolation of the building, it is envisioned that social buffer areas appropriated by gender are established. These areas will cater to the needs of the genders commercially while acting as a meeting places and passive security zones. In general, movement of people only filtering through, or those using the toilet facilities, will be in a north-south manner. Those using the building for longer periods will move in an east-west direction as the building is used, possibly at some point entering the existing buildings east and west of the channel. Those who use the building for bathing will descend into the central courtyard, where enclosure is complete. Staff movement is accommodated in the form of a bridge over the channel, allowing for people and goods to move through the service areas. The service areas further include vertical circulation in the form of stairs and service lifts to move goods vertically. Deliveries are accommodated to the south of the service areas, where access is gained from Grand street.

BOOM STREET

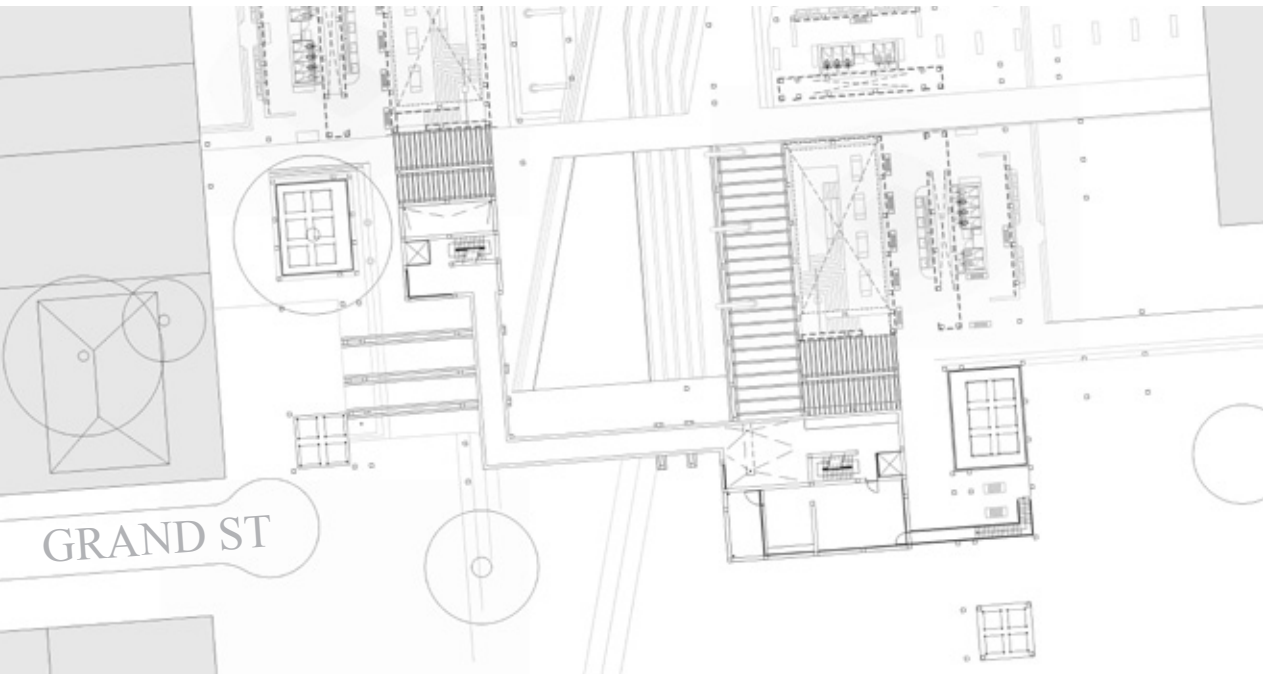




BOOM ST



GROUND FLOOR PLAN
nts



FIRST FLOOR PLAN
nts



Figure 86. (opposite)
Ground floor plan, first floor plan.

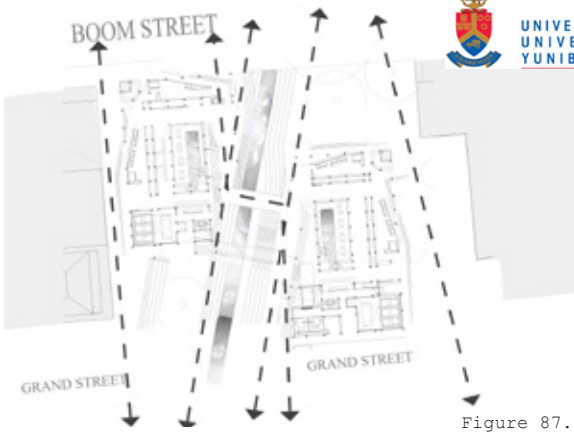


Figure 87.

Figure 87. Pedestrian movement through the site, people only passing through.

Figure 88. Pedestrian movement of people using the public toilet facilities. Note basins on outside skin of building, projecting the programme into the public realm.

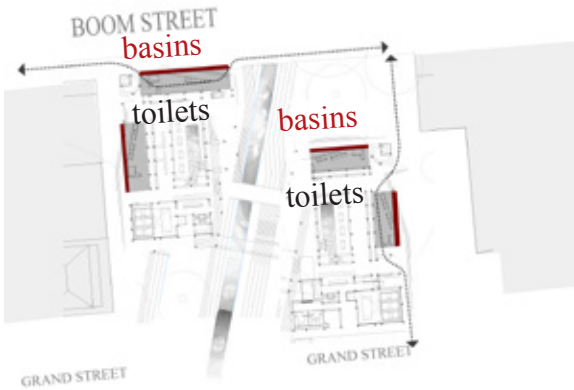


Figure 88.

Figure 89. Movement of people who use the bathing facility and appropriated surrounds, such movement manifests as an east-west pattern. The red blocks indicate meeting, rest and waiting spaces.

Figure 90. Movement of staff and goods within the building, vertical circulation indicated in red.

Figure 91. collage of all circulation through the bathhouse.

Figure 92. Section diagram illustrating movement downward to private bathing and social area through a filter provided by service areas.



Figure 90.



Figure 91.

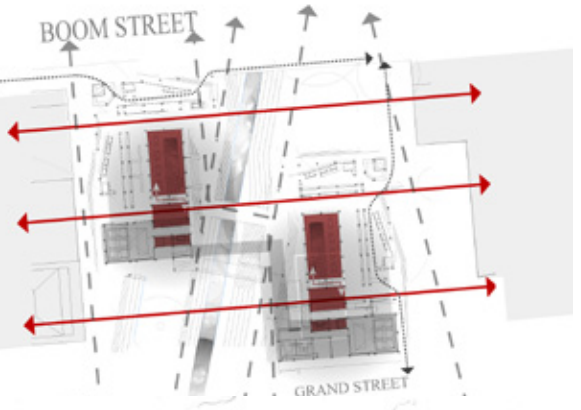
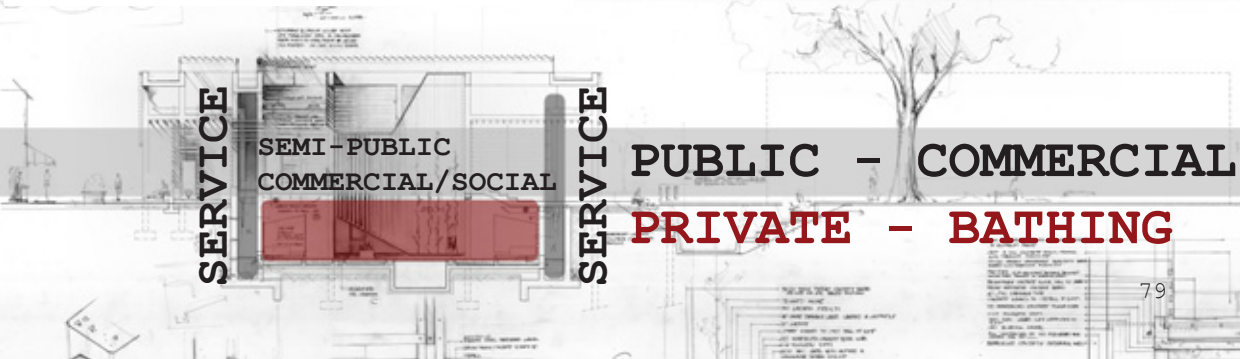


Figure 92.



Ventilation

As the building consists of layers of permeable concrete skins, ventilation of the structure occurs naturally. In the case of the louvred roof being closed, ventilation is still accommodated for in the roof construction. Operable glazing sections as part of the shelter construction allows for a measure of control over ventilation conditions. The plant and mechanical equipment used in the service areas can generate uncomfortable levels of heat; these areas are therefore isolated and mechanically ventilated. Implying the a mixed mode ventilation strategy.

Climate control

The thermal mass of the building is used as a method of regulating thermal conditions inside the building. Heavy mass elements are able to absorb heat and re-radiate it into a building at a later time. Concrete provides good thermal mass (Green building council of Australia, 2005:40). A strategy to ventilate the mass that gathered heat during the day at nighttime during summer is investigated. This ensures that the heat of the day only reaches the interior at night, ventilating rids the structure of this heat. During winter months the mass is encouraged to retain its heat by not ventilating the structure at night. As a large section of the building is located below the ground level and the earth below 500mm is very constant in temperature even when the outdoor temperature undergoes great fluctuation (Green building council of Australia, 2005:41). The temperature of the building mass is tempered by the building being earth sheltered, using the earth as a heatsink.

Again a mixed mode strategy is employed, areas of permanent occupancy or of heat buildup, are mechanically maintained, aided by the passive mechanisms. Decentralized roof mounted air-conditioning units are proposed to regulate the service areas. Taking precedent from ancient baths, the system of raised floors is retained. The raised floor aids in water drainage and allows for warm air from service areas to be pumped into the cavity, heating the space above.

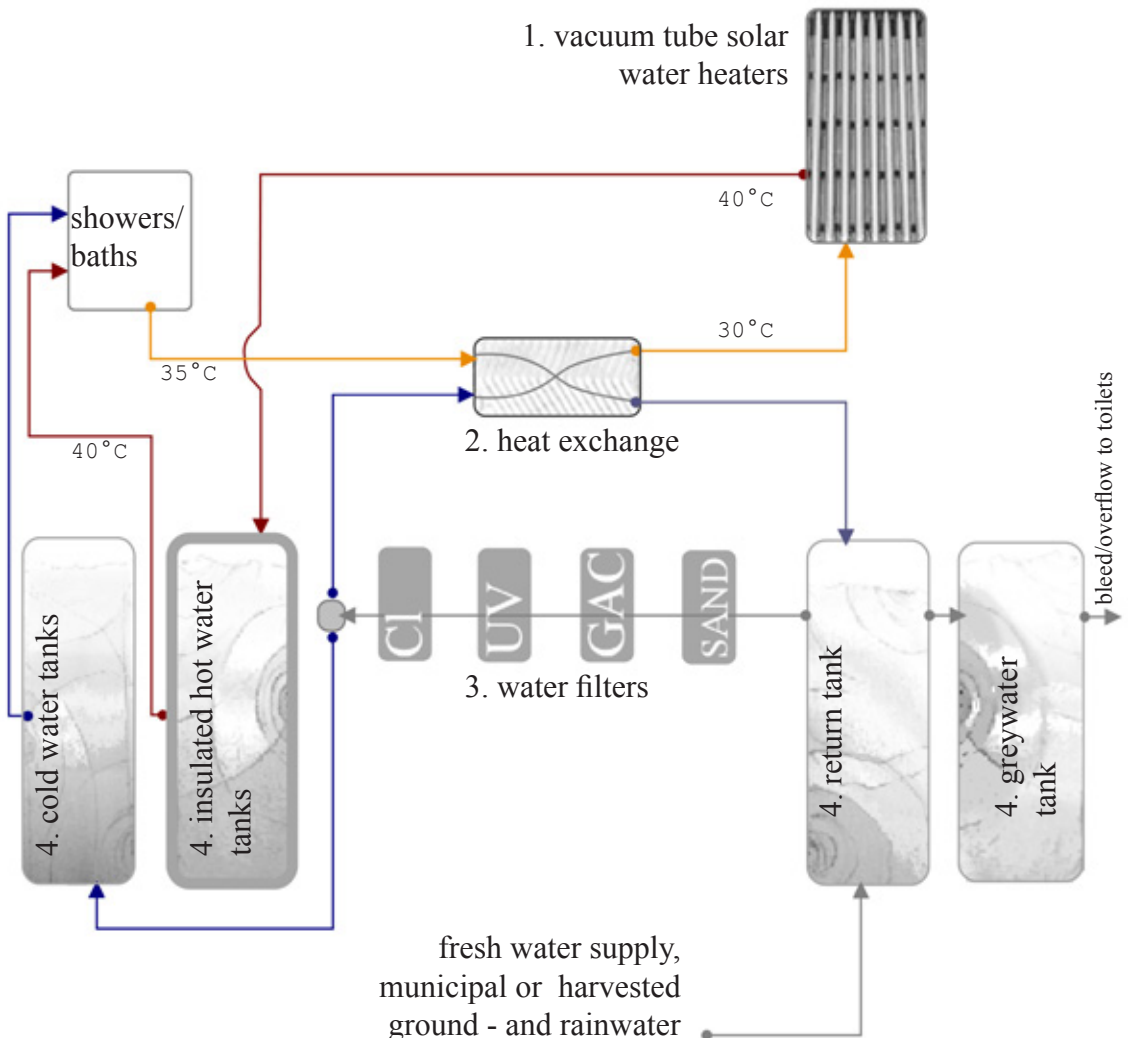


Figure 93. Photograph of the raised floor of the thrermae of Pompeii. showerman 356

Water management

Water management plays a crucial role in ensuring the feasibility of the facility. A potentially large amount of water is used within the building, implying that an efficient method of water harvesting, use and re-use is proposed. Municipal water supply will be the primary source of water, augmented by rainwater and ground-water harvesting. When used for washing, on-site greywater treatment will clean and re-use the water; potable water will have municipal water as source. The primary method of water heating will be solar, using vacuum tube solar water heaters installed on the roof. The intent is to provide an efficient, not necessarily self-sufficient system. Water heated during the previous day is stored and maintained through the night. All sanitary fittings are water efficient, vandal resistant and operated through IR sensors. All hot water pipes and storage tanks are insulated to prevent heat-loss.

Figure 94. Diagram of water re-circulation treatment and heating system.



1. Vacuum tube solar water heater

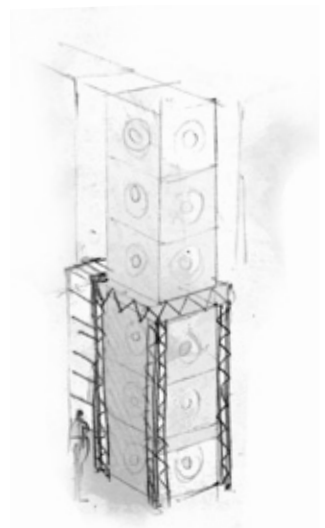
Each Vacuum tube consists of two transparent borosilicate glass tubes. The outer tube is manufactured according to SABS standards. The inner tube is coated with a special selective coating, which has excellent solar heat absorption and minimal heat reflection properties. The air between the tubes is removed to form a vacuum, which eliminates conductive and convective heat loss, enabling the tubes to absorb the energy from the sun's infrared rays which can pass through the clouds. Wind and low temperatures have less of an effect on the performance of the vacuum tubes compared to flat plate collectors due to the insulating properties of the vacuum. The tubes passively track the sun's heat all day. The shape of the tubes provides superior absorption as the tube is round, the sun's rays are always striking the tube's surface at right angles, minimizing reflection (Sun Africa, 2009:2-3). A split collector system is proposed, the collector is split from the storage tank and water is pumped through the system. The collectors are placed at an angle of 25 degrees, facing North, maximizing solar exposure year round. One split collector is capable of heating 250 l of water by 40°C in 4 hours in cloudy conditions using a 2.7m² collector (SolarTech, 2009). Extrapolating this implies that a 2.7m² collector will heat 500 l of water by 10°C in 1 hour. Based on water requirement calculations below, 54m² of vacuum tube collectors are required.

2. Heat exchange

A heat exchange is employed to increase the efficiency of the system, made of a highly conductive metal, fluids of differing temperatures exchange heat as the flow through the unit simultaneously. Warm water returning from the showers exchanges its heat with cold water on its way to solar water heaters. The water never mix, only heat is exchanged.

3. Water filtration strategy

A combination of filters are used to address the cleaning of greywater based on the requirements of programme, these include (in order) a coarse sand filter, a sand-granular activated carbon (GAC) filter, an ultraviolet (UV) filter and a chlorinator. The coarse sand filter intends to trap large particles. The fine sand and GAC filter removes soap and organic material from the water as soap bound to organics, in turn bind to the porous carbon granules. The UV filter neutralizes any pathogens that passed through the carbon filter, while the chlorinator serves the purpose of ensuring the long term cleanliness of water in case of storage. All filters use pumps and operate under pressure.



Water storage tank sizes are calculated based on the requirements of programme, locally manufactured Ibeco water storage tanks are used.

Showers: 26 @ 50 l per use (10 min)
= 1300 l per hour @ 6 uses/hr
= 7800 l per hr
7.8 m³/hr storage capacity required

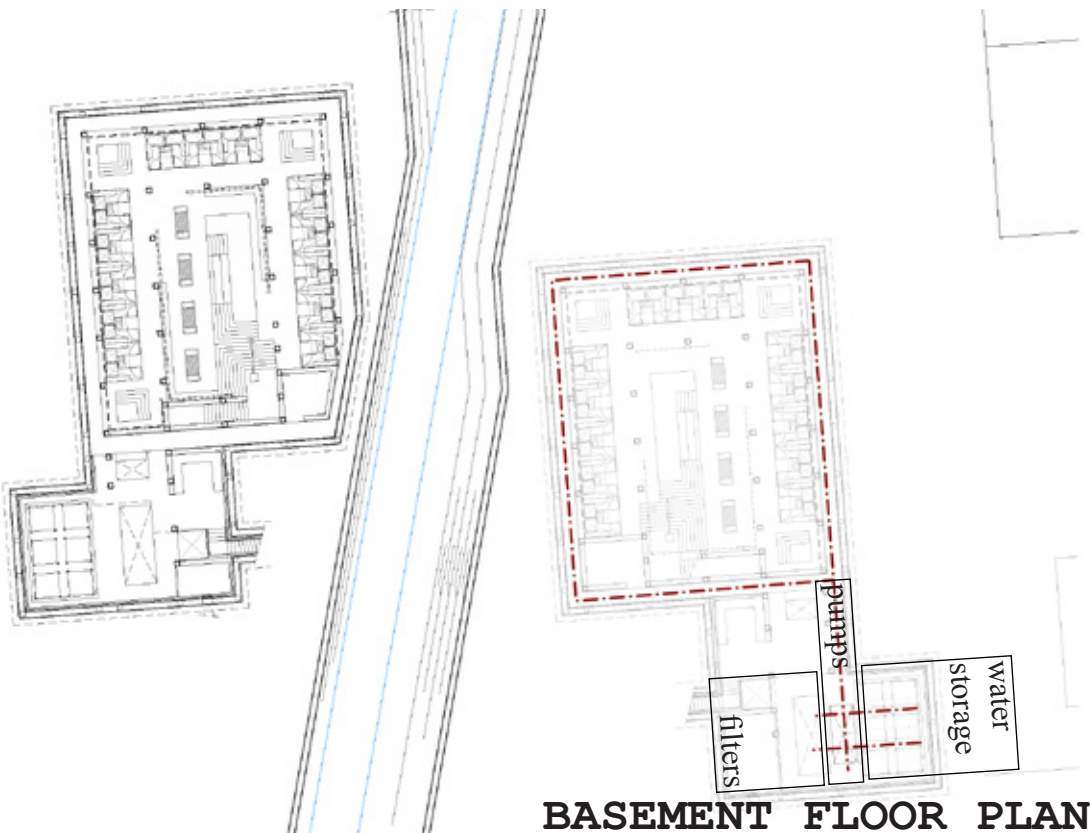
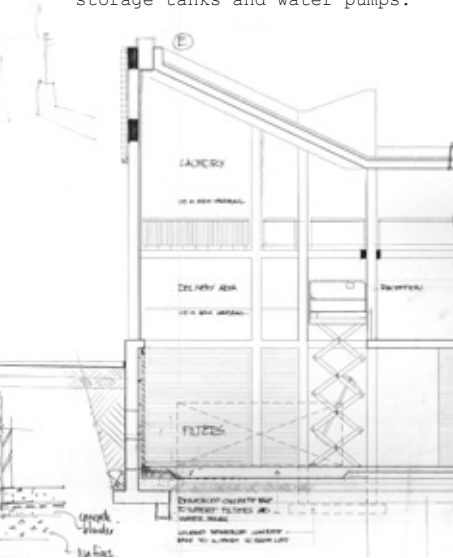
baths: 3 (1m x 1.2m x 1.2m)
= 4.5 m³
@ 1 change per hr
= 4.5m³
per hour storage capacity required

Total water use = 12 m³ per hour (peak loads, all showers running a full hour)

Modular Ibeco water storage tanks employed measure 1.728 m³ per module @ 6 modules per tower = 10.4 m³ per tower. Six towers are used, 10.4 m³ for returning water, 20.8 m³ for hot water storage and 20.8 m³ for cold water. The sixth tower is used to store water returning from pipes and showers when the facility is not in full use. Two towers per water use implies that while one is drained, the other is filled with water returning from the filters and heaters. These calculations apply for one half of the facility and is applied twice.

Figure 95. (opposite)
Modular water storage tanks stacked and supported to form towers.

Figure 96. Section through service areas, note reinforced floor to support filters, water storage tanks and water pumps.



BASEMENT FLOOR PLAN

Figure 97.