



W E T A
P O L
I S



metapolis

Virtual Reality vs. Real Virtuality in a Digital Art Pavillion

by Leanne (Lila) Kruger

UNIVERSITY OF PRETORIA | 2011

Submitted in partial fulfilment of the requirements for the degree of Magister in Architecture (Professional) in the Faculty Engineering, Built Environment and Information Technology.

Study Leader	Gary White
Mentor	Jacques Laubscher
Editor	Greta van der Merwe



+ METAPOLIS | meta + polis

A metaphysical cityscape of information that is draped over the physical metropolis. This city can no longer be defined as an island: it must be seen as a wide spectrum of situations — 'cities inside the city', a 'hyper-place', a 'place of places'.

(Gausa *et al*, 2003: 37)

Programme	Digital Art Pavillion
Site	Corner of Proes & van der Walt Street, Pretoria CBD, Tshwane, 0001
GPS Coordinates	25°44'35.94"S 28°11'37.05"E
Research Field	Architecture in the Information Age

+ Abstract

This dissertation focuses on architecture in the information age.

Information technology is evolving at an alarming rate, which opens up a vast landscape of possibilities within the architectural realm. These possibilities are discussed and implemented into an architectural intervention, with a specific focus on the relationship between the *real* and the *virtual*.

A digital art pavilion is proposed on the corner of Proes and van der Walt street in Pretoria CBD, where the *Munitoria* Complex (Tshwane Municipal Offices) is currently situated.

This intervention should act as a catalyst for positive change by narrowing the digital divide that is currently causing social and cultural segregation; providing a tool for upliftment by informing city dwellers. This negates the current *culture of ignorance* by stimulating a *culture of knowledge*.

Keywords | information age | digital divide | virtual vs. real | digital architecture



Chapter Outline

This chapter provides a broad overview of the evolution of the Information Age and the issues arising within it

The design brief, client and accommodation schedule is briefly discussed

This chapter sketches the problems that will be dealt with, including the problem statement and research questions

Theoretical premises are discussed, including the notions of *intelligent buildings*, *digital architecture* and the transformations in the architectural milieu due to the Information Age

The city, city precinct and site is introduced,

The proposed urban design framework is delineated

Relevant precedents, in terms of typology, tectonic qualities and technical details, are examined

This chapter includes an in-depth analysis of the site and its immediate context concluding, in a proposed site development diagram. This is followed by the inception of design concepts, which develop into design generating principles. Environmental considerations and material choices are also evaluated

The tectonic detail of the proposed intervention is investigated and developed

A concluding statement about the outcomes of the architectural investigation

Examples of emerging forms of digital art is introduced

An investigation was conducted into the way urban surfaces are used and what alternative elements are introduced for 'sitting' by city dwellers, in order to determine certain shortcomings in the existing urban environment

- 01** Introduction
- 02** Design Brief & Programme
- 03** Outline & Reasoning
- 04** Theoretical Discourse
- 05** Context & Site
- 06** Urban Framework
- 07** Precedents & Case Studies
- 08** Design Development
- 09** Technical Resolution
- 10** Conclusion
- 0A** Appendix A: Digital Art
- 0B** Appendix B: Seating Mapping



i | List of Figures

iv | List of Illustrations

01

01 | Introduction

- 05 The Information Age
- 05 The Catalyst: The Internet
- 07 Inevitable Change: Life and Architecture
- 09 The Digital Divide
- 09 The Nature of the Problem
- 10 Bridging The Digital Divide
- 11 Challenges Facing the Process
of Bridging

02

13 | Outline & Reasoning

- 14 Problem Statement
- 14 Addressing the Problem
- 14 Objectives
- 14 Research Questions
- 14 Delimitations

03

17 | Design Brief & Programme

- 19 Brief

04

21 | Theoretical Discourse

- 22 A Developing Society in the Digital Age:
Stimulating a Culture of Knowledge
- 24 Architecture in the Digital Age: A Paradigm Shift
- 26 Intelligent Architecture
- 26 Smart vs. Intelligent
- 28 Augmented Space

05

31 | Context & Site

- 32 Context: the City of Pretoria
- 33 The Development of the City
- 36 Site
- 36 History of the Site

06

47 | Urban Framework

- 39 From City Council to Munitoria
- 42 The Great Munitoria Fire
- 44 After the Fire
- 44 Then It All Came Down
- 45 From Catastrophe to Opportunity

- 48 Rekgabisa Tshwane Framework
- 50 Urban Framework
- 52 Macro Planning Principles:
Pedestrian vs. Vehicle
- 53 Micro Planning Principles: Spatial
- 54 Edge Conditions
- 54 Design Guidelines
- 55 Urban Comfort
- 55 Urban Experience
- 55 Urban Opportunities

07

59 | Precedents & Case Studies



- 60 Circa on Jellicoe by studioMAS
- 64 Bloch Building at the Nelson Atkins Museum
by Steven Holl
- 66 Central Signal Box by Herzog & de Meuron
- 68 Storefront for Art and Architecture
by Steven Holl
- 72 Chicken Point Cabin by Tom Kundig

08

77 | Design Development

- 78 Site Analysis
 - 78 Urban Mapping
 - 80 Edge Conditions
 - 80 Formal & Informal Trading
 - 82 Pedestrian Pace
 - 82 Public Transport Infrastructure
- 85 Site Development
 - 85 Urban Cavity as Proposed Square
 - 87 Spatial Development
 - 88 Osmosis: Programmable Cell Walls
 - 89 Multiple Thresholds
 - 90 Programmatic Symbiosis

- 90 Introduction to Ahmed Alkayyali's *Stairway*
- 91 Site Development Plan
- 93 Design Guidelines
 - 94 Spatial Development
 - 95 Practical Considerations
 - 96 Theoretical Premises
 - 100 Materials
- 101 Environmental Considerations
 - 101 Social Sustainability
 - 101 Intelligent Architecture
 - 102 Location and Site
 - 102 Building Systems
- 104 Finalised Design Proposal

09

113 | Technical Resolution

- 114 Site Plans
- 116 Layout Drawings
- 124 Details
- 130 Axonometric Details

10

135 | Conclusion

139 | List of References

0A

145 | Appendix A: Digital Art

- 146 Information Graphics
- 150 Projections
- 152 Projection Mapping
- 156 Interactive Projection

0B

157 | Appendix B: Seating Mapping

- 154 Experimental Mapping Exercise
- 160 Findings and Conclusions

0C

165 | Appendix C: Photographs of Model

169 | Acknowledgements

01

- 4 | **Figure 1.1:** Timeline of the development of information technologies (Author, 2011)
- 5 | **Figure 1.2:** Map of the Internet (Lumenta Corporation, 2007: 90)
- 8 | **Figure 1.3:** *Byte into an Apple: The Digital Divide*. Graffiti, City of London (Banksy, 2011)
- 9 | **Figure 1.4:** Graph illustrating the percentage of households in Tshwane with access to information technologies (Author, 2011)
- 10 | **Figure 1.5:** Diagram of the digital divide (Author, 2011)
- 10 | **Figure 1.6:** Diagram illustrating the bridging of the gap (Author, 2011)
- 11 | **Figure 1.7:** Diagram illustrating the advantages of bridging the digital divide (Author, 2011)

02

- 15 | **Figure 2.1:** Digital Architecture: Lattice Inherent System (Ramillo, 2010)

04

- 23 | **Figure 4.1:** Diagram illustrating a network of information access points dotted throughout the urban landscape (Author, 2011)
- 24 | **Figure 4.2:** Euclidean geometry: Axonometric view of Villa Vavoye by Le Corbusier (Hruszeczy, 2011)
- 25 | **Figure 4.3:** Non-Euclidean geometry: Plan of Burnham Pavilion by Zaha Hadid (Litvin, 2009)
- 25 | **Figure 4.4:** Non-Euclidean geometry: Sections of Burnham Pavilion (Litvin, 2009)

05

- 32 | **Figure 5. 1:** Figure ground of Pretoria (Author, 2011)
- 34 | **Figure 5. 2:** Diagram of Tshwane illustrating the mountain ranges enclosing the city of Pretoria (Author & other students, 2010)
- 34 | **Figure 5. 3:** Diagram illustrating the development of the city of Pretoria as informed by its rivers and mountain ranges (Jordaan, 1989. Edited by Author)
- 36 | **Figure 5. 4:** Partial figure ground of Pretoria indicating the proposed site (Author, 2011)
- 38 | **Figure 5. 5:** Site plan of Blackwood Villa, 1951 (Unknown author, 1951)
- 40 | **Figure 5. 6:** Plan of Munitoria indicating the L-shaped West- & South wing as well as proposed future wings. Not to scale. (Burg, Lodge & Burg, 1965. Edited by Author)
- 41 | **Figure 5. 7:** Sections of Munitoria. Not to scale. (Burg, Lodge & Burg, 1965. Edited by Author)

06

- 48 | **Figure 6.1:** The Rekgabisa Tshwane framework (The City of Tshwane, 2006. Edited by Author)
- 50 | **Figure 6.2:** Diagram illustrating the connections between different interventions as well as existing public spaces (Author, 2011)
- 51 | **Figure 6.3:** Diagram illustrating the framework precinct as well as proposed sites (Author, 2011)
- 52 | **Figure 6.4:** Diagram illustrating the macro planning principles (Gehl, 2010. Edited by Author)
- 53 | **Figure 6.5:** Diagram illustrating the proposed spatial planning principles (Author, 2011)
- 54 | **Figure 6.6:** Diagram illustrating inviting edge conditions as apposed to repelling conditions (Gehl, 2010. Edited by Author)
- 56 | **Figure 6.7:** Section A-A with interventions highlighted (Author, 2011)
- 56 | **Figure 6.8:** Section B-B with interventions highlighted (Author, 2011)
- 56 | **Figure 6.9:** Section C-C with interventions highlighted (Author, 2011)

57 | **Figure 6.10:** Master plan of urban framework (Author, 2011)

07

- 62 | **Figure 7.1:** Form generating geometry (Arch Dia, 2010)
- 63 | **Figure 7.2:** North and South elevations of Circa Gallery (Arch Dia, 2010)
- 63 | **Figure 7.3:** Section through Circa Gallery (Arch Dia, 2010)
- 63 | **Figure 7.4:** Plans of Circa Gallery (Architeria, 2009)
- 65 | **Figure 7.5:** Diagram analysing the u-profile double glazing facade system (Author, 2011)
- 65 | **Figure 7.6:** Diagram of structure and facilities (Saieh, 2008)
- 65 | **Figure 7.7:** Section through Nelson Atkins Museum and the Bloch building (Saieh, 2008)
- 68 | **Figure 7.8 :** Plan of the gallery indicating the rotations of each panel (Anon, [2001])
- 68 | **Figure 7.9:** Axonometric diagram of the gallery (Anon, [2001])
- 74 | **Figure 7.10:** Concept sketch of the swivelling facade by Tom Kundig (Ngo, 2006.)
- 74 | **Figure 7.11:** Concept sketch of the counter weight mechanism by Tom Kundig (Ngo, 2006.)
- 75 | **Figure 7.12:** Analytical drawing of the counter weight and gear system in Chicken Point Cabin (McLeod, 2007)

08

- 78 | **Figure 8.1:** Mapping area of Van der Walt Street, Munitoria indicated in grey (Author, 2011)
- 80 | **Figure 8.2:** Mapping of edge conditions in Van der Walt Street (Author, 2011)
- 80 | **Figure 8.3:** Mapping of formal and informal trading in van der Walt Street (Author, 2011)
- 82 | **Figure 8.4:** Urban mapping of pedestrian pace in Van der Walt Street (Author, 2011)
- 82 | **Figure 8.5:** Urban mapping of public transport infrastructure in Van der Walt

Street (Author, 2011)

- 84 | **Figure 8.6:** Diagram illustrating a part of the public space network of which the proposed square forms part (Author, 2011)
- 87 | **Figure 8.7:** Spatial parti diagram illustrating the spatial development strategy (Author, 2011)
- 88 | **Figure 8.8:** Diagram illustrating the concept of osmosis (Author, 2011)
- 89 | **Figure 8.9:** Diagram illustrating the current street edge condition and thresholds (Author, 2011)
- 89 | **Figure 8.10:** Diagram illustrating the proposed street edge condition - introducing multiple thresholds (Author, 2011)
- 90 | **Figure 8.11:** Conceptual perspective of *the Stairway* (Alkayyali, 2011)
- 91 | **Figure 8.12:** Diagram illustrating the proposed site development (Author, 2011)
- 92 | **Figure 8.13:** Photographs of a concept model illustrating the symbiotic relationship between the two interventions, the *Art Pavillion* highlighted (Author, 2011)
- 93 | **Figure 8.14:** Diagram illustrating the formal development (Author, 2011)
- 94 | **Figure 8.15:** Spatial development diagram resulting in a conceptual lower ground floor plan (Author, 2011)
- 95 | **Figure 8.16:** Diagram illustrating the vertical and horizontal circulation routes (Author, 2011)
- 96 | **Figure 8.17:** Separate gallery spaces (Author, 2011)
- 96 | **Figure 8.18:** Interweaved gallery spaces (Author, 2011)
- 96 | **Figure 8.19:** Unified open gallery space (Author, 2011)
- 97 | **Figure 8.20:** Diagram illustrating the multifunctional exhibition towers - night club (Author, 2011)
- 98 | **Figure 8.21:** Digital pattern no. 1 (Author, 2011)
- 98 | **Figure 8.22:** Shadow study of the wall simulating digital pattern no. 1 (Author, 2011)
- 98 | **Figure 8.23:** Section through the reception wall (Author, 2011)
- 98 | **Figure 8.24:** Diagram illustrating the experimental reception wall simulating digital pattern no. 1 (Author, 2011)
- 99 | **Figure 8.25:** Digital pattern no. 2 (Author, 2011)
- 99 | **Figure 8.26:** Shadow study of the screen simulating digital pattern no. 2 (Author, 2011)
- 99 | **Figure 8.27:** Detail of the 'digital' screen (Author, 2011)
- 99 | **Figure 8.28:** Diagrams illustrating the screen simulating digital pattern no. 2 (Author, 2011)
- 100 | **Figure 8.29:** Analytical digital of the Pilkington PROFILIT™ u-profile glass system (Author, 2011)

- 101 | Figure 8.30:** Diagram of intelligent building systems (Author, 2011)
- 102 | Figure 8.31:** Combination ventilation diagrams: cross ventilation in the closed position, stack ventilation in the open position (Author, 2011)
- 103 | Figure 8.32:** Diagram of the proposed water harvesting and recycling system (Author, 2011)

09

- 114 | Figure 9.1:** Locality Plan (Author, 2011)
- 115 | Figure 9.2:** Site Plan (Author, 2011)
- 116 | Figure 9.3:** Lower Ground Floor Plan (Author, 2011)
- 118 | Figure 9.4:** Ground Floor Plan (Author, 2011)
- 119 | Figure 9.5:** First Floor Plan (Author, 2011)
- 120 | Figure 9.7:** Perspective of Section A-A (Author, 2011)
- 122 | Figure 9.8:** Section B-B (Author, 2011)
- 124 | Figure 9.9:** Perimeter detail (Author, 2011)
- 125 | Figure 9.10:** Roof detail (Author, 2011)
- 126 | Figure 9.11:** Rotating floor details from Section B-B (Author, 2011)
- 128 | Figure 9.12:** Rotating floor details from *fig. 9.11* (Author, 2011)
- 130 | Figure 9.13:** Axonometric detail of rotating floor (Author, 2011)
- 132 | Figure 9.14:** Typical details of the Pilkington Profilit u-profile glass system (Author, 2011)
- 133 | Figure 9.15:** Axonometric detail of façade system (Author, 2011)

0B

- 158 | Figure b.1:** Map indicating informal vendor distribution within the mapping area (Author & other students, 2011)
- 159 | Figure b.2:** Photographs of percentage of seating by adaptation, in graph form (Author & other students, 2011)
- 160 | Figure b.3:** Photographs of percentage of seating by acquisition, in graph form (Author & other students, 2011)

- 161 | Figure b.4:** Photographs of percentage of seating by appropriated urban surface, in graph form (Author & other students, 2011)
- 162 | Figure b.5:** Photographs of percentage of seating by re-use, in graph form (Author & other students, 2011)
- 163 | Figure b.6:** Photographs of percentage of seating by design, in graph form (Author & other students, 2011)

03

- 18 | Illustration 3.1:** Camera Rosetum (an animated projection) by Sean Capone, Manhattan bridge archway, New York, 2009 (Cernius, 2009. Edited by Author)
- 18 | Illustration 3.2:** Camera Rosetum (an animated projection) by Sean Capone, Manhattan bridge archway, New York, 2009 (Cernius, 2009. Edited by Author)
- 19 | Illustration 3.3:** Primal Source (an interactive digital projection onto water vapour) by Usman Haque, GLOW festival, Santa Monica pier, Santa Monica, 2008 (NOTCOT Archives, 2008. Edited by Author)

04

- 24 | Illustration 4.1:** Euclidean geometry: Photograph of Villa Savoye by Le Corbusier (1887-1965), Poissy, France, 1931 (CCSF, 2011)
- 25 | Illustration 4.2:** Non-Euclidean geometry: Photograph of Burnham Pavilion by Zaha Hadid Architects, Millennium Park, Chicago, 2009 (Litvin, 2009)
- 25 | Illustration 4.3:** Non-Euclidean geometry: Photograph of Burnham Pavilion by Zaha Hadid Architects, Millennium Park, Chicago, 2009 (Litvin, 2009)
- 28 | Illustration 4.4:** An illustration of the concept of augmented space in a literal manner - the city (Matsuda, 2010: 13)
- 29 | Illustration 4.5:** Photograph of ancient Egyptian hieroglyphics (Crystalinks, [2004])
- 29 | Illustration 4.6:** Photograph of Ndebele patterns on a hut façade (Author, 2011)
- 29 | Illustration 4.7:** An illustration of the concept of augmented space in a literal manner - the kitchen (Matsuda, 2010: 3)

05

- 35 | Illustration 5. 1:** Photograph of Church square c.1927 (Cleland, 2009)
- 37 | Illustration 5. 2:** Proposed site (Author, 2011)
- 39 | Illustration 5. 3:** Photograph of Munitoria under construction during the mid1960s (Leitch, 2008: 9)
- 39 | Illustration 5. 4:** Photograph of Munitoria under construction during the late1960s

iv | List of Illustrations

(Leitch, 2008: 48)

- 42 | Illustration 5.5:** Munitoria on the night of the fire as seen from Proes Str. (Leitch, 2008: 8)
- 43 | Illustration 5.6:** Munitoria the night after the fire as seen from Van der Walt Str. (Leitch, 2008: 8)
- 44 | Illustration 5.7:** Munitoria the morning after (Leitch, 2008: 13)
- 44 | Illustration 5.8:** Munitoria on fire, viewed through the monument for victims of terrorism (Leitch, 2008: 8)
- 45 | Illustration 5.9:** The 3 second implosion of the West wing of Munitoria (Leitch, 2008: 13)

07

- 60 | Illustration 7.1:** Photograph of Circa Gallery (studioMAS, 2009. Edited by Author)
- 61 | Illustration 7.2:** Photograph of Circa Gallery (Architeria, 2009. Edited by Author)
- 62 | Illustration 7.3:** Photograph of the aluminium exterior screen with diagram of aluminium fins on plan (Author, 2011)
- 62 | Illustration 7.4:** Photograph of entrance staircase (Author, 2011)
- 62 | Illustration 7.5:** Photograph of an interior exhibition space (Architeria, 2009. Edited by Author)
- 64 | Illustration 7.6:** Photograph of the Bloch building at the Nelson Atkins Museum, by Adam Ryan (Saieh, 2008)
- 65 | Illustration 7.7:** Photograph of the Bloch building illuminated at night, by Andy Ryan (Saieh, 2008)
- 65 | Illustration 7.8:** Photograph of the interior of Bloch building during daytime, by Andy Ryan (Saieh, 2008)
- 65 | Illustration 7.9:** Photograph of the Bloch building at the Nelson Atkins Museum, by Andy Ryan (Saieh, 2008)
- 66 | Illustration 7.10:** Photograph of Central Signal Box (QBN, 2009)
- 67 | Illustration 7.11:** Photograph of the copper strip screen (Polich, 2011)
- 67 | Illustration 7.12:** Detail of the twisted copper strip screen (Polich, 2011)
- 67 | Illustration 7.13:** Photograph of the Central Signal Tower (QBN, 2009)
- 68 | Illustration 7.14:** Photograph of the facade when opened (Brake, 2008)
- 69 | Illustration 7.15:** Photograph of the street elevation (Warchol, 2002)
- 70 | Illustration 7.16:** Photograph of the façade when closed , from exterior (AITC, 2001)
- 70 | Illustration 7.17:** Photograph of the façade when open, from interior (AITC, 2001)

- 71 | Illustration 7.18:** Photograph of the street elevation (Norsworthy, 2008)
- 72 | Illustration 7.19:** Photograph of the rotating facade of Chicken Point Cabin (Benschneider, 2011. Edited by Author.)
- 73 | Illustration 7.20:** Photograph of the rotating facade of Chicken Point Cabin viewed from the first floor (Coleman, 2009. Edited by Author)
- 73 | Illustration 7.21:** Photograph of the gear system of the rotating facade (Benschneider, 2011. Edited by Author)

08

- 94 | Illustration 8.1:** Photograph of the remaining urban cavity with the *Transvaal building* in the background (Author, 2011)
- 85 | Illustration 8.2:** Photograph of the remaining urban cavity (Author, 2011)
- 86 | Illustration 8.3:** Photograph illustrating the temporal strata on the surfaces in the urban cavity (Ahmed Alkayyali, 2011)
- 100 | Illustration 8.4:** Photograph of Pilkington PROFILIT's™ light diffusing qualities, with the chosen product indicated (NSG, [2010]b: 5)
- 104 | Illustration 8.5:** Aerial perspective illustrating the position of the Stairway and the Digital Art Pavilion (Author, 2011)
- 105 | Illustration 8.6:** Exploded axonometric drawing of the intervention (Author, 2011)
- 106 | Illustration 8.7:** South West elevation of the Digital Art Pavilion (Author, 2011)
- 106 | Illustration 8.8:** North East elevation of the Digital Art Pavilion (Author, 2011)
- 107 | Illustration 8.9:** North elevation of the Digital Art Pavilion as seen from Proes Street (Author, 2011)
- 108 | Illustration 8.10:** Exterior perspective of the Digital Art Pavilion from the square (Author, 2011)
- 109 | Illustration 8.11:** Perspective view of the seating area (Author, 2011)
- 109 | Illustration 8.12:** Perspective view of the café seating area (Author, 2011)
- 110 | Illustration 8.13:** South West perspective from square (Author, 2011)
- 111 | Illustration 8.14:** Interior perspective of artist studio (Author, 2011)
- 111 | Illustration 8.15:** Interior perspective of café seating area (Author, 2011)
- 111 | Illustration 8.16:** Interior perspective of Information Technology Facilities (Author, 2011)
- 111 | Illustration 8.17:** Interior perspective of the entrance foyer and reception area (Author, 2011)

0A

- 146 | Illustration a.1:** Facebook users' connectivity diagram (Facebook, 2010)
- 148 | Illustration a.2:** Colours in Culture. Information graphic illustrating what various cultures associate with different colours (McCandless, 2009: 76)
- 149 | Illustration a.3:** When Sea Levels Attack. Information graphic indicating rising sea levels (McCandless, 2009: 74)
- 150 | Illustration a.4:** Projections by Jenny Holzer, Massachusetts Museum of Contemporary Art, 2007 (Johnson, 2007)
- 150 | Illustration a.5:** Projections by Jenny Holzer, Unknown Location, 2007 (Johnson, 2007)
- 151 | Illustration a.6:** Projections by Jenny Holzer, Massachusetts Museum of Contemporary Art, 2007 (Johnson, 2007)
- 152 | Illustration a.7:** Tijuana Projection by Krzysztof Wodiczko, Tijuana, Mexico (HTFA, 2010)
- 153 | Illustration a.8:** Fremont Troll sculpture with a video art projection--here, the face is replaced with one of a Native American Chief. (Unknown Artist, 2004)
- 153 | Illustration a.9-a.11:** 555 Kubik by Unknown Artist, Galerie Der Gegenwart, Hamburg, 2009 (Leeb, 2009)
- 154 | Illustration a.12:** Primal Source by Usman Haque, GLOW festival, Santa Monica pier, Santa Monica, 2008 (NOTCOT Archives, 2008. Edited by Author)

0C

- 166 | Illustration c.1:** Photographs of model (Author, 2011)



UNIVERSITEIT VAN PRETORIA
UNIVERSITY OF PRETORIA
YUNIBESITHI YA PRETORIA

01

01 | Introduction



Information.

We can glean it from the pages of a book or the morning newspaper and from the glowing phosphors of a video screen. Scientists find it stored in our genes and in the lush complexity of the rain forest. And it's always in the air where people come together, whether to work, play, or just gab. - Business Week

(Nunberg, 1996^o: 7)

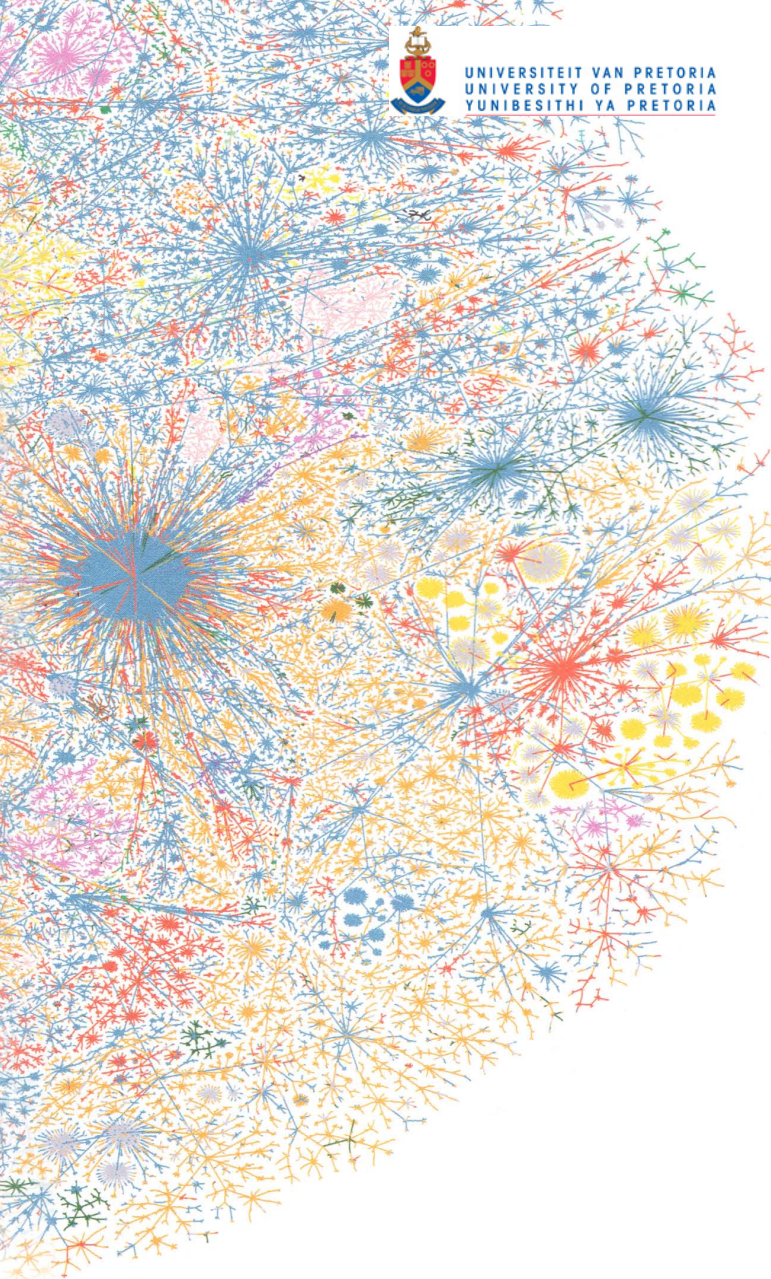

+ Inevitable Change: Life and Architecture

A virtual avalanche of change has been triggered by the eruption of new information technologies and is affecting humanity in a magnitude of dimensions. The way information is accessed and managed, people's manner of self-education, trade and commerce, socialising and other mundane routine activities have been relocated to this domain. Alberts & Papp (1997: 2) suggest that we are passengers of an expedition in which information and communication is becoming the primary influencing factors in the moulding of human action and human interaction. The defining temperament of such a time is unquestionably its *complexity* and the *change* induced by it. The authority on the subject, Castells (1996: 31), emphasises the fact that these transformations are all characterized by their ubiquitous nature; it infiltrates all realms of human life "not as an exogenous source of impact, but as the fabric in which such activity is woven." The domain of information is amorphous¹, yet it holds the potential for inconceivable wonders. Therefore, architecture can no longer occupy the physical realm alone. The setting of its physicality has expanded to the intangible and virtual.

"Architecture is no longer simply the play of masses in light. It now embraces the play of digital information in space."

(Mitchell, 2000: 41)



Figure 1.3:
Byte into an Apple: The Digital Divide.
Graffiti, City of London (Banksy, 2011)

Byte into an Apple is a graffiti artwork illustrating the dire need for information access as compared to that of food.

+ The Digital Divide

A new type of segregation is emerging in the developing world. Although we live in the Information Age, the average city dweller in Pretoria is not connected to this information network. A report done by Statistics SA (2009: 17) indicated that only 28% of households in Tshwane own a computer and a mere 12.8% have Internet access (fig. 1.4). In South Africa in general, information technology users are restricted to more affluent urban and suburban areas. This creates, what is called, a *digital divide*¹ (fig. 1.5). In the Information Age, lack of access to information implies detachment from the global society and its advantages. It is a wall inhibiting the growth of the global culture and is to the detriment of the ignorant.

+ The Nature of the Problem

Internet users presently only amount to 15-20% percent of the world's populace (WIS, 2011). There is an impending potential to be mined by connecting the other 80% to the sphere of information. Wilson (2004) clearly illustrates that, in the developing world, not only does the digital divide symbolise a societal and infrastructural bias amid the information-rich and information-poor, but a cultural divide as well. The digital divide leaves communities with little to no access to the virtual globe behind in the evolution of a technological culture. It is evident that this gap needs to be bridged (fig. 1.6).

"In the twenty-first century, the capacity to communicate will almost certainly be a key human right. Eliminating the distinction between the information-rich and information-poor is also critical to eliminating economic and other inequalities between North and South, and to improve the life of all humanity." (Wilson, 2004: 1)

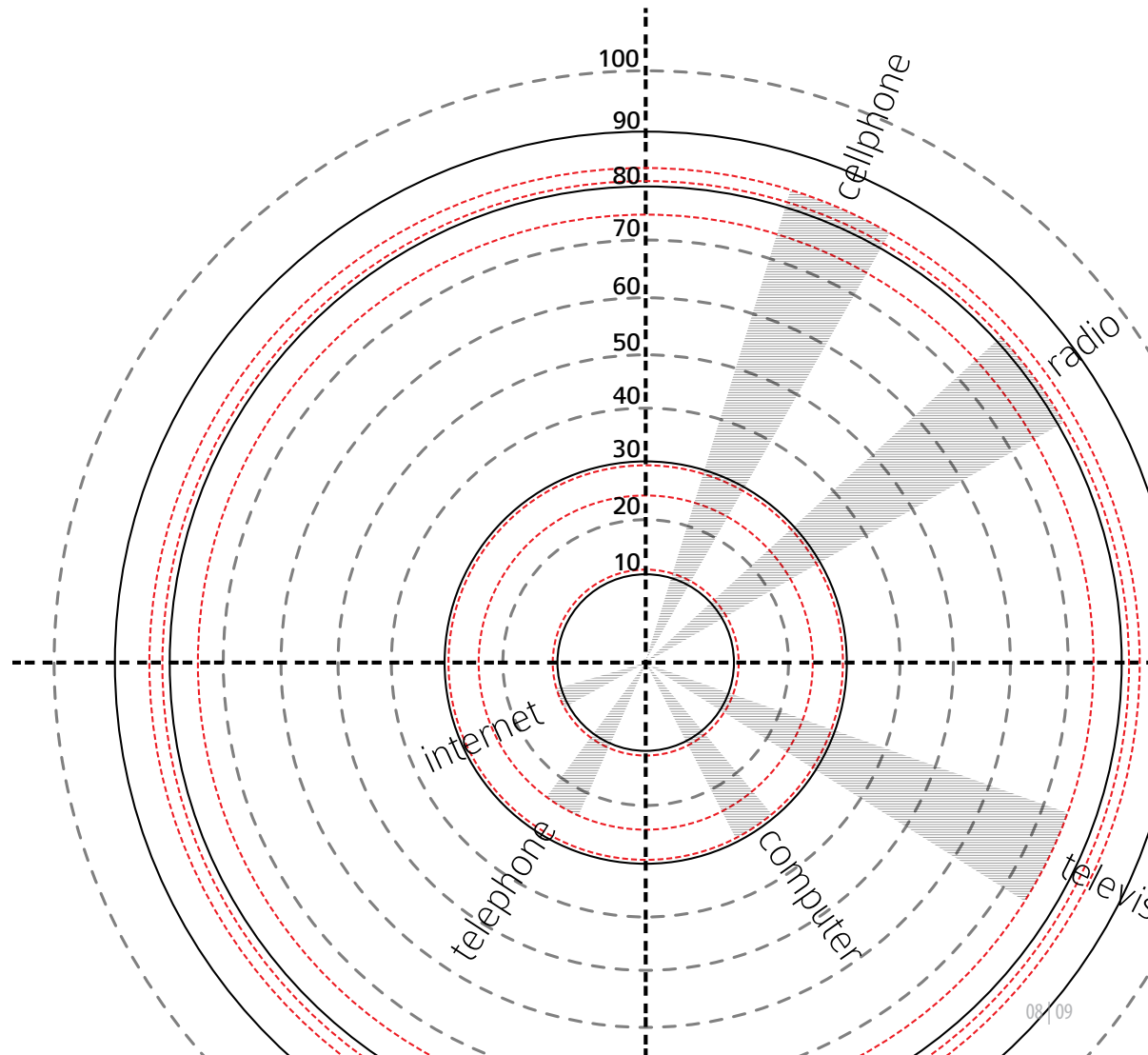
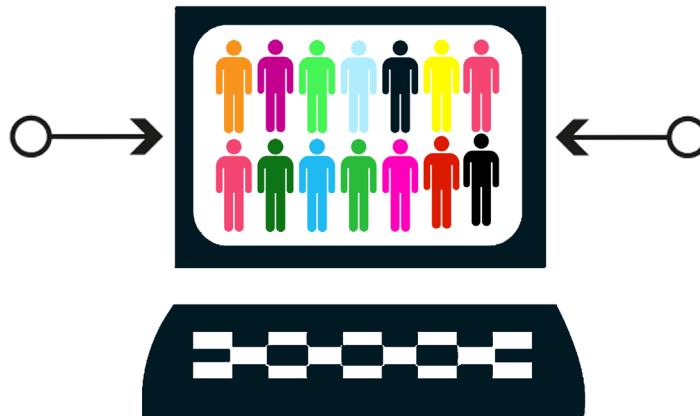
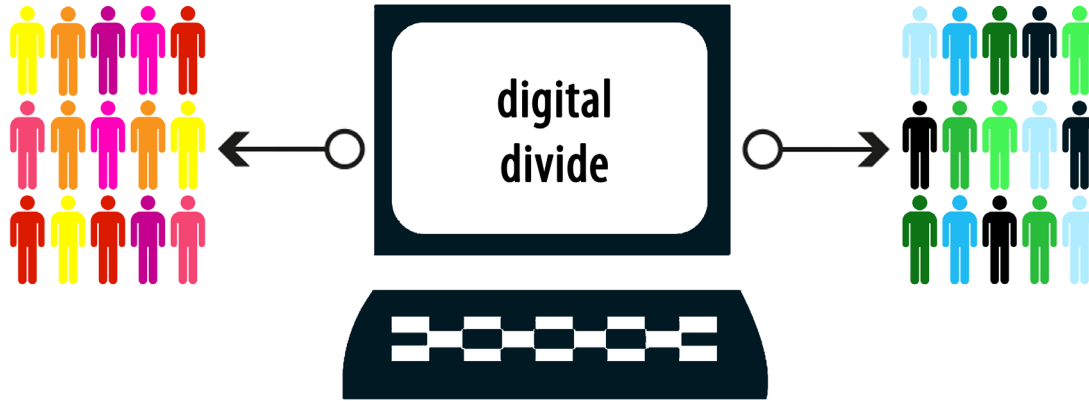

Figure 1.4:

Graph illustrating the percentage of households in Tshwane with access to information technologies (Author, 2011)

01. The term originally represented the gap in computer ownership between different groups of people. It is now defined as the gap between individuals and communities that have and don't have access to information technologies.



+ Bridging The Digital Divide

Cities within a *subsistence economy*¹ are developing a cultural or technological divide that strengthens the existing patterns of socio-economic segregation. This occurrence creates, what Schön, Sanyal & Mitchell (1999: 27) refers to as an *urban schizophrenia* or *dual city*. The dual cityscape is polarized; social segregation has undergone metamorphosis to become a spatial segregation of the informed (usually associated with the opulent) and the information-deprived (the underprivileged). Within this new *ad hoc* system, power is no longer associated with wealth, but with knowledge.

In order for underprivileged or disconnected citizens to have access to the advantages of the interconnected global society (as listed in Chapter 1) they need to be introduced to and made aware of the advantages, in order to...

- 01 | ...negate the stumbling block that is currently hindering progress in developing countries
- 02 | ...tap into the endemic knowledge system (fig. 1.7)
- 03 | (In doing so, users will) ...contribute to the collaboration of minds and ideas and influence the shaping of this digital environment to suit their specific needs (fig. 1.7)
- 04 | ...create equality among different income and cultural groups² (as Nelson Mandela suggested) (fig. 1.7)
- 05 | (This should also) ...alleviate the socio-segregation of the dual city by socio-integration

From top to bottom |

Figure 1.5: Diagram of the digital divide

(Author, 2011)

Figure 1.6: Diagram illustrating the bridging of the gap

(Author, 2011)

+ Challenges Facing the Process of Bridging

As Mitchell (Schön et al, 1999: 392) explained:

"We would need design scenarios, action strategies, and action research that could influence policy and feed into longer-term planning for the use of information technology in low-income communities. In the wake of such an experiment both the low-income community and the technology would be transformed."

- 01| Supplying new technologies to the masses can prove to be incredibly costly. This indicates that information technologies should rather be located in a public location in order to serve a critical mass.
- 02| Teaching computer-illiterates how to utilize the devices and applications is another conundrum. For faster learning, these technologies should be accessed communally where users can feed off the collective knowledge of the group.
- 03| Completely illiterate participants cannot teach themselves by reading instructions, therefore the information has to be translated into visual form.
- 04| By talking to the general public in the inner city, it became evident that there exists a strong prejudice toward technology in the developing world. It is believed to be incomprehensible and foreign. This image needs to be shattered by making people aware of the possibilities and advantages thereof. New strategies need to be investigated and implemented in order to cultivate a culture of knowledge.

01. A subsistence economy refers to the developing world where survival is considered the highest priority. Luxuries are ranked low on the list. Information technologies are often considered a luxury, but does in fact contribute to survival and wellbeing.
02. A study by Chen, Bozso, Abcouwer, Scharff & Shaffer ([2009]: 3) indicated that between 1997-2005, middle and higher-income groups showed growing equality due to the narrowing of the digital divide, while low income groups suffered a decrease in the level of equality to higher income groups (Chen et al, [2009]: 3).

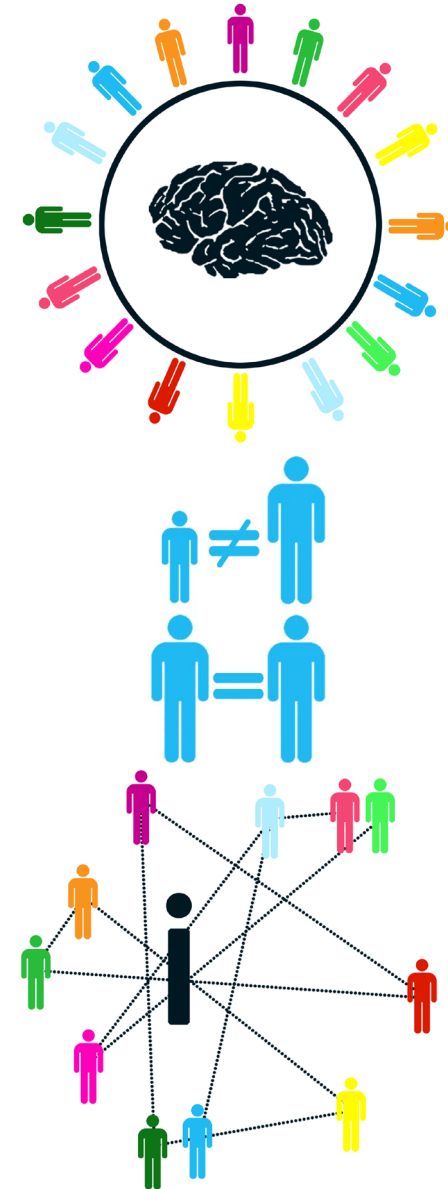

Figure 1.7: Diagram illustrating the advantages of bridging the digital divide (Author, 2011)



02

+ Problem Statement

The general public is not aware of the advances in the field of information technologies. This creates a *digital divide* that stimulates a culture of ignorance rather than a culture of knowledge, which can in turn lead to a state of de-evolution.

+ Addressing the Problem

This problem needs to be addressed by informing the ignorant, creating an awareness of the advantages and providing access to the emerging technologies. If this is not achieved the developing world will be left behind in the rapid evolution of a global digital community, which could lead to even greater socio-economic concerns in the developing nations.

+ Objectives

- 01 | Narrowing the gap caused by the digital divide
- 02 | Introducing a programme into the public realm which creates an awareness and informs the civil society of Pretoria

+ Research Questions

- 01 | How can architecture contribute to bridging the digital gap?
- 02 | Can physical elements be designed in order to be perceived as digital?
- 03 | Can the virtual be perceived as real in an architectural intervention?
- 04 | How can the dynamics of a single space/spaces be altered to act as an adaptive multifunctional space?

+ Delimitations

This dissertation does not deal with *virtual architecture*¹, but rather with *digital architecture*² and the emerging relationship of the virtual realm to architecture. Technical aspects regarding 'Intelligent Building Systems' are also not explored in depth as it would require specialist design in fields that fall outside of architecture.

- 01. *Virtual architecture refers to architecture intended for the virtual realm only: spaces and buildings in video games and cyber worlds*
- 02. *Digital architecture refers to physical architecture created via digitally enabled design processes. It allows complex calculations that delimit architects and allow a diverse range of complex forms to be created with great ease using computer algorithms.*

Figure 2.1: Digital Architecture: Lattice Inherent System (Ramillo, 2010)

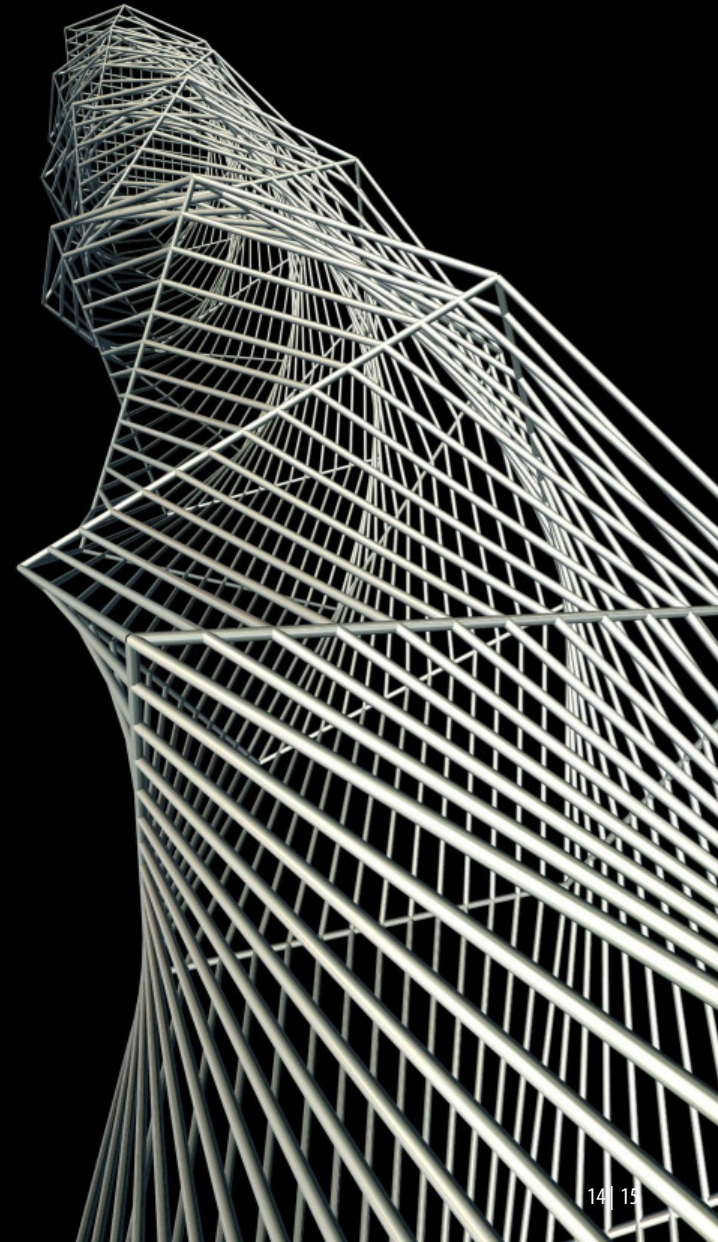

03



+ Brief

The project calls for a truly public facility where the average city dweller is introduced to new and emerging information technologies as well as the possibilities it holds. These technologies should be accessible to all in order to be used freely and experimented with for self-edification and self-enrichment.

+ Programme : Digital Art Pavilion

Due to the new age of information technologies, new artforms and mediums of expression are emerging in the form of *digital art*. This art form is still in its infancy and is therefore in the process of being explored and established. New mediums for expression are: virtual and holographic projections, LED lighting graphics, animations, interactive screens and installations, laser art, information graphics, projection mapping and augmented sculptures among others - all of which are exhibited on various different surfaces and materials. (See Appendix A)

A space for the experimentation and exhibition of digital art becomes a necessity for the evolution of this new art form. Different artists would be invited to work in the building for a set period of time, after which their work is exhibited in the building for the public (similar to the entrance foyer in the Tate Modern, London).

This space should be adaptive in order to accommodate various events (i.e. the structure could be used as a nightclub on one occasion and a museum on another) and different forms of digital art.

Client: Google

Accommodation Schedule:

- | | |
|-------------------------|---|
| 01 Artist studios | 03 An information technology access point |
| 02 Exhibitions spaces | 04 A café to cater for events |

Opposite |

Illustration 3.1 & 3.2:

Camera Rosetum (an animated projection) by Sean Capone, Manhattan bridge archway, New York, 2009 (Cernius, 2009. Edited by Author)

This page |

Illustration 3.3:

Primal Source (an interactive digital projection onto water vapour) by Usman Haque, GLOW festival, Santa Monica pier, Santa Monica, 2008 (NOTCOT Archives, 2008. Edited by Author)

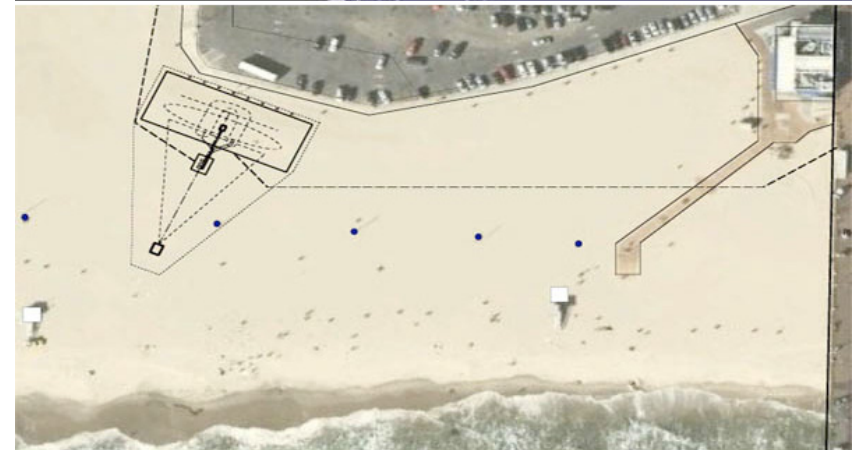
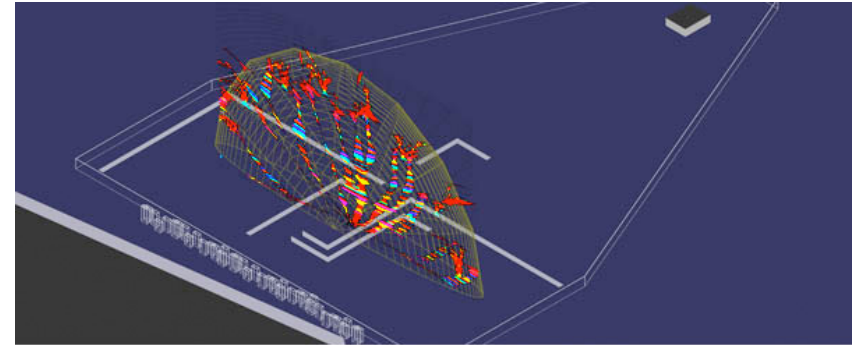

04

A Developing Society in the Digital Age:

+ Stimulating a Culture of Knowledge

Wilson (2004: 310) advocates that in order to construct a culture of knowledge (in developing countries), the first step is to establish awareness; awareness of the growing information system, the positive influences it has on everyday life and the simplicity thereof. The stigma around the complexity of information technologies should be eradicated by expressing a level of transparency. This must be followed by providing points of access. The nature of these environments should spark an interest and encourage a motivation to learn. But access alone is not the answer. In order to ensure that users make use of the *access points*, a second surge of encouragement is necessary. A realisation of the ability to contribute as well as the gratification of an individual's contributions, needs to be fully understood.

The *Age of Participation*, as referred to by many writers and experts (such as Tapscott & Williams (2006), Mitchell (2000) and Castells (1996)), indicates that users are not merely consumers of digital content, but have in fact also become the producers. Don Tapscott, a co-writer of *Wikinomics* (Tapscott & Williams, 2006), has labelled this new 'species' of users as *prosumers*. In the book it is stated that while the *Net Generation's* "parents were passive consumers of media, youth today are active creators of media and hungry for interaction" (*ibid*: 47).

It goes without saying that information spaces (or access points) should be places of participation and collaboration seeing as learners are encouraged by active engagement (Schön *et al* 1999: 161). In contrast to traditional educational systems, where information is transmitted by a teacher and the learner can either choose to accept or decline the knowledge, active participants have a hold over the process of edification (*ibid*: 269). This also creates a sense of responsibility. According to Schön *et al* (1999: 402) it is necessary to cultivate "an ensemble of values, expectations, norms, and incentives that impels more and more individuals to want to create and become active, engaged members in a knowledge society".

The manner in which people innovate, explore and discover with technologies is predominantly influenced by this degree of peer-production or interaction. In essence, the following steps need to be taken in order to achieve a culture of knowledge:

- 01 | Create an awareness that dissolves the stigma
- 02 | Provide access points
- 03 | Stimulate interest among the society
- 04 | Interaction and creative learning

With the aforementioned steps in place the user has the opportunity to continue to an ideal additional two steps:

- 05 | Self-education
- 06 | Innovation and upliftment

These steps need to be reinterpreted in order to be translated to relevant architectural guidelines:

- 01 | An informational building should be transparent and announce its programme
- 02 | Physical access is an important consideration
- 03 | The intervention should intrigue the public (by means of distinctive characteristics i.e. rendering a new spatial typology or form)
- 04 | Encourage interaction

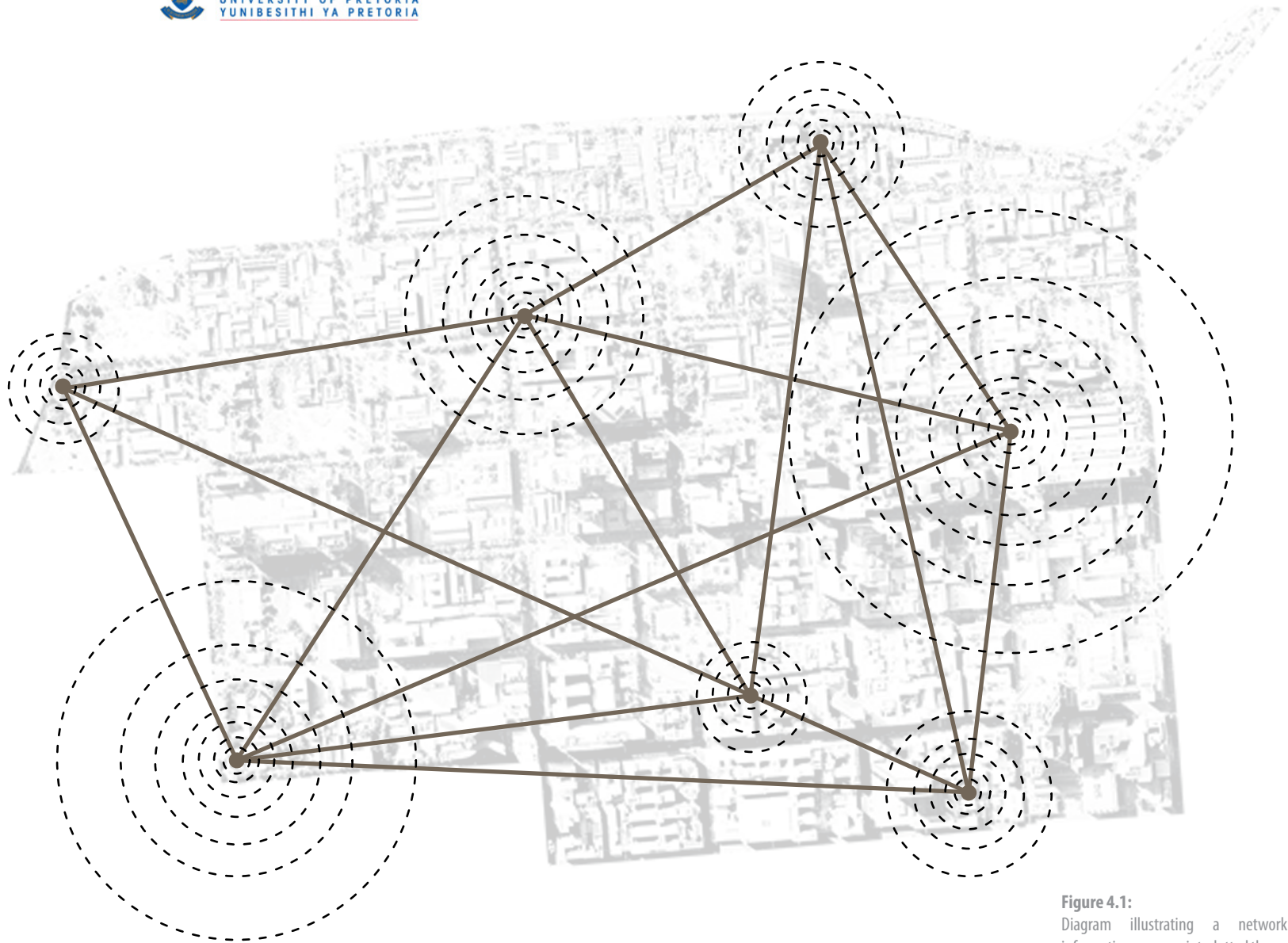

Figure 4.1:
Diagram illustrating a network of information access points dotted throughout the urban landscape (Author, 2011)

Architecture in the Digital Age:

+ A Paradigm Shift

With the increasingly evident impact of digital technologies on architecture, the design, manufacturing methodology and construction process is becoming dependent on and reconditioned by it. As representational tools change “[a]rchitecture’s definitive boundaries [also] transform” (Norman & Tilder, c2003: 5). Digital technologies are redefining conventional ideas of place, space and time, which raises the question: how will architecture be redefined?

In *Differences: Topographies of Contemporary Architecture* (1997: 117), Ignasi de Sola Morales puts forth that:

“Having abandoned the discourse of style, the architecture of modern times is characterized by its capacity to take advantage of the specific achievements of that same modernity: the innovations offered it by present-day science and technology. The relationship between new technology and new architecture even comprises a fundamental datum of what are referred to as avant-garde architectures, so fundamental as to constitute a dominant albeit diffuse motif in the figuration of new architectures.”

Even though computer-aided design (CAD) has supported the field of architecture since the 1980s, only in the last decade has it induced a significant paradigm shift within architectural thinking. It is unlocking formal and construction possibilities that has, until recently, been financially unfeasible and problematic to construct using traditional building technologies.

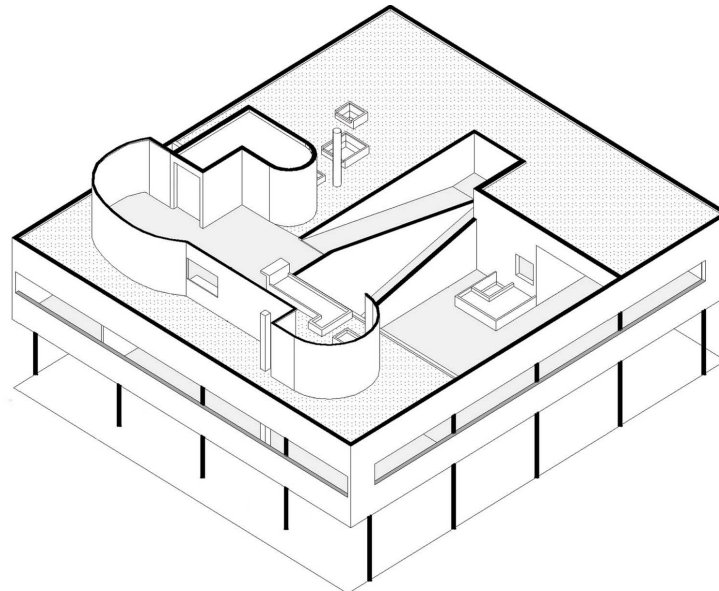
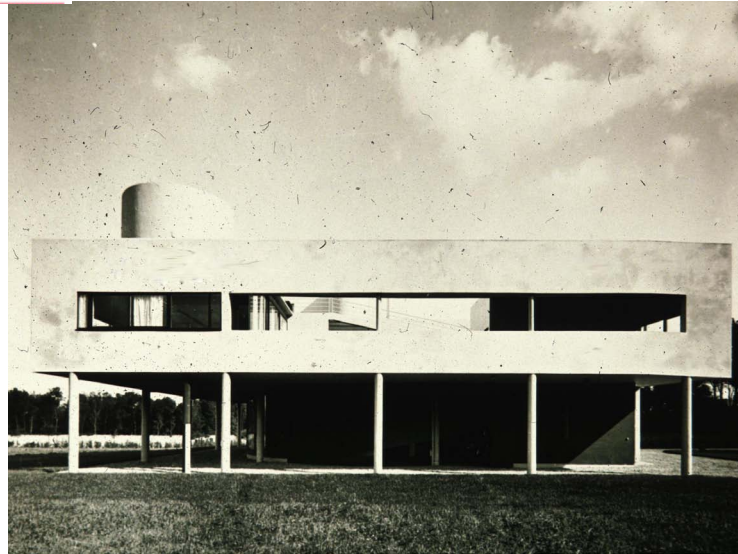

01. Denoting the system of geometry based on the five postulates of Euclid. The five postulates are:
 - a. Any two points can be joined by a straight line.
 - b. Any straight line segment can be extended indefinitely in a straight line.
 - c. Given any straight line segment, a circle can be drawn having the line segment as radius and an endpoint as centre.
 - d. All right angles are congruent.
 - e. The parallel postulate- If two lines are drawn that intersect a third in such a way that the sum of inner angles on one side is less than the sum of two right triangles, then the two lines will intersect each other on that side if the lines are extended far enough. (Barnhart, 1988)
02. Relating to any of several modern geometries that are based on a set of postulates other than the set proposed by Euclid. (Barnhart, 1988)
03. Mass customization is the use of flexible computer-aided manufacturing systems to produce custom output. Those systems combine the low unit costs of mass production processes with the flexibility of individual customization. Kaplan, Schoder and Haenlein (2007:102) describes it as the process of creating “... customized products with production cost and monetary price similar to those of mass-produced products”.

Top to bottom |

Illustration 4.1: Euclidean geometry: Photograph of Villa Savoye by Le Corbusier (1887-1965), Poissy, France, 1931 (CCSF, 2011)

Figure 4.2: Euclidean geometry: Axonometric view of Villa Savoye (Hruszeczy, 2011)

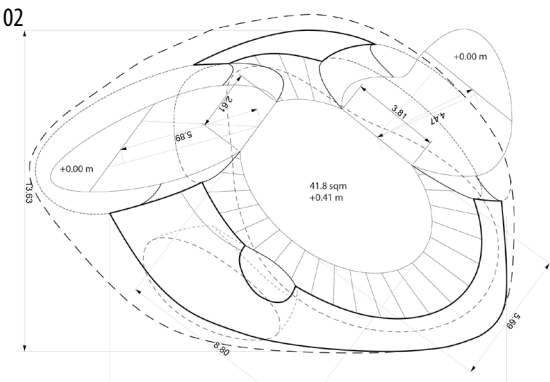

Illustration 4.2 (1): Non-Euclidean geometry: Photograph of Burnham Pavilion by Zaha Hadid Architects, Millennium Park, Chicago, 2009 (Litvin, 2009)

Figure 4.3 (2): Non-Euclidean geometry: Non-Euclidean geometry: Plan of Burnham Pavilion (Litvin, 2009)

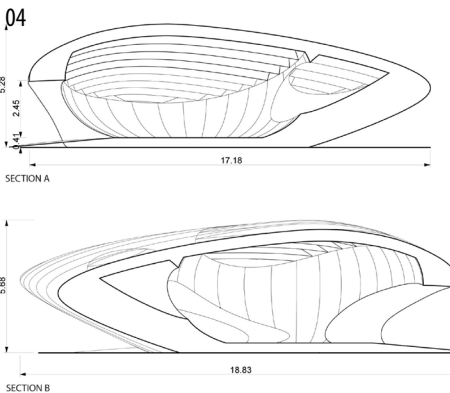

Illustration 4.3 (3): Non-Euclidean geometry: Photograph of Burnham Pavilion by Zaha Hadid Architects, Millennium Park, Chicago, 2009 (Litvin, 2009)

Figure 4.4 (4): Non-Euclidean geometry: Sections of Burnham Pavilion (Litvin, 2009)

According to Kolarevic (2001: 117), the transformations should be profound due to new digitally driven design, fabrication - and construction processes contesting the historic architecture-construction relationship. He suggests that a direct link exists between the traditional drawing apparatus used, i.e. the T-square, ruler, and drawing compass, and the rectilinear structures of the past. When William Mitchell (2001: 358), the authority on the digital age, described the influence of the traditional architect's tools on the building, he noted that architects drew what they could build and built what they could draw. With the advancement in CAD technologies, "digitally-driven design processes, characterised by dynamic, open-ended and unpredictable but consistent transformations of three-dimensional structures, are giving rise to new architectonic possibilities" (Kolarevic, 2003: 3). These 'possibilities' resulted in a new *genre* in architecture namely, *digital architecture*. It refers to architecture created *via* digitally enabled design processes, allowing complex calculations and forms that delimit architects to be created with great ease.

Computers and CAD technologies offer the three-dimensional freedom which motivate digitally generated forms that discard the conventional discourse of *style*. This technological *means* uncovers what other historic architectural tools have previously concealed – "the architectonics of architecture" (Mahalingam, c2003: 3). *Non-Euclidean*¹ (topological, curvilinear and irregular) geometries are produced as effortlessly as *Euclidean*² geometries. The plan is no longer the dominant design generator, while sections take on merely an investigative role. The validity of repetition and symmetry is negated as unlimited variability becomes as feasible as modularity and as *mass customization*³ replaces mass production (Kolarevic, 2001: 123). This technological progress in combination with the global energy debate has brought about the concept of 'intelligent buildings' that are energy efficient and environmentally responsible.

+ Intelligent Architecture

The modernist hypothesis of building as a *machine for living* has not yet been successfully reinterpreted into a 21st Century rendition where the dwelling is rather viewed as a *living machine* (Hunt, 1997: 30). Cybernetician, Gordon Pask (1969), has been endorsing the symbiotic relationship of man and machine since the late 1960s. He believes that there needs to exist intimate interaction between *cybernetics*¹ and architecture in order to facilitate new psychological and physical environments.

According to Sherbini & Krawczyk (2004:137), the idea of *intelligent buildings* was conceived shortly after an increasing interest in *automated building systems* arose. These systems communicate and exchange information in order to ensure a building's optimal performance in terms of economy and comfort. *Building Management Systems* (BMS) has the ability to regulate indoor air temperature, ventilation, illumination, security and other aspects that need constant control;

*“...responding to the demands of the physical...
[while] interacting with the digital.”*

(Gausa, Guallart, Müller, Soriano, Porras, & Morales, 2003: 345)

+ Smart vs. Intelligent

Academics have defined *intelligent* building as a structure in which some or all of its services are automated or utilises the most up-to-date technology (Hunt, 1997: 30; Sherbini & Krawczyk, 2004: 139). Their computerized and mechanical processes are preset and definite, responding only according to set parameters within a specified margin of calculated actions. Subsequently, it does not embody the ability to anticipate our shifting individual requirements or the capacity to communicate with its users in, what Hunt (1997: 30) calls, “a relational context”. This not-so-critical adoption of the term *intelligent* building leads to a general confusion. In the words of Droege (1997: 359), there is nothing about “roboticness that entails mindfulness”. The aforementioned definition should rather be applied to *smart* buildings.

Modern-day computers have the ability to assimilate and transfer information, correspond with other technology and calculate a response. Essentially, it can *think*. When this abstract characteristic is incorporated into the physical realm, the man-made world would gain the aptitude of *thought*. Architecture becomes *intelligent* in the moment of the acquisition of a *thinking ability* (Sherbini & Krawczyk, 2004: 138).

Sherbini & Krawczyk (2004: 140) have listed the following criteria for a building to be rendered *intelligent*:

- 01 | An input system that assimilates information by means of data receiver
- 02 | The capacity to process and analyse information
- 03 | An output system that reacts to the input (responsiveness)
- 04 | Timely responses
- 05 | The ability to learn

One of Mitchell's premises in *City of Bits* (1997) is that not only *intelligent* architecture, but *intelligent* public spaces should be decidedly receptive and responsive to the individual requirements of its users: an *e-topia* (Mitchell, 2000) of physical and virtual organisms. The primary precedent of this new discipline should be the evolutionary and interactive capacity of ecological systems and biological organisms. This could introduce an autonomous, holistic philosophy and systemic approach to the urban environment. The scientist, Richard Gardiner, believes that the answer lies in the "way that our synthetic world will be guided by the same philosophy as our natural world" (Hunt, 1997: 30).

In an architectural dictionary pertaining to this emerging paradigm, Gausa *et al* (2003) refer to this type of system as *advanced architecture*. It is "to the digital society what modern architecture was to the industrial society: an architecture bound up with interchange and information. With the capacity for displacement and modification" (Gausa *et al*, 2003: 36). It translates the ever-changing mutation of processes, context and situation into its associated spatial form; an architecture capable of conveying its own *thoughts* and *movements*, while concurrently exposing the agents that mould it. This creates a dynamic *ecosystem* that interacts with its biological, physical or virtual *ecology*; simultaneously "reinforcing...and recycling it" (Gausa *et al*, 2003: 36). This progressive nature demands qualitative change. Such environments are not limited by its complexity, but is rather given the opportunity to surpass all expectation by embracing *waiting* possibilities.

In John Frazer's (1995: 10) writings on *cybernetic*¹ architecture, he explains that:

"It will conserve information while using the processes of autopoiesis²...to generate new forms and structures...Not a static picture of being, but a dynamic picture of becoming and unfolding - a direct analogy with a description of the natural world."

01. *Cybernetics is the science of communications and automatic control systems in both machines and living things.*
02. *The term autopoiesis refers to "auto(self)-creation" and was introduced in 1972 by Chilean biologists Francisco Varela and Humberto Maturana. From the Greek: auto (αὐτο) for self- and poiesis (ποίησις) for creation or production. An autopoietic system is self-governing and self-maintaining. It embodies the ability of component producing. In other words, the spontaneous generation of living systems.*



+ Augmented Space

With the emergence of the Internet as an integral and ubiquitous part of daily life during the 1990s, the focus was turned to the virtual realm. This sphere was first perceived as ominous due to its underlying potential, but it soon became domesticated as an *electronic suburb* (as coined by Norman Klein). Recently, this focus has shifted back to the physical; the real world filled with virtual data and visual information. A new *augmented reality* (Manovich, 2011) is occupying the space where we once found the traditional city. This term refers to the overlaying of dynamic information over the physical layer of urban surfaces and spaces. This layer of digital media is no longer confined to flat static surfaces.

This virtual-real relationship transforms physical space into data-space (*ibid*) by extracting information from the physical, reacting to it in the virtual and finally augmenting the real with a digital layer of information.

A complex multicity is created: a multitude of digital cities within the physical metropolis, creating a *metapolis*. Gausa *et al* (2003: 37) defines this in *The Metapolis Dictionary of Advanced Architecture* as “[a] city of cities conceived as a *hyperplace*: a place of places... A metapolis that would unfold on the territory as a flexible mesh of diverse landscape of spaces and interspaces. Grids, matrixes, topographies or fabrics.”

Electronic billboards and screens stand in contrast to this new breed of *augmented space* as it strictly occupies a predefined part of the physical realm (as in the tradition of *Alberti's window*¹ and the television screen) and is not overlaid in a three dimensional manner. Historic architecture has always incorporated information and symbolism if we consider ornament, iconography and visual narratives (such as ancient Egyptian hieroglyphics, Medieval cathedral windows, Gothic narrative sculptures and Ndebele patterns). Robert Venturi, the advocate of Post Modernism, suggested to George Legrady in a conversation (Manovich, c2006: 232), that architecture should return to its traditional definition of iconography where architecture should become *information surfaces* once more.

01. *Alberti's window* was a conceptual method for Renaissance artists to understand perspective. Leon Battista Alberti (1404-1472) wrote in his book, *De Pictura* (1435): “On the surface on which I am going to paint, I draw a rectangle of whatever size I want, which I regard as an open window through which the subject to be painted is seen” (Albetri 1991: 54). Here, it refers to the idea that information occupies a predetermined space within the physical world.

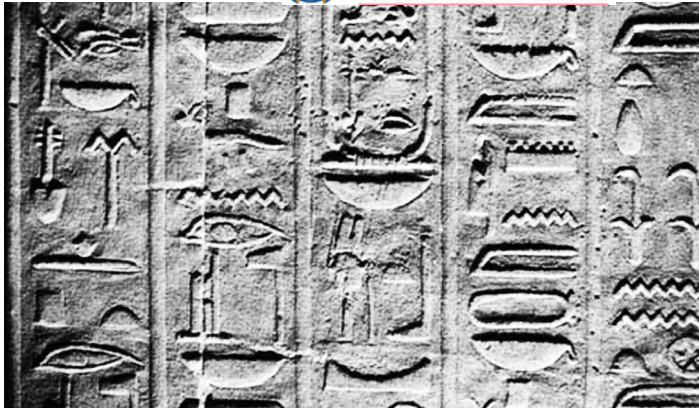

01



02

Opposite |

Illustration 4.4:

An illustration of the concept of augmented space in a literal manner - the city (Matsuda, 2010: 13)

This page |

Illustration 4.5 (1):

Photograph of ancient Egyptian hieroglyphics (Crystalinks, [2004])

Illustration 4.6 (2):

Photograph of Ndebele patterns on a hut façade (Author, 2011)

Illustration 4.7 (3):

An illustration of the concept of augmented space in a literal manner - the kitchen (Matsuda, 2010: 3)



03

05

+ Context: the City of Pretoria

Tshwane, the capital of South Africa is a city exemplifying the characteristics of a post-colonial African metropolis. It is a city that, since apartheid, has undergone a rapid metamorphosis in terms of its social and cultural milieu. Change of such magnitude has physical implications on a city, and it is the task of the space maker (urban designer, architect, landscape architect and interior architect) to effectuate its transformation.

An influx of a previously disadvantaged populace as well as the exodus of a sizable portion of its former inhabitants has resulted in a somewhat schizophrenic city of segregated developments connected by large automotive roadways. Although relatively well inhabited, the majority of its working population reside on the outskirts of the city. Consequently, each morning the city has to accommodate for a massive inundation of mini-bus taxi's from outlying townships and private vehicles from suburbia. This leads to a city suffering from the effects of daytime congestion and nighttime abandonment (a migrating culture).

Pretoria, the inner city of Tshwane (area of study), is rich in historical significance with its structures standing firm as monuments within an environment of change. The existing built fabric of Pretoria offers to the space maker a canvas rich in contradiction and possibility, and the task of unpacking and reshuffling these complex archaeologies of place takes on a new urgency in the current social climate of transformation and integration.





+ The Development of the City

The city has developed according to contextual aspects, universal principles and cultural ideals (Jordaan, 1989: 26). The city is clearly defined and 'contained' by its natural elements; the *Witwatersberg* mountain range to the North with the *Apies* River running at its foot, curving in a Western direction, to outline the Eastern boundary of the city. *Steenhovenspruit* defines the Western perimeter, while Pretoria formations of the *Magaliesberg*, i.e. *Langeberge* and *Skurweberg*, delineate the South. The city form is a direct result of the interpretation of these governing natural elements (Jordaan, 1989: 26) which offer a level of sympathy with its context.

The grid of Pretoria was laid out according to the Roman planning principle of the *Cardo-Decomanus*. The *Cardo* is a north-south oriented street that formed an integral component of Roman city planning. It was lined with shops and traders, and served as the economic hub of the city. Most Roman cities also had a *Decomanus* - an east-west oriented street that served as a secondary main arterial. The *Forum*¹ was normally located at the intersection of the two (Bosanquet, 1915: 289).

Similarly, Church Square is situated on the crossing of the two main arteries: Paul Kruger -, the former *Markstraat* (Market

Street, due to its primary function, as the *Cardo*) and Church Street (*Decomanus*). It is the symbolic *nucleus* of the city around which all development was centred (*fig. 5.3*). The square itself emphasises its importance by articulating the crossing of the two main axis as well as its *mandalā* form (*illus. 5.1*).

Church square is symbolically linked to the landscape by its connections with the 'poorte' or natural gateways (Daspoort to the North and Fountains Valley to the South) as well as its link to the rivers on the Eastern and Western periphery of the city.

Pretoria's city blocks are much larger (80x120m) than the average city block which was a result of the water channel system³. This lead to a rigid gridiron street layout that only changes orientation where it intersects with a dominating natural element (see *fig. 5.3* - note the grid orientation directly East of the *Apies* river).



01. The public space in the centre of the traditional Roman city. This square was multifunctional: a market place, a gathering place of great social significance, and often the scene of sundry activities, including political debates, meetings and social interaction.

02. A religious geometrical figure representing the universe or the notion of 'completeness'

03. Water channels were dug from the Fountains Valley to Church Square. From here it was redistributed to the residents of Pretoria's erven. This grid layout was the most effective and economic to achieve this (reference).

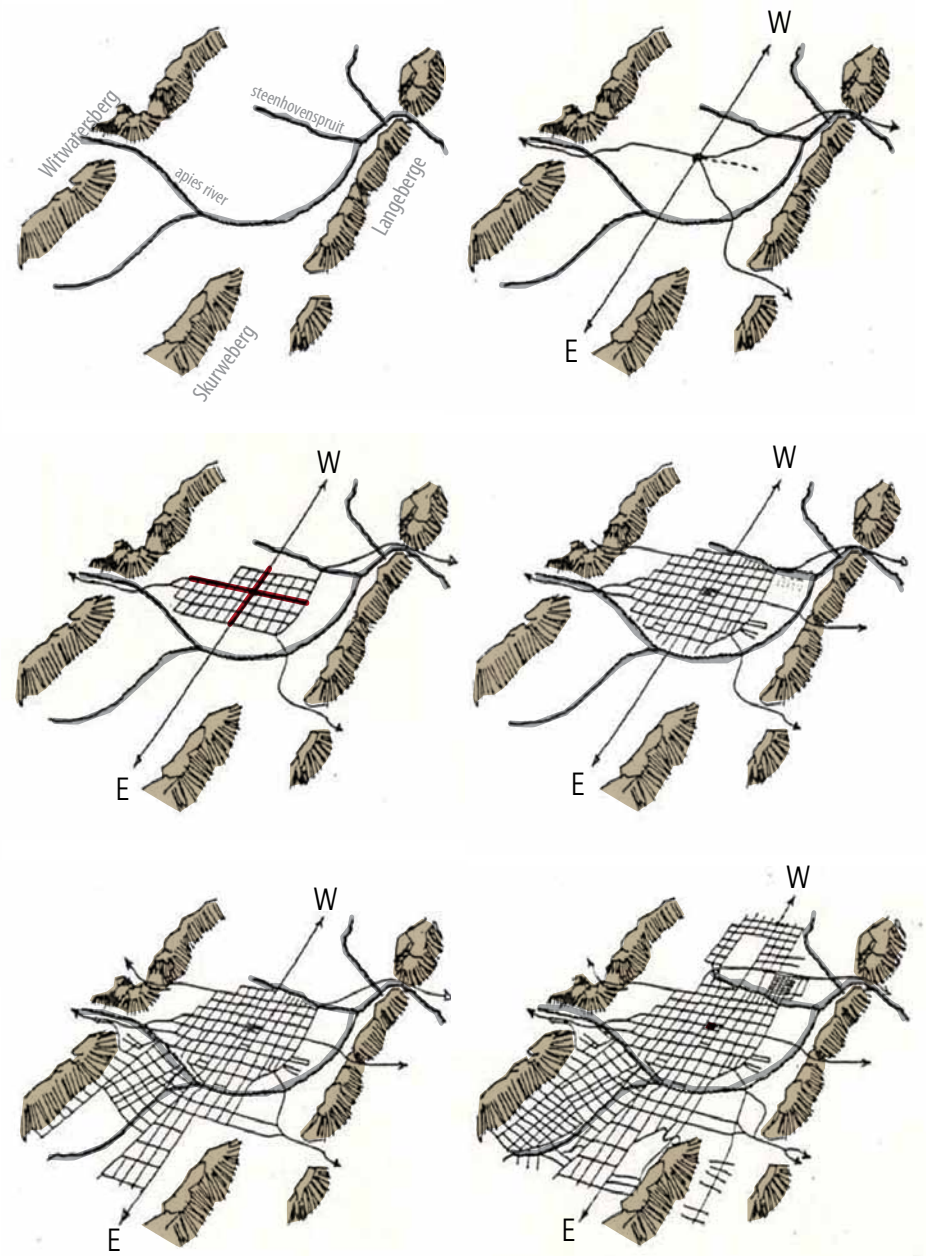
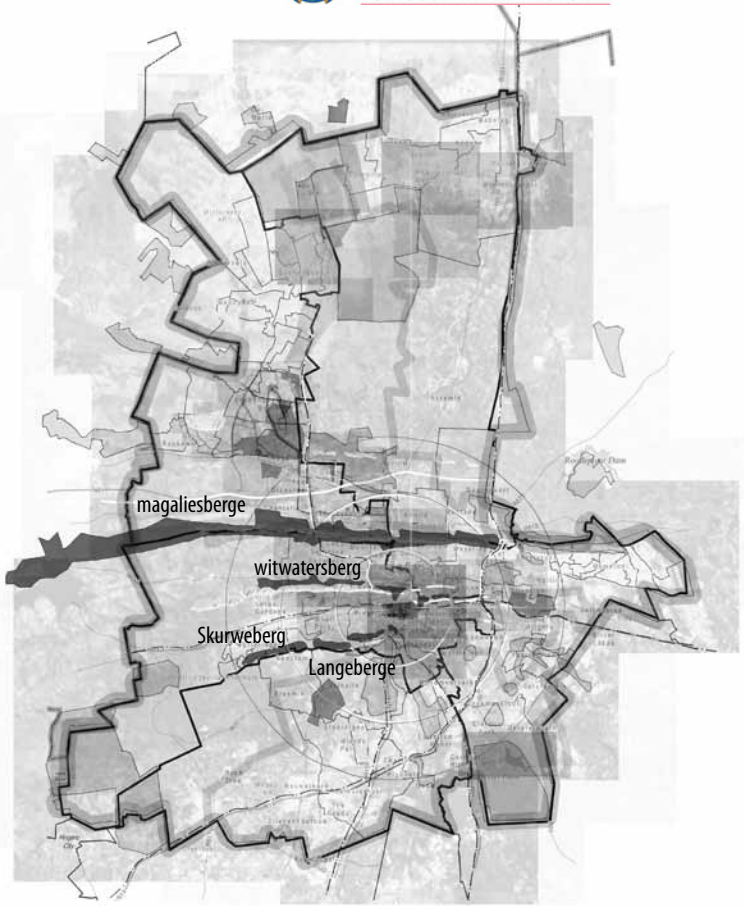

This page (left to right) |

Figure 5. 2:
 Diagram of Tshwane illustrating the mountain ranges enclosing the city of Pretoria (Author & other students, 2010)

Figure 5. 3:
 Diagram illustrating the development of the city of Pretoria as informed by its rivers and mountain ranges (Jordaan, 1989. Edited by Author)

Opposite |

Illustration 5. 1:
 Photograph of Church square c.1927 (Cleland, 2009)

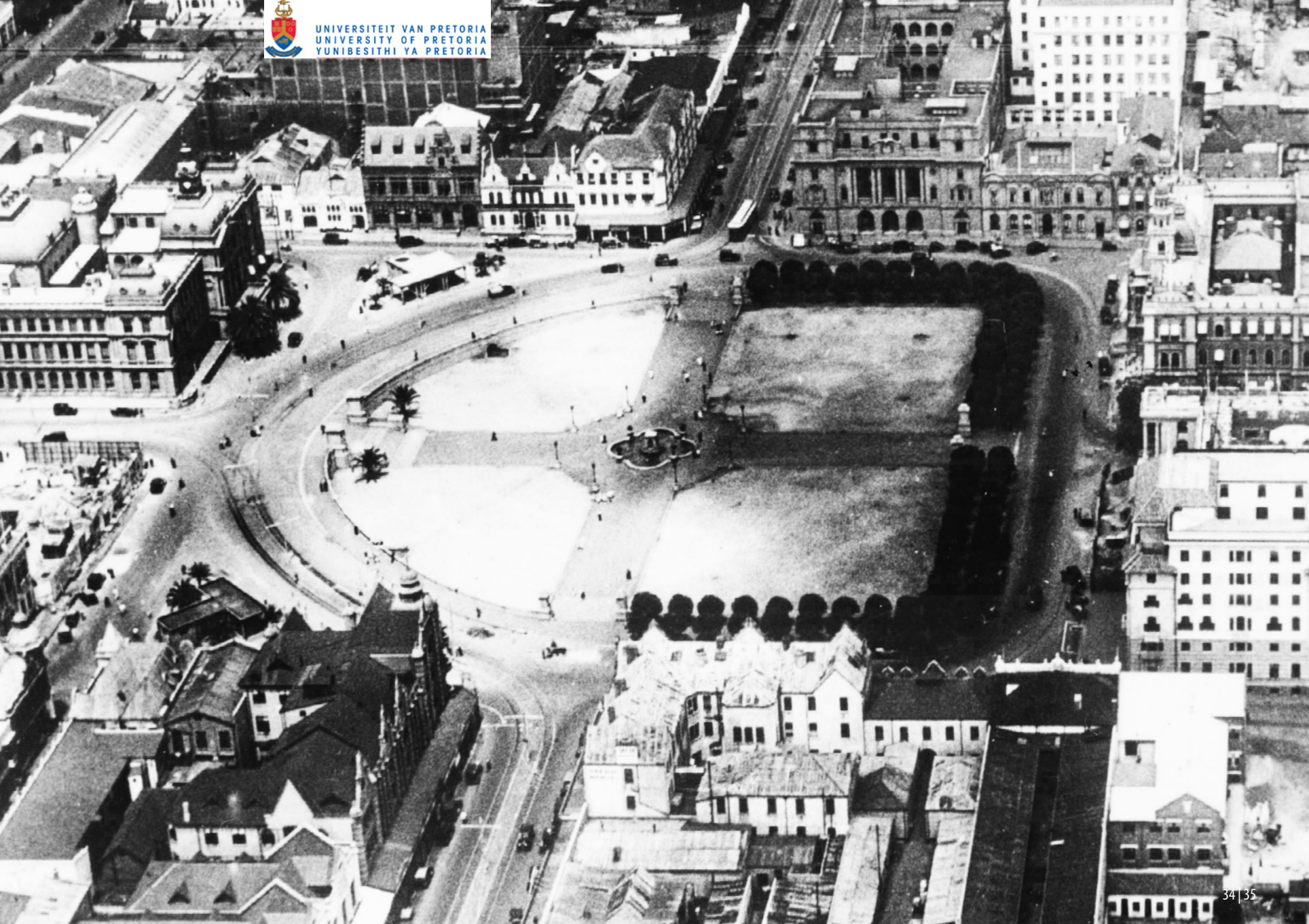



+ Site

144 Van Der Walt Street, c/o Vermeulen, Erf 3200, Pretoria, City of Tshwane

The proposed site is currently home to the Munitoria Complex (Municipal Offices of Pretoria). Ahmed Alkayali (fellow student) and the author are working in a very close proximity on the terrain.

+ History of the Site

The block, consisting of 12 erven, bounded by Vermeulen, Prinsloo, Van der Walt and Proes Street (*illus. 5.2*) originally belonged to President Marthinus Wessels Pretorius, the founder of Pretoria.

According to Leitch (2008: 47), he sold it for R25 each (a total of R300) in 1876 to a Mr. T. W. Beckett, a British businessman who immigrated to South Africa from Australia. When Mr. Beckett built his first thatch roof dwelling on the premises, he planted a few of what he thought was the Australian *blackwood* tree, but what was in all probability the *casuarina* trees (also native of Australia)¹.

A few years later he and his family moved to ‘Merton Keep’ in Arcadia, currently the location

of the French Embassy. On the vacant premises he erected one of Pretoria’s first hotels which adopted the name *Blackwood Villa*, named after the trees in the yard (Leitch, 2008: 48).

With the development of the city centre in the following decades, *Blackwood Villa* lost its popularity due to the erection of larger hotels and was subsequently converted into a boarding house.

In 1936 Mr. G. W. Beckett (Mr. T. W. Beckett’s heir) offered the 12 erven he inherited to the City Council for R80 000. They refused the high price and looked for alternative sites. Only after World War II did they realise the value of the site, in terms of location, and bought it for R190 000 in 1945 (Leitch, 2008: 48).

01. These trees were still found on the site before the site work for the new offices for the City Council of Pretoria (Munitoria) commenced (Leitch, 2008)

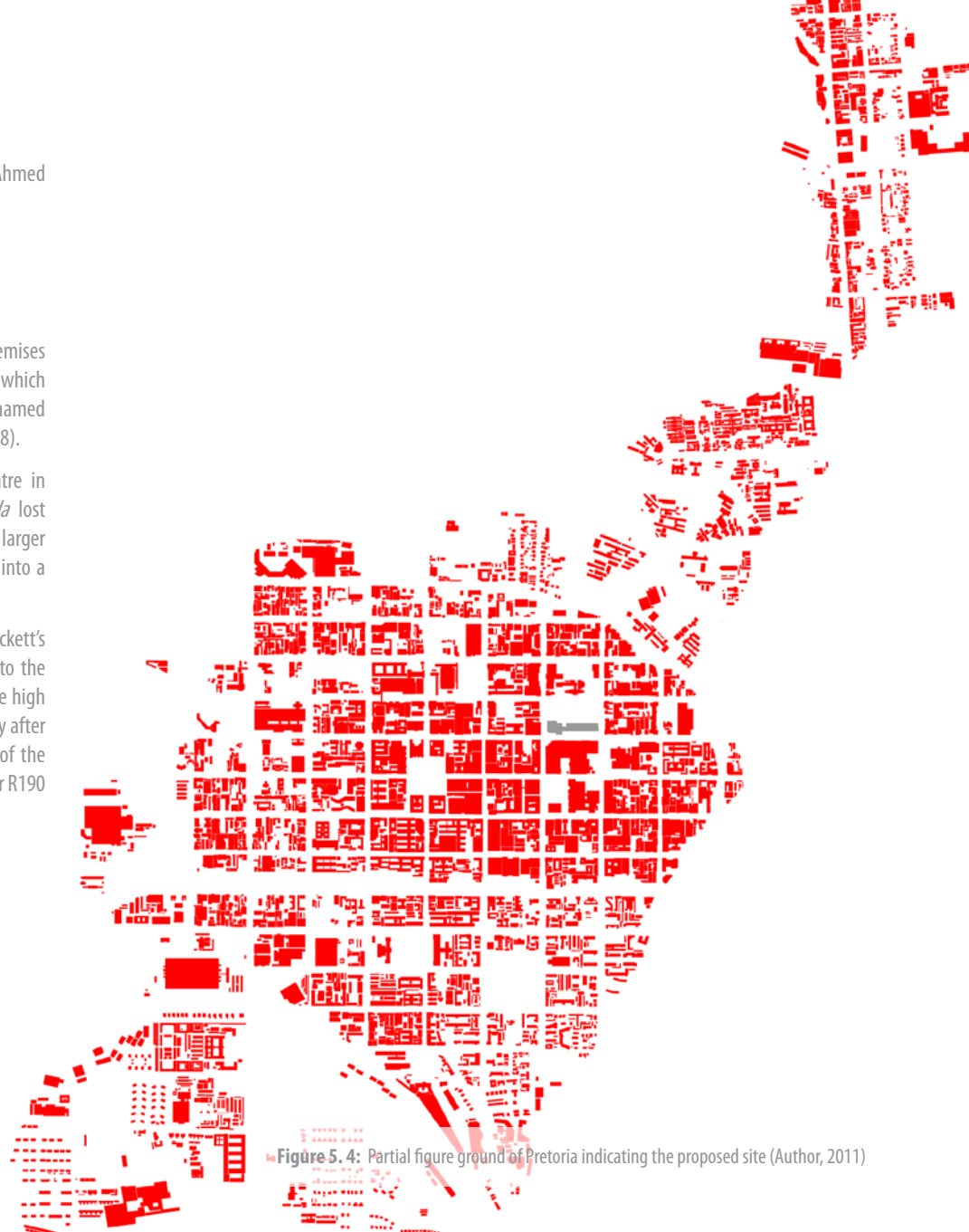

Figure 5. 4: Partial figure ground of Pretoria indicating the proposed site (Author, 2011)

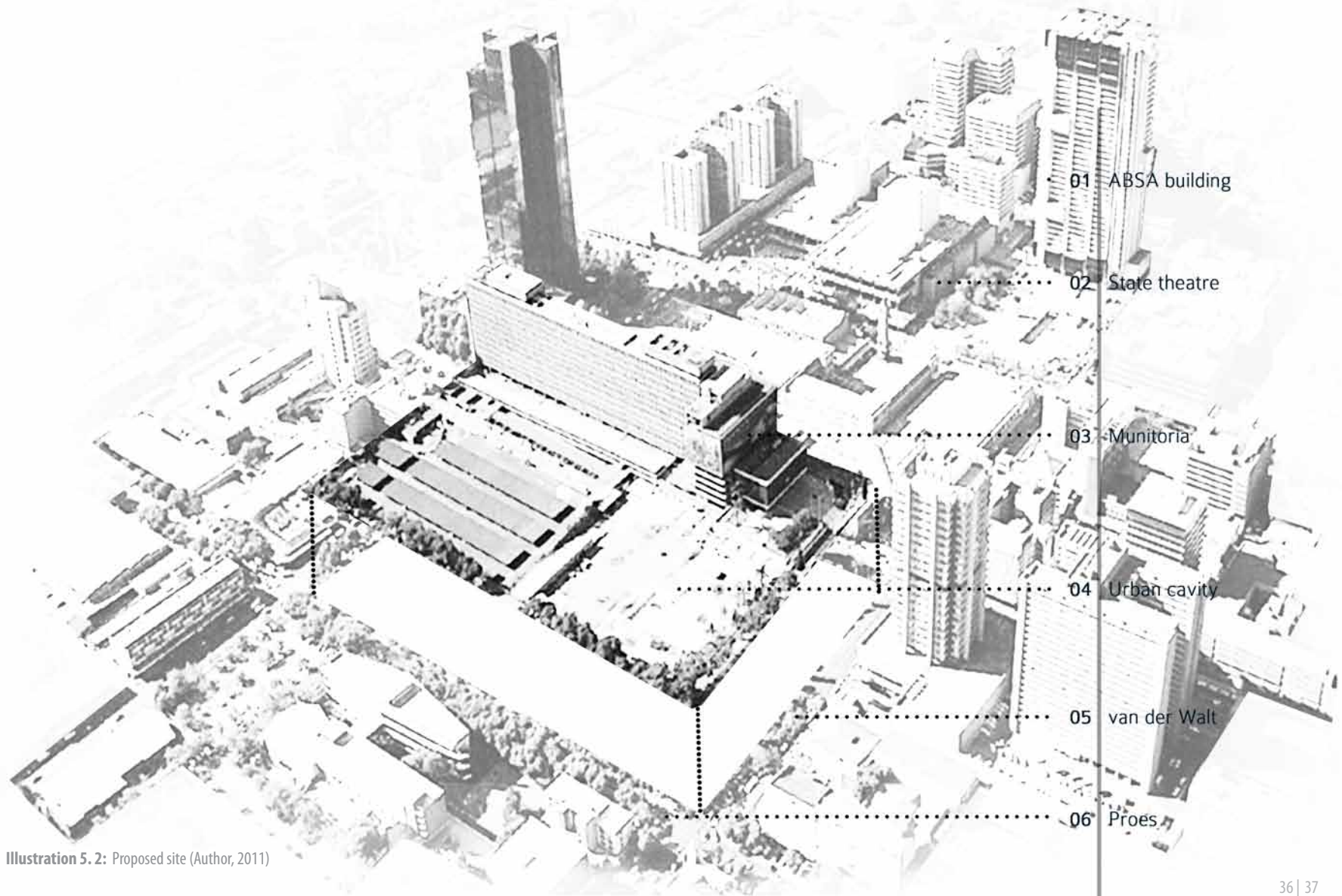
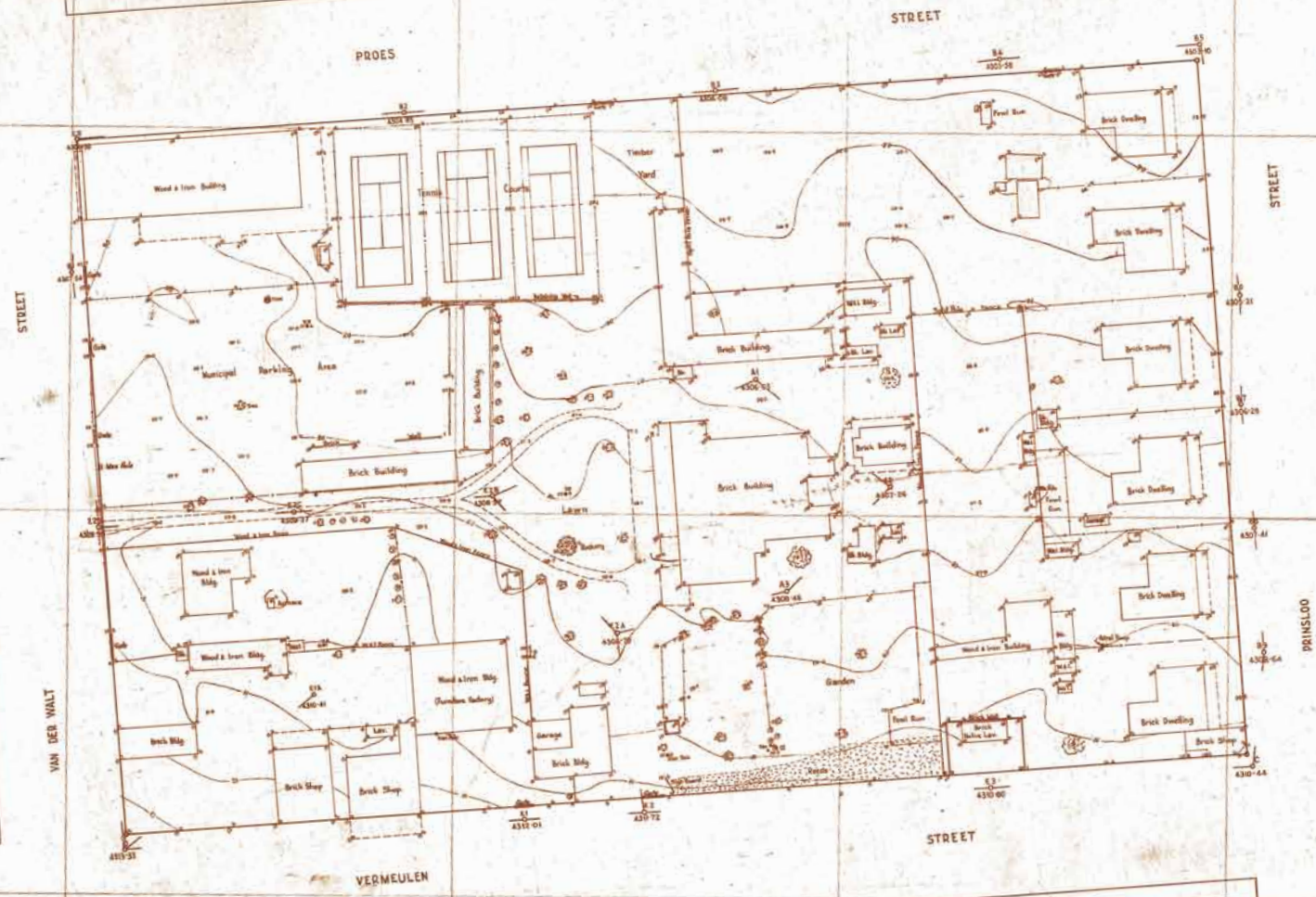

Illustration 5. 2: Proposed site (Author, 2011)



161

BLACKWOOD VILLA SITE
 MUNICIPAL PROPERTY
 1" = 40' FT.
 Assumed Co-ordinates
 Levels Pretoria Datum

AD W. 2. 1103 H
 6.3.10. 29. 3. 31
 1" = 40' E
 22.10.

Figure 5. 5: Site plan of Blackwood Villa, 1951 (Unknown author, 1951)
 Context & Site

+ From City Council to Munitoria

Before the construction for the new offices of the City Council commenced, a competition (with a R100 cash prize) was organised for the naming of the new building. Of the 9 036 entries, 126 entrants suggested 'Munitoria', derived from the combination of 'muni-cipality' and 'Pre-toria'. This name was accepted on March 31, 1965 (Leitch, 2008: 48).

When the Munitoria building was completed in 1969, it became the most prominent modern building in the city to date. In February that same year the City Council moved into their new home. The new L-shaped structure (*fig. 5.6*) consisted of an 11-storey West wing, a 9-storey South wing and a 4 storey addendum housing the council chambers, auditorium and the original entrance hall.

From left to right |

Illustration 5. 3:

Photograph of Munitoria under construction during the mid1960s (Leitch, 2008: 9)

Illustration 5. 4:

Photograph of Munitoria under construction during the late1960s (Leitch, 2008: 48)

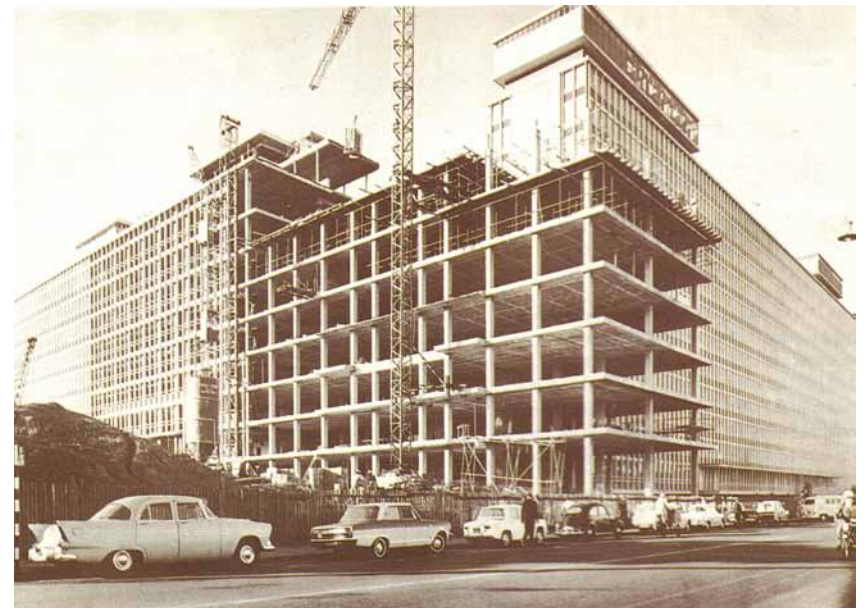

Not only is this structure exemplary of the Modern Movement in architecture, but it was also designed by a notorious Modern architect, Anthony Doherty (1930 - 2010) from Burg, Lodge & Burg (now Burg, Doherty, Bryant & Partners - a firm commended for their contribution to the rich inheritance of Modern Architecture in the city: the Pretoria Art Museum and the Reserve Bank Head Quarters among others).

The "Miesian-modernist" building, as described by Professor Schalk le Roux (Botes & Le Roux, 1991: 40-41), - referring to the work of infamous Modern architect, Mies van der Rohe (1886 - 1969) - is characterized by its unmistakable vertical articulation, pure functionality and a prominent glazed envelope, as typical of the Modern *zeitgeist* (*fig. 5.7*). According to Le Roux (1991: 41), the building's significance lies in its prominent location and programme.

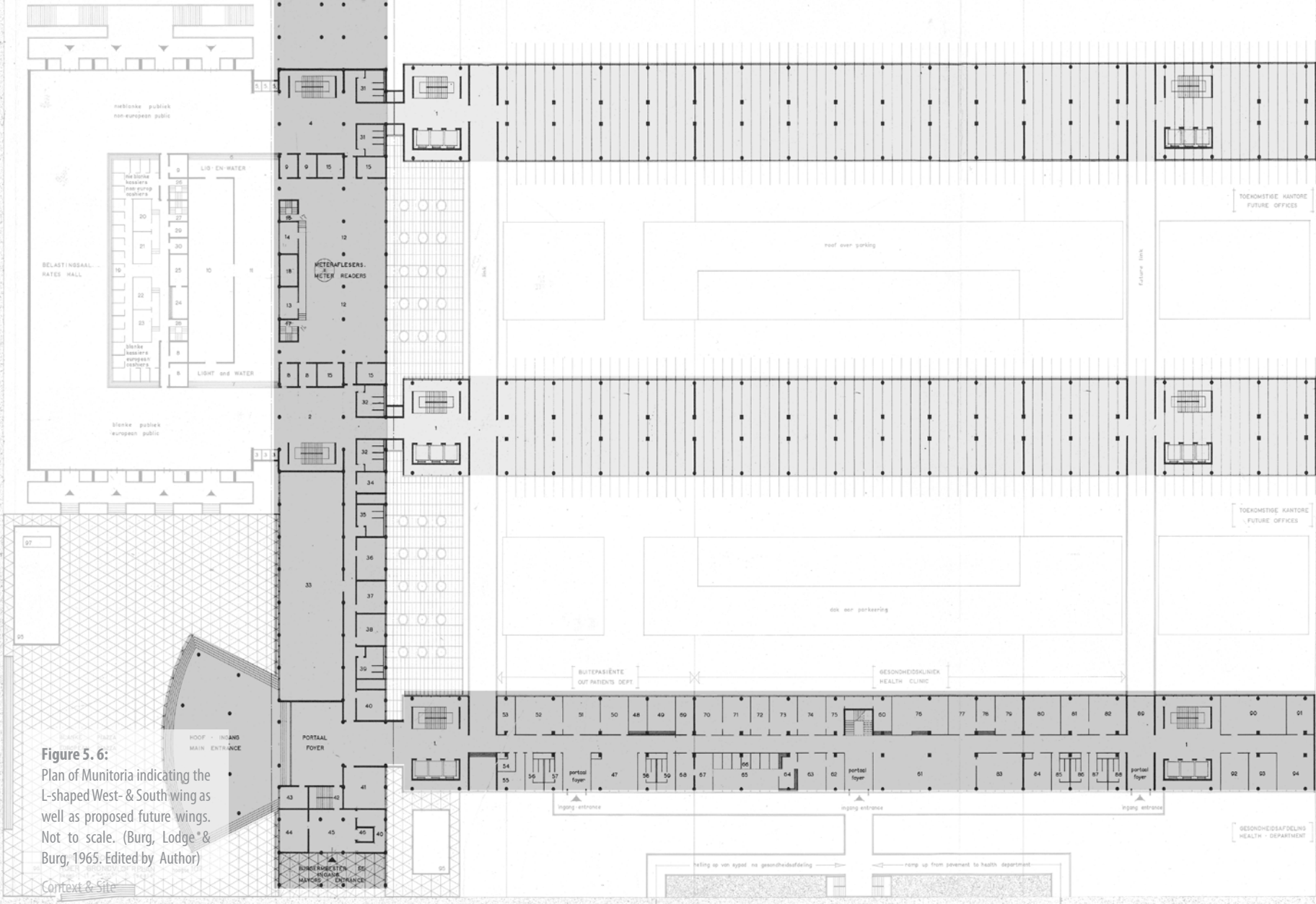
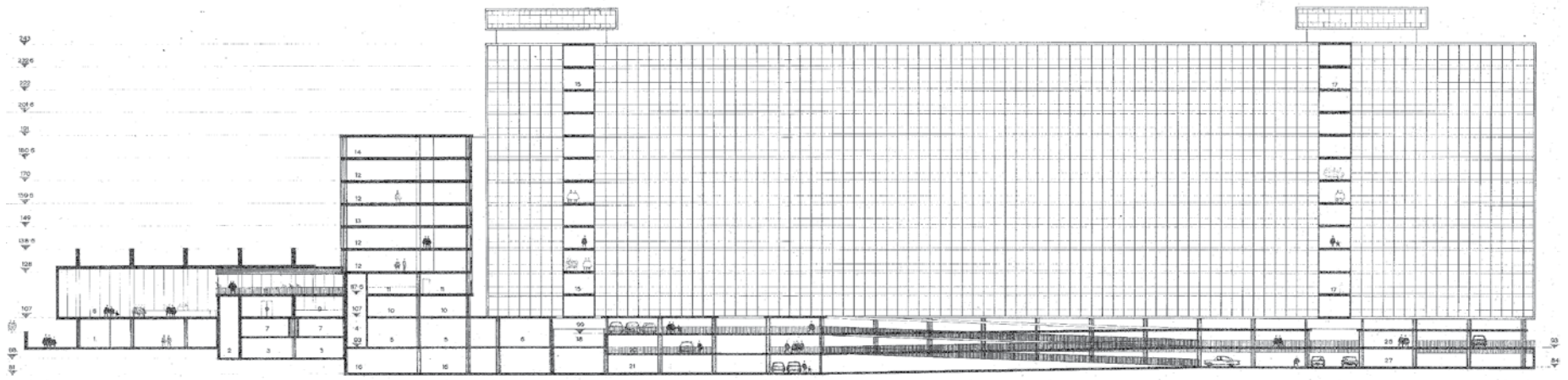
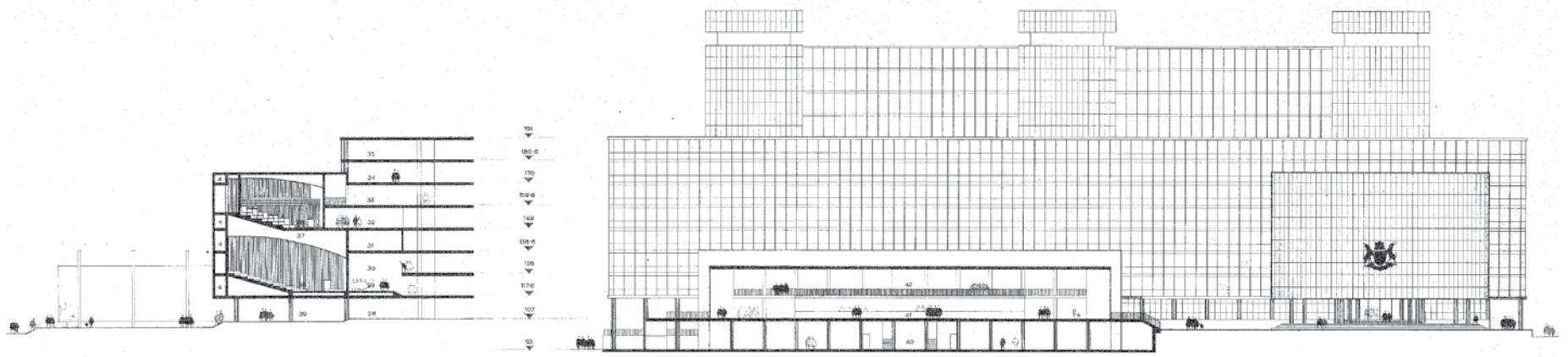

Figure 5.6:
 Plan of Munitoria indicating the L-shaped West- & South wing as well as proposed future wings. Not to scale. (Burg, Lodge & Burg, 1965. Edited by Author)



LANGSNIË DEUR BELASTINGSZAAL
LONG SECTION THROUGH RATES HALL



SNIT DEUR RAADZAAL EN GEDORSZAAL
SECTION THROUGH COUNCIL CHAMBER AND AUDITORIUM

DWARSNIË DEUR BELASTINGSZAAL
CROSS SECTION THROUGH RATES HALL

Figure 5. 7: Sections of Munitoria. Not to scale. (Burg, Lodge & Burg, 1965. Edited by Author)

+ The Great Munitoria Fire

A fire was noticed in the Licensing department in the basement level of the West wing on the 3rd of March 1997. The Fire and Ambulance Control Centre received the first reports of the alleged fire at 18:24 that night. A fire fighting team arrived at the scene 6 minutes later. As the fire spread and turned into a towering inferno, the incident commander requested assistance from the Centurion and Akasia fire departments. Further support came from as far afield as Sandton and the East Rand a few hours later (Leitch, 2008: 8).

The blaze was eventually extinguished at approximately 8:30 on the 4th of March, after a 12 hour battle to contain the flames and prevent it from reaching the bridge linking Munitoria to the Sammy Marx building. The fire unfortunately re-ignited on the evening of the 4th and continued to burn and smoulder for a further three days before being completely extinguished on 7 March (Leitch, 2008: 9).

A multiparty forensic investigation, into the cause of the fire, was conducted in the days following the disaster. It was initially believed that accelerants were present in the area where the fire was initiated, but it was later proven that the fire was caused by a defective electrical light fitting. This ruled out any possibility of arson, but rumours about the Truth and Reconciliation Commission's amnesty hearings for five former security policemen who were allegedly guilty of murder, were still circulating¹.

01. *The day preceding the night of the fire, the Truth and Reconciliation Commission's committee had been provided with evidence (in the Munitoria building's council chambers) to prove Colonel Marthinus Ras and other policemen guilty of murder. Colonel Ras gave orders to the 'death squad' (Jacques Hechter and Paul van Vuuren) to kill a Mamelodi policeman, Sergeant Richard Matosi, in 1988. Sergeant Matosi was accused of being an ANC informant, but this was based on unsubstantial proof. In the process Matosi's wife, Irene, was also killed, leaving their baby boy orphaned. It was later found that the real motive for the 'elimination' was because Sergeant Matosi was involved in a claim against the police force. The evidence and transcripts proving Colonel Ras guilty was housed in Munitoria on the night of the blaze. The fire completely derailed the amnesty hearing's proceedings for quite some time. In the early hours of the morning on the 4th of March a Munitoria official, Koki Mpshe, was escorted into the building by firemen and returned with two briefcases containing the hearings' transcripts. Ras's confession was not destroyed and if the fire was caused by sabotage it would have proven to be unsuccessful. (Green, 1997)*

This page | Illustration 5.5: Munitoria on the night of the fire as seen from Proes Str. (Leitch, 2008: 8)

Opposite | Illustration 5.6: Munitoria the night after the fire as seen from van der Walt Str. (Leitch, 2008: 8)



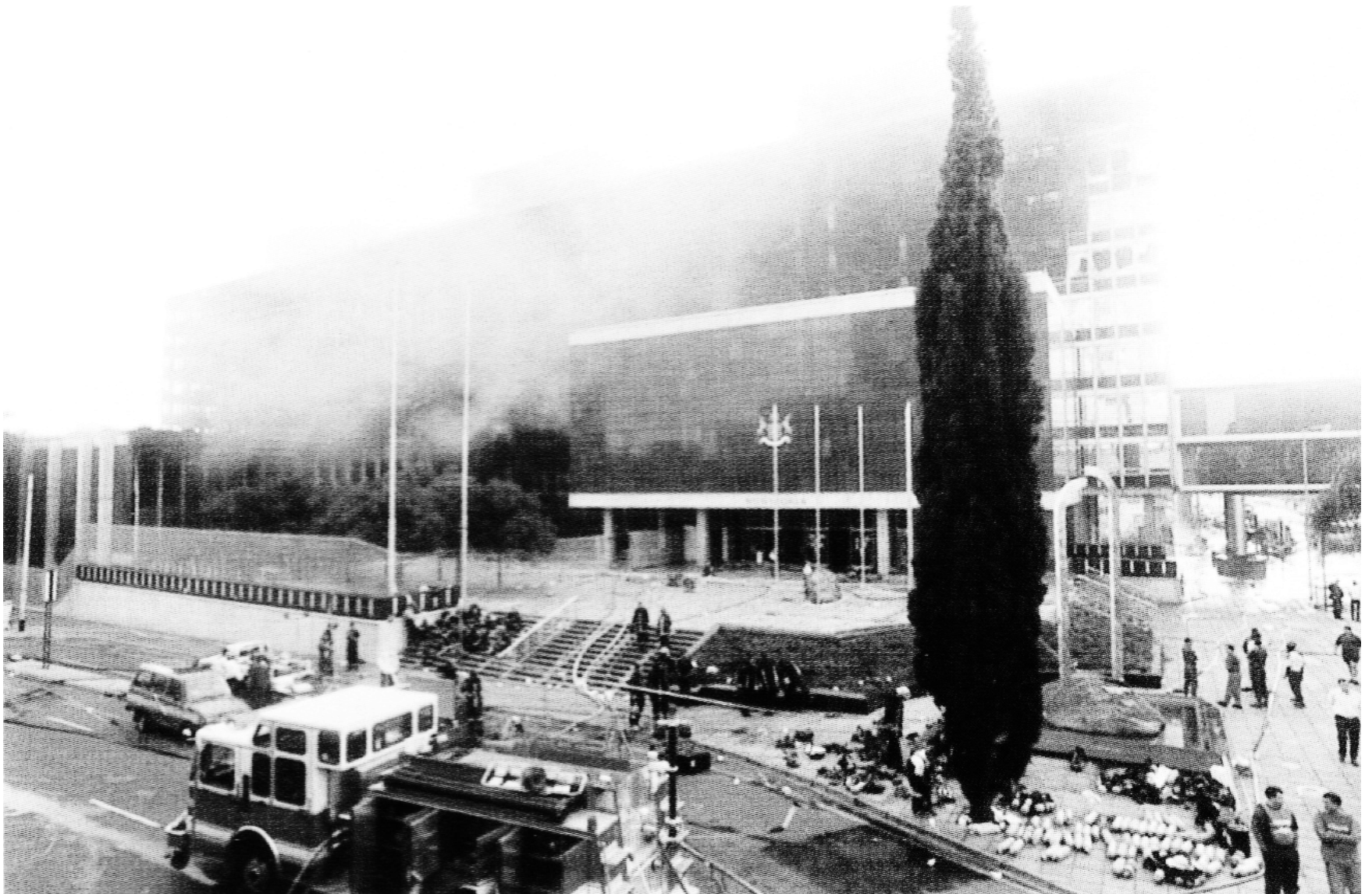

+ After the Fire

The City Council needed to find accommodation for their entire staff of 4500 employees immediately. Although the South wing did not suffer any fire damage it was declared unfit due to smoke and water damage. The building would have to remain evacuated for at least one year until major renovations have been completed (Leitch, 2008: 9).

The obvious site to temporarily relocate to was PREMOS (Pretoria Municipality Training Centre) in Centurion (Leitch, 2008: 23), but it could not facilitate all the stranded employees and additional premises were therefore still needed. The Council found office space in eight different high rise buildings in the CBD. Various departments were now scattered throughout the city.



+ Then It All Came Down

A specialised team investigated the structural integrity of the burnt down structure and came to the conclusion that the structure would have to be demolished by means of explosives (Leitch, 2008: 10).

On the 1st of February the following year, the West block of the prominent city landmark, was reduced to a 40 000 tonne mountain of debris in a mere 3 seconds (*illus. 5.9*). Mr Henry Enslin, the Town Clerk at the time, remarked on the occasion that the rubble was representative of a fresh start for the City Council. He continued to say that almost one year ago he had observed "in horror" as the a fire consumed the West block of Munitoria. "The far less painful 3 second implosion was almost welcome, because now the black scar, which served as a constant reminder of that night of horror, has been removed." (Leitch, 2008: 10)

From left to right |

Illustration 5.7: Munitoria the morning after (Leitch, 2008: 13)

Illustration 5.8: Munitoria on fire, viewed through the monument for victims of terrorism (Leitch, 2008: 8)



+ From Catastrophe to Opportunity

Even though the fire was an immense stumbling block for the effective operation of the City Council, it also created many opportunities for improvement. The redevelopment of a new, more appropriate and efficient local authority was now achievable. Most of the former civic planning and administration systems (which were associated with old patriarchal planning ideals) were destroyed in the fire. After the long ruling of the former National Party (NP) in South Africa, the nationalist¹ way of thinking in terms of government buildings and the management of information could now be rethought and amended.

While badly damaged in the devastating fire, the building continues to be a landmark in the city today. The absence of its West wing and the remaining remnants (in the form of an urban 'cavity' where

the basement used to be and visible 'footprints' of the demolished structure) creates an awareness of what once was and the tragedy that led to what it has become. Currently, the possibility of demolishing the entire building in order to build a new *African* municipal centre exists, but the decision is still pending. Thorough heritage and other assessments are presently underway.

The author does not agree with this proposal as the Munitoria building is one of the hand-full Modern buildings that greatly contribute to the specific character of Pretoria. The building is essentially problematic in its stark functionality and isolated nature, but its memory and parts of (or the whole of) the structure should definitely be retained.

01. *Nationalist ideals mainly emphasise the devotion to the interests or culture of one's nation. The belief that a nation will benefit from acting independently rather than collectively, emphasizing national rather than international goals. An extreme form of this is marked by a feeling of superiority over other countries, races and cultures.*

Illustration 5.9: The 3 second implosion of the West wing of Munitoria (Leitch, 2008: 13)

06

UNION BUILDINGS



01

UNION BUILDINGS



02

UNION BUILDINGS



03

UNION BUILDINGS

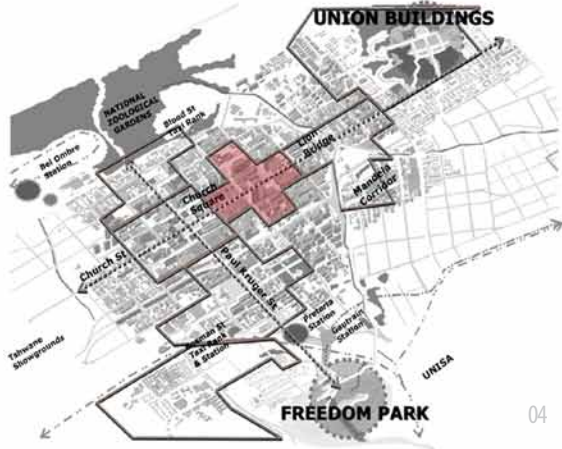

04

UNION BUILDINGS

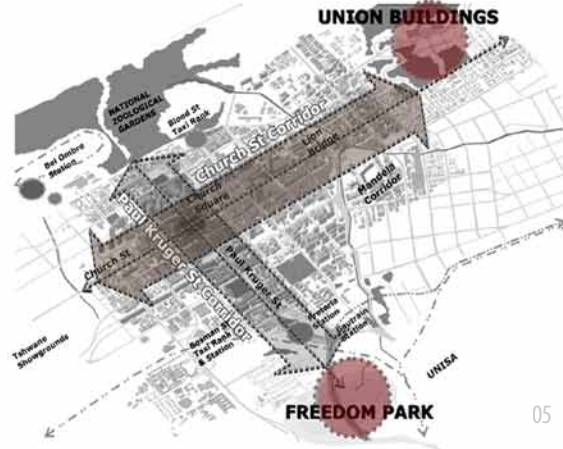



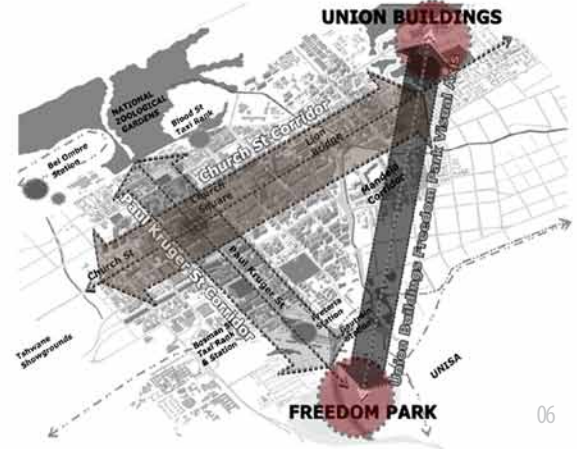

05

UNION BUILDINGS



06

-  corridor axis
-  visual corridor
-  functional corridor
-  symbolic sites

+ Rekgabisa Tshwane Framework

The *Rekgabisa Tshwane* framework (Tshwane Inner City Programme and Spatial Development Framework) is a macro scale urban development framework with the intention of creating sustainable urban development. It is currently the intended framework for implementation.

The framework is mainly based on creating an infrastructure spine in terms of transport and services (The City of Tshwane, 2006).

The main principles as broadly:

- 01 | The development of Paul Kruger Street and Church Street as focal axis in terms of identity, edge function and movement. With the addition of a visual axis from Freedom Park to the Union Buildings.
- 02 | The creation of a pedestrian friendly inner city through the implementation of an improved public transport system which runs between the CBD and the periphery, together with the introduction of consolidated parking facilities to alleviate traffic.
- 03 | The establishment of a public space network, connecting active public spaces throughout the city including river edges and green spaces.
- 04 | The symbolic linking of sites (visual corridors).
- 05 | Strategically locating Government Offices to support systems, especially around the development corridors.

After group analysis of the framework it was found that although based on sound principles, the Rekgabisa Framework has potential shortcomings that could be addressed:

- 01 | A hierarchical system may benefit the function of the network of public spaces. Currently each one is proposed to be hard-surfaced and similar in size. The programming of their edges have also not been considered thoroughly.
- 02 | The governmental programming of the 'functional spines' are questioned as government institutions are predominantly private and do little to add to the quality of their surrounding environments.
- 03 | The effect of informal trade has not been considered or designed for.
- 04 | City blocks are still based on original agrarian concept, they are too large and more suitable to a predominantly vehicular orientated city. Therefore it could be beneficial to further improve inter-block pedestrian movement with smaller, inter-dispersed open spaces as well as arcade systems.

Opposite page |

Figure 6.1: The Rekgabisa Tshwane framework (The City of Tshwane, 2006. Edited by Author)

- 01 | The focus area
- 02 | The public space network
- 03 | The main axis
- 04 | The seven development precincts (with the Sammy Marx precinct highlighted)
- 05 | The functional corridors or 'spines'

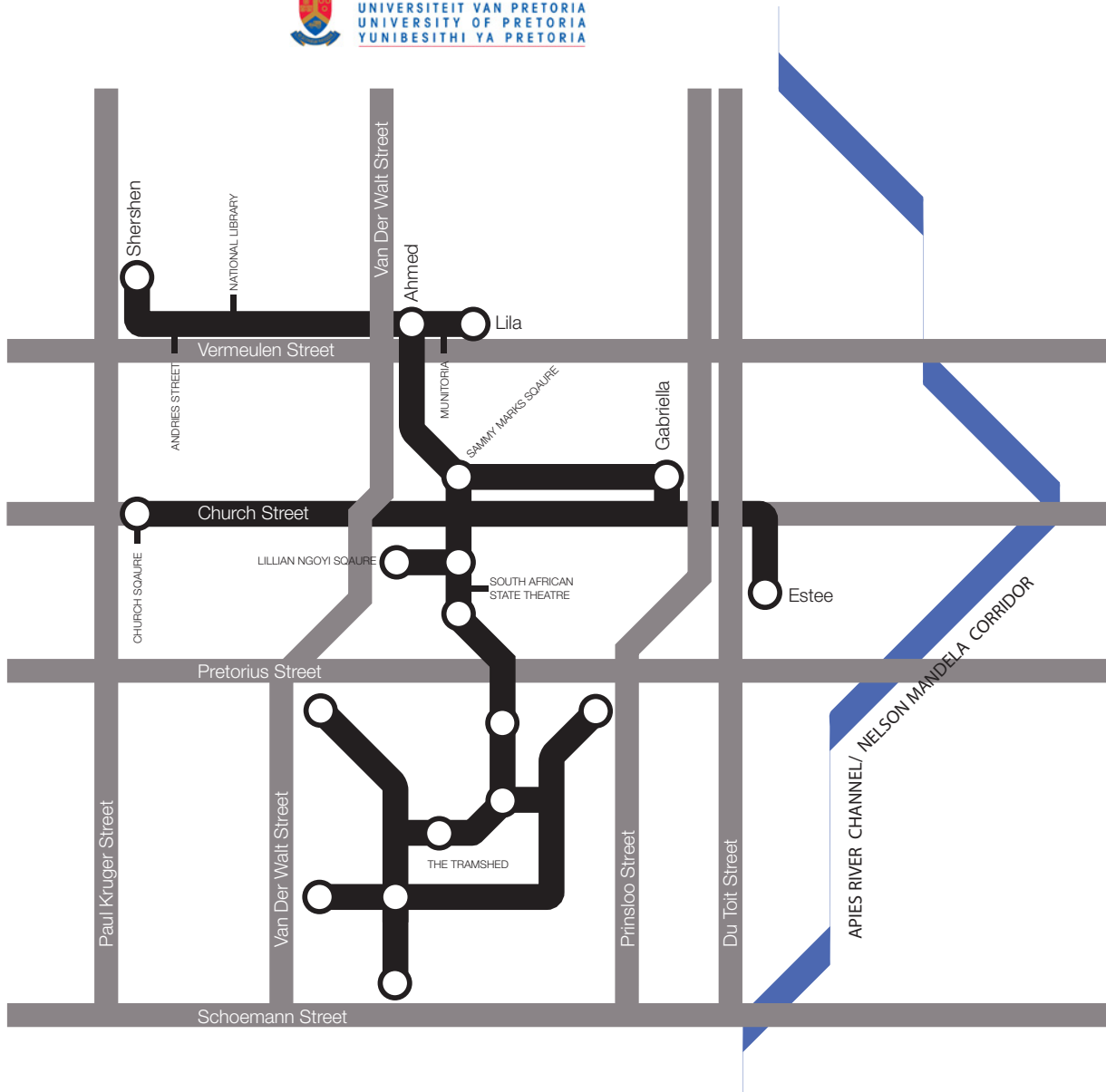

+ Urban Framework

The proposed urban framework is a contextual framework aiming to strengthen the existing urban fabric by reacting to and consolidating existing infrastructure, which therefore does not impose on the existing urban layers. A particular emphasis is also placed on the connectivity of the study area and the linking of the different proposed interventions. Four different scales are addressed: urban (macro planning strategies), block (micro planning strategies), architectural (edge conditions) and detail level (design guidelines).

Figure 6.2: Diagram illustrating the connections between different interventions as well as existing public spaces (Author, 2011)

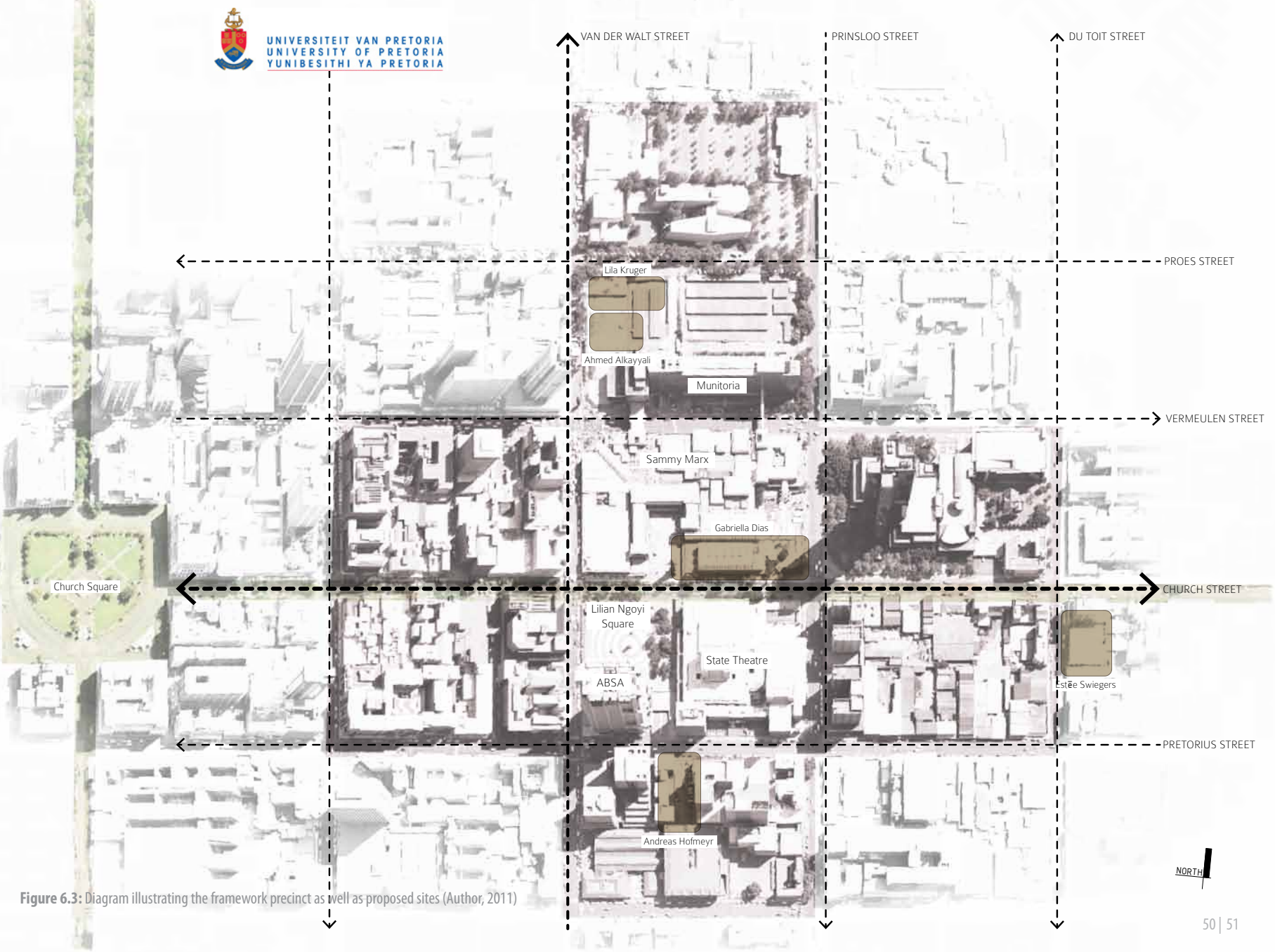

Figure 6.3: Diagram illustrating the framework precinct as well as proposed sites (Author, 2011)

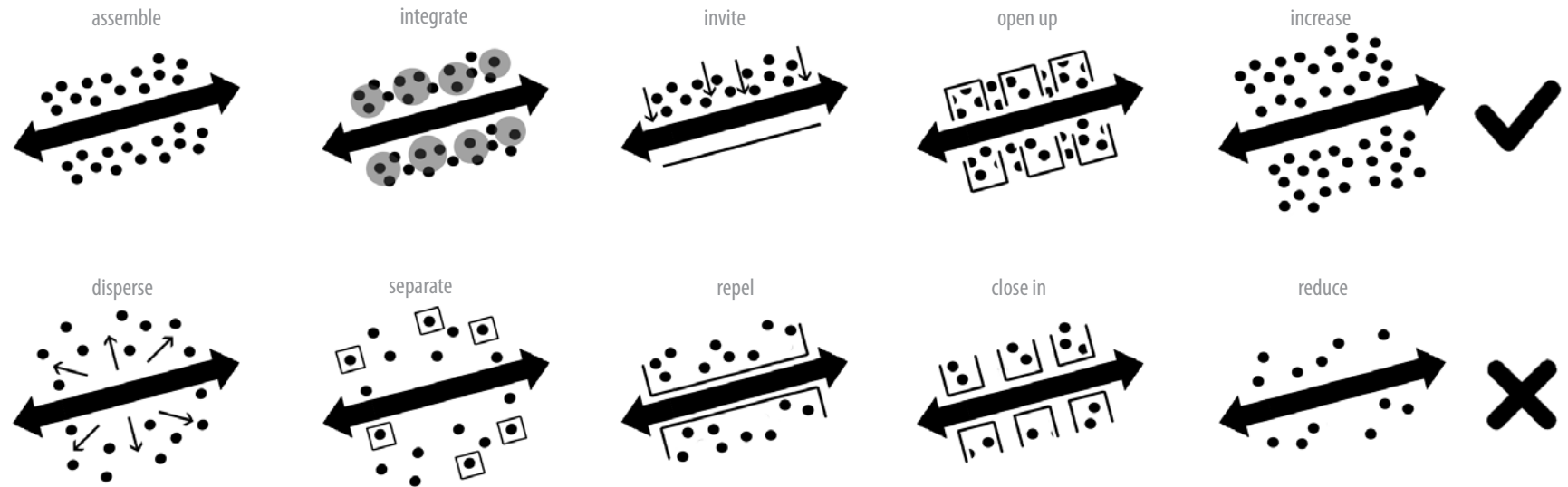

Figure 6.5: Diagram illustrating the proposed spatial planning principles (Author, 2011)

+ Macro Planning Principles

The historic planning of Pretoria (as discussed in Chapter 5) is readdressed. The city's blocks are currently vehicle oriented with large 'superblocks' which hinder comfortable pedestrian movement. By introducing inter-block movement and reactivating the arcade system, the blocks are fragmented to a human scale which is more pedestrian oriented, but still allows for vehicular access (fig. 6.3).

This also contributes to a public space network that would be connected and *fed* by these movement routes. This allows for the public squares to become pedestrian oriented rather than vehicle oriented spaces.

+ Micro Planning Principles

Multifunctional block typologies, with basement parking, are proposed in order to free up negative space on street edges and give it back to the public realm. Introduction of housing units is proposed in order to counteract the migrating culture, densify and add to the notion of a 24 hour city.

In terms of spatial planning, the principles, as explained in *Cities For People* (Gehl, 2010), illustrated in figure 6.4 should be implemented on a block scale within the public space network. Public spaces that invite users into the space allow for interaction and integration on a social level as well as with the urban fabric itself. This breathes life into the city and contributes to a more dynamic character.

+ Edge Conditions

Interactive street edges that invite rather than repel need to be created implementing the following principles (figure 6.5):

- 01 | The architecture needs to allow for permeability and transparency on street level
- 02 | Spaces need to be defined (narrowing of spaces at strategic points) in order to encourage interaction - interaction between users, the user and the city and direct interaction between user and building.
- 03 | Interactive edges also slow the pace of pedestrians which create the possibility for trade opportunities and social relations to develop.

+ Design Guidelines

The emphasis of the design guidelines are *urban comfort*, *urban experience* and *urban opportunities*. These principles all contribute to a richer urban environment and experience. *Urban comfort* deals with the protection against unpleasant sensory experience, crime, violence as well as traffic and accidents. *Urban experience* entails positive sensory experiences, thermal and climatic comfort and urban scales. *Urban opportunities* propose creating urban environments where everyday recreational activities are provided for, such as sitting, waiting, walking, talking and playing.

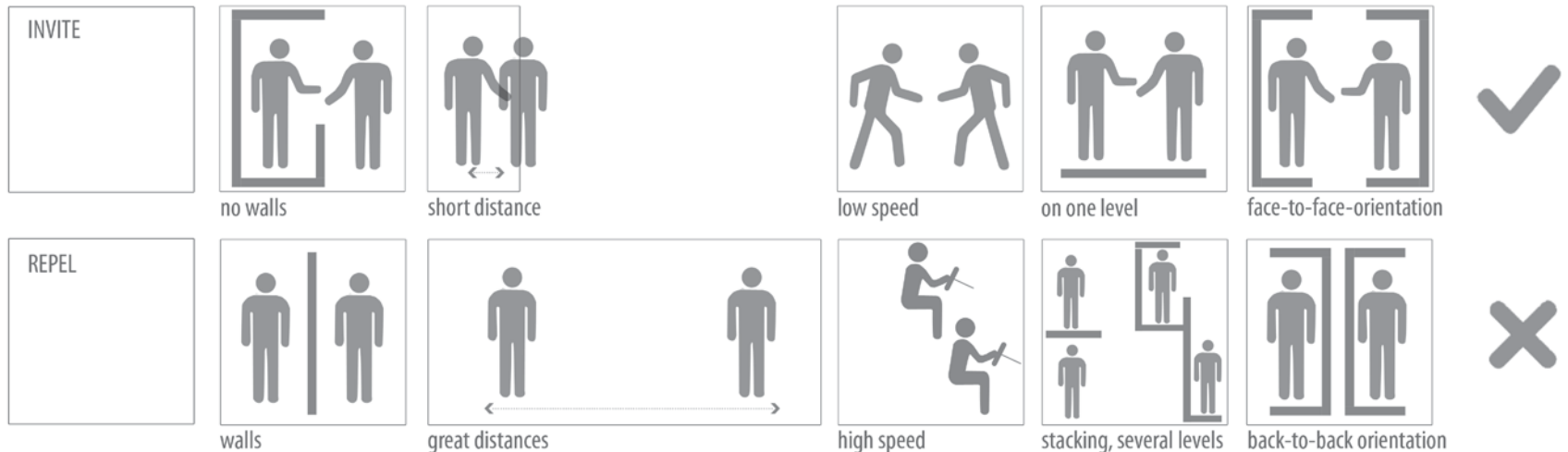

Figure 6.6: Diagram illustrating inviting edge conditions as opposed to repelling conditions (Gehl, 2010. Edited by Author)

+ Design Guidelines (Gehl, 2010)



+ Urban Comfort

Protection against:

- 01 | Unpleasant Sensory Experience
wind & rain
pollution & dust
noise & glare
- 02 | Crime & Violence
lively public realm
eyes on the street (passive surveillance)
overlapping of functions (day & night)
good lighting
- 03 | Traffic & Accidents
protection for pedestrians (bollards,
eliminating fear of traffic)

+ Urban Experience

Design for:

- 01 | Human Scale
buildings and spaces designed to human
scale
- 02 | Enjoy Climate
sun / shade
heat / coolness
breeze
- 03 | Positive Sensory Experience
good design & detailing
good materials
fine views
trees, plants, water



+ Urban Opportunities

Opportunities to:

- 01 | Sit
zones for sitting
utilising advantages: view, sun, people
benches for resting
- 02 | Stand & Stay (Wait)
edge effect / attractive zones for standing
supports for standing
- 03 | Walk
room for walking
no obstacles
good surfacing
accessibility for everyone
interesting facades
- 04 | See
reasonable viewing distances
unhindered sight lines
interesting views
lighting (when dark)
- 05 | Talk & Listen (social interaction)
low noise levels
street furniture that provides 'talkscapes'
- 06 | Play & Exercise
invitations for creativity, physical activity, exercise & play
by day & night
in summer & winter

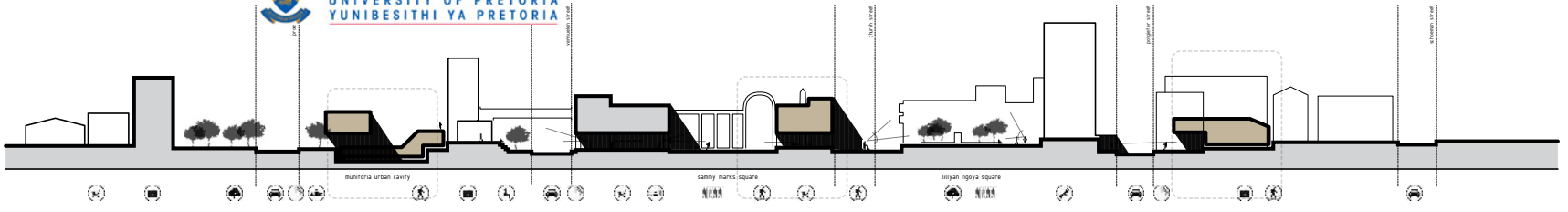



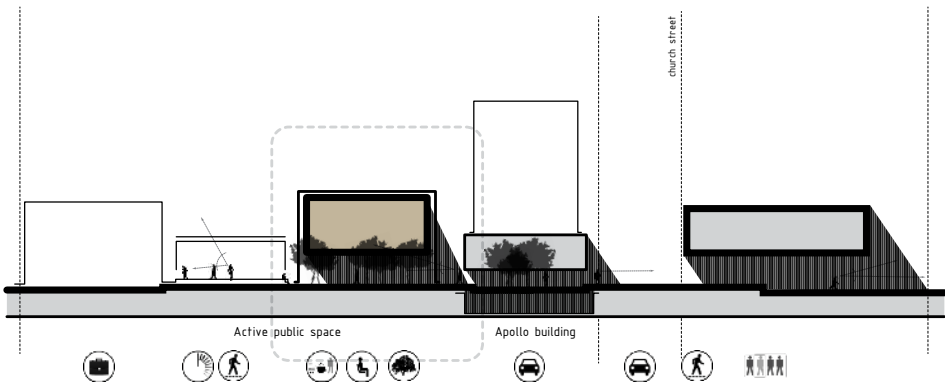

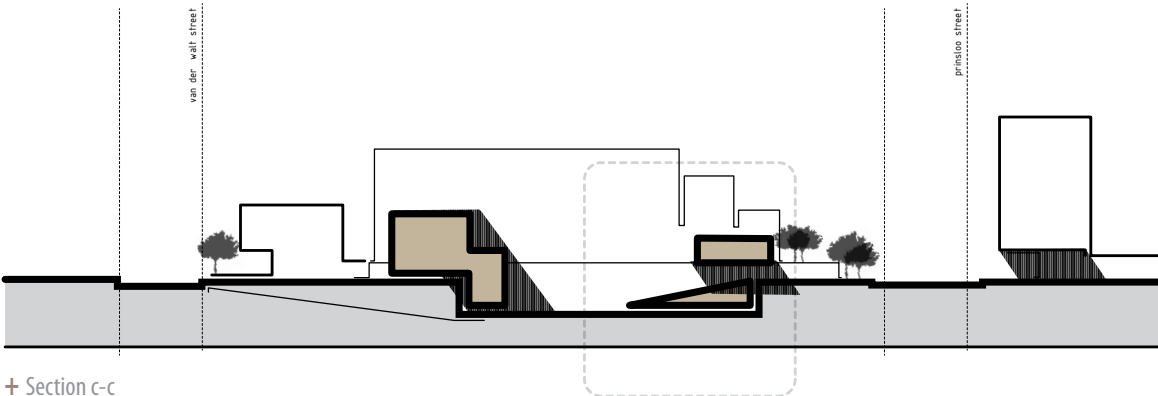

+ Section a-a



+ Section b-b



+ Section c-c

-  housing and residential
-  commercial & institutional
-  retail & shopping
-  culture & religious
-  entertainment spaces
-  informal trading stalls
-  private vehicle parking
-  pedestrian activity & arcades
-  seating spaces
-  shaded green spaces
-  waiting spaces
-  public squares & public spaces

This page | top to bottom
 Figure 6.7: Section A-A with interventions highlighted (Author, 2011)
 Figure 6.8: Section B-B with interventions highlighted (Author, 2011)
 Figure 6.9: Section C-C with interventions highlighted (Author, 2011)
 Opposite page |
 Figure 6.10: Master plan of urban framework (Author, 2011)



- main squares
- secondary squares
- green spaces
- connection route between projects
- arcade system
- boulevard
- proposed sites

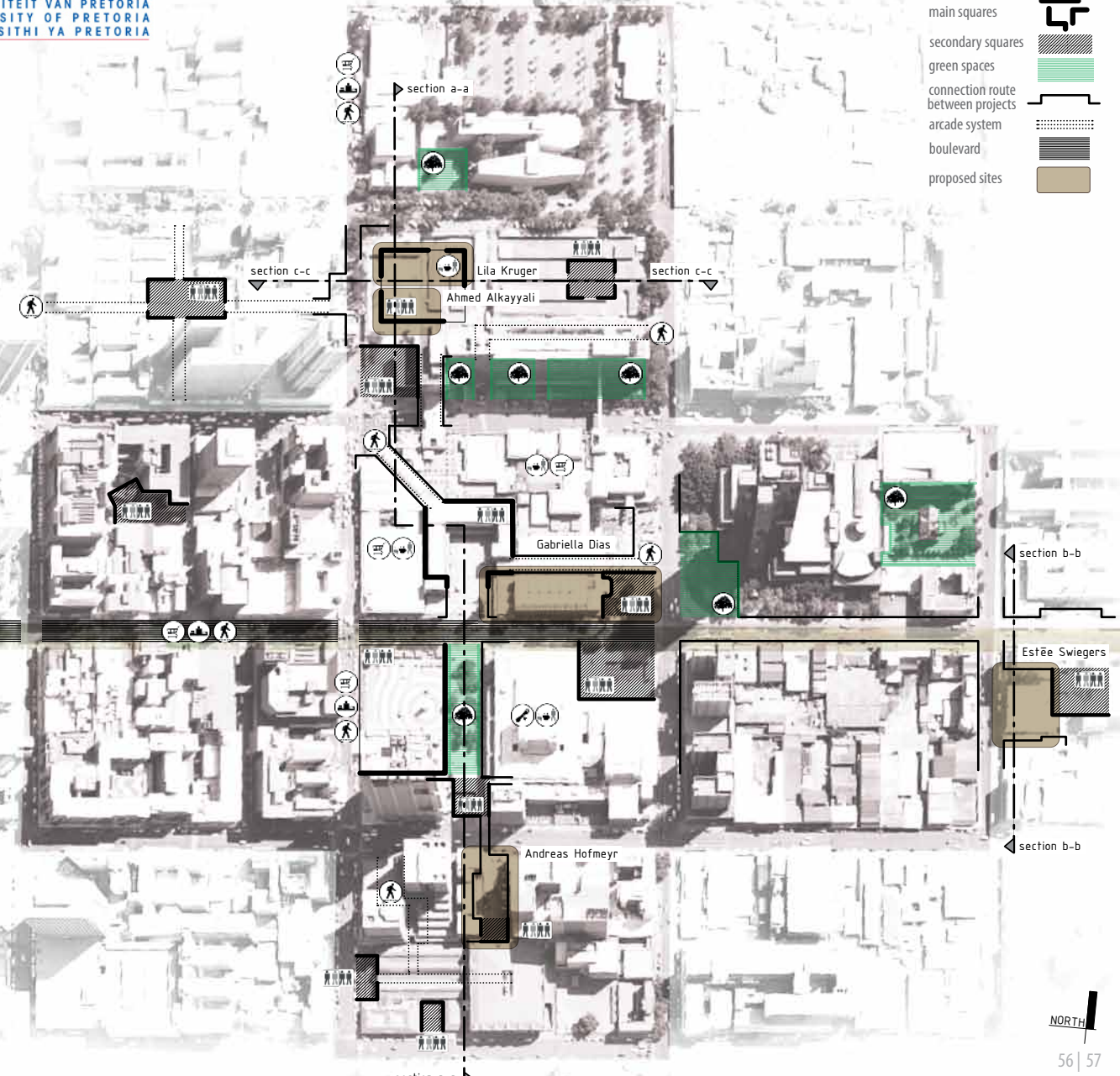



07





01



02



UNIVERSITEIT VAN PRETORIA
UNIVERSITY OF PRETORIA
YUNIBESITHI YA PRETORIA



03

This page |

Illustration 7.3 (1): Photograph of the aluminium exterior screen with diagram of aluminium fins on plan (Author, 2011)

Illustration 7.4 (2): Photograph of entrance staircase (Author, 2011)

Illustration 7.5 (3): Photograph of an interior exhibition space (Architeria, 2009. Edited by Author)

Figure 7.1 (4): Form generating geometry (Arch Dia, 2010)

Opposite |

Figure 7.2 (5): North and South elevations of Circa Gallery (Arch Dia, 2010)

Figure 7.3 (6): Section through Circa Gallery (Arch Dia, 2010)

Figure 7.4 (7): Plans of Circa Gallery (Architeria, 2009)

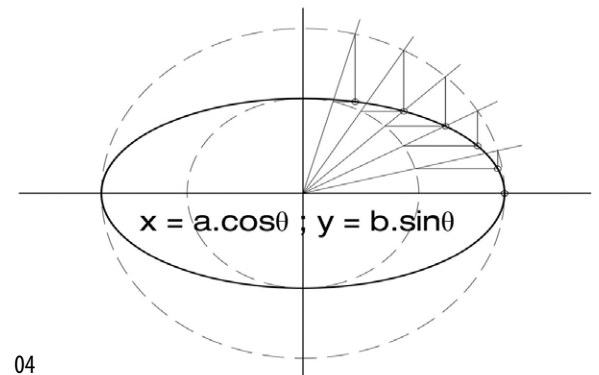

04

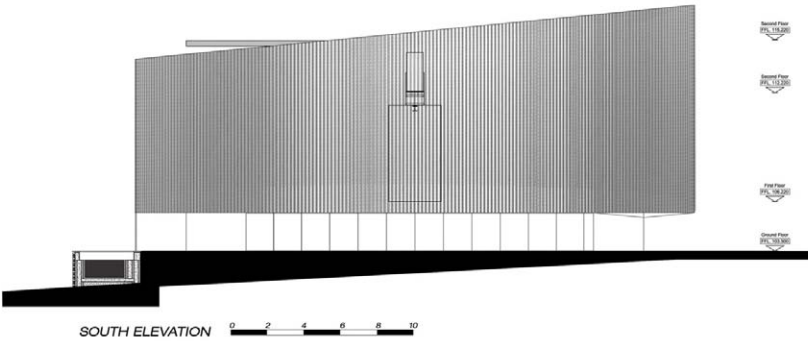
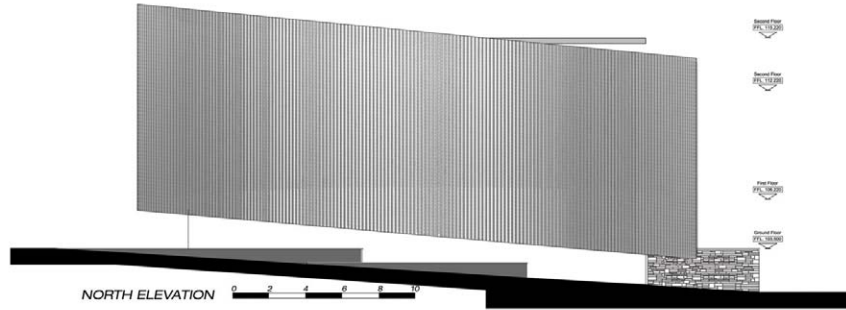

05

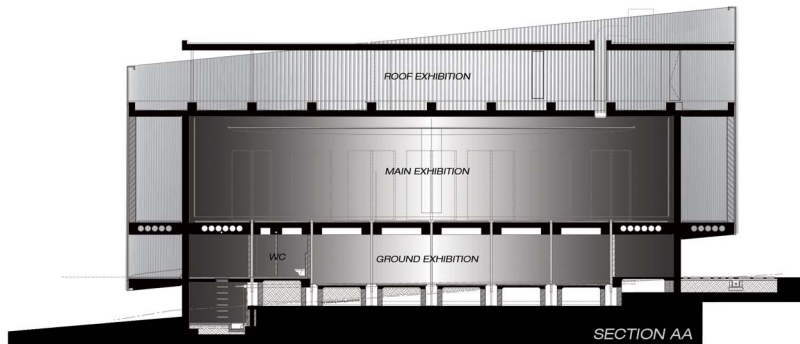

06

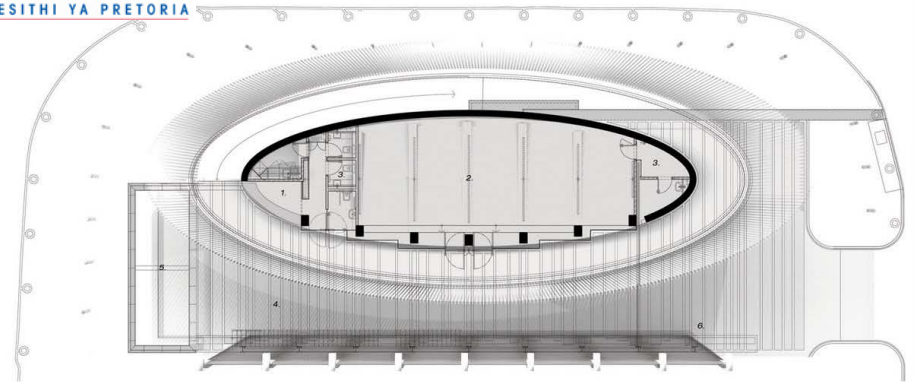

GROUND FLOOR PLAN



- 1. RECEPTION
- 2. EXHIBITION
- 3. WC
- 4. GATHERING SPACE
- 5. POOL
- 6. PLANTED SCREEN
- 7. ENTRANCE RAMP
- 8. MAIN EXHIBITION
- 9. CIRCULATION
- 10. OFFICE + DECK
- 11. FIRE ESCAPE

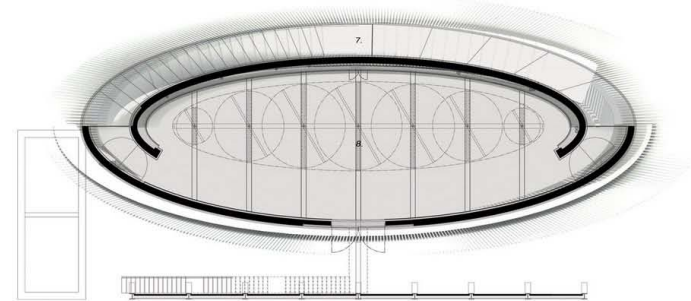

FIRST FLOOR PLAN

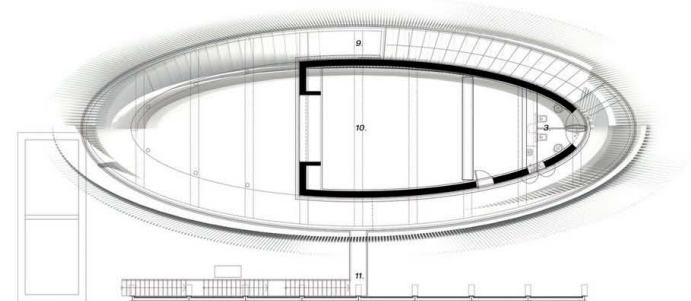

SECOND FLOOR PLAN



07

PRECEDENT TYPE
Tectonic

PROJECT NAME
Bloch Building at the
Nelson Atkins Museum

ARCHITECT
Steven Holl &
BNIM Architects

BUILDING TYPE
Museum

CONSTRUCTION TYPE
Extension &
Renovation

LOCATION
Kansas City, MO

YEAR
2006



+ U-profile Glass

The Bloch building at the Nelson Atkins Museum of Art, is designed as a longitudinal space, submerged beneath the vast expanse of lush lawn, with five interconnected structures arranged around it. These structures emerge from below in order to allow light into the lower levels. Steven Holl uses the metaphor of *lenses* to describe the intent of these architectural elements. The building does not impose on or overshadow the existing *Beaux Arts* building, but enhances its character by the stark contrast.

The *showpiece* of the design, is undoubtedly, the luminous appearance of the glass façade system. This system is constructed of u-profile glass panels (arranged to form a cavity). The translucent (but not transparent) glass allows indirect daylight to be dispersed into the gallery spaces which create the desired luminosity. At night the opposite occurrence illuminates the facade, allowing light from the interior to emit an ethereal glow on the museum grounds.



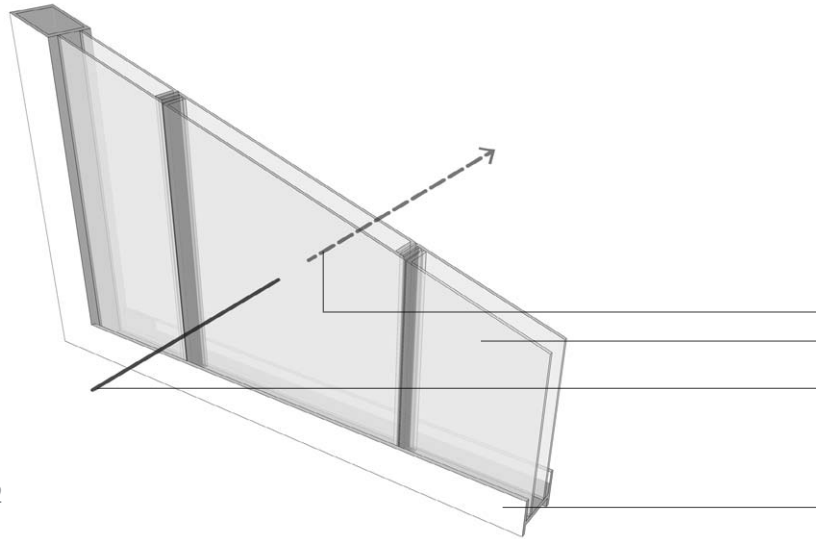

Channel glass, traditionally used in industrial architecture, was at this stage a relatively new building material in the commercial sector, but many systems have since become available from various manufacturers. Systems include double glazing options which can act as a climate-wall to regulate indoor air temperature as well as humidity levels.

subtle indirect and dispersed light
 u-profile glass panels arranged to fit into one another
 direct light
 aluminium support frame

Opposite |

Illustration 7.6 (1):

Photograph of the Bloch building at the Nelson Atkins Museum, by Adam Ryan (Saieh, 2008)

This page |

Figure 7.5 (2):

Diagram analysing the u-profile double glazing facade system (Author, 2011)

Figure 7.6 (3):

Diagram of structure and facilities (Saieh, 2008)

Figure 7.7 (4):

Section through Nelson Atkins Museum and the Bloch building (Saieh, 2008)

Illustration 7.7 (5):

Photograph of the Bloch building illuminated at night, by Andy Ryan (Saieh, 2008)

Illustration 7.8 (6):

Photograph of the interior of Bloch building during daytime, by Andy Ryan (Saieh, 2008)

Illustration 7.9 (7):

Photograph of the Bloch building at the Nelson Atkins Museum, by Andy Ryan (Saieh, 2008)



02

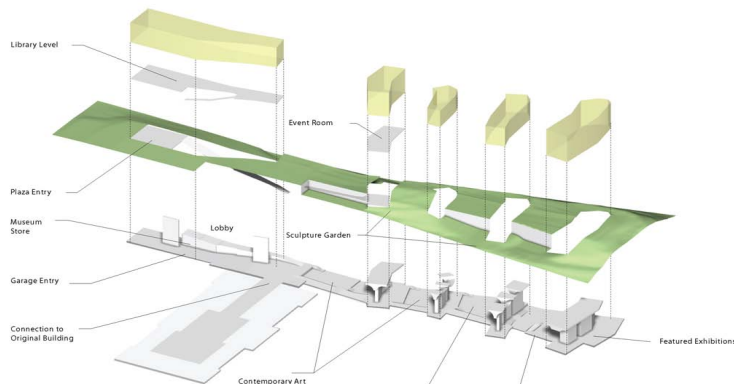

03

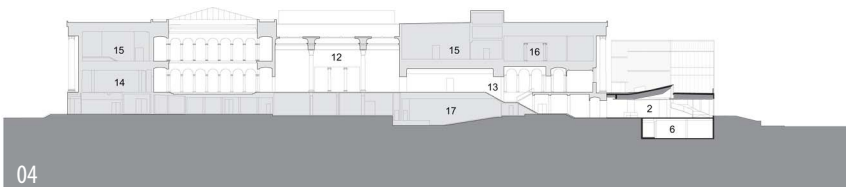

04



UNIVERSITEIT VAN PRETORIA
UNIVERSITY OF PRETORIA
YUNIBESITHI YA PRETORIA

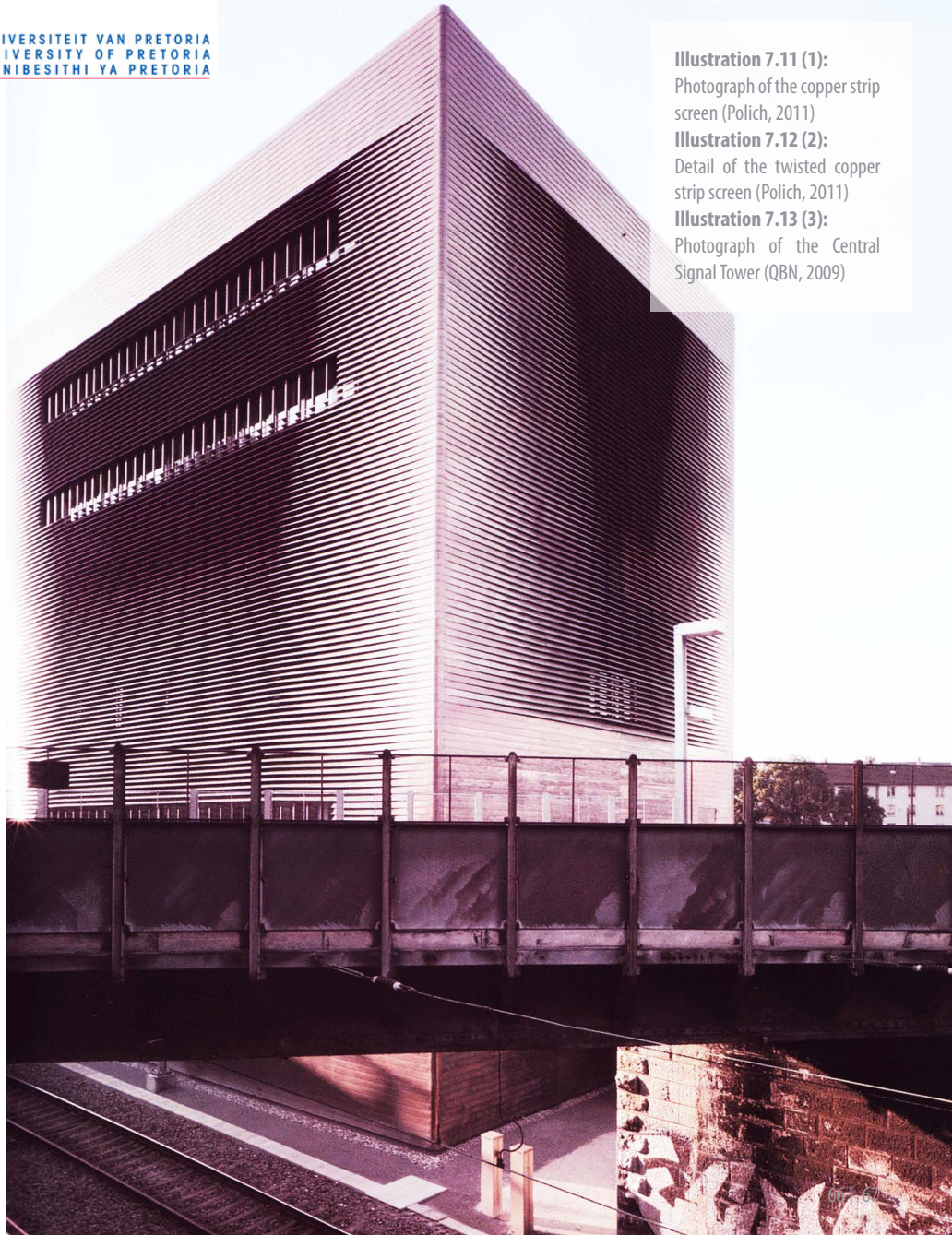
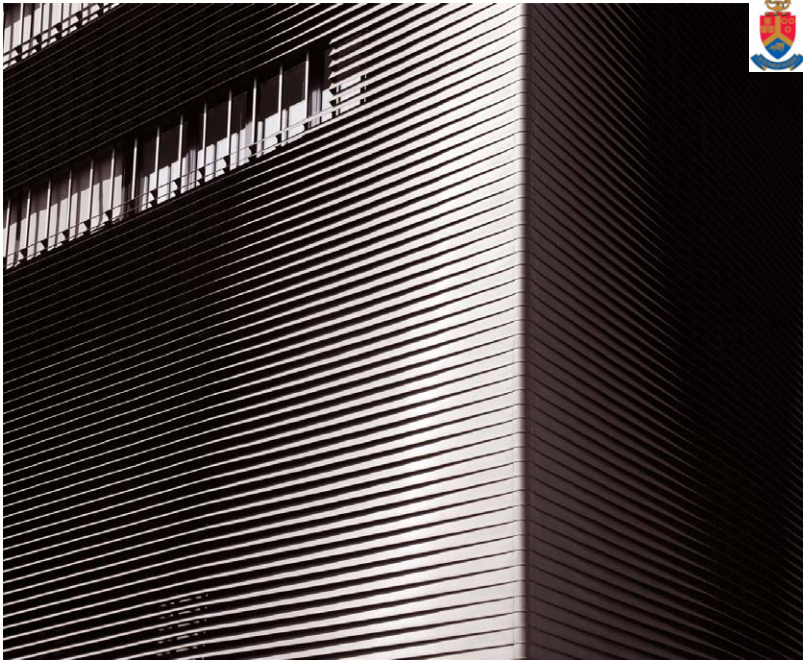

Illustration 7.11 (1):
Photograph of the copper strip screen (Polich, 2011)
Illustration 7.12 (2):
Detail of the twisted copper strip screen (Polich, 2011)
Illustration 7.13 (3):
Photograph of the Central Signal Tower (QBN, 2009)



PRECEDENT TYPE
Tectonic &
Mechanical

PROJECT NAME
Storefront for Art &
Architecture

ARCHITECT
Steven Holl &
Vito Acconci (artist)



UNIVERSITEIT VAN PRETORIA
UNIVERSITY OF PRETORIA
YUNIBESITHI YA PRETORIA
Art Gallery

CONSTRUCTION TYPE
Renovation

LOCATION
Soho, NY

YEAR
1993

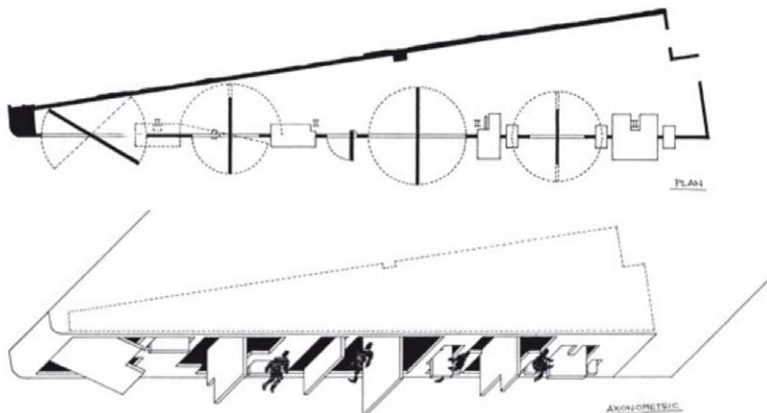

Precedents & Case Studies

+ Dynamic Building Elements

The Storefront for Art and Architecture commissioned a collaborative team for the renovation of the gallery's decaying façade. The building is a slender wedge-shaped structure with an intimate triangular gallery space. Due to its distinct form, the building's most dominant element is its long street elevation.

According to Steven Holl (2008), the objective was to introduce improbability by contesting the "symbolic border which underlines the exclusivity of the art world", where the inside belongs to the elite alone. The two designers proposed a chain of swivelling façade panels¹ configured in a puzzle-like format. The façade seems to dissolve when the panels are secured in the open position, allowing the interior of the gallery to extend onto the sidewalk and into the urban context.

This page | top to bottom

Illustration 7.14:

Photograph of the facade when opened (Brake, 2008)

Figure 7.8 :

Plan of the gallery indicating the rotations of each panel (Anon, [2001])

Figure 7.9:

Axonometric diagram of the gallery (Anon, [2001])

01. A composite material, comprised of concrete and recycled fibres was employed as a lightweight infill material for the swivelling panels.



setting



scale

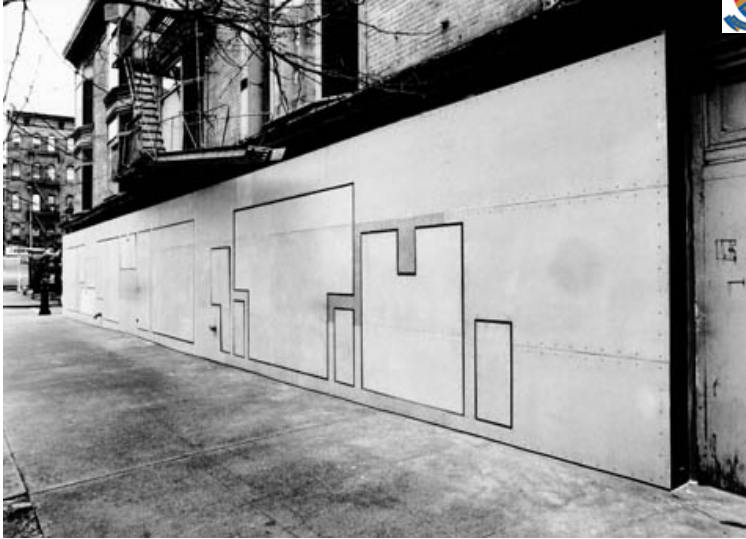

Illustration 7.15:
Photograph of the street elevation (Warchol, 2002)





The simple introduction of these design elements alter the dynamics of both the interior and exterior space tremendously when opened. By introducing dynamic elements, whether it be sliding, alternating or rotating, the character of a space can be manipulated sporadically in order to enhance the user's experience as well as the spatial quality.



This page | top to bottom

Illustration 7.16:

Photograph of the facade when closed, from exterior (AITC, 2001)

Illustration 7.17:

Photograph of the facade when open, from interior (AITC, 2001)

Opposite |

Illustration 7.18:

Photograph of the street elevation (Norsworthy, 2008)

PRECEDENT TYPE	PROJECT NAME	ARCHITECT	BUILDING TYPE	CONSTRUCTION TYPE	LOCATION	YEAR
Mechanical	Chicken Point Cabin	Olson Kundig Architects	Residential: Lakeside Cabin	New Building	Idaho, USA	2002



+ Mechanical System

Chicken Point Cabin is an all-year-round weekend retreat for a young family. The main notion influencing the design of Chicken Point Cabin was: “to open the architectural experience to a larger landscape” (Ngo, 2006: 51). The first concepts included counter weight systems that utilise sandbags and an electronically operated facade that functions similar to a garage door. Both these options proved to be lacking as the designer advocated that user interaction enhances the experience and value. The *gizmo*, a gear-and-chain rotating wheel system, eventually complied with all the requirements.

The *gizmo*, as Tom Kundig refers to it, is what gives Chicken Point Cabin’s facade its life; a large rotating window which links the interior to the surrounding natural landscape. The system utilises the simple principle of counter weights in order to keep the window balanced when in the opened position (Ngo, 2006: 79). This is achieved by both sides of the window’s cross axel being equal in weight.



setting



scale





The details of the *gizmo* serves as a good technical precedent for the intended dynamic elements in the Digital Pavilion as the scales and movement of the elements are similar (see Chapter 9).

Opposite |

Illustration 7.19:

Photograph of the rotating facade of Chicken Point Cabin (Benschneider, 2011. Edited by Author.)

This page | left to right

Illustration 7.20:

Photograph of the rotating facade of Chicken Point Cabin viewed from the first floor (Coleman, 2009. Edited by Author)

Illustration 7.21:

Photograph of the gear system of the rotating facade (Benschneider, 2011. Edited by Author)



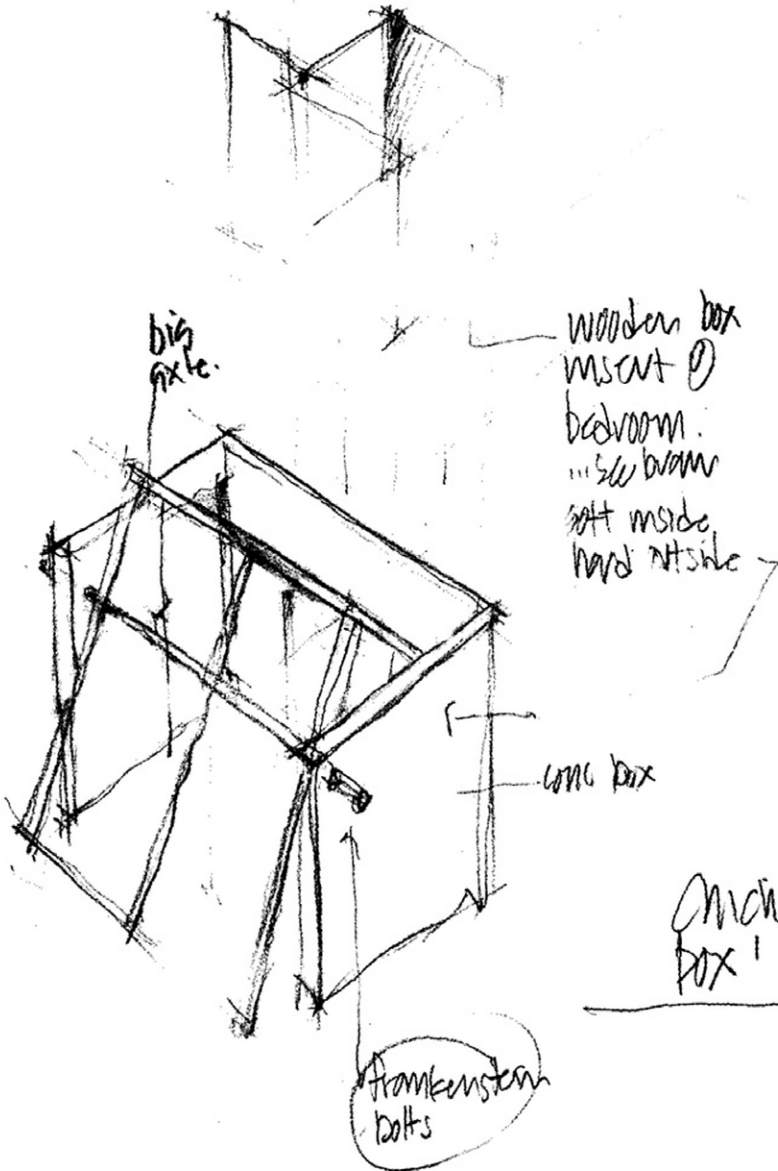

Chicken Point
'big window' gr.

Chicken
box!

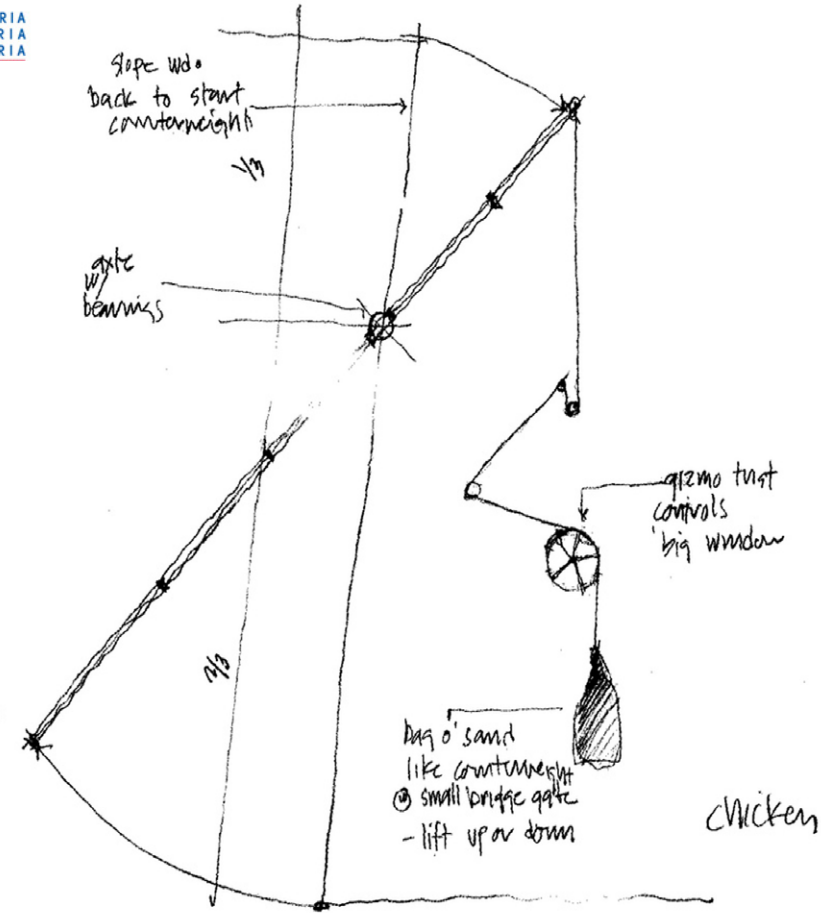

This page |
 Figure 7.10 (1):
 Concept sketch of the swivelling facade by Tom Kundig (Ngo, 2006.)
Figure 7.11 (2):
 Concept sketch of the counter weight mechanism by Tom Kundig (Ngo, 2006.)

Opposite |
Figure 7.12:
 Analytical drawing of the counter weight and gear system in Chicken Point Cabin (McLeón, 2007)
 01 | Manual turning wheel
 02 | Kinetic sculpture detail
 03 | Bevel gear and chain detail

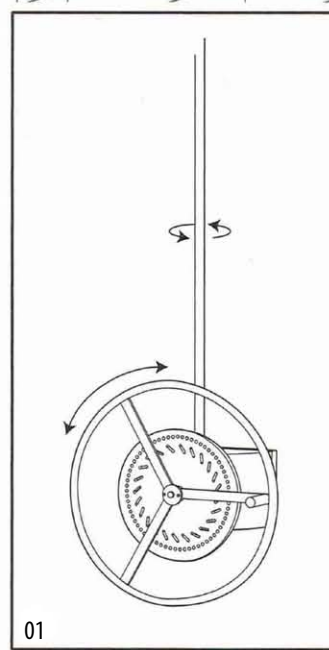
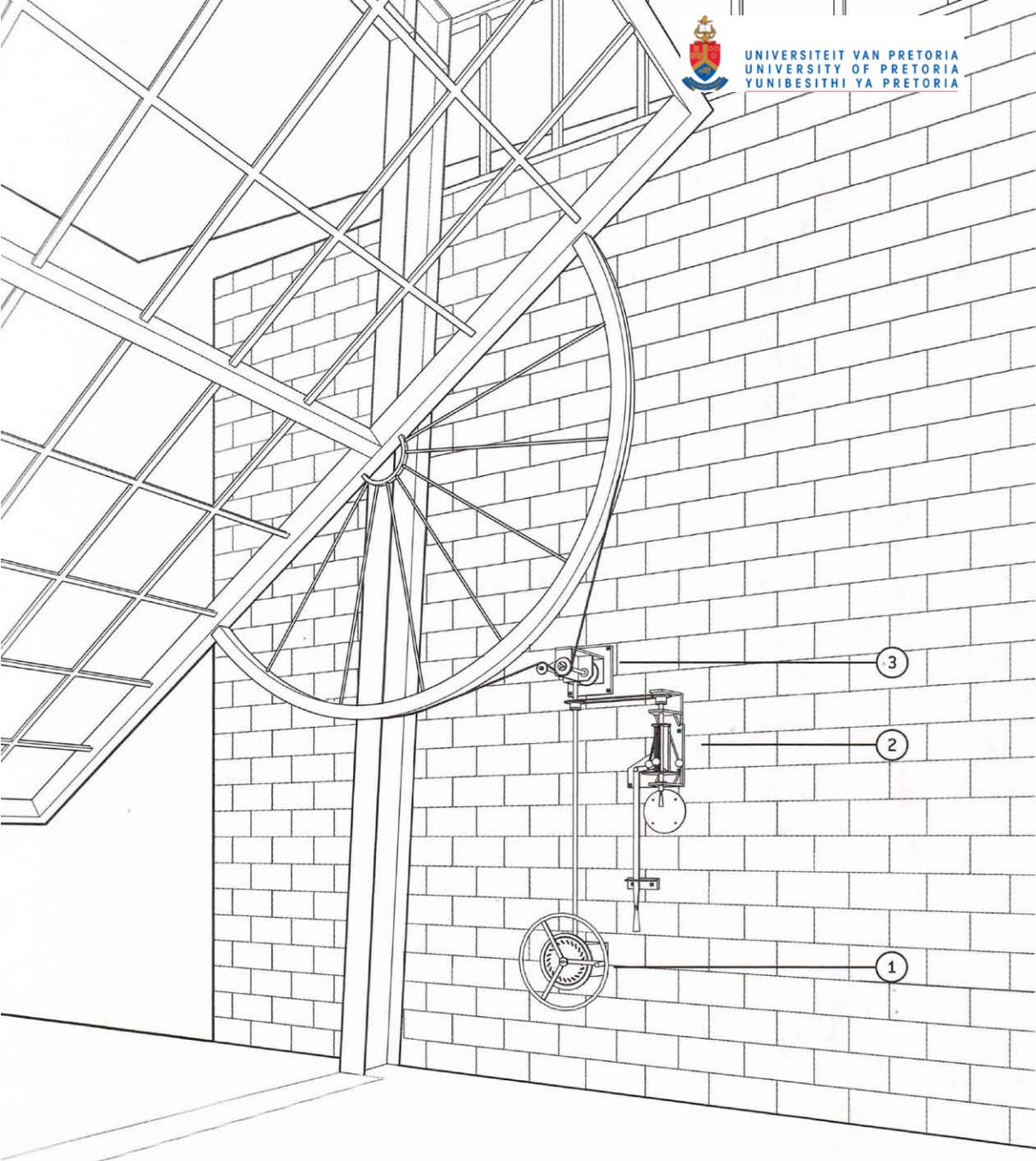

01

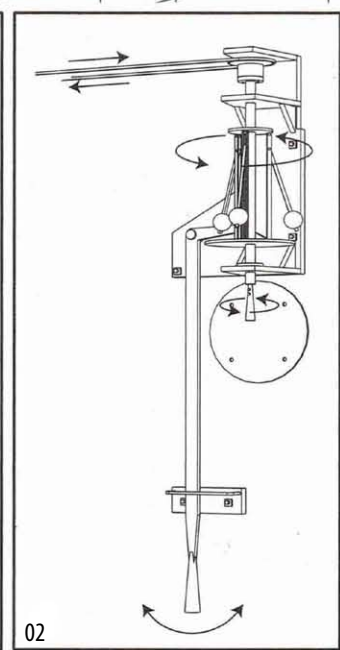

02

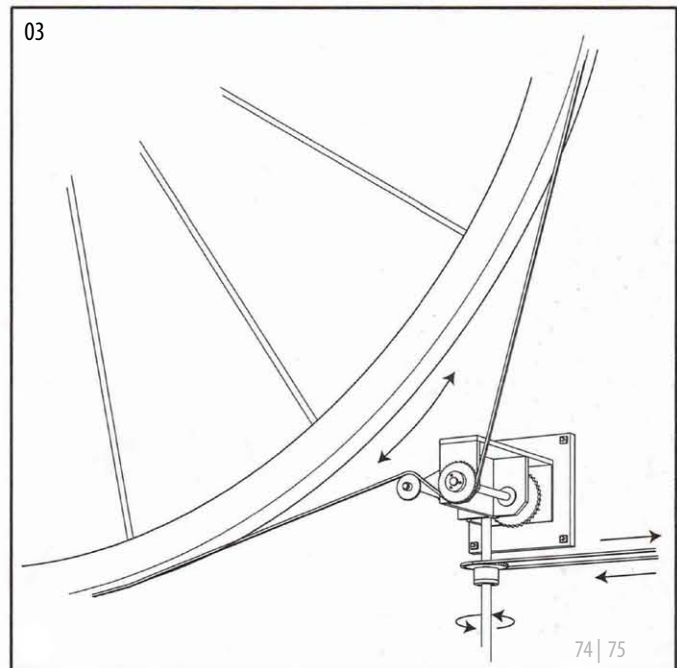

03



Site Analysis

+ Urban Mapping

Various mappings of Van der Walt Street inform the design as well as indicate different manners in which different edge conditions are used by city dwellers and the influences thereof:

- 01| Interactive edges (*fig. 8.2*) are often associated with a large amount of informal trading (*fig. 8.3*) as well as a pedestrian on a leisurely stroll (*fig. 8.4*), whereas a fenced-off or hard edge has little to no informal traders, a low energy concentration of pedestrians as well as a fast paced walking speed due to unfavourable conditions.
- 02| Small recesses in the street edge (i.e. articulated shop entrances) implies an inevitable concentration of informal traders and social interaction (*fig. 8.3*).
- 03| Interactive of textured edges (*fig. 8.2*) that provide an overhang or has a lane of deciduous trees on the sidewalk make for more ideal conditions. These edges encourage a slower pedestrian pace (*fig. 8.4*), which in turn encourages trading possibilities as well as interaction with the urban environment and other city dwellers.
- 04| A lane of deciduous trees is more favourable in winter, as it does not cast shadows and create cold spaces that encourage a higher pedestrian pace and discourage informal traders.
- 05| A concentration of informal traders occur on the Western street edge due to sunny conditions in the mid morning and shadows cast by buildings in the afternoon (*fig. 8.3*). The traders situated on the Eastern edge of Van der Walt Street utilise makeshift shading devices or gazebos. The opposite of this is true during winter months.
- 06| Areas around main taxi ranks (*fig. 8.5*) are also the preferred location for informal traders (*fig. 8.3*) as it is more convenient for consumers to acquire produce in the proximity of a transport node, as opposed to carrying it far distances.
- 07| Loose food products are sold towards the eastern part of Van der Walt Street where there is a lower pedestrian energy level and few taxi ranks, assumingly because it is intended for immediate consumption, whereas larger quantities are available toward the Northern periphery.
- 08| Private parking often causes a negative space between the static vehicle and the built edge. It is evident that this condition discourages high energy levels, social interaction and informal trading (*fig. 8.3 & fig. 8.5*). Public transport parking, however, seem to be promoting the exact opposite situation where it acts as a catalyst for events and activities.

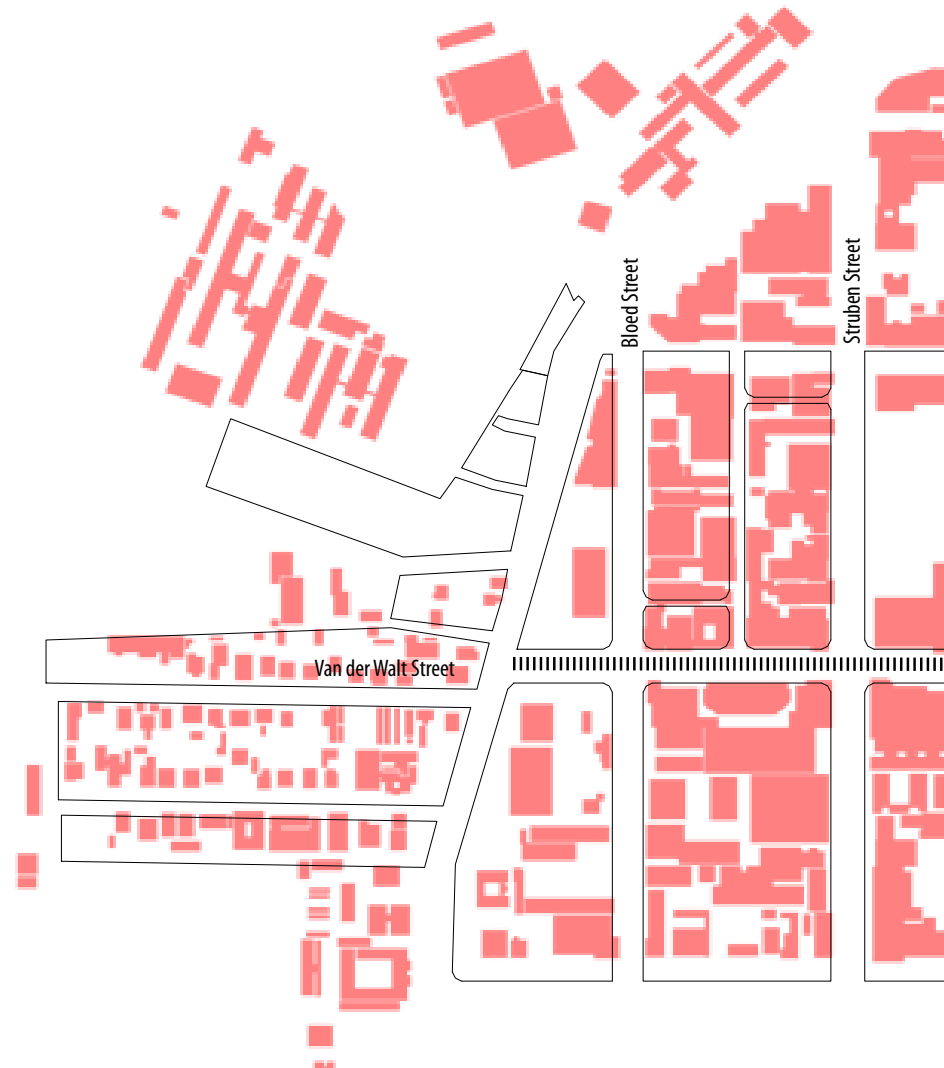

From top to bottom |

Figure 8.1: Mapping area of Van der Walt Street, Munitoria indicated in grey (Author, 2011)

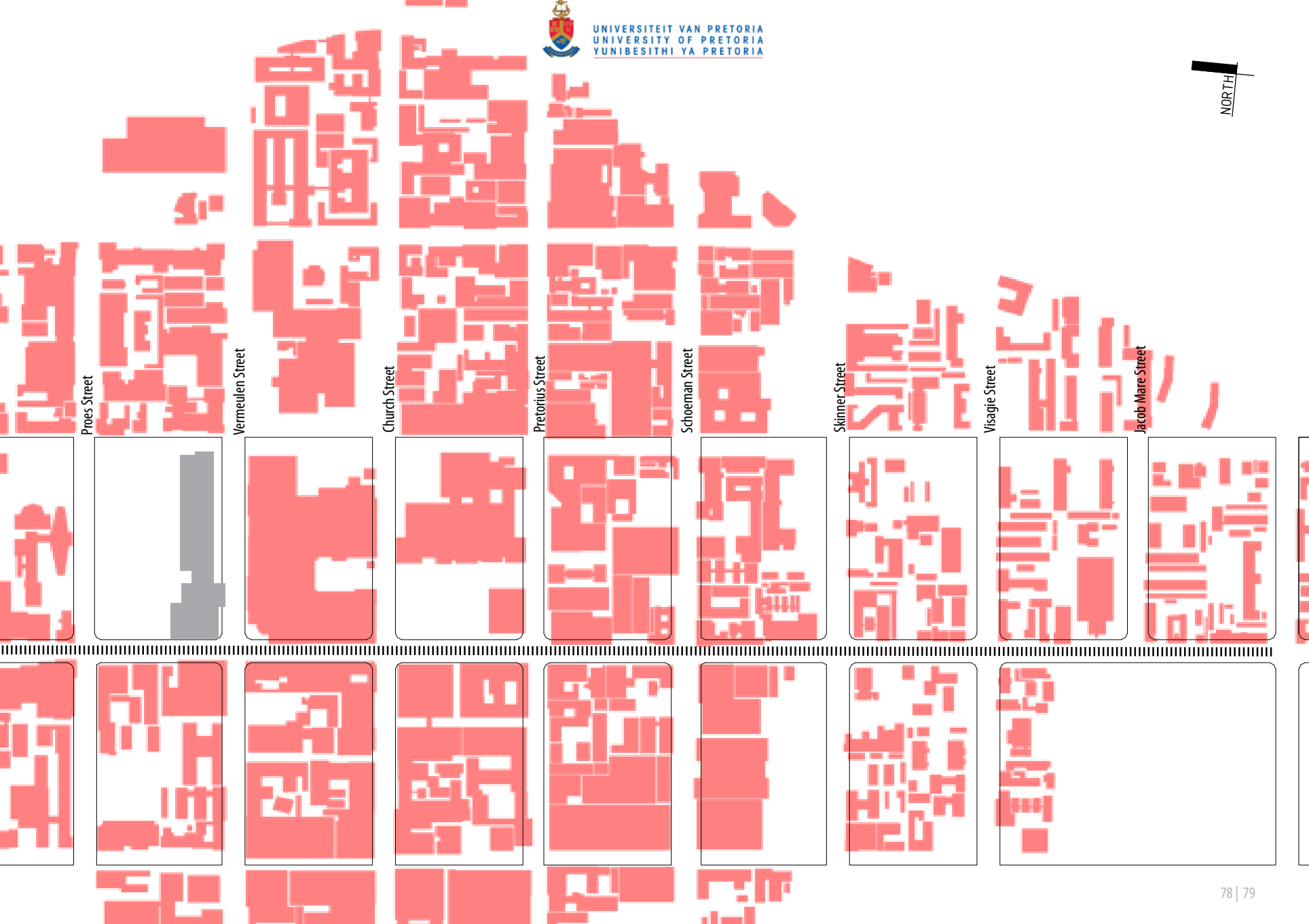



+ Edge conditions

- textured edge
- active edge allowing interaction
- hard edge minimal interaction
- fenced, excluding or controlled edge

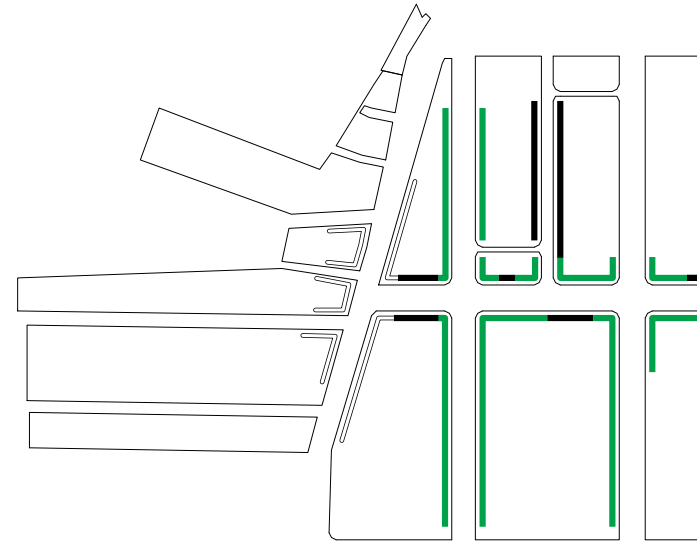

+ Formal & informal trading

- inactive formal trading
- active formal trading
- informal trading

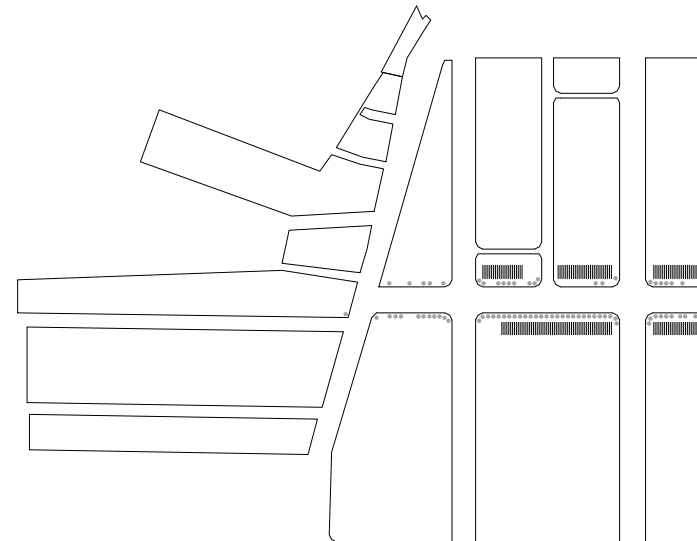



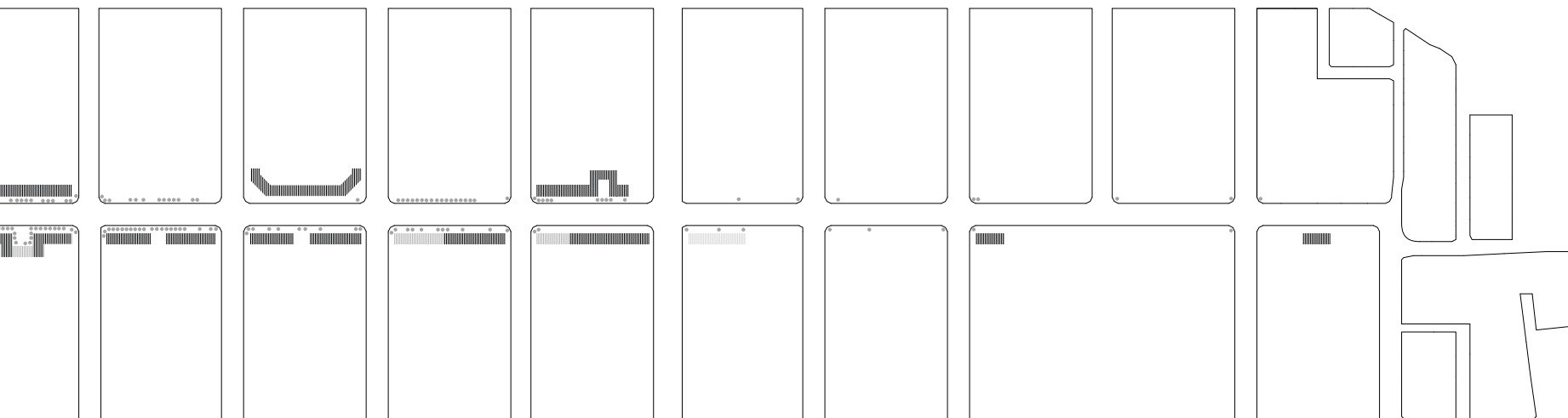
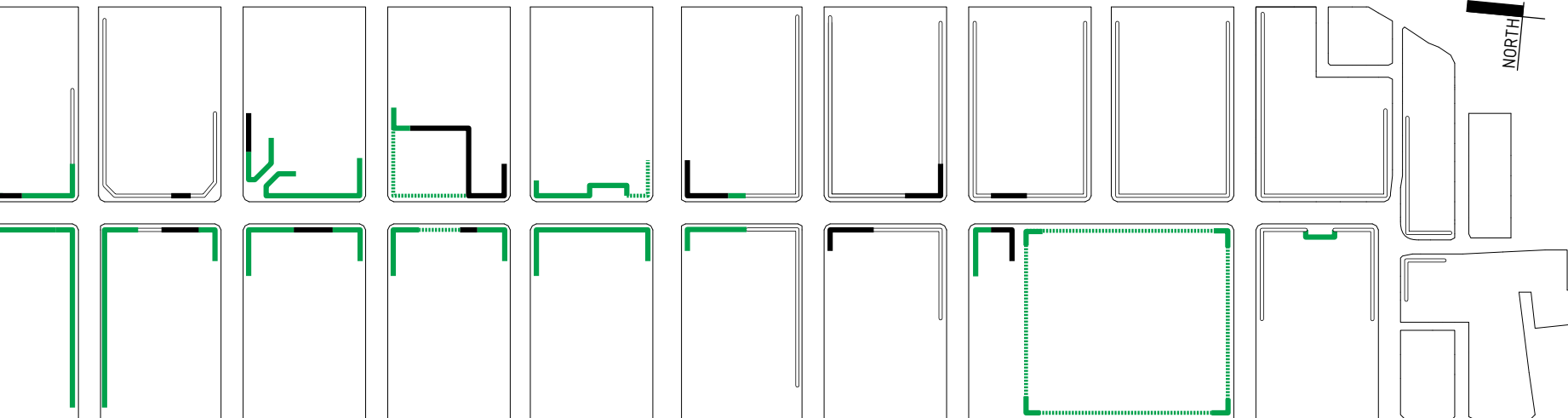

From top to bottom |

Figure 8.2: Mapping of edge conditions in Van der Walt Street (Author, 2011)

Figure 8.3: Mapping of formal and informal trading in Van der Walt Street (Author, 2011)



+ Pedestrian pace

-  leisurely stroll
-  fast pace
-  slow pace
-  movement interruption due to high vehicular traffic
-  movement interruption due to vehicular traffic

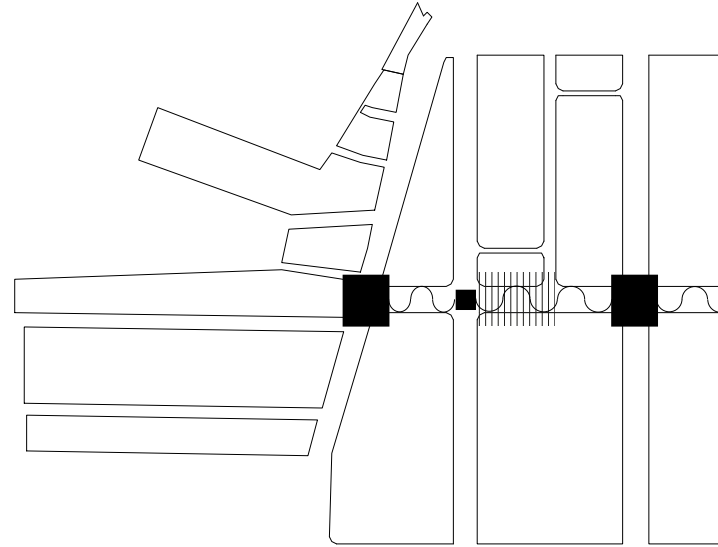

+ Public Transport Infrastructure

-  bus stop
-  ===== taxi stop or taxi rank
-  - - - - - private vehicle stops or private parking

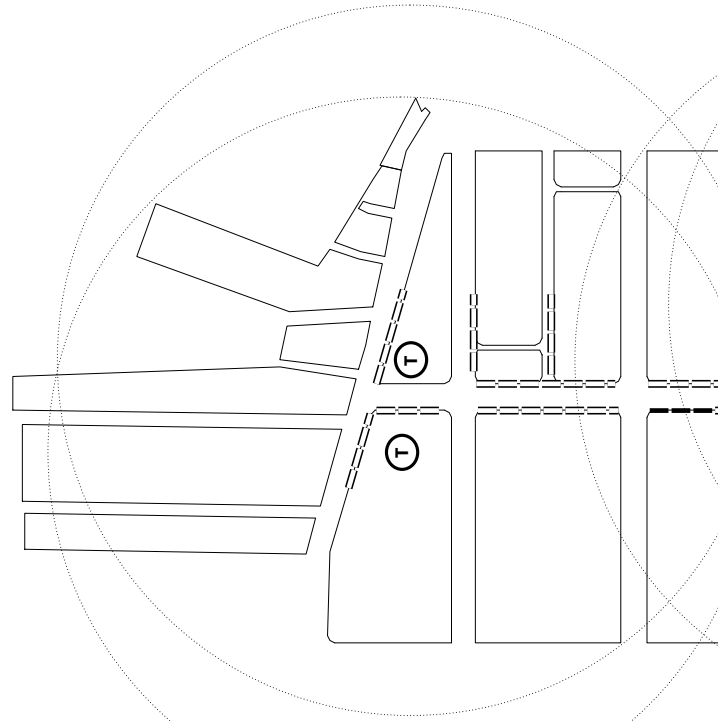

From top to bottom |

Figure 8.4: Urban mapping of pedestrian pace in Van der Walt Street (Author, 2011)

Figure 8.5: Urban mapping of public transport infrastructure in Van der Walt Street (Author, 2011)

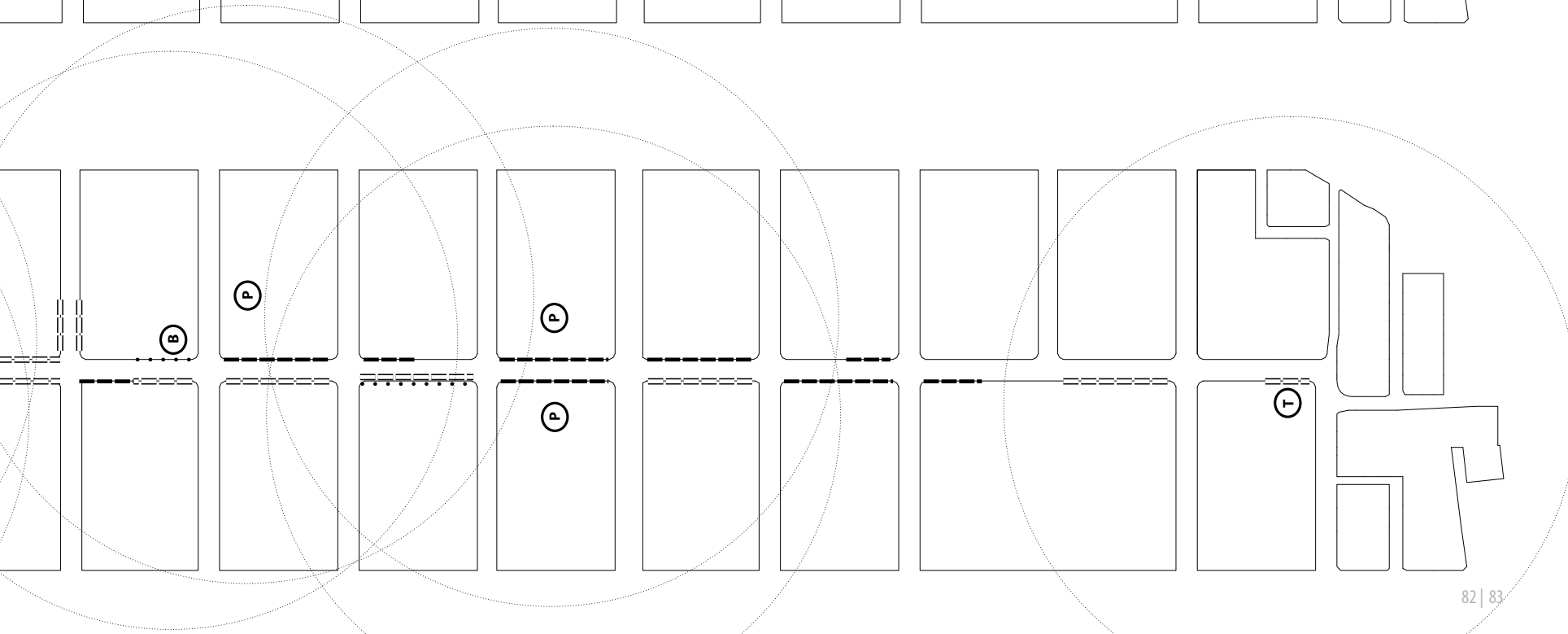
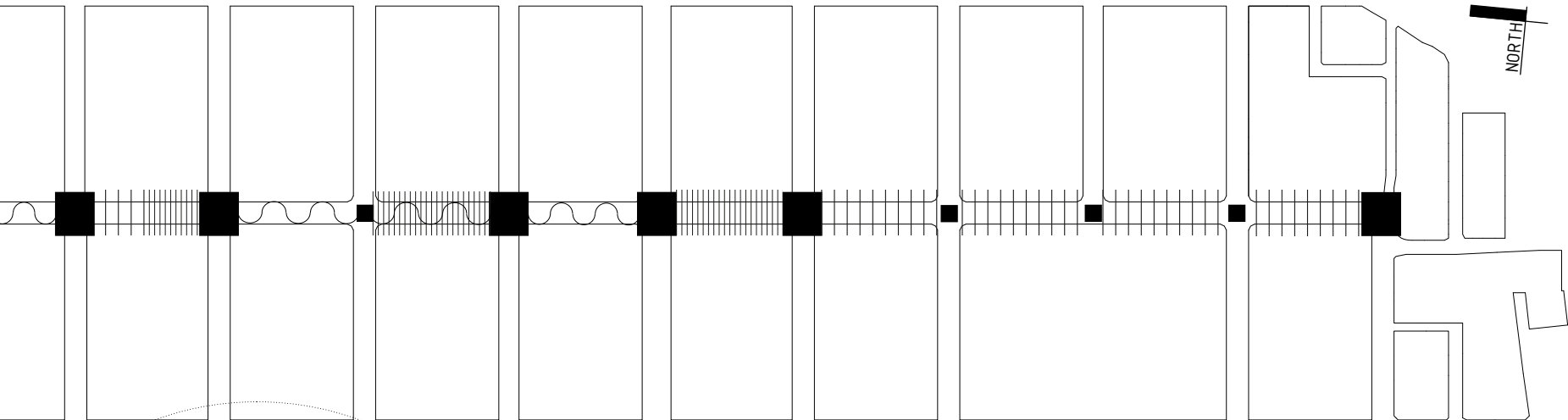



UNIVERSITEIT VAN PRETORIA
UNIVERSITY OF PRETORIA
YUNIBESITHI YA PRETORIA

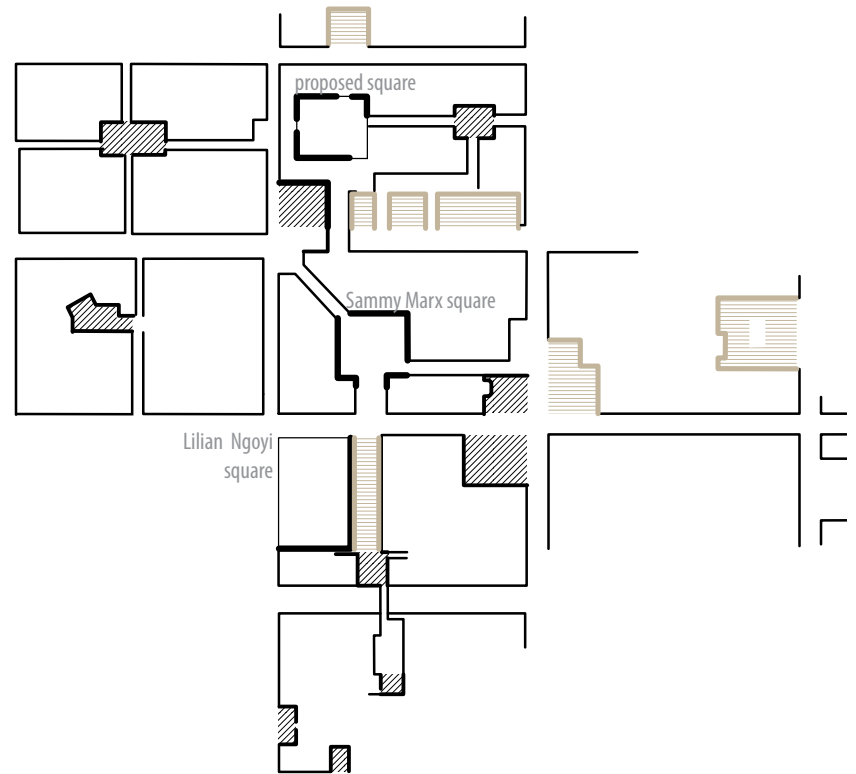

Site Development

+ Urban Cavity as a Proposed Square

According to hierarchical public space principles, the site is ideally located to propose a public square (as also proposed in most existing urban frameworks for the precinct). This square could fulfil the dual function of acting as an entrance *foyer* to a new entrance for the Munitoria building, as well as a public interface with the building itself.

“Community facilities scattered individually through the city do nothing for the life of the city”
- Christopher Alexander (1977)

Alexander (1977) argues that the available public spaces are scattered too thinly across urban communities. He states that studies have shown that people naturally seek out concentrations of people. In order to create these concentrations, facilities must be grouped densely around smaller public spaces which function as nodes - with most pedestrian movement in the community organised to pass through these nodes.

These nodes require four properties:

- 01 | The surrounding programmes should be selected according to their symbiotic relationship in order to react in a cooperative manner
- 02 | The square should be of an appropriate scale (not too large) in order to concentrate activity
- 03 | Main pedestrian routes in the surrounding neighbourhood should converge within the space
- 04 | Nodes must be distributed evenly throughout the community

This square would become a node in a network of distributed public spaces (*fig. 8.6*) which are made accessible via existing pedestrian routes as well as proposed inter-block movement routes. An intimate square is created by placing the new interventions (public buildings) around the perimeter of the square as defining thresholds.

Opposite | left to right

Illustration 8.1: Photograph of the remaining urban cavity with the *Transvaal building* in the background (Author, 2011)

Figure 8.6: Diagram illustrating a part of the public space network of which the proposed square forms part (Author, 2011)

This page |

Illustration 8.2: Photograph of the remaining urban cavity (Author, 2011)





The urban cavity is overlaid with a rich layer of temporal' strata; the column grid of the burnt down West wing, visible remains of the floor plan, previous paint layers as well as portions of floor tiles, are all visible and preserved. It is of great importance to conserve this layer as it conveys a connection with time as well as the site's history. It also adds value and character to the place by evoking a sense of nostalgia.

Illustration 8.3: Photograph illustrating the temporal strata on the surfaces in the urban cavity (Ahmed Alkayyali, 2011)

+ Spatial Development

The development of the *urban cavity* needs to be addressed very delicately as it holds a great deal of potential for the rejuvenation of its immediate surroundings, but could similarly create various urban problems. The following spatial *parti* diagram illustrates the proposed edge conditions and spatial planning strategies.

01 | Current condition:
Current existing thresholds, creating negative space within the urban environments (urban cavity).



02 | Negative condition:
Filling the cavity with an imposing architecture would create a semi permeable and access-controlled space. The temporal layers are covered by a single ideology.



03 | Positive condition:
Creating a penetrable edge condition around of the cavity would preserve the rich temporal layers as well as define the public square.



04 | Developed positive condition:
Creating access to the square in the form of a transitional space that bridges the level difference between the street and square.

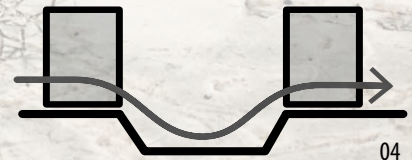

05 | Proposed ideal condition:
Programming the vertical elements to provide a privacy gradient, allowing for multifunctional space.



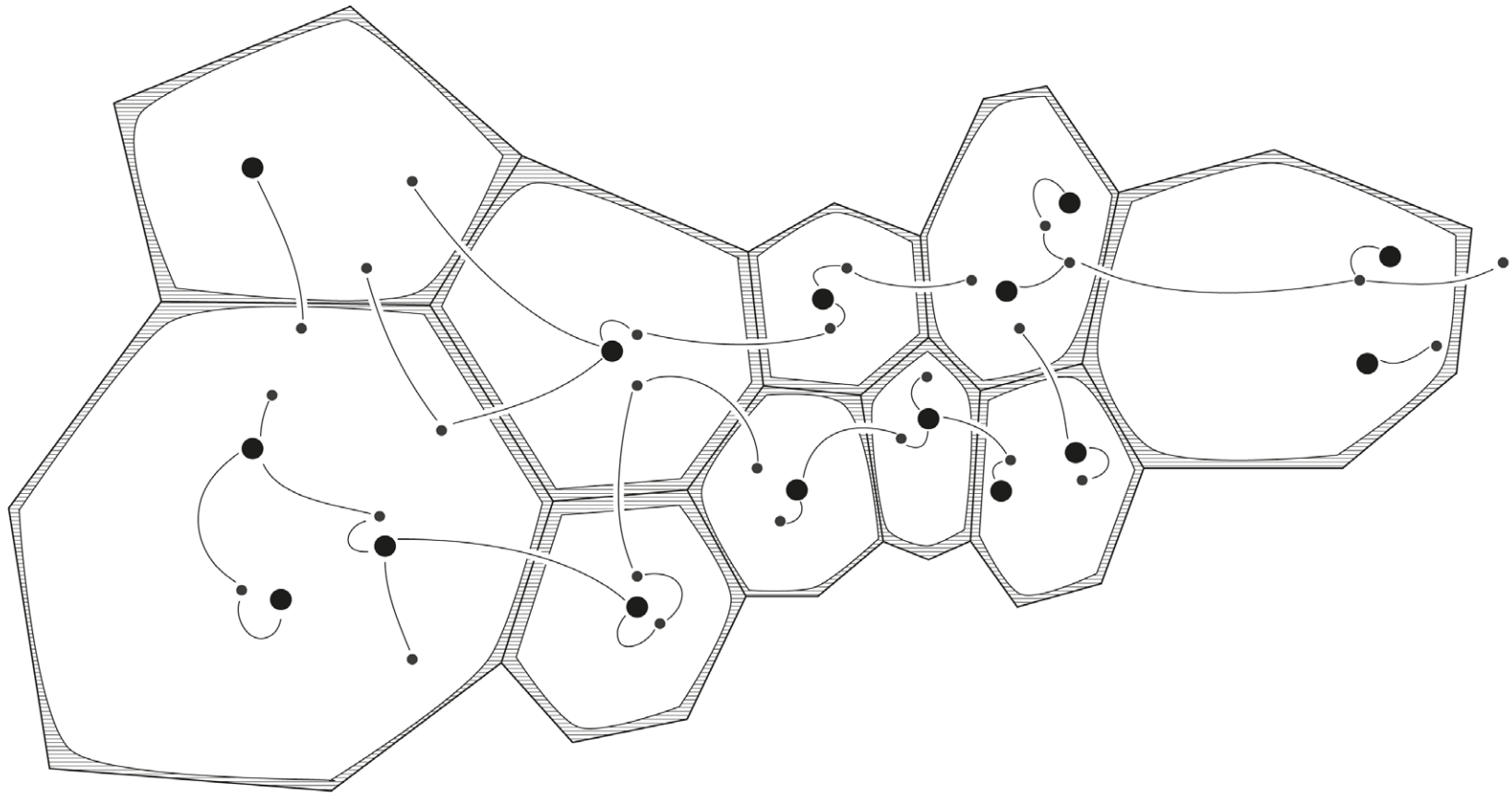

+ Osmosis: Programmable *Cell Walls*

“The cell wall of an organic cell is, in most cases, as large as, or larger than the cell interior. It is not a surface which divides inside from outside, but a coherent entity in its own right, which preserves the functional integrity of the cell but also provides for a multitude of transactions between cell interior and the exterior ambient fluids. Therefore, the cell wall is a place in it’s own right.” (Alexander, 1977: 87)

The proposed alterations to the existing edge conditions create multiple thresholds. Each threshold may be individually programmed to create interfaces, each dedicated to a specific urban function (creating urban opportunities as proposed in the urban framework), similar to the membranes surrounding cells. As stated by Alexander, these membranes are “spaces in their own right” that “provide a multitude of transactions between the interior and the exterior.”

This page |

Figure 8.8: Diagram illustrating the concept of osmosis (Author, 2011)

Opposite |

Figure 8.9: Diagram illustrating the current street edge condition and thresholds (Author, 2011)

Figure 8.10: Diagram illustrating the proposed street edge condition - introducing multiple thresholds (Author, 2011)



+ Multiple Thresholds

The current condition creates only three thresholds, of which none are specifically dedicated to pedestrian use. Through bridging the level difference and introducing structure, the number of thresholds is increased to seven. Each of the thresholds may be programmed to accommodate a different urban function (urban opportunity), thereby creating a multi layered, functional urban interface. The programming of thresholds will be a form generator in the design process.

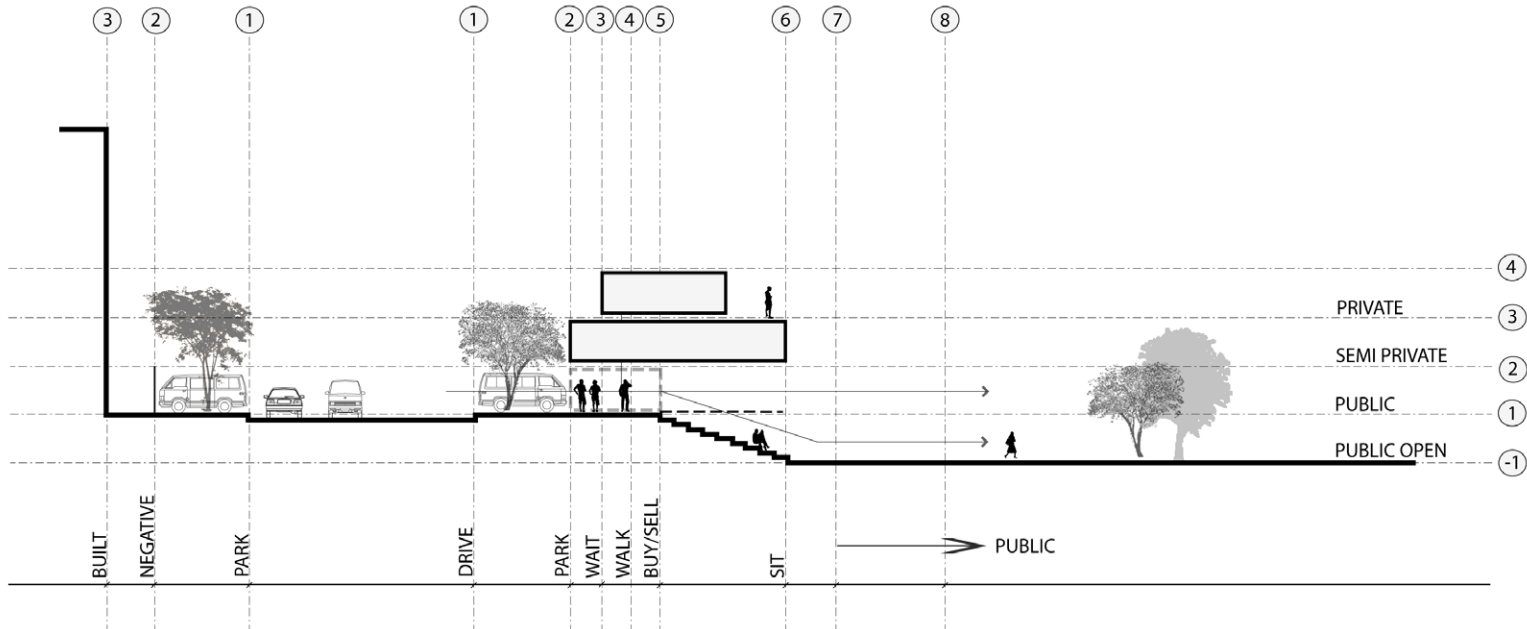
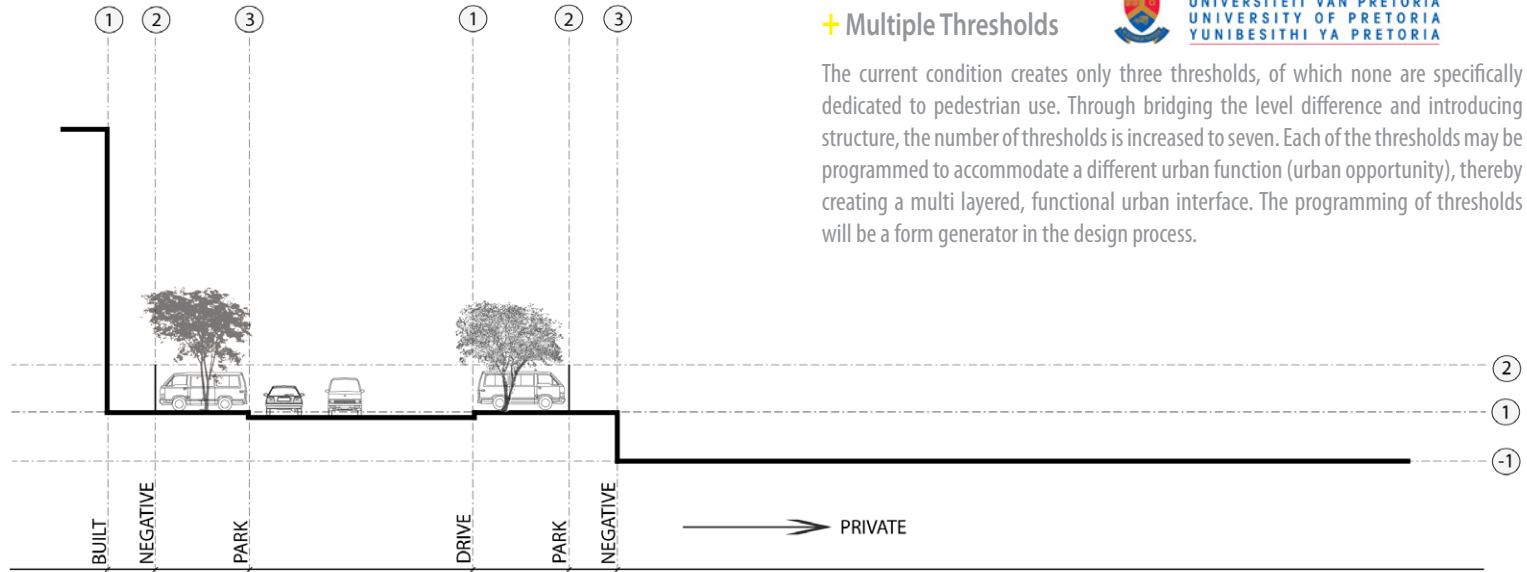

+ Programmatic Symbiosis

The two proposed interventions (Ahmed Alkayyali's *Stairway* and the *Digital Art Pavilion*) attempt to create a form of programmatic symbiosis¹. This is to be achieved through the overlapping of cooperative programmes and the sharing of common interests. Through the intersection of programme, a supportive background is created for each of the individual proposals.

Cooperative Concept:

The establishment of a supportive background for public activity and perception through the process of "making aware." Thereby presenting a different "way of looking".

The common denominator between the programmes, being the "process of making aware", responds to a temporal² layer captured within the site, ranging from past through to the present and projecting into the future: *Munitoria* personifies the past and past ideals, *the Stairway* project creates an awareness of present through encouraging everyday activities, whilst the *Digital Art Pavilion* showcases the future in terms of the latest technological advances and possibilities.

Common interests induce a physical symbiotic relationship, where *the Stairway* becomes an amphitheatre to the *Digital Art Pavilion* on occasion (public events where the façade of the *Pavilion* is used as a projection screen for either the surveillance footage or digital art).

As mentioned in Chapter 5 (p.44), *Munitoria* embodies the nationalist approach to public buildings and the management of information. These ideals are inverted in the *Digital Art Pavilion* by challenging the archaic approach to information management and transferring, which in turn creates a programmatic link to the existing on-site facilities.

+ Introduction to Ahmed Alkayyali's Stairway (Liminal Public Infrastructure)

The project investigates the quotidian (or *everyday*) context of the city. Where the city is seen to contain both the 'settings' and the 'props' for these everyday activities. A conceptual inhabited "stairway" is proposed to bridge the level change of the urban cavity. Through the manipulation of the urban surface, the stairway brings together a multiplicity of programmes through the celebration and enhancement of the everyday context. *The Stairway* thus forms a new public building typology, whereby the inhabitation of the stairs (that form the urban surface) is identified as a new archi-type: defining liminal support architecture for an *active public space*, rather than the *static* form of public space which we find within the city.

As a result the building encloses a series of private and public space. On a public level, the stairway responds to the context by providing an inhabitable urban surface, providing amenities that support the everyday activities of the public realm. On a private level, the spaces below the stairway, which are perceived as secretive spaces, are occupied by the CCTV surveillance policing, whereby the city is surveyed on a detailed level. This intensive video surveillance is then filtered and carried over to the neighbouring digital arts pavilion, whereby artists can re-interpret the data and use it to generate various art forms. (Alkayyali, 2011)

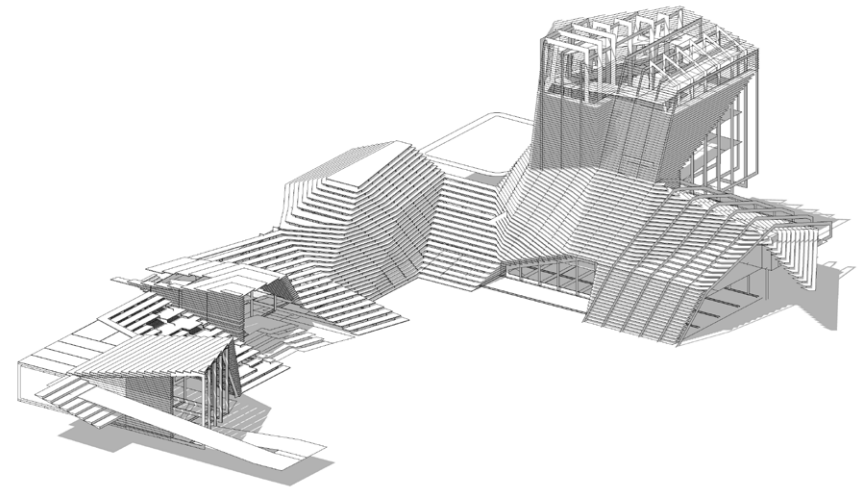













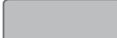

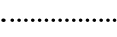



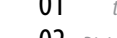

Figure 8.11: Conceptual perspective of the *Stairway* (Alkayyali, 2011)

01. A mutually beneficial relationship between different entities

02. Pertaining to time, or a connection with time

Figure 8.12:
Diagram illustrating the proposed
site development (Author, 2011)

-  housing and residential
-  commercial & institutional
-  retail & shopping
-  culture & religious
-  entertainment spaces
-  informal trading stalls
-  basement parking below
-  pedestrian activity
-  seating spaces
-  shaded green spaces
-  waiting spaces
-  public squares
-  new interventions
-  proposed buildings
-  secondary squares
-  pedestrian routes
-  arcade system
-  public transport infrastructure
-  new landscaping
-  existing palm
-  pedestrian bridge connection
- 01 *the Stairway (Alkayyali)*
- 02 *Digital Art Pavillion (Kruger)*

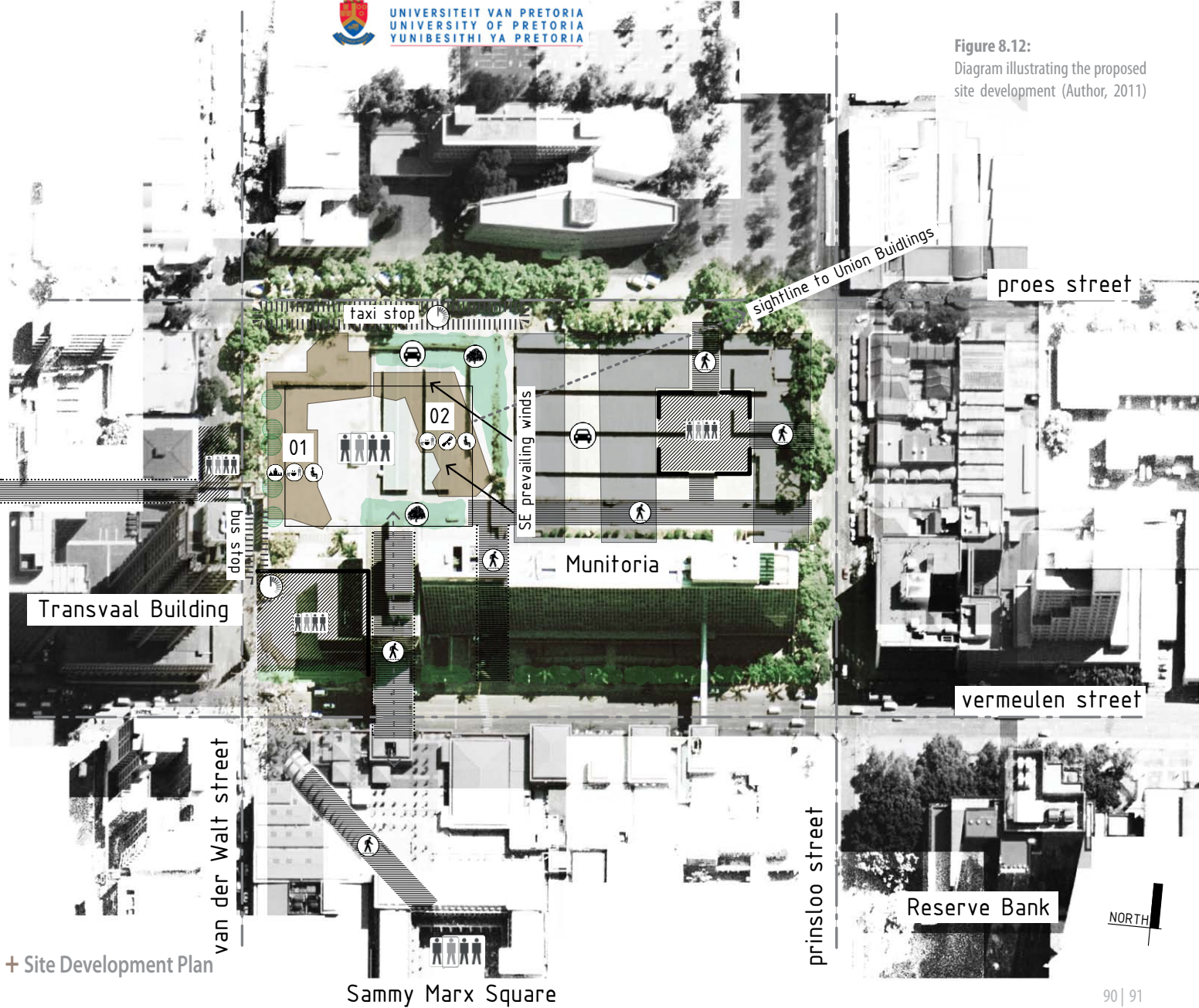

+ Site Development Plan

Sammy Marx Square

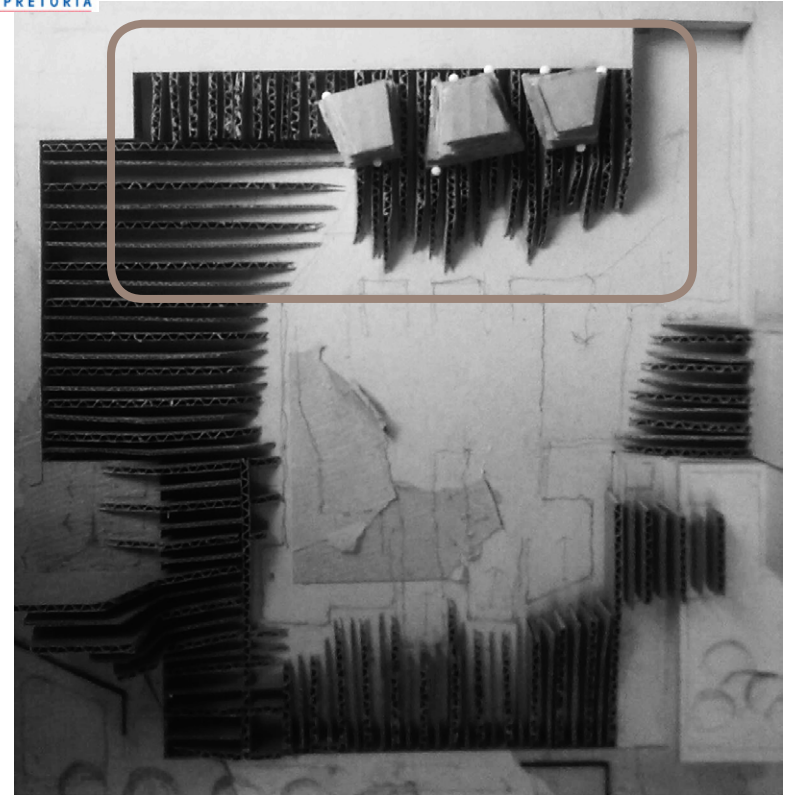
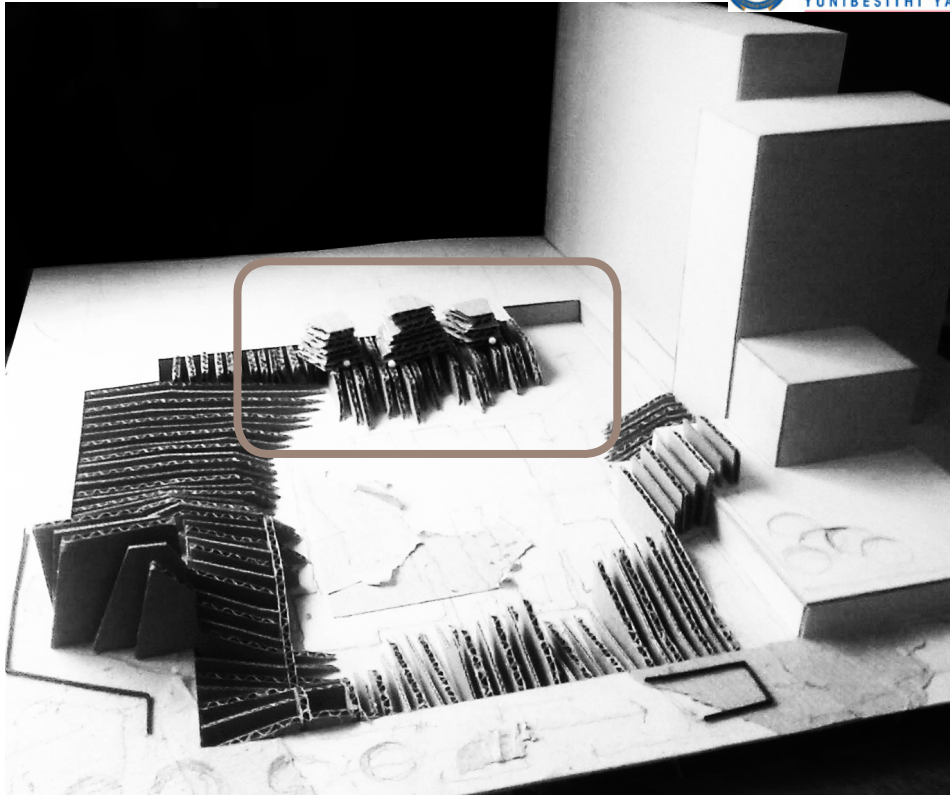

Figure 8.13:
Photographs of a concept model illustrating the symbiotic relationship between the two interventions, the *Art Pavilion* highlighted
(Author, 2011)

+ Design Guidelines

01 | Formal guidelines

The emergence of *digital architecture* allows for the design of irregular forms, which were previously considered unfeasible and unpractical. This attribute of the contemporary architectural climate needs to be manifested in the design in order to provide a degree of transparency by announcing the building programme. This will also illustrate the possibilities arising in the architectural profession into the current epoch.

02 | Stereotomic vs. Tectonic

The structure is divided into permanent programmes (artist studios, information technology facilities and the café) at the base of the building, whilst temporary programmes are located in the multifunctional exhibition towers. The design should express this duality by means of material uses and massing (fragmenting masses and tectonic qualities toward the vertical elements).

03 | Square Periphery

The edge defining the public square needs to create an interactive threshold by establishing visual connections into the building, as well as providing defined seating and recreational spaces which generate an 'active' edge condition. Edge continuity is imperative in order to create a legible and clearly defined public space, especially when considering the extreme proximity of the proposed interventions. The schemes should be integrated to ensure the transition appears seamless.

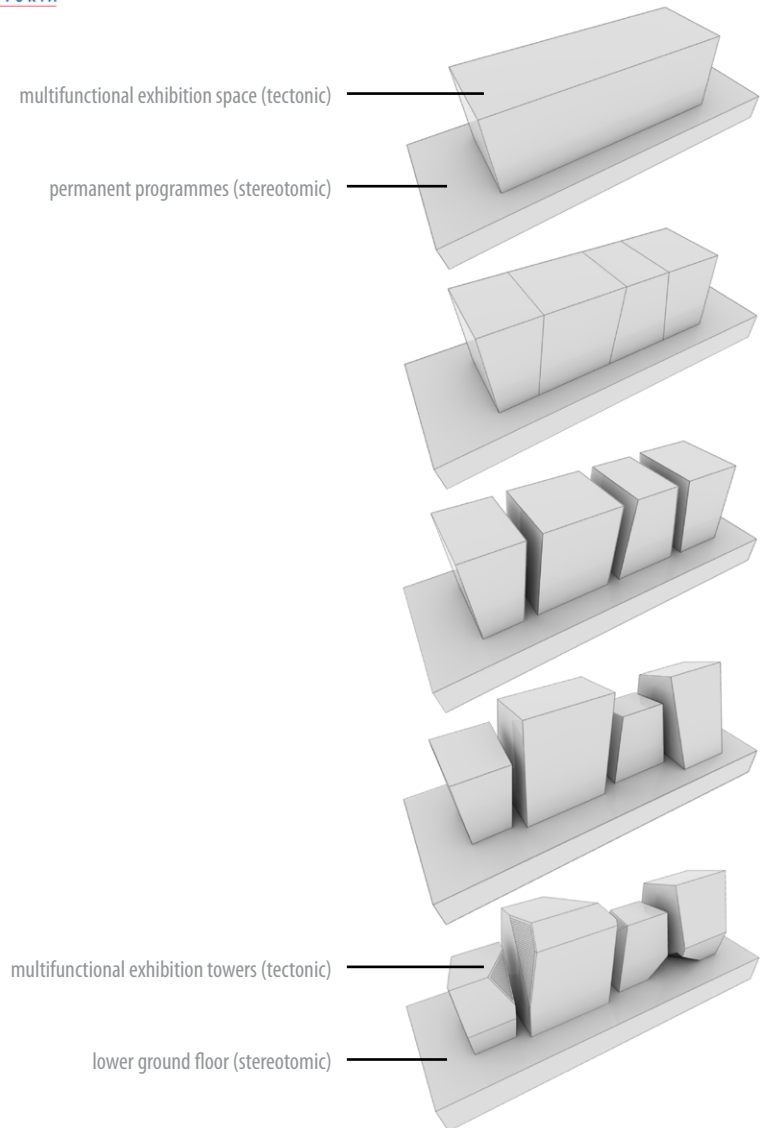
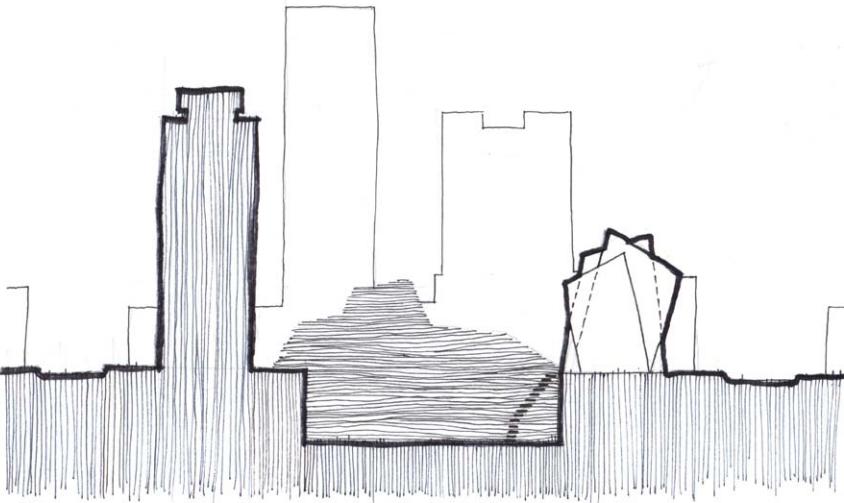

Figure 8.14: Diagram illustrating the formal development (Author, 2011)

+ Spatial Development

The orientation of the building is a result of sight lines toward the Union buildings as well as the optimization of natural ventilation due to Pretoria's South East prevailing winds (fig. 8.17). The grids are set out according to the angles in *The Staircase* project in order to echo the governing lines and create a uniform geometry.

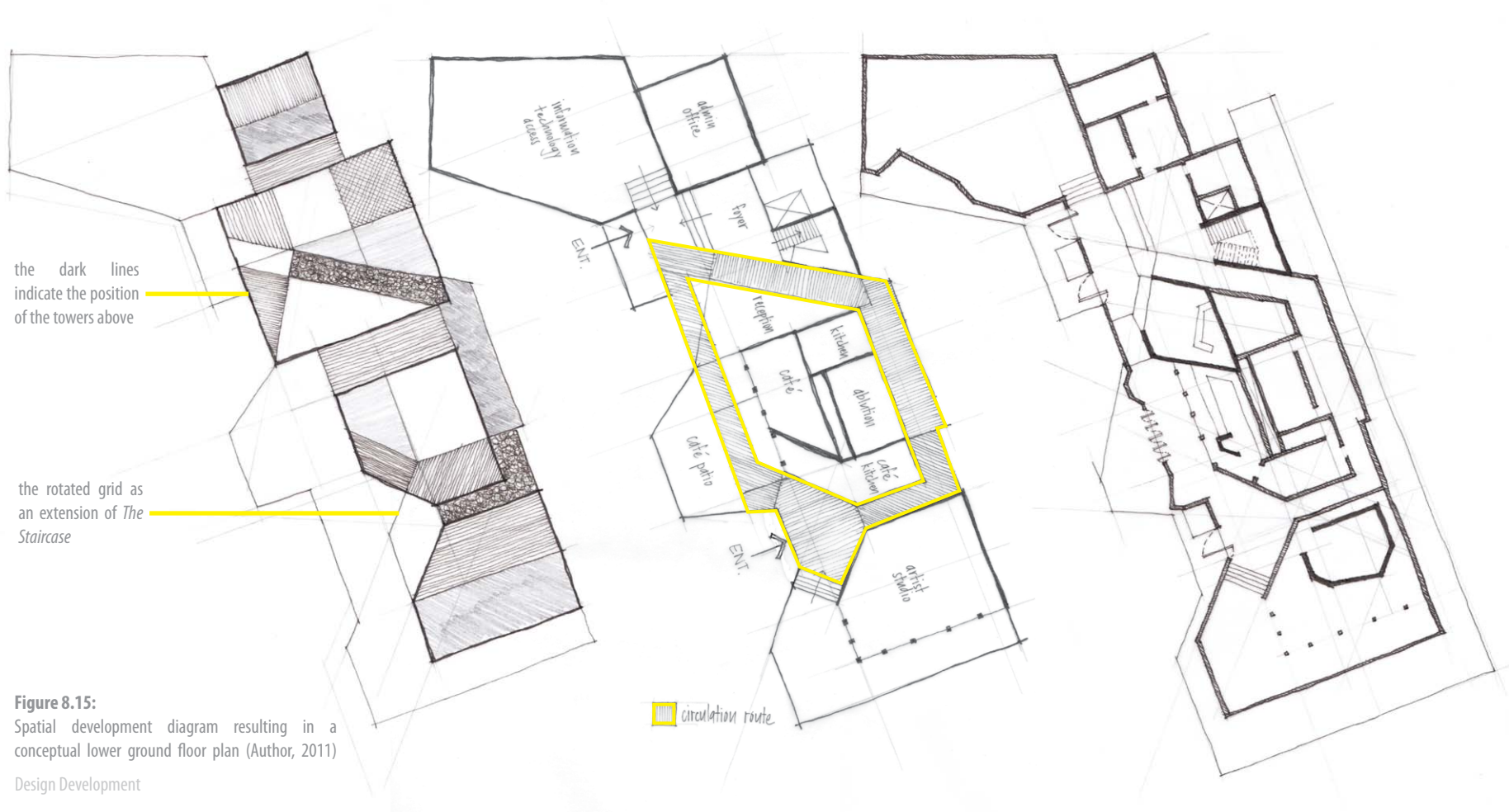

Figure 8.15:
Spatial development diagram resulting in a conceptual lower ground floor plan (Author, 2011)

+ Practical Considerations

01 | Circulation (*fig. 8.16*)

02 | Daylighting & ventilation on Lower Ground Floor - light shafts are introduced

03 | Multifunctional and adaptable exhibition spaces

Due to the nature of digital art (ranging from the size of a computer screen to the size of an entire building), the exhibition towers have to be able to accommodate various scales of exhibitions (different types of information). This calls for adaptable spaces which have the ability to alter the scale and dynamics of a space sporadically.

It also allows for various temporary programmes to be introduced into the building i.e. a nightclub for a specific events, art auctions or digital technology shows (*fig. 8.20*).

04 | Lighting requirements

Digital displays require low indirect lighting levels on the interior, while the glow of projections need to penetrate the façade from the interior outwards in order to inspire interest in passersby. This is achieved by the utilisation of a translucent, but not transparent, glazing material (see *Pilkington Profilit*™ glass system, p.100) as well as a shading screen.

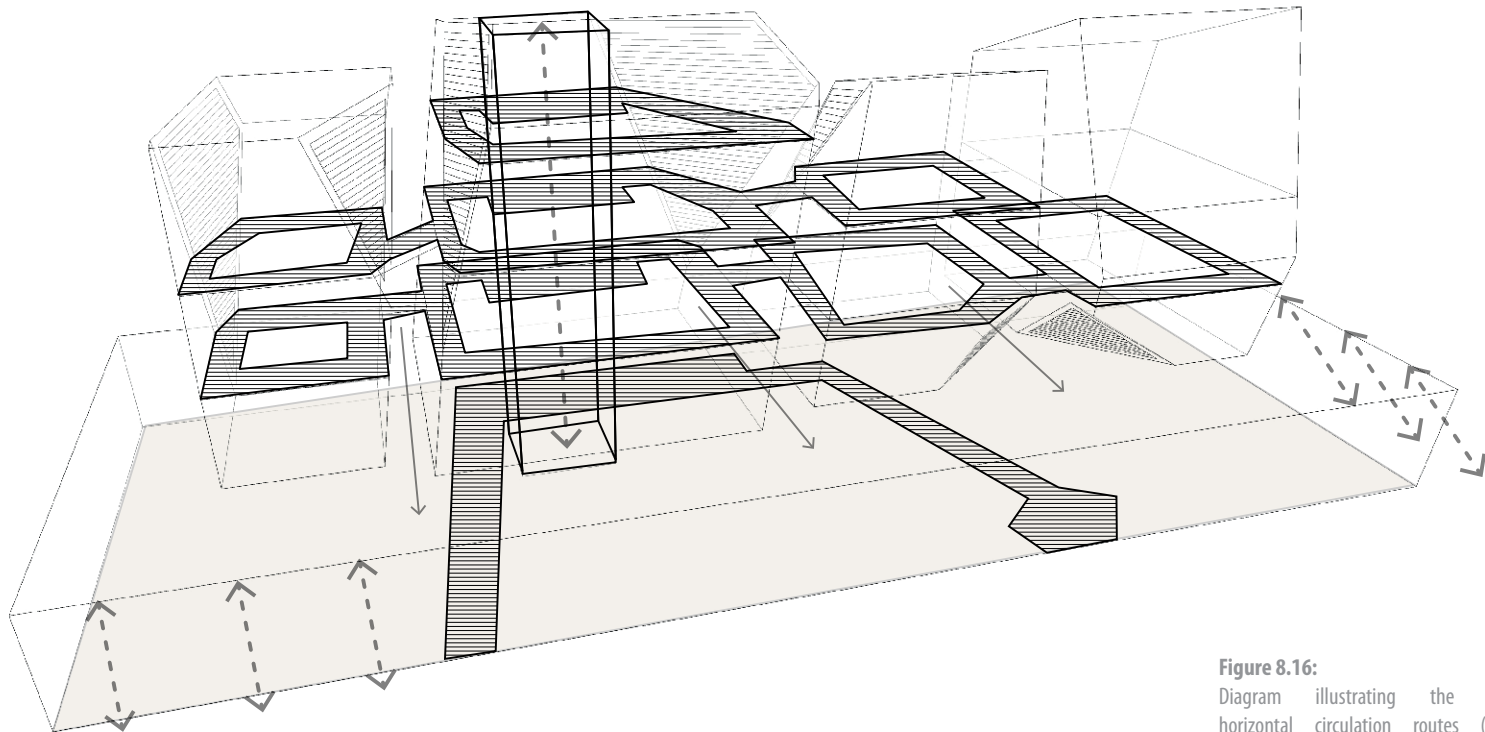

Figure 8.16:
Diagram illustrating the vertical and horizontal circulation routes (Author, 2011)

+ Theoretical Premises

Information has become dynamic and virtual, therefore the relationships between the dualism that arise from this are explored:

01 | Static vs. Dynamic

This relationship is illustrated by introducing rotating floors which alter the multifunctional spaces sporadically (figs. 8.17, 8.18 & 8.19).

02 | The Virtual (a-tectonic) vs. the Physical (tectonic)

This relationship is firstly expressed by allowing digital images to become *real*. Projections are used as space defining elements on the interior, while the virtual glow is perceived from the exterior. This gives the intangible concept of digital information a place in real time, breathing life into it, making it tangible. Permitting the digital world to perpetually transform and grow in the *real* by superimposing an intangible layer of data over the tangible objects of the urban environment (augmented space).

Secondly, the inverse of this is investigated by allowing physical elements to appear virtual. The exterior screen and reception walls are designed to create the illusion of a changing digital screen.

By employing the informational capacity of the principal creation of the Information Age, the internet, a search was conducted to find, what is considered to be, digital patterns. The most recurring patterns (fig. 8.21 & 8.25) were selected to be incorporated into the architecture by means of experimental design elements. The contrast between light and shadow is utilised in the same manner as pixels on a digital device, whereas movement past the element induces the shifting of the configuration.

Reception walls: The idea is to create a temporary installation that can be replaced from time to time (fig. 8.23).

Screen: The metal strips are weaved with the intention of casting calculated shadows which simulate the digital pattern. This emulates traditional African weaving, but is however applied in a contemporary fashion (fig. 8.27).

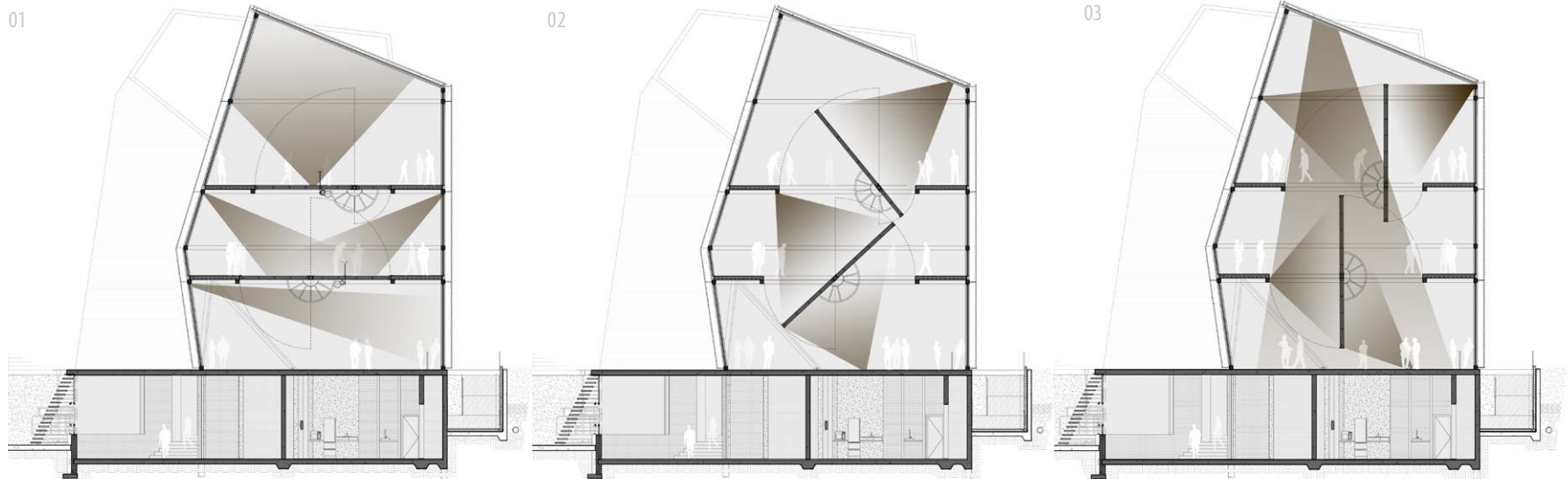

Opposite |

Diagrams illustrating the influence of dynamic elements on spatial qualities as well as virtual images as space defining elements:

Figure 8.17 (1):

Separate gallery spaces (Author, 2011)

Figure 8.18 (2):

Interweaved gallery spaces (Author, 2011)

Figure 8.19 (3):

Unified open gallery space (Author, 2011)

This page |

Figure 8.20:

Diagram illustrating the multifunctional exhibition towers - night club (Author, 2011)

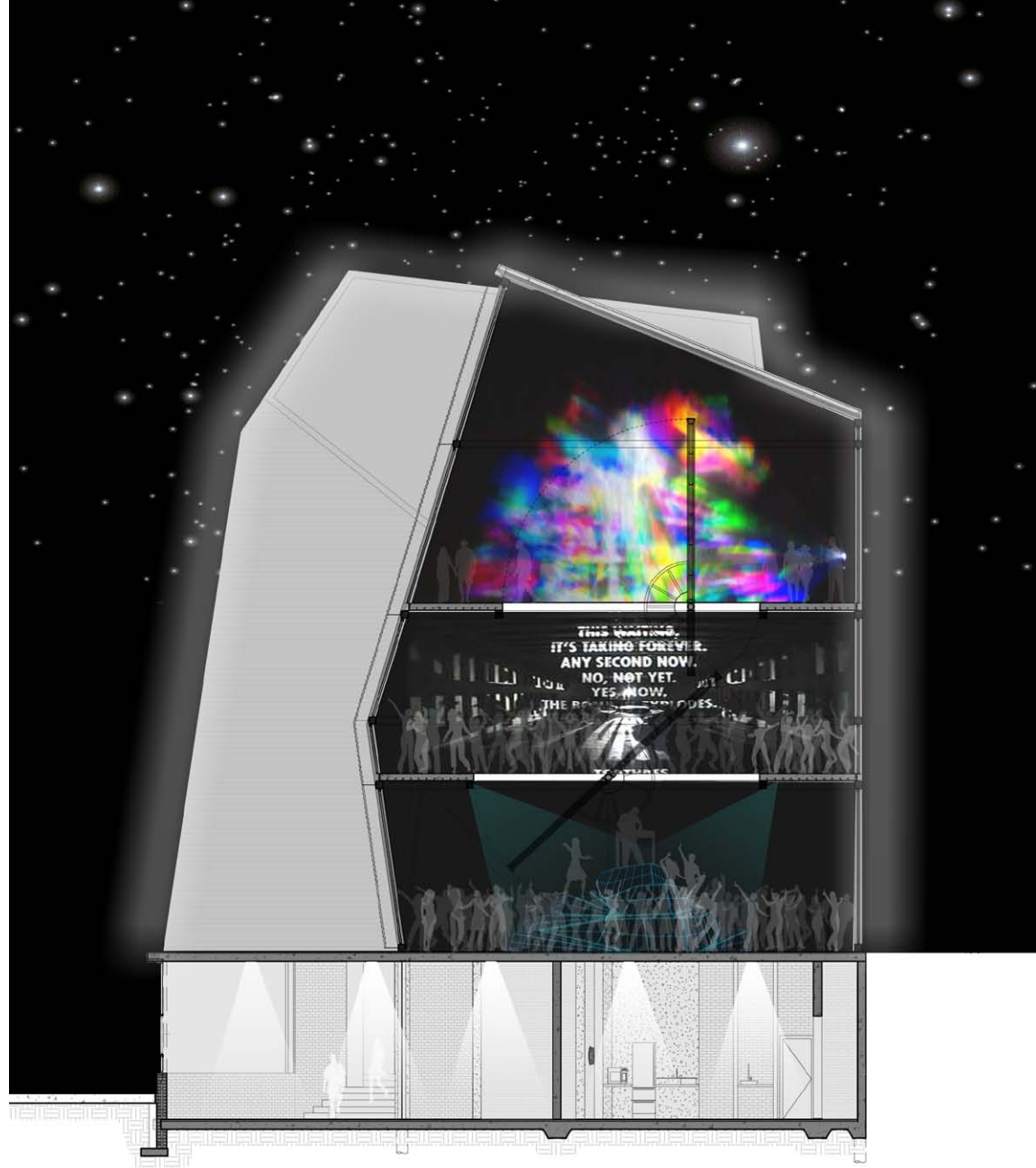

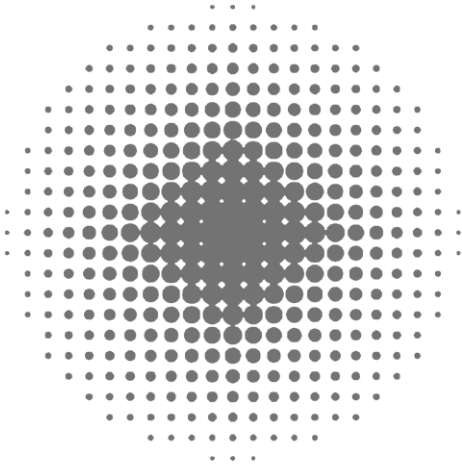

01

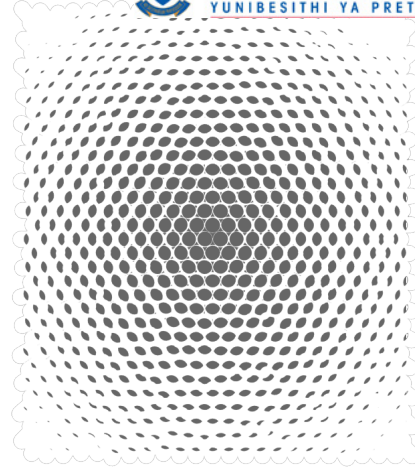

02



03

Figure 8.21 (1):
Digital pattern no. 1 (Author, 2011)

Figure 8.22 (2):
Shadow study of the wall simulating
digital pattern no. 1 (Author, 2011)

Figure 8.23 (3):
Section through the reception wall
(Author, 2011)

Figure 8.24 (4):
Diagram illustrating the experimental
reception wall simulating digital pattern
no. 1 (Author, 2011)

04

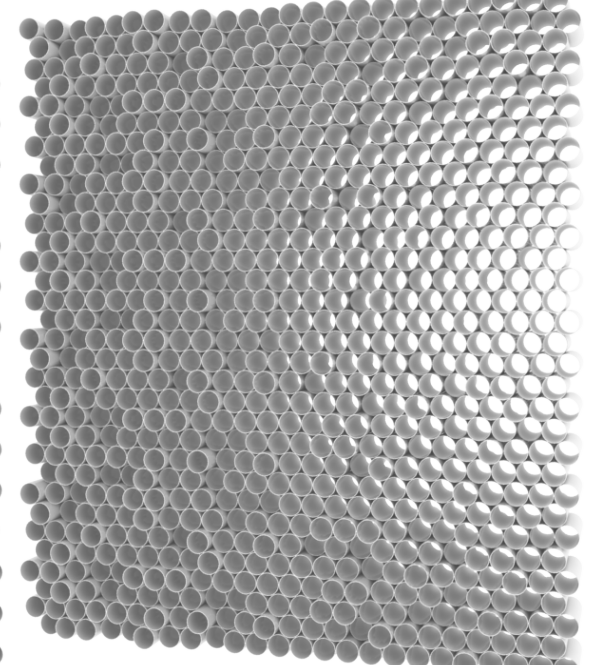
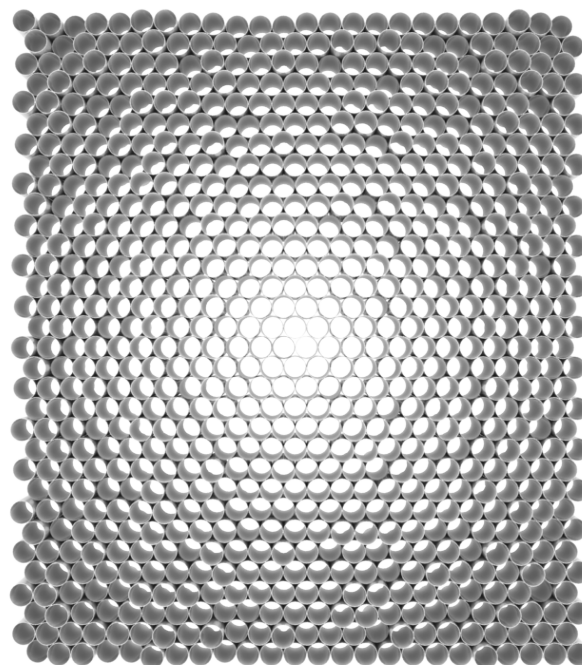
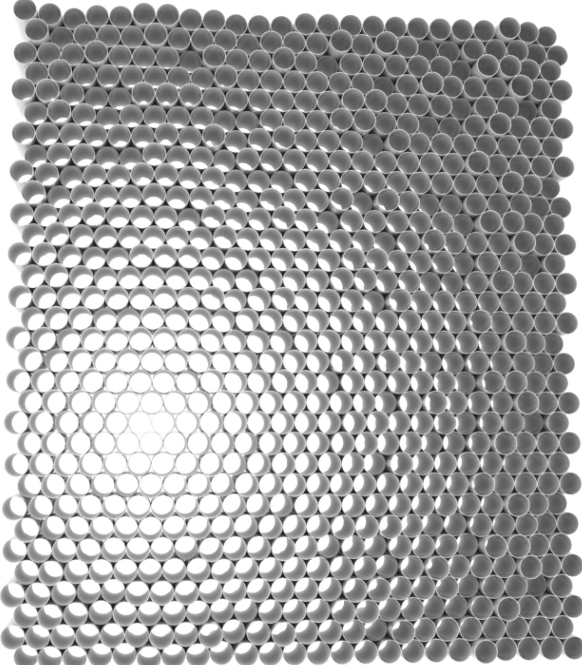



01



02

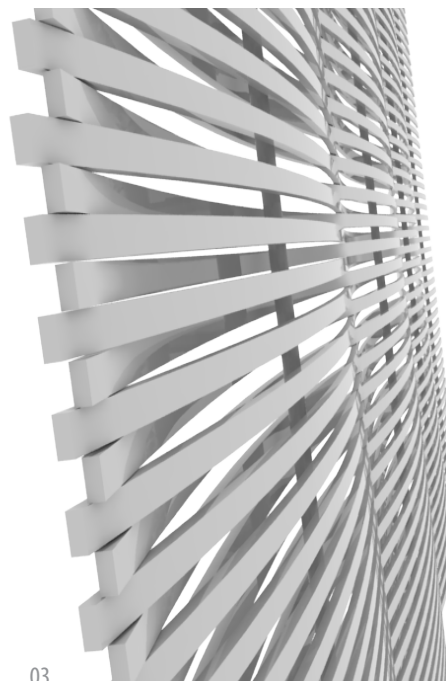
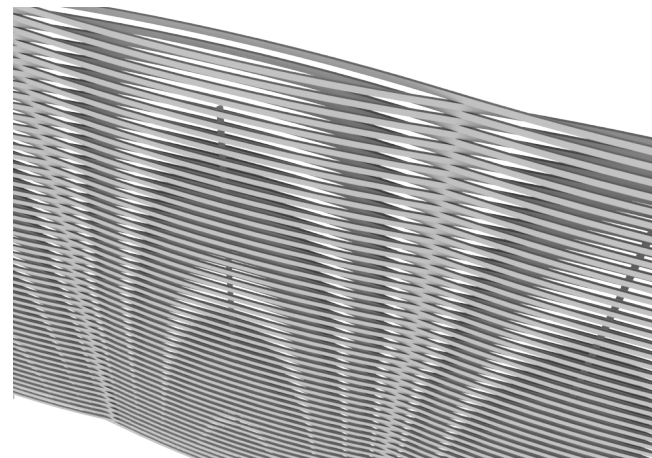

03

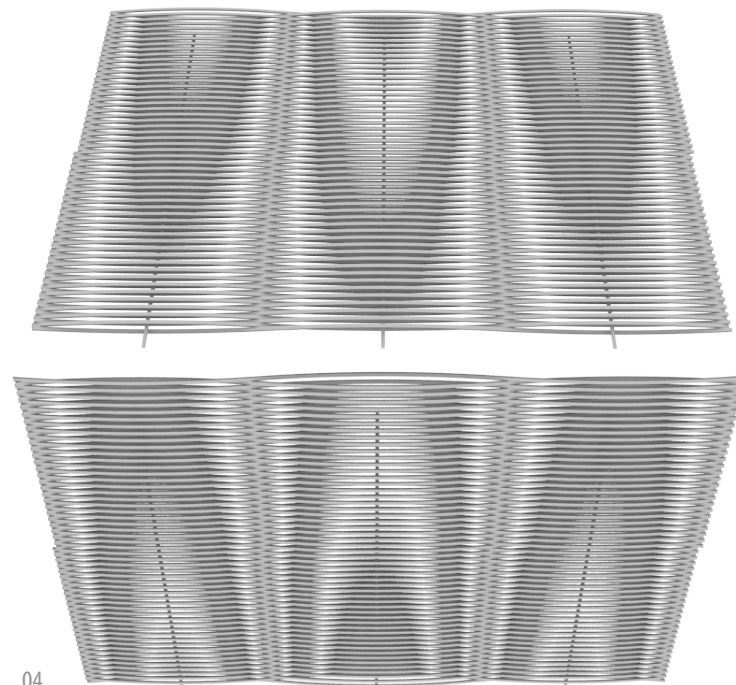

04

Figure 8.25 (1):

Digital pattern no. 2 (Author, 2011)

Figure 8.26 (2):

Shadow study of the screen simulating digital pattern no. 2 (Author, 2011)

Figure 8.27 (3):

Detail of the 'digital' screen (Author, 2011)

Figure 8.28 (4):

Diagrams illustrating the screen as perceived from different angles (Author, 2011)

+ Materials

- 01 | Due to the irregular form of the *exhibition towers* a steel structural frame is proposed
- 02 | Shading screen: malleable metal strips
- 03 | Pilkington Profilit™ (u-profile glazing) is used as a façade system (fig. 8.29).

This double glazing system is categorised under *advanced glazing systems* which contribute extra points in the BREEAM environmental rating system. It offers thermal insulation, solar control, excellent sound reduction as well as safety characteristics (NSG, [2010]^a).

According to NSG [2010]^b it provides the most cost-efficient glass wall systems currently available on the market. This progressive material should encourage the use of advanced materials and new technologies in future architectural developments.

- 04 | Fibre-reinforced concrete stairs

The stairs forming the edge of the square are 55mm lightweight fibre-reinforced concrete. This material was chosen to form a uniform edge with *the Staircase*, as well as for its robust characteristics.

Illustration 8.4 (1):

Photograph of Pilkington PROFILIT's™ light diffusing qualities, with the chosen product indicated (NSG, [2010]^b: 5)

Figure 8.29 (2):

Analytical digital of the Pilkington PROFILIT™ u-profile glass system (Author, 2011)

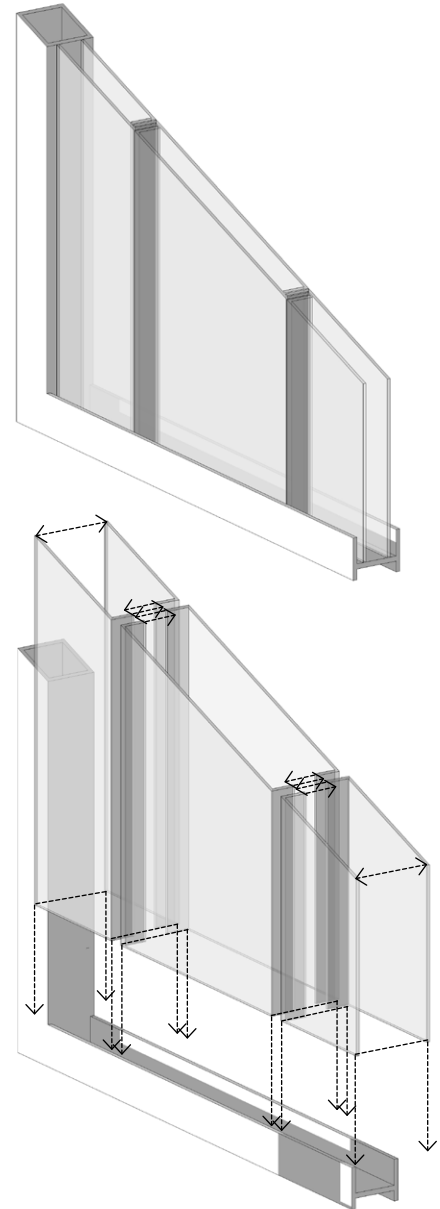
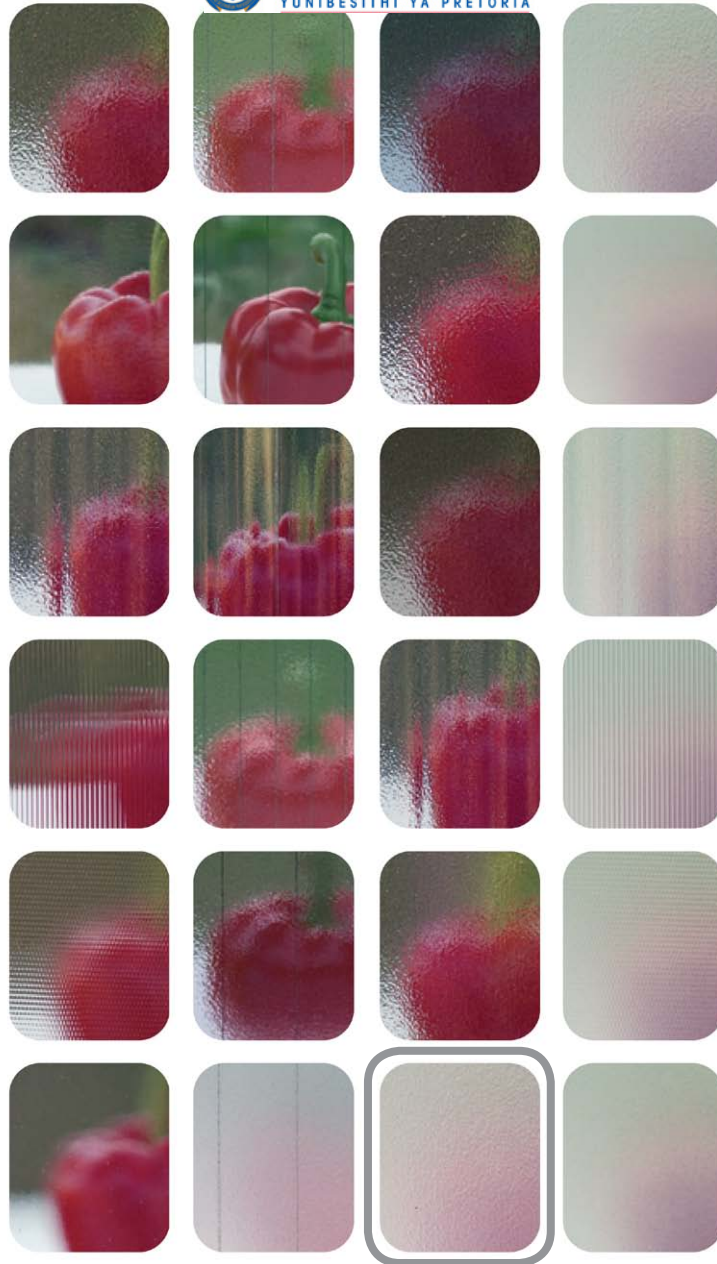

Environmental Considerations

+ Social Sustainability

- 01 | Information technology facilities contribute to education and upliftment
- 02 | Recycling sorting facilities are proposed in the basement which create job opportunities

+ Intelligent Architecture

Intelligent Building Systems (IBS) will manage and maintain various elements within the building. These elements are monitored and controlled via a computer-operated *Building Management System (BMS)* situated in the data room.

Administered facets include *security and safety* as well as *interior comfort levels* and *energy saving strategies* (fig. 8.30):

- 01 | Security and safety
Fire and smoke detection sensors will close the automatically-operated louver windows in order to stop air circulation and avoid the spread of flames and smoke when a threat is detected
- 02 | Comfort levels and energy savings
All sensors will be managed according to building zones to improve efficiency and energy savings.
- 01 | Various sensors and apparatus will be employed in the management of window openings (ventilation):
 - 1.1 A thermostat measuring the mean interior air temperature (signalling space heating to be turned on or off, as well as adjusting the ventilation rate (litres fresh air/ m2/second))
 - 1.2 Humidity meter to achieve constant ideal humidity levels
 - 1.3 Air content indicator measuring the chemical composition of the fresh intake air (if toxic gasses or high levels of CO₂ are detected, the system will adjust all windows to the fully open position for rapid ventilation)
 - 1.4 The rotating floors send a signal to the BMS system when being opened (individual cross ventilation of floors changes to an integrated stack ventilation system as in fig. 8.31)
- 02 | Light meters will adjust the artificial lighting levels when natural lighting is insufficient in order to maintain the desired luminosity for a digital gallery space (low ambient lighting levels). During all other daylight hours only natural indirect lighting will be used.

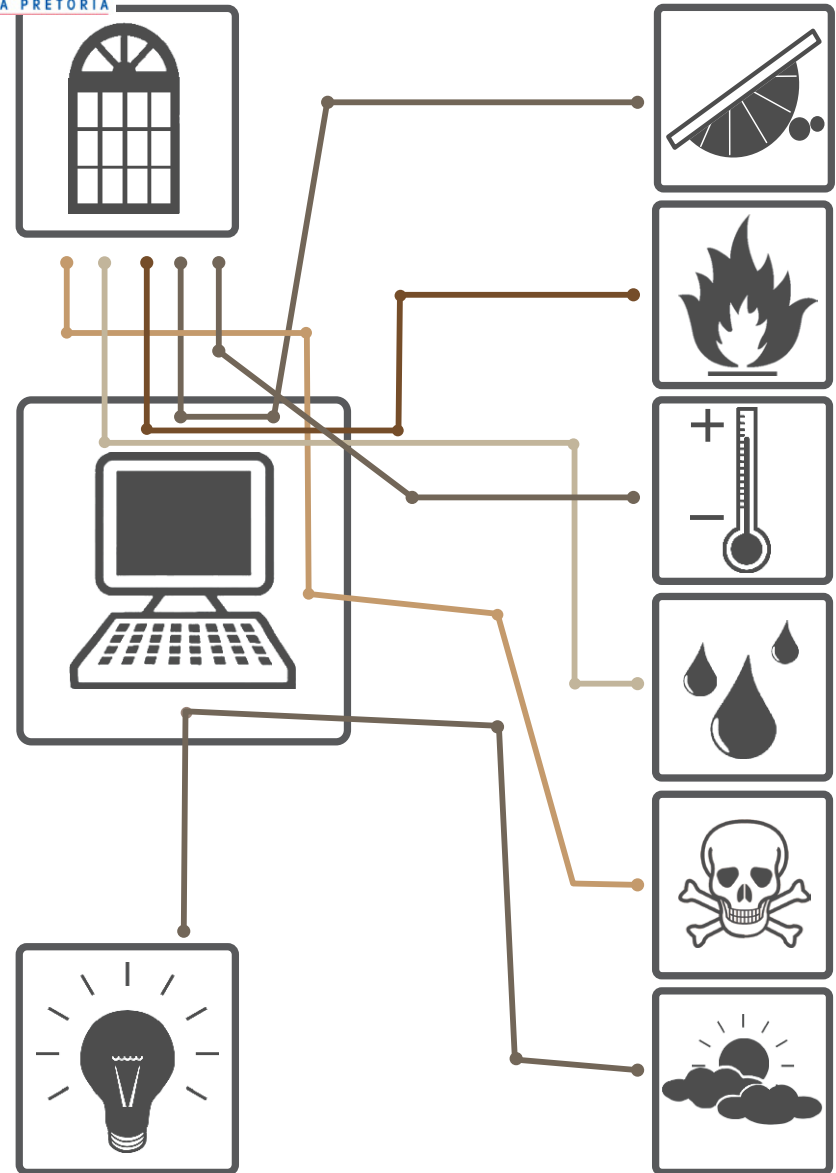

Figure 8.30: Diagram of intelligent building systems (Author, 2011)

+ Location and Site (See fig. 8.11)

- 01 | The site is centrally located near all amenities
- 02 | Transport: on-site public transport facilities include a bus stop on the South West corner, an existing informal (proposed as formalised) taxi stop in Proes Street. The *metro mall* (a large public transport interchange node) is located one block North as well as a train station in the near vicinity.
- 03 | The heat island effect is minimised and CO₂ levels are reduced by introducing new planting around the site's periphery
- 04 | Parking: the minimum amount of parking is provided with preferential parking for disabled users, motorcycles, car pooling and hybrid vehicles (see Lower Ground Floor Plan in Chapter 9)
- 05 | Bicycle storage facilities are located in the basement with a locker area and showers on ground floor level (see Lower Ground Floor Plan in Chapter 9)
- 06 | A garbage sorting facility is proposed in the basement in order to create work opportunities as well as to encourage recycling programs (see Lower Ground Floor Plan in Chapter 9).

+ Building Systems

- 01 | The structure is strategically orientated (according to Pretoria's prevailing winds) to maximise natural ventilation (see fig. 8.11)
- 02 | Combination ventilation: stack ventilation is used in combination with passive cross ventilation according to the spatial configuration of the floors (fig. 8.31).
- 03 | Interior comfort levels are achieved by a combination of material choices (thermal double glazing system, cavity walls and roof insulation), architectural devices (a shading screen) and automatically operated ventilation and lighting systems (BMS).
- 04 | Water harvesting and re-use (fig. 8.32): rainwater is harvested from the square's surface as well as roofs after which it is circulated through a filtering system before being reused for irrigation. Greywater is recycled and reused for flushing of water closets.
- 05 | Photovoltaic panels (a solar plant) are installed on the roof *Munitoria* in order to alleviate the municipal electricity supply. The solar-generated energy will be used for lighting and digital projections in the exhibition towers and public square.
- 06 | Solar absorbers are used for water heating requirements. The water will be distributed to the ablution facilities via insulated pipes in order to minimise heat loss.
- 07 | Individual lighting zones are proposed in order to reduce electricity demands.
- 08 | Fixtures: all specified fixtures are to be environmentally responsible products: dual flush cisterns, waterless urinals, motion sensor aerated taps and aerated shower heads (in bicycle amenities)
- 09 | All materials used are to be VOC-free (volatile organic compound)

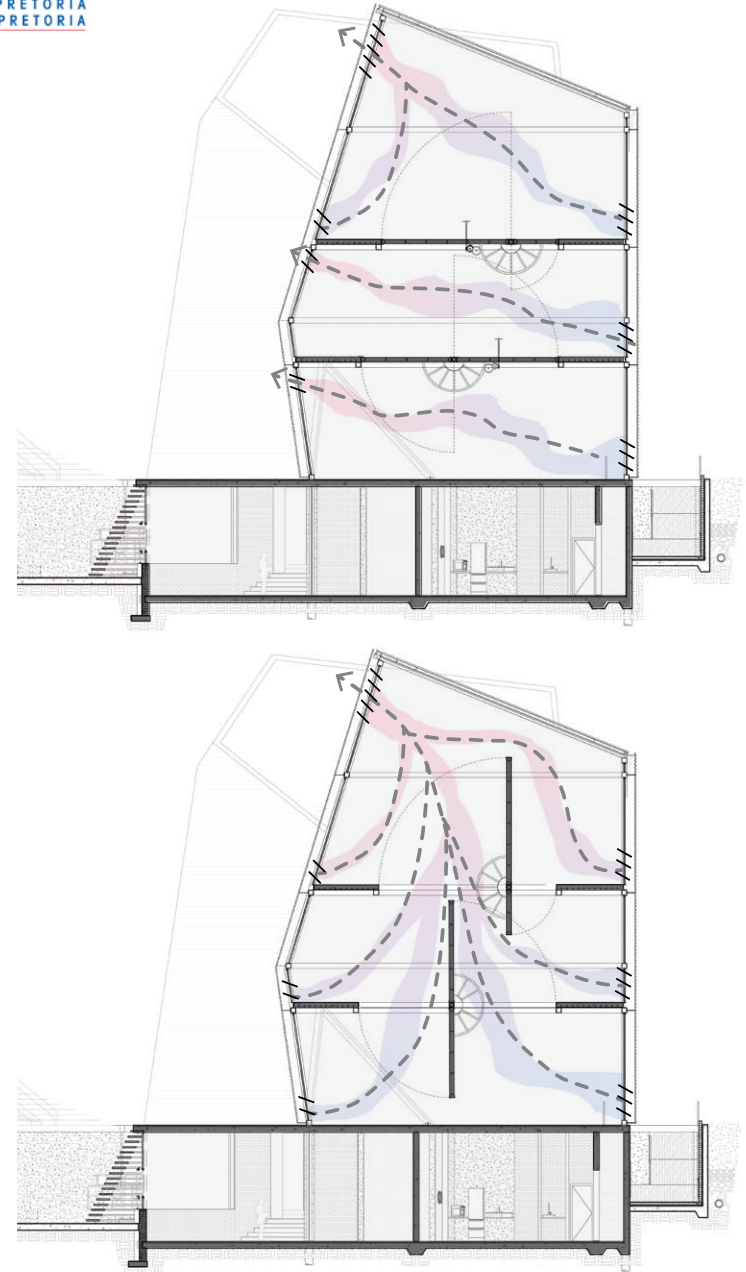

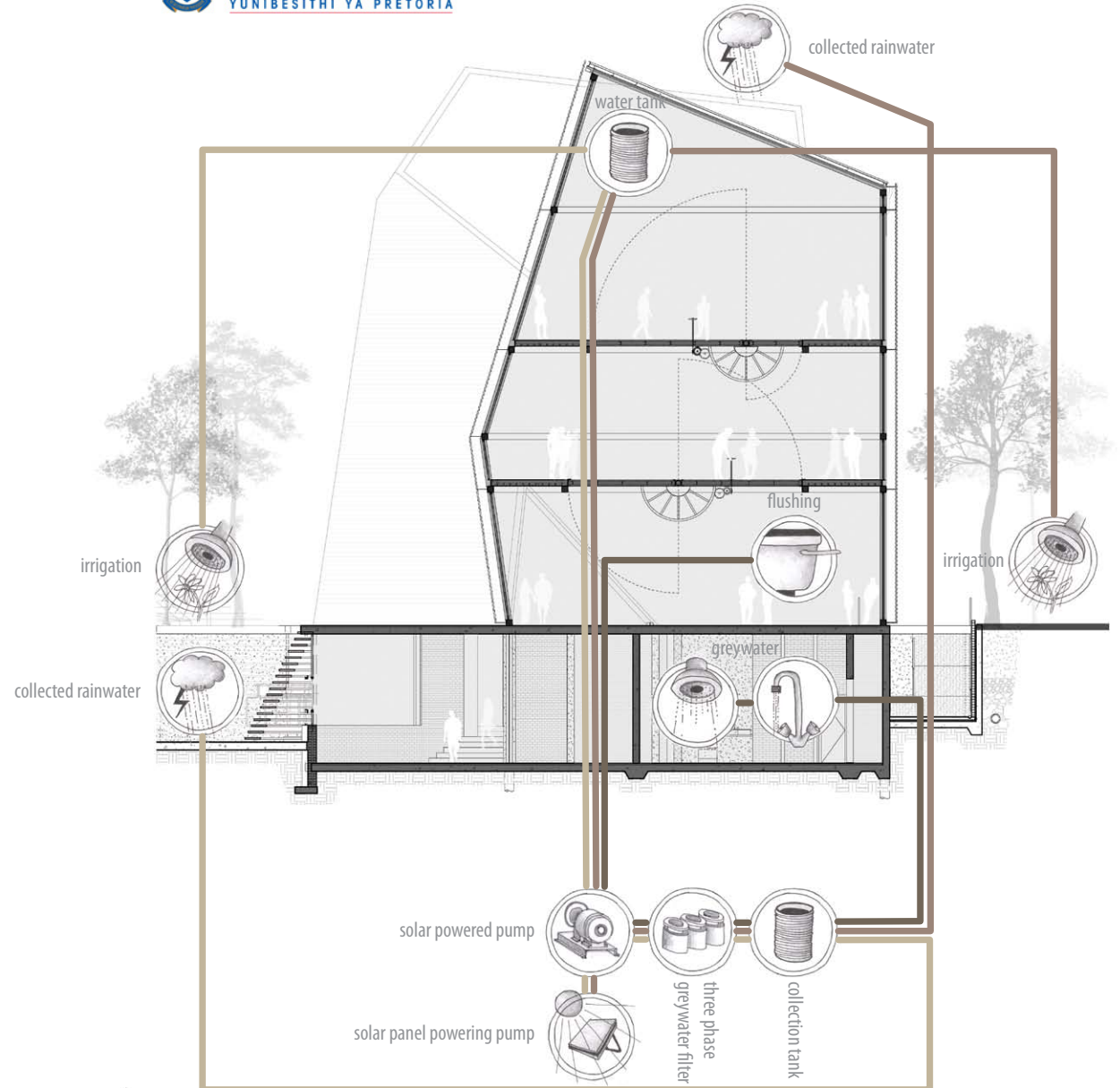

Opposite|

Figure 8.31:

Combination ventilation diagrams: cross ventilation in the closed position, stack ventilation in the closed position, stack ventilation in the open position (Author, 2011)

This page |

Figure 8.32:

Diagram of the proposed water harvesting and recycling system (Author, 2011)

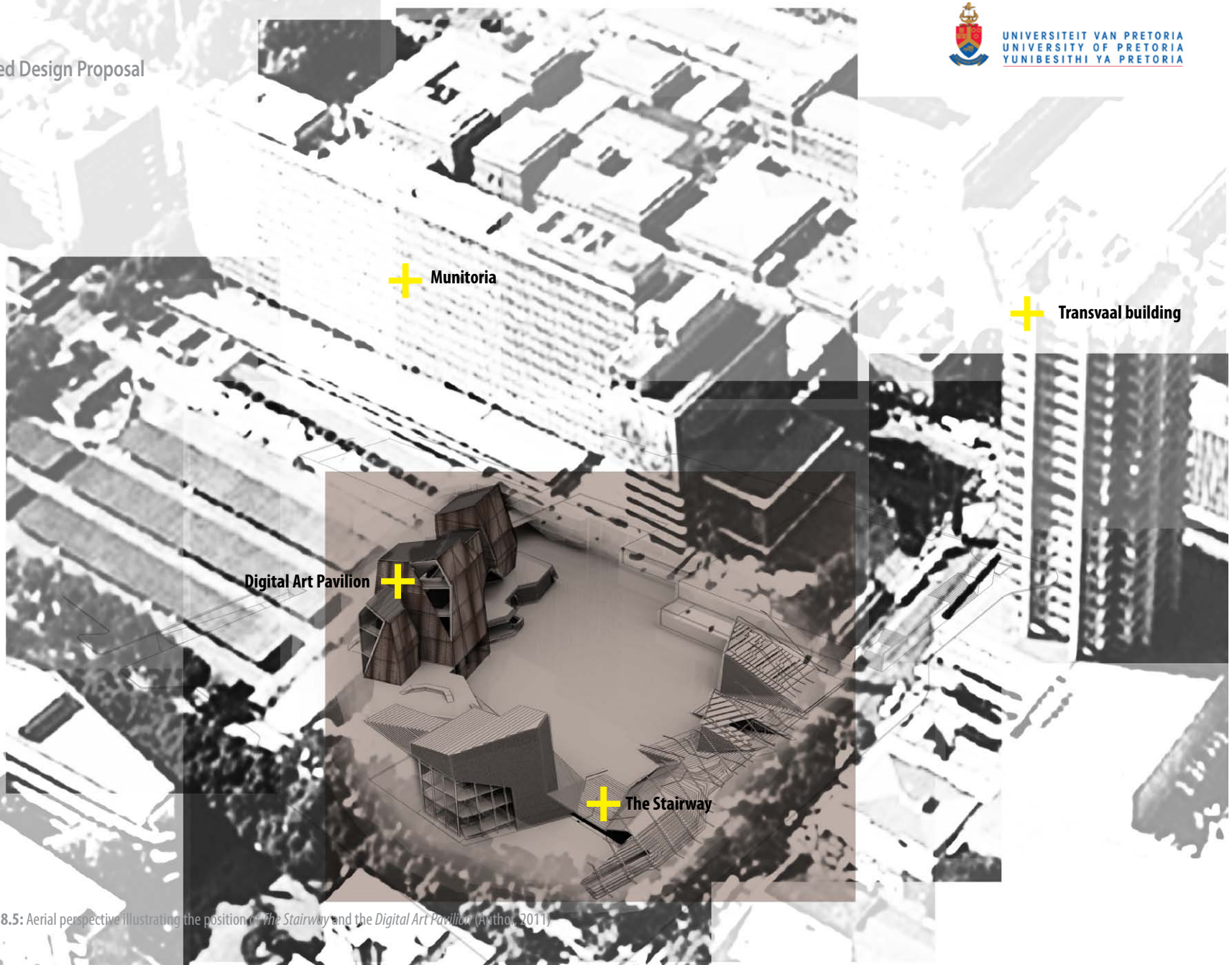

Illustration 8.5: Aerial perspective illustrating the position of *The Stairway* and the *Digital Art Pavilion* (Aythya, 2011)



+ lightweight steel roof

+ 'weaved' shading screen

+ structural frame with
u-profile glass façade

+ composite floors

+ lower ground floor

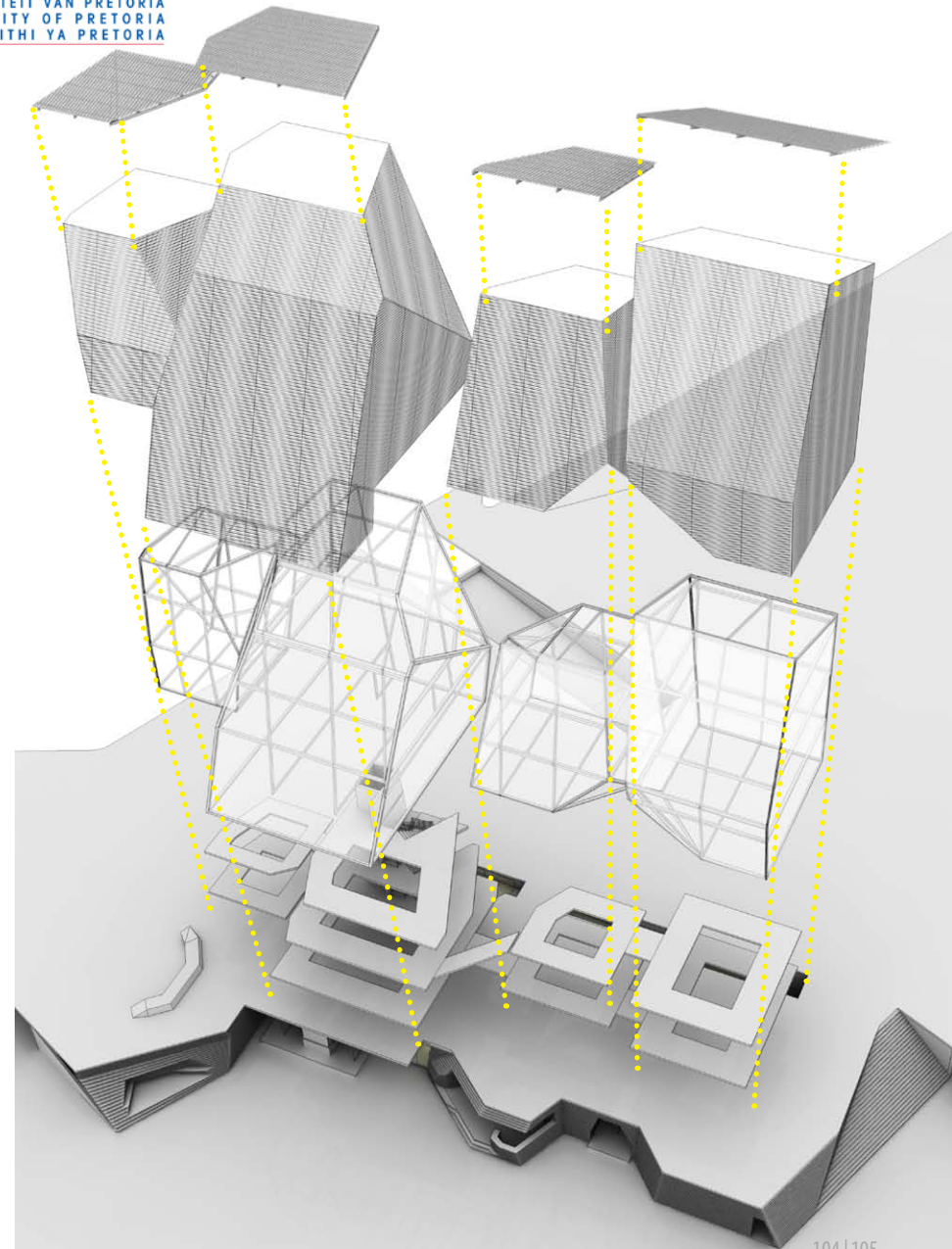

Illustration 8.6: Exploded axonometric drawing of the intervention (Author, 2011)



Top to bottom |

Illustration 8.7: South West elevation of the Digital Art Pavilion (Author, 2011)

Illustration 8.8: North East elevation of the Digital Art Pavilion (Author, 2011)

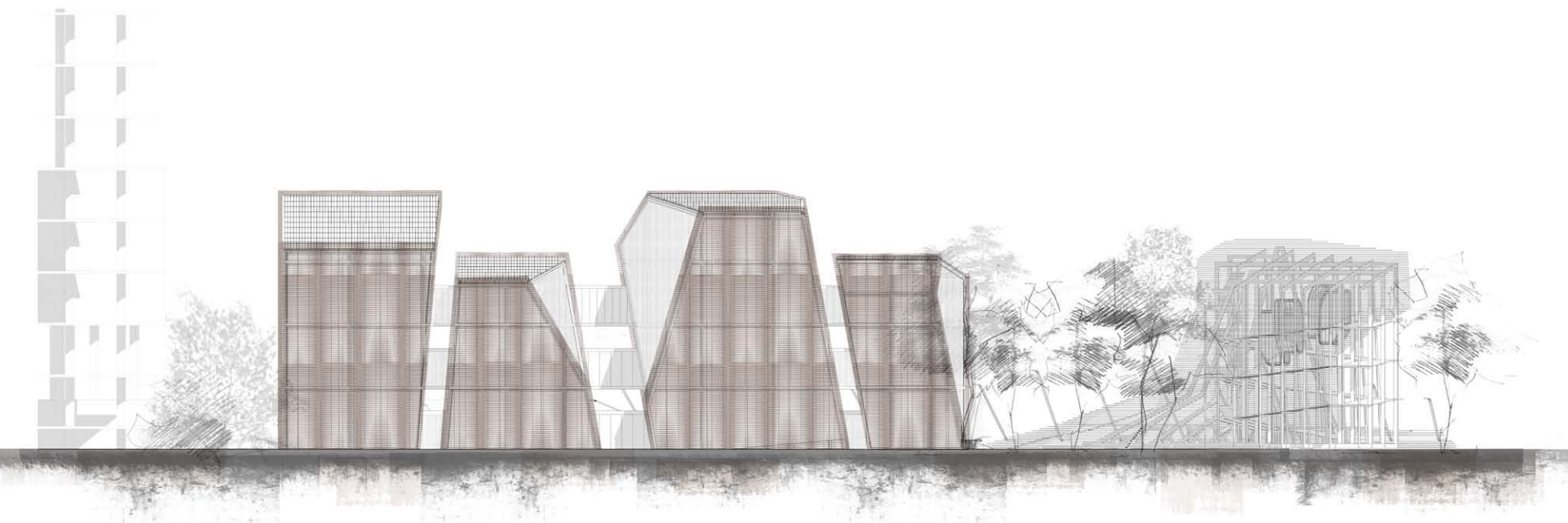
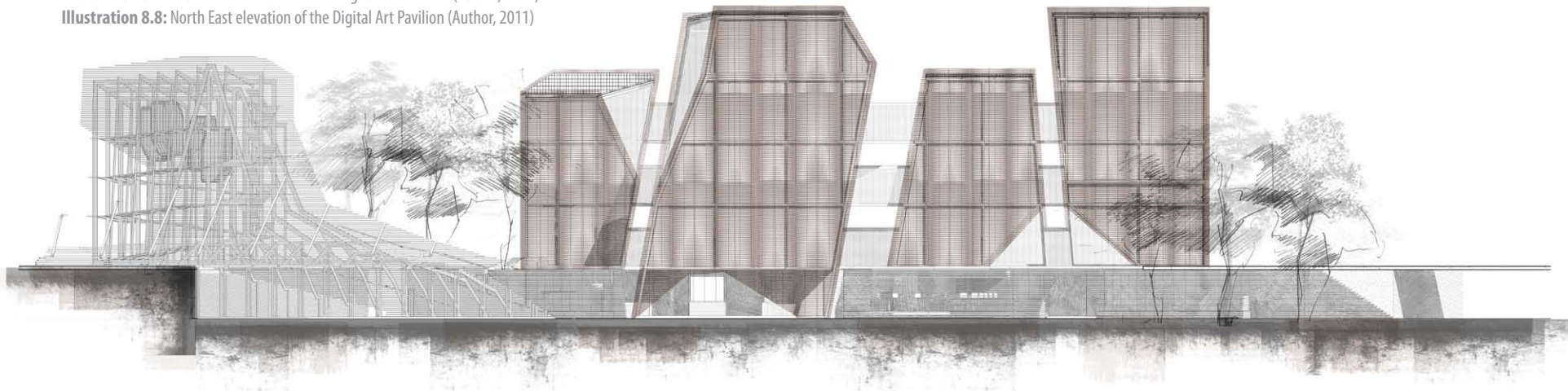
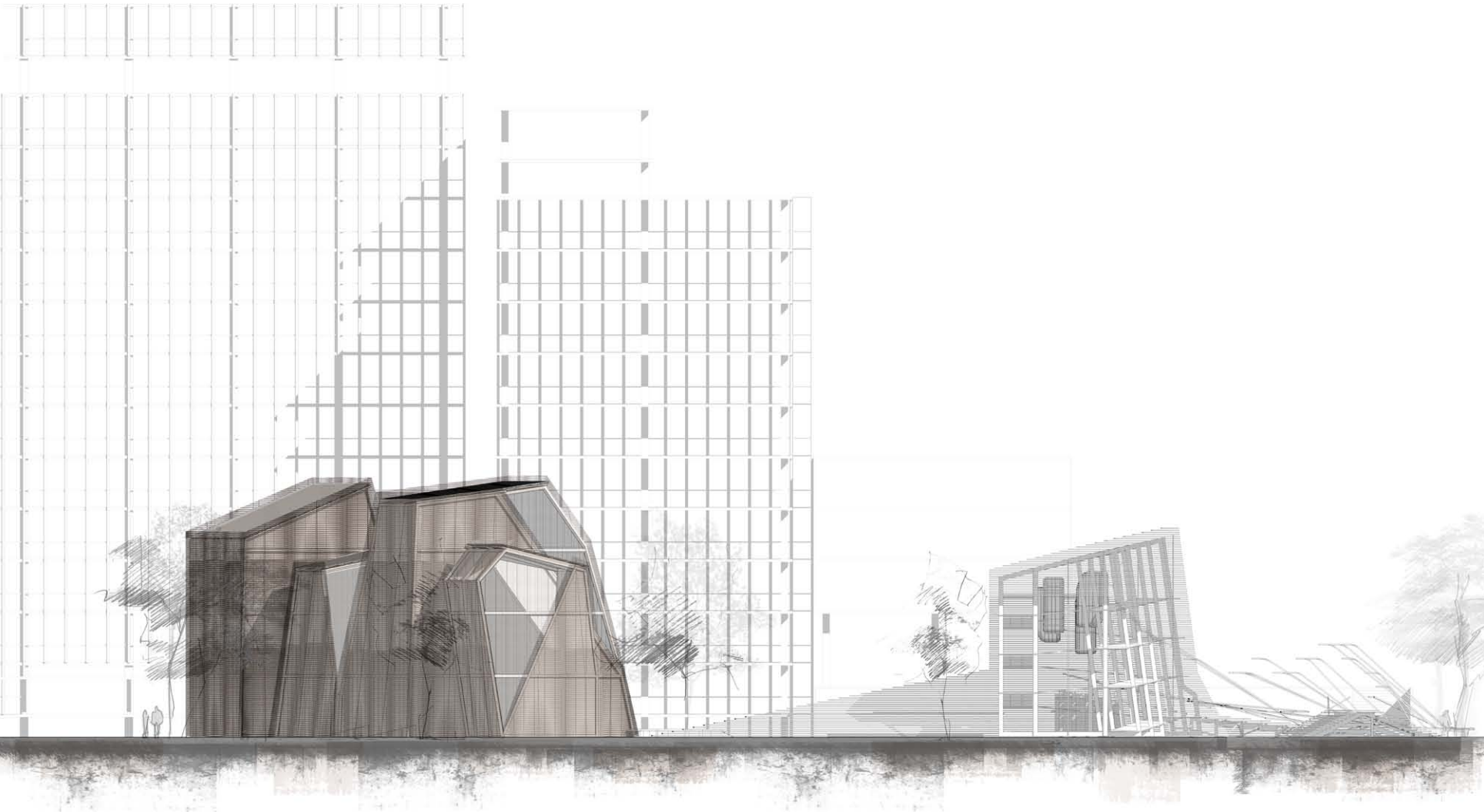



Illustration 8.9: North elevation of the Digital Art Pavilion as seen from Proes Street (Author, 2011)



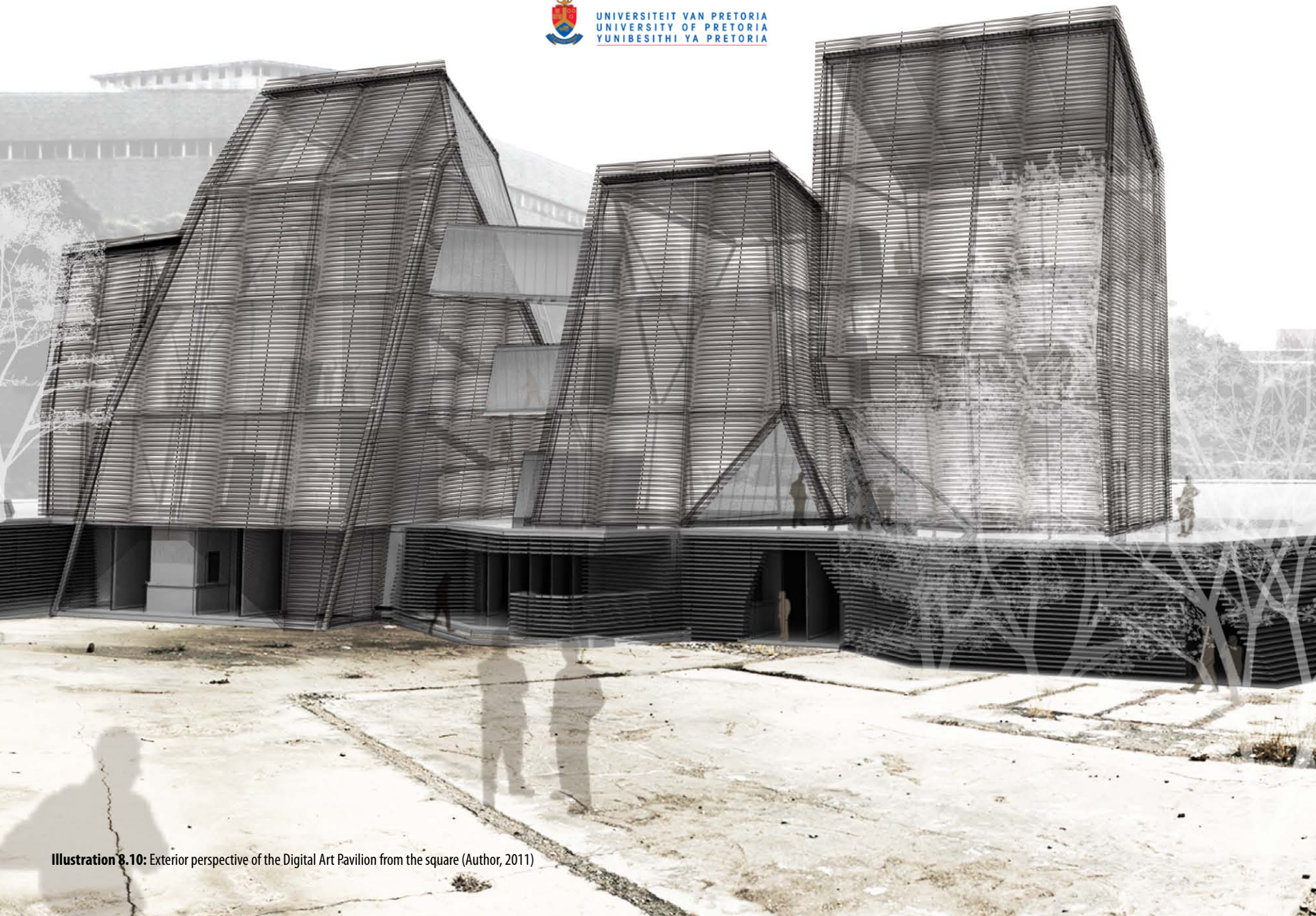
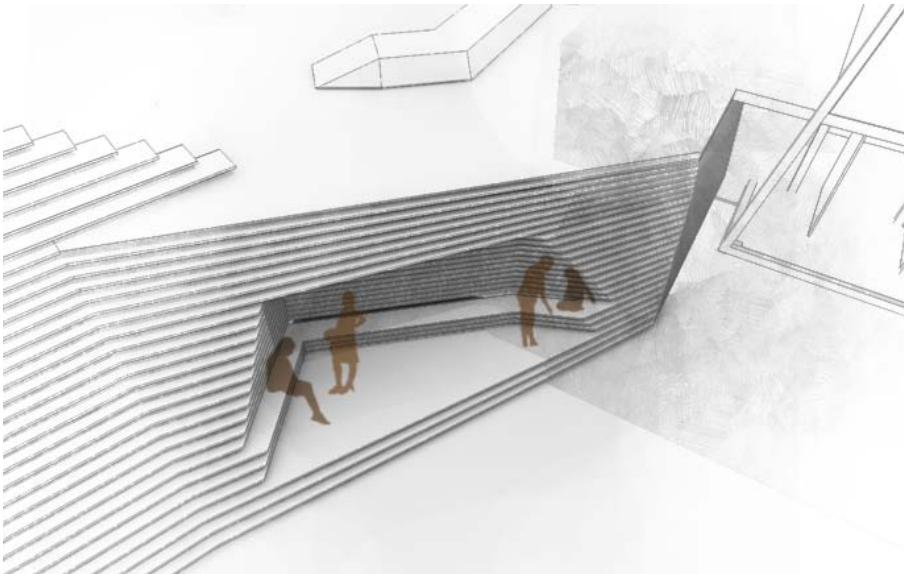
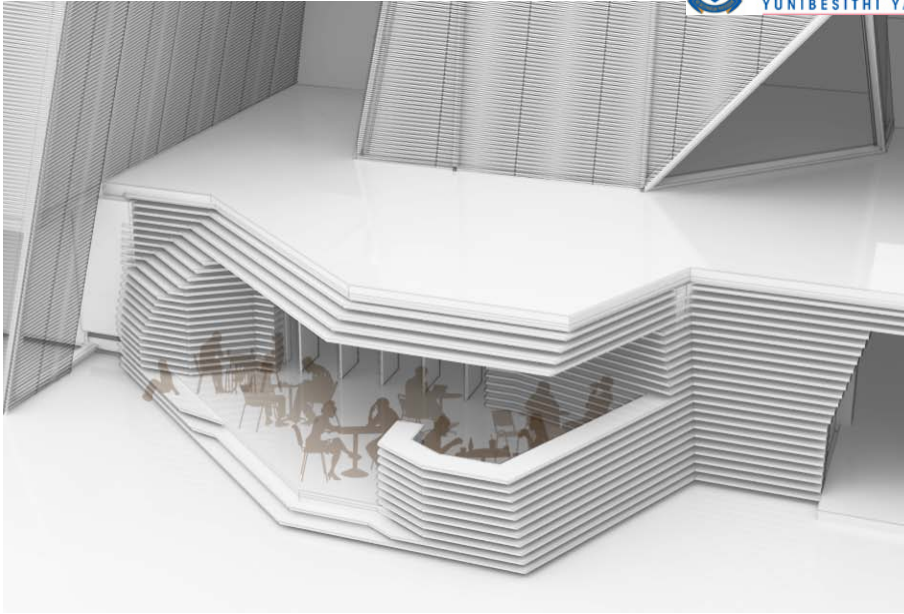

Illustration 8.10: Exterior perspective of the Digital Art Pavilion from the square (Author, 2011)



Top to bottom |

Illustration 8.11: Perspective view of the seating area (Author, 2011)

Illustration 8.12: Perspective view of the café seating area (Author, 2011)

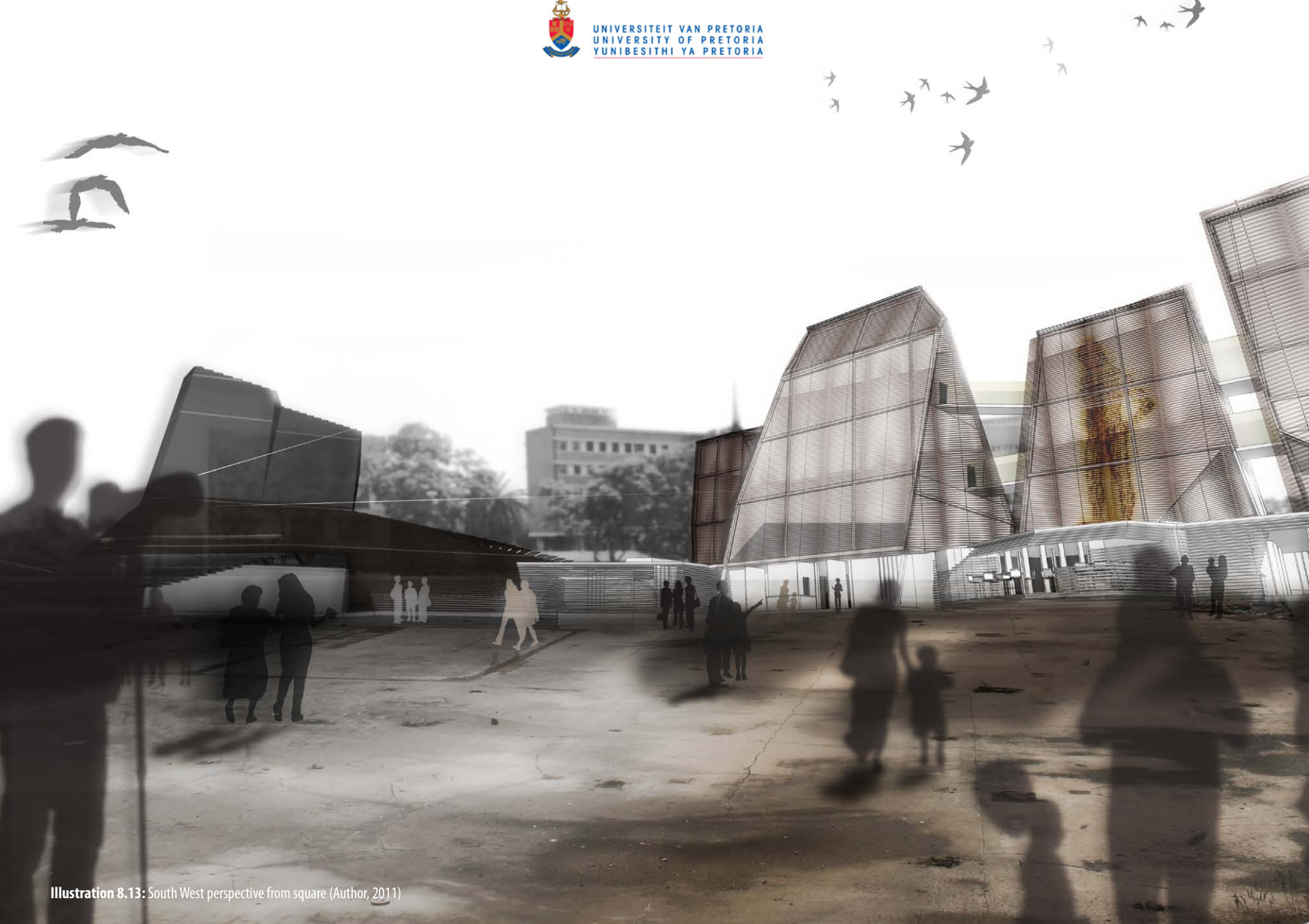

Illustration 8.13: South West perspective from square (Author, 2011)

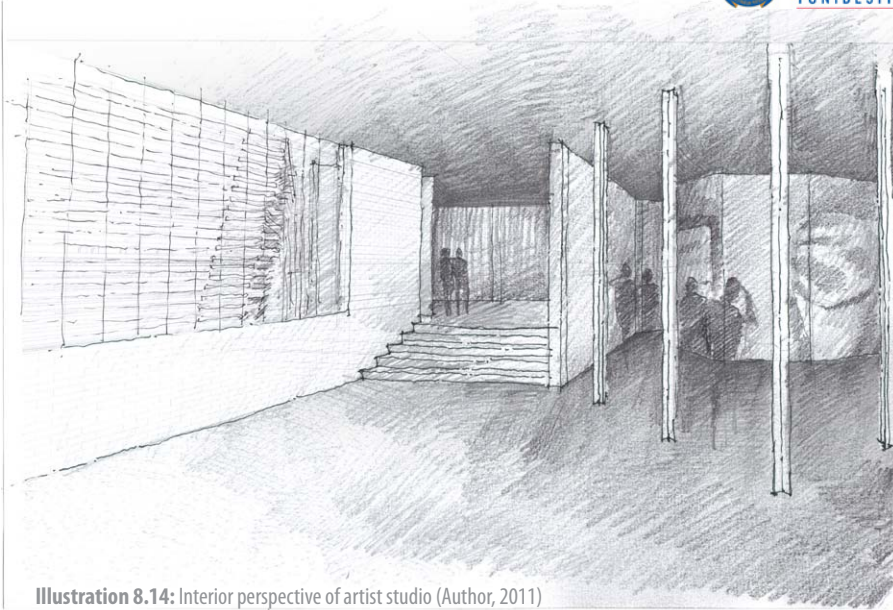

Illustration 8.14: Interior perspective of artist studio (Author, 2011)

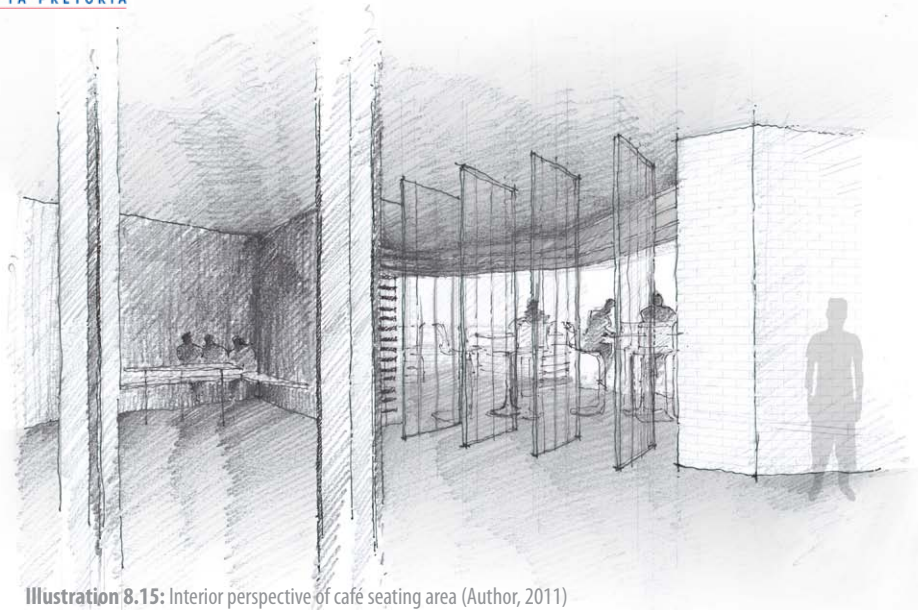

Illustration 8.15: Interior perspective of café seating area (Author, 2011)

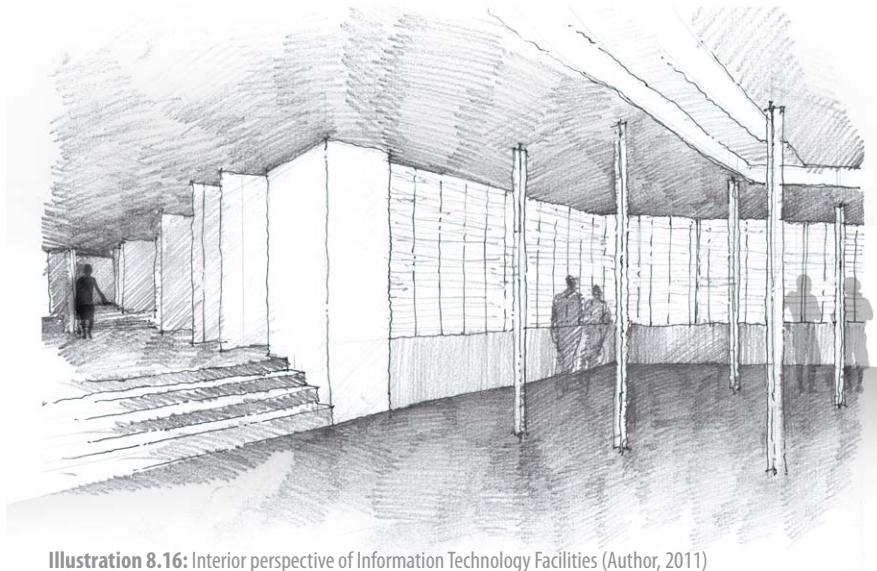

Illustration 8.16: Interior perspective of Information Technology Facilities (Author, 2011)



Illustration 8.17: Interior perspective of the entrance foyer and reception area (Author, 2011)



09

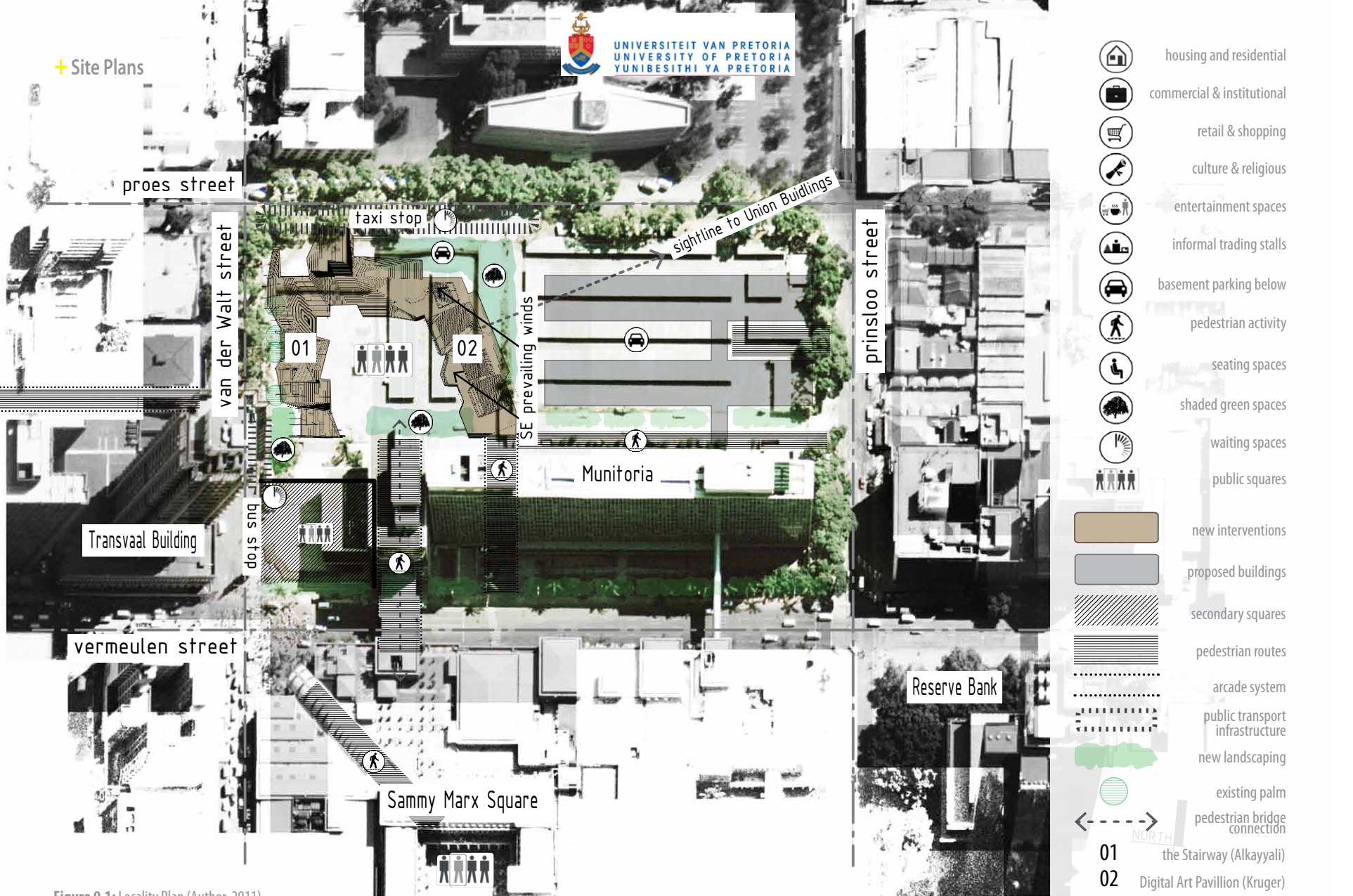
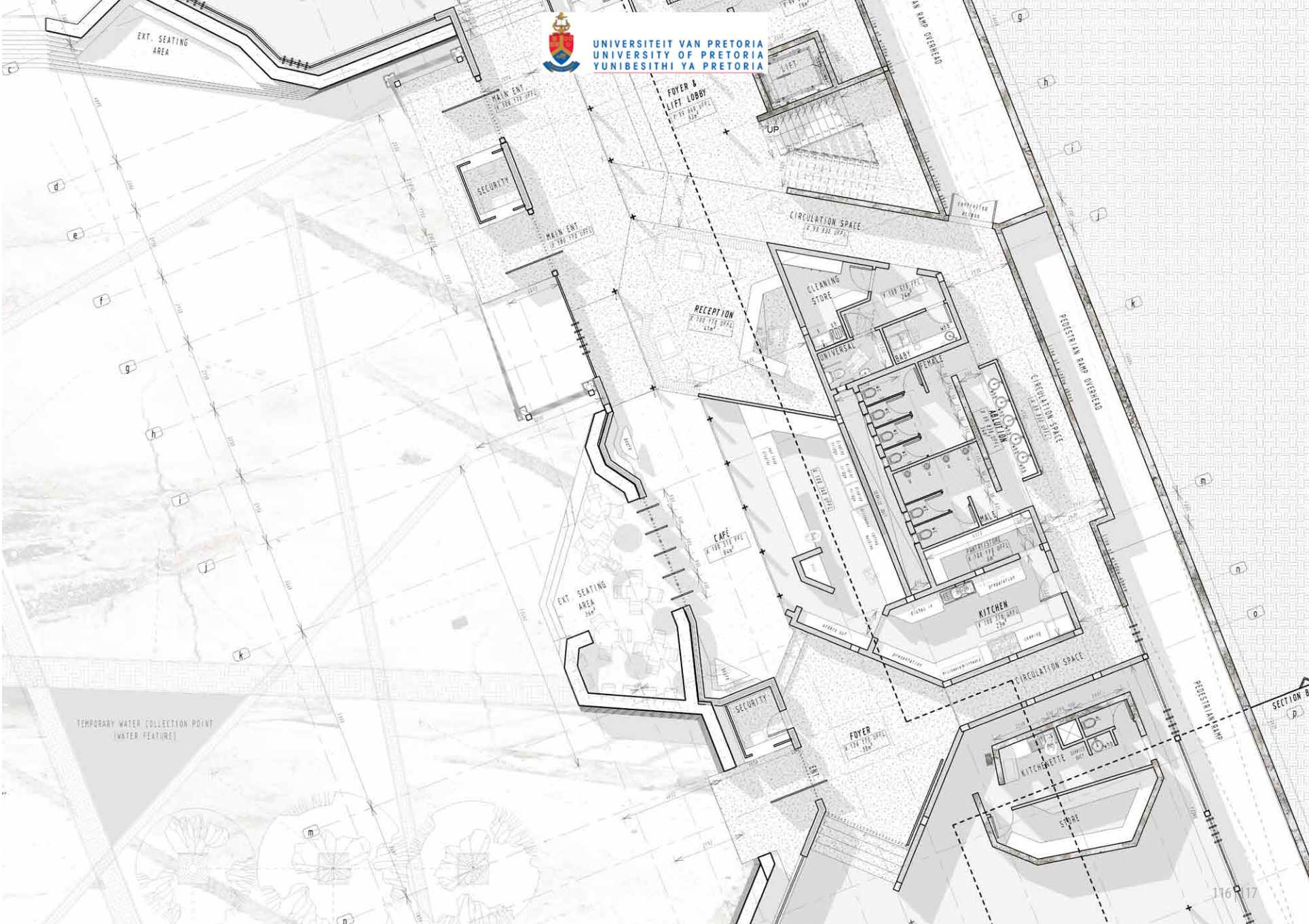

Figure 9.1: Locality Plan (Author, 2011)

Technical Resolution



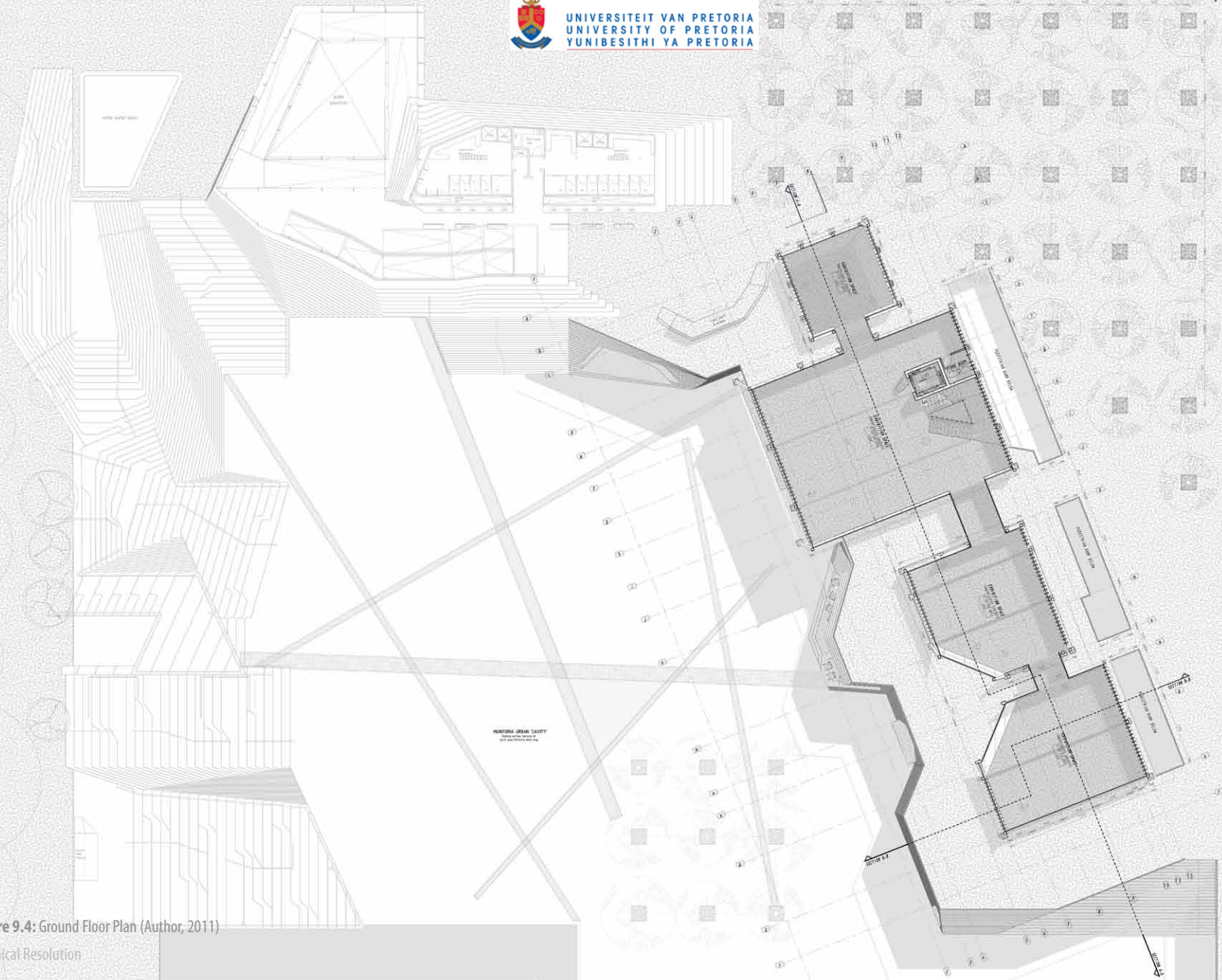

Figure 9.4: Ground Floor Plan (Author, 2011)

Technical Resolution

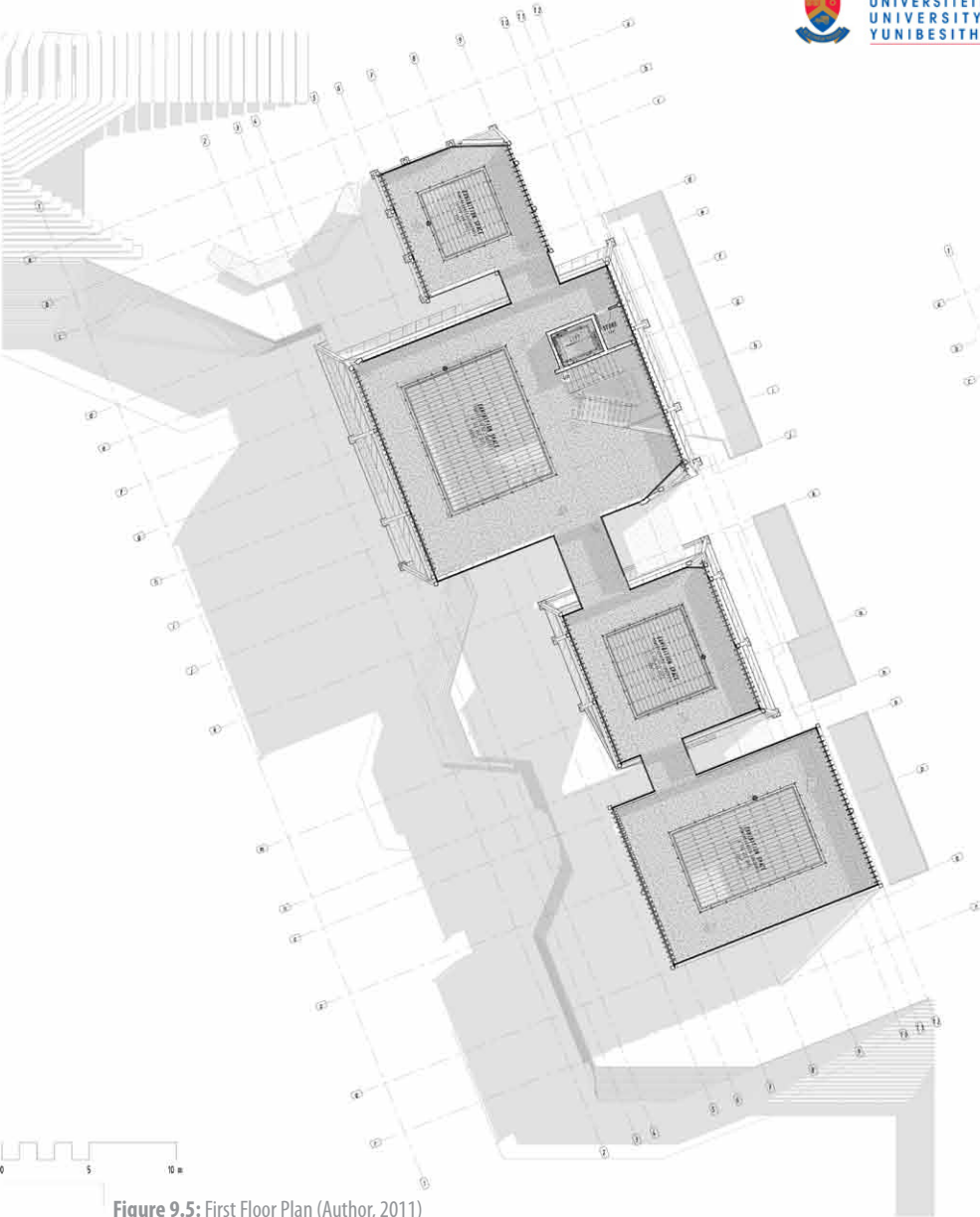

Figure 9.5: First Floor Plan (Author, 2011)

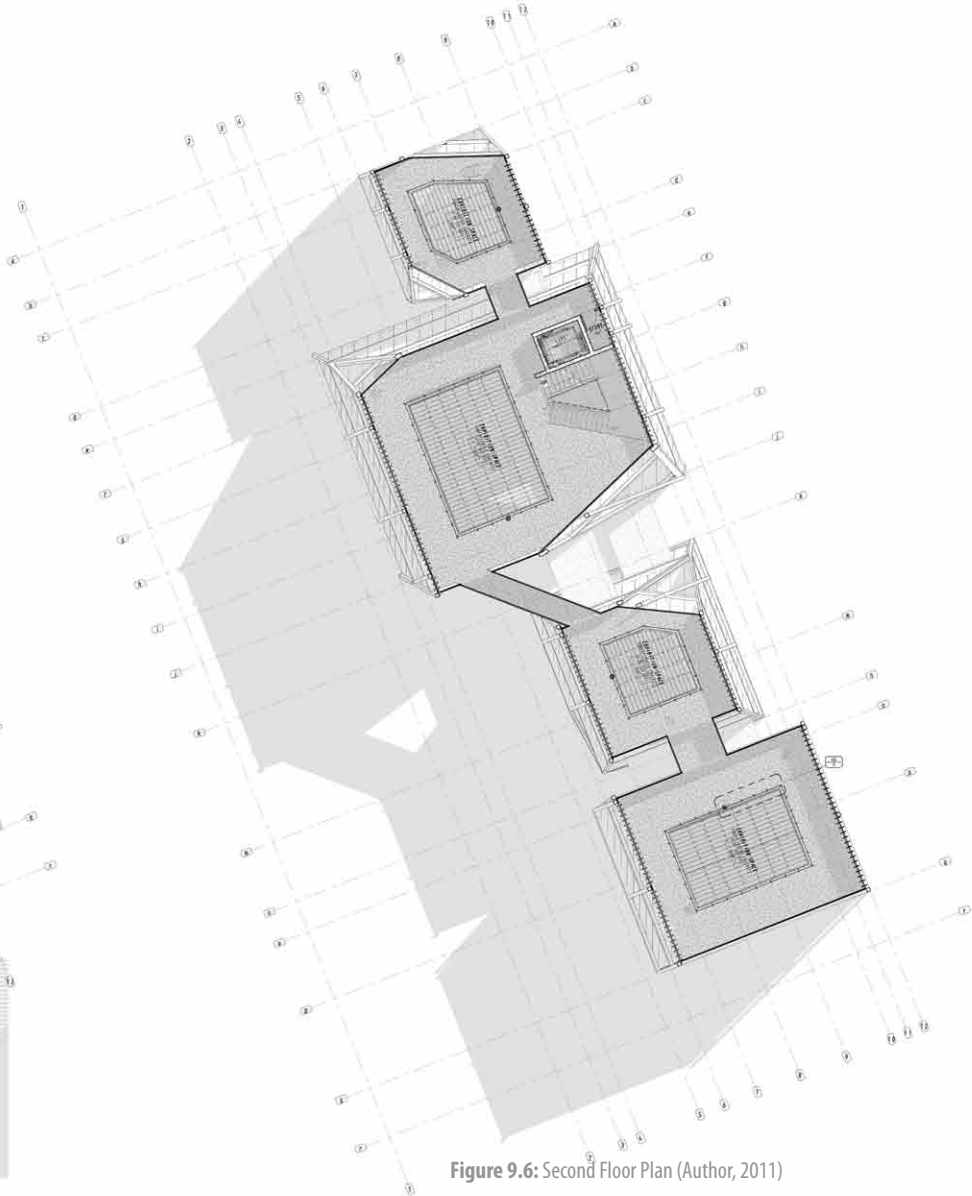

Figure 9.6: Second Floor Plan (Author, 2011)



UNIVERSITEIT VAN PRETORIA
UNIVERSITY OF PRETORIA
YUNIBESITHI YA PRETORIA



- EXHIBITION SPACE
POWER FLOATED CONCRETE
- ARTIST STUDIO
SELF-LEVELLING EPOXY SCREED
- ENTRANCE VOYER
POWER FLOATED CONCRETE
- CAFE
POWER FLOATED CONCRETE
- RECEPTION
POWER FLOATED CONCRETE
- CIRCULATION SPACE
POWER FLOATED CONCRETE

Figure 9.7: Perspective of Section A-A (Author, 2011)

Technical Resolution



LIGHTWEIGHT STEEL ROOF AS PER DETAIL
200X200 SQUARE HOLLOW SECTION STEEL
STRUCTURAL FRAME

PILKINGTON U-PROFILE GLAZING SYSTEM

WEAVED COPPER STRIP SHADING SCREEN

HELP DESK
CERAMIC TILE

STORE ROOM
CERAMIC TILE

BASEMENT PARKING
BRUSHED CONCRETE

+ Details

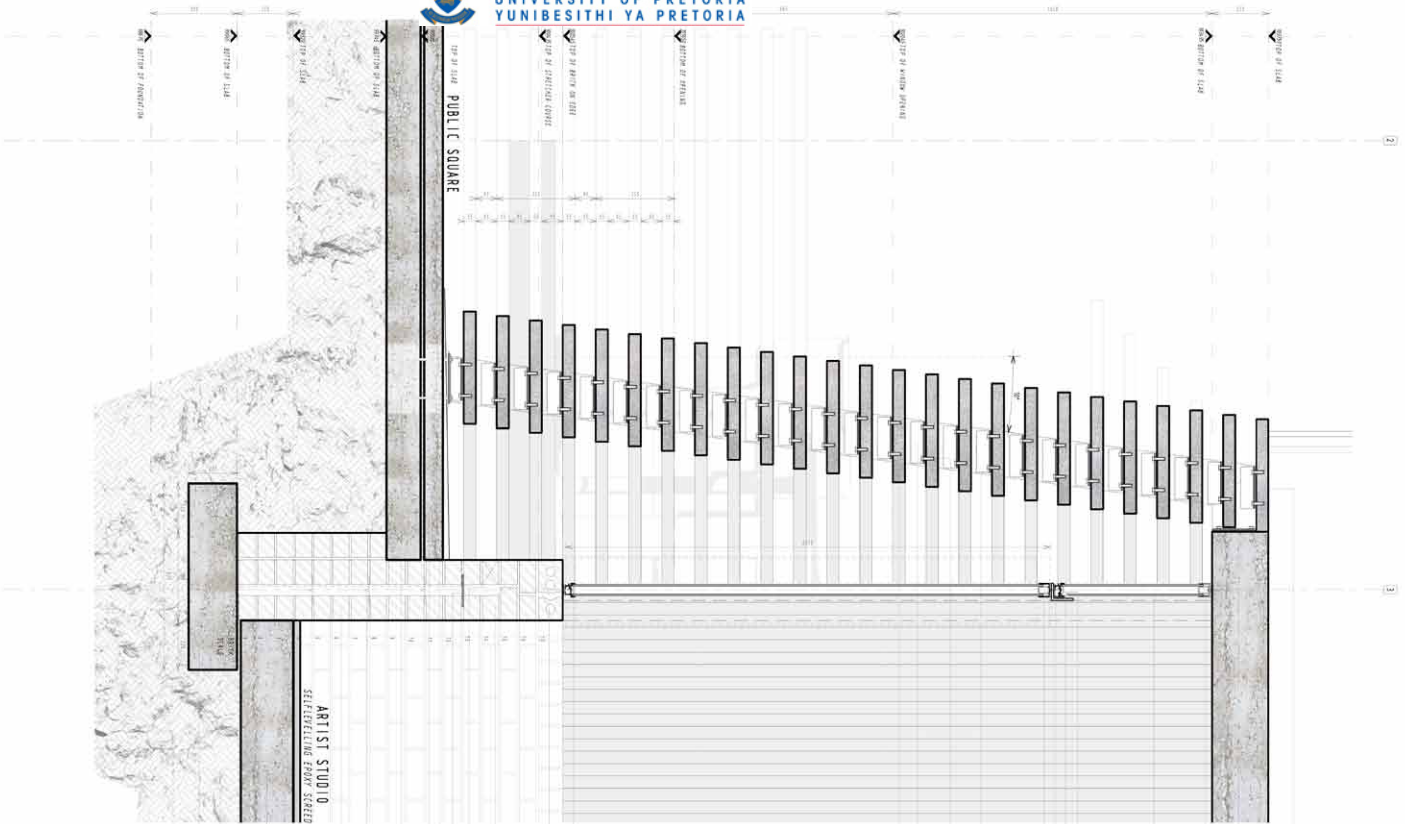

NOTES: Section through floor slabs and walls to be finished in situ. All concrete to be finished with a smooth surface. All concrete to be finished with a smooth surface. All concrete to be finished with a smooth surface.

SEATING/STAIRS/SCREEN: Seating to be finished in situ. Stairs to be finished in situ. Screen to be finished in situ.

BUILDING SYSTEM: Building system to be finished in situ. Building system to be finished in situ.

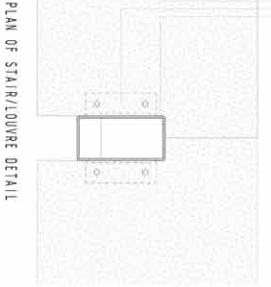

1. The drawing shows the plan of the staircase and louver system. The staircase is shown as a series of steps leading up to the louver system. The louver system is shown as a series of louvers that can be opened or closed. The drawing includes dimensions and annotations for the structural elements.

2. The drawing shows the plan of the staircase and louver system. The staircase is shown as a series of steps leading up to the louver system. The louver system is shown as a series of louvers that can be opened or closed. The drawing includes dimensions and annotations for the structural elements.

3. The drawing shows the plan of the staircase and louver system. The staircase is shown as a series of steps leading up to the louver system. The louver system is shown as a series of louvers that can be opened or closed. The drawing includes dimensions and annotations for the structural elements.

4. The drawing shows the plan of the staircase and louver system. The staircase is shown as a series of steps leading up to the louver system. The louver system is shown as a series of louvers that can be opened or closed. The drawing includes dimensions and annotations for the structural elements.

5. The drawing shows the plan of the staircase and louver system. The staircase is shown as a series of steps leading up to the louver system. The louver system is shown as a series of louvers that can be opened or closed. The drawing includes dimensions and annotations for the structural elements.

6. The drawing shows the plan of the staircase and louver system. The staircase is shown as a series of steps leading up to the louver system. The louver system is shown as a series of louvers that can be opened or closed. The drawing includes dimensions and annotations for the structural elements.

7. The drawing shows the plan of the staircase and louver system. The staircase is shown as a series of steps leading up to the louver system. The louver system is shown as a series of louvers that can be opened or closed. The drawing includes dimensions and annotations for the structural elements.

8. The drawing shows the plan of the staircase and louver system. The staircase is shown as a series of steps leading up to the louver system. The louver system is shown as a series of louvers that can be opened or closed. The drawing includes dimensions and annotations for the structural elements.

9. The drawing shows the plan of the staircase and louver system. The staircase is shown as a series of steps leading up to the louver system. The louver system is shown as a series of louvers that can be opened or closed. The drawing includes dimensions and annotations for the structural elements.

10. The drawing shows the plan of the staircase and louver system. The staircase is shown as a series of steps leading up to the louver system. The louver system is shown as a series of louvers that can be opened or closed. The drawing includes dimensions and annotations for the structural elements.

11. The drawing shows the plan of the staircase and louver system. The staircase is shown as a series of steps leading up to the louver system. The louver system is shown as a series of louvers that can be opened or closed. The drawing includes dimensions and annotations for the structural elements.

12. The drawing shows the plan of the staircase and louver system. The staircase is shown as a series of steps leading up to the louver system. The louver system is shown as a series of louvers that can be opened or closed. The drawing includes dimensions and annotations for the structural elements.

13. The drawing shows the plan of the staircase and louver system. The staircase is shown as a series of steps leading up to the louver system. The louver system is shown as a series of louvers that can be opened or closed. The drawing includes dimensions and annotations for the structural elements.

14. The drawing shows the plan of the staircase and louver system. The staircase is shown as a series of steps leading up to the louver system. The louver system is shown as a series of louvers that can be opened or closed. The drawing includes dimensions and annotations for the structural elements.

Figure 9.9: Perimeter detail (Author, 2011)

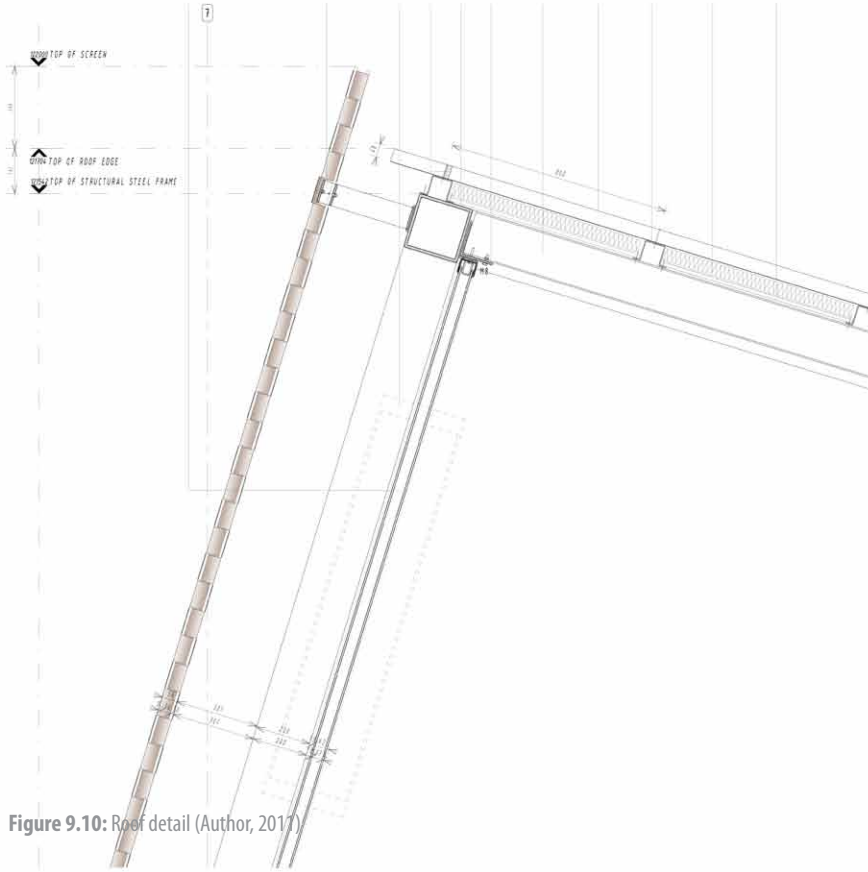

Figure 9.10: Roof detail (Author, 2017)

43224766 Polystyrene insulation 40mm
specify glazing system as per detail (leaf 9.16)

weaved shading screen as per weaved screen detail (leaf screen note)

specification of 43224766 Polystyrene 40mm (100mm thickness) is profile
glazing system panel as window as per detail (leaf 9.16)

cross-section polystyrene polystyrene

200x200x10 steel hollow section structural frame

120x120x8 galvanneal steel equal leg angle iron, welded to 200x200x10 square hollow
section structural frame & bolted to top of roof beam with 10mm steel bolts

1PE100 (160x20) steel roof beams bolted to 200x200x10
square hollow section frame with M8 steel bolts

400x40x8 B Brownbilt profile steel roof sheets, with 53 finishing clips to
both sides. With 20 starting clips and 53 finishing clips at ends

1000 polyethylene thermal insulation board
with self tapping screws

1000 polyethylene thermal insulation board fixed
to IPE 100 roof beams with self tapping screws

12.5 mm Rhinobond Flash Jacking Ceiling board @ 600 mm centres, fixed to
roof beams with self tapping screws through polystyrene insulation board

12.5 mm Rhinobond Flash Jacking Ceiling board @ 600 mm centres, fixed to
roof beams with self tapping screws through polystyrene insulation board

1000 polyethylene thermal insulation board fixed
to IPE 100 roof beams with self tapping screws

1PE100 (160x20) steel roof beams, ends cut & welded to detail

400x40x8 B Brownbilt profile steel roof sheets, with 53 finishing clips to
both sides. With 20 starting clips and 53 finishing clips at ends

1200x1000 galvanneal steel equal leg angle iron, welded to 200x200x10 square hollow
section structural frame & bolted to IPE 100 roof beams with M8 steel bolts

1000 polyethylene thermal insulation board fixed to
IPE 100 roof beams with self tapping screws

cross-section polystyrene polystyrene

200x200x10 galvanneal steel hollow section structural frame

1000 polyethylene thermal insulation board fixed to
IPE 100 roof beams with self tapping screws

welded to 200x200 steel hollow section structural frame

300x150 (8mm thickness) galvanneal steel PFC gutter, sloped to downpipe (leaf)

M8E Brimwater down pipe, fixed to 200x200x10
square hollow section structural frame column

43224766 Polystyrene insulation 40mm
specify glazing system as per detail (leaf 9.16)

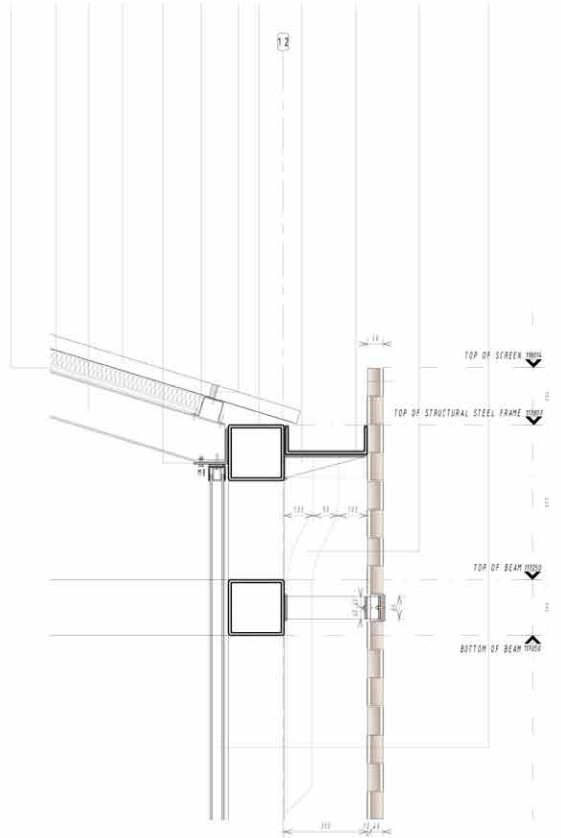

- ROOF:**
Lightweight steel roof
400x40x8 B Brownbilt profile steel roof sheets, with
Gloalcoat[®] Finish to both sides. With 20 starting clips and
53 finishing clips at end and closed-cell polystyrene
polyurethane. On 1000x1000 galvanneal steel top hat purlins @
max. 1000 centres, fixed to IPE 100 roof beams with self
tapping screws, ends cut to detail. With 70mm polyethylene
board insulation.
IPE100 beams welded to 200x200 steel hollow section
structural frame.
- STEEL WORK:**
All steel sections to be galvanneal and finished with 2
coats zinc chromate primer (spray application). All steel
fasteners to be galvanneal steel. All welding to be shop
welded where possible & all bolting to be done on site.
- STRUCTURAL FRAME:**
200x200 Square hollow sections, galvanneal and finished
with 2 coats zinc chromate primer (spray application). Shop
welded according to detail.
- WEAVED SHADING SCREEN:**
M10 galvanneal steel rod spaced @ min. 1000 centres, with
100x4 B copper strips weaved between rods as per detail,
supported by 60mm steel flat bar (bolted to detail)
rods fixed to flat bar element with self-tapping (MS)
steel u-bolts. Flat bar element to be welded to structural
steel frame

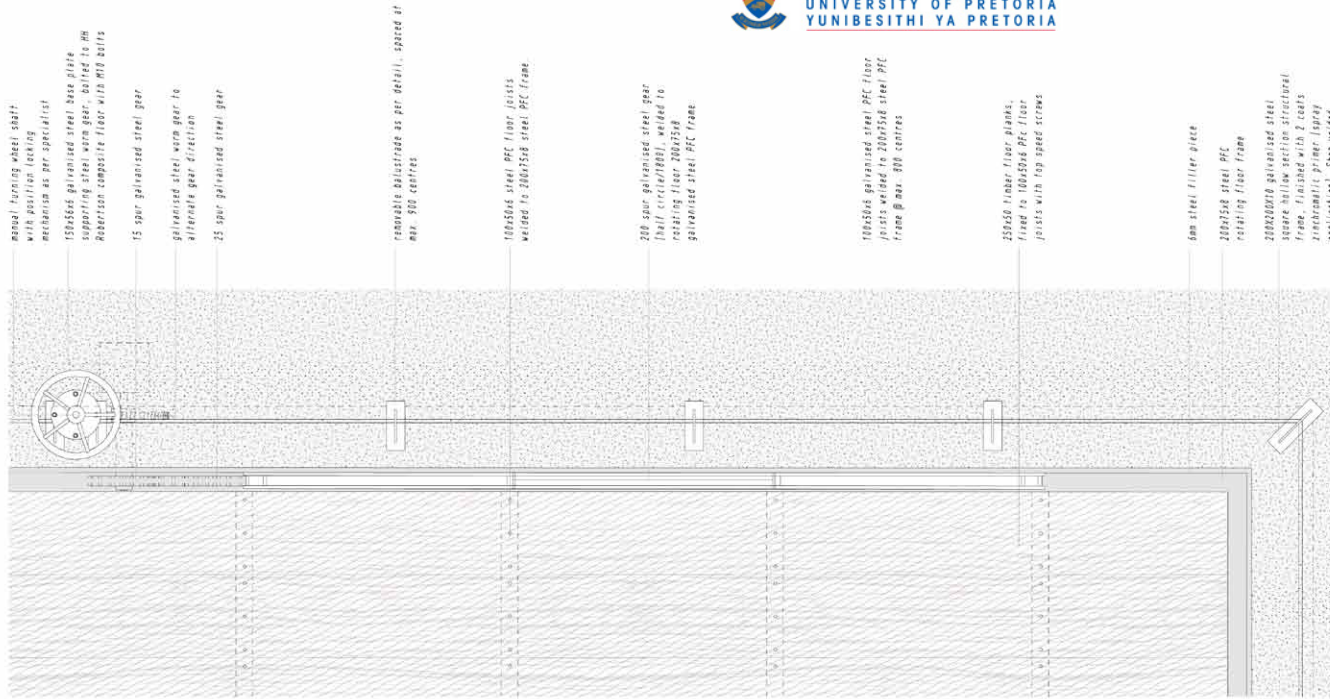

2 | PLAN: Rotating Floor System | 1:10

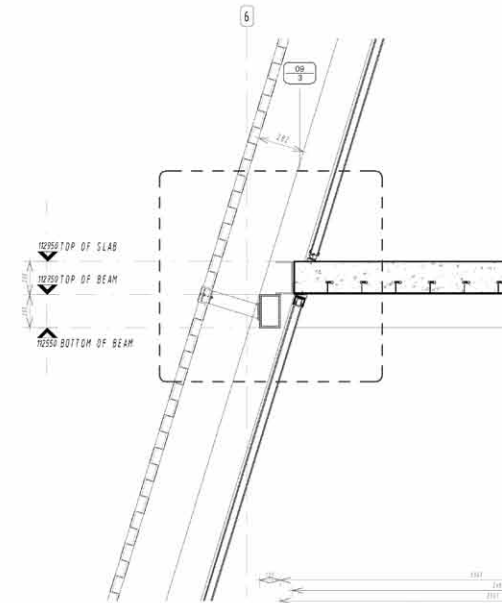

1 | SECTION: Rotating Floor

Figure 9.11: Rotating floor details from Section B-B (Author, 2011)

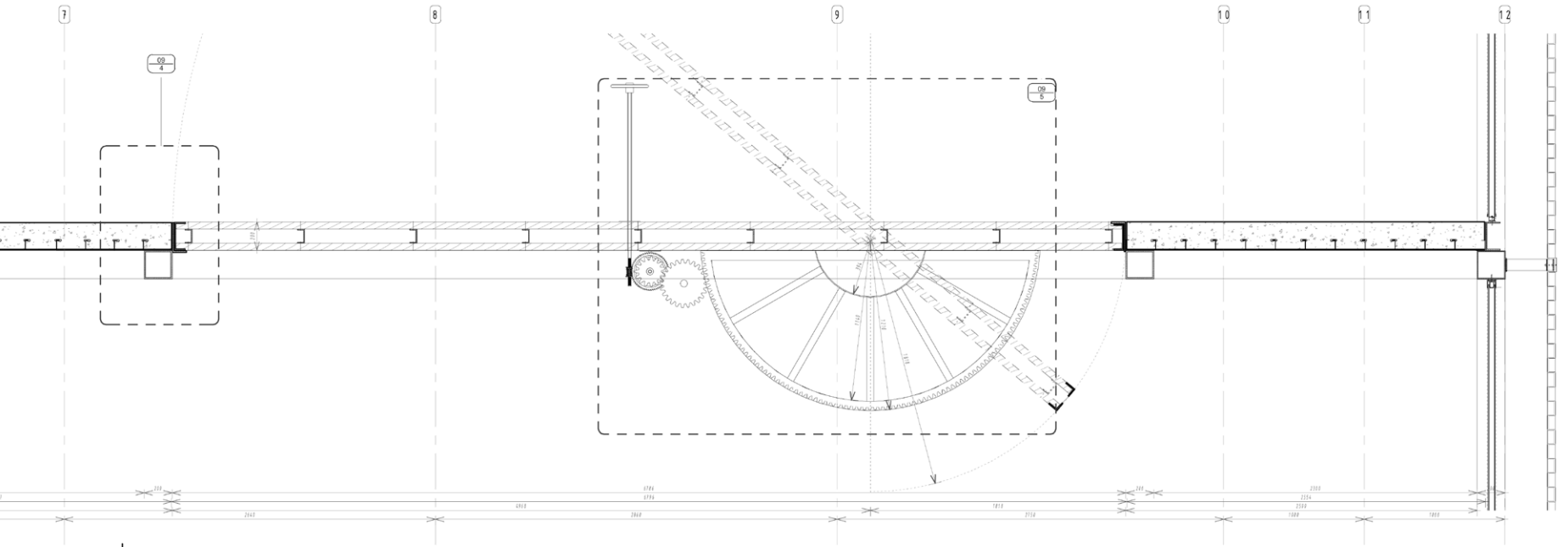

r System | 1:20

REVISIONS
1. 2024-01-15: Initial design
2. 2024-02-01: Client feedback
3. 2024-02-15: Final design

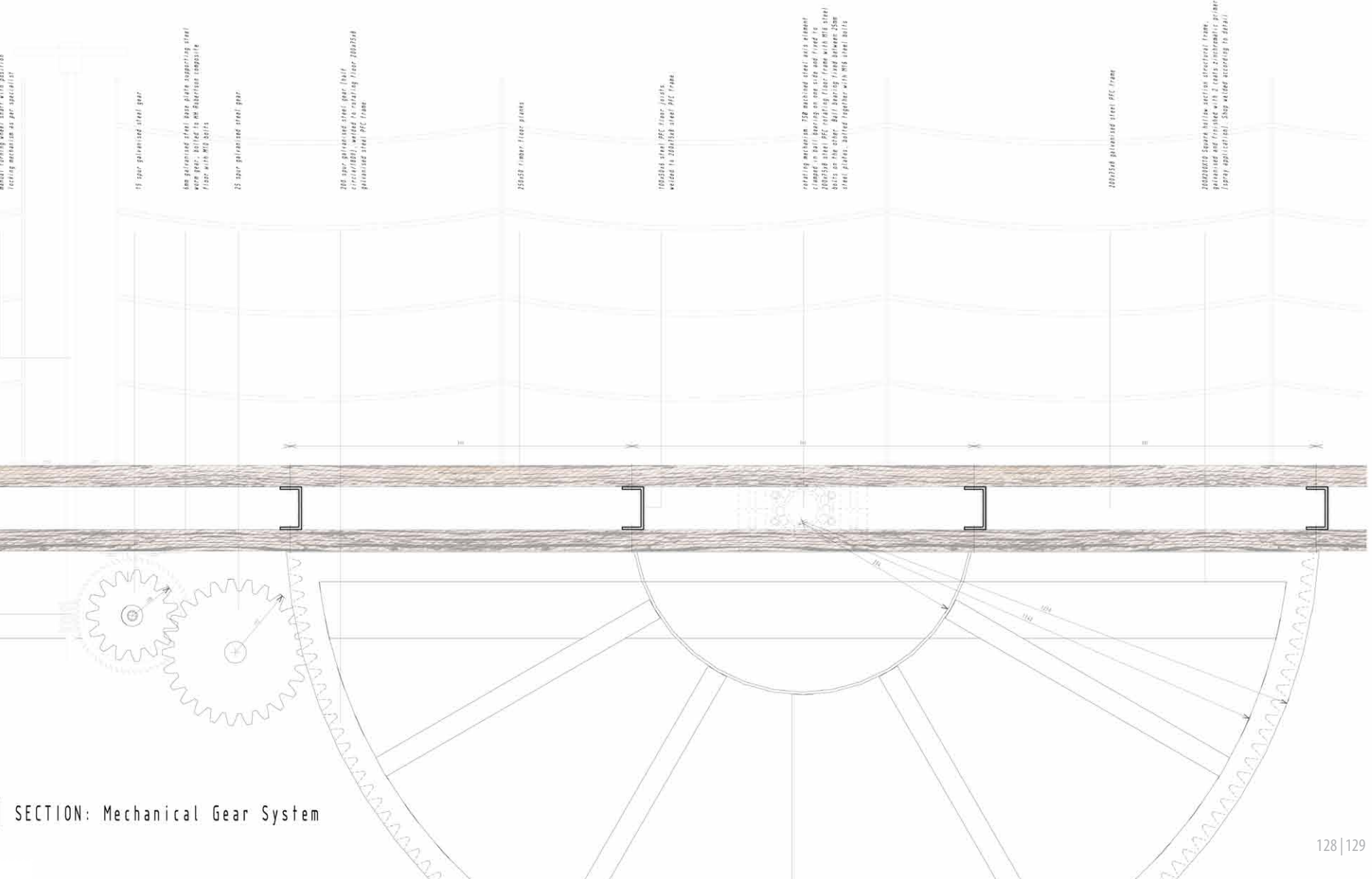

15 mm galvanized steel plate

100 galvanized steel plate supporting steel
work gear, bolted to an Aluminium composite
plate with M16 bolts

35 mm galvanized steel plate

100 mm galvanized steel plate (steel plate
supporting steel plate frame)

150x60 mm steel plate

100x50 mm steel plate (steel plate)
welded to 200x50 mm steel plate frame

100x50 mm steel plate (steel plate)
welded to 200x50 mm steel plate frame

200x50 mm galvanized steel plate frame

200x50 mm galvanized steel plate frame
(steel plate)

SECTION: Mechanical Gear System

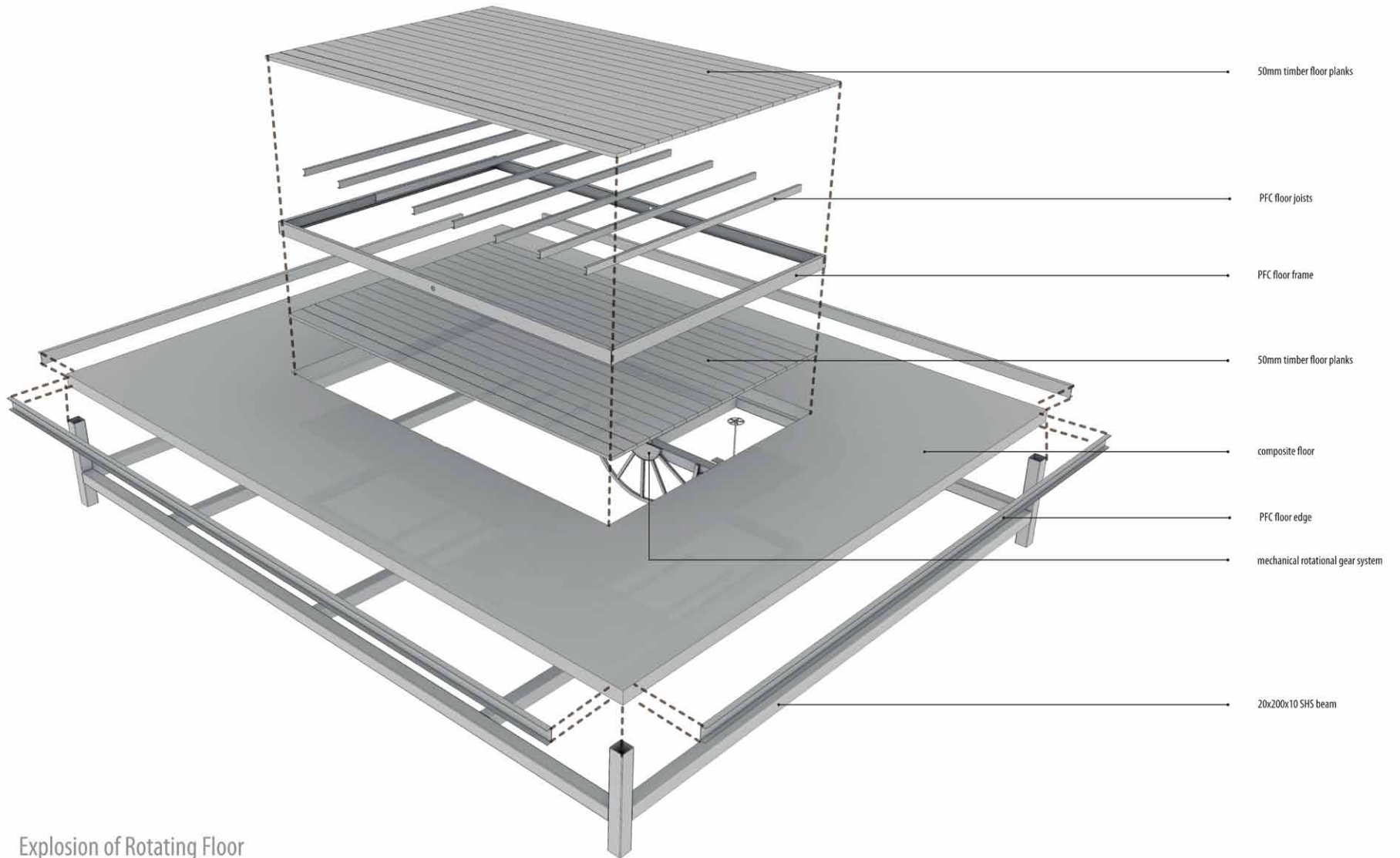

Explosion of Rotating Floor

Figure 9.13: Axonometric details of rotating floor (Author, 2011)

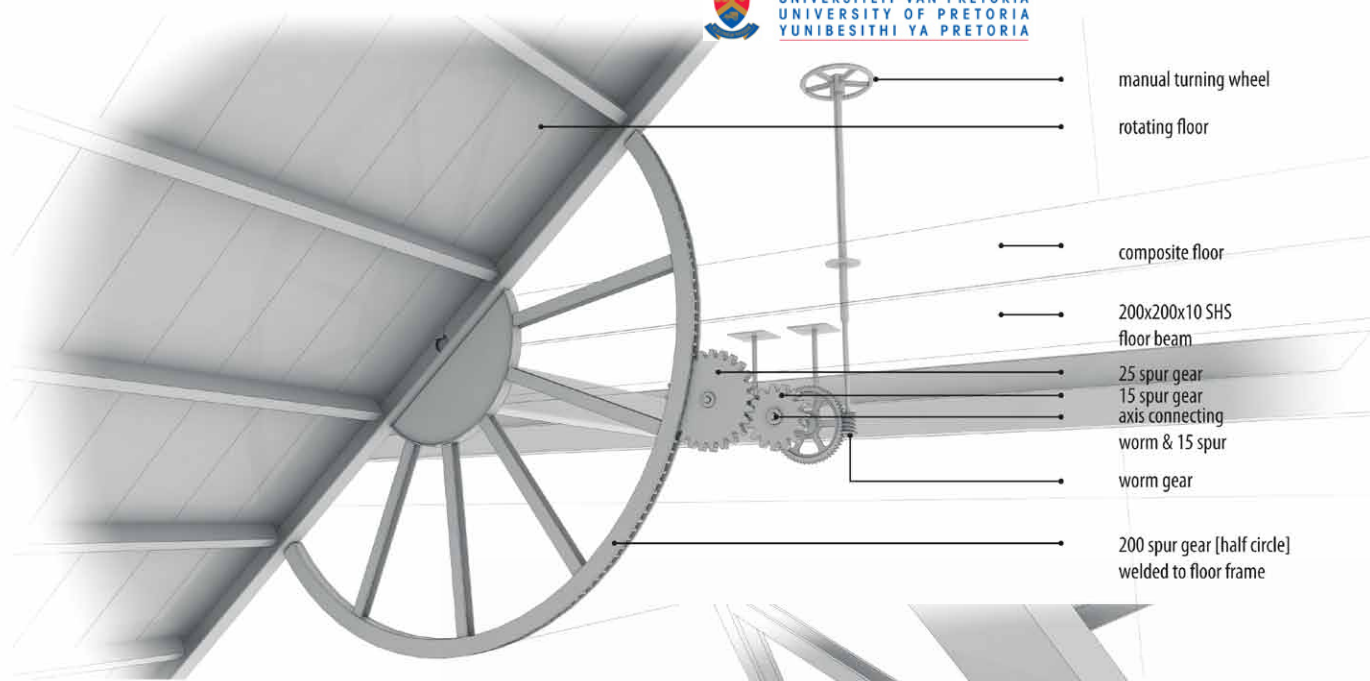

- manual turning wheel
- rotating floor
- composite floor
- 200x200x10 SHS floor beam
- 25 spur gear
- 15 spur gear
- axis connecting worm & 15 spur
- worm gear
- 200 spur gear [half circle] welded to floor frame

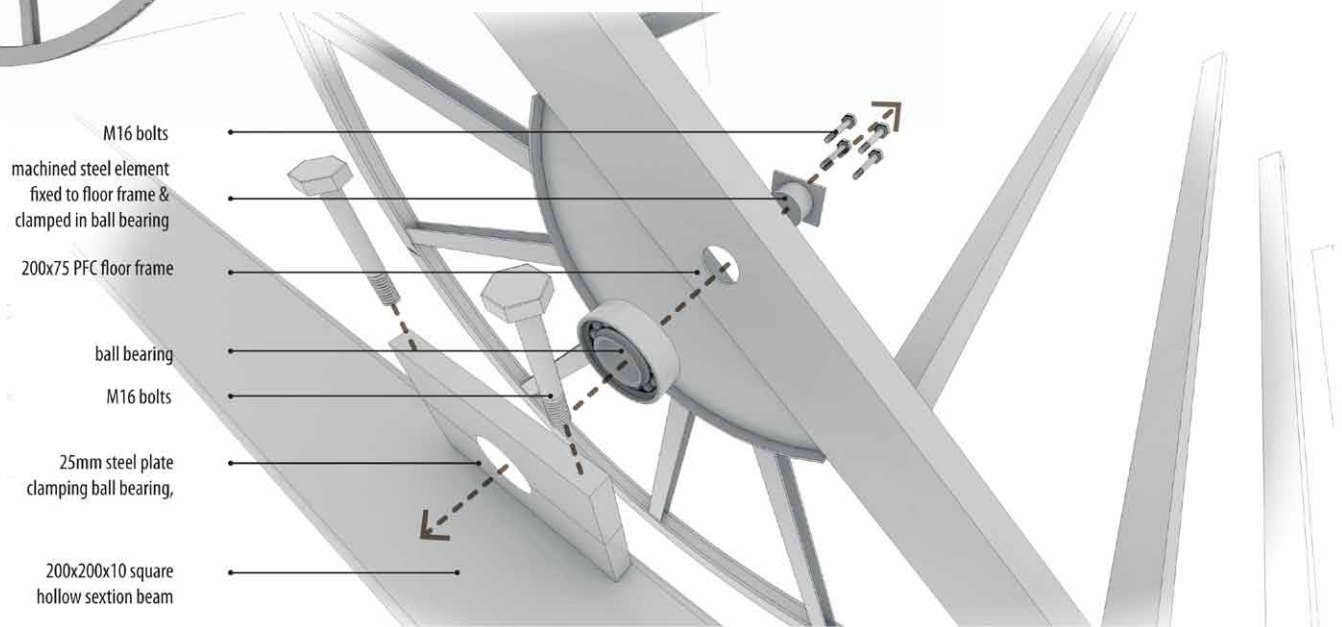

- M16 bolts
- machined steel element fixed to floor frame & clamped in ball bearing
- 200x75 PFC floor frame
- ball bearing
- M16 bolts
- 25mm steel plate clamping ball bearing,
- 200x200x10 square hollow section beam

Figure 9.14: Typical details of the Plkington Profilut u-profile glass system (Author, 2011)

PLAN: U-profile glass façade detail

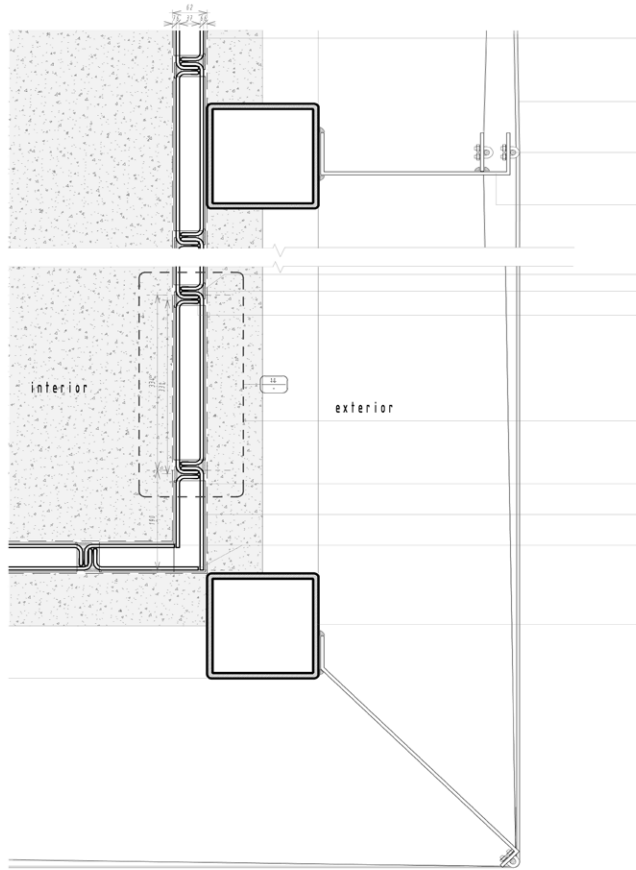

K12 series powdercoated aluminium frame (P.N. 961WA)

100X0.8mm copper strips waved (as per detail) between Ø10 steel rods

Ø10 galvanised steel rod spaced @ min. 1000 centres, fixed to flat bar with 6x13.7x33x20 (M6) steel u-bolt

6mm galvanised steel flat bar bent & welded to detail

glass shim (P.N. 41-244)

high quality silicone sealant

gasket (P.N. 166)

HH Robertson QC Composite Steel and Concrete Flooring, on 205x75x1.2 OC steel permanent formwork panels. Panels fixed joined together with clips @ 500mm centres. QC panels fastened to supporting steelwork with two self-tapping screws per unit at end bearing points

PVC insert (P.N. 961-2)

331x41x6 (K32/41/6 series) u-profile glass panels

high quality silicone sealant

200X200X10 Square hollow sections, galvanised and finished with 2 coats zincchromatic primer (Spray application). Shop welded according to detail.

SECTION: U-profile glass façade connection detail

HH Robertson QC Composite Steel and Concrete Flooring, on 205x75x1.2 OC steel permanent formwork panels. Panels fixed joined together with clips @ 500mm centres. QC panels fastened to supporting steelwork with two self-tapping screws per unit at end bearing points

P.N. 95WT non-thermally broken powdercoated aluminium frame 200X200X10 Square hollow sections, galvanised and finished with 2 coats zincchromatic primer (Spray application). Shop welded according to detail.

6mm galvanised steel flat bar bent & welded to detail

Ø10 galvanised steel rod spaced @ min. 1000 centres, fixed to flat bar with 6x13.7x33x20 (M6) steel u-bolt

100X0.8mm copper strips waved (as per detail) between Ø10 steel rods

331x41x6 (K32/41/6 series) u-profile glass panels

P.N. 95WT non-thermally broken powdercoated aluminium frame

P.N. 961WT non-thermally broken powdercoated aluminium frame

HH Robertson QC Composite Steel and Concrete Flooring, on 205x75x1.2 OC steel permanent formwork panels. Panels fixed joined together with clips @ 500mm centres. QC panels fastened to supporting steelwork with two self-tapping screws per unit at end bearing points

200X200X10 Square hollow sections, galvanised and finished with 2 coats zincchromatic primer (Spray application). Shop welded according to detail.

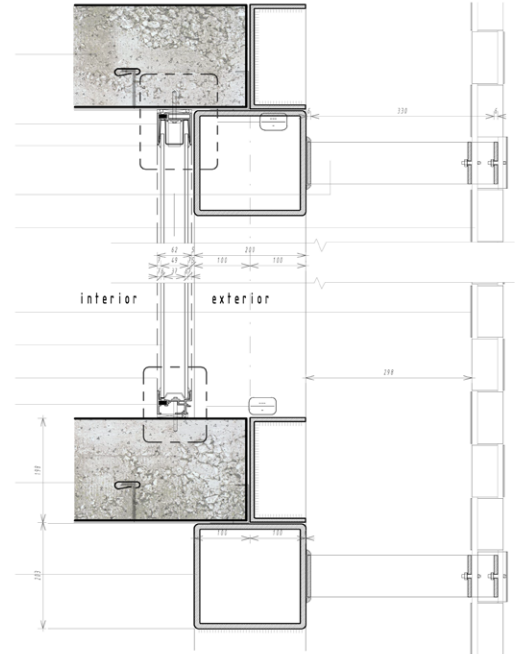
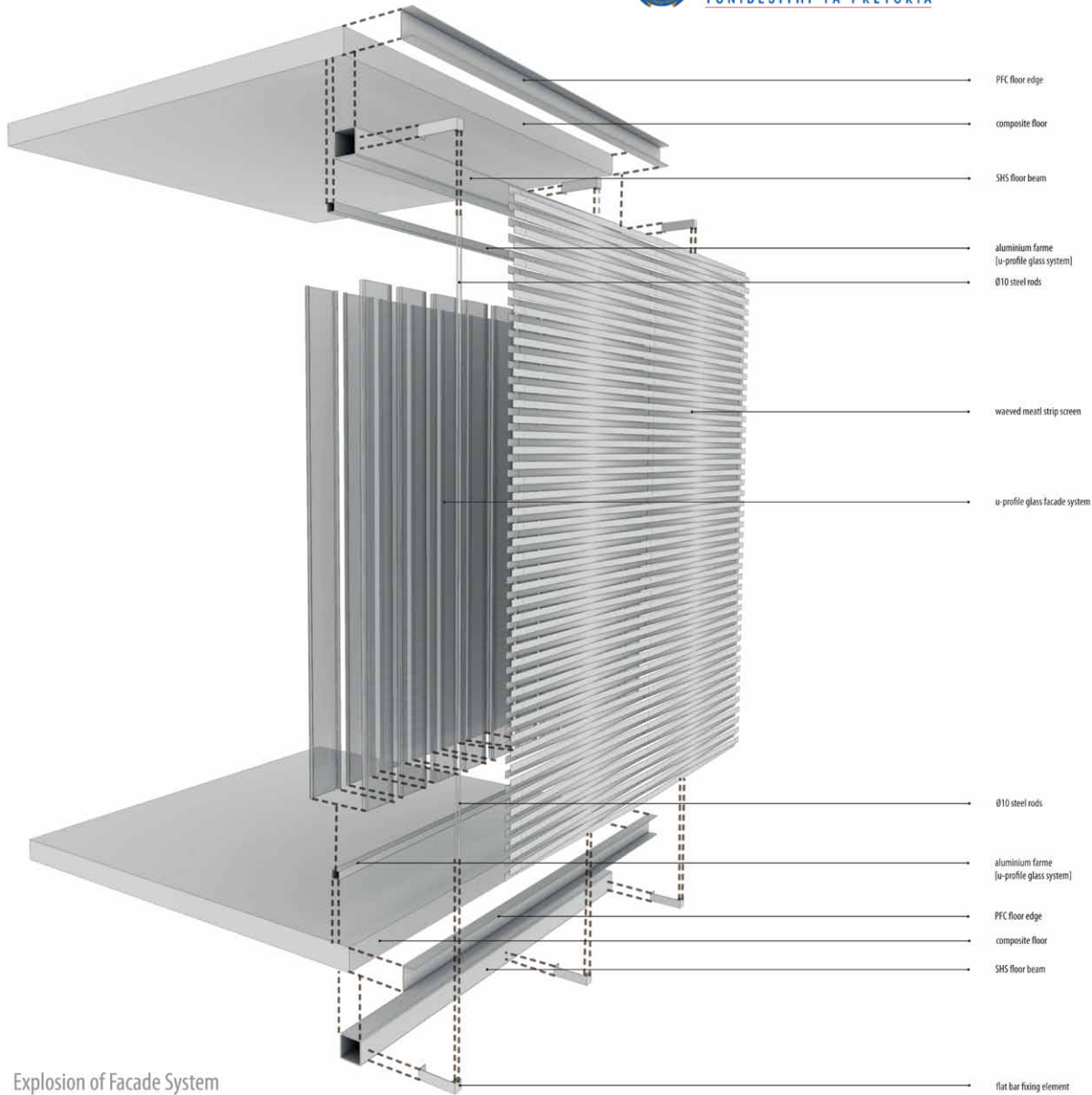



Figure 9.15: Axonometric details of façade system (Author, 2011)



Explosion of Façade System

10



+ Conclusion

The main objectives of narrowing the current *digital divide* by means of an architectural intervention as well expressing and exploring the relationship between the *real* and the *virtual* in an architectural form was, in the opinion of the author, successfully achieved.

By introducing a programme into the urban context, which informs civil society, the intervention would create a definite awareness of the emerging technologies and the possibilities it holds which, in turn, stimulates a culture of knowledge and encourage the integration of city dwellers into the global digital society. The provided access to these technologies should allow for self-edification and opportunities for self-upliftment by encouraging users to gain an understanding of digital technologies as well as develop the necessary skills. This answers the first research question: how can architecture contribute to bridging the digital gap? Architecture can narrow the divide by strategic design strategies that inform users and 'broadcast' its contents.

The answer to the second research questions lies in the method used to 'broadcast' the intentions and programme of the building: the u-profile glass façade and weaved shading screen system. This facade system indicates that physical elements can in fact be perceived as digital elements when it is designed accordingly (as in the simulated digital patterns of the shading screen and reception wall installation). The opposite objective is also realised by means of the same façade system, where the virtual is perceived as physical when allowing it to become part of the architecture - the projections appear to be digital façades from the exterior while interior projections act as space defining elements. The spatial dynamics of the exhibition towers is effectively altered by the introduction of rotating floors which allow the size, use and nature of the space to be adapted sporadically.

The architectural problem is therefore resolved by an informative architectural intervention which clearly illustrates the relationships between the traditional physical landscape and the emerging metaphysical environment. The setting of the building is, as a result, an augmented space which becomes the transitional zone between *digital architecture* and *virtual architecture*.

The *Digital Art Pavilion* would have a significant impact on the urban context not only in terms of its informative characteristics, but also as a catalyst for similar developments which spark an interest and act as a pulling force in the city of Pretoria.

AITC, 2001. See Art In The City.

ALBERTI, L.B. 1991. *On painting*. Translated by Cecil Grayson from Italian *De pictura*, 1435. London: Penguin

GRAYSTON, C. (trans) 1991. *On painting*. From Alberti L.B. 1435. *De pictura*. London: Penguin

ALBERTS, D.S. & Papp, D.S. (eds.). 1997. *The information age: an anthology on its impact and consequences*. Washington: National Defense University Press

ALEXANDER, C., Ishikawa, S. & Silverstein, M. 1977. *A pattern language: towns, buildings, construction*. New York: Oxford University Press

ALKAYYALI, A. 2011. Liminal public infrastructure. Dissertation, Faculty of Engineering, Built Environment and Information Technology, University of Pretoria, South Africa

ARCH DIA, 2010. Circa gallery.
<http://archi-dia.blogspot.com/2010/06/circa-gallery.html>
[20 June 2010]

ARCHITERIA, 2009. Circa gallery architecture design by studioMAS.
<http://www.architeria.com/gallery-design/circa-gallery-architecture-design-by-studiomas> [1 December 2009]

ART IN THE CITY (AITC), 2001. Precedents: Steven Holl, storefront for art and architecture, 1993.
<http://www.arch.mcgill.ca/prof/mellin/arch671/winter2001/dkouba/drm/holl.htm>
[3 February 2010]

AUDIRAC, I. 2003. Information-age landscapes outside the developed world. *Journal of the American planning association*, 69 (1): 16-32. India: Bangalore; Mexico: Guadalajara

BANKSY, 2010. Byte into an apple: the digital divide. Graffiti artwork, City of London, England

BARNHART, R.K. 1988. *The American heritage science dictionary*, 2nd edn.
Harcourt: Houghton Mifflin Company

BERMUDEZ, J. & Klinger, K. (eds.), c2003. *Digital Technology & Architecture - White Paper*. NAAB Validation Conference: Association for Computer Aided Design in Architecture

BENSCHNEIDER, B. 2011. Chicken point cabin. Reproduced by Olsen Kundig Architects.
<http://www.olsonkundigarchitects.com/Projects/101/Chicken-Point-Cabin>
[15 March 2011]

BOSANQUET, R.C. 1915. Greek and Roman towns 1: streets. *The town planning review*, vol. 5, no. 4: 286-93.

BOTES, N. & Le Roux, S. (eds). 1991. *Plekke en geboue van Pretoria*, vol. 2. Pretoria: Stadsraad van Pretoria

BRAKE, A. G. 2008. Holl, Accorci get facelift: Storefront reopens after restoration. *The Architects Newspaper*, 10 February 2008. <http://archpaper.com/news/articles.asp?id=2856>
[10 February 2008]

CASTELS, M. 1996. *The rise of the network society. The information age: economy, society & culture*. Oxford: Blackwell

CASTELS, M. (ed.) 2004. *The network society: a cross-cultural perspective*. Cheltenham & Northampton: Edward Elgar

CCSF, 2011. Photograph of Villa Savoye.
http://frontpage.ccsf.edu/artarchive/index_11.html
[10 April 2011]

CERNIUS, J. 2009. BLNK: DAC's art under the bridge.
<http://www.artfagcity.com/2009/09/30/blink-dacs-art-under-the-bridge>
[30 September 2009]

CHEN, J., Bozso, C., Abcouwer, N., Scharf, L. & Shaffer, C. [2009]. Digital divide.
<http://www.contrib.andrew.cmu.edu/~cbozso/digitaldivide.ppt>
[12 March 2011]

CLELAND, J.S. 2009. Aerial photograph of Church Square, Pretoria (c. 1927) from the John S. Cleland Collection.



- <http://hdl.handle.net/2263/10971>
[9 June 2011]
- COLEMAN, E.** 2009. When you can't believe no one thought of that before...
<http://elizacoleman.blogspot.com/2009/08/when-you-cant-believe-no-one-thought-of.html>
[8 August 2009]
- CRYSTALINKS**, [2004]. Ancient Egyptian writing and hieroglyphs.
<http://www.crystalinks.com/egyptwriting.html>
[10 March 2010]
- DE SOLA MORALES, I.** 1997. *Differences: topographies of contemporary architecture*. Cambridge: MIT Press
- DROEGE, P.** 1997. *Intelligent environments: spatial aspects of the information revolution*. Amsterdam: Elsevier
- FACEBOOK.** 2010. Connectivity map of Facebook by Paul Butler. In What the beautiful Facebook map tells us: 5 takeaways, *The Week*, 16 December 2010.
<http://theweek.com/article/index/210426/what-the-beautiful-facebook-map-tells-us-5-takeaways>
[16 December 2010]
- FRAZER, J.** 1995. *An evolutionary architecture*. London: Architecture Association
- GAUSA, M.,** Guallart, V., Müller, W., Soriano, F., Porras, F. & Morales, J. 2003. *The metapolis dictionary of advanced architecture: city, technology and society in the information age*. Barcelona: Actar Birkhäuser
- GEHL, J.** 2010. *Cities for people*. Washington: Island Press
- GIDDENS, A.** 1999. *The BBC Reith lectures: runaway world*. Lecture 1: globalisation, 10 November. London: BBC [Video Lecture].
<http://news.bbc.co.uk/1/hi/english/static/events/reith99/week1/week1.htm>
[09 March 2011]
- GREEN, P.** 1997. The flames and the death squad. *Mail & Guardian*, 7 March 1997
- HERZOG, J.** [2002]. Central Signal Box, Basel, Switzerland.
<http://www.herzogdemeuron.com/index/projects/complete-works/026-050/049/IMAGE.html>
[5 May 2008]
- HIGH TECH FOLKART (HTFA)**, 2010. Krzysztof Wodiczko.
<http://hightechfolkart.wordpress.com/2010/12/03/krzysztof-wodiczko/>
[3 December 2010]
- HOLL, S.** 2008. Storefront for art and architecture.
<http://www.stevenholl.com/project-detail.php?id=24&search=storefront>
[10 May 2008]
- HRUSZECKY, I.** 2011. Villa Savoye technical drawings.
<http://ivanarch1201.blogspot.com/2011/03/villa-savoye-technical-drawings.html>
[22 March 2011]
- HUNT, G.** 1997. *Intelligent architecture: cybernetic theory and architecture*. Chicago: Proceedings of the International Symposium on Electronic Art (ISEA)
- JOHNSON, K.** 2007. Jenny Holzer makes light of poems and beats swords into paintings. Art review. *New York Times*, 26 December 2007
- JORDAAN, G.** 1989. Pretoria as *urbs quadrata*. *Architecture SA*, May/June: 26-29.
- KAPLAN, A.M.,** Schoder, D. & Haenlein, M. 2007. Factors influencing the adoption of mass customization: the impact of base category consumption frequency and need satisfaction. *Journal of product innovation management*, 24(2): 101-116
- KOLAREVIC, B.** 2001. Designing and manufacturing architecture in the digital age. In *Architectural information management – 05 design process*, no. 3: 117-123. Pennsylvania: University of Pennsylvania
- KOLAREVIC, B.** (ed.). 2003. *Architecture in the digital age: design and manufacture*. New York & London: Spon
- LALLANA, E.C.** 2003. *The information age*. International: e-ASEAN Task Force and the UNDP Asia Pacific



- Development Information Programme.
<http://www.eprimers.org>
[12 March 2011]
- LEEB, W.** 2009. 555 KUBIK, Hamburg. Media Architecture Institute.
<http://www.mediaarchitecture.org/555-kubik-hamburg/>
[9 September 2009]
- LEITCH, J.** (ed.). 2008. *Opportunity from disaster: the great Munitoria fire*. Special publication by the City Council. Johannesburg: Brooke Patrick (Pty) Ltd.
- LITVIN, M.** 2009. Burnham pavilion by Zaha Hadid Architects, Millenium Park, Chicago.
<http://www.zaha-hadid.com/architecture/burnham-pavillion/#>
[15 May 2010]
- LUMENTA CORPORATION.** c.2007. Map of the internet. In McCandless, D. 2009. *Information is beautiful*. London: Harper Collins
- MAHALINGAM, G.** c.2003. Digital tools. In Bermudez, J. & Klinger, K. (eds.). *Digital technology & architecture - white paper*. NAAB Validation Conference: Association for Computer Aided Design in Architecture
- MANOVICH, L.** c.2006. The poetics of augmented space. In *Visual communication*, vol. 5(2): 219-240. London: SAGE Publications
- MANOVICH, L.** 2011. The poetics of urban media surfaces. *First Monday*, Special Issue (4).
- MATSUDA, K.** 2010. *Domesti/City: the dislocated home in augmented space*. Dissertation, Bartlett School of Architecture, University College London
- MCCANDLESS, D.** 2009. *Information is beautiful*. London: Harper Collins
- MCLEOD, V.** 2007. *Detail in contemporary residential architecture*. London: Laurence King Publishing Ltd.
- MITCHELL, W.J.** 1997. *City of bits: space, place and the infobahn*. London & Cambridge: MIT Press
- MITCHELL, W.J.** 2000. *E-topia*. Cambridge: MIT Press
- MITCHELL, W.J.** 2001. Roll over Euclid: how Frank Gehry designs and builds. In Ragheb, J.F. (ed.). *Frank Gehry, architect*. New York: Guggenheim Museum Publications: 352-363
- NGO, D.** (ed.) 2006. *Torn Kundig: houses*. New York: Princeton Architectural Press
- NORMAN, F.S. & Tilder, L.** c.2003. Digital tools. In Bermudez, J. & Klinger, K. (eds.). *Digital technology & architecture - white paper*. NAAB Validation Conference: Association for Computer Aided Design in Architecture
- NORSWORTHY, S.** 2008. Storefront for art and architecture - Steven Holl.
<http://www.flickr.com/photos/scottnorsworthy/3046797776/> [8 October 2008]
- NOTCOT Archives**, 2008. Usman Haque's primal source.
<http://www.notcot.com/archives/2008/07/usman-haques-pr.php> [21 July 2008]
- NSG Group**, [2010]⁹. Achieving BREEAM credits with advanced glazing products. NSG Group, London
- NSG Group**, [2010]⁹. Profiled glass with system Pilkington PROFILIT™ created to design: product examples. NSG Group, London
- NUNBERG, G.** 1996⁹. Farewell to the information age. In Nunberg, G. (ed.) 1996. *The future of the book*. Berkley & Los Angeles: California University Press: 103-138
- NUNBERG, G.** (ed.) 1996⁹. *The future of the book*. Berkley & Los Angeles: California University Press
- PASK, G.** 1969. The architectural relevance of cybernetics. *Architectural design*, 7(6): 494-496
- POLICH, T.A.** 2011. Herzog and de Meuron, facade tectonics (early work).
<http://tylerapolich.wordpress.com/2009/08/07/herzog-and-de-meuron-facade-tectonics-early-work/basel-central-signal-box-skin-detail/>
[2 February 2011]
- QBN**, 2009. Architecture of the day.
<http://www.qbn.com/topics/586759/?page=2>

[24 March 2009]

RAGHEB, J.F. (ed.). 2001. *Frank Gehry, architect*. New York: Guggenheim Museum Publications

RAMILO, R. 2010. Digital architecture: lattice inherent system.
<http://www.coroflot.com/rami/digital-architecture/8>
[28 December 2010]

REAGAN, R. 1989. *The Guardian*. London, 14 June 1989: 24

SAIEH, N. 2008. The Nelson-Atkins museum of art / Steven Holl architects.
<http://www.archdaily.com/4369/the-nelson-atkins-museum-of-art-steven-holl-architects/>
[30 July 2008]

SCHÖN, D.A., Sanyal, B. & Mitchell, W.J. (eds.). 1999. *High technology and low-income communities*. Cambridge & London: MIT Press

SHERBINI, K. & Krawczyk, R. 2004. *Overview of intelligent architecture*. Proceedings of the 1st ASCAAD International Conference, e-Design in Architecture KFUPM, Dhahran, December: 137-152

STATISTICS SA. 2009. *Community survey 2007: basic results - Gauteng*. Pretoria: Statistics SA

STUDIOMAS, 2009. Circa on Jellicoe.
<http://www.studiomas.co.za/circa-on-jellicoe.php>
[2 March 2011]

TAPSCOTT, D. & Williams, A.D. 2006. *Wikinomics*. New York: Portfolio

THE CITY OF TSHWANE. 2006. *Relgabisia Tshwane framework: Tshwane inner city spatial development framework (TICP-SDF)*. Pretoria: The Department of Public Works

VENTURI, R. 2002. Conversation with George Legrady at the entertainment and value conference, University of California, Santa Barbara. 4 May 2002

WARCHOL, P. 2002. Storefront for art and architecture.
<http://www.stevenholl.com/project-detail.php?id=24&search=storefront>
[12 May 2002]

WILSON, E.J. III. 2004. *The information revolution in developing countries*. Cambridge: MIT Press

WORLD INTERNET STATS (WIS). 2011. Internet statistics.
<http://www.internetworldstats.com/stats.htm>
[1 May 2011]



+ Information Graphics

A depiction of statistical - or other information in a graphic and visual form.

Illustration a.1:

Facebook users' connectivity
diagram (Facebook, 2010)



facebook



Colours In Culture

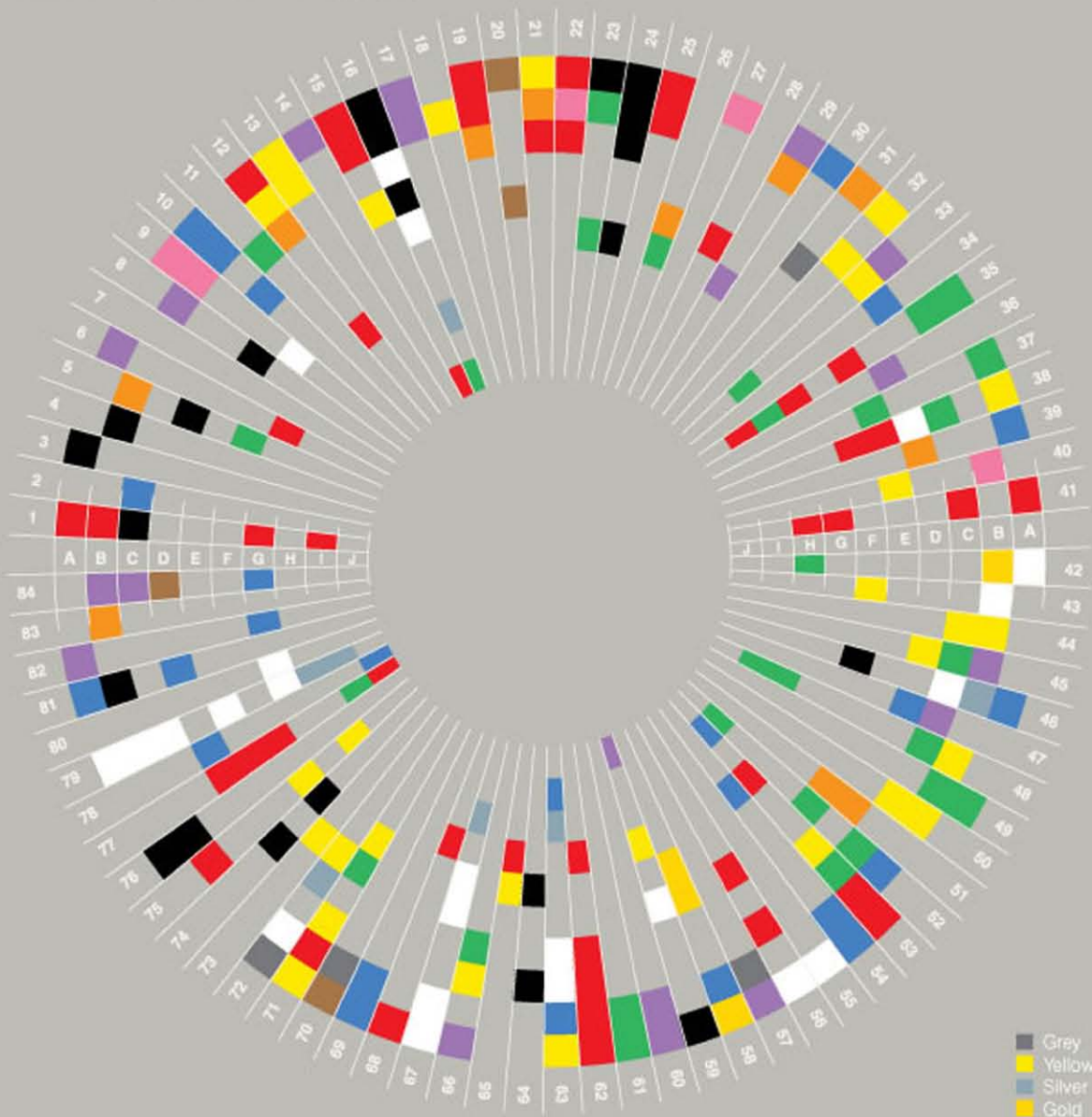

- | | |
|----------------------|--------------------|
| A Western / American | F Asian |
| B Japanese | G Eastern European |
| C Hindu | H Muslim |
| D Native American | I African |
| E Chinese | J South American |

- | | |
|--------------------|---------------------|
| 1 Anger | 43 Holiness |
| 2 Art / Creativity | 44 Illness |
| 3 Authority | 45 Insight |
| 4 Bad Luck | 46 Intelligence |
| 5 Balance | 47 Intuition |
| 6 Beauty | 48 Religion |
| 7 Calm | 49 Jealousy |
| 8 Celebration | 50 Joy |
| 9 Children | 51 Learning |
| 10 Cold | 52 Life |
| 11 Compassion | 53 Love |
| 12 Courage | 54 Loyalty |
| 13 Cowardice | 55 Luxury |
| 14 Cruelty | 56 Marriage |
| 15 Danger | 57 Modesty |
| 16 Death | 58 Money |
| 17 Decadence | 59 Mourning |
| 18 Deceit | 60 Mystery |
| 19 Desire | 61 Nature |
| 20 Earthy | 62 Passion |
| 21 Energy | 63 Peace |
| 22 Erotic | 64 Penance |
| 23 Eternity | 65 Power |
| 24 Evil | 66 Personal power |
| 25 Excitement | 67 Purity |
| 26 Family | 68 Radicalism |
| 27 Femininity | 69 Rational |
| 28 Fertility | 70 Reliable |
| 29 Flamboyance | 71 Repels Evil |
| 30 Freedom | 72 Respect |
| 31 Friendly | 73 Royalty |
| 32 Fun | 74 Self-cultivation |
| 33 God | 75 Strength |
| 34 Gods | 76 Style |
| 35 Good Luck | 77 Success |
| 36 Gratitude | 78 Trouble |
| 37 Growth | 79 Truce |
| 38 Happiness | 80 Trust |
| 39 Healing | 81 Unhappiness |
| 40 Healthy | 82 Virtue |
| 41 Heat | 83 Warmth |
| 42 Heaven | 84 Wisdom |

years sea level



8000 80m



TOTAL CONTRIBUTIONS

Antarctic ice sheet
(South Pole)
61m

1000 20m

Greenland ice sheet
7m

West Arctic ice sheet
6m

8m

7m

400 6m

5m

300 4m

200 3m

2m

100 1m



Heating ocean
expanding
1m per century



Already happened
20-40cm

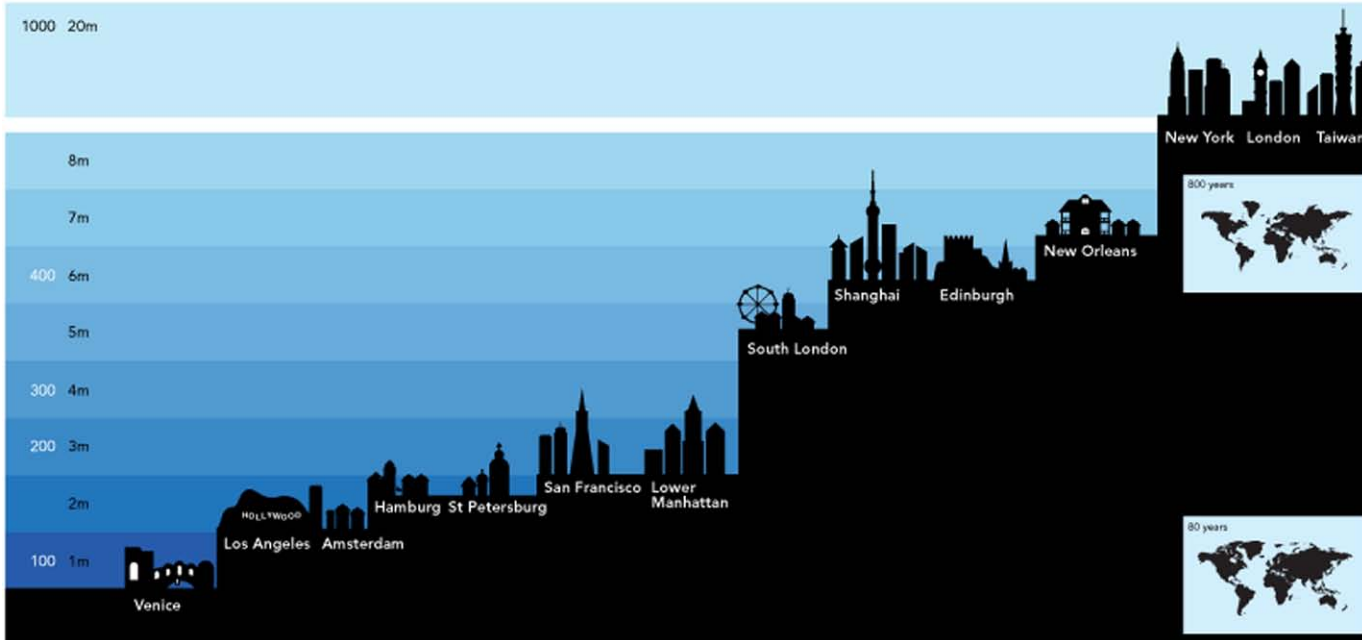

Opposite |

Illustration a.2: *Colours in Culture.* Information graphic illustrating what various cultures associate with different colours (McCandless, 2009: 76)

This page |

Illustration a.3: *When Sea Levels Attack.* Information graphic indicating rising sea levels (McCandless, 2009: 74)

+ Projections

Images, graphics and animations projected onto different surfaces.

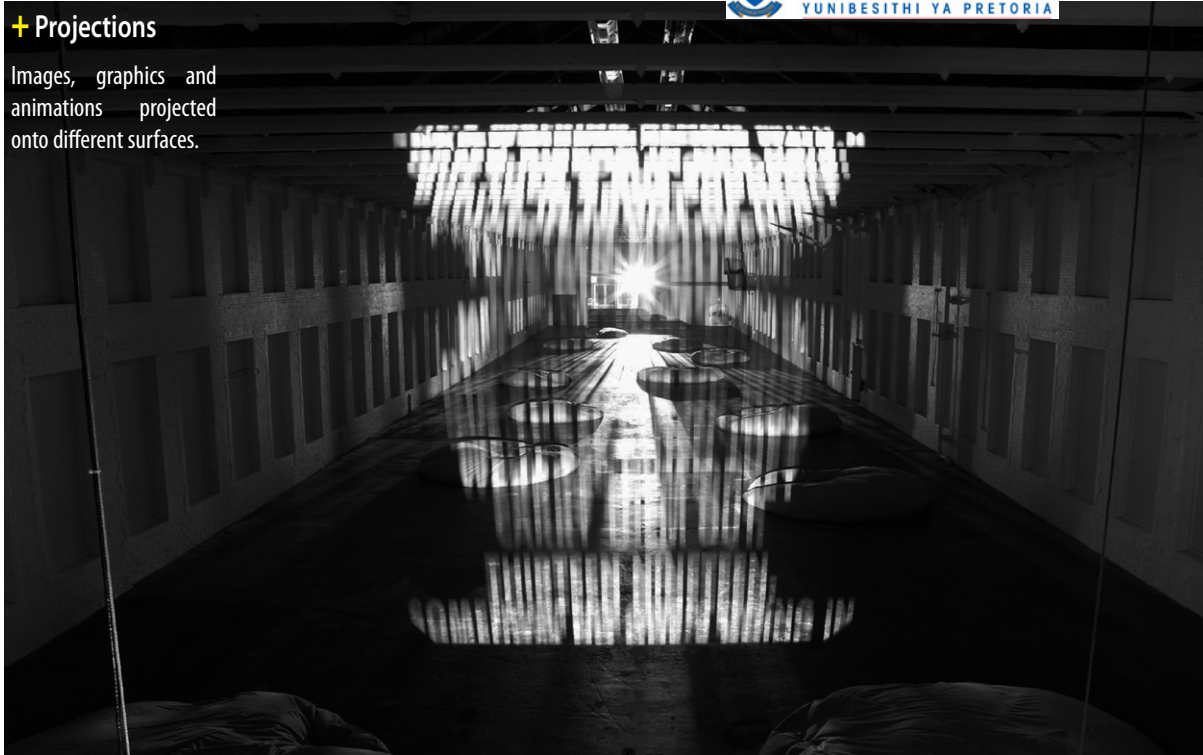

Left to right |

Illustration a.4: *Projections* by Jenny Holzer, Massachusetts Museum of Contemporary Art, 2007 (Johnson, 2007)

Illustration a.5: *Projections* by Jenny Holzer, Unknown Location, 2007 (Johnson, 2007)

Illustration a.6: *Projections* by Jenny Holzer, Massachusetts Museum of Contemporary Art, 2007 (Johnson, 2007)





+ Projection Mapping

Images, graphics and animations projected onto a three dimensional surface. A digital map of the surface has to be created in order for the projections to be displayed accurately.

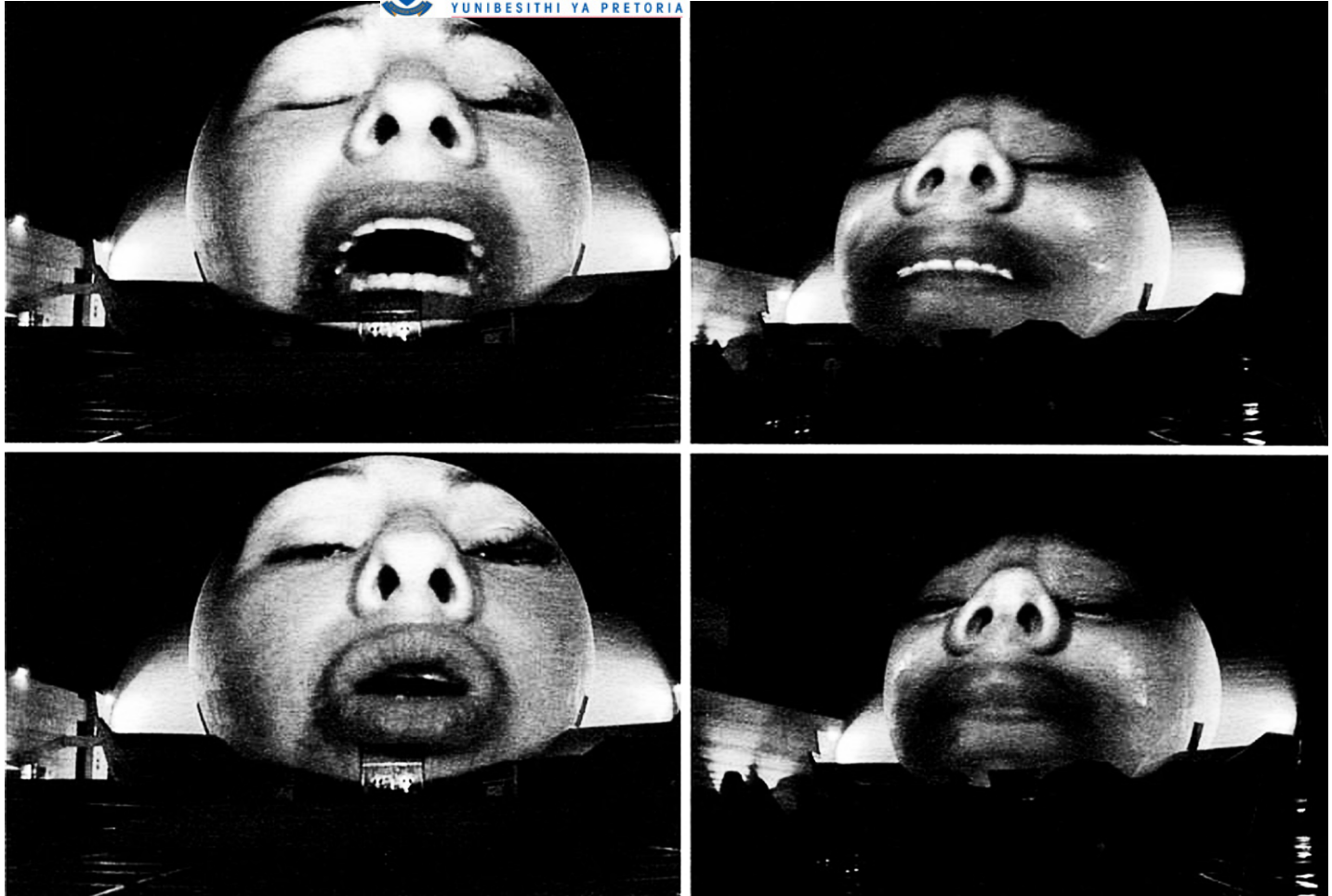
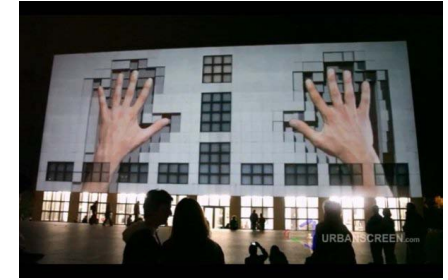

Illustration a.7:

Tijuana Projection by Krzysztof Wodiczko,
Tijuana, Mexico (HTFA, 2010)



Left to right (top to bottom) |

Illustration a.8: Fremont Troll sculpture with a video art projection. Here, the face is replaced with one of a Native American Chief. (Unknown Artist, 2004)

Illustration a.9-a.11: 555 Kubik by Unknown Artist, Galerie Der Gegenwart, Hamburg, 2009 (Leeb, 2009)

+ Interactive Projection

Primal Source is an example of an interactive digital artwork projected onto water vapour. The projected graphics are animated according to the noise levels and types of sounds surrounding the installation.

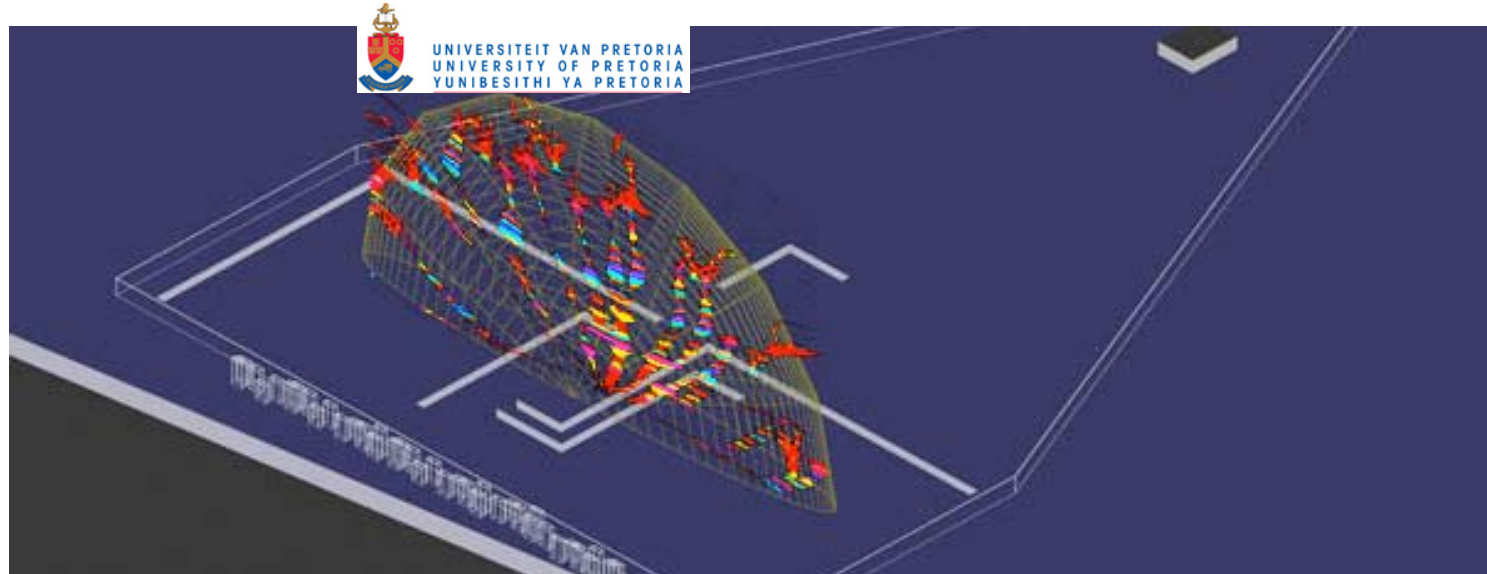
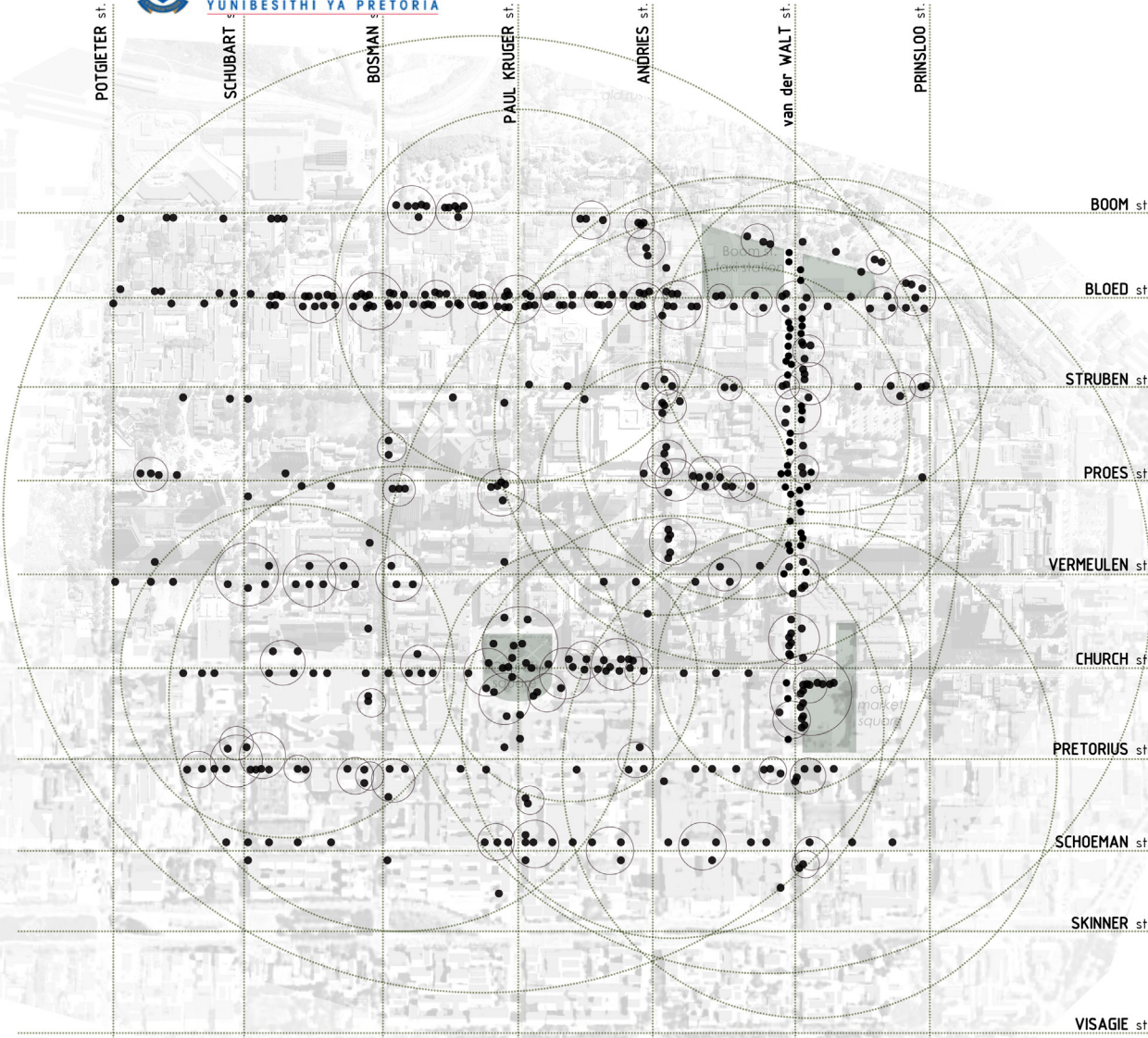

Illustration a.12:

Primal Source by Usman Haque, GLOW festival, Santa Monica pier, Santa Monica, 2008 (NOTCOT Archives, 2008. Edited by Author)







+ Experimental Mapping Exercise

An investigation was conducted into the way urban surfaces are used and what alternative elements are introduced for 'sitting' by city dwellers, in order to determine certain shortcomings in the existing urban environment.

+ Aim of the exercise:

- 01 | Identifying hidden patterns within the city
- 02 | Exploring whether or not the urban surfaces are used as intended
- 03 | To determine what edge conditions architecture should encourage on the street edge

Figure b.1:
Map indicating informal vendor distribution within the mapping area (Author & other students, 2011)

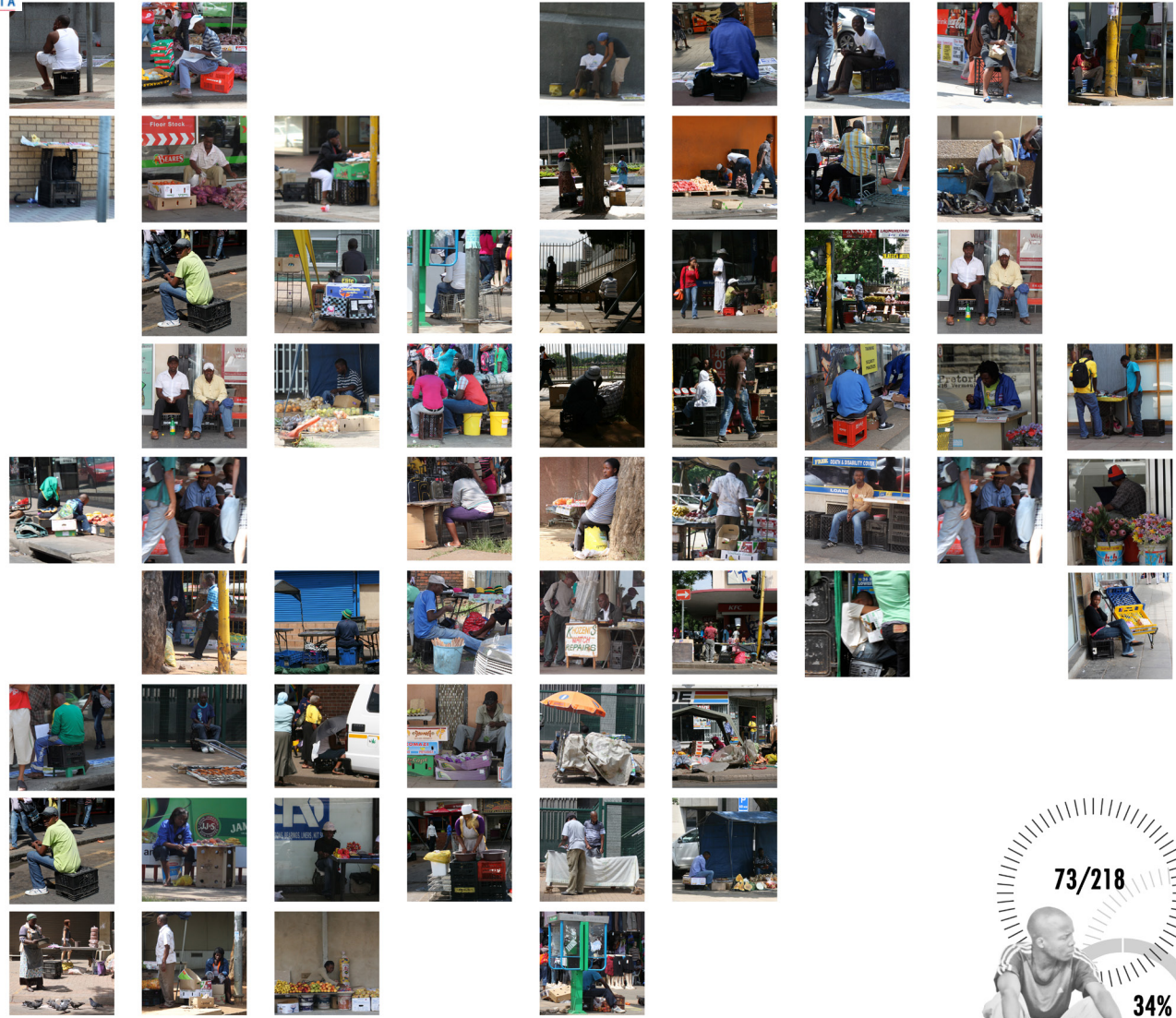

Figure b.2: Photographs of percentage of seating by adaptation, in graph form (Author & other students, 2011)

+ Seating by Adaptation

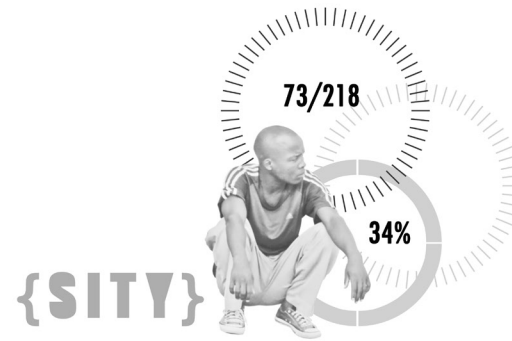



Figure b.3:
Photographs of percentage of seating by acquisition,
in graph form (Author & other students, 2011)

+ Seating by Acquisition

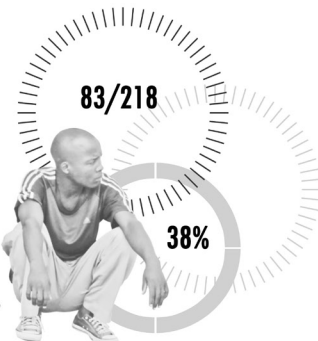



Figure b.4:
Photographs of percentage of seating by appropriated urban surface, in graph form (Author & other students, 2011)

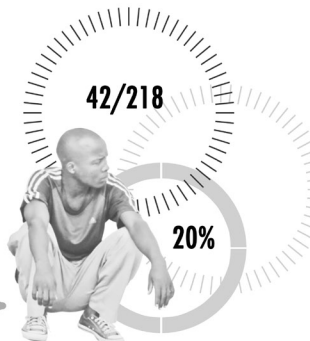
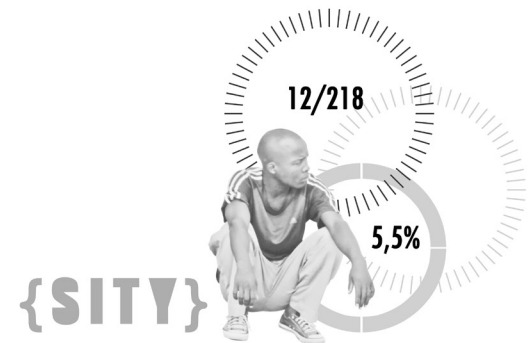



Figure b.5:
Photographs of percentage of
seating by re-use, in graph form
(Author & other students, 2011)

+ Seating by Re-use

Appendix B





+ Findings & Conclusions

- 01 | Where urban surfaces are appropriateable they are favoured (walls & steps)
- 02 | If no urban surface allows for re-appropriation, external seating elements are introduced. This indicates that there is not enough correctly designed seating in the city.
- 2.1 | Crates are used by vendors who bring their produce in it (mostly edible products ex. potato chips and sweets)
- 2.2 | Plastic chairs are mostly used by vendors who bring their products in boxes (can't sit on it, ex. fresh fruit)
- 2.3 | Office chairs mainly occur at more permanent vendors such as barbers or stalls that utilise electricity (telephone services)
- 03 | Formal seating is used for recreation by pedestrians, not vendors, due to its placement outside of the main pedestrian stream. Informal seating is used by traders. Building edges should allow for appropriation by introducing steps or low walls
- 04 | In certain high energy areas vendors prefer to sit with their back toward the street as the main pedestrian flow occurs on the 'inside' of the sidewalk.
- 05 | The concentration of people and spaza shops are in the direct vicinity of transport nodes and on main pedestrian routes
- 06 | Products sold vary in different urban and commercial sectors, therefore products are an indication of the area's commercial activity
- 07 | Vendors are mostly found on streets. Streets have become the new public spaces and should be designed accordingly
- 08 | Architecture mainly provides horizontal elements or surfaces, thus a lack of vertical elements exist
- 09 | Old buildings are preferred by informal traders as most contemporary architecture does not allow for appropriateable urban surfaces
- 10 | Pedestrian and vendor congestion shifts daily according to shading patterns (shaded areas are congested in summer, while sunny areas are favoured in winter). For this reason, deciduous trees are the most appropriate shading devices for undefined street edges as it promotes comfort during all seasons.

Figure b.6:
Photographs of percentage of seating by design, in graph form (Author & other students, 2011)

+ Seating by Design

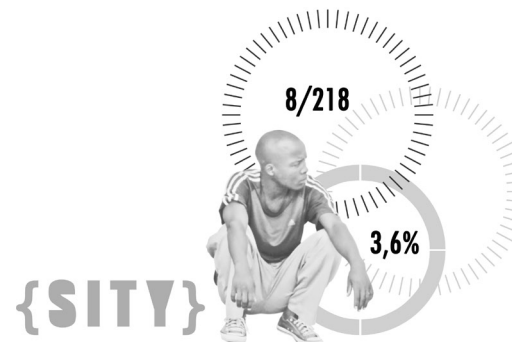

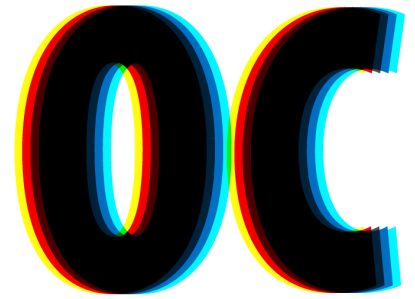

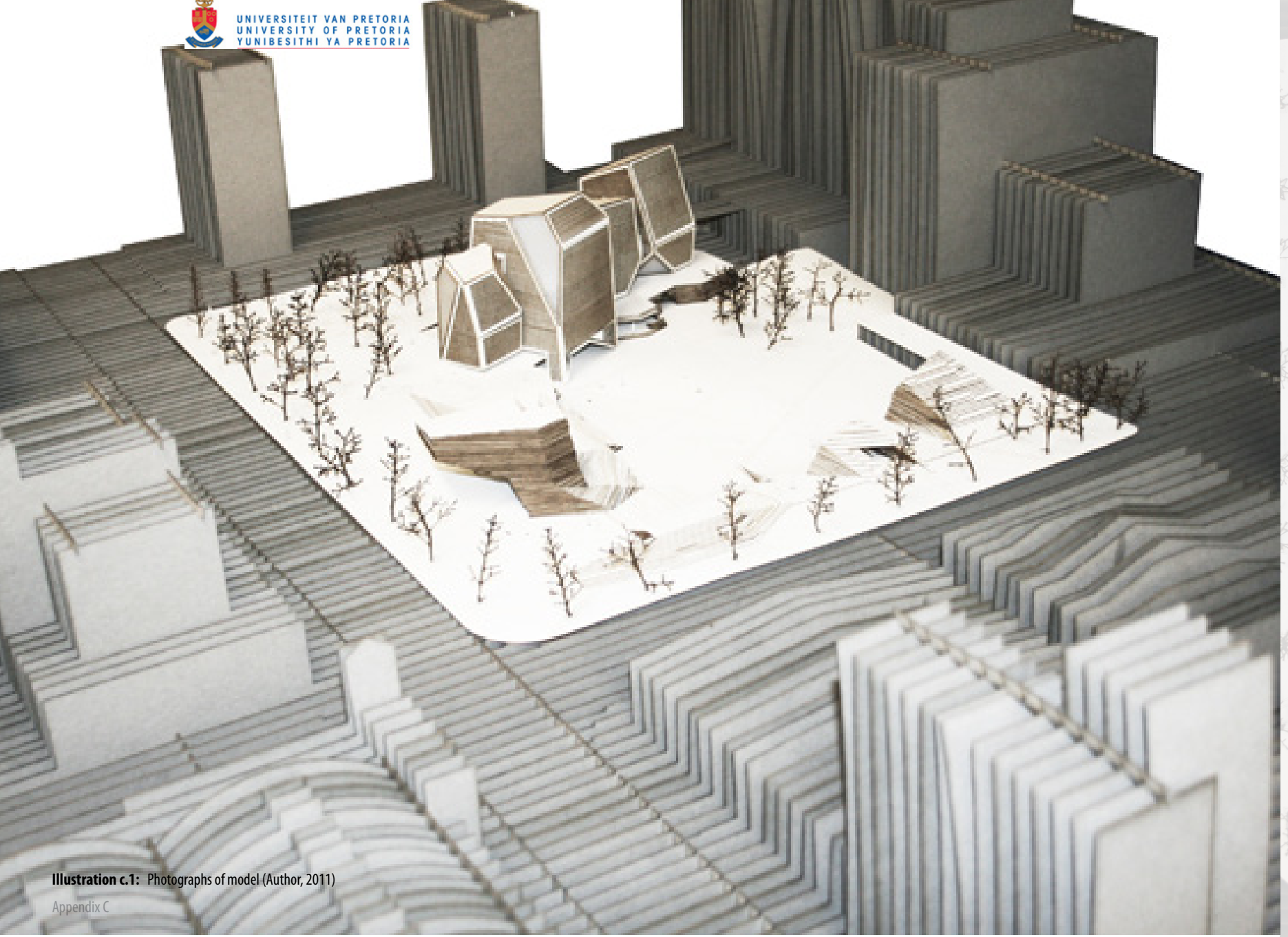

Illustration c.1: Photographs of model (Author, 2011)

