



Site Analysis

+ Urban Mapping

Various mappings of Van der Walt Street inform the design as well as indicate different manners in which different edge conditions are used by city dwellers and the influences thereof:

- 01| Interactive edges (*fig. 8.2*) are often associated with a large amount of informal trading (*fig. 8.3*) as well as a pedestrian on a leisurely stroll (*fig. 8.4*), whereas a fenced-off or hard edge has little to no informal traders, a low energy concentration of pedestrians as well as a fast paced walking speed due to unfavourable conditions.
- 02| Small recesses in the street edge (i.e. articulated shop entrances) implies an inevitable concentration of informal traders and social interaction (*fig. 8.3*).
- 03| Interactive of textured edges (*fig. 8.2*) that provide an overhang or has a lane of deciduous trees on the sidewalk make for more ideal conditions. These edges encourage a slower pedestrian pace (*fig. 8.4*), which in turn encourages trading possibilities as well as interaction with the urban environment and other city dwellers.
- 04| A lane of deciduous trees is more favourable in winter, as it does not cast shadows and create cold spaces that encourage a higher pedestrian pace and discourage informal traders.
- 05| A concentration of informal traders occur on the Western street edge due to sunny conditions in the mid morning and shadows cast by buildings in the afternoon (*fig. 8.3*). The traders situated on the Eastern edge of Van der Walt Street utilise makeshift shading devices or gazebos. The opposite of this is true during winter months.
- 06| Areas around main taxi ranks (*fig. 8.5*) are also the preferred location for informal traders (*fig. 8.3*) as it is more convenient for consumers to acquire produce in the proximity of a transport node, as opposed to carrying it far distances.
- 07| Loose food products are sold towards the eastern part of Van der Walt Street where there is a lower pedestrian energy level and few taxi ranks, assumingly because it is intended for immediate consumption, whereas larger quantities are available toward the Northern periphery.
- 08| Private parking often causes a negative space between the static vehicle and the built edge. It is evident that this condition discourages high energy levels, social interaction and informal trading (*fig. 8.3 & fig. 8.5*). Public transport parking, however, seem to be promoting the exact opposite situation where it acts as a catalyst for events and activities.

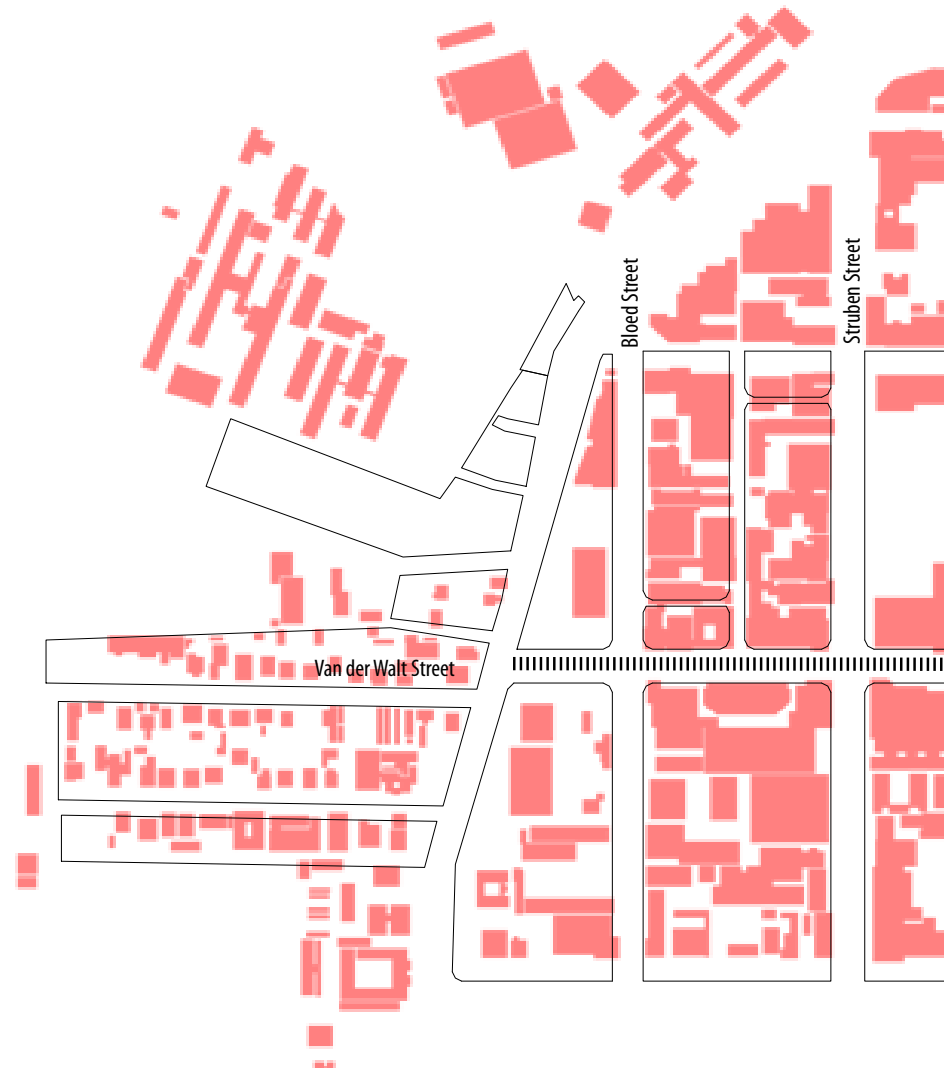

From top to bottom |

Figure 8.1: Mapping area of Van der Walt Street, Munitoria indicated in grey (Author, 2011)

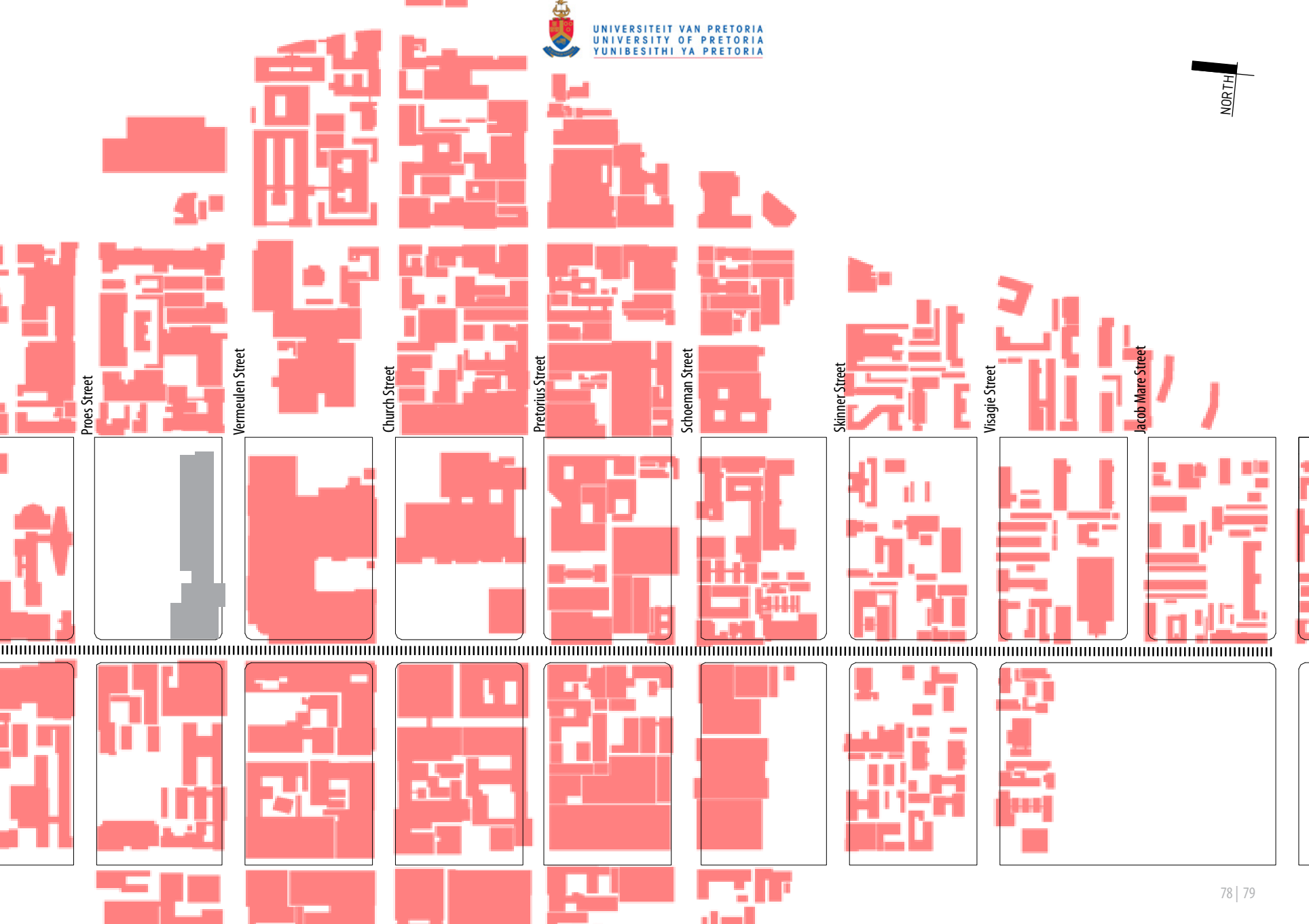

Proes Street

Vermeulen Street

Church Street

Pretorius Street

Schoeman Street





Skinner Street

Visagie Street

Jacob Mare Street



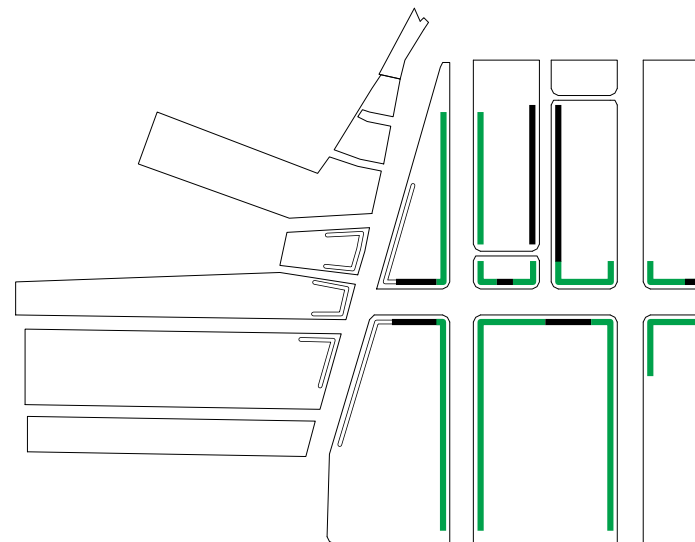

+ Edge conditions

-  textured edge
-  active edge allowing interaction
-  hard edge minimal interaction
-  fenced, excluding or controlled edge



+ Formal & informal trading

-  inactive formal trading
-  active formal trading
-  informal trading

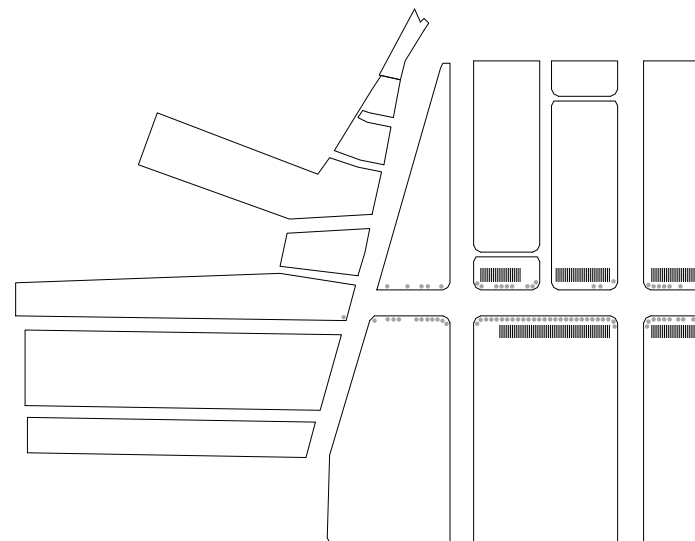

From top to bottom |



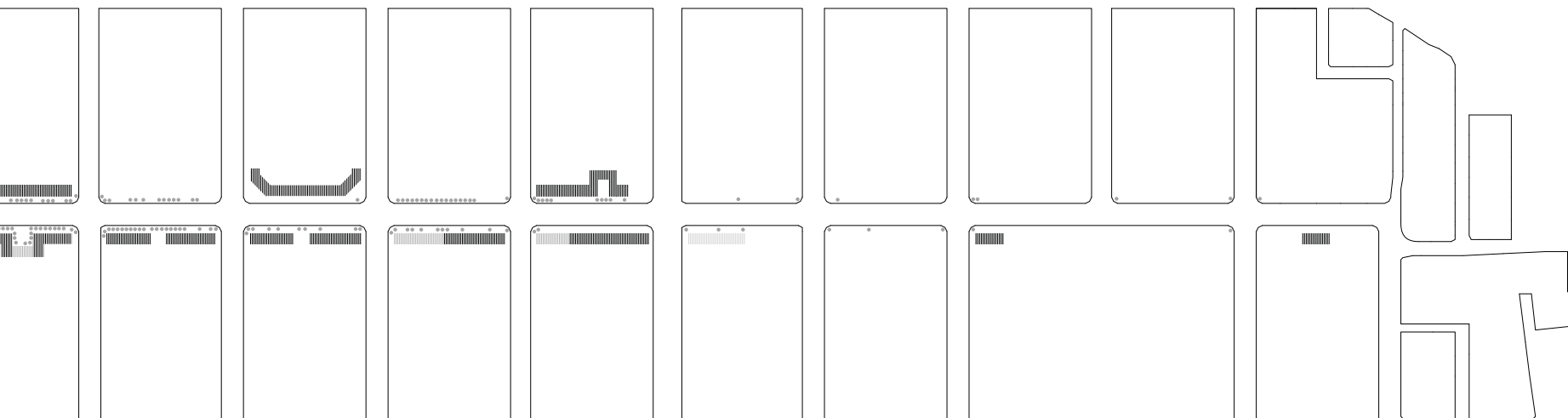
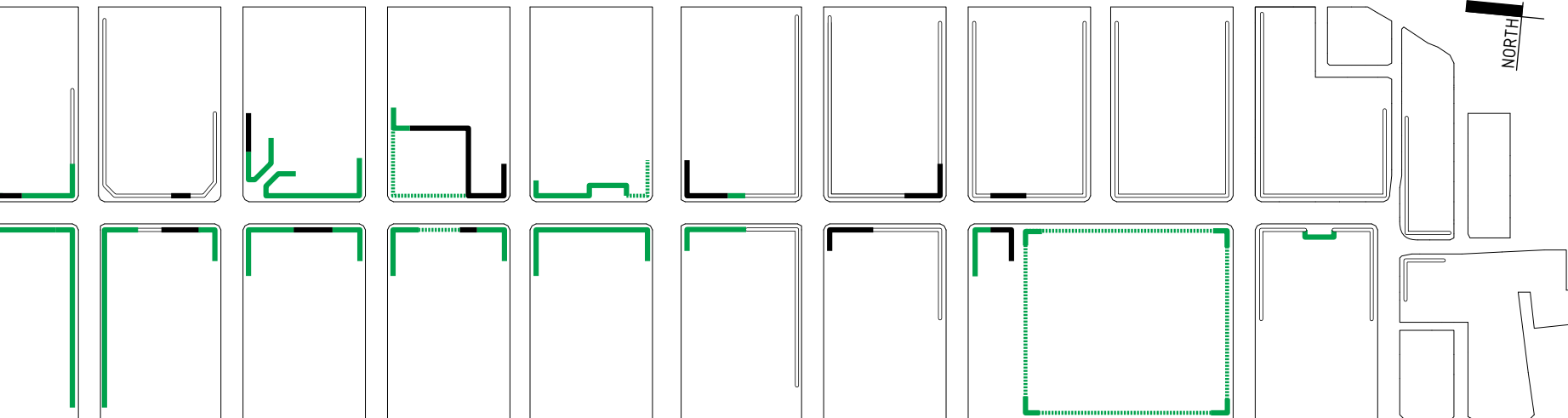

Figure 8.2: Mapping of edge conditions in Van der Walt Street (Author, 2011)

Figure 8.3: Mapping of formal and informal trading in Van der Walt Street (Author, 2011)





+ Pedestrian pace

-  leisurely stroll
-  fast pace
-  slow pace
-  movement interruption due to high vehicular traffic
-  movement interruption due to vehicular traffic

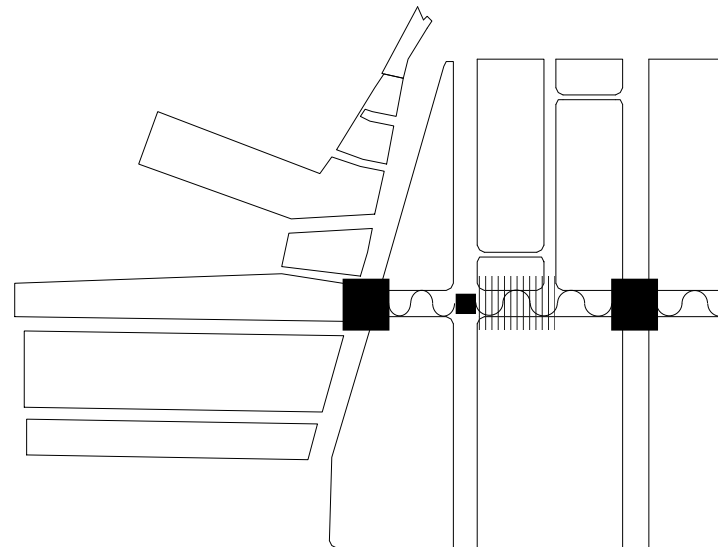

+ Public Transport Infrastructure

-  bus stop
-  ===== taxi stop or taxi rank
-  - - - - - private vehicle stops or private parking

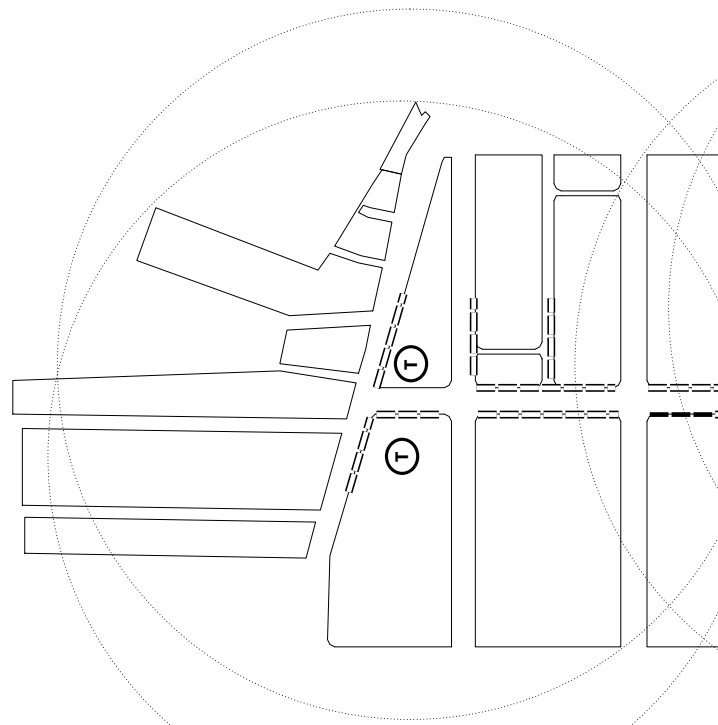

From top to bottom |

Figure 8.4: Urban mapping of pedestrian pace in Van der Walt Street (Author, 2011)

Figure 8.5: Urban mapping of public transport infrastructure in Van der Walt Street (Author, 2011)

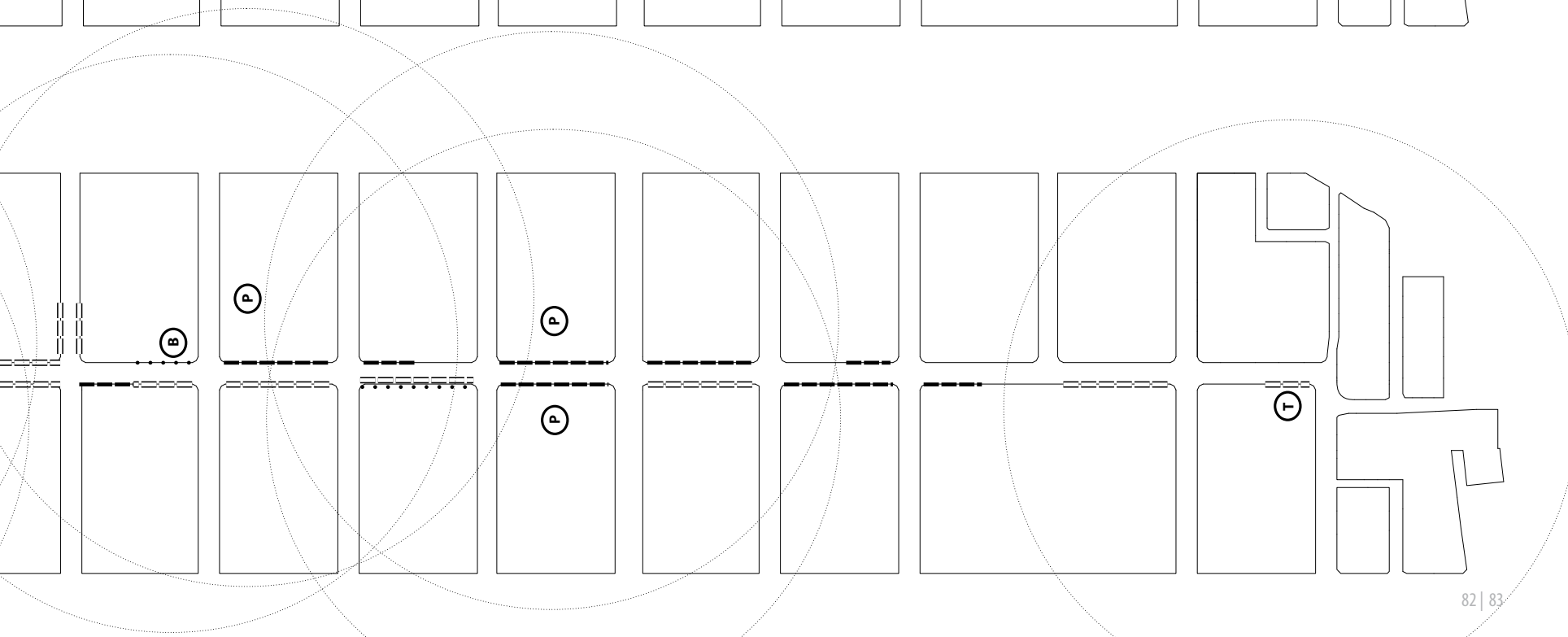
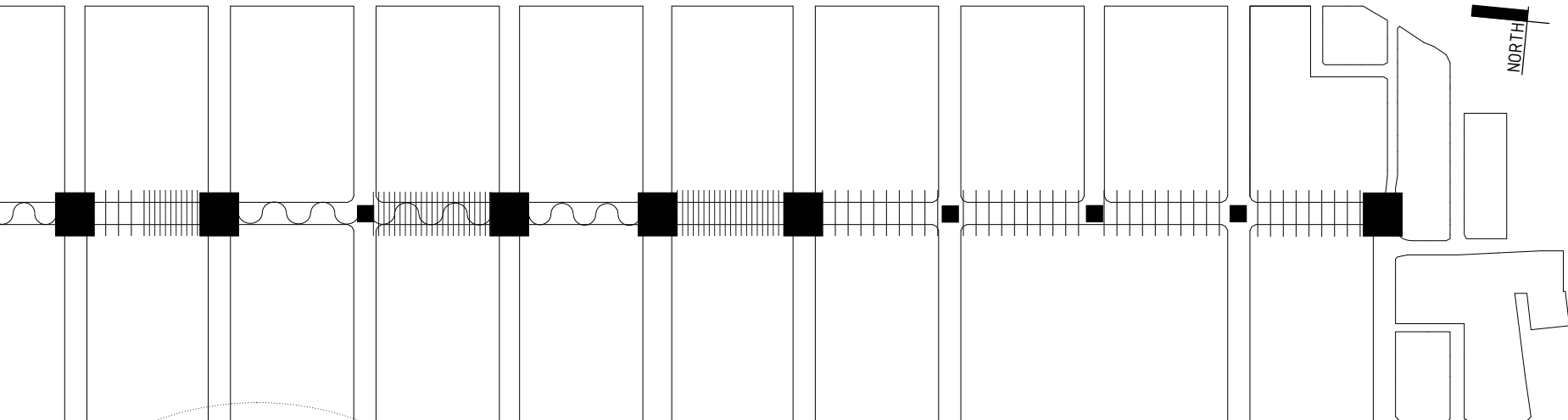



UNIVERSITEIT VAN PRETORIA
UNIVERSITY OF PRETORIA
YUNIBESITHI YA PRETORIA

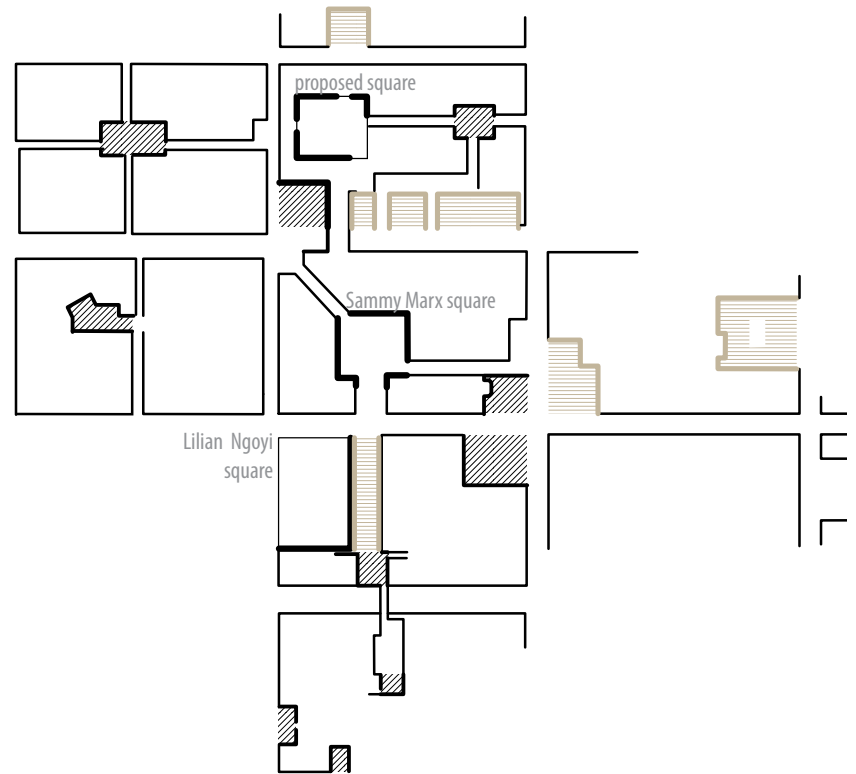

Site Development

+ Urban Cavity as a Proposed Square

According to hierarchical public space principles, the site is ideally located to propose a public square (as also proposed in most existing urban frameworks for the precinct). This square could fulfil the dual function of acting as an entrance *foyer* to a new entrance for the Munitoria building, as well as a public interface with the building itself.

“Community facilities scattered individually through the city do nothing for the life of the city”
- Christopher Alexander (1977)

Alexander (1977) argues that the available public spaces are scattered too thinly across urban communities. He states that studies have shown that people naturally seek out concentrations of people. In order to create these concentrations, facilities must be grouped densely around smaller public spaces which function as nodes - with most pedestrian movement in the community organised to pass through these nodes.

These nodes require four properties:

- 01 | The surrounding programmes should be selected according to their symbiotic relationship in order to react in a cooperative manner
- 02 | The square should be of an appropriate scale (not too large) in order to concentrate activity
- 03 | Main pedestrian routes in the surrounding neighbourhood should converge within the space
- 04 | Nodes must be distributed evenly throughout the community

This square would become a node in a network of distributed public spaces (*fig. 8.6*) which are made accessible via existing pedestrian routes as well as proposed inter-block movement routes. An intimate square is created by placing the new interventions (public buildings) around the perimeter of the square as defining thresholds.

Opposite | left to right

Illustration 8.1: Photograph of the remaining urban cavity with the *Transvaal building* in the background (Author, 2011)

Figure 8.6: Diagram illustrating a part of the public space network of which the proposed square forms part (Author, 2011)

This page |

Illustration 8.2: Photograph of the remaining urban cavity (Author, 2011)





The urban cavity is overlaid with a rich layer of temporal' strata; the column grid of the burnt down West wing, visible remains of the floor plan, previous paint layers as well as portions of floor tiles, are all visible and preserved. It is of great importance to conserve this layer as it conveys a connection with time as well as the site's history. It also adds value and character to the place by evoking a sense of nostalgia.

Illustration 8.3: Photograph illustrating the temporal strata on the surfaces in the urban cavity (Ahmed Alkayyali, 2011)

+ Spatial Development

The development of the *urban cavity* needs to be addressed very delicately as it holds a great deal of potential for the rejuvenation of its immediate surroundings, but could similarly create various urban problems. The following spatial *parti* diagram illustrates the proposed edge conditions and spatial planning strategies.

01 | Current condition:
Current existing thresholds, creating negative space within the urban environments (urban cavity).



02 | Negative condition:
Filling the cavity with an imposing architecture would create a semi permeable and access-controlled space. The temporal layers are covered by a single ideology.



03 | Positive condition:
Creating a penetrable edge condition around of the cavity would preserve the rich temporal layers as well as define the public square.



04 | Developed positive condition:
Creating access to the square in the form of a transitional space that bridges the level difference between the street and square.

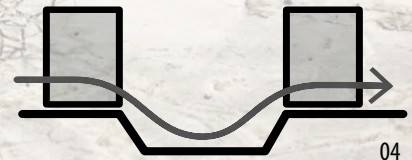

05 | Proposed ideal condition:
Programming the vertical elements to provide a privacy gradient, allowing for multifunctional space.



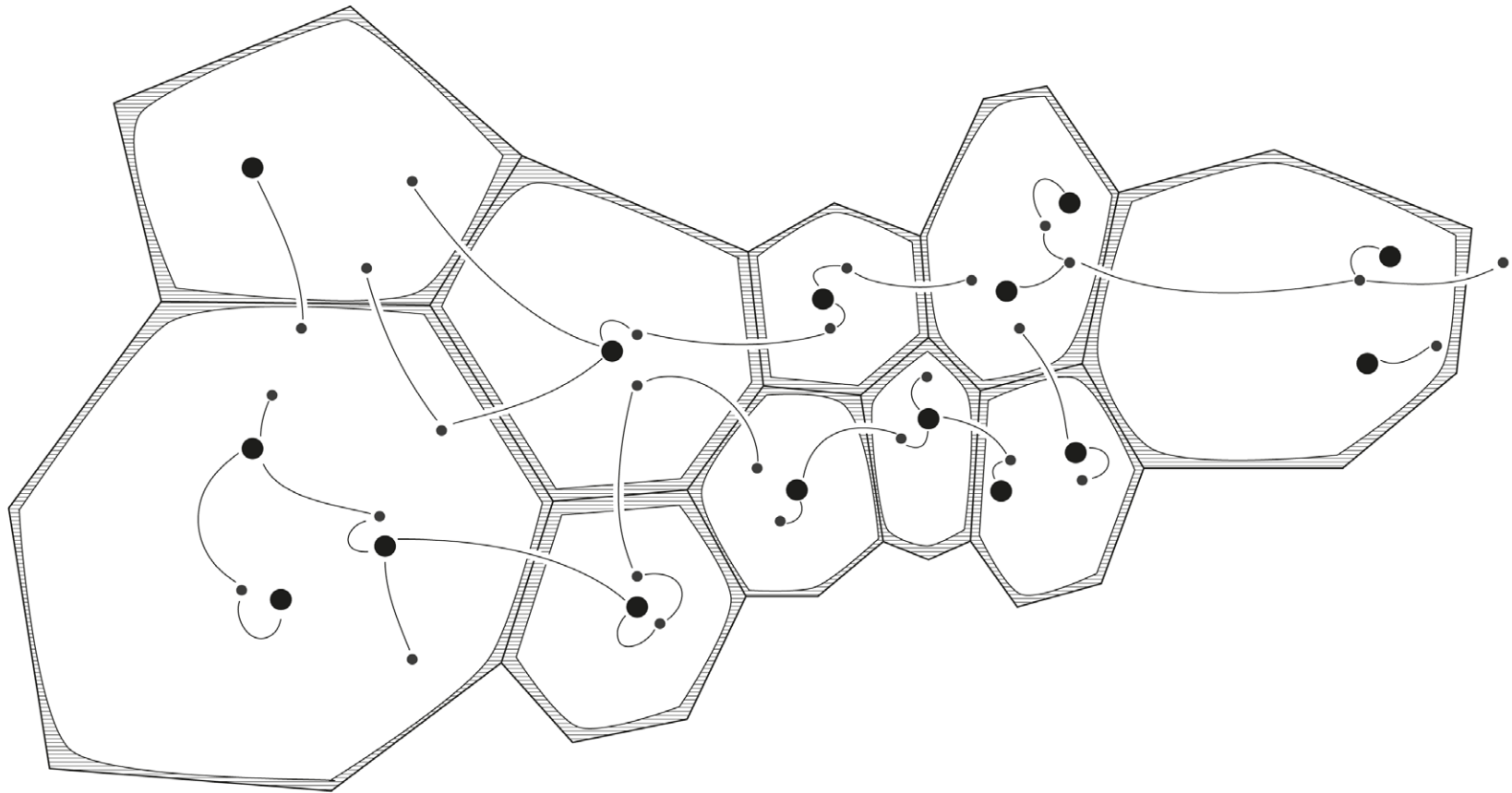

+ Osmosis: Programmable *Cell Walls*

“The cell wall of an organic cell is, in most cases, as large as, or larger than the cell interior. It is not a surface which divides inside from outside, but a coherent entity in its own right, which preserves the functional integrity of the cell but also provides for a multitude of transactions between cell interior and the exterior ambient fluids. Therefore, the cell wall is a place in it’s own right.” (Alexander, 1977: 87)

The proposed alterations to the existing edge conditions create multiple thresholds. Each threshold may be individually programmed to create interfaces, each dedicated to a specific urban function (creating urban opportunities as proposed in the urban framework), similar to the membranes surrounding cells. As stated by Alexander, these membranes are “spaces in their own right” that “provide a multitude of transactions between the interior and the exterior.”

This page |

Figure 8.8: Diagram illustrating the concept of osmosis (Author, 2011)

Opposite |

Figure 8.9: Diagram illustrating the current street edge condition and thresholds (Author, 2011)

Figure 8.10: Diagram illustrating the proposed street edge condition - introducing multiple thresholds (Author, 2011)



+ Multiple Thresholds

The current condition creates only three thresholds, of which none are specifically dedicated to pedestrian use. Through bridging the level difference and introducing structure, the number of thresholds is increased to seven. Each of the thresholds may be programmed to accommodate a different urban function (urban opportunity), thereby creating a multi layered, functional urban interface. The programming of thresholds will be a form generator in the design process.

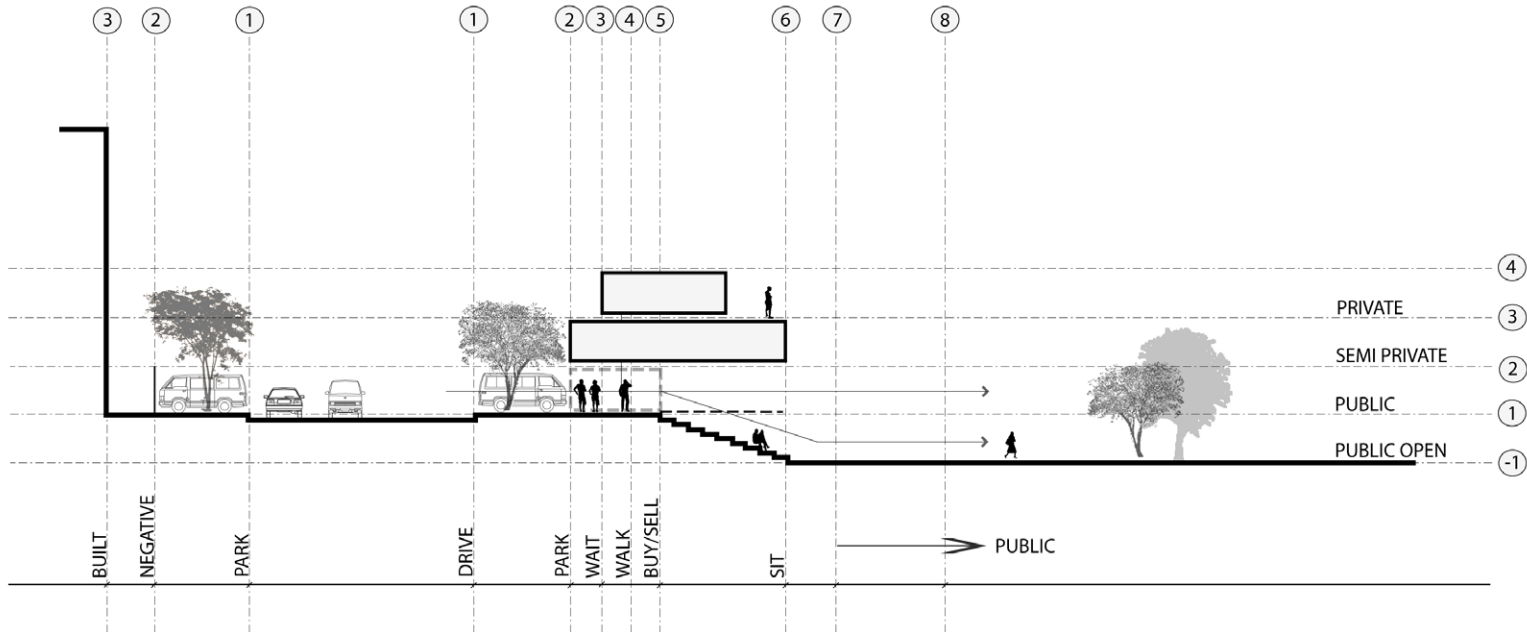
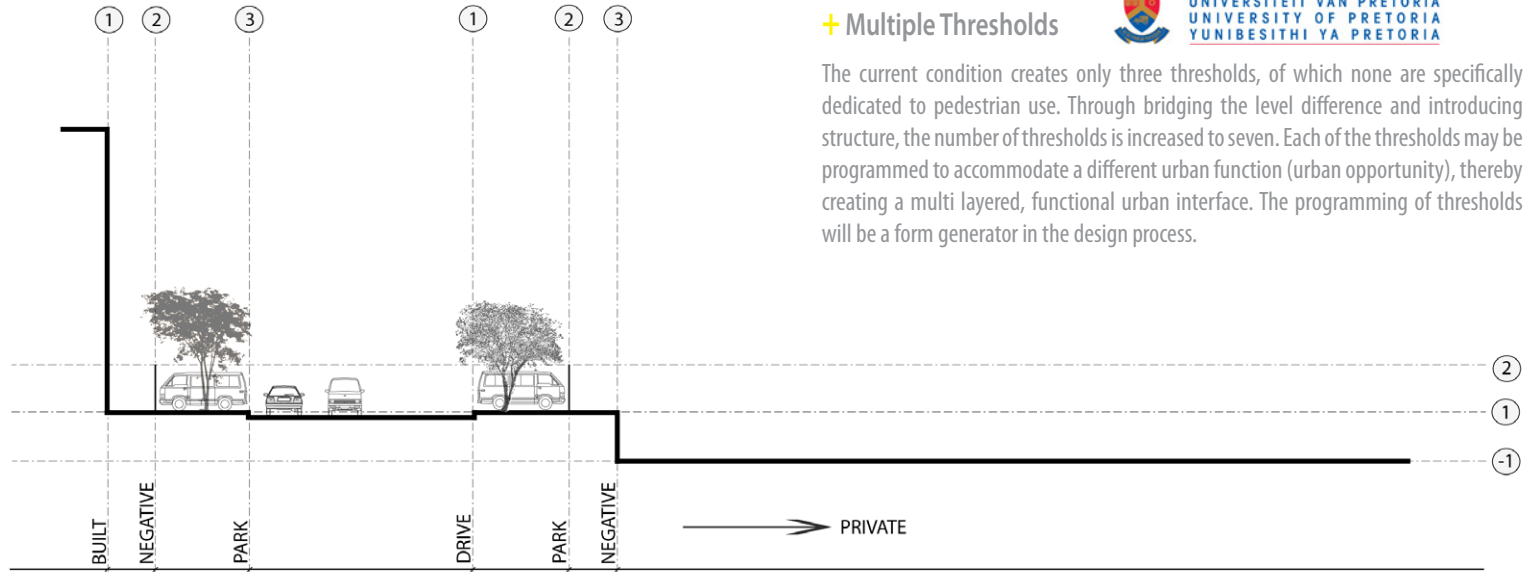

+ Programmatic Symbiosis

The two proposed interventions (Ahmed Alkayyali's *Stairway* and the *Digital Art Pavilion*) attempt to create a form of programmatic symbiosis¹. This is to be achieved through the overlapping of cooperative programmes and the sharing of common interests. Through the intersection of programme, a supportive background is created for each of the individual proposals.

Cooperative Concept:

The establishment of a supportive background for public activity and perception through the process of "making aware." Thereby presenting a different "way of looking".

The common denominator between the programmes, being the "process of making aware", responds to a temporal² layer captured within the site, ranging from past through to the present and projecting into the future: *Munitoria* personifies the past and past ideals, *the Stairway* project creates an awareness of present through encouraging everyday activities, whilst the *Digital Art Pavilion* showcases the future in terms of the latest technological advances and possibilities.

Common interests induce a physical symbiotic relationship, where *the Stairway* becomes an amphitheatre to the *Digital Art Pavilion* on occasion (public events where the façade of the *Pavilion* is used as a projection screen for either the surveillance footage or digital art).

As mentioned in Chapter 5 (p.44), *Munitoria* embodies the nationalist approach to public buildings and the management of information. These ideals are inverted in the *Digital Art Pavilion* by challenging the archaic approach to information management and transferring, which in turn creates a programmatic link to the existing on-site facilities.

+ Introduction to Ahmed Alkayyali's Stairway (Liminal Public Infrastructure)

The project investigates the quotidian (or *everyday*) context of the city. Where the city is seen to contain both the 'settings' and the 'props' for these everyday activities. A conceptual inhabited "stairway" is proposed to bridge the level change of the urban cavity. Through the manipulation of the urban surface, the stairway brings together a multiplicity of programmes through the celebration and enhancement of the everyday context. *The Stairway* thus forms a new public building typology, whereby the inhabitation of the stairs (that form the urban surface) is identified as a new archi-type: defining liminal support architecture for an *active public space*, rather than the *static* form of public space which we find within the city.

As a result the building encloses a series of private and public space. On a public level, the stairway responds to the context by providing an inhabitable urban surface, providing amenities that support the everyday activities of the public realm. On a private level, the spaces below the stairway, which are perceived as secretive spaces, are occupied by the CCTV surveillance policing, whereby the city is surveyed on a detailed level. This intensive video surveillance is then filtered and carried over to the neighbouring digital arts pavilion, whereby artists can re-interpret the data and use it to generate various art forms. (Alkayyali, 2011)

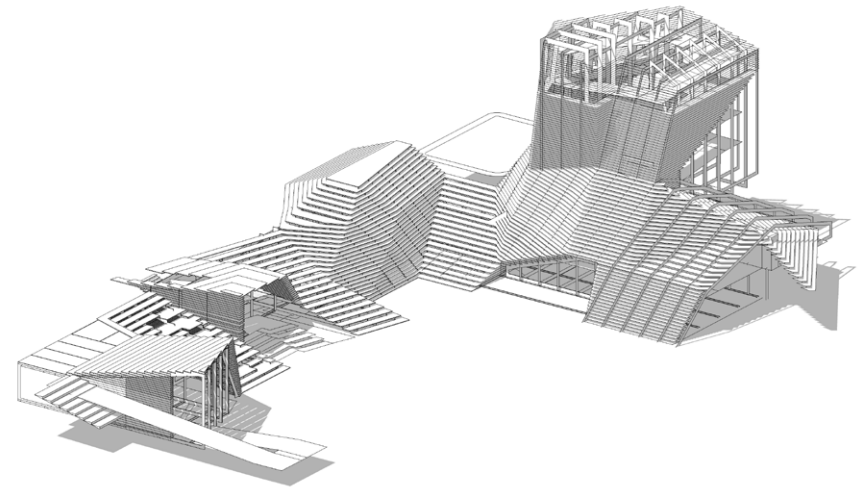























Figure 8.11: Conceptual perspective of the *Stairway* (Alkayyali, 2011)

01. A mutually beneficial relationship between different entities

02. Pertaining to time, or a connection with time

Figure 8.12:
Diagram illustrating the proposed
site development (Author, 2011)

-  housing and residential
-  commercial & institutional
-  retail & shopping
-  culture & religious
-  entertainment spaces
-  informal trading stalls
-  basement parking below
-  pedestrian activity
-  seating spaces
-  shaded green spaces
-  waiting spaces
-  public squares
-  new interventions
-  proposed buildings
-  secondary squares
-  pedestrian routes
-  arcade system
-  public transport infrastructure
-  new landscaping
-  existing palm
-  pedestrian bridge connection
- 01 *the Stairway (Alkayyali)*
- 02 *Digital Art Pavillion (Kruger)*

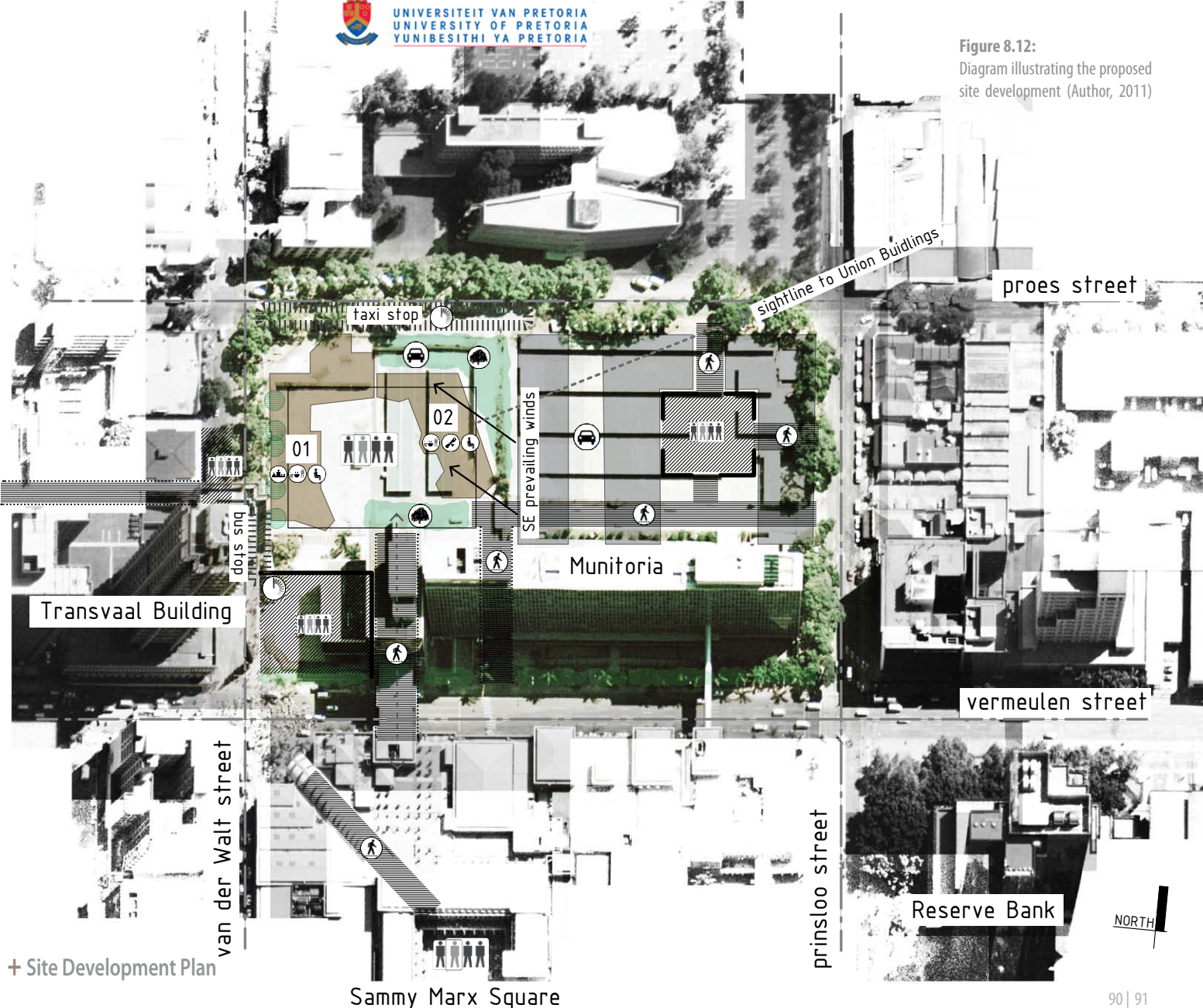

+ Site Development Plan

NORTH

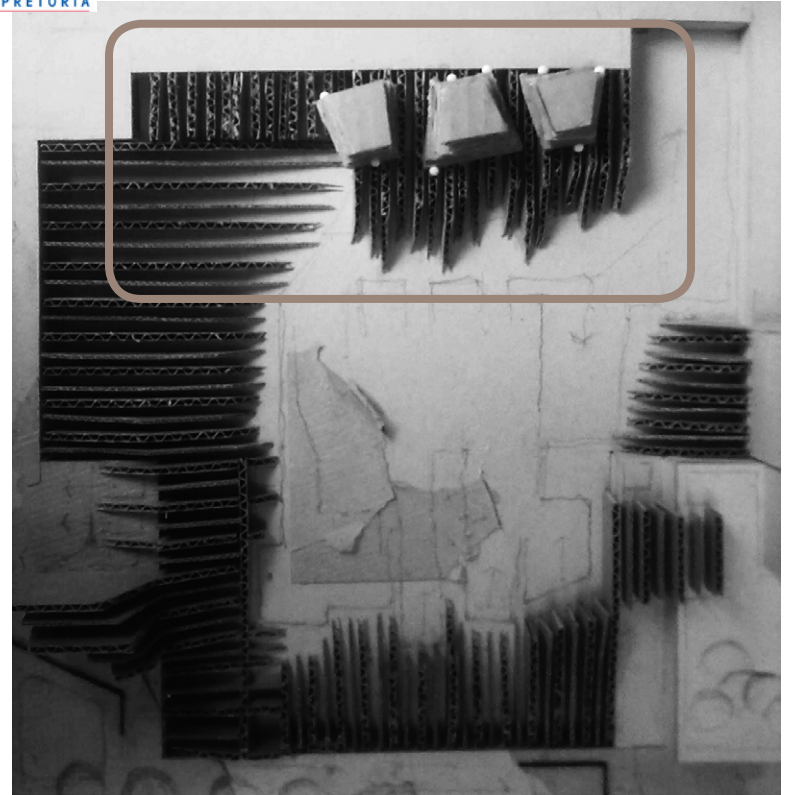
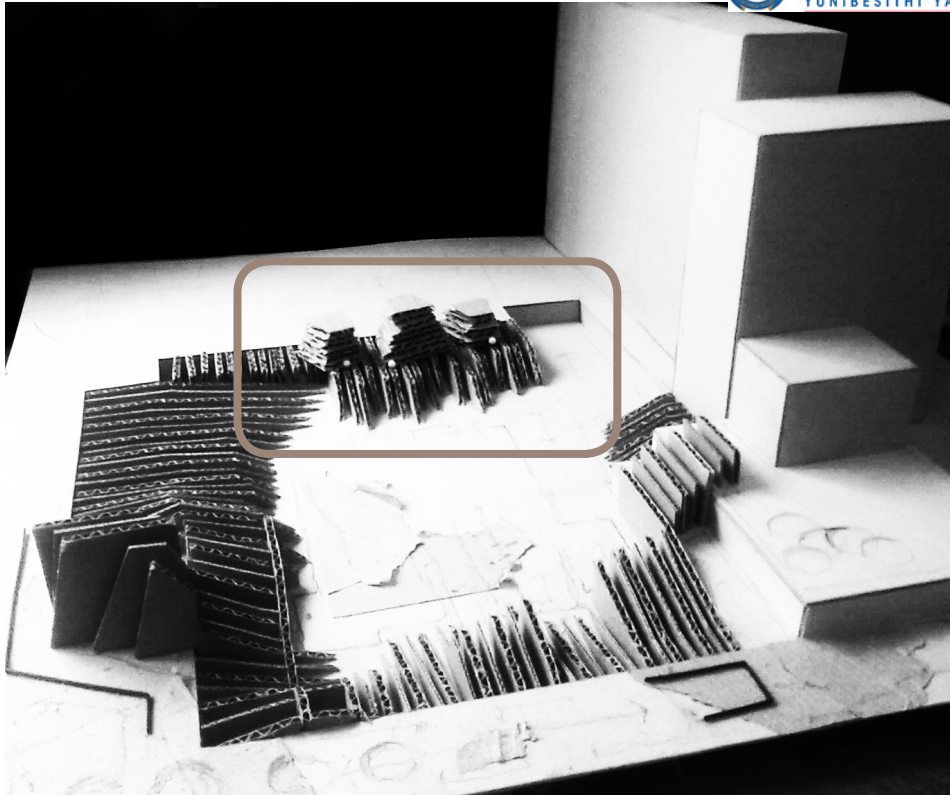

Figure 8.13:
Photographs of a concept model illustrating the symbiotic relationship between the two interventions, the *Art Pavillion* highlighted (Author, 2011)

+ Design Guidelines

01 | Formal guidelines

The emergence of *digital architecture* allows for the design of irregular forms, which were previously considered unfeasible and unpractical. This attribute of the contemporary architectural climate needs to be manifested in the design in order to provide a degree of transparency by announcing the building programme. This will also illustrate the possibilities arising in the architectural profession into the current epoch.

02 | Stereotomic vs. Tectonic

The structure is divided into permanent programmes (artist studios, information technology facilities and the café) at the base of the building, whilst temporary programmes are located in the multifunctional exhibition towers. The design should express this duality by means of material uses and massing (fragmenting masses and tectonic qualities toward the vertical elements).

03 | Square Periphery

The edge defining the public square needs to create an interactive threshold by establishing visual connections into the building, as well as providing defined seating and recreational spaces which generate an 'active' edge condition. Edge continuity is imperative in order to create a legible and clearly defined public space, especially when considering the extreme proximity of the proposed interventions. The schemes should be integrated to ensure the transition appears seamless.

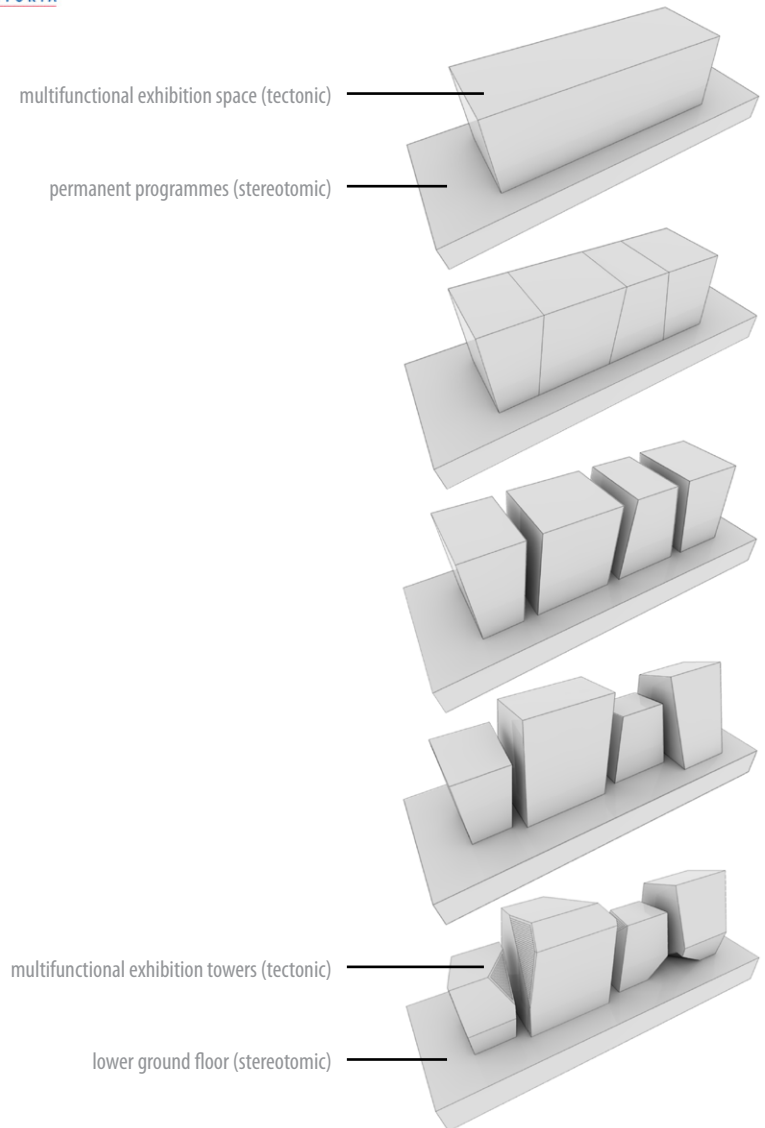
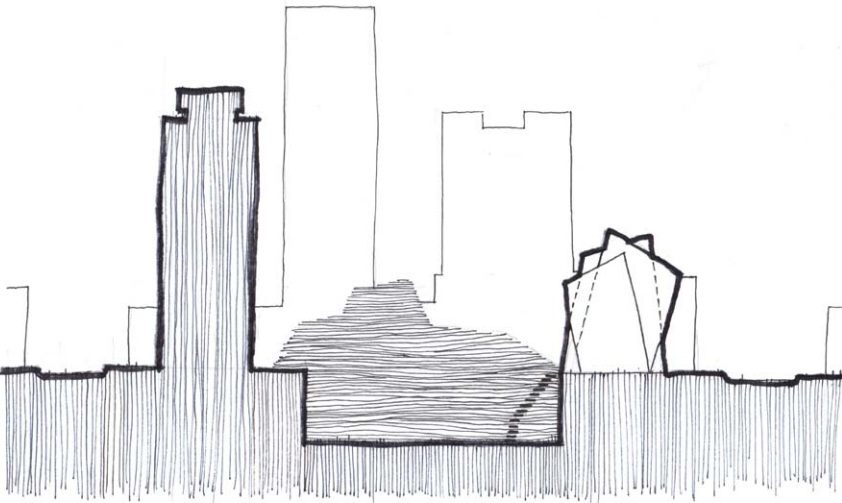

Figure 8.14: Diagram illustrating the formal development (Author, 2011)

+ Spatial Development

The orientation of the building is a result of sight lines toward the Union buildings as well as the optimization of natural ventilation due to Pretoria's South East prevailing winds (fig. 8.17). The grids are set out according to the angles in *The Staircase* project in order to echo the governing lines and create a uniform geometry.

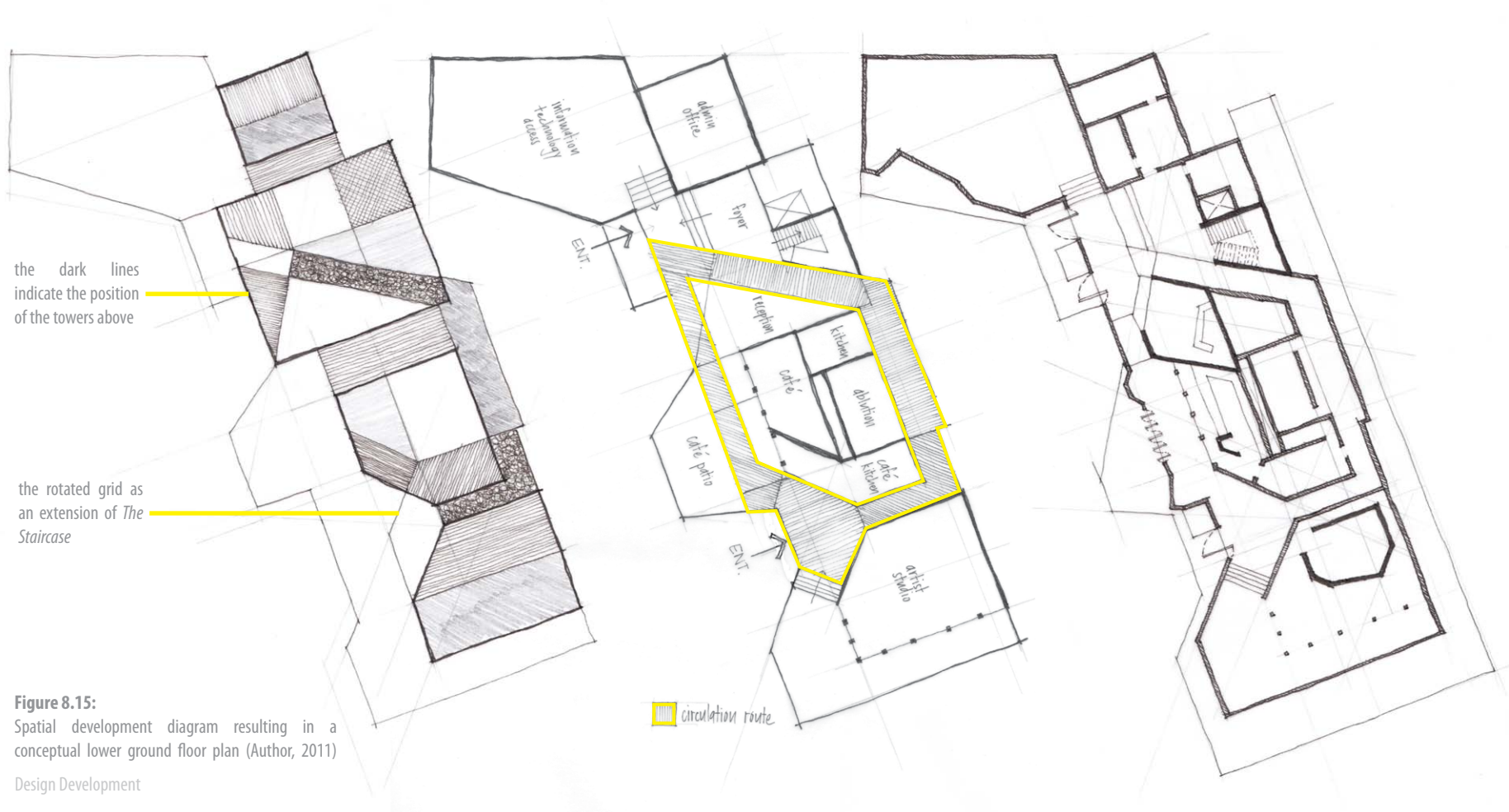

Figure 8.15:
Spatial development diagram resulting in a conceptual lower ground floor plan (Author, 2011)

+ Practical Considerations

01 | Circulation (*fig. 8.16*)

02 | Daylighting & ventilation on Lower Ground Floor - light shafts are introduced

03 | Multifunctional and adaptable exhibition spaces

Due to the nature of digital art (ranging from the size of a computer screen to the size of an entire building), the exhibition towers have to be able to accommodate various scales of exhibitions (different types of information). This calls for adaptable spaces which have the ability to alter the scale and dynamics of a space sporadically.

It also allows for various temporary programmes to be introduced into the building i.e. a nightclub for a specific events, art auctions or digital technology shows (*fig. 8.20*).

04 | Lighting requirements

Digital displays require low indirect lighting levels on the interior, while the glow of projections need to penetrate the façade from the interior outwards in order to inspire interest in passersby. This is achieved by the utilisation of a translucent, but not transparent, glazing material (see *Pilkington Profilit*™ glass system, p.100) as well as a shading screen.

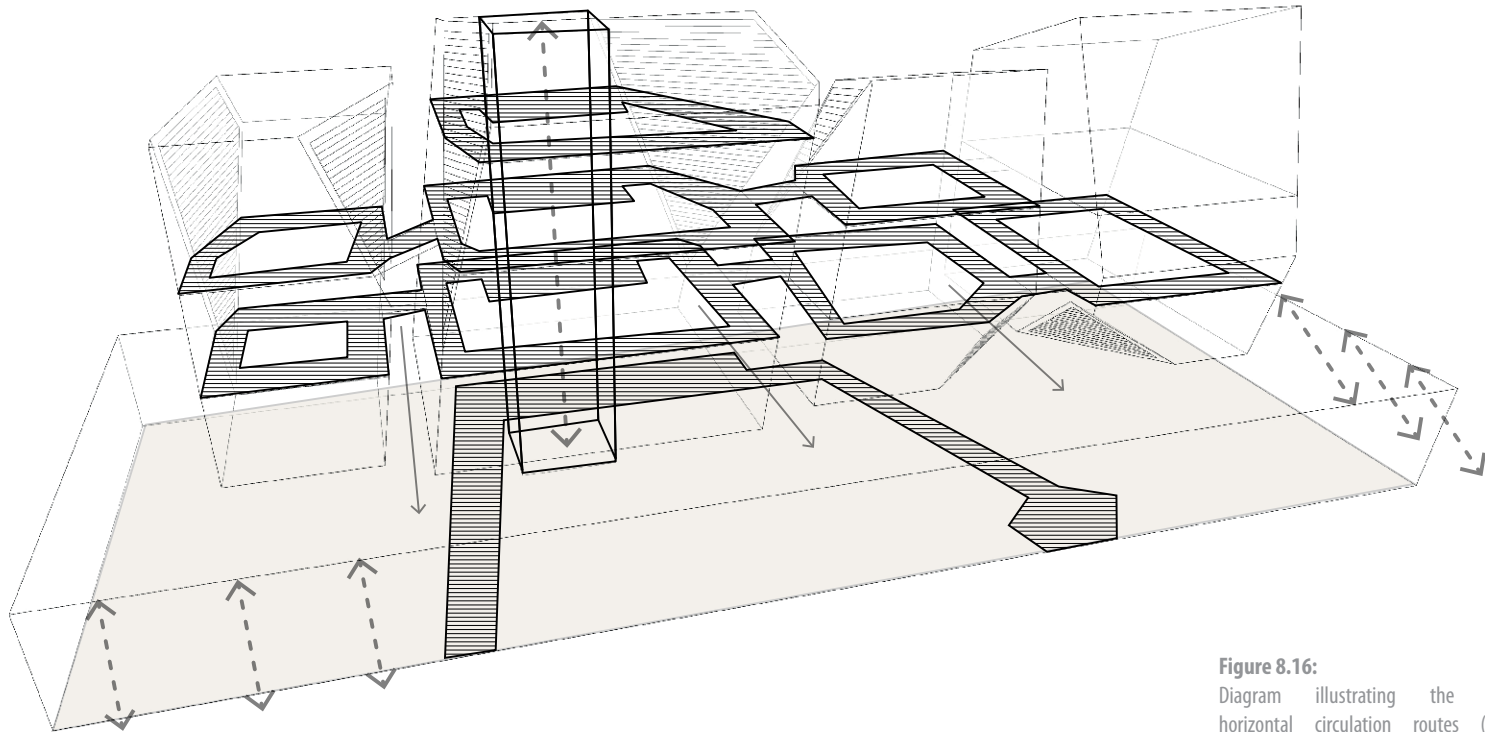

Figure 8.16:
Diagram illustrating the vertical and horizontal circulation routes (Author, 2011)

+ Theoretical Premises

Information has become dynamic and virtual, therefore the relationships between the dualism that arise from this are explored:

01 | Static vs. Dynamic

This relationship is illustrated by introducing rotating floors which alter the multifunctional spaces sporadically (figs. 8.17, 8.18 & 8.19).

02 | The Virtual (a-tectonic) vs. the Physical (tectonic)

This relationship is firstly expressed by allowing digital images to become *real*. Projections are used as space defining elements on the interior, while the virtual glow is perceived from the exterior. This gives the intangible concept of digital information a place in real time, breathing life into it, making it tangible. Permitting the digital world to perpetually transform and grow in the *real* by superimposing an intangible layer of data over the tangible objects of the urban environment (augmented space).

Secondly, the inverse of this is investigated by allowing physical elements to appear virtual. The exterior screen and reception walls are designed to create the illusion of a changing digital screen.

By employing the informational capacity of the principal creation of the Information Age, the internet, a search was conducted to find, what is considered to be, digital patterns. The most recurring patterns (fig. 8.21 & 8.25) were selected to be incorporated into the architecture by means of experimental design elements. The contrast between light and shadow is utilised in the same manner as pixels on a digital device, whereas movement past the element induces the shifting of the configuration.

Reception walls: The idea is to create a temporary installation that can be replaced from time to time (fig. 8.23).

Screen: The metal strips are weaved with the intention of casting calculated shadows which simulate the digital pattern. This emulates traditional African weaving, but is however applied in a contemporary fashion (fig. 8.27).

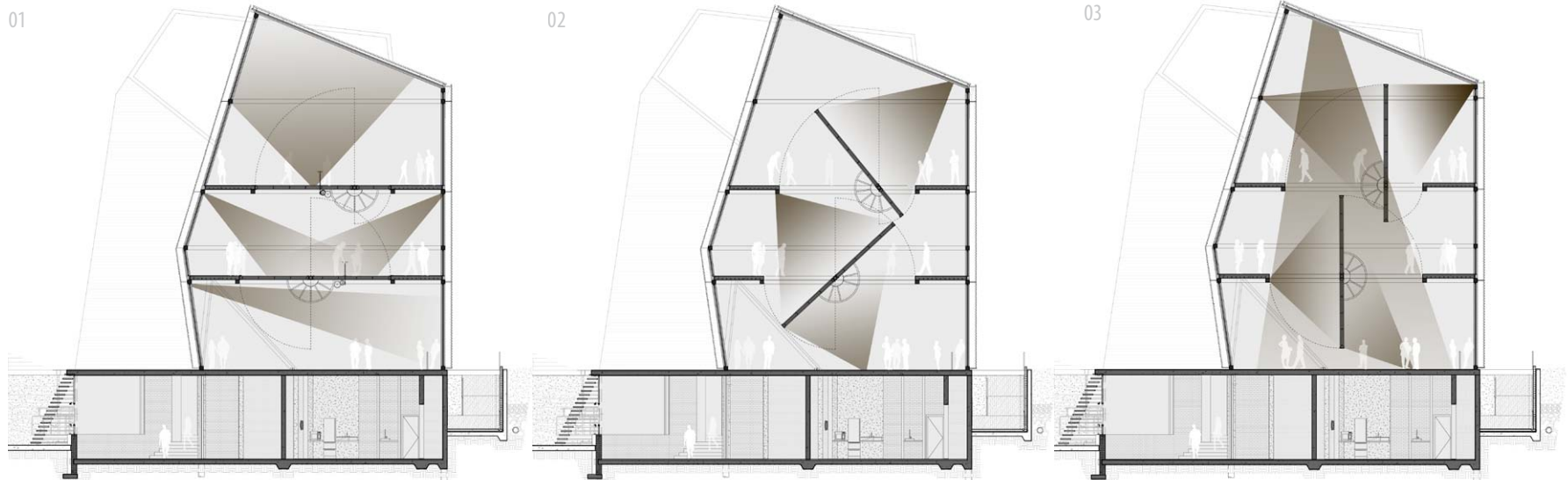

Opposite |

Diagrams illustrating the influence of dynamic elements on spatial qualities as well as virtual images as space defining elements:

Figure 8.17 (1):

Separate gallery spaces (Author, 2011)

Figure 8.18 (2):

Interweaved gallery spaces (Author, 2011)

Figure 8.19 (3):

Unified open gallery space (Author, 2011)

This page |

Figure 8.20:

Diagram illustrating the multifunctional exhibition towers - night club (Author, 2011)

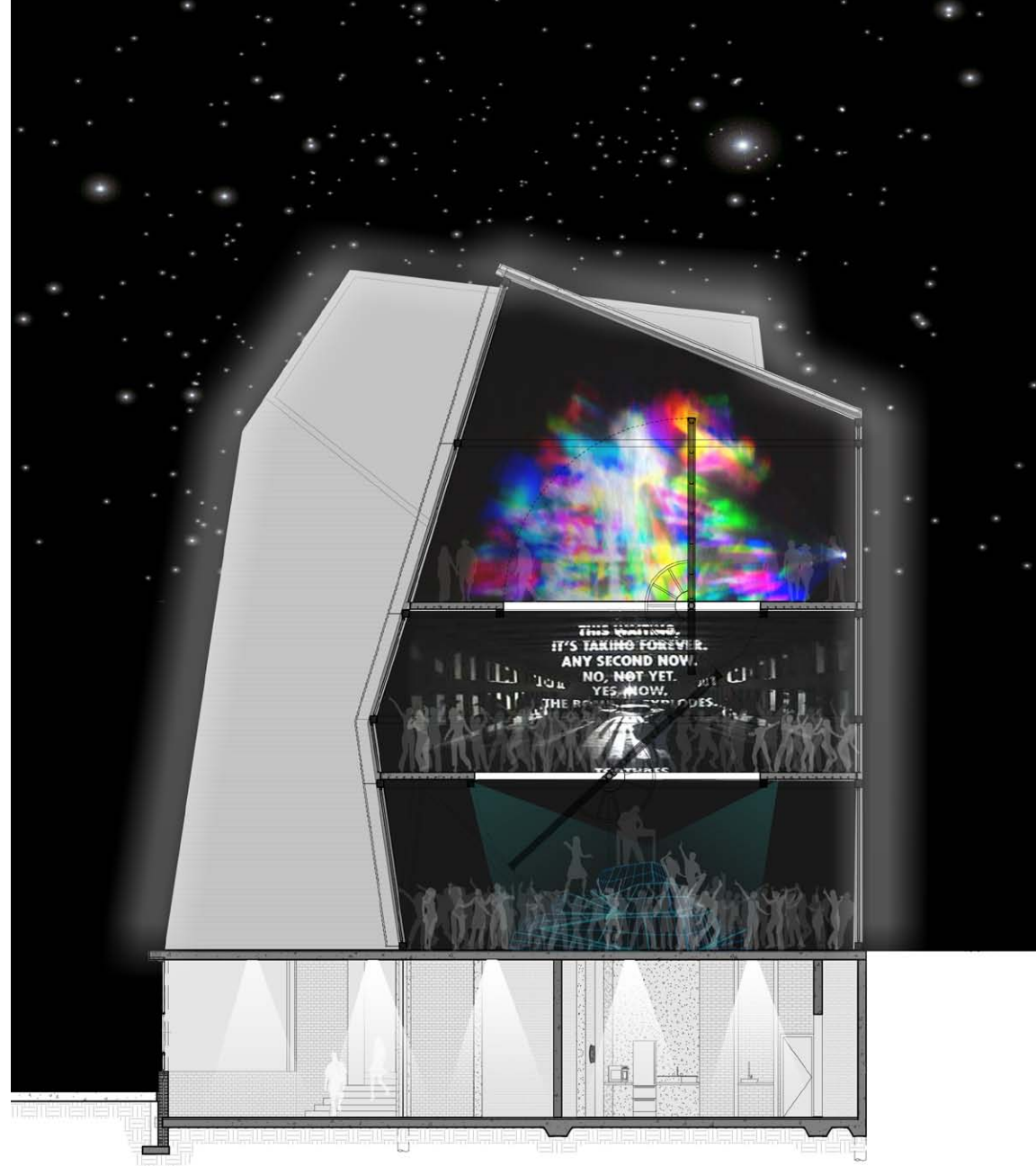

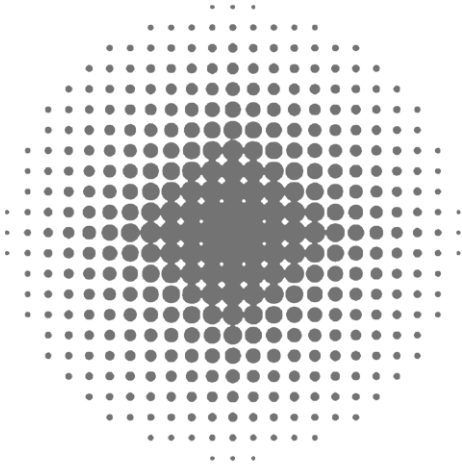

01

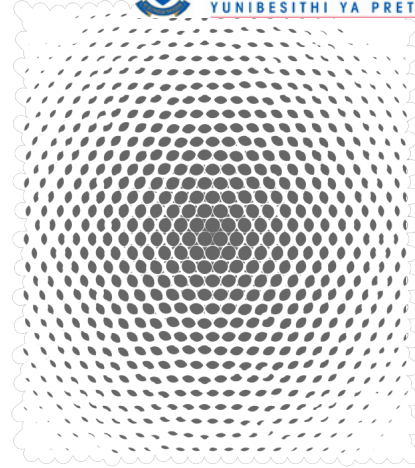

02



03

Figure 8.21 (1):
Digital pattern no. 1 (Author, 2011)

Figure 8.22 (2):
Shadow study of the wall simulating
digital pattern no. 1 (Author, 2011)

Figure 8.23 (3):
Section through the reception wall
(Author, 2011)

Figure 8.24 (4):
Diagram illustrating the experimental
reception wall simulating digital pattern
no. 1 (Author, 2011)

04

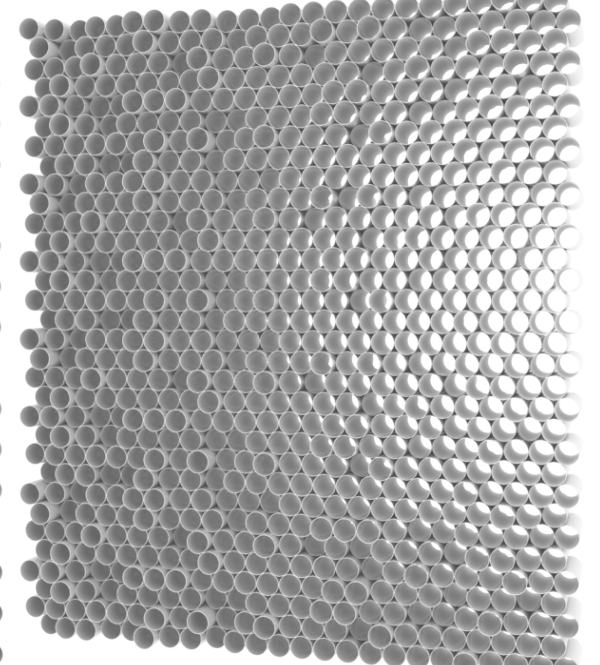
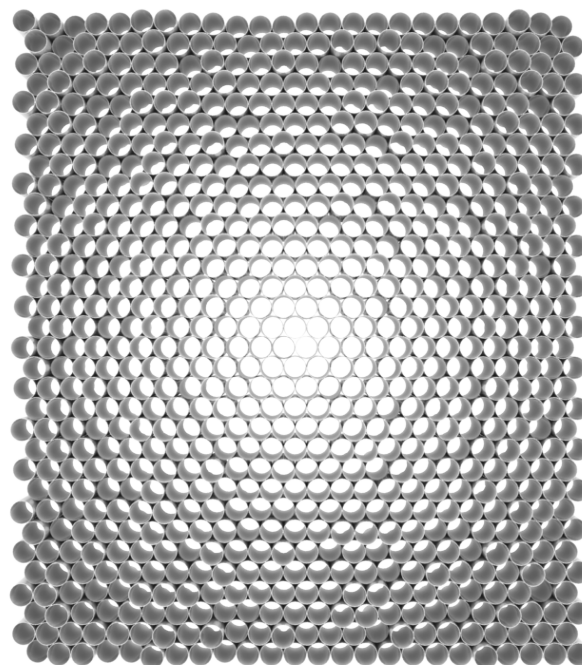
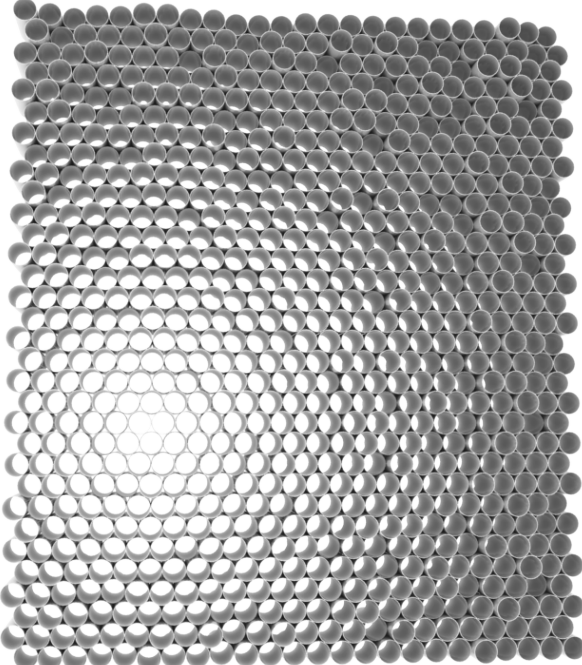



01



02

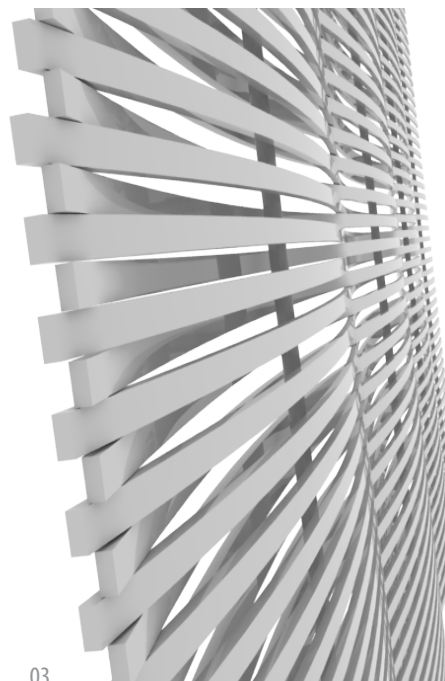
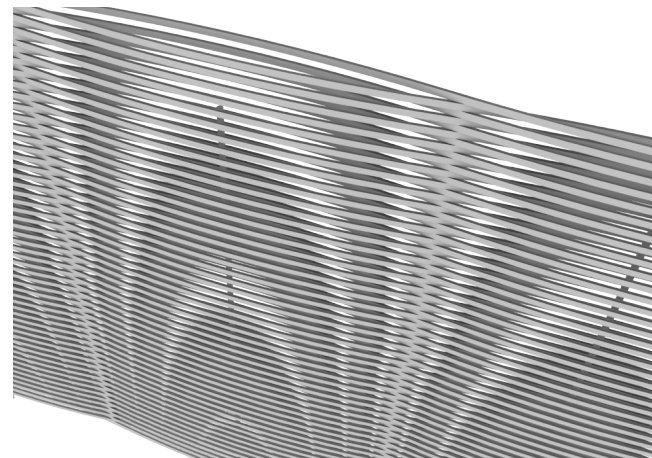

03

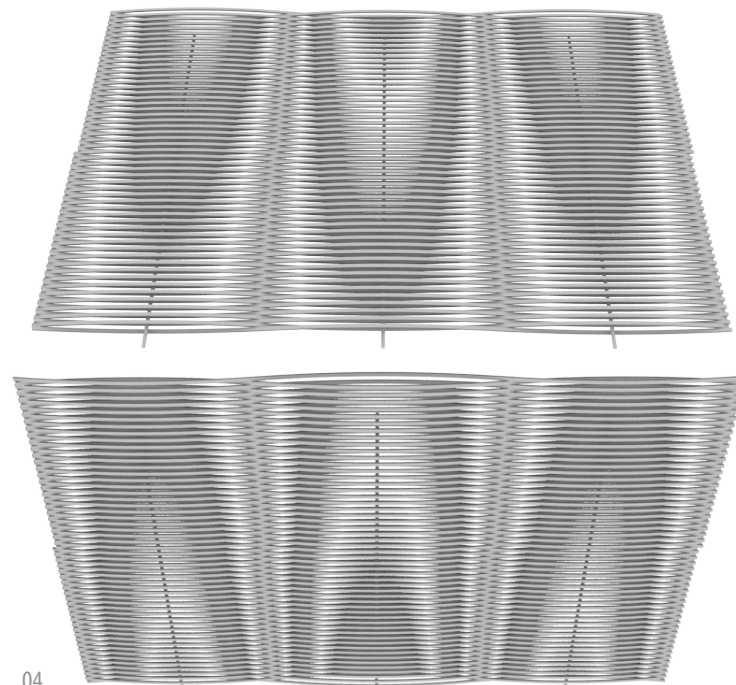

04

Figure 8.25 (1):

Digital pattern no. 2 (Author, 2011)

Figure 8.26 (2):

Shadow study of the screen simulating digital pattern no. 2 (Author, 2011)

Figure 8.27 (3):

Detail of the 'digital' screen (Author, 2011)

Figure 8.28 (4):

Diagrams illustrating the screen as perceived from different angles (Author, 2011)

+ Materials

- 01 | Due to the irregular form of the *exhibition towers* a steel structural frame is proposed
- 02 | Shading screen: malleable metal strips
- 03 | Pilkington Profilit™ (u-profile glazing) is used as a façade system (fig. 8.29).

This double glazing system is categorised under *advanced glazing systems* which contribute extra points in the BREEAM environmental rating system. It offers thermal insulation, solar control, excellent sound reduction as well as safety characteristics (NSG, [2010]^a).

According to NSG [2010]^b it provides the most cost-efficient glass wall systems currently available on the market. This progressive material should encourage the use of advanced materials and new technologies in future architectural developments.

- 04 | Fibre-reinforced concrete stairs

The stairs forming the edge of the square are 55mm lightweight fibre-reinforced concrete. This material was chosen to form a uniform edge with *the Staircase*, as well as for its robust characteristics.

Illustration 8.4 (1):

Photograph of Pilkington PROFILIT's™ light diffusing qualities, with the chosen product indicated (NSG, [2010]^b: 5)

Figure 8.29 (2):

Analytical digital of the Pilkington PROFILIT™ u-profile glass system (Author, 2011)

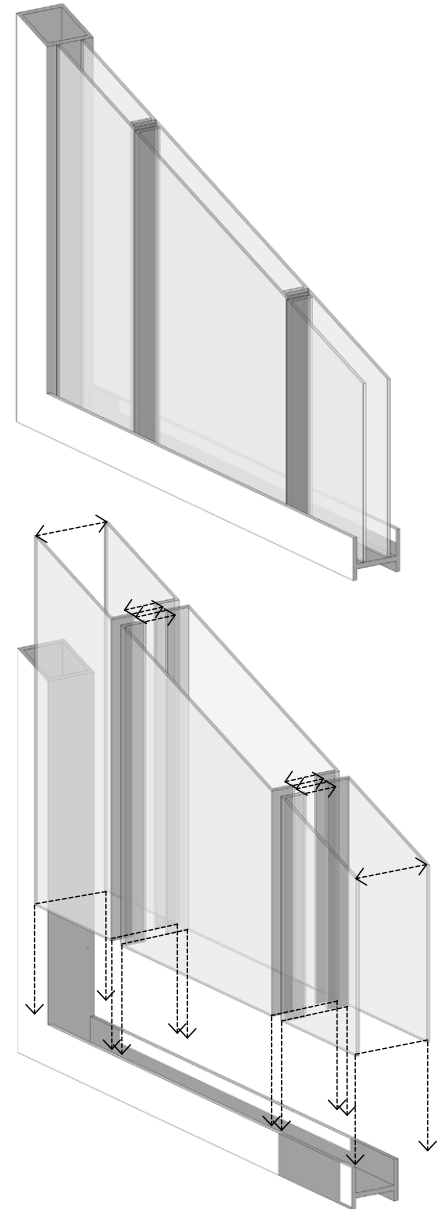
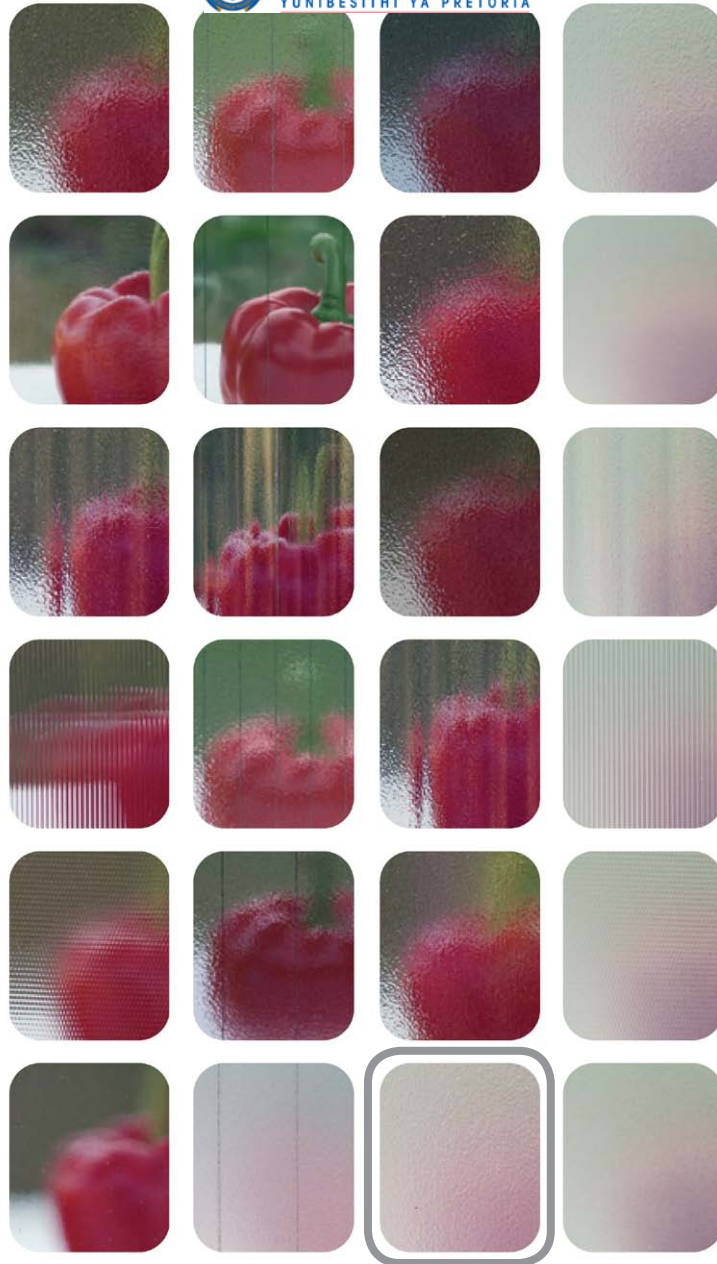

Environmental Considerations

+ Social Sustainability

- 01 | Information technology facilities contribute to education and upliftment
- 02 | Recycling sorting facilities are proposed in the basement which create job opportunities

+ Intelligent Architecture

Intelligent Building Systems (IBS) will manage and maintain various elements within the building. These elements are monitored and controlled via a computer-operated *Building Management System (BMS)* situated in the data room.

Administered facets include *security and safety* as well as *interior comfort levels* and *energy saving strategies* (fig. 8.30):

- 01 | Security and safety
Fire and smoke detection sensors will close the automatically-operated louver windows in order to stop air circulation and avoid the spread of flames and smoke when a threat is detected
- 02 | Comfort levels and energy savings
All sensors will be managed according to building zones to improve efficiency and energy savings.
- 01 | Various sensors and apparatus will be employed in the management of window openings (ventilation):
 - 1.1 A thermostat measuring the mean interior air temperature (signalling space heating to be turned on or off, as well as adjusting the ventilation rate (litres fresh air/ m2/second))
 - 1.2 Humidity meter to achieve constant ideal humidity levels
 - 1.3 Air content indicator measuring the chemical composition of the fresh intake air (if toxic gasses or high levels of CO₂ are detected, the system will adjust all windows to the fully open position for rapid ventilation)
 - 1.4 The rotating floors send a signal to the BMS system when being opened (individual cross ventilation of floors changes to an integrated stack ventilation system as in fig. 8.31)
- 02 | Light meters will adjust the artificial lighting levels when natural lighting is insufficient in order to maintain the desired luminosity for a digital gallery space (low ambient lighting levels). During all other daylight hours only natural indirect lighting will be used.

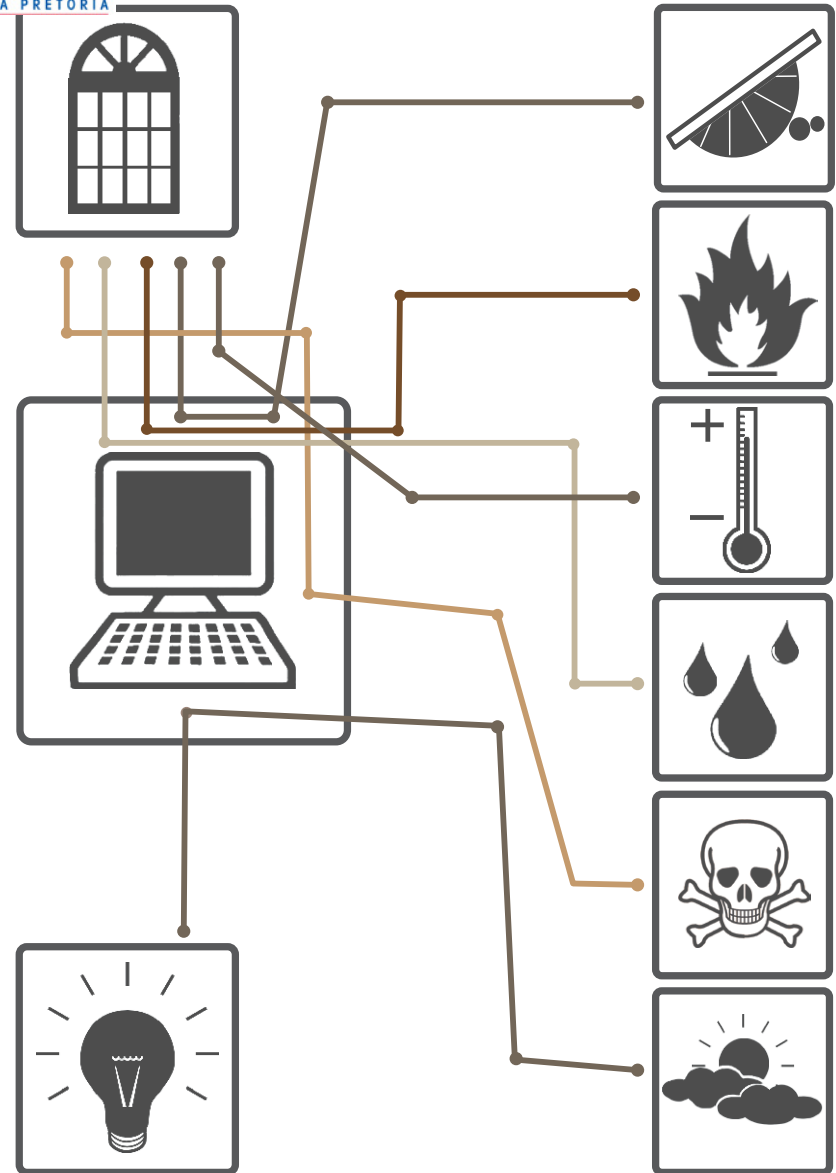

Figure 8.30: Diagram of intelligent building systems (Author, 2011)

+ Location and Site (See fig. 8.11)

- 01 | The site is centrally located near all amenities
- 02 | Transport: on-site public transport facilities include a bus stop on the South West corner, an existing informal (proposed as formalised) taxi stop in Proes Street. The *metro mall* (a large public transport interchange node) is located one block North as well as a train station in the near vicinity.
- 03 | The heat island effect is minimised and CO₂ levels are reduced by introducing new planting around the site's periphery
- 04 | Parking: the minimum amount of parking is provided with preferential parking for disabled users, motorcycles, car pooling and hybrid vehicles (see Lower Ground Floor Plan in Chapter 9)
- 05 | Bicycle storage facilities are located in the basement with a locker area and showers on ground floor level (see Lower Ground Floor Plan in Chapter 9)
- 06 | A garbage sorting facility is proposed in the basement in order to create work opportunities as well as to encourage recycling programs (see Lower Ground Floor Plan in Chapter 9).

+ Building Systems

- 01 | The structure is strategically orientated (according to Pretoria's prevailing winds) to maximise natural ventilation (see fig. 8.11)
- 02 | Combination ventilation: stack ventilation is used in combination with passive cross ventilation according to the spatial configuration of the floors (fig. 8.31).
- 03 | Interior comfort levels are achieved by a combination of material choices (thermal double glazing system, cavity walls and roof insulation), architectural devices (a shading screen) and automatically operated ventilation and lighting systems (BMS).
- 04 | Water harvesting and re-use (fig. 8.32): rainwater is harvested from the square's surface as well as roofs after which it is circulated through a filtering system before being reused for irrigation. Greywater is recycled and reused for flushing of water closets.
- 05 | Photovoltaic panels (a solar plant) are installed on the roof *Munitoria* in order to alleviate the municipal electricity supply. The solar-generated energy will be used for lighting and digital projections in the exhibition towers and public square.
- 06 | Solar absorbers are used for water heating requirements. The water will be distributed to the ablution facilities via insulated pipes in order to minimise heat loss.
- 07 | Individual lighting zones are proposed in order to reduce electricity demands.
- 08 | Fixtures: all specified fixtures are to be environmentally responsible products: dual flush cisterns, waterless urinals, motion sensor aerated taps and aerated shower heads (in bicycle amenities)
- 09 | All materials used are to be VOC-free (volatile organic compound)

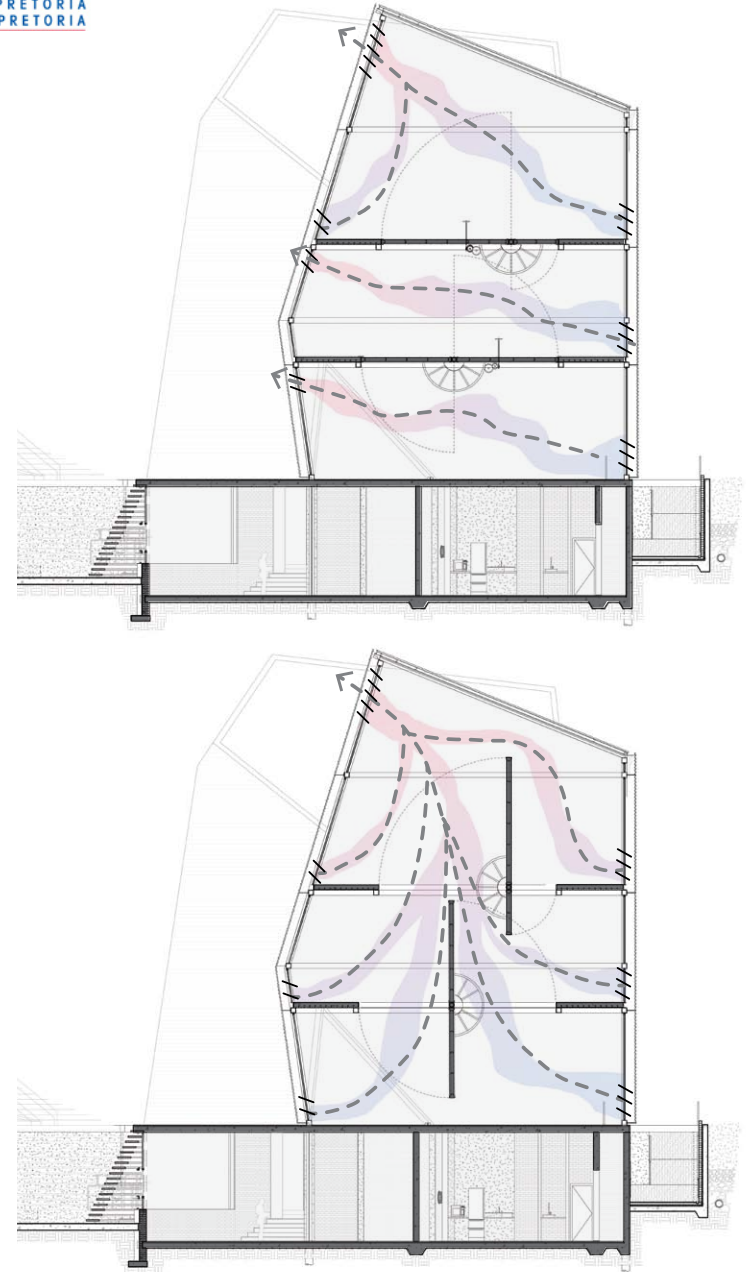

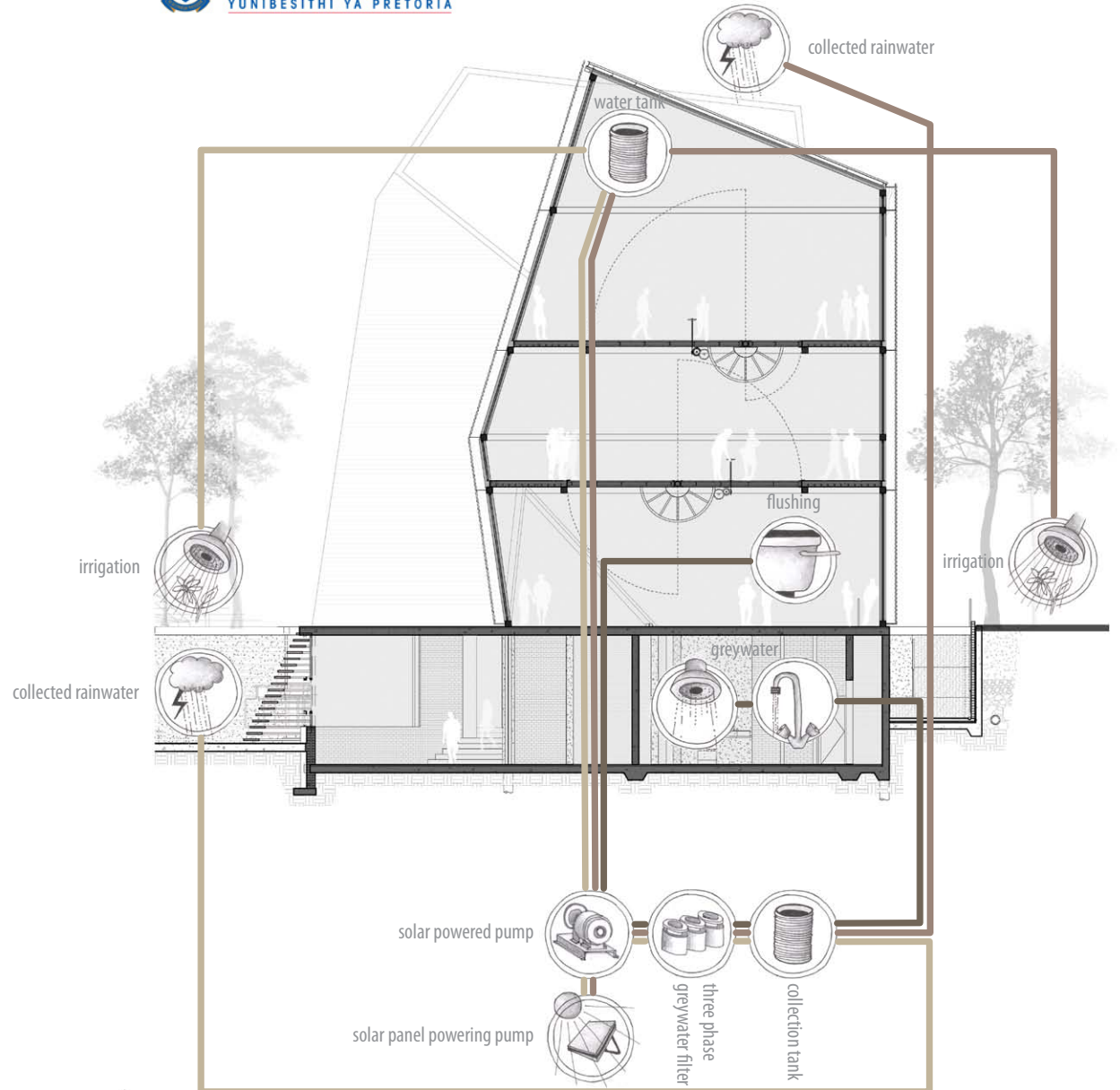

Opposite|

Figure 8.31:

Combination ventilation diagrams: cross ventilation in the closed position, stack ventilation in the closed position, stack ventilation in the open position (Author, 2011)

This page |

Figure 8.32:

Diagram of the proposed water harvesting and recycling system (Author, 2011)

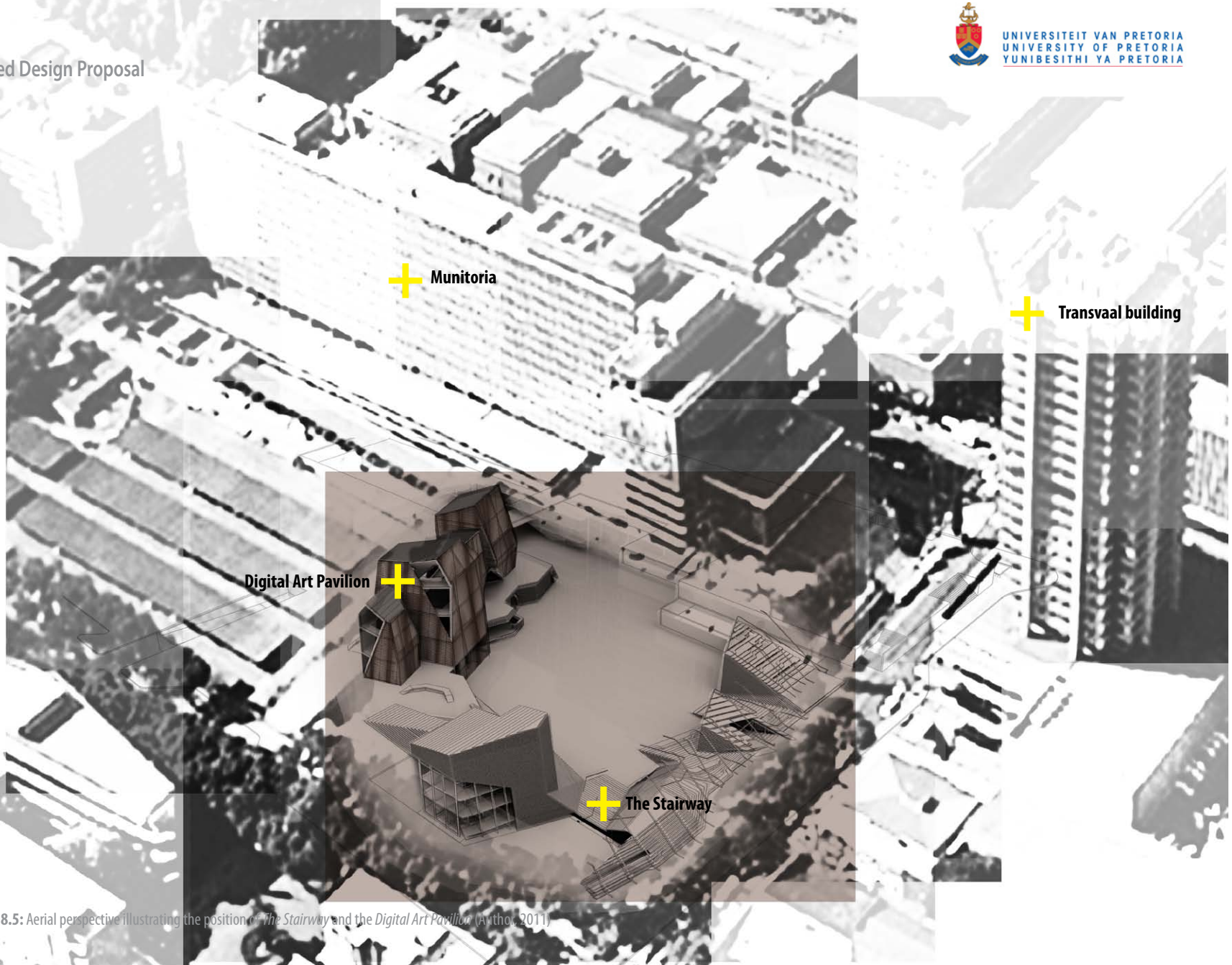

Illustration 8.5: Aerial perspective illustrating the position of *The Stairway* and the *Digital Art Pavilion* (Aythya, 2011)



+ lightweight steel roof

+ 'weaved' shading screen

+ structural frame with
u-profile glass façade

+ composite floors

+ lower ground floor

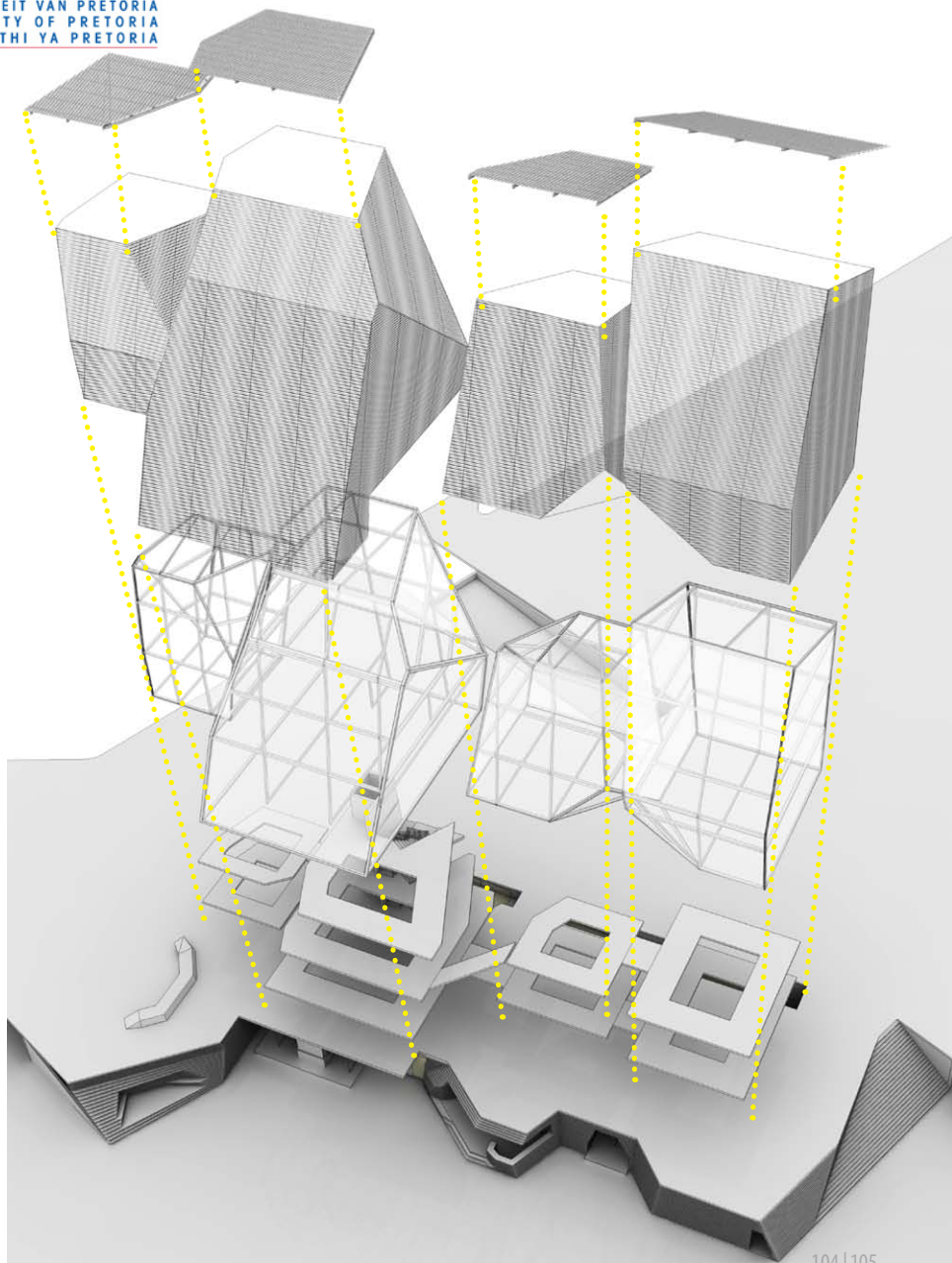

Illustration 8.6: Exploded axonometric drawing of the intervention (Author, 2011)



Top to bottom |

Illustration 8.7: South West elevation of the Digital Art Pavilion (Author, 2011)

Illustration 8.8: North East elevation of the Digital Art Pavilion (Author, 2011)

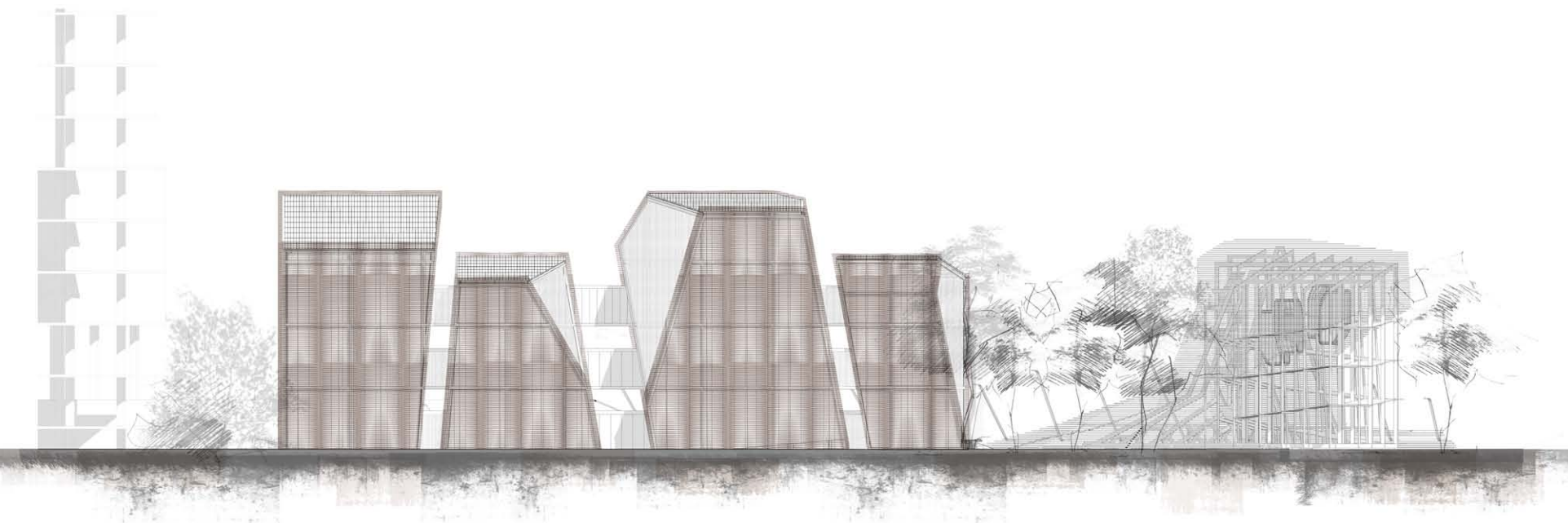
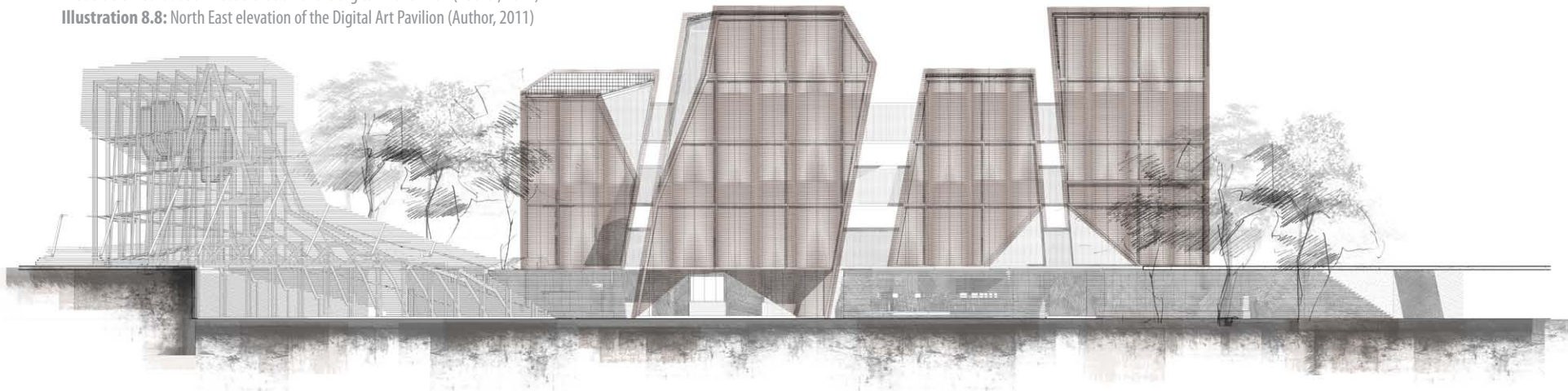



Illustration 8.9: North elevation of the Digital Art Pavilion as seen from Proes Street (Author, 2011)

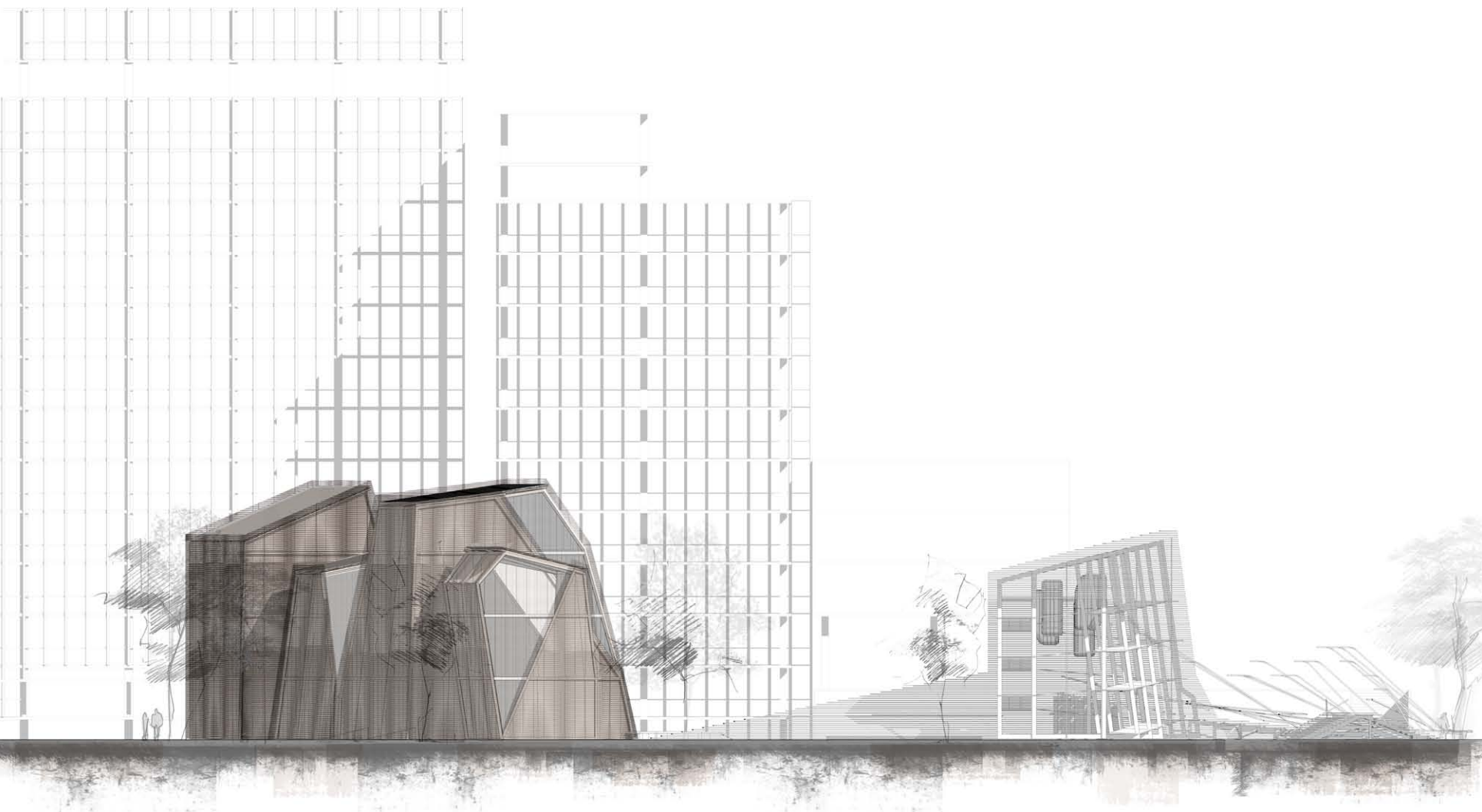
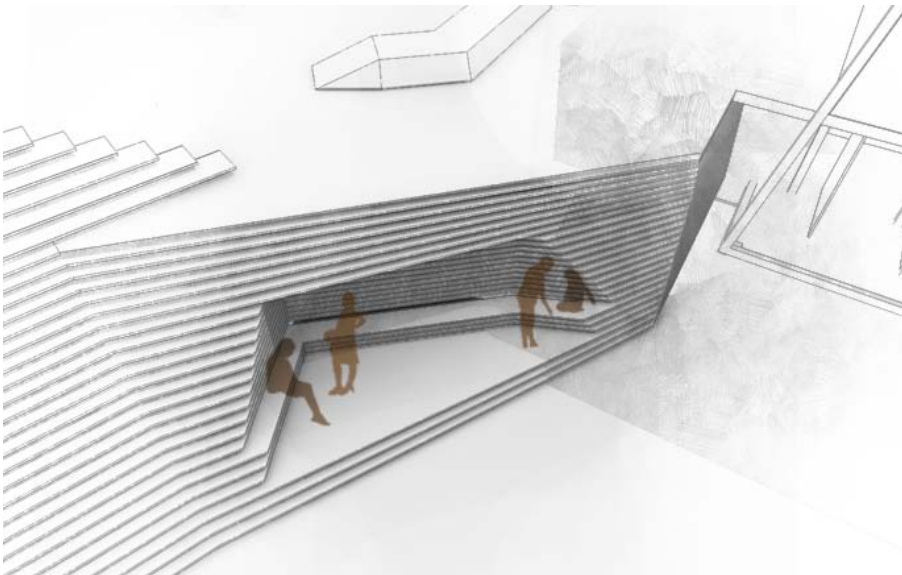
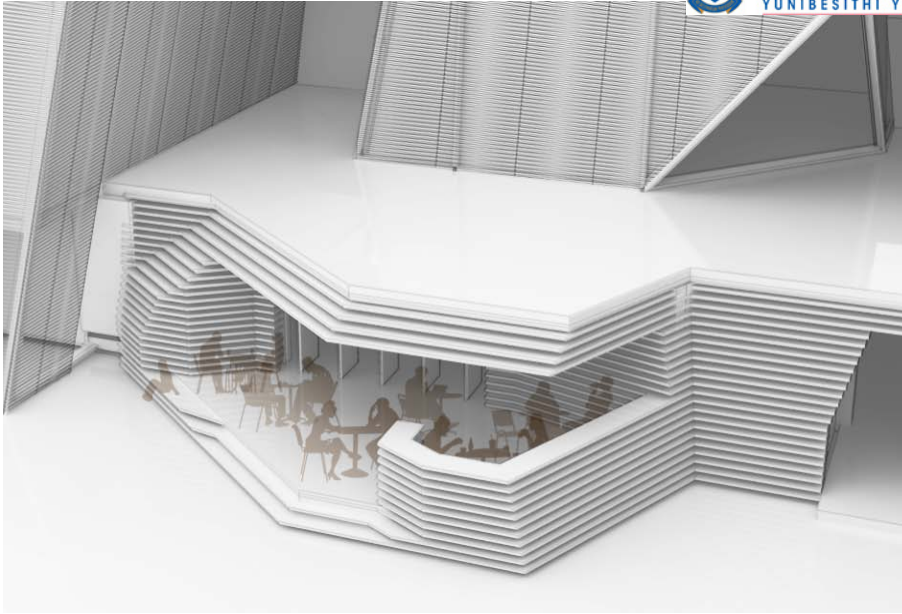



Illustration 8.10: Exterior perspective of the Digital Art Pavilion from the square (Author, 2011)



Top to bottom |

Illustration 8.11: Perspective view of the seating area (Author, 2011)

Illustration 8.12: Perspective view of the café seating area (Author, 2011)



Illustration 8.13: South West perspective from square (Author, 2011)

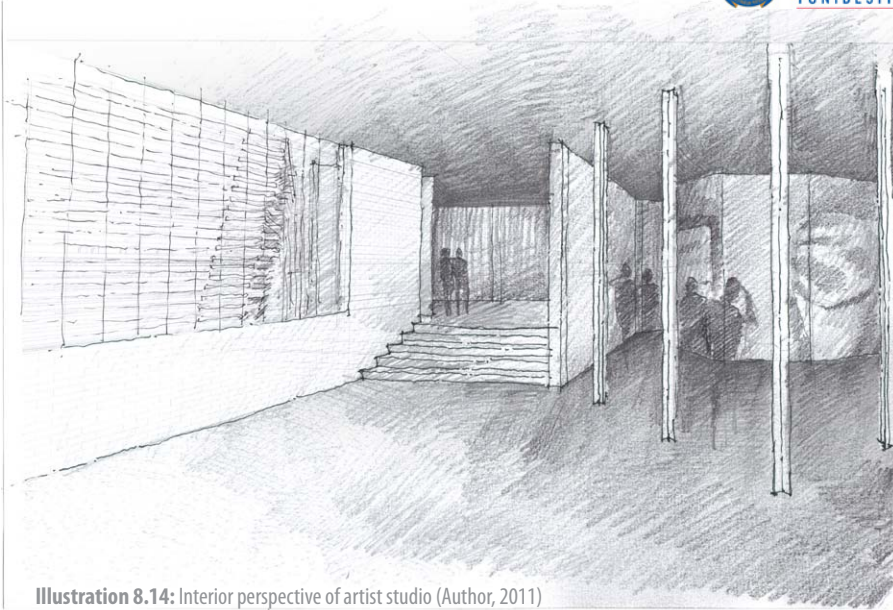

Illustration 8.14: Interior perspective of artist studio (Author, 2011)

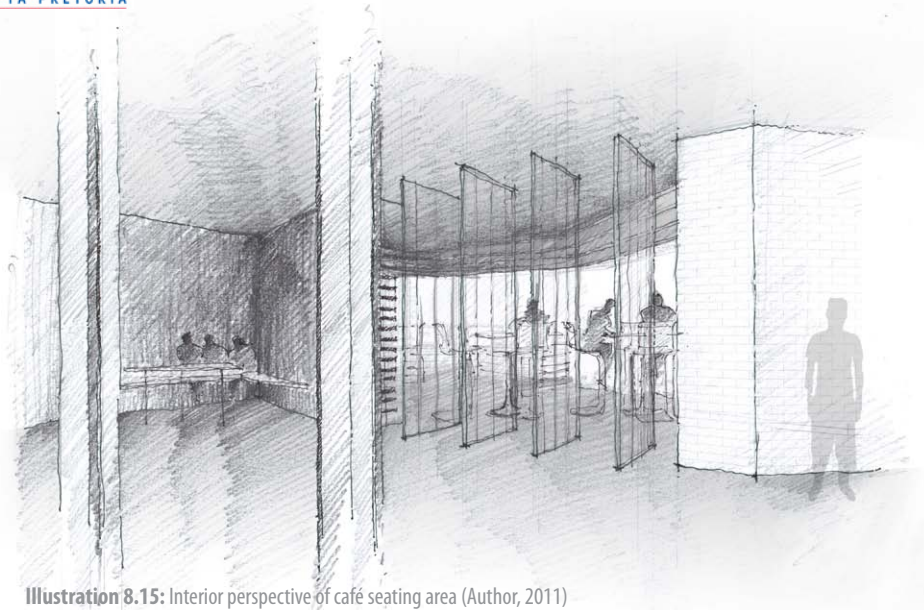

Illustration 8.15: Interior perspective of café seating area (Author, 2011)

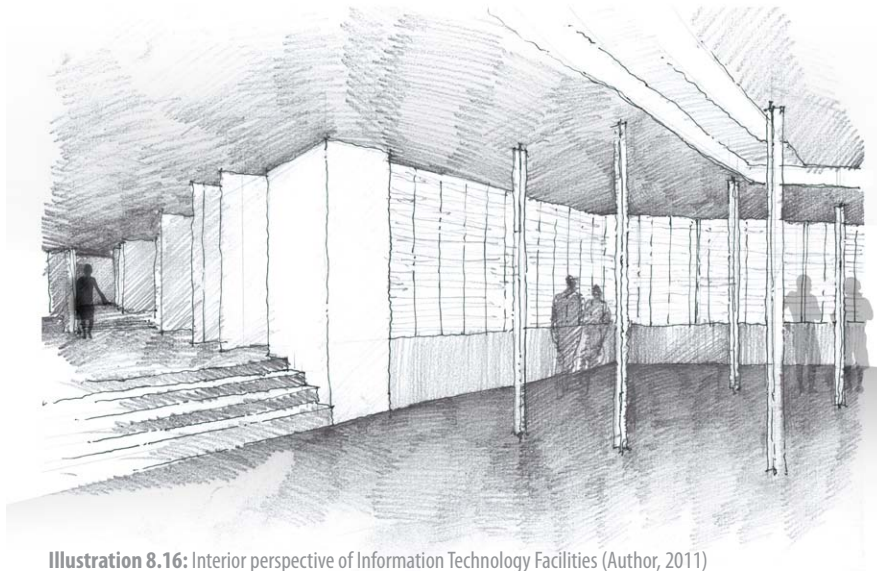

Illustration 8.16: Interior perspective of Information Technology Facilities (Author, 2011)

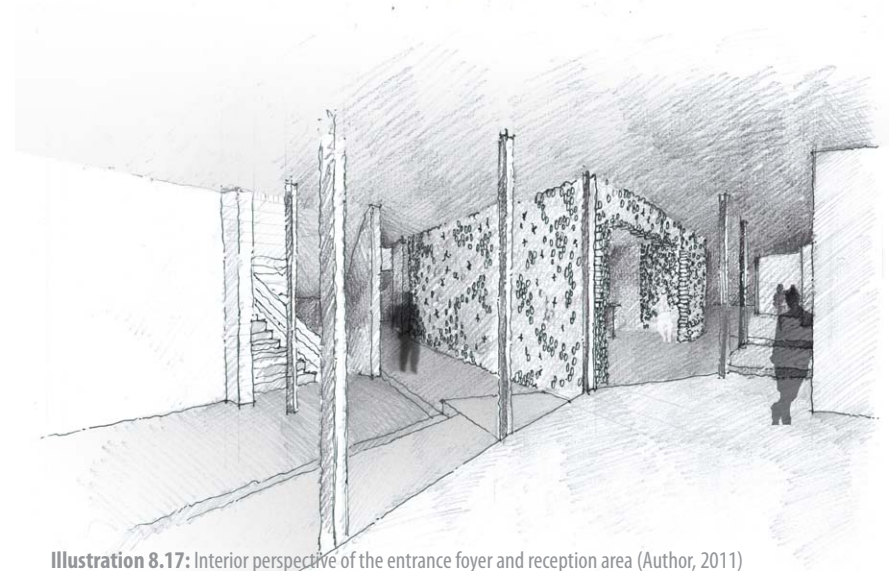

Illustration 8.17: Interior perspective of the entrance foyer and reception area (Author, 2011)