

B-well

A Community Link Project for Weskoppies Psychiatric Hospital



Mental health is described by WHO as:

“... a state of well-being in which the individual realizes his or her own abilities, can cope with the normal stresses of life, can work productively and fruitfully, and is able to make a contribution to his or her community“ (WHO 2001a, p.1).



Figure 2.7. Sketch of existing building on Westopple's campus.

FROM LUNATIC ASYLUM TO COMMUNITY CARE:
THE CHALLENGE OF INCLUSIVE BUILT ENVIRONMENTS FOR THE MENTALLY ILL

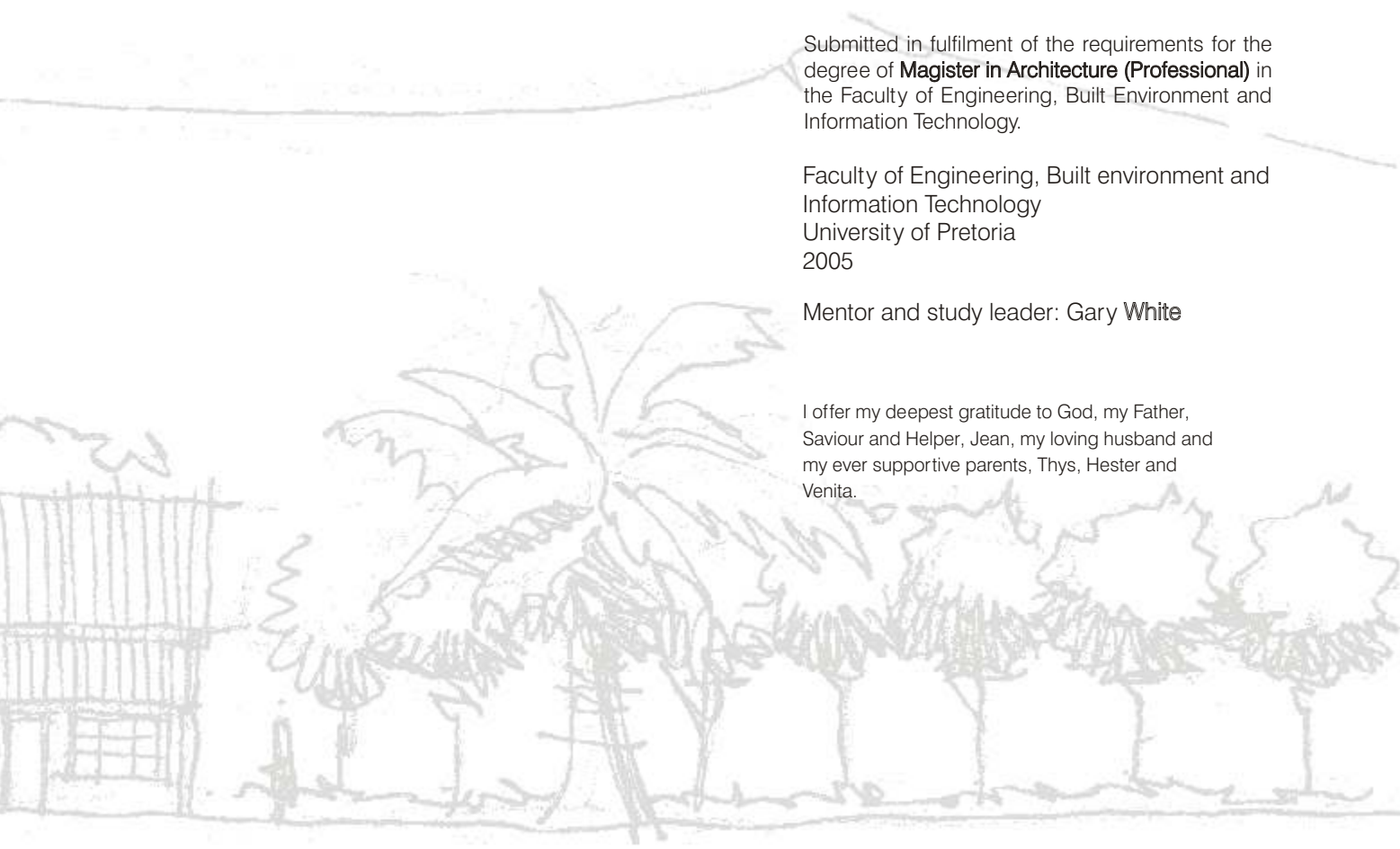
Annelize Geel
23400553

Submitted in fulfilment of the requirements for the degree of **Magister in Architecture (Professional)** in the Faculty of Engineering, Built Environment and Information Technology.

Faculty of Engineering, Built environment and Information Technology
University of Pretoria
2005

Mentor and study leader: Gary White

I offer my deepest gratitude to God, my Father, Saviour and Helper, Jean, my loving husband and my ever supportive parents, Thys, Hester and Venita.



I
N
T
R
O
D
U
C
T
I
O
N

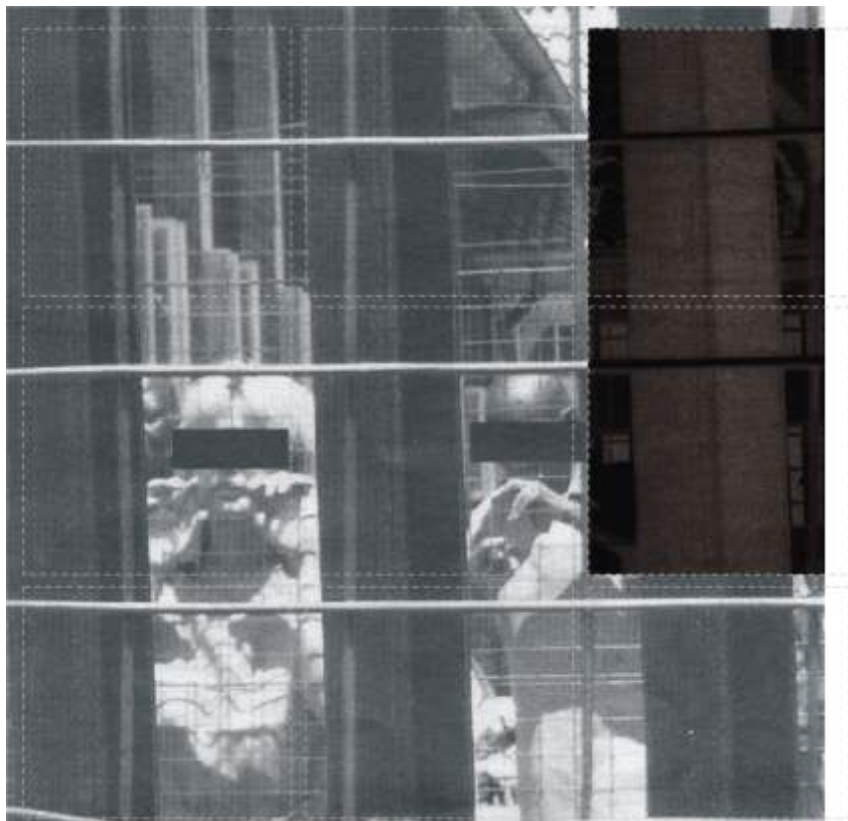


Figure 1.2: A photo published in *The Sowetan* on 28 February 2005 depicting Weskoppies patients as "caged" and "kept docile through a variety of drugs".

*"It is not by confining one's neighbour
that one is convinced of one's own sanity."*

Dostoyevsky

This thesis deals with the architecture of the inclusive built environment.

The hypothesis argues that social barriers can be challenged through the physical formation of the city, its buildings and spaces.

The platform used to explore this premise is Weskoppies Hospital situated in Pretoria West. The stigmatization and institutionalisation of the mentally ill has been a hotly debated issue for a long time. Recently the topic has received a lot of attention in the media, parliament and medical circles.

The issues underpinning the hypothesis deals with the “power of architecture to address social, economic, political and cultural forces by way of form- and place-making.” (Yudell 1997:134)

On the one hand, millions of dollars are committed to alleviating ill-health through individual intervention. Meanwhile we ignore what our everyday experience tells us, i.e. the way we organize our society, the extent to which we encourage interaction among the citizenry and the degree to which we trust and associate with each other in caring communities is probably the most important determinant of our health (Lomas 1998 p. 1181).

N O R M A T I V E A P P R O A C H Our cities, buildings and public spaces are manifestations of our beliefs and aspirations as a society. In our cities our social, economic, political and cultural aspirations take form in concrete, brick and mortar. One could say that our built environment is the mirror image of our goals and perceptions.

It is a pity, though, that the power to shape these environments lies in the hands of an elect few. Often the weak among us, those existing on the fringes of society, have no say in the spaces that they are forced to exist in. Often they are not considered, they remain neglected, forgotten.

Yet, we as a society cannot call ourselves civilized, if we do not create for all and seek to uplift all to co-exist in equality. "Umntu ngumuntu ngabantu. Motho ke motho ka batho". These are, respectively, the Zulu and Sotho versions of a traditional African aphorism, often translated as: "a person is a person through other persons" (Ramose, 1999:49f; Shutte, 1993:46). At the heart is the concept of 'Ubuntu', which means "humanity", "humanness", or even "humaneness".

The South African Governmental White Paper on Social Welfare officially recognises Ubuntu as:

The principle of caring for each other's well-being....and a spirit of mutual support..... Each individual's humanity is ideally expressed through his or her relationship with others and theirs in turn through a recognition of the individual's humanity. Ubutu means that people are people through other people. It also acknowledges both the rights and the responsibilities of every citizen in promoting individual and societal well-being.

(<<http://www.gov.za/whitepaper/index.html>>).

Thus, we as architects, creators of cities, community buildings and spaces, can ask ourselves, what is our role in promoting individual and societal well-being?

I believe, as Constance Perin, architect and designer, that the best use of the foresight of designers and planners is to maximize the possibilities of others. He states:

"It is no contradiction to design for spontaneity and for self-determination. We must learn how to define our design problems so that we can let their solutions become a collaborative enterprise. To arrive at these definitions, we must bring into the design process an explicitness about its humane consequences - another way of saying that the development of theory in environmental design is essential. We must also extend outward from our drawing boards to more actively shape the values not always explicit in public policy."

(Lang, Burnette, Moleski and Vachon 1974:43)

It is imperative that we, as designers, develop our understanding of the social structures and human behaviour of our communities. Our successes in creating positive environments depend on our ability to understand and predict these concepts. We have this responsibility towards our communities, which implies that we cannot design frivolously.

“Community is a fragile and precious phenomenon. It forms the foundation for our sense of identity and well-being; indeed, its is critical to the survival of our societies. Too often, architects feel powerless in creating places for community. At times we abdicate entirely, ignoring our potential to affect the people who dwell in our buildings. Perhaps we have been conditioned to feel that social, economic, political and cultural forces are too powerful or complex to address by way of form- and place-making. But such an attitude undermines the power of architecture and the potency of architects as builders of community and society.”
(Yudell 1997:134)

The mentally ill makes up a part of our communities. This should be acknowledged in order for them to experience a sense of identity and well being. If we exclude their environment by way of form giving, we refuse them their survival in society.

Buildings communicate messages to their inhabitants and, in fact, all those who are exposed to them. They have “the power to shape behavioural patterns”. (Spivack 1984:97)

The built environment can either be used to form the bridges designed to cross boundaries of race, inequality, discrimination and exclusiveness (as our country dream of), or it can be the very force that creates the divide.

These concepts are nowhere more strongly felt than in the institutional environment. It is behind the walls of institutions that

the sting of exclusion and stigmatization is most strongly felt. The message conveyed through a language in a silent conversation between civilization and the institutionalized. The medium of this language; the built form. Here, our perceptions are built on remote locations. Behind gates and thick walls we retain our opinions of the “unacceptable, the abnormal and the non-functional”.

In South Africa mental healthcare has long been known as the stepchild of healthcare. This is glaringly obvious when one looks at the state of our mental healthcare facilities: prisons. They tell the Cinderella story of an unwanted child taken in unwillingly, looked upon in scorn, hidden away in shame....

Policies surrounding mental healthcare have changed, as our Government has come to the realization that this is a form of healthcare needed by all members of our society. Neglecting this aspect of health within our communities will have a far reaching negative effect on our country.

The current challenge is the implementation and physical manifestation of these policies. The ideal would be to line-up the perceptions of our communities, the policies of the new Mental Health Care Act and the realities of our mental healthcare facilities. Alternatives to improve, destigmatise and de-institutionalize the mental asylum must be sought and implemented.

The role of the designer in this process is to mediate the abstract concepts of equality and humanity, in the institution, with the use of physical form. To create a built environment for the mentally ill, without the walls of exclusion, with the foundations of equality and the inclusion of all within our communities, allowing mental healthcare to be accessible in a dignified, honorable and acceptable environment.

09 Brief

- 1.1 Problem Statement
- 1.2 The Project

13 Context

- 2.1 Introduction
- 2.2 Historic Context
- 2.3 Location: Study Area
- 2.4 Location: Project Area
- 2.5 City Wide Context
- 2.6 Status Quo: Study Area
- 2.7 Status Quo: Project Area
- 2.8 Context Analysis: Issues,
Opportunities and Constraints
- 2.9 Conclusion

41 Campus Framework

- 3.1 Nature of the Problem
- 3.2 Integrating the Campus
- 3.3 Proposal: A Public Island
- 3.4 Concept: Public Island as a Park
- 3.5 Installations to the Site and on
the Public Island
- 3.6 Conclusion

49 Site Selection

- 4.1 Nature of the Problem
- 4.2 Proposed Site
- 4.3 Integration with the City
- 4.4 The Site as Threshold
- 4.5 Conclusion

57 Programming

- 5.1 Methodology
- 5.2 Precedents
- 5.3 Human Considerations
- 5.4 Environmental Considerations



- 5.5 Cultural Considerations
- 5.6 Temporal Considerations
- 5.7 Economic Considerations
- 5.8 Safety Considerations
- 5.9 Conclusion

89 Design Discourse

- 6.1 Site Forces
- 6.2 Site Implications
- 6.3 General Strategy
- 6.4 Influences
- 6.5 Cluster Organization
- 6.6 Circulation
- 6.7 Building Response
- 6.8 Connections and Contact
- 6.9 Space Definition
- 6.10 Design Themes
- 6.11 Design Principles
- 6.12 Five Buildings

115 Technical Investigation

- 7.1 Design Philosophy
- 7.2 Space Enclosing System
- 7.3 Space Defining System
- 7.4 Passive Systems
- 7.5 Material use and Detailing
- 7.6 Fire Strategy
- 7.7 Rainwater Harvesting

133 Technical Report

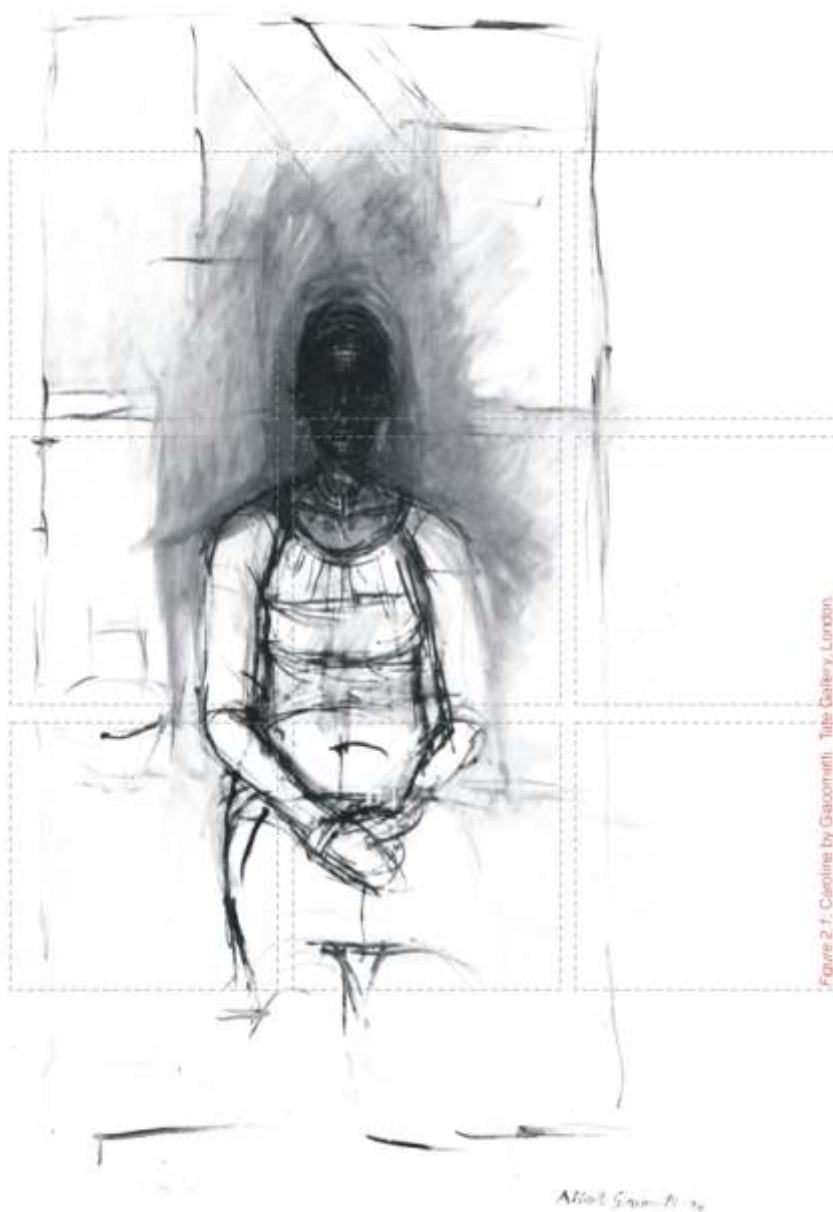
167 Appendices

193 Conclusion

"Men are so necessarily mad, that not to be mad would amount to another form of madness."

Pascal

BRIEF



1.1 Problem Statement

1.1.1 BACKGROUND

Weskoppies Psychiatric Hospital is a training hospital, dealing mainly in psychiatry and is situated in the west of Pretoria. The hospital has roughly 1400 beds and a bed occupation of 95%. Approximately 5 000 patients are admitted annually, whilst the outpatient section handles approximately 5 200 patients per year. (<http://www.facultyoftraining.up.ac.za.html>)

When the idea of a mental asylum for Pretoria was first conceived in 1889 the causes and treatment of mental illness was still very underdeveloped. Although limited medication and treatment was available then, doctors already knew that the natural environment could have a positive impact on patients.

In order to create this hospital in a natural environment, Weskoppies was built in the old Botanical gardens of Pretoria. At the time, Weskoppies was heralded as 'a beautiful building very healthily situated, with large gardens and cultivated fields'.

Since then Weskoppies has been through turbulent times, including the Anglo Boer war.

Currently Weskoppies is known as the place where 'sick' people go and it is greatly stigmatized. A combination of factors has fostered a deep and enduring division between Weskoppies and the community. These include:

- **The isolation and exclusion of Weskoppies from the community:** The initial concept of an asylum meant that from the starting point a social barrier was created between Weskoppies and the outside world. This led to the social isolation and institutionalisation of the patients.
- **The developed form of the built environment:** When Weskoppies was first built, it was located in a natural environment within Pretoria West, which was then a thriving and wealthy neighbourhood. Since then an industrial belt has formed around the edge of the site and conditions in Pretoria West have deteriorated.
- **Emphasis on sickness:** As many hospitals tend to do, Weskoppies also put the emphasis on sickness. A healthcare system which is actually capable of keeping people healthy, in mind and body, must put its emphasis on health, not sickness. Because Weskoppies has failed to do this, it has become a place associated with sick people and has, therefore, no place in a healthy community.
- **Perceptions:** The relationship that exists between architecture and perceptions has had a negative effect on the built environment of the mentally ill. The disciplinary and professional boundaries of medicine have conditioned the

perception of what is possible within the design of mental healthcare facilities. Internationally these perceptions are being challenged as researchers discover the healing power of therapeutic environments and the positive effect it has on the patients. As Weskoppies has not endeavored to implement these new concepts, perceptions of institutionalisation are not challenged within the hospital structure.

The current conditions at Weskoppies are demoralizing to both the patient and the community. Instead of the public turning to a 'healing' environment, it avoids any contact for fear of stigmatization and institutionalization. This is damaging to

"If community forms the foundation of our sense of identity and well-being, then a healthy environment should include a community component."

society. Mental health is as important as physical health to the over-all well-being of individuals, societies and countries.

According to the WHO's World Health Report 2001, one in four people in the world will be affected by mental or neurological disorders at some point in their lives. This counts for both developed and developing countries. Around 450 million people currently suffer from such conditions, placing mental disorders among the leading causes of ill-health and disability world wide.

Gauteng is no exception. In this province 120 000 people suffer from severe mental illness. (Sunday Times, 2004:5) Primary mental healthcare facilities were implemented to serve these individuals in the community, but they have proven to be insufficient and many sufferers have landed up in state institutions. Many habitually relapse after being de-institutionalised due to a lack of support systems.

This becomes a concern to state institutions, as they are under grave pressure to release patients. State psychiatric hospitals have been forced to cut their chronic beds by roughly half the levels of 1997. (Sunday Times, 2004:5)

1.1.2 THE WAY FORWARD

A healing environment should be a community environment. Not only to serve the patient by establishing him in the community and thereby enforcing his sense of well-being, but also to empower the community through creating access to healing, therapeutic environments.

1.2 The Project

1.2.1 INTRODUCTION

A community treatment and wellness center is envisaged for Weskoppies. This facility will provide treatment to community members and patients, offering the latest in best practice for patient-focused quality care in healthcare design.

The center marks the transformation of Weskoppies Psychiatric Hospital to a new model of community care, mixing outpatients services with private wellness services, in a radically different healthcare environment.

The vision of the project is to create a refreshing, healthful image for Weskoppies with an uplifting ambience within the existing campus.

1.2.2 THE AIM OF THE PROJECT

The aim of the project is, firstly, to create a community focused mental healthcare facility. Through this facility a help-line will be offered to members of the public who needs support, information and treatment in the area of mental health.

Secondly, the project will aim at bringing society members together to support and affirm each other. It is hoped that, through this project, people will understand each other and become tolerant. This implies freedom for the sufferer and power to the society.

1.2.3 WHY A COMMUNITY TREATMENT AND WELLNESS CENTER FOR THE MENTALLY ILL?

A new generation of healthcare facilities is emerging that are very different from the familiar institutional models. Based on patient-centered care and of healing the whole person, these health centers are spiritual sanctuaries with gardens, fountains, natural light, art and music. Researchers are learning how emotions are linked to disease and that healing is promoted by surroundings that reduce stress and engage the senses in therapeutic ways.

The community will benefit through:

- **Prevention**

Mental disorders represent not only an immense psychological, social and economic burden to society, but also increase the risk of physical illnesses. Given the current limitations in effectiveness of treatment modalities for decreasing disability due to mental and behavioural disorders, the only sustainable method for reducing the burden caused by these disorders is prevention. (Prevention of Mental Disorders, 2004:18)

- **Promoting mental health**

- Mental health is essential for the well-being and functioning of individuals.
- Good mental health is an important resource for individuals, families, communities, and nations.
- Mental health, as an indivisible part of general health, contributes to the functions of society, and has an effect on overall productivity.
- Mental health concerns everyone as it is generated in our everyday lives in homes, schools, workplaces, and in leisure activities.
- Positive mental health contributes to the social, human, and economic capital of every society.
- Spirituality can make a significant contribution to mental health promotion and mental health influences spiritual life.

- **Maintaining health**

In some communities, time-honoured practices and ways of life maintain mental health even though mental health may not be identified as the outcome, or identified by name. In other communities, people need to be convinced that making an effort to improve mental health is realistic and worthwhile. (Promoting Mental Health, 2004:23)

Christopher Alexander writes, in *A Pattern Language*, that: "Health Centers should adopt the philosophy of maintaining health. The emphasis should fall away from treatment of illness and lean towards the maintenance of health.



Figure 2.2: City : Pretoria



Figure 2.3: Campus : Weskoppies



Figure 2.4: Site

Weskoppies will benefit through:

- A community link project for Weskoppies would mean greater openness, influence and scrutiny from the public, which could have a positive effect on Weskoppies. Through the community project Weskoppies should actively seek the input of the public and should use this open system to inform and educate the public about the facilities functioning.
- The extension of the hospitals outpatient division through the introduction of the community center will accommodate the expected influx of noninstitutionalized patients.

“A community facility created to inform, support and treat public suffering from mental illness or the effects thereof.”

1.2.4 METHODOLOGY

- **City-wide context:** Ways of including Weskoppies as a site into the city context will be investigated through an analysis of the city context.
- **Campus context:** A campus framework will be designed through analysis of the campus context in order to improve the functioning of Weskoppies as a campus and indicate a suitable location for a community treatment and wellness center.
- **Site context:** The site will be selected according to the campus framework and analysed in order to produce an appropriate architectural intervention in the creation of an inclusive built environment that will function as a community link project and an extension to the hospital.

1.2.5 DESIGN OBJECTIVES

The main objective is to create a social upliftment platform within the context of a therapeutic environment that focuses on the inclusive nature of an environment bringing different people together.

1.2.6 THE CLIENT: THE DEPARTMENT OF HEALTH

In the 1990's South Africa was one of the few countries in the world where wholesale transformation of the health system started with a clear political commitment to restructure the health system according to a 'district health system' (DHS) and deliver health care according to the principles of the primary health care (PHC) approach.

The PHC approach is described in the Declaration of Alma Ata which was adopted by the World Health Organisation (WHO) in 1978. The essential aspects of this Declaration are:

- an emphasis on preventative health measures rather than on curative measures;
- the importance of participation of individuals and groups in the planning and implantation of health care;
- an emphasis on maternal and child health care;
- the importance of education on health problems;
- giving high priority to the provision of health care to the vulnerable and high risk groups, such as women, children and underprivileged elements of society; and
- equal access of individuals and families to health care at a cost the community can afford.

The constitutions' recognition of the right of access to health care services marked an initial victory for millions of South Africans. As has been noted, the White Paper on Health seeks to make health services accessible, affordable and equitable with particular attention being accorded to disadvantaged and vulnerable groups. It further seeks to educate the public on issues of health, to foster community participation in the provision of health services, as well as to facilitate the monitoring of health services.

Environment

in the built environment
(Patterns)

University of Pretoria etd - Geel, A. (2005)



CONTEXT

Introduction

Weskoppies hospital is located in Pretoria West in the peaceful "Botanical Garden".

In the 1870's Pretoria West was reserved for burgher-right erven. Although there was an agreement that the Voortrekkers would receive land in the Transvaal, many preferred to remain in Pretoria West. In 1902 the city received a great influx of farmers' settling in the city. By this time Pretoria West had expanded rapidly. There was some opposition from the Foreigners and local authorities but the area retained its rural character (Meiring, 1980: 13).

The railway track runs through Pretoria West, many railway employees lived here through the years.

Pretoria West is a melting pot of a vast variety of land-uses. Here you find industrial plants, residential developments, commercial and business areas and public amenities in close proximity.

On an economic scale, Pretoria West is one of the poorer areas in Tshwane. This implies that there are many unemployed in this area that are struggling financially, many with substance abuse problems and many who come from dysfunctional homes.

STUDY AREA

The study area includes Pretoria West, the Weskoppies and reaches to the central business district. The aim of studying Pretoria West is to seek ways to link the study area with the CBD and surrounding areas.

PROJECT AREA

The project area is not a single site, rather the whole of the Weskoppies campus. The development will have an effect on the surrounding area.

Areas that constitute the metropolitan area of Tshwane:

1. Ga-Rankuwa
2. Centurion
3. Temba
4. Mabopane
5. Winterveld
6. The area of the Northern Pretoria Metropolitan Substructure
7. Soshanguve
8. Pretoria
9. Pienaarsrivier
10. Crocodile River
11. Wallmannsthal and Hammanskraal



Figure 3.2: Tshwane Metropolitan Region

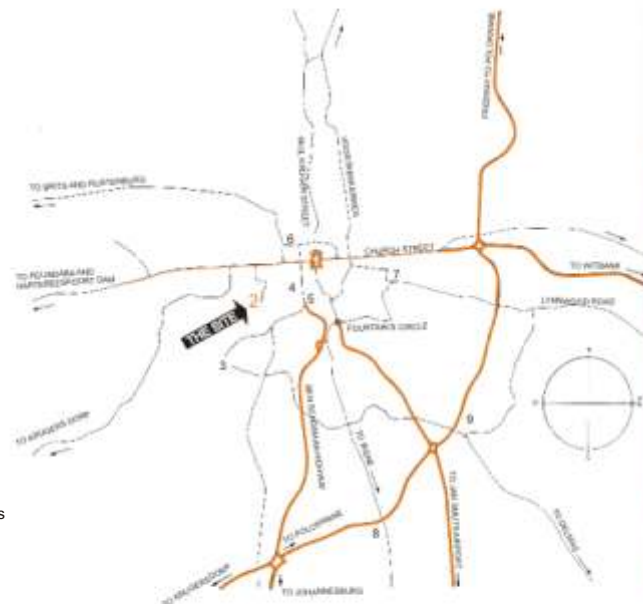


Figure 3.3: Map of the Pretoria area as drawn by Harmes Meiring.

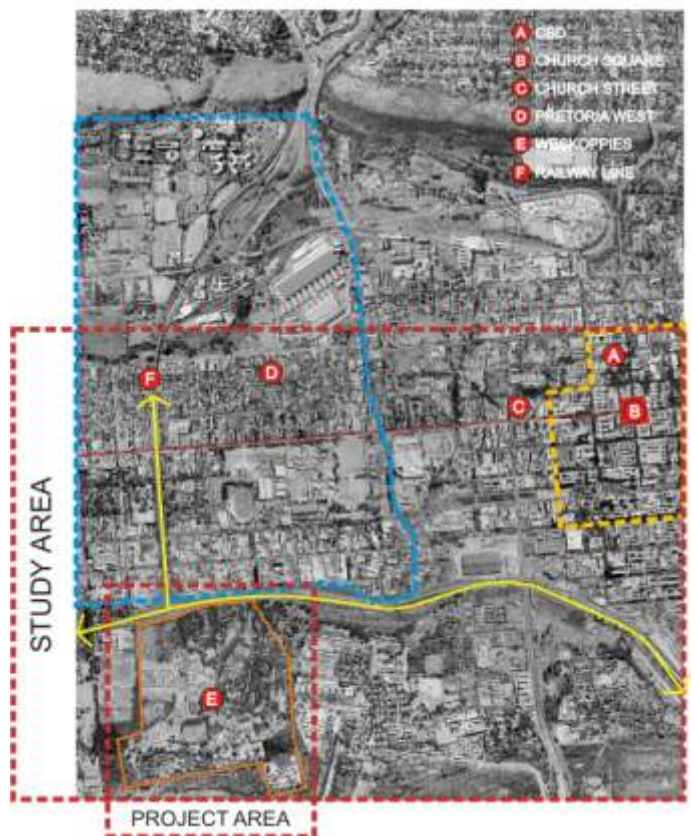


Figure 3.4: Aerial photograph indicating site location within Tshwane city context.

2.2 Historic Context

2.2.1 ESTABLISHMENT OF THE ASYLUM

By 1890 there were already several mental hospitals in South Africa, namely those at Grahamstown (1875), Pietermaritzburg (1880), Bloemfontein (1883), and Port Alfred (1889), while the hospital at Valkenberg was established soon thereafter. None of these, however, was in the independent Zuid-Afrikaansche Republiek (ZAR) (South African Medical Journal, 1992: 218).

It was decided to build the institution in the West of Pretoria in the “Old Botanical Garden”. Sytze Wopkes Wierda, then the head of the department of Public Works for the Zuid-Afrikaansche Republic, worked as government engineer and architect with his staff on the design for the hospital. In 1892 the Krankzinnigengesticht te Pretoria (Pretoria Lunatic Asylum) was established as the first and only psychiatric institution in the old Transvaal. The hospital was erected 3km west of the Pretoria railway station, where it has remained to this day (South African Medical Journal, 1992: 218).

The original buildings built in 1892 from the designs of Wierda and his staff is excellent and sympathetic. “The five three-storey buildings, of a most attractive red brick, with their pitched roofs and rows of white-painted, small-paned windows, stand in a row among the giant jacarandas and large gardens; the castle-like clock tower at the back gives the ensemble something of the air of an Italian monastery.” (Meiring 1980:17).

Although one urgent case was dealt with in 1892, the institution was only fully ready to admit patients in May of that year. Advertisements were placed in a number of newspapers to inform the public that the curators were ready to consider applications for admission and to solicit applications for the post of female attendant (South African Medical Journal, 1992: 219).

Some 25 of the earliest patients were transferred to the asylum from prisons in the ZAR, where they had been kept for want of more appropriate accommodation. This practice had to be resorted to again during the early years of this century, owing to overcrowding (South African Medical Journal, 1992: 219).

Considering the state of development of the Transvaal at the time, the institution’s facilities were initially quite satisfactory. It even had a telephone installed as early as April 1892, owing to its distant position’. However, the number of black patients, in particular, turned out to be much larger than expected and plans for additional accommodation were already under consideration before the institution was even officially opened. After some additional rooms, houses and outbuildings had been acquired during the first 3 years, no more money was available for new permanent buildings and the accommodation problem continued to worsen.



Figure 3.5: North view of the main administration building as drawn by Hannes Meiring.



Figure 3.6: North west view of the main administration building by Hannes Meiring.



Figure 3.7: The new buildings of the "Pretoria Lunatic Asylum", completed in 1906.



Figure 3.8: Weskoppies 1907

2.2.2 TREATMENT

The asylum was declared as both a custodial institution for chronic patients and an institution of healing for acute patients. This approach was in line with Article 1 of the curators' instructions to employees, which required that every effort should be made to promote the expected eventual cure of patients (South African Medical Journal, 1992: 220).

Treatment options were limited and indirect. Proper physical care appeared to lead to significant improvement in the condition of many patients. The curators initially reported that: 'If we now after lengthy observation see what improvement may already be detected in the condition of several patients, who could not but worsen previously due to the often poor environment in which they were placed before their admission to the asylum, then we can declare with confidence that



Figure 3.9: Woman's ward, part of historic precinct.

the money appropriated to thereto was well spent, and wish to congratulate the county with the establishment of an institution such as this' (South African Medical Journal, 1992: 220). In a more sober vein it was noted that patients' physical condition often improved during the first 2 months, 'in general they become fatter' (South African Medical Journal, 1992: 220), but thereafter their condition remained the same owing to their 'unemployed existence'. The importance of various forms of work and recreation was stressed. Such activities were considered to form part of effective treatment on the assumption that they made constructive use of a patient's remaining mental faculties. The main advantage, however, was to counteract the deleterious effects of institutionalisation.

During later years additional facilities for treatment were acquired for treatment. These included hot baths for treating acute mania, a padded cell and a dispensary. The view that physical restraint should not be used against patients was generally accepted by then.

2.2.3 THE ANGLO-BOER WAR

Conditions during the Anglo-Boer war deteriorated considerably in the hospital. Serious overcrowding led to the erection of many temporary cells of galvanised iron. There also existed a lack of space to separate violent from calm patients and there was a shortage of suitable attendants.

During 1899 the Johannesburg newspaper, the *Transvaal Leader*, reported that the hospital was dark, poorly ventilated, overcrowded, insanitary, lacking facilities for work and recreation and run by untrained attendants, including 'a half-witted girl of sixteen' in charge of the children's ward. These were probably the most difficult time in the hospital's history.

The hospital's staff shortage was finally relieved in May 1901, when 4 attendants and 4 nurses arrived from the asylum near Grahamstown. New rules regulating the conduct of attendants were drawn up and the certification and detention of patients by the new regime were properly legalised by Proclamation 36 of 1902 (South African Medical Journal, 1992: 221).

Other improvements took more time. New buildings were soon planned, but were only ready for occupation in 1906 (South African Medical Journal, 1992: 221). Gradually, the hospital was restored to what it had been in its earliest years: a beautiful building, situated on large and pleasant grounds with a quiet and tranquil atmosphere.

2.3 Location : Study Area

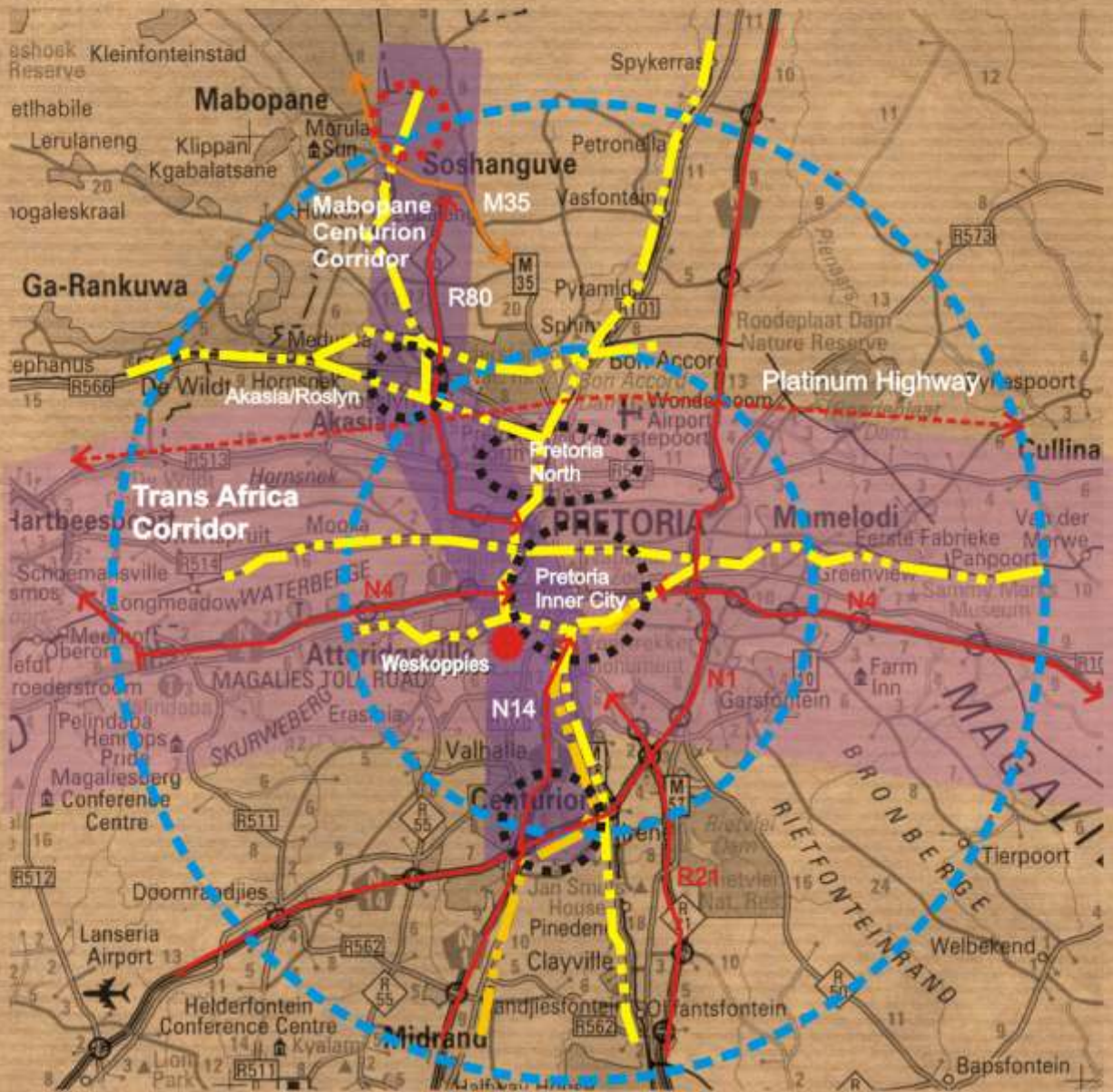


Figure 2.10: Location in the Region (Source: GAPP Satynkop Development Framework July 2003 Draft Report)



2.3.1 STUDY AREA

As illustrated in Figure 3.10, within the broader region:

- The site is situated in proximity to the Southwest Gateway to Pretoria Inner City. It also falls within both the Mabopane Centurion, Trans Africa Development Corridors (N14/N4) and the Pretoria Economic Node.
- It is sited in close proximity to several major access ways through the area, both road based and mass public transport (rail), as well as the Gautrain Project, proximate to a proposed station for the rapid rail system at Pretoria Station.
- The site is thus situated at such a location as to be accessible and usable to the greater Pretoria area.
- The site has the potential to play a role in the diverse activities made available to the cities inhabitants through the public realm.

2.4 Location : Project Area

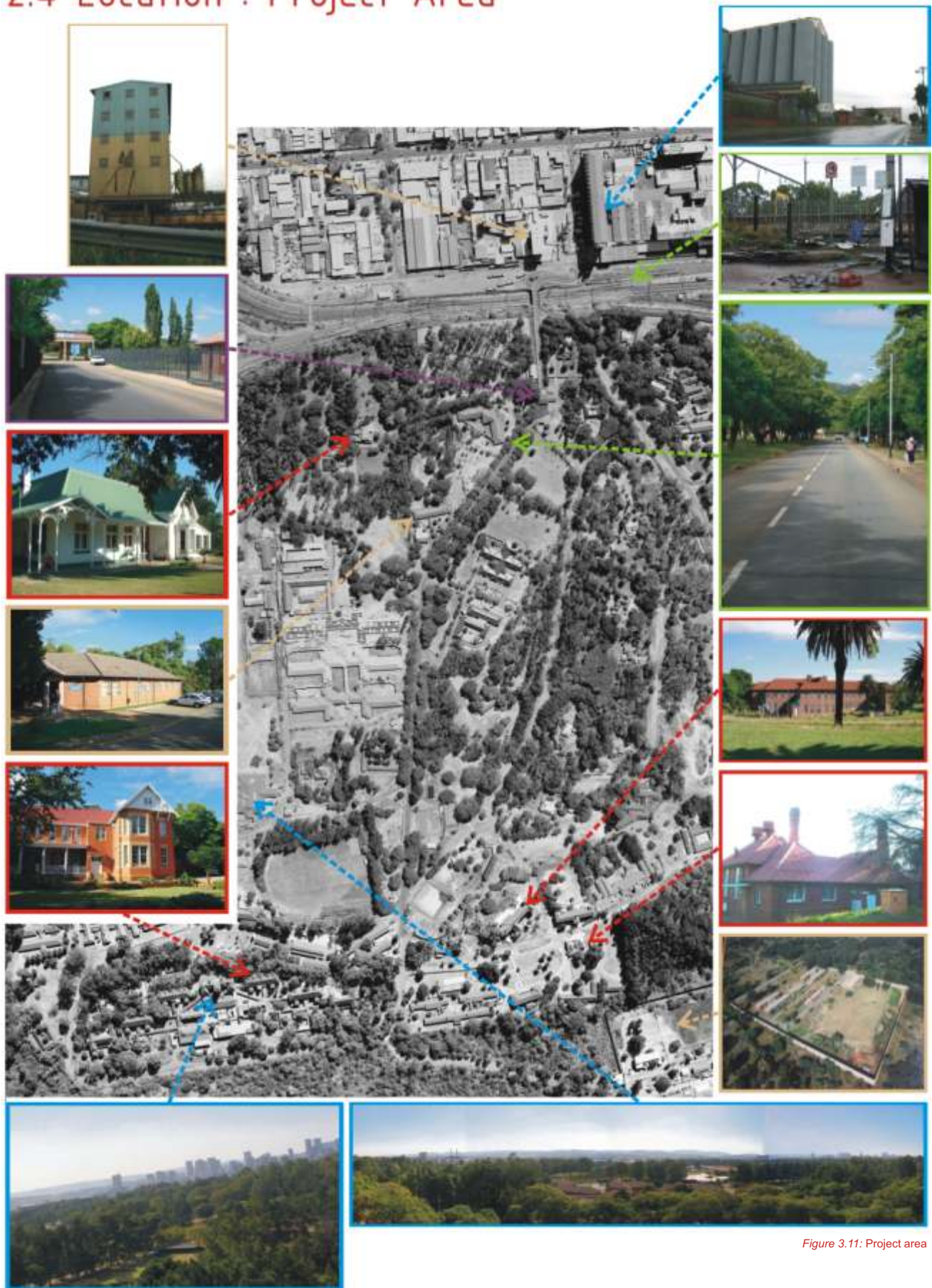


Figure 3.11: Project area

KEY									
	Gateway		Historic Buildings		Views		Streetscapes		Other buildings

2.5 City-Wide Context

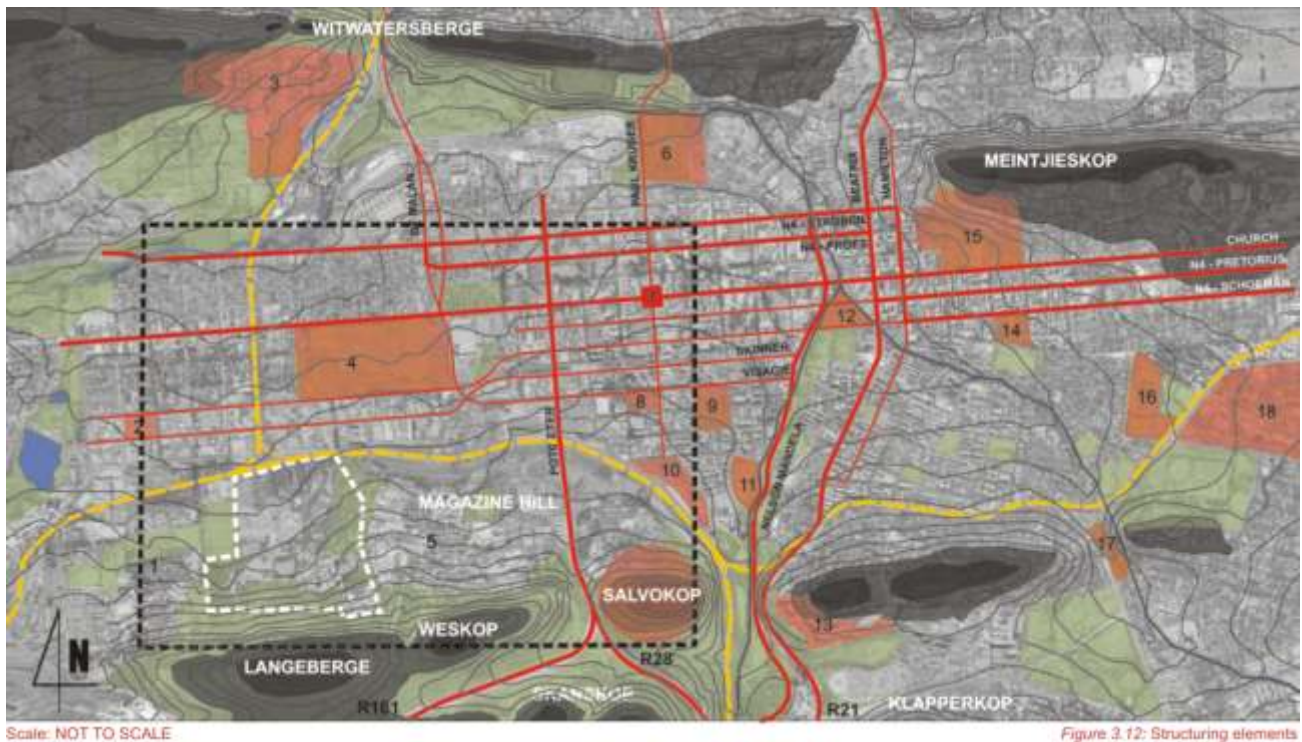
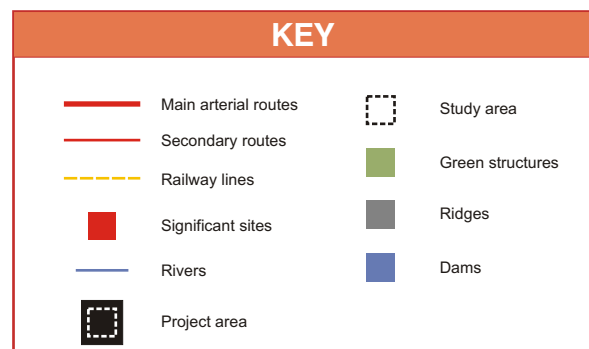


Figure 3.12: Structuring elements

Significant sites:

- | | |
|--|---------------------------------|
| 0. Iscor | 12. Caledonians sports grounds |
| 1. SAPS College | 13. Unisa |
| 2. Kruger square | 14. Pretoria art museum |
| 3. Tshwane university of Technology | 15. Union Buildings and gardens |
| 4. Pilditch stadium and Pretoria showgrounds | 16. Loftus Versfeld stadium |
| 5. Military barracks | 17. Magnolia Dell park |
| 6. Zoological gardens | 18. University of Pretoria |
| 7. Church square | |
| 8. Pretorius square and the City hall | |
| 9. Burgers park | |
| 10. Pretoria station | |
| 11. Berea park | |



2.5.1 LOCATION

As illustrated in figure 3.12:

- The site is situated on the slopes of the Langeberge,
- The site is cut-off from the Inner City due to the railway line,
- The site is removed from main arterial routes, but in close proximity to secondary arterials,
- Thus a substantial connection to the city needs to be made in order to integrate the site with the greater context.
- The site is positively situated as a therapeutic environment within the tranquil setting of the Langeberge.

2.5.2 STUDY AREA/PROJECT AREA

Figure 3.12:

The project area is bordered by the railway line to the North, the South African Defense Force to the East, the Langeberge to the South and the South African Police Service College to the West.

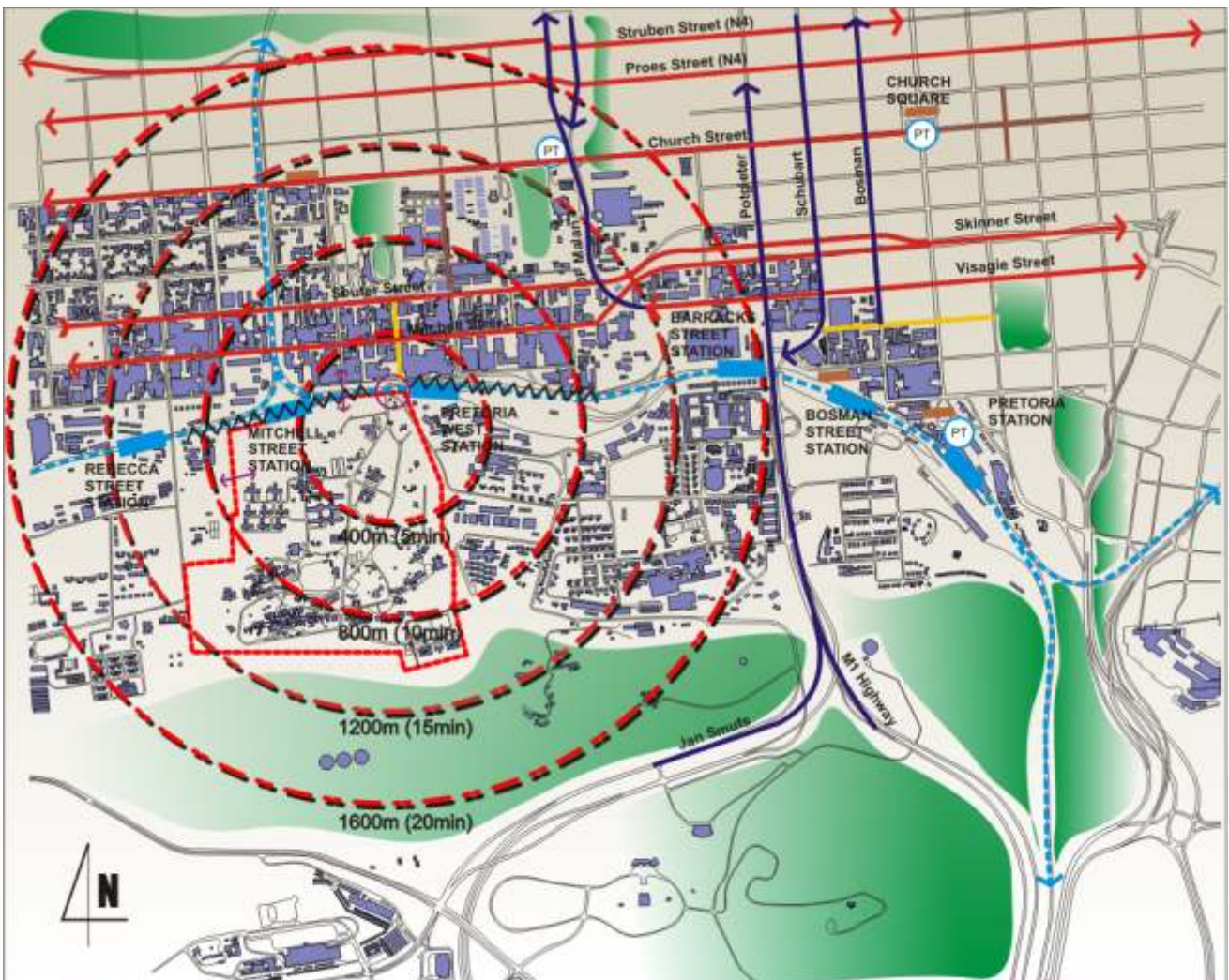
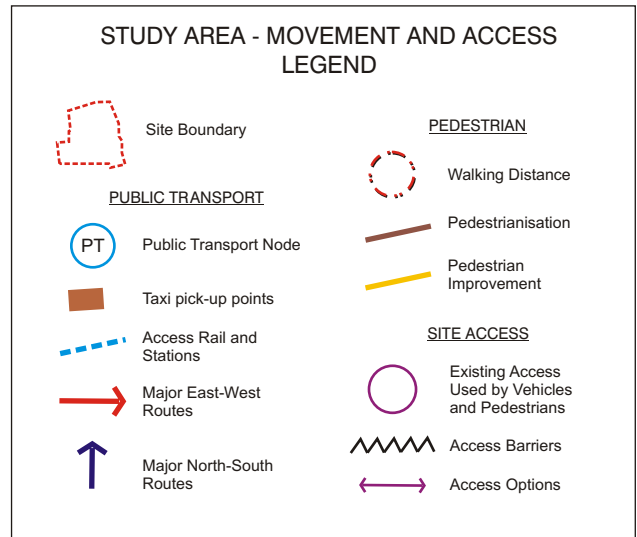
This indicates that the immediate area surrounding the hospital is of a strong institutional nature, with the city and the natural environment set on opposite poles.

2.6 Status Quo : Study Area

2.6.1 MOVEMENT AND ACCESS (see fig 3.13)

Although the site is regionally highly accessible, the local access is poor, with only a single entry point into the campus, from Ketjen Street on the Northern edge. It is severed from the main Central City arterial system by means of the railway line. However it is in close proximity to Souter and Mitchell streets that are secondary arterial roads leading in to the CBD. There are busses and taxis that frequent these roads and also some busses that accommodate drop-offs on the campus.

There exist the possibility to create direct access to other secondary roads (Maltzan Street), but this would have huge capital cost implications in terms of infrastructure.



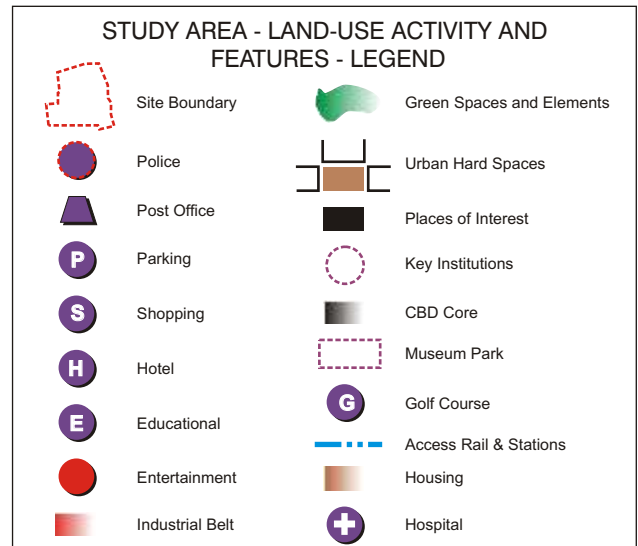
Scale: 1:30 000

Figure 3.13: Study Area - Movement and Access

2.6 Status Quo : Study Area

2.6.2 LAND-USE, ACTIVITY & FEATURES (see fig. 3.14)

- The campus is primarily surrounded by industrial uses, housing and the natural setting of the Langeberge to the Southern edge.
- Primary activities in the vicinity of the site include Pilditch Stadium, Iscor club, Piet van der Walt Theatre, and the Kruger Square.
- There are shopping facilities within proximity of the site.
- Freedom Park and the Salvokop precinct is also situated within 10minutes walking distance of the site.
- The South African Defense Force is situated to the East of the site and the Police Training Collage to the West.



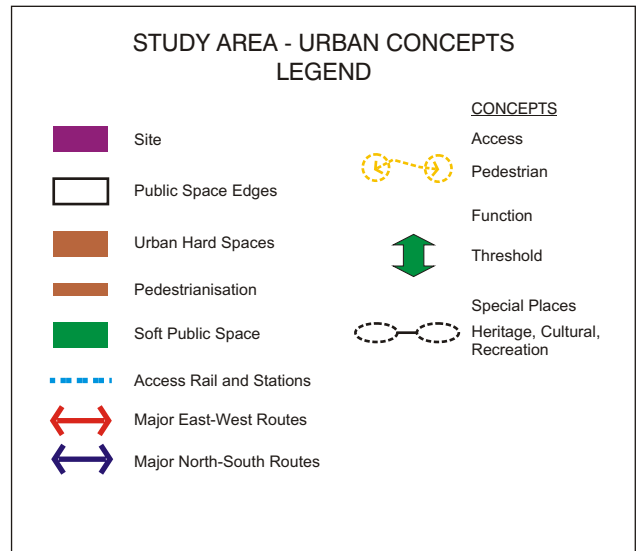
Scale: 1:30 000

Figure 3.14: Land-use, Activity & Features

2.6.3 URBAN CONCEPTS (see fig 3.15)

No framework has been set out for the site in terms of the Tshwane Spatial Development Framework. The following interventions are proposed:

- Develop open space continuity, definition and ecological protection.
- Investigate opportunities where heritage elements can be transformed into assets.
- Define public spaces within the streets in order to create a more public friendly environment around the site.
- Incorporate newly developed public spaces and transport nodes with existing transport systems, linking them up into the site.



Scale: 1:30 000

Figure 3.15: Urban Concepts

2.7 Status Quo : Project Area

2.7.1 ENVIRONMENTAL CONTEXT (see fig. 3.16)

The environmental context consist of the natural systems, the topography and the climate.

excellent position in relation to views into the city. The ridge is an important natural asset and contains many plant species. Generally the ecological sensitivity of the site is high.

2.7.2 NATURAL SYSTEMS (see fig.3.17)

The city is structured by a system of ridges. The site backs onto one of these ridges, the Langeberge. These ridges have an

2.7.3 WESKOPPIE'S NATURAL SYSTEM

- The quartzite ridges of Gauteng are regarded as one of the most important natural assets in the entire region of the northern provinces of South Africa.

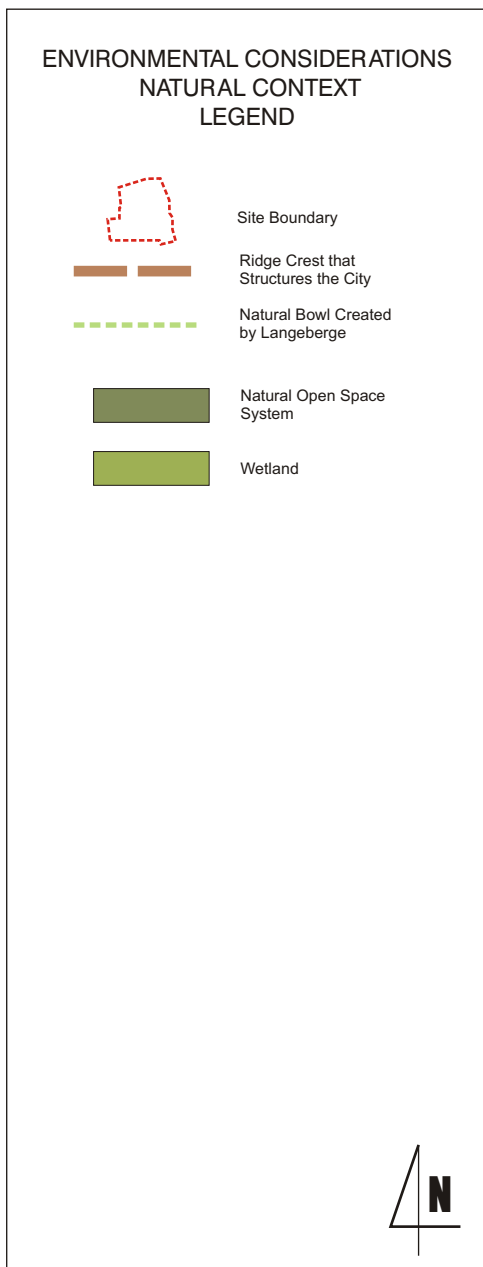


Figure 3.16 Natural Context

- They are characterized by a unique plant species composition that is found nowhere else in South Africa or the world.
- The general ecological sensitivity of Weskoppies is high.

site with maximum exposure to the Northern sun. Views to the Central City can be explored.

2.7.4 TOPOGRAPHY

Topographically the site slopes North toward the Inner City. From a climatic point of view this provides a positive micro climate for the

2.7.5 WESKOPPIES VEGETATION (see fig. 3.17)

A valuable open space which has a very high ecological value that must be protected in its natural state. The lower slopes of the hill are being invaded by alien vegetation originating in the residential area.

**ENVIRONMENTAL CONSIDERATIONS
VEGETATION
LEGEND**

ZONE 1 NO ECOLOGICAL VALUE

The area has little ecological value due to the presence of the railway line and the high level of littering.

Cleaning up of the area and the development of indigenous vegetation should be encouraged.

ZONE 2 LOW TO MEDIUM VALUE

The area is severely disturbed due to development over the years. Some indigenous species exist and many exotic plant and trees are in the process of being removed. This to the detriment of the aesthetic and cultural value of the landscape.

The planting of indigenous trees on a large scale should be encouraged.

ZONE 3 MODERATE TO HIGH

The area consist of mainly indigenous species which have a moderate to high ecological value.

It is important to keep the area free of alien species which are tending to invade the area.






Figure 3.17: Vegetation

Scale: NOT TO SCALE





Area 1	Geology	Soil	Hydrology	Rain	Vegetation	Common	Noise	Value
	Shale	Mesotropical; red soil	None	650-700mm	Disturbed urban temperate bushveld	Bushveld	Road Railway	Aesthetic feature

Area 2	Geology	Soil	Hydrology	Rain	Vegetation	Common	Noise	Value
	Shale	Mesotropical; red soil	None	700-750mm	Disturbed urban temperate bushveld	Bushveld	Road Railway	Aesthetic feature

Area 3	Geology	Soil	Hydrology	Rain	Vegetation	Common	Noise	Value
	Shale	Mesotropical; red soil	None	700-750mm	Euclea-Acacia caffra	Temperate mountain bushveld	None	Aesthetic, panoramic feature

Area 4	Geology	Soil	Hydrology	Rain	Vegetation	Common	Noise	Value
	Quartzite	Mesotropical; red soil	None	700-750mm	Euclea-Acacia caffra	Temperate mountain bushveld	None	Aesthetic, panoramic feature

LOCAL NATURAL ENVIRONMENT LEGEND

-  Site Boundary
-  Railway Line
-  Direction and steepness of site
-  Noise Pollution

2.7.6 SITE GEOLOGY (see fig. 3.16)

The area lies within the Timeball Hill formation of the Pretoria group of the Transvaal Sequence. The dominant rock types are shale and quartzite.

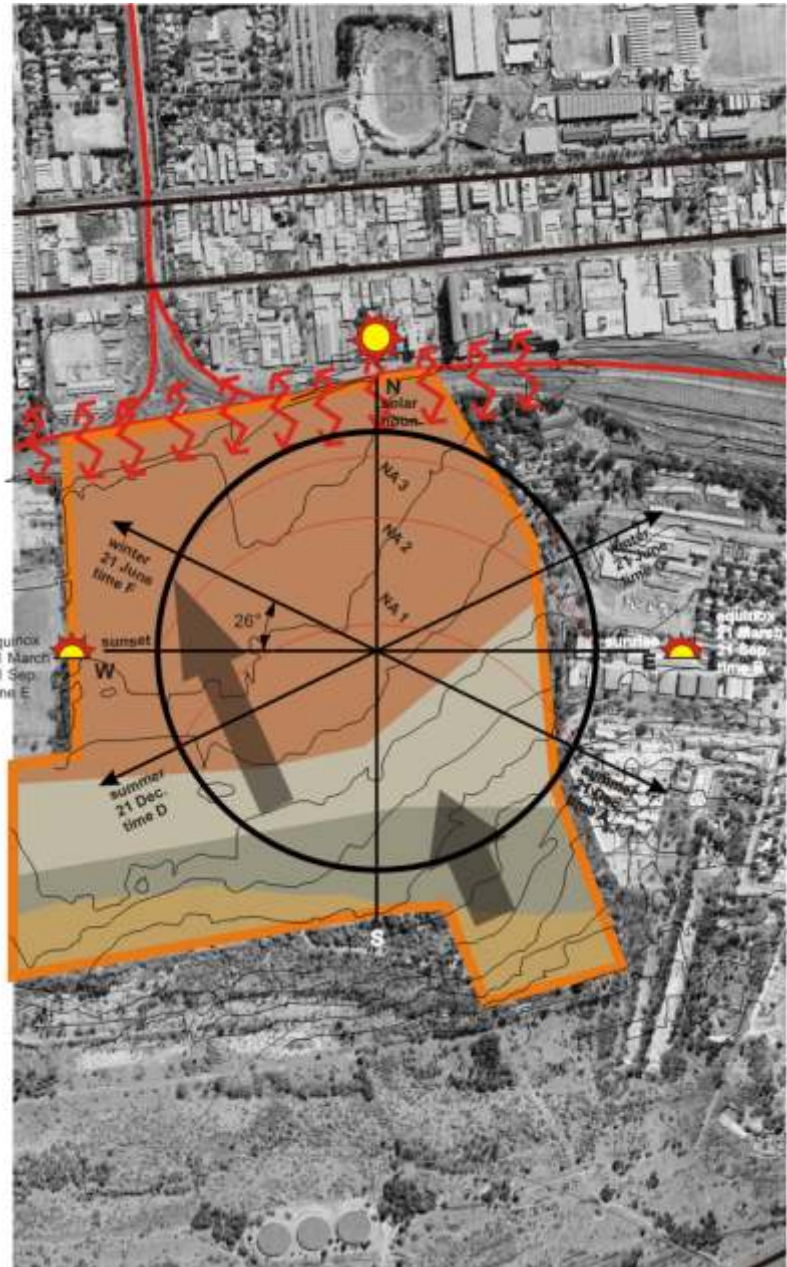


Figure 3.18 Local Natural Environment

Scale: NOT TO SCALE



Figure 3.19: View point 1



Figure 3.21: View point 3







Figure 3.20: View point 2



Figure 3.22: View point 4

ENVIRONMENTAL CONSIDERATIONS
VEGETATION
LEGEND

-  Street trees with aesthetic value
-  Landscape with historical and cultural value
-  Viewing point
-  No ecological value

2.7.7 EXISTING VEGETATION (see fig. 3.23)

The existing "ring-road" on the campus is lined by dense trees indicating the importance of the road. It is proposed that existing indigenous trees be kept intact and maintained as far as possible. The landscapes planted around the historic precincts are of particular importance and can be restored in many regards to their original states.



Figure 3.23: Vegetation

Scale: NOT TO SCALE

2.7 Status Quo : Project Area

2.7.8 CLIMATE

Pretoria falls in the temperate eastern plateau region. Generally this area are predominantly grassland with scattered trees in the wetter parts. Summers are warm to hot, with fairly dry air, relieved by thunder storms generated from thermal air movement. Hail is not uncommon. Winter days are pleasantly sunny with clear cold to very cold nights (Napier, 2000).

The temperate eastern plateau regions' climate is moderate and do not necessitate extreme governing principles for the design of buildings.

2.7.9 RAIN

The rainy season occurs in November to March, peaking in January. Fifty to eighty days of rain can be expected annually.

The high rainfall in the area can be harvested and stored for domestic use. Because of the possibility of hail in the area, the design of gutters need to be considered if rainwater is to be harvested.

2.7.10 CLIMATE FACTS

January temperature:	20 to 25°C
June temperature:	10 to 15°C
Prevail winds:	N-E in summer and N-E to N-W in winter
Relative humidity:	30%
Hours sunshine:	60%
Average rainfall:	674mm
Winter solstice:	22 June - 44°
Summer solstice:	22 December 87°

SUNRISE clock time			SUNSET clock time			Na1	Na2	Na3
TIME A	TIME B	TIME C	TIME D	TIME E	TIME F	SUMMER	EQUINOX	WINTER
5:28	6:18	7:08	19:08	18:18	17:28	88°	64°	40°

1. Summer solstice (82,5 degrees)
Section shows no sun penetration on 22 December due to the roof overhang.
2. Winter solstice (35,5 degrees)
Section shows the extent of sun penetration at noon 22nd June. The roller screens allows for further sun control.
3. Equinox (59 degrees)
Section shows the extent of sun penetration at noon 21st March and 23rd September.

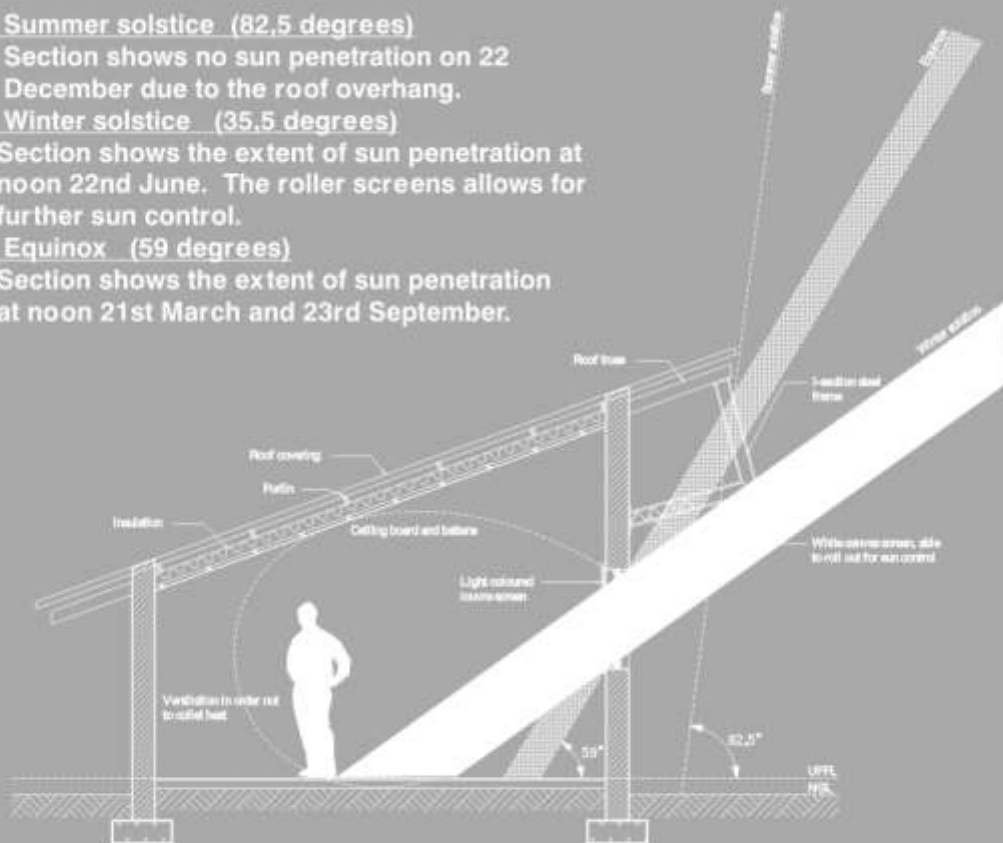


Figure 3.24: Climatic considerations

Scale: NOT TO SCALE

2.7.11 MICRO CLIMATE

Air will cool down and fall to the lowest level of the site (towards the railway line). Siting lower down the slope will ensure cooler conditions due to the air movement. Prevailing winds from the north-east can be funneled to cool down the buildings in summer, while protection against prevailing winter winds can be incorporated along the north-west facades.

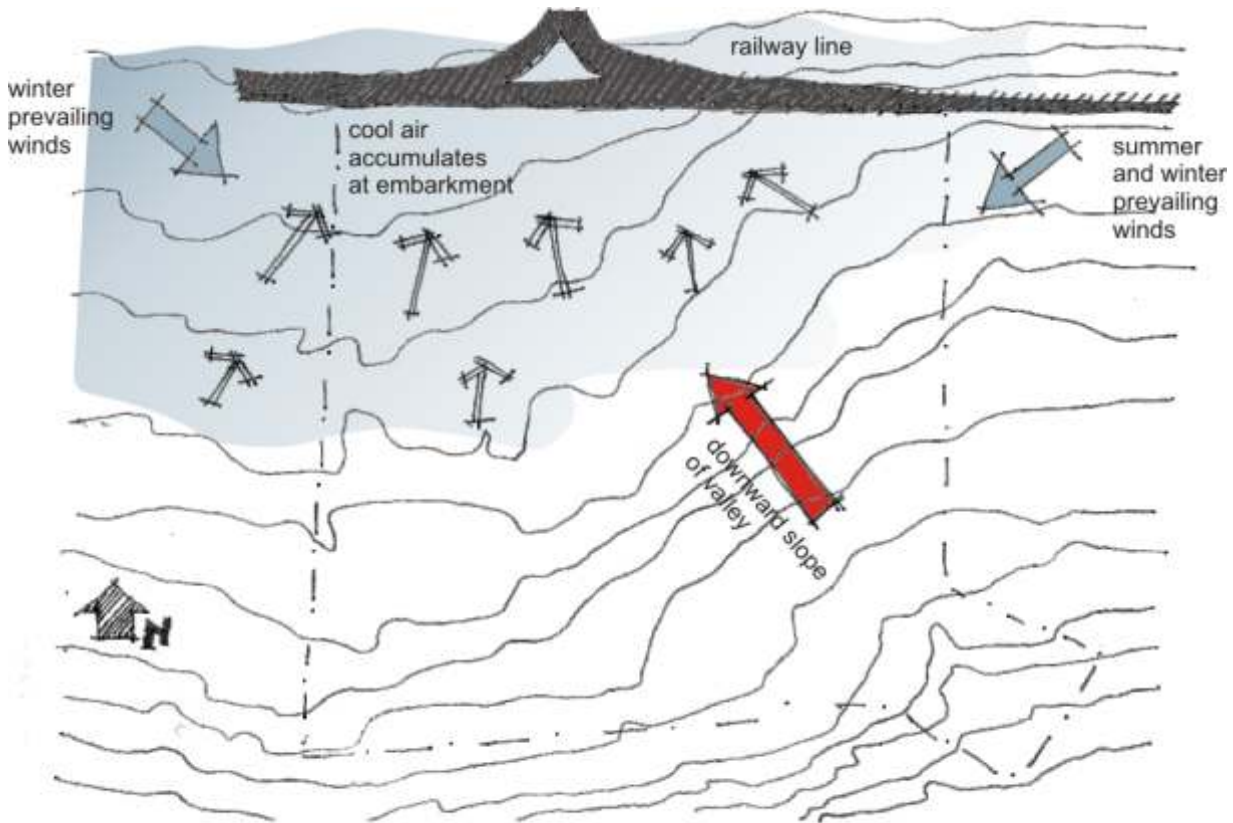


Figure 3.25: Temperature inversion from plan

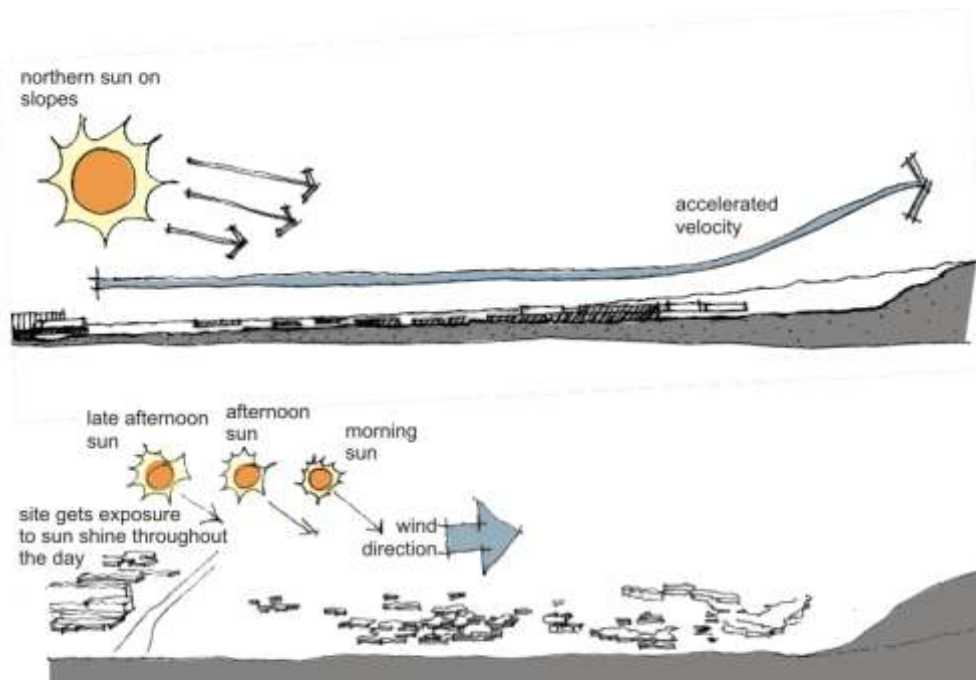


Figure 3.26: Air movement and sun

2.7.12 AIR MOVEMENT AND SUN

The slope in question (where Weskoppies is situated) receives optimum norther sun and is exposed to prevailing winds.

This creates ideal conditions for the development since the buildings will be exposed to the maximum amount of preferred sunlight, while at the same time be able to be cooled by the prevailing winds.

2.7 Status Quo : Project Area

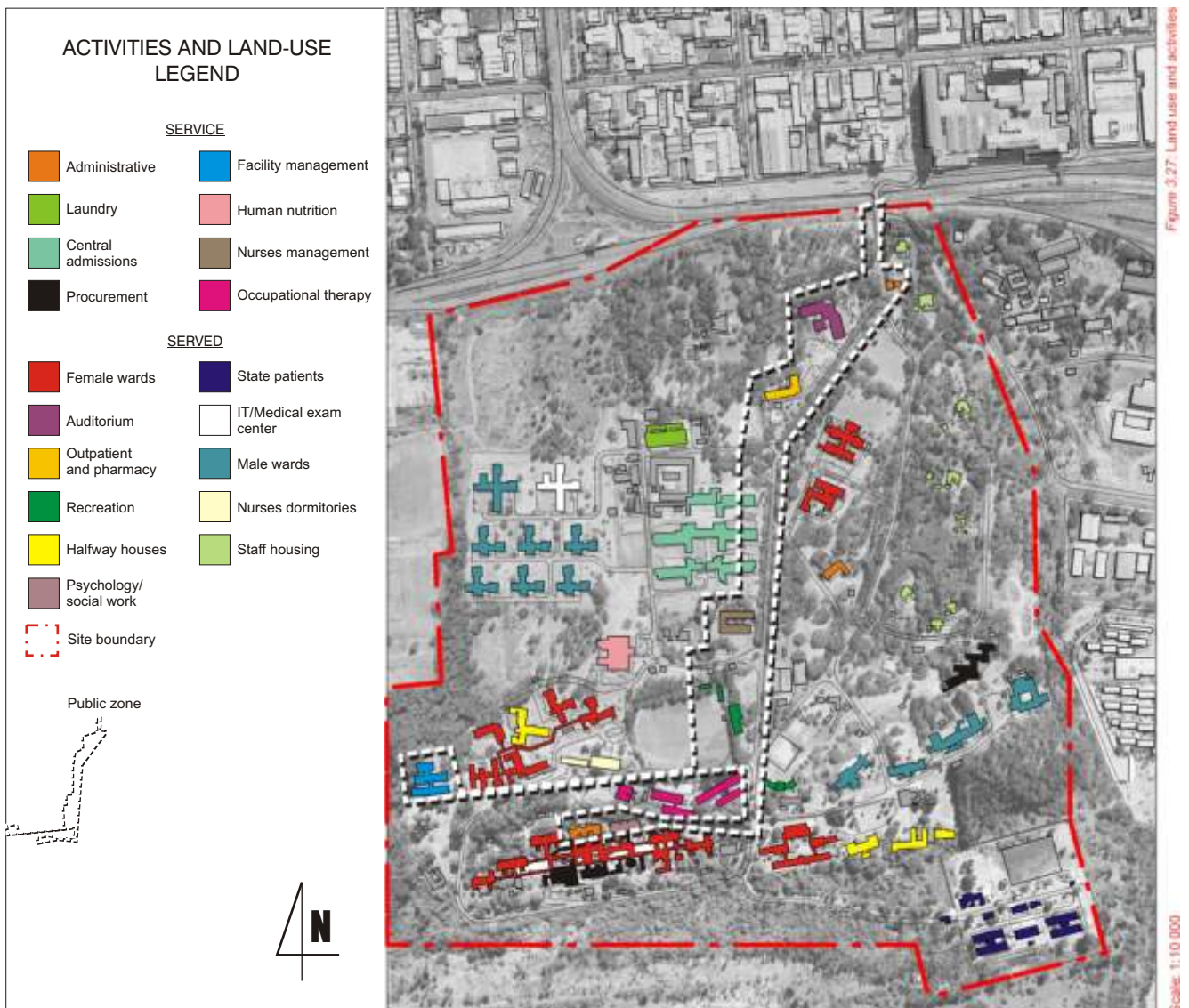
2.7.13 LAND USE AND ACTIVITIES (see fig. 3.27)

As mentioned, Weskoppies is a tertiary in-patient mental institution. The land uses include all the facilities needed for the infrastructure, treatment and housing of the patients and staff.

From the diagram it becomes clear that both service and servant uses exist within the public realm.

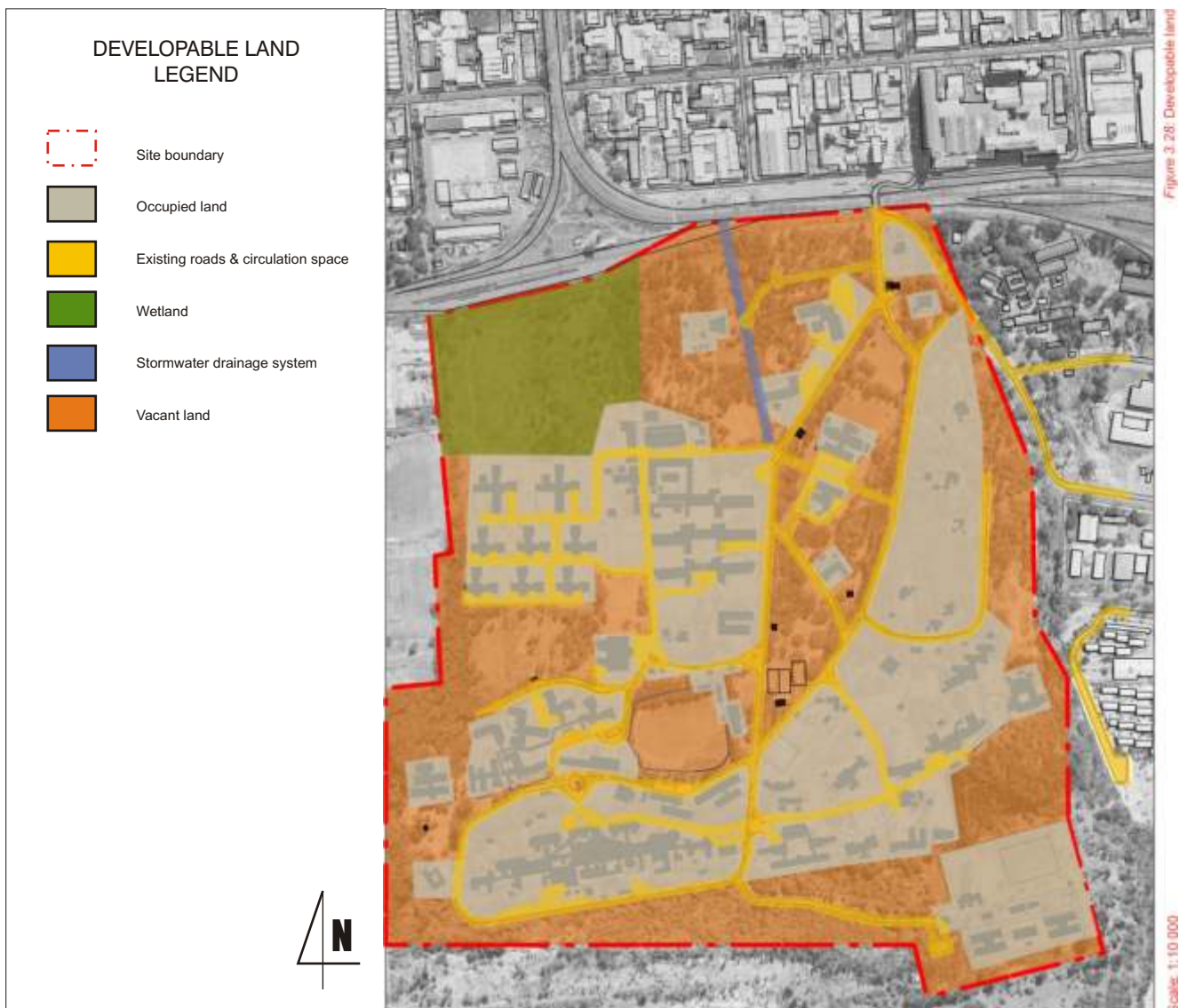
It also becomes obvious that there exist a lack of open space and recreational facilities. The strongest open space system that exist on the site (that is used by the patients and public) is the main arterial road linking the gate building and the administration facilities, leading visitors deep into the site to the heritage buildings that also accommodate the female patients.

There exist no independent information facility.



2.7.14 DEVELOPABLE LAND (see fig. 3.28)

The majority of the developable land is situated on the periphery of the site. A "island" within the heart of the campus comprises of a substantial amount of open land within close proximity.





2.7.15 MOVEMENT AND ACCESS (see fig. 3.31)

Nature of pedestrian movement

There exist no formalized pedestrian movement systems and many of the pedestrians move along the vehicular roads. A formalized movement system is of integral importance since many patients working during the day walk to work and many outpatients use the public transport systems to reach the site.

A bridge provides access to the campus and is utilized by vehicles and pedestrians. Since the bridge is very narrow this creates an environment that is not ideal for pedestrian movement.

Nature of public transport systems

Busses accommodate drop-offs and pick-ups on the site and use the high order connector route for this purpose.

Movement needs

The vehicular movement systems are well developed ad serve the site appropriately. The pedestrian movement systems need to be formalized to ensure pedestrians moving comfortably across the site away from public scrutiny .

Bus stops on the site are placed as singular elements on the site and do not relate appropriately to public spaces. Their singular aim currently is to provide protection from the elements.

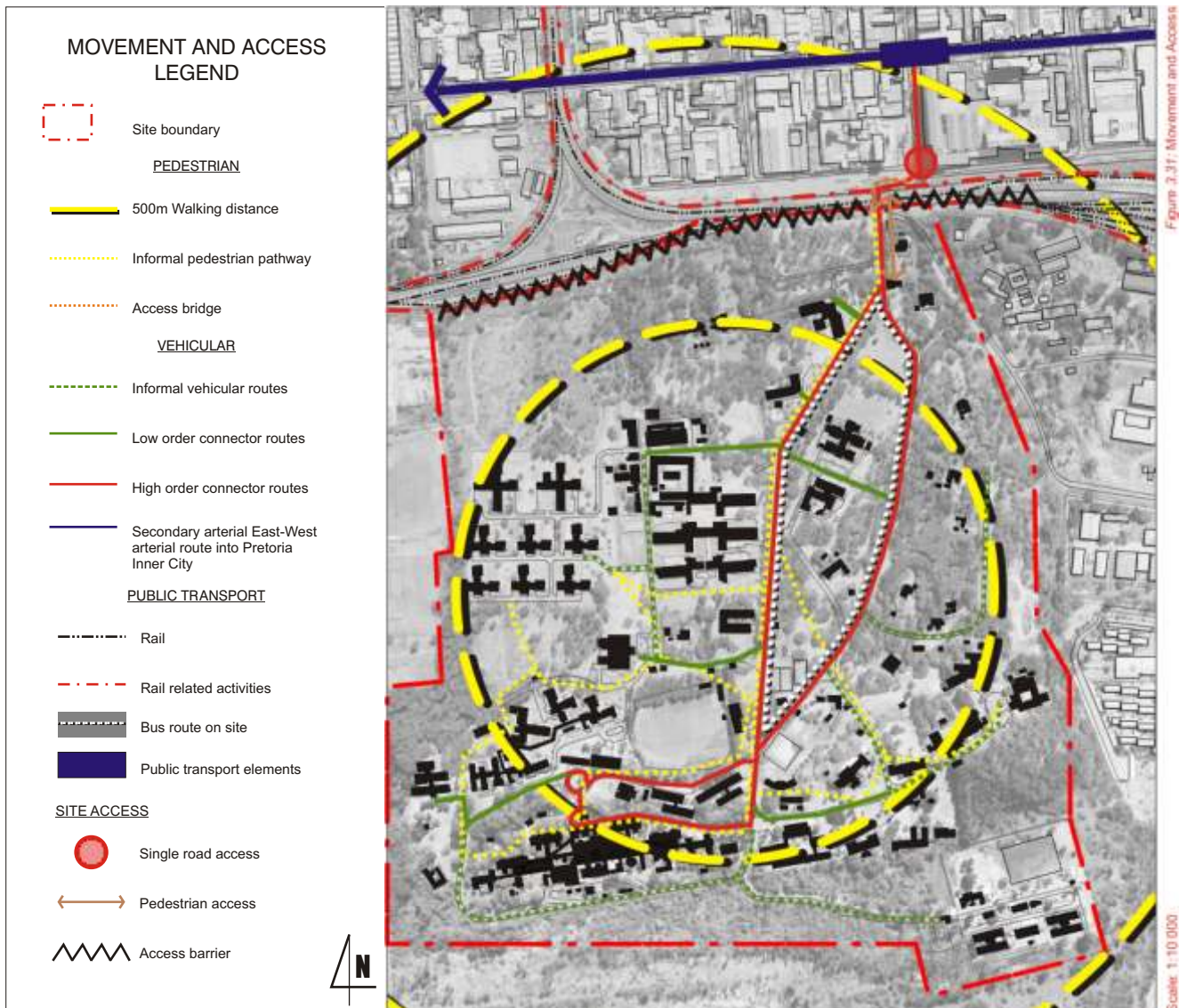




Figure 3.32: View point 1 - Main administration building (1892)



Figure 3.33: View point 2 - Male ward (1980's)



Figure 3.34: View point 3 - Central admissions (2000's)



Figure 3.35: View point 4 - Central admissions (2000's)

2.7.16 HERITAGE CONTEXT (see fig. 3.36)

The original buildings on the site date back to 1892. The facades of main administration building is protected by SAHRA. There exist houses that were also built during this time, now inhabited by staff members. These houses are however not protected since neither the houses nor the site have been declared heritage.

Recommendations on heritage context

- The heritage assets of Weskoppies must be conserved, including historical houses and individual structures.
- Public access to identified structures should be incorporated into the envisaged framework due to the integrity and authenticity of the buildings.
- Guidelines for future development must be implemented in order to protect the integrity of the site and the historic buildings

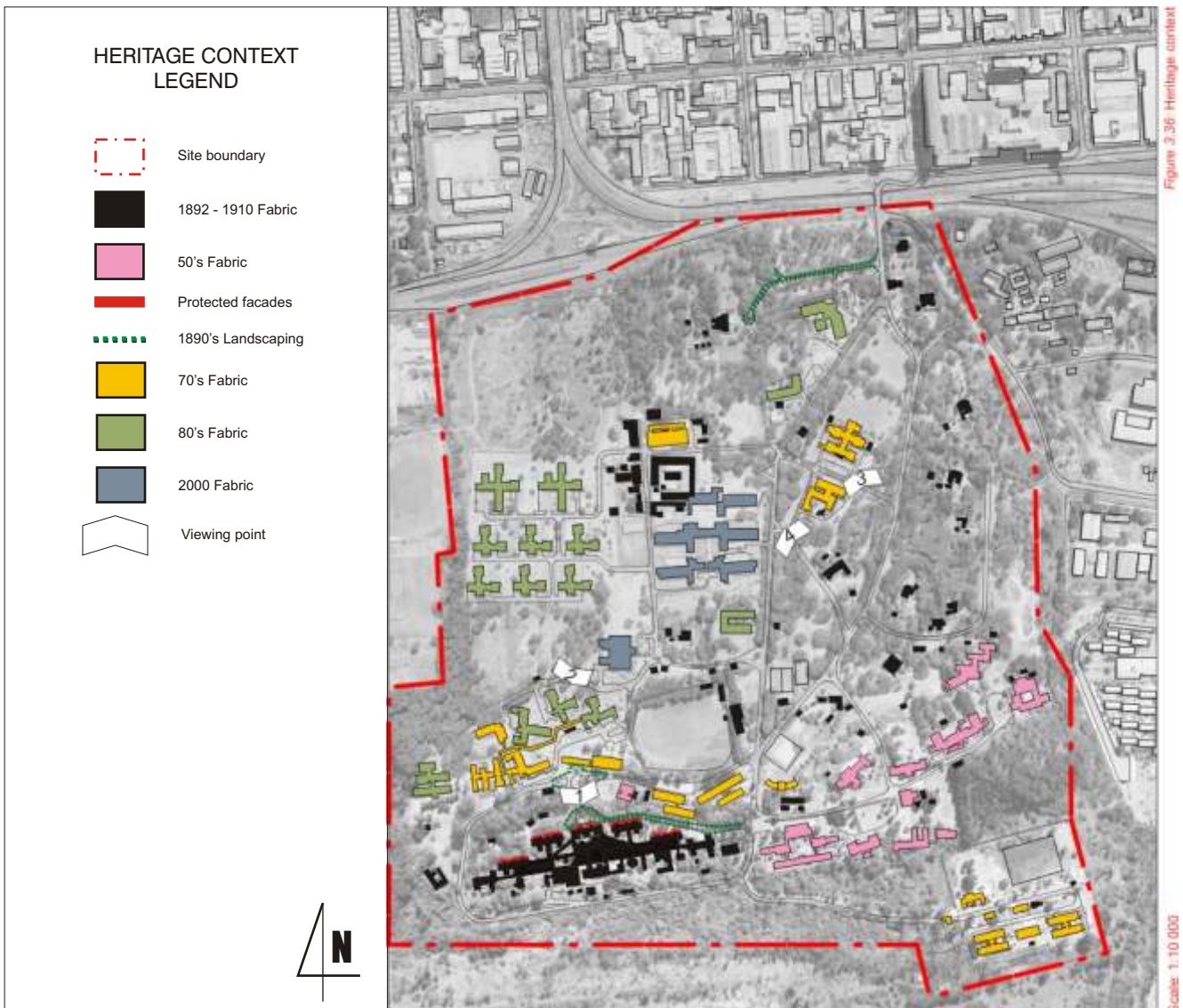


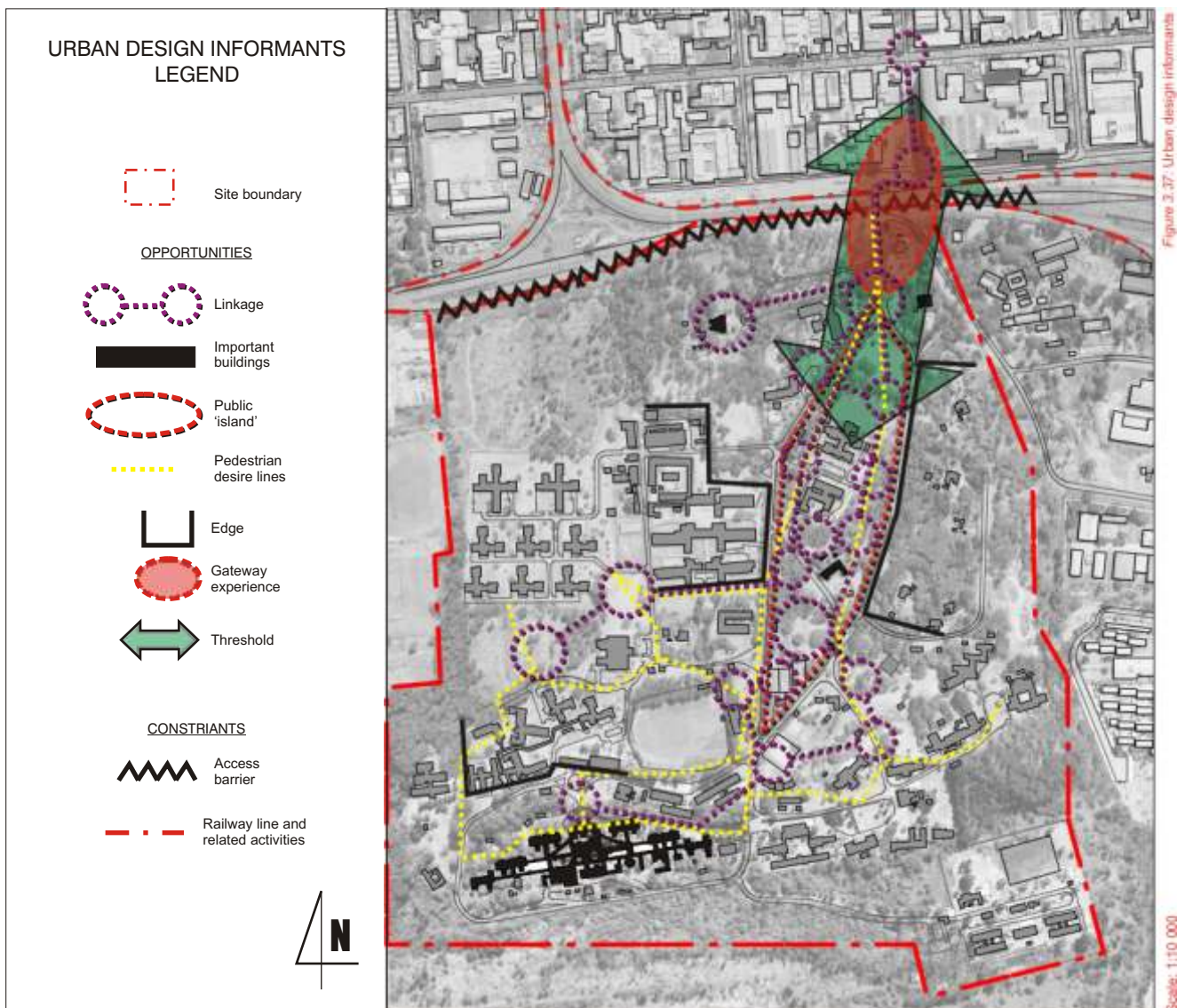
Figure 3.36: Heritage context

Scale: 1:10 000

2.7 Status Quo : Project Area

2.7.17 URBAN DESIGN INFORMANTS (see fig.37)

- Acknowledge the existing visual axes within the site
- The idea of creating nodes and spatial links within the site
- Developing existing connections into the site to form an access gateway
- Respecting and enhancing the existing street grid, reinforcing it by using street landscaping and improved pedestrian accommodation
- Respecting pedestrian desire lines and formalizing them as pathways
- Respecting the heritage assets, which should be protected and utilized, to provide an attraction to the site and enhance the experience of the site
- Looking to create a hierarchy of enclosure that defines levels of privateness and publicness
- Respecting and enhancing the green space opportunities on site



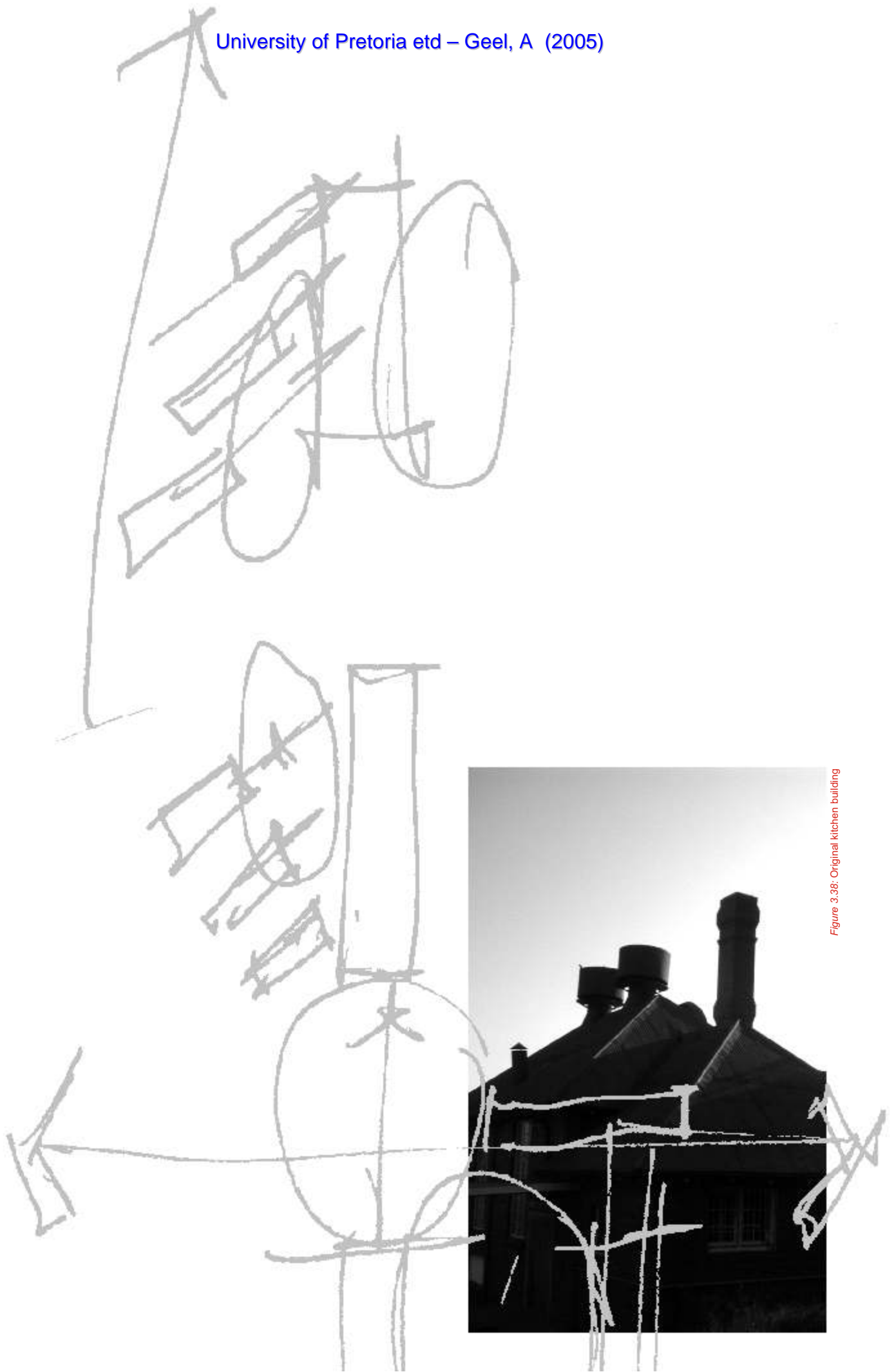


Figure 3.38: Original kitchen building



Figure 3.39: Chinese courtyard housing allows for flexible growth within the family fabric.

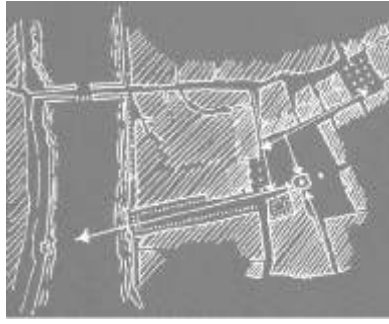


Figure 3.40: At the Uffizi, a powerful new geometry links the River Arno with the Piazza della Signoria.

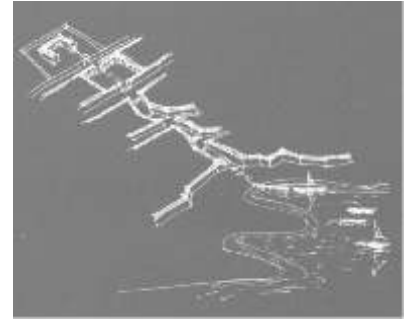


Figure 3.41: At Lake Patzcuaro, an episodic procession winds uphill, linking harbour with the plaza and church beyond.

2.8 Context Analysis: Ideas, Opportunities & Constraints

In terms of the opportunities and constraints for the development of a spatial development framework seven key issues were identified and then summarized into a brief statement of constraints and opportunities.

2.8.1 Integration of the campus into the larger city context.

The fact that Weskoppies is severed from the city through the industrial belt and the formation of negative space leading to the site does not match the role of the campus.

Integration constraints:

- Limited accessibility
- Unattractive existing urban fabric

Integration opportunities:

- The function of the site has the potential to play an integral role in the city as a place of healing and rejuvenation and should be 'read' by the public accordingly.
- Possibility of using site as a threshold between city and natural landscape.

2.8.2 Consideration of the Heritage Resources and their impact on development options.

Heritage constraints:

- The resources are not well known and have to be promoted.

Heritage opportunities:

- Heritage conservation supports development through adding value, but special development solutions are required.
- Heritage conservation is part of a sustainable development approach.

2.8.3 The creation of a interconnected, fluid figure of open space.

The incremental formation of a figure of public space is essential to the scale and character of a campus. People who live and work in campus settings depend on the

definition of a network of campus places to enrich both their daily lives and their sense of identity. Since the campus is constructed sequentially through individual projects that precisely define new elements of building, open space and landscape, the whole is affected every time the smallest physical change takes place.

Open space constraints:

- The configuration of the existing built fabric on the campus is very confusing.

Open space opportunities:

- Low density of site gives enough flexibility to insert new buildings strategically among the old and create place making through that.

2.8.4 Create scales of habitation

Individuals and communities understand and experience their lives at multiple scales simultaneously. On the campus overlapping scales of a place is experienced: the region, the locale (city, suburb, countryside), the campus context, the building context and the building components (such as individual rooms, clusters of rooms, circulation, exterior spaces and special social spaces at the smaller scale). Each of these scales presents different opportunities for revealing the particularities of a site (see figure 3.39).

Scales of habitation opportunities:

- The existing buildings are clustered in groups of similar use and accommodation. The nature of this accommodation can easily be strengthened through the articulation of the particularities of the group.

2.8.5 Create hierarchy of public and private domain

The graduation from public to private realms should be intensified on the campus. The individuality of domains within the campus (residential, educational) can provide a source of pride and identity. Social custom and physical articulation can aid in the flexible expression of domain.

“The architecture of the city is probably the most demanding and exacting art. Meaningful places are those where life is celebrated; where equity and overlap are achieved in access to the facilities of the city; where there is a balance between constraint and freedom to act; where the common human needs are accommodated; where community and that necessary sense of belonging can exist freely and where complexity and therefore secrecy make areas most livable”.

Hierarchies of domain are enhanced by the development of what Moore, Ruble and Yudel (Campus and Community, 1997, pg. 134) call a 'social plaid'. Buildings and rooms are placed so that each realm has multiple dimensions of identity (see figure 3.40).

2.8.6 The creation of a pedestrian connection system.

The geometric specificity of the site and flow of pedestrian desire lines provide powerful cues for connecting new buildings to the existing fabric, for fostering a range of social interaction, and for investing new places with particularity and memorability (see figure 3.41).

2.8.7. Create a choreography of community.

Places that invite a kinesthetic experience of space heighten one's involvement with both the place and other inhabitants. The 'fit' between buildings and their inhabitants can vary from loose to tight, allowing for a range of spatial and social experience. A choreographically rich place can balance both clarity and memorability of place with the chance for serendipity and a multiplicity of experience in space and time.

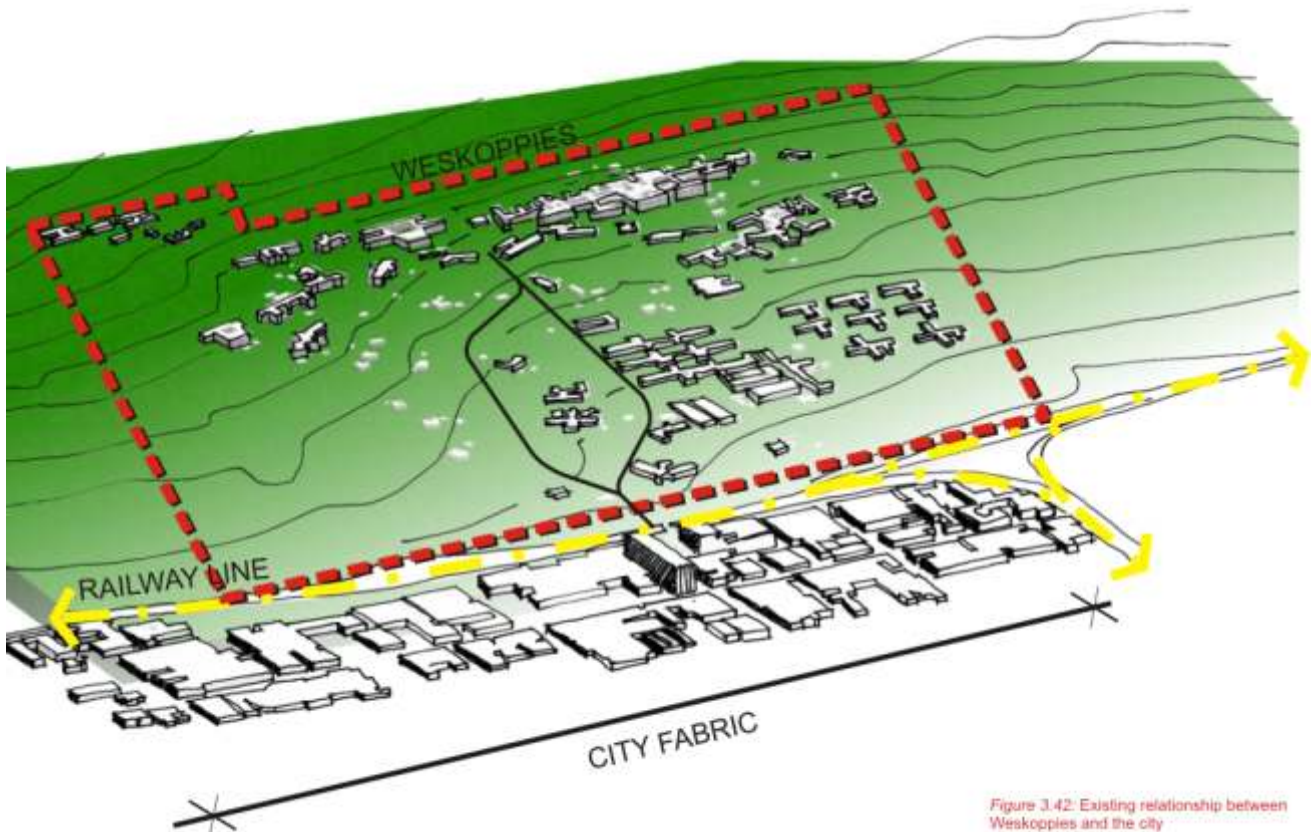


Figure 3.42: Existing relationship between Weskoppies and the city

2.8 Context Analysis: Ideas, Opportunities & Constraints

2.8.4 THE SITE AS A STOEP

The house can be used as a metaphor for the city. A house has many rooms that facilitate different uses. The optimum use of rooms will depend on the legibility of the functions that are to take place within the spaces. The concept would be to identify what the room is, thus the function and how this function is tied together with the rest of the house.

The location and current use of the site identifies it as a stoep to the city. It is in the transition zone between the city (house) and the natural environment. Together with the garden, the stoep forms a threshold to the natural environment.

2.8.5 THE STOEP

A place that is half house property, half public way. The house itself cannot be built on it, but it may be used for steps up to the high ground floor. The stoep is a functional transition between the public way and the private house. It is conceptually the meeting of the family with the urban world. From the house to street it is a link by mediation.

The stoep is actually part of the house and the owner takes immense pride in maintaining it. It is also a social place where neighbours exchange gossip and children play. By raising the ground floor of the house, it gives privacy to the residence.

The stoep, together with the garden, would be the place where we escape from the hustle and bustle of the house and find peace and quiet. It is the place where we go to rest, reflect and get rejuvenated.

If the site is considered in this light, it becomes evident that the city needs the site and that the site can play an integral role in the healthy functioning of the city. The development of the site in relation to the city and in integration of the city is thus a contribution to the current structure.



Figure 3.43: Weskoppies as stoep.

2.8.6 THE SITE AS PART OF THE COUNTRYSIDE

The informal structuring of the site is arranged in such a fashion as to resemble that of countryside developments. It is nestled between the rigid formation of the city and organic flow of the natural landscape.

Inherently this type of development will connect with the city's grid in some way, but also be governed by the natural flow of the topography and vegetation systems of the natural landscape.

It is according to these systems that the site needs to be developed hence forth as a sensitive interwoven fabric of city grid and organic flow.

Once again we associate country living with escaping from the city. It is the place we go to when the stressful living of the city weighs down to heavily upon us. It is the place we associate with rest, peace, rejuvenation, to clear our heads and take in the therapeutic effect of the natural environment.

If these concepts can be understood, the site can be developed into the place it wants to be. This is the message that should be conveyed through campus design, landscaping and built environment.

As for the development framework of the site, the implication of the vision is that the site should be accessible to the city as a whole, rendering this use of the city available to all.

2.8.7 INTEGRATION OF MOVEMENT AND ACCESS

The essential principles are the:

- Establishment of existing access as a gateway to support integration to the site
- Improvement of safe comfortable pedestrian accommodation, and connection from and to the Inner City
- Capitalise on the public transport facilities opportunity

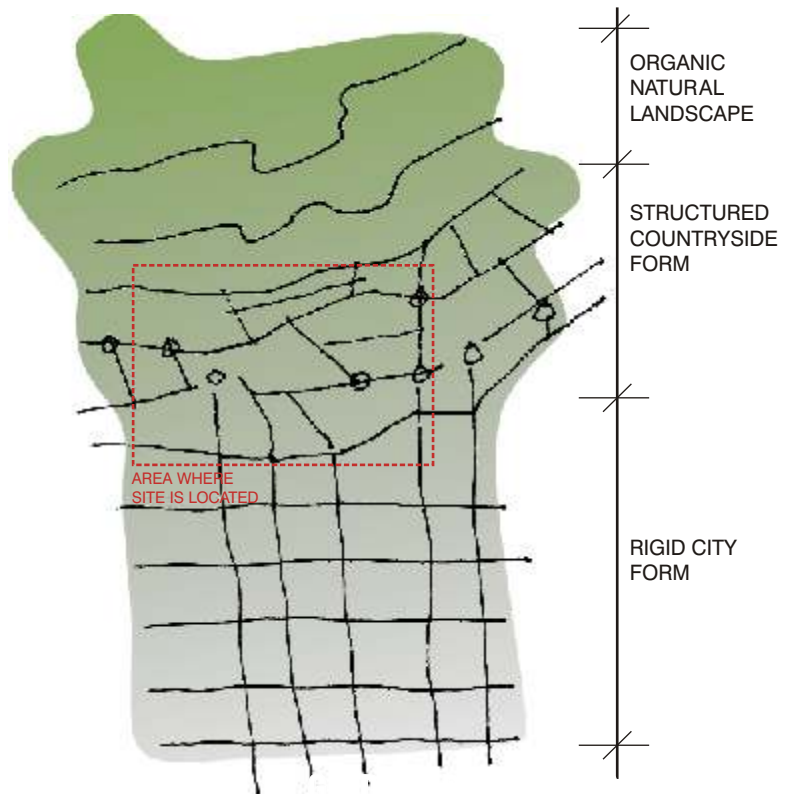


Figure 3.44: Campus structure

- Establishing an internal movement hierarchy to support redevelopment

2.8.8 CREATING SPECIAL PLACES

The creation of a series of special places by capitalizing on the current assets of the site such as the Heritage Resources and the natural setting of the site.

The Heritage resources

- Enhancing and developing the linkage with external activities
- Respect the edges and massing defining the historic developments
- Enhance the visual axes and connections to the historical buildings.

The environmental assets

- Creation of a new ecological system
- Establish bio-diversity parks within the campus that promotes indigenous flora and prevents alien transfer. This initiative can be incorporated in the landscape re-development initiative.
- Creating a range of hard and soft landscaped spaces including both public and private activities.

2.9 Conclusion

2.9.1 VISION AT CITY SCALE

At the scale of the City context the proposed Vision for the development has six key elements. These key elements are spatially illustrated in Figure 3.45 :

- The creation of a pedestrian open space linking system that ties Church Street, Souter Street and Mitchell together with the route crossing the railway line
- The public pedestrianisation of the link between Church Street and Souter Street, crossing Pilditch stadium.
- A gateway precinct connecting the two spaces on either side of the railway line and formulating it as an entrance experience to the site.
- A Heritage precinct that will restore the Heritage on the site and render it more publicly acceptable.
- A public precinct acting as the heart of the campus and linking the gateway precinct and the Heritage precinct.
- The development of a bio-diversity park that will protect the natural environment and that can be used as an educational tool.

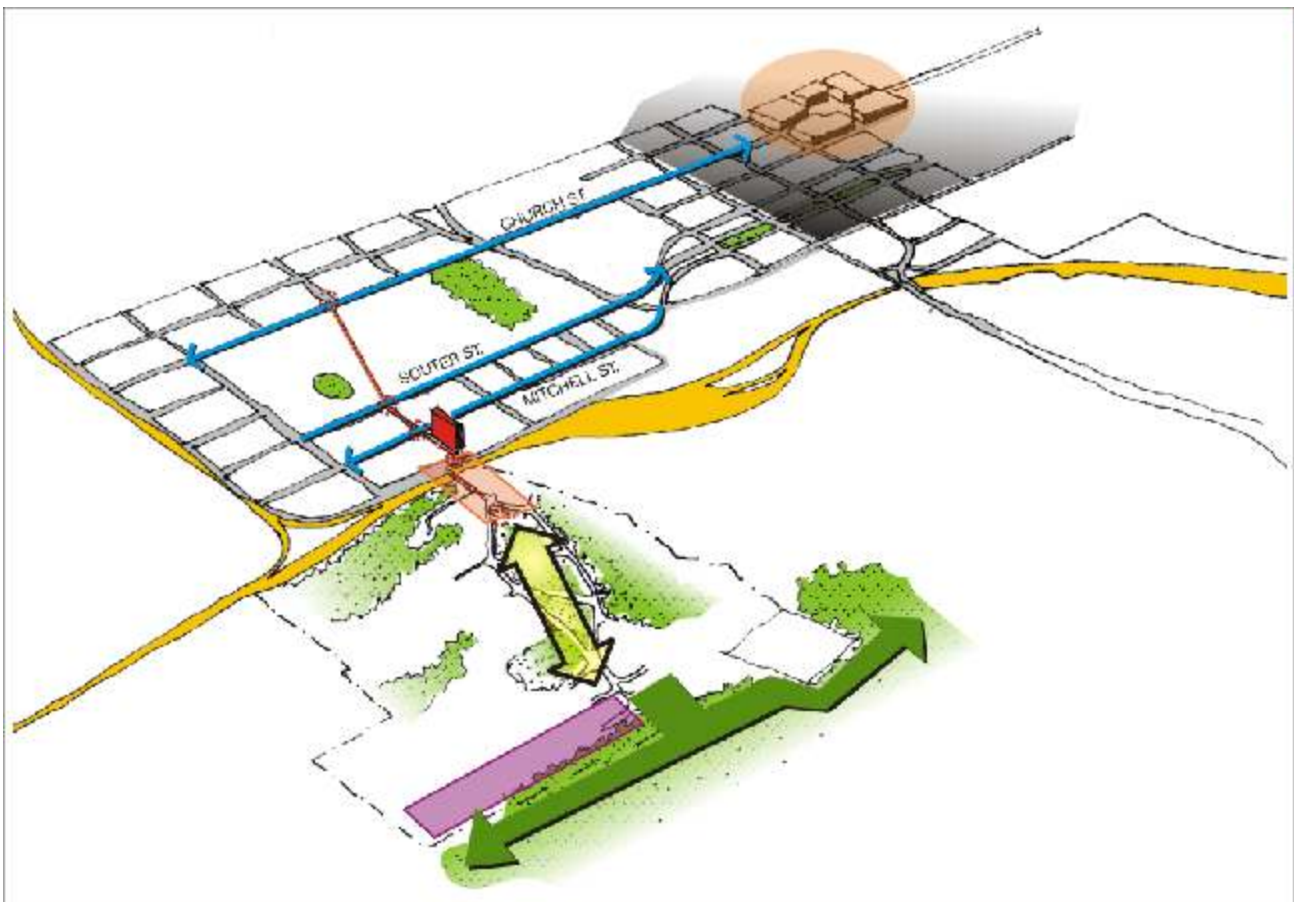
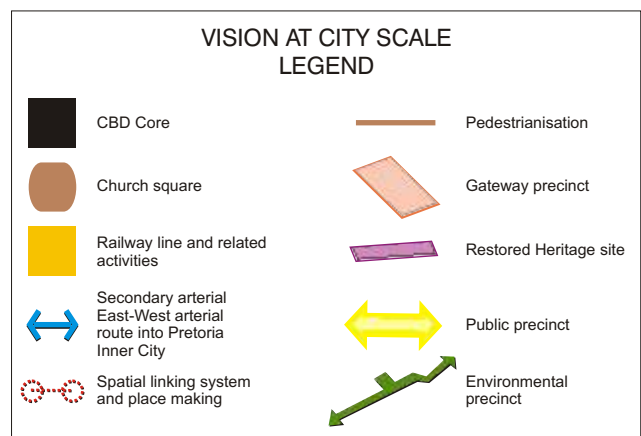
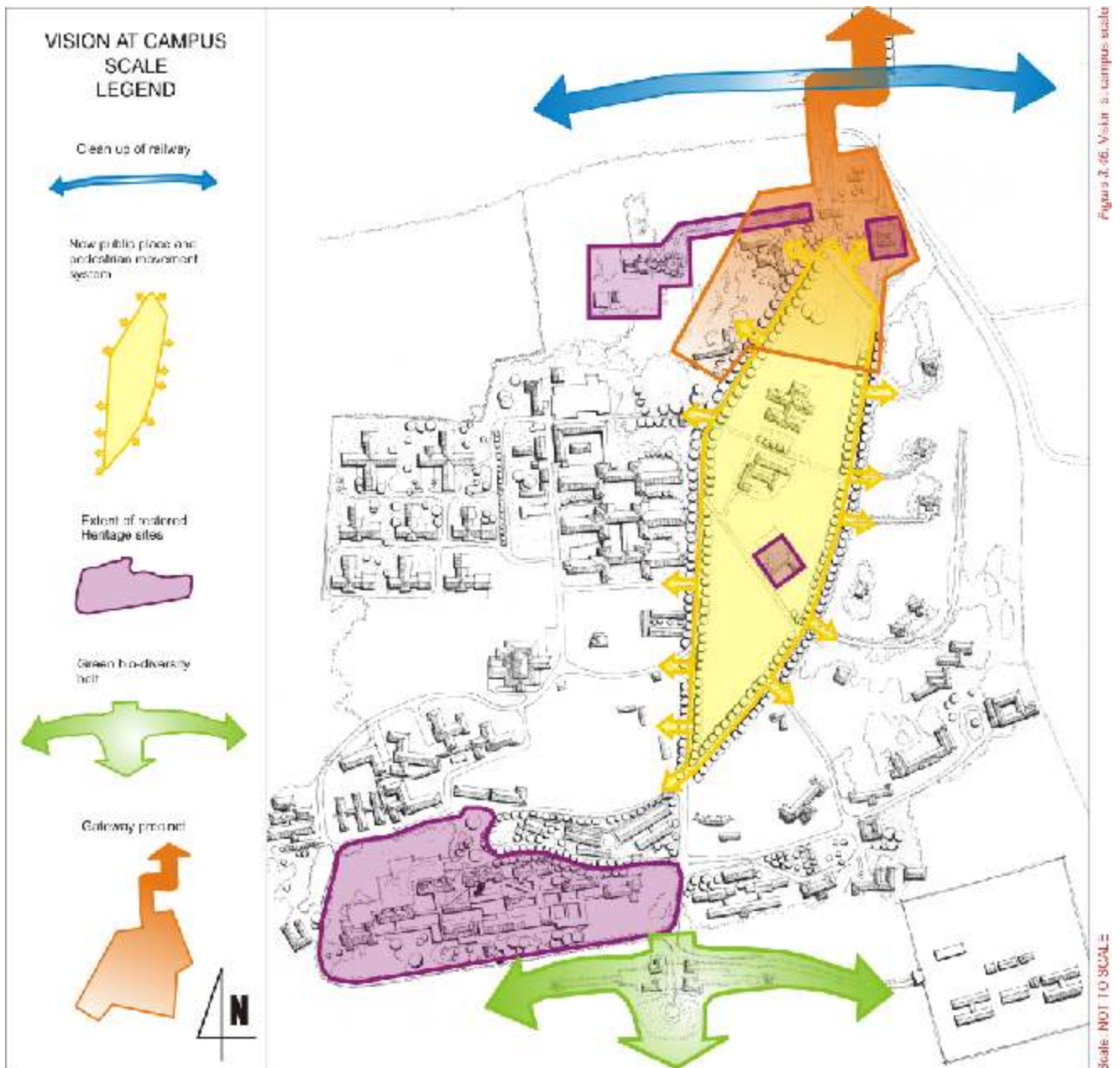


Figure 3.45. Vision at city scale

2.9.2 VISION AT CAMPUS SCALE

- Establish access route through a series of place making and enhance point of arrival as a gateway node.
- Develop public core and pedestrian movement system.
- Enhance sense of appreciation of the natural landscape and utilize the environment and its views.
- Restore existing Heritage sites and declare additional historic houses as Heritage buildings and restore.
- Create a gateway precinct that will enhance the public zone including exciting auditorium and outpatient buildings.



“As the stigma associated with the treatment of mental disorders has declined, more individuals are seeking help to deal with problems associated with family, job, or the stresses of contemporary living.”
Malikin

CAMPUS FRAMEWORK

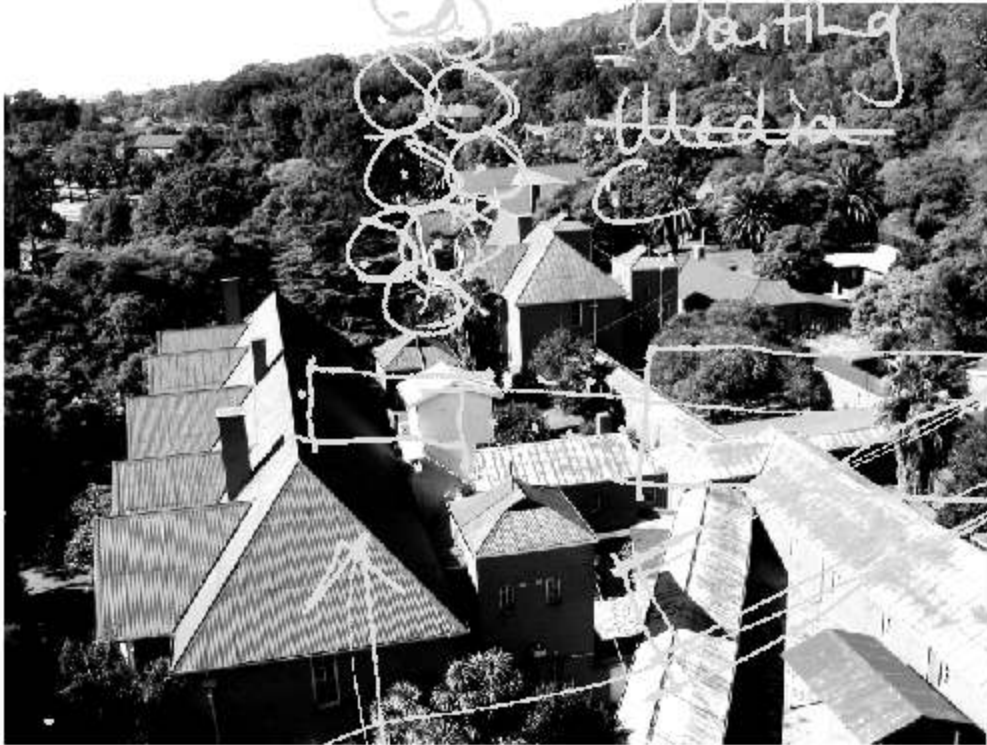


Figure 4.1: Top view of left wing of main administration building.



3.1 Nature of the Problem

- Campus has no “address”.
- The site is cut-off from the city and there is no integration.
- People on campus is “lost in space” and there exist hardly any place-making.



Heating garden/
swimming pool/
therapy



Figure 4.2: Approaches to collective form: compositional form, megaform, group form

3.2 Integrating the Campus

3.2.1 COLLECTIVE FORM AND LINKAGE

In a paper called *Investigations in Collective Form* published in 1964 by the Washington University, Fumihiko Maki wrote about appropriate master forms that inform an adequate spatial language to be used in urban design that can create and organize space within the master program.

He argues that there exists an absence of coherent theory beyond that of single buildings. Therefore he investigated the nature of “collective form” concerned with groups of buildings - the segments of our cities.

He identified collective form, however, not as a collection of unrelated, separate buildings, but as buildings that have a reason to be together.

The first step in his investigation was to analyse the structural principles involved in making collective form. He established three major approaches.

Compositional Form	Compositional Approach
Megastructure/Megaform	Structural Approach
Group Form	Sequential Approach

3.2.2 COMPOSITIONAL FORM

In the creation of the compositional form the elements that comprise the collective form are conceived and determined separately. Proper functional, visual and spatial (sometimes symbolic) relationships are established on a two-dimensional plane.

The compositional form is a static approach because the act of making a composition itself has a tendency to complete the formal statement.

3.2.3 THE MEGASTRUCTURE

The megastructure is a large frame in which all the functions of a city or part of the city are housed. It has been made possible by present-day technology. Maki describes it as a human-made feature of the landscape.

The megastructure has great promise for several fields:

- Environmental engineering
- Multifunctional structures
- Infrastructure as public investment



Figure 4.7: Compositional form: Brasilia, Oscar Niemeyer



Figure 4.8: Megaform: a community for 25,000 people, Kenzo Tange

3.2.4 GROUP FORM

Group form is form that evolves from a system of generative elements in space. Some of the basic ideas of group form can be recognized in historical examples of town buildings.

Factors which determine the spatial organization of these towns are:

- Consistent use of basic materials and construction methods as well as spontaneous but minor variations in physical expression;
- Wise and often dramatic use of geography and topography;
- Human scale preserved throughout the town (frequently in contrast to superhuman land forms); and
- Sequential development of basic elements such as dwellings, open spaces between houses, and the repetitive use of visual elements such as walls, gates, towers, open water and so forth.

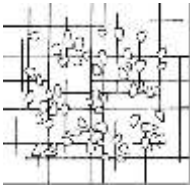


Figure 4.3: Mediation: connection with intermediate elements or implying medium (including composed open space)

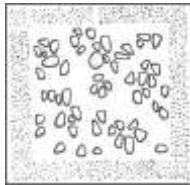


Figure 4.4: Definition: enclosing disparate structures with a sensible barrier; producing unity within the barrier and separating from what is outside

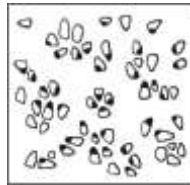


Figure 4.5: Repetition: giving each element a feature that is common to all in the group so that each is identifiable as a part of the same order

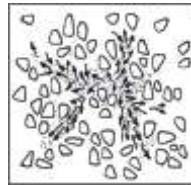


Figure 4.6: Sequential Path: placing activities that are performed in sequence in identifiable spatial relation to one another

Sequential form develops over a much longer period of time than the other types of form.

“A pedestrian movement system will be established, unifying the campus as a whole”.

Lessons to be learned from group form:

- Forms in group form have their own built-in links, whether expressed or latent, so that they grow within the system. They define basic environmental space which also partakes of the quality of systematic linkage.
- Group form and its spaces are prototype elements, because of the implied system and linkage. The elements and growth patterns are reciprocal - both in design and in operation. The elements suggest a manner of growth, and that in turn demands further development of the elements in a type of feedback process.
- The elements of group form are often the essence of collectivity, a unifying force, functionally, socially and spatially.

The group form evolves from society rather than from powerful leadership.



Figure 4.9: Group form: a Greek village



Figure 4.10: Japanese linear village: a beautifully spine of growth.

3.2.5 LINKAGE

Fumihoko describes linkage as the “glue of the city”. He states: “Linkage is the act by which we unite all the layers of activity and resulting physical form in the city. Insofar as linkage is successful, the city is a recognizable and humanly comprehensible entity. We depend on understanding how we can get from place to place in the city. Each at its own level contributes to our ability to know and enjoy experience - social, temporal and spatial linkage.”

Fumihoko identified five basic linking operations:

- To mediate
- To define
- To repeat
- To make a sequential path
- To select: to establish unity in advance of the design process by choice of site.

3.2.6 APPLICATION

Weskoppies, as a campus, can be described as a group form since it is a collection of buildings that have a reason to be together that have developed over an extended period of time.

At Weskoppies one finds consistent use of brick and mortar as building materials, used in similar construction fashion. The buildings on campus flow with the topography of the site, although in a somewhat stifled manner. All buildings on site have an inherent quality of human scale. The historical buildings exhibit this to a greater extent.

If it is true that the campus is a group form, then there should exist inherent built-in links within the site as Maki suggests. It is the purpose of this exercise to identify those links and strengthen them through the connection of old linkage systems with proposed new ones (as derived from pedestrian desire lines and the five basic linking operations as set out by Maki). A pedestrian movement system will be established unifying the campus as a whole.



Figure 4.11: My Sky Hole 97-2 project by Bukichi Inoues

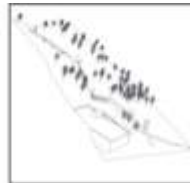


Figure 4.12: Dani Karavan's project Way to the Hidden Garden - Sappora Art Park



Figure 4.13: My Sky Hole 97-2 project by Bukichi Inoues



Figure 4.14: My Sky Hole 97-2 project by Bukichi Inoues

3.3 Proposal: A Public Island

3.3.1 CONCEPTS FOR SPATIAL DEVELOPMENT FRAMEWORK

The concept is to develop the internal "ring road" to be more legible. The island in the core of the campus can then be developed as a public "central park" for the campus where public life is embraced and enhanced.

The indication of building blocks on the public island does not indicate that there should be buildings on those spots, but rather a system of open spaces that link the campus together. If new buildings are added to the island, though, these open spaces should be respected and buildings should form around them.

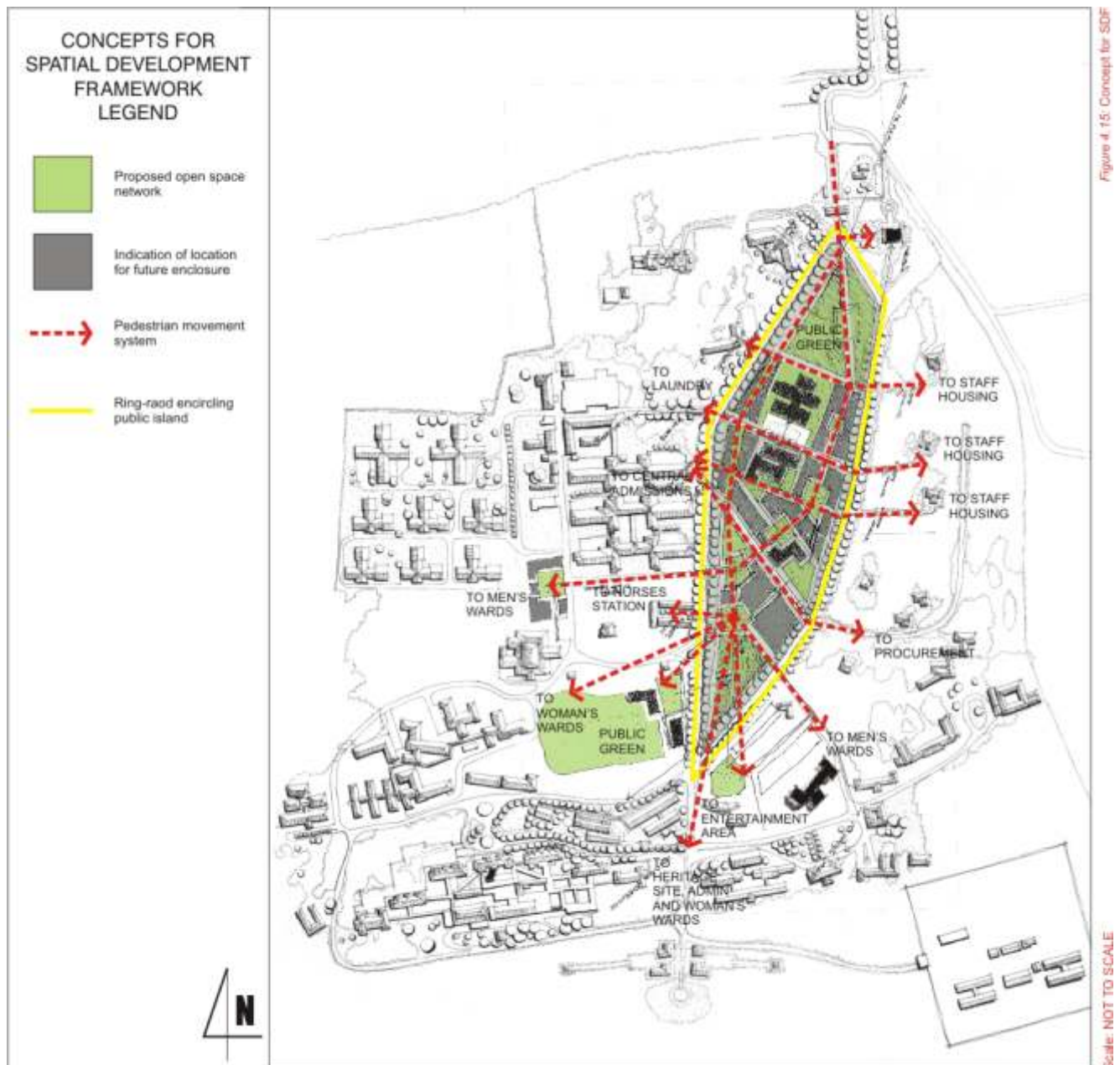




Figure 4.16: My Sky Hole 97-2 project by Bukichi Inoues



Figure 4.17: Hakon open air museum

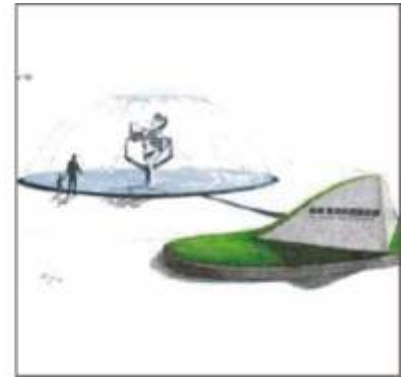


Figure 4.18: Landscaping and sculpture creates memory

3.4 Concept: Public Island as a Park

The concept of the public island as a park within the city will be a open space linking system of public places. The different places can function on different levels, some more private (to sit and contemplate) some more public (to play games).

This concept ties in with the concept of the campus as a stoep. The open space will allow for the public to utilize the campus in this manner.

The open space system also creates the opportunity for a pedestrian movement system to follow along this linking route, as it connects to all clusters of buildings. This then allows the patient and visitor to walk along a pedestrian route that is more sheltered from the scrutiny of the vehicle drivers along the main ring road.

3.4.1 PRECEDENT - MY SKY HOLE - BUKICHI INOUE & WAY TO THE HIDDEN GARDEN - DANI KARAVAN

The combined use of art and public space is an issue that Japan has tackled in a special way, by privileging sculpture for the enrichment of urban landscapes and accompanying its projects with a 'poetic vision of nature'. Its approach lies midway between the open-air museum and the French conception of it as a cultural device capable of affecting social life. The works and especially the installation-sequences of Bukichi Inoue represent well this attitude to public space.

A counter-attraction to Inoue's work is that of Dani Karavan, the leading exponent of 'urban humanism', which occupies a position homothetic to that of the Japanese artist.

This precedent was chosen to inform the design of the public island in terms of creating open space. Sculpture and art can be used to create open spaces with individual characters. Place making is enhanced through such installations.

3.4.2 PRECEDENT - HAKONE OPEN AIR MUSEUM - NEBUKAKA SHIKANA

The project is an outdoor museum not far from Takyo. The architect successfully demonstrates the relationship between architecture, landscape and culture. Places of memory, rest and movement is created as one travels across the site.

Memory can be captured through landscape installations. In the case of Weskoppies, the site is layered with history and events. These events and places in time can be celebrated through art installations. This will portray a culture of healing, where we have been and how we have grown, and give a sense of pride to the inhabitants of the campus.

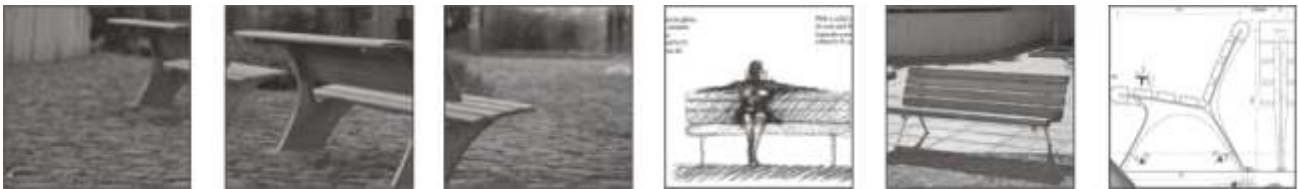


Figure 4.19-22: SUDESTE: Leandro Heine. A solid cast iron frame with seat and backrest in Lapacho essence.

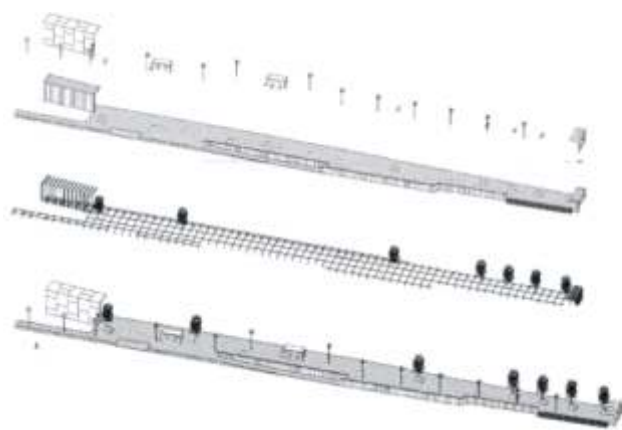
Figure 4.23-24: RECOLETO: Leandro Heine & Alejandra Ferrugia. Base in cast aluminum and seat in polished & waterproofed Lapacha

3.5 Installations to the Site and on the Public Island

3.5.1 URBAN INSTALLATION

The urban installations will comprise of bus stations and appropriate shelters, public lighting, sufficient greening, seating, signage indicating the location of the hospital and community center and appropriate paving and pedestrian crossings.

Urban installations are proposed along the main pedestrian routes to the campus. This is due to the extensive use of public transport of both visitors and in-patients of the hospital.



3.5.2 LANDSCAPE INSTALLATION

Landscape installations will be introduced within the public island, a designated piece of land within the campus that is encircled by the campus' main ring-road.

The concept is that the installations will accommodate the intension of place-making within the island and facilitate the use of the island as a public park within the campus.

Facilities will include public ablution, information kiosks, seating, picnic facilities and sculptures.



Figure 4.29: Picnic area - Fjordane, Norge



Figure 4.30: Exhibition area - Fjordane, Norge



Figure 4.31: Public ablution - Fjordane, Norge

3.5.3 PRECEDENT - TOURIST PARKING AREAS AND SERVICES ALONG MOUNTAIN ROAD - JENSEN AND SKOTVIN

The "Tourism Project" has been undertaken under the auspices of the Norwegian Department of Transportation in a number of districts. This installation was done at Fjordane.

The aim of the project is to rectify the relative absence of services for travelers along the most popular tourist routes.



Figure 4.28: Tourist Project in Fjordane, Norge - Jensen and Skotvin

3.5.4 LESSONS LEARNED

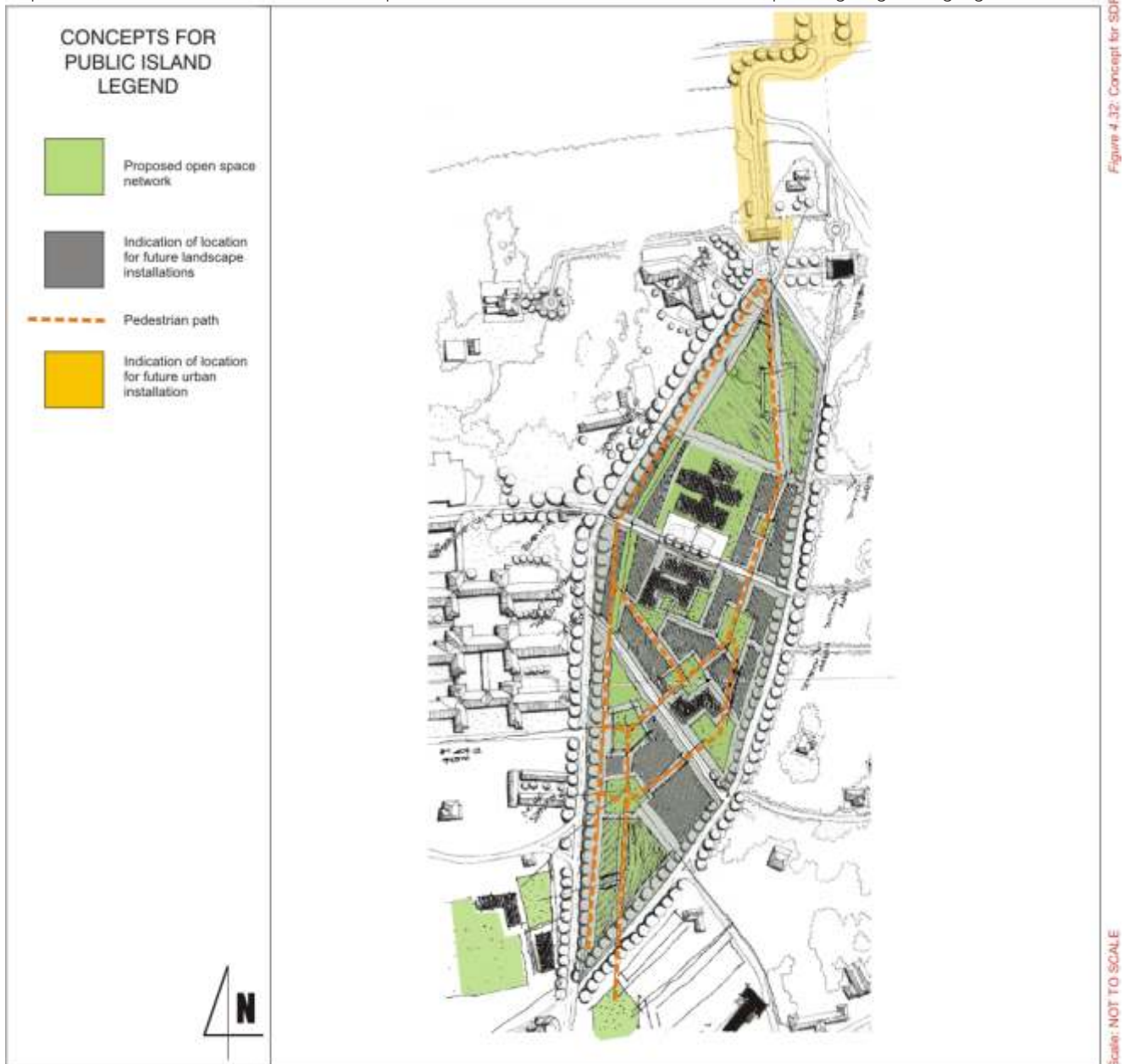


Figure 4.25-27: CARNAMUSA: Alejandra Ferrugia & Daniel D'Andrea. Fore pressed pieces shaped like bits linked one to the other by a galvanized iron rod.

3.6 Conclusion

3.6.1 CONCEPTS FOR THE PUBLIC ISLAND

- As the SDF indicated, the island will contain a pedestrian movement system that will allow pedestrians to move across the core of the campus in a more desirable fashion than simply along the main ring road.
- Spaces will be created along these paths. Some will have a public character, while others will give a sense of rest and rejuvenation. The creation of these public spaces will allow patients, staff and visitors to utilize the campus core in a positive way.
- Amenities will be placed strategically along the path in order to serve the user, aid the patient and visitor in orientation and creating a sense of place within the island. Within the landscape context, services such as seating, public ablution and exhibition and information pavilions will be installed. Within the urban context services will include bus shelters, public lighting and signage.



S I T E S E L E C T I O N

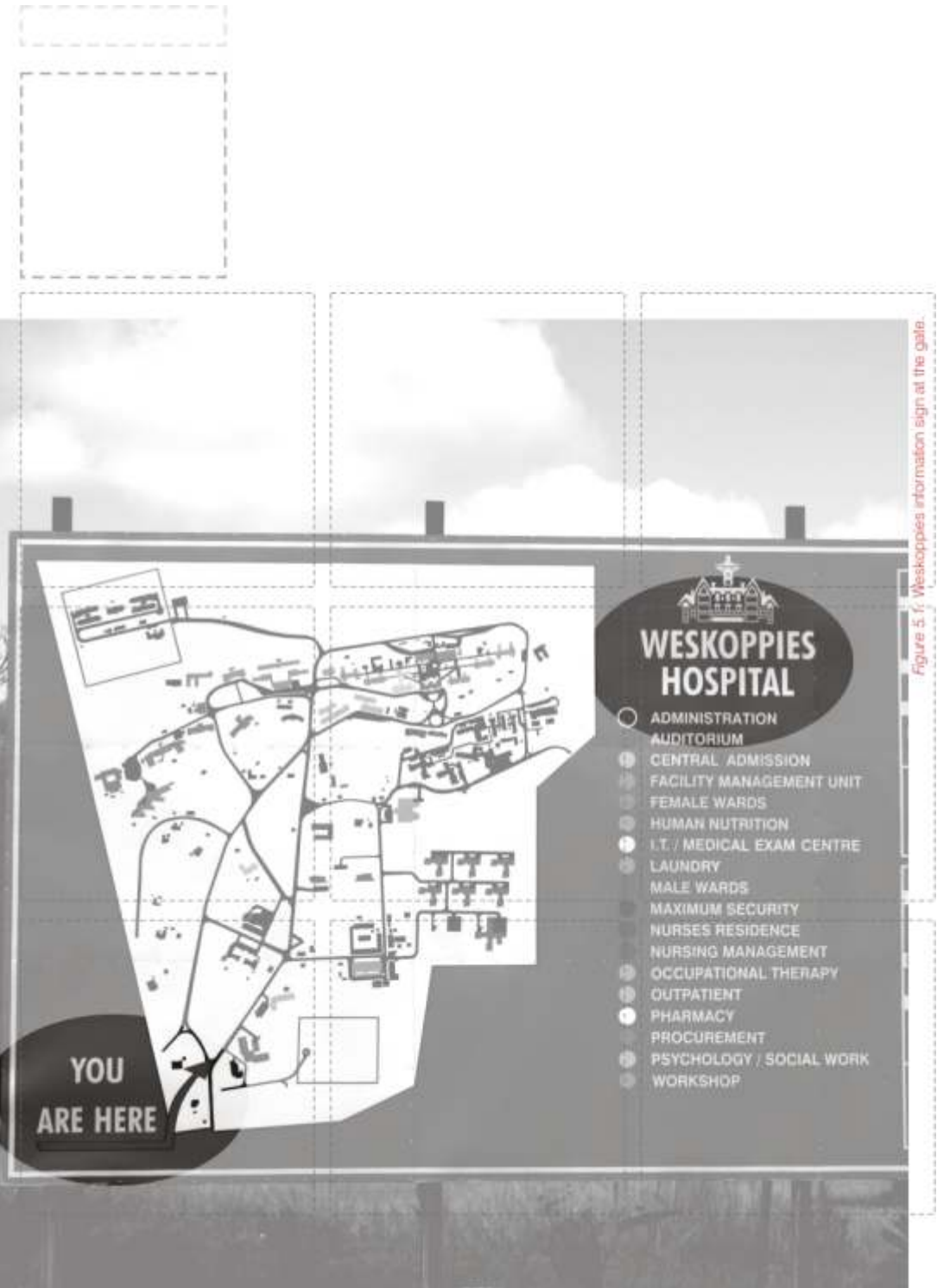


Figure 5.1: Weskoppies information sign at the gate.

4.1 Nature of the Problem

- The site should respond to the campus's need to link with the city.
- The site needs to address the establishment of an arrival node and enhance the sense of arrival on the campus.
- The site is situated on the threshold between the campus and the city and should be developed accordingly.
- The site is isolated and does not relate to any existing buildings directly.

4.2 Proposed Site

4.2.1 SITE SELECTION

The site was selected for the following reasons:

- It's strategic location in the gateway precinct.
- It's location in proximity to the auditorium and outpatient buildings.
- It's accessibility.
- The possibility of the development to act as a catalyst between the campus and the city and the community.



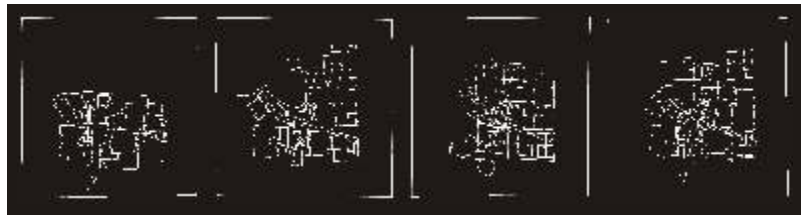


Figure 5.3: Study sketches

4.3 Integration with the City - Precedent

4.3.1 A CENTER FOR THE VISUAL ARTS, THE OHIO STATE UNIVERSITY COMPETITION - TROTT & BEAN, ARCHITECTS AND EISENMAN/ROBERTSON, ARCHITECTS

The project was an entry for the Ohio State University and entailed the design for a new center for the visual art at the gateway of the campus.

Peter Eisenman and the team won the competition in which, amongst others, Michael Graves competed. What gave Eisenman and the team the edge was a comprehensive understanding of the site, the needs of the students and community and the integration concept through which the project linked the community to the city. (Robertson 1984:113)

The proposal was underpinned by the following concepts:

- A sensitive approach to the significant history of the site and campus.
- Enhancing of the campus and its surroundings in a powerful, but not overpowering manner.
- The integration of the geometries of both the Columbus grid and the Oval, which is a green public place at the entrance of the campus.
- The celebration of the intersection of the two grids that symbolises the intersection of the arts with the community.
- The creation of architecture as an event, rather than a monumental “palace”. This gives importance to the place and not a single building.
- A solution that is at once a forceful presence and a delicate integration into the campus - a building that defines a new context and simultaneously defers to it and becomes part of it.



Figure 5.6: Model view

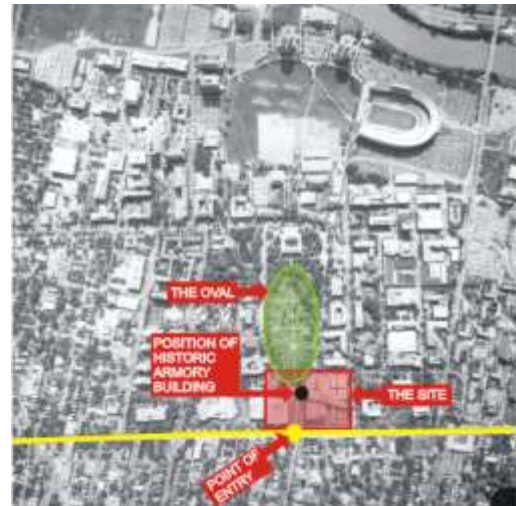


Fig. 5.3 Aerial indication position of site

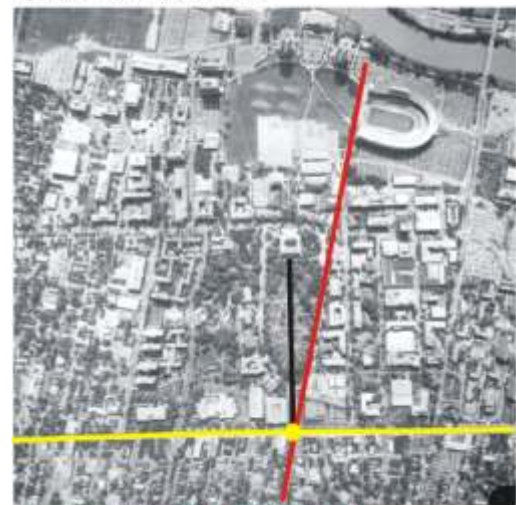


Figure 5.4: Extension of city grid into the campus.

4.3.2 LESSONS LEARNED

The project gives insight into issues that can be compared to those experienced on the site at Wekoppies.

Guidelines that can be derived from the precedent are the following:

- Integration of campus and city through the articulation of grids and pedestrian desire lines.
- The creation of a gateway in a subtle, unobtrusive fashion.
- The notion of capturing memory and thereby giving recognition to the context.
- The use of landscaping in articulating movement lines.



Figure 5.5: Lateral approach to Kimbell art museum from the south. The end vaults are left open as porticoes, hybrid elements that are as much landscape as architecture.

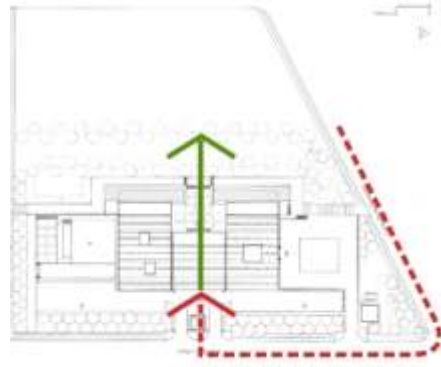


Figure 5.6: Plan of Kimbell art museum, indicating threshold concepts: distance between occupant and threshold object.

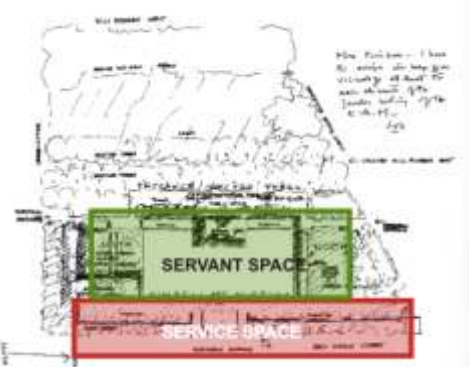


Figure 5.7: Kahn placed the service spaces at the vehicle access of the building, allowing the servant spaces to flow into the gardens (threshold space).

4.4.1 THRESHOLD

There are two concepts particularly relevant to exploring the operation of a threshold:

- From psychology, the threshold as the point at which a stimulus is of sufficient intensity to begin to produce an effect, as in “threshold of consciousness” or “threshold of pain”.
- From ecology, the value of the edge between two ecosystems as the zone of highest exchange and diversity. In ecological terms, thresholds are the most important part of a system. The place where field meets forest is more important than either the field or the forest itself.

Thresholds are where transformations begin, where exchange between unlikely things occurs, and where identities are declared.

Thresholds hold the potential of an inclusive realm, where the introduction and maintenance of difference is possible. Unlike an idea of inclusion as “melting pot”, where identities are blurred to create a compromised whole, threshold as an operation entails the preservation of differences, as well as the creation of something new from their coexistence.

4.4.2 PRINCIPLES THAT RELATE TO THRESHOLDS IN TERMS OF ARCHITECTURE INCLUDE:

- Because thresholds are the result of dynamic relations - in this case between the city and the campus, architecture and landscape, the community and the mentally ill - closure in terms of meaning and space is resisted.
- Hierarchy, reversal and deferral of passage and scale are some of the strategies that may contribute to a threshold's autonomy.
- The operation of threshold can provide a way to represent the identity of an institution or place in spatial terms, rather than relying on facade or other image-based means (as in the Kimbell Art Museum by Louis Kahn).
- A condition of distance between a threshold and its occupants can enable the occupants to confront and absorb the threshold from the outside, as object or image, prior to experiencing it spatially.

4.4.3 KIMBELL ART MUSEUM - LOUIS KAHN

The Kimbell Art Museum owes its origin to the collection enthusiasm of Key Kimbell. Kahn was appointed in October 1966 to design the museum, located in Fort Worth, Texas. (Brawne 1992:4)

Threshold concepts that informed the building:

- The long dimension of the barrel vaults that form the building is parallel to the allees of trees and the contours, continuing the layered structure of the outdoor space.
- The main entrance is pedestrian, regulating automobile access from service spaces.
- The siting of a bosque of Yaupon trees immediately outside the main entrance, preventing full view of the building from a distance, is the first sign that the threshold is not a space merely to pass through.
- The entry is affirmed by the bosque containing the space through forming a visual screen.
- The space of the threshold, rather than the image of the facade is chosen to represent the institution.
- The threshold suggest a space of inhabitation through the modification of climate, the deep shade of the bosque, the reflection of water on the underside of the porticoes, and the sound of water cascading to the pools. What is typically a place of passage, becomes a place of rest.

4.4.4 LESSONS LEARNED

- Physical distance induces a contemplative relationship with the threshold artifact that temporarily shifts emphasis and works to delay passage.
- Through the containment of the threshold space and the involvement of all senses, including the body through activity, threshold space can become a place and not merely a “passing through space”.
- The direct flow from servant space to threshold space forms a continuum of concept, allowing the occupant to grow accustomed to the threshold.

4.4 The Site as a Threshold – Precedents

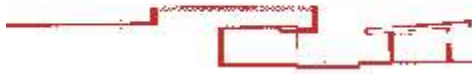


Figure 5.8: Section of pool complex

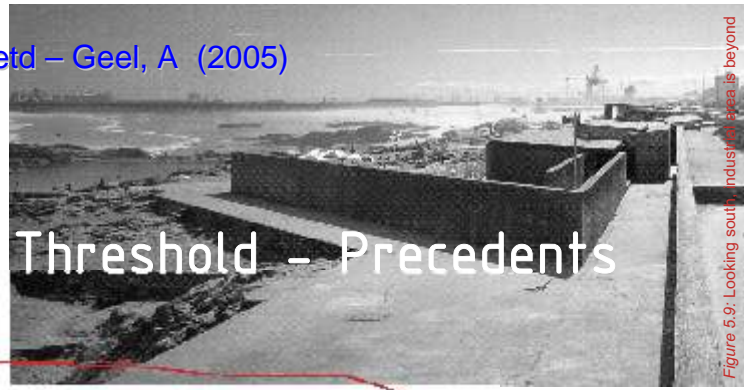


Figure 5.9: Looking south. Industry area is beyond

4.4.5 MUNICIPAL OCEAN SWIMMING POOL - ALVARO SIZA

The municipal ocean swimming pool complex is located on an exposed and rocky stretch of the Atlantic coast at Leça de Palmeira, Matushinos, Portugal. The project consist of two swimming pools: a rectangular one for adults at the shoreline, and a smaller semicircular one for children adjacent to a protected sand beach. Ramps and walkways connect the pools with sunbathing platforms, a café situated on a large terrace, changing facilities, and the coastal road.

Siza's architecture defines multiple thresholds between land and sea, constructed and natural, road and beach. This expansive site with its endless horizon and uncontrollable sea is made representable and inhabitable through the overlaying of scales of body, building and landscape. The project engages the regional scale of the rocky coastal landscape, but also represents smaller dimensions of human activity.

The architect transported town and coast into formal, spatial and material operations of threshold. While a functionally driven solution would merely have made it easier to pass from road to ocean, the project multiplies the layers of the site to make the passage through it more memorable.

The dialog between the road and the sea is facilitated through the use of architecture. Inland parallel layers of similarly dimensioned vertical and horizontal surfaces are formed - an architecture that allows itself to integrate with the road. These layers become progressively fragmented until the sea finally enters the form of the architecture.

The project is sited so that the roofs of the concrete building containing the checkroom, changing rooms, toilets and bar barely rise above the level of the road. This marks the beginning o a journey that heightens the transformation that occurs between the road and the water's edge.

Visitors penetrate the thickness of the linear concrete building in stages, alternating between dark and light, compression and release. As they descend the entry ramp, whose walls angle inward to create a forced perspective, visitors lose sight of the sea along a route where the program is discovered rather than announced.

Passing through the showers, visitors emerge finally onto a bridge, surrounded by animated swimmers and sunbathers, children running back and forth underneath, and the roaring presence of the panoramic horizon of the open ocean.

4.4.6 LESSONS LEARNED

- The site as a threshold becomes habitable through the overlay of scales.
- Spaces, forms and material can signify operation of threshold.
- Multiple layers of development makes the passage through the threshold an event.

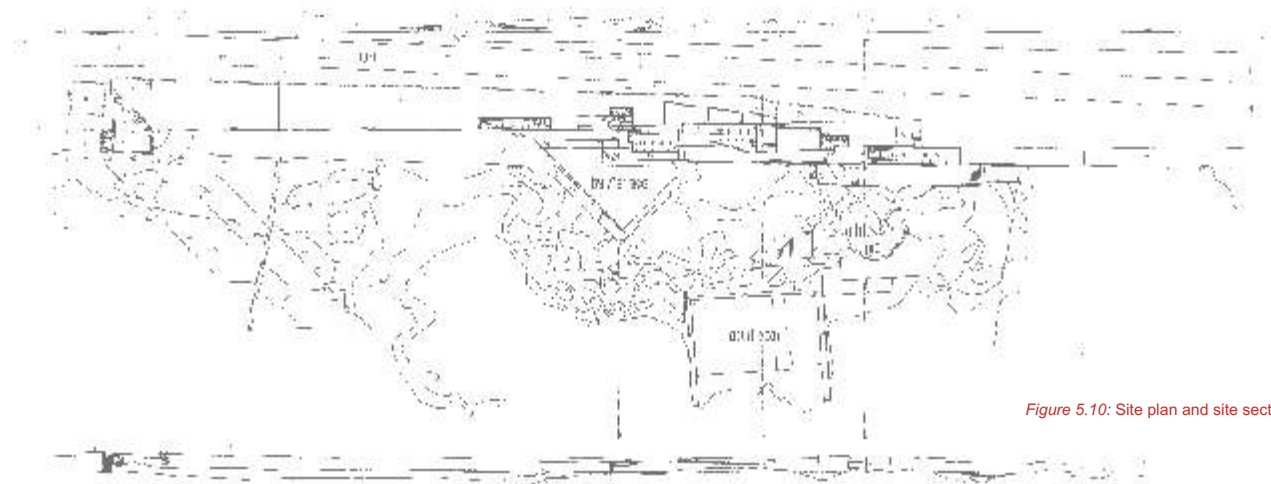


Figure 5.10: Site plan and site section

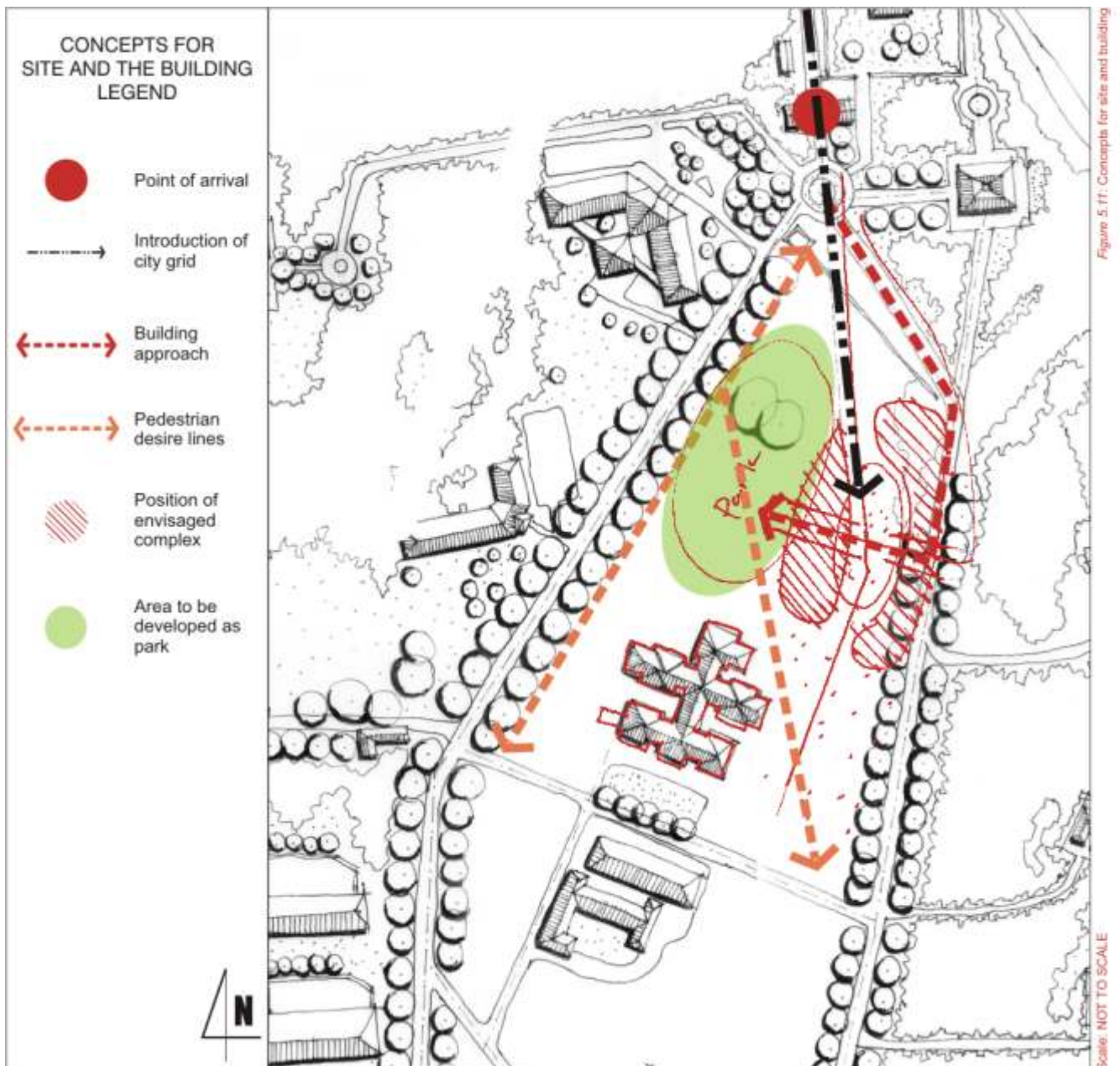
“...a dynamic sequence of spaces, rather than a monumental ‘place’”.

4.5 Conclusion

4.5.1 VISION FOR THE SITE

The intension of the development of the site would be to add an architecturally significant setting for the community treatment facility on the hospital grounds.

The development comprises of two main components: the building complex and the park. The social platform will be created by the site as a whole, since an attempt to create isolated buildings would fail to do what the center must achieve above all: project treatment and healing into the life of the campus and gather the community at large on many and diverse occasions.



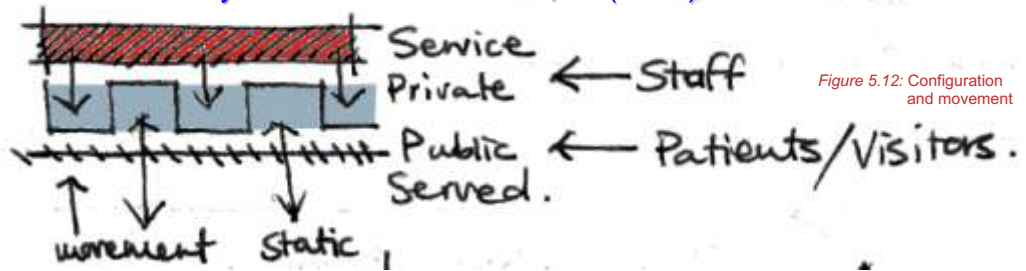


Figure 5.12: Configuration and movement

4.5.2 INTEGRATION THROUGH INTRODUCTION OF CITY AND SITE GRID

The concept is the introduction of the geometry of the city grid into the new complex. The intersection created by the axes of the city grid and complex grid marks the formation of a platform for social integration.

The public green will define the intersection of the grids and thus symbolize the intersection of the treatment and wellness facility with the city - or an institution within the city.

4.5.3 INTEGRATION THROUGH MOVEMENT LINES

The structuring of the building to accommodate movement lines integrates the building and the site into a continuous set of events. The building guides the pedestrian and welcomes him. The threshold is also strengthened and made identifiable through the structuring of its nature.

Movement through the complex implies a transparent process which challenges the concept of the traditional institutional building.

4.5.4 POINT OF ARRIVAL/ BUILDING APPROACH AND SERVICE AND SERVED SPACES

The roundabout approach to the building increases the sense of threshold and at the same time allows the viewer to comprehend the threshold object before entering.

The different routes for vehicles and pedestrians allow the pedestrian to gain direct access to the served spaces and the parking to become part of the service space.

4.5.5 SERVICE AND SERVED

A stronger continuity of space from the buildings to the threshold space, the park, can be achieved by placing the served spaces in direct relation to the public green. This will locate service areas to the back of the complex, which form an edge to the street and a buffer between the vehicular movement and the served spaces.

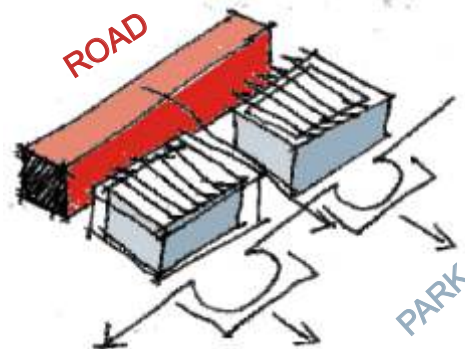
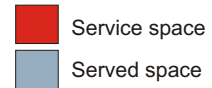


Figure 5.13: Service and served spaces

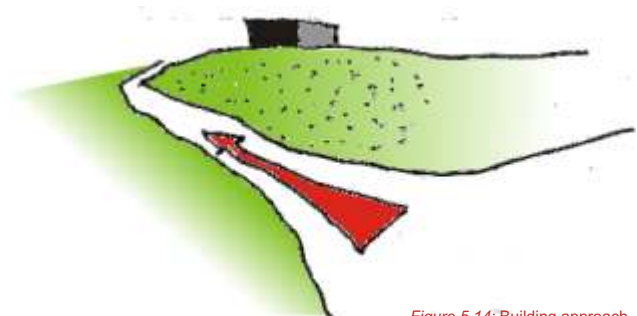


Figure 5.14: Building approach

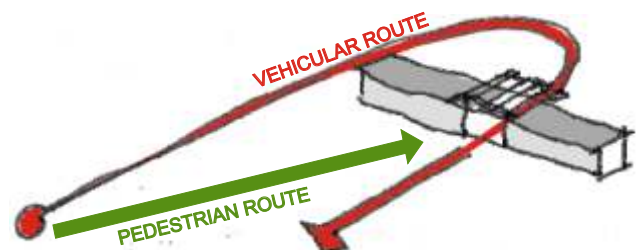


Figure 5.15: Building approach

P R O G R A M M I N G

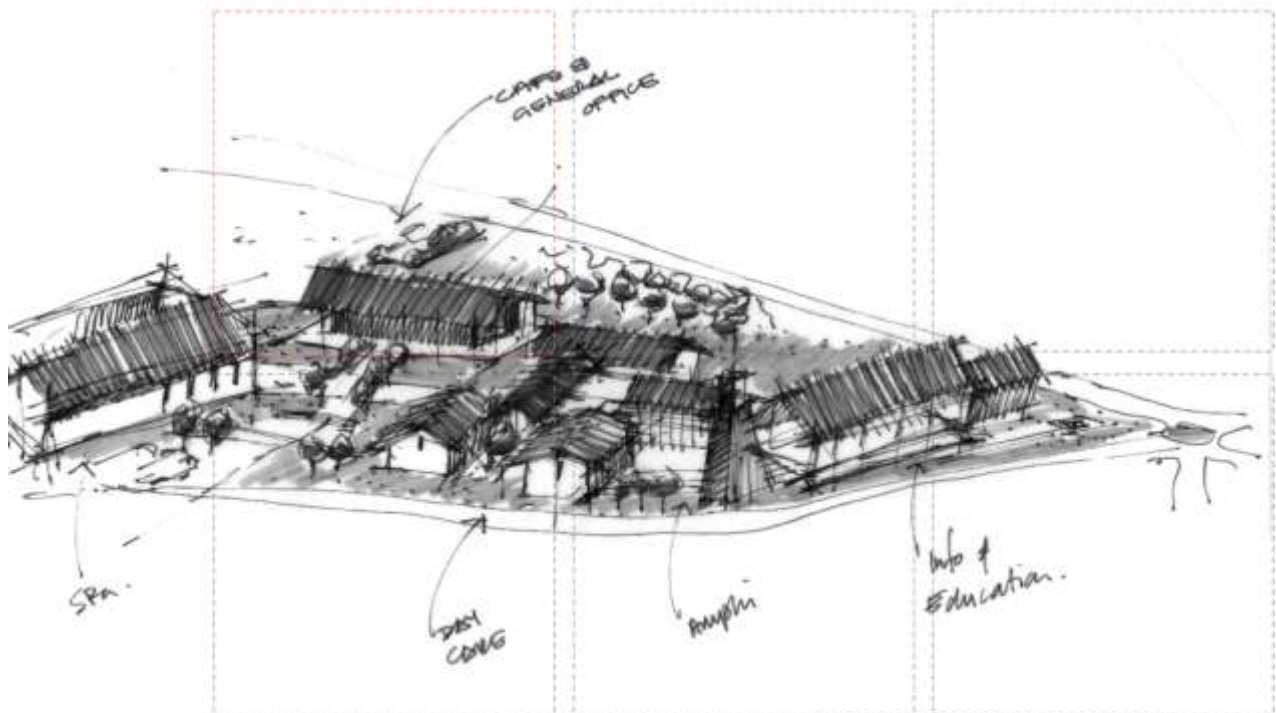


Figure 6.1: Concept sketch

"The programme of the building is the primary generator of the governing idea of order."

Kahn

“ Mental health care should be provided through general health services and community settings. Large and centralized psychiatric institutions need to be replaced by other more appropriate mental health services.”

5.1 Methodology

A combination of two methods of setting up guidelines or baselines for projects has been used:

5.1.1 VALUE-BASED PROGRAMMING

There are several different approaches to architectural programming. These include:

- Design-based architectural programming
- Knowledge-based architectural programming
- Agreement-based architectural programming
- Value-based architectural programming

For the purpose of this project, the approach of value-based architectural programming was chosen for the following reasons (Hershberger 1999:25-34):

- Value-based programming makes certain that the most important design issues are addressed in the programme document.
- Value-based programming uses systematic information

gathering procedures to ensure that important information is not overlooked in the programming process.

- The intent of value-based programming is to let the most important values or issues set the tone of the programming effort, while making certain that recurring value areas are not inadvertently omitted.

5.1.2 SBAT

The performance prioritisation for the project was adopted from the Sustainable Building Assessment Tool. The tool has been developed by the Sustainable Building group of the division of Building and Construction Technology, CSIR, Pretoria.

The purpose of the tool is to assess the sustainability of buildings. For this project the performance priorities, as stipulated by SBAT, have been used as an informant for the baseline criteria in order for it to function as a decision support tool.



Figure 6.2: The Pioneer Health Center (1926)

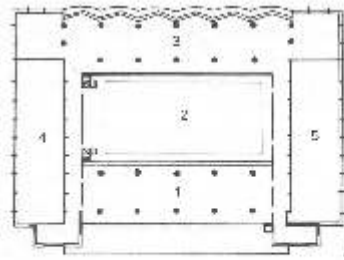


Figure 6.3: Ground floor

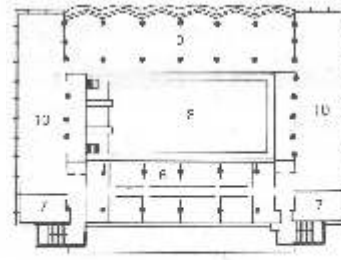


Figure 6.4: First floor

- 1 Lounge & cafeteria
- 2 Swimming pool
- 3 Lounge
- 4 Upper part gym
- 5 Upper part lecture hall
- 6 Medical rooms
- 7 Dental
- 8 Upper part pool
- 9 Library & rest room
- 10 Study & recreation

5.2 Precedents

Two precedents were chosen to inform the process of programming for health care centers. These precedents proved to be very successful, therefore, an attempt was made to try and understand why they worked so well.

5.2.1 PIONEER HEALTH CENTER - PECKHAM

Chapter one

The Pioneer Health Center at Peckham in South London was a voluntary experiment, independent of government and the local authority. It began in a small way in 1926 and was finally established, much expanded, in purpose-built premises in 1935. Intended as a center for the local community, where the emphasis was on the promotion and monitoring of health, local families were invited to use it as a club and as a condition of membership were offered periodic health overhaul of the whole family. It also provided ancillary services for infants, children and adults.

Philosophy

The function of the Pioneer Health Center was primarily preventative and did not extend to treatment, and its nature was deliberately that of a community center.

The Pioneer Health Center was praised by Christopher Alexander in *A Pattern Language* as the only health center that they know of which actually devoted itself to health instead of sickness. The incident of emotional disturbance and childhood psychosis among children in later years, he reports, was drastically reduced within the Peckham population, starting exactly from the year when the health center began its operation.

Accommodation

Intended for the leisure use of 2000 families the Center was planned around an indoor swimming pool and had a day nursery and playground, a gymnasium, lounge, cafeteria, library and lecture room and a few rooms for medical and dental inspection.

Flow diagram

The servant and service spaces identify the flow of use, as well as the public and private entrances as used by the community and the staff.

Analysis

- The treatment spaces are situated together with other quiet spaces on the first floor. This aids to create a more therapeutic environment and privacy.
- The noisy spaces are situated around the pool area which creates the core of the project.
- The service spaces are allocated in vicinity to the entrance which is used by the public and the staff.
- Staff circulate primarily on the first floor.

Chapter two

A new health center was designed for Peckham in 1995. It formed part of a planned revitalisation of an area of Peckham. Southwark Council's architects designed a health center that deliberately echoes the ideals of Owen Williams' nearby Pioneer Health Center.

Situated on a 'backlands' site, the new building is intended to draw people into the area. It will therefore be as transparent as possible, with the exception of the consulting rooms.

Philosophy

Like its predecessor, the new center's medical ethos is to promote health rather than deal with sickness and so it will contain a mixture of health facilities and consulting rooms.

Although the focus is on health, the building was designed to be as non-therapeutic as possible, promoting the idea of fitness as pleasurable as well as healthy.

Accommodation

All the facilities center on the swimming pool, one of which has a raising floor to enable it to be used by people with health problems. There is also a gym, dance/fitness studios and play area - many of the attributes of a private health center. In this case, though, many of the facilities are on offer on doctor's prescriptions.

Beside the entrance is the café, in a dramatic ovoid structure. Consulting rooms are tucked to the side, so they are easily accessible, but do not dominate the space. Facilities on the ground floor should be easily accessible to all.

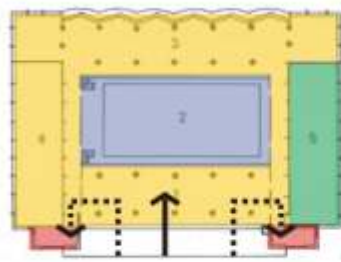


Figure 6.5: Ground floor analysis

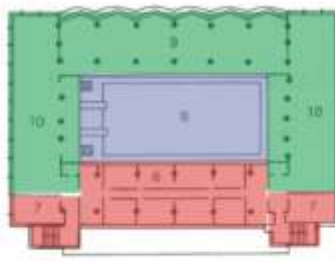
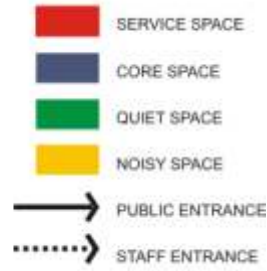


Figure 6.6: First floor analysis



Flow diagram

- Separate entrances are allocated for public and staff.
- The café forms part of the entrance and do not connect with any other functions of the building.
- Service spaces are placed together.
- Entry to the pool is regulated by movement through the play area.

Structure

It is interesting to note that the main aim of both structures, in the Pioneer Health Center and the Peckham Health Center, was to be able to cross the enormous span over the swimming pool.

Contemporary technology and material use allowed the Peckham Center a greater roof span. The new center speaks the architectural language of a shed, maybe a contemporary version of the old Pioneer Center who reminds one of a factory.

Analysis

The purpose for analysis of this health center was to investigate an alternative way of rendering a health service in a community setting.

Because the impact on the mental state of users was so astonishing, the precedents were appropriate for a community center for the mentally ill.

Where the approach of the proposed community mental healthcare center will differ, though, is that although the center will also uphold health and the maintenance of health as a primary function, it will need to be therapeutic as well.

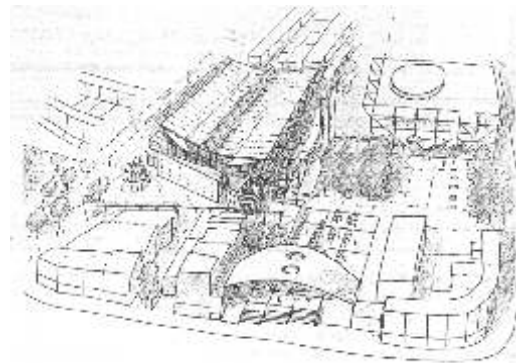


Figure 6.7: Perspective view



Figure 6.8: Section



Figure 6.9: West elevation

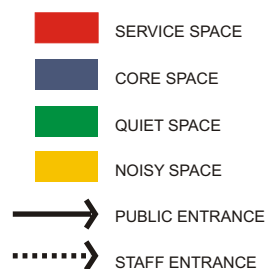


Figure 6.10: Ground floor plan analysis



Figure 6.11: Main entrance off courtyard



Figure 6.12: Corner view of Wood Green Community Mental Health Center

5.2 Precedents

5.2.2 WOOD GREEN COMMUNITY MENTAL HEALTH CENTER - MACORMAC JAMIESON PRICHARD

Wood Green Community Mental Health Center was conceived as part of a program of moving services out of Friern Barnet Hospital, a large and austere psychiatric hospital that was closed as part of the Care in the Community initiative in March 1993. The center provides counseling, treatment and support for people who would otherwise have to attend hospital.

“Although much controversy surrounds the execution of the change (in policy) the basic movement has been to de-institutionalise and de-stigmatise this area of health care and make it more accessible.”

The architect described the project as a relatively new building type created to bring facilities for mental care into the community. He said: “Although much controversy surrounds the execution of the change (in policy) the basic movement has been to de-institutionalise and de-stigmatise this area of health care and make it more accessible.

and places where incidental meetings can happen, so enhancing the life of the corridor.

Two vertical movement systems are used from the main entrance: a set of stairs for staff and a lift for patients.

The project is an umbrella for two day-care units, a Community Mental Health Center (CMHC) and an Acute Day Hospital (ADH). The units required autonomy from each other, but share staff, catering and administration facilities.

Circulation

Visitors enter the building at a corner junction and come into a double volume space that provides an impression of lightness and openness. The centers two wings radiate from the reception, so the building is clearly and easily understood.

The corridors are opened up and developed into a sequence of double volumes formed by pushing back rooms on alternate sides. On the ground floor, this creates breathing spaces to the side of the main circulation route, making informal waiting areas

Accommodation

Reception	Archive
Secretaries	Nurses unit
Occupational therapy	Occupational therapy office
Training kitchen	Community psychiatric nurses
Student resources	Head psychiatric nursing
Seminar room	Social work room
Admin/co-ord room	Waiting room
Café	Kitchen
Clinic	Mother/baby room
Utility room	Interview rooms
Family therapy	Psychology
Domiciliary	



Figure 6.13: Ventilation chimneys link each room to a low level inlet and a high level outlet



Figure 6.14: Daylit hallway passing through ventilation wall

Lessons learned

This precedent was chosen because of its similarities in use and purpose to that of the envisaged project. The accommodation list informed the project, as well as circulation and placement concepts. The siting of the building, however, causes the building to respond inwards, shutting out the public realm. This is due to noise and air pollution.

The following guidelines apply:

- Daycare and community care should function autonomously, but staff can be shared.
- Many facilities are shared between the community and the daycare patients, creating a hybrid center of care.



Figure 6.15: Ground floor analysis

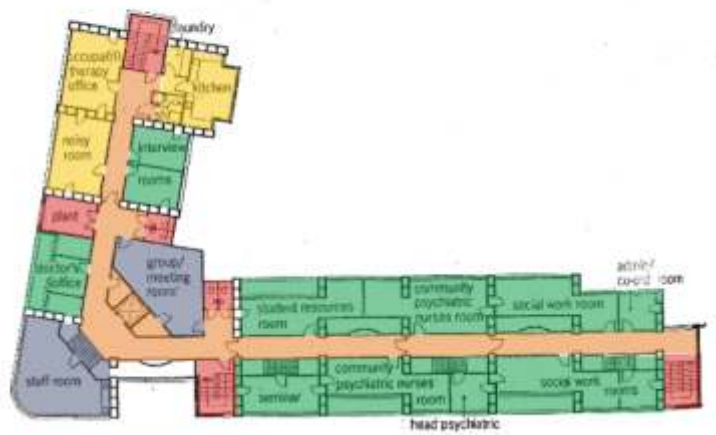


Figure 6.16: First floor analysis

5.3 Human Considerations

5.3.1 FUNCTIONAL CONSIDERATIONS

The health facility will aim to bring healing on different levels to mentally ill sufferers, their family, friends and the community at large.

The focus of the facility is to bring healing to the mind, body and spirit.



Figure 6.17: Mentally ill patient

- **Mind:** Information on illnesses and treatment will be made available to visitors.

Training in basic skills will help recovering sufferers to adapt to society.

- **Body:** Recent cross-sectional studies and controlled trials have suggested that exercise provides both physical and psychological benefits. These benefits include greater life satisfaction, positive mood states and mental well-being, reductions in psychological distress and depressive symptoms and lower blood pressure. (Geneva; 2004; p.108)

A wellness center equipped with a pool will be made available to visitors that will facilitate water aerobics.

The park will encourage exercise through non-strenuous walking.

- **Spirit:** The wellness center will provide healing therapy through massage, sauna and spa. This process of treatment calms, relaxes and soothes and will encourage the renewal of mind, body and spirit.

The spa can be classified as a health hydro and will center on water treatments. Medical personal will facilitate the center. Strict control will be exercised over clients, their diets and treatments. The approach is a holistic one and is recognised by both conventional and complementary medicine.

Concept for site layout.

Based on Rudolf Steiner's theory of anthroposophy (science of the spirit) the design decision was strengthened to develop the health facility as a series of buildings, rather than a singular building.

The concept is that each building should express and support one specific activity. This will inform the visitor of the purpose of the spaces.

For example:

- **The health hydro:** This is the realm of earth and water, filled with strong scents of oils and ointments made from healing plants. Here the user should feel protected, secure and grounded.
- **The dining room (restaurant):** This building should be filled with light and function as a typical dayroom and have a strong social character.
- **Music workshop:** The atmosphere is exuberant, created by a soaring space.
- **Art workshop:** The space should be more constricted, mirroring the intense concentration associated with therapeutic activity.



Figure 6.18: Concept site plan

FORMAL COMMUNITY
MENTAL HEALTH
SERVICES AS
IDENTIFIED BY THE
WORLD HEALTH
ORGANIZATION:

Rehabilitation services

a. Community mental

health centres/outpatient
clinics

b. Clubhouses

c. Day care centres

d. Drop-in centres

e. Support groups

f. Employment/rehabilitation
workshops

g. Sheltered workshops

h. Supervised work

placements

i. Cooperative work

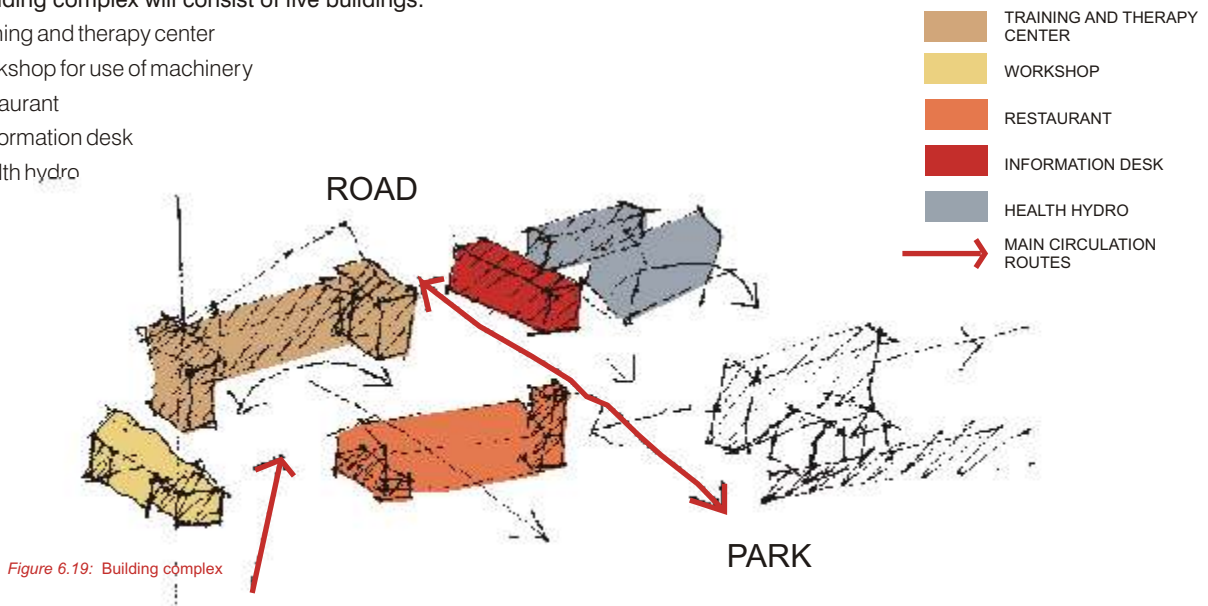
schemes

j. Supported employment
programmes

Accommodation

The building complex will consist of five buildings:

- A training and therapy center
- A workshop for use of machinery
- A restaurant
- An information desk
- A health hydro



Training and therapy center

The training and therapy will be accommodated in one building as to function as a modern-day daycare center, but on a more loosely formulated arrangement.

Inpatients, outpatients and the community can make use of the facilities and join classes at free will. No person will be restrained and can leave as they choose. The concept is that of a clubhouse.

In America clubhouse architecture for recovering psychiatric patients is becoming a fast growing concept, due to the need for facilities for the mentally ill that do not hospitalize. New York's Fountain House originated the clubhouse model, the main concepts of which have been highly influential, spurring 300 similar clubhouses world wide.

The basic premise of the clubhouse movement is that people with mental illness have a right to decent housing, meaningful employment and social interaction, all of which were denied to hospitalized patients.

The training and therapy center will be a place to go to for the recovering patient. Here he can receive training, take part in recreational activities or simply relax in the gardens.

TRAINING AND THERAPY CENTER																																																																					
Space function:																																																																					
Training division: ground floor					Therapy division: first floor																																																																
• Computer labs					• Reception for center																																																																
• Arts and crafts room					• Waiting rooms																																																																
• Music and multi-purpose room					• Staff room																																																																
• Ablution					• Offices																																																																
• Storage					• Counseling and therapy rooms																																																																
Occupancy:																																																																					
Training division: 80 students					Therapy division: 24 patients per two hours																																																																
Teaching places:																																																																					
N _t = number of teaching places required																																																																					
N _s = number of students (80)																																																																					
H _w = hours per week per student (25)																																																																					
H _a = total number of available hours a week for accommodation (40)																																																																					
F = net utilization factor (80%)																																																																					
$N_t = N_s \times \frac{H_w}{H_a} \times \frac{100}{F}$																																																																					
Thus: 62,5 teaching places is required for 80 students																																																																					
AREA:																																																																					
<table border="1"> <thead> <tr> <th>nr.</th> <th>Space description</th> <th>m²/student</th> <th>students</th> <th>Area</th> </tr> </thead> <tbody> <tr> <td>1.</td> <td>Computer labs (x2)</td> <td>1,89m²/s*</td> <td>10</td> <td>18,5m²</td> </tr> <tr> <td>2.</td> <td>Arts and crafts room</td> <td>5,20m²/s*</td> <td>15</td> <td>78,0m²</td> </tr> <tr> <td>3.</td> <td>Music and multi-purpose</td> <td>5,20m²/s*</td> <td>15</td> <td>78,0m²</td> </tr> <tr> <td>4.</td> <td>Storage (per workshop)</td> <td>0,60m²/s*</td> <td>15</td> <td>9,0m²</td> </tr> </tbody> </table>					nr.	Space description	m ² /student	students	Area	1.	Computer labs (x2)	1,89m ² /s*	10	18,5m ²	2.	Arts and crafts room	5,20m ² /s*	15	78,0m ²	3.	Music and multi-purpose	5,20m ² /s*	15	78,0m ²	4.	Storage (per workshop)	0,60m ² /s*	15	9,0m ²	<table border="1"> <thead> <tr> <th>nr.</th> <th>Space description</th> <th>pers.</th> <th>m²/pers.</th> <th>area</th> </tr> </thead> <tbody> <tr> <td>1.</td> <td>Reception and secretary</td> <td>1</td> <td>-</td> <td>12,0m²</td> </tr> <tr> <td>2.</td> <td>Waiting rooms (x2)</td> <td>8</td> <td>3,0m²/p</td> <td>24,0m²</td> </tr> <tr> <td>3.</td> <td>Staff room and kitchenette</td> <td>12</td> <td>4,0m²/p</td> <td>48,0m²</td> </tr> <tr> <td>4.</td> <td>Head psychiatrist office</td> <td>1</td> <td>-</td> <td>12,0m²</td> </tr> <tr> <td>5.</td> <td>Counseling room (x2)</td> <td>4</td> <td>-</td> <td>15,0m²</td> </tr> <tr> <td>6.</td> <td>Group therapy room (x2)</td> <td>8</td> <td>-</td> <td>20,0m²</td> </tr> </tbody> </table>					nr.	Space description	pers.	m ² /pers.	area	1.	Reception and secretary	1	-	12,0m ²	2.	Waiting rooms (x2)	8	3,0m ² /p	24,0m ²	3.	Staff room and kitchenette	12	4,0m ² /p	48,0m ²	4.	Head psychiatrist office	1	-	12,0m ²	5.	Counseling room (x2)	4	-	15,0m ²	6.	Group therapy room (x2)	8	-	20,0m ²
nr.	Space description	m ² /student	students	Area																																																																	
1.	Computer labs (x2)	1,89m ² /s*	10	18,5m ²																																																																	
2.	Arts and crafts room	5,20m ² /s*	15	78,0m ²																																																																	
3.	Music and multi-purpose	5,20m ² /s*	15	78,0m ²																																																																	
4.	Storage (per workshop)	0,60m ² /s*	15	9,0m ²																																																																	
nr.	Space description	pers.	m ² /pers.	area																																																																	
1.	Reception and secretary	1	-	12,0m ²																																																																	
2.	Waiting rooms (x2)	8	3,0m ² /p	24,0m ²																																																																	
3.	Staff room and kitchenette	12	4,0m ² /p	48,0m ²																																																																	
4.	Head psychiatrist office	1	-	12,0m ²																																																																	
5.	Counseling room (x2)	4	-	15,0m ²																																																																	
6.	Group therapy room (x2)	8	-	20,0m ²																																																																	
*As per New Metric Handbook																																																																					
<table border="1"> <thead> <tr> <th>Ablution*staff</th> <th>m</th> <th>f</th> </tr> </thead> <tbody> <tr> <td>wc</td> <td>1</td> <td>2</td> </tr> <tr> <td>whib</td> <td>1</td> <td>1</td> </tr> <tr> <td>ur</td> <td>1</td> <td>-</td> </tr> </tbody> </table>			Ablution*staff	m	f	wc	1	2	whib	1	1	ur	1	-	<table border="1"> <thead> <tr> <th>Ablution*stud</th> <th>m</th> <th>f</th> </tr> </thead> <tbody> <tr> <td>wc</td> <td>1</td> <td>3</td> </tr> <tr> <td>whib</td> <td>3</td> <td>4</td> </tr> <tr> <td>ur</td> <td>2</td> <td>-</td> </tr> </tbody> </table>			Ablution*stud	m	f	wc	1	3	whib	3	4	ur	2	-	<table border="1"> <thead> <tr> <th>Ablution*</th> <th>m</th> <th>f</th> </tr> </thead> <tbody> <tr> <td>wc</td> <td>1</td> <td>1</td> </tr> <tr> <td>whib</td> <td>1</td> <td>1</td> </tr> <tr> <td>ur</td> <td>-</td> <td>-</td> </tr> </tbody> </table>				Ablution*	m	f	wc	1	1	whib	1	1	ur	-	-																								
Ablution*staff	m	f																																																																			
wc	1	2																																																																			
whib	1	1																																																																			
ur	1	-																																																																			
Ablution*stud	m	f																																																																			
wc	1	3																																																																			
whib	3	4																																																																			
ur	2	-																																																																			
Ablution*	m	f																																																																			
wc	1	1																																																																			
whib	1	1																																																																			
ur	-	-																																																																			
*As per National Building Regulations																																																																					
Critical factors:																																																																					
Natural ventilation and sufficient daylighting must be provided. Additional light will have to be provided for the workshops, as well as the therapy and counselling rooms. Wheel chair access to all spaces must be ensured																																																																					
Parking provision:																																																																					
Adult training:					Health care:																																																																
1 space per 2 staff					1 space per doctor																																																																
1 handicap vehicle per 4 attendants					1 space per 2 staff																																																																
Total parkings					2 space per consulting room																																																																
					Total parkings																																																																

The workshop

A separate workshop will be allocated for the use of machinery. This is due to the nature of the vocational therapy that can be quite messy and noisy. The workshop will be used for woodworking, leather tooling and metal work.

The ablution facilities calculated for the training facility has taken the occupancy of the workshop in consideration and will therefore be shared by the two buildings.

All the training facilities, including the workshop will be utilized during the day, but can be occupied by other users during the evenings such as support groups etc.

WORKSHOP				
Space function:				
<ul style="list-style-type: none"> • Workshop • Storage 				
Occupancy:				
10 students				
Area:				
nr.	Space description	m²/student	students	area
1.	Workshop	5,0m ² /s*	10	50m ²
2.	Storage	3,30m ² /s*	10	33,0m ²
*As per New Metric Handbook				
Critical factors:				
Natural ventilation and sufficient daylighting must be provided. Additional light will have to be provided for the workshop. Wheel chair access to all spaces must be ensured				
Parking provision:				
Adult training:				
1 space per 2 staff				1
1 handicap vehicle per 4 attendants				2
Total parkings				3

The restaurant

The restaurant will function as a dayroom within the clubhouse set-up. Rooms will be incorporated where visitors can just sit, relax and read or play games. The dining room will cater for all visitors, inpatients and their family and friends, outpatients and staff.

The restaurant creates the opportunity for family, caregivers and patients to engage and thus enables social support to the sufferer. It would be preferable that the restaurant be naturally lit with access to nature and garden views.

Table sizes and shapes should accommodate different groups. In the lounges a variety of seating should be available for the same reason. In general the restaurant should be warm, inviting and accessible.

THE RESTAURANT																					
Space function:																					
<ul style="list-style-type: none"> • Lounge • Dining room • Service counter • Kitchen 					<ul style="list-style-type: none"> • Storage • Fridge • Freezer • Ablution 																
Occupancy:																					
150 visitors																					
Area:																					
nr.	Space description	m²/person	persons	area	nr.	Space description	m²/person	persons	area												
1.	Lounge	2,5m ² /p	20	50,0m ²	5.	Storage	-	-	5m ²												
2.	Indoor dining room	1,4m ² /p*	74	100,0m ²	6.	Fridge	-	-	3m ²												
3.	Service counter	-	-	20,0m ²	7.	Freezer	-	-	3m ²												
4.	Kitchen	-	5	30,0m ²	8.	Outside eating area	1,4m ² /p*	56	78m ²												
*As per New Metric Handbook																					
<table border="1"> <thead> <tr> <th>Ablution*</th> <th>m</th> <th>f</th> </tr> </thead> <tbody> <tr> <td>wc</td> <td>1</td> <td>2</td> </tr> <tr> <td>whb</td> <td>1</td> <td>2</td> </tr> <tr> <td>ur</td> <td>1</td> <td>-</td> </tr> </tbody> </table>										Ablution*	m	f	wc	1	2	whb	1	2	ur	1	-
Ablution*	m	f																			
wc	1	2																			
whb	1	2																			
ur	1	-																			
*As per National Building Regulations																					
Critical factors:																					
Natural ventilation and sufficient daylighting must be provided. Wheelchair access to all spaces must be ensured																					
Parking provision:																					
1 space per 3 staff				4																	
1 space per 2 seats				75																	
Total parkings				79																	

The information desk

The information desk will serve as a reception for the complex as a whole and, to an extent, the hospital. It should be located central to the complex and be highly accessible and visible.

Information on the hospital, location of buildings and time schedules will be made available at this point. If patients or visitors need to be located or called to the center it can be done from the info desk. Ablution for the center and park will also be provided within this building, since not all visitors will use the other buildings and their amenities.

The area around the information desk can be used as exhibition space due to its central location and highly visible nature.

THE INFORMATION DESK															
Space function:															
<ul style="list-style-type: none"> • Information desk • Ablution 															
Occupancy:															
1 Clerk															
Area:															
nr.	Space description	area													
1.	Information office	12,0m ²													
2.	Ablution block	45,0m ²													
<table border="1"> <thead> <tr> <th>Ablution*</th> <th>m</th> <th>f</th> </tr> </thead> <tbody> <tr> <td>wc</td> <td>2</td> <td>4</td> </tr> <tr> <td>whb</td> <td>2</td> <td>2</td> </tr> <tr> <td>ur</td> <td>2</td> <td>-</td> </tr> </tbody> </table>				Ablution*	m	f	wc	2	4	whb	2	2	ur	2	-
Ablution*	m	f													
wc	2	4													
whb	2	2													
ur	2	-													
*As per National Building Regulations															
Critical factors:															
Natural ventilation and sufficient daylighting must be provided. Wheelchair access to all spaces must be ensured															
Parking provision:															
1 space per 1 staff			1												
Total parkings			1												

The health hydro

The health hydro should be located where privacy can be optimized. Due to the nature of the accommodation quiet surroundings and a tranquil setting is essential.

The concept is to make spa facilities available to the wider public at affordable rates and at the same time expose visitors to mental health care facilities. Both the mental health care and hydro spa will facilitate good mental health.

Treatments

- Hydrotherapy and underwater massage.
- Hot stone therapy
- Lymphatic drainage

“Touching, kneading and rubbing the body has physical benefits. Even Freud is said to have prescribed massage therapy to cure hysteria.”

- Aeromotherapy.
- Body wraps.
- Deep tissue massage.
- Indian massage
- Steam bath

Spa health bar

Healthy light meals will be served, as well as refreshments.

Exercise

Swimming is an excellent form of exercise and also one of the safest. The indoor/outdoor pool can be used in all seasons. Aqua aerobics classes can be facilitated which is a calm, safe and quiet form of exercise.

Sauna

It is not uncommon to find public saunas at health clinics and medical institutions. The sauna ritual cleanses the pores of the skin, like bathing, but also removes impurities from the body and forces the mind to relax.

Resting and relaxation

Resting areas for cooling and while waiting for treatments will be provided. They should be protected from wind and be kept warm.

HEALTH HYDRO																					
Space function:																					
General areas: • Lobby • Reception • Head somatologist office • Linen room • Archive • Health bar • Lounge • Indoor pool • Single massage room • Double massage room					Hydro areas: • Sauna • Steam room • Massage shower • Jet bath • Plunge pool • Showers • Lockers • Ablution																
Occupancy:																					
• 20 Males for the spa • 20 Females for the spa • 20 People for the pool																					
Area:																					
nr.	Space description	m ² /person	people	area	nr.	Space description	m ² /person	people	area												
1.	Lobby	3,0m ² /p	8	28m ²	1.	Sauna	1,25m ² /p	8	10m ² **												
2.	Reception	-	2	22m ²	2.	Steam room	1,25m ² /p	4	5m ² **												
3.	Head somatologist office	-	4	12m ²	3.	Massage shower	-	2	3m ² **												
4.	Linen room	-	1	12m ²	4.	Jet bath	1,25m ² /p	6	8m ² **												
5.	Archive	-	-	7m ²	5.	Plunge pool	2,00m ² /p	2	4m ² **												
6.	Health bar	1,5m ² /p*	12	18m ²	6.	Showers	2,00m ² /p	3	6m ² **												
7.	Lounge (x2)	3,0m ² /p	4	12m ²	7.	Lockers	-	28	8m ² **												
8.	Indoor pool	-	-	54m ²	*All these facilities will be doubled to cater for a male spa and female spa division																
9.	Single massage room (x2)	-	2	6m ²																	
10.	Double massage room (x2)	-	4	12m ²																	
*As per New Metric Handbook																					
					<table border="1"> <thead> <tr> <th>Ablution*</th> <th>m</th> <th>f</th> </tr> </thead> <tbody> <tr> <td>wc</td> <td>2</td> <td>2</td> </tr> <tr> <td>whb</td> <td>2</td> <td>2</td> </tr> <tr> <td>ur</td> <td>-</td> <td>-</td> </tr> </tbody> </table> <p>*Ablution facilities will facilitate the spa and pool areas. These figures include toilets for the handicapped</p>					Ablution*	m	f	wc	2	2	whb	2	2	ur	-	-
Ablution*	m	f																			
wc	2	2																			
whb	2	2																			
ur	-	-																			
Critical factors:																					
<ul style="list-style-type: none"> • The salon should be well ventilated. • Therapists should be able to access hot and cold water from treatment points. • The spa <ul style="list-style-type: none"> - should be kept at 25°C. - Non-slip flooring material. - No sharp edges. - Grabrails should be provided. - Drainage and hosing appliances should be provided for cleaning. - Walls: waterproof and durable material (Tile/mosaic). - Underfloor heating. - Warm and well ventilated to prevent condensation. • Massage rooms <ul style="list-style-type: none"> - Sound proof. - Kept at 21°C - Shelves should be provided for oils/towels. - Rooms should be well ventilated - No direct sunshine in the rooms • Sauna <ul style="list-style-type: none"> - Circulation space should be kept to a minimum - As much space as possible should be allocated to benches - Bigger saunas are more comfortably fitted with U-shaped benches - Keep the ceiling as low as possible • The spas and baths could use the pool's support equipment to help to pump, filter and purify the water. 																					
Parking provision:																					
Health hydro and swimming pool:																					
1 space per 2 staff								4													
1 space per 10m ² pool area								16													
Total parkings								20													



Figure 6.20: Jaqueline Fiske Healing garden, Jupiter Medical Center - positive outdoor space (Roy Fisher Associates - Florida)



Figure 6.21: Jaqueline Fiske Healing garden, Jupiter Medical Center - choice of seating (Roy Fisher Associates - Florida)



Figure 6.22: Jaqueline Fiske Healing garden, Jupiter Medical Center - touchable water (Roy Fisher Associates - Florida)

5.3.2 SOCIAL CONSIDERATIONS

Therapeutic environment

The environment, whether it be natural or man made, has a profound effect on feelings, behaviours, general health, and productivity. The discipline of environmental psychology grew from the collaboration between architects and psychologists in the 1950's to improve mental hospitals. A discipline that began with investigating the effects of colour and chair arrangements on patients has now moved to a much wider field, and includes such diversity as noting the needs of visitors to our national parks to studying the stresses associated with urban living.

A healthcare environment is therapeutic when it does all of the following:

- Supports clinical excellence in the treatment of the physical body
- Supports the psycho-social and spiritual needs of the patient, family, and staff
- Produces measurable positive effects on patients' clinical outcomes and staff effectiveness

Healthcare architects, interior designers, and researchers have identified four key factors which, if applied in the design of a healthcare environment, can measurably improve patient outcomes:

- **Reduce or eliminate environmental stressors:**
 - Acoustical separation from other patients, mechanical noises, public address systems
 - Acoustical treatment of corridors adjacent to patient rooms
 - Appropriate lighting systems; "lighting can be a stressor that alters mood, increases stress, disrupts daily rhythms, and modulates hormone production" (J. Roberts, Ph.D.)
 - Provide lighting that supports natural circadian rhythm; "Provide natural daylighting where possible, or bright white lights (400-600nm) in the daytime.
 - Provide comfortable furnishings and comfortable layouts
 - Maintain good indoor air quality and ventilation
 - Appropriate use of color

- **Provide positive distractions:**

- Views of nature wherever possible from lobby, waiting, and other 'high stress' areas
- Access to nature, healing gardens
- Chapel, meditation room, and meditation gardens
- Artwork depicting nature, including back-lighted photographs of nature
- Music; live piano in a public area, recorded music in patient room when programmed specifically to create a healing environment
- Mild physical exercise; corridors, public spaces, and gardens that invite walking when appropriate
- Pets and other activities or elements that allow for a sense of stimulation that help nurture a patient's sense of positive wellbeing

- **Enable social support:**

- Provide places where patients can engage socially with family and other caregivers, such as places where families can eat together
- Ensure culturally sensitive environments

- **Give a sense of control:**

- Give the patient control over the immediate environment; i.e., operable windows, operable blinds, adjustable furniture and fittings.
- Wayfinding; the built environment should provide clear visual cues to orient patients and families, and guide them to their destination and return. Landscaping, building elements, color, texture, and pattern should all give clues, as well as artwork and signage
- Provide mini-medical library and computer terminals so patients can research their conditions and treatments
- Choice of lighting; patients and staff can benefit from personal dimming controls
- Choice of artwork
- Volume and programming control of televisions in waiting areas
- Menu selection



Figure 6.23: Highline Community Hospital Medical Office Building and Cancer Center - space illustrates textural variety and careful use of colour. (Northwest Architects - Seattle)



Figure 6.24: Parker Adventist Community hospital indicating good use of colour, texture and light. (HKS, Inc. - Dallas)

Social contact

The concept is that in-patients, outpatients, visiting patients, visitors and community members share facilities and be visually accessible to each other in order to cultivate an inclusive environment. Often more healthy patients see themselves as elite, and do not want to mix with sicker patients. Visitors or community members might also regard the mental patient as not worthy to communicate with. The center will be designed into integrate all classes regardless of disability and allow these groups to look into each others lives.

- **Visual contact**

Visual contact between patient spaces and visitor spaces, staff spaces and patient spaces increase the sense of transparent and accessible relations.

- **Physical contact**

Contact between all parties will be supported. Spaces for socializing can be enhanced. Corridors can be widened to arouse patients' interest in activity and create gathering spaces for patients, visitors and community members. Dayrooms, the healing garden and the spa and pool areas can also induce socializing.

Healing environment

Many factors have been considered in the creation of healing environments:

- **Noise control**

- Sounds of footsteps in corridor
- Slamming doors, clanking latches
- Loudspeaker paging systems
- Staff conversations from nurses' stations or staff lounge
- Televisions
- Clanking of dishes and food carts

- **Air quality**

- Need for fresh air
- Avoidance of noxious off-gassing from synthetic materials, including certain types of paint
- Avoidance of odiferous cleaning agents
- Adequate number of air changes

- **Thermal comfort**

- Ability to control room temperature, humidity and air circulation to suit personal needs.

- **Light**

- Patients should be able to control light

- **Communication**

- Ability to contact staff when needed
- Comfortable places to visit with family
- Television, radio and telephone available as needed

- **Views of nature**

- Views of trees, flowers or mountains from lounges
- Indoor landscaping

- **Colour**

- Careful use of colour to create mood, lift spirit, and make rooms cheerful

- **Texture**

- Introduce textural variety in wall surfaces, floors, ceilings, furniture, fabrics and artwork

- **Accommodation for families**

- Provide place for family members to make them feel welcome, rather than intrusive
- Provide visitors lounges and access to vending machines, telephones, and cafeteria

“As social beings
with interests and
values, planners
do care about and
are committed to
bringing about a
certain kind of
world through
their efforts.
Planners are
always affecting
the world in a
particular direction
and closing off
other directions.”

5.3 Human Considerations

5.3.3 PHYSICAL CONSIDERATIONS

Inclusive design

Definition and premise of inclusive design:

Inclusive Design is a process that results in inclusive products or environments which can be used by everyone regardless of age, gender or disability. (adapted from Shipley 2002)

It is however an evolving and complex concept, whose definition can be extended to address not only age, gender and disability, but also race, income, education, culture etc....

It is useful to supplement this open ended definition with an understanding of the basic premise, which lies behind inclusive design and its consequences, that is: the built environment can exclude and discriminate against certain groups in society at certain times.

Guiding principles

All people should:

- have full and equal access to all elements of society, in an inclusive way if they so choose, rather than in a way that subjects them to separate treatment or segregation;
- not encounter discrimination through the design and operation of the built environment;
- have the freedom to choose how they access the activities they wish to pursue and the premises in which they occur, according to their own personal requirements;
- expect the planning process, the building control system, and the law, to ensure that the built environment is accessible to disabled people over time;
- have the opportunity to influence the planning, design and operation of the built environment through meaningful consultation.

Design guidelines for the disabled:

- Public transport within 100m of the facility
- Routes must be smooth and even
- Levels - ramps at slope 1:12
- Toilets for the disabled should be accessible

5.3.4 PHYSIOLOGICAL CONSIDERATIONS

Wayfinding

Wayfinding can be defined in many ways; in this context it is an orientation or traffic management system for hospitals. Mentally ill sufferers can easily be disorientated by their surroundings. Guidelines can be used during the design stage to avoid confusion.

Wayfinding facilitators

Behavioural scientists generally agree on three major conditions that are prerequisites for ease of wayfinding (Garling 1984):

- Degree of differentiation: the degree of sameness or variation of interior spaces affects a person's ability to recognize it and use it as a landmark.
- Visual access: being able to see one part of the building from another or being able to see the lobby, an atrium, a bridge or another architectural feature enables a person to maintain a point of reference.
- Complexity of spatial layout: the number of possible routes to a destination and the frequency of intersections with jogs or odd angles.

Components of a wayfinding system

Four principle elements help to guide people through a hospital:

- Destination: a destination is the entrance to an inpatient or outpatient department or to a waiting room, cafeteria, or other public space.
- Main artery: the main artery corridor is the principle circulation spine connecting points of entry with various destinations and vertical circulations such as elevators or stairs.
- Landmark: a landmark is a highly memorable image that can be used as a point of reference when giving directions, and one that would be recalled by the exiting first-time user or the repeat visitor.
- Reinforcement: additional supporting elements that reassure wayfinder that he or she is on the right path.

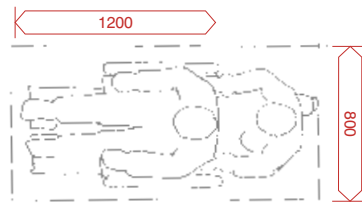


Figure 6.25: Wheelchair and attendant envelope

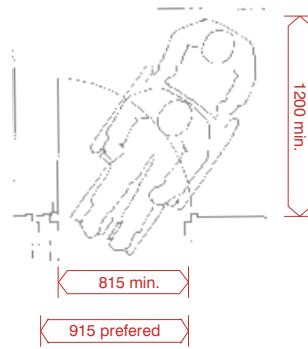


Figure 6.26: Wheelchair movement through door

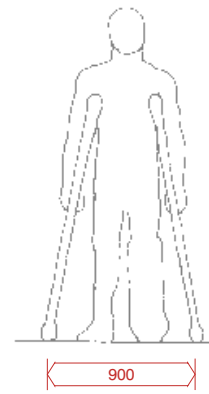


Figure 6.27: Use of crutches

Designing for the mentally ill

Design guidelines:

The following design guidelines are aimed at psychiatric inpatients facilities and are therefore applicable to the severely disturbed patient. Some of the proposals can, however, be kept in mind whilst designing for the recovering mentally ill user:

- Nothing sharp
- Tamper-proof hardware
- No glass or mirrors
- Tamper-proof grilles for heating, ventilation and air conditioning, locate in ceilings or high on walls
- Tamper-proof screws
- Avoid design details that can easily be destroyed
- No suspended ceilings
- Prevent patients from locking themselves in
- Door hardware with flush handles and hinges that swing in both directions
- Fire doors with alarm-release locks

Designing for the disabled

Many of the mentally ill that will visit the center will be wheelchair bound or using walking sticks or crutches. It is therefore essential to design for these individuals.

Walls:

- Rough finishes on walls can cause hand abrasions
- Objects projecting from walls should be kept to a minimum

Doors:

- Sliding doors are generally an obstacle to wheelchair users
- No revolving doors may be used
- A space less than 1981mm can become a wheelchair trap
- Doors must have openings of no less than 810mm
- Lever handles should be used on all doors
- Doors must open at a maximum of 3,6kg
- Bathroom doors should swing outwards

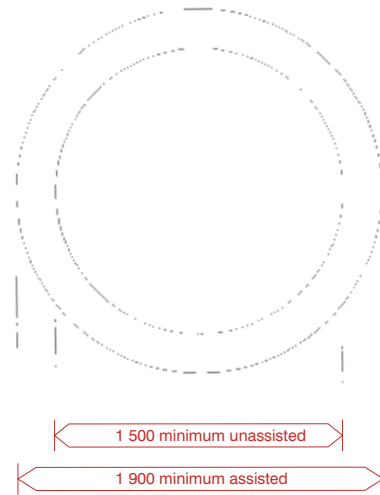


Figure 6.28: Turning circles for wheelchairs

Floors

- Steps and curbs should be eliminated. The maximum threshold or curb height is 250mm
- No slippery floor finishes or uneven floors
- No grating should inter vere with wheelchair travel

Space

- Wheelchair parking space is required (see accommodation p.69)
- Increased aisle space is required in cafeterias, restaurants and libraries
- Public toilets and phone booths should be spacious enough to accommodate wheelchairs

Reach

- Phones, drinking fountains, vending machines, light switches and fire alarms should be within reach. The hand reach zone is 914mm-1219mm as measured from the floor

Walkways and ramps

- The maximum recommended grade for walkways are 3% with 1219mm wide rest areas
- Ramps have a general grade of 5-8% with rest areas every 9m and handrails on both sides
- Ramps should be textured to provide non-skid surfaces

5.4 Environmental Considerations



Figure 6.29: Training auditorium
Weskoppies is a training hospital for the University of Pretoria. The auditorium is mainly used by for the students for lectures.



Figure 6.31: Gatehouse
The proposal is for a new gatehouse to be designed that will function as an appropriate gateway forming an established entry node and facilitating services such as a bus stop and ablution.



Figure 6.32: Historic house
The house is currently occupied by staff members, but the proposal is for it to serve as a museum for the hospital and tea garden in the gateway precinct. The concept is to preserve the historic context and create a point of interest for the community.

Figure 6.33: Site context



Figure 6.30: Outpatients facility
The outpatient facility is used as a support to patients who have been released. The facility is insufficient in capacity.



Figure 6.34: Family and child care unit
The facility houses children on the campus and also functions as the information desk for the hospital. The accommodation of both functions, in a single building, is not ideal.

5.4.1 SITE CONTEXT

The site is surrounded by buildings that date from different periods, and all of them are, architecturally, fairly insignificant.

There exist no relation between the buildings and the challenge would be to create a co-herency through the new intervention.



Figure 6.35: View point 2

The site consists of rolling, green lawns and large clusters of trees. Many of these trees are exotic and are being removed. A strategy for replacing these trees should thus considered in the planning and design of the new complex. The setting of the site is public in its location, at the gate, but peaceful and tranquil in its nature.



Figure 6.36: View point 4

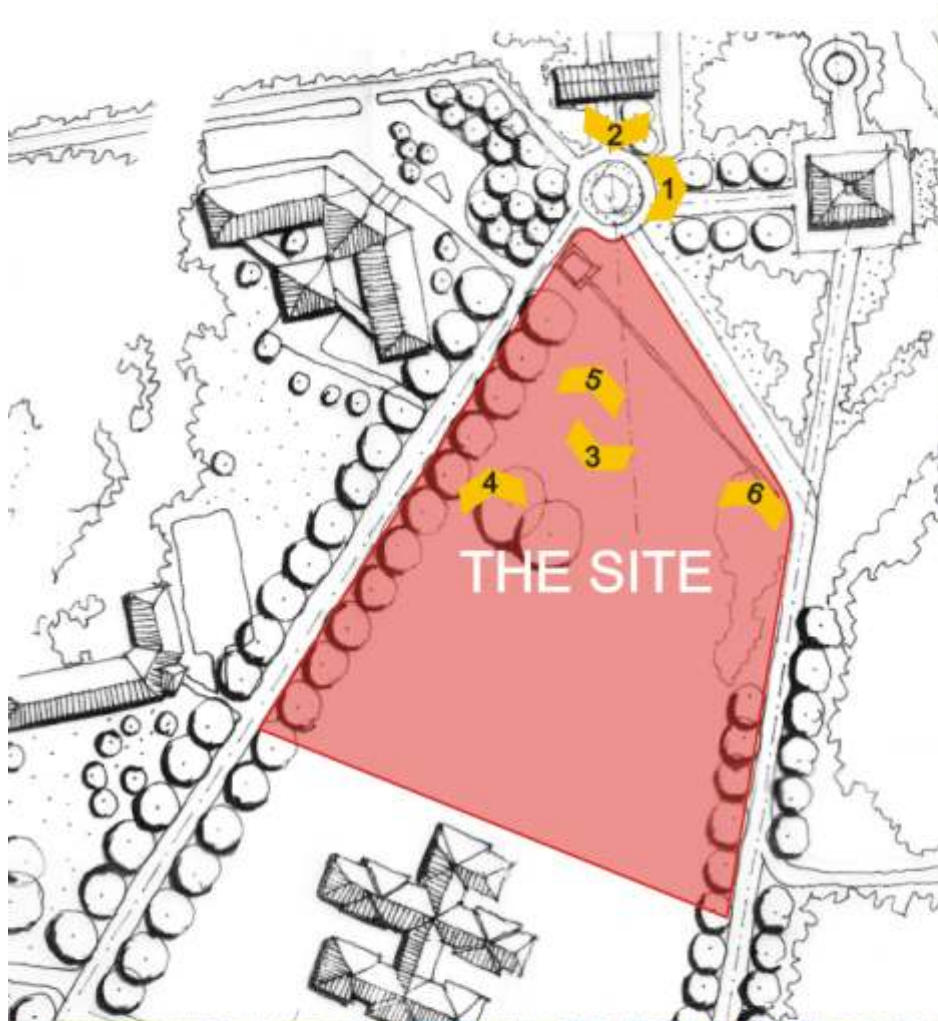


Figure 6.37: View point 1



Figure 6.38: View point 5



Figure 6.39: View point 6



Figure 6.40: View point 3

Guiding principles:

- Create co-herency between existing buildings through new intervention.
- Maintain and enhance natural aspects of the site.

5.4 Environmental Considerations

5.4.2 SITE

The site is not a virgin site, but can certainly not be considered a brownfield site either. The vegetation has been estimated as a zone 2, which means that it has low to medium environmental value and that the planting of indigenous trees on a large scale should be encouraged.

Extensive vegetation on site will thus be cultivated, which supports the concept of creating a park on the site. This will provide a habitat for birds, of which there are numerous on site.

Planning and design

During planning and design, the regional and microclimatic conditions of the site, existing vegetation, topographical conditions, the intended use, desires of the owner, and the zoning of plant materials according to their water needs, need to be taken into account.

Planning:

- Design of floor plans and foundations should reflect the site topography.
- Because the building orientation is not on a east-west axis, special care will have to be taken in regards to the treatment of the western and eastern elevations. Shading devices, and the channeling of wind for natural ventilation will decrease energy demands for cooling, particularly when combined with proper placement of shade producing plants.
- Preserve and protect as much existing vegetation as possible. Incorporate existing trees when locating structures and powerlines, allowing room for them to grow if they are not at mature size.
- If areas around trees must be paved, use pervious materials or, at a minimum, leave large holes spaced at regular intervals in the tree's root zone (openings will help give trees needed air and water).

Carefully planned building placement should:

- Minimize storm water runoff
- Minimize habitat disturbance
- Protect open space
- Reduce the risk of erosion
- Save energy by providing for passive solar, natural ventilation, and daylighting.

Design to minimize impacts to site

- Natural Site Features
 - Preserve natural drainage systems.
 - Locate driveways, parking, entrances, and loading docks on the building's south side.
 - Minimize ground-level wind loads.
- Vegetation
 - Minimize native vegetation disruption.
 - Minimize visual impacts. Use natural vegetation and adjust the building plan to diminish the visual impact of facilities and to minimize imposition on environmental context.
- Hydrology
 - Avoid hydrological system contamination.
 - Allow precipitation to naturally recharge groundwater.
 - Provide ample planting to reduce flow of surface water.
 - Trees reduce impact of heavy rainfall on surface, cutting down erosion.
 - Trees keep ground damp longer and reduce evaporation.
 - Soakage trenches are spread over a wide area to cope with heavier downfalls, to give good subterranean distribution.
 - Berms dam excessive surface water allowing it to percolate over a longer period.
- Geology/Soils
 - Minimize excavation and disturbance to groundcover.
 - Minimize erosion. Avoid large impervious surface areas and building footprints that collect rain and create concentrated runoff onto site.
- Heat Island Effect
 - Use trees for shade, use fewer pavements, reduce or avoid air conditioning use and use reflective coatings on pavement and roofs to help reduce a building's contribution to the heat island effect.

Site Development

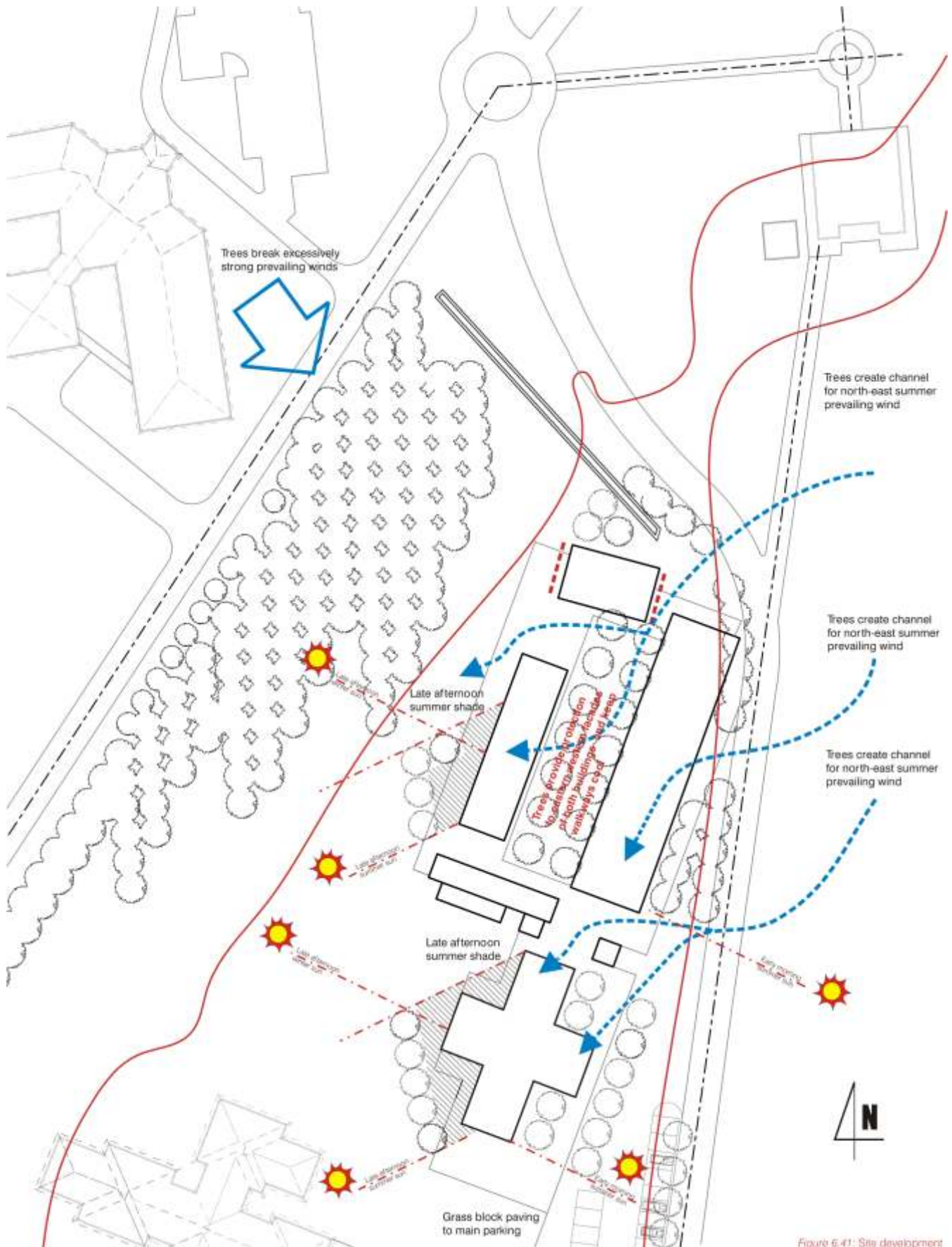


Figure 6.41: Site development

5.4 Environmental Considerations

Landscaping for energy saving

It is possible to achieve as much as a 30% reduction in cooling and heating costs through careful landscape planning. Landscaping can reduce direct sun from striking and heating up building surfaces and create enough shade to lower roof and wall temperatures by up to 20 degrees. It can prevent reflected light carrying heat into a building from the ground or other surfaces. By reducing wind velocity, an energy conserving landscape slows air leakage in a house. Additionally, the shade created by trees and the effect of grass and shrubs will reduce air temperatures adjoining the building and provide evaporative cooling. The use of dense tree and shrub plantings on the west and south-west sides of a building will block the summer setting sun. This is the most effective landscape planting strategy.

Shading

Trees are primary in an energy conserving landscape. Trees can have a canopy large enough to shade roofs, reducing cooling costs and increasing comfort.

The best locations for deciduous trees are on the north, west and east sides of a house. When these trees drop their leaves in the winter, sunlight can reach the house to help in heating the home. Note: Even without leaves, trees can block as much as 60% of the sun, making placement of trees critical to effectiveness. Evergreen trees on the west side afford the best protection from the setting summer sun.

Windbreaks

Characteristics of an effective windbreak:

- The windbreak extends to the ground.
- Foliage density on the windward side is optimally 60%.
- Two to three rows of evergreen trees in staggered order should be used. If using deciduous trees, there should be five to six rows.
- The length of a windbreak should be 11.5 times the mature width of the stand of trees.
- The tree heights within the windbreak should be varied.

Vines for Shading

When trees are young and not providing much shade, vines can be used to provide shading on walls and windows. Some vines such as English Ivy will cling to any wall surface. This can harm wood surfaces. Trellises placed close to the walls can be used to support vine growth without touching the walls. Using vines which lose foliage in the winter can be used for summer shading

as long as vine stems do not significantly block winter sun.

Evergreen vines will shade walls in the summer and reduce the effects of cold winds in the winter.

Absorbent and Reflective Materials

Groundcover and/or turf also have a cooling effect from evapotranspiration (the loss of water from the soil by evaporation and by the transpiration of the plants growing therein).

The temperature above a groundcover will be 10 to 15 degrees cooler than above a heat absorbent material such as asphalt or a reflective material such as light coloured gravel or rock.

A heat absorbent material like asphalt will also continue to radiate heat after the sun has set. It is best to either minimize the use of heat absorbent and reflective materials near a house and/or shade them from any direct sun.

Paving

Pervious Paving Materials

Pervious materials permit water to enter the ground by virtue of their porous nature or by large spaces in the material.

Water-pervious materials such as gravel, crushed stone, open paving blocks or pervious paving blocks for driveways, parking areas, walkways, and patios minimize runoff from those areas, as well as increase infiltration. Some pervious paving options can retain turf and carry autos and trucks evenly without creating tracks or other heavy traffic wear signs.

Parking areas

The approach taken in regards to the parking is that of cars in a park. The parking areas will be covered in natural vegetation and hardened surfaces is only provided for wheel tracks and wheelchair parking bays.

Trees must not shed damaging or staining fruit or leaves on vehicles.

Site Water

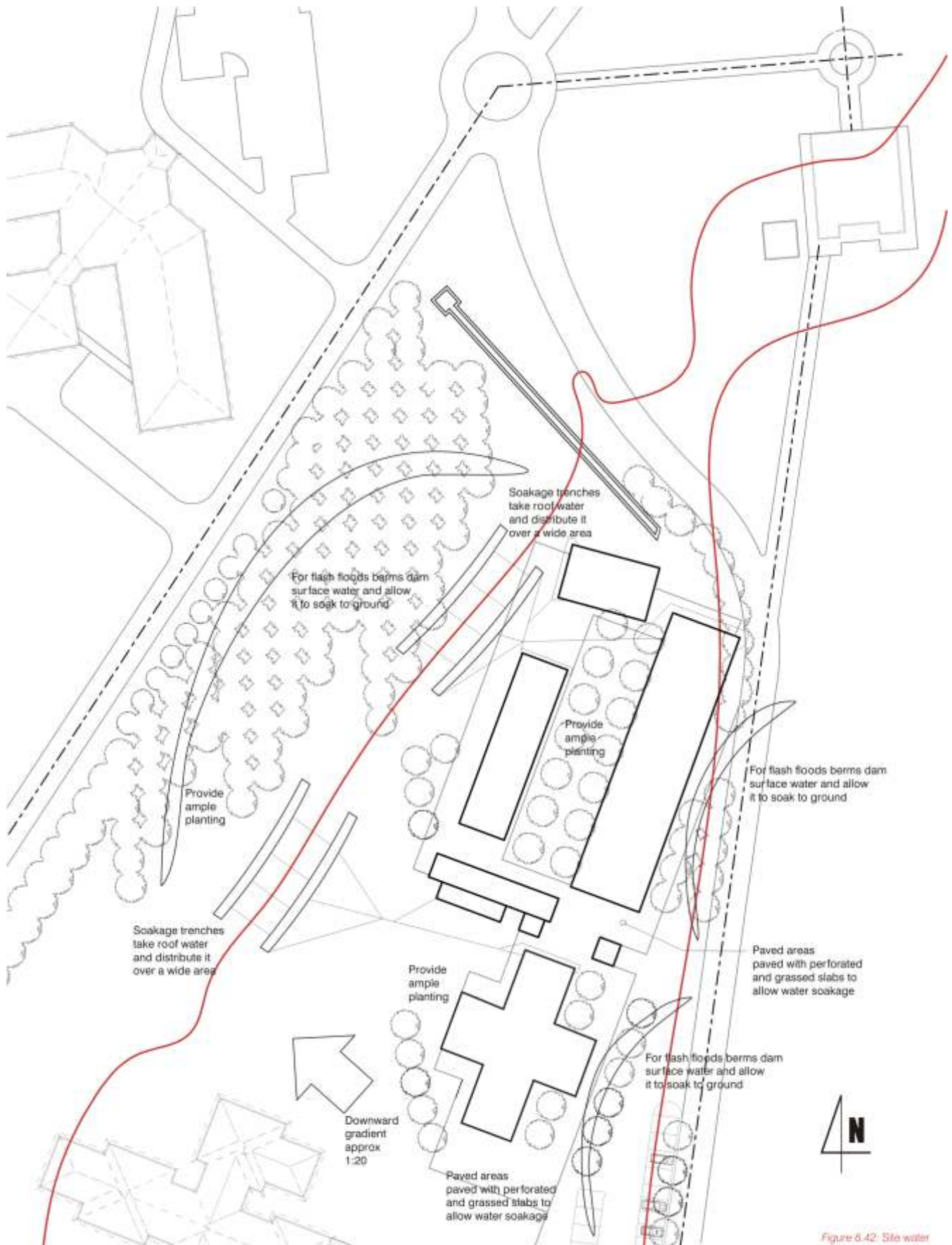


Figure 6.42: Site water



Figure 6.43: Low rise community buildings



Figure 6.44: Smaller building size



Figure 6.45: Spring Harbour Psychiatric Facility - smaller sized low rise units were designed for the facility that are not only energy conserving, but also lends a domestic and human scale to the complex. (MorrisSwitzer - Environments for health - Westbrook)

5.4 Environmental Considerations

5.4.3 RESOURCES

Energy

Low rise building:

Low rise buildings are envisaged for the center as they are responsive to the changing social and demographic profiles of community building arrangements.

Low rise buildings are flexible, efficient and can be environmentally responsive. The organization of low rise buildings is adaptable to urban as well as to rural settings.

Smaller building size:

A group of smaller buildings could be more energy efficient as they could more easily be designed to make more efficient use of interior spaces while retaining solar and ground access. In turn, these buildings have smaller footprints which help to create a more compact, efficient and affordable community development.

The benefits for both the low rise buildings and smaller building size include:

- lower impact on the natural environment
- more compact and accessible developments which promote community
- reduced infrastructure expenditures
- reduced costs for materials and construction
- reduced servicing, maintenance and energy expenditures (life-cycle costs)

Natural ventilation:

Natural ventilation serves to provide both comfort and health to indoor environments. Using natural ventilation can result in both capital cost and energy savings and reduce the need for mechanical ventilation and air conditioning systems. It serves two functions with differing airflow requirements, namely: to maintain acceptable indoor air quality by replacing indoor air with fresh indoor air and to provide thermal comfort (comfort ventilation).

The main design features that will be incorporated in the design, which will affect the indoor ventilation conditions are:

- Narrow building section to allow easy cross ventilation
- Windows at ceiling level for the escape of hot air
- Total area of openings
- Operable windows
- Use of casement windows, as they offer better air flow
- Minimizing interior obstructions
- Slightly larger wind outlets

Passive solar heating

Passive heating is a system that collects solar heat, without the use of external mechanical power to distribute it. The building itself is designed as a solar collector with windows acting as the collection source. Solar collection may be either direct (solar radiation entering directly into a space) or indirect (solar radiation heats an area which then continues to heat the area when the solar exposure has passed).

Solar heating depends upon:

- proper siting of building with 50 - 60% of the building glazing oriented to the sun
- thermal mass - materials for indirect solar collection should relate to the window size and the volume of the space being heated
- systems for controlling heat in the space including, awnings, louvers, blinds, and shutters

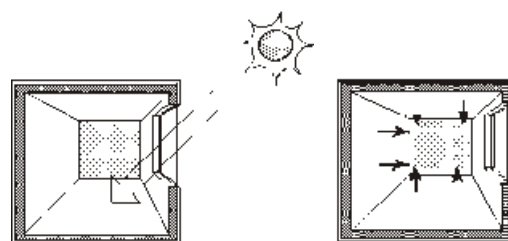


Figure 6.46: Thermal mass in the interior absorbs the sunlight and radiates the heat at night



Figure 6.47: An indoor room receiving daylighting through a skylight

Passive solar cooling

Design strategies that minimize the need for mechanical cooling systems include proper window placement and daylighting design, selection of appropriate glazings for windows and skylights, proper shading of glass when heat gains are not desired, use of light-colored materials for the building envelope and roof, careful siting and orientation decisions, and good landscaping design.

Shading Strategies:

- Fixed shading devices, using correctly sized overhangs and patios. Fixed shading devices, which are designed into a building, will shade windows throughout the solar cycle. The depth and position of fixed shading devices will be carefully engineered to allow the sun to penetrate only during predetermined times of the year. In the winter, overhangs will allow the low winter sun to enter. In the summer, the overhangs will block the higher sun.
- Plant trees and/or bushes to shade the windows at the right time of day and season.
- Exterior shutters. Vertical shutters on the western facade can be designed to eliminate late summer sun in the building, while still allowing visual access from the building.

Cooling Strategies

- The building will be designed to take advantage of natural ventilation. Natural ventilation uses the passive stack effect and pressure differentials to bring fresh, cooling air through a building without mechanical systems. This process cools the occupants and provides comfort. Features will include fresh air inlets located near floor level, use of ceiling fans, and the increase of floor to ceiling height with hot air outlets at ceiling level.

Daylighting:

Daylighting has become increasingly important to reduce the energy demands of a building and to create healthier interior environments. Electric lighting accounts for approximately 25% of the total electrical energy used in buildings.

A goal is to reduce the electric lighting requirements wherever possible. As a design feature, the use of daylighting within a building produces a more pleasant and stimulating atmosphere for its inhabitants.

Generally, north, east and west facing windows can be controlled for good daylighting while south facing windows can provide uniform daylighting without controls. Because different wall orientations receive different amounts of sunlight throughout the day and throughout the seasons, optimal window design will differ for each orientation as will the lighting controls.

Daylighting strategies must consider heat gain, glare and variations in light availability and solar penetration. These are addressed through aperture size and spacing, shading devices, glazing materials and surface reflectance characteristics.

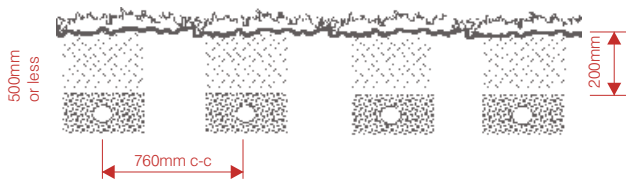
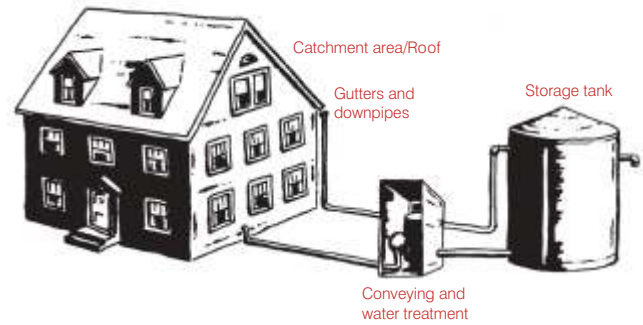


Figure 6.48: Shallow trench section view



5.4 Environmental Considerations

Water

Greywater

The mesotrophic and red soil on the site is of favourable texture, structure, drainage and permeability for a greywater system. The site is also not at risk of flooding, which further renders it acceptable for greywater irrigation. However, because the slope of the site is beyond 15%, additional design and engineering work may be needed.

Greywater used for irrigation on this project will be wastewater produced from the health hydro's jet baths, pools and showers, linen washers, and wash hand basins from the project as a whole. The wastewater generated by toilets, kitchen sinks, and dishwashers is called blackwater and can not be used for irrigation. The use of greywater for irrigation requires separate blackwater and greywater waste lines in the building. This is not a difficult task in new construction.

The primary method of greywater irrigation that will be implemented is through sub-surface distribution, or more specifically, shallow trenches.

In this system, greywater flows from the building through pre-treatment and is piped into shallow trenches (pipe placed 200mm deep). These pipes are placed close enough to the surface to feed the plant roots.

The distinction between a conventional septic tank system and a shallow trench subsurface landscape irrigation system occurs in the absorption field design. Conventional septic tank systems are designed for disposal only; therefore, the distribution pipes are usually placed too deep for efficient irrigation and the spacing of the trenches is sometimes too wide. Consequently, irrigation gaps may occur which will need additional watering to prevent a lawn from having a striped effect.

Rainwater harvesting

Rainwater harvesting systems are required by law in new construction in Bermuda and the US Virgin Islands. California offers a tax credit for rainwater harvesting systems and financial incentives are offered in cities in Germany and Japan.

Harvested Rainwater is rainwater that is captured from the roofs of buildings. Harvested rainwater will be used for irrigation purposes, which simplifies the system in terms of conveying and water treatment. Rainwater collection systems can be costly, with the primary expense being the storage tank.

Capacity

- The capacity of a rainwater harvesting system depends on the amount of rainfall, size of collection area, storage capacity, and the demand for water.

Rainwater for Irrigation

The largest need for irrigation water is during the summer when temperatures are at their highest. This also happens to be during the time of highest rainfall and therefore no water will need to be captured and stored prior to summer.

- The size of the storage system may be prohibitive for using rainfall for the sole source of irrigation water in large or water-intensive landscapes, therefore a low water demanding landscape is envisaged.



Materials

Local materials

A goal of sustainable buildings is to integrate the use of local building materials as well as local building sources and practices.

The embodied energy of materials factors in costs related to the transport and distribution of building materials which, in some cases, is costly. Recognizing the continuation of traditional / local building techniques with regional resources helps to foster local economies and can contribute significantly to creating a sense of place.

Local materials such as stone, clay (brick) and wood can be used in most forms of smaller scale construction, such as the buildings envisaged for the project. These materials are labour-intensive rather than energy-intensive and can reduce the life-cycle costs of a building.

A decentralized construction industry could help to recognize and to facilitate the use of local building materials and practices.

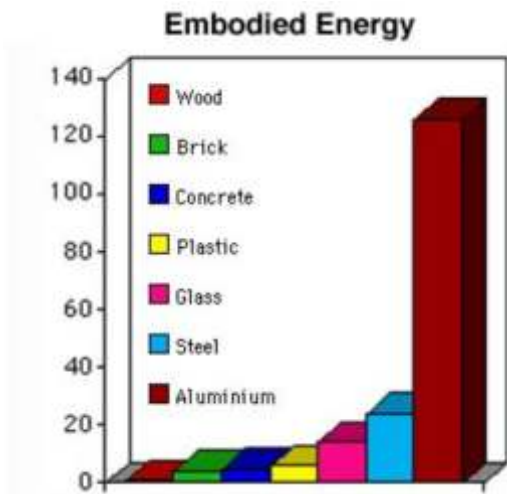


Figure 6.51: Embodied energy of materials



Figure 6.52: Pre-fab modular components

5.4 Environmental Considerations

Embodied energy

Embodied energy is the amount of direct and indirect energy needed to produce a certain type of material. Direct energy is associated with the extraction of natural resources, transportation to the factory, processing the material (molding, forming, etc.), transportation back to the construction site, and placing the processed material in the structure. Indirect energy is associated with the quantity of energy required to manufacture the equipment and materials needed to produce a certain material. Both direct and indirect energy has a proportion of their energy invested in the processed material.

Low embodied energy materials require less direct and indirect energy to extract, transport, process, manufacture, construct, maintain and dispose of. There is a strong correlation between the embodied energy in the extraction and manufacture of common materials and its return to the earth before refinement. In other words, if the material needs very little effort in processing or extracting, it is likely to be a low energy material. Materials such as sand, gravel, wood, concrete, sand-lime brickwork, and lightweight concrete are examples of low energy materials. Plasterboard, common brickwork, cement, mineral fiber insulation, and glass are medium energy materials. High energy materials such as plastics, steel, lead, copper, and aluminum require the most energy output.

Medium energy materials:

- plasterboard 1.0
- brickwork 1.2
- cement 2.2
- mineral fibre insulation 3.9
- glass 6.0

High energy materials:

- plastics 10.0

- steel 10.0
- lead 14.0
- copper 16.0
- aluminum 56.0

Pre-fab modular components:

Prefabricated modular and componentized buildings have been growing in use over the last century. Today, off or on site prefabrication is directed to: a more efficient use of materials; the reduction of energy (production and construction); the reduction of waste; the reduction of construction time on site and; increasing quality control. Economies of scale are achieved through mass production which helps to address housing affordability.

Modular structures are typically factory finished and only need to be connected on site, where they are connected to each other or to other building systems. Componentized structures are made from wall panels, roof trusses, partitions, floor assemblies, mechanical cores, and so on. Single and multi unit dwelling configurations, modular and componentized, are growing in availability as are other building types.

Recycling building products:

Used building materials can be remanufactured and reused in a variety of ways. There are economic and ecological benefits to reusing building materials such as reducing material mass in landfills and reduced extraction and refinement of resources. These include: dimensional lumber and timbers, doors, cabinetry and other wood items; precast and prestressed concrete slabs; steel structural members and cladding; glazing, and; other modular construction elements.



Figure 6.53: Patrick H. Dollard Discovery Health Center, New York state, Catskill Mountains - Guenther 5

The impact of the development on both land and water reserves was minimised as part of a strategy of environmental restoration. Considerations include optimised energy performance, use of recycled materials and intelligent use of resources.

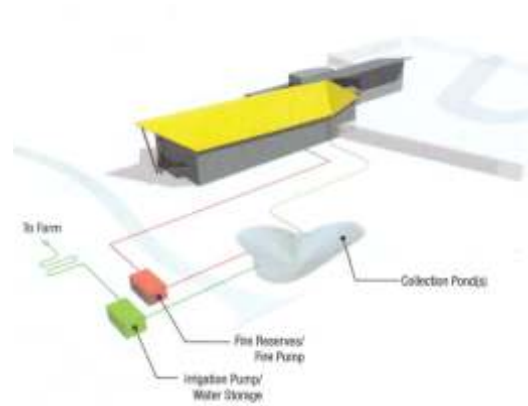


Figure 6.54: Water strategy minimises impact on reserves

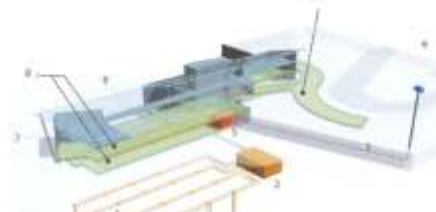


Figure 6.55: Geothermal design cuts heating and cooling costs

5.4.4 Recycling and reuse

Compost System

Compost is created by the decomposition of organic matter such as yard waste. Compost systems confine compost so that it can receive air and create suitable temperatures for proper decomposition into fertilizer.

Composting results in:

- saving landfill space
- saving energy for transporting the material
- the creation of a high quality fertilizer at the location where it can be used (thereby again saving energy)
- saving plastic garbage bags

Construction Waste

Construction waste recycling is the separation and recycling of recoverable waste materials generated during construction and remodeling. Packaging, new material scraps and old materials and debris all constitute potentially recoverable materials. In renovation, appliances, masonry materials, doors and windows are recyclable.

4 Tons of waste are typically thrown into the landfill during the construction of a 186m² home.

Materials that can be recycled include:

- Appliances and fixtures
- Brush and Trees
- Cardboard and Paper
- Lumber and Plywood (in reusable form)
- Masonry (in reusable form or as fill)
- Metals
- Plastics - numbered containers, bags and sheeting

- Roofing (in reusable form)
- Windows and Doors

“...a clear correlation between environmental health and patient well-being.”

Inorganic waste

A built-in kitchen recycling center is a section of kitchen cabinetry designed to accommodate easy sorting of recyclables. A built-in recycling holding area is a location within the building complex that conveniently holds sorted recyclables until picked up or taken to a collection point.

The primary location in the building complex where refuse is received and collected is the kitchen. This is the best location to initially separate materials that can be recycled. Recycling is more likely if it can be accomplished in a neat convenient manner.

The recycling holding area is the next step for making recycling convenient and routine. After materials have accumulated in the kitchen, they can then be transferred to containers in an area convenient to conveying them to the street for pickup or car to be taken to a collection center.

Guidelines:

Kitchen Recycling Centers

- These are simply components inside a standard section of a kitchen cabinet that can hold multiple containers (usually three) and easily slide in and out or hinge out of the cabinet.
- They require only standard installation skills or procedures.

Recycling Holding Area

- This can be as simple as providing three trash containers with wheels (for locations with curbside pickup) in an assigned section in the kitchen that will not interfere with other activities in the kitchen.



Figure 6.57(A): Sketch of historical houses on site

5.5 Cultural Considerations

5.5.1 HISTORICAL

The Weskoppies campus has a very strong historical context that becomes tangible through its built form. The layering of time and event is intensely sensed through the *genius loci* of the campus.

As stated previously the original buildings were built in 1892 and the campus was developed over many years with additional building added as required. The historic buildings included the main administration building and a few historic houses of which some are located in close proximity to the proposed new project.

Addition to the campus should entail principles of conservation.

Policy that should be adopted for the design of any structures on the campus:

- The knowledge that the place is important
- An understanding of the significance of the place
- An understanding of the existing fabric
- The significance should guide decisions
- Design should relate in meaning and memory to the existing



Figure 6.58(Background): Memory wall on campus



Figure 6.59: Drill Hall, Johannesburg - Michael Hart Architects, Urban Designers cc
The transformation of the hall is an example of a responsible design intervention on a historical site. Elements from the original building was reintroduced, such as the form and the use of red brick, while the transformation of the hall is represented by the use of new materials such as off-shutter concrete and full-height glazing.



Figure 6.60: Administration building, Unisa satellite campus, Tshwane
The administration building is part of a series of additions to the original campus. The historic buildings are also of the Edwardian style. The new buildings continued in the traditional architectural language, but merely simplified certain aspects.



Figure 6.61: Edwardian: Travato, Wynberg, 1898



Figure 6.62: Edwardian: Travato, Wynberg, 1898

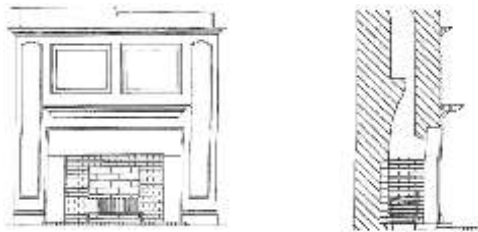


Figure 6.63: Edwardian: Welgelegen, 1899



Figure 6.64: Edwardian: Travato, Wynberg, 1898

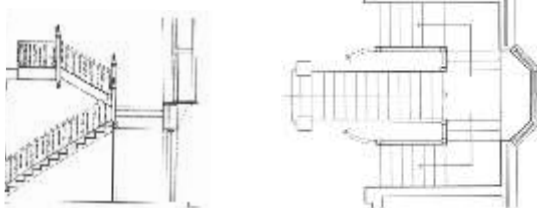


Figure 6.65: Edwardian: Vredenhof House, 1907 (Internal)

During the time when the original buildings of Weskoppies were designed, the British influence dominated. This was around 1806 - 1914. It included Georgian (1806 - 1840), Queen Anne, Regency, early Victorian, mid (1865 - 1883) and late (1884 - 1902) Victorian, Arts and Crafts and Edwardian styles.

Characteristics of the Edwardian style include:

Front doors

Three identifiable trends occur during this period: Neo Baroque, Arts and Crafts and Neo Georgian. The Arts and Crafts influence seemed to be widespread. Fanlights are usually small paned, lead lights, and the timber is 'chunky' or generous in proportion. Around 1900 the influence of Art Nouveau is also in evidence. Here stained glass, incorporating curvilinear organic forms, is also common.

Fireplaces

Chimney pieces were either Art Nouveau influenced or Tudor, so they ranged from being decorated with organically inspired tiles to having much plainer, brick-built English-inspired fittings.

Windows

In Britain, the Tudor revival as a true British style and a reaction to what was perceived to be an overzealous and enthusiastic response to European influences resulted in an increase of exposed timber on the exterior walls. Windows using a simplified, chunky but visually less busy 'surround' developed. The sizing of timber was increased in line with the medieval origin of this style. It was short-lived, however, as it was inevitably overshadowed by the forces of Internationalism and Modernism.

Stairs

During the Edwardian period, the staircase was often not highlighted as a separate element - it became incorporated into the structure. The stringer was closed, and the stairs became visually heavier or more solid, as part of the structure.

5.5 Cultural Considerations

5.5.2 INSTITUTIONAL

The values that an institution embraces should have a strong influence on its form.

The architecture should communicate the institutions nature and place in society. Through the expression of form and space, the occupant should understand the value and purpose of the institution and its facilities.

The community mental healthcare center planned for Weskoppies will embrace a set of values in serving society. Since the center is aimed at preparing people to better cope in society, it would be inherently wrong to remove the sufferer from society and confine them. Thus the emphasis on community involvement.

The fundamental reason for the facility is the belief that the mentally ill are individuals with the potential for growth and development and that mentally ill individuals have the right to self respect and deserve the opportunity of education and training.

The notion of healing, comfort and acceptance could be expressed through the use of warm material and human scale.

The application of high quality materials and design will convey the concept of a community and institution that values the mentally ill and their potential.

The sufferer will understand that he is trusted through an architecture that affords freedom, a concept far removed from the traditional institutional buildings with their window bars

“The institutions are the houses of the inspirators: schools, libraries, laboratories and gymnasia. The architect considers the inspiration before he can accept the dictates of a space desired. He asks himself what is the nature of one that distinguishes itself from another. When he senses the difference, he is in touch with its form. Form inspires design.” Louis Kahn



Figure 6.66: Izingolweni clinic and community center, The farm 'Eden', Kwazulu Natal - Llew Bryan Architects and Ashworth Burke Partnership.

The center had to respond to the concept of rural community orientated architecture which revolves around two issues, community participation and utilisation of local labour and resources. The building has an institutional nature, but the architecture is appropriate to the community. The center is simple, versatile and functional and the architectural language vernacular.



Figure 6.67: Umkhumbane community health center, Durban - Robert Johnson Architect and Associates in association with ZAI Consultants cc

The purpose for this building was to create a 'place of wellness'. The architectural interpretation of this concept was that of a 'shopping mall for health services'. The projection of this image was achieved through the use of industrial building technology.



Figure 6.68: Kotulong community center, Gauteng - cbs architects.

The main aim for the designers was to create a dignified space for terminally ill patients, as well as providing a nurturing environment for orphans. This intention was expressed through the generous use of light, within the buildings, as well as the use of colour and texture.



Figure 6.69: Perbál rehabilitation center for disabled young people, Perbál, Hungary - Tamas Karacsony and Peter Janesch.

The center was designed for the accommodation of disabled and mentally retarded people. The basis for the architecture was that of 'poetic' dwelling. This notion was manifested in a complex of buildings that are intimate, but not confining. The center portrays a change in the attitude of charity organizations toward the mentally ill.

5.6 Temporal Considerations

5.6.1 GROWTH

The buildings for the mental health care facility should be of such a nature that it will be able to expand as the need for the facility changes. If the center becomes redundant, it must be designed in such a way that the buildings can be utilized for other functions.

5.6.2 CHANGE

The health care industry is of such a nature that spaces required for facilities change continually as technology develops. It is therefore necessary that the internal spaces be flexible to adapt to changing needs.

5.7 Economic Considerations

5.7.1 LOCAL ECONOMY

Local contractors

80% of the construction is to be carried out by contractors based within a 40km radius of the campus. This will facilitate upliftment of the community and increase employment for workers within the area.

Local building material and component supply

80% of construction materials and components is to be produced from local factories, other building products and components to be supplied within a 200km radius of the site.

Repairs and maintenance

All repairs and maintenance of the building to be carried out by contractors within a 200km radius of the site/local community members.

5.7.2 EFFICIENCY OF USE

Space use

Service areas should not make up more than 20% of total area. Reducing the space required for general service creates more usable space.

Occupancy schedule

The building and all working spaces will be occupied 80% of the time with a minimum of 40 hours a week. Workshop spaces can be used by support groups after hours.

Management of spaces

Spaces will be managed correctly to prevent wasted space. Correct management of the facility is crucial to ensure the effective productivity of the building.

Use of technology

The facility uses simple technology that will not require extensive user manuals. The connections to systems and internet will be operable from one protected server in the secretaries' office.

Disruption and downtime

This will not have a major effect on the facility, but generators will be on stand by.

5.7.3 ADAPTABILITY AND FLEXIBILITY

Vertical dimensions

No floor to ceiling heights are less than 3m, which ensures possible change of accommodation within spaces.

Internal partitions

The use of modular technology and movable divisions between spaces can be considered within the workshop spaces.

Services

Easy access to all services will be provided

5.7.4 ONGOING COST

Maintenance

Specification of materials to be such that maintenance cost are kept to a minimum. All components must be readily available and cost effective to replace.

Cleaning

All cleanable surfaces need to be accessible, such as windows.

Security and care taking

Cost needed for security will be limited through design.

Cost monitoring

Cost for insurance, water usage, energy and sewerage will be monitored and reported to users in order to create an awareness of wasted cost.

5.7.5 CAPITAL COST

Build-ability

The facility will utilize local construction methods in order for the buildings to build easily and cheaply. This will also be possible through simple design.

Construction

The project will be able to be executed in phases.

5.8 Safety Considerations

5.8.1 CRIMINAL

Strategies

Three categories of urban safety are identified and the strategies for designing out crime are the following:

- Awareness of the environment

Designing places with an understandable layout. This means the ability to see and understand the significance of what is around and what is ahead. Through adequate lighting, clear sight lines and elimination of entrapment spots, dangerous situations can be avoided.

- Visibility by others

Designing urban environments where people would not be isolated. This includes the ability to be seen, through reduction of isolation, improvements to the mixture and intensity of land use and the intelligent use of activity generators.

- Finding help

Designing environments in such a manner that people can get assistance from others. Providing clearly marked avenues to assistance (emergency exits) enabling people to escape from a dangerous situation and enabling individuals to get help through improved signage and legible design, are but a few examples of achieving this goal.

5.8.2 PUBLIC SAFETY

To ensure the safety of the general public, the facilities shall comply with Part D of the National Building Regulations.

5.8.3 FIRE

In this facility the fire regulations as set out in Part T of the National Building Regulations will be adhered to.

5.8.4 STRUCTURAL

The buildings will be designed to comply with the deemed-to-satisfy rules contained in Part B of the National Building Regulations.

5.9 Conclusion

The programme informs the project in three ways:

- General principles that outline the broad and conceptual directions design should take. Different facilities will require varying responses and will generate specific designs.
- Facility design guidelines provide conceptual design differences between building types.
- Accommodation and space standards give reference and information in establishing functional uses or environments.

This not only ensures that the design is up to standard, but steers the project to a unique and 'purpose made' solution.



Figure 6.70: Inside the clock tower of the main administration building

D E S I G N D I S C O U R S E

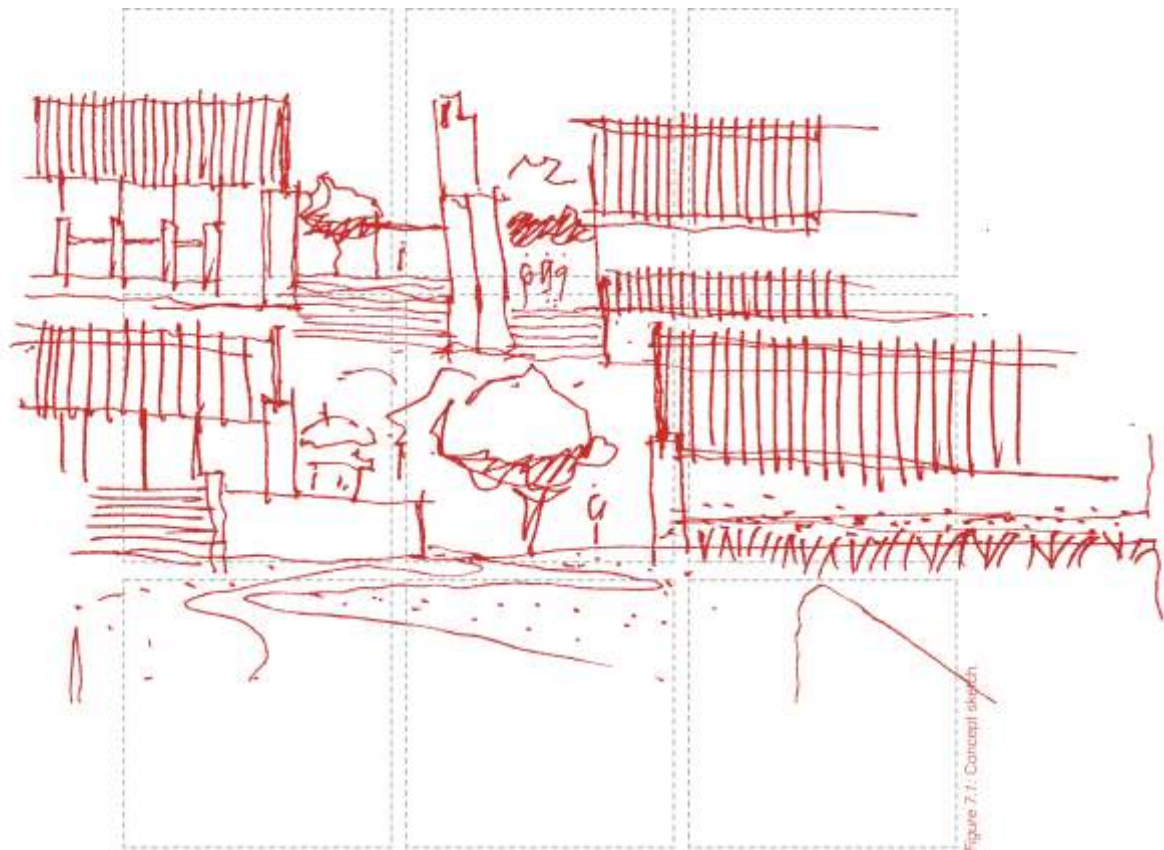


Figure 7.1: Concept sketch

"The truly serious attitude considers art to be a 'means' to something beyond it, which may be reached by giving up art itself".

Péter Janesch

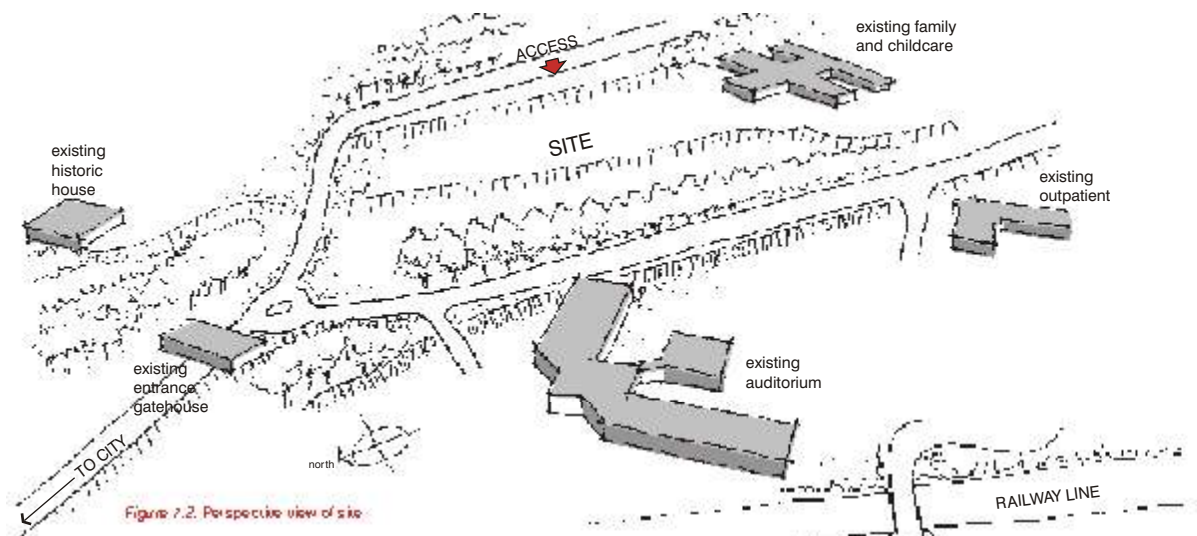


Figure 7.2. Perspective view of site

6.1 Site forces

6.1.1 SLOPE

The site has a slope of approximately 1:20 causing a linear axis along the fall.

6.1.2 ACCESS

Primary access to the site is as conceptualized in chapter 4 pg.59.

6.1.3 VIEWS

The site has landscape views approximately 360°. The main view, however, would be those focused on the slope and landscape of the site.

6.1.4 EXISTING BUILDINGS

All existing buildings are single storey.

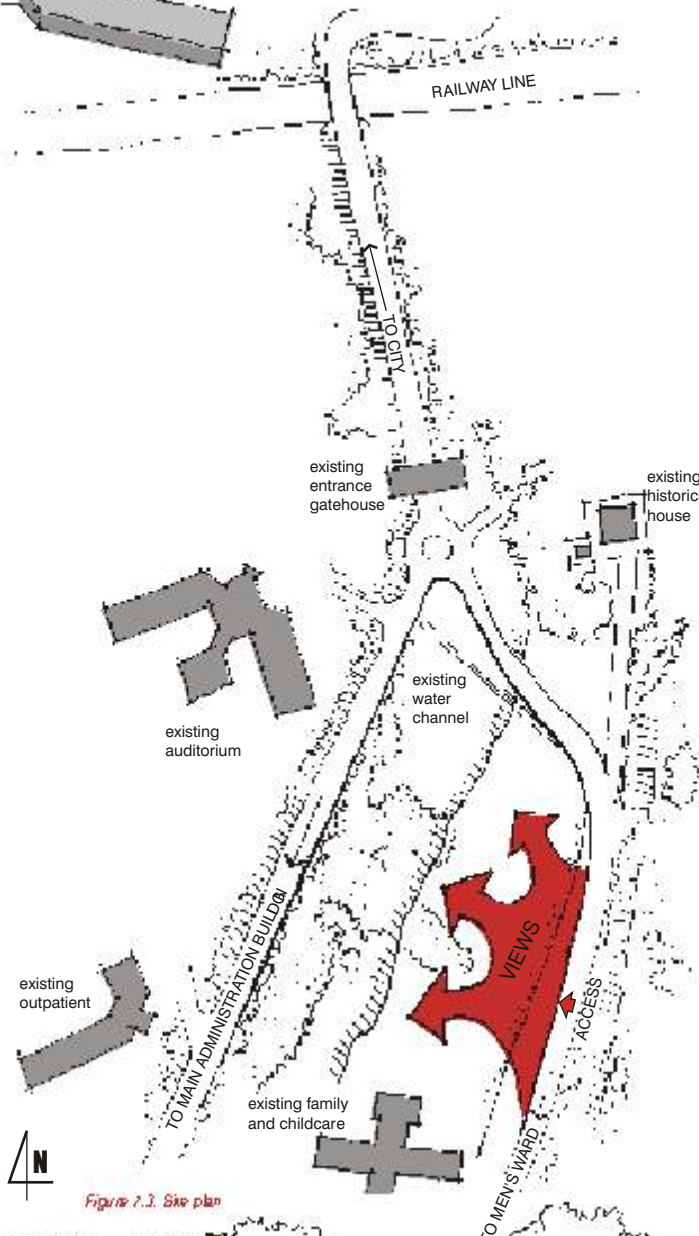


Figure 7.3. Site plan

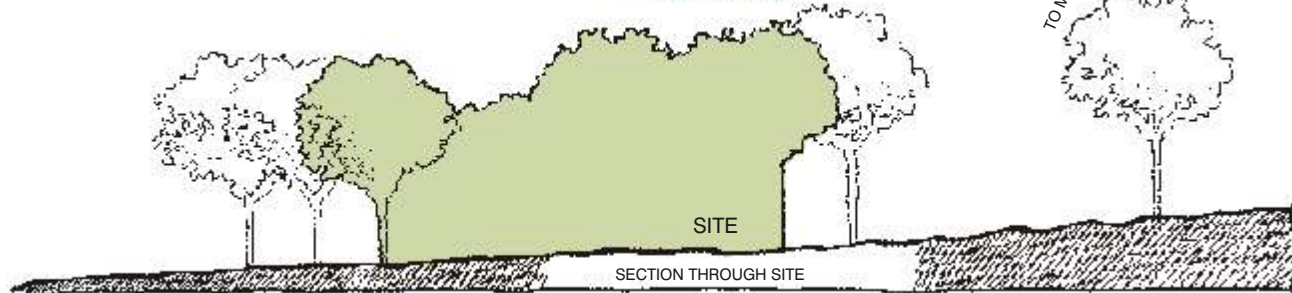


Figure 7.4. Section through site

6.2 Site implications

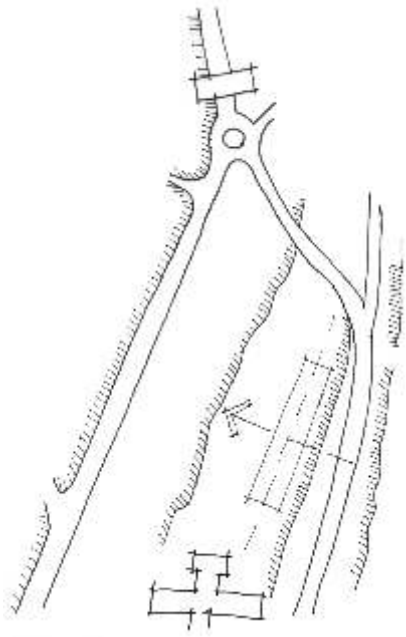


Figure 7.5: Building footprint reflect topography

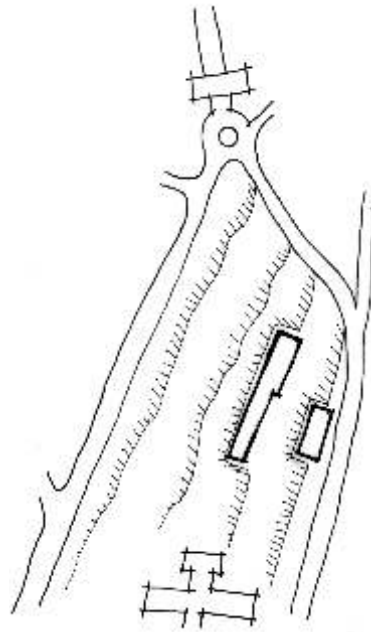


Figure 7.6: Place-making through elevated plane

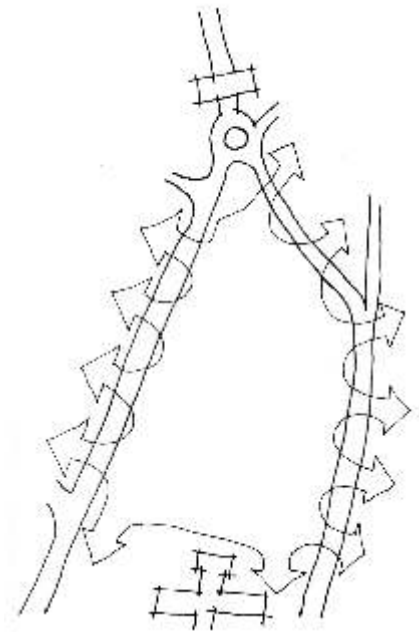


Figure 7.7: Site must be contained plane

Integrating the building with the site can be achieved by designing the footprint of the building to reflect the topography of the site. This allows the buildings to become one with the site.

Frank Lloyd Wright described this as one of the qualities of organic architecture. He described organic architecture as “pertaining to a certain organization not accidental”.

The first principle of any growth, according to Henry Russell Hitchcock is that the thing grown be no mere aggregation. In his book, *In the nature of materials*, he states that: “Integration as entity is first essential. And integration means that no part of anything is of any great validity in itself except as it be an integrated part of the harmonious whole.”

Through integrating the buildings into the site in this manner, it is hoped that the building and the landscape be one as to function as a therapeutic complex in its entirety.

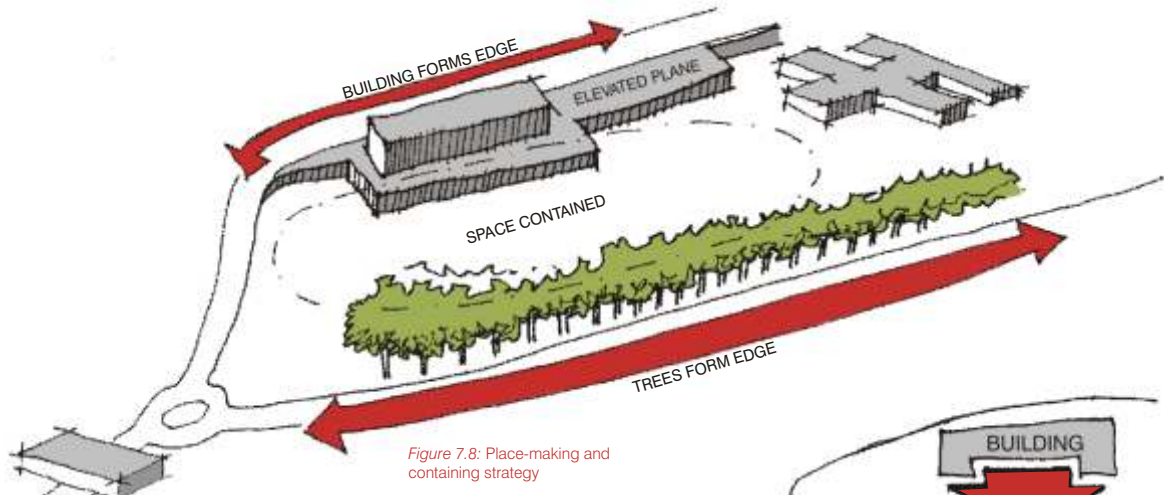


Figure 7.8: Place-making and containing strategy

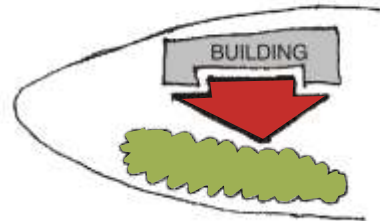


Figure 7.9: Site development concept

6.3 General strategy

6.3.1 ELEVATED BASE PLANE

Elevating a portion of the base plane will create a field of space within a larger spatial context.

6.3.2 MOVEMENT

The pedestrian desire lines and the movement from the parking area to the park break up the building footprint.

6.3.3 OVERHEAD PLANES

Overhead planes create a sense of enclosure and contain the space. This creates a continuity of space from the buildings to the landscape.

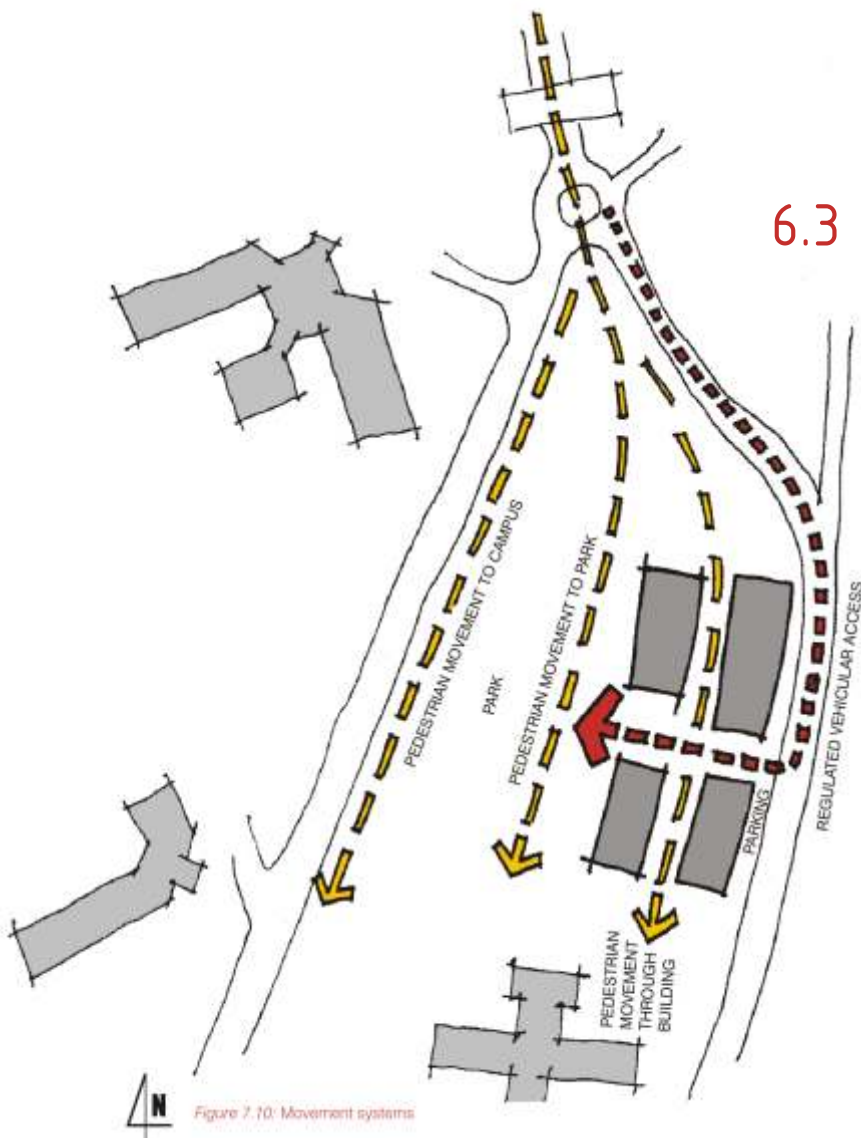


Figure 7.10: Movement systems

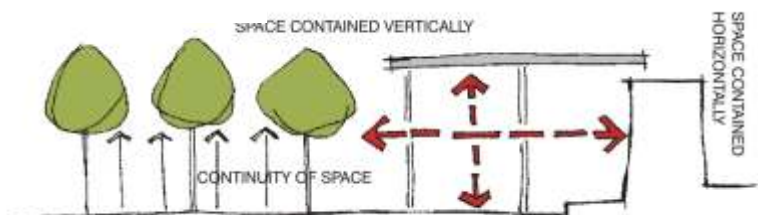


Figure 7.11: Space containment strategies

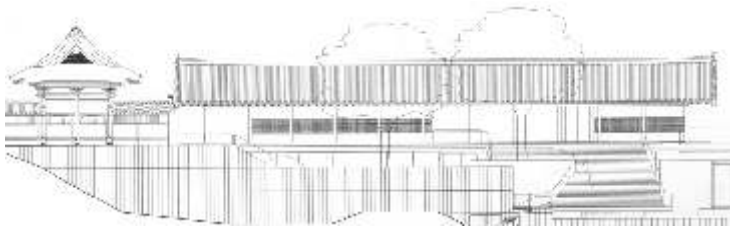


Figure 7.12: Saikan: east elevation



Figure 7.13: Saikan

6.4 Influences

The characteristics of therapeutic environments are difficult to establish, and the delivery of mental health care is continually under review. Current research indicates that the best type of environment is one that has a domestic ambience and promotes a feeling of comfort, security and self-esteem in consumers.

There is one type of architecture that possesses all these qualities and that is the traditional Japanese architecture. Japanese architecture is inherently peaceful, tranquil, calm and serene.

In trying to understand what some of the underpinning principles of this architecture might be, a superficial study of a contemporary Japanese building project was undertaken.

The project is Project Konpira by Ryoji Suzuki, constructed in Kagawa, Japan in April 2002. The project is a Shrine town consisting of a number of buildings located 238m above sea level on Mt. Zozu. The following principles seemed to constitute the design.

The concept would be to apply these principles in the design of the community mental health care center in order to create a therapeutic environment for the consumer.



Figure 7.14: Shrine facilities



Figure 7.15: Saikan: cross section



Figure 7.16: Juyojo: first floor plan



Figure 7.17: Artificial ground



Figure 7.18: Juyojo: north elevation

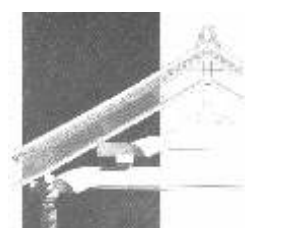


Figure 7.19: Detail: Juyojo

6.4.1 INTEGRATION WITH THE LANDSCAPE

The project achieves complete integration with the landscape through:

- creating a complex of small buildings instead of one big footprint
- the restructuring of open space through place-making
- a building focus on vistas

6.4.2 SCALE

The architect has an understanding of human scale which was very appropriately used in this project. Of a form or space's three dimensions, its height has a greater effect on its scale. While the walls of a room provide enclosure, the height of the ceiling plane overhead determines its qualities of shelter and intimacy.

6.4.3 LAYERING

Layering in the design is achieved on a vertical and horizontal level. The effect of layering is created through the degree of enclosure of space, as determined by the configuration of its defining elements and the pattern of its openings. The layering sets up a hierarchy of spaces to be utilized and creates a range of spaces from public to private.

6.4.4 COMPLEXITY AND SIMPLICITY

The buildings and configuration of spaces and elements have a complex, yet simple quality that puts the user at ease, while still capturing his interest. This is due to the use of simple elements, configured in a complex layering with deep meaning and symbolism.

6.4.5 PROPORTION

Proportion of the buildings and spaces is derived from mainly three sources:

- Material proportion: materials is used in a rational and honest fashion that is reflected in the proportions
- Structural proportion: the size and proportion of elements are directly related to the structure
- Modular unit: the ken is used as measurement

6.4.6 ATTENTION TO DETAIL

The intense attention to detail lends a superior quality to the design of the buildings. This conveys the noble and honest intention. It expresses thoughtfulness and care toward the user.

Characteristics of cluster organizations



Figure 7.20: Clustered pattern

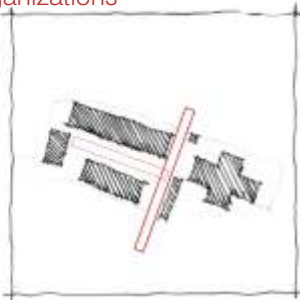


Figure 7.21: Grouped along a path

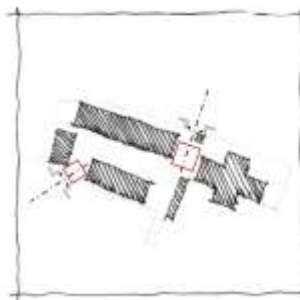


Figure 7.22: Clustered around an entry

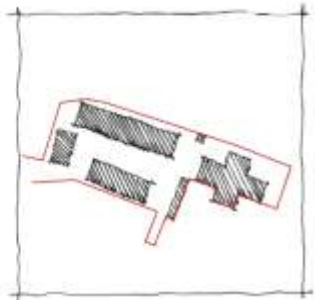


Figure 7.23: Contained within a space

6.5 Cluster organization

6.5.1 SPATIAL ORGANIZATION

The building complex is organized as a cluster of forms and spaces. This was due to three main considerations:

- **To allow for movement through the complex.**
The traditional institutional building is one that is enclosed and unaccessible. This is the cause for great speculation as to what is happening inside the buildings. The stigma around institutional buildings can be contributed partly due to this. Through the design of permeable structures arranged in an accessible configuration, a transparent process is communicated
- **To allow a range of users to utilize the facilities.**
Visitors will utilize the facilities in a number of ways that might not include necessarily all the functions of the center. Through grouping suitable accommodations together in separate buildings, the visitor can use spaces without disrupting others
- **To create different types of spaces with varying levels of publicness.**
The site is so vast that it became necessary to distinguish smaller spaces in order to allow the patient to choose setting in which he/she would be comfortable

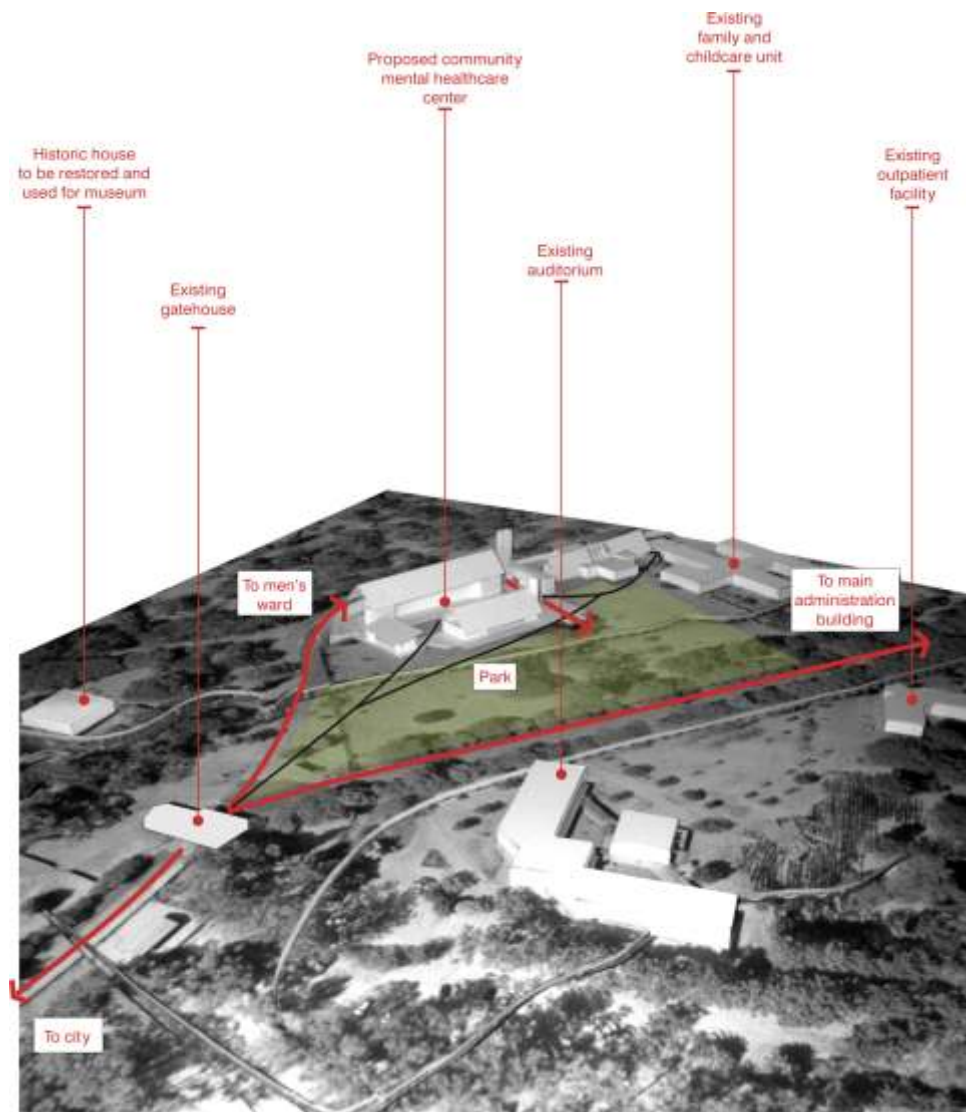


Figure 7.24: Concept model

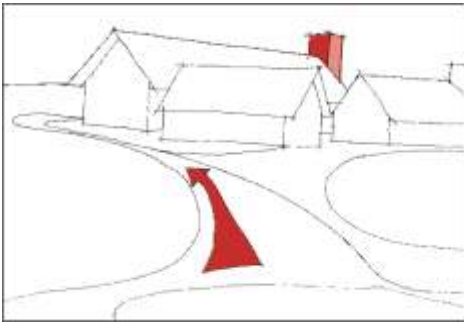


Figure 7.25: Spiral primary building approach

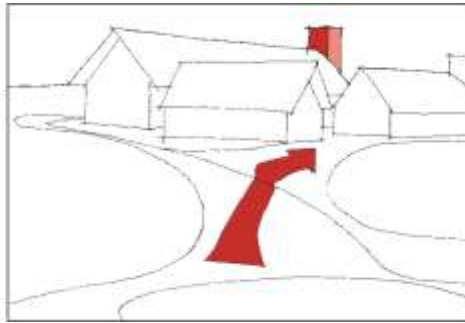


Figure 7.26: Oblique secondary building approach

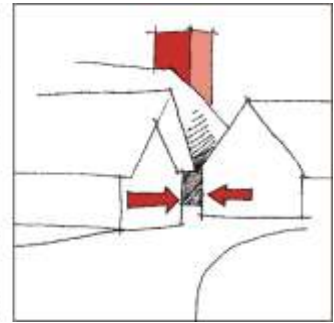


Figure 7.27: Secondary entrance

6.6 Circulation

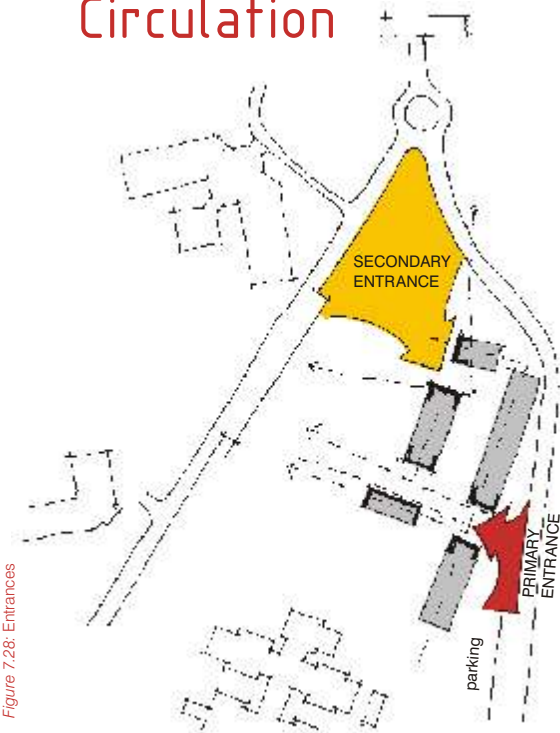


Figure 7.28: Entrances

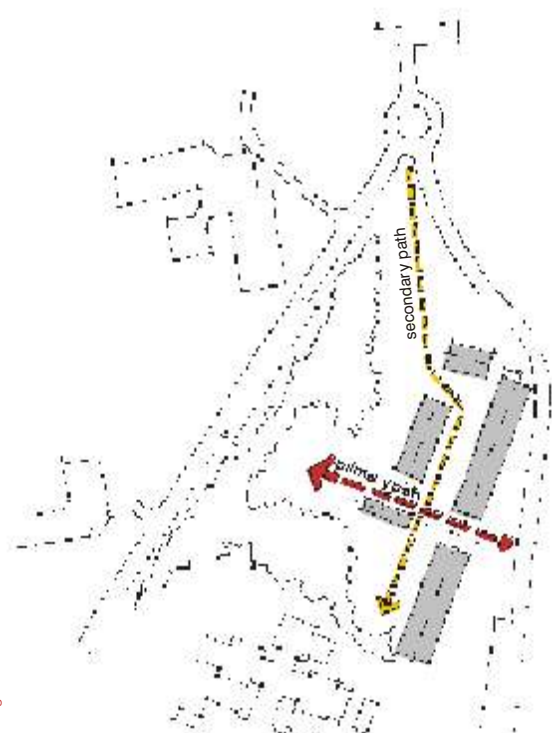


Figure 7.29: Paths

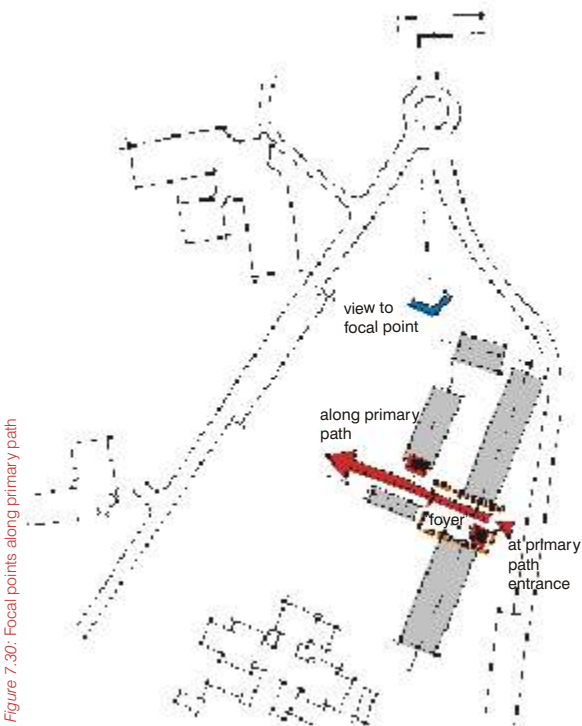


Figure 7.30: Focal points along primary path

6.6.1 BUILDING APPROACH

The primary approach is spiral which prolongs the sequence of the path and emphasizes the tree-dimensional form of the buildings parameter.

The secondary approach, which is oblique, enhances the effect of perspective on the buildings front facades. Since the path is re-directed two times, the sequence of the path is also delayed.

Both these approaches strengthen the awareness of the park and the threshold object.

6.6.2 ENTRANCE

The primary focal point celebrates the primary entrance. The secondary entrance is visually enforced by making it narrower than expected.

6.6.3 CONFIGURATION OF PATH

Both primary and secondary paths are linear and organize a series of spaces.

6.6.4 PATH-SPACE RELATIONSHIPS

The paths pass by spaces. This maintains the integrity of each space and allows the paths to be flexible.



Figure 7.31: The park will play a significant role in place-making on campus and as part of the community platform.

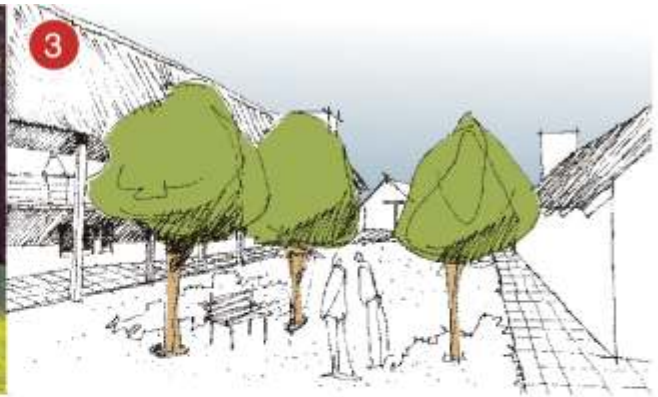


Figure 7.32: Smaller public spaces are created to allow users to choose levels of interaction and socialization



Figure 7.33: The center 'foyer' is an open space linking the entrances to different buildings with the information desk central to the space

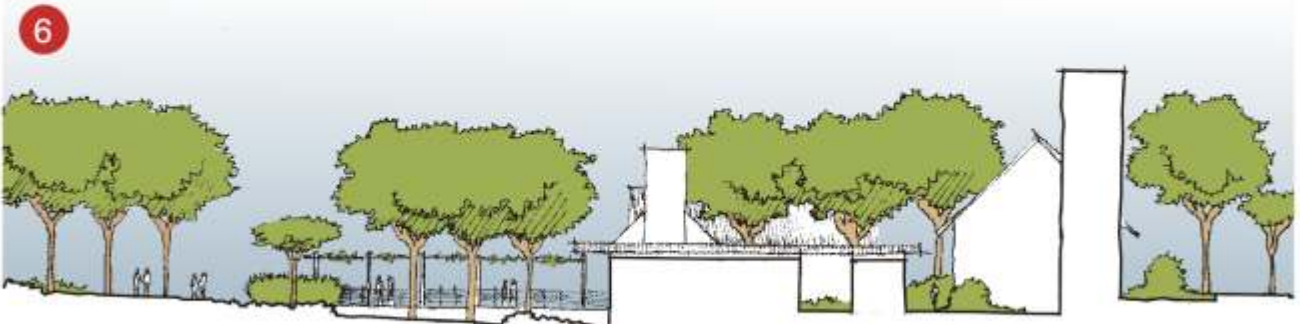
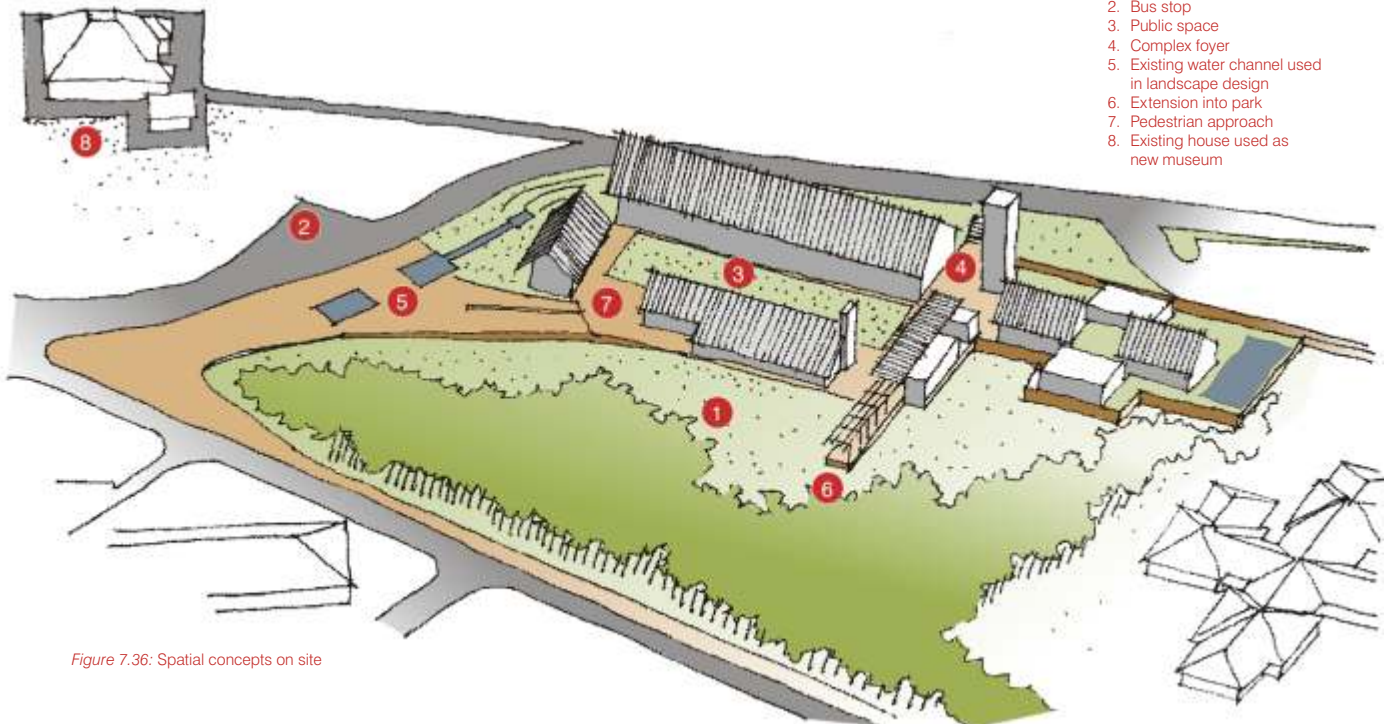


Figure 7.35: The complex reaching into the park (integration of building and landscape)



1. Park
2. Bus stop
3. Public space
4. Complex foyer
5. Existing water channel used in landscape design
6. Extension into park
7. Pedestrian approach
8. Existing house used as new museum

Figure 7.36: Spatial concepts on site

6.7 Building Response

6.7.1 TRAINING AND THERAPY CENTER (5)

The training and therapy center will be located on street front. Service areas fronting the street ensure a strong edge to the street, while servant spaces connects to the inner courtyard.

6.7.2 WORKSHOP (4)

The workshop forms an edge of the secondary entrance. It is shifted on the grid to allow the entrance into the inner courtyard to be accentuated.

6.7.3 RESTAURANT AND LOUNGE (6)

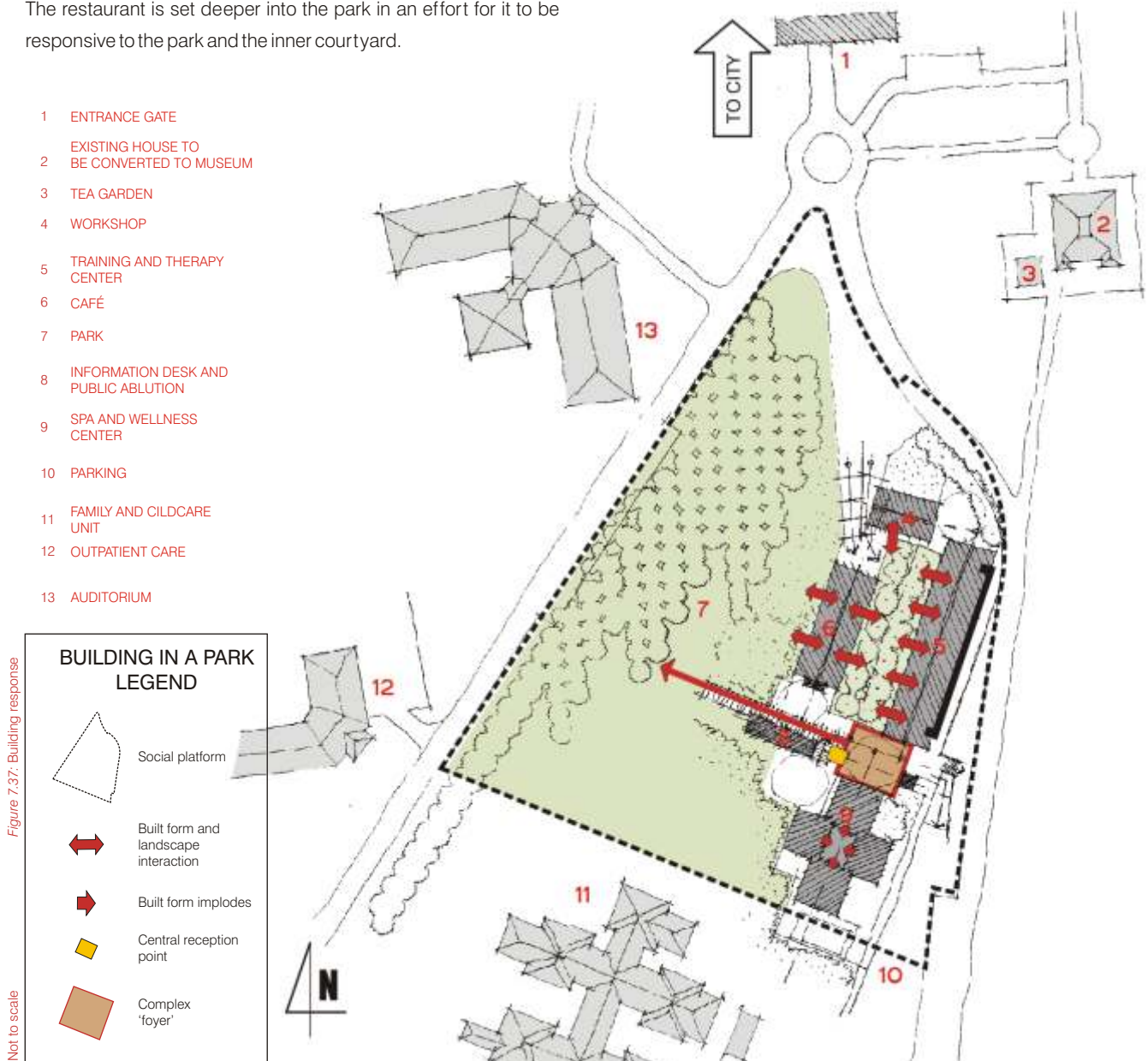
The restaurant is set deeper into the park in an effort for it to be responsive to the park and the inner courtyard.

6.7.4 INFORMATION DESK AND PUBLIC ABLUTION (8)

The information desk acts as a reception for the whole of the complex and is centrally located at the 'foyer'. The 'foyer' is a public space situated at the primary entrance from where people disperse to separate buildings.

6.7.5 HEALTH HYDRO (9)

The hydro is located at the back of the site where it is more private. The building spaces implode upon an inner courtyard to connect with landscaping, while maintaining it privacy.



“One does not physically experience space simply by gazing at buildings or looking at them from above. Space is experienced only through sequential movement. Space, like music, can be a source of elemental joy, something to which one can give up oneself entirely.” - Fumihiko Maki

6.7.2 MOVEMENT

The movement system becomes part of the buildings and is defined by spatial elements. These elements are dynamic and enhance the notion of movement through their rhythmic configuration.

Where there exist no movement the buildings become enclosed, indicating a grounded, static form.

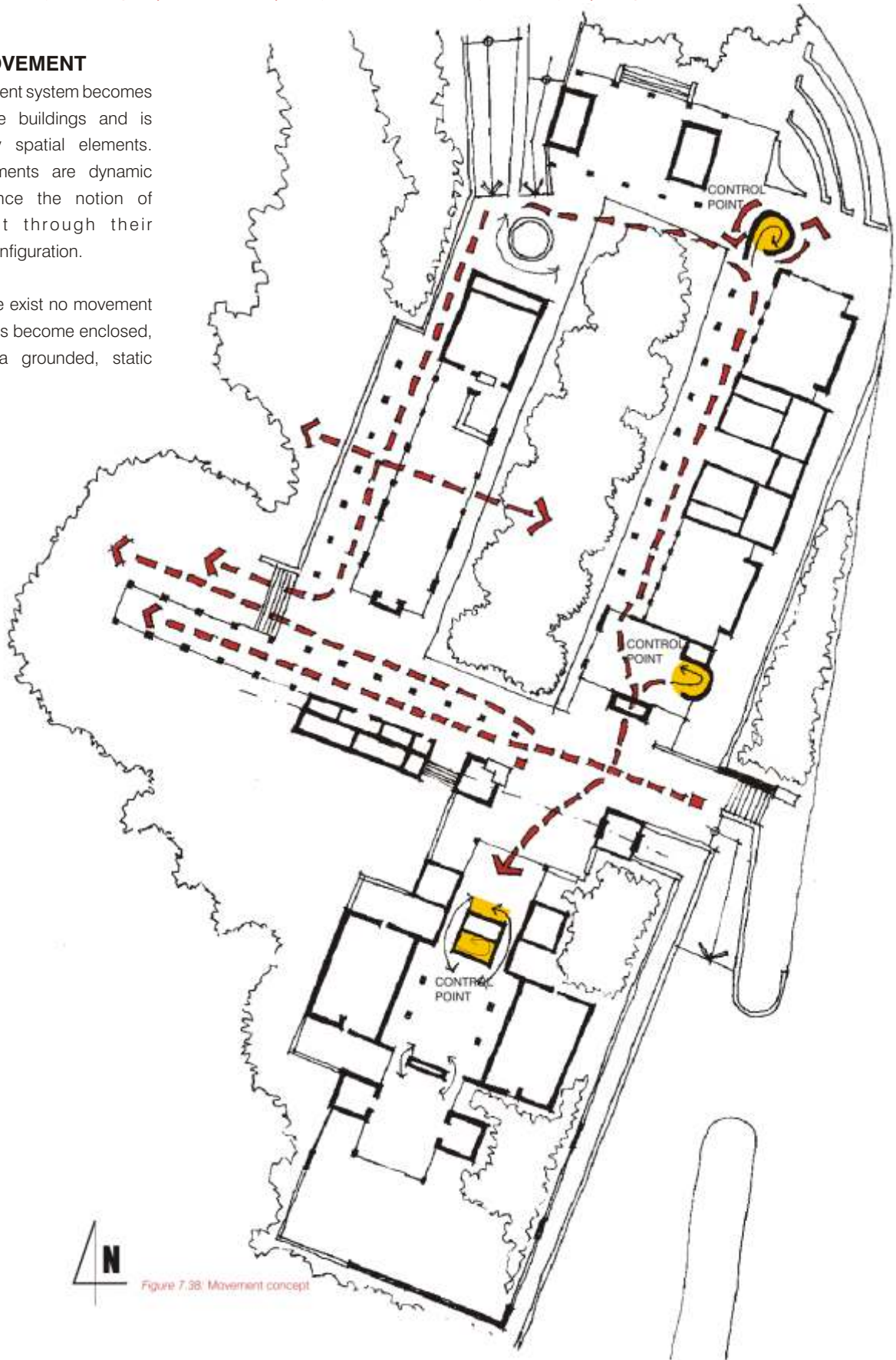


Figure 7.38: Movement concept

6.8 Connections and Contact

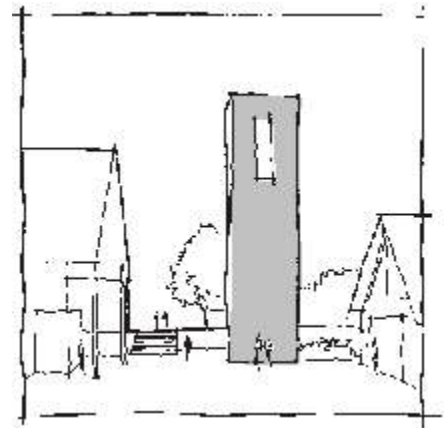
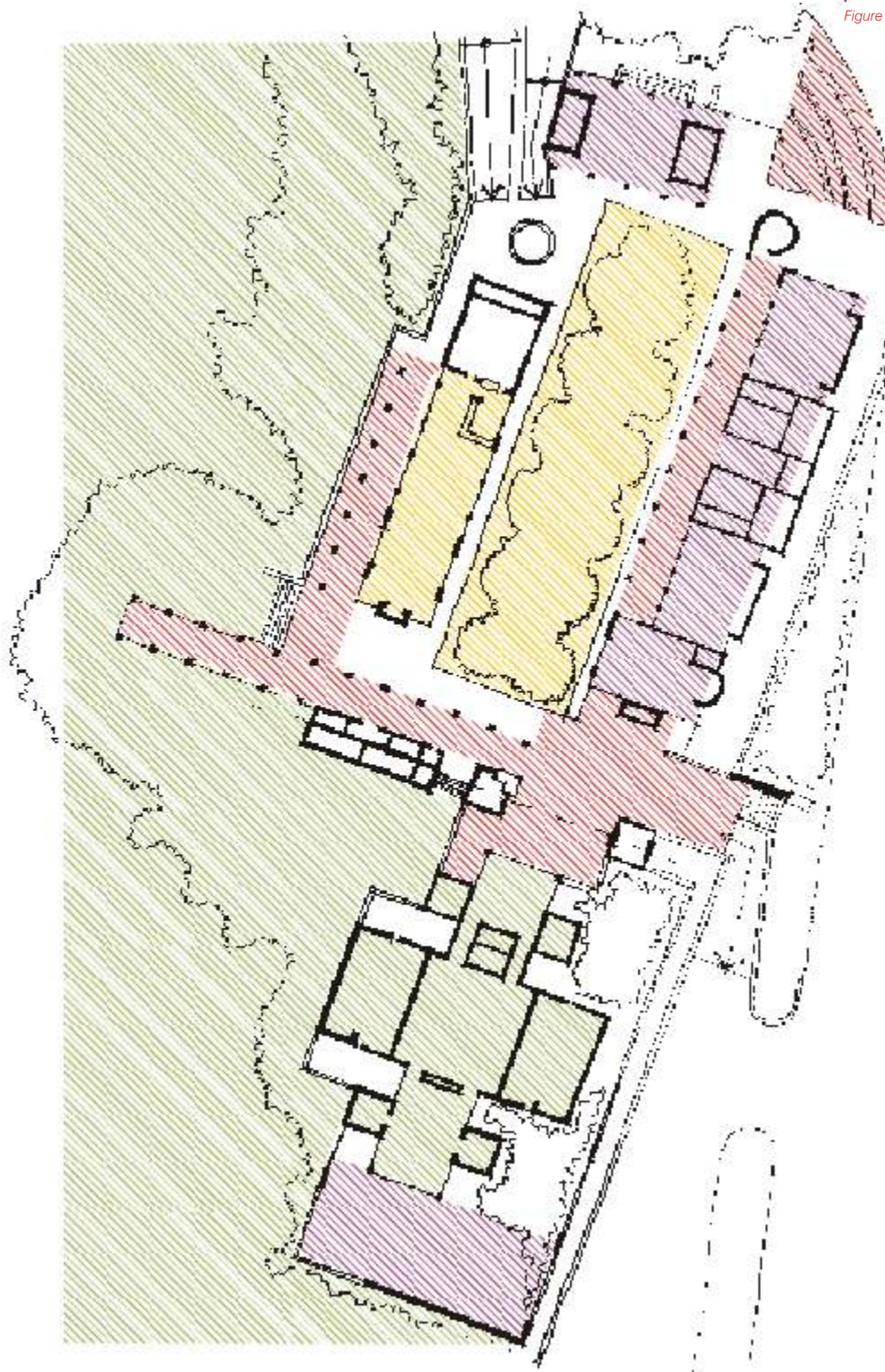


Figure 7.40: Landmark structure at primary entrance



PUBLIC

6.8.1 PHYSICAL CONTACT

Interaction occurs on mainly three levels:

- individuals that want to isolate themselves to conserve energy
- individuals on their way to recovery that want to move out of isolation
- individuals in stages of recovery that want to experiment with socializing

All of these levels of socializing must be accommodated to provide the user with choices and create a healing environment.

6.8.2 VISUAL CONTACT

Visual connectivity allows a transparent process to be maintained. This facilitates awareness, stimulation and wayfinding within the complex.

CONNECTIONS AND CONTACT LEGEND

-  Spontaneous
-  Social
-  Active
-  Therapeutic

Figure 7.39: Connections and contact
Not to scale



Figure 7.41: The information desk located at the complex foyer

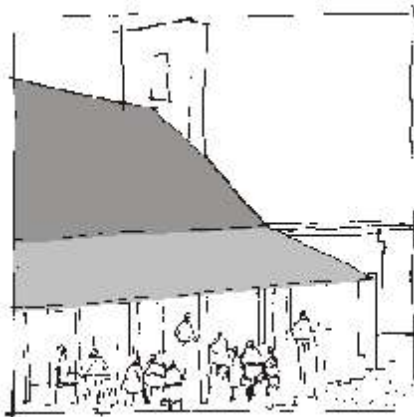


Figure 7.42: The restaurant's steep

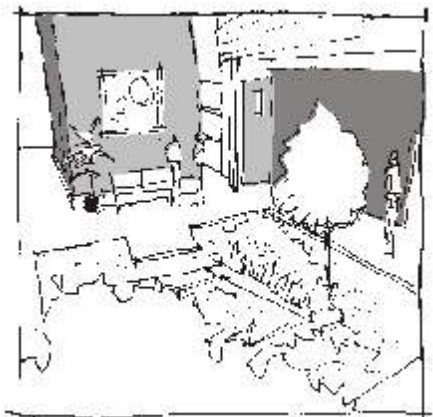


Figure 7.43: The inner courtyard of the health hydro

INTIMATE

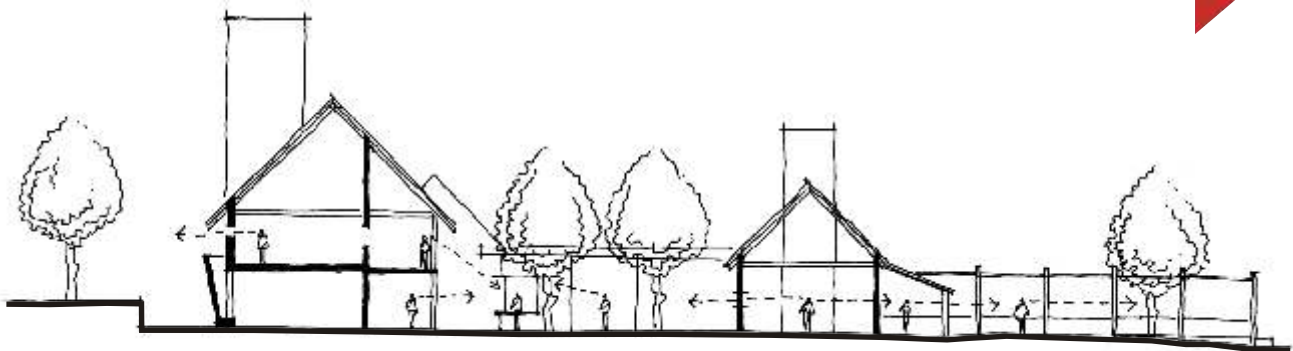


Figure 7.44: Visual connectivity indicated on section.

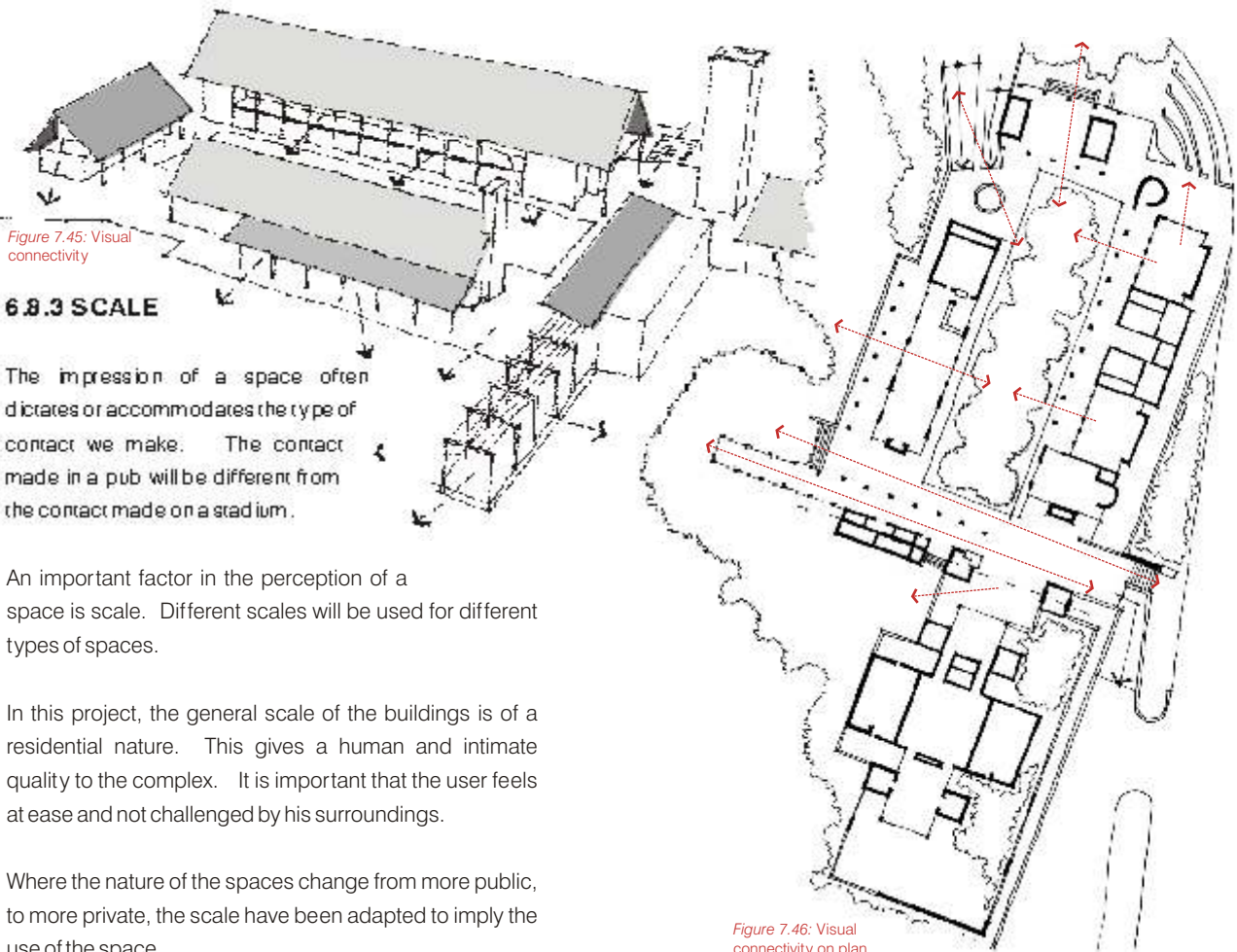


Figure 7.45: Visual connectivity

6.8.3 SCALE

The impression of a space often dictates or accommodates the type of contact we make. The contact made in a pub will be different from the contact made on a stadium.

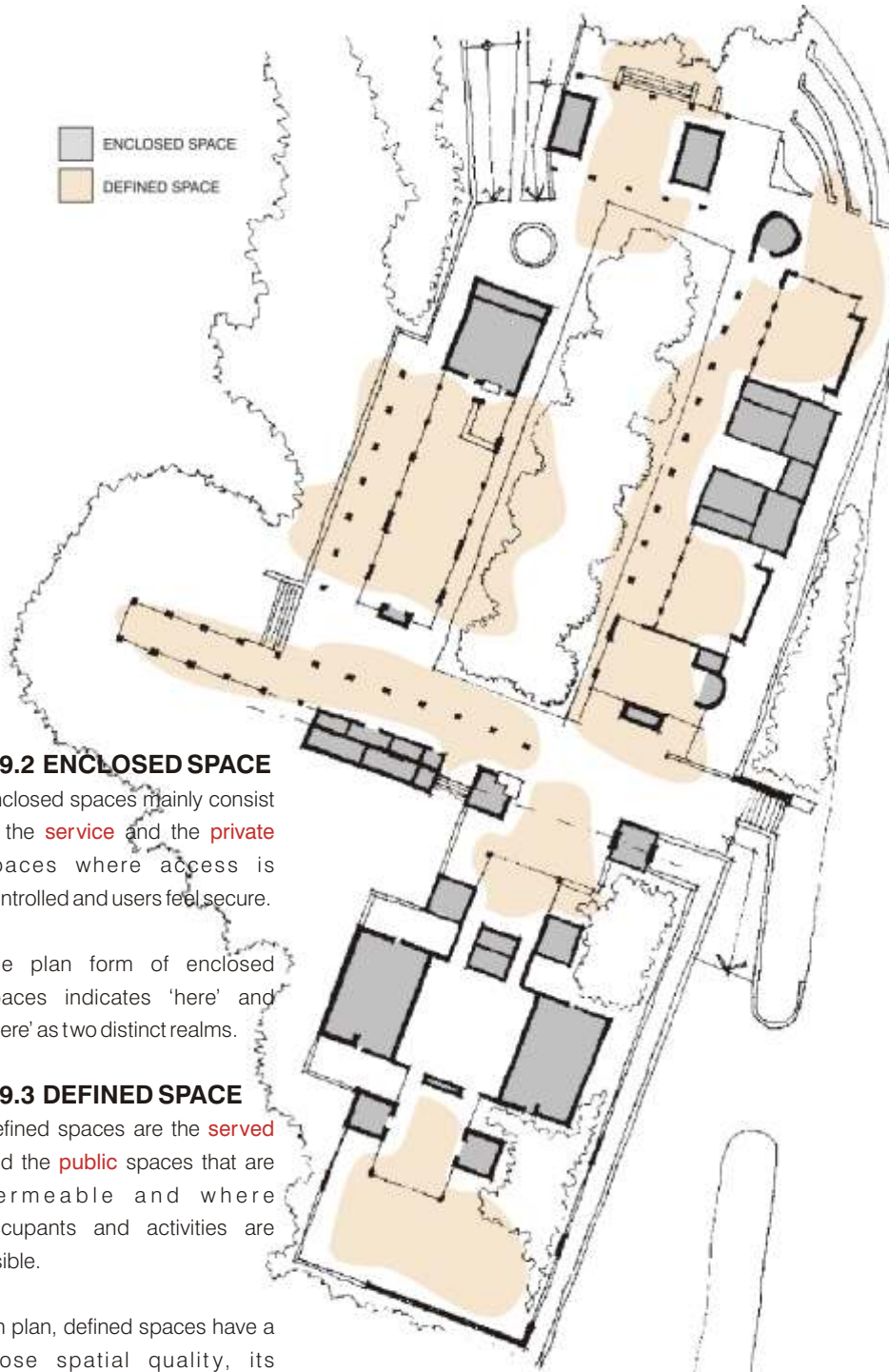
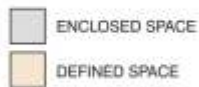
An important factor in the perception of a space is scale. Different scales will be used for different types of spaces.

In this project, the general scale of the buildings is of a residential nature. This gives a human and intimate quality to the complex. It is important that the user feels at ease and not challenged by his surroundings.

Where the nature of the spaces change from more public, to more private, the scale have been adapted to imply the use of the space.

Figure 7.46: Visual connectivity on plan

6.9 Space Definition



6.9.2 ENCLOSED SPACE

Enclosed spaces mainly consist of the **service** and the **private** spaces where access is controlled and users feel secure.

The plan form of enclosed spaces indicates 'here' and 'there' as two distinct realms.

6.9.3 DEFINED SPACE

Defined spaces are the **served** and the **public** spaces that are permeable and where occupants and activities are visible.

On plan, defined spaces have a loose spatial quality, its dominant feature is to connect' and maintain spatial continuity between building and landscape spaces.

6.9.1 DESIGN PHILOSOPHY:

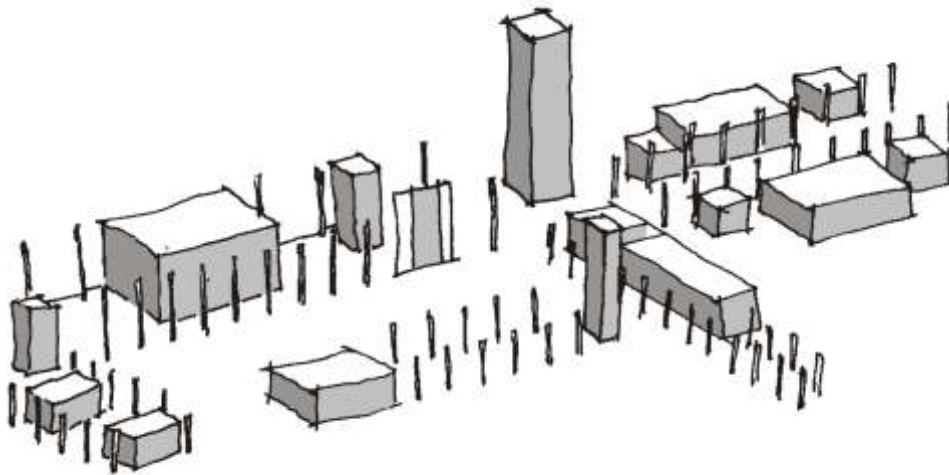
Two systems are used in the space forming of the project, space defining and space enclosing systems. This is due to the nature of the accommodation. The amount of privacy is controlled through the amount of enclosure. The amount of accessibility and permeability is allowed through the space definition.

The two systems are expressed architecturally through the structure, form, openings and detailing of the buildings.

It is essential that the buildings communicate private and public functions in this manner as these systems replace the traditional institutional systems of high walls and bars in front of windows. The inclusive quality of the buildings is not influenced by the permeability of the structures, but the human friendly buildings that allow for informed choices to be executed by the user.

For the space defining system a steel structure and roof is used that integrates with a space enclosing system that is expressed mainly through brick and concrete walls.

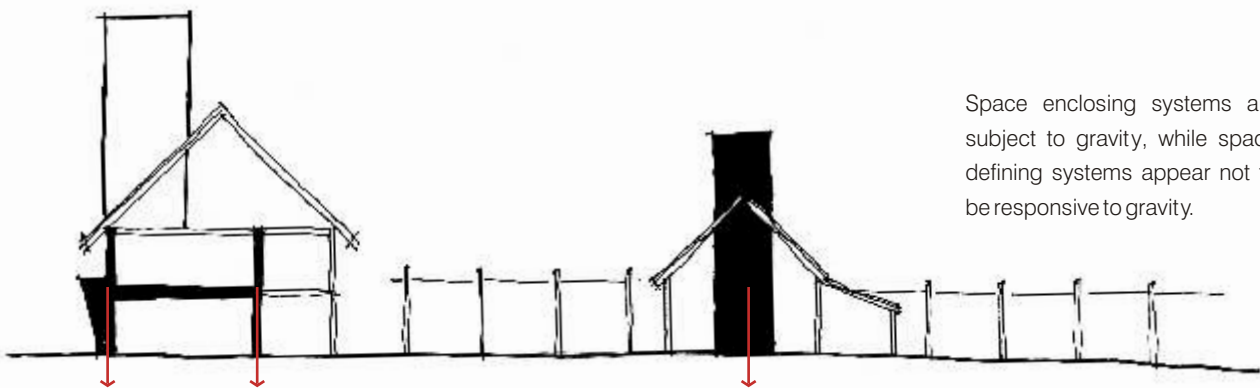
Figure 7.47: Space definition



Space enclosing systems separate inside from outside and establish differences between different space types.

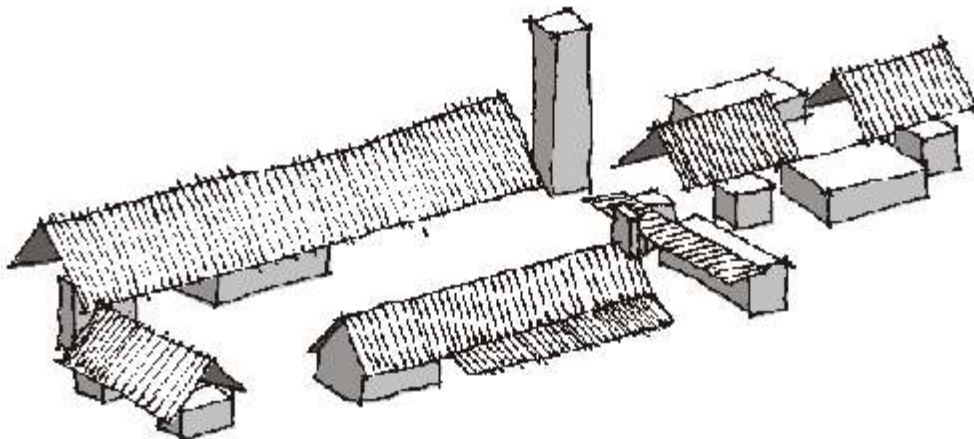
Space defining systems merge inside and outside and try to maintain connections and the idea of spatial continuity.

Figure 7.48: Enclosing and defining systems



Space enclosing systems are subject to gravity, while space defining systems appear not to be responsive to gravity.

Figure 7.49: The perception of gravity



Space enclosing systems contain volume and have spatial limits. This type of space is also representational and has a back, front, top and bottom.

Space defining systems define space and are part of a limitless spatial system. The systems tend to be abstract and can be viewed from all sides.

Figure 7.50: Space enclosing system

Space enclosing systems are hierarchically ordered, while

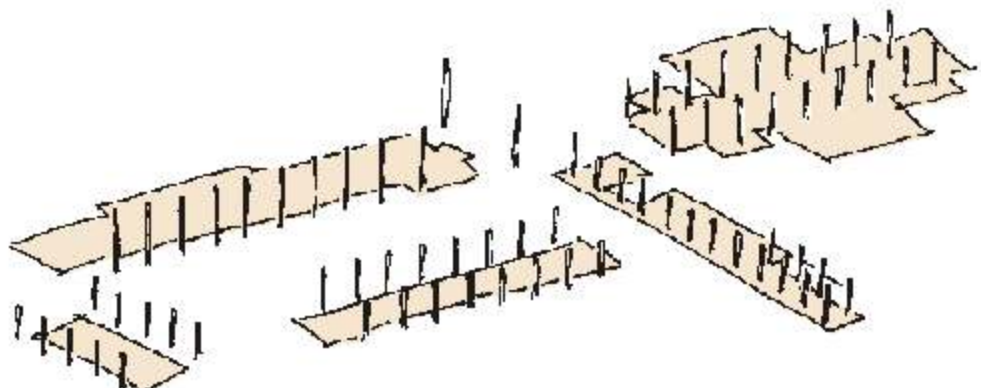


Figure 7.51: Space defining system



Figure 7.52: Main administration building on site built in 1892



Figure 7.53: Typical sandstone and brick (english bond) construction



Figure 7.54: Contemporary fascia detail for steel roofs

6.10 Design Themes

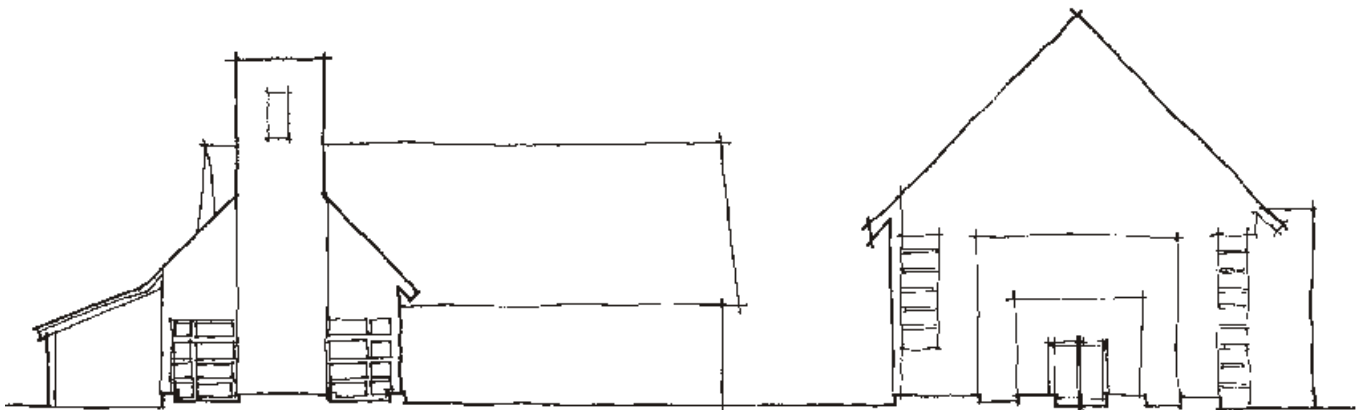


Figure 7.55: Elevational impact

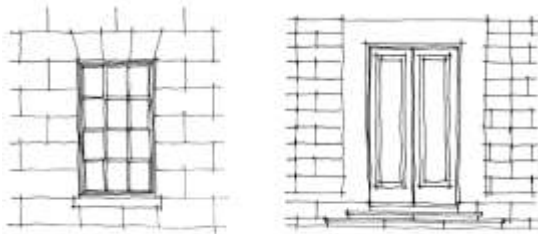


Figure 7.56: Treatment of doors and window as of historic buildings on site



Figure 7.57: Form and massing reminiscent of heritage context

6.10.1 HERITAGE CONTEXT

The heritage context is echoed in the design through form, use of materials and treatment of openings.

The roofs will be sheet metal with a 45° pitch, as the traditional roofs are.

Enclosed spaces will either be plastered or red face brick, english bond, as with the existing buildings. A simplified sandstone plinth will be used.

Timber frames will be used for the windows and doors. This will not only refer to the historic context, but bring warmth to the buildings.

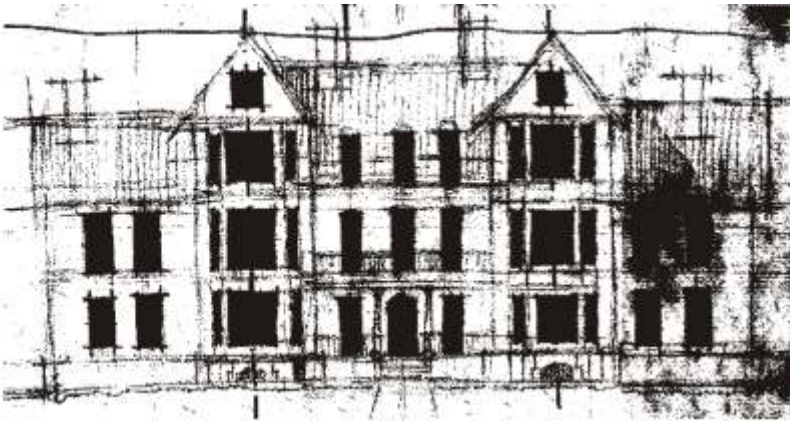


Figure 7.58: Window study of historic main administration building



Figure 7.59: Rustic country design

6.10.2 VERNACULAR ARCHITECTURE

“In vernacular architecture the process of evolution using a model continues with adjustments and variations. The dwelling is now built by tradesmen. Vernacular architecture does not have theoretical or aesthetic pretensions and models develop in accordance with regional, climatic and economic factors.” (Geoffrey H. Baker 1989:15)

The design of the center is a simple response to climatic conditions and incorporates local construction methods and materials.

This produces an architectural language that the community can relate to and of which the meaning is inherently understood. It is imperative that the particular consumer, the mentally ill, relate to and be able to interpret his surroundings.

The vernacular model is one that has stood the test of time and that is effective in both practical and symbolic sense.

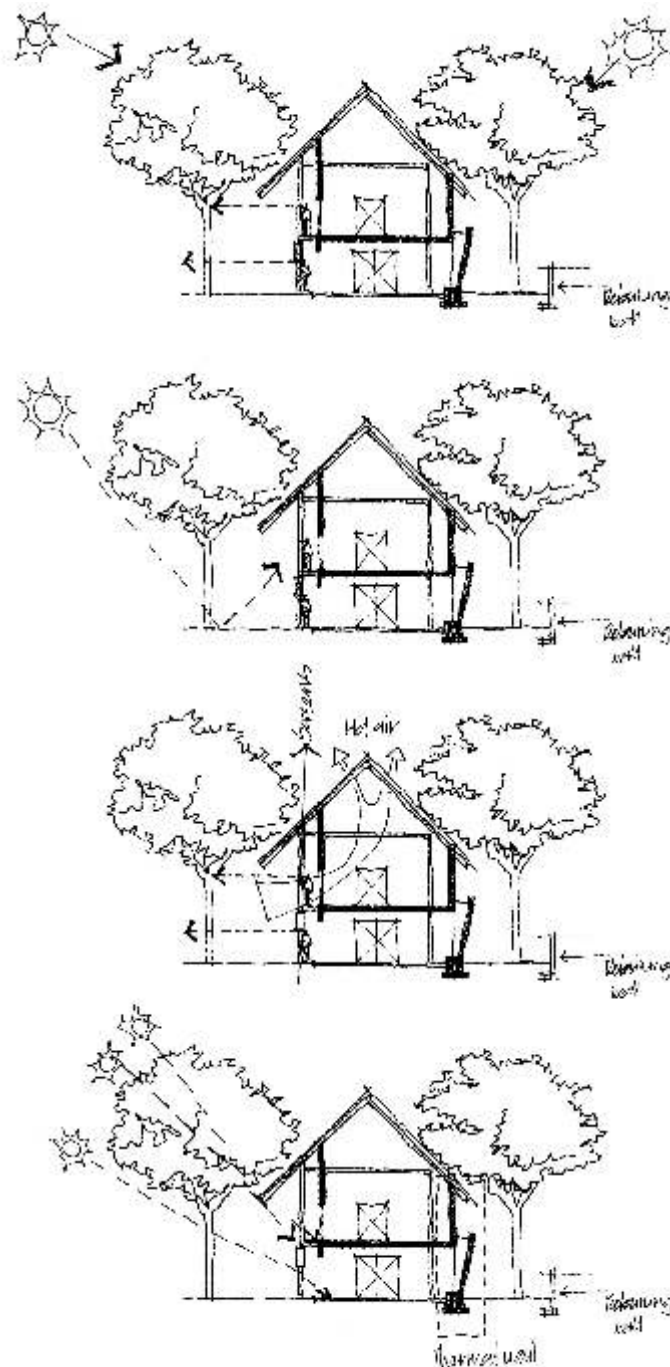


Figure 7.60: Climatic response

6.11 Design Principles

6.11.1 HARMONY

The theme of harmony is depicted through the use of centroidal configurations, the square and the rectangle.

The plan sets the whole structure of the development. A grid ties the plan together and forms the basis of mass, coherence, rhythm and expression.

6.11.2 AXIS

The axis was used as a regulating device, creating balance within the composition.

6.11.3 SYMMETRY

Symmetry within the composition and buildings strengthens the harmony of the design.

6.11.4 HIERARCHY

Hierarchy is created through the exceptional size of the landmark figure to reflect importance. The composition is also strengthened by the landmark and gives the eye a place to rest.

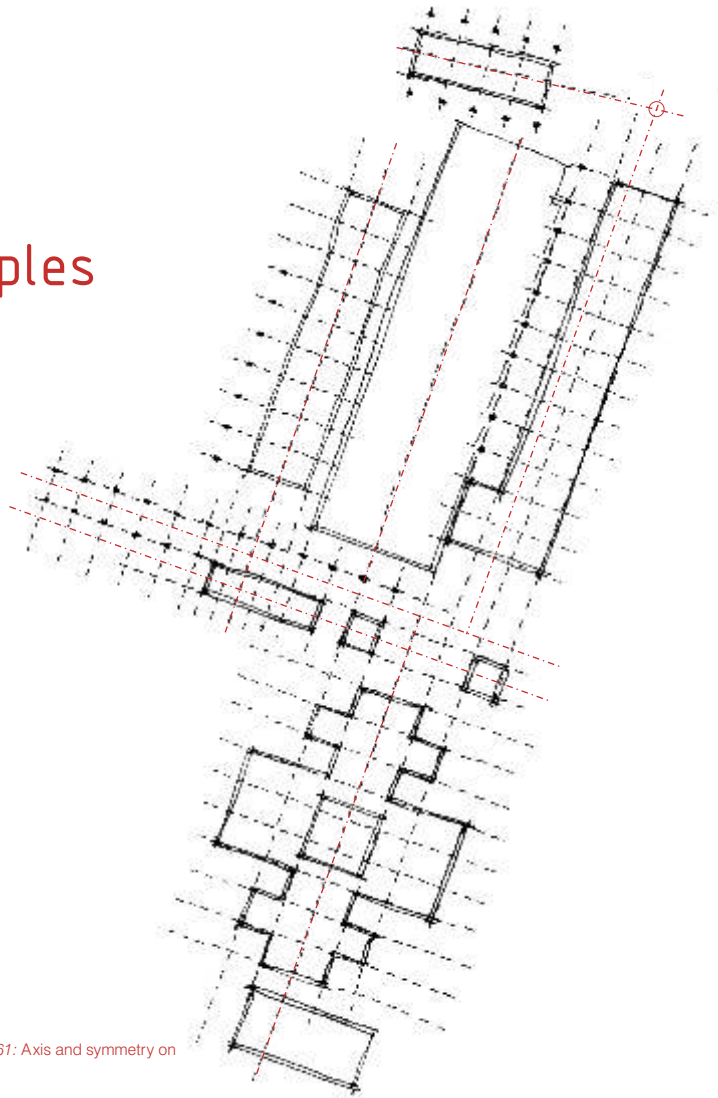


Figure 7.61: Axis and symmetry on plan

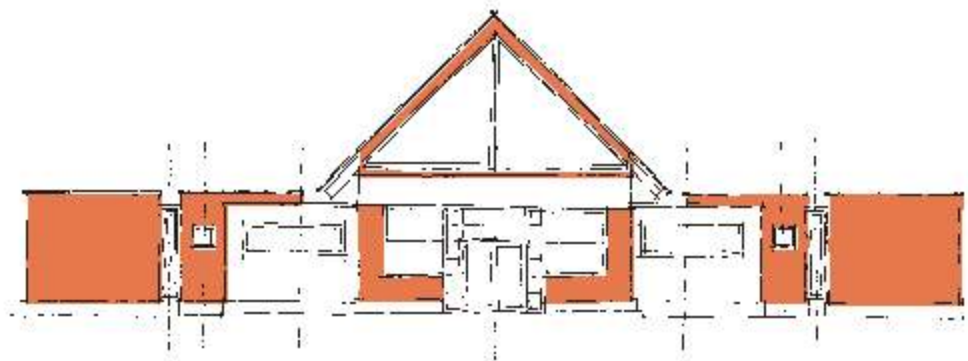


Figure 7.62: Symmetry expressed on the health hydro's elevation

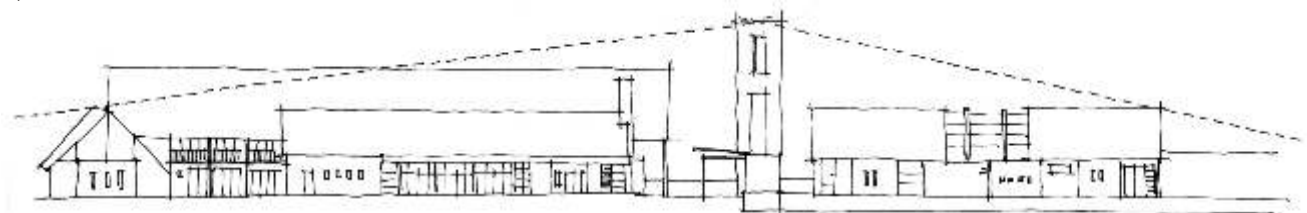


Figure 7.63: Hierarchy in the composition

6.11.5 DATUM

Datum refers to an element to which other element in a composition can relate.

The main circulation path acts as a datum element on plan, forming a common edge within the organization.

On elevation the datum is created by the vertical planes of the walls.

6.11.6 RHYTHM

Rhythm organizes lines, shapes, forms or colours harmoniously. The repetition of the space defining columns form repetitive structural bays and modules of space within the composition.

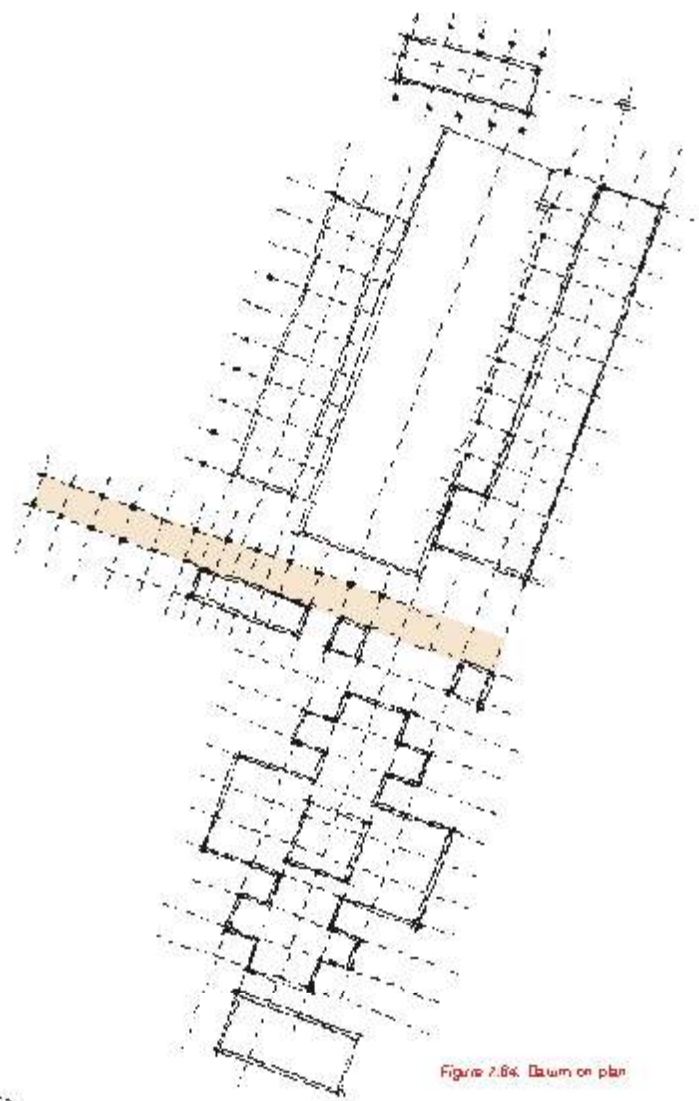


Figure 7.64: Datum on plan

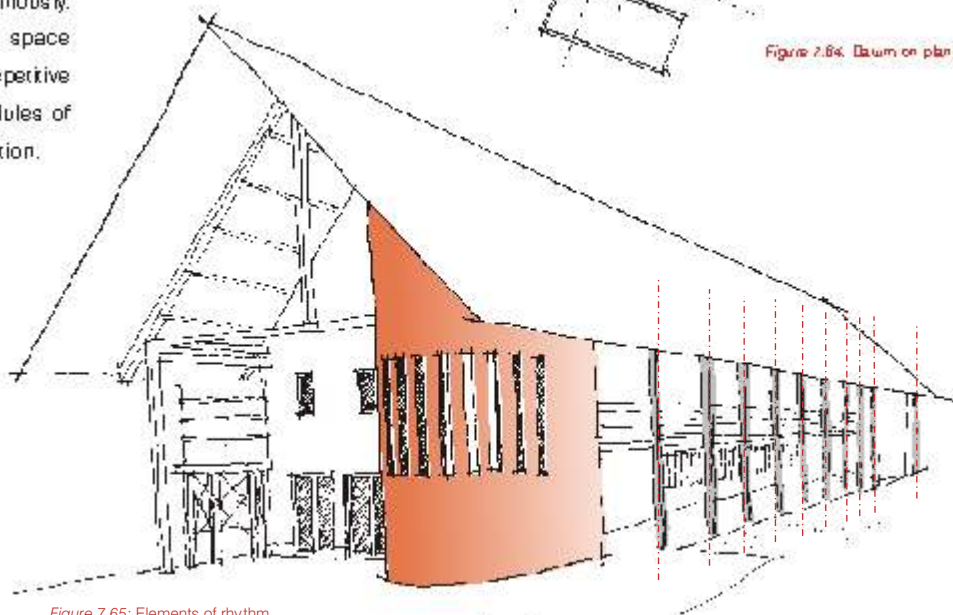


Figure 7.65: Elements of rhythm

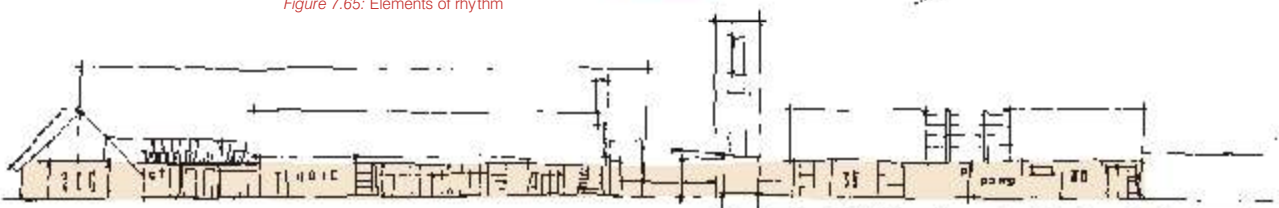
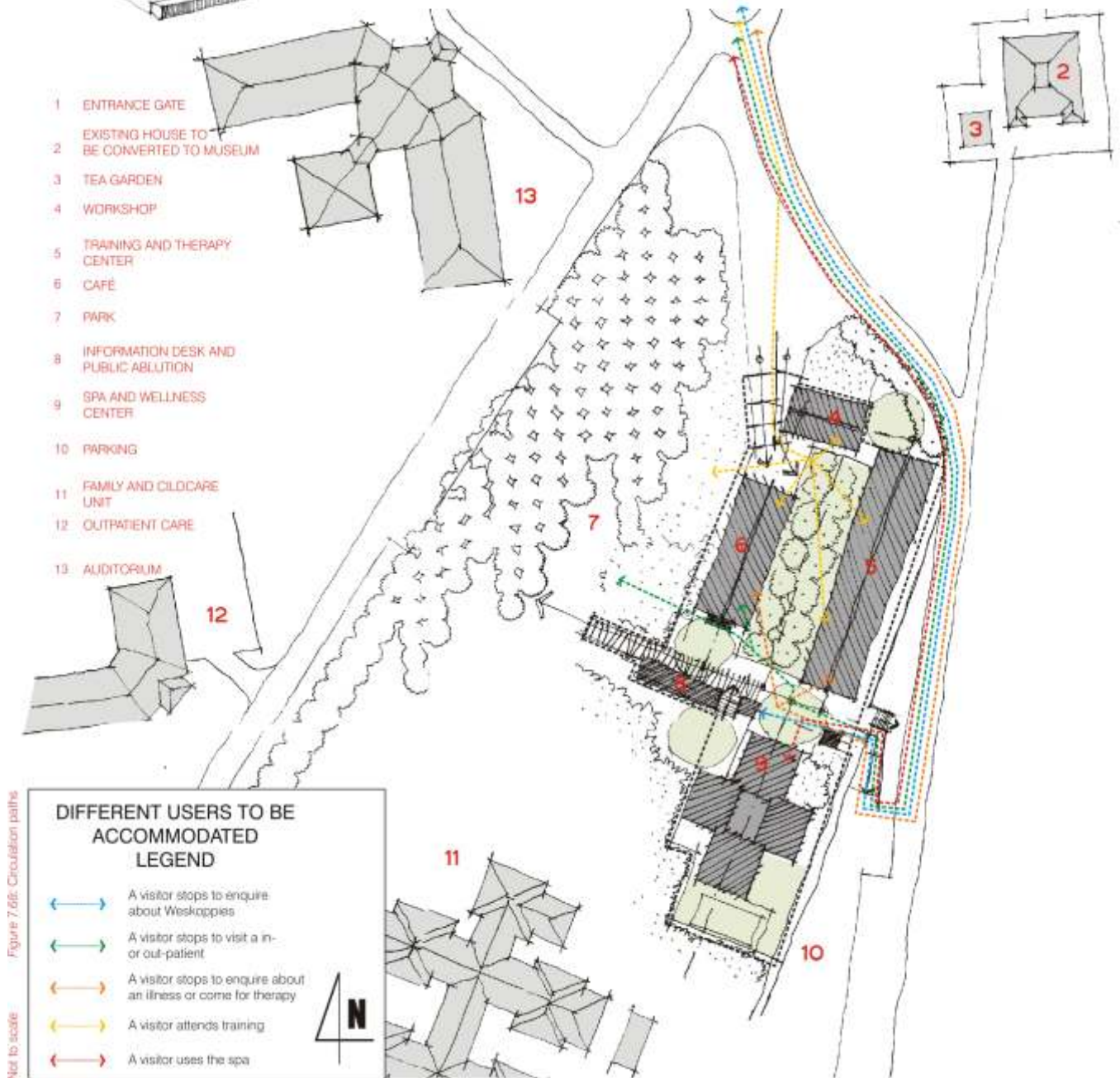


Figure 7.66: Datum on elevation



Figure 7.67. Perspective of main entrance

6.12 Five Buildings



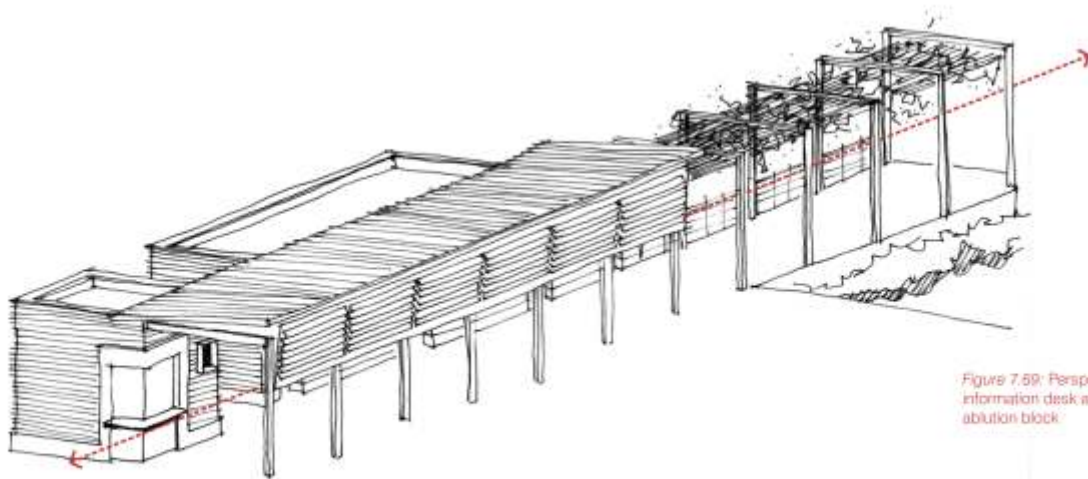


Figure 7.69: Perspective of information desk and public ablution block.



Figure 7.71-72: Installation in park

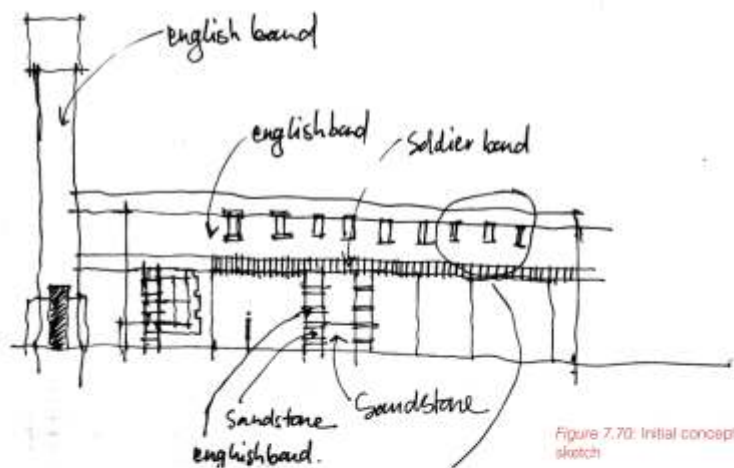


Figure 7.70: Initial concept sketch

6.12.1 THE INFORMATION DESK AND PUBLIC ABLUTION BLOCK

The information desk and ablution block are service spaces and therefore enclosed. Their location along the main movement path is suggested through the roof structure and steel columns.

Light: Information desk - 500lux, ablution - 200lux

Ventilation: Natural ventilation

Materials: The floor finishes must be even and wheelchair friendly.

Electricity: 15a plugs supplied at information desk.

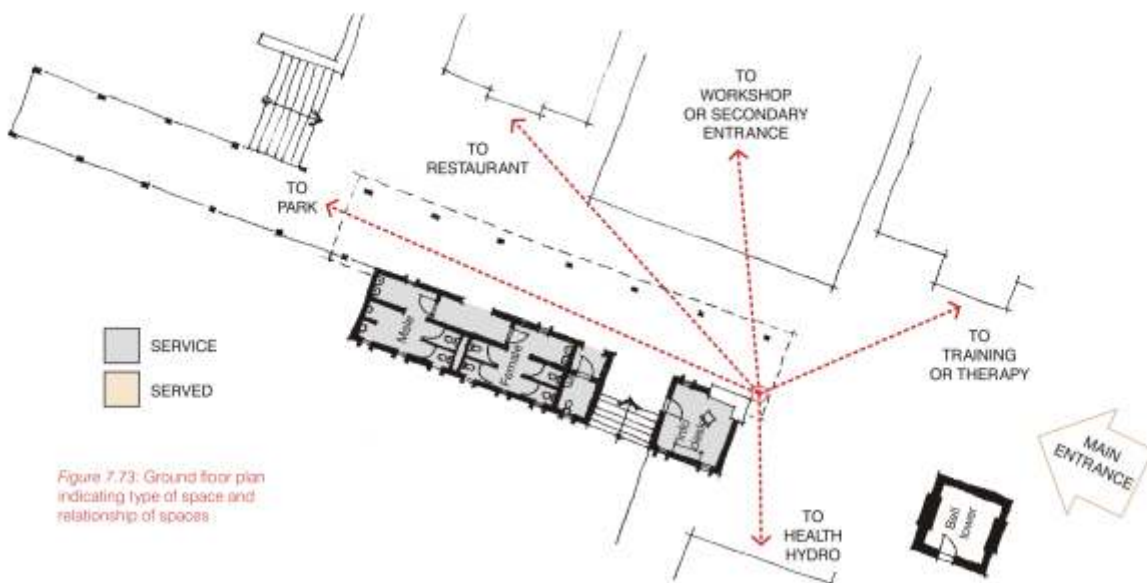


Figure 7.73: Ground floor plan indicating type of space and relationship of spaces

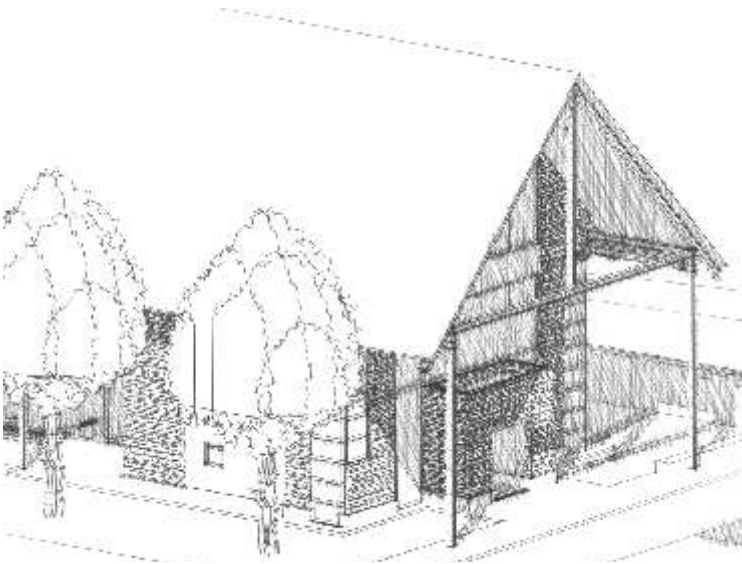


Figure 7.74: South-west perspective of treatment and therapy center's entrance

6.12.2 TRAINING AND THERAPY CENTER

The two main components of the center are able to function separately. The therapy center is located on the first floor, affording it privacy and controlled access.

The training facilities are located on ground floor. This allows for spatial continuity between the workshops and the inner courtyard.

Spatial continuity between the floors is created through the lobbies. The stair and lift shaft physically links the floors in the lobby space.



Figure 7.75: Ground floor plan of therapy and treatment center

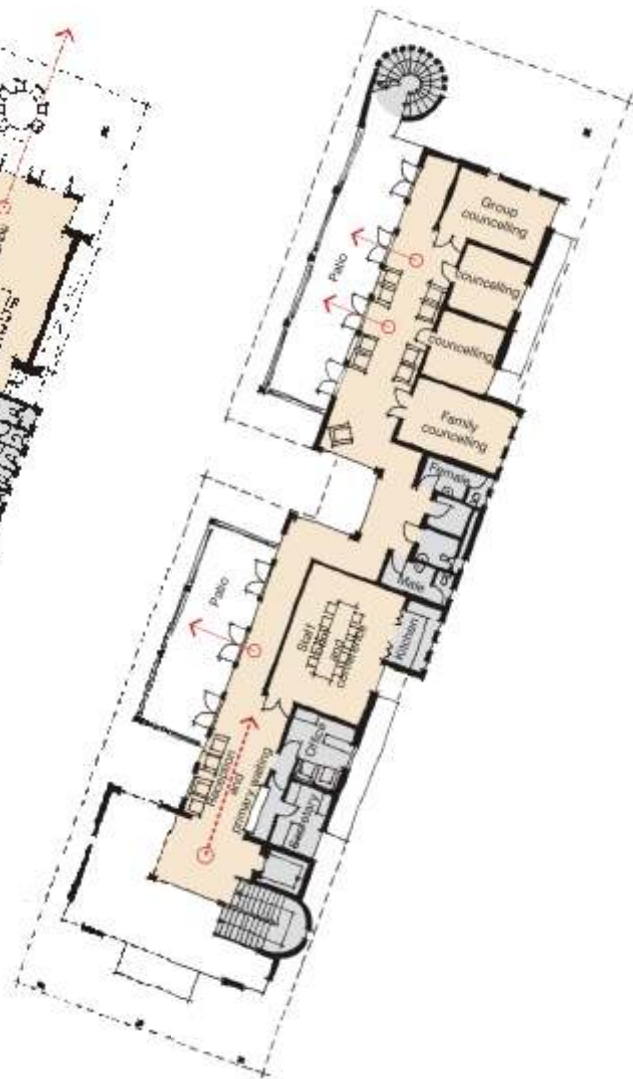


Figure 7.76: First floor plan of therapy and treatment center

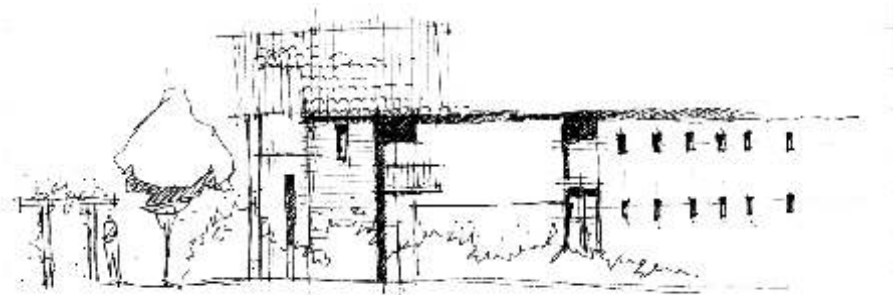


Figure 7.77: Elevational development of training and therapy center

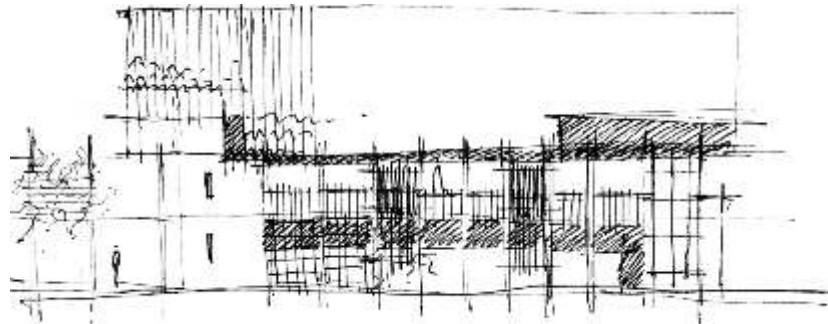


Figure 7.78: Elevational development of training and therapy center

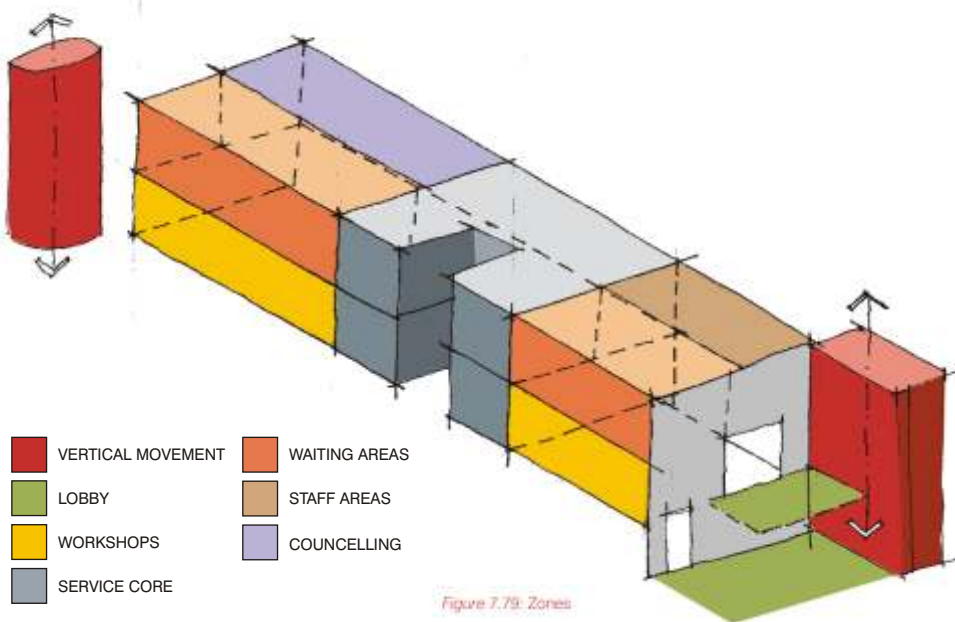


Figure 7.79: Zones

Lobby:

The lobby is the introduction to the center. The design of this space sets expectations for quality of care.

Guidelines:

- Seating grouped to provide privacy
- Elevators easy to locate
- Reception clearly defined
- Interesting works of art
- Seating options
- Variety of light sources

Light: 150lux

Ventilation: Natural ventilation at 0,5 w/m² °C

Reception:

Books, magazines and Tv's can be used to occupy time while waiting.

Light: 500lux

Ventilation: Natural ventilation at 0,33 w/m² °C

Electricity: 15a plugs supplied

Conference room:

Light: 750lux

Ventilation: Natural ventilation at 0,67 w/m² °C

Electricity: 15a plugs supplied

Class rooms

Light: 500lux

Ventilation: Natural ventilation at 0,67 w/m² °C

Electricity: 15a plugs supplied

Workshops:

Light: 300lux

Ventilation: Natural ventilation at 0,33 w/m² °C

Electricity: 15a plugs supplied

Staff rooms:

Light: 200lux

Ventilation: Natural ventilation at 0,33 w/m² °C

Electricity: 15a plugs supplied

Counseling rooms:

Light: 500lux

Ventilation: Natural ventilation at 0,67 w/m² °C

Electricity: 15a plugs supplied



Figure 7.80: Concept for lobby

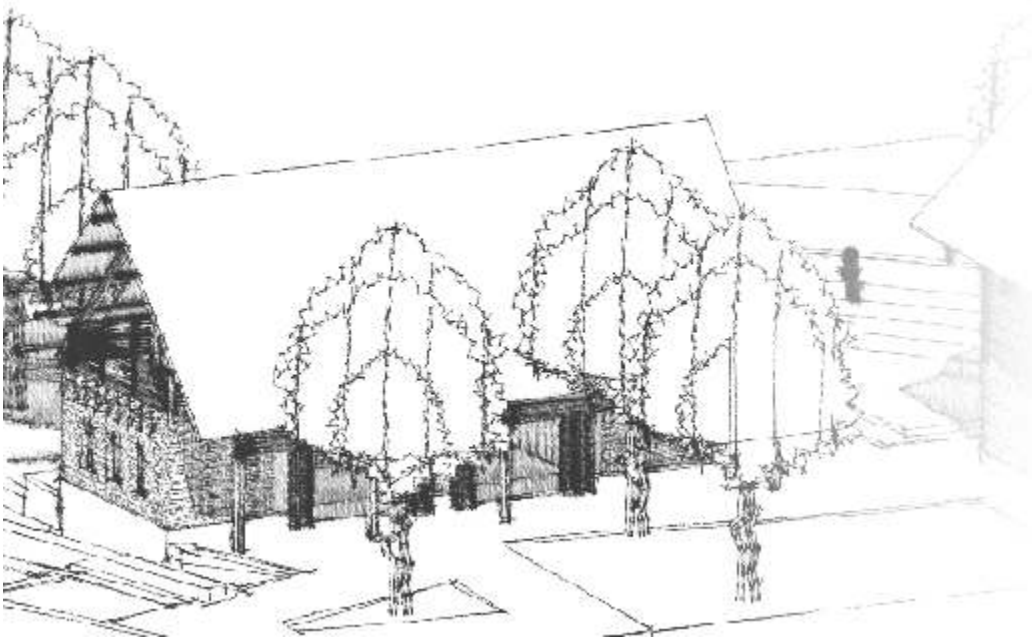


Figure 7.81: Perspective view of workshop from inner courtyard

6.12.3 WORKSHOP

The workshop is part of the training facilities. It is set as a separate building, housing all heavy machinery. Ample storage is supplied for materials and tools.

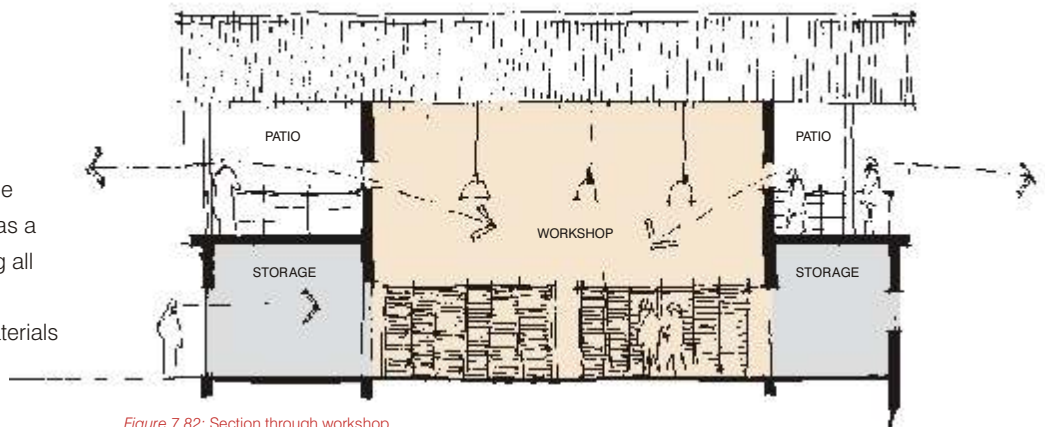


Figure 7.82: Section through workshop

Decks on the first floor create additional exterior spaces affording view over the amphitheater, park, workshop and inner courtyard.

Workshop:

Light: 300lux

Ventilation: Natural ventilation at 0,33 w/m² °C

Electricity: 15a plugs supplied

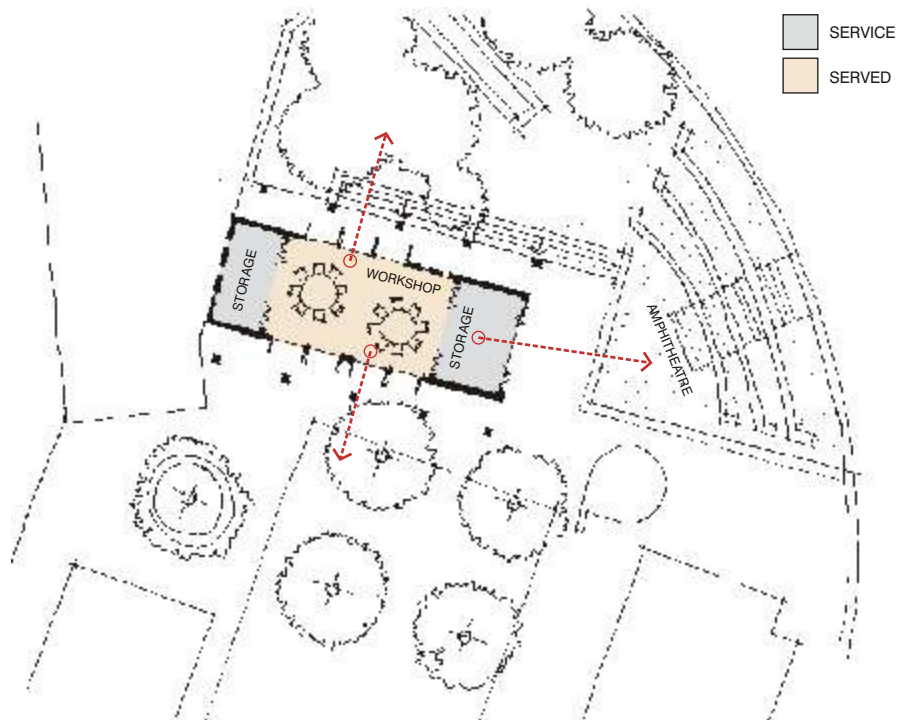


Figure 7.83: Ground floor plan of workshop

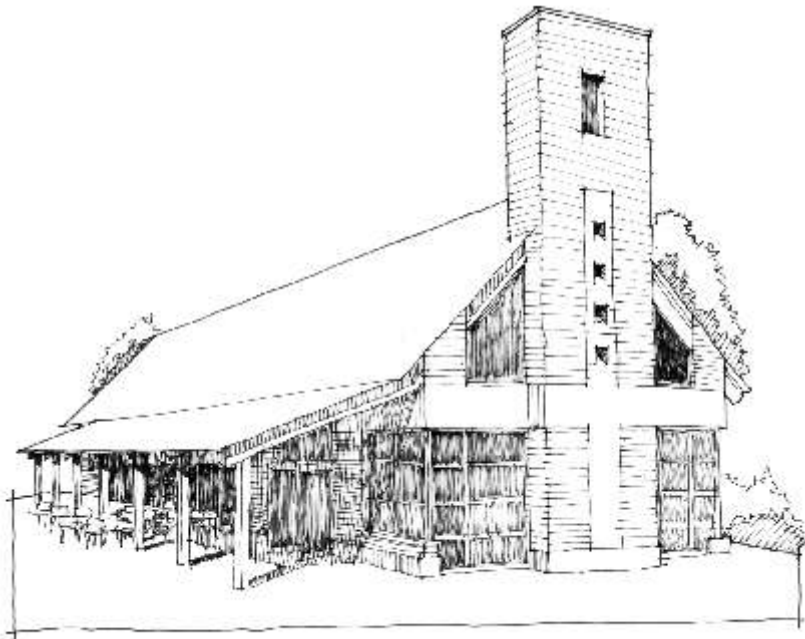


Figure 7.84: South-west perspective of restaurant

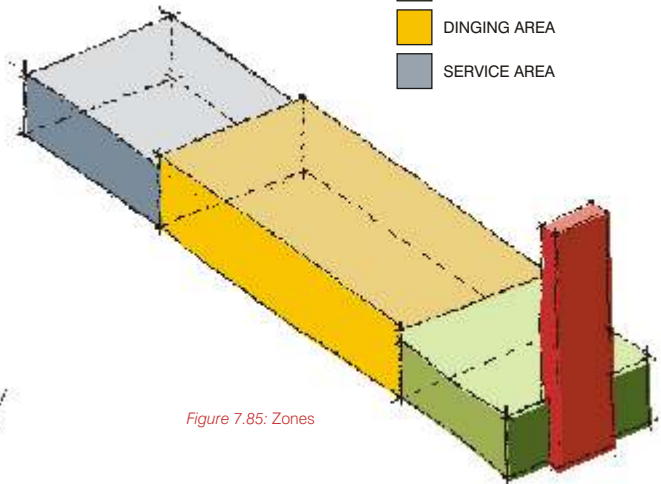
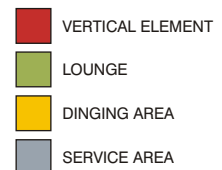


Figure 7.85: Zones

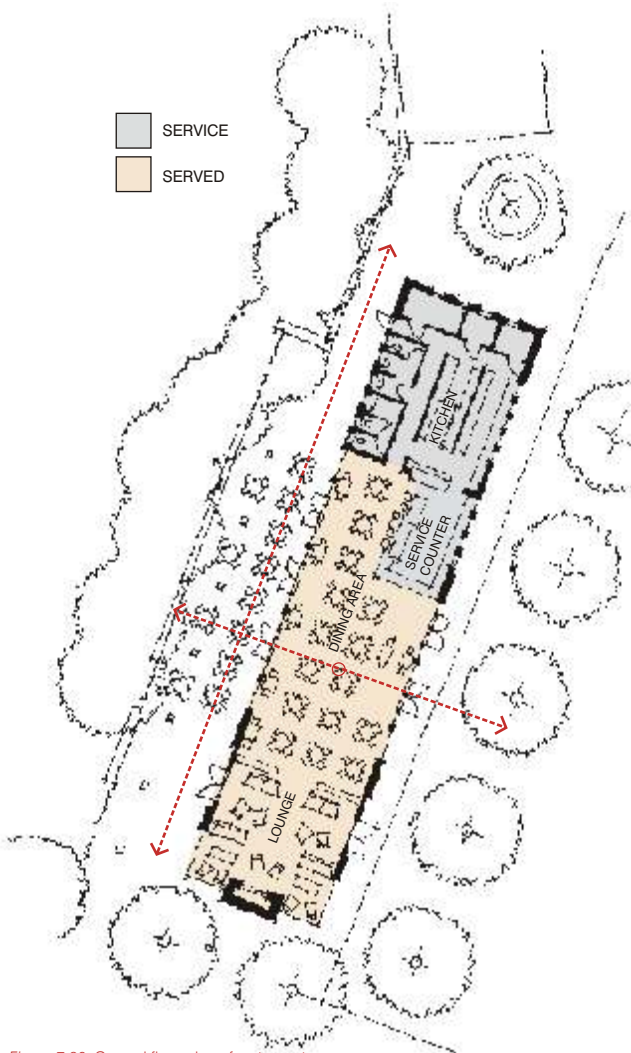


Figure 7.86: Ground floor plan of restaurant indicating space types and relationships

6.12.4 RESTAURANT

The restaurant is set most central to the park. It responds to the park and the inner courtyard. The dining area is most permeable, with the lounge being more enclosed to afford privacy and control. The service area is most enclosed.

The lounge acts as a day room. A mini library will make reading material available. A variety of seating arrangements provide choice to the users.

Dining area and lounge:

Light: 200lux

Ventilation: Natural ventilation at 0,33 w/m² °C

Electricity: 15a plugs supplied

Kitchen:

Light: 500lux

Ventilation: Natural ventilation at 0,5 w/m² °C and extractor fans above cooking area

Electricity: 15a plugs supplied

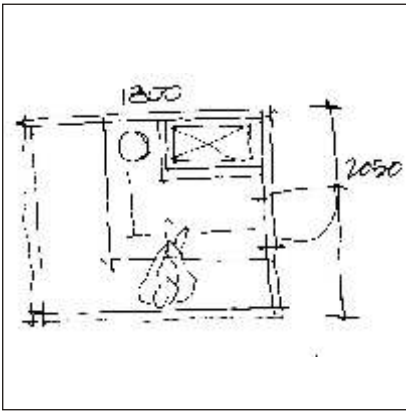


Figure 7.87: Sauna plan

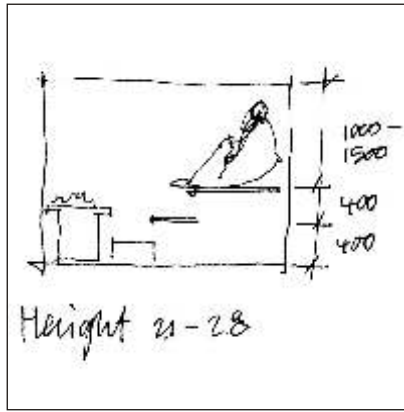


Figure 7.88: Sauna section

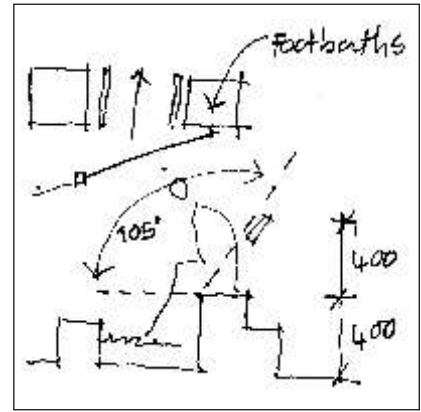


Figure 7.89: Footbath

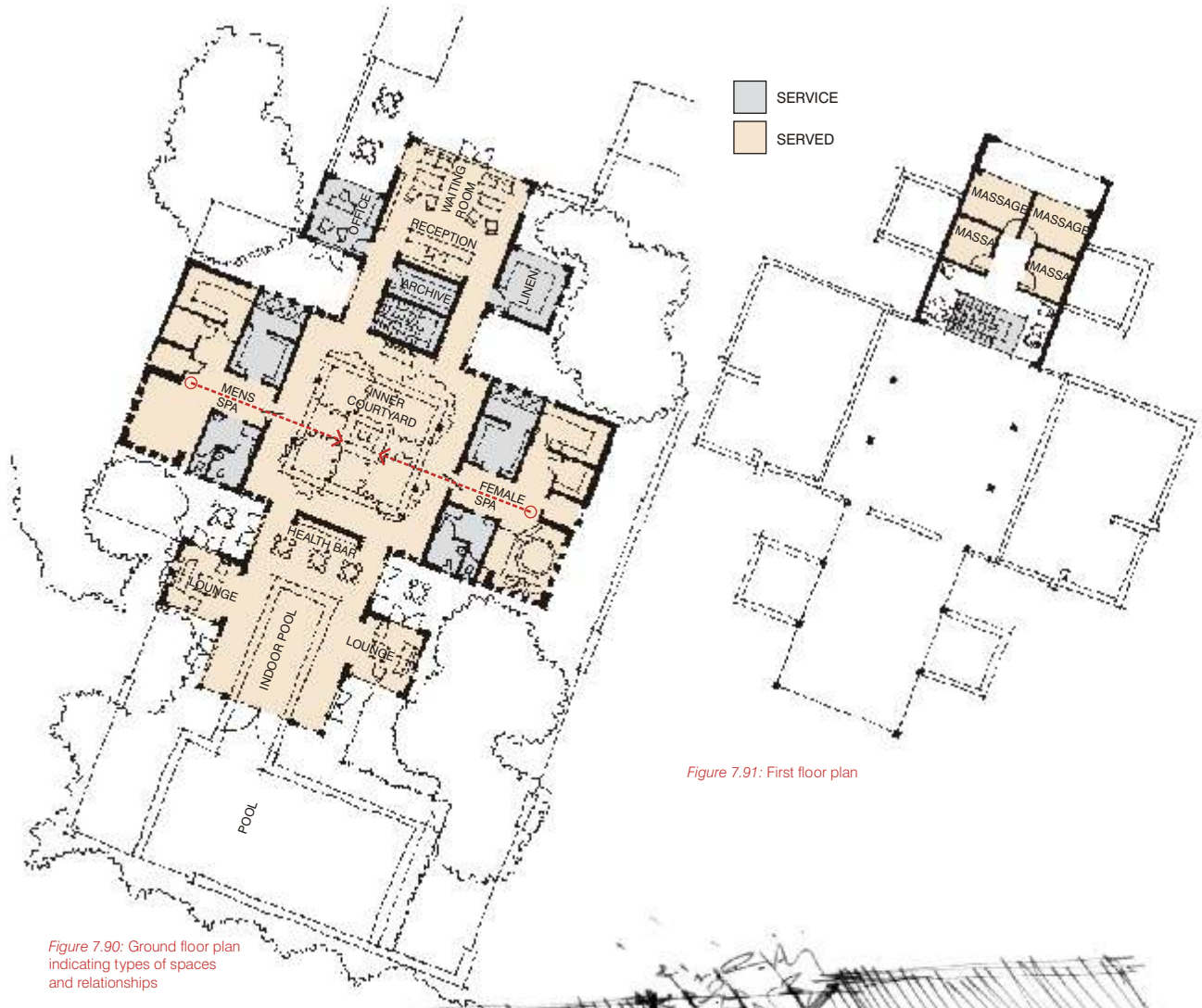


Figure 7.90: Ground floor plan indicating types of spaces and relationships

Figure 7.91: First floor plan

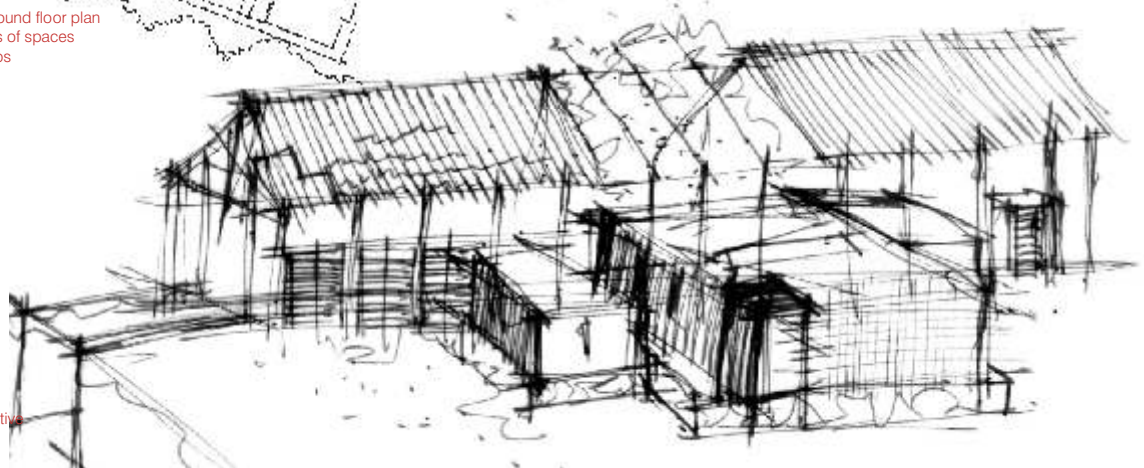


Figure 7.92: Perspective of health hydro

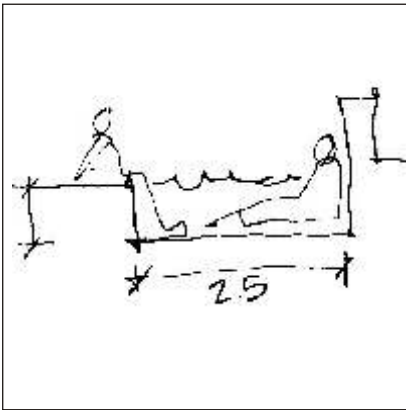


Figure 7.93: Section of plunge pool

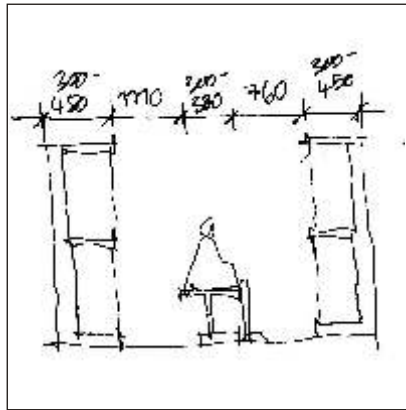


Figure 7.94: Locker room

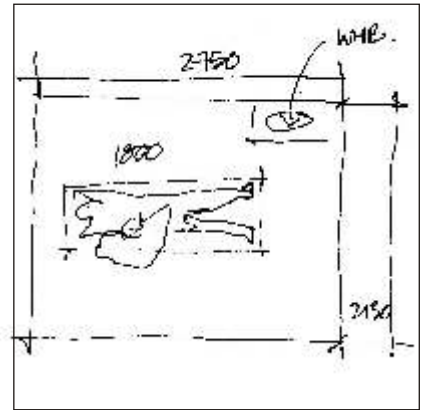


Figure 7.95: Massage room plan



Figure 7.96: Jardin d'Asie health hydro in France

6.12.6 HEALTH HYDRO

The main design consideration of the hydro was privacy and a tranquil, peaceful setting in a natural environment.

This is achieved by imploding the hydro. The spaces are set around an internal courtyard with open roof and dense landscaping.

Reception:

Books, magazines and Tv's can be used to occupy time while waiting.

Light: 500lux

Ventilation: Natural ventilation
0,33 w/m² °C

Room temperature: 21°C

Electricity: 15a plugs supplied

Pool area and spa:

Light: 500lux

Ventilation: Natural ventilation
at 0,17 w/m² °C

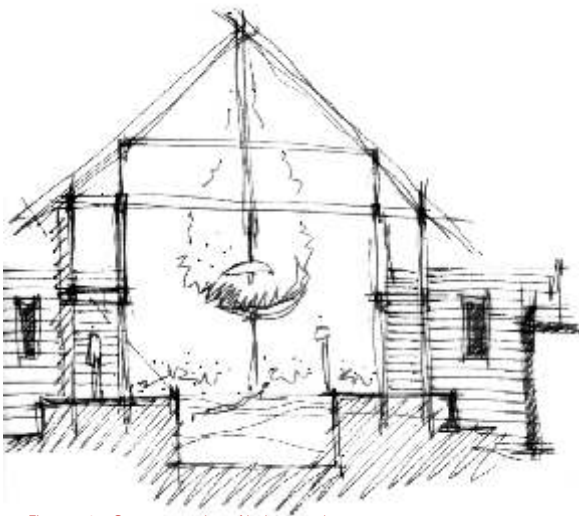


Figure 7.97: Concept section of indoor pool area



Figure 7.98: Concept section through hydro

“How do we define
and recognise the
characteristics of
buildings that are
socially concerned
and humanitarian
in their objectives.”

TECHNICAL INVESTIGATION

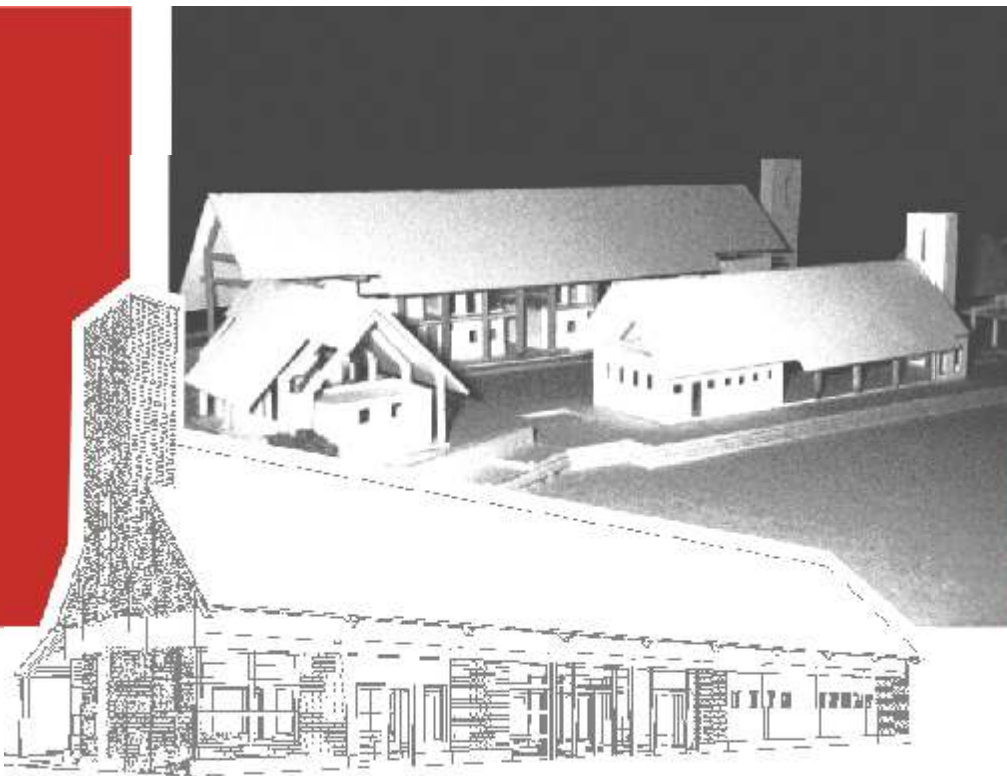


Figure B.1: Concept model
Figure B.2: Perspective view of restaurant

7.1 Design Philosophy

As previously discussed, the design philosophy is built around the concept of the enclosed space accommodating the service or private functions and the defined space housing the served or public functions. This philosophy is based on the inherent characteristics of these space structuring systems.

By nature space enclosing systems are more private and conveys the perception of safety and security, while space defining systems seems to be more permeable, accessible and free.

This design philosophy will be extended beyond conceptualization and be utilized in the manifestation of the spaces. These two space structuring systems have technical characteristics that will be implemented in an attempt to produce buildings that communicate their functions and characters to the user.

SPACE ENCLOSING

SPACE DEFINING

SPACE ENCLOSING

SPACE DEFINING

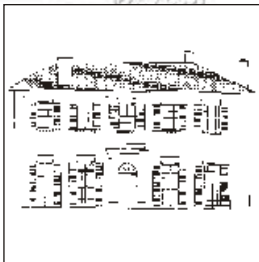


Figure 8.3: Light sources are visible and it has recognisable doors and windows.

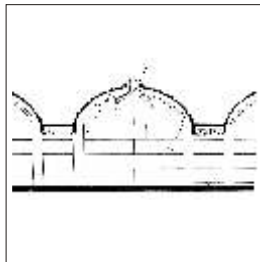


Figure 8.4: Has hidden light sources.



Figure 8.5: Has recognisable doors and windows, signs of 'human occupancy'.

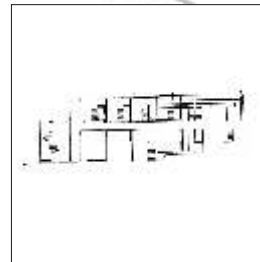


Figure 8.6: Openings are 'gaps' in the fabric of the assemblage - it gives few clues that the assemblage is occupied.

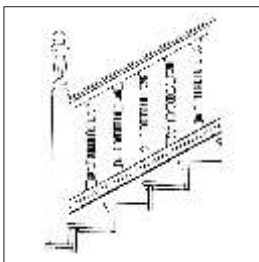


Figure 8.7: Components are 'joined'.

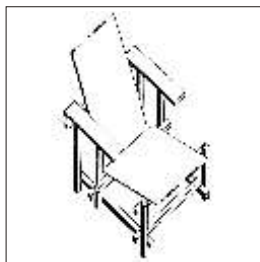


Figure 8.8: Components are visually distinct or separate.

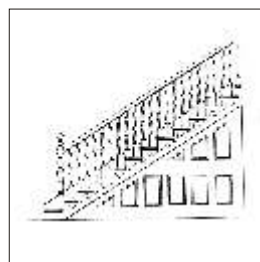


Figure 8.9: The articulation of the relationship between elements is positive.

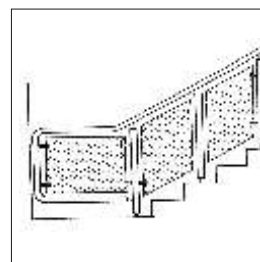


Figure 8.10: The articulation is not based on joining elements, but on maintaining a relationship between components. Surface is discontinuous.

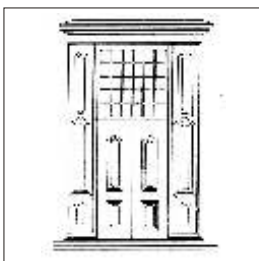


Figure 8.11: Components are framed and edged.



Figure 8.12: Components are spatially separate.



Figure 8.13: Openings are primary elements.

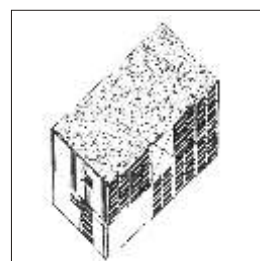


Figure 8.14: Frames or panels are primary.

Figure 8.3-14: Drawings (Righini 2000:145-146)

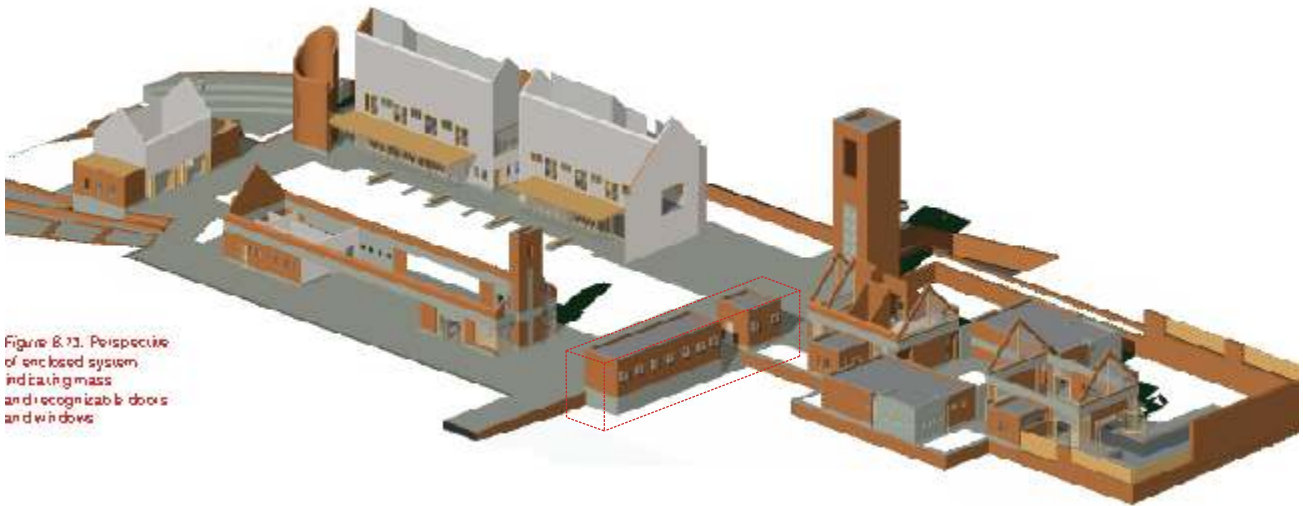


Figure 8.73. Perspective of enclosed system indicating mass and recognizable doors and windows

7.2 Space Enclosing System



Figure 8.16: Interior view of the courtyard of Säynätsalo Town Hall, Jyväskylä, Finland - Alvar Aalto
Aalto's use of brick and timber has a cultural reference in that these materials are widely used in Finland. The massing quality of the brick produces strong and bold forms.

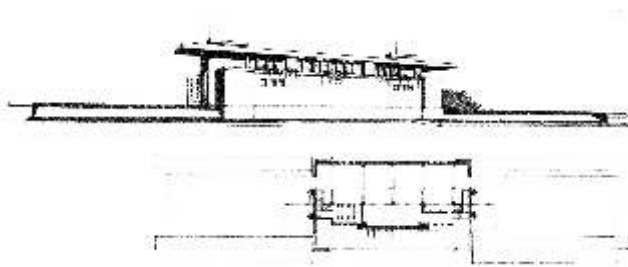


Figure 8.17: Yahara Boat Club, Madison, Wisconsin - Frank Lloyd Wright
The plan reflects the use of brick in the massing of the material. A strong modular arrangement exist due to the manufacturing properties of brick.

Brick was chosen as enclosing system due to its reference to the historical context, local availability and low maintenance cost.

7.2.1 BRICK

Brick is often described as the poor man's stone (Righini, 2000: 25). The brick used in this project is 220 x 110 x 75 kiln fired, solid wirecut bricks. Common bricks are used for plastered walls and red bricks for face brick facades.

The red brick's appearance is caused by iron oxide. It will be specified to match the historical brick and applied in english bond with flush mortar joints.

Proportion

Material proportion

Masonry units are strong in compression and depend on their mass for strength.

Structural proportion

It is due to its compressive strength that the structural form of loadbearing walls are thicker. This will influence the design and appearance of the plan form.

Manufactured proportion

The process of forming and manufacturing the bricks gives them their size and proportion. Bricks are produced as modular building blocks and this should be considered in the design of the buildings.

Modular co-ordination and design

Grid

A grid of 1870mm x 1870mm have been used to co-ordinate brickwork with the dimensions of the building. This ensured the use of brick without modification.

Co-ordinating sizes

In the enclosed system custom made doors and window were used that complied with the modular sizes of bricks.

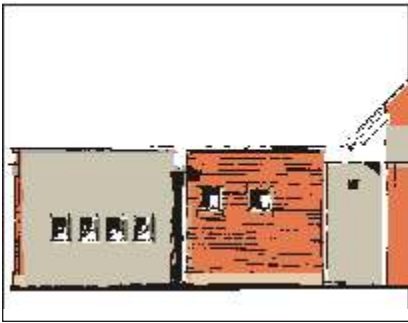


Figure 8.18: Exterior elevation of health hydro - the enclosed space seem to be framed and edged

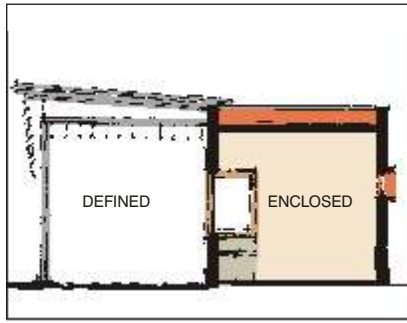


Figure 8.19: Section through information desk - the enclosed nature of the information desk is in clear contrast to the walkway roof structure

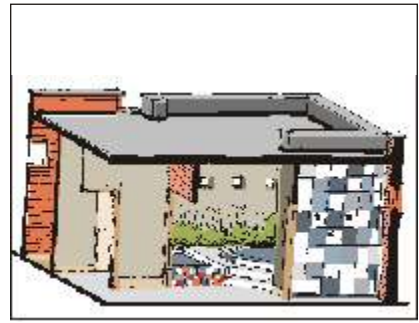


Figure 8.20: Interior perspective showing the jet bath and plunge pool in the health hydro - articulation between relationship of elements are positive and light sources are visible

The information desk and public ablution block was chosen as case study for the enclosing space system. The general construction components apply to all the enclosed spaces.



Figure 8.21: North elevation

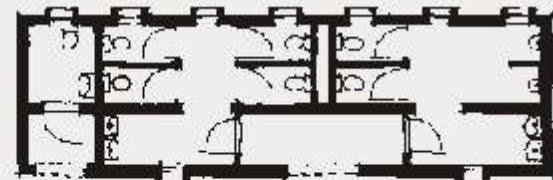
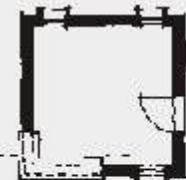


Figure 8.22: Ground floor plan

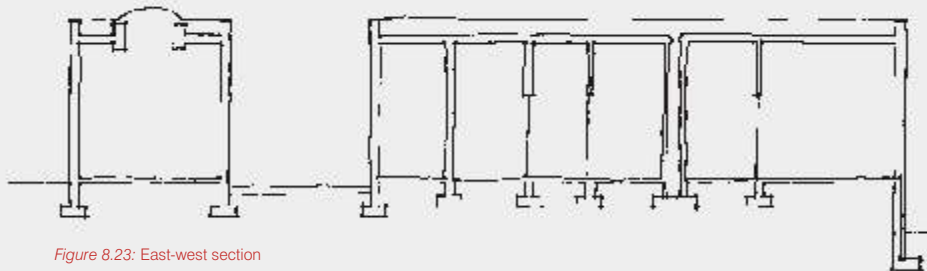


Figure 8.23: East-west section

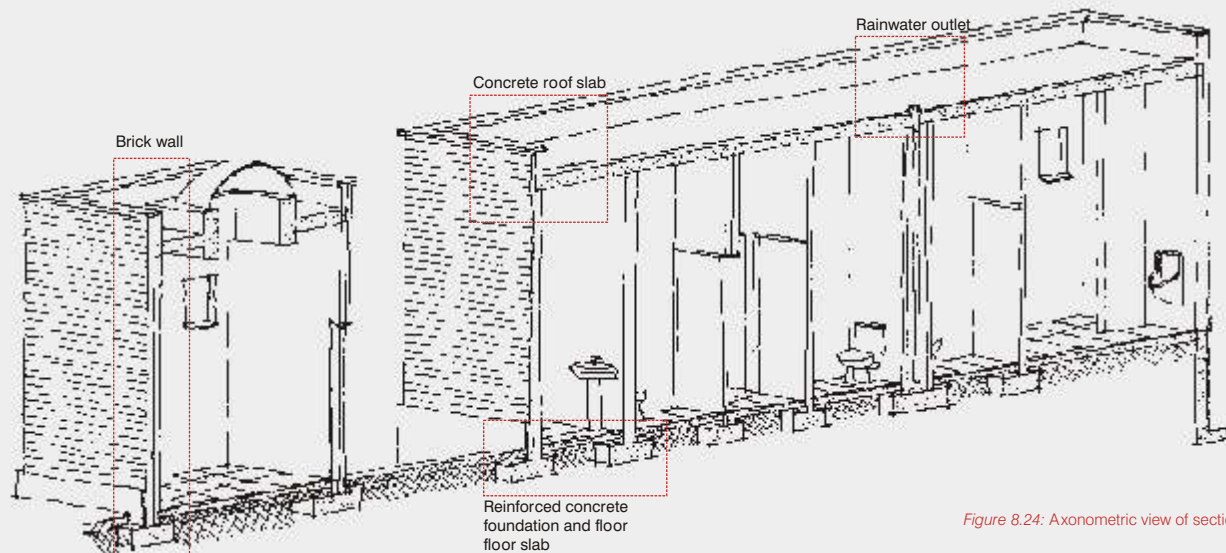


Figure 8.24: Axonometric view of section

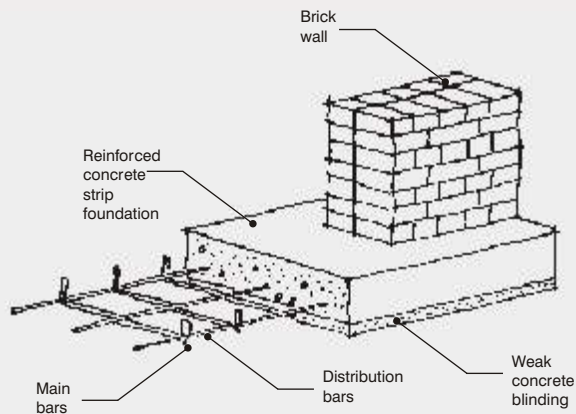


Figure 8.25: Reinforced concrete strip foundation

7.2.2 FOUNDATIONS

The load imposed on the soil due to the weight of the buildings can be compared to that of a house. Reinforced concrete footings will be sufficient. The depth of the footing will be at least equal to the overhang. The only foundations that will require additional design considerations are those of the landmark structures. Conventional strip foundations are used, as the prevailing soil conditions are not extreme.

“A room is an enclosed space; it reflects ‘here’ and ‘there’ as two distinct realms.”

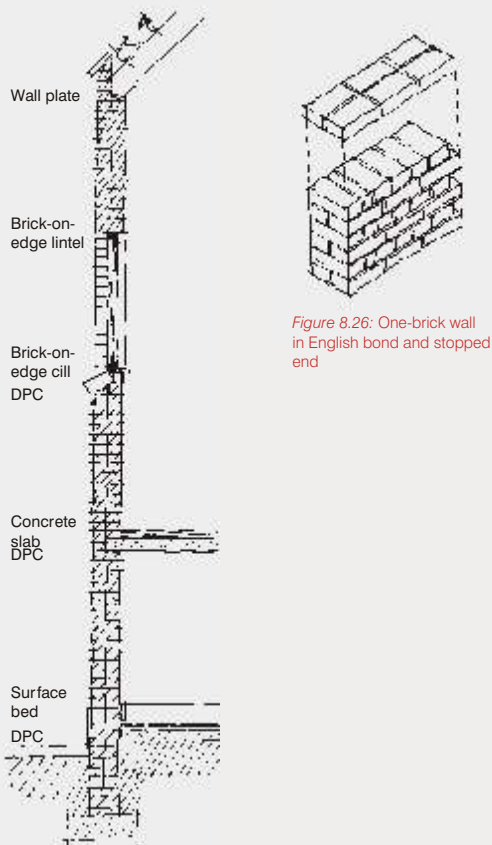


Figure 8.26: One-brick wall in English bond and stopped end

Figure 8.27: Brick wall

7.2.3 BRICK WALLS

Structural strength and stability

Walls will have adequate strength and stability for their purpose.

Durability

Masonry units shall be sufficiently durable to resist local exposure conditions for the intended life of the building.

Accommodation of movement

Control joints will comply with SABS 0249 and reinforcement with SABS 0145

Weatherproofness

Single brick exterior wall will be sufficient and shall comply with SABS 0249 and SABS 021

Acoustic properties

Shall comply with minimal values of Agrément Board of South Africa

Fire resistance

All brick walls shall comply with Section T of the National Building Regulations 0040

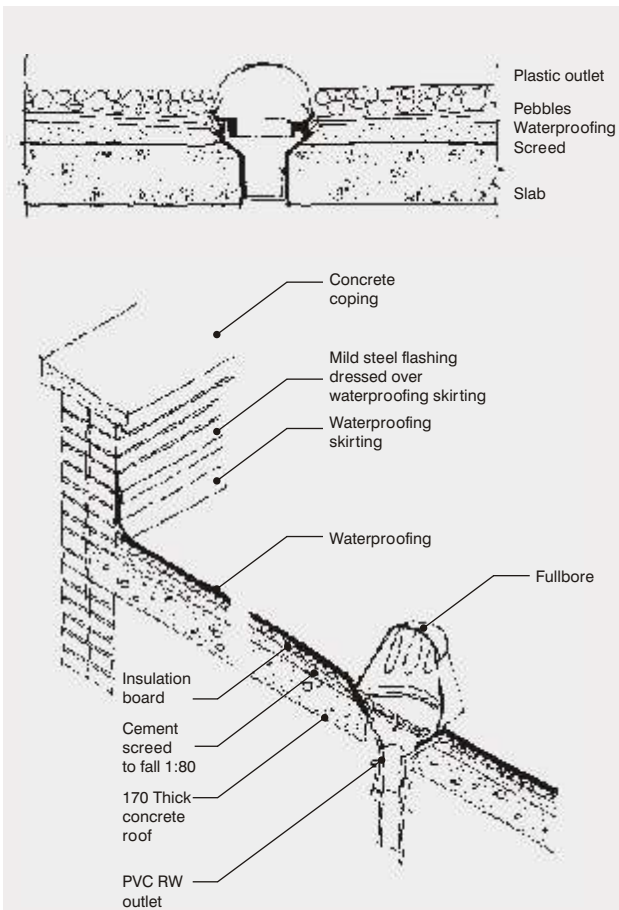


Figure 8.28: Rainwater outlet in concrete roof

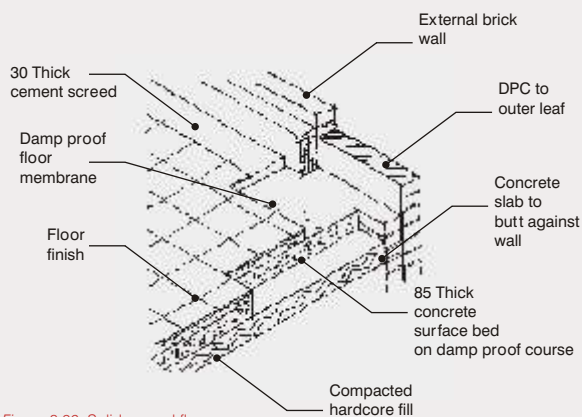


Figure 8.29: Solid ground floor

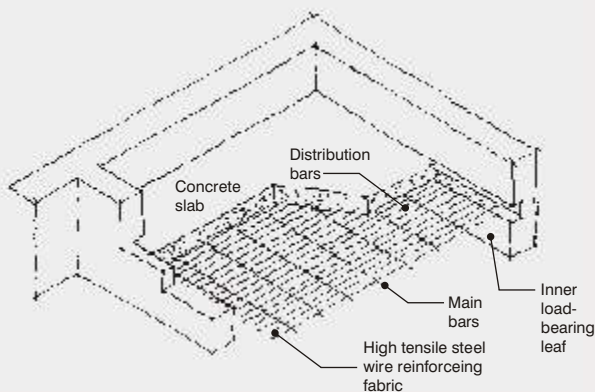


Figure 8.30: In-situ concrete floor slab

7.2.4 CONCRETE ROOF SLABS

Roof slab

Concrete roof slabs will be used for the enclosed systems such as the information desk, public ablution block, spa area and landmark structures. 170mm Thick roof slab will be sufficient for all concrete roofs in this project.

The roof slab has to support

- The weight of the screeding placed on top of the structural slab and tapered in thickness to allow water to run off the roof into the outlets provided
- The weight of the asphalt required for waterproofing the roof
- The weight of the pebbles used on roofs that will be visible from the double storey training and therapy center
- The imposed loads
- The weight of the plaster on the underside of the slab
- The weight of the slab itself

Rainwater outlet

The rainwater outlets in the concrete slabs are of cast iron, consisting of a funnel-shaped head. A plastic domical removable grating is secured by a single center hook bolt.

The rainwater outlet will be accommodated within the sanitary duct in the center of the slab.

7.2.5 CONCRETE FLOOR SLAB

Ground floor slab

Hardcore is put down to reduce capillary rise of ground moisture, to act as a filling to provide a horizontal surface and to form a firm, dry working surface. The concrete slab is 85mm thick and the top surface is finished with a power float to take a 30mm thick cement screed. 30mm Thick sandstone tiles will mainly be used.

Reinforced concrete floor

Reinforced concrete floor slabs will only be used for the first floors of the training and therapy center and the health hydro. The maximum clear span is 7480mm. Through consultation with an engineer, it was decided that 255mm thick slabs will be sufficient for both buildings.

The floor slabs will be in situ cast, one-way spanning slabs with the reinforcement acting in one direction only between two supports.

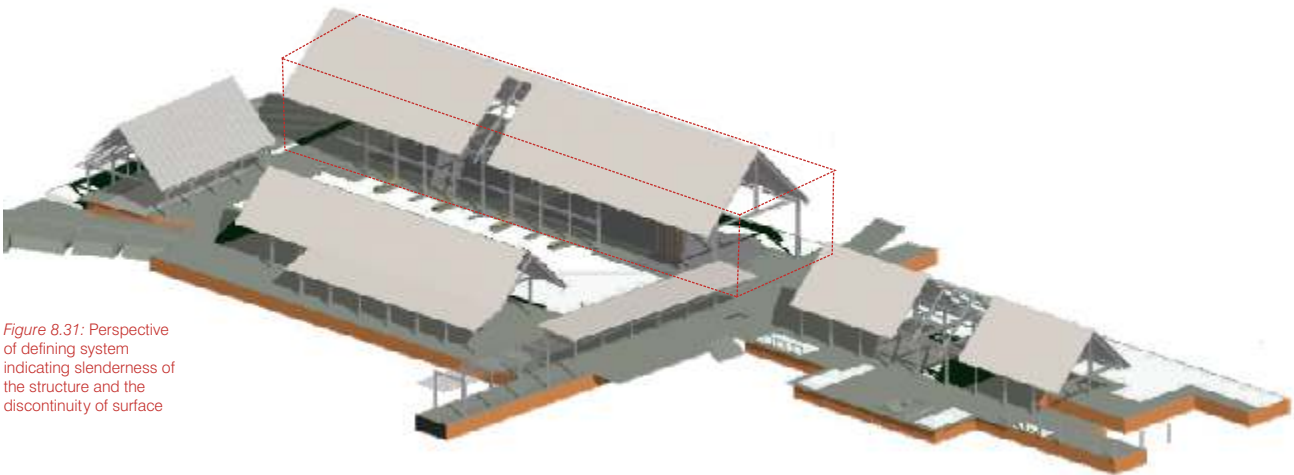


Figure 8.31: Perspective of defining system indicating slenderness of the structure and the discontinuity of surface

7.3 Space Defining System



Figure 8.32: Eames House - Charles and Ray Eames. This was an aesthetic based on technology. This building was one of the first 'patter-book' buildings, using components that could be ordered from catalogues.

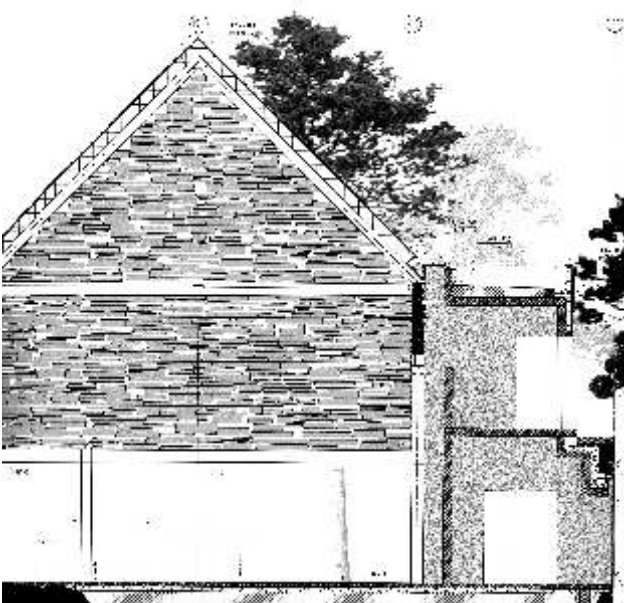


Figure 8.33: Mortensrud Church, Mortensrud, Oslo, Norway - Jensen & Skodvin. The main structure of this building is a steel frame, with a stone wall carrying the roof. The architects found that using basic techniques and methods, produced a cheaper building and afforded them greater architectural freedom.

Steel was chosen as structural material for the defining system as the members are smaller than aluminum, ensuring a lighter appearance. Steel would be easier to maintain than timber frames and cheaper than reinforced concrete frames.

7.3.1 STEEL CONSTRUCTION

Hot rolled structural steel is used for all components of the assemblage. Bolted connections will mainly be used as this is the most common connector, requiring little special equipment.

Proportion

Material proportion

Steel is the material that is used in the majority of framed structures because of its good compressive and tensile strength and favourable strength to weight ratio. Because of its strength in compression and tension, steel can be formed into linear columns and beams as well as planar sheet material.

Structural proportion

The skeletal structure defines modules of space. The spaces are articulated by the size and proportion of the components, giving the space scale and hierarchy. This is due to the increase in component size as loads and spans of buildings and spaces increases. This can clearly be seen in figure 8.25.

Modular co-ordination

Grid

The spacing for steel columns of a lattice truss construction is between 3 and 5 meters. The columns have been spaced at 3740mm centers which is double the spacing of the brick grid that is 1870mm.

Functional requirements

Strength and stability

The design of the structural system will be carried out in accordance with SABS 0160 (for loads) and SABS 0162.

Fire

Steel structure shall comply with section TT 7 of SABS 0040.

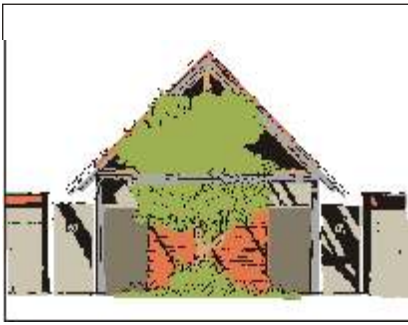


Figure 8.34: Internal view of inner courtyard of health hydro. Components are visibly distinct and light sources are not visible.



Figure 8.35: The articulation is not based on joining elements, but on maintaining a relationship between components. The lobby of the training and therapy center is a defined space, with the timber screen and steel columns giving definition. The stair, however, is placed in a brick box that suggest continuity with the enclosed structure as in the historic Edwardian tradition.

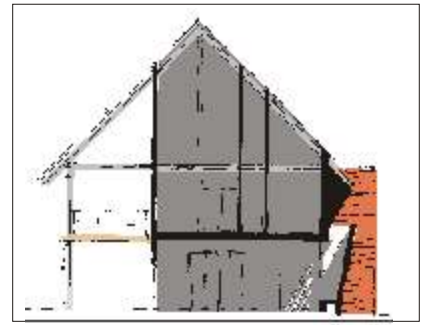


Figure 8.36: The concrete seats in the workshops are another type of defining structure. It has a hidden light source and causes discontinuity with the surface.

The training and therapy center was chosen as case study for the space defining system. The general construction components apply to all the defined spaces.



Figure 8.37: West elevation

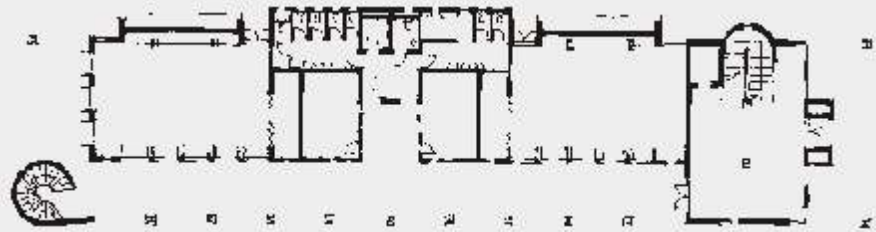


Figure 8.38: Ground floor plan

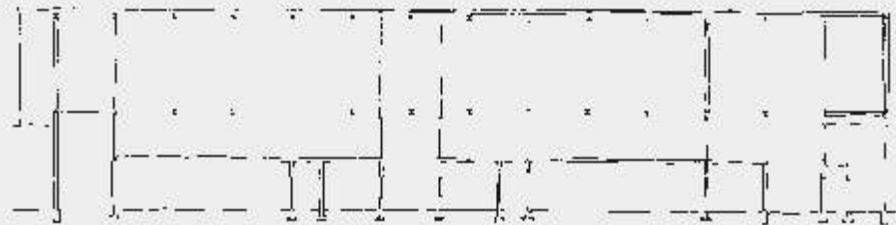


Figure 8.39: North-south section

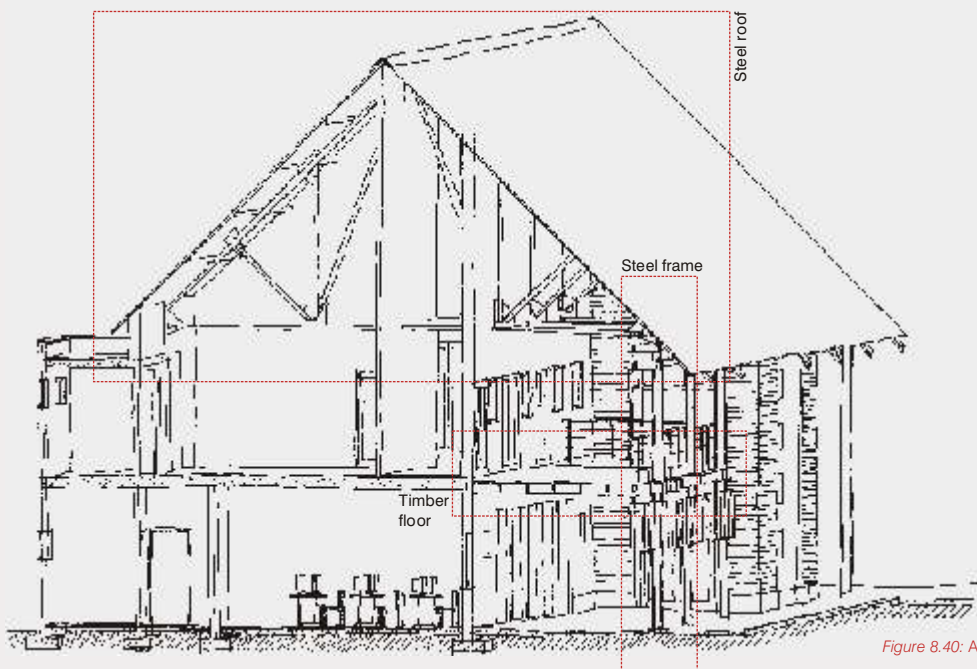


Figure 8.40: Axonometric view of section

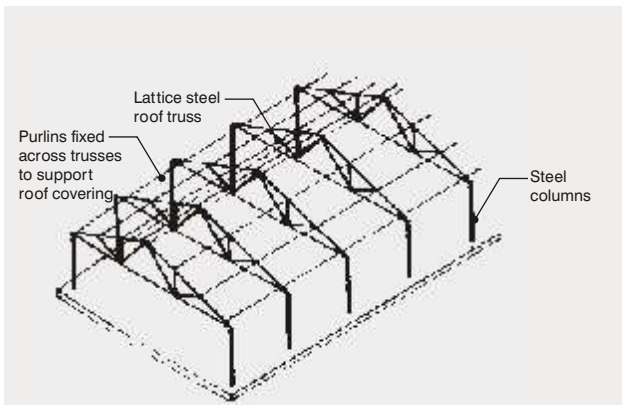


Figure 8.41: Symmetrical pitch lattice steel roof on columns

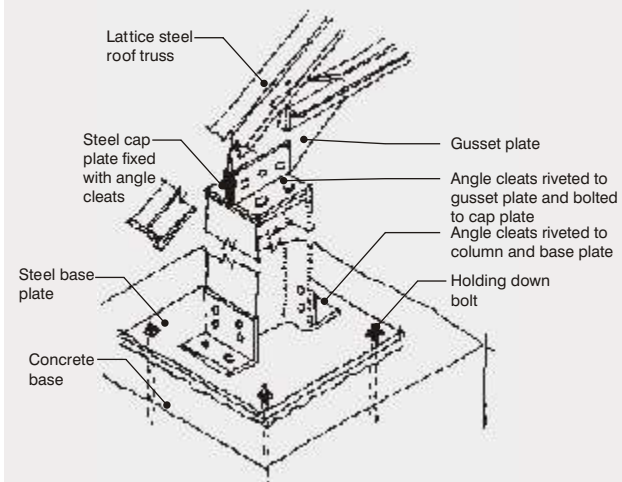


Figure 8.42: Cap and base of steel column support for lattice steel truss

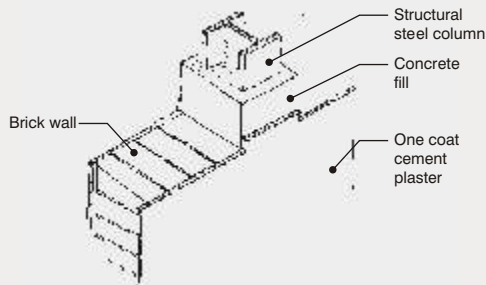


Figure 8.43: Steel frame in concrete column

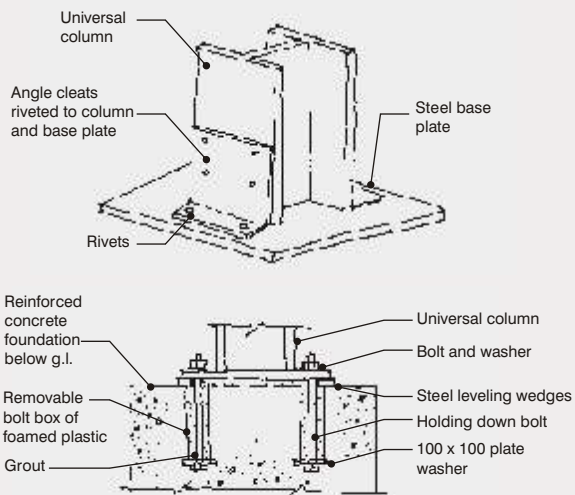


Figure 8.44: Steel slab base on concrete pad foundation

7.3.2 STEEL CONSTRUCTION

Lattice truss construction

The lattice steel trusses are fabricated from small, mild steel sections bolted together to form a triangular symmetrical-pitch roof frame. The considerable depth of the roof frames at mid span provides adequate strength and rigidity in supporting dead and imposed roof loads. 203 x 203mm H-section steel columns spaced at 3740mm c-c will be used with 120 x 120mm steel angle purlins fixed across the trusses to support roof sheeting.

Steel connections

The system comprises of a lattice steel truss, a gusset plate joining the members of the steel truss, a cap on top of columns, steel columns and base plates fixed on a concrete base.

The structure will mainly be bolted as little special equipment is required and parts can be assembled on site.

Steel columns in brick walls

Where the steel columns are built into brick walls, they will be cast into concrete.

7.3.3 FOUNDATIONS

The simplest and most economical solution is to provide each column in the buildings with its own base. The size of the base depends on the bearing capacity of the soil and load on the column base.

The depth of the concrete is equal to the projection of the concrete beyond the base plate, assuming an angle of dispersion of load in concrete 45 degrees.

For heavier loads, reinforced-concrete bases will be used, since it requires less depth of concrete and less excavation.

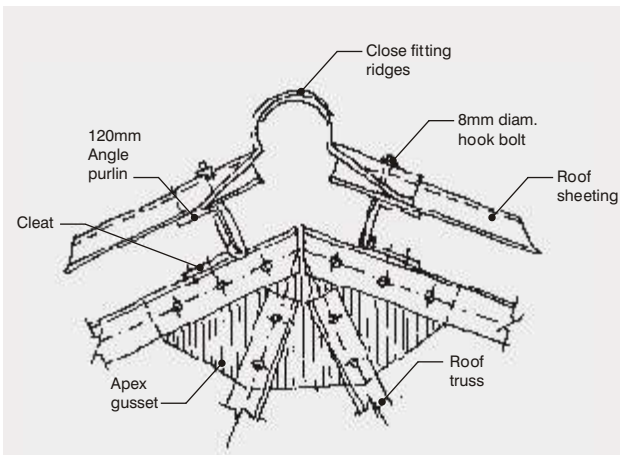


Figure 8.45: Corrugated sheet ridge detail

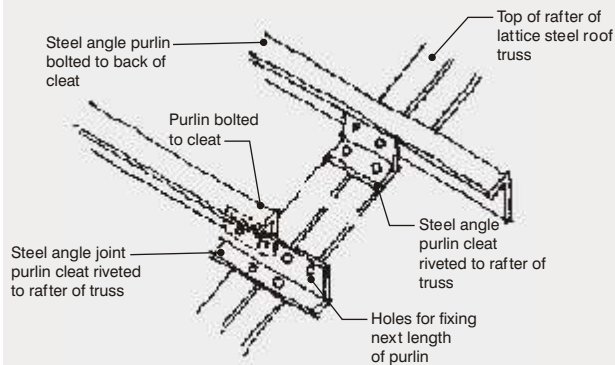


Figure 8.46: Connection of purlin to truss

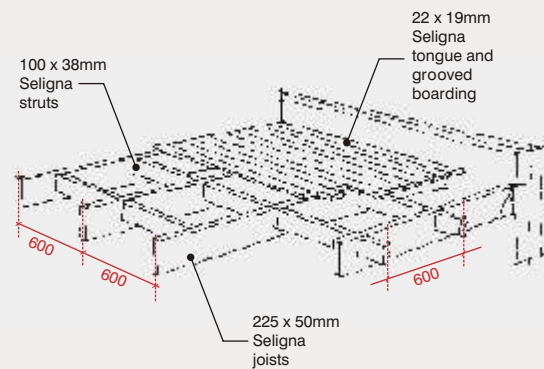


Figure 8.47: Timber balcony construction

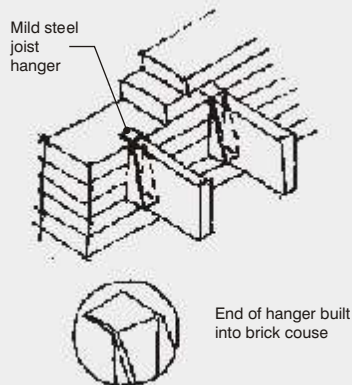


Figure 8.48: Support of joists

7.3.4 STEEL ROOF

Purlins are fixed across roof trusses to provide support and fixing for the roof and insulation. IBR roof sheeting will be used, requiring that purlins be spaced no more than 2 150mm c-c. Hot-dip galvanized steel sheets will be used for the roof coverings.

The composite roof system will comprise of cladding sheets and pre-formed insulation supported on profiled steel inner lining sheets which serve as a vapour check and provide a smooth, painted soffit. The roof is fixed to the purlins with self drilling, self tapping screws.

“Space is defined by placing of elements - it has a ‘loose’ quality, its dominant feature is about ‘connecting’ and maintaining continuity.”

7.3.5 TIMBER BALCONY

Timber balconies are used as first floors for the space defining system. The construction is appropriate for defining systems, since the components are spatially separate and visually distinct.

The decks have three components; the joists, the struts and the floor boarding. The joists are fixed across the shortest distance between the wall and the support. They are 225 x 50 thick Seligna boards spaced at 600 c-c.

Stiffening is required when joists are deep in order to avoid winding or buckling at the top of the joists. The struts give lateral support to the decks. They are 100 x 38 thick Seligna boards spaced at 600 c-c.

22 x 96 Thick Seligna tongue and groove boarding will be used for the flooring. Tongue and grooved boarding is preferable to plain-edge because it is able to transmit point loads on one board to adjacent boards. This reduces the intensity of load on individual boards.

Mild steel joist hangers will support the joist ends on the inner leaf of the walls.

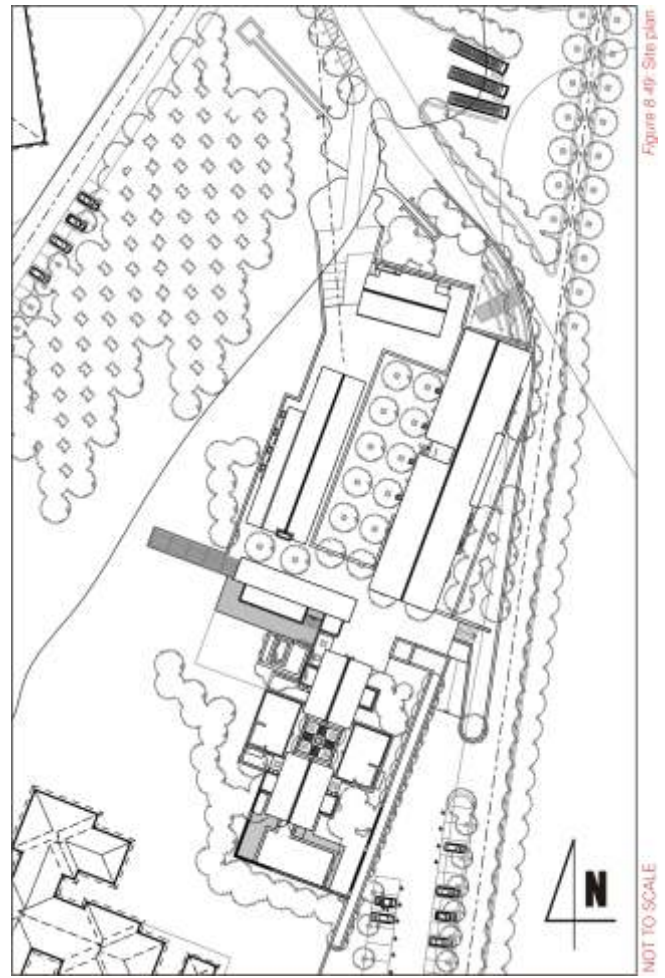
7.4 Passive Systems

7.4.1 ORIENTATION

Due to the design intent the buildings were orientated predominantly north-south. This implies that the longer elevations of the buildings are exposed to early morning sun and late afternoon sun. The following guidelines apply:

- Avoid direct heat gain and solar radiation through overhangs and shading devices.
- Maintain views, natural light and natural ventilation regardless of shading devices.

The sun study is used to indicate seasonal sun exposure in order to assist in the design of windows, placing of patios, window shades, placing of trees etc. In summer one would want to shade the buildings, whereas in winter one would want to expose them to the sun for warmth.



SUN STUDY

SUMMER: 21 DECEMBER

WINTER: 21 JUNE



Figure 8.50: Time: 7:45 am



Figure 8.53: Time: 14:30 pm



Figure 8.56: Time: 7:05 am



Figure 8.59: Time: 13:20 pm



Figure 8.51: Time: 10:00 am



Figure 8.54: Time: 16:45 pm



Figure 8.57: Time: 9:10 am



Figure 8.60: Time: 15:25 pm



Figure 8.52: Time: 12:15 am



Figure 8.55: Time: 19:00 pm



Figure 8.58: Time: 11:15 am



Figure 8.61: Time: 17:30 pm

7.4.2 DAYLIGHTING

Design strategy

The strategy selected for lighting the building interior is by predominant daylight, supplemented by artificial light where necessary.

The buildings layouts enable good natural lighting with no person being further than 3,5m away from natural daylight in any room. East, west and north facing windows are controlled for good daylighting and south facing windows provide uniform daylighting without control.

Daylighting strategies consider heat gain, glare, variation in light availability and solar penetration. These are addressed through opening size and spacing, shading devices, glazing materials and surface reflectance materials.

Opening size and spacing

The opening size required for each room has been calculate in order to obtain the correct daylight factor (see appendix). Where the windows occur on the east or west facades they will be shaded to avoid heat gain.

Where possible windows will be provided in more than one wall in each room, so that brightness of framing wall-areas around windows are raised (by cross-lighting), thus reducing contrast between dark wall surface and bright sky.

High windows for daylighting are preferable because, if properly designed, they bring light deeper into the interior and eliminate glare.

Shading devices

As illustrated in fig. 8.49 shading devices include: roof overhangs, external louvres and vegetation. These devices are used without compromising daylighting.

Glazing materials

Double glazing is used on the western and eastern facades in order to minimize heat gain. Single glazing will be used on the northern facade to maximize heat gain in the winter.

Surface reflectance materials

Once the daylight enters the room, the surrounding wall, ceiling, and floor surfaces are important light reflectors. Using high reflectance surfaces will better bounce the daylight around the room and it will reduce extreme brightness contrast.

Window frame materials will be light-colored to reduce contrast with the view and have a non-specular finish to eliminate glare spots.

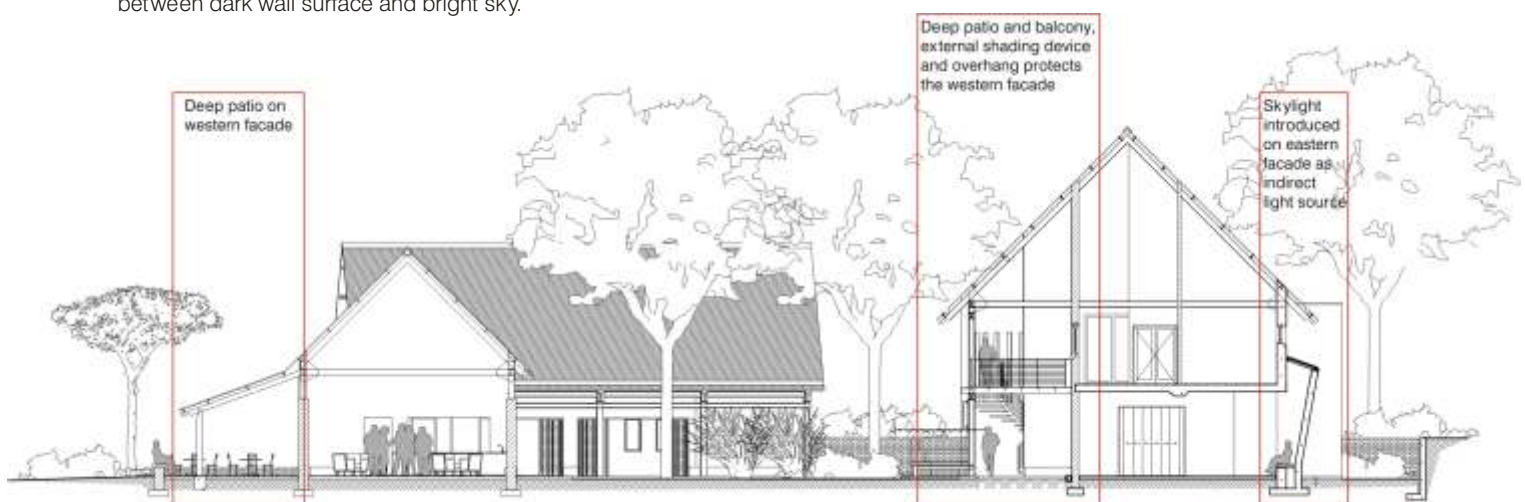


Figure 8.62: Shading devices

7.4 Passive Systems

7.4.3 PASSIVE HEATING

Passive heating is a heating system that collects solar heat, without the use of external mechanical power to distribute it. The building itself is designed as a solar collector with windows acting as the collection source. Solar collection may be either direct (solar radiation entering directly into a space) or indirect (solar radiation heats an area which then continues to heat the area when the solar exposure has passed).

Direct passive heating is used in the buildings, as they will be used during the day and therefore indirect systems will not be appropriate.

Direct gain

The overhangs are designed to allow winter sun to enter directly into the building, while keeping summer sun out. This causes the interior of the building to be heated in winter by the sun's energy, while remaining cool during the summer.

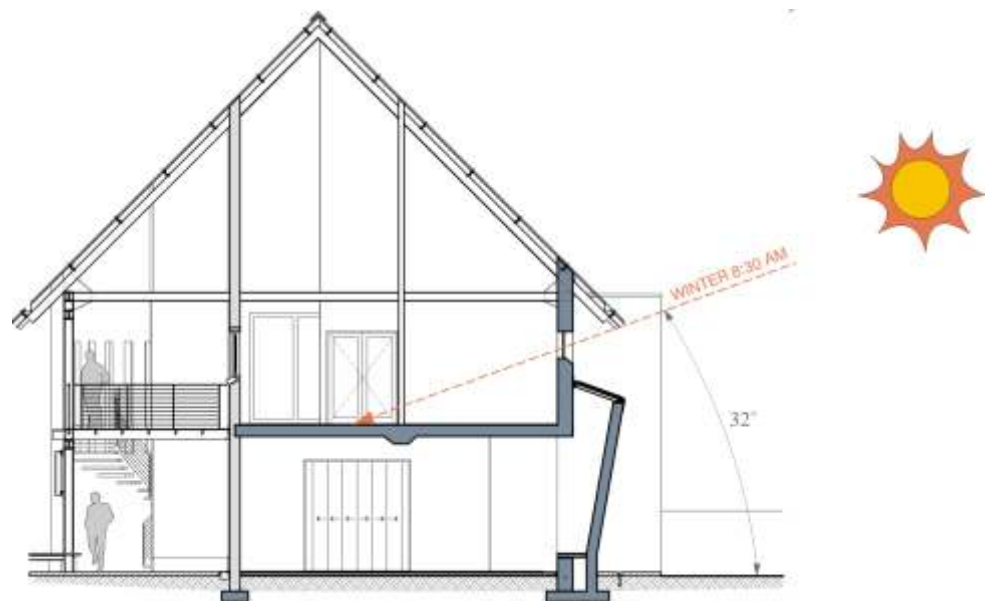


Figure 8.63: Direct solar heat gain during winter

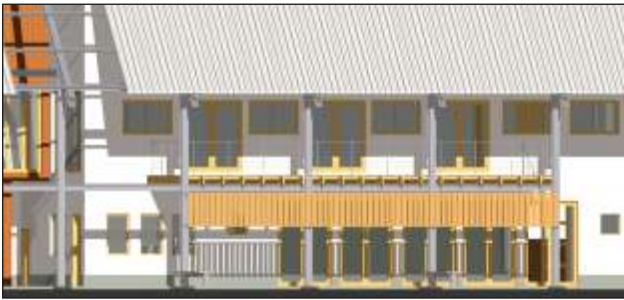


Figure 8.64: Vertical louvres and overhangs are designed as shading devices on the western facade of the training and therapy center.



Figure 8.65: Leafless trees admit sun in winter



Figure 8.66: Deciduous trees shade the building and garden in summer

7.4.4 PASSIVE COOLING

Passive cooling strategies include shading devices, thermal mass, overhangs, balconies and patios, high ceilings, applying the correct finishes and natural ventilation.

Shading devices

Exterior louvres

Vertical adjustable louvres are applied to the western facade of the training and therapy center. They are distant from the windows, fixed to the steel structure, and therefore warmed air is prevented from entering the interior of the building. Figure 8.54 illustrates that the louvres are designed not to compromise the view from the interior spaces to the inner courtyard. Timber louvres will be used, treated with exterior wood stains and set in a steel frame.

Landscaping

Deciduous vegetation is an attractive and inexpensive form of shading, because it follows the local seasons. Trees are strategically planted on the east and west sides of the buildings to block the rising and setting sun. Bushes are also positioned to block undesirable low sun angles from the east or west.

Thermal mass

The eastern wall of the training and therapy center consist of mass concrete which acts as a thermal wall. The cool structural mass will absorb heat from the interior during day time, provided that the thermal wall is shaded.

Overhangs

Where possible, overhangs were designed to allow for maximum shading of opening without compromising view and natural ventilation.

Natural ventilation

The buildings are orientated at roughly 45° angles to the prevailing summer and winter winds. Winter winds are blocked by vegetation, but summer prevailing winds are allowed to cross ventilate the buildings. Where possible open plans allow air movement. The area of operable windows have been calculated for each room (see appendix). Full height opening have been implemented where possible in order to provide maximum cooling. Multiple mullions in full height windows allow for the user to control the amount of natural ventilation in the interior spaces.

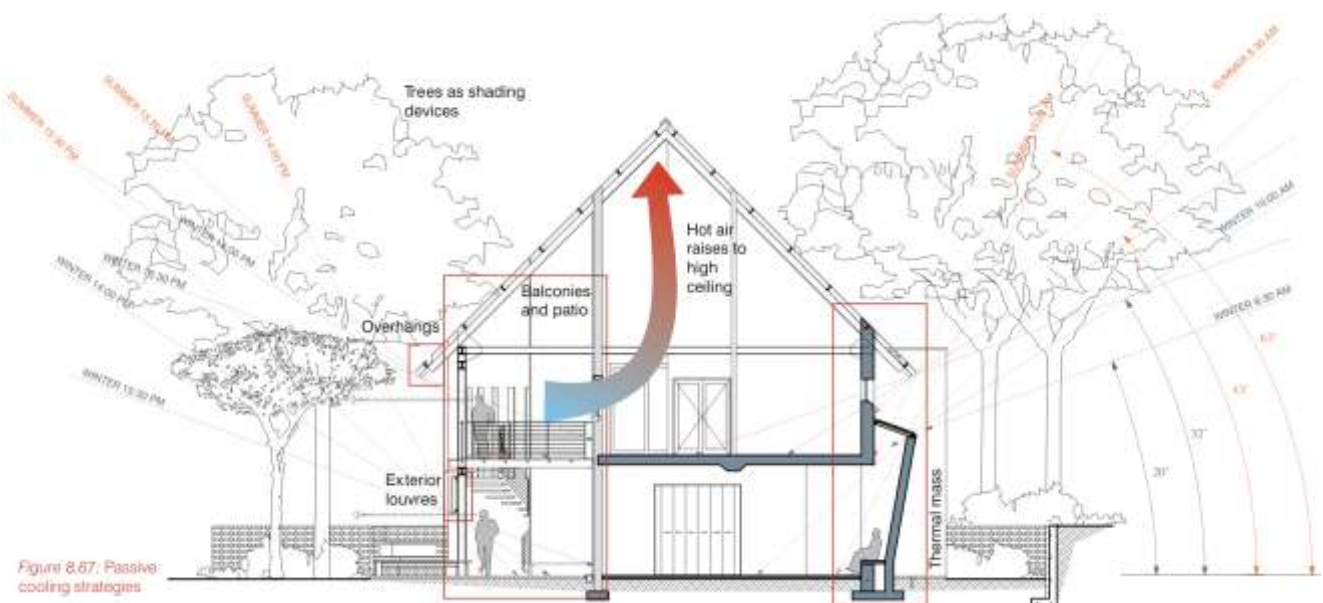


Figure 8.67: Passive cooling strategies



Figure 8.68: Perspective of west facade of training and therapy center indicating timber and steel composite seat and louver system and timber balcony.



Figure 8.69: Use of galvanised corrugated steel sheeting for the roof.



Figure 8.70: South-west elevation of training and therapy center indicating the use of brick, off-shutter concrete and steel for the structural frame and roof.



Figure 8.71: An internal view of the training and therapy center lobby as seen from the stair. Timber is used internally to create warmth.

7.5 Material Use and Detailing

The training and therapy center was used as prototype of all the buildings.

Basic building materials such as wood, concrete, brick and steel are boldly used to create a lively, yet calm building. Traditional detailing was used throughout the building to accommodate the limited skills resources available to the construction industry in South Africa.

A corrugated steel roof is supported by a simple steel frame, enclosing brick and concrete walls. A great number of Bloekom trees are being uprooted on site and therefore Seligna is used for all timber components. Timber is used for window and door frames, balconies, louvres and seats as this adds warmth to the building.

203 x 203 x 12 thick hot rolled grade 300W structural steel frame, primed and cleaned according to SABS 064, and painted with two coats of zinc phosphate primer to comply with SABS 1319. Structural steel components designed in accordance with SABS 14713, and galvanised to comply with SABS ISO 1461.

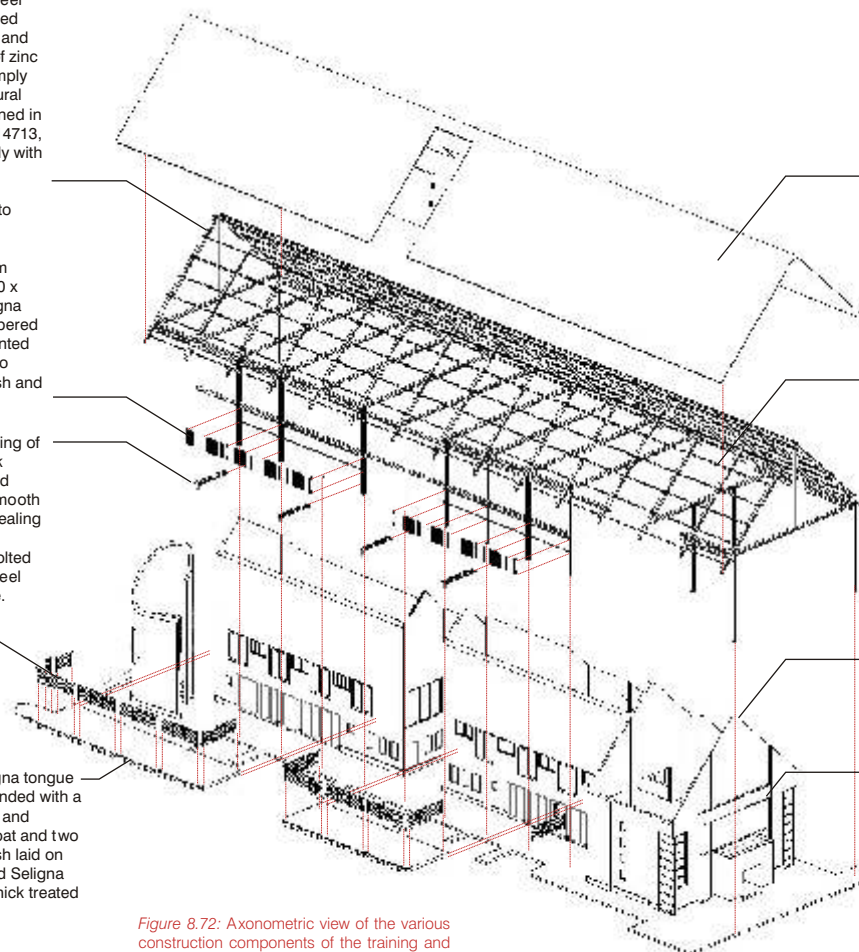
Ordinary bolt assembly to comply with SABS 1700.

Composite louvre system comprising of 100 x 1000 x 25mm thick treated Seligna machined slabs sandpapered to smooth finish and painted with sealing coat and two coats of approved varnish and bolted to steel flats.

Composite seat comprising of 2670 x 100 x 25mm thick treated Seligna machined slabs sandpapered to smooth finish and painted with sealing coat and two coats of approved varnish and bolted to hot rolled structural steel 152 x 152 x 10mm frame.

1000 x 80 x 15mm Steel plate balustrade at 1000mm intervals with 21,4 daim. cold rolled steel tube horizontal balustrades

22 x 96mm Treated Seligna tongue and groove boarding sanded with a mechanical floor sander and painted with a sealing coat and two coats of approved varnish laid on 225 x 50mm thick treated Seligna joists and 100 x 38mm thick treated Seligna struts.



0,6mm thick mild steel sheet coated with class Z185 galvanising, primed with an epoxy-based primer, and painted with silicon polyester paint for normal exterior use, to 0,02mm thickness, on both sides.

120 x 120 x 8mm thick hot rolled structural steel angle iron purlin cleat riveted to rafter

12mm Thick normal strength laminated safety glass to comply with SABS 1263, set in treated Seligna frame with frame, subframe and glazing beads profiled and sized as specified.

850mm Deep off-shutter concrete beam. Smooth formwork with surface within degree of accuracy 2 to comply with SABS 0155.

Figure 8.72: Axonometric view of the various construction components of the training and therapy center. The other buildings will follow the same principles and use of materials.

7.6 Fire Strategy

7.6.1 FIRE RESISTANCE OF EXTERNAL WALLS

According to SABS 0040 TT2.1, structural elements are to have a fire resistance as follows:

Occupancy	Fire resistance, minutes
Workshops	120
Classrooms	90
Offices	60
Counselling rooms	90
Restaurant	120
Health hydro	120

Timber

As timber beneath the charred layer does not lose significant strength, with known rates of charring, initial size of structural members can be calculated which would continue to support design loads after various periods of exposure to fire. Metal fastenings must be within the residual section and be protected, eg. with timber of appropriate thickness, securely fixed.

Brick

The fire resistance ratings of loadbearing walls constructed of solid masonry units are as follows:

Thus, single leaf walls in the workshops, restaurant and health hydro, should be plastered, as this will improve the fire resistance rating.

Construction	Thickness (excluding plaster) in mm, min., for fire resistance rating in minutes of	
	220	110
Unplastered	190	150
Plastered	150	90

Concrete

In concrete's fire resistance of the elements of structure depends largely upon the properties of the aggregates. Light weight aggregates used in reinforced concrete elements would be appropriate for the fire resistance requirements. Light weight aggregates have a loose bulk density of not more than 1200kg/m³ for fine aggregates and not more and not more than 1000kg/m³ for coarse aggregates.

Steel

Structural steel will require a fire resistant coating. This will consist of a primer, the intumescent base coat, and a decorative top coat.

7.6.2 PROVISION OF ESCAPE ROUTES

According to SABS 0040 section TT16, emergency escape routes are not be required where the travel distance measured to the nearest escape door is not more than 45m, such building is not more than two storeys high. Therefore, no escape routes or exit door will be needed.

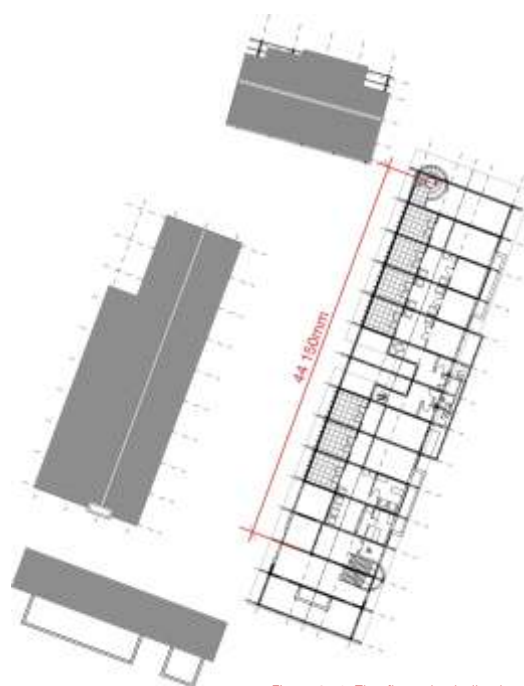


Figure 8.73: First floor plan indicating distance to nearest escape door.

7.7 Rainwater Harvesting

Rainwater harvesting will be feasible, due to the large roof area of the development. The water harvested will be used for irrigation purposes only and not for human consumption. This implies that there will be no need for water treatment. Rainwater can simply be stored for use when needed, or used directly for irrigation.

The financial gain brought about by the rainwater harvesting system in the long run, is its biggest advantage. In this case 1 276kl of water can be salvaged. At a cost of R3 per kl of water R3 828 can be saved annually.

System components

- Catchment area/roof, the surface upon which the rain falls;
- Gutters and downspouts, the transport channels from catchment surface to storage;
- Leaf screens and roof washers, the systems that remove contaminants and debris;
- Cisterns or storage tanks, where collected rainwater

is stored;

- Conveying, the delivery system for the treated rainwater, either by gravity or pump

Catchment area

Metal roofing is the preferred material because of its smooth surface and durability.

Gutters and downspouts

Standard galvanised steel gutter will suffice. The only addition would be a continuous leaf screen to keep leaves and other debris from entering the system. The screen is made of 6mm wire mesh in a metal frame, installed along their entire length of the gutter.

Storage tank

A 1000l standard reinforced fibreglass water tank will be used at the training and therapy center. Rainwater from the other roofs will be directly applied for irrigation purposes through soakage trenches.

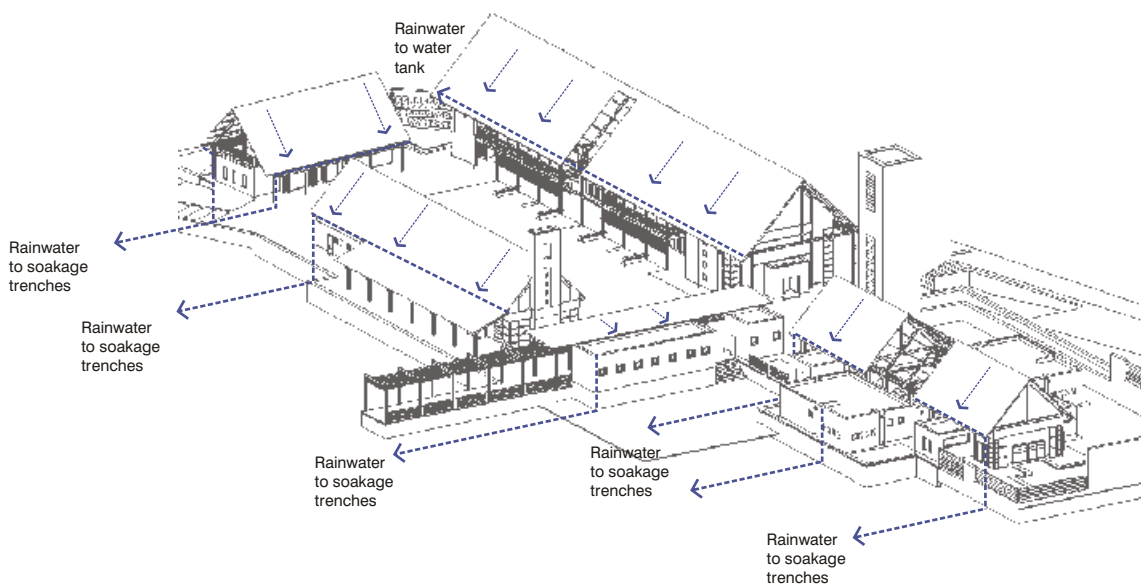


Figure 8.74: Rainwater harvesting strategy

Month	Aggregate rainfall in mm/month for Pretoria	Total water harvesting area = 1 717m ² Total amount of water harvested (kl)
January	101.3	174
February	108.8	187
March	63.8	110
April	37.5	64
May	48.4	83
June	3.8	7
July	2.3	4
August	2.3	4
September	11.3	19
October	82.5	141
November	168.8	290
December	112.5	193
Total	745.27mm	1276kl

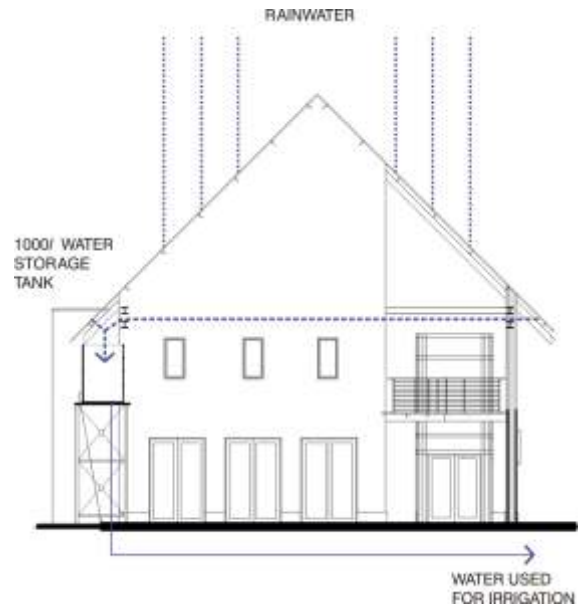


Figure 8.75: Rainwater stored from the training and therapy center roof

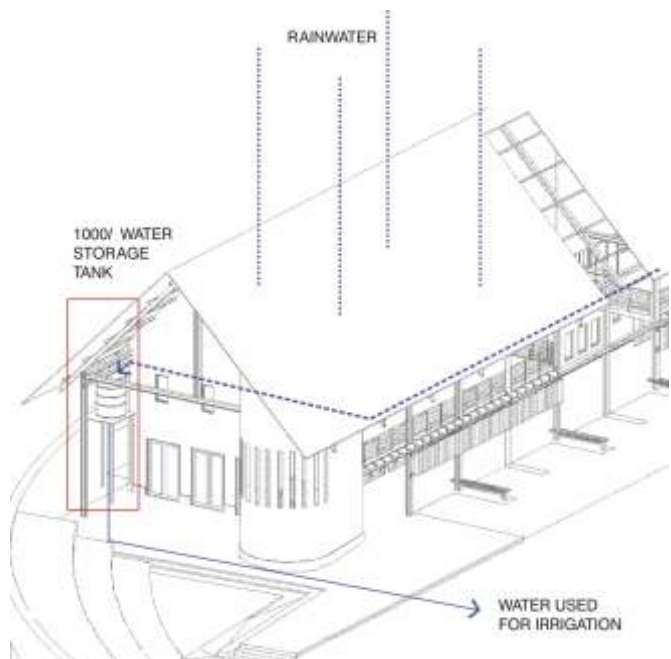


Figure 8.76: Rainwater stored from the training and therapy center roof

TECHNICAL REPORT



Figure 2.1: North perspective of complex.

8.1 List of Drawings

page 135	Building images
page 136	Site plan
page 137	Building image
page 138	Ground floor plan
page 140	First floor plan
page 142	North and east elevations
page 144	South and west elevations
page 146	Section A and B
page 148	Section C and D
page 150	Section E and F
page 152	Section G and H
page 154	Section J
page 155	Section K
page 156	Section L
page 157	Section M
page 158	Section N
page 159	Section P
page 160	Building images
page 161	Detail A
page 162	Detail B
page 163	Detail C
page 164	Detail D
page 165	Detail E
page 166	Detail F



Figure 9.2: Bell tower at main entrance

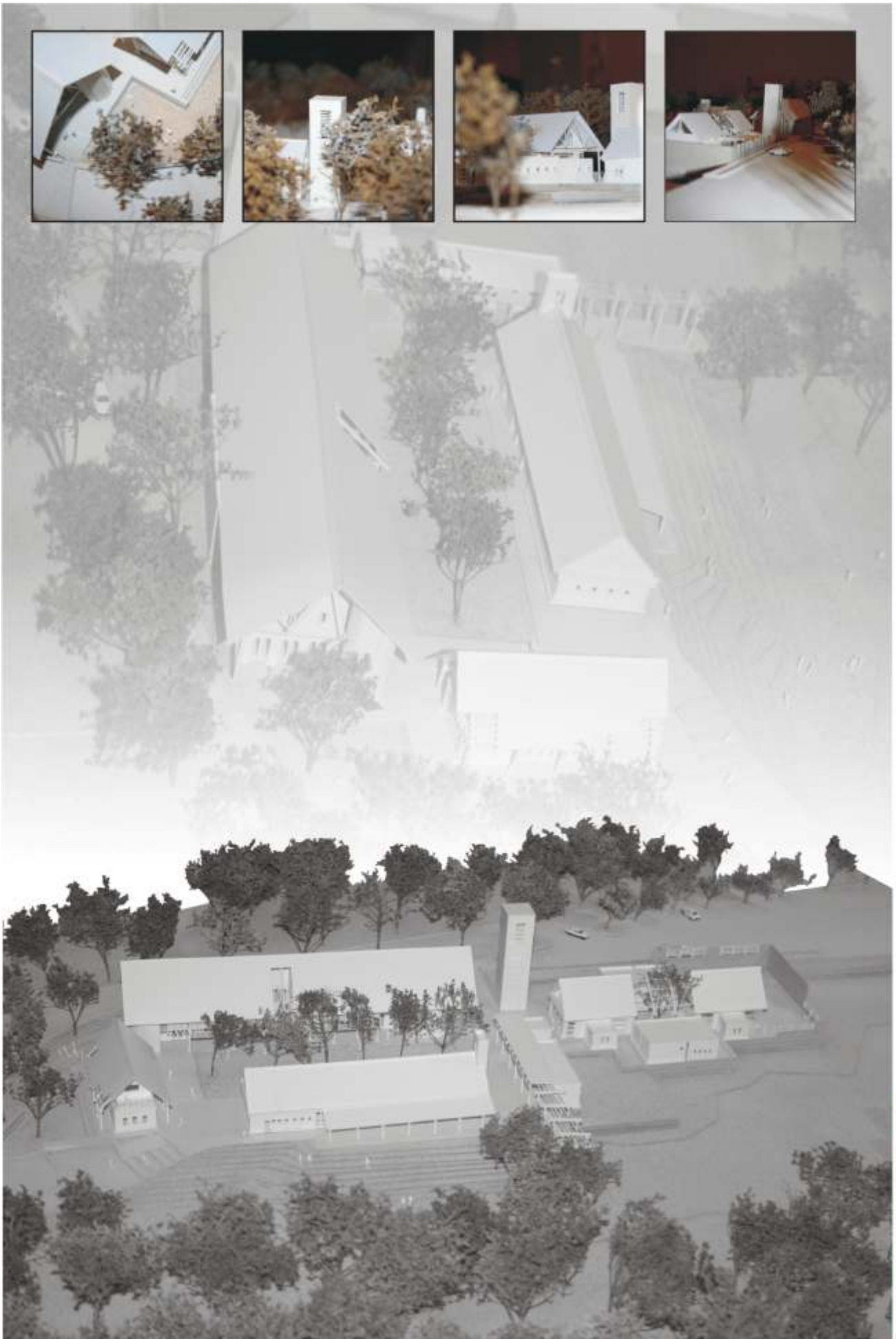


Figure 9.3 Images of the proposed building complex.

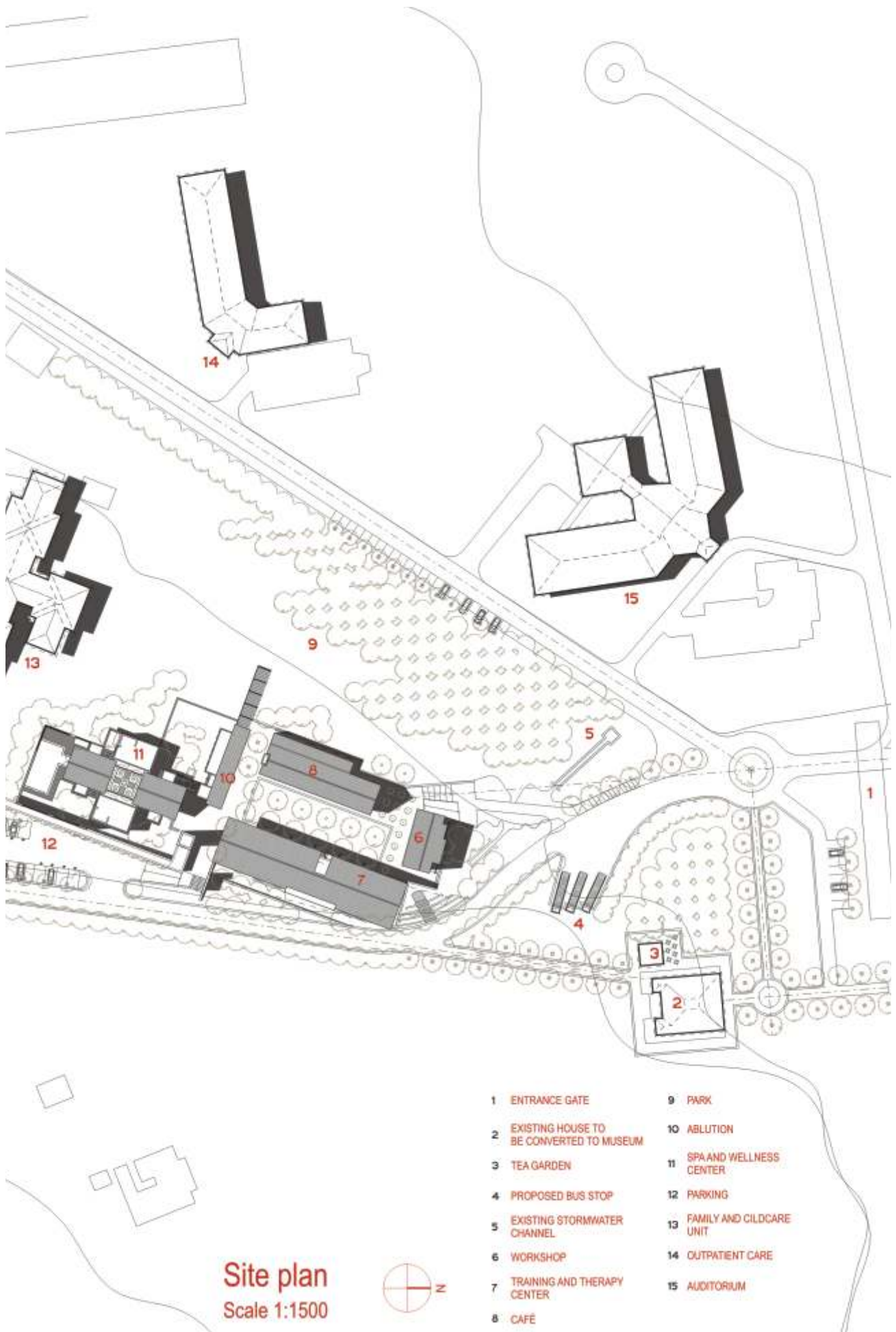




Figure 9.4: Bell tower as seen from parking area



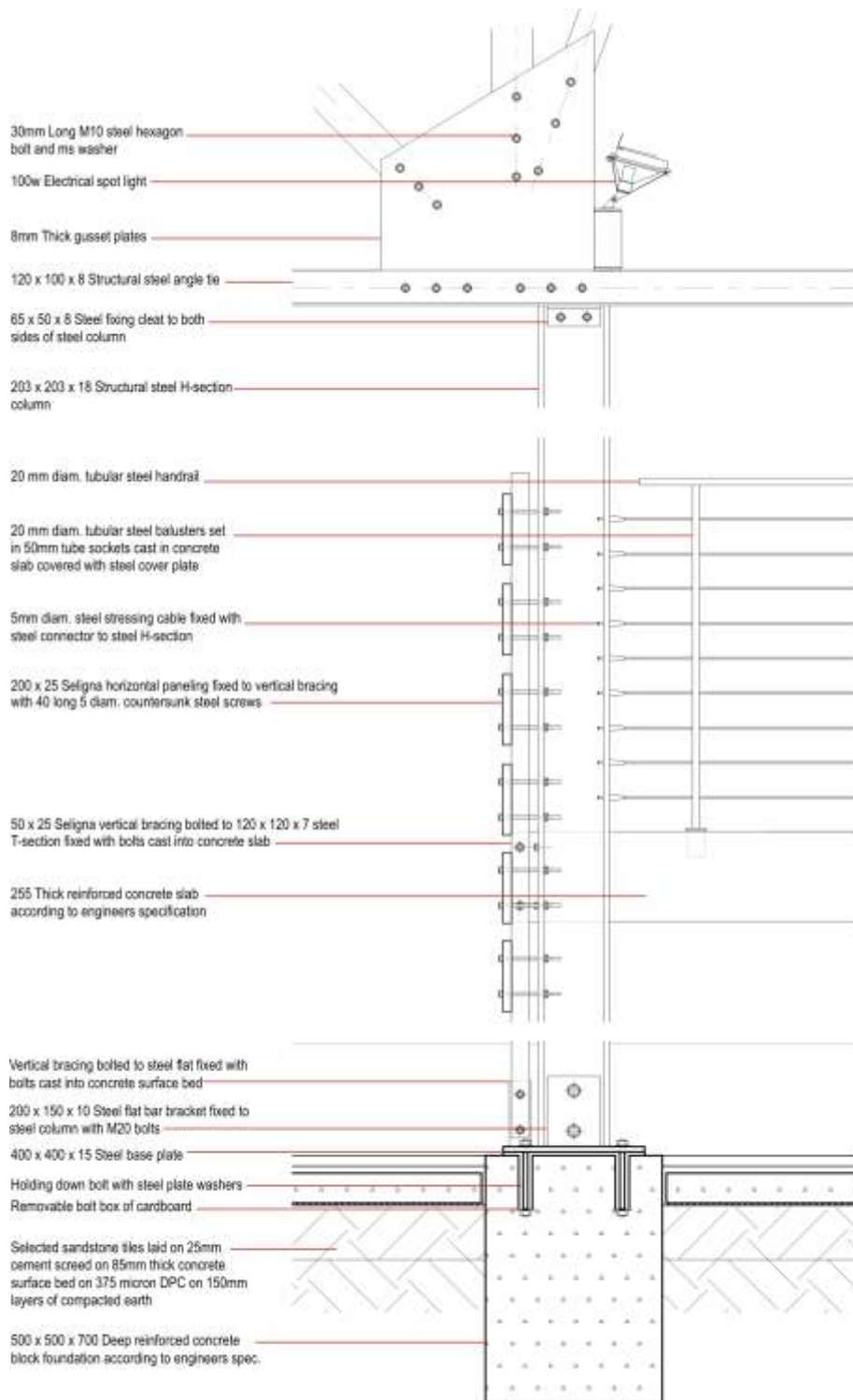
Figure 9.5: South-west perspective of workshop



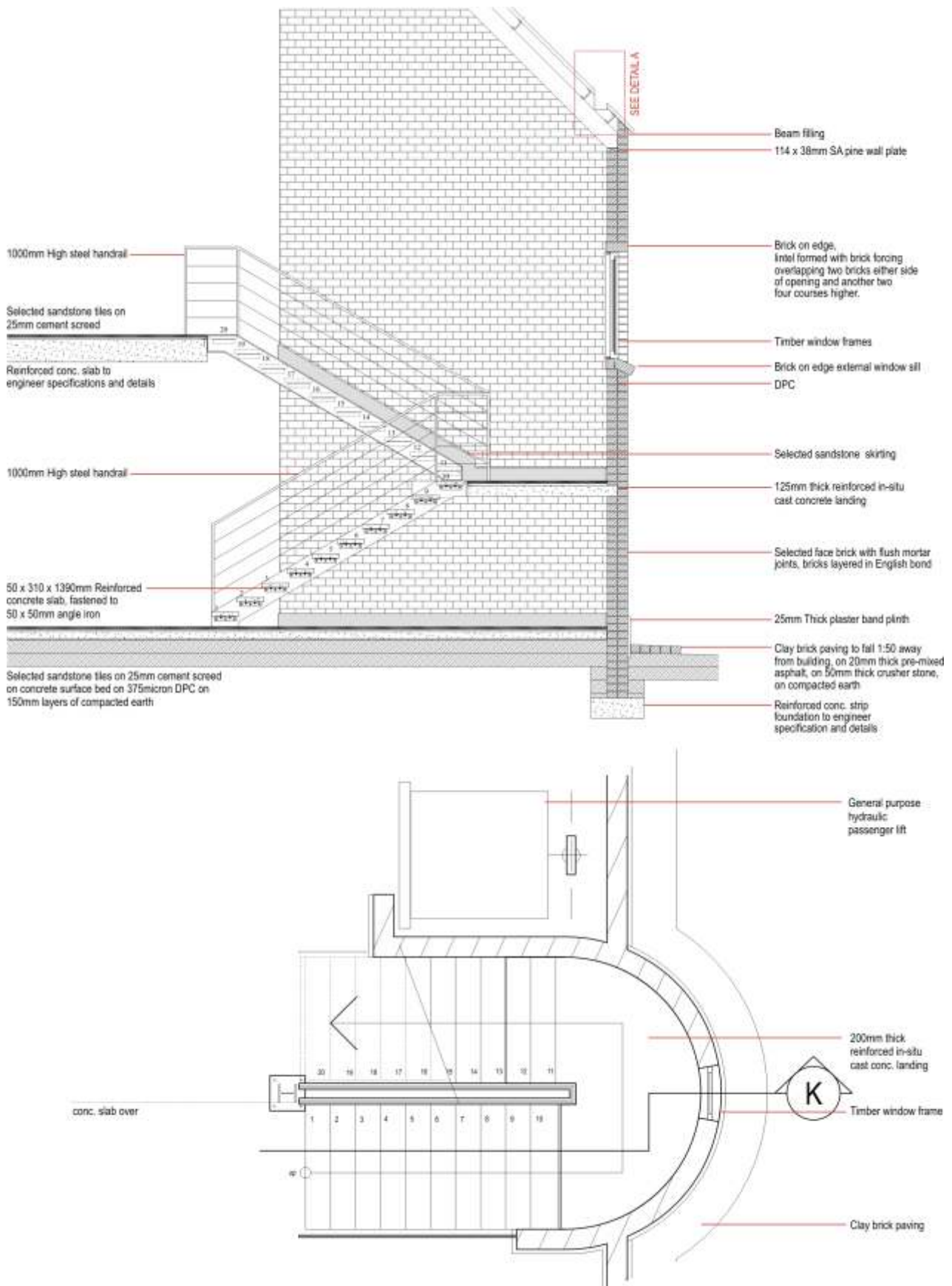
Figure 9.6: North-west perspective of training and therapy center and workshop



Figure 9.7: Complex tower



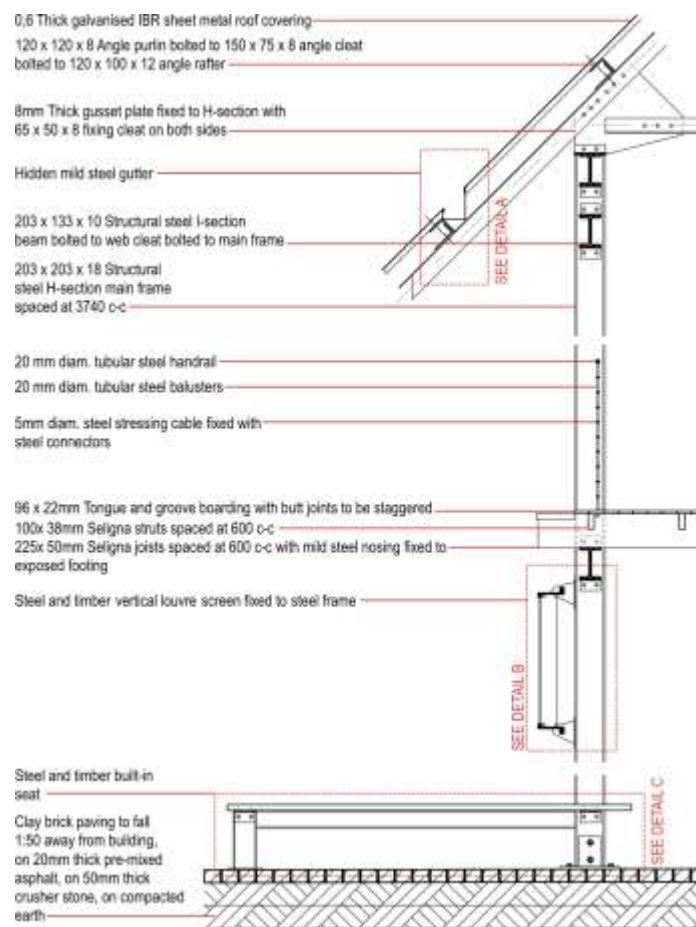
SECTION J - TIMBER SCREEN AND STEEL COLUMN
 Scale 1:20



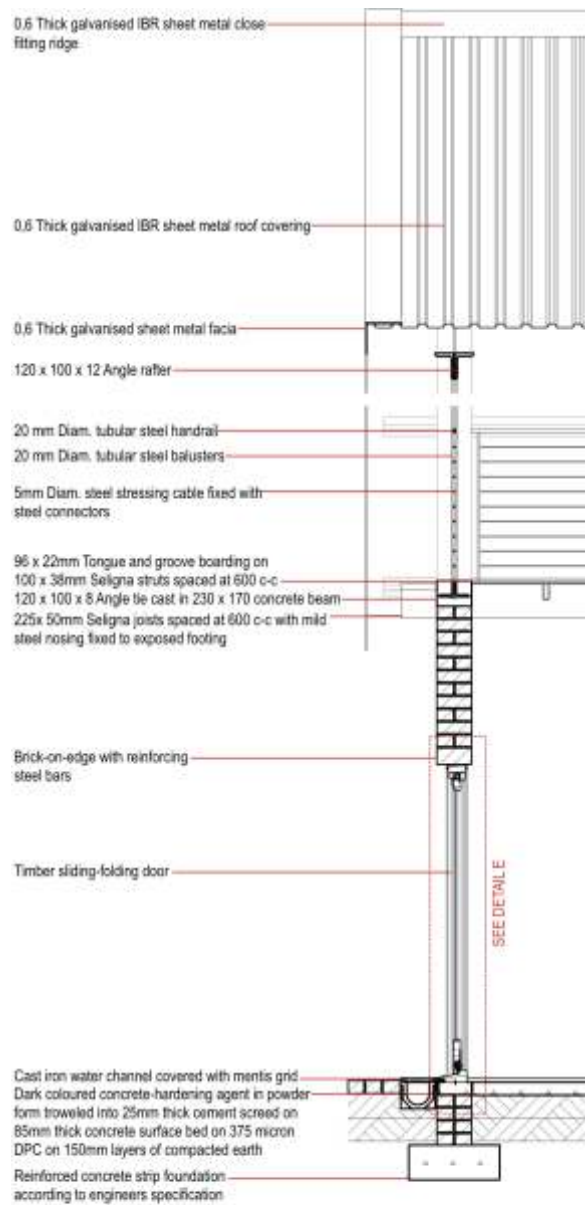
SECTION K - TRAINING AND THERAPY CENTER STAIR DETAIL
 Scale: Not to scale



Figure 9.8: Training and therapy center's west facade



SECTION L - TRAINING AND THERAPY CENTER'S WEST FACADE
 Scale 1:50



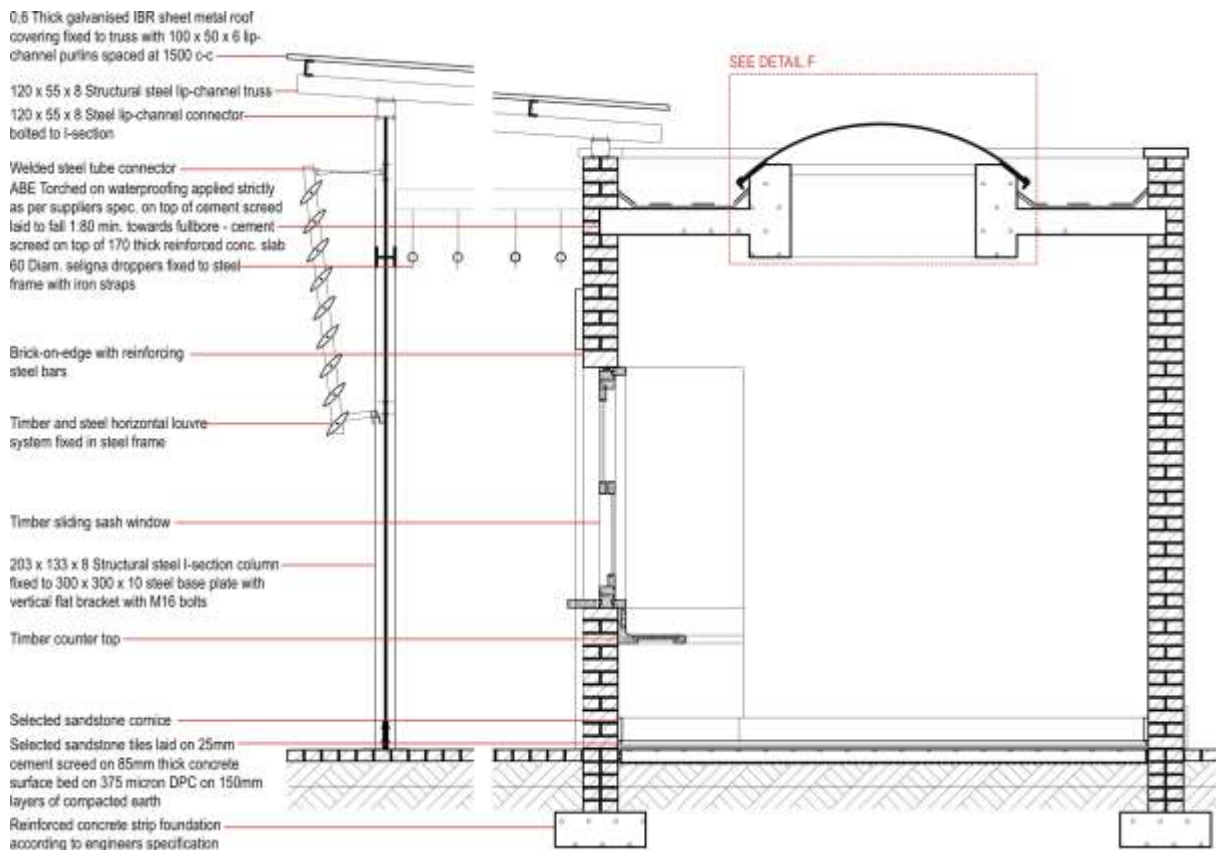
SECTION M - WORKSHOP'S EAST FACADE
 Scale 1:50



Figure 9.9: View from primary movement path



Figure 9.10: View of ablution block and restaurant



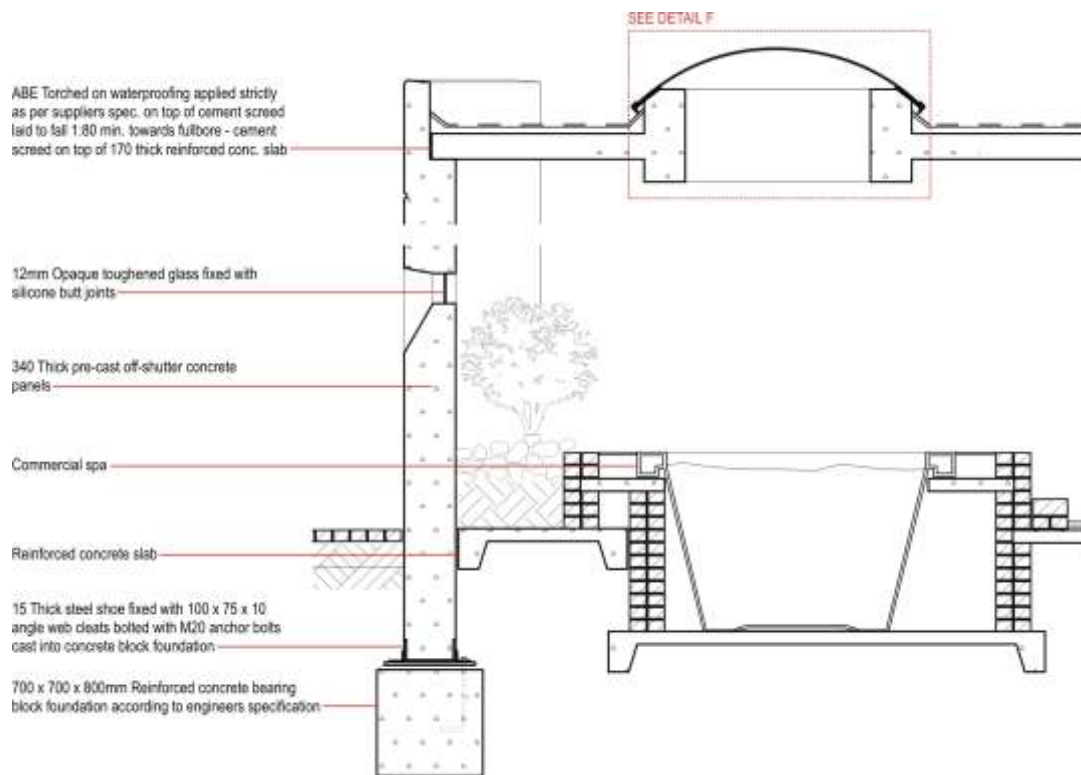
SECTION N - INFORMATION DESK AND COVERED WALKWAY
Scale 1:50



Figure 9.11: View of pool area at health hydro



Figure 9.12: View of pool area at health hydro



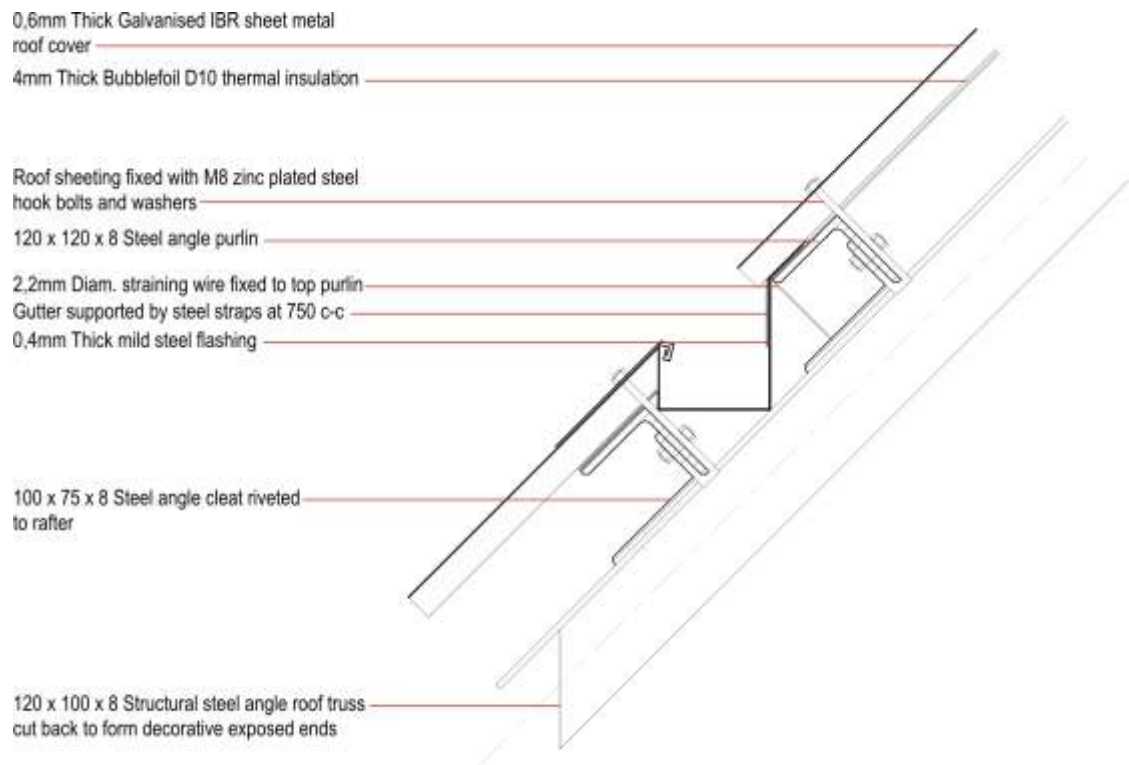
SECTION P - HEALTH HYDRO SPA AND PLANTER
Scale 1:50



Figure 9.13: View of outdoor and indoor pool and lounge at health hydro



Figure 9.14: Entrance to health hydro

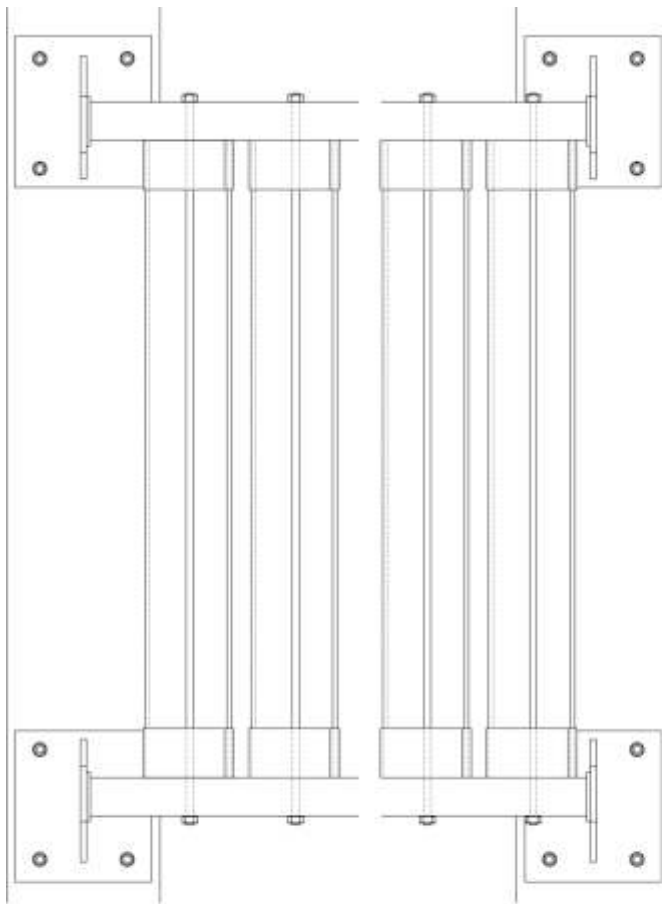


DETAIL A - HIDDEN GUTTER

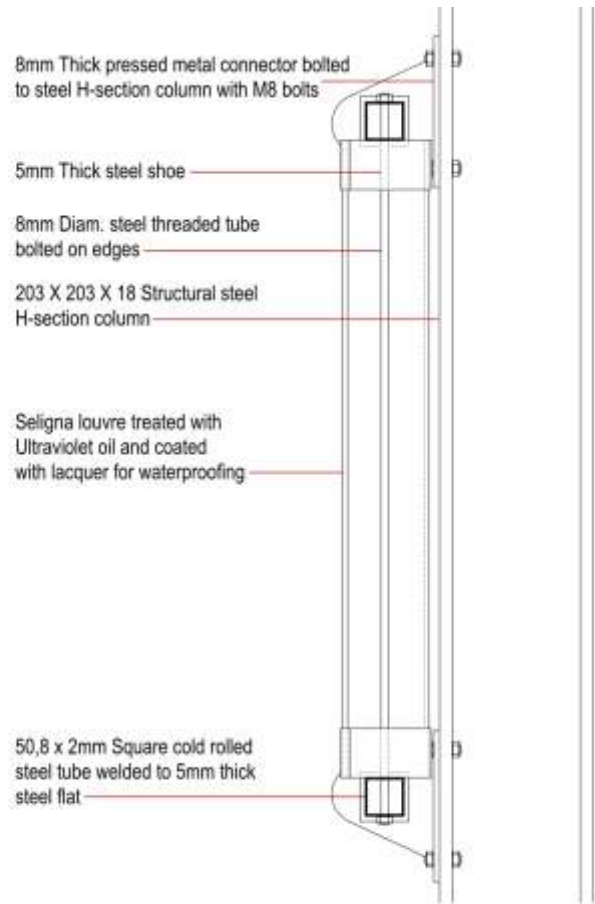
Scale 1:10



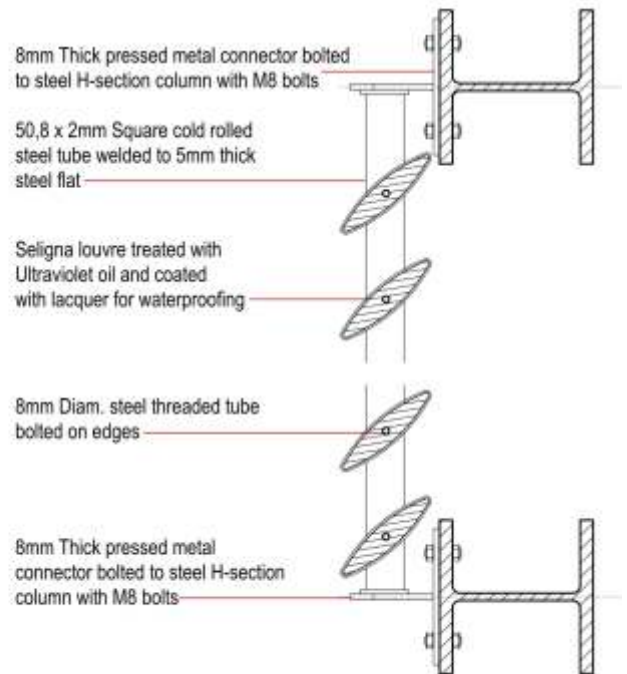
Figure 9.15: View of rooftops



ELEVATION



SECTION



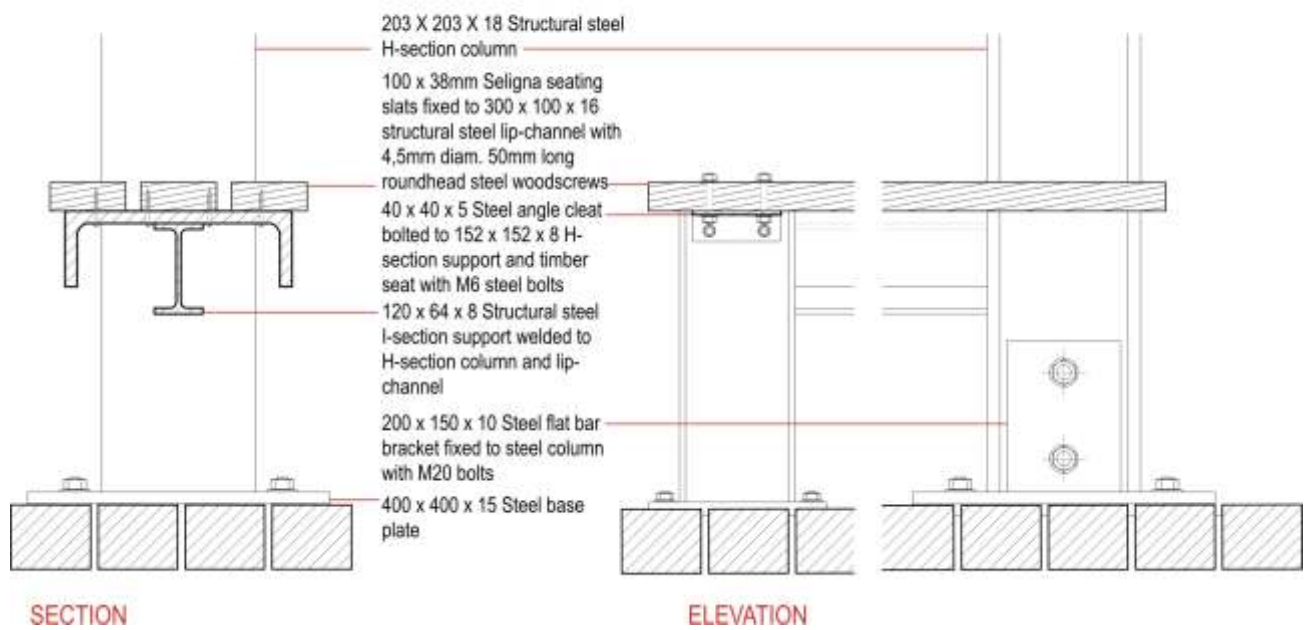
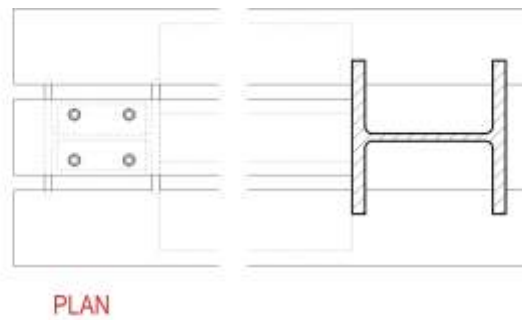
PLAN

DETAIL B - VERTICAL LOUVRE SYSTEM

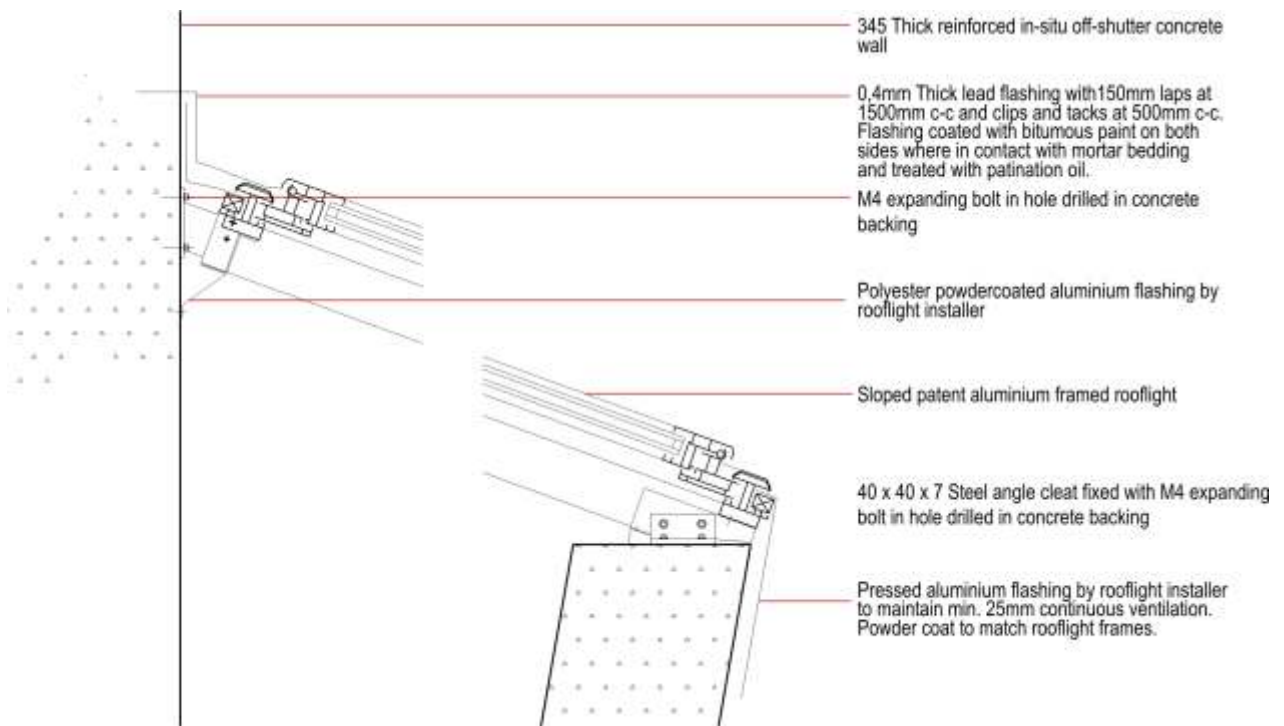
Scale 1:10



Figure 9.16: Built-in seat at training and therapy center



DETAIL C - BUILT-IN TIMBER AND STEEL SEAT
Scale 1:10

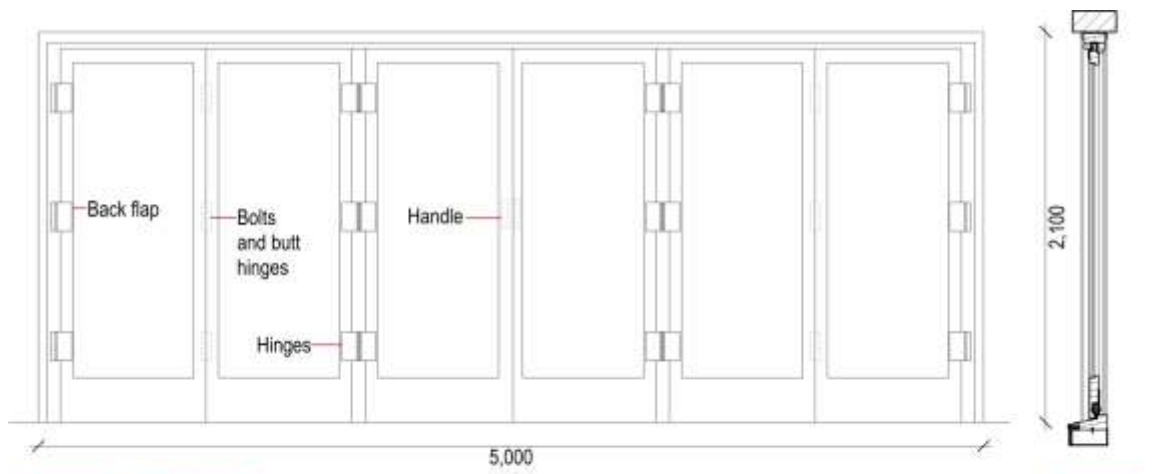


DETAIL D - ROOFLIGHT FOR CONCRETE SEAT

Scale 1:10

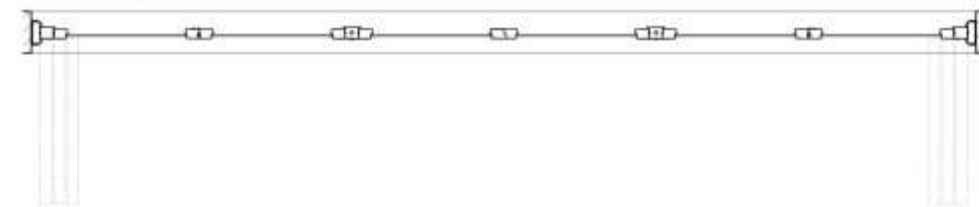


Figure 9.17: North-east perspective of training and therapy center

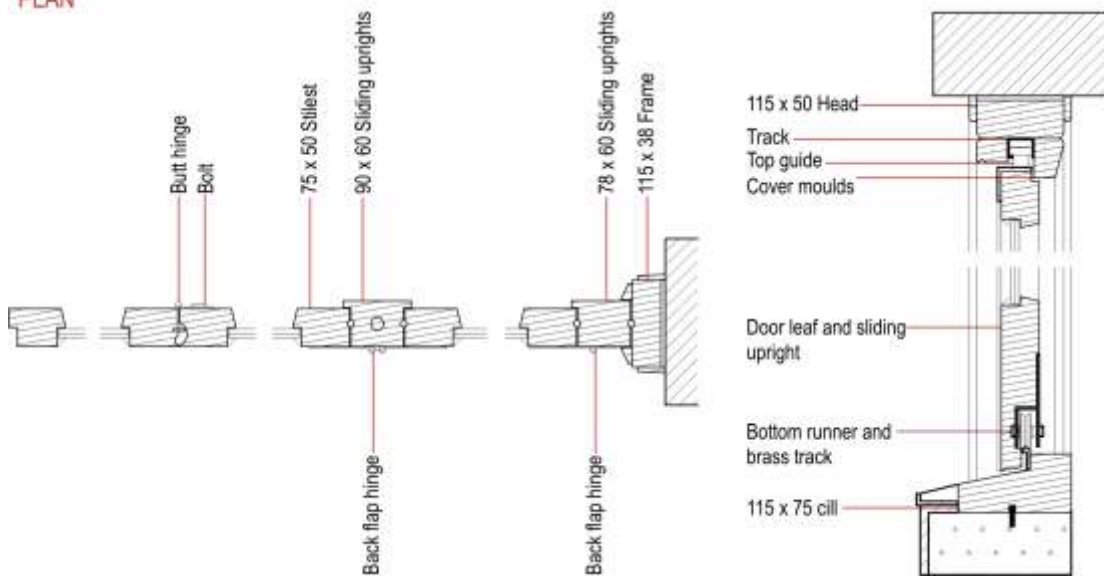


EXTERNAL ELEVATION

SECTION

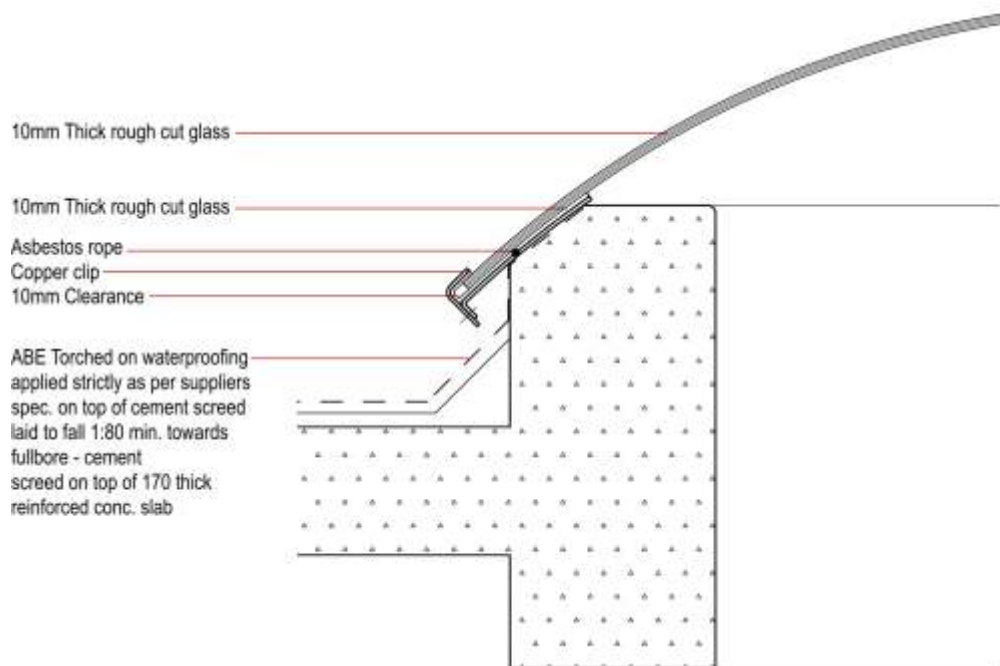
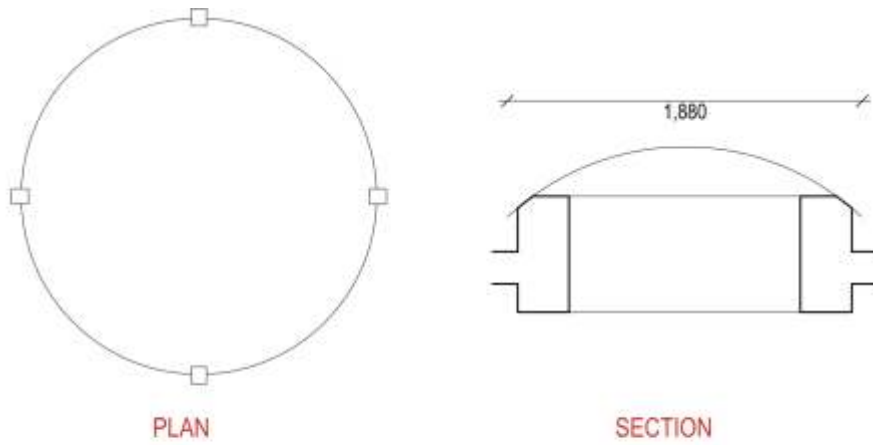


PLAN



DETAIL E - SLIDING-FOLDING DOOR

Scale 1:10



DETAIL F - DOME ROOFLIGHT
Scale 1:10

APPENDICES



Figure 10.1: Entrance gate at historic house on campus

9.1 Appendix A: Treatment of mental illness

	± 1800	± 1900	± 2000
PERCEPTION	<p>In ancient times, abnormal behaviour was viewed as being caused by demons.</p>  <p>In the past, we saw demons that caused psychological disorders as largely external, subject to extrication via exorcism. Today, we see demons as largely internal, requiring psychological treatment.</p>	<p>“Both architectural historians and social historians have tended to frame their views of the Modern Period around the apparently increased institutionalisation of society since the mid-18th century in England. Foucault described the earlier French experience as the “Great Confinement”, a product of Enlightenment thought that found expression throughout Western culture. Criticism of large-scale institutional care was a growing concern since the 1950’s, coming from both the left and from monetarists. Decentralisation however, only became a reality in the UK in the 1980’s. One sees an increasing move away from the older model toward an ever increasing decentralisation and dispersal of social services to the local level, to ‘community care’.” (Weiner 2003:1)</p>	<p>Mental health care has begun to address issues that distresses people on a day-to-day basis such as crime, violence, HIV/AIDS, depression etc.</p> <p>Large-scale institutional care was greatly criticized, resulting in the increasing decentralisation and dispersal of social services to the local level, to ‘community care’.</p>  <p>It is now understood that we are all susceptible to some sort of mental illness. It is estimated that 1 out of every 5 Americans suffer from some sort of mental disorder.</p>
TREATMENT	 <p>Exorcism through flogging, drowning or starving the suspected demoniac in the attempt to drive out evil spirits.</p> <p>During earlier eras, persons who were behaving in ways that did not conform to societal expectations often were subject to torture techniques, such as “dunking”, used for extracting confessions of witchery. The accused witch was repeatedly submerged. The longer it took her to die, the more fervently her accusers would assert that the devilish powers were permitting her to survive.</p>	<p>Patients were seen as having a psychological base of abnormal behaviour that needed to be treated. A lot of experimentation was done on humans and animals.</p> <p>During later years disorders were starting to become identifiable and could be treated with appropriate medication. Theory of personality development and psychotherapy.</p>  <p>French neurologist Jean Martin Charcot instructed medical students on the use of hypnosis as a method to cure hysteria and other mental illness.</p>	<p>Humanistic psychology: Focus on free will and self-actualization of human potential; focus on conscious rather than unconscious experience.</p> <p>Psychotherapy: advantages of group therapy may include reduced cost, greater social pressure to effective positive changes and greater diversity of persons who may offer a fresh perspective on a troubling situation.</p> <p>Health psychology: company-sponsored employee exercise programmes often yield financial benefits for the employer, as well as fitness benefits for the employees.</p>  
BUILT ENVIRONMENT	<p>Institutions resembled overcrowded prisons more than a true hospital and its inmates were treated more like prisoners than like patients. Many inmates were chained to the walls of the cramped quarters, often in positions that did not allow them to sleep properly. Others were chained to large iron balls, which they to drag along with them wherever they went.</p> 	<p>Small purpose-built ‘community care’ facilities providing specialized care.</p>  <p>Maap Architects’ design for residential mental health care at Highcroft Hospital in Bermingham pioneers a new wave of small-scale facilities. Drawing of the older Adult Acute Unit.</p>	<p>The latest hospitals bring in the perspectives of patients, their families, and the local community, in addition to those of doctors and staff. Hospitals have adapted to a rapidly evolving health-care environment by becoming more inclusive places.</p> 
CONCLUSION	<p>Because society was afraid of the mentally, it resorted to not only confining the “possessed”, incarcerating these unfortunate souls, but chained them to walls.</p> <p>This practice of imprisonment stemmed from a lack of understanding that produced warped perceptions and in turn inappropriate actions.</p>	<p>The better understanding of mental illness within the medical profession had a huge impact on the built environment. Suddenly the fear of the mentally ill started dissipating and the buildings used as prisons to incarcerate patients where increasingly criticized.</p> <p>De-centralized facilities were the next step. The aim of these units was to allow patients to become part of their communities, or be community based. The reality, though, is that these groups of people were still misunderstood by society, therefore rejected.</p> <p>A personal view is that this type of building type can not be called community care, as the patients do not stem from the community, but institutions. These facilities are not accessible for the general public to receive support and treatment, but are for the use of the institutions.</p>	<p>Modern day treatment facilities are primarily focused on maintaining health, rather than curing the sick. The perspectives of the people being served, their families and even the surrounding communities are being incorporated in hospitals. New perceptions of the needs of patients, carers and the community have posed new demands on design solutions, including siting, private space, gender, discipline, dependancy and responsibility, as well as sound, light and colour.</p> <p>“Very few overviews or assessments have been made in terms of the design of new community mental health centers - a new building type - either in terms of stated needs and ambitions or in terms of what these buildings say of the society that produced them.” (Deborah Weiner, 2004).</p> <p>What do the new designs, spaces and sites mean for providers for medicine, for patients and community? What have been the contributions of architects and designers to this transformation in mental health care?</p>

9.2 Appendix B: Newspaper Article 1

State dumps the mentally ill

Thousands of chronically sick people are being turned out of hospitals, but community support services are in a shambles

HOWA PHILIP

THE state dumped Peter Dotsis on the family's doorstep because it argued that he would get better care at the same institution as he was getting in hospital.

The 32-year-old was discharged into "voluntary mental health care", the chronically mentally ill man, however, his need against the wall every day, he is picked up by police almost every week and has attacked and harmed his wife and three children.

Dotsis, 32, had received an indication of mandatory care whatsoever. The government dumped him from the home of a woman, when healthy, was so thoughtful that he phoned regularly with a message that he would not have had to pay for a night. At most psychiatric hospitals are forced to cut their chronic beds by roughly half the levels of 1997, chronically mentally ill patients are being rejected from hospitals and dumped with no talking or supervised leaders.

A Swaziland Times investigation has found that the comprehensive services which the government decided to replace psychiatric hospital care, but doesn't exist, that people like Dotsis have been simply abandoned.

Public psychiatrist, Dr John Winkler, said he thought he had become his "trailer" and had "a right to his freedom" after seven years of confinement at Kwekwe State Clinic west of Johannesburg. But Winkler acknowledged that chronically mentally ill people had been abandoned with "a burden".

Dotsis's mother, Melia Dotsis, said: "I can't live like this — I am afraid to go out to attack her as well. There, there, help and no one helps us."

On two occasions, Winkler has walked the alien road with Melia Dotsis to the station, that which she and psychiatric hospital staff had never had the opportunity to get any medicines for him.

This week, abandoned state psychiatric — whose state wards are now equipped with reduced deinstitutionalised patients — declared community services a disaster.



OUTCAST: Steven Muboko backs at a world that doesn't care. Pictures: SYDNEY SESHIBIDI



TRAGIC: Maria Willemse is terrified of her chronically mentally ill son Fanie Dotsis, left.

When I know they are potentially violent, and that their families are at risk," said Minister Mokoena (Mandela) of this, they say "We are afraid, Doctor, and I say to you, I cannot keep them in. The obliged to empty beds."

"Some cases of long-term discharge were, but about 70% of our patients are "incomplete discharges".

Following administrative head to give long-term mental patients the chance to develop outside hospital, provincial health departments responded to pressure from the national department last year.

Professor Mervyn Freeman, who led the team that drafted the law, said this week he hoped the Act would see far more mentally ill people employed under the Employment Equity Act, because of the provision that no one may discriminate against a person because of mental ill health.

"It's very rights-oriented, and it empowers community care," said Freeman. However, he admitted that no indication was given to temporarily certify a person, pending a later assessment by a doctor.

"It acknowledges various approaches of psychiatric patients that dated back to the apartheid era and allowed for human rights abuses such as late psychiatric diagnoses to confer political protection, summary sterilisation and the use of electric shock therapy without consent."

Freeman said the new law also dealt with the limitations of the mental health care sector. Presently, two psychiatrists or three surgeons were required to "certify" a person as an involuntary patient. Now the signature of two health workers will be enough to temporarily certify a person, pending a later assessment by a doctor.

chronic shortage of psychiatric nurses and mental workers.

Outcasts are commonly not seen at all in South Africa because there are now more than 90 state psychiatric facilities to treat patients countrywide. There are only two in the whole of Johannesburg.

At the height of the government's cuts on how an 18th level-mentally ill patient is housed at the Graham South Department was forced to look for a very narrow bed for a patient who had never before been in a hospital.

"On July 28 2003 of 120 000 severely mentally ill people in custody — the province with the best community health resources — severe mental community care, a patient with a severe mental illness was taken to a psychiatric hospital clinic — Madisa Clinic in Durban — over the jobs of three nurses, a pharmacist and a clerk. During this week that none of the 500 patients who received medication had ever been followed up due to a chronic staff and transport shortage."

This week, Madisa Clinic considered that the policy was "to ensure that the policy was 'to ensure that they were in hospital, and that they were not even prepared to take the fact that community services are far from what they would be if it was successful (the right we are exercising on the province) to get it up to scratch."

"It is the function of the psychiatric state to do whatever, but there is no transport. Unfortunately, that is the reality."

Solly Phakiso, a former assistant occupational therapist at Madisa West, admitted that a dozen inmates who had been in custody for 18 months and had been subjected to their own mental health care had been subjected to their own mental health care.

Phakiso said that had been kicked out of their homes, and had either had their own mental health care or had been subjected to their own mental health care.

Phakiso said that had been kicked out of their homes, and had either had their own mental health care or had been subjected to their own mental health care.

The many worlds of George Syllas

HOWA PHILIP

GEORGE Syllas negotiates with social leaders every week.

This week, he followed that he had negotiated the financing of the Madisa West project. But in the past, he had been a social worker and a social worker and a social worker.

Syllas, 33, also has a full-time job — a social worker — and a part-time job — a social worker. He is a graduate of a social work degree system between hospital and society. He is a social worker, a social worker, and a social worker.

Syllas is both a staff member and resident at "Madisa West", a halfway house and "psychiatric" hospital for severely mentally ill patients.

A former superintendent and bakery assistant, Syllas has a health degree and a social work degree. He is a social worker, a social worker, and a social worker.

He added he was recovering in a multiple combination of people — a combination of people — a combination of people — a combination of people.

He said: "I am not a social worker. I am a social worker. I am a social worker. I am a social worker."

He said: "I am not a social worker. I am a social worker. I am a social worker. I am a social worker."

other severe mental illnesses, including personality and bipolar disorders. Most were discharged to the houses from psychiatric hospitals.

But in one there is a patient in the bed and all go home every night, and the residents themselves are in charge of the day-to-day running of the facility.

Most residents have left houses and some have jobs. Last week, Syllas, clinical director of the foundation, overhauled all employees and laid cards for the weekend when a member behind another to become a staff member. The resident executive could not do it.

The trick is to keep a sense of humor and not to let the two worlds get mixed up — a lot of the people I speak to are mad as hell," Syllas said. "The fact is, I have been living with it for some time, but I am not a social worker. I am a social worker. I am a social worker. I am a social worker."

Syllas works in the street and in the home. He is a social worker, a social worker, and a social worker.

He added he was recovering in a multiple combination of people — a combination of people — a combination of people — a combination of people.

He said: "I am not a social worker. I am a social worker. I am a social worker. I am a social worker."

He said: "I am not a social worker. I am a social worker. I am a social worker. I am a social worker."

He said: "I am not a social worker. I am a social worker. I am a social worker. I am a social worker."

Figure 10.2: Newspaper article from Sunday times, dated March 14 2004

New law emphasises patients' rights

A RADICAL new law is aimed at making psychiatric beds available to mental health patients by reducing the role of imprisonment and granting massive and other health workers the power to confine psychiatric people temporarily.

However, it also makes it much more difficult to keep patients in their mental hospitals for 30 days of assessment and giving patients the right to appeal against their treatment, and only needs to do so.

Repealing the Mental Health Act of 1973 — which had the effect of keeping both patients and treatment behind locked doors — the Mental Health Care Act of 2003 is expected to come into effect in a few months.

The law outlines a new charter of patients' rights — to be displayed in the walls of mental health institutions — and the

introduction of review boards to ensure proper treatment and that no one is confined to psychiatric hospital indefinitely.

However, it limits the rights of health-care workers their rights to confine psychiatric people in their own homes.

Professor Mervyn Freeman, who led the team that drafted the law, said this week he hoped the Act would see far more mentally ill people employed under the Employment Equity Act, because of the provision that no one may discriminate against a person because of mental ill health.

"It's very rights-oriented, and it empowers community care," said Freeman. However, he admitted that no indication was given to temporarily certify a person, pending a later assessment by a doctor.

"It acknowledges various approaches of psychiatric patients that dated back to the apartheid era and allowed for human rights abuses such as late psychiatric diagnoses to confer political protection, summary sterilisation and the use of electric shock therapy without consent."

Freeman said the new law also dealt with the limitations of the mental health care sector.

Presently, two psychiatrists or three surgeons were required to "certify" a person as an involuntary patient. Now the signature of two health workers will be enough to temporarily certify a person, pending a later assessment by a doctor.

"It acknowledges various approaches of psychiatric patients that dated back to the apartheid era and allowed for human rights abuses such as late psychiatric diagnoses to confer political protection, summary sterilisation and the use of electric shock therapy without consent."

Freeman said the new law also dealt with the limitations of the mental health care sector.

Presently, two psychiatrists or three surgeons were required to "certify" a person as an involuntary patient. Now the signature of two health workers will be enough to temporarily certify a person, pending a later assessment by a doctor.

Freeman said the new law also dealt with the limitations of the mental health care sector.

Presently, two psychiatrists or three surgeons were required to "certify" a person as an involuntary patient. Now the signature of two health workers will be enough to temporarily certify a person, pending a later assessment by a doctor.

"It acknowledges various approaches of psychiatric patients that dated back to the apartheid era and allowed for human rights abuses such as late psychiatric diagnoses to confer political protection, summary sterilisation and the use of electric shock therapy without consent."

Freeman said the new law also dealt with the limitations of the mental health care sector.

Presently, two psychiatrists or three surgeons were required to "certify" a person as an involuntary patient. Now the signature of two health workers will be enough to temporarily certify a person, pending a later assessment by a doctor.

ANALYSIS

Mental health care functions on three levels.

- Primary mental healthcare

This type of mental health care is integrated with other health care services and is supposed to be accessible to the general public as a first point of contact if help, information or treatment is needed.

- Secondary mental healthcare

General hospitals serve as secondary mental health care facilities, but are obviously not primarily concerned with the mental health of the general public. According to the new Mental Health Care Act the function of the general hospital is only to retain a patient for observation during a 72 hour period in order to determine whether the patient should be admitted to a institution.

- Tertiary mental health care

Weskoppies hospital is classified as a tertiary mental hospital. This is where patients are admitted when in need of specialist treatment. Weskoppies's primary aim is also not for community mental health, but if primary mental healthcare do not function optimally, it becomes their concern.

SYNTHESIS

- Patients are discharged into "community mental healthcare", but do not receive help.
- As most psychiatric hospitals are forced to cut their chronic beds by roughly half the levels of 1997, chronically mentally ill patients are being evicted from hospitals and dumped with unwilling or untrained families.
- A Sunday Times investigation has found that the comprehensive service which the government devised to replace psychiatric hospital care just doesn't exist.
- That same week, anguished state psychiatrists - whose acute wards are now swamped with relapsed de-institutionalised patients - declared community services a disaster.
- Doctors discharge patients knowing they are not ready because they are obliged to empty beds.
- About 70% of the patients in some hospitals are re admissions.
- The money saved by discharge - roughly R3 000 a patient a month - were supposed to go to community mental healthcare.
- Out patients are commonly not seen or assessed at clinics because there are now fewer than 80 state psychiatrists available to treat patients countrywide.
- The families the government counts on have so little involvement with relatives in hospitals that, in the case of

Rand West, the Gauteng Health Department was forced last year to hire amateur investigators to trace 100 families who had never bothered to visit.

- Only 38 000 of 120 000 severely mentally ill people in Gauteng - the province with the best community health resources - receive any formal community care.
- Edith Madela-Mntla, head of the national Directorate of Mental Health and Substance Abuse, confirmed that "we are not even prepared to hide the fact that community services are far from what they should be. It is an enormous challenge; we are depending on the provinces to get it up to scratch."
- The new Mental Health Care Act of 2002 omits the rights of families and increases their role in caring for the mentally ill people in the community.
- Professor Melvyn Freeman, who led the team that drafted the law, said that "no assistance was guaranteed for the families of patients".
- Gauteng psychologist Dr Gale Ure, author of *Principles of Recovery and Psychosocial Rehabilitation*, said "The law sounds lovely, but if you really read it, it still basically says: 'We'll lock you up as long as we like'."
- The promised system of follow-ups and home visits by social and health workers simply does not exist, because there are no vehicles, and because of a chronic shortage of psychiatric nurses and social workers.

When primary mental healthcare is "not up to scratch" the patients become the burden of State hospitals, family and the community. This situation is worsened by the State trying to get rid of patients, and rightfully so. Weskoppies costs the State R8 million a month to sustain.

9.3 Appendix C: Newspaper Article 2

Monday February 28 2005

Sowetan

THE SOUL TRUTH

Late Final R2.50

R100 000
up for grabs
With **Sunail**

INSIDE

STOP THIS MADNESS



Jasper van der Blik
Patients of Pretoria's
Weskoppies Mental Hospital
live under shocking conditions,
a Sentinel investigation
has revealed.

Our team spent two weeks
investigating various allegations
of mistreatment at the
state-run institution.

The claims — all vehemently
denied by management at the hospital —
included:

- Suicide is common at
the hospital;
- Patients are assaulted
regularly;
- Some security guards
are corrupt and are
often bribed by
patients;
- Dangerous criminals
mix freely with other
patients, and
- Even patients are
harassed.

See pages 4 and 5

41 SOWETAN Monday February 28 2005

CHAOS, CRUELTY

State patients subject to horrific abuse



REPORTER VAN DER BLIK
In a room that has been called
"Weskoppies' hell" by a patient, a
man in a white shirt looks at
the camera with a grimace.
The man is Jasper van der Blik,
a reporter for the newspaper.
He is in a room that has been
called "Weskoppies' hell" by a
patient. The man is Jasper van
der Blik, a reporter for the
newspaper. He is in a room
that has been called "Weskoppies'
hell" by a patient. The man is
Jasper van der Blik, a reporter
for the newspaper. He is in a
room that has been called
"Weskoppies' hell" by a patient.

DEREGULATION OF TELECOMMUNICATIONS
MEANZ THE NET GATE IS LOWER THAN ALL THE OTHERS
SOBU ECU CAN GAIN
A financial boost of a **million billion Rand**
Telecommunications industry

LIMITED BUSINESS OPPORTUNITY

**There are a million of
"10 million a year" in
business we discover
signs of success in the
past months"**

Your future starts here
Career opportunities 2005

ANALYSIS

The mental institution can be an intimidating and frightening place for patients and visitors. Institutions can be damaging and there are many factors that contributes to this.

SYNTHESIS

Steffan Davies described his own personal experience gained in a high security institution where he worked. He contributes many of the problems to a lack of understanding by the media, politicians and even their own staff.

He describes the institution, based on E. Goffman, the author of *Asylums*, as possessing the following characteristics:

- a barrier to social intercourse with the outside and to departure, which is often built-in (e.g. high walls);
- all aspects of life are conducted in the same place and under a single authority;
- each member's daily activities is carried out in the company of a batch of others;
- all phases of the day's activities are tightly scheduled;

- the activities are brought together in a single rational plan purportedly designed to fulfil the official aims of the institution;
- a basic split between a large managed group (inmates) and a small supervisory staff;
- grossly restricted social mobility between the two strata;
- the staff control information, decision-making and access to the institutions hierarchy;
- being resident in an institution is incompatible with family life.

Some of the harmful effects according to Davis:

- *Loss of liberty* Patients may not be free to leave, move around the institution, have access to their own possessions
- *Social isolation* Difficulty for family visiting, restrictions on phone calls and letters, discouragement from staff, stigma on families, peers who may not be amenable/desireble social contacts.
- *Institutionalisation* Reduced interaction, impoverished social skills, loss of motivation, reduced communication.



Figure 10.3: Newspaper article in the Sowetan on 28 February 2005

Conflicts in care:

- Public attitudes, especially mixed message
- Punishment v. rehabilitation
- Public safety v. patient rights
- Empathetic therapeutic relationship v. disgust at crimes
- Caution and safety v. pressure to admit and discharge
- High quality v. cost pressures
- Victims v. aggressors (it is not unusual to be both)

INTERVENTION

From analyzing the institution the following interventions can be proposed:

- Patient groups with differing needs can be more difficult to manage. Therefore, care should be given to illness specific groups.
- Insufficient care can often be contributed to a lack of resources. Thus it could be a viable option for the community center to gain an additional income.
- Physical environments should be maintained as a

poor physical environment can contribute to poor care.

- Every effort should be put in to combat a negative and demoralizing culture within the confines of the site.

- *Deteriorating mental health* Lack of stimulation, depression, hopelessness, substandard psychiatric treatment.
- *Poor physical health* Poor diet, lack of exercise, poor physical health care, smoking, side-effects of medication
- *Death* Suicide, neglect, lack of care, murder

Mechanisms of harm

- Consequences of poor practice
- Institutional needs taking precedence over patient care
- Insufficient quantity and quality of care
- Well-intentioned but misguided care
- Neglect
- Direct, malicious assault

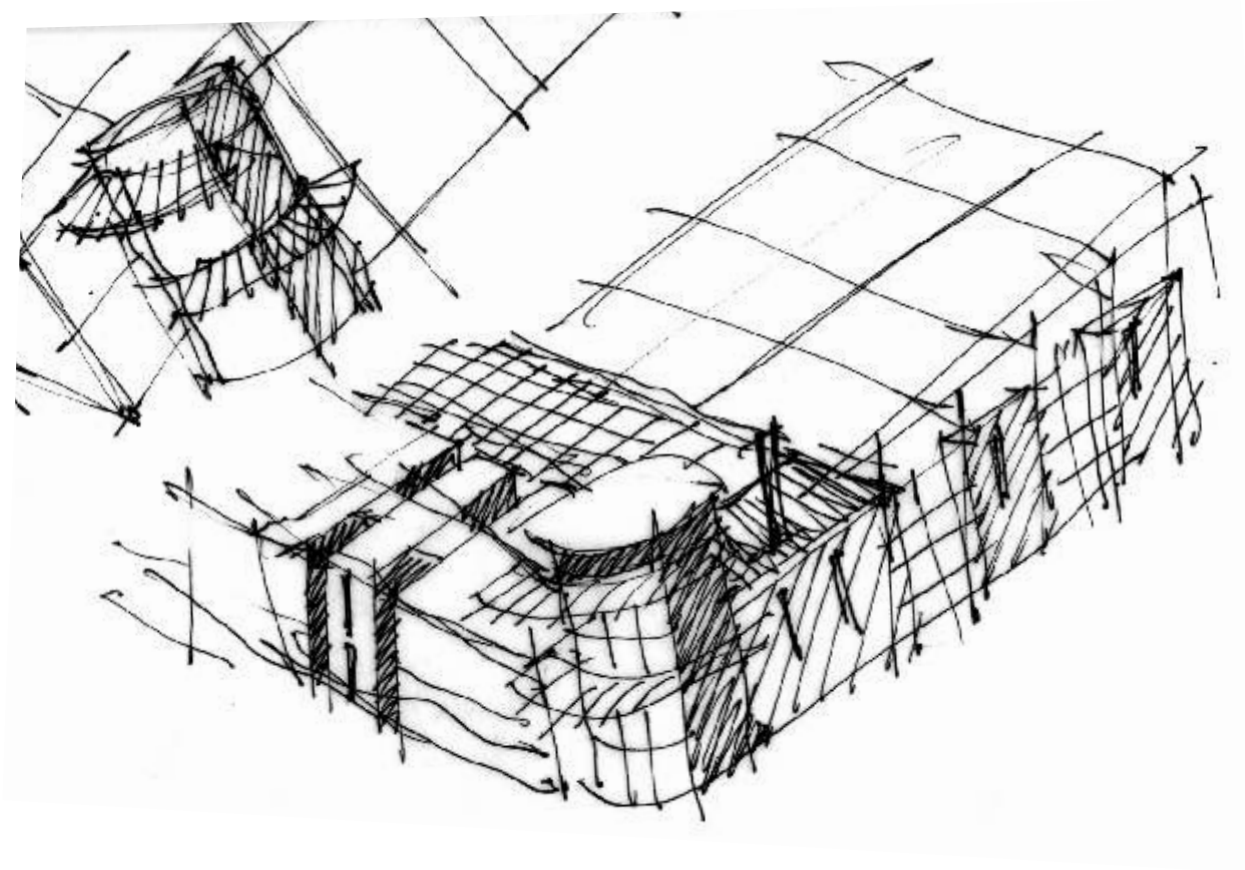
Institutions are usually created to deal with social problems. Their inmates, residents or patients are therefore, according to Davies, often also economically deprived, mentally disordered, criminal, delinquent, poorly educated and poorly integrated in society. (Davies 2004:25)

IMPLEMENTATION

Some factors can be implemented to maintain healthy mental facilities:

- Openness to the outside world, to new ideas and external scrutiny. In the case of Weskoppies, they have functioned to long without community input and this contributed to negative publicity, that is not necessarily true.
- Political and public understanding of the facilities functions
- Clarity of purpose, realistic expectations and explicit values
- Good-quality physical environment and healthy therapeutic milieu
- An ability to tolerate uncertainty and to learn from mistakes
- Robust systems for training, development and supervision of staff. (Davies 2004:29)

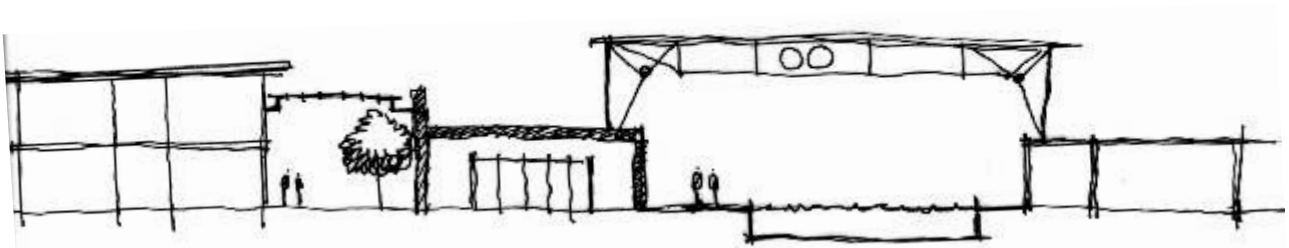
9.4 Appendix D: Concepts



9.4.1 CONCEPT 1

In this concept the building as a corner focal point was explored. The café formed a focal point on the main axis from where two wings radiated from it. The idea was that the edges of the site, where pedestrians moved, would be strengthened.

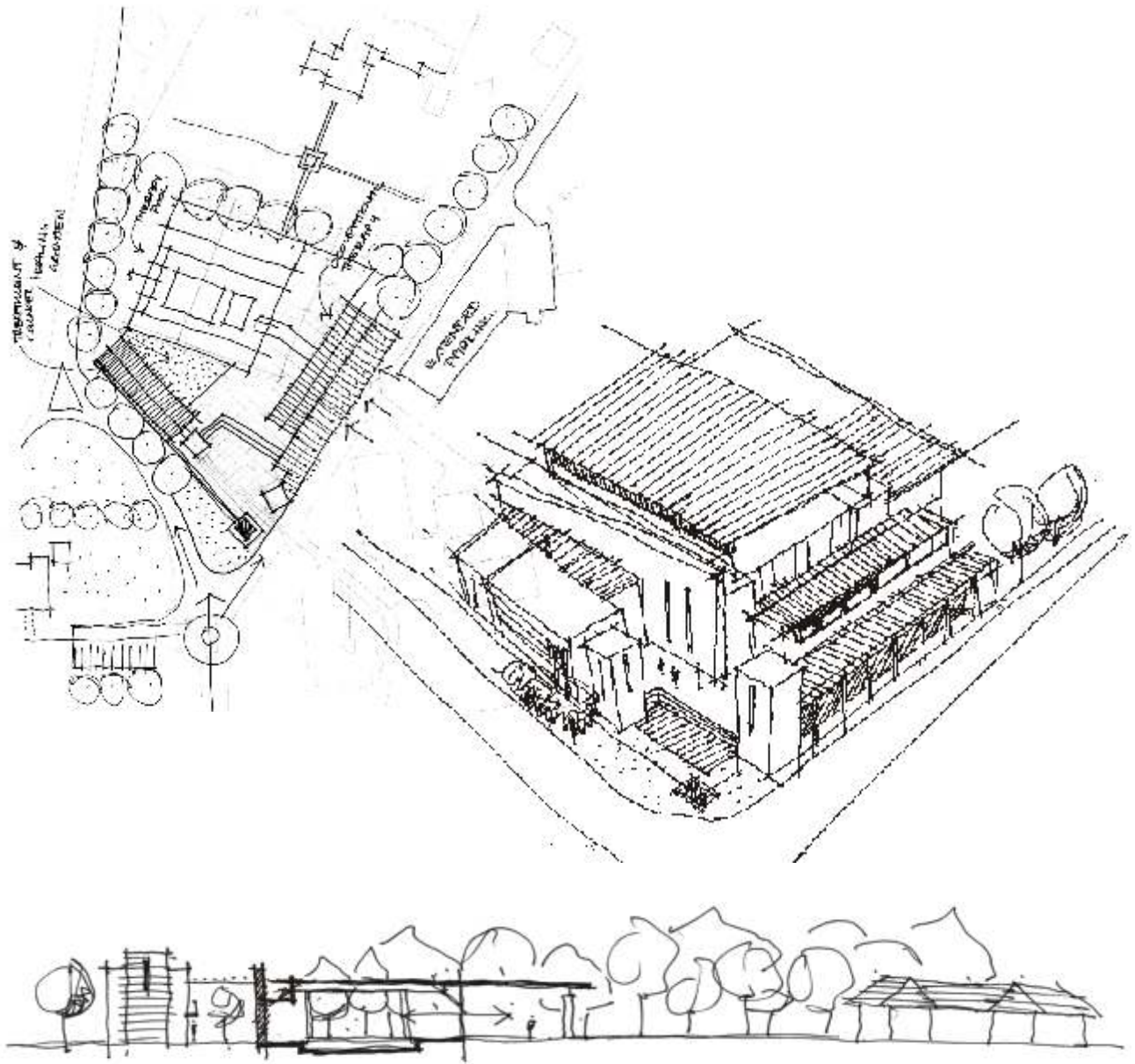
The architectural language of the this concept was to harsh and communicated as an urban form. The inside-outside connection was not successful.

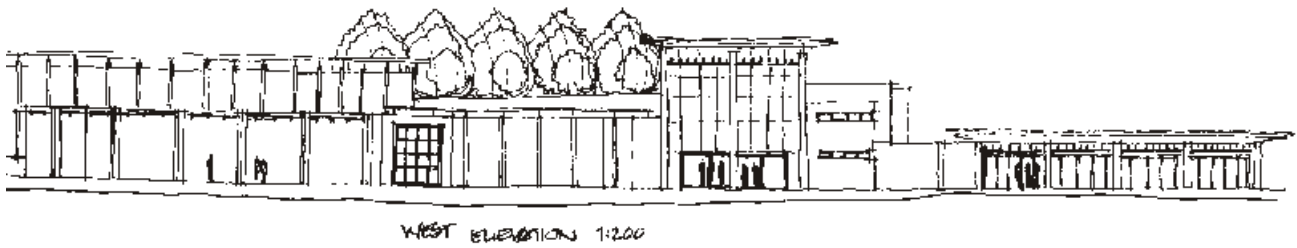


9.4.2 CONCEPT 2

From concept one it became clear that the corner of the site had to be open in order for the building to appear more receptive and welcoming.

The plan was kept the same, but alternative ways were sought to accommodate movement of pedestrians.





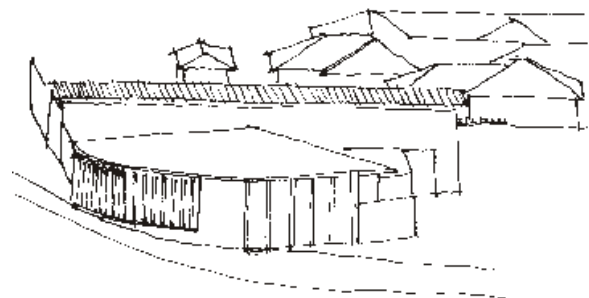
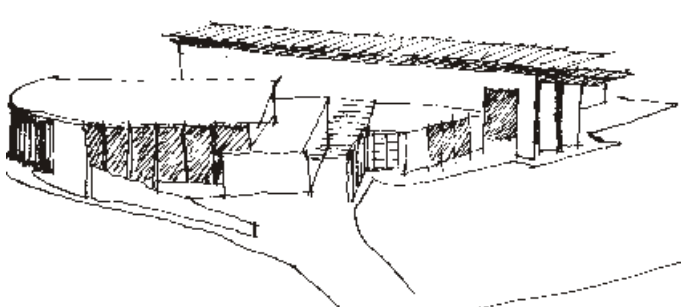
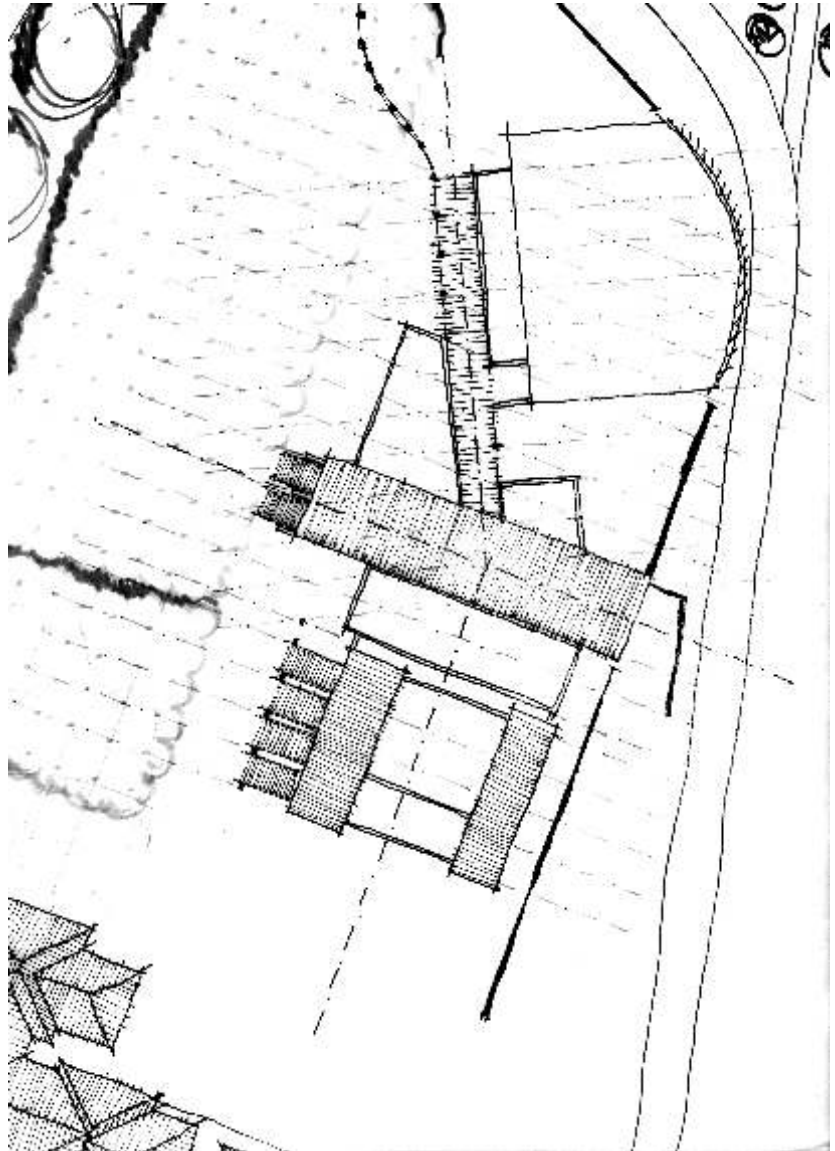
9.4.3 CONCEPT 3

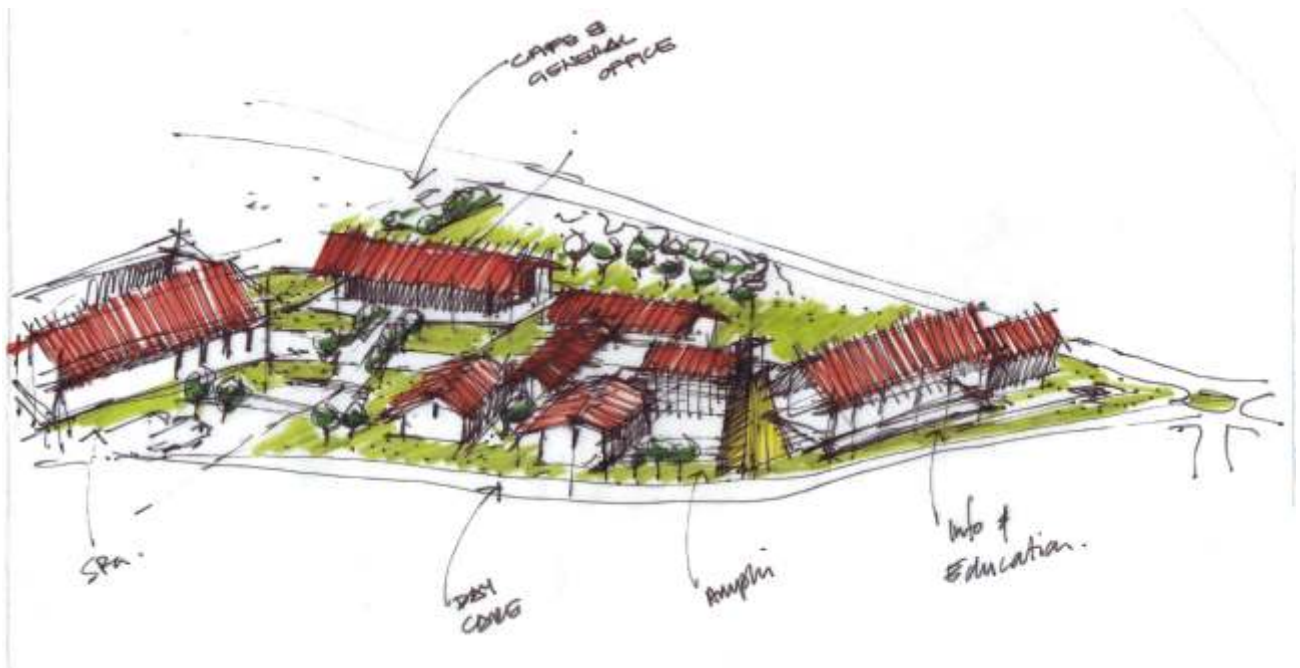
In concept three the building was placed on the eastern edge of the site, allowing visitors to view the building from a distance as they entered.

The axes of the city and site were merged and became the pivot around which the built spaces took shape. This later became an important concept.

It became apparent, however that the enclosing of the spines stifled movement along these axes, exactly the opposite of the intention.

The building still did not seem to integrate with the site or landscape, but to a large extent, was imploding.





9.4.4 CONCEPT 4

In a reaction to concept 3, concept 4 aimed to maintain movement along axes instead of closing them up.

This was then an inverted built form of concept 3. Closed space became open and open space became closed.

This rendered a complex of buildings, linked by a system of open spaces. The buildings seemed to have a stronger link with the landscape.

The smaller buildings allowed the complex to achieve an intimate human scale more conducive to the user.

The pitched roofs further strengthened the concept of a safe, familiar environment to which the user would be able to relate and not feel challenged by.

9.5 Appendix E: Daylighting Calculations

Lighting

<u>Situation</u>	<u>Standard service illuminance (lux)</u>	
1. Corridors	100	2%
2. Stair	150	3%
3. Entrance lobby	150	3%
waiting + enquiry desk	500	10%
4. Kitchen: Store	150	3%
Working	500	10%
5. Consulting + treatment	500	10%
Rest	150	3%
6. Canteen/dining	200	4%
7. Staff	150	3%
8. Workshops Casual	200-300	6%
9. Libraries	300	6%
10. Teaching	300	6%
11. Art room	300	6%
12. Conference	750	15 35 %
13. Computer	500	10%

<u>Daylight</u>	<u>Daylight factor</u>	<u>Position</u>	<u>Limit</u>
1. Foyer	1	travels	Workplace 24
2. Stair	2	travels	-
3. Classroom	5	Desk	21
4. Art room	5		21
5. Staff	5		23
6. Pool	5		23

Daylight factor of 11. = 50 lux.

Area of glazing to provide daylight factor
 $= P = 10 \times D$
 $P = \text{area of glazing as percentage of floor area}$
 $D = \text{minimum daylight factor.}$

\therefore Floor area 100 m^2
 W Daylight 2

20% of $100 \text{ m}^2 = \text{glazing}$

Daylighting glazing

1. Workshop: $p = 10 \times D(5)$
 $= 50\%$ of $80 \text{ m}^2 = 40 \text{ m}^2$
2. Multi-purpose: $p = 10 \times D(5)$
 $= 50\%$ of $88 \text{ m}^2 = 44 \text{ m}^2$
3. arts room: $p = 10 \times D(5)$
 $= 50\%$ of $88 \text{ m}^2 = 44 \text{ m}^2$
4. Class room: $p = 10 \times D(5)$
 $= 50\%$ of $19 \text{ m}^2 = 9,5 \text{ m}^2$
5. Lobby + stair: $p = 10 \times D(2)$
 $= 20\%$ of $65 \text{ m}^2 = 13 \text{ m}^2$
6. Waiting: $p = 10 \times D(2)$
 $= 20\%$ of $40 \text{ m}^2 = 8 \text{ m}^2$
7. Secretary: $p = 10 \times D(5)$
 $= 50\%$ of $12 \text{ m}^2 = 6 \text{ m}^2$
8. Office: $p = 10 \times D(5)$
 $= 50\%$ of $12 \text{ m}^2 = 6 \text{ m}^2$
9. Big consultation: $p = 10 \times D(5)$
 $= 50\%$ of $20 \text{ m}^2 = 10 \text{ m}^2$
10. Small consultation: $p = 10 \times D(5)$
 $= 50\%$ of $12 \text{ m}^2 = 6 \text{ m}^2$
11. Staff $p = 10 \times D(5)$
 $= 50\%$ of $30 \text{ m}^2 = 15 \text{ m}^2$
12. Cafe $p = 10 \times D(2)$
 $= 20\%$ of $135 \text{ m}^2 = 27 \text{ m}^2$
13. Kitchen $p = 10 \times D(5)$
 $= 50\%$ of $50 \text{ m}^2 = 25 \text{ m}^2$
14. Library $p = 10 \times D(4)$
 $= 40\%$ of $77 \text{ m}^2 = 30,8 \text{ m}^2$
15. SPA lobby $p = 10 \times D(2)$
 $= 20\%$ of $61 \text{ m}^2 = 12,2 \text{ m}^2$
16. Spa $p = 10 \times D(2)$
 $= 20\%$ of $44 \text{ m}^2 = 8,8 \text{ m}^2$

9.6 Appendix F: Natural Ventilation Calculations

Natural ventilation

	Ventilation allowance
Dining	0.33 $\text{W/m}^2\text{C}$
Recreation	0.33
Stair	0.50
foyers	0.50
Public rooms + Studios	0.33
Waiting rooms	0.33
Patient areas	0.67
Reading (Library)	0.25
Classroom	0.67
Swimming	0.17

ACR l/s :

1. Classroom 7,5 pp
2. Library 6,5 pp
3. Cafe 7,5 pp
4. Kitchen 17,5 pp
5. Spa 7,5 pp
6. locker 7,5 pp
7. lobby 5 ~~2,5~~ pp
8. Meeting 5 pp
9. Room with Shower 25 pp

$$V = 0,6 \times A \times v$$

V = volume flow rate (m^3/s)

A = area of openings

v = windspeed 90° to opening

45° flowrate is half.

= 1.

$$\therefore \frac{\text{Floor area} \times \text{ACR}}{1000} = V$$

Training = 60 students.

Natural ventilation. Area operable window1. Workshop: $80 \text{ m}^2 \therefore [12]$ students @ $6,5 \text{ m}^2/\text{student}$

$NU =$ Floor area: 80 m^2
 ACR : $7,5 \text{ m}^3/\text{s}$
 Windspeed: $1 @ 45^\circ$

$$V = 0,6 \times A \times V \quad (V = 0,16 \text{ m}^2/\text{s})$$

$$A = \frac{V}{0,6 \times 1} = \frac{0,6}{0,6} = 1 \text{ m}^2 \text{ (double for } 45^\circ)$$

$$= 2 \text{ m}^2$$

2. Multipurpose + music: $88 \text{ m}^2 \therefore [14]$ students @ $6,5 \text{ m}^2/\text{s}$

$NU =$ Floor area: 88 m^2
 ACR : $7,5 \text{ l/s}$
 Windspeed: $1 @ 90^\circ$

$$V = \frac{88 \text{ m}^2 \times 7,5 \text{ l/s}}{1000}$$

$$= 0,66 \text{ m}^2/\text{s}$$

$$A = \frac{V}{0,6 \times 1} = \frac{0,66}{0,6} = 1,1 \text{ m}^2$$

3. Art room: $88 \text{ m}^2 \therefore [14]$ students $NU =$ same as above4. Class rooms ^(x2): $19 \text{ m}^2 \therefore [10]$ students @ $1,9 \text{ m}^2/\text{s}$ $NU =$ floor area 19 m^2 ACR : $7,5 \text{ m}^3/\text{s}$ Windspeed: $1 @ 45^\circ \underline{E}$

$$A = \frac{V}{0,6 \times 1} = 0,24 \text{ m}^2 \times 2$$

$$= 0,5 \text{ m}^2$$

5. Lobby down stairs: 65 m^2

$$\begin{aligned} \text{NV} &= \text{Floor area: } 65 \text{ m}^2 \\ \text{ACR} &: 5 \text{ l/s} \\ \text{Wind speed} &: 7 \text{ m/s @ } 90^\circ \\ \therefore V &= 0,3 \text{ m}^2 \end{aligned}$$

$$A = \frac{0,3}{0,6} = 0,5 \text{ m}^2$$

6. Lobby upstairs: 40 m^2

$$\begin{aligned} \text{NV} &= \text{Floor area: } 40 \text{ m}^2 \\ \text{ACR} &: 5 \text{ l/s} \\ \text{WS} &: 7 \text{ m/s @ } 90^\circ \\ \therefore V &= 0,2 \text{ m}^2 \end{aligned}$$

$$A = \frac{0,2}{0,6} = 0,3 \text{ m}^2$$

7. Secretary: 12 m^2

$$\begin{aligned} \text{NV} &= \text{Floor area: } 12 \text{ m}^2 \\ \text{ACR} &: 7,5 \text{ l/s} \\ \text{WS} &: 7 \text{ m/s @ } 90^\circ \\ \therefore V &= 0,09 \end{aligned}$$

$$A = \frac{0,09}{0,6} = 0,15 \text{ m}^2$$

8. Head psychiatrist: 12 m^2

$$\begin{aligned} \text{NV} &= \text{Floor area: } 12 \text{ m}^2 \\ \text{ACR} &: 7,5 \text{ l/s} \\ \text{WS} &: 7 \text{ m/s @ } 90^\circ \\ \therefore V &= 0,09 \end{aligned}$$

$$A = 0,15 \text{ m}^2$$

(x2)

9. Big consultation : ~~15~~²⁰ m²

$$NU = FA : 20 \text{ m}^2$$

$$ACR : 5 \text{ l/s}$$

$$WS : 1 \text{ m/s @ } 90^\circ$$

$$\therefore V = \frac{20}{16} = 0,1$$

$$A = \frac{0,1}{0,6} = 0,16 \text{ m}^2$$

10. Small consultation (x2) : ~~12~~¹² m²

$$NU = FA : 12 \text{ m}^2$$

$$ACR : 5 \text{ l/s}$$

$$WS : 1 \text{ m/s @ } 90^\circ$$

$$\therefore V = 0,06$$

$$A = \frac{0,06}{0,6} = 0,1 \text{ m}^2$$

11. Staff room : 30 m²

$$NU = FA : 30 \text{ m}^2$$

$$ACR : 7,5 \text{ l/s}$$

$$WS : 1 \text{ m/s @ } 90^\circ$$

$$\therefore V : 0,225$$

$$A = \frac{0,225}{0,6} = 0,375 \text{ m}^2$$

12. Cafe : 135 m² $\pm 90^\circ$ @ 1.5 m²/person.

$$NU = FA = 135 \text{ m}^2$$

$$ACR = 7,5 \text{ l/s}$$

$$WS : 1 \text{ m/s @ } 90^\circ$$

$$\therefore V : 1,0$$

$$A = \frac{1}{0,6} = 1,7 \text{ m}^2$$

13. Kitchen: 50 m^2

$$NU = FA = 50 \text{ m}^2$$

$$ACR = 17,5 \text{ l/s}$$

$$WS = 1 \text{ m/s @ } 90^\circ$$

$$\therefore V = 0,875$$

$$A = \frac{0,875}{0,6} = 1,5 \text{ m}^2$$

14. Library / audio visual : 77 m^2

$$NU = FA = 77 \text{ m}^2$$

$$ACR = 6,5 \text{ l/s}$$

$$WS = 1 \text{ m/s}$$

$$\therefore V = 0,5$$

$$A = \frac{0,5}{0,6} = 0,8 \text{ m}^2$$

15. Spa lobby: 61 m^2

$$NU = FA = 61 \text{ m}^2$$

$$ACR = 5 \text{ l/s}$$

$$WS = 1 \text{ m/s}$$

$$\therefore V = 0,3$$

$$A = \frac{0,3}{0,6} = 0,5 \text{ m}^2$$

16. Spa : 44 m^2

$$NU = FA = 44 \text{ m}^2$$

$$ACR = 7,5 \text{ l/s}$$

$$WS = 1 \text{ m/s}$$

$$\therefore V = 0,33$$

$$A = \frac{0,33}{0,6} = 0,6 \text{ m}^2$$

17. locker = 7 m^2

$$NU = FA = 7 \text{ m}^2$$

$$ACR = 7,5 \text{ l/s}$$

$$WS = 1 \text{ m/s}$$

$$\therefore V = 0,05$$

$$A = \frac{0,05}{0,6} = 0,09 \text{ m}^2$$

18. Shower 7 m^2

$$NU = FA = 7 \text{ m}^2$$

$$ACR = 25 \text{ l/s}$$

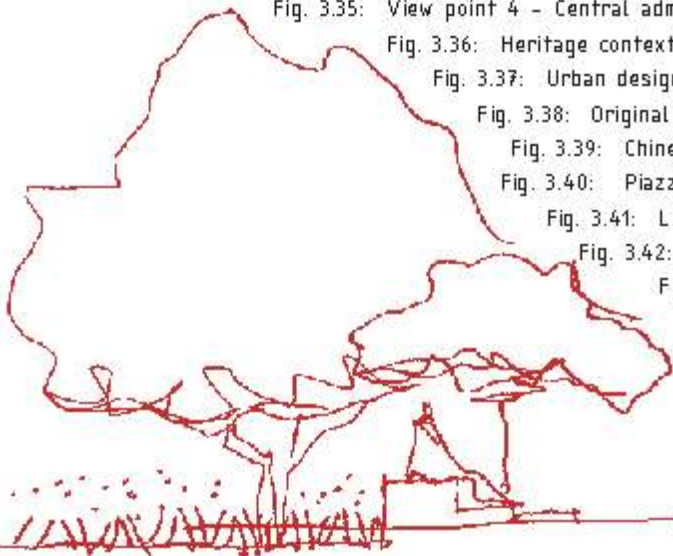
$$W_s = 1 \text{ m/s}$$

$$\therefore V = 0,2$$

$$A = \frac{0,2}{0,6} = 0,3 \text{ m}^2$$

19. Spa office = $0,15 \text{ m}^2$

- Fig. 1.1: Sketch of existing buildings on Weskoppies campus (author)
 Fig. 1.2: Patients at Weskoppies (Sowetan; 2005; p.1)
- Fig. 2.1: Caroline by Giacometti (Raynes; 1979; p244)
 Fig. 2.2: Map of Gauteng (author)
 Fig. 2.3: Aerial of Pretoria-west (author)
 Fig. 2.4: Aerial of Weskoppies Campus (author)
- Fig. 3.1: Sketches of Weskoppies (author)
 Fig. 3.2: Tshwane Metropolitan Region (author)
 Fig. 3.3: Map of Pretoria Area (Meiring; 1980; p.4)
 Fig. 3.4: Aerial of Tshwane indicating project and study areas
 Fig. 3.5: North view of the main administration building on Weskoppies Campus (Meiring; 1980; p.13)
 Fig. 3.6: North-west view of the main administration building on Weskoppies Campus (Meiring; 1980; p.13)
 Fig. 3.7: Main administration building 1906 (South African Medical Journal; 1992; p221)
 Fig. 3.8: Weskoppies 1907 (Weskoppies archives)
 Fig. 3.9: Woman's ward in left wing of historic precinct (author)
 Fig. 3.10: Location of study area in region (GAPP Salvokop Development Framework; 2003)
 Fig. 3.11: Project area (author)
 Fig. 3.12: Structuring elements (author)
 Fig. 3.13: Study area - Movement and access (author)
 Fig. 3.14: Land-use activity and features (author)
 Fig. 3.15: Urban concepts (author)
 Fig. 3.16: Natural context (author)
 Fig. 3.17: Vegetation (author)
 Fig. 3.18: Local natural environment (author)
 Fig. 3.19: View point 1 (author)
 Fig. 3.20: View point 2 (author)
 Fig. 3.21: View point 3 (author)
 Fig. 3.22: View point 4 (author)
 Fig. 3.23: Vegetation (author)
 Fig. 3.24: Climatic considerations (author)
 Fig. 3.25: Temperature inversion from plan (author)
 Fig. 3.26: Air movement and sun (author)
 Fig. 3.27: Land-use and activities (author)
 Fig. 3.28: Developable land (author)
 Fig. 3.29: View leaving site (author)
 Fig. 3.30: View approaching site (author)
 Fig. 3.31: Movement and access (author)
 Fig. 3.32: View point 1 - Main admin building (1892) (author)
 Fig. 3.33: View point 2 - Male ward (1980's) (author)
 Fig. 3.34: View point 3 - Children's and family unit (1970's) (author)
 Fig. 3.35: View point 4 - Central administration (2000's) (author)
 Fig. 3.36: Heritage context (author)
 Fig. 3.37: Urban design informants (author)
 Fig. 3.38: Original kitchen building on campus (author)
 Fig. 3.39: Chinese courtyard housing (Ojeda, O'Connor & Kohn; 1997; p.241)
 Fig. 3.40: Piazza Aelia Signoria (Ojeda, O'Connor & Kohn; 1997; p.241)
 Fig. 3.41: Lake Patzudro (Ojeda, O'Connor & Kohn; 1997; p.241)
 Fig. 3.42: Existing relationship between Weskoppies and city (author)
 Fig. 3.43: Weskoppies as stoep (author)
 Fig. 3.44: Campus structure (author)
 Fig. 3.45: Vision at city scale (author)
 Fig. 3.46: Vision at campus scale (author)



9.7 Appendix G: List of Figures

- Fig. 4.1: Top view of historic main administration building (G. Brand)
- Fig. 4.2: Approach to collective form (
- Fig. 4.3: Mediation (
- Fig. 4.4: Definition (
- Fig. 4.5: Repetition (
- Fig. 4.6: Sequential path (
- Fig. 4.7: Compositional form (
- Fig. 4.8: Mega form (
- Fig. 4.9: Group form (
- Fig. 4.10: Japanese linear village (
- Fig. 4.11: My sky hole by Bukichi Inoues (Domus; 1999; p.86)
- Fig. 4.12: Way to the Hidden garden by Dani Karavan (Domus; 1999; p.87)
- Fig. 4.13: My sky hole by Bukichi Inoues (Domus; 1999; p.86)
- Fig. 4.14: My sky hole by Bukichi Inoues (Domus; 1999; p.86)
- Fig. 4.15: Concept for SDF (author)
- Fig. 4.16: My sky hole by Bukichi Inoues (Domus; 1999; p.86)
- Fig. 4.17: Hakon open air museum (Domus; 1999; p.88)
- Fig. 4.18: Landscaping and sculpture (Domus; 1999; p.88)
- Fig. 4.19-22: Seat by Leandro Heine (Domus; 2000; p.91)
- Fig. 4.23-24: Seat by Leandro Heine and Alejandra Ferrugia (Domus; 2000; p.92)
- Fig. 4.25-27: Seat by Alejandra Ferrugia and Daniel O'Andrea (Domus; 2000; p.92)
- Fig. 4.28: Tourist project in Fjordane, Norge by Jensen and Skotvin (Domus; 2000; p.76)
- Fig. 4.29: Picnic area (Domus; 2000; p.77)
- Fig. 4.30: Exhibition area (Domus; 2000; p.76)
- Fig. 4.31: Public ablution (Domus; 2000; p.77)
- Fig. 4.32: Concept for SDF (author)
-
- Fig. 5.1: Weskoppies information sign at the entrance gate (author)
- Fig. 5.2: Site selection map (author)
- Fig. 5.3: Study sketches (Robertson; 1984; p.34)
- Fig. 5.4: Extension of city grid into the campus (Robertson; 1984; p.28)
- Fig. 5.5: Lateral approach to Kimbell Art museum (Brawne; 1992; p.59)
- Fig. 5.6: Plan of Kimbell Art museum (Brawne; 1992. p.19)
- Fig. 5.7: Service and served spaces (
- Fig. 5.8: Section of pool complex (
- Fig. 5.9: South perspective (
- Fig. 5.10: Site plan and site section (
- Fig. 5.11: Concept for site and building (author)
- Fig. 5.12: Configuration and movement (author)
- Fig. 5.13: Service and served spaces (author)
- Fig. 5.14: Building approach (author)
- Fig. 5.15: Building approach (author)
-
- Fig. 6.1: Concept sketch (author)
- Fig. 6.2: The Pioneer Health Center 1926 (Bobrow; 1978; p.25)
- Fig. 6.3: Ground floor (Bobrow; 1978; p.26)
- Fig. 6.4: First floor (Bobrow; 1978; p.26)
- Fig. 6.5: Ground floor analysis (author)
- Fig. 6.6: First floor analysis (author)
- Fig. 6.7: Perspective view (The Architect's Journal; 1995; p.18)
- Fig. 6.8: Section (The Architect's Journal; 1995; p.18)
- Fig. 6.9: West elevation (The Architect's Journal; 1995; p.18)
- Fig. 6.10: Ground floor analysis (The Architect's Journal; 1995; p.18)
- Fig. 6.11: Wood Green main entrance off courtyard (Architectural Record; 1999; p.76)
- Fig. 6.12: Corner view of Wood Green community mental health center (Architectural Record; 1999; p.76)
- Fig. 6.13: Ventilation chimneys (Architectural Record; 1999; p.77)
- Fig. 6.14: Daylit halfway passing through ventilation shaft (Architectural Record; 1999; p.76)
- Fig. 6.15: Ground floor analysis (author)
- Fig. 6.16: First floor analysis (author)

- Fig. 6.17: Mentally ill patient
- Fig. 6.18: Concept site plan (author)
- Fig. 6.19: Building complex (author)
- Fig. 6.20: Jaqueline Fiske Healing Garden, Jupiter Medical Center – positive outdoor space
- Fig. 6.21: Jaqueline Fiske Healing Garden, Jupiter Medical Center – choice of seating
- Fig. 6.22: Jaqueline Fiske Healing Garden, Jupiter Medical Center – touchable water
- Fig. 6.23: Highland Community Hospital Medical Office building and cancer center
- Fig. 6.24: Parker Adventist Community Hospital
- Fig. 6.25: Wheelchair attendant and envelope
- Fig. 6.26: Wheelchair movement through door
- Fig. 6.27: Use of crutches
- Fig. 6.28: Turning circle of wheelchairs
- Fig. 6.29: Training auditorium (author)
- Fig. 6.30: Outpatient facility (author)
- Fig. 6.31: Gatehouse (author)
- Fig. 6.32: Historic house (author)
- Fig. 6.33: Site Context (author)
- Fig. 6.34: Family and Childcare unit (author)
- Fig. 6.35: View Point 2 (author)
- Fig. 6.36: View Point 4 (author)
- Fig. 6.37: View Point 1 (author)
- Fig. 6.38: View Point 5 (author)
- Fig. 6.39: View Point 6 (author)
- Fig. 6.40: View Point 3 (author)
- Fig. 6.41: Site development (author)
- Fig. 6.42: Site water (author)
- Fig. 6.43: Low rise community buildings
- Fig. 6.44: Smaller building size
- Fig. 6.45: Spring Harbour psychiatric facility
- Fig. 6.46: Passive heating
- Fig. 6.47: Example of daylighting
- Fig. 6.48: Shallow trench section view
- Fig. 6.49: Rainwater harvesting system main components
- Fig. 6.50: House at Nxumalo, Soweto
- Fig. 6.51: Embodied energy of materials
- Fig. 6.52: Pre-fab modular components
- Fig. 6.53: Patrick H. Dollard Discovery Health Center, New York State (The Architectural Review, 2005, p.68)
- Fig. 6.54: Water strategy (The Architectural Review, 2005, p.70)
- Fig. 6.55: Geothermal design (The Architectural Review, 2005, p.70)
- Fig. 6.56: Sketches of historical house on site (author)
- Fig. 6.57: Sketches of historical house on site (author)
- Fig. 6.58: Historical buildings on site (author)
- Fig. 6.59: Drill Hall, Johannesburg (Digest of South African Architecture, 2004/2005, p.32)
- Fig. 6.60: Administration building on Unisa satellite campus
- Fig. 6.61: Edwardian: Travato, Wynberg, 1898 (Rigini; 2000; p.157)
- Fig. 6.62: Edwardian: Travato, Wynberg, 1898 (Rigini; 2000; p.157)
- Fig. 6.63: Edwardian: Welgelegen, 1899 (Rigini; 2000; p.161)
- Fig. 6.64: Edwardian: Travato, Wynberg, 1898 (Rigini; 2000; p.155)
- Fig. 6.65: Edwardian: Vredenhof House, 1907 (Rigini; 2000; p.159)
- Fig. 6.66: Izingolweni clinic (Digest of South African Architecture, 2004, p.52)
- Fig. 6.67: Umkhabane community health center (Digest of South African Architecture, 2004, p.38)
- Fig. 6.68: Kotulong community center (Digest of South African Architecture, 2004, p.72)
- Fig. 6.69: Perbal rehabilitation center (Domus, 2000, p.22)
- Fig. 6.70: Inside the clock tower of the main administration building (G. Brand)

- Fig. 7.1: Concept sketch (author)
- Fig. 7.2: Perspective view of site (author)
- Fig. 7.3: Site plan (author)
- Fig. 7.4: Section through site (author)
- Fig. 7.5: Building footprint reflect topography (author)
- Fig. 7.6: Place-making through elevated plane (author)
- Fig. 7.7: Site must be contained (author)
- Fig. 7.8: Place-making and containing strategy (author)
- Fig. 7.9: Site development concept (author)
- Fig. 7.10: Movement system (author)
- Fig. 7.11: Space containment strategy (author)
- Fig. 7.12: Saikan: east elevation
- Fig. 7.13: Saikan
- Fig. 7.14: Shrine facilities
- Fig. 7.15: Saikan: cross section
- Fig. 7.16: Juyojo: first floor plan
- Fig. 7.17: Artificial ground
- Fig. 7.18: Joyojo: north elevation
- Fig. 7.19: Detail: Juyojo
- Fig. 7.20: Clustered pattern (author)
- Fig. 7.21: Grouped along a path (author)
- Fig. 7.22: Clustered around an entry (author)
- Fig. 7.23: Contained within a space (author)
- Fig. 7.24: Concept model (author)
- Fig. 7.25: Spiral primary building approach (author)
- Fig. 7.26: Oblique secondary building approach (author)
- Fig. 7.27: Secondary entrance (author)
- Fig. 7.28: Entrances (author)
- Fig. 7.29: Paths (author)
- Fig. 7.30: Focal points along primary path (author)
- Fig. 7.31: The park
- Fig. 7.32: Public space (author)
- Fig. 7.33: The center foyer (author)
- Fig. 7.34: Landscape intervention (Leading architecture and design; 2003; p.23)
- Fig. 7.35: Integration of building and landscape (author)
- Fig. 7.36: Spatial concepts on site (author)
- Fig. 7.37: Building response (author)
- Fig. 7.38: Movement concept (author)
- Fig. 7.39: Connections and contact (author)
- Fig. 7.40: Landmark structure (author)
- Fig. 7.41: Information desk (author)
- Fig. 7.42: The restaurant stoep (author)
- Fig. 7.43: Inner courtyard of the health hydro (author)
- Fig. 7.44: Visual connectivity on section (author)
- Fig. 7.45: Visual connectivity (author)
- Fig. 7.46: Visual connectivity (author)
- Fig. 7.47: Space definition (author)
- Fig. 7.48: Enclosing and defining systems (author)
- Fig. 7.49: The perception of gravity (author)
- Fig. 7.50: Space enclosing system (author)
- Fig. 7.51: Space defining system (author)
- Fig. 7.52: Main administration building on site (author)
- Fig. 7.53: Typical sandstone and brick construction (author)
- Fig. 7.54: Contemporary facia detail for steel roofs (Architecture; 2003; p.88)
- Fig. 7.55: Elevational impact (author)
- Fig. 7.56: Treatment of doors and window as of historic building (author)
- Fig. 7.57: Form and massing reminiscent of heritage context (author)
- Fig. 7.58: Window study of historic main administration building (author)
- Fig. 7.59: Rustic country design (Architecture; 2003; p.89)

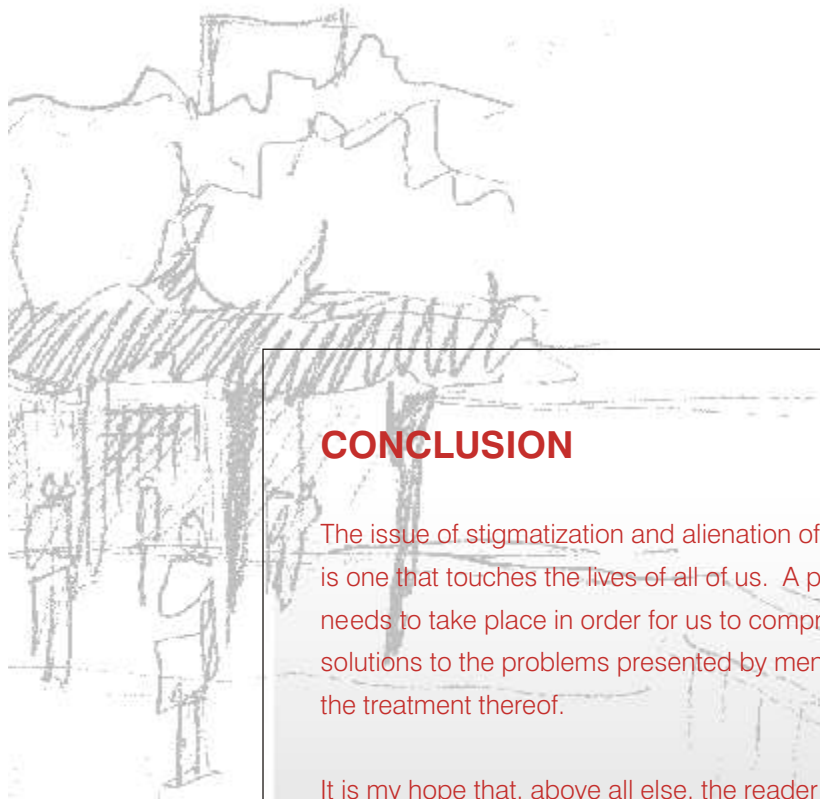
- Fig. 7.60: Climatic response (author)
 Fig. 7.61: Axis and symmetry on plan (author)
 Fig. 7.62: Symmetry expressed on the health hydro's elevation (author)
 Fig. 7.63: Hierarchy in the composition (author)
 Fig. 7.64: Datum on plan (author)
 Fig. 7.65: Elements of rhythm (author)
 Fig. 7.66: Datum on elevation (author)
 Fig. 7.67: Perspective of main entrance (author)
 Fig. 7.68: Circulation paths (author)
 Fig. 7.69: Perspective of information desk and public ablution block (author)
 Fig. 7.70: Initial concept sketch (author)
 Fig. 7.71 – 72: Installation in park (author)
 Fig. 7.73: Ground floor plan (author)
 Fig. 7.74: South-west perspective of training and therapy center's entrance lobby (author)
 Fig. 7.75: Ground floor plan (author)
 Fig. 7.76: First floor plan (author)
 Fig. 7.77 – 78: Elevational development (author)
 Fig. 7.79: Zones (author)
 Fig. 7.80: Concept for lobby (author)
 Fig. 7.81: Perspective view of workshop from inner courtyard (author)
 Fig. 7.82: Section through workshop (author)
 Fig. 7.83: Ground floor plan (author)
 Fig. 7.84: South-west perspective of restaurant (author)
 Fig. 7.85: Zones (author)
 Fig. 7.86: Ground floor plan (author)
 Fig. 7.87: Sauna plan (author)
 Fig. 7.88: Sauna section (author)
 Fig. 7.89: Foot bath (author)
 Fig. 7.90: Ground floor plan (author)
 Fig. 7.91: First floor plan (author)
 Fig. 7.92: Perspective of health hydro (author)
 Fig. 7.93: Section of plunge pool (author)
 Fig. 7.94: Locker room (author)
 Fig. 7.95: Massage room plan (author)
 Fig. 7.96: Jardin 'd Asie health hydro in France
 Fig. 7.97: Concept section of indoor pool area (author)
 Fig. 7.98: Concept section through hydro (author)
- Fig. 8.1: Concept model (author)
 Fig. 8.2: Perspective view of restaurant (author)
 Fig. 8.3: Light sources (Rigini; 2000; p.145)
 Fig. 8.4: Light sources (Rigini; 2000; p.145)
 Fig. 8.5: Openings (Rigini; 2000; p.146)
 Fig. 8.6: Openings (Rigini; 2000; p.146)
 Fig. 8.7: Components (Rigini; 2000; p.145)
 Fig. 8.8: Components (Rigini; 2000; p.145)
 Fig. 8.9: Articulations between elements (Rigini; 2000; p.146)
 Fig. 8.10: Articulations between elements (Rigini; 2000; p.146)
 Fig. 8.11: Components (Rigini; 2000; p.145)
 Fig. 8.12: Components (Rigini; 2000; p.145)
 Fig. 8.13: Openings (Rigini; 2000; p.147)
 Fig. 8.14: Openings (Rigini; 2000; p.147)
 Fig. 8.15: Perspective of enclosed system
 Fig. 8.16: Saynatsalo Town Hall – Alvar Aalto (Lahti; 2004; p.56)
 Fig. 8.17: Yahara Boat Club – Frank Lloyd Wright (Ching; 1979; p.67)
 Fig. 8.18: Exterior elevation of health hydro (author)
 Fig. 8.19: Section through information desk (author)
 Fig. 8.20: Interior perspective showing jet bath and plunge pool (author)
 Fig. 8.21: North elevation (author)

- Fig. 8.22: Ground floor plan (author)
 Fig. 8.23: East-west section (author)
 Fig. 8.24: Axonometric view of section (author)
 Fig. 8.25: Reinforced concrete strip foundation (author)
 Fig. 8.26: One-brick wall in English bond (author)
 Fig. 8.27: Brick wall (author)
 Fig. 8.28: Rainwater outlet in concrete slab (author)
 Fig. 8.29: Solid ground floor (author)
 Fig. 8.30: In-situ concrete floor slab (author)
 Fig. 8.31: Perspective of defining system (author)
 Fig. 8.32: Eames house (Architecture SA; 1992; p.25)
 Fig. 8.33: Mortensrud Church – Jensen and Skodvin (UME; 2005; p.53)
 Fig. 8.34: Internal view of inner courtyard of health hydro (author)
 Fig. 8.35: Training and therapy center lobby (author)
 Fig. 8.36: Concrete seats (author)
 Fig. 8.37: West elevation (author)
 Fig. 8.38: Ground floor plan (author)
 Fig. 8.39: North-south section (author)
 Fig. 8.40: Axonometric view of section (author)
 Fig. 8.41: Lattice steel roof on columns (author)
 Fig. 8.42: Cap and base of steel column support for lattice steel truss (author)
 Fig. 8.43: Steel column in concrete column (author)
 Fig. 8.44: Steel slab base on concrete pad foundation (author)
 Fig. 8.45: Corrugated sheet ridge detail (author)
 Fig. 8.46: Connection of purlin to truss (author)
 Fig. 8.47: Timber balcony construction (author)
 Fig. 8.48: Support of joists (author)
 Fig. 8.49: Site plan (author)
 Fig. 8.50 – 61: Sun study (author)
 Fig. 8.62: Shading heat gain (author)
 Fig. 8.63: Solar heat gain (author)
 Fig. 8.64: Vertical louvres and overhangs (author)
 Fig. 8.65: Leafless trees admit sun in winter (author)
 Fig. 8.66: Deciduous trees shade the building and garden in summer (author)
 Fig. 8.67: Passive cooling strategies (author)
 Fig. 8.68: Perspective of west facade of training and therapy center (author)
 Fig. 8.69: Use of galvanised corrugated steel sheeting for roof (author)
 Fig. 8.70: South-west elevation of training and therapy center (author)
 Fig. 8.71: An internal view of the training and therapy center lobby (author)
 Fig. 8.72: An axonometric view of construction components (author)
 Fig. 8.73: First floor plan (author)
 Fig. 8.74: Rainwater harvesting strategy (author)
 Fig. 8.75 – 76: Rainwater stored from the training and therapy center roof (author)
- Fig. 9.1: North perspective of building complex (author)
 Fig. 9.2: Bell tower at main entrance (author)
 Fig. 9.3: Images of proposed building complex (author)
 Fig. 9.4: Bell tower as seen from parking area (author)
 Fig. 9.5: South-west perspective of workshop (author)
 Fig. 9.6: North-west perspective of training and therapy center (author)
 Fig. 9.7: Complex foyer (author)
 Fig. 9.8: Training and therapy center's western facade (author)
 Fig. 9.9: View from primary movement path (author)
 Fig. 9.10: View of ablution block and restaurant (author)
 Fig. 9.11 – 12: Pool area at health hydro (author)
 Fig. 9.13 – 14: Images of health hydro (author)
 Fig. 9.15: View of rooftops (author)
 Fig. 9.16: Built-in seat at training and therapy center (author)
 Fig. 9.17: North-east perspective of training and therapy center (author)

9.8 Appendix H: Bibliography

- MOUNTON, J. 2001. How to succeed in your Master's & Doctoral Studies: A South African guide and resource book. Pretoria: Van Schaik Publishers
- STERNBERG, R.J. 1994. In Search of the Human Mind. Florida: Harcourt Brace & Company
- MEIRING, H. 1980. Pretoria 125. Cape Town: Human & Resseau Publishers
- PLUG, C. & ROOS, J.L. 1992. Weskoppies Hospital, founded 1892 the early years. South African Medical Journal, 15 February 1992, vol. 81, p.218-221.
- GINDROZ, R. 2003. The Urban design handbook. New York: W. W. Norton & Company
- NAPIER, A. 2000. Enviro-friendly methods in small building design for South Africa. Published by the author
- OJEDA, O.R., O'CONNOR, J.M. & KOHN, W. 1997. Campus and community: Moore, Ruble Yudell architecture & planning. Massachusetts: Rockport publishers
- FOUCAULT, M. 1967. Madness and civilization: A history of insanity in the age of reason. Great Britain: Tavistock Publications Limited
- South Africa. Pretoria: Government Printer.
- LANG, J., BURNETTE, C., MOLESKI, W. & VACHON, D. 1974. Designing for human behavior: Architecture and the behavioral science. Pennsylvania: Dowden, Hutchinsonson & Ross, Inc.
- WEINER, D. 2003. The architecture of De-institutionalisation: mental health care in the community. PhD thesis. Princeton University.
- PHILP, R. 2004. State dumps the mentally ill. Sunday Times, 14 March 2004, p4-5.
- Drill Hall, Johannesburg. Digest of South African Architecture. 2004/2005, vol.9. p.32-33
- Izingolweni Clinic and Community Center, The Farm 'Eden', Kwazulu Natal. Digest of South African Architecture. 2004, vol.8, p.52-53
- Umkhumbane Community Health Center. Digest of South African Architecture. 2004/2005. vol.9. p.38-39
- Kotulong Community Center. Digest of South African Architecture. 2004/2005. vol.9. p.72-73
- FERKAI, A. 2000. Rehabilitation center for disabled young people at Perbál, Hungary. Domus. February 2000. vol.823. p.22-29.
- EVANS, B. 2004. Community Service. The Architects' Journal, 11 November 2004, p.27-31.
- EVANS, B. 2005. Rebuilding Lives. The Architects' Journal, 17 March 2005, p. 24-28.
- FINCH, P. 2005. Doctors' Orders. The Architectural Review, May 2005, vol.217/1299, p.44-45.
- SLESSOR, C. 2005. Healing in the Heartland. The Architectural Review, May 2005, vol.217/1299, p.64-67.
- SLESSOR, C. 2005. Healthy Serendipity. The Architectural Review, May 2005, vol.217/1299, p.68-72.
- YOUNG, G. 2003. Peter Walker. Leading Architecture & Design, July/August 2003, p. 20-23.
- VAN DER BLIEK, J. 2005. Stop this madness. Sowetan, 28 February 2005, p1, 4-5.
- SLAVID, R. 1995. New health centre for Peckham. The Architect's journal, 29 June 1995, vol. 201/26, p.8-9.
- PEARSON, C.A. 1999. Hospitals: designing inclusive places. Architectural Record, July 1999, vol. 187/7, p.127-144.
- Building study: care in the community. 1994. The Architect's Journal, 8 December 1994, vol. 200/22, p. 24-34.
- EVANS, B. 2002. Building study: high flier, low profile. The Architect's Journal, 14 November 2002, vol.216/18, p.26-33.
- NUTTALL, J. A pavilion, Johannesburg, 1992. Architecture SA, September/October, vol.9.10/92, p.19-31.
- JENSEN, J. O. Mortensrud, Oslo, Norway Mortensrud Church. UME, vol.19, p.46 55.

- DAVIES, S. 2004. Toxic institutions. In *From Toxic Institutions to Therapeutic Environments: Residential Settings in Mental Health Services*. Edited by P.Campling, S. Davies and G. Farquharson. 1st ed. London: Royal College of Psychiatrists. p. 20-31.
- ALEXANDER, C., ISHIKAWA, S. & SILVERSTEIN, M. 1977. *A Pattern Language: Towns, buildings, construction*. New York: Oxford University Press
- COX, A. & GROVES, P. 1990. *Design & development guides: Hospitals & health-care facilities*. London: Butterworth & Co. (Publishers) Ltd
- ABBOT, G.R. 1983. *General ward: briefing and design guide*. Pretoria: Council for Scientific and Institutional Research
- BOBROW, M. L. 1978. Planning the hospital for a changing system of health service. In *Hospitals and Health care Facilities*. Edited by L.G. Redstone. 2nd ed. New York: McGraw-Hill Book Company, p. 5-7.
- BRAWNE, M. 1992. *Kimbell Art Museum Louis I Kahn*. London: Phaidon Press Ltd.
- TYNG, A. 1984. *Beginnings Louis I. Kahn's Philosophy of Architecture*. Canada: John Wiley & Sons, Inc.
- RIGHINI, P. 2000. *Thinking Architecturally An introduction to the creation of form and place*. Cape Town: University of Cape Town Press.
- COOPER, P. 2003. *Interiorscapes Gardens within Buildings*. London: Octopus Publishing Group Ltd.
- BENTLEY, I., ALCOCK, A., MURRIAN, P, McGLYNN, S. & SMITH, G. 1985. *Responsive Environments A manual for designers*. London: The Architectural Press.
- CRANE, R. & DIXON, M. 1991. *Architects' Data Sheets Indoor sports spaces*. London: Architecture Design and Technology Press.
- ROBERTSON, J. 1984. Comments on the Center for the Visual Arts. In *A Center for the Visual Arts The Ohio State University Competition*. Edited by P.Arnell & T. Bickford. New York: Rizzoli International Publications, Inc. p. 113.
- FABIAN, D. 1960. *Bäder Handbuch für Bäderbau und Badewasen*. München: Callwey
- FABIAN, D. 1970. *Aquatic Buildings Bäderbauten*. München: Callwey
- IZZO, A. & GUBITOSI, C. 1978. *Le Corbusier Dessins, Drawings, Disegni*. Paris: L'Equerre
- SERGEANT, J. 1976. *Frank Lloyd Wright's Usonian Houses The case for organic architecture*. New York Watson-Guptill Publications, Inc.
- HITCHCOCK, H.R. 1947. *In the nature of materials*. New York: Duell, Sloane & Pearce.
- HERSHBERGER, R.G. 1999. *Architectural programming and predesign manager*. New York: McGraw-Hill Companies, Inc.
- RAYNES, J. 1979. *Figure drawing and anatomy for the artist*. London: Chancellor Press.
- Geneva. Department of Mental Health and Substance Abuse. 2004. *Prevention of Mental Disorders: Effective Intervention and Policy Options*. France: Geneva.
- Geneva. Department of Mental Health and Substance Abuse. 2004. *Promoting Mental Health: Concepts, Emerging Evidence, Practice*. France: Geneva.
- CHING, D.K. 1979. *Architecture: form, space and order*. New York: Van Nostrand Reinhold.
- BAKER, G.H. 1984. *Le Corbusier: an analysis of form*. New York: Van Nostrand Reinhold Company.
- BAKER, G.H. 1989. *Design strategies in architecture: an approach to the analysis of form*. New York: Van Nostrand Reinhold Company.
- LAHTI, L. 2004. *Alvar Aalto 1898-1976. Paradise for the man in the street*. Los Angeles: Taschen.
- MATHEWS, P.J. 2003. *Architecture*. Pretoria: Visual Books.

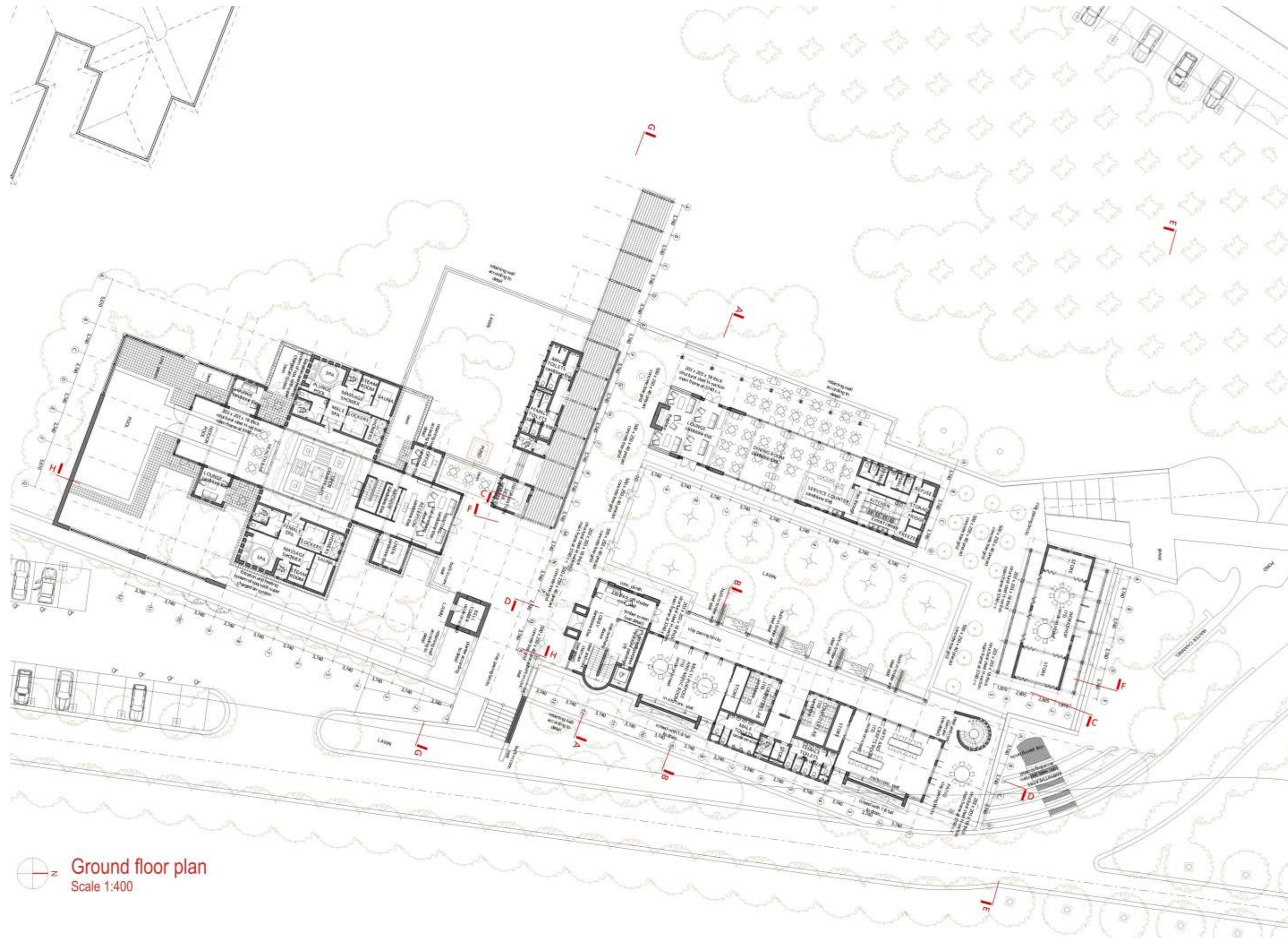


CONCLUSION

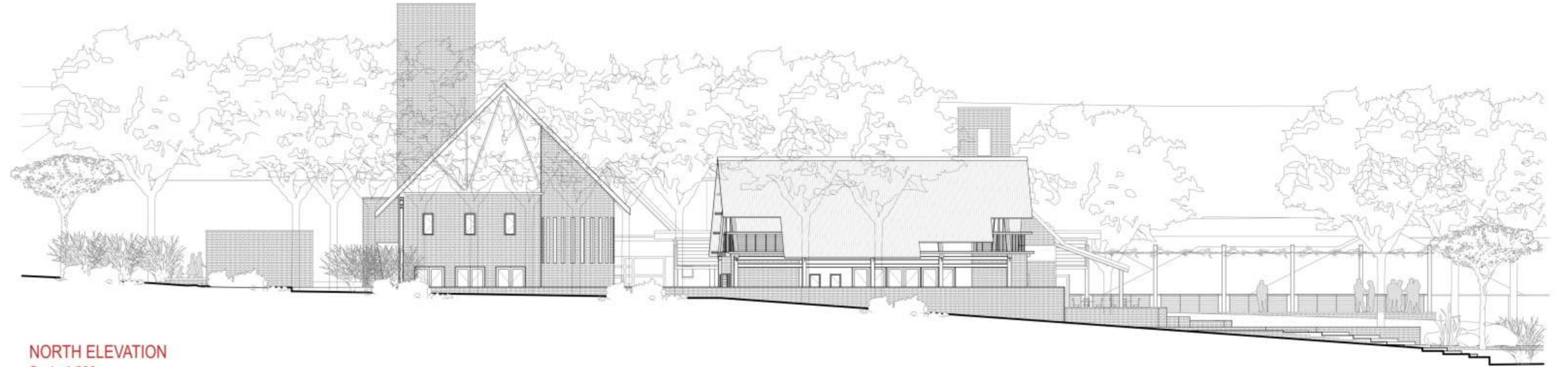
The issue of stigmatization and alienation of the mentally ill is one that touches the lives of all of us. A paradigm shift needs to take place in order for us to comprehend new solutions to the problems presented by mental illness and the treatment thereof.

It is my hope that, above all else, the reader will think differently now about the mentally ill than before he has read this dissertation. Every individual within our society deserves respect and dedicating our time and effort to afford them that is our profession's privilege.

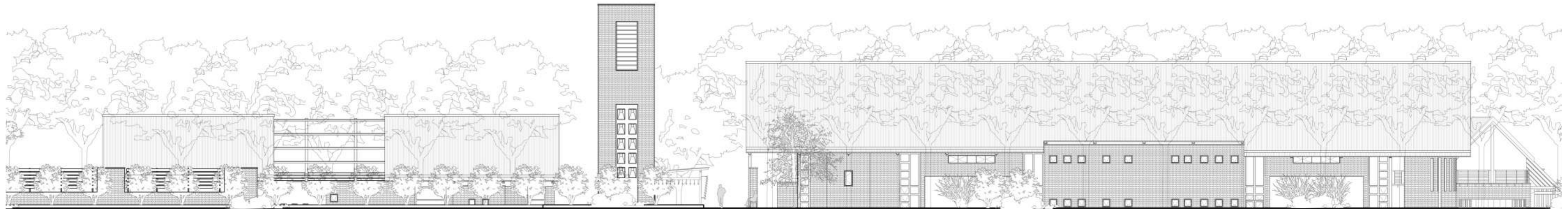




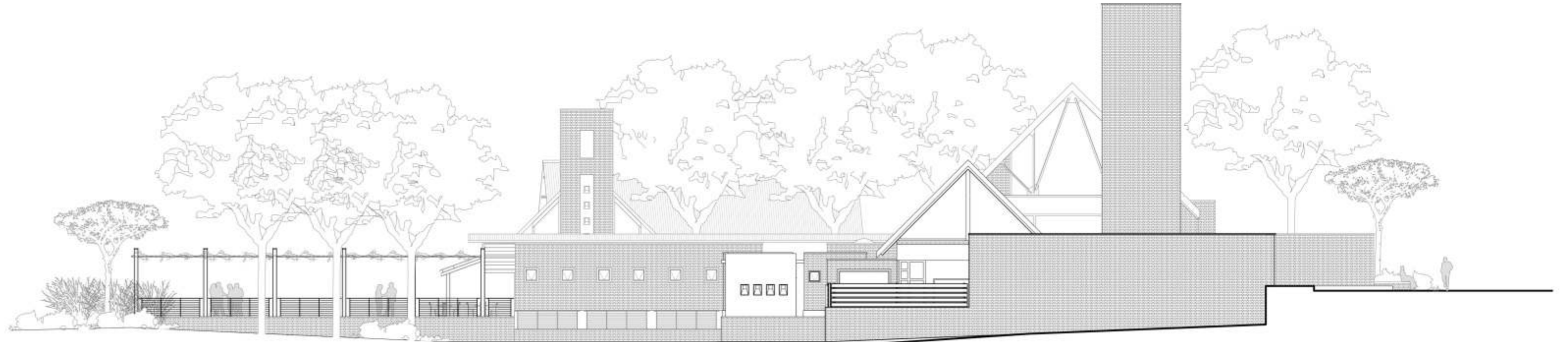
Ground floor plan
Scale 1:400



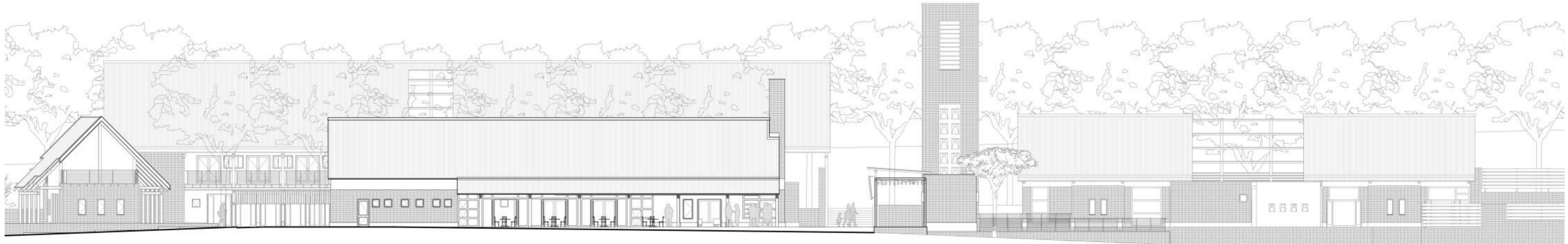
NORTH ELEVATION
Scale 1:200



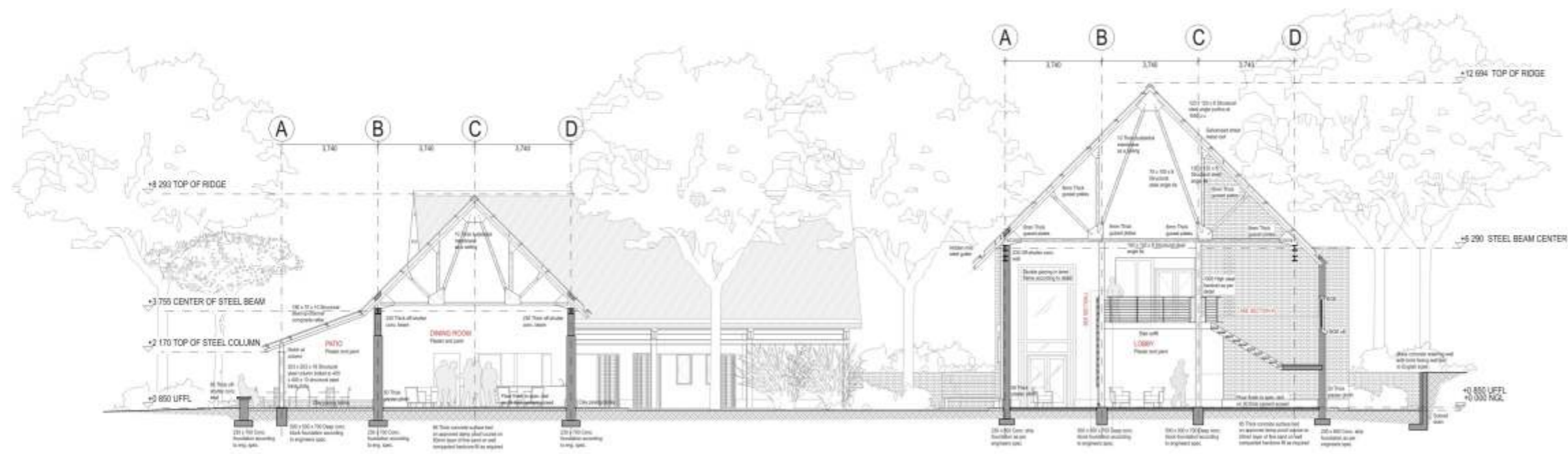
EAST ELEVATION
Scale 1:200



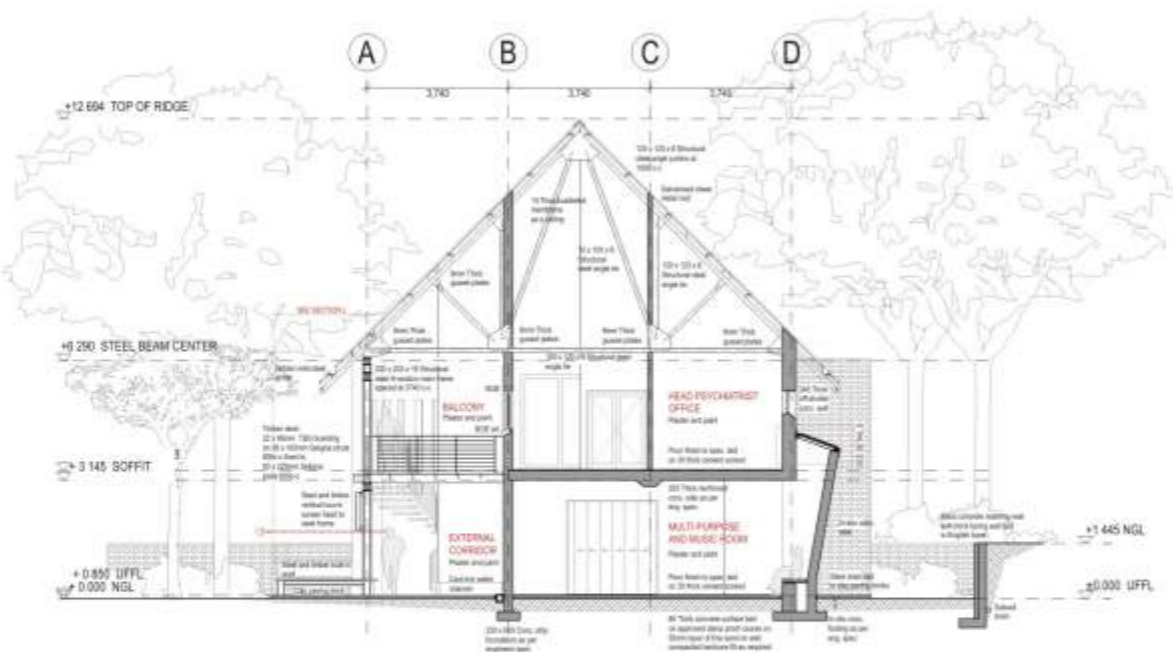
SOUTH ELEVATION
Scale 1:200



WEST ELEVATION
Scale 1:200



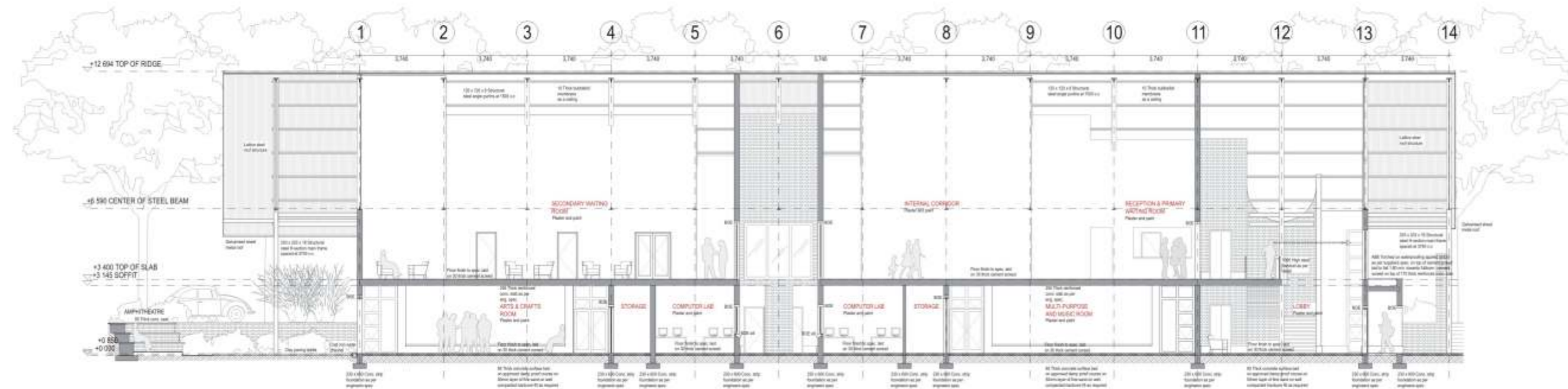
SECTION A - CROSS SECTION TRAINING AND THERAPY CENTER AND RESTAURANT
Scale 1:200



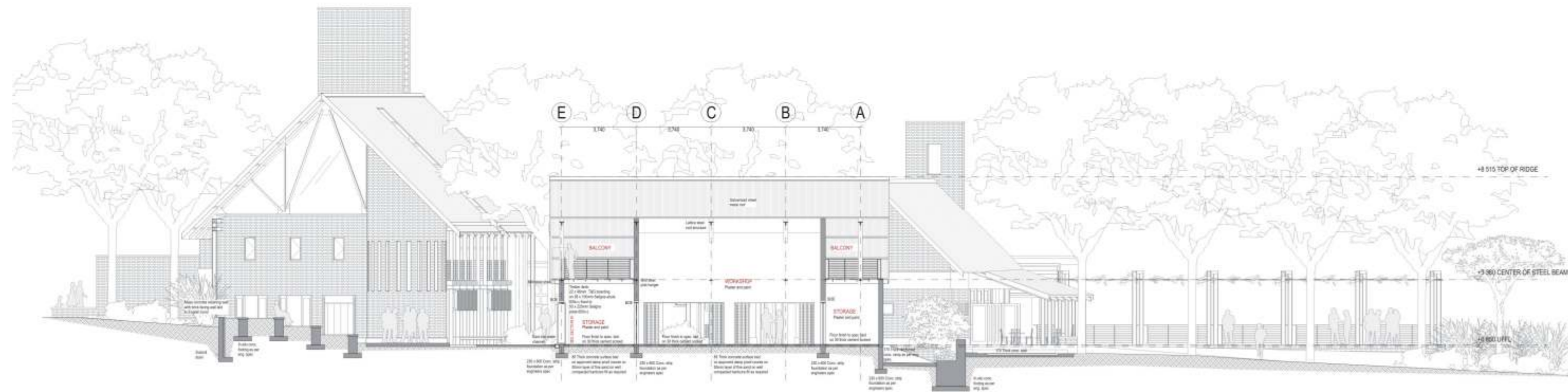
SECTION B - CROSS SECTION TRAINING AND THERAPY CENTER
Scale 1:200



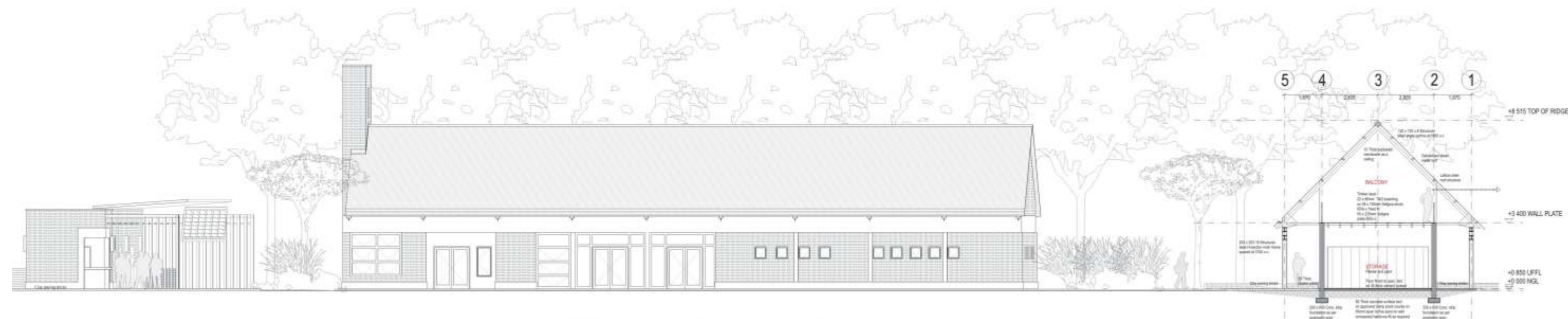
SECTION C - CROSS SECTION INFORMATION DESK
Scale 1:200



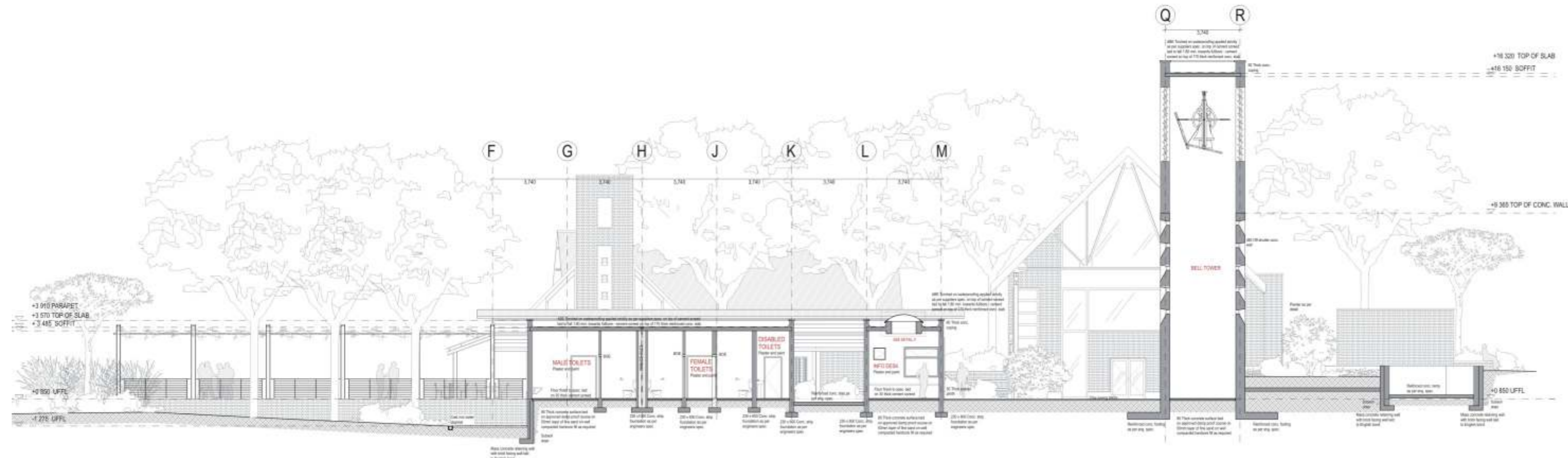
SECTION D - LONGITUDINAT SECTION TRAINING AND THERAPY CENTER
Scale 1:200



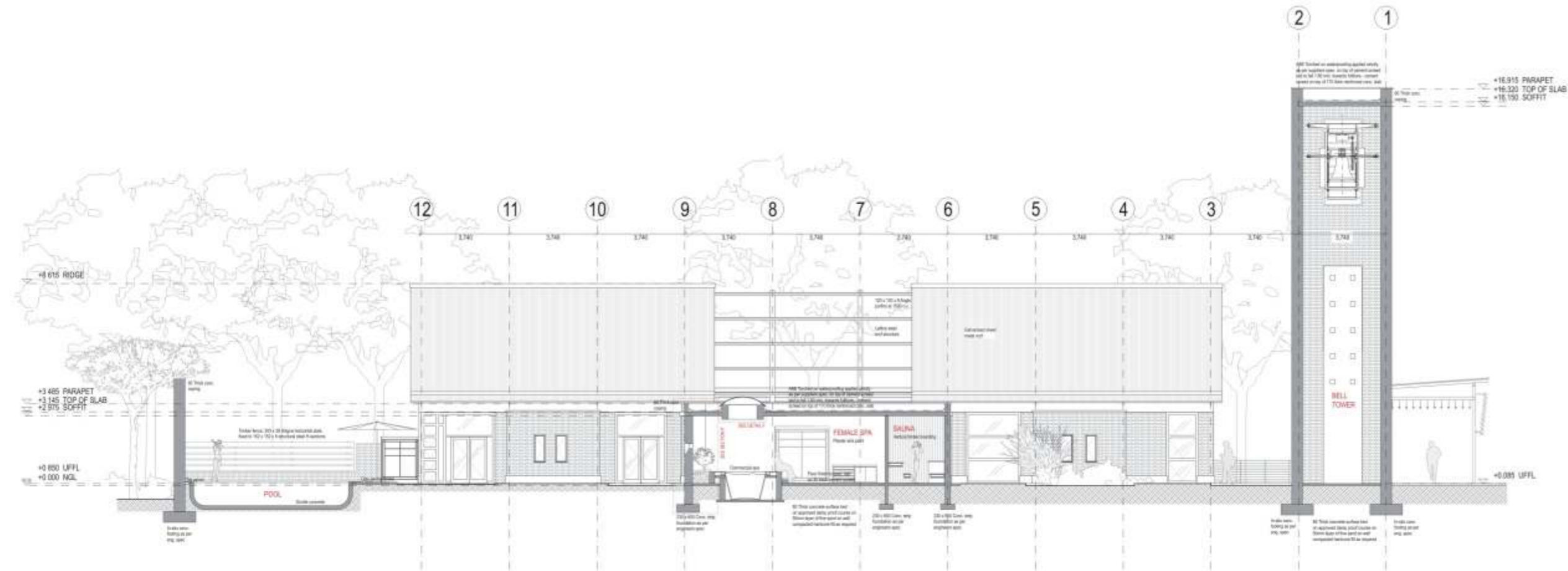
SECTION E - LONGITUDINAL SECTION WORKSHOP
Scale 1:200



SECTION F - CROSS SECTION WORKSHOP
Scale 1:200



SECTION G - LONGITUDINAL SECTION INFORMATION DESK, PUBLIC ABLUTION AND BELL TOWER
Scale 1:200



SECTION H - CROSS SECTION FEMALE SPA
Scale 1:100