

Incubation

© University of Pretoria



FIG 1-1: ANTOINETTE UYS/ UNIVERSITY OF PRETORIA

Ryno Dreyer

Study leader: Mr. G. Young

Submitted in fulfillment of part of the requirements for the degree, Magister in Architecture (Professional), in the Faculty of Engineering, Built Environment and Information Technology, University of Pretoria, South Africa. November 2008

PROJECT

## incubator of innovation

A business incubator for recent graduates of the University of Pretoria in the particular fields of design/art and engineering.

The artwork, photos and sculpture images used on the front page of each chapter, and indicated with /UNIVERSITY OF PRETORIA, are Fourth Year Fine Arts students of 2007. These images are incorporated in my book to display the innovative competence and excellence achieved from studying at the University of Pretoria. This is just some indication of the potential the University of Pretoria can foster in the Visual Arts Department. The Faculty of Engineering as well as the Faculty of the Built Environment provides the same degree of excellence to the world, but to provide images to illustrate that would require piles of books.

chapter 1	INCUBATION	1 - 2
introduction	PROBLEM STATEMENT	3 - 4
	THE NEED	5
	RESEARCH QUESTIONS	6
	RESEARCH GOAL	7
	THE CLIENT	8
chapter 2	GLOBAL CONTEXT	1
context	CITY CONTEXT	2 - 6
	URBAN FOCUS	7 - 12
	FOCUS AREA	13 - 16
	LYNNWOOD ROAD NARRATIVE	17 - 20
	TRIPLE BOTTOM LINE	21 - 23
chapter 3	INTRODUCTION	1 - 2
literature study	BUSINESS INCUBATORS	3 - 10
	SPATIAL REQUIREMENTS	11 - 14
	URBAN DESIGN	15 - 22
chapter 4	INTRODUCTION	1
precedent study	BUSINESS INCUBATORS	2 - 8
	AESTHETICS	9 - 10
	SPATIAL REQUIREMENTS	11 - 12
	EXHIBITION SPACES	13 - 15

## contents

---

chapter 5 site analysis & concept	SITE ANALYSIS	1 - 5
	CONCEPT	6 - 7
	DESIGN BRIEF & ACCOMMODATION	8
	INITIAL MASS EXPLORATION	9 - 10
	SPATIAL RELATIONSHIPS	10 - 14
	SHAPE OF BUILDING	15
	CONCEPT DEVELOPMENT	16
	FINAL CONCEPT MODEL	17
chapter 6 urban framework	INTRODUCTION	1
	TRANSPORT	2 - 6
	PARKING	7
	ROAD CROSSINGS	8 - 9
	SUBSIDIARY ENTRANCES	10 - 11
	PATHS AND LANES	12
	UNIVERSITY PRECINCT	13 - 17
	SOUTH CAMPUS	18 - 19
	FRONT FACADE	20 - 23
chapter 7 design discourse	DESIGN PRODUCT	1
	ACCESS	2
	SPATIAL RELATIONSHIPS	3
	ACCESS, SPATIAL RELATIONSHIPS & NATURAL VENTILATION	4 - 9
	DRAWINGS	10 - 16
	3D IMAGES	17 - 25

## contents

chapter 8		
technical investigation	STRUCTURE	1 - 6
	PASSIVE COOLING	7 - 9
	WATERPROOFING	10
	RAINWATER HARVESTING	11 - 13
	AIR-CONDITIONING & EXTRACTOR FANS	14 - 17
	MATERIALS	18
	SOLAR ENERGY	19 - 20
	DRAWINGS	21 - 35
	LIST OF FIGURES	
	LIST OF REFERENCES	
	ACKNOWLEDGMENTS	

## contents

---

"I lift up my eyes to the hills - where does my help come from?  
My help comes from the Lord, the Maker of heaven and earth."  
Psalm 121:1-2

FIG 1-2: JENNA BURCHELL/UNIVERSITY OF PRETORIA

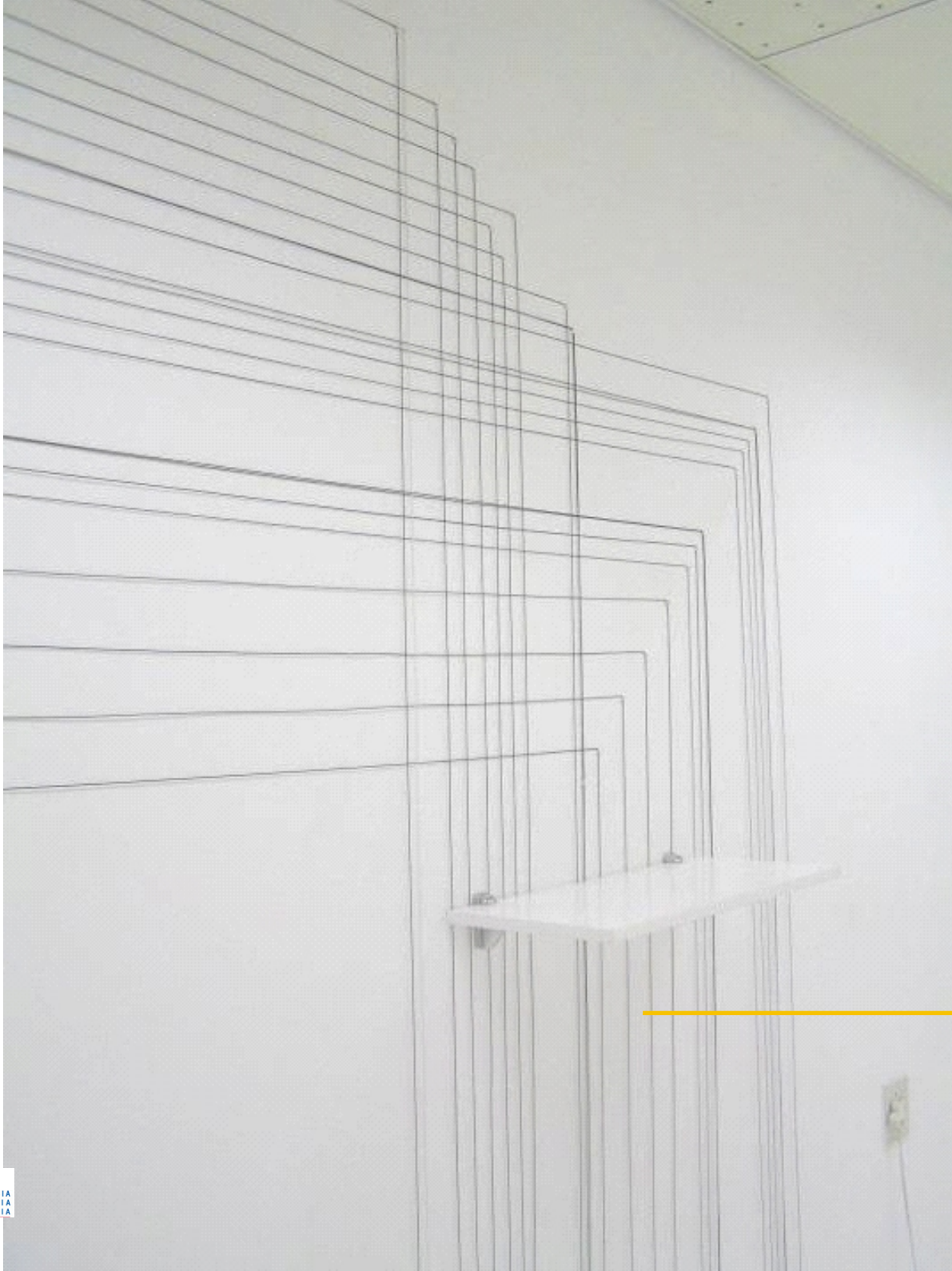



1

1

## incubation

Incubation is the term used to describe a period or a phase that is required within the early stages of life when an organism is unable to sustain its own life. It therefore requires external influences or providence to protect and nurture it, in order to survive and reach maturity or independence.

Business incubation is a process that provides entrepreneurs with business support through targeted resources and services that accelerates the successful development of their start-up company. Resources and services are provided, according to the needs and requirements of the entrepreneurs, and the process is orchestrated by the incubator management in order to create a successful incubator.

This business incubator would be specifically developed for the University of Pretoria and therefore the resources and services provided there will be according to the needs and requirements of recently graduated entrepreneurs in the fields of design/art and engineering. This incubator shall serve as the representation or the product of years of translating information to the students, honoring the University of Pretoria.

There is a narrative describing the University of Pretoria, it is the narrative of 'Translating Information' and it is constantly being written in the minds of the public sector. The incubator shall therefore be the conclusion to the narrative, displaying the result of the translated information and the competency of graduates in the fields of design/art and engineering, in order to form an interface between the university and the business world.

## business incubation

"Business incubation is a unique and highly flexible combination of business development processes, infrastructure and people designed to nurture new and small businesses by helping them to survive and grow through the difficult and vulnerable early stages of development." (Business Incubation Limited 2006)

1

2

## problem statement

The leap from the university to the industry or business world, is for many new graduates too large to take in order to establish their own company. They usually don't have the capital investment and cannot afford to start up their own business with the required facilities, equipment, software or man-power. "So many brilliant ideas have died in the garage because technologists didn't have the know-how to find resources to assure their survival in a competitive landscape." (Richards 2002: 3)

Innovative newly qualified graduates need to prove themselves to the world through their God-given talents and ideas and can only really put their name on the map by starting their own company. Graduates being compelled to join a company to attain, over a number of years, the necessary capital investment and business skills, cannot flourish and reach their full potential whilst being overshadowed by the company.

There is a need for an interface between the university and the industry, a middle ground and an incubator where newly graduates can be nurtured into maturity in order to be independent. An opportunity for innovative entrepreneurs to start his/her own company by providing them with the necessary services and conveniences, immediate and grand exposure as well as training in the field of business management.

Lynnwood Road as the front facade of the University of Pretoria, forms the visual interface with the public sector. Lynnwood Road is a narrative journey describing the translating of information being offered by the University of Pretoria. This narrative is formed in each person's own thoughts driving along Lynnwood Road, but the narrative is incomplete as it is without a conclusion. There isn't a building that serves as an exhibition space for the university to display the products and innovations that comes from absorbing years of information at the University of Pretoria.

## problem statement

Most graduates, studying in the field of design and engineering, don't have the necessary business skills, such as business management, finance and tax, labour relations as well as project management and marketing which are all required to make a success of a business.

## the need

---

There is a need for a building that provide recently qualified graduate entrepreneurs, in the fields of design/art and engineering, with the necessary resources and services for their start-up businesses. An opportunity to develop and display their innovations and artwork to the world. An iconic building to form the conclusion to the Lynnwood Road narrative, showcasing the competence of the university, in order to form the interface between the University of Pretoria and the business world.

How did business incubation start?  
How does business incubation work?  
Is there a need for business incubators?  
What are the benefits for South Africa?  
Who goes in for incubation?  
What should be provided to the graduates in order for the building to serve as an incubator and an interface between the university and the business world?  
What are the characteristics of an incubator?  
What would be the determining factor to prove their readiness and independence?  
How can Business Enterprises and Continuing Education of the University of Pretoria be incorporated?  
Who will be the client or operator that will orchestrate this incubator?  
Where should the building be allocated?  
How can the building represent the conclusion to the narrative of 'Translating Information'?  
How can the building maximize the exposure for the newly graduates?  
What should the iconic building look like?  
How can the space inside be designed to create an optimal environment for the flow of creative ideas?  
How can the concept of 'open building' allow for easy in and out lease agreements?  
How can the building's aesthetics represent an incubator for innovative ideas?  
How can urban regeneration take place alongside Lynnwood Road, in order to form an university precinct where a student can feel comfortable and relate to?

## research questions

These research questions were formulated to guide the required research to be conducted in order to build up a sound argument, which would render my project viable.

"Resources are the missing link between the companies that make it and those that crash and burn." (Richards 2002: 6) The incubator should therefore provide services and facilities to the inventor to enable the development of their ideas and then provide for an exhibition space which would be transparent to Lynnwood Road. The incubator would function by providing the tenants with shared facilities and commodities, making it possible for each individual of about ten recently qualified mechanical engineers, fashion designers, etc. to start their own business. The shared facilities or commodities should take place in four main categories namely space, man-power, software and equipment.

Most innovative entrepreneurs in design/art and engineering have the brilliance and creativity but they are not business people. The incubator should therefore provide the tenants with the necessary programs in the field of business management for them to successfully run their own business in order for it to be sustainable. There should be continuous development programs available, relevant to their particular field in order for the tenants to be informed and updated with the latest developments and innovations. Research would also involve the discovering of principles and techniques in designing the optimum environment which stimulates creative thinking and guides innovative thought in order to create an unique and sustainable commercial product.

This Incubator should be placed at the end of the narrative journey and should be an iconic building to represent the conclusion of the narrative of 'Translating Information'. The building should serve as an exhibition space for the university, displaying the results and products of years of translated information, in order to honor the University of Pretoria. Incorporate urban design principles in order to better present and utilize Lynnwood Road as the front facade of the University of Pretoria. Through urban principles, stitch the university back into the urban fabric where it was cut off by Lynnwood Road.

## research goal

To provide a space where recently qualified innovative graduates can be given the opportunity to develop and present their ideas and talents within a sustainable environment, in order to form an interface between the university and the business world. This space should be an incubator where they can be nurtured into maturity, in order to establish their own company or be grasped up by big innovative companies. The incubator's main focus will be to develop and exhibit innovative ideas, to provide publicity and exposure for firstly the inventor and secondly for the University of Pretoria.

The incubator would be managed in two ways namely the direct and indirect method of management. The direct method requires the Incubator management group to do market research in order to establish where the need lies for innovative ideas. Once they have established the need, they would approach the university for innovative graduates, who would then develop an innovation at the Incubator of Innovation which would best suite that need.

The indirect method functions where the inventor with his/her invention would approach the incubator, in order for the management group to market his/her innovation to the relevant people. Then once an investor have been established the graduate is invited to develop it at the Incubator of Innovation and start his/her own business.

Therefore in both cases it would be the Incubator who establishes the investor in order for the graduates' business to start, but the intellectual property remains the graduates' own. The graduates would therefore have no need for capitalization as they would already start with a salary from day one of development.

Enterprises@UP would receive a percentage fee of each individual's fee which comes from either their investors or the profit made, in order to make a profit for the University of Pretoria. The building that would be designed would also accommodate for the Continuous Education@UP group within the area schedule to form part of the interface between the university and the business world.

## the client

The client would be Enterprises@UP who is currently handling the corporate affairs of the university. They already consist of two departments namely Business Enterprises@UP and Continuing Education@UP and I propose to add a third department which would be the Incubator@UP. Enterprises@UP would therefore be the orchestrators of the Incubator of Innovation.



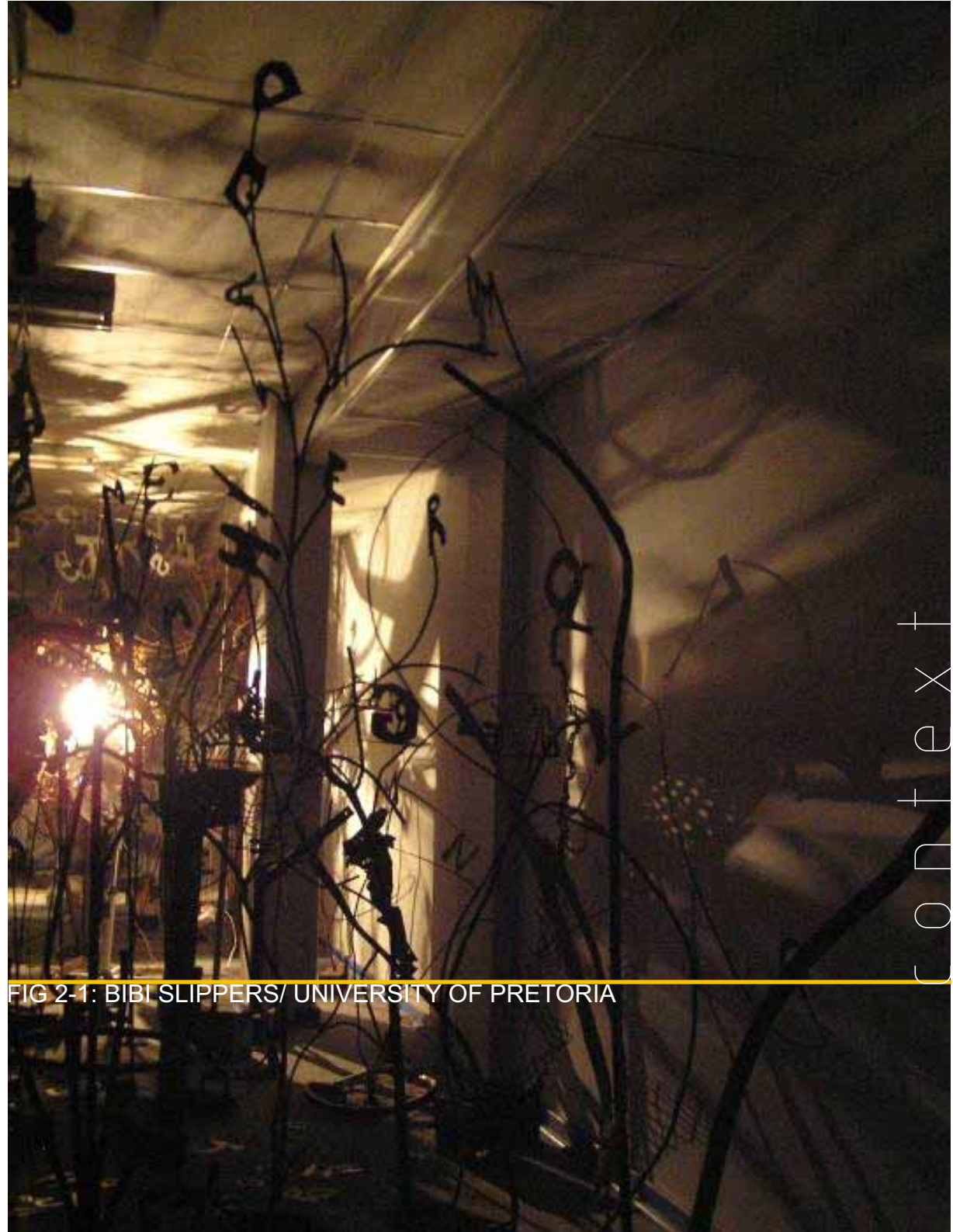

FIG 2-1: BIBI SLIPPERS/ UNIVERSITY OF PRETORIA

Context



FIG 2-2: AFRICAN CONTINENT

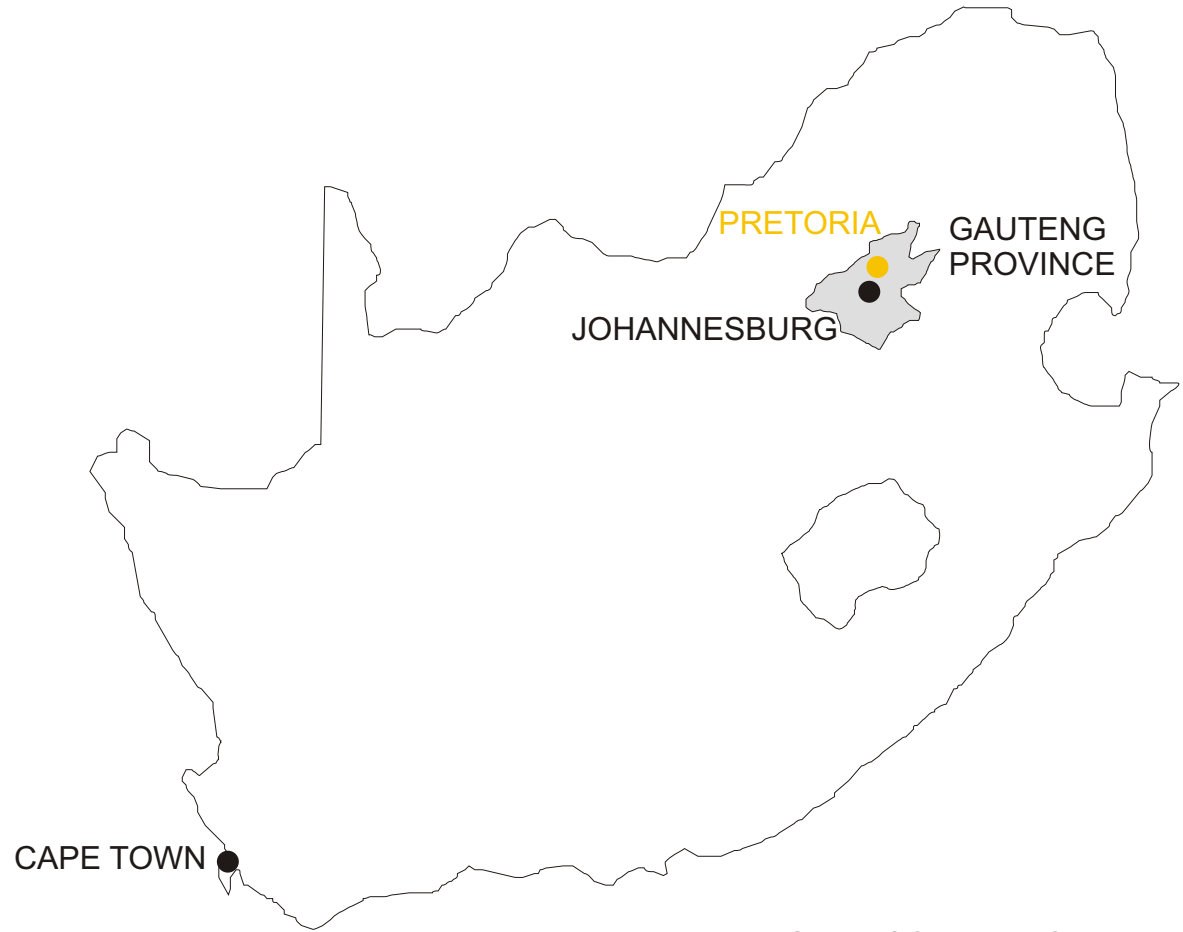

FIG 2-3: CONTEXT OF PRETORIA

CONTEXT

## global context

The University of Pretoria, being close to the CBD of Pretoria, is situated in the Gauteng province in South Africa on the African continent. Indicated is the wealthiest cities in South Africa and also where the most innovative ideas come from, due to the creative and growing companies wanting to be in these economically stable environments. Pretoria, being the capital of South Africa, is connected with Johannesburg and Cape Town through the N1 Highway. By 2010 the Gautrain project will be finished, which is a submerged high speed train commuting between Pretoria and Johannesburg.

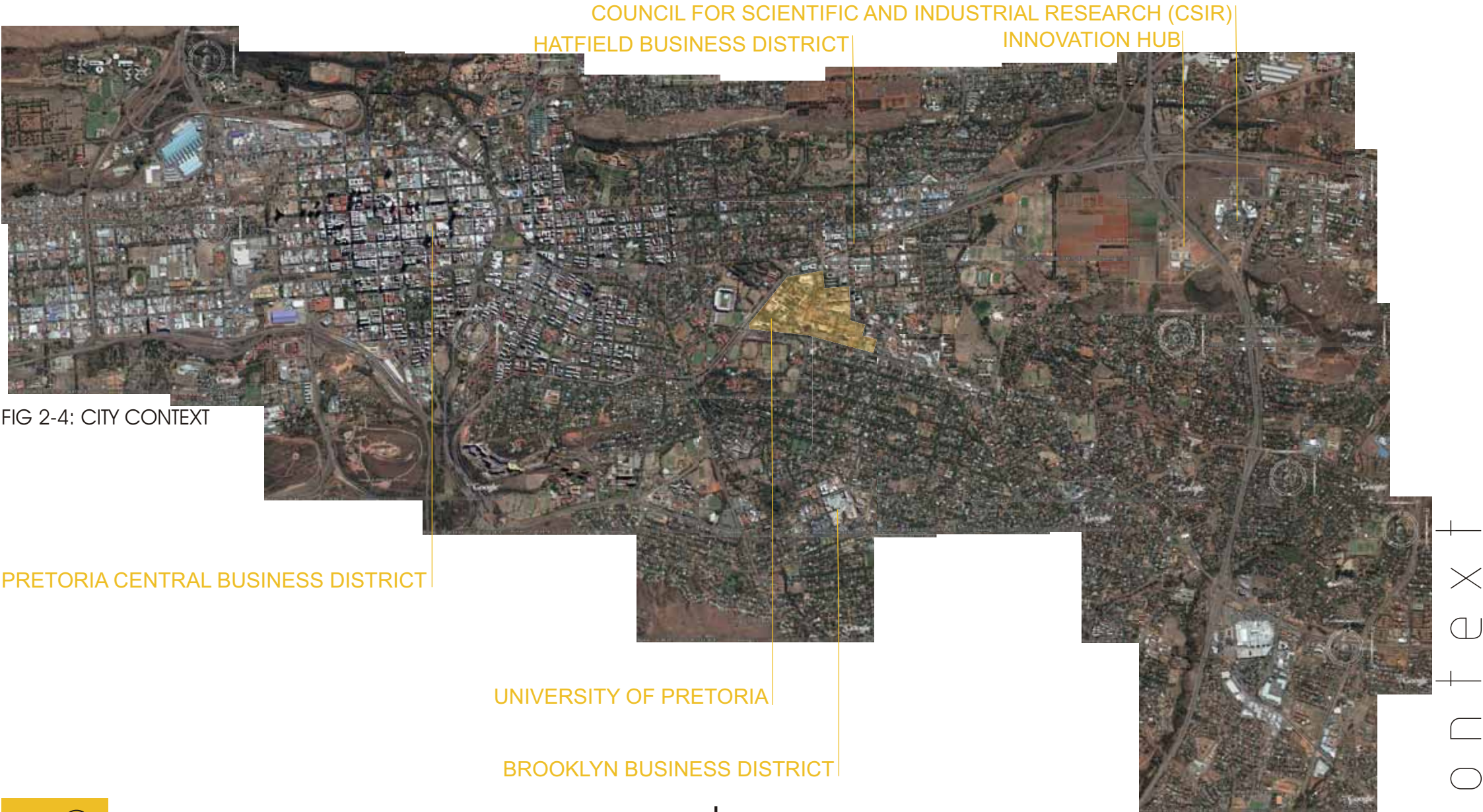

FIG 2-4; CITY CONTEXT

C O N T E X T

## urban arena

Pretoria expanded and developed from the centre of town into all directions with the University of Pretoria established on the eastern side. The university is within close proximity to the CBD as well as Hatfield and Brooklyn's Business Districts. The Incubator will be located on the university's premises forming the interface between the university and the surrounding as well as the international business world. The Innovation Hub and the CSIR is also relatively close to the university which serves to create an inspiring environment for the young entrepreneurs' startup innovative companies.



FIG 2-4: CITY CONTEXT

C  
O  
N  
T  
E  
X  
T

2  
3

## important corridors

The N1 highway is the most important corridor in South Africa, connecting places from the southern tip of Africa in Capetown, to Cairo at the top of Africa. The corridor is however not called the N1 once it crosses the South African border but the principle still applies. The N1 also crosses the N4 highway which connects places from the western to the eastern sea border. The University of Pretoria is relatively close to both these important corridors, and when considering that the Incubator would be situated on these premisses, initiating an internationally acclaimed incubator of innovation could be possible.



FIG 2-4; CITY CONTEXT

C O N T E X T

## important corridors

The University of Pretoria is situated on Lynnwood Road which is one of the most prominent roads in Pretoria. It connects the university with central business district of Pretoria on the western side and with the N1 highway on the eastern side. People coming from the east and from the highway therefore utilizes Lynnwood Road to get to the CBD or to Loftus Versveld sport stadium. The buildings situated on this road will receive enormous public exposure. Therefore with the Incubator situated on the university's premisses on Lynnwood Road, there will be prime exposure for the young entrepreneur's startup businesses.



FIG 2-4; CITY CONTEXT

C O N T E X T

## important corridors

The Gautrain connects Johannesburg, which is the largest city in South Africa, with Pretoria with a high speed submerged train. Therefore through this ease of transport made possible by the Gautrain, huge business opportunities are opened up. There is a railway track to the north of the university, with two Gautrain stations on this track. A train station right opposite the university connects the university with the CBD, the Gautrain and thus Johannesburg. Through this connectivity, accessibility to the Incubator is increased and thus motivating business opportunities.

FIG 2-5: CITY FRAMEWORK



CORRIDORS



GREEN AREAS AND SPORTS FACILITIES



RESIDENTIAL AREAS AND EDUCATIONAL FACILITIES

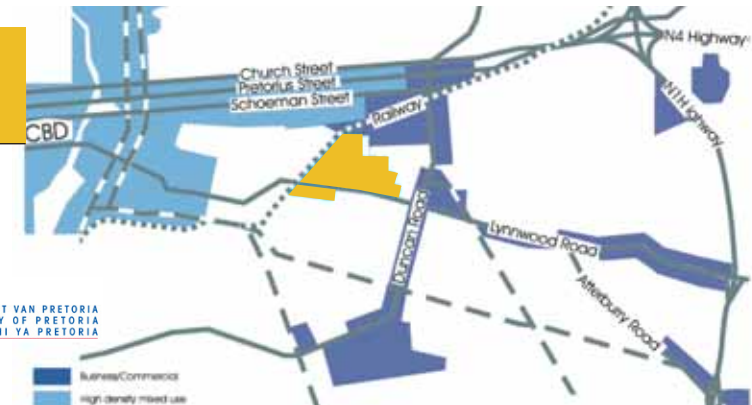

BUSINESSES/COMMERCIAL AND MIXED USE

## city framework

The University of Pretoria is well connected and well situated in the urban framework of Pretoria with nearby surrounding residential areas, facilities of education as well as nearby green areas and sports facilities. Most important of all is the fact that the university is within close proximity to businesses, which is beneficial for the business incubator.



LOFTUS VERSVELD

BOYS HIGH SCHOOL

UNIVERSITY OF PRETORIA  
SOUTH CAMPUS

PRETORIA-OOS SCHOOL

UNIVERSITY OF PRETORIA  
MAIN CAMPUS  
BROOKLYN RESIDENTIAL AREA

SITE

HILLCREST BUSINESS CENTER

2  
7

## urban focus

This is the Main Campus of the University of Pretoria with the South Campus on the southern side of Lynnwood Road. The site where the Incubator will be located is situated on Lynnwood Road to gain maximum exposure. It would be the last building of the university from the west and the first building from the east. Loftus Versveld is a sports stadium situated to the west of the university which attracts sports fans from all over the country. Through Loftus Versveld people from all over the country pass by the university as well as the Incubator, providing tremendous exposure for the entrepreneurs' businesses.

C  
O  
N  
T  
E  
X  
T





RAILWAY  
TRAIN STATION

LYNNWOOD ROAD

ROPER STREET

MAIN ENTRANCE

SITE  
DUNCAN STREET

## urban focus

The main entrance to the university is on Lynnwood Road with the most prominent buildings facing it in order to make Lynnwood Road the front facade of the University of Pretoria. Duncan Street connects the Brooklyn business district with Hatfield business district which also has corporate businesses alongside the road. Therefore with the site for the Incubator on Lynwood Road and close to Duncan Road, the entrepreneur's businesses would add to the corporate 'genius loci'.

C O N T E X T

FIG 2-7: 3D IMAGE OF THE UNIVERSITY OF PRETORIA

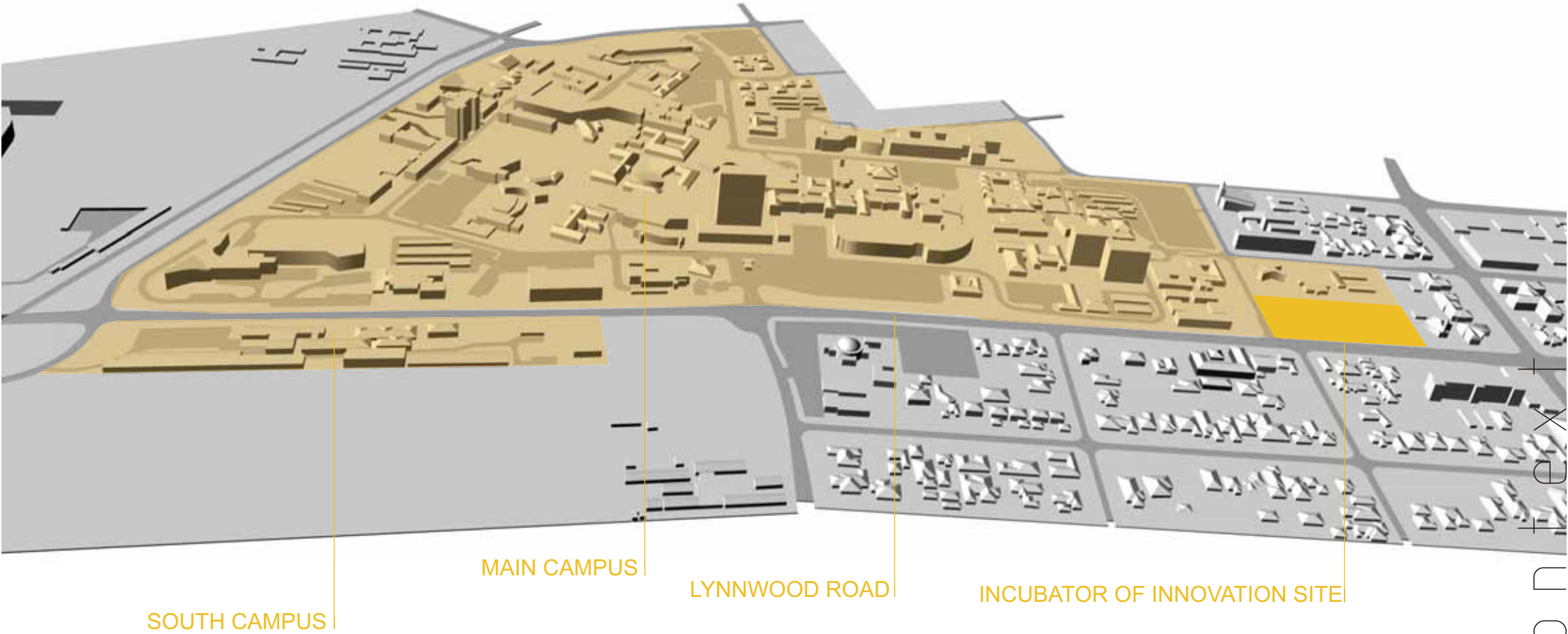

SOUTH CAMPUS

MAIN CAMPUS

LYNNWOOD ROAD

INCUBATOR OF INNOVATION SITE

university of pretoria

FIG 2-8: FIGURE GROUND STUDY - URBAN STITCHING



## urban stitching

The university is cut off by the railway and Lynnwood Road from the rest of the urban fabric, creating a fragmented island which prohibits integration with the surrounding urban fabric. Therefore urban stitching is required through urban design techniques in order to integrate the university with the Brooklyn residential area to the south of Lynnwood Road. Through this also establish and emphasize an identifiable character suited for a university precinct. Houses to the south of the university that are not of architectural or historical value can be utilized for high density mixed use student housing in order to achieve integration.



FIG 2-9: 3D IMAGE - URBAN STITCHING

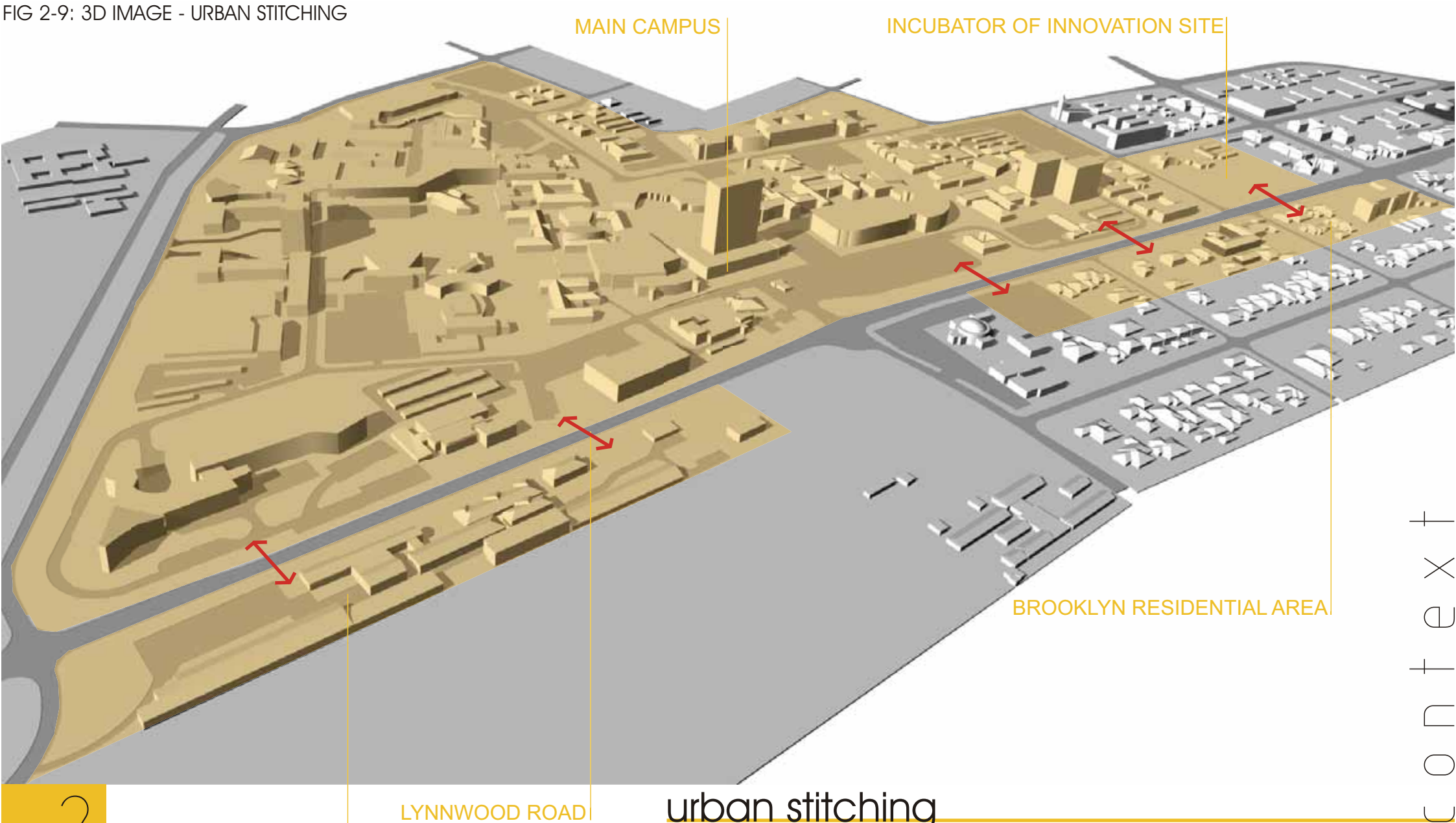

MAIN CAMPUS

INCUBATOR OF INNOVATION SITE

BROOKLYN RESIDENTIAL AREA

LYNNWOOD ROAD

urban stitching

SOUTH CAMPUS

C O N T E X T

2  
11



## EXISTING BUILDINGS

## CAR DOMINATION

## GREEN AREAS

### existing urban framework

The figure ground study indicates the existing urban framework of the University of Pretoria as well as the area to the south of Lynnwood Road. As can be seen the urban fabric of the university is much more coarse than the residential area as a result of the larger buildings. In order for urban stitching to take place this should be examined as this is part of the reason why there isn't integration between the areas. The other reason is as a result of Lynnwood Road dividing the two areas and creating a barrier which prohibits integration.



FIG 2-11: FIGURE GROUND STUDY - FOCUS AREA

## focus area

The diagram indicates where the focus area of the thesis would be as this area would have the most impact on the design decisions taken for my building. Therefore a thorough urban analysis and urban design will take place in this area in order to present the decisions taken for my building successful. The area encompasses the part of the University of Pretoria that faces Lynnwood Road, which is the front facade. The thesis will deal with Lynnwood Road itself as well as the area to the south of Lynnwood Road, which includes the South Campus and the Brooklyn residential area.

SOUTH CAMPUS

MAIN CAMPUS

LYNNWOOD ROAD

INCUBATOR OF INNOVATION SITE

focus area

BROOKLYN RESIDENTIAL AREA

2

14

C O N T E X T

FIG 2-12: 3D IMAGE - FOCUS AREA

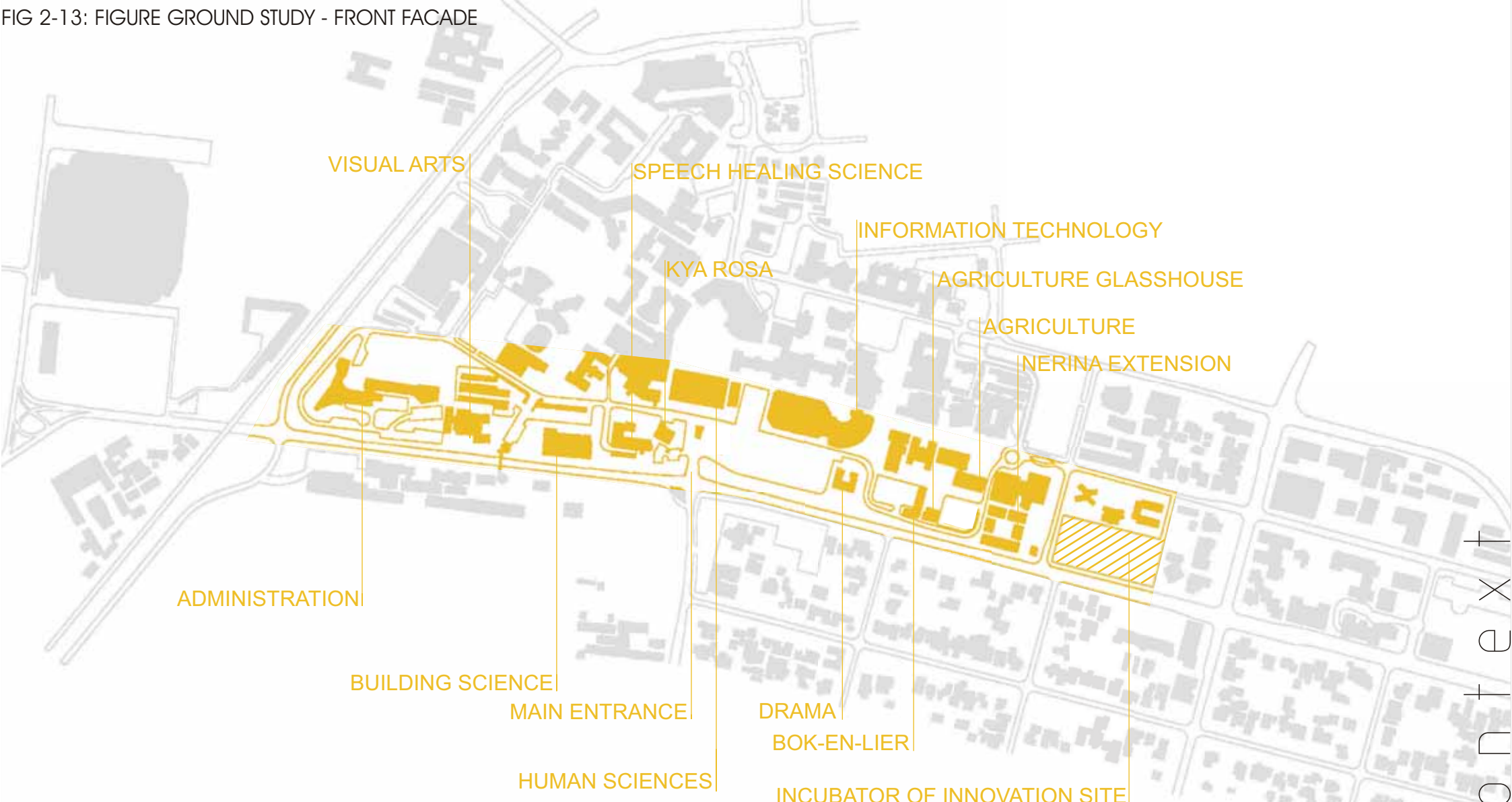

## front facade

The front facade indicates and display in a physical way, the competency of the University of Pretoria and should therefore be examined to ensure the displaying of excellence. The buildings which contribute to the aesthetics of the facade is indicated on the diagram. The facade is currently extremely fragmented with large open spaces used for parking. There are also buildings such as the Bok-en-Lier and the Agriculture Glasshouse which is of no architectural or historical value and does not contribute to the facade. The new extension to the Nerina residence has toilet windows facing Lynnwood Road!



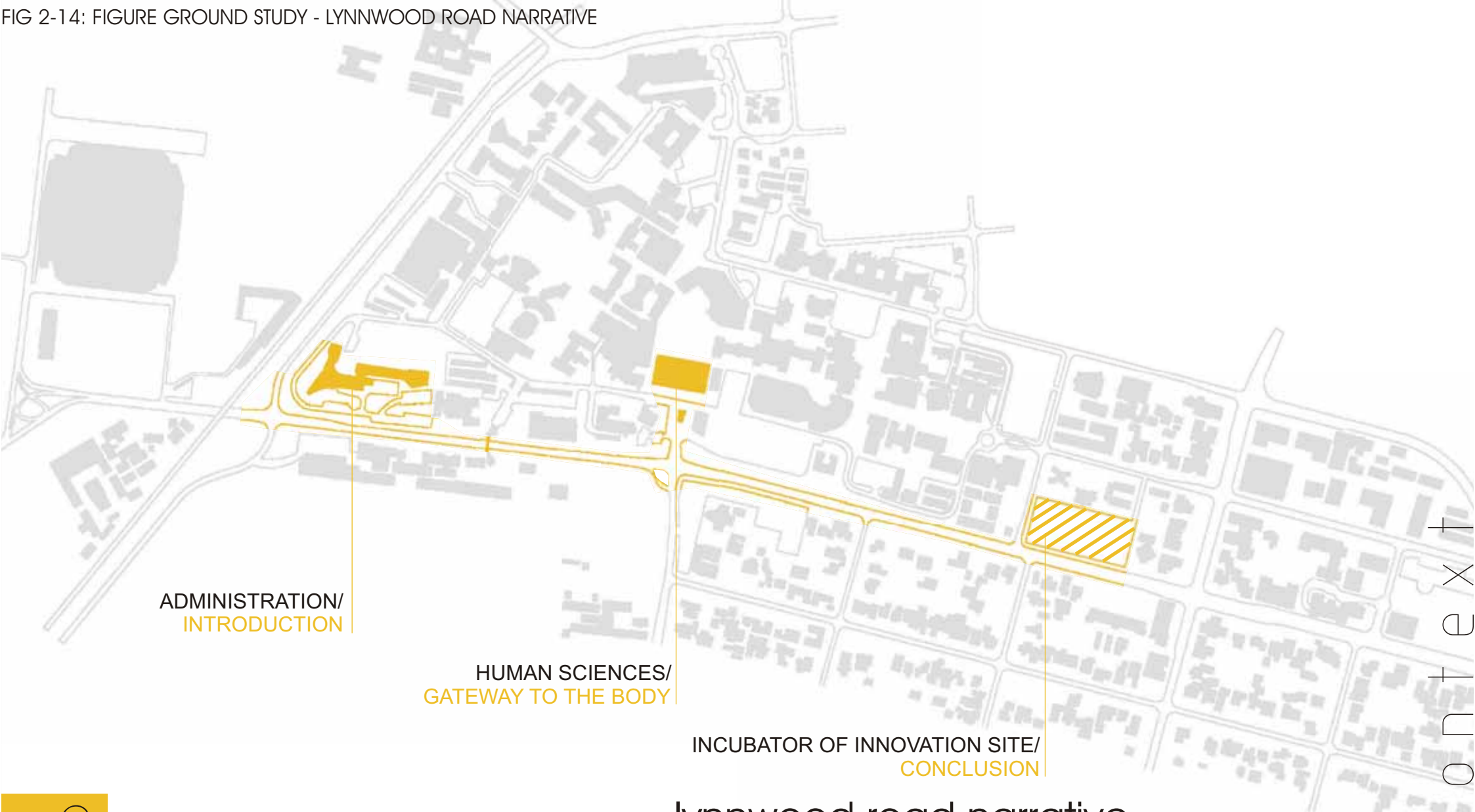

ADMINISTRATION/  
INTRODUCTION

HUMAN SCIENCES/  
GATEWAY TO THE BODY

INCUBATOR OF INNOVATION SITE/  
CONCLUSION

2

16

## lynnwood road narrative

Lynnwood Road as the front facade of the University of Pretoria, forms the visual interface with the public sector. Lynnwood Road is a narrative journey describing the translating of information being offered by the University of Pretoria. This narrative is formed in each person's own thoughts driving along Lynnwood Road, but the narrative is incomplete as it is without a conclusion. There isn't a building that serves as an exhibition space for the university to display the products and innovations that comes from years of absorbing information at the University of Pretoria.

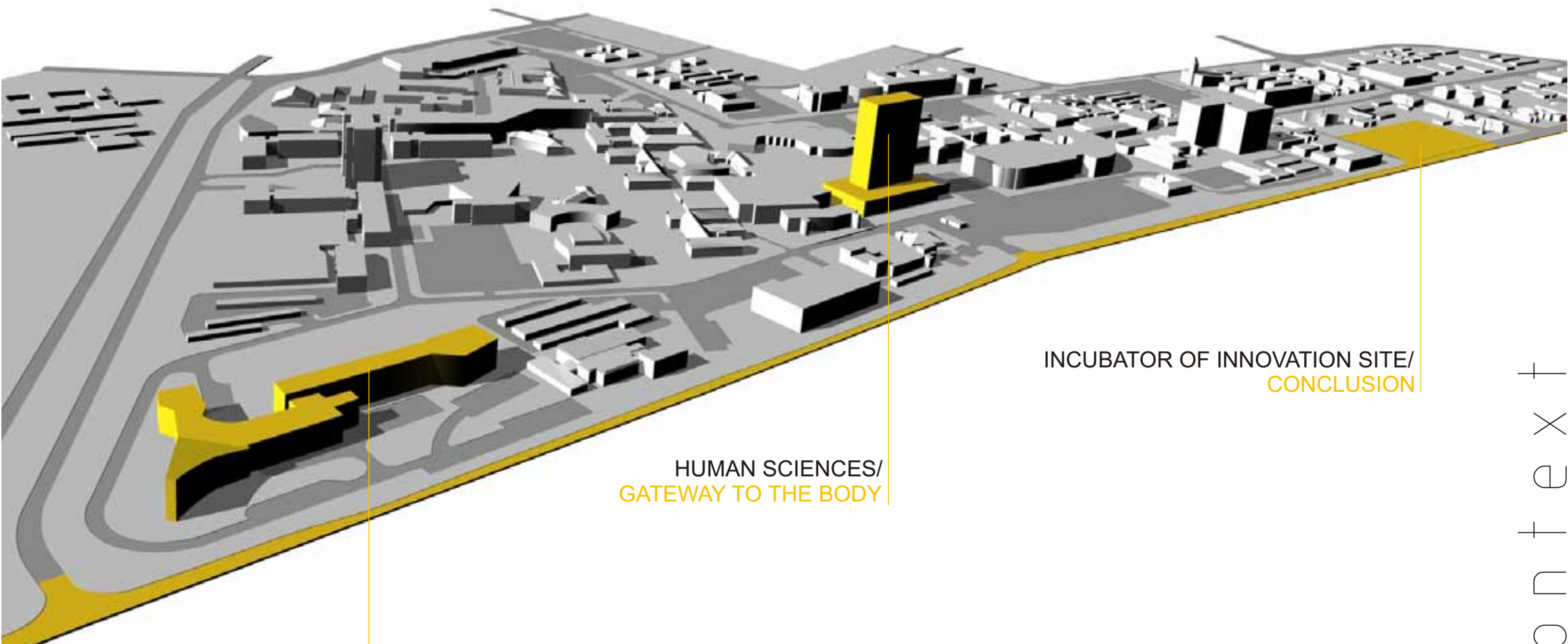

ADMINISTRATION/  
INTRODUCTION

HUMAN SCIENCES/  
GATEWAY TO THE BODY

INCUBATOR OF INNOVATION SITE/  
CONCLUSION

2

17

## lynnwood road narrative

It was the intention that when one is approaching the university from the central business district in the west, that there would be an iconic building representing the introduction or the start of the university narrative, which would also serve to be a landmark for Pretoria. The Administration building of the university serves to be just that, it is one of the most prominent landmark buildings in Pretoria, due to its extraordinary architectural design.

C  
O  
N  
T  
E  
X  
T

HUMAN SCIENCES/  
GATEWAY TO THE BODY

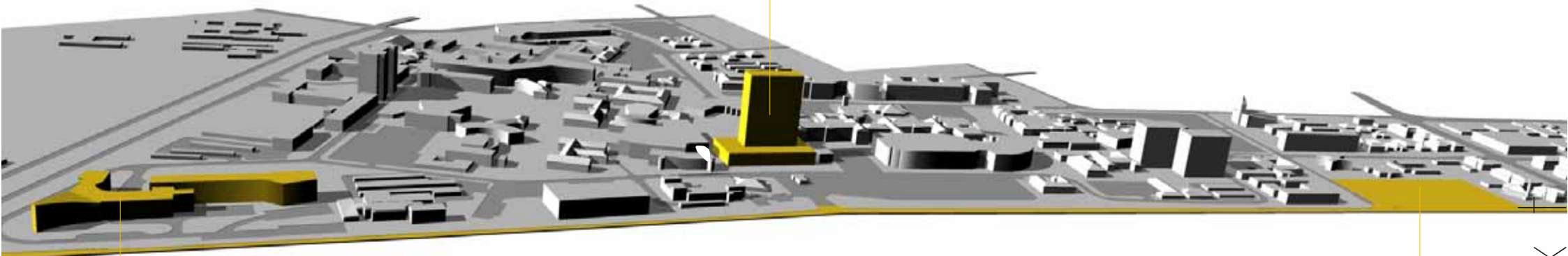

ADMINISTRATION/  
INTRODUCTION

INCUBATOR OF INNOVATION/  
CONCLUSION

2

18

## lynnwood road narrative

When driving past the university, old students are reminded of their years of studying, their friends and of all the good times as well as the sad times. The buildings however display the history of translating information of the different sciences with the Human Sciences building represented as the gateway to this information hub. Passing this iconic building, there is a world of information available to those who are fortunate enough to be accepted to the university. The Human Sciences building is therefore represented as the body of the Lynnwood Road narrative.

C  
O  
N  
T  
E  
X  
T

ADMINISTRATION/  
INTRODUCTION

INCUBATOR OF INNOVATION SITE/  
CONCLUSION

CLIENT SERVICES CENTER/  
GATEWAY TO THE BODY

## lynnwood road narrative

The narrative that is constantly being written in the minds of the people passing the university, is a narrative of 'Translating Information'. The Incubator of Innovation should be placed at the end of the narrative journey and should be an iconic building to represent the conclusion of the narrative and the product of the university. The building should be an exhibition space for the university, displaying the results and products of years of translated information, in order to honor the university and showcasing their competency.

2

19

FIG 2-18: PHOTOGRAPH - LYNNWOOD ROAD NARRATIVE

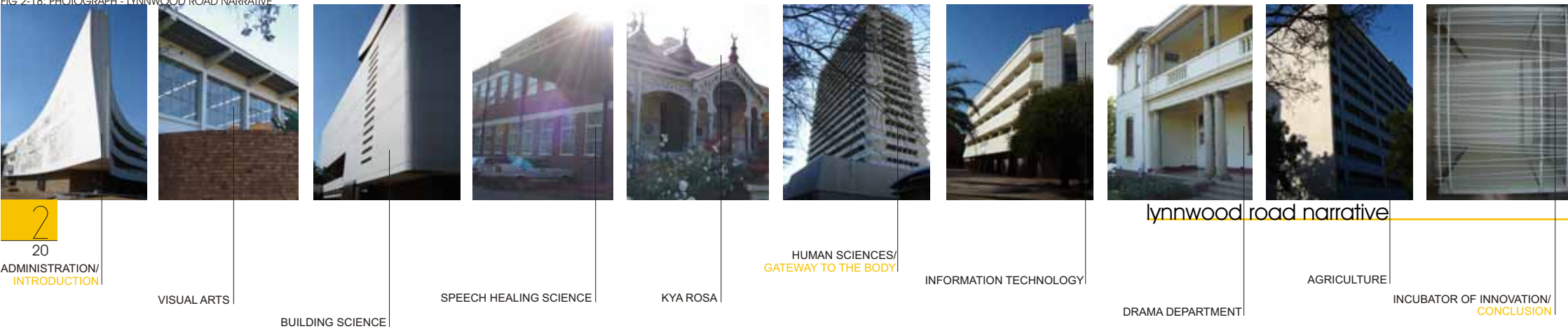

Within the socio-economic context of South Africa there are an enormous need for job creation, empowerment and social upliftment. New and small firms are extremely important for the country's economic well-being as it increases the employment rate, unfortunately some statistics have shown that there is a very high failure rate of new small businesses. The main reasons for that being a lack of business management expertise and under-capitalization.(Roure and Keeley 1990)

Business incubators aim to solve these problems by nurturing start-up companies into maturity. This Incubator@UP will achieve this by providing graduates in the fields of design/art and engineering, with the necessary business skills as well as shared facilities in order to minimize their capitalization and start producing innovations. Once help is available to the entrepreneurs, the starting of new businesses will be motivated which would in turn create more jobs in South Africa.

Society in general pay the most money for intelligence and creativity, therefore when combined to form an innovation it is a recipe for success and economic upliftment. Therefore the most sustainable economies in the world are those driven by innovation and entrepreneurship. The incubator's main focus is to develop innovation and provide maximum exposure to the newly graduates. This shall be utilized for firstly their own development and economic upliftment and secondly for South Africa's socio-economic upliftment.

Regarding the ecological context, the single largest contributor to global warming is the building sector. As illustrated in the figure below, buildings not only use more than 40% of the planets energy demand but also uses a great deal of water and raw materials. Buildings also generate waste and potentially harmful atmospheric emissions, which have a huge impact on the ecology.

## triple bottom line

The triple bottom line deals with the social, economical and ecological aspects which my project could effect, and which could effect my project. The decisions therefore made in this project and every project to come, will be evaluated according to the triple bottom line principle.

# Environmental Impact of Buildings

Percentage of U.S., Annual Impact

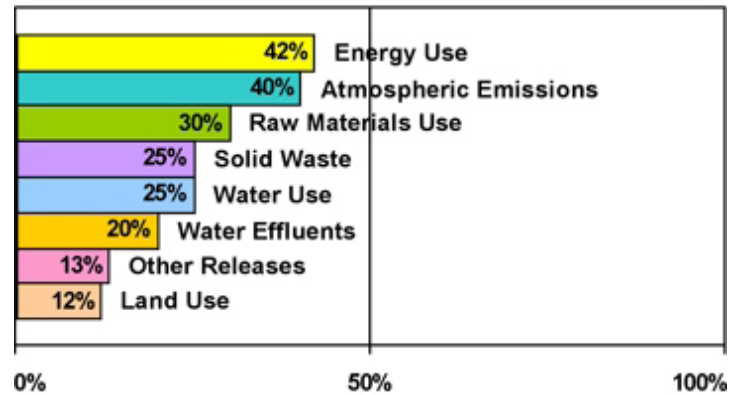

FIG 2-19: ENVIRONMENTAL IMPACT OF BUILDINGS

When considering the facts above there should be a drastic change in the way we design, manufacture, supply, install and maintain buildings. It is therefore important to design with these facts in mind, and any design whether it is developed in architecture, interior or landscape architecture or urban design, should be energy, water and waste sufficient. Buildings should be designed to save resources, be sustainable and conserve our planet for the generations to come.

There is a 2030 challenge for all design professionals with regard to reducing global warming. This challenge, initiated by Edward Mazria and Architecture 2030, requires design professionals to create buildings which use substantially less energy and reduce greenhouse gas emissions, whilst maintaining a healthy and comfortable space. The challenge includes targets such as an immediate reduction of 50% energy use for all new buildings. By 2010 - 60% with a 10% increase every five years in order to reach a carbon-neutral building environment by 2030.

triple bottom line

Architecture 2030 is a non-profit organization, which was established by Edward Mazria in 2002 in direct response to the current global-warming crisis. Their goal is: "To achieve a dramatic reduction in the global-warming-causing greenhouse gas (GHG) emissions of the Building Sector by changing the way buildings and developments are planned, designed and constructed." (Mazria, 2002) We as designers should adopt this goal of Architecture 2030 in order to be set in the right frame of mind which would allow us to create sustainable buildings.

The building to be designed, will be situated within a legislative context which is defined by the local authorities. The process of design shall therefore comply with all National, Provincial and Local laws and acts that may pertain to my project, with specific reference to the National Building Regulations.

triple bottom line

---

+  
X  
E  
+  
N  
O  
U

2

23



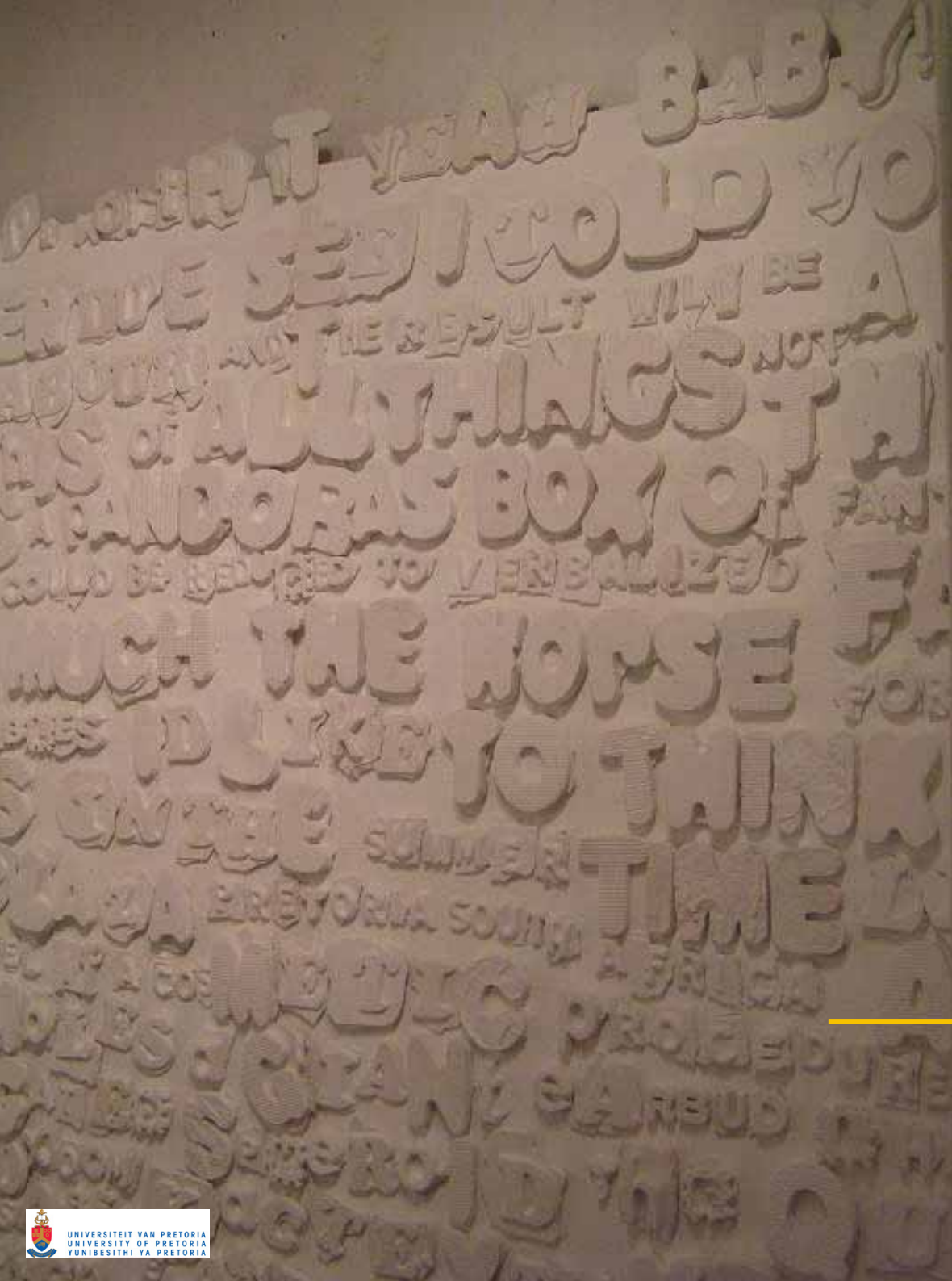

FIG 3-1: BIBI SLIPPERS/ UNIVERSITY OF PRETORIA

There is ample theory available on business incubators to get a complete understanding of what it is, and how it works. The literature will demonstrate that business incubators is the ideal location for new graduates to develop and grow their start-up businesses. Literature will show how to design a business incubator which will be the accelerator for successful businesses. It will be evident to see that business incubators promotes entrepreneurship through providing the needed facilities, services and programs.

I will be studying literature that shows the key issues involved with business incubators and to establish it in such a way that it is sustainable. The Literature will sketch the characteristics of the environment in order for it to be a complete and tailored business support incubator in order for graduates to reach their full potential within the business world. The research will show how to implement the concept to create positive spin-off effects within the socio-economic context of South Africa in order to promote economic well being.

Spatial relationships is important when designing an environment which have to optimize the function of being the Incubator of Innovation. The literature will indicate how to accommodate creative beings who need to upgrade and change their environment in order to be inspired. Each year there will be tenants leaving and new tenants coming in with different needs and requirements. I will be studying the concept of Open Building which accommodates the phenomena of inevitable change, to make it easier, less costly and more sustainable.

The urban design literature will indicate key concepts and principles to apply to my project. By studying and adopting some of the patterns described in Christopher Alexander's book of A Pattern Language (Alexander, Ishikawa &

## introduction

The introduction to the literature study gives a brief overview of what the study would encompass as well as the relevant books pertaining to a specific subject.

V  
P  
U  
T  
S  
E  
J  
U  
T  
E  
J  
E  
T  
I

Silverstein 1977), I would be able to strengthen a sound argument within an urban and architectural context. Kevin Lynch in his book of Image of the City (Lynch 1960), talks about how a person orientates oneself in a place. I will be incorporating his theories of paths, nodes, edges, landmarks and districts in order to strengthen my project within the urban setting. The book of Responsive Environments (Bentley, Alcock, Murrian 1985) is able to provide me with some guidance to knit the university back into the urban fabric in order to complement the environment.

## introduction

---

## How did business incubation start?

The first so-called incubator started in 1959 in a near-derelict building in New York where the term 'incubator', credited to Joseph Manusco (Barrow 2001:11), started off as a joke. The building was used for the initiative to make space for small firms to get started. However it was the British Steel Industry in 1975 who would have the first proper business incubator, initiated to help create employment for areas affected by the scaling down of steel production in Europe. They not only offered shared workspace but provided capital loans as well as training and advice to the start-up firms.

In 1980, the Rensselaer Polytechnic Institute(RPI) Technological University, was looking for ways to expose their students to the business world. Business people came to lecture the students on techniques to start a business and students worked with these businesses to get first-hand experience on how a business function. Students and professors then started their own companies which propelled the incubator, boosting the local economy and proving through this concept that small companies could revive the local economy . During the 1980s a few hundred such facilities were distributed all over the United States, Canada, Europe and Australia. A study (Harley 2001) have indicated that the number of incubators worldwide literally doubled every five years, from a few hundred in 1985 to more than 3450 business incubators in 2000.

## How does business incubation work?

Most entrepreneurs are in need of incubation as they have the innovative brilliance but they are not business people (Richards 2002: 6). Business incubators function through providing strengthened business skills, business services and facilities, improved operating environment and business

## incubator

A business incubator is a multifaceted operating space which provides entrepreneurs with business support through targeted resources and services that accelerates the successful development of their start-up company. Resources and services are provided, according to the needs and requirements of recently graduated entrepreneurs, and the process is orchestrated by the incubator management in order to create a successful incubator.

networking to nurture early-stage businesses into maturity, increasing their prospects for business survival and growth. Professor Swierczek states that incubation or innovation centers form the "interaction between the research community and the business community" (Swierczek 1992 in Barrow 2001: 6). Business incubators in general aim to produce sustainable graduate businesses, insuring an increased income whilst creating a return on shareholder's investment as well as economic development for the local community.

Critical elements of a successful incubation program:

- A broad range of supporting stakeholders such as common wealth, state or local governments as well as community based groups or a even private company.
- Service the demand from the local entrepreneurs who wants to improve their survival and growth of their early stage small businesses.
- Provide tailored facilities and services and not just office space for the tenants nurturing period.
- Effective incubator management group for the continuing support, development and sponsorship of their start-up businesses.
- The success of an incubator is dependent on insuring a regular turnover of graduate businesses.
- The incubator should deliver the required outcomes and provide profitable investment for the relevant stakeholders.

Is there a need for business incubators?

It is innovative companies with their creative ideas that are the drivers of a sustainable economy, and incubators build the bridge that connects genius to commerce (Richards 2002: 6) One study (Harley 2001) reported in 2000, a total

incubator

3

4

number of 3450 incubators worldwide and today there are over 4000 business incubators. Prof. David Birch, in his landmark work emphasizing the importance of new businesses (Birch 1979), discovered two reasons for the increase in number of incubators. Firstly, small businesses who employs less than twenty workers, were responsible for over two-thirds of the increase in employment in the United States between 1969-1976 (Birch 1979). Secondly Prof. Birch's research have indicated that although this was the case, these small businesses were also extremely fragile. He noted that approximately eight million of those companies in the United States closed down each year (Birch 1979).

Another study done by Prof. David Birch have shown that only half of all small firms will survive more than five years (Birch 1987). Statistics done by Bates and Nucci have indicated that, although new business creation had increased profusely, the failure rate of such businesses were still towering (Bates and Nucci 1989). Roure and Keeley have determined that the reason for the high failure rate is as a result of a lack in management expertise as well as under-capitalization (Roure and Keeley 1990). Therefore in response to these problems business incubators are developed, providing business management skills and the needed capitalization, in order to foster and protect small start-up companies in their fragile early-stages of development.

### What are the benefits for South Africa?

Through the implementation of business incubators, small businesses are assured of their survival in the capitalist business world. Entrepreneurs are therefore motivated to be creative in developing innovative concepts and products for their own firm, in order to show the world what they're made of through their God-given abilities.

## incubator

---

All governments, whether local or national, want to create new jobs above any other goal as it is the basis for socio-economic growth. As discussed above and under the socio-economic context of South Africa, these small innovative companies are the drivers of any sustainable economy. Therefore through these incubation programs, ensuring the survival of these small firms, there would be job creation evident, causing economic and social upliftment for South Africa.

Incubators are not only advantageous for the firms that go in for incubation and the local economy, but it also has profitable opportunities for South Africa's private sector. Governments would be enthusiastic in putting money into such initiatives which would be profitable for the orchestrators of such an incubator. As explained under the Client, the orchestrator could also receive a percentage fee of the individual's investors or from the profit made.

### Who goes in for incubation?

It is well managed intelligence and creativity that generates income, therefore when combined by entrepreneurs to form innovative thinking become the drivers of the economy. It is innovative entrepreneurs that are needed and not small business men or women. Most new business start-ups are not entrepreneurs, but indeed just poor copies of the already existing ideas and businesses. Entrepreneurs are individuals who has the capacity and the passion to develop innovations or ideas of the future in order to "shift economic resources out of an area of lower and into an area of higher productivity and greater yield" (Say 1800 in Barrow 2001: 22).

There are different types of incubators catering for various individuals. Some companies have their own in-house incubators where new employees would

incubator

work in collaboration with more experienced individuals. There are also public incubators open for any entrepreneurs but for the purpose of this thesis, the focus would be on an incubator for the University of Pretoria.

## Have universities been involved with incubators before?

When it comes to developing incubators, universities have always been at the forefront, which by the 1980's already had several hundred campus-based incubators. (Barrow 2001: 43) Among these was the Yale University's incubator which was facilitated by Dr Sam Chauncey, who persuaded the Olin Company to donate a vacant small arms factory building to the university in 1982. Dr Chauncey raised a million dollars from the city, the state and private sources to remodel the building into an incubator facility, which had incubated over a 100 companies and created 500 jobs within a period of five years (Barrow 2001: 43). Another is the Utah Innovation Center which was built in the Utah University's research park, which offered a broad spectrum of incubating services to clients in return for equity stakes.

There were also a number of university incubators developed in the United Kingdom, one of which was the Cambridge Science Park. This incubator at Cambridge is an excellent example of how new enterprises are stimulated through a business incubation program facilitated by a university but I will elaborate and discuss it further in more detail under the precedent studies.

## What does a typical model look like?

It is as a result of a lack in resources, facilities and business management skills that there is a high failure rate in business start-ups. Therefore these start-ups must be able to depend on the incubators for these nurturing capabilities.

# incubator

---



Incubators' role is to "contribute to their companies so they are stronger, better and faster than those that are not in incubations" (Richards 2002: 45). In order to be nurtured by such an incubator, the entrepreneur should have capital available to pay for rent, provide the initial funds needed for the materials to develop such an innovation, as well as funds with regard to the cost of living. This capital should also be available until such time that the product is commercialized, is selling and making a profit and if such funds are not available, the entrepreneur's dreams would remain only dreams.

"The incubator has to have the ability to help raise capital for its companies" (Orion 2001 in Richards 2002: 46). Whether the means entails being hooked into a low interest alternative lending source, or getting grant funding or whether it is allocating a capital investor. Allocating an investors are a necessity to build a bridge between a genius idea and a commercial product. Knowing that innovative small firms are the drivers of a sustainable economy, investors would be keen to invest in it, once they are assured that their particular investment are within a safe and secure environment, which would ensure a successful return on investment.

The incubators should set reasonable and obtainable goals and should know the market extremely well in order to align themselves with the right partners, get the right investors and support the right companies. Therefore an exceptionally experienced business person, who is well networked in the economic environment should manage such an incubator.

According to Tyler Orion (Orion 2001 in Richards 2002: 43), director of Orion, which is a company who look at the needs and resources of an incubator, the heart of incubation is mentoring and business development as well as assistance with marketing and finance.

## incubator

---

Orion states that just by giving them a secretary, a copy machine and a mail room was never a good model. (Orion 2001 in Richards 2002) The incubator must be tailored to the needs of the entrepreneurs in order to accommodate their unique innovation. The incubator should provide the resources and funding, technology and facilities, business skills as well as marketing and licensing opportunities in order to function as a real incubator.

### What are the specific characteristics?

Their should be some sort of criteria involved or a selection process, in order to accept only clients with a viable business concept or innovation. The incubator The incubator should require that the start-ups meet their milestones and should hold them accountable for their progress. Providing direct investment and access to growth capital or at least establishing channels for financing is an absolute necessity for the incubation process. Accommodating for the ever-changing area needs of the tenant through flexible and customizable spaces, is a necessity for a successful incubator. However it is the provision of businesses services which is key to the incubators' value-adding capabilities.

Business services can be subdivided into two categories namely general and professional. General business services includes office as well as specialized equipment in laboratories and workshops; internet access; shipping, receiving and mailing services; clerical and administrative services; reception services. In regard to the professional business services the incubator should provide services for legal matters; intellectual property; accounting; book-keeping, recruitment and staff selection as well as education and training programs. Wisdom and experience in business and management skills are offered to the entrepreneurs through qualified coaching, advisory groups and training programs (Barrow 2001 : 49).

## incubator

These business management services include the preparation of business plans; marketing and business strategy formulation; public relations; research and development; employee relations including employee share ownership issues; international trade; government relations and procurement, and networking.

The incubator should establish synergy among the clients to enable a network of relationships in creating alliance between the collective ventures. An extremely good knowledge of the current needs of the industry is needed in order to establish whether the innovation is a viable investment. The incubator should have a successful launch record with successful people on the management team. Throughout the process the incubators are there to add value, champion the client as well as provide the support for the successful execution of the company's business objectives.

Incubators need to operate as a business and have their own source of sustainability. (Barrow 2001: 45) The incubator themselves should be viable and should therefore make a profit, in order to operate as a sustainable business. There should be equity involved through either implementing royalties, or the start-ups should offer enough of an incentive to the incubator to make it a worthwhile proposition.

The intellectual property should however remain the entrepreneurs', and therefore by keeping ownership when they leave, after the contract duration, they have the right to all profit. The contract duration would provide the fledglings a two to three years incubation program, depending on there development. Through undergoing the entire development program, it would classify them as mature enough to leave the nest and start flying.

## incubator

---

3

10

The conventional way of dividing internal spaces with brickwork in commercial and office buildings, inhibits changing or remodeling it according to the needs of the tenant and thus also restrain their progress and in the end their success. Some statistics in the United States (Department of Commerce) have shown that remodeling of existing buildings exceed the value of new construction each year. The trend of altering buildings and spaces according to the need of an occupant, occurs more frequently in buildings for commercial and office use as well as buildings for leasing purposes.

When considering the spatial relationships of a building, designers have to assess what is the current requirements and should predict what the need will be in the future in order for their ideas to last a lifetime. With every lease agreement, especially with office or commercial buildings, it is almost inevitable that there would be internal changes. Designers should therefore leave many options open for likely users and their requirements.

Stewart Brand explains in his book, How Buildings Learn (Brand 1994), that change in buildings are inevitable and that buildings learn from their owners, how to behave. Those who will live in a space need to be involved in its planning, and the building needs to be able to accommodate what cannot be foreseen (Habraken 1972: 42).

Open Building is a contemporary design and building method that recognizes and deals with this ever-changing social and technical environment in which we live and work. Open Building enhances the efficiency of the building process through an innovative approach to design, whilst increasing the variety, flexibility and quality of the product (Bensonwood Homes 2008: 1).

## spatial requirements

People's needs change and different people have different needs and requirements. Permanent places of occupancy, whether commercial, office or residential have always been changing through remodeling, renovating and updating it according to the current needs of the occupants. Most buildings have numerous layers of wallpaper or paint, new additions or had their floor plans altered in order to suite the peoples requirements. In our capitalist society today, it is only the industries which are changing and adopting quickly to our modern world that is is thriving and making a success (Benson 1997).

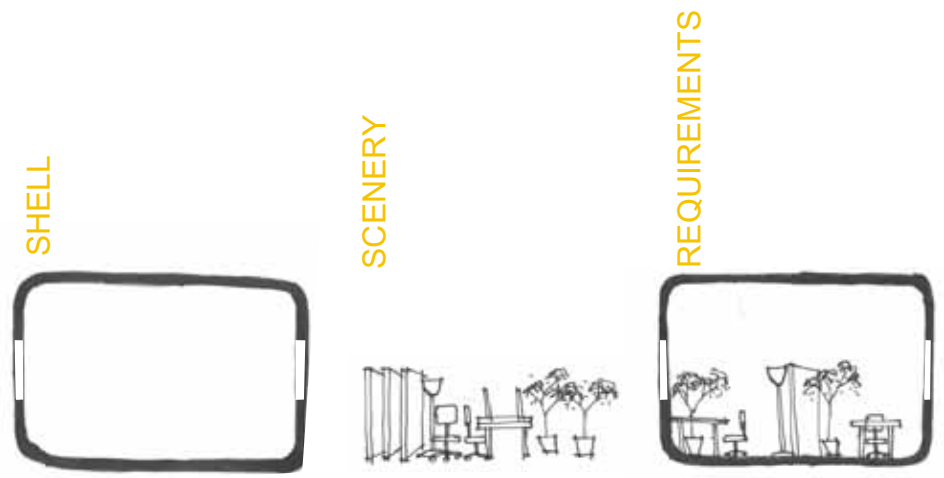

FIG 3-2: SHELL, SCENERY AND REQUIREMENTS

The concept of Open Building is described as a well-organized combination of systems and sub-systems, which can be coordinated to form a better process and product for the tenant. (Bensonwood Homes 2008: 1) The key systems involve the building site, structural frame and envelope, the internal space divisions as well as the services and furniture. Open Building allows for the ability to disconnect and reorganize the systems and sub-systems in order to create a more efficient space with increased control through quality, variety and flexibility. Open Building addresses the need of present and future occupants, which makes the remodeling of the space easier and more affordable.

When referring to the shell of the building it is "all that is provided for the duration of the life of the building: the structure, the envelope and the basic services." (Duffy, Cave & Worthington 1976: 8) "A scenery has a much shorter life than a shell. Its role is to take up the tolerance between the precise needs of the tenants and the loose fit of the building shell" (Duffy, Cave & Worthington 1976: 10) The shell should be extremely versatile and loose fit with well thought through positions of openings, structural elements and services which can work for the different scenes. The successful design of the shell is determined by how useful the space will be to the tenants throughout the life of the building. (Duffy, Cave & Worthington 1976)

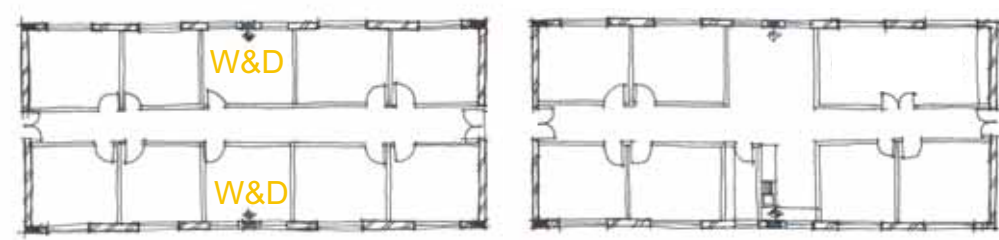

FIG 3-3: INTERNAL PARTITIONING

Through predictive planning inevitable change can be accommodated for in order to make changes affordable and much less complicated. One of the options that should be implemented where possible, is changing the material of internal space divisions from brickwork to partitioning. Partitioning is constructed by using a lightweight aluminium frame which is clad with lightweight gypsum board. By incorporating partitioning future internal changes can be done with less complications, more affordable and more sustainable.

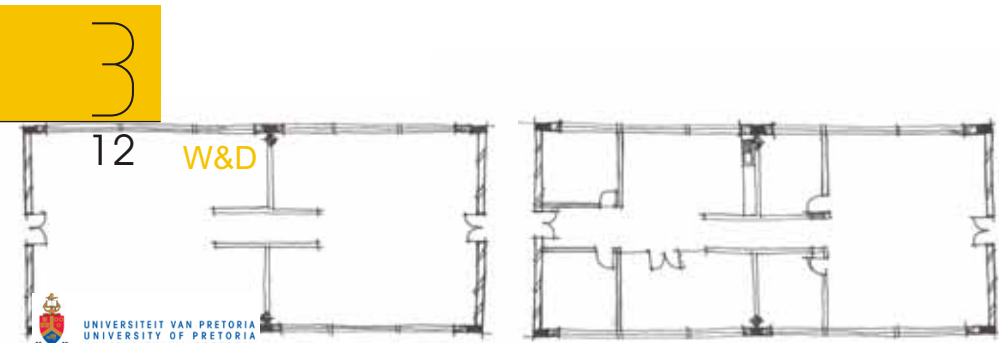
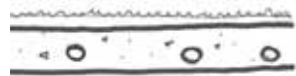

FIG 3-4: OPEN BUILDING

## spatial requirements

The diagrams in the middle indicates how the plan of a space could be changed from just offices into a boardroom, a kitchen and lunch room etc., through the use of partitioning. The services also accommodates the changes by providing water and drainage points in the walls. The diagrams at the bottom indicates how the technique of Open Building could be applied to the partition layout in order for the tenant to change his/her environment according to their needs. The shell accommodates the partition changes through mullions in the windows and by arranging the structure as not to restrict the changes.

CONVENTIONAL WAY



SUSPENDED FLOOR

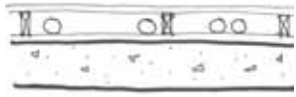

RIVER SAND

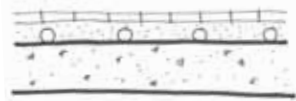

SUSPENDED CEILING

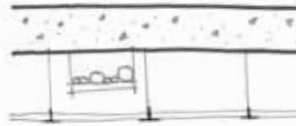

FIG 3-5: SERVICES FOR OPEN BUILDING

The other conventional way of building, is by placing service pipes and conduits in the concrete floors which prohibits any changes to the services of a particular space. "Open webs between the floor and ceiling for electrical, plumbing, and heating ducts make installation and later renovations relatively simple" (Bensonwood Homes 2008: 2). Therefore with Open Building, service changes is accommodated for by using suspended timber or laminated floors where conduits and pipes could be placed. Through this concept many changes of the tenant could be accommodated for.

Suspended floors can however not work in all spaces such as the mechanical workshops, due to the load of the machinery. Therefore river sand is used to accommodate the pipes with interlocking concrete pavers on top. Suspended ceilings should also be used to accommodate adaptable services. The grid system also allows one to put lights in any position as well as rearranging it according to any need. The ceiling panels could also be change into different colours or textures.

Incubators for innovative purposes should create an environment and a atmosphere which stimulate innovative ideas. The environment should therefore be extremely creative, innovative and continually changing in order to inspire and motivate the individual which is being incubated. The incubators accommodates for laboratories, studio space and workshops, as well as offices, presentation rooms, lecture rooms and exhibition spaces.

Incubators would need to provide for new tenants every year, which would all have different spatial requirements. The spaces in the incubator will have a large degree of flexibility and variety not only for practical reasons of leasing agreements but to stimulate the entrepreneurs' creativeness.

## spatial requirements

We as designers and architects should recognize the human need to constantly upgrade and alter our living environments. Creative people especially prefer to setup and change their own environment, which is tailored to their own liking in order to perform optimally. Buildings in general and specifically incubators, should therefore accommodate and not complicate this phenomena to allow the industry to reach their full potential. It is therefore an important aspect to consider when designing buildings to be sustainable.



V  
D  
N  
T  
S  
E  
J  
U  
T  
E  
J  
E  
T  
I

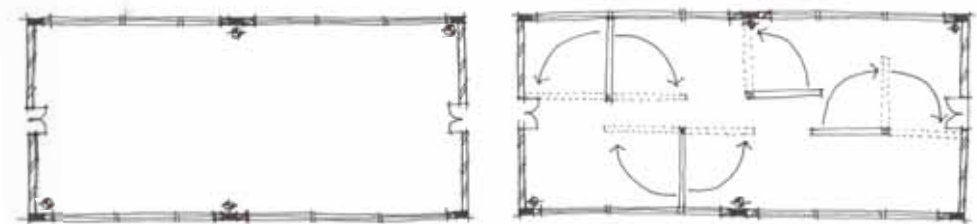

FIG 3-6: OPEN BUILDING - CREATIVE SPACE

The individuals should be able to move furniture around, rearrange spaces as well as changing the colours and textures. "Screens and furniture are now used to divide and define space" (Duffy, Cave & Worthington 1979: 10). Scenes are tailored to the tenants needs and requirements by installing adjustable and moveable screens. Furniture is used to define and divide scenes rather than making use of demountable partitions. Within the scene the worker have then the opportunity to manipulate and change his/her own workspace. The furniture used in the Incubator for Innovation should also not be conventional furniture but highly innovative in order to inspire and stimulate the entrepreneurs' creative thinking.

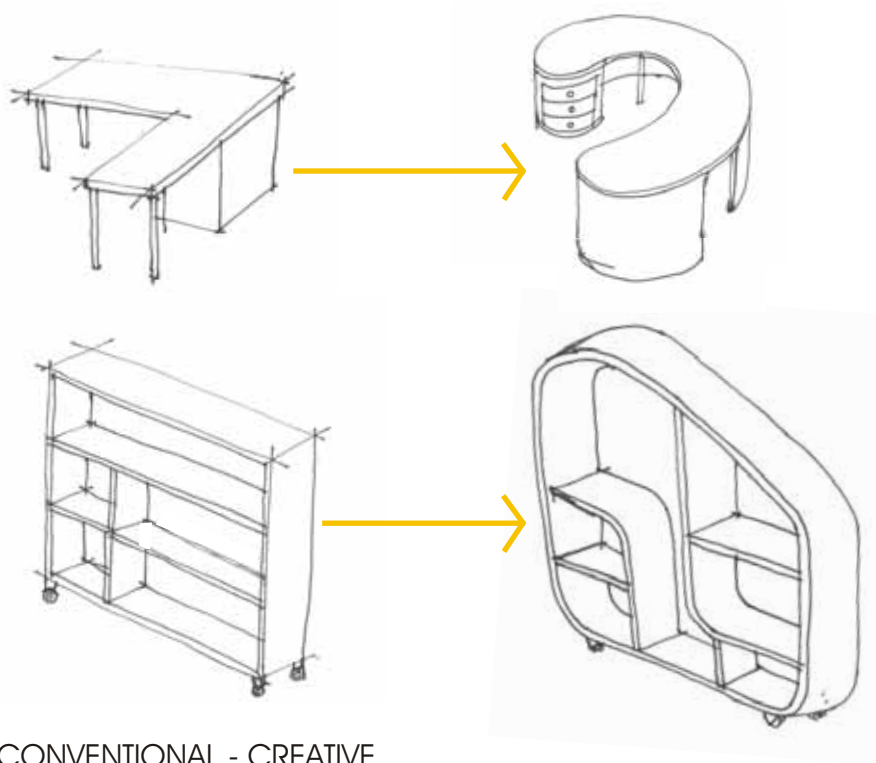

FIG 3-7: CONVENTIONAL - CREATIVE

The exhibition space will also be constantly changing which means the space should be extremely loose fit. It should have high ceiling volumes and large open spaces without columns to affect the ambiance of the space or restrict the flow of people. Again by applying the concept of Open Building there shouldn't be any fixed internal division but the space should be divided by movable screens which can be removed to increase flexibility. Services can again be accommodated in suspended ceiling and floor voids.

The spaces of the Incubator of Innovation would constantly be altered and remodeled, either for new tenants or by existing tenants executing their creativity for their own comfort. Therefore by implementing the concept of Open Building, create flexible, loose fit spaces which allow spaces to change according to needs. The creative individual can be incubated in a creative inspired and ever-changing environment. Change can now also be economically affordable, socially unproblematic and environmentally sustainable.

## spatial requirements

## How can Pattern Language (Alexander, Ishikawa & Silverstein 1977) assist with the regeneration of the urban environment?

Alexander states that where fast moving cars and pedestrians meet in the cities, the cars overwhelm the pedestrians. The car is king, and people are made to feel small (Alexander, Ishikawa & Silverstein 1977: 286). He explains that although cars increase peoples opportunities and give them freedom, they can also destroy the social life of an environment. We have grown so dependent on cars that one can't imagine an environment without them, and people refuse to give up the degree of freedom a private high speed car offer. It is undoubtably so that cars ruin their environment, ecologically and socially to create places where people don't feel welcome.

This occurrence of cars destroying the social environment of an area, is extremely apparent in many places including the University of Pretoria alongside Lynnwood Road. Cars not only destroy the social character of the areas but also the social interaction between neighborhoods. As a result of this dividing power cars have, areas get cut off from the rest of the urban fabric. For this problem to be solved, car volumes would have to decrease drastically through implementing a well functioning public transport system.

Roads should be dominated by public transport and not by private vehicles. One wouldn't be able to lessen the amount of people that utilize Lynnwood Road, but one can most certainly lessen the amount of private vehicles by introducing a well functioning public transport system. One of the reasons which give cars such a destructive character is as a result of the speed at which they commute. Speed limit signs and speed traps alone is not enough to restrict people from driving to fast.

## urban design

---



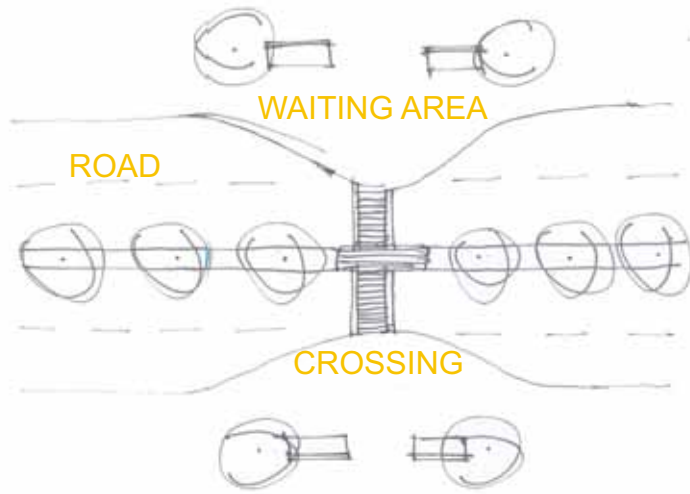

FIG 3-8: ROAD CROSSING



FIG 3-9: PEDESTRIAN PATH AND BICYCLE LANE

Therefore one should apply pattern (54) Road Crossing (Alexander, Ishikawa & Silverstein 1977: 280) which suggests narrowing the road and providing a waiting area for the pedestrians on either side of the road. It should be a raised walkway with a different base material, which will not only slow the cars down and emphasize the crossing but would give the pedestrians a sense of domination over the cars.

There should also be an island in the middle which would allow people to watch the cars coming from the other direction making it less terrifying for people to cross. Through the implementation of these road crossings, traffic would slow down to an inconvenient pace, which would discourage people to use private vehicles and utilize a well managed public transport system. This will assist in the integration process between the university and the Brooklyn area.

Bicycles should rather be used, they increase peoples health and are environmentally sustainable and urban friendly. As explained in pattern (56) Bike Paths and Racks (Alexander, Ishikawa & Silverstein 1977: 289), people are discouraged to use them as they are threatened by cars and trucks on the road. The same applies to pedestrians, they are also threatened by bicycles when they share the same path. There should be designated bike paths with a distinct surface material which can be easily recognized and should be kept separate from the pedestrian path.

The city should be designed in such a way that people are able to distinguish their part of the city from the rest. It should have a unique character and sense of place to create the 'genius loci' that a certain individual can identify with and feel comfortable to live there. In the pattern (14) Identifiable Neighborhood (Alexander, Ishikawa & Silverstein 1977: 80) it is stated that people need that identifiable spatial unit in order to belong.

## urban design

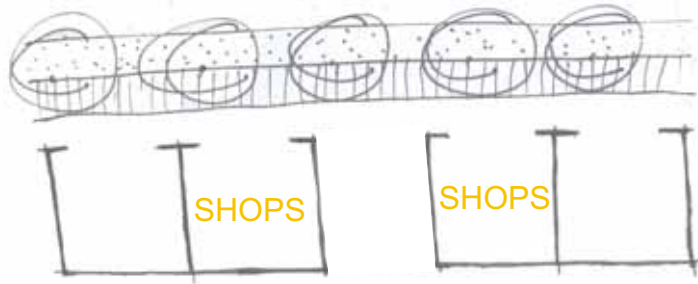

FIG 3-10: SHOPPING STREET



FIG 3-11: FOUR STOREY LIMIT

When considering this there should be a distinct character around the university, which portrays the social culture of students. A student social culture can be depicted spatially by high density student accommodation on top of shops, coffee shops and restaurants linked by shaded pedestrian and bicycle lanes. Through incorporating restaurants, coffee shops and street cafes, create some quite night life alongside Lynnwood Road, which can during the day form a shopping street similar to pattern (32) Shopping Street (Alexander, Ishikawa & Silverstein 1977: 174).

These mixed-use blocks should be knit together, and as described in pattern (33) Night Life, it should be well lit, safe and lively places (Alexander, Ishikawa & Silverstein 1977: 179). This would increase pedestrian activity at night. These buildings should not be higher than four stories according to pattern (21) Four Storey Limit (Alexander, Ishikawa & Silverstein 1977: 114), as buildings higher than that, can destroy the social life and promote crime. Through this, serve to create the 'genius loci' which a student can identify with, feel comfortable in and have a sense of belonging.

The different parts of the town all have boundaries, which is usually in the minds of the inhabitants, marking the end of an activity or a kind of place. According to pattern (53) Main Gateways (Alexander, Ishikawa & Silverstein 1977: 276), any part of town identified as a precinct should be reinforced by gateways. The identity and the activity of a place is emphasized more when the boundary in the minds of people, are also physically presented. These gateway boundaries can be represented in a number of ways, rather than having to physically drive under or through something. A boundary can be indicated by a change in the base material or the gateway could be marked by a landmark in the form of a building. The Administration building serves just that, with the proposed Incubator of Innovation being the other gateway.

## urban design

## How can Kevin Lynch's Image of the City (Lynch 1960) improve the image and legibility of the area?

Kevin Lynch describes that the image of an area is defined by the character and portrayed by the main elements of the city such as paths, edges, districts, nodes and landmarks (Lynch 1960). Paths are channels along which the observer moves to experience an area, which include streets, walkways, canals or railroads. Lynch states that providing a concentration of a certain unique activity alongside the path would give it prominence in the minds of the observer (Lynch 1960).

It is also the unique spatial qualities expressed by the architecture and landscape as well as the visual exposure and topographical qualities of the street itself, which gives a street its significance. On the southern side of Lynnwood Road, which is an extremely public road, there isn't that unique spatial quality which enriches the university and it should therefore be created. According to Lynch (Lynch 1960), a path can also derive its importance from being next to or within close proximity to a special feature such as a park, river or an university such as the case of Lynnwood Road. Lynnwood Road also has clear and significant origins and destinations, which help tie the city together and orientate the city users.

Edges are linear elements which is considered as boundaries between two areas (Lynch 1960). These boundaries are sometimes perceived as being barriers which closes off one area from another. These edges could also act as seams along which two related areas are joined together or could act as organizing features in holding together related areas and presented as a outline of a region or city.

## urban design

The image of an area is influenced by the social meaning, the function, climate, aesthetics in both architecture and landscape, as well as the name or history of the area. This image is different to most individuals but some of these images is shared by a number of individuals. There should be an image or a sense of place created for the university which can be easily recognized as the university precinct. A space where a student social culture is created in order for them to feel comfortable.

Lynnwood Road, due to the amount of private vehicles as well as the speed at which they travel, is perceived as the edge of Brooklyn area, with the university being in another area. Through the implementation of urban design principles Lynnwood Road should be a seam which knit the two areas together. There should be activities alongside the road to form the feature that integrate the two areas with each other, in order for the areas to be perceived as one.

Districts are medium-to-large sections of the city, which an observer mentally enters inside, recognized by an identifiable character (Lynch 1960). The physical characteristics that determine a district are the texture, space, form, detail, symbol, building type, use, activity inhabitants, degree of maintenance and topography. These elements are used to create a sense of place which make people want to enter in or stay away and should therefore be carefully managed. These elements should be used to define the area around the university, in order for it to be recognized as the university precinct or district.

Nodes are points in a city into which an observer can enter, which is the intensive foci to and from where he is traveling (Lynch 1960) These could be primary junctions, a crossing or convergence of paths but can also be concentrations gaining importance from being a condensation of a certain use, function or character, such as an enclosed square. Some of these nodes, such as the University of Pretoria, could be the focus of the district, which govern the concept or character of the area in order to influence the surrounding functions of the buildings and spaces.

Currently when driving along Lynnwood Road, there is no indication of what the focus is of the area. The vehicles are driving at such a high speed, one would consider the fact that the cars are the focus of the area.

## urban design

Lynnwood Road, as well as the architecture and urban spaces alongside it, should indicate that the university is the focus of the area. Everything in the area should therefore support a 'genius loci' which can easily be recognized as being an area for student social culture.

Landmarks are external point-references which are physical objects such as buildings, signs or stores including natural elements such as a mountain or even a large tree (Lynch 1960) These landmarks are singled out of a number of possibilities and therefore it should be prominent and easily identifiable. Towers or tall buildings are used to orientate oneself and symbolizes a constant direction through their extreme prominence and visibility. This is the case with the Administration building at the University of Pretoria. This building with its extraordinary architectural design, symbolizes the start of the university and with the proposed Incubator of Innovation symbolizing the end.

### How can Responsive Environments (Bentley, Alcock & Murrian 1985) assist in the urban integration?

The book discusses the design of places with regard to their permeability, variety, legibility, robustness, visual appropriateness as well as the richness and personalization. Permeability deals with the degree of accessibility or the number of alternative ways to move through an environment (Bentley, Alcock & Murrian 1985). For an environment to function successfully within the rest of the urban fabric it should have good permeability.

With the University of Pretoria on Lynnwood Road, traffic restricts pedestrian permeability moving across Lynnwood Road to the southern residential area and 'visa versa'. Due to the connectivity the road establishes between the N1

## urban design

highway and the central business district, the road cannot be closed off and used solely for the university, but the road can be altered and the amount of private vehicles could be lessened by implementing a well managed public transport system in order to increase permeability with the university.

Variety considers the different types of uses or the number of choices available to the people in order to get a diversity of experiences. (Bentley, Alcock & Murrian 1985). Through the variety of uses of one specific area, different people from different places with a different desire can utilize one area. Through this array of options integration between different areas can be achieved.

When considering the area to the south of the university, there is no diversity present. It is a single use residential area, although it is close to Hatfield Business and Brooklyn business center, there are no shops or coffee shops alongside Lynnwood Road to offer some variety to the area. With the student being the focus of the area, there is very little options attracting them. Therefore by creating variety focused on students alongside Lynnwood Road, such as high density housing, shops and nightlife, integrate the Brooklyn area to the south of Lynnwood Road with the university.

The degree of changeability of a place, in order to be used for different purposes, is identified as robustness. (Bentley, Alcock & Murrian 1985) The buildings to be built on the edge of the residential area, forming the threshold between the university, should have spaces on the ground floor which are extremely robust. There would be student housing at the top floors, but the ground floor will be ever changing. The space could be a restaurant the one year and the next year a tenpin bowling space. The appearance or image of the place should inform the user of the different choices the place has to offer.

## urban design

The different sensory experiences offered to people using a particular space is termed richness. (Bentley, Alcock & Murrian 1985) When driving down Lynnwood Road, one is disappointed to witness single use dwellings on the opposite side of an university. Therefore by providing mixed-use four storey building, serve to increase the richness of scenery adding to the 'genius loci'.

Humans are creative beings and the term personalization, investigates the degree to which a space could be modified to their own taste (Bentley, Alcock & Murrian 1985). Students especially enjoys not only customizing their space but changing it often. This could be accommodated for through creating a robust space and incorporating the concept of Open Building, but it should be controlled as not to be eclectic.

The relative ease with which people can understand an area or layout is defined by the legibility of that area. (Bentley, Alcock & Murrian 1985) The area the thesis would be based in should be defined as a university precinct. Due to the fact that the Lynnwood Road is the front facade of the university, the area should depict the university social culture. There are currently just single dwellings which doesn't provide a sense of place to the area. Therefore the buildings to be built alongside the road should depict student social culture, creating an image which is legible.

urban design



FIG 4-1: REBECCA EMERY/ UNIVERSITY OF PRETORIA



There are incubators internationally as well as locally and almost none of the incubators provide the same services, facilities or incubation program. The Innovation Hub will be studied, as one of their departments is an incubator, in order to serve as a South African example. International incubators will also be analyzed to get a holistic idea of what to incorporate and what to provide to innovative graduates of the University of Pretoria requiring incubation.

Architectural precedents will be studied with regard to the aesthetics suitable for an incubator of innovation, in order to indicate a successful design product. Precedents for the internal spaces of the incubator will be analyzed. These spaces should incorporate the concept of Open Building in order to accommodate the phenomena of inevitable change. Precedents will also illustrate creative internal spaces which provide an environment where innovative entrepreneurs can flourish.

## introduction

4

1

## The Massachusetts Innovation Center (MIC)

The Massachusetts Innovation Center (MIC) offers growing businesses access to the required space and facilities which would have otherwise not been available to the young start-ups. The MIC affiliates have access to conference rooms and flexible and affordable business space. These spaces can be customized and expanded according to the business needs and growth of the tenant. All the office spaces have direct and high-speed internet connections through OC48 fibre optic cables as well as successful telecommunications system. They also provide office reception services as well as the use of the latest office equipment including copiers, fax machines and audio-visual equipment.

The MIC, situated in Fitchburg, is well located and within close proximity to central business districts namely Boston and Worcester and near important corridors such as Massachusetts Route 2 as well as major highways being Route 495 and Massachusetts Turnpike.

## Panasonic Digital Concepts Center (Wu 1999)

The Panasonic Digital Concepts Center (PDCC) incubates companies that provide emerging technologies in order to create partnerships that provide value for the next generation of networked consumers. The organization consist of a corporate venture arm which offers funding to the incubator companies, the Technology Partnerships unit that filters strategic opportunities and an incubator that grows startups. The PDCC's mission is "to form partnerships with startup and private technology companies in order to create new technology." (Wu 1999) Companies find PDCC ,as a community of entrepreneurs, an enriching experience where they can learn from one another.

# incubators

4

2

Entrepreneurs sharing ideas with each other has always been the core of building strong companies. It is during this incubating period, and within this safe environment, where you learn from others' mistakes and successes in order to reach maturity. PDCC's incubator offers market rate rent with furniture included and shared common spaces. They provide mentoring programs as well as getting professionals to come in and give advice to the young entrepreneurs. The management team introduce the entrepreneurs to possible partners, investors and customers in order to startup their company.

### San Jose: Software Business Cluster (Erickson 1994)

This is an incubator supported by the city of San Jose in order to create software companies that will infiltrate their tax-base infrastructure after graduation. At that stage the incubator have already graduated about 60 companies into the world where most of the companies have remained and contributed to San Jose. The reason for setting up an incubator there, was to create an environment in downtown San Jose that would attract technology companies in order to make San Jose the capital of Silicon Valley.

The incubator not only provides the usual amenities such as office space, furniture, shared conference rooms, and a internet line but also consultation with the SBC director, advisors and executive associates. They provide business development seminars as well as business assistance through a network of business professionals. In order to get the startups going, they provide introductions to business resources including the capital investment community.

### The Nidus Center for Scientific Enterprise (Calcaterra 2000)

The Nidus Center is developed by many people and organizations which had one thing in common, which is to make St. Louis the hub of all agricultural

## incubators

biotech and life sciences research and companies. Their vision is enriching lives through applied technology and in order to achieve this, they nurture entrepreneurs, protect and grow innovative ideas as well as commercialize new technologies and attracting investment capital.

This incubator offers business plan development, coaching, management expansion, consulting services as well as business seminars and data networking technology. The Nidus Center also offers wetlabs and the required equipment through charging over and above the normal rent fee, an additional monthly fee, which is not nearly as much as obtaining the services on their own. They provide equipment and product testing services, hazardous waste removal, Nuclear Regulatory Commission Radioactive Materials licence, scientific photographic film development facilities as well as a growth chamber.

Applicants were only admitted to the Nidus Center if it is a technology-based in the plant science/life science industry and which has a novel product or manufacturing process. They only admit companies to the incubator if they have business models that make sense and whether the company will be a self-sustaining company.

### Enterprise Development, Inc. (Zeman 1988)

Enterprise Development, Inc. (EDI) is a catalyst for economic growth in Northeast Ohio which assist entrepreneurs to find, assemble and effectively employ the four main ingredients for a business to be a success, namely technology, capital, facilities and personnel. EDI provide programs to help entrepreneurs achieve their goals through offering education courses and Minority Assistance Programs in order to start and grow their business.

## incubators

Y  
P  
U  
T  
S  
T  
U  
E  
P  
E  
U  
E  
F  
D

The sole purpose behind the program development of the EDI is to grow companies in Ohio which would sustain and feed the state's economy. Their mission is to "incubate, educate, and recognize entrepreneurs and growing businesses that have potential to have a significant impact in the region" (Zeman 1988).

When looking at what they are offering, one of the most valuable is flexible incubation space which can be customized or expanded to accommodate companies' high growth potential. Entrepreneurs interact a lot amongst themselves, they share ideas, learn from each other and also make deals with one another. Therefore networking and making introductions is extremely important when it comes to innovative thinking and the space should allow for these kind of relationships. They provide educational programs through inviting business professionals and CEO's of successful companies to come and share their experiences in order to ensure the startups rapid business growth.

### The Cambridge Science Park (Cambridge University 1973)

The Cambridge Science Park incubator is located on the university's premises in the city of Cambridge. This development was proposed by the university's committee in response to the Whitehall who had urged UK universities to increase their contact with the industry. Their objective was to increase technology transfer, increase payback from investments made in basic research as well as functioning as an expansion to higher education, specifically for new technologies.

It was then developed close to Cambridge to take maximum advantage of the scientific expertise, equipment and libraries, in return to increase feedback from industry into the Cambridge scientific community.

Accompanying this development was St. John Collage's incubator, which

## incubators

provided business support and accommodation to start-up companies. They provided free advice to tenants on business issues as well as engaging them to partake in university department programs which would promote the knowledge of wealth creation. The incubator assists the entrepreneurs in order to get access to funding and also act as a catalyst in promoting technology development.

They offered flexible accommodation and shared communal facilities including conference rooms and a restaurant. It offers advice on sources of assistance in the university; product innovation, design and manufacture; human resource management; finance, venture capital and grants as well as marketing and public relations. They also provided company administration, secretarial and accounting services, which would assist the young entrepreneurs.

### Innovation Hub (Blue IQ 2000)

The Innovation Hub is a project of the Gauteng Provincial Government's Blue IQ Investment Holdings, to invest in economic development infrastructure in Gauteng. It is situated in Pretoria next to the N1 highway close to the CSIR and and next to the University of Pretoria's experimental farm.

The Innovation Hub's guiding vision is to grow the wealth and quality of life of the people of Gauteng by the full implementation of The Innovation Hub as a Science Park, founded upon innovation and collaboration, and driven by a 'cluster' -centric focus. Their core values include innovation, integrity, teamwork and partnerships as well as having an entrepreneurial approach and mind-set, in order to create high value concepts and products.

## incubators

4

6

## BUSINESS PURPOSE

- Developing and growing entrepreneurs in high-tech sectors within the Province
- Acting as a catalyst in bridging 'the commercialization chasm' to significantly increase local innovative technology development and its business application
- Becoming the centre of gravity of innovation knowledge economy initiatives and thereby entrenching The Innovation Hub brand
- Supporting the sustainable growth of the provincial economy through the development of a critical mass of knowledge workers in a cluster of innovative businesses
- Assisting in the creation of a Smart Province and connected community in the Global City Region of Gauteng.

The Innovation Hub harnesses and nurtures a networked flow of knowledge and information to enable and drive national growth, and helps to create the global competitiveness needed to successfully build Gauteng as a global city region. The Innovation Hub facilitates the interface between the research and development and its business community.

The Innovation Hub's Science Park environment harnesses the exploitation of innovation through co-location, infrastructure design and management, and nurtures vibrant interaction and the cross-fertilization of ideas to create networks, and to share learning and experience. (Mashatile 2007) It is mandated to develop knowledge-intensive business clusters as a foundation for the generation of intellectual property in order to support entrepreneurship and thus their impact on the economy. The emphasis of the development of the Innovation Hub has been on creating a balance between the provision of infrastructure and value-adding services to residents. It is designed to stimulate collaboration, interaction and networking, and by providing exhibition spaces,

## incubators

4

7

to showcase new developments. Business support services are aligned with the needs of precinct occupants. Conference venue and restaurant form part of the infrastructure to stimulate interaction and provide facilities for events, workshops and seminars.

The Maxum Incubator at The Innovation Hub continued its focus on attracting technologically innovative companies with high growth potential by offering them the following:

- flexible leases,
- appropriate infrastructure and services
- business mentors which provide advice and coaching
- networking with established companies
- access to sources of funds
- media exposure
- shared common spaces such as meeting, restaurant and catering facilities

The CoachLab attract postgraduate students to be part of a year-long leadership development program, in order to breach the gap between the academic and business worlds. Coach lab offers the following:

- Opportunities to work on projects with industry leaders
- Networking with business leaders
- Action learning and leadership development
- Mentorship on technical and business skills

## incubators



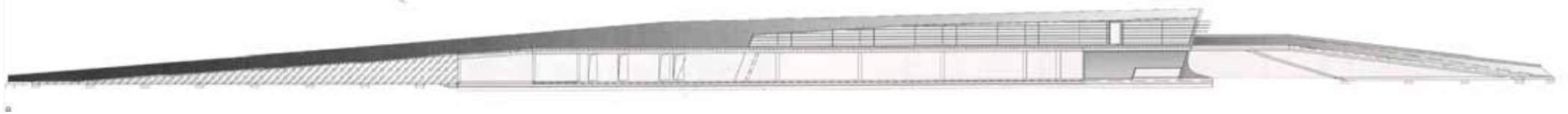

FIG 4-2: LANDSCAPE FORMATION ONE - SECTION 1

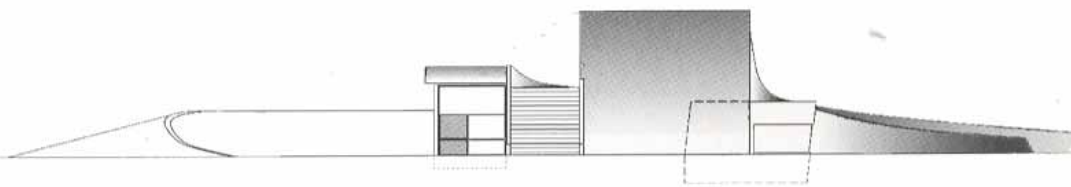

FIG 4-3: LANDSCAPE FORMATION ONE - SECTION 2

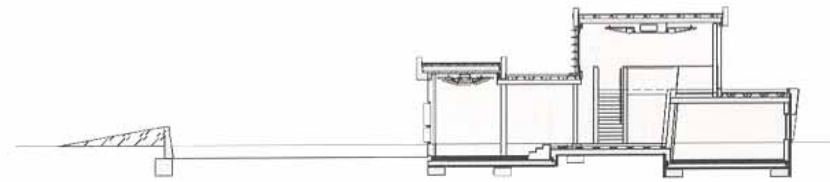

FIG 4-4: LANDSCAPE FORMATION ONE - SECTION 3

Hadid, Zaha. 1999. **Landscape Formation One**. Weil am Rhein, Germany. This building, designed by Zaha Hadid, serves to be an event and exhibition space. The building's tectonics and especially the curvilinear and flowing lines makes it a highly innovative building. The building respects the existing network of paths by emerging out of the ground and making it part of the landscape as well as being interwoven with them through the fluid form.

Zaha Hadid used concrete extensively, purely for aesthetic reasons, making the building high in embodied energy and unsustainable. The more sustainable alternative to the concrete would have been stabilized earth compaction. Aesthetically it would have also been more pleasing to use the soil from the terrain in order to increase the connection with the landscape and thus strengthening her concept of being a landscape formation.



FIG 4-5: LANDSCAPE FORMATION ONE - FRONT PERSPECTIVE



FIG 4-6: LANDSCAPE FORMATION ONE - REAR PERSPECTIVE

4  
9

PREC  
 DE  
 UN  
 ST  
 PD  
 Y

aesthetics

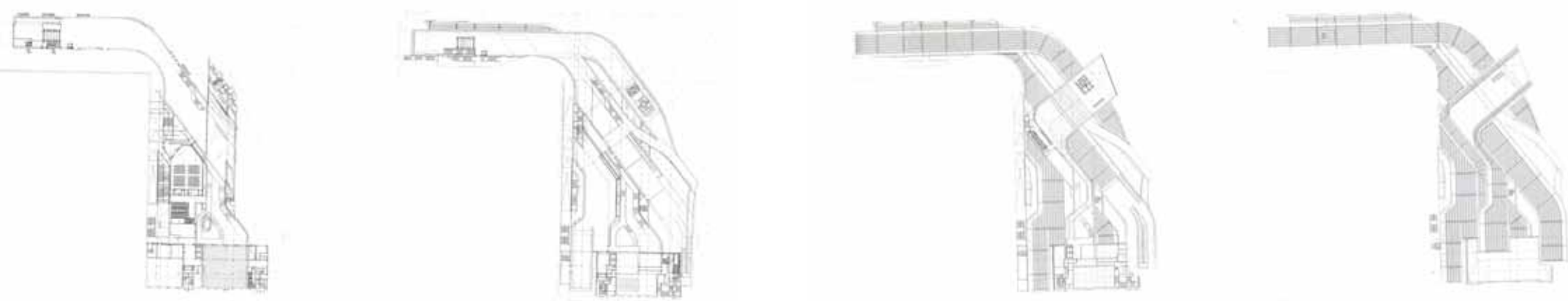

FIG 4-7: NATIONAL MUSEUM OF XXI CENTURY ARTS - PLANS

Hadid, Zaha. 1997. **National Museum of XXI Century Arts**. Rome, Italy. The building, designed by Zaha Hadid, is a museum for contemporary arts. The building is a response to the urban context to form curvilinear lines, which is derived from imitating a nearby river. Again it is the building's curvilinear form which makes it extraordinary and innovative. The fluid shape of the building guides people from the road into the building.

The glass roofs would however not work in South Africa due to the climate we experience by being so close to the equator. The buildings built in South Africa should not have exposed glass facades on the northern, western or eastern side without adequate sun protection or the correct overhangs.



FIG 4-8: NATIONAL MUSEUM OF XXI CENTURY ARTS - PHYSICAL MODEL

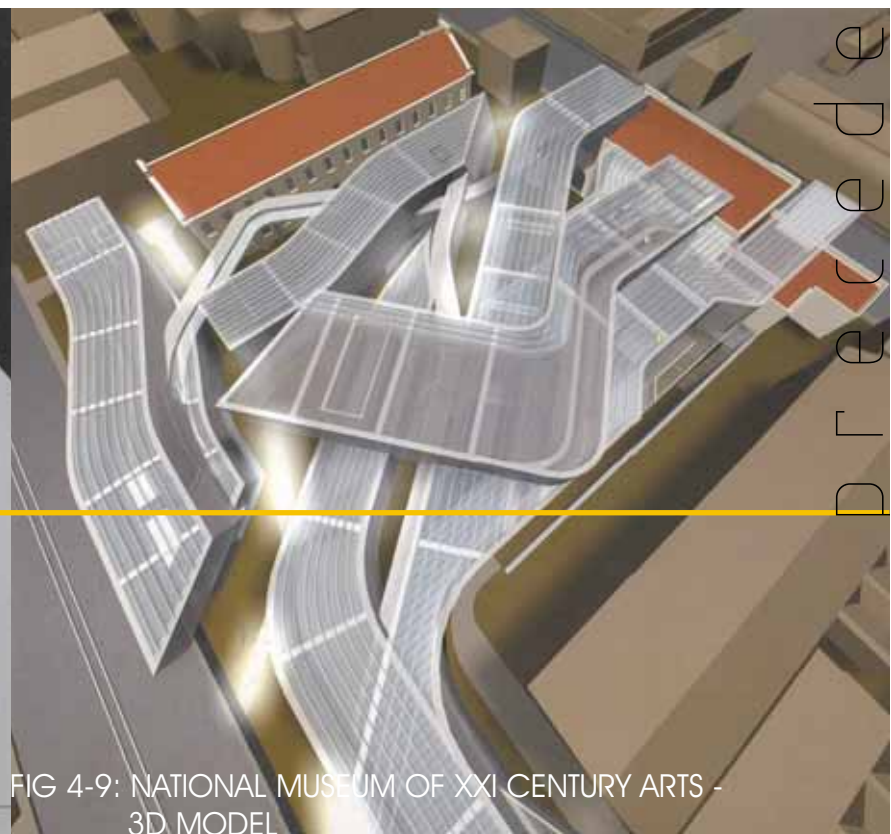

FIG 4-9: NATIONAL MUSEUM OF XXI CENTURY ARTS - 3D MODEL

s t u d y  
 n t  
 d r e e d e n t

It is not necessary to have internal divisions within office spaces. It could just be a large open space where everyone works. Through this open plan method, people are not isolated from each other, which means that people could not only assist each other with work related problems but social interaction can take place, making work less tedious. The loose furniture that where chosen can be arranged to form some enclosure, but it is however too rigid and repetitious, forming an uncreative environment..

Miralles, Enric. 2007. **Benedetta Tagliabue**. Palafolls, Spain. Work shouldn't be a place that is despised, but a space where your passion could be outlived amongst people who have the same enthusiasm and drive. The individual should be able to customize his or her own workspace in order for the person to feel comfortable. The space and the furniture should be able to be rearranged with relative ease, in order to make a space flexible and creative.

Adjaye Associates. 2004. **Idea Store**. London. The office should be fitted with a durable floor to allow a suspended floor to be fitted and again removed if required. The furniture placed in these spaces should be highly innovative in order to assist in establishing a creative environment for the entrepreneurs.



FIG 4-10: OFFICE SPACE



FIG 4-11: OFFICE SPACE



FIG 4-12: OFFICE SPACE



The open plan of this studio space allows people to rearrange the current furniture as well as bringing in other furniture such as coaches to form new spaces. It is in such spaces, where people are constantly interacting with each other and where creative ideas are born.



FIG 4-13: STUDIO SPACE

Again it is not necessary to have internal divisions within the laboratories, it could just be a large open space where everyone can assist each other. Where the space doesn't require services to be moved for future changes, suspended flooring isn't necessary and the floor can be made extremely durable by tiles or a pigmented screed.



FIG 4-14: LABORATORY

Spaces can be divided by using furniture rather than partitioning, which makes interaction between individuals easier. The dividing furniture provides some privacy but more importantly it creates a space for the individual. A creative person enjoys customizing their own space, making themselves not only feel comfortable but in control of their own environment.



FIG 4-15: STUDIO SPACE

## spatial requirements

The stairs and circulation leading from the one exhibition space to the other should form part of the exhibition journey. Every space should be loose fit in order to be custom designed at any given time.



FIG 4-16: CIRCULATION SPACE

Art is not just canvas on a wall but multifaceted and multidimensional. Therefore projectors with screens could be used in the exhibition spaces as well. When using a suspended ceiling, the colour of the ceiling tiles could be changed to create different scenes.



FIG 4-17: Architecture and Design Exhibition

Suspended timber flooring can be used at certain places to create a change in level or to provide space for needed services.



FIG 4-18: EXHIBITION SPACE

## exhibition spaces

The shell of the building should be a creative and timeless design. The spaces should be versatile with high double volume spaces where people from other spaces can look from.

When the shell of the building is long life and loose fit, the scenery of the exhibition space could be changed by using and molding gypsum plaster board. This can then be removed again to make space for yet another make-over.

Again a loose fit shell provides a space which allows artist and set designers to do anything in order to present the scenery highly creative and innovative.



FIG 4-20: EXHIBITION SPACE

## exhibition spaces

FIG 4-21: EXHIBITION SPACE

FIG 4-19: Yokosuka Museum of Art

Here in this exhibition space partitioning is used to divide the internal spaces. It is however tedious to take down if one should decide to use the two spaces for one large open space. Therefore movable screens should be incorporated which will make the space more flexible.



FIG 4-22: EXHIBITION SPACE

The exhibition space should have high volume ceilings in order to accommodate large pieces of art, models or sculptures. Other spaces should be able to look onto the exhibition space to make them part of the excitement.



FIG 4-23: IMM COLOGNE

The presenting of an exhibition space shouldn't just be the dividing of spaces through the use of moveable screens but should be innovative and exciting.



FIG 4-24: EXHIBITION SPACE



FIG 5-1: RETHA FERGUSON/ UNIVERSITY OF PRETORIA



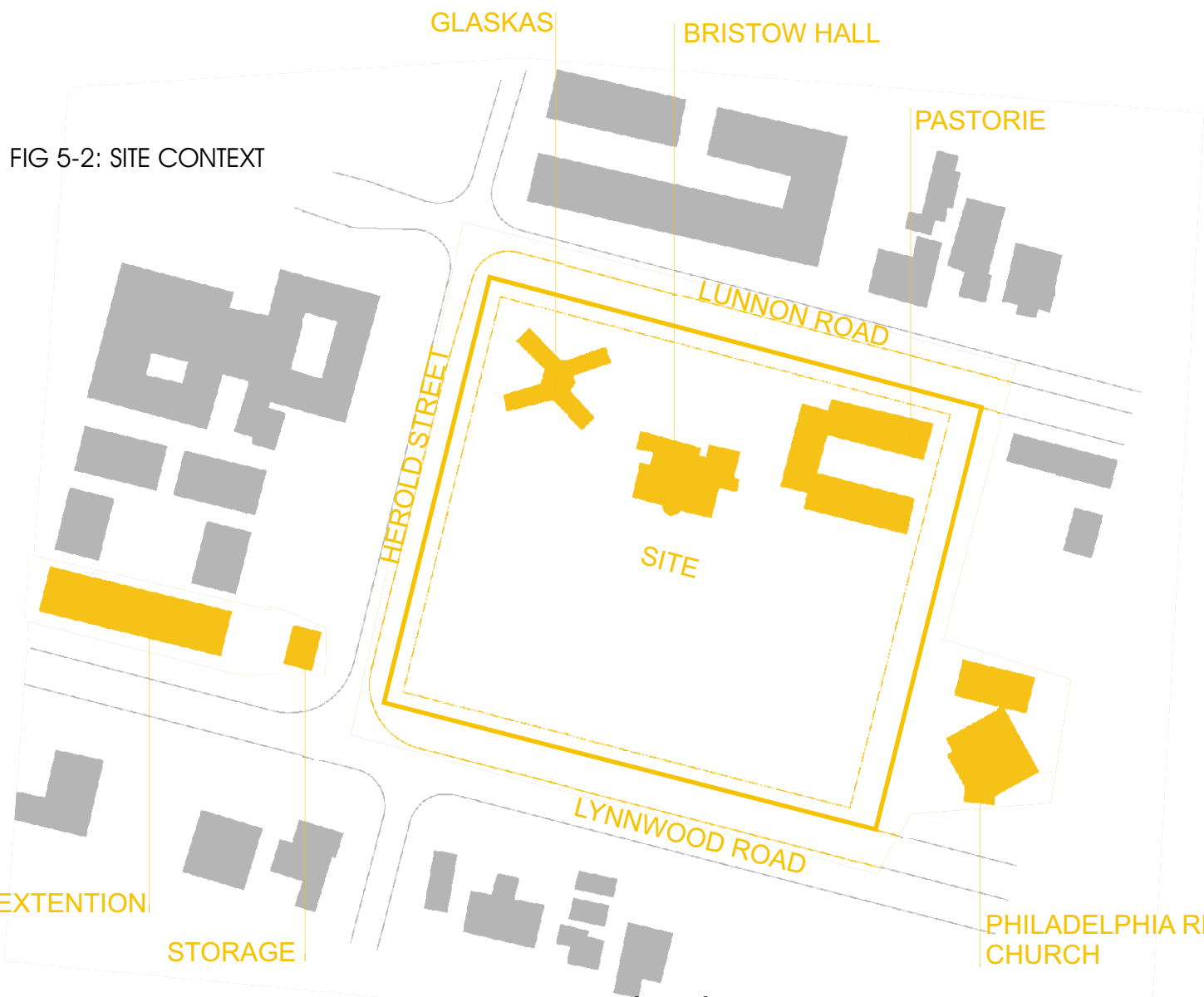
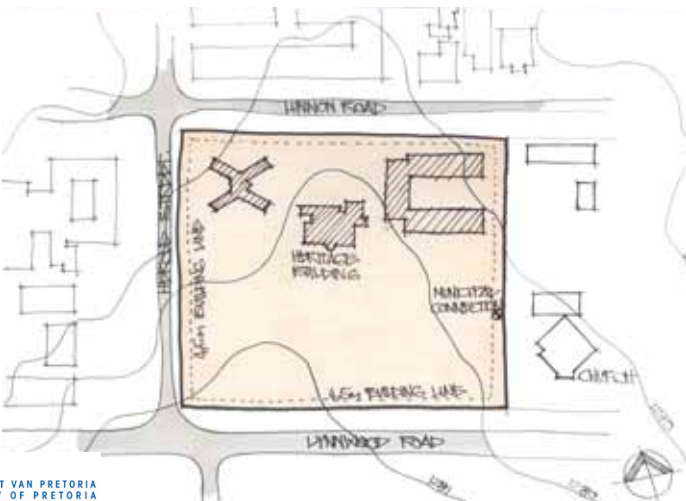
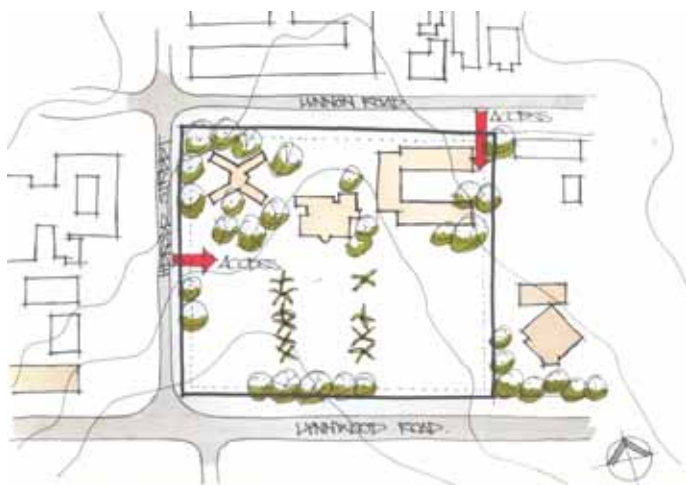

FIG 5-2: SITE CONTEXT

## context

Indicated is the buildings which would influence the decision making of my design proposal. The Nerina extension has a terrible facade with toilet windows facing Lynnwood Road. There is also a storage building, which obviously has no aesthetic value. The Glaskas is one of few international style buildings in Pretoria. The Bristow Hall is protected by the heritage association act as it was built in 1921. The Pastorie however is of no historical or architectural value. All three existing buildings on the site is used for accommodation. The Church, being of architectural value, should be complemented.



## Climate

Temperature - Average maximum - 26,3deg. Celsius

Average minimum - 9,1deg. Celsius

Relative humidity - Average summer - 62%

Average winter - 57%

Rainfall - Summer - 131mm

Winter - 6mm

Solstice - Summer - 88deg. Equinox - 64,5deg.

Winter - 41deg

## Access

There are currently two access points to the site, one on the north and another to the west. Access could be obtained directly from Lynnwood Road, but the facade as well as the space in front of the building should be kept clean of cars in order to be reserved for presentation. However the main entrance to the building should be on Lynnwood Road, as pedestrians and people traveling by public transport would enter the site from the road. The main vehicular access to the site is on Herold Street, there should be therefore a secondary entrance from the north. The northern access from Lynnwood Road will be used for delivery access needed for the workshops as well as the restaurant.

## Municipal information

Zoning - Educational

Coverage - 50%

Height restriction - 19m

Floor area ratio - 1,5

Area - 19 036sqm

Building lines - 4,5m

## site



FIG 5-4: GLASKAS



FIG 5-5: BRISTOW HALL



FIG 5-6: PASTORIE

GLASKAS

BRISTOW HALL

PASTORIE

FIG 5-7: AERIAL PHOTOGRAPH OF SITE



The existing buildings on the site is indicated on the diagram. The International Style Glaskas building should still be used for accommodation. The Bristow Hall heritage building should be used for Tuks Alumni offices, who keeps in contact with previous students of the university, which could assist the Incubator of Innovation for potential candidates. The Pastorie which is of no architectural or historical value and should be demolished for a green space, considering there would be a lot of people accommodated for not only in the incubator program but people for exhibitions as well as lectures given by CE@UP.

HEROLD STREET

MAIN VEHICULAR ACCESS TO SITE

PHILADELPHIA REFORMED CHURCH  
CHURCH SHOULD BE COMPLEMENTED

INCUBATOR OF INNOVATION SITE  
CURRENTLY USED FOR PARKING



FIG 5-8: LYNNWOOD ROAD FRONTAGE

LYNNWOOD ROAD  
FRONT FACADE OF BUILDING

lynnwood road frontage

5

4

analysis site

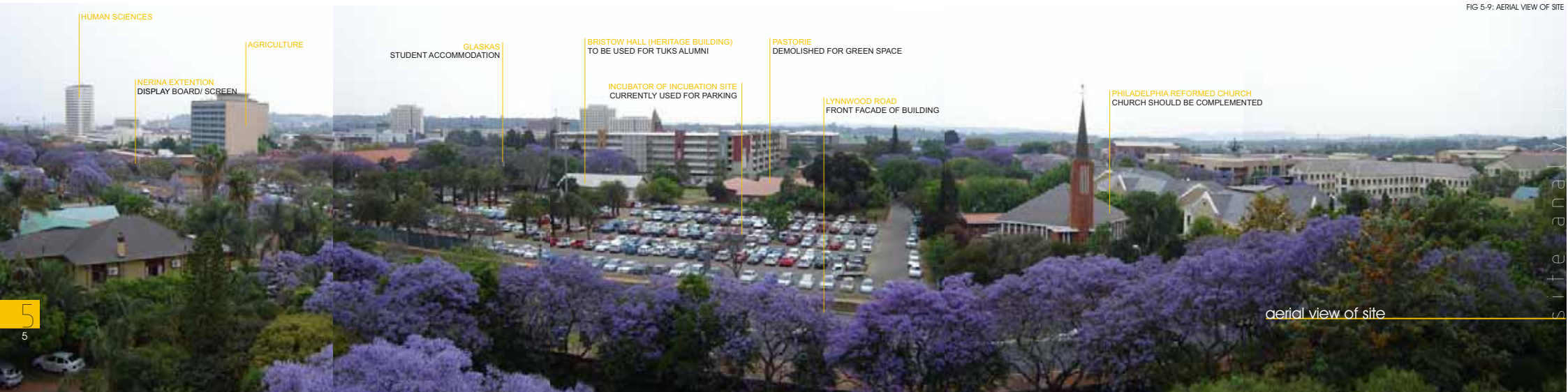

FIG 5-9: AERIAL VIEW OF SITE

## guiding innovative thought

Being an Incubator of Innovation, the focus is to guide the entrepreneur's innovative thoughts into a commercial product in order to start a business. Therefore the architecture should display this concept of guiding along a path, and should not be harsh geometric shapes. The building should have a curvilinear form with flowing lines. The building should represent the product of the University of Pretoria and should therefore be highly innovative, form and aesthetically driven, in order to be the pinnacle performance of the narrative.

5

6

FIG 5-10: CONCEPT MODEL



5  
7

guiding innovative thought

concept

## Exhibition spaces - 1 760sqm

Ground floor - 900sqm

First floor - 80sqm

Second floor - 700sqm

Third floor - 80sqm

## Studios, workshops and laboratories - 1 500sqm

Mechanical and electrical engineering workshop - 385sqm

Electronic and computer engineering workshop - 285sqm

Chemical engineering lab - 75sqm

Architecture studio - 285sqm

Fashion and graphic design studio - 280sqm

Fine arts/photography - 190sqm

## Lecture rooms - 600sqm

Lecture hall 1 - 45 people - 70sqm

Lecture hall 2 - 45 people - 70sqm

Lecture hall 3 - 45 people - 70sqm

Lecture hall 4 - 145 people - 160sqm

Lecture hall 5 - 145 people - 160sqm

Computer lab - 25 people - 70sqm

## Offices - 1 005sqm

Mechanical and electrical engineering offices together with

Electronic and computer engineering offices - 460sqm

Chemical engineering offices - 75sqm

Incubator@UP & Administration - 310sqm

Continuous Education@UP - 160sqm

## Restaurant - 300sqm

Kitchen and Catering - 100sqm

Seating space - 200sqm

## design brief & accommodation

Design a business incubator facility for the development of innovations, which will be orchestrated by Enterprises@UP for the University of Pretoria graduates in the fields of design/art and engineering. The facility should accommodate exhibition spaces, lecture rooms, laboratories, studios, workshops and offices. The building should accommodate offices and lecture rooms for Continuous Education@UP. It should be an iconic building representing the product of the university. The building should be sustainable by making use of passive cooling systems and solar power as well as harvesting rainwater for use on site.

5

8



FIG 5-11: INITIAL MASS MODEL

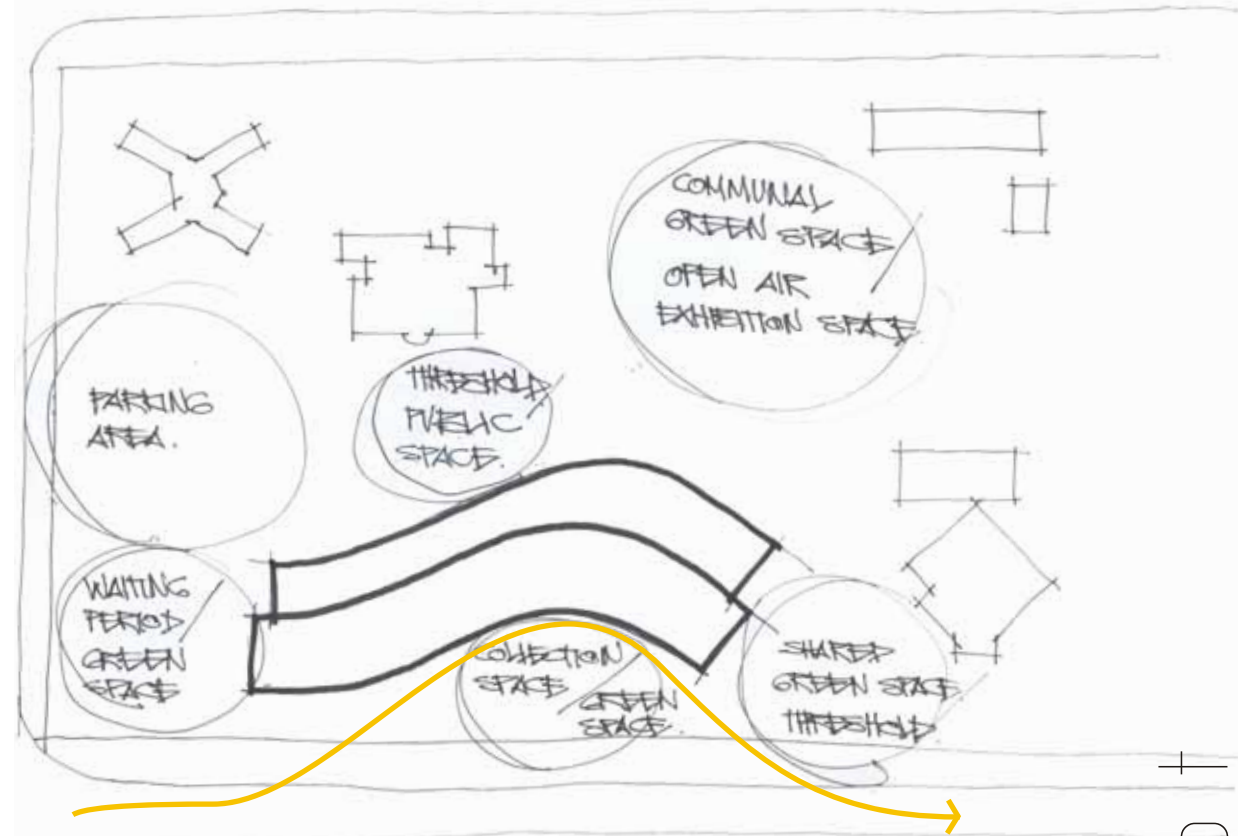
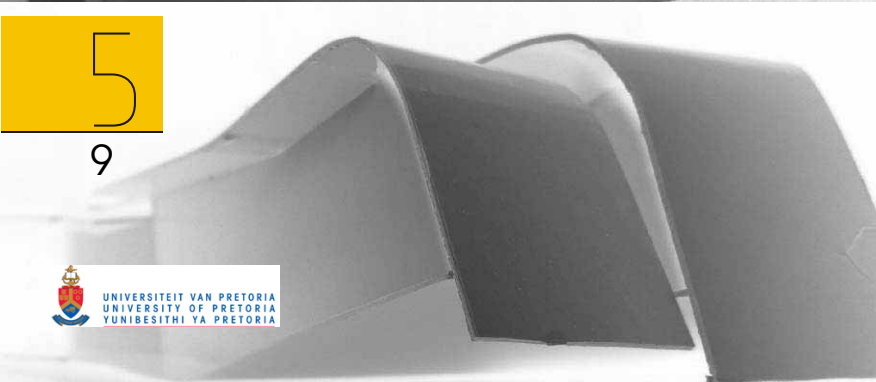
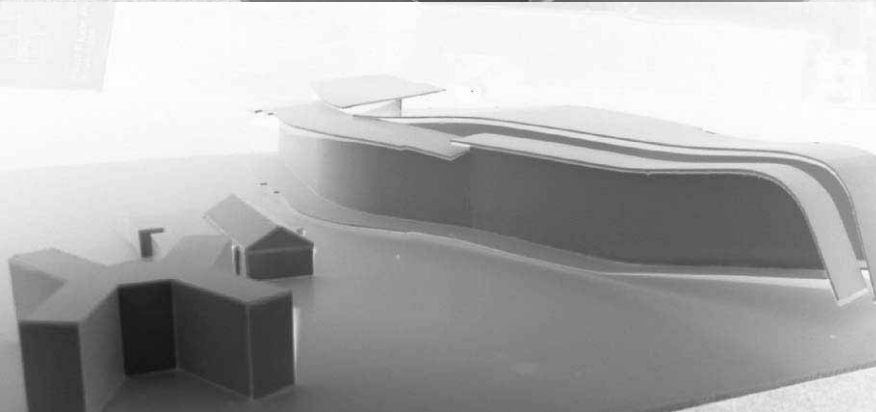
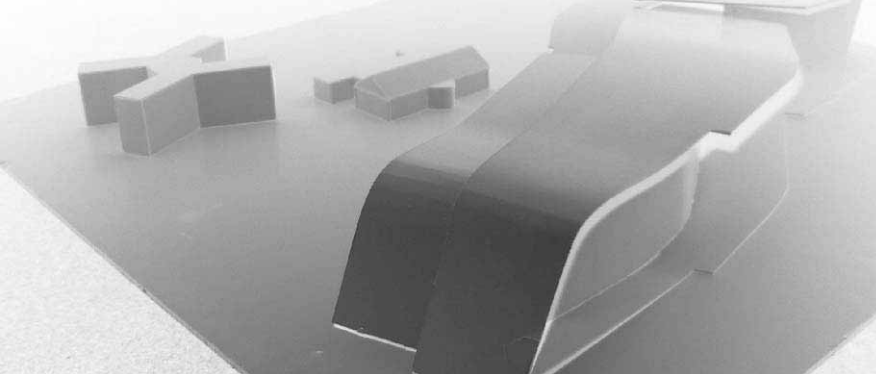
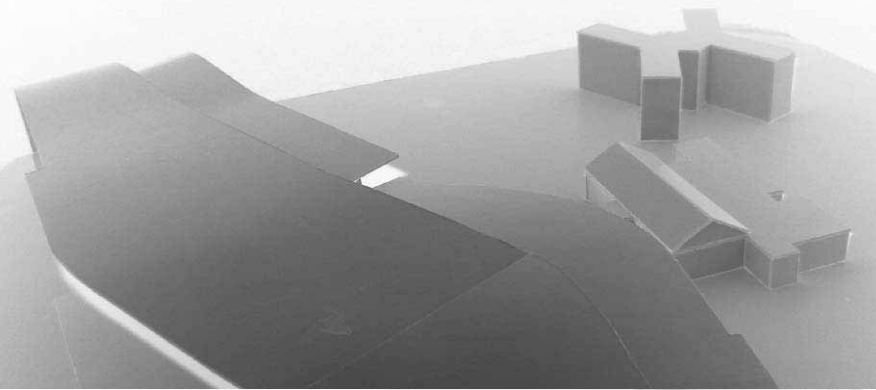

FIG 5-12: SPACE DEVELOPMENT

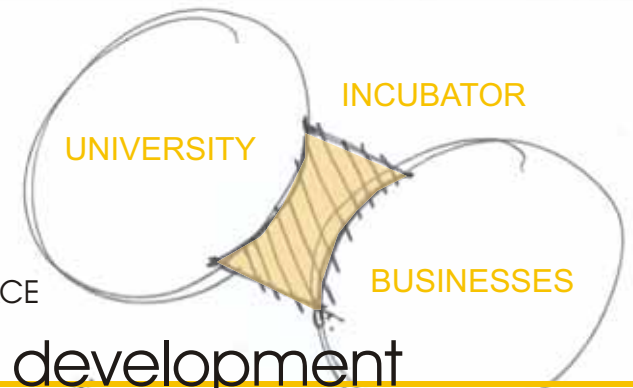
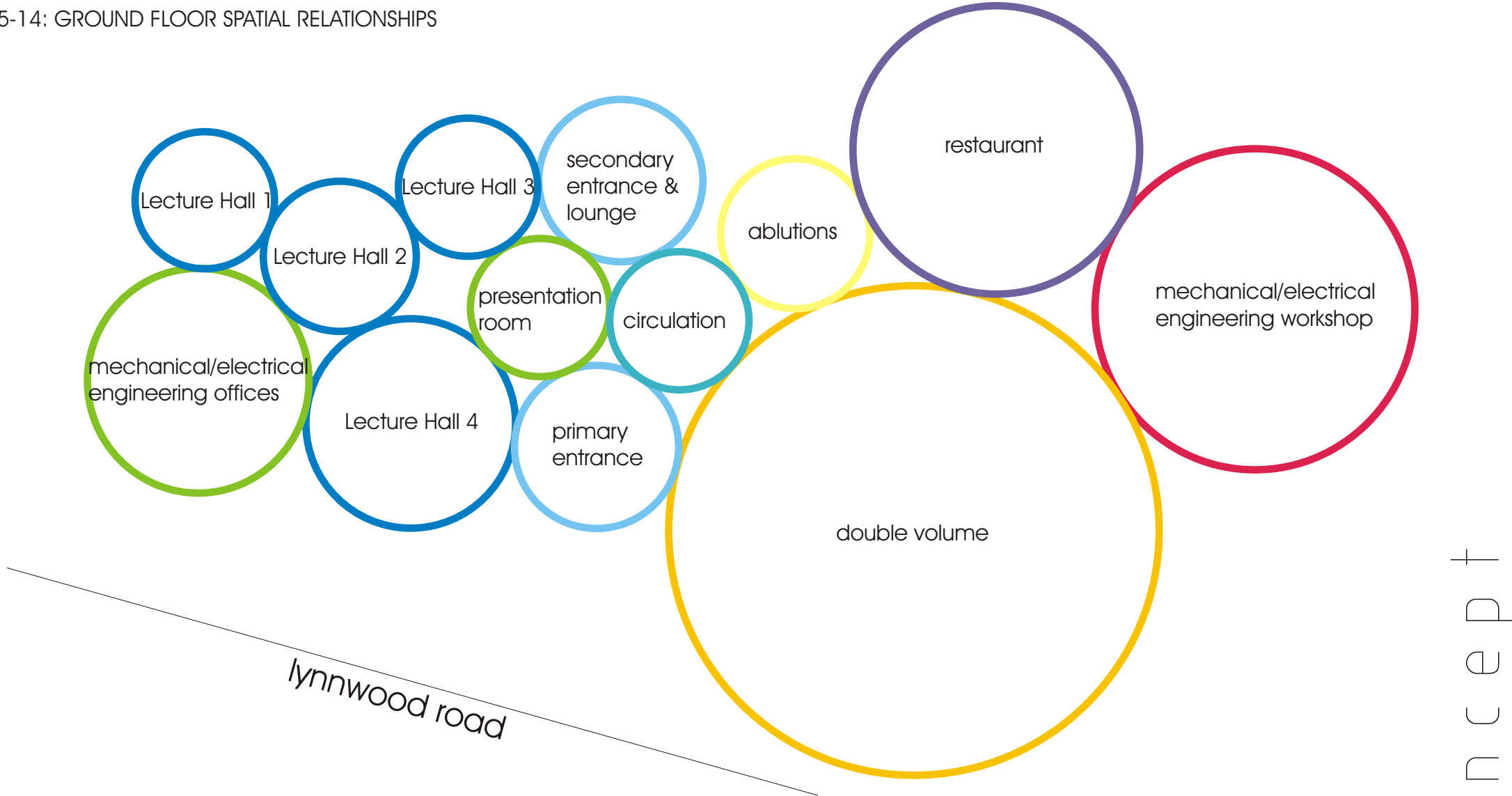

FIG 5-13: INTERFACE

## space and mass development

The waiting period provided through the green space in front of the building serves to be a comma before the rest of the sentence continues. The shape of the building should draw people into a collection space from where they can enter the building. The shared green space between the Incubator and the church serves as a threshold in order to respect the presence of the church. The threshold public space between Bistow Hall could be the secondary entrance gathering space. The Incubator is not included in the universities fence as it serves to be the threshold or interface between the university and businesses.

FIG 5-14: GROUND FLOOR SPATIAL RELATIONSHIPS



U  
N  
I  
V  
E  
R  
S  
I  
T  
Y  
O  
F  
P  
R  
E  
T  
O  
R  
I  
A

## spatial relationships - ground floor

There are entrances to the north and south of the building and situated in the center of the building. The most publically utilized spaces are the closest to the entrances, such as main circulation, lecture halls, toilets and the exhibition space. The exhibition space face Lynnwood Road to the south, for displaying purposes. The toilets is placed next to the main circulation to the north of the building away from Lynnwood Road. The restaurant should be next to the exhibition space for catering purposes and face north towards the green area. The mechanical/electrical workshop are placed to the north for easy access.

5

10

FIG 5-15: FIRST FLOOR SPATIAL RELATIONSHIPS

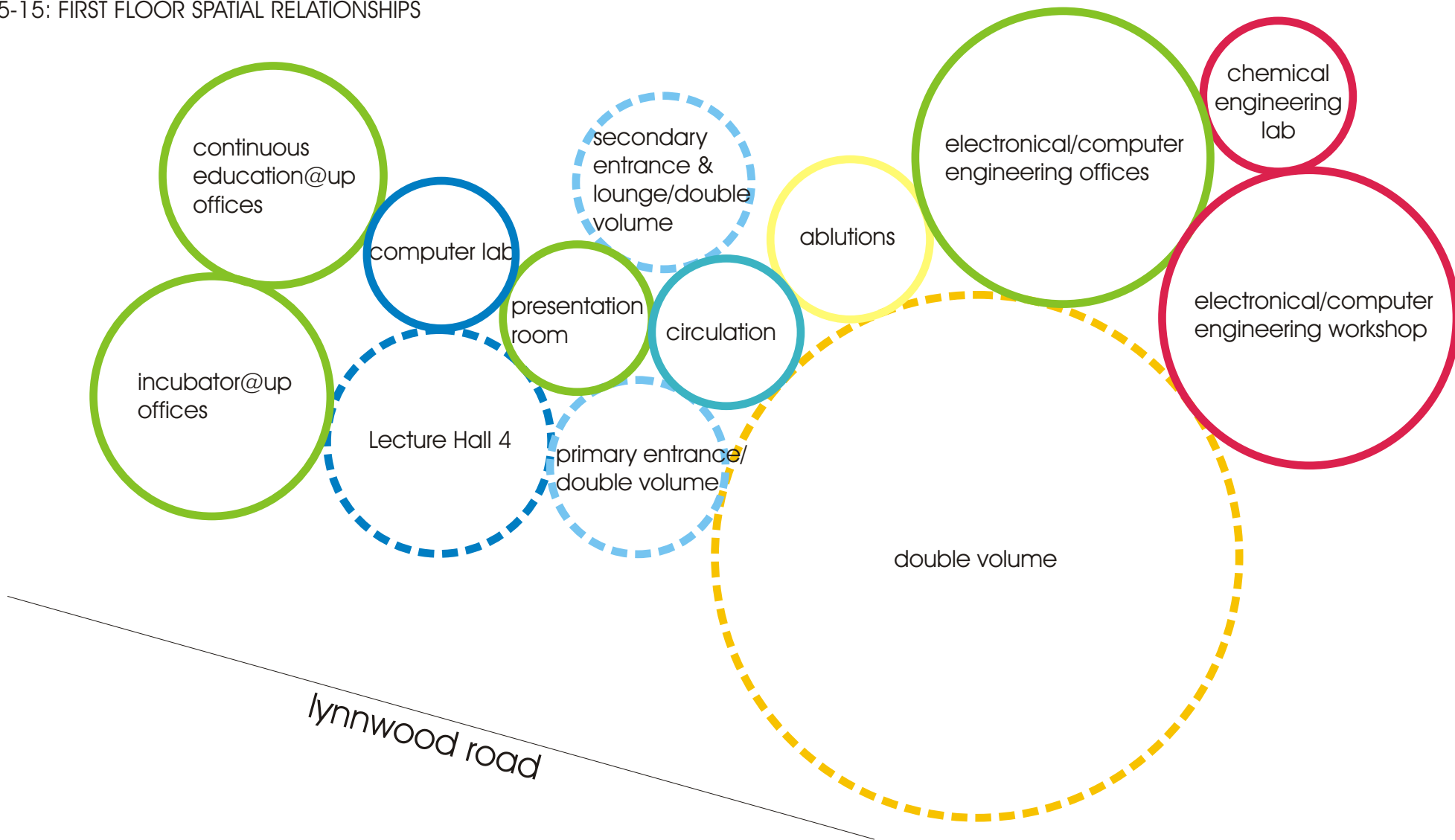

U  
N  
I  
V  
E  
R  
S  
I  
T  
Y

## spatial relationships - 1st floor

The entrance foyers are given double volumes to give it prominence. The exhibition space has a double volume to create a space suitable for the amount of people who will be utilizing the space. The double volume also gives flexibility to the exhibition space, which allows large innovative products to be displayed. Through the double volume, other spaces such as the main circulation, offices and workshops can look onto the exhibition space.

FIG 5-16: SECOND FLOOR SPATIAL RELATIONSHIPS

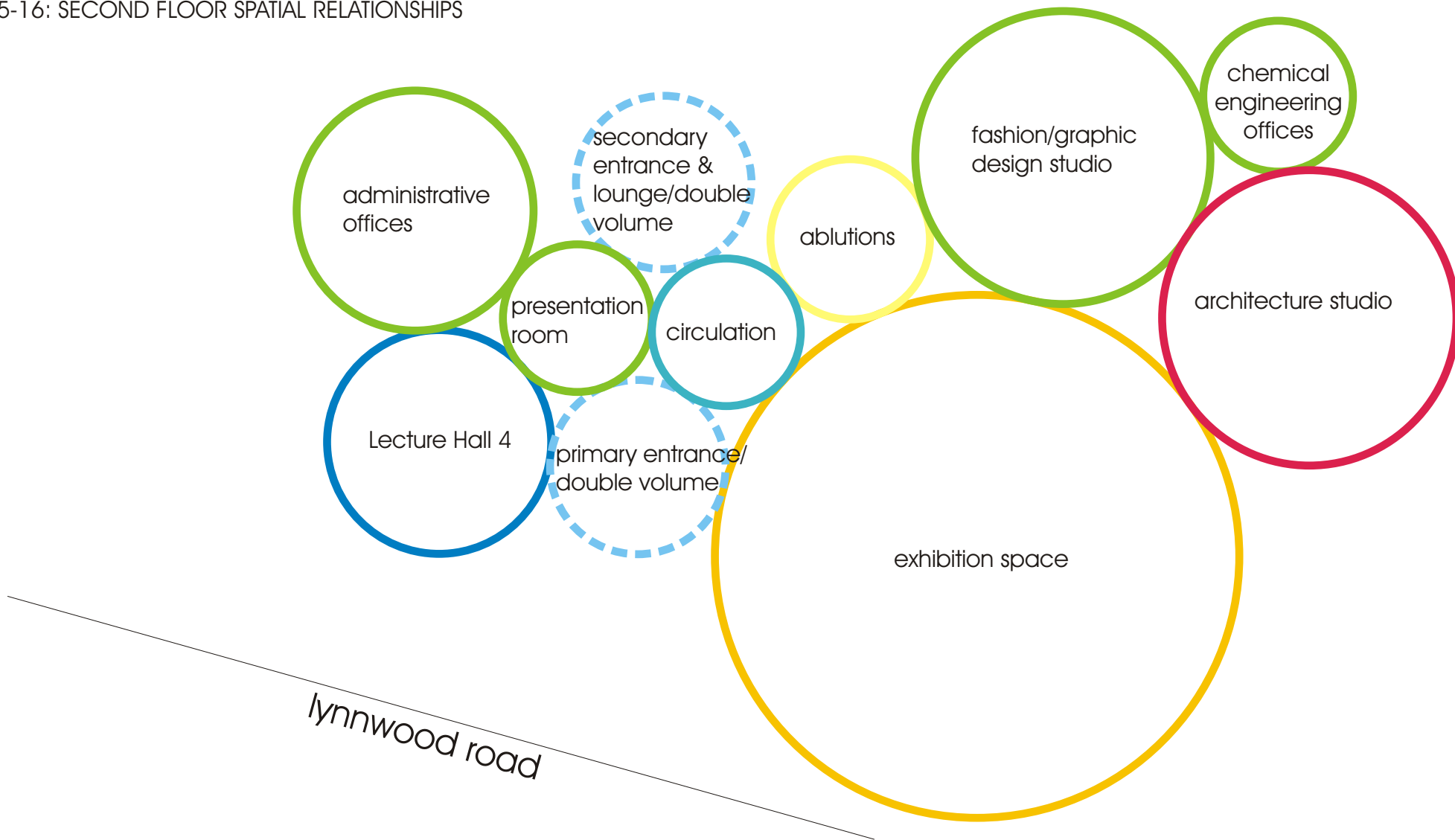

U  
N  
I  
V  
E  
R  
S  
I  
T  
Y  
O  
F  
P  
R  
E  
T  
O  
R  
I  
A

### spatial relationships - 2nd floor

There is another large exhibition space on this floor which should have yet another double volume above. The spaces to the west also start diminishing in order for the building to lead up towards the pinnacle of the building.

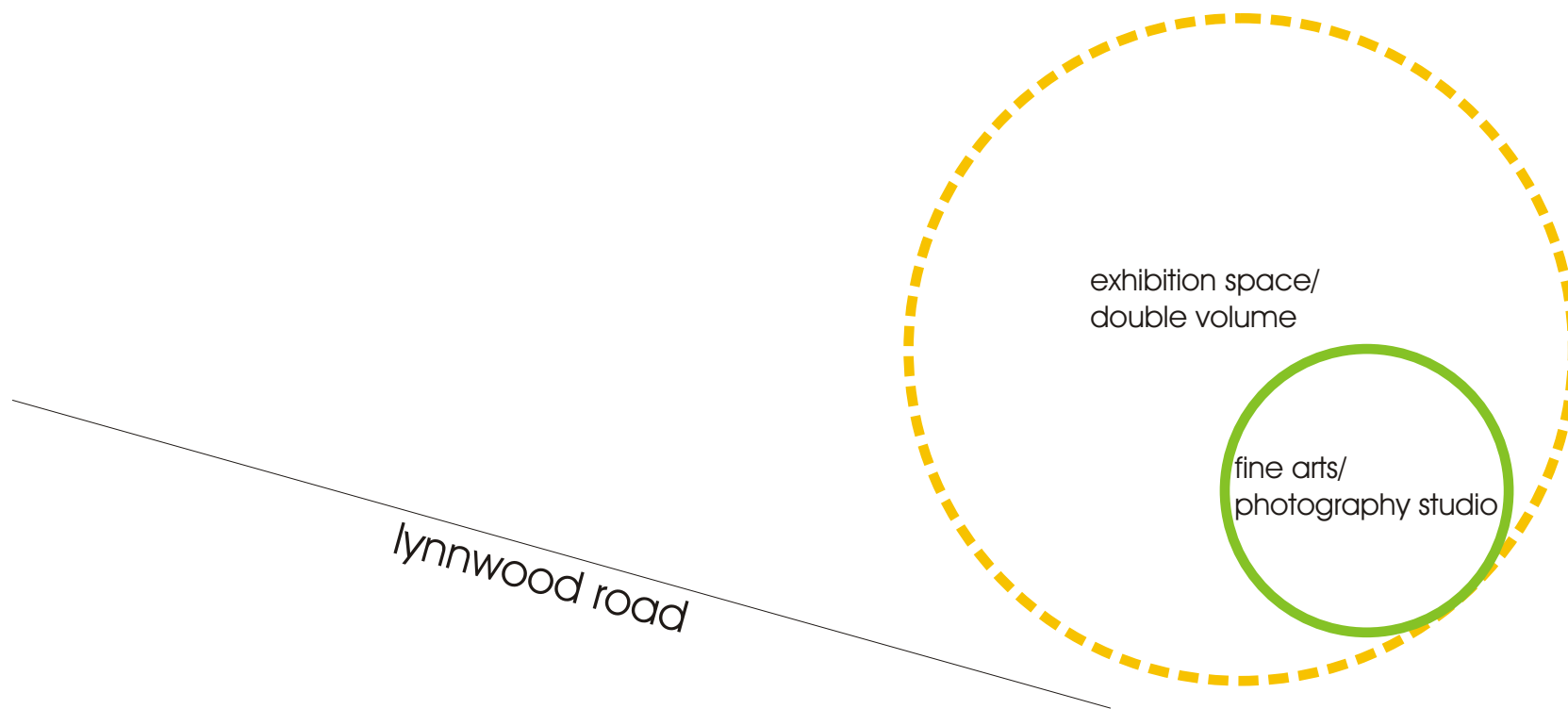

U  
N  
I  
V  
E  
R  
S  
I  
T  
Y  
O  
F  
P  
R  
E  
T  
O  
R  
I  
A

## spatial relationships - 3rd floor

The fine arts/photography studio is the only space that will be on the 3rd floor as this would be the highest point of the building. The entire building would lead towards this point to make this the focus, which is therefore the exhibiting of innovative and creative ideas. The studio will look upon the exhibition space making it part of the exhibition to create an atmosphere which would inspire the individuals.

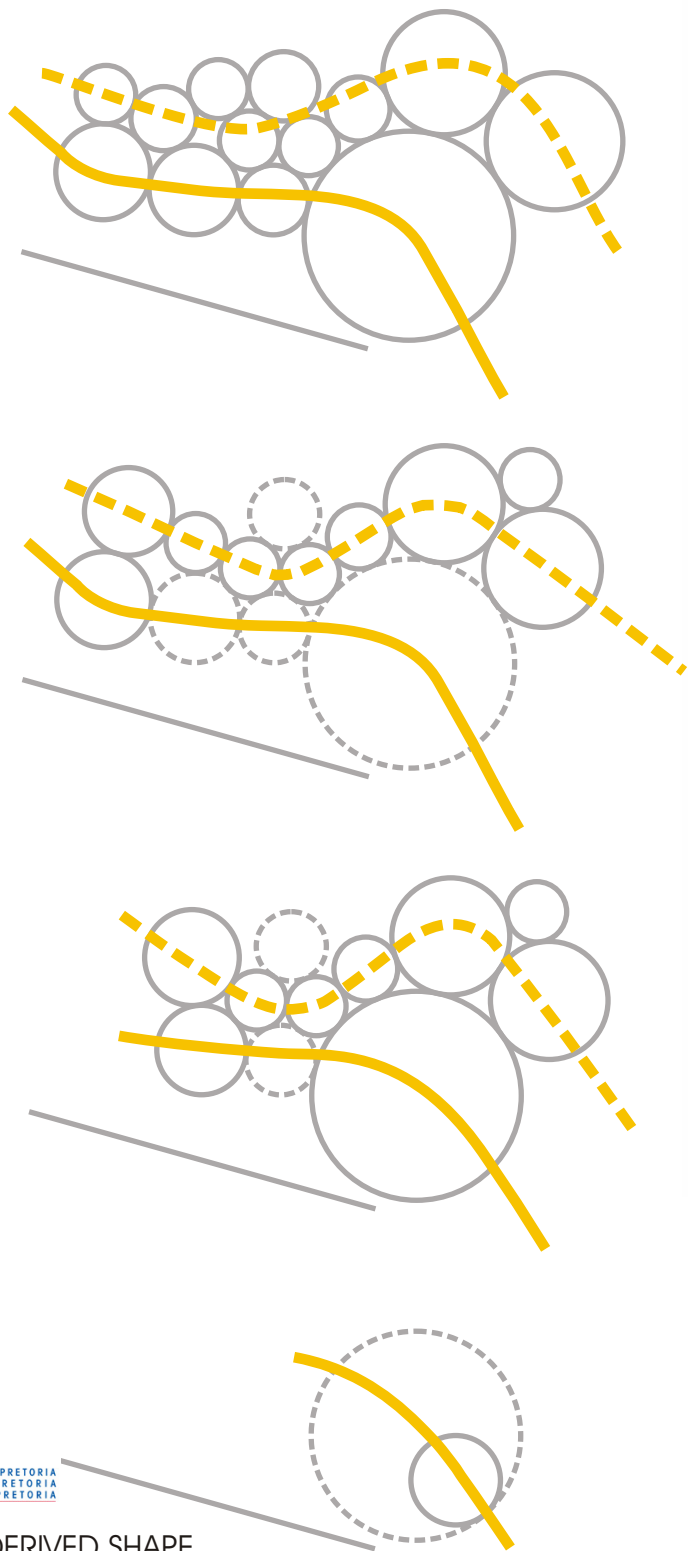
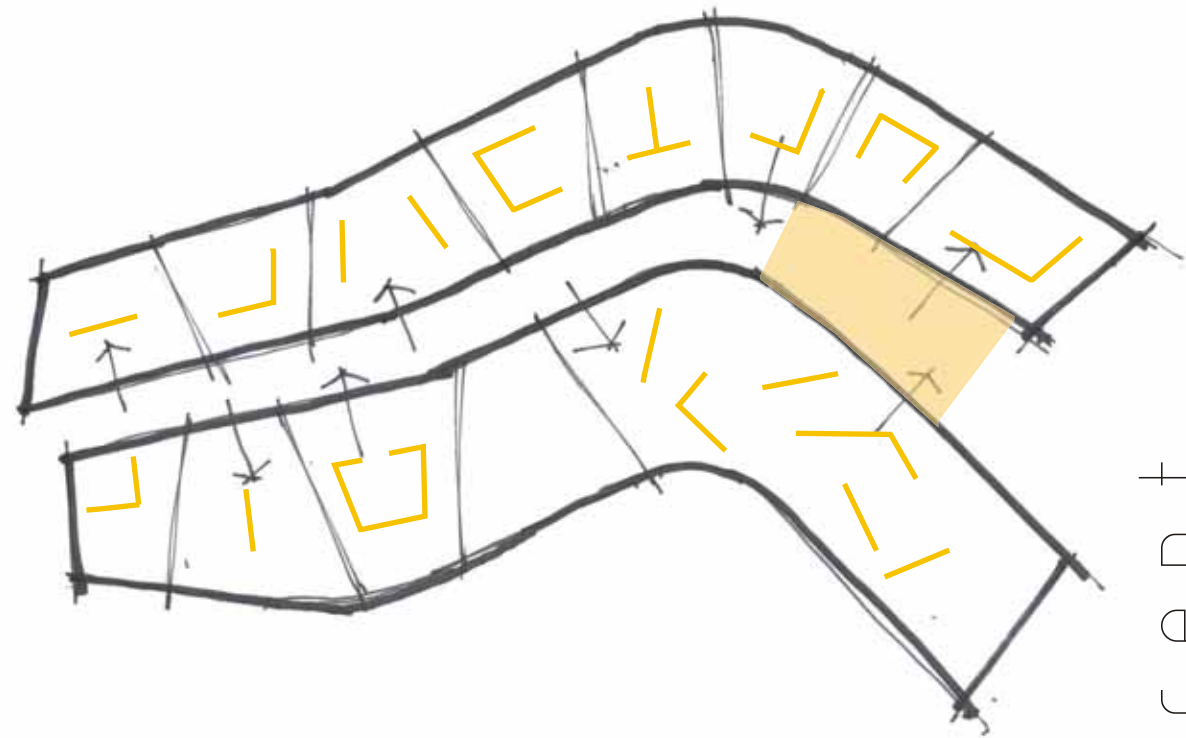

FIG 5-19: INTERNAL SPACE DEVELOPMENT



U  
N  
C  
O  
N  
C  
E  
P  
T

FIG 5-18: THE DERIVED SHAPE

## spatial relationships - shape

Through the spatial relationships the shape of the building can be derived. The building should through its curvilinear lines and fluid forms draw people into the narrative of the building. This plan should therefore also strengthen the concept of Guiding Innovative Thought. The building should function by having a central circulation flow from where all the spaces can then be enter from. The circulation should flow towards a central atrium space. The spaces entered into should be open plan, and the internal spaces can be managed by the creative individuals through movable partitions.



FIGURE 5-20: PINNACLE PERFORMANCE

5  
15

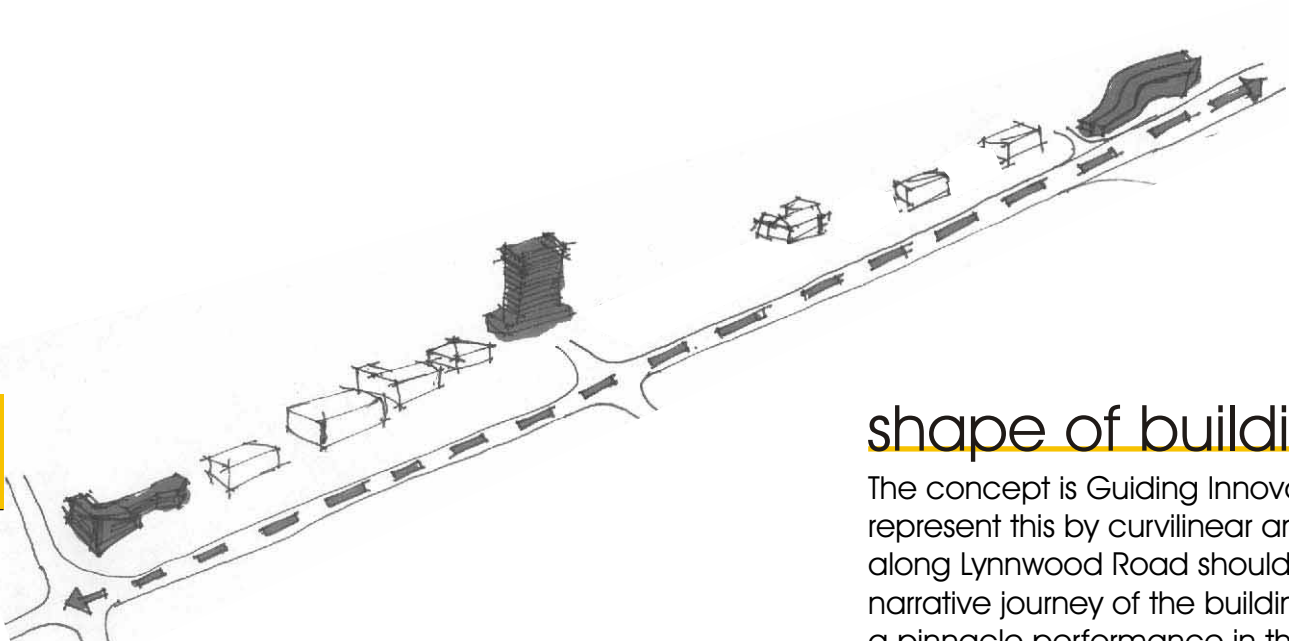

FIGURE 5-21: LYNNWOOD ROAD NARRATIVE

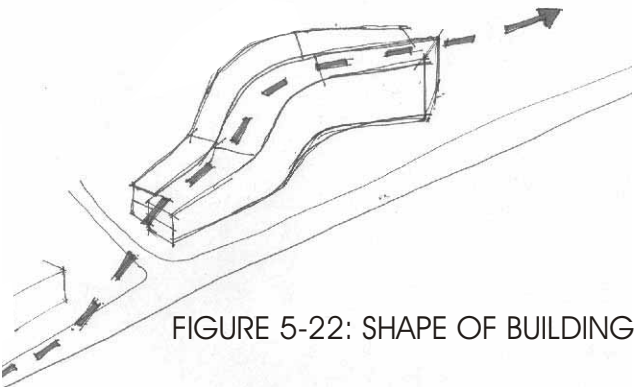

FIGURE 5-22: SHAPE OF BUILDING

shape of building

The concept is Guiding Innovative Thought, therefore the building should represent this by curvilinear and fluid lines. The attention of the people that drive along Lynnwood Road should be drawn towards the building and into a narrative journey of the building. The building should lead the attention towards a pinnacle performance in the whole Lynnwood Road narrative, which is the displaying of the product of innovation that is achieved by studying at the University of Pretoria. Therefore the exhibition space, having a high volume, is at the end of the building, marking the end and conclusion of the narrative.

U  
N  
I  
V  
E  
R  
S  
I  
T  
Y  
O  
F  
P  
R  
E  
T  
O  
R  
I  
A

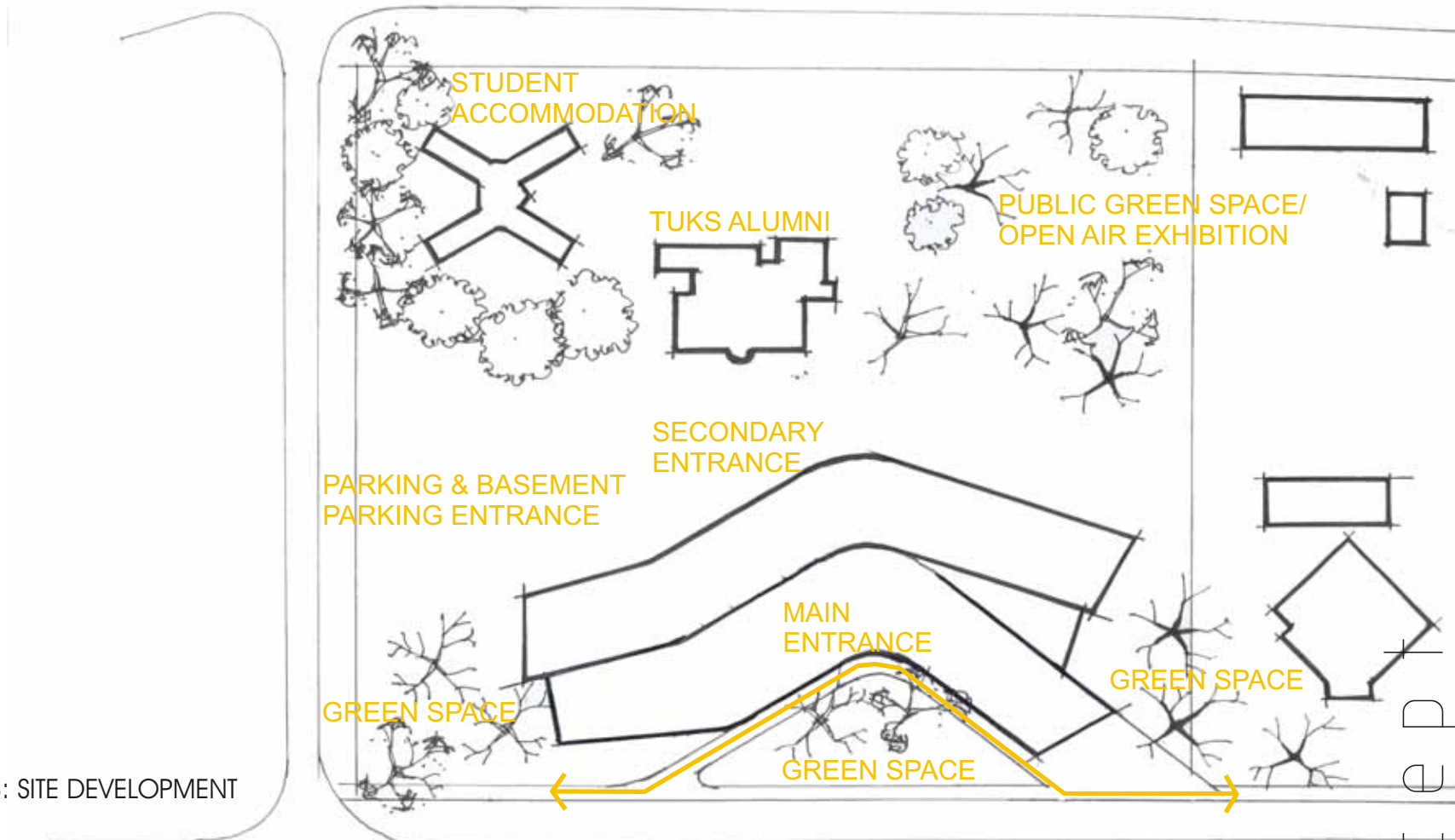
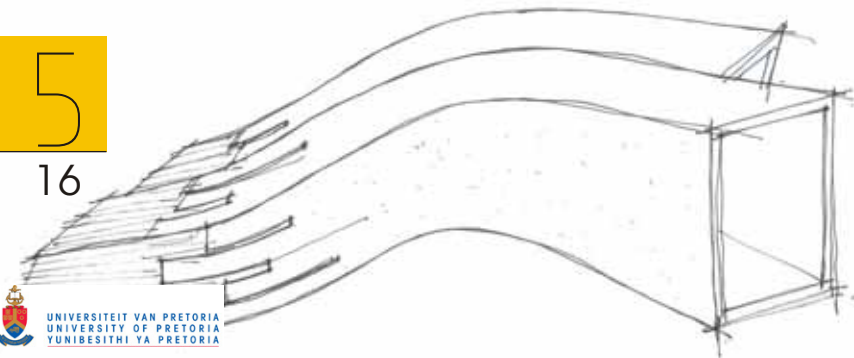

FIG 5-23: SITE DEVELOPMENT

5

16



## concept development

The concept of Guiding Innovative Thought is further developed where the building speaks of a narrative taking place with regard to the incubation process. The building starts off to be extremely fragmented as to represent a person coming into the incubator with a concept but must still develop it. He doesn't have a business plan or the necessary business skills to make it work. As the person progresses through the incubation program, the concept starts to formalize and his business is starting to get on its feet. Further progressing, the product solidifies to have in the end a solid innovative commercial product.

FIG 5-24: NARRATIVE OF THE BUILDING



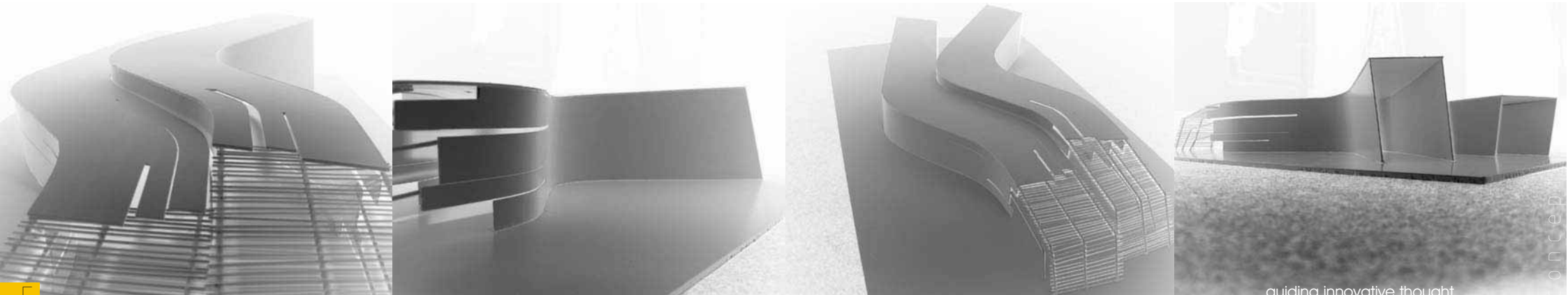

5

FIG 5-25: FINAL CONCEPT MODEL

17

guiding innovative thought

ONCE

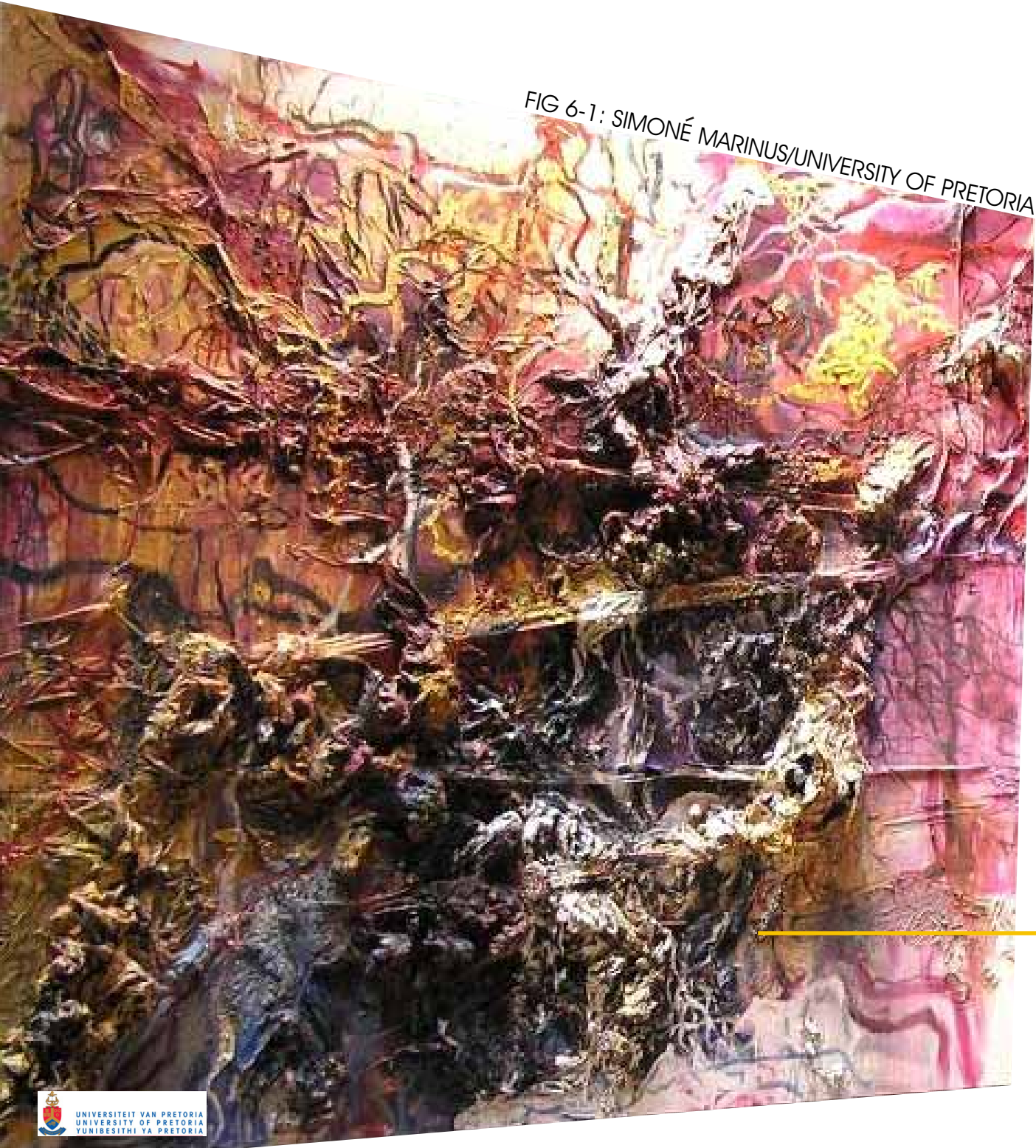
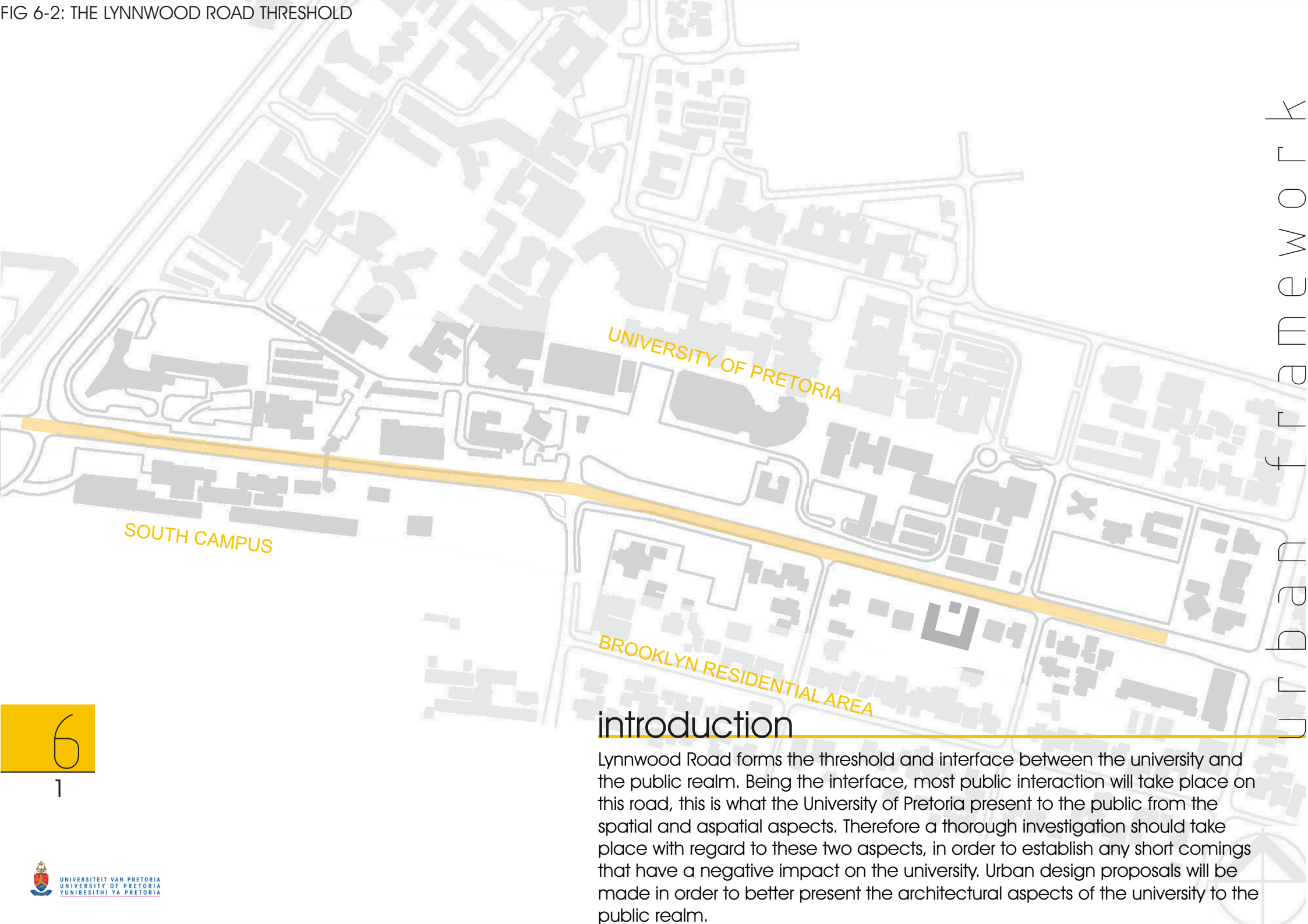

FIG 6-1: SIMONÉ MARINUS/UNIVERSITY OF PRETORIA



URBAN FRAMEWORK

## introduction

Lynnwood Road forms the threshold and interface between the university and the public realm. Being the interface, most public interaction will take place on this road, this is what the University of Pretoria present to the public from the spatial and aspatial aspects. Therefore a thorough investigation should take place with regard to these two aspects, in order to establish any short comings that have a negative impact on the university. Urban design proposals will be made in order to better present the architectural aspects of the university to the public realm.

As a result of the connectivity that Lynnwood Road provide between the N1 highway and Pretoria CBD, there is a high volume of people utilizing the road. There isn't currently a well functioning public transport system. Mini-busses are sometimes not road worthy and people feel unsafe to use them. Busses circulate the areas with no clear indication of the direction or destination and arrive after large time intervals. Therefore the majority of the people making use of the roads as well as Lynnwood Road, utilizes private vehicles which mostly transports only the driver with having no passengers.

As discussed, cars can destroy the social and ecological aspects of an area, and by the rate the petrol price is increasing, it is also busy destroying the economy. This observable fact of cars destroying the social environment of an area, is extremely evident at the university on Lynnwood Road. As a result of the dividing power of the cars, the university is left a desolate island with no social interaction between the university and the Brooklyn residential area to the south of Lynnwood Road. For this problem to be solved, the amount of private vehicles and the speed at which they travel should decrease drastically.

All roads including Lynnwood Road should be dominated by public transport and not by private vehicles. The idea is not to lessen the amount of people that utilize Lynnwood Road, but the amount of private vehicles by introducing a well functioning public transport system. We all know that most private vehicles on the road only transport one person, and when considering that a single level bus can transport at least fifty people at a time. Consequently every thousand cars can be decreased to only twenty busses. Busses are also the most economical vehicular transport there is as it can transport the most people.

## transport

The amount of private vehicles can be decreased by implementing a well managed bus transport system. The busses should be safe with a bus arriving every 15 minutes and should have a completely different in colour such as red, to be easily distinguishable from the other busses. The buss route should run the entire length of Lynnwood Road from the CBD right pass the N1 highway. Through this, the amount of vehicles passing the university would be less than half of the current situation, making the integration of the university to the community to the south of Lynnwood Road possible.

6

2



FIG 6-3: PUBLIC TRANSPORT

## transport

Urban design principles indicates that 400m is a comfortable distance for people in-general to walk. Therefore every 400m there should be a bus pickup indicated by the circles. The circles also indicate from where in the community people could walk to a bus pickup. The people further than that would need other public transport or use cars to get to the pickup, therefore at every bus pickup there should be secure basement parking provided where cars can be left for a period of time and picked up when returning. There are also bus pickups at the highway where busses from the highway can drop off people.

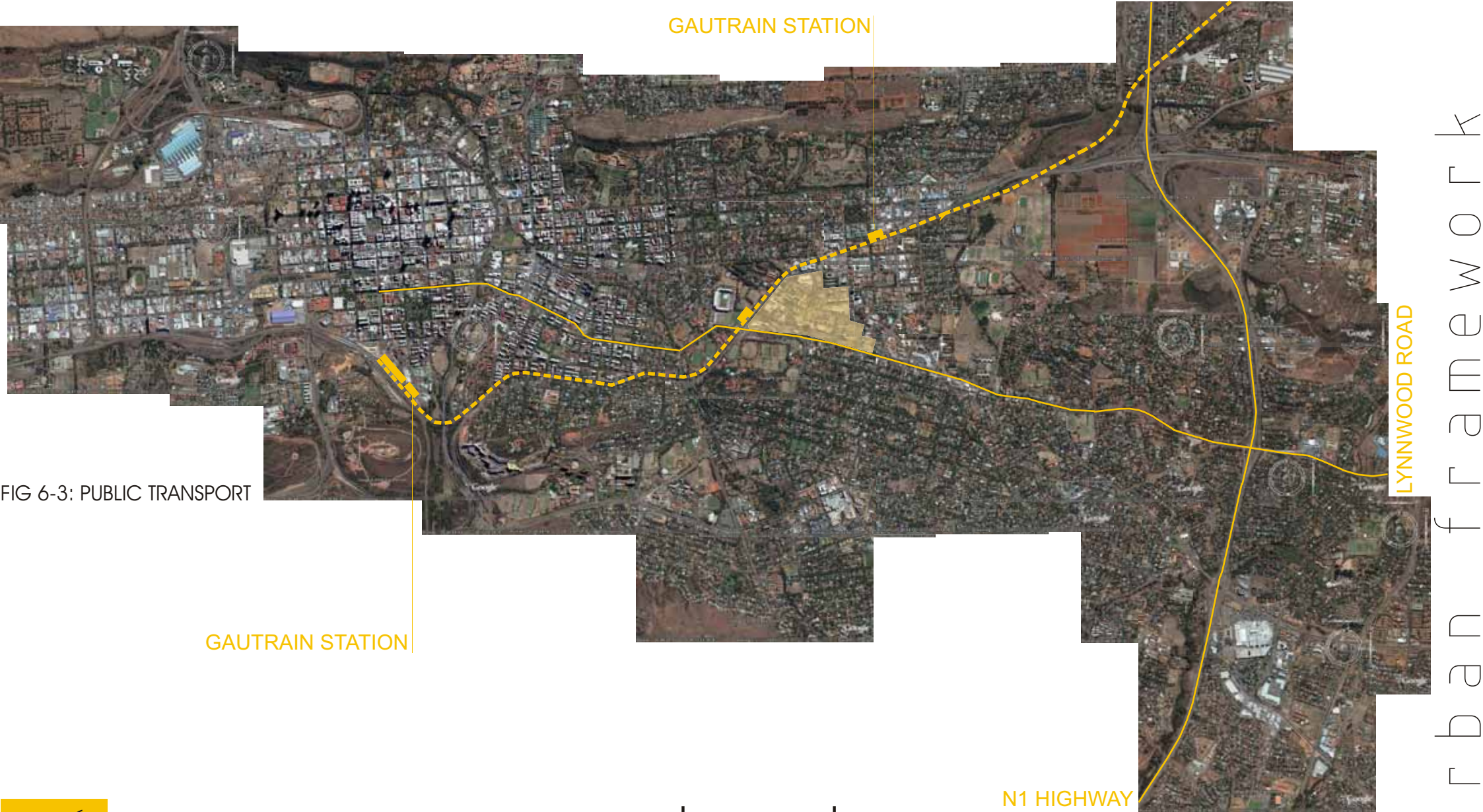

FIG 6-3: PUBLIC TRANSPORT

## transport

The Gautrain, which is a high speed submerged train connecting Johannesburg and Pretoria, is currently under construction and will be finished in the year 2010. There are cars traveling on Lynnwood road, which come from Johannesburg and are on their way to the CBD. Therefore when considering the Gautrain, a lot of the cars from Johannesburg will be eliminated which would again lessen the volume of private vehicles.



FIG 6-4: BUS PICKUPS

## transport

Through this well managed bus transit system, many students making use of this, would no longer need to arrive at the university by car. They would either walk to the nearest bus pickup as explained or would leave their cars at one of the secure basement parking at the particular bus pickup. As can be derived from the previous diagram, which indicates the 400m walking circles, the university would need one bus pickup at the Administration building, one at the main entrance and one at the Incubator of Innovation. The bus pickups should be opposite each other, increasing the social interaction between people.

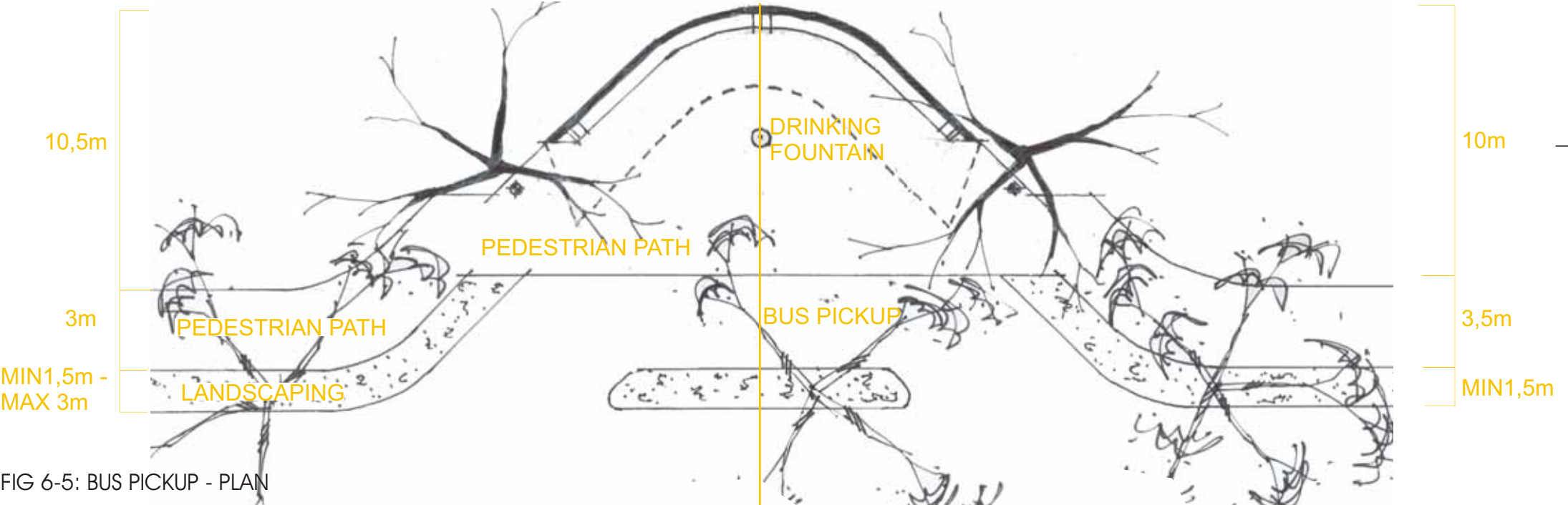

FIG 6-5: BUS PICKUP - PLAN



FIG 6-6: BUS PICKUP - SECTION

transport

The bus pickup should be a shelter which shape emphasize a concept of 'pickup' and not 'stop' and should therefore have a fluid form. The shelter should be cross ventilated through adjustable aluminium louvers at the top. The space must be well lit and provided with dustbins and a drinking fountain in the middle of the space.



FIG 6-7: BASEMENT PARKING

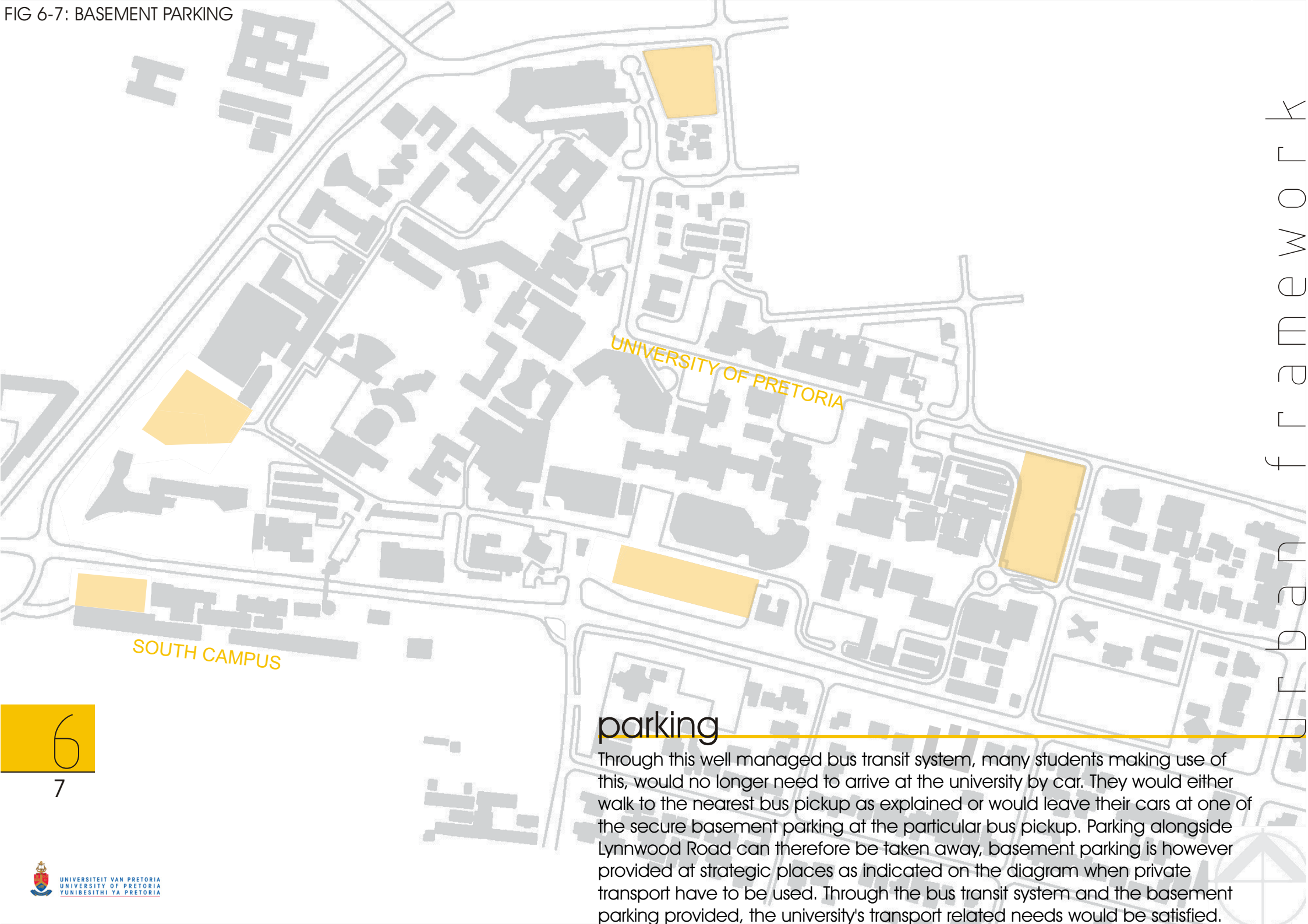

6  
7

## parking

Through this well managed bus transit system, many students making use of this, would no longer need to arrive at the university by car. They would either walk to the nearest bus pickup as explained or would leave their cars at one of the secure basement parking at the particular bus pickup. Parking alongside Lynnwood Road can therefore be taken away, basement parking is however provided at strategic places as indicated on the diagram when private transport have to be used. Through the bus transit system and the basement parking provided, the university's transport related needs would be satisfied.



URBAN FRAMEWORK

6

8

## road crossings

The traffic should be slowed down to make it easier for pedestrians and bicycles to cross Lynnwood Road. Through the implementation of raised road crossings where indicated, traffic would slow down to an inconvenient pace, discouraging the use of private vehicles in order to utilize the public transport system. This place is not for cars, it is for people and the urban environment should reflect the importance of students even if it effects private vehicles. Through the implementation of these crossings the integration of the university with the Brooklyn area and the South Campus is enhanced.

FIG 6-9: RAISED ROAD CROSSING

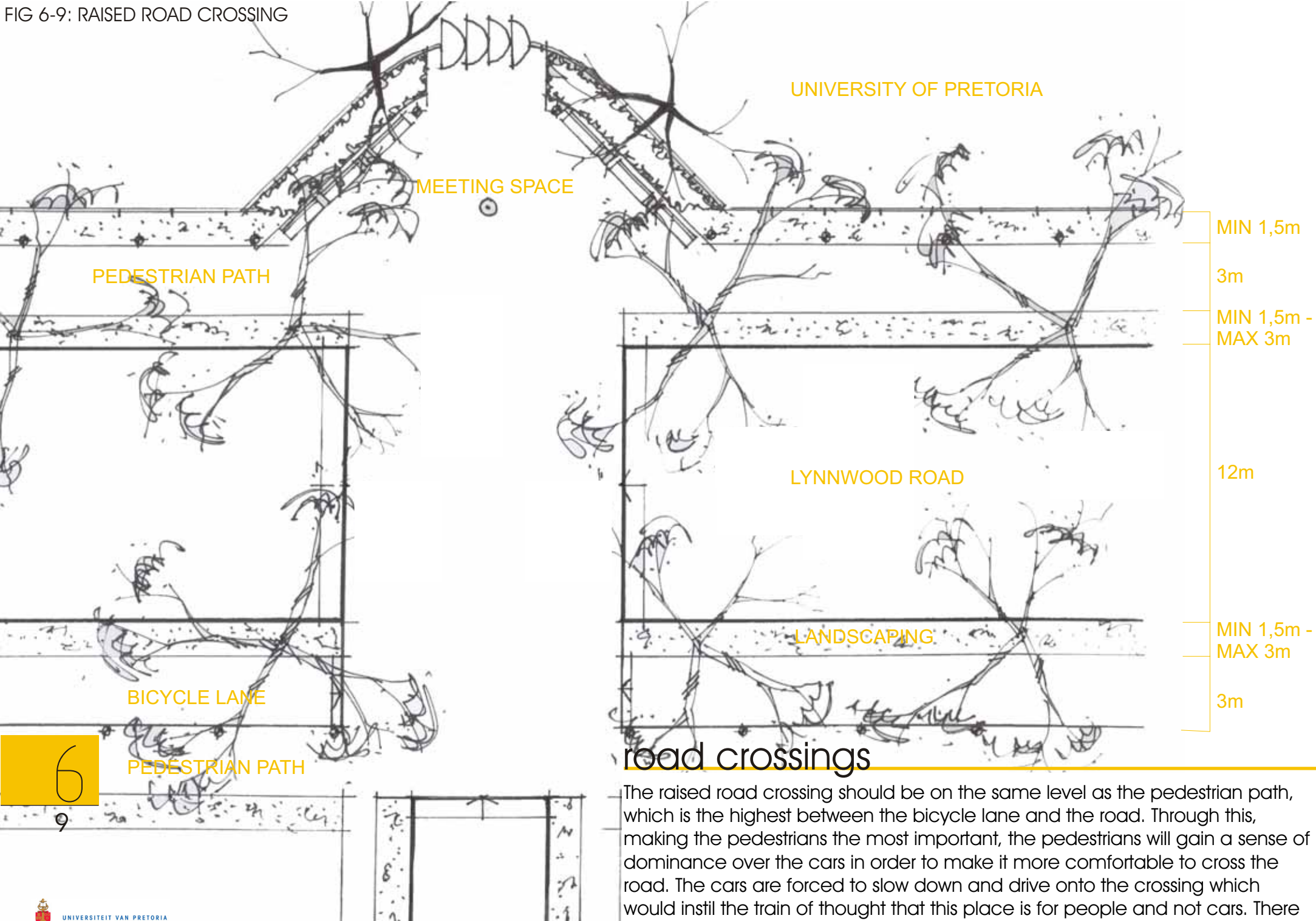

### road crossings

The raised road crossing should be on the same level as the pedestrian path, which is the highest between the bicycle lane and the road. Through this, making the pedestrians the most important, the pedestrians will gain a sense of dominance over the cars in order to make it more comfortable to cross the road. The cars are forced to slow down and drive onto the crossing which would instil the train of thought that this place is for people and not cars. There should be a pedestrian and bicycle entrance to the university at these crossings or within close proximity to it, in order to increase the permeability.

URBAN FRAMEWORK

FIG 6-10: ENTRANCE MEETING SPACE - PLAN

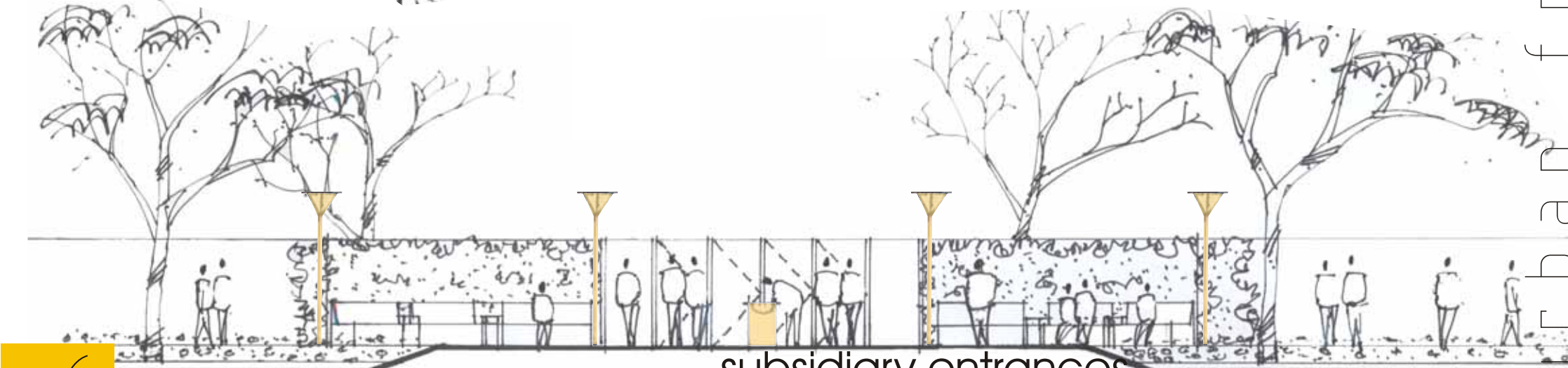
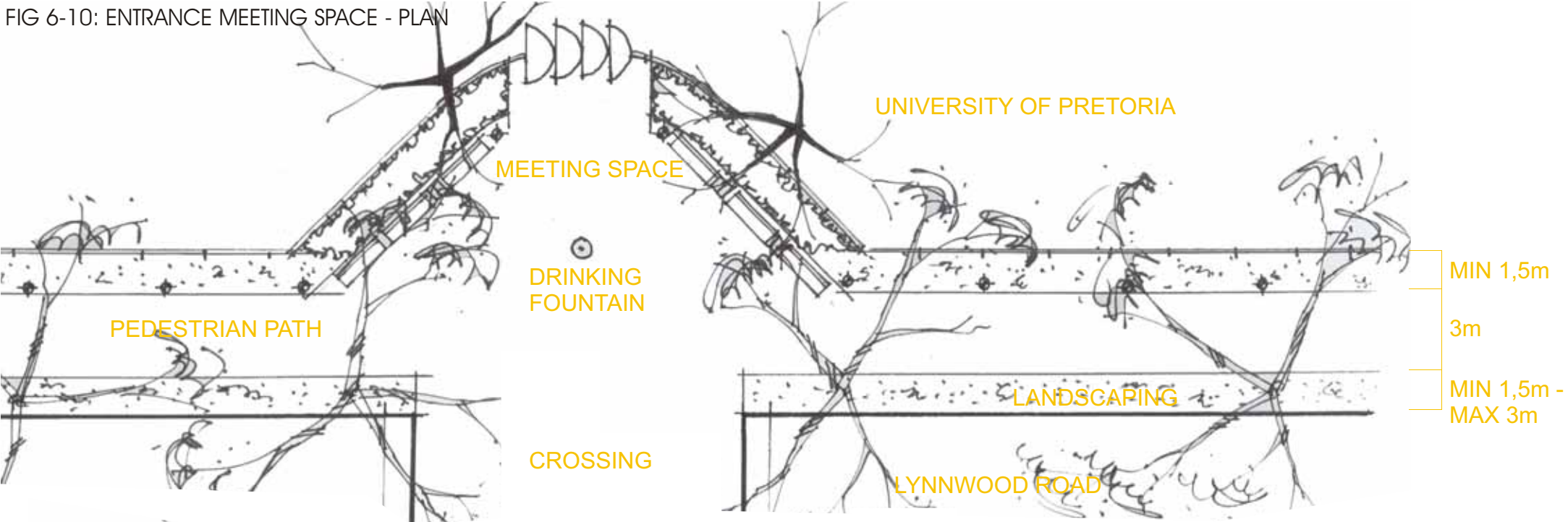

6  
10

FIG 6-11: ENTRANCE MEETING SPACE - SECTION

### subsidiary entrances

There should be a meeting space in front of these entrances where students could wait for friends or simply rest and read a book. These spaces should be shaded and well lit and provided with dustbins and a drinking fountain.

urban framework

FIG 6-12: CONNECTION BETWEEN CAMPUSES

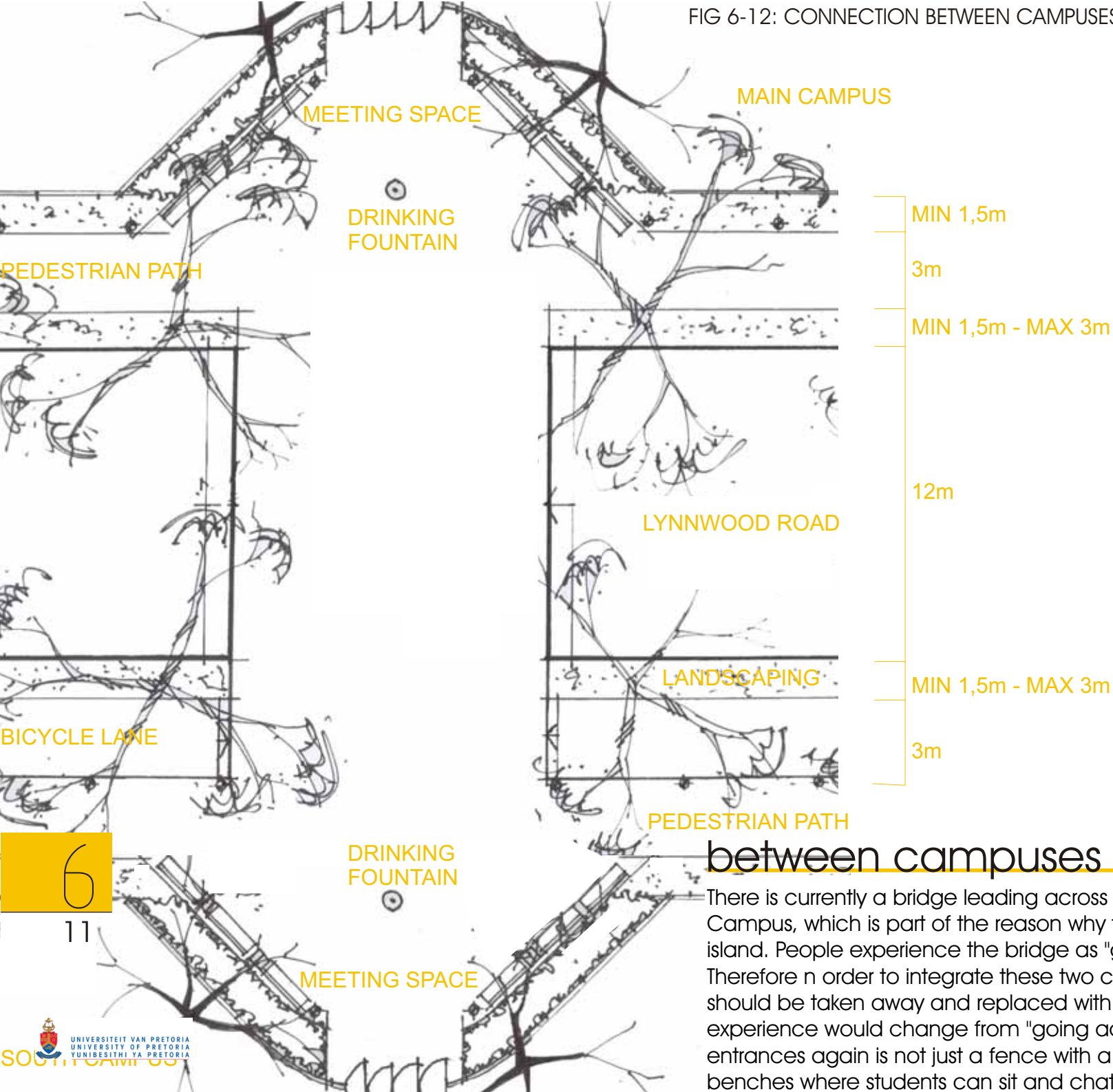

## between campuses

There is currently a bridge leading across the road from Main Campus to South Campus, which is part of the reason why the university feels like a desolate island. People experience the bridge as "going across to the other side". Therefore in order to integrate these two campuses with each other the bridge should be taken away and replaced with a raised road crossing. The experience would change from "going across" to "going next door". The entrances again is not just a fence with a gate, but a shaded well lit space with benches where students can sit and chat or wait for other people.

FIG 6-13: SECTION THROUGH  
LYNNWOOD ROAD

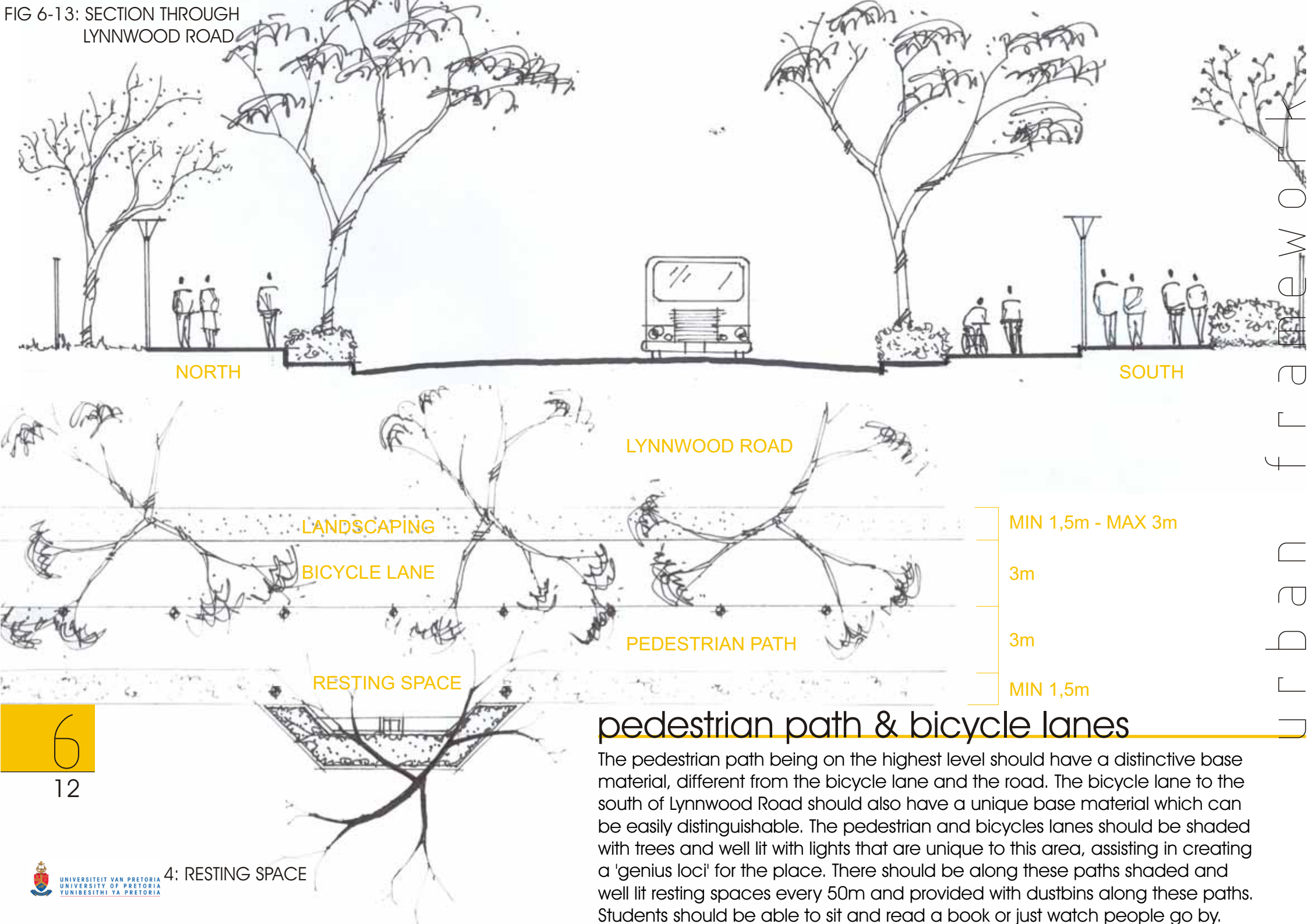

6

12

## pedestrian path & bicycle lanes

The pedestrian path being on the highest level should have a distinctive base material, different from the bicycle lane and the road. The bicycle lane to the south of Lynnwood Road should also have a unique base material which can be easily distinguishable. The pedestrian and bicycles lanes should be shaded with trees and well lit with lights that are unique to this area, assisting in creating a 'genius loci' for the place. There should be along these paths shaded and well lit resting spaces every 50m and provided with dustbins along these paths. Students should be able to sit and read a book or just watch people go by.

Urban for a new order

There is a sense of place created for the student to the north of the university in Hatfield, but that character is not present when considering the southern side which is the most prominent side as well as the public interface with the university. When driving down Lynnwood Road this is what is extremely apparent, there is very little identifiable connection between the university and the Brooklyn area. With the university being on the northern side of Lynnwood Road, there should be a character which describes student life on the south side.

To the south of Lynnwood Road the area is single use residential dwellings with no variety. One can argue that the reason for this is that it is so close to the Hatfield business center as well as the Brooklyn business center. This is true but the edges should be mixed-use to form the threshold between the business centers outside and the residential area inside.

The area has achieved this to an extent on Duncan Road's side with a mixture of houses and businesses alongside the road, but it is still mostly single dwelling houses alongside Lynnwood Road with one mono-functional six storey flat complex. Developers have however just finished a student housing complex alongside the road, but it is single use.

Therefore introduce high density mixed-use buildings alongside the road. It should be four storeys high buildings with student housing on top and shops and coffee shops. Through this increase the variety of the area in order to offer the individual some choice in the area. Through this initiate some quite nightlife, which would serve to create a 'genius loci' where a student can feel comfortable.

## university precinct

The social character of Lynnwood Road is completely lost, there should be high density student housing on top of shops and coffee shops alongside the road. By the implementation of urban principles, the student social culture should be emphasized and restored. This would assist in defining the precinct as a university precinct which would increase the legibility. By creating a student social culture on the southern side of Lynnwood Road, serve to integrate and stitch the university back into the community.

6

13



FIG 6-15: AERIAL VIEW OF LYNNWOOD ROAD

RENOVATE - HIGH DENSITY MIXED USE MAKING IT THREE STOREYS WITH COMMERCIAL AT THE BOTTOM

DEMOLISH - HIGH DENSITY MIXED USE SOME ARCHITECTURAL VALUE BUT SINGLE USE

DEMOLISH - HIGH DENSITY MIXED USE NO ARCHITECTURAL OR HISTORICAL VALUE, SINGLE USE AND SINGLE STOREY

REMAIN - ITALIAN EMBASSY



REMAIN - HIGH DENSITY STUDENT HOUSING ARCHITECTURAL VALUE AND HIGH DENSITY

DEMOLISH - HIGH DENSITY MIXED USE NO ARCHITECTURAL OR HISTORICAL VALUE, SINGLE USE AND SINGLE STOREY

RENOVATE - HIGH DENSITY MIXED USE MAKING IT THREE STOREYS WITH COMMERCIAL AT THE BOTTOM

REMAIN - HIGH DENSITY STUDENT HOUSING SOME ARCHITECTURAL VALUE AND HIGH DENSITY

DEMOLISH - HIGH DENSITY MIXED USE SOME ARCHITECTURAL VALUE BUT SINGLE USE

DEMOLISH - HIGH DENSITY MIXED USE NO ARCHITECTURAL OR HISTORICAL VALUE, SINGLE USE

REMAIN - STUDENT ACCOMMODATION ARCHITECTURAL AND HISTORICAL VALUE

REMAIN - STUDENT ACCOMMODATION ARCHITECTURAL AND HISTORICAL VALUE

DEMOLISH - HIGH DENSITY MIXED USE NO ARCHITECTURAL OR HISTORICAL VALUE, SINGLE USE AND SINGLE STOREY

PARKING AREA - HIGH DENSITY MIXED USE BASEMENT PARKING PROVIDED

aerial view of lynnwood road



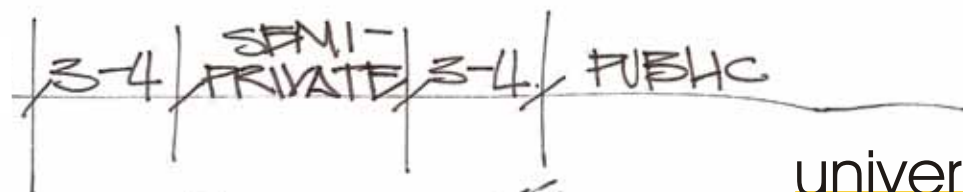

FIG 6-16: SEMI-PRIVATE SPACE BEHIND MIXED-USE BUILDING

FIG 6-17: PUBLIC SEMI-ENCLOSED SPACES



FIG 6-18: SHOPS AND COFFEE SHOPS BELOW RESIDENTIAL UNITS



## university precinct

Space is only created once it is defined through enclosure or semi-enclosure by making use of natural or built-form elements. The created space has the potential to be part of the public realm or the private realm, but it is the specific function that renders it to be public or private. Buildings should be placed at the perimeter of the site in order to create an inside and an outside space. The outside shall act as public fronts and the inside could act as semi private or communal backs, to be used for the housing on top. The inside space with increased permeability could be a public square.

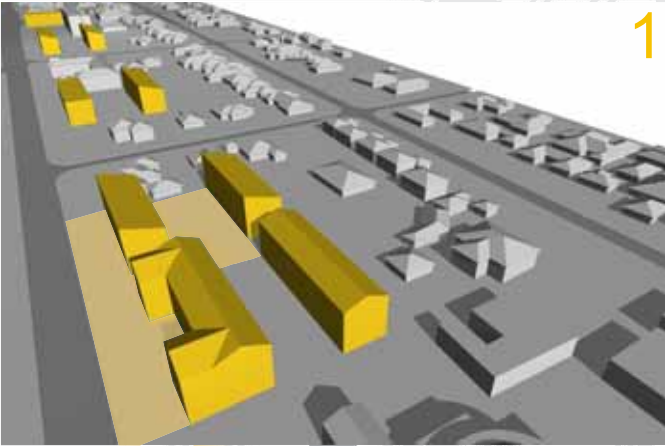

FIG 6-20: FOUR STOREY MIXED-USE BUILDINGS

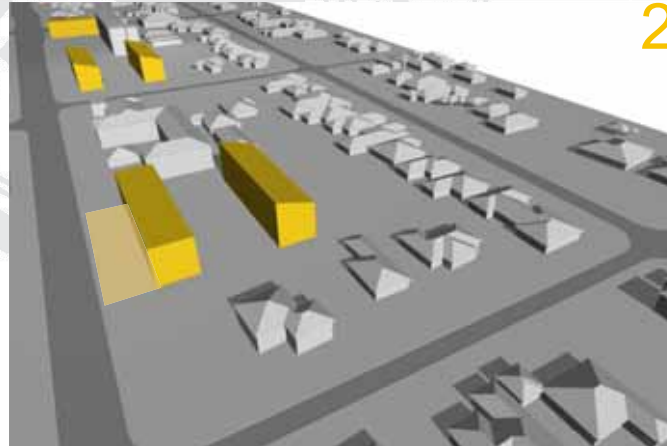

FIG 6-21: FOUR STOREY MIXED-USE BUILDINGS

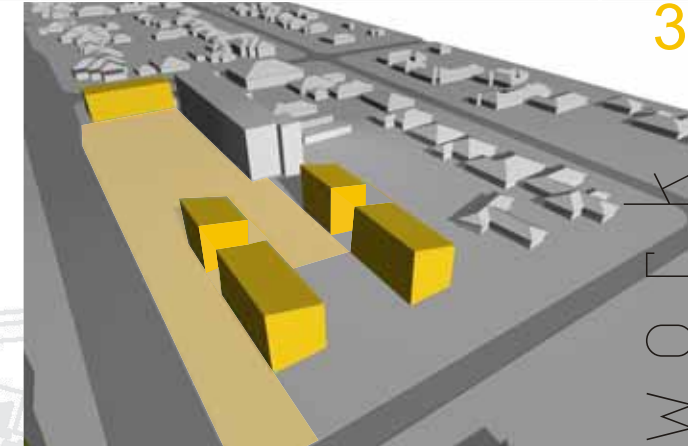

FIG 6-22: FOUR STOREY MIXED-USE BUILDINGS

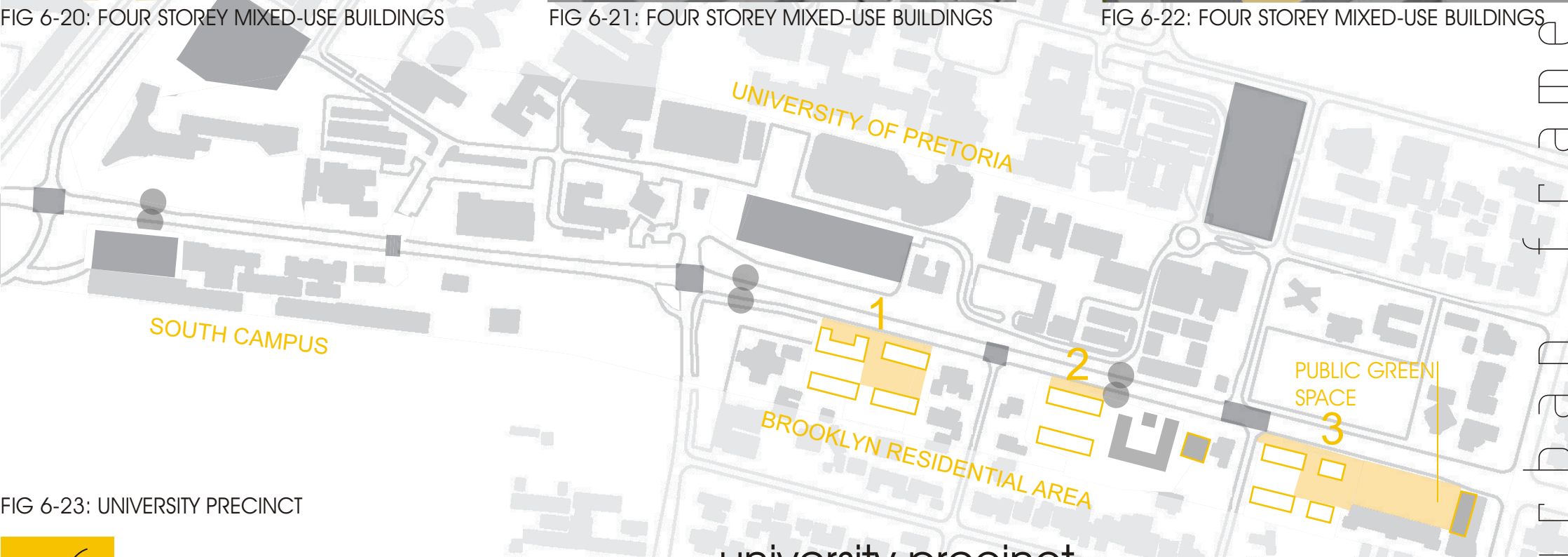

FIG 6-23: UNIVERSITY PRECINCT

## university precinct

Indicated is where the proposed high density mixed use will be situated. The yellow fill indicates the public spaces, which include public squares and green spaces. The spaces behind the buildings in white would be semi-private or for communal use by the students residing there. 360 degrees perimeter buildings have problems with the orientation with regard to the western sun. Therefore the shape of the buildings are rectangular in order for the buildings to be orientated towards north. Through this shape and orientation, spaces are enclosed but there is still a degree of openness on the sides.



FIG 6-24: TYPICAL ELEVATION OF MIXED-USE BUILDINGS

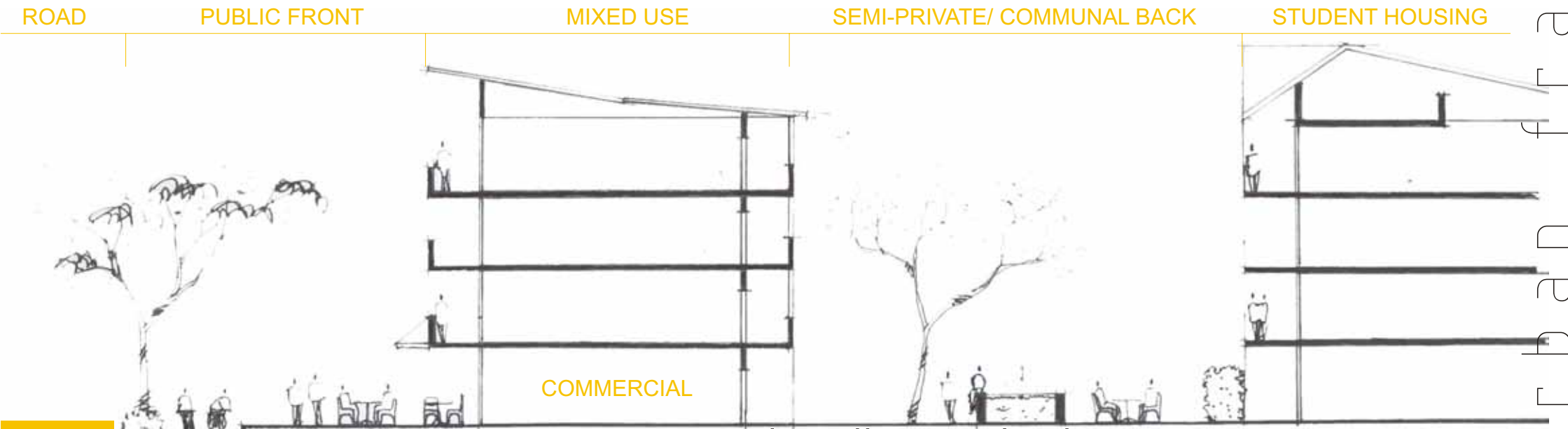

FIG 6-25: TYPICAL SECTION OF MIXED-USE BUILDINGS

## university precinct

High density urban housing should be incorporated with a mixture of other activities in order to sustain a neighbourhood. The success of high-density urban housing is dependant on high quality urban design which determines the arrangement of public and private spaces and how people move from the public to the private space. Through the use of front and back perimeter blocks, the building forms the most apparent threshold between the public and private realm, where the front of the building face the public space and the back opens up onto the communal or semi-private space.



LOST SPACE - FOUR STOREY BUILDINGS IN FRONT OF GREEN SPACE



BUILDING 8



BUILDING 4 - GREEN SPACE IN FRONT OF BUILDING



PARKING AREA - BASEMENT PARKING WITH FOUR STOREY BUILDINGS IN FRONT PUBLIC SPACE

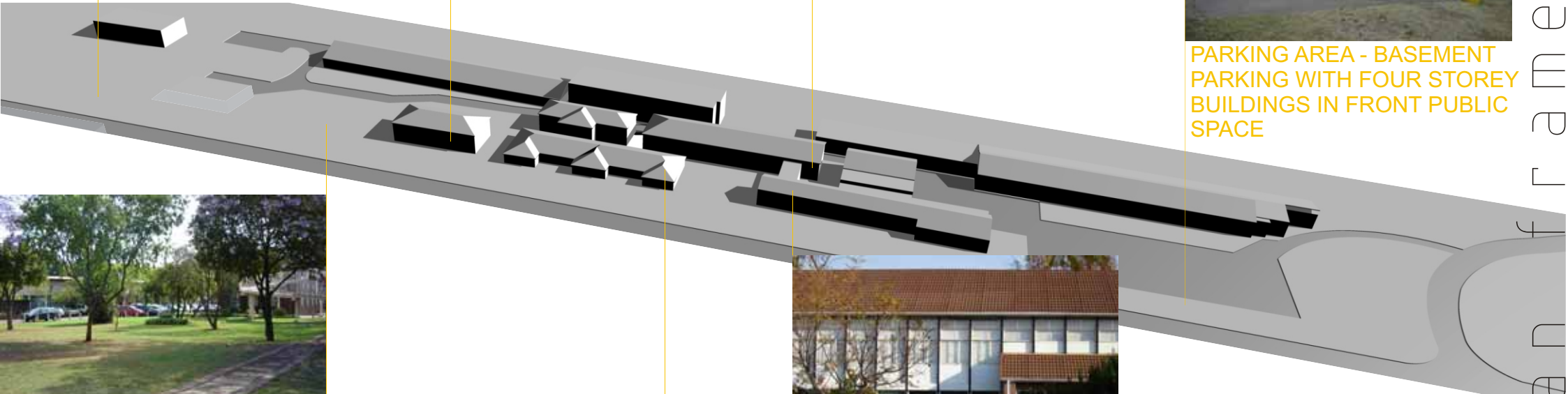

GREEN SPACE - FOUR STOREY BUILDINGS IN FRONT OF GREEN SPACE



BUILDING 8



BUILDING 2

FIG 6-26: 3D IMAGE OF EXISTING SOUTH CAMPUS

south campus

6

18

URBAN NETWORK

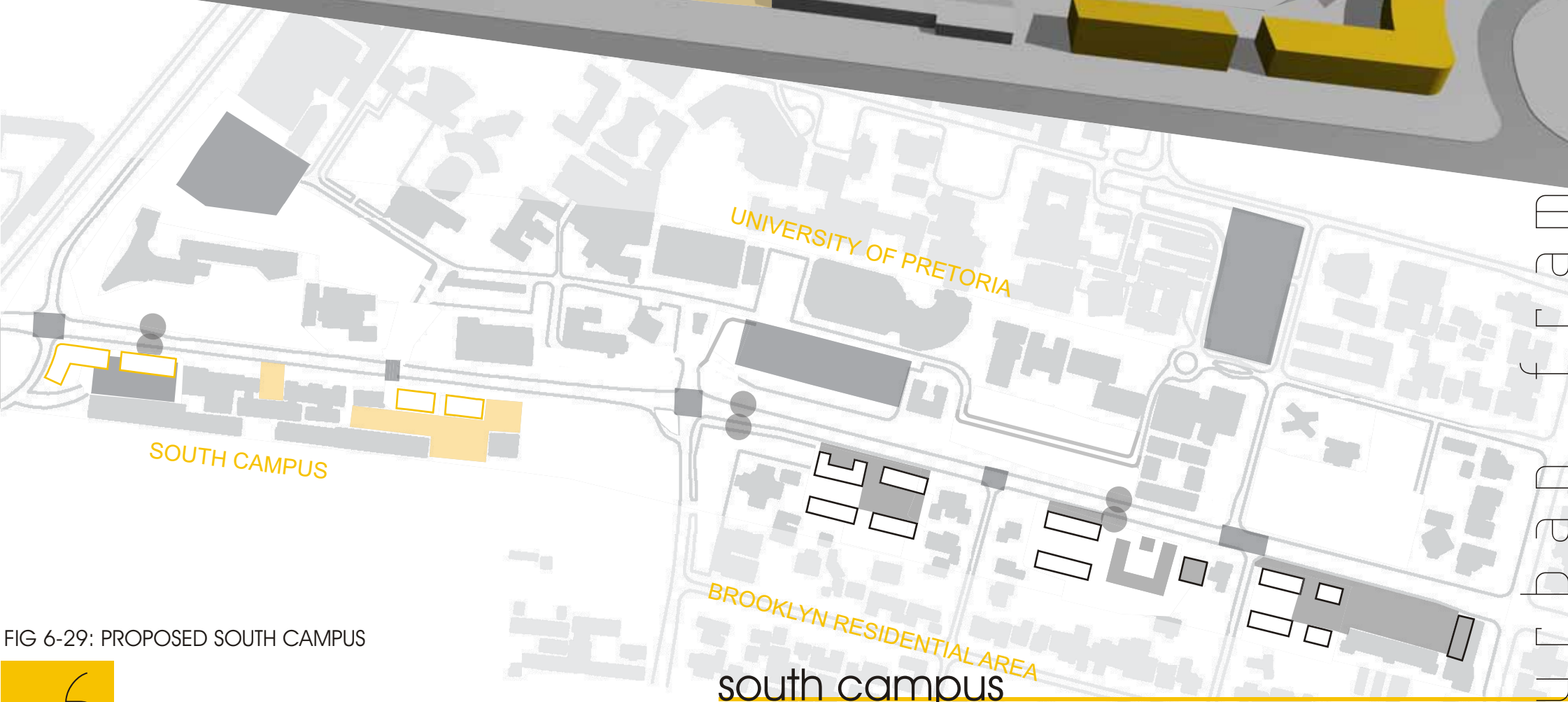
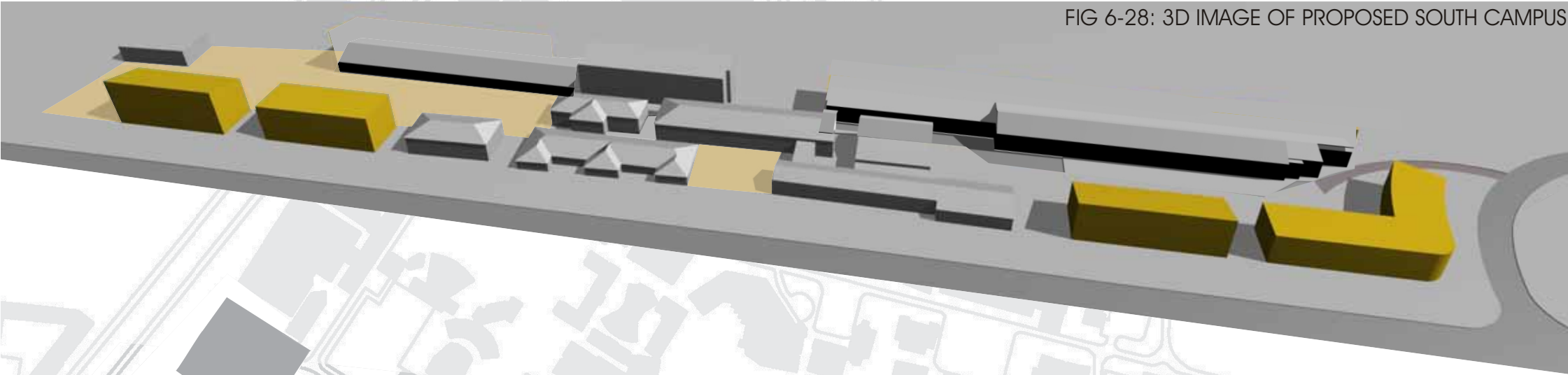

FIG 6-29: PROPOSED SOUTH CAMPUS



## south campus

There are currently areas on South Campus which can be better presented to the public realm. The facade along Lynnwood Road display parking areas at places as well as areas which is lost space. There should be three to four storey buildings defining the edge of the street and providing an attractive image to the public sector. Parking for the entire South Campus is provided by the basement at the entrance of the campus, creating a public square on top. Through the basement the need for parking elsewhere is eliminated, creating more space for green areas which is indicated by the yellow fills.

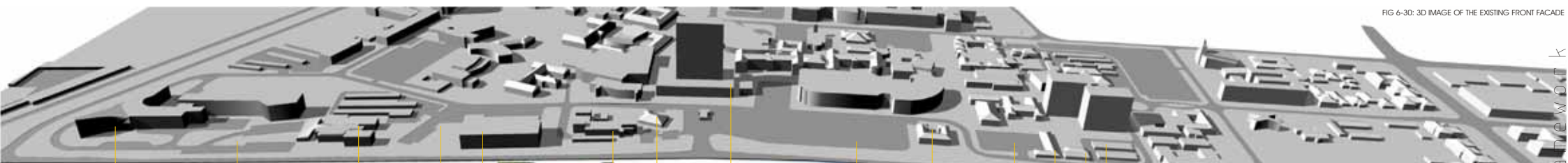

FIG 6-30: 3D IMAGE OF THE EXISTING FRONT FACADE

 <p>ADMINISTRATION</p>	 <p>VISUAL ARTS BUILDING</p>	 <p>SPEECH THERAPY PARKING AREA &amp; LOST SPACE IN FRONT OF BUILDING - GREEN SPACE BASEMENT PARKING PROVIDED</p>	 <p>HUMAN SCIENCE &amp; MAIN ENTRANCE</p>	 <p>DRAMA - GREEN SPACE IN FRONT OF BUILDING</p>	 <p>PARKING AREA - FOUR STOREY BUILDINGS IN FRONT OF GREEN SPACE BASEMENT PARKING PROVIDED</p>	 <p>PARKING AREA - FOUR STOREY BUILDINGS IN FRONT OF GREEN SPACE BASEMENT PARKING PROVIDED</p>	 <p>RENOVATE - SCREEN/DISPLAY WALL IN FRONT OF BALCONIES USED TOILET WINDOWS ARE FACING THE FRONT FACADE</p>	 <p>PARKING AREA - INCUBATOR OF INNOVATION BASEMENT PARKING PROVIDED</p>
 <p>PARKING AREA - PUBLIC GREEN SPACE BASEMENT PARKING PROVIDED</p>	 <p>PARKING AREA &amp; LOST SPACE - GREEN SPACE BASEMENT PARKING PROVIDED</p>	 <p>KYA ROSA PARKING AREA &amp; LOST SPACE IN FRONT OF BUILDING - GREEN SPACE BASEMENT PARKING PROVIDED</p>	 <p>BUILDING SCIENCE</p>	 <p>PARKING AREA - BUILDINGS IN FRONT OF BASEMENT PARKING</p>	 <p>DEMOLISH - FOUR STOREY BUILDING NO ARCHITECTURAL OR HISTORICAL VALUE, SINGLE STOREY</p>	 <p>DEMOLISH - FOUR STOREY BUILDING NO ARCHITECTURAL OR HISTORICAL VALUE, SINGLE STOREY</p>	<p>front facade</p>	

FIG 6-31: PHOTOGRAPHS OF BUILDINGS FACING LYNNWOOD ROAD



## front facade

Lynnwood Road, as the front facade of the University of Pretoria, is one of the ways the university will be showcasing their character and competency. Therefore from an urban design point of view, there are currently many areas of the facade that can be better presented. The facade is extremely fragmented with large open spaces between buildings. These spaces are either lost space or used for parking areas. The edge of the university should be defined by buildings and green spaces in front or in between the buildings. Potential buildings are indicated with the yellow fills representing green spaces.

FIG 6-32: 3D IMAGE OF PROPOSED FRONT FACADE

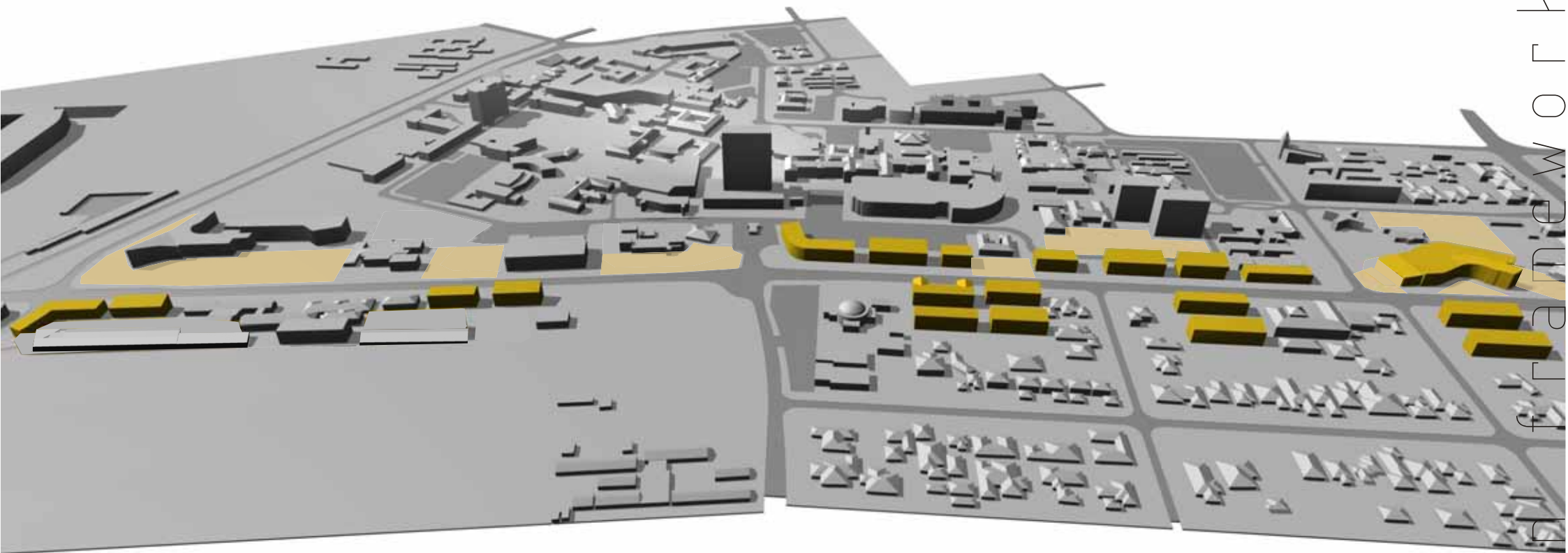

front facade

6

22

urban  
front facade



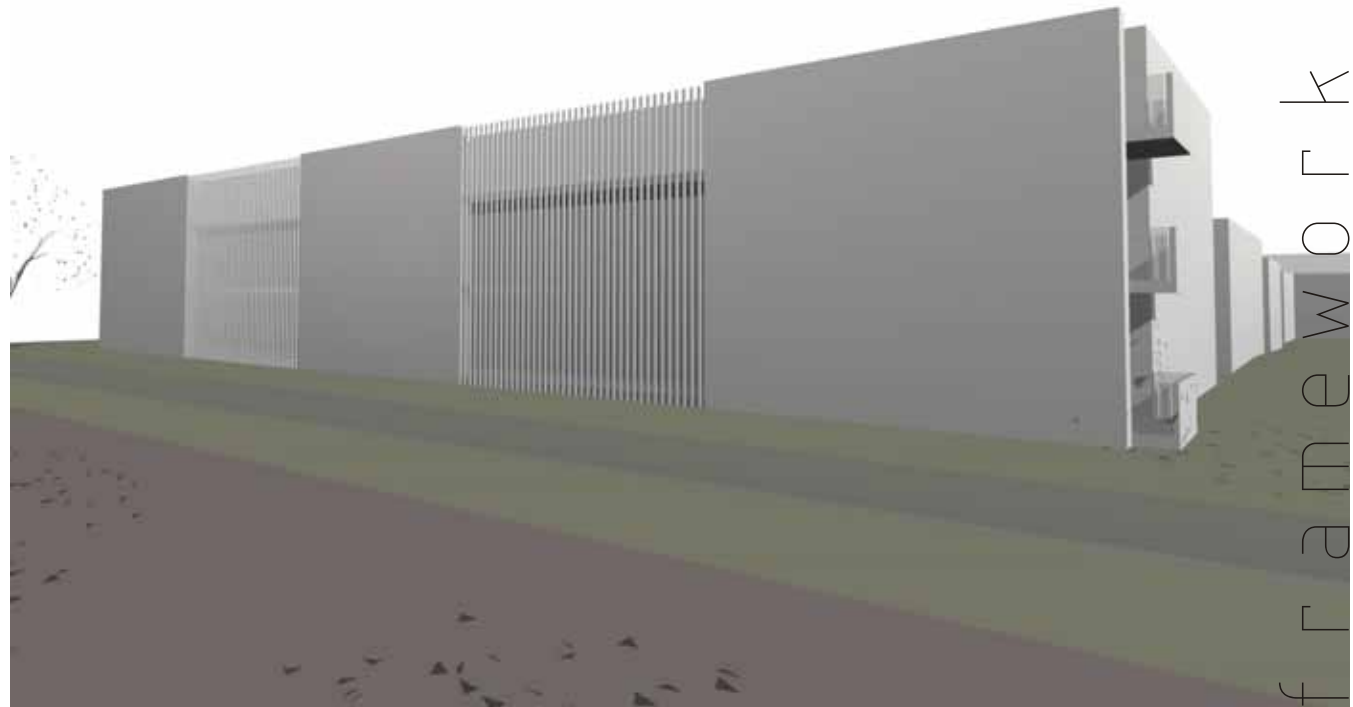

FIG 6-34: 3D MODEL OF PROPOSED RENOVATION OF THE NERINA EXTENTION



FIG 6-33: EXISTING FACADE OF THE NERINA EXTENTION

## front facade

The Nerina extension doesn't contribute to the front facade of the university as there are toilet windows facing Lynnwood Road. Therefore display screens or boards should be constructed in front of protruding balconies for the living units. These screens would serve to inform the public as well as students studying at the university about current and future events which would take place at the university. There would be three screens/display boards with ventilation grills between them, which would serve to hide the toilet windows but still provide for the adequate flow of air.

FIG 7-1: TONI VAN JAARVELD/UNIVERSITY OF PRETORIA





7

1

## design product

The building has curvilinear lines and a flowing shape in order to emphasize the concept of Guiding Innovative Thought. The building increases in height from a two storey building on the west to a four storey building on the east. The wing to the north of the building increases in height from two storeys to three. On Lynnwood Road the facade increases in solidity from the west to the east, to illustrate the concept of formalizing and solidifying an innovative concept. This narrative the building illustrates, is finished off at the end with a mosaic artwork on the side of the wall which are changed over a period of time.

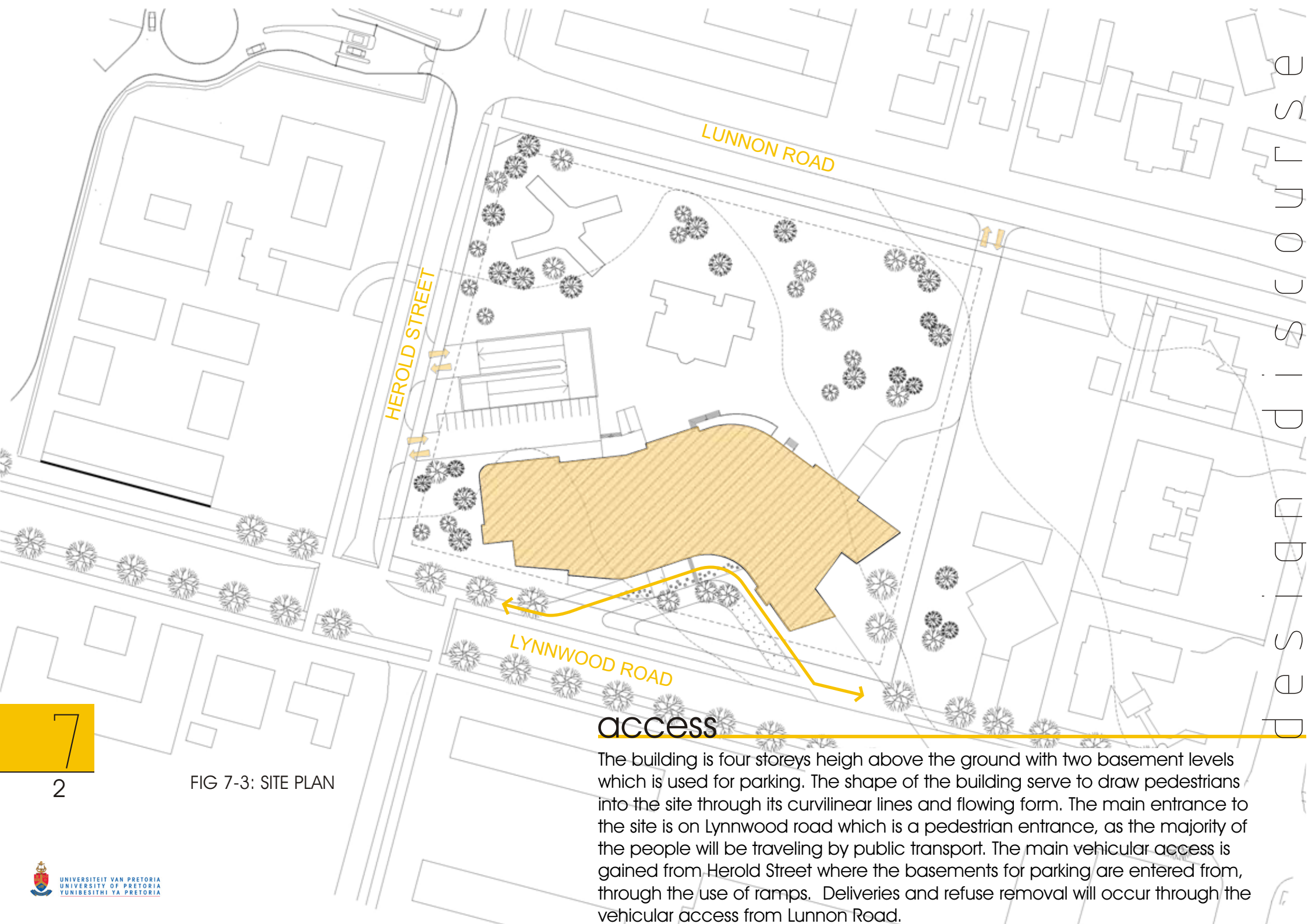
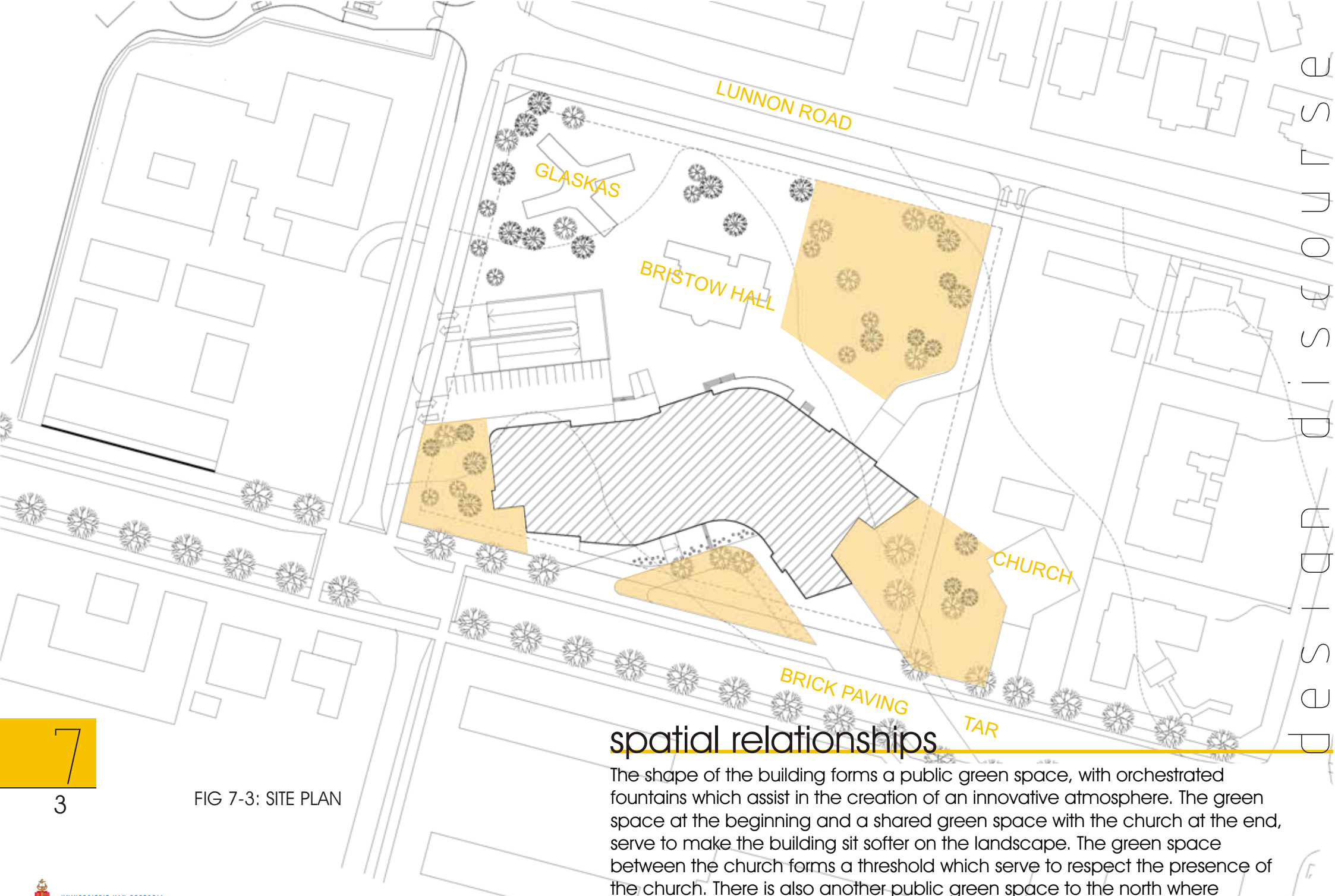

FIG 7-3: SITE PLAN

### access

The building is four storeys high above the ground with two basement levels which is used for parking. The shape of the building serve to draw pedestrians into the site through its curvilinear lines and flowing form. The main entrance to the site is on Lynnwood road which is a pedestrian entrance, as the majority of the people will be traveling by public transport. The main vehicular access is gained from Herold Street where the basements for parking are entered from, through the use of ramps. Deliveries and refuse removal will occur through the vehicular access from Lunnon Road.



## spatial relationships

The shape of the building forms a public green space, with orchestrated fountains which assist in the creation of an innovative atmosphere. The green space at the beginning and a shared green space with the church at the end, serve to make the building sit softer on the landscape. The green space between the church forms a threshold which serve to respect the presence of the church. There is also another public green space to the north where exhibitions can take place. The building is a landmark, marking the end of the university precinct, with the base material assisting in creating the 'genius loci'.

7

3

FIG 7-3: SITE PLAN

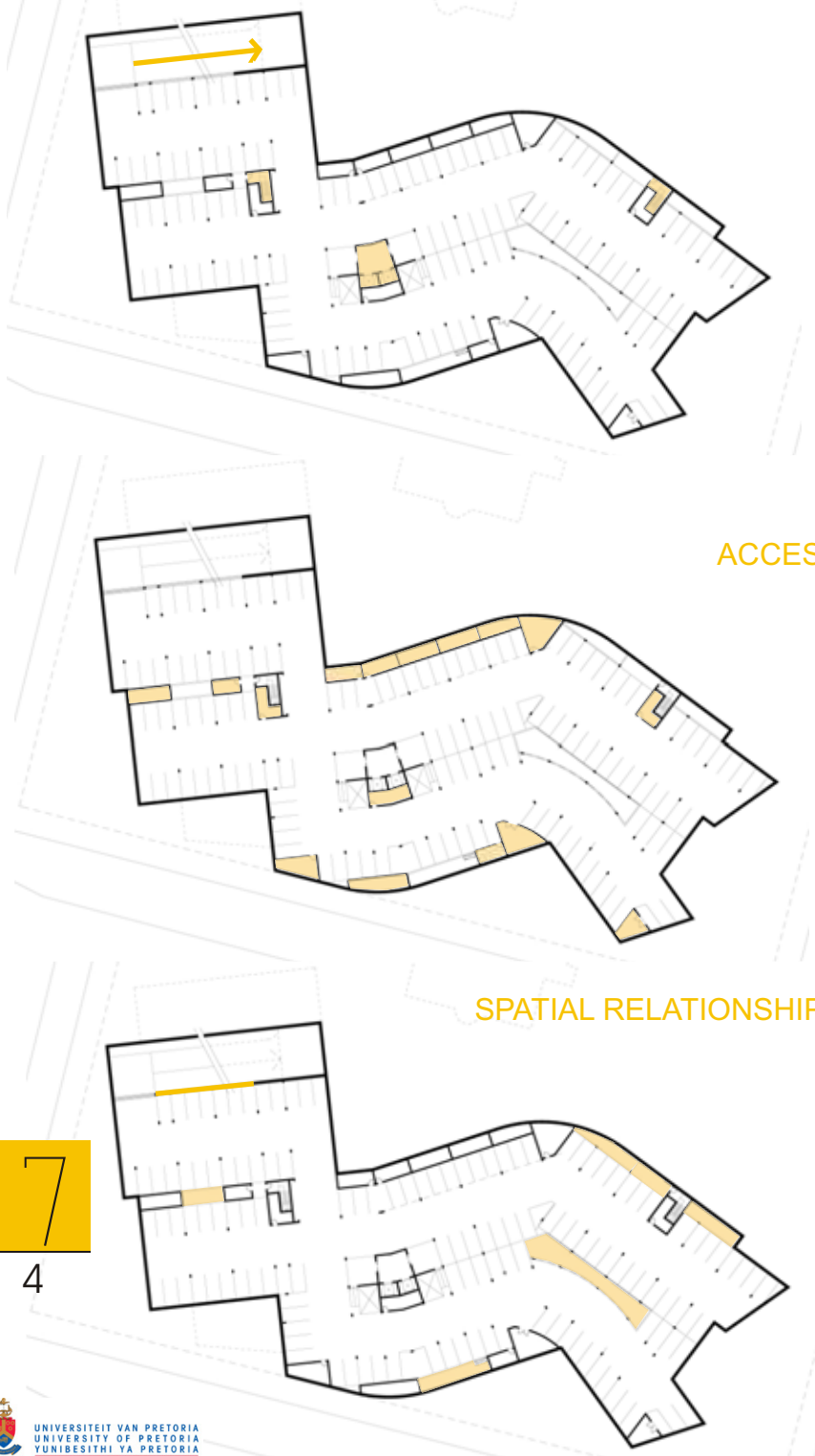

## Access

Vehicular access takes place through a 1:8 ramp. There are two lifts which give access to the rest of the building, which in-turn is accessed through a ventilated lobby. The air in the lobby is filtered through a solar powered air-condition split unit and the space is kept closed by automatic doors. This system is further discussed under the technical investigation and systems. The two fire escape stairs provide escape routes, which lead directly to the outside with no direct connection to the rest of the building above ground.

## SPATIAL RELATIONSHIPS

The basement provides for 131 parking bays including 2 paraplegic parking bays. It provides spaces for store rooms which are rented by the tenants as well as space for rainwater harvesting tanks and their pump rooms. The rainwater systems is discussed under the technical investigation and systems.

## Natural light and ventilation

To the northeast, natural light enters the basement through openings in the slab of the basement above, which in-turn enters through opening grills in the walls. Natural light also enters through grill openings at the ramp. In the middle, light enters through the opening in the slab above from opaque winblocks situated in the slab of the atrium where direct sun will enter.

Plant boxes are situated to the northeast where the sunlight enter as well as in the middle where the atrium provides light. These plant boxes will get enough sunlight and would serve to soften the harshness of the basement. Ventilation occurs through the grill openings at the ramp and also to the top basement through openings in the slab above, which is ventilated to the outside.

## basement -2

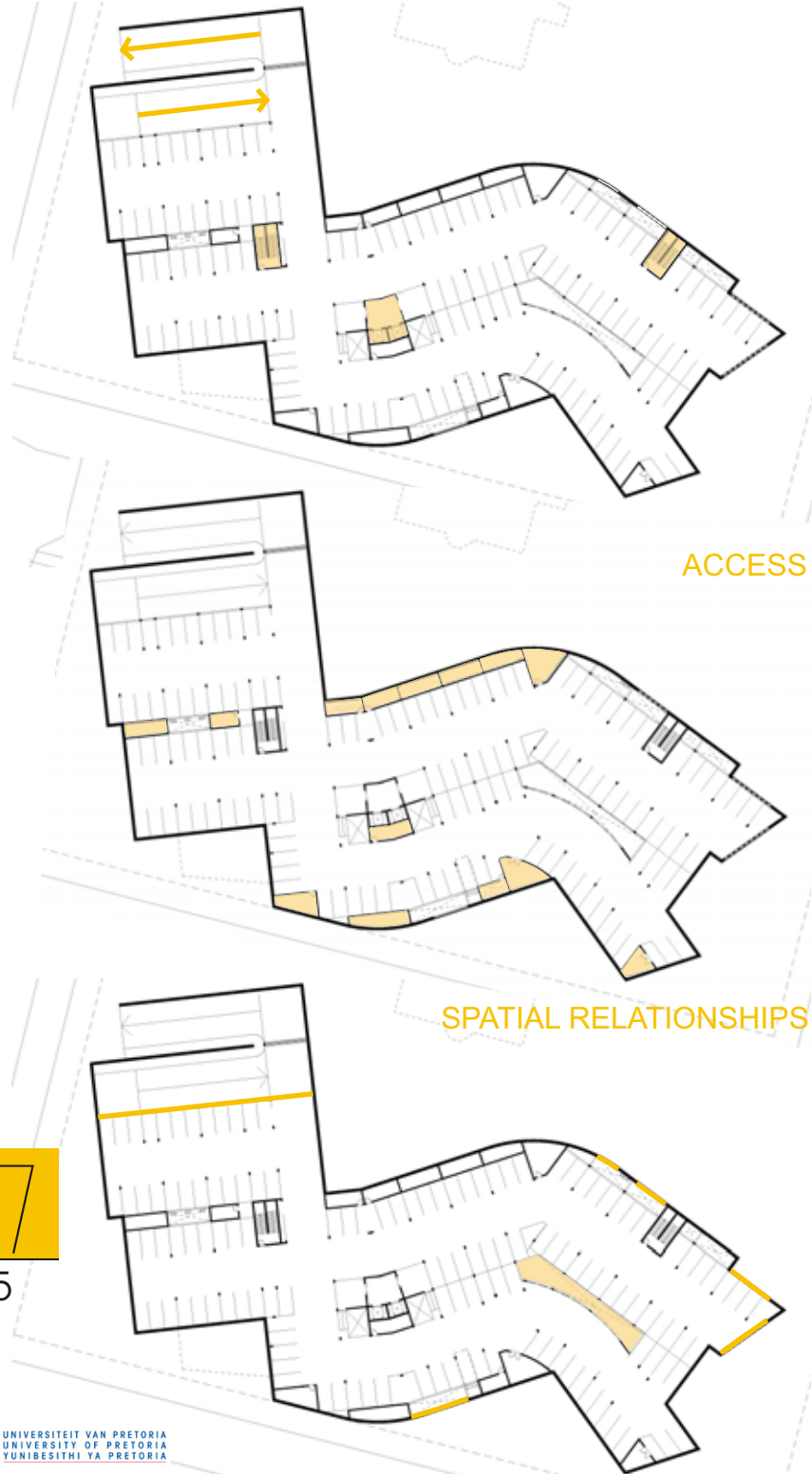

## Access

Vehicular access again takes place through a 1:8 ramp. The lifts are accessed through the ventilated lobby, which give access to the rest of the building. The two fire escape stairs provide escape routes, which lead directly to the outside with no direct connection to the rest of the building above ground.

## SPATIAL RELATIONSHIPS

The basement provides for 131 parking bays including 2 paraplegic parking bays. It provides again spaces for store rooms which are rented by the tenants as well as space for rainwater harvesting tanks and battery rooms for the photovoltaic panels situated on the roof. This system will be discussed in detail under the technical investigation and systems.

## Natural light and ventilation

To the northeast natural light enters the basement through opening grills in the walls and also through openings at the ramp. In the middle, light enters through opaque winblocks situated in the slab of the atrium above where direct sun will enter between March and September.

Ventilation occurs through the openings at the ramp and to the northeast and south through grill openings. Ventilation is enhanced through the use of solar powered fans situated at the northern openings in order to draw cool shaded air from the south and southeast. The system is further discussed under the technical investigation and systems.

## basement -1

7

5

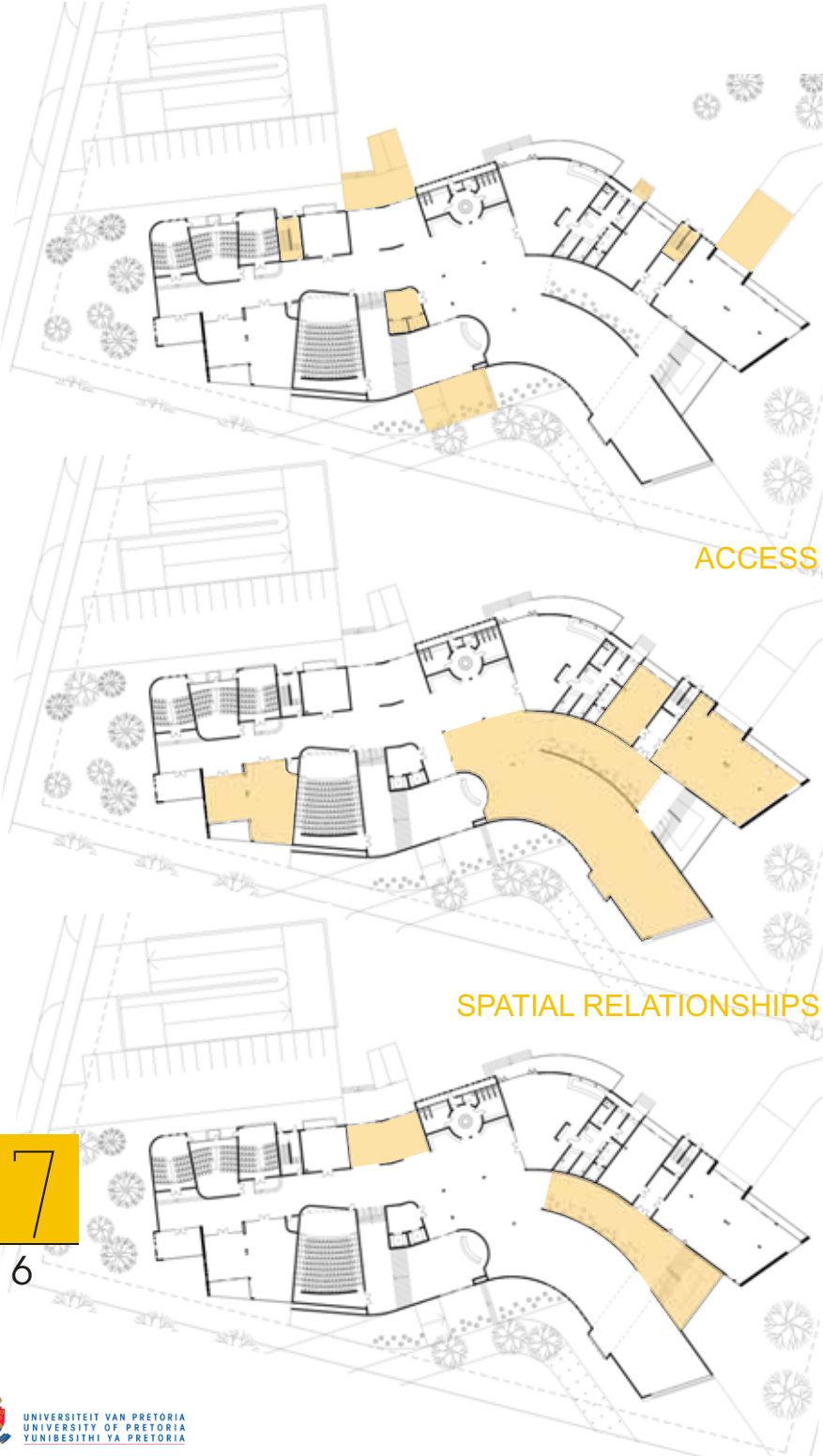

## Access

The main entrance to the building is to the south on Lynnwood Road as the majority of the people will be pedestrians, arriving by public transport. There is a secondary entrance to the north as well. There is a separate entrance to the northeast for the mechanical workshop in order for heavy machinery to have easy access. The restaurant also have a separate entrance for deliveries as well as refuse to be taken out. Access to the floor is also gained through the two lifts and escape provided by the two fire escape staircases.

## SPATIAL RELATIONSHIPS

Indicated is the spaces that are left open and without internal divisions, such as the offices, workshops and the exhibition space. In these areas, spaces and rooms are managed by creative individuals through the use of moveable partitions. There are water and drainage points provided in the offices and workshops, one in the middle of the space to make it a public gathering, and one elsewhere for an alternative. The large exhibition space would be changed and redesigned with each exhibition and is therefore open plan and robust.

## Natural light and ventilation

Natural light enters the building through glass facades and windows and direct sun light is managed through adjustable aluminium louvers and balcony overhangs. Natural light penetrates right through the building through the atriums. Ventilation takes place through adjustable glass louvres or windows. Ventilation for the large lecture hall is intricate and will be discussed under the systems. Indicated is where the atriums are, as the entire building's ventilation is enhanced through the stack ventilation that takes place at the atriums through clerestory adjustable louvers. The ventilation is enhanced through solar powered fans but is discussed in more detail under the systems.

## ground floor



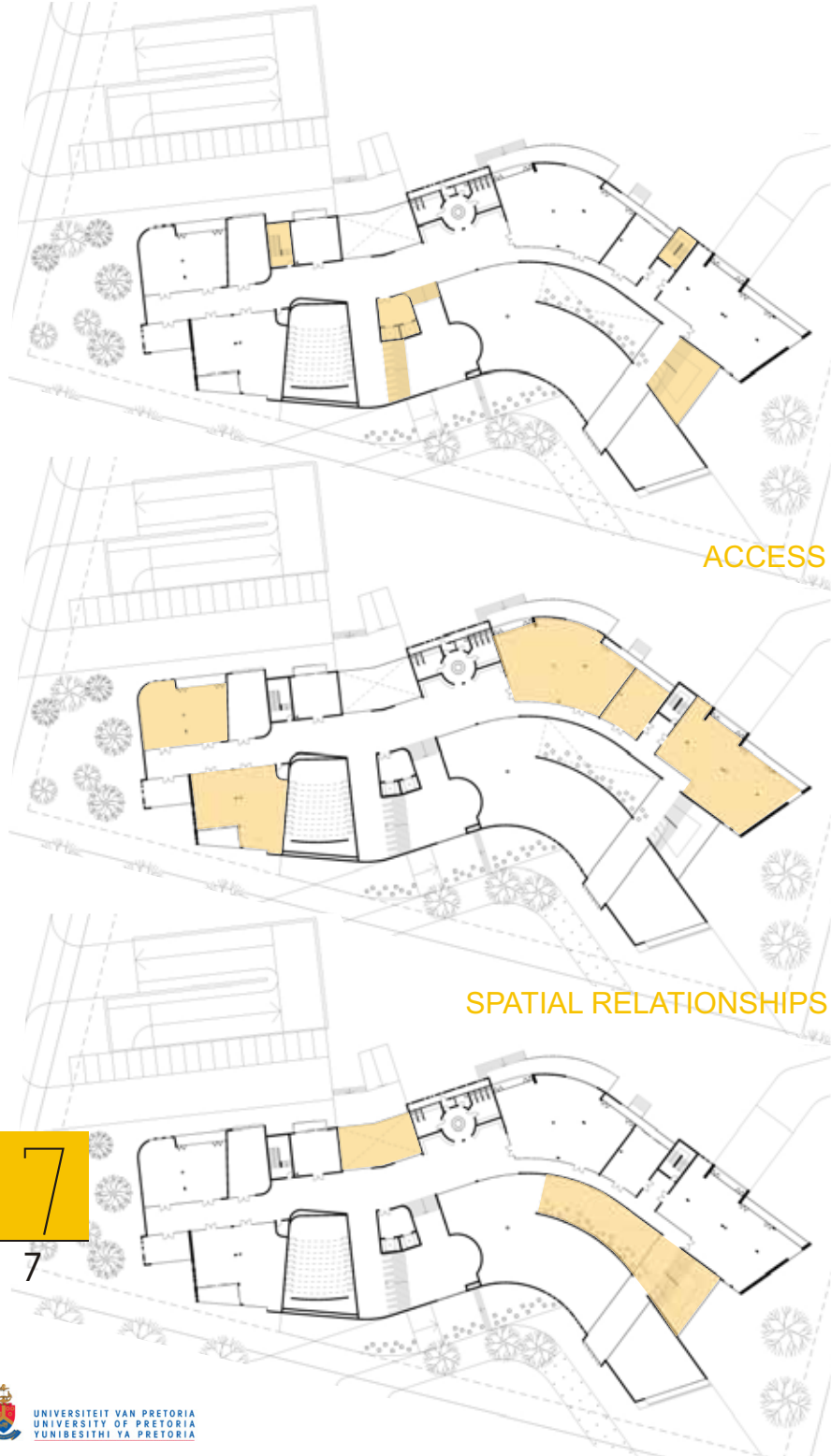

## Access

The main access to the floor is gained through the central mezzanine stair which encircles the lift core. Another important access is gained from the exhibition space below through a staircase which also serve to be part of the exhibition space. The two lifts are again present for easy access as well as for disabled persons. The two fire escapes provide the escape routes.

## SPATIAL RELATIONSHIPS

The exhibition space becomes a double volume for the other spaces to look upon the exhibition. The double volume give the exhibition space a high volume to create the ambiance fit for an exhibition space. Through the double volume other spaces can be part of the exhibition in order to inspire and motivate. Indicated again is the offices, workshops and labs which are without internal divisions, to be managed by the creative individuals themselves through the use of moveable partitions. The water and drainage points are again provided in these offices and workshops, one in the middle of the space to make it a public gathering, and one elsewhere for an alternative position.

## Natural light and ventilation

Again natural light enters the building through glass facades and windows and direct sun light is managed through adjustable aluminium louvers and balcony overhangs. The atriums are indicated again where the natural light penetrates right through the building and where ventilation is enhanced through the use of solar powered fans situated at the clerestory glass louvers.

## first floor

7  
7

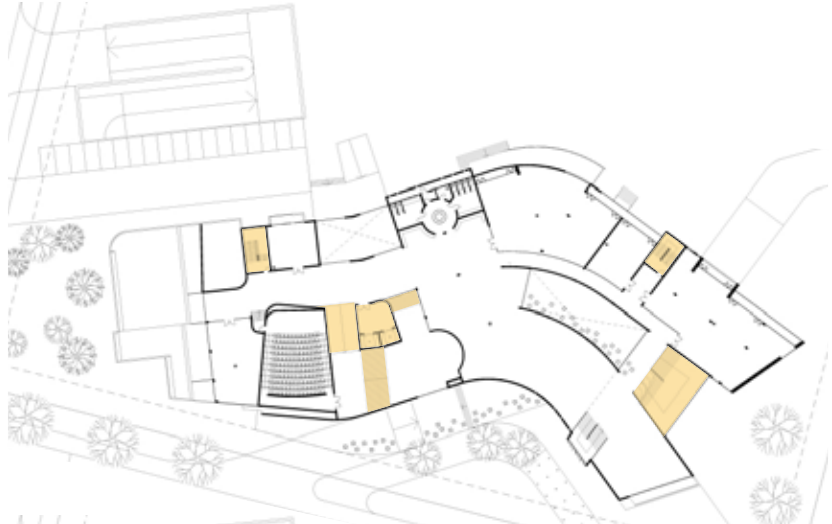

ACCESS

## Access

Again the main access to the floor is gained through the central mezzanine stair which encircles the lift core and includes a ramp in order for disabled persons to get access to the exhibition space. Another access is again the staircase to the east which is part of the exhibition space. The two lifts are again present for easy access as well as for disabled persons. The two fire escapes provide the escape routes.

## SPATIAL RELATIONSHIPS

Again indicated is the offices, studios and labs which are without internal divisions, to be managed by the creative individuals themselves through the use of moveable partitions. The water and drainage points are also provided in these offices and workshops.

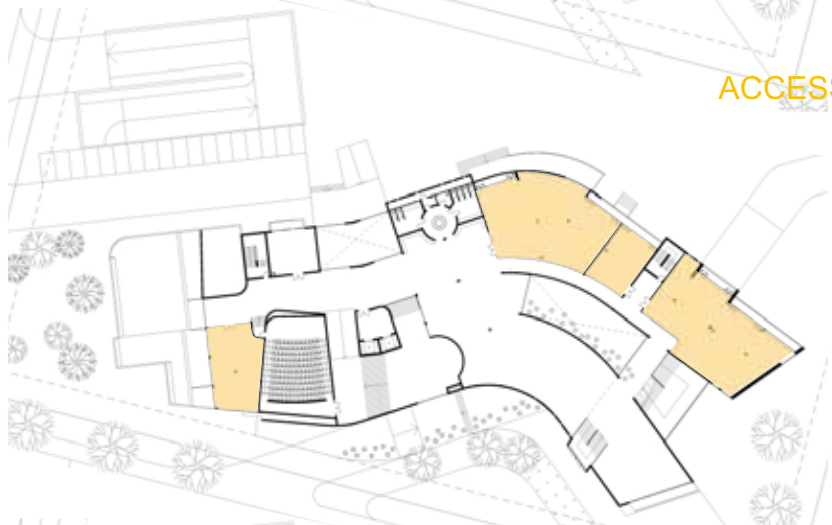

SPATIAL RELATIONSHIPS

## Natural light and ventilation

Again natural light enters the building through glass facades and windows and direct sun light is managed through adjustable aluminium louvers and balcony overhangs. The atriums are indicated where the natural light penetrates right through the building and where ventilation is enhanced through the use of solar powered fans situated at the clerestory glass louvers.

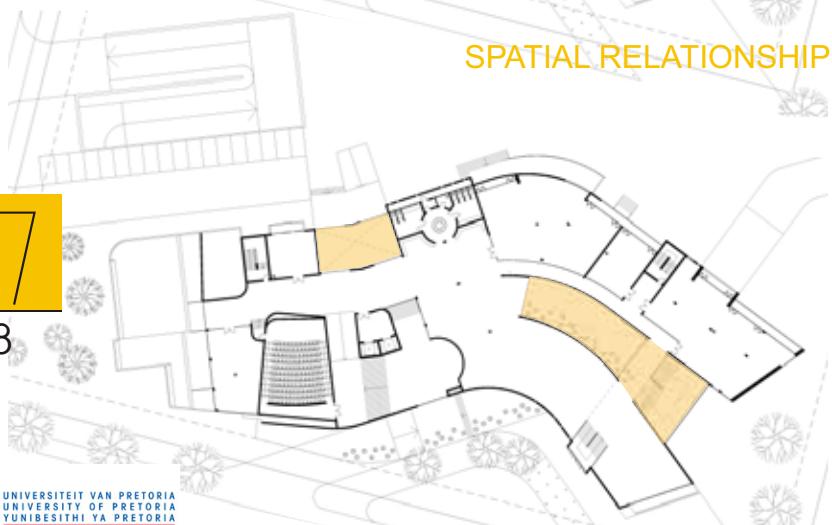

## second floor

7

8

E  
S  
I  
N  
O  
U  
S  
I  
D  
U  
D  
I  
S  
E  
P

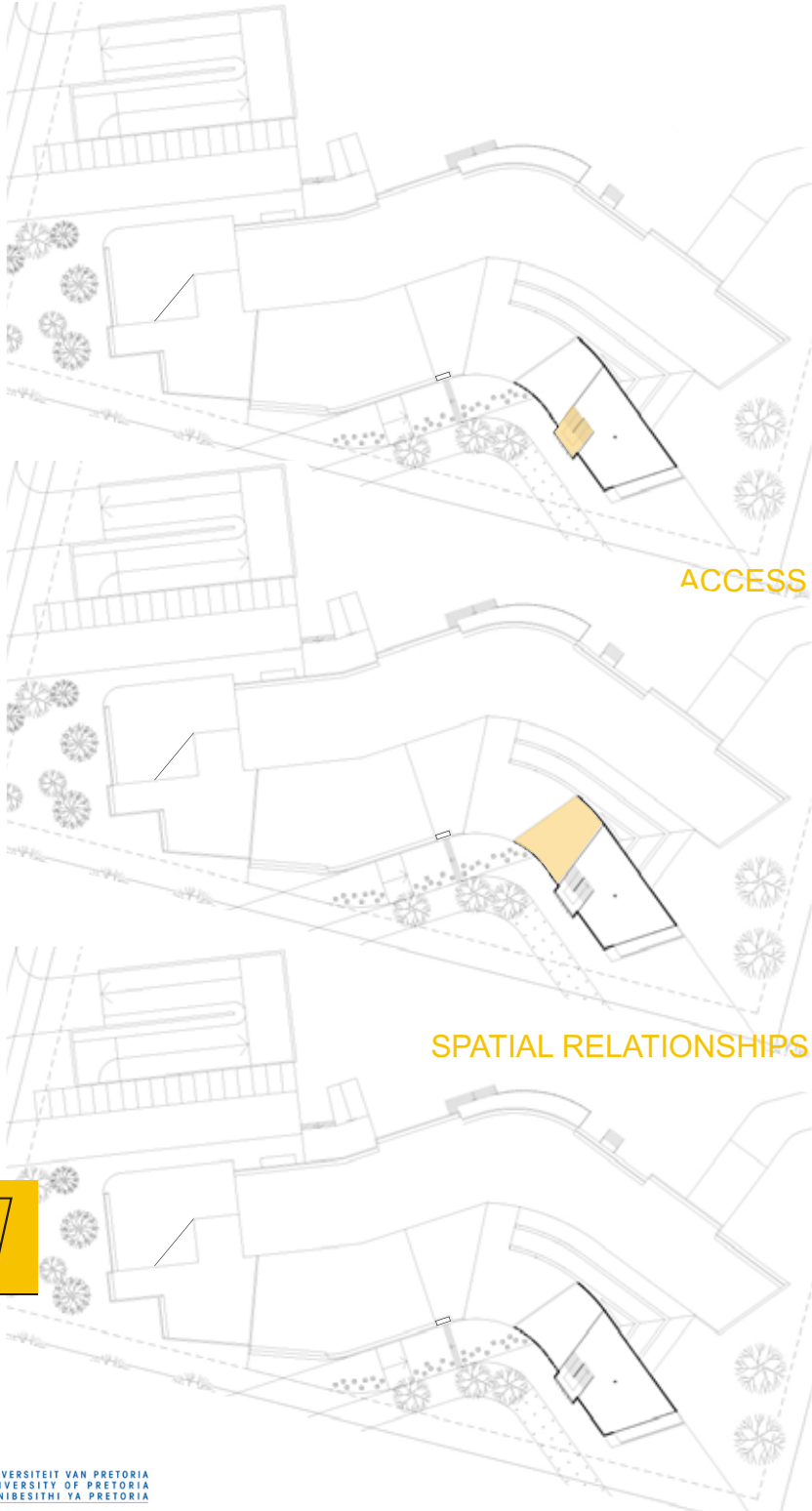

### Access

The studio space is accessed through a staircase situated in the exhibition space below. The wide enough to form part of the exhibition space in order to decrease the transitional space between the two spaces.

### SPATIAL RELATIONSHIPS

This is the studio is for the fine arts and photography individuals. The internal divisions are managed by the creative individuals themselves through the use of moveable partitions and water and drainage points are provided. Indicated is the double volume where the studio will look upon the exhibition space in order to make it part of the exhibition innovative atmosphere, which would inspire the individuals.

### Natural light and ventilation

Natural light enters the studio through the glass facade to the southeast. There are windows which open to provide the adequate ventilation for the space.

## third floor

7  
9



basement -2

7

10

FIG 7-4: BASEMENT -2

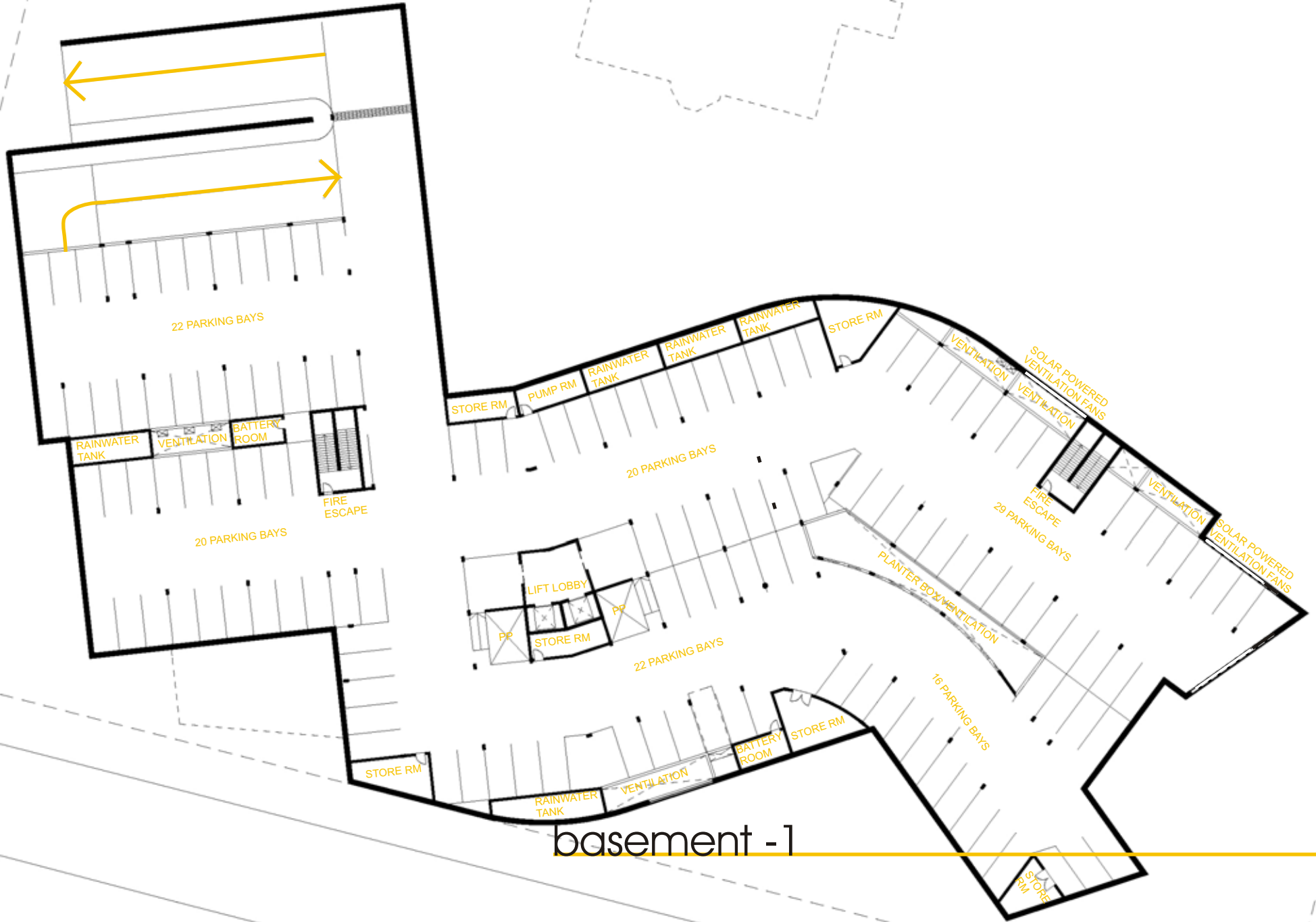

basement -1

7

11

FIG 7-5: BASEMENT -1

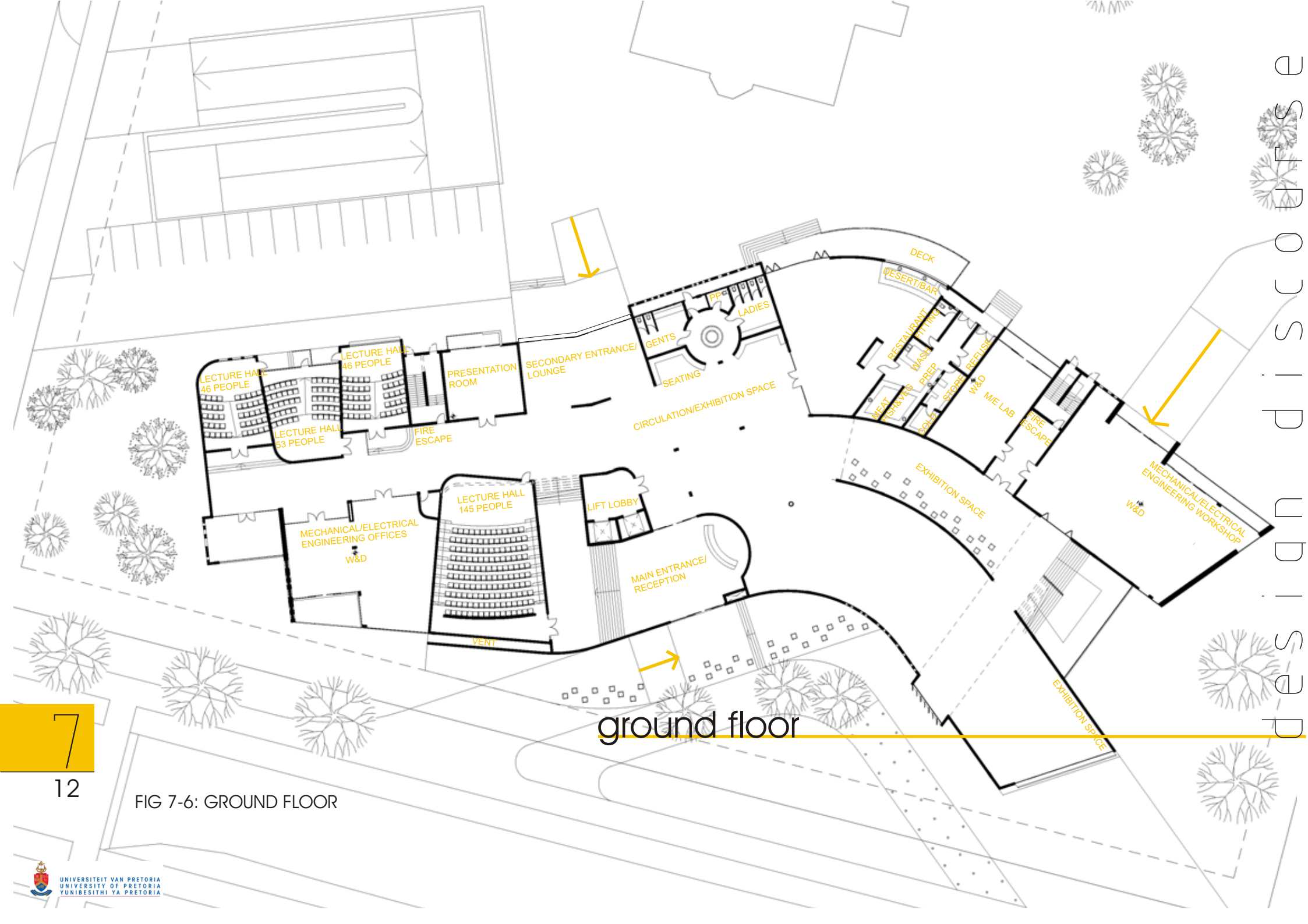

7

12

FIG 7-6: GROUND FLOOR

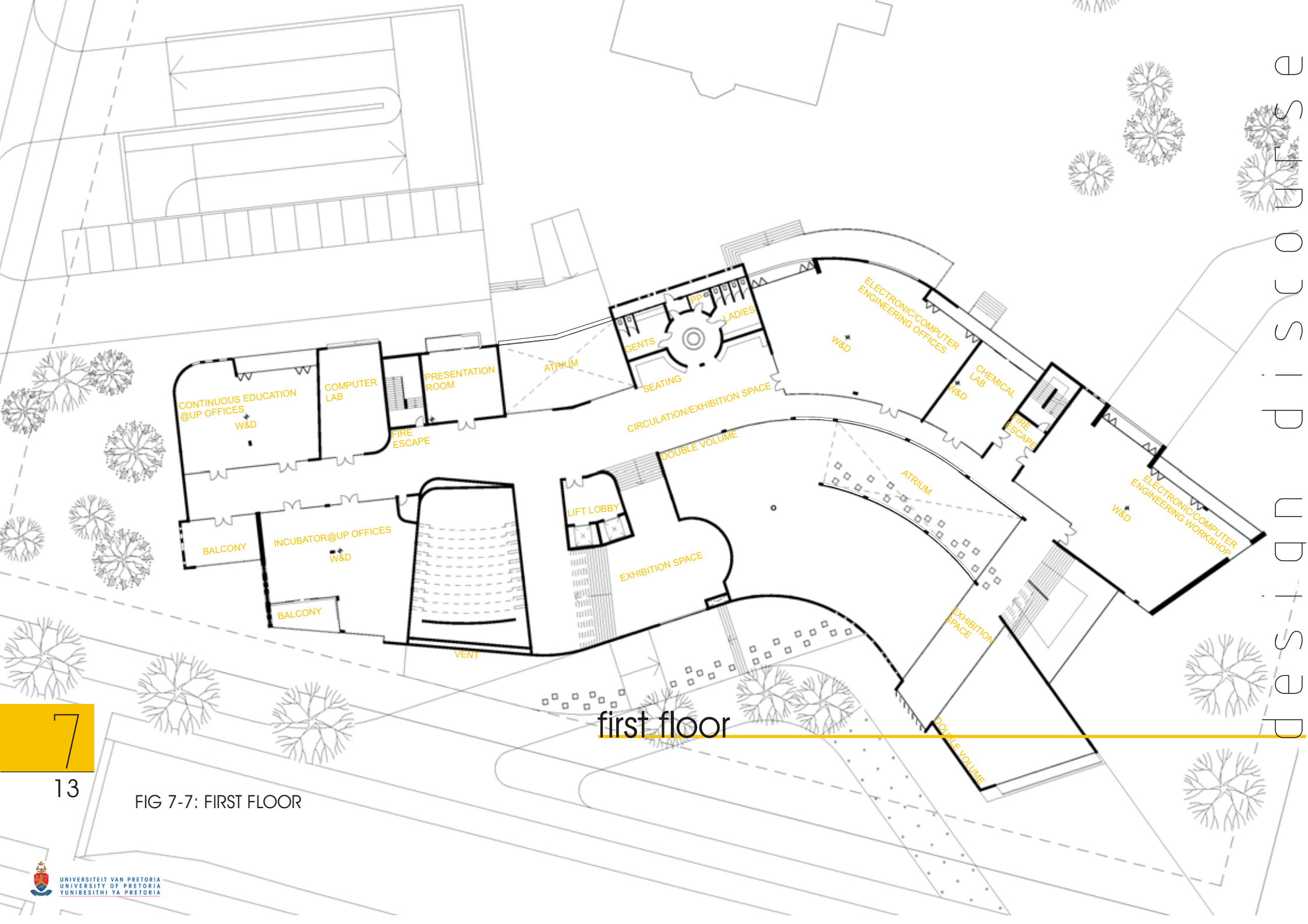

first floor

7

13

FIG 7-7: FIRST FLOOR

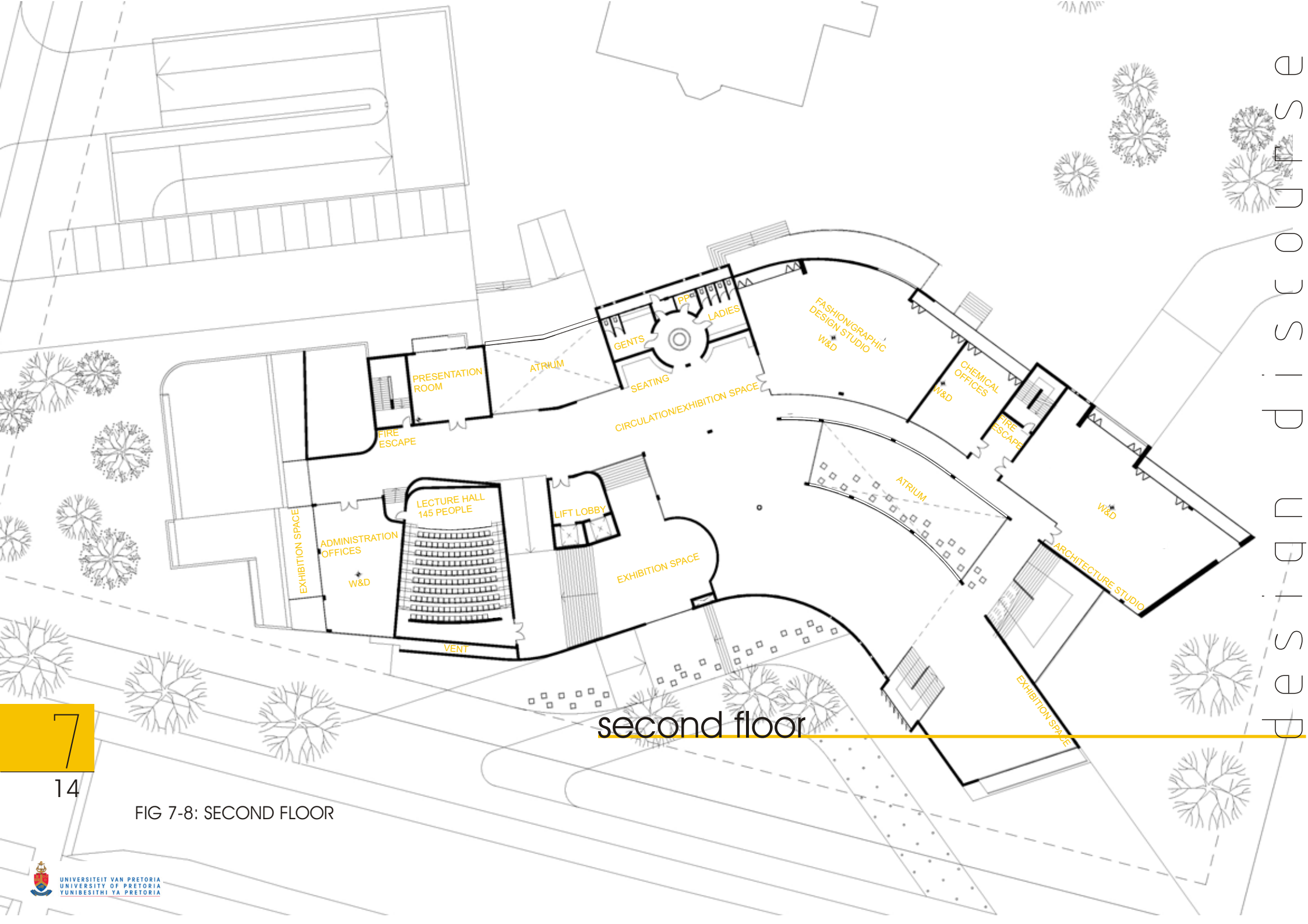

second floor

7

14

FIG 7-8: SECOND FLOOR



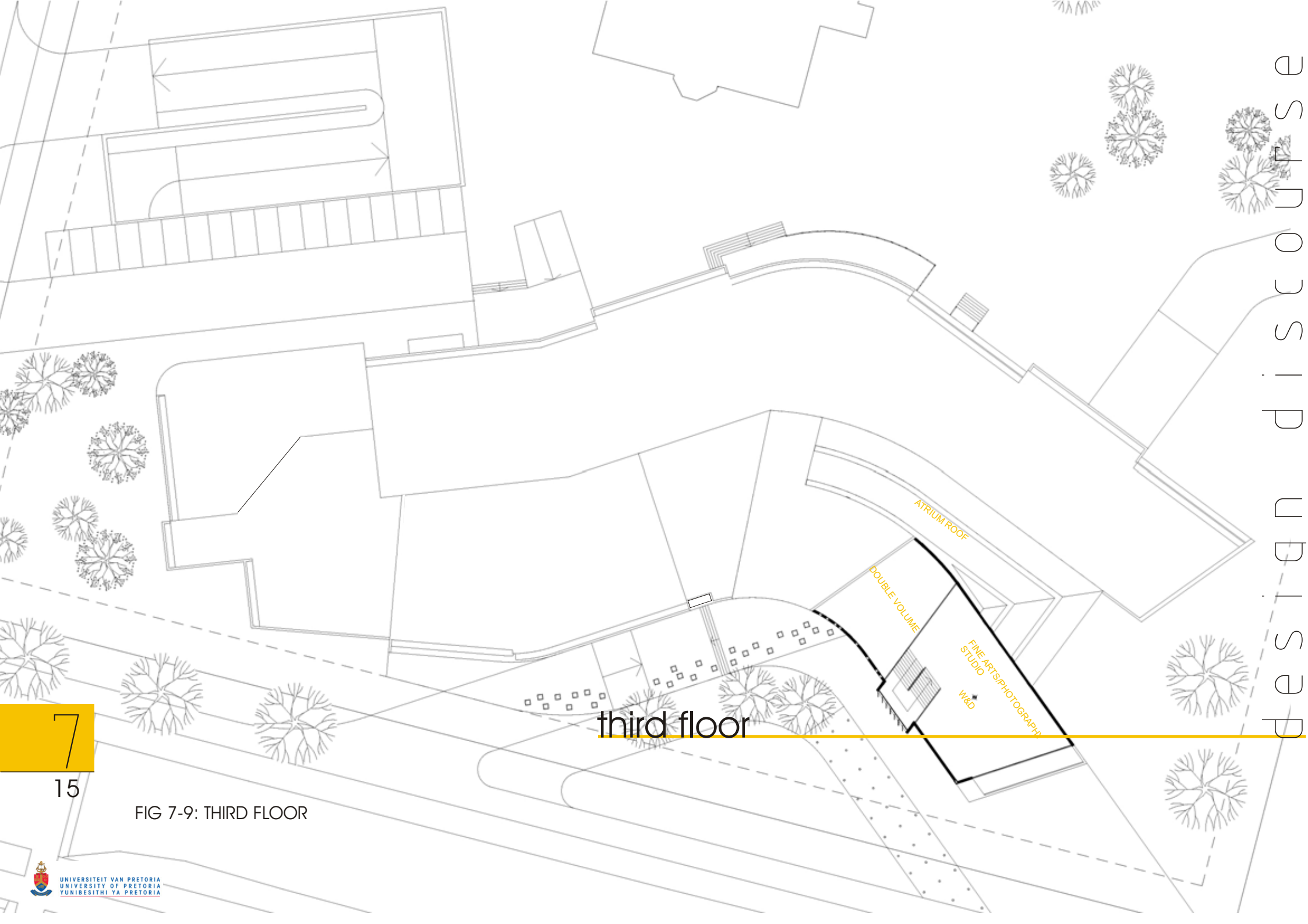

third floor

FIG 7-9: THIRD FLOOR



site plan

7

16

FIG 7-10: SITE PLAN



DESIGN DISCUSSION

7

17

## eastern perspective

The Glaskas and the Bristow Hall is indicated as well as where the basement entrance is. The green space to the north of the building should not just be used for recreational purposes but should also be an open-air exhibition space. The ramp of the mechanical workshop can be seen as well as the road leading to it, which would also be used for the deliveries of the restaurant. The clerestory glass louvers of the atrium where stack ventilation takes place and where natural light penetrate through can be seen. The public green space to the east serves to be the threshold between the church and the incubator



E  
S  
J  
N  
O  
S  
I  
P  
U  
N  
D  
S  
E  
P

7

18

## narrative

The facade speak of a narrative, where the entrepreneur enter the incubator with a concept but must still develop it. He/she also doesn't have a business plan or business management skills in order to make the concept work. Therefore the idea is still fragmented and unresolved. As the entrepreneur moves through the incubation program the idea is formalized and the concept starts getting tangible. Passing through the entire incubator process the concept starts to become a viable commercial product, in order to in the end, produce the final product.

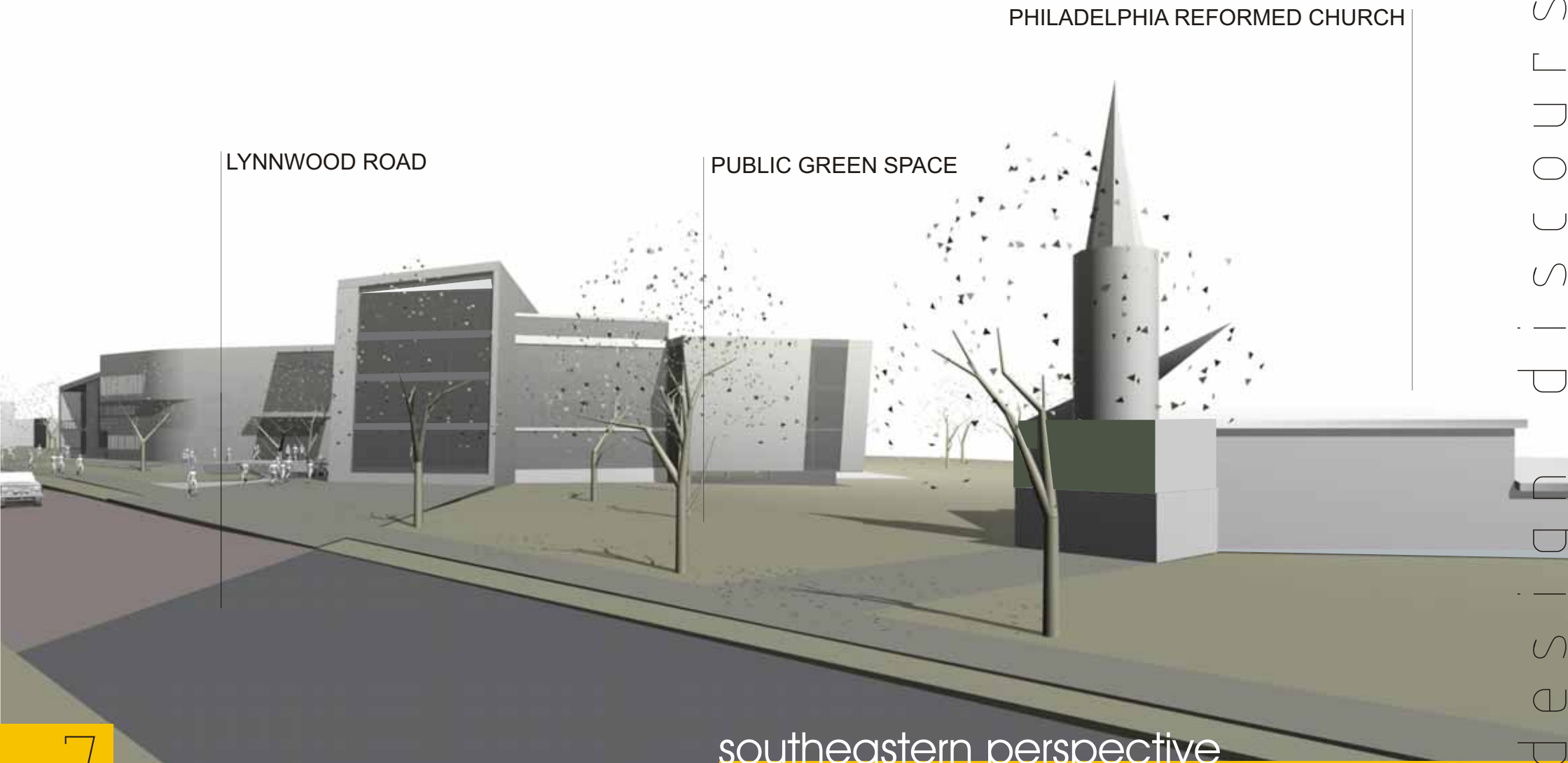

E S J N O U S I P U D I S E P

7

19

## southeastern perspective

The building contrasts the church through its curvilinear lines and flowing forms, which emphasize the traditional church design in order to give the church more prominent stature. The public green space serves to be the threshold between the incubator and the church in order to respect the presence of the church. The base material is changed as indicated, which draw the attention to the building and serves to indicate the university precinct. This southeastern facade of the building is all about displaying the innovations developed by University of Pretoria graduates.

FIG 7-14: 3D MODEL OF BUILDING

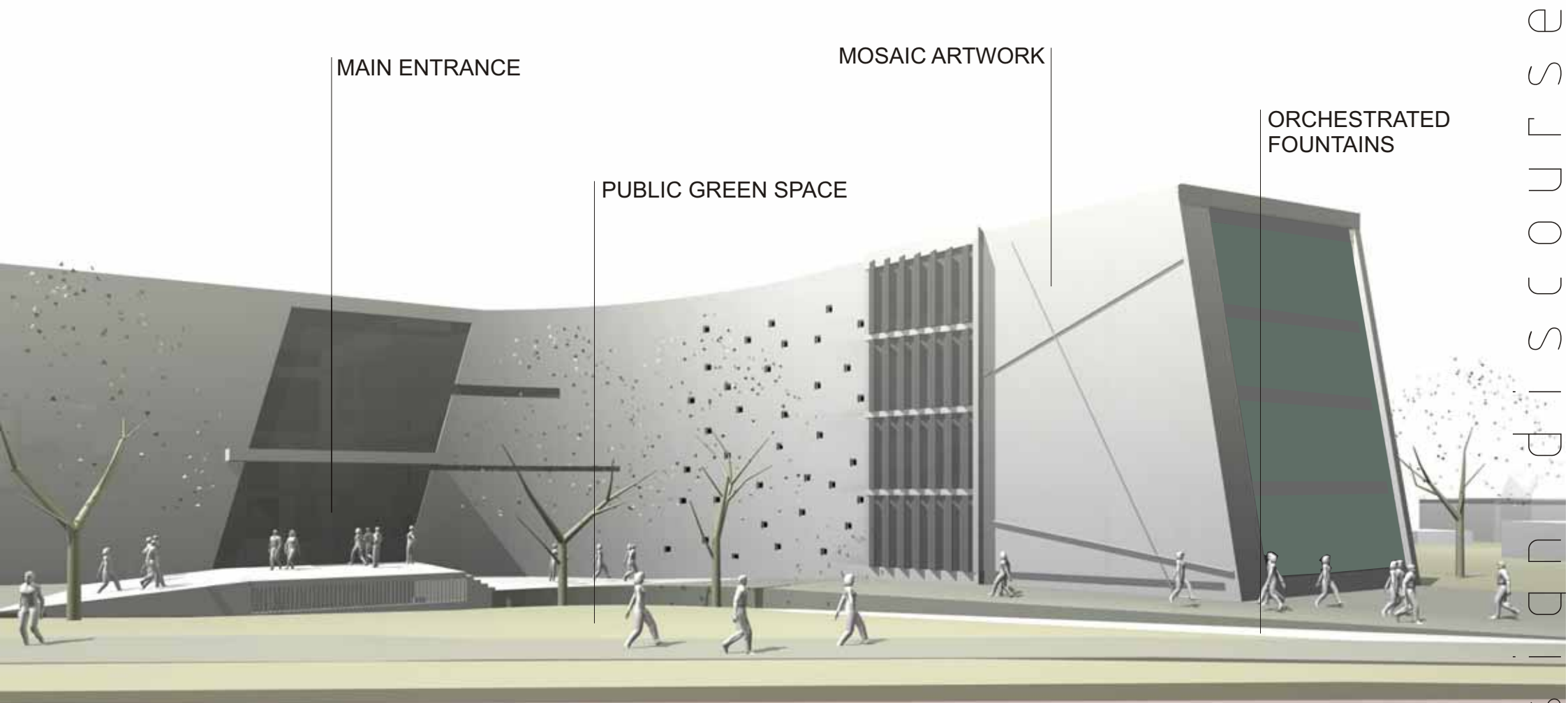

DESIGN GUIDELINES

## southern perspective

The mosaic artwork on the wall concludes the concept of guiding an innovative thought which represents the final product. This artwork is changed over a period of time which illustrates innovativeness. The main entrance is covered and emphasized through the large butt-jointed glass panel. The louvers are for protection against the western sun. The shape of the building draws people into the site towards the entrance and creates a public green space in front of the building with orchestrated fountains which serve to create an innovative atmosphere.



DESIGN GUIDELINES

7

21

### eastern perspective

The glass facade of the atrium faces southeast which eliminates direct northern sun, keeping the building cool. The glass strip on the side of the building is the same width of the church tower in order to acknowledge the church. To the north the correct overhangs are used to let sun in only between March and September.



PUBLIC GREEN SPACE

CORRECT OVERHANGS

## northern perspective

The restaurant spills out onto a deck which overlooks the green area. The kitchen of the restaurant serve to provide for catering events as well. The green space, used for recreation and an open-air exhibition space, is also utilized as a catering space for events. The sun is controlled through the correct balcony and roof overhangs.





## northern perspective

The toilet windows and drain pipes are hidden behind a screen wall which is ventilated to the outside through openings. The screen wall is decorated with mosaic artwork which can be changed over a period of time to emphasize the idea of innovation. Natural anodized aluminium louvers are used at for the atrium above the secondary entrance/lounge in order to achieve the correct protrusion for sun control.



## northern perspective

The bottom louvers at the left lecture hall are closely spaced in front of a glass facade, for sun control purposes as well as to be able to close it completely for presentation purposes. The middle lecture hall has a glass facade at the back with the correct balcony overhang covering it. Blinds to the inside of the lecture hall is used to control the amount of natural light. The lecture hall to the right as well as the space at the top have windows which has adjustable aluminium louvers to the outside to control direct sun light. The louvers can be closed completely in order to eliminate natural light.

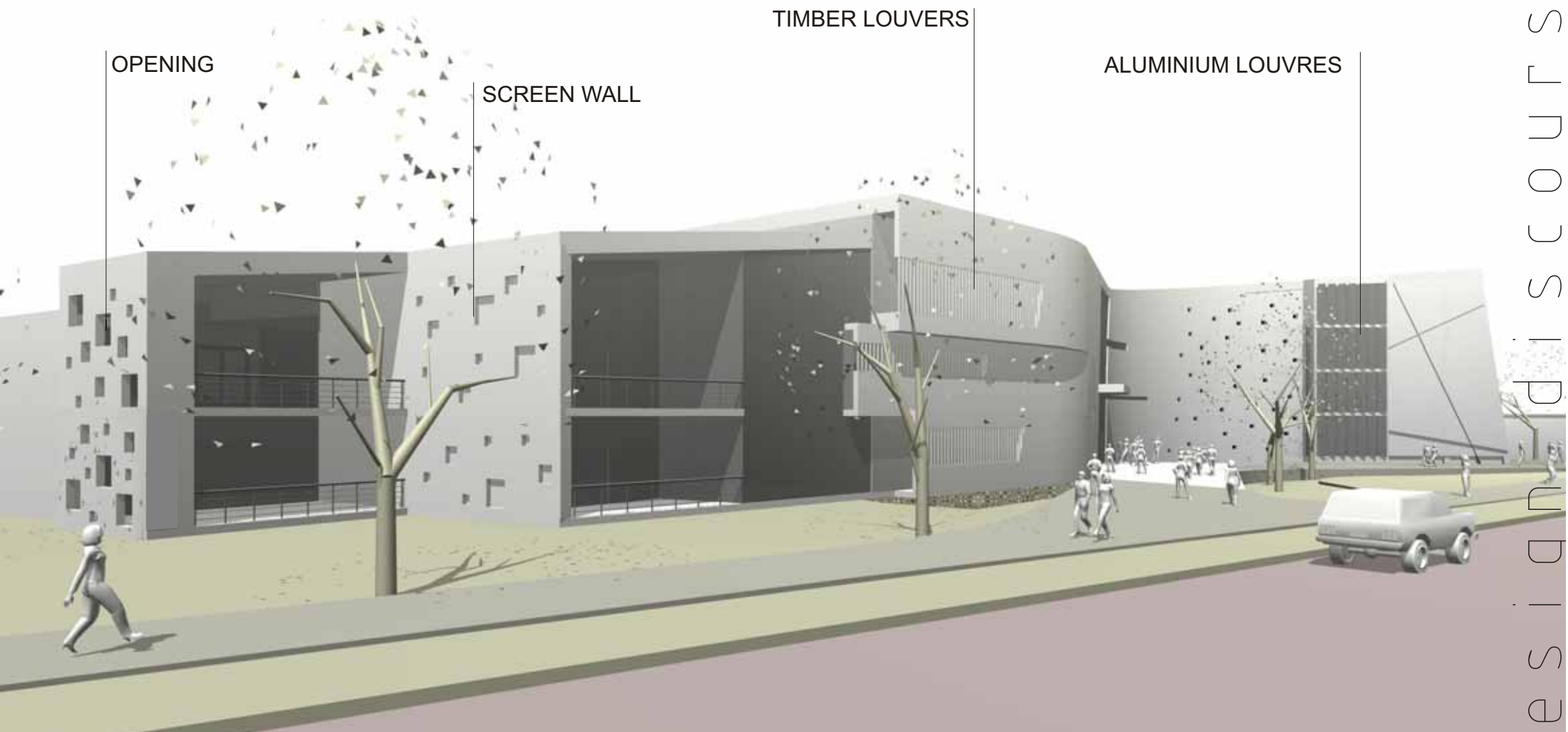

DESIGN DISCIPLINES

7

25

## southwestern perspective

The southwestern facade represents the fragmented beginning when starting at the incubator. The sun that penetrates the openings to the west will fall on the next wall and would not enter the building. The western sun is screened from entering the building through solid walls or aluminium vertical louvers. The timber louvers provide ventilation to the two large lecture halls. Air will flow from the cool southern side of the building into a shaded vent, from there it flows over a rock bed to be cooled further and be utilized. This system is illustrated under the systems.

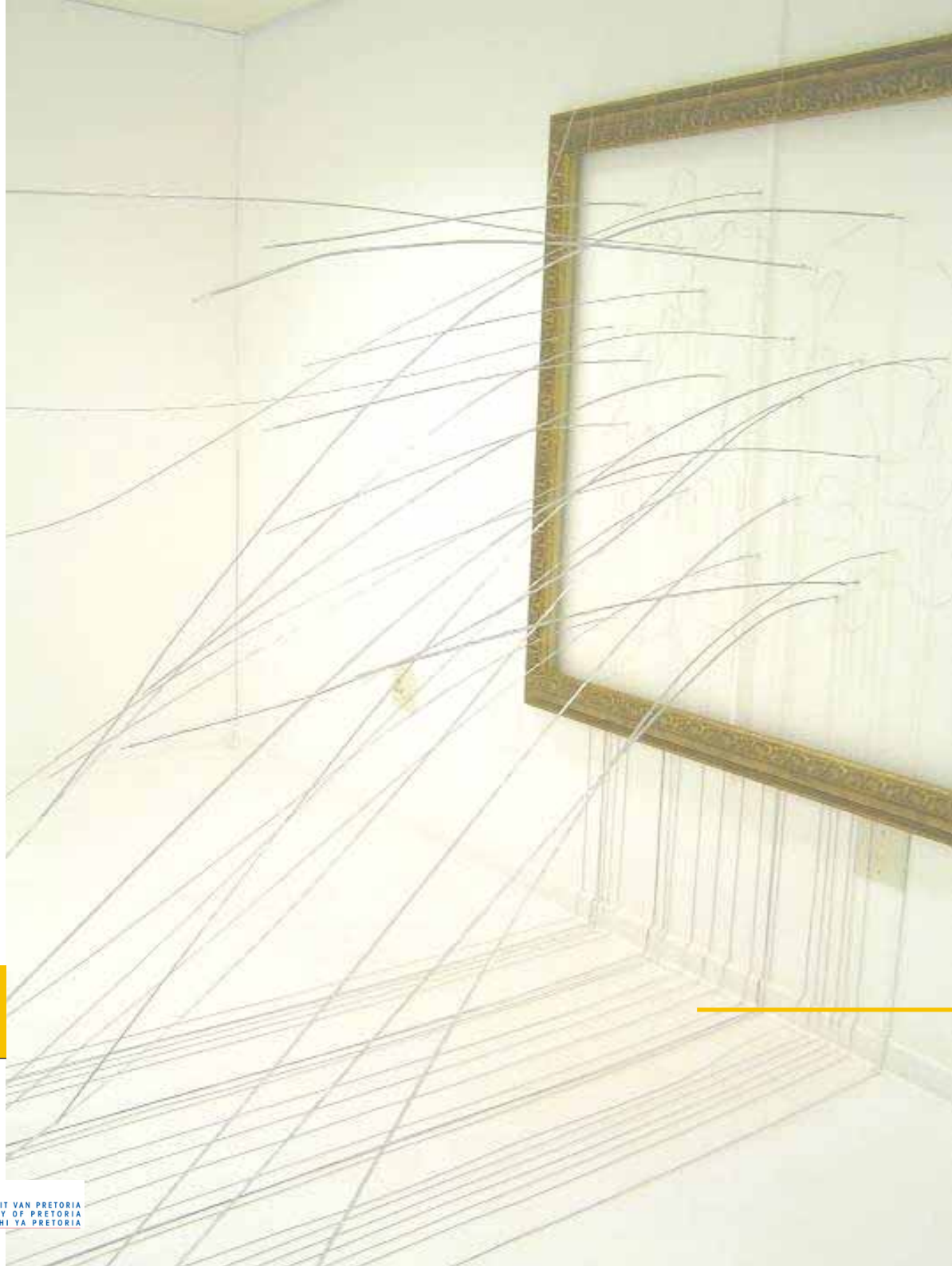

FIG 8-1: JENNA BURCHELL/UNIVERSITY OF PRETORIA

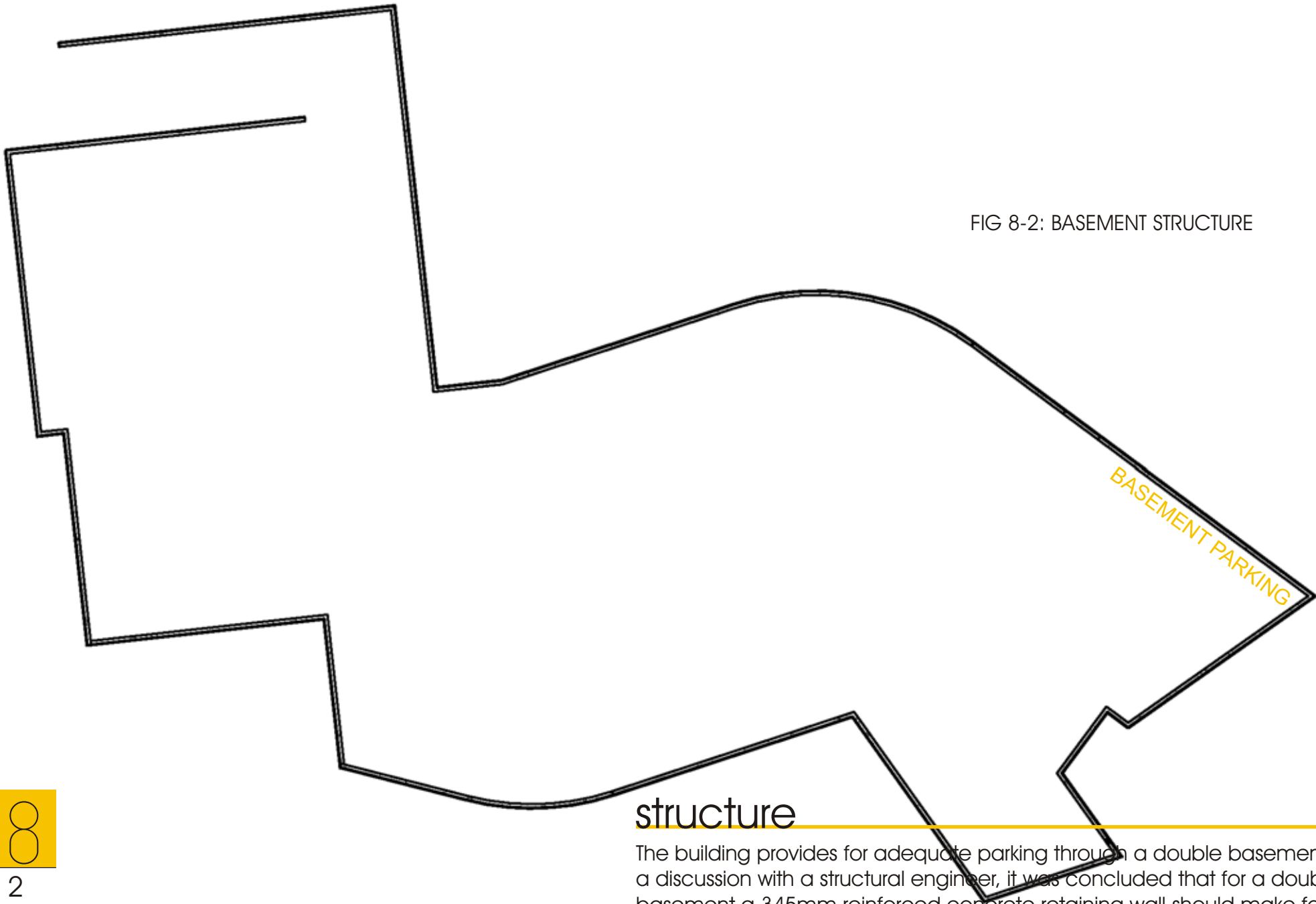
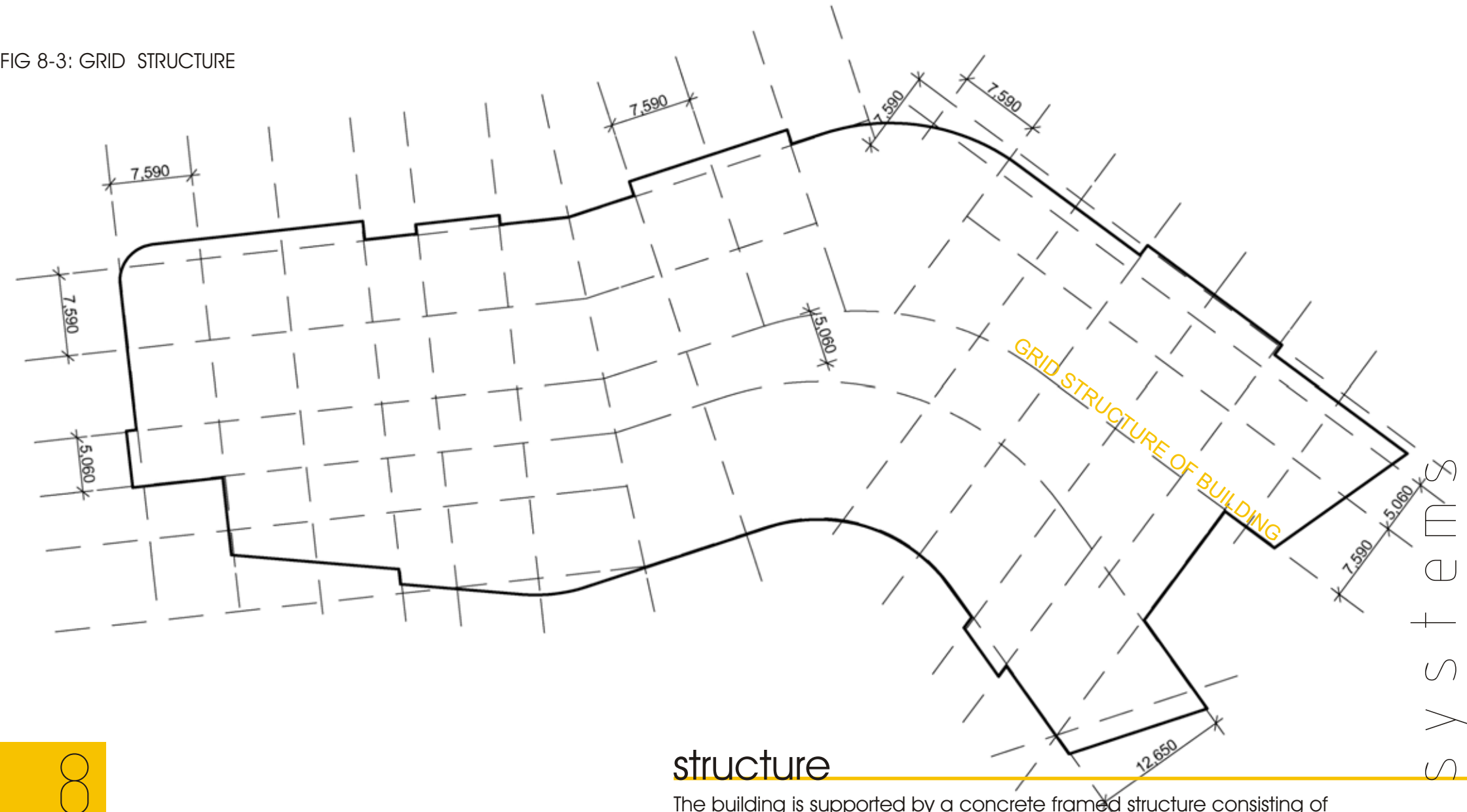

FIG 8-2: BASEMENT STRUCTURE

## structure

The building provides for adequate parking through a double basement. After a discussion with a structural engineer, it was concluded that for a double basement a 345mm reinforced concrete retaining wall should make for a sound structure. The structural engineer specified a 340 x 1500 reinforced concrete footing for such a retaining wall. The basement surface bed can be 85mm thick provided that the concrete has a strength of 45MPa.

FIG 8-3: GRID STRUCTURE



S  
Y  
S  
T  
E  
M  
S

## structure

The building is supported by a concrete framed structure consisting of reinforced concrete columns, beams and slabs. The position where concrete columns would be placed is determined by the grid structure, meaning where the gridlines intersect. The concrete beams would therefore also be situated on the gridlines in order to be supported by the columns. The gridline spacing is determined by optimum concrete beam spans as well as to suite parking bays which should therefore fit within increments of 2530mm. Therefore the grid structure is 5060mm, 7590mm and 12 650mm according to brick scale.



FIG 8-4: COLUMNS

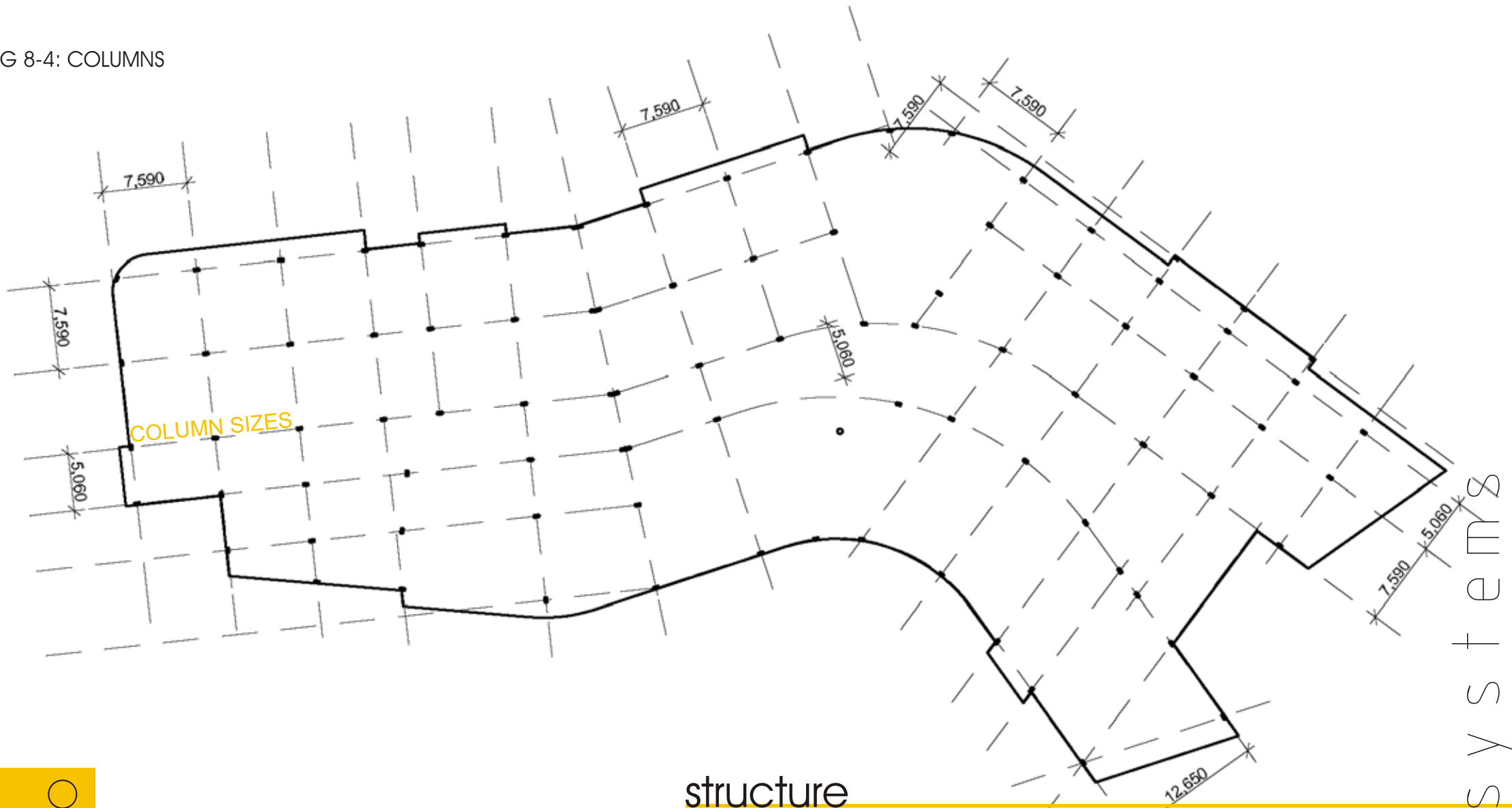

## structure

The concrete columns, which would make part of the concrete framework, is a 230 x 460 reinforced concrete column, which shall be according to the structural engineer's design and specification.



FIG 8-5: SPANNING ELEMENTS



## structure

There are three types of structural elements that span between the column supports, namely reinforced concrete- slabs, beams and coffer slabs. The beams span between columns, the slabs span between beams and the coffer slab is a combination of beams and slabs. The slab is a 255mm reinforced concrete slab, the 230 x 510 reinforced concrete beams span upto 7 590mm and the 230 x 680 reinforced concrete beam upto 12 650mm. The coffer slab is used where there are limited supports for spatial reasons and span upto 13 000mm. All members are to structural engineer's design and specification.



FIG 8-6: SECTION THROUGH STRUCTURE

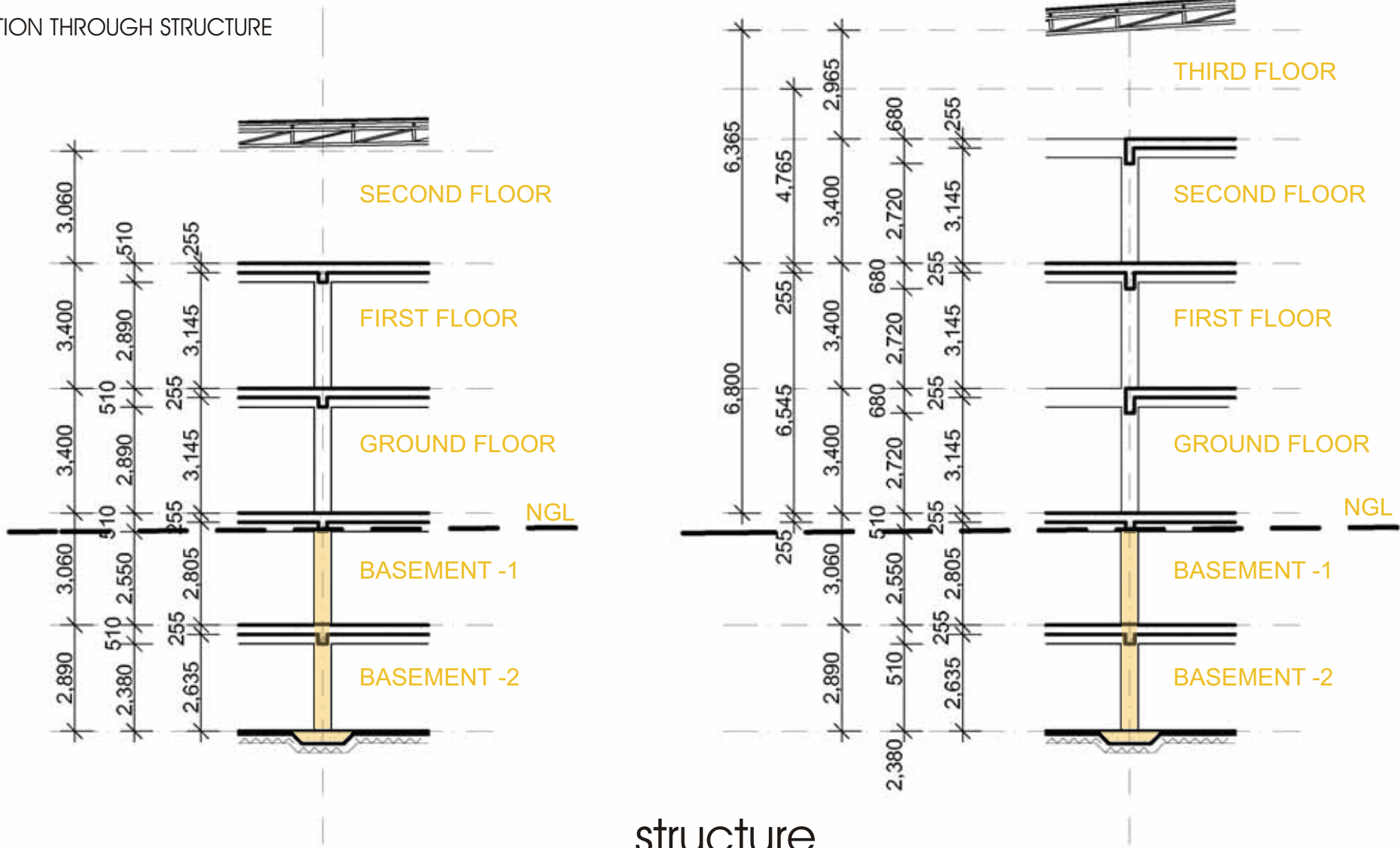

## structure

It is a four storey building with two basement parking levels with floor-to-floor dimensions as indicated. The foundation system for a four storey building usually consist out of piles in order to reach the adequate soil bearing capacity. However, through the two basements adequate stable soil will be reached, which allows the columns of the basement to act as piles. The foundations is therefore a 1140 x 910 x 340 reinforced concrete pad foundations to structural engineer's design and specification. It shall be level with the surfacebed for ease of the tanking membrane and provided with expansion joints around it.



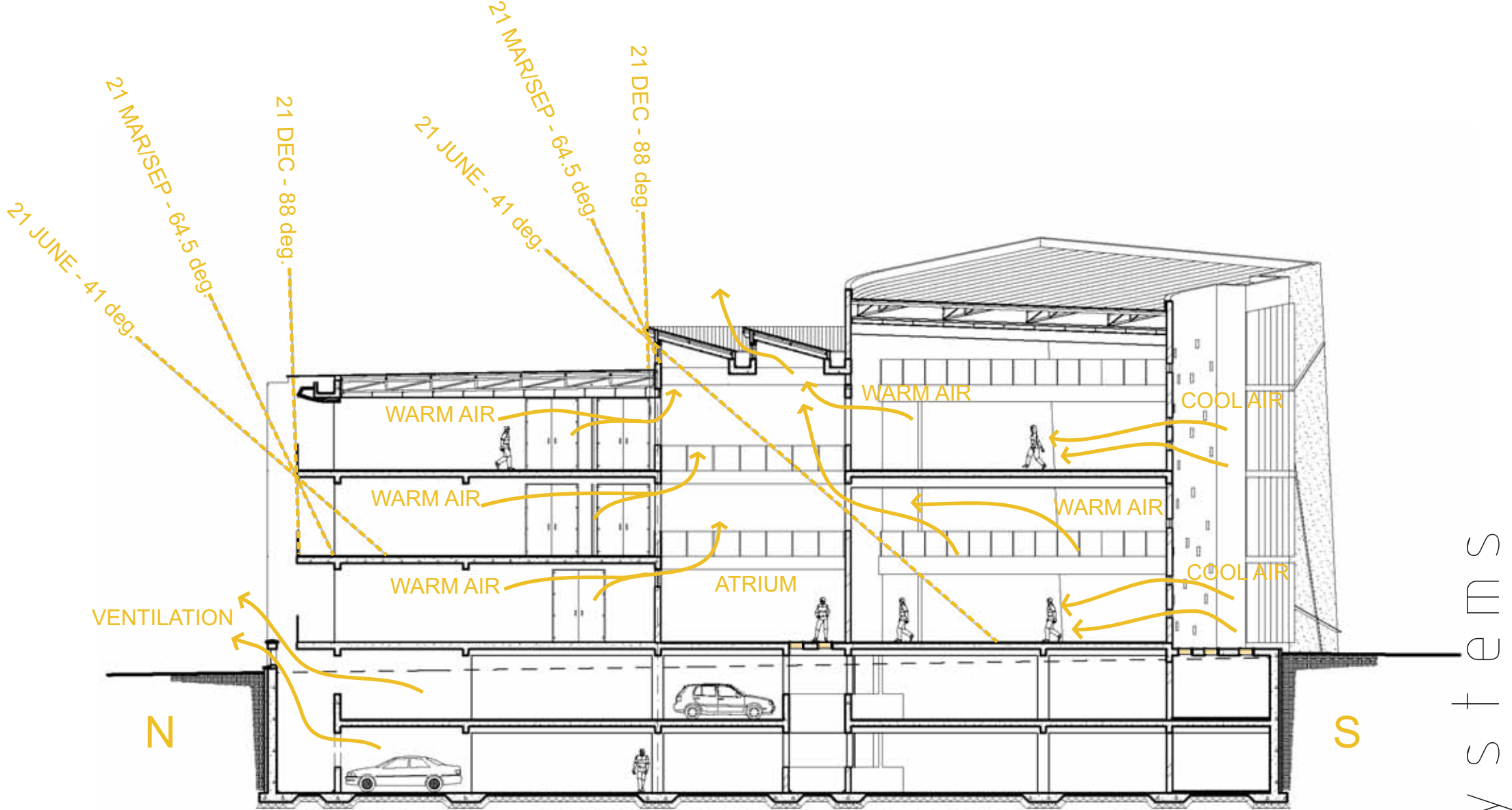

FIG 8-7: SECTION A-A

## passive cooling

Through the use of balcony overhangs and roof overhangs, allow the sun to only enter the building between 21 March-21 September. The atrium provides for stack ventilation as well as cross ventilation to take place through adjustable glass clerestory louvers. Cool air is drawn in from the southern side and stack ventilation is enhanced through solar powered fans situated at the clerestory louvers. Natural light is allowed into the basement through opaque windows in floor slabs. The basement is ventilated through openings and grills which is enhanced through the use of solar powered fans.

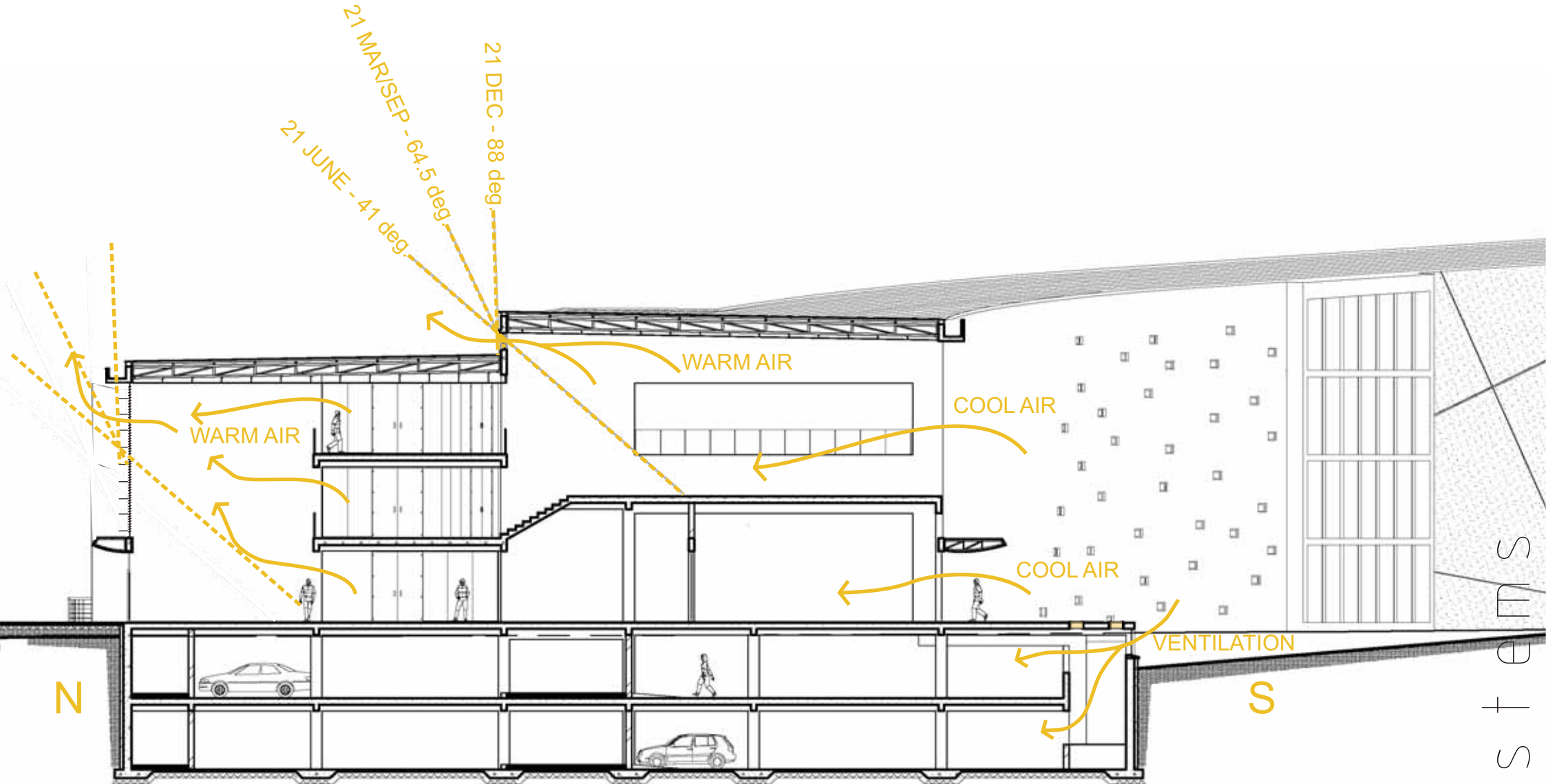

FIG 8-8: SECTION B-B

## passive cooling

Through the use of aluminium louvers, allow the sun to only enter the building between 21 March-21 September. The atrium provides for stack ventilation as well as cross ventilation to take place through adjustable glass louvers. Cool air is drawn in from the southern side and stack ventilation is enhanced through solar powered fans situated at the clerestory louvers. Natural light is allowed into the basement through opaque windows in floor slabs. The basement is ventilated through opening grills, which is enhanced through the use of solar powered fans to the north, in order to draw cool air in from the south.

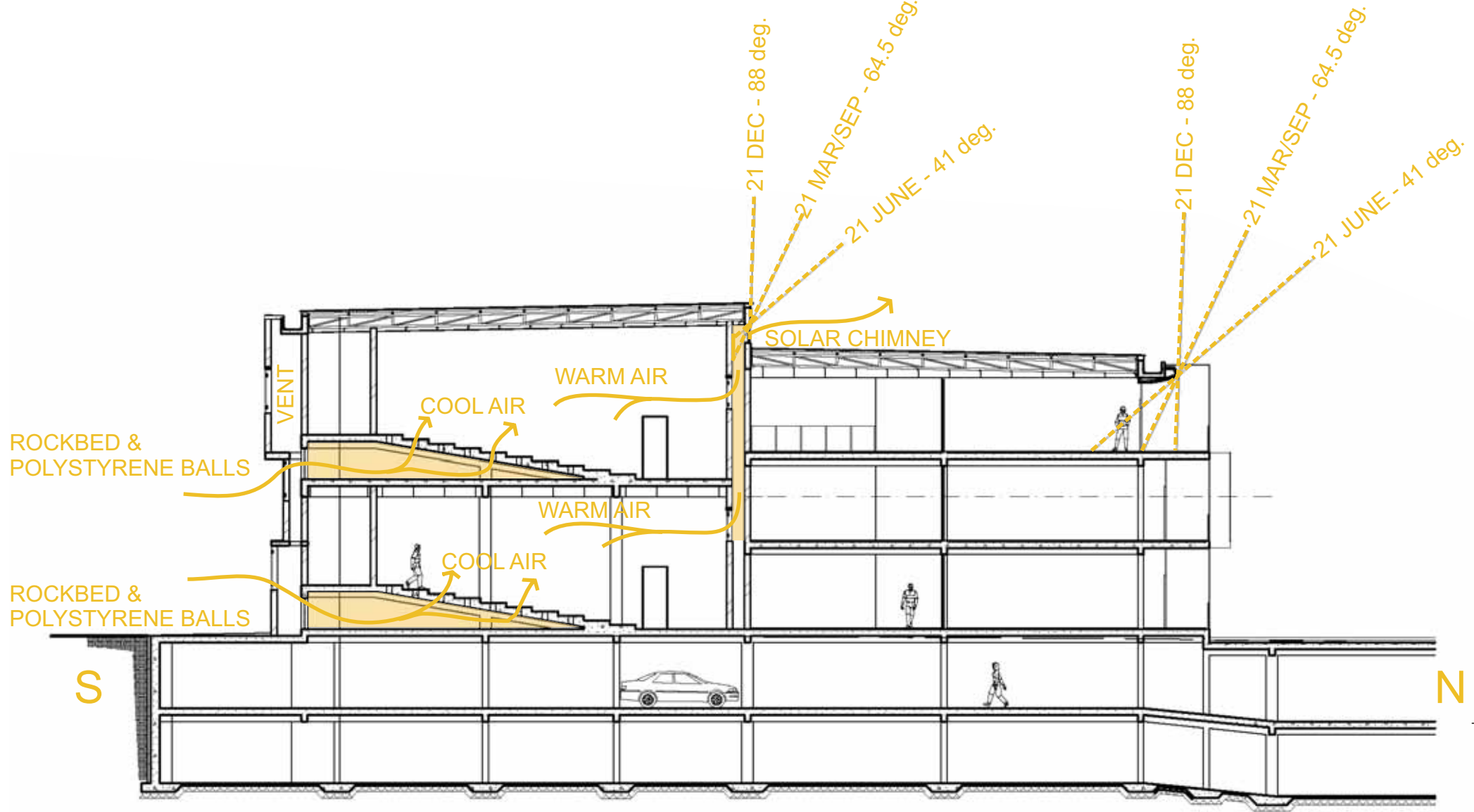

FIG 8-9: SECTION C-C

## passive cooling

The auditorium is passively cooled by drawing cool air in from the southern side of the building. It is drawn into a shaded vent which flows from there into a rockbed mixed with polystyrene balls to lessen the dead load of the rocks. The rockbed would then further cool the air to about 18°C. A solar chimney is implemented to provide for an updraft causing a vacuum, drawing air from the rockbed. The process is enhanced through the use of a solar powered fans situated at the top of the chimney. The system is controlled for comfort through the use of adjustable louvers and setting the speed of the fans.

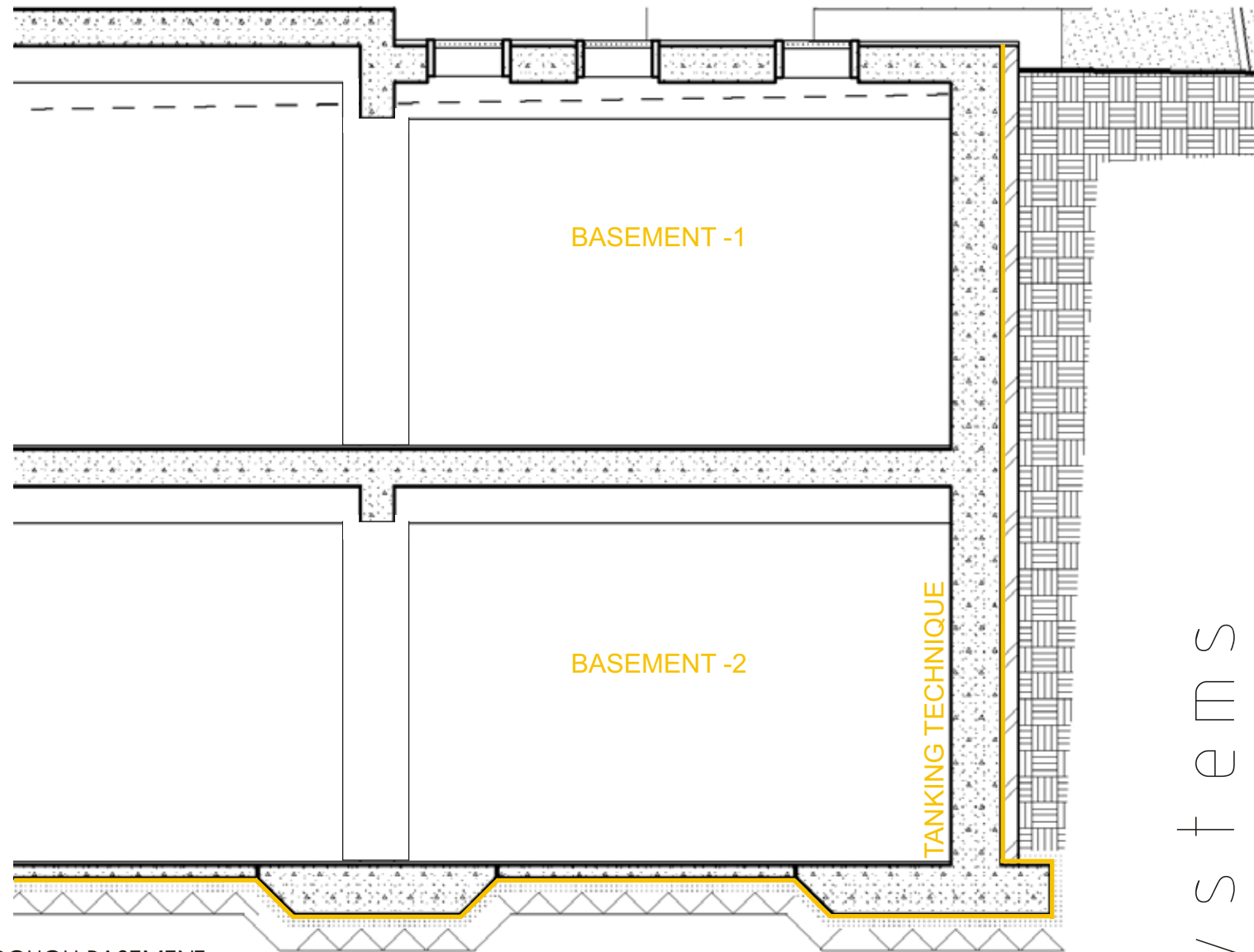

FIG 8-10: SECTION THROUGH BASEMENT

## waterproofing

Tanking is a waterproofing technique which renders your basement waterproof, preventing any water penetration into the building. The description of tanking is as a result of the comparison between a basement with a waterproof tank completely submerged in water. The tanking membrane is a 1000 micron Gunplas hyperlastic orange which is protected by a single brick skin at the retaining wall and with 100mm river sand blinding layer below the surface bed and foundations.

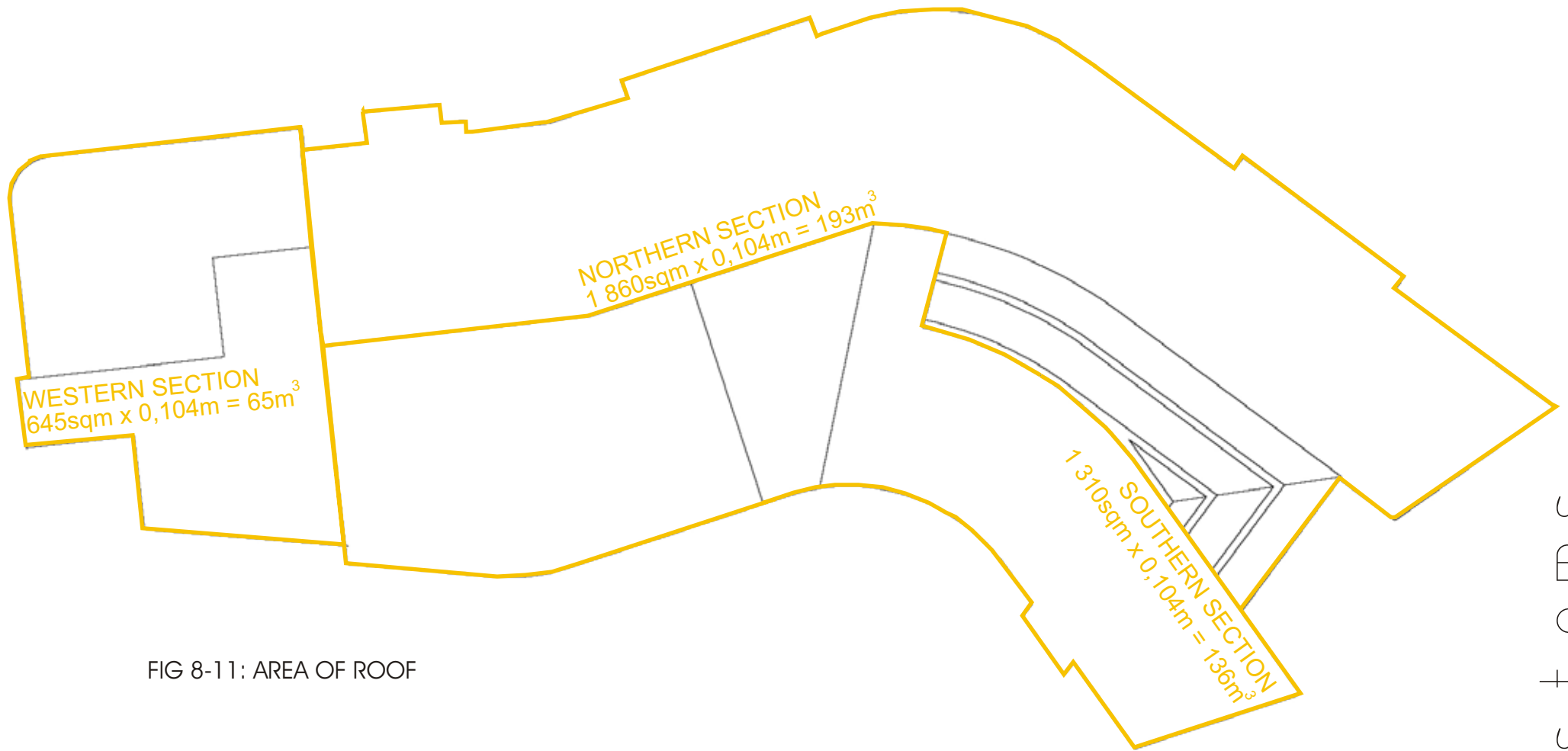

FIG 8-11: AREA OF ROOF

## rainwater harvesting

There are three roof sections identified for collection, namely the northern section which includes the atrium, the southern section and the western section. The northern section has a roof area of 1 860sqm, the southern section 1 310sqm and the western 645sqm. The max monthly rainfall for Pretoria is 130mm, for which storage capacity is allowed for. There would also be 80% efficiency on the collection due to evaporation and therefore storage would allow for 104mm.



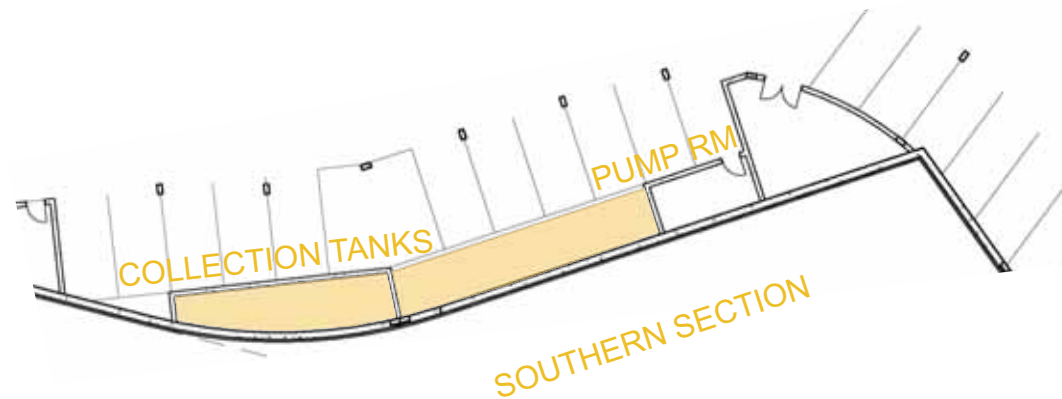
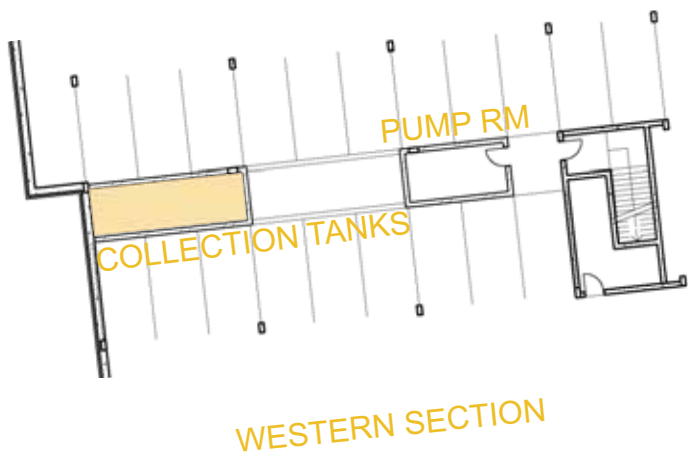
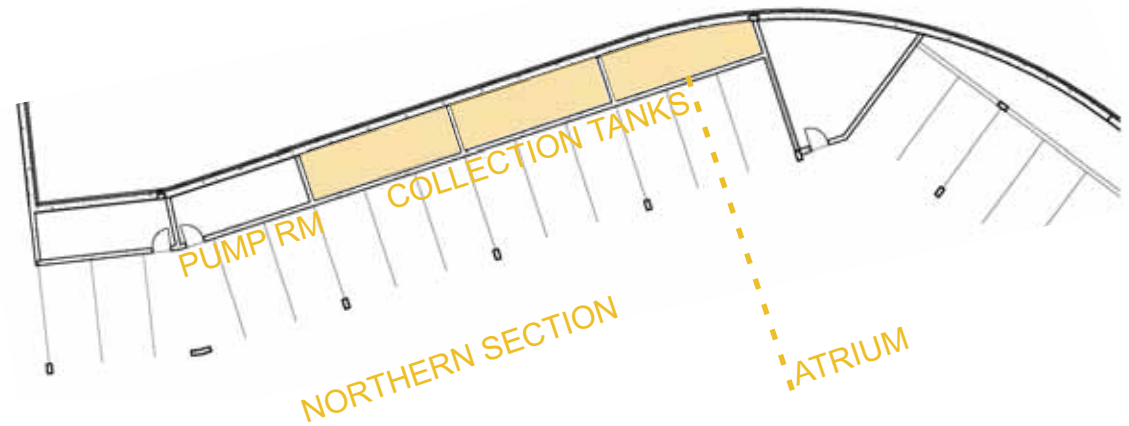
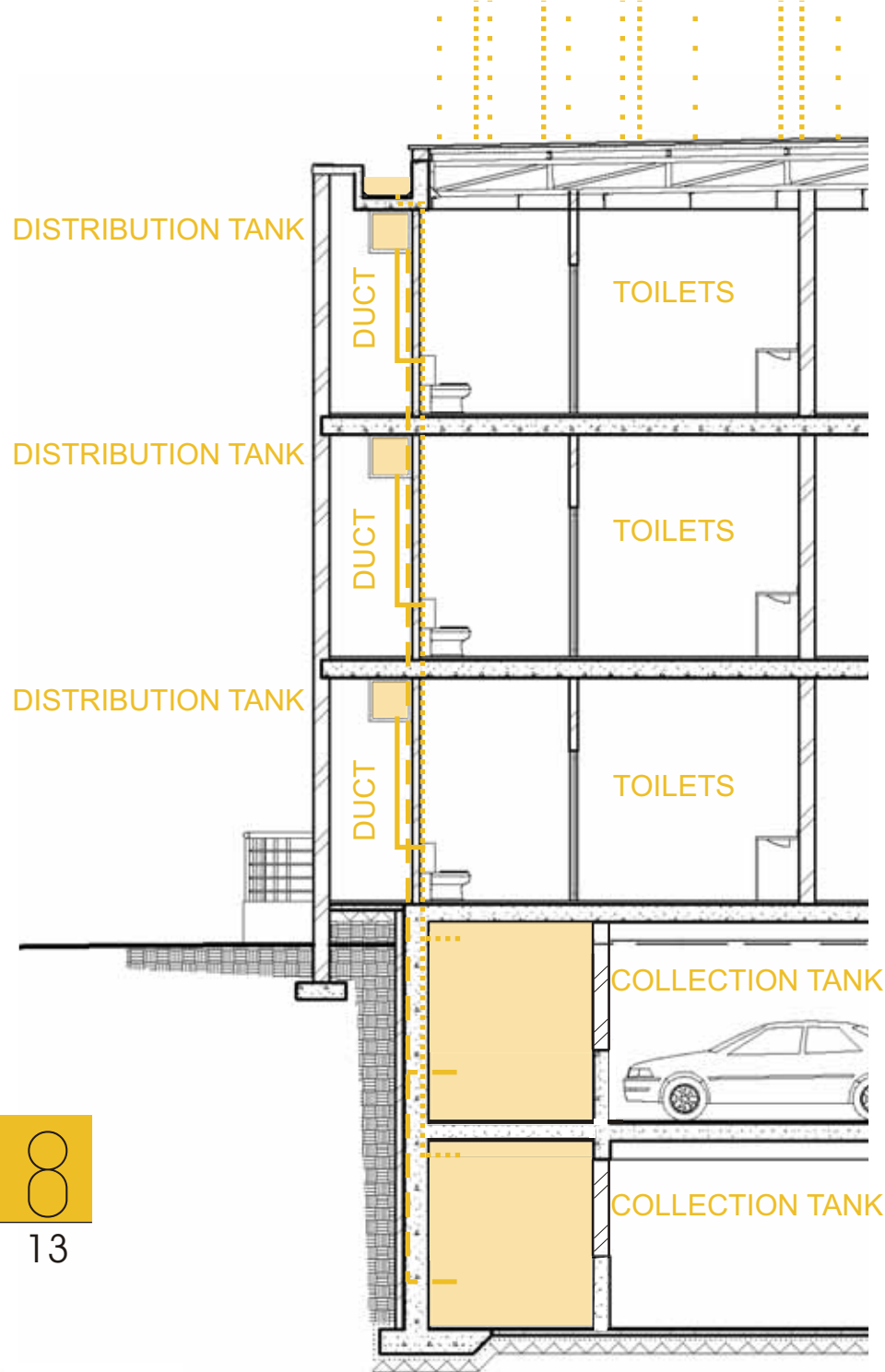

FIG 8-12: POSITION OF RAINWATER COLLECTION TANKS

## rainwater harvesting

Each section of the roof is provided with collection tanks in both basements as well as a pump room in the lower basement. The water of the atrium is discharged to the tanks through a 100mm dia. UPVC pipe encased in concrete below the surface bed. The water from the northern section is used for the toilets and urinals on the various floors, whilst the water from the southern and western sections will be used for irrigation purposes. Northern section requires 193m<sup>3</sup> = provided 222m<sup>3</sup>; southern section requires 136m<sup>3</sup> = provided 150m<sup>3</sup>; western section requires 65m<sup>3</sup> = provided 67m<sup>3</sup>



## rainwater harvesting

The rainwater collected from the roof flows from the concrete box gutter through rainwater downpipes, situated in the concrete columns, and into the collection tanks in the basements. From the collection tanks the northern roof section's water is pumped by solar powered pumps through filters up to distribution tanks situated on the various floors. From these 250litre distribution tanks seven toilets and three urinals on each floor are provided with water. The southern and western roof section's water is pumped out directly for irrigation purposes.

FIG 8-13: RAINWATER CIRCULATION



CONCRETE has a very high embodied energy and is used as little as possible and thus only for structural purposes and not merely for aesthetical reasons.

CLAY BRICKS are relatively low in embodied energy and is therefore used for all permanent internal walls as well as the exterior walls used as in-fill to the concrete framework.

MILD STEEL which is also very high in embodied energy, is again used wisely and mostly for structural purposes such as the roof trusses and purlins but also for the balustrades.

GALVANIZED SHEETMETAL has a relatively high embodied energy and is only used for the roofs as it is the most effective roofing material for a building this size.

Thermal INSULATION in the roof structure is a necessity to keep a building cool and energy efficient. Therefore a noncombustible fibre glass with reinforced kraft aluminium foil is used for insulation. For acoustic insulation mineral wool fibre insulation is used at the back of the lecture rooms and auditoriums.

ALUMINIUM frames are used for all the windows and doors in the building. Although it has a relatively high embodied energy, it is however sustainable due to its low maintenance characteristics. Through the use of anodized aluminium it is protected from all weather conditions which eliminates rust, rendering it maintenance free.

GYP SUM flush plaster ceiling board are used in the some of the areas and gypsum fibre reinforced acoustic ceiling board is used in the lecture rooms and auditoriums.

## sustainability conscious

Due to the current environmental situation, with specific regard to the global warming issue, materials are chosen with sustainability in mind. Materials are selected which has a low embodied energy and is environmentally friendly. Those materials with a high embodied energy, which use is unavoidable, is used wisely and sparingly.



The term "photovoltaic," commonly referred to as PV, is derived from a combination of "photo," the Greek word for light, and "Volta," the name of the Italian physicist, Alessandro Volta, who invented the chemical battery in 1800. A photovoltaic module, also called solar panels or solar cells, does not generate heat, but uses the energy available in sun light and converts it into direct current electricity. This means that solar panels can be used anywhere, from the Arctic to the Sahara, as power generation is dependant on light intensity and not on heat.

Photovoltaic modules are manufactured by using the "Cast" method and normally fabricated using special semiconductors such as a ceramic/silica or polycrystalline material that allows electrons to be freed from their atoms when they are energized due to exposure to sunlight. Once freed, they can move through the material and carry an electric current. The current flows in one direction, and thus the electricity generated is termed direct current (DC).

The direct current (DC) electricity can be used to drive specially developed products such as the fans used in this building or can be used to charge lead-acid batteries that acts as a storage devise. Most appliances including the air-conditioning system used in the building, requires an alternating current and is achieved by drawing the energy stored in batteries through an inverter, both situated in battery rooms in the basement, and changing it from DC to AC.

There are three major types of photo voltaic systems currently available in the market namely an autonomous, a hybrid and a grid-connected system. An Autonomous systems are the most cost-effective source of electrical power, which is completely independent of any other power sources. An autonomous system relies exclusively on solar energy to meet the need for electricity and is ideal for remote or rural areas.

## photovoltaic

As indicated on the drawings, solar energy is used for fans in the basement to promote ventilation, at the clerestory windows to enhance the stack effect as well as at the top of solar chimney in the auditorium. Solar energy is also used for the air conditioning system where indicated and the extractor fans of the kitchen. These are all solar powered through the use of photovoltaic cells which is either situated on the specific units, such as the fans, or it is powered through photovoltaic panels situated on the roof for the air conditioning, extractor fans and the rainwater pumps.

Hybrid photovoltaic system, also used in stand-alone systems, consist of PV modules with an additional source such as a wind and/or fuel-fired generator. The additional source accompanying the PV modules makes it more steady and reliable but still cost-effective. A hybrid system is a good option, when there is not enough sun at certain times of the year, or if you want to lower your capital investment in PV modules and storage batteries.

A grid-tied system is connected to the local municipal electricity whilst incorporating photovoltaic panels. This PV system is normally used where the building already has an existing electrical grid system and is then used to synchronize its output with the existing grid to slow down the electrical meter and save electricity. This is the system that this building would operate on, as solar energy is only used for the automatic doors, the fans as indicated, the rainwater pumps as well as the air conditioning system and the cold room of the restaurant. The building therefore is kept cool on solar energy, thus using less grid-electricity making it more sustainable.

The most energy is used with heating a space and especially water. The building doesn't have any showers or baths but where there is a need for hot water for whatever reason, solar water heaters are implemented to eliminate the use of energy for water heating. The solar absorbers are installed on the roof at a angle of 25,5 deg. for maximum heat gain during the year.

There are two types of solar water heaters, namely a direct and indirect system. Through an indirect system a secondary fluid contained in tubes is heated up by solar radiation to act as a heat conducting element to heat up the primary fluid such as the water. With the direct system, which is the system used in this building, the water is however directly heated by solar radiation.

## solar water heaters



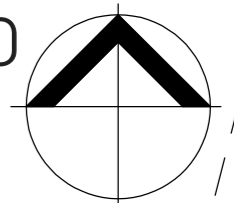



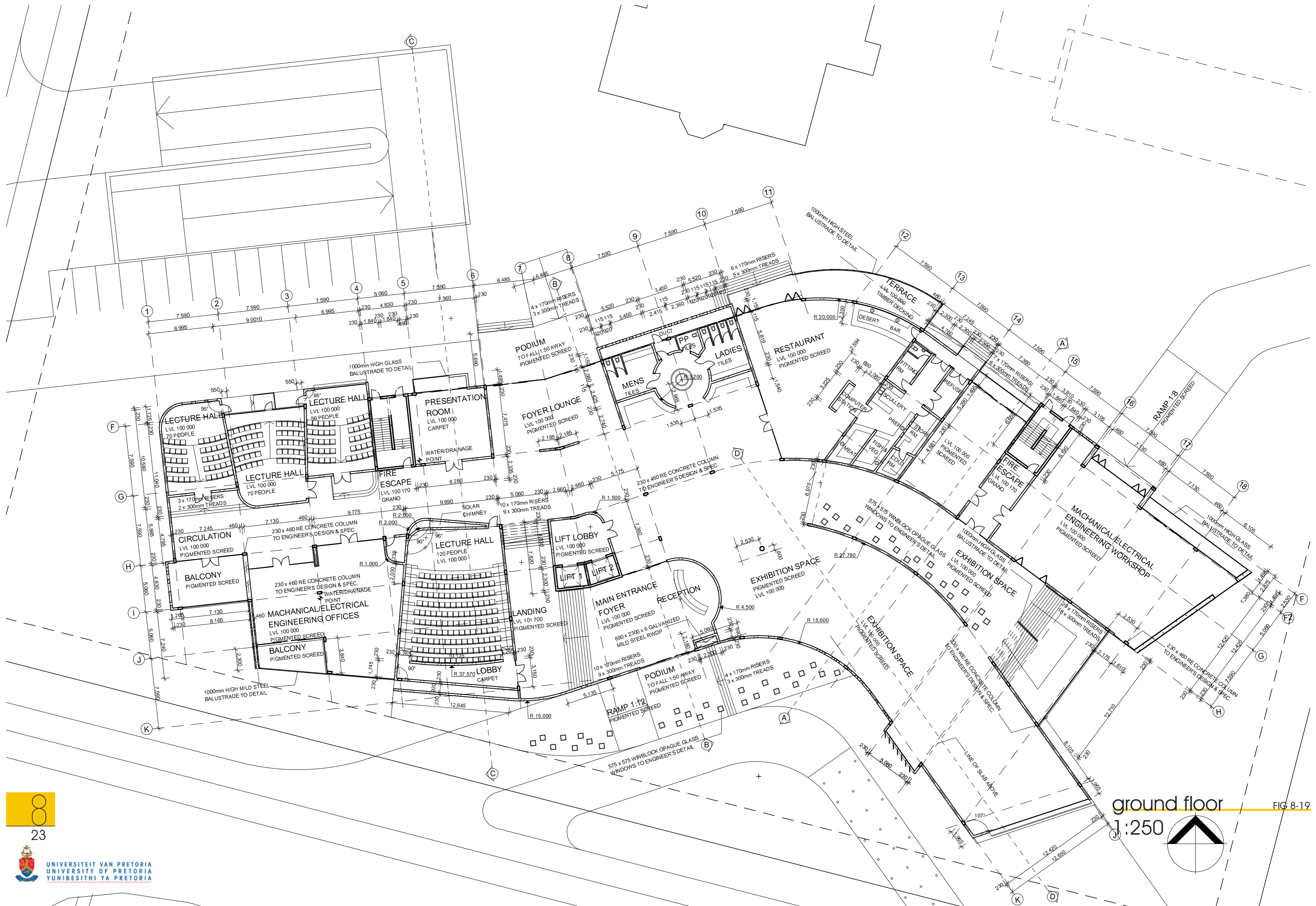

ground floor

1:250

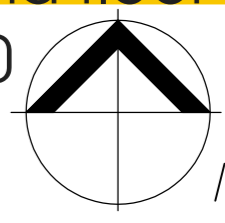
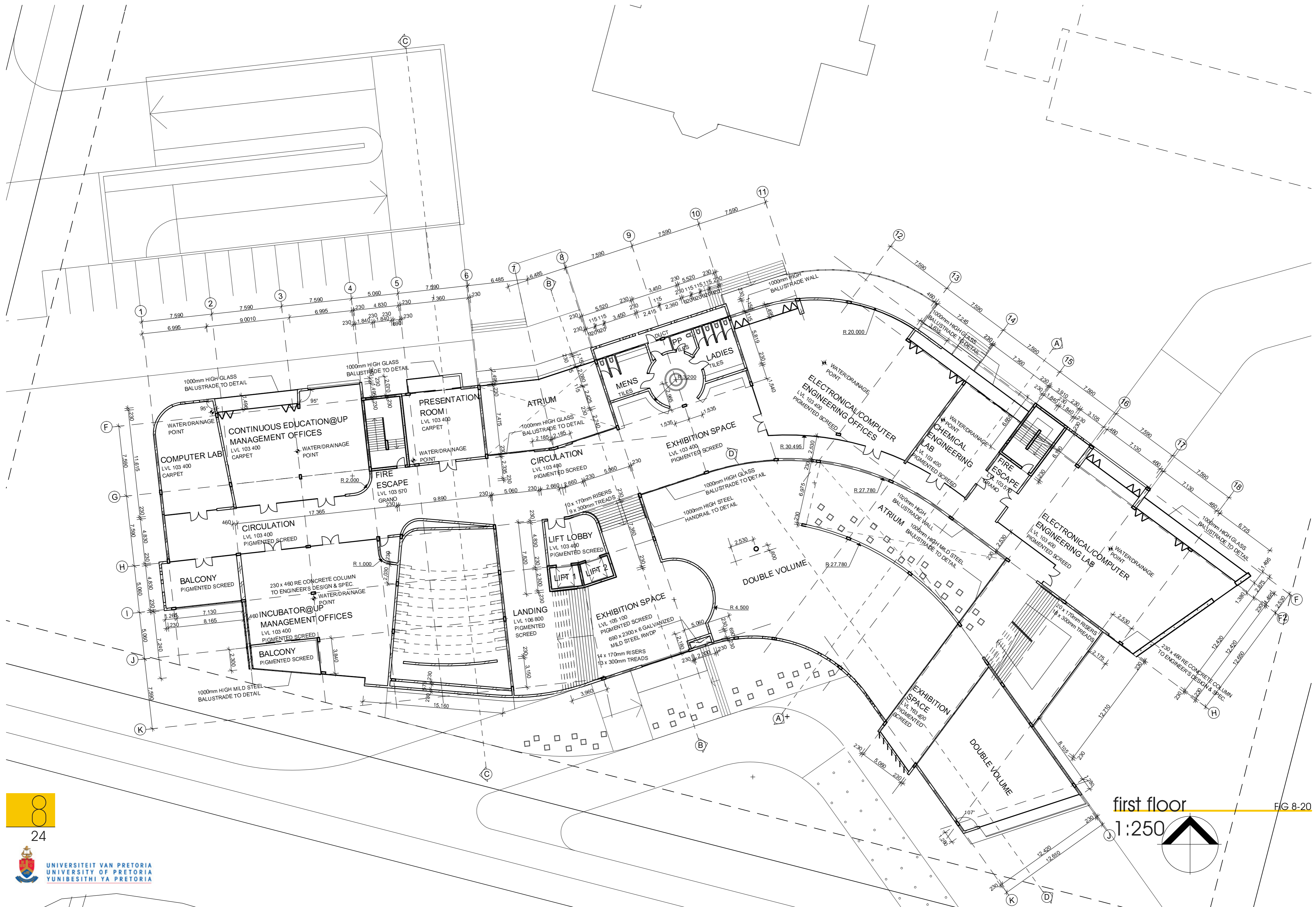

FIG 8-19



23

UNIVERSITEIT VAN PRETORIA  
UNIVERSITY OF PRETORIA  
YUNIBESITHI YA PRETORIA



first floor

1:250

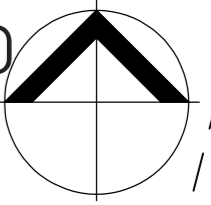
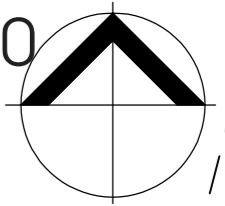
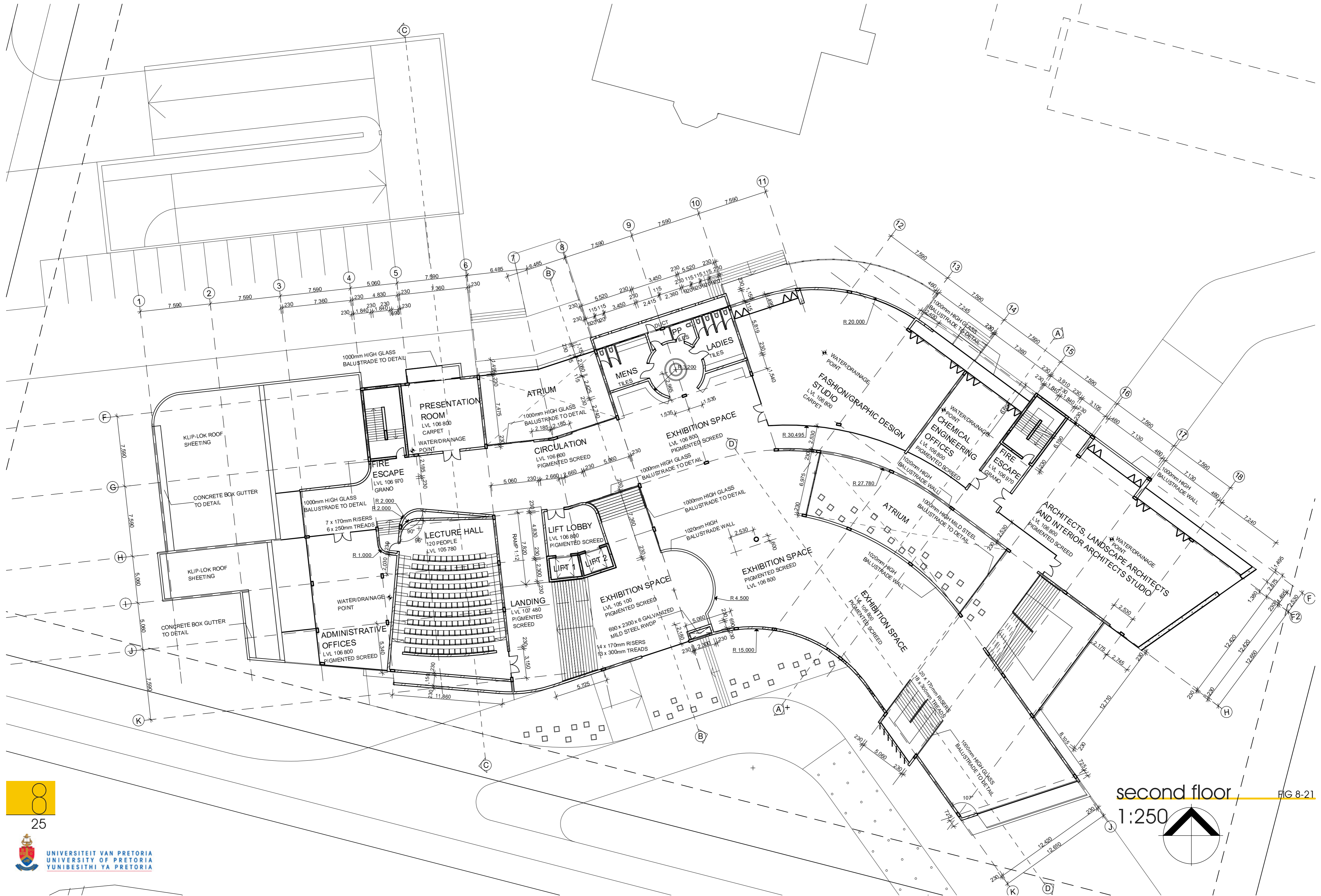

FIG 8-20



24







site plan  
1:500

FIG 8-23



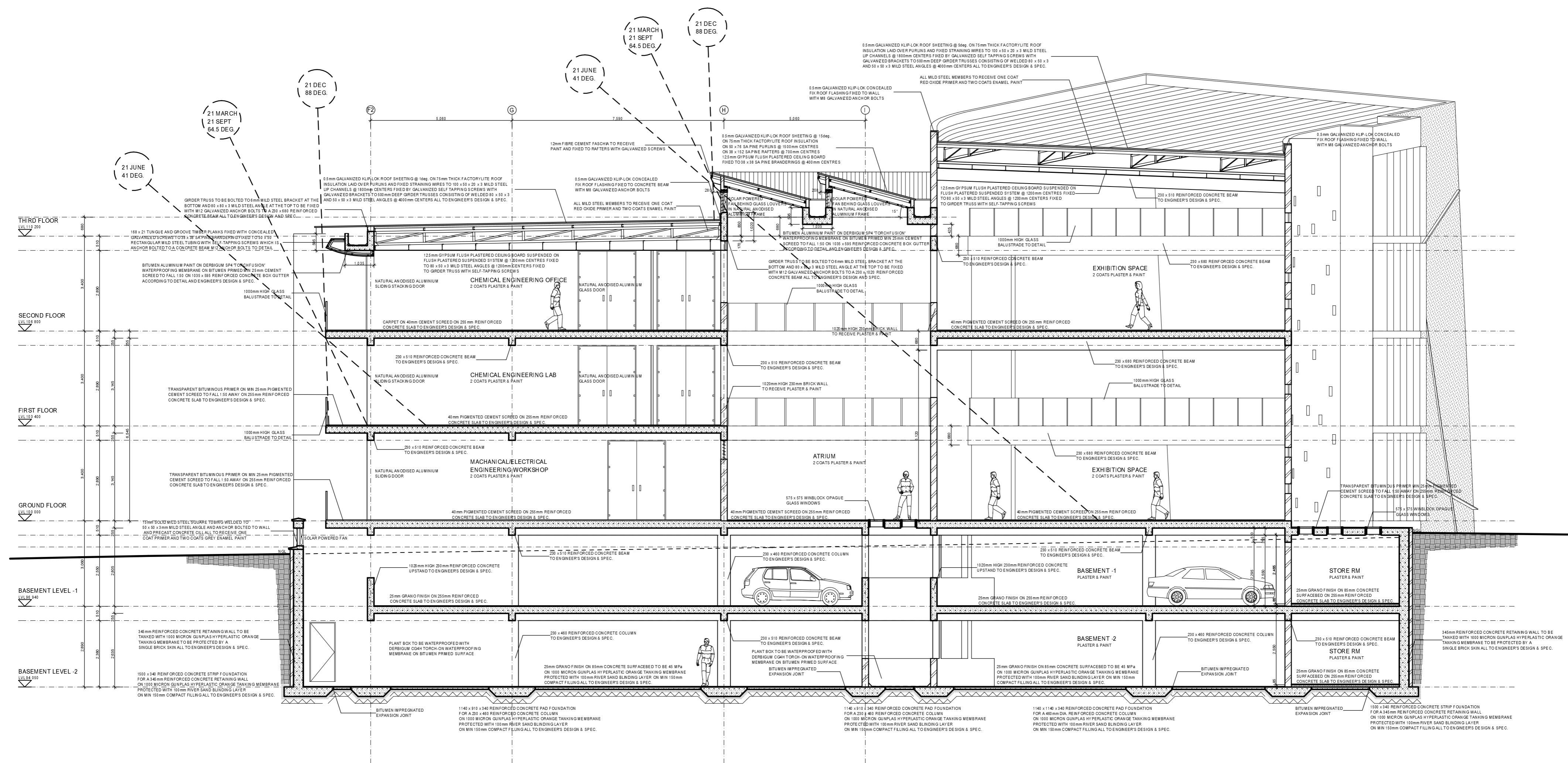

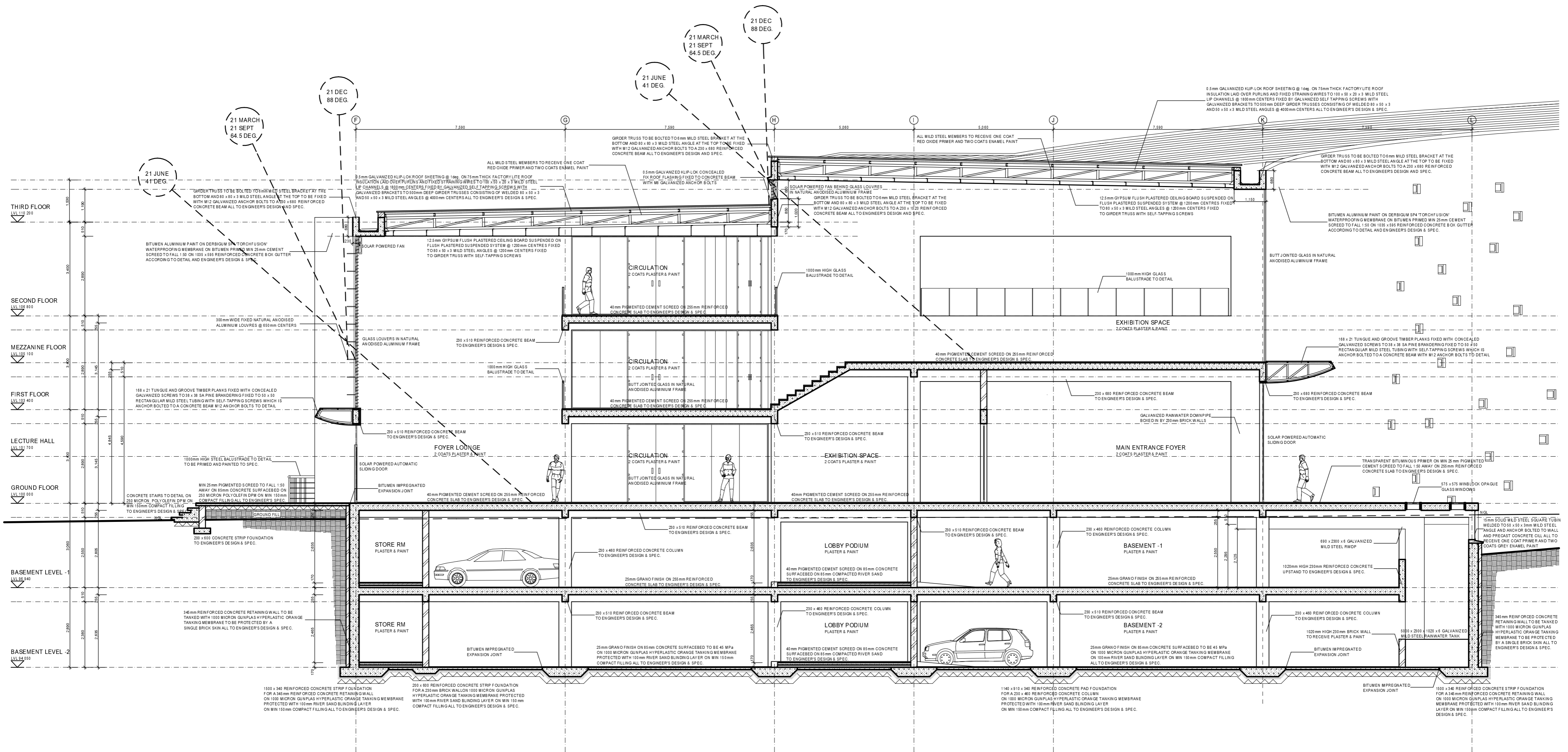

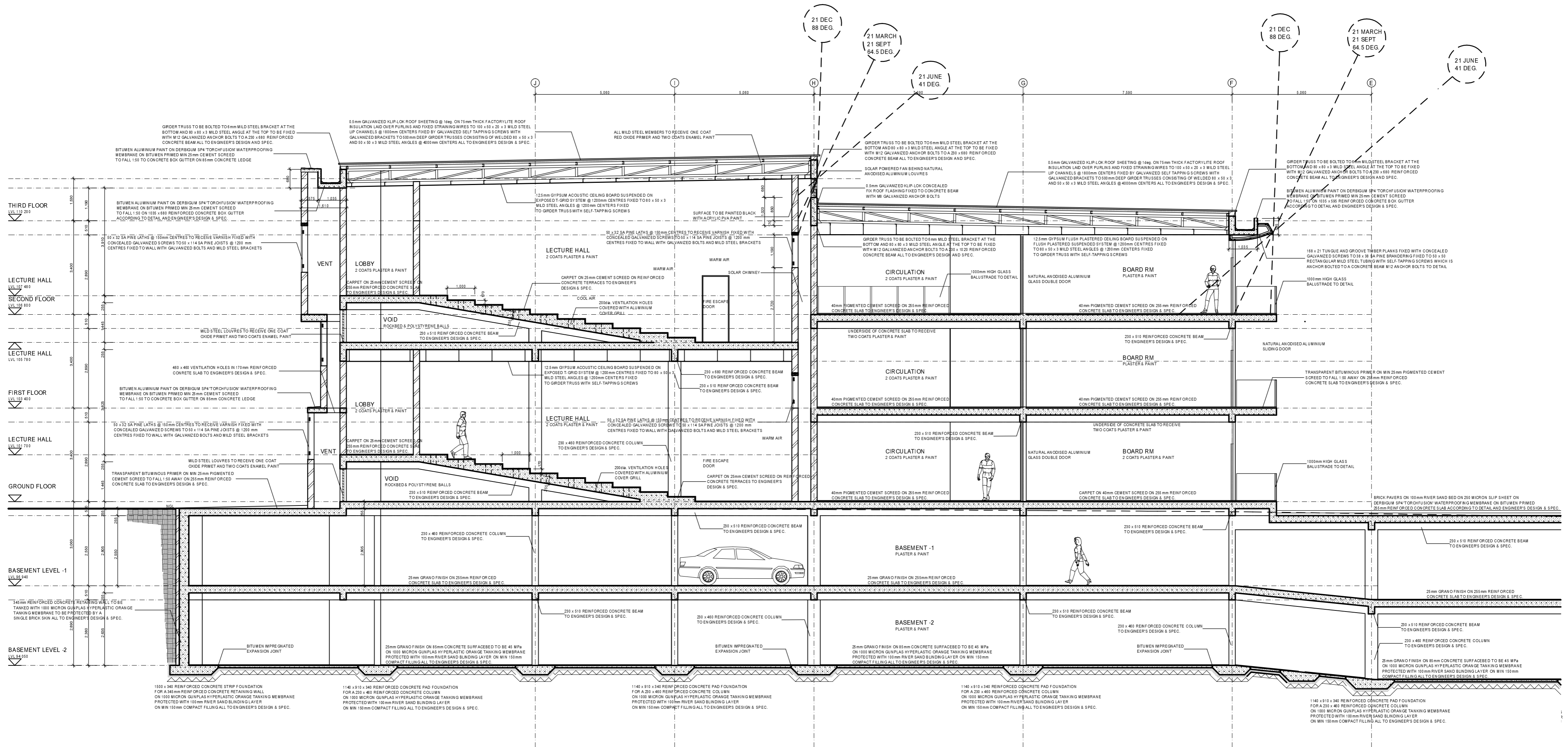

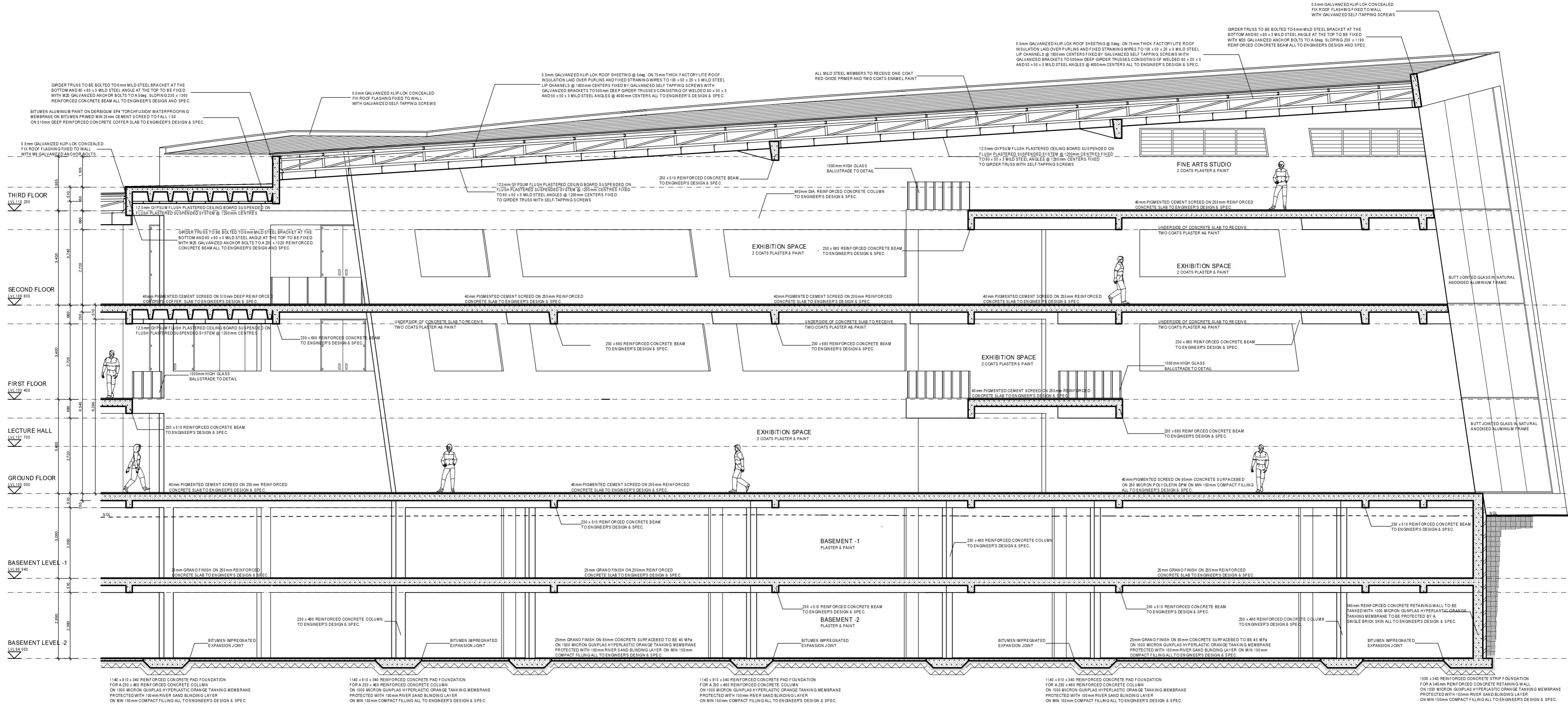

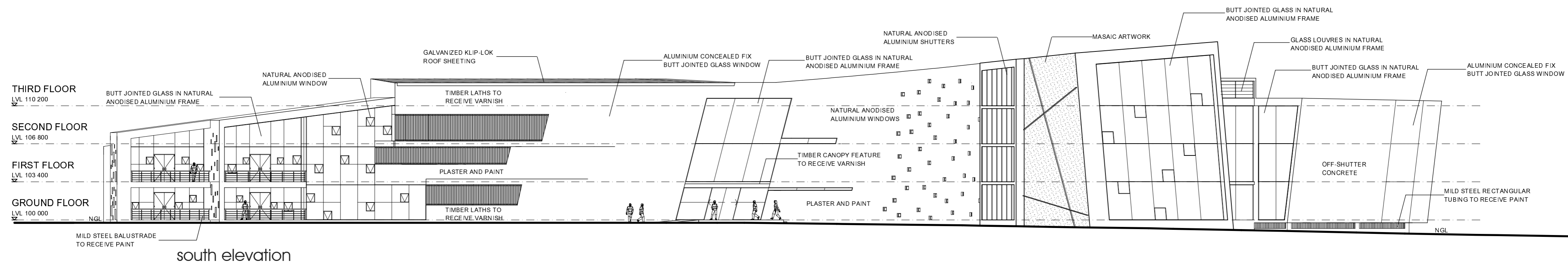
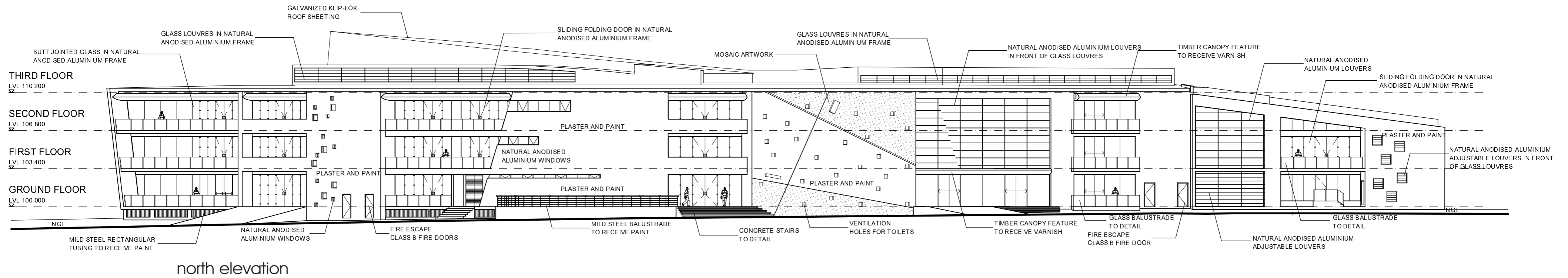

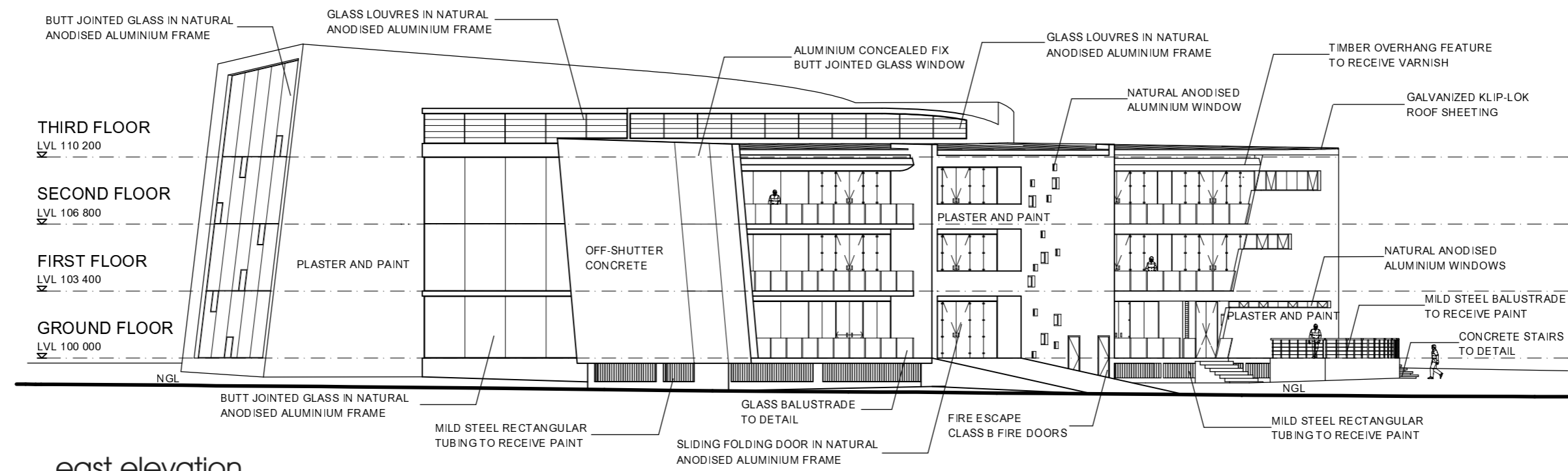

east elevation

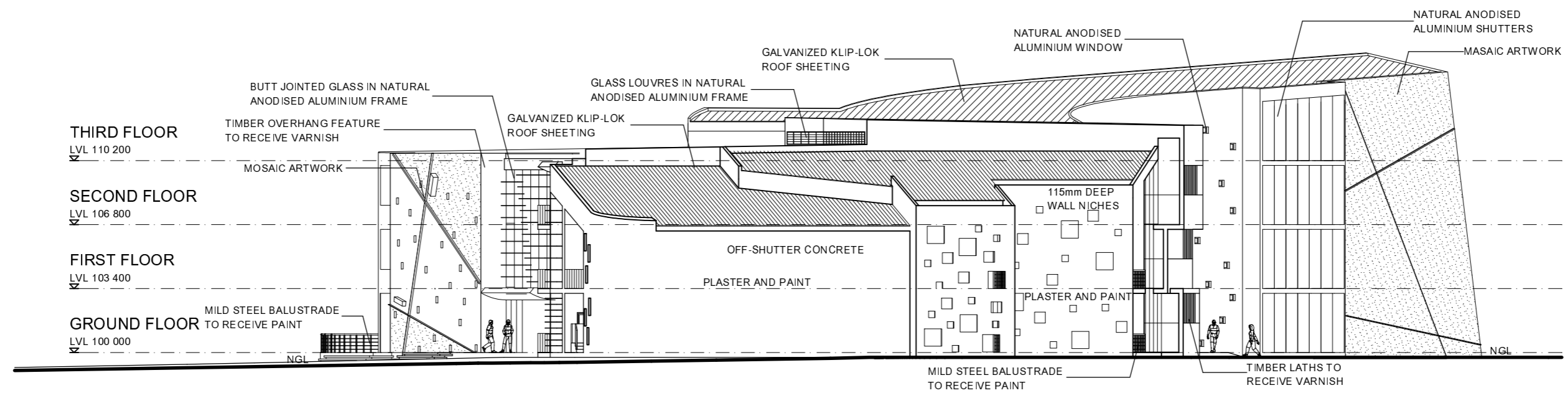

west elevation

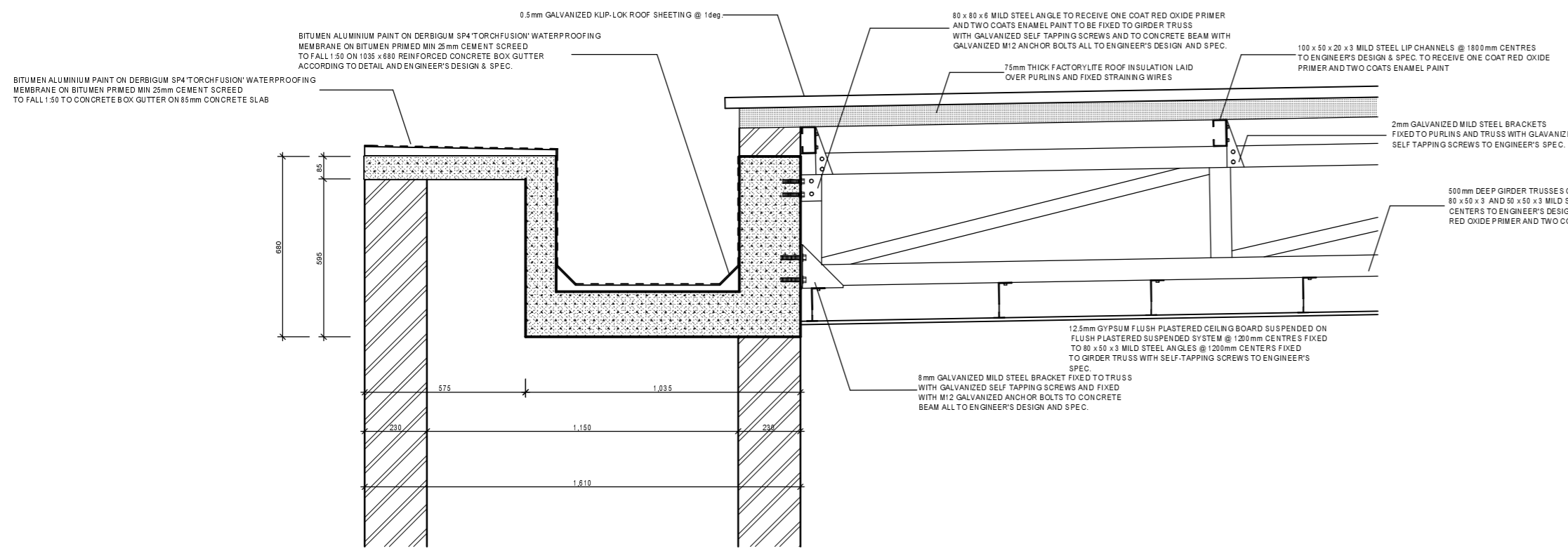

concealed box gutter

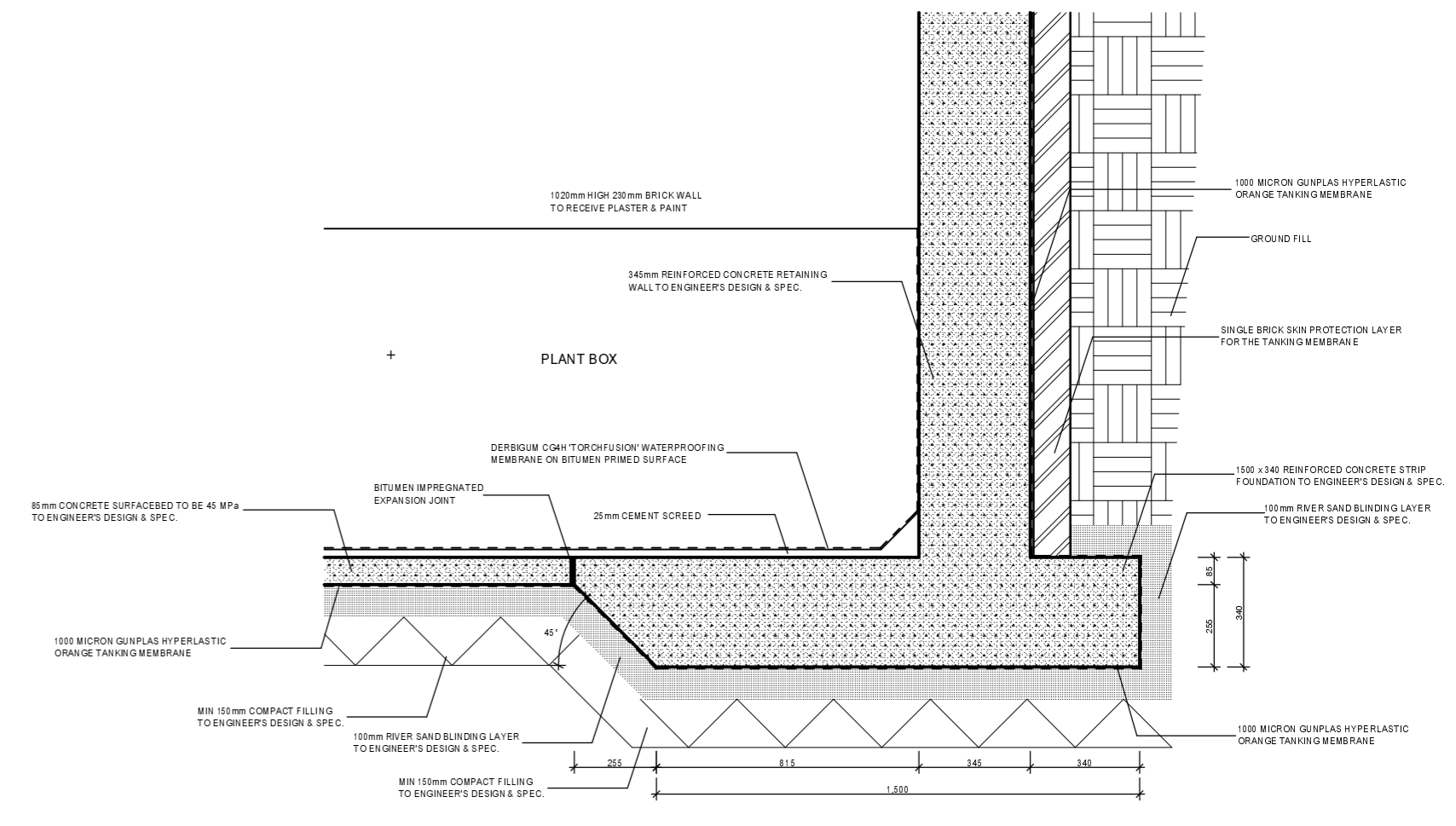

retaining wall

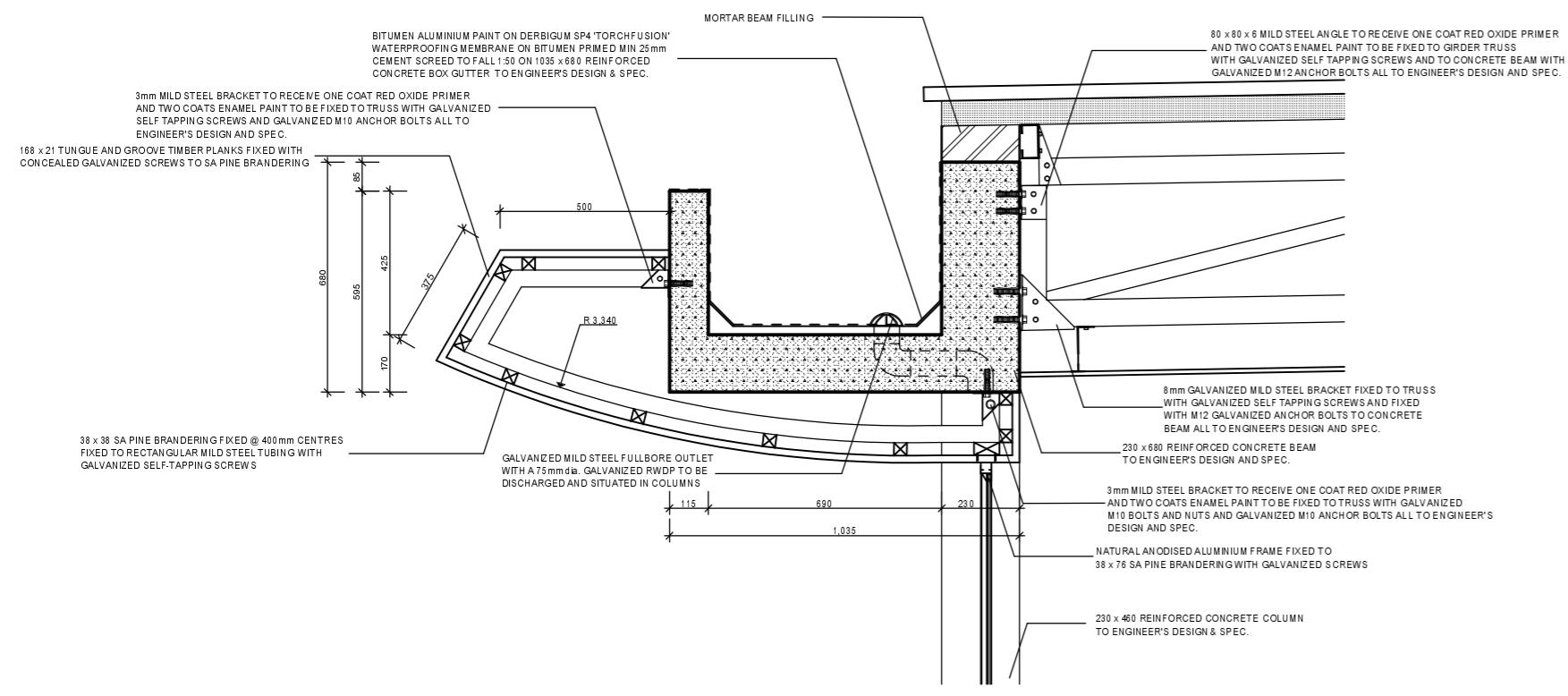

cladded box gutter

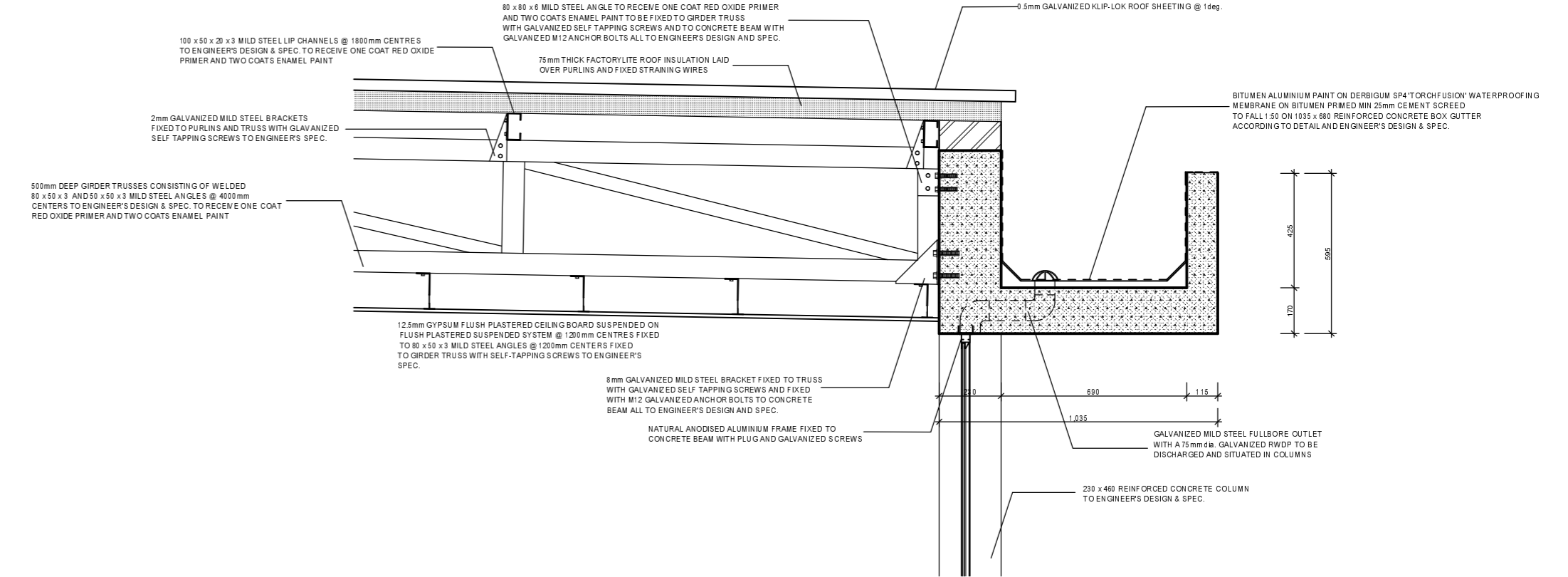

roof detail

details  
1:10



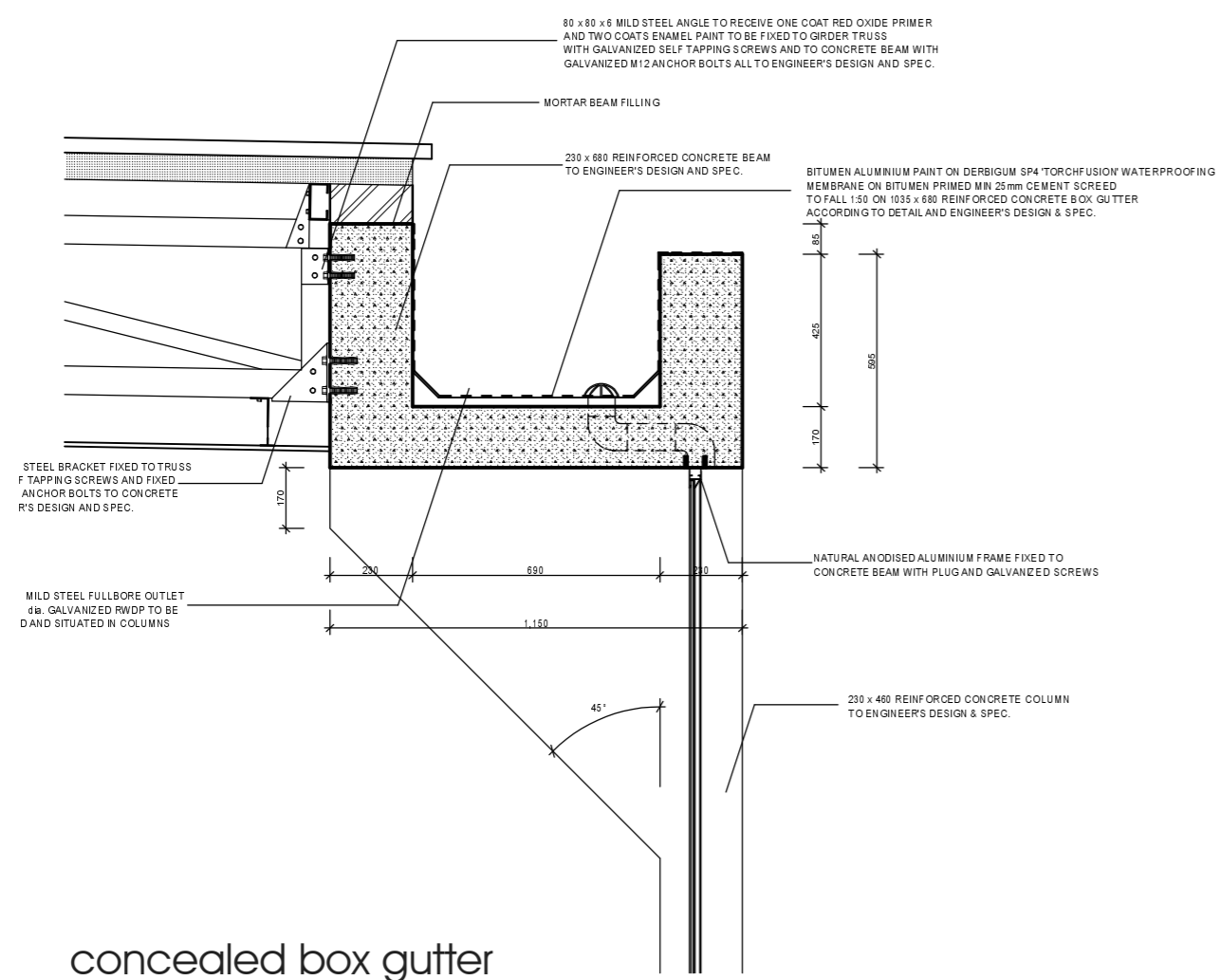

concealed box gutter

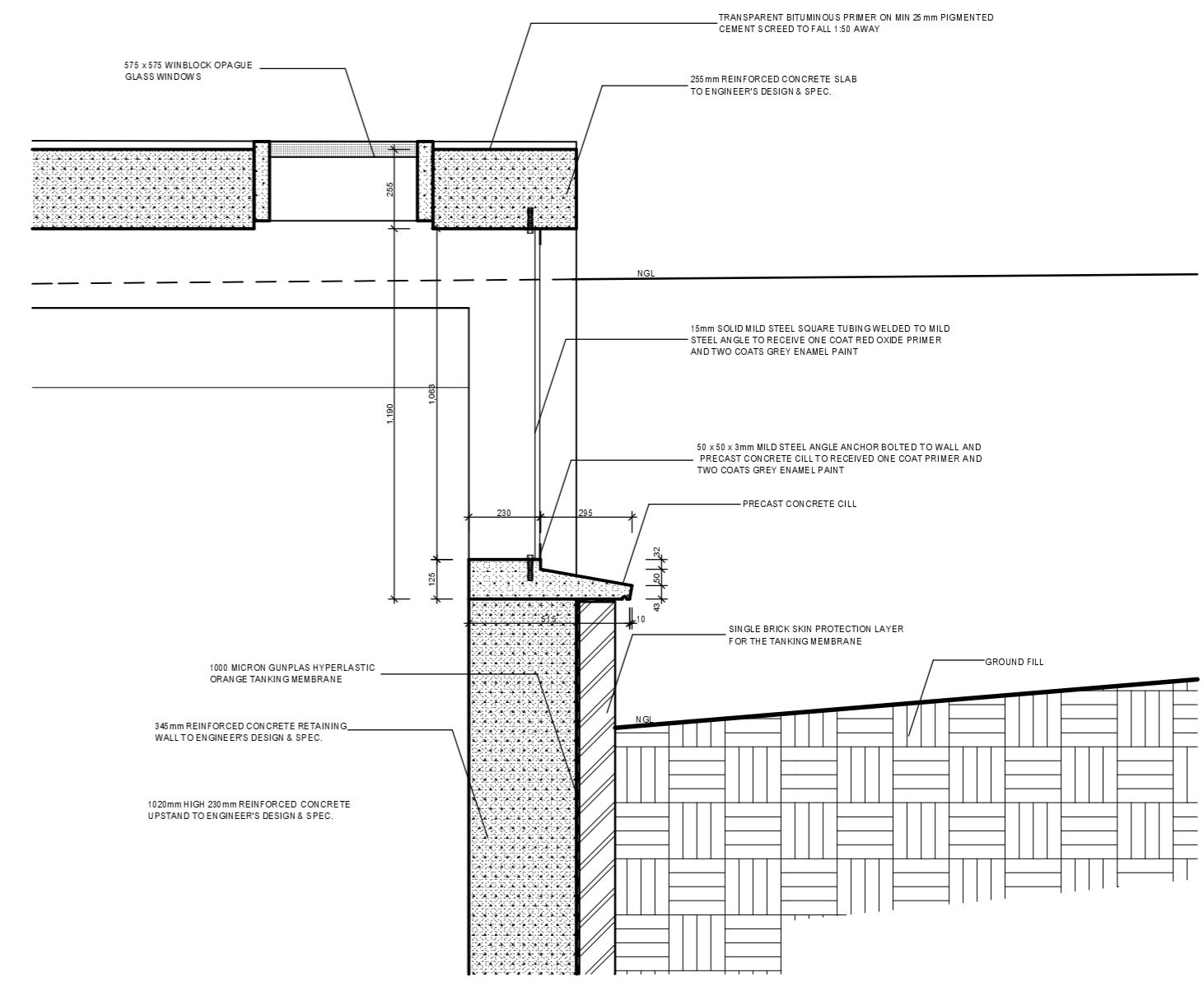

basement ventilation

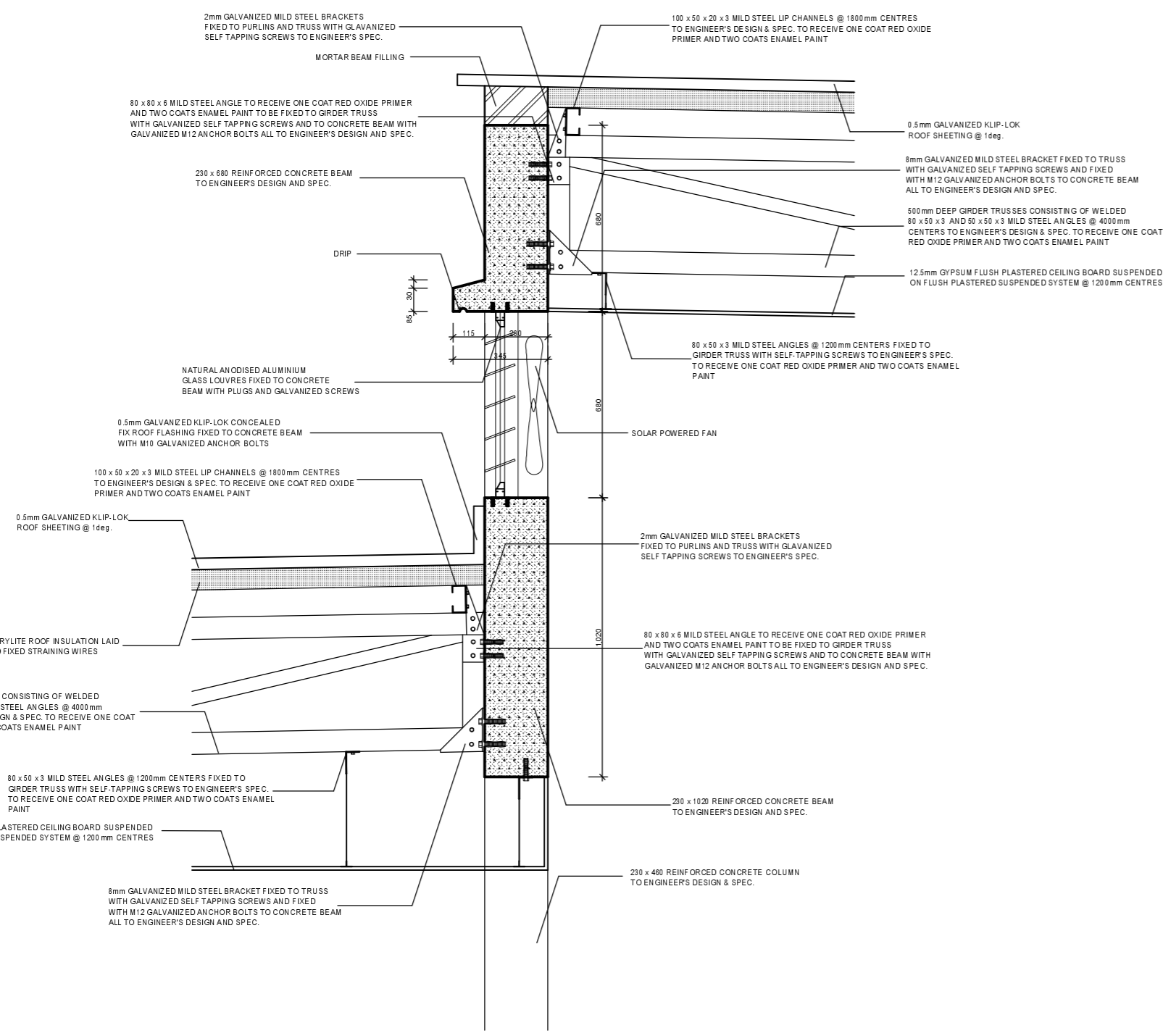

roof threshold

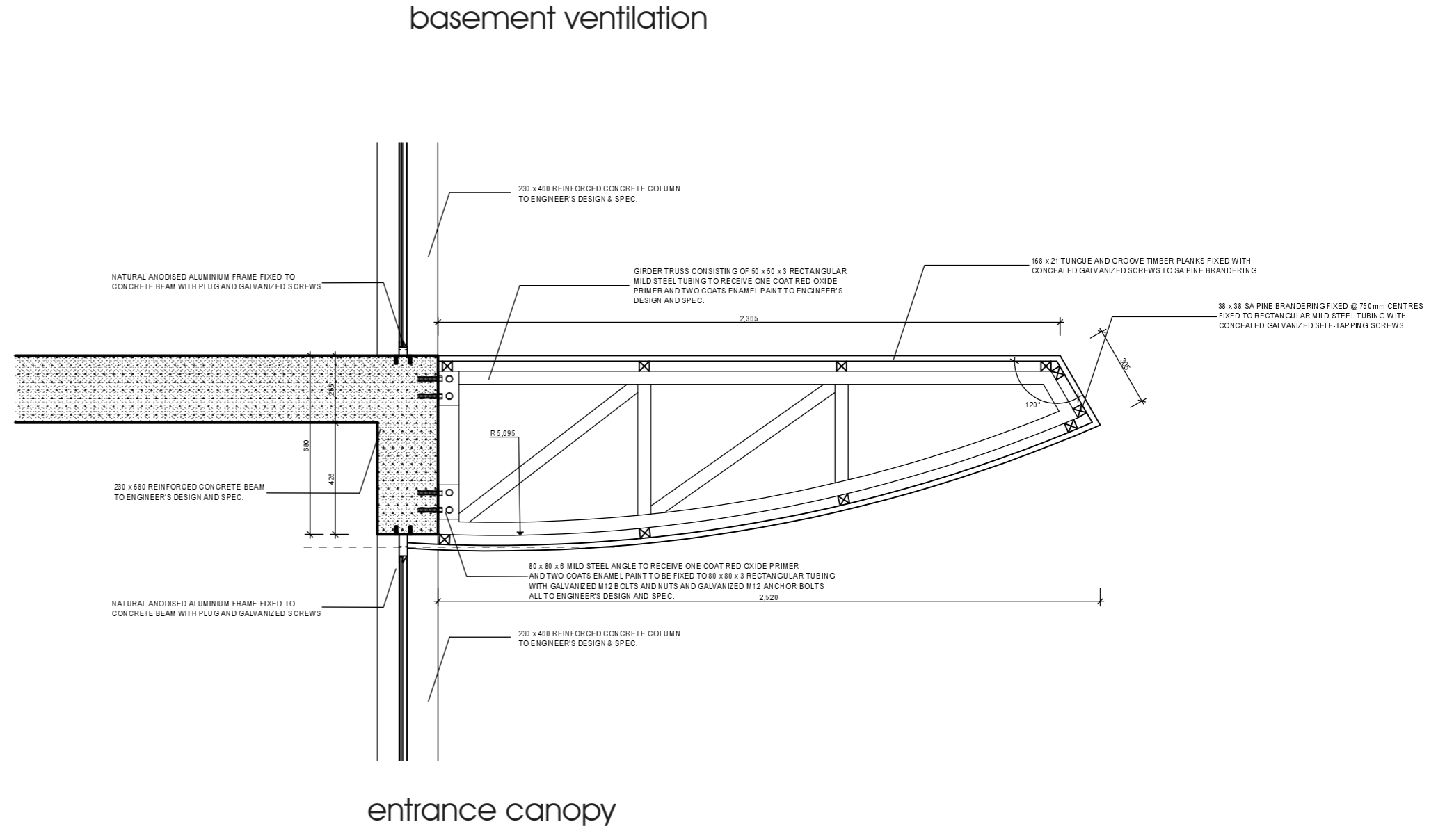

entrance canopy

details  
1:10

FIG 8-31

## chapter 1

FIGURE 1-1: ANTOINETTE UYS/UNIVERSITY OF PRETORIA  
FIGURE 1-2: JENNA BURCHELL/UNIVERSITY OF PRETORIA

## chapter 2

FIGURE 2-1: BIBI SLIPPERS/ UNIVERSITY OF PRETORIA  
FIGURE 2-2: AFRICAN CONTINENT  
FIGURE 2-3: CONTEXT OF PRETORIA  
FIGURE 2-4: CITY CONTEXT  
FIGURE 2-5: CITY FRAMEWORK  
FIGURE 2-6: URBAN FOCUS  
FIGURE 2-7: 3D IMAGE OF THE UNIVERSITY OF PRETORIA  
FIGURE 2-8: FIGURE GROUND STUDY - URBAN STITCHING  
FIGURE 2-9: 3D IMAGE - URBAN STITCHING  
FIGURE 2-10: URBAN FRAMEWORK OF THE UNIVERSITY  
FIGURE 2-11: FIGURE GROUND STUDY - FOCUS AREA  
FIGURE 2-12: 3D IMAGE - FOCUS AREA  
FIGURE 2-13: FIGURE GROUND STUDY - FRONT FACADE  
FIGURE 2-14: FIGURE GROUND STUDY - LYNNWOOD ROAD  
NARRATIVE  
FIGURE 2-15: 3D IMAGE - LYNNWOOD ROAD NARRATIVE  
FIGURE 2-16: 3D IMAGE - LYNNWOOD ROAD NARRATIVE  
FIGURE 2-17: 3D IMAGE - LYNNWOOD ROAD NARRATIVE  
FIGURE 2-18: PHOTOGRAPH - LYNNWOOD ROAD  
NARRATIVE

## introduction

Uys, Antoinette. 2007. **Unknown**. Pretoria: University of Pretoria  
Burchell, Jenna. 2007. **Lilies**. Pretoria: University of Pretoria

## context

Slippers, Bibi. 2007. **Verdwaaltaal**. Pretoria: University of Pretoria  
Author, Drawing

Google Earth. 2008. Google TM.  
Author, Drawing

Google Earth. 2008. Google TM.  
Author, Three dimensional model  
Author, Drawing  
Author, Three dimensional model  
Author, Drawing

Author, Three dimensional model  
Author, Drawing

Author, Three dimensional model

Author, Photograph

## list of figures

FIGURE 2-19: ENVIRONMENTAL IMPACT OF BUILDINGS

## chapter 3

FIGURE 3-1: BIBI SLIPPERS/ UNIVERSITY OF PRETORIA

FIGURE 3-2: SHELL, SCENERY AND REQUIREMENTS

FIGURE 3-3: INTERNAL PARTITIONING

FIGURE 3-4: OPEN BUILDING

FIGURE 3-5: SERVICES FOR OPEN BUILDING

FIGURE 3-6: OPEN BUILDING - CREATIVE SPACE

FIGURE 3-7: CONVENTIONAL - CREATIVE

FIGURE 3-8: ROAD CROSSING

FIGURE 3-9: PEDESTRIAN PATH AND BICYCLE LANE

FIGURE 3-10: SHOPPING STREET

FIGURE 3-11: FOUR STOREY LIMIT

## chapter 4

FIGURE 4-1: REBECCA EMERY/ UNIVERSITY OF PRETORIA

FIGURE 4-2: LANDSCAPE FORMATION ONE - SECTION 1

FIGURE 4-3: LANDSCAPE FORMATION ONE - SECTION 2

FIGURE 4-4: LANDSCAPE FORMATION ONE - SECTION 3

FIGURE 4-5: LANDSCAPE FORMATION ONE - FRONT PERSPECTIVE

FIGURE 4-6: LANDSCAPE FORMATION ONE - REAR PERSPECTIVE

FIGURE 4-7: NATIONAL MUSEUM OF XXI CENTURY ARTS - PLANS

FIGURE 4-8: NATIONAL MUSEUM OF XXI CENTURY ARTS -PHYSICAL MODEL

Levin, H. 1997. **Systematic Evaluation and Assessment of Building Environmental Performance**. Paris: Buildings and Environment.

## literature study

Slippers, Bibi. 2007. **White Noise**. Pretoria: University of Pretoria  
Author, Sketch

## precedent study

Emery, Rebecca. 2007. **Unknown**. Pretoria: University of Pretoria

Hadid, Zaha. 1999. **Landscape Formation One**. Weil am Rhein, Germany

Hadid, Zaha. 2008. **National Museum of XXI Century Arts**. Rome, Italy

## list of figures

S  
S  
E  
h  
t  
f  
P  
R  
O  
f  
f  
h  
A  
C  
h  
M

FIGURE 4-9: NATIONAL MUSEUM OF XXI CENTURY ARTS - 3D MODEL

FIGURE 4-10: OFFICE SPACE

FIGURE 4-11: OFFICE SPACE

FIGURE 4-12: OFFICE SPACE

FIGURE 4-13: STUDIO SPACE

FIGURE 4-14: LABORATORY

FIGURE 4-15: STUDIO SPACE

FIGURE 4-16: CIRCULATION SPACE

FIGURE 4-17: EXHIBITION SPACE

FIGURE 4-18: EXHIBITION SPACE

FIGURE 4-19: YOKOSUKA MUSEUM OF ART

FIGURE 4-20: EXHIBITION SPACE

FIGURE 4-21: EXHIBITION SPACE

FIGURE 4-22: EXHIBITION SPACE

FIGURE 4-23: IMM COLOGNE

FIGURE 4-24: EXHIBITION SPACE

## chapter 5

FIGURE 5-1: RETHA FERGUSON/ UNIVERSITY OF PRETORIA

FIGURE 5-2: SITE CONTEXT

FIGURE 5-3: SITE ANALYSIS

Hadid, Zaha. 2008. **National Museum of XXI Century Arts**. Rome, Italy

Phaidon. 2005. **10 x 10: 10 Critics, 100 Architects**. London: Phaidon Press Limited

Miralles, Enric. 2007. **Benedetta Tagliabue**. Palafoxs, Spain

Adjaye Associates. 2004. **Idea Store**. London

GA Document. 2007. **99**. Japan: ADA Edita

GA Document. 2007. **99**. Japan: ADA Edita

GA Document. 2007. **99**. Japan: ADA Edita

Phaidon. 2005. **10 x 10: 10 Critics, 100 Architects**. London: Phaidon Press Limited

Hadid, Zaha. 2007. **Architecture and Design, Design Museum**. London, United Kingdom

GA Document. 2008. **100**. Japan: ADA Edita

Yamamoto, Riken. 2006. **Yokosuka Museum of Art**. Kanakawa, Japan

GA Document. 2008. **100**. Japan: ADA Edita

Deutsche Bank. 2005. **25 Years Collection, Deutsche Guggenheim**. Berlin, Germany

GA Document. 2008. **100**. Japan: ADA Edita

Hadid, Zaha. 2007. **IMM Cologne**. Cologne, Germany

Phaidon. 2005. **10 x 10: 10 Critics, 100 Architects**. London: Phaidon Press Limited

## site analysis & concept

Ferguson, Retha. 2007. **Unknown**. Pretoria: University of Pretoria

Author, Drawing

Author, Sketch

## list of figures

FIGURE 5-4: GLASKAS  
FIGURE 5-5: BRISTOW HALL  
FIGURE 5-6: PASTORIE  
FIGURE 5-7: AERIAL PHOTOGRAPH OF SITE  
FIGURE 5-8: LYNNWOOD ROAD FRONTAGE  
FIGURE 5-9: AERIAL VIEW OF SITE  
FIGURE 5-10: CONCEPT MODEL  
FIGURE 5-11: INITIAL MASS MODEL  
FIGURE 5-12: SPACE DEVELOPMENT  
FIGURE 5-13: INTERFACE  
FIGURE 5-14: GROUND FLOOR SPATIAL RELATIONSHIPS  
FIGURE 5-15: FIRST FLOOR SPATIAL RELATIONSHIPS  
FIGURE 5-16: SECOND FLOOR SPATIAL RELATIONSHIPS  
FIGURE 5-17: THIRD FLOOR SPATIAL RELATIONSHIPS  
FIGURE 5-18: DERIVED SHAPE  
FIGURE 5-19: INTERNAL SPATIAL DEVELOPMENT  
FIGURE 5-20: PINNACLE PERFORMANCE  
FIGURE 5-21: LYNNWOOD ROAD NARRATIVE  
FIGURE 5-22: SHAPE OF BUILDING  
FIGURE 5-23: SITE DEVELOPMENT  
FIGURE 5-24: NARRATIVE OF THE BUILDING  
FIGURE 5-25: FINAL CONCEPT MODEL

## chapter 6

FIGURE 6-1: SIMONE MARINUS/ UNIVERSITY OF PRETORIA  
FIGURE 6-2: THE LYNNWOOD ROAD THRESHOLD  
FIGURE 6-3: PUBLIC TRANSPORT

Author, Photograph

Author, Photograph of physical model

Author, Sketch

Author, Drawing

Author, Sketch

Author, Photograph & drawing

Author, Sketch

Author, Drawing

Author, Sketch

Author, Physical model

## urban framework

Marinus, Simone. 2007. **Unknown**. Pretoria: University of Pretoria

Author, Drawing

Google Earth. 2008. Google TM.

## list of figures

MARCH (P L O F) T H E S I S

FIGURE 6-4: BUS PICKUPS  
 FIGURE 6-5: BUS PICKUP - PLAN  
 FIGURE 6-6: BUS PICKUP - SECTION  
 FIGURE 6-7: BASEMENT PARKING  
 FIGURE 6-8: ROAD CROSSINGS  
 FIGURE 6-9: RAISED ROAD CROSSING - PLAN  
 FIGURE 6-10: ENTRANCE MEETING SPACE - PLAN  
 FIGURE 6-11: ENTRANCE MEETING SPACE - SECTION  
 FIGURE 6-12: CONNECTION BETWEEN CAMPUSES  
 FIGURE 6-13: SECTION THROUGH LYNNWOOD ROAD  
 FIGURE 6-14: RESTING SPACE  
 FIGURE 6-15: AERIAL VIEW OF LYNNWOOD ROAD  
 FIGURE 6-16: SEMI-PRIVATE SPACE BEHIND MIXED-USE BUILDING

FIGURE 6-17: PUBLIC SEMI-ENCLOSED SPACES  
 FIGURE 6-18: SHOPS AND COFFEE SHOPS BELOW RESIDENTIAL UNITS

FIGURE 6-19: SEMI-PRIVATE AND PUBLIC SPACES  
 FIGURE 6-20: FOUR STOREY MIXED-USE  
 FIGURE 6-21: FOUR STOREY MIXED-USE  
 FIGURE 6-22: FOUR STOREY MIXED-USE  
 FIGURE 6-23: UNIVERSITY PRECINCT  
 FIGURE 6-24: TYPICAL ELEVATION OF MIXED-USE BUILDINGS  
 FIGURE 6-25: TYPICAL SECTION OF MIXED-USE BUILDINGS  
 FIGURE 6-26: 3D IMAGE OF EXISTING SOUTH CAMPUS  
 FIGURE 6-27: PHOTOGRAPHS OF BUILDINGS FACING LYNNWOOD ROAD  
 FIGURE 6-28: 3D IMAGE OF PROPOSED SOUTH CAMPUS

Author, Drawing

Author, Sketch

Author, Drawing

Author, Sketch

Author, Photograph

Neal, P. 2003. **Urban Villages and the Making of Communities**. New York: Spon Press

Unknown

Unknown

Author, Sketch

Author, Drawing

Author, Sketch

Author, Three dimensional model

Author, Photograph

Author, Three dimensional model

## list of figures

MARCH (P.F.O.) THESE . I S

FIGURE 6-29: PROPOSED SOUTH CAMPUS  
FIGURE 6-30: 3D IMAGE OF EXISTING FRONT FACADE  
FIGURE 6-31: PHOTOGRAPHS OF BUILDINGS FACING LYNNWOOD ROAD  
FIGURE 6-32: 3D IMAGE OF PROPOSED FRONT FACADE  
FIGURE 6-33: EXISTING FACADE OF THE NERINA EXTENTION  
FIGURE 6-34: 3D MODEL OF PROPOSED RENOVATION OF THE NERINA EXTENTION

## chapter 7

FIGURE 7-1: TONI VAN JAARVELDT/ UNIVERSITY OF PRETORIA  
FIGURE 7-2: 3D MODEL OF BUILDING  
FIGURE 7-3: SITE PLAN  
FIGURE 7-4: BASEMENT -2  
FIGURE 7-5: BASEMENT -1  
FIGURE 7-6: GROUND FLOOR  
FIGURE 7-7: FIRST FLOOR  
FIGURE 7-8: SECOND FLOOR  
FIGURE 7-9: THIRD FLOOR  
FIGURE 7-10: SITE PLAN  
FIGURE 7-11: 3D MODEL OF BUILDING  
FIGURE 7-12: 3D MODEL OF BUILDING  
FIGURE 7-13: 3D MODEL OF BUILDING  
FIGURE 7-14: 3D MODEL OF BUILDING  
FIGURE 7-15: 3D MODEL OF BUILDING  
FIGURE 7-16: 3D MODEL OF BUILDING

Author, Drawing  
Author, Three dimensional model  
Author, Photograph  
Author, Three dimensional model  
Author, Photograph  
Author, Three dimensional model

## design discourse

van Jaarsveldt, Toni. 2007. **Unknown**. Pretoria: University of Pretoria  
Author, Three dimensional model  
Author, Drawing

Author, Three dimensional model

## list of figures

MARCH (PROF) THESES

FIGURE 7-17: 3D MODEL OF BUILDING  
FIGURE 7-18: 3D MODEL OF BUILDING  
FIGURE 7-19: 3D MODEL OF BUILDING

## chapter 8

FIGURE 8-1: JENNA BURCHELL/ UNIVERSITY OF PRETORIA  
FIGURE 8-2: BASEMENT STRUCTURE  
FIGURE 8-3: GRID STRUCTURE  
FIGURE 8-4: COLUMNS  
FIGURE 8-5: SPANNING ELEMENTS  
FIGURE 8-6: SECTION THROUGH STRUCTURE  
FIGURE 8-7: SECTION A-A  
FIGURE 8-8: SECTION B-B  
FIGURE 8-9: SECTION C-C  
FIGURE 8-10: SECTION THROUGH BASEMENT  
FIGURE 8-11: AREA OF ROOF  
FIGURE 8-12: POSITION OF RAINWATER COLLECTION TANKS  
FIGURE 8-13: RAINWATER CIRCULATION  
FIGURE 8-14: SPLIT UNIT AIR-CONDITIONING - LECTURE HALLS  
FIGURE 8-15: SPLIT UNIT AIR-CONDITIONING - KITCHEN  
FIGURE 8-16: SPLIT UNIT AIR-CONDITIONING - LIFT LOBBY  
FIGURE 8-17: BASEMENT -2  
FIGURE 8-18: BASEMENT -1  
FIGURE 8-19: GROUND FLOOR  
FIGURE 8-20: FIRST FLOOR  
FIGURE 8-21: SECOND FLOOR  
FIGURE 8-26: SECTION C-C

Author, Three dimensional model

## technical investigation

Burchell, Jenna. 2007. **Lilies**. Pretoria: University of Pretoria  
Author, Drawing

list of figures



FIGURE 8-22: THIRD FLOOR  
FIGURE 8-23: SITE PLAN  
FIGURE 8-24: SECTION A-A  
FIGURE 8-25: SECTION B-B  
FIGURE 8-27: SECTION D-D  
FIGURE 8-28 & 29: ELEVATIONS  
FIGURE 8-30 & 31: DETAILS

Author, Drawing

list of figures

Alexander, Christopher; S Ishikawa & M Silwerstein. 1977. **A Pattern Language: Towns, Buildings, Construction**. New York: Oxford University Press.

Bates, T; A Nucci. 1989. **An analysis of small business size and rate discontinuence**. Journal of Small business Management. p. 1-7.

UK Business Incubation. 2007. **Business Incubation Development Framework**. United Kingdom: Mediascope. URL: <http://www.ukbi.co.uk> [April 2008]

Harley, B. 2001. **Business incubators: good old models vs exciting new models**. The First International Workshop on Technology Business Incubators in India. India. 29-31 January

Wikipedia. 2008. **Business Incubators**. United States: Wikimedia Foundation Inc. URL: [http://en.wikipedia.org/wiki/Business\\_incubator](http://en.wikipedia.org/wiki/Business_incubator) [ April 2008]

Department of Environmental Affairs. 1986. **Climate of South Africa: Climate Statistics up to 1984**. South Africa: Government Printer.

Charmaz, Kathy. 2006. **Constructing Grounded Theory: A practical guide through qualitative analysis**. California: Sage Publications Inc.

Artim, Nicholas. 1993. **Cultural Heritage Fire Suppression Systems: Alternatives to Halon 1301**. Massachusetts: WAAC

Marshall, Catherine & Gretchen B Rossman. 2006. **Designing Qualitative Research**. 4th ed. California: Sage Publications Inc.

Brand, Steward. 1994. **How Buildings Learn**. New York: Penguin Books.

## list of references

---

Barrow, Collin. 2001. **Incubators: A realist's guide to the world's new business accelerators**. Chichester: John, Wiley & Sons Ltd.

Richards, Sally. 2002. **Inside Business Incubators & Corporate Venture**. New York: John Wiley & Sons.

Birch, D. 1987. **Job Creation in America: How our smallest companies put most people to work**. New York: The Free Press.

Juta & Co LTD. 2007. **Juta's Statutes of South Africa 2007/2008 Vol 3**. Cape Town: Juta & Co LTD.

Duffy, F; C Cave & J Worthington. **Planning Office Space**. London: The Architectural Press Ltd.

Roure, J; R Keeley. 1990. **Predictors of success in new technology-based ventures**. Journal of Business Venturing. p. 201-220

Leedy, Paul D & Jeanne E Ormrod. 2004. **Practical Research and Planning**. 8th ed. New Jersey: Pearson Prentice Hall.

Bentley, I; A Alcock & D Murrian. 1985. **Responsive Environments: A Manual for Designers**. London: Architectural Press Ltd.

Richards, Lyn & Janice M Morse. 2007. **Read Me First Users Guide to Qualitative Methods**. 2nd ed. California: Sage Publications Inc.

Swierczek, F.W. 1992. **Strategies for business innovation: Evaluating the prospects of incubation in Thailand**. Technovation. p. 521-533

## list of references

---

Habraken, N.J. 1972. **Supports: An Alternative to Mass Housing**. England: Architectural Press.

Lynch, Kevin. 1960. **The Image of the City**. Cambridge: MIT Press & Harvard Press.

Birch, D. 1979. **The Job Creation Process**. MIT Programme in Neighbourhood and Regional Changes. Cambridge: MA.

Benson, Tedd. 1997. **Toward the Realization of the Sustainable Wood Architecture**. Research Forum of Wood Architecture, International Conference.

UK Business Incubation. 2007. **What is Business Incubation?**. United Kingdom: Mediascope. URL: <http://www.ukbi.co.uk> [April 2008]

Bensonwood Homes. 2003. **What is Open Building?**. Bensonwood Homes. URL: <http://www.bensonwood.com> [October 2008]

Phaidon. 2004. **World Atlas of Contemporary World Architecture**. London: Phaidon Press Limited

GA Document. 2008. **100**. Japan: ADA Edita.

GA Document. 2008. **101**. Japan: ADA Edita.

Phaidon. 2005. **10 x 10: 10 Critics, 100 Architects**. London: Phaidon Press Limited

GA Document. 2008. **99**. Japan: ADA Edita.

## list of references

---

S  
-  
S  
E  
H  
+  
(  
f  
O  
F  
P  
(  
H  
C  
[  
A  
M

"I can do all things through Christ who strengthens me."  
Philippians 4:13

To Jesus Christ God Almighty:

All the honor to You my Lord and Savior, Jesus Christ. Lord Jesus you are my intelligence, my creativity, my hope and my strength. Where I didn't make the requirements and was not accepted to the university, You were my requirement and gave me acceptance.

To my family:

Thank you Mom! It is as a result of your continuous prayers, inspiration and motivation that I am making a success of my life. Thank you Dad and Werner for your continuous prayers and support throughout the years.

To my friends:

Thank you to each one of you who has prayed and supported me even if it was just a word of encouragement.

To Mr. G. Young and Dr. P. Vosloo:

Thank you for the guidance and assistance throughout my masters year.

acknowledgements

---

S  
I  
S  
E  
H  
+  
)  
+  
O  
F  
(  
P  
C  
H  
(  
P  
L  
O  
F  
O  
M  
A  
R  
C  
H