

# conclusion

“Experience of space is the foundation and framework of all our knowledge of the spatio-temporal world.”

[HERMAN WEYL in HILLIER\_1984:29]



"The total perception of architectural spaces depends as much on the material and detail of the haptic realm as the taste of a meal *depends* on the flavours of authentic ingredients."

[HOLL\_2000:WWW.CURBED.COM]"

technical resolution

## SITE PERIMETER

**7.1.1 CONCRETE SKIN:** A cast in-situ concrete structure defines the perimeters of the enclave. It is an 800mm **slab and beam** construction and spans 10m. The concrete slab is filled with **lightweight concrete panels** made of moulded Styrofoam contained between two sheets of wire meshes, a product known as **B-panels**®. The **B-Panels**® are primarily used for its light weight qualities; decreasing the structures dead weight, and reducing column sizes. The Styrofoam panels have excellent **noise, vibration** and **thermal insulative** properties.

An **up stand beam** that expands the whole length of the enclave is **inclined** at 15° on

the edge and **cantilevers** over the sidewalk. The inclination of the beam transfers noise over the street restoring the precincts sense of educational place. The **angularity blurs the boundary** between interior and exterior. Two movement joints are spaced at intervals of 100m. The continuous beam is based on a principle of Christopher Alexander from his book *The Nature of Order*; **NOT SEPARATE**. The space is fragmented in different spaces, each with its own function. Although they function separately, a continuous element ties them into a unified space. The beam is painted two coats **Plascon**® white Professional Low Sheen Pure Acrylic subtly contrasting with the grey retaining wall on adjacent

sides of the enclave, and also mirroring the stylistic qualities of the Main Administration Building across the street.

**7.1.2 COLUMNS:** **700mm Ø columns** support the weight of the structure. The columns are spaced at 6,750m intervals throughout, aligned on the reference grid of the palm trees. The columns are **set back 1m from** the edge of the sidewalk to allow the exterior space to flow into the interior. The columns are painted two coats **Plascon**® grey Professional Low Sheen Pure Acrylic with a 150mm top and bottom shadow gap, allowing them to appear as if they are floating in space; suspended between the concrete skin.

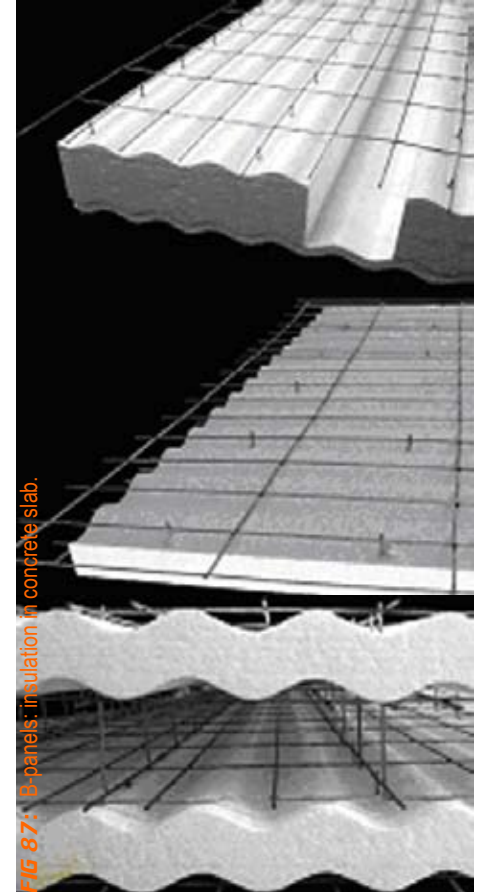

FIG 87: B-panels: insulation in concrete slab.

**7.1.3 SOFFIT SURFACE:** The soffit is painted two coats white **Plascon®** Professional Copolymer Acrylic continuing the exterior into the interior. The white reflects the light and enhancing the **ambient light quality** in the space.

**7.1.4 FLOOR SURFACE:** Kalk white Pigmented Floorcote is used as a unified floor finish allowing flow through a seamless space. The Bicycle transition zone is defined with marble grey exposed aggregate Pigmented Floorcote integrating the sidewalk and the interior space. Pigmented Floorcote is a **hard wearing utilitarian floor coating** system from **Earthcote®**, specifically for high traffic areas. Transaction zones are accentuated with 10mm **bright reflective white epoxy** screed.



**7.1.5 TRANSITION ZONE:** High traffic and density in the Transition zones are accentuated with the installation of Scintilla light-reactive polymer in the floor surface. **SensiTiles®** are made of a light conducting matrix embedded within a substrate. Similar to the process that makes fibre optics possible, the tiles transport light from one surface point to another by a process called ‘total internal refraction’. **SensiTiles®** respond to shadows that fall on their surfaces. They redirect and scatter any incoming light. The overhead light fitting increases the ambient light, which allows shadow-producing movements around a **SensiTiles®** to produce a rippling effect.

**SensiTiles®** also absorb and bleed colours. If coloured light falls on a **SensiTiles®**, echoes of that colour are dispersed throughout its surface. If multiple colors are present, they become blended, rearranged, and scrambled. **SensiTiles®** properties are inherent, therefore no power is required. The light effects are created passively from external light sources and they last as long as the material does. Scintilla incorporates a translucent acrylic polymer, giving the tiles a high density of light-reactive points.

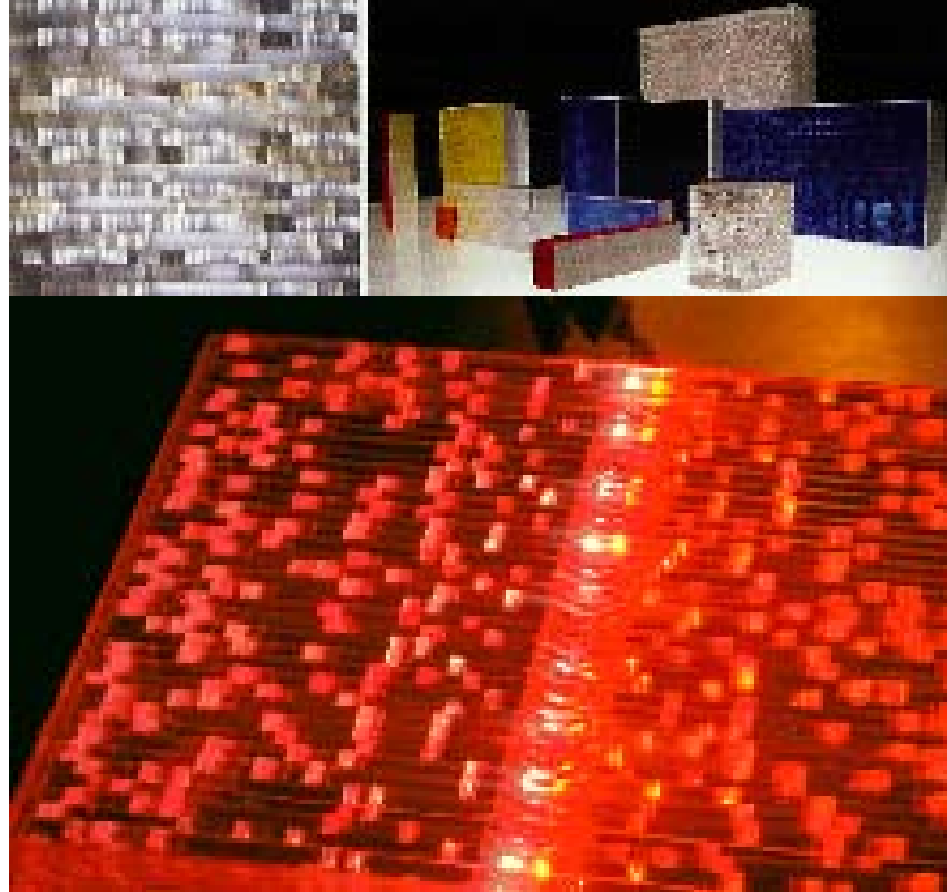

FIG 90: SensiTiles

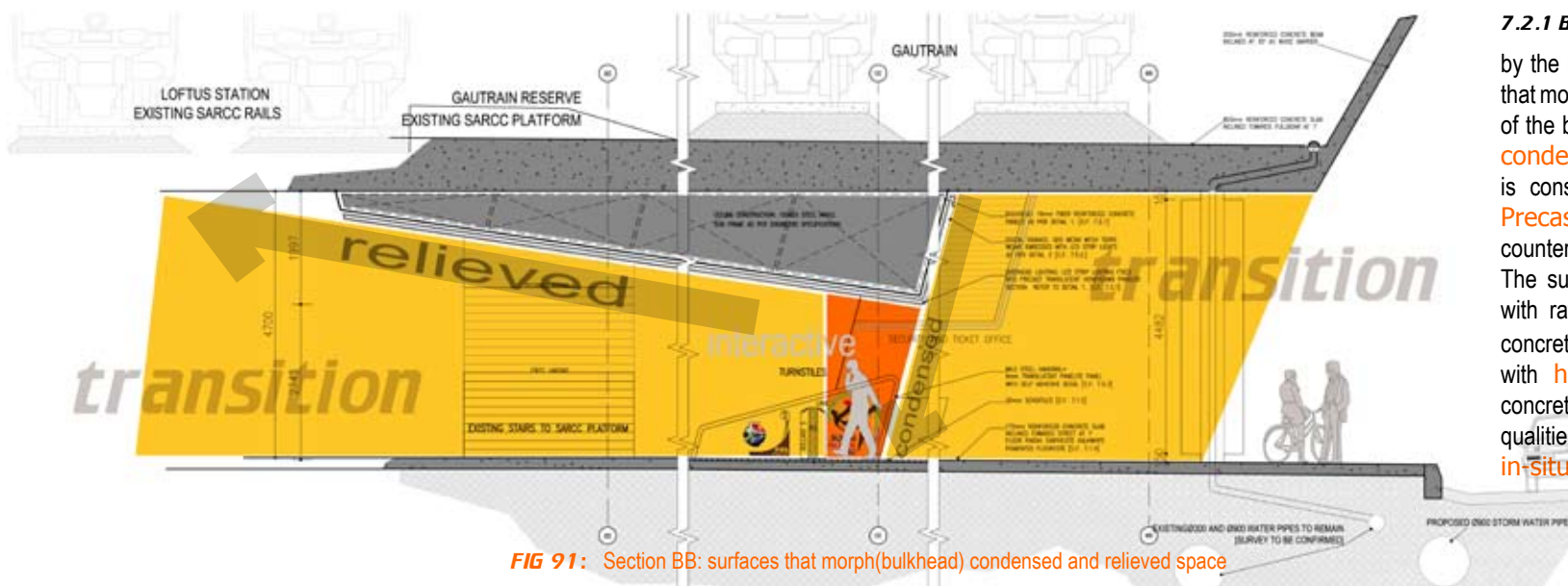

FIG 91: Section BB: surfaces that morph(bulkhead) condensed and relieved space

**7.2.1 BULKHEAD:** Spatial typologies are defined by the manipulation of space through surfaces that morph from the platform (ceiling). Inclination of the bulkhead determines how the space is condensed and relieved. The bulkhead is constructed of 16mm Fibre-Reinforced Precast Concrete panels, bolted with countersunk steel bolts on a steel sub-frame. The sub-frame is bolted to the concrete slab with rawl bolts. The fibre-reinforced precast concrete panels are lightweight structures with high strength. Reinforced precast concrete panels are also used for its aesthetic qualities; seemingly growing from the cast in-situ structure.



**7.2.2 COUNTER:** The counter of each transaction pod is designed as objects that develop out of the ground (floor) in the same boundary line as the bulkhead. Juxtaposed from the 15° inclined boundary these objects manipulate the spatial edge to accommodate a condensed interactive space. The counter is constructed of white precast Fibre-Reinforced Precast Concrete sections. The durable material has excellent **hard wearing qualities** essential for high density public space. The precast **lightweight** counter saves time on installation and precast methods ensure **precision cut aesthetics**. A distinctive **texture** from the synthetic fibres embedded in the concrete **reveals visual depth** in the finished material. The counter is cast as separate 700mm modular components, then each section is bolted to the floor with two chemical bolts.

The counter has an orange tinted **translucent structural honeycomb cast section**. The translucent section is warmer to touch and claims the interactive point of contact in the transition space. **Signage** is incorporated in the translucent material casting a solid colour that floats in the translucent counter. Continuous **fibreglass reinforced-resin edging** each side exposes the honeycomb pattern while providing **additional structural strength**.



FIG 92: Storefront for art and architecture: fibre reinforced precast concrete panel.

FIG 93: Extreme concrete: fibre reinforced concrete counter



FIG 94: Orange tinted, honeycomb Panelite section

FIG 95: Orange tinted, honeycomb Panelite counter



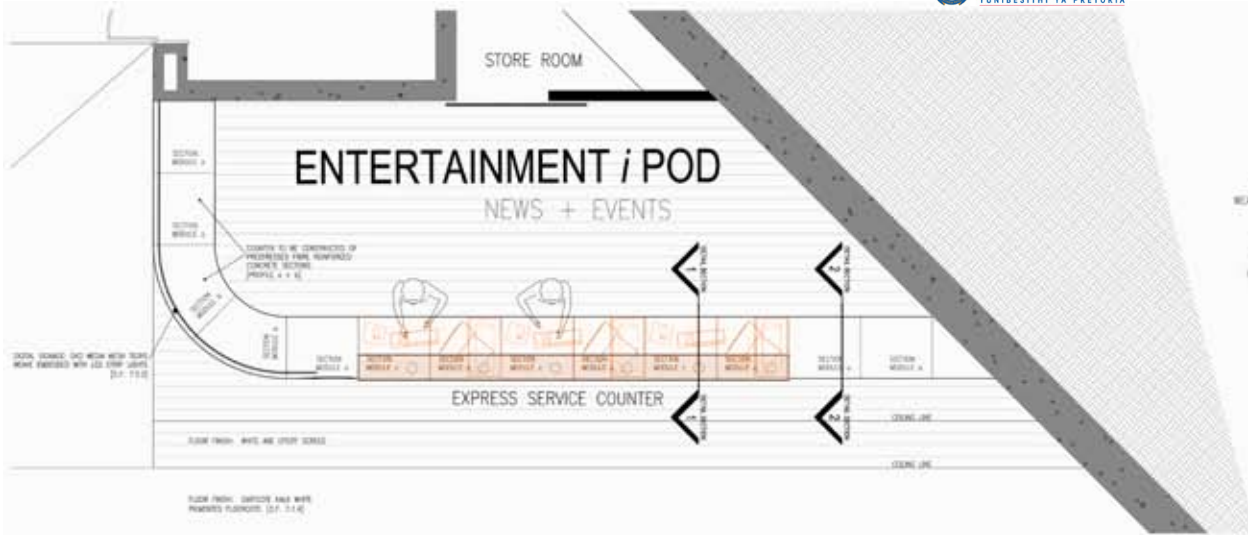

entertainment ipod plan

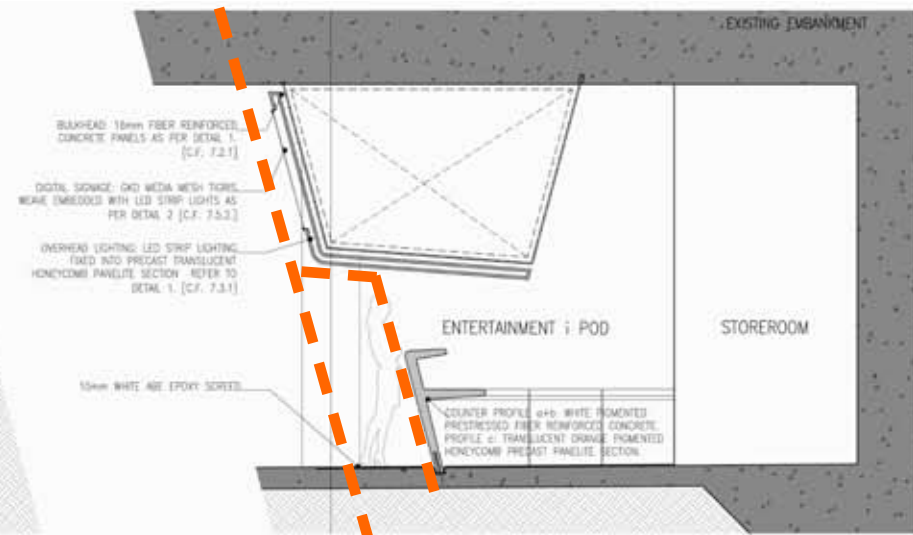

section ee

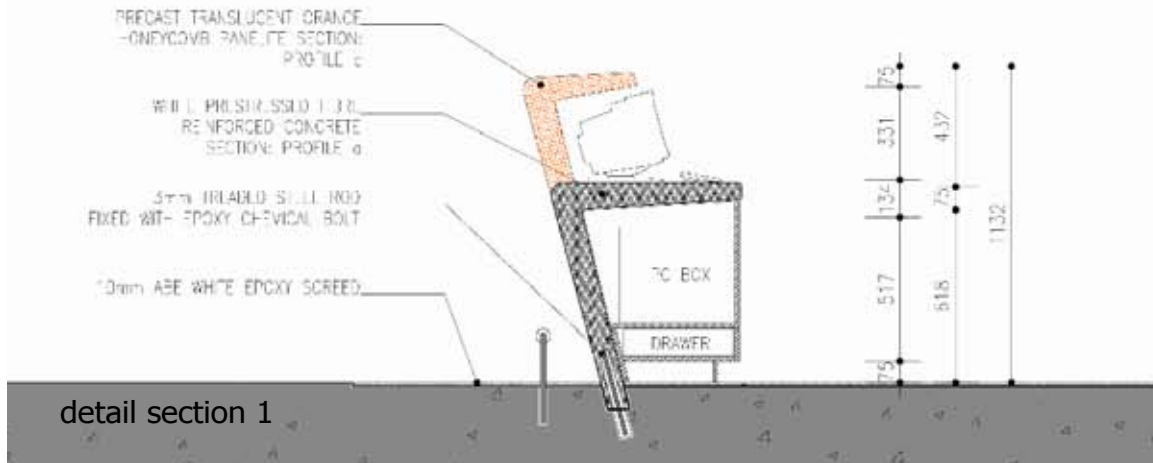

detail section 1

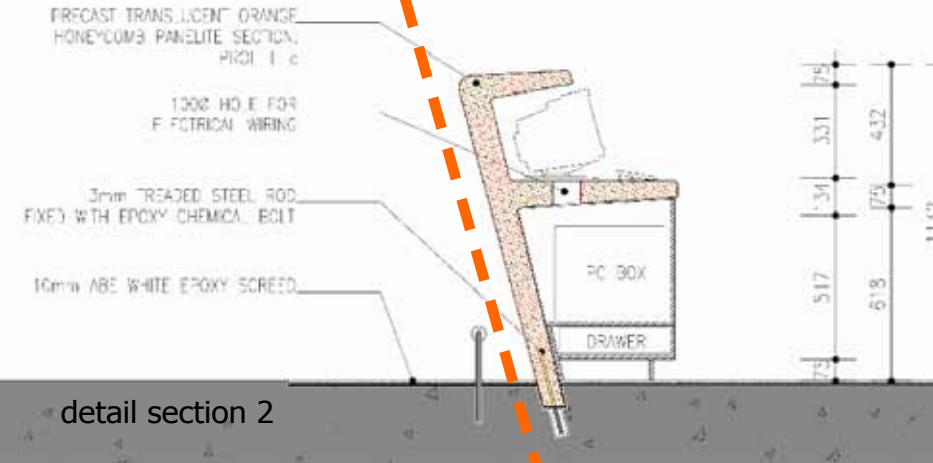

detail section 2

FIG 96: Technical drawings of surfaces that morph: transaction ipod counter.

**7.3.1 OVERHEAD:** A translucent light fitting enfolds the edge of the bulkhead rendering the boundary of the surface and space invisible. The light fitting is constructed of translucent honeycomb panels with laminated cast resin facings for additional strength. The lighting panel protrudes with the inclination of the bulkhead revealing the mild steel sub-frame. Way-finding signage is incorporated in the overhead light fitting, which are cast as a bright orange solid resin elements floating in the overhead boundary. LED lights are fixed in the honeycomb panels allowing a luminous glow in the transition and transition zones and increasing overall ambient light.

**7.3.2 INTERACTIVE:** Interactive spaces require concentrated lighting. Round brushed aluminium down-lights are positioned in the concrete. The Spazio low voltage tilted Edge, utilizes a unique clipping system to hold the lamp in place and secure easy installation.



lighting mund  
2211 53W 12V Cx 6.3  
Remote transformer required

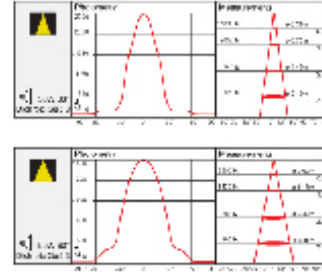
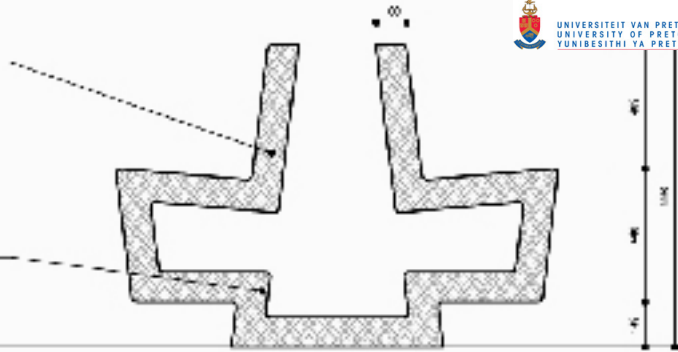

FIG 97: Spazio. Edge Downlight.

WHITE PRESTRESSED FIBRE  
REINFORCED CONCRETE

PRECAST ORANGE TRANSLUCENT  
HONEYCOMB PANELITE INSERTS  
EMBEDDED WITH LED STRIP LIGHT



detail section 3

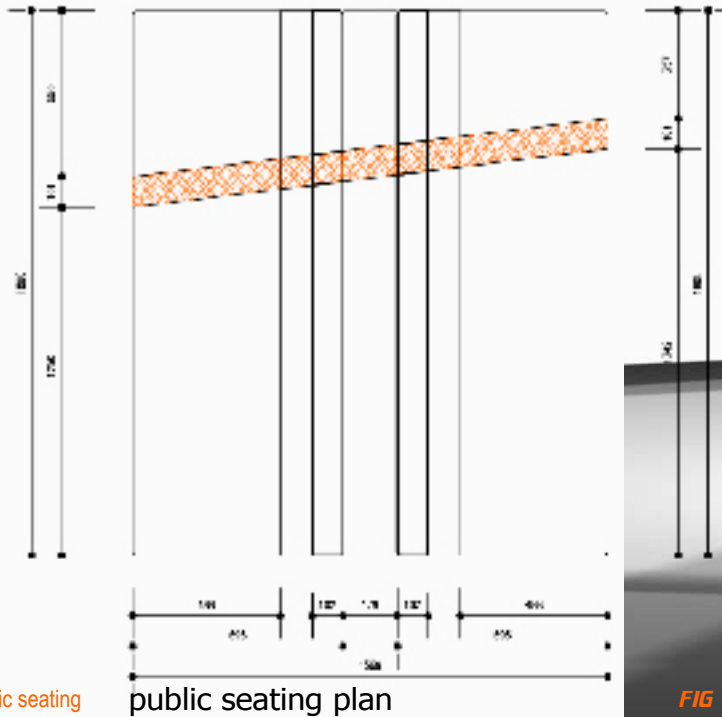

public seating plan

FIG 99: Technical drawings of public seating

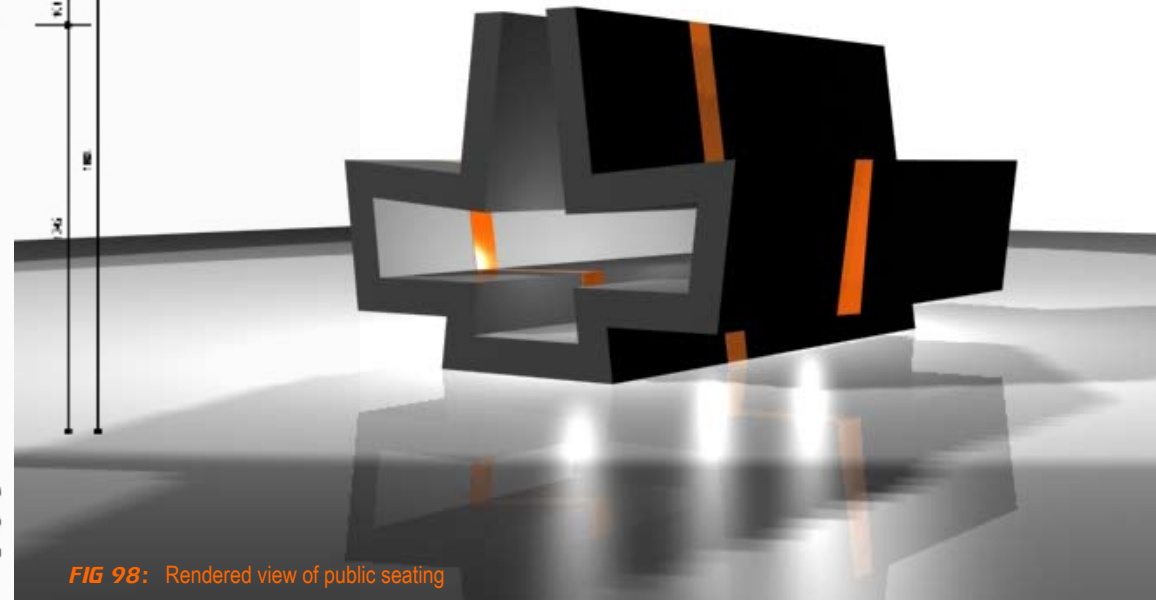

FIG 98: Rendered view of public seating

## OBJECTS IN SPACE

## 7.4

### 7.4.1 PUBLIC SEATING:

**FIG 100:**

Rendered perspective of internet unit

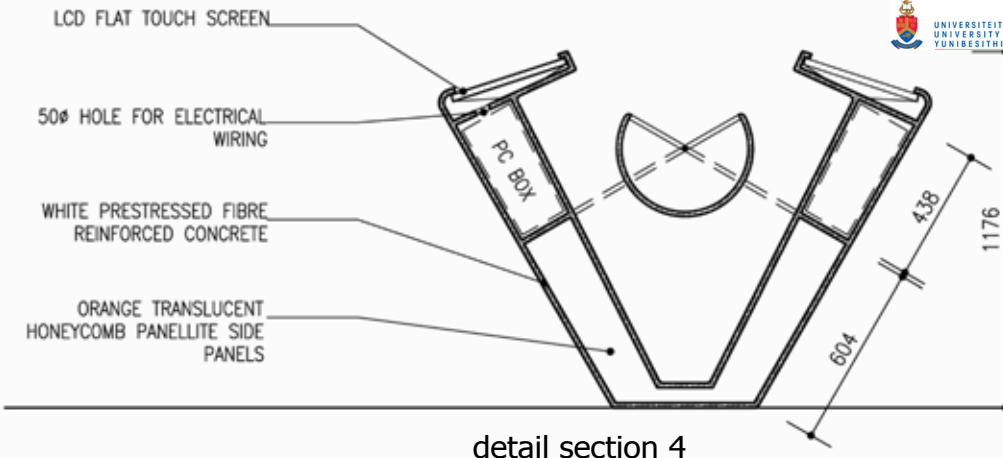

detail section 4

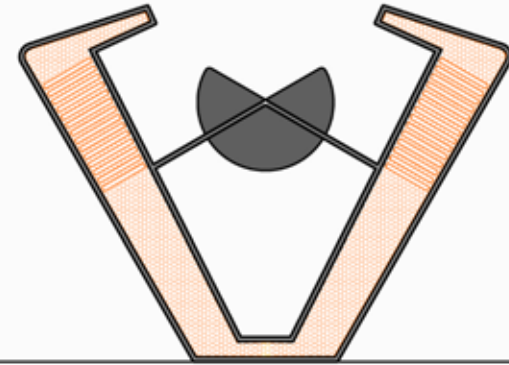

detail elevation

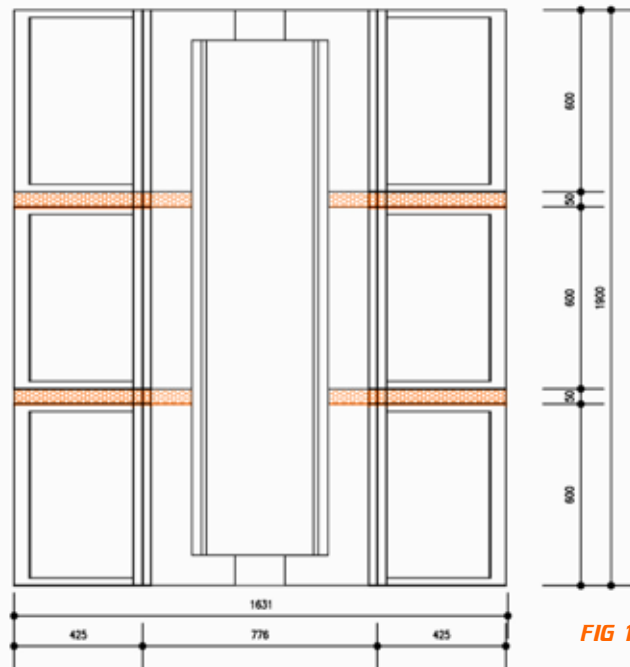

internet satellite plan

FIG 101: Technical drawings of internet satellite

**7.5.1 PERMANENT:** Way-finding systems are an integral part of a transit space. Bright orange cast resin signage is incorporated in the translucent honeycomb elements of the overhead light fitting and the counters sections.

**7.5.2 DIGITAL:** **Mediamesh®** is a stainless steel mesh with LED profiles with integrated and connected media controls. The LEDs reflect the images onto the facade, creating a display for a wide spectrum of graphics, text and video. **Mediamesh®** is weather resistant, which is important for this semi-enclosed public space. **Mediamesh®** is a transparent system, fixed to the overhead light fitting with a mild steel l-angle floating in the boundary between physical and space. The Mesh is easy to install and increases the capabilities of the urban fabric to evolve rapidly in a intelligent connected system. The Mesh has low power capabilities, and live video input keeps commuters globally connected. For ease of installation, **Mediamesh®** can also be produced as prefabricated modules that are ready for installation.

“Mediamesh® is also ideal for transit spaces such as airport terminals and train stations, as well as for shopping and congress centers. It can serve as a flexible, programmable guidance system which is simultaneously an organic element of the interior architecture. As opposed to typical display systems, Mediamesh® combines aesthetic integration capabilities with a highly functional added value: the application can be extended at all times with news or advertising - from logos to animation.”  
[www.gkd.com]

**7.5.3 ROTARY:** Separating the turnstiles in the transition zone are translucent honeycomb panels suspended between mild steel handrails. **3m®** self adhesive decals are fixed to the translucent board creating a three-dimensional ambiance on the panel. The signage is removable and changes as the space reflects the atmosphere of the city's events. A laminated film is placed over the self-adhesive decal to create an extra bright, high gloss finish, which provides wear and weathering fade protection in a high traffic area and ensures a tamper proof material.



FIG 102: GKD Creativeweave: Mediamesh.



## NOISE ATTENUATION

## 7.6

**7.6.1 NOISE BARRIER:** SARCC operates electrical trains, which are quiet. They are also **set back** from University road to dampen possible noise hazard. With the development of the Gautrain, **noise and vibration impacts** have been raised as a concern during the Environmental Impact Assessment; **noise barriers** will be constructed to ensure that noise levels do not exceed acceptable standards. The concrete beam that sits over the enclave is inclined, functioning as an improved noise barrier. The noise reverberation will not bounce back and forth between the train and vertical barrier but rather be directed over University Road and dampened by the Western Façade of the Main Administration Building.

**7.6.2 TRAFFIC CALMING:** A **traffic circle** is to be initiated at the Lynnwood and University Roads intersection, to re-establish the cultural sense of place of UP as an academic precinct. (c.f. 3.1.2) The speed and noise of vehicular movement interfere with a calm working environment honoured by UP, and impede on the **pedestrian friendly terrains** in and around the campus.