

intro- duction

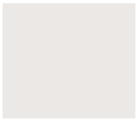
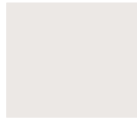

abstract

Sustainability requires a new pathway and our industry must evolve to be a contributor to finding the right answer, rather than delivering the trusted solutions that have served us well in an industry of unconstrained resources.

Aspiration of initiating a dialogue about our professional responsibility: the dialogue must engage with matters beyond engineering and find relevance in the disparate academic research, to drive the pragmatic decision making required by industry.

This thesis is not intended to be the final word, but rather a contribution to the body of knowledge that can be used to focus dialogue in this important area.

Our current methods of evaluating design fall a long way short of meeting the needs of a sustainable future. We have an obligation to embrace the search for ways of quantifying the impacts of our design decisions.

Will it be nirvana? No, but it will be a world considerably more decent and durable than what lay in prospect in the early 20th century.



"The earth cannot keep up with the demands [our] economy is placing on its ecological assets. Evidence is mounting that the sheer volume of resources flowing through the global economy has become today's key environmental challenge. With the world's population set to increase to 10 billion in 2050 and as human demand for resources grow; the earth's life-supporting natural capacity will be liquidated at ever-increasing rates. Signs of ecological pressure include climate change, collapsing fisheries, specie extinction, deforestation and desertification."

[WWF 2007 publication: 'Sustainability - one planet business-creating value within planetary limits.']



The following document considers a theory perceived by Ralph Abraham, a professor at the University of California and pioneer of the Chaos Theory. He explores Hesoid, a trinity made up of the Chaos, the Gaia and the Eros theories.

Chaos theory [born in 1975] is the branch of mathematics that provides models for intrinsically irregular natural processes.

The Gaia hypothesis [formulated in 1973] suggests that the Earth, as a whole, is a complex system capable of self-regulation.

Erodynamics [appearing in 1989] applies the theory of dynamical systems to human societies, the creative impulse, the spiritual medium that links Chaos and Gaia. The chaos theory provides us with new tools to understand these global complex systems by translating the context into a concrete form - sustainability. It teaches us to spot biospheric changes through discontinuities, unperceived tendencies, domino effects and vicious circles.

Rene Passet, one of the fathers of bio-economy, declared we should concern ourselves not with the sustainability of things but with the sustainability of functions. The Cartesian notion of the world, makes us believe that the only draw back of late reaction is to operate from a less favorable position, but in reality the process of unsustainability is life with discontinuities in which slow variations alternate with lightning-quick changes.

Arthur Battram, in *Navigatin Complexity*, reminds us possibilities is created by means of a language. It is not important for its capacity to describe the world, instead to invent new worlds. It is in this time that we can shed inappropriate paradigms and acquire suitable skills. He suggests a few aspects to reform: - the instinct to an integrating vision, humanity forms an inseparable part of nature; and transformation is an intrinsic property, it will outlast individual memory which proves we have the capacities to be sustainable, to build healthier societies.



UNIVERSITEIT VAN PRETORIA
UNIVERSITY OF PRETORIA
YUNIBESITHI YA PRETORIA



The Earth - satellite image showing ice receding

001 [b]



002

Coral reeves threatened by global warming



003

Biodiversity is threatened

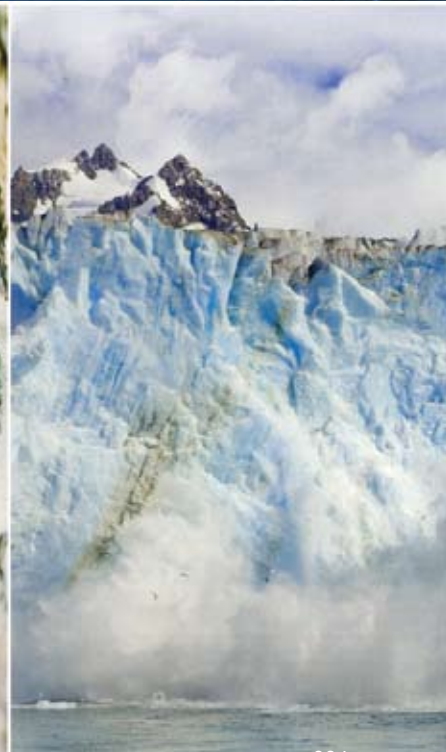

004

Iceland - Glaciers melting

A new social, cultural and political attitude, beyond the skeptical rejectionism of the recent late-century, will spur more qualitative construction environments. If we express our territory through the construction of environments, an optimistic belief in the capacity for innovation, in the possibility of combining research and creation in new operative concepts, would generate knowledge and promote new criteria for new methodologies towards evolutionary action. This expresses the growing importance of areas of knowledge and the need for institutions promoting positive innovation of the environment. It allows for productive settings, which entails reflection on new technological challenges of the digital society, translating into re-equilibrium.

_the sustainable design challenge - project S.O.S:

It's a serious environmental emergency and results in an extreme imbalance in our planet's ecosystem. With this in mind, responding to the pivotal issue, at the core of our every action, is not something which can be bolted onto our comfortable lifestyles - ruled by constant technological innovation, an advance phenomena, ensuring continuous forms of change in every single field. A function holding the key to a promising future, if applied in a proper manner, but currently one of the causes of our biggest concerns; climate change. To establish an equilibrium of the ebbs and flows of these ecosystems, we need to add some effort, recognize our interdependency on these resources and start to integrate these facets socially and economically - naturally applying it to all scales of life. In essence, the challenge becomes a design challenge, and we as designers have to evolve from being individual authors to facilitators of change. To plan and develop high-performance resource efficient infrastructure networks combined with cohesive neighbourhoods to support a healthy urban life as a post carbon twenty-first century society. The concept of sustainable development is not new, but it needs to find a path in society, fitting within the framework as an opportunity for implementation.



Modernist architecture is architecture, starting from an illusion, focussing on the aesthetic end-product, instead of a resource efficient product. Creative solutions through innovative, advance technological design, is essential to enable us to achieve an environmental friendly design. It all depends on how the technology is used, and right now, its used in insufficient isolated packages, not available to the public society, remaining in scientific laboratories, not reaching its prime audience. A facilitator with an integrated system, connecting the data and the facts is needed in order to allow us to "get wired" and see the connections, to design a resource efficient project as our optimal goal, [Technology: The application of practical or mechanical sciences to industry or commerce; scientific methods used in a particular field [Collins English Dictionary].

_climate change - nature or human nature?

Climate change, a phenomena becoming the greatest challenge in our lifetime, proving global warming is no longer a myth, but instead, a well-known reality we need to address. Although this prognosis has complex and contradicting viewpoints, we have to start realising the degree of importance. Climate change is a threat with physical evidence, which can alter the natural world of human society - how we provision ourselves with food, shelter, energy and water. It can revolutionize economies, shift from energy efficiency to hyper-efficiency, culminating in a world powered by sunlight, solar energy and biomass. The design revolution will grow from disciplines we call industrial ecology, natural systems, biomimicry and ecological engineering. An urgent matter we have to act on, otherwise, we will face dire consequences in the blink of an eye. Whether its a natural process in a sequence of climate changes or a human driven act, the relevant question remains: how is the human race going to adapt and embrace these changes?



evidence



UNIVERSITEIT VAN PRETORIA
UNIVERSITY OF PRETORIA
YUNIBESITHI YA PRETORIA

storms

There has been a definite increase in the severity and frequency of storms over recent decades. In 2000 Mozambique experienced catastrophic floods, repeated in 2001. In 2002 devastating floods occurred across Europe, creating one of the worst flood catastrophes cities like Prague has ever seen.



floods

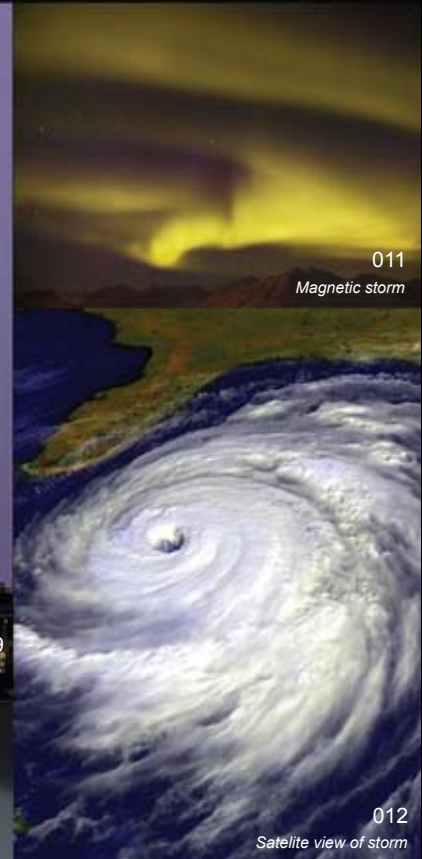



- *Southeast Asia* experienced exceptional rainfall in 2004, leaving 30 million Bangladesh citizens homeless.
- El Nino has produced severe effects due to the warming of the *Pacific ocean*. Sea temperatures in the Antarctica are rising at five times the global average. An increase of 2.5C since 1940. *Antarctic* summers have lengthened by 50 percent since 1970, resulting in receding of polar ice and rapid flora expansion. In Iceland Europe's largest glacier is breaking up, likely to slide into the north Atlantic, threatening the sea levels [The Observer, 22 October 2000].
- The sea level has risen 250 mm since 1860, due to thermal expansion. At the same time massive melting of the Alps glaciers occur, losing 50 per cent of their ice.
- The *Himalayas* are also receding faster than anywhere else on earth.
- In *Alaska* general thinning of sea ice due to warmer winters, leading to a change in migration patterns and numbers of wildlife species, posing threats to Eskimos [New Scientist, 14 November 1998].
- Since the later nineteenth century, the global mean surface air temperature has increased between 0.3 and 0.6 C. In 1998, the temperature surpassed the previous record in 1995 by 0.2C - the largest jump ever recorded [Worldwatch Institute in Scientific American, March 1999].
- According to NASA scientists, *Greenland* landbased ice sheet is thinning by 1m per year, which leads directly to a rise in sea level, threatening coastal regions [Nature, 5 March 1999]
- Spring in the *northern hemisphere* is arriving at least one week earlier than 20 years ago, with extreme heat episodes especially in the summer of 2003.
- Oceans, being our largest carbon sink, are becoming less efficient as a result of a temperature increase.

ice melting

Thomas Jefferson - Architect [1789]: "I say earth belongs to each generation. No generation can contract depths greater than may be paid during the course of its own existence."

Albert Einstein 1956: "The world will not evolve past its current state of crisis by using the same thinking that created the situation."

__the nature of the problem

Scientists continue investigating the complicated relationship that govern the Earth's climate and temperature, and even with hard core evidence, the occurrence of natural disasters all over the globe, society is still struggling to commit to resource efficient living. The key element for life on Earth, Carbon, forms the basis of micro-organisms, plants, and animals. These compounds play a major part in ensuring the planet's temperature is warm enough to support its rich diversity. But, true to our human nature, addicted to the luxuries of life provided by fossil based energy, this delicate balance is disrupted. Under natural conditions, the release of carbon is equalised by the absorption of CO2 by plants. Our interference overturns this delicate balance and in the process adds a further 6 billion tonnes of carbon to the atmosphere above the natural flux each year.

The sooner the vastness of the serious threat can be understood, the sooner we can commit to renewable energy sources and bioclimatic architectural design.





UNIVERSITEIT VAN PRETORIA
UNIVERSITY OF PRETORIA
YUNIBESITHI YA PRETORIA

But even if the severity of our current situation is understood, there are still several factors prohibiting to commit in this regard. The main three factors are:

_political:

On October 18, 1973, newspapers announced the end of a period of growth and prosperity. Arab countries decided to impose an embargo on oil exports, to Western nations supporting Israel in the fourth Arab-Israeli War. The price of oil doubled, followed by an economic crisis altering the production system. Initially researchers started experimenting with alternative renewable energy resources, but after the second oil crisis in '79, the oil price declined and the necessity to find alternative energy sources was gradually forgotten. The reason, limitless development was driven by particularly cheap oil, defined as the age of Hydrocarbon man - a turning point in the field of architecture. Allowing the human race to maintain the lifestyle of energy addicts, not realising these luxuries come at a high price. Today, faced with a recurrence of the same problem, it's obvious we haven't learned from our previous mistakes, and history repeats itself. Except today's energy problem is accompanied by a heightened environmental crisis.

_psychological:

A good law does not necessarily make a good citizen, especially where the awareness-raising consensus varies from one country to the next, from one belief system to another. What instruments can be used to persuade the global society to live according to resource efficient lifestyles, prompting them to forget the luxury of choice in order to work towards a twenty-first post carbon society? There is no magic formulae, in some cases coercion is necessary, in other persuasion or incentive. The most convincing way is to demonstrate, create awareness among the public realm. In short, educate

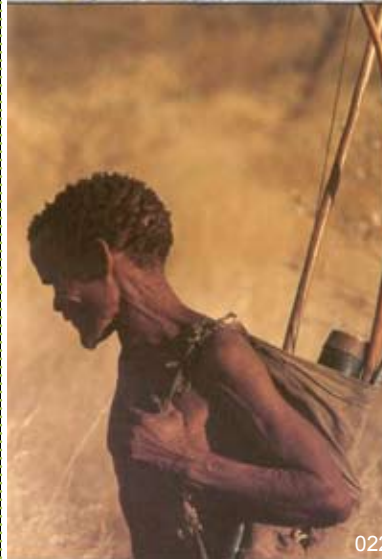

and inform our new generations to be able to find futuristic solutions for our current problem situation. We need to turn the "system" around, and that entails proper communication with the next generation.

_cultural:

We are part of nature, and all changes to nature have a direct impact on us, making this challenge partly cultural. We are currently stuck in a certain traditional belief system, bewitched by a high entropy concept of quality, a luxury, using astronomical amounts of energy to achieve. A paradigm shift should question the assumptions we've made towards our lifestyles. Rather evolving our typical social patterns into a better combination of solutions towards sustainable living. In Africa, the San-khoi khoi's traditional respect for the environment was always shown. Their belief system revolves around the knowledge that we're not the masters but only a part of the cosmos. They are able to adapt to change, even though their political and economic problems do tend to gain the upper hand. These basic cultural principles need to be applied to all cultural groups. We have to create a new cultural-aesthetic way of looking at life and how we live it, embrace these changes, sacrifice our living standards to enable ourselves to prepare for a position in which we can accommodate the global challenges that await us.



timeline



_the roots of green architecture

The polarization between views on the topic of green, sustainable architecture, reflects two profoundly opposed philosophical approaches. For some, through radical change, with economic growth ceasing, a shift back to simple community-based lifestyles - resulting in local vested solutions. Others believe innovative technology might be the answer, if practiced in an 'appropriate' manner. They prefer the formation of new structures and communities, instead of delving in the past, resulting in a more interventionist approach to solve our ecological disaster.

Neither of the above mentioned views will prevail. If we can find a middle ground between these strong view points, turn it into a coherent strategy, it might lead us to an equilibrium.

_post modernity ecologicalism:

_resource efficiency:

Apart from a few exceptions, Frank Lloyd Wright and Mies van de Rohe, the International movement did not take resource efficiency into account. While post-modern buildings, has developed a more energy conscious regard to quantity, type, location and renewable resources.

_replace what is displaced:

Frank Lloyd Wright viewed land as a resource, connecting the building with its surrounding environment. The rest merely placed the building within the landscape, functioning as an external expression. The Post-modern movement tend to integrate the building with the landscape. Either through, under or over the building, using its natural qualities to filter the air, convert carbon dioxide and assist in a healthy micro-climate less reliant on mechanical and artificial systems. The building takes some responsibility to achieve resource self-sufficiency. Harvesting energy, recycle it and apply it for re-use, minimising the ecological footprint of the building.

Hence, the building becomes co-responsible for its energy consumption.

_flexibility:

The International movement, did not facilitate society's needs, merely projected their view of architecture as an object set within the landscape. Instead the movement focussed on designing sculptural architecture, not able to adapt and change through time, Post-modern buildings accept the future use of buildings might change, and design accordingly. Enabling the skin and internal functions to change without affecting the structural integrity.

_transforming society views:

While the Modern Movement focused on social transformation, the Post-modern movement recognised the existence of different world views, allowing and encouraging society to participate and designers to open the building to self-express the users needs and opinions. This encourage users to add something to the building and subsequently retract something from it, making it more than just an object, becoming a memory through its making and its use.

To follow is a time-line, describing green architecture's roots and its evolution through time:

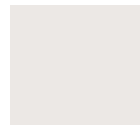

INDUSTRIALIZATION AND TRANSFORMATION OF ARCHITECTURE

- 1771: Society of Engineering established
- 1799: Iron-framed cotton mill at Salford

SIGFRIED GIDEON IN SPACE, TIME AND ARCHITECTURE:

"The industrial revolution, the abrupt increase in production brought about...introduction of the factory system and the machine, changed the whole appearance of the world..."

Middle of the 19th century, new methods of construction exploited ever more ambitious structures. Distinction between engineering and architecture firmly established.

NIKOLAUS PEVSNER and SIGFRIED GIEDION - great historians of the origin of the Modern Movement, based their claims on material use, structure and construction methods. The authority of technology, the tectonic aspects of Architecture.

- 1818: John Nash; Royal Pavilion at Brighton. Establish the institute of Civil Engineering.

ROBERT BRUEGMANN: The first environmental-service was introduced to buildings - the control of heating and ventilation.

ORIGINS: TECHNOLOGY AND ARCHITECTURE OF THE 19th CENTURY

- 1750-1900: Critical phase in development of new industrial methods. During this time power of steam and cool-gas production were invented and the generation of electricity perfected.

Over these years Western man's relationship changed with the environmental natural resources. Late 18th century. Cookle-stove heating system, after Bruegmann

- 1784: William Cook, steam heating system.
- 1792-1825: Sir John Soane, conventional Georgian town house using a centralized heating system.
- 1831: Pressurized hot-water system, Jacob Perkins, USA engineer

- 1837: Robert Adam, Edinburgh Register Office, showing Perkins hot-water-heating system.

- 1829: House of Parliament, design ventilation: Charles Barry



028



029



UNIVERSITEIT VAN PRETORIA
UNIVERSITY OF PRETORIA
YUNIBESITHI YA PRETORIA



026



030



031

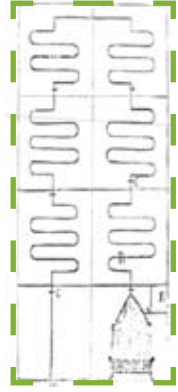

027



032

1835-1852: Charles Barry, architect, David Boswell Reid, engineer Houses of Parliament, London, front heating and ventilation system; after Hawkes.

1841: Ground floor plan showing air shafts Charles Barry, Reform Club, London; after Olley.

1841-1854: Cross-section showing ventilation ducts H. L. Eimes, architect, David Boswell Reid, engineer, St. George's Hall, Liverpool; after Olley.

THE MODERN MOVEMENT AND THE NEW SYNTHESIS

1843-1850: Synthesis of new technology and architecture. Labrouste - at the forefront to apply new environmental tools.

1858-1868: Fully integrated warm-air system Henri Labrouste, Bibliotheque Nationale, Paris.

1874: Used advanced systems of heating, ventilation and cooling. Network of collecting mixing heating chamber from which air mix into an appropriate temperature. [Gottfried Semper, Hofburg Theatre, Vienna.]

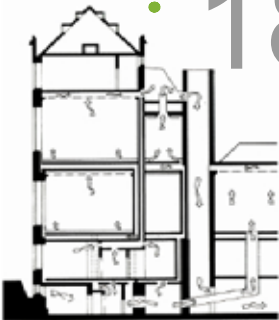

035

1841

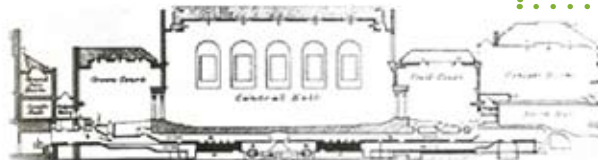

036



033

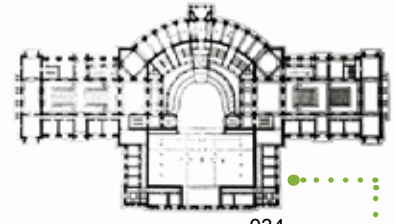

034



037



1925

1925: Le Corbusier, Cinque points d'une architecture nouvelle. Load bearing wall-punctured by window openings, with structural frame and light, largely transparent enclosing skin. Distinct technical function are given expression through specific and separate elements of the composition.



038

1919: Mies van der Rohe, glass skyscraper project, Berlin; after Hawkes

Building envelope reduced to faceted transparent skin. Building to be habitable, they would have to be serviced by environmental mechanisms of sophistication that did not exist at the time



041

1929-1933: A sealed glass facade with a full air-conditioning system, which supplies and extracts tempered and filtered air. This was to be maintained at 18 C with the aim of achieving a universal environmental standard.

1929: Drawing to illustrate the fundamentals of the system Le Corbusier proposed.

CONCEALED POWER VERSUS EXPOSED POWER

1929: Le Corbusier, Villa Savoye, Poissy, living room illustrating the new synthesis of the 20th century meant that the status of service installations within the visible order of architecture was open for reconsideration.

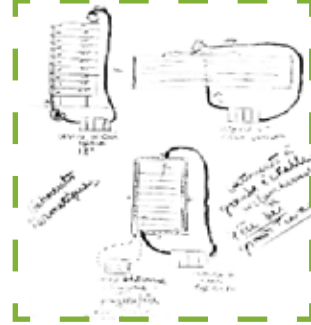

039

Linear light fitting is the key element, without concealing the cast iron radiators. It would be equally possible visually to reveal the apparatus of heating, ventilation and artificial lighting.



040



042



UNIVERSITEIT VAN PRETORIA
UNIVERSITY OF PRETORIA
YUNIBESITHI YA PRETORIA

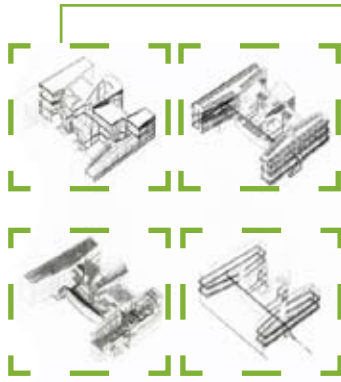

043



044



045

Le Corbusier, Cite de Refuge, interior.
Status of service installations within the visible order of Architecture was open for reconsideration. Now it was possible to express the difference between the building structure and its enclosure. Discreet accommodation of the system in use.

'Modernist' virtues: natural light
fresh air
large windows - cross ventilation
concealed radiant ceiling heating
accessible ducts for plumbing and electrical services

1935: Berthold Lubetkin, Highpoint flats, Highgate London. Environmental and services installations

REYNER BANHAM, ARCHITECTURE OF THE WELL TEMPERED ENVIRONMENT

It consisted of two approaches:
Physical incorporation of plant and services into the building fabric

1. Concealed Power
 2. Exposed Power
- Banham predominantly suggested systems in the Modern Movement to conceal services

1938: Berthold Lubetkin, Finsbury, Health Centre, London - Showing integration of services
Four distinct technical systems:
Construction; heating; electrical; plumbing

Radiant heating panels on ceiling
Ventilation at head of fixed light
Reinforced concrete walls, forming service ducts to the exterior of the building

Structural and service system diagrams: systems located in a void between the main structural beams and curtain walling

KENNETH FRAMPTON: STUDIES IN TECTONIC CULTURE

Mies: suspended ceiling covering services
representation of 'abstract materiality'
CONTRADICTION TO
actual materiality of his structures and natural material of floors

1958: Seagram Building, New York
Vision of seamless, imperceptible, but ideal environment. Invisible supplied brought to complete realization.



046



047

1938

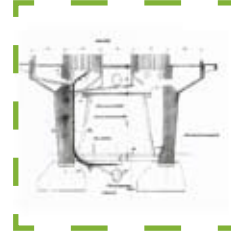

048



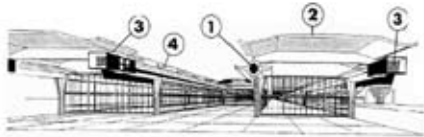

052

1964: Cut-away section showing relation of structure and mechanical system, Marco Zanuso, Olivetti Factory, Argentina.

Explore new ways to express the relationship between structure and services. Exposed air-conditioning plugged into hollow tubular roof beams. Roof becomes a combined structural and environmental canopy over the of space.

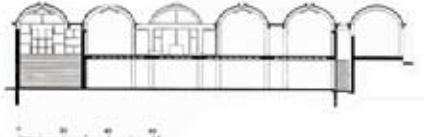

053

1961: Cut-away axonometric showing services ducts integrated into facade, Franco Albini, Rinascenente department store, Rome.

Services carried in voids formed within the precast concrete cladding

1966: SCSD school prototype, roof space acting as return air plenum

USA - exploitation of environmental-design given utilitarian expressions the programme.

Structure - a light steel roof over a deep-planned space, offering alternative service arrangements.

All serviced by artificial lighting and air-conditioning supplies. This speaks loudly of the triumph of technology over nature, artificial environment replace local climate conditions.



054

1972: Louis Kahn, Kimbell Art Museum, Fort Worth
Section perspective showing relation of structure and services - 'served' and 'servant' spaces.

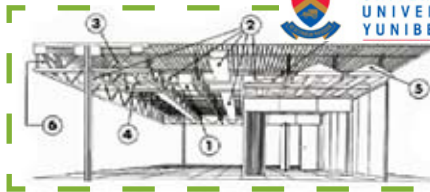

049

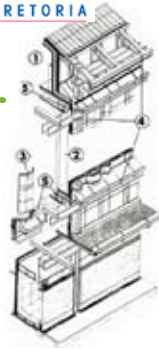

050

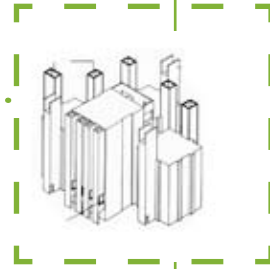

051

Louis Kahn: " I do not like ducts, I do not like pipes. I hate them really thoroughly, but because I hate them so thoroughly, I feel that they have to be given their place. If I just hated them and took no care, I think that they would invade the building and completely destroy it."

1977: Renzo Piano and Richard Rogers, Pompidou Centre, Paris
East 'service' facade

The influence of Kahn can be traced, but it was adapted in a completely different approach. Questioning the materiality and the representation of it.

1984: Richard Rogers, Lloyds Building, London.
Postmodern Movement, preoccupied with new kinds of interpretation over the tectonic.
Questions of environmental control and system organization received little attention.

1991: Robert Venturi, Sainsbury Wing, National Gallery, London.
Postmodern environment can be characterized as the scenographic over the tectonic.
Although lighting and air quality are crucial for the safe display of art, an illusion of constant natural light is created through an artificial light source.

THE EVOLVING ENVELOPE

1930: Le Corbusier added a new element to Modern Architecture - BRISE-SOLEIL

1936-1945: Le Corbusier and Lucio Costa,
Ministry of Education
Rio de Janeiro.

The brise-soleil, added to the standard repertoire, signalling the beginning of the external envelope of the modern building in service of environmental control.

1959-1061: Louis Kahn, Project for US Consulate, Luanda, Angola. Axonometric cut-away showing environmentally layered envelope.

Envelope combines areas of solid and void in proportions appropriate to the building function.
A sun-roof provide shade and promote natural ventilation, responding to the equatorial climate.

1965-1972: Louis Kahn, Library, Phillips Academy, New Hampshire.
Enclosed envelope, with distinct environmental zones, create a stable interior environment easy to maintain.



058



059

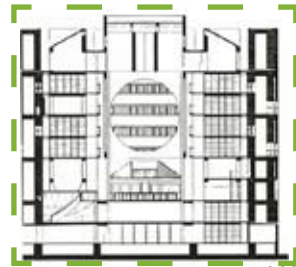

060



055



056

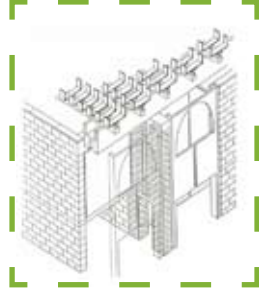

057



NATURAL VERSUS MECHANICAL ENERGY

The 'Vitruvian model of environmental design - this paradigm survived Modernism. International Style, Le Corbusier, proposing one house for all countries. 20th century building trends confirmed this idea. But the last quarter of the 20th questions the continuing of it. Awareness of fossil fuel resources, continued consumption with irreversible consequences. Therefore a new perspective emerge - Methods of Environmental control

1963: 'Interlocking field of climate balance, after Victor Olgay
Design with the climate, strengthen the relationship between Architecture and the climate.

1963: 'Flattening the curve, after Victor Olgay
Establishing the balance between environmental-function of Architecture and technology. Define stages by which variations climate might be modified

Steve Baer House, New Mexico - bioclimatic architecture, working with nature, using passive solar power for heating requirements. Cambridge Autonomous House Project, cross section 'Autonomy', where dwelling's servicing needs could be met without dependence on main services.

1991-1993: Norman Foster, Lycee Piyvalent, France.
Respect for orientation
Cross-section manipulated to promote controllable natural ventilation

1989-1993: Short Ford, Queen's Building, De Montfort University, Leicester, UK
Combine brick tradition with natural ventilation stacks.

1986-1994: Thomas Herzog, Congress and Exhibition Hall, Linz, Austria.
The arched roof form promotes natural ventilate

1989-1992: Ken Yeang, Menara Mesiniaga, Selangor, Malays. Bioclimatic Skyscraper with a systematic approach - design an envelope to bear extreme climate conditions.

A TAXONOMY OF ENVIRONMENTAL ARCHITECTURE

Environmental design is a combination of expanded tectonic environmental repertoire. Contemporary practice exhibits a greater diversity than ever before. The basis of this diversity rests on the relationship between environment function of form and fabric of building combined with mechanical service system.

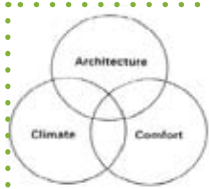

066



067

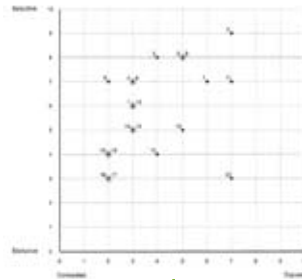

068



061

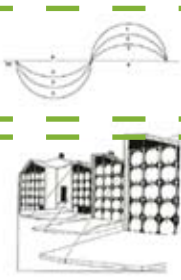

062



UNIVERSITEIT VAN PRETORIA
UNIVERSITY OF PRETORIA
YUNIBESITHI YA PRETORIA

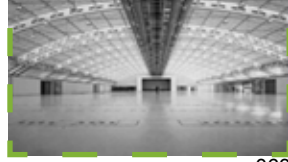

063



064



065