

Chapter 1

Introduction

1.1. *Organic pollutants and human health*

Over the decades numerous chemicals have been introduced to improve industrial processes, agricultural production, medical treatments, and the manufacture of cosmetic and household care products. Offsetting the convenience of such chemicals has been the increasing concern over potentially adverse effects on human health and the environment arising from their use and disposal.

Industry and society at large have become ever more aware of the harmful nature of natural and synthetic pollutants released into the environment every year. Of particular concern have been the very low levels at which certain pollutants can cause harm. For example, both the man-made and naturally occurring hormonal estrogens, ethinylestradiol (the contraceptive “pill”) and estradiol respectively, which typically enter the environment through waste water systems [1-6], have demonstrated their ability to disrupt the endocrine system of living organisms at the part-per-trillion level (ppt) [1, 2, 4,6, 7]. Such compounds are classified as endocrine disrupting compounds (EDCs).

The World Health Organization has defined an EDC as an exogenous substance or mixture that alters the function(s) of the endocrine system and consequently causes adverse health effects in an organism, or its progeny, or (sub) populations [1, 2, 3, 5]. An EDC priority list has been identified by the Global Water Research Coalition (GWRC) to include hormones, pesticides and herbicides, industrial chemicals such as alkyl phenols, phthalates and polychlorinated biphenyl compounds (PCBs) and heavy metals such as cadmium [5]. Of the organic compounds, the hormones exhibit the highest potency [5].

Bisphenol-A (BPA) and alkylphenols, particularly *tert*-octylphenol (TOP) and 4-nonylphenol (NP) are infamous pollutants found in water [1, 6-9]. TOP and NP are indirectly released into the environment through the anaerobic biological breakdown of non-ionic surfactants namely nonyl- and octylphenol ethoxylates. However, the ethoxylates exhibit neither the toxicity nor the estrogenic effects of their

Chapter 1 - Introduction

breakdown products [10]. Alkylphenol ethoxylates are released into the environment through wastewater, principally from the use of domestic laundry detergents, industrial soap, paints, toiletries and cosmetics [6]. Several isomers of commercial nonylphenol are available, of which 4-nonylphenol is the most common. No standard method currently exists for the sampling, storage and analysis of nonylphenol [9]. Bisphenol-A is used as an intermediate in the production of polycarbonate, epoxy resins and flame-retardants. Low levels of BPA are frequently released into the environment during the manufacturing, processing and use of these products [8].

During an experiment investigating the impact of estrogens on breast cancer cells, it was found that nonylphenol leached from the plastic containers used in the testing laboratory, caused the cancer cells to multiply rapidly [6]. It was established that nonylphenol at concentrations of 50 $\mu\text{g} / \text{L}$ (50 ppb) in water was sufficient to disrupt the reproductive cycle of fish [6]. In addition to decreased sperm counts in male fish, this disruption is also observed when the male fish start to produce *vitellogenin*. This is a female egg yolk protein, used in female ovaries to produce eggs. [6]. The more potent estrogen β -ethinylestradiol produces the same effect at 0.1 ng / L (0.1 ppt) [1, 2, 4, 6, 7].

Recently, it has also been revealed that the exposure of pregnant mothers to BPA leaching from polycarbonate bottles (hard clear plastic used to make baby bottles amongst others) and food cans lined with BPA resins, may have caused harm to their developing fetuses. These resulting children are born underweight; they then become and remain overweight for the rest of their lives [11]

Plant estrogens or phytoestrogens [12] have also been found to interfere with the endocrine system [6, 12, 13]. Various *isoflavones* in clover and *coumestans* found in sunflower oil and seeds and in soy, green and red beans have been identified as having estrogenic activity [6]. This discovery was prompted by sheep in Australia suffering from reproductive problems after eating a certain species of clover [6]. Recently, it was shown that exposure to phytoestrogens, in the form of lavender and tee tree oil used in the manufacture of body creams, caused prepubertal breast development in teenage boys [13].

Not all pollutants are found in aquatic systems. Several are airborne and are equally, if not more, harmful than the compounds already mentioned. Formaldehyde is classified as a probable human carcinogen by the U.S. Environmental Protection Agency (EPA), Occupational Safety and Health

Chapter 1 - Introduction

Administration (OSHA), National Institute for Occupational Safety and Health (NIOSH), as well as by the American Conference of Governmental Industrial Hygienists (ACGIH) [14-16]. Low molecular-mass aldehydes and amines are typically eye, nose, and throat irritants [16-18]. As volatile polar compounds, they are notoriously difficult to analyze, especially as they occur at the part-per-billion level.

Given their negative impact on human health it is urgent to monitor these pollutants at extremely low levels in both air and water.

Trace analysis has been defined as the detection and measurement of analytes below the concentration level of 100 μg per gram of sample, i.e. below 100 part-per-million [19]. Analysis of organic pollutants, at trace levels using liquid chromatography or gas chromatography combined with mass spectrometry has been used extensively over the years to monitor pollution levels. Recently, however, the occurrence of pollutants, which are harmful at the ppt / ppb level, has pushed analytical chemistry into the realm of ultra-trace analysis. Detection at a lower level, i.e., a decrease by an order of magnitude implies an increase of equal magnitude in sample complexity. Successful analysis of ultra-trace analytes requires not only extra sensitivity but also the introduction of an additional step to ensure selectivity prior to the final measurement.

1.2. The role of liquid chromatography – mass spectrometry in pollution analyses

Of the known organic species, 80% of them are analysed by liquid chromatography (LC) and the remaining 20% by gas chromatography (GC) [20]. Only volatile and thermally stable compounds can be analysed by GC and often only those with molecular mass < 800 by gas chromatography / mass spectrometry (GC/MS) [20], figure 1.1. However, GC has the greater separation power than LC and is preferred for the analysis of unknowns in complex samples. As GC/MS is an established technique, extensive unimolecular electron impact (EI) mass spectral libraries exist for the identification of unknowns. Much effort has gone into bringing LC to the same level as GC, especially with the development of liquid chromatography / mass spectrometry (LC/MS) and LC/MS/MS. For the measurement of target analytes at the ppt level, LC/MS/MS has demonstrated equivalent if not better detection limits to those obtained by GC/MS/MS [1].

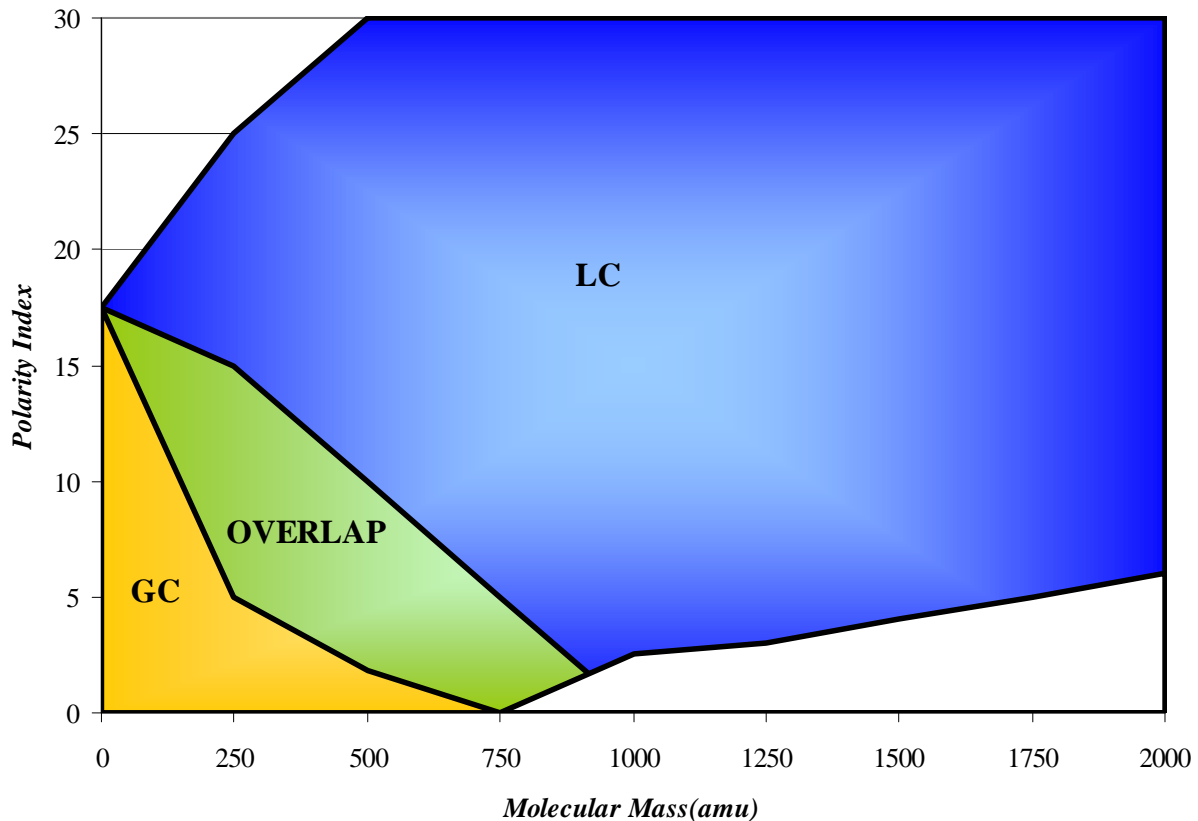

Figure 1.1 Graph showing the analytical domain of GC and LC using polarity versus molecular mass [20]. Copyright Global View Publishing, Pittsburgh, Pennsylvania, U.S.A. Reproduced with permission.

The three most common analytical techniques used for the analysis of estrogens from wastewaters are GC/MS, LC/MS and immunochemical techniques such as ELISA (enzyme linked immunosorbent assays) [21]. Furthermore LC/MS/MS and GC/MS/MS are able to accurately identify and quantify the estrogens at the required detection levels of 0.1 ng / L (ppt) or less [2, 3, 21-25], whereas the immunoassay techniques display measurement variation and can deliver false positives due to non-specific binding of estrogens and estrogen-like compounds to the antibody [3, 21-23, 26, 27].

MS/MS techniques provide added selectivity for very similar compounds. Selectivity is achieved when a certain mass fragment, unique to a particular analyte (or perhaps co-eluting with another) is allowed to move on to the second quadrupole (or TOFMS) for further fragmentation, while the other fragments are deflected. This is an advantage when estrogens having very similar structures cannot be separated effectively by the chromatographic system.

Chapter 1 - Introduction

For the analysis of estrogens in wastewater for example, where both conjugated and non-conjugated estrogens occur, no deconjugation of the estrogens is required since LC can easily separate larger molecules. This contrasts with GC analyses, where deconjugation and derivatization are required.

LC/MS suffers from several limitations, including the fact that only volatile buffers may be used as the LC mobile phase, often making separation of complex mixtures more complicated. In addition, complex samples, e.g. sewage water, often cause matrix effects which results in poor electrospray ionization of the analytes and therefore poorer and less reproducible sensitivity [28]. A general examination of the analytical methods used by GWRC members for monitoring of EDCs in water indicates that the majority of countries still prefer GC/MS [28].

In addition to this, LC/MS/MS is the most costly form of analysis due to the high cost of instrumentation, figure 1.2 [21]. The most common instruments found in the majority of routine analytical laboratories, particularly in South Africa, are those in the lower cost range, namely GC-FID, HPLC-UV, GC/MS and LC/MS (particularly in the pharmaceutical/ drug testing industries).

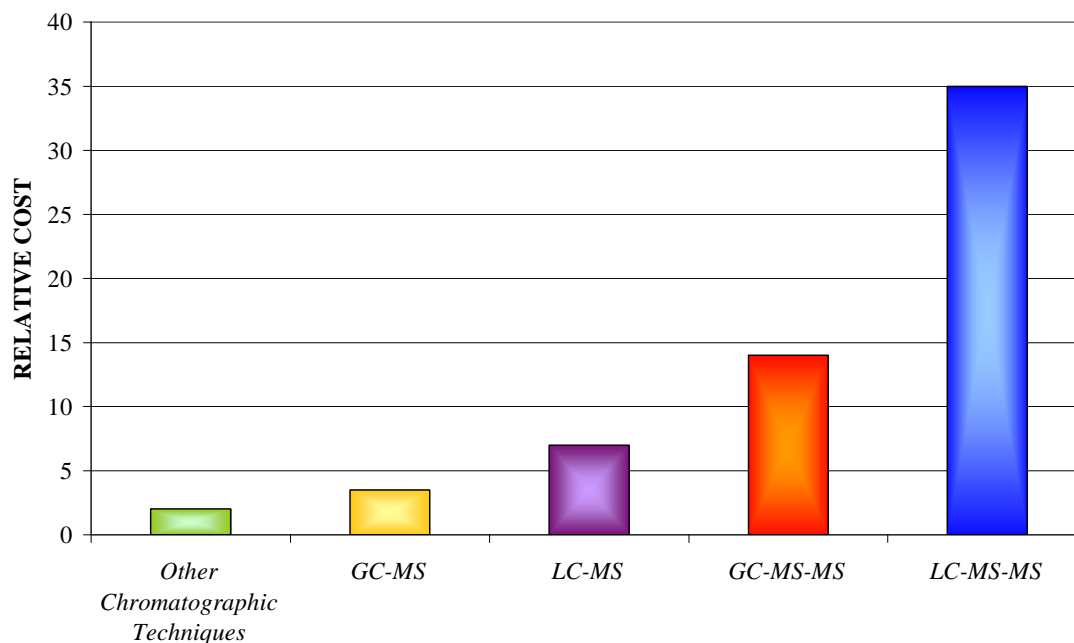

Figure 1.2 Chart representing the relative cost of the commercially available chromatographic and MS-hyphenated chromatographic instrumentation based upon data published in ref.21. Other chromatographic techniques are GC with flame ionisation or electron capture detection and HPLC with UV or fluorescence detection.

1.3. Gas chromatography-mass spectrometry and the need for derivatization

The routine use of GC/MS for the analysis of most compounds implies that a number of analytes have to undergo derivatization in order to be amenable to GC analysis. Regardless of the instrument used, some form of pre-concentration of the analytes is required before they can be physically detected by the analytical instrumentation. For extremely complex samples several possibilities are available to improve selectivity and ultimately the sensitivity of the measurement. In some cases, this can be achieved by including some form of derivatization during the sample preparation step. Alternatively, the instrument itself can enhance selectivity. For example, two-dimensional separations using GCxGC/MS can remove interference from the matrix, allowing for minimal sample cleanup [29]. A complex matrix can also be simplified using selective ionization techniques, with or without prior separation by GC or LC. These include negative chemical ionization (NCI) [29, 30] or the lesser known but extremely powerful resonance enhanced multiphoton ionization (REMPI) technique [31-37].

Real-time monitoring of trace organic compounds, such as polyaromatic hydrocarbons (PAHs) and polychlorinated biphenyls (PCBs), in air or process gases is not easily achieved. Measurement usually requires extended pre-concentration, cleanup of sample and instrumental analysis, for example by GC/MS, in a well-equipped analytical laboratory [38-40]. It involves a time-consuming and labour-intensive process that prevents the timely generation of data required for effective pollution-control measures. Recently, several on-line monitoring methods based on direct inlet mass spectrometry (MS) with soft and selective ionization methods have been established. These include chemical ionization MS [41] as well as photo-ionization MS techniques [32-36, 42-46].

One particularly powerful approach for real-time monitoring of aromatic compounds is resonance-enhanced multiphoton ionization time-of-flight mass spectrometry (REMPI-TOFMS). With this technique only aromatic compounds or compounds possessing conjugated systems are ionized before entering the TOFMS, thereby reducing the complexity of the sample matrix. This combination of selectivity and immediate availability of mass spectral information eliminates the time-consuming separation step of gas chromatography. Unfortunately, the relatively simple one colour two-photon REMPI process cannot easily detect compounds such as aliphatic aldehydes and amines that do not possess an aromatic chromophore.

Chapter 1 - Introduction

A fast method for the on-line detection of aldehydes and amines would have several potential applications in the field of process gas analysis, ambient air monitoring or emissions analysis. Furthermore, it would be desirable to benefit from the advantages gained by the REMPI-TOFMS method (i.e., selectivity, sensitivity, and measurement speed) in the detection of these aliphatic compounds.

1.4. Sample enrichment and preparation

Without the use of specialised instrumentation, sample preparation remains the most time-consuming analytical step prior to analysis. Much effort has gone into improving this process. The trend has been to move away from the use of toxic and expensive solvents to extract pollutants to other techniques that require either very few or no solvents at all. This often involves concentration of analytes on adsorbent materials followed by elution with a small volume of solvent, evaporation to 1 ml and injection of 1 μ l into the instrument. Alternatively the adsorbed analytes are thermally desorbed and introduced into the instrument, allowing for quantitative transfer of the entire sample into the instrument and therefore potentially lower detection limits.

Adsorbents are known to have several disadvantages. They possess active sites, which can result in chemical reactions either with the sorbed analytes being analysed or with the reagent used for derivatization. Tenax®, for example, is known to release benzaldehyde as one of its thermal degradation products, making it unsuitable for use in benzaldehyde analysis [47]. Some compounds may be irreversibly adsorbed on the sorbent. This is especially the case when polar compounds adsorb onto carbon sorbents [48]. Additionally, sorbents must undergo several pre-treatment steps before being packed into collection tubes. After the analysis, the sorbent must once again be subjected to several reconditioning and preparation steps before re-use. The entire process therefore becomes time-consuming. The ideal sorbent should be chemically inert, thermally stable and immediately reusable.

Over the last 15 years, polydimethylsiloxane (PDMS) or silicone rubber has gained widespread favour as the ideal liquid-like absorbent for pollutant concentration [47]. Analytes dissolve into the phase as they would in a solution. The silicone absorbent has a larger capacity or concentration range for which the partition isotherm is linear. In contrast, for adsorbents, once all available sites are occupied by a mono-layer, the adsorbent shows less retention for any further analytes entering the trap (non-linear

Chapter 1 - Introduction

partition isotherm). Furthermore, during thermal desorption, degradation of the silicone produces polymethylsiloxane compounds with reproducible retention times. In addition, these polymethylsiloxane compounds are easily distinguished by their electron impact (EI) mass spectral fragments. After thermal desorption, the silicone rubber is ready for use again. Two commercial PDMS devices have already gained widespread use namely solid phase microextraction (SPME) and stir bar sorptive extraction (SBSE - “Twister”) devices. The PDMS multichannel trap (MCT) developed in our laboratory has demonstrated its commercial potential. The use of derivatization in conjunction with PDMS has also been investigated. Unlike our MCT, which can be used in field sampling, the main drawback of the commercial devices is that they require bulky samples to be taken back to the laboratory for further preparation [47, 49].

Typical methods for determining the estrogens, alkylphenols and bisphenol-A are liquid-liquid extraction and solid phase extraction [1, 8, 9]. More recently PDMS has been used to concentrate these analytes from water, usually after conversion to their acetyl esters [50-56]. Typical detected levels of alkylphenols are in the low $\mu\text{g/L}$ range in river water and industrial effluents [57]; in freshwater sediments they are between 1 and 100 000 ng/g [58]. The lowest detection limits obtained for these compounds are at the low ng/L level [1].

The ideal analysis is on-site analysis. A significant reduction in errors is to be expected since the possibility of the sample changing during transport and storage is eliminated. However, a disadvantage at the moment is the poorer performance of the necessarily robust on-site instrumentation [59]. A compromise can be found by combining on-site sampling with off-site analysis since it has been stated by Pawliszyn [59], that analytes are more stable in the extraction phase than in the natural matrix [59]. As such, both the MCT as well as SBSE can be used for off-line concentration and storage of analytes in the PDMS matrix. However, the MCT sample collection procedure requires no electricity and is portable and rugged enough for field sampling, while the SBSE procedure requires a magnetic stirrer plate, for sample enrichment.

The open tubular structure of the MCT allows for the easy movement of air and water through the trap, including particulates. This makes the trap particularly suitable for sampling in the field (e.g. placed in a river) without any additional sample preparation. This also removes the additional complication of transporting large volumes of water and avoids losses resulting from the storage of dilute samples in glass containers. The advantage of the MCT lies in the minimal contact of analytes with container

Chapter 1 - Introduction

materials during sample collection and desorption. This reduces contamination arising from additional sample preparation steps. Any additional derivatization step required (to improve chromatographic elution and obtain additional selectivity and sensitivity) should therefore be performed *in situ*.

The PDMS MCT appears to be the simplest device for solventless sampling, concentration, derivatization and injection of air or water pollutants, as all these processes occur within the trap itself. The resulting chemical simplicity and minimum surface area provides the most inert conditions possible to minimize loss of analytes (including false negatives) and reduce other artifacts (including potential false positives due to sample carry-over) that so often invalidate results in ultra-trace analysis.

1.5. Aim of our study

Sampling methods for analytes in the environment are required that (1) reduce the complexity and cost of the sampling system involved (2) reduce the experimental uncertainties/errors and (3) lower the limit of detection. Versatile sampling methods that can cater for both air and water samples are of special importance.

On this basis, our research was carried out to develop an on-line concentration and derivatization method for low molecular mass aldehydes and alkyl amines, which could fulfil the above requirements using the polydimethylsiloxane (PDMS) open tubular traps and a mobile resonance enhanced multiphoton ionization time-of-flight mass spectrometer (REMPI-TOFMS).

In addition, multichannel silicone rubber traps (MCT) developed in our laboratories [61, 63-68] can be used to determine EDCs from water in combination with gas chromatography – flame ionization detection (GC-FID) and gas chromatography – mass spectrometry (GC/MS). Despite these compounds having a phenolic hydroxyl group, the bulk of the molecules are lipophilic in nature as expressed by their large octanol-water partition coefficients, rendering them ideal for PDMS extraction.

Chapter 1 - Introduction

Our aim was (1) to prepare stable gas standards of volatile aldehydes and amines (2) select and introduce a derivatizing reagent into the PDMS matrix in a convenient repeatable manner (3) demonstrate the efficient pre-concentration of the gaseous and aqueous standards on the reagent-coated PDMS traps (4) quantitatively recover and analyse the contents of the traps (5) demonstrate *in situ* derivatization on the PDMS traps for real samples.

1.6. Our approach

Sorptive extraction of alkylphenols, using SBSE, involves acetylation of the analytes *prior* to extraction. It has, however, been shown that there is no significant increase in the PDMS extraction of alkylphenols from water with or without acetylation. The extraction of bisphenol A, in contrast, improves dramatically with prior derivatization [54].

To demonstrate the versatility of the PDMS MCT, two approaches for concentration in PDMS would be investigated in this study, namely, 1) the on-line concentration and *in situ* derivatization of volatile polar analytes from air followed by REMPI-TOFMS detection, and 2) the concentration of phenolic lipophilic analytes from water requiring derivatization prior to analysis by GC/MS.

To render aldehydes and amines accessible to REMPI-TOFMS detection, a concept would be developed to convert the non-aromatic analytes into specific aromatic derivatives, which would then be detectable by REMPI-TOFMS (“photo-ionization labelling”). Derivatization reactions that in principle can be used for “photo-ionization labelling” are usually performed in liquid solutions. It has recently been demonstrated that a PDMS matrix can also be used as the reaction medium. A PDMS-based device, for example, has been used for *in situ* derivatization of low-molecular-mass aldehydes for GC/MS analysis [60, 61].

The principle of the “photo-ionization labelling” derivatization that would be investigated is as follows; the analytes from the sample gas current (i.e. containing traces of the amines or aldehydes to be analyzed) as well as the derivatization reagent are co-absorbed in a PDMS trap. After a short enrichment phase, the trap is heated. The heating induces both the derivatization reaction itself and the thermal desorption of the formed derivatives. The desorbed derivatives are subsequently transferred to

Chapter 1 - Introduction

the REMPI-TOFMS spectrometer for analysis. This procedure can be repeated at close intervals for on-line analysis.

The concept of using the multichannel PDMS trap as a “one-pot” concentration and derivatization device would be tested for the extraction of alkylphenols from water. Our approach would be first to extract the analytes into the PDMS matrix, and then to derivatize *in situ* in order to convert the hydroxyl functional group to an ester. The ability of the MCT to efficiently extract the alkylphenols directly from water, followed by an efficient conversion to their trifluoroacetate [62] derivatives *in situ* would be investigated.

1.7. Arrangement and presentation

Chapter 2 introduces sample preparation techniques for concentrating analytes from air and water, focussing on pre-concentration devices, particularly those using PDMS. Chapter 3 presents the concept of derivatization as well as the derivatization reactions available for the determination of aldehydes and amines in air, and estrogens/ alkylphenols in water. Various modes of sample introduction into the analytical instrument are summarised in chapter 4. Chapter 5 describes the application of on-line PDMS open tubular trapping with *in situ* derivatization to the determination of low molecular mass aldehydes and alkylamines from air. Chapter 6 discusses initial derivatization studies of estrogens; the application of our multichannel PDMS traps for concentrating and derivatizing alkylphenols and bisphenol-A from water. Conclusions are summarized in chapter 7 and the accredited journal publication of results obtained in chapter 5 appears in the appendix.

Chapter 2

Concentration Techniques

2. Introduction

Samples, which require analysis, are often too dilute, too complex or otherwise incompatible with the chromatographic system. Hence, some form of sample preparation is essential prior to instrumental analysis. Ideally, sample preparation should involve limited effort and expense. Minimal sample preparation will decrease the amount of experimental uncertainty in the results obtained. The diagram in figure 2.1 shows a brief summary of the enrichment and recovery techniques that are most commonly used for concentrating analytes from gaseous and aqueous phase samples.

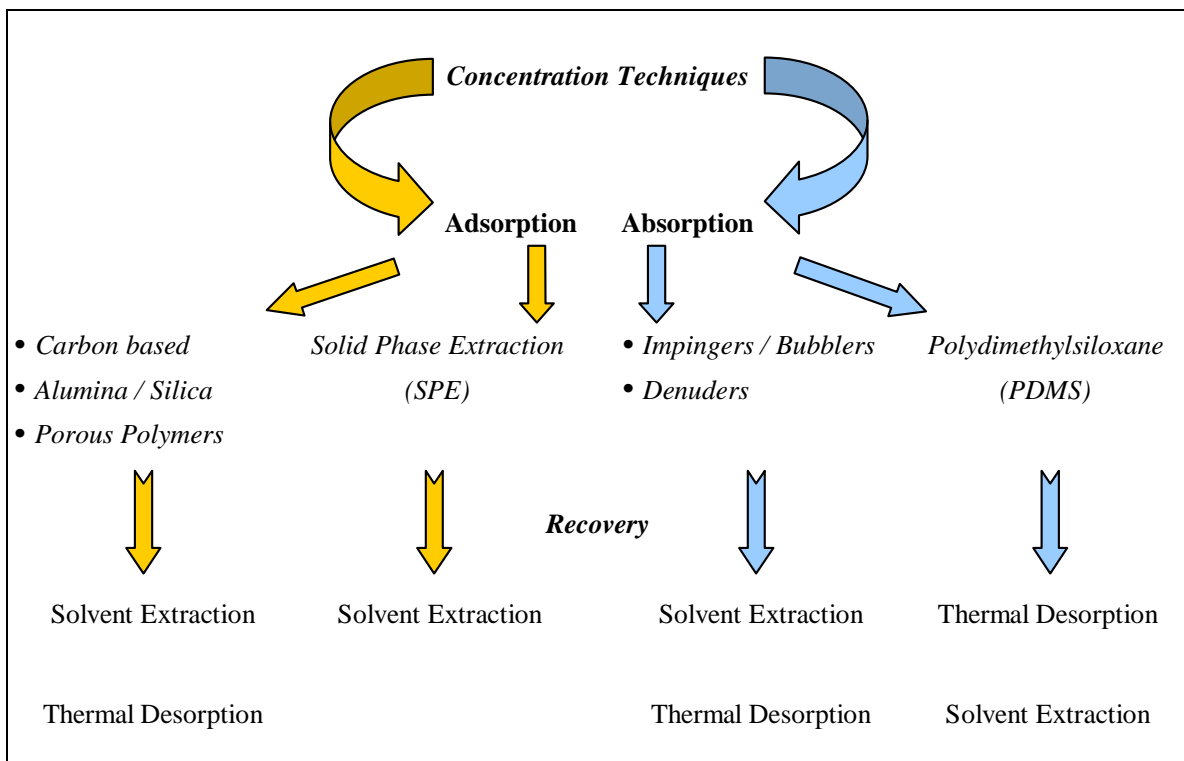

Figure 2.1 Diagram of concentration and recovery techniques most commonly used for concentrating analytes from gaseous and aqueous phase samples.

2.1. Adsorption

Adsorption is a physical process occurring on the surface of adsorbents. As analytes are retained on active surfaces on the sorbent, the amount of adsorption that occurs is related to the available surface area of the sorbent, which in turn is related to the porosity of the sorbent material. The rate of adsorption is determined by the structure both of the micropores and of the molecules moving into the pores [69]. Table 2.1 in Appendix 1 lists the types of adsorbents most commonly used for pre-concentration, as well as their structures, surface areas and pore diameters, uses, advantages and disadvantages.

2.1.1. Carbon-based, alumina, silica and porous polymers

Adsorption tubes are prepared by packing the sorbent into glass tubes of varying sizes depending on the required application. When choosing a sorbent for pre-concentration, it is important to see not only how well compounds are adsorbed, that is their retention, but also how easily they can be recovered. Carbon-based adsorbents are cheap, all purpose pre-concentration sorbents. However, desorption of the adsorbates (particularly polar compounds) may prove difficult and water accumulation is high, making them unsuitable for thermal desorption with cryogenic focusing [48].

Porous polymers are typically used for pre-concentrating high molecular mass and non-volatile compounds such as pesticides. They are popular because they are relatively inert, have large surface areas and are hydrophobic. They also permit the collection of large sample volumes (100 L) at high flow rates [70]. However, general disadvantages of porous polymers include the displacement of VOCs especially by CO₂ [48], and the irreversible adsorption of certain compounds, such as amines [48]. Furthermore oxidation, hydrolysis and polymerisation of the sample may occur [48]. Except for Tenax®, these adsorbents are thermally unstable above 250°C, which makes them unsuitable for thermal desorption as this leads to artefact formation [48]. At the same time, these sorbents are not reusable after solvent desorption. Careful purification of these sorbents, which usually involves soxhlet extraction with high purity solvents, is compulsory before they can be used for trace analysis [48]. Finally, porous polymers are more expensive than the charcoals.

Chapter 2 – Concentration Techniques

Most solid sorbents are well-suited for trapping specific compounds. In order to trap a wider range of compounds, multi-layered traps, utilising the best features of each adsorbent, have been prepared [71, 72]

Sorbents generally used with solvent extraction include silica gel, activated charcoal, Anasorb 747, carboxens (carbonised porous polymers), porous polymers and carbon molecular sieves. Those used in sampling with thermal desorption include Tenax®, Chromosorb 106, graphitised carbons and carbon molecular sieves [69].

2.1.2. Solid phase extraction (SPE)

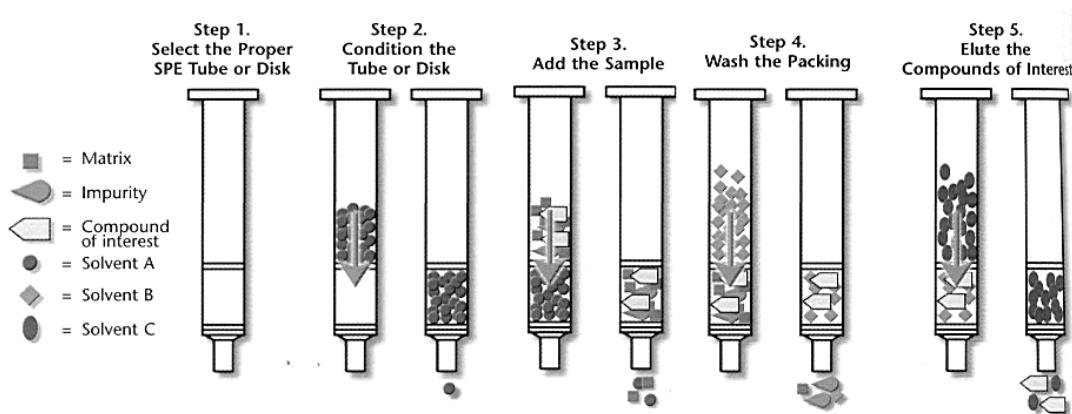

Figure 2.2 Use of a SPE device [73].

Unlike liquid-liquid extraction (LLE), which involves partitioning of the analyte between two immiscible liquid phases, SPE involves partitioning of the analyte between a solid and a liquid phase. The analyte is extracted when its affinity for the solid phase is greater than for the liquid phase. Later, the analyte is removed by extraction with a solvent for which the analyte has a greater affinity. The SPE device is depicted in Figure 2.2. The SPE cartridge consists of a packed adsorbent column between two fritted plastic/metal disks in a polypropylene open syringe barrel [73].

Chapter 2 – Concentration Techniques

The liquid phase is passed through the cartridge by gravity, suction or positive pressure (e.g. gas pressure from a syringe). Retention is caused by the intermolecular forces experienced between the analyte, the active sites on the sorbent-surface and the liquid phase [74].

SPE is not, traditionally, a technique used for pre-concentrating gaseous compounds. It has been used, predominantly, as a reagent coated sorbent [75-77] for derivatization, and for the extraction of derivatized products formed during liquid extraction [78].

Common sorbents used for SPE are based on silica gel with a modified surface. According to the chemical groups bonded to the silica, the phases are classified as non-polar, polar or ion-exchangers. Octadecyl surface phases (C18) are used for the reverse-phase extraction of non-polar compounds in aqueous solution. The shorter octyl phases (C8), are used to extract medium polarity compounds, while silica gel and alumina (Al_2O_3) are used to extract polar compounds [79].

SPE is simple, requires less solvent and less time than LLE, and is easily automated. However, the many steps required to prepare the sorbent and then extract the analyte, as depicted in figure 2.2., can be tedious. Also, the packing quality varies from cartridge to cartridge [78]. Granted, not all modern synthetic phases require sorbent preparation. The synthetic (non-silica based) SPE packings have not demonstrated significant variation between cartridges or batches.

Background contaminants from SPE have been measured at the 2 ng/mL level. They include phthalates and other plasticizers originating from the manufacture of the plastic frits and syringe barrels.

Undecane, originating from the sorbent material (C18), has been measured at 5 ng/mL [80].

To overcome problems encountered with the SPE cartridges, disk devices have been developed, namely, membranes or sorbents that have been packed into circular disks 0.5 mm thick and 4 to 96 mm in diameter. The sample processing rates are faster than those of the traditional SPE columns and the small diameter disks are ideal for processing smaller samples [78].

2.1.3. Cryo-trapping from the gas phase

Gaseous volatile compounds can be trapped at temperatures lying far below their respective boiling points. This is usually achieved by collecting whole air samples through steel tubes or capillaries, which are cooled by using either liquid nitrogen or carbon dioxide. To increase the condensing surface, the tubes are packed with an inert material that possesses a high surface area such as glass-wool or beads. The tubes are then heated ballistically to a suitable injection temperature and the analytes are transferred onto the column. This set-up is not always sufficiently portable for field work, and extra care must be taken when sampling in humid environments as pre-concentrated water will freeze and block the trap [48].

2.2. Absorption – dissolution of analytes from gases and liquids

Absorption is synonymous with dissolution and partitioning. In this process, the analyte is dissolved into a liquid where it is retained until it can be thermally desorbed or preferentially extracted into a different solvent for which the analyte has a greater affinity. This can typically be expressed as a gas-liquid extraction (when a gas phase analyte is involved) or liquid-liquid extraction (when a liquid phase analyte is involved).

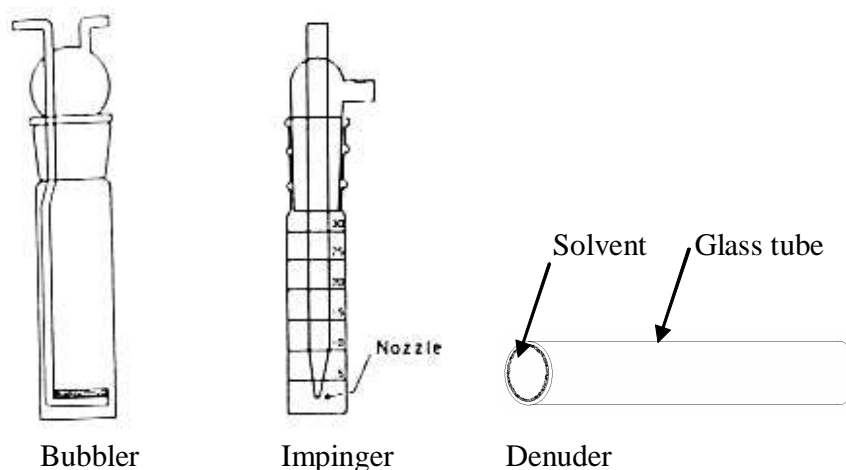

Figure 2.3 Liquid phase extraction devices [81].

2.2.1. Impingers and bubblers for gaseous samples

Special devices such as impingers and bubblers are used to disperse sampled gas in a solvent, see Figure 2.3. The finely divided gas bubbles rise from the bottom of the vessel, allowing for more contact between the gas bubbles and the solvent as the bubbles move toward the surface. In the case of reactive compounds such as formaldehyde, a derivatizing reagent is included with the solvent to improve extraction efficiency and simultaneously provide a more stable compound [81]. Adjusting the temperature of the solvent may also improve extraction. These devices are often used for sampling of gases from industrial stacks and automobile exhausts. However, large sample volumes are generally needed requiring the use of large pumps and extraction devices that are clumsy to wear for personal occupational sampling. Due to the large volumes of solvent used a dilution factor is also present and an additional concentrating step is required [47, 81].

2.2.2. Denuders for gaseous samples

Denuders are open glass tubes that have been coated on the inside with a thin layer of solvent as in Figure 2.3. As air is sucked through the tubes, analyte gas, present in the air, is extracted into the solvent. Unlike impingers and bubblers, higher collection flow-rates may be used. The extract is more concentrated on account of the smaller volume of solvent used [47]. Impingers and denuders have the advantage that any appropriate solvent can be used to trap a desired compound.

2.2.3. Polydimethylsiloxane (PDMS) as dissolution medium

Unlike the previous two techniques, extraction into PDMS can be viewed as dissolution into a “gum-like” phase, as opposed to a liquid phase solvent. Adsorbents, LLE and SPE techniques, are undesirable because they carry contaminants into the final extracted sample, along with the analytes of interest, producing a high background in the analysis. Recently, polydimethylsiloxane (silicone) has emerged as an alternative to adsorbents and organic solvents traditionally used for pre-concentration [49, 60, 63-66, 82-90]. The PDMS structure is depicted in figure 2.4.

Chapter 2 – Concentration Techniques

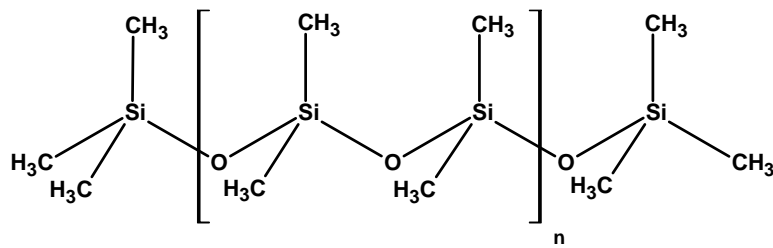

Figure 2.4 The structure of polydimethylsiloxane (PDMS).

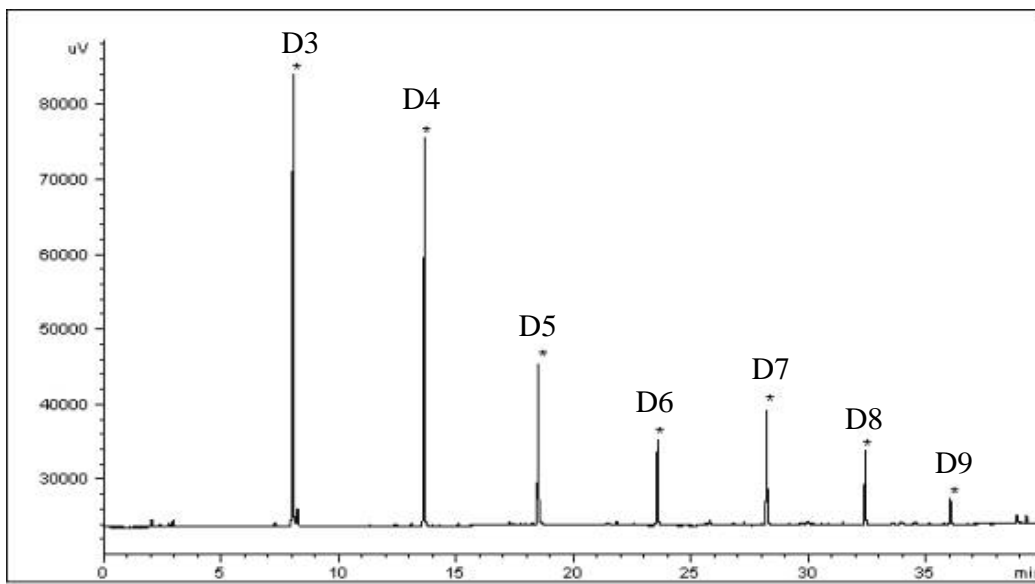

Figure 2.5 Thermal desorption run of a blank PDMS MCT.

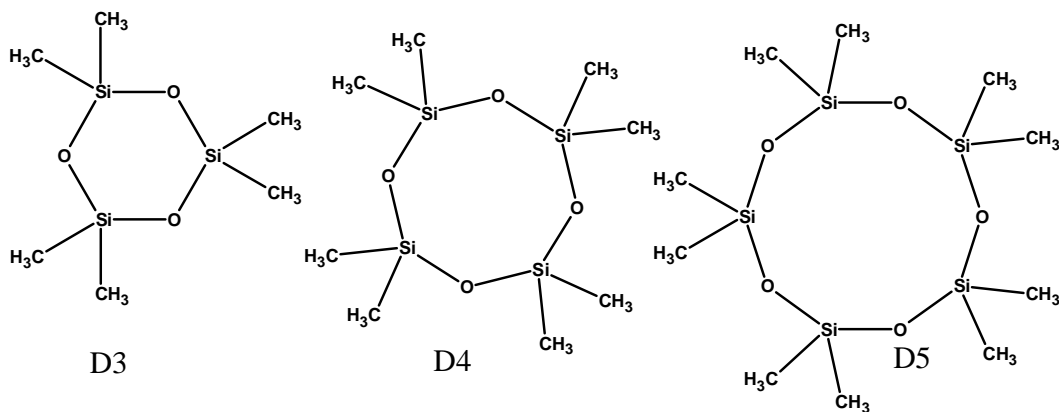

Figure 2.6 Structure of the PDMS methylsiloxane degradation products D3, D4 and D5.

Chapter 2 – Concentration Techniques

Polydimethylsiloxane is a non-polar, homogeneous liquid stationary phase used in GC capillary columns, generally known as SE-30, DB-1 or HP-1 columns. Just as the sample mixture injected onto a GC column will partition between the mobile and stationary phases, leading to a separation of components, so too, will gaseous mixtures in air partition into silicone. As previously discussed, the breakthrough volume of analytes determines their retention in the trap. The trapped contents in the silicone can then be extracted either by using a solvent [91] or by thermal desorption [66, 82].

Apart from being inert, the silicone “fluid” is thermally stable (between 150 and 250°C) under oxygen-free conditions [79]. The advantage of thermally desorbing the silicone lies in the immediate reusability of the material. In addition, all the silicone degradation peaks reveal repeatable retention times (see figure 2.5), as well as characteristic electron impact (EI) mass spectral fragments m/z 73, 207, 211 and 281. The main volatile silicone degradation products are methylcyclosiloxanes, the most abundant of these being hexamethylcyclotrisiloxane (D3) followed by gradually decreasing amounts of the higher molecular mass cyclic siloxanes (D4, D5, D6...) see figure 2.6 [92]. Figure 2.7 demonstrates how desorption temperature impacts on the amount of PDMS degradation that will occur. PDMS degrades significantly at desorption temperatures above 220°C.

As “like-dissolves-like”, polar compounds will have lower retention on a non-polar phase. Modified polymers e.g. polymethylacrylates etc. [49, 83, 93] have therefore been developed in an attempt to increase the polarity of the stationary phase. However, these polymers no longer exhibit a dissolution process, but rather an adsorptive process with all associated disadvantages, particularly high backgrounds during thermal desorption [83]. As opposed to other adsorbents on the market, silicone, has predictable thermal degradation products (by retention time and mass spectral fragments), displays a large linear partition isotherm and is immediately reusable after thermal desorption. Due to these remarkable properties silicone has been widely used as an adsorbent, leading to several possible configurations as described below, and depicted in figure 2.8, 2.9 and 2.10.

Chapter 2 – Concentration Techniques

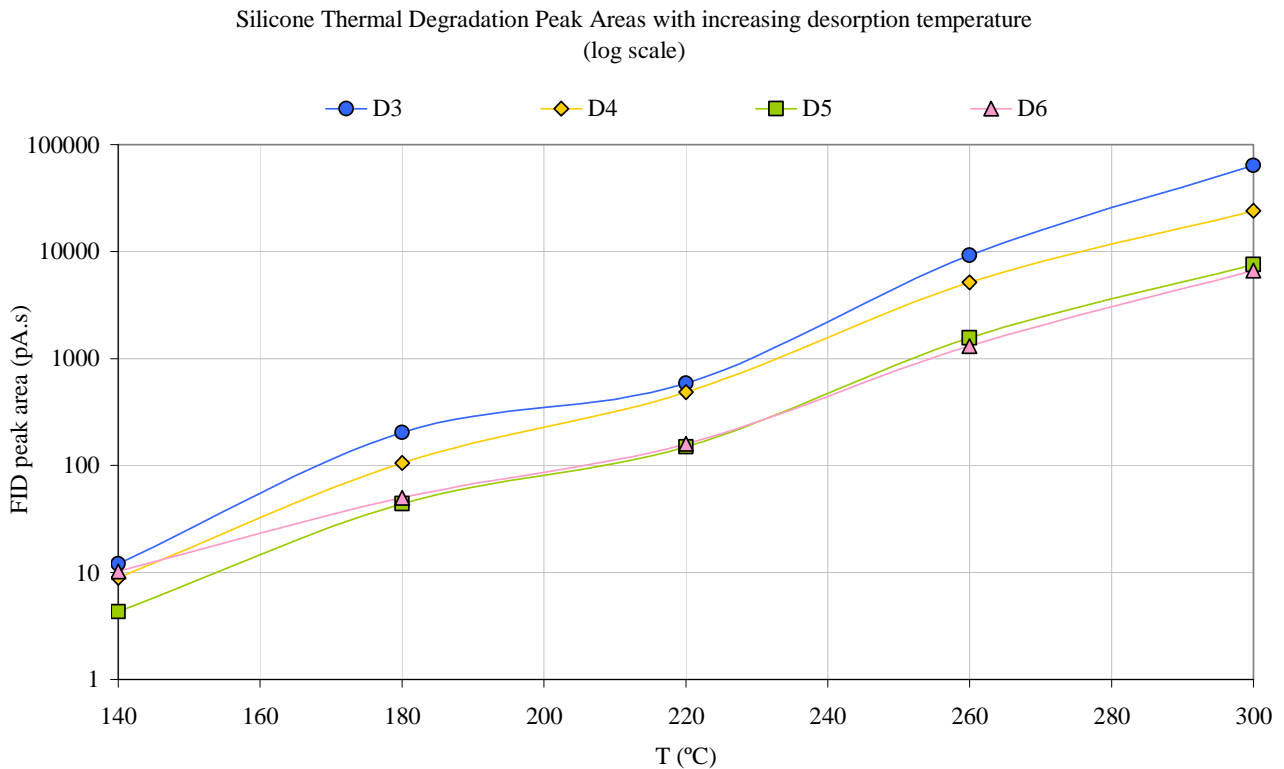

Figure 2.7 Increased thermal degradation of PDMS with increasing temperature.

Data obtained by desorbing a PDMS MCT for 10 min at each of the indicated desorption temperatures, desorb flow-rate 50 ml/min, cryotrap -100°C, inject for 1 min at 300°C. The respective siloxane degradation peaks were integrated to obtain peak areas (which were plotted on a logarithmic scale) versus desorption temperature.

The majority of silicone elastomers incorporate fillers. They act as material extenders but also reinforce the cross-linked polymer matrix. Fumed silica (SiO_2) fillers produce silicone rubbers with high tensile strength, reduced stickiness, increased hardness and elongation capability [94]. Silicone elastomers for medical applications use only fumed silica fillers [94]. According to Baltussen *et al* [95], commercial PDMS tubing contains approximately 40% v/v fumed silica (SiO_2) as filler. The PDMS volumes depicted in figure 2.8 represent the corrected (40% less) PDMS substance available for concentration.

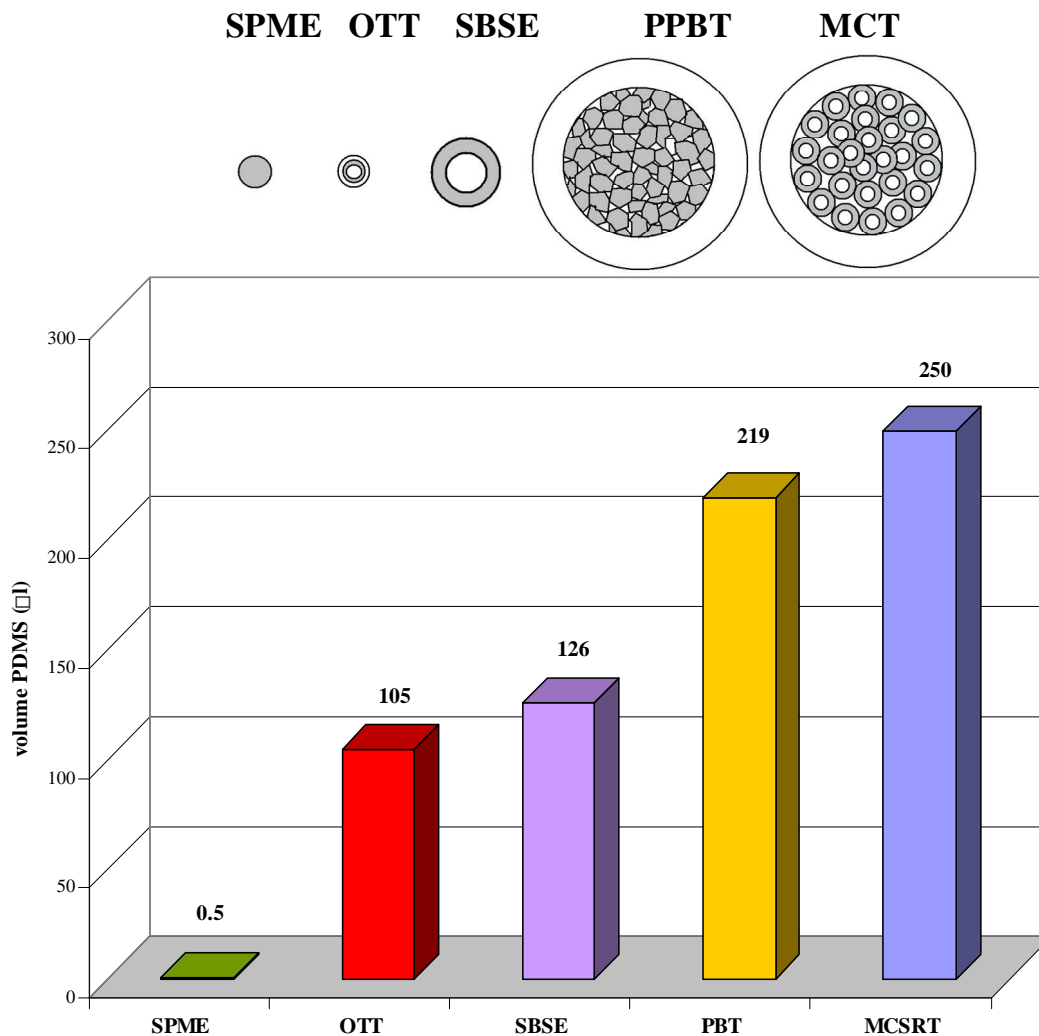

Figure 2.8 Cross-sections of the various PDMS configurations, with their corresponding PDMS volumes graphically depicted below them [95, 96*].

SPME: 100 μm PDMS solid phase microextraction fibre (PDMS volume 0.5 μl*)

OTT: Ultra thick film open tubular trap, consisting of a silicone rubber tube (d_f 145 μm) inserted in a 1 m long wide bore capillary (PDMS volume ~ 105 μl)

SBSE: Maximum PDMS commercially available 20 mm length x d_f 1.0 mm PDMS film coating a magnetic glass stir bar (PDMS volume 126 μl)

PPBT: Pulverized silicone rubber particles (PDMS volume 219 μl)

MCT: 32 silicone rubber tubes (0.63 mm o.d. x 0.3 mm i.d. x 5 cm lengths) arranged in parallel (PDMS volume 250 μl)

2.2.3.1. Open tubular traps (OTT)

Grob and Habich [97] introduced the use of OTTs to overcome problems experienced due to incomplete transfer of desorbed analytes from packed column traps onto GC capillary columns. The difference in flow rates obtained when moving from a packed column to a capillary column was eliminated by using the OTT, which has similar dimensions to a capillary column. Different coatings, ranging from activated charcoal to SE30, were used inside the OTTs for the pre-concentration of various compounds [84, 91, 97-98].

This led to the development of ultra thick film OTTs, by Blomberg and Roeraade [85, 86], and Burger *et al* [84, 87]. Blomberg and Roeraade used dynamic coating techniques that require special instrumentation. By comparison, Burger's technique is easier to prepare. A single 1m long silicone rubber tube is inserted into a fused silica capillary, to provide a film thickness of 145 μm . The silicone tube is first stretched and then immersed into liquid nitrogen. In this way it is sufficiently manageable to allow for insertion into the capillary, figure 2.8. The capillary is then fitted into a modified GC where it can be thermally desorbed onto another GC column for analysis. However, the OTTs show limited sampling capacity and can only operate under low sampling flow rates (10 ml/min).

A more modern and user-friendly application of OTT, called in-tube solid phase microextraction (SPME), was developed by Pawliszyn *et al* [100]. In this case a length of open tubular capillary, with an appropriate stationary phase, is housed within the SPME needle assembly, used to pierce the sample vial, figure 2.10 [100, 49]. The entire sampling and desorption steps are automated via a six-port valve. During in-tube sampling the aqueous sample is repeatedly aspirated from the sample vial through the OTT and then dispensed back to the vial by movement of the syringe. Following the extraction step, the six-port valve is switched to desorb the analytes from the OTT by flushing an appropriate solvent, contained in another vial, through the capillary. This flushed volume is taken up in the sample loop and injected into the HPLC or GC system [100-103]. This technique has the advantage of having a variety of stationary phases available to concentrate analytes of varying polarity, and are stable towards solvents used in LC for solvent desorption of the OTT. In-tube SPME has been applied to the analysis of polar thermally labile phenyl urea pesticides on an Omegawax 250 GC capillary column (0.25 mm

i.d., 0.25 μm film thickness). Here the 1.4 ml sample undergoes up to 50 aspirate/dispense steps at a sample flow rate of 63 $\mu\text{L}/\text{min}$. Detection limits for this method were later improved upon, by using a custom made polypyrrole-coated capillary, which showed superior extraction efficiency [103].

2.2.3.2. *The multichannel silicone rubber trap (MCT)*

Ortner and Rohwer developed the multichannel silicone rubber trap [61, 63-68]. It is based on the same principle as the open tubular traps developed by Burger *et al* [87]. However, instead of inserting a single long silicone rubber tube inside a fused silica capillary, the MCT is made more compact by arranging several shorter lengths of silicone rubber tubes in parallel inside a glass tube, depicted in figure 2.8. This makes the trap suitable for desorption in a conventional desorption unit. Due to its open tubular design the MCT exhibits a lower pressure drop than levels associated with packed beds, allowing for higher sampling flow rates of up to 1 L/min, particularly for the collection of non-volatile analytes. To improve the extraction of semi-volatile analytes from the gas phase into the silicone [64, 65] the MCT is operated under low sampling flow rates (15 ml/min) where an increased number of plates (N) is required. For aqueous samples extremely low flow rates of 75 $\mu\text{l}/\text{min}$ are typically used. At this flow rate benzene afforded 11 plates on the 32 multichannel trap [63].

The use of MCT's has already been demonstrated for concentrating semi-volatiles in air and water, and geosmin, low molecular mass amines and aldehydes in air and beer aromas [61, 63-68, 104].

The MCT consists of a glass tube containing several smaller silicone rubber tubes, each 10 cm long, arranged in parallel [61, 63-68, 104] as shown in Figures 2.8. and 2.9. SIL-TEC medical grade silicone tubing for the silicone rubber trap was obtained from Technical Products Inc. (Georgia, U.S.A). It has been shown that the MCT has a very low pressure drop (or flow resistance) with properties similar to the packed PDMS trap described below.



Figure 2.9 A polydimethylsiloxane multichannel trap (PDMS MCT). This trap has 32 x ~2 cm lengths of PDMS tubes arranged in parallel inside a glass tube. This shorter arrangement is suitable for trapping less volatile analytes which require longer desorption times.

2.2.3.3. Packed particle bed traps (PPBT)

Baltussen *et al* [82, 83, 88-90] packed a glass tube with equally sized particles of pulverised 100% polydimethylsiloxane, shown in figure 2.8. As this method of packing allows for a low-pressure drop over the trap along with turbulent flow, high sampling flow rates (500 ml/min) can be used. These packed beds have been successfully applied to the analysis of organic acids, PAHs and nitro-PAHs from air [88], for characterisation of natural gas [82], for the monitoring of nicotine in air [90], and of amines, pesticides and PAHs in aqueous samples [83, 89]. An added benefit of these traps is the fact that breakthrough volumes for gas phase analytes can be calculated and predicted through their retention on an SE-30 column [82]. For aqueous samples, the removal of water before thermal desorption and cryo-trapping, is essential. However, all volatile analytes are lost in this process [83, 89].

2.2.3.4. Solid phase microextraction (SPME)

The SPME technique developed by Pawliszyn *et al*, is in principle a solventless liquid extraction [49]. The SPME device resembles a syringe. A 1 cm long thin fibre coated with a polymer, normally silicone, is attached to the tip of the syringe plunger, which can be retracted into the syringe barrel, as

Chapter 2 – Concentration Techniques

depicted in figure 2.9 [105]. This device is practical for piercing septa and only exposing the fibre to a hot GC inlet, vial etc.

Unlike the other pre-concentration techniques, which are typically dynamic as they involve a flowing stream of gas passing over the sorbent, SPME is a static sampling technique. The fibre is either exposed to the headspace of a sample or immersed in a liquid sample in a sealed vial for a precise period of time. The analytes will partition into the liquid phase until a distribution-equilibrium is reached. This process usually takes between 2-30 min. Equilibrium can be attained more quickly in headspace SPME than in immersion SPME, as the analytes can diffuse more rapidly towards the fibre. This extraction step is equivalent to one theoretical plate (N). From the equation below [49, 105], it can be seen that the amount extracted (n), is directly proportional to the concentration of the analyte in the sample (C_0).

$$n = \frac{K_{fs} V_f V_s C_0}{K_{fs} V_f + V_s} \quad (2.1)$$

Where K_{fs} is the distribution coefficient between the fibre and sample. V_f is the volume of the fibre, V_s is the sample volume and C_0 the initial concentration of the analyte in the sample [49, 105].

Consequently, trace analysis of analytes having a small partition coefficient (K_{fs}) will require sensitive instrumentation.

As for solvent extraction, the extraction efficiency of SPME can be improved by adjusting the pH, temperature, fibre (“solvent”) polarity, fibre thickness, salt content and agitation. Various SPME fibre coatings, of differing thickness, have been developed by forming copolymers with the silicone (e.g. PDMS/DVB for semi non-polars), adding adsorbent material to the coating (e.g. Carbowax/PDMS), or by using a different polymer (e.g. polyacrylate for polar compounds). However, these variations do not exhibit dissolution properties as described for the liquid silicone polymer above [105].

Chapter 2 – Concentration Techniques

When the analyte is too volatile or unstable, derivatization techniques can be used. Derivatization is performed either in the aqueous medium prior to extraction, or by coating the fibre with derivatizing reagent followed by reaction with the analyte (*in situ* derivatization) or, after extraction where analytes in the fibre are derivatized by exposure to the reagent headspace or by direct immersion in the reagent [60, 106]. SPME is suitable for the analysis of large sample volumes, as shown by equation (2.2), taken from (2.1) where $V_s \gg K_{fs}V_f$ [49, 105],

$$n = K_{fs} V_f C_o \quad (2.2)$$

As the amount extracted by the fibre is independent of the sample volume, the thickness of the fibre plays a larger role. Compounds with a low K_{fs} , are efficiently extracted by using a thicker fibre. After extraction, the fibre is conveniently thermally desorbed in a hot GC inlet during the splitless mode. Or in the case of HPLC the elution solvent dissolves / purges the analytes off the fibre [107].

For precision and to save time, reproducible fibre exposure time, desorption time, vial size, sample volume and other sampling parameters are much more important parameters than obtaining full equilibration between fibre and analyte.

This sample preparation technique has become popular because it is simple, rapid and solventless while also demonstrating low detection limits. However, the fibre has proven fragile and is easily destroyed if not handled with care. Also, due to memory effects resulting from the complexity of the sample and desorption conditions used, the fibre may not be reusable. Contaminants arising from the SPME fibre (DVB or CW) have been measured below 2 ng/mL. These include 1, 9- nonanediol and highly bis-substituted phenols (originating from the epoxy glue used to attach the fibre to the stainless steel needle). Bis (2-ethylhexyl) phthalate has been measured between 5 to 20 ng/mL [80]. Under ideal conditions, the fibre assembly can provide 50-100 extractions [105].

Chapter 2 – Concentration Techniques

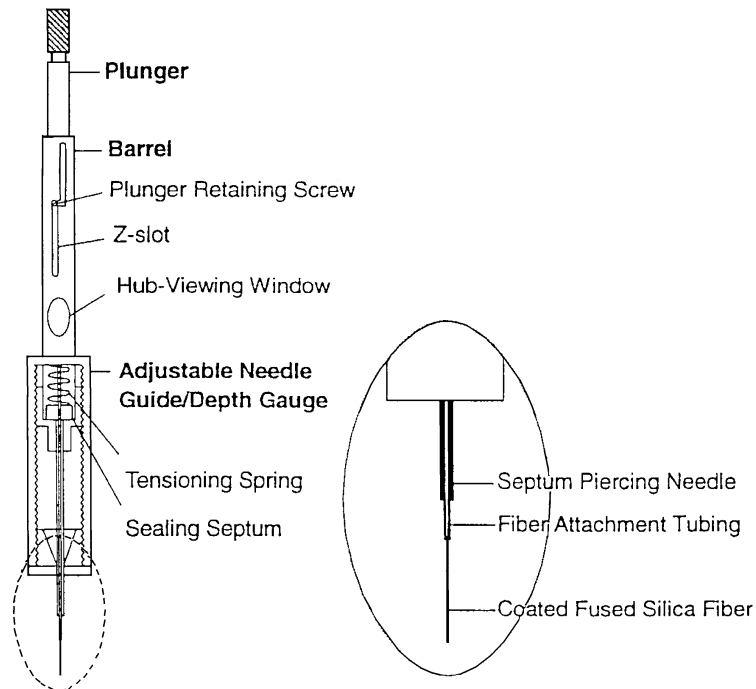

Figure 2.10 The first commercial SPME device from Supelco [49].

As an application of SBSE, headspace sorptive extraction (HSSE) [108, 109], uses a small glass rod coated with a large amount of polydimethylsiloxane (50 mg). As is the case for the SPME fibre, the rod is exposed to headspace samples. However, it is then thermally desorbed in an automated thermal desorber. The HSSE technique shows increased sensitivity over SPME, as the volume of absorbent (V_f) is much larger.

Another new, though similar approach called a sample enrichment probe (SEP) was developed by Burger *et al* [110]. A 15-mm sheath of PDMS tubing is stretched over a stainless steel rod (13 cm x 1.5 mm). The PDMS is evened out by rolling the PDMS-coated rod between glass plates. The resulting volume of PDMS is larger than for SPME and similar to HSSE. However, the probe is desorbed in a GC inlet, removing the need for an expensive thermal desorption unit. The probe is custom-made with matching thread to fit the septum cap of a Carlo Erba® GC. Sampling bottles are adapted to fit the probe. The carrier gas is switched on shortly after desorption has occurred. A thick film column is used to aid focussing of the desorbed analytes [110]. A comparison between SPME and the SEP for

extraction of the headspace volatile compounds in Rooibos tea has demonstrated the superior extraction properties of the SEP relative to SPME [110].

2.2.4. Stir bar sorptive extraction (SBSE)

Stir bar sorptive extraction (SBSE), introduced by Sandra and co-workers, consists of a glass stir bar coated with 50-300 μl PDMS [95]. The stir bar is placed inside an aqueous sample where the analytes may partition into the PDMS whilst being stirred. Depending on the sample volume and the stirring speed, equilibration times are expected to lie between 30 to 60 minutes.

The amount of analyte recovered is described by the equation:

$$\frac{m_{PDMS}}{m_0} = \frac{\left(\frac{K_{O/W}}{\beta}\right)}{1 + \left(\frac{K_{O/W}}{\beta}\right)} \quad (2.3)$$

Where m_{PDMS} is the mass of analyte in the stir bar, m_0 is the total mass of analyte in the sample, $K_{O/W}$ is the octanol-water partition coefficient for the analyte and β is the phase ratio ($\beta = V_w / V_{PDMS}$) [95].

The stir bar is then removed and may undergo either thermal or solvent desorption [95, 111]. SBSE has also been applied to biological fluids and heterogeneous matrices such as fruit pulp [112, 113] in addition to several other applications mentioned in chapter 3. Unlike SPME, a thermal desorption unit with cryogenic focussing is required to thermally desorb the stir bars. However, the SBSE has a much higher analyte capacity, owing to the larger volume of PDMS available for concentration, and can therefore reach much lower detection levels than SPME.

2.3. *Dynamic and static equilibrium*

SPME, SBSE and HSSE are static sampling techniques; OTT, PPBT and MCT are dynamic sampling techniques [114]. In the case of static sampling the sample and the extractant are in contact with each other the whole time. The analytes first have to diffuse towards the extractant and then partition into it until an equilibrium is reached between the 2 phases. To encourage diffusion of analytes towards the extractant the sample is agitated through stirring, mixing or sonication [114]. Selection of the extractant is based on the “like-dissolves-like” principle, described in the section entitled solvent extraction below.

During dynamic sampling the sample is introduced to the extractant over time i.e. not all at once. This is comparable to a chromatographic system where the extractant is the stationary phase and the sample is the mobile phase [114].

The sample enters the trap at an optimum flow rate that provides the “column” with the maximum number of plates. The various analytes in the sample partition into the PDMS with an effectiveness determined by their distribution coefficients (for gaseous analytes $K_{\text{PDMS/GAS}}$ obtained from GC retention indices; for aqueous analytes : $K_{\text{PDMS/W}} \approx K_{o/w}$). At a given point in time, a certain analyte will have partitioned entirely into the PDMS, while the sample (“mobile phase”) continues to move through the “column”. The continued movement of the sample (behaving as the “mobile phase”) through the column will cause the retained analyte in the PDMS to start eluting off the “column” once it has exceeded its retention volume on the trap. When the analyte starts to leave the trap it has reached its breakthrough volume. Depending on which analyte is of interest in the sample, sampling is generally stopped when 5 % or less of the initial analyte concentration has broken through. The process is called breakthrough sampling. Figure 2.11 demonstrates the extraction of analyte from a finite sample onto a PDMS trap.

Chapter 2 – Concentration Techniques

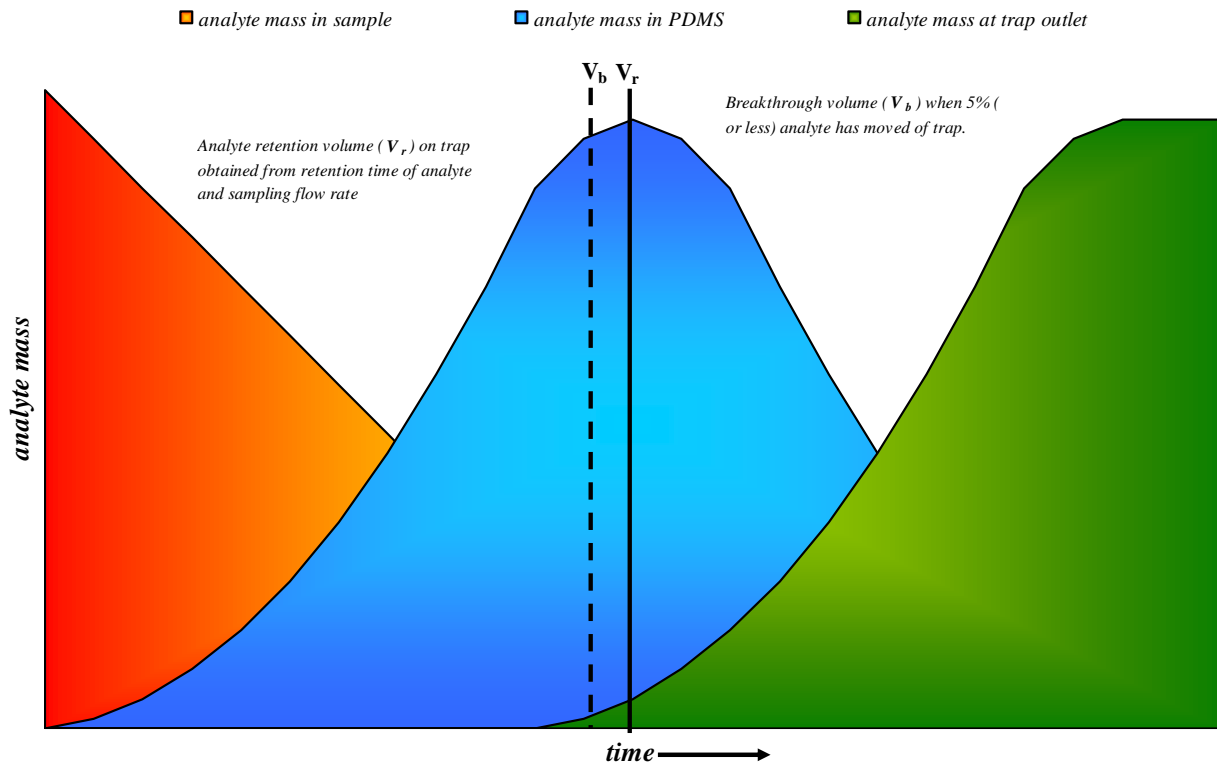

Figure 2.11 Mass profiles over time for the dynamic sampling of a finite sample on a PDMS trap. The analyte mass in the sample reduces as the analyte accumulates in the PDMS, before the analyte reaches its retention volume on the trap it will breakthrough and can be measured at the outlet of the trap.

When an unlimited amount of sample is available, then dynamic equilibrium sampling is an option. In this case, sampling continues beyond the breakthrough volume of the selected analyte of interest. Equilibrium extraction occurs at the point where the analyte concentration in the sample equals the analyte concentration exiting the trap. The process is depicted in figure 2.12. This process requires a much longer period of time.

Determination of extraction efficiencies / recoveries using PDMS static and dynamic sampling in the gas and aqueous phases are described below.

Chapter 2 – Concentration Techniques

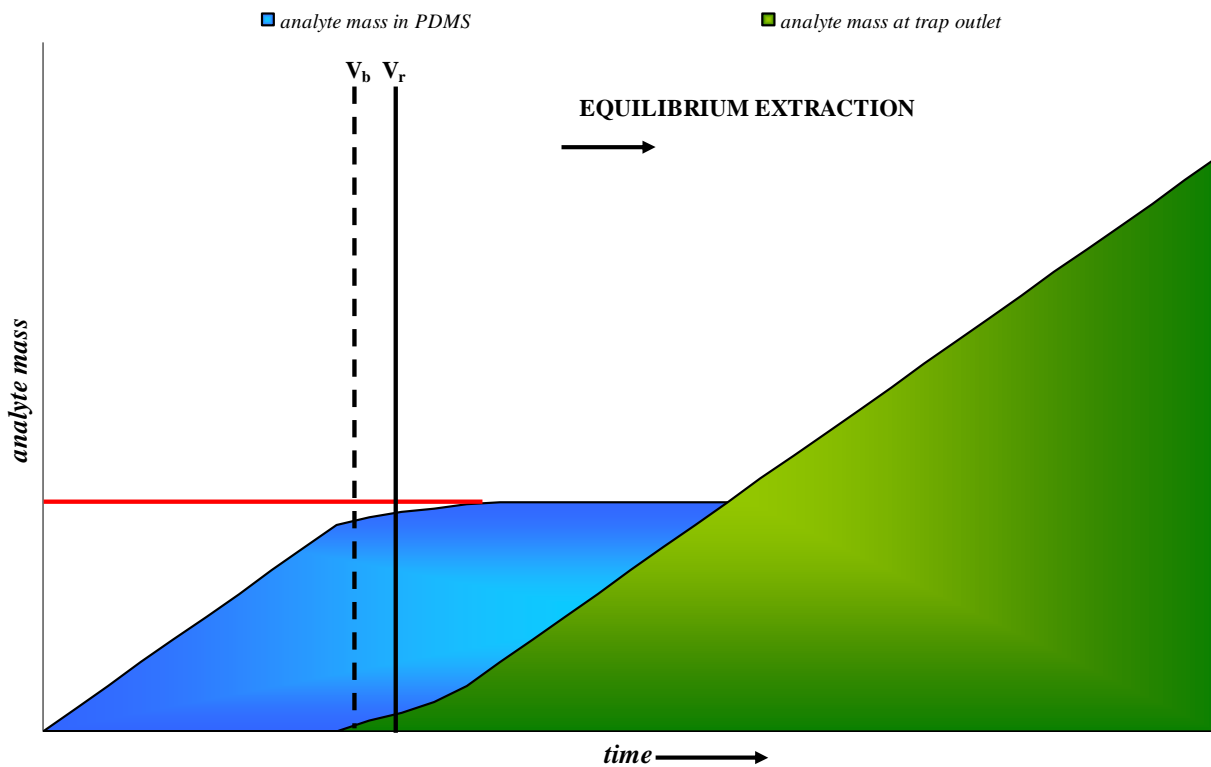

Figure 2.12 Mass profiles over time for the dynamic sampling of a constant supply of a bulk sample on a PDMS trap. Equilibrium extraction occurs when the analyte concentration entering the trap is the same as the analyte concentration exiting the trap.

2.4. Gas and Liquid phase PDMS extraction

In brief, the partitioning between analytes in the gas phase and PDMS can be predicted by the retention of analytes in a PDMS capillary column and a carrier gas (dominated largely by the volatility of the analyte), while the partitioning of analytes in water into PDMS can be predicted by the octanol-water partition coefficients of the analytes. Account is taken of the fact that octanol is slightly more polar than PDMS and that $K_{\text{PDMS}/\text{W}}$ is not equal to $K_{\text{o/w}}$.

2.4.1. Gas Phase Static Sampling

The maximum amount of analyte extracted by a SPME fibre is given by equation 2.1.

$$n = \frac{K_{fs} V_f V_s C_o}{K_{fs} V_f + V_s} \quad (2.1)$$

K_{fs} , the fibre coating/ sample distribution constant, which plays a large role in the extraction efficiency of the fibre, can be predicted using isothermal GC retention times for a given analyte, on a column that has an identical stationary phase and temperature to the SPME fibre, e.g. PDMS fibre with SE30 column at sampling temperature[49].

For a gaseous sample the correlation between K_{fs} and retention time is described by the following:

$$K_{fh} = K_{fg} = (t_r - t_m) \times F \times \frac{T}{T_m} \times \frac{p_m - p_w}{p_m} \times \frac{3}{2} \times \frac{(p_i / p_o)^2 - 1}{(p_i / p_o)^3 - 1} \times \frac{1}{V_L} \quad (2.4)$$

Where K_{fh} and K_{fg} , are the respective fibre/ headspace and fibre/gas distribution constants, t_r and t_m , are the retention times for the analyte and unretained compound respectively. F is the column flow rate; T_c and T_m are the respective temperatures of the column and flow meter; p_m , p_w , p_i and p_o are the pressures of the flow meter, saturated water vapour, column inlet and outlet, respectively. V_L , is the volume of stationary phase present in the capillary column [49].

Another alternative to determine K_{fh} at the sampling temperature – often room temperature, is to use the linear temperature programmed retention index system (LTPRI) available from published tables [49].

Chapter 2 – Concentration Techniques

For PDMS:

$$\log K_{fh} = \log K_{fg} = 0.00415 \times \text{LTPRI} - 0.188 \quad (2.5)$$

If the LTPRI is not available for a particular analyte, it can be determined experimentally from a GC run from the definition below:

$$\text{LTPRI} = (100 \times N) + \left[100 \times \frac{t_{R(A)} - t_{R(N)}}{t_{R(N-1)} - t_{R(N)}} \right] \quad (2.6)$$

N, is the number of carbon atoms for the n-alkane; $t_{R(A)}$, $t_{R(N)}$ and $t_{R(N-1)}$ are the retention times for the analyte, n-alkane and n-1 alkane, respectively [49].

2.4.2. Gas Phase Dynamic Sampling

Breakthrough volume is a measure of the retention of an analyte on a sorbent i.e. retention capability. Tubes packed with ad/absorbents can be regarded as chromatographic columns operating under frontal analysis conditions with a constant concentration of analyte. The analyte will continue to be ad/absorbed in the trap until it reaches its breakthrough volume (V_b). This is usually when 5% or less of the initial concentration of the analyte has started to elute from the trap. The maximum sampling volume or breakthrough volume (V_b), is described by Raymond and Guiochon [115] as:

$$V_b = V_r \times \left(1 - \left(\frac{2}{\sqrt{N}} \right) \right) \quad (2.7)$$

Where V_r is the retention volume and N the number of plates of the trapping column. However, for short “columns” with a low number of plates (N), Lövkvist and Jönsson [96], have suggested a more realistic model for breakthrough volume. This can be described by:

Chapter 2 – Concentration Techniques

$$V_b = V_r \times \left(a_0 + \left(\frac{a_1}{N} \right) + \left(\frac{a_2}{N^2} \right) \right)^{-1/2} \quad (2.8)$$

Where a_0 , a_1 and a_2 are coefficients for different values of the breakthrough level b described as [96]:

b = total amount of analyte eluted from trap / total amount of analyte sampled

b can vary from 0.1, 1, 2 to 10%, the popular value being 5%.

Baltussen *et al* [47, 82] have applied this theory for breakthrough volume at 5%, to their PPBT's, giving:

$$V_b = V_0 \times (1+k) \times \left(0.9025 + \left(\frac{5.360}{N} \right) + \left(\frac{4.603}{N^2} \right) \right)^{-1/2} \quad (2.9)$$

Where V_0 is the trap dead volume and k the capacity factor.

The capacity factor k can be calculated by:

$$k = \frac{K}{\beta} \quad (2.10)$$

Where β is the phase ratio and K the equilibrium distribution coefficient that for an alkane in PDMS at any temperature can be calculated as follows:

$$K = \exp \left(\frac{950 + 905 \times C}{1.987 \times T} - 0.59 \times C - 1.8 \right) \quad (2.11)$$

T is the absolute temperature and C the carbon number of the alkane.

Chapter 2 – Concentration Techniques

To determine K for non-alkanes an alternative formula was derived by Baltussen *et al* [47, 82], using Kovats Retention Indices (RI) defined as follows:

$$RI = 100 \times \frac{\log(t'_A) - \log(t'_z)}{\log(t'_{z+1}) - \log(t'_z)} + 100 \times Z = 100 \times \frac{\log(K_A) - \log(K_z)}{\log(K_{z+1}) - \log(K_z)} + 100 \times Z \quad (2.12)$$

Where Z is the number of carbons in the *n*-alkane eluting just before the compound of interest (A), t'_i is the net retention time and K_i is the equilibrium constant of the component *i*.

This definition can be rearranged to give:

$$\log(K_A) = \log(K_z) + \left(\frac{RI}{100} - Z \right) \times (\log(K_{z+1}) - \log(K_z)) \quad (2.13)$$

The RI values of analytes at a specific trapping temperature are available as published data sets [47], K_{Z+1} and K_Z can be calculated using Equation 2.11.

To solve equation 2.9, the plate number N needs to be determined using the Knox equation for packed columns [47]:

$$h_r = 3\nu^{1/3} + \frac{1.5}{\nu} + 0.05\nu \quad (2.14)$$

h_r , is the reduced plate height and ν the reduced velocity in the trap (packed column) which are defined as follows [47]:

$$h_r = \frac{H}{d_p} = \frac{L}{N \times d_p} \quad (2.15)$$

$$\nu = \frac{u \times d_p}{D_M} \quad (2.16)$$

Chapter 2 – Concentration Techniques

Where H is the plate height (m), d_p is the diameter (m) of the particles used to pack the trap, L , the length of the trap “column”, u , the linear velocity ($\text{m}\cdot\text{s}^{-1}$) in the trap and D_M is the diffusion constant ($\text{m}^2\cdot\text{s}^{-1}$) of the analyte in the mobile phase. It should be noted that these equations are only valid if the pressure drop over the trap is negligibly small [47, 82, 114].

2.4.3. Aqueous Phase Static Sampling

The extraction efficiency of analytes from aqueous phase samples into PDMS is largely determined by the partition coefficient between water and PDMS. These coefficients can be determined through a laborious process. Alternatively the octanol-water partition coefficient $K_{o/w}$, which correlates well to PDMS-water partitioning, can be used to predict the extraction of aqueous analytes into PDMS [95, 114].

$$K_{O/W} \approx K_{PDMS/W} = \frac{C_{PDMS}}{C_W} = \frac{m_{PDMS}}{m_W} \times \frac{V_W}{V_{PDMS}} \quad (2.17)$$

Since the phase ration β is described by:

$$\beta = \frac{V_W}{V_{PDMS}} \quad (2.18)$$

Equation 2.17 can be rewritten to give:

$$\frac{K_{O/W}}{\beta} = \frac{m_{PDMS}}{m_W} = \frac{m_{PDMS}}{m_0 - m_{PDMS}} \quad (2.19)$$

Where m_0 is the total amount of analyte present in the sample.

Chapter 2 – Concentration Techniques

After rearranging equation 2.19, the extraction efficiency or recovery can then be described by equation 2.3:

$$\frac{m_{PDMS}}{m_0} = \frac{\left(\frac{K_{O/W}}{\beta}\right)}{1 + \left(\frac{K_{O/W}}{\beta}\right)} \quad (2.3)$$

2.4.4. Aqueous Phase Dynamic Sampling

The retention volume of an analyte from water on a dynamic sampling trap can be determined from the equation:

$$V_r = V_0 \left(1 + \frac{K_{O/W}}{\beta}\right) \quad (2.20)$$

Where V_r and V_0 are the trap's retention and void volumes respectively.

If V_r is known, then the breakthrough volume can be determined from Lövkvist and Jönsson's equation:

$$V_b = V_r \left(0.9025 + \frac{5.360}{N} + \frac{4.603}{N^2}\right)^{-1/2} \quad (2.21)$$

Where V_b represents a breakthrough volume at 5% sample concentration at the trap outlet and N , the number of plates in the trap.

For the PPBT, developed by Baltussen *et al* [114], the Knox equation is used to determine N as described in equations 2.14 and 2.15.

Chapter 2 – Concentration Techniques

For the MCT, developed by Rohwer et al [63-68], N is experimentally determined from:

$$N = 16 \left(\frac{V_r}{\omega} \right)^2 \quad (2.22)$$

where ω is the base width of the analyte peak (obtained from elution analysis) between the peak tangents [66].

2.4.5. Equilibrium extraction in dynamic sampling

As indicated above, with an unlimited supply of sample, it is possible to stop sampling well past the breakthrough volumes of the analytes [114]. At this point the analytes are in complete equilibrium with the PDMS, i.e. the concentration of analyte entering the PDMS is equivalent to the concentration of analyte leaving the PDMS. The analyte concentration (C) in the sample can therefore be described by the following equation (for K values significantly larger than 1):

$$C = \frac{m_{PDMS}}{V_r} = \frac{m_{PDMS}}{V_0 \times \left(1 + \frac{K}{\beta} \right)} \approx \frac{m_{PDMS}}{V_{PDMS} \times K} \quad (2.23)$$

where m_{PDMS} is the mass of analyte absorbed in the PDMS, V_r , V_0 and V_{PDMS} are the retention, void and PDMS volumes respectively. K is the equilibrium distribution coefficient and β the phase ratio [114].

2.5. Phase ratio and analyte capacity

From equation 2.3,

$$\frac{m_{PDMS}}{m_0} = \frac{\left(\frac{K_{O/W}}{\beta}\right)}{1 + \left(\frac{K_{O/W}}{\beta}\right)}$$

it can be seen that for static sampling from aqueous phases, the phase ratio, β , plays a critical role in the recovery of analyte. The phase ratio β , is defined as the ratio of sample to trapping phase i.e. V_w / V_{PDMS} .

Figure 2.11 represents graphically equation 2.3 for 3 different PDMS configurations (for a 10 ml water sample). SPME has the largest phase ratio (20 000), followed by SBSE (100) and the MCT (40). This implies that in order to get good recoveries SPME requires very large $K_{O/W}$'s. Figure 2.11 shows that SPME never reaches 100% recoveries, even with extremely large $K_{O/W}$, whereas SBSE and the MCT achieve ~ 100% recovery for $K > 1000$. Although the MCT is not a static sampling technique, when operating under equilibrium extraction conditions (sampling beyond the breakthrough volumes) it is essentially operating near static equilibrium sampling conditions. The MCT displays improved recoveries compared with SBSE at the $K_{O/W} < 1000$. For example, for a $K_{O/W}$ of 100, the MCT can obtain recoveries of 70% while the SBSE obtains only 50%.

Chapter 2 – Concentration Techniques

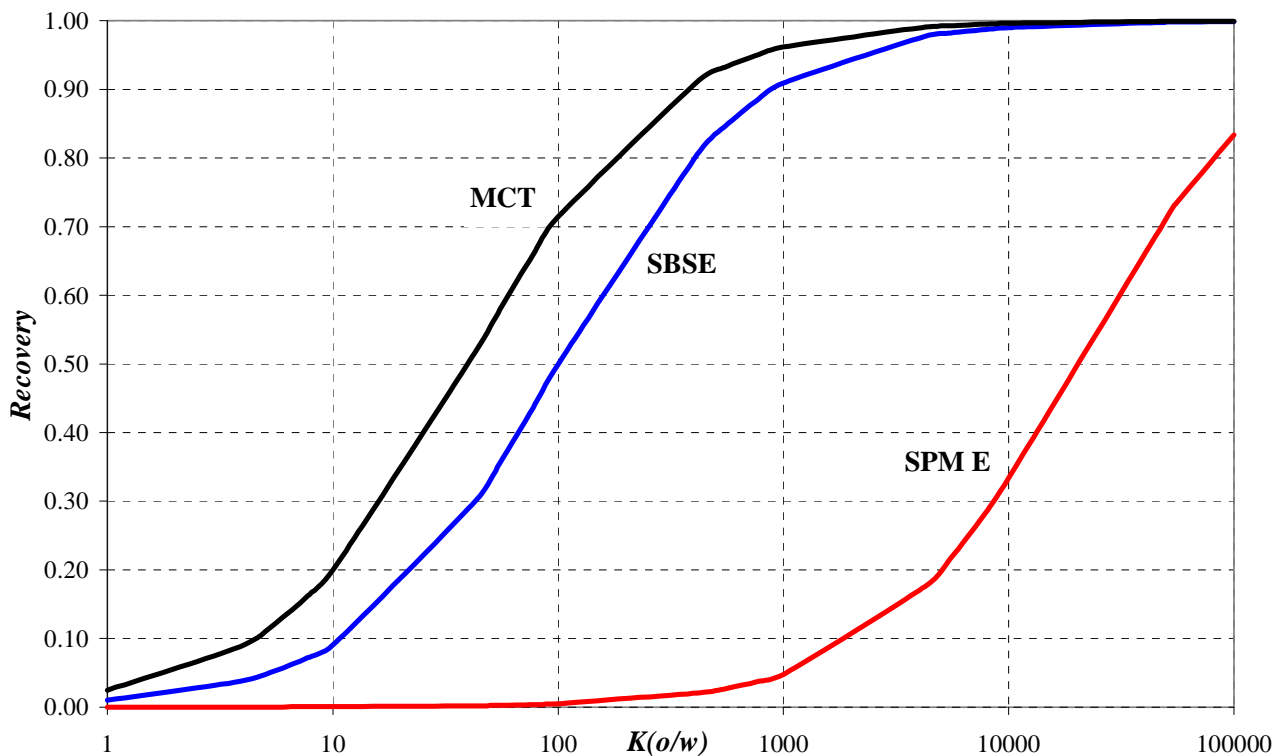

Figure 2.13 Recovery as a function of the octanol-water partition coefficient (K_{ow}) of the analyte in 3 different PDMS configurations. The graph was obtained by calculation using equation 2.3 and values for β as stated in section 2.5.

2.6. Recovery

2.6.1. Solvent Extraction

This technique is otherwise known as liquid-liquid extraction [81, 116]. A solvent can be used to isolate analytes from a liquid sample or from a solid, in our case the sorbents. The technique relies on a distribution of the analyte between two immiscible liquid phases. For acids and bases the distribution coefficient ($K = C_{\text{solvent}} / C_{\text{sample}}$) is easily affected by the pH of the solution. In this way the extraction can be made more selective. In general, the principle that “like-dissolves-like” is applied. Polar analytes will dissolve into polar solvents and non-polar analytes into non-polar solvents.

Chapter 2 – Concentration Techniques

The sample solution is shaken up with an equal amount of solvent in a separation funnel. When the 2 phases separate, the desired fraction is collected. The extraction efficiency increases with the number of extractions. Because the final fraction still contains a large amount of solvent, an extra step is required to concentrate the extract before it can be analysed. Analytes with small K 's or large sample volumes require continuous extraction or counter current extraction to achieve a complete separation [81, 116]. Overall, this is a simple but time-consuming technique. The general trend is to move away from these methods. In addition, the large volumes of high purity solvents required for such extractions have proven toxic and expensive.

Recently, these disadvantages have been minimised with the introduction of liquid-liquid micro-extractions. Typically, 1 ml of solvent is added to 10ml of sample in a vial. The extract can then be injected without further pre-concentration.

2.6.2. Thermal Desorption

Thermal desorption is the process through which the analytes on a sorbent are removed by heat energy. During this process, the analytes are transferred onto the chromatographic column. However, it is common to have a refocusing step before transfer onto the column. Usually, a second trap is cooled, using either liquid nitrogen or CO_2 gas, to sub-ambient temperatures ranging from 0°C to -100°C . This second trap is heated ballistically after desorption, in order to transfer the analytes in a narrow plug onto the column. A description of the instrument used for thermal desorption is given in chapter 4.

Thermal desorption has several advantages over solvent extraction, principally the removal of the dilution effect. With solvent extraction only a small fraction of the entire extract is injected for analysis. In addition, thermal desorption requires no expensive high purity solvents or labour to perform the liquid extractions as automated thermal desorption units allow for desorption of several traps overnight. Disadvantages include the occasional blocking of the cryogenic trap, although this can be prevented by avoiding the use of hydrophilic sorbents. Furthermore, instrumentation and use of large quantities of liquid nitrogen are expensive [47, 48].

Chapter 3

Derivatization

3. Introduction

In analytical chemistry, derivatization is the process of chemically modifying a compound to produce a new compound that has properties that are suitable for instrumental analysis.

Whether gas or liquid chromatography is used for the analysis of analytes, at some point or another derivatization of certain analytes will be required. In the case of gas chromatography it is most often a matter of improving the chromatographic properties of the analyte. Gas chromatographic analysis of compounds, having functional groups with “acidic” hydrogens such as -COOH, -OH, -NH₂, -NH and -SH, are of great concern. These functional groups tend to form intermolecular hydrogen bonds, which affect the volatility and thermal stability of the compound. Moreover they will often interact unfavourably with active sites in the GC inlet and with the stationary phase of a poorly deactivated capillary column. Strong interactions between the “acidic” hydrogen and silanol groups on the inner surface of the capillary column result in nonlinear adsorption effects. These effects manifest themselves as tailing peaks in the chromatogram. Integration of these chromatographic peaks particularly at trace levels yields results with poor precision. As a result, several methods exist to convert most analyte functional groups such as carbonyls, carboxylic acids and alcohols into their less interactive Schiff bases and esters. In addition, this process also improves the physical, chemical and thermal stability of the analytes before GC analysis [107, 117-119].

In both LC and GC, derivatization is used to improve the detection properties of the analyte towards a specific detector. Careful selection of derivatizing reagents allows, for example, the introduction of a fluorescent chromophore onto an analyte permitting sensitive HPLC- fluorescent detection of the analyte. Halogenated derivatives deliver increased detection by electron capture, negative chemical ionization and selected ion mass spectrometric detection. Halogenation has the additional benefit of providing heavier ions in the mass spectrum, without changing the volatility (and therefore the GC retention) of the analyte. This provides mass selectivity in GC-MS runs. Also a reagent that reacts

Chapter 3 - Derivatization

selectively with one particular functional group in the presence of others, will decrease the sample complexity whilst simultaneously improving the sensitivity of the analysis [107, 117-119].

Ideally, a good derivatization reagent should provide a single derivative with a high and reproducible yield. Apart from the formation of the derivative, the reagent should not cause any restructuring of the original analyte e.g. formation of enols or dehydration reactions. The derivative should be distinguishable and separable from the starting materials. The reaction should proceed rapidly at room temperature and not require complicated laboratory techniques. It should be selective and avoid the use of hazardous reagents or harsh reaction conditions [107, 117-119].

It would appear that the advantages of derivatization should appeal to everyone undertaking analyte detection. However, derivatization is generally only used as a final resort, as it is always preferable to limit the amount of sample preparation to a minimum so that no additional contamination or errors are introduced into the analyses. Table 3.1 below summarizes the advantages and disadvantages of analyte derivatization.

In this chapter, emphasis is placed on the derivatization of aldehydes, amines and phenol and alkyl-hydroxylated compounds, as these are the types of analytes investigated in this study.

Table 3.1 Advantages and disadvantages of analyte derivatization.

<i>Advantages</i>	<i>Disadvantages</i>
Improved detection properties of the analyte i.e. increased sensitivity	Additional sample preparation steps, solvents and reagents required
Improved mass selectivity as derivatives yield higher masses in the mass spectrum	Incomplete analyte conversion
Improved physical (volatility), chemical (polarity and acidity) and thermal properties of the analyte	Potential sample contamination from impurities in the reagents and solvents used
Selective conversion of analytes decreases complexity of the sample matrix	Sample losses due to additional use of glassware etc.

3.1. Classification

In general derivatization reactions can be classified either according to the functional group that needs to be converted, for example carboxylic acids (-COOH) and alcohols (-OH), or by the nature of the resulting derivative, for example, a silyl (-SiR₃), alkyl (-R) or acylated (-COR) derivative [107, 117-119]. Each type of derivative, if appropriately selected for an application, has its own benefits. A brief summary of the 3 main derivative categories is described below.

3.1.1. Alkylation

Alkylation is the replacement of the “acidic” or “active” hydrogen in carboxylic acids (R-COOH), alcohols (R-OH), thiols (R-SH), and amines (R-NH₂) with an aliphatic alkyl or aryl group. The general rule of thumb is that “as the acidity of the active hydrogen decreases, the strength of the alkylating reagent must be increased”. Although this implies that the selectivity and applicability of the method becomes more limited as the reagents and conditions become harsher [120-125].

Alkylation has largely been applied to the conversion of organic acids into esters, particularly methyl esters. This process is sometimes referred to as esterification. In a typical reaction esterification involves the condensation of the carboxyl group of an acid and the hydroxyl group of an alcohol, with the resulting elimination of water [120-125].

Trimethylsilyl derivatives of carboxylic acids are more easily formed than the alkyl derivatives. However, they offer limited stability compared to the alkyl esters which can, if required, be isolated and stored for extended periods of time [120-125].

3.1.2. Acylation

Acylation involves the replacement of the “acidic” hydrogens on alcohols (-OH), thiols (-SH), and amino (-NH) groups with an acyl group to form esters, thioesters and amides respectively. Insertion of perfluoracyl groups is very popular as these also permit electron capture detection (ECD) and

Chapter 3 - Derivatization

thus negative chemical ionization mass spectrometry (NCI-MS) as well. In addition, the carbonyl groups adjacent to halogenated carbons enhance the response of the ECD. An extra benefit of acylation is the formation of fragmentation-directing derivatives for GC-MS analysis.

Perfluoroacylation reagents can be classified into three main groups: fluoro acid anhydrides, acyl chlorides and fluoracylimidazoles [121, 122].

The fluorinated anhydride derivatives of alcohols, phenols and amines are both stable and highly volatile. However, these derivatives produce acidic by-products, which must be removed prior to instrumental analysis. Typically, an organic base such as triethylamine is used to drive the reaction to completion whilst consuming the acidic by-products. However, it is critical that a pH less than 6 is used during the reaction and extraction steps, as the unprotonated base will catalyze the hydrolysis of the just-formed derivatives [126].

The fluoracylimidazoles react readily with hydroxyl groups and secondary or tertiary amines to form acyl derivatives. In this case the imidazole by-product is relatively inert and does not require removal prior to analyses [126].

3.1.3. Silylation

Silylation is the most widely used derivatization technique, as it can convert nearly all functional groups hydroxyls, carboxylic acids, amines, thiols and phosphates into silyl derivatives. In this case the “acidic” hydrogen on the analyte is replaced with an alkylsilyl group, most frequently, trimethylsilyl (-SiMe₃).

Silylation reagents and their derivatives react rapidly with water and thus require extremely anhydrous reaction conditions. The *tert*-butyl dimethylsilyl derivatives are slightly less sensitive to moisture due to their bulky nature, although this also means that their formation requires more time.

Trimethylchlorosilane (TMCS), together with trimethylsilyl-imidazole (TMSI) or *tert*-butyldimethylchlorosilane (TBCS) and *tert*-butyldimethylsilyl-imidazole (TBSI), are usually added as catalysts to enhance derivatization.

Chapter 3 - Derivatization

TMS derivatives are notorious for the formation of silylation artefacts [127]. Very pure solvents should be used to avoid the formation of excessive peaks in the final chromatogram. Under certain conditions functional groups such as aldehydes, amides, carboxylic acids, esters and ketones will form additional silyl derivatives and by-products. The silylation reagent often reacts with itself, other inorganic/organic reagents and/or organic solvents to yield artefacts [127].

Silylation reagents can accumulate in the analytical system. The silyl imidazole reagents form inert by-products that should neither accumulate nor damage the analytical system. Extra care should be taken not to avoid introducing silylation reagents into systems that contain “active” hydrogens e.g. Carbowax® columns [121, 122].

3.1.4. Schiff bases

The formation of a Schiff base occurs when a carbonyl functional group (on aldehydes and ketones) condenses with an amine functional group to release water. Depending on which analyte is to be derivatized, one group will be the reagent the other the target analyte. This reaction is extremely selective as only the carbonyl or amine group will be converted.

3.2. Derivatization of aldehydes

As the low molecular mass aldehydes acetaldehyde, acrolein, crotonal, propanal, butanal and particularly formaldehyde were selected for this study, a review of only the derivatization techniques most commonly used for determining these aldehydes, will be described below.

3.2.1. Hydrazones

2,4-DINITROPHENYLHYDRAZINE (DNPH)

In other studies formaldehyde has been collected in an impinger [128] and bubbler [129] containing DNPH, on DNPH coated sorbents [130-132], DNPH coated glass fibre [133], sintered glass [134] and

PDMS SPME fibre [106]. HCHO reacts *in situ* with the DNPH solution to form the 2,4-dinitrophenylhydrazone chromophore which can be determined using HPLC with UV detection or GC-ECD/MS/FID/TSD [106, 131, 133]. The reaction takes place under strongly acidic conditions. Although this reagent has been used with GC analysis, removal of excess DNPH is required prior to injection to avoid column and detector deterioration [38, 39, 133]. Frequent cleaning of the inlet liner [135].

High oven temperatures are required because of the low volatility of the derivative [136]. Hence, HPLC-UV is favoured for this method, being both sensitive and easy to implement [38, 39, 135]. This technique is employed as a standard method for formaldehyde determination by the EPA, (EPA-TO11)[14], and NIOSH, (Method 2016)[16]. To accommodate the poor resolution and detection of an HPLC, a new detection method using diode array ultraviolet spectroscopy and atmospheric pressure negative chemical ionization mass spectrometry for liquid chromatography was introduced. The set-up showed a significant increase in resolution (34 carbonyls) and sensitivity in the ppb range [137]. Figure 3.1 shows the reaction scheme.

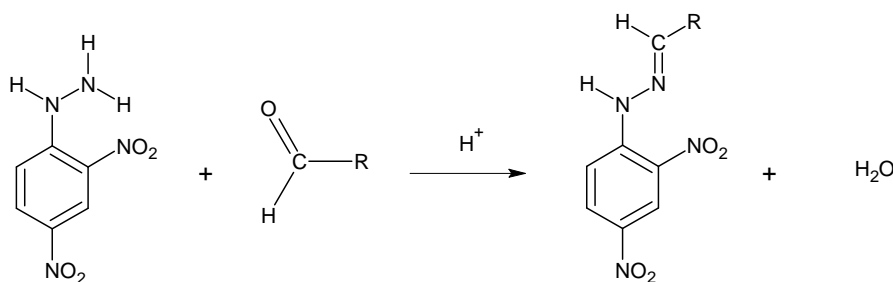

Figure 3.1 Reaction scheme for 2,4-DNPH with an aldehyde [106, 128-134, 137, 138].

DANSYLHYDRAZINE (DNSH) – (1-dimethyl-aminonaphthalene-5-sulfonylhydrazine)

Schmied *et al*, developed a method for determining aldehydes and ketones simultaneously by derivatization on silica gel coated with DNSH. The reaction scheme is shown in figure 3.2. This reaction is highly efficient and allows for collection flow rates of 2 L/min. After collection, the hydrazones are extracted and separated by HPLC with fluorescence detection. DNSH is purified before each use. Detection limits are in the picogram range [75].

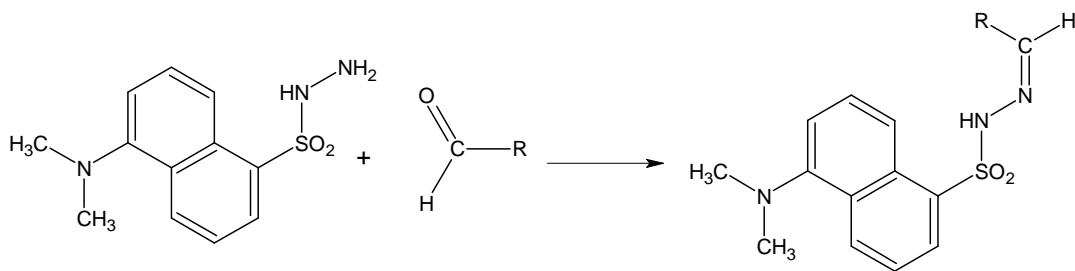

Figure 3.2 Reaction scheme for DNSH with an aldehyde [75].

O- (2,3,4,5,6-PENTAFLUOROPHENYL) HYDRAZINE (PFPH)

The hydrazine's detectability using ECD is enhanced by the pentafluoro-moiety. To date, the reagent has only been used in the study of lipid peroxidation in which volatile carbonyl compounds are formed [78, 139]. Stashenko *et al* [78], heated a vegetable oil sample in a test tube and added PFPH solution. After the carbonyls reacted at room temperature with the PFPH, they were extracted into non-polar phases using either LLE or SPE. The extracts were analysed by GC-FID/ECD/MS-SIM. Detection limits of 10^{-14} and 10^{-12} mol/ml per aldehyde were obtained using ECD and MS-SIM respectively. More recently, using the same concept, Pawliszyn used a SPME fibre to pre-concentrate carbonyls using *in situ* derivatization on a PFPH coated PDMS/DVB fibre which, following desorption in the GC inlet, was analysed by GC with ECD to obtain a detection limit of 10-90 fmol [60, 139]. The reaction scheme is shown in figure 3.3 below.

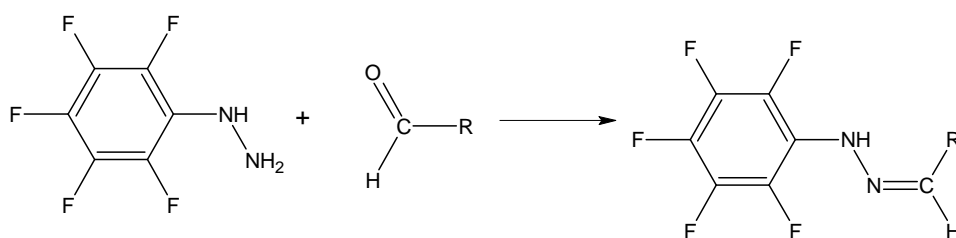

Figure 3.3 Reaction scheme for PFPH with an aldehyde [78, 139].

2,4,6-TRICHLOROPHENYLHYDRAZINE (TCPH)

This reagent was introduced to reduce the problems experienced using 2,4-DNPH and GC analysis. An octadecyl silica cartridge impregnated with TCPH is used to collect HCHO. Thereafter the cartridge is held at 100°C for 6 min to allow for complete reaction. The cartridge is eluted with acetonitrile followed by GC-ECD analysis. Detection limits are determined by the blank. In the case of HCHO the

Chapter 3 - Derivatization

limit of detection is 0.1 ppb, while other carbonyls have even lower limits. An ozone scavenger has been used to eliminate the interference of ozone at concentrations above 300 ppb [76]. The reaction scheme is shown in figure 3.4 below.

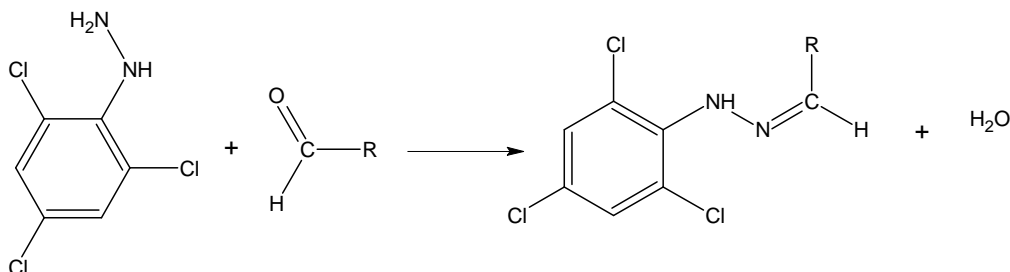

Figure 3.4 Reaction scheme for TCPH with an aldehyde [76].

3.2.2. Oximes

Oximes are ideal for GC analysis due to their volatility, providing a possibility to obtain a good separation, while the reaction conditions are mild, unlike those for hydrazone formation [136]. Typical amine reagents used in HCHO derivatization reactions followed by GC analysis are discussed below.

BENZYLHYDROXYLAMINE AND METHOXYAMINE

Benzylhydroxylamine and methoxyamine can be applied to automobile exhaust and stationary source analysis. The reagents are not suitable for ambient air measurements since their reaction with low molecular mass aldehydes yield volatile products. Detection limits have therefore not been reported for benzyloximes. Figure 3.5 shows the reaction schemes for benzylhydroxylamine with an aldehyde, and for methoxyamine with an aldehyde. The carbonyls were collected on silica gel, eluted with water, derivatized with benzylhydroxylamine and analysed by GC-NPD. Derivatives were well separated and could be detected to the picogram level [136]. O-Methyloximes provided detection limits of 40 ppb for aldehydes in air. For the determination of unsaturated aldehydes, particularly acrolein and crotonal, their respective O-methyloximes and benzyloximes are brominated and analysed using GC-ECD. The brominated acrolein methyloxime was detected at 0.5 ppb in a 40 L air sample [136].

Chapter 3 - Derivatization

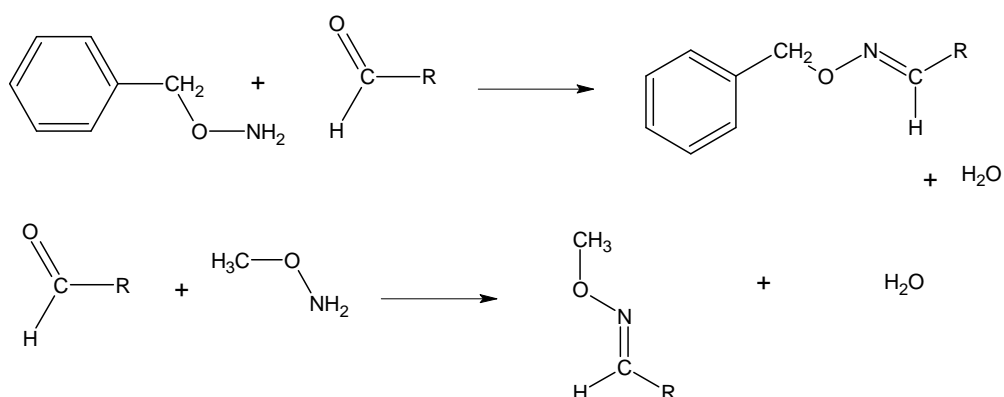

Figure 3.5 Reaction scheme for first, benzylhydroxylamine with an aldehyde. Second, methoxy amine with an aldehyde [136].

O-(2,3,4,5,6-PENTAFLUOROBENZYL) HYDROXYLAMINE (PFBHA)

This reagent is ideal for the determination of trace amounts of volatile aldehydes in air samples [136]. The oximes that are formed are volatile and stable to high temperatures allowing for GC analysis. All the oximes have a common base peak of m/z 181, which allows for easy identification with Mass Spectrometry [140]. The reagent has typically been used for determining aldehydes in drinking water with electron-capture detection (ECD) [141] (EPA method 556) and mass spectrometry (MS) [140] as well as in beer [142], cognac [143] and vegetable oils [144]. Recently PFBHA has also been used for indoor air and headspace sample analysis. C-18 silica gel cartridges coated with PFBHA were used to determine aldehydes in air emitted by vegetation as terpene oxidation products. After elution of the derivatives with hexane, a 50 L air sample provided a detection limit of 2 ppb using GC-MS [77]. Wu and Que Hee [145] developed a dynamic personal air sampler consisting of Tenax-GC solid sorbent coated with PFBHA. The formed PFBHA derivatives were eluted from the sorbent with hexane and analysed by GC-MS. The detection limit for acrolein was 0.025 ppm. Later, Wu and Que Hee [146] developed a passive sampler by applying the same concept. Martos and Pawliszyn introduced the use of a SPME PDMS/DVB fibre, for the *in situ* derivatization of HCHO. The headspace of an aqueous PFBHA solution coats the fibre, which is then exposed to the HCHO atmosphere or headspace of a sample. The fibre is then desorbed in the inlet of a GC oven. The technique is excellent for grab sampling and time weighted averaging for indoor air. Detection limits were as low as 15 ppb using GC-FID [60, 147]. Figure 3.6 shows the reaction scheme.

Chapter 3 - Derivatization

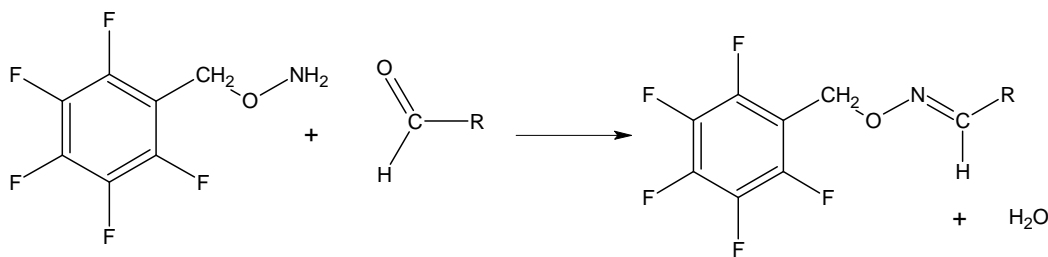

Figure 3.6 Reaction scheme for PFBHA with an aldehyde [140].

3.2.3. Cyclization Reactions

N - (BENZYLETHANOL) AMINE (BEA) -COATED SORBENT TUBE METHOD

Formaldehyde and most carbonyl compounds react rapidly with secondary aminoethanols to form the cyclic oxazolidine derivative, as shown in figure 3.7. Formaldehyde was collected on BEA coated Chromosorb® sorbent. The derivative was extracted with isooctane and separated using GC-FID. Detection was in the range of 0.55-4.71 mg/m³ [136]. The method lacks sensitivity due to the low sampling rate required to ensure derivative formation, and high blank levels. Thus, the reagent is unsuitable for ambient air analysis. The use of a nitrogen specific detector enhances sensitivity slightly. Acid gases/mists will react with the BEA and convert it to the ammonium salt, resulting in lower BEA reagent availability [39].

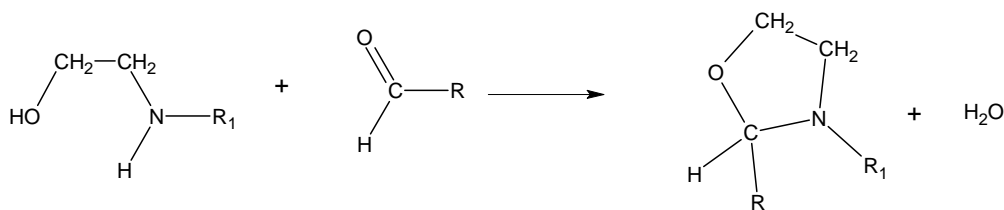

Figure 3.7 Reaction scheme for ethanolamine with an aldehyde [39, 136].

2-HYDROXYMETHYLPIPERIDINE (HMP)

Kennedy, *et al.* determined acrolein in air by pre-concentration on a XAD-2 sorbent tube coated with 2-HMP. Acrolein forms a bicyclo-oxazoline, which can then be determined by gas chromatography - nitrogen specific detection (GC-NSD) in the 0.13-1.5 mg/m³ range [148]. Formaldehyde can also be determined by conversion to hexahydrooxazolo [3,4- α] pyridine in a denuder tube coated with 2-HMP (with a back-up tenax sorbent tube). Figure 3.8 shows the reaction scheme. Recovery is achieved by thermal desorption followed by GC-MS analysis for which the limit of detection is in the range of 0.03 to 0.51 mg/m³ [149]. NIOSH uses this technique for the determination of formaldehyde and acrolein in air (Method 2541) with a detection range of 0.3-20 mg/m³ [150], as well as aldehyde screening (Method 2539)[151] using GC -FID/MS detection.

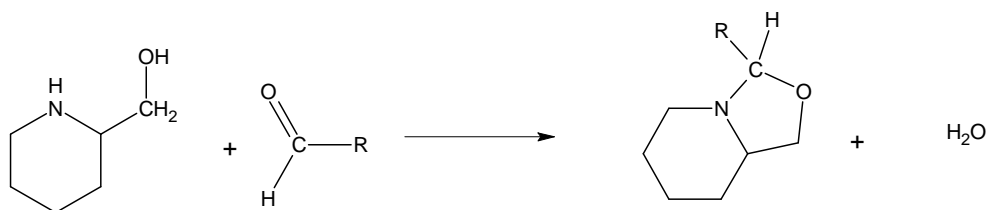

Figure 3.8 Reaction scheme of 2-HMP with an aldehyde [148-151].

CYSTEAMINE (2-AMINOETHANETHIOL)

Cysteamine reacts readily with carbonyl compounds at room temperature and neutral pH. However, it does not react with β -unsaturated aldehydes such as acrolein and crotonaldehyde. Unlike certain derivatizing reagents, no *cis-trans* isomers of the reaction product are formed making quantitation easier [136]. This reagent has been used in the determination of volatile carbonyl compounds in cigarette smoke [152] and automobile exhausts [153]. The smoke/exhaust is collected in a vessel containing an aqueous solution of cysteamine. The carbonyl compound is converted to the thiazolidine as shown in figure 3.9, followed by analysis with GC with NPD. Detection limits are in the picogram range.

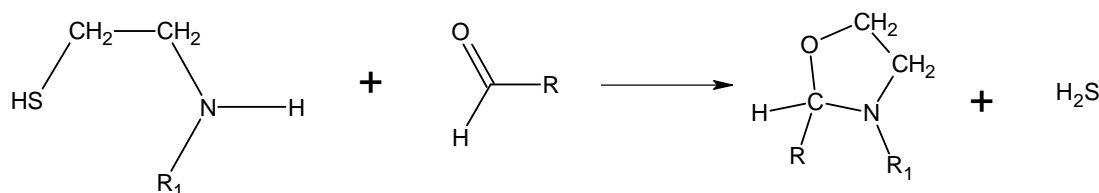

Figure 3.9 Reaction scheme of cysteamine with an aldehyde [136, 152, 153].

AMMONIA

Formaldehyde is collected on a silica gel sorption cartridge coated with polyethylene glycol (PEG-400), to increase the polarity of the adsorbent. The pre-concentrated HCHO is extracted using aqueous ammonia, with which HCHO reacts exclusively to form a hexamethylenetetramine, as shown in figure 3.10, which is then analysed using GC-FID. Detection limits fall in the same range as for the use of 2,4-DNPH, but with the use of thermionic detection, the limit can be improved [154].

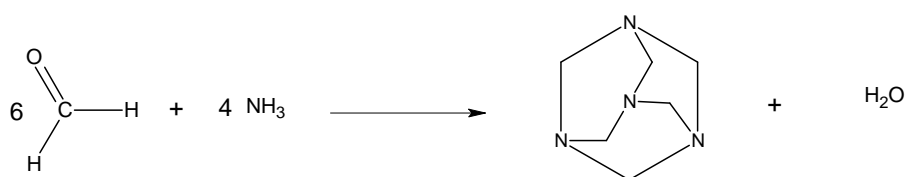

Figure 3.10 Reaction scheme for an aldehyde with aqueous ammonia [154].

ACETYLACETONE OR DIMEDONE (5,5-DIMETHYL-1,3-CYCLOHEXANDION)

Aldehydes in air were determined by pumping air through a bubbler to which dimedone, ethanol and piperidine were added. An extensive sample workup consisting of washing, refluxing for 20 minutes, a triple extraction and drying produces an extract, which is analysed by GC-ECD. This method, unlike the 2,4-DNPH for GC method, can separate *o*-, *m*- and *p*-tolualdehyde as well as acrolein, propanal and acetone which are poorly separated by HPLC. The detection limit for acrolein was 80 pg and for benzaldehyde 17 pg [155]. Figure 3.11 shows the reaction scheme.

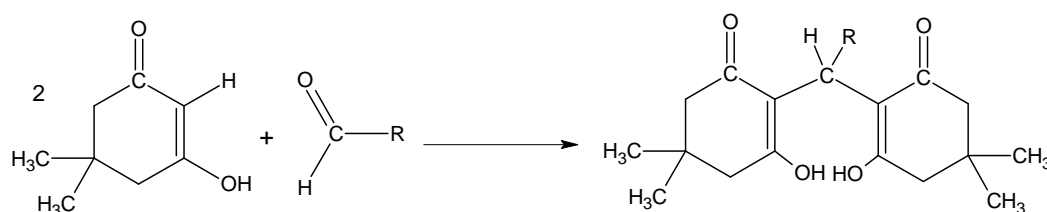

Figure 3.11 Reaction scheme for Dimedon with an aldehyde [155].

The reaction of the dimedone reagent with HCHO in the presence of ammonia is otherwise known as the Hantzsch reaction. The reaction scheme is shown in figure 3.12. Formaldehyde has been simultaneously derivatized in, and extracted by supercritical fluid using the Hantzsch reaction [156].

Chapter 3 - Derivatization

LC-MS has also been used to determine the derivatives of the Hantzsch reaction. An advantage of this reaction is that only the product exhibits fluorescent properties. Problems with increasing fluorescence in the reagent blank, however, were experienced [157].

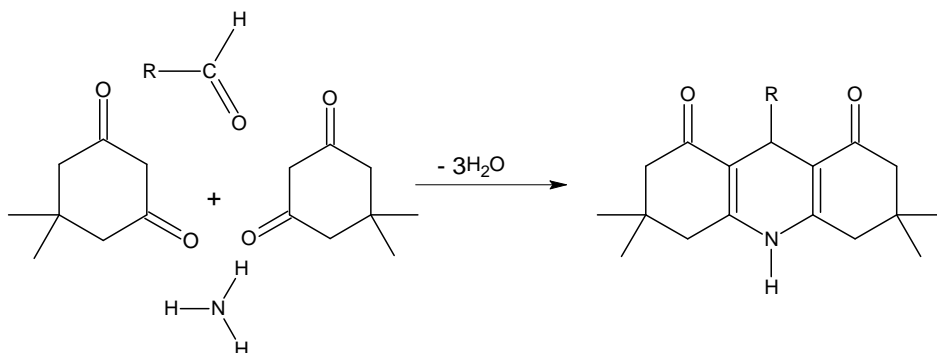

Figure 3.12 Hantzsch reaction scheme [156, 157].

3.3. *Derivatization of amines*

Emphasis is placed in this study on the derivatization of primary alkyl amines, as these were selected for investigation. Further information on the derivatization reactions for the determination of amines by gas chromatography and their applications in environmental analysis can be obtained from a useful review by Kataoka [121].

3.3.1. *Schiff base formation*

Traditionally, benzaldehyde has mainly been used for Schiff base condensations with primary amines. Benzaldehyde imines form with high yields after 10-30 min slight warming [121, 158].

Pentafluorobenzaldehyde (PFBA) has been used to derivatize small alkyl amines in water (pH 10), followed by headspace SPME (polyacrylate fibre) of the imine derivatives and GC/FID analysis [159].

The derivatives were formed after 20 min at 80°C. The limits of detection were determined by the reagent blank and fell between 26-0.4 ng /ml.

Chapter 3 - Derivatization

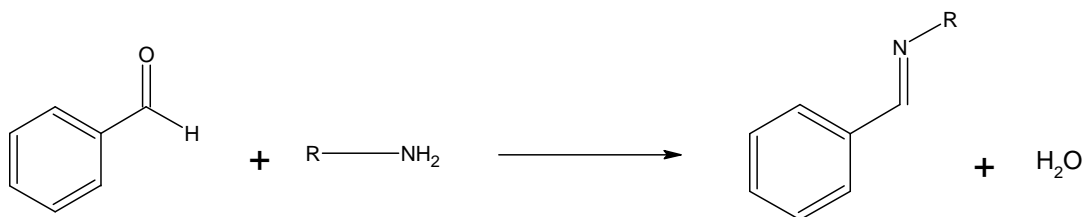

Figure 3.13 Reaction scheme for the condensation of an aldehyde with a primary amine. R = alkyl or aryl substituent [121].

3.3.2. Acylation

PERFLUOROACYLANHYDRIDES

Heptafluorobutyric acid anhydride (HFBA) has been used to derivatize the primary amine on tocainide, an antiarrhythmic drug [160]. The derivative yield was 92% in toluene with a reagent concentration of only 0.01% v/v. However, the authors found that an excess of HFBA, and similarly for trifluoro- and propionic acid anhydride [161], degraded the formed derivatives [160]. A combination of HFBA and heptafluorobutanoyl chloride (HFBCl) 2:8 v/v, has been used to derivatize amphetamine-like drugs from urine [162]. A headspace *in situ* SPME derivatization reaction was used, as the rate at which the water hydrolyzed the reagent was much faster than the rate of the acylation reaction of the amines with the reagent. A glass insert, with 12 holes, containing the derivatizing reagents, was placed in the vial containing the urine sample. The SPME fibre was exposed to the headspace above the glass insert. While the vial was heated, the volatile amphetamine-like drugs diffused into the insert where they were simultaneously derivatized and absorbed by the PDMS SPME fibre. The detection limits of this method were in the range of 0.016–0.193 ng/ml [162].

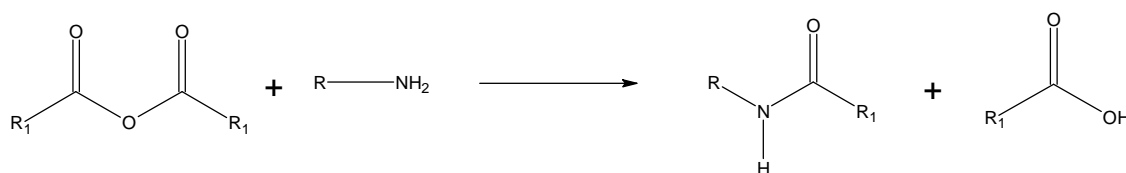

Figure 3.14 Reaction scheme for the reaction of a perfluoroacyl anhydride reagent with a primary amine. R = alkyl or aryl substituent, R₁ = CH₃, CF₃, C₂F₅ or C₃F₇ [121].

ACYL CHLORIDE

Amphetamine in buffered human urine has been extracted *in situ* using a pentafluorobenzoyl chloride (PFBCl)-coated PDMS SPME fibre, followed by GC/ECD or GC/MS analysis [163]. However, excess PFBCl was required since most of the PFBCl loaded on to the fibre reacted with the water and matrix compounds in the sample. An interfering matrix compound caused the limit of detection to vary between 100 pg/ml and 250 pg/ml for reagent loading times of 1 min and 5 min respectively [163].

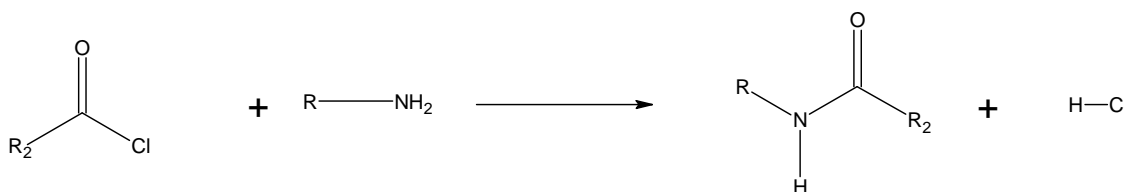

Figure 3.15 Reaction scheme for the reaction of an acyl chloride with a primary amine. R = alkyl or aryl substituent, R₂ = CH₃, C(CH₃)₃, CCl₃, C₆F₅, C₆H₄-NO₂, C₆H₃(NO₂)₂ [121].

ACYL IMIDAZOLE

The acyl imidazoles have a very high reactivity due to the delocalization of the nitrogen's electrons into the heterocyclic ring [158]. The imidazole by-product from the reaction is volatile and does not interfere with the GC analysis. Heptafluorobutyl (HFB) imidazole has been used as derivatization reagent for analysis of drugs with a primary or secondary amine functional group [121]. HFB, PFP and TFA – imidazole derivatization reactions usually occur in a fairly non-polar organic solvent and require a certain amount of heating which is dependant on the size of the amine-bearing compound [158].

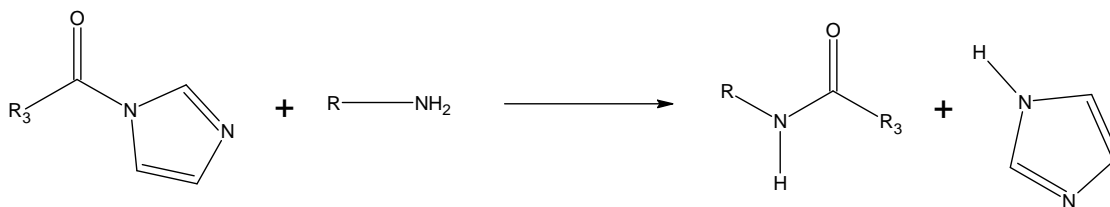

Figure 3.16 Reaction scheme for the reaction of an acyl imidazole with a primary amine. R = alkyl or aryl substituent, R₁ = CH₃, CF₃, C₂F₅ or C₃F₇ [121].

***N*-SUCCINIMIDYL BENZOATE (SIBA)**

Primary alkyl amines in water have been derivatized with a newly developed reagent called SIBA. SIBA was added to the buffered aqueous solution and heated at 60°C for 20 min. The formed derivatives were extracted with a SPME fibre coated with polyphenylmethylsiloxane. The fibre was exposed for 1 hour to the vial headspace, while the vial contents were magnetically stirred and held at 80°C [164]. Detection limits of the derivatized amines were 0.13–7.2 nmol/l for analysis by GC-FID [164].

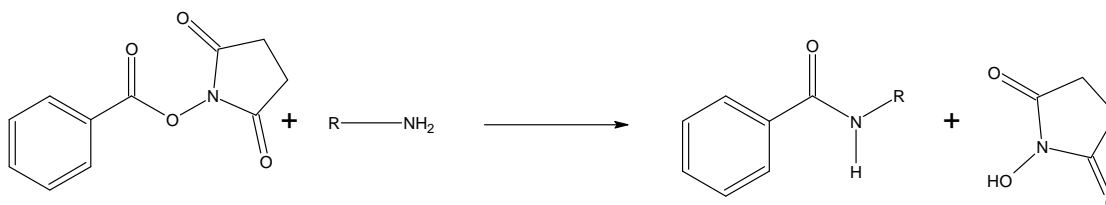

Figure 3.17 Reaction scheme for the reaction of *N*-succinimidyl benzoate, SIBA, with a primary amine. R = alkyl or aryl substituent [164].

3.3.3. Dinitrophenylation

2,4-dinitrofluorobenzene (DNFB), better known as Sanger's reagent, has been used to derivatize primary alkyl amines in wastewater for GC/MS analysis [165]. The determination limits were in the range of 1 µg/L [165]. The reaction is fairly tedious, occurring in a basic medium for 60 min at room temperature, then for another 60 min at 90°C to hydrolyze the excess DNFB. In addition, 3 wash steps are required to remove 2,4-dinitrophenol, one of the hydrolysis products of the DNFB, to prevent any damage to the GC column [165]. DNFB has also been used as a pre-column reagent to derivatize paromomycin in human plasma and urine for analysis by HPLC-UV [166]. Amphetamine enantiomers were resolved and identified by HPLC - circular dichroism spectroscopic analysis, after DNFB derivatization [167].



Figure 3.18 Reaction scheme for the reaction of 2, 4-dinitrofluorobenzene (DNFB) with a primary amine. R = alkyl or aryl substituent [121].

Chapter 3 - Derivatization

2, 4-Dinitrobenzene sulphonic acid (DNBS) is water soluble, while the DNB derivatives are not, allowing for an easy separation of excess reagent before analysis. DNBS reacts only with amino groups, unlike DNFB which reacts with amines, thiols, imidazoles and hydroxyls. However, longer reaction times and strongly alkaline reaction conditions are required by DNBS [121].



Figure 3.19 Reaction scheme for the reaction of 2, 4-dinitrobenzenesulphonic acid (DNBS) with a primary amine. R = alkyl or aryl substituent [121].

3.3.4. Sulphonamide formation

An alkaline aqueous mixture of primary, secondary and tertiary amines can be separated by a one-pot selective derivatization and extraction procedure described by Hinsberg *et. al.* [121] Benzenesulphonyl chloride and *p*-toluenesulphonyl chloride are two reagents that react selectively with primary and secondary amines. Separation is achieved when the hexane extraction removes the water-insoluble sulphonamide derivative of the secondary amine and not the water-soluble primary amine derivative. The tertiary amine remains unchanged [121].

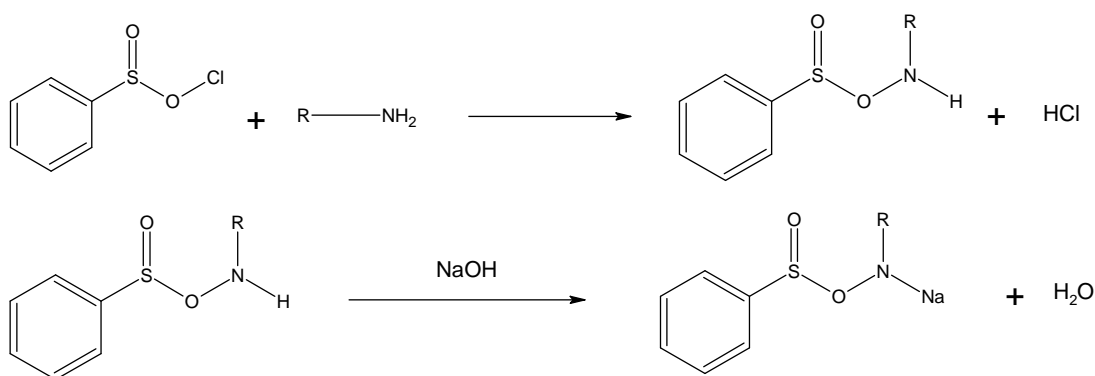

Figure 3.20 Reaction scheme for the sulphonation reaction of benzenesulphonyl chloride with a primary amine. R = alkyl or aryl substituent [121].

3.3.5. Silylation

Silylation of amines generally requires strong silylation reagents and harsh reaction conditions [121, 122]. BSA, BSTFA and MTBSTFA have been used to silylate primary and secondary amines. However, in addition to the associated disadvantages mentioned above, these reagents also react with hydroxyl and carboxylic acid groups [121, 122].

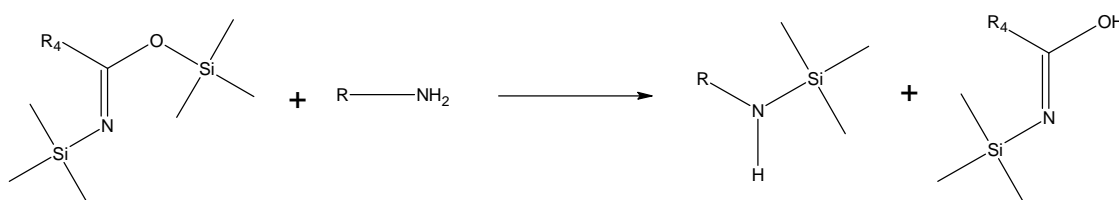

Figure 3.21 Reaction scheme for the reaction of $R_4 = \text{CH}_3$ (BSA) or CF_3 (BSTFA) with a primary amine, $R =$ alkyl or aryl substituent [121].

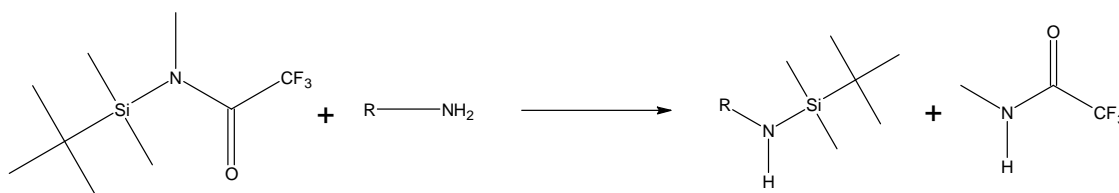

Figure 3.22 Reaction scheme for the reaction of MTBSTFA with a primary amine [121].

3.3.6. Carbamate formation

2-(9-anthryl) ethyl chloroformate has been used, in an automated process, as a precolumn derivatization agent for determining amino acids. Both primary and secondary amines were converted to stable carbamate derivatives before being analysed by HPLC. The reaction occurred at room temperature in a buffered aqueous medium, after removal of excess reagent prior to injection. The anthracene chromophore provided lower UV and fluorescence detection limits of 0.5 pmol and 0.06 pmol, respectively, than the better-known 9-fluorenylmethyl chloroformate [168, 169]. For GC analysis, smaller molecular tags are used for carbamate formation, typically the methyl, ethyl and isobutyl chloroformates [112, 169]. Trichloro- and pentafluorobenzyl chloroformates have also been developed for ECD detection [169].

Chapter 3 - Derivatization

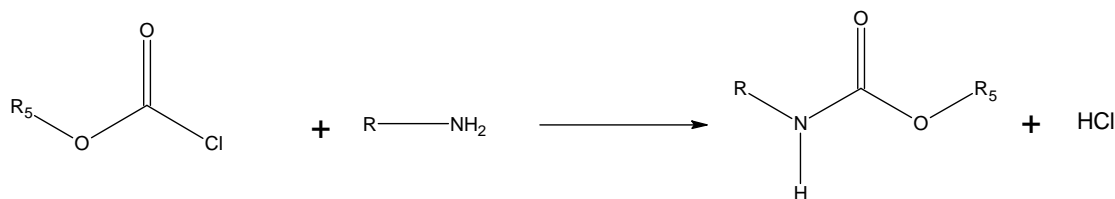

Figure 3.23 Reaction scheme for the formation of a carbamate from the reaction of an alkyl chloroformate with a primary amine. R= alkyl or aryl substituent, R₅ = C₂H₅, CH₂CH(CH₃)₂, C₅H₁₂, CH₂CF₃.

3.4. Derivatization of alcohols and phenols

3.4.1. Acylation

ACYL ACID ANHYDRIDES

Acetic acid anhydride (AAA) is by the far the most popular reagent for derivatizing phenols. The stable methyl ester derivatives form rapidly under aqueous alkaline conditions followed by extraction into an organic solvent or polymeric sorbent [122, 170].

AAA has been used to derivatize chlorophenols in tap water for analysis by plasma atomic emission detector [171], pentachlorophenol in leather using supercritical fluid extraction [172], phenol and methylphenol isomers in soil [173], bisphenol A in river water using liquid phase microextraction (LPME) [174] and alkylphenols in water by FIA and membrane introduction mass spectrometry [175].

There are several applications of *in situ* derivatization using AAA. These use stir bar sorptive extraction (SBSE) to extract and concentrate the formed derivatives followed by thermal desorption GC/MS analysis. Using this method, the following have been determined; estrone, 17 β -estradiol and 17 α -ethinylestradiol [55, 176], alkylphenols and bisphenol-A in human urine samples [51] and in river water [54, 177], chlorophenols in river and tap water as well as human urine [178], hydroxy-PAH's in water [179], phenols in human urine [112], lake and ground water [180]. Detection levels were typically at the

Chapter 3 - Derivatization

ppt level. 17α -Ethinylestradiol was extracted and derivatized by SBSE with AAA and BSTFA to convert both the phenolic and sterically hindered alkyl hydroxyl group. A multishot desorption of 5 stir bars resulted in a detection limit of 0.1 ng/L [181].

For improved detection trifluoroacetic (TFA) [182]-, pentafluoropropionic (PFP) and heptafluorobutyric (HFB) acid anhydrides have frequently been used [122]. Several haloacyl anhydrides were tested for the determination of 21 endocrine disrupting compounds, of which TFAA and HFBA proved most useful [62]. Unlike most other derivatization reactions described in the relevant literature, these reactions all proceeded to completion within 5 min [62].

Estrone, 17β -estradiol and 17α -ethinylestradiol have been concentrated and cleaned from sewage water using SPE. The extract was derivatized with PFPAA and analyzed by GC-MS (SIM). Detection limits were in the range of 5 - 10 ng/L [21, 183]. Estrone, 17β -estradiol, estriol, nonylphenol and bisphenol-A were determined from sediments. After ultrasonic extraction and silica gel fractionation, the extract was derivatized with PFPAA and analyzed by GC-MS (SIM). Detection limits were in the range of 0.1 – 1.5 ng/g [184].

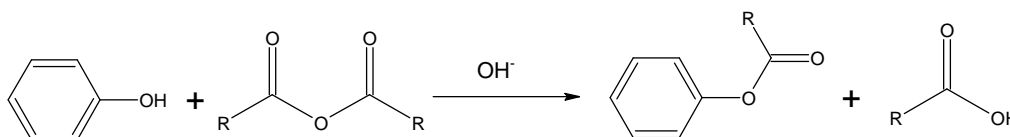

Figure 3.24 Reaction scheme for the reaction of phenol functional groups with an acyl anhydride to form the ester and carboxylic acid by-product.

ACYL HALIDES

Pentafluorobenzoyl chloride (PFBCl) has become a very popular acylation reagent for phenols. PFBCl has been used to determine phenols [185, 186] and chlorophenols in water, wastewater and sludge by GC/ECD [187]. The PFB esters could be detected down to 1 pg [186].

Chapter 3 - Derivatization

PDMS/ DVB SPME of chlorophenols in tap water has been achieved *via in situ* derivatization of the analytes in the fibre with PFBCl [188]. PFBCl headspace was loaded onto the PDMS/DVB fibre for 20 min at 40°C followed by immersion for 10 min at 40°C into the buffered aqueous solution containing the chlorophenols. The SPME fibre was then desorbed for 3 min at 260°C in the GC inlet [188]. Limits of detection of 0.005 – 0.8 µg/L were obtained from GC/ECD analysis [188].

The following have been determined as their PFB derivatives by GC/NCI-MS: Alkylphenols in cod at the low µg/kg level [189]; alkylphenols in produced water from offshore oil installations at the low ng/L level [190]; and β-estradiol in bovine urine (LOD 287 pg/ml) [191]. The estrogens estrone, 17β-estradiol, estriol and 17α-ethinylestradiol have been determined in various waste and drinking waters. The samples were cleaned and concentrated by SPE followed by evaporation and derivatization with PFBCl. Remarkable detection limits 0.03 – 0.2 ng/L were reached for each estrogen [192, 193].

Perfluorooctanoyl chloride has been used to derivatize fatty alcohols in order to move the molecular ions into the higher mass ranges of 600-700 m/z [194]. Reaction times of 2 min were obtained using microwave irradiation [194].

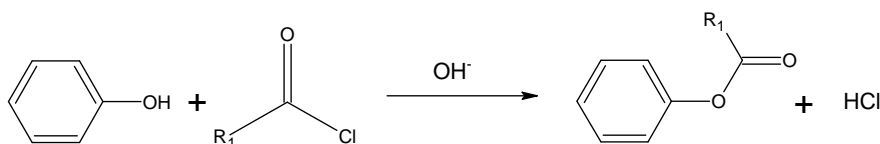

Figure 3.25 Reaction scheme for the reaction of a phenol functional group with an acyl chloride to form the ester and haloacid by-product.

3.4.2. Silylation

Silylation reactions are typically used for improving the volatility and thermal stability of the analytes. Most silylations occur on the phenol / alcohol groups of large bulky molecules, for example steroids. Investigation into the use of various catalysts and solvents for different applications is generally

required since yields fluctuate according to these parameters [195, 196]. The most commonly used reagents described in the relevant literature are highlighted below.

***N*-METHYL-*N*-(TRIMETHYLSILYL)-TRIFLUOROACETAMIDE (MSTFA)**

Estrogens from water have been extracted using a polyacrylate SPME fibre followed by headspace derivatization using MSTFA [197, 198]. MSTFA, unlike other reagents, is capable of converting both phenolic and aliphatic alcohols into their TMS ethers. Conversion of both groups occurred at 60°C after 30 min. Detection limits of 0.2-3 ng/L were obtained [198].

Natural and synthetic estrogens in water samples were determined using SPE and derivatization with MSTFA, followed by analysis using GC/MS or GC/MS/MS. Quantification limits were found to lie between 1 and 3 ng/L [199].

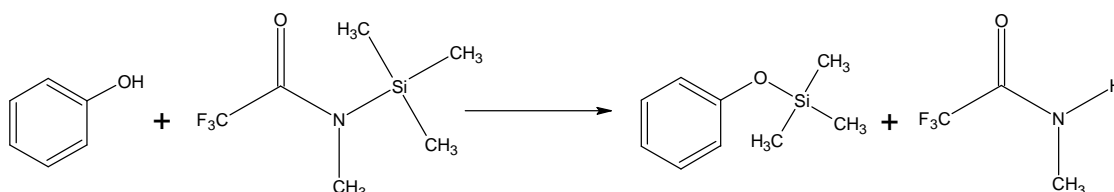

Figure 3.26 Reaction scheme for the formation of phenyl trimethylsilyl ether from the reaction of MSTFA with a phenol.

***N*-*O*-BIS (TRIMETHYLSILYL) TRIFLUOROACETAMIDE (BSTFA)**

Li *et al* investigated the simultaneous silylation of alkylphenols, chlorophenols and bisphenol-A for GC/MS analysis using BSTFA. Optimum quantitative reaction conditions for BSTFA were found in acetone at room temperature. Removal of excess BSTFA through hydrolysis provided enhanced long-term stability of the formed trimethylsilyl derivatives eliminating one of the drawbacks of BSTFA [200].

Chapter 3 - Derivatization

Alkylphenols in water have been determined by SBSE and in-tube silylation using BSTFA by Kawaguchi *et al* [55]. Detection limits were at the sub ppt level. A dual derivatization “multishot” technique using SBSE, *in situ* acylation with AAA and in-tube silylation with BSTFA, was tested for the analysis of 17 β -estradiol in river water, also by Kawaguchi *et al* [181]. AAA forms the methyl acetate ester on the phenolic group while the BSTFA forms the trimethylsilyl ester on the aliphatic alcohol. A detection limit of 0.1 pg/ml was obtained for this method [181]. SPE of estrogens in river water followed by derivatization using PFBBBr and BSTFA, to form the PFB-TMS derivatives, and analysis by GC-NCI/MS provided detection limits of 0.10 to 0.28 ng/L [30].

Alkylphenols and steroid hormones in biological samples and water has been determined by polyacrylate (PA) SPME and headspace BSTFA derivatization [201, 202]. Limits of quantitation were in the low ppb range lower levels than this were not possible due to matrix effects [201, 202]. The SPME fibres are destroyed by direct contact with the liquid BSTFA [201]. The same technique was previously also used to determine hydroxy - PAHs in urine samples with method detection limits in the range of 0.01–0.1 ng/mL [203]. Headspace PA SPME followed by BSTFA derivatization was used to determine bisphenol-A from plastic containers [52], and *tert*-octylphenol, nonylphenol and bisphenol-A from underground and seawater [197]. Detection by GC-MS (SIM) provided detection limits of 0.4 ng/L [52] and 100 ng/L [197] respectively.

BSTFA has also been used to derivatize alkylphenols and bisphenol-A from seawater samples after extraction by porous polysulfone hollow fibre membrane (PS-HFM). Detection limits ranged between 0.07 and 2.34 ng/L [50]. The estrogens: estrone, 17 β -estradiol, estriol and 17 α -ethinylestradiol have been determined in river water. The samples were cleaned and concentrated by SPE followed by evaporation and derivatization with BSTFA and 1% Trimethylchlorosilane (TMCS). Detection by GC – ITD/MS provided detection limits in the range of 5 ng/L for each estrogen [196].

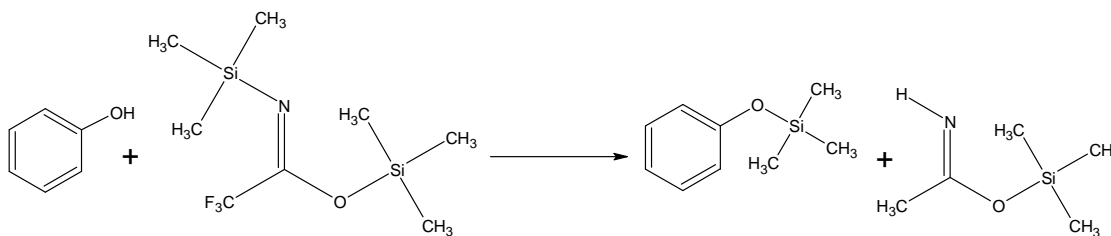

Figure 3.27 Reaction scheme for the formation of phenyl trimethylsilyl ether from the reaction of BSTFA with a phenol.

***N* - (*tert* - BUTYLDIMETHYLSILYL)-*N*-METHYLTRIFLUOROACETAMIDE
(MTBSTFA)**

MTBSTFA has been used to derivatize hydrolysed lipids [204]. The *tert*-butylsilyl esters provided higher resolution and sensitivity than the corresponding methyl esters on a GC/FID [204].

Both MSTFA and MTBSTFA have been used to determine 19-norandrosterone in human urine [205]. Despite the *tert*-butylsilyl derivative having a slightly lower sensitivity than the trimethylsilyl derivative, the *tert*-butylsilyl derivative eluted much later and the molecular ion fell in the higher mass range allowing for unambiguous identification of the steroid [205].

More than 50 substituted phenols have been detected at the ng/L level from environmental samples having high matrix content [206]. After SPE, the phenols were derivatized using MTBSTFA. The characteristic ion $[M-57]^+$ resulting from *tert*-butyl cleavage, allowed for very low detection by GC/EI-MS in the SIM mode [206].

Endocrine disrupting estrogens in water have been derivatized using MTBSTFA and analyzed by GC tandem MS and GC/MS [207, 208]. Detection limits were 1 ng/L and 4 – 6 ng/L, respectively [207, 208].

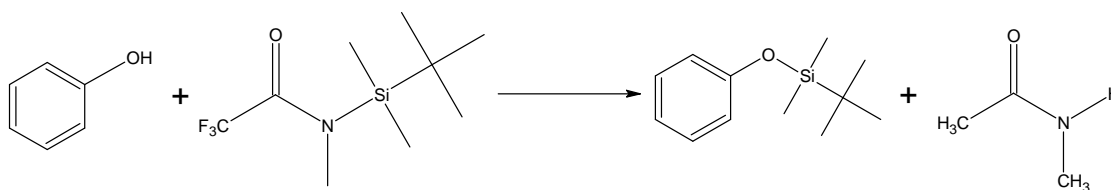

Figure 3.28 Reaction scheme for the formation of phenyl *tert*-butylsilyl ether from the reaction of MTBSTFA with a phenol.

Chapter 3 - Derivatization

N-TRIMETHYLSILYLIMIDAZOLE (TMSI)

Fine *et al*, determined estrogens in ground water and swine lagoon samples using NCI-GC/MS/MS, after derivatization of the phenolic groups with pentafluorobenzylbromide (PFBBr), and of the hydroxyl groups with TMSI [209]. Limits of quantitation of 1 ng/L and 40 ng/L were obtained for the 2 samples respectively [209].

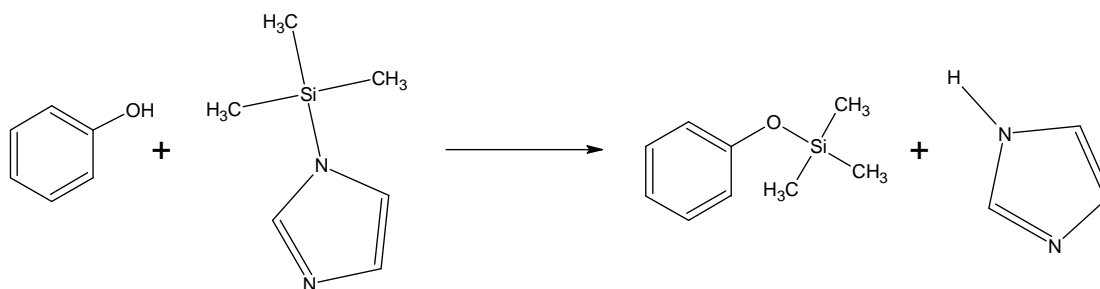

Figure 3.29 Reaction scheme for the formation of phenyl trimethylsilyl ether from the reaction of TMSI with a phenol.

3.4.3. Alkylation

Pentafluorobenzylbromide is often used as alkylation reagent for hydroxyl and phenol groups [62]. Alkylation reactions are more often used for the conversion of carboxylic acids into their esters than for the conversion of alcohols into ethers, as the reactions tend to be tedious reactions [62, 210]. PFBBr has been used to convert hydroxy PAHs from urban aerosols, into their corresponding PFB ethers, for analysis by GC/ECD and GC/MS [210]. Detection limits of 0.01 and 3.3 pg in ECD and (NCI)-SIM-MS were respectively obtained [210]. The estrogens: estrone, 17 β -estradiol, estriol and 17 α -ethinylestradiol have been determined in river, ground and swine lagoon water. Trimethylsilyl-imidazole (TMSI) was used as catalyst and acid scavenger. The detection limit fell in the range of 0.1 – 40 ng/L [30, 209].

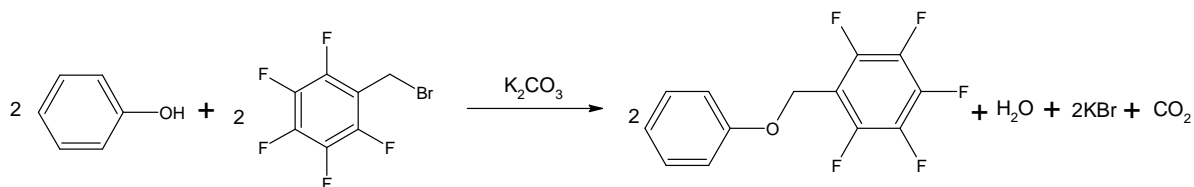

Figure 3.30 Reaction scheme for the formation of pentafluorobenzyl ether from the reaction of PFBBr with a phenol.

3.5. Derivatization and pre-concentration

Table 3.2 summarises the sample preparation, concentration and derivatization techniques used for the analysis of endocrine disruptors from various matrices. It also lists the detection limits obtained by GC/MS and LC/MS/MS (where no derivatization was utilized). Excellent detection limits are obtained when GC- (NCI) MS, after derivatization with PFBCl, is used. Pre-concentration using SPME or SBSE appears to yield similar results using only GC- (EI) MS.

When pre-concentration techniques are used for analytes requiring derivatization, it is necessary to determine the most suitable time to perform the derivatization reaction. The principal objective is to obtain maximum selective concentration and consequently maximum sensitivity.

3.5.1. Pre-derivatization

Derivatization is often performed before extraction if it will significantly enhance the partitioning of the analyte into the extraction medium. For example, in order for *aqueous* polar analytes to be extracted by SBSE, a non-polar concentration medium (100 % PDMS), they must be converted into their corresponding non-polar derivatives before they will partition into the PDMS. Phenols are first derivatized in a buffered aqueous medium using AAA, to form their corresponding methyl esters, prior to SBSE. The following have been determined using this technique: alkylphenols and bisphenol-A in human urine samples [51] and in river water [54, 177], chlorophenols in river and tap water as well as human urine [178], hydroxy-PAH's in water [179], phenols in human urine [112], lake and ground water [180]. Very low detection limits, typically at the ppt level have been achieved, as detection is enhanced through selective extraction of non-polar derivatives into the stir bar.

3.5.2. In situ derivatization

In situ derivatization is frequently used when working at ultra trace levels where all possible sample losses due to use of additional extra glassware need to be avoided. It is not necessarily required that the extraction medium have the same polarity as the analyte, since the analyte is converted while simultaneously being extracted. For example, the derivatization reagent PFBHA headspace is dissolved

Chapter 3 - Derivatization

into the PDMS of the multichannel silicone rubber trap, simultaneously derivatizing airborne low molecular mass aldehydes and concentrating their corresponding hydroxylamine derivatives within the PDMS [61]. Similarly, a SPME fibre has been simultaneously exposed to the headspace of the derivatizing reagent (HFBCl) and analytes (amphetamine-type drugs), allowing the analytes to be derivatized in and extracted into the fibre [162].

3.5.3. Post-derivatization

Post derivatization can only occur if the concentrating medium and analyte have similar polarity. In this case only the detection properties of the analytes are enhanced prior to analysis, since partitioning into the concentrating medium is not affected by the derivatization reaction. SPME benefits the most from this type of extraction because it has an assortment of fibres with different polarity. This means that it can extract a wide range of analytes without requiring derivatization prior to extraction. However, the extracted analytes can still be made amenable to GC analysis by derivatization prior to or during desorption in the GC inlet. Alkylphenols and steroid hormones in biological samples and water have been determined by extraction onto a polyacrylate SPME fibre followed by headspace BSTFA derivatization [201, 202].

3.6. Conclusions

From the above review above it is apparent that every reagent has its own inherent set of advantages and disadvantages. Selection of a reagent should therefore be undertaken in a manner that ensures that the majority of analysis requirements are met, particularly in terms of enhancing the selectivity and sensitivity of the reaction and the analyses.

Table 3.2 Sample preparation, concentration and derivatization techniques used for analysis of endocrine disruptors from various matrices

Analytes	Matrix	Sample preparation	Preconcentration	Derivatization	Instrumental analysis	LOD (LOQ) ng/ L (ppt)	Year	Reference
E1, E2, E3, EE2	Ground. River and sewage water	SPE	SPE & evaporation	PFBCl	GC- (NCI) MS	0.2, 0.03, 0.06, 0.05	2001	[192]
E1, E2, EE2	Surface & drinking water	SPE	SPE & evaporation	PFBCl	GC- (NCI) MS	0.05-0.15	2001	[193]
E1, E2, E3, EE2	Human urine	pH adjustment & enzyme hydrolysis	LLE & evaporation	PFBCl	GC- (NCI) MS	100	2000	[247]
TOP, NP	Sea water	Anion exchange SPE	SPE & evaporation	PFBCl	GC- (NCI) MS	103, 102	2004	[190]
E1, E2, E3, EE2	River water	SPE	SPE & evaporation	PFBBBr, TMSI	GC- (NCI) MS	0.1 – 0.28	2001	[30]
E1, E2, E3, EE2	Ground & swine lagoon water	Centrifuge & filter	SPE	PFBBBr, TMSI	GC – (NCI) MS/MS	(1 (ground)) (40 (swine))	2003	[209]
E1, E2, E3, EE2	River water	SPE	SPE & evaporation	BSTFA + 1% TMCS	GC- (ITD) MS	(5)	2003	[196]
BPA	Plastic containers		Headspace PA SPME	BSTFA + 1 % TMCS	GC- (EI) MS (SIM)	0.4	2005	[52]
TOP, NP, BPA	Sea water		Hollow fibre SPME	BSTFA	GC- (EI) MS (SIM)	0.07 – 2.34	2005	[50]
E1, E2, EE2, TOP, BPA	Waste water	SPE		BSTFA	GC- (EI) MS (SIM)	4.0-26.5	2004	[262]
TOP, NP, BPA	Sea water	Silyl SPE & derivative kit	SPE	BSTFA	GC- (EI) MS (SIM)	100, 190, 138	2001	[200]

Analytes	Matrix	Sample preparation	Preconcentration	Derivatization	Instrumental analysis	LOD (LOQ) ng/ L (ppt)	Year	Reference
OP, NP, E1, E2, DES	River water & blood serum		In-sample PA SPME	BSTFA	GC- (EI) MS (SIM)	2 – 378 (8 – 1261)	2006	[202]
TOP, NP, BPA	Underground & sea		Headspace PA SPME	BSTFA	GC- (EI) MS (SIM)	100	2001	[197]
E1, E2, E3, EE2	River & sewage water	SPE	SPE & evaporation	MSTFA	GC- (EI) MS (SIM)	(1-3)	2004	[199]
E2, EE2	Surface	SPE		MTBSTFA	GC- (EI) MS (SIM)	50-300	2000	[208]
E1, E2, EE2	Reservoir, river & waste water	SPE		MTBSTFA & 1% TBDMCS	GC- (EI) MS/MS	1	2000	[207]
E1, E2, EE2	Surface & waste water	SPE	HPLC fraction	Sil A reagent	GC- (EI) MS/MS	0.1-2.4	1999	[263]
EE2	River water		SBSE	AAA & BSTFA	TD-GC- (EI) MS (SIM)	0.5 (2) 0.1 multishot	2006	[181]
E1, E2, EE2	River water		Multishot 5 x SBSE	AAA	TD-GC- (EI) MS (SIM)	0.2, 0.5, 1	2004	[55, 176]
TOP, NP, BPA	Human urine	Protein precipitation & centrifuge	SBSE	AAA	GC- (EI) MS (SIM)	10, 50, 20	2005	[51]
TOP, NP, BPA	River water		SBSE	AAA	TD-GC- (EI) MS (SIM)	0.1 – 3.2	2004	[54]
BPA	River water		LPME	AAA	GC- (EI) MS (SIM)	2 (10)	2006	[174]
TOP, NP, BPA	River water		SBSE	AAA	GC- (EI) MS (SIM)	0.5, 5, 2	2004	[177]
E1, E2, E3, NP, BPA	Sediment	Ultra-sonic extraction, silica gel fractionation		PFPAA	GC- (EI) MS (SIM)	0.6, 0.8, 1.5, 0.2, 0.1 ng/g	2006	[184]
E1, E2, EE2	Sewage water	SPE		PFPAA	GC- (EI) MS (SIM)	5-10	1998	[21, 183]

Analytes	Matrix	Sample preparation	Preconcentration	Derivatization	Instrumental analysis	LOD (LOQ) ng/ L (ppt)	Year	Reference
NP, NPEO	Tap & river water		Headspace CW-DVB SPME	Dimethylsulphate/NaOH	GC- (EI) MS (SIM)	20-1500	2002	[264]
E1, E2, EE2	Sewage water	SPE	HPLC fraction		GC-MS	0.5-1	2001	[21, 265]
NP, BPA, EE2	Sewage water		Hollow fibre membrane extraction		GC- (EI) MS (SIM)	100, 300, 20	2003	[266]
NP, BPA, EE2	Waste water		Automated PA SPME		GC- (EI) MS (SIM)	800, 1000, 40	2003	[267]
E1, E2, EE2	Sewage water	SPE	HPLC fraction & LLE		GC- (EI) MS (SIM)	0.2	1998	[21, 268]
E1, E2, EE2, TOP, BPA	Waste water	SPE			GC- (EI) MS/MS	2.5-27.5	2004	[262]
EE2	River water		Molecularly imprinted polymers		LC/MS	1.8 (5.4)	2006	[269]
E1, E2, E3, EE2	River water	SPE	SPE & evaporation		LC- (ESI) MS (SIM)	0.1- 0.2	2005	[270]
E1, E2, EE2, TOP, NP, BPA	River & waste water		PA SPME		HPLC-UV-ED	300-1100 (UV) 60 – 80 (ED)	2002	[271]
E1, E2, E3, EE2	Sewage, surface & drinking water	SPE	SPE & evaporation		LC-DAD-MS (APCI, ESI±)	50-500 (DAD) 2-500 (ESI) 20-5000 (APCI)	2000	[272]
E1, E2, E3, EE2, DES	River water & sediment	On- & Off-line SPE			LC- DAD- (ESI) MS (SIM)	< 1	2001	[273]

Analytes	Matrix	Sample preparation	Preconcentration	Derivatization	Instrumental analysis	LOD (LOQ) ng/ L (ppt)	Year	Reference
TOP, NP, BPA	Mineral water & soda beverages	SPE	SPE & evaporation		LC- (ESI) MS/MS (MRM)	(0.04, 0.03, 0.2)	2005	[8]
E1, E2, E3, EE2, DES	Surface & waste water	0.2 µm nylon filtration	In-tube SPME (PLOT capillary)		LC- (ESI) MS/MS	2.7 – 11.7	2005	[274]
E1, E2, E3, EE2, DES	River & Sewage water	0.45µm filtration	On-line SPE		LC- (ESI) MS/MS (SRM)	(0.02 – 1.02)	2004	[275]
E1, E2, E3, EE2	River & sewage water	SPE	SPE & evaporation		LC- (ESI) MS/MS	(0.008- 0.9)	2000	[276]
EE2	River & Sewage water	Glass fibre filtration			Chemiluminescence ELISA	0.2±0.1 (1.4±0.8)	2005	[26]
E1	Sewage plant water	SPE	SPE & evaporation		ELISA	1.25	2004	[27]

Abbreviations:

(E1) Estrone; (E2) 17β-Estradiol; (E3) Estriol; (EE2) 17α-Ethinylestradiol; (DES) Diethylstilbestrol; (TOP) *tert*-octylphenol; (OP) Octylphenol; (NP) 4-n-nonylphenol; (NPEO) Nonylphenoethoxylate; (BPA) Bisphenol-A; (GC) Gas Chromatography; (LC) Liquid Chromatography; (HPLC) High Performance Liquid Chromatography; (MS) Mass Spectrometry; (EI) Electron Impact Ionization; (NCI) Negative Chemical Ionization; (ITD) Ion Trap Detector; (SIM) Selected Ion Monitoring; (TD) Thermal Desorption; (ESI±) Positive/Negative Electrospray Ionization; (APCI) Atmospheric Pressure Chemical Ionization; (SRM) Selected Reaction Monitoring; (MRM) Multiple Reaction Monitoring; (UV) Ultraviolet; (ED) Electrochemical Detection; (SPE) Solid Phase Extraction; (LPME) Liquid Phase Microextraction; (LLE) Liquid-liquid extraction; (SPME) Solid Phase Microextraction; (SBSE) Stir Bar Sorptive Extraction; (PA) Polyacrylate; (CW-DVB) Carbowax-Divinylbenzene; (PLOT) Packed Layer Open Tubular; (PFBCl) Pentafluorobenzoyl chloride; (PFBBBr) Pentafluorobenzylbromide; (TMSI) Trimethylsilyl-imidazole; (BSTFA) Bis(trimethylsilyl)trifluoroacetamide; (TMCS) Trimethylchlorosilane; (MSTFA) Methyl(trimethylsilyl)trifluoroacetamide; (MTBSTFA) Methyl(*tert*-butyldimethylsilyl) methyltrifluoroacetamide; (TBDCMS) *tert*-butyldichloromethylsilane; (AAA) Acetic acid anhydride; (PFPA) Pentafluoropropionic acid anhydride; (NaOH) Sodium hydroxide
 Additional reviews can be obtained from [1-3, 21, 23-25, 243]

Chapter 4

Sample Introduction

4. Introduction

Volatile organic compounds, which have been pre-concentrated in a solvent or on ad/absorbents, need to be quantitatively transferred as a narrow injection band into the GC capillary column. A brief description of the various inlet techniques used during this study is presented below. The GC inlet was used to introduce prepared derivatives for confirmation using GC/MS and for desorption of SPME fibres. The Chrompack® and Gerstel® Thermal desorbers were used to desorb traps in the off-line concentration of alkylphenols from water, and the Airsense® EDU and thermal modulator array were used for the on-line concentration and derivatization of aldehydes and amines for introduction into a Resonance Enhanced Multi Photon Ionization Time of Flight Mass Spectrometer (REMPI-TOFMS).

4.1. GC inlets

By far the most common sample introduction technique for GC analysis is the split / splitless injector, figure 4.1. In general, the syringe is inserted through a leak tight rubber septum, where the injected sample is released into the heated zone of a glass inlet liner. An incoming stream of carrier gas pushes the vaporised sample into the GC capillary column, maintained at least 50°C lower than the inlet temperature. The sample is injected instantaneously so that, in combination with the high temperature of the inlet, e.g. 250°C, the volatilised components in the sample are focussed onto the cooler column, e.g. at 40°C, as a narrow injection band.

When the sample is too concentrated or injected as a large volume, split injection is used. At a preset split-ratio only a small proportion of sample, usually a few nanolitres, is transferred onto the column. The presence of a high gas flow rate through the inlet ensures that the reduced sample vapour rapidly enters the column as a narrow solute band [211, 212]. Split injection is not suitable for trace analysis and discrimination effects based on boiling point of analytes do occur [212, 255]

When sample components are present in trace amounts the entire sample can be transferred onto the column by splitless injection, thereby improving detection limits [211]. However, for a splitless



injection the injection volume should not exceed the internal volume of the splitless inlet liner [212]. This will cause the expanded vaporised sample to escape from the inlet chamber through the septum purge, split outlet or into the carrier gas inlet, resulting in sample losses and future memory effects [211,212]. It usually takes between 10-40 seconds for the vaporized sample to enter the column. The split valve must be opened when the transfer is almost complete in order to purge the remaining sample out of the inlet [212]. A low initial column temperature will ensure that condensation and re-concentration of the sample occurs in the column. Cold trapping and the solvent effect are two re-concentration mechanisms often used with splitless injections [212, 255].

Large volume splitless injection techniques were introduced to overcome the limitations of splitless injections on a normal split/splitless inlet. The most popular large volume splitless injection techniques use either a programmed thermal vaporization inlet (PTV) with solvent splitting [212, 255] or the on-column retention technique developed by Grob *et al* [212, 255]. The cold inlet system (CIS) described below is essentially operating as a PTV (with a solvent splitting option available). The on-column retention technique uses an on-column liner packed with an appropriate packing material (often glass wool or other poor heat conductors) [212]. The sample is injected into the inlet where the sample liquid is deposited on the cooler packing. As the solvent evaporates it maintains the inlet vaporizing chamber temperature at the solvent's boiling point until evaporation is almost complete. The solvent vapour exits through the septum purge (which is wide open) or it is allowed to expand to outside the vaporizing chamber hence the term "overflow" technique. The injector temperature is then raised and the solutes evaporate and are transferred onto the column by the carrier gas [212].

When SPME is used for pre-concentration, the fibre is typically desorbed in a split / splitless inlet. The SPME fibre is protected by the syringe barrel, which is used to pierce through the rubber septum. The fibre is exposed once the syringe barrel is inside the inlet. Here, it is essential that the fibre is exposed in the heated zone of the inlet; this is usually towards the centre of the inlet as the ends are generally cooler. Desorption usually occurs in the splitless mode for 2-5 min depending on the nature of the desorbed analytes and the desorption temperature. The fibre is then retracted into the syringe barrel and removed from the inlet, while the split flow is opened and the desorbed analytes are transferred onto the cooler GC column.

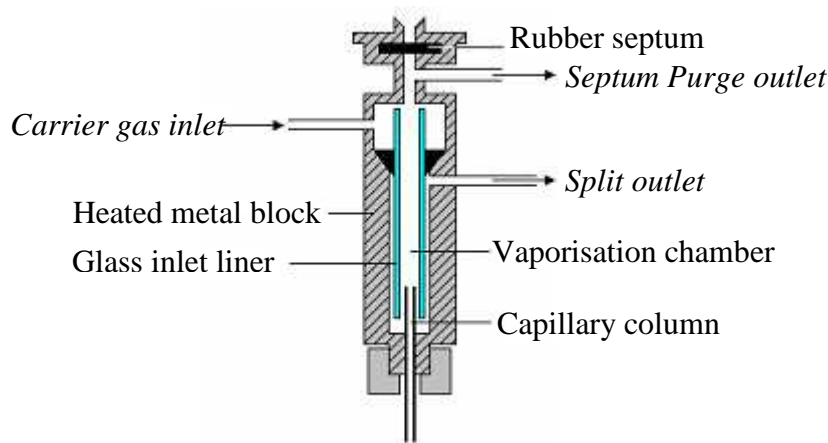

Figure 4.1 A split / splitless inlet [211]. Copyright Wiley-VCH Verlag GmbH & Co. KGaA. Reproduced with permission.

4.2. Thermal Desorption Units

4.2.1. Chrompack®

A Chrompack® 4020 desorption unit was initially used in our study, Figure 4.2[213]. A glass tube, either empty or packed with sorbent, is placed in the desorption oven, where it is heated while the carrier gas transfers the volatiles from the tube onto a cold trap.

The cold trap consists of a fused silica capillary, 30 cm long with an internal diameter of 0.53 mm, which is coated with a thick film of non-polar stationary phase to increase its capacity. During desorption, the cold trap is cooled and maintained at sub-ambient temperatures ranging from 0°C to -100°C by using liquid nitrogen. Upon completion of desorption the cooling flow is stopped. A metal capillary tube, which surrounds the fused silica cold trap, is heated ohmically. This ensures a ballistic temperature increase from, for example -100°C to 250°C within 1 minute. Within that time, the carrier gas transfers the contents of the cold trap and refocuses it onto the GC capillary column, which is at a lower temperature. Figure 4.2 shows the 2 main phases, namely desorption and injection, in the TCT - CP 4020 [213].

This system is no longer manufactured as it has several flaws, namely: insertion of the glass trap tubes into the desorption oven requires tightening of the Swagelok® nut and graphite ferrule at the base of the glass tube. To obtain leak tight connections often leads to over tightening and breakage of the glass trap tubes. The thermal gradient across the cold trap during the injection phase is such

that there are cold spots at the inlet and outlet ends of the capillary trap, which lead to incomplete transfer and tailing of higher boiling analytes. The software has a default injection time of 1min at a maximum temperature of 300°C. Trying to override the injection time manually, in order to obtain complete transfer, leads to a malfunction of the heating element and thermocouple.

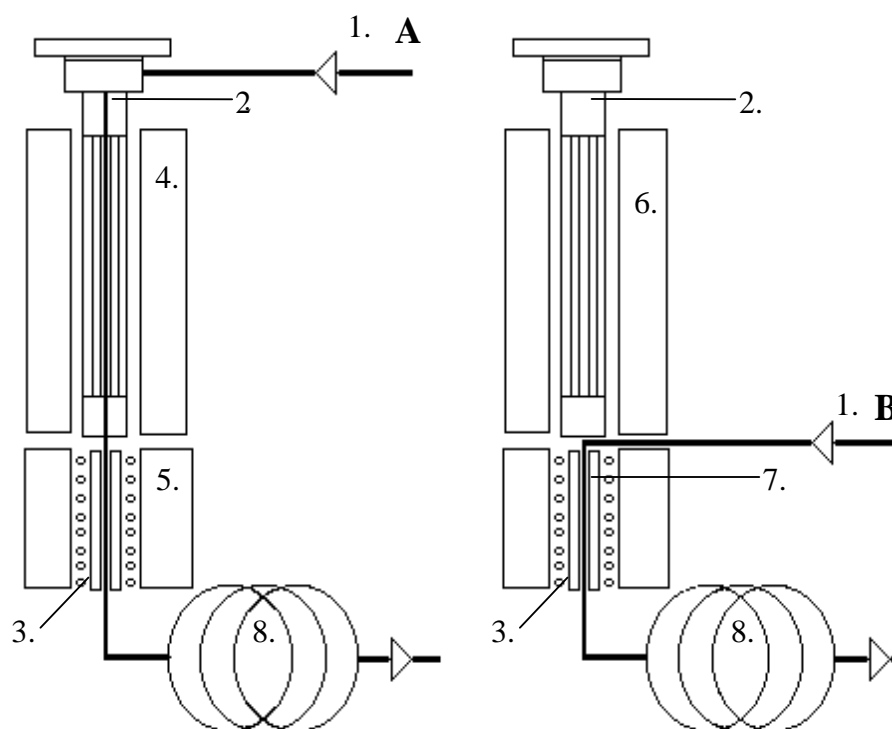

Figure 4.2 The 2 main phases in the TCT 4020 thermal desorption unit:

A: Desorption Phase

B: Injection Phase

1. A: High purity helium carrier gas flow during desorption phase

1. B: High purity helium carrier gas flow during injection phase

2. Glass tube containing ad/absorbent

3. Wide-bore fused silica capillary cold trap

4. Heated desorption oven

5. Liquid nitrogen – cooled chamber

6. Ambient desorption oven

7. Ballistically heated cold trap

8. Gas Chromatograph

4.2.2. Gerstel® Thermal Desorption System – Cold Inlet System (TDS-CIS)

Figure 4.3 shows a cross section of the Gerstel® desorption unit. The Thermal Desorption System (TDS 2) is connected to the Cooled Injection System (CIS 4) by way of a 15 cm long stainless steel capillary transfer line, maintained at a temperature of at most 400°C. High temperature o-rings and a lock-tight mechanism, provide a leak-tight seal as desorption tubes are inserted horizontally into the TDS oven. The tubes may be cooled while excess solvents, residual water and oxygen are removed from the tubes by the carrier gas, prior to desorption.

Desorbed analytes are trapped in the CIS at -100°C or lower. The CIS doubles up as a cryogenic trap and a GC inlet. Analytes are focussed in the inlet liner, in our case a glass baffled liner, before being transferred onto the GC column as a narrow band. Various inlet liners are available for different applications, allowing for greater flexibility when trapping analytes and protection of the column [214].

This desorption unit is a vast improvement on the Chrompack® desorption unit. A short stainless steel transfer line is heated uniformly across the length of the tube; thus, as depicted in figure 4.3[214] no cold or hot spots should occur in the system. The software allows one to programme different desorption and injection temperature gradients from ambient temperatures up to maximum 400°C. Operation of the TDS in split / splitless sampling modes provides a wide dynamic range. High desorption flow rates with splitless transfer allows for lower detection limits. In addition, the manual TDS can be converted into an automated system able to desorb up to twenty tubes.

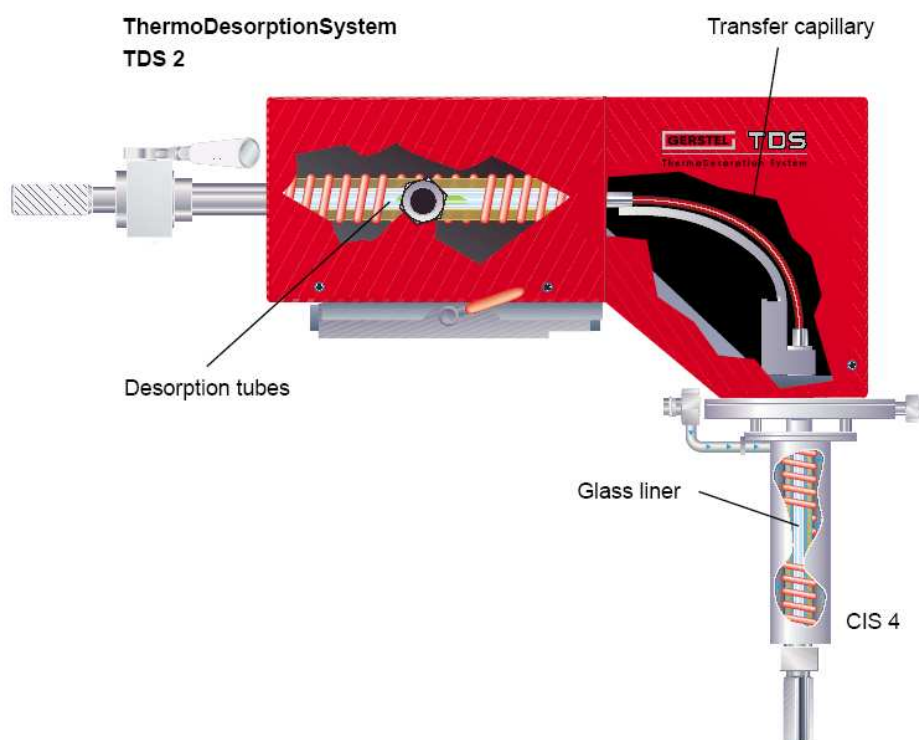

Figure 4.3 Cross section of the Gerstel® TDS-CIS desorption unit [214].

4.2.3. *Airsense® Enrichment Desorption Unit (EDU)*

The EDU system used in this study was a unique trap and thermal desorption system developed by Airsense Analytics (Airsense Analytics, Schwerin, Germany) for the Institute of Ecological Chemistry, GSF. The design allows for the on-line concentration of exhaust gases from various combustion sources. Gaseous substances are trapped at sampling temperatures (ambient or less) on, for example, Tenax adsorption tubes and analyzed after thermal desorption. Temperatures of the adsorbent during sampling and desorption phases can be adjusted via settings within the related software EDU. For increasing the speed of analysis, very small tubes, with inner diameters of 1.5 mm, filled with Tenax-TA can be used. Peltier cooling is used in order to achieve sampling temperatures of 4°C. After sampling, the tubes are desorbed by resistive heating. With this flash desorption, temperature increments of 200°C are possible in just 4 s. By sucking air through a cold adsorption tube, the analytes are trapped. In the case of sampling hot gases, it is also possible to dilute the sampling gas to reduce the temperature of the gas. After sampling, a post sampling step can be introduced to remove unappealing gases and vapours (e.g. moisture). To extract analytes off the trap, thermal desorption is performed. For injection, the gas flow is reversed and led into the detection system. Afterward, the tube is cleaned by heating it to a higher temperature than the desorption temperature and flushing the tube with cleaned air. After cooling to near ambient temperatures, the trap is ready for the next measurement [215].

For on-line real-time analytical applications, however, analyte focusing can also be important, not for the enhancement of the chromatographic resolution, but for time resolution and sensitivity (as is the case for on-line REMPI-TOFMS). Analyte focusing can be achieved, by repetitive thermal modulation. In this study, the EDU was used in combination with a segmented thermal modulator array (TMA), described below.

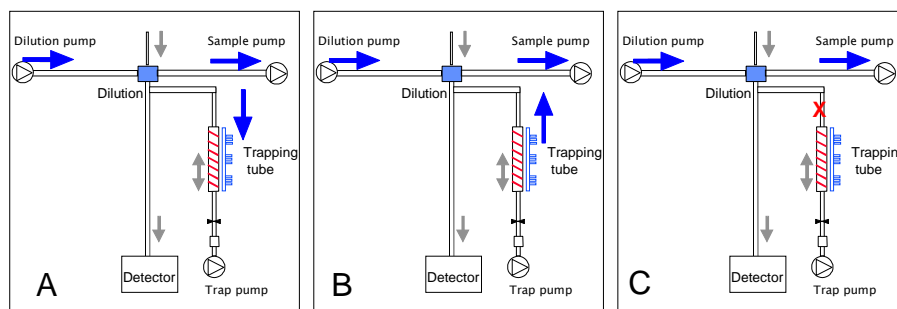

Figure 4.4 Gas flow configuration for the Airsense EDU custom-made for the GSF [215]:

- A: Sampling Phase**
- B: Desorption Phase**
- C: Injection Phase**

4.3. Thermal Modulator Array (TMA)

The segmented thermal modulator array [216] was developed by Ben Burger and co-workers. The modulator houses a narrow-bore capillary coated on the inside with a thick film of PDMS (capillary trap). This capillary represents the concentrating /derivatizing device such as the open tubular traps (OTT) described in chapter 2.

Modulators have predominantly been developed for use as an interface between two columns in comprehensive two-dimensional gas chromatography [217]. Their function is to rapidly focus fractions of effluent from the first column onto the head of the second column. In this study, a segmented thermal modulator array, developed by Ben Burger *et al* [216] was used to transfer and focus the effluent from the capillary trap or EDU, into the REMPI-TOFMS. In principle, the sorption and desorption of effluent from the stationary phase in the modulator capillary can be controlled by careful manipulation of the temperature of the capillary. The thermal modulator array uses rapid resistive heating of consecutive segments of a stainless steel tube surrounding the

capillary to focus the effluent inside the modulator capillary. This ensures a “sweeping” heat motion without disadvantageous cold spots or moveable parts, typical of other modulators [218-223]. The segmented heating of the effluent in the capillary speeds up the chromatographic process in the capillary column, “compressing” zones from the rear and providing a focused chromatographic band that enters the REMPI-TOFMS. Although not providing the shortest injection pulse widths, the TMA is simple and compact; it does not require cryogenic cooling and can operate unattended, making it suitable for on-line analysis with the REMPI-TOFMS.

In greater detail, in this study the modulator capillary consisted of a fused-silica capillary column (0.2 mm i.d.) coated with non-polar phase PS-255 (3- μm film, DB-1 equivalent). A capillary of 20 cm length was used with 5 cm of the stationary phase stripped off at both ends, as described in reference 216. A stainless steel capillary (105 mm x 0.6 mm o.d. x 0.35 mm i.d.) was converted to function as a modulator [216]. An electronic sequencer was used to provide current to the modulator in steps from 1 to 10 A at 5 V with a time duration of 10-2500 ms. To maintain reasonable flow rates and operate at atmospheric pressure, jet restrictors yielding a flow rate of between 0.6 and 1.0 mL/min were prepared from fused silica capillaries, according to the method described in reference 36 from an uncoated capillary (30 cm x 0.32 mm i.d.). The restrictor was coupled to the modulator capillary by a suitable press-fit. All transfer capillaries and connection points were either directly heated to 150 °C, by a heating mantle or surrounded by a copper tube, which was then heated by a heating mantle.

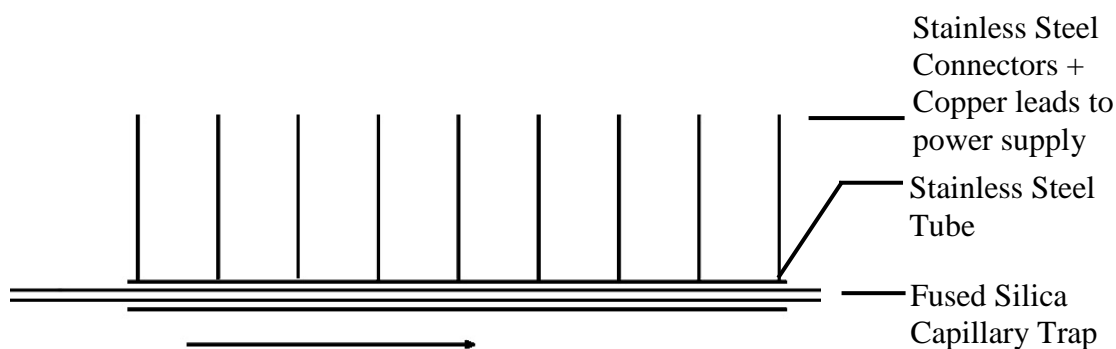

Figure 4.5 Longitudinal section of a Thermal Modulator Array [216].