

**DATA MARTS AS MANAGEMENT INFORMATION  
DELIVERY MECHANISMS: Utilisation in Manufacturing  
Organisations with Third Party Distribution**

by

Shana Rachel Ponelis

Submitted in fulfilment  
of the requirements for the degree

Magister Informationis Scientiae specializing  
in INFORMATION SCIENCE

in the

Department of Information Science  
Faculty of Humanities  
University of Pretoria  
Pretoria

Supervisor: Prof. J. J. Britz

November 2002

The financial assistance of the National Research Foundation (NRF) towards this research is hereby acknowledged. Opinions expressed and conclusions arrived at, are those of the author and are not necessarily to be attributed to the National Research Foundation.

DATA MARTS AS MANAGEMENT INFORMATION DELIVERY  
MECHANISMS: Utilisation in Manufacturing Organisations with Third  
Party Distribution

A study by  
Shana Rachel Ponelis

Supervisor: Prof. J. J. Britz  
Department: Information Science  
Degree: Magister Informationis Scientiae specializing in  
INFORMATION SCIENCE

**ABSTRACT:** Customer knowledge plays a vital part in organisations today, particularly in sales and marketing processes, where customers can either be channel partners or final consumers. Managing customer data and/or information across business units, departments, and functions is vital. Frequently, channel partners gather and capture data about downstream customers and consumers that organisations further upstream in the channel require to be incorporated into their information systems in order to allow for management information delivery to their users. In this study, the focus is placed on manufacturing organisations using third party distribution since the flow of information between channel partner organisations in a supply chain (in contrast to the flow of products) provides an important link between organisations and increasingly represents a source of competitive advantage in the marketplace. The purpose of this study is to determine whether there is a significant difference in the use of sales and marketing data marts as management information delivery mechanisms in manufacturing organisations in different industries, particularly the pharmaceuticals and branded consumer products. The case studies presented in this dissertation indicates that there are significant differences between the use of sales and marketing data marts in different manufacturing industries, which can be ascribed to the industry, both directly and indirectly.

**OPSOMMING:** Aangesien kennis rakende kliënte, waar die kliënte of kanaal medewerkers of uiteindelijke verbruikers is, 'n kritiese rol in vandag se organisasies speel, veral in bepaalde bemarking en verkope prosesse, is die bestuur van data en/of inligting oor die grense van besigheidseenhede, departemente, en funksies krities. Dikwels, samel medewerkers data oor kliënte in wat ook deur ander organisasies in die kanaal benodig word en wat dan in hierdie organisasies se inligtingstelsels geïnkorporeer moet word om sodoende bestuursinligting aan interne gebruikers te kan lewer. In hierdie

konteks val die fokus op vervaardigingsorganisasies wat van derde party verspreiding gebruik maak aangesien die vloei van inligting tussen kanaal medewerker organisasies in 'n aanvoerketting (in kontras met die vloei van produkte) 'n belangrike skakel tussen organisasies vorm en toenemend 'n bron van kompeterende voordeel in die mark vorm. Die doel van hierdie ondersoek is om te bepaal of daar 'n betekenisvolle verskil is in die gebruik van bemarking en verkope "data marts" as bestuursinligting aan die betrokke gebruikersgemeenskap te voorsien in vervaardigingsorganisasies in verskillende industrieë, in besonder in die farmaseutiese en die handelsmerkverbruikersgoedere industrieë, wat toe te skryf is aan die industrie, beide direk en indirek.

**KEYWORDS:** manufacturing, pharmaceuticals, branded consumer products, sales, marketing, management information requirements, data communications, information systems, information dissemination, data mart, data warehouse, online analytical processing (OLAP), query and reporting, sales forecasting, third party distribution, supply chain

## TABLE OF CONTENTS

<b>CHAPTER 1 INTRODUCTION .....</b>	<b>12</b>
1.1. BACKGROUND .....	12
1.2. PROBLEM STATEMENT, DEMARCATION AND METHODOLOGY .....	12
1.2.1. <i>Problem Statement</i> .....	12
1.2.2. <i>Relevance of Study</i> .....	14
1.2.3. <i>Research Methodology</i> .....	14
1.2.3.1. Literature Study.....	14
1.2.3.2. Qualitative Case Study Research .....	15
1.2.4. <i>Demarcation of Study</i> .....	15
1.2.5. <i>Assumptions</i> .....	16
1.3. TERMINOLOGY.....	16
1.3.1.1. Management.....	16
1.3.1.2. Data and Information .....	17
1.3.1.3. Management Information.....	17
1.3.1.4. Supply Chain and Supply Chain Management.....	18
1.3.1.5. Third Party Distribution .....	19
1.4. DIVISION OF CHAPTERS .....	19
<b>CHAPTER 2 THE ROLE OF INFORMATION IN ORGANISATIONS’ SALES AND MARKETING STRATEGIES.....</b>	<b>21</b>
2.1. THE FOCUS IS ON THE CUSTOMER.....	21
2.1.1. <i>Changing Nature of Knowledge Gathered About the Customer</i> .....	22
2.1.2. <i>Customer-Organisation Relationship is a Form of Intellectual Capital</i> .....	23
2.1.3. <i>Move from Mass Production to Mass Customisation</i> .....	24
2.2. SALES AND MARKETING IN ORGANISATIONS .....	25
2.2.1. <i>Perform Market Segmentation</i> .....	27
2.2.2. <i>Develop a Pricing Strategy</i> .....	28
2.2.3. <i>Select Channels of Distribution</i> .....	30
2.2.4. <i>Develop Sales Forecast(s)</i> .....	32
2.3. MANAGEMENT INFORMATION AND DATA SOURCE REQUIREMENTS .....	35
2.4. DATA FLOW FROM CUSTOMER-FACING CHANNEL PARTNER FIRMS .....	37
2.5. CHAPTER CONCLUSION.....	40
<b>CHAPTER 3 DATA MARTS AS MANAGEMENT INFORMATION DELIVERY MECHANISMS .....</b>	<b>41</b>

3.1. DEFINITIONS OF DATA WAREHOUSES AND DATA MARTS .....	41
3.1.1. <i>Data Warehouse</i> .....	43
3.1.2. <i>Data Marts</i> .....	46
3.1.2.1. Dependent Data Mart .....	47
3.1.2.2. Independent Data Mart.....	48
3.1.2.3. Interdependent Data Mart .....	50
3.1.3. <i>Relationship between Data Warehouse and Data Mart</i> .....	53
3.2. ADVANCED ANALYTICAL TOOLS TO ACCESS DATA MARTS.....	54
3.2.1. <i>Query and Reporting</i> .....	56
3.2.2. <i>Online Analytical Processing</i> .....	56
3.2.3. <i>Data Mining</i> .....	57
3.3. NATURE OF USAGE .....	59
3.4. USING DATA PROVIDED BY CHANNEL PARTNERS .....	64
3.5. CHAPTER CONCLUSION.....	65
<b>CHAPTER 4 USE OF DATA MARTS IN MANUFACTURING ORGANISATIONS WITH THIRD PARTY DISTRIBUTION .....</b>	<b>67</b>
4.1. CASE STUDY 1: BRANDED CONSUMER PRODUCTS INDUSTRY .....	68
4.1.1. <i>Overview of the Branded Consumer Products Industry</i> .....	68
4.1.1.1. Managing the Brand.....	68
4.1.1.2. Understanding the Market and Customers .....	69
4.1.1.3. Managing the Supply Chain.....	70
4.1.2. <i>Context of the Branded Consumer Products Organisation</i> .....	71
4.1.3. <i>Sales and Marketing Data Mart Solution Requirements</i> .....	73
4.1.3.1. User Community .....	73
4.1.3.2. Management Information Requirements.....	74
4.1.3.3. Data Mart Access Tool Requirements.....	75
4.1.3.4. Sources of Data .....	75
4.1.4. <i>Assessment of the Use of the Sales and Marketing Data Mart</i> .....	77
4.2. CASE STUDY 2: PHARMACEUTICALS INDUSTRY .....	78
4.2.1. <i>Overview of the Pharmaceuticals Industry</i> .....	78
4.2.1.1. High Degree of Regulatory Influence .....	79
4.2.1.2. Product Liability .....	79
4.2.1.3. Emerging Customer and Consumer Power .....	80
4.2.1.4. Increasing Cost Pressures.....	80
4.2.1.5. Patient Privacy .....	81
4.2.2. <i>Context of the Pharmaceutical Organisation</i> .....	81
4.2.3. <i>Sales and Marketing Data Mart Solution Requirements</i> .....	82

4.2.3.1. User Community .....	83
4.2.3.2. Management Information Requirements .....	85
4.2.3.3. Data Mart Access Tool Requirements.....	89
4.2.3.4. Sources of Data .....	90
4.2.4. <i>Assessment of the Use of the Sales and Marketing Data Mart</i> .....	92
4.3. CHAPTER CONCLUSION.....	93
<b>CHAPTER 5 COMPARATIVE ANALYSIS AND CONCLUSION .....</b>	<b>94</b>
5.1. COMPARATIVE ANALYSIS OF CASE STUDIES .....	94
5.1.1. <i>User Community</i> .....	94
5.1.2. <i>Management Information Requirements</i> .....	95
5.1.3. <i>Data Mart Access Tool Requirements</i> .....	96
5.1.4. <i>Sources of Data</i> .....	97
5.1.5. <i>Assessment of the Use of the Data Marts</i> .....	99
5.2. CONCLUSION .....	100
5.3. SUGGESTIONS FOR FUTURE RESEARCH.....	101
<b>BIBLIOGRAPHY .....</b>	<b>102</b>
<b>APPENDIX A: MANAGEMENT REPORTS REQUIRED BY THE BCP ORGANISATION .....</b>	<b>109</b>
<b>APPENDIX B: LAYOUT OF FILES RECEIVED BY THE BCP ORGANISATION FROM THE THIRD PARTY DISTRIBUTOR (3PL) .....</b>	<b>115</b>

## LIST OF TABLES

TABLE 1: ABBREVIATIONS USED .....	11
TABLE 2: COMPARISON OF DIRECT AND INDIRECT DISTRIBUTION CHANNELS .....	31
TABLE 3: TYPICAL MANAGEMENT INFORMATION REQUIREMENTS BY GENERIC SALES AND MARKETING PROCESSES.....	35
TABLE 4: DATA SOURCES REQUIRED TO MEET INFORMATION REQUIREMENTS BY GENERIC SALES AND MARKETING PROCESSES .....	37
TABLE 5: STRATEGIC SALES AND MARKETING MANAGEMENT INFORMATION REQUIREMENTS (XU, 1999:268) .....	37
TABLE 6: COMPARISON BETWEEN TRANSACTION PROCESSING SYSTEMS AND DATA WAREHOUSES ((DAPHNESOFT, 2001:76), (LEVINE AND SIEGEL, 2001:42), (RUDIN, 1998:45)) .....	44
TABLE 7: COMPARISON OF DATA WAREHOUSE AND TYPES OF DATA MARTS.....	52
TABLE 8: COMPARISON OF CLASSES OF DATA MART ACCESS TOOLS WITH CONSOLIDATION .....	55
TABLE 9: EXAMPLES OF OLAP TOOL FUNCTIONALITY.....	57
TABLE 10: EXAMPLES OF DATA MINING TOOL FUNCTIONALITY.....	58
TABLE 11: MAPPING OF STAGES OF DATA MART USE (SWIFT, 2000) AGAINST CLASS OF ACCESS TOOL .....	59
TABLE 12: CATEGORIES OF END-USER APPLICATION CLASSIFICATIONS.....	59
TABLE 13: EXAMPLES OF INFORMATION REQUIREMENTS BY ACCESS TOOL AND FUNCTIONAL AREAS (BASED ON ALTER, 1999:163).....	60
TABLE 14:SUMMARY OF STRATEGIC USES OF DATA WAREHOUSING IN SELECTED INDUSTRIES (TURBAN ET AL, 2001:440), (SHARMA, 1997:18) .....	60
TABLE 15: APPLICATIONS FOR WHICH DATA WAREHOUSES AND/OR DATA MARTS ARE USED (PALO ALTO MANAGEMENT GROUP, 2001:278) .....	61
TABLE 16: PRINCIPAL RESPONSIBILITIES BY POSITION IN THE BCP MANUFACTURING ORGANISATION.....	74
TABLE 17: BCP MANUFACTURER’S DATA MART ACCESS TOOL REQUIREMENTS.....	75
TABLE 18: PRINCIPAL RESPONSIBILITIES BY POSITION IN PHARMACEUTICAL MANUFACTURING ORGANISATION .....	84
TABLE 19: REPRESENTATIVE LIST OF BUSINESS QUESTIONS TO BE ANSWERED BY DATA MART .....	86
TABLE 20: REPRESENTATIVE SAMPLE OF PHARMACEUTICAL MANUFACTURER’S DATA MART ACCESS TOOL REQUIREMENTS.....	90
TABLE 21: COMPARISON OF USER COMMUNITY FOR RESPECTIVE SALES AND MARKETING DATA MARTS BY MANAGEMENT LEVEL.....	95
TABLE 22: SUMMARISED OVERVIEW OF APPLICATIONS OF SALES AND MARKETING DATA MARTS IN CASE STUDY ORGANISATIONS .....	96
TABLE 23: DIFFERENCES IN DATA MART ACCESS TOOL REQUIREMENTS BETWEEN THE ORGANISATIONS.....	96
TABLE 24: ORGANISATIONS' PROGRESS ON THE STAGES OF DATA MART USE .....	97



TABLE 25: COMPARISON OF DATA AND DATA SOURCES FOR THE DATA MARTS FROM THE ORGANISATIONS’  
VIEWPOINT..... 98

TABLE 26: BENEFITS DERIVED FROM THE IMPLEMENTATION OF DATA MARTS IN CASE STUDY ORGANISATIONS  
..... 99

TABLE 27: SUMMARY OF COMPARATIVE ANALYSIS BETWEEN CASE STUDY DATA MARTS ..... 100

## LIST OF FIGURES

FIGURE 1: CONCEPTUAL DEMARCATION OF STUDY .....	16
FIGURE 2: USE OF MANAGEMENT INFORMATION IN ORGANISATIONS (O'BRIEN, 1999).....	18
FIGURE 3: CHANGE IN SOURCE OF AN ORGANISATION'S KNOWLEDGE OF CUSTOMERS OVER TIME .....	22
FIGURE 4: STRUCTURE OF AN ORGANISATION'S MARKETING EFFORT (BASED ON BALLOU (1987:33)) .....	25
FIGURE 5: LINK BETWEEN DEMAND CREATION AND FULFILMENT .....	26
FIGURE 6: CONCEPTUAL VIEW OF INFORMATION AND PRODUCT FLOW BETWEEN SUPPLY CHAIN CHANNEL PARTNERS .....	32
FIGURE 7: FLOW OF INFORMATION WITHIN AND OUTSIDE THE BOUNDARIES OF AN ORGANISATION (BUTCHER, 1998:7).....	38
FIGURE 8: SCHEMATIC REPRESENTATION OF DATA FLOW IN A DATA WAREHOUSE ENVIRONMENT .....	46
FIGURE 9: DATA FLOW WHEN USING A DEPENDENT DATA MART .....	48
FIGURE 10: DATA FLOW WHEN USING INDEPENDENT DATA MARTS .....	49
FIGURE 11: DATA FLOW WHEN USING INTERDEPENDENT DATA MARTS .....	51
FIGURE 12: INTERDEPENDENT DATA MARTS RESULTING IN A DISTRIBUTED DATA WAREHOUSE .....	52
FIGURE 13: RELATION OF A DATA MART TO A DATA WAREHOUSE .....	54
FIGURE 14: ARCHITECTURE OF DATA WAREHOUSE, INDEPENDENT OR INTERDEPENDENT DATA MART (GRAY AND WATSON, 1998:17).....	55
FIGURE 15: HIGH-LEVEL SPECTRUM OF FUNCTIONALITY ADDRESSED BY QUERY AND REPORTING, AND OLAP TOOLS .....	58
FIGURE 16: DATA FLOW BETWEEN ORGANISATIONS' OPERATIONAL SYSTEMS .....	64
FIGURE 17: DATA FLOW BETWEEN ORGANISATIONS' ANALYTICAL SYSTEMS .....	65
FIGURE 18: DATA FLOW FROM ONE ORGANISATION'S OPERATIONAL SYSTEM TO ANOTHER'S ANALYTICAL SYSTEM.....	66
FIGURE 19: FLOW OF PRODUCTS FROM THE BRANDED CONSUMER PRODUCTS MANUFACTURER.....	71
FIGURE 20: DATA FLOW SURROUNDING THE DATA MART IN THE BCP CASE STUDY .....	77
FIGURE 21: FLOW OF PRODUCTS FROM PHARMACEUTICAL MANUFACTURER TO THE CUSTOMER.....	81
FIGURE 22: DATA FLOW SURROUNDING THE DATA MART IN THE PHARMACEUTICAL CASE STUDY .....	91

## ABBREVIATIONS

The abbreviations listed in Table 1 are used in this study.

Abbreviation	Expansion and/or Description
3PL	Third party logistics
ABC	Activity-based costing
ABM	Activity-based management
AIDS	Acquired immune deficiency syndrome
ASP	Average Selling Price
BCP	Branded Consumer Products
DSS	Decision support system
EDI	Electronic data interchange
EIP	Enterprise information portal
EIS	Executive information system
ERP	Enterprise Resource Planning, generally referred to as ERP software which is used as enterprise-wide software for operational purposes
FDA	Food and Drug Administration
FTP	File Transfer Protocol, a protocol used for file transfers between information systems
GCP	Good Clinical Practice
GLP	Good Laboratory Practice
GMP	Good Manufacturing Practices
HIV	Human Immunodeficiency Virus
MIS	Management information system
MTD	Month-to-date
ODS	Operational data store
OLAP	Online analytical processing
OTC	Over the counter, generally medicines bought by consumers without requiring a prescription from a medical practioner
PoM	Prescription only Medicine
ROI	Return on investment
SDF	Solid Dosage Format
SOP	Standard Operating Procedures
SQL	Structured query language, used to interrogate relational databases
YTD	Year-to-date

Table 1: Abbreviations used

## CHAPTER 1 INTRODUCTION

### 1.1. Background

Organisations that manufacture products, which are physically distributed to customers and consumers by a third party distributor, are faced with a problem regarding the distribution data. The distribution data is captured by the third party distributor(s) during the distribution process and includes, for example, the invoiced transaction details, customer details, inventory levels and outstanding orders. Manufacturers need this data in order to optimise their distribution channels, to understand the demand in the marketplace, and to offer their customers better service by better understanding and responding to their requirements.

Third party distributor(s) will normally make this data available to the manufacturer. The manufacturer then has to meet its own management information requirements, that is, making this data internally accessible in order to support and optimise decision-making regarding sales and marketing, functions as well as other related business such as production. Manufacturers must determine how best to meet this management information need.

The need to use an information system to address this need is obvious: information systems “enable companies to share information regarding customers, production, inventory, and finance with their supply channel partners” with the result that “... all levels of management will be able to make effective decisions based on timely, global [i.e. integrated] information that adequately reflects the current state of the marketplace” (Ross, 1998:55). There are many mechanisms or information systems, which can be used to deliver management information in organisations. One possibility is the use of a data warehousing approach, in particular the use of data marts.

Data marts have been utilised with success by organisations in numerous industries, including the manufacturing sector and in many business functions, including sales and marketing. The aim of this study is to determine whether there are differences in the use of sales and marketing data marts as management information delivery mechanisms between manufacturing organisations in different industries with a particular focus on the pharmaceuticals and branded consumer products industries respectively.

### 1.2. Problem Statement, Demarcation and Methodology

#### 1.2.1. Problem Statement

The central problem statement of this study takes the form of a hypothesis that is tested by means of evidence presented. The hypothesis is that there is no significant difference in the use of sales and

marketing data marts as management information delivery mechanisms in manufacturing organisations in different industries, particularly the pharmaceuticals and branded consumer products.

In order to test the above hypothesis, a number of sub-problems need to be addressed, namely:

- The role of information in organisations' sales and marketing strategies, in particular management information;
- Data marts as management information delivery mechanisms;
- The use of data marts in manufacturing organisations with third party distribution in different industries together with a comparative analysis of the case studies presented.

The first two sub-problems justify further expansion in terms of the constituent research objectives. In order to determine the role of information in organisations' sales and marketing strategies, the following objectives must be met:

- To indicate the increasing significance of the role of customers and their data in organisations;
- To indicate the need for a single/integrated view of the customer;
- To indicate the vital role of sales and marketing strategies in organisations given the increasing significance of customers;
- To provide an overview of generic sales and marketing processes related to the development of sales and marketing strategies within an organisation;
- To explore generic management information requirements within the context of the organisational sales and marketing processes;
- To indicate the importance of external data sources to an organisation in meeting these management information requirements;
- To determine sources of data required given generic management information requirements within sales and marketing; and
- To explain the role of customer-facing firms with regard to gathering of customer data and the importance of forming channel partnerships as a method to assure organisations' access to data gathered by customer-facing firms.

In order to examine data marts as management information delivery mechanisms, the following objectives must be met:

- To compare and contrast the data warehouse and types of data marts in order to arrive at an understanding of what it is;
- To indicate the relationship between data warehouses and data marts;

- To describe, classify and characterise the access tools to data marts/data warehouses as management information delivery mechanisms;
- To define criteria to select the appropriate data mart access tool(s); and
- To explore the use of data warehouses and data marts in organisations, particularly within the context of sales and marketing, as discussed in literature.

### **1.2.2. Relevance of Study**

The research will examine the use of data marts, which is a specific type of information system, to deliver management information. Information systems are addressed in a number of disciplinary fields, the most relevant being: information science (specifically relevant are the areas of information organisation and retrieval, and information management), computer science (specifically software engineering, database design), and informatics (specifically systems analysis and design, and MIS or management information systems). Furthermore, the study examines the provision of management information in a specific context relating to transfer and use of data across the supply chain and is therefore also relevant to logistics, marketing and other management disciplines.

### **1.2.3. Research Methodology**

The methodology for this study is based on a review of literature and qualitative case study research, each of which is expanded upon below.

#### **1.2.3.1. Literature Study**

As a first step in the investigation of the use of data marts by manufacturing organisations using third party distribution, a literature study of the subject field will be conducted. This is important since it will help define key concepts, and lay a framework for the delineation and discussion of the case studies.

Literature from the following academic disciplines, which are closely linked to the relevant disciplines (see 1.2.2. ), is consulted:

- Computer Science with particular focus on Database Management Systems;
- Information Science;
- Informatics;
- Logistics Management with particular focus on Supply Chain Management; and
- Management Information Systems.

The literature study allows the following research objectives to be met:

- To determine the role of information in organisations' sales and marketing strategies, in particular management information; and
- To examine data marts as management information delivery mechanisms.

#### 1.2.3.2. Qualitative Case Study Research

The empirical evidence is taken from actual sales and marketing data mart implementations in organisations and will be presented as case studies followed by a comparative analysis. Based on Cashman's (2000:49) opinion that organisations can "benchmark approach against other firms with similar circumstances and goals," the case studies can be used for comparative analysis; the case studies examine two organisations with very circumstances and goals but slightly different profiles with regard to size (small and medium), IT sophistication and resources, reasons for using data marts, industry, and the nature of their respective competitive environments. The case studies draw on a combination of personal observations (the author was a member of these data mart implementation project teams) and qualitative data from interview transcripts and responses to answer the stated research questions (see 1.2.1. ).

The use of qualitative case study research allows the following research objective to be met:

- To describe the use of data marts in manufacturing organisations with third party distribution in different industries.

Note that a condition for the use of these case studies is that the confidentiality of the particular organisations is protected.

#### 1.2.4. **Demarcation of Study**

In order to demarcate this study and clarify the scope, the following specific limitations are identified:

- The approaches to decision-making in organisations i.e., as a process, are not included in the study, but the information required to support decision-making is.
- The methodology followed to build a data warehouse or data mart is not included in the scope. Thus the detailed steps to gather business and/or user requirements are not covered although the business requirements in terms of management information are included in the case studies.
- There are other options for delivering management information within this context. The purpose of this dissertation is not to do a comparative analysis between these, thus the use of so-called portals or enterprise information portals (EIP), central digital exchanges or marketplaces, and data warehousing within a context of knowledge management are excluded.

- The technology, for example, electronic data interchange (EDI), TCP/IP, XML etc., used to physically transfer data is not included.

The scope of the study can be summarised as the examination of data acquisition from a third party logistics provider, the use of the data to populate a data mart and the subsequent delivery of management information with a sales and marketing focus to the intended user community. This is depicted schematically in Figure 1.

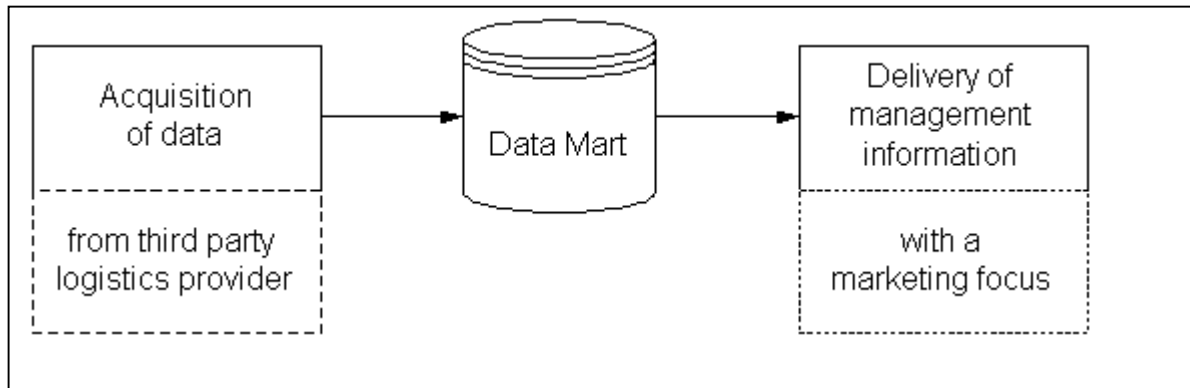

**Figure 1: Conceptual demarcation of study**

### **1.2.5. Assumptions**

The following theoretical assumption govern this study:

- It is assumed that the differences between the management information requirements attributed to the respective industries are not sufficiently different to impact the comparison of the use of data marts as delivery mechanisms of management information in order to test the hypothesis.

## **1.3. Terminology**

This section aims to clarify terminology used in the dissertation. It is not intended to be a complete definition but rather a working definition within the context of the research documented in this dissertation.

### **1.3.1.1. Management**

Management is characterised by the performance of functions within an organisational context: management is the act or art of managing, the conducting or supervising of something, for example an organisation. Management is also seen as the collective body of those who manage or direct an organisation.



### 1.3.1.2. Data and Information

The question of definitions of data and information has been the subject of continuous debate in a number of disciplines, such as information science and philosophy, particularly with the recent interest in the concept of knowledge management. Although there are no unambiguous and commonly accepted definitions of data and information, many working definitions can be found in academic literature.

According to Turban and Frenzel (1992:10-11) “*data* refers to numeric or alphanumeric strings that by themselves do not have meaning. These can be facts or figures *to be processed*. *Information* is data organised so that it is meaningful to the person receiving it.” These definitions are made with computer science, particularly artificial intelligence, being the point of departure. Another view is that of Harris (1996:1) that “the lowest level of known facts is *data*. Data has no intrinsic meaning. It must be sorted, grouped, analysed and interpreted. When data is processed in this manner, it becomes information. *Information* has a substance and a purpose”

Although there are many possible definitions depending on one’s point of departure, the working definition accepted in this study is that information is processed data that imparts meaning to a receiver, i.e., the lowest level of known facts, such as numeric or alphanumeric strings, which has been processed, for example, sorted or grouped. As such information has the following characteristics (Butcher, 1998:91-95):

- Relevant (timely, accurate, precise, quality);
- Accessible;
- Complete and comprehensive; and
- In a suitable presentation and format.

### 1.3.1.3. Management Information

The phrase management information implies a specific category or subset of information (or processed data) qualified by the use of the word ‘management’. Depending on the audience and purpose the main focus then of this qualifier can indicate either:

1. Information for management; or
2. Information to manage.

The first category implies that those in management use information in order to manage. The second category is broader in that it also encompasses roles beyond those formally considered management roles, which use information to perform management functions within their roles. O’Brien (1999) classifies management information (Figure 2) as supporting the organisation at progressively more focused levels:

- Support for business operations;
- Support for managerial decision-making; and
- Support for strategic advantage.

Support for business operations could be seen as the second broader category of information used to manage whereas support for managerial decision-making and strategic advantage is the more narrow information for management. Within the context of this research the working definition of *management information* is taken to be the latter, i.e. narrower category of information used by management.



Figure 2: Use of management information in organisations (O'Brien, 1999)

#### 1.3.1.4. Supply Chain and Supply Chain Management

The supply chain starts from the origin of the raw material and ends once the product has been discarded or recycled. In essence, the overall aim of the supply chain is to get the right product to the right place in the right quantity with the right quality at the right cost. Against this background the primary decisions made within the supply chain are related to:

- Sourcing, e.g., choice of suppliers;
- Production, e.g., product quality, plant capacity;
- Inventory, e.g., how much inventory to hold; and
- Logistics, e.g., distribution.

The main objectives of a supply chain include:

- Increased communication along all nodes of the supply chain to create an uninterrupted flow of materials;
- Decreased inventory while maintaining high customer service levels; and
- Reduced supplier base together with supplier relationships in order to reduce overall costs.

Supply chain management (SCM) then is, unlike management in a traditional organisation, “a collaborative effort among various organizations or entities whose well being relies on dependency relationships” (Green, 2001:208) within a supply chain. The focus of management in a supply chain is on the collaborative effort amongst many organisations in order to reach its stated objectives.

#### 1.3.1.5. Third Party Distribution

The phrase third party distribution is a specific aspect of third party logistics, often shortened to 3PL. The term 3PL describes businesses that provide one or many of a variety of logistics-related services such as warehousing, transportation management, distribution management, and freight consolidation. A 3PL provider may take over all receiving, storage, value added, shipping, and transportation responsibilities on behalf of a manufacturer and either conduct them in the 3PL’s warehouse using its own equipment and employees or may manage one or all of these functions in the manufacturer’s facility using their equipment, or anything combination of the above. Thus third party distribution is the outsourcing of the distribution function to a 3PL.

### 1.4. Division of Chapters

In Chapter 1 an introduction and overview of the research problem, literature on the topic, and methods of investigation will be discussed.

The role of information in organisations’ sales and marketing strategies is discussed in Chapter 2. First, the increasing significance of customers to organisations in the current marketplace is indicated, and second, the generic processes in the sales and marketing function of organisations are explored. Based on these processes, generic sales and marketing management information requirements are highlighted together with the corresponding data sources required to satisfy these needs. Last, the data required upstream by channel partners in a supply chain context is considered.

In order to explore data marts as management information delivery mechanisms in Chapter 3, data warehouses and data marts are defined and different types of data marts distinguished. The analytical tools used to access data marts, namely query and reporting, online analytical processing and data mining, are described, classified and characterised after which the evolutionary nature of use is discussed together with

the possible uses of data marts for sales and marketing purposes currently occurring in practice. The possible configurations for using data sourced externally, particularly from a 3PL for use by a manufacturer.

The use of data marts in manufacturing organisations with third party distribution is discussed in Chapter 4 by means of case studies in two manufacturing organisations in two industries, fast moving consumer goods (FMCG) and pharmaceuticals, respectively. The structure of the discussion of each these case studies is to provide an overview of the external environment in which the manufacturing organisation functions by means of industry-specific issues in order to contextualise the case study, an overview of the particular organisation, the internal environment, including the motivation for selecting a data mart as the choice of solution, the sales and marketing management information requirements; the data sources, both internal and external; and a qualitative assessment of the data mart solution in terms of the delivery of the required management information and the impact on the organisation by members of the user community.

The key qualitative results and findings of this study will be presented in the last chapter (Chapter 5) by means of a comparative analysis of the case studies discussed in the previous chapter. The findings will be summarised and evaluated against the original problem statement and research objectives. The chapter concludes with suggestions for further research.

## CHAPTER 2 THE ROLE OF INFORMATION IN ORGANISATIONS' SALES AND MARKETING STRATEGIES

*“Bringing together the right information with the right people will dramatically improve a company’s ability to develop and act on strategic business opportunities”*

– Bill Gates, Business @ The Speed of Thought: Succeeding in the Digital Economy

An understanding of the importance of the sales and marketing function and the role of management information therein is required prior to commencing an investigation into management information delivery mechanisms for sales and marketing purposes. The aims of this chapter are to provide material to aid this understanding by:

- To indicate the increasing significance of the role of customers and their data in organisations.
- To indicate the need for a single/integrated view of the customer;
- To indicate the vital role of sales and marketing strategies in organisations given the increasing significance of customers;
- To provide an overview of generic sales and marketing processes related to the development of sales and marketing strategies within an organisation;
- To explore generic management information requirements within the context of the organisational sales and marketing processes;
- To indicate the importance of external data sources to an organisation in meeting these management information requirements;
- To determine sources of data required given generic management information requirements within sales and marketing; and
- To explain the role of customer-facing firms with regard to gathering of customer data and the importance of forming channel partnerships as a method to assure organisations’ access to data gathered by customer-facing firms.

### 2.1. The Focus is on the Customer

Marketing has become as a key component of an organisation’s strategy, particularly because of the explosion of customer choice and the constant expansion of customer’s expectations for service. The main objective is to cultivate customer loyalty by enabling an organisation to establish a relationship with each customer as an individual and differentiate in its service and/or product based on personal data gathered from the customers. Customer loyalty is partly a result of the effort expended by the customer in providing

data regarding, for example, his/her preferences, and as a result locks the customer into a relationship with the organisation. Some of the reasons for this shift are:

- Changing nature of knowledge gathered about the customer;
- Customer-organisation relationship is a form of intellectual capital; and
- Move from mass production to mass customisation.

Each of these is explored in further detail below. This section is based on a research reported by Ponelis and Britz (2002).

### 2.1.1. Changing Nature of Knowledge Gathered About the Customer

The source of organisations' knowledge about their customers has changed: years ago a shopkeeper knew his/her customers through personal contact. This model of tacit knowledge through personal contact has become infeasible since it cannot scale beyond a local level. For a regional, national or global organisation, this tacit knowledge must be substituted by explicit knowledge obtained through the capture of the customer's transactional and personal data in an integrated manner allowing for analysis. This is depicted schematically in Figure 3.

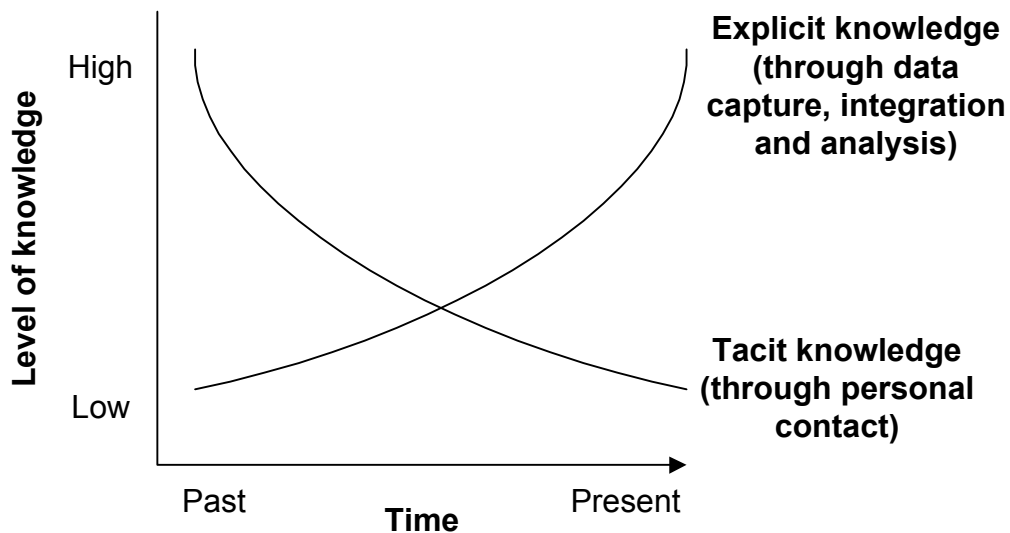

Figure 3: Change in source of an organisation's knowledge of customers over time

According to some, however, “capturing large quantities of sales receipt data is inexpensive, but is rarely helpful in building useful knowledge” (Lesser *et al*, 2000:35). Thus “any serious effort to manage customer knowledge must go beyond transaction-data analysis” (Davenport *et al*, 2001:70) to include customer comments, sales and service reports, a salesperson's interpretation of a customer interaction. This is confirmed by the Fournier *et al* (1998:44) who asks how organisations “follow through on the assertion that

we value one-on-one relationships with our customers?” Organisations’ lack of appropriate response is demonstrated in the following customer anecdote:

*“One woman told us of her frustration at being asked to disclose personal information each time she patronizes a certain hotel chain. “I volunteer vital statistics every time,” she explained. “Name, address, method of payment, travel for business or pleasure, number of hotel visits per year. The use to which this information is put remains a mystery to me. ... Are the product offerings improved? Not to my knowledge. Do I get a special discount? Certainly not. Am I greeted in some special way each time I return? No” (Fournier et al, 1998:44).*

Furthermore, Hagel and Rayport (1997:55) remarked that customers:

*“have become aware that the ability of companies to collect information far outstrips their ability – or inclination – to deliver meaningful value in return. And the gap is widening as vendors amass huge databases of detailed information about their customers and wrestle with the challenge of mining the data for value.”*

Some organisations, however, have been collecting electronic customer data for years but found it cumbersome to integrate the data to form an integrated view of the customer: “... a large Japanese consumer electronics company found that the consumer data it collects are never used because the company doesn't have the software installed to engage in an ongoing dialogue with its customers” (Pralhad and Krishnan, 1999:111). A pharmaceutical organisation realised that their problem was not to gather the data but rather that “[t]he problem lay in turning this data into information to better assess market patterns, direct selling energies, and optimize inventory levels” (Gaskin, 1994). According to Schultz, integrated marketing communications professor at the Medill School of Journalism at the Northwestern University in the United States, “the key to the future will not be to get more data, but to try to understand what we have” (Palmquist and Ketola, 1999:30).

### **2.1.2. Customer-Organisation Relationship is a Form of Intellectual Capital**

According to Skandia, a Swedish insurance that company developed a model for accounting for the intangible asset, intellectual capital, customer capital forms part of structural capital, which together with human capital, constitutes intellectual capital (Edvinsson, 1997:369). Wiig (1997:401) states that customer capital is “the value of the enterprise's relationships with its customers.” Roos and Roos (1997:416), however, categorised intellectual capital as human capital, organisational capital, and customer and relationship capital. In their study of intellectual capital in Scandinavia, they found that “relationship capital was the most important necessary factor for success” (Roos and Roos, 1997:417). Whichever way,

intellectual capital is subdivided, it is clear that customers and the organisation's relationship with them form an integral part of it.

### **2.1.3. Move from Mass Production to Mass Customisation**

The move from mass production to mass customisation has also led to changes in the nature of the relationship between the organisation and its customers. Mass customisation is defined as "the use of flexibility and responsiveness to deliver affordable goods and services with enough variety that comes close to satisfying different needs" (Samarajiva, 1998:278).

An important implication of this shift is that there is "an enormous demand for detailed data on the behavior of consumers" (Samarajiva, 1998:277) in order to customise products and services on such a large scale. Due to this demand even "hitherto discrete anonymous transactions are converted to information-yielding relationships, exemplified by frequent-shopper programs" (Samarajiva, 1998:279). This results in large volumes of customer data that needs to be stored and analysed.

It is clear that customer data has become a valuable organisational asset and resource: "in order to work more effectively with customers a supplier [to the customer] has to bring a considerable amount of information to bear" (Randall, 1994:74). As Zuboff (1996:73) accurately states, in "an information economy, information is the core resource that firms exploit in order to create the value their customers seek." The aim is to grow revenue by leveraging the data at the organisation's disposal but the success depends heavily on customer data at the desired level of detail being available and accessible. At the same time, organisations have the responsibility to collect data and use it appropriately.

Capturing customer data, however, is not enough. In many organisations the data gathered each time a customer makes an inquiry or a purchase, or pays a bill, is never assimilated. Organisations have been collecting customer data electronically for years, but it was cumbersome to integrate the data to form an integrated view of the customer (Prahalad and Krishnan 1999:111). Hagel and Rayport (1997:55) remarked that customers have become aware of the ability of companies to collect information but that it far outstrips their ability, or inclination, to deliver meaningful value in return. Thus, while companies have access to large volumes of transactional data about their customers, that data typically resides in separate databases.

Organisations that create a single, integrated "view" of each of their customers do so by integrating the information from a number of databases using information technology, thereby creating a single, holistic view of each customer, rather than storing unconnected data from each transaction. Organisations then use this information to nurture long-lasting relationships with existing customers, recognising that acquiring a new customer costs an estimated five times as much as retaining an existing customer.



It is clear that sales and marketing depends crucially on information and that this dependence is increasing. The organisation's ability to utilise information in relating with customers offers opportunities for real strategic advantage (Randall, 1994:74).

## 2.2. Sales and Marketing in Organisations

According to Ballou (1987:32), an organisation's sales and marketing effort has two main purposes:

- Obtaining demand, i.e. sales in the form of orders from customers; and
- Servicing demand, i.e. fulfilment of the orders.

Obtaining demand is “the result of the promotional efforts of marketing, as well as the price and product mix offered to consumers” (Ballou, 1987:32). Once the demand has been created, it must be fulfilled or serviced. Servicing demand involves putting “the right product in the right place at the right time to meet the demand requirements” (Ballou, 1987:32). Product availability, prompt delivery, and accurate order filling are just a few of the services an organisation offers that can satisfy a customer. It is the organisation's service level that binds the promotional and distribution efforts together. This relationship is depicted schematically in Figure 4.

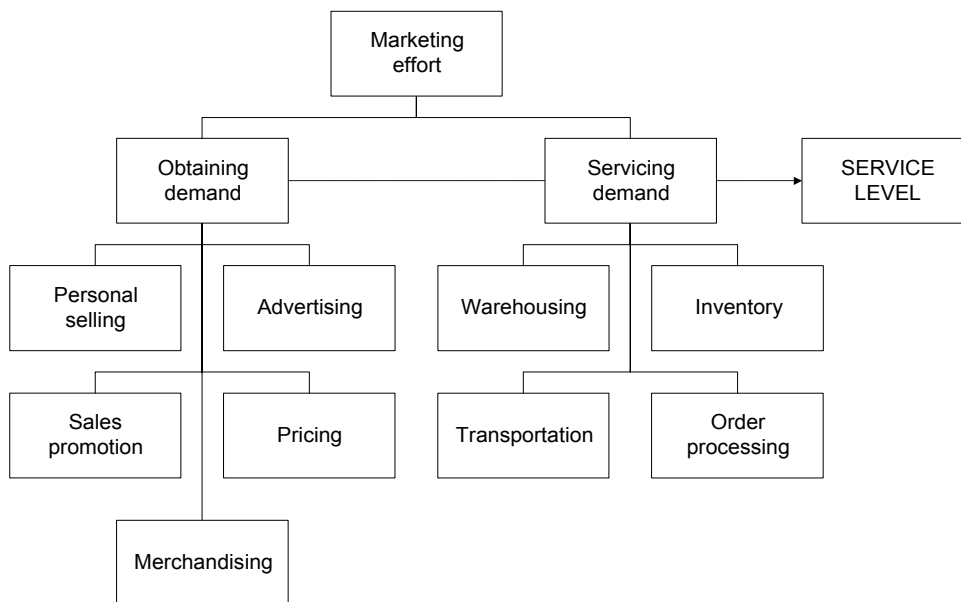

**Figure 4: Structure of an Organisation's Marketing Effort (based on Ballou (1987:33))**

The relationship between the creation of demand and the fulfilment of demand can also be linked as schematically as shown in Figure 5 which clearly shows the link between the customer-facing sales and marketing effort and production.

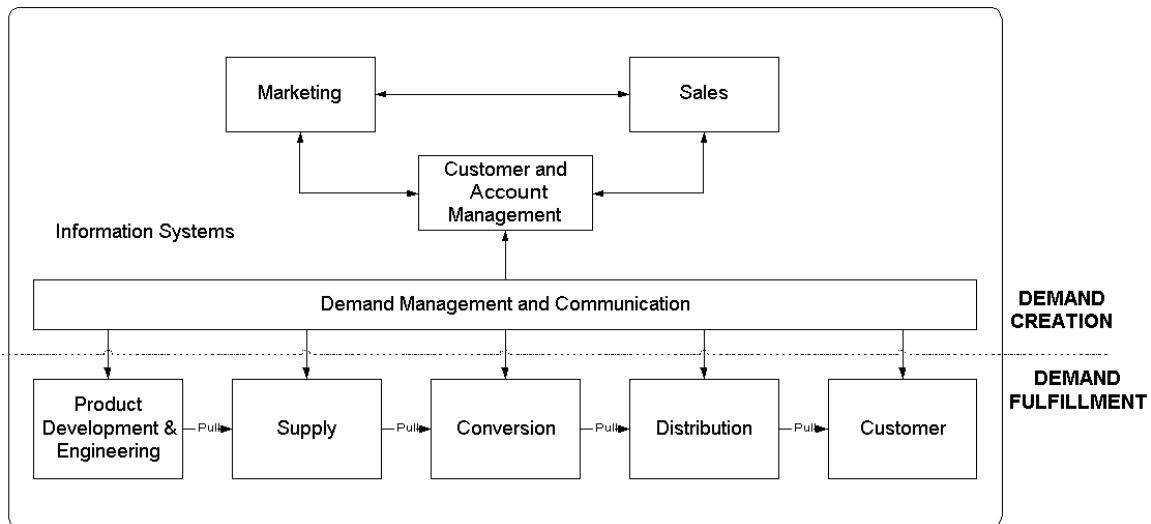

**Figure 5: Link between Demand Creation and Fulfilment**

The sales and marketing functions are mutually dependent. Sales is primarily about reporting the past for performance purposes of, for example, sales representatives, and forecasting future sales as an input to operations processes, for example, production planning. Any marketing initiatives such as trade promotions, and new product development, will impact on the sales forecasted.

In order to create value organisations need to incorporate customer knowledge into its planning and operating activities. As Lesser *et al* (2000:36) states: “[c]ustomer knowledge provides guidance and direction to these processes by improving the enterprise’s understanding of the factors that influence customer decision making, leading to more effective marketing and sales strategies.”

An organisation’s sales and marketing strategies play a significant role in its success or failure. Sales and marketing strategies drive the organisation’s revenues, to a large extent its profitability, and critical issues such as customer satisfaction, retention, and loyalty. An organisation’s sales and marketing function must seek to keep up with changes in the marketplace and customers’ constantly evolving needs and wants.

Sales and marketing strategies define the priorities and the key objectives for a number of fundamental business activities, including:

- Studying customers needs and wants;
- Satisfying, retaining, and building a base of loyal customers;
- Defining products, services, and markets;
- Developing new products and services on an ongoing basis;

- Partnering with appropriate channels of distribution;
- Pricing products and services;
- Researching what affects the organisation in its external environment;
- Managing advertising, direct marketing, public relations, publicity, sales promotion, special events, and Internet-related activities;
- Leading the sales force; and
- Controlling and measuring the financial performance of sales and marketing activities.

The following generic processes form an integral part of an organisation's sales and marketing function:

1. Identify market segments;
2. Develop a pricing strategy;
3. Select channels of distribution; and
4. Develop sales forecast(s).

Processes 1 and 2 are primarily focused on customers whilst processes 3 and 4 are implicitly focused on customers but with a more direct focus on demand and distribution. It is important to note that sales and marketing processes are not limited to the processes mentioned above. Rather, these processes form a foundation, which in turn supports other processes, both in the sales and marketing function and other organisational functions. In order to examine the management information requirements of within these generic sales and marketing processes, it is necessary to examine these processes in more detail.

### **2.2.1. Perform Market Segmentation**

Market segmentation helps organisations identify distinct differences and preferences among customers and develop targeted sales and marketing programs to address their unique needs by identifying groups of customers who are similar enough in their motivations and buying behaviour to respond alike to marketing programs and strategies. Recognising that the most valuable customers command a higher level of attention, organisations analyse data gathered from customers to determine which customers represent the most value to them. Customers are then divided into two or more segments.

By segmenting customers into segments, organisations can develop and implement marketing programs, channel strategies, product packaging and development, customer service criteria, and sales programs tailored to the needs of specific segments and ultimately leverage technology to develop one-to-one relationships with customers. This information can then be used to provide the products and services that customers seek. By cultivating enduring customer relationships over the long term, organisations not only build brand loyalty, but the organisation also makes profit more easily than it would with a steady stream of high-turnover, new customers.

Market segmentation involves analysing secondary data sources such as census data, and independent market research, in combination with primary research, such as surveys and focus groups, together with demographics, lifestyle choices, and customer profitability data. Because of this dependency on data, which includes sales transactions, it must be reliable, relevant, and manageable, and readily accessible to internal decision-makers.

The success of market segmentation is measured by improved market performance, i.e. profitability. Other indicators of performance that can measure market segmentation success include:

- Increased sales:
  - Overall;
  - By segment;
  - By customer or account;
  - By product;
- Reduced expenses:
  - Costs of marketing programs (resulting from targeted marketing versus mass marketing);
  - Promotional expenditures or trade marketing;
- Market share;
- Customer acquisition rate; and
- Customer retention rate.

### **2.2.2. Develop a Pricing Strategy**

An organisation's pricing strategy reflects value perceptions, market position, and quality of its products or services. For this reason, the pricing strategy should be consistent with all other aspects of an organisation's strategy, i.e. encompass from marketing and distribution plans to the organisation's overall vision.

An optimal pricing strategy relies on an understanding of how price-sensitive an organisation's product or service is in the market. It integrates these external considerations of costs and customers with internal financial constraints to find a point at which customers receive good value and an organisation maximises profits. Thus organisations need a broad understanding of both internal and external factors to be able to price effectively:

- Internal factors:
  - True costs of products or services;

- External factors:
  - Customers—Customers are key in determining a product's value. Not only must products deliver value to customers, but customers must also recognise that value and perceive it in the same way as the organisation that sells the product. When organisations understand how customers perceive value, they can price in a way that maximises this value perception.

When an organisation truly understands its customers—their buying patterns, their product usage habits, how they feel about various products and services—the organisation increases its intangible value to customers and, by extension, the value of its products. The ability to price in a way that reflects the value perceptions of both the organisation and the customer leads to greater price stability and customer satisfaction; and

- Competitors—Organisations also have to heed marketplace dictates in setting pricing. The price of competitors' products and overall industry trends impact the pricing decision. Therefore, in order to determine a realistic price for products, as dictated by the marketplace, organisations determine the target price and then work backward to align costs.

In summary, customer values and competitive realities impact the final pricing decision, but costs frame the decision-making process. A full understanding of the costs of producing goods or services is required to price in a manner that delivers both value to the customer and profits to the organisation.

Pricing policies usually take one of three forms:

- Fixed pricing, where all similar buyers pay the same amount for a specific product or service offering;
- Variable pricing, where products are sold to similar buyers at different prices; and
- Hybrid pricing, which reflects elements of both pricing forms.

Monitoring the actual price at which products sell helps organisations understand pricing patterns and improve profitability. Organisations that discount too much inevitably experience price erosion, as discounts slowly eat into list prices. Factors that contribute to price erosion include discounts for prompt payment or volume buying, rebate or bonus offers, and cooperative advertising allowances. When these discounts are subtracted from the invoice price, the net price emerges.

By tracking this final price on a case-by-case basis, organisations can get a graphic profile of the price ranges at which their products sell and to whom. The information gleaned can then be used to develop strategies for dealing with the best and worst transactions and accounts. For example, profitable accounts—ones that consistently buy products at full price—can be targeted for increased volume, and customers who are not as profitable as desired can be targeted for improved price levels or possibly dropped.

Performance measures for developing pricing strategy may encompass a variety of financial measures. An organisation should decide what performance indicators to measure, based on what goals it is trying to achieve with a pricing strategy. Measures may include some of the following:

- Improved overall profitability;
- Improved contribution margins;
- Unit volume increase;
- Cost reductions;
- Operating profit improvement; and
- Market share gains.

### **2.2.3. Select Channels of Distribution**

Distribution or marketing channels are the routes organisations use to reach customers with products and services. Specifically, channels refer to the different organisations that participate in making products and services available to final consumers. Selecting appropriate channels involves choosing those ones that efficiently meet the manufacturer's needs and effectively serve consumers and increase their satisfaction.

In addition to helping manufacturers serve customers, channels allow manufacturers to transfer a portion of their marketing costs to channel partners, such as distributors or retailers. The marketing costs transferred to channel partners usually include the costs of inventory, sales and promotions, order handling, and credit functions. Manufacturers retain a portion of marketing costs to perform distribution-related functions including:

- Deploying a field sales force to handle direct accounts;
- Developing marketing programs to support the channel's sales activities; and
- Carrying a minimal amount of finished goods inventory.

There are two categories of channels, direct and indirect. Each category is described in Table 2.

	Direct	Indirect
Characteristics	<ul style="list-style-type: none"> <li>Controlled by manufacturer</li> <li>Support the manufacturer exclusively</li> </ul>	<ul style="list-style-type: none"> <li>Carry multiple product brands and lines</li> <li>Serve more than one manufacturer</li> </ul>
Example	<ul style="list-style-type: none"> <li>Field sales force</li> </ul>	<ul style="list-style-type: none"> <li>Distributors</li> <li>Sales agents or representatives</li> </ul>

**Table 2: Comparison of Direct and Indirect Distribution Channels**

Direct channels provide manufacturers with the greatest control over the channel but are more costly than indirect channels. Indirect channels help manufacturers maximise market coverage and are more cost-effective because they assume many of the costs of doing business from the manufacturer. Indirect channels also offer important value-adding services to consumers, for example, buying convenience, delivery, and credit, which may not be available directly from a manufacturer.

In today's environment, which is characterised by multiple channels and extensive product selection, the consumer wields significant influence over a manufacturer's channel decisions. Making products available when and how customers want them becomes critical to survival. As a result, distribution channels have to be more responsive than ever to keep pace with rapidly changing customer and market demands. Undertaking a customer segmentation analysis helps organisations learn about the buying behaviour of customers and their preferred channels. With this knowledge, organisations are better able to evaluate the degree of compatibility between possible new channels and customers and potential customers.

Once selected, channel partners essentially become an extension of a manufacturer. Many manufacturers today are using third party distribution as channel partners to fulfil demand, i.e. perform inventory management, warehousing of finished goods, transportation, and distribution on behalf of the manufacturing organisation. This is a very important component of their product offering since "logistics adds competitive advantage by adding value to the customer that extends far beyond the simple performance of product transaction activities" (Ross, 1998:27). Manufacturers monitor the selected partners' performance to ensure they continue to perform in a way that delivers value and profits to the manufacturer.

In many cases, channel partners are a manufacturer's only link to customers and/or consumers, not only through the service levels but also the data captured about the customers and/or consumers. According to Lummus and Vokurka (1999:18) "[t]he issue for most partners in the demand chain is determining what information should be shared with all partners and establishing a system to make the information available." Information that typically need to be shared include sales data, inventory levels, and order quantities. Information about promotions, forecasts, and new product information and design can also be shared. Actual information sharing needs to be mutually decided upon and stipulated in the service level

agreement together with the method data will be made available to other channel partners. Each organisation must then decide how this data will “translate into improved business decisions” (Lummus and Vokurka, 1999:19). The ideal situation would be to allow “order and market information to flow upstream continuously from the point of sale, while data on product availability and inventory levels flow downstream ” (Poirer and Bauer, 2001:120) as illustrated in Figure 6. This is confirmed by Singh’s (1996, 30) view that an integrated supply chain is the sum of goods movement and information flow: “A supply chain is integrated by combining goods movement with the flow of operational and financial information between the relevant (internal and external) parties.”

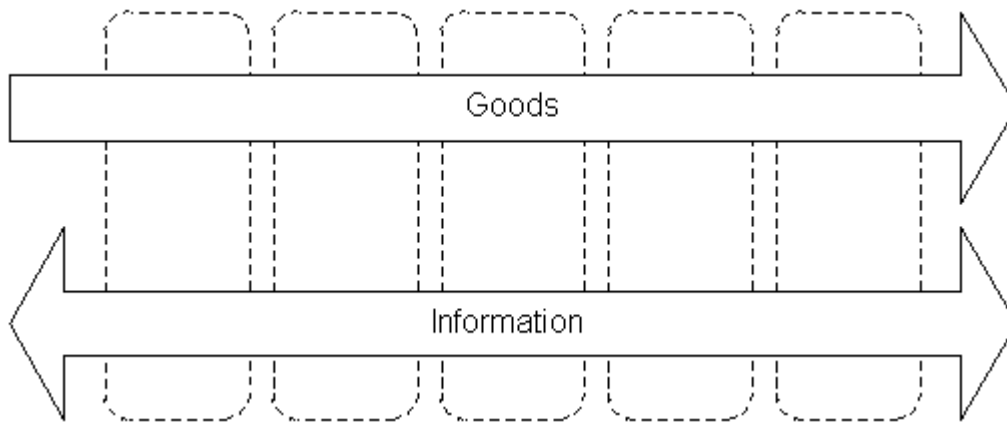

**Figure 6: Conceptual view of information and product flow between supply chain channel partners**

#### **2.2.4. Develop Sales Forecast(s)**

The sales forecast and its derivatives drive planning and decision-making and is used to populate the revenue portion of the budget. An organisation can use a complex, highly sophisticated forecasting tools or an informal, subjective process. However, the more quantified a sales forecast is, the more confidence with which decisions can be made regarding:

- Capital expenditures, investments, and cash flow;
- Production, purchasing, inventory, and facility planning;
- Sales, marketing, logistics, and distribution planning; and
- Human resource planning, including labour requirements and sales force allocation.

Preparing a forecast is a planning activity and is an iterative process. As such, sales forecasting helps an organisation shape its goals and strategies as these goals and strategies shape the forecast. A meaningful



sales forecasting process is more than simply looking at past sales records and adding 5, 10, or 15 percent as a growth goal.

The overall benefit of having a rigorous forecasting process is that it reduces the uncertainty of future demand for products and services. This enables an organisation to:

- Minimise its investment in inventory;
- Rid itself of outdated products in order to eliminate carrying costs; and
- Reduce the costs associated with rush supply orders, production schedule revisions, line set-up changes, short production runs, and product back orders.

Forecasting is a process with far-reaching implications beyond the sales and manufacturing functions. Accurate sales forecasting helps organisations better manage all aspects of their business. It improves decision making in critical areas such as production scheduling, personnel deployment, and logistics planning which can increase sales opportunities and optimise the organisation to reduce operational costs to maximise profits (Brooke and MacTavish, 2001). When forecasts are on target, organisations run like well-oiled machines: producing the right amount of product at the right time, keeping inventories moving, and thus avoiding losses associated with overstocked inventories. Additionally, relationships with customers solidify, as customers develop confidence in an organisation's ability to consistently meet their needs. This is confirmed by Moon and Mentzer (1999):

*“The first step any company needs to take is to convince senior sales managers that excellence in sales forecasting is critical to the health and well-being of their company. Without effective sales forecasting, not only will sales managers be unable to develop realistic sales plans for their territories, but the rest of the company will be unable to develop the financial, marketing, and operational plans necessary to support their sales plans.”*

Forecast accuracy should be monitored as new sales data becomes available. This activity provides insights to further shape the model and improve its usefulness. As new data becomes available for a period, the forecast can be compared with actual sales. The remainder of the forecast can then be updated with this new data to reflect any changes in trends or other patterns. The forecast model itself can also be changed to improve the reliability of the forecast.

Lack of or inaccurate forecasts “lead to misguided business plans, errant decisions and a lack of collaboration and consensus, which limits buy-in across the organization” (Brooke and MacTavish, 2001). Furthermore, organisations “may be unable to deliver goods and services to customers in a timely way,

which will affect customer satisfaction levels and jeopardize good relationships that have been established with large customers” (Moon and Mentzer, 1999).

Most organisations producing reliable forecasts begin with objective, statistics-based forecasts and then adjust these based on the judgment of experts within the organisation. Executives are best at providing insights that shape forecasts for entire product lines or markets; salespeople excel at forecasting at the individual product or stock keeping unit or SKU level. Combining bottom-up (from the sales force) and top-down (from executives) forecasts takes advantage of the strengths of each to produce a more reliable forecast. Involving salespeople also ensures that they buy into the forecast, which is especially important when sales quotas are based on forecasts. Most final forecasts are the result of combining several forecasts—generally, calculated forecasts based on data and inferential forecasts based on the insights and experience of experts.

The data used in forecasting is extremely important, and the most readily accessible data is not always the most useable or meaningful. Organisations need to collect both internal and external data and generate their own primary data when it is not available from other sources. It has been shown above that organisations need to obtain external data when dealing with channel partners. For example, in a retail channel setting a statistics-based forecasting process involving multiple partners might use some of the following data sources:

- Manufacturer shipments;
- Wholesaler warehouse shipments and inventories;
- Retailer distribution centre withdrawals and inventories; and
- Retail store point-of-sale (POS) data and inventories (Lapide, 1999/2000:13).

In particular, statistics-based forecasts are based on historical data, which frequently requires large volumes of data, particularly over time in order to increase extrapolation accuracy; as stated by a marketing director in a survey conducted by Ashill and Jobber (2001:57), historical information enables executives to establish what will likely happen in the marketplace.

Measures for forecasting performance can help identify process improvement opportunities. Cost measures, such as total forecasting costs, can be used to track the efficiency of the forecasting process. Quality measures, such as the percentage of forecasts that over or under estimate actual sales (negative skew) can help uncover cultural influences that encourage salespeople or managers to develop inaccurate forecasts. Performance measures include:

- Inventory levels;

- Inventory turnover;
- Out of stock situations;
- Number of backorders;
- Conformance to promised delivery date;
- Percentage of sales force at or above budgeted revenue; and
- Budgeted and/or forecasted to actual income variance.

### 2.3. Management Information and Data Source Requirements

Based on the above discussion of generic processes forming part of the sales and marketing effort of an organisation, the primary management information requirements can be ascertained. Table 3 below contains the typical management information requirements identified in the previous section.

Generic Sales and Marketing Process	Typical Management Information Requirements
Perform Market Segmentation	<ul style="list-style-type: none"> <li>• Sales:                             <ul style="list-style-type: none"> <li>○ Overall;</li> <li>○ By segment;</li> <li>○ By customer or account;</li> <li>○ By product;</li> </ul> </li> <li>• Expenses:                             <ul style="list-style-type: none"> <li>○ Costs of marketing programs (resulting from targeted marketing versus mass marketing);</li> <li>○ Promotional expenditures or trade marketing;</li> </ul> </li> <li>• Market share;</li> <li>• Customer acquisition and retention rate; and</li> <li>• Profitability.</li> </ul>
Develop a Pricing Strategy	<ul style="list-style-type: none"> <li>• Average selling prices (ASP) and unit forecasts by product and territory;</li> <li>• Contribution margins;</li> <li>• Costs;</li> <li>• Market share;</li> <li>• Operating profit improvement;</li> <li>• Profitability;</li> <li>• Promotions; and</li> <li>• Unit volumes.</li> </ul>
Selection Channels of Distribution	<ul style="list-style-type: none"> <li>• Delivery time;</li> <li>• Conformance to promised delivery date; and</li> <li>• Promotions.</li> </ul>
Develop Sales Forecast(s)	<ul style="list-style-type: none"> <li>• Inventory levels;</li> <li>• Inventory turnover;</li> <li>• Out of stock situations;</li> <li>• Backorders;</li> <li>• Budgeted and/or forecasted to actual income variance; and</li> <li>• Percentage of sales force at or above budgeted revenue.</li> </ul>

**Table 3: Typical management information requirements by generic sales and marketing processes**

In conclusion, sales and marketing management information requirements are (Ashill and Jobber, 2001:57):

- Qualitative in nature, for example, shifts in buyer behaviour and competitive threats;
- Internal facts, for example, costs, profitability;
- External facts, for example, broad environmental changes, industry environment changes;
- Historical; and
- Future-orientated.

Profitability requires further clarification. Using profitability analysis an organisation can determine where money is being made or lost, allowing it to properly align strategies to specific market segments. As such it is a valuable tool for management decision-making. Profitability is derived from revenue, expense and cost data, with expenses and costs subtracted from revenue. Profitability analysis can focus on:

- Customers;
- Products;
- Sales force;
- Territories; or
- Vendors.

Examining the data sources required as listed in Table 4, it is clear data sources to meet the information requirements are both internal and external as mentioned, particularly where third-party distribution is used. The supplier is dependent on the organisation to access to the data collected by the organisation, particularly relating to customers. Another view on management information requirements within the sales and marketing function is given in Table 5.

When a manufacturing organisation uses third party distribution to distribute products to its customers, the third party distributor will produce the invoices, goods delivery notes, etc. Should the third party distributor handle orders on behalf of the manufacturer, the distributor will hold all order-related information. Should the distributor also perform a warehousing function of finished goods, inventory levels and out of stock situations will be monitored by the distributor. It is clear that important data reside outside of the manufacturing organisation's boundaries with customer-facing firms such as a third party distributor as channel partners.

Generic Sales and Marketing Process	Data Sources
Perform Market Segmentation	<ul style="list-style-type: none"> <li>• Sales transactions, linked to customers</li> <li>• Costs, preferably linked to customers</li> <li>• Demographics, customer surveys and focus groups, lifestyle choices</li> <li>• Expenses, preferably linked to customers</li> <li>• Independent market research, census data</li> </ul>
Develop a Pricing Strategy	<ul style="list-style-type: none"> <li>• Actual price or true product cost</li> <li>• Promotions</li> <li>• Sales transactions, including units sold</li> </ul>
Selection Channels of Distribution	<ul style="list-style-type: none"> <li>• Delivery data</li> <li>• Order data</li> <li>• Promotions</li> </ul>
Develop Sales Forecast(s)	<ul style="list-style-type: none"> <li>• Budget</li> <li>• Inventory levels</li> <li>• Order data</li> <li>• Sales transactions, preferably linked to customers if forecasting by customer</li> <li>• Shipments (manufacturer and/or distributor)</li> </ul>

**Table 4: Data sources required to meet information requirements by generic sales and marketing processes**

	Internal	External
<b>Strategic support</b>	Trends monitoring Effectiveness monitoring Strength / Weakness New product development	Market positioning Competitors mapping Opportunities / Threats Benchmarking Environmental scanning
<b>Operational support</b>	Sales promotion Advertising Product pricing Sales force management	Market research Direct marketing (database, Internet) Contact management Public relations

**Table 5: Strategic sales and marketing management information requirements (Xu, 1999:268)**

## 2.4. Data Flow from Customer-Facing Channel Partner Firms

Given that important data reside outside of the organisation, the implication is that data must be managed across the boundaries of an organisation, not only internally across departments or functional areas, for example, marketing, and operations; but also externally across other organisations in the supply chain as depicted in Figure 7.

For customer-facing organisations this is not a problem as they interact directly with the customer but there are a multitude of other role players as Kumar (2001:58) accurately describes:

*“Customer-facing firms at the retail level, whether large department stores, automobile dealerships, or fast-food franchises, are only the tip of the iceberg. Behind them exist*

*entire networks of manufacturers and distributors, transportation and logistics firms, banks, insurance companies, brokers, warehouses and freight-forwarders, all directly or indirectly attempting to make sure the right goods and services are available at the right price, where and when the customers want them.”*

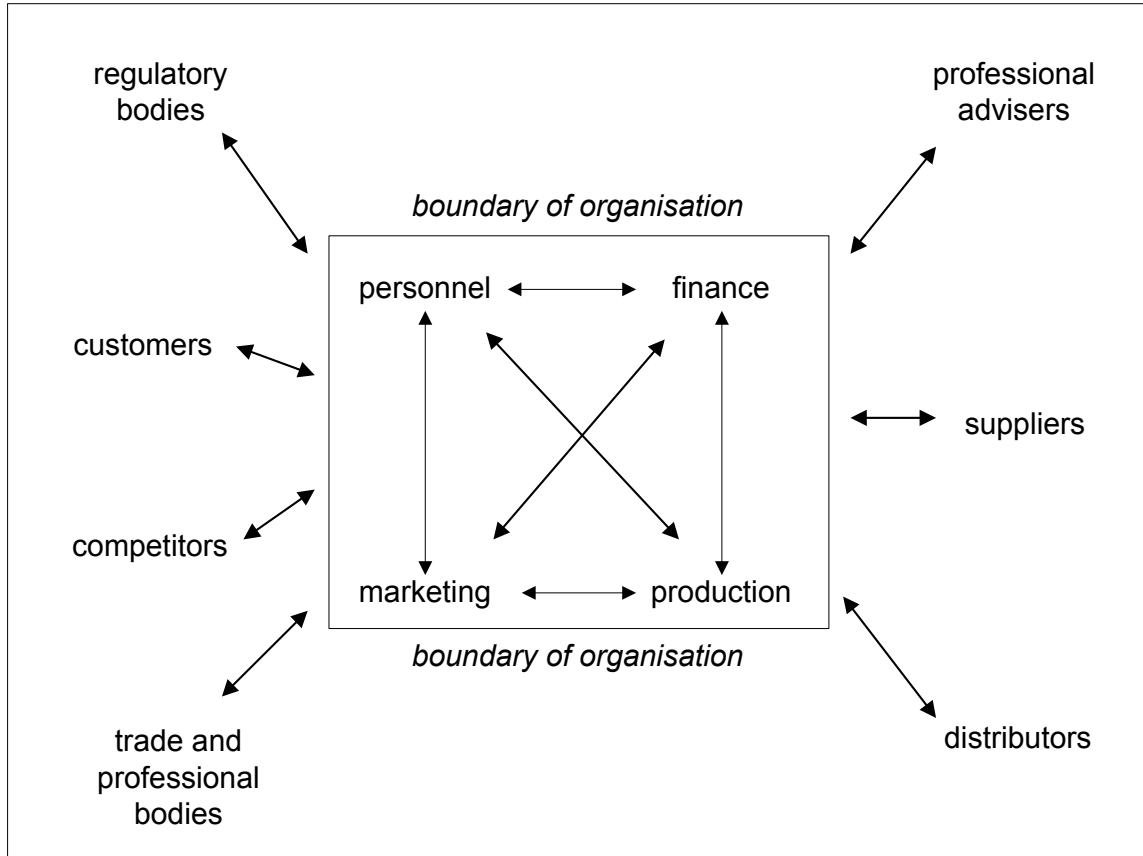

**Figure 7: Flow of information within and outside the boundaries of an organisation (Butcher, 1998:7)**

Since the organisations beyond the customer-facing organisations are unable to have direct contact or interaction with customers “the role of information becomes even more crucial to creating a customer-oriented organization” (Lumms and Vokurka, 1999:16). Aaker’s (1998:281) view on the link between manufacturing and retailer organisations is that it is increasingly being reinforced by information technology. As a result, “[t]he ability to control the information generated by retail scanners can be key to the strategies of manufacturers and retailers” (Aaker, 1998:281). Many organisations, however, experience problems with the obtaining customer data (Prahalad and Krishnan, 1999:113):

*“Consider a company’s primary supplier relationships and the application software that mediates these interfaces. Supplier relationships used to be fairly stable. But increasingly, the basis for value creation in these relationships is changing dramatically. More and*

*more information is being exchanged, and each party is becoming more dependent on the other's information systems. The volume and frequency of interactions with a supplier can affect the nature of company-supplier relationships and the characteristics of software required for managing those interfaces ... But in the traditional business system, managers don't have direct access to this information because dealers and distributors act as intermediaries. So it is Wal-Mart, not Procter & Gamble, that manages the interface with customers and collects the information."*

This is reaffirmed by Lapide (1999/2000:13) when discussing obtaining data from channel partners:

*"While at first glance this sounds easy, it is not, since getting it on a routine basis from all trading partners, especially electronically, is unlikely to happen. Not all trading partners are willing to participate and some may not be capable of doing it. For example, POS [point-of-sale] data may only be gotten from a few retailers and obtained in a format that is difficult to interface with one's ... system."*

In order to counter this, channel partners form partnerships. According to Corbett *et al* (1999:71) even "... modest partnerships [can] lead to rapid improvements in logistics facilitated by candid information exchange and better coordination." Furthermore, "[f]ailing to collaborate results in the distortion of information as it moves through a supply chain, which in turn, can lead to costly inefficiencies. ... Through the more open, frequent, and accurate exchange of information typical of a long term supply-chain partnership, companies can eliminate many of these problems [excess inventories, slow response, and lost profits] and ensure ongoing improvement" (Corbett *et al*, 1999:71). Thus partnerships go a long way to ensure that data is available/accessible to manufacturer's on a continuous basis from third party distributors:

- "... information must flow between people within the organisation, and between the organisation and the external world. Such communication is vital for the successful functioning of the organisation, and most organisations establish formal mechanisms and processes with vertical and horizontal channels of communication to provide for the exchange of such information" (Butcher, 1998:5).
- international research on third-party service providers shows that "partnerships are extremely important to help minimize some of the problems associated with information flow that can easily damage the supplier-customer relationship." (Handfield and Nicols, 1999:47)

It is clear that information flow from the physical distribution process plays an important role in the sales and marketing processes of manufacturing organisations. Finding an effective means to share the data is

vitaly important in order to make both tactical and strategic decisions in both marketing and production. For this purpose information systems are used. Talvinen and Saarinen (1995:18) accurately summarises the role of information systems in such organisations:

*“To handle the increasing external and internal information flow and to improve its quality, companies have to take advantage of the opportunities offered by modern information technology (IT) and information systems (IS). Managing marketing information by means of IT has become one of the most vital elements of effective marketing.”*

This view is reinforced by Ross (1998:51-52):

*“... today’s market leaders must view information and communication technologies not only as critical management tools that shorten cycle times and increase productivity of business functions through automation but also as key enablers providing the enterprise with the opportunity to activate highly competitive cultures and structures both within the organization and outside in the supply channel in search for marketplace excellence.”*

## **2.5. Chapter Conclusion**

Customer knowledge plays a vital part in organisations today, particularly in several sales and marketing processes. The customers can either be channel partners or the final consumers. Managing data and/or information across business units, departments, and functions is vital but problematic. Frequently, channel partners gather and capture data about customers that the other organisations in the channel require and which must be incorporated/catered to in the receiving organisations’ information systems in order to allow for management information delivery to users.



## CHAPTER 3 DATA MARTS AS MANAGEMENT INFORMATION DELIVERY MECHANISMS

*“A firm’s IQ is determined by the degree to which its IT infrastructure connects, shares, and structures information. Isolated applications and data, no matter how impressive, can produce idiot savants but not a highly functional corporate behavior.”*

– Steve H. Haeckel and Richard L. Nolan, *Managing by Wire: Using IT to Transform a Business*

An understanding of the definition of and distinction between data warehouses and data marts is required prior to commencing an empirical investigation of data marts as management information delivery mechanisms. The aims of this chapter are to provide material to aid this understanding by:

- To compare and contrast the data warehouse and types of data marts in order to arrive at an understanding of what it is;
- To indicate the relationship between data warehouses and data marts;
- To describe, classify and characterise the access tools to data marts/data warehouses as management information delivery mechanisms;
- To define criteria to select the appropriate data mart access tool(s); and
- To explore the use of data warehouses and data marts in organisations, particularly within the context of sales and marketing, as discussed in literature.

### 3.1. Definitions of Data Warehouses and Data Marts

In 1997, White (1997, 7) stated that there is “considerable debate and confusion in the industry about the role and value of a data mart, and even about what a data mart is.” This debate and confusion has not subsided in subsequent years as is evident from the following representative definitions found in literature:

- A data mart is an “implementation of the data warehouse in which the data scope is somewhat limited compared to the enterprisewide [sic] data warehouse. A data mart may contain lightly summarized departmental data and is customized to suit the needs of a particular department that owns the data; in a large enterprise, data marts tend to be a way to build a data warehouse in a sequential phases approach; a collection of data marts composes an enterprise-wide data warehouse; conversely, a data warehouse may be construed as a collection of subset data marts” (Berson and Smith, 1997:15). Furthermore, “Mostly, data marts are presented as an inexpensive alternative to a data warehouse that takes significantly less time and money to build” (Berson and Smith, 1997:124).

- “When the term *data mart* came into vogue, it was generally used to describe an environment that would receive a subset of a data warehouse’s contents and then would be the primary point of data access for a subset of the organization’s total user base (i.e., one or two departments)” (Simon, 1998:4). This was because “smaller-scale data warehousing efforts, the ones that were being developed in three to six months with scaled-back functionality, were usually successful” (Simon, 1998:6). In order to distinguish these successful efforts from the less successful enterprise-wide data warehouse efforts “the phrase *data mart* was extended to refer not only to an environment sourced by a data warehouse, but *any* smaller-scale effort with a relatively short time from concept to deployment” (Simon, 1998:6).
- “... the term data mart, which has been used variously to describe a small standalone data warehouse or a distributed secondary level of storage and distribution in conjunction with a data warehouse.” (Dodge and Gorman, 1998:11)
- “A data mart, often referred to as a subject-oriented data warehouse, represents a subset of the data warehouse comprised of relevant data for a particular business function (e.g., marketing, sales, finance, etc.)” (Poe et al, 1998:18).
- “The term data mart is used to refer to a small-capacity data warehouse designed for use by a business unit or department of a corporation” (Gray and Watson, 1998:103).
- “A scaled-down version of a data warehouse that is tailored to contain information likely to be used only by the target group” (Gates, 1999:493).
- “A data mart is simply a smaller data warehouse. Usually the data in a mart is a subset of data that is found in an enterprisewide warehouse, as follows:
  - A data warehouse is for data throughout the enterprise.
  - A data mart is specific to a particular department” (Microsoft Corporation, 1999:3).
- “... the definition of a [data] mart as a single-purpose warehouse serving a single allied group of users” (Palo Alto Management Group, 2001:275).
- “A data mart contains a subset of corporate-wide data that is of value to a specific group of users. The scope is confined to specific selected subjects” (Han and Kamber, 2001:67).
- “A data mart is smaller, less expensive, and more focused than a large-scale data warehouse. Data marts can be a substitution for a data warehouse, or they can be used in addition to it” (Turban et al, 2001:759).

From these definitions in literature, the following can be concluded:

1. A data mart is smaller in scope and/or size than a data warehouse;
2. A data mart appears to be less expensive to build than a data warehouse; and
3. Data marts can take a number of forms, namely:

- An optional part of a data warehouse, for reporting purposes, dependent, an alternative to directly accessing the data warehouse with the data warehouse being a single centralised repository. In these instances it is generally can be departmental or business process specific;
- A small stand-alone independent data warehouse.
- Data marts developed in a coordinated manner with conformed dimensions to form a distributed data warehouse.

From the points 1 and 2 it is clear that there appears to be some difficulty in determining the exact boundary between a data mart and a data warehouse, with the definition of a data mart frequently referring to a data warehouse in order to provide a definition. Before exploring the different data marts outlined in point 3 in depth, it is necessary to elaborate on the concept of the data warehouse.

### 3.1.1. Data Warehouse

Data that is captured and stored during the processing of transactions can be used to produce valuable information to end-users, especially management. This management information can be used to plan, monitor, and control business operations (Whitten *et al*, 1998:53). In order to exploit this data asset, organisations began creating data warehouses to satisfy these demands for decision-making (Gates, 1999:250).

According to Inmon (2002:31), a data warehouse is “a subject-oriented, integrated, non-volatile [database not updated directly by users] , time-variant collection of data in support of management’s decisions.” This definition is concise but not without controversial points requiring interpretation:

- “Subject-oriented”—In the marketplace, the term subject-oriented implies functionally-aligned, for example, sales data is separated from marketing data is separated from manufacturing data, and each forms a separate “data warehouse” which is then a data mart.
- “Serves management”—There has been a change in managerial theory and organisational design which has resulted in decision points being pushed down the organisational hierarchy, out to the boundaries of the firm. However, in many organisations, management information is still confined to middle and senior management with information flow down the hierarchy when deemed necessary.

Whitten *et al* (1998:53) is of the opinion that management reporting and by implication management information is a natural extension of transaction processing. According to Kimball (1996:310) a data warehouse is “a copy of transaction data specifically structured for querying and reporting.” Kimball’s definition eliminates problematic points in Inmon’s definition are eliminated. Furthermore, this implies that the data warehouse is a separate database used for analytical purposes where all data is stored but in a

different structure, which is optimised for analytical purposes whereas operational databases are usually optimised for day-to-day business operations, for example, transaction updates. The data is reorganised to reflect the way it will be used. The reason for a different structure is for performance reasons—data structures are optimised for queries requiring summarised data rather than individual records at transactional level since two types of applications competing for resources negatively impacts on the performance of both. The differences between transactional or operational databases and analytical databases such as a data warehouse are listed in Table 1.

	Operational Databases	Analytical databases
<b>Business Purpose</b>	Supports tactical day-to-day decisions	Supports long-term, strategic decisions
<b>Nature of Use</b>	<ul style="list-style-type: none"> <li>• Repetitive</li> <li>• Continuous updates</li> <li>• Predictable pattern of usage</li> </ul>	<ul style="list-style-type: none"> <li>• Investigative</li> <li>• Problem-solving</li> <li>• Unpredictable pattern of usage</li> </ul>
<b>Nature of Users</b>	<ul style="list-style-type: none"> <li>• Serves clerical, transactional community</li> <li>• Large numbers of operational managers (hundreds of thousands)</li> </ul>	<ul style="list-style-type: none"> <li>• Serves managerial community</li> <li>• Small number of strategic managers (tens or hundreds)</li> </ul>
<b>Nature of Queries</b>	<ul style="list-style-type: none"> <li>• What is happening?</li> </ul>	<ul style="list-style-type: none"> <li>• What happened?</li> <li>• Why did it happen?</li> <li>• What will happen next?</li> <li>• What if?</li> </ul>
<b>Nature of Data</b>	<ul style="list-style-type: none"> <li>• Detailed data</li> <li>• Current</li> <li>• Volatile / highly dynamic</li> </ul>	<ul style="list-style-type: none"> <li>• Detailed and summarised data</li> <li>• Historical</li> <li>• Non-volatile / static</li> </ul>
<b>Typical analysis</b>	Simple, for example: <ul style="list-style-type: none"> <li>• Sum</li> <li>• Average</li> <li>• Count</li> </ul>	Advanced, for example: <ul style="list-style-type: none"> <li>• Trend</li> <li>• Forecasting</li> <li>• Monthly averages</li> <li>• Year-to-date totals (YTD)</li> <li>• Prior period totals</li> </ul>
<b>Access</b>	Structured Query Language (SQL) Custom-developed front-end tools	Advanced analytical tools
<b>Workload</b>	Users execute transactions that only affect a small number of rows	Users execute queries that might scan millions of rows
<b>Nature of database modifications</b>	Continuous (via transactions)	Performed at regular intervals (via batch loads)
<b>Performance criteria</b>	Throughput is most important	Response time (for queries) is most important

**Table 1: Comparison between transaction processing systems and data warehouses ((Daphnesoft, 2001:76), (Levine and Siegel, 2001:42), (Rudin, 1998:45))**

It is clear that data warehousing involves separating the data used for analytical applications from the data used for transaction processing. A separate database is created by taking data from the organisation’s operational databases and storing it in a structure that facilitates user-friendly access for users. The main reasons for this are:

- Reduction of operational database workload;
- Optimisation of databases to cater for different requirements; and
- Integration of data from diverse sources.

A descriptive definition of a data warehouse is that of Han and Kamber (2001:67): “An enterprise warehouse collects all of the information about subjects spanning the entire organization. It provides corporate-wide data integration, usually from one or more operational systems or external information providers, and is cross-functional in scope.” However, this definition does not cover the target audience or users of the data warehouse. Whitten and Bentley (1998:40) places more focus on the users by defining a data warehouse is “a read-only, informational database that is populated with detailed, summary, and exception information that can be accessed by end-users and managers with DSS tools that generate a virtually limitless variety of information in support of unstructured decisions.”

Other definitions of a data warehouse found in literature include:

- A data warehouse is a “database that can access all of a company’s information. While the warehouse can be distributed over several computers and may contain several databases and information from numerous sources in a variety of formats, it should be accessible to users through simple commands” (Gates, 1999:493).
- A data warehouse provides “a unified corporate picture to the end-users by combining the data from many operational systems and incompatible databases without affecting the performance of the running operational systems” (Turban *et al*, 2001:758)
- “The data warehouse is an environment, not a product. It is an architectural construct of information systems that provides users with current and historical decision support information that is hard to access or present in traditional operational data stores. In fact, the data warehouse is a cornerstone of the organization’s ability to do effective information processing, which among other things, can enable and share the discovery and exploration of important business trends and dependencies that otherwise would have gone unnoticed” (Berson and Smith, 1997:5).
- “Data is extracted from multiple sources (usually operational databases), pruned, cleansed, reconciled and transformed into a more usable format and then loaded into the data warehouse for subsequent access by multiple interested consumers” (Schulte, 1996).

The process described in these definitions is depicted in Figure 1.

Based on the above definitions, a data warehouse can be summarised that it:

- Integrates sources from multiple, diverse operational sources;
- Allows for analysis of data over time;
- Provides analysis capabilities to decision makers;

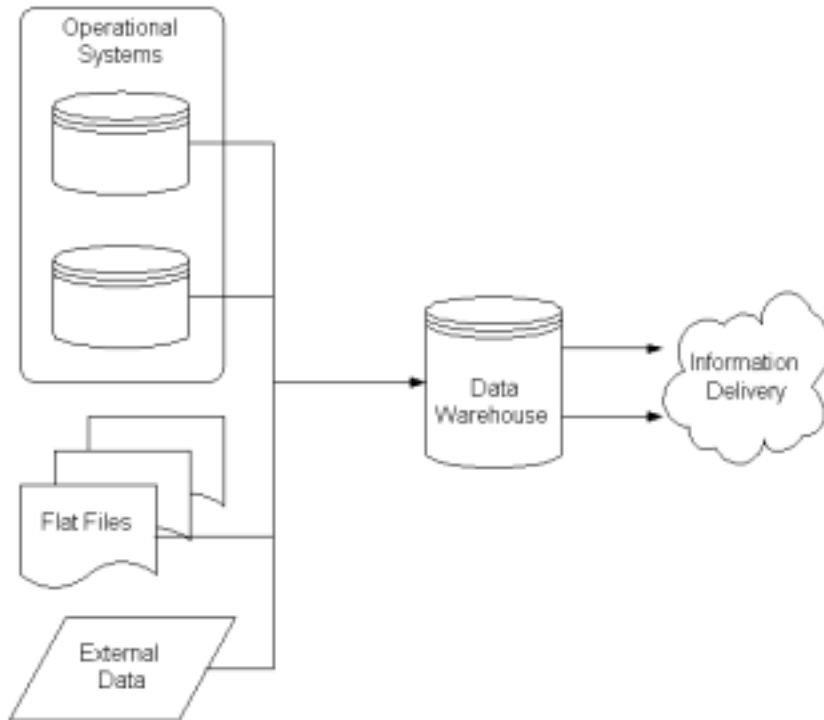

**Figure 1: Schematic Representation of Data Flow in a Data Warehouse Environment**

- Provides improved performance for complex analytical queries;
- Relieves processing burden on transaction-oriented databases; and
- Converts enterprise data into strategic information (Heise, 2001: 34).

Furthermore, the data warehouse takes a “top-down perspective is that a completely centralized, tightly designed master database must be completed before parts of it are summarized and published as individual data marts [see 3.1.2.1. ]” (Kimball *et al*, 1998:18-19).

### 3.1.2. Data Marts

A data warehouse presents a solution for storing and accessing analytical data. There are a number of advantages in building a data mart:

- The cost of building a data mart is generally lower;
- The implementation timeframe is shorter; and

- Data marts contain less information than a data warehouse and therefore have more rapid response and are more easily understood and navigated by users than an enterprise data warehouse (Gray and Watson, 1998:103-104).

Based on the initial definitions from literature, it emerged that data marts can be one of a number of different designs or architectures. Han and Kamber (2001:67) explain that the source of data determines the data mart. As Gray and Watson (1998:104-105) states, a data mart may be:

- A subsidiary of a centralised data warehouse;
- Operate independently; or
- Integrated into a distributed data warehouse.

Each of these data mart architectures are referred to using specific terminology:

- A subsidiary of a centralised data warehouse is known as a dependent data mart; and
- A data mart that operates independently is known as an independent data mart
- A data mart integrated into a distributed data warehouse does not have a specific term assigned to it except that a number of data marts constructed in this way results in a distributed data warehouse. In this dissertation, this type of data mart will be referred to as an interdependent data mart.

These data mart architectures are explored in the following sections.

### 3.1.2.1. Dependent Data Mart

Data marts populated with data sourced from the enterprise data warehouse are called dependent data marts (Berson & Smith, 1997:124, and Han & Kamber, 2001:67). These are sometimes also called replicated data mart since the data mart is populated with a portion of the data warehouse's data through replication (Gray & Watson, 1998:104). This is depicted schematically in Figure 2.

By integrating data from various sources into a data warehouse and then letting the integrated data flow to a number of dependent data marts each containing limited content tailored to the needs of the departmental user community gives users the benefit without central co-ordination being sacrificed (Dodge & Gorman, 1998:572-573). The information provided to each data mart is determined by the departmental or divisional needs for centralised information. It is also possible for locally generated and used information to be stored in the dependent data mart. Furthermore, because the use is localised, alternative analytical tools to those used to access the underlying data warehouse can be used (Simon, 1998:4-5). What is important to note is that data is "never transmitted by the owner of the data mart to other portions of the organization" (Gray and Watson, 1998:105).

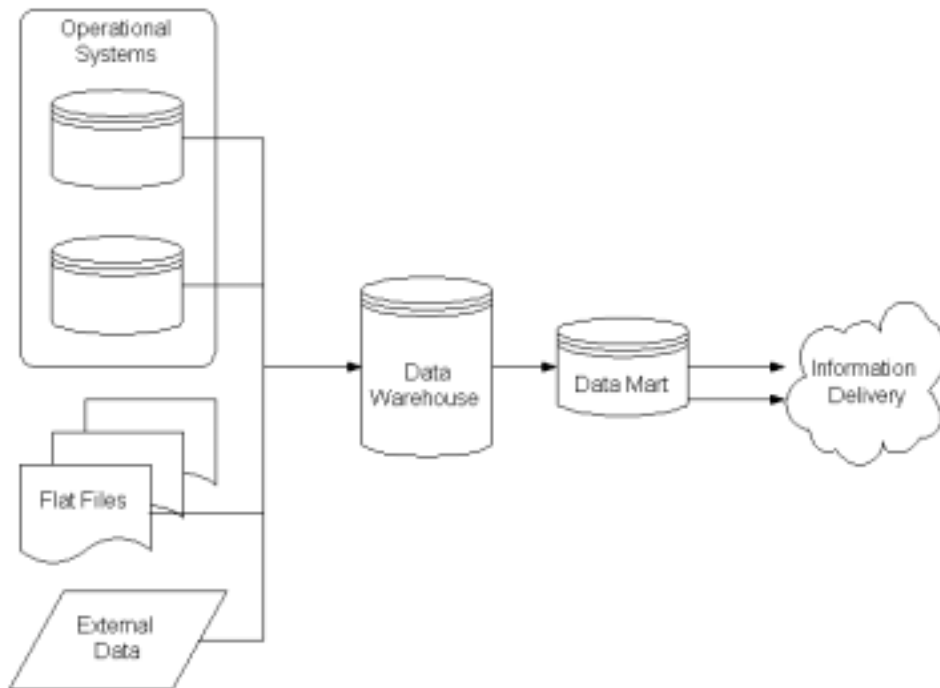

**Figure 2: Data flow when using a dependent data mart**

The dependent data mart architecture assumes enterprise data warehouse exists. History has shown during the past 10 years that successfully implementing an enterprise data warehouse is extremely challenging from a business and technical perspective (Friedman, 2002, and Han & Kamber, 2001:67). Examples of these challenges are (Simon, 1998:5):

- Technical challenges, for example, scalability issues, such as handling very large databases; and
- Business challenges, for example, cross-organisational cooperation that is usually needed for a data warehouse and the negative impact of corporate politics and determining the business value sought from the data warehouse and relating that value back to specific functionality and data needs.

The result was that data warehouses were either only partially deployed or deployed but never used because of problems such as data integrity, or cancelled completely.

### 3.1.2.2. Independent Data Mart

Problems with implementing an enterprise-wide data warehouse and the associated costs led to development of the independent data mart. Independent data marts are populated with data captured from one or more operational systems or external data sources, or with data generated locally within the



department (Han & Kamber, 2001:67). This is depicted in Figure 3. The result is, theoretically, that each department or division has its own data mart. This situation can result when vendors, unable to sell a data warehouse to the whole enterprise, sell scaled-down versions of their product as a data mart to a department or division.

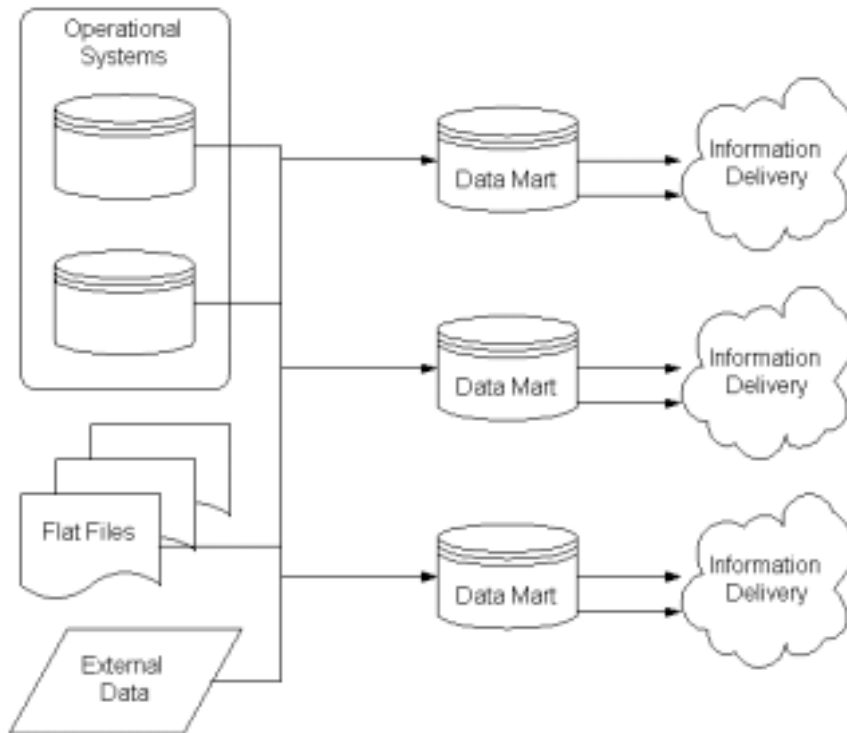

**Figure 3: Data flow when using independent data marts**

While solving the problem of the particular department or division, a stand-alone data mart can result in serious fragmentation in the organisation or so-called “islands of information.”<sup>1</sup> When data marts are not integrated with one another, they can generate inconsistent and conflicting data because for each independent data mart assumptions are made about how to consolidate the data, and the data across several data marts may not be consistent (Berson & Smith, 1997:125) with separate representations. These differences can be a result of different definition of terms, reporting periods, and time lags in recording information which is the reason that cannot be integrated with one another (Gray & Watson, 1998:104-105) or in identification of source systems or in the extract, reformatting, and summarisation processing (Dodge & Gorman, 1998:572). As Berson and Smith (1997:125) correctly state, the independent data mart architecture does not include what is central to the concept of data warehousing, namely data integration.

---

<sup>1</sup> “In some situations, building separate data marts may be a good solution if there is *no* intent to interact with other departments” (Microsoft Corporation, 1999:4). However, assuming no interaction will ever occur is a rather strong assumption.

According to Berson and Smith (1997:125) independent data marts should rarely be deployed within an overall technology or applications architecture since independent data marts “may involve complex integration in the long run if its design and planning were not enterprise-wide” (Han & Kamber, 2001:67). As Kimball *et al* (1998:18-19) states, the “bottom-up perspective is that an enterprise data warehouse can be assembled from disparate and unrelated data marts” which has been shown in practice not to be the case. This is confirmed by industry experts who have “acknowledged that, a majority of the time, data marts must be rebuilt entirely according to a conformed ... dimensional framework before they can be rolled up into a data warehouse successfully [see 3.1.2.3. ]” (Microsoft Corporation, 1999:4).

### 3.1.2.3. Interdependent Data Mart

In order to address the problems experienced with both the enterprise data warehouse together with the dependent data mart, and the independent data mart, a co-ordinated set of data marts are used where the planning and design is at an enterprise level (Han & Kamber, 2001:67).

According to Berson and Smith (1997:126) the “key to a successful data mart strategy is the development of an overall scalable data warehouse architecture; and the key step in that architecture is identifying and implementing the common dimensions.” Kimball, the proponent of the dimensional modelling approach, refers to the common dimensions as conformed dimensions: “the only ... way to combine the data from these separate tables and achieve an integrated enterprise data warehouse is if the dimensions of the data mean the same thing across these tables” (Kimball *et al*, 1998:18-19). Kimball’s conformed dimensions are explained by Berson and Smith (1997:125-126) as follows: “For any two data marts in an enterprise, the common dimensions must conform to the *equality and roll-up rule*, which states that these dimensions are either the same or that one is a strict roll-up [or subset] of another.” By predefining the characteristics of dimensions to be used throughout multiple interdependent data marts a conformity or dependency between data marts is created which allows for “easy rollup into an enterprise-level data warehouse” (Microsoft Corporation, 1999:4).

According to Kimball *et al* (1998:18-19) the only feasible solution is to blend the top-down or bottom-up approaches, where separate pieces, i.e., interdependent data marts, are designed guided by a proper architecture. As Poe *et al*, (1998:18) state, organisations may choose to “begin their corporate data warehouse project with a small pilot project for a specific subject area (business function). In so doing, those organizations have taken a bottom-up approach to the implementation of a decision support environment—and they have essentially created both a data mart and their first data warehouse simultaneously.”

This approach requires that a significant amount of work to be spent during the design of the first interdependent data mart in order to ensure future data marts can fit with the dimensions (Dodge & Gorman, 1998:572). If this is not done, the result will be multiple independent data marts. Note that the only difference between an independent and an interdependent data mart when building the first data mart is the intention and the design of the data model. The structure will appear the same when depicted diagrammatically. Figure 4 depicts diagrammatically the distributed data warehouse resulting from multiple interdependent data marts.

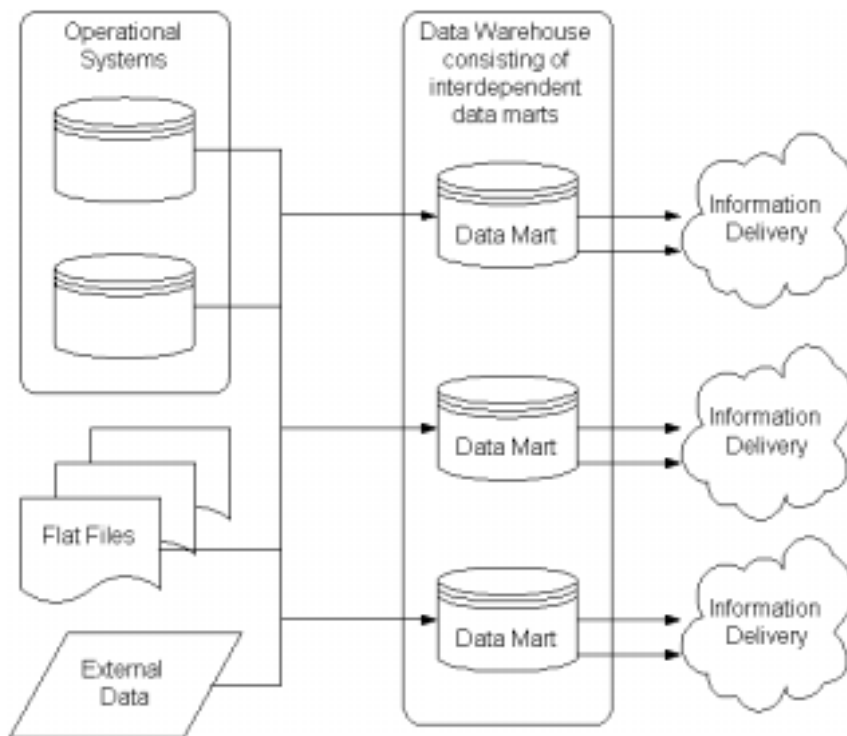

**Figure 4: Data flow when using interdependent data marts**

Two or more interdependent data marts result in a distributed data warehouse. This approach to data warehousing is preferred to a single enterprise data warehouse since it is possible to deliver a data mart to business users in a far shorter timeframe thereby lowering project costs which accelerates the return on investment (ROI). This also serves to gain credibility and get buy-in for further warehousing projects from management. Furthermore, the initial hardware costs are also much less costly than investing in the infrastructure required to support a large data warehouse (Martin, 1999). However, a distributed data warehouse is the result of planning: “Each data mart is assigned a specific set of information for which it is responsible. A central organization, such as IT, specifies the rules for the metadata so that the information kept by each mart is compatible with that provided by all the other marts” (Gray & Watson, 1998:104-105).

Figure 5 illustrates diagrammatically the distributed data warehouse from resulting from several interdependent data marts.

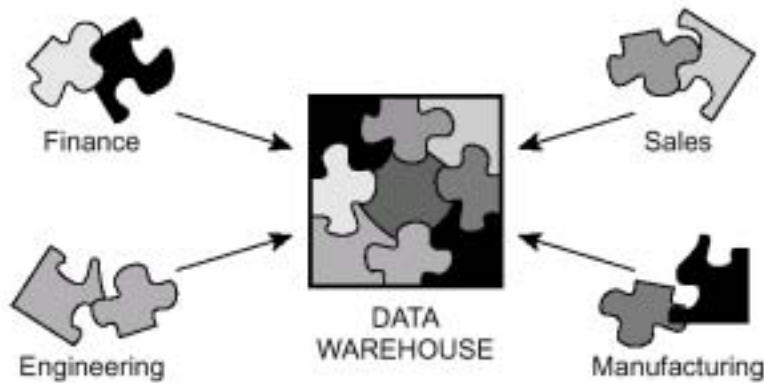

**Figure 5: Interdependent data marts resulting in a distributed data warehouse**

Against the above definitions and descriptions, a summarised comparison of a data warehouse and the different types of data marts are provided in Table 2.

	Data warehouse	Data mart		
		Dependent	Independent	Interdependent
<b>Scope</b>	Enterprise-wide	Subject or department		
<b>Basic architectural assumption</b>	Centralised	Centralised	Distributed	Distributed
<b>Size</b>	Up to several terabytes	Megabytes to gigabytes		
<b>Approach</b>	Top-down		Bottom-up	Middle-up-down
<b>Data source</b>	Operational systems	Underlying enterprise data warehouse	Operational systems	Operational systems
<b>Level of data</b>	Detailed	Summarised	Detailed and summarised	Detailed and summarised
<b>Next level of migration</b>	Data mart	Not applicable	Data warehouse	Data warehouse
<b>Distinguishing characteristics (if any)</b>	<ul style="list-style-type: none"> <li>Enterprise wide</li> </ul>	<ul style="list-style-type: none"> <li>Derived and aggregated</li> </ul>	<ul style="list-style-type: none"> <li>Independent</li> </ul>	<ul style="list-style-type: none"> <li>Shared, conformed dimensions</li> <li>Distributed data warehouse</li> <li>Independent and atomic</li> </ul>
<b>Benefits</b>	<ul style="list-style-type: none"> <li>Integrated</li> </ul>	<ul style="list-style-type: none"> <li>Quicker response times than data warehouse</li> </ul>		<ul style="list-style-type: none"> <li>Integrated by design</li> <li>Shorter development time</li> </ul>
<b>Drawbacks</b>	<ul style="list-style-type: none"> <li>Long development time</li> </ul>	<ul style="list-style-type: none"> <li>Requires enterprise data warehouse</li> </ul>	<ul style="list-style-type: none"> <li>Fragmentation of data</li> <li>Possible integration issues</li> <li>Multiple extracts for update/refresh</li> </ul>	

**Table 2: Comparison of data warehouse and types of data marts**

### 3.1.3. Relationship between Data Warehouse and Data Mart

From the quotations in literature, it is evident that there is a relationship between the concept of a data warehouse and the concept of a data mart. In particular, dependent data marts form part of the overall data warehouse environment and derive their data from the data warehouse. Independent data marts are constructed in lieu of a data warehouse but are built on the same principles. In the case of interdependent data marts, the collection of data marts *is* the data warehouse. It is also worthwhile to note the following statement by Gray and Watson (1998:103) in this regard:

*“The dichotomy between a data warehouse and a data mart is partially dependent on the size of the organization. A large organization’s data mart may well be a small organization’s data warehouse.”*

Furthermore, as Watterson, quoted in Turban *et al* (2001:437), states data marts “ can be a substitution for a data warehouse or they can be in addition to it, holding only part of the data warehouse content”

This relationship is succinctly described in the following excerpt by Microsoft Corporation (1999:4), a vendor of data warehousing software:

*“Both data warehouses and data marts describe the process of collecting data from other sources. Data is summarized into a read-only format that is convenient for querying and analysis. ... Both data warehouses and data marts have the common objective of better business decisions through better use of data.”*

Simon (1998:4) corroborates this statement:

*“You develop a data mart for the same reason you develop a data warehouse: to provide a consolidation of data regardless of platform, geographic, application, and organizational barriers. And once you’ve consolidated that data, you have created an environment that will provide users with business intelligence.”*

Logically and by definition, therefore, the terms *data warehouse* and *data warehousing* encompass that of a *data mart*, a data mart being a data warehouse with more particular characteristics. A data mart is, therefore, conceptually and theoretically a subset of a data warehouse although the boundaries are increasingly being blurred. This is illustrated in Figure 6.

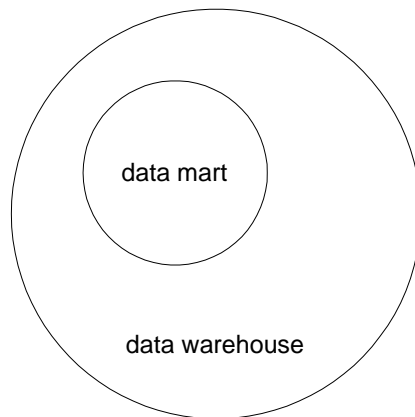

**Figure 6: Relation of a data mart to a data warehouse**

In literature, reference to a data warehouse frequently also imply reference to a data mart. Throughout the text, whenever reference to a data warehouse or data warehousing is made this must be taken to also apply equally to a data mart except where explicitly indicated otherwise.

### **3.2. Advanced Analytical Tools to Access Data Marts**

The data mart, as physically stored in the database, is not accessible to users in a user-friendly manner. In order to access the data contained within the data mart one or more front-end tools is required. Advanced analytical tools serve this purpose, namely, to “provide a graphical user interface to the data warehouse. The user will interact directly with the table structures, sometimes with a layer of abstraction to allow him or her to assign business names to the different tables and columns” (Poe *et al*, 1998:23). Berson and Smith (1997:120) confirms this view: “[t]he principal purpose of data warehousing is to provide information to business users for strategic decision making. These users interact with the data warehouse using front-end tools.” This is reiterated in a white paper of Daphnesoft (2001:78), which states that a “data warehousing solution would be imperfect without an efficient data access tool that provides business intelligence.”

According to McKinnon and Bruns (in Butcher, 1998:15) “most managers prefer to have facilities available to enable them to design their own reports or at least have someone design them with their specific needs in mind.” Similarly, Mintzberg (1975) points out, formal information systems tend to aggregate data and, as a result, a lot of the available information is too general to be of much use. Designers of systems seem to believe that data must be aggregated in order not to swamp the manager with information but in doing so the data often ceases to be of use to the individual manager” (in Butcher, 1998:15). This is illustrated in

Figure 7. Thus the term data mart refers to this complete architecture, i.e. the back-end, the data mart itself as created in the database, and the front-end tools.

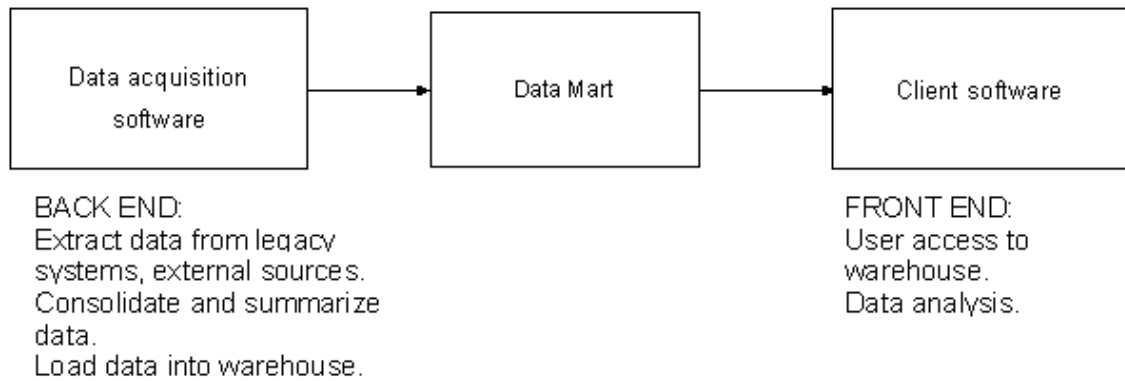

**Figure 7: Architecture of data warehouse, independent or interdependent data mart (Gray and Watson, 1998:17)**

The particular analytical tool(s) chosen depends on the nature of the user requirements. Users who fulfil different tasks have different requirements and even users who fulfil the same task may have different requirements to execute the task. Analytical tools will offer differing functionality, which will satisfy user requirements. Analytical or access tools can be divided into groups or classes based on the specific user needs each fulfils. Whilst this classification is useful for discussion purposes, it is a simplification because a single product can serve multiple purposes (Gray and Watson, 1998:123). Table 3 contains a comparison of the different classes of data warehouse access tools found in literature together with the consolidation of these classifications for use in this dissertation.

Gray and Watson (1998:123)	Berson and Smith (1997:223)	Tanler (1997:95)	Poe (1998: 233-234)	Consolidation of classifications
Queries	Reporting	Query and Reporting	Data Access/Query Tools	Query and reporting
Managed query environments	Managed query		Report Writers	
Executive information systems	Executive information (EIS)		Executive Information Systems (EISs)	
Decision support systems	On-line analytical processing	Multidimensional analysis	Multidimensional Database Management Systems [MOLAP] Advanced decision support tools	OLAP
Data mining	Data mining	Data mining (agent processing) Statistical analysis (user-directed)		Data mining

**Table 3: Comparison of classes of data mart access tools with consolidation**

This consolidation of data mart access tool classifications is discussed in detail in the sections below. It is important to note that, as Alter (1999:160) states: “the categories are not mutually exclusive ... information system categories often overlap and change as new applications combine new capabilities with old ones.” Furthermore, “Any discussion of types of information systems faces a difficult problem because categories simply won’t hold still” (Alter, 1999:160).

### **3.2.1. Query and Reporting**

The aim of query and reporting tools are to allow users to retrieve and present information from the data mart to perform some pre-defined or ad-hoc analysis.

Characteristics of query and reporting tools include:

- Define and build typical structured or standard reporting;
- Build customised reporting;
- Provide graphic capabilities to present the results;
- Support for exception reporting facilities;
- Includes both straight query tools, which allow direct access to the data itself, and managed query environments, where a metadata layer provides a business-oriented interface between the user and the data;
- Can store and reuse queries;
- Ability to support stored shared queries and to share results;
- Ability to perform consecutive queries on saved results;
- Ability to estimate and limit query size and response time;
- Ability to cancel a query;
- Provides dissemination of information, such as support for distribution of results through e-mail;
- Used to analyse metrics and business indicators; and
- Accesses summarized information with the ability to drill down.

### **3.2.2. Online Analytical Processing**

The aim of an online analytical processing (OLAP) tool is to allow users to intuitively navigate and analyse information along business dimensions, independent of the way the data is stored, and highlighting the underlying reasons or causes for business issues and opportunities. These tools are also sometimes referred to as advanced decision support tools (Poe *et al*, 1998:23). They are designed for unstructured problem solving.



Characteristics of OLAP tools include:

- Provides analysis of data including scenario, trending, time series and what-if analysis;
- Presence of traffic lighting and exception reporting facilities;
- Includes predefined, semi-structured queries allowing variable constraints on limited data;
- Includes functional or vertical applications (for example, campaign management);
- Provides guided analysis of summarised, aggregated data along a series of dimensions such as time, product, geography, etc.;
- Used in forecasting and planning;
- Allows trending, slicing, rotation or pivoting, drill down, drill through, etc.;
- Supports an iterative process most business analysts use, where asking and answering one question generates three or four additional questions;
- Presents data graphically to improve its comprehension; and
- Provides ability to comprehend massive amounts of data or data with complex interrelationships.

The functionality of OLAP tools can best be illustrated with the concrete examples in Table 4.

Function	Example
Track performance	Sales for a specific region
Provide different views	Receivables by month vs. receivables by customer
Arrange information	Top 10 account representatives

**Table 4: Examples of OLAP tool functionality**

### 3.2.3. Data Mining

Data mining is a “decision support process in which we search for patterns of information in data” (Information Discovery, Inc. 2001:198), i.e. the discovery of meaningful new patterns, relationships and trends in large volumes of data stored in a database or data mart by using pattern recognition technologies and statistical and mathematical techniques (Mattison, 2001:181). The two main types of models used in data mining are:

- Descriptive models, which describe patterns in existing data to guide decision making; and
- Predictive models, which use data with known results to explicitly predict result values for different sources of data.

According to Pelletier and Todaro, (2000:1) data mining tools are “especially important for marketing departments because marketing efforts succeeded when they single out customer segments with high profit potential” which required manually analysing large volumes of data.



### 3.3. Nature of Usage

Swift (2000) discusses the evolutionary use of a data warehouse or data mart. This use progresses through three stages, starting with reporting. Even reporting from the data warehouse to determine what happened, mostly through predefined queries, “provides new views and an ability to use combined, cross-organisational detailed data to understand the past” (Swift, 2000). The second stage of use is characterised by analysis focusing on reasons for what happened. The final and most sophisticated stage, also presenting the most competitive advantage, is predicting what will happen by means of analytical techniques. These stages are summarised and mapped against the different classes of access tools in Table 6.

<b>Stage of use</b>	Reporting	Analysis	Prediction
<b>Class of Access Tool</b>	Query and reporting	OLAP	Data mining

**Table 6: Mapping of stages of data mart use (Swift, 2000) against class of access tool**

Reporting and analysis both seek to answer questions that are historical or focused on the past whereas prediction is focused on the future. This distinction in focus can be formulated more firmly. Deductive tools support the “process of applying specific—though probably ad hoc—questions against the available data” (3Com, 2001:38) whereas inductive tools support the “process of interrogating the available data before a specific questions has been formulated” (3Com, 2001:39). Thus reporting and analysis using query and reporting and OLAP tools are deductive in nature whereas prediction using data mining tools is inductive in nature. This is summarised in Table 7.

<b>Deductive</b>	Query and reporting
	OLAP
<b>Inductive</b>	Data mining

**Table 7: Categories of end-user application classifications**

The natural progression from reporting to analysis to prediction normally takes place over time. One would expect that the simplest needs, i.e. reporting needs would be satisfied first before progressing to analytical needs and again, satisfying analytical needs before progressing to predictive needs. In line with this expectation, the most common tools in use today in organisations are query and reporting, and OLAP tools. There is, however, growing interest in the potential of data mining and statistical tools, and artificial intelligence, for example expert systems to automate increasingly decision-making with larger organisations particularly in the financial and retail industries utilising advanced analytical techniques for prediction.

In order to further illustrate the purpose and use of these tools, examples of information requirements each tool is capable of satisfying is given for two functional areas within an organisation, namely sales and marketing, and manufacturing in Table 8.

Use	Access Tool	Sales and marketing examples	Manufacturing examples
<b>Reporting</b>	<b>Query and reporting</b>	<ul style="list-style-type: none"> <li>• Weekly sales report by product by region</li> <li>• Consolidation of sales projections by product, region, and sales representative</li> <li>• Flexible access to sales data by product and region</li> </ul>	<ul style="list-style-type: none"> <li>• Weekly production report by production and operation</li> <li>• Determination of planned purchases based on a production schedule</li> <li>• Flexible access to production data by product and operation</li> </ul>
<b>Analysis</b>	<b>OLAP</b>	<ul style="list-style-type: none"> <li>• Marketing data and models to analyse and forecast sales</li> <li>• System helping insurance sales people test alternative policies</li> </ul>	<ul style="list-style-type: none"> <li>• Production data and models to analyse production results</li> <li>• System displaying current priorities for machine operator</li> </ul>
<b>Prediction</b>	<b>Data mining</b>	<ul style="list-style-type: none"> <li>• Profit generating potential of customers based on profiles</li> <li>• Product placement in retail space</li> </ul>	<ul style="list-style-type: none"> <li>• Learning patterns and sequences of faults on a production line to predict downtime</li> </ul>

**Table 8: Examples of information requirements by access tool and functional areas (based on Alter, 1999:163)**

The use of data warehousing also differs according to the industry in which it is used. The use determines the nature of the questions to be answered and will therefore determine the data mart access tool selected.

Table 9 summarises the strategic uses of data warehousing.

Industry	Functional Area	Applications / Use
Airline	Operations and Marketing	<ul style="list-style-type: none"> <li>• Crew assignment</li> <li>• Aircraft deployment</li> <li>• Mix of fares</li> <li>• Analysis of route profitability</li> <li>• Frequent flyer programme promotions</li> </ul>
Clothing	Distribution and Marketing	<ul style="list-style-type: none"> <li>• Merchandising</li> <li>• Replenishment</li> </ul>
Banking	Product Development, Operations and Marketing	<ul style="list-style-type: none"> <li>• Customer service</li> <li>• Trend analysis</li> <li>• Product and service promotions</li> <li>• Reduction of IS expenses</li> </ul>
Personal Care Products	Distribution and Marketing	<ul style="list-style-type: none"> <li>• Distribution decision</li> <li>• Product promotions</li> <li>• Sales decision</li> <li>• Pricing policy</li> </ul>
Retail Chain	Distribution and Marketing	<ul style="list-style-type: none"> <li>• Trend analysis</li> <li>• Buying pattern analysis</li> <li>• Pricing policy</li> <li>• Inventory control (maintaining exact levels)</li> <li>• Location-targeted sales promotions planning</li> <li>• Optimal channel distribution</li> <li>• Vendor pricing and performance analysis</li> </ul>
Steel	Manufacturing	<ul style="list-style-type: none"> <li>• Pattern analysis (quality control)</li> </ul>
Telecommunications	Product Development, Operations and Marketing	<ul style="list-style-type: none"> <li>• New product and service promotions</li> <li>• Reduction of IS budget</li> <li>• Profitability analysis</li> </ul>

**Table 9: Summary of strategic uses of data warehousing in selected industries (Turban et al, 2001:440), (Sharma, 1997:18)**

## University of Pretoria, etd - Ponelis, S

It is clear that data warehouses and data marts are used in variety of functional areas. The use of data warehousing, independent of the industry in which it is applied, is summarised accurately by Norris *et al* (2000:105), stating that it allows organizations to:

- Improve customer marketing;
- Streamline business operations; and
- Better understand and forecast their financial position.

Based on Table 9, the functional areas for which data warehousing is used include:

- Distribution and marketing;
- Manufacturing;
- Operations and marketing; and
- Product development, operations and marketing.

Marketing is an important area of application for data warehousing. This is confirmed by the applications for which data warehouses and data marts are used in organisations listed in Table 10.

Applications	Percent of Market (%)	Related to Sales and Marketing
Financial analysis	11	
Customer marketing	10	✓
Product performance	8	✓
Sales force analysis	8	✓
Quality	8	
Promotion/marketing campaigns	7	✓
Risk management	6	
Vendor performance/partner management	6	✓
Churn analysis	6	✓
Category management	6	✓
Market basket analysis	6	✓
Supply chain analysis	6	
Fraud detection	5	
Other	3	
Yield analysis	3	
Network/traffic pattern analysis	2	

**Table 10: Applications for which data warehouses and/or data marts are used (Palo Alto Management Group, 2001:278)**

The functional area that is particularly dominant is marketing, listed for each of the industries, and with more than 50% of the applications of sales and marketing-related focus (indicated in Table 10), which accounts for 57% of the market. According to Turban *et al* (2001:452) the data warehousing applications with the highest impact are found in the area of marketing.

According to a study by Palo Alto Management Group (2001:281), the most prominent driving forces for investing in data warehousing and related solutions are to:

- Improve the decision and/or management processes;
- Satisfy the need to maintain a competitive edge;
- Reduce the operating costs;
- Improve customer service;
- Retain customers; and
- Identify new customers.

Among these most prominent driving forces customers feature prominently—integral to the sales and marketing function. The importance use of data warehouses are echoed by Schroek (1998), who comments that the positive impact of marketing data warehouses “can be measured as the ability to:

- Attract new customers through target marketing;
- Retain “at-risk” customers through advanced churn analysis, letting companies take action before losing customers;
- Reduce costs through fraud detection programs;
- Provide better customer service by collecting all customer activity and making the information available; and
- Improve financial results through detailed customer and product profitability analysis and activity-based management.”

Tanler (1997:7) states that “[m]arketing data warehouses are designed to allow users to evaluate the business performance of a product or service from multiple perspectives.” According to Sharma (1997:17), the increase in sales revenue by leveraging detailed data was “initially the dominant factor, accounting for 80% of the motivation to invest in data warehousing. ... Only 20% of the motivation was process-oriented (in other words, the business need for more detailed information is to support operations).”

According to the definitions, a subject-specific data warehouse is a data mart. Therefore, referring to a marketing data warehouse is, by definition, a contradiction. The author suggests that it could rather be called a customer-centric data warehouse within this context where the entire data warehouse is focussed entirely on customers. For example, a marketing data mart may be limited to customers, items, and sales (Han and Kamber, 2001:67).

Organisations worldwide are using data warehousing solutions to “achieve strategic advantage by gaining better and more timely access to information about their business, products, customers and competition” (Schroeck, 1998). Examples illustrating the use of data warehousing solutions are:

- “A pharmaceutical company analyses the results of its recent sales force activity to improve targeting of physicians who should be first contacted; it also determines which marketing activities will have the greatest impact in the next few months. The data include competitor market activity as well as information about the local health care systems. The results are distributed to the sales force via the Internet, intranets, or a private wide-area network that enables the representatives to review the decision-making recommendations” (Turban et al, 2001:455).
- “A large consumer package goods company applies data mining to improve its sales process to retailers. Data from consumer panels, shipments, and competitor’s activity are examined to understand the reasons for brand and store switching. Through this analysis, the manufacturer can select promotional strategies that best reach its target customer segments” (Turban et al, 2001:455).
- “Supermarket chains regularly analyze reams of cash register data [normally referred to as point-of-sale or POS data] to discover what items customers are typically buying at the same time. These shopping patterns are used for issuing coupons, designing floor layouts and products’ location, ... and creating shelf displays” (Turban et al, 2001:454).
- “Many manufacturing companies, including Polaroid, and retail organizations, such as Target Stores, have very sophisticated product data warehouses that are designed specifically to support their marketing operations. Both organizations are attempting to improve total product sales by improving the quality of the information available for the thousands of decisions that are necessary to continuously improve the marketing of products in dynamic and highly competitive businesses” (Tanler, 1997:7-8).

Furthermore, Tanler (2000) indicated that data warehouses must operate outside the boundaries of a single enterprise and that “extending the boundaries of data warehousing ... has the potential to change the rules for how a company operates and competes.” Thus, a data warehouse or data mart can play an important role in making data received from channel partners available to users. When data is sourced from channel partners, i.e., the data source is located outside of the organisation’s boundaries, there are a number of options for integrating this data into the organisation’s information systems.

### 3.4. Using Data Provided by Channel Partners

Given the requirement for integration between different organisations discussed in **Error! Reference source not found.** and the types of systems discussed in this chapter, there are a number of possible options for the inclusion of data received from channel partners involving either the operational or analytical, i.e., the data warehouse or data mart, systems or both. This discussion on the use of data provided by channel partners is particular to a third party logistics provider, such as a distributor, providing data to a manufacturing organisation.

The generally ideal, theoretically acceptable model is for data from the distributor's operational system to be interfaced into the manufacturer's operational system. There can be no analytical system at either organisation implying the use of operational reporting capabilities or an analytical system at either or both organisations which is populated with data from the operational systems. This is depicted diagrammatically in Figure 9. A critical component of this option is the "alignment is the existence of open-system computer architectures that provide for the seamless interlinkage of business systems with other enterprise operational system, thereby unifying the marketing, production, and distribution activities of the entire supply channel" (Ross, 1998:53).

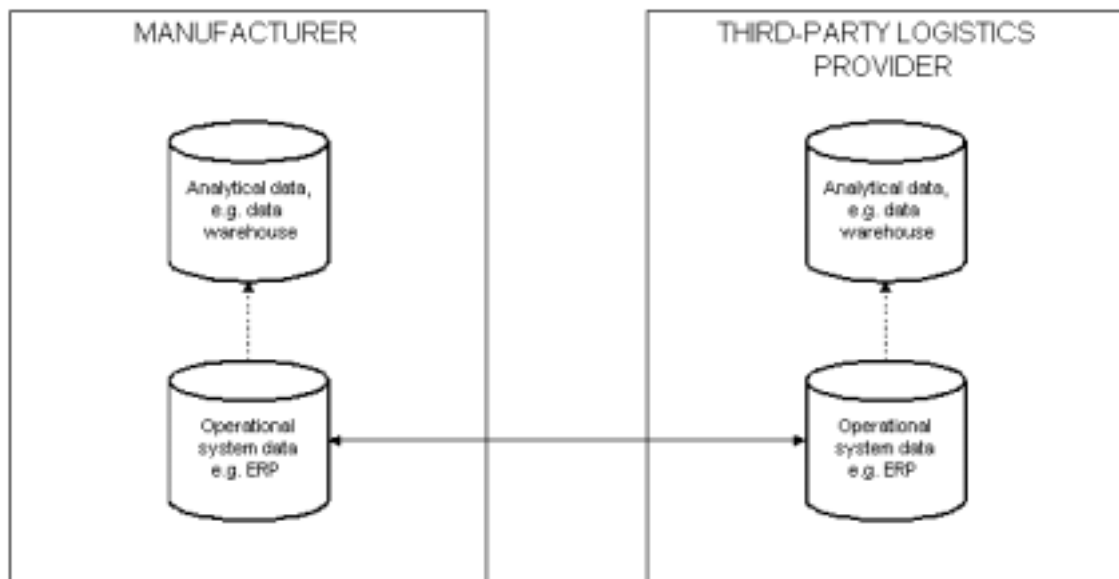
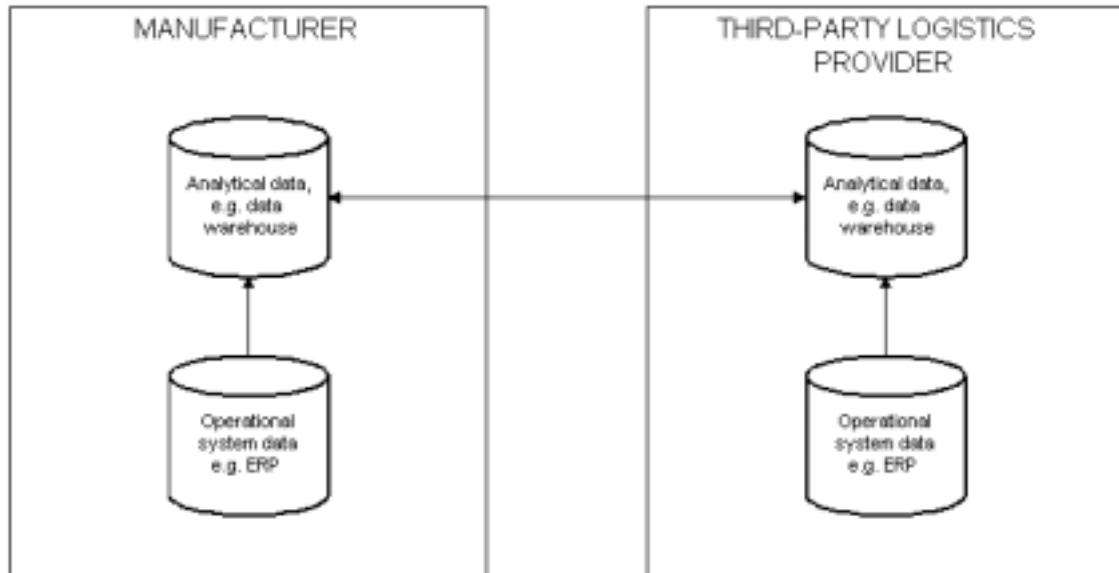

**Figure 9: Data flow between organisations' operational systems**

The second option is, rather than exchange data at the operational level, to exchange data at an analytical level. Here the data used for management information purposes only is interfaced, generally by means of the use of metadata through, for example, XML. This is depicted diagrammatically in Figure 10. This



option can exhibit some of the operational functionality of the first option if data is fed into the operational system(s) from the analytical system.



**Figure 10: Data flow between organisations' analytical systems**

The third option is for the operational data from the data from the third party logistics provider to be fed into the analytical system of the manufacturer. This is depicted diagrammatically in Figure 11. Although the first two options above are theoretically acceptable and clean solutions, this option is a hybrid solution not found in literature, either academic or trade. However, this option does occur in practice. The 3PL's operational system is treated as a source system similar to the manufacturer's in-house operational systems rather than having to include the data in an in-house operational system first.

In order to illustrate the use of data marts within this context further, the next chapter examines two case studies in the pharmaceutical and branded consumer products industries where data originates in systems outside the organisational boundaries utilising the third option, namely the hybrid solution, to utilise data sourced from a channel partner, namely a third party distributor.

### 3.5. Chapter Conclusion

The data warehouse, specifically the marketing data mart, by its very nature, is the repository where customer data are integrated from where it is analysed. A data mart is accepted to be a departmental and/or subject-specific data warehouse with a shorter implementation timeframe than a data warehouse of 3 to 6 months. Data marts were previously defined by its size but this is no longer generally accepted. The attraction of data marts lie in this rapid development, as it is a less costly alternative to the data warehouse to provide a subset of enterprise data to users. Data marts can either be dependent on a data warehouse as a

data source or independent, receiving its data from one or more operational systems. A data mart also encompasses one or more access tools, which allows end-users to access the data contained in the data mart

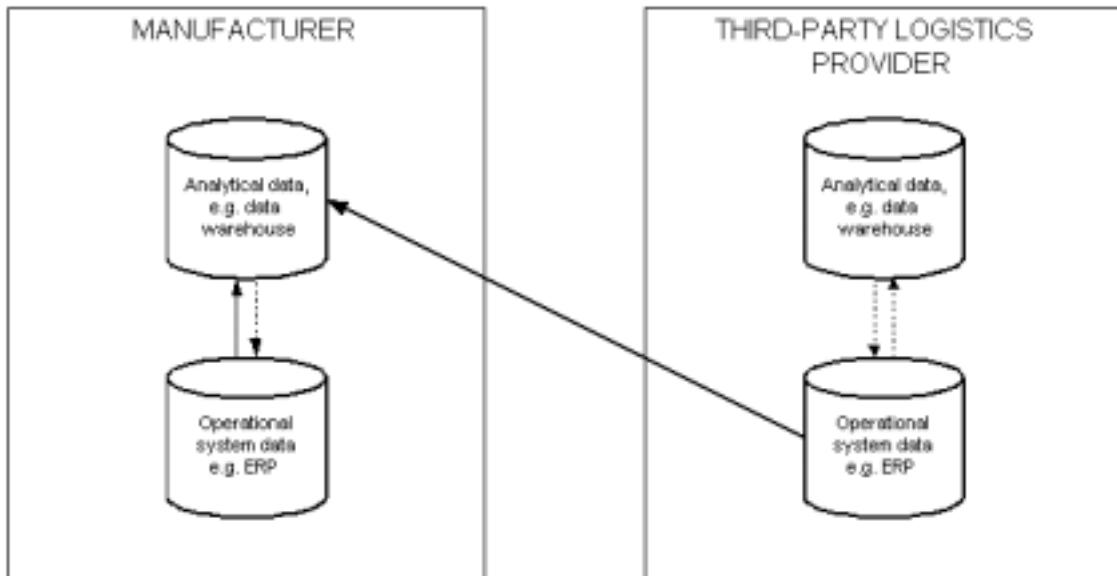

**Figure 11: Data flow from one organisation's operational system to another's analytical system**

database. These access tools can be divided into one of three main categories, namely, query and reporting, OLAP, and data mining. Each of these categories serves a particular purpose in delivering management information. Data warehouses and data marts are predominantly built for sales and marketing applications. In addition, data warehouses and data marts can play a vital role in making the data received from channel partners available in an organisation.

## CHAPTER 4 USE OF DATA MARTS IN MANUFACTURING ORGANISATIONS WITH THIRD PARTY DISTRIBUTION

*“The map is not the territory.”*

*- Alfred Korzybski*

Two medium-sized manufacturing organisations developed data marts for a very similar purpose: to integrate and make accessible to managers management information based on data received from third party distributors. The aim of this chapter is to:

- To describe why and how manufacturing organisations using third party distribution used data marts to deliver sales and marketing management information in two industries, namely, fast moving consumer goods (FMCG) and pharmaceuticals.

The first case study is a data mart implementation for a FMCG organisation, specifically branded consumer goods, which took 4 months to complete. The second case study covers a data mart implementation for a pharmaceutical organisation, which took 6 months to complete. The disparity in timeframes is due to the increased complexity of requirements of the second organisation. The database design, i.e. the logical and physical data models are excluded from the case studies as these are outside the scope of this dissertation. Furthermore, please note that no reference is made to particular products since the purpose of this dissertation is not to address the selection of a particular vendor but rather to identify the type of access tool required based on the users' information requirements (vendor and tool selection follow once the appropriate tool(s) is identified.)

The structure of the discussion of each these case studies is:

- Overview of the external environment in which the manufacturing organisation functions by means of industry-specific issues in order to contextualise the case study, particularly since the case studies differ with respect to industry, and the nature of their respective competitive environments as stated in Chapter 1;
- Overview of the particular organisation, the internal environment, including the motivation for selecting a data mart as the choice of solution;
- Sales and marketing management information requirements;
- Data sources, both internal and external; and
- Qualitative assessment of the data mart solution in terms of the delivery of the required management information and the impact on the organisation by members of the user community.

The case studies will be compared and evaluated in the concluding chapter.

## 4.1. Case study 1: Branded Consumer Products Industry

### 4.1.1. Overview of the Branded Consumer Products Industry

The branded consumer products (BCP) industry encompasses a wide variety of organisations that compete intensely in a number of segments. The organisations in this industry distinguish themselves from other manufacturers of consumer goods by their ability to obtain premium pricing for their branded products hence the name *branded* consumer products. The industry can be divided into the following segments:

- Packaged foods;
- Meat, produce and other fresh foods;
- Alcoholic beverages;
- Non-alcoholic beverages;
- Apparel and accessories;
- Non-durable consumer packaged goods; and
- Durable consumer packaged goods.

In order to be successful, BCP organisations must perform well at the following processes (Arthur Andersen, 2000):

- Managing the brand;
- Understanding the market and customers; and
- Managing the supply chain.

#### 4.1.1.1. Managing the Brand

Most of the leading organisations in the industry believe that the best way to sustain profitable growth is to maintain a portfolio of exceptional brand name products. Brands are built over time through advertising and promotion. Ettenberg (*Who's wearing the trousers?*, 2001), who focuses particularly on the importance of branding in an online environment, is of the opinion that marketing has not kept pace with the changes in other organisational functions, i.e. the internal environment, or the marketplace, the external environment. The rules of marketing continue to focus on the product and where to sell it, rather than the customer. The new approach to marketing needs to be on building a brand rather than a product—to sell a lifestyle or a personality, or to appeal to emotions—because brands are a conduit through which influence flows between organisations and customers and consumers. Increasingly it will be the consumers that dictate to organisations and ultimately decide their fate, rather than the other way round.

In a study of premium brands, Vishwanath and Mark (1997:123) found that although “[c]onventional wisdom holds that market share drives profitability” this view is not completely accurate. They found that market share alone does not account for the profitability of a brand. Instead “a brand’s profitability is driven by *both* market share *and* the nature of the category ... if a category is composed largely of premium brands, then most of the brands in the category are – or should be – profitable. If on the other hand, the category is composed mostly of value and private-label brands, then returns will be lower across the board” (Vishwanath and Mark, 1997:124).

In recent years, however, brand loyalty has been increasingly threatened by the consumer orientation toward shopping for value, along with the improving quality of private label or store branded goods. Retailers may also be more inclined to promote their private label over brand names, and be more experimental and less committed with new products; in fact, retailers’ own brands are increasingly “being used as a marketing tool and a point of leverage against branded manufacturers” (From mass to class, 2000:35). To warrant higher prices for premium brands, BCP manufacturers need to distinguish themselves in the consumer’s mind as having superiority by maintaining high-quality products and better packaging than retailers’ own brands. However, BCP organisations may not have access to retailers’ real-time, internal data placing them at a disadvantage in analysing the market.

In future, BCP manufacturing organisations will streamline their brand assortments, creating leaner but more powerful portfolios. As a result, the remaining brand assortments will be stronger and better funded; thus, marketing efficiency will increase as the effort will be concentrated on the best performers, and organisations can better invest in building customer relationships as funding will no longer be as fragmented. In order to build customer relationships BCP manufacturers require an understanding of the market in which they operate and the customers which they serve and/or target.

#### 4.1.1.2. Understanding the Market and Customers

While many BCP manufacturers face similar challenges associated with managing their brand and understanding their consumers, many of the most critical issues that these organisations must contend with are driven by their retail customers. As retailers consolidate, develop and disappear, BCP manufacturers are required to continually cater to the demands of the increasingly powerful retailer customers (Vivier, 2001). An example of the effect that retailers have on manufacturers is illustrated by the following example: Procter & Gamble, a major US-based manufacturer, recently shifted their focus from end-consumers in order to “focus on managing explicit knowledge about key retailer chains [such as Wal-Mart, a well-known retailer in the United States] as customers” (Davenport *et al*, 2001:65) because of “their growing concentration and power” (Davenport *et al*, 2001:64).

Retailers are increasingly demanding value-added services such as specialised packaging, and specific promotional materials. Manufacturers are under intense pressure to execute precisely according to retailer requests or risk back charges and loss of prime shelf space. Manufacturers are also being forced to assume greater responsibility for the supply chain's inventory as retailers expect more frequent, smaller deliveries and vendor-managed inventory programmes. This, together with the other costs incurred such as, for example, sales force effort, is called trade spending (Randall, 1994:78).

Marketing to the retail and distributive trades, i.e., the promotion of products to sellers of products as opposed to the actual consumers of products, is called trade marketing. Spending on trade marketing continues to increase and manufacturers are frustrated by the inability to measure and manage its effective use. The trade payments that manufacturers make to retailers are often just hidden price concessions with only about half of the total payment earning something definite, such as shelf space. Manufacturers are rethinking the use of trade spending, trying to identify a way to ensure that price concessions reach consumers.

Manufacturers are trying to understand account-level profitability to ensure that trade spending is used effectively. According to Brooke and MacTavish (2001) many BCP organisations “spend an average of 13 percent of revenue on promotions and are questioning whether these promotions are effective.” Furthermore, the implementation of promotional management applications will allow organisations to “regain control of these [promotional] activities and maximize the return on trade spending” (Brooke and MacTavish, 2001). Accurate sales and demand forecasts will support more effective trade spending, which will reduce costs, and result in increased profitability. Although understanding the market and customers, particularly retail customers, is vital to success in the marketplace, the flow of products from manufacturer to retailer, or the supply chain, must also be managed efficiently.

#### 4.1.1.3. Managing the Supply Chain

Organisations that obtain and maintain their competitive edge in the market will be those excelling at managing the supply chain, where products and services are provided to customers at the least total landed cost, in very short lead-times, with the highest quality and service rates. Thus, organisations will face more management and coordination issues, and will need to make effective use of their systems and software in order to manage strategic partnerships within a supply chain (Rogers, 2000:44-45). Furthermore, organisations will need to align fulfillment efficiently in order to meet demand and eliminate out-of-stock situations. Out-of-stock situations continue to rise because of poor demand and promotion forecasting, communication, and coordination between retailers and suppliers. This leads to lost revenue and lost market share by eroding consumer loyalty and forcing defections. Therefore, BCP manufacturers and retailers are looking to collaborative techniques to better forecast demand and minimise the occurrence of out-of-stock situations (Inventory management: leveraging the supply pipeline, 2000). BCP organisations

will continue to increase focus on integration and to increase responsiveness with respect to both suppliers and retailers, referred to as supply chain optimisation, by integrating with supply chain partners' back-end systems (Achabal *et al*, 2000: 430-454), .

All these efforts of better managing and integrating the supply chain creates the need for a closer and stronger relationships between BCP manufacturers and retailers, who will favour larger BCP manufacturers because they can invest more in the infrastructure required (Frederick, 2000:10). These relationships are particularly important due to the requirement for increased sharing of data (Mentzer *et al*, 2000: 549).

The common and central issue arising from these three processes is that retailers are becoming more powerful in the retailer-manufacturer relationship because the retailers control access to the consumer, and to the data captured during the interactions with these consumers. Instituting collaborative relationships and agreements with retailers will allow manufacturers to regain some control of the manufacturer-retailer relationship. This collaboration would also have several desirable results:

- Improved data maintenance and synchronisation;
- Improved promotion management; and
- Visibility to forecasting information processes.

#### 4.1.2. Context of the Branded Consumer Products Organisation

A listed South African-based BCP organisation has several subsidiaries, one of which manufacture packaged foods that require refrigerated storage. The manufacturer has an agreement with a third party distributor, which provides chilled and frozen storage from 13 national depots, to warehouse and distribute finished goods. The organisation's major customer group is retailers, for example, supermarkets, hypermarkets, convenience stores, etc. Retailers obtain products either:

- Through the third party distributor; or
- Direct procurement from organisation's factory premises.

This flow of products from the BCP manufacturer down the supply chain is illustrated in Figure 19.

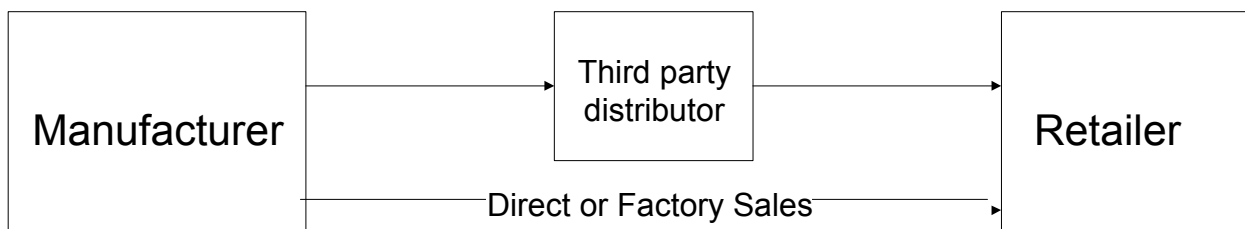

Figure 19: Flow of products from the Branded Consumer Products manufacturer

Orders are entered on the manufacturer's system where after orders are uploaded onto the distributor's system. Factory sales directly to customers without any involvement from the distributor are also recorded in the manufacturer system. The distributor is responsible for:

- Warehousing finished goods in chilled depots;
- Performing physical distribution;
- Producing invoices, goods received notes; and
- Maintaining master data for customers and products, together with pricing data.

Historically, this business unit was part of another, larger organisation. However, a part of this larger organization was sold to another organisation, which is now in direct competition with this business unit of the BCP manufacturer. Prior to this separation, a legacy single sales reporting system with data in a single database was used. By mutual agreement after the split the single reporting system continued to be used by both organisations. This is a rather unusual situation since both competitors have access to each other's sales data.

The BCP manufacturer decided to replace its portion of the sales reporting system with a stand-alone system in order to:

- Remove the data and reporting function off the system shared with its competitor and relocate the new system to the head office of the manufacturer located in another city; and
- Allow better access to the data. Users did not have direct access to data and had to request reports from one person who was frequently unable to respond in a timely manner due to the workload. This required user training in the reporting tool but also a change in mindset, as they were now responsible for satisfying their own reporting needs.

The organisation intended to expand the solution to include other strategic business units in the sales and marketing functional area and to expand to other functional areas. Given this requirement, the decision was made to build an independent data mart with a focus on the sales and marketing functional area, which was to be the first in a series of interdependent data marts which would then result in a distributed data warehouse. The particular sales and marketing data mart solution requirements are discussed in the next section.



### 4.1.3. Sales and Marketing Data Mart Solution Requirements

The requirements for the sales and marketing data mart were determined by means of interviews. The data gathered on the sales and marketing data mart solution requirements through these processes are discussed in this section as follows:

- User community;
- Management information requirements;
- Data mart access tool requirements; and
- Nature and sources of data used to populate the data mart.

#### 4.1.3.1. User Community

The user community for the sales and marketing data mart consists of members of senior and middle management. The members of senior management that require sales and marketing-related management information are:

- Financial Director; and
- Sales and Marketing Director.

The members of middle management that require sales and marketing-related management information are:

- Regional Sales Managers; and
- National Account Managers.

A non-exhaustive list of the primary responsibilities, which require sales and marketing-related management information, is contained in Table 16 by position.

Position	Principal responsibilities, including but not limited to:
Financial Director	<ul style="list-style-type: none"> <li>• Design, develop and implement financial strategy.</li> <li>• Report and analyse financial results.</li> <li>• Provide insight and recommendations to the Managing Director.</li> <li>• Report to the holding company.</li> </ul>
Sales and Marketing Director	<ul style="list-style-type: none"> <li>• Develop product lines that meet customer's needs.</li> <li>• Evaluate market trends to develop strategies to better the organisation's position in the marketplace.</li> <li>• Generate forecasts and develop overall product strategies to maximize market share and profit and loss position.</li> <li>• Deliver sales results to meet budgeted targets.</li> <li>• Meet all expense budgets.</li> <li>• Along with Financial Director, devise the annual and quarterly compensation programs for sales force.</li> <li>• Develop specific programs and assist sales force in implementing these programs.</li> </ul>

	<ul style="list-style-type: none"> <li>• Establish pricing guidelines on a product-by-product basis.</li> <li>• Develop successful business and profitability plans using accurate forecasting and market coverage.</li> <li>• Responsible for Regional Sales Managers' and National Account Managers' sales activities.</li> </ul>
Regional Sales Managers	<ul style="list-style-type: none"> <li>• Analyse regional market penetration and travel logistics and implement programs to achieve optimal territory coverage.</li> <li>• Co-ordinate and monitor sales representative pull through among targeted providers.</li> <li>• Provide accurate forecasts to Regional Sales Director of predicted revenue levels.</li> <li>• Investigate the accuracy and validity of account plans and assumptions presented by the sales force.</li> </ul>
National Account Managers	<ul style="list-style-type: none"> <li>• Meet and/or exceed sales goals for assigned regional.</li> <li>• Execute national account promotions.</li> <li>• Develop, recommend and implement consumer sales and marketing initiatives for accounts to market and price products within the industry.</li> <li>• Manage the relationship with key suppliers.</li> <li>• Co-ordinate trade marketing reviews with key accounts.</li> </ul>

**Table 16: Principal responsibilities by position in the BCP manufacturing organisation**

In order to fulfil the responsibilities listed in Table 16, which are primarily focussed around decision-making and assessment of performance, accurate management information is required. The management information requirements resulting from these users are discussed in the following section.

#### 4.1.3.2. Management Information Requirements

Based on interviews conducted with the senior members of the user community, the minimum user acceptance requirement for the sales and marketing data mart was the replication of the existing standard management reports (see *Appendix A: Management Reports required by the BCP Organisation* for a more detailed description of each report):

- Daily sales report by customer by product by region;
- Trade marketing – spend vs. sales by major customer;
- Sales by region and by product;
- Customer ranking by value and volume;
- Channel distribution analysis (direct or factory sales versus normal sales, i.e. through the third party distributor);
- Invoiced sales versus returns (credit notes) analysis;
- Product promotions, including location-targeted sales promotions planning;
- Retailer pricing and promotional reviews;
- Rebates analysis;
- Profitability analysis, both for customers and products; and
- Stock on hand by depot.

The following remarks are pertinent to the management information requirements:

- Users are accustomed to having standard reports available, that is, reports that are pre-defined in the system which they only need to open and/or run or even receiving paper-based reports on a regular basis. One of the main benefits of data mart access tools is that users are able to construct their own reports based on their information need at a particular time.
- The standard management reports prior to implementation of the data mart contained year-to-date and month-to-date figures with year-on-year comparisons as well as budget versus actual comparisons, also referred to as gap analyses.
- Reports were produced by manipulating data extracted from the legacy system in PC-based spreadsheets: additional data were captured manually in the spreadsheets that were not available in the existing reporting system; year-to-date figures were calculated as these were not available in the existing reporting system; and reports were formatted according to user specifications.

#### 4.1.3.3. Data Mart Access Tool Requirements

Based on the management information reporting requirements, the data mart access tool requirement can be determined. This is detailed in Table 17.

Management Information Requirement	Stage of Use	Nature	Data Mart Access Tool
Daily Sales	Reporting	Deductive	Query and Reporting
Sales and Marketing	Reporting	Deductive	Query and Reporting
Trade Marketing	Reporting	Deductive	Query and Reporting
Sales by Region	Reporting	Deductive	Query and Reporting
Sales by Product by Region	Reporting	Deductive	Query and Reporting
Ranking of Top 30 Customers	Reporting	Deductive	Query and Reporting
Direct vs. Normal Sales	Reporting	Deductive	Query and Reporting
Sales vs. Returns	Reporting	Deductive	Query and Reporting
Promotional Review	Reporting	Deductive	Query and Reporting
Rebates	Reporting	Deductive	Query and Reporting
Customer Profitability	Reporting	Deductive	Query and Reporting
Product Profitability	Reporting	Deductive	Query and Reporting

**Table 17: BCP manufacturer’s data mart access tool requirements**

The sources of data used to meet these management information requirements are reviewed in the following section.

#### 4.1.3.4. Sources of Data

Based on the management information requirements, the sources of data to be used to populate the data mart were determined. The sources listed are according to whether the data originate within or outside of the organisational boundaries.

### Internal Data Sources

The internal sources of data are:

- Budgets, created and stored in spreadsheet format;
- Pricing data; and
- Orders.

### External Data Sources

The distributor uses an in-house developed system for operational and financial purposes. The manufacturer also used a reporting system based on the same technology with data residing in a fixed length indexed file structure, i.e. not in a relational database. There were no relationships between these files, but the files are linked by means of look-ups in the indexes. These data files were updated daily after download via FTP of a data file generated by the distributor.

The BCP manufacturer downloads the following data in flat files from the distributor via FTP (see *Appendix B: Layout of files received by the BCP organisation from the third party distributor (3PL)*):

- Invoices issued on the previous day;
- Customer master data of additions and modifications;
- Product master data of additions and modifications;
- Stock levels in the respective depots;
- Distributor channels;
- Distributor customer groupings; and
- Audit or balancing figures of cumulative daily sales balances.

Of these files received, the external sources of data used to populate the data mart are:

- Invoices issued on the previous day;
- Customer master data of additions and modifications;
- Product master data of additions and modifications; and
- Stock levels in the respective depots.

The balancing report is used to ensure correct upload of data into the database. The manufacturer wanted to capture additional data particular to its operations on both the customer and product master data. This required a custom-developed application. The volume of sales transactions is approximately 600 to 800 transactions per day. The distributor-related files were not used, as these are specific to the third party distributors system. Although it is not common practice, the manufacturer does not match or reconcile

orders and invoices and/or credit notes; as a result the data mart does not use or supply data to the internal operational financial system.

Given the sources and requirements of the data mart, the flow of data to deliver management information through a data mart is depicted in Figure 20.

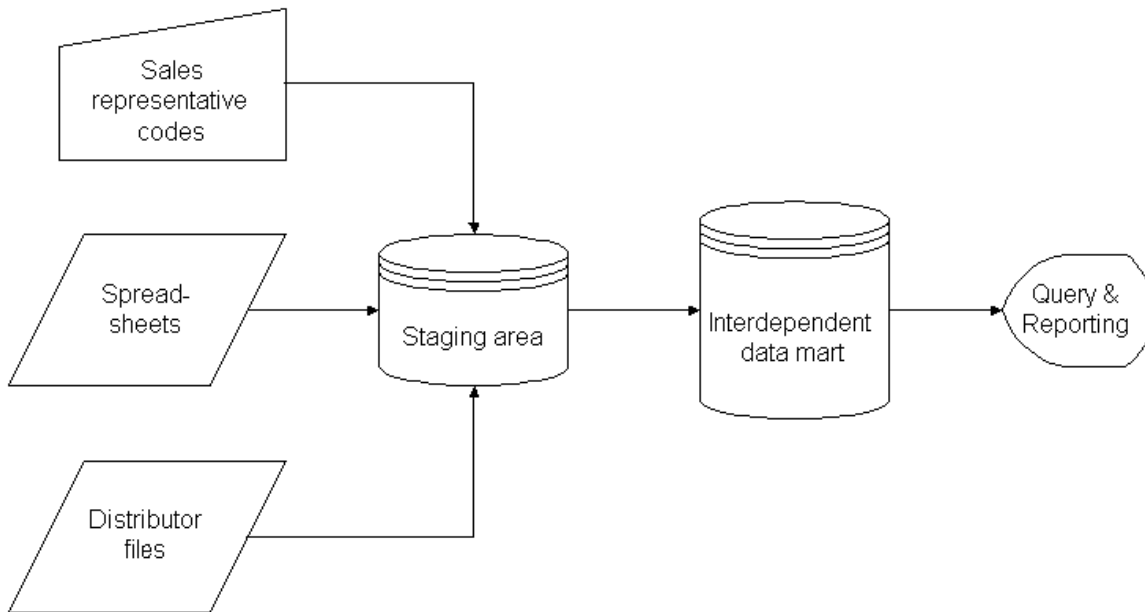

**Figure 20: Data flow surrounding the data mart in the BCP case study**

#### **4.1.4. Assessment of the Use of the Sales and Marketing Data Mart**

The assessment of the sales and marketing data mart after completion of the implementation as a management information delivery mechanism is that it led to significant improvements in the manufacturing organisation. Previously users had to request management information from a single person with access to a legacy system, which presented a significant bottleneck, as it was a time consuming process to communicate requirements and then time consuming to produce ad hoc reports. This has been eliminated with users preparing their own reports when required allowing more flexibility (Robson, 2000). However, users required significant training to become accustomed to using the system themselves to meet their information requirements.

The system has helped to improve information flow in the organisation. The BCP manufacturer has been able to increase its sales through improved targeted trade marketing and monitoring of the outcome. Sales improved as well as forecasting accuracy and sales representatives were better prepared for sales visits (McLachlan, 1999).

## 4.2. Case study 2: Pharmaceuticals Industry

### 4.2.1. Overview of the Pharmaceuticals Industry

The standard definition of the pharmaceuticals industry is the manufacture of drugs used to affect the body chemistry of both humans and animals. In practice, a wider definition includes (SSA, 2000):

- *Ethical pharmaceuticals* are named drugs based on chemical or biological technology that addresses a specific disease under patent. These drugs are normally prescribed by a doctor and are known as Prescription only Medicines (PoMs).
- *Generic drugs* are drugs as above whose patents have expired and which are chemically identical substances made by a variety of producers, for example, penicillin. These drugs are generally also PoMs.
- *Over-the-counter (OTC)* medicines often started as ethical pharmaceuticals. Over time they became recognized as safe for self-medication, for example, aspirin.
- *Nutritional supplements*, specifically vitamins and minerals, form a high-volume sector of the pharmaceutical industry. They are most commonly sold over the counter and are often combined with OTC active substances – for example, cold and flu remedies contain Vitamin C and paracetamol.
- *Medical devices* include drug delivery systems (inhalers, etc.), vision care products, high-volume consumables such as wound dressings, needles, sutures, and catheters. Sterilisation is often a crucial part of the production process.
- *Medical diagnostic equipment and re-agents* includes equipment for injecting blood products into the blood stream, and
- *Blood products and supplements* include plasma, saline and other types of drip, nutritional supplements injected directly into the bloodstream, and ancillary equipment.
- *Animal health drugs* market can be subdivided into agricultural and domestic pet sectors. For example, broiler chickens routinely are fed antibiotics throughout their lifetime.
- *Speciality chemicals* include chemicals manufactured for use in drugs, food additives, etc.

Pharmaceutical organisations are engaged in the discovery, development, manufacture, distribution and sales of products in one or more of these areas. The pharmaceuticals industry is facing major changes in its environment (Lurquin, 1996:6) resulting in a number of critical business issues currently facing organisations:

- High degree of regulatory influence;
- Product liability issues;

- Emerging customer and consumer power;
- Increasing cost pressures; and
- Patient privacy.

#### 4.2.1.1. High Degree of Regulatory Influence

The pharmaceuticals industry is among the most heavily regulated of industries because of the potential for damage to the human body. Accordingly, the health care industry is forced to adopt a strategy of compliance with standards, such as Good Manufacturing Practices (GMP), Good Laboratory Practice (GLP) and Good Clinical Practice (GCP). For example, GMP mandates standards for activities, such as record keeping, Standard Operating Procedures (SOPs), lot traceability, and cleanliness. Organisations using enterprise systems must ensure that the software supports lot traceability, formulation integrity, inventory recording, amongst others. These standards are created and enforced on a national or regional basis. Non-compliance can lead to the withdrawal of licenses to manufacture a product.

Regulatory compliance to regulatory standards is a costly and increasingly requires organisations to divert valuable resources from their primary undertaking to compliance-related activities: “industry estimates indicate that up to 70% of laboratory resources ... are now devoted to compliance-related activities” (Zenie and Halpin, 2000:12). The strengthening of regulatory requirements both in terms of new products efficacy and manufacturing leading to escalation of costs as well as longer lead-time for change implementation.

The regulatory agencies worldwide have been placing more and more emphasis on computer systems’ validation over the past five years. The United States’ regulatory agency, the Food and Drug Administration or FDA (Food and Drug Administration, 2000:45), defines validation as follows:

*“A documented program that provides a high degree of assurance that a specific process, method, or system will consistently produce a result meeting pre-determined acceptance criteria.”*

Regulatory agencies now routinely demand documentary evidence that drug production software has been validated. Validating an enterprise system can be costly and add months to an implementation schedule. The ability to electronically acquire data at the source and store in a secure and compliant database will save time and costs over the manual review, and capture of data from paper-based sources into systems which commonly in practice today (Zenie and Halpin, 2000:14).

#### 4.2.1.2. Product Liability

In the event of a product recall, it is critical for pharmaceutical organisations to easily and quickly obtain a complete history of all information regarding a particular lot of product. Not only is it important to find out

where a product has been shipped, i.e. the customer(s), but also to know the lots of the raw materials used in the production process. This is closely linked to the regulatory process. Apart from the regulatory and product liability issues, the pressure from the customer and consumer is exerting increased influence.

#### 4.2.1.3. Emerging Customer and Consumer Power

In the past, the pharmaceutical organisation's main customers<sup>2</sup> were general practitioners (or GPs) who were responsible for the purchasing decisions although there are certain products where the purchaser may have been a hospital specialist. The possibility of generic and therapeutic substitution by a pharmacist, the growing power of medical aid and insurance organisations, prescribing committees and the awareness of patients themselves is now altering this. This change in the customers of the pharmaceutical manufacturers will have a major impact on the supply chains of pharmaceutical companies (Booth, 1996:6). As a result, many pharmaceutical organisations have increasingly been using direct consumer advertisements to market their drugs with the intention that consumers will ask their general practitioners or other medical services provider about a particular drug in order to build up brand preference with customers and consumers. Since most patients are reimbursed for the bulk of their drug purchases by third parties such as medical aids or managed healthcare organisations, price is not an issue to the consumer. However, these third parties are now applying pressure to lower the cost of drugs. Customers as patients are also entitled and increasingly aware of their right to privacy regarding their medical information which limits the possibility of utilising CRM by limiting the customer data legally available to organisations.

#### 4.2.1.4. Increasing Cost Pressures

Health care in most countries is changing. Managed care continues a strong growth in addition to all the issues associated with government-provided care. In many cases, this means managed healthcare organisations is placing enormous pressure on pharmaceutical organisations to reduce costs and increasingly is considering generic substitutes and buying-group influence. In addition, developing countries' governmental health authorities are attempting to contain expenditure by demanding concessions from pharmaceutical manufacturers for certain drugs, particularly anti-retroviral drugs, either at cost price or free on moral grounds and with reference to human rights. (Kirkman, 2001). In addition, the advent of substitution with generics (see 4.2.1.3. ) further threatens ethical pharmaceutical organisations' traditionally high levels of profitability.

Furthermore, the price of medicine is a function of distribution costs (Kirkman, 2001). Reducing costs by ensuring effective and efficient distribution translates either in price decreases for the customer or increased profit margins for the manufacturer or a combination of both.

---

<sup>2</sup> The term *customer* is used to refer to the more immediate purchaser, whether physician, pharmacist or hospital, and the term *consumer* is used to describe the end-user of the product.



#### 4.2.1.5. Patient Privacy

By law pharmaceutical organisations are not allowed access to patient details with regard to prescribed drugs, as this would infringe on their right to privacy with regard to medical information. This issue has recently gained prominence amongst the public in South Africa due to the legal requirement for confidentiality of a person's HIV/AIDS status. As a result, this places a limitation on the possible CRM programs that pharmaceutical organisations can develop.

#### 4.2.2. Context of the Pharmaceutical Organisation

The pharmaceutical organisation manufactures generic and OTC drugs. The organisation is a subsidiary of a multinational pharmaceuticals organisation, which manufactures ethical pharmaceuticals, nutritional supplements, medical devices, medical diagnostic equipment and re-agents, blood products and supplements, animal health drugs, and speciality chemicals.

The pharmaceutical organisation uses a distributor, which is jointly owned by 12 pharmaceutical manufacturing organisations, to warehouse and distribute finished goods in 5 national warehouses and handle all order entry-related activities. The distributor sells both directly to its customers, mostly hospitals, clinics, pharmacies and doctors in the private and public sector, and also to wholesalers who then sell to these and other customers. Customers can be located nationally or internationally. Whilst the distributor handles the majority of the sales, the manufacturer occasionally sells raw materials directly to customers or exports directly to customers due to the pricing of the distributor. This is depicted in Figure 21.

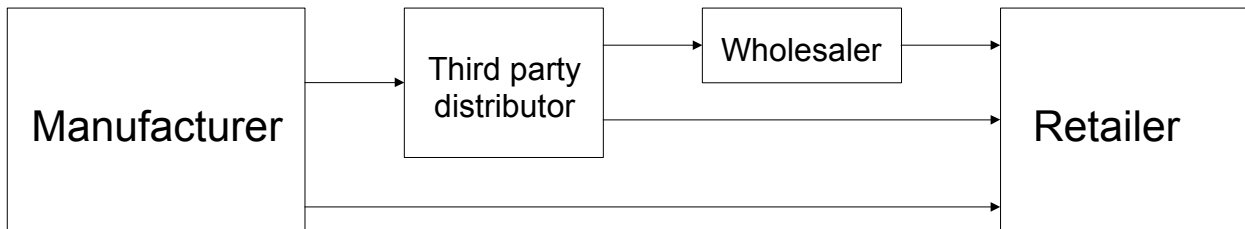

**Figure 21: Flow of products from pharmaceutical manufacturer to the customer**

The distributor is responsible for:

- Warehousing finished goods;
- Capturing of customer orders;
- Performing physical distribution;
- Producing invoices and goods received notes; and
- Maintaining master data for customers together with pricing data.

The organization implemented several financial and manufacturing modules of an enterprise resource planning (ERP) software package. An OLAP tool was used to provide reporting and analysis of sales data received from the distributor to the senior and middle management in the sales and marketing function. Whilst this particular tool allowed for online analytical processing, it did not meet all user requirements since it did not, for example, integrate other data sources such as costing data which allows for profitability to be analysed. In addition, the data structures were not appropriate for the data or for the query and analysis requirements of users which resulted in users frequently requesting reports from the third party distributor which was costly and time consuming.

Apart from the OLAP tool, other data sources included a magnitude of spreadsheets on a number of file servers in user directories (which were generally password protected). This presented a significant hurdle: not only in accessing the data, and understanding and interpreting the many interrelated spreadsheets with business rules implicitly contained in the formulas, but also convincing potential users that it was in the best interest of the organization to do so and should not be seen as a threat to their positions as 'gatekeepers' to information. In short, the organisation found itself in a situation similar to that of Elf Atochem which:

*"... found itself hampered by the fragmentation of critical information systems ... Ordering systems were not integrated with production systems. Sales forecasts were not tied to budgeting systems or to performance measurement systems. ... As a result of the many incompatible systems, operating data were not flowing through the organization, and top management was not getting the information it needed to make sound and timely business decisions"* (Davenport, 1998:128-129).

The organisation knew that it wanted to eventually build an enterprise-wide data warehouse. However, it was decided that sales and marketing was most urgently in need of information and most likely to deliver a "quick win". The organisation intended to include other functional areas, namely, finance, production planning and scheduling, as well as external market intelligence data in future. Therefore, a dependent sales and marketing data mart would be the first in a series of interdependent data marts resulting in a distributed data warehouse. The particular sales and marketing data mart solution requirements are discussed in the next section.

#### **4.2.3. Sales and Marketing Data Mart Solution Requirements**

The requirements for the sales and marketing data mart were determined by means of interviews. The data gathered on the sales and marketing data mart solution requirements through these processes are discussed in this section as follows:

- User community;
- Management information requirements;
- Data mart access tool requirements; and
- Nature and sources of data used to populate the data mart.

#### 4.2.3.1. User Community

The user community for the sales and marketing data mart consisted of members of senior and middle management. The members of senior management that require sales and marketing-related management information:

- Managing Director;
- Financial and Operations Director;
- Marketing Director
- Sales Director; and
- New Business Development Director.

The members of middle management that require sales and marketing-related management information:

- Marketing Research Manager;
- Regional Sales Managers; and
- National Account Managers.

A non-exhaustive list of the primary responsibilities, which require sales and marketing-related management information, is contained in Table 18 by position.

<b>Position</b>	<b>Principal responsibilities, including but not limited to:</b>
Managing Director	<ul style="list-style-type: none"> <li>• Responsible for full profit and loss.</li> </ul>
Financial and Operations Director	<ul style="list-style-type: none"> <li>• Report and analyse financial results.</li> <li>• Design, develop and implement financial strategy.</li> <li>• Adequately maintain inventory levels together with Sales and Marketing Directors.</li> <li>• Provide insight and recommendations to the Managing Director.</li> <li>• Report to the Board of Directors.</li> </ul>
Marketing Director	<ul style="list-style-type: none"> <li>• Evaluate market trends, reviewing competitor information and business ranking data to develop strategies to better the organisation's position in the marketplace.</li> <li>• Evaluate new business opportunities.</li> <li>• Collect market intelligence.</li> <li>• Generate forecasts (annual and five year) and develop overall product strategies to maximize market share and profit and loss position.</li> <li>• Understand customer segmentation and translate this into operating strategies and tactics appropriate to the revenue potential of each in order to drive overall revenues</li> </ul>

	<ul style="list-style-type: none"> <li>and gross margins for the organization.</li> <li>• Design, develop and implement an effective channel distribution strategy.</li> </ul>
Sales Director	<ul style="list-style-type: none"> <li>• Deliver sales results to meet budgeted targets.</li> <li>• Meet all expense budgets.</li> <li>• Along with Financial and Operations Director, devise the annual and quarterly compensation programs for sales force.</li> <li>• Develop specific programs and assist sales force in implementing these programs.</li> <li>• Establish pricing guidelines on a product-by-product basis.</li> <li>• Develop successful business and profitability plans using clear and sound analysis, including accurate forecasting and market coverage.</li> <li>• Participate in the selling activities to large and/or strategic accounts.</li> <li>• Work to eliminate or avoid conflict in the channels that the organisation uses to sell products, particularly to wholesalers.</li> <li>• Use appropriate analysis techniques to identify business problems and issues, including GAP analysis on sales performance, risk management and contingency planning.</li> <li>• Responsible for Regional Sales Managers' and National Account Managers' sales activities.</li> </ul>
New Business Development Director	<ul style="list-style-type: none"> <li>• Plan and execute new business development strategy for the firm.</li> <li>• Monitor success of new products in marketplace.</li> <li>• Establish branded generic products in the marketplace.</li> </ul>
Marketing Research Manager	<ul style="list-style-type: none"> <li>• Participate in the development of pricing and product positioning strategies.</li> <li>• Conduct industry-wide analyses and study market and drug utilisation trends.</li> <li>• Understand and implement forecasting and business planning processes.</li> <li>• Identify key business issues that impact short-term and long-range product and market forecasts.</li> <li>• Create product-specific long-range forecasts models and benchmarks.</li> <li>• Maintain up-to-date forecast models, reflecting current data and assumptions for sales and operations planning purposes.</li> <li>• Compile and analyse secondary marketing and sales data.</li> <li>• Collect competitive intelligence within targeted plans and customer business units.</li> <li>• Report to Sales and Marketing Directors.</li> </ul>
Regional Sales Managers	<ul style="list-style-type: none"> <li>• Analyse regional market penetration and travel logistics and implement programs to achieve optimal territory coverage.</li> <li>• Co-ordinate and monitor sales representative pull through among targeted providers.</li> <li>• Provide accurate forecasts to Regional Sales Director of predicted revenue levels.</li> <li>• Investigate the accuracy and validity of account plans and assumptions presented by the sales force.</li> <li>• Manage and operate fiscal budgets.</li> </ul>
National Account Managers	<ul style="list-style-type: none"> <li>• Meet and/or exceed sales goals for assigned regional.</li> <li>• Execute national account promotions.</li> <li>• Develop, recommend and implement consumer sales and marketing initiatives for accounts to market and price products within the industry.</li> <li>• Manage the relationship with key suppliers.</li> </ul>

**Table 18: Principal responsibilities by position in pharmaceutical manufacturing organisation**

In order to fulfil the responsibilities listed in Table 18, which are primarily focussed around decision-making and assessment of performance, accurate management information is required. The management information requirements resulting from these users are discussed in the following section.

4.2.3.2. Management Information Requirements

Given that the user community had been exposed to the functionality of data mart access tools, they were able to articulate their management information requirements in the form of the type of information to be available and the business questions to be answered by the system rather than particular reports. This is a more appropriate means of communicating requirements for a data mart project.

The data mart should be able to provide answers to the following specific business questions of which a representative list is provided in Table 19.

<p><b>Market-related questions</b></p>	<ul style="list-style-type: none"> <li>• Who are our strongest competitors?</li> <li>• Are we gaining or losing market share?</li> <li>• Are your competitors gaining or losing market share? Is it at your expense?</li> <li>• Which market segments should we target?</li> <li>• Where are our new markets located?</li> <li>• Where are we making profits / incurring losses?</li> <li>• What are the forecasted sales for the next 24 months?</li> <li>• Where are the potential sales improvements by market?</li> <li>• What is our market share today, last week, last month, a year ago?</li> <li>• What is our market share by product line, brand, or model? By sales territory? By channel?</li> <li>• If we lowered prices, would we increase market share?</li> </ul>
<p><b>Customer-related questions</b></p>	<ul style="list-style-type: none"> <li>• Who are our best customers?</li> <li>• Who are our worst customers?</li> <li>• How many customers have we lost and why?</li> <li>• Where are the potential sales improvements by customers?</li> <li>• What percent of my business is coming from old customers vs. new customers?</li> <li>• Who are my top 5 customers? 10? 20?</li> <li>• What percent of my business is coming from my top 5 customers? 10? 20?</li> <li>• Who are the top customers this year vs. top customers last year?</li> <li>• Who are the top 5 customers by region? By product?</li> <li>• Do existing customers buy more over time or less?</li> <li>• Can we measure the impact of your marketing promotions on profitability?</li> <li>• What percentage of deliveries to customers is on time as promised?</li> </ul>
<p><b>Product-related questions</b></p>	<ul style="list-style-type: none"> <li>• How well is each of our products doing?</li> <li>• What is the sales history of each product?</li> <li>• What is the life cycle of each product?</li> <li>• What is the actual and intended return on investment of each product?</li> <li>• What is the competition doing with similar products?</li> <li>• Do we have the right products matched with the right markets?</li> <li>• Where are the potential sales improvements by product line?</li> <li>• Display all products with sales 5 percent or more below budget and which represent more than 2 percent of total sales.</li> <li>• Display all products where sales were less than last year.</li> <li>• What is the 13-week moving average trend of sales?</li> </ul>
<p><b>Sales force-related questions</b></p>	<ul style="list-style-type: none"> <li>• Who are the best performing sales representatives?</li> <li>• How are they ranked based on performance?</li> <li>• How are they ranked based on percent actual performance to plan?</li> <li>• Is my top 5 performing sales representatives selling to old customers or new customers?</li> </ul>

	<ul style="list-style-type: none"> <li>• Who are the worst performing sales representatives?</li> <li>• What percent of customers that are new do my poorest performing sales reps sell to?</li> <li>• How many sales representatives do we need?</li> <li>• How many sales calls per market segment should we make?</li> <li>• What is the optimal compensation plan that will reward good sales performance and also maximize corporate objectives?</li> <li>• How do sales representatives who leave the organisation affect us?</li> <li>• In which territories can we expect the greatest sales improvements?</li> <li>• Who are the top 5 sales representatives selling to?</li> <li>• What if we added more sales representatives?</li> </ul>
<b>Analysis of profitability</b>	<ul style="list-style-type: none"> <li>• How much of our markets are the most profitable?</li> <li>• Which distribution channel is most profitable?</li> <li>• How has product mix changed over the past 52 weeks?</li> <li>• Is there a more profitable way to sell my products and services?</li> <li>• Are there some products we should stop selling immediately?</li> <li>• Is the third party distributor performing given the cost charged<sup>3</sup>?</li> </ul>

**Table 19: Representative list of business questions to be answered by data mart**

Given the above business questions, the management information requirements can be categorised as:

- Internally focused marketing information, such as sales, costs, marketing performance indicators;
- Externally focused marketing information, such as industry trends and competitive intelligence;
- Historical marketing information, such as sales, profitability, market trends;
- Future-orientated marketing information, such as environmental scanning information;
- Quantitative marketing information, such as costs, profitability, market share; and
- Qualitative, often subjective marketing information, such as buyer behaviour, competitor strategy information.

All the above information needs to be available at different levels of aggregation or detail, for example, around time periods, (daily, monthly quarterly, annual) or around products or markets, i.e., sales data specific to product lines and market segments.

These business questions can be answered through specific management reports, which allow for user interaction. An overview of management reports is given in the sections below in order to evaluate the data mart access tool requirements in the next section.

---

<sup>3</sup> The third party distributors calculates its distribution costs as a percentage of the invoiced value with differing percentages for the different distribution channels which are private, export or on tender to the state.

### Sales-related management information

Sales-related reporting evaluates daily, month-to-date (MTD), and year-to-date (YTD) actual sales against the corresponding annually determined budget and the more regularly updated forecast. This is available by region, product line or product, by channel, or by representative. Since the sales are also compared to targets set for the sales force, it allows the organisation to assess the effectiveness of the sales force. The actual sales figures contained in this report are used for calculating commissions by means of a specified commission model.

Sales forecasts are included in the scope of the project as these forecasts are related to and based on historical sales performance. By comparing the budget, and sales forecasts, which is a vital input in production planning, forecasting accuracy can be measured. Improving the accuracy of forecasts is vital to ensure manufacturing co-operation and to enable engineering efficiency through a better understanding of the market and consumer needs. It is important to take non-availability of products due to manufacturing problems into account when measuring the accuracy of the sales forecast.

### Marketing-related management information

Marketing-related management information incorporates sales-related management information since this is the measure of the success of the marketing effort. However, it also requires other information. By analysing the average selling prices (ASP) and unit forecasts (in solid dosage format SDF for comparative analysis)<sup>4</sup> for the different products, the marketing function can review pricing policies and procedures, modify pricing agreements, and identify the more lucrative markets.

The effectiveness of promotions needs to be gauged. The pharmaceutical industry relies heavily on promotions, particularly seasonal promotions around particular products, for example, for winter colds and influenza. In addition, promotions are planned around the introduction of new products as well as being location-targeted sales promotions planning.

---

<sup>4</sup> Pharmaceutical products are specified, and therefore sales are analysed, according to specific characteristics, which include:

- Trade or brand name, if applicable;
- Generic name, if applicable;
- Chemical name, which is normally the active ingredient(s);
- Pharmaceutical form, for example, syrup, tablets, etc.;
- Size;
- Dosage;
- Use; and
- Pharmacological classification.

New product development requires product-line analysis and new product introduction control, which is evaluated with respect to existing product lines in order to evaluate the market, the potential share of the market, pricing, distribution, profitability and ultimately the return on investment (ROI).<sup>5,6</sup>

### Inventory-related management information

Inventory-related management information focus on inventory levels and the expiry dates, which is particularly important in the pharmaceutical industry, and back order information, which provides insights into the flow-through of product. This allows manufacturing and distribution to eliminate back-order or over-production situations, and improve forecasts and customer service. The Rand value of the back order or out-of-stock situation translates to possible lost sales.

### Distribution-related management information

Distribution-related management information aims to analyse the vendor pricing and performance as well as the optimal channel distribution (wholesalers versus retailers).

### Profitability or margin-related management information

Since the organisation does not use activity-based costing (ABC) or management (ABM) direct and indirect expenses cannot readily be determined. As an estimate the direct operational expenses incurred by sales representatives during the sales process, for example, entertainment, hotel, travel and car, continuing medical education, cell phone, sponsorships, etc., is attributed to products based the product's sales based on list price over the 6 month period as a percentage contributed to the total. Specific expenses are derived from the sales value and must be calculated on a monthly prior to attributing the expenses. These expenses are:

- Sales representatives' commissions based on actual sales to each representative's assigned customer base.
- Rebates according to annual contractual agreements with one or more customers belonging to a specific customer rebate group.
- Distribution fee calculated by percentages specific to particular distribution channels, i.e. private, State tender and export.

---

Sales in SDF are calculated by multiplying the size with the quantity sold, for example, the number of tablets sold rather than the number of packets of tablets sold. Using SDFs when performing analysis allows for comparative analysis of product sales where different sizes of the same product line are sold.

<sup>5</sup> Note that in order to evaluate the success of new products in the marketplace it is frequently necessary to rely on the sales force for customer information since they spend a significant amount of time with customers (Gordon *et al*, 1997:33).

<sup>6</sup> The ROI in generics is less critical than in ethical pharmaceuticals where significant research and development is required to develop a formulation and is then protected by patent.



Profitability reports are then available to management by brand or product, by representative and/or by region for actual, budget and forecast. Profitability is not analysed by customers since the manufacturing organisation has more than 10,000 customers. Customers are evaluated using ranking reports with the best and worst performing customers in terms of sales value or unit volume. This is not a totally accurate reflection of the true value, i.e. the profitability or lack of, of the customers but is the best approximation.

The following remarks are pertinent to the management information requirements:

- An important regulatory requirement is the ability to recall batches which implies that batch/lot numbers must be stored as part of the sales transaction data in order to be able to trace customers who bought one or more products from a particular lot. The data mart must comply with this stipulation.
- Given the business questions that the user community want answered, there is a definite need for market or competitor intelligence. This cannot be satisfied with data obtained from the third party distributor as this is limited to the manufacturing organisation's own performance. In order to measure the organisation's competitive position in the market, competitive intelligence must be purchased externally to augment the already available data. Given this dire need, it was decided that the integration of competitive intelligence was to be a second phase of the sales and marketing data mart.
- Identification of potential accounts and opportunities is excluded as is customer care and satisfaction since this normally consists of qualitative information gathered by the sales force and communicated to middle and senior management through regular meetings.

#### 4.2.3.3. Data Mart Access Tool Requirements

Based on the management information reporting requirements, the data mart access tool requirement can be determined. This is detailed in Table 20.

Management Information Requirement	Stage of Use	Nature	Data Mart Access Tool
Sales-related: <ul style="list-style-type: none"> <li>• Sales report</li> <li>• Sales forecast</li> </ul>	Reporting Analysis	Deductive	Query and Reporting OLAP
Marketing-related: <ul style="list-style-type: none"> <li>• ASP and unit forecasts</li> <li>• Promotions</li> <li>• New business development</li> </ul>	Reporting Analysis	Deductive	Query and Reporting OLAP
Inventory-related: <ul style="list-style-type: none"> <li>• Stock on hand</li> <li>• Back orders</li> </ul>	Reporting	Deductive	Query and Reporting

Profitability or margin analysis	Reporting Analysis	Deductive	Query and Reporting OLAP
Rebates	Reporting	Deductive	Query and Reporting
Commissions	Reporting	Deductive	Query and Reporting
Distribution-related: • Costs	Reporting Analysis	Deductive	Query and Reporting OLAP

**Table 20: Representative sample of pharmaceutical manufacturer’s data mart access tool requirements**

The sources of data used to meet these management information requirements are reviewed in the following section.

**4.2.3.4. Sources of Data**

Based on the management information requirements, the sources of data to be used to populate the data mart were determined. The sources listed are according to whether the data originate within or outside of the organisational boundaries.

**Internal Data Sources**

The internal sources of data used to populate the data mart are:

- Budget data—historical data from a custom-developed database application, future budgeting to be performed within data mart environment;
- Expenses data—historical data from another custom developed MS Access application, incremental data from operational system (ERP);
- Costing data—historical and incremental data from an operational system (ERP).

**External Data Sources**

The pharmaceutical manufacturer downloads the following data in flat files from the distributor via FTP:

- Invoices issued on the previous day;
- Customer master data of additions and modifications;
- Inventory levels in the respective warehouses;
- Orders picked but not yet invoiced;
- Outstanding or backorders;
- Inventory transactions; and
- Balancing report consisting of cumulative month-to-date balances.

Of these files received, the external sources of data used to populate the data mart are:

- Invoices issued on the previous day;
- Customer master data of additions and modifications;
- Inventory levels in the respective warehouses;
- Orders picked but not yet invoiced; and
- Outstanding or backorders.

The balancing report is used to ensure correct upload of data into the database. The manufacturer wanted to capture additional data particular to its operations on both the customer and product master data. This required a custom-developed application. The volume of sales transactions is approximately 800 to 1000 transactions per day. The inventory transactions were omitted as inventory levels required monitoring only and did not require that inventory transactions be kept in any of the manufacturer's systems.

Traditionally, the operational system(s) serves only as a source for a data mart in the case of an independent or interdependent data mart or a data warehouse. Recently, however, an operational system can also be a target for a data mart or warehouse, receiving data from it. This is referred to as 'closing the loop' or a closed-loop approach. In the case of the pharmaceutical organisation the data mart was required not to be purely analytical but also to fulfil an operational role namely to be a data source for the operational financial system (ERP) with regard to sales and inventory levels consolidated by customer channels. Given the sources and requirements of the data mart, the flow of data to deliver management information through a data mart is depicted in Figure 22.

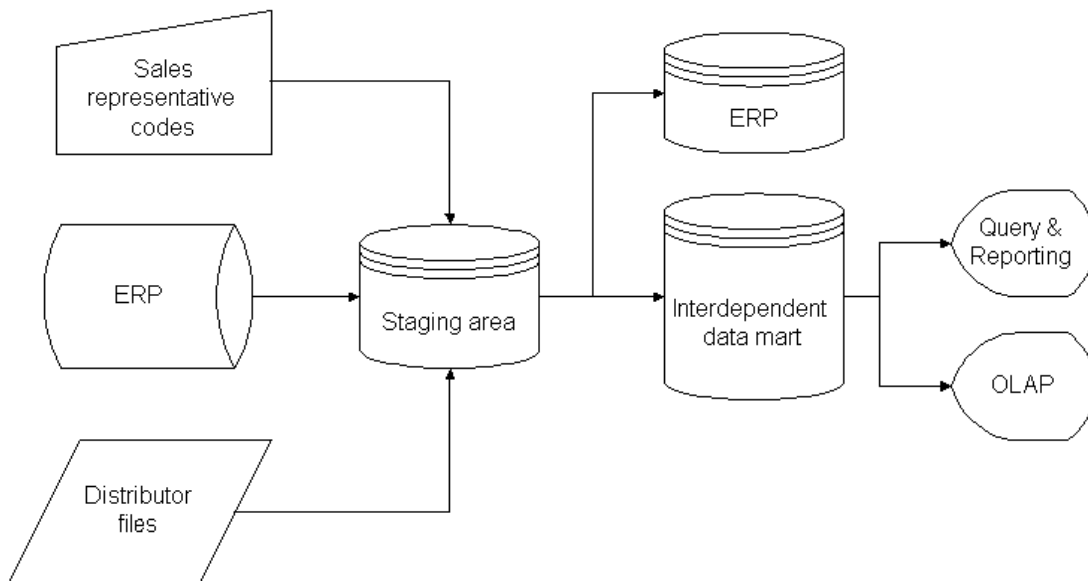

Figure 22: Data flow surrounding the data mart in the pharmaceutical case study

A facility to allow for the capture of data specific to the organisation for analysis is required, for example, the sales representatives responsible for specific customers needed to be captured since the operational source system is under the distributor's control – any changes to this system would have contractual implications.

#### **4.2.4. Assessment of the Use of the Sales and Marketing Data Mart**

The assessment of the sales and marketing data mart after completion of the implementation as a management information delivery mechanism is that it had a significant impact on the manufacturing organisation. Information that was previously too difficult to derive because of multiple source systems is now available on the users desktops. For example, analysing tender volume trends now takes only a few minutes where it used to take a few days compiling spreadsheets with data from different source systems. According to the Sales Director (Trevorrow, 2000) reams of paper reports and isolated spreadsheets have been eliminated. Information flows up and down the organisation much faster, increasing the speed and quality of key marketing and sales decisions. Most importantly, the organisation has seen a significant improvement in the accuracy of its sales forecasts. One comment was that by the nature of the system it continued to overemphasise quantitative data over qualitative data.

The increased visibility of data through direct access using the data mart access tools exposed the low quality of the data received from the third party distributor. Initially this was ascribed to the new system. However, once users were shown the source files from which the data was received it became clear that the service provided by the third party distributor with regard to data capture and provision was lacking. This is a frequent result of data warehouse or mart implementations (Kimball and Merz, 2000). As a result the results of analysis undertaken using the data mart were viewed with increased credibility given the ability of the data mart to process vast and complex data with speed and in detail.

According to the marketing director (Just, Reinholdt, 2000) senior management realised prior to commencement of the implementation that one of the main benefits of a data mart solution is that it enables managers to augment and expand their decision-making capabilities beyond previous levels by making information access both more efficient and more effective. Other organisational improvements as a result of the implementation included:

- Improved internal communication;
- Improved customer information;
- Organisational time saving; and
- Reduced paper work.

Technology costs to support ad hoc reporting and maintain multiple systems have been reduced. Costs incurred as a result of requesting reports from the third party distributor have also been eliminated. Overall, the organisation has improved the design and control of its marketing programs.

### **4.3. Chapter Conclusion**

Sales and marketing data marts are used in manufacturing organisations in different industries (branded consumer goods and pharmaceuticals) as a management information delivery mechanism when the data source is located outside of the organisations' boundaries, for example, with third party distributors. The use of these data marts has improved information flow to the intended user community, which consists primarily of management. The users' requirements for access to the data marts centre on query and reporting and OLAP.

## CHAPTER 5 COMPARATIVE ANALYSIS AND CONCLUSION

*“The big work behind business judgment is in finding and acknowledging the facts and circumstances concerning technology, the market, and the like in their continuously changing forms. The rapidity of modern technological change makes the search for facts a permanently necessary feature.”*

– Alfred P. Sloan, Jr., My Years with General Motors

In the preceding chapter, the use of sales and marketing data marts as a management information delivery mechanism in manufacturing organisations when the data source is outside of the organisations’ boundaries, namely third party distributors was shown through two case studies. The aims of this chapter are to:

- Perform a comparative analysis of the case studies presented in the preceding chapter;
- Evaluate the hypothesis stated in Chapter 1 based on the comparative analysis; and
- Identify future research opportunities stemming from this research.

### 5.1. Comparative Analysis of Case Studies

As stated in the research methodology pertaining to the case studies (see 1.2.3.2. *Qualitative Case Study Research*), the two organisations examined in the case studies have very similar profiles, which supports the validity of the comparative analysis. The case studies presented in Chapter 4 is analysed comparatively in this section according to the same structure in which the case studies were discussed, namely:

- User community;
- Management information requirements;
- Data mart access tool requirements; and
- Nature and sources of data used to populate the data mart.

#### 5.1.1. User Community

The target user communities for the respective organisations were senior and middle management. The comparison between the BCP and pharmaceutical manufacturing organisations in terms of positions requiring access to the sales and marketing data mart is listed in Table 21 by management level.

The user community of the sales and marketing data marts in both organisations are largely similar with matches in 5 of the 7 positions affected. The differences can be attributed to the different industry characteristics of the two organisations, the pharmaceutical manufacturer requiring significantly more and

Management Level	Case Study 1: Branded Consumer Products (BCP)	Case Study 2: Pharmaceutical	Match?
Senior	—	Managing Director	✘
	Financial Director	Financial Director	✓
	Sales and Marketing Director	Sales Director	✓
		Marketing Director	✓
Middle	Regional sales managers	Regional sales managers	✓
	National account managers	National account managers	✓
	—	Marketing research manager	✘

**Table 21: Comparison of user community for respective sales and marketing data marts by management level**

more sophisticated market research and competitive intelligence. The use of the data mart by the Managing Director was personal preference to have direct access to data rather than indirect access through directors reporting to him/her, which is a reflection of the management style and organisational culture.

### 5.1.2. Management Information Requirements

In the first case study, the user community expressed their management information requirements in terms of existing management reports, which had to be reproduced whilst in the second case study, the users were able to formulate business questions that the data mart should be able to answer. Since not all the questions could be answered by the data that were to be used to populate the data mart, it was clear that a second phase was required to incorporate competitive intelligence. It is worthwhile to note here that as implemented the sales and marketing data mart solution is suitable only for quantitative data and not qualitative data which includes, for example, competitive intelligence, although qualitative is as important in the decision-making in sales and marketing. A summarised overview of the applications of the respective sales and marketing data marts in the case study organisations are listed in Table 22.

Industry	Functional Area	Applications / Use
Branded Consumer Products	Sales and Marketing	<ul style="list-style-type: none"> <li>• Sales</li> <li>• Customer ranking by value and volume</li> <li>• Trade marketing – spend vs. sales by major customer</li> <li>• Invoiced sales versus returns (credit notes) analysis</li> <li>• Returns</li> <li>• Product promotions, including location-targeted sales promotions planning</li> <li>• Retailer pricing and promotional reviews</li> <li>• Rebates analysis</li> <li>• Profitability analysis, both by customer and product</li> <li>• Channel distribution analysis, i.e., direct or factory sales versus normal sales, i.e. through the third party distributor</li> <li>• Inventory control</li> </ul>

Pharmaceutical	Sales and Marketing,	<ul style="list-style-type: none"> <li>• Sales</li> <li>• Customer service, e.g., monitoring number and status of products on back order</li> <li>• Sales forecasts and accuracy measurement</li> <li>• Inventory control, e.g., maintaining exact levels, production planning and replenishment</li> <li>• Location-targeted sales promotions planning</li> <li>• New product and service promotions</li> <li>• Pricing policy (average selling prices)</li> <li>• Product promotions</li> <li>• Profitability analysis – customer and product</li> <li>• Sales force management, including commissions</li> <li>• Vendor pricing and performance analysis</li> <li>• Optimal channel distribution</li> <li>• Rebates analysis</li> </ul>
	Operations	<ul style="list-style-type: none"> <li>• Commissions (calculation)</li> <li>• Rebates (calculation)</li> </ul>

**Table 22: Summarised overview of applications of sales and marketing data marts in case study organisations**

The applications or use of the data marts are mostly similar in nature and are also in line with those listed in 2.3. *Management Information and Data Source Requirements* as well as with Table 14 and Table 15. However, although the management information requirements are similar in nature, they differs with regard to extent of data required to fulfil the information needs as well as the method used to specify requirements, namely replicating existing reports versus answering a variety of business questions. It can be concluded that the pharmaceutical organisation is somewhat more sophisticated than the BCP organisation with regard to management information requirements.

### 5.1.3. Data Mart Access Tool Requirements

Both organisations developed independent data marts with a view to developing a distributed data warehouse by means of interdependent data mart. However, the access tool requirements from these data marts differed somewhat as listed in Table 23.

Aspect	Case Study 1: Branded Consumer Products Organisation	Case Study 2: Pharmaceuticals Organisation
Functionality required	Required analytical functionality only	Required analytical functionality and some operational capabilities, particularly direct expense calculation to determine profitability
Type of data mart access tool	Query and reporting for standard management information reporting	Query and reporting for standard reports and ad hoc queries and OLAP for analytical purposes

**Table 23: Differences in data mart access tool requirements between the organisations**



The BCP organisation only required query and reporting whilst the pharmaceutical organisation required both query and reporting and OLAP. Thus, one organisation is still at the first stage of use, namely reporting, and the other has progressed to analysis (see 3.3. *Nature of Usage*). Neither organisation has yet explored the possibility of the predictive use of data through data mining. The organisations' progress is indicated in Table 24. As previously indicated, progression through the stages of use is evolutionary and use will progress as organisations and its users develop and become comfortable with the concept and use of data mart access tools.

Stage of use	Reporting	Analysis	Prediction
Class of Access Tool	Query and reporting	OLAP	Data mining
Categories	Deductive	Deductive	Inductive
Case Study 1: Branded Consumer Products Organisation			
Case Study 2: Pharmaceuticals Organisation			

Legend:

- Implemented
- Not yet implemented

**Table 24: Organisations' progress on the stages of data mart use**

#### 5.1.4. Sources of Data

Both organisations in the case studies used the hybrid option, i.e., operational data from the data from the third party logistics provider is fed into the analytical system of the manufacturer, in order to deliver management information to the user community which is based on data provided by a channel partner (see 3.4. *Using Data Provided by Channel Partners*).

The data sources used to populate the sales and marketing data marts in the case studies are listed in Table 25 together with an indication of whether the data originates internally or externally to the manufacturing organisation.

Thus the data sourced externally that is common to both organisations are:

- Balancing figures;
- Customer master data;
- Inventory levels; and
- Invoices.

Data Source	Internal <sup>7</sup>	External
Backorders		2
Balancing figures		1, 2
Budget	1, 2	
Costs	2	
Customer master		1, 2
Distribution		1
Expenses	2	
Inventory levels		1, 2
Inventory transactions		2
Invoices		1, 2
Orders picked but not yet invoiced		2
Orders placed	1	
Price lists	1	2
Product master	2	1

Legend:

1 = Branded Consumer Products organisation

2 = Pharmaceuticals organisation

**Table 25: Comparison of data and data sources for the data marts from the organisations' viewpoint**

On the other hand, data sourced externally that is particular to one of the organisations are:

- Backorders;
- Orders picked but not yet invoiced; and
- Product master data.

The reasons for the differences between the organisations with regard to externally sourced data are:

- Order data is held by the BCP manufacturer in one instance and by the pharmaceutical organisation's distributor in another; and
- Although both manufacturers maintain product master data, the BCP manufacturer's distributor maintains this data and the manufacturer decided to utilise the external source for cross-reference purposes.

In both instances small volumes of transactions are handled on a daily basis resulting in a relatively small database size although the transactions are complex in nature and therefore require complex processing.

A difference in the utilisation of the data marts in the respective organisations is with regard to the integration of the analytical data mart solution with internal operational systems. In the case of the BCP organisation no integration with the financial system was required. In the case of the pharmaceutical

---

<sup>7</sup> Note that where only one organisation is indicated, only that organisation requires the particular data source.

organisation, however, the transactional data received into the data mart was required also to be fed into the financial system together with a balancing of figures between financial system and data mart.

### 5.1.5. Assessment of the Use of the Data Marts

The benefits derived from the implementation of the data marts in each of the case study organisations are listed in Table 26.

Nature of benefit	Derived benefit	Case Study 1: Branded Consumer Products Organisation	Case Study 2: Pharmaceuticals Organisation
Tangible	Improved sales improved through improved targeted trade marketing and monitoring of the outcome	✓	✓
	Improved forecasting accuracy	✓	✓
	Sales representatives were better prepared for sales visits	✓	✗
	Exposed the lack of underlying data quality	✗	✓
	Reduced paperwork	✗	✓
	Improved customer information	✗	✓
	Reduced expenditure	✗	✓
Intangible	Direct user access to a single integrated source of management information through a data mart access tool	✓	✓
	Improved information flow and communication with a perceived positive impact on decision making	✓	✓
	Organisational time saving	✗	✓

**Table 26: Benefits derived from the implementation of data marts in case study organisations**

Both organisations derived significant benefits from the implementation of the sales and marketing data marts. A significant number of benefits derived are similar between the two organisations although it appears as if the pharmaceutical organisation received more benefits relative to the BCP organisation, in particular with regard to tangible benefits.

The concerns that emerged were that in the case of the BCP organisation significant user training was required, and in the case of the pharmaceutical organisation qualitative data had not been incorporated. With the introduction of the concepts of data warehousing in an organisation a significant change in mindset is required, for example, the phrasing of management information requirements as business questions to be answered rather than specific reports to be produced. Together with this paradigm shift, it is necessary to become acquainted with the tools that allow direct access to the underlying database, in this instance the data mart. Investment in training is costly but is an investment that will produce many benefits in future in terms of the decision-making processes. In order to address the second concern it would be necessary to explore the possibilities of implementing a document management or knowledge management solution.

It is also vital to note in comparing these data mart implementations that although the nature of the sales and marketing data marts in both organizations were similar, it is clear that a data mart solution is also specific to a particular organisation’s business requirements in order to handle organisation-specific issues. As Cashman (2000:49) correctly states, data warehousing solutions are not “one-size-fits-all” and “implementation will generate company-specific issues.” Therefore, if an organisation is considering implementing a data mart to provide access to data received from a distributor, different organisational requirements will result in a solution that is specific to the organisation although the solution from the point of view of design rather than implementation is similar.

In summary, the comparative analysis of the sales and marketing data mart solutions as in the two organisations discussed in the previous chapter is listed in Table 27.

<b>User community</b>	Mostly similar but differences are due to a difference in the organisational size and the industries in which the organisations operate.
<b>Management information requirements</b>	Similar in nature but differs with regard to extent of data required to fulfil information needs and the methods used to specify requirements—the pharmaceutical organisation is somewhat more sophisticated in its specification of management information requirements.
<b>Data mart access tool requirements</b>	Different levels of progression with regard to the nature of use.
<b>Nature and sources of data used to populate the data mart</b>	Largely similar in volume and complexity with differences due to where orders are placed and where product master data is held.
<b>Assessment of the data mart implementations</b>	Largely similar benefits were derived between the two organisations although it appears as if the pharmaceutical organisation received more benefits relative to the BCP organisation due to more sophisticated management information requirements.

**Table 27: Summary of comparative analysis between case study data marts**

## 5.2. Conclusion

Since customer knowledge plays a vital part in organisations today, particularly in several sales and marketing processes, with customers being either channel partners or the final consumers, managing data and/or information across business units, departments, and functions is vital but problematic. Frequently, channel partners gather and capture data about customers that the other organisations in the channel require and which must be incorporated/catered to in the receiving organisations’ information systems in order to allow for management information delivery to users. It has been demonstrated in the preceding chapters, as Ross (1998:52) also accurately summarises, that the thread that draws partners in a supply chain together is “information, and the tools they [channel partners] utilize are the information and communication technologies they develop and implement.”

The data warehouse, specifically the marketing data mart, by its very nature, is the repository where customer data are integrated from where it is analysed. Data warehouses and data marts are predominantly built for sales and marketing applications. In addition, data warehouses and data marts can play a vital role in making the data received from channel partners available in an organisation.

Given the summary of the comparative analysis above (in Table 27) of sales and marketing data marts as management information delivery mechanisms in manufacturing organisations, there are differences that can be attributed to size, IT sophistication, and level of information usage. Slight differences in the locations of data storage also impact the population of the data mart but not on the use as a management information delivery mechanism from the user community's point of view. As a result the benefits derived from the data mart implementations also differed. The hypothesis of this study as stated in Chapter 1 is that there is no significant difference in the use of sales and marketing data marts as management information delivery mechanisms in manufacturing organisations in different industries, particularly the pharmaceuticals and branded consumer products. Based on the evidence presented, the hypothesis is rejected, i.e., there are significant differences between the use of sales and marketing data marts in different manufacturing industries, which can be ascribed to the industry variable. Furthermore, the required level of information usage can be seen as a variable co-dependent on the industry since different industries require different levels of information usage.

### **5.3. Suggestions for Future Research**

The research contained in this study indicates that there is a significant qualitative difference in the use of sales and marketing data marts as management information delivery mechanisms in manufacturing organisations in different industries. Quantifying the difference in use of data marts by the various variables, for example, size, IT sophistication, resources, etc., can serve as confirmation of the findings of this study and also assist in the development of data mart access tools by software vendors, for example, confirm that industry-specific tools are called for rather than generic tools in the different classes. If differences in data mart use by industry are known these can also be factored into the planning of implementations allowing for more accurate timeframes.

## BIBLIOGRAPHY

3COM. 2001. Data Warehousing Solutions. High-Availability, High-Performance Networks Support Superior Business Decisions. In *Data Warehousing: The Ultimate Guide to Building Corporate Business Intelligence*. Ed. SCN Education B.V. Wiesbaden: Vieweg. Pp. 37-46.

AAKER, D.A. 1998. *Developing Business Strategies*. 5th Ed. New York: John Wiley & Sons, Inc.

ACHABAL, D. D., MCINTYRE, S. H., SMITH S. A., AND KALYANAM, K. 2000. A decision support system for vendor managed inventory. *Journal of Retailing*, 76(4):430-454.

ALTER, S. 1999. *Information systems: a management perspective*. Massachusetts, United States: Addison-Wesley.

ARTHUR ANDERSEN. 2000. *Branded Consumer Products Point of View Guidebook*. Reference Information. July 2000.

ASHILL, N.J. AND JOBBER, D. 2001. Defining the information needs of senior marketing executives. *Qualitative Market Research: An International Journal*, 4(1):52-60.

BALLOU, R.H. 1987. *Basic Business Logistics: Transportation, Materials Management, Physical Distribution*. 2<sup>nd</sup> edition. New Jersey: Prentice-Hall, Inc.

BERSON, A. AND SMITH, S. J. 1997. *Data warehousing, data mining, and OLAP*. New York: McGraw-Hill.

BOOTH, R. 1996. The role of supply-chain re-engineering in the pharmaceutical industry. *Logistics Information Management*, 9(3):4-10.

BROOKE, K. AND MACTAVISH, D. 2001. *Forecasting the Future – Planning for Tomorrow* [online]. Available from: [http://www.dmreview.com/editorial/dmreview/print\\_action.cfm?EdID=3896](http://www.dmreview.com/editorial/dmreview/print_action.cfm?EdID=3896) [accessed November 23, 2002].

BUTCHER, H. 1998. *Meeting managers' information needs*. London: Aslib, The Association for Information Management.

CASHMAN, M. R. 2000. Data Warehouses Can Become Treasure Troves. *Financial Executive*, 16(1): 49.

- CORBETT, C.J. BLACKBURN, J.D., VAN WASSENHOVE, L.N. 1999. Case Study: Partnerships to Improve Supply Chains. *Sloan Management Review*, Summer 1999, pp. 71-82.
- CORR, L. AND KIMBALL, R. 2000. *Data Warehousing Design Techniques*. Berkshire, UK: Kimball University (DecisionOne Consulting Ltd & Ralph Kimball Associates).
- DAPHNESOFT. 2001. Building Corporate Business Intelligence: From Datamarts to the Enterprise Data Warehouse. In *Data Warehousing: The Ultimate Guide to Building Corporate Business Intelligence*. Ed. SCN Education B.V. Wiesbaden: Vieweg. pp. 75-82.
- DAVENPORT, T. H., HARRIS, J. G. AND KOHLI, A. K. 2001. How Do They Know Their Customers So Well? *MIT Sloan Management Review*, Winter 2001, pp. 63-73.
- DAVENPORT, T.H. 1998. Putting the Enterprise into the Enterprise System. *Harvard Business Review*, July-August 1998, pp. 121-131.
- DODGE, G. AND GORMAN, T. 1998. *Oracle8 Data Warehousing*. New York: John Wiley & Sons, Inc.
- EDVINSSON, L. 1997. Developing Intellectual Capital at Skandia. *Long Range Planning*, 30(3), 366-373.
- FREDERICK, J. 2000. Retailers, suppliers seek advances in supply chain management. *Drug Store News*, 22(6):10.
- FRIEDMAN, T. 2002. *Data Warehouse Infrastructure: Hitting the Moving Target of User Needs*. Gartner conference Business Intelligence–Managing Effectively in Times of Economic Uncertainty. Amsterdam, 31 January – 1 February 2002.
- FROM MASS TO CLASS. 2000. *Soap, Perfumery and Cosmetics*, 73(5):34-36.
- FOOD AND DRUG ADMINISTRATION. 2000. Good Manufacturing Practice Guide for Active Pharmaceutical Ingredients [online]. Available from <http://www.fda.gov/cder/guidance/4011dft.pdf> [accessed October 16, 2001].
- GASKIN, B. 1994. Using DSS to Boost Sales and Marketing. *CMA, the Management Accounting Magazine*, pp. 13-16.
- GATES III, W. 1999. *Business @ The Speed of Thought: Succeeding in the Digital Economy*. England: Penguin Books.
- GORDON, G. L., SCHOENBACHLER, D. D., KAMINSKI, P. F., AND BROUCHOUS, K. A. 1997. New product development using the salesforce to identify opportunities. *Journal of Business & Industrial Marketing*, 12(1):33-50.

- GRAY, P. AND WATSON, H.J. 1998. *Decision Support in the Data Warehouse*. New Jersey, United States: Prentice-Hall PTR.
- GREEN, F. B. 2001. Managing the unmanageable: integrating the supply chain with new developments in software. *Supply Chain Management: An International Journal*, 6(5): 208-211.
- HAGEL, J., III, AND RAYPORT, J.R. 1997. The Coming Battle for Customer Information. *Harvard Business Review*. January-February 1997, 53-65.
- HAN, J. AND KAMBER, M. 2001. *Data Mining: Concepts and Techniques*. San Diego, USA: Academic Press.
- HANDFIELD, R.B. AND NICHOLS, E.L., Jr. 1999. *Introduction to supply chain management*. New Jersey, USA: Prentice-Hall, Inc.
- HARRIS, D. B. 1996. *Creating a knowledge centric information technology environment* [online]. Available from <http://www.htcs.com/ckc.htm> [accessed September 30, 1996].
- HEISE, D. 2001. What is Data Warehousing? In *Data Warehousing: The Ultimate Guide to Building Corporate Business Intelligence*. Ed. SCN Education B.V. Wiesbaden: Vieweg. Pp. 33-35.
- INFORMATION DISCOVERY, INC. 2001. DataMines for DataWarehouse. In *Data Warehousing: The Ultimate Guide to Building Corporate Business Intelligence*. Ed. SCN Education B.V. Wiesbaden: Vieweg. Pp. 195-210.
- INMON, B. 2002. *Building The Data Warehouse*. Third edition. New York: John Wiley & Sons.
- INVENTORY MANAGEMENT: LEVERAGING THE SUPPLY PIPELINE. 2000. *Chain Store Age*, New York.
- KIMBALL, R. 1996. *The Data Warehouse Toolkit*. New York: John Wiley & Sons.
- KIMBALL, R. AND MERZ, R. 2000. *The Data Webhouse Toolkit: Building the Web-Enabled Data Warehouse*. New York: John Wiley & Sons.
- KIMBALL, R., REEVES, L., ROSS, M. AND THORNTHWAITTE, W. 2000. *The Data Warehouse Lifecycle Toolkit: Expert Methods for Designing, Developing, and Deploying Data Warehouses*. New York: John Wiley & Sons, Inc.
- KIRKMAN, M. 2001. *The Impact of Recent and Proposed Legislation on the Pharmaceutical Industry*. Andersen Products, Retail and Services Workshop. Gordon Institute of Business, Johannesburg. November 12, 2001.



- KUMAR, K. 2001. Technology for Supporting Supply Chain Management. *Communications of the ACM* (44):6, pp. 58-61.
- LAPIDE, L. 1999/2000. New Developments in Business Forecasting. *The Journal of Business Forecasting Methods and Systems*, 18(4):12-14.
- LESSER, E., MUNDEL, D. AND WIECHA, C. 2000. Managing Customer Knowledge. *Journal of Business Strategy*, November/December 2000, pp. 35-37.
- LEVINE, M. AND SIEGEL, J. 2001. What the Accountant Must Know About Data Warehousing. *The CPA Journal*. January 2001:38-42.
- LURQUIN, M. G. 1996. Streamlining the supply chain in the pharmaceuticals industry. *Logistics Information Management*, 9(6):6-10.
- LIPSCHITZ, L. AND STOUT, R. 2001. *Managing the FMCG Supply Chain*. Andersen Products, Retail and Services Workshop. Gordon Institute of Business, Johannesburg. November 13, 2001.
- MATTISON, R. 2001. Data Mining: Statistical Analysis. In *Data Warehousing: The Ultimate Guide to Building Corporate Business Intelligence*. Ed. SCN Education B.V. Wiesbaden: Vieweg. Pp. 181-194.
- MCLACHLAN, M. 1999. Interview with Shana Ponelis. September 1999.
- MENTZER, J. T., MIN, S., AND ZACHARIA, Z. G. 2000. The nature of interfirm partnering in supply chain management. *Journal of Retailing*, 76(4):549-568.
- MICROSOFT CORPORATION. 1999. *Microsoft SQL Server 7.0 Data Warehousing Training Kit*. Redmond, Washington: Microsoft Press
- MOON, M.A. AND MENTZER, J.T. 1999. Improving salesforce forecasting. *The Journal of Business Forecasting Methods & Systems*, 18(2), pp. 7-12.
- O'BRIEN, JAMES A. 1999. *Management information systems: managing information technology in the international enterprise*. Intl Ed. United States: Irwin/McGraw-Hill.
- PALMQUIST, J. AND KETOLA, L. 1999. Turning Data into Knowledge: database marketing steers marketers to the future. *Marketing Research*. Summer 1999, pp. 29-32.
- PALO ALTO MANAGEMENT GROUP, INC. 2001. Database Solutions. In *Data Warehousing: The Ultimate Guide to Building Corporate Business Intelligence*. Ed. SCN Education B.V. Wiesbaden: Vieweg. pp. 271-282.

- PELLETIER, M., AND TODARO, T. 2000. Proper use of BI tools can enhance your business. *Online Product News*, 19(11):1.
- POE, V., KLAUER, P., AND BROBST, S. 1998. *Building a data warehouse for decision support*. Second edition. New Jersey: Prentice-Hall, Inc.
- POIRER, C. C. AND BAUER, M.J. 2001. *E-Supply Chain: using the Internet to revolutionize your business*. San Francisco: Berrett-Koehler Publishers, Inc.
- PONELIS, S. AND BRITZ, J.J. 2002. Customer-Centric Data Warehousing in Organisations and the Privacy of the Individual as a Customer: A Call for Re-Examination [online]. *South African Journal of Information Management*, March 2002, 4(1): Available WWW: <http://general.rau.ac.za/infosci/RAUjournal/default.asp?to=peer1vol4nr1> [accessed March 24, 2002].
- PRAHALAD, C.K. AND KRISHNAN, M.S. 1999. The New Meaning of Quality in the Information Age. *Harvard Business Review*. September-October 1999, pp. 109-118.
- RANDALL, G. 1994. *Trade Marketing Strategies: The Partnership Between Manufacturers, Brands and Retailers*. 2<sup>nd</sup> revised edition. Oxford: Butterworth-Heinemann.
- RAO, S. K. AND SHENBAGA, S. 2000. Developing Customer Databases. *Marketing Health Services*, Winter 2001, pp. 11-14.
- ROBSON, G. 2000. Interview with Shana Ponelis. November 2000.
- ROGERS, P. 2000. The ABCs of distribution. *Candy Industry*, 165(2):44-45.
- ROOS, G. AND ROOS, J. 1997. Measuring your Company's Intellectual Performance. *Long Range Planning*, 30(3), 413-426.
- ROSS, D. F. 1998. *Competing through supply chain management: creating market-winning strategies through supply chain partnerships*. Chapman & Hall Materials Management/Logistics Series. Series editor: Magad, E.L. New York, United States: Chapman & Hall (International Thompson Publishing).
- ROSSI, P., DELURGIO, P. AND KANTOR, D. 2000. Making Sense of Scanner Data. *Harvard Business Review*, March-April 2000, p. 24.
- RUDIN, K. 1998. Transaction Processing Today. *DBMS*, 11(1):40-45.
- SAMARAJIVA, R. 1998. Interactivity as Though Privacy Mattered. In: *Technology and Privacy: The New Landscape*. Edited by Agre, P.E. and Rotenberg, M. Cambridge, Massachusetts: The MIT Press, pp. 277-310.

- SCHROECK, M. 1998. Data Warehousing Is Worth The Investment. *InternetWeek*. June 8, 1998 no. 718 p. 47.
- SCHROECK, M. 2000. *E-Analytics – The Next Generation of Data Warehousing* [online]. DM Review, August 2000. URL: <http://www.dmreview.com/master.cfm?NavID=198&EdID=2551> [accessed August 11, 2000].
- SCHULTE, R. 1996. *Overview of Six Modern IT Architectures, Part 2*. Gartner Research and Advisory Services, August 12, 1996.
- SHARMA, R. 1997. Decision Enabling in the Retail Information Revolution. *Canadian Manager/Manager Canadien*, Fall 1997, pp.17-18.
- SIMON, A. 1998. *90 Days to the Data Mart*. New York: John Wiley & Sons, Inc.
- SINGH, J. 1996. The importance of information flow within the supply chain. *Logistics Information Management*, 9(4):28-30.
- SSA. *Pharmaceutical & Speciality Chemicals* [online]. Available from <http://www.ssagt.com/product/industry/industry.htm> [accessed February 15, 2000].
- SWIFT, R. 2000. *The Stages of Growth for CRM and Data Warehousing* [online]. Available WWW: <http://www.dmreview.com/master.cfm?NavID=55&EdID=2632> [accessed September 13, 2001].
- TALVINEN, J. M. AND SAARINEN, T. 1995. MkIS support for the marketing management process: perceived improvements for marketing management. *Marketing Intelligence & Planning*, 13(1):18-27.
- TANLER, R. 1997. *The Intranet data warehouse: tools and techniques for building an intranet-enabled data warehouse*. New York: John Wiley & Sons, Inc.
- TANLER, R. 2000. *The Next Big Thing for Data Warehouses* [online]. DM Review, July 2000. URL: [http://dmreview.com/master\\_sponsor.cfm?NavID=193&EdID=2370](http://dmreview.com/master_sponsor.cfm?NavID=193&EdID=2370) [accessed August 20, 2000]
- TREVORROW, R. 2000. Interview with Shana Ponelis. May 2000.
- TURBAN, E. AND FRENZEL, L. E. 1992. *Expert Systems and Applied Artificial Intelligence*. New York: MacMillan.
- TURBAN, E, MCLEAN, E. AND WETHERBE, J. 2001. *Information Technology for Management: Making Connections for Strategic Advantage*. New York: John Wiley & Sons, Inc.
- VISHWANATH, V. AND MARK, J. 1997. Your Brand's Best Strategy. *Harvard Business Review*. May-June 1997, pp. 123-129.

VIVIER, F. 2001. *The Impact of B2B Technology on the Products Industry. Andersen Products, Retail and Services Workshop*. Gordon Institute of Business, Johannesburg. November 12, 2001.

WHITE, C.J. 1997. *Building a Corporate Information System: The Role of the Data Mart* [online]. Prepared for Sagent Technology, Inc. by Database Associates International. Available <http://www.dmreview.com/whitepaper/dmc.pdf> [accessed July 13, 2000]

WHITTEN, J. L. AND BENTLEY, L. D. 1998. *Systems Analysis and Design Methods*. Fourth edition. Boston, Massachusetts: Irwin/McGraw-Hill.

WHO'S WEARING THE TROUSERS? 2001. *The Economist* [online]. September 6, 2001. Available <http://www.chass.utoronto.ca/~jovb/ECO310Y/economist/Economist2.pdf> [accessed January 18, 2002].

WIIG, K. 1997. Integrating Intellectual Capital and Knowledge Management. *Long Range Planning*, 30(3), 399-405.

XU, X. M. 1999. The strategic orientation of marketing information systems - an empirical study. *Marketing Intelligence & Planning*, 17(6):262-271.

ZENIE, F. AND HALPIN, E. 2000. A Fully Integrated Approach to Paperless GMP/GLP Compliance. *Pharmaceutical Technology*, pp. 12-16.

ZUBOFF, S. 1996. The emperor's new information economy: Information technology and changes in organisational work. In: *Information technology and changes in organizational work: Working conference proceedings*. December 7-9, 1995. Ed. Orlikowski, W.J. et al. London: Chapman & Hall, pp. 13-17.

## APPENDIX A: MANAGEMENT REPORTS REQUIRED BY THE BCP ORGANISATION

Management Report Name	Pages	Rows	Columns	Calculations
<b><i>Sales and Marketing</i></b>	<ol style="list-style-type: none"> <li>1. National (sum of 2. Below)</li> <li>2. Per TCC region (depot)</li> </ol>	Product lines: <ul style="list-style-type: none"> <li>• Major, intermediate and minor multiplied by quantities</li> <li>• Factory sales (manually captured)</li> </ul>	<ul style="list-style-type: none"> <li>• Product description</li> <li>• Tonnage:                             <ul style="list-style-type: none"> <li>• MTD and YTD for comparison years</li> </ul> </li> <li>• Value:                             <ul style="list-style-type: none"> <li>• MTD and YTD for comparison years (with Budget figures captured manually)</li> </ul> </li> <li>• Realisation:                             <ul style="list-style-type: none"> <li>• Comparison years and rand variance</li> </ul> </li> </ul>	<ul style="list-style-type: none"> <li>• Actual/Budget * 100</li> <li>• Actual (this year) / Actual (previous year) * 100</li> <li>• Actual rand value / actual tonnage * 100 (=Realisation)</li> <li>• Realisation (this year) – Realisation (previous year) (=Rand variance)</li> </ul>
<b><i>Trade Marketing</i></b>	<ol style="list-style-type: none"> <li>1. National (sum of 2. Below)</li> <li>2. Per region (Gauteng, Free State, Natal, Eastern Cape, Western Cape)</li> <li>3. Twelve month trend figures per region (with regions as in 2.)</li> </ol>	Business review accounts Rest of Trade Factory	<ul style="list-style-type: none"> <li>• Account</li> </ul> For 1. and 2.: <ul style="list-style-type: none"> <li>• MTD current and previous financial year</li> <li>• Growth (MTD)</li> <li>• YTD current and previous financial year</li> <li>• Growth (YTD)</li> </ul> For 3.: <ul style="list-style-type: none"> <li>• October to September with values month-ends completed</li> <li>• Total</li> </ul>	For 1. and 2.: <ul style="list-style-type: none"> <li>• (MTD this year – MTD last year)/MTD last year (=Growth MTD)</li> <li>• (YTD this year – YTD last year)/YTD last year (=Growth YTD)</li> </ul> For 3.: <ul style="list-style-type: none"> <li>• Sum of October to September values (=Total)</li> </ul>

University of Pretoria, etd - Ponelis, S

<i>Sales By</i>	<ol style="list-style-type: none"> <li>1. Account by region</li> <li>2. Account by product by region</li> <li>3. Account by region by product</li> </ol>	<p>Business review accounts (same accounts as in Trade Marketing)</p> <p>Account Total Rest of Trade Regional Total Factory Sales Grand Total</p>	<p>For 1.:</p> <ul style="list-style-type: none"> <li>• Account</li> <li>• Region</li> <li>• YTD value (previous and current year)</li> <li>• Contribution % <ul style="list-style-type: none"> <li>• Total contribution to SAM</li> </ul> </li> <li>• YTD volume (current previous year)</li> <li>• Contribution % <ul style="list-style-type: none"> <li>• Total contribution to SAM</li> </ul> </li> <li>• Growth</li> </ul> <p>For 2:</p> <ul style="list-style-type: none"> <li>• Similar to 1. except for product (TCC stock no, description and pack description)</li> </ul>	<p>Growth calculation</p>
-----------------	--	---	---	---------------------------

University of Pretoria, etd - Ponelis, S

<b>Daily Sales</b>	National	<ul style="list-style-type: none"> <li>TCC regions (depots)</li> <li>Totals by region (Gauteng, Free State, Natal, Eastern Cape, Western Cape, Southern Transvaal, Northern Transvaal)</li> <li>Sub-total for TCC regions</li> <li>C/T factory and trading stock (captured manually)</li> <li>Total of TCC and factory figures</li> </ul>	<p>Depot/region</p> <p>Daily:</p> <ul style="list-style-type: none"> <li>Value</li> <li>Mass</li> <li>Realisation (day)</li> </ul> <p>Month to Date:</p> <ul style="list-style-type: none"> <li>Value <ul style="list-style-type: none"> <li>Actual</li> <li>Budget</li> <li>Pro Forma %</li> </ul> </li> <li>Mass <ul style="list-style-type: none"> <li>Actual</li> <li>Budget</li> <li>Pro Forma %</li> </ul> </li> <li>Realisation month <ul style="list-style-type: none"> <li>Actual</li> <li>Budget</li> </ul> </li> </ul> <p>Year to Date:</p> <ul style="list-style-type: none"> <li>Same MTD above</li> </ul> <p>Trading stock mass</p> <ul style="list-style-type: none"> <li>MTD</li> <li>YTD</li> </ul>	Realisation (day) Pro forma %
<b>Ranking (Top 30 customers)</b>	<ol style="list-style-type: none"> <li>National (month)</li> <li>National (YTD)</li> <li>Regional (month)</li> <li>Regional (YTD)</li> </ol>	Top 30 outlets sorted by descending value	<ul style="list-style-type: none"> <li>Outlet number</li> <li>Outlet address (first line)</li> <li>Exclusive value</li> <li>Mass</li> </ul>	
<b>Rebates (Tiger)</b>	<ol style="list-style-type: none"> <li>Month</li> <li>YTD</li> <li>Quarter</li> </ol>	<ul style="list-style-type: none"> <li>By customer (group, division and region name)</li> <li>Total by group</li> <li>Other sales</li> <li>Grand total</li> </ul>	<ul style="list-style-type: none"> <li>Group</li> <li>Division name</li> <li>Region name</li> <li>Total</li> </ul>	Sales and Marketing YTD figure for current financial year – the total of the sales captured = Other sales

University of Pretoria, etd - Ponelis, S

<p><i>Direct vs. Normal Sales</i></p>	<ol style="list-style-type: none"> <li>1. National</li> <li>2. Spar by TCC region</li> </ol>	<p>Products to pack description level</p>	<ul style="list-style-type: none"> <li>• TCC stock no</li> <li>• Description</li> <li>• Pack description</li> <li>• Directs:             <ul style="list-style-type: none"> <li>• Exclusive Value</li> <li>• Mass</li> <li>• Total Value %</li> </ul> </li> <li>• Normal:             <ul style="list-style-type: none"> <li>• Exclusive Value</li> <li>• Mass</li> <li>• Total Value %</li> </ul> </li> <li>• Total             <ul style="list-style-type: none"> <li>• Exclusive Value</li> <li>• Mass</li> </ul> </li> </ul>	<ul style="list-style-type: none"> <li>• Total Value %</li> </ul>
---------------------------------------	--	---	--	---



University of Pretoria, etd - Ponelis, S

<p><b>Sales vs. Returns</b></p>	<ol style="list-style-type: none"> <li>1. Customer (major group)</li> <li>2. Depot by customer (major)</li> <li>3. Depot by value</li> <li>4. Depot by mass</li> </ol>	<p>For 1:</p> <ul style="list-style-type: none"> <li>• Major group description</li> <li>• Total</li> </ul> <p>For 2:</p> <ul style="list-style-type: none"> <li>• Major group description</li> <li>• Subtotal by depot</li> <li>• Total</li> </ul> <p>For 3:</p> <ul style="list-style-type: none"> <li>• Depot description</li> <li>• Subtotal by region</li> <li>• Total margarine</li> </ul> <p>For 4:</p> <ul style="list-style-type: none"> <li>• Depot description</li> <li>• Subtotal by region</li> <li>• Total margarine</li> </ul>	<p>For 1,2:</p> <ul style="list-style-type: none"> <li>• Description</li> <li>• Delivery (DEL)</li> <li>• Price adjustment credit (PAC)</li> <li>• PAC %</li> <li>• Saleable return not associated with a delivery (SAR)</li> <li>• SAR %</li> <li>• Unsaleable credit (USC)</li> <li>• USC %</li> <li>• Total</li> </ul> <p>For 3, 4:</p> <ul style="list-style-type: none"> <li>• Description</li> <li>• Delivery (DEL)</li> <li>• Price adjustment credit (PAC)</li> <li>• PAC %</li> <li>• Number of PAC</li> <li>• Saleable return not associated with a delivery (SAR)</li> <li>• SAR %</li> <li>• Number of SAR</li> <li>• Unsaleable credit (USC)</li> <li>• USC %</li> <li>• Number of USC</li> <li>• Total</li> <li>• Total number of credit notes</li> </ul>	<ul style="list-style-type: none"> <li>• PAC%</li> <li>• SAR%</li> <li>• USC%</li> <li>• Total no of credit notes</li> </ul>
<p><b>Promotional Review</b> <i>(based on ad-hoc sample provided)</i></p>	<p>Sales for region by store</p>	<ul style="list-style-type: none"> <li>• Major group down to pack (Description (major group), inter group and description, outlet number and name, product line description and pack description)</li> <li>• Total per outlet</li> </ul>	<p>Previous financial year:</p> <ul style="list-style-type: none"> <li>• Exclusive value</li> <li>• Mass</li> </ul> <p>Current financial year:</p> <ul style="list-style-type: none"> <li>• Exclusive value</li> <li>• Mass</li> </ul>	

<p><b>Profitability Reports</b> <i>(Analysis of Variable Selling)</i></p>	<p>There are two reports with the same rows but different columns.</p>	<ul style="list-style-type: none"> <li>• By product</li> <li>• By intergroup by product</li> <li>• By intergroup</li> <li>• By major group by product</li> <li>• By depot by product</li> <li>• By customer (combination of major, inter and minor groups)</li> </ul>	<p>For 1:</p> <ul style="list-style-type: none"> <li>• Mass (kg)</li> <li>• Gross sales</li> <li>• Sales (R/ton)</li> <li>• Variable selling %</li> <li>• Net sales</li> <li>• Cost of sales (R)</li> <li>• Gross margin (R)</li> <li>• Gross margin (R/ton)</li> <li>• Gross margin %</li> <li>• Direct overhead</li> <li>• Indirect overhead</li> </ul> <p>For 2:</p> <ul style="list-style-type: none"> <li>• TCC commission</li> <li>• Merchandising</li> <li>• TCC selling</li> <li>• Quarterly SAM</li> <li>• Annual growth SAM</li> <li>• Quarterly Tiger</li> <li>• Annual growth Tiger</li> <li>• Coads</li> <li>• DC allowance</li> <li>• Settlement discount</li> <li>• Transport</li> <li>• Swell allowance</li> <li>• Total</li> </ul>	<p>For 1:</p> <ul style="list-style-type: none"> <li>• <math>\text{Net Sales} = \text{Sales (R/ton)} * (100 - \text{VS\%})/100</math></li> <li>• <math>\text{Gross Margin (R)} = \text{Net Sales} - \text{Cost of Sales}</math></li> <li>• <math>\text{Gross Margin (R/ton)} = \text{Gross Margin (R)}/\text{Mass(kg)} * 1000</math></li> <li>• <math>\text{Gross Margin \%} = \text{Gross Margin (R)}/\text{Gross Sales}</math></li> <li>• <math>\text{Net Margin} = \text{Gross Margin (R)} - \text{Direct Overhead} - \text{Indirect Overhead}</math></li> </ul> <p>For 2:</p> <ul style="list-style-type: none"> <li>• Total = all preceding column values</li> </ul>
---	--	---	---	---

## APPENDIX B: LAYOUT OF FILES RECEIVED BY THE BCP ORGANISATION FROM THE THIRD PARTY DISTRIBUTOR (3PL)

Filename: STTRAN			
Column Name	Type	Range of Values	Used for
REGION	CHAR(2)	Valued values between 01 to 30	Indicates the 3PL depot. Renamed to 3PL region in the BCP's system.
OUTLET	CHAR(5)		3PL debtor's code at assigned at an outlet level.
PRODUCT	CHAR(9)		Only digits 5 to 9 contain values other than 0.
STORE	CHAR(1)	B = Bulk store C = Chilled D = Direct drops R = Returns store W = Frozen warehouse	Indicates location of goods in 3PL depots
TYPE	CHAR(1)	C = Credit Note D = Direct (CN/Invoice) I = Invoice R = Return (CN/Invoice)	Indicates type of transaction for which details are recorded.
QTY	NUMBER(7)	Positive integer	Quantity involved in transaction measured in cases (except for part returns which are rounded either up or down).
MASS	NUMBER(10) Decimal=3	Positive real number	Total mass of in kilograms.
SALE	NUMBER(10) Decimal=2	Positive real number	Sale value in Rands.
REASON	CHAR(2)	Assigned codes between 01-99	Codes used to indicate reasons for transactions
ROUTE	CHAR(3)	-	Transport route number for delivery.
TRAN_DATE	CHAR(6) YYMMDD	Valid date in required format	Transaction date.
GROSS	NUMBER(10) Decimal=2	-	Not used by The Cold Chain.
CLAIM	NUMBER(10) Decimal=2		Used in claim back report for 3PL commission. Could be used by the BCP organisation to calculate/estimate claim back amount at month end.
COST	NUMBER(10) Decimal=2		Cost of sales, i.e. price of goods from SA Margarine
DEAL	NUMBER(10) Decimal=2		Rand value of deal – empty if no deal exists and sale uses list price.
TAX	NUMBER(9) Decimal=2		Rand value of VAT charged.

## University of Pretoria, etd - Ponelis, S

QTY_CHANGED	NUMBER(3)		Records changes to quantity for the transaction e.g. quantity ordered is more than the available stock.
MANU	CHAR(3)	-	Value is 220 for SA Margarine.
DOC_NO	CHAR(8)		Transaction document number e.g. invoice number, credit note number etc.
PRICE_REF	CHAR(16)		Reference captured by the person from BCP organisation capturing the price on 3PL system.
EXTRA_REF	CHAR(10)		Reference calculated by the system when pricing information is captured e.g. M220010937.
ORIG_OUTLET	CHAR(5)	-	Used for crediting purposes: link the GRV account and the debtors for payment of credit notes.
CUST_REF	CHAR(20)	Alphanumeric text	Used as comment field. Normally the order number is captured here.
DEPOT	CHAR(1)	B = Bloemfontein, C = Cape Town D = Durban E = East London G = George J = City Deep K = Klerksdorp L = Nelspruit N = Dundee O = Midrand P = Port Elizabeth T = Pietersburg W = Welkom	3PL depot which was responsible for the delivery.
COMMENT	CHAR(8)	Alphanumeric text	Comment field
COLLECT	CHAR(1)	Y = Yes N = No	Indicates collect customer.
PRICE_CHANGED	CHAR(1)	Y = Yes N = No	Indicates that there was an override on the price, normally on credit notes and trading stock.
CRED_RELEASE	CHAR(1)	Y = Yes N = No	Release suspended invoice
WEEK_NO	CHAR(2)	1 to 52	3PL week number based on 3PL financial year
USER	CHAR(5)	Valid user name	User who captured sales transaction.

Filename: GEOUTLMS			
Column Name	Type	Range of Values	Used for
REGION	CHAR(2)	Two digit positive integer combination referring to valid region	Number of 3PL depot which serves the outlet/customer.
OUTLET	CHAR(5)	Positive integer.	3PL debtor's code at assigned at an outlet level.
CUST_NAME	CHAR(30)	Alphanumeric text	Name of customer.
CUST_ADDRESS_1	CHAR(26)	Alphanumeric text	Line in customer address
CUST_ADDRESS_2	CHAR(26)	Alphanumeric text	Line in customer address
CUST_SHORTAD	CHAR(20)	Alphanumeric text	Shortened version of customer address
CUST_STATUS	CHAR(1)	A = Active D = Discontinued	Status of customer's/debtor's account with 3PL
CUST_TYPE	CHAR(1)	C = Catering I = Inter-group R = Retail W = Wholesale	Type of customer.
CUST_ICS	CHAR(1)	B = Barlows C = C.G. Smith I = ICS Group R = Region S = Staff	Indicates whether an outlet is a member of ICS. Not in use by 3PL
RECORD_STATUS	CHAR(1)	I = Inactive A = Active	
SUMMARY_TYPE	CHAR(1)	Blank S = Summary account	Used to indicate whether debtor belongs to a summary account for group accounting purposes.
SALES_MGR	CHAR(1)	-	3PL's sales manager.
AREA_MGR	CHAR(1)	-	3PL's area manager.
FILLER_1	CHAR(1)	-	Additional space provided should future addition of field to file be required.
REP_CODE	CHAR(2)	-	3PL's representative code
EAN13_CUST	CHAR(12)	-	Barcode supplied by customer – mostly not maintained.
SAM_SALESMAN	CHAR(2)	-	SA Margarine's salesperson responsible for sale. No longer captured by 3PL.
ROUTE	CHAR(3)	-	Route on which delivery is made by 3PL.
EXPORT	CHAR(1)	Y = Yes N = No	Indicates whether customer requires the exportation of goods.

TAXZONE	CHAR(2)	01 = South Africa 02 = Swaziland	Indicates zone for tax purposes
COD	CHAR(1)	Y = Yes N = No	Indicates Cash on Delivery
REG_NO	CHAR(1)	-	If ICS customer, then a registration number would be recorded.
DATE_LAST_TRAN	CHAR(6) YYMMDD	Valid date for YYMMDD format	Date last transaction was recorded for the outlet/customer.
CUST_BRANCH	CHAR(6)	-	Not used at present. Available for future EDI/eCommerce applications
CONTROL_CODE	NUMBER(5)	-	No longer used.
CHANNEL	CHAR(3)	Valid values between 000 and 999	Used for grouping to do pricing. BCP organisation uses this a guideline when classifying their customers on their system.
SUB_CHANNEL	CHAR(3)	Valid values between 000 and 999	Used for grouping to do pricing. BCP organisation uses this a guideline when classifying their customers on their system.
CUST_GROUP	CHAR(2)	Valid values between 00 to 99	Used for customer grouping for reporting purposes. BCP organisation uses this a guideline when classifying their customers on their system.
CUST_DIV	CHAR(2)	Valid values between 00 to 99	Used for customer grouping for reporting purposes. BCP organisation uses this a guideline when classifying their customers on their system.
CUST_REGION	CHAR(2)	Valid values between 00 to 99	Used for customer grouping for reporting purposes. BCP organisation uses this a guideline when classifying their customers on their system.
DATE_LAST_UPDATED	CHAR(6) YYMMDD	Valid date for YYMMDD format	Date debtor's (of 3PL) information was last updated.

**University of Pretoria, etd - Ponelis, S**

<b>Filename: GEPRODMS</b>			
<b>Column Name</b>	<b>Type</b>	<b>Range of Values</b>	<b>Used for</b>
PRODUCT	CHAR(9)		Product number assigned by 3PL
DESC	CHAR(30)	Alphanumeric text	Description of product
SHORT_DESC	CHAR(15)	Alphanumeric text	Short description of product
PROD_STATUS	CHAR(1)	A = Active D= Discontinued	Status of product
RANDOM	CHAR(1)	Y = Yes N = No	Sold by random weight or not (not applicable in case of SA Margarine)
SOLD_BY_MASS	CHAR(1)	C = Cases M = Mass (kg)	
COMM_TYPE	CHAR(1)	-	Not used. Indicates whether commission is calculated using mass (kg) or a fixed percentage
COMMISSION	NUMBER(5) Decimal=2	-	Not used. Rate at which commission is received on a product
BUDG_GROUP	CHAR(2)	-	Allocation for 3PL budget purposes.
BUDG_TYPE	CHAR(2)	-	Allocation for 3PL budget purposes.
DATE_OPENED	CHAR(6) YYMMDD	Valid date for YYMMDD format	Date product was opened.
UNITS_PER_CRATE	NUMBER(3)	-	Not applicable to SA Margarine i.e. will always be equal to 1
MANU	CHAR(3)	-	Value is 220 for SA Margarine
STORAGE	CHAR(1)	2 = Chilled	
PROD_GROUP	CHAR(2)		
PACK_TYPE	CHAR(2)		
PROD_TYPE	CHAR(2)		
EAN13_CODE	NUMBER(12)	-	Barcode supplied by customer – mostly not maintained.
ITF14_PREFIX	CHAR(1)	-	Check digit for EAN13_CODE.
CARTON_MASS	NUMBER(5) Decimal=3		Physical weight of packaging used in kilograms
LINK_PRODUCT	CHAR(9)	Valid product number with a 9 prefixed	If the field contains values, it indicates that there is trading stock on this product. <i>Originally used to indicate substitute product if</i>

			Originally used to indicate substitute product if enough stock was not on hand.
DATE_LAST_USED	CHAR(6) YYMMDD	Valid date for YYMMDD format	Date of last sale.
PACK_QTY	NUMBER(3)		Number of products in case e.g. 30 (500g)
PACK_MASS	NUMBER(5) Decimal=3		Mass in kilograms e.g. 15.000
TAX_LEVEL	CHAR(1)	0 = Non-taxable 1 = Taxable	Indicates whether product is taxable or not
REGION_* (*=1-30)		Valid value between 01 to 30	Indicates 3PL depot(s) from where product is sold
MAX_DISCOUNT	NUMBER(3)	0-100	SA Margarine supplies this percentage as the maximum discount that can be given to customers by 3PL. Used in pricing.
LIST_PRICE	NUMBER(8) Decimal=2	Positive real number	Normal selling price if there is no existing deal which overrides this value



<b>Filename: GESTOCKS</b>			
<b>Column Name</b>	<b>Type</b>	<b>Range of Values</b>	<b>Used for</b>
BRANCH	CHAR(1)	B = Bloemfontein C = Cape Town D = Durban E = East London G = George J = City Deep K = Klerksdorp L = Nelspruit N = Dundee O = Midrand P = Port Elizabeth T = Pietersburg W = Welkom	Indicates the 3PL depot (branch) where stock is held.
WAREHOUSE	CHAR(1)	W = Warehouse	Indicates warehouse of 3PL (as opposed to direct drop in BCP organisation's system, indicated by B)
PRODUCT	NUMBER(5)	Any product number contained in the product master file	3PL product number
ALLOC	NUMBER(6)	Zero or positive integer	Number of cases allocated to customer(s) but not yet delivered
QTY	NUMBER(6)	Zero or positive integer	Number of cases on hand (including allocated) i.e. free stock = QTY - ALLOC

**University of Pretoria, etd - Ponelis, S**

<b>Filename: GECHANMS</b>			
<b>Column Name</b>	<b>Type</b>	<b>Range of Values</b>	<b>Used for</b>
CHANNEL	CHAR(3)	Valid values between 000 and 999	Used for grouping to do pricing.
SUB_CHANNEL	CHAR(3)	Valid values between 000 and 999	Used for grouping to do pricing.
DESC	CHAR(30)	Alphanumeric text	Description of channel.
SHORT_DESC	CHAR(15)	Alphanumeric text	Description of channel.
EAN13_CUST	NUMBER(12)	-	Barcode supplied by customer – mostly not maintained.
REPORTING	CHAR(1)	Y = Yes N = No	Indicates if channel is active (Y) or not (N). Used for report listings.
INCL_VAT	CHAR(1)	I = Inclusive E = Exclusive	Indicates whether VAT is included.
OPEN_CYCLE	CHAR(1)	Y = Yes N = No	Not used by 3PL
FILLER__1	CHAR(1)	-	Additional space provided should future addition of field to file be required.
REGION_* (* = 1 TO 30)	CHAR(2)	01 to 30	3PL depot numbers

<b>Filename: GECRPMS</b>			
<b>Column Name</b>	<b>Type</b>	<b>Range of Values</b>	<b>Used for</b>
CUST_GROUP	CHAR(2)		Customer grouping.
CUST_DIV	CHAR(2)		Customer grouping.
CUST_REGION	CHAR(2)		Customer grouping.
DESC	CHAR(30)		Description of customer grouping.
SHORT_DESC	CHAR(15)		Shortened description of customer grouping.
REPORTING	CHAR(1)	Y = Yes N = No	
RECORD_STATUS	CHAR(1)	A = Active I = Inactive	
GROUP_TYPE	CHAR(1)	A = Agency C = Catering I = Inter-group R = Retail W = Wholesalers	
CHANNEL	CHAR(3)	Valid values between 000 and 999	Used for grouping to do pricing.
SUB_CHANNEL	CHAR(3)	Valid values between 000 and 999	Used for grouping to do pricing.