

## CHAPTER 3 DATA MARTS AS MANAGEMENT INFORMATION DELIVERY MECHANISMS

*“A firm’s IQ is determined by the degree to which its IT infrastructure connects, shares, and structures information. Isolated applications and data, no matter how impressive, can produce idiot savants but not a highly functional corporate behavior.”*

– Steve H. Haeckel and Richard L. Nolan, *Managing by Wire: Using IT to Transform a Business*

An understanding of the definition of and distinction between data warehouses and data marts is required prior to commencing an empirical investigation of data marts as management information delivery mechanisms. The aims of this chapter are to provide material to aid this understanding by:

- To compare and contrast the data warehouse and types of data marts in order to arrive at an understanding of what it is;
- To indicate the relationship between data warehouses and data marts;
- To describe, classify and characterise the access tools to data marts/data warehouses as management information delivery mechanisms;
- To define criteria to select the appropriate data mart access tool(s); and
- To explore the use of data warehouses and data marts in organisations, particularly within the context of sales and marketing, as discussed in literature.

### 3.1. Definitions of Data Warehouses and Data Marts

In 1997, White (1997, 7) stated that there is “considerable debate and confusion in the industry about the role and value of a data mart, and even about what a data mart is.” This debate and confusion has not subsided in subsequent years as is evident from the following representative definitions found in literature:

- A data mart is an “implementation of the data warehouse in which the data scope is somewhat limited compared to the enterprisewide [sic] data warehouse. A data mart may contain lightly summarized departmental data and is customized to suit the needs of a particular department that owns the data; in a large enterprise, data marts tend to be a way to build a data warehouse in a sequential phases approach; a collection of data marts composes an enterprise-wide data warehouse; conversely, a data warehouse may be construed as a collection of subset data marts” (Berson and Smith, 1997:15). Furthermore, “Mostly, data marts are presented as an inexpensive alternative to a data warehouse that takes significantly less time and money to build” (Berson and Smith, 1997:124).

- “When the term *data mart* came into vogue, it was generally used to describe an environment that would receive a subset of a data warehouse’s contents and then would be the primary point of data access for a subset of the organization’s total user base (i.e., one or two departments)” (Simon, 1998:4). This was because “smaller-scale data warehousing efforts, the ones that were being developed in three to six months with scaled-back functionality, were usually successful” (Simon, 1998:6). In order to distinguish these successful efforts from the less successful enterprise-wide data warehouse efforts “the phrase *data mart* was extended to refer not only to an environment sourced by a data warehouse, but *any* smaller-scale effort with a relatively short time from concept to deployment” (Simon, 1998:6).
- “... the term data mart, which has been used variously to describe a small standalone data warehouse or a distributed secondary level of storage and distribution in conjunction with a data warehouse.” (Dodge and Gorman, 1998:11)
- “A data mart, often referred to as a subject-oriented data warehouse, represents a subset of the data warehouse comprised of relevant data for a particular business function (e.g., marketing, sales, finance, etc.)” (Poe et al, 1998:18).
- “The term data mart is used to refer to a small-capacity data warehouse designed for use by a business unit or department of a corporation” (Gray and Watson, 1998:103).
- “A scaled-down version of a data warehouse that is tailored to contain information likely to be used only by the target group” (Gates, 1999:493).
- “A data mart is simply a smaller data warehouse. Usually the data in a mart is a subset of data that is found in an enterprisewide warehouse, as follows:
  - A data warehouse is for data throughout the enterprise.
  - A data mart is specific to a particular department” (Microsoft Corporation, 1999:3).
- “... the definition of a [data] mart as a single-purpose warehouse serving a single allied group of users” (Palo Alto Management Group, 2001:275).
- “A data mart contains a subset of corporate-wide data that is of value to a specific group of users. The scope is confined to specific selected subjects” (Han and Kamber, 2001:67).
- “A data mart is smaller, less expensive, and more focused than a large-scale data warehouse. Data marts can be a substitution for a data warehouse, or they can be used in addition to it” (Turban et al, 2001:759).

From these definitions in literature, the following can be concluded:

1. A data mart is smaller in scope and/or size than a data warehouse;
2. A data mart appears to be less expensive to build than a data warehouse; and
3. Data marts can take a number of forms, namely:

- An optional part of a data warehouse, for reporting purposes, dependent, an alternative to directly accessing the data warehouse with the data warehouse being a single centralised repository. In these instances it is generally can be departmental or business process specific;
- A small stand-alone independent data warehouse.
- Data marts developed in a coordinated manner with conformed dimensions to form a distributed data warehouse.

From the points 1 and 2 it is clear that there appears to be some difficulty in determining the exact boundary between a data mart and a data warehouse, with the definition of a data mart frequently referring to a data warehouse in order to provide a definition. Before exploring the different data marts outlined in point 3 in depth, it is necessary to elaborate on the concept of the data warehouse.

### 3.1.1. Data Warehouse

Data that is captured and stored during the processing of transactions can be used to produce valuable information to end-users, especially management. This management information can be used to plan, monitor, and control business operations (Whitten *et al*, 1998:53). In order to exploit this data asset, organisations began creating data warehouses to satisfy these demands for decision-making (Gates, 1999:250).

According to Inmon (2002:31), a data warehouse is “a subject-oriented, integrated, non-volatile [database not updated directly by users] , time-variant collection of data in support of management’s decisions.” This definition is concise but not without controversial points requiring interpretation:

- “Subject-oriented”—In the marketplace, the term subject-oriented implies functionally-aligned, for example, sales data is separated from marketing data is separated from manufacturing data, and each forms a separate “data warehouse” which is then a data mart.
- “Serves management”—There has been a change in managerial theory and organisational design which has resulted in decision points being pushed down the organisational hierarchy, out to the boundaries of the firm. However, in many organisations, management information is still confined to middle and senior management with information flow down the hierarchy when deemed necessary.

Whitten *et al* (1998:53) is of the opinion that management reporting and by implication management information is a natural extension of transaction processing. According to Kimball (1996:310) a data warehouse is “a copy of transaction data specifically structured for querying and reporting.” Kimball’s definition eliminates problematic points in Inmon’s definition are eliminated. Furthermore, this implies that the data warehouse is a separate database used for analytical purposes where all data is stored but in a

different structure, which is optimised for analytical purposes whereas operational databases are usually optimised for day-to-day business operations, for example, transaction updates. The data is reorganised to reflect the way it will be used. The reason for a different structure is for performance reasons—data structures are optimised for queries requiring summarised data rather than individual records at transactional level since two types of applications competing for resources negatively impacts on the performance of both. The differences between transactional or operational databases and analytical databases such as a data warehouse are listed in Table 1.

	Operational Databases	Analytical databases
<b>Business Purpose</b>	Supports tactical day-to-day decisions	Supports long-term, strategic decisions
<b>Nature of Use</b>	<ul style="list-style-type: none"> <li>• Repetitive</li> <li>• Continuous updates</li> <li>• Predictable pattern of usage</li> </ul>	<ul style="list-style-type: none"> <li>• Investigative</li> <li>• Problem-solving</li> <li>• Unpredictable pattern of usage</li> </ul>
<b>Nature of Users</b>	<ul style="list-style-type: none"> <li>• Serves clerical, transactional community</li> <li>• Large numbers of operational managers (hundreds of thousands)</li> </ul>	<ul style="list-style-type: none"> <li>• Serves managerial community</li> <li>• Small number of strategic managers (tens or hundreds)</li> </ul>
<b>Nature of Queries</b>	<ul style="list-style-type: none"> <li>• What is happening?</li> </ul>	<ul style="list-style-type: none"> <li>• What happened?</li> <li>• Why did it happen?</li> <li>• What will happen next?</li> <li>• What if?</li> </ul>
<b>Nature of Data</b>	<ul style="list-style-type: none"> <li>• Detailed data</li> <li>• Current</li> <li>• Volatile / highly dynamic</li> </ul>	<ul style="list-style-type: none"> <li>• Detailed and summarised data</li> <li>• Historical</li> <li>• Non-volatile / static</li> </ul>
<b>Typical analysis</b>	Simple, for example: <ul style="list-style-type: none"> <li>• Sum</li> <li>• Average</li> <li>• Count</li> </ul>	Advanced, for example: <ul style="list-style-type: none"> <li>• Trend</li> <li>• Forecasting</li> <li>• Monthly averages</li> <li>• Year-to-date totals (YTD)</li> <li>• Prior period totals</li> </ul>
<b>Access</b>	Structured Query Language (SQL) Custom-developed front-end tools	Advanced analytical tools
<b>Workload</b>	Users execute transactions that only affect a small number of rows	Users execute queries that might scan millions of rows
<b>Nature of database modifications</b>	Continuous (via transactions)	Performed at regular intervals (via batch loads)
<b>Performance criteria</b>	Throughput is most important	Response time (for queries) is most important

**Table 1: Comparison between transaction processing systems and data warehouses ((Daphnesoft, 2001:76), (Levine and Siegel, 2001:42), (Rudin, 1998:45))**

It is clear that data warehousing involves separating the data used for analytical applications from the data used for transaction processing. A separate database is created by taking data from the organisation’s operational databases and storing it in a structure that facilitates user-friendly access for users. The main reasons for this are:

- Reduction of operational database workload;
- Optimisation of databases to cater for different requirements; and
- Integration of data from diverse sources.

A descriptive definition of a data warehouse is that of Han and Kamber (2001:67): “An enterprise warehouse collects all of the information about subjects spanning the entire organization. It provides corporate-wide data integration, usually from one or more operational systems or external information providers, and is cross-functional in scope.” However, this definition does not cover the target audience or users of the data warehouse. Whitten and Bentley (1998:40) places more focus on the users by defining a data warehouse is “a read-only, informational database that is populated with detailed, summary, and exception information that can be accessed by end-users and managers with DSS tools that generate a virtually limitless variety of information in support of unstructured decisions.”

Other definitions of a data warehouse found in literature include:

- A data warehouse is a “database that can access all of a company’s information. While the warehouse can be distributed over several computers and may contain several databases and information from numerous sources in a variety of formats, it should be accessible to users through simple commands” (Gates, 1999:493).
- A data warehouse provides “a unified corporate picture to the end-users by combining the data from many operational systems and incompatible databases without affecting the performance of the running operational systems” (Turban *et al*, 2001:758)
- “The data warehouse is an environment, not a product. It is an architectural construct of information systems that provides users with current and historical decision support information that is hard to access or present in traditional operational data stores. In fact, the data warehouse is a cornerstone of the organization’s ability to do effective information processing, which among other things, can enable and share the discovery and exploration of important business trends and dependencies that otherwise would have gone unnoticed” (Berson and Smith, 1997:5).
- “Data is extracted from multiple sources (usually operational databases), pruned, cleansed, reconciled and transformed into a more usable format and then loaded into the data warehouse for subsequent access by multiple interested consumers” (Schulte, 1996).

The process described in these definitions is depicted in Figure 1.

Based on the above definitions, a data warehouse can be summarised that it:

- Integrates sources from multiple, diverse operational sources;
- Allows for analysis of data over time;
- Provides analysis capabilities to decision makers;

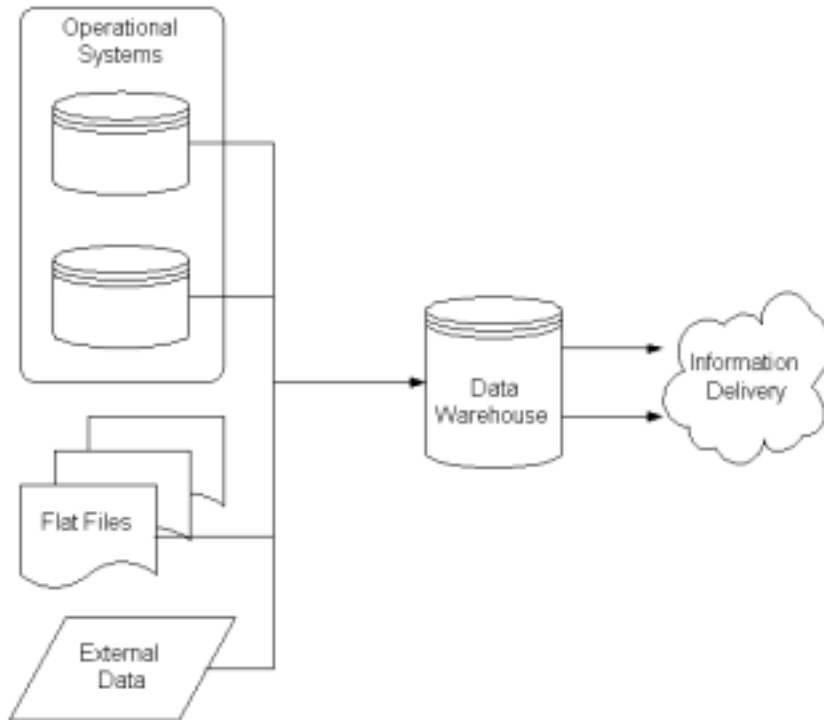

**Figure 1: Schematic Representation of Data Flow in a Data Warehouse Environment**

- Provides improved performance for complex analytical queries;
- Relieves processing burden on transaction-oriented databases; and
- Converts enterprise data into strategic information (Heise, 2001: 34).

Furthermore, the data warehouse takes a “top-down perspective is that a completely centralized, tightly designed master database must be completed before parts of it are summarized and published as individual data marts [see 3.1.2.1. ]” (Kimball *et al*, 1998:18-19).

### 3.1.2. Data Marts

A data warehouse presents a solution for storing and accessing analytical data. There are a number of advantages in building a data mart:

- The cost of building a data mart is generally lower;
- The implementation timeframe is shorter; and

- Data marts contain less information than a data warehouse and therefore have more rapid response and are more easily understood and navigated by users than an enterprise data warehouse (Gray and Watson, 1998:103-104).

Based on the initial definitions from literature, it emerged that data marts can be one of a number of different designs or architectures. Han and Kamber (2001:67) explain that the source of data determines the data mart. As Gray and Watson (1998:104-105) states, a data mart may be:

- A subsidiary of a centralised data warehouse;
- Operate independently; or
- Integrated into a distributed data warehouse.

Each of these data mart architectures are referred to using specific terminology:

- A subsidiary of a centralised data warehouse is known as a dependent data mart; and
- A data mart that operates independently is known as an independent data mart
- A data mart integrated into a distributed data warehouse does not have a specific term assigned to it except that a number of data marts constructed in this way results in a distributed data warehouse. In this dissertation, this type of data mart will be referred to as an interdependent data mart.

These data mart architectures are explored in the following sections.

### 3.1.2.1. Dependent Data Mart

Data marts populated with data sourced from the enterprise data warehouse are called dependent data marts (Berson & Smith, 1997:124, and Han & Kamber, 2001:67). These are sometimes also called replicated data mart since the data mart is populated with a portion of the data warehouse's data through replication (Gray & Watson, 1998:104). This is depicted schematically in Figure 2.

By integrating data from various sources into a data warehouse and then letting the integrated data flow to a number of dependent data marts each containing limited content tailored to the needs of the departmental user community gives users the benefit without central co-ordination being sacrificed (Dodge & Gorman, 1998:572-573). The information provided to each data mart is determined by the departmental or divisional needs for centralised information. It is also possible for locally generated and used information to be stored in the dependent data mart. Furthermore, because the use is localised, alternative analytical tools to those used to access the underlying data warehouse can be used (Simon, 1998:4-5). What is important to note is that data is "never transmitted by the owner of the data mart to other portions of the organization" (Gray and Watson, 1998:105).

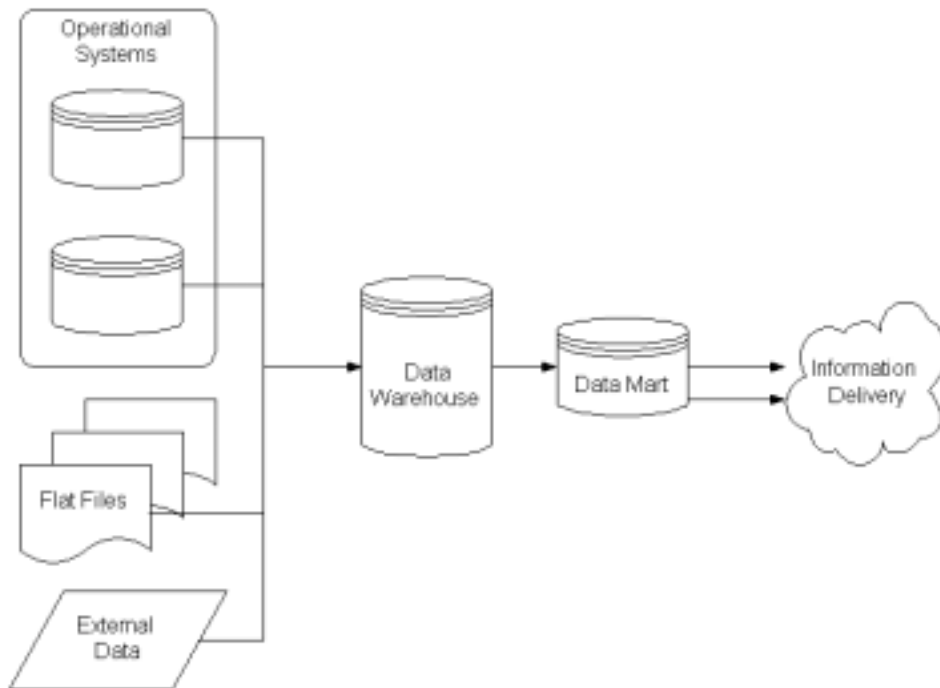

**Figure 2: Data flow when using a dependent data mart**

The dependent data mart architecture assumes enterprise data warehouse exists. History has shown during the past 10 years that successfully implementing an enterprise data warehouse is extremely challenging from a business and technical perspective (Friedman, 2002, and Han & Kamber, 2001:67). Examples of these challenges are (Simon, 1998:5):

- Technical challenges, for example, scalability issues, such as handling very large databases; and
- Business challenges, for example, cross-organisational cooperation that is usually needed for a data warehouse and the negative impact of corporate politics and determining the business value sought from the data warehouse and relating that value back to specific functionality and data needs.

The result was that data warehouses were either only partially deployed or deployed but never used because of problems such as data integrity, or cancelled completely.

### 3.1.2.2. Independent Data Mart

Problems with implementing an enterprise-wide data warehouse and the associated costs led to development of the independent data mart. Independent data marts are populated with data captured from one or more operational systems or external data sources, or with data generated locally within the



department (Han & Kamber, 2001:67). This is depicted in Figure 3. The result is, theoretically, that each department or division has its own data mart. This situation can result when vendors, unable to sell a data warehouse to the whole enterprise, sell scaled-down versions of their product as a data mart to a department or division.

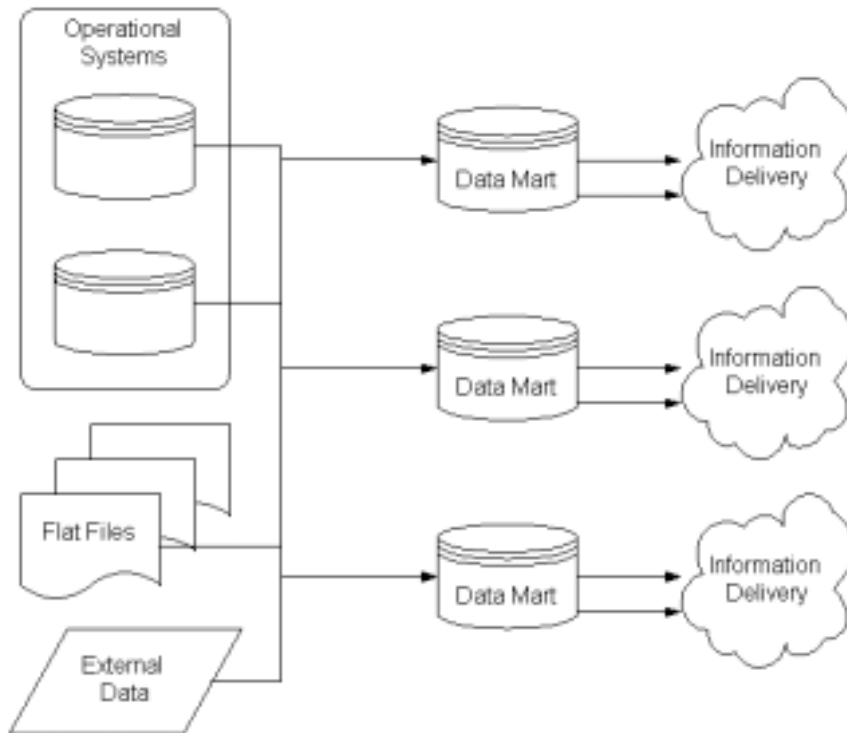

**Figure 3: Data flow when using independent data marts**

While solving the problem of the particular department or division, a stand-alone data mart can result in serious fragmentation in the organisation or so-called “islands of information.”<sup>1</sup> When data marts are not integrated with one another, they can generate inconsistent and conflicting data because for each independent data mart assumptions are made about how to consolidate the data, and the data across several data marts may not be consistent (Berson & Smith, 1997:125) with separate representations. These differences can be a result of different definition of terms, reporting periods, and time lags in recording information which is the reason that cannot be integrated with one another (Gray & Watson, 1998:104-105) or in identification of source systems or in the extract, reformatting, and summarisation processing (Dodge & Gorman, 1998:572). As Berson and Smith (1997:125) correctly state, the independent data mart architecture does not include what is central to the concept of data warehousing, namely data integration.

---

<sup>1</sup> “In some situations, building separate data marts may be a good solution if there is *no* intent to interact with other departments” (Microsoft Corporation, 1999:4). However, assuming no interaction will ever occur is a rather strong assumption.

According to Berson and Smith (1997:125) independent data marts should rarely be deployed within an overall technology or applications architecture since independent data marts “may involve complex integration in the long run if its design and planning were not enterprise-wide” (Han & Kamber, 2001:67). As Kimball *et al* (1998:18-19) states, the “bottom-up perspective is that an enterprise data warehouse can be assembled from disparate and unrelated data marts” which has been shown in practice not to be the case. This is confirmed by industry experts who have “acknowledged that, a majority of the time, data marts must be rebuilt entirely according to a conformed ... dimensional framework before they can be rolled up into a data warehouse successfully [see 3.1.2.3. ]” (Microsoft Corporation, 1999:4).

### 3.1.2.3. Interdependent Data Mart

In order to address the problems experienced with both the enterprise data warehouse together with the dependent data mart, and the independent data mart, a co-ordinated set of data marts are used where the planning and design is at an enterprise level (Han & Kamber, 2001:67).

According to Berson and Smith (1997:126) the “key to a successful data mart strategy is the development of an overall scalable data warehouse architecture; and the key step in that architecture is identifying and implementing the common dimensions.” Kimball, the proponent of the dimensional modelling approach, refers to the common dimensions as conformed dimensions: “the only ... way to combine the data from these separate tables and achieve an integrated enterprise data warehouse is if the dimensions of the data mean the same thing across these tables” (Kimball *et al*, 1998:18-19). Kimball’s conformed dimensions are explained by Berson and Smith (1997:125-126) as follows: “For any two data marts in an enterprise, the common dimensions must conform to the *equality and roll-up rule*, which states that these dimensions are either the same or that one is a strict roll-up [or subset] of another.” By predefining the characteristics of dimensions to be used throughout multiple interdependent data marts a conformity or dependency between data marts is created which allows for “easy rollup into an enterprise-level data warehouse” (Microsoft Corporation, 1999:4).

According to Kimball *et al* (1998:18-19) the only feasible solution is to blend the top-down or bottom-up approaches, where separate pieces, i.e., interdependent data marts, are designed guided by a proper architecture. As Poe *et al*, (1998:18) state, organisations may choose to “begin their corporate data warehouse project with a small pilot project for a specific subject area (business function). In so doing, those organizations have taken a bottom-up approach to the implementation of a decision support environment—and they have essentially created both a data mart and their first data warehouse simultaneously.”

This approach requires that a significant amount of work to be spent during the design of the first interdependent data mart in order to ensure future data marts can fit with the dimensions (Dodge & Gorman, 1998:572). If this is not done, the result will be multiple independent data marts. Note that the only difference between an independent and an interdependent data mart when building the first data mart is the intention and the design of the data model. The structure will appear the same when depicted diagrammatically. Figure 4 depicts diagrammatically the distributed data warehouse resulting from multiple interdependent data marts.

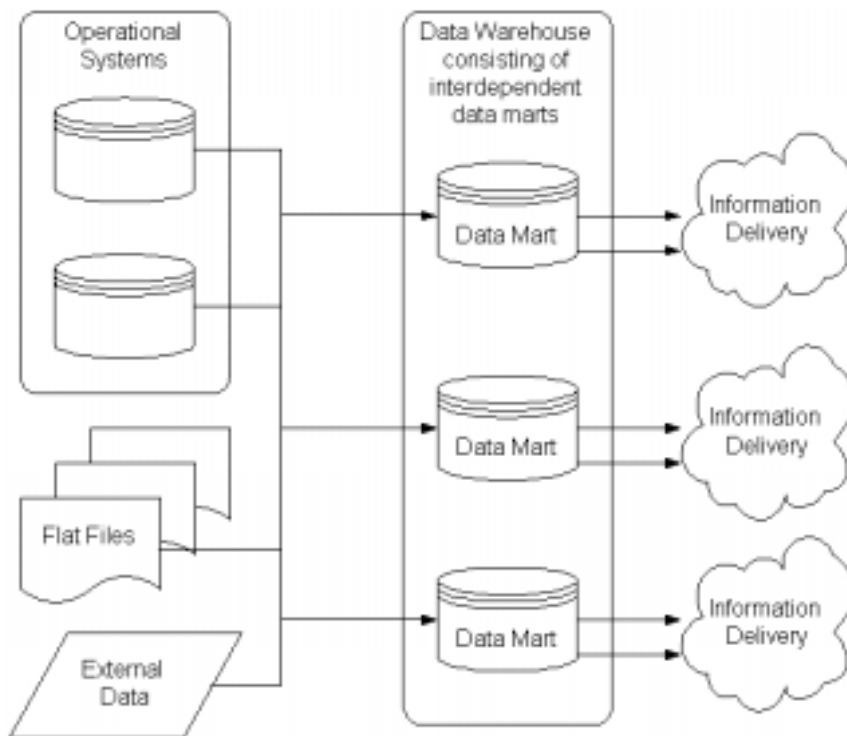

**Figure 4: Data flow when using interdependent data marts**

Two or more interdependent data marts result in a distributed data warehouse. This approach to data warehousing is preferred to a single enterprise data warehouse since it is possible to deliver a data mart to business users in a far shorter timeframe thereby lowering project costs which accelerates the return on investment (ROI). This also serves to gain credibility and get buy-in for further warehousing projects from management. Furthermore, the initial hardware costs are also much less costly than investing in the infrastructure required to support a large data warehouse (Martin, 1999). However, a distributed data warehouse is the result of planning: “Each data mart is assigned a specific set of information for which it is responsible. A central organization, such as IT, specifies the rules for the metadata so that the information kept by each mart is compatible with that provided by all the other marts” (Gray & Watson, 1998:104-105).

Figure 5 illustrates diagrammatically the distributed data warehouse from resulting from several interdependent data marts.

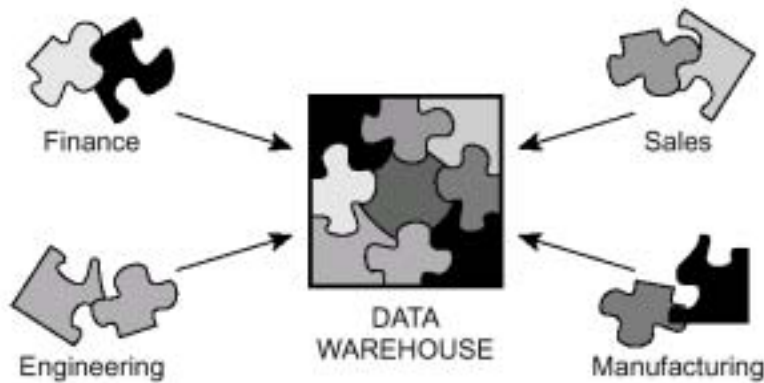

**Figure 5: Interdependent data marts resulting in a distributed data warehouse**

Against the above definitions and descriptions, a summarised comparison of a data warehouse and the different types of data marts are provided in Table 2.

	Data warehouse	Data mart		
		Dependent	Independent	Interdependent
<b>Scope</b>	Enterprise-wide	Subject or department		
<b>Basic architectural assumption</b>	Centralised	Centralised	Distributed	Distributed
<b>Size</b>	Up to several terabytes	Megabytes to gigabytes		
<b>Approach</b>	Top-down		Bottom-up	Middle-up-down
<b>Data source</b>	Operational systems	Underlying enterprise data warehouse	Operational systems	Operational systems
<b>Level of data</b>	Detailed	Summarised	Detailed and summarised	Detailed and summarised
<b>Next level of migration</b>	Data mart	Not applicable	Data warehouse	Data warehouse
<b>Distinguishing characteristics (if any)</b>	<ul style="list-style-type: none"> <li>Enterprise wide</li> </ul>	<ul style="list-style-type: none"> <li>Derived and aggregated</li> </ul>	<ul style="list-style-type: none"> <li>Independent</li> </ul>	<ul style="list-style-type: none"> <li>Shared, conformed dimensions</li> <li>Distributed data warehouse</li> <li>Independent and atomic</li> </ul>
<b>Benefits</b>	<ul style="list-style-type: none"> <li>Integrated</li> </ul>	<ul style="list-style-type: none"> <li>Quicker response times than data warehouse</li> </ul>		<ul style="list-style-type: none"> <li>Integrated by design</li> <li>Shorter development time</li> </ul>
<b>Drawbacks</b>	<ul style="list-style-type: none"> <li>Long development time</li> </ul>	<ul style="list-style-type: none"> <li>Requires enterprise data warehouse</li> </ul>	<ul style="list-style-type: none"> <li>Fragmentation of data</li> <li>Possible integration issues</li> <li>Multiple extracts for update/refresh</li> </ul>	

**Table 2: Comparison of data warehouse and types of data marts**

### 3.1.3. Relationship between Data Warehouse and Data Mart

From the quotations in literature, it is evident that there is a relationship between the concept of a data warehouse and the concept of a data mart. In particular, dependent data marts form part of the overall data warehouse environment and derive their data from the data warehouse. Independent data marts are constructed in lieu of a data warehouse but are built on the same principles. In the case of interdependent data marts, the collection of data marts *is* the data warehouse. It is also worthwhile to note the following statement by Gray and Watson (1998:103) in this regard:

*“The dichotomy between a data warehouse and a data mart is partially dependent on the size of the organization. A large organization’s data mart may well be a small organization’s data warehouse.”*

Furthermore, as Watterson, quoted in Turban *et al* (2001:437), states data marts “ can be a substitution for a data warehouse or they can be in addition to it, holding only part of the data warehouse content”

This relationship is succinctly described in the following excerpt by Microsoft Corporation (1999:4), a vendor of data warehousing software:

*“Both data warehouses and data marts describe the process of collecting data from other sources. Data is summarized into a read-only format that is convenient for querying and analysis. ... Both data warehouses and data marts have the common objective of better business decisions through better use of data.”*

Simon (1998:4) corroborates this statement:

*“You develop a data mart for the same reason you develop a data warehouse: to provide a consolidation of data regardless of platform, geographic, application, and organizational barriers. And once you’ve consolidated that data, you have created an environment that will provide users with business intelligence.”*

Logically and by definition, therefore, the terms *data warehouse* and *data warehousing* encompass that of a *data mart*, a data mart being a data warehouse with more particular characteristics. A data mart is, therefore, conceptually and theoretically a subset of a data warehouse although the boundaries are increasingly being blurred. This is illustrated in Figure 6.

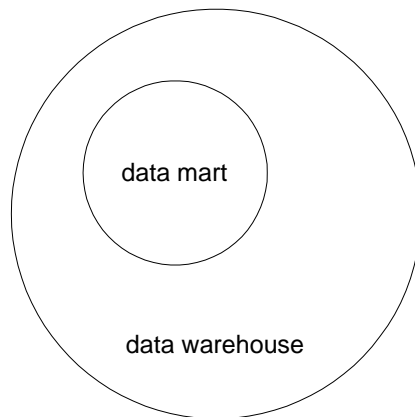

**Figure 6: Relation of a data mart to a data warehouse**

In literature, reference to a data warehouse frequently also imply reference to a data mart. Throughout the text, whenever reference to a data warehouse or data warehousing is made this must be taken to also apply equally to a data mart except where explicitly indicated otherwise.

### **3.2. Advanced Analytical Tools to Access Data Marts**

The data mart, as physically stored in the database, is not accessible to users in a user-friendly manner. In order to access the data contained within the data mart one or more front-end tools is required. Advanced analytical tools serve this purpose, namely, to “provide a graphical user interface to the data warehouse. The user will interact directly with the table structures, sometimes with a layer of abstraction to allow him or her to assign business names to the different tables and columns” (Poe *et al*, 1998:23). Berson and Smith (1997:120) confirms this view: “[t]he principal purpose of data warehousing is to provide information to business users for strategic decision making. These users interact with the data warehouse using front-end tools.” This is reiterated in a white paper of Daphnesoft (2001:78), which states that a “data warehousing solution would be imperfect without an efficient data access tool that provides business intelligence.”

According to McKinnon and Bruns (in Butcher, 1998:15) “most managers prefer to have facilities available to enable them to design their own reports or at least have someone design them with their specific needs in mind.” Similarly, Mintzberg (1975) points out, formal information systems tend to aggregate data and, as a result, a lot of the available information is too general to be of much use. Designers of systems seem to believe that data must be aggregated in order not to swamp the manager with information but in doing so the data often ceases to be of use to the individual manager” (in Butcher, 1998:15). This is illustrated in

Figure 7. Thus the term data mart refers to this complete architecture, i.e. the back-end, the data mart itself as created in the database, and the front-end tools.

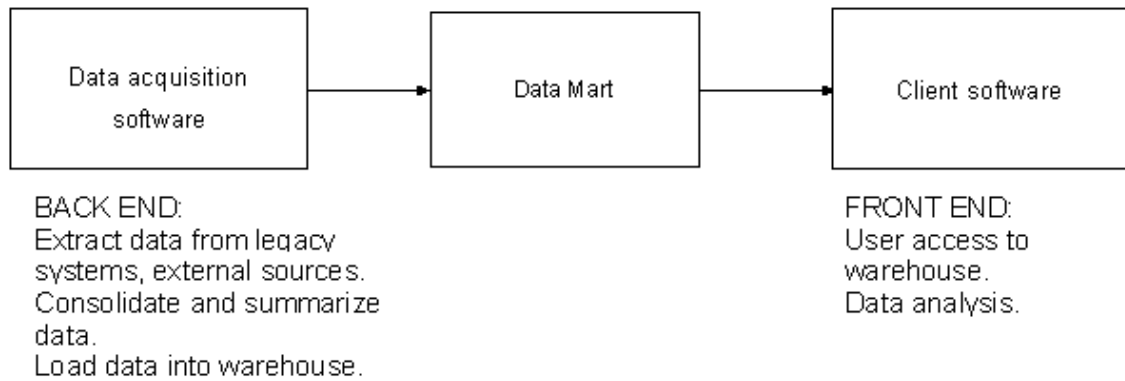

**Figure 7: Architecture of data warehouse, independent or interdependent data mart (Gray and Watson, 1998:17)**

The particular analytical tool(s) chosen depends on the nature of the user requirements. Users who fulfil different tasks have different requirements and even users who fulfil the same task may have different requirements to execute the task. Analytical tools will offer differing functionality, which will satisfy user requirements. Analytical or access tools can be divided into groups or classes based on the specific user needs each fulfils. Whilst this classification is useful for discussion purposes, it is a simplification because a single product can serve multiple purposes (Gray and Watson, 1998:123). Table 3 contains a comparison of the different classes of data warehouse access tools found in literature together with the consolidation of these classifications for use in this dissertation.

Gray and Watson (1998:123)	Berson and Smith (1997:223)	Tanler (1997:95)	Poe (1998: 233-234)	Consolidation of classifications
Queries	Reporting	Query and Reporting	Data Access/Query Tools	Query and reporting
Managed query environments	Managed query		Report Writers	
Executive information systems	Executive information (EIS)		Executive Information Systems (EISs)	
Decision support systems	On-line analytical processing	Multidimensional analysis	Multidimensional Database Management Systems [MOLAP] Advanced decision support tools	OLAP
Data mining	Data mining	Data mining (agent processing) Statistical analysis (user-directed)		Data mining

**Table 3: Comparison of classes of data mart access tools with consolidation**

This consolidation of data mart access tool classifications is discussed in detail in the sections below. It is important to note that, as Alter (1999:160) states: “the categories are not mutually exclusive ... information system categories often overlap and change as new applications combine new capabilities with old ones.” Furthermore, “Any discussion of types of information systems faces a difficult problem because categories simply won’t hold still” (Alter, 1999:160).

### **3.2.1. Query and Reporting**

The aim of query and reporting tools are to allow users to retrieve and present information from the data mart to perform some pre-defined or ad-hoc analysis.

Characteristics of query and reporting tools include:

- Define and build typical structured or standard reporting;
- Build customised reporting;
- Provide graphic capabilities to present the results;
- Support for exception reporting facilities;
- Includes both straight query tools, which allow direct access to the data itself, and managed query environments, where a metadata layer provides a business-oriented interface between the user and the data;
- Can store and reuse queries;
- Ability to support stored shared queries and to share results;
- Ability to perform consecutive queries on saved results;
- Ability to estimate and limit query size and response time;
- Ability to cancel a query;
- Provides dissemination of information, such as support for distribution of results through e-mail;
- Used to analyse metrics and business indicators; and
- Accesses summarized information with the ability to drill down.

### **3.2.2. Online Analytical Processing**

The aim of an online analytical processing (OLAP) tool is to allow users to intuitively navigate and analyse information along business dimensions, independent of the way the data is stored, and highlighting the underlying reasons or causes for business issues and opportunities. These tools are also sometimes referred to as advanced decision support tools (Poe *et al*, 1998:23). They are designed for unstructured problem solving.



Characteristics of OLAP tools include:

- Provides analysis of data including scenario, trending, time series and what-if analysis;
- Presence of traffic lighting and exception reporting facilities;
- Includes predefined, semi-structured queries allowing variable constraints on limited data;
- Includes functional or vertical applications (for example, campaign management);
- Provides guided analysis of summarised, aggregated data along a series of dimensions such as time, product, geography, etc.;
- Used in forecasting and planning;
- Allows trending, slicing, rotation or pivoting, drill down, drill through, etc.;
- Supports an iterative process most business analysts use, where asking and answering one question generates three or four additional questions;
- Presents data graphically to improve its comprehension; and
- Provides ability to comprehend massive amounts of data or data with complex interrelationships.

The functionality of OLAP tools can best be illustrated with the concrete examples in Table 4.

Function	Example
Track performance	Sales for a specific region
Provide different views	Receivables by month vs. receivables by customer
Arrange information	Top 10 account representatives

**Table 4: Examples of OLAP tool functionality**

### 3.2.3. Data Mining

Data mining is a “decision support process in which we search for patterns of information in data” (Information Discovery, Inc. 2001:198), i.e. the discovery of meaningful new patterns, relationships and trends in large volumes of data stored in a database or data mart by using pattern recognition technologies and statistical and mathematical techniques (Mattison, 2001:181). The two main types of models used in data mining are:

- Descriptive models, which describe patterns in existing data to guide decision making; and
- Predictive models, which use data with known results to explicitly predict result values for different sources of data.

According to Pelletier and Todaro, (2000:1) data mining tools are “especially important for marketing departments because marketing efforts succeeded when they single out customer segments with high profit potential” which required manually analysing large volumes of data.

Characteristics of data mining tools include:

- Provides exploratory analysis for expert analysts and statisticians;
- Discovers hidden patterns, trends, relationships, and predictive indicators;
- Users must understand how to condition data and structure and manage queries, including knowledge of various data mining techniques;
- Desktop tools provide graphical interface to statistical modelling techniques;
- Presents data graphically to improve its comprehension; and
- Provides ability to comprehend massive amounts of data or data with complex interrelationships.

The functionality of OLAP tools can best be illustrated with the concrete examples in Table 5.

Function	Example
Uncover relationship	Percentage of new home buyers that also buy ovens
Assemble profiles	Prospective customers
Predict behaviour	Characteristics of customers that are likely to defect

**Table 5: Examples of data mining tool functionality**

Once the rules and patterns associated with a particular business problem have been discerned, this logic can be embedded into a production application. Users see results of the rules being applied to data, such as identification of a customer at risk to defect, or to automatically score prospects or customers to determine their receptivity to a new product.

Although there are different points of view on where the repository or database for data mining resides, this is beyond the scope of this dissertation. However, the dissertation is based on the assumption that this repository resides within the data mart with data mining tools sourcing data from the data mart. For more detail on other options, including above or beside the warehouse, refer to Information Discovery, Inc. (2001).

Based on the above discussion, the range of end-user functionality required and the tools that satisfy these can be summarised on a continuum as depicted in Figure 8.

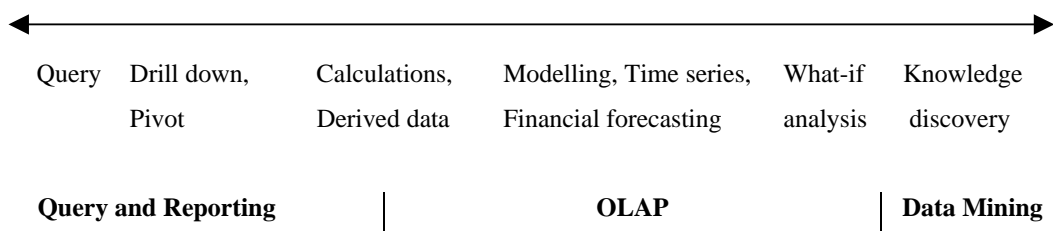

**Figure 8: High-level spectrum of functionality addressed by query and reporting, and OLAP tools**

### 3.3. Nature of Usage

Swift (2000) discusses the evolutionary use of a data warehouse or data mart. This use progresses through three stages, starting with reporting. Even reporting from the data warehouse to determine what happened, mostly through predefined queries, “provides new views and an ability to use combined, cross-organisational detailed data to understand the past” (Swift, 2000). The second stage of use is characterised by analysis focusing on reasons for what happened. The final and most sophisticated stage, also presenting the most competitive advantage, is predicting what will happen by means of analytical techniques. These stages are summarised and mapped against the different classes of access tools in Table 6.

<b>Stage of use</b>	Reporting	Analysis	Prediction
<b>Class of Access Tool</b>	Query and reporting	OLAP	Data mining

**Table 6: Mapping of stages of data mart use (Swift, 2000) against class of access tool**

Reporting and analysis both seek to answer questions that are historical or focused on the past whereas prediction is focused on the future. This distinction in focus can be formulated more firmly. Deductive tools support the “process of applying specific—though probably ad hoc—questions against the available data” (3Com, 2001:38) whereas inductive tools support the “process of interrogating the available data before a specific questions has been formulated” (3Com, 2001:39). Thus reporting and analysis using query and reporting and OLAP tools are deductive in nature whereas prediction using data mining tools is inductive in nature. This is summarised in Table 7.

<b>Deductive</b>	Query and reporting
	OLAP
<b>Inductive</b>	Data mining

**Table 7: Categories of end-user application classifications**

The natural progression from reporting to analysis to prediction normally takes place over time. One would expect that the simplest needs, i.e. reporting needs would be satisfied first before progressing to analytical needs and again, satisfying analytical needs before progressing to predictive needs. In line with this expectation, the most common tools in use today in organisations are query and reporting, and OLAP tools. There is, however, growing interest in the potential of data mining and statistical tools, and artificial intelligence, for example expert systems to automate increasingly decision-making with larger organisations particularly in the financial and retail industries utilising advanced analytical techniques for prediction.

In order to further illustrate the purpose and use of these tools, examples of information requirements each tool is capable of satisfying is given for two functional areas within an organisation, namely sales and marketing, and manufacturing in Table 8.

Use	Access Tool	Sales and marketing examples	Manufacturing examples
<b>Reporting</b>	<b>Query and reporting</b>	<ul style="list-style-type: none"> <li>• Weekly sales report by product by region</li> <li>• Consolidation of sales projections by product, region, and sales representative</li> <li>• Flexible access to sales data by product and region</li> </ul>	<ul style="list-style-type: none"> <li>• Weekly production report by production and operation</li> <li>• Determination of planned purchases based on a production schedule</li> <li>• Flexible access to production data by product and operation</li> </ul>
<b>Analysis</b>	<b>OLAP</b>	<ul style="list-style-type: none"> <li>• Marketing data and models to analyse and forecast sales</li> <li>• System helping insurance sales people test alternative policies</li> </ul>	<ul style="list-style-type: none"> <li>• Production data and models to analyse production results</li> <li>• System displaying current priorities for machine operator</li> </ul>
<b>Prediction</b>	<b>Data mining</b>	<ul style="list-style-type: none"> <li>• Profit generating potential of customers based on profiles</li> <li>• Product placement in retail space</li> </ul>	<ul style="list-style-type: none"> <li>• Learning patterns and sequences of faults on a production line to predict downtime</li> </ul>

**Table 8: Examples of information requirements by access tool and functional areas (based on Alter, 1999:163)**

The use of data warehousing also differs according to the industry in which it is used. The use determines the nature of the questions to be answered and will therefore determine the data mart access tool selected.

Table 9 summarises the strategic uses of data warehousing.

Industry	Functional Area	Applications / Use
Airline	Operations and Marketing	<ul style="list-style-type: none"> <li>• Crew assignment</li> <li>• Aircraft deployment</li> <li>• Mix of fares</li> <li>• Analysis of route profitability</li> <li>• Frequent flyer programme promotions</li> </ul>
Clothing	Distribution and Marketing	<ul style="list-style-type: none"> <li>• Merchandising</li> <li>• Replenishment</li> </ul>
Banking	Product Development, Operations and Marketing	<ul style="list-style-type: none"> <li>• Customer service</li> <li>• Trend analysis</li> <li>• Product and service promotions</li> <li>• Reduction of IS expenses</li> </ul>
Personal Care Products	Distribution and Marketing	<ul style="list-style-type: none"> <li>• Distribution decision</li> <li>• Product promotions</li> <li>• Sales decision</li> <li>• Pricing policy</li> </ul>
Retail Chain	Distribution and Marketing	<ul style="list-style-type: none"> <li>• Trend analysis</li> <li>• Buying pattern analysis</li> <li>• Pricing policy</li> <li>• Inventory control (maintaining exact levels)</li> <li>• Location-targeted sales promotions planning</li> <li>• Optimal channel distribution</li> <li>• Vendor pricing and performance analysis</li> </ul>
Steel	Manufacturing	<ul style="list-style-type: none"> <li>• Pattern analysis (quality control)</li> </ul>
Telecommunications	Product Development, Operations and Marketing	<ul style="list-style-type: none"> <li>• New product and service promotions</li> <li>• Reduction of IS budget</li> <li>• Profitability analysis</li> </ul>

**Table 9: Summary of strategic uses of data warehousing in selected industries (Turban et al, 2001:440), (Sharma, 1997:18)**

## University of Pretoria, etd - Ponelis, S

It is clear that data warehouses and data marts are used in variety of functional areas. The use of data warehousing, independent of the industry in which it is applied, is summarised accurately by Norris *et al* (2000:105), stating that it allows organizations to:

- Improve customer marketing;
- Streamline business operations; and
- Better understand and forecast their financial position.

Based on Table 9, the functional areas for which data warehousing is used include:

- Distribution and marketing;
- Manufacturing;
- Operations and marketing; and
- Product development, operations and marketing.

Marketing is an important area of application for data warehousing. This is confirmed by the applications for which data warehouses and data marts are used in organisations listed in Table 10.

Applications	Percent of Market (%)	Related to Sales and Marketing
Financial analysis	11	
Customer marketing	10	✓
Product performance	8	✓
Sales force analysis	8	✓
Quality	8	
Promotion/marketing campaigns	7	✓
Risk management	6	
Vendor performance/partner management	6	✓
Churn analysis	6	✓
Category management	6	✓
Market basket analysis	6	✓
Supply chain analysis	6	
Fraud detection	5	
Other	3	
Yield analysis	3	
Network/traffic pattern analysis	2	

**Table 10: Applications for which data warehouses and/or data marts are used (Palo Alto Management Group, 2001:278)**

The functional area that is particularly dominant is marketing, listed for each of the industries, and with more than 50% of the applications of sales and marketing-related focus (indicated in Table 10), which accounts for 57% of the market. According to Turban *et al* (2001:452) the data warehousing applications with the highest impact are found in the area of marketing.

According to a study by Palo Alto Management Group (2001:281), the most prominent driving forces for investing in data warehousing and related solutions are to:

- Improve the decision and/or management processes;
- Satisfy the need to maintain a competitive edge;
- Reduce the operating costs;
- Improve customer service;
- Retain customers; and
- Identify new customers.

Among these most prominent driving forces customers feature prominently—integral to the sales and marketing function. The importance use of data warehouses are echoed by Schroek (1998), who comments that the positive impact of marketing data warehouses “can be measured as the ability to:

- Attract new customers through target marketing;
- Retain “at-risk” customers through advanced churn analysis, letting companies take action before losing customers;
- Reduce costs through fraud detection programs;
- Provide better customer service by collecting all customer activity and making the information available; and
- Improve financial results through detailed customer and product profitability analysis and activity-based management.”

Tanler (1997:7) states that “[m]arketing data warehouses are designed to allow users to evaluate the business performance of a product or service from multiple perspectives.” According to Sharma (1997:17), the increase in sales revenue by leveraging detailed data was “initially the dominant factor, accounting for 80% of the motivation to invest in data warehousing. ... Only 20% of the motivation was process-oriented (in other words, the business need for more detailed information is to support operations).”

According to the definitions, a subject-specific data warehouse is a data mart. Therefore, referring to a marketing data warehouse is, by definition, a contradiction. The author suggests that it could rather be called a customer-centric data warehouse within this context where the entire data warehouse is focussed entirely on customers. For example, a marketing data mart may be limited to customers, items, and sales (Han and Kamber, 2001:67).

Organisations worldwide are using data warehousing solutions to “achieve strategic advantage by gaining better and more timely access to information about their business, products, customers and competition” (Schroeck, 1998). Examples illustrating the use of data warehousing solutions are:

- “A pharmaceutical company analyses the results of its recent sales force activity to improve targeting of physicians who should be first contacted; it also determines which marketing activities will have the greatest impact in the next few months. The data include competitor market activity as well as information about the local health care systems. The results are distributed to the sales force via the Internet, intranets, or a private wide-area network that enables the representatives to review the decision-making recommendations” (Turban et al, 2001:455).
- “A large consumer package goods company applies data mining to improve its sales process to retailers. Data from consumer panels, shipments, and competitor’s activity are examined to understand the reasons for brand and store switching. Through this analysis, the manufacturer can select promotional strategies that best reach its target customer segments” (Turban et al, 2001:455).
- “Supermarket chains regularly analyze reams of cash register data [normally referred to as point-of-sale or POS data] to discover what items customers are typically buying at the same time. These shopping patterns are used for issuing coupons, designing floor layouts and products’ location, ... and creating shelf displays” (Turban et al, 2001:454).
- “Many manufacturing companies, including Polaroid, and retail organizations, such as Target Stores, have very sophisticated product data warehouses that are designed specifically to support their marketing operations. Both organizations are attempting to improve total product sales by improving the quality of the information available for the thousands of decisions that are necessary to continuously improve the marketing of products in dynamic and highly competitive businesses” (Tanler, 1997:7-8).

Furthermore, Tanler (2000) indicated that data warehouses must operate outside the boundaries of a single enterprise and that “extending the boundaries of data warehousing ... has the potential to change the rules for how a company operates and competes.” Thus, a data warehouse or data mart can play an important role in making data received from channel partners available to users. When data is sourced from channel partners, i.e., the data source is located outside of the organisation’s boundaries, there are a number of options for integrating this data into the organisation’s information systems.

### 3.4. Using Data Provided by Channel Partners

Given the requirement for integration between different organisations discussed in **Error! Reference source not found.** and the types of systems discussed in this chapter, there are a number of possible options for the inclusion of data received from channel partners involving either the operational or analytical, i.e., the data warehouse or data mart, systems or both. This discussion on the use of data provided by channel partners is particular to a third party logistics provider, such as a distributor, providing data to a manufacturing organisation.

The generally ideal, theoretically acceptable model is for data from the distributor’s operational system to be interfaced into the manufacturer’s operational system. There can be no analytical system at either organisation implying the use of operational reporting capabilities or an analytical system at either or both organisations which is populated with data from the operational systems. This is depicted diagrammatically in Figure 9. A critical component of this option is the “alignment is the existence of open-system computer architectures that provide for the seamless interlinkage of business systems with other enterprise operational system, thereby unifying the marketing, production, and distribution activities of the entire supply channel” (Ross, 1998:53).

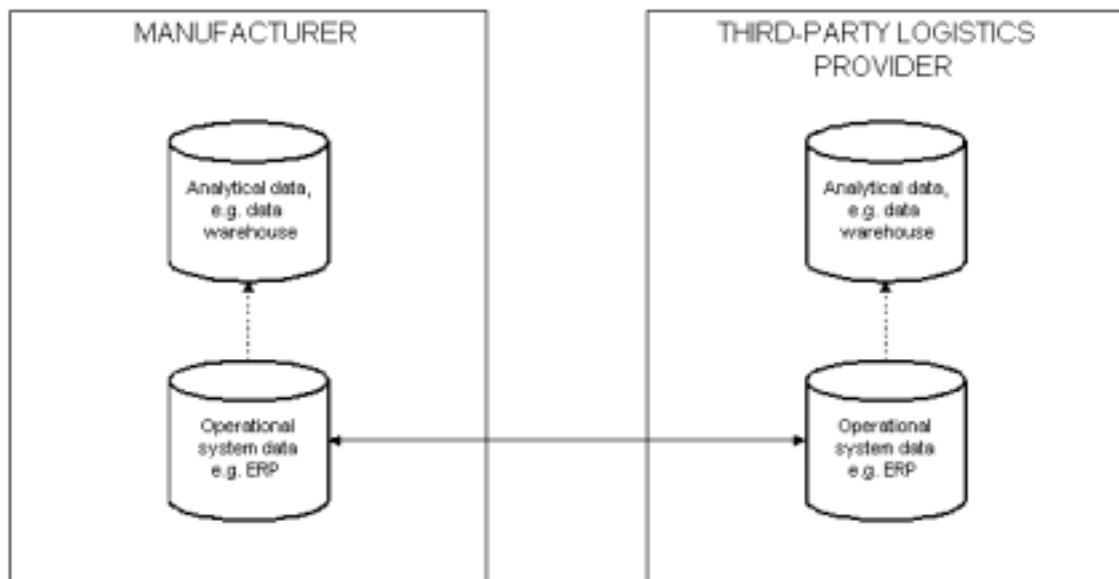
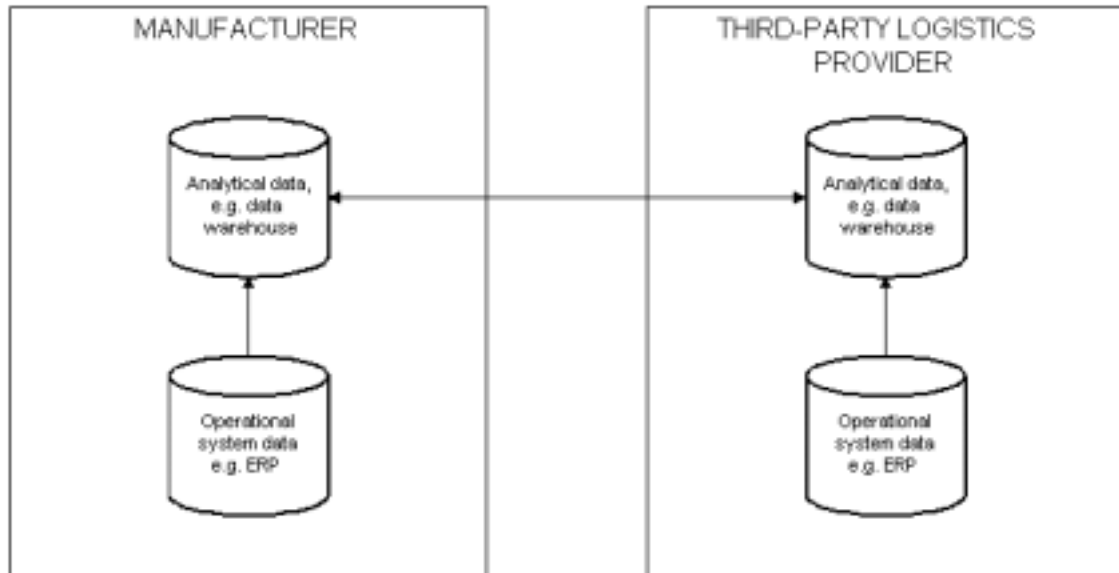

**Figure 9: Data flow between organisations’ operational systems**

The second option is, rather than exchange data at the operational level, to exchange data at an analytical level. Here the data used for management information purposes only is interfaced, generally by means of the use of metadata through, for example, XML. This is depicted diagrammatically in Figure 10. This



option can exhibit some of the operational functionality of the first option if data is fed into the operational system(s) from the analytical system.



**Figure 10: Data flow between organisations' analytical systems**

The third option is for the operational data from the data from the third party logistics provider to be fed into the analytical system of the manufacturer. This is depicted diagrammatically in Figure 11. Although the first two options above are theoretically acceptable and clean solutions, this option is a hybrid solution not found in literature, either academic or trade. However, this option does occur in practice. The 3PL's operational system is treated as a source system similar to the manufacturer's in-house operational systems rather than having to include the data in an in-house operational system first.

In order to illustrate the use of data marts within this context further, the next chapter examines two case studies in the pharmaceutical and branded consumer products industries where data originates in systems outside the organisational boundaries utilising the third option, namely the hybrid solution, to utilise data sourced from a channel partner, namely a third party distributor.

### 3.5. Chapter Conclusion

The data warehouse, specifically the marketing data mart, by its very nature, is the repository where customer data are integrated from where it is analysed. A data mart is accepted to be a departmental and/or subject-specific data warehouse with a shorter implementation timeframe than a data warehouse of 3 to 6 months. Data marts were previously defined by its size but this is no longer generally accepted. The attraction of data marts lie in this rapid development, as it is a less costly alternative to the data warehouse to provide a subset of enterprise data to users. Data marts can either be dependent on a data warehouse as a

data source or independent, receiving its data from one or more operational systems. A data mart also encompasses one or more access tools, which allows end-users to access the data contained in the data mart

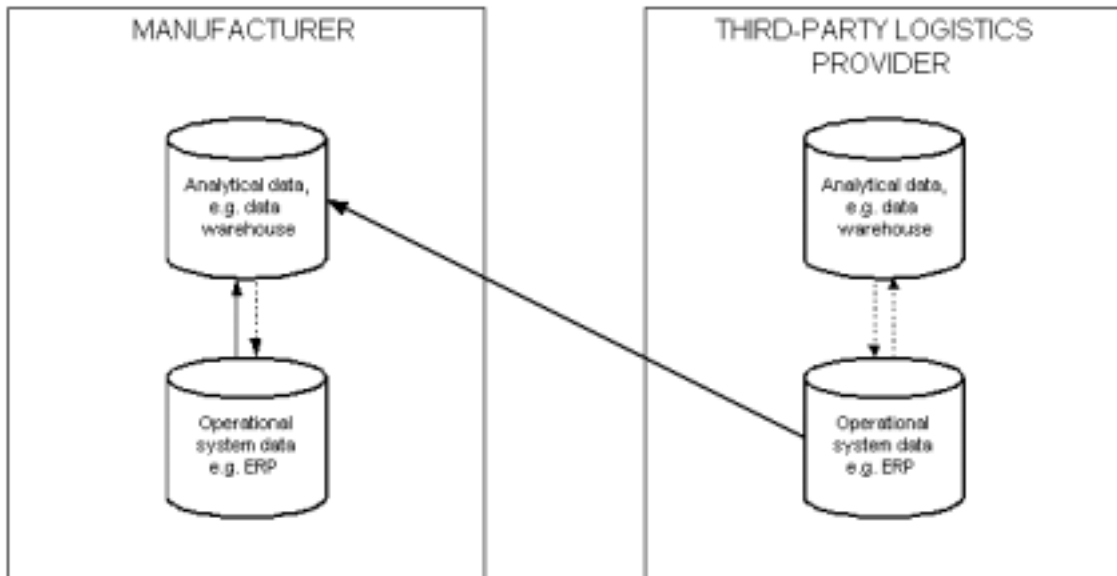

**Figure 11: Data flow from one organisation's operational system to another's analytical system**

database. These access tools can be divided into one of three main categories, namely, query and reporting, OLAP, and data mining. Each of these categories serves a particular purpose in delivering management information. Data warehouses and data marts are predominantly built for sales and marketing applications. In addition, data warehouses and data marts can play a vital role in making the data received from channel partners available in an organisation.