

CHAPTER 5: BRIEF AND PROGRAM

P.	64	CRITERIA FOR SITE SELECTION
	65	LIST OF PROBLEMATIC ASPECTS
	67	TENURE AND POTENTIAL FUNDING
	67	INTERESTED AND AFFECTED PARTIES
	69	PROGRAM
	71	INHABITING THE BOUNDARY WALL
	72	CASE STUDY: PROGRAMMATIC FORM
	76	CASE STUDY: INDUSTRIAL FORM

Criteria for site selection

In Chapter 2 the theoretical site of interest is identified as the urban port, which is host to action, event and the meeting of global and local form identities. Of the various functions along the Maputo Port strip of land, the Maputo Fisheries Port (MFP) is seen to have a diverse spectrum of economic role players: the site is host to both the commercial fisheries sector as well as the artisanal. Industrial fishing boats collect and process their harvest in the fisheries warehouse and the bulk of this harvest is exported. Local artisanal fishermen negotiate the sale of the harvest to agents on the ground who then, in turn, sell the fish to the general public either on the street outside the harbour in the afternoon or at one of the various markets within the city.

Within the framework of port redevelopment the MFP is selected as the site for the design investigation due to the fishing industries strong links to the general public. This has bearing on two aspects of the design:

1. An opportunity to make portions of the MFP public.
2. An opportunity to redevelop the site without replacing its port functions, thereby strengthening the marine identity of the area.



Figure 5.1: Informal street eatery outside the Maputo Fisheries Port on Marques de Pombal Street.

List of Problematic Aspects

Tomas Nyambir (2002: 9-15) names potential opportunities for the improvement and development of the MFP. Although he wrote the text a decade ago it is still applicable today as the port remains largely unchanged. For this reason several of Nyambir's observations and recommendations form part of the design brief for the redevelopment of the MFP:

- The bay of Maputo is surrounded by the fishing villages of Matola, Catembe and Inhaca. With Maputo inner city as a main centre for distribution and sale of fish, the MFP is a primary location for fishermen from these villages to unload and sell their catch and to prepare boats for sail. While the majority of boats using the harbour are artisanal and concerned primarily with local distribution, the facilities provided are strongly geared towards the handling of frozen fish (as mass commercial produce). The harbour has minimal facilities catering towards local distribution - where the demand is high for fresh, iced produce - for these reasons the harbour is under utilized (Nyambir, 2002: 12). Furthermore the local distribution of fish into Maputo is given little platform within the harbour with the majority of fresh fish sales marginalised to just beyond the fence on the street's edge (figures 5.6 -5.8). This is read as a primary example of a functional segregation of scales of economy between the port and the historic core of the Baixa (discussed in the 'Outline of the Study' in chapter 1).
- Nyambir also observes: ***Insufficient attention [is] paid by fishing port authorities to the importance of the urban quality surrounding the port and of how port-related activities can be transformed into new opportunities for leisure and recreation to open up the city to tourists.*** (Nyambir, 2002: 13).



Figure 5.2: Image showing trawlers landed in the Maputo Fisheries Harbour.



Figure 5.3: Image showing dhows landed in the Maputo Fisheries Harbour with trawlers in the background.

Tenure and Potential Funding

The Mozambican government maintains ownership of the MFP which is managed by the Ministry of Fisheries. The Ministry works closely with various financially independent organisations that fund developments within the fisheries sector. Some of these include the Fisheries Development Fund, the National Fisheries Research Institute and the National Small-scale Fisheries Development Institute. The primary benefactor of the project is likely to be the Small-scale Fisheries Development Institute due to its aim of improving facilities for small-scale artisanal fishermen.

Interested and affected parties

The following agents influence and determine the brief and program for the design investigation:

a. Port Management and Administration: Presently the artisanal fishing sector of the MFP is poorly managed. There is little up to date information regarding the number of boats landed in the harbour as well as details on the type and volume of fish caught. This lack of information is potentially harmful to the long term sustainability of the fisheries sector - specifically the lack of regulation of threatened species and harvesting methods. By providing facilities for management and researchers in close proximity to a new fish processing facilities this poor management is intended to be alleviated. By improving communication across these lines, management gains access to the knowledge of local fishermen regarding potentially illegal foreign harvesting and other activities within the Mozambican waters.



Figure 5.4: Recent extension of fish sale area at the Maputo Municipal Market



Figure 5.5: Fish sale area at the Maputo Municipal Market

b. Local Fishermen: As already stated there is a need for the provision of processing facilities intended for local sale and consumption. These facilities include ice, temporary chill storage and adequate auction space for the sale of large quantities of fish. Artisanal fishermen mainly use one of two types of vessels, namely, small scale trawlers (figure 5.2) and dhows (figure 5.3). Those using dhows are involved in the transfer of more than just fish. After unloading their catch, they often stock up with supplies for their local villages. The trawlers are more exclusively involved with the handling of fish and therefore often dock over night.

c. Fish traders: The daily afternoon sale of fish from the harbour occupies the street fronting the MFP (figures 5.6 - 5.8) These traders are mostly women, some of whom are the relatives of fishermen whilst others act as independent agents. The street represents a space where trade is free and no rent is paid, however, these traders battle with a lack of adequate access to fresh water, a lack of ice and a lack of waste disposal. This lack of facilities coupled with the outdoor and exposed condition of street vending lead to frequent spoiling of portions of the catch that aren't sold promptly.

Program

The program for the design investigation is an extension and accommodation of existing activities on the site as well as a provision for the problems identified in this chapter. The building can therefore be described as a **Fish Processing, Auction and Public Distribution Centre** and can be divided into zones according to this description. The intention is that these zones (processing, auction and distribution) relate to a common set of urban infrastructure as well to a common urban design spatial gesture but that they behave independently with a freedom of expansion, flow and movement around and between them.



Figure 5.6: Informal street eatery outside the Maputo Fisheries Port on Marques de Pombal Street.



Figure 5.7: Informal afternoon street fish market outside the Maputo Fisheries Port on Marques de Pombal Street. Scene 1



Figure 5.8: Informal afternoon street fish market outside the Maputo Fisheries Port on Marques de Pombal Street. Scene 2

Inhabiting the boundary wall

In Chapter 4 (with reference to figure 4.3) the fence at the entrance to the MFP is largely criticised as an poor response to the surrounding urban form, it is further criticised for its exclusion of the general public from an event that it has a direct relation to. The reasons for the establishment of fences in a private economic sector cannot, however, be wholly ignored. These reasons include security and the exclusion of public from semi industrial, potentially hazardous activities.

While the intention of the design investigation is to make the harbour accessible to the general public, there is still a need for the restriction of certain areas. The idea is that portions of the design become a so called 'inhabitable wall'; serving as an infrastructure to trade and simultaneously functioning as a barrier of exclusion and security for restricted portions of the harbour.

Today the wall is a machine for guarding land against occupation by the poor, the masses... The property line, originally a concept and abstract legal division designed to divide, enclose, and exclude, has materialised into a vertical wall whose surface has become an attractor for use, contamination, and the establishment of new economies. The wall has come to be taken for granted as an infrastructure that supports and serves a host of economies and small-scale industries. The wall itself can be used as the support for carpets, or security gates; in conjunction with a drain, it forms a thickened swath of space between the plot/compound and the street. This space is occupied by vulcanizers, petty traders, and can even accommodate sleeping in its width. The wall can also become a three-dimensional barrier, with a depth of 3 to 4 feet, that can be used as a marketable space. (Koolhaas et. al., 2001: 663)

CASE STUDY: PROGRAMMATIC FORM

Fish Market, Benicarló, Spain

GPS Location: 40°24'46.43"N; 0°25'53.48"E

Project Team :

Architects: Eduardo de Miguel & José María Urzelai

Developer: Valencian Regional Government,
Infrastructure and Transport Ministry

Surveyor: David Navarro

Contractor: CYES

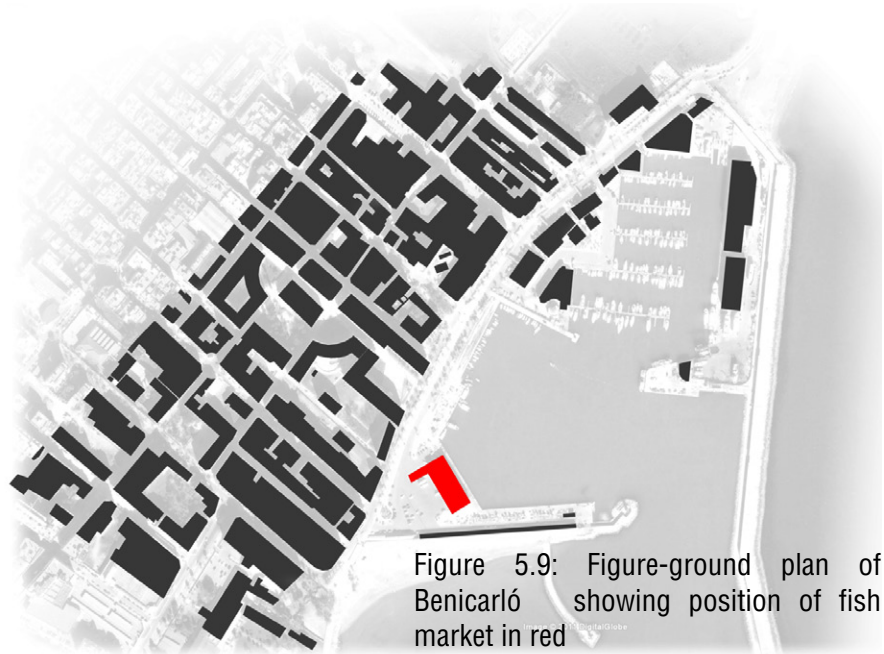

Figure 5.9: Figure-ground plan of Benicarló showing position of fish market in red



Figure 5.10 (left): Exterior view of collections side of building.



Figure 5.12 (right): Exterior view of fish market from street.

The building was intended to be forceful, displaying itself as infrastructure and gathering around it all the land-based fishing-related activities.
(Miguel, 2007: 38)



Figure 5.11 (left): View showing the internal and external skin of fish market building.

Figure 5.13 (right): Exterior view of deliveries and unloading side of building.

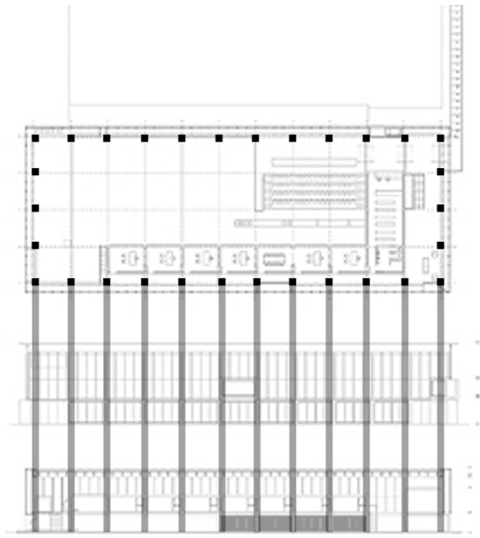

Figure 5.14: Structure diagram: columnar perimeter to reveal planar void in centre

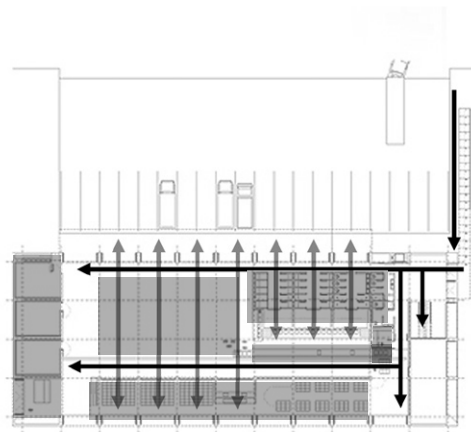

Figure 5.15: Circulation to use diagram



Figure 5.16: Repetitive to Unique diagram: the primary structure is revealed in repetitive rhythm on the building's exterior, this repetition is interrupted in the revelation of primary points of entry.



Figure 5.17: Additive to Subtractive diagram: additive form is separated from the ground plane in the expression of the extension of harbour functions freely through the building.



Figure 5.18: Unit to whole diagram



Figure 5.19: View across harbour



Figure 5.20: View up ramp to entrance

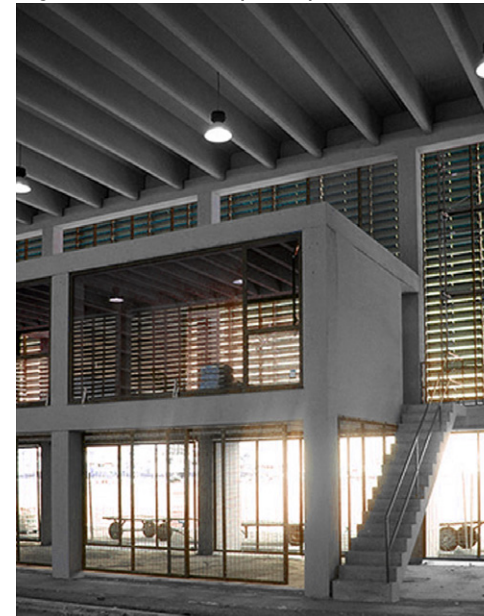

Figure 5.21: Internal view showing administration offices on upper level

Design Principles

Responding to the competition brief to design a fish market for the rehabilitation of the Port of Benicarló, architects Miguel and Urzelai established the concept of consolidating all the functional requirements of the building within a single continuous skin of containment and to limit and condense the infrastructural requirements of the building to one of its halves on plan. Administrative functions are elevated so as to create as much freedom on the ground floor plane as possible. Through a permeability of ground floor edges the building serves as a simple well connected extension of fishery harbour functions. In response to the requirements of flexibility demanded in a harbour environment the building assumes a program of infrastructure supporting a simple and free ground floor plane.

1. Reinforced concrete ring beam
2. 400 mm reinforced concrete pillar
3. Reinforced concrete ribbed floor slab cast in situ
4. 100 x 40 mm hot dipped galvanized steel rectangular hollow section
5. 100 x 40 mm hot dipped galvanized steel double rectangular hollow section, welded
6. 120 x 180 x 15 mm steel anchoring plate
7. 300 x 15 mm steel continuous flange
8. M 18 - 20 stainless steel anchoring bolt
9. 12.7 x 76.2 x 4 mm wire mesh grating
10. 8 mm laminated safety glass, fixed in double neoprene gasket
11. 3 mm stainless steel tray screwed to mullions
12. 600 x 270 x 15 mm extruded ceramic stoneware

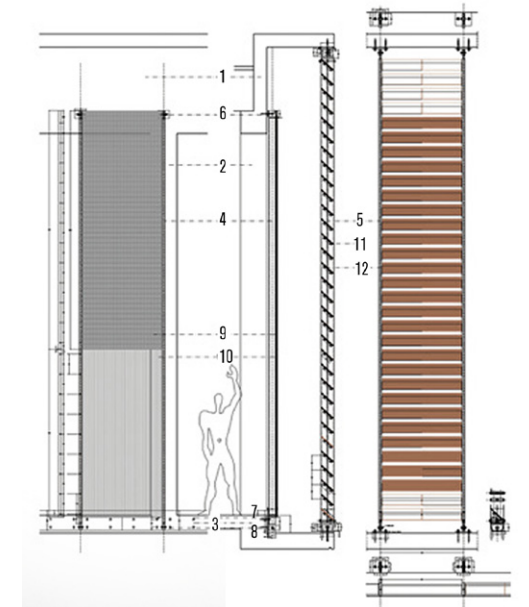

Figure 5.22: External screen detailing

CASE STUDY: INDUSTRIAL FORM

TriBeCa Coffee Factory, Centurion, South Africa

GPS Location: 25°54'4.28"S 28° 9'34.08"E

Architect: Henk Bakker

Client: TriBeCa Coffee Company

Civil Engineer: Hanness Claassen Engineering &

EGC Consulting Engineers

Contractor: Fabucon Construction

Landscaping: Intu-it



Figure 5.24.1: East elevation



Figure 5.24.2: West elevation

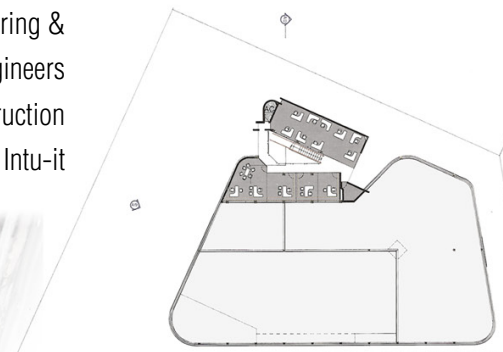

Figure 5.24.3: First floor plan

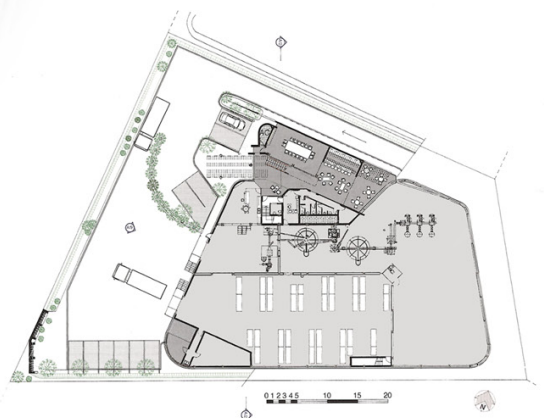

Figure 5.24.4: Ground floor plan



Figure 5.25: View looking southeast showing public entrance of the building

The TriBeCa Coffee Factory is located in the Highway Business Park, in the northern triangle formed by the crossing of the N1 and the Old Johannesburg Road. This context consists largely of industrial to semi-industrial buildings. The focus of this study is the mode in which the TriBeCa Coffee Factory reveals itself and connects to public and commercial functions while still retaining the restrictions, safety and privacy that industrial functions so often command.

From the outside the building appears as a solid form of steel sheeting that floats above either the ground or a red face-brick plinth. This continuum of steel sheeting then folds in on itself as though to form a backdrop and niche in which a sculptural concrete mass manifests. Architect, Henk Bakker, speaks of the merging of the steel surface with the concrete, and notes that these surfaces find their harmony when they are seen not to join. Concrete and steel come together in the inside corner; their seam is essentially one of void and shadow. (Bakker, 2011)

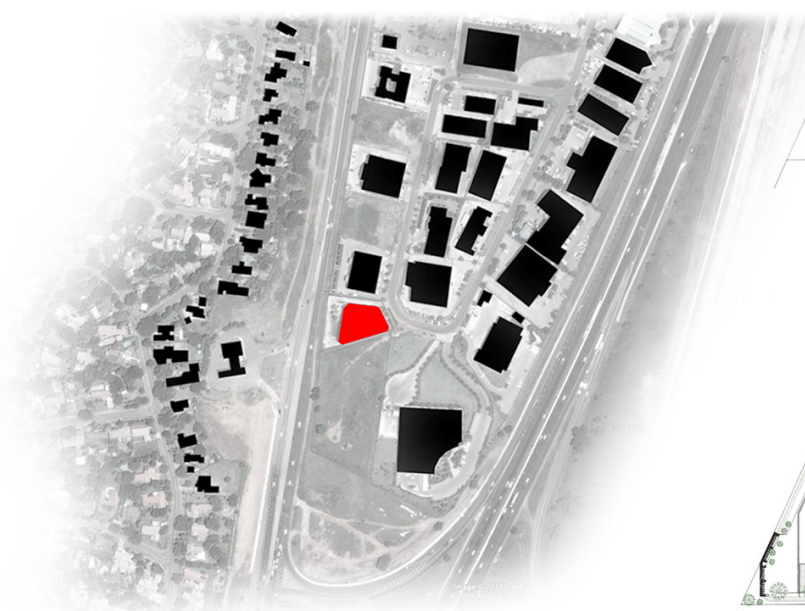

Figure 5.23: Figure-ground plan of Highveld Business Park showing position of TriBeCa Coffee factory



Figure 5.26: Image showing window between factory and laboratory



Figure 5.27: Steel sheeting adjacent to concrete wall with shadow gap



Figure 5.28: Delivery and collection area for factory



Figure 5.29: Steel sheeting forming shadow line above concrete

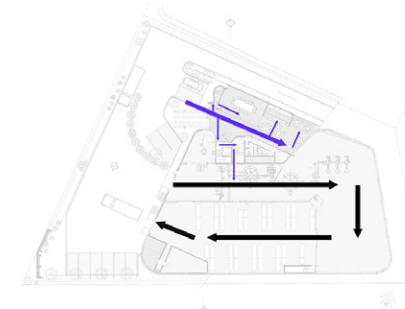

Figure 5.30.1: Circulation

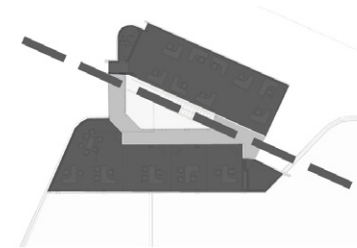

Figure 5.30.2: Additive to subtractive

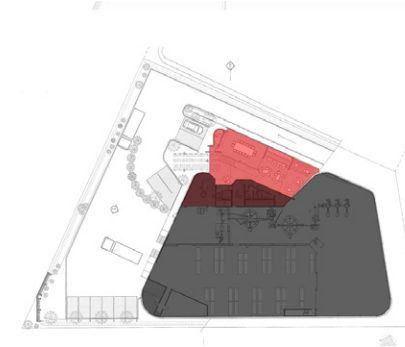

Figure 5.30.3: Unit to whole

The Design of the factory seeks to combine the industrial functions (roasting and testing of coffee beans) with those of human habitation (TriBeca head-office, boardroom and coffee bar) into the single facility. It is along this niche that this integration takes place. The space of public function (the concrete mass) undergoes a spatial subtractive process at its center (see additive to subtractive diagram) - the axis of this subtractive process is made up of the entrance, the double volume beyond the entrance, a portion of the coffee bar, and finally an outdoor seating area beyond the coffee bar

This axis intersects the two points at which steel finds concrete on the factory's exterior. This axis informs the experience of use in the building (see circulation to use diagram). Upon entry one is confronted with an expanse of seemingly continuous green glass spanning a double volume from ground to roof. It is with this glass entrance that steel is most obviously isolated from concrete via a most dramatic void. Upon entry into the double volume one notes public spaces to the front and left (boardroom, coffee bar and open plan offices) and fixed functions (offices, laboratory and ablutions) to the right. This primary axis, as a gesture towards the primary concept, then terminates with a view onto the steel envelope - and so celebrates the industrial of which it is a part.

In the interior, a brick wall and internal windows divide the offices and the factory. These two opposing function are staged onto each other via these internal glass windows - again the merging becomes void. The detail in figure 5.31.1 represents the design intention for this connection (although the detail as built differs). Here the pragmatic concerns of dirt in the factory are dealt with - the glazing is flush with the inside factory wall while a windowsill is placed on the office side of this wall.

Architect, Henk Bakker, speaks of the factory form as recollective of the coffee bean and considers the office portion is the figurative hilum of that bean: *...the scar at the in-curving side of the bean where the seed was attached to the pod.* (Bakker 2009: 58). The factory's form is simple; its shape is largely an offset of the shape of the site - this maximizing floor area. This form is then filleted to give the factory its look of continuum. Circulation is a simple linear U-formation; with delivery point at one end and distribution point at the other.

It is clear that the concept of the coffee bean (as highlighted by the architect) is one that abstracts itself in many ways and on many scales. Ultimately the success of this design lies in its ability to express this concept in the smallest of details as well as in its greater context. Despite its location (in an industrial office park) the building commands a strong orientation towards the Old Johannesburg Road. It proclaims its industrial function and communicates strongly its fold that reveal solid sculpture and the articulated void between.

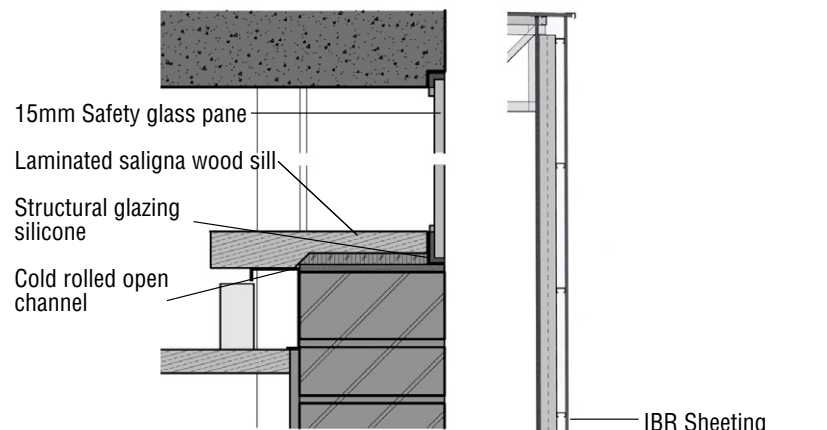

Figure 5.31.1: Detail of window between factory and offices

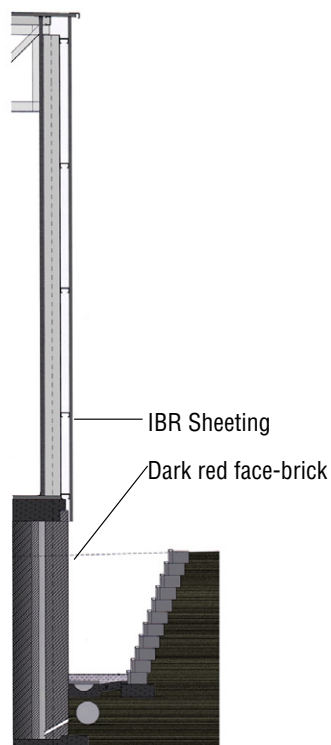

Figure 5.31.2: Detail of southern wall

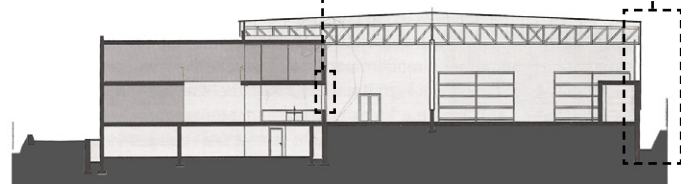

Figure 5.31.3: North - South Section through building

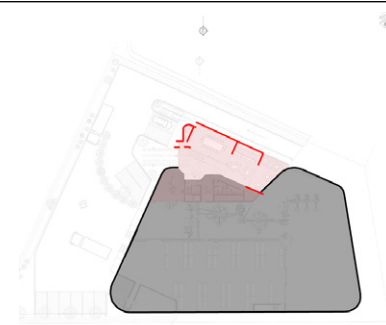

Figure 5.32.1: Repetitive to unique diagram

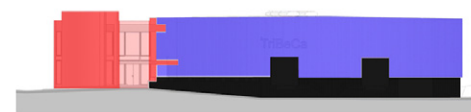

Figure 5.32.2: Geometry diagram



Figure 5.32.3: Symmetry and balance

Figure 5.33: View of main entrance of TriBeCA Coffee Factory



CHAPTER 6: DESIGN DEVELOPMENT

P.	084	THE HARBOUR PRECINCT
	087	PORT AS THRESHOLD
	090	INFRASTRUCTURE IN RESPONSE TO THE TEMPORAL
	090	THE AXIS
	094	DESIGN SYNTHESIS AND DEVELOPMENT
	100	PLANS
	102	FORMAL PRINCIPLES ILLUSTRATED

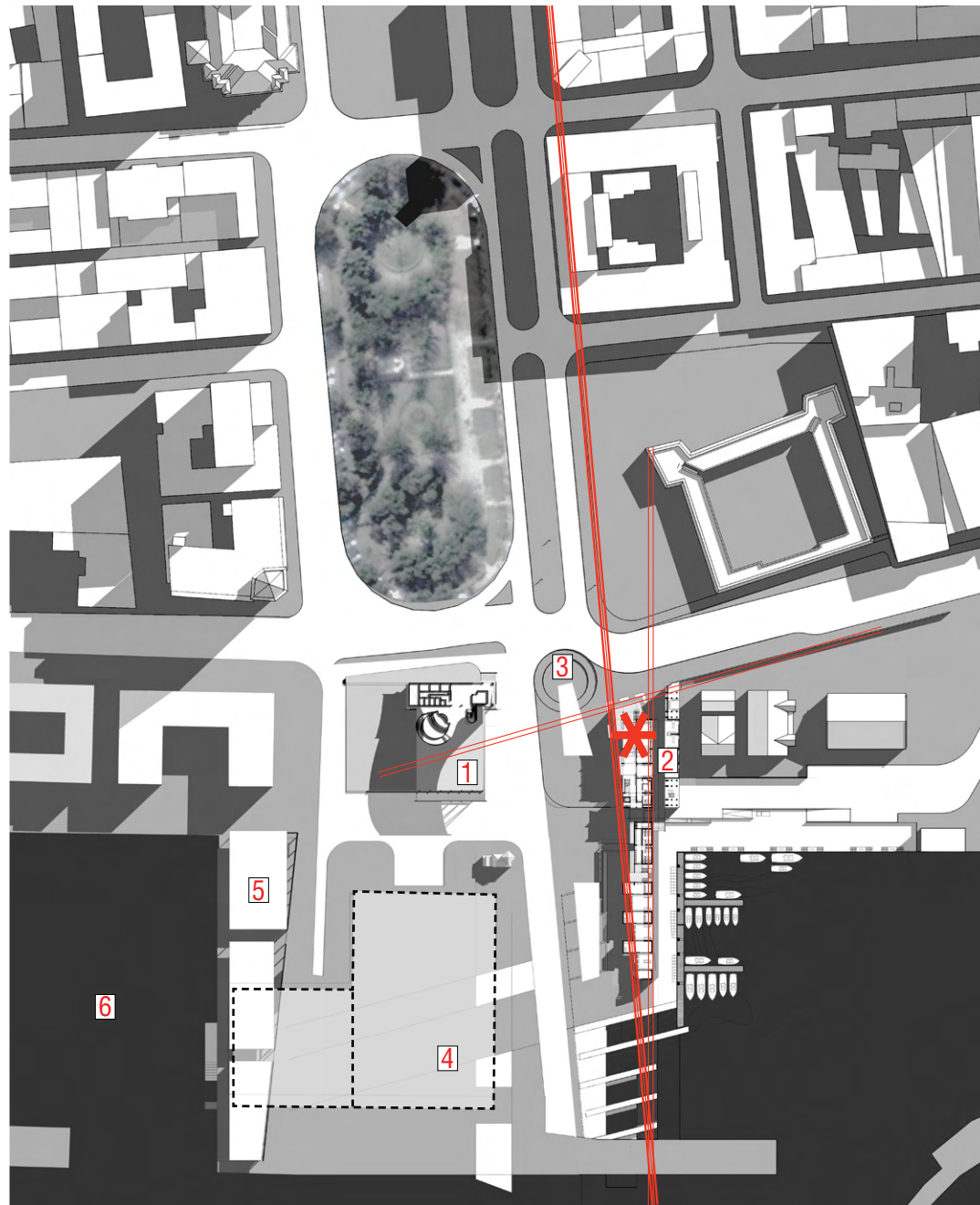

- Legend
- Phase 1
- 1 Fishery museum
 - 2 Fish processing and auction building
 - 3 Harbour precinct entrance plaza
- Phase 2:
- 4 Commercial fisheries warehouse
 - 5 Ferry terminal
 - 6 Second harbour

Figure 6.1: Harbour precinct development plan and phasing

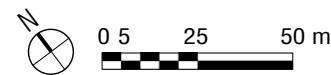

The harbour precinct

The harbour precinct's development is phased in 2 stages.

First Phase: Gateway to the harbour precinct from the city

The fisheries museum designed by Jose Forjaz together with the fish processing and auction building frame a gateway plaza to the harbour precinct. The establishment of this gateway plaza as well as the resolution of the fish processing and auction building forms the focus of the design investigation

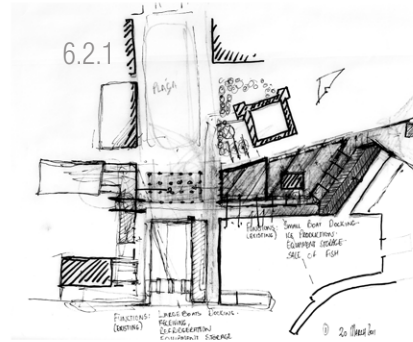

Second Phase: Ferry terminal as gateway to the city

In Chapter 5 of this dissertation the tendency for the relocation of global ports beyond the confines of the inner cities is discussed. The commercial fisheries warehouse currently handles international imports and exports. As the demand for inner city harbour land increases it is likely that this facility will also be relocated. In line with the Cultural forum 2004 development (discussed in chapter 5) the proposal is that this site be developed as a cultural events precinct and entry point to the city, framed and supported by a ferry terminal on its western edge. The design of this ferry terminal forms the basis of the design investigation of a colleague of mine, Catherine Deacon, and was completed in November 2011.

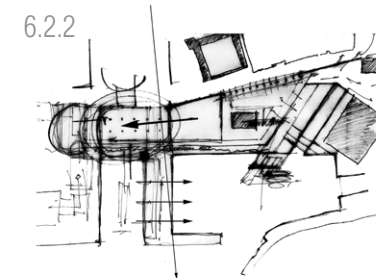

Owing to the proximity of the fish auction building as well as the proximity of the ferry terminal the precinct will accommodate on a daily basis a large amount of informal traders, recreational areas similar to those found at Catembe ferry terminal on the other side of Maputo Bay as well as viewing decks. It is, however, also suggested that such a plaza be designed to accommodate annual city events such as the Maputo/ Brazil Carnival and the annual swim across the bay .

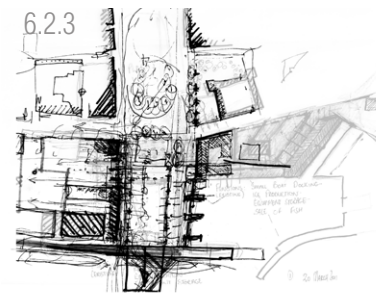

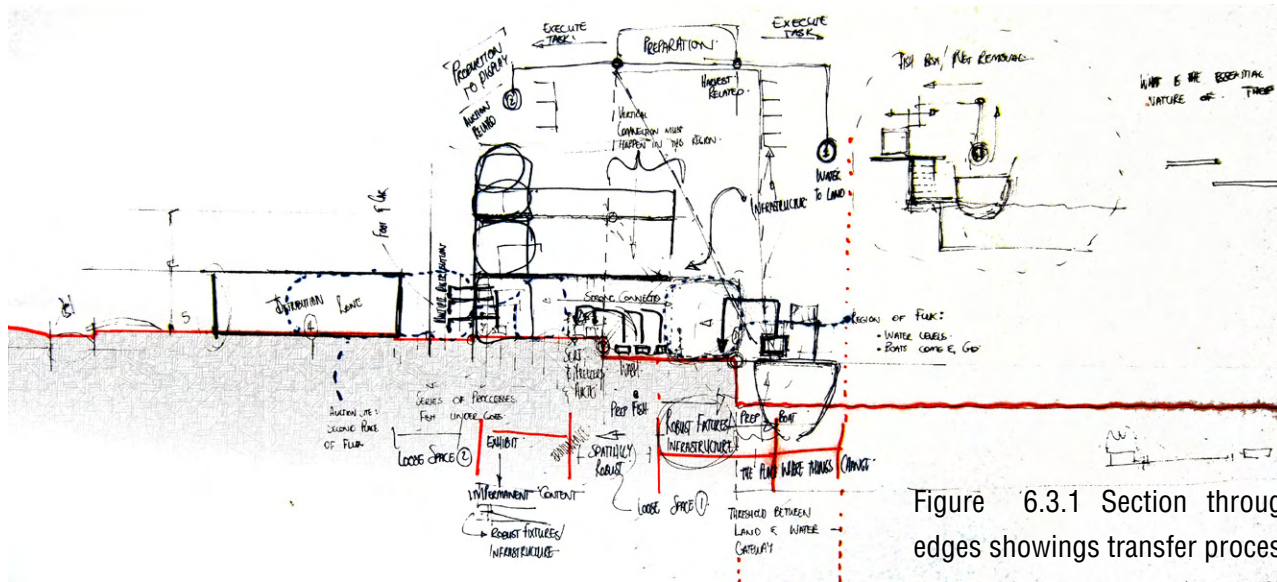

Figure 6.3.1 Section through harbour edges showings transfer process

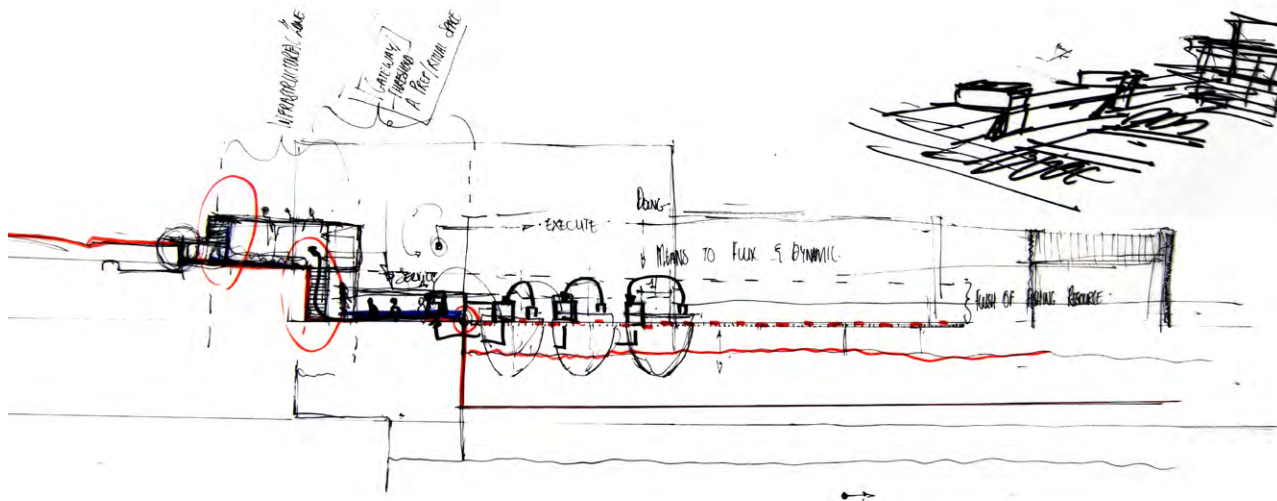
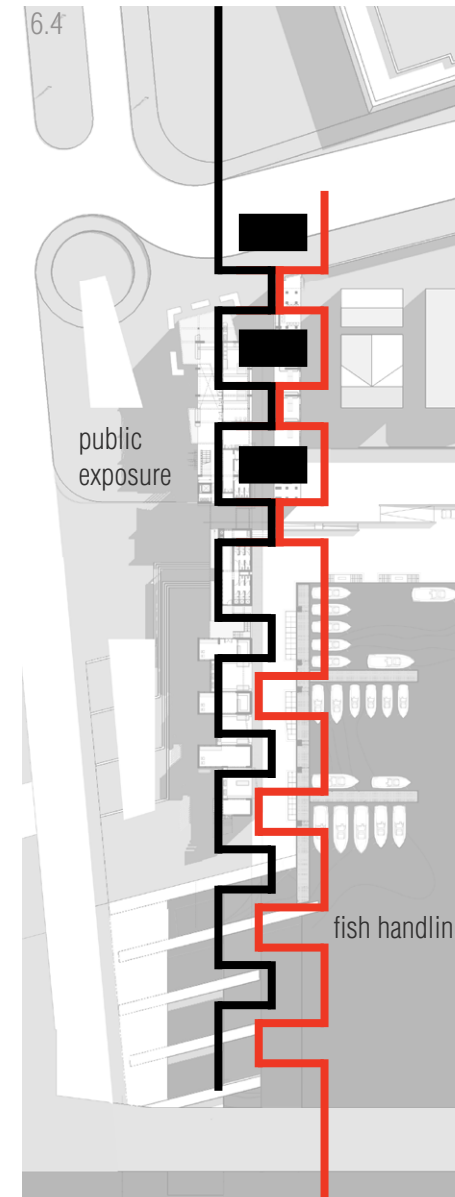

Figure 6.3.2 Section through harbour edges showings transfer process



Architectural Form

a. Port as threshold

In chapter 3 the port is identified as a site of migration and mediation of resources and people. The port therefore becomes a highly temporal site, which is required to absorb expanding and contracting volumes of people and products. Ports act as a threshold and gateway to the city. The transfer of goods across this threshold is analyzed in figures 6.3.1 and 6.3.2 in which containers of fish are transferred from boats to a landing site, this fish is then unpacked, cleaned, weighed and packaged for either direct sale or distribution.

In line with the intension of establishing the harbour as an accessible platform to the general public, the processing of fish comes into contact with the public in 2 ways. The first is a scenario where the handling of fish is made visible to the public but no interactive exchange takes place. The second is the act of sale or exchange. Figures 6.4 - 6.5.2 demonstrate the diagrammatic concepts that underlie these two scenarios.

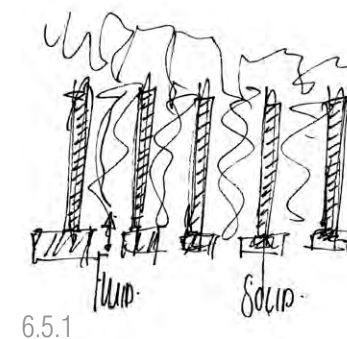

6.5.1

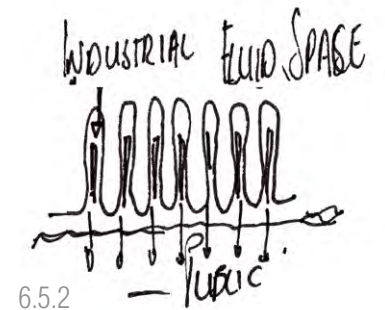

6.5.2

6.6

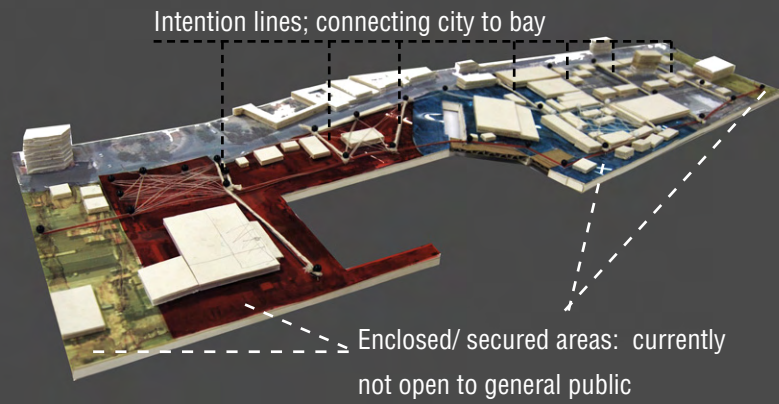
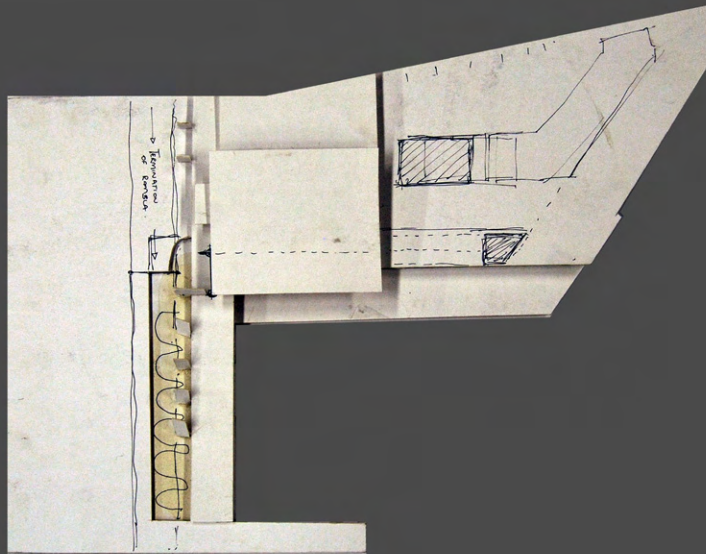

Figure 6.6: Design development series: A study of the harbour as barrier between the city and the bay as well as potential bridging areas

6.7.1



Figures 6.7.1 - 6.7.3: Design development series. A study of the harbour edge condition of permeability and its potential influence on form,

6.7.2

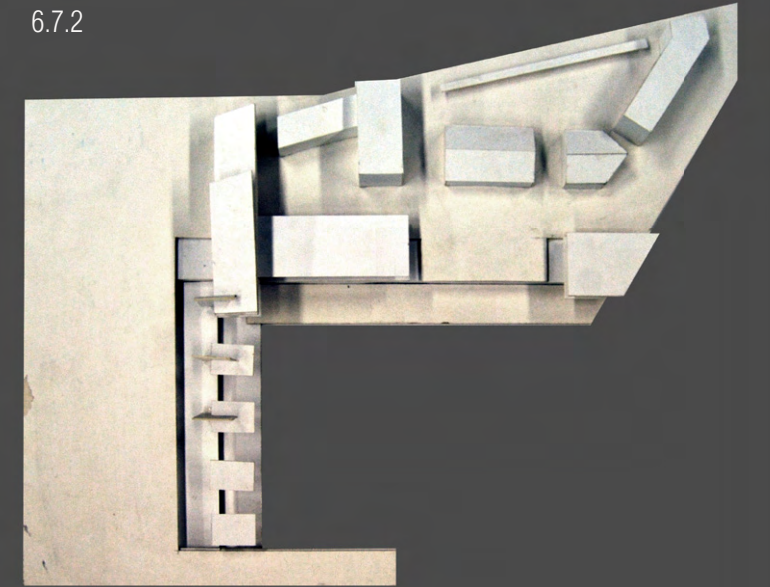

6.7.3

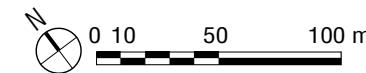
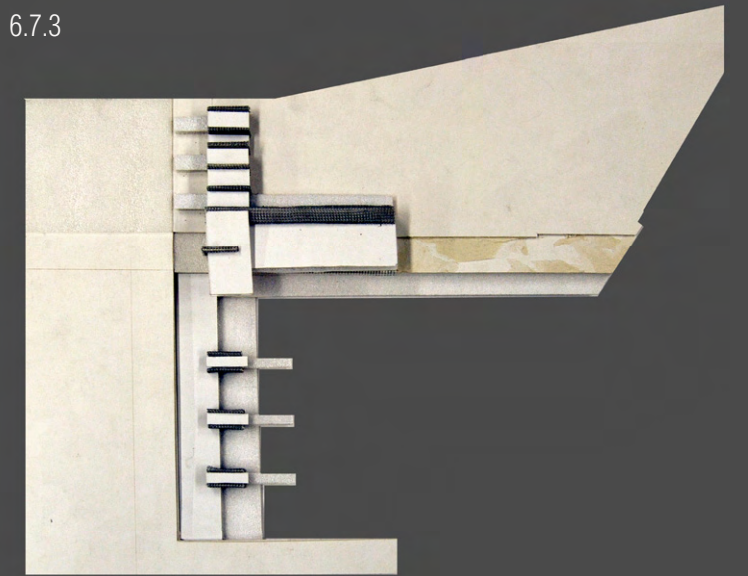

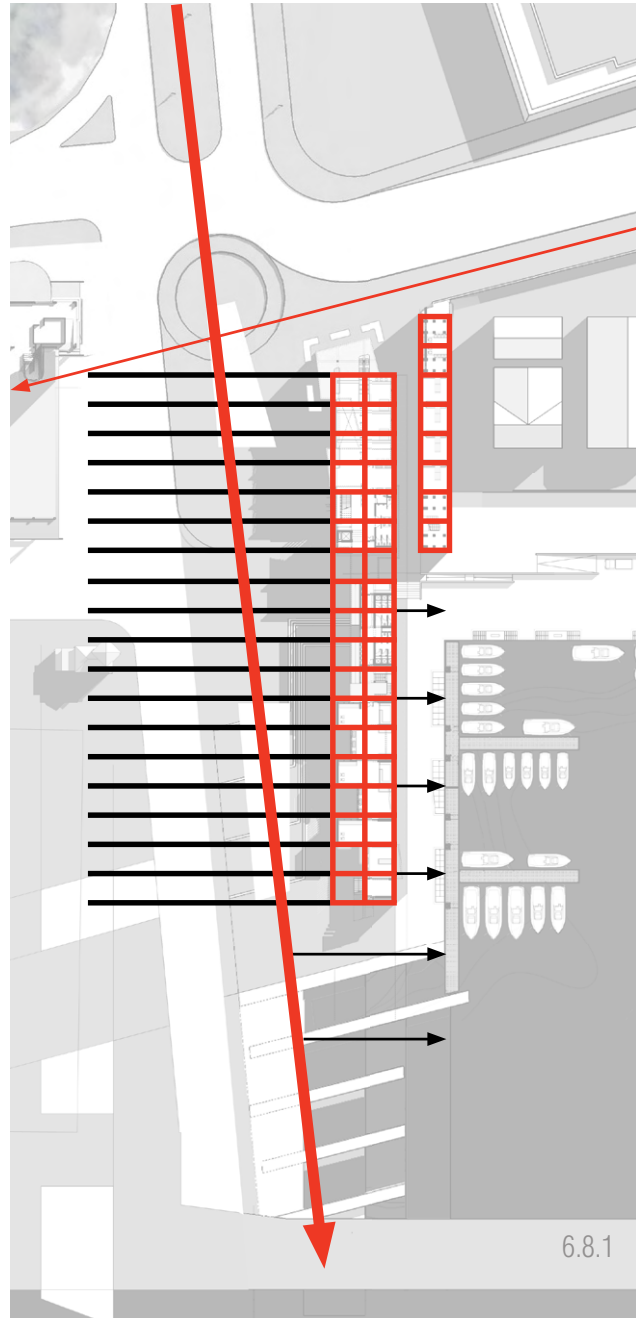

6.8.1 The grid

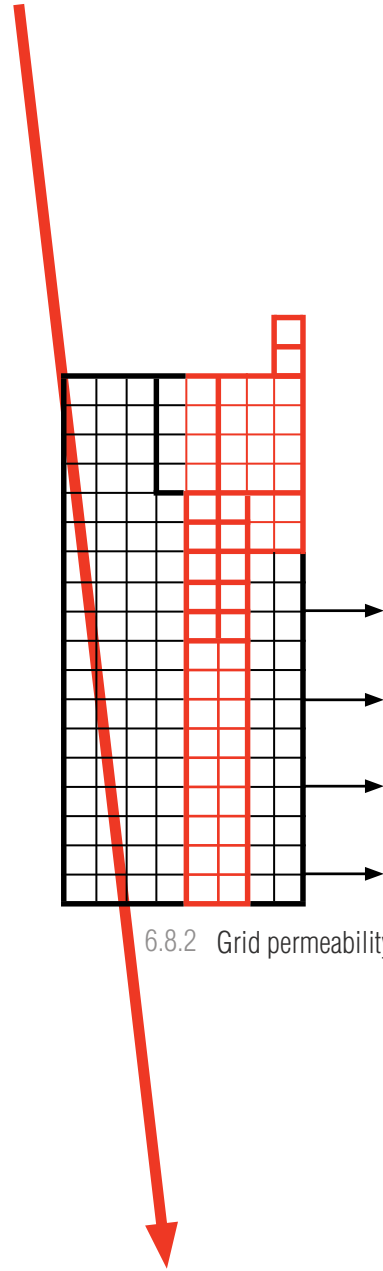

6.8.2 Grid permeability

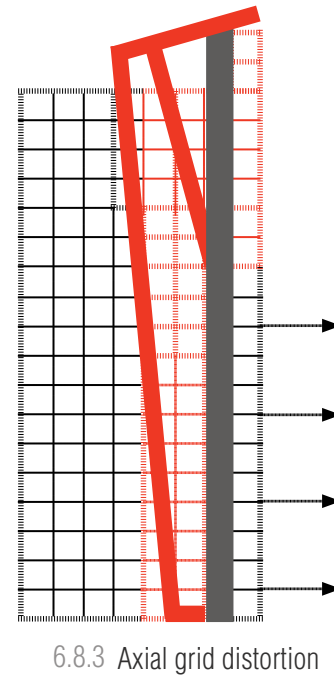

6.8.3 Axial grid distortion

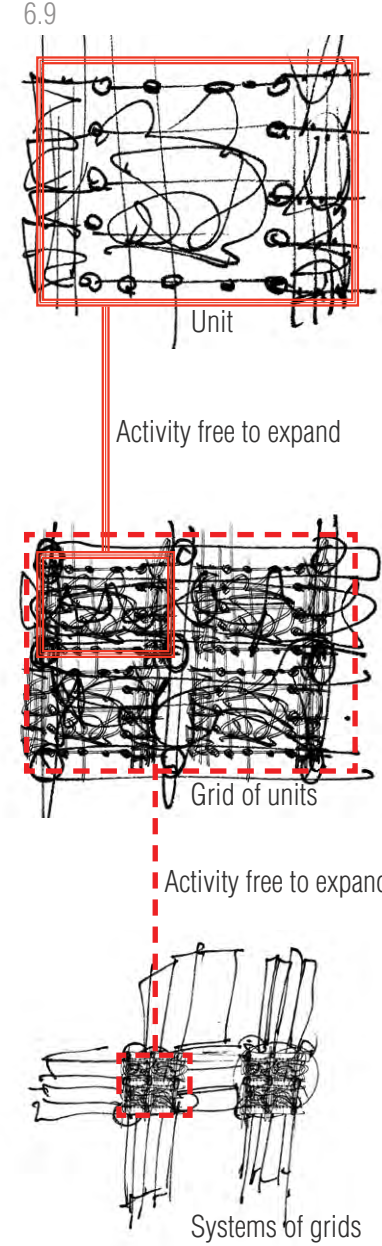

6.9

b. Infrastructure in response to the temporal

A requirement in port planning is the accommodation of fluctuations in traffic (Jonkhoff & Manshanden, 2011: 49). Spatial boundaries therefore continuously shift as transfer activities occupy less or more space.

In the design development process the acknowledgement of this requirement of spatial temporality takes the conceptual form of the grid. The bidirectional square grid is a non-hierarchical system that subdivides its surface into equal accessible units (Ching, 2007: 72). Where divisions are permeable the activities occurring in any given unit easily expand and fill into its adjacent units as demand requires. In other words the degree to which grid line divisions are articulated informs the degree to which activities within that region are free to spatially expand and contract (demonstrated in figures 6.8.2 and 6.9). The infrastructure referred to in the previous paragraph is understood as the services and utilities required for the operation of the fisheries harbour. These include access to and disposal of water, waste management, mooring areas in the harbour itself, areas geared to the handling, washing and packing of fish and access to electricity amongst others. The grid as described above serves as the organisational mechanism for the resolution of these and other infrastructure requirements in the harbour.

c. The axis

As demonstrated in figure 6.8.1 the geometry of this grid (which is aligned the harbour) is intersected at an angle of 7° by the axis of Avenida (Avenue) Samora Machel, discussed in detail in Chapter 5. In composition in art the diagonal is cited as a tool to introduce movement or tension to a painting:

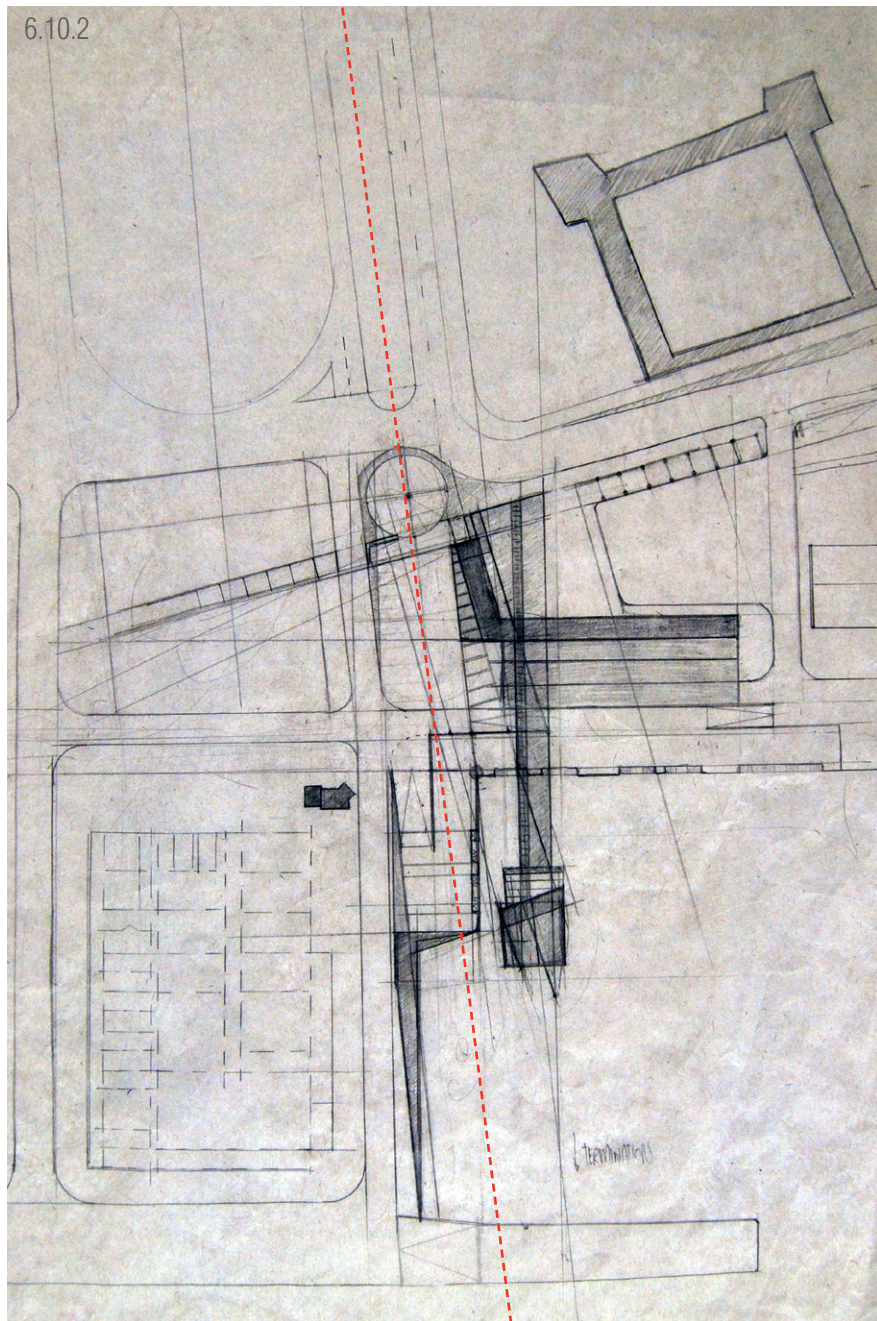
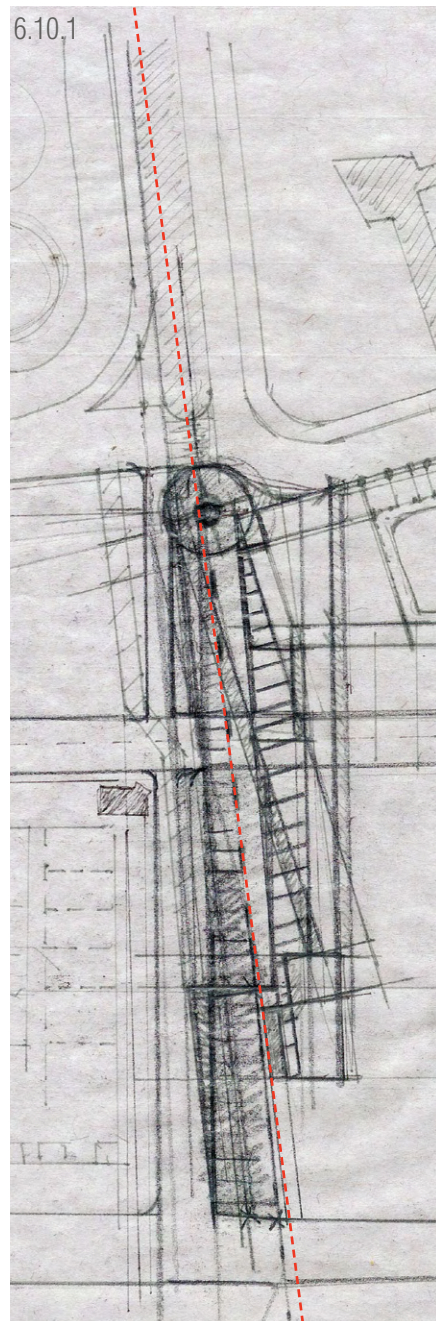

Figures 6.11.1 - 6.11.4:
Design development: Contextual
geometries explored in 3 dimension

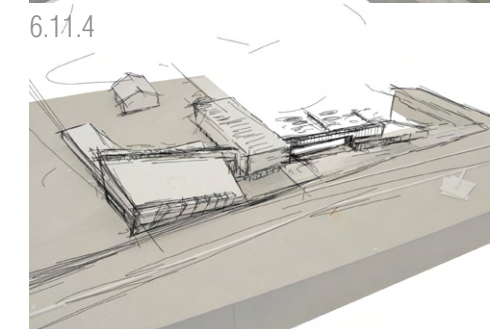
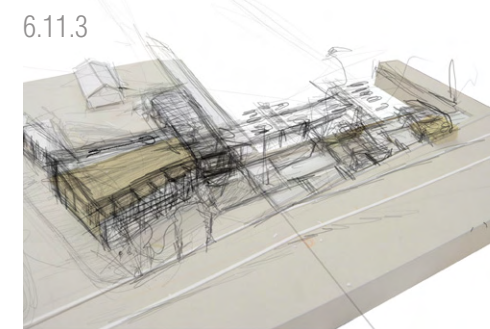
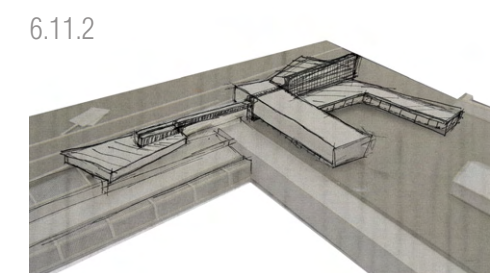
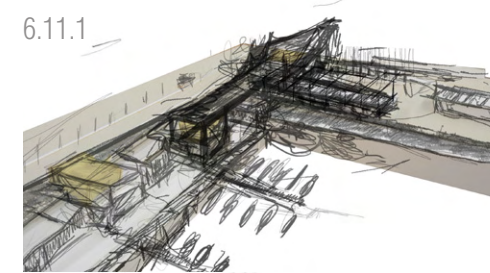

The axis (continued)

This [rectangular] shape provides consistent vertical and horizontal edges to which lines within the composition can be related. Vertical and horizontal lines, then, repeat a direction that is already present and reinforce a feeling of stability in the work. By contrast, diagonal lines violate this stability and create a sense of tension or movement. (Fichner-Rathus, 2007: 30)

Figures 6.10.1 & 6.10.2:
Design development: Contextual
geometries explored on plan

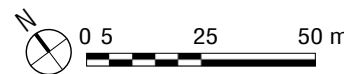

When two grid systems converge the one becomes a reference point for the other, the perception of which creates the sense of a dynamic tension. In the design process the direction of the urban axis is brought into dialog with the grid and orientation of the harbour. This grid is referential, the axial distortion of this grid communicates and celebrates the force, movement or thrust with which this axis meets the vista of the ocean. Figures 6.10.1- 6.20 demonstrate explorations in the design process in the resolution of this distortion.

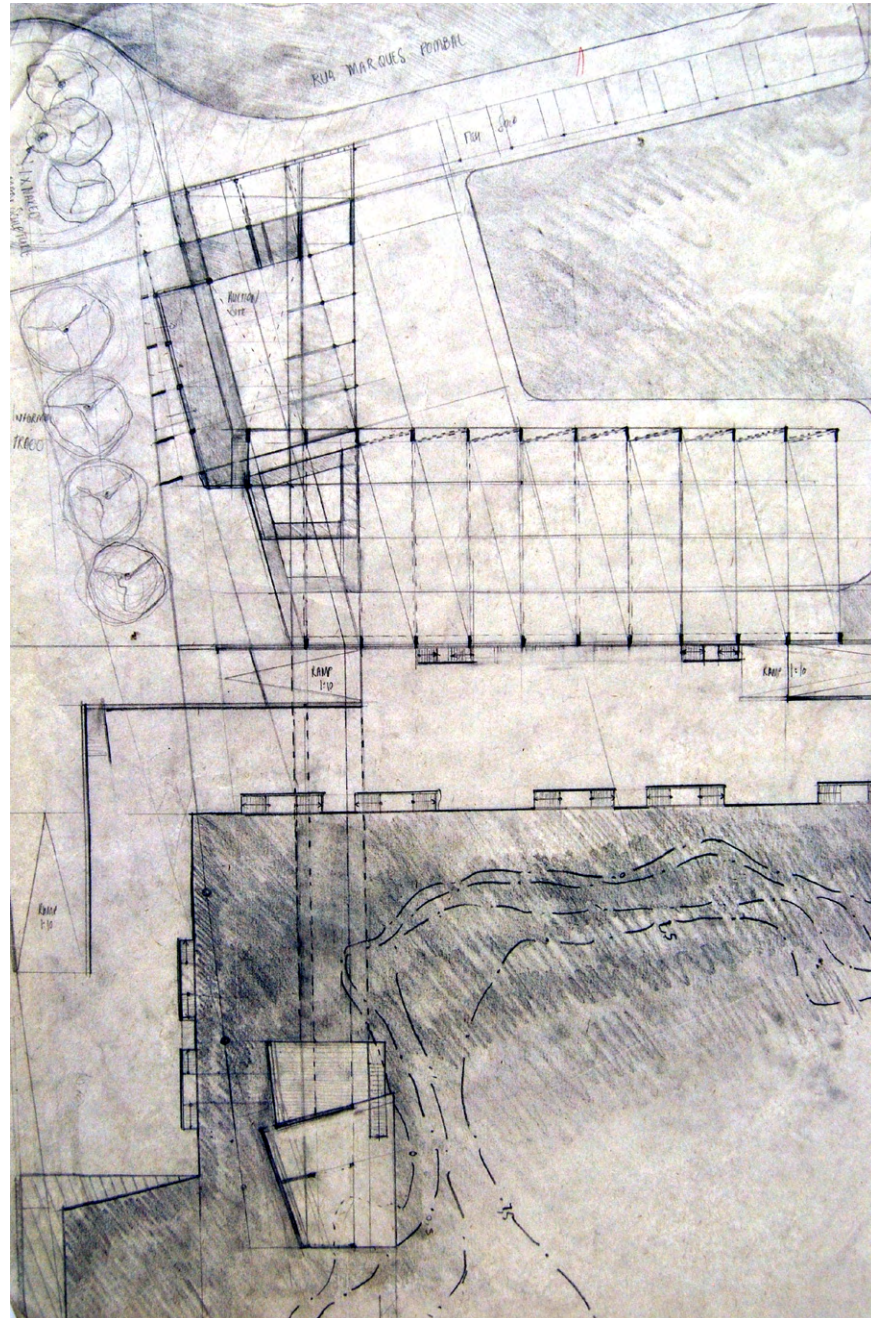
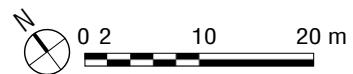
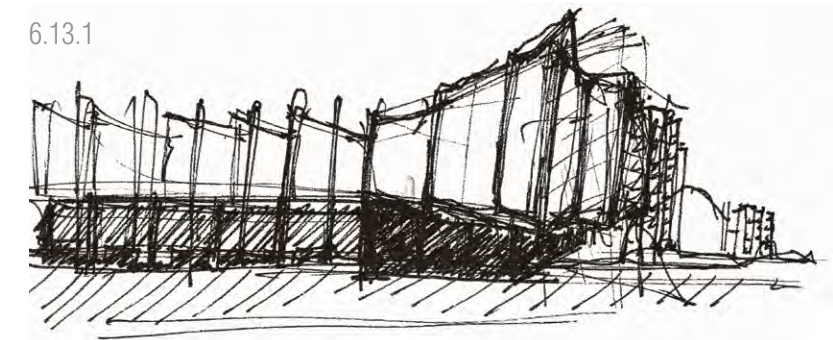

Figure 6.12: Design development: Contextual geometries explored on plan



Figures 6.13.1 - 6.13.3:
Design development: Contextual
geometries explored in 3 dimension



6.13.1
Rhythmic modifications



6.13.2
Screen detached from main structure

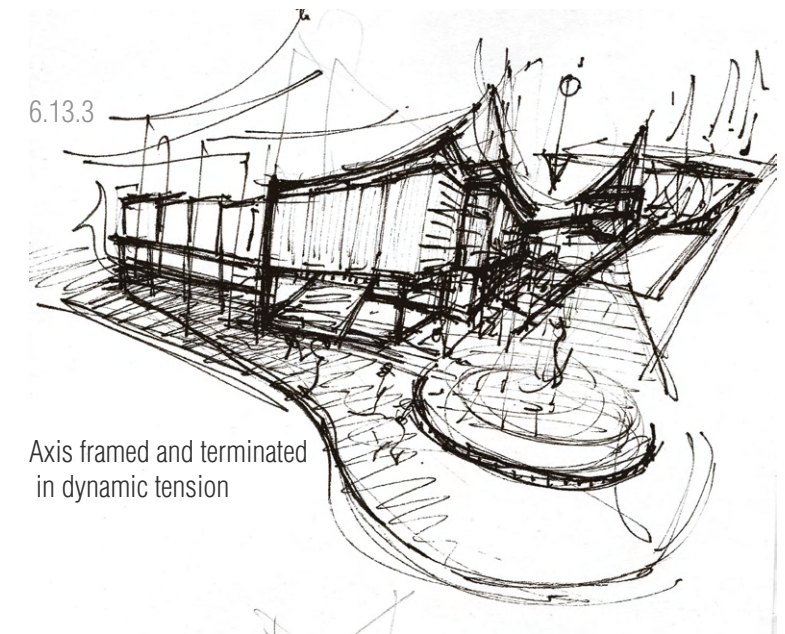

6.13.3
Axis framed and terminated
in dynamic tension

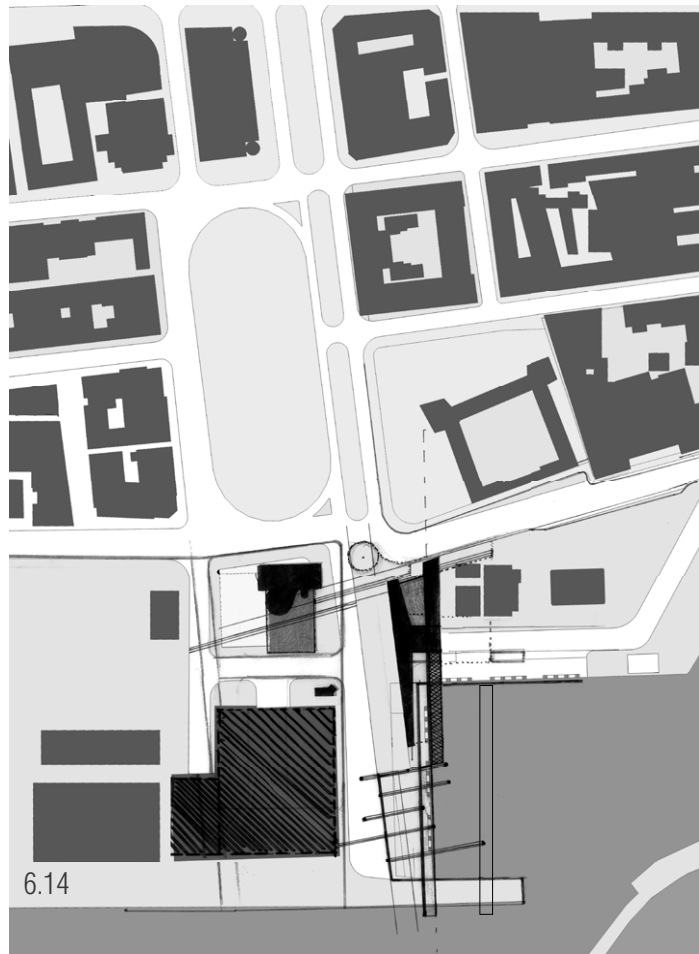

6.14

Figure 6.14: Design development: Form in context plan
 Figure 6.15.1: Design development: Form in context model
 Figure 6.15.2: Design development: Form in context; rectilinear structure framed by a series of diagonal aprons.

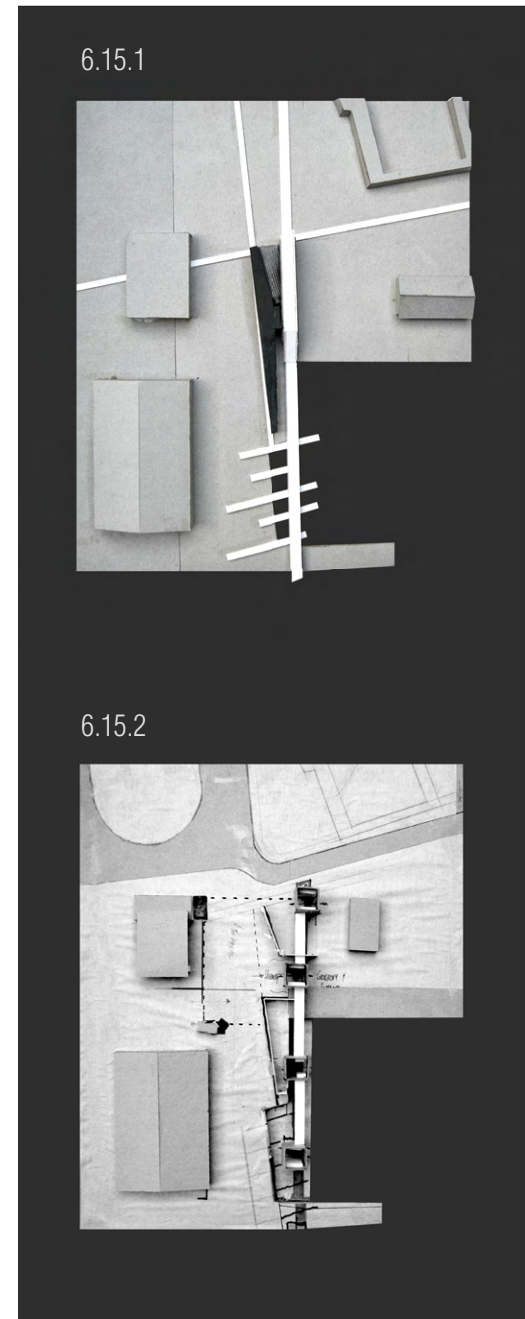

6.15.1

6.15.2

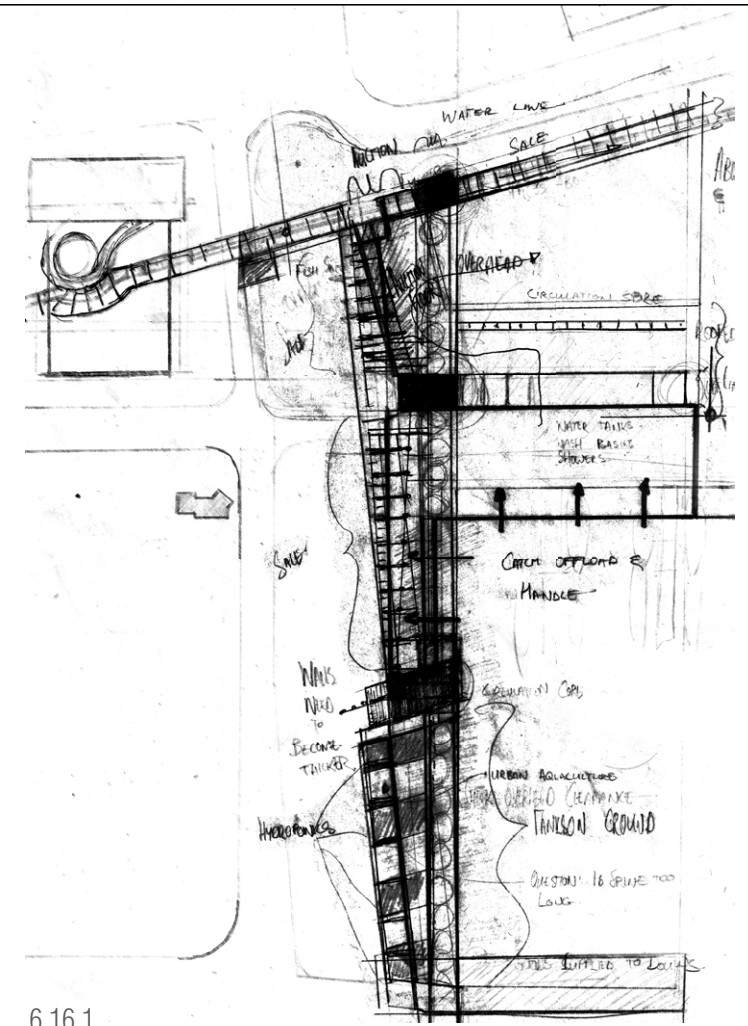

6.16.1

Figure 6.16.1 - 6.16.2: Design development: Contextual geometries explored on plan to establish the nature of the relationship between the experiential diagonal axis and the utility based rectilinear form.

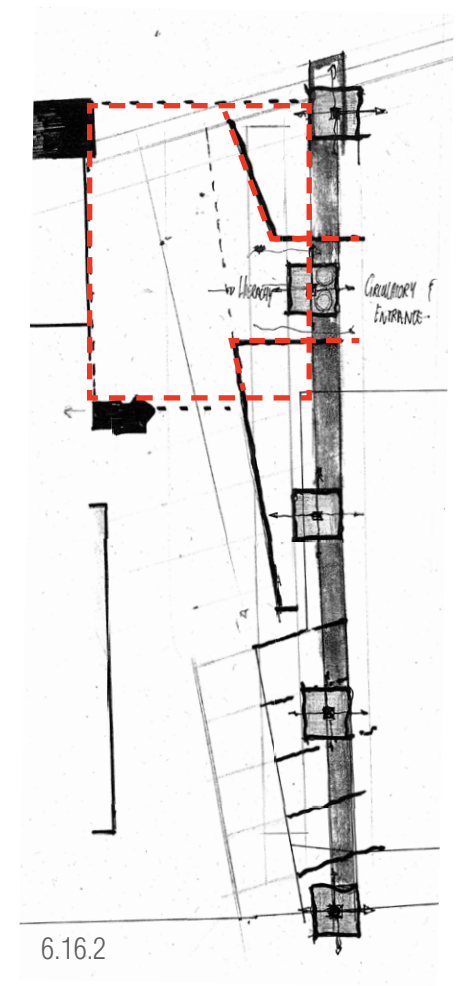

6.16.2

Figure 6.17.1 - 6.17.3 & 6.20: Design development: Sectional explorations in which the volume is reduced as the building comes into closer proximity to the water

Figure 6.18: Concept sketch: The rectilinear form acts as datum to the diagonal screen

Figure 6.19.1 - 6.19.4: Design development: The evolution of the plan

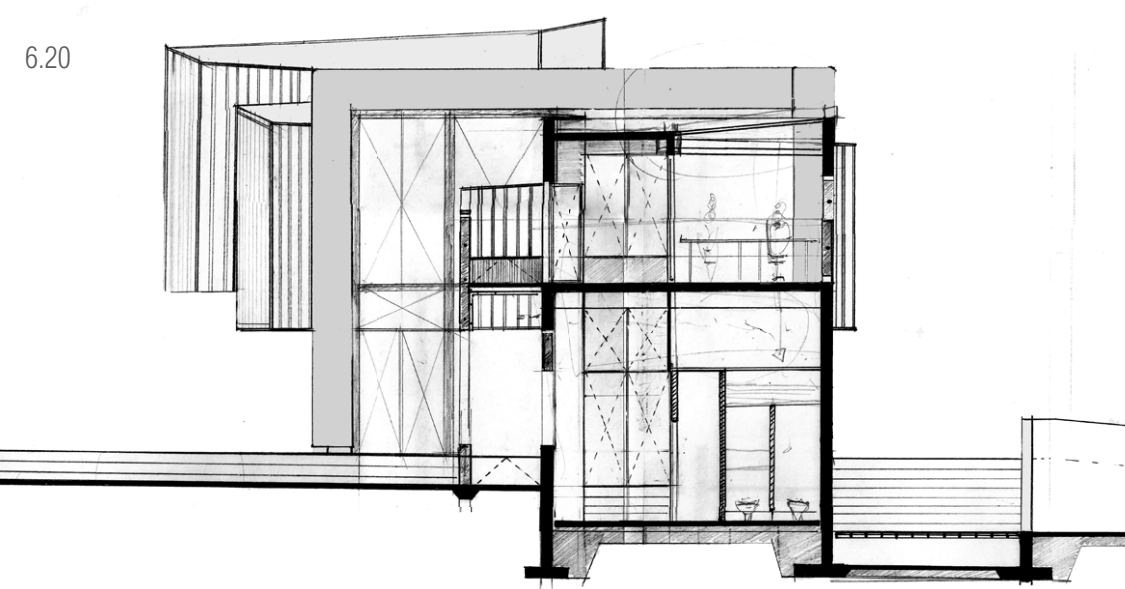
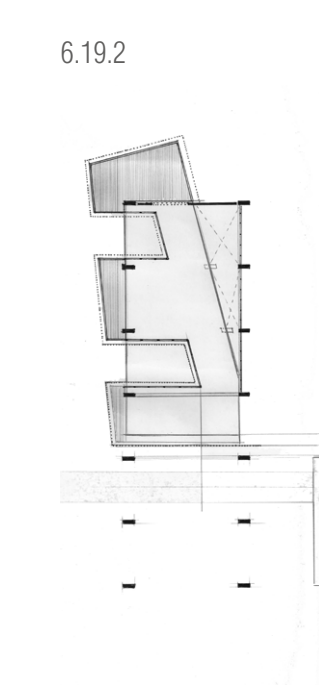
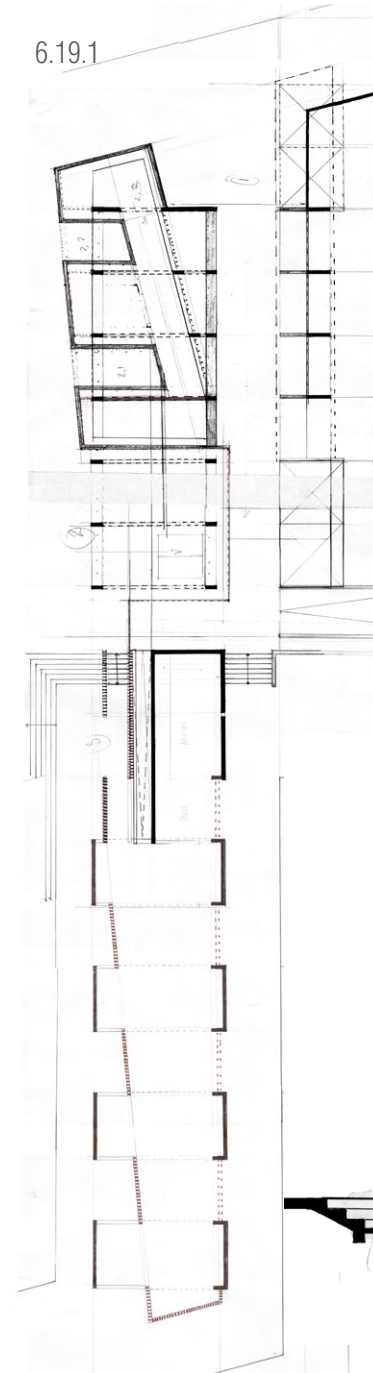
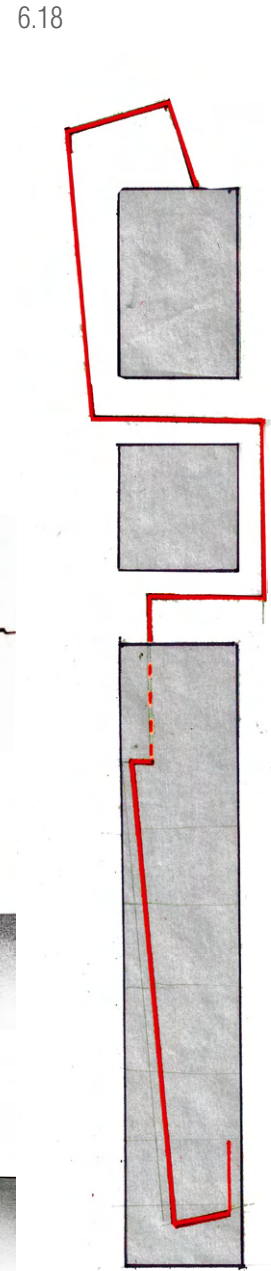
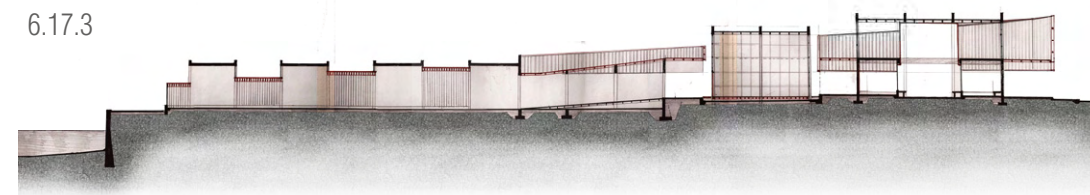
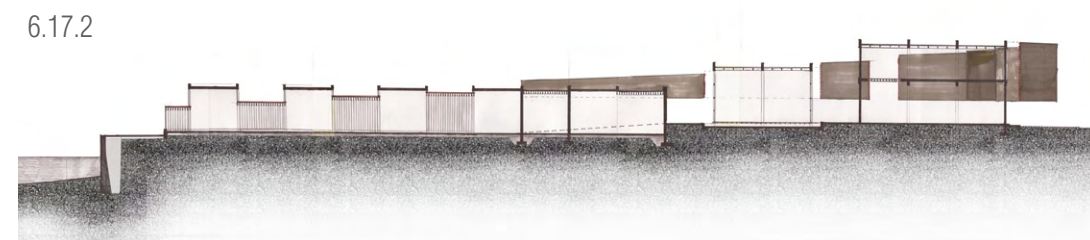
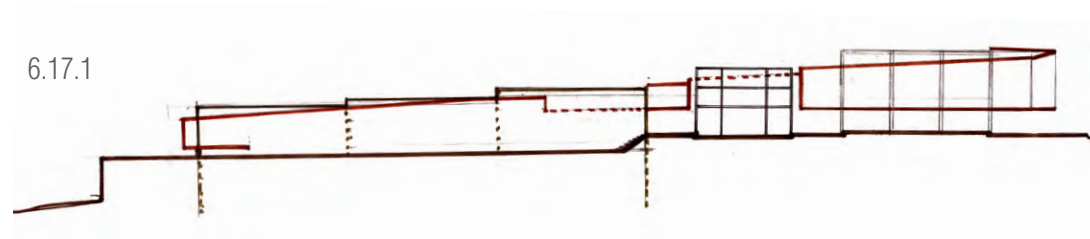

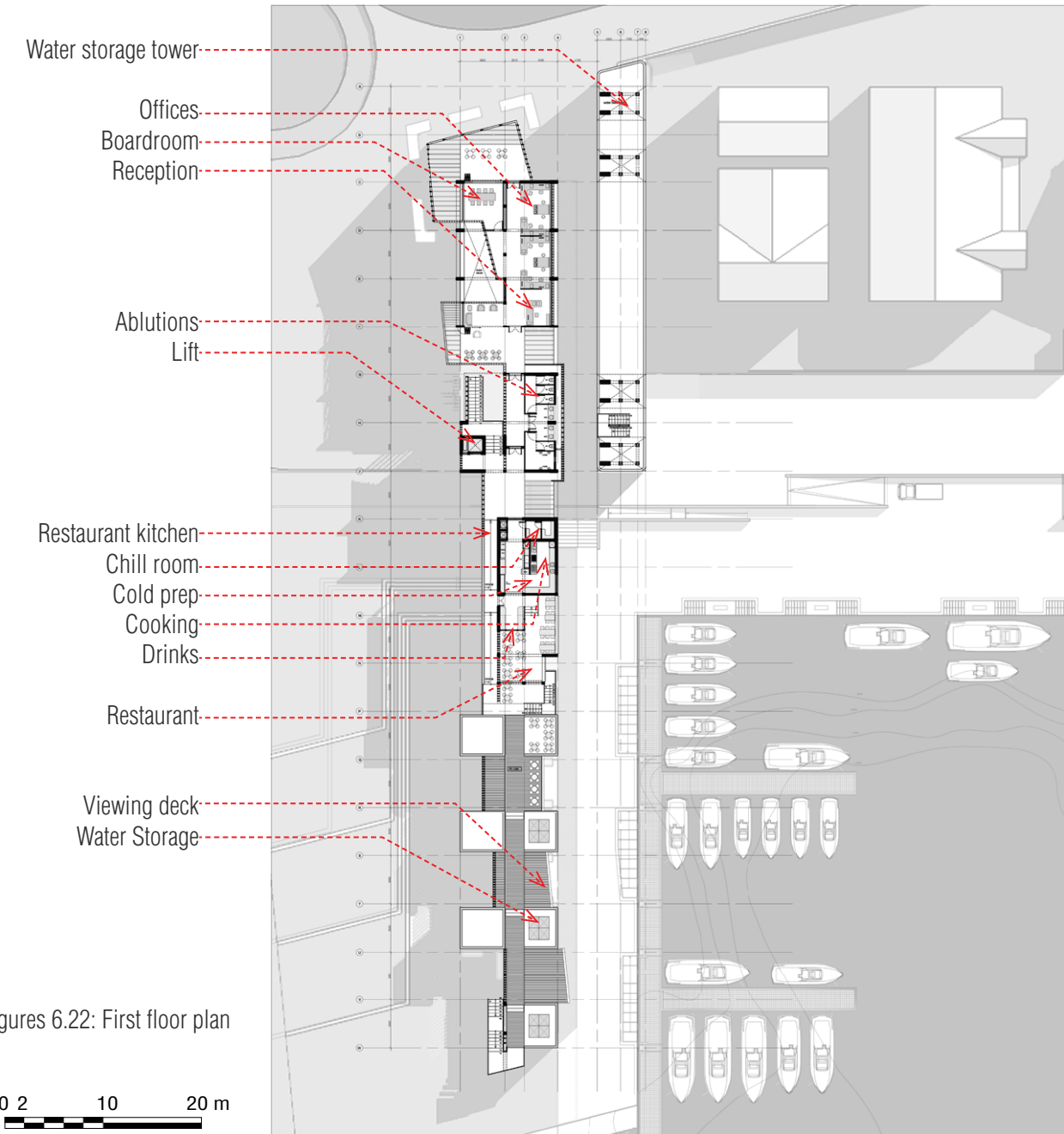
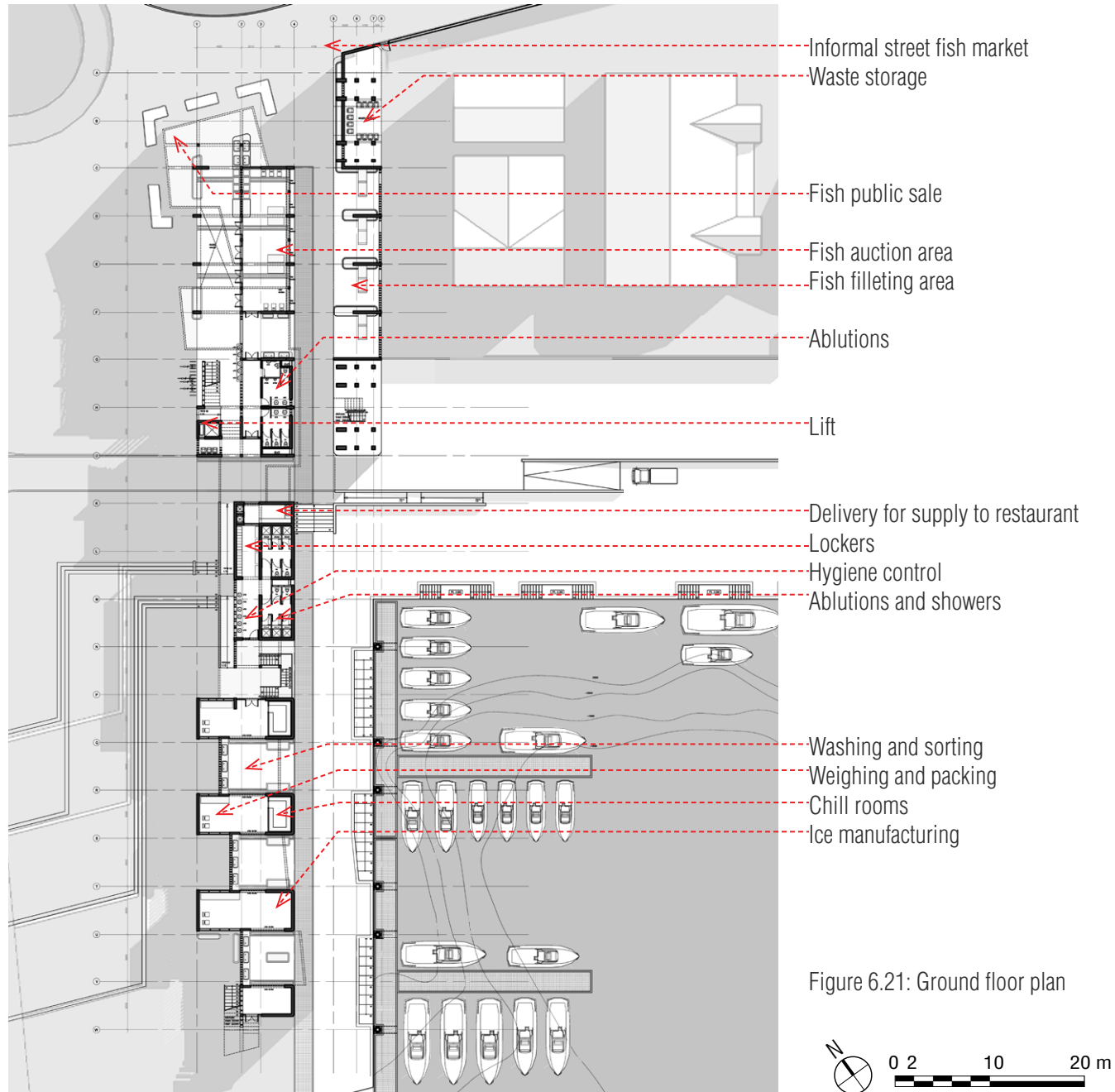

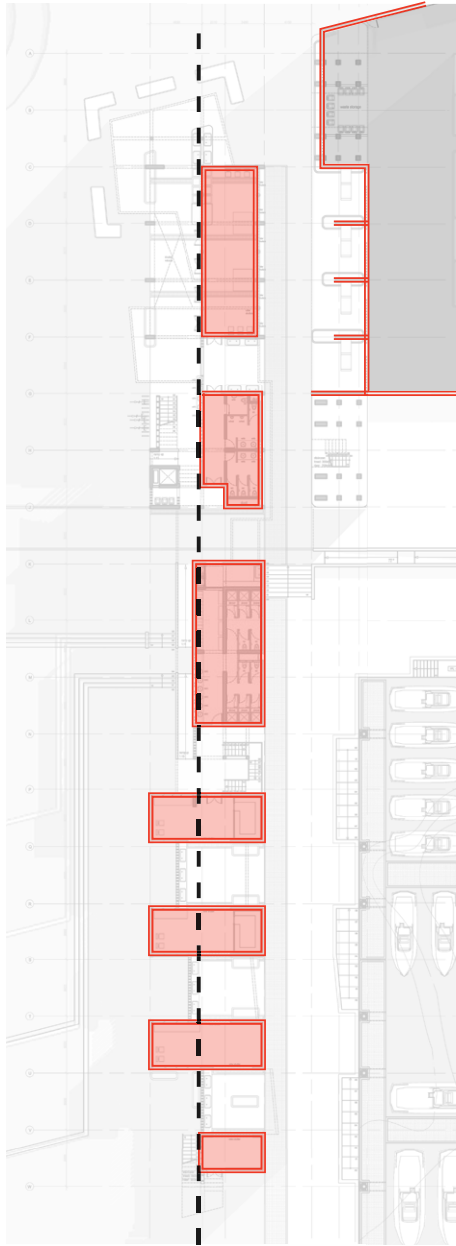

Figure 6.23.1: Inside/outside: Lockable zones

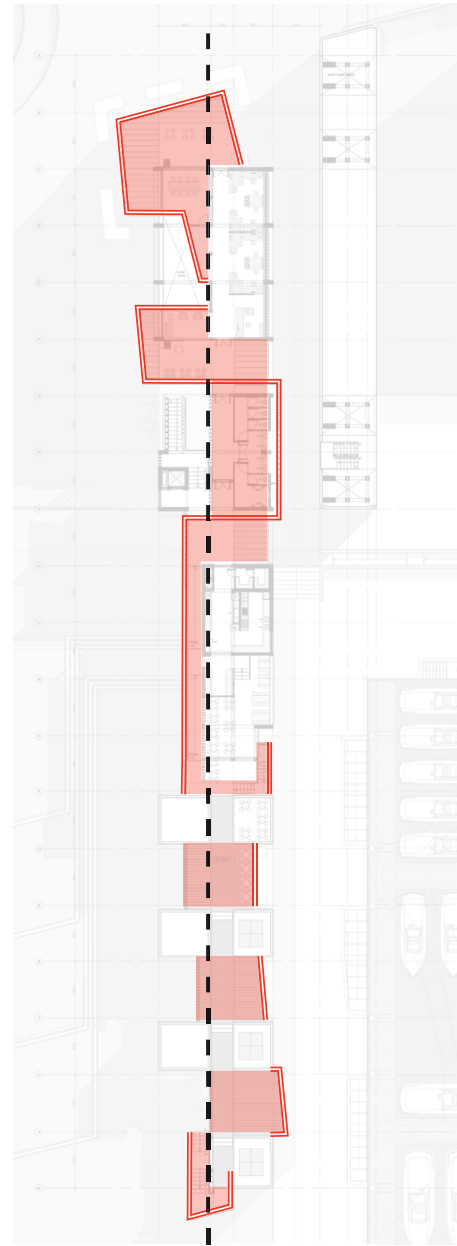

Figure 6.23.2: Main building as datum line to screen

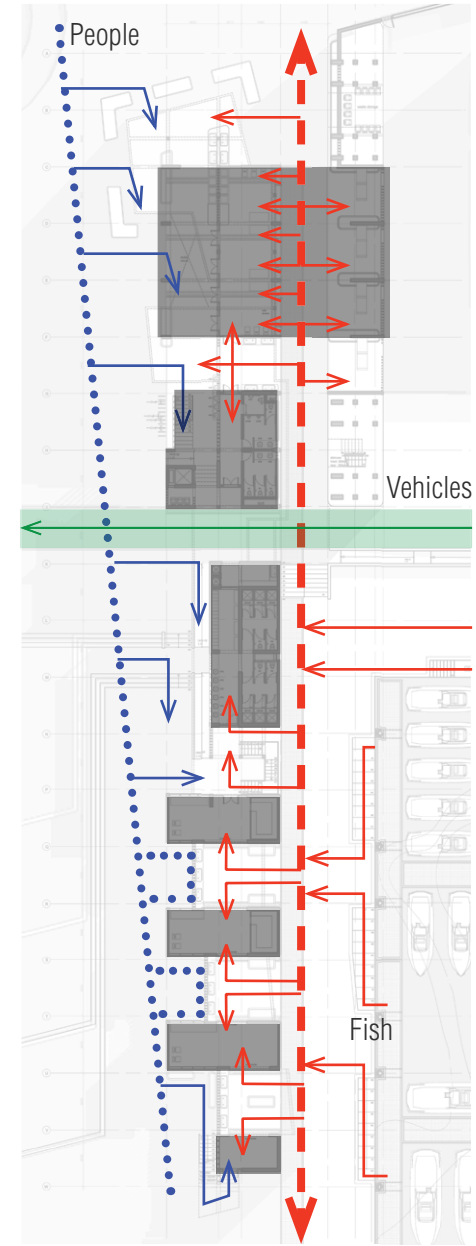

Figure 6.23.3: Circulation to use

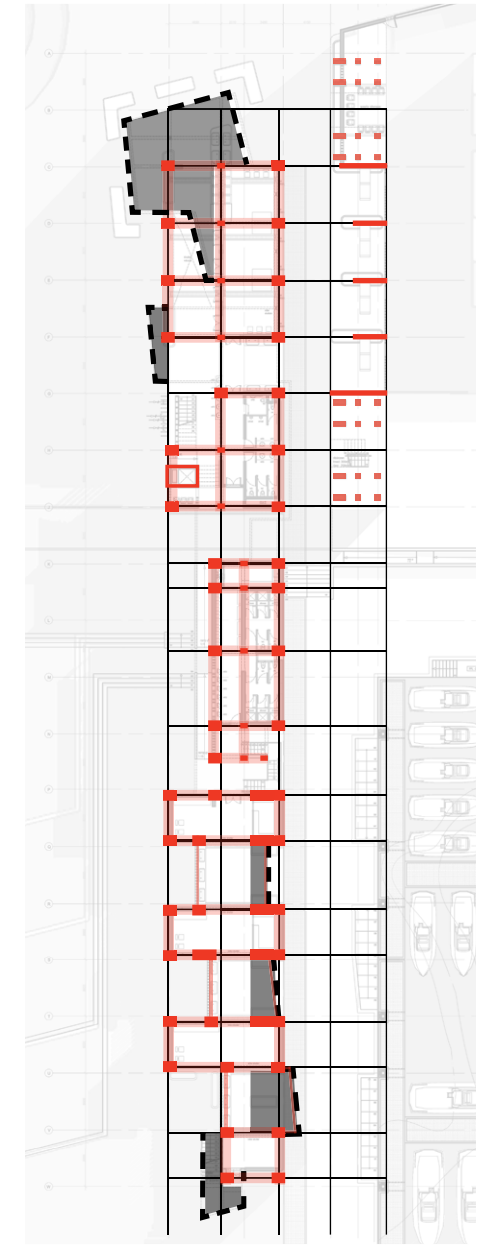

Figure 6.23.4: Rhythm: Repetitive to unique