

**Incidence and characterisation of *Bacillus sporothermodurans* isolated from UHT milk**

by

**Frederick Tawi Tabit**

submitted in fulfilment of the requirements for the degree

PhD Food Science

in the

Department of Food Science

Faculty of Natural and Agricultural Sciences

University of Pretoria

Pretoria

Republic of South Africa

May 2010

## **DECLARATION**

I hereby declare that the thesis submitted at the University of Pretoria for the award of a PhD degree is my work and has not been submitted by me for a degree at any other university or institution of higher education.

Frederick Tawi Tabit

May 2010



## **DEDICATION**

I dedicate this work to the Almighty God, the creator of heaven and earth and to my father, Peter Akwayi Tabit; my mother, Theresia Omah Tabit and my son, Nkosi Tawi Tabit.

## ACKNOWLEDGEMENTS

My sincere gratitude is extended to my supervisor, Prof. Elna Buys for the guidance and encouragement she has given me throughout this PhD research. Special thanks are also due to Prof. A. Minnaar, Head of Department of Food Science, Prof. John Taylor and Dr. Gyebi Duodu for their support and words of wisdom.

I should like to thank my father and mother, as well as my brothers and sisters for all the support they have given to me.

My appreciation is also extended to Mr. Chrisanthus Akam and his wife, Irene Akam, for their support during difficult times.

## ABSTRACT

*Bacillus sporothermodurans*, which was first detected in UHT milk in Germany in 1990, can affect the stability and shelf life of contaminated commercial UHT milk and cause economic losses. Due to the unusual thermal resistance of *B. sporothermodurans* spores, *B. sporothermodurans* can survive UHT treatment and proceed to grow in stored products causing instability because of their proteolytic activity (Huemer *et al.*, 1998). This study was conducted to determine the level of *B. sporothermodurans* contamination in South African dairies and to understand the mechanism of *B. sporothermodurans* spore destruction in order to investigate ways of inactivating these spores without severe heating. The objectives were to determine the presence of *Bacillus sporothermodurans* in retail UHT milk along with milk from different points of a processing line and isolates from UHT milk in South Africa, UP20A and a reference strain of *B. sporothermodurans*, DSM 10599 from Deutsche Sammlung von Mikroorganismen und Zellkulturen GmbH (DSMZ) in Germany were characterised using PCR. The effect of chilling, pre-heating, UHT, reprocessing and H<sub>2</sub>O<sub>2</sub>, individually and in combination, on the survival of *B. sporothermodurans* was also investigated in broth. Spores were heated at 130 °C for 4, 8 and 12 min in order to investigate the mechanism of structural damage and survival.

The adopted real time (RT) PCR with SYBR Green method was effective for the confirmation of *B. Sporothermodurans*. The structural damage on heated spores was determined using the Transmission Electron Microscopy (TEM), while High Performance Liquid Chromatography (HPLC) and spectrophotometry were used to quantify Dipicolinic acid (DPA) and soluble proteins released from the filtrate of heated spore suspensions. All statistical analyses were done using STATISTICA. *B. sporothermodurans* was detected in retail UHT milk packs from only one processor. The combination of chilling and UHT was more effective in eliminating *B. sporothermodurans* spores to a non detectable level than UHT treatment alone. H<sub>2</sub>O<sub>2</sub> was also effective in eliminating *B. sporothermodurans* spores, from 6.31 to 1.64 log cfu/ml after 15 min of exposure and. The release of DPA during wet heat treatment coincides with visible signs of structural damage and significant inactivation of

spores. Visible signs of spore structural damage emanate at different rates. The amount of protein release seems to be strain specific.

This research is the first to detect the presence of *B. sporothermodurans* in UHT milk in South Africa and to determine the effect of UHT processing stresses on its survival. These results can be used to design processing parameters so as to effectively eliminate *B. sporothermodurans* spores during UHT processing. Similarly, this research is the first in which RT PCR with SYBR Green has been used to characterise *B. sporothermodurans* as well as to determine the effect of wet heat treatment on the structure of *B. sporothermodurans* spores. This research aims to contribute to the insight regarding the mechanisms of destruction of *B. sporothermodurans* spores by wet heat.

## TABLE OF CONTENTS

<b>CHAPTER 1: INTRODUCTION AND PROBLEM STATEMENT .....</b>	<b>1</b>
1.1 Problem statement.....	1
<b>CHAPTER 2: LITERATURE REVIEW .....</b>	<b>4</b>
2.1 Current trends in UHT milk production and consumption.....	4
2.2 Quality and safety of raw milk .....	5
2.3 Bacterial composition of raw milk.....	6
2.4 Quality and age gelation of UHT milk.....	9
2.5 Rapid methods to determine the bacterial quality of milk .....	9
2.5.1 Bacterial stains .....	9
2.5.2 Aminopeptidase activity of Gram-negative bacteria .....	10
2.5.3 BactiFlow™ flow cytometer .....	10
2.5.4 Petrifilm™ and SimPlate™ plates .....	11
2.5.5 Propidium monoazide and real-time PCR .....	11
2.6 Milk contamination routes.....	12
2.7 Background to UHT milk contamination.....	13
2.8 Thermal processes and properties of treated milk .....	15
2.8.1 Pasteurisation of milk .....	15
2.8.2 UHT processing of milk.....	16
2.8.3 Important definitions regarding UHT processing .....	17
2.8.4 UHT treatment systems.....	18
2.8.5 Holding time during thermal processing of liquid milk .....	20
2.8.6 Tubular heat exchanger fouling by milk during thermal processing.....	21
2.8.7 Changes in milk on storage as a result of UHT treatment .....	22
2.9 <i>Bacillus sporothermodurans</i> .....	23
2.10 <i>B. sporothermodurans</i> characterisation techniques .....	24
2.10.1 16S rRNA gene sequencing .....	24
2.10.2 Polymerase chain reaction (PCR).....	25
2.10.3 Amplified ribosomal DNA restriction analysis (ARDRA).....	25
2.11 <i>Bacillus sporothermodurans</i> spores.....	26
2.12 Analysis <i>B. sporothermodurans</i> spore components.....	26
2.13 Thermal inactivation kinetics of <i>Bacillus sporothermodurans</i> .....	27
2.14 Stress response adaptation of <i>Bacillus</i> Species.....	30
2.15 Other <i>Bacillus</i> species related to thermally processed milk .....	31
2.15.1 <i>Bacillus cereus</i> .....	31
2.15.2 <i>Bacillus licheniformis</i> .....	32
2.15.3 <i>Bacillus stearothermophilus</i> .....	32
2.15.4 <i>Paenibacillus</i> spp.....	32
2.15.5 <i>Anoxybacillus</i> spp. ....	33
2.15.6 Research trends on <i>B. sporothermodurans</i> . ....	33
<b>CHAPTER 3: OBJECTIVES AND HYPOTHESES .....</b>	<b>34</b>
3.1 Objectives .....	34
3.2 Hypotheses.....	34



<b>CHAPTER 4: RESEARCH .....</b>	<b>35</b>
4.1 Incidence and survival of <i>Bacillus sporothermodurans</i> during UHT processing.....	35
4.1.1 Abstract.....	35
4.1.2 Introduction.....	36
4.1.3 Materials and methods .....	38
4.1.4 Results.....	43
4.1.5 Discussion .....	52
4.1.6 Conclusions.....	56
4.2 The effects of wet heat treatment on the structural and chemical components of <i>Bacillus sporothermodurans</i> spores.....	57
4.2.1 Abstract.....	57
4.2.2 Introduction.....	58
4.2.3 Materials and methods .....	59
4.2.4 Results.....	62
4.2.5 Discussion .....	71
4.2.6 Conclusion.....	74
<b>CHAPTER 5: GENERAL DISCUSSION .....</b>	<b>75</b>
5.1 Methodological considerations .....	75
5.2 Incidence and survival of <i>Bacillus sporothermodurans</i> during UHT processing.....	78
5.3 Effects of wet heat treatment on the structural and chemical components of <i>Bacillus sporothermodurans</i> spores .....	82
5.4 Proposals for future research .....	84
<b>CHAPTER 6: CONCLUSION AND RECOMMENDATIONS .....</b>	<b>87</b>
<b>CHAPTER 7: REFERENCES .....</b>	<b>88</b>



## LIST OF TABLES

Table 2.1	Food borne pathogens associated with milk and milk products .....	8
Table 2.2	Hazard analysis chart for thermal processing of milk .....	14
Table 4.1	Bacterial quality of milk collected from retail and during processing of processor D.....	45
Table 4.2	Effect of heating at 120 or 140 °C for 4s, and repeat UHT with 10% reprocessing on the survival of two strains of <i>Bacillus sporothermodurans</i> .....	48
Table 4.3	Effect of pre-heating (78 °C for 15s), UHT (120 °C for 4s) and a combination of pre-heating and UHT, on the survival of <i>Bacillus sporothermodurans</i> .....	49
Table 4.4	Effect of UHT treatment (120 °C/4s), with and without chilling (24h at 7 °C), on spores of <i>B. sporothermodurans</i> strains .....	50
Table 4.5:	Effect of 30% H <sub>2</sub> O <sub>2</sub> , on <i>B. sporothermodurans</i> spores, at different exposure times.....	51

## LIST OF FIGURES

Figure 2.1	Percentage composition of the South African liquid market (Coetzee & Maree, 2009) .....	5
Figure 2.2	Possible sources of cross contamination of pasteurised milk (Burgess, Heggum, Walker & Van Schothorst, 1994).....	12
Figure 2.3	Flow diagram for production of UHT milk (Sandrou & Arvanitoyannis, 2000).....	18
Figure 2.4	Diagram of UHT injection and infusion systems (Lewis & Heppel, 2000).....	19
Figure 2.5	Schematic layout of a UHT system using a tubular heat exchanger (Grijnspeerdt <i>et al.</i> , 2004).....	20
Figure 2.6	Schematic layout of a UHT system using a plate heat exchanger (Grijnspeerdt <i>et al.</i> , 2004).....	20
Figure 2.7	Thermal death time curves of <i>B. stearothermophilus</i> spores ( $\Delta$ ) and <i>B. sporothermodurans</i> spores J16B ( $\blacktriangle$ ); best plot lines through experimental data (Huemer <i>et al.</i> , 1998).....	28
Figure 2.8	Survival of <i>Bacillus sporothermodurans</i> spores from different origins in a pilot ultra-high temperature (UHT) installation (direct mode). $\blacklozenge$ , Feed concentrate isolate MB 1316; $\circ$ Feed concentrate isolate MB 1317; industrial spores (Scheldeman <i>et al.</i> , 2006).....	29
Figure 4.1	Gel photograph of PCR products confirming the identity of some of the UHT milk isolates. Lane 1 and 9, <i>B. sporothermodurans</i> DMSZ No. 10599 (Germany); lanes 3, 4, 5, 6, 7, 10, 11, 12 and 15, isolates from UHT milk detected as <i>B. sporothermodurans</i> ; lanes 13 and 14, isolates that were not positive for <i>B. sporothermodurans</i> ; Lane 2, <i>Bacillus stearothermophilus</i> as negative control; Lane 7, 100 bp DNA ladder (Fermentas, South Africa).....	46
Figure 4.2	Real time PCR melting curve ( $T_m = 86$ ) specific for <i>Bacillus sporothermodurans</i> using the BSPO-F2 and BSPO-R2 primers.....	46
Figure 4.3	Regression equation of the survival of <i>Bacillus sporothermodurans</i> spores following exposure to 30% $H_2O_2$ at different time ( $D_{30\%} = 3.33$ ).....	51
Figure 4.4	a & b: Micrographs generated from TEM analysis, showing the detail structures of unheated spores of <i>Bacillus sporothermodurans</i> UP20A, harvested from 14 days old BHI agar plates. NB: The spore structures of both strains as revealed by TEM analysis were similar. ....	64
Figure 4.5	a, b, c & d: Micrographs generated from TEM analysis, showing the structure of the spore of <i>Bacillus sporothermodurans</i> UP20A, heat treated at 130 °C for 4 min. NB: The spore structures of both strains as revealed by TEM analysis were similar. ....	65

Figure 4.6	a, b, c & d: Micrographs generated from TEM analysis, showing the structure of <i>Bacillus sporothermodurans</i> UP20A spores, heat treated at 130 °C for 8 min. NB: The spore structures of both strains as revealed by TEM analysis were similar. ....	66
Figure 4.7	a, b, c & d: Micrographs generated from TEM analysis, showing the structure of <i>Bacillus sporothermodurans</i> UP20A spores, heat treated at 130 °C for 12 min. NB: The spore structures of both strains as revealed by TEM analysis were similar. ....	67
Figure 4.8	Inactivation trend of spores of two strains of <i>B. sporothermodurans</i> : DSM 10599 and UP20A, following heat treatment at 130 °C at different times. Different letters a, b and c denote statistical differences at $p \leq 0.05$ ( $n = 3$ ). Log cfu/ml of 0 represent counts ranging from 1 to 0 spore/ml ( $n = 3$ ). ....	69
Figure 4.9	Protein released ( $\mu\text{g/ml}$ ) from spores of two strains of <i>Bacillus sporothermodurans</i> : DSM 10599 and UP20A, following heat treatment at 130 °C at different times. Different letters a, b and c denote statistical differences at $p \leq 0.05$ ( $n = 3$ ). Log cfu/ml of 0 represent counts ranging from 1 to 0 spore/ml ( $n = 3$ ). ....	70
Figure 4.10	DPA released ( $\mu\text{g/ml}$ ) from spores of two strains of <i>Bacillus sporothermodurans</i> : DSM 10599 and UP20A, following heat treatment at 130 °C at different times. Different letters a, b and c denote statistical differences at $p \leq 0.05$ ( $n = 3$ ). Log cfu/ml of 0 represent counts ranging from 1 to 0 spore/ml ( $n = 3$ ). ....	71

## CHAPTER 1: INTRODUCTION AND PROBLEM STATEMENT

### 1.1 PROBLEM STATEMENT

UHT (ultra-high temperature) milk processing plants in South Africa sporadically experience contamination with *Bacillus sporothermodurans*. Often this contamination is believed to be due to the reprocessing of UHT milk. It may occur as a result of UHT milk from packages used for quality control, UHT milk from defective packaging, or inadequately processed UHT milk caused by other problems that may occur during processing. It should be noted that the main reason for reprocessing is to avoid economic losses.

Internationally in 2008, there was an overall shift towards the consumption of UHT milk (Tetra Pak Dairy Index, 2009). Between 2000 and 2003 there was an increase in the consumption of UHT treated milk compared to pasteurised milk in some European countries like Spain (4%), UK (3%) and Portugal (1%) (Rysstad & Kolstad, 2006). In South Africa UHT milk consumption stood at 32% of all liquid milk and liquid milk products consumed towards the end of 2009 while 60% of the dairy products consumed within this period were in the form of liquid milk and liquid milk products (Coetzee & Maree, 2009).

*B. sporothermodurans*, first detected in UHT milk in Germany in 1990, affects the stability and the shelf life of commercial UHT milk. This is due to the unusual thermal kinetics of *B. sporothermodurans* spores that enable them to survive high temperatures, namely, 130 °C for 4s of UHT treatment (Huemer, Klijn, Vogelsang & Langeveld, 1998). These spores germinate during storage in UHT products causing instability due to their proteolytic activities thereby reducing the shelf life and affecting consumer acceptability.

Increasing the temperature or the holding time in an attempt to inactivate *B. sporothermodurans* spores affects the organoleptic and nutritional qualities of UHT milk (Claeys, Ludikhuyze & Hendrickx, 2001). Severe heating will lead to protein

denaturation, Maillard reactions and lactose isomerisation. Protein denaturation and sugar modification are responsible for the ‘cooked’ taste while the Maillard reactions induce a decrease of the protein nutritional value by irreversible alteration of the lysine residues (Claeys *et al.*, 2001). It is currently not clear exactly how the structural and chemical components of *B. sporothermodurans* spores influence their extreme wet heat resistance during heating at UHT temperatures (Klijn, Herman, Langeveld, Vaerewijck, Wagendorp, Huemer & Weerkamp, 1997).

*B. sporothermodurans* spores have been found to be more resistant than other heat resistant spores at temperatures above 130 °C with  $D_{140}$  ranging from 3.4–7.9s and Z-values ranging from 13.1–14.2 °C (Huemer *et al.*, 1998).  $D_{140}$  is the time required when heating at 140 °C to inactivate *B. sporothermodurans* spores by one log cycle. Similarly, the Z-value is the temperature required to reduce the D-value by one log cycle (Juneja, Snyder & Marmer, 1997).

When unopened packages of UHT treated milk are incubated at 30 °C for 15 days, *B. sporothermodurans* counts may reach a maximum of  $10^5$  cfu/ml. Even though *B. sporothermodurans* is not a risk to the consumer, dairy operators are required to address quality problems in order to meet legal demands and avoid trade restrictions (Hammer, Lembke, Suhren & Heeschen, 1995).

*B. sporothermodurans* has not been isolated from raw milk because of its inability to grow and compete with other bacteria in raw fresh milk. On the other hand, it encounters no competition from other bacteria in UHT treated milk in which it grows without restraint (Huemer *et al.*, 1998). Different authors have postulated possible routes of contamination by *B. sporothermodurans*. Cited are contamination from soil, fodder, digestive tract, dung, udder, teat, milking utensils, raw milk and feed (Vaerewijck, De Vos, Lebbe, Scheldeman, Hoste & Heyndrickx, 2001). Reprocessing of contaminated lots of UHT products and contaminated milk powder has been identified as another possible route of contamination with *B. sporothermodurans* spores during processing (Hammer *et al.*, 1995). However, the precise route of contamination by *B. sporothermodurans* has not yet been established

and this makes it difficult to control contamination (Guillaume–Gentile, Scheldeman, Marugg, Herman, Joosten & Heyndrickx, 2002).

## CHAPTER 2: LITERATURE REVIEW

### 2.1 CURRENT TRENDS IN UHT MILK PRODUCTION AND CONSUMPTION

Between 1997 and 2007, milk production in the world expanded by 122 million tonnes giving an average annual growth of 1.9%. The annual growth rates of milk in 2006 and 2007 were 2.5% and 1.3% respectively with the growth rate expected to increase in 2008 and 2009. Globally there is shift towards the consumption of UHT milk. Consumption of UHT milk increased 18.7% in 2004 to 23% in 2008. An annual growth rate of 5.2% was predicted before 2012 (Tetra Pak Dairy Index, 2009).

In South Africa the total dairy consumption showed positive growth in the five years prior to 2008, however, there was a downward trend in the first quarter of 2008. Pasteurised liquid milk and UHT milk are the major liquid products as shown in Figure 2.1 (Coetzee & Maree, 2009). The world milk consumption and the consumption of other liquid dairy products is expected to rise by an annual growth rate of 2.2% over the next three years, according to a research report released by Tetra Pak which is one of the biggest stakeholders in world food processing and packaging (Tetra Pak Dairy Index, 2009).

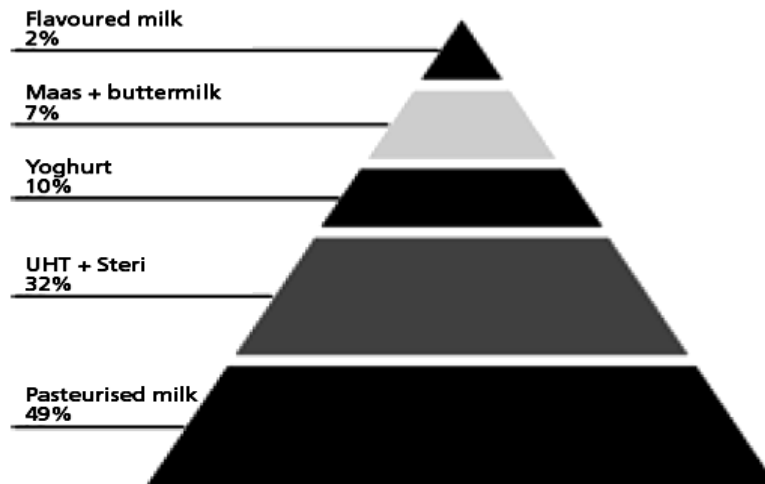

Figure 2.1 Percentage composition of the South African liquid market (Coetzee & Maree, 2009)

## 2.2 QUALITY AND SAFETY OF RAW MILK

Raw milk and products which have not been pasteurised pose a health risk to consumers, as do pasteurised milk products but to a lesser extent, considering that they have also been implicated in outbreaks (Leedom, 2006). The consumption of raw milk and raw milk products should be avoided especially by high-risk consumer groups because the risk outweighs the sensory good taste benefits associated with it (Leedom, 2006). The shelf life of pasteurised fluid milk is determined by the quality of the raw milk that was processed. Similarly, the bacterial and somatic cell counts of the raw milk determine the amount of heat stable enzymes, plasmin and lipase in the heat-treated milk (Barbano & Santos, 2006). For many years raw milk has been recognised as a vehicle for the transmission of food pathogens. Outbreaks associated with the consumption of raw milk occur routinely every year in different parts of the world. Examples of outbreaks include campylobacteriosis, in USA in May 1983, *Listeria monocytogenes* infection in Canada 1998 and *Yersinia enterocolitica* infection in the USA in 1992 and 1997 (Jayarao, Donaldson, Straley, Sawant, Hegde & Brown, 2006).



## 2.3 BACTERIAL COMPOSITION OF RAW MILK

The availability of carbohydrates, proteins and fat, together with the neutral pH makes milk a perfect medium for bacterial microbial growth. Different sorts of bacteria can be found in raw milk. These may include psychrotrophs, coliforms and other Gram-negative bacteria. Different psychrotrophic bacteria belonging to different genera have been isolated from milk. They include: *Pseudomonas*, *Enterobacter*, *Flavobacterium*, *Klebsiella*, *Aeromonas*, *Acinetobacter*, *Alcaligenes* and *Achromobacter* spp. Some genera isolated from milk are both psychrotrophic and thermotolerant. They include: *Bacillus*, *Clostridium*, *Microbacterium*, *Micrococcus* and *Corynebacterium* spp. (Hayes & Boor, 2001). Some thermotolerant bacteria that have been isolated from milk are *Microbacterium* (Kazwala, Daborn, Kusiluka, Jiwa, Sharp & Kambarage, 1998), *Micrococcus* (García, Rodríguez, Bernardo, Tornadijo & Carballo, 2002), *Bacillus* spores, *Clostridium* spores (Te Giffel, Wagendorp, Herrewegh & Driehuis, 2002), *Alcaligenes* (Samaras, Kehagias, Arkoudelos & Bocaris, 2003), and *Microbacterium* (Kazwala *et al.*, 1998). Similarly, some psychrotrophic bacteria isolated from milk are *Pseudomonas*, *Acinetobacter*, *Flavobacterium*, *Aerobacter* (Sørhaug & Stepaniak, 1997), *Alcaligenes* (Samaras *et al.*, 2003), and *Bacillus* (Te Giffel *et al.*, 2002).

The incidence of toxigenic *Bacillus cereus* has been found to be high in milk and cream in particular as toxin production has been linked with aeration (agitation) during growth at 8 °C (Christiansson, Naidu, Nilsson, Wadstrom & Pettersson, 1989). However, the very low incidence of milk-borne food poisoning by *B. cereus* has been attributed to its inability to produce toxin under normal storage conditions of fresh milk (Christiansson *et al.*, 1989). *B. licheniformis*, *B. pumilus*, *B. subtilis*, *B. sphaericus*, *B. thuringiensis* and *B. brevis* have been linked to food-borne illness, while *B. anthracis* and *B. cereus* are the only bacilli able to infect humans (Pirttijärvi, Andersson & Salkinoja-Salonen, 2000). Examples of bacterial pathogens associated with milk and the diseases they cause can be seen in Table 2.1.

The contamination of raw milk with bacteria can be due to one or many of the following sources of contamination: interior of the udder, exterior of the udder and milking instruments. Seasonal incidence of spores of *B. cereus* in raw milk has been linked to the pasturing of cattle, considering that housing them in a shelter while they are being fed has been found to reduce the levels of milk contamination (Slaghuis, Te Giffel, Beumer & André, 1997). Automated milking and restricted pasturing have been found to reduce the levels of *B. cereus* spores in raw milk. Examples of thermophilic and psychrotrophic bacteria found in milk can be seen in Table 2.1.

The production of raw milk with a standard plate count (SPC) consistency of less than 10 000 cfu/ml is a reflection of good hygienic practices while an SPC more than 10 000 cfu/ml is a reflection of poor hygienic practices during raw milk production (Cousin & Bramley, 1981). According to the regulations relating to milk and dairy products of the South African Government Notice No. R1555, an SPC of less than 200 000 cfu/ml is recommended for raw milk intended for use or consumption (Regulations relating to milk and dairy products, 1997).

Table 2.1 Food borne pathogens associated with milk and milk products

Organism	Illness
<b>Enterobacteriaceae</b>	
Pathogenic <i>E. coli</i> (Buyser <i>et al.</i> , 2001)	Gastroenteritis, hemolytic uremic syndrome
<i>Salmonella enterica</i> (Jayarao & Henning, 2001)	Gastroenteritis, typhoid fever
<i>Yersinia enterocolitica</i> ( Jayarao & Henning, 2001)	Gastroenteritis
<b>Other Gram-negative bacteria</b>	
<i>Aeromonas hydrophila</i> (Lafarge <i>et al.</i> , 2004)	Gastroenteritis
<i>Brucella melitensis</i> (Hamdy <i>et al.</i> , 2002)	Brucellosis (Bang's disease)
<i>Campylobacter jejuni</i> ( Jayarao & Henning, 2001)	Gastroenteritis
<i>Escherichia coli</i> (Griffin <i>et al.</i> , 1991)	
<b>Gram-positive spore formers</b>	
<i>Bacillus cereus</i> (Christiansson <i>et al.</i> , 1989)	Gastroenteritis (emesis and diarrhoea)
<i>Clostridium botulinum</i> (Franciosa <i>et al.</i> , 1999)	Botulism
<b>Gram-positive cocci</b>	
<i>Staphylococcus aureus</i> (Buyser <i>et al.</i> , 2001)	Emetic intoxication
<i>Streptococcus agalactiae</i> (Gillespie <i>et al.</i> , 1997)	Mastitis
<i>Streptococcus zooepidemicus</i> (Francis <i>et al.</i> , 1993)	Pharyngitis, nephritic sequelae
<b>Miscellaneous Gram-positive bacteria</b>	
<i>Corynebacterium ulcerans</i> (Barrett, 1986)	Diphtheria
<i>Listeria monocytogenes</i> ( Hayes <i>et al.</i> , 1986)	Listeriosis
<i>Mycobacterium bovis</i> (Kazwala <i>et al.</i> , 1998)	Tuberculosis
<i>Mycobacterium tuberculosis</i> (Kazwala <i>et al.</i> , 1998)	Tuberculosis
<i>Mycobacterium avium</i> subsp. Paratuberculosis (Ayele <i>et al.</i> , 2005)	Johne's disease (ruminants)
<b>Rickettsia</b>	
<i>Coxiella burnetii</i> (Kim <i>et al.</i> , 2005)	Q fever
<b>Viruses</b>	
FMD virus (Tomasula <i>et al.</i> , 2007)	Foot-and-mouth disease
<b>Fungi</b>	
Molds (Wouters <i>et al.</i> , 2002)	Mycotoxins
<b>Protozoa</b>	
<i>Entamoeba histolytica</i> (Rai <i>et al.</i> , 2008)	Amoebiasis

## 2.4 QUALITY AND AGE GELATION OF UHT MILK

Proteolytic activities in UHT milk during storage can give rise to a bitter flavour, gelation and sedimentation which can lead to the reduction of the quality of stored products. Proteolysis in UHT milk is largely due to the presence of bacterial proteinase and the natural milk alkaline serine proteinase, known as plasmin (Topçu, Numanoglu & Saldamli, 2006). The proteolysis deficiencies can be alleviated by conducting UHT processing at a higher temperature (above 150 °C), but this will also lead to the production of a ‘cooked’ taste in the UHT milk (Topçu *et al.*, 2006). Gelation in UHT milk takes place when whey proteins, especially  $\beta$ -lactoglobulin, interact with casein, mainly  $\kappa$ -casein of the casein micelle to form a three-dimensional protein complex ( $\beta$ -lactoglobulin-  $\kappa$ -casein complex) (Datta & Deeth, 2001).

The process of age gelation can be divided into two steps. In the first step, the  $\beta k$ -complexes detach from the casein micelles because of the breakdown of various attachment sites on  $k$ -casein. In the second step, these complexes aggregate into a three-dimensional matrix. Upon reaching a critical volume, the  $\beta k$ -complex forms a gel of custard-like consistency (Datta & Deeth, 2001). Factors that affect the age gelation of UHT milk are the nature of the heat treatment, proteolysis during storage, milk composition and quality, seasonal milk production factors and storage temperature (Datta & Deeth, 2001).

## 2.5 RAPID METHODS TO DETERMINE THE BACTERIAL QUALITY OF MILK

### 2.5.1 Bacterial stains

Gram-positive and Gram-negative bacteria in milk can be analysed using a staining technique. In such a technique, the milk sample often pre-treated with EDTA can be filtered through a polysulfone membrane to concentrate the bacteria in the sample. The bacteria on the membrane are stained with toluidine blue and then treated with ethonal-acetic acid which decolourises Gram-negative bacteria while the Gram-

positive bacteria retain the blue colour of toluidine (Yazdankhah, Sørum, Larsen & Gogstad, 2001). The detection limit of this method is at  $5 \times 10^6$  cfu/ml for *Staphylococcus aureus* and  $1 \times 10^6$  cfu/ml for *Escherichia coli* for milk samples (Yazdankhah *et al.*, 2001). Resazurin (7-Hydroxy-3H-phenoxazin-3-one 10-oxide) is the bluish dye used as an oxidation-reduction indicator to test for the presence of bacteria. It has been found to be more sensitive than methylene blue or turbidity alone as an indicator of microbial growth (Takeno, Ohnishi, Komatsu, Masaki, Sen & Ikeda, 2007). The methylene blue dye reduction test (MBRT) has been used to successively count up to 800 live cells within a time frame of 200s (Bapat, Nandy, Wangikar & Venkatesh, 2006). Colony-forming units (cfu) equivalent to 800 live cells have been successfully quantified using MBRT (Bapat *et al.*, 2006). Bacteria can also be enumerated by measuring the amount of adenosine triphosphate (ATP) using the luciferase bioluminescent reaction, however, it is difficult to differentiate between bacterial and somatic ATP (Siragusa & Cutter, 1995).

### **2.5.2 Aminopeptidase activity of Gram-negative bacteria**

The aminopeptidase test can be used to analyse the microbial quality of milk according to the standard set by the European Union. This method has been designed to measure the aminopeptidase of Gram-negative bacteria. The sensitivity of the assay is at  $2 \times 10^4$  cfu/ml that is an acceptable limit with respect to the regulations of many countries (Manzano, Ordoez, De La Hoz & Fernandez, 2005). Using this method, the Gram-negative population can be estimated within 2.5h.

### **2.5.3 BactiFlow™ flow cytometer**

The BactiFlow™ flow cytometer can be used to analyse the bacterial population of milk by utilising their esterase activity (Flint, Walker, Waters & Crawford, 2007). The cytometer has the Chemunex system that utilises bacterial esterase activity to label and detect viable cells. The protocol used to analyse viable cells can be modified to analyse only thermophilic bacteria by heat-treating the milk sample. Milk samples that have been diluted with 0.1% peptone are mixed with 0.8%

ethylenediaminetetraacetic acid to minimise the interference from the background (Flint *et al.*, 2007).

#### **2.5.4 Petrifilm™ and SimPlate™ plates**

The performance of the Petrifilm™ aerobic count and the SimPlate™ total plate count of pasteurised milk has been found to decline with a decrease in the bacterial quality of the milk (Beloti, Barros, Nero, Pachemshy, de Santana, Bernadette & Franco, 2002). This can be resolved by introducing a preliminary concentration on a filter with the Petrifilm™ technique (Vail, Morgan, Merino, Gonzales, Miller & Ram, 2003). However, the straightforwardness, reliability and low cost of Petrifilm™ plates make them ideal for routine analysis. The counting range of the SimPlate™ is high, with > 1 600 the most probable number (MPN) per single dilution. As a result, SimPlate™ needs fewer dilutions of samples. Some foods, for example, raw liver, wheat flour and nuts contain enzymes that have produced false-positive reactions on SimPlates™. Nevertheless, the SimPlate™ total plate count method is a suitable alternative to conventional SPC for estimating aerobic bacteria in a wide range of foods (Beuchat, Copeland, Curiale, Danisavich, Gangar, King, Lawlis, Likin, Okwusoa, Smith & Townsend, 1998).

#### **2.5.5 Propidium monoazide and real-time PCR**

This assay allows for the quantification of only viable bacterial cells present in fermented milk products because propidium monoazide penetrate the dead cells and bind to the DNA that is then cross-linked by photo induction (García-Cayueta, Tabasco, Peláez & Requena, 2009). Propidium monoazide is utilised to discriminate viable and non-viable bacteria in conjunction with real time PCR quantification (Nocker, Cheung & Camper, 2006).

## 2.6 MILK CONTAMINATION ROUTES

Silage is an important source of contamination of raw milk by bacterial spores and the level of raw milk can be minimised if the spore load in silage is reduced. In addition to silage, factory equipment and packaging materials also contribute to the quality of milk (Te Giffel, Wagendorp, Herrewegh & Driehuis, 2002). A number of milk-contaminating bacteria have been found in the air surrounding the processing machine, in the condensed water on the filling nozzles and in wastewater at the bottom of the filling machine. The majority of these bacteria were identified as *Pseudomonas fluorescens*, *P. putida*, *P. corrugate* and *Janthinobacterium lividum* (Eneroth, Christiansson, Brendehaug & Molin, 1998). Molecular typing methods have been used to reveal genetic diversity of *Bacillus* isolates from dairy farms and dairies from the same location. It has been found that bacteria associated with dairy contamination have not necessarily originated from raw milk, thereby confirming the theory of contamination and propagation during the manufacturing process (Banyakó & Vyletřlová, 2008). The contamination route can be either external or internal as shown in Figure 2.2 below.

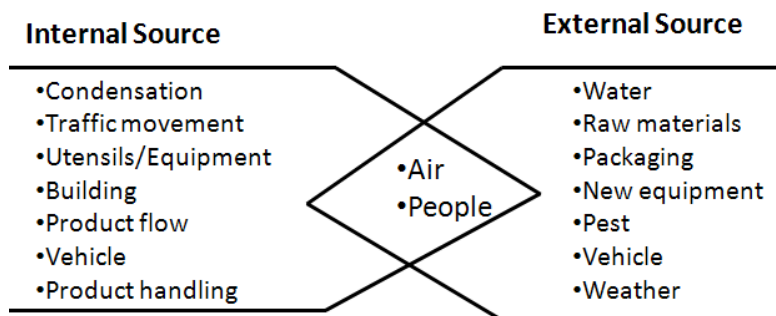

Figure 2.2 Possible sources of cross contamination of pasteurised milk (Burgess, Heggum, Walker & Van Schothorst, 1994)

The high level of Gram-negative psychrotrophic bacteria in refrigerated milk is due to post-pasteurisation contamination at the filling level (Eneroth *et al.*, 1998). In order to extend the shelf life of fluid milk all bacteria that emanate from the raw milk supply

sources have to be eliminated. Different studies conducted have suggested multiple potential entry points for psychrotolerant endospore-forming bacteria into the raw milk at the farm as well as various points of recontamination during the entire production line (Huck, Sonnen & Boor, 2008).

High numbers of *B. cereus* in pasteurised milk can be due to teat contamination especially during grazing (Svensson, Eneroth, Brendehaug, Molin & Christiansson, 2000). Spores of *B. cereus* are very hydrophobic and as such, can adhere to surfaces of steel, glass and rubber but are effectively eliminated during efficient cleaning (Svensson *et al.*, 2000).

## **2.7 BACKGROUND TO UHT MILK CONTAMINATION**

In 1985, certain types of *Bacillus* species were detected in UHT treated milk in many European countries (Hammer *et al.*, 1995). During that time spoilage encountered in UHT treated milk was thought to have been caused by contamination during filling. Members of the genus *Bacillus*, especially *B. badius*, *B. cereus*, *B. licheniformis*, *B. polymyxa*, *B. subtilis*, and *B. stearothermophilus*, were identified as responsible for the spoilage of UHT milk (Pettersson, Lembke, Hammer, Stackebrandt & Priest, 1996).



Table 2.2 Hazard analysis chart for thermal processing of milk

Process step	Identified hazard	Preventive measures	CCP
Raw milk receiving	Microbiological (M) – Pathogens, <i>Staphylococcus</i> toxin	Pasteurisation, Temperature control Antibiotic test	Yes
Filter	Chemical (C)-Animal residues Physical – foreign object.	Passage of foreign object that can be a hazard	No
Raw milk storage	Microbiological (M) – Pathogens, <i>Staphylococcus</i> toxin	Pasteurisation, Temperature control	Yes
Clarifier/separator	Microbiological (M) – Pathogens, <i>Staphylococcus</i> toxin	Pasteurisation, resident times not enough for <i>Staphylococcus</i> toxin production	No
Raw cream storage			
Homogenisation			
Vitamin addition	Microbiological (M) – Pathogens, <i>Staphylococcus</i> toxin	Prerequisite programme for ingredient reception, usage record and pump calibration	Yes
Pasteurisation/UHT	Microbiological (M) – Pathogens	Pathogens are eliminated by pasteurisation/UHT	Yes
Pasteurised/UHT storage	Introduction of pathogens, hazard after pasteurisation	Prerequisite programmes are in place to prevent post-contamination	No
Packaging materials	Introduction of pathogens, chemical, or physical hazard after pasteurisation	Pasteurisation/UHT contamination	Yes
Filters			
Cold storage	Properly pasteurised, packaged product contain no hazard	Not applicable	No
Distribution			

Source of table: Byrne and Bishop, 2001

However, it was also found that certain heat resistant spores could survive UHT and autoclaving and subsequently grow in the stored products. These bacteria with highly heat resistant spores were first detected in Southern Europe in 1985. The first detection in UHT milk was in Germany in 1990. Subsequently, the problem was experienced in several other countries (Hammer, Lembke, Suhren & Heeschen, 1995).

In 1985, the European Council (EC) Milk Hygiene Directive 85/397 stipulated a maximum of 10 cfu/0.1 ml for UHT milk after an incubation period of 15 days at 30 °C and this led to a change in the quality control protocol for the UHT treated milk. When the German government enforced the EC Milk Hygiene Directive 85/397 in their national legislation through the Hygiene Ordinance of June 1989 (Klijn *et al.*, 1997) the quality control for UHT milk was modified to include bacteriological analysis techniques instead of the usual physio-chemical methods like pH, sensory and stability tests, which were not effective enough to detect slow-growing spore forming bacteria (Klijn *et al.*, 1997). The bacterium responsible for the non-sterility of UHT milk was identified to be *B. sporothermodurans* (Pettersson *et al.*, 1996). The execution of Hazard Analysis Critical Control Point (HACCP) by the dairy industry is expected to improve consumer confidence in products and decrease the barriers in international trade (Sandrou & Arvanitoyannis, 2000). Figure 2.2 and Table 2.2 above shows the hazard analysis and critical control chart for UHT milk.

## **2.8 THERMAL PROCESSES AND PROPERTIES OF TREATED MILK**

### **2.8.1 Pasteurisation of milk**

According to the International Dairy Federation (IDF), pasteurisation is a process whereby products such as milk are heat-treated in such a way as to minimise possible hazards due to pathogens, without changing the physical, chemical and sensory properties of the product (Lewis, 1986). Raw milk prior to pasteurisation is expected to be of good quality. It should be free of pathogens and should have an acceptable colony count with a minimum of  $10^5$  cfu/ml.

Regulations relating to milk and dairy products of the South African Government Notice Number R. 1555 of 21 November 1997 state that every particle of milk should be heated at a temperature not less than 63 °C and not more than 65.5 °C and held at that temperature for at least 30 min. The heating should be followed by cooling within 30 min to a temperature lower than 5 °C. On the other hand, every particle of the milk can be heated to a temperature of at least 72 °C and held at that temperature

for at least 15s with same cooling pattern as mentioned above (Regulations relating to milk and dairy products, 1997).

According to the IDF, pasteurisation should be conducted as follows. For milk use, it is 72 °C for 15s (continuous flow pasteurisation) or 63 °C for 30 min (batch pasteurisation). Other equivalent conditions can be obtained by plotting the line passing through these points on a log of times versus temperature graph. For cream, use 75 °C for 15s (10-20% fat), 80 °C for 15s (above 20% fat) and 65 °C for 30 min (batch pasteurisation) (Codex Committee on Milk and Milk Products, 2000).

### **2.8.2 UHT processing of milk**

UHT treatment of milk is the process within which milk is rendered commercially sterile by heating at temperatures exceeding 135 °C for 1–2s (Kessler, 1981). The processing of milk at high temperatures is aimed at destroying vegetative cells as well as endospores present in raw milk so that it can be stored for prolonged periods, generally several months without refrigeration (Kessler, 1981). According to the IDF, the temperatures for UHT treatment range from 135 to 150 °C used in combination with the appropriate holding times such as 140 °C for 2.3s. The temperatures for sterilisation should be 110 to 125 °C in combination with appropriate holding times such as 121 °C for 3 min or 115 °C for 13 min (Codex Committee on Milk and Milk Products, 2000).

Other equivalent conditions to give an  $F_0$  value of 3 min can be obtained by plotting the line passing through the above temperature/time combinations on a log time versus temperature graph (Codex Committee on Milk and Milk Products, 2000). The  $F_0$  value is any equivalent heat treatment that will cause the same destruction ration of spores similar to that of a reference temperature (Mafart, Couvert, Gaillard & Lequerinel, 2002). The heat process for milk is specifically designed to ensure the safety of products. However, heating might lead to protein denaturation, Maillard reactions and lactose isomerisation (Claeys, Ludikhuyze & Hendrickx, 2001).

Regulations relating to milk and dairy products of the South African Government Notice Number R. 1555 of 21 November 1997 state that UHT treatment comprises heating above 100 °C and aseptic packaging so that the end product, after incubation for not less than 14 days at a temperature of 30 °C, is free from spoilage microorganisms.

UHT plants operate in a manner to maintain the temperature-time relationship in a given range. There are two types of UHT processes: the direct UHT, which includes a heating and cooling phase, and the indirect UHT. The heating and cooling phases increase with a higher temperature during indirect UHT processes. This implies a longer holding time and, therefore, an increase in the undesired heat-induced changes in milk (Kessler, 1981). For the direct UHT process, which could be either injection or infusion, a high heating temperature can be achieved without the heating and cooling phases. The use of flash evaporation to cool milk rapidly in direct UHT has a problem of heat loss compared to indirect UHT processes. This is because after the flash evaporation the steam form is approximately 80 °C and can be used only for milk preheating (Grijspeerdt, Mortier, Block & Renterghem, 2004).

### **2.8.3 Important definitions regarding UHT processing**

UHT treatment involves a high-temperature/short-time heat treatment aimed at producing a commercially sterile product that can be stored at room temperature. This process aims to destroy all microorganisms. Residual microorganisms are unlikely to cause spoilage under normal storage conditions. UHT-treated milk and cream are packaged aseptically into sterilised, hermetically sealed containers. The total heat treatment is equivalent, in terms of its effectiveness against heat-resistant bacterial spores, to a minimum  $F_0$ -value of 3 min. A hermetically sealed container is a container that is designed and intended to be secure against the entry of microorganisms (Codex Committee on Milk and Milk Products, 2000).

Sterilisation involves a high-temperature/long-time heat treatment aimed at producing a commercially sterile product that can be stored at room temperature. The process

aims to destroy all microorganisms. Residual microorganisms are unlikely to cause spoilage under normal storage conditions. Sterilisation is an in-container, batch-wise heating process using minimum temperature-time conditions that achieve an  $F_0$ -value of 3 min (Codex Committee on Milk and Milk Products, 2000).

### 2.8.4 UHT treatment systems

UHT treatment systems can be divided into two types when considering the nature of the equipment used, the direct and the indirect systems (Figure 2.3).

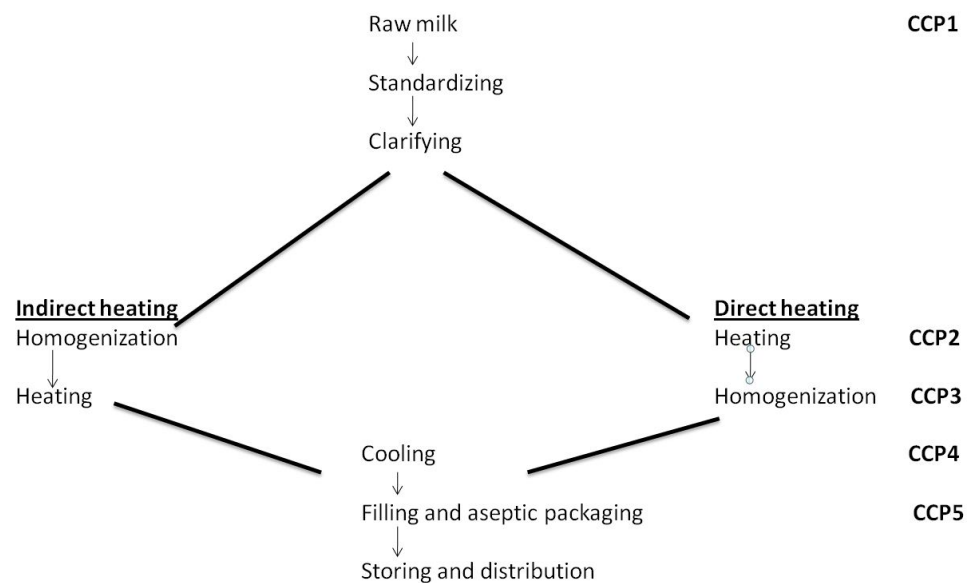

Figure 2.3 Flow diagram for production of UHT milk (Sandrou & Arvanitoyannis, 2000)

#### 2.8.4.1 Direct UHT system

With the direct UHT system, heating is performed by mixing the product and steam at high pressure of about 9 bars. With this system the heat transfer is higher than that of indirect UHT and because the residence time is very short, results in less fouling. This process is difficult to control and therefore not often used (Grijpspeerdt *et al.*, 2004). There are two types of the direct heating system: direct heating by injection and direct heating by infusion as shown in Figure 2.4. In the injection system, the

steam injected comes into contact with the product through a specially designed nozzle. With the infusion system, the product is distributed in strings across the centre of a chamber in which steam is distributed.

#### 2.8.4.2 Indirect UHT system

The indirect UHT system consists of a solid barrier that separates the heat transfer medium (often water or steam) and the dairy product. The indirect system can further be subdivided into two types depending on the nature of the heat exchanger incorporated into it. The two types of heat exchanger are the plate and tubular heat exchangers as shown in Figure 2.5 and Figure 2.6 (Grijpspeerd *et al.*, 2004). The quality of UHT milk in packs processed via indirect UHT differed from that produced by direct UHT when they were analysed after storage for 24 weeks. Thermally induced changes in lactulose, furosine and acid-soluble whey proteins revealed that directly heated UHT milks suffer less heat damage than indirectly heated milk (Elliott, Datta, Amenu & Deeth, 2005).

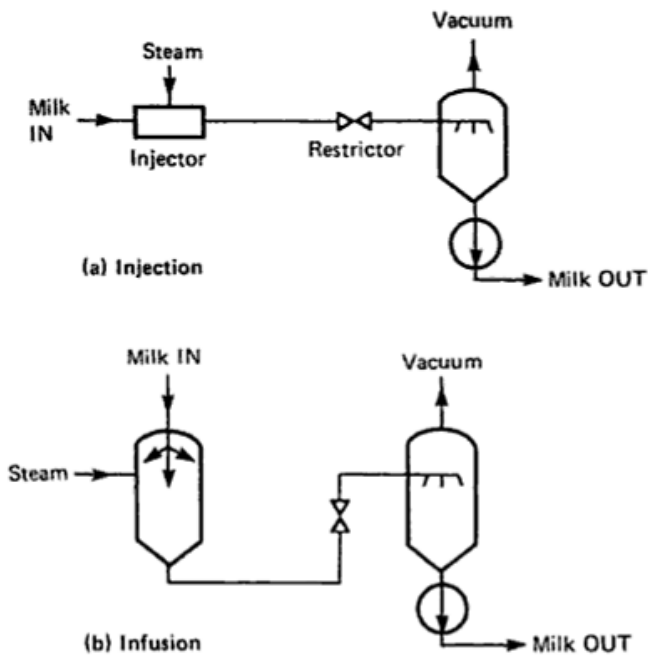

Figure 2.4 Diagram of UHT injection and infusion systems (Lewis & Heppel, 2000)

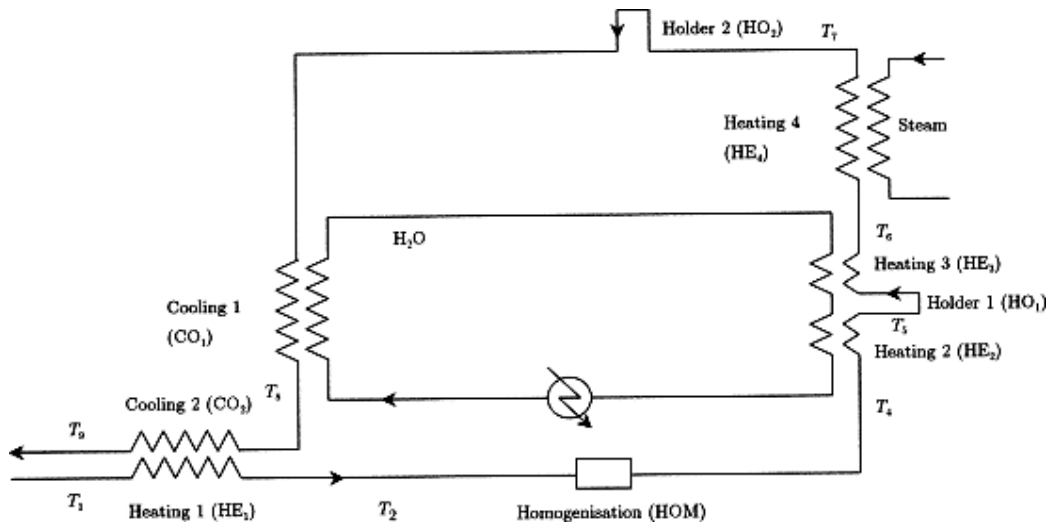

Figure 2.5 Schematic layout of a UHT system using a tubular heat exchanger (Grijnspeerd *et al.*, 2004)

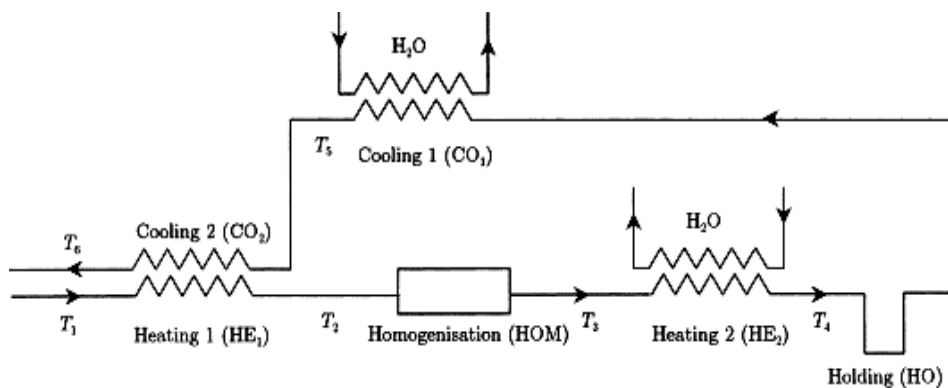

Figure 2.6 Schematic layout of a UHT system using a plate heat exchanger (Grijnspeerd *et al.*, 2004)

### 2.8.5 Holding time during thermal processing of liquid milk

When liquids flow through a pipe, there is a distribution of holding (residence) time along the pipe. It is possible to measure and analyse this distribution using various methods. One method involves the injection of a pulse of a tracer material in a liquid followed by sampling and analysing the outlet stream at defined intervals (Lewis, 1986). Based on this method, three types of flow have been determined: the plug flow, streamline flow and turbulent flow. The plug flow is the ideal situation where

the velocity profiles within a liquid do not vary. Due to internal friction or the viscosity of the fluid, there is always velocity distribution within the tube. This distribution of velocity and the flow type (streamline or turbulent) can be determined by using a dimensionless constant known as the Reynolds number (Re) (Lewis, 1986).

$$\text{Re} = \frac{VDP}{U} \quad \text{or} \quad \frac{4QP}{\Pi UD}$$

$V$  = Average velocity (m/s)

$D$  = Tube diameter (m)

$P$  = Fluid density ( $\text{kg/m}^3$ )

$U$  = Dynamic Viscosity ( $\text{Ns/m}^2$ )

$Q$  = Volumetric flow rate ( $\text{m}^3/\text{s}$ )

$$\Pi = \frac{22}{7}$$

$VOT$  = Volumetric of tube ( $\text{m}^3$ )

The resident time ( $t_{av}$ ) is based on the average velocity and the length of the tube.

$$\text{Resident time } (t_{av}) = \frac{L}{V} \quad \text{or} \quad \frac{VOT}{Q}$$

### 2.8.6 Tubular heat exchanger fouling by milk during thermal processing

Fouling, which is the accumulation of unwanted deposits on the surfaces of food processing equipment, mostly heat exchanger, causes resistance to heat transfer and as a result reduces the efficiency of thermal processing (Swartzel, 2007). The presence of these deposits represents a resistance to heat or mass transfer and therefore reduces the efficiency of the particular food process. Fouling may be as a result of an accumulation of the following: constituents of the fluid food being processed or products of chemical reactions occurring during the processes or particulate matter suspended in the fluid or microorganisms (Bansal & Chen, 2006). Two different types of fouling are commonly found in the food industry: thermal fouling and membrane fouling. Each manifests distinctly different mechanisms and processes. A



holistic approach is recommended in controlling fouling within the entire plant rather than focusing solely on the heat exchangers as fouling may shift to other parts of the plant (Bansal & Chen, 2006). The fouling of milk commences when milk is heated at 80 °C. At this temperature, milk starts to form deposits that can be monitored by weighing or indirectly by monitoring the pressure drop in the system. In practice the time taken for the pressure to drop varies considerably. When the pressure starts to drop, it does so in an increasingly parabolic pattern until a limiting pressure is reached (Lewis, 1986). It should be noted that the formation of different types of deposits is temperature dependent. Deposits formed between 80 °C and 105 °C, are a white, voluminous precipitate that is mainly protein. Beyond 110 °C the deposits are granular and are of mineral origin. At this stage build-up of deposit is usually within the final heating compartment, hence reducing heat transmission (Lewis, 1986).

The quality of milk also determines the speed of fouling and ageing of milk. The stability of raw milk with regards to deposit formation during processing has been shown to improve when held at 4 °C for 10–24h. This is probably due to the lypolytic activity that must have taken place during ageing. Milk with high levels of  $\beta$ -casein can easily form deposits (Lewis, 1986). Equal volumes of alcohol and milk can be mixed to determine the heat stability of the milk (Lewis, 1986).

### **2.8.7 Changes in milk on storage as a result of UHT treatment**

Plasmin, which is an alkaline proteinase, is the main proteolytic enzyme in bovine milk. This bovine milk plasmin is found in two forms, the active and the inactive forms. This inactive form, otherwise known as plasminogen, turns to the active form upon activation as discussed in the following paragraphs. Plasmin is a trypsin-like serine proteinase that can hydrolyse  $\beta$ -casein and  $\alpha_{s2}$ -casein readily and  $\alpha_{s1}$ -casein slowly (Enright, Bland, Needs & Kelly, 1999).

Plasminogen activators are responsible for activating plasminogen to plasmin. In milk there are two types of plasminogen activators: the tissue-type (tPA) and the urokinase-type (uPA). There are also varied systems of inhibitors in milk that prevent

the activity of plasmin. These include the inhibitors to plasmin activator and inhibitors of plasmin itself. Pasteurisation of milk gives rise to an increase in the proteolytic activity of plasmin in milk. This might be due to the inactivation of inhibitors of plasmin activators, causing an increase in the activation of plasminogen (Enright *et al.*, 1999). An increase in the severity of preheating during UHT treatment, for example, 72 °C for 30s to 80 °C for 30 min, delays gelation of UHT milk during storage. This is due to increased levels of whey protein, mostly  $\beta$ -lactoglobulin denaturation (Datta & Deeth, 2001).

## **2.9 BACILLUS SPOROTHERMODURANS**

*B. sporothermodurans* are psychrotolerant, mesophilic aerobic endospore-forming bacteria which produce extreme heat-resistant spores. When incubated for 2 days at 37 °C on a Brain Heart Infusion (BHI) agar plate, they are rod shaped which could become filamentous rods after laboratory cultivation. This filamentous morphology is linked to growth in laboratory media. They react with Gram stain producing a granular appearance and staining is not even (Hammer *et al.*, 1995).

*B. sporothermodurans* are aerobic spore formers of considerable importance in the food industry considering their ubiquitous nature. Regularly used pasteurisation processes that are adequate in inactivating vegetative cells have failed to inactivate *B. sporothermodurans* spores. The surviving spores may germinate and grow rapidly in products with little or no competition from other growing bacteria (Scheldeman, Herman, Foster & Hendrickx, 2006). *B. sporothermodurans* is not known to be pathogenic but can cause milk spoilage during production, storage and distribution thereby rendering products unsuitable for human consumption which can lead to considerable economic losses despite modern manufacturing techniques (Scheldeman *et al.*, 2006).

In 1995, *B. sporothermodurans* were detected for the first time in raw milk from farms. In 1996, 100 raw milk samples were screened using PCR fingerprints and only three samples from the same geographical area tested positive for *B.*

*sporothermodurans*. This positive result could not be confirmed in subsequent samplings. Only 2 out of 120 feed samples of corn, grass silage and sugar beets tested positive. These results suggest that contamination of raw milk at the farm through feed samples such as corn silage, grass silage and sugar beets are only incidental (Hammer *et al.*, 1995).

## **2.10 B. SPOROTHERMODURANS CHARACTERISATION TECHNIQUES**

BHI agar plates that have been supplemented with Vitamin B<sub>12</sub> are used for the isolation of *B. sporothermodurans* when incubated at 37 °C. Due to the competitive nature of the background flora, it is difficult to isolate *B. sporothermodurans* from raw milk or other farm sources. However, if samples are heated at 100 °C for 30–40 min and plated on BHI agar, *B. sporothermodurans* can be isolated (Scheldeman *et al.*, 2006). Different molecular methods have been used to identify and characterise *B. sporothermodurans*. Conventional PCR using the primers: BSPO-F2 (forward) (5' ACG GCT CAA CCG TGG AG 3') and BSPO-R2 (reverse) (5' GTA ACC TCG CGG TCT A 3') specific for *B. sporothermodurans* have been used to amplify portions of the 16SrRNA gene. The sizes of amplicons are used to confirm the presence of *B. sporothermodurans* (Scheldeman, Herman, Goris, De Vos & Hendrickx, 2002). Similarly, sequencing of the 16S rRNA gene can be used for the identification of *B. sporothermodurans* because the 16S rRNA genes have regions with high variability (Klijn *et al.*, 1997).

### **2.10.1 16S rRNA gene sequencing**

The 16S rRNA genes of *B. sporothermodurans* can be amplified by PCR using conserved specific primers and the resulting PCR products purified and subsequently sequenced. A combination of the 16S rRNA gene sequencing primers can be used to generate a continuous stretch of the 16S rRNA gene (Scheldeman, Pil, Herman, De Vos & Heyndrickx, 2005).

In order to identify unknown bacteria, the 16S rRNA gene can be sequenced and the identity of the bacteria obtained by matching the sequence to those present on known databases. The 16S rRNA sequence analysis of *B. sporothermodurans* is complicated by the occurrence of many 16S rRNA gene copies in the bacterial genomic DNA but it can be used to determine other species that are closely related to *B. sporothermodurans* (Klijn *et al.*, 1997).

### **2.10.2 Polymerase chain reaction (PCR)**

This is a PCR reaction in which primers specific to the 16S rDNA gene of *B. sporothermodurans* are used to amplify segments that can be analysed on agarose gel electrophoresis. Different authors have published primers that are used to detect *B. sporothermodurans* (Scheldeman *et al.*, 2002; Herman *et al.*, 1997).

Generally, a form of PCR reaction in which primers, specific to a region containing repetitive sequences in genomic DNA, is amplified. These amplified sequences, which could be of different lengths, can further be separated by denaturing polyacrylamide gel electrophoresis and then stained. At present, REP-PCR has only been used to successfully distinguish *B. sporothermodurans* from other known *Bacillus* species.

### **2.10.3 Amplified ribosomal DNA restriction analysis (ARDRA)**

ARDRA is a PCR-based analysis in which the ribosomal DNA of bacteria is amplified with specific primers and the resulting amplicons are restricted using restriction enzymes. After restriction, fragments are analysed on a gel and robotypes are generated. This technique has been used to discriminate *B. sporothermodurans* from other *Bacillus* spp. isolated from milk (Guillaume-Gentile *et al.*, 2002). Of all the typing molecular techniques used to analyse *B. sporothermodurans*, only the REP-PCR with gel separation (Klijn *et al.*, 1997) and ribotyping (Guillaume-Gentile *et al.*, 2002) can present maximum discrimination between strains of *B. sporothermodurans* and other closely related species of *Bacillus*. These two molecular typing methods

have been used to reveal great genetic heterogeneity among *B. sporothermodurans* isolates from dairy farms and hence have been used to distinguish isolates of *B. sporothermodurans* from different origins (Guillaume-Gentile *et al.*, 2002).

## **2.11 BACILLUS SPOROTHERMODURANS SPORES**

The analysis of *B. sporothermodurans* spores using Transmission Electron Microscopy (TEM) revealed structural differences between spores of *B. sporothermodurans* isolates emanating from various origins and from those of other species. The spores of the UHT strains either belonging to *B. sporothermodurans* or *Paenibacillus lactis* had cores that were very dense and the surrounding cortex comparatively large. The spores of *B. sporothermodurans* originating from raw milk and of *B. cereus* had cores that were proportionally larger in relation to the cortex size and less compact (Scheldeman *et al.*, 2006). The spores of *B. sporothermodurans* originating from feed concentrate showed intermediate properties. A compact spore core could be the quality of a more complete dehydration, an important aspect in heat resistance.

## **2.12 ANALYSIS B. SPOROTHERMODURANS SPORE COMPONENTS**

It is possible to quantify micrograms of protein using the principles of protein-dye binding as described by Bradford (1976). This involves the use of Coomassie Brilliant Blue G-250 dye to bind protein. The binding of the dye to protein causes the dye's maximum absorption to shift from 465 to 595 nm; hence the absorption at 595 nm is used for monitoring the dye protein complex. Potassium and sodium cations, as well as carbohydrate such as sucrose, have little or no interference on this assay. On the other hand, large amounts of detergents such as sodium dodecyl sulphate, Triton X-100, and commercial glassware detergents can interfere on this assay. Small acid soluble proteins (SASP), which are small molecular weight proteins located in the core of *Bacillus* spores, can be potential biomarkers for the identification of spores of *Bacillus* species by mass spectrometry considering that genetically distinct species

and strains have differentiated and their identity been confirmed by genetic analysis (Hathout, Setlow, Cabrera-Martinez, Fenselau & Setlow, 2003).

Dipicolinic acid (DPA), a component of the spore core, is often used to measure the integrity of the spore after subjection to stress. DPA extractions are often conducted by heating about 0.1 to 2 mg of spores per ml in 0.2 M K phosphate at pH 1.8 for up to 10 min at 100°C. Spore dipicolinic acid can be analysed using the reverse-phase liquid chromatography according to the method described by Warth (1979).

### **2.13 THERMAL INACTIVATION KINETICS OF *BACILLUS SPOROTHERMODURANS***

Studies based on the heat resistance of spores of three *B. sporothermodurans* strains isolated from non-sterile UHT milk and *B. sporothermodurans* spores conducted within the temperature ranges of 110–145 °C and 130–145 °C revealed that for higher temperatures, the  $D_{140}$  values of *B. sporothermodurans* (3.4–7.9s) were higher when compared to that of *B. stearotherophilus* (0.9 s) as shown on Figure 2.7 below. Similarly, the Z-value of *B. sporothermodurans* (13.1–14.2 °C) was higher when compared to that of *B. stearotherophilus* (9.1 °C) (Huemer *et al.*, 1998). Furthermore, spores *B. sporothermodurans* isolated from UHT have been found to possess high heat resistance compared to that isolated from the feed, as seen in Figure 2.8 below.

Major factors that contribute to the wet heat resistance of bacterial spores include (Melly, Genest, Gilmore, Little, Popham, Driks & Setlow, 2002):

- The core water content
- Mineralisation of the spore core due to accumulation of high levels of divalent cations and DPA
- Presence of  $\alpha/\beta$ -type SASP.

An increase in the mineralisation of spores due to high levels of divalent cations and DPA increases the wet heat resistance of bacterial spores (Paidhungat, Setlow, Driks & Setlow, 2000). SASP binds to spore DNA thereby protecting it from wet heat and other treatments like chemicals, radiation, and so forth (Setlow, Atluri, Kitchel, Koziol-Dube, & Setlow 2006).

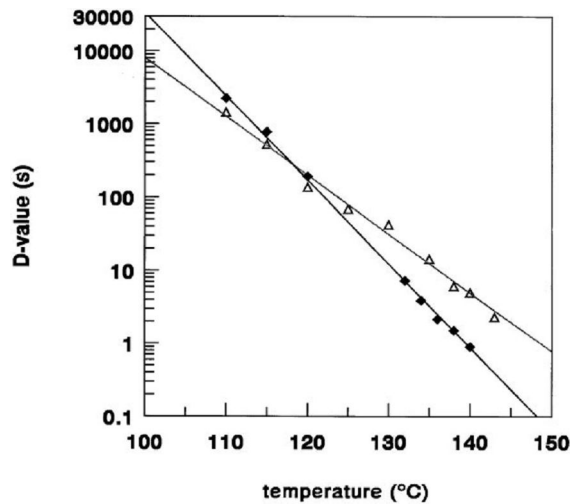

Figure 2.7 Thermal death time curves of *B. stearothermophilus* spores (Δ) and *B. sporothermodurans* spores J16B (▲); best plot lines through experimental data (Huemer *et al.*, 1998)

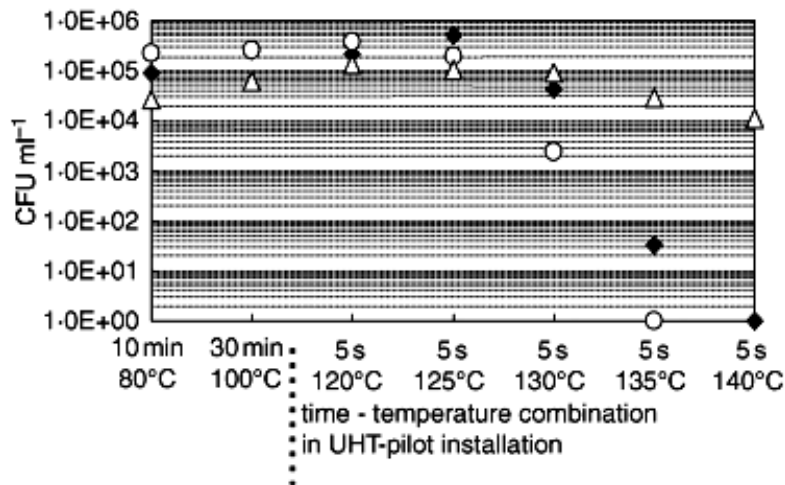

Figure 2.8 Survival of *Bacillus sporothermodurans* spores from different origins in a pilot ultra-high temperature (UHT) installation (direct mode). ◆, Feed concentrate isolate MB 1316; ○ Feed concentrate isolate MB 1317; industrial spores (Scheldeman *et al.*, 2006)

The SASP are of two types ( $\alpha/\beta$ -type and  $\gamma$ -type) and have an average molecular weight ranging from 5–10 kilodaltons named after the major protein(s). These types in *B. subtilis* spores are synthesised only in developing spores late in sporulation (Hathout *et al.*, 2003). It has been reported that killing spores by wet heat is not through DNA damage but rather by rupturing the spore's inner membrane permeability barrier and the inactivation of core enzymes (Warth, 1980; Setlow, 2000).

The heat resistance of spores has been found to increase about tenfold for sporulation between 30–44 °C while sporulation at 52 °C did not show any additional increase in heat resistance in the 100–120 °C treatment temperature (Condon, Bayarte & Sala, 1992). The condition of a particular food product prior to heat treatment is very crucial considering that the waiting time at warm temperature can lead to non-sterility in the processed food (Leguérinel, Couvert & Mafart, 2007).



## 2.14 STRESS RESPONSE ADAPTATION OF *BACILLUS* SPECIES

Bacteria stress response adaptation is of interest to the dairy industry because it influences the survival of *Bacillus* spp. during processing. When *Bacillus* spp. adapt to a particular stress they become more resistant to that stress during subsequent application (Van Schaik & Abee, 2005). After being exposed to a certain stress, bacteria may overcome subsequent sub-lethal stresses only to survive in food systems (Hill, Cotter, Sleator & Gahan, 2002). Furthermore, a stress response to one stress can lead to an adaptive response to other stresses (Hill *et al.*, 2002).

Most bacteria possess networks that enable them to adapt to their changing environments and survive under certain stress conditions. Therefore, these networks can affect processing and storage under certain circumstances (Abee & Wouters, 1999). Bacteria adaptive responses are due to certain genetic transformations within the genome that modify the metabolism of bacteria. Most regulatory systems involve the alteration of sigma ( $\sigma$ ) factors whose main function is to attach to the core RNA polymerase giving promoter specificity which directs the expression of heat-shock genes involved in heat-shock response (Abee & Wouters, 1999).

Heat-shock spores (activated spores) have been found to be more heat resistant than those that have not been heat-shocked for the same spore type, despite both having the same protoplast density. It appears that spore heat-shock causes the cortical peptidoglycan to expand against the intact spore coats thereby resulting in lower water content in the protoplast and higher water content in the cortex (Beaman, Pankratz & Gerhardt, 1998). Heat-shock has been found to cause complete and partial deactivation of spores causing disruption and relaxation of the outer membrane. These spores also release some of their dipicolinic acid (DPA) and minerals, increasing their ability to germinate as well as acquiring heat-induced resistance (Teofila, Pankratz & Gerhardt, 1998).

## 2.15 OTHER *BACILLUS* SPECIES RELATED TO THERMALLY PROCESSED MILK

*Bacillus* species, particularly *B. licheniformis* and *B. cereus*, are the most commonly isolated species of *Bacilli* present in milk at various processing stages. *B. licheniformis* counts were found to be higher in heated milk during winter while *B. cereus* was found to be higher during summer according to studies conducted in the United Kingdom (Crielly, Logan & Anderton, 1994). However, this pattern was found to change when milk samples were pre-incubated before plate counts due to the fact that *B. cereus* grows faster at ambient temperature than *B. licheniformis* does. *Bacillus* species that are frequently isolated from milk include: *B. circulans*, *B. firmus*, *B. subtilis*, *B. coagulans*, *B. sphaericus* and *B. mycoides*. However, the identity of some *Bacillus* strains remains undetermined (Crielly *et al.*, 1994).

### 2.15.1 *Bacillus cereus*

*B. cereus* are ubiquitous microorganisms which can be found in the soil, air, dust, water as well as in some processed food products consisting of rice, dairy products, meat, spices and egg. They cause food spoilage and with doses as low as  $10^3$ – $10^4$  bacteria/g, they can cause food poisoning (Andersson, Rönner & Granum, 1995).

Quality problems caused by *B. cereus* include aggregation of the creamy layer of pasteurised milk owing to their lecithinase activity. They also cause sweet curdling of milk in low pasteurised milk that occurs without any rise in pH. Processing techniques such as pasteurisation tend to target spore producing, non-competitive bacteria by eliminating the vegetative cells while the spores survive. The spores become heat activated and proceed to germinate in the stored products (Andersson *et al.*, 1995). *B. cereus* causes two types of food poisoning. The first type is caused by an emetic toxin and results in vomiting, while the second is caused by enterotoxins and results in diarrhoea. However, the two types of symptoms can occur at the same time in situations where both toxin types are produced (Granum & Lund, 1997).

### **2.15.2 *Bacillus licheniformis***

*B. licheniformis* has been linked with septicemia, peritonitis, ophthalmitis and food poisoning in humans as well as in bovine toxemia and abortions in cattle. *B. licheniformis* is a regular contaminant of dairy products. However, it is mostly linked to cooked meats and vegetables. Heat-stable toxin-producing *B. licheniformis* and *B. pumilus* have been detected in milk from mastitis cows (Salkinoja-Salonen, Vuorio, Scoging, Kämpfer, Andersson & Honkanen-Buzalski, 1999). An isolate was considered toxin producing when it inhibited motility of boar sperm upon exposure to boiled bacterial suspension ( $\leq 4$  mg wet wt. of bacteria per ml) within a 3-day exposure.

### **2.15.3 *Bacillus stearothermophilus***

*B. stearothermophilus* are often related to the contamination of dairy products, especially milk powder. They produce thermophilic spores that can withstand pasteurisation at 73 °C for 15s and can grow at 65 °C. They can cause spoilage in circumstances involving the reconstitution of milk powder. The growth of *B. stearothermophilus* during the manufacture of milk powder is considered to take place as a biofilm. Biofilms are defined as the growth of microorganisms and their extracellular polymeric material on a surface (Abraham, Debray, Candau & Piar, 1990). *B. stearothermophilus* have been found to enhance the acidic conditions in milk and lactose solution. Their growth effects protein stability during processing which results in accelerated aggregation of milk proteins (Yoo, Hardin & Chen, 2006).

### **2.15.4 *Paenibacillus* spp.**

*Paenibacillus* are psychrotolerant endospore-forming bacteria that also can cause spoilage in raw and pasteurised milk. These bacteria produce endospores that can withstand pasteurisation and can survive and reproduce at refrigeration temperatures (Huck, Sonnen & Boor, 2008).

Strains of *Paenibacillus* have been isolated from a variety of sources that include the soil, the rhizosphere, water, diseased insect larvae and foods. They produce endospores that can withstand industrial sterilisation and UHT processing of milk. Furthermore, they have been isolated from UHT milk alongside *Bacillus sporothermodurans* (Scheldeman, Goossens, Rodríguez-Díaz, Pil, Goris, Herman, De Vos, Logan & Heyndrickx, 2004). Examples are: *Paenibacillus lautus*, *Paenibacillus azotofixans*, *Paenibacillus polymyxa* and *Paenibacillus macerans*.

#### **2.15.5 *Anoxybacillus* spp.**

Strains of *Anoxybacillus flavithermus* alongside other *Bacillus* spp have been found in milk powders irrespective of the origin. These *Bacillus* spp can impart significant economic loss when they exceed limits set aside by regulatory authorities (Rueckert, Ronimus & Morgan, 2005).

#### **2.15.6 Research trends on *B. sporothermodurans*.**

Previous research studies on *B. sporothermodurans* have demonstrated the extreme heat resistance of its spores (Huemer *et al.*, 1998). Similarly PCR techniques that can detect *B. sporothermodurans* from both sterilized or UHT treated as well as those from non heated milk sources such as the feed (Scheldeman *et al.*, 2002). Different analyses have been conducted to determine the clonal relationship of *B. sporothermodurans* isolated from different sources (Herman *et al.*, 2000). Further research need to be conducted to determine the mechanism of destruction of *B. sporothermodurans* spores in order to come up with ways of inactivating them during UHT processing, using less severe heat treatment hence maintaining the sensory properties of treat milk products.

## CHAPTER 3: OBJECTIVES AND HYPOTHESES

### 3.1 OBJECTIVES

1. To determine the incidence of *B. sporothermodurans* in retail UHT milk within South Africa;
2. To determine the effect of UHT processing stresses; pre-heating, chilling, H<sub>2</sub>O<sub>2</sub> and UHT re-processing on the survival of *B. sporothermodurans*;
3. To study the effect of ultra-high temperature treatment, 130 °C for 4s, on the survival, structure and chemical components of *B. sporothermodurans* spores.

### 3.2 HYPOTHESES

The exposure of *B. sporothermodurans* to sub-lethal stresses such as preheating, chilling, H<sub>2</sub>O<sub>2</sub> and UHT re-processing will lead to an increase in heat resistance during UHT treatment because of adaptation responses to these stresses. The heat resistance of spores is influenced by many factors, before, during and after heat treatment (Scheldeman *et al.*, 2006). These factors may include the sporulation condition, heat-induced resistance and conditions of recovery from stress (Scheldeman *et al.*, 2006; Nicholson, Munakata, Horneck, Melosh & Setlow, 2000).

*Bacillus sporothermodurans* spore inactivation at UHT temperature is as a result of structural damage due to heating, resulting in the leakage of vital spore components such as dipicolinic acid and small acid-soluble proteins (Setlow *et al.*, 2006).

## CHAPTER 4: RESEARCH

### 4.1 INCIDENCE AND SURVIVAL OF *BACILLUS SPOROTHERMODURANS* DURING UHT PROCESSING

(Accepted for publication in the *British Food Journal* on 9 December 2009)

#### 4.1.1 Abstract

The presence of *Bacillus sporothermodurans* in retail UHT milk along with milk from different points of a processing line was determined. The effect of chilling, pre-heating, UHT, reprocessing and H<sub>2</sub>O<sub>2</sub>, individually and in combination on the survival of *B. sporothermodurans* was also investigated in broth. Standard plate counts were conducted for all milk samples and isolates from UHT milk were characterised using PCR. *B. sporothermodurans* vegetative cells and spores in broth were subjected to various stresses encountered during UHT processing of milk. Survival counts were conducted after all treatments. *B. sporothermodurans* were detected in retail UHT milk packs from only one processor. UHT treatment at 140 °C for 4s eliminated *B. sporothermodurans* in broth. The combination of chilling and UHT was more effective in eliminating *B. sporothermodurans* spores than UHT treatment alone. H<sub>2</sub>O<sub>2</sub> was also effective in eliminating *B. sporothermodurans* spores after 15 min of exposure. The adopted real time (RT) PCR with SYBR Green method was effective for the confirmation of *B. sporothermodurans*. This research is the first to be conducted with regards to the detection of *B. sporothermodurans* in UHT milk in South Africa and determining the effect of UHT processing stresses on their survival. These results can be used to design processing parameters so as to effectively eliminate *B. sporothermodurans* spores during UHT processing. This research is the first in which RT PCR with SYBR Green has been used to characterise *B. sporothermodurans*.

Key words: UHT, milk, processing, *B. sporothermodurans*, spores.

#### 4.1.2 Introduction

UHT milk processing plants in South Africa sporadically experience contamination with *Bacillus sporothermodurans*. Often this contamination is believed to be due to the reprocessing of UHT milk. Contamination occurs in UHT milk from packages used for quality control, in UHT milk from defective packaging or in inadequately processed UHT milk as a result of other problems that may occur during processing. It should be noted that the main reason for reprocessing is to avoid economic losses.

*B. sporothermodurans*, first detected in UHT milk in Germany in 1990, affects the stability and the shelf life of commercial UHT milk (Hammer *et al.*, 1995). This is due to the unusual thermal kinetics of the spores that allows survival at high temperatures, up to 130 °C for 4s during UHT treatment (Klijn *et al.*, 1997). These spores germinate in UHT products during storage thereby causing instability and reducing shelf life. *B. sporothermodurans* spores have been found to be more resistant than other heat resistant spores of other *Bacillus* spp. at temperatures above 130 °C (Klijn *et al.*, 1997).

Based on the different identification and detection methods, *B. sporothermodurans* can be classified into heat resistant spore (HRS) formers or non-heat resistant spore (non-HRS) formers. So far, the HRS group of *B. sporothermodurans* has been isolated exclusively from heat sterilised or UHT processed milk, making it difficult to predict their origin (Scheldeman *et al.*, 2002). Increasing the temperature and/or the holding time in an attempt to inactivate *B. sporothermodurans* spores affects the organoleptic properties as well as the nutritional quality of UHT milk (Van Boekel, 1998). The denaturation of whey protein and the accumulation of advanced products of Maillard reaction are indicators of the severity of heat treatments during UHT processing of milk (Birlouez-Aragon, Sabat & Gouti, 2002). Protein denaturation and sugar modifications due to heat treatment cause UHT to have a ‘cooked’ taste and Maillard reaction decreases the protein nutritional value by irreversible alteration of the lysine residue (Claeys *et al.*, 2001). An increase in the temperature of sporulation has been linked to an increase in the heat resistance of the resulting spores (Teofila *et*

*al.*, 1998). Currently, it is still not clearly understood how the structural and chemical properties of *B. sporothermodurans* spores influence their heat resistance (Klijn *et al.*, 1997).

Stress response adaptation of bacteria is of interest to the dairy industry because it influences the survival of *Bacillus* spp. during processing. After being exposed to certain stresses, *Bacillus* spp. may overcome subsequent sub-lethal stresses to survive in food systems (Abee & Wouters, 1999). Furthermore, a response to one stress can lead to induced-resistant responses to other stresses (Abee & Wouters, 1999).

Heat shock has been found to cause complete and partial deactivation of spores, giving rise to the disruption and relaxation of the outer membrane. These spores also release some of their dipicolinic acid (DPA) and minerals thereby increasing their ability to germinate as well as the induction of heat resistance (Teofila *et al.*, 1998).

H<sub>2</sub>O<sub>2</sub> is used to sterilise packaging material during the UHT processing of milk. H<sub>2</sub>O<sub>2</sub> is a useful chemical sterilising agent because it neither imparts an unpleasant odour to the packaged product nor does it leave residues on packaging material (Toledo, Escher & Ayres, 1973). Bacterial spores are more resistant than vegetative cells to H<sub>2</sub>O<sub>2</sub>. The inactivation of bacterial spores by H<sub>2</sub>O<sub>2</sub> depends on various factors including the nature of the spores, a wet or dry environment, the concentration of H<sub>2</sub>O<sub>2</sub> and the species of the spore former present (Toledo *et al.*, 1973).

Experiments conducted to determine the mechanism of action of H<sub>2</sub>O<sub>2</sub> in the killing of spores have not been conclusive (Melly *et al.*, 2002). In one experiment, *B. subtilis* spores killed by H<sub>2</sub>O<sub>2</sub> maintained their permeability barrier which prevented the core contents, in particular DPA, from leaking out but there was no indication as to whether the heat resistance of spores was affected (Melly *et al.*, 2002). Until now, no study has been conducted on the presence and the characterisation of *B. sporothermodurans* in the South African dairy environment. Furthermore, understanding how vegetative cells and spores of *B. sporothermodurans* are influenced by processing such as pre-heating, chilling, reprocessing and H<sub>2</sub>O<sub>2</sub>



exposure, is of importance as it determines the stability of UHT milk products during storage. Therefore, the aim of this study was to determine the incidence of *B. sporothermodurans* in retail milk in South Africa and the effect of UHT processing stresses on the survival of *B. sporothermodurans* strains.

#### 4.1.3 Materials and methods

##### 4.1.3.1 Samples of UHT milk used in the study

###### (a) Retail samples

Two packages of UHT milk from 6 processors (A–F) were bought from local supermarkets.

###### (b) In-process samples

Milk samples were collected at different processing steps from processor D. They include the following:

- Fresh raw milk that had just been received from the farms: 24h raw fresh milk that had been in the storage tank for 24h at 4 °C;
- 2% fat pasteurised milk, pasteurised skim milk; and
- Pasteurised cream: UHT milk from defective packages removed from the processing line, kept for reprocessing, to be mixed with fresh milk to a 10% v/v final concentration and subjected to another round of UHT treatment.

(c) UHT milk directly after processing together with samples of water that have been used to rinse the filter or the sterilisers.

#### 4.1.3.2 Microbiological counts

##### (a) Standard plate count (SPC)

SPCs were carried out by plating serial dilutions (1:10) of the milk samples. UHT milk samples were plated on BHI agar plates while the pasteurised and raw milk samples were plated on nutrient agar. Triplicate analyses were made for each milk sample by counting duplicate plates containing 30–100 colony-forming units (cfu) after incubation for 24h at 37 °C. In order to determine absolute sterility SPCs were also conducted for UHT milk that had been incubated for 15 days at 30 °C.

##### (b) Spore counts

Spore counts were conducted by plating serial dilutions of milk or broth samples that had been heat treated at 95 °C for 30 min. Spore counts were conducted by counting colony-forming units on BHI agar plates after incubation for up to 15 days at 37 °C. Triplicate analyses were made for each heat-treated sample by counting duplicate plates containing colony-forming units after incubation for 24h at 37 °C.

#### 4.1.3.3 Molecular identification of isolates

##### (a) Preparation of DNA for PCR

The isolation of genomic DNA for PCR with agarose gel detection was conducted as described by Scheldeman *et al.* (2002), with some modifications. DNA templates were extracted from 3-day-old pure cultures from BHI agar plates which had been washed three times by centrifugation at  $13\,000 \times g$  for 3 min followed by re-suspension in distilled water. 100  $\mu$ l solution of 0.1 M NaOH and 0.25% sodium lauryl sulphate (Merck, South Africa) was added to the washed pellets and heated for 17 min at 90 °C. The boiled samples were again centrifuged at  $13\,000 \times g$  for 3 min and crude DNA was collected from the supernatants.

##### (b) PCR Procedure

The PCR reactions were conducted using *B. sporothermodurans* specific primers of BSPO-F2 (5'-ACG GCT CAA CCG AG-3') and BSPO-R2 (5'-GTA ACC TCG CGG

TCT A-3') as described by Schelderman *et al.* (2002). Primers prepared by Iqaba Biotechnical, Pretoria, South Africa were used to amplify fragments of about 664 base pairs from the 16S rDNA gene. For the PCR detection with agarose gel electrophoresis, 100 ng of genomic DNA was used as template for the PCR reaction in a total reaction volume of 25  $\mu$ l, using 1.25 U Taq DNA polymerase, 200 nM of each primer, 50 mM KCl, 10mM Tris-HCl (pH 8.3), 1.5 mM MgCl<sub>2</sub> and 0.2 mM of NTP mix (Fermentas, South Africa). The mixture was subjected to 30 cycles of amplification in a thermal cycler (iCycler Thermal Cycler, BIO-RAD, South Africa). The first cycle was preceded by an initial denaturation step of 2 min at 94 °C. Subsequently, each cycle consisted of a denaturation step of 20s at 94 °C, an annealing step of 45s at 45 °C and an elongation step of 60s at 72 °C. The last cycle included a final extension of 7 min at 72 °C. 10  $\mu$ l of PCR products were analysed on a 1% agarose gel containing 0.5  $\mu$ g/ml ethidium.

#### (c) Preparation of DNA for RT PCR

DNA for real time PCR was extracted from 3-day-old pure cultures on BHI agar plates. About 5 or 6 colonies were dissolved in 300  $\mu$ l of double distilled water and pure DNA was extracted and purified using the ZR Fungal/Bacterial DNA Kit<sup>TM</sup> (Zymo Research Corporation, USA), following the manufacturer's protocol. The concentration of extracted DNA was analysed using the DNA Nanodrop Spectrophotometer and samples were stored at -20 °C until they were used as PCR templates.

#### (d) RT PCR procedure

For the real time PCR, 1 ng of pure genomic DNA was mixed with iQTM SYBR<sup>®</sup> Green Supermix (Bio-rad, South Africa) primers and sterile distilled water to a total of 25  $\mu$ l reaction volume. The reaction was conducted using the DNA Engine<sup>®</sup> Peltier Thermal Cycler incorporated with a Chromo 4 real time PCR detector (Bio-rad, South Africa). Primer concentrations and reaction conditions were the same as that of the PCR detection with agarose gel electrophoresis.

#### 4.1.3.4 Treatment regimes used on *B. sporothermodurans* isolates

##### (a) Preparation of raw and pasteurised milk isolates

After plating and incubation of raw and pasteurised samples, about five individual colonies that displayed the morphology of a *Bacillus* colony were harvested and transferred into different eppendorf tubes containing BHI broth for the establishment of a pure culture.

##### (b) Preparation of UHT milk isolates

Similarly, four individual colonies were randomly picked from each BHI plate spread with samples from different UHT milk packs and transferred into separate eppendorf tubes containing BHI broth to establish pure cultures of UHT milk isolates.

##### (c) Preparation of control strains

A reference strain of *Bacillus sporothermodurans* (DSM No 10599), a control being obtained from Deutsche Sammlung von Mikroorganismen und Zellkulturen GmbH (DSMZ), Germany, and a local *B. sporothermodurans* isolate from UHT milk in South Africa, were used to determine the effect of UHT processing stresses on their survival. In order to prepare pure cultures, a single colony of each isolate was collected from BHI agar plates and transferred into 1.5 ml eppendorf tubes containing 1 ml of freshly prepared Brain Heart Infusion broth and then incubated for 24h at 37 °C. A ml of each culture was centrifuged at  $10\,000 \times g$  for 3 min and pellets were subsequently diluted to approximately 0.5 McFarland Standard prepared by adding 0.5 ml of 0.048 M BaCl<sub>2</sub> to 99.5 ml of 0.18 M H<sub>2</sub>SO<sub>4</sub> (1% w/v) with physiological saline (8.5 g/L NaCl) as diluents (Andrews, 2005).

##### (d) Preparation of spore suspension of test isolates

From an overnight pure culture of each strain, 1 ml of culture was collected and spread on BHI agar plates and incubated for 15 days at 37 °C. Growths on each plate were checked for sporulation using a light microscope until *ca.* 100% sporulation was attained. Spores were harvested by scraping the dense growth on the surface of agar plates with a sterile loop and transferred into a 1.5 ml eppendorf tube containing

sterile physiological saline. Spores were washed with double distilled water, centrifuged at  $10\,000 \times g$  for 3 min and pellets were diluted to *ca.*  $10^8$  spores per ml with sterile physiological saline using 0.5 McFarland Standard.

(e) UHT treatment process

Heating was conducted with some modifications as described by Huemer *et al.* (1998). UHT treatment was conducted with sterile pressure tubes with threaded type B plugs (Sigma Aldrich, Midrand, South Africa) with an outer diameter of 25 mm and wall thickness of 2 mm and an oil bath. The tubes were filled with 3 ml spore suspension and 1 ml of BHI broth. The tubes were closed with stoppers and were submerged in an oil bath for either  $120 \pm 1$  °C for 4s or  $140 \pm 1$  °C for 4s. The temperature equilibrium time was determined with the aid of a thermocouple mounted on a pressure tube.

(f) Simulation of the reprocessing of UHT milk

*B. sporothermodurans* culture suspensions of both isolates (3 ml) were mixed with 1 ml of BHI broth and subjected to UHT treatment at 120 °C and 140 °C for 4s individually then followed by incubation at 37 °C for 24h. To simulate reprocessing practices in industry, the incubated culture suspension was mixed with fresh milk to a 10% v/v total and subjected to another round of UHT treatment at 120 °C and 140 °C for 4s.

(g) Pre-heating treatment

Pre-heating treatment was conducted to determine the effect of double heat processes on the survival of *B. sporothermodurans* during UHT processing. *B. sporothermodurans* culture suspensions of both isolates (3 ml) were mixed with 1 ml of BHI broth and were either subjected to pre-heating (78 °C for 15s) then UHT heating (120 °C for 4s) or pre-heating only or UHT only.

It should be noted that BHI cultures instead of milk cultures were preferred because *B. sporothermodurans* growth in milk culture rarely exceeds 3 logs. In order to get a

clear response to treatments, higher levels of *B. sporothermodurans* in BHI culture were required.

(h) Chilling treatment

Chilling treatments were conducted to determine the effect of chilling followed by immediate UHT treatment on the survival of *B. sporothermodurans* spores. *B. sporothermodurans* spore suspensions of both strains (3 ml) were mixed with 1 ml of BHI broth and were subjected to chilling (24h at 7 °C), UHT heating (120 °C for 4s) or a combination treatment of chilling plus UHT.

(i) Treatment with H<sub>2</sub>O<sub>2</sub>

H<sub>2</sub>O<sub>2</sub> (Sigma Aldrich, Midrand, South Africa) was mixed with spores in distilled water to form spore suspensions containing 30% H<sub>2</sub>O<sub>2</sub> concentration. The suspensions were incubated for 0, 3, 6, 9 or 15 min at room temperature. After each interval, 1 ml was collected from each of the incubated suspensions and added to 9 ml of catalase solution (0.4 mg per ml distilled water), allowing it to stand for 1 min for the complete removal of active H<sub>2</sub>O<sub>2</sub> prior to viable spore count. The effective removal of catalase was tested by dipping a potassium iodide starch paper (Macherey-Nigel GmbH & Co KG, Germany) into the mixture after the 1 min duration. A colourless potassium iodide starch paper indicated the complete removal of H<sub>2</sub>O<sub>2</sub> while a blue-black colouration indicated the presence of active H<sub>2</sub>O<sub>2</sub>.

#### 4.1.4 Results

##### 4.1.4.1 Bacterial quality of UHT milk at retail level

Of all the retail UHT milk samples analysed from processors A–F, UHT milk from only processor D was positive for bacterial growth (Table 4.1). UHT milk packs from the other processors remained commercially sterile even after they were incubated for 15 days at 30 °C (data not shown).

#### 4.1.4.2 Bacterial quality of milk from processor D processing line

Similar to the retail UHT milk, UHT milk obtained immediately after processing from processor D was not commercially sterile (Table 4.1). The spore counts of UHT milk packs that were incubated for 15 days at 30 °C were higher than those that were not incubated for 15 days at 30 °C (Table 4.1). The SPC of all the contaminated UHT milk packs from the retail level and UHT milk from the processing line of processor D, with or without incubation for 15 days, did not differ. Values ranged from 2.5–3 log cfu/ml (Table 4.). The skim milk, wash water, raw fresh milk and full cream milk had SPC values that ranged from 5–7 log cfu/ml.

The SPC values for 24h raw milk, 2% fat milk and UHT milk for reprocessing ranged from 7–8 log cfu/ml. The pasteurised cream had the worst quality with SPC levels above 8 log cfu/ml. The bacterial quality of the milk samples decreased in this order: UHT milk < pasteurised skim milk < raw fresh milk < pasteurised full cream milk < 24h raw milk < 2% fat pasteurised milk < UHT milk for reprocessing < pasteurised cream. The spore counts of fresh UHT milk after heat treatment at 90 °C for 30 min were at the limit of detection (1 cfu/ml), while those of incubated UHT milk were close to 20 times higher (Table 4.1).

#### 4.1.4.3 Identification of UP20A isolates using PCR

From a total of 74 UHT milk isolates obtained from different batches of contaminated UHT milk packages, 29 tested positive with PCR with agarose gel electrophoresis. By contrast, 32 isolates out of 33 tested positive using RT PCR coupled with SYBR Green. Some isolates that displayed a negative result using PCR tested positive when RT PCR was used. By comparison to positive control samples, all contaminated UHT milk packages from processor D contained *B. sporothermodurans* when considering that these isolates produced bands and melting curve similar to that of the control (Figure 4.1). The melting temperature ( $T_m$ ) of the amplified segment during the RT PCR fluctuated from 86–87 °C (Figure 4.2). Isolates from fresh and pasteurised milk tested negatively as they did not produce the required band for *B. sporothermodurans*

Table 4.1 Bacterial quality of milk collected from retail and during processing of processor D

Milk sample	Treatment	SPC (log cfu/ml)	Spore count (spores/ml)
<sup>a</sup> Fresh raw	Chilled (4 °C)	6.06 (± 0.17)	nd
<sup>b</sup> 24h raw		7.31 (± 0.22)	nd
Full cream	Pasteurised	6.73 (± 0.10)	nd
Cream		8.85 (± 0.08)	nd
2% fat		7.80 (± 0.13)	nd
Skim		5.67 (± 0.14)	nd
<sup>c</sup> UHT	From defective packs	7.92 (± 0.08)	nd
<sup>d</sup> Wash water (sterilisers)		5.27 (± 0.50)	nd
Wash water (filters)		nd	nd
UHT	Directly after processing	2.67 (± 0.16)	1.0 (± 0.33)
UHT	Incubated (15 days, 30 °C)	3.01(± 0.12)	20 (± 2.73)
UHT	Retail level	2.96 (± 0.21)	nd

a = milk that has just been received from farms

b = raw fresh milk that had been in the storage tank for 24 hrs at 4 °C

c = UHT milk from defective packages removed from the processing line to be mixed with fresh milk to a 10% v/v final concentration and subjected to another round of UHT treatment

d = water that had been used to rinse the filter or the sterilisers prior to another round of UHT processing, and spore count determination

nd = not detected for levels below 1 cfu/ml

Values = mean (± SD)



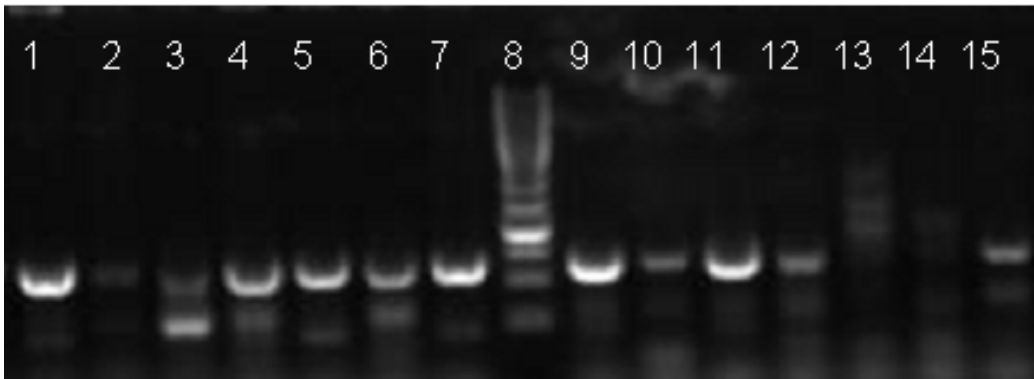

Figure 4.1 Gel photograph of PCR products confirming the identity of some of the UHT milk isolates. Lane 1 and 9, *B. sporothermodurans* DMSZ No. 10599 (Germany); lanes 3, 4, 5, 6, 7, 10, 11, 12 and 15, isolates from UHT milk detected as *B. sporothermodurans*; lanes 13 and 14, isolates that were not positive for *B. sporothermodurans*; Lane 2, *Bacillus stearothermophilus* as negative control; Lane 7, 100 bp DNA ladder (Fermentas, South Africa)

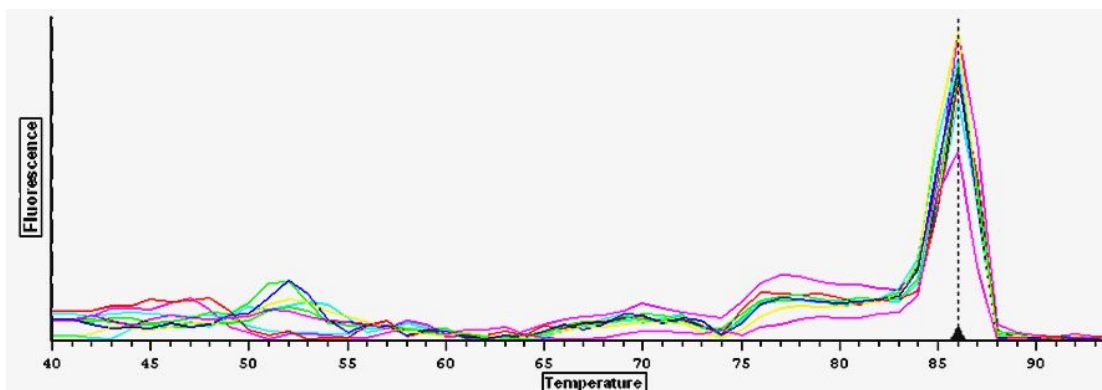

Figure 4.2 Real time PCR melting curve ( $T_m = 86$ ) specific for *Bacillus sporothermodurans* using the BSPO-F2 and BSPO-R2 primers

#### 4.1.4.4 Effect of UHT only and UHT reprocessing

The counts of *B. sporothermodurans* after heat treatment at 120 for 4s were significantly different ( $p \leq 0.05$ ) from those heated at 140 °C for 4s (Table 4.2). *B. sporothermodurans* were significantly ( $p \leq 0.05$ ) reduced by 4 log cfu/ml, but were not completely eliminated after heat treatment at 120 °C for 4s; from log cfu/ml 6.86

to 2.11 and log cfu/ml 5.78 to 1.81 for DMS10599 and UP20A respectively. After heating at 140 °C for 4s, no *B. sporothermodurans* were detected. The two *B. sporothermodurans* strains were not affected differently by the two heat treatments with respect to survival counts. After reprocessing the *B. sporothermodurans* levels for the 120 °C heated cultures were similar to those recorded after initial heating at 120 °C and no *B. sporothermodurans* were detected for the 140 °C heated cultures (Table 4.2).

#### *4.1.4.5 Effects of pre-heating (78 °C for 15s), UHT (120 °C for 4s) and a combination of pre-heating and UHT treatments, on the survival of B. sporothermodurans*

Strain UP20A was affected more by pre-heating than the DMS10599 strain (Table 4.3). However, after subsequent UHT treatment no growth was detected for either strain. Similarly no growth was detected for either strain when cultures were subjected to UHT treatment (Table 4.3).

#### *4.1.4.6 Effects of UHT treatment with and without chilling on the survival of B. sporothermodurans spores following UHT treatment*

There were significant differences ( $p \leq 0.5$ ) in the survival of spores after the two treatments of UHT treatment with and without prior chilling (Table 4.4). The effect of chilling on the survival of spores was significant at  $p \leq 0.5$ . However, the strain effect and the strain-time interaction effects on the survival of *B. sporothermodurans* spores were not significant at  $p \leq 0.5$  (Table 4.1). UHT treatment alone caused a 5 log reduction in the survival count of spores for both strains while chilling combined with UHT treatment was more effective in reducing the *B. sporothermodurans* counts as both strains were inactivated to undetectable levels.

Table 4.2 Effect of heating at 120 or 140 °C for 4s, and repeat UHT with 10% reprocessing on the survival of two strains of *Bacillus sporothermodurans*

UHT temp (°C)	Treatment	Strain	Survival (log cfu/ml)
120	Before UHT	DMS10599	6.86 (±0.67) <sup>a</sup>
		UP20A	5.78 (±0.92) <sup>a</sup>
	After UHT	DMS10599	2.11 (±0.01) <sup>b</sup>
		UP20A	1.81 (±0.27) <sup>b</sup>
	10% reprocessing	DMS10599	1.65 (±0.45) <sup>b</sup>
		UP20A	1.31 (±0.54) <sup>bc</sup>
140	Before UHT	DMS10599	6.43 (±0.41) <sup>a</sup>
		UP20A	5.58 (±0.84) <sup>a</sup>
	After UHT	DMS10599	nd
		UP20A	nd
	10% reprocessing	DMS10599	nd
		UP20A	nd
p-values	p = 0.68 <sup>1</sup>	p = 0.53 <sup>2</sup>	p = 0.89 <sup>3</sup>

<sup>a</sup> = 10% reprocessing, the addition of an overnight UHT treated culture to a fresh culture to a 10% v/v final concentration and subjected to another round of UHT treatment

Superscripts: a, b and c if similar denote statistical significant difference at  $p \leq 0.05$ , otherwise statistical similarity (n = 3)

1 = treatment effect, 2 = strain effect and 3 = strain-treatment interaction effect

nd = not detected for levels below 1 cfu/ml

Values = mean (± SD)

Table 4.3 Effect of pre-heating (78 °C for 15s), UHT (120 °C for 4s) and a combination of pre-heating and UHT, on the survival of *Bacillus sporothermodurans*

Treatment	Strain	Survival (log cfu/ml)
Before treatment	DMS10599	5.50 (±0.11) <sup>a</sup>
	UP20A	5.78 (±0.92) <sup>a</sup>
Pre-heating only	DMS10599	1.50 (±0.46) <sup>c</sup>
	UP20A	0.57 (±0.51) <sup>b</sup>
UHT only	DMS10599	nd
	UP20A	nd
Combined pre-heating and UHT	DMS10599	nd
	UP20A	nd
$p \leq 0.05$ <sup>1</sup>	$p = 0.31$ <sup>2</sup>	$p \leq 0.05$ <sup>3</sup>

Superscripts: a, b and c if similar denote statistical significant difference at  $p \leq 0.05$ , otherwise statistical similarity ( $n = 3$ )

1 = treatment effect, 2 = strain effect and 3 = strain-treatment interaction effect

nd = not detected for levels below 1 cfu/ml

Values = mean (± SD)

#### 4.1.4.7 Effects of 30% H<sub>2</sub>O<sub>2</sub> on the survival of *B. sporothermodurans* spores

The exposure time to H<sub>2</sub>O<sub>2</sub> significantly affected the *B. sporothermodurans* spore level for both strains at  $p \leq 0.05$  and as the exposure time increased the *B. sporothermodurans* level decreased (Table 4.5). With each 3 min increase in the exposure time to 30% H<sub>2</sub>O<sub>2</sub> the *B. sporothermodurans* level decreased linearly (Figure 4.3). The reduction in *B. sporothermodurans* spore survivals within the first 15 min was preceded by an initial abrupt decrease for both strains for the first 3 min. There was a constant decrease and significant decrease in the survival of spores after each exposure time (Table 4.3). By using the regression equation, the D30% of H<sub>2</sub>O<sub>2</sub> was calculated to be 3.33 min (Figure 4.3).

Table 4.4 Effect of UHT treatment (120 °C/4s), with and without chilling (24h at 7 °C), on spores of *B. sporothermodurans* strains

Treatment	Strain	Survival (log cfu/ml)
Before UHT treatment	DMS10599	7.40 ( $\pm 0.01$ ) <sup>a</sup>
	UP20A	7.24 ( $\pm 0.10$ ) <sup>a</sup>
After UHT	DMS10599	2.25 ( $\pm 0.10$ ) <sup>b</sup>
	UP20A	2.25 ( $\pm 0.16$ ) <sup>b</sup>
Combined chilling and UHT	DMS10599	nd
	UP20A	nd
$p \leq 0.05$ <sup>1</sup>	$p = 0.18$ <sup>2</sup>	$p = 0.56$ <sup>3</sup>

Superscripts: a, b and c if similar denote statistical significant difference at  $p \leq 0.05$ , otherwise statistical similarity (n = 3)

1 = treatment effect, 2 = strain effect and 3 = strain-treatment interaction effect

nd = not detected for levels below 1 cfu/ml

Values = mean ( $\pm$  SD)

Table 4.5: Effect of 30% H<sub>2</sub>O<sub>2</sub>, on *B. sporothermodurans* spores, at different exposure times

H <sub>2</sub> O <sub>2</sub> Exposure (min)	Strain	survival (log cfu/ml)
0	DMS10599	6.31 (±0.03) <sup>a</sup>
	UP20A	6.23 (±0.11) <sup>a</sup>
3	DMS10599	4.84 (±0.06) <sup>b</sup>
	UP20A	4.84 (±0.05) <sup>b</sup>
6	DMS10599	4.08 (±0.03) <sup>c</sup>
	UP20A	3.99 (±0.12) <sup>c</sup>
9	DMS10599	3.25 (±0.05) <sup>d</sup>
	UP20A	3.28 (±0.10) <sup>d</sup>
12	DMS10599	2.36 (±0.07) <sup>e</sup>
	UP20A	2.36 (±0.07) <sup>e</sup>
15	DMS10599	1.67 (±0.08) <sup>f</sup>
	UP20A	1.64 (±0.21) <sup>f</sup>
$p \leq 0.05$ <sup>1</sup>	$p = 0.36$ <sup>2</sup>	$p = 0.84$ <sup>3</sup>

Superscripts: a, b and c if similar denote statistical significant difference at  $p \leq 0.05$ , otherwise statistical similarity (n = 3)

1 = treatment effect, 2 = strain effect and 3 = strain-treatment interaction effect

Values = mean (± SD)

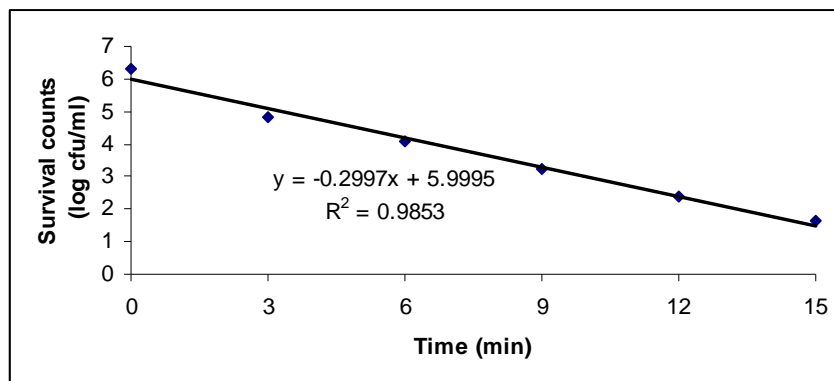

Figure 4.3 Regression equation of the survival of *Bacillus sporothermodurans* spores following exposure to 30% H<sub>2</sub>O<sub>2</sub> at different time ( $D_{30\%} = 3.33$ )

#### 4.1.5 Discussion

##### 4.1.5.2 Incidence of *B. sporothermodurans* in South African milk

The SPC values of raw milk from processor D were higher than the 300 000 (log 5.48) cfu/ml maximum acceptable SPC level for raw milk prior to pasteurisation as stipulated by the European Council Directives 85/397/EEC, 1985. This is a reflection of poor fresh milk handling sanitation and herd health conditions (Muir, 2007). Export of UHT milk with this quality will therefore not be permitted. Ineffective cooling, poor maintenance of milking equipment and poor water quality are often the cause of a high bacterial load in fresh milk (Muir, 2007). Similarly, the pasteurised milk packages had SPC higher than 50 000 (log 4.70) cfu/ml which is the maximum SPC level stipulated by the European Council Directives 85/397/EEC, 1985, for pasteurised milk. This is similar to the level endorsed by the Dairy Standard Agency (DSA) in South Africa and is a reflection of the poor quality of the raw milk that was used.

The results of the PCR reactions indicated that isolates from contaminated UHT milk packages were *B. sporothermodurans*. Considering that at least one isolate from each of the UHT milk packages of different batches from processor D tested positive for *B. sporothermodurans*, the incidence of this highly heat-resistant spore-producing bacteria in the local dairy environment is confirmed. UHT milk packages of other processors remained sterile even after incubation for 15 days at 30 °C. This implies that *B. sporothermodurans* contamination is not widespread or extensive in the South African milk industry.

Although the SPC of the contaminated UHT milk packages were higher than the 10 cfu/0.1 ml maximum stipulated by the European Council Directives 85/397/EEC in 1985, they were less than 10<sup>5</sup> cfu/ml recorded for 37% of contaminated Italian UHT milk packages analysed over a period of two years (Montanari, Borsari, Chiavari, Ferri, Zambonelli & Grazia, 2004). It should be mentioned that this value is the maximum *B. sporothermodurans* load that has been reported so far for contaminated

UHT milk packages after incubation for 15 days at 30 °C (Montanari *et al.*, 2004). The SPC of contaminated UHT milk packages did not show a difference that would have been expected between UHT milk packages that were incubated for 15 days at 30 °C and those that were not. This could be due to growth restraint associated with *B. sporothermodurans*, taking into consideration that  $10^5$  cfu/ml is the maximum *B. sporothermodurans* load in UHT that has been noted in different publications so far (Montanari *et al.*, 2004). This also explains the similarities in the SPC values of successive batches of UHT milk packs.

The fact that high *B. sporothermodurans* counts were determined for UHT treated milk that was to be reprocessed is of great concern. It is inevitable that spores and vegetative cells originating from the previous UHT treatment would be re-introduced into the UHT processing line. This practice has grave implications, as it is likely to result in enhanced resistance and proliferation of *B. sporothermodurans* in UHT milk packs during further processing and storage. Furthermore, spores of *B. stearothermophilus* that survived a sub-lethal heat treatment have been found to exhibit a heat-induced resistance to subsequent heat treatment (Etoa & Michiels, 1988). Therefore, spores of *B. sporothermodurans* that may have survived a previous UHT treatment and have not germinated could acquire a heat-induced resistance.

The spore counts of the contaminated UHT milk from the retail level and from the end of the processing line, without prior incubation could barely reach detectable levels. The reason is that most of the vegetative cells of *B. sporothermodurans* had not yet undergone sporulation or if already sporulated, spore at this stage could not support the 95 °C for 30 min heating. The resistance of spores of a *Bacillus* spp. has been linked to different stages in spore development with researchers noting that the older the spore the higher its resistance to heat (Knott, Russell & Dancer, 1995).

The SPC of the wash-water of the sterilisers was high. This could be due to the presence of spores, considering that pockets of biofilm containing high concentrations of spores located within the sterilisers may have been washed off during the rinsing



process. In addition, vegetative cells are likely to have been killed during UHT processing of milk (Brown, 2000).

#### 4.1.5.2 Identification of *B. sporothermodurans* using two different methods

The adoption of the RT PCR methodology used in this research to detect *B. sporothermodurans* in place of the PCR methodology of Schelderman *et al.* (2002) was successful. In addition, this is the first time that *B. sporothermodurans* have been detected using RT PCR with SYBR Green along with the primers of BSPO-F2 (5'-ACG GCT CAA CCG AG-3') and BSPO-R2 (5'-GTA ACC TCG CGG TCT A-3'). The adopted RT PCR methodology was efficient as 32 out of 33 isolate tested positive after a single run. The fluctuation of the  $T_m$  between 86–87 °C could be attributed to minor variations in the nucleotide sequences within the amplified segment of the 16S rRNA gene. A similar fluctuation was observed in a study involving the melting curve analysis for the identification of *Plum poxvirus* strains (Varga & James, 2005).

#### 4.1.5.3 Effect of different treatment regimes on *B. sporothermodurans* isolates

The significant difference in *B. sporothermodurans* survival following heating at 120–140 °C is understandable, considering that 140 °C is a more rigorous heat treatment than 120 °C. Heat treatment at 120 °C for 4s did not eliminate *B. sporothermodurans* as counts were obtained when treated cultures were incubated for 24h. It is possible *B. sporothermodurans* survived this treatment or revived from injury (Gonzalez, Lopez, Mazas, Gonzalez & Bernardo, 1995). Heat treatment at 140 °C for 4s was severe enough to completely inactivate spores and vegetative cells for both strains. This finding is contrary to the finding of Huemer *et al.* (1998) where spores of *B. sporothermodurans* were found to be more resistant at temperatures above 130 °C. Huemer's finding was based on *B. sporothermodurans* spores that were harvested from a 7-day-old ONA<sup>+</sup> agar plate culture. The *B. sporothermodurans* culture used in this study could only possibly have contained spores that were 24h old. The older the spore, the higher is its resistance to heat (Knott *et al.*, 1995).

Recontamination of *B. sporothermodurans* culture with a UHT treated culture of *B. sporothermodurans* did not influence the survival of *B. sporothermodurans* spores following a second UHT treatment. This may indicate that spores and vegetative cells from the heat-treated *B. sporothermodurans* culture used for recontamination of the fresh *B. sporothermodurans* culture, did not acquire heat-induced resistance. Only sub-lethal heat treatment of spores has been associated with induced heat resistance of spores and the resistance was found to be dependent on the duration of exposure to sub-lethal temperatures (Teofila *et al.*, 1998). More research needs to be done to assess the effect of high levels of recontamination during reprocessing (repeated UHT treatment) on the survival of *B. sporothermodurans* following UHT treatment.

The practice of reprocessing milk often occurs in order to avoid milk wastage when a producer realises that packages of a particular batch are defective or if it is observed that samples kept for shelf-life determination are defective. This may contribute to the recontamination of UHT milk with *B. sporothermodurans* during processing. However, this study has indicated that there were no recontamination impediments associated with the 10% reprocessing level applied during the study at temperatures of 120–140 °C as no detection of an increase of the *B. sporothermodurans*' load in the final product was detected. More research needs to be done with higher levels of *B. sporothermodurans* recontamination during re-processing to ascertain the behaviour of *B. sporothermodurans* with regard to heat resistance.

The pre-heating of broth culture before UHT treatment did not influence the survival of *B. sporothermodurans* contrary to the findings of Teofila *et al.* (1998) where pre-heating was found to induce heat resistance in spores of *Bacillus* spp. This may be attributed to the fact that spores did not attain the required level of induction given that heat-induced resistance is relative to the duration of exposure to sub-lethal temperature (Teofila *et al.*, 1998). They also found that the activation of dormant spores is a process that progresses with time until an abrupt structural change in individual spores occurs. Heat-induced resistance only becomes effective at the point where there is an expansion of the cortical peptidoglycan against an intact coat resulting in more water in the cortex and less water in the protoplast, which is a

prerequisite characteristic for heat resistance to occur in spores. In this experiment, heat exposure was brief so as to reflect some practices associated with UHT milk processing.

#### **4.1.6 Conclusions**

*B. sporothermodurans* is present in UHT milk but the incidence is not extensive or widespread. Heat treatment at 140 °C, unlike 120 °C, eliminates *B. sporothermodurans* in broth whereas chilling renders *B. sporothermodurans* spores more susceptible to UHT treatment. The PCR detection protocol adopted for RT PCR is effective in confirming *B. sporothermodurans*.

## 4.2 THE EFFECTS OF WET HEAT TREATMENT ON THE STRUCTURAL AND CHEMICAL COMPONENTS OF *BACILLUS SPOROTHERMODURANS* SPORES

(Accepted for publication in the *International Journal of Food Microbiology* on 21 March 2010)

### 4.2.1 Abstract

The objective of this research was to study the rate of structural damage and survival of *Bacillus sporothermodurans* spores following treatment at high temperatures by determining the amount of Dipicolinic acid (DPA) and soluble protein leakage over time. A reference strain of *B. sporothermodurans* (DSM 10599) and a South African strain (UP20A) isolated from UHT milk were used to determine the survival of spores heated at 130 °C for 4, 8 and 12 min. To check the viability of spores, plate counts were determined. Structural damage was determined using transmission electron microscopy (TEM). The filtrate of the heated spore suspension was analysed for the amount of DPA and soluble protein release due to heating. The amount of DPA released was quantified by HPLC analysis while the amount of soluble protein released from heated spores was quantified using the Bradford method. The log values of spore counts, released DPA and soluble proteins from triplicate experiments were analysed.

The results of this study indicate that inactivation of *B. sporothermodurans* spores during wet heat treatment is due to the penetration of hot moisture into the spore which then moistens the spore components and inactivates enzymes. Because of the high water pressure, vital spore components such as proteins and DPA in solution leak out of the spore. Interestingly, the vast majority of heated spores were inactivated before a significant amount of DPA was released. This research is the first to determine the effect of high temperature wet heat treatment on the structure of *B. sporothermodurans* spores and gives an insight regarding the mechanisms of destruction of *B. sporothermodurans* spores by wet heat.

Key words: *Bacillus*, spores, Dipicolinic acid, spore protein, TEM, UHT

#### 4.2.2 Introduction

*Bacillus sporothermodurans*, first detected in UHT milk in Germany in 1990, affects the stability and the shelf life of commercial UHT milk (Pettersson *et al.*, 1996). This is due to the unusual thermal kinetics of *B. sporothermodurans* spores that enable them to survive at high temperatures (130 °C for 4s) of UHT treatment (Huemer *et al.*, 1998). Spores germinate during storage in UHT products causing instability due to their proteolytic activities thereby reducing shelf life and consumer acceptability. Spoilage due to *B. sporothermodurans* growth can be in the form of a slight change in the colour of the milk, 'off flavours' and destabilisation of casein micelles (Klijn *et al.*, 1997). Increasing the temperature or the holding time in an attempt to inactivate *B. sporothermodurans* spores affects the organoleptic and nutritional qualities of UHT milk (Claeys *et al.*, 2001). Severe heating will lead to protein denaturation, Maillard reactions and lactose isomerisation. Protein denaturation and sugar modification are responsible for the 'cooked' taste, while the Maillard reactions induce a decrease of the protein nutritional value by irreversible alteration of the lysine residue (Claeys *et al.*, 2001). The mechanisms in which the structural and chemical components of *B. sporothermodurans* spores are influenced during wet heat inactivation are currently not clear (Klijn *et al.*, 1997).

Bacterial spore layers consist of the following layers: exosporium, spore coats, outer membrane, cortex, germ cell wall, inner membrane and central core (Setlow, 2006). The exosporium and the spore coats have not been associated with wet heat resistance of spores. Removal of the outer spore membrane along with coat proteins also did not produce a major effect on spore resistance to wet heat (Nicholson *et al.*, 2000). The cortex, which is made up of peptidoglycan (PG), has been linked to the production of dormant spores with low core water content, however, the mechanism of dormant spore production is still unclear (Setlow, 2006). The core is the innermost layer of the spore and is comparable to the protoplast of the vegetative cell. The spore core consists of spore enzymes, DNA, ribosomes, tRNA, divalent cations, small acid

soluble proteins (SASP) and dipicolinic acid (DPA) (Setlow, 2006). The major factors that contribute to the wet heat resistance of bacterial spores are the core water content, mineralisation of the spore core due to the accumulation of high levels of divalent cations and DPA and the presence of high levels  $\alpha/\beta$ -type SASP in the spore core (Melly *et al.*, 2002). An increase in the mineralisation of spores due to high levels of divalent cations and DPA increases the wet heat resistance (Paidhungat *et al.*, 2000). SASP binds to spore DNA protecting it from wet heat and other treatments such as chemicals, radiation, and so forth (Setlow, 2006). The SASP consist of  $\alpha/\beta$ -type 56 and  $\gamma$ -type with the average molecular weight ranging from 5–10 kD. In *B. subtilis* spores these SASP types are only synthesised in developing spores late in sporulation (Hathout *et al.*, 2003).

It has been reported that the killing of spores by wet heat is not through DNA damage but rather by the rupturing of the spore's inner membrane permeability barrier and the inactivation of core enzymes (Warth, 1980; Setlow, 2000). Nevertheless, the exact target for lethal damage by wet heat and the mechanism behind it have not been ascertained. Therefore, there is a need to understand the structural integrity of *B. sporothermodurans* spores following UHT treatment in relation to their survival. The objective of this research was to study the survival of *B. sporothermodurans* spores and structural damage as affected by wet heat.

### 4.2.3 Materials and methods

#### 4.2.3.1 *B. sporothermodurans* strains

A reference strain of *Bacillus sporothermodurans* DSM 10599 was obtained from Deutsche Sammlung von Mikroorganismen und Zellkulturen GmbH (DSMZ), Germany while *B. sporothermodurans* UP20A was isolated from UHT milk in South Africa. In order to prepare pure cultures, a single colony of each isolate was collected from BHI agar plates and transferred into 1.5 ml eppendorf tubes containing 1 ml of freshly prepared Brain Heart Infusion (BHI) broth and incubated for 24h at 37 °C.

One ml of each culture was centrifuged at  $10\,000 \times g$  for 3 min and pellets were subsequently diluted to approximately 0.5 McFarland Standard (Andrews, 2004).

#### 4.2.3.2 Spore preparation

From an overnight pure culture of each strain, 1 ml of culture was collected and spread on BHI agar plates and incubated for 14 days at 37 °C. Growths on each plate were checked for sporulation using a light microscope until *ca.* 100% sporulation was attained. Spores were harvested by scraping the dense growth on the surface of agar plates with a sterile loop and transferred into a 1.5 ml eppendorf tube containing sterile physiological saline. Spores were washed with double distilled water, centrifuged at  $10\,000 \times g$  for 3 min and pellets were diluted to about  $10^8$  spores per ml with sterile physiological saline using 0.5 McFarland Standard.

#### 4.2.3.3 Heat treatment of spores

Heating was conducted, with some modifications, as described by Huemer *et al.* (1998). Spore suspensions were heated in sterile pressure tubes with a threaded type B plug (Sigma Aldrich, Midrand, South Africa) with an outer diameter of 25 mm and wall thickness of 2 mm in an oil bath. The tubes were filled with 3 ml of spore suspension, closed with stoppers and submerged in an oil bath set at 130 °C. To check the viability of spores, standard plate counts were conducted by plating 10 times serial dilutions of heated spore on BHI agar plates and incubated at 37 °C for 4 days.

#### 4.2.3.4 Transmission Electron Microscopy (TEM) analyses of spores

TEM was conducted with heated spores, as described by Van der Merwe and Coetzee (1992) with some modifications. Spores were centrifuged at  $3\,000 \times g$  for 3 min and pellets were re-suspended in a solution containing 3 ml of 2.5% gluteraldehyde, 15 ml 0.15 M sodium phosphate buffer and 30 ml double distilled water and incubated for 24 hr at room temperature and centrifuged. The pellets were washed by resuspension

in 50% 0.15 M sodium phosphate buffer for 15 min followed by centrifugation at  $3\,000 \times g$  for 3 min. This procedure was repeated three times. After washing, pellets were dissolved in 1% 100 OsO<sub>4</sub> and allowed to stand for 1h prior to another round of washing in 50% 0.15 M sodium.

The pellets were dehydrated by washing once in 50% ethanol for 15 min followed by centrifugation at  $3\,000 \times g$  for 3 min. This procedure was repeated in 70% and 80% ethanol in succession. The resulting pellets were washed 3 times in 100% ethanol and passed through 33%, 66% and 100% resin (29.8% Quetol, 44.6% Nadic Methyl Anhydride, 16.6% Dodenyl Succinic Anhydride, 2% Araldite RD2, 1% 2, Dimethylaminoethane), prior to polymerisation. Thin sections of resin-polymerised spores were made with a microtome and placed on grids and stained with uranyl acetate and lead citrate. Micrographs were taken using the Philips EM301 transmission electron microscope (Eindhoven, Netherlands).

#### *4.2.3.4 Analysis of soluble protein leakage from heated spores*

Analysis of leaked soluble protein was conducted with the filtrate obtained from filtering the 3 ml spores suspension ( $10^8$  spores/ml) of *B. sporothermodurans* that had been heated at 130 °C for 0, 4, 8 or 12 min. Filtration was through a 2 µm filter and the filtrates were used to estimate the concentration of leaked soluble protein using the method determined by Bradford (1976).

#### *4.2.3.5 HPLC analysis of leaked dipicolinic acid*

The filtrate of the heated spore suspension described above was used to analyse DPA. DPA analysis was conducted using the Breeze HPLC System equipped with the following: Waters 2487 detector, Waters 1525 HPLC Pump with a 250 x 4.6 mm, 5 µm particle sizes, C12 reverse phase HPLC column (Waters Corporation, Milford, USA). Elution was with 1.5% tert-amyl alcohol in 0.2 M K phosphate at pH 1.8 that had been filtered with a 0.2 µm membrane filter with a flow rate of 1.5 ml per min at 25 °C. Chromatograms were generated following UV absorbance at 271 nm (Warth,



1979). Commercial dipicolinic acid (Sigma Aldrich, Midrand, South Africa) was used as standard. The peak area, which is a reflection of the DPA concentration, was generated using a HPLC analyser.

#### 4.2.3.5 Statistical analysis

The effects of the main factors which were the strain and time on the log values of spore survival counts and values of the amount of released DPA and soluble proteins, each from triplicate experiments, were determined using ANOVA (STATISTICA, Statsoft Inc., Tulsa, OK). Least square means were also used to determine significant difference.

### 4.2.4 Results

#### 4.2.4.1 TEM analyses of spores

As seen on Figure 4.4a and from the core outward, a *B. sporothermodurans* spore consists of four noticeable layers, namely: cortex, spore coats, exosporium and surface layer. The core is a centralised dense structure of approximately 500 nm in diameter and surrounded by the cortex, which is close to 62 nm wide. The coat is also surrounded by the exosporium, which is about 187 nm wide. The exosporium is the widest of all the layers and surrounded by the surface layers. All measurements were estimated using the measurement lengths on micrographs. Looking at the differences in intensity of the different layers on the TEM micrographs, the density of the layers are in this order; core > coats > cortex > exosporium (Figure 4.4a). The spore coat consists of two layers; the outer spore coat and the inner spore coats with a loose space between the outer and inner spore coats (Figure 4.4b). Between the inner spore coat and the cortex, lies the cortical membrane while the inner exosporial membrane is located between the outer spore coat and the exosporium (Figure 4.4b). The surface layer also consists of a surface membrane that is underlined by coat-like structures (Figure 4.4b). Both strains have similar TEM profiles.

Structural damage was observed when *B. sporothermodurans* spores were heated at 130 °C for 4 min (Figure 4.5a–d). Structural damage (marked X) within the cortical membrane region, beneath the spore coats was clearly visible. This depicts a pull away of the coat structures from the cortex within the cortical membrane after heating for 4 min. However, some spores in the same crop did not show any visible sign of structural damage at this stage (Figure 4.5d).

After heating for 8 min, the damage in the cortical membrane widened (marked X) and some of the cortical materials were lost at this stage, rendering it less dense (marked Z) (Figure 4.6a, b, c and d). Similarly, the exosporium lost some of its content and was compressed (marked Y) on Figure 4.6b and c. The spore core had also started losing some of its components (Figure 4.6d).

The exosporium and the cortex were severely damaged and had lost most of their components after heating for 12 min and there was a reduction in the density of the core. The surface layers, exosporium and spores coats collapsed on each other at this time (marked X) on Figure 4.7a, b, c, when compared to that of unheated spores (Figure 4.6a and b). The spore core at this stage was severely damaged and most of its contents had been washed away (Figure 4.7a, b, c and d).

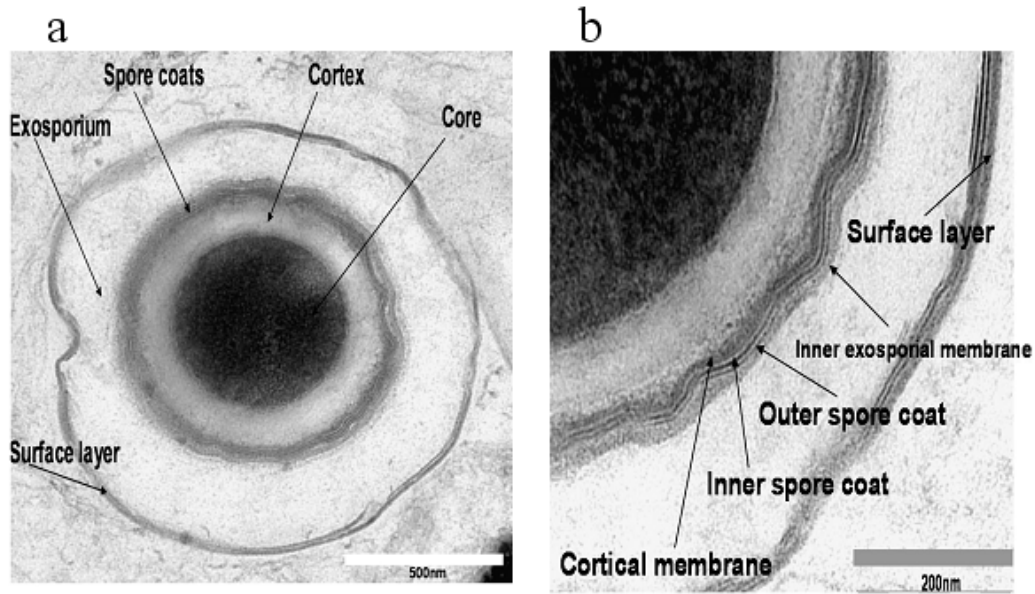

Figure 4.4 a & b: Micrographs generated from TEM analysis, showing the detail structures of unheated spores of *Bacillus sporothermodurans* UP20A, harvested from 14 days old BHI agar plates. NB: The spore structures of both strains as revealed by TEM analysis were similar.

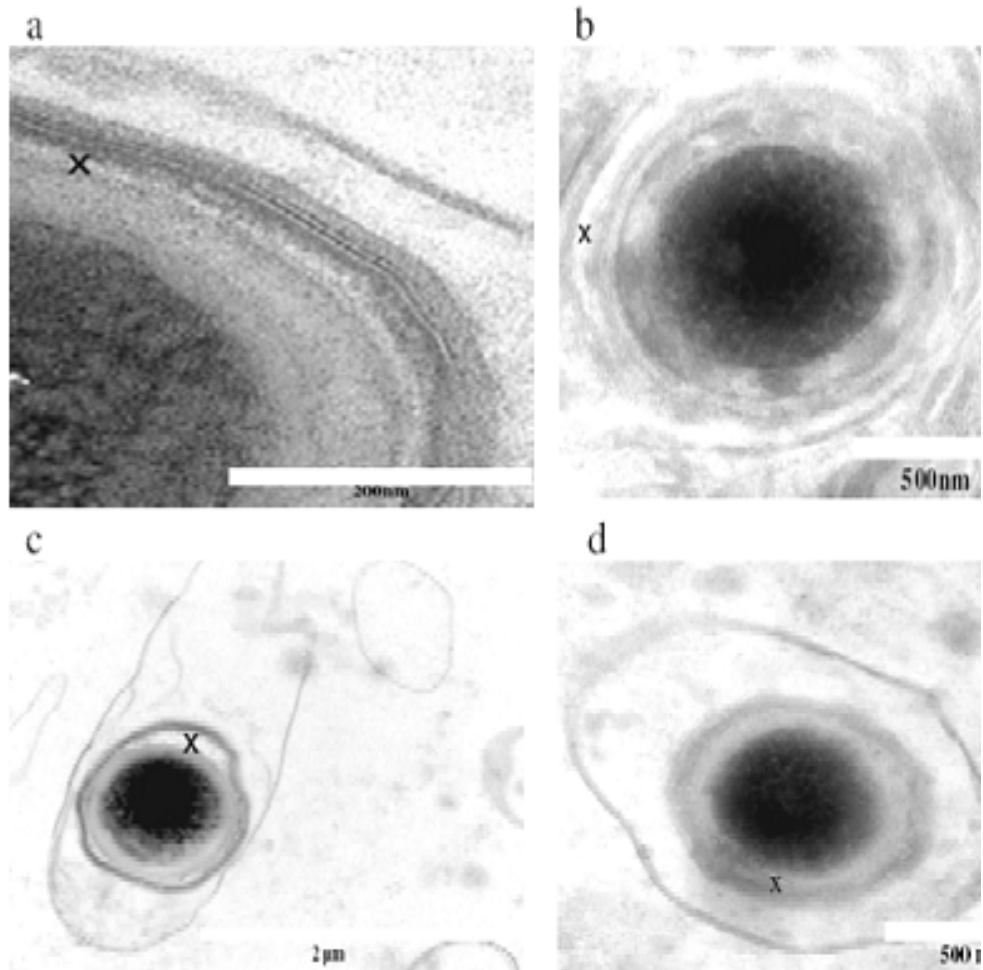

Figure 4.5 a, b, c & d: Micrographs generated from TEM analysis, showing the structure of the spore of *Bacillus sporothermodurans* UP20A, heat treated at 130 °C for 4 min. NB: The spore structures of both strains as revealed by TEM analysis were similar.

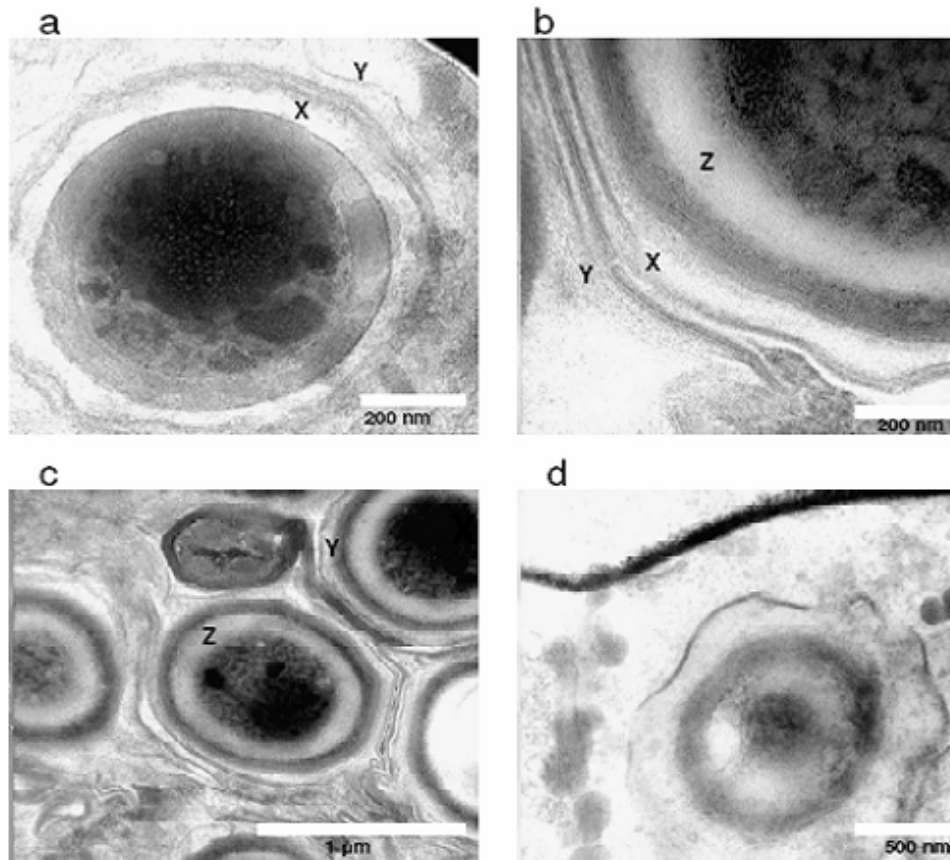

Figure 4.6 a, b, c & d: Micrographs generated from TEM analysis, showing the structure of *Bacillus sporothermodurans* UP20A spores, heat treated at 130 °C for 8 min. NB: The spore structures of both strains as revealed by TEM analysis were similar.

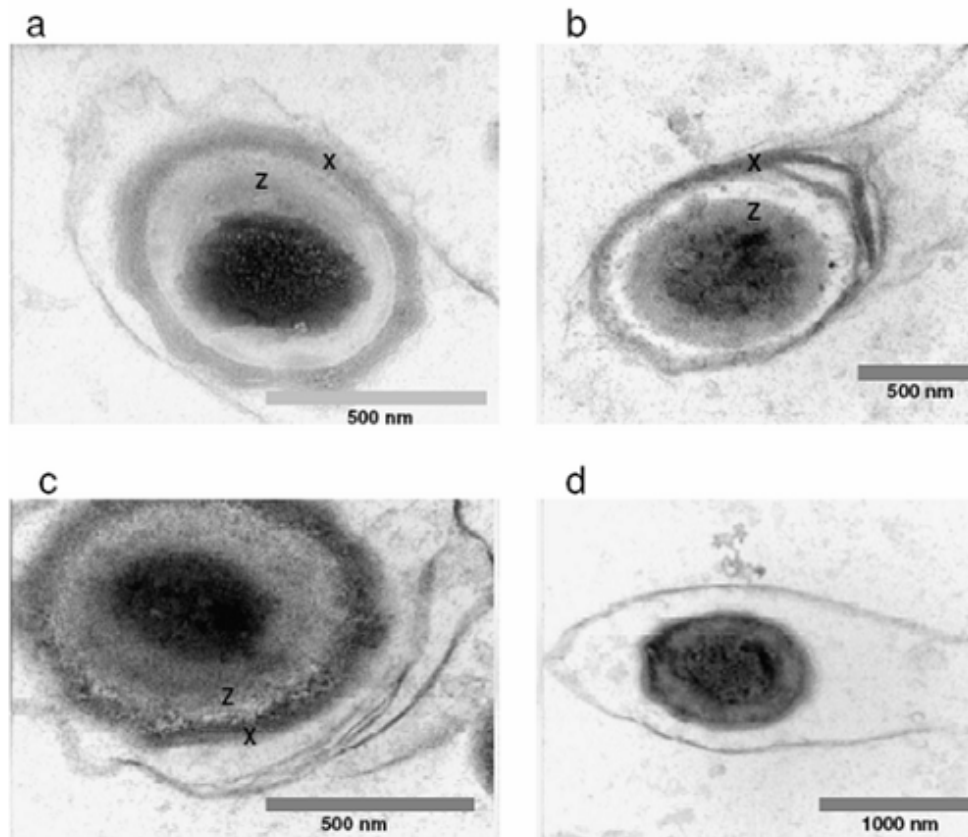

Figure 4.7 a, b, c & d: Micrographs generated from TEM analysis, showing the structure of *Bacillus sporothermodurans* UP20A spores, heat treated at 130 °C for 12 min. NB: The spore structures of both strains as revealed by TEM analysis were similar.

#### 4.2.4.2 Spore viability following treatment at 130 °C

Spores from both strains reacted in a similar way to heat treatments, considering that neither the strain effect nor the strain-time interaction effect on the survival count were not significant at  $p = 0.36$  and  $p = 0.84$  respectively. Conversely, the time effect on the survival count was significant at  $p \leq 0.05$ . The effect of time is shown by the 7.5 log reduction in the survival of spores after heating for 4 min for both strains. Spores of neither strain survived heating for 8 min (Figure 4.8).

#### 4.2.4.3 Protein released from *Bacillus sporothermodurans* spores following treatment at 130 °C

The time effect and the strain effect on the release of soluble protein were significant at  $p \leq 0.05$ . Similarly, the time-strain interaction effect on the release of soluble protein was also significant at  $p \leq 0.05$ . Looking at the trend of soluble protein ( $\mu\text{g/ml}$ ) released from both strains it can be seen that there was a significant increase in the amount of soluble protein released after each heating period, which explains the time effect on the amount of protein released (Figure 4.9).

The release of soluble protein was similar for both strains after heating for 4 min but differed significantly after heating for 8 min during which the protein released from DSM 10599 spores was higher. However, by 12 min the protein released from the DSM 10599 spores slowed to a value which was not significantly different from that released from the UP20A spores.

#### 4.2.4.4 DPA from *Bacillus sporothermodurans* spores following treatment at 130 °C

The time effect and the time-strain interaction effect on the release of DPA from heated spores were significant at  $p \leq 0.05$ . On the other hand, the strain effect on the release of DPA was not significant at  $p = 0.59$ . Looking at Figure 4.10, it can be seen that there was a non-significant increase in the release of DPA after heating for 4 min for both strains. After 8 min of heating there was a significant increase in the DPA amount of UP20A, while for DSM 10599 the increase was not significant.

A reverse trend was observed after heating for up to 12 min in which the amount of DPA released from UP20A was not significant while that for DSM 10599 was significant. Looking at the overall trend, there was a gradual increase in the release of DPA over time, explaining the strain effect. Between 4–12 min of heating, both strains reacted differently over time, explaining the time-strain interaction effect (Figure 4.10).

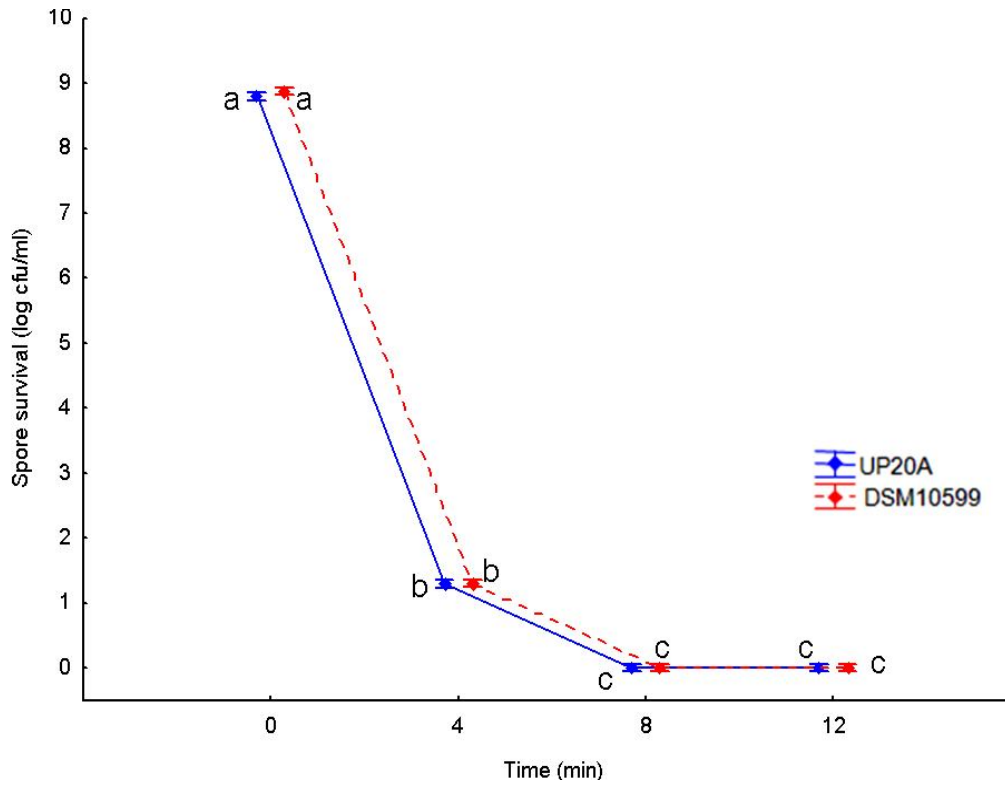

Figure 4.8 Inactivation trend of spores of two strains of *B. sporothermodurans*: DSM 10599 and UP20A, following heat treatment at 130 °C at different times. Different letters a, b and c denote statistical differences at  $p \leq 0.05$  ( $n = 3$ ). Log cfu/ml of 0 represent counts ranging from 1 to 0 spore/ml ( $n = 3$ ).



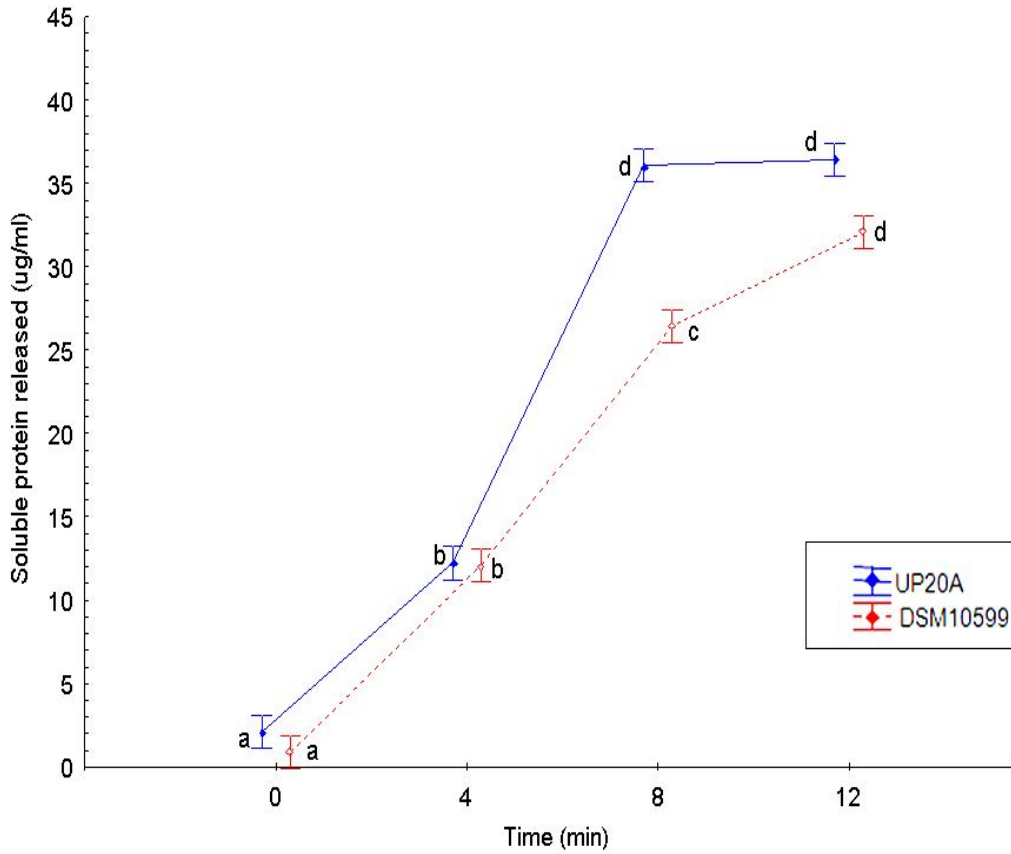

Figure 4.9 Protein released ( $\mu\text{g/ml}$ ) from spores of two strains of *Bacillus sporothermodurans*: DSM 10599 and UP20A, following heat treatment at  $130\text{ }^\circ\text{C}$  at different times. Different letters a, b and c denote statistical differences at  $p \leq 0.05$  ( $n = 3$ ). Log cfu/ml of 0 represent counts ranging from 1 to 0 spore/ml ( $n = 3$ ).

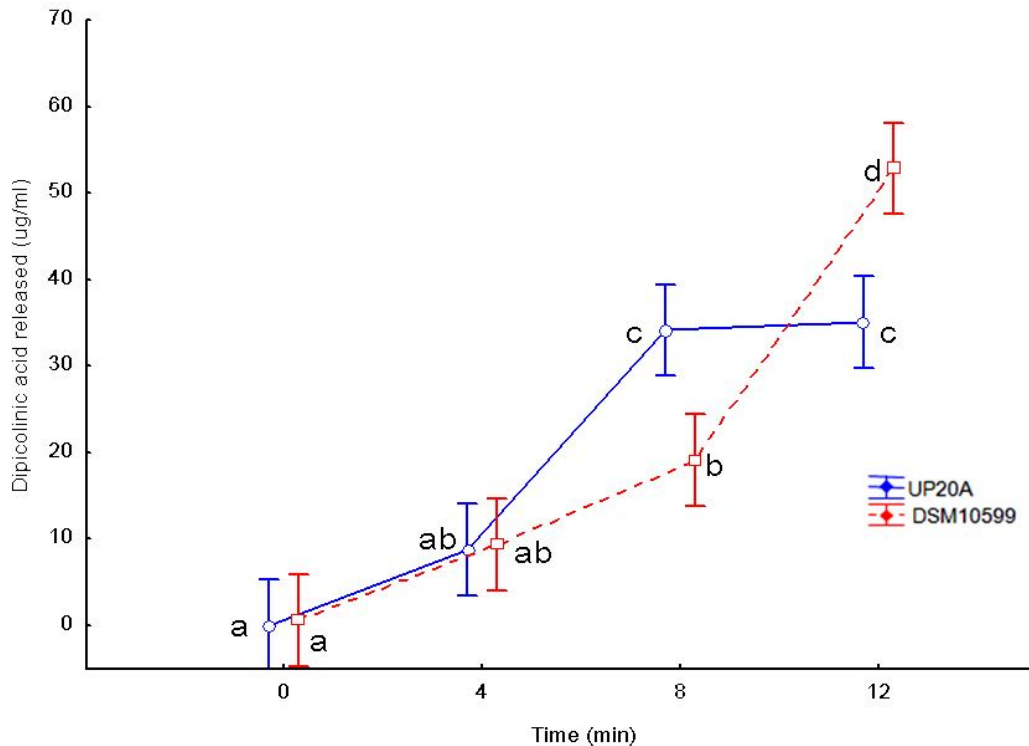

Figure 4.10 DPA released ( $\mu\text{g/ml}$ ) from spores of two strains of *Bacillus sporothermodurans*: DSM 10599 and UP20A, following heat treatment at  $130\text{ }^{\circ}\text{C}$  at different times. Different letters a, b and c denote statistical differences at  $p \leq 0.05$  ( $n = 3$ ). Log cfu/ml of 0 represent counts ranging from 1 to 0 spore/ml ( $n = 3$ ).

#### 4.2.5 Discussion

The TEM did not reveal any structural differences between the unheated spores and treated spores of both strains. This could be attributed to structural similarities between the two strains. On the contrary, the release of protein ( $\mu\text{g/ml}$ ) was significantly ( $p \leq 0.05$ ) different between the two strains. This could be attributed to structural difference in protein composition of both strains considering that the composition of the exosporium and coat structures of *Bacillus* spores have been found to be species and strain specific (Henriques & Moran, 2007). However, the release of DPA throughout the heating times was not significantly different between the two strains. This is in agreement with similarities observed in the inactivation pattern and structural damage of both strains at different heating times.

From the TEM, spores began losing their structural components after 4 min of heating. The cortical membrane was the area first affected by wet heat, which was where the first visible signs of structural damage appeared. The reason for this early damage is due to the washing away of peptidoglycan materials, which are the main constituent of the cortex (Setlow, 2006). Perhaps heat penetrated the spore layers and entered the spore core resulting in the release of more protein than DPA. This finding is in agreement with findings of Coleman, Chen, Li, Cowan and Setlow (2007) on *Bacillus subtilis* spores in which DPA release was accompanied by a large amount of protein damage.

The fact that a small proportion of spores did not show visible structural damage after 4 min of heating could be that damage is not acquired at the same rate by all spores. This is in agreement with findings of a similar study in which *B. stearothermophilus* spores were found to be inactivated at different rates following heating at UHT temperatures (Feeherry, Munsey & Rowley, 1987). The more dehydrated spores are, the more their resistance to wet heat treatment increases (Setlow, 2006).

The majority of spores were inactivated after 4 min of heating during which the amount of DPA released was very small. This result is in agreement with findings in which the rate of DPA release was found to be slower than the rate of spore death following heating at UHT temperature (Mallidis & Scholefield, 1985). The appearance of DPA was a clear sign of a breach in the protective barrier of spores following wet heat treatment and the onset of spore inactivation. More research needs to be done to determine the exact amount of DPA to be released for inactivation to take place.

After 8 min of heating there was total inactivation of spores. The cortical membrane lost most of its components at which point the structural damage became clearer on the micrographs. This is due to the fact that continued heat induces damage, which results in the washing away of more peptidoglycan from the cortex. Similarly, the spore core and exosporium also lost some of their components after 8 min but the damage was not severe compared to that of the cortex. The reason why the cortex

degraded faster than the exosporium and the spore core could be due to differences in their components. This implies the peptidoglycan matrix is more susceptible to wet heat treatment.

When compared to the small amount of DPA released after 4 min when the majority of spores were inactivated, a significant ( $p \leq 0.05$ ) amount of DPA was released only after total inactivation. This finding is in agreement with studies conducted on *B. subtilis* spores (Coleman *et al.*, 2007). Therefore, DPA release is an indication that considerable destruction of spores has taken place and is not linked to spore resistance.

By 12 min, there was complete destruction of spore components with the cortex almost washed off completely leaving behind a reduced and less dense spore core surrounded by a loosely attached coat and surface layer. This is due to the total destruction of spores after prolonged heating which resulted in the flushing out of a considerable amount of soluble protein from spores. Levelling off of protein release occurs between 8–12 min of heating. Contrary to soluble protein, the amount of DPA release at this stage did not level off. As cited earlier, this is attributed to the fact that DPA is located exclusively in the spore core which was the last area in which visible structural damage was noted during the entire heating time as seen on the TEM (Kuwana, Kasahara, Fujibayashi, Takamatsu, Ogasawara & Watabe, 2002).

By integrating the TEM, protein and DPA analyses, the mechanism of *B. sporothermodurans* spore inactivation with time can be summarised. Heat penetrates into the spore core. Hot moisture follows thereafter and rehydrates the spore. Finally, spore structures are destroyed resulting in a massive inactivation of spores (small amounts of DPA leak out) to total inactivation of spores (large amounts of DPA leak out).

#### **4.2.6 Conclusion**

The onset of DPA release during wet heat treatment coincides with visible signs of structural damage and significant inactivation of spores. Visible signs of spore structural damage emanate at different rates. The amount of protein released seems to be strain specific.

## CHAPTER 5: GENERAL DISCUSSION

The general discussion chapter initially elucidates the methodology of the research project followed by observations regarding the incidence and survival of *Bacillus sporothermodurans* during UHT processing. The observations regarding the effects of wet heat treatment on the structural and chemical components of *B. sporothermodurans* spores will also be elucidated.

### 5.1 METHODOLOGICAL CONSIDERATIONS

SPCs were conducted for all retail milk samples (raw, pasteurised and UHT treated) in order to determine their bacterial quality. Similarly, milk samples at various points of the processing line at processor D were also collected and the bacterial quality determined. It is essential to use SPC which is a conventional technique employed by most quality assurance laboratories. An alternative method that could have been used to enumerate bacteria in milk samples is the flow cytometry. However, flow cytometry requires the clearing of milk and the staining of bacteria with a fluorescent stain thereby making sample handling cumbersome. Despite the rapid nature of flow cytometry, it has a particularly low detection limit with up to  $10^4$  total bacteria per ml in some cases. However, it can detect non-culturable, dead and injured cells (Gunasekera, Attfield & Veal, 2000). It would have been interesting to enumerate the bacteria using both methods.

The pure cultures of all the samples were then analysed using the *B. sporothermodurans* specific PCR to determine whether or not isolates were *B. sporothermodurans*. The choice of 4 or 5 colonies taken per plate was to ensure that tested isolates were representative of the total bacterial flora in the different milk packages. It would have been useful to profile all the bacteria isolated from each milk sample using extragenic palindromic polymerase chain reaction (REP-PCR) and sequencing in order to determine their identity and genetic relationship considering that REP-PCR has been used successfully to differentiate *Bacillus sporothermodurans* species (Herman & Heyndrickx, 2000). This technique would have enabled us to

alternatively confirm the absence *Bacillus sporothermodurans* in raw and pasteurised milk as established in this research.

The determination of viable spore counts of UHT milk samples was conducted by plating serial dilutions of milk or broth samples that have been heat treated at 95 °C for 30 min followed by SPC. The direct epifluorescent filter technique (DEFT), which is a rapid technique for viable spore enumeration, could have been very useful in this research. This technique includes heat activation followed by germination with l-alanine and the subsequent counting of green and orange fluorescing cells (Moran, Rowe & Gilmour, 1991). This method can be used alongside the SPC method considering both methods have been found to have a good correlation factor ( $r= 0.98$ )

*B. sporothermodurans* spores to be used for thermokinetic analysis were obtained from BHI agar plate growth that had been incubated for 15 days at 37 °C. The reason why plates were incubated for 15 days at 37 °C was to ensure complete sporulation. Spores at this stage must have attained complete maturity. In this study, spores were washed and thermokinetics studies were conducted without delay to ensure that spores did not undergo any physiological changes prior to analysis.

In this study, the thermokinetic characteristics of spores were obtained by heating spores suspension ( $10^8$  spores/ml) in sterile pressure tubes. The use of a UHT steriliser would have been ideal to monitor the inactivation and the effect of wet heat treatment on spores. However, this was not case because of lack of equipment as well as knowing that local milk processors would not wish to have their UHT sterilisers inoculated with spores.

In order to observe the mechanisms of destruction of spores at different times, TEM analysis of resin-polymerised spores was conducted. The TEM analysis can only show structural differences in spores across the different heating times. It would have been interesting to do scanning electron as well as phase contrast microscopy in order to see morphological changes across the different heating times.

The analysis of leaked protein and DPA was carried out in order to determine the amount released at different times. Even though the amount of DPA release is not a reflection of heat resistance, it gives an indication of the mechanism of spore destruction as well as an indication of the extent of destruction during which death occurs.

Two methods of extraction were used to extract the genomic DNA for molecular analysis in this study. The isolation of genomic DNA for PCR with agarose gel detection was conducted as described by Schelderman *et al.* (2002) with some modifications. The modifications introduced were the centrifugation of the boiled bacteria and the quantification of the DNA in the supernatant. This enables the determination of the right amount of genomic DNA required for the PCR reactions. However, the quantification of DNA from crude cell lysate was problematic due to the presence of impurities but this did not influence the PCR reaction as DNA was diluted in the PCR reaction volumes. On the other hand, DNA for real time PCR with SYBR Green was extracted and purified from pure cultures using the ZR Fungal/Bacterial DNA Kit<sup>TM</sup> (Zymo Research Corporation, USA) because real time PCR will not give accurate results if the genomic DNA utilised is not pure.

The molecular identification of *B. sporothermodurans* was conducted using *B. sporothermodurans* specific primers described by Schelderman *et al.* (2002). An alternative PCR primer developed by Herman *et al.* (1997) can also be used to detect *B. sporothermodurans*. The problem with this PCR is that it can detect only heat resistant spore forming *B. sporothermodurans* while the method described by Schelderman *et al.* (2002) can detect both heat resistant spore formers as well as non-heat resistant spore formers. Other reputable identification techniques like the REP-PCR with gel separation (Klijn *et al.*, 1997; Herman *et al.*, 1997) and ARDRA (ribotyping) (Guillaume-Gentile *et al.*, 2002) were not considered because they are more complex than the normal PCR identification.



## 5.2 INCIDENCE AND SURVIVAL OF *BACILLUS SPOROTHERMODURANS* DURING UHT PROCESSING

The SPC values of raw milk from processor D were higher than the 300 000 (log 5.48) cfu/ml maximum acceptable SPC level for raw milk prior to pasteurisation as stipulated by the European Council Directives 85/397/EEC, 1985. The same limit is also endorsed by the Dairy Standard Agency of South Africa. SPC values of this magnitude reflect poor fresh milk handling sanitation and herd health conditions (Muir, 2007). Export of UHT milk with this quality is prohibited particularly to EU member countries and the USA. Ineffective cooling, poor maintenance of milking equipment and poor water quality are often the cause of a high bacterial load in fresh milk (Muir, 2007). Similarly, the pasteurised milk packages had SPC higher than 50 000 (log 4.70) cfu/ml which is the maximum SPC level stipulated by the European Council Directives 85/397/EEC, 1985 and the Dairy Standard Agency of South Africa. This level is also a reflection of the poor quality of the raw milk that was pasteurised. It should be noted that the quality of processed milk is reflected by the quality of the raw fresh milk.

The fact that high *B. sporothermodurans* counts were determined in UHT treated milk to be used for re-processing is of great concern because of the inevitable re-introduction of spores and vegetative cells originating from spores that survived the previous UHT treatment in the UHT processing line. This practice has grave implications, as it is likely to result in the introduction of a high quantity of bacterial protein from vegetative cells into UHT milk destined for a long period of storage. Furthermore, spores of *B. stearothermophilus* that survived a sub-lethal heat treatment have been found to exhibit a heat-induced resistance to subsequent heat treatment (Etoa & Michiels, 1988). Therefore, spores of *B. sporothermodurans* that may have survived a previous UHT treatment and have not germinated could acquire a heat-induced resistance thereby increasing their survival during subsequent UHT reprocessing. However, results from this research did not indicate any heat-induced resistance and proliferation of *B. sporothermodurans*.

In a similar experiment, pre-heating of broth culture before UHT treatment did not influence the survival of *B. sporothermodurans*, contrary to the findings of Teofila *et al.* (1998), where pre-heating was found to induce heat resistance in spores of *Bacillus* spp. This may be attributed to the fact that spores had not attained the required level of heat resistance induction during pre-heating considering that heat-induced resistance is relative to the duration of exposure to sub-lethal temperature (Teofila *et al.*, 1998). Heat-induced resistance only becomes effective at the point where there is an expansion of the cortical peptidoglycan against an intact coat resulting in more water in the cortex and less water in the protoplast. The idea behind the pre-heating experiment was to determine the effect of pre-heating on the survival of *B. sporothermodurans* following UHT treatment as this may have some implication for UHT processes in dairy industries with *B. sporothermodurans* contamination. However, looking at the results of this research, pre-heating did not affect the survival of *B. sporothermodurans* following UHT treatment.

The SPC of contaminated UHT milk in this study were less than  $10^5$  cfu/ml that was obtained from 37% of contaminated Italian UHT milk packs analysed over a period of two years (Montanari *et al.*, 2004). It should be mentioned that  $10^5$  cfu/ml is the maximum *B. sporothermodurans* load that has been reported so far for contaminated UHT milk packs after incubation for 15 days at 30 °C. Even though this research has confirmed the presence of *B. sporothermodurans* in the South African dairy industry, the exact route of contamination remains unknown. This is exacerbated by the fact that the many attempts to isolate *B. sporothermodurans* from raw and pasteurised milk have been futile.

The results of the PCR reactions indicated that isolates from contaminated UHT milk packages were *B. sporothermodurans*. Given the fact that at least one isolate from each of the UHT milk packs tested positive for *B. sporothermodurans*, confirmed the incidence of this highly heat-resistant spore-producing bacteria in the South African dairy. The adoption of the PCR methodology of Schelderman *et al.* (2002) to the RT PCR methodology used in this research to detect *B. sporothermodurans* was successful. This is the first time in which *B. sporothermodurans* has been detected

using RT PCR with SYBR Green using the primers; BSPO-F2 (5'-ACG GCT CAA CCG AG-3') and BSPO-R2 (5'-GTA ACC TCG CGG TCT A-3').

The adopted RT PCR methodology was efficient considering that 32 out of 33 isolates tested positive after a single run. This result could be due to the introduction of the DNA extraction kit that enabled extraction of pure DNA, unlike the case of crude DNA extraction when the method described by Schelderman *et al.* (2002) was used. The high number of false negative results after a single run using the PCR detection agarose gel electrophoresis was a result of the crude DNA extracts which contained impurities that might have interfered with the PCR reaction. Impurities in the crude DNA might also have hampered the accurate quantification of the crude DNA. The presence of an inappropriate amount of genomic DNA in the reaction mixture can result in the replication of the wrong segment or abort the PCR reaction (Roux, 1995).

In addition, the detection method of the RT PCR with SYBR Green is internalised and is more robust and less labour intensive than the agarose gel electrophoresis detection method. The fluctuation of the  $T_m$  between 86–87 °C could be attributed to minor variations in the nucleotide sequences within the amplified segment of the 16S rRNA gene. A similar fluctuation was observed in a study involving the melting curve analysis for the identification of *Plum poxvirus* strains (Varga & James, 2005).

Herman *et al.* (2000) used REP-PCR combined with non-denaturing separation in polyacrylamide gel to analyse 37 *B. sporothermodurans* strains. This technique offers a very powerful tool to discriminate between species and strain of *B. sporothermodurans* and other *Bacillus* spp. The PCR detection technique used in this research can be used in combination with the REP-PCR molecular typing to study the contamination route of *B. sporothermodurans* in raw and heated milk as well as on farms. When comparing the different PCR methods utilised for the identification of *B. sporothermodurans*, it can be concluded that RT PCR with SYBR Green was quicker and less labour intensive than other methods.

The spore counts of the contaminated UHT milk from the retail level and from the end of the processing line and without prior incubation, could barely reach detectable levels because most of the vegetative cells of *B. sporothermodurans* had not yet undergone sporulation or, if already sporulated, could not survive the 95 °C for 30 min heating. Considering that the resistance of spores of a *Bacillus* spp. have been linked to the different stages in spore development, the older the spore the higher the resistance to heat (Knott *et al.*, 1995).

UHT treatment at 140 °C for 4s in this research was severe enough to completely inactivate broth cultures of *B. sporothermodurans*. This finding is contrary to the finding of Huemer *et al.* (1998) where spores of *B. sporothermodurans* were found to be more resistant at temperatures above 130 °C. However, Huemer's finding was on *B. sporothermodurans* spores that were harvested from a 7-day-old ONA<sup>+</sup> agar plate culture. The 24h *B. sporothermodurans* culture used in this study could only possibly have contained spores that were older than 24h and mature enough to display high heat resistance (Knott *et al.*, 1995). It should be recalled that the aim of this research was to find out if the spores present in broth cultures for not more than 24h could acquire heat-induced resistance after reprocessing.

In an experiment conducted to determine the thermokinetics of *B. sporothermodurans* spores, Huemer *et al.* (1998) found that *B. sporothermodurans* spores have heat resistance comparable to that of *B. stearothermophilus* and *B. subtilis* within the 110–125 °C temperature range. On the other hand, they also discovered that *B. sporothermodurans* exhibited an extremely high heat resistance within the 130–145 °C temperature range. The spores used in that thermokinetic study were from *B. sporothermodurans* cultures that were cultured on ONA<sup>+</sup> agar plate for seven days at 37 °C or 55 °C.

Chilling rendered *B. sporothermodurans* spores susceptible to UHT treatment when compared to spores that were not subjected to chilling prior to UHT treatment. This result is in agreement with research conducted by Movahedi and Waites (2002) in which *Bacillus subtilis* spores were found to be susceptible to temperatures above

100 °C, but not to an increase in heat resistance observed at temperatures between 85–90 °C. Movahedi and Waites (2002) did not elucidate on the mechanism through which chilling followed by heating affects the components of *Bacillus subtilis* spores to make them more susceptible to high temperatures. Until now, no work has been done to determine the effects of chilling at 85–90 °C on the heat resistance of spores of *B. sporothermodurans* and what effect this has on the UHT processing of milk contaminated with *B. sporothermodurans* spores. Such findings could be used to modify processing technology so that spores may be inactivated by a relatively less severe heat treatment.

It is logical to determine the effect of H<sub>2</sub>O<sub>2</sub> on spores of *B. sporothermodurans* considering that it is one of the most widely used disinfectants for sanitising UHT milk packaging materials. The significant differences in the survival counts of the spores observed during the different exposure time intervals was due to the effectiveness of the sporicidal activity of 30% H<sub>2</sub>O<sub>2</sub> which increases with increasing incubation times (Toledo *et al.*, 1973). The inactivation of *B. sporothermodurans* spores followed a first order kinetic with a D<sub>30%</sub> value of 3.33 min indicating that 30% H<sub>2</sub>O<sub>2</sub> concentration can be used as a sterilising agent to disinfect packages for UHT treated milk contaminated with *B. sporothermodurans* spores. For this to be effective, treatment with 30% H<sub>2</sub>O<sub>2</sub> should be followed by the application of hot air (Khadre & Yousef, 2001). The sporicidal properties of H<sub>2</sub>O<sub>2</sub> have been well documented by many authors. Conversely, the exact mechanism of spore inactivation has not been determined (Melly *et al.*, 2002).

### **5.3 EFFECTS OF WET HEAT TREATMENT ON THE STRUCTURAL AND CHEMICAL COMPONENTS OF *BACILLUS SPOROTHERMODURANS* SPORES**

In this research, spores of *B. sporothermodurans* were found to have compact cores and a relatively large cortex, which is in agreement with previous findings (Scheldeman *et al.*, 2006). The release of protein (µg/ml) from heated spores was significantly ( $p \leq 0.05$ ) different between the two isolates. This could be attributed to

structural difference in protein composition within the spores of the different *B. sporothermodurans* isolates. The composition of the exosporium and coat structures of *Bacillus* spores has been found to be species and strain specific (Henriques & Moran, 2007). On the other hand, the release of DPA across the heating times was not significantly different between the two strains. This is in agreement with similarities observed in the inactivation pattern and structural damage of both strains at different heating times.

From the TEM, spores began losing their structural components after 4 min of heating. The cortical membrane was the area first affected by wet heat and had the first visible signs of structural damage. The reason for this early damage is due to the washing away of peptidoglycan materials that are the main constituent of the cortex (Setlow, 2006). At this time, heat must have penetrated the spore layers into the spore core resulting in the release of more protein than DPA. This finding is in agreement with previous findings in which the DPA release from heated *Bacillus subtilis* spores was accompanied by a large amount of protein release (Coleman *et al.*, 2007).

The fact that a small proportion of spores did not show visible structural damage after 4 min of heating could be that damage is not acquired at the same rate by all spores. This is in agreement with findings of a similar study in which *B. stearothermophilus* spores had been inactivated at different rates following heating at UHT temperatures (Feeherry *et al.*, 1987).

The majority of spores were inactivated after 4 min of heating during which the amount of DPA released was very small. This result is in agreement with findings in which the rate of DPA release was found to be slower than the rate of spore death following heating at UHT temperature (Mallidis & Scholefield, 1985). The appearance of DPA was a clear sign of a breach in the protective barrier of spores following wet heat treatment and marks the onset of spore inactivation. More research is needed to determine the exact amount of DPA to be released for inactivation to take place.

By 12 min there was complete destruction of spore components with the cortex almost entirely washed off leaving behind a reduced and less dense spore core surrounded by loosely attached coat and surface layers. This is due to the total destruction of spores after prolonged heating which results in the flushing out of a considerable amount of soluble protein from spores. This is explained by the levelling off of protein release between the 8th and the 12th min of heating. Contrary to soluble protein release, the amount DPA released at this stage did not level off. DPA is located exclusively in the spore core, the last area in which visible structural damage was detected during the entire heating time as seen on the TEM.

By integrating the TEM, protein and DPA analyses, the mechanism of *B. sporothermodurans* spore inactivation over time can be summarised as follows: heat penetrates into the spore core; hot moisture follows and rehydrates the spore; spore structures are destroyed; massive inactivation of spores occur (small amounts of DPA escape); finally, total inactivation of spores occurs (large amounts of DPA escape). The release of soluble protein levels off while the DPA release rises until there is complete spore destruction.

Bacteria spores following heat treatment often die as a result of injury acquired during heating. These injuries often lead to the inability of spores to germinate in the vegetative cells. However, bacterial spores can recover from their heat injury. The recovery time differs among individual spores with some taking longer than others (Speck & Busta, 1968). This phenomenon is of major concern considering that quality control testing procedures do not take into account any injured spores with a longer recovery duration. In this research, injured spores that took long to germinate were accounted for by incubating BHI agar plates for up to one week.

#### **5.4 PROPOSALS FOR FUTURE RESEARCH**

For rapid identification and quantification more research needs to be conducted on *B. sporothermodurans*. Such techniques should be able to detect and quantify *B. sporothermodurans* in milk samples without culturing. Such techniques should be

simple in order to be incorporated easily into an automated system. It should be mentioned that current detection techniques involve culturing and isolation of suspected colonies before identification.

More research needs to be done to determine the effect of recontamination during processing using large volumes of milk. This research used broth cultures. Similarly, it would be interesting to determine the response of *B. sporothermodurans* to UHT processing with larger percentage recontamination. Only 10% recontamination was used in this study.

Based on findings in this research, spore death occurs after hot moisture has breached the structural barrier of spores and gained entry to the spore's core. In this regard, more research should be conducted to identify various non-thermal methods to compromise the structural barrier of spore prior to UHT treatment. If this is achieved, technological processes could be modified in such a way that the inactivation of *B. sporothermodurans* would be achieved with a less severe heat treatment. In addition, further research could determine the possibility of activating and germinating spores in milk prior to UHT treatment, as this will also enable the inactivation of spores using a less severe heat treatment.

In this research, chilling was found to render *B. sporothermodurans* spores susceptible to UHT treatment at 130 °C. Further research should be conducted with spores in a large volume of milk using a pilot plant in order to ensure industrial application and also to ascertain how chilling prior to UHT treatment would affect the quality of the end product.

Further research needs to be conducted to determine the production of stress response protein within spores of *B. sporothermodurans* after having subjected the growing cell and spores to various types of stress considering that the production of spore protein is driven by morphogenetic factors in the mother cell (Henriques & Moran, 2007). Studies on the production of heat-shock protein will be of great interest considering the unusual thermokinetic properties of *B. sporothermodurans*.



The prospect of modifying processing parameters in order to enhance the inactivation of *B. sporothermodurans* spores with the application of a comparatively less severe heating should also be studied. The coupling of non-thermal processing techniques such as high-pressure and high-voltage pulse electric field processes that can cause some structural defect on spores prior to the application of heat treatment could be a solution. This idea is feasible considering that spore death is due to the movement of heat into the spore. Any method that accomplishes this compromises the structural integrity of spores and increases the severity of inactivation.

## CHAPTER 6: CONCLUSION AND RECOMMENDATIONS

*B. sporothermodurans* is present in UHT milk but the incidence is not extensive or widespread and the PCR detection protocol adopted for the RT PCR is effective in confirming *B. sporothermodurans*. Chilling renders *B. sporothermodurans* spores more susceptible to UHT treatment while the onset of DPA released during wet heat treatment coincides with visible signs of structural damage and significant inactivation of spores. Visible signs of spore structural damage emanate at different rates while the amount of protein release seems to be strain specific.

Further research should be conducted to explore the mechanism of spore destruction during wet heat treatment in order to provide a less severe heat treatment that will ensure the inactivation of spores without high-level thermally induced changes in UHT milk. Non-thermal techniques such as High Voltage Pulse Electric technology and High Pressure technology could be explored in this regard.

## CHAPTER 7: REFERENCES

- Abee, T. & Wouters, J.A. 1999. Microbial stress response in minimal processing. *International Journal of Food Microbiology* 50 (1–2), 65–91.
- Abraham, G., Debray, E., Candau, Y. & Piar, G. 1990. Mathematical model of thermal destruction of *Bacillus stearothermophilus* spores. *Applied Environmental Microbiology* 56 (10), 3073–3080.
- Andersson, A., Rönner, U. & Granum, P.E. 1995. What problems does the food industry have with the spore-forming pathogens *Bacillus cereus* and *Clostridium perfringens*? *International Journal of Food Microbiology* 28, 145–155.
- Andrews, J.M. 2004. BSAC standardized disc susceptibility testing method (version 3). *Journal of Antimicrobial Chemotherapy* 53, 713–28.
- Andrews, J.M. 2005. BSAC Working Party on Susceptibility Testing, BSAC standardized disc susceptibility testing method (version 4). *Journal of Antimicrobial Chemotherapy* 56 (1), 60–76.
- Ayele, W.Y., Svastova, P., Roubal, P., Bartos, M. & Pavlik, I. 2005. *Mycobacterium avium* subspecies *paratuberculosis* cultured from locally and commercially pasteurised cow's milk in the Czech Republic. *Journal of Applied and Environmental Microbiology* 71 (3), 1210–1214.
- Bansal, B. & Chen, X.D. 2006. A critical review of milk fouling in heat exchangers. *Comprehensive Reviews in Food Science and Food Safety* 5 (2), 27–33.
- Banykó, J. & Vyleťelová, M. 2008. Determining the source of *Bacillus cereus* and *Bacillus licheniformis* isolated from raw milk, pasteurised milk and yoghurt. *Letters in Applied Microbiology* 48 (3), 318–323.

- Bapat, P., Nandy, S.K., Wangikar, P. & Venkatesh, K.V. 2006. Quantification of metabolically active biomass using Methylene Blue dye Reduction Test (MBRT): Measurement of cfu in about 200s. *Journal of Microbiological Methods* 65(1), 107–116.
- Barbano, D.M., Ma, Y. & Santos, M.V. 2006. Influence of raw milk quality on fluid milk shelf life. *Journal of Dairy Science* 89 (E Suppl.), E15–E19.
- Barrett, N.J. 1986. Communicable disease associated with milk and dairy products in England and Wales: 1983–1984. *The Journal of Infection* 12 (3), 265–72.
- Beaman, T.C., Pankratz, H.S. & Gerhardt, P. 1988. Heat shock affects permeability and resistance of *Bacillus stearothermophilus* spores. *Journal of Applied Environmental Microbiology* 54, 2515–2520.
- Beloti, V., Barros, M.F., Nero, L.A., Pachemshy, J.A., de Santana, E.H.W., Bernadette, D.G.M. & Franco, B.D.G.M. 2002. Quality of pasteurised milk influences the performance of ready-to-use systems for enumeration of aerobic microorganisms. *International Dairy Journal* 12 (5), 413–418.
- Beuchat, L.R., Copeland, F., Curiale, M. S., Danisavich, T., Gangar, V., King, B.W., Lawlis, T.W., Likin, R.O., Okwusoa, J., Smith, C.F. & Townsend, D.E. 1998. Comparison of the SimPlate™ total plate count method with Petrifilm, Redigel and conventional pour plate methods for enumerating aerobic microorganisms in foods. *Journal of Food Protection* 61, 14–18.
- Birlouez-Aragon, I., Sabat, P. & Gouti, N. 2002. A new method for discriminating milk heat treatment. *International Dairy Journal* 12 (1), 59–67.
- Bradford, M.M. 1976. A rapid and sensitive method for the quantitation of microgram quantities of protein utilizing the principle of protein-dye binding. *Analytical Biochemistry* 72, 248–254.

- Brown, K.L., 2000. Control of bacterial spores, *British Medical Bulletin* 56 (1), 158–171.
- Burgess, K., Heggum, C., Walker, S. & Van Schothorst, M. 1994. *Bulletin of the IDF* 292, 12–19.
- Buyser, M.L.D., Dufour, B., Maire, M. & Lafarge, V. 2001. Implication of milk and milk products in food-borne diseases in France and in different industrialised countries. *International Journal of Food Microbiology* 67 (1–2), 1–17.
- Byrne, R.D. & Bishop, J.R. 2001. Control of microorganisms in the dairy processing: Dairy product safety systems. In: Marth, E.H. & Steele, J.L. (eds), *Applied Dairy Microbiology*. New York: Marcel Dekker.
- Christiansson, A., Naidu, A.S., Nilsson, I., Wadstrom, T. & Pettersson E.H. 1989. Toxin production by *Bacillus cereus* dairy isolates in milk at low temperatures. *Journal of Applied and Environmental Microbiology* 55 (10), 2595–2600.
- Claeys, W.L., Ludikhuyze, L.R. & Hendrickx, M.E. 2001. Formation kinetics of hydroxymethylfurfural, lactulose and furosine in milk heated under isothermal and non-isothermal conditions. *Journal of Dairy Research* 68, 287–301.
- Codex Committee on Milk and Milk Products, joint FAO/WHO food standards programme codex committee on milk and milk products. Fourth Session Wellington, New Zealand, 28 February–3 March 2000. Accessed at <http://www.fao.org/docrep/meeting/005/x4888e/x4888e00.htm> on 8 April 2010.
- Coetzee, K. & Maree, D. 2009. Lactodata-statistics: A Milk South Africa publication compiled by the Milk Producers' Organisation. *Lactodata*, 12 (1), 1–7. Accessed at, <http://www.dairyconnect.co.za/dairyMail/lactodata.pdf>, on 19 February 2010.

- Coleman, W.H., Chen, D., Li, Y.Q., Cowan, A.E. & Setlow, P. 2007. How moist heat kills spores of *Bacillus subtilis*. *Journal of Bacteriology* 189, 8458–8466
- Condon, S., Bayarte, M. & Sala, F.J., 1992. Influence of the sporulation temperature upon the heat resistance of *Bacillus subtilis*. *Journal of Applied Bacteriology* 73 (3), 251–256.
- Council Directive 85/397/EEC, 1985 Health and animal health problems affecting intra-community trade in heat-treated milk. *Official Journal of the European Community* No. L226:13–29 of 24.08.1985.
- Cousin, C.M. & Bramley, A.J. 1981. The microbiological quality of raw milk. In: *Dairy Microbiology Volume 1*. Robinson, R.K. (ed.) London: Applied Science Publisher.
- Crielly, E.M., Logan, N.A. & Anderton, A. 1994. Studies on the *Bacillus* flora of milk and milk products. *Journal of Applied Bacteriology* 77, 256–263.
- Datta, N. & Deeth, H.C. 2001. Age gelation of UHT milk: A review. *Food and Bioproducts Processing* 79 (4), 197–210.
- Elliott, A.J., Datta, N., Amenu, B. & Deeth, H.C. 2005. Heat-induced and other chemical changes in commercial UHT milks. *Journal of Dairy Research* 72, 442–446.
- Eneroth, Å., Christiansson, A., Brendehaug, J. & Molin, G. 1998. Critical contamination sites in the production line of pasteurised milk, with reference to the psychrotrophic spoilage flora. *International Dairy Journal* 8, 829–834.
- Enright, E., Bland, A.P., Needs, E.C. & Kelly A.L. 1999. Proteolysis and physicochemical changes in milk on storage as affected by UHT treatment, plasmin activity and KIO<sub>3</sub> addition. *International Dairy Journal* 9 (9), 581–591.

- Etoa, F.X. & Michiels, L. 1988. Heat-induced resistance of *Bacillus stearotherophilus* spores. *Letters in Applied Microbiology* 6 (3), 43–45.
- Feeherry, F.E., Munsey, D.T. & Rowley, D. B. 1987. Thermal inactivation and injury of *Bacillus stearotherophilus* spores. *Journal of Applied and Environmental Microbiology* 53, 365–370.
- Flint, S., Walker, K., Waters, B. & Crawford R. 2007. Description and validation of a rapid (1h) flow cytometry test for enumerating thermophilic bacteria in milk powders. *Journal of Applied Microbiology* 102 (4), 909–915.
- Franciosa, G., Pourshaban, M., Gianfranceschi, M., Gattuso, A., Fenicia, L., Ferrini, A.M., Mannoni, V., De Luca, G. & Aureli, P. 1999. *Clostridium botulinum* spores and toxin in mascarpone cheese and other milk products. *Journal of Food Protection* 62 (8), 867–871.
- Francis, A.J., Nimmo, G.R. Efstratiou, A. Galanis, V. & Nuttall, N. 1993. Investigation of milk-borne *Streptococcus zooepidemicus* infection associated with glomerulonephritis in Australia. *Journal of Infection* 27 (3), 317–23.
- García, M.C., Rodríguez, M.J., Bernardo, A., Tornadijo, M.E. & Carballo, J. 2002. Study of enterococci and micrococci isolated throughout manufacture and ripening of San Simón cheese. *Journal of Food Microbiology* 19 (1), 23–33.
- García-Cayuela, T., Tabasco, R., Peláez, C. & Requena, T. 2009. Simultaneous detection and enumeration of viable lactic acid bacteria and bifidobacteria in fermented milk by using propidium monoazide and real-time PCR. *International Dairy Journal* 19 (6–7), 405–409.
- Gillespie, B.E., Jayarao, B.M. & Oliver S.P. 1997. Identification of *Streptococcus* species by randomly amplified polymorphic deoxyribonucleic acid fingerprinting. *Journal of Dairy Science* 80 (3), 471–476.

- Gonzalez, I., Lopez, M., Mazas, M., Gonzalez, J. & Bernardo, A. 1995. The effect of recovery conditions on the apparent heat resistance of *Bacillus cereus* spores. *Journal of Applied Microbiology* 78 (5), 548–554.
- Granum, P.E. & Lund, T. 1997. *Bacillus cereus* and its food poisoning toxins. *FEMS Microbiology Letters* 157 (2), 223–228.
- Griffin, P.M. & Tauxe, R.V. 1991. The epidemiology of infections caused by *Escherichia coli* O157:H7, other enterohemorrhagic *E. coli*, and the associated hemolytic uremic syndrome. *Epidemiologic Reviews* 13, 60–98.
- Grijpsperdt, K., Mortier, L., Block, J.D & Van Renterghem, R. 2004. Applications of modelling to optimise ultra high temperature milk heat exchangers with respect to fouling. *Journal of Food Control* 15 (2), 117–130.
- Guillaume-Gentile, O., Scheldeman, P., Marugg, J., Herman, L., Joosten, H. & Heyndrickx, M. 2002. Genetic heterogeneity in *Bacillus sporothermodurans* as demonstrated by ribotyping and repetitive extragenic palindromic-PCR fingerprinting. *Journal of Applied and Environmental Microbiology* 68 (9), 4216–4224.
- Gunasekera, T.S., Attfield, P.V. & Veal, D.A. 2000. A flow cytometry method for rapid detection and enumeration of total bacteria in milk. *Journal of Applied and Environmental Microbiology* 66 (3), 1228–1232.
- Hamdy, M.E.R. & Amin, A.S. 2002. Detection of *Brucella* species in the milk of infected cattle, sheep, goats and camels by PCR. *The Veterinary Journal* 163 (3), 299–305.
- Hammer, P., Lembke, F., Suhren, D. & Heeschen, W. 1995. Characterisation of heat resistant mesophilic *Bacillus* species affecting quality of UHT milk: A preliminary report. *Kieler Milchwirtschaftliche Forschungsberichte* 47 (4), 303–311.



- Hathout, Y., Setlow, B., Cabrera-Martinez, R.M., Fenselau, C. & Setlow P. 2003. Small acid-soluble proteins as biomarkers in mass spectrometry analysis of *Bacillus* spores. *Journal of Applied and Environmental Microbiology* 69, 1100–1107.
- Hayes, M.C. & Boor, K. 2001. Raw milk and fluid milk product products. In Marth, E.H. & Steele J.L. (eds), *Applied Dairy Microbiology*. New York: Marcel Dekker.
- Hayes, M.C., Feeley, J.C, Graves, L.M, Ajello, G.W & Fleming, D.W., 1986. Isolation of *Listeria monocytogenes* from milk. *Journal of Applied and Environmental Microbiology* 51, 438-440.
- Henriques, A.O. & Moran, C.P. Jr. 2007. Structure, assembly, and function of the spore surface layers. *Annual Review of Microbiology* 61, 555–588.
- Herman, L. & Heyndrickx, M. 2000. The presence of intragenically located REP-like elements in *Bacillus sporothermodurans* is sufficient for REP-PCR typing. *Research in Microbiology* 151 (4), 255–261.
- Herman, L., Vaerewijck, M., Moermans, R. & Waes, G. 1997. Identification and detection of *Bacillus sporothermodurans* spores in 1, 10 and 100 millilitres of raw milk by PCR. *Applied and Environmental Microbiology* 63 (8), 139–3143.
- Hill, C., Cotter, P.D., Sleator, R.D. & Gahan, C.G.M. 2002. Bacterial stress response in *Listeria monocytogenes*: jumping the hurdles imposed by minimal processing. *International Dairy Journal* 12, 273–283.
- Huck, J.R., Sonnen, M. & Boor, K.J. 2008. Tracking heat-resistant, cold-thriving fluid milk spoilage bacteria from farm to packaged product. *Journal of Dairy Science* 91 (3), 1218–1228.

- Huemer, I.A., Klijn N., Vogelsang, H.W.J. & Langeveld, L.P.M. 1998. Thermal death kinetics of spores of *Bacillus sporothermodurans* isolated from UHT milk. *International Dairy Journal* 8, 851–855.
- Jayarao, B.M., Donaldson, S.C., Straley, B.A., Sawant, A.A., Hegde, N.V. & Brown, J.L. 2006. A survey of foodborne pathogens in bulk tank milk and raw milk consumption among farm families in Pennsylvania. *Journal of Dairy Science* 89, 2451–2458.
- Jayarao, B.M. & Henning, D.R., 2001. Prevalence of foodborne pathogens in bulk tank milk. *Journal of Dairy Science*, 81, 2157-2162.
- Juneja, V.K., Snyder, Jr. O.P. & Marmer, B.S., 1997. Thermal destruction of *Escherichia coli* 0157:H7 in beef and chicken: determination of D and Z-values. *International Journal of Food Microbiology* 35930, 231–237.
- Kazwala, R.R., Daborn, C.J., Kusiluka, L.J.M., Jiwa, S.F.H., Sharp, J.M. & Kambarage, D.M. 1998. Isolation of *Mycobacterium* species from raw milk of pastoral cattle of the Southern Highlands of Tanzania. *Tropical Animal Health and Production* 30 (4), 1573–7438.
- Kessler, H.G., 1981. *Food Engineering and Dairy Technology*. Verlag A. Kessler, Freising, Germany.
- Khadre, M.A. & Yousef, A.E. 2001. Sporicidal action of ozone and hydrogen peroxide: a comparative study. *International Journal of Food Microbiology* 71 (2–3), 131–138.
- Kim, S.G., Kim, E.H., Lafferty, C.J. & Dubovi, E. 2005. *Coxiella burnetii* in bulk tank milk samples, United States. *Emerging Infectious Diseases* 11 (4), 619–21.

- Klijn, N., Herman, L., Langeveld, L., Vaerewijck, M., Wagendorp, A.A, Huemer, I. & Weerkamp, A. 1997. Genotypical and phenotypical characterisation of *Bacillus sporothermodurans* strains surviving UHT sterilization. *International Dairy Journal* 7, 421–428.
- Knott, A.G., Russell, A.D. & Dancer, B.N. 1995. Development of resistance to biocides during sporulation of *Bacillus subtilis*. *Journal of Applied Bacteriology* 79 (5), 492–498.
- Kuwana, R., Kasahara, Y., Fujibayashi, M., Takamatsu, H., Ogasawara, N. & Watabe, K. 2002. Proteomics characterization of novel spore proteins of *Bacillus subtilis*. *Microbiology* 148, 3971–3982.
- Lafarge, V., Ogier, J.C., Girard, V., Maladen, V., Leveau, J.Y., Gruss, A. & Delacroix-Buchet, A. 2004. Raw cow milk bacterial population shifts attributable to refrigeration. *Journal of Applied and Environmental Microbiology* 70 (9), 5644–5650.
- Leedom, J.M. 2006. Milk of non-human origin and infectious diseases in humans. *Clinical Infectious Diseases* 43, 610–615.
- Leguérinel, I., Couvert, O. & Mafart, P. 2007. Modelling the influence of the sporulation temperature upon the bacterial spore heat resistance, application to heating process calculation. *International Journal of Food Microbiology* 114 (1), 100–104.
- Lewis, M. & Heppel, N. 2000. *Continuous thermal processes*. USA: Aspen.
- Lewis, M.J. 1986. Advances in heat treatment of milk. In: *Modern Dairy Technology Volume 1*. Robinson R.K. (ed.). London: Applied Science Publisher.

- Mafart, P., Couvert, O., Gaillard, S. & Lequerinel, I. 2002. On calculating sterility in thermal preservation methods: application of the Weibull frequency distribution model. *International Journal of Food Microbiology* 72(1-2), 107-113.
- Mallidis, G. & Scholefield, J. 1985. The release of dipicolinic acid during heating and its relation to the heat destruction of *Bacillus stearothermophilus* spores. *Journal of Applied Bacteriology* 59, 479-486.
- Manzano, S., Ordoez, J.A., De La Hoz, L. & Fernandez, M. 2005. A rapid method for the estimation of the microbiological quality of refrigerated raw milk based on the aminopeptidase activity of Gram-negative bacteria. *International Dairy Journal* 15 (1), 79-84.
- Melly, E., Genest, P.C., Gilmore, M.E., Little, S., Popham, D.L., Driks, A. & Setlow, P. 2002. Analysis of the properties of spores of *Bacillus subtilis* prepared at different temperatures. *Journal of Applied Microbiology* 92, 1105-1115.
- Montanari, G., Borsari, A., Chiavari, C., Ferri, G., Zambonelli, C. & Grazia, L. 2004. Morphological and phenotypical characterization of *Bacillus sporothermodurans*. *Journal of Applied Microbiology* 97 (4), 802-809.
- Moran, L., Rowe, M.T. & Gilmour, A. 1991. Evaluation of a direct epifluorescent filter technique (DEFT) for the enumeration of bacterial spores in raw milk. *International Dairy Journal* 1 (4), 253-261.
- Movahedi, S. & Waites, W. 2002. Cold shock response in sporulating *Bacillus subtilis* and its effect on spore heat resistance. *Journal of Bacteriology* 184 (19), 5275-5281.
- Muir, D.D. 2007. The shelf life of dairy products: Raw milk and fresh products. *International Journal of Dairy Technology* 49 (2), 44-48.

- Nicholson, W.L., Munakata, N., Horneck, G., Melosh, H.J. & Setlow, P. 2000. Resistance of *Bacillus* endospores to extreme terrestrial and extra-terrestrial environments. *Microbiology and Molecular Biology Reviews* 64 (3), 548–572.
- Nocker, A., Cheung, C.Y. & Camper, A.K. 2006. Comparison of propidium monoazide with ethidium monoazide for differentiation of live vs. dead bacteria by selective removal of DNA from dead cells. *Journal of Microbiology Methods* 67 (2), 310–320.
- Paidhungat, M., Setlow, B., Driks, A. & Setlow, P. 2000. Characterization of spores of *Bacillus subtilis* which lack dipicolinic acid. *Journal of Bacteriology* 182, 5505–5512.
- Pettersson, B., Lembke, F., Hammer, P., Stackebrandt, E. & Priest, F.G. 1996. *Bacillus sporothermodurans*, a new species producing highly heat-resistant endospores. *International Journal of Systemic Bacteriology* 46, 759–764.
- Pirttijärvi, T.S.M., Andersson, M.A. & Salkinoja-Salonen, M.S. 2000. Properties of *Bacillus cereus* and other bacilli contaminating biomaterial-based industrial processes. *International Journal of Food Microbiology* 60 (2–3), 231–239.
- Rai, A.K., Chakravorty, R. & Paul, J. 2008. Detection of *Giardia*, *Entamoeba* & *Cryptosporidium* in unprocessed food items from northern India. *World Journal of Microbiology and Biotechnology* 24 (12), 2879–2887.
- Regulations relating to milk and dairy products. 1997. South African Government Notice No. R. 1555 of 21 November 1997. The Minister of Health in terms of section 15(1) of the Foodstuffs, Cosmetics and Disinfectants Act, 1972 (Act No. 54 of 1972). Accessed on 5 March 2010 at <http://www.doh.gov.za/docs/regulations/foodstuff/milk-dairy.pdf>
- Roux, K.H. 1995. Optimization and troubleshooting in PCR. *PCR Methods and Applications* 4 (5), 85–94.

- Ruecket, A., Ronimus, R.S & Morgan, H.W. 2005. Rapid differentiation and enumeration of total, viable vegetative cell and spore content of thermophilic bacilli in milk powder with reference to *Anoxybacillus flavithermus*. *Journal of Applied Microbiology* 99(5), 1246–1255.
- Rysstad, G. & Kolstad, J. 2006. Extended shelf life of milk: Advances in technology. *International Journal of Dairy Technology* 59 (2), 85–96.
- Salkinoja-Salonen, M.S., Vuorio, R., Andersson, M.A., Kämpfer, P., Andersson, M.C., Honkanen-Buzalski, T. & Scoging, A.C. 1999. Toxigenic strains of *Bacillus licheniformis* related to food poisoning. *Journal of Applied and Environmental Microbiology* 65, 4637–4645.
- Samaras, F.I., Kehagias, C., Arkoudelos, J.S. & Bocaris, M.I. 2003. Investigation on ropiness development by isolates of the genera *Lactobacillus*, *Alcaligenes* and Feta cheese starter cultures. *Journal of Food Microbiology* 20 (5), 503–509.
- Sandrou, D.K. & Arvanitoyannis, I.S. 2000. Implementation of hazard analysis critical control point (HACCP) to the dairy industry: current status and perspectives. *Food Reviews International* 16 (1), 77–111.
- Scheldeman, P., Goossens, K., Rodríguez-Díaz, M., Pil, A., Goris, J., Herman, L., De Vos, P., Logan, N.A. & Heyndrickx, M. 2004. *Paenibacillus lactis* sp. nov., isolated from raw and heat-treated milk. *International Journal of Systemic and Evolutionary Microbiology* 54, 885–891.
- Scheldeman, P., Herman L., Foster, S.M. & Heyndrickx, M. 2006. *Bacillus sporothermodurans* and other highly heat-resistant spore formers in milk. *Journal of Applied Microbiology* 101 (3), 542–555.
- Scheldeman, P., Herman, L., Goris, J., De Vos, P. & Heyndrickx, M. 2002. Polymerase chain reaction identification of *Bacillus sporothermodurans* from dairy sources. *Journal of Applied Microbiology* 92 (5), 983–991.

- Scheldeman, P., Pil, A., Herman, L., De Vos, P. & Heyndrickx, M. 2005. Incidence and diversity of potentially highly heat-resistant spores isolated at dairy farms. *Journal of Applied and Environmental Microbiology* 71 (3), 1480–1494.
- Setlow, P. 2000. Resistance of bacterial spores. In: Storz, G., Hengge-Aronis, R. (eds). *Bacterial Stress Responses*. Washington DC: American Society of Microbiology.
- Setlow, P. 2006. Spores of *Bacillus subtilis*: Their resistance to and killing by radiation, heat and chemicals. *Journal of Applied Microbiology* 101, 514–525.
- Siragusa, G.R. & Cutter, C.N. 1995. Microbial ATP bioluminescence as a means to detect contamination on artificially contaminated beef carcass tissue. *Journal of Food Protection* 58 (7), 764–769.
- Slaghuis, B.A., Te Giffel, M.C., Beumer, R.R. & André, G. 1997. Effect of pasturing on the incidence of *Bacillus cereus* spores in raw milk. *International Dairy Journal* 7 (4), 201–205.
- Speck, M.L. & Busta, F.F. 1968. Sterilization and aseptic packaging of milk products-microbiological trend. *Journal of Dairy Science* 1 (7), 1146–1151.
- Sørhaug, T. & Stepaniak, L. 1997. Psychrotrophs and their enzymes in milk and dairy products: Quality aspects. *Trends in Food Science and Technology* 8 (2), 35–41.
- Svensson, B., Eneroth, Å., Brendehaug, J., Molin, G. & Christiansson, C. 2000. Involvement of a pasteuriser in the contamination of milk by *Bacillus cereus* in a commercial dairy plant. *Journal of Dairy Research* 67 (3), 455–460.
- Swartzel, K.R. 2007. The role of heat exchanger fouling in the formation of sediment in aseptically processed and packaged milk. *Journal of Food Processing and Preservation* 7(4), 247–257.

- Takeno, S., Ohnishi, J., Komatsu, T., Masaki, T., Sen, K. & Ikeda, M. 2007. Anaerobic growth and potential for amino acid production by nitrate respiration in *Corynebacterium glutamicum*. *Applied Microbiology and Biotechnology* 75, 1173–1182.
- Te Giffel, M.C., Wagendorp, A., Herrewegh, A. & Driehuis, F. 2002. Bacterial spores in silage and raw milk. *Antonie van Leeuwenhoek, International Journal of General and Molecular Microbiology* 81 (1-4), 625-630.
- Teofila, C.B., Pankratz, H.S. & Gerhardt, P. 1998. Heat shock affects permeability and resistance of *Bacillus stearothermophilus* Spores. *Journal of Applied and Environmental Microbiology* 54 (10), 2515–2520.
- Tetra Pak Dairy Index: A biannual news and information source about the dairy industry. Issue 1-June 2009. Accessed on 19 February 2010 at [http://www.tetrapak.com/Document%20Bank/Food\\_categories/Tetra\\_Pak\\_Dairy\\_Index\\_2009\\_1.pdf](http://www.tetrapak.com/Document%20Bank/Food_categories/Tetra_Pak_Dairy_Index_2009_1.pdf).
- Toledo, R.T., Escher, F.E. & Ayres J.C. 1973. Sporicidal properties of hydrogen peroxide against food spoilage organisms, *Journal of Applied Microbiology* 26 (4), 592–597.
- Tomasula, P.M., Kozempel, M.F., Konstance, R.P., Gregg, D., Boettcher, S., Baxt, B. & Rodríguez, L.L. 2007. Thermal inactivation of foot-and-mouth disease virus in milk using high-temperature, short time pasteurisation. *Journal of Dairy Science* 90, 3202–3211.
- Topçu, A., Numanoğlu, E. & Saldamli, I. 2006. Proteolysis and storage stability of UHT milk produced in Turkey. *International Dairy Journal* 16 (6), 633–638.



- Vaerewijck, M.J.M., De Vos, P., Lebbe, L., Scheldeman, P., Hoste, B. & Heyndrickx, M. 2001. Occurrence of *Bacillus sporothermodurans* and other aerobic spore-forming species in feed concentrate for dairy cattle. *Journal of Applied Microbiology*, 91 (6), 1074–1084.
- Vail, J.H., Morgan, R., Merino, C.R., Gonzales, F., Miller, R. & Ram, J.L. 2003. Enumeration of waterborne *Escherichia coli* with Petrifilm plates. *Journal of Environmental Quality* 32 (1), 368–373.
- Van Boekel, M.A.J.S. 1998. Effect of heating on Maillard reactions in milk. *Food Chemistry* 62 (4), 403–414.
- Van der Merwe, C.F. & Coetzee, J. 1992. Quetol 651 for general use: A revised formulation. *Electronic Microscopy Society of Southern Africa* 22, 31–32.
- Van Schaik, W. & Abee, T. 2005. The role of  $\sigma$ B in the stress response of Gram-positive bacteria – targets for food preservation and safety. *Current Opinion in Biotechnology* 16 (2), 218 – 224.
- Varga, A. & James, D. 2005. Real-time RT-PCR and SYBR Green I melting curve analysis for the identification of *Plum poxvirus* strains C, EA, and W: Effect of amplicon size, melt rate, and dye translocation. *Journal of Virological Methods* 132 (1-2), 146–153.
- Warth, A.D. 1979. Liquid chromatographic determination of dipicolinic acid from bacterial spores. *Journal of Applied and Environmental Microbiology* 38, 1029–1033.
- Warth, A.D. 1980. Heat stability of *Bacillus cereus* enzymes within spores and in extracts. *Journal of Bacteriology* 143, 27–34.
- Wouters, J.T.M., Ayad, E.H.E., Hugenholtz, J. & Smit, G. 2002. Microbes from raw milk for fermented dairy products. *International Dairy Journal* 12(3), 91–109.

- Yazdankhah, S.P., Sørum, H., Larsen, H.J.S. & Gogstad, G. 2001. Rapid method for detection of gram-positive and -negative bacteria in milk from cows with moderate or severe clinical mastitis. *Journal of Clinical Microbiology* 39, 3228–3233.
- Yoo, J.A., Hardin, M.T. & Chen, X.D. 2006. The influence of milk composition on the growth of *Bacillus stearothermophilus*. *Journal of Food Engineering* 77(1), 96–102.