

WILDLIFE RESEARCH & REHABILITATION FACILITY

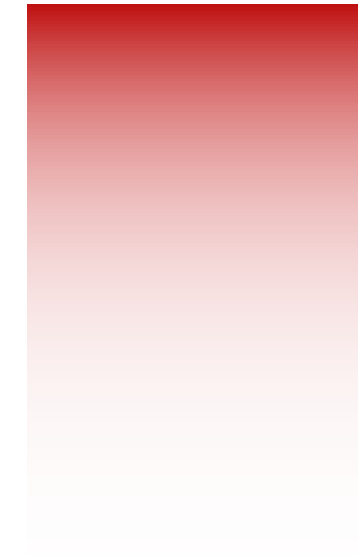

SUBMITTED AS PART OF THE REQUIREMENTS FOR THE DEGREE MAGISTER IN
INTERIOR ARCHITECTURE (PROFESSIONAL) IN THE FACULTY OF ENGINEERING,
BUILT ENVIRONMENT AND INFORMATION TECHNOLOGY

UNIVERSITY OF PRETORIA
DEPARTMENT OF ARCHITECTURE

NOVEMBER 2004

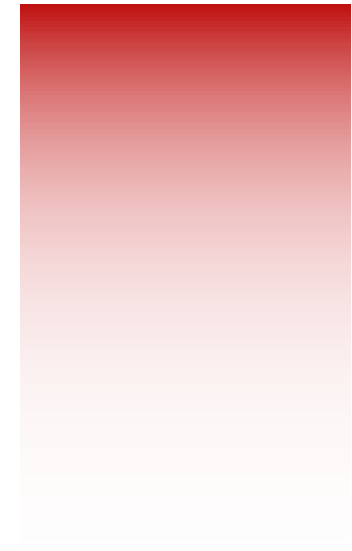

THE PURPOSE OF THIS PROJECT IS TO EVOKE A SENSE OF **TIME** AND **PLACE** IN DESIGN. IT IS AN INVESTIGATION OF THE **DYNAMIC** THAT DEVELOPS BETWEEN **OLD** ARCHITECTURE AND A **CONTEMPORARY** APPROACH IN REFURBISHMENT, AS WELL AS THE **RELATIONSHIP** THAT EXISTS BETWEEN **HUMAN** CREATION AND **NATURAL** CONDITION. THE DESIGN DRAWS ON THE **NEEDS** OF HUMANS AND WILDLIFE AS **GENERATORS OF SPACE**.



TABLE OF CONTENTS



LIST OF FIGURES	V
LIST OF APPENDICES	IX
BRIEFING DOCUMENT	001
INTRODUCTION - a real world problem	002
CLIENT - abstract	002
CONTRACT AGREEMENT - a legal context	002
THESIS - problem statement	003
PROJECT BRIEF - design of a wildlife research and rehabilitation centre	003
FACILITIES AND SERVICES	
RESEARCH	
REHABILITATION AND BREEDING	
STUDENT TRAINING AND EDUCATION	
PUBLIC SECTOR AND FUND GENERATION	
BASIC SERVICES AND FACILITIES	
COMMERCIALISING AND ADVERTISING	
SITE - selection	004
CONTEXT STUDY	005
CLIENT - University of Pretoria	006
UNIVERSITY OF PRETORIA - involved parties	006
FACULTY OF NATURAL AND AGRICULTURAL SCIENCES	
DEPARTMENT OF ZOOLOGY	
DEPARTMENT OF ANIMAL AND WILDLIFE SCIENCES – <i>Centre for Wildlife Management</i>	
FACULTY OF VETERINARY SCIENCE	
DEPARTMENT OF ANATOMY AND PHYSIOLOGY	
DEPARTMENT OF PARACLINICAL SCIENCES	
DEPARTMENT OF VETERINARY TROPICAL DISEASES	
VETERINARY WILDLIFE UNIT	
VETERINARY ACADEMIC HOSPITAL	
ANIMAL CARE – surrounding facilities	008
WILDLIFE – facilities in Gauteng	008
DOMESTIC – veterinarians and veterinary clinics	008
SITE - physical location	008
LOCATION - site within the Experimental Farm	009
SITE CHOICE	
SURROUNDING FACILITIES	
LOCATION - Experimental Farm within Pretoria	010
SITE ACCESS	
UNIVERSITY MAIN CAMPUS	
ONDERSTEPSPOORT	
CLIMATE	
SITE - University of Pretoria Research Farm	011
RESEARCH FARM - Historical Background	011
RESEARCH FARM - educational environment	012
RESEARCH FARM - Innovation Hub	012



RESEARCH FARM - Wildlife Research and Rehabilitation Centre	013
RESEARCH FARM - visual context of existing structures and landscape	013
PHILOSOPHY - Design	015
PRECEDENT STUDIES	017
HUMAN SPACE - design for human use and animal interface	018
SCOTTISH SEABIRD CENTRE - educational visitors facility	018
ZOO EXHIBIT & RECLAMATION PROJECT - nature versus artifice	019
DESIGN THESIS INFLUENCE	020
ANIMAL SPACE - design for animal needs and human interface	020
ZOO DEVELOPMENT - design for wildlife	020
DESIGN THESIS INFLUENCE	021
ARCHITECTURE - design approach	022
SAB VISITORS' CENTRE - design and restoration for new use	022
BANK HEADQUARTERS, BUDAPEST - design and restoration for new use	023
DESIGN THESIS INFLUENCE	023
DESIGN DISCOURSE	025
DEVELOPMENT - a landscaping design approach	026
DEVELOPMENT - an architectural design approach	027
DESIGN PROCESS - finding a structural aesthetic	027
DESIGN PROCESS - influential form	028
DESIGN PROCESS - zones of interaction and use	029
DESIGN - Wildlife Research and Rehabilitation Facility	030
DESIGN - overview of concept development-	030
DESIGN - experiencing the final product-	031
<u>EXTERNAL IMPRESSION</u>	031
<u>TRANSFORMATION OF THE OLD FARM BUILDING</u>	032
<u>EXPLORING NEW SPACE</u>	034
SYMBOLISM OF COLOUR	034
FUNCTIONAL DESIGN FOR DRAMATIC IMPACT	034
THE AUDITORIUM	035
COMMUNICATING AN IDENTITY	035
METAPHORIC INTERPRETATION	036
RELATIONSHIPS BETWEEN ELEMENTS	039
LECTURE AND CONFERENCE ROOM	040
STUDENT STUDIO	042
DESIGN INVESTIGATION TREATISE	043
TECHNICAL RESOLUTION – design detail	044
ACOUSTICS - sound in the auditorium	044
HVAC - heating, ventilation and air-conditioning system	044
SUSTAINABILITY - response to baseline document	045
SOCIAL CRITERIA – occupant comfort	045
SOCIAL CRITERIA – participation and control	046
SOCIAL CRITERIA – inclusive environments	046

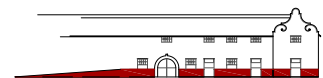

SOCIAL CRITERIA – access to facilities	047
SOCIAL CRITERIA – education, health and safety	047
ECONOMIC ISSUES – local economy	047
ECONOMIC ISSUES – efficiency of use	048
ECONOMIC ISSUES – adaptability and flexibility	048
ECONOMIC ISSUES – ongoing costs	048
ECONOMIC ISSUES – capital costs	049
ENVIRONMENTAL ISSUES - water	049
ENVIRONMENTAL ISSUES – energy	050
ENVIRONMENTAL ISSUES – recycling and re-use	050
ENVIRONMENTAL ISSUES – site	050
ENVIRONMENTAL ISSUES – materials and components	050
DESIGN DRAWINGS	051
CONCLUSION	087
LIST OF SOURCES	089
APPENDICES	093



LIST OF FIGURES



FIGURE 01.	Serval, photo taken at Moholoholo	002
FIGURE 02.	Vervet Monkey, photo taken at ART	003
FIGURE 03.	Educational Centre at Hoedspruit Cheetah Project	004
FIGURE 04.	Centre for Wildlife Management, Experimental Farm	006
FIGURE 05.	Faculty of Veterinary Science, Onderstepoort (www.up.ac.za/academic/veterinary)	007
FIGURE 06.	Wildlife cages at ART	008
FIGURE 07.	Map of Experimental Farm and site	009
FIGURE 08.	Plan view of site and surrounding structures	009
FIGURE 09.	Aerial view of site and surrounding facilities	010
FIGURE 10.	Access to site through sports grounds via South street	010
FIGURE 11.	Proximity of the site to U.P. main campus	010
FIGURE 12.	Access between Onderstepoort and the Experimental Farm	011
FIGURE 13.	Early 20th century views of old stables on Farm (UP archive, JN Bonsma photo album)	011
FIGURE 14.	Early 20th century views of old stables on Farm (UP archive, JN Bonsma photo album)	011
FIGURE 15.	Innovation Hub Impression (www.itweb.co.za)	012
FIGURE 16.	Contour map of site	013
FIGURE 17.	Visual access and tree placement on site	013
FIGURE 18.	Front view of the main old stable building	014
FIGURE 19.	Eastern view of old stable buildings	014
FIGURE 20.	Exterior view of stone cattle housing	014
FIGURE 21.	Small pavillion to the side of the cattle shelter	014
FIGURE 22.	Steel cattle shelter	015
FIGURE 23.	Equipment and feed storage shed	015
FIGURE 24.	Concrete troughs	015
FIGURE 25.	Material hierarchy	015
FIGURE 26.	'Flying' monopitch roof (FRASER 2000:37)	018
FIGURE 27.	Stretched canvas reflectors (FRASER 2000:38)	018
FIGURE 28.	Man-made bridge in desert landscape (SORVIG 2001:61)	019
FIGURE 29.	View over zoo fencing from elevated pathway (SORVIG 2001:61)	019
FIGURE 30.	Shelled coastline (MARTON 1997:54)	020
FIGURE 31.	Habitat replication of Henry Doorly Zoo (POWELL 1997:81)	021
FIGURE 32.	Hoedspruit Cheetah Project Centre, entrance	022
FIGURE 33.	Moholoholo, wildlife holdings and display	022
FIGURE 34.	SAB Visitors Centre (JAPHA 1998:26)	022
FIGURE 35.	Front view of Bank Headquarters (McGUIRE 1995:28)	023
FIGURE 36.	Section of Bank Headquarters (McGUIRE 1995:30)	023
FIGURE 37.	Wildlife holdings concept sketches	026
FIGURE 38.	Wildlife holdings concept sketches	026
FIGURE 39.	Gable of the main farm building	027
FIGURE 40.	Moulded rectangular spaces of new construction	028
FIGURE 41.	Existing axis with track mark	028
FIGURE 42.	Visual of building along new movement axis	028
FIGURE 43.	New axes	028



FIGURE 44. Access zones and movement of the wildlife	029
FIGURE 45. Concept - entrance at side of building, defined by ramp	030
FIGURE 46. Arched entrance to main building	030
FIGURE 47. Concept - auditorium cut in behind retaining wall	030
FIGURE 48. Concept - shift of ramp and auditorium	030
FIGURE 49. Movement diagram	031
FIGURE 50. Cluster of Pine Trees	031
FIGURE 51. Perspective of exterior of building	031
FIGURE 52. Concrete columns and beams as seen from outside	032
FIGURE 53. Steel cocopan track as seen from end of building	032
FIGURE 54. Stone retaining wall behind main building	032
FIGURE 55. Floating glass boxes	033
FIGURE 56. Ramp inside building interior	033
FIGURE 57. Placement of colour	034
FIGURE 58. Door concepts	034
FIGURE 59. Perspective view into auditorium	034
FIGURE 60. Stone of old retaining wall	035
FIGURE 61. Perspective of stairs and stage	035
FIGURE 62. Contour wall lighting	036
FIGURE 63. Inside auditorium, walls become one with stage	036
FIGURE 64. Joining detail of stage and wall	036
FIGURE 65. Wall detail and I-beam connection	037
FIGURE 66. View inside auditorium of crevice light spilling onto doors	037
FIGURE 67. Movement in auditorium after rotation	037
FIGURE 68. Movement in auditorium before rotation	037
FIGURE 69. Steel seating structure	038
FIGURE 70. Chairs attached to seating surface	038
FIGURE 71. Stair illumination	038
FIGURE 72. Pivoting doors between lecture room and auditorium	039
FIGURE 73. Ventilation grill detail	039
FIGURE 74. Airflow diagram	039
FIGURE 75. Adjustable louvres used together with corrugated iron	040
FIGURE 76. Stair perspective detail	040
FIGURE 77. Swivel doors	041
FIGURE 78. Window system by Kahn	041
FIGURE 79. Sliding window/handrail concept	041
FIGURE 80. Airflow diagram	041
FIGURE 81. Inside of silo	042
FIGURE 82. Acoustic reflection	044
FIGURE 83. Small, high window of main building	045
FIGURE 84. Ventilation fan, existing architecture	046
FIGURE 85. Site example of proposed material use	047
FIGURE 86. Area between retaining wall and back wall of building	048
FIGURE 87. Calf holding	049
FIGURE 88. Southe end site structures	050

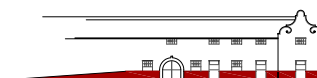

LIST OF APPENDICES



APPENDIX A	094
DETAIL INFORMATION – briefing document & context study	094
CONTRACTUAL AGREEMENT - a legal context	094
SITE - identification	094
USER PROFILES – requirements of the Facility	095
UP STAFF AND STUDENTS	
PHARMACEUTICAL EMPLOYEES	
LABOUR FORCE	
VISITORS	
APPENDIX B	097
BASELINE STUDY– setting sustainable goals	098
SOCIAL CRITERIA – occupant comfort	098
SOCIAL CRITERIA – participation and control	098
SOCIAL CRITERIA – inclusive environments	098
SOCIAL CRITERIA – access to facilities	098
SOCIAL CRITERIA – education, health and safety	098
ECONOMIC ISSUES – local economy	099
ECONOMIC ISSUES – efficiency of use	099
ECONOMIC ISSUES – adaptability and flexibility	099
ECONOMIC ISSUES – ongoing costs	099
ECONOMIC ISSUES – capital costs	099
ENVIRONMENTAL ISSUES - water	099
ENVIRONMENTAL ISSUES – energy	099
ENVIRONMENTAL ISSUES – recycling and re-use	100
ENVIRONMENTAL ISSUES – site	100
ENVIRONMENTAL ISSUES – materials and components	100
APPENDIX C	101
SCHEDULE OF ACCOMMODATION - regulations	102
SABS 0400 – regulations applied	103



TO ALL WHOSE INFLUENCE MADE THE PAST FIVE YEARS POSSIBLE

NICO, AN INSPIRATION

MY FAMILY FOR THEIR CONSTANT LOVE AND SUPPORT

KYLE FOR ALWAYS BEING THERE

MY FRIENDS FOR ALL THE MEMORIES



BRIEFING DOCUMENT

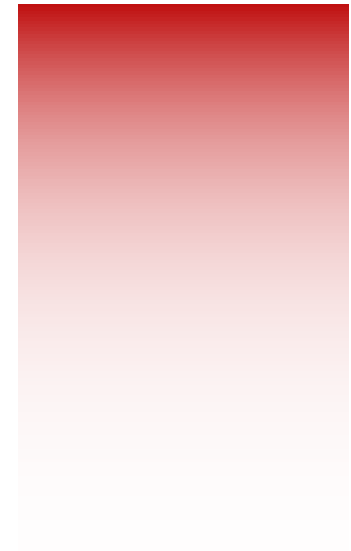

“The actions of mankind threaten to destroy perhaps half of the species that now inhabit it within the next few decades. These species will not be lost because of poachers or overhunting, but because of the destruction of habitat - the end result of overpopulation and inadequate land-management policies.”

Landscape architecture (1997:98)

An increasing global population causes cities to expand constantly and metropolitan areas to penetrate into natural habitats. This intrusion into ecosystems diminishes natural sites in which wildlife species can prosper. Depletion of food sources and breeding ground is one of the main reasons for the depletion of wildlife. Driven from their dwellings by invasive human settlement, species are forced to look for new 'home range'¹ in decreasing natural habitation. Wildlife that has managed to adapt to urban environments struggle with the threat of injury or fatality associated with human encounter.

There is an apparent need for increased awareness in, and education of, people about wildlife and the elimination of misconceptions that surround certain species. Global focus is shifting towards conservation and sustainable approaches. Facilities such as wildlife centres are beneficial to wildlife and the global community since they educate the public, and contribute to the rehabilitation, breeding and research of animals and birds.

abstract - CLIENT

The University of Pretoria is developing a Wildlife Research and Rehabilitation Centre on University property. The Facility strives towards becoming an institute of excellence and higher learning with educational facilities for academic research and practical training. The University will receive financial support and medical supplies from a pharmaceutical company in exchange for research on final phase drug testing and use of the facility. Additional monetary sourcing such as sub-contracting and sponsorships are to be explored.

The establishment of the Facility answers the growing need for a practical training centre for students, who study in the fields of wildlife and conservation, and allows staff members to expand their practical contribution to their fields of work. The Facility will be a fully functioning wildlife treatment, care and rehabilitation facility contributing to nature conservation and the community by establishing itself as a centre for public education and awareness, and as a job creation endeavour. The University sees the project as an investment and possible income generator while receiving international recognition from scientific and educational bodies.

a legal context - CONTRACTUAL AGREEMENT

Contracting is done through *Research and Contracting, University of Pretoria*. A University of Pretoria standard contract is used and adjusted according to terms and conditions agreed upon by both parties (Rita Snyders, Contract Administrator: Personal Interview). An extract from a standard University of Pretoria contractual agreement, adapted for the contracting of an outside company for the involvement in the Wildlife Research and Rehabilitation Project, can be referred to in Appendix A (p.094).

(Footnotes)

¹ Home range is a big area utilized by an animal or bird on an annual basis if not migratory (Landscape Architecture 1997:92).



Fig. 01 - Serval



Existing wildlife centres and treatment facilities are in most cases ill-equipped and under funded. Most are non-profit organisations that largely depend on the backing of the community and generosity of sponsors, although the lack of public knowledge and awareness in this field is one of the biggest problems and reasons for insufficient support. There has been little opportunity for detailed design development of wildlife centres from conception with regard to their specific needs and inherent potential. The chance to design a full-fledged wildlife facility from inception can uncover previously unexplored possibilities and opportunities.

People in urban areas come into contact with wildlife everyday, although often oblivious to this fact. The everyday exposure and firsthand experience of wildlife makes 'metropolitan wildlife' a suitable starting point for creating community awareness and encouraging conservation.

design of a wildlife research and rehabilitation facility - PROJECT BRIEF

Design and develop a research and rehabilitation facility for wildlife as per request of the University of Pretoria. The Facility is to be developed on University property and is a centre for students in theoretical and practical training. It is envisaged as a treatment and care facility for injured, orphaned and endangered wildlife species, and will work primarily with wildlife caught up in Metropolitan expansion and in need of assistance. A rehabilitation and breeding program is to be established with related research and documentation. A visitor's centre will establish interaction with the public by educating and creating awareness. There will be fund generation through possible inclusion of recreational facilities.

FACILITIES AND SERVICES

The following essential and suggested facilities and services are to be researched and considered to fulfil the needs of the centre:

RESEARCH

Research is to be carried out by staff and students. Laboratories and areas for documentation and storage of data are required. These facilities are to be made available for use by personnel of the involved Pharmaceutical Company.

REHABILITATION AND BREEDING

Facilities to be appropriately designed for use in activities transpiring in breeding and rehabilitation programs. The Facility should accommodate animals and reptiles, sizes small to medium and birds. Needs of nocturnal creatures are to be considered as opposed to the needs of those that are diurnal. A hospital is to be developed with a surgical area and an intensive care unit. A quarantine area is needed and storage for all necessary equipment and supplies. Produce storage and preparation kitchen to be included.

STUDENT TRAINING AND EDUCATION

Provision for an indoor lecture area for theoretical classes and training preparation. A storage area/locker room for secure placement and storage of staff and student personal belongings while at the Centre and workstations or communal areas where theoretical work can be carried out need to be considered.



Fig. 02 - Vervet Monkey

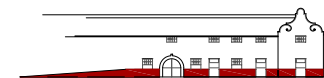

PUBLIC SECTOR AND FUND GENERATION

With a focus on encouraging public awareness and education an informative exhibition, the inclusion of facilities such as a seminar room or auditorium for lectures and video viewing, could facilitate intended community project educational programs. These are to be made available to schools, corporations, interest groups, clubs, local communities and individuals. The programs and possible interactive tours through the facility can be used for fund generation along with the possible inclusion of a picnic area, petting zoo, outsourced coffee shop or restaurant and souvenir shop.

BASIC SERVICES AND FACILITIES

The Facility is to accommodate various working areas related to the provision of care for wildlife, and laboratories for related research. Educational venues are required for lectures and theory workshops for both students and the public. A visitor's centre should entertain and inform members of the public and should include an educational exhibition. Outside activities and wildlife interaction for young and adult visitors need to be designed, considering site layout and placement of wildlife holdings. Offices are required for administration and facility management, and the inclusion of a venue for food and beverages. Accessibility to kitchens or refreshment stations and areas of social interaction and relaxation are of importance to staff and students. Sufficient sanitary facilities and parking with consideration to all users and specific needs is pertinent (refer to accommodation schedule p.102).

COMMERCIALISING AND ADVERTISING

Development of a public image for the facility and visitor's centre is necessary, through architectural and design approach, and recognisable imagery and signage.

selection - SITE

The choice of site greatly influences development possibilities and design potential. Selection criteria for the identification of a suitable site include:

The site needs to be on property currently owned by the University of Pretoria.

A brownfield site with any kind of pre-existing structure, suitable for refurbishment and development with possible addition to and expansion of the existing structure.

Large open segments of land situated within a suburban area, between the central business district and rural development where natural and man-made worlds meet.

A site easily accessible to staff and students as well as public visitors, close to main access routes.

Preferable visual access to the site from roads to create public awareness of the facility, establishing a visual node.



Fig. 03 - Education Centre at Hoedspruit Cheetah Project



CONTEXT STUDY



The study researches the context in which the project will be developed, establishing a framework within which design decisions can be made, reacting contextually for or against.

University of Pretoria – CLIENT

involved parties – UNIVERSITY OF PRETORIA

In the study of wildlife, first hand experience is an irreplaceable educational tool and related departments have similar needs and requirements. Unnecessary segregation has caused the University to look at uniting some of these departments (Haupt, Lecturer at the Department of Zoology: Personal Interview). The Wildlife Research and Rehabilitation Facility is a resource that provides the opportunity for different fields of study to work together, combine efforts and share equipment and facilities. The following faculties and departments are sectors of the University of Pretoria that will be involved in the Facility. The diverse disciplines all have distinctive spheres of expertise to offer the project, which will ensure a specialist facility.

FACULTY OF NATURAL AND AGRICULTURAL SCIENCES

DEPARTMENT OF ZOOLOGY

The *Zoology department* is based on the University main campus. Limited funding and large travelling distances to suitable facilities make exposing students to practical training and theory application difficult. According to Martin Haupt, a departmental lecturer, there is a recognized need for more practical exposure, and the development of a training facility in close proximity would ensure continuous Zoology involvement.

DEPARTMENT OF ANIMAL AND WILDLIFE SCIENCES – *Centre for Wildlife Management*

The importance of effective wildlife management has grown over the past few years, both locally and internationally according to the Centre for Wildlife Management. The Centre facilitates postgraduate University degrees in Wildlife Management, and is situated on the University of Pretoria Experimental Farm grounds. Course research includes topics such as wildlife ecology and wildlife management, habitat management and vegetation studies, individual wildlife species, and predator ecology and herbivore nutrition. Students spend large amounts of time on practical projects (University of Pretoria, Centre for Wildlife Management pamphlet).

The Centre for Wildlife Management is the force behind the EcoWorld project. EcoWorld aims to provide a platform for discussing wildlife and ecotourism issues and subjects concerning wildlife management (University of Pretoria, Centre for Wildlife Management pamphlet).

FACULTY OF VETERINARY SCIENCE

The University of Pretoria's Faculty of Veterinary Science is situated on a satellite campus at Onderstepoort. Departments in the Faculty of Veterinary Science focus mainly on livestock and domestic animals, although several sub-divisions deal with wildlife and cover a range of topics such as parasitology, infectious diseases, pharmacology, toxicology, radiology, anatomy and reproduction.



Fig. 04 - Centre for Wildlife Management, Experimental Farm



DEPARTMENT OF ANATOMY AND PHYSIOLOGY

The main focus of research in Anatomy at the *Department of Anatomy and Physiology*, is on the anatomy of wild animals and the reproductive biology of birds and mammals.

DEPARTMENT OF PARACLINICAL SCIENCES

The *Department of Paraclinical Sciences* has selected several key areas of interdisciplinary research of local and international relevance. Research includes surveillance, monitoring and control of diseases and management of wildlife, as well as the conduct of pharmacological studies and use of veterinary medicines on wildlife.

DEPARTMENT OF VETERINARY TROPICAL DISEASES

The *Department of Veterinary Tropical Diseases* focuses on defining disease problems, developing and applying innovative and appropriate methods to diagnose, prevent and control or eradicate infectious and parasitic diseases. Research includes diseases that arise as a result of environmental and human factors that manifest at the wildlife/domestic animal interface and fieldwork is an integral component.

VETERINARY WILDLIFE UNIT

The Faculty of Veterinary Science supports a *Veterinary Wildlife Unit* specialising in the fields of ecophysiology, capture physiology and pharmacology. Studies include the measurement of stress and stress related diseases, diseases of captive carnivores; reproduction, contraception and fertility control in wildlife.

VETERINARY ACADEMIC HOSPITAL

Onderstepoort Veterinary Academic Hospital provides mobile and rural clinic services as part of the a teaching mission in which the students are involved.

There are postgraduate courses that deal with wildlife but students are forced to make use of wildlife centres outside of the University. According to Professor Bertschinger, head of the Department of Reproduction (*Personal Interview*), the Faculty is looking at expanding on the existing courses and including pre-graduate courses. Bertschinger voiced a rising need for more practical facilities in this field. Research networking encourages local and international final year veterinary students to do their clinic practical at Onderstepoort. The demand is very high and an additional clinic will allow for acceptance of more students throughout the year, offering the chance to work exclusively with wildlife.

SOURCE: University of Pretoria, Faculty of Veterinary Science Web page



Fig. 05 - Faculty of Veterinary Science, Onderstepoort

The intention of the Wildlife Research and Rehabilitation Facility is to make effective use of available expertise. Staff and students conduct research while practical training provides for the needs of the wildlife and demands of the facility. Educational tours and lectures could be offered to the public by Faculty staff, as extension to community contribution projects.

Direct contact with the EcoWorld project will keep the Research and Rehabilitation Facility up to date on relevant issues while creating opportunities to build contacts with related organisation. The Facility will in future be automatically represented at important functions and congresses attended by the Faculty of Veterinary Science, creating opportunities for participation and the prospect of becoming pro-active on a large scale.

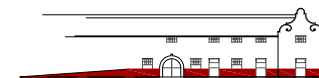

surrounding facilities – **ANIMAL CARE**

facilities in Gauteng - WILDLIFE

Most Facilities that work with wildlife are situated on the outskirts of towns and cities or in rural areas. Except for zoos, which are often located near the city centre, restricted access, lack of accessibility and long distances limit the contact of the general population with these facilities. Removed from public view with minimal exposure, people are often unaware of the existence of most of these centres.

There are three known wildlife centres or facilities in Gauteng: ART- Animal Rescue Team, Johannesburg; Free Me, Johannesburg and Wildcare Africa, Pretoria. Wildcare Africa - wildlife rehabilitation centre and intensive care unit, is situated at Kameeldrift and is the biggest and most developed of the centres. Wildcare is one of the most well known and well funded of South Africa's wildlife centres.

It is important for the Animal Research and Rehabilitation Facility to develop working relationships with the existing centres in order to establish a support system

veterinarians and veterinary clinics - DOMESTIC

Ignorant to the existence and whereabouts of wildlife rehabilitation facilities, members of the community who come across injured wild animals or birds in need of medical attention commonly take the creature to the closest veterinarian for assistance. Veterinarians, often ill equipped and uneducated in working with wildlife, are unable to help.

Forming relationships with veterinarians and animal clinics within Gauteng will allow these facilities to refer any wildlife cases straight to the Wildlife Research and Rehabilitation Facility. The Facility can be contacted for referral to other nearby centres or to fetch the animal or bird.

physical location - SITE

The selected site is on the Research Farm of the University of Pretoria (For site identification refer to Appendix A p.094). A 4-acre piece of land has been set-aside with possible development outside its borders. The site is currently zoned as educational land and suited for the development of an educational centre (City of Tshwane Metropolitan Municipality).

The Research farm is located in the suburb of Hatfield, Pretoria East, Gauteng Province, South Africa

The Geographical coordinates are: 25° 45' S Latitude

28° 16' E Longitude

(South African weather service)



Fig. 06 - Wildlife cages at ART



SITE CHOICE

The site chosen for the placement of the Wildlife Research and Rehabilitation Facility is the land surrounding and including the current Milking Unit and management of large livestock. The established area is on the western side of the Experimental Farm grounds (Fig.07).

There are open fields and several existing structures on the selected area of land. The largest and main structure on the site is a farm-style building designed for the administration of large livestock and housing of both horses and cattle. The building includes horse and cattle stables, storage space, sleeping quarters and a functioning milking unit. Three loose-standing rectangular buildings line up with two silos right behind the main building, and house an office, laboratory space and calf pens. Surrounding this focal point there is also an open cattle shed, a large storage shed, concrete storage basins, another similar silo structure, a small concrete pavilion and stone cattle holdings (Fig.08).

The open fields surrounding these facilities are fenced off and used for cattle holding and grazing. Only an estimated 20% of the mentioned structures are in use with most quarters empty and no longer operational. Functioning areas include the milking unit, an office and the sleeping quarters. All stables are deserted with cattle only occupying the open shed and calf pens.

Gravel roads link most of the structures. There is little established parking on or near the site, with only small paved areas around the main building and a 3-car carport next to it.

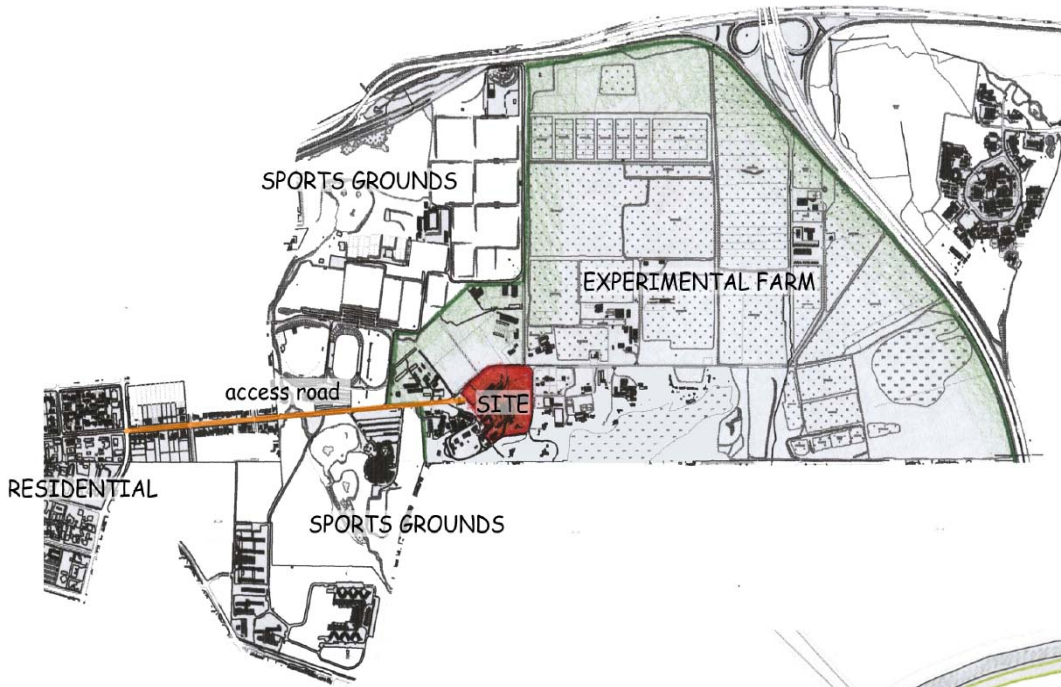

Fig. 07 - Map of Experimental farm and site

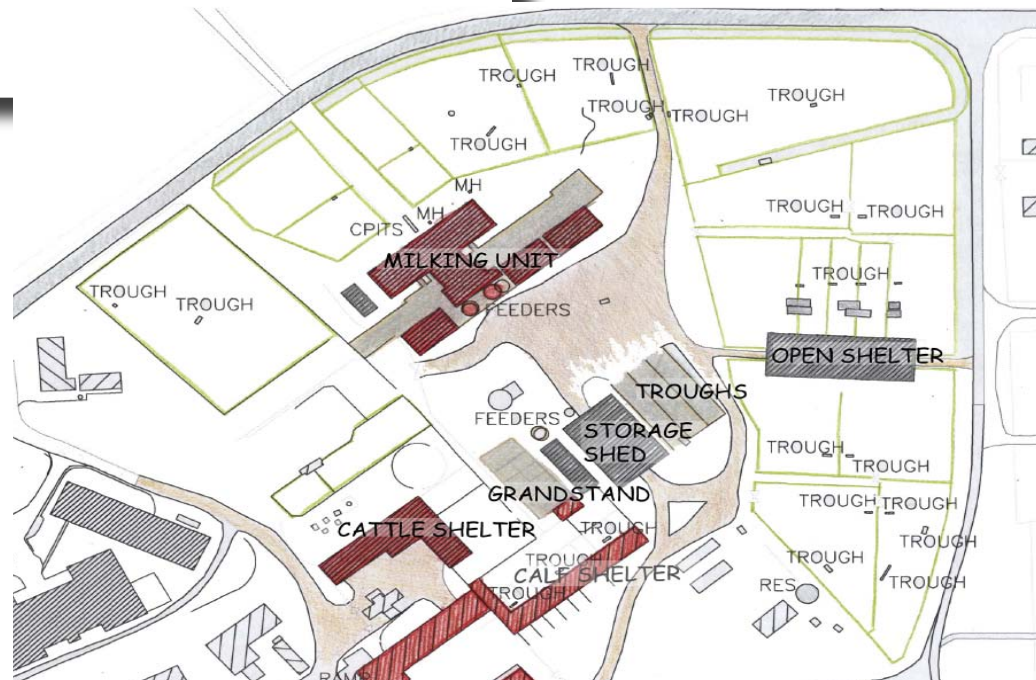

Fig. 08 - Plan view of site and surrounding structures

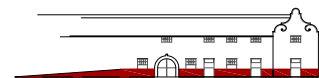



Fig. 09 - Aerial view of site and surrounding facilities

SURROUNDING FACILITIES

All buildings on the Farm of direct significance to the new Facility are in close proximity. The selected site is situated within 300m of the western entrance of the Farm and approached by the main access road that passes in front of it. Access is also possible by a secondary road that runs around the back of the site. Just west of the site is the Administration building and the Centre for Wildlife Management, situated between the entrance and the site (Fig.09).

Experimental Farm within Pretoria - LOCATION

SITE ACCESS

The Experimental Farm borders on the University of Pretoria Sports Grounds, and the west entrance to the farm is accessed through the sports grounds via South Street (Fig.10). University Security regulates access to the sports grounds and Experimental Farm by means of security booms.

UNIVERSITY MAIN CAMPUS

The site is situated to the East of the University, approximately 2.5km from the University of Pretoria main campus entrance (Fig.11). The Farm is in close proximity to the University main campus, and thus close to the Department of Zoology which is situated on main campus grounds.

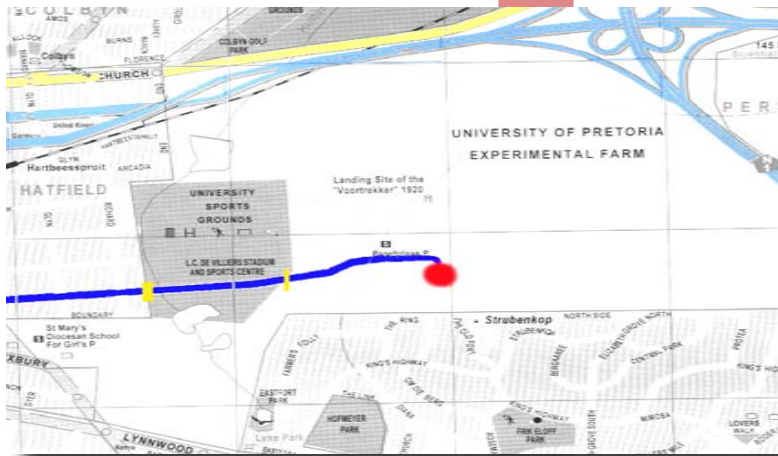
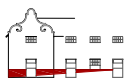

Fig. 10 - Access to site through sports grounds via South street



Fig. 11 - Proximity of the site to U.P. main campus



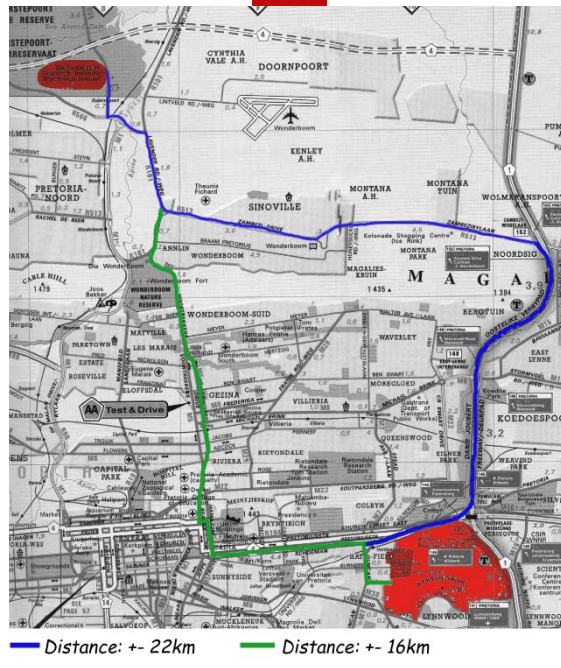

Fig. 12 - Access between Onderstepoort and the Experimental Farm

ONDERSTEPOORT

Onderstepoort is situated northwest of the Experimental Farm, approximately 20km by road and approximately 30 minutes by car. Two main routes linking the two campuses, one passing through Pretoria central, and the other making use of the N1 South highway (Fig.12).

CLIMATE

Pretoria has a very warm, dry climate. Hot summer temperatures reach a maximum temperature range between 27 and 29 degrees Celsius and a minimum temperature range between 16 to 18 degrees Celsius. Winters are rather moderate with maximum temperatures between 19 and 22 degrees, dropping to a minimum range between 5 and 8 degrees Celsius.

Thunderstorms bring a summer rainfall with a precipitation average in January of 136mm per month, which drops in winter to its lowest average of 3mm per month in July. Wind direction is predominantly north-east.

Climatic conditions are pertinent with regard to the needs of the wildlife and greatly influence design requirements of the wildlife holdings. Climatic conditions affect design approaches towards human comfort within buildings and building use.

SOURCE: South African weather Service

University of Pretoria Research Farm - SITE

Historical Background - RESEARCH FARM



Fig. 13 and 14 - Early 20th century views of the old stables on the Experimental Farm

The Hatfield Experimental Farm is the property of the University of Pretoria and is the result of years of discussion and negotiation, which culminated in its realization in 1920, and the completion of most of the buildings by 1925 (Fig.13 & Fig.14).

The Hatfield experimental Farm is a very valuable property and a scientifically unique national asset. There has been pressure applied over the years to use the land for other purposes due to its prime location. Land has been lost to various developments in the process, including the CSIR, National Botanical gardens, Christian Brother's College, the N4 and N1 highways, and Persequor Park - part of which has been sold for private enterprise. The University also used Experimental Farm land for establishing the University sports grounds and related facilities, as well as the men's hostel. The Experimental Farm has shrunk significantly to 270 hectares since it's founding (Tukkievaria 2000: 4).



The farm generates approximately two-thirds of its own financial capacity, with the University only having to provide around one-third of its total funding as confirmed by the Experimental Farm manager Roelf Coertze (Personal interview).

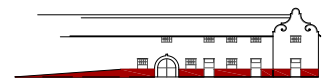

The Hatfield Experimental Farm is home to a very active scientific and research community. It is solely used for research and academic purposes and the farm's educational value is increased through its close proximity to the Pretoria University main campus. The University strives to compete on a national and international level and this can be seen in the amount of projects the Farm undertakes (Tukkievaria 2000: 4). According to Mr. Coertze, approximately 250 projects are presently being run at the Farm.

"We believe this project will spur the next wave of knowledge-intensive industries in the country."

- Blue IQ CEO Pradeep Maharaj
(www.itweb.co.za)

The Innovation Hub is a Blue IQ, smart industry development project aimed at developing Tshwane as the intellectual capital of the country and Gauteng as the "smart" province. The Hub is envisioned as a Science and Technology Park, and as stated by Gauteng premier Mbhazima Shilowa, aims to create a place where education, research, businesses, hi-tech entrepreneurs, and venture capital would work and meet to enhance the innovative capacity and economic development of the province (Whitford: www.itweb.co.za). Innovation Hub CEO Neville Comins believes the project "would help keep talent in SA by providing an environment in which skilled and talented people could build businesses that could compete globally" (Whitford: www.itweb.co.za).

This R300 million initiative is a joint venture between the Gauteng provincial government and SERA with an alliance established between the University of Pretoria and the CSIR. The Gauteng Development Facilitation Act Tribunal approved the University of Pretoria's application to establish the Innovation Hub's main centre on a part of its Experimental Farm, on a "knowledge axis" between the University of Pretoria and the CSIR (www.theinnovationhub.com). The Hub is ideally positioned to attract foreign research and development companies, and develop a significant R&D outsourcing industry, according to Blue IQ CEO Pradeep Maharaj. The Principal of the University of Pretoria, Calie Pistorius, welcomes the development and says that it will benefit both the local community and civil society at large (www.itweb.co.za). Post-graduate students, mainly from the University of Pretoria, are to be recruited by Epiuse and exposed to company-related projects, giving them market exposure and creating opportunity for the employment of some of the students (Whitford: www.itweb.co.za).

The development philosophy, according to 'The Innovation Hub' - www.theinnovationhub.com, aims to "increase the wealth of its community by promoting the culture of innovation and the competitiveness of its associated businesses and knowledge-based institutions." Design, construction and operation have drawn on international best practices, taking into account local economic, social, and environmental context. Location, design and management stimulate cross-fertilisation of ideas and the flow of knowledge that comes with innovation and dynamic social interaction. The environment is responsive to the lifestyle preferences of today's knowledge workers and a high-tech cluster will accommodate the changing needs of new businesses and education, research and incubation practices.

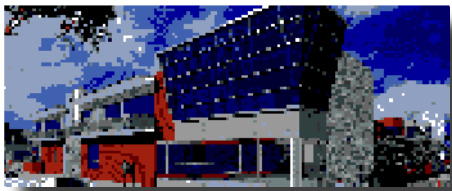

Fig. 15 - Innovation Hub impression



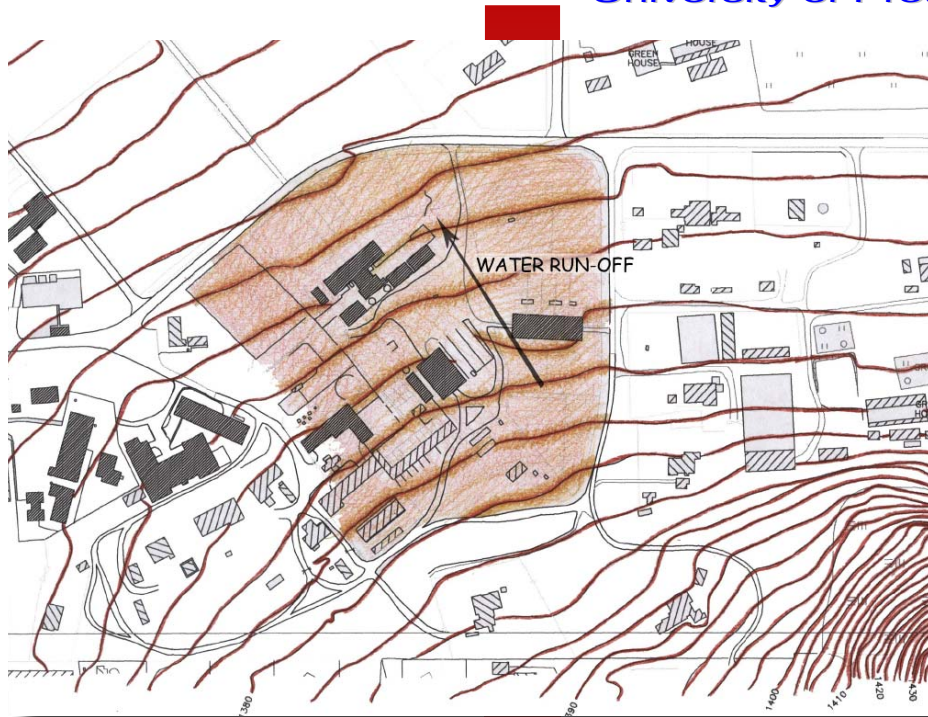

Fig. 16 - Contour map of site

It is the writer's opinion that the establishment of the Innovation Hub on the Experimental Farm will have a profound effect on the future of the Farm and further development. The position of the Hub on the eastern side of the Experimental Farm could open the Farm up to alternative and public access, and may in future become the primary entrance. The architectural development will most likely set the bar concerning expectation of any new projects undertaken, and alter the context of the Farm as it stands now.

Due to the fact that the Farm falls within the 'knowledge-axis' that is being established, the Wildlife Research and Rehabilitation Facility is likely to benefit from this association and that of the Innovation Hub. The Facility carries the same vision of creating a knowledge-based institution that further instructs students, while exposing them to the working world and establishing links to job opportunities by attracting local and foreign research and development companies and researchers.

Wildlife Research and Rehabilitation Facility - RESEARCH FARM

The introduction of a Wildlife Research and Rehabilitation Facility into the Farm is an attempt to maintain the Experimental Farm's relevance in the national and international realm without surrendering the land to total corporate development but nurturing open pieces of land. With a focal shift in society towards issues of sustainability and conservation, addressing wildlife concerns has become a very relevant matter. Broadening the disciplines within the Experimental Farm increases its sphere of influence and reaffirms the Farm's standing as a unique national asset.



Fig. 17 - Visual access and tree placement on site

The establishment of the Facility as an educational centre for research and training fits the required academic quota of the Farm and provides students in several interrelated wildlife disciplines with a 'classroom' for hands on experience. Wildlife care and research documentation administered by students guarantees an annual workforce at no labour cost.

By contracting an external company as an invested sponsor, the Facility is not solely dependent on University subsidy for construction and operational costs. By establishing a working relationship with an outside sponsor and creating outsourcing possibilities, the Facility will potentially require little financial support from the University. The use of existing structures and established services aids in lowering project costs. Generation of additional funding through the Facility by offering educational tours and lectures to the public could provide the Facility with greater financial independence and opportunity for improvement.

visual context of existing structures and landscape - RESEARCH FARM

The site gradually slopes down to the Northern sector of the Experimental Farm (Fig.16); this aids visual orientation and comprehension of the site and structure positioning when looking up at the site from the access road that passes in front of it (Fig.17). Grazing fields surround the structures on the terrain, leaving buildings exposed. Mostly exotic trees surround the buildings on site with indigenous trees positioned randomly along pasture edges. Approaching the front of the main building, there is a defined cluster of tall pine trees on the left, off-set by a large, old wild fig tree on the right. Trees on site are relatively few but many are rather old and grown very large, starting to obscure structures from view (Fig.17).

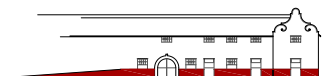



Fig. 18 - Front view of the main old stable building



Fig. 20 - Exterior view of stone cattle housing



Fig. 19 - Eastern view of the old stable buildings



Fig. 21 - Small pavilion to the side of the cattle shelter

The most prominent structure on the site is the old farmhouse type building. The building echoes Cape Dutch style architecture with gables, small windows and off-white plastered walls. A red tiled roof is complimented by red brick detail with dark brown, painted wooden doors and window frames. A stone retaining wall adds texture, almost contrasting the smooth architecture and finishing off the rural farmhouse feel. Two silos at the back of the building add a new dimension, contrasting the repetitive rectangular forms, yet reinforcing the farm overtone.

The silos are symmetrically placed on either side of a very strong symmetrical axis. The axis runs between the towering silos and through the prominent arch entrance of the symmetrical façade of the main building, down the gravel road that leads to the entrance (Fig.18). The gravel road is emphasised by paddocks on both side and crosses the main access round that runs past the front of the sites, carrying on for several meters into the distance. The other structures fan out behind the building that is front and central to the site,. It is the focal point of the site and a recognised node within the Experimental Farm (Fig.19).

Red coloured stone structures attract attention to the south-western corner of the site. These permanent buildings visually connect to the previous building through the use of stonewalls, brown painted wooden doors and window frames and red pitched corrugated roofs. The buildings were used to house cattle and include small outside pens (Fig.20). Next to the cattle shelters is a small pavilion. It is an off-white plastered structure supporting a corrugated iron roof (Fig. 21). These structures look as if they are part of the earlier development on the site around the same time as the construction of the main building.

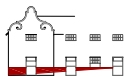



Fig. 22 - Steel cattle shelter



Fig. 23 - Equipment and feed storage shed



Fig. 24 - Concrete troughs

More recent additions to the site include an open steel shelter roofed with corrugated iron for cattle on the south-eastern corner of the site (Fig.22). There is a storage shed (Fig.23) for equipment and feed built of steel, corrugated iron and exposed concrete alongside three concrete troughs (Fig.24). These crude structures contrast the permanence and design of the main building yet maintain the feel of the site as a farm, suggesting change of infrastructure with progress of time and related needs.

The importance of structures on site is conveyed through use of materials, visually establishing a material hierarchy (Fig.25). Materials such as steel and corrugated iron that are accordingly classified low down the material hierarchy, are the materials that suggests development and new solutions.

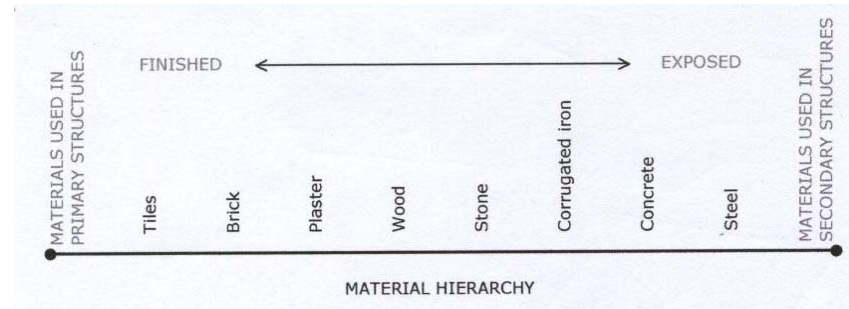

Fig. 25 - Material hierarchy

Design - PHILOSOPHY

Whether artificial environments should be made to look natural, in terms of facilities such as zoos where wildlife are worked with and displayed, is currently under debate. Do environments need to look natural to be ecologically sound? This is the central issue around which the landscaping design and the development of the site needs to be approached. The needs of the wildlife are of utmost importance and their well-being should never be compromised in an architectural resolution.

The existing structures on site should be made use of as extensively as possible. The structures retain an aesthetic value, and the importance of the structures should be weighed and considered in the design development. The visual communication of the Cape Dutch building is very important as it carries the memory of a prominent South African architectural style, and relays the 1920's time frame in which the building was constructed (The Cape Dutch Revival). The building retains historical significance and should be handled with great respect. The Cape Dutch style sets a point of departure to which new construction should respond.

It is important for the physical centre to echo exactly that for which it stands. The Facility is looking to create awareness concerning the natural environment and the conservation and sustaining thereof. The inclusion of a sustainable architectural approach is imperative and should reinforce its importance.

Three different fields of approach need to be researched for a cognitive understanding of the demands on the project:

- Human spaces and design requirements as determined by function, and the treatment of the interface that develops where human space comes into contact with wildlife.
- Wildlife spaces and the needs of animals and birds influencing design, and the interface where wildlife comes into contact with humans.
- Contemporary design approaches to working with buildings of historical significance, conserving the architecture yet enhancing the experience.

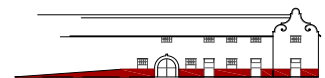

PRECEDENT STUDY



University of Pretoria etd – Lippi, N (2005)

The study of precedents is used to set objectives and aspirations for the project and extended facility, establishing a conceptual context from which the design of structures and spaces can develop. The aim is to develop a context based on real life problems and resolutions, and not to dictate architecturally based decisions.



Fig. 26 - 'Flying' monopitch roof

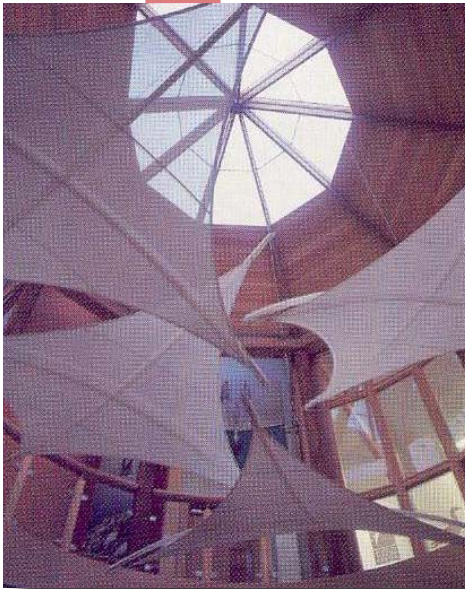

Fig. 27 - Stretched canvas reflectors

design for human use and animal interface - HUMAN SPACE

educational visitors facility - SCOTTISH SEABIRD CENTRE

Fidra, Lamb, Craigleith and Bass Rock are islands situated just off the East Lothian Coast and are home to a vast number of seabirds. The Scottish Seabird Centre opened in 2000 and sits on the main coastline, looking out over the islands.

The building serves as a 'contemporary reinterpretation of the traditional seaside pavilion' (p 38). Simpson and Brown committed to a simple, wholesome, new building design, fusing both sound ecological principles and ethics with the experience of traditional materials and techniques. The footprint of the building is quite small with maximum use of natural light and ventilation. The battered stonewalls were inspired by local harbour walls and built by a local craftsman.

Visitors to the Centre are able to view the bird life on the island through telescopes and by remote control TV cameras, as if from a large bird hide. Interactive displays and latest telemetry enable visitors to control cameras placed on the island. Rotation, pan and zoom allow for the best views of the birds in their natural environment without disturbing them. Large screens display these images while an auditorium shows a specially commissioned film of Scotland's seabirds at regular intervals. The Centre is supported through ticket sales, for viewing of the exhibition, and by a small shop and café/restaurant accommodated at the centre.

A conscious attempt was made to use the roof as an expressive element. The 'flying' cantilevered monopitch was designed with the idea of a 'birds wing' and 'swooping curves', which give the building its special identity (Fig.26). Suspended canvas stretched screens diffusing light from a glazed cupola and wing-like reflector lights hint at the same source of inspiration (Fig.27).

DESIGNER: Simpson and Brown Architects
SOURCE: Architects' Journal, 2 November 2000

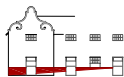

The following two articles examine two very different projects but are both caught in the debate over 'nature versus artifice'.

In *Desert meets Desert*, the article explores the development of a zoo exhibit called Desert Lives, which incorporates natural desert land features into a comparison of animal and human adaptation in arid regions that exist in a separate part of the world.

The zoo experience has shifted from the small, barren cages of the early zoos, where environments were unhealthy and misrepresented trapped species, to a naturalism approach, where whole environments are reproduced. This raises the question of how far exhibits should go to hide human artifice in these recreations of natural scenes and does it send the wrong message that humans can create nature, "Is naturalism really a dead end?" (p.57). Landscape projects almost always need to balance artifice with existing ecological systems. Many educational exhibits represents a concept of nature that for most part excludes humans, yet humans are a part of, and hugely impact on nature. Should a balance not also exist in zoo landscapes? "... the best exhibits celebrate a diversity of viewpoints" (p.59).

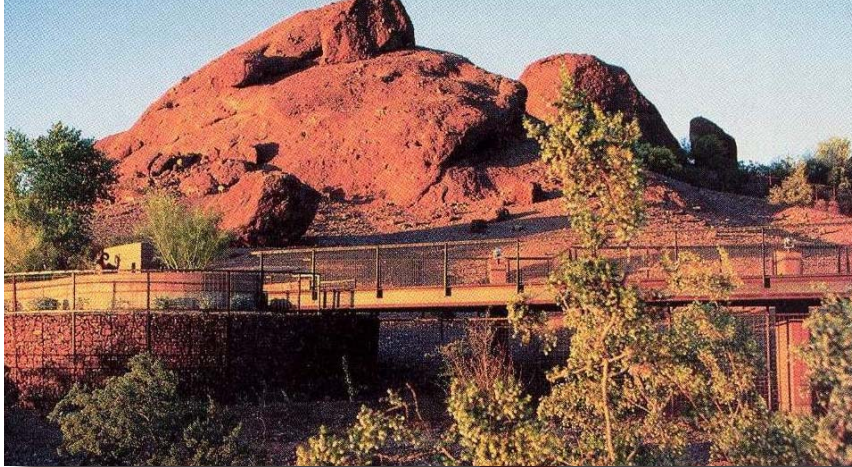

Fig. 28 - Man-made bridge in desert landscape

Desert Lives took the straight approach, which dictates that which has been built by humans should look built. Fake materials and elements were banned, like artificial rock, and designs tried to emphasize the existing landscape. Materials chosen were environmentally responsible and connected to the physical and historical context of the site. Architectural elements, constructed walls, paths and bridges can not be mistaken for natural features, yet fit in well with the landscape through design and choice of material (Fig.28). The experience of the zoo exhibit is fine tuned by elevating pathways to keep people from looking through fences, and through limited naturalistic designs (Fig.29). Naturalism is a broad term, interpreted in unique ways by most zoos and botanical gardens.

DESIGNER: Weddle Gilmore Architects

: Floor and Associates

SOURCE: Landscape Architecture, January 2001

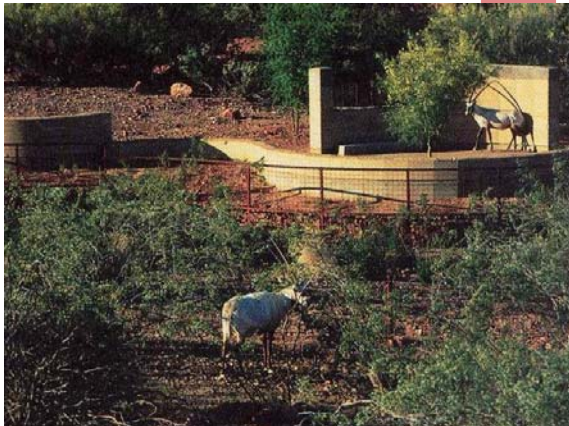
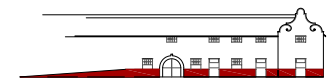

Fig. 29 - View over zoo fencing from elevated pathway

On the other side of the spectrum, *Nature Reconstructed* is the creating of a natural system on post-industrial ground. The site is now a nature preserve on the Eastern Scheldt in Holland, where land meets sea.

The common approach to introducing a functioning ecosystem would have been the design of a landscape that imitates nature. The reality is that a design does not need to mimic nature to function ecologically and fulfil its purpose. Although West 8 was commissioned to transform deposits of sand into man-made dunes, but the firm opposed that approach. "The artificial naturalism of dunes in a completely man-made landscape ran counter to West 8's design philosophy" (p.54).

West 8 suggested a whole new strategy. The proposed dunes would obscure views to sea and the horizon. With the preserve off-limits to people, the only interaction humans have is visual access from a highway that runs through the sections of land. Visual impact is thus very important. With an extensive understanding of the Dutch landscape ecology and the ordered systems manipulated since the thirteenth century, a design emerged that fulfills the needs of wildlife and reflects the "constructed nature of the landscape"(p.56) while stimulating motorists passing through.



University of Pretoria etd – Lippi, N (2005)

The sand depots were levelled into large plateaus, opening up the visual link to the sea. Three areas were breeding habitats for bird colonies and were covered in shells. The shells were waste products from shellfish farms in the nearby area, and are representative of the farmers and their farms. Light cockleshells and dark mussel shells are arranged in broad bands and, check blocks of white and black, across the sections of land. Seeking place to nest, many bird species are attracted to the shells and adapted well to the new environment (Fig.30). The black-and-white compositions are visually very striking, creating rhythm for motorists passing at high speed and flocks of birds a source of constant activity.

The success of the project stimulates the debate of natural systems and whether a landscape needs to be natural in appearance to function properly. The shell field designs are an example of possibilities for human development and functioning ecosystems to co-exist in a vibrant environment.

DESIGNER: West 8

SOURCE: Landscape Architecture, July 1997

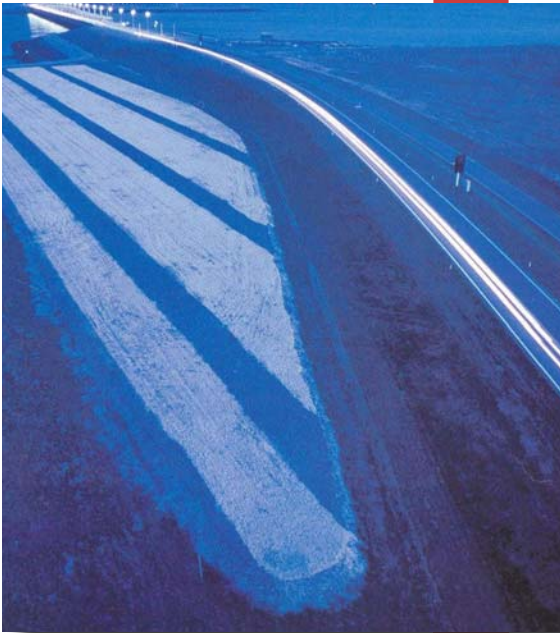

Fig. 30 - Shelled coastline

DESIGN INFLUENCE

The debate on 'nature versus artifice' has not been resolved and leaves room for design interpretation and artistic licence. Every project has different objectives and there is no single recipe for working with nature. In an article about the design of a children's zoo (Dean 1998:34-39), the debate of the role of the artificial in 'natural' environments is again brought to the fore. To communicate on the intellectual level of a child, the educational experience was enhanced through the incorporation of artifice.

Design approaches have changed over time and we are now in an era where the holistic mindset towards nature and the influence of man is in limbo. A landscape design does not need to mimic nature in order to function ecologically and a balanced approach to the relevant issues is producing some of the best results. Just like landscapes are starting to respond to the surrounding built environment in their design, so should buildings take account of the surrounding environment and respond to it. Local influence can be included through use of local materials and labour. The study of the a Wildlife Educational Centre on the Teifi Marshes Nature Reserve (Architects' Journal 1994: 33-42) showed a similar approach in which the shape of the site influenced the building shape and building materials were chosen to manipulate visual impact, presenting a positive image of conservation.

design for animal needs and human interface - ANIMAL SPACE

design for wildlife - ZOO DEVELOPMENT

The revolution we are witnessing in zoo design is redefining the term 'zoo' and reinventing the whole experience for the visitors and the animals alike. The departure from conventional zoo design reflects a shift in philosophy from the homocentric view of zoos as a display of human power over nature, to a biocentric view by which the zoo is seen as an educational medium that strives to explain the interrelationships between animals and nature. The Victorian era saw the beginnings of the modern zoo, when zoos assumed the form of urban menageries. Animals were viewed as curiosities or valuable collectibles housed in cages. Carl Hagenbeck introduced a more biocentric approach to twentieth-century zoo design in 1907 when he established his 'bar less' zoo. Believing that providing animals with as much freedom as possible was beneficial to both animal and visitor, steep artificial rockwork and large dry moats contained the animals in his zoological park. The biocentric approach is a basic conservation approach with advancement in captivity conditions and 'landscape immersion', which seek to place the visitor within the animals' habitat. The idea is to immerse people into habitats that they would otherwise not be able to experience,



bringing humans face to face with the animals that inhabit those environments. This reinforces the understanding that the animal and habitat are inseparable, reinforcing the principles of conservation.



Fig. 31 - Habitat replication at Henry Doorly Zoo

The Woodland Park gorilla exhibit took the zoo community's breath away and instantly rewrote the definition of Zoo. As the first realistic replication of habitats for gorillas, it enhanced the effectiveness of a zoo exhibit as conservation education, by providing an experience of encountering gorillas 'in the wilderness' and increasing the visitors appreciation of the gorilla itself (Fig.31). The levels of activity observed in animals while in their natural habitats are vastly higher than the levels of activity of animals confined to cages. In their new home their behaviour showed renewed curiosity and active engagement with their environment. Grant Jones and Jon Charles Coe were the landscape architects that created the gorilla exhibit in collaboration with director David Hancocks. Hancocks, an architect by training, sees landscape architects as leading the revolution in zoo design. The zoo-design field has become incredibly technical and architecturally challenging because there are no criteria. The most demanding challenges are those posed by the design concepts themselves, calling for recreation of natural habitats that meet the physical and psychological needs of wild animals. This high form of stagecraft helps achieve an appreciation of true wilderness. It is about changing people's attitudes, and the active experience encourages a receptive response to the educational message that lies at the heart of the zoo's mission.

Zoo design comes down to the animals. A zoo should be a place where people, animals, and plants interact. The only differences between wildlife parks, wildlife reserves and urban zoos should be the difference in the degree of the interaction and not the kind. There is no way that artificially created habitats will ever be truly natural. Predicting a shift towards a merge among similar institutions, L. Azeo Torre, FASLA, sees the future zoo expanding

into a collection of facilities including museums, nature centres, science centres, children's museums and botanical gardens, all historically segregated. Hancocks boldly states that zoos have outlived their time and purpose. He proposes that zoological and botanical gardens should become ecology gardens and he foresees that zoos will disappearing.

"Replenishment of the wild could be a next logical goal." - L. Azeo Torre (p.99)

SOURCE: Landscape Architecture, April 1997

DESIGN THESIS INFLUENCE

The well being of wildlife is positively affected when retained in a space that mimicks their natural environment. There is also an increased understanding of animals and nature by the public, and a heightened emotional connection to wildlife when viewed in these 'natural environments'. The application of artifice can become both an art and a science resolving human and animal needs.

Needs of wildlife determine the design of the facilities that house them. This was the case for the design of the RSPC wildlife hospital in Norfolk (Lindley 1993: 35-43). Specialists in the field of wildlife and animal care were consulted for input into design development. The Hospital supports public access to facilities for educational purposes but access is limited and the wildlife shielded as extensively as possible from the people. Neglect in the design for the human user can be seen in building. Although the animals are of utmost importance the human element cannot be ignored.

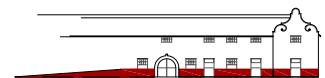



Fig. 32 - Hoedspruit Cheetah Project Centre, entrance



Fig. 33 - Moholoholo, wildlife holdings and display

The Hoedspruit Cheetah Project is a South African research and breeding centre for endangered species, established as a breeding and research program for cheetahs (Fig.32), expanded to include the breeding and conservation of other African species for re-introduction into the wild. The Centre provides the opportunity for the public to view the animals in closed natural habitats. This generates the main source of income for the running of the project (Karien Smit, Student Program Manager: Personal interview). The project has one of the best-developed facilities in the country, although Moholoholo Wildlife Rehabilitation Centre is the biggest (Fig.33). Brian Jones, founder and Manager of Moholoholo (personal interview), believes that a lack of public awareness is the biggest problem faced in conservation, and limited funding the biggest challenge for wildlife centres. Although the visitors are important to both centres, the wildlife/human interface is still under-developed.

design approach – ARCHITECTURE

design and restoration for new use - SAB VISITORS' CENTRE

South African Breweries (SAB) centenary celebration saw the adaptation of the Newlands Brewery, the oldest brewery and malt house in the country, into a visitors centre. The idea behind the visitors centre was to restore the old Mariendahl Brewery (1859) and malthouse with kiln (1892) for new use as a reconstruction of the history of beer-making for visitors guided through this "most historic part of Newlands" (Japha 1998:13).

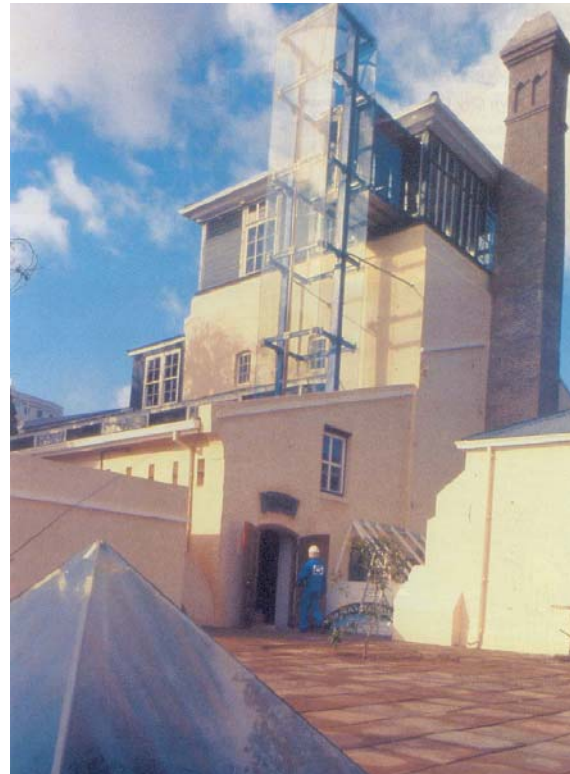

Fig. 34 - SAB Visitors Centre

The brief also called for the redesign of the landscape, provision of parking, lecture halls, dining and pub facilities for both staff and visitors and a memento shop. The 1863 distillery was also to be re-used as an environmental centre. The four discrete historic buildings are connected by a clearly defined visitors' movement spine and flow patterns for vehicles and staff. The new structures act as an ordering mechanism, connecting the historical elements and extending between the existing structures. Fagan's approach to conservation allows the historic fabric to acquire new use while the new is inserted carefully, visually separated from old - "coloured and coded as new" (De Beer 1995:13). Newly constructed walkways are literally colour-coded and constructed of modern materials, clearly contrasting with, and distinct from, the existing fabric, while leading visitors. High technology solutions used also show contrast: an information counter is freed from the floor through suspension, allowing the original to pass through and the counter to exist as installation (Fig.34).

Restoration, accommodation of new uses in old spaces and insertion of new materials and new structures are both creative and sensitive. Loose fitting structures order space and interventions are unmistakably legible, maintaining the integrity of the old while revealing themselves to the observer.

DESIGNER: Gabriel Fagan Architects
SOURCES: Architecture S.A., October 1995
S.A. Architect, November 1998





Fig. 35 - Front view of Bank Headquarters

“Since the 1960’s architects and developers in the West have had to devise acceptable ways of dealing with history, other than knocking down inconvenient old buildings... Crudest of all has been... whereby the exterior has been kept to satisfy planners while interior has been gutted... The other extreme of imagination is exemplified by work... where the new structure barely impinging upon the antique host shows how exhilarating can be conjunction of old and new” (p 28).

The Dutch practice of Erick van Egeraat Associated Architects was to convert an Italianate, nineteenth century building into the headquarters of the Nationale-Nederlanden Hungary and ING Bank (Fig.35). This rather conventional refurbishing project gained life and verve when a new structure protruded through the roof, disclosing the presence of the twentieth century in the building.

Unlike the glass and steel structure of Coop Himmelblau that appears to have swooped down on top of roof of a law firm in Vienna, a foreign structure seems to have evolved organically, swelling both down into the building and bursting out of the roof. The structure houses a boardroom, café and connecting staircase. This addition is known as the whale, its form grown out of special requirements, irregular curves moulding to the confines of the existing building.

The structure also acts as a lantern, bringing southern light into the building. Constructed mainly of wood and glass, the structure echoes the “structural grace” (p 31) of an old wooden ship as it ‘floats’ in a glass roof (Fig.36).

The first visual encounter is defined by extraordinary contrast. Rooted in Empirical pretension, the old building is ordered by solid, architectural, Classicism hierarchies. The new structure is organic, devoid of straight lines and angles. The architecture is expressed in light and air. At first there were public concerns about the presentation of the existing buildings integrity, but connections can be made between the abstract qualities of the old and the new, both informed by sensuality.

DESIGNER: Erick van Egeraat

SOURCE: The Architectural Review, July 1995

DESIGN INFLUENCE

New life can be breathed into an old building without destruction of its value and integrity. The dignity of the original structure and its architecture can be preserved through restoration and the accentuation of that which is new and has been added or changed. The use of original elements of the existing structure can bring value to the project and new additions while, contrasting of elements acknowledges time passed and the difference between the old and the new, the past and the present. Exposing some of the new interventions in the building to the outside shows honesty in the refurbishment approach.

The refurbishment of Hamilton Hall (Fraser 2004: 110-114), a stone clad neogothic building on an active university campus, shows the bridging of two time periods, moving the old building into a new stage of life. The exterior of the building was left unchanged while a modernist interior formed inside. This project shows how two contrasting architectural styles can be brought together. The needs of the user were researched and formed the basis of the design, giving the building new significance. Importantly the project shows how the making of substantial changes to sentimental old buildings will always be controversial to the public, even when the design is a success.

Approaches to working with historical buildings change over time with the development of contemporary ideas and underlining mindset of the period.

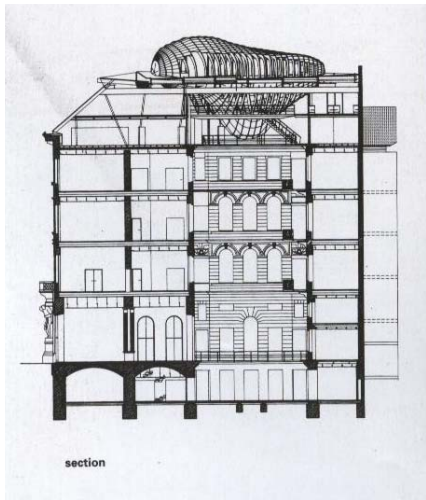
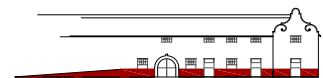

Fig. 36 - Section of Bank Headquarters



DESIGN DISCOURSE



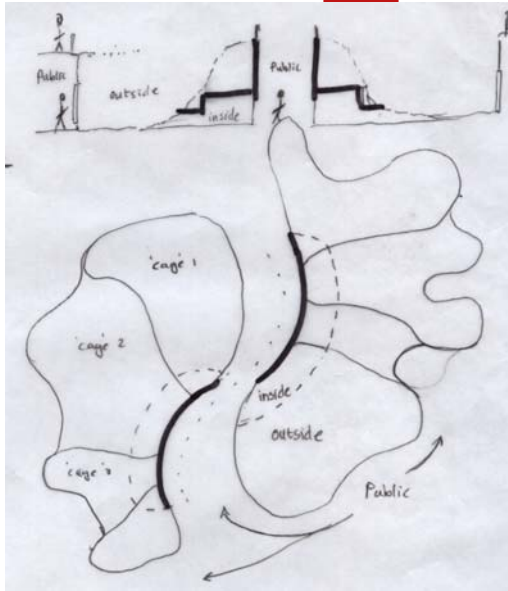

Fig. 37-Wildlife holdings concept sketches

The struggle between nature and human development takes place daily, as designers are constantly confronted by this interface. Man has become very conscious of the earth's finite support capacity and all fields of design have turned their focus to the preservation and the appreciation of our natural surroundings. A search has developed for an approach to balance these two forces. Conflicting needs and interests make design a constant challenge and, no perfect solution exists although there are many opinions on the subject.

Contemporary literature on the subject and the research of precedent studies (pg.18 - pg.23) has laid the basis for the site development for the Wildlife Research and Rehabilitation Facility. The driving question behind the project is: should man-made artefacts mimic nature and do simulated environments need to look natural in order to sustain a healthy ecosystem? Decisions made were based on two important dynamics that occur within such a facility. First is the effect simulated natural environments have on animals in captivity as opposed to more prominently artificial environments. The second is the educational approach to wildlife and their natural environments.

For the welfare of the wildlife, it was decided that wildlife be retained in environments similar to their natural ecosystems. This approach has also proved itself good for educational purposes, presenting the animal in its 'natural surroundings'. People need to get close to the wildlife without disturbance and changes in behavioural patterns. The wildlife enclosures are to be naturally developed as far as possible. No decorative artifice mimicking nature is to be used, and where human construction is added, the additions are to look man-made, but where possible, be constructed out of natural materials readily found in nature such as wood and stone.

The conceptual designs for wildlife holdings suggest means of developing the interface between wildlife environments and connected human space (Fig.37 & Fig.38). Landscaping can be used for segregating spaces, controlling traverse movement. Screens could allow people to see the animals while shielding them from animal view. The rehabilitated habitation is not confined to the wildlife holdings, but natural vegetation continues out into human spaces of movement, connecting the physically separated spaces.

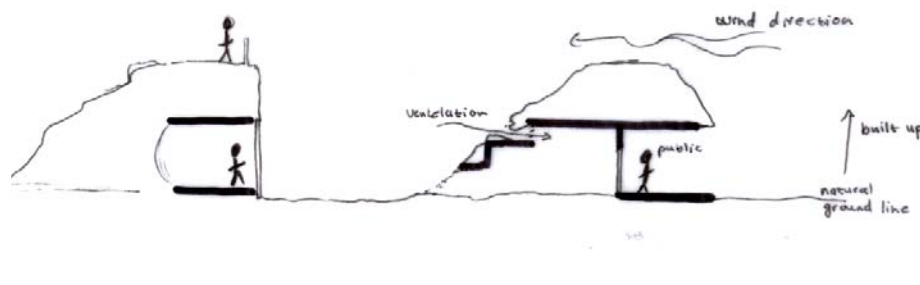
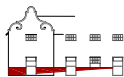

Fig. 38 - Wildlife holdings concept sketches



The unique characteristics of the Experimental Farm as site have a direct impact on the architectural decisions made in the development of the project and moulded the design approach. The strong existing axes generated by the design of the main buildings on site, influenced the formation of a new order around which new development is structured. The rigid rectangular shape of these separate, symmetrical buildings, inspired the shape of new spacial development that flows from, penetrates into, and forms between existing structure and links them. The new order, spacial approach, and material choice, are distinct from the primary buildings to which they respond, and are influenced by the new functions that are accommodated, visually conveying that there has been a change in use.

Finding a structural aesthetic - DESIGN PROCESS

The structures on site all have distinctive visual impacts and bring a variety of materials and connotations to the overall experience.

The pivotal point of departure is the unmistakable Gerhard Moerdijk approach to a Cape Dutch derivative architecture, and demands attention, establishing the farm building as the focal point. One is humbled by the presence of the building and the significance of the old architecture (Fig. 39). The building exudes a sense of history and provokes feelings of nostalgia, hinting at times past and what the building was used for. Important and defining elements of the original architecture are to be maintained and restored as close to the original design as possible. This approach shows respect for the existing and upholds the dignity of the original building.

Changes and additions made to the main building and the associated structures immediately behind it are to be acknowledged. This is achieved through the use of a contrasting architectural approach, making use of design elements to create a sense of juxtaposition playing old against new, light against heavy, light against dark. The heavy concrete architecture of the old is accentuated by light transparent façades of the new, creating a dynamic, which evokes the contemplation of space and experience.

The functional shed type structures on the site are the inspiration for the newly developed architectural language of the project extensions. As examined in the context study, the shed structures were added to the site after the development of the original structures and explore an alternative approach to structure and construction. The original architecture relies on thick-load bearing walls and numerous heavyset concrete columns, whereas the sheds use of a steel skeletal structure frees the façades and reduces the amount and size of support columns needed. The shed structures also influenced the choice of material and material use. Referring back to the context study (pg. 015), the existence of a material hierarchy can be deduced, and the materials used in the construction of the 'secondary type' structures are predominantly used in the new architecture. The concrete of the primary existing buildings, is painted, as well as the wooden doors and windows. The roof of the main building is tiled but the related structures of less importance have painted corrugated iron roofs. Looking at the shed structures, steel and corrugated iron is extensively used and left visually in its 'raw' state. This is also true of the use of concrete. When materials are joined, the joints are also left exposed and convey the function of the different elements, promoting and honesty with regard to structure.

A direction of progression in structural development is thus already established on site, and points to a more hi-tech approach as the possible next step. The intended effect is for the new architecture to establish a relationship with the old, where the new does not detract from the old by overpowering it. Conversely, the new should not be submissive to the point at which the importance of the new function of the building is lost or undermined. The new architectural language should establish its own sense of space and place while relating to and complementing the old architecture through means of contrast.



Fig. 39 - Gable of the main farm building

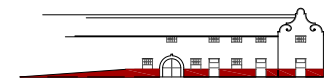

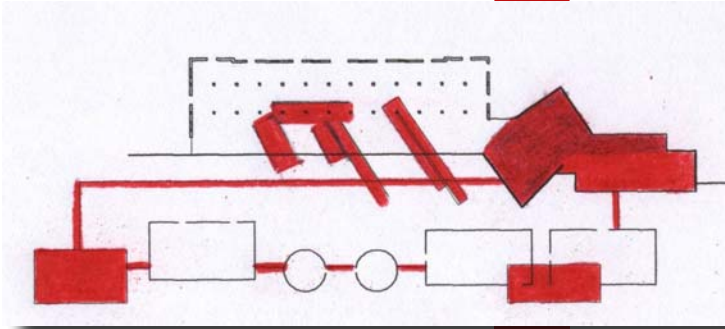

Fig. 40 - Moulded rectangular spaces of new construction

The main farm building and the three small buildings right behind it are all separately developed boxes of rectangular shape. In order to maintain a connection between the special experience of the old and new, newly developed spaces are based on this geometrical shape. The repetition creates rhythm and ease in recognition. In keeping with the less rigid approach of the new structural aesthetic, some of the new rectangular spaces are subtly deformed, stretched and moulded to relate to each other and the functions they house (Fig.40).

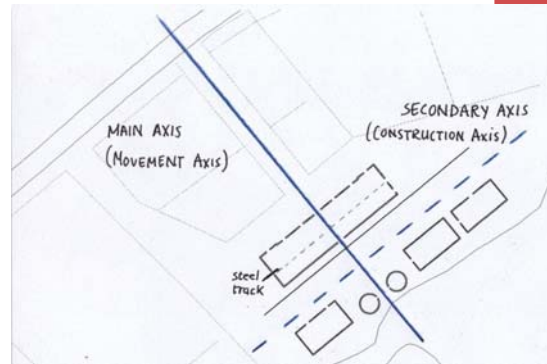

Fig. 41 - Existing axes

The Cape Dutch architectural style embraces symmetry and is prominent in the plan and façades of the main building. As established, a very strong axis runs up to the front façade of the main building and out between the two silos establishing a line of movement. The rectangular form of the main building and the related structures behind it are orientated perpendicular to this line forming a secondary axis. The secondary or 'construction' axis is emphasised within the main building by its elongated shape and a steel track embedded in the concrete floor, right in the centre, running from one end of the building to the other (Fig.41). To establish a new identity for the new architecture, and help distinguish old from new, a new axis is established to order construction.

Approaching the site on the main access road from the established western entrance of the Farm, the first visual encounter with the building is on a west-east orientation. Having moved past a shield of trees, you are confronted with this unexpected architectural node. A gravel road branching off the tarred main road leads the eye up to the centre of the short end of the main building, lining up with a silo protruding from behind the roof (Fig.42). One is drawn down this path. This line establishes the direction of the new 'movement' axis. As with the old axes, a new secondary axis line or 'construction' axis is established perpendicularly to the new movement axis (Fig.43). The new movement axis takes reference from the past, acknowledging the original entrance and access to the site while the new construction axis makes reference to the future, acknowledging the new entrance to the Farm and progression in the development of the Experimental Farm.



Fig. 42 - Visual of building along new movement axis

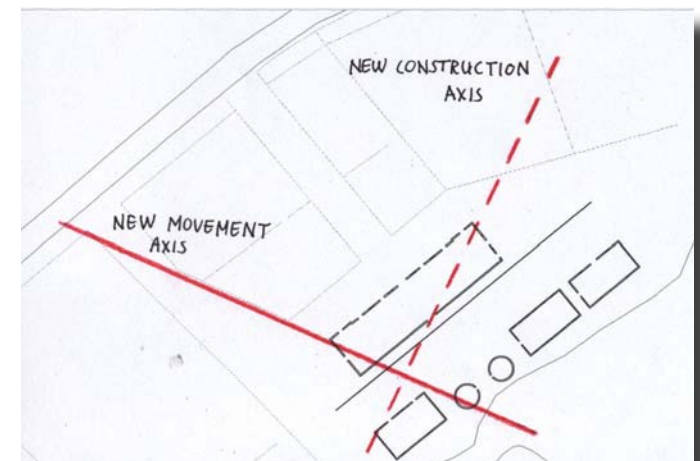

Fig. 43 - New axes



By establishing the new set of axes a new order is developed within the architecture, which not only distinguishes itself from the old but also emphasises the old order through contrast.

zones of interaction and use - DESIGN PROCESS

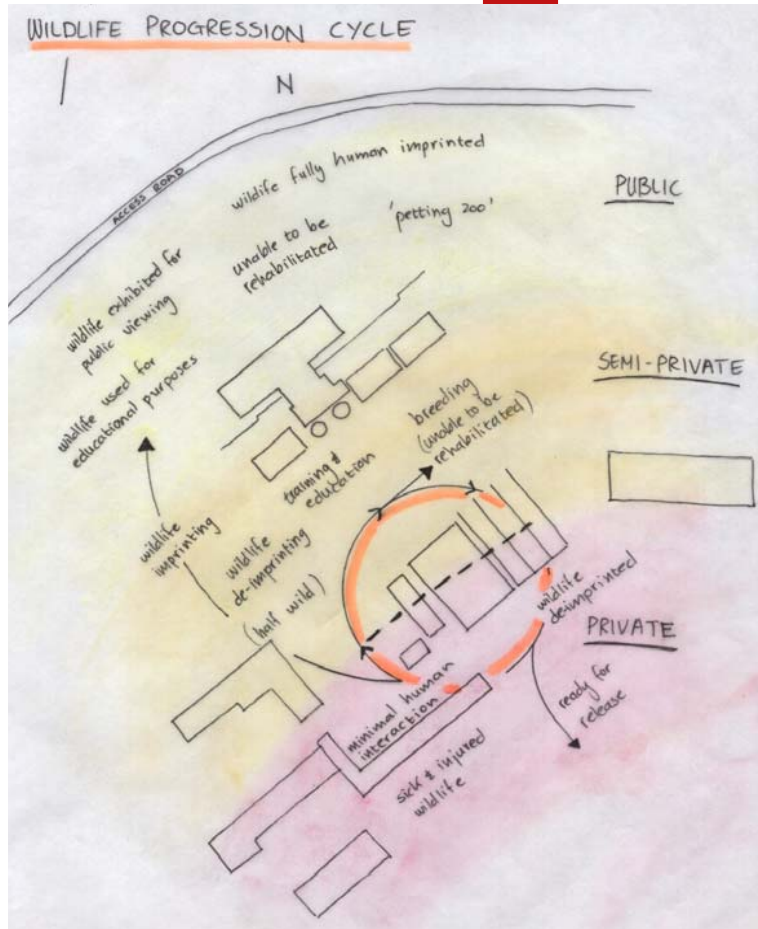

Fig. 44 - Access zones and movement of the wildlife

The project requires three main functions: retention of wildlife in healthy environments; education, medical care and research development; and public education and entertainment. The idea behind the centre is to help educate the public through exposing them to some of the working facilities that are the basis of the project, while taking into consideration the specific needs of the wildlife. In order to regulate the extent of interaction between visitors to the Centre and the people who work on the premises, and the interaction between wildlife and humans, three zones of interface are established (Refer to user profiles in the Appendix A (p. 095) for information on the needs of the human user as linked to the zones).

The first zone is the public zone where visitors move freely through areas of educational entertainment, positioned on the north end of the site closest to the main access road. The main farm building falls within the periphery of this zone, functioning as a point of transition to the next. The wildlife housed in this zone are animals and birds that have come to the Facility but are unable to be fully rehabilitated back into the wild. This wildlife is familiar with human interaction and used for educational purposes.

The second zone is a semi-private zone. This zone acts as a buffer between the public and private areas. The zone includes the formal educational areas and the start of practical working areas associated with animal care, and related research. It is an interface between visitors to the Centre and people who have functions to perform at the Facility. This interface allows an extent of interaction between the two groups and gives the visitor insight into the functioning of the Facility and the realities that surround it. Access to wildlife in this zone is controlled, granted only to specific groups of visitors. Viewing of wildlife demands distance than in the public zone to shield the wildlife from excessive human interaction. Wildlife in these zones are animals and birds undergoing rehabilitation in its earlier phases and wildlife that are unable to be fully rehabilitated and are in a breeding program.

The third zone is the private zone. This zone is under strict control and not to be accessed by any visitor to the Centre and only open to workers who have been granted access. This sector includes working areas related to the medical care of the wildlife and research. The wildlife that is held in this area, are animals and birds that are sick or injured and in need of intensive care and observation, or quarantine. Wildlife in final phase rehabilitation and ready for release are also held here, as they require as little human interaction as possible. The zone is positioned on the southern end of the site, furthest away from the main access route but next to a secondary access road for the movement of wildlife to and from the site, and for the delivery of medical and food supplies (Fig.44).

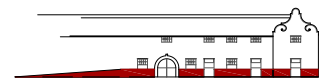

Wildlife Research and Rehabilitation Facility – DESIGN

overview of concept development - DESIGN

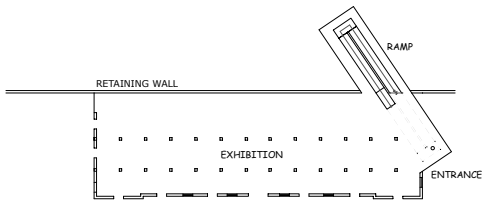

Fig. 45 - Concept
- entrance at side of building, defined by ramp



Fig. 46 - Arched entrance to main building

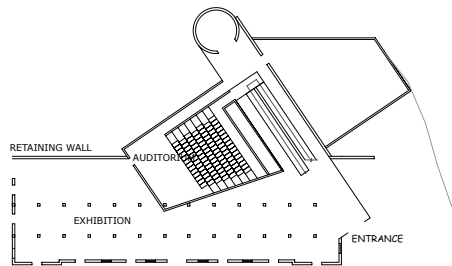

Fig. 47 - Concept
- auditorium cut in behind retaining wall

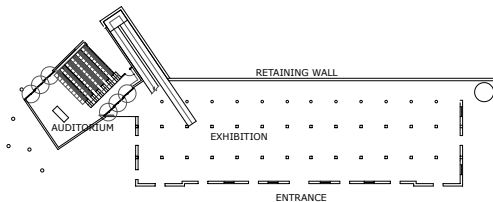

Fig. 48 - Concept
- Shift of ramp and auditorium

The main farm building was immediately established as the Facility's Visitor's Centre. The building is closest to the main access road, and together with the structures right behind it, has cumulatively the most space to offer for the Centre's extended needs. The building is visually the most important as it is a focal point on site. The existing structure is already an established visual icon identified with the farm and used to create an identity for the new facility. The Centre becomes a public interface where visitors are introduced to the facility and its workings.

The main building and the related structures right behind it were developed to house the following functions: an exhibition space, an auditorium, lecture rooms, laboratories, administration facilities and a refreshment area. The functions to be accommodated by the existing structures to the south of the site were the practical and medical care facilities for the wildlife, the wildlife kitchen and a wildlife drop-off area where sick and injured animals are admitted.

As the design developed, certain functional spaces were moved to adapt to a more informed design. The main entrance to the farm building initially remained as the main entrance to the new facility, but with the development of the new axis that approach the building at an angle, the access changed and a new entrance was punctured through the side of the building on the angle of the new movement axis (Fig.45). Further examination showed that, although the entrance was adequate when approaching the building from the original western entrance to the Farm, it has little impact when approached from the east, which is likely to become established as the main direction of approach in the future. This new entrance was also undermined by the visual impact of the original large arched doorway, which screams ENTRANCE (Fig.46). For these reasons the decision was taken to maintain the original point of entry, and a double story glass box encloses the arch doorway, defining a 'new' entrance to a new building function.

The large size of an auditorium made the space hard to place. If placed inside the old farm building, the largest existing volume, it would take up too much space. The auditorium is zoned as semi-private and not for use by general visitors. This makes placement of the auditorium in the main structure inappropriate, as the main building is primarily a visitor's centre. Finding placement for this function led to experimental utilisation of the 'space' behind the retaining wall, below the retained ground level (Fig.47). The auditorium finally punctured out the northeast end of the old farm building, separating itself from the building and the public space, yet maintaining easy access for the public from this structure (Fig.47). The placement of the auditorium ignited the development of other semi-private functions around it.

A ramp was decided upon as means of moving between ground level and 'first floor' on the elevated ground level behind the retaining wall. This decision was made in direct response to the need for disability access. The ramp was formed on the order of the new movement axis. Working at an angle made it easier to handle the substantial required length of the ramp in such a narrow space. Initially positioned on the southwest end of the building (Fig.48), the ramp helped define the side entrance before the entrance changed back to its original place. The ramp was settled on the opposite side of the building (Fig.48), influenced by encouraged movement patterns. The ramp visually starts to separate public zone from semi-public area. As you enter the building, the functions to the right of the ramp are orientated towards public interaction and entertainment. The facilities developed to the left of the ramp are more educationally orientated towards student lecturing, practical work and educational visitor programs.



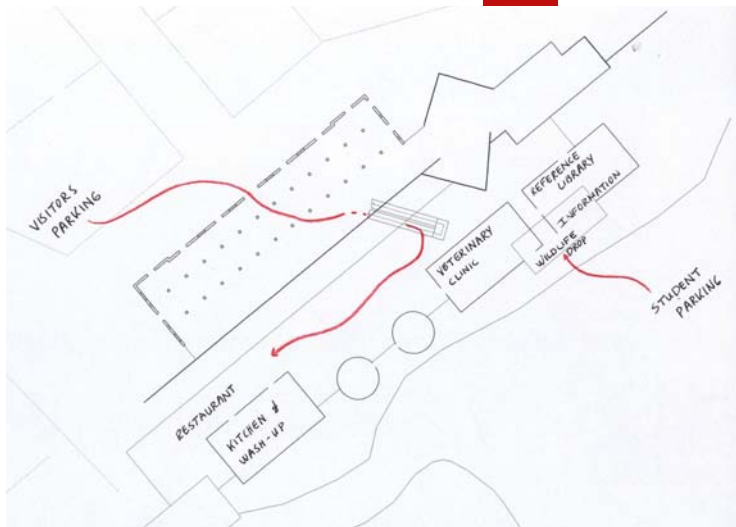

Fig. 49 - Movement Diagram

Limited space and the need for the laboratories to be close to the medical care facilities saw the shift of the laboratories up to the southern end of the site. Alternatively the access of the public to the south of the site to deliver injured wildlife was inappropriate. An animal drop-off for use by facility workers was kept at the south end, but there was a need for the inclusion of a wildlife drop accessible to the public within a semi-privately zoned area. The drop developed behind the auditorium as a student practical area along with a temporary holding and veterinary clinic. The drop is accessed from the employee parking area (Fig.49). The refreshment area moved with the shifting of the other facilities and elements in the design. This area was finally established behind the main building on the southwest corner of the first floor level. The facility falls within the developed public zone and looks out over the children's educational playground so that parents can keep an eye on their children while relaxing. The Facility is easily accessed from the visitors parking either through the main building or from the outside. When accessed from inside the building, visitors are drawn up the ramp where a visual connection is made with the veterinary clinic, encouraging visitors to have a look before moving on (Fig.49).

experiencing the final product- DESIGN

EXTERNAL IMPRESSION

Approaching the Wildlife Research and Rehabilitation Facility from the new eastern entrance to the Experimental Farm, the old Cape Dutch farm building comes into view. Although focus falls upon the main building, one's eye is drawn to the closest end of the building where a familiar yet foreign structure protrudes out the side, its form broken by a cluster of old pine trees (Fig.50 & Fig.51). Moving closer, the façade of a new building starts to clarify.



Fig. 50- Cluster of Pine Trees

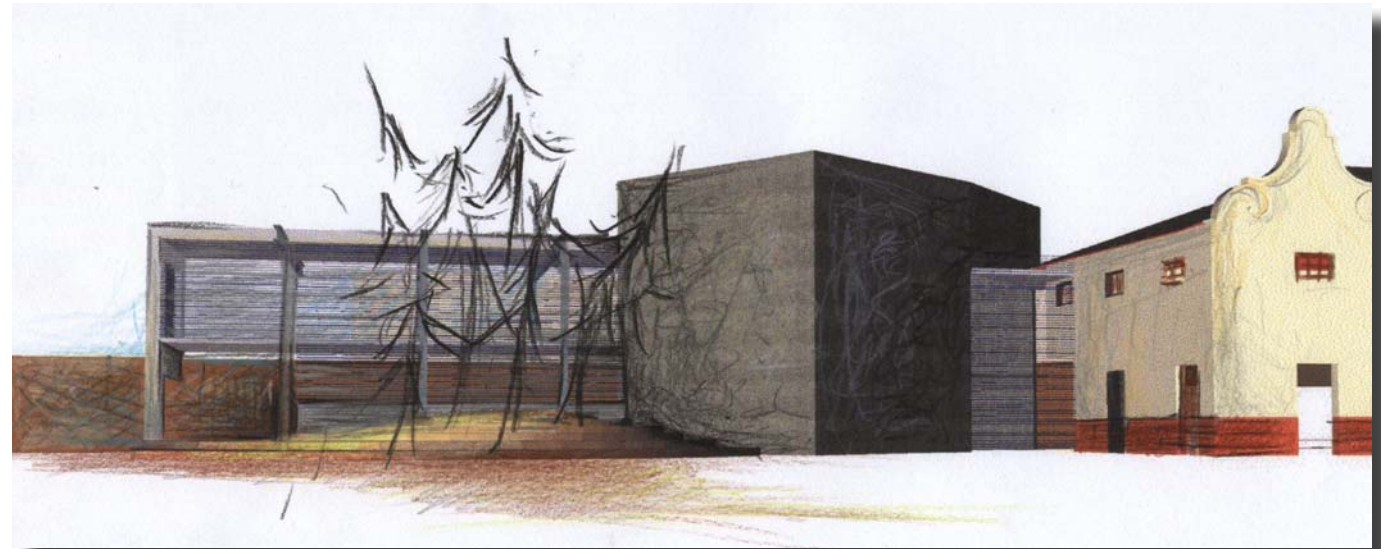

Fig. 51 - Perspective of exterior of building

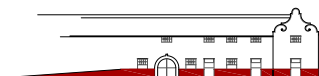



Fig. 52 - Concrete columns and beams as seen from outside



Fig. 53 - Steel cocopan track as seen from end of building

Lightweight and almost transparent, the façades seem to hang from a pronounced steel structure. Large steel I-beams relate to the load-bearing concrete walls of the old building by forging an impression of raw strength and stability while remaining comparatively light in weight. The repeated steel columns find extended rhythm in the repetition of tall pine tree trunks. A glass-front façade creates the impression of a volume open to the outside. Aluminium sun louvers soften the sleek glass plane and minimise glare. The steel support structure and use of corrugated iron in the façades connect visually with the typical farm shed structures further up the site. The beams carry a concrete slab roof, as if drawn out of the concrete wall of the old building, which lies across the top of the steel beams and turns 90 degrees towards the ground to form a load-bearing wall. A reinforced concrete edifice protrudes at an unexpected angle defining the light steel structure on the one side from the old heavy building on the other. The concrete connects back to the walls of the old building, but with the concrete surface left unfinished, the new structure establishes a connection with the raw concrete feed troughs and shed construction on site.

A grass-topped outcrop of earth leads up to the front of the glass façade of the new structure. Large swivel glass doors open up onto this grassed area, and although this entrance to the building is inviting, the entrance is not pronounced, and is sheltered by the cluster of trees. This communicates a feeling of privacy. One's attention is thus drawn back to the old farm building as one moves towards its prominent red brick arch entrance.

TRANSFORMATION OF THE OLD FARM BUILDING

Entering through the double wooden doors of the arched entrance, the building opens up into double volume. Concrete support columns and beams define a grid that structures the ground floor volume, although no longer supporting the concrete floor slab that used to separate it from first floor (Fig.52). The roof is entirely supported by the load-bearing external walls, leaving a large open space. Drifting into this volume, foreign boxes lightly settle on retained sections of the original concrete floor slab. The sides and tops of the boxes consist mostly of glass and some corrugated iron. Visual access into these spaces is controlled with horizontal louvers. The spaces connect aesthetically and structurally to the architecture encountered outside the building (Fig. 55).



Fig. 54 - Stone retaining wall behind main building

The old, polished concrete ground floor is retained, fragmented by marks left by the demolished internal walls. A transparent liquid epoxy is poured over the existing floor surface to level the walking surface while preserving the original flooring. A cavity in the centre of the floor houses the rail of a steel cocopan (Fig.53). Also filled with transparent epoxy, the rail is conserved in a solid cast while forming an even walking surface. The roof trusses are left exposed, while interior walls, concrete beams and columns are repainted in the original white paint finish.

Reducing the surface of first floor and creating a double volume, light quality is significantly improved in the new space due to light penetration previously separated, collectively illuminating the space. The back wall of the ground floor is replaced by steel columns, exposing the stone clad retaining wall behind it (Fig.54). The use of steel I-beams to support the concrete façade of first floor connects to the new architecture, and visually conveys that this is a change made to the original building. The newly created space behind the columns is covered by glass running at an angle from the façade of the first floor to the retaining wall that is the new back wall. Natural light floods into the building through the new glass roof, increasing lux levels and



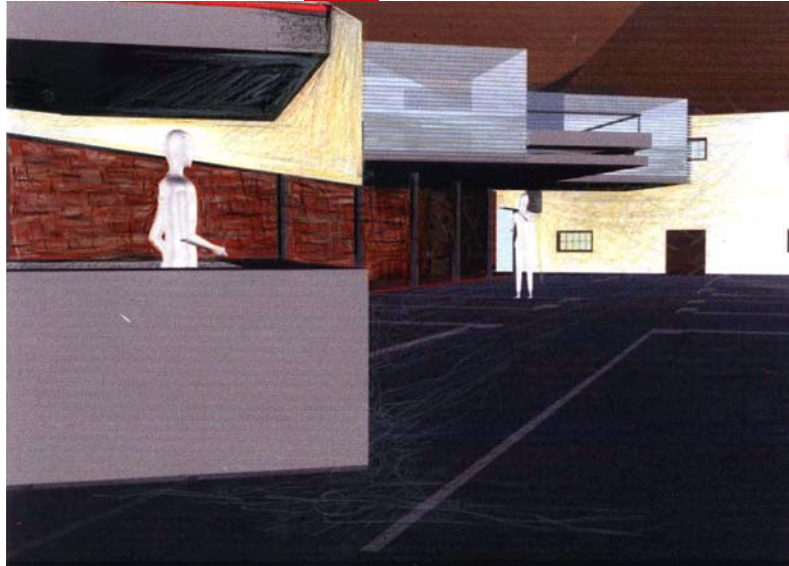

Fig. 55 - Floating glass boxes

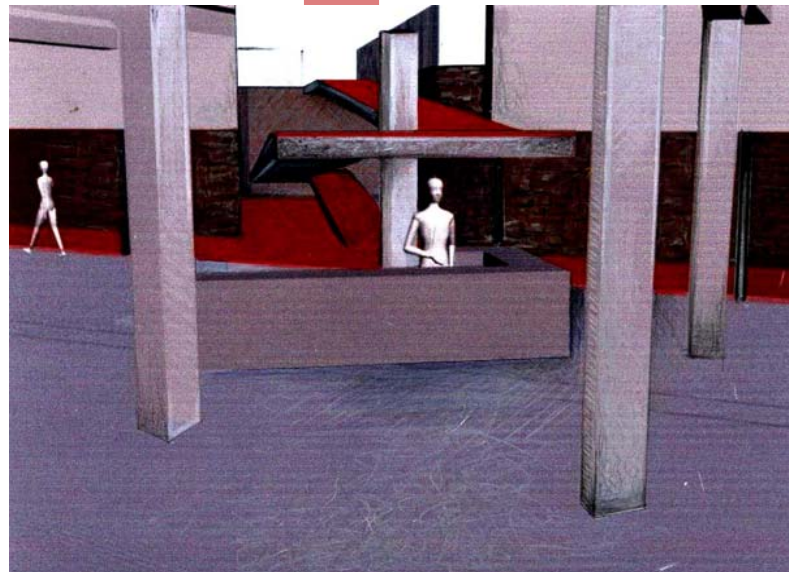

Fig. 56 - Ramp inside building interior

illuminating the stonewall which is a defining feature. The decision to open ground floor right up to the retaining wall will help cool the air temperature within the main building. Ventilation grills are introduced at this interface to facilitate natural airflow through the building, effectively increased by the prominent air circulation that forms within a double volume.

The main building houses the educational exhibition space. Exhibition material can be suspended from, attached to or stretched between the concrete columns and beams, engaging the old with the new. Large boards could swivel on central axes, directing flow of movement in different directions. Full advantage should be taken of the created double volume. It is proposed that interactive television screens form part of the display. Live video feed could be shown from inside wildlife cages inaccessible to the public and controlled via display panels. Cameras could be placed inside laboratories and the medical care facilities to give visitors a look into the functioning of the Facility.

Dichroic reflector lamps are to be used as spotlights for the exhibition where additional illumination is needed, for example, on reading material, and for night time illumination. These small lamps can run across the bottom of the concrete beams and be suspended on cable between the outer walls running in the same direction but placed above the spaces between the beams. The same lamps are used in floor fittings placed along the base of the stone retaining wall to light it up at night. Air conditioning is exposed and runs along the middle of roof, suspended from the roof trusses (Refer to Technical Resolution p.044 for information on the air conditioning system).

The ramp is a prominent feature in the building, and is orientated at an angle in the direction of the entrance. On entering the space, the ramp is situated to your left with the exhibition running from the right, up to the ramp. To the left of the ramp a foyer space for the auditorium unfolds drawing a line between entertainment orientated and serious educational facilities as previously examined (Fig.56). Symbolic of the rehabilitation process, the ramp starts by puncturing into the earth behind the retaining wall. Gabions are used for the new retaining wall and are formed close around the ramp. The triple twist wire used for the gabions connotes the wire cages traditionally used to hold animals and birds. The walk up to the first landing, into this 'cage' represents the admitting of the injured or sick wildlife to the Facility, and its medical treatment and initial recovery in intensive care. One of the walls consists of panelling for pictures and photographs. The next rise is the longest and symbolises the road to full recovery. The ramp leads out into the double volume to the second landing suspended in the space between building walls. From intensive care, the creature is placed in a larger holding close to its natural habitat but still confined. The last rise symbolises the final phase of rehabilitation, which involves weaning the creature off human dependence and releasing it back into the wild. This can be seen in the movement of the ramp out of the main building and ending alongside an external landscaped area. The ramp consists of unfinished reinforced concrete which links to the raw concrete floors in animal cages and the feeding troughs on the site. The walking surface of the ramp is a bright red liquid epoxy, which hints at the floors and work surfaces in laboratories and animal clinics.

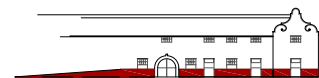

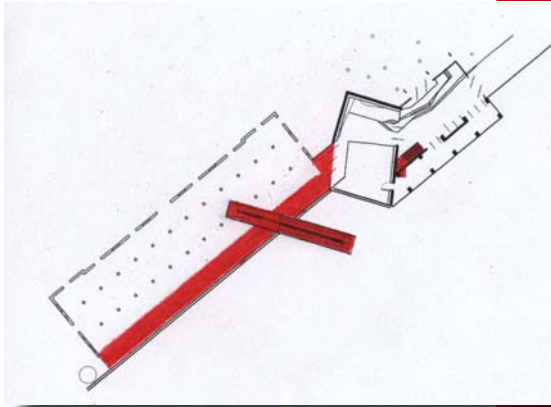

Fig. 57 - Placement of colour

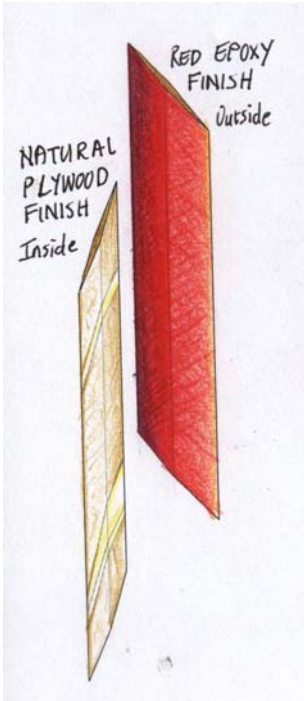

Fig. 58 - Door concepts

SYMBOLISM OF COLOUR

Just beyond the far corner of the eastern façade, two storey high doors announce the beginning of a new space. The doors are finished in a brilliant, shiny red epoxy that links to the ramp. Just like its use on the ramp, the red becomes an indicator of transition across boundaries or the movement into a different zone classification (refer to p29, zones of interaction and use). The ramp cuts through the stone retaining wall and creates a path of movement from the one side to the other, symbolising a new path of transition across an old boundary (Fig.57). The doors separate the public exhibition space and foyer from the semi-private zone of the auditorium and lecture room beyond. The red liquid plastic looks like it has run off the vertical surface of the doors and onto the floor. A red floor surface lies between the red façade of the doors and the concrete floor finish of old building. The red floor becomes an indicator of transition across the old façade into the new space or auditorium. Red epoxy flooring then runs along the stone retaining wall, between the retaining wall and demolished back wall of the building, again showing movement across a previously existing boundary into newly created space.

FUNCTIONAL DESIGN FOR DRAMATIC IMPACT

As the transition between spaces is such an important design point of departure, the doors have become more than just functional objects but have developed into design elements of orientation, and the separating and merging of spaces. The doors leading to and from the auditorium are the boldest example (Fig.58). The height of the doors, which range between 2.5m and 6m, makes them look narrow although they are 1.8 metres wide. Their narrow appearance is also due to the refined fin shape, as seen on plan, with the door narrowing to its ends and a seam line created down the middle where the door is at its widest. The doors swivel on a central mechanism and can move along a track. The swivel mechanism allows for the doors to be opened separately, as many and as wide as required. Directional rotation of the doors can be used to direct traffic flow in smooth lines or the doors can be moved to the sides to open up the façade totally. When closed, the door panels overlap for acoustic sound insulation purposes, and the tapering of the doors allows for a smooth, wavelike façade finish.

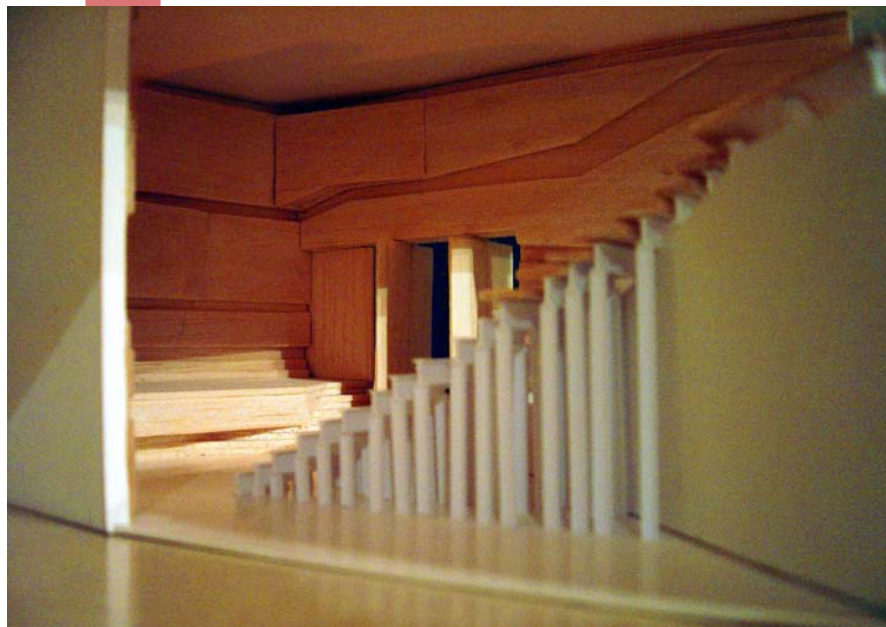

Fig. 59 - Perspective view into auditorium

THE AUDITORIUM

When the doors are swivelled open, a warm, natural, wood clad auditorium is revealed. Natural light floods the space through the glass façade that joins the old building and the auditorium (Fig.59). Finished in wood, linking to the finishes of the auditorium, the inside of the doors contrasts with their external red plastic finish. As you move into the auditorium, a steel I-beam structure supports raked seating for 60 people. The beams and columns join together in a manner that visually recalls the steel support structure in the new architecture. The old stone retaining wall that runs along the back of the main building, slices through the middle of the auditorium as the seating structure starts to climb over it on long steel legs. The open structure of the raked seating contrasts the solidity of the thick, clad walls that surround it.



Three air-conditioning ducts push through the stonewall and curve 90 degrees upward ending in ventilation grills. The exposed ducting communicates well with the steel in the space and the exposed joints of the structure. The colours that come together in the auditorium are the ochre yellows of the wood, the yellow, brick-red and blue-grey in the stone of the retaining wall (Fig.60), and the steel-grey of the steel from the seating structure. A new concrete floor runs through the auditorium and the adjoining lecture room. Where a section of the old retaining wall was removed to make space for the raked stairs and movement between the spaces, stone has been laid into the concrete, flush with the walking surface, as a reminder.



Fig. 60 - Stone of old retaining wall

COMMUNICATING AN IDENTITY

The auditorium itself is a space of transition and integrates design elements of the old with elements of the new architectural language and functions of the facility. The visual solidity and thickness of the auditorium wall connects back to the concrete load-bearing walls of the original architecture. The use of plywood planks as wall cladding brings a sense of nature into the interior, which is an important concept behind the new architecture. Although wood has been used in the existing building, the wood product and its application in the auditorium is new. The old wooden doors and windows are painted in a dark brown, hiding its natural qualities while the plywood is treated to maintain the colour and texture of the wood. The comparatively light steel seating structure speaks more clearly of the new construction and choice of materials beyond. Epoxy flooring is chosen for the horizontal surfaces that cover the seating structure. Previous use of epoxy in red, and its transparent form maintains continuity in the finishes. The surface looks textured and is a light wood colour.

METAPHORIC INTERPRETATION

The lecture room adjoining the auditorium cuts away a section of an existing outcrop of earth. The cluster of pine trees takes root in the raised piece of ground, and is of great aesthetic influence. The trees are old and have a historic link to the identity of the old farm building. Cutting into this mound raises the level at which movement between the inside and outer landscape can take place. As the natural contour of the land was disturbed, metaphoric contours developed in interpretive horizontal planes. The abstracted contours move down into the building, symbolically pulling nature into the building without using imitation. This approach links to conclusions drawn from the debate about whether an artificial creation should be made to look like nature. Horizontal planes occur in 200mm thick layers and create steps that rise to the same level as the apex of the earthy mound. Among the stairs, planes stretch out to form larger landings and edges join to create vertical drops. The 'contour stairs' go beyond their function as an aesthetic feature or means of movement between internal and external space, by becoming a space of potential congregation and interaction where people stand and sit on the different levels. The stairs are clad in wood, indicative of their origin in nature. The contours are not retained in the lecture room but flow into the auditorium. The contours form steps up to a 'plateau' that is a stage. Top horizontal planes join to define a stage that juts out as bottom layers under-cut (Fig.61). Halogen tube lights are to be placed in a void under the cantilevering stage to create the illusion of a floating stage.

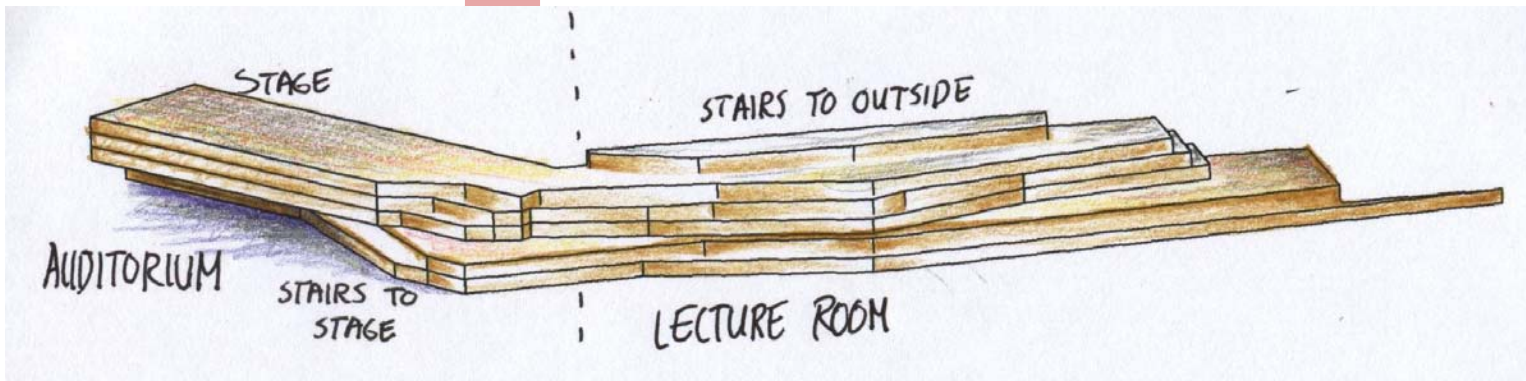

Fig. 61 - Perspective of stairs and stage

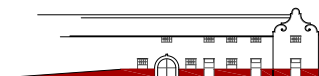



Fig. 62 - Inside auditorium, walls become one with stage

The stage/stairs that flow into the auditorium are embraced by the room, and the contours do not remain isolated but spread up the walls and cocoon around the space. Crevices cut into walls and run from the front of the auditorium down the sides in lines that emulate the stylised contours of the stairs and stage. Horizontal wall surfaces separated by crevices move out of the straight plane into the auditorium volume and angle back into the walls, as can be seen on plan, and form the projection surface where a hidden screen pulls out. The walls are clad in wooden planks, becoming one with the stairs and stage (Fig 62). The flow of line and directional change in planes stimulates a feeling of movement, bringing the inner shell of the auditorium to life. The auditorium walls are made up of 200mm wide concrete structural walls to which a specially designed steel frame is attached. The frame forms the contours of the wall that is then clad in plywood planks. The crevices are formed into the wall at different depths, emphasising the thickness of the walls. Florescent tube lights are positioned within the crevices, out of view. The voids in the walls are brightly lit while indirect light filters out into the auditorium creating atmospheric lighting (Fig.63).

RELATIONSHIPS BETWEEN ELEMENTS

The stairs/stage structure and the wall cladding structure are designed to relate to each other structurally and visually, and communicate as one. This is visible in the detailed interface where stage meets wall (Fig 64). At the back of the stage the floor plane meets the wall at a right angle where the wall cladding extends straight up for 200 mm and then cuts horizontally into the wall, forming the first contour crevice. The wall cladding then proceeds to move vertically upwards for another 200mm before cutting horizontally deeper into the wall. The steps that form the stage look as if they continue into the wall, becoming one entity. On the left side of the stage, the protruding stage platform slips straight into one of the contour crevices in the sidewall. The two structures fit together perfectly and the wall looks as if it had formed around the stage over time. In the same way the walls accommodate the

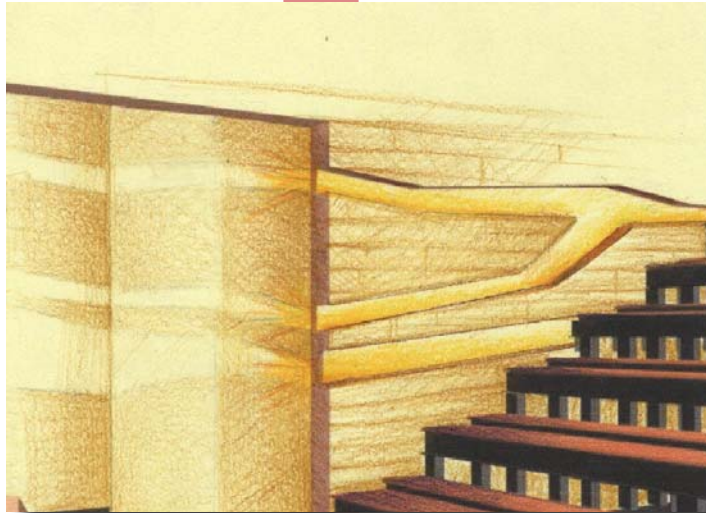

Fig. 63 - Contour wall lighting

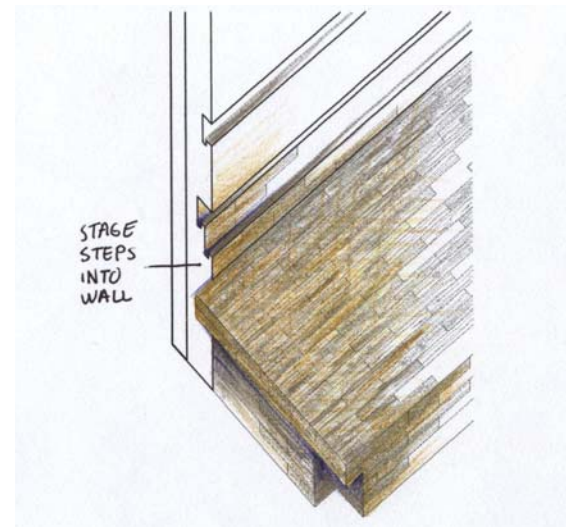

Fig. 64 - Joining detail of stage and wall

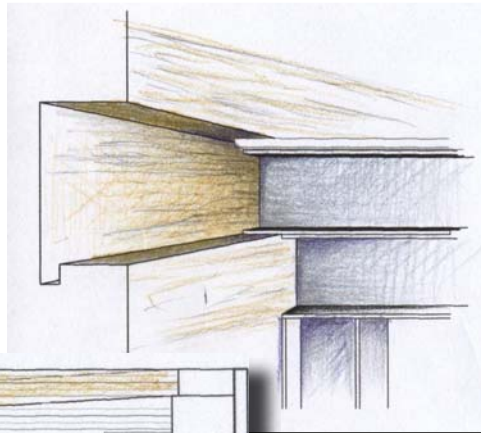

Fig. 65-Wall detail and I-beam connection

presence of the foreign, steel seating structure (Fig.65). Where contour crevices run perpendicular to steel beams, the beam extends into the cavity. These two very different elements thus begin to communicate.

The door surfaces that face the inside of the auditorium have the same plywood finish as that of the walls, but the plywood boards are used in large sheets. The fin shape of the doors and choice of material link them to the walls, but visual differences help maintain a separate identity. Where crevices in the walls meet the surface of closed doors, laminated plywood of a lighter colour is layed into the door finish, continuing the contour. Where walls make space for doors, wall ends expose the ends of the tube lamps placed inside, spilling light subtly out the sides, illuminating the contours on the doors like they do the contours of the wall (Fig.66). This detail shows the relationship that exists between adjoining doors and walls.

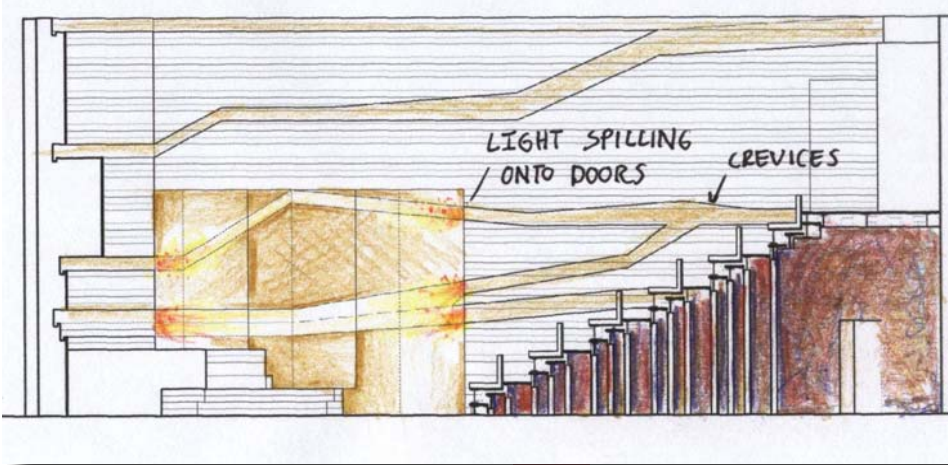

Fig. 66 - View inside auditorium of crevice light spilling onto doors

The steel seating structure does not communicate the same concept as the rest of the space that encapsulates it. The structure looks as if it was lightly placed into the auditorium and did not developed out of its surroundings. Slightly rotated within the space, the front of the seating structure is not parallel to the front wall or line of the stage but angled. This unusual shift assists flow of movement from the old building to the lecture room beyond, and has an impact on one's experience of it (Fig.67 & Fig.68). This twist encourages contemplation of the space.

Constructed of steel I-beams, the seating structure visually connect to the steel support structure of the roof and suspended floor in the adjoining lecture room. The steel structure is comparatively lighter than a visually solid seating structure,

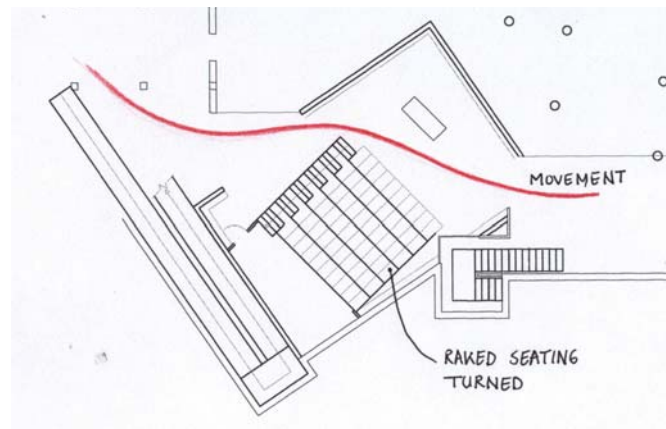

Fig. 67 - Movement in auditorium after rotation

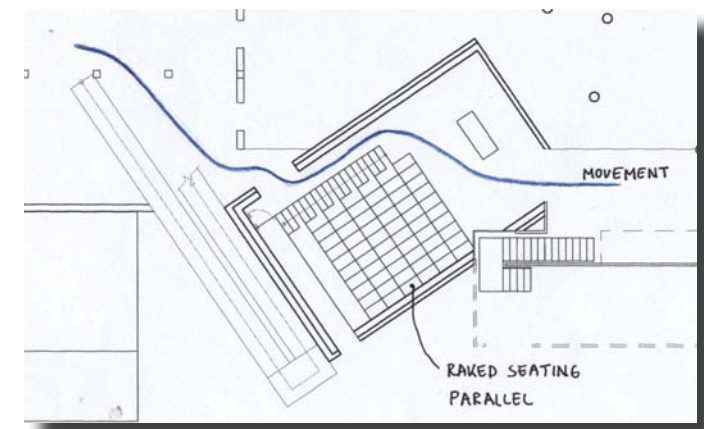
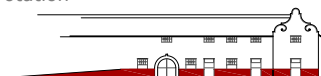

Fig. 68 - Movement in auditorium before rotation



yet heavy in design (Fig.69). It conveys an impression of strength and stability and is not overwhelmed by the thick surrounding walls and heavy retaining wall. The epoxy finish on the horizontal surfaces that cover the structure relates to the new architecture in that it is a relatively technologically advanced material not ordinarily used for this application. Added silica sand gives the epoxy a granular, slip resistant finish, and the subtle grey colour does not detract from the importance of the structure but links to the concrete floor. Connected to the seating surfaces are the bases of the seats, made of blonde plywood (Fig.70). Attached to this is sponge cushioning, covered in textile. The fabric is the colour of the surrounding wood but in a darker tone that does not show dirt as easily. The sponge cushions are easily detached from their plywood base for ease of cleaning or re-upholstery. Small foldaway writing surfaces can be folded out for note taking during lectures or seminars, and store away at the side of the chair.

Halogen tube lights placed within the walls provide the soft, atmospheric lighting for the auditorium, as previously discussed. The dichroic, sunken floor fittings used along the retaining wall in the old building, run right through into the auditorium, lighting the wall that disappears under the raked stairs. Cables suspending dichroic reflector lamps are spun across the auditorium from the one side to the other. One string of lamps runs above the stage while one runs in front of and another one behind the raked seats, illuminating the paths of movement. The number of lamps and the height at which they are strung is determined by quality of lux needed at these points and by the safety regulations for public movement 'corridors' according to the SABS 0400. Mini halogen tube lights are strategically attached to the raked seating structure, softly illuminating the treads of the stairs and walking surfaces in front of the chairs (Fig.71).

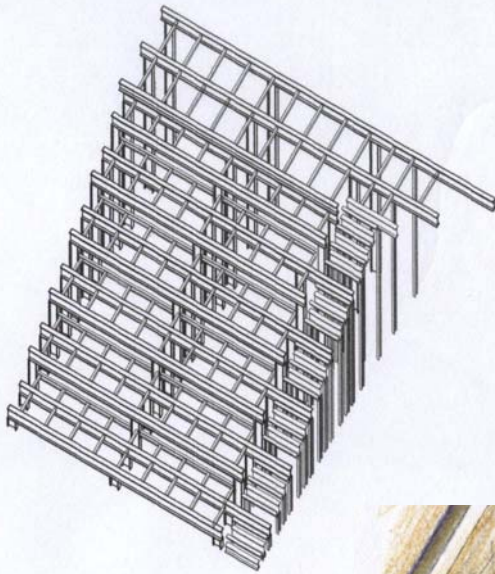

Fig. 69 - Steel seating structure

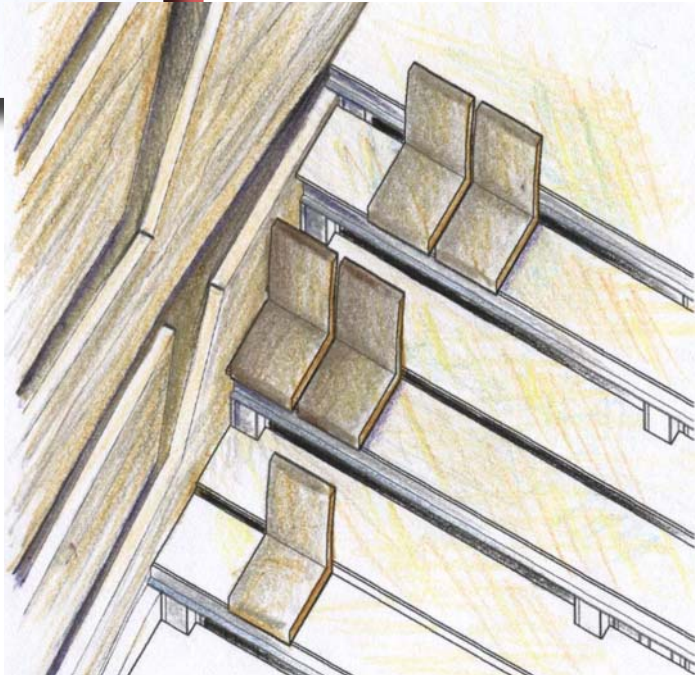

Fig. 70 - Chairs attached to seating surface

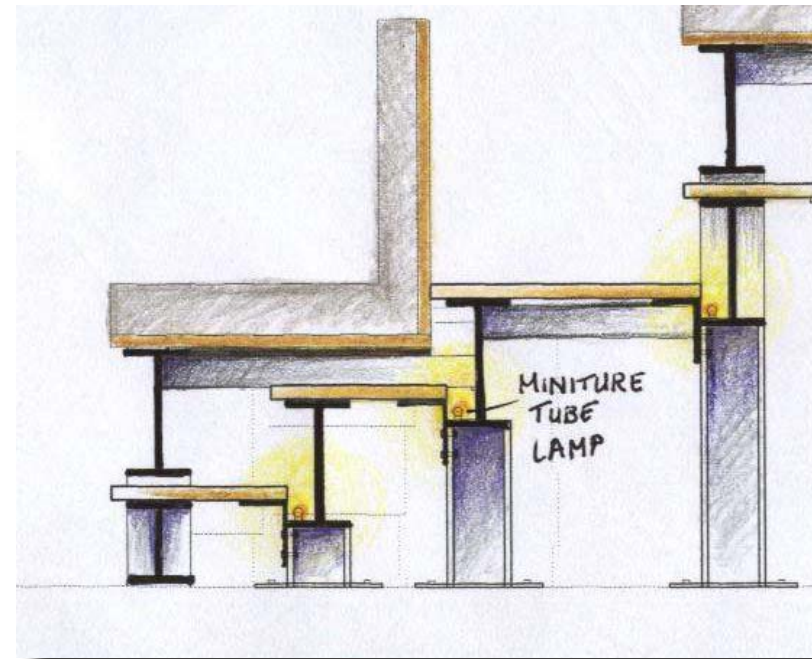

Fig. 71 - Stair illumination

LECTURE AND CONFERENCE ROOM

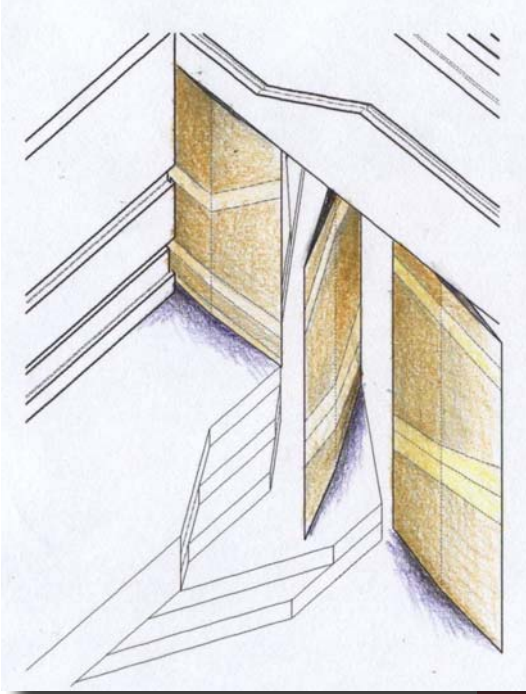

Fig. 72 - Pivoting doors between lecture room and auditorium

The threshold between the auditorium and lecture room consists of three of the fin shaped, swivelling wood panel doors (Fig.72). The first door sits on ground level and opens up the primary path of movement between the spaces. The second door is on a landing of the stair structure and the third door on stage level but is fixed and completes the façade. Opening up the façade establishes visual connection between the spaces and facilitates airflow. The lecture room can accommodate 14 people when used for educational purposes and more when used for conferencing or entertainment space for the auditorium. The structural space is double volume with the first floor cutting into the space like a mezzanine, suspended from the I-beams that support the slab concrete roof. The floor space can be arranged according to requirements.

The contoured stairs move up to the base of a double storey glass façade, while on the opposite side of the room, corrugated iron doors fill in, between concrete columns. The use of corrugated iron explores the use of an industrial material, ordinarily used for roofs or temporary structures, as a flexible finish able to move into the interior, blurring the boundary between inside and outside. Three of the doors swing open and slide into an audiovisual cupboard that houses a television, video machine/DVD player and storage space for audiovisual recordings or other visual aids. The remaining doors swivel on a central axis and shift along a track to reveal a large storage space. The storage area will serve the lecture room as well as the auditorium and exhibition space if necessary. Large objects can be stored due to the ability of the doors to move, and adjustable shelves between columns provide storage for smaller objects. The storage area links to a storage area under the raked stairs in the auditorium.

Glass pane doors, maintain a link with the outside while closing off the furthest end of the room. The doors also swivel and move along a track, opening up the façade to the outside, encouraging unhindered movement and free airflow. Moving out of the room through the open façade the first floor continues overhead for a short distance, forming a sheltered outside area. The protruding first floor shields the doors from direct sunlight.

The suspended first floor in the lecture room is lifted higher than the retained first floor behind the retaining wall to allow natural ventilation to penetrate through to ground floor from the east facing side of the building. The suspended first floor is accessed from the retained floor level by an I-beam step structure. Air moves through the open structure of the stairs into the building through adjustable ventilation grills (Fig.73). The cool air is then pulled from the back of the lecture room to the front as hot air rises through the double volume and escapes through the high positioned windows (Fig.64). The stimulation of natural airflow through the new building decreases dependency on air-conditioning. As in the old farm building, the cool groundmass from behind the new retaining wall will assist in maintaining a cool inside temperature in the new building. An exposed air-conditioning duct runs lengthwise across the roof of the double volume and vents distribution air down into the lecture room, and into the student studio next to it (Fig.74).

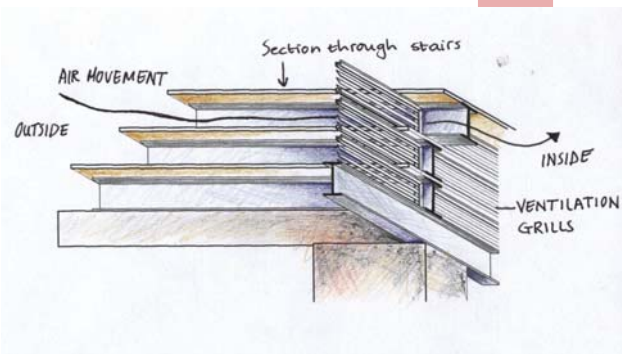

Fig. 73 - Ventilation grill detail

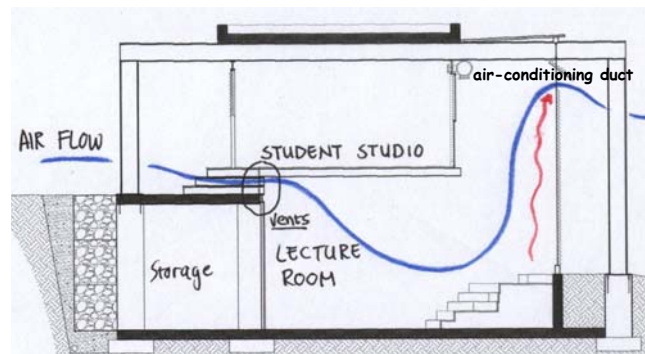
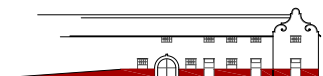

Fig. 74 - Airflow diagram



University of Pretoria etd – Lippi, N (2005)



Fig. 75 - Adjustable louvres used together with corrugated iron

The double storey frontal glass façade allows for a panoramic view to the outside, visually drawing the landscape into the building and giving the feeling of being outside. The façade contains a strip of celestial windows across the very top that pivots horizontally, linking back to the idea of swivel door. The glass allows plenty of natural light into the building, illuminating both ground and first floor. The glass panes need to be shielded from direct sunlight to stop excessive heat gain into the building through heat radiation from the glass. Although the cluster of large pine trees outside does shade the façade, the shade provided is not enough and sun louvers are added to the exterior of the building. The louvers are installed across the front of the glass, on the outside of the building. They filter direct sunlight while maintaining a view to the outside. Fine aluminium louvers are spaced to visually harmonise with the horizontal peaks and dips of the corrugated iron sheeting used elsewhere on the building (Fig 75). The louvers are fully adjustable from the inside and can be shut to block out all light. Closing the louvers will block out glare when making use of the audiovisual equipment in the lecture room. Louvers up to the first floor level function separately from the first floor level louvers, to allow the bottom set to be closed when needed while light still illuminates the top floor and filters down to the bottom without creating glare problems.

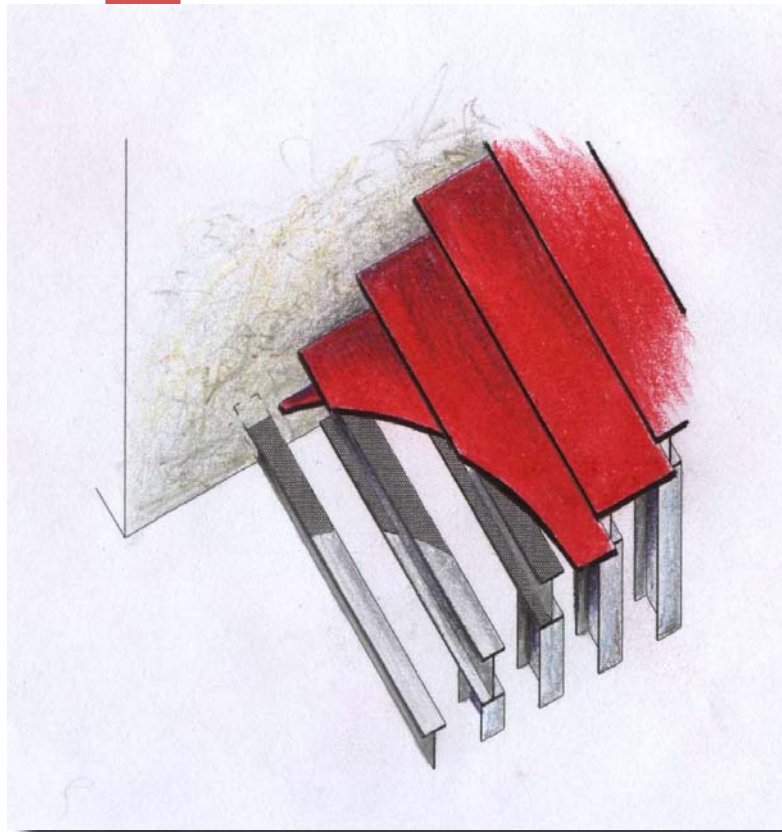

Fig. 76 - Stair perspective detail

Artificial illumination inside the lecture room consists of dichroic reflector lamps spun lengthwise across the room. The lighting is intended for visually intensive work such as writing. Dichroic lamps of lower lux and less in number are spun above the contoured stairs, high up in the double volume. These lamps are for atmospheric light. The staircase is well lit from above by dichroic lamps sunk into the ceiling, following the centre line of movement.

Stairs lead out from the lecture room up to first floor level, ending in a circulation area from which the auditorium, student studio, animal drop-off and clinic can be accessed. As the stairs cross the boundary between ground floor and first floor the staircase turns, emphasising the transition. Steel I-beams are cast perpendicularly into concrete wall along the back of the room. At the other end of the beam, steel I-beams are used as support columns, the same end detail that can be seen in the raked seating structure and the roof support structure (Fig.76). The treads of the stairs have a red epoxy floor finish like that of the ramp which again defines the stairs as a new and important link across the change in level.

STUDENT STUDIO

The student studio is accessed from outside and the semi-private circulation area, which links all the educational facilities. The boundary between the circulation area and social outside area right next to it is a glass façade. The façade includes two large glass swivel doors that open up the entire path of movement. The use of glass visually connects to the landscape and re-affirms the new buildings awareness of the natural surroundings, including it where possible. Sunk back between the two structures and facing an easterly direction, there is no need for louvers. The stairs that lead up to the slightly elevated studio floor run along the entire length of the studio both outside and in, blurring the boundary.

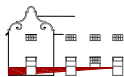

The student studio is a space intended for students participating in practical modules to sit and do theoretical work. It is a study room that encourages students to interact with each other and share knowledge. The studio is furnished with worktables and chairs and numerous power points with Internet connections for laptops. A small reference library with permanent computers for work and research purposes forms part of the animal drop-off and information building right across from the studio. The façade above the strip of stairs that access the studio consists entirely of swivel doors. A track allows the entire façade to open up, creating free movement and airflow between inside and outside, studio and circulation area. The ends of the doors are shaped at an angle to allow the door to overlap at the ends when closed while maintaining a flush surface. When the doors are closed, horizontal sliding windows allow in natural light and controlled amounts of natural ventilation, while adjustable louvers keep out direct sunlight (Fig.77). Where studio space meets the double volume of the lecture room, a glass division separates the two spaces for deterrence of noise transfer. Frosted glass panels run along the bottom half, while transparent glass panels, inspired by a Louis Kahn design (Fig.78), slide down like large sliding window panes, forming a hand railing (Fig.79). Air prompted by the natural wind direction thus moves into the studio through the doored façade, past the glass divide and out the windows in the opposite façade (Fig.80).

The floor of the studio is epoxy flooring and is the same finish used in the auditorium for the raked seating surfaces. The finish cleans very easily which makes it ideal for the space because of all the movement between inside and out, and the colour does not show dirt easily. The same finish moves outside of the studio where it is used for the treads of the steps that lie across the steel I-beams, and as a floor finish in the wildlife drop-off and clinic areas.

Two rows of dichroic lamps are spun lengthwise across the studio, emitting enough light for visual intensive work. Above the stairs leading to and from the studio, dichroic lamps are recessed into the roof, clearly lighting the change in level.

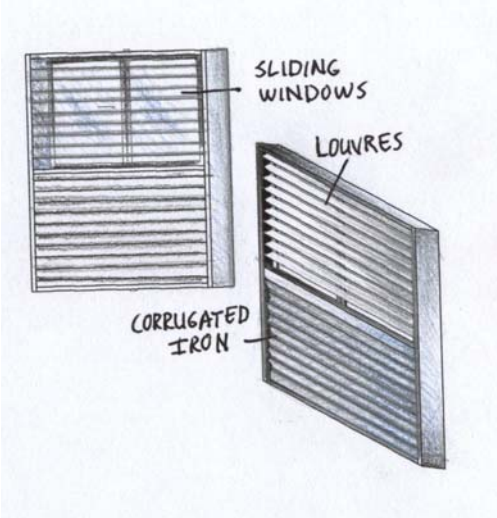

Fig. 77 - Swivel doors, type E

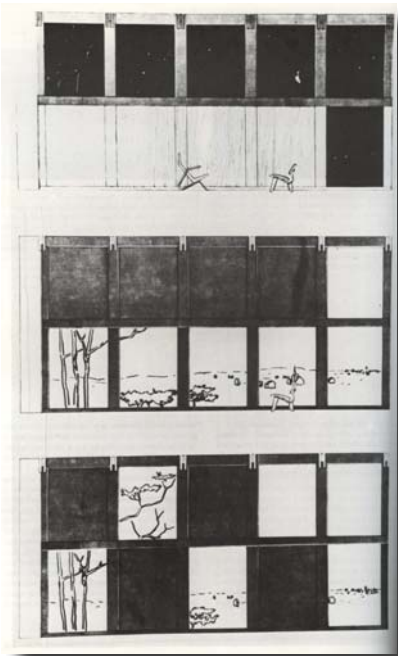

Fig. 78 - Window system by Kahn

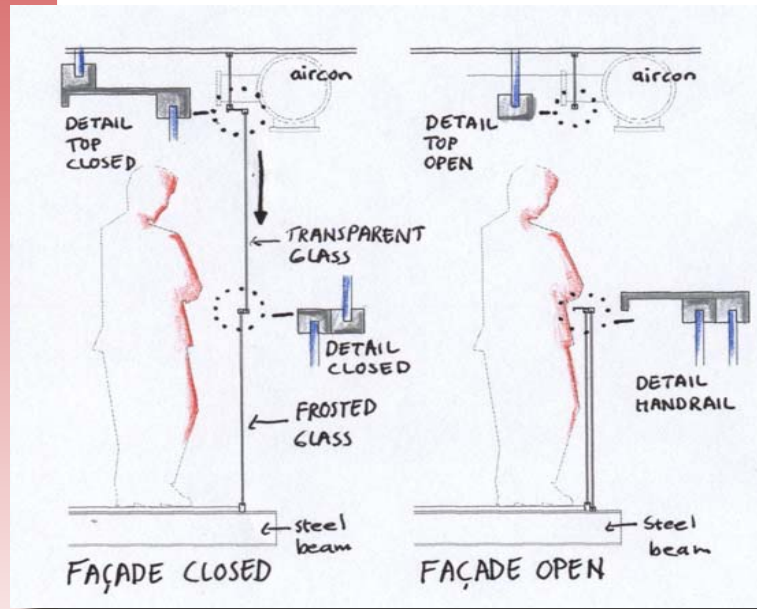

Fig. 79 - Sliding window/handrail concept

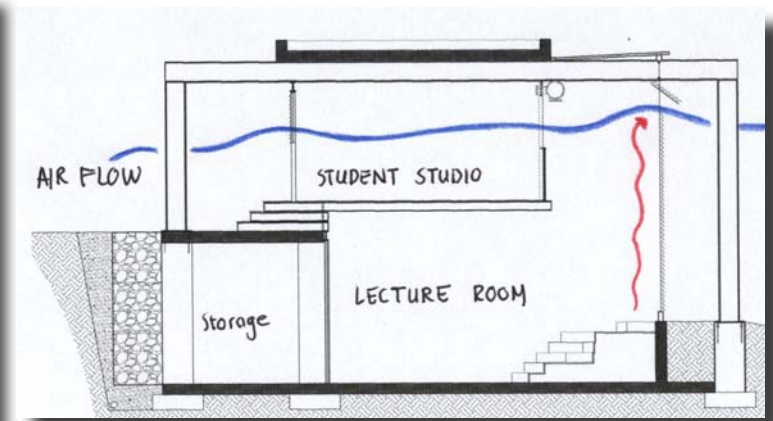
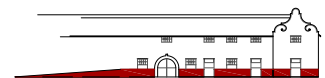

Fig. 80 - Airflow diagram



REST OF THE CENTRE

A covered space stretches lengthwise behind the main building and links the freestanding buildings and silos behind it. The distribution area outside the studio, reference library, and auditorium, is on the one end while a coffee shop is on the other. The space allows movement between public and private and is the interface where visitors interact with staff and students. From this transitional space there is visual access into a veterinary clinic, access to water closet facilities, and an administration sector that juts back into the main building at first floor level. Glass and corrugated iron boxes rest on the concrete beams inside the building and house a reception area, two offices and a boardroom. Across from this a steel I-beam structure breaks through and wraps around one of the silos, with steps leading to the top of the silo where a lookout allows views of the entire facility (Fig.81). Small windows also puncture through the concrete cylinder, allowing specific glimpses of the terrain. Between the main building and the new space, there is an outside space, hard landscaped as a social area. The façade between the new and outside space again opens up to allow for free movement between the spaces, and movement of air to the inside. The end section of the coffee shop also opens up entirely to offer a covered outside area during good weather and a completely sheltered area with views to the outside for use during bad weather conditions. A separate water closet structure is linked to the coffee shop for use by customers and also opens outwards for use by employees working outside.

All new additions to the site are designed to encourage the integration of inside and outside through the manipulation of façades that separate them. The materials and makeshift type structures allow for further development and ease of functional changes of spaces. The new and the old relate through juxtaposition, and together create a whole new visual impact and dynamic spacial experience.



Fig.81 - Inside of silo

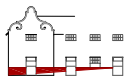

DESIGN INVESTIGATION TREATISE

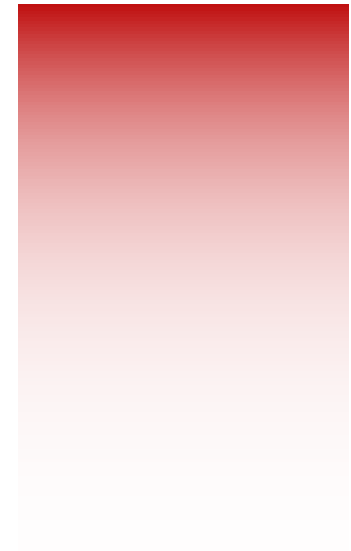

Acoustics had a direct influence on design decisions and development of the auditorium. The slight deformation of the initial rectangular space and the internal rotation of the stage and seating structure within the space prevent the formation of unwanted flutter echoes that occur between parallel surfaces. For good sound enhancement the front of the auditorium and the sidewalls are clad in plywood which constructively reflect the high frequencies that carry information into the audience and absorbs low base sounds that generate noise. The addition of glass wool in the cavity between the plywood surface and the concrete wall enhances the low frequency absorption. The back wall needs to be highly absorbent of all frequencies and should consist of a high-density material. There are many foam products on the market, aesthetically designed for such uses. Due to the small size of the auditorium, the ceiling need not be raked and does not require sounding boards but should consist of a reflective material, except for the section above the stage and at the back of the space which need to be absorbent (Fig.82). A loudspeaker system is not necessary for such a small space.

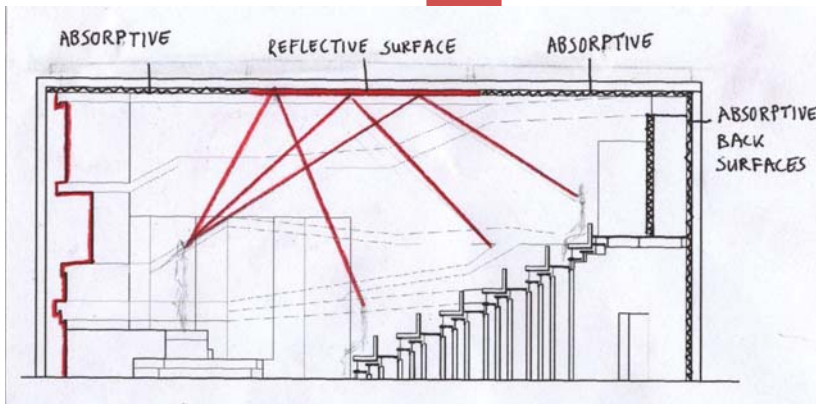

Fig. 82 - Acoustic reflection

The shape of the interior space is between 1.2 and 2 times as long as it is wide, which is generally the suited proportion for auditoria. The raked seating places all listeners in the direct sound path of the source, and avoids sound shadows cast when seated behind another person. The chair surfaces are of an absorbent material to ensure a constant level of sound absorption whether the auditorium is full or empty, thus limiting the effect on sound quality. Acoustic material is also used inside the storage space under the raked stairs in order to insulate any air-conditioning noise from the ducts inside.

Source: Acoustics notes. JP Nel, Building Plan DNA

Although passive temperature control is included in the building design, an additional HVAC (Heating, Ventilation and Air-Conditioning) system is still required because of the classification of the building uses. The air conditioning system suggested is the chilled water fan-coil unit. It provides excellent air quality and individual temperature control for multiple zones while running at a comparatively low operational cost. Air is not circulated between zones as in variable air volume (VAV) systems. This is imperative due to the air supply to laboratory and clinic areas, which needs to be regulated.

Source: HVAC notes. P Kulher, Spoomaker & Partners Inc.

The air-conditioning plant is positioned on top of the roof of the auditorium. The auditorium is rather central to the Visitors Facility and on top of the roof the plant is out of sight. In an auditorium, it is preferred for air-conditioning to cool the space from below the raked seating for optimum user comfort. For this reason air conditioning ducts move down from the roof through the projection room into the storage area below the seating structure. The air conditioning ducts can be seen pushing through the old retaining wall where the storage space ends and the steel structure is exposed.

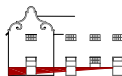

A sustainable approach is taken throughout the development of the project and construction of the Facility. Sustainability is promoted on several levels, setting an example of conservation and sustainable living through the incorporation of sustainable and environmentally sensitive design and technologies. Jeoff Lockward from Delta Environmental Centre emphasises how important it is that the design of an educational facility conveys the same message as that which it teaches (Personal Interview).

The design of the Wildlife Research and Rehabilitation Facility is to be based on the following criteria set up with regard to the context of the project and a sustainability approach. Refer to baseline document (p.098) for outline of goals set up for the project with regard to designing responsibly and sustainably.

occupant comfort - SOCIAL CRITERIA

Maximising natural light while controlling light ray penetration and glare is a very important aspects to the design with regard to user comfort. The existing architecture makes use of thick load-bearing walls with small sized windows to maintain a moderate inside temperature (Fig.83). The set back is that the small, high positioned windows hinder views to the beautiful surroundings, and a lack of sufficient natural light brings about a high dependency on the provision of supplementary artificial lighting for creating appropriate human environments that comply with SABS 0400 standards. By replacing the main building's ground floor back wall with columns, and opening space up to the retaining wall roofed by glass, allows natural light to flow in and illuminate ground level. Reducing the surface area of first floor, double volumes are created, allowing for further light distribution and stimulation of natural airflow. Passive climate control is incorporated into refurbishment as extensively as possible. Such an approach is ecologically friendlier and economically more viable long term than dependency on artificial provisions. The development of the Visitor's Centre up against a retaining wall passively cools the inside temperature, due to contact of air inside the building with the cool underground mass, of a constant 19 degrees Celsius, through the retaining wall.

The new architectural language used for structural additions to the site is contrasted by the existing architecture in that it aims to create airy, light spaces with thin façades that make maximum use of views, natural ventilation and natural light. Accommodating users that constantly move between inside and outside, the façades are designed to open up, increasing ease of access to outside activity and external social areas. The approach takes advantage of a climate not regularly prone to extreme conditions, and emphasises the natural surroundings that form the basis of the Facility. Ample windows and doors allow for temperature regulation by occupants during warmer or colder weather conditions and relatively narrow shaped spaces ensure that users are within 6m of a window. Glass is used extensively for appreciation of views and light penetration. A louver system shades glass exposed to direct sunlight to minimise light ray penetration and internal heating due to radiation. The louvers also minimise glare that affects the wildlife retained adjacent to the Visitors Centre. The louvers are adjustable and can be manipulated by the user from the inside to increase occupant interaction and comfort.

Various tasks are separated by barriers to prohibit the carry of unwanted noise, with several of the barriers able to open up where connection between areas is sought, as, for example, between the auditorium and lecture room.

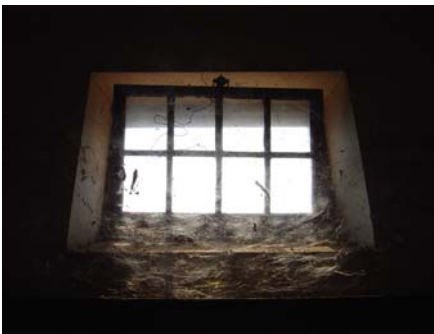
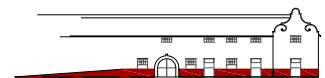

Fig. 83 - Small, high window of main building



The user is considered in the adaptation of the building although design is restricted by the existing structures. Opportunities are created for occupants to control their personal environments in the older structures, and user control with regard to natural and artificial ventilation and temperature control, natural and artificial lighting, and furniture arrangement in flexible spaces are important design influence in the new architecture (Fig.84). Adjustable barriers and façades that open up, and either link or separate spaces and activities inside and outside, provide an added degree of flexibility.

Activity placement was generated by their functions in relation to one another and the movement of the intended users with regard to their needs. Sanitary facilities are provided on both floors for use by students and visitors, and placement was determined by accessibility and the number of sanitary provisions demanded per capita by the SABS 0400 standards. Refreshment is provided by an eatery and take-away accessible form both inside and outside. Situated on the first floor, the eatery is close to ground floor, and the closest point to the rest of the facility just south of the main building. The eatery is for use by the workers on site and visitors to the Centre.

In an attempt to educate and create awareness while establishing a source of income to help maintain the Facility and fund projects, a primary goal is to attract the public and encourage community involvement. Interactive educational experiences that are informative and entertaining, as well as more serious educational lectures and seminars are offered to the public in venues designed for visitors and students.

inclusive environments - SOCIAL CRITERIA

The Visitors Centre or main building of the Facility is the interface between the public and the personnel or students, and is designed with consideration to disabled persons visiting the Centre. A ramp with an incline of 1 /12 links ground and first floor exceeding all minimal SABS 0400 standards in its design. Provision has been made for disabled water closets on ground floor and first floor, designed to satisfy all necessary requirements. Floor surfaces include concrete and industrial liquid plastic flooring that are even and easily navigable by wheelchair, while all door thresholds have a minimum width of 1 metre. There is provision made for wheelchairs in the auditorium and parking for disabled close to the Centre.

Braille is included in the design of the exhibition and on information-bearing boards outside wildlife holdings. There is clear definition of spaces and surfaces throughout the building to assist the visually impaired although the contour steps that lead outside from the lecture/ conference room and up to the stage are not standard and can cause a problem if a visually impaired person is unassisted. These stairs are not situated in the critical path of movement and do not necessarily need to be used by such parties.

(For extended information on the regulations complied to in the design of facilities for disabled persons, refer to Appendix C, p.103)

access to facilities - SOCIAL CRITERIA

The site is situated in an urban environment and very closely located to a range of services. Close to both residential and business districts, the Wildlife Care and Rehabilitation Facility offers easy access to retail, banking and childcare services within a 3km to 5km radius. The construction of the Industrial Hub on the Experimental Farm could also provide certain services in future.



Fig.84 - Ventilation fan, existing architecture



Although current access to the site is through the University of Pretoria sports grounds to the west of the Farm, an on and off ramp connection to the N1 is currently under construction to provide the Innovation Hub with an additional and easily accessible entrance at the east end of the Farm.

The position of the site places the Facility close to students that attend the University of Pretoria's main campus and staff that work there. Situated within Hatfield, many of the people intended to work at the facility are likely to reside within 12km of the site, except for students residing at Onderstepoort hostels.

The facility itself provides access to telephones and computers for easy communication.

education, health and safety - SOCIAL CRITERIA

The Wildlife Research and Rehabilitation Facility is an educational facility, backed by the positive reputation of the University of Pretoria, who provides constant and efficient educational support and stimulation. Additional educational association stems from the fact that the Facility is situated within the developing knowledge axis (Refer to the Innovation Hub p.012)

The University provides for security on the Experimental Farm but with the current development of the Innovation Hub on Farm grounds, security is likely to be reassessed and increased.

No smoking areas are provided within the Visitors Centre but there is constant access to the outside where bins are in adequate supply. A section of the eatery opens up to form a roofed outside area where users of the Centre can smoke. Sufficient external lighting is added to illuminate appropriate areas without the disturbance of the retained wildlife.

local economy - ECONOMIC ISSUES

Constructors, manufacturers and material suppliers utilized in the construction and maintenance of the Facility are mainly local, sourced within close distances. This is made possible in the project by a choice of readily available material. Manufacturing of the materials and building products is widespread, such as the standard sized steel I-beams, corrugated iron sheeting, concrete and glass (Fig.85). Local contractors and workers are all likely to be familiar with these materials and building products, and their application. The choice of Gabions for soil retention provides labour intensive work for unskilled people.

Involving various companies on an outsourced basis enables parties to benefit from an agreement of exchange, lowering additional costs for all parties involved. Stakeholders who have a vested interest in its success thus sustain the project. The Facility establishes outsourcing opportunities in the form of an eatery to be run by a sourced company, and by hiring out its various facilities, such as those connected with conferencing and entertainment, as well as laboratory and practical areas. Security on the Farm is currently provided by an outsourced company and additional security provision could be acquired if deemed necessary.



Fig.85 - Site example of proposed material use

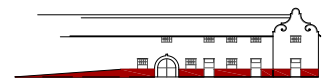

The construction of a shared educational and training facility benefits several departments of the University. Study directions focus on different aspects of the Facility, combining efforts and sharing knowledge and equipment. The range of expertise allows for the Facility to function without outside assistance and permits the centre to sustain itself.

With all existing structures earmarked for new use, space use efficiency is raised to a maximum. The new facilities make rather effective use of space by creating additional space right in front of the old retaining wall, and behind it, under the existing constructed first level area (Fig.86). Additional space is thus acquired without increasing the footprint of the building. The Facility is in constant use seven days a week and over public holidays. The wildlife at the Facility needs constant supervision and daily feeding while the wildlife drop-offs and related care facilities are continuously on standby for patient admittance. As school holidays will be the busiest time for the Visitors' Centre, most of the facilities at the Centre will be in use throughout the year. Occupancy of the buildings on site is thus very high.

At the Visitors' Centre, little circulation space is needed to move between facilities because of the rather flexible, open plan design and placement of related facilities together. The plantroom for the air-conditioning system is placed on top of the roof of the auditorium and does not use up otherwise usable space.

adaptability and flexibility - ECONOMIC ISSUES

The existing building has thick load-bearing walls that support the roof, and it has concrete columns on ground floor to support the first floor slab, freeing internal partitions for removal. All new structures have been designed with relative flexibility and non load-bearing partitions within the interior to increase the lifespan of the building through adaptability of use over the long term. The exterior façades are also non load-bearing and flexible. The steel structural skeleton and the very light weight and relatively inexpensive corrugated iron and glass façades allow for easy addition to the structure and change in design, or replacement of the façades.

In the design, new construction breaks through existing structure where there is a lack of space, or space appropriate for a certain required activity - such as space to accommodate the auditorium without taking up most of the main building. A load-bearing wall at the back of the main building gives way to support columns that open up the space behind them and similarly the construction of a new retaining wall allows the use of 'wasted' space behind the old one. Areas of first floor floor-slab in the main building give way for the opening up of double volume space from below, accommodating the requirements of the ground floor activity.

ongoing costs - ECONOMIC ISSUES

The project provides for several uses within the Facility and thus several groups of people make use of different areas at different times. The wildlife intensive care unit provides accommodation for persons on over night surveillance of critical wildlife patients. This constant occupation of the Facility provides additional security at no additional cost.

While keeping within the established design context and developed architectural language, many of the primary materials selected for use are relatively inexpensive to purchase and easy to work with. The materials require very low maintenance and minimal cleaning at low cleaning costs. The choice of materials and finishes are all hard wearing and have long life spans, which saves on costly replacement of refurbishment over an extended period of time. The air-conditioning system is left exposed and thus offers easy access for maintenance,



Fig.86 - Area between retaining wall and back wall of building



while the plantroom is situated on top of the roof of the auditorium and creates minimal disturbance when maintenance is required. Water and energy consumption is well regulated within the Visitors Centre building, and users are instructed in this regard. Concerning the rest of the facility, working with animals requires large amounts of water and consumes large amounts of energy. These costs are to be minimised through the use of alternative energy and water sources, and by making use of low energy and water usage equipment as discussed below.

capital costs - ECONOMIC ISSUES

By sharing building costs between two parties: The University of Pretoria and a pharmaceutical company, capital costs are reduced. Contracting a Sponsor into the project makes the realisation of the project more feasible. Lowering the required monetary expense of the University allows the initially expensive sustainable approaches to be explored. Sharing of facilities between parties also reduces maintenance costs, encouraging proper upkeep. The Facility meets the requirements of both parties, which negates the need for two separate facilities and prevents unnecessary development.

The use of existing structures cuts down on construction expenses significantly. Refurbishments and additions to the existing buildings make use of materials relatively low in cost, which allows more money to be spent on the wildlife sector and technologies that support a more extensive sustainable approach. Less expense on the physical facility allows more community programs to be funded that admit lower income community members into otherwise costly educational programs.

Choice of material and products for extensive use include the following:

Façades of the newly constructed sections consist of corrugated iron and safety glass; concrete and industrial epoxy is used for floor finishes, and plywood for floor surface and wall cladding. These materials carry low costs. The usage of steel on the outside and inside is likely to be the most costly. Purchasing of the adjustable louvers can greatly increase expenditure, but will recover the initial cost over the long-term, by minimising extensive use of artificial cooling. A gabion retaining wall is opted for instead of the more expensive concrete construction alternatives.

To reduce capital and ongoing costs, consultant fees are not to be calculated as part of the total but are to make use of incentives.

water - ENVIRONMENTAL ISSUES

Water efficiency devices are to replace old water facilities in all the buildings to reduce water consumption. Rainwater is to be harvested off the roofs of the practical and training facilities to the southern end of the site, and grey water from these facilities will be recycled and used for watering vegetation and flushing toilets.

The abundance of natural vegetation will reduce water runoff over the gradually sloped site, and the indigenous vegetation required for the housing of wildlife is lower on water consumption than exotic species that are to be removed.

energy - ENVIRONMENTAL ISSUES

The urban location of the Centre places the facility within walking distance of public transport. With new façades designed to open up to various degrees, considerable manipulation of natural airflow through the buildings is achieved. This natural ventilation system is to be used



Fig.87 - Calf holding

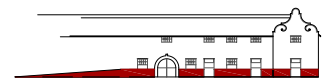

for the regulation of air temperature inside the buildings for a large part of the year, although an alternative heating and air-conditioning system is needed for periods of harsher weather conditions and for use in the auditorium.

Energy efficient light fittings are used wherever possible, and solar panels could possibly be installed on the roofs of the buildings on the southern end of the site in order to produce energy for electrical and heating purposes (Fig.88).

recycling and reuse - ENVIRONMENTAL ISSUES

Appropriate arrangements are made for the disposal of hazardous or inorganic waste along with the waste of the rest of the Experimental Farm. Organic animal waste is to be recycled on the Farm and used for fertilisation purposes. Construction waste should be minimal due to the use of existing buildings, and due to the fact that additional structures are constructed of materials that leave minimal rubble. All sewerage is to be connected to a French-drain system suited to the agricultural terrain.

site - ENVIRONMENTAL ISSUES

The chosen site is a sustainable start to an ecologically sensitive project, as it is classified as a brownfield site and does not intrude on any undisturbed ecosystems. Existing and, for the most part, currently unused structures are to be utilised and refurbished to house required facilities. Naturally vegetated sections of land are essential to the project and the current footprint should shrink due to rehabilitation of land. The structures on site are at a relative distance from one another and have no direct, negative effect on each other.

Landscaping on site is determined by wildlife needs, which results in dynamic, natural habitats. The planting of indigenous vegetation encourages further eco-systemic growth and self sustained environments. Minimal human intervention is required, except when possible harm could come to the retained wildlife, for example harmful insects, ticks and other pests that need to be eradicated.

materials and components - ENVIRONMENTAL ISSUES

The effect that the construction process has on the environment is minimised by developing the project on an already disturbed ecosystem, and by the use of existing structures. The amount of construction required is thus also minimised.

Materials with low embodied energy are specified for use due to their more sustainable nature and their connection to the already existing 'secondary' structures. Materials sourced from renewable resources include wood, glass and concrete, which can in future be reused. Stone is used for the construction of the retaining wall and, although it is not a renewable source, it is a natural material that occurs in great abundance, which can be collected on site, and requires no manufacturing process. Steel and aluminium have high embodied energy and sourced from a non-renewable source but can be recycled. The epoxy finish is the most unsustainable material although used in small quantity and has many advantages. All materials removed during demolition and refurbishment of the old structures that could possibly be reused should be recycled and reincorporated.



Fig.88 - South end site structures



CONCLUSION



Designing a wildlife research and rehabilitation facility, the underlying criteria for this thesis evolved out of the functional needs of such an endeavor. The landscape is important, as it becomes the interface to which design for human use and the design for wildlife react, linking them.

The design project centers on the refurbishment of an old building and its development into a centre for education and entertainment. The objective is for the new building to react to the old architectural style and the natural landscaping that supports it. The final design enhances the qualities of the old architecture through restoration and the contrast of new additions to the building. The new structures are qualitatively in juxtaposition to the solidity and permanency of the old, and make a connection with the outside through permeability and a more sensitive and temporary type of architecture. The internal spaces of new additions developed along with the exterior shell, shaping the new architectural language and drawing it into the interior as design resolution and aesthetic influence. This influence was then drawn into the existing structures, connecting the spaces visually.

The design focuses on the primary educational area of the Visitor's Centre as a pivotal point of user interaction, from which movement patterns develop and influence the growth of the rest of the Centre. The final product is a blueprint of a single development phase in the project, and the design allows for ease of further development and expansion as the needs of the Facility change.

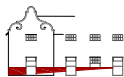

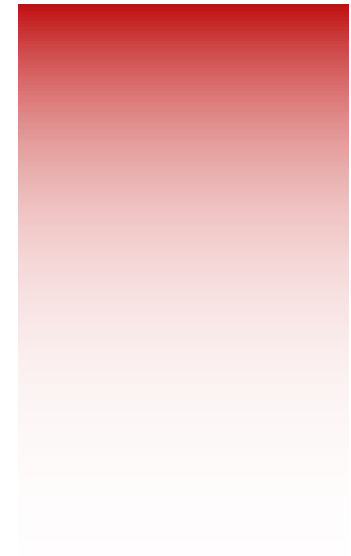

DESIGN DRAWINGS



DEMOLITION PLAN

contours slope down in a north-west direction
 wind direction predominantly north-east

-  training facility
-  educational centre
-  existing structures
- proposed use in rest of project

TEXT current structure use
TEXT proposed function distribution

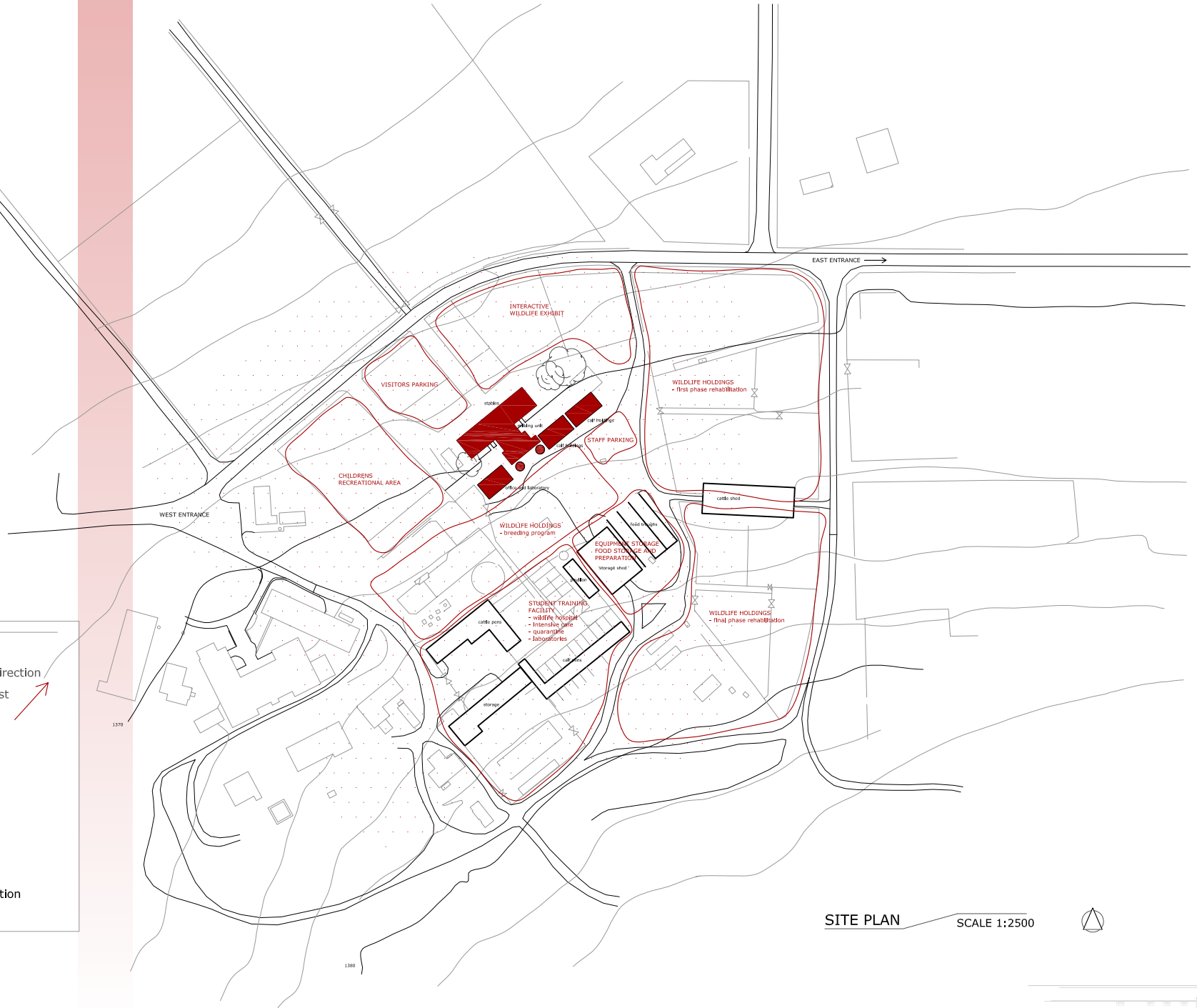

SITE PLAN SCALE 1:2500

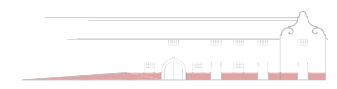

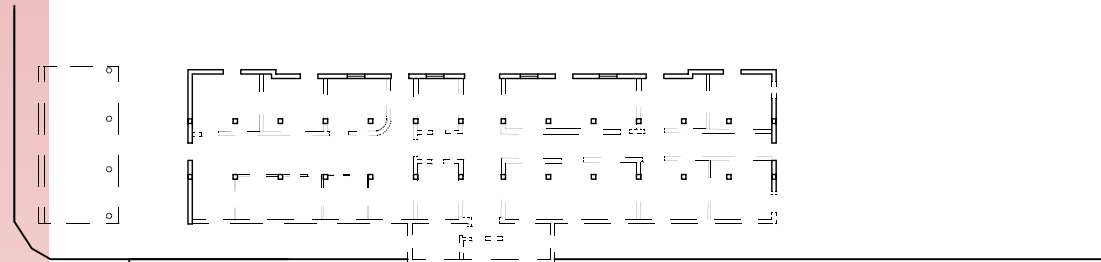

DEMOLITION PLAN

SCALE 1:500

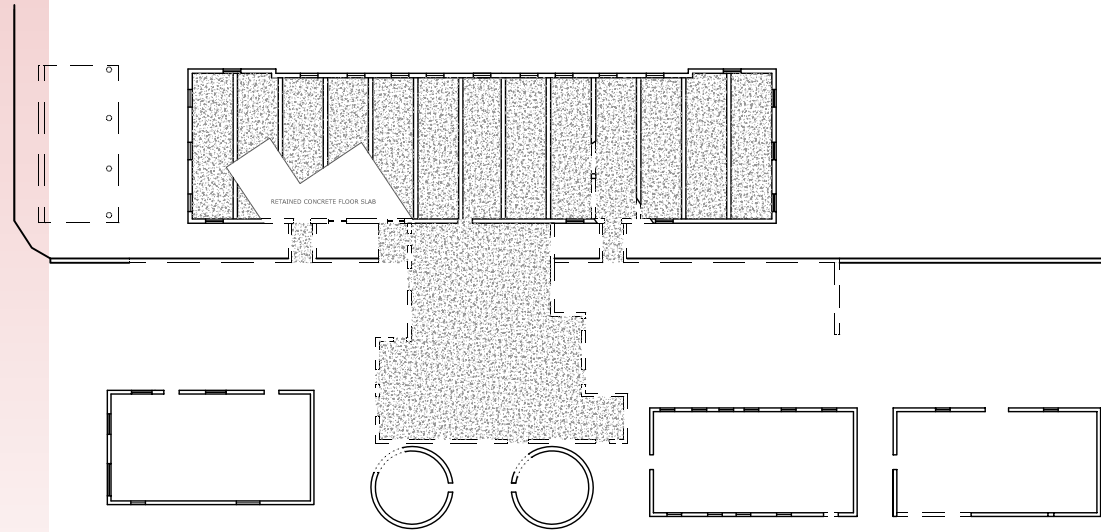

DEMOLITION PLAN

SCALE 1:500



DEMOLITION PLAN

- Structure to be demolished
- ▨ Floor slabs and finishes to be removed
- - - Concrete beam structure hidden beneath floor slab

All internal walls to be demolished
All external paving to be removed



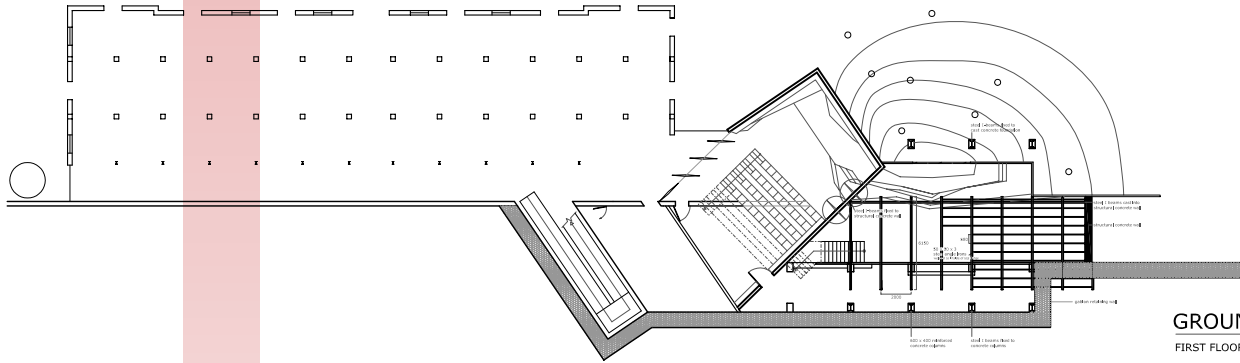

GROUND FLOOR PLAN
FIRST FLOOR SUPPORT STRUCTURE

SCALE 1:500

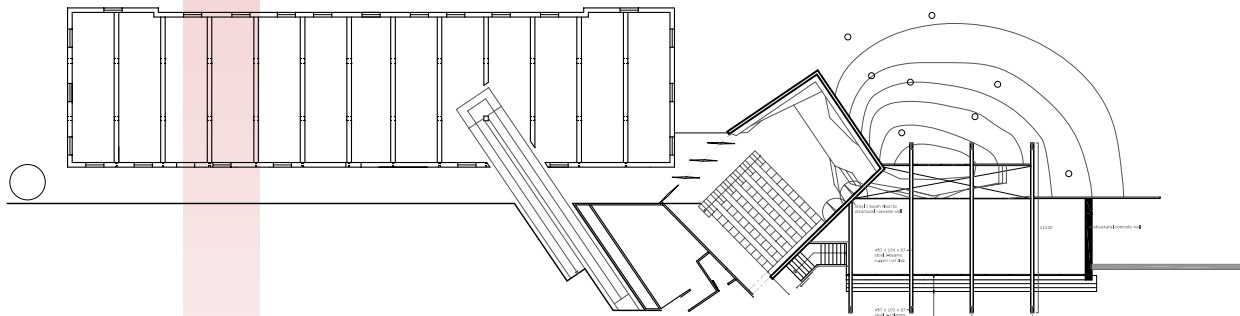

FIRST FLOOR PLAN
ROOF SUPPORT STRUCTURE

SCALE 1:500

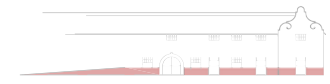

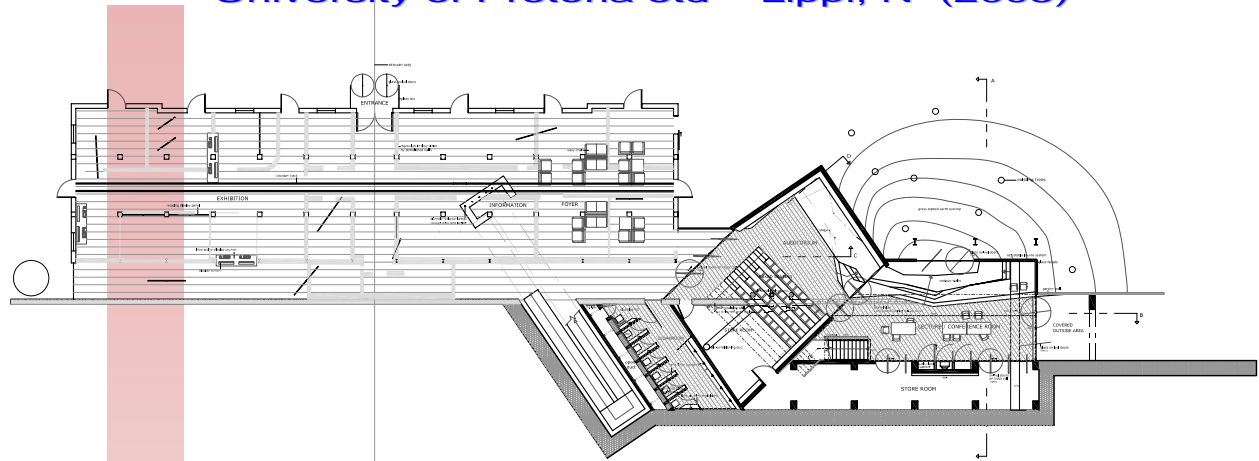

GROUND FLOOR PLAN

SCALE 1:500

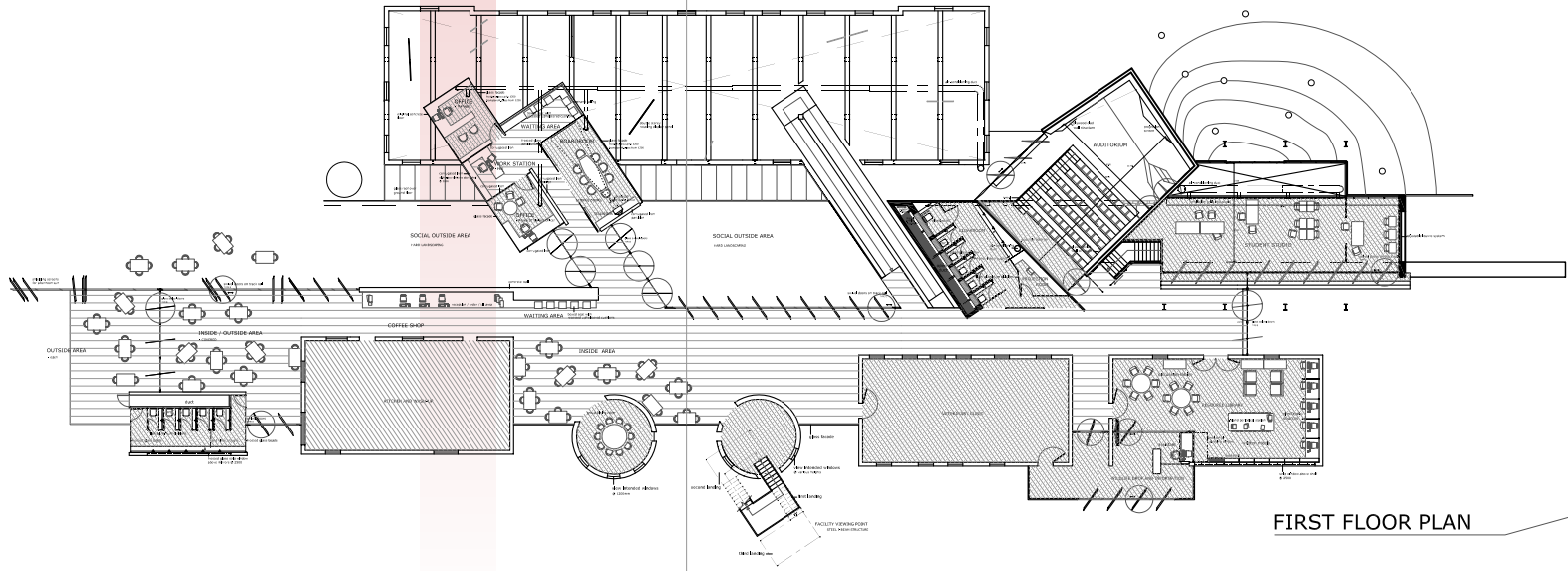

FIRST FLOOR PLAN

SCALE 1:500

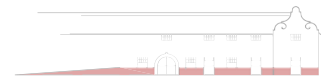

DESIGN DRAWINGS



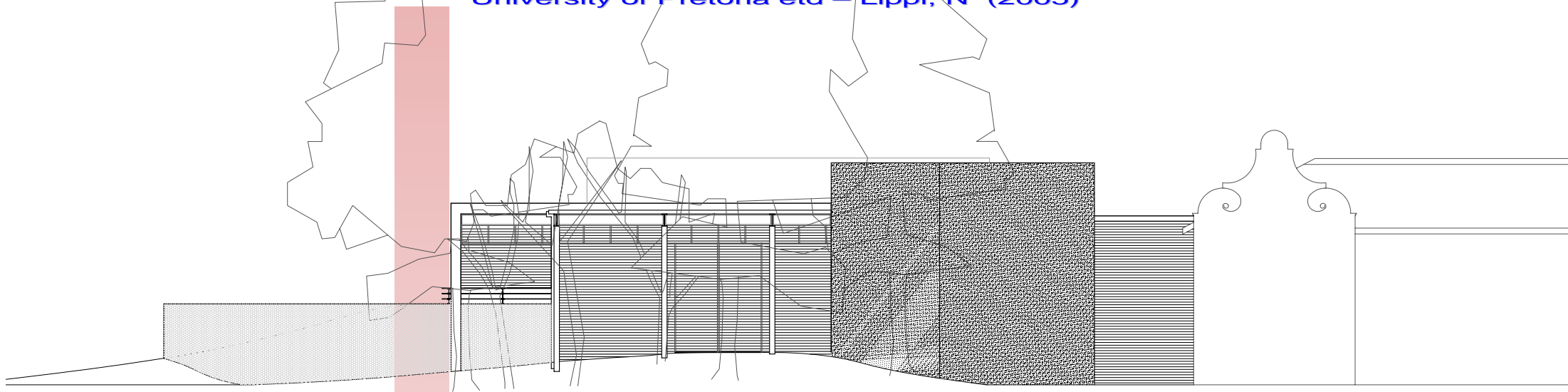

NORTH WEST ELEVATION

SCALE 1:200

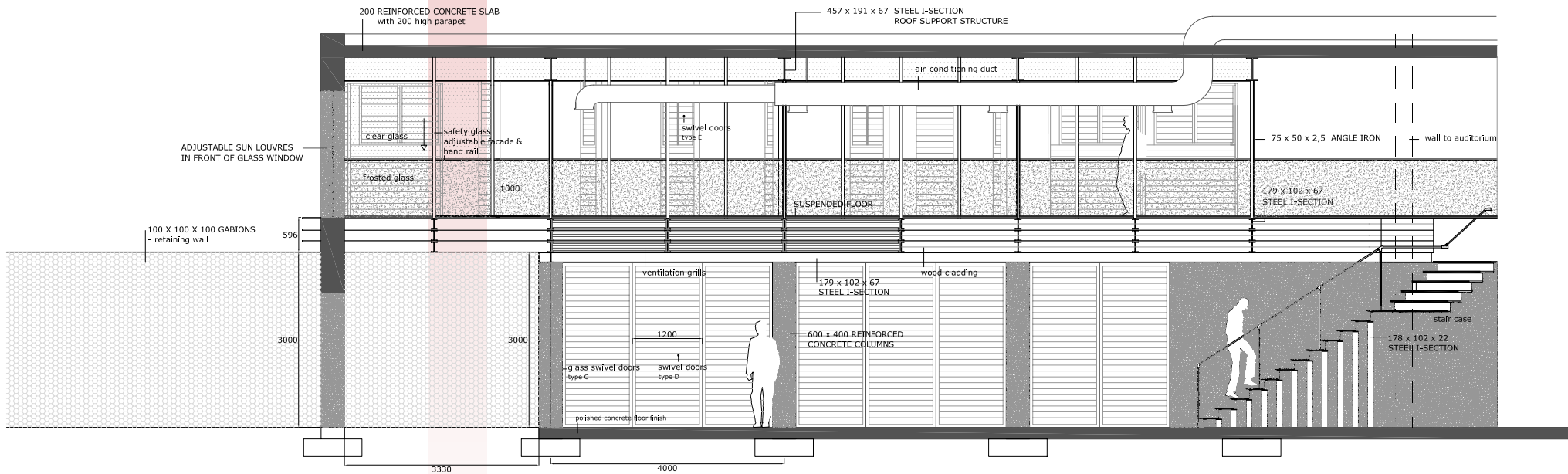

SECTION B

SCALE 1:100

INDICATED ON GROUND FLOOR PLAN

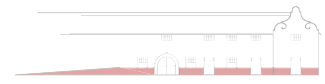

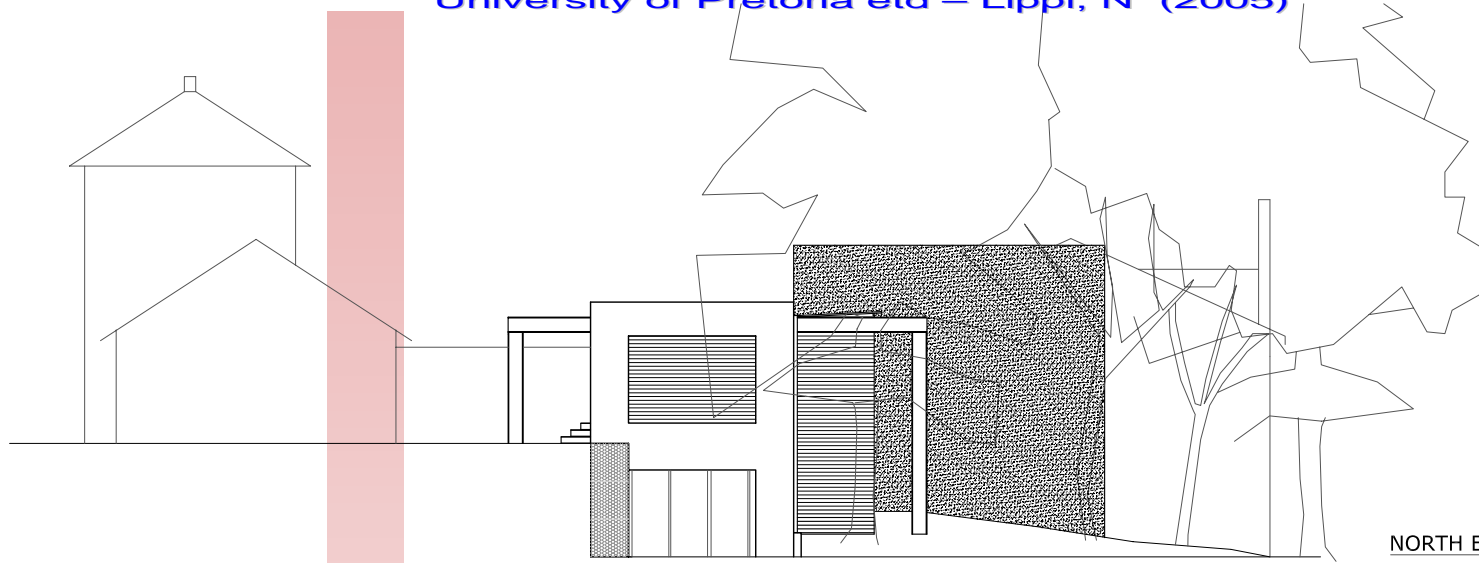

NORTH EAST ELEVATION

SCALE 1:200

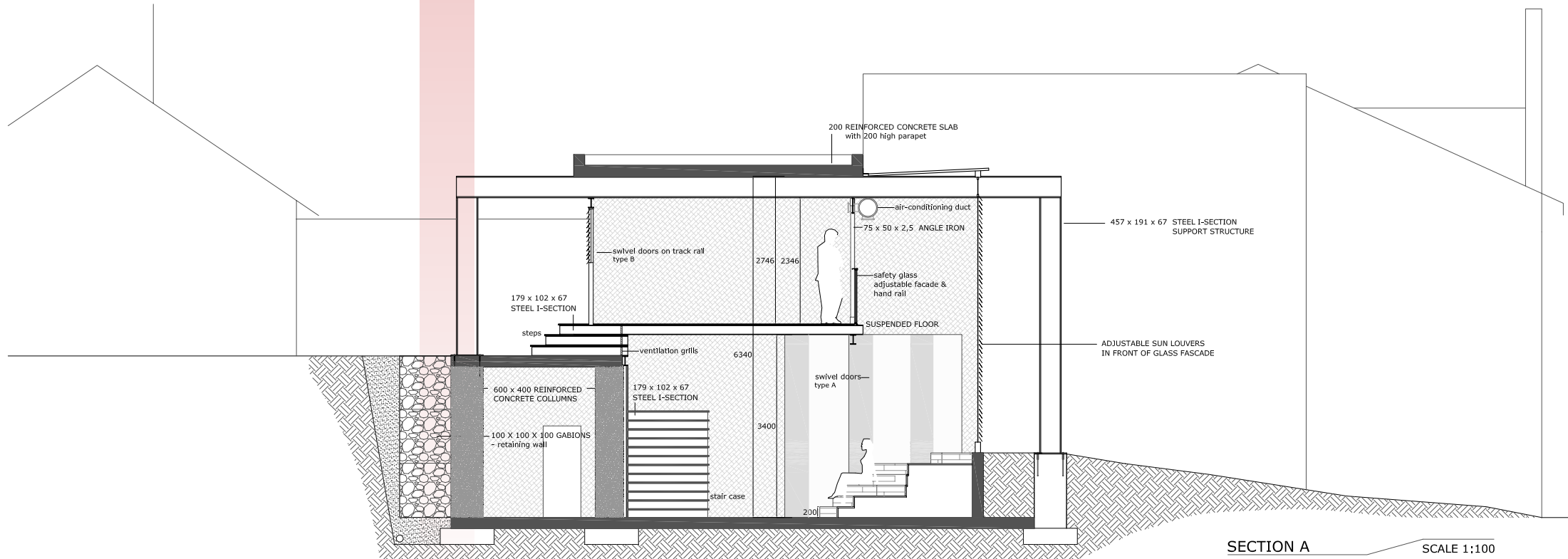

SECTION A

SCALE 1:100

INDICATED ON GROUND FLOOR PLAN



DESIGN DRAWINGS

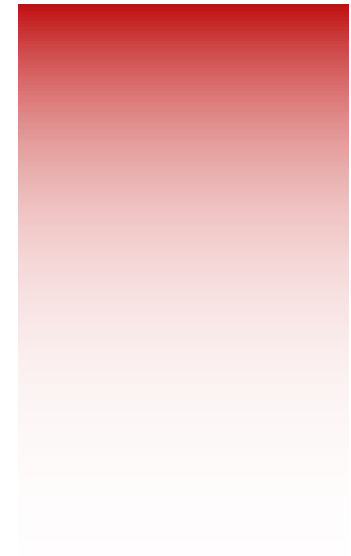

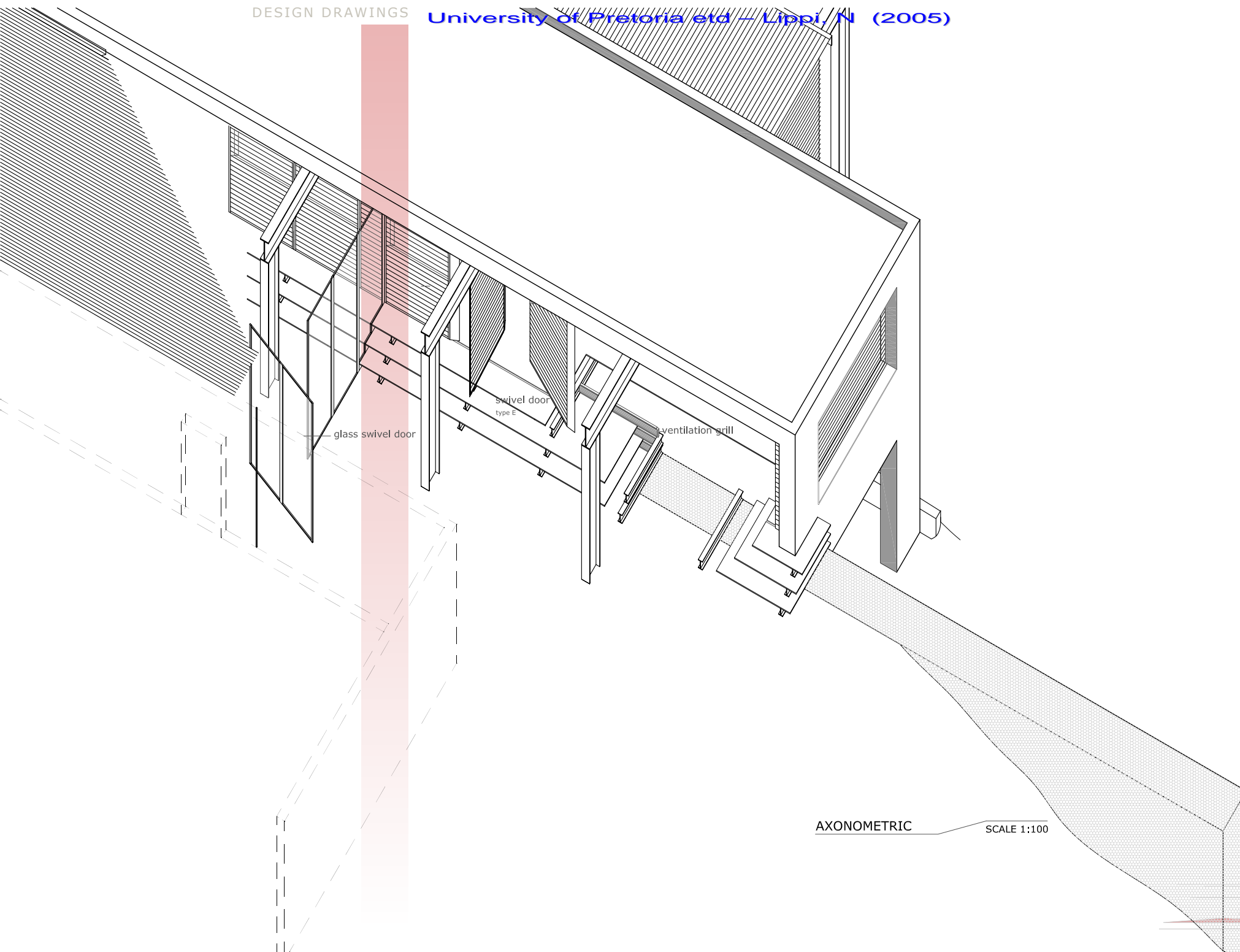

AXONOMETRIC

SCALE 1:100

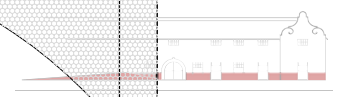

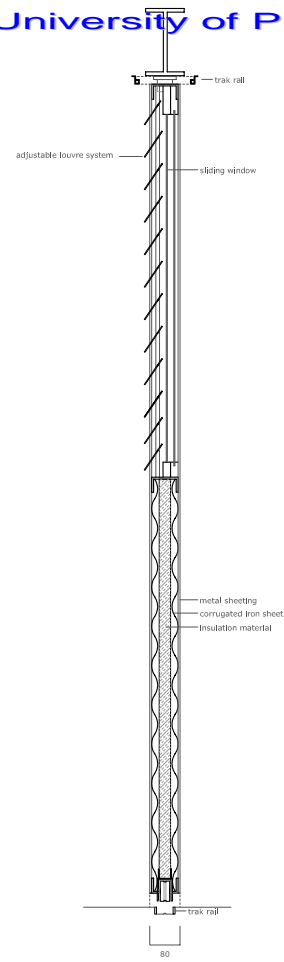

VERTICLE SECTION

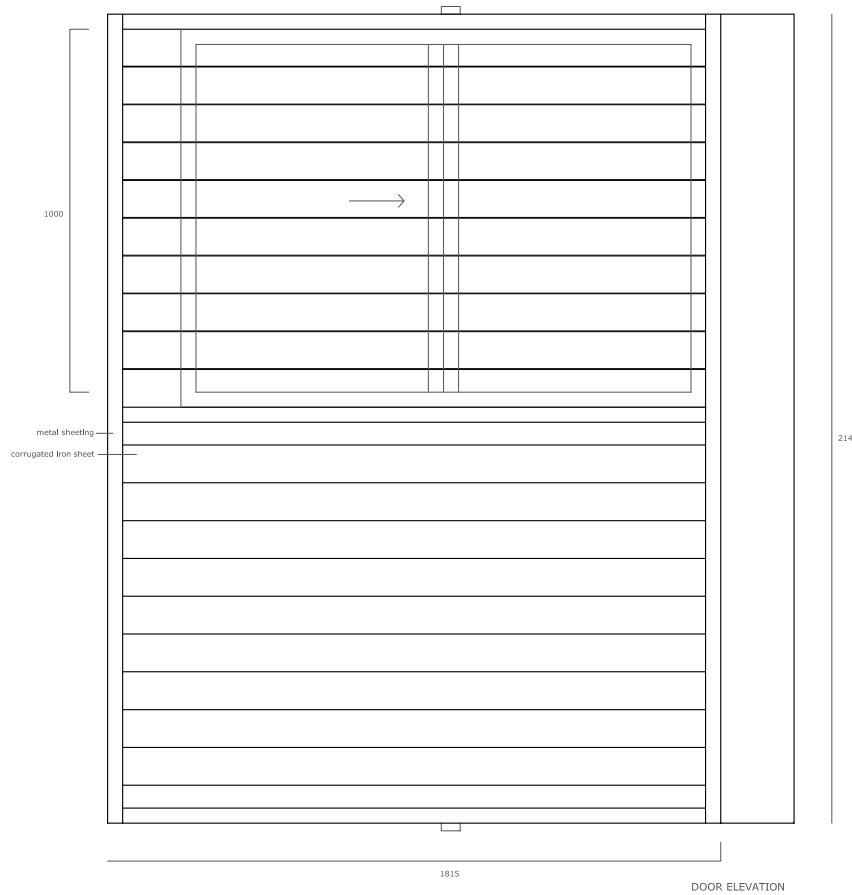

DOOR ELEVATION

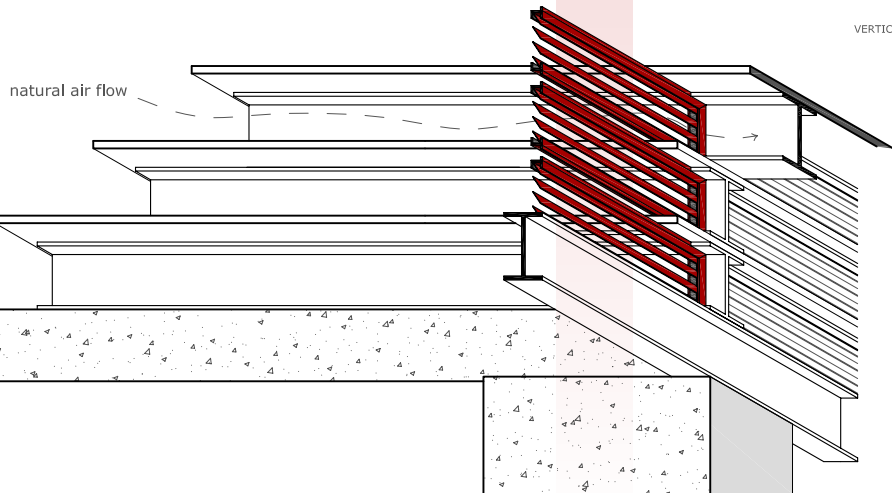

VENTILATION GRILL DETAIL

SCALE 1:20

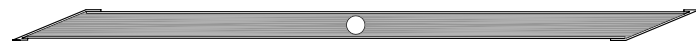

PLAN VIEW



HORIZONTAL SECTION



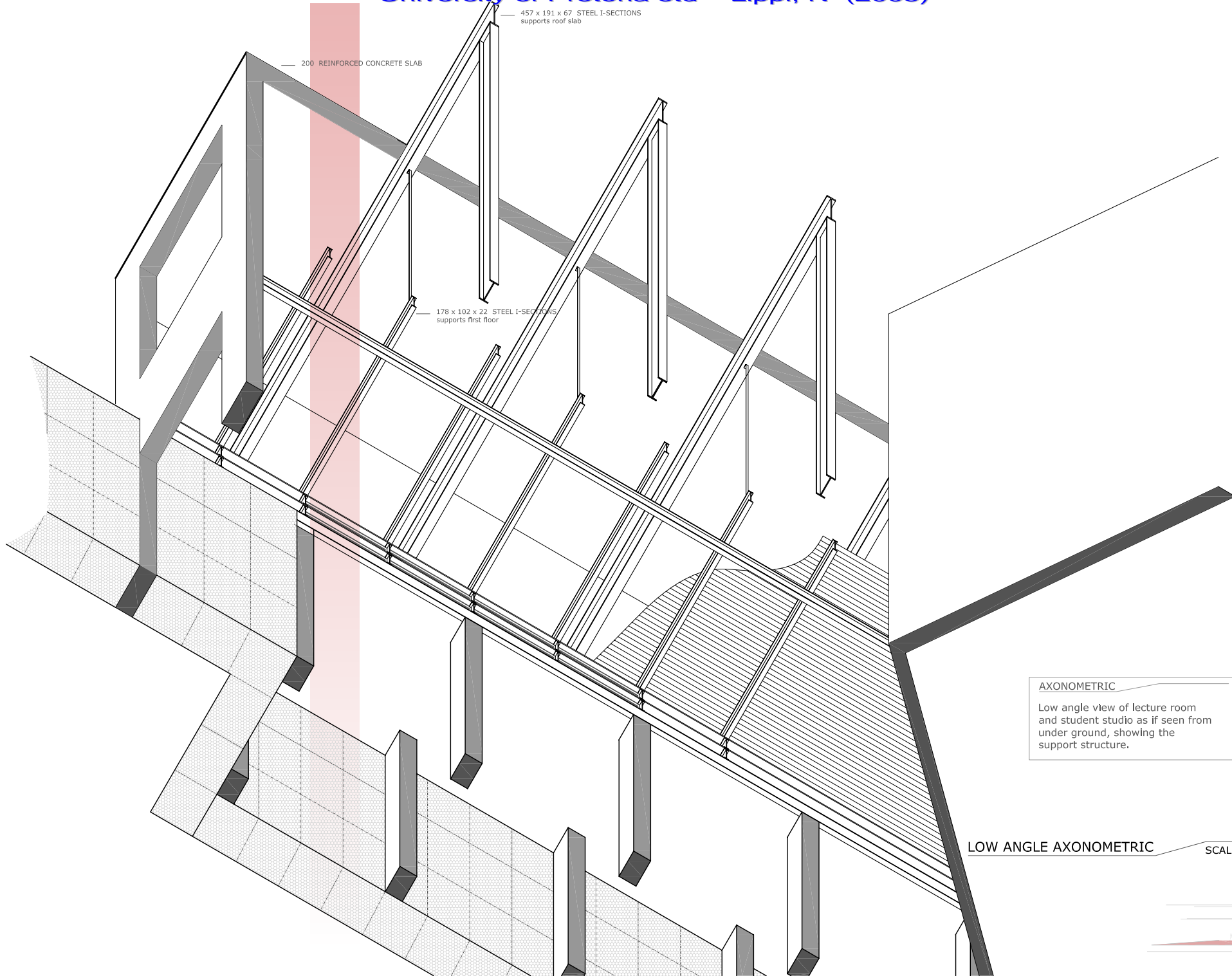

— 200 REINFORCED CONCRETE SLAB

— 457 x 191 x 67 STEEL I-SECTIONS supports roof slab

— 178 x 102 x 22 STEEL I-SECTIONS supports first floor

AXONOMETRIC
Low angle view of lecture room and student studio as if seen from under ground, showing the support structure.

LOW ANGLE AXONOMETRIC SCALE 1:100



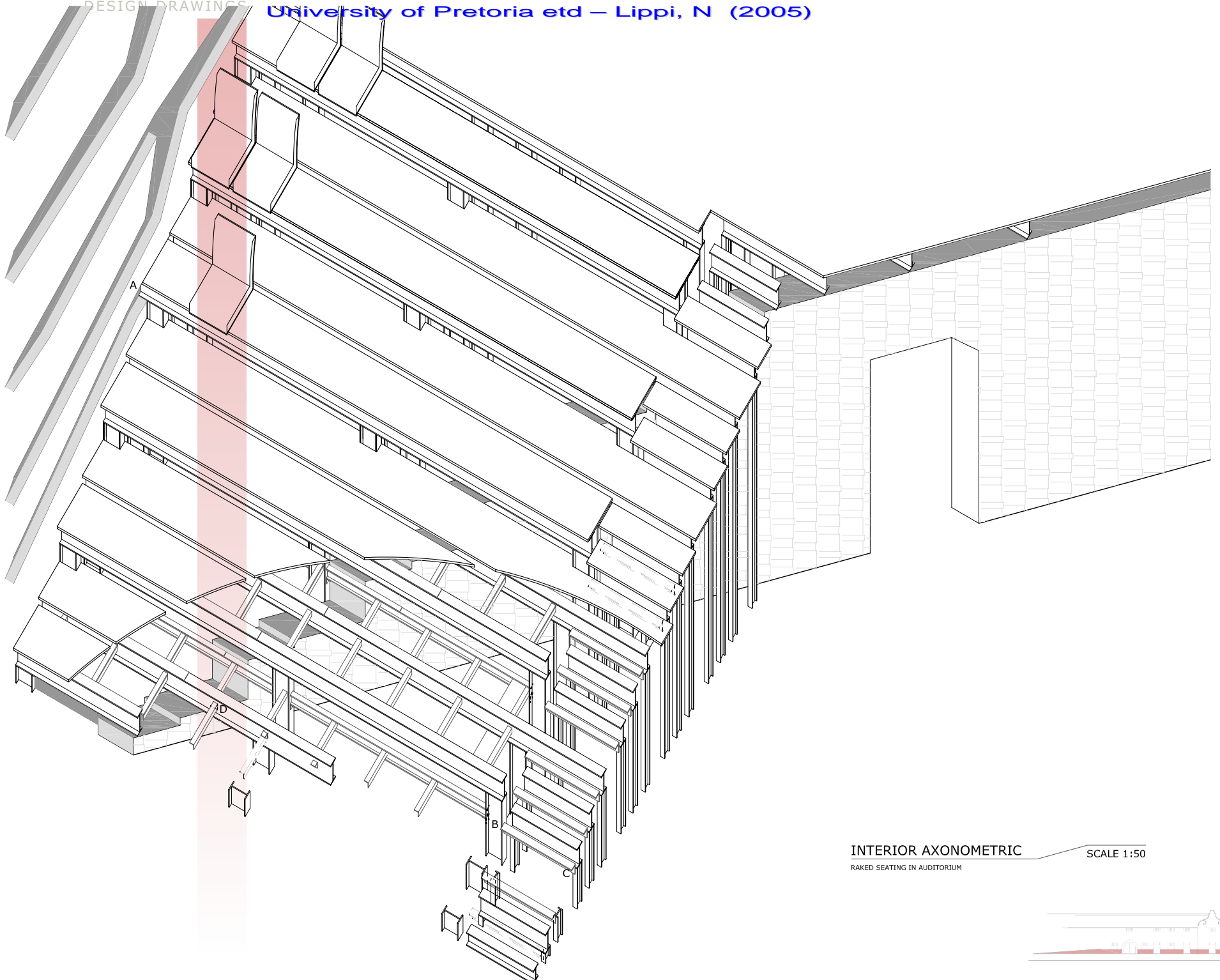

INTERIOR AXONOMETRIC
RAKED SEATING IN AUDITORIUM

SCALE 1:50



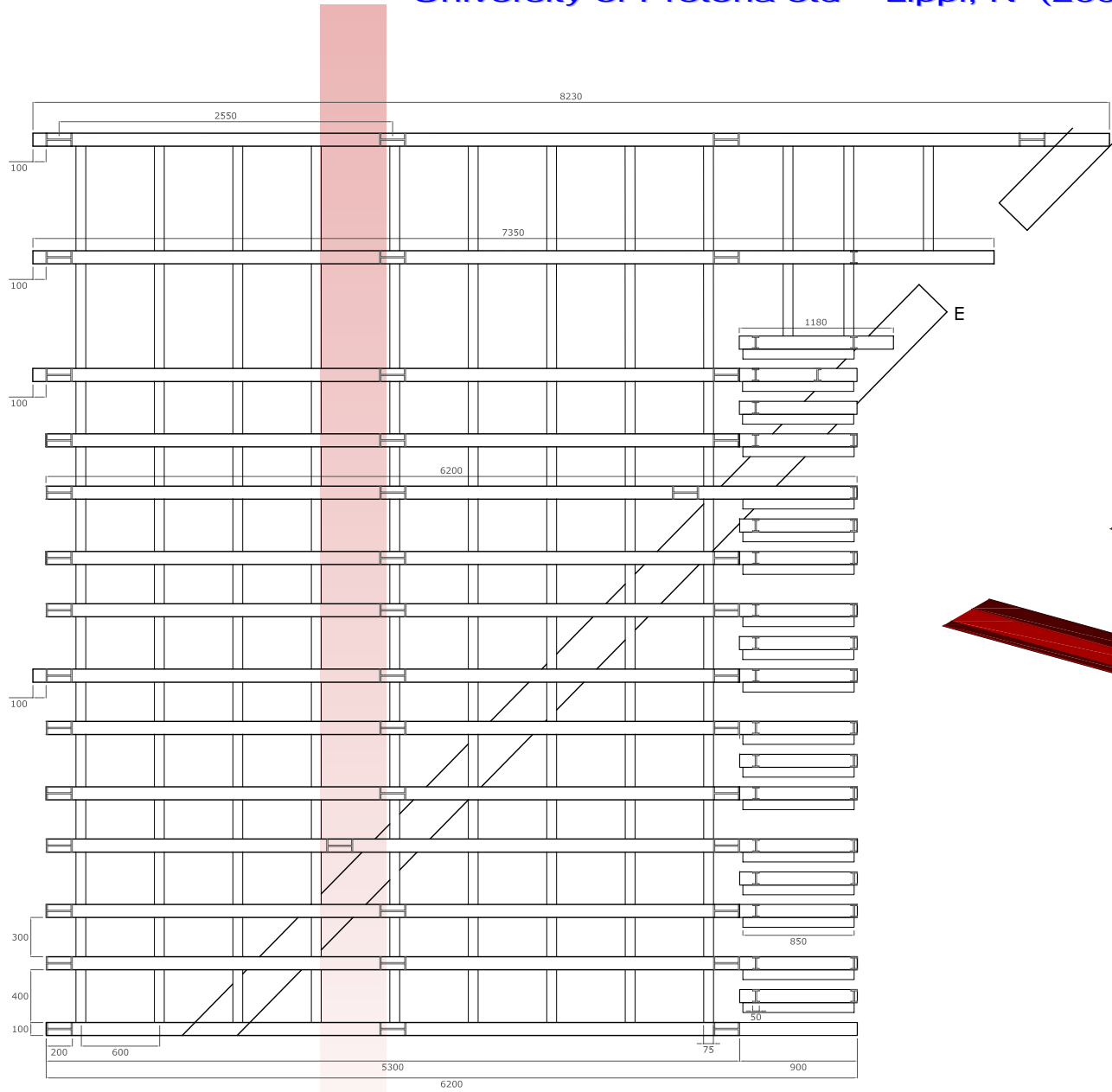

SEATING STRUCTURE

SCALE 1:50

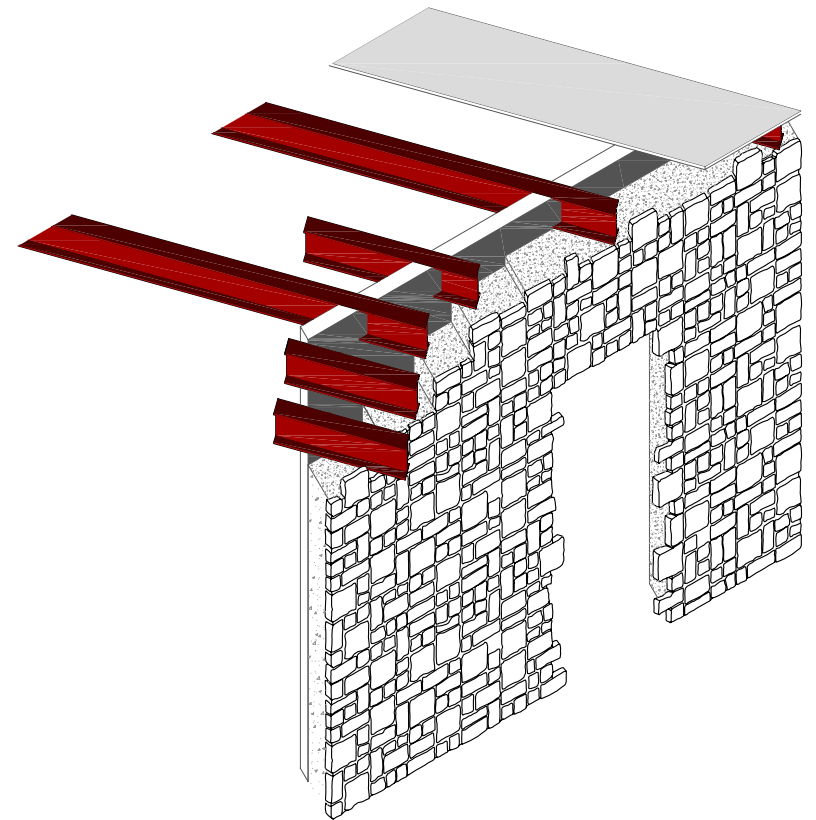

AXONOMETRIC DETAIL E

CUTTING THROUGH RETAINING WALL

SCALE 1:50

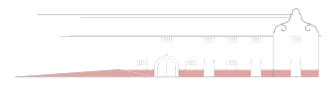

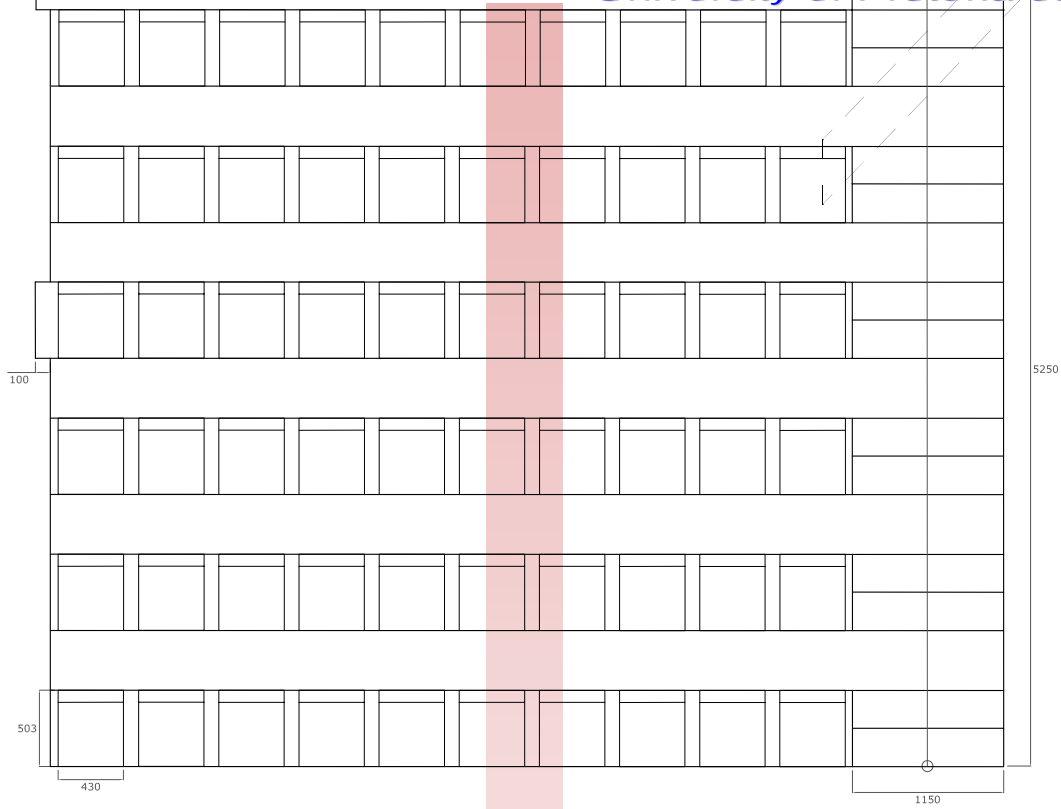

SEATING PLAN SCALE 1:50

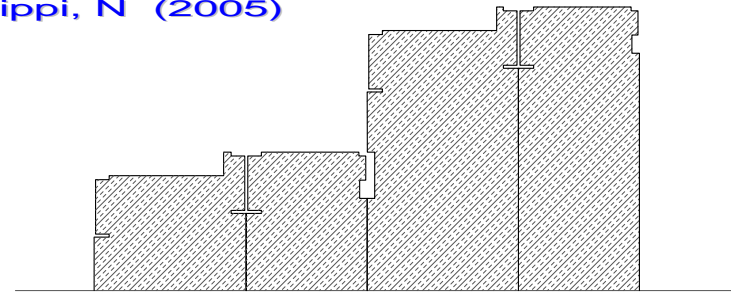

INSULATION BEHIND RETAINING WALL SCALE 1:20

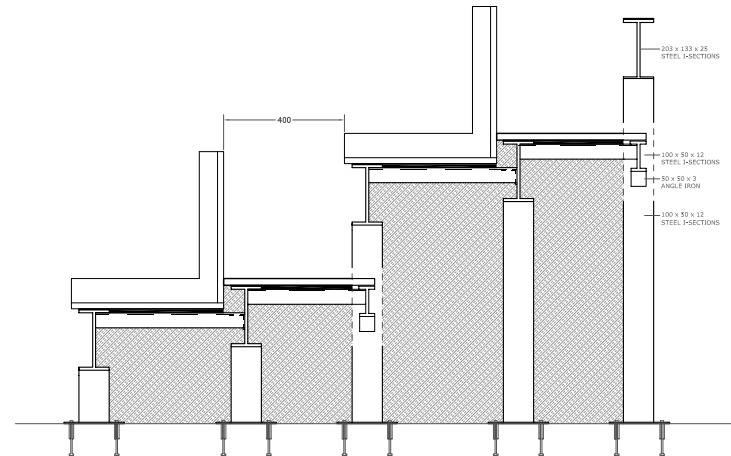

SIDE SECTION SEATING STRUCTURE SCALE 1:20

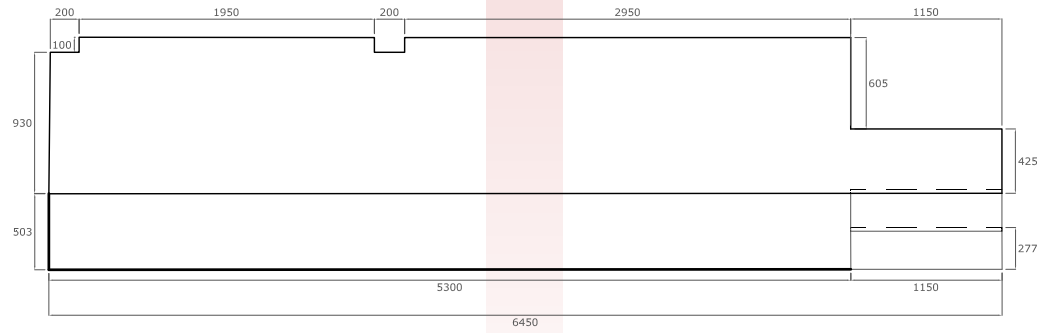

VERTICAL SURFACES PLAN VIEW SCALE 1:50

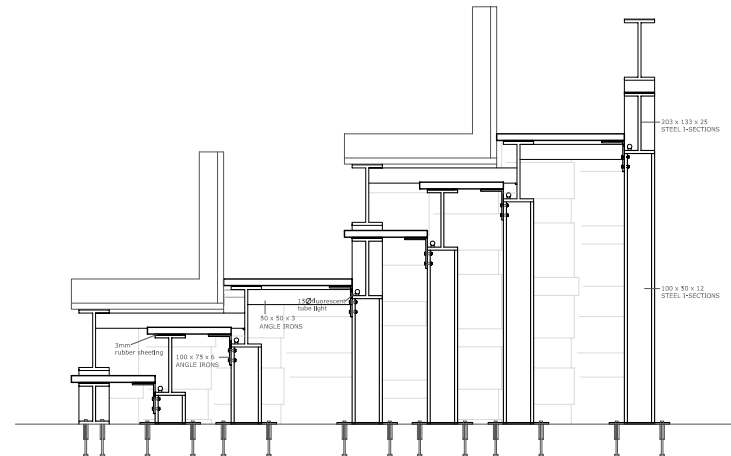

SIDE ELEVATION SEATING & STEP STRUCTURE SCALE 1:25

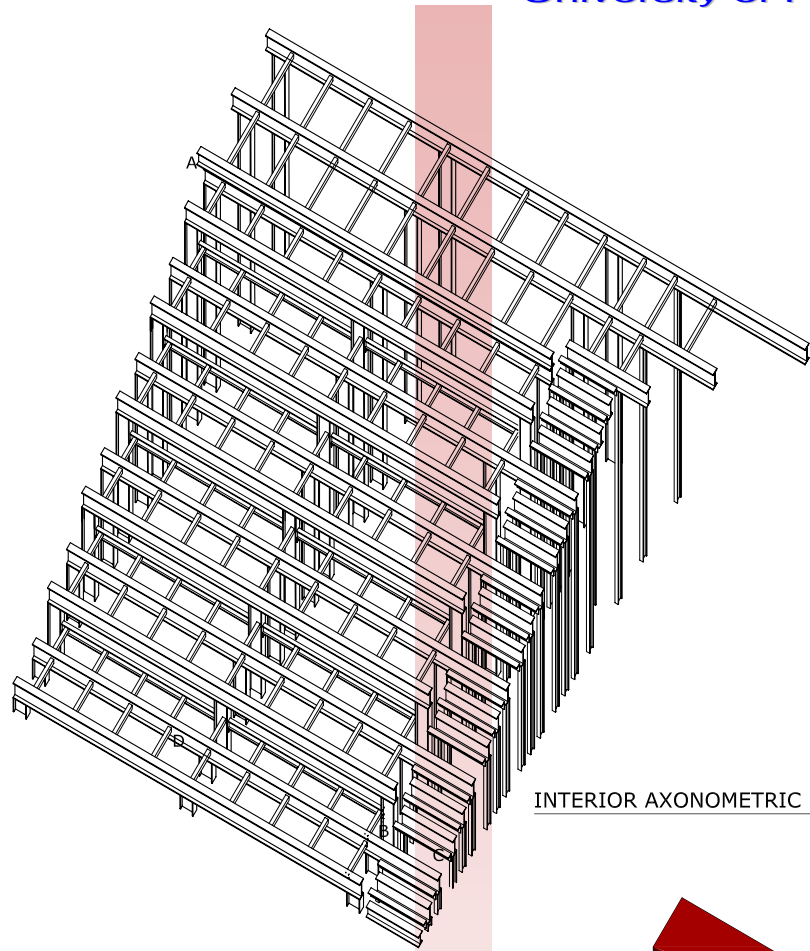

INTERIOR AXONOMETRIC SCALE 1:100

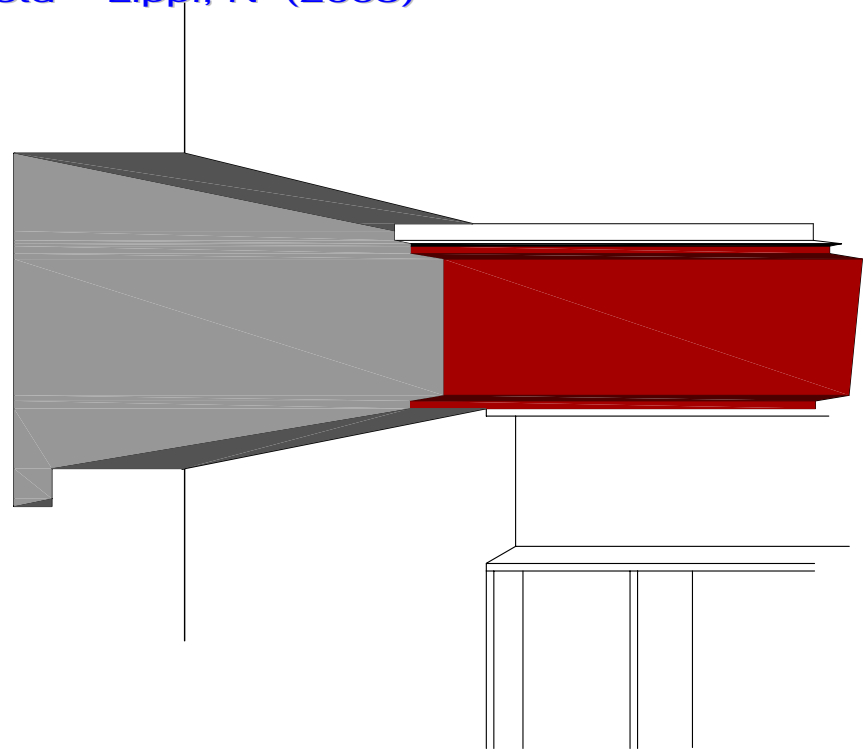

ELEMENT RELATION DETAIL SCALE 1:10
DETAIL A

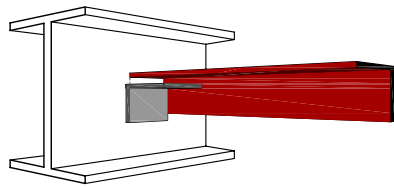

JOIN DETAILS SCALE 1:10
WITH WELDED JOINTS
DETAIL D

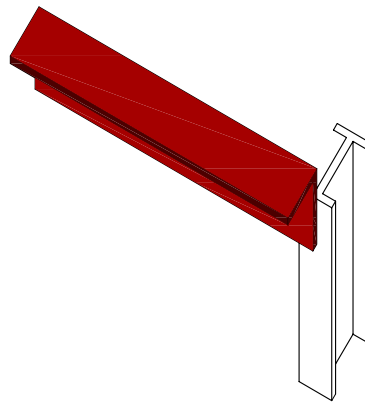

JOIN DETAILS SCALE 1:10
WITH WELDED JOINTS
DETAIL C

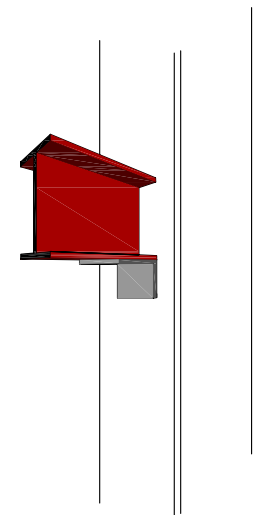

JOIN DETAILS SCALE 1:10
WITH WELDED JOINTS
DETAIL B

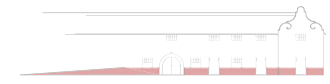

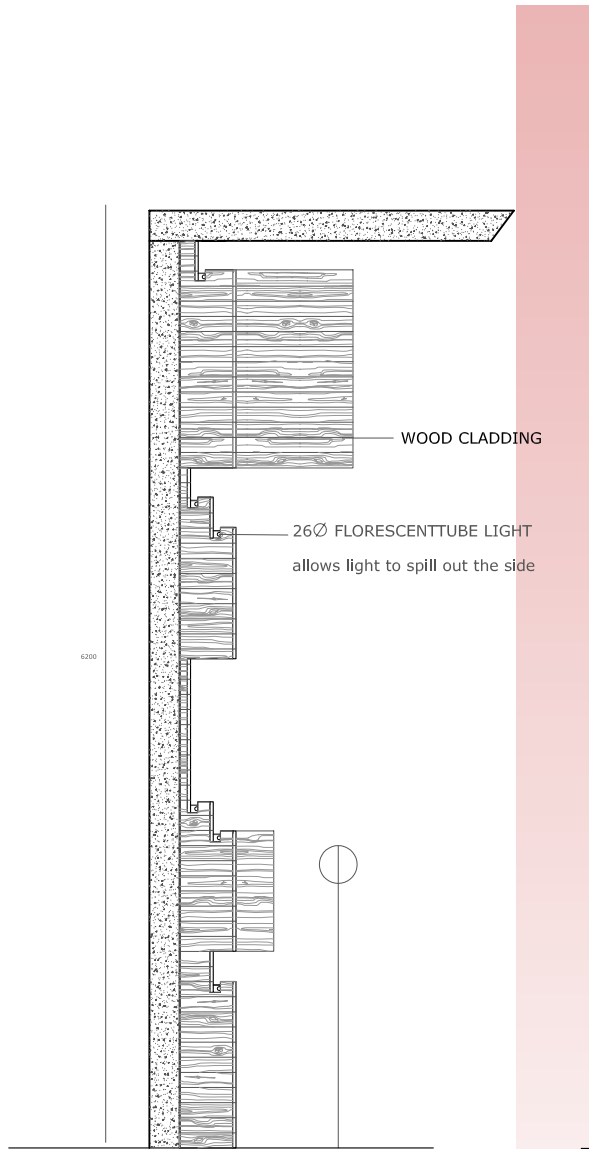

ELEVATION OF WALL END SCALE 1:20

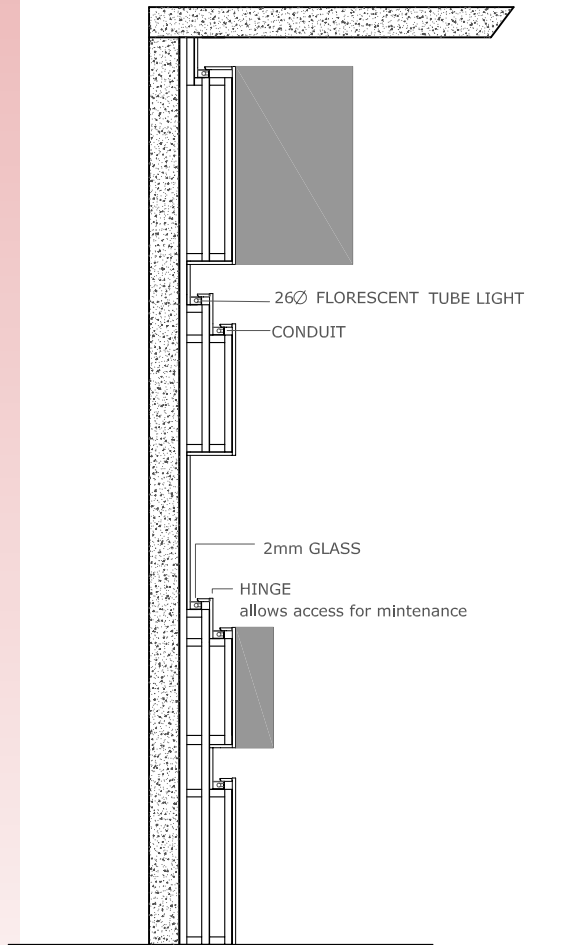

SECTION THROUGH WALL SCALE 1:20
INDICATED ON AXONOMETRIC

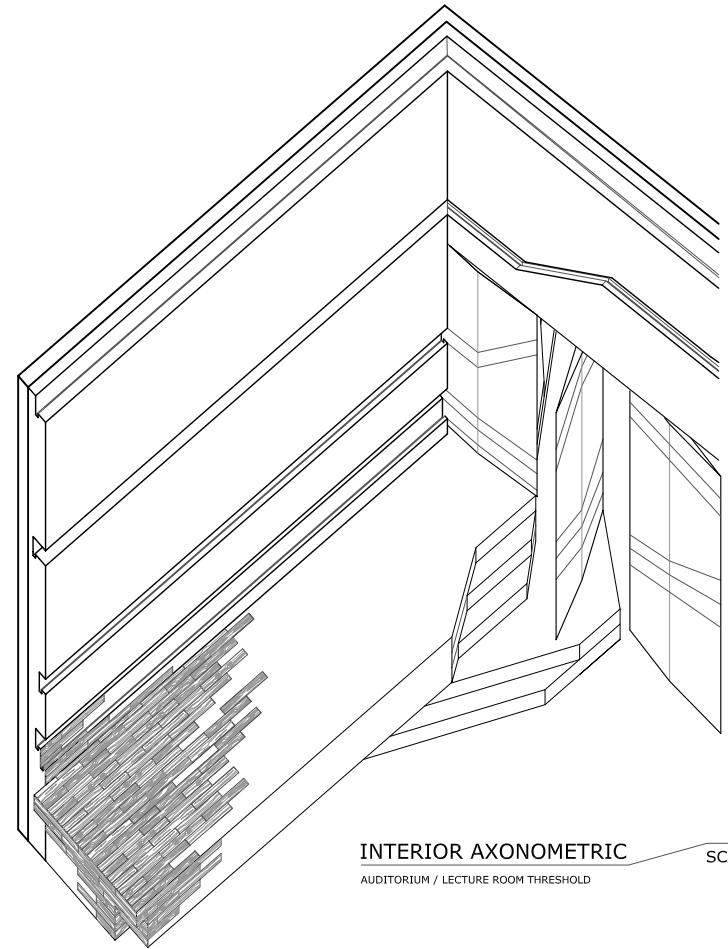

INTERIOR AXONOMETRIC SCALE 1:100
AUDITORIUM / LECTURE ROOM THRESHOLD

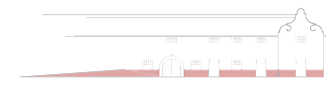

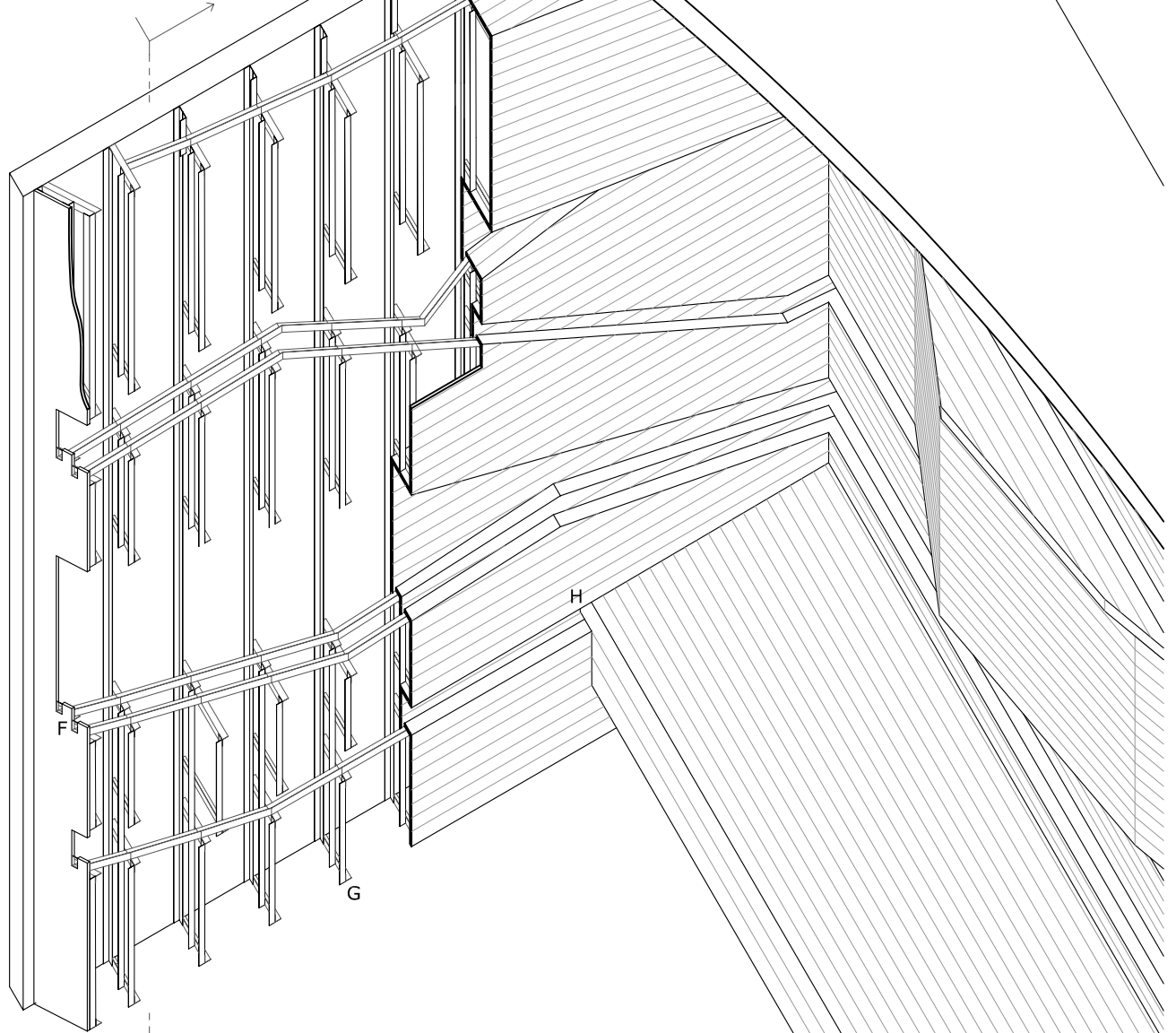
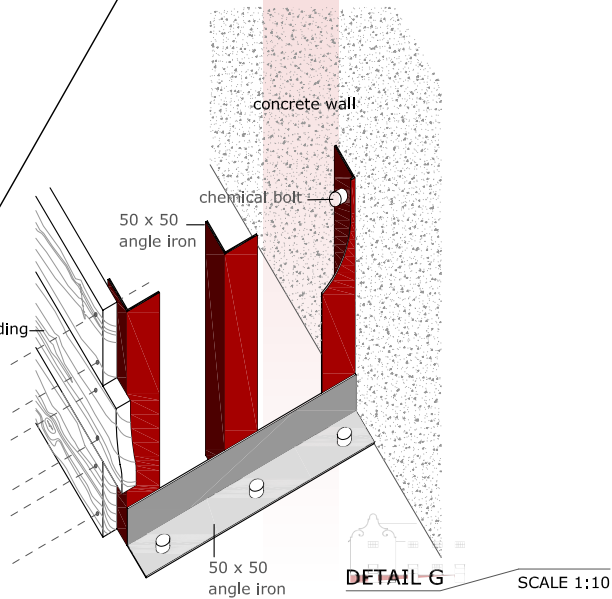
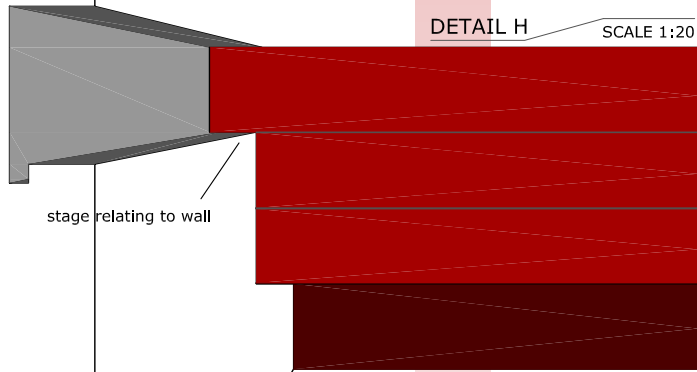
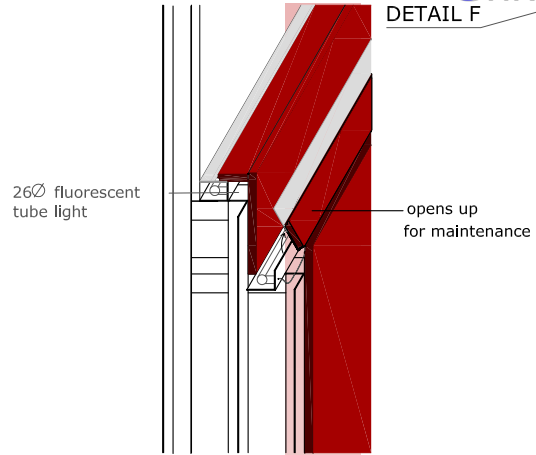

INTERIOR AXONOMETRIC
WALL CLADDING AND STRUCTURE
SCALE 1:50

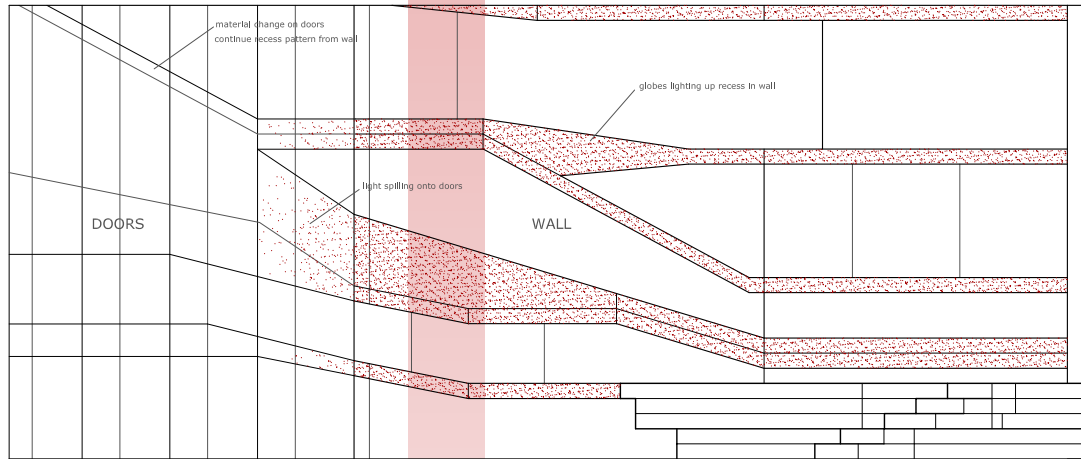

SECTION C
INDICATED ON GROUND FLOOR PLAN

SCALE 1:100

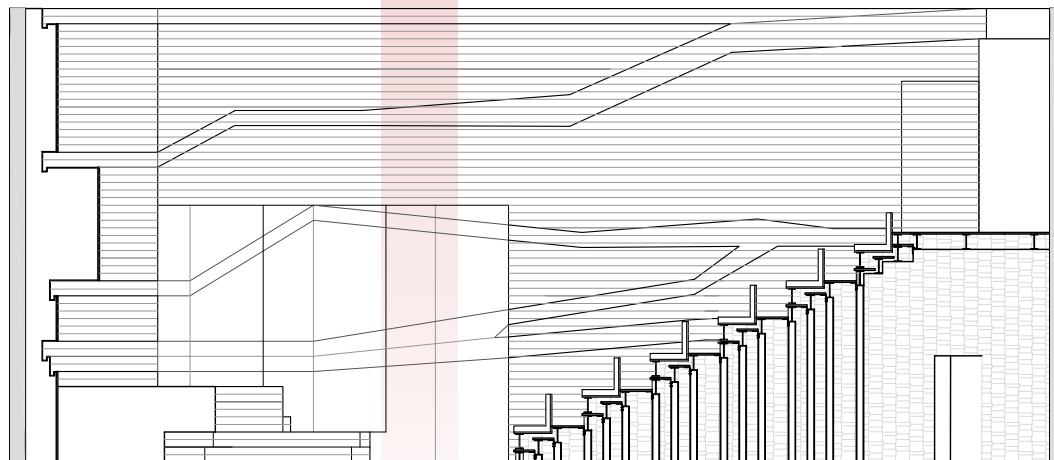

SECTION D
INDICATED ON GROUND FLOOR PLAN

SCALE 1:50

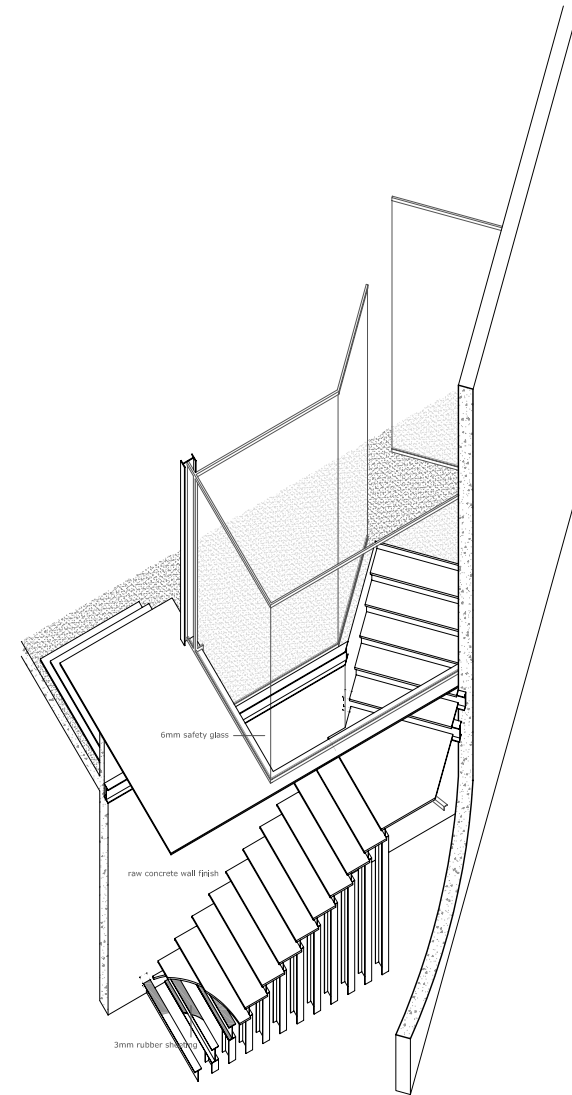

STAIRCASE AXONOMETRIC
LECTURE ROOM

SCALE 1:100



LIST OF SOURCES



PRINTED

Acoustic notes. *Notes compiled by Nel, J.P.* Mechanical Engineer, Building Plan DNA & acoustics lecturer Department of Architecture, University of Pretoria. Unpublished.

Aspects of wildlife: building study. 1994. *Architects' Journal*, 17 November 1994, vol. 200, no. 19, p.33-42.

DEAN, A, O. 1998. A child's-eye view: design. *Landscape Architecture*, May 1998, vol. 88, no. 5, p.34-39.

DE BEER, I. 1995. SAB Visitors' Centre – Newlands. *Architecture S A*, October 1995, vol. 9, no. 10, p.13-16.

FRASER, D. 2000. Watching Brief: building study. *Architects' Journal*, 2 November 2000, vol. 212, no. 16, p.32-41.

FRASER, J, L. 2004. New School Blues. *Frame*, July/August 2004, no. 39, p. 110-114.

FROMNOT, F. 1995. *Glen Murcutt works and projects*. London: Thames and Hudson.

HVAC: Heating ventilation and air-conditioning. *Notes as provided by Kulher, P.* Spoomaker & Partners Inc. Engineering Consulting.

JAPHA, V. 1998. SAB Visitors' Centre: SAIA Awards for Excellence. *S.A. Architect*, November 1998, p.26-29.

KURTICH, J & EAKEN, G. 1993. *Interior Architecture*. New York: Van Nostrand Reinhold.

LINDLEY, A. 1993. Designing for animal welfare. *Architect's Journal*, 3 November 1993, vol. 198, no. 17, p.35-43.

MARTON, D. 1997. Nature Reconstructed. *Landscape Architecture*, July 1997, vol. 87, no. 7, p.54-59.

McGUIRE, P. 1995. Hungarian Rhapsody. *The Architectural Review*, July 1995, vol. 196, no. 1181, p.35-43.

POWELL, A, E. 1997. Gardens of Eden. *Landscape Architecture*, April 1997, vol. 87, no. 4, p.78-87 & p.92-99.

SORVIG, K. 2001. Desert Meets Desert. *Landscape Architecture*, January 2001, vol. 91, no. 1, p.56-61 & 84.

SOUTH AFRICAN BUREAU OF STANDARDS 0400. 1990. *Code of Practice for the application of the National Building Regulations*. Republic of South Africa: Bureau of Standards.

The Hatfield Experimental Farm. 2000. *Tukkievaria*. 22 May 2000, vol. 17, no. 9, p.4-5.

University of Pretoria. 2004. Centre for Wildlife Management, *pamphlet*
Available: From the Centre of Wildlife Management
Attained: 2 March 2004

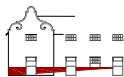

INTERVIEWS

BERTSCHINGER, H, J. Head of Department of Reproduction and Wildlife Unit, Onderstepoort. Personal Interview. 8 March 2004.

COERTZE, R. Farm Manager, University of Pretoria Experimental Farm. Personal interview. 21 October 2004.

HAUPT, M. Lecturer at the Department of Zoology, University of Pretoria. Personal interview. 25 March 2004.

JONES, B. Founder and Manager, Moholoholo Wildlife Rehabilitation Centre. Personal Interview. 26 April 2004.

LOCKWARD, J. Delta Environmental Centre Consultant. Personal interview. 3 March 2004.

SMIT, K. Student Program Manager, Hoedspruit Cheetah Project. Personal Interview. 25 April 2004.

SNYDERS, R. Contract Administrator, Research Contracting University of Pretoria; Pretoria. Personal interview. 24 March 2004

INTERNET AND TELEFONIC

City of Tshwane Metropolitan Municipality. 2004. Building plan enquiries.
Telephone: (012) 3587770

ITWeb Staff writer. 17 January 2003. Innovation Hub moves into full swing.
Available: <http://www.itweb.co.za>.
Accessed: 11 May 2004

South African Weather Service. 1961 - 1990. Climate Statistics.
Telephone (012) 3676000
Available: <http://www.weathersa.co.za>
Accessed: 29 March 2004

The Innovation Hub. [sa]. Grass Roots to Blue Skies
Available: <http://www.theinnovationhub.com/background.cfm>
Accessed: 11 May 2004

University of Pretoria. 2004. Faculty of Veterinary Science at Onderstepoort.
Available: <http://www.up.ac.za/academic/veterinary>
Accessed 17 February 2004

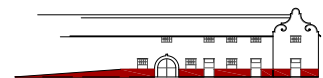

APPENDIX_A

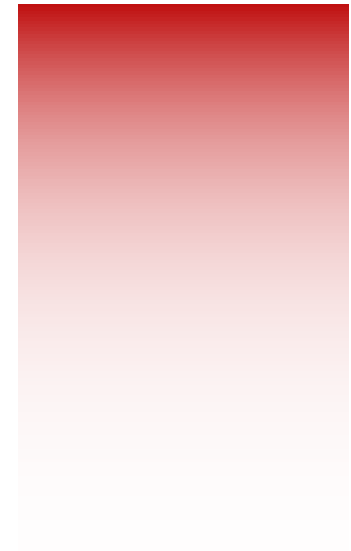

a legal context - CONTRACTUAL AGREEMENT

The following is an extract from a standard UP contracting document adapted for the Wildlife Research and Rehabilitation Facility (Research Contracting University of Pretoria).

CLIENT: University of Pretoria

SPONSOR: Pharmaceutical Company X

The *University of Pretoria*, a public education institution and a juristic person in terms of the Higher Education Act 01 of 1997 as amended by Section 25 of Act 23 of 2001, enters into contractual agreement with *Company X*, regarding the founding, development and administration of a research and educational facility, as an institute of excellence and higher learning.

identification - SITE

Two sites were identified as possibilities for the development of the project.

SITE ONE: Onderstepoort

Onderstepoort is the satellite Veterinary campus of the University of Pretoria. It is situated 20km north northwest of the University Main Campus in Onderstepoort. The campus is accessed by a main route but is surrounded by rural land and far from the main campus. It is conveniently close for students attending class at Onderstepoort, although not easily accessible to the general public. A large portion of the campus is visible from the main road that passes right in front of it and the campus itself can be seen as an identifiable node. An existing infrastructure allows for access to established services. Buildings on this campus are all in full use, which present a problem with regard to the incorporation of an existing structure into project development.

SITE TWO: University of Pretoria Experimental Farm

The Experimental Farm is used by the University for research and academic purposes. It is situated in Hatfield, close to the University main campus. The farm is a large portion of land around which a suburb has developed. Central placement of the site makes it easily accessible to staff, students and the public, although existing security hinders the free movement of visitors. Surrounded by an extensive network of roads, it is set just off Lynwood and borders on the N1. Publicly accessed through the University sports grounds, entry into the Farm is inconvenient but an entrance to the east end of the Farm, off the N1 highway, is currently under construction. There is an existing infrastructure to provide certain established services. An area of land has been identified with an existing building and surrounding structures that has fallen into a state of derelict and is almost entirely disused. The Farm is visible from the N1 but the area identified for possible development is not.

SITE TWO was selected for the development of the project, as it meets more of the pertinent and influential criteria. The unique outcrop of agricultural holding, surrounded by extensive urban development makes the Experimental Farm ideally situated for the intended purpose of the facility. The revitalization of an almost idle building and neglected structures would re-establish the usefulness of the site, adding value to Farm itself.



UP STAFF AND STUDENTS

Access to all facilities and private work areas as required and cleared by the Centre. Connection to visitors' educational and recreational areas, private employee social areas and personal storage.

PHARMACEUTICAL EMPLOYEES

Access to concerned research facilities, visitors' educational and recreational areas, and private employee social areas and personal storage. Possible clearance to remaining private work facilities.

LABOUR FORCE

Access to public areas, private work areas and storage as cleared by the Centre with regard to individual employment. Access to employee social areas and personal storage.

VISITORS

Public facilities - Access to educational and recreational facilities open to public use. These facilities include an informative exhibition on the Facility, the work it does and how it operates with glimpses into work areas. There is access to holdings of tame wildlife unsuited for rehabilitation and a children's educational recreation area.

Semi-private - Restricted access, for use by paying customers. The educational program includes group lectures on environmental and wildlife topics and special guided tours through wildlife holdings and facilities usually restricted from the public.

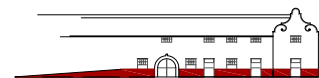

APPENDIX_B



It is imperative for people to realize the importance of introducing sustainability into the way we work and live. Human activity is depleting non-renewable resources and constantly damaging the environment. A development project can support sustainability by encouraging informed design decisions that considers the extended impact of the project both short term and long term. The design of the Wildlife Research and Rehabilitation Facility is to be based on the following criteria set up with regards to the context of the project and a sustainable approach. The baseline study sets out the design principles that the project is striving to achieve with regard to economic, social and environmental issues.

occupant comfort - SOCIAL CRITERIA

All aspects relevant to the comfort of the users of the facility are to be addressed as full as possible considering the limited flexibility and restrictions posed by the use of existing structures. Issues attended to will include trying to maximise the penetration of natural light and control of the light ray penetration and glare as the existing architecture has few and small windows. An effort will be made at increasing natural ventilation in existing structures and means of natural ventilation will be included in the design of any new structures. Decibel levels are to be controlled through segregation of various tasks and the combination of similar activities. Appropriate use of materials for construction and finishing are considered to help contain noise. Making full use of external views of the natural surroundings is important, as well as easy access to the outside due to the nature of the facility where movement between inside and outside is constant.

participation and control- SOCIAL CRITERIA

The use of existing structures again limits adaptation of the building and design for full flexibility. The user will be considered at all times and an effort made to design for adaptation and control of personal environments and flexibility. Social areas and easy access to refreshment and sanitary facilities will be ensured. The encouragement of community involvement through educational sessions forms part of the development strategy.

inclusive environments - SOCIAL CRITERIA

Public access is for most part limited and design of the facility should foremost consider the wildlife and functions personnel are to perform. For this reason designing for the disabled does not take priority but will be addressed as extensively as possible regarding both wheelchair users and the visually impaired.

access to facilities - SOCIAL CRITERIA

The site is situated in an urban environment, close to both residential and business districts and in short distance of a range of services.

education, health and safety - SOCIAL CRITERIA

At an educational facility of this nature, there is constant and efficient educational support and stimulation. Security is already provided for on the Experimental Farm but sufficient external lighting is needed around the buildings and along walkways that connect the buildings and animal holdings. All buildings on site are to comply with all necessary health and safety requirements and address smoking laws.



Local Constructors, manufacturers and material suppliers are to be used in the construction and maintenance of the facility where possible and sources within close distance. The facility also opens itself up to any outsourcing opportunities created in the development of the facility.

With only an approximate 20% of the structures on the site currently in use, the new establishment has the potential of improving the current efficiency of use by 80%. A conscious effort will be made to design the facilities to efficiently maximise use of space all-round with the design of shared spaces to establish a high occupancy ratio within all sectors of the facility.

Making use of existing structures it is difficult to control the adaptability and flexibility of the building with regard to vertical dimensions, existing non-load bearing inside partitioning and ease of access to existing services or modification of them without extensive cost implications. The approach taken in this project is the consideration of these aspects when adding to a structure or making viable adjustments when refurbishing. New construction shall make use of an external support structure and non-load bearing partitions that can easily be removed in the future.

Where possible, while keeping with the design context, maintenance and cleaning costs are to be kept to a minimum through selection of materials that are low in cost to maintain and do not need regular cleaning. Consumption of water and energy is to be regulated. The heating, ventilation and air-conditioning system and related plantroom is to be made easily accessible for maintenance purposes.

Capital costs are reduced though having project development costs shared between parties. The use of existing buildings is hugely cost beneficial and several groups of people will be sharing use of facility. Construction and material choices will be considered to lower initial capital costs.

Rainwater is to be harvested and grey water recycled, using the water from basins for watering vegetation and flushing toilets. Water efficiency devices are to be introduced to reduce water consumption. Exotic plant species are to be replaced with indigenous vegetation and hard landscaping kept to a minimum.

The urban placement of the facility makes use of public transport possible. Heating and cooling, passive ventilation, and passive ventilation principles will be incorporated as extensively into the existing structure as possible. Energy efficient light fittings are to be used wherever appropriate and solar panels installed to produce energy for electrical and heating purposes.

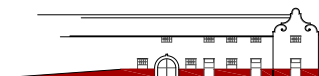

recycling and reuse - ENVIRONMENTAL ISSUES

Appropriate arrangements are to be made to dispose of hazardous waste. Recycled organic wastes could possibly be used on the Farm. Construction waste should be accumulated on site and disposed of. The use of environmentally friendly toilets or on site drainage systems will be explored.

site - ENVIRONMENTAL ISSUES

The chosen site a brownfield site and use of existing structures is suggested with limited additions that will increase the existing footprint. The structures on site and the surrounding buildings are positioned far apart, currently having no adverse effects on one other. The site consists mainly of kukuyu grass for cattle grazing. Kukuyu is an invasive, exotic grass specie that is not appropriate for use around wildlife. The grass also requires more water than local grasses and should be removed. Natural habitats will be formed for the retained wildlife that should need little artificial input.

materials and components - ENVIRONMENTAL ISSUES

A sustainable approach will minimise the environmental effect of construction. Design choices will consider the embodied energy of materials and whether materials are obtained from a renewable source and could be reused or recycled. The use of materials removed from the existing structures should be incorporated into the new construction or donated for use in underprivileged community development.



APPENDIX_C



APPLICATION (Reference)	ZONE	OCCUPANCY (SABS 0400)		AREA (SABS 0400)	LIGHTING	AIR REQUIREMENTS (SABS 0400)
VISITORS CENTRE	Public/ Semi-Private	Occupancy Class	Maximum No Of People	Area in m ²	Illumination In lux	Minimum In l/s
EXHIBITION	Public	C1	48	480	200	3.5
AUDITORIUM	Semi-private	A3	60	92	200	7.5
LECTURE ROOM	Semi-private	A3	14	85	300	7.5
STUDENT STUDIO	Semi-private	A3	16	80	300	7.5
INFORMATION SECTOR	Public/Semi-private			94		
Wildlife drop and information	Public	GI	3	40	200	5.0
Reference library	Semi-private	A3	18	90	300	6.5
VETERINARY CLINIC	Semi-private	B3	6	94	300	7.5
ADMINISTRATION	Semi-private	G1		65		
Office - Manager	Semi-private	G1	1	16	300	5.0
Office - Research liaison	Semi-private	G1	1	14	300	5.0
work station - Public relations officer	Semi-private	G1	1	10	300	5.0
Boardroom	Semi-private	G1	8	25	300	5.0
COFFEE SHOP	Public			194		
Reating area	Public	A1	100	100	200	5.0
Kitchen & Wash-up	Private	B3	6	94	500	17.5
WATER CLOSET FACILITIES	Public	X	120	18 toilets	100	



PART M - stairways

- MM2.1 The stairway leading from the lecture room to the circulation area on first floor level has headroom provided no less than 2,1 m as measured vertically from the pitch line, and the width of the stairway is no less than 75mm.
- MM2.2 The vertical rise between the ground floor and the landing on the first floor does not exceed 3m.
- MM2.3 The risers of the steps are 165mm and do not exceed the maximum 200mm.
- MM2.4 The widths of the treads are 260mm, more than the required 250mm
- MM3 (a) The stairs are protected on both sides at all times. The balustrade on the side is not less than 1m in height.
 (b) A continuous handrail extends the full length of the staircase and securely fixed at a height no less than 850mm and not higher than 1m as measured vertically from the pitch line to the upper surface of the rail.
 (c) The width of the flight of stairs is more than 1,1m wide and thus has two handrail, one on either side.
- MM4 The stairway is compliant with all fire requirements contained in Section T Of the SABS 0400

PART S – Facilities for disabled persons

SS2 Ramps

The ramp providing movement between the ground floor of the old farm building and the first floor is designed to fulfill all the deemed-to-satisfy rules of part S – Facilities for disabled persons, p152-p153.

The gradient measured along the centreline of the ramp is 1:12 and can be used by persons in wheelchairs.

The trafficable surface is clear and more than 1,1m wide and constructed out of epoxy with a textured finish for slip resistance.

Landings are provided within every 1,5m of vertical rise and are not less than that of the ramp. The landing at the top of the ramp is more than 1,2m in length while the landings that provide a range in direction between two straight sections of ramp have a length more than 1,2m as measured along the centerline.

Handrails are provided for the entire length of the ramp, the top surface of which is between 850mm and 1000mm above the surface of the ramp. The handrail is finished off as not to present a hazard to users and follows the gradient of the ramp for its full length.

SS4 Doors

The leaf of all single doors and at least one of a double door when open at 90degrees provides a clear opening more than 750mm wide at a right angle to the direction of travel.

All handles, fitted to door levels of emergency and feeder routes, and the disabled toilet facilities are lever type handles installed at a heights not more than 1,2m above floor level.

Any difference in surface levels of floors at thresholds is not more than 15mm.

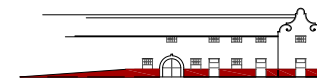

SS5 Toilet Facilities

There are two WC pans suitable for persons in wheelchair, suited to a population of up to 120 people. The placements of the WC pans are such that disabled persons travel less than 200m from any point inside the building to a WC pan.

The doors to the compartments designed for the disabled, containing a WC pan, opens outwards and the door leafs are fitted with locking devices but still openable from the outside by a suitable device.

The WC compartments suitable for use by disabled persons have a minimum area of 2,9m² and a minimum plan dimension of 1,6m. The distance between the centreline of the WC pan and the nearest wall is between 450mm and 500mm with grab rails fixed to the nearest wall and rear wall. The distance from the rear wall to the edge of the WC pan is not less than 160mm and the top surface of the seat of the pan is between 460mm and 480mm above the floor level. The pan flushing control and toilet paper holder are easily accessible.

The washbasin in the compartment is mounted to the wall without legs or a pedestal. The top surface is less than 830mm high and the vertical clearance under the basin is 650 from the floor finish (measured at no less than 160mm from the front of and under the basin). The basins are fitted with lever handles and the cold tap within reach of the WC pan while sitting.

