



- 1 Focus area
- 2 Problem
- 3 The detail of LU
- 4 Supporting theories
- 5 Approach
- 6 Analysis
- 7 Concept
- 8 Concept development
- 9 Design development



UNIVERSITEIT VAN PRETORIA  
UNIVERSITY OF PRETORIA  
YUNIBESITHI YA PRETORIA

# design development 08



UNIVERSITEIT VAN PRETORIA  
UNIVERSITY OF PRETORIA  
YUNIBESITHI YA PRETORIA



Fig:130. View of historic coal bunkers 1933 and 1945 (Author 2010)

## 9. Design development

### 9.1. Focus Area

The area I have selected for my detail intervention is the parcel of land between Buitenkant Street and the new train station. It is bordered by Mitchell Street to the north and the new bio-diesel plan to the south. The site includes the 1933 and 1945 coal bunkers.

### 9.2. Problem

The site forms the entrance to the power plant complex as well as the station. The existing coal bunkers form a barrier between the street and the station, blocking access. This is further perpetuated by the height difference between the street and the station ranging between 1 m and 3 m.

The bunkers are both older than 60 years and are therefore protected under SAHRA act, therefore cannot be removed. The bunkers are between 6 m and 11 m deep making them difficult to access.

Furthermore in context of the broader open space network, the site needs to contribute to a healthy and sustainable urban environment at a detailed scale.

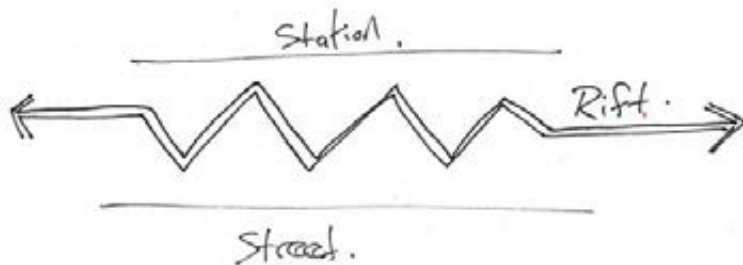

Fig:131. Diagram showing bunker as barrier of rift (Author 2010)

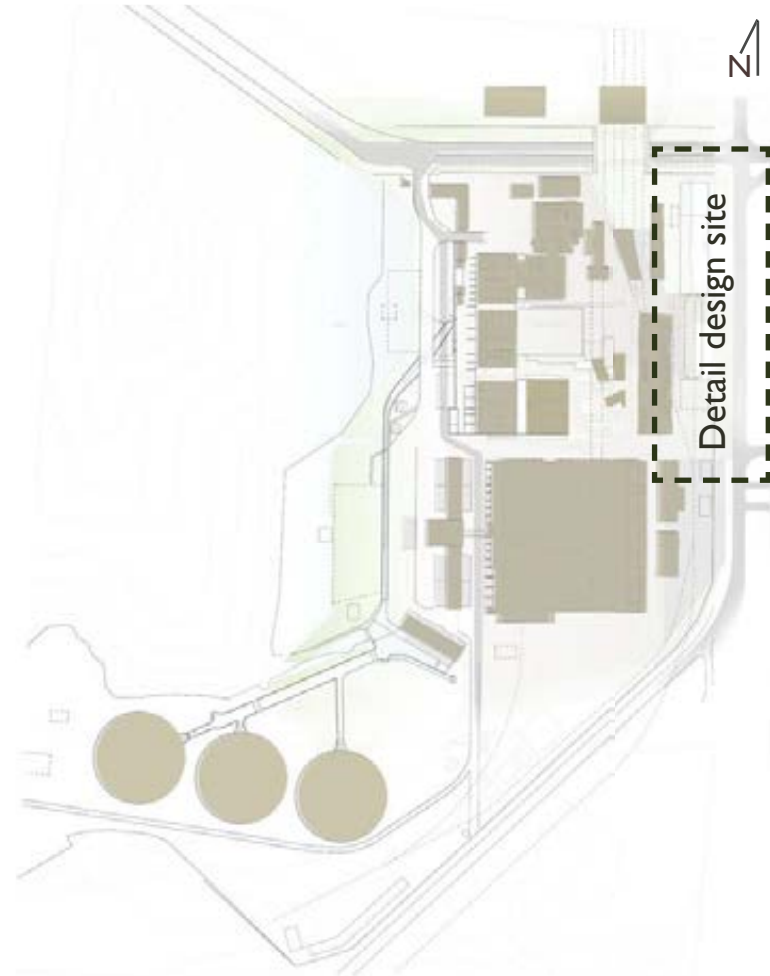

Fig:132. Diagram showing Focus area (Author 2010)



Fig:133. New orientation of plans with North to the left (Author 2010)





Fig:134. Digital Collage showing a series of spaces. (Author 2010)



“What make a space memorable or meaningful is not necessarily related to its function but rather to the intricate quality of space (Gehl 2007: 16).”

### 9.3. The detail of landscape urbanism.

When it comes to detail design, landscape urbanism offers very little design guidance. It remains a rather illusive body of theory that operates best at large scales where it has no need to be too prescriptive. Though the principles certainly have merit when dealing with the complexity of contemporary urban environments and often filter to a small scale, LU cannot address the complexity of every-day life, nor in fact does it try to.

It is easy to state that sites should be process driven and should be open ended so that they can evolve over time and accommodate multiple functions. Also that they should capture the imagination and use new and innovative methods of operations. But how does that relate to form? How does it look, feel, sound and taste?

In my opinion LU is not a design profession on its own nor can it be. It remains a body of theory that binds together the urban design professions to a state of enhanced intercommunication and a greater consciousness. In other words, LU provides the vision in which architecture, landscape architecture, and urban design and planning work together to achieve healthier, more sustainable urban environments that deal with current and relevant urban issues. It lays the foundation of a healthy landscape and unearths new potentials which make individual design interventions possible.

The design professions still function in their individual capacity, each with its unique contributions. With the combined contributions and inter-relationships of these professions we can most accurately address design problems at a detail scale.

LU is not all inclusive and there will always be need for other theories and design practices, although these can slot into a broader formwork it creates.



Fig: 135. Vegetables garden between coal bunker and fence (Author 2010)





## 9.4. Supporting theories

It is at the detail scale however that man interacts with landscape; it is here that he experiences and relates to it. There are many theories and principals outside of LU that can aid detail design while not conflicting with its broader principals.

### 9.4.1. Jan Gehl

Jan Gehl is an acclaimed theorist and urban designer who believes that public space should change along with the society they serve, or they will soon become redundant. This resonates with Corners theory of processes over time.

He continues by saying that where function is dominant, quality is often neglected and in a society where public space becomes a matter of choice the quality of space is crucial to the success thereof. The quality of the public spaces has, in the present day society, to be carefully attended to, or the spaces will not be used. We live “in a time where lively, attractive, safe and sustainable, with healthy individual lifestyles have become increasingly important (Gehl 2007: 17).”

He believes there are three essential aspects of public open space. These are:

1. Protection
2. Comfort
3. Enjoyment

#### 1. Protection

Good public spaces offer protection against accident, insecurity and discomfort such as vehicle traffic, crime, violence as well as unpleasant sensory experiences. This

could be achieved by creating a safe pedestrian environment that offers a good mix of uses and activities, thereby ensuring passive surveillance. Basic considerations such as shade or shelter from wind or rain should also be considered as well as lighting and 24 hour activity.

#### 2. Comfort.

Pedestrians should have excellent opportunity for walking, good level surfaces free of tripping hazards and other obstacles and harassments. Spaces should offer pleasant and interesting views, appropriate opportunity for either standing or sitting. Good public spaces offer opportunity for seeing as well as hearing and talking. It should cater for diverse age groups as well as active and passive recreation.

#### 3. Enjoyment

Creating thoroughly enjoyable spaces is highly dependent on utilizing the qualities, attractions and special amenities found in and around city spaces (Gehl 2007: 20).

These spaces should be dimensioned according to the human body and senses so that the visitors feel comfortable. They should further provide opportunity to enjoy positive climatic aspects, provide interesting sensory experiences, fine views and overall enjoyment.

### 9.4.2. Newman & Jennings

Peter Newman and Isabella Jennings, in their book *Cities as Sustainable Ecosystems: Principals and Practices* highlight the importance of sense of place in creating sustainable cities. They too have ideas that resonate with Corners ideas. They state that a sense of place encompasses a feeling of connection to a place, a lived engagement with people and land, and an understanding and appreciation of the patterns and processes in time and space (Newman & Jennings 2008:



145).

They go on to say that in developing connections between people and their bioregion, creates a greater sense of belonging. It offers psychological enrichment and encourages sustainable practices, as people develop ties of affection for their environments. Ecological design begins with the intimate knowledge of a place. It is small-scale and direct, responsive to local conditions and people. If we are sensitive to the nuances of place, we can inhabit without destroying thereby utilising existing potential while retaining its initial character. "Designing for place is one of the core principles of ecological design (Newman & Jennings 2008: 145)."

They offer five strategies for fostering sense of place:

1. Protecting important existing elements and their natural and cultural heritage
2. Designing to make historical and current social and ecological processes more visible

3. Connecting the urban form with the wider bioregion
4. Using cultural practices and the arts to nurture and deepen a sense of place
5. Discover city "song lines" (the patterns that people form in habituating the city)

### 9.5. Approach

My approach to dealing with the design at this scale will be a combination of the above mentioned principles and the qualitative and quantitative approach developed earlier in the master plan scale.

The qualitative aspects at this scale include the inherent potential and heritage of the existing structures and the experience it can offer the user. On the quantitative side aspects such as movement, hydrology and sustainability will be considered.

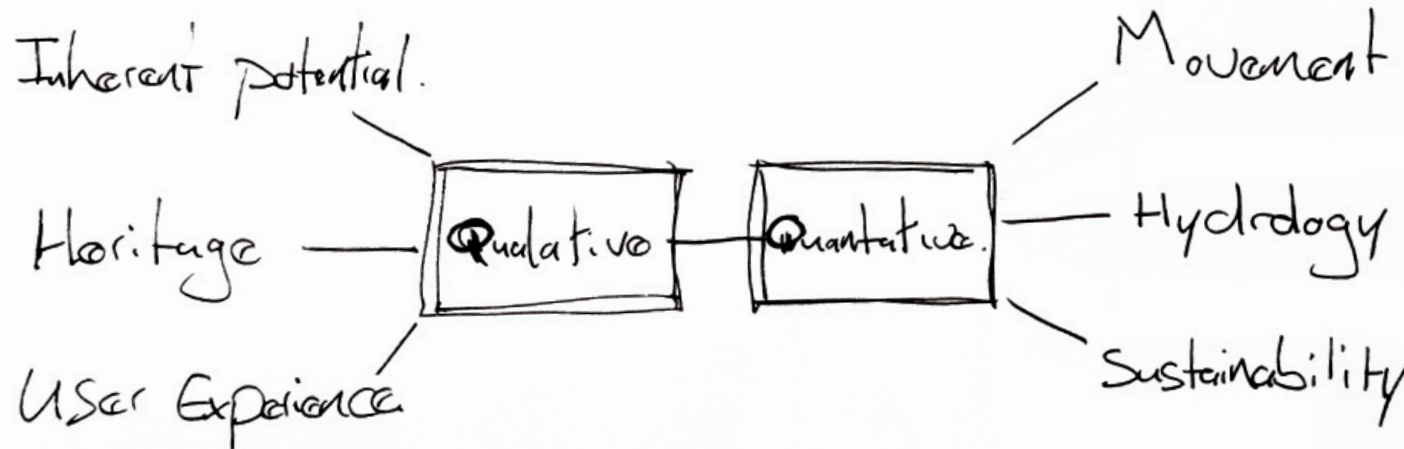

Fig:136. Diagram showing qualitative and quantitative aspects (Author 2010)



Bunker B

Bunker A

Fig:137. View of coal bunkers (Author 2010)





UNIVERSITEIT VAN PRETORIA  
UNIVERSITY OF PRETORIA  
YUNIBESITHI YA PRETORIA



Fig:138. North-East-ward panorama of site (Author 2010)



Fig:139. South-ward panorama of site (Author 2010)





UNIVERSITEIT VAN PRETORIA  
UNIVERSITY OF PRETORIA  
YUNIBESITHI YA PRETORIA







UNIVERSITEIT VAN PRETORIA  
UNIVERSITY OF PRETORIA  
YUNIBESITHI YA PRETORIA



Fig:140. Inside bunker A (Author 2010)





UNIVERSITEIT VAN PRETORIA  
UNIVERSITY OF PRETORIA  
YUNIBESITHI YA PRETORIA







Fig:141. Inside bunker B (Author 2010)



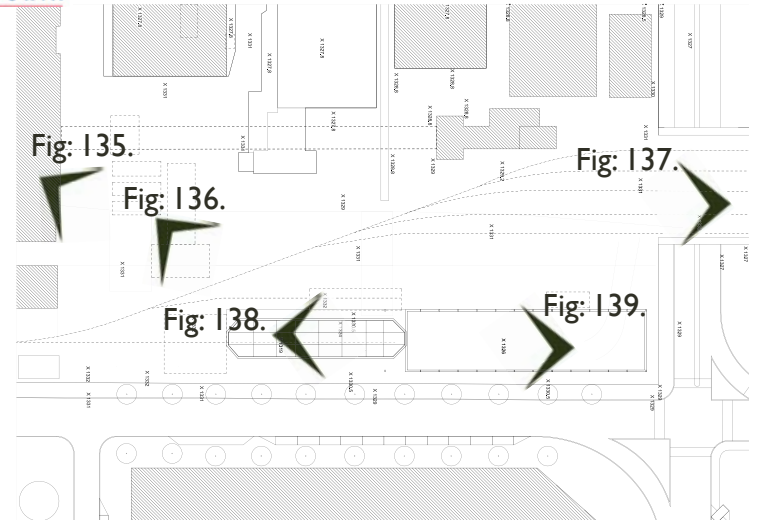

Fig: I42. Viewpoints for panoramas (Author 2010)



## 9.6. Analysis

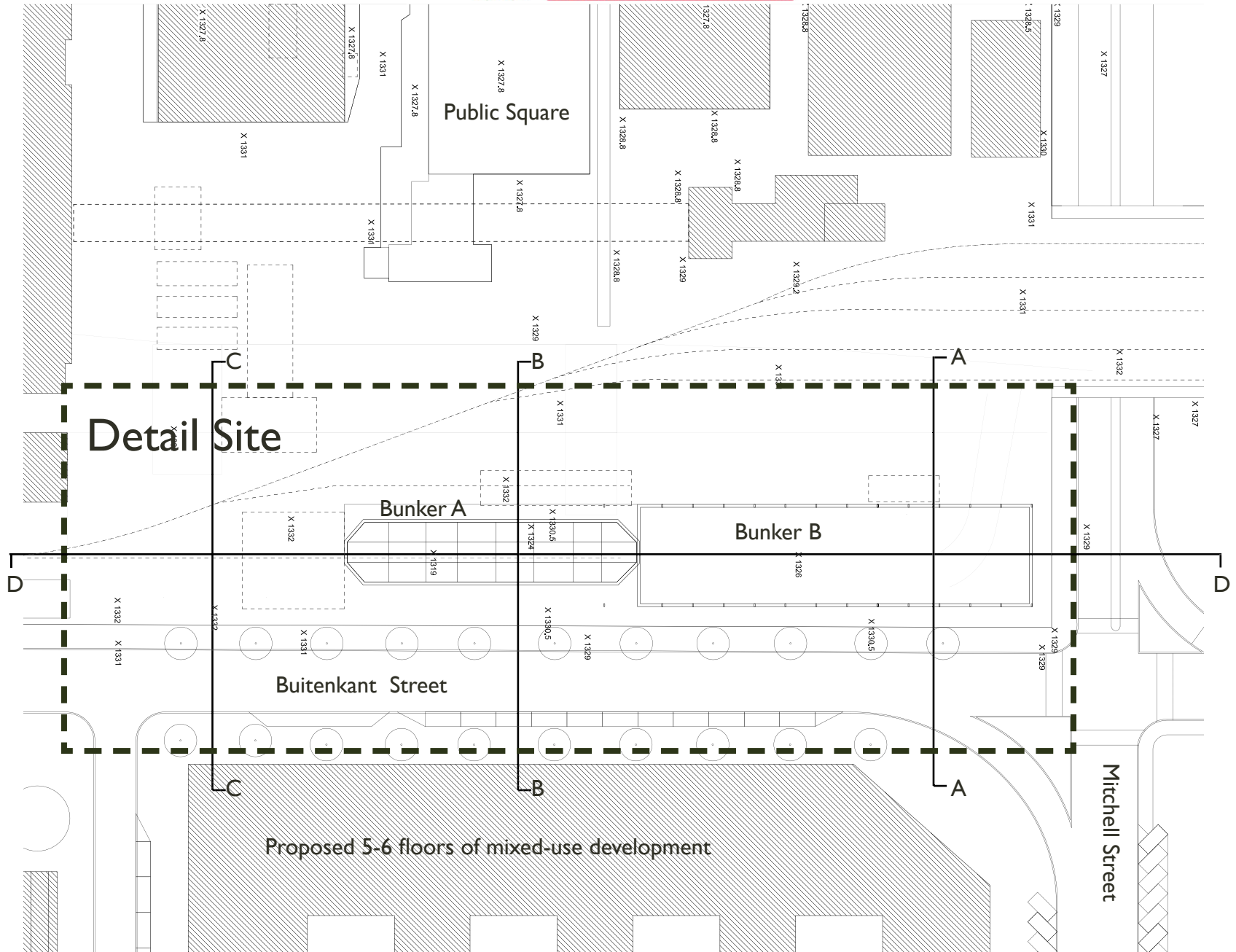

Fig:143. Plan Showing Existing site (Author 2010)

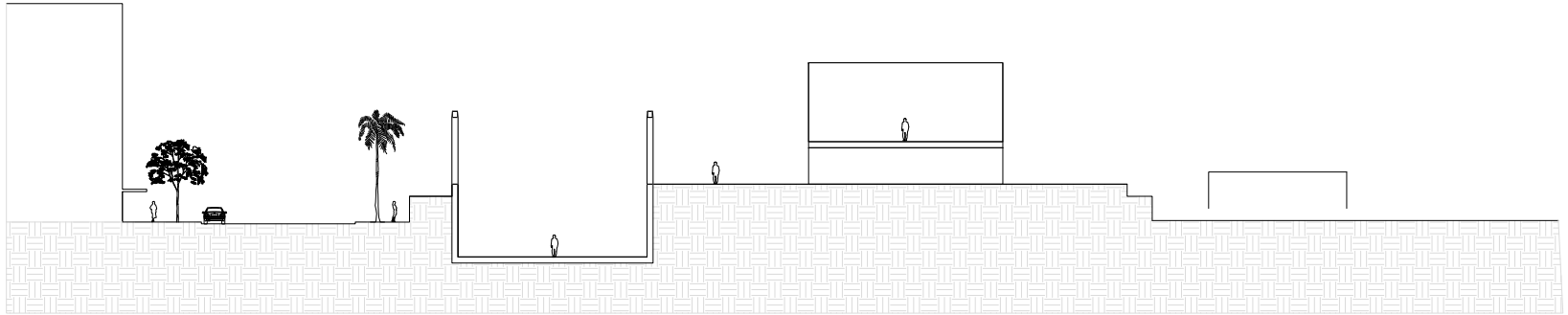

Fig:144. Existing section AA (Author 2010)

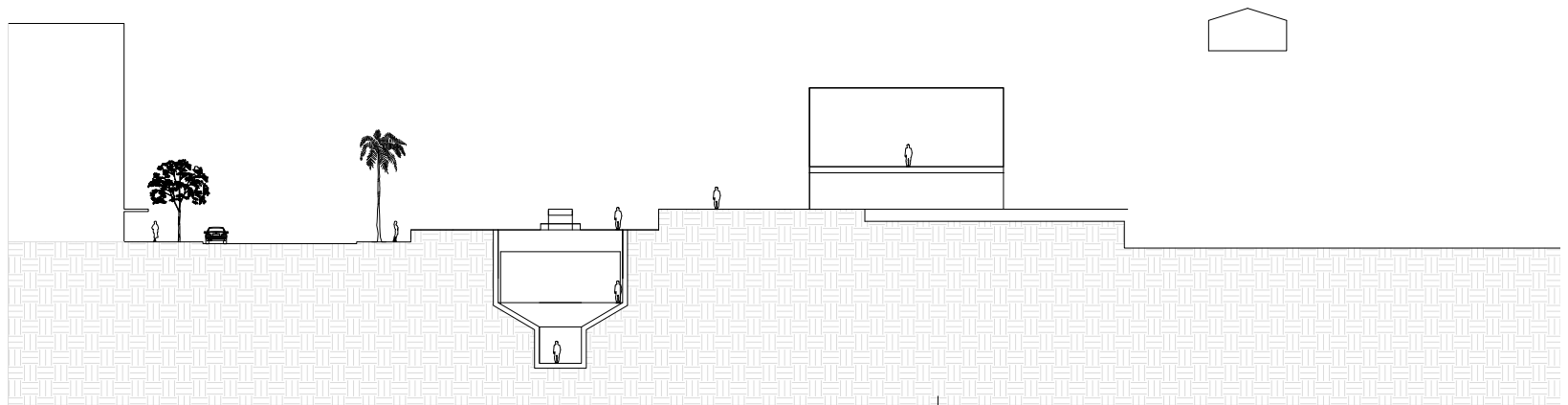

Fig:145. Existing section BB (Author 2010)

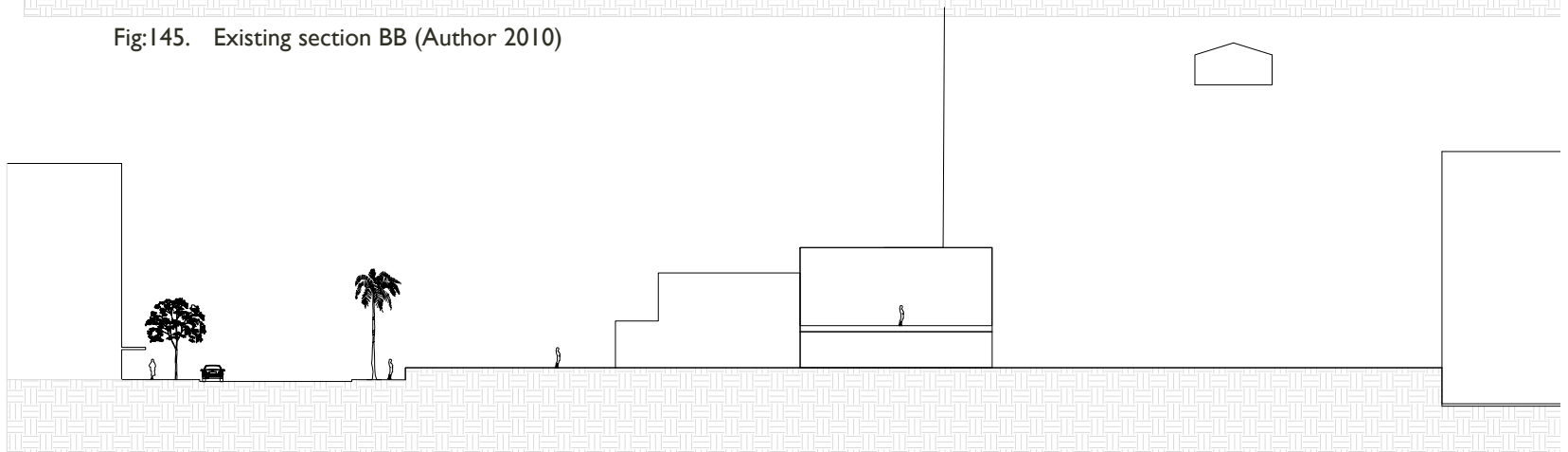

Fig:146. Existing section CC (Author 2010)

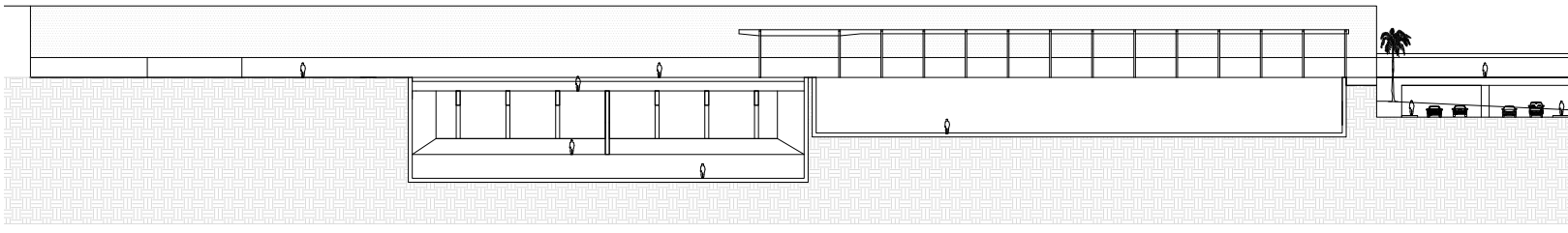

Fig:148. Existing section DD (Author 2010)

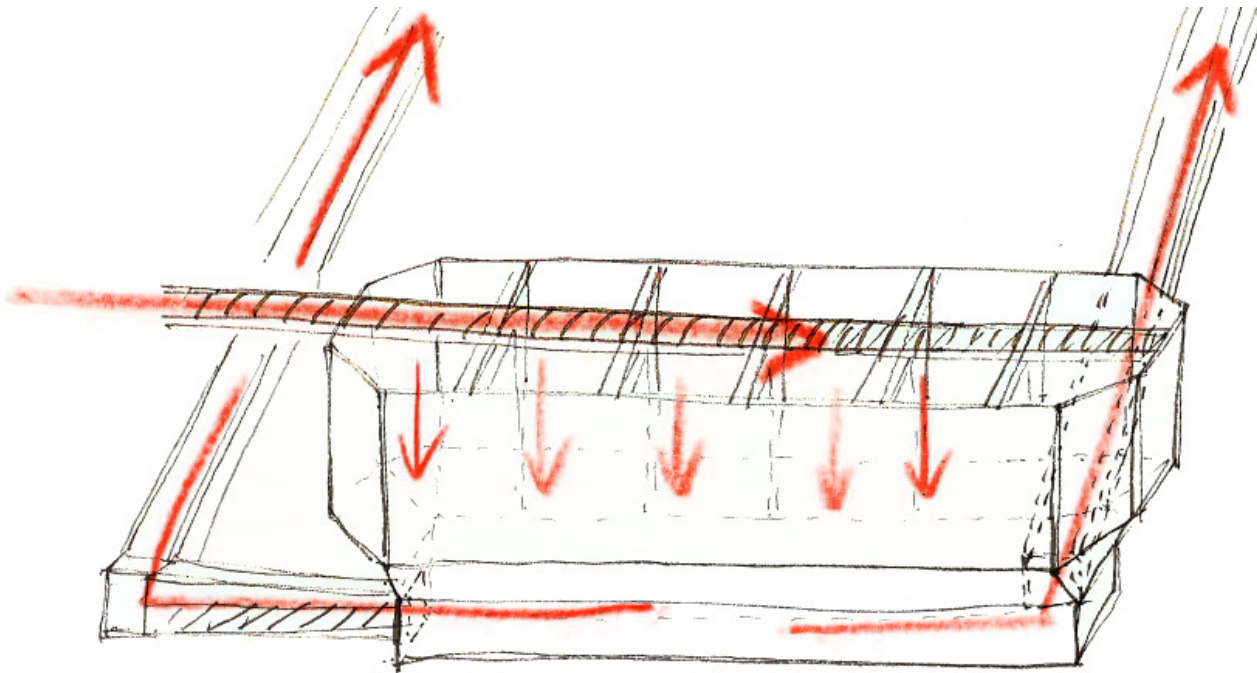

Fig:147. Diagram showing process of storing and extracting coal through old conveyors (Author 2010)



### 9.6.1. Statement of significance

The landscape of the power plant site is one that has shifted and evolved over time. With every addition made the land was cut and filled giving it its irregular character and leaving traces of that which has gone before.

The structures were built between 1933 and 1945. There is a certain mystery connected to them because no one who knows exactly how they use to operate or where the ducts use to enter into the bunkers. There are pipes and underground tunnels that lay dormant waiting to be rediscovered. It speaks of an age gone by. Now one can still relate the bunkers to the powerplant, but in years to come the powerplant itself will become an artefact of bygone process. The 1933 bunker was never emptied of its contents. The coal that remained have over time become the growth medium for a chaotic forest.



Fig:149. Excavation of 18933 bunker (Power station archive)



Fig:150. Moving of coal (Power station archive)





Fig:151. Raised walkways in Andre Citroen Park (<http://architypes.net/image/parc-andre-citroen-walkways-over-gardens>)



Fig:152. Romantic garden (<http://malcolmkirk.com/images/gallery/3>)

## 9.7. Concept

The bunkers were once of key importance on the site, because they were the vessels in which the coal was contained. Coal is the fuel that the power plant runs on; it is the source of energy that gives life to the city. The bunkers also protected the surrounding environment from being contaminated by coming into contact with the coal.

Once the plant is decommissioned and redeveloped into a cultural and economic centre, the plant will run on a new fuel; the people who will inhabit and pulse through it will be the new source of energy. The plant will then once again provide power to the city - this time not to generate electricity but to regenerate urban form.

The concept for the site is firstly to create a series of bridges and entrance squares to facilitate access to the site and station, thereby addressing the functional requirements.

Secondly to create a series of spaces or gardens within the bunkers that allow people to move through, to rest for a while and then move on. These spaces will offer an escape from the fast previous urban environment surrounding it. This is a poetic inversion where the bunkers now protect its internal environment from the contamination of the everyday urban environment.

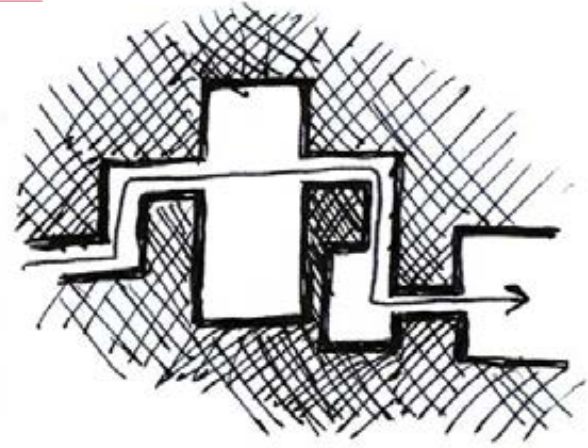

Fig:153. Series of Spaces (Author 2010)

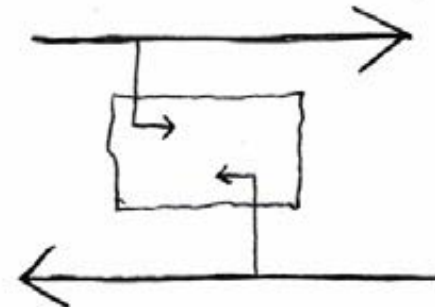

Fig:154. Detour spaces (Author 2010)

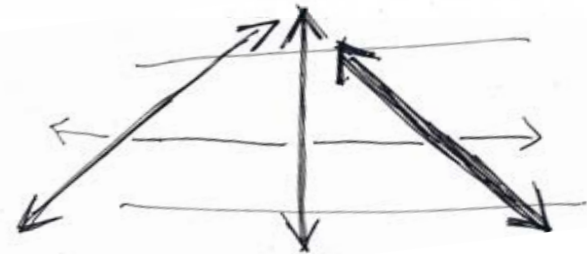

Fig:155. Bridging the bunkers(Author 2010)

## 9.8. Concept development

### 9.8.1. Inherent potential

What opportunities does the site offer that will influence the design approach and programming?

The Bunkers are sunken, therefore are visually cut off from its surroundings, offering seclusion. They are located in the middle of various busy movement systems, but because of their articulation they have the potential to become islands of escape.

Bunker A is introverted in its articulation and therefore offers more intimate spaces whereas bunker B is more extroverted and therefore will have more public functions.

Bunker B is equipped with an overhead crane that runs on a concrete structure, offering the opportunity to move things in and out of the bunker. Bunker A on the other hand has an existing overhead railway structure that can facilitate movement.

The different surface levels offer exciting design challenges.

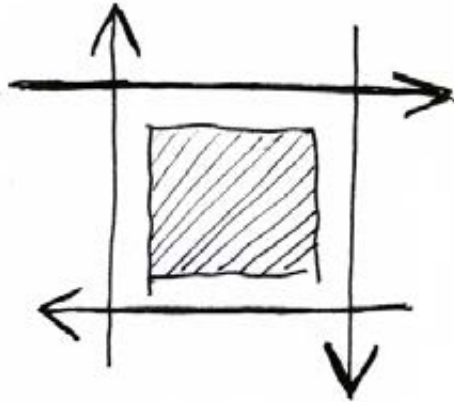

Fig:156. Bunkers function as island of escape (Author 2010)

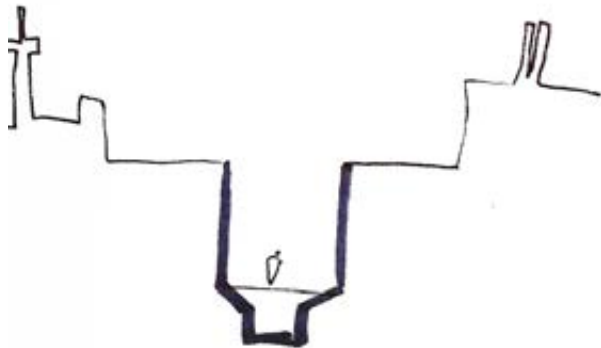

Fig:157. Seclusion from surroundings (Author 2010)

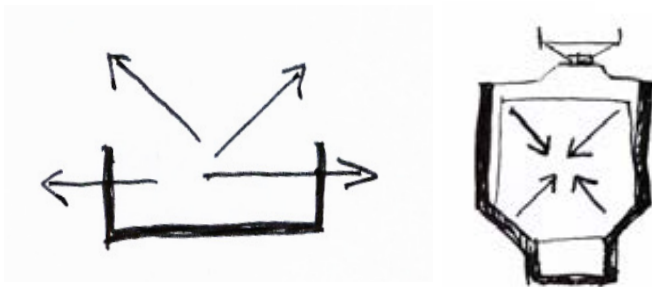

Fig:158. Extroverted and introverted bunkers (Author 2010)

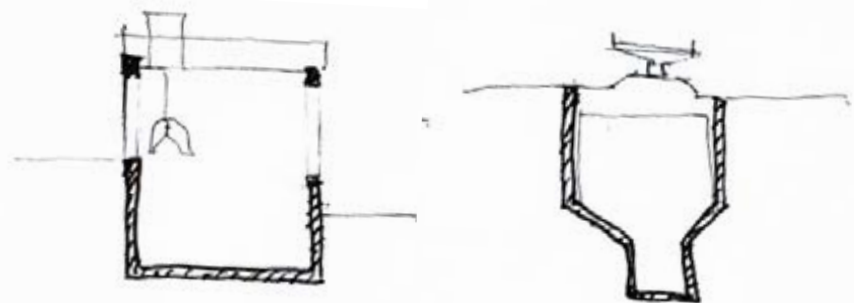

Fig:159. Existing Structures (Author 2010)

## 9.8.2. Heritage

The because of their age and vital historical function the bunkers the design must have a strong heritage component.

Therefore the major structures and unique features must be maintained. However in order to access and reprogram the bunkers it will require modification. The approach to heritage will be one that reveals historic processes and structures through showcasing them or by contrasting them.

New materials have to contrast old, without distracting attention and fixtures will either be mounted onto or suspended from existing structures. New circulation routes will be cut behind existing structures to insure the integrity of the internal volumes of the bunkers.

The design should be both bold and sensitive allowing people to experience and explore the narratives of the site.

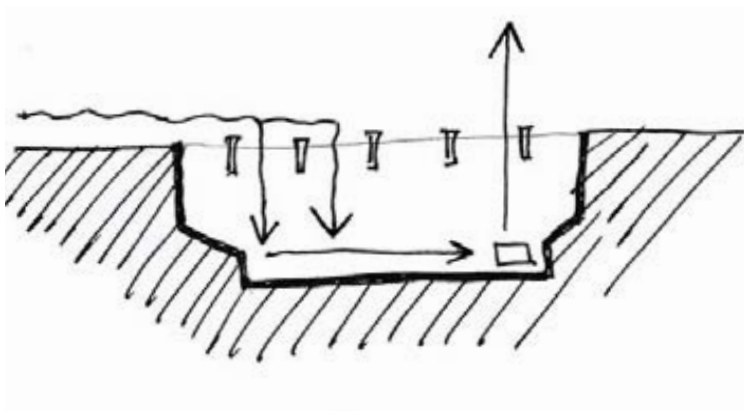

Fig:160. Historical process (Author 2010)

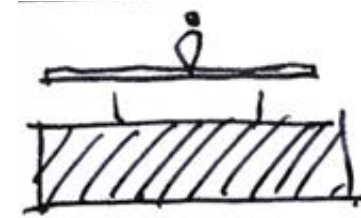

Fig:161. New interventions hover mounted onto existing (Author 2010)

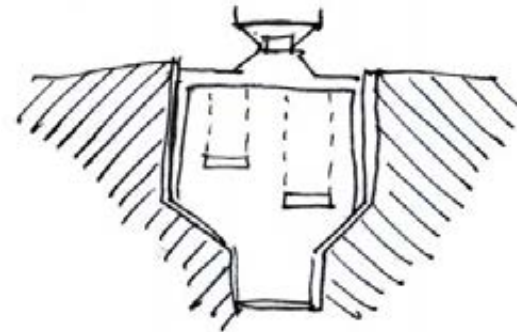

Fig:162. New interventions suspended from existing (Author 2010)

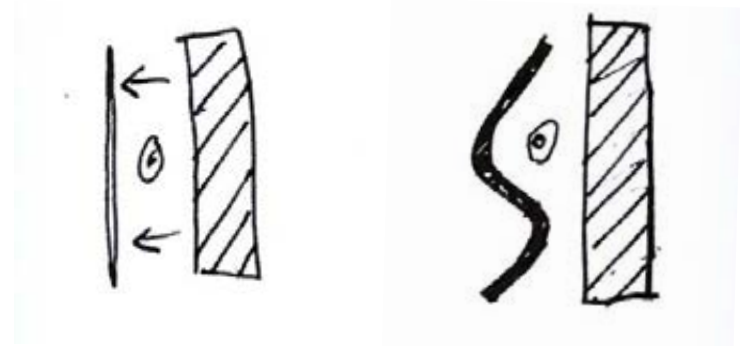

Fig:163. Cut in behind and contrast existing structure (Author 2010)



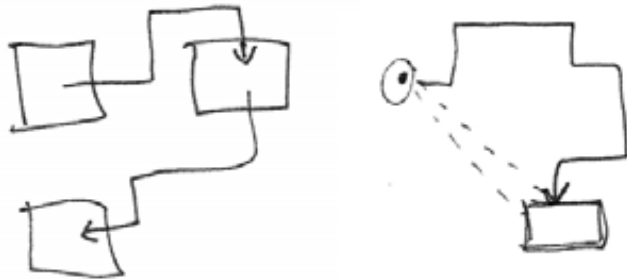

Fig:164. Series of spaces offering hints of the next (Author 2010)

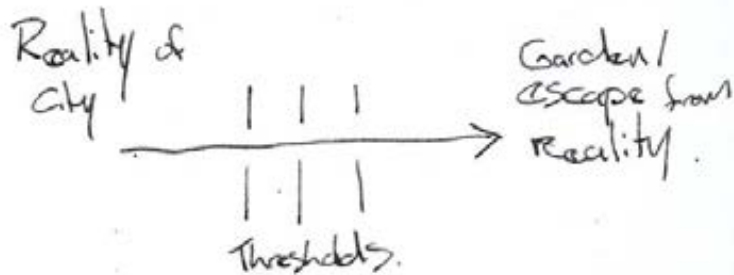

Fig:165. Series of thresholds (Author 2010)

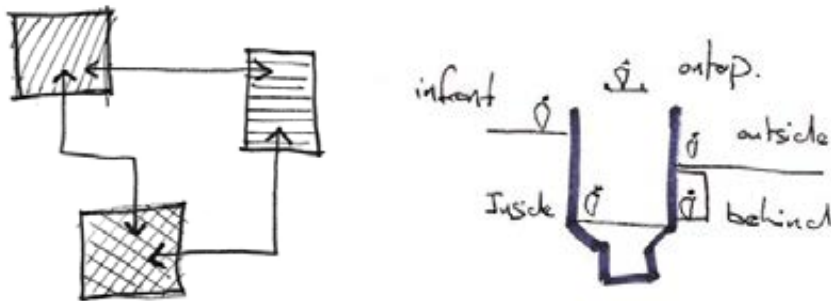

Fig:166. Variety of spatial characters and levels of experience (Author 2010)

### 9.8.3. User experience

It is at this scale that people experience landscape the most intimately. How does one address the need for landscape at a detail scale in order to address problems at an urban scale?

The answer is that the landscape should provide the escape, the recreation and the relaxation that the suburbs provide. Places with a strong identity where one can interact with nature at an intimate level. These spaces should be easily accessible by the general public but also provide the safety and comfort of private gardens.

This draws one back to the medieval and romantic notions of walled garden, where the garden was a place of beauty that excludes negative influences of the outside world.

The series of walled gardens must offer an alternate reality where one can enter and as one moves across thresholds one is further and further removed from reality.

These spaces must offer a variety of peaceful yet stimulating environment which the user can explore, each offering hints of the next one.

The user should be able to experience the bunkers from all angles.

#### 9.8.4. Movement

Movement is one of the most important informants within the design with the first priority of linking the street to the station and secondly navigating the level differences.

A series of terraces is introduced to mitigate the significant level differences. These serve a dual function of navigating the level difference and creating spaces.

There is a hierarchy of movement routes ranging from direct routes to secondary and tertiary routes. This allows the user to decide how much of the site he is willing to explore.

#### 9.8.5. Hydrology

Bunker A forms the lowest point of on site of up to 11m below ground level. Thus water will naturally congregate there, thus it will now form part of the storm water strategy as a detention facility to store water for subsequent slow release. The water will pass through vegetation and soil filters that will cleanse it in the process. Some of this water can then be used for irrigation purposes.

#### 9.8.6. Sustainability

In terms of sustainability, the design will rely heavily on materials recycled and manufactured from site. It will also look to labour intensive construction methods as a means of job creation.

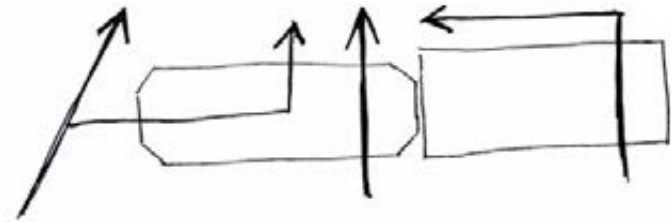

Fig:167. Bridging of bunkers (Author 2010)

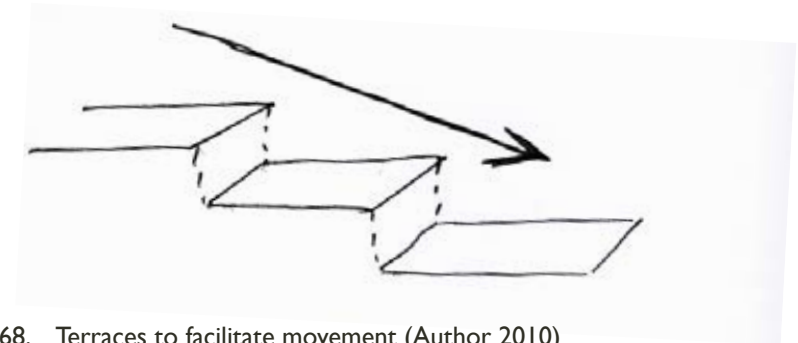

Fig:168. Terraces to facilitate movement (Author 2010)



Fig:169. Retention and filtration of water (Author 2010)



Fig:170. Use of recycled materials to construct design (Author 2010)

### 9.8.7. Other principles

In terms of Gehl's theory of protection, enjoyment and comfort the design should offer passive surveillance and controlled access. It should also provide good and comfortable access with ample opportunity for seating. Micro climate should also be taken into consideration. Furthermore the design should offer interesting sensory experiences.

According to Newman & Jennings theory the existing elements and character should be safeguarded whilst making historical and current social and ecological processes more visible. It is also important to connect urban form with the wider bioregion, thus using elements such as vegetation to reference the broader region.

Furthermore using cultural practices and the arts to nurture and deepen a sense of place. The design should eventually form part of the day to day activities of the surrounding community.

## 9.9. Design development

### 9.9.1. Context

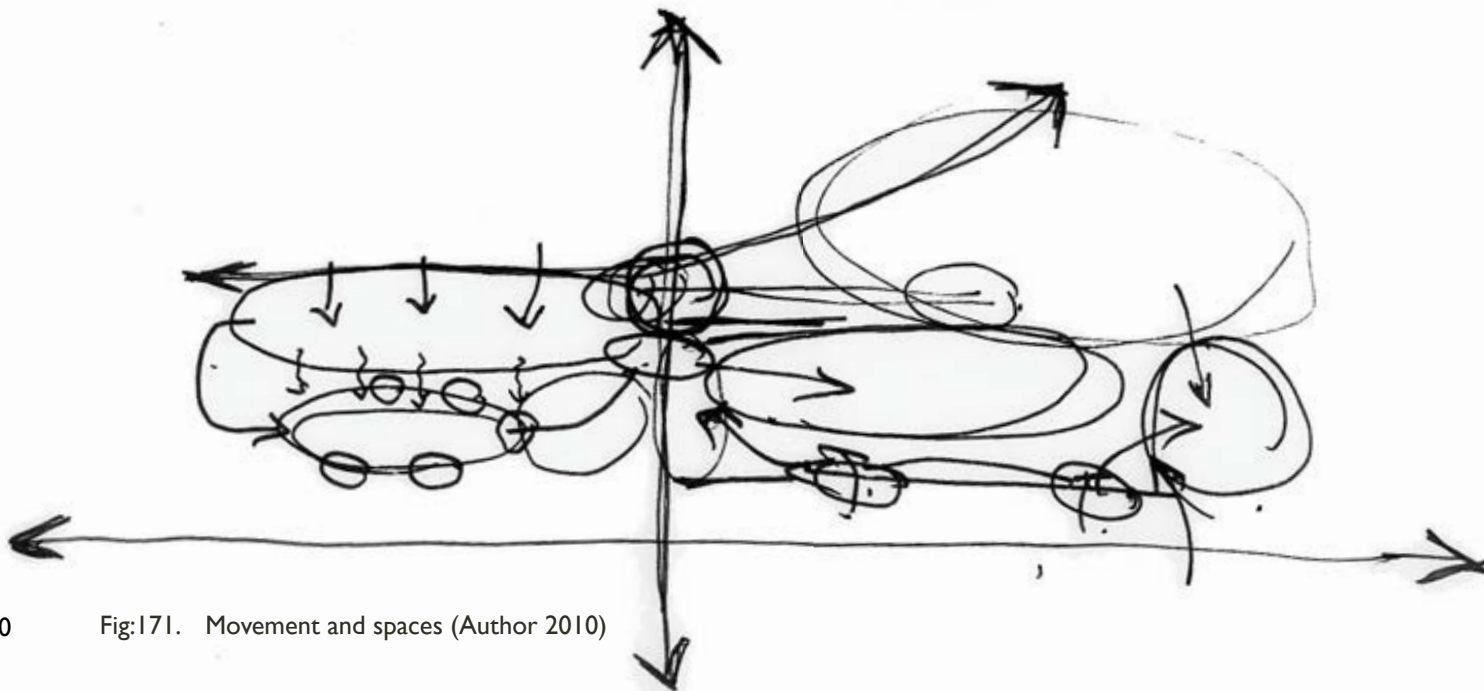

180 Fig:171. Movement and spaces (Author 2010)

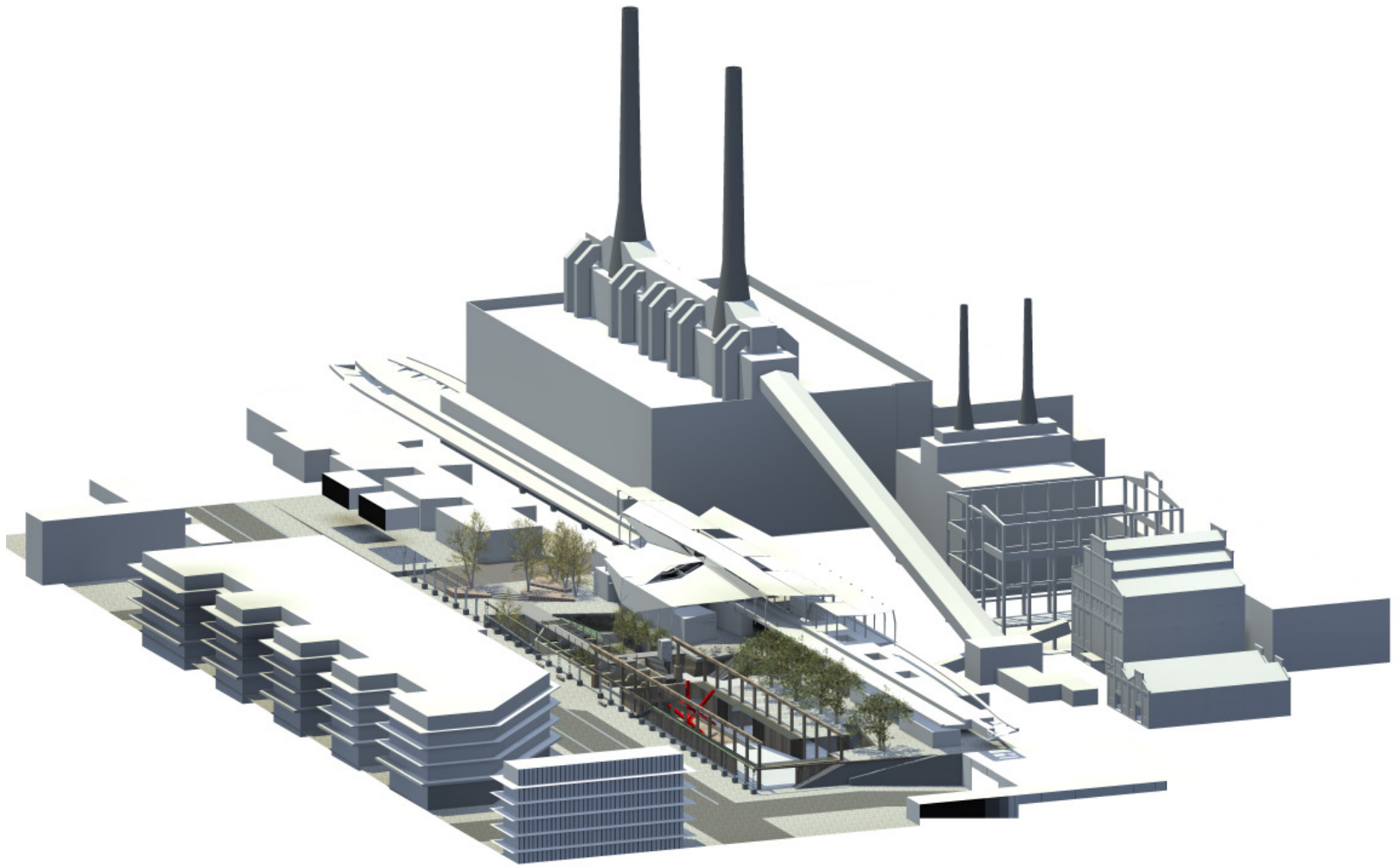
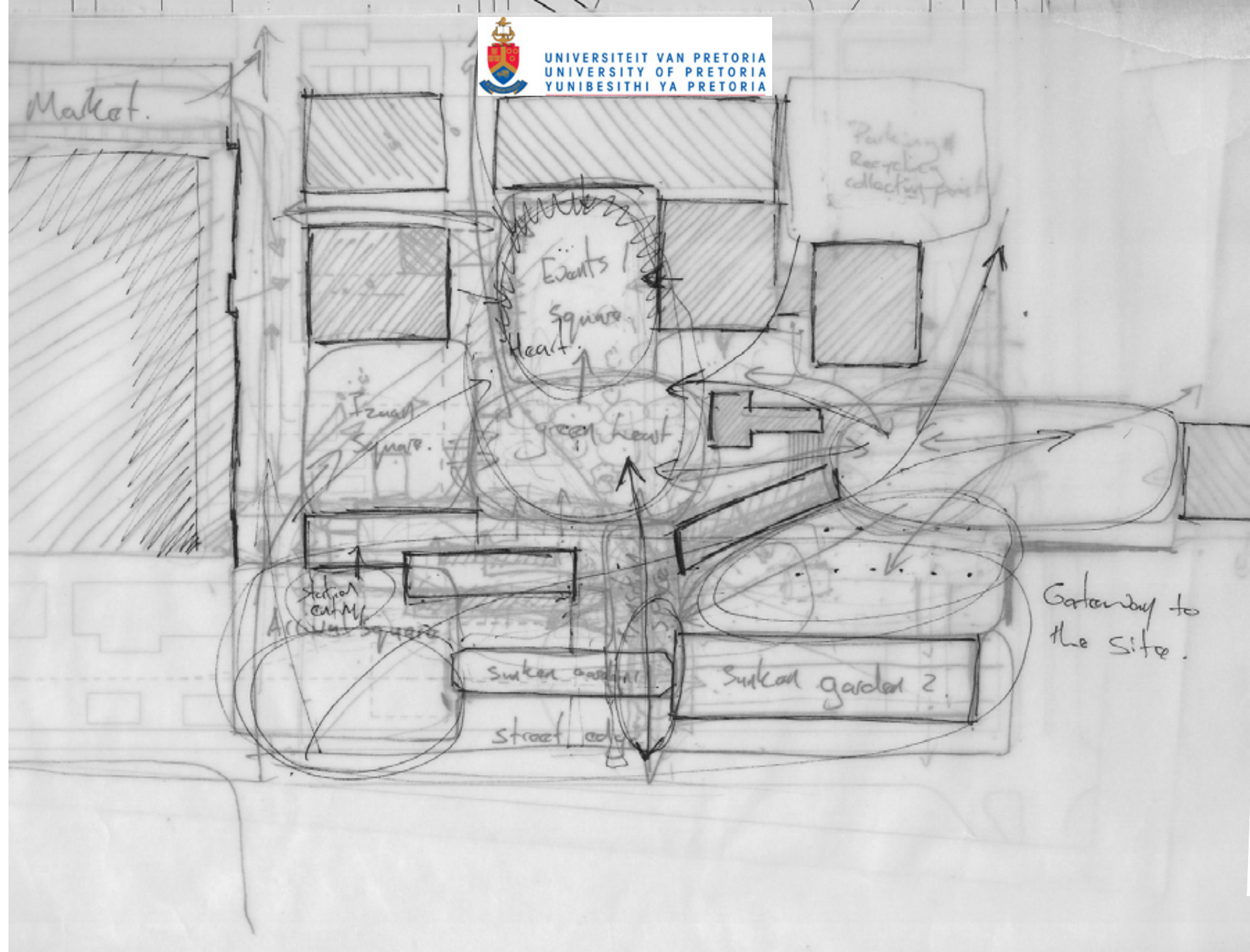

Fig:172. The design in context (Author 2010)





182 Fig:173. Diagram identifying public open spaces and the connections between them (Author 2010)

### 9.9.2. Shaping of levels

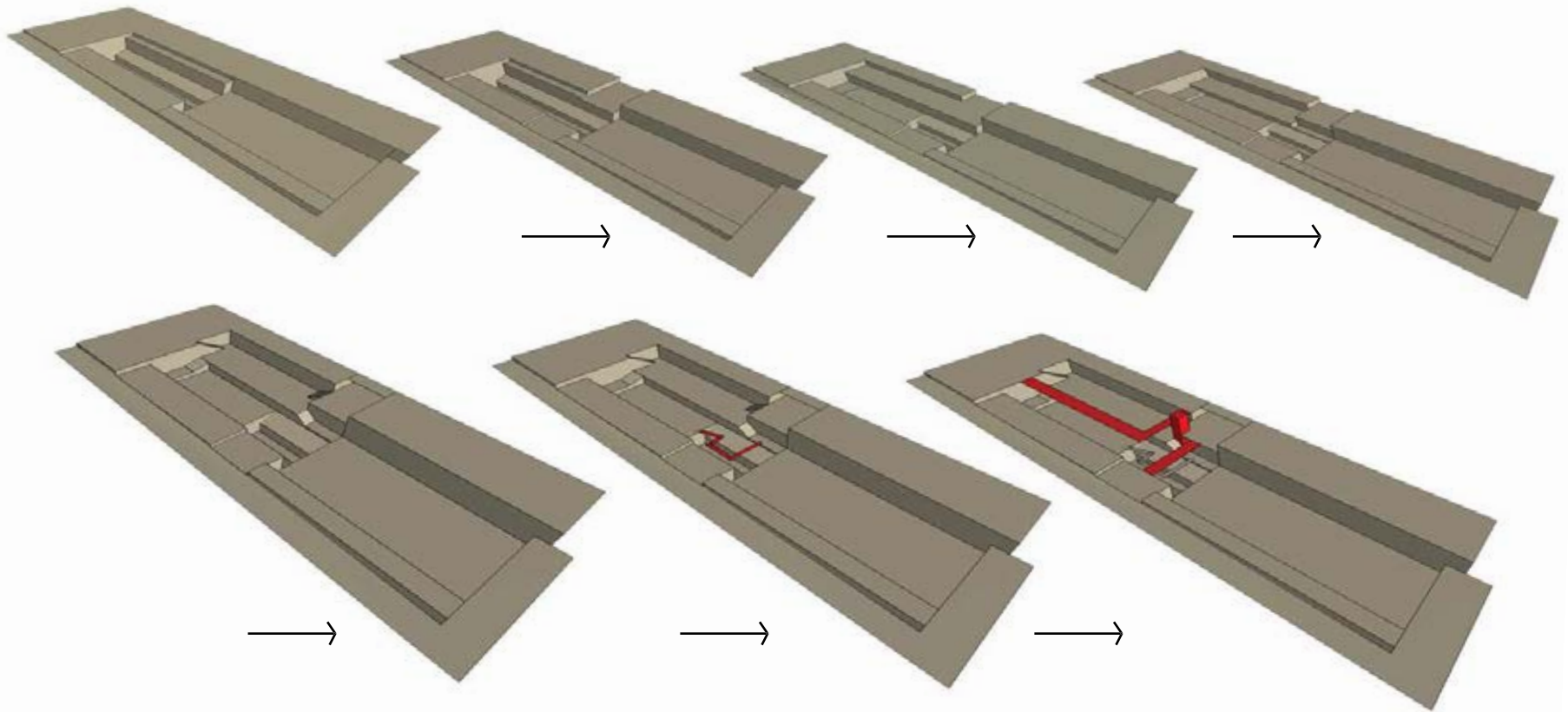

Fig:174. Shaping of levels to create spaces and facilitate movement (Author 2010)



### 9.9.3. Working models

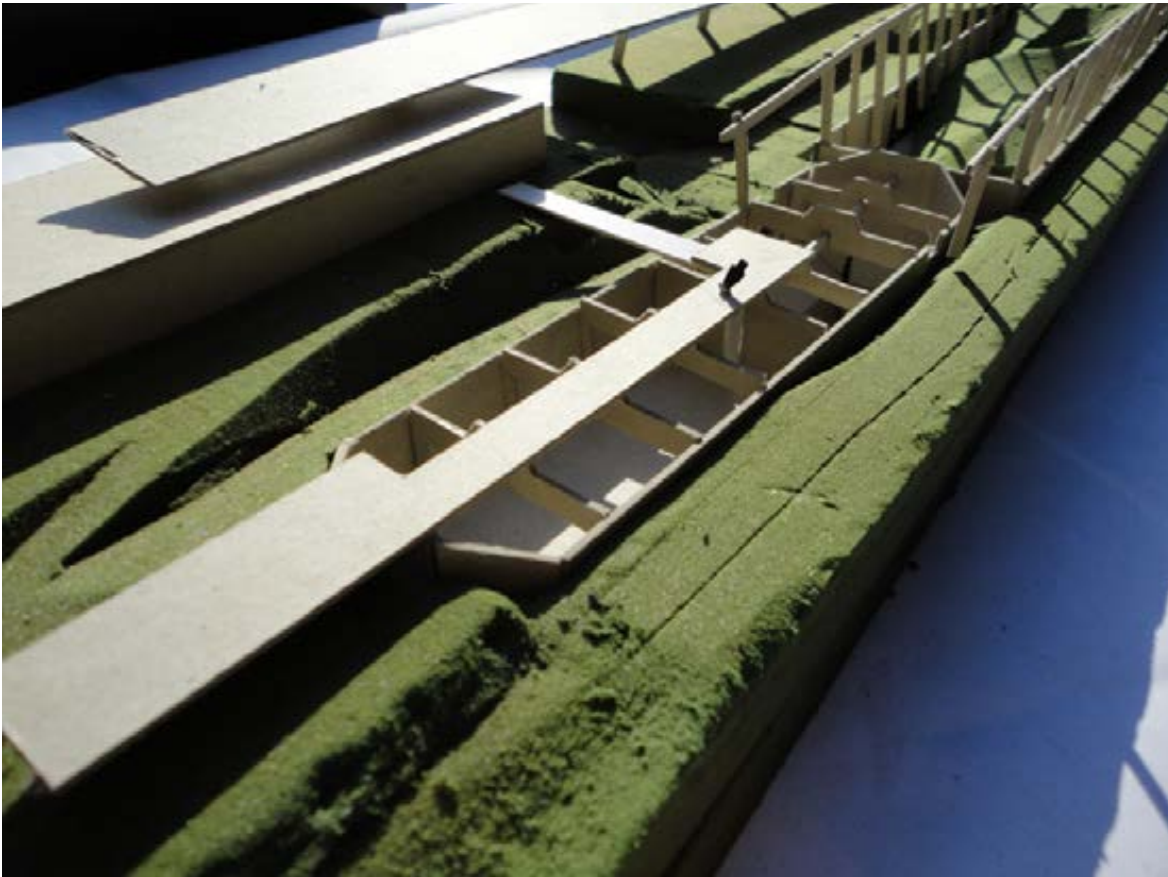





Fig:175. Working models exploring spatial impacts of design decisions (Author 2010)





Fig:176. Intervention must line nor fill space (Author 2010)



Fig:177. Entrances based on historic process (Author 2010)

#### 9.9.4. Bunker A

The internal volume of the bunkers is important both symbolically and spatially and should therefore not be obstructed. Intervention should take place on its edges thereby respecting the volume.

The entry points the bunker were determined by the location of the old conveyors, thereby symbolising man as new energy source.

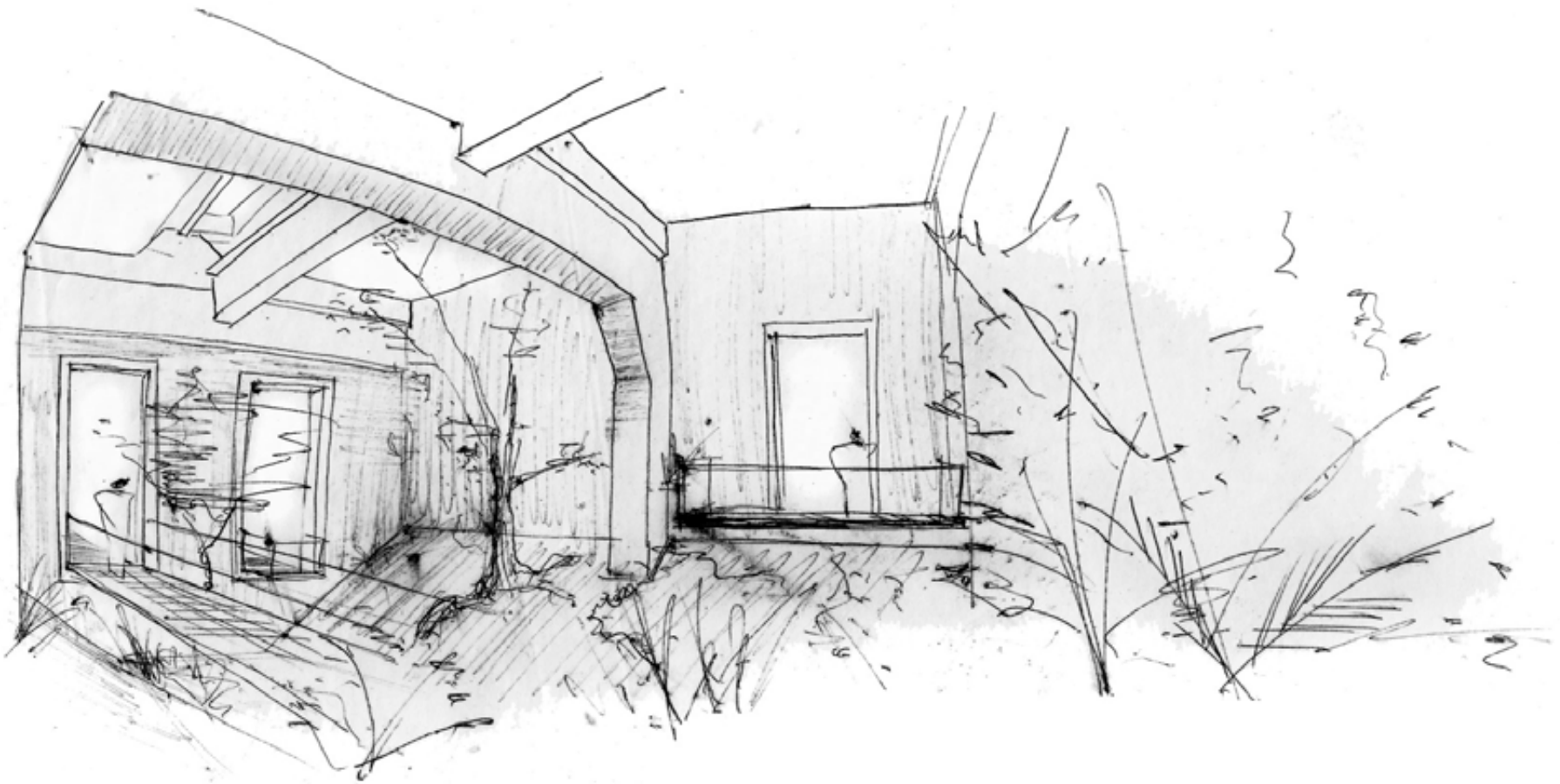

Fig:178. Vision for Bunker A (Author 2010)

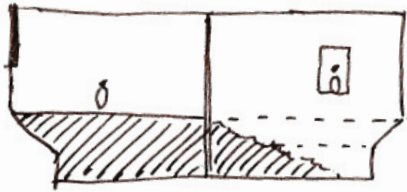

Fig:179. Entrances based on historic process (Author 2010)

Because the sides of the bunker are at an angle it is difficult to use therefore certain areas of the bunker will be filled to create level surfaces. However in order to display the full extent of the bunker the northern section will only be partially filled at an angle. This will serve two purposes, firstly to maximise the sun angle as well as create a basin for detaining water for slow subsequent release.

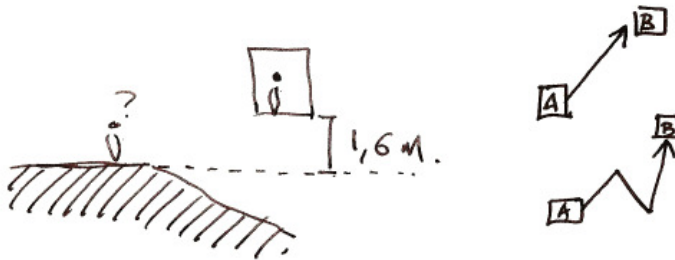

Fig:180. Entrances based on historic process (Author 2010)

The level difference between the entrance in the northern section and the platform in the southern section is approximately 1.6m and will have to be linked by at least 18m of ramp. The distance between these two points is only 15m. Therefore the ramps need to wind its way between these points in order to make up the height difference.

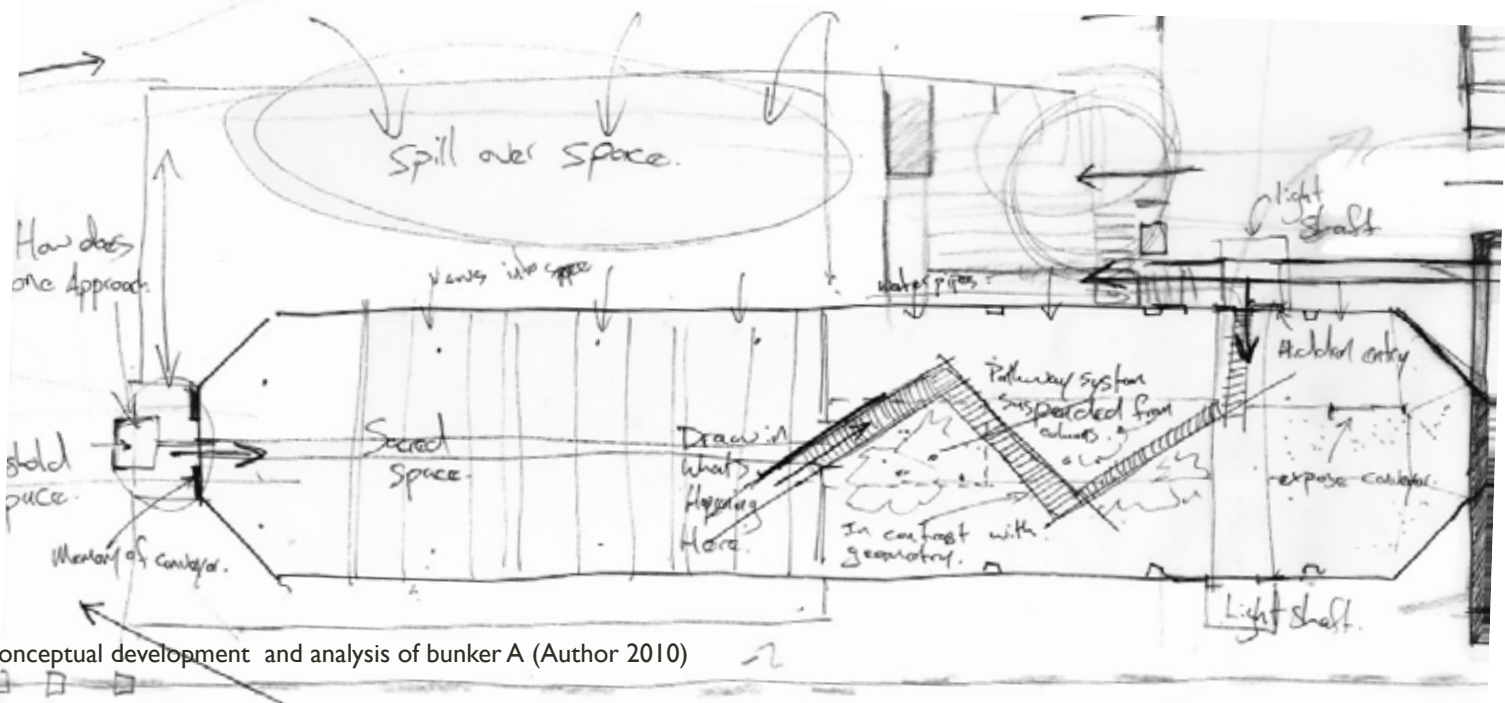

Fig:181. Conceptual development and analysis of bunker A (Author 2010)



Ramps are suspended from overhead columns and their intervals dictate where the ramps can be anchored. A model was used to determine the composition of the walkways.

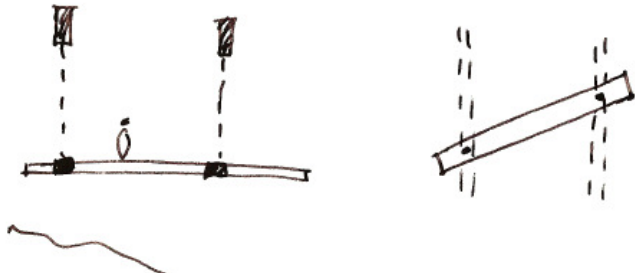

Fig:182. Diagram showing suspension of walkways between columns (Author 2010)

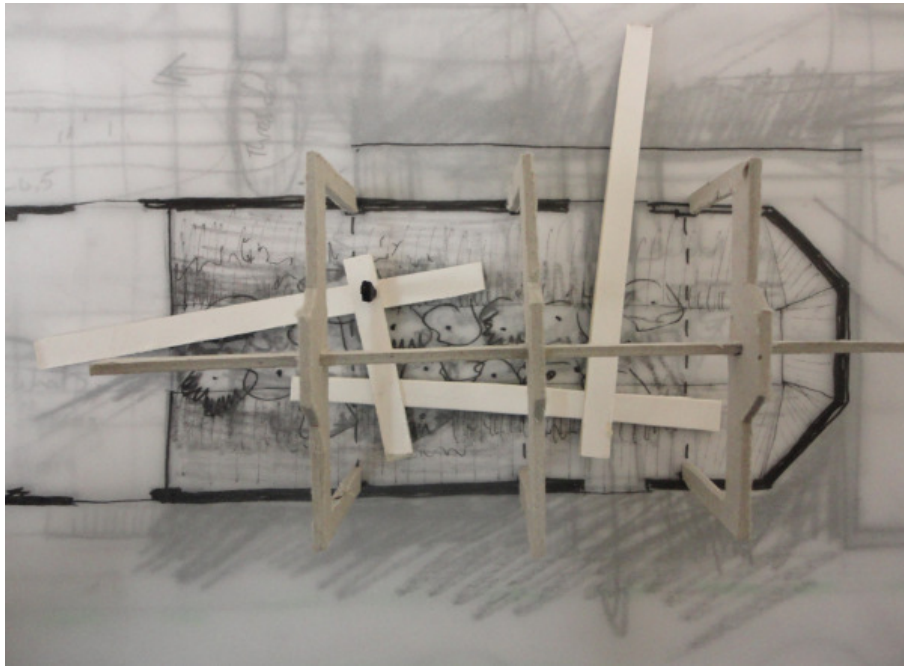
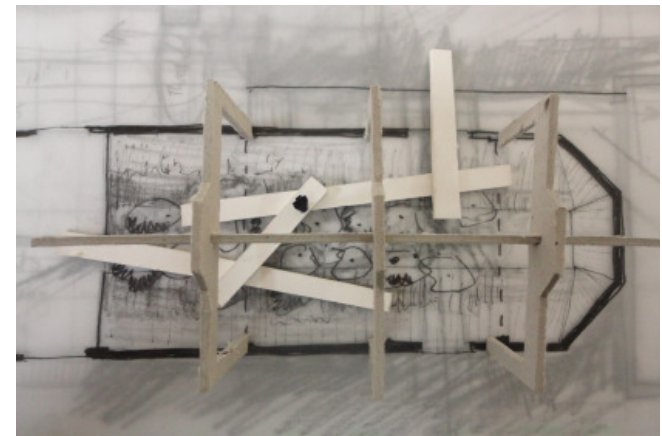
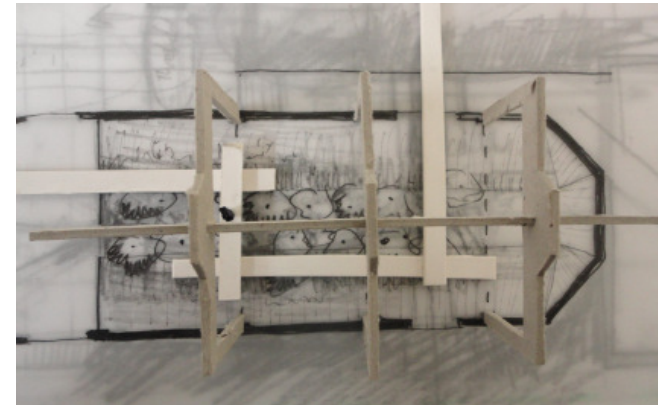
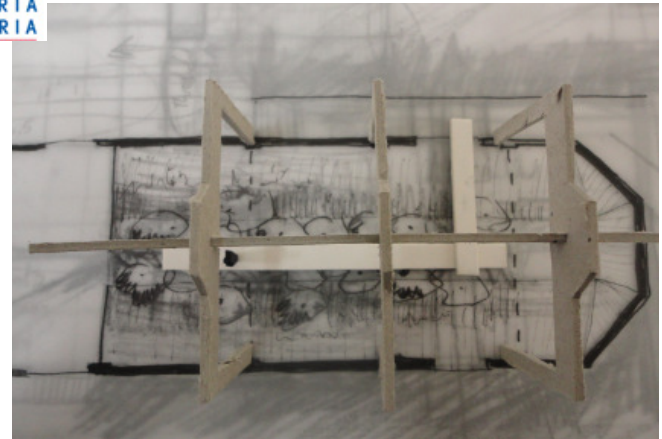

Fig:183. Model development of suspension of walkways between columns (Author 2010)



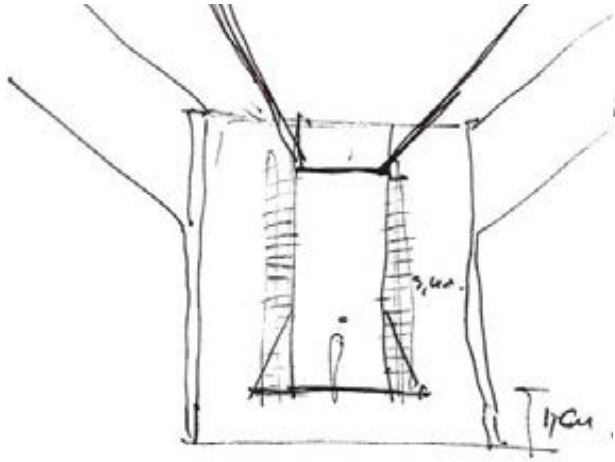

Fig:184. Entrance (Author 2010)

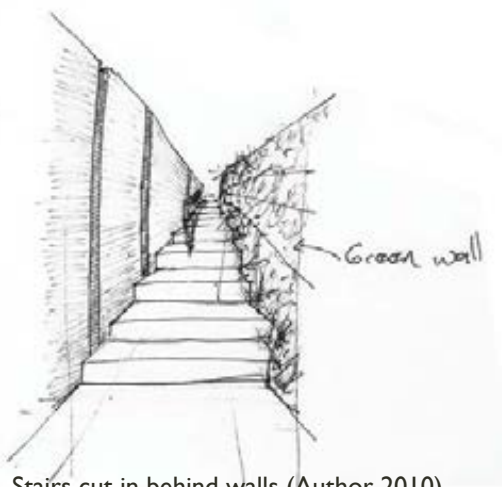

Fig:185. Stairs cut in behind walls (Author 2010)

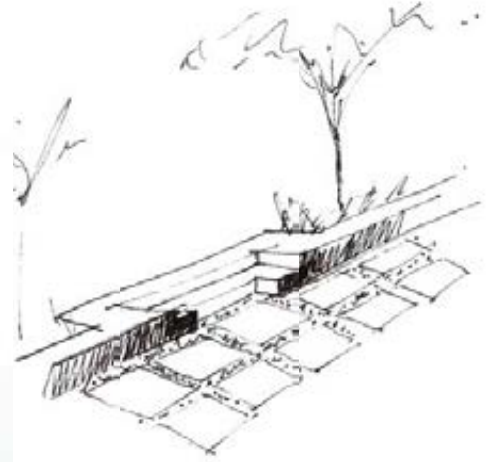
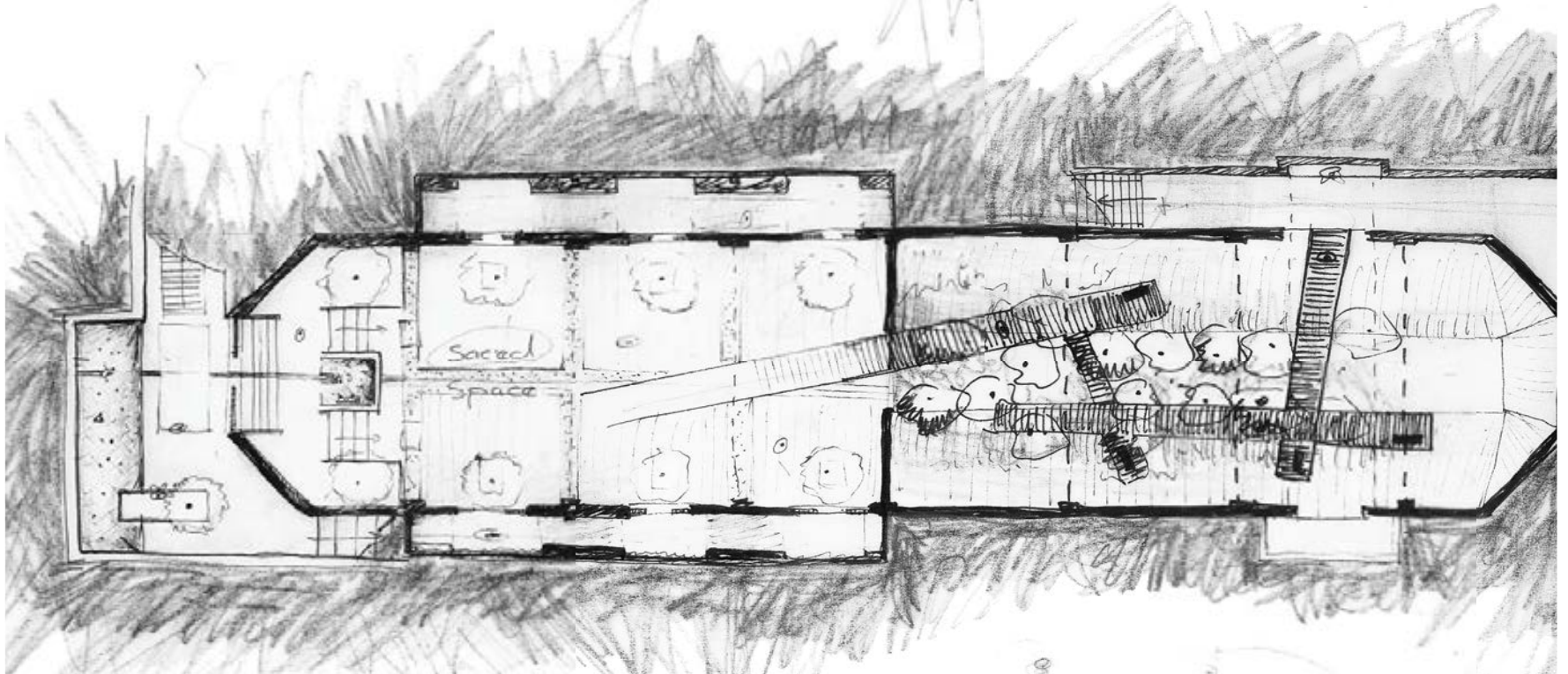
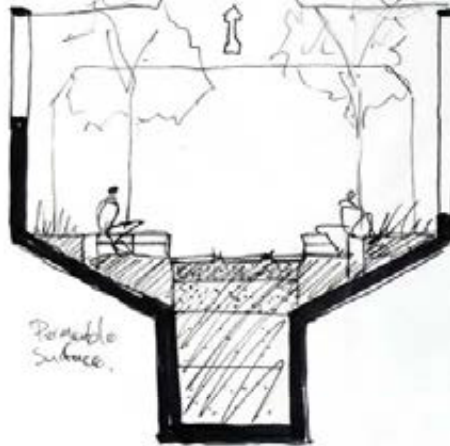
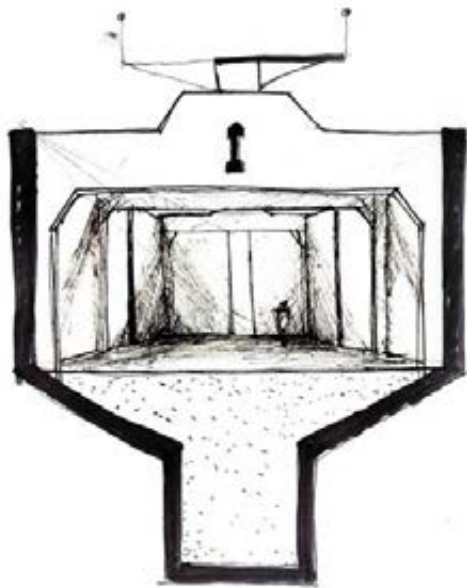

Fig:189. Seating area (Author 2010)



190 Fig:186. Design development bunker A (Author 2010)





Possible  
Surface.

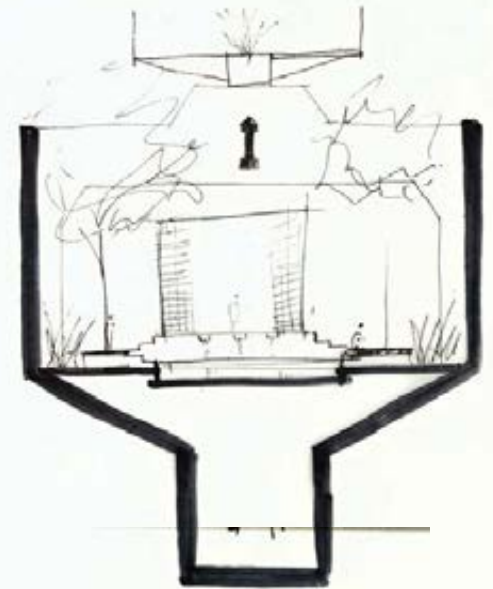

Fig:187. Introduction of the lift (Author 2010)

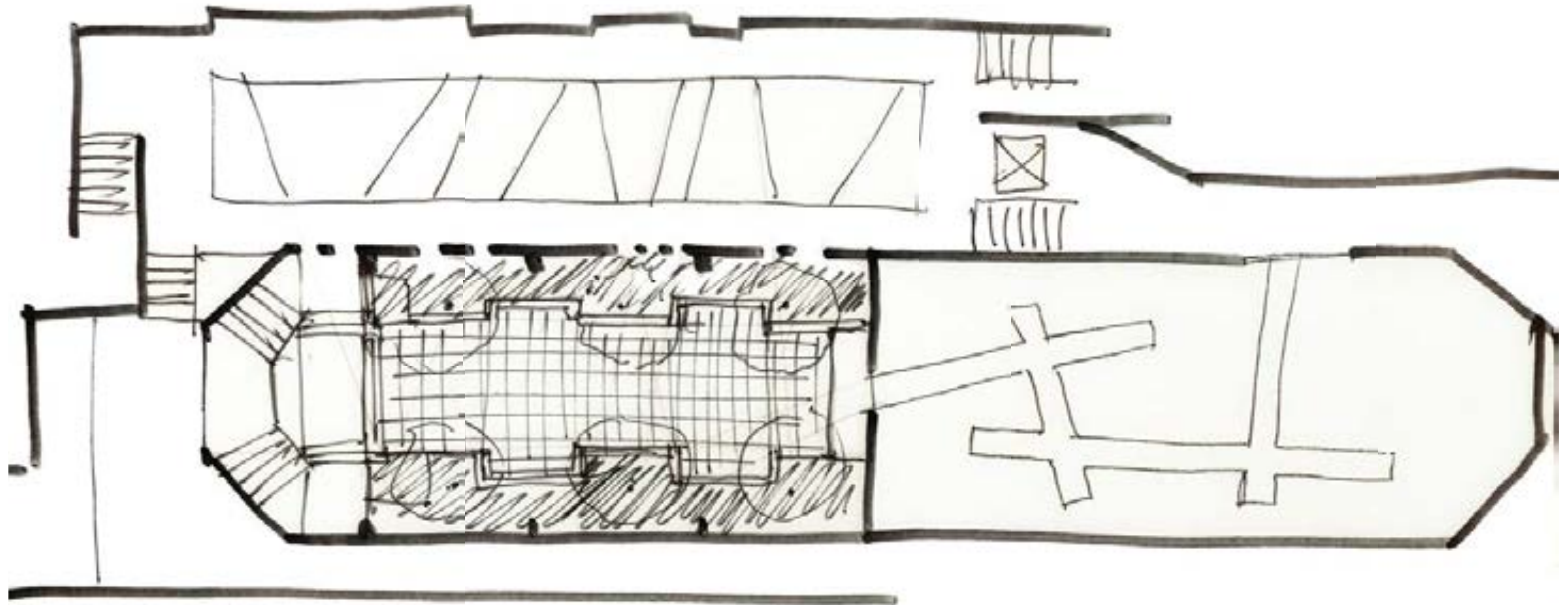

Fig:188. Design development, cutting away behind bunker walls to create spaces bunker A (Author 2010)



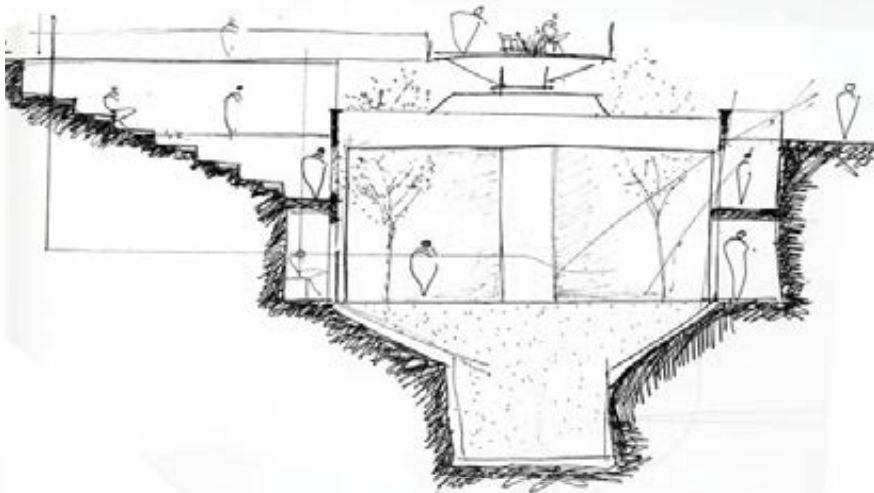

Fig:190. Cutting in behind bunker walls (Author 2010)

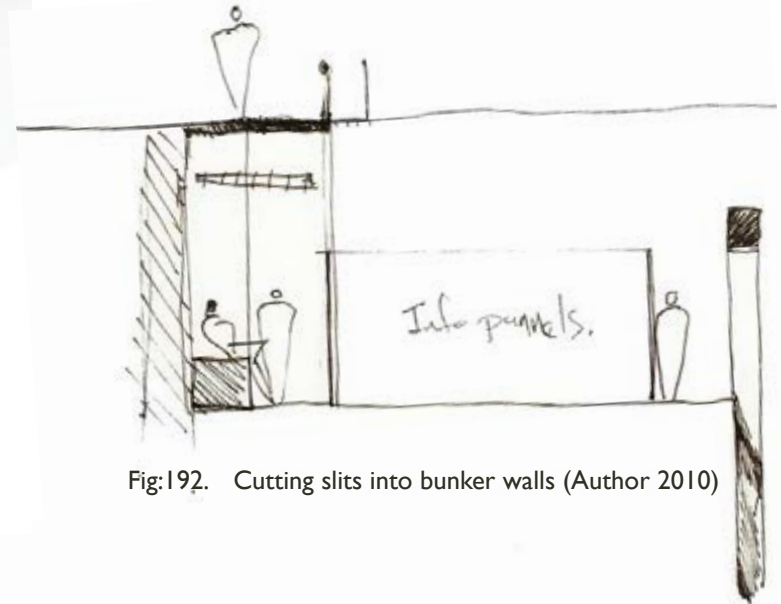

Fig:192. Cutting slits into bunker walls (Author 2010)

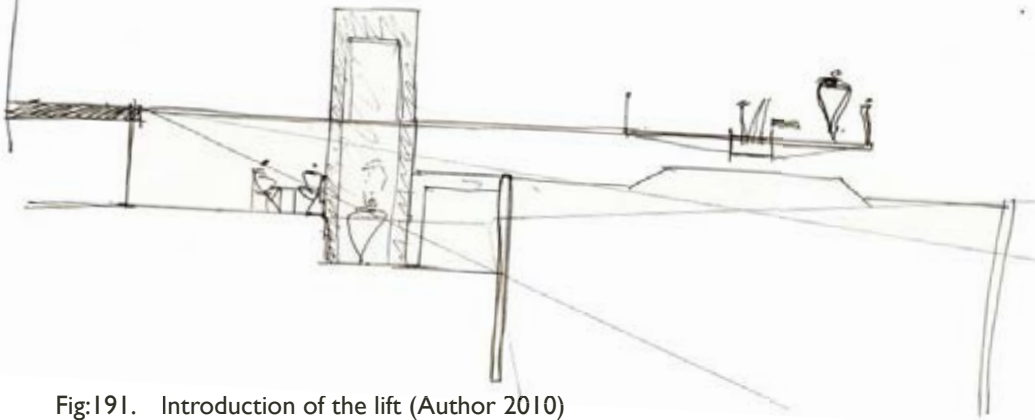

Fig:191. Introduction of the lift (Author 2010)

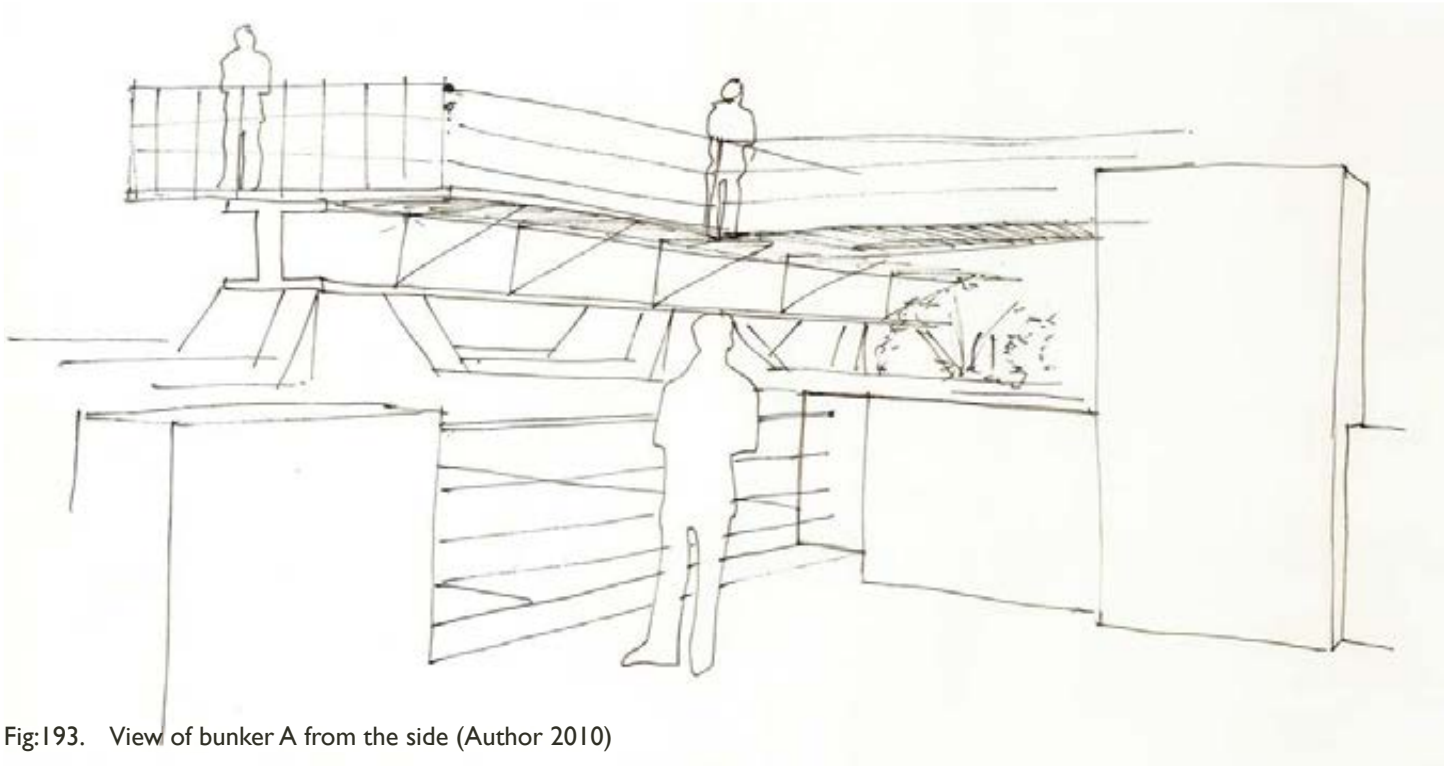

Fig:193. View of bunker A from the side (Author 2010)

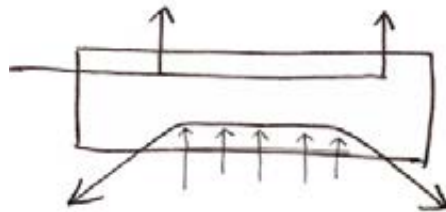

Fig:194. Entry points (Author 2010)



Fig:195. Soft landscape in harsh bunker (Author 2010)

#### 9.9.5. Bunker B

Bunker B is more open and versatile than bunker A. It is also only partially sunken on the street side and creates a dead facade. Thus creating interaction with the street is important. Its character is extroverted in that it is open to the sky and can be engaged with at various surface levels. It is also easy to look into the bunker.

The bunker is quite a harsh environment and the initial ideas were to cut into the sides and introduce a soft landscape inside. Turning the bunker into a wetland or a display of natural succession with walkways and sheltered seating spaces.



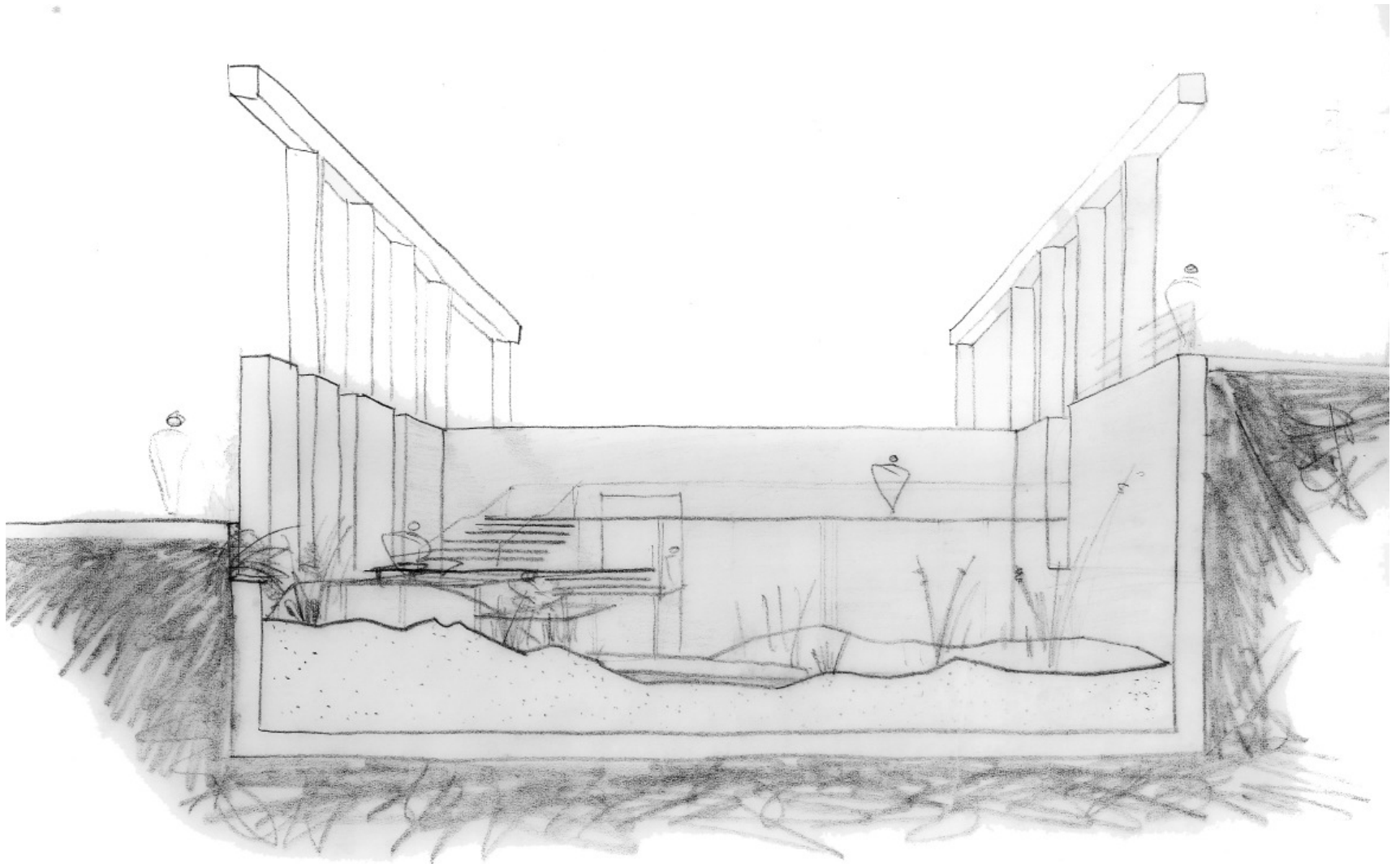

Fig:196. Section showing vision for Bunker B (Author 2010)

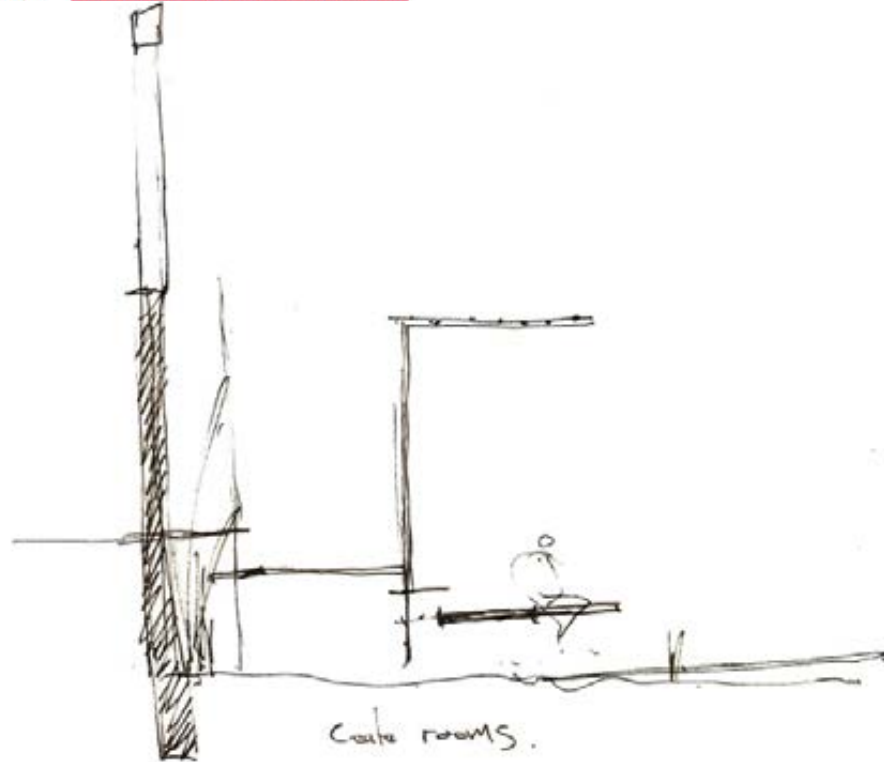

Fig:197. Creating platforms and natural over natural landscape in Bunker B (Author 2010)

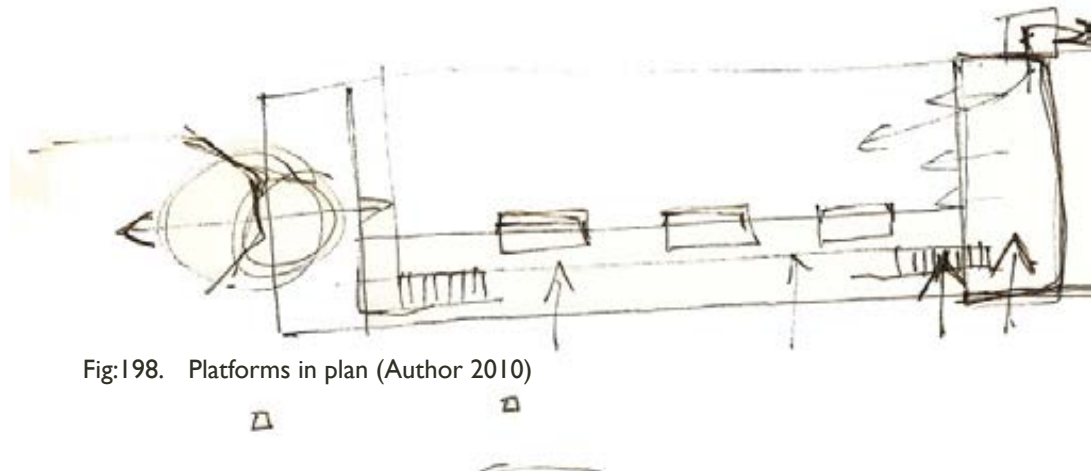

Fig:198. Platforms in plan (Author 2010)



The overhead structure is a key feature of its historic function the bunker and offers many possibilities. In this proposal it was not being fully utilised. The other problem was that the integrity of the initial structure was being lost through this intervention

This coupled with its multi level access and good views brought about the concept of turning it into a rotational exhibition space for larger than life sculptures such as Tate Modern in London however smaller and outdoors. The crane and overhead structure can then be used both for installations and moving things around, offering a robust and versatile space.

The bunker would then house or create energy that will fuel the site. The exhibition space could be launched by creating huge sculptures by using local artist and the mass scrap metal from the dismantled plant. These sculptures can then later be moved into the park making way for new and exciting exhibitions.

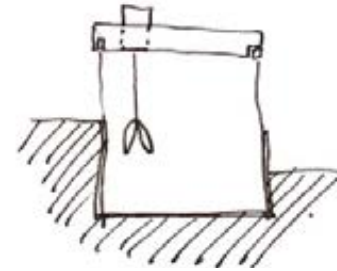

Fig:199. Overhead crane structure (Author 2010)

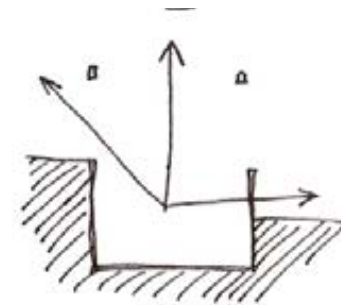

Fig:200. Connection to sky and surroundings (Author 2010)

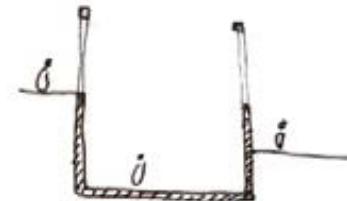

Fig:201. Levels of interaction (Author 2010)

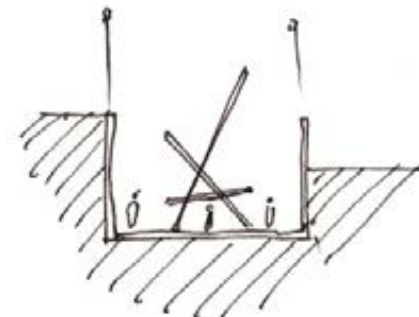

Fig:202. Converting bunker into a gallery (Author 2010)



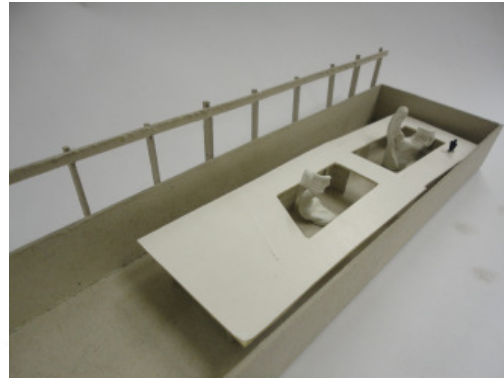
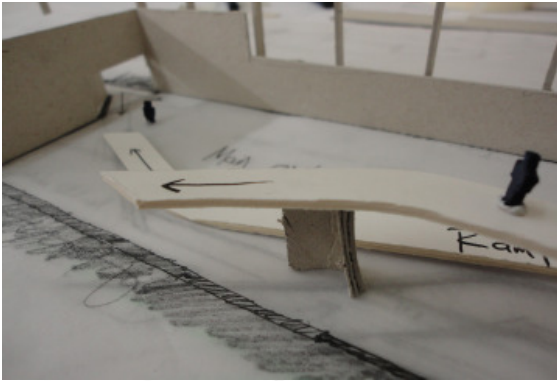
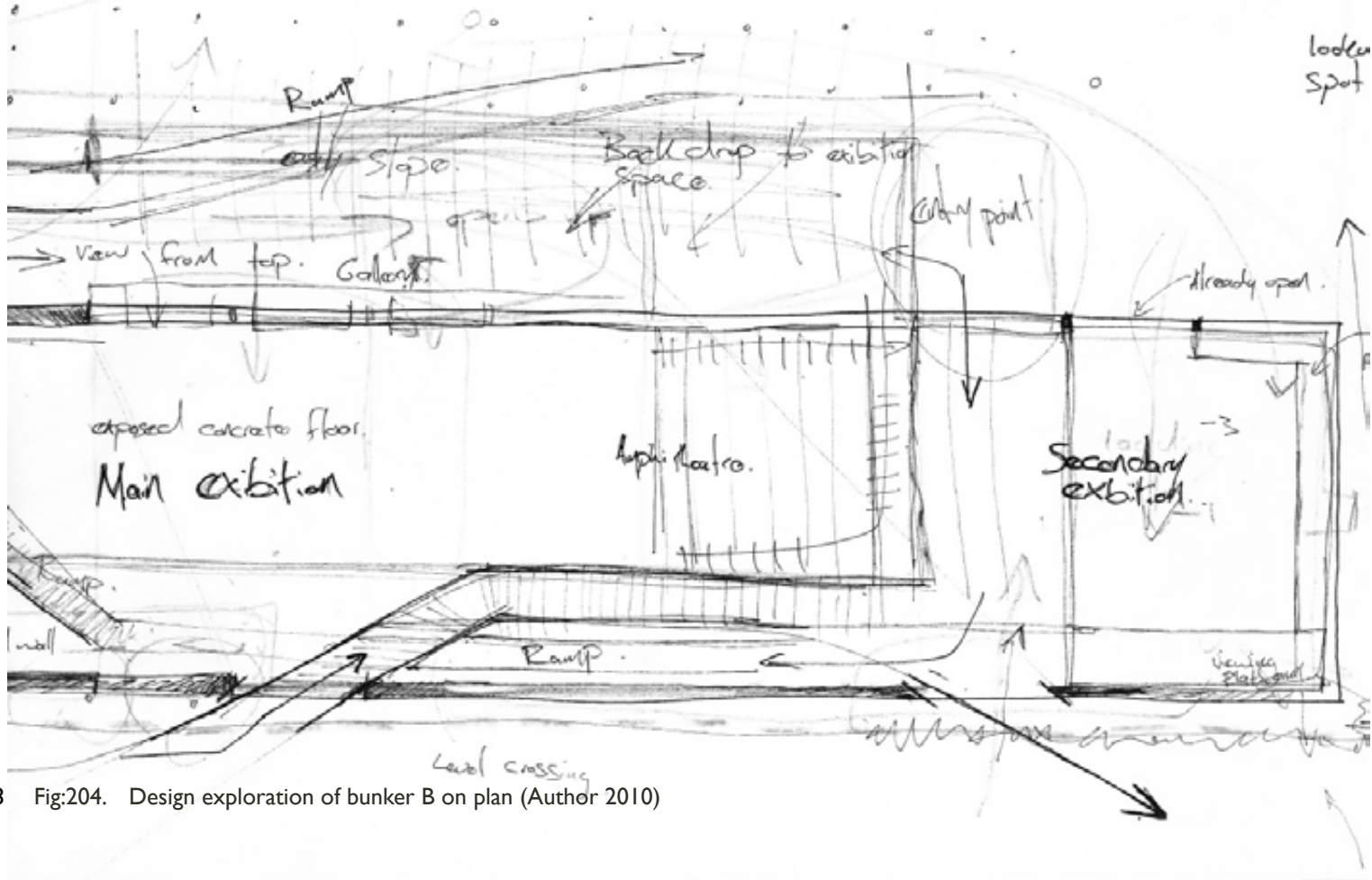

Fig:203. Model exploration of gallery in bunker B (Author 2010)



198 Fig:204. Design exploration of bunker B on plan (Author 2010)

This now creates the problem that the bunker can no longer be freely accessible from the street and requires controlled access. The street now needs a new form of interaction.

This is achieved by once again cutting into the bunker wall to create viewport and screens such as seen in Jean Novel's Center de Poblenou Park in Barcelona.

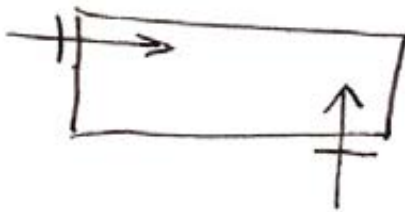

Fig:207. Controlled access (Author 2010)

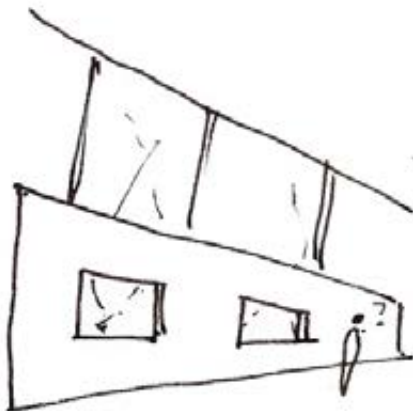

Fig:208. Viewports in bunker walls (Author 2010)



Fig:205. Gate by Jean Novelle in Center de Poblenou Park (<http://www.designws.com/fotopagina08/barcelona12.htm>)



Fig:206. Viewports in boundary wall creates interaction with street (<http://2.bp.blogspot.com>)

### Entry square

This square is the main pedestrian entrance from the Buitenkant Street to the train station and power plant complex. The most important consideration is movement and secondly creating pleasant micro climates for seating areas.

This is achieved through creating strong unobstructed routes that link points of interest and the placing of large deciduous trees in areas of low traffic.

The initial idea was to create raised planters with seating walls however planted areas function as catchment pits for surrounding paved areas therefore cannot be raised.

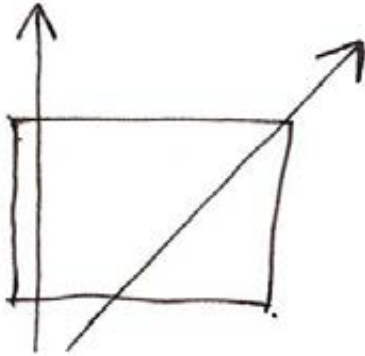

Fig:209. Main movement across square (Author 2010)



Fig:210. Deciduous trees for shade (Author 2010)

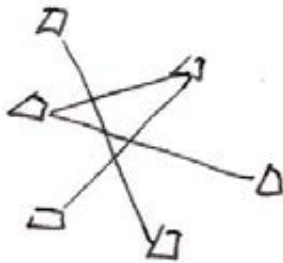

Fig:211. Connecting points of interest (Author 2010)

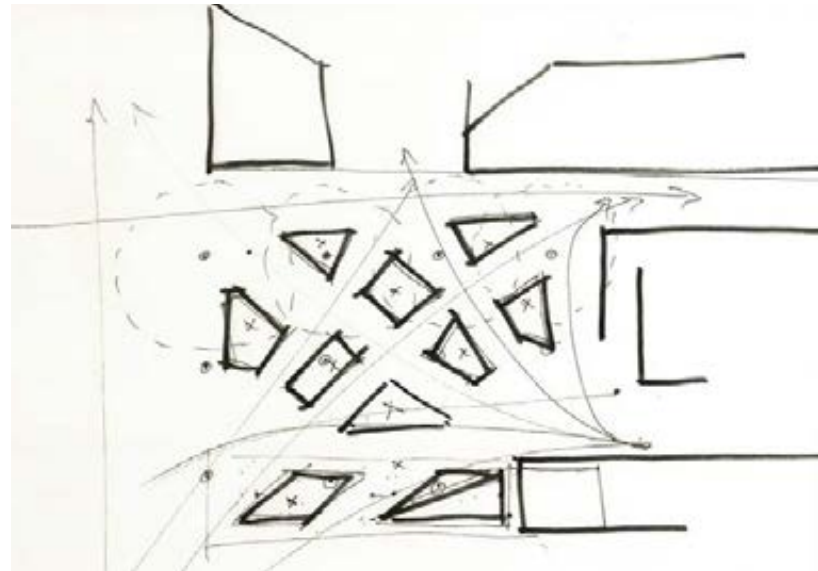

Fig:212. Defining busy and quiet zones (Author 2010)



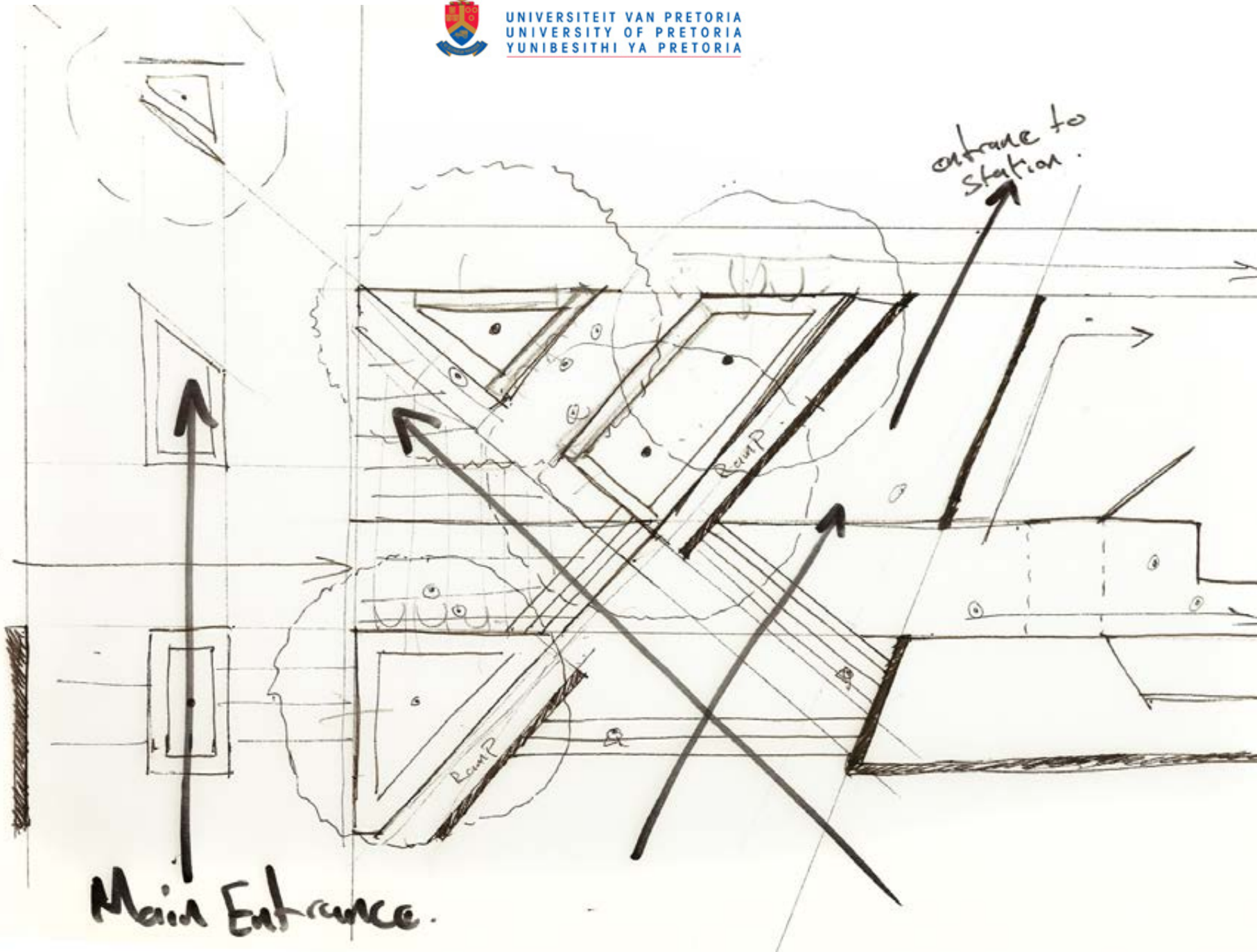

Fig:213. Plan showing the development of the entrance square (Author 2010)



Fig:214. Vision of bunker B as exhibition space (Author 2010)  
202



“In a landscape urbanism strategy, the site becomes the controlling instrument of the interface between culture and nature; site phenomena are generative devices for new forms and programs (De Meulder & Shannon 2010: 73).”