

11/10/2011

**BAKKAVOR**

 **SPRING VALLEY FOODS**

BAKKAVOR  
SPRING  
VALLEY  
FOODS

REDUCING VARIANCE RELATED COSTS  
THROUGH IMPROVEMENT OF TRACEABILITY AND  
OPTIMIZATION OF SYSTEMS

ALICHA LEOLA MEEK

27047033

SUPERVISOR: PROF. K. ADENDORFF

## Table of Contents

INTRODUCTION .....	1
Background of Bakkavor Spring Valley Foods (SVF) .....	1
Problem Background .....	1
Traceability and Automation .....	3
PROJECT AIM.....	4
PROJECT SCOPE .....	4
LITERATURE REVIEW.....	5
ANALYSIS OF STORES DEPARTMENT .....	6
IDEFØ Parent Diagram.....	6
IDEFØ Child Diagram (As-Is).....	8
DEVELOPMENT OF CONCEPTUAL DESIGN/SOLUTION .....	11
PROBLEM IDENTIFICATION .....	11
Pallet and bin traceability .....	12
Pack house activities.....	12
Issuing .....	12
Stock sheet .....	12
IDEFØ Child Diagram (To-Be) .....	13
PROBLEM SOLVING AND RESULTS .....	14
SOLUTION FORMULATION.....	14
PALLET NUMBER.....	14
BIN NUMBER .....	14
Pack house activities.....	15
Pack House Background.....	15
Concept Design.....	16
Design .....	17
Issuing .....	19
Stock sheet .....	20
Justification .....	22
Bin and Pallet Traceability.....	23
Pack House Activities.....	23
GRN Booklet .....	23

EXCEL Interface.....	23
Sage.....	23
Implementation.....	23
Bin and Pallet Traceability.....	23
Pack House Activities.....	24
Issuing.....	24
CONCLUSIONS & RECOMMENDATIONS .....	25
Conclusions .....	25
Recommendations .....	26
REFERENCES.....	27
APPENDICES .....	28
Appendix A: GRN Booklet .....	28
Appendix B: Altered Stock Sheet.....	29
Appendix C: GRN Sticker Changes.....	30
Appendix D: Training document for GRN sticker .....	31
Appendix E: Receiving Procedure Flowchart .....	36
Appendix F: EXCEL Interface User Manual-Pack House .....	37
Appendix G: EXCEL Interface User Manual-Issuing.....	43

## List of Tables and Figures

Figure 1: Previous Inventory Management System
Figure 2: Concept pyramid for traceability method
Figure 3: Basic concept flowchart
Figure 4: IDEFØ Parent diagram
Figure 5: IDEFØ Child Diagram (As-Is)
Table 1: IDEFØ Diagram Summation
Figure 6: Diagram Indicating Static and Dynamic Data of Materials
Figure 7: Cause-and-effect diagram
Figure 8: IDEFØ Child Diagram (To-Be)
Table 2: Factors to consider, approach and reasoning for pallet and bin traceability
Figure 9: Layout of Pack House
Figure 10: Pillars of Traceability
Figure 11: Traceability resource
Figure 12: Sage Warehouse Transfer Function
Table 3: Justification Table
Table 4: Conclusion Table

# INTRODUCTION

---

## Background of Bakkavor Spring Valley Foods (SVF)

Bakkavor is an internationally leading provider of fresh prepared foods and produce. Bakkavor has operations in 10 countries and employs over 19,000 people. Bakkavor businesses share a common goal – to manufacture and supply world-class fresh prepared foods and produce to the global marketplace. SVF is the South African subsidiary of Bakkavor situated in Bapsfontein, Gauteng. SVF manufacture and produce fruit-based products for Woolworths in South Africa and Marks & Spencers in the United Kingdom. Raw materials for SVF are supplied from a variety of countries which include; South Africa, Israel, Egypt and Mozambique. The procurement department orders raw materials from a wide range of suppliers. The materials are delivered to the SVF plant's stores department which is a subsection of the procurement department and falls under the authority of the procurement manager. After receiving, the raw materials are stored. Certain types of raw materials are sorted at the pack house into different categories of maturity. The stores department issues the raw materials to production upon request. SVF uses a computer-based information system named Sage that keeps the company up to date about information regarding raw materials, production, engineering material etc. Sage is a leading supplier of business management software and services to more than 6 million customers worldwide. From small start-ups to larger organisations, Sage promises to make it easier for companies to manage their business processes. The procurement department uses the Sage database to keep inventory information of the raw materials that were received and issued to production.

## Problem Background

The problem addressed in this project and the origin thereof can be explained with reference to the processes of the stores department. Figure 1 shows the previous inventory management system in terms of the processes. The receiving and issuing areas manage inventory and activities with the database, Sage, while the storing and sorting areas manage inventory and activities with paper methods.

*Figure 1: Previous Inventory Management System*

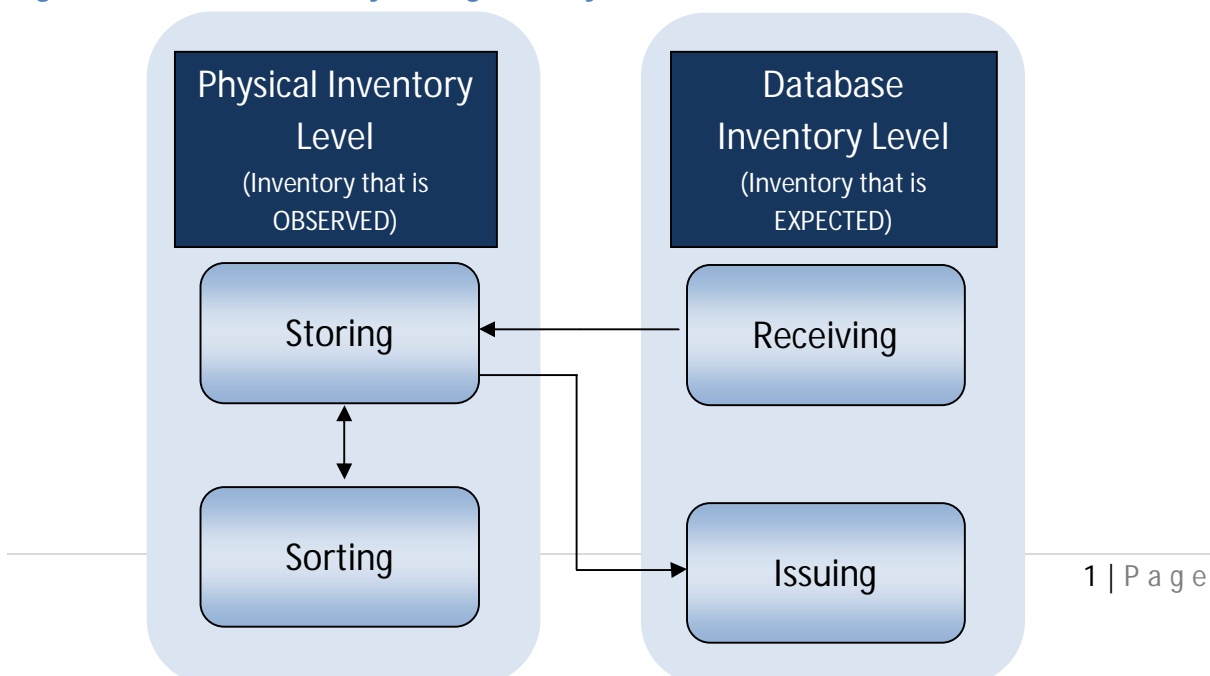

## Database Inventory Level

### Receiving

When raw materials are received from a supplier they are given an alphanumeric identification name, called a GRN. The GRN uniquely identifies the batch by specifying the delivery date, supplier name, transporter, amount delivered (in number of bins as well as weight) and date of picking. The GRN information is recorded onto a sticker that is placed onto the pallet containers as well as a GRN book which holds the information that will be transferred to the database. The receiving transaction on the database will indicate all the information required for the successful identification of a batch.

### Issuing

Materials are issued to production according to the requirements of the production plan. After raw materials have been issued to production a Sage controller directly captures the transaction onto Sage and this transaction on the database will show that the raw materials were issued. In addition the transaction will deduct the amount of raw material issued to production from the amount of raw material received.

## Physical Inventory Level

### Sorting

During the lifetime of certain raw materials such as mango and avocado amongst others, a further task must be performed before issuing can take place. This is the task of sorting and is performed continually to determine the amount of materials that are; ready to issue (R.T.I), still under ripe (U/R) or over ripe (dump). After the raw materials have been sorted, their weights are recorded onto a new GRN sticker. After each sorting a variance can be observed, however, information regarding these variances were irrelevant and of no use to the department.

### Storing

After the materials have been received and/or sorted, they are returned to the storage units where the physical stock count is taken. The weight of the raw materials can be affected by many different factors up until the time of sorting and/or issuing and it is for this reason that a physical stock count is taken every night and recorded onto a stock sheet.

## Summary

Large variances have been observed between the physical (stock sheet) and the database inventory level. Some of these variances however, can be explained by moisture loss which occurs in all types of fruit. These are called expected variances and can account for up to 8% of weight differences. Any variances in excess of the expected variances are unexpected and a disadvantage to the procurement department.

At the end of each work week a variance report is drawn. The variance report shows the difference between the amount (in kilograms) of raw materials available on the database (expected) and the amount available on the physical stock sheet (observed). Based on the information from this report, adjustments are made on the database. The amount of raw material available on the database is adjusted to correspond to the information on the physical stock sheet.

This brings forth the unfortunate discovery of paying for raw materials that disappeared or issuing raw materials that are no longer available.

The cost incurred by unexpected variances and the adjustments they cause are undesirable and often in large amounts. The unexpected variances are also untraceable, which makes the task of identifying the problem areas close to impossible.

In conclusion, it was found that the problem addressed in this project can be managed by an improved traceability system.

## Traceability and Automation

The definition of automation by the Encarta Dictionary: English (U.K) says that automation is, “a system in which a workplace or process has been converted to one that replaces or minimizes human labour with mechanical or electronic equipment”. Consequently automation aids the traceability process in the sense that it increases the accuracy of the traced information and speeds up the process. It also does not necessarily mean employees will be replaced, but rather that the effect of their mistakes will be minimised.

First and foremost automation is not possible without understanding its main purpose, which is to automatically capture correct and valid information, store and present the information when required. With that in mind the department must gain knowledge of what to automate, which information is important to capture and how it can eventually be captured automatically. The design of the traceability system is based on four phases shown in the concept pyramid diagram. Unfortunately due to time constraints this project won't be able to focus on complete automation. This project will however focus on laying the groundwork, phases one to three, for the last phase- complete automation.

*Figure2: Concept pyramid for traceability method*

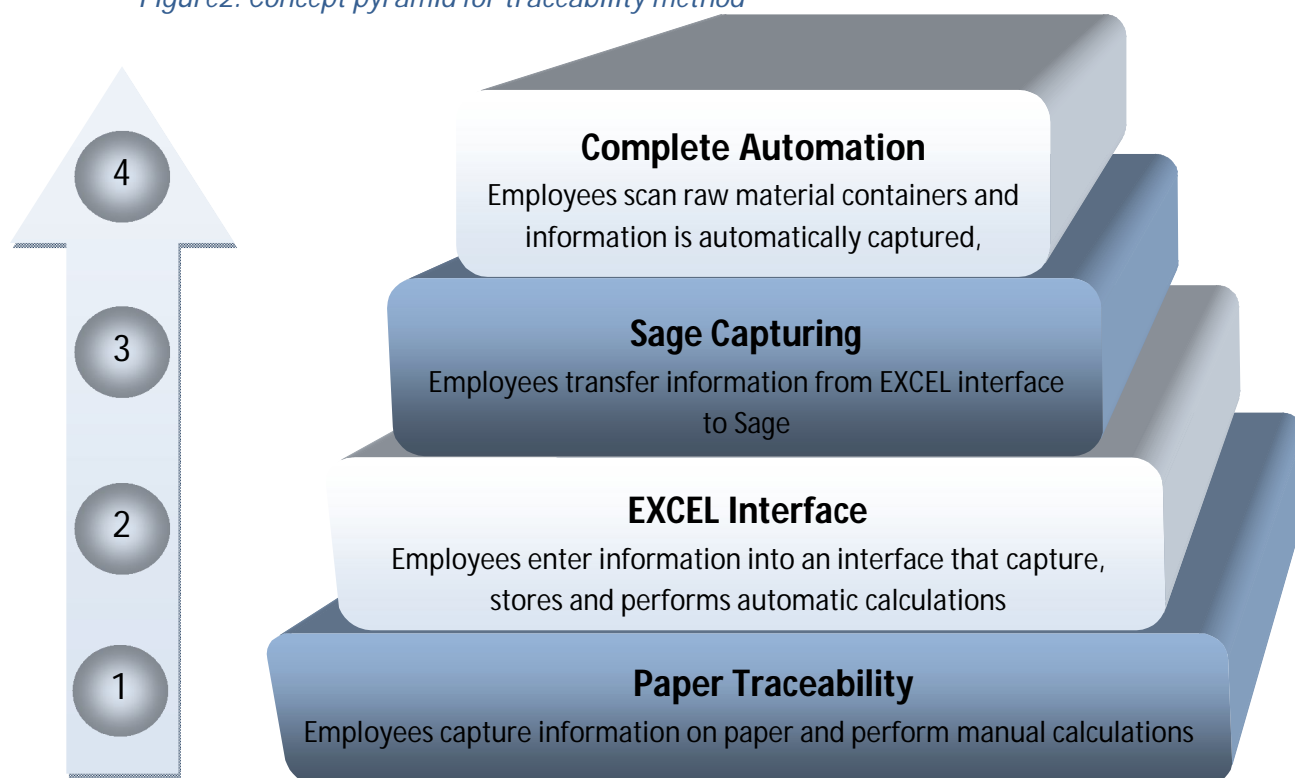

# PROJECT AIM

---

The aim of this project is to improve the traceability of raw material as it moves through the stores department of Bakkavor SVF. The development of a model assisting traceability of materials will reduce variances and as a result variance related costs.

# PROJECT SCOPE

---

This project encompasses the entire stores department, in each area, from receiving to issuing; changes are made to improve traceability. These changes are shown in the Problem Solving part of this document. The basic flow of the raw materials in the stores department is illustrated by figure 3.

*Figure3: Basic concept flowchart*

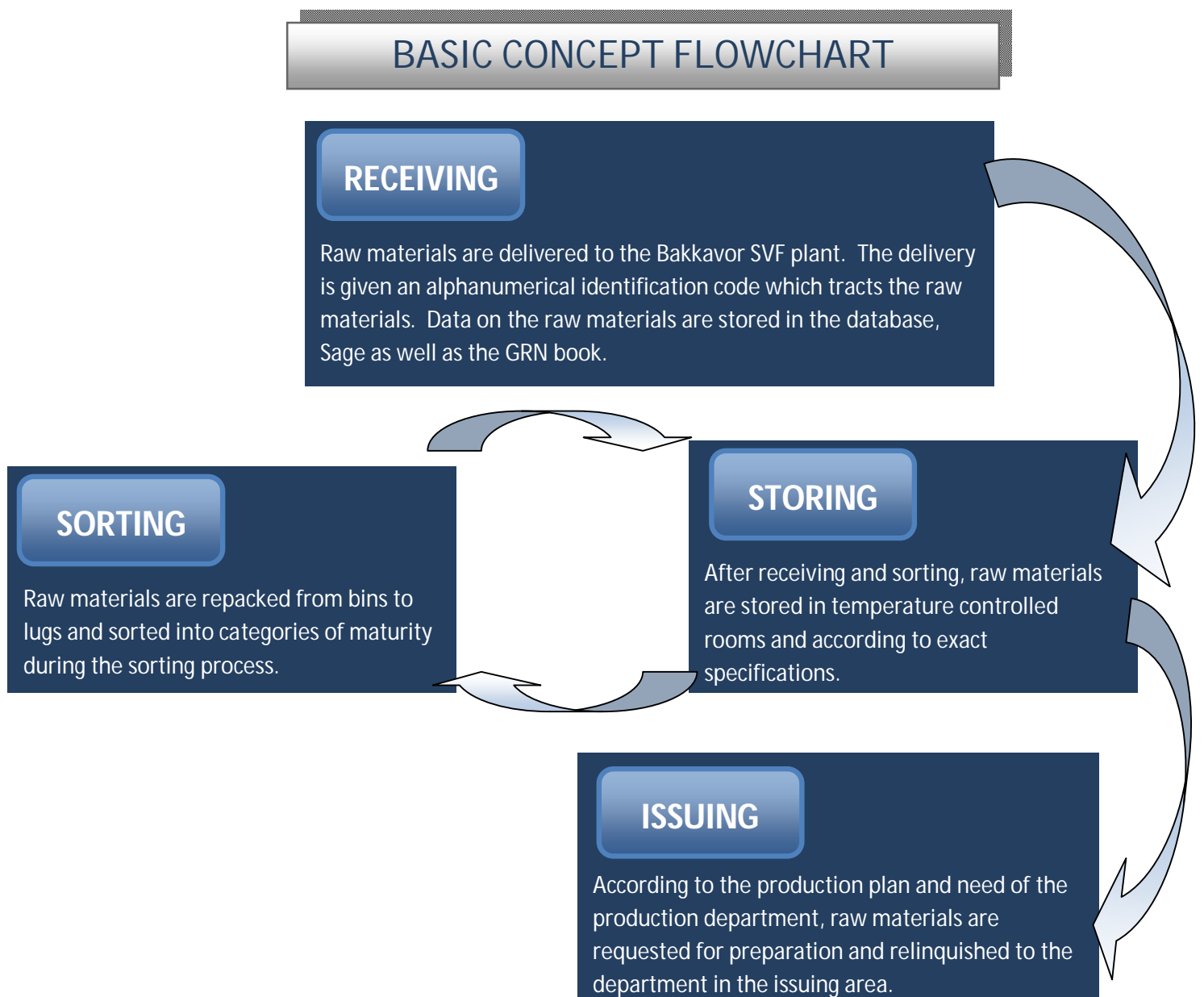

# LITERATURE REVIEW

---

Traceability in the supply chain of the food industry is a subject that has been studied extensively. According to ISO Quality Standards, traceability is defined as: "the ability to trace the history, application or location of an entity by means of recorded information" (ISO 8402:1994). Many papers and journals emphasize the importance and advantages of traceability in the supply chain. Advantages include; improved process control, a direct link between raw material and end product, the uneconomical mixing of high- and low-quality materials and an easier quality auditing process can be carried out. In addition these papers and journals supply the various divisions in the supply chain with the techniques, models and information systems to improve the traceability of their raw materials and/or products.

After the need for improved traceability has been established, the task of designing a traceability system can be attempted. According to researchers (Kelepouris, Pramataris & Doukidis 2007, p. 187-190) traceability requirements must first be outlined and identified. These requirements will specify how an item can be uniquely identified, the batch distribution of an item, the operations an item undergoes and the location of an item throughout the supply chain.

RFID (Radio frequency identification) was considered for the traceability system of the stores department, but after an interview with the procurement manager RFID as a traceability system was not considered to be feasible due to its financial aspects. A bar coding system was considered to be feasible; however the Procurement Manager wishes to have proper operating systems in place before a bar coding system can be attempted.

According to an article in Journal of Food Engineering 81 (2007 pp .347-356) by researchers (A. Regattieri, M. Gamberi, R. Manzini (2007) pp. 347-356) a product traceability system, and particularly a food traceability system, is fundamentally based on 4 pillars: product identification, data to trace, product routing, and traceability tools. Product identification deals with the physical characteristics of raw materials. Data to trace focuses on the characteristics of the information that is being traced. Product routing records the activities performed on raw materials. Traceability tools and methods focus on the degree of automation. These four pillars will be used as the basis for the automation goal.

EXCEL interfaces were developed after an interview with the Information technology (IT) specialist of Bakkavor SVF. EXCEL was chosen because of its ease of implementation, understanding and design language. In addition EXCEL is frequently used at Bakkavor SVF. The Information technology specialist was consulted at times in regards to the programming and development of the EXCEL interfaces.



# ANALYSIS OF STORES DEPARTMENT

IDEFØ is part of the Integrated Definition Methods (IDEF) family. Integrated Definition Methods (IDEF) is a structured approach to enterprise modelling and analysis. IDEFØ is the function modelling method and is designed to model the decisions, actions, and activities of an organization or system. IDEFØ has two modelling components the first of which is functions and the second is data and objects. Data and objects are further partitioned into classes namely; inputs, controls, mechanisms and outputs. The functions of the systems are represented by rectangles and the data and objects are represented by arrows. An IDEFØ diagram is decomposed from a parent diagram to child diagram, where the parent diagram models the general function of the department and the child diagram is the partitioning of the general function into component functions.

The IDEFØ parent diagram was used to model the function of the stores department and is depicted below.

## IDEFØ Parent Diagram

Figure 4: IDEFØ Parent diagram

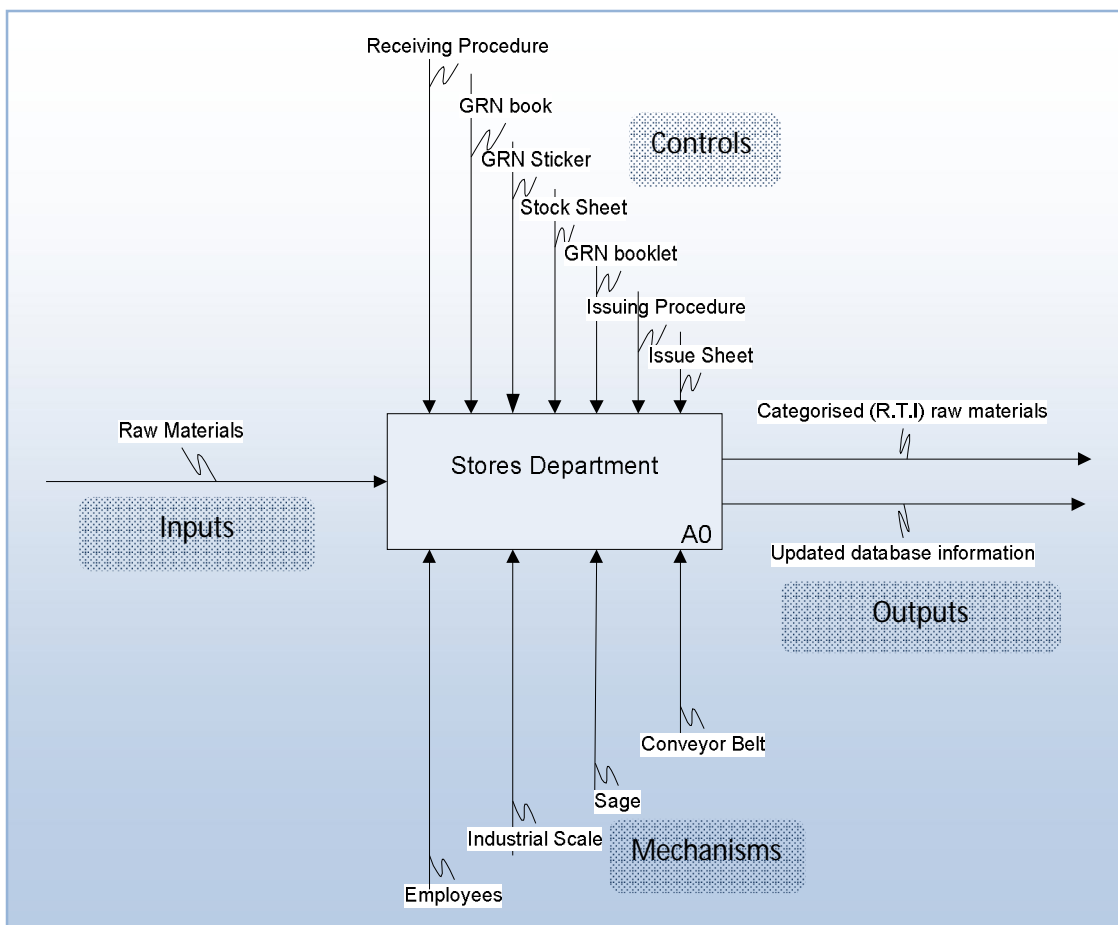

## Inputs

Inputs are the arrows entering the left side of the function rectangle and are objects that enter a process from the outside and are transformed to deliver an output. The only inputs the stores department receive and transform are the raw materials which, in the case of Bakkavor SVF, are fruit.

## Outputs

The outputs are the arrows exiting the function rectangle on the right side and are the inputs transformed by the activities of the stores department. The outputs are somewhat smaller in the degree of transformation when compared to the production department. Since the raw materials that are used as resources by Bakkavor SVF are perishable products (fruit), the handling and ripening of those raw materials are vital activities to the organization. Therefore, it is firstly essential for the materials to be ripe in accordance with specifications upon issuing. Secondly, it is equally as important to indicate that the materials are no longer part of the stores department and for this reason the database must be updated.

## Controls

Controls are a form of input, but they seldom change and are used to direct the activity of the process and they are represented by the arrows entering the top side of the function rectangle. In the stores department the controls are procedures that employees must follow and templates that direct and steer the information they record and the manner in which they record it. There are documented issuing and receiving procedures that direct the activities of the stores department. In addition the GRN booklet, GRN sticker, GRN book, stock sheet and issue sheet are templates that guide the activities of the stores department. The GRN sticker is the most vital control of stores department because it is utilized in all the subdivisions.

## Mechanisms

Mechanisms are resources and tools necessary to complete the process and are represented by the arrows entering the bottom side of the function rectangle. Employees are also perceived as mechanisms because they possess particular skills involving the knowledge and correct handling of fruit. The Sage database is an extremely important mechanism although it is not used in all sub-processes in the department. The industrial scale and conveyor belt are the mechanical mechanisms used in the department. The industrial scale weighs the material during receiving and sorting. The conveyor belt moves the raw material that was deposited on the belt from one end to another. During this movement employees establish the ripeness of the fruit and classify it into categories of maturity. Each classification of fruit flows in different directions where it drops into lugs at the end of the conveyor belt.

### IDEF0 Child Diagram (As-Is)

In the IDEF0 Child Diagram the stores function is divided into its function components with their respective data and object classes and these function components are the different areas of the stores department. The IDEF0 method was used to analyse the previous operating systems of the department and will later in the report be changed to illustrate the modified to-be operating systems. The operations and transformations of the raw materials in each area and function components can be seen in the diagram below.

Figure 5: IDEF0 Child Diagram (As-Is)

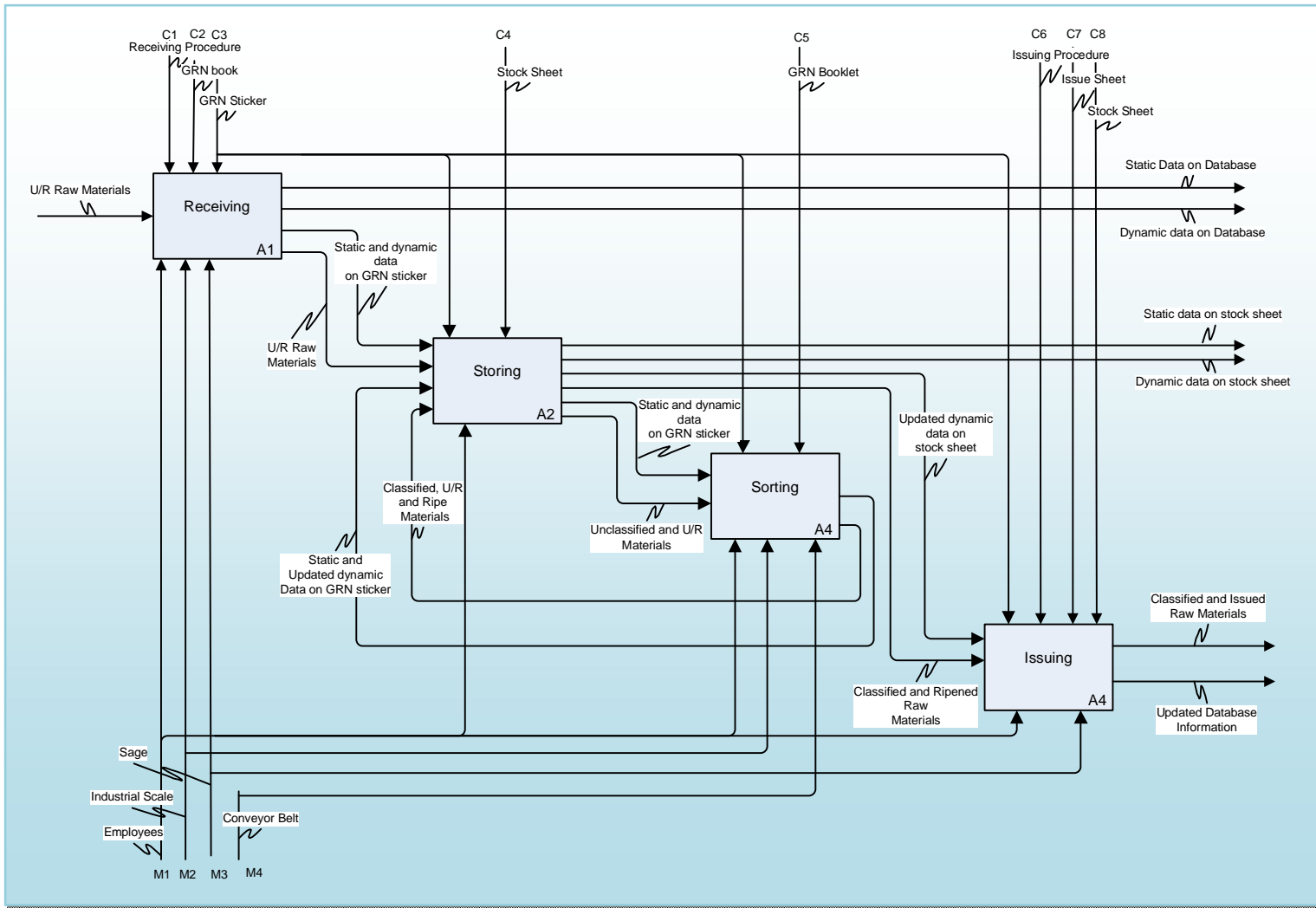

All the arrows indicating the data and object classes can be confusing in such a diagram, therefore a table summarising the classes are shown along with a diagram indicating the static and dynamic data of the materials.

Table 1: IDEF0 Diagram Summation

Data and Object Classes	Function Components			
	Receiving	Storing	Sorting	Issuing
<b>Inputs</b>	<ul style="list-style-type: none"> <li>Under ripe raw materials</li> </ul>	<ul style="list-style-type: none"> <li>Static and dynamic data on GRN sticker</li> <li>Static and updated dynamic data on GRN sticker</li> <li>U/R raw materials</li> <li>Classified U/R and ripe materials</li> </ul>	<ul style="list-style-type: none"> <li>Unclassified and under ripe raw materials</li> <li>Static and dynamic data on GRN sticker</li> </ul>	<ul style="list-style-type: none"> <li>Updated dynamic data on stock sheet</li> <li>Classified and ripened raw materials</li> </ul>
<b>Controls</b>	<ul style="list-style-type: none"> <li>Receiving procedure</li> <li>GRN book</li> <li>GRN sticker</li> </ul>	<ul style="list-style-type: none"> <li>GRN sticker</li> <li>Stock sheet</li> </ul>	<ul style="list-style-type: none"> <li>GRN sticker</li> <li>GRN booklet</li> </ul>	<ul style="list-style-type: none"> <li>GRN sticker</li> <li>Issuing procedure</li> <li>Issue sheet</li> <li>Stock sheet</li> </ul>
<b>Mechanisms</b>	<ul style="list-style-type: none"> <li>Employees</li> <li>Industrial scale</li> <li>Sage</li> </ul>	<ul style="list-style-type: none"> <li>Employees</li> </ul>	<ul style="list-style-type: none"> <li>Employees</li> <li>Industrial scale</li> <li>Conveyor belt</li> </ul>	<ul style="list-style-type: none"> <li>Sage</li> <li>Employees</li> </ul>
<b>Outputs</b>	<ul style="list-style-type: none"> <li>Static and dynamic data on GRN sticker</li> <li>Static and dynamic data on database (Sage)</li> <li>U/R raw materials</li> </ul>	<ul style="list-style-type: none"> <li>Static and dynamic on stock sheet</li> <li>Updated dynamic data on stock sheet</li> <li>Static and dynamic data on GRN sticker</li> <li>Unclassified and U/R raw materials</li> <li>Classified and ripened raw materials</li> </ul>	<ul style="list-style-type: none"> <li>Classified, under ripe and ripe materials</li> <li>Static and updated dynamic data on GRN sticker</li> </ul>	<ul style="list-style-type: none"> <li>Classified and issued raw materials</li> <li>Updated information on database</li> </ul>

Figure 6: Diagram Indicating Static and Dynamic Data of Materials

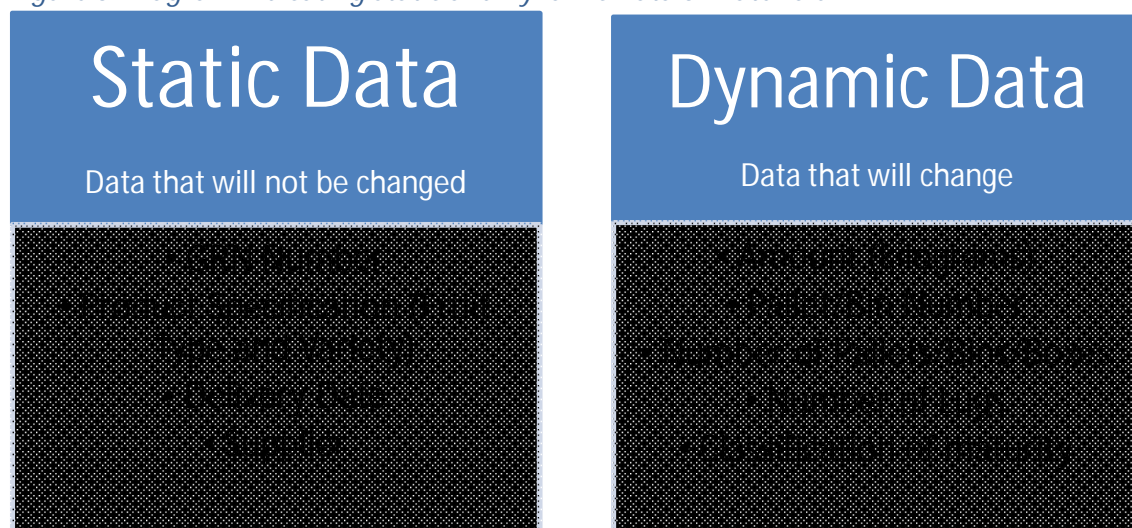

- Receiving: The raw materials enter the department in the receiving area where they are given static and dynamic data
- Storing: The static and dynamic data given to a batch at the receiving area will be recorded onto the stock sheet during the storing processes
- Sorting: During the sorting process the dynamic data change for the first time. After the sorting processes the materials return to the storage rooms and again the static and dynamic data is recorded onto the stock sheet
- Issuing: During the issuing process the static and dynamic data is transferred to the Issue Sheet and the issue sheet is used to capture the information onto the database

For the purpose of this project when referring to the following their definitions will be:

- Bins  
When a GRN is received the transporter delivers the material in a number of bins. This is a large plastic container which weighs up to 400 kilograms when filled with fruit. A wooden pallet will carry up to three of these bins. Upon receiving raw materials each bin will be given a GRN sticker specifying its static and dynamic data.
- Pallet  
A wooden pallet, after a material has been de-boxed, will carry up to 56 lugs, which are small black plastic crates which weigh approximately 20 kilograms when filled with fruit. After sorting the material are again packed into lugs and onto the pallet. This is the pallet that is referred to in this project, the pallet containing the lugs. Each lug cannot be traced, because that degree of detail is too extensive.

# DEVELOPMENT OF CONCEPTUAL DESIGN/SOLUTION

---

This part of the project will focus on the changes that need to be made to improve the traceability. To formulate solutions for all problems identified, the following process was applied.

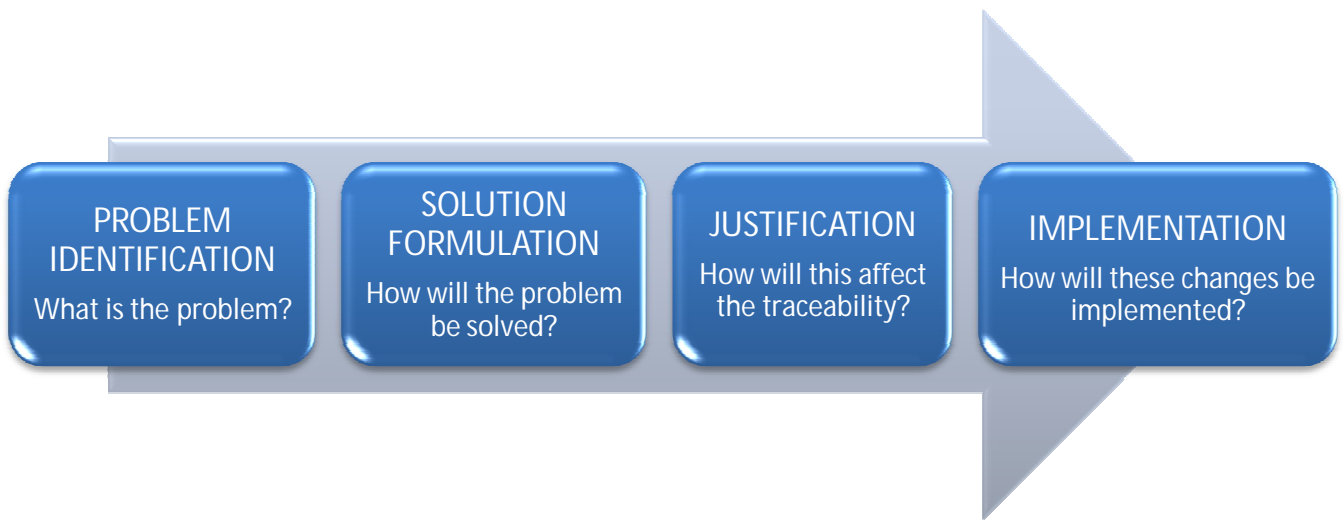

## PROBLEM IDENTIFICATION

A cause-and-effect diagram illustrates the four main aspects of concern and their overall effect. These aspects were identified after studying and participating in the day to day activities of the stores department.

*Figure 7: Cause-and-effect diagram*

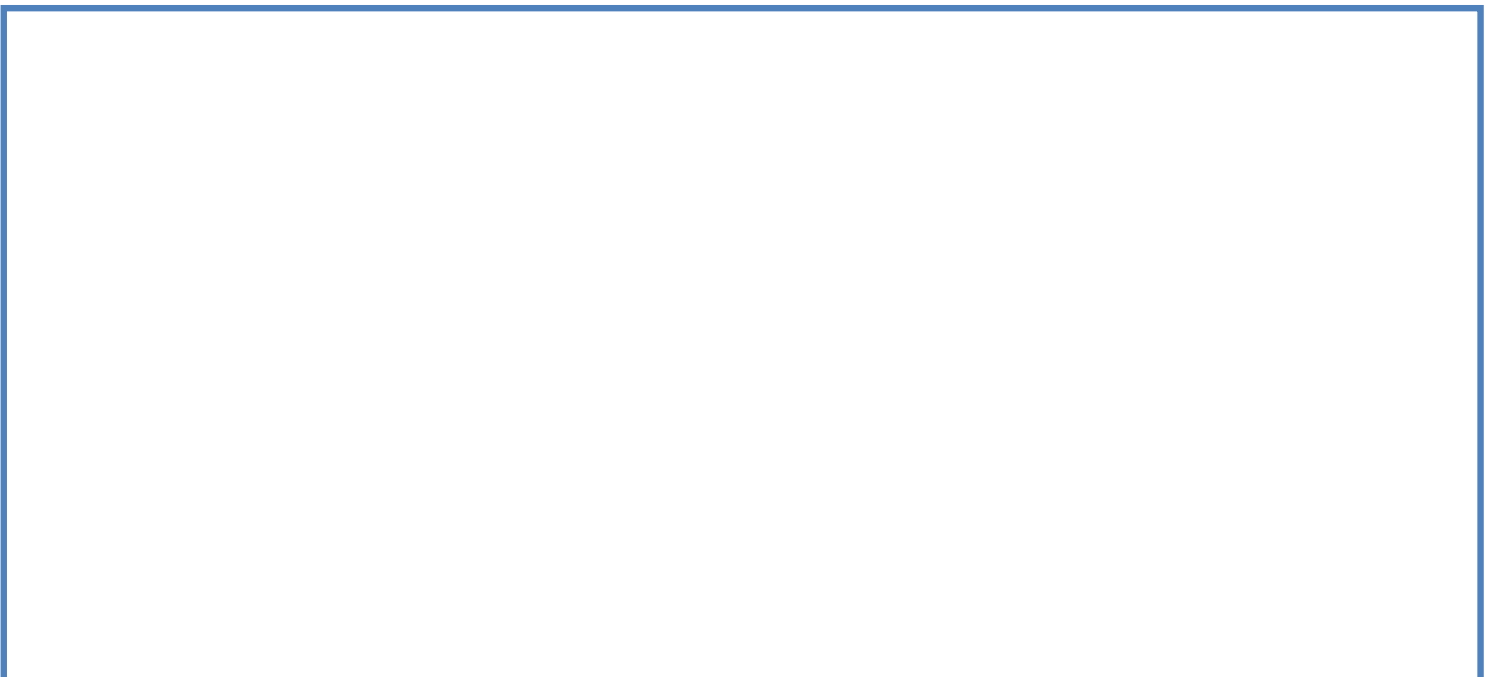

### **Pallet and bin traceability**

Pallets with GRN stickers enter the pack house to be sorted. The weights of all such pallets entering the pack house are recorded as well as a sum of the total. After the materials are sorted into their respective classifications of maturity they are weighed once more to identify the newly specified category. The weights of all the categorised materials are added and compared to the weights of the pallets that entered. Problems occurred when there was no cross checking of the pallets of a GRN. There was a lack of knowledge concerning the location of pallets in a certain time frame and what activities these pallets had undergone.

### **Pack house activities**

No official traceability system existed within the pack house. The traceability system is classified as such, since the paper methods used to document activities in the pack house will within a month of creation be found in a box in the archives of Bakkavor SVF. As previously stated, material information is captured onto the Sage database when entering the stores department in the receiving area. The transfer of materials to production in the issuing area is also captured on Sage. The activities of the pack house however, were never captured on Sage. This was a problem because the weights of the materials already show variances during these activities.

### **Issuing**

The materials that are issued in production are not weighed. Not all of the materials go through a sorting process. In other words, materials that do not go through the sorting process are only weighed once. The possibility of issuing incorrect weights of materials to production is a traceability risk.

### **Stock sheet**

After a thorough inspection of the stock sheet and the contained data, it was found that the data was frequently incorrect. Furthermore the incorrect information about a batch (GRN) has a ripple effect reaching the variance problem. As mentioned before, the database inventory level is adjusted to correspond to the physical inventory level. Since the stock sheet data is unreliable, this may not be the best method of controlling and managing inventory.

### IDEF0 Child Diagram (To-Be)

The second IDEF0 child diagram depicts the To-Be situation. After studying and evaluating the activities of the stores department the solutions indicated in the IDEF0 child diagram (To-Be) were developed to address each problem. Integration of new systems and controls with mechanisms already available to the stores department as far as possible is the most cost-efficient method to implement proposed changes.

The blue arrows indicate the data and objects that will be created or changed, used and implemented.

Figure 8: To-Be IDEF0 Child Diagram

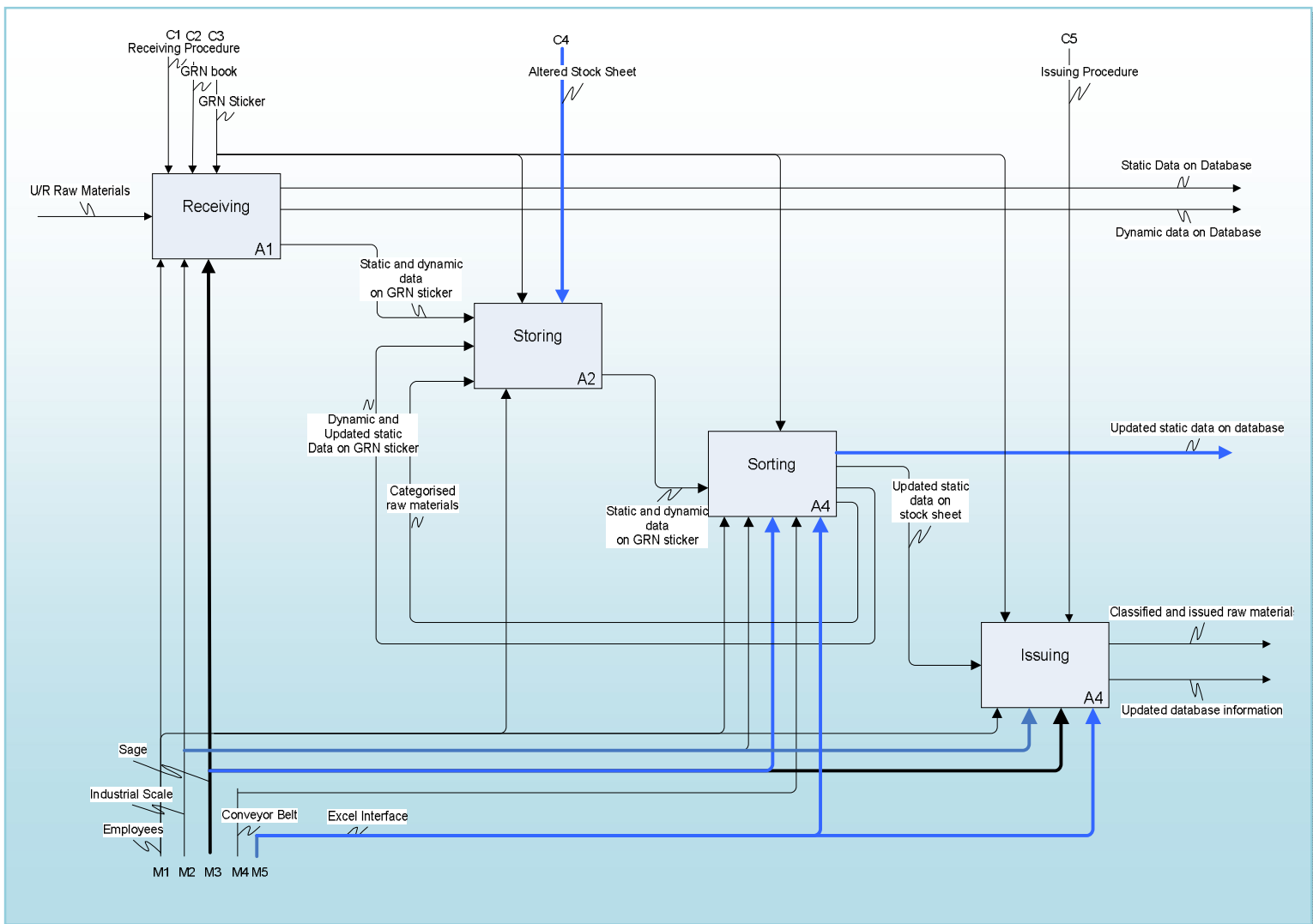



# PROBLEM SOLVING AND RESULTS

## SOLUTION FORMULATION

### Pallet and bin traceability

The first step was to determine how the bins or pallets will be traced. Bearing in mind that each delivery already has a unique level one identification (the alphanumeric GRN number), it was concluded that best possible solution would be to give each bin or pallet its own identification number. To create this identification number certain factors must be taken into account. Table 2 shows the factors to consider and an approach to encompassing each factor.

*Table 2: Factors to consider, approach and reasoning for pallet and bin traceability*

No.	Factors to consider	Approach	Reasoning
1	The identification number must be found on every pallet or bin	Use GRN sticker	The GRN sticker is the only control that is used in all the areas of the stores department
2	The pallet or bin must have a connection with its level one identification, namely the GRN	Use GRN number in the ID	This will successfully link the level one and two identification
3	The number must be unique for every pallet or bin	Count the number of pallets and bins in the ID	Integers counting the bins or pallets combined with the GRN will uniquely identify a bin or pallet
4	The number must somehow reveal the transformations or operations the pallet or bin has undergone	Add a section indicating "d" for de-boxing, "1" for the first sort, "2" for the second sort and etc.	To show the operations performed on a GRN will assist in managing knowledge of GRNs

The results of table 1 assisted in the design of the pallet and bin number as shown in the diagrams below.

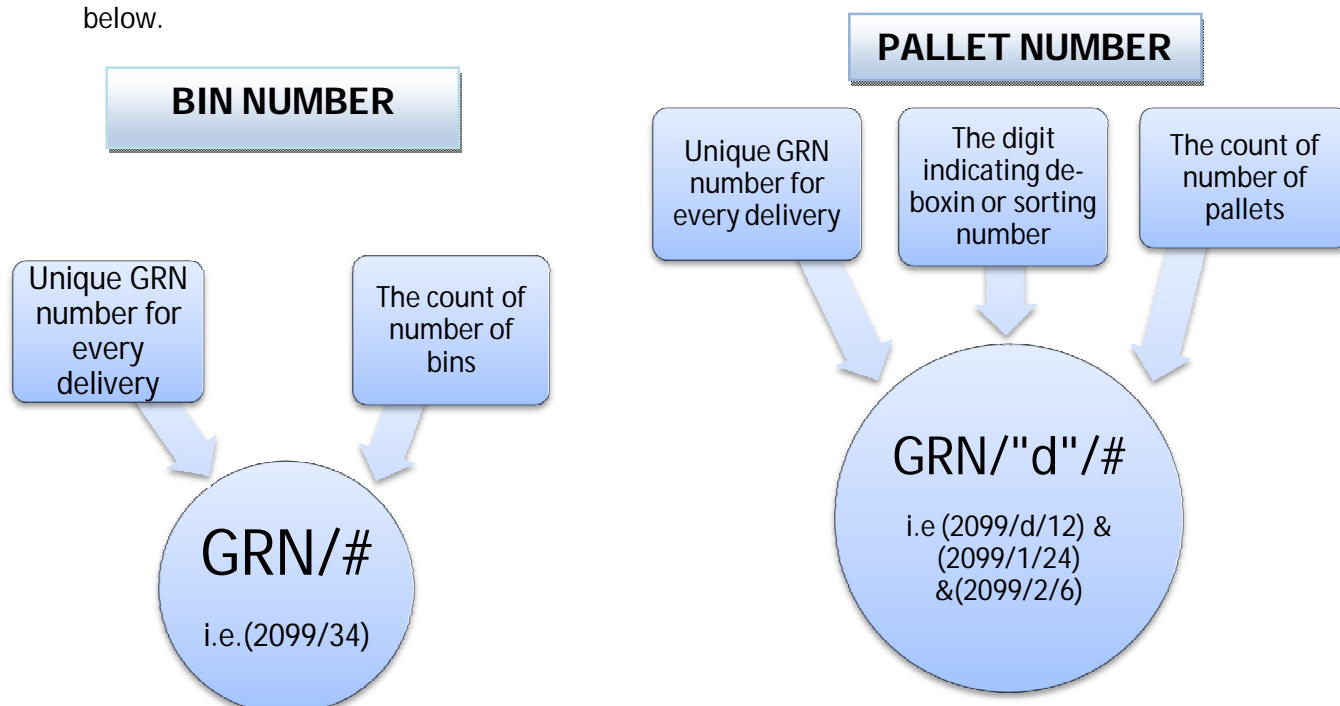

### Pack house activities

Traceability in the pack house is non-existent and it is for this reason that the pack house was chosen for the starting point of implementing and testing a new traceability method.

### Pack House Background

A prerequisite for designing such a traceability method is thorough knowledge of the area where the implementation is desired. A layout of the pack house and activities will communicate this knowledge.

Figure 9: Layout of Pack House

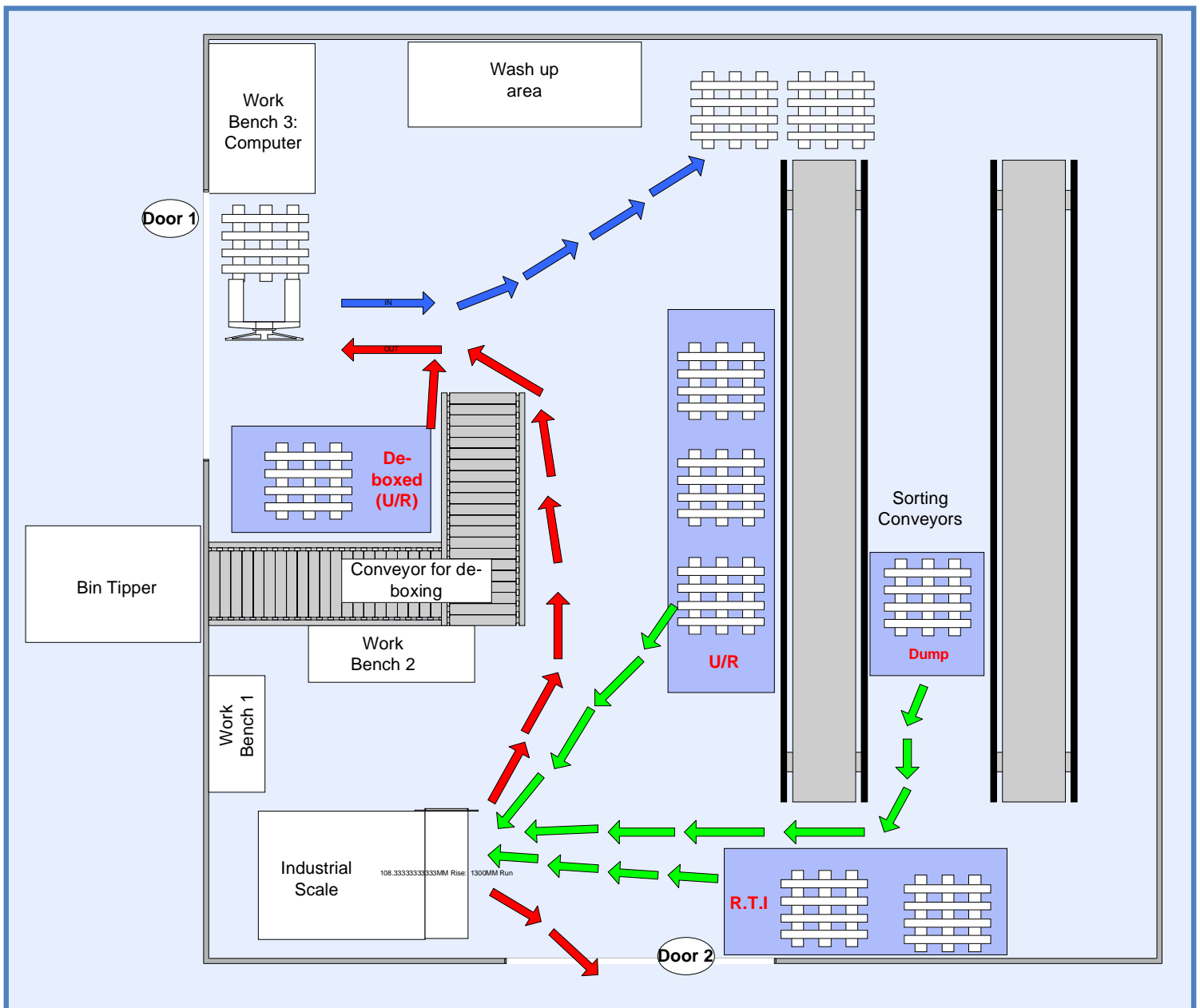

As shown in the figure:

1. The employee uses a pallet jack to transport the pallet into the pack house following the blue arrows where they are deposited onto the conveyor belt
2. After transporting the pallet, the employee removes the GRN sticker that identified the pallet and hands it over to the admin controllers at workbench one and two. This is the case with de-boxing a GRN as well; however the pallets do not enter the pack houses before they are de-boxed
3. On the sorting conveyors materials are placed on a destination path leading to one of the three classification areas. This is illustrated by the blue areas; R.T.I (ready to issue), U/R (under ripe) and dump. When the material reach the classification area it is deposited into a lug and stacked onto a nearby pallet
4. On the conveyor for de-boxing the materials only have one destination and are all classified as U/R
5. Specifications dictate that the maximum amount of lugs allowed on a U/R pallet is 56 and an R.T.I pallet is 48.
6. When the lug total is according to specification the pallets are transported by pallet jack to the industrial scale where they are weighed and given a new GRN sticker.
7. The materials leave the pack house by pallet jack following the red arrows. The red arrows leading to door number 2 are only used when a GRN requires rapid ripening because the temperature controlled room for this purpose is located directly outside door number 2.

### Concept Design

The activities of the pack house will be traced using the concept of four pillars of traceability by (Regattieri et al.). The diagram below shows this concept and how it will be employed.

Figure 10: Pillars of Traceability



**Product identification** deals with the physical characteristics of raw materials. The materials are physically identified by a GRN sticker.

**Data to trace** focuses on the characteristics of the information that is being traced. The degree of detail is established to a level two identification. The level one identification is the alphanumerical GRN number.

**Product routing** records the activities performed on raw materials. The pack house activities are recorded for the first time.

**Traceability tools and methods** focus on the degree of automation and the tools used. The EXCEL interfaces and the Sage database are the tools used to trace the material and the interfaces set the degree of automation.

## Design

### *Phase 1: GRN Booklet*

---

The GRN Booklet is the first step towards complete automation. The GRN booklet enables the admin controllers in the pack house to correctly capture information about the GRNs entering and exiting the pack house. The design of the GRN booklet is based on three simple principles.

Principle one: Store all information about pack house activities performed on a GRN together.

Principle two: Record pallets entering and exiting the pack house.

Principle three: Record variances of GRN weights after pack house activities

The GRN booklet format can be seen in Appendix A. The booklet consists of three basic information capturing sections. The first page captures the information about the de-boxing of a GRN. Pages two to seven capture information about each sorting activity of a GRN, depending on the amount of times a GRN is sorted. The last page records the variances between all activities and the overall variance of a GRN after it has been sorted for the last time.

### *Phase 2: EXCEL Interface*

---

In principle the EXCEL interface is the first actual stage of automation. The interface uses the principles of the GRN booklet with automated forms and calculations to eliminate certain errors caused by employees. The ideal would be to eliminate all errors caused by employees, but that is simply not possible, therefore the aim is to ensure that the most important information is correct. The traceability resource diagram shows the components used to execute the processes produced by the EXCEL interface. The components form the resource that is utilized in order to capture information and improve traceability. The EXCEL sheet is saved on the network of Bakkavor SVF under the stores section as Pack House.

Figure 11: Traceability resource

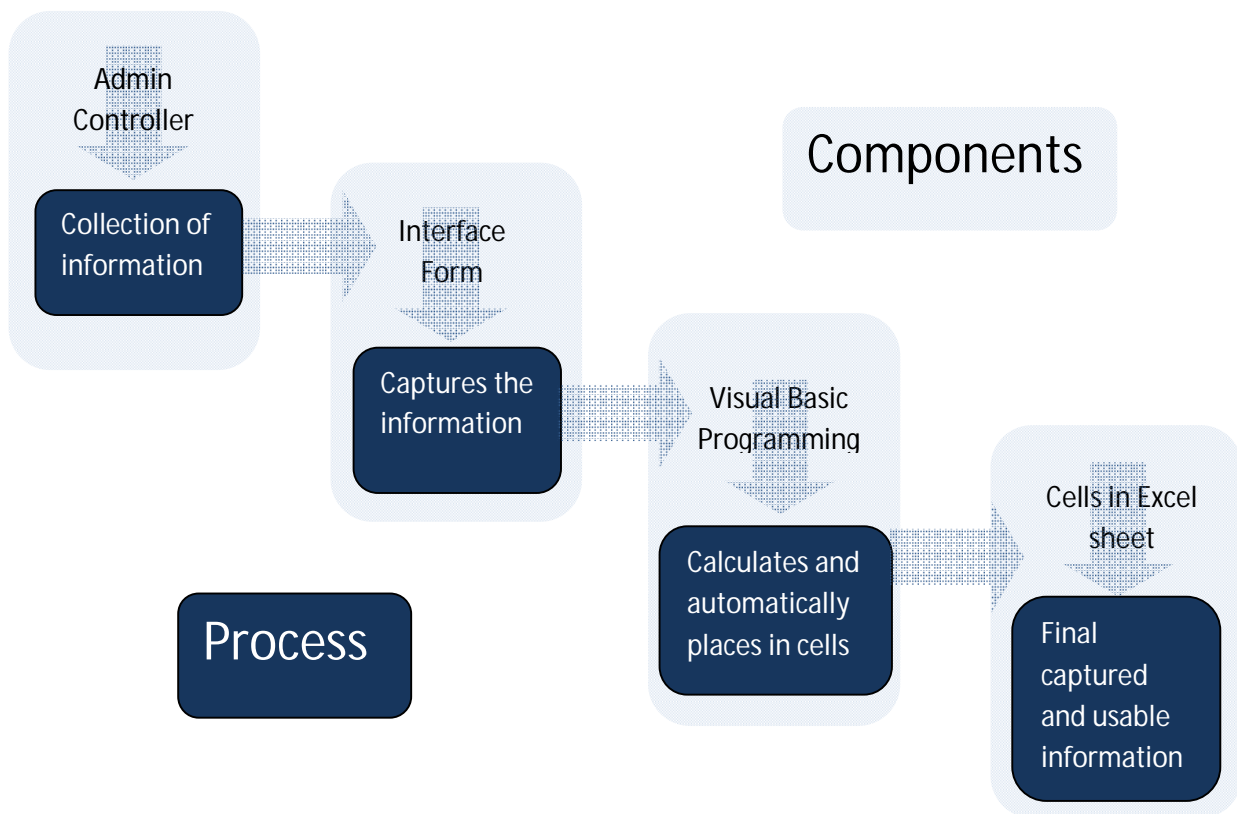

### Phase 3: Sage

The database used at Bakkavor SVF is named Sage. Sage as a database is rather complicated; once a report or function has been created it is impossible to change unless the Sage consultants are called in. Therefore a plan to capture the information onto Sage through current functions was designed.

#### The Function

The function used is called "Warehouse Transfer". On Sage the stores department is in warehouse AA. A new warehouse is created by the Sage Manager named AP.

#### The Method

Using the information on the network in EXCEL form, the total weight of the GRN to be sorted or de-boxed is transferred from warehouse AA to AP. The total weight of the GRN now sorted or de-boxed is with classification as a comment transferred back from warehouse AP to AA.

Figure 12: Sage Warehouse Transfer Function

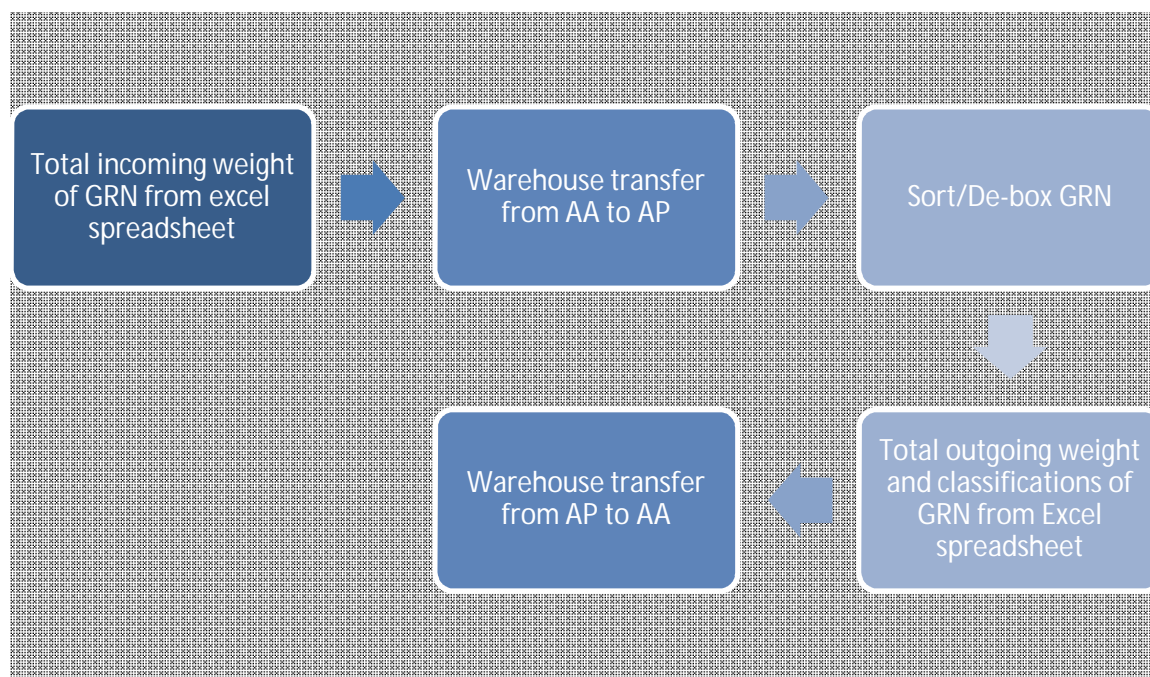

### The Conclusion

Any deviation from the expected norm in terms of moisture loss and issuing of materials is immediately detected when capturing the pack house data onto Sage.

## Issuing

### Phase 1: Issue Sheet

---

The issue sheet is the first phase of traceability for the stores department. It is a paper traceability method and is based on two principles

Principle one: Record amounts (in kilograms) of fruit variety issued for each individual GRN number

Principle two: Record level two identification numbers (pallet numbers) of GRNs issued

### Phase 2: EXCEL Interface

---

The basic design of the interface for the pack house is changed to include information relevant to the issuing of specific types of materials while keeping the concept of the traceability resource the same. The traceability resource diagram can be seen in figure 11. The EXCEL interface used in the Issuing area is, as in the case of the pack house interface, based on the principles of the Issue Sheet. The EXCEL sheet is saved on the network of Bakkavor SVF under the stores section as Issuing.

### Phase 3: Sage

---

As shown in the IDEFØ Child Diagram (As-Is) the issuing activities are transferred to Sage and no further change is necessary.

## Stock sheet

The objective of the stock sheet is to capture information because the activities performed on certain raw materials (i.e. sorting processes) are not captured on sage. The changes made in the sorting area (EXCEL interface and Sage transactions) integrate the activities of the sorting area and the data of the stock sheet, therefore removing the stock sheet will not affect the traceability. Unfortunately the issuing employees make use of the stock sheet to locate the storage room of the material requested by production.

Without an automated system it is difficult to keep track of the locations of materials, especially since the materials are perishable products which are frequently handled and moved. Two alternatives were designed to address this element of the stock sheet problem. These alternatives are evaluated below.

### Alternative A

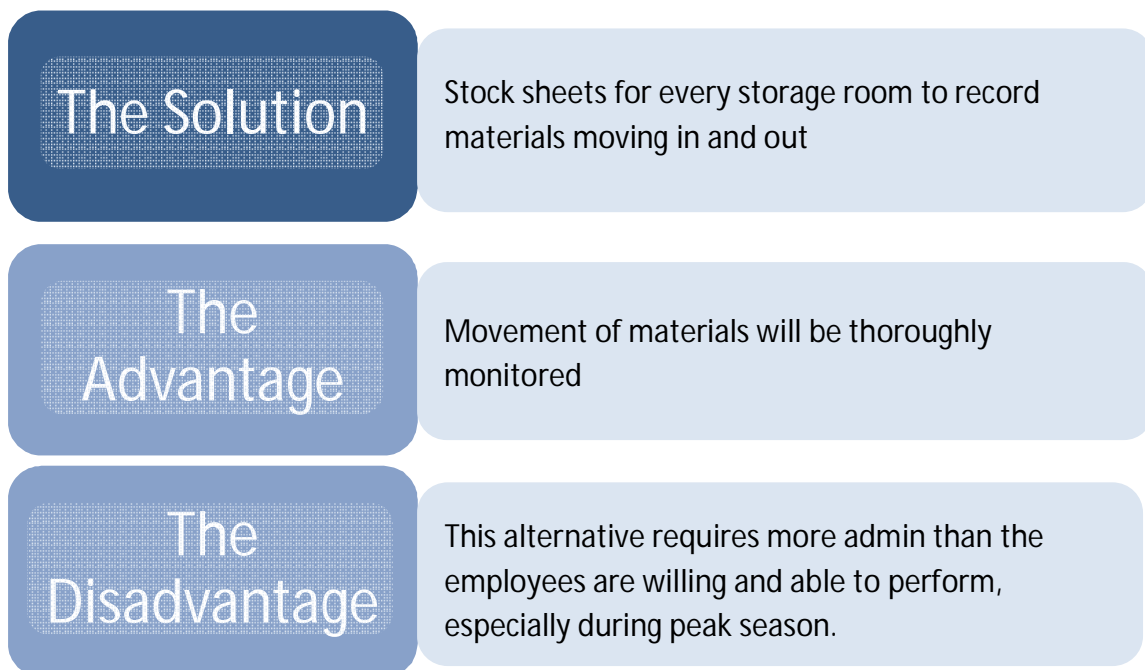

## Alternative B

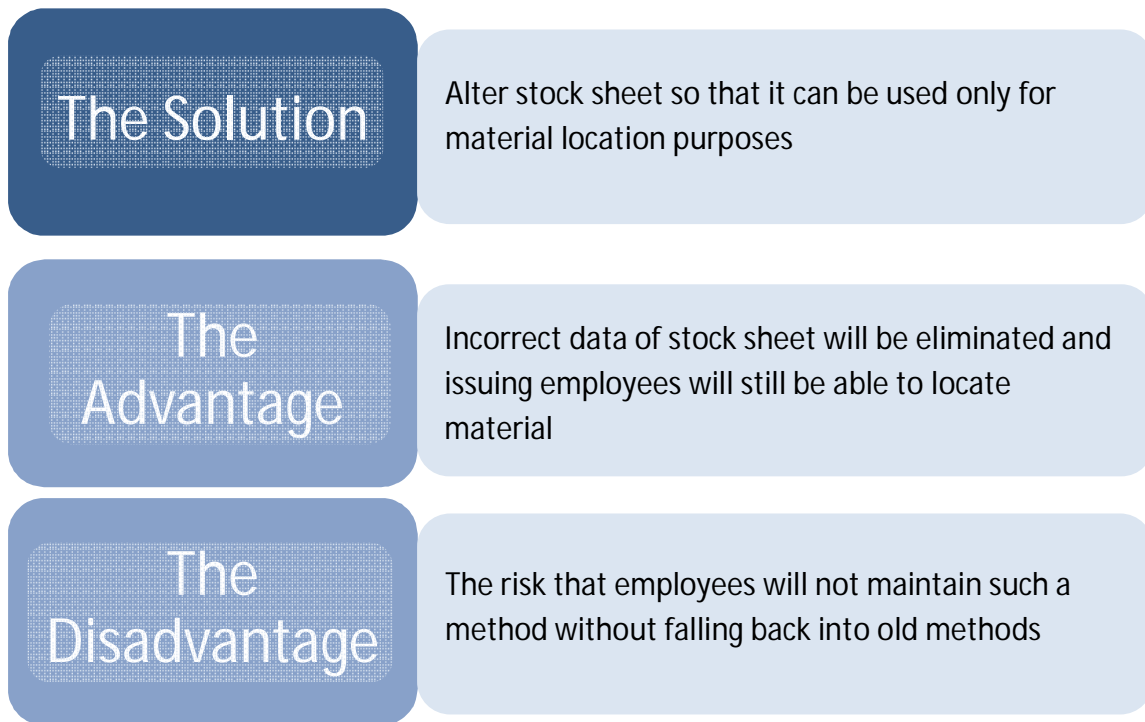

The disadvantage of Alternative A is the opinion of the Procurement Manager and was rejected. Consequently Alternative B is the only alternative worth pursuing without the option of an automated system. In addition with this alternative there will still be a use for the stock take employees. The design of the altered stock sheet is simple and can be seen in Appendix B.



## Justification

The justification part of the process will validate the traceability improvement accomplished by each change that is implemented. The solution formulation for each of the problems identified and the effect they have on the traceability system of the stores department based on the four pillars is shown in table 3.

*Table 3: Justification Table*

	<b>Product identification</b>	<b>Data to trace</b>	<b>Product routing</b>	<b>Traceability methods and tools</b>
<b>Bin and pallet traceability</b>	The GRN Sticker uniquely identifies a batch. The GRN sticker also indicates the category of maturity for each pallet	The degree of detail is increased from level one identification (GRN number) to level two identification (Pallet and bin number)	Activities performed on GRN is seen in the pallet number	GRN sticker
<b>Pack house activities</b>			Activities transferred to sage and available in interface records before exiting stores department	EXCEL interface: The cost is low, the data accuracy and reliability is high because the degree of automation can be programmed according to requirements
<b>Issuing area</b>			Activities transferred to sage and available in interface records materials exiting stores department	EXCEL interface: See above
<b>Stock sheet</b>	If the stock sheet does not display incorrect data, employees will not base issuing activities upon incorrect data			

## Bin and Pallet Traceability

With proper bin or pallet identification the pack house admin controllers now have the means to gain knowledge of which pallets entered and exited the pack house. The pallet and bin numbers will also facilitate the product routing pillar of the traceability framework, since the activities performed in the pack house (de-boxed, number of times sorted) are displayed in the pallet or bin number.

## Pack House Activities

The changes made to the pack house will integrate the information related to the activities with the data of the stock sheet. This is a vast improvement to the traceability of the stores department because the previous operating systems did not effectively capture information of pack house activities. The previous operating systems of the pack house were implemented by the preceding Pack House Manager who is no longer at SVF. Over a period of time the information captured during pack house activities became irrelevant to management. By implementing these changes information on pack house activities can be monitored and activities can be supervised and managed efficiently by management.

## GRN Booklet

The GRN Booklet as the first phase of the automation goal will hold all the information of a GRN together.

## EXCEL Interface

The EXCEL interface, together with the improvement made by the GRN booklet, will eliminate calculation errors made by employees. The EXCEL interface will also keep electronic data which is easier to manage and control. This facilitates the goal of automation in the sense that electronically stored data can with some programming be automatically transferred to Sage.

## Sage

Sage is the database that is currently being used and it is preferred by management that all data be processed by this program.

## Implementation

The implementation of changes firstly requires certain resources to be modified or constructed and finally the implementation of new operating systems requires informed and trained employees.

## Bin and Pallet Traceability

### Changes and required resources

Table 2 indicates that the first factor to consider when designing the pallet and/or bin traceability is that the identification number must be found on every pallet and/or bin. The approach to this factor is to use the GRN sticker because the GRN sticker is the only control that is used in all areas of the stores department. The GRN is the resource required and changes must be made to this resource to encompass the new pallet and/or bin traceability. After studying the GRN sticker and its uses it was found that there are fields on the sticker that were not used. The Packaging and Consumables Manager was contacted to request changes to the GRN sticker format. The changes can be seen in Appendix C.

### Training Document

The training document is written in accordance with the average education level of most of the employees. The training document can be seen in Appendix D. A receiving procedure flowchart is given to the employees to ensure they remember the new implementation. The flowchart can be seen in Appendix E.

## Pack House Activities

### Changes and required resources

The main and only resource required for the changes made to the pack house activities is a functional computer which is connected to the network of SVF. No additional computer is required because the pack house is in possession of a computer. The computer however needed to be updated and relocated to the specific area where employees execute tasks. The engineering team relocated the computer with necessary security measures and the information technology (IT) specialist prepared the hardware and software changes required for the functional operation of the computer. Referring to figure 9 which is the layout of pack house, the computer was moved from workbench 3 to workbench 1.

### Training Document

The GRN booklet was the first step towards complete automation and a training session was held in which the GRN booklet, its contents and method of recording were explained.

A user manual shown in Appendix F explains how to operate the EXCEL interface and it is therefore used as the training document.

## Issuing

### Changes and required resources

The resources required for the changes to the issuing area operations, though not utilized, were already in place. An industrial scale and fully functional computer is positioned at the entrance of the production area where the materials are issued.

### Training Document

A user manual shown in Appendix G explains how to operate the EXCEL interface and it is therefore used as the training document.

# CONCLUSIONS & RECOMMENDATIONS

## Conclusions

A traceability system to aspire to is an automated one. If the ultimate goal is to eventually create an automated traceability system, the correct groundwork can be laid as the phases that need to be achieved for the implementation of this system, can then be realized at the beginning of the project. Since there is no automated system of traceability at Bakkavor SVF and no system to automate, the project starts with the development of a system. To create a system a simple yet effective process was followed; identifying the problem, formulating a solution, justifying the improvement to traceability the change will make and implementing the change. This process was begun with the analysis of the department to identify the problem areas.

*Table 4: Conclusion Table*

Problem Identification	Solution Formulation	Justification	Implementation
<b><u>Pallet and bin traceability:</u></b> Pallets are never identified and there is no knowledge about their movements	Using the GRN sticker which each pallet and bin receive, record a pallet or bin number(level two identification) which is linked to the GRN(level one identification)	The flow of the pallets and bins into and out of the pack house are monitored	Changing the format of the GRN sticker to include fields for pallet and bin numbers and a training document
<b><u>Pack house activities:</u></b> Pack house activities and new categorisation of materials are never transferred to sage	Creation of the GRN Booklet in which to record the activities and relevant information of the pack house. Based on the principles of the GRN booklet, creation of an EXCEL interface which captures and calculates this information automatically and finally capturing this information onto Sage by means of a warehouse transfer	The GRN booklet holds all relevant information of a GRN together. The EXCEL interface captures information automatically and without calculation errors and the capturing of transactions onto Sage comply to the requirements of management	Relocating the pack house computer to where employees perform tasks. A training session for the GRN booklet and a user manual for the EXCEL interface
<b><u>Stock Sheet:</u></b> The stock sheet data is unreliable and more often than not incorrect	Altering the stock sheet once the implementation of the Sage activity is complete to exclude dynamic data except for room no.	Errors and incorrect data will no longer affect the variance problem	Removing the stock sheet
<b><u>Issuing:</u></b> Materials are not weighed when they are issued to production	Creation of an EXCEL interface that captures and calculates the information of the issuing process automatically and weighing the materials as a last measuring tool	An interface eliminates certain errors. Weighing the material as a last measuring tool indicates unexpected and unwanted variances	A user manual for the EXCEL interface.

With the implementation of the changes, the first three phases of an automated traceability system is in place. The methods, techniques and the design itself of the systems will enable the eventual and complete automation of the traceability system.

## Recommendations

The groundwork for an automated system is complete with the implementation of the changes made to each area. Another step towards complete automation is the automatic printing of GRN stickers. All industrial scales can be updated to automatically capture the weight that it is presented with. This weight displayed by the scale will then be transferred automatically to a computer where the NETT weight is calculated and the GRN sticker is printed. With the implementation of both EXCEL interfaces in the areas where materials can and are being weighed the updated scales is a goal that can be reached within a couple of months. After automatic printing of GRN stickers the Procurement Manager can look into the implementation of a bar coding system.

# REFERENCES

---

1. Cloete, D. Procurement Manager. 2011. [Personal Communication]. July
2. Steyn, D. Information Technology (IT) Specialist. 2011. [Personal Communication]. August
3. Wilks, N. Financial Manager. 2011. [Personal Communication]. August
4. Kelepouris, T. Pramataris, K. Doukidis, G. (2007) "RFID-enabled traceability in the food supply chain", *Industrial Management & Data Systems*, Vol. 107 Iss: 2, pp.183 - 200
5. Dimitris Folinas, Ioannis Manikas, Basil Manos, (2006) "Traceability data management for food chains", *British Food Journal*, Vol. 108 Iss: 8, pp.622 – 633
6. Massimo Bertolini, Maurizio Bevilacqua, Roberto Massini, (2006) "FMECA approach to product traceability in the food industry", *Food Control*, Vol. 17 Iss: 2, pp.137 – 145
7. A. Regattieri, M. Gamberi, R. Manzini (2007) "Traceability of food products: General framework and experimental evidence", *Journal of Engineering*, 81(2007) 347-356
8. Facilities: Automation Aids Traceability. Available from:  
[http://www.cableveyag.com/news/fds13\\_8223.pdf](http://www.cableveyag.com/news/fds13_8223.pdf) / (Accessed 28 August 2011).
9. IDEF0 Function Modeling Method. Available from:  
[www.idef.com/IDEF0.htm](http://www.idef.com/IDEF0.htm) (Accessed 22 August 2011).
10. <http://www.microafrica.co.za/tass/idef0.htm>
11. [http://syque.com/quality\\_tools/tools/Tools19.htm](http://syque.com/quality_tools/tools/Tools19.htm)
12. The Sage Group plc – Home. Available from:  
<http://www.Sage.com/> (Accessed 30 September 2011).

# APPENDICES

## Appendix A: GRN Booklet

Page 1

GRN BOOKLET					
GRN		GROWER		DATE	
P.O. NUMBER	042000	FRUIT VARIETY		ADMIN CONTROLLER	
		DEL. DATE		PAGE	1
				START TIME	
				END TIME	
				GRN	

De-Boxing																																									
<b>RECEIVED</b>		<b>DE-BOXED</b>			<table border="1" style="width: 100%; border-collapse: collapse;"> <thead> <tr> <th colspan="2" style="text-align: center;">PALLETS NOT SORTED</th> </tr> <tr> <th style="width: 5%;">PALLETS</th> <th style="width: 5%;">PALLETTNO.</th> </tr> </thead> <tbody> <tr><td>1</td><td></td></tr> <tr><td>2</td><td></td></tr> <tr><td>3</td><td></td></tr> <tr><td>4</td><td></td></tr> <tr><td>5</td><td></td></tr> <tr><td>6</td><td></td></tr> <tr><td>7</td><td></td></tr> <tr><td>8</td><td></td></tr> <tr><td>9</td><td></td></tr> <tr><td>10</td><td></td></tr> </tbody> </table> <table border="1" style="width: 100%; border-collapse: collapse;"> <thead> <tr> <th colspan="2" style="text-align: center;">DUMP</th> </tr> </thead> <tbody> <tr><td>1</td><td></td></tr> <tr><td>2</td><td></td></tr> <tr><td>3</td><td></td></tr> <tr><td>4</td><td></td></tr> <tr><td>5</td><td></td></tr> </tbody> </table>	PALLETS NOT SORTED		PALLETS	PALLETTNO.	1		2		3		4		5		6		7		8		9		10		DUMP		1		2		3		4		5	
PALLETS NOT SORTED																																									
PALLETS	PALLETTNO.																																								
1																																									
2																																									
3																																									
4																																									
5																																									
6																																									
7																																									
8																																									
9																																									
10																																									
DUMP																																									
1																																									
2																																									
3																																									
4																																									
5																																									
NETT WEIGHT	BIN NO.	U/R	PALLET NO.	R.T.I		PALLET NO.																																			
1	XXX	000/0																																							
2	XXX	000/1		XXX		000/1/1																																			
3	XXX	000/2		XXX		000/2/1																																			
4	XXX	000/3																																							
5	XXX	000/4																																							
6																																									
7																																									
8																																									
9																																									
10																																									
11																																									
12																																									
13																																									
14																																									
15																																									
16																																									
17																																									
18																																									
19																																									
20																																									
21																																									
22																																									
23																																									
24																																									
25																																									
26																																									
27																																									
28																																									
29																																									
30																																									

Page 2 - 7

SORTING NO. <u> X </u>			
DATE		START TIME	
ADMIN CONTROLLER		END TIME	
PAGE		GRN	

SORTING NO. Y		SORTING NO. X				<table border="1" style="width: 100%; border-collapse: collapse;"> <thead> <tr> <th colspan="2" style="text-align: center;">PALLETS NOT SORTED</th> </tr> </thead> <tbody> <tr><td>1</td><td></td></tr> <tr><td>2</td><td></td></tr> <tr><td>3</td><td></td></tr> <tr><td>4</td><td></td></tr> <tr><td>5</td><td></td></tr> <tr><td>6</td><td></td></tr> <tr><td>7</td><td></td></tr> <tr><td>8</td><td></td></tr> <tr><td>9</td><td></td></tr> <tr><td>10</td><td></td></tr> </tbody> </table> <table border="1" style="width: 100%; border-collapse: collapse;"> <thead> <tr> <th colspan="2" style="text-align: center;">DUMP</th> </tr> </thead> <tbody> <tr><td>1</td><td></td></tr> <tr><td>2</td><td></td></tr> <tr><td>3</td><td></td></tr> <tr><td>4</td><td></td></tr> <tr><td>5</td><td></td></tr> </tbody> </table>	PALLETS NOT SORTED		1		2		3		4		5		6		7		8		9		10		DUMP		1		2		3		4		5	
PALLETS NOT SORTED																																								
1																																								
2																																								
3																																								
4																																								
5																																								
6																																								
7																																								
8																																								
9																																								
10																																								
DUMP																																								
1																																								
2																																								
3																																								
4																																								
5																																								
TO BE SORTED	PALLET NO.	U/R	PALLET NO.	R.T.I	PALLET NO.																																			
1																																								
2																																								
3																																								
4																																								
5																																								
6																																								
7																																								
8																																								
9																																								
10																																								
11																																								
12																																								
13																																								
14																																								
15																																								
16																																								
17																																								
18																																								
19																																								
20																																								
21																																								
22																																								
23																																								
24																																								
25																																								
26																																								
27																																								
28																																								
29																																								
30																																								
		TOTAL																																						

### Appendix B: Altered Stock Sheet

#### STOCK SHEET

FRUIT VARIETY	GRN	DEL. DATE	CLASSIFICATION	ROOM NO.
i.e. AVOCADO	i.e. AV1940	i.e. 06/07/2011	i.e. R.T.I	i.e. 5,6,7



### Appendix C: GRN Sticker Changes

BIN No.: \_\_\_\_\_  
~~BATCH NO.:~~ \_\_\_\_\_  
DEL: \_\_\_\_\_  
SORTED: \_\_\_\_\_  
PRODUCT: \_\_\_\_\_  
GROWER: \_\_\_\_\_  
WEIGHT: \_\_\_\_\_  
USE BY: \_\_\_\_\_  
GRN NO.: \_\_\_\_\_

PALLET NO.: \_\_\_\_\_  
~~BATCH NO.:~~ \_\_\_\_\_  
NO. OF LUGS \_\_\_\_\_  
~~U/RIPE-RTI.:~~ \_\_\_\_\_  
DEL.: \_\_\_\_\_  
SORTED: \_\_\_\_\_  
PRODUCT.: \_\_\_\_\_  
GROWER: \_\_\_\_\_  
WEIGHT: \_\_\_\_\_  
USE BY: \_\_\_\_\_  
GRN NO.: \_\_\_\_\_

**Appendix D: Training document for GRN sticker**

	<b>Title:</b>		<b>Bin Number</b>		
	Owner:		H. Jooste		
	Area(s):		Receiving		
	Version:		BN.1		
	Trainer:		Name	Signature	
Date:					

● **WHAT**

Every bin that arrives will be identified.  
 If there are 60 bins from a delivery there will be 60 bin numbers.  
 It identifies a bin.

● **WHY**

If a bin is identified we will know which bin has what weight.  
 This will help to track the GRN.

● **WHEN**

When the GRN is received, we will produce a bin number.

● **HOW**

When a GRN is received, the bin number will be;

- the last 3 numbers of the P.O. number
- a dash
- a digit (from 0 – “the number of bins”)

- Step 1. Get P.O. number before delivery starts
- Step 2. Scratch out “BATCH NO. :”
- Step 3. Write “BIN NO.”
- Step 4. Write new bin no. in space on top of line

<b><u>EXAMPLE BIN NUMBER</u></b>	
<b>Bin 1:</b>	<b>670/1</b>
<b>Bin 2:</b>	<b>670/2</b>
<b>Bin 3:</b>	<b>670/3</b>
<b>Bin n:</b>	<b>670/n</b>

Step 3. → BIN No.:  
 Step 2. → ~~BATCH NO.:~~ XXX/n ← Step 4.

**DEL:** \_\_\_\_\_

**SORTED:** \_\_\_\_\_

**PRODUCT:** \_\_\_\_\_

**GROWER:** \_\_\_\_\_

**WEIGHT:** \_\_\_\_\_

**USE BY:** \_\_\_\_\_

**• RECOMMENDATIONS**

---

---

---

---

---

---

---

---

---

---

---

---

---

---

---

---

---

---

---

---

---

---

---

**• DECLARATION**

I hereby declare that;

- 1. I understood the training document
- 2. I understand what is expected of me
- 3. I promise to apply what I have learned
- 4. I promise to write the correct bin number to every GRN sticker every time
- 5. I have asked questions about things I didn't understand
- 6. I have said the things that I think will be problems
- 7. I have mentioned any recommendations I might have

Name: \_\_\_\_\_

Signature: \_\_\_\_\_

<b>Training Document</b>	<b>Title:</b>	<b>Pallet Number</b>	
 	Owner:	H. Jooste	
	Area(s):	Sorting	
	Version:	PN.1	
	Trainer:	Name	Signature
Date:			

- **WHAT**

Every pallet that is de-boxed or sorted will be identified.

If there are 20 pallets after de-boxing or sorting there will be 20 pallet numbers.

It identifies a pallet.

- **WHY**

If a pallet is identified we will know which pallet has what weight.

This will help to track the GRN.

- **WHEN**

When the GRN is de-boxed, we will produce a pallet number.

- **HOW**

When a GRN is de-boxed, the pallet number will be;

- the last 3 numbers of the P.O. number
- a dash
- the letter "d"
- a dash
- a digit (from 1 – "the number of pallets")

Step 1. Take first three numbers of the BIN NO on the GRN stickers  
OR

The last three numbers of the P.O. number (it's the same thing)

Step 2. Scratch out BATCH NO.

Step 3. Write PALLET NO.

Step 4. Write PALLET NO. on top of space

The diagram shows a GRN sticker with the following fields: PALLET NO.: \_\_\_\_\_, BATCH NO.: XXX/n, U/RIPE-R.T.I.: \_\_\_\_\_, DEL.: \_\_\_\_\_, SORTED: \_\_\_\_\_, PRODUCT.: \_\_\_\_\_, GROWER: \_\_\_\_\_, WEIGHT: \_\_\_\_\_, USE BY: \_\_\_\_\_, and GRN NO.: \_\_\_\_\_. Arrows indicate that Step 2 points to the BATCH NO. field, Step 3 points to the PALLET NO. field, and Step 4 points to the space above the PALLET NO. field.

**EXAMPLE OF PALLET NUMBER**

Pallet 1:	670/d/1
Pallet 2:	670/d/2
Pallet 3:	670/d/3
Pallet n:	670/d/n

When a GRN is sorted, the pallet number will change to;

- the last 3 numbers of the P.O. number
- a dash
- a digit (from 1 to "the number of pallets")
- a dash
- the sorting number (from 1 to sorting no. \_\_)

**EXAMPLE OF PALLET NUMBER**

Pallet 1:	670/1/1
Pallet 2:	670/2/1
Pallet 3:	670/3/1
Pallet n:	670/n/ (sorting number)

- **RECOMMENDATIONS**

---

---

---

---

---

---

---

---

---

---

---

---

---

---

---

---

---

---

---

---

---

---

---

- **DECLARATION**

I hereby declare that;

1. I understood the training document
2. I understand what is expected of me
3. I promise to apply what I have learned
4. I promise to write the correct pallet number to every GRN sticker every time
5. I have asked questions about things I didn't understand
6. I have said the things that I think will be problems
7. I have made any recommendations I might have

Name: \_\_\_\_\_

Signature: \_\_\_\_\_

### Appendix E: Receiving Procedure Flowchart

<b>RECEIVING PROCEDURE</b>  	Owner:	H. Jooste
	Area(s):	Receiving
	Version:	1.1
	Section leader:	Lucky Rumo
	Line Leader:	Lindi Mbonani
	Line Leader:	Amos Nkambule

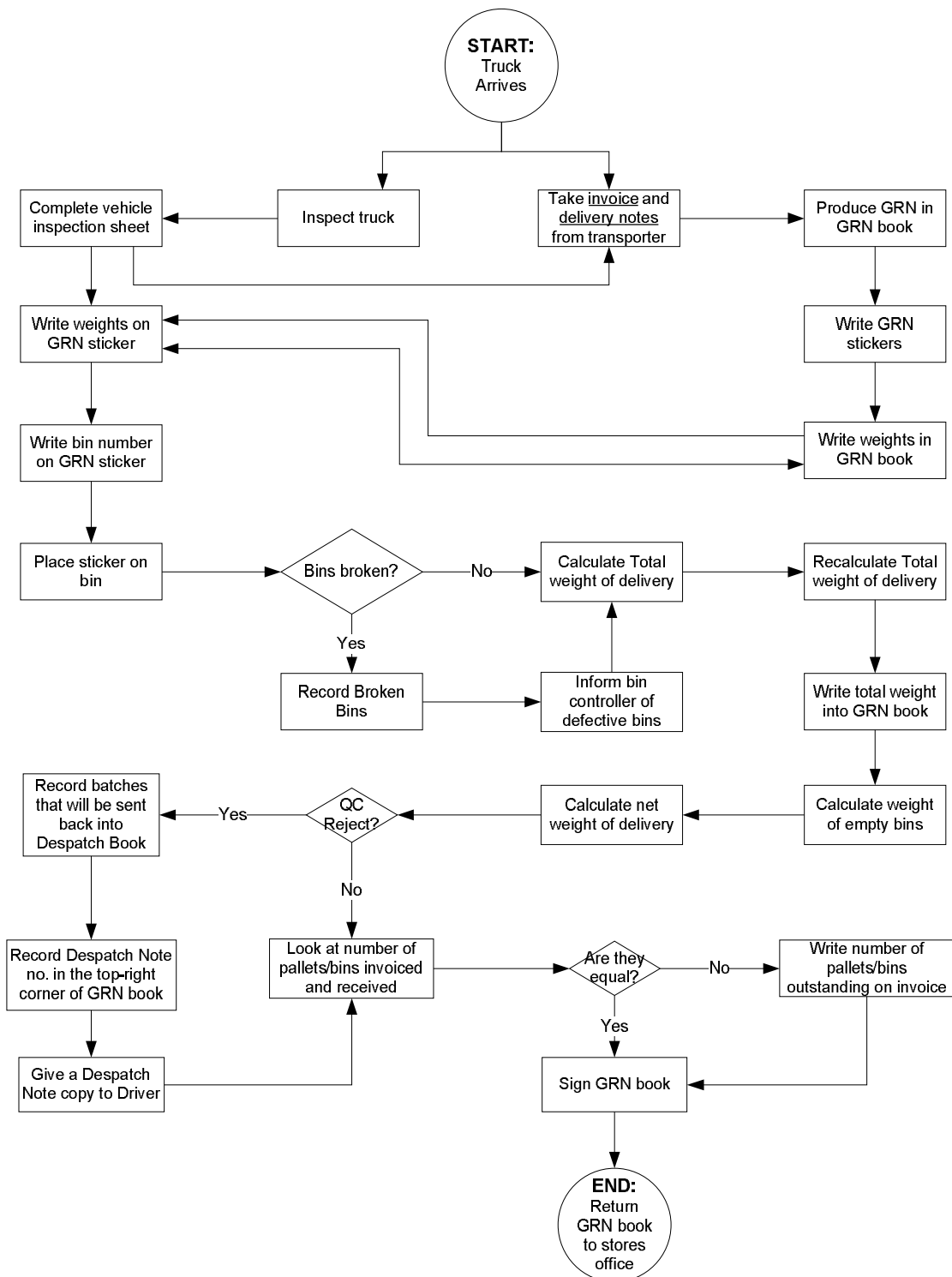

## Appendix F: EXCEL Interface User Manual-Pack House

### STEP ONE

Open the EXCEL document on the first sheet. This is the interface you will see.

1	START				ADMIN CONTROLLER						
2					DE-BOXING DATE						
3	GRN	GROWER	FRUIT VARIETY	DEL. DATE	START TIME						
4					END TIME	08:02:09 PM					
5	<b>RECEIVED</b>				<b>SORTED</b>						
7	ADD INCOMING		TOTAL INCOMING		TOTAL OUTGOING	ADD OUTGOING					
10	BIN NO.	WEIGHT	0		0	PALLET NO.	GROSS WEIGHT	SUBTRACTIONS	NETT WEIGHT	CLASSIFICATION	COMMENT
11											
12											
13	ACTIVITY SUMMARY										
14											
15											
16											
17											
18											
19											
20											
21											
22											
23											

### STEP TWO

Click on the "START" button to display the "GRN Booklet" form

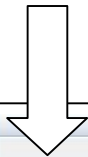

**GRN Booklet**

GRN

GROWER

FRUIT VARIETY

DEL. DATE

### STEP THREE

Fill in the information of the GRN in the text boxes provided and click on the "NEXT" button

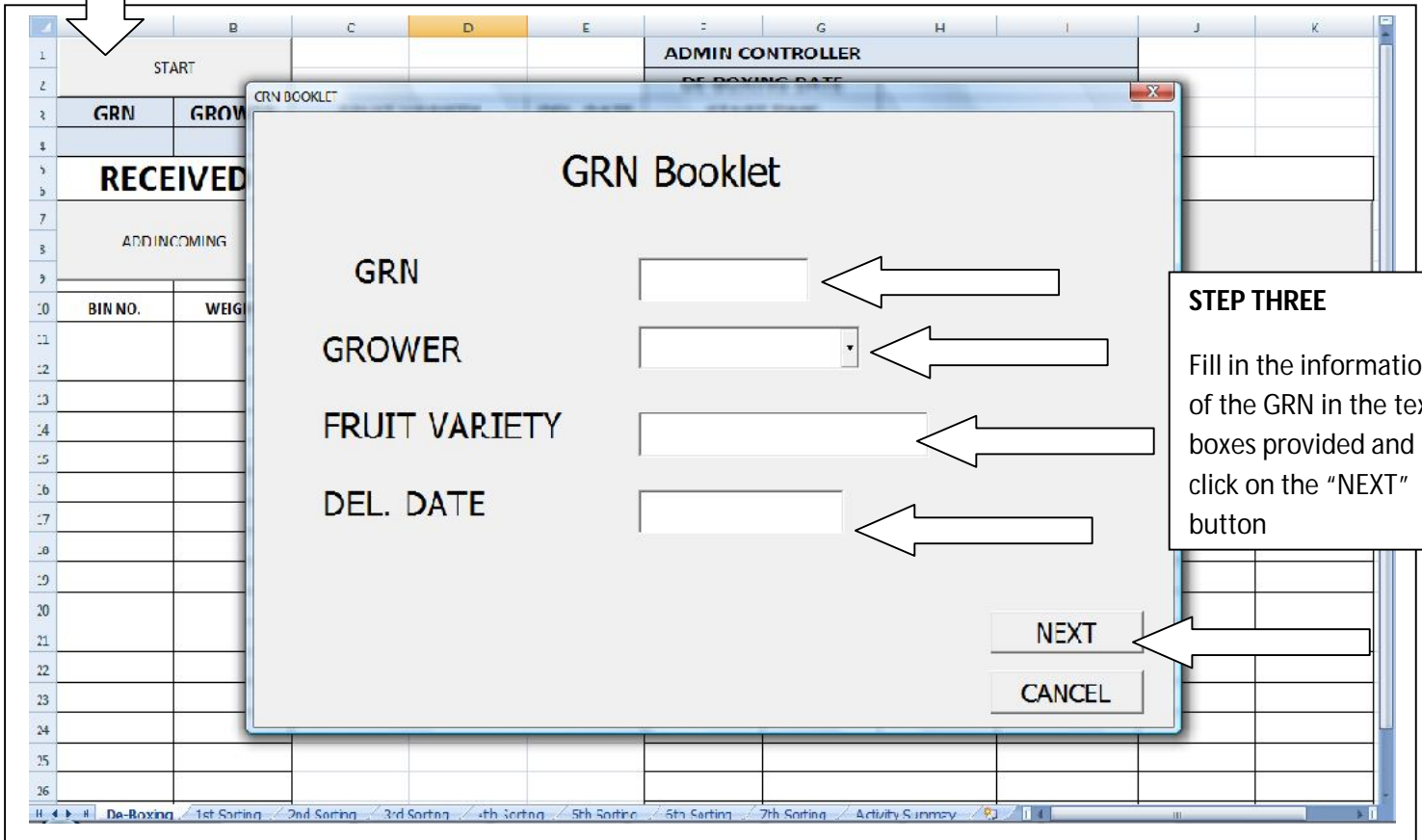
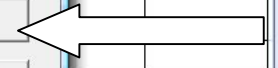



The GRN information will automatically be entered into the cells as shown below

**STEP FOUR**

The sorting info form will automatically open. The De-Boxing date will already be there and you cannot edit that text box. Select your name from the drop down list and click "OK"

**STEP FIVE**

When a bin arrives that is de-boxed click on the ADD INCOMING button

The information from the SORTING INFO form will automatically be updated including START TIME

**STEP SIX**

Fill in the BIN NUMBER and GRN STICKER WEIGHT in the spaces provided and click OK. Repeat this step for all the bins to be de-boxed

1	START			
2				
3	<b>GRN</b>	<b>GROWER</b>	<b>FRUIT VARIETY</b>	<b>DEL. DATE</b>
4	XXXX	GROWER	FRUIT VARIETY	DEL.DATE
5	<b>RECEIVED</b>			
6				
7	ADD INCOMING		TOTAL INCOMING	TOTAL OUTGOING
8				
9				
10	<b>BIN NO.</b>	<b>WEIGHT</b>	0	0
11	XXXX/Y	XXX		
12	XXXX/Z	XXX		
13	XXXX/W	XXX		
14				
15				
16				
17				

The weights and bin numbers will automatically be entered into the cells. You don't need to change anything.

**STEP SEVEN**  
When a pallet has been de-boxed into lugs, placed onto a pallet and weighed click on the ADD OUTGOING button

**STEP EIGHT**  
Fill in the required information in the spaces provided on the pallet form and click OK

The information will automatically be inserted into the cells. You will find the weight that must be written onto the GRN in the column NETT WEIGHT. You don't need to do a calculation

ADD OUTGOING					
PALLET NO.	GROSS WEIGHT	SUBTRACTIONS	NETT WEIGHT	CLASSIFICATION	COMMENT
XXXX/d/X	100	3	97	R.T.I	
XXXX/d/Y	100	4	96	R.T.I	
XXXX/d/Z	100	7	93	U/R	COMMENT

**STEP NINE**  
Once you have received all the bins that you will have to de-box press the TOTAL INCOMING button. The total weight of all the bins will be displayed in the text box below the button as shown

**STEP TEN**  
When the GRN has been completely de-boxed, click on the TOTAL OUTGOING button. The total weight of all the pallets will be displayed in the text box below the button as shown. The end time of the job will also automatically be updated in the cell as shown

RECEIVED		TOTAL INCOMING		TOTAL OUTGOING		SORTED			
ADD INCOMING						ADD OUTGOING			
BIN NO.	WEIGHT	30		286		PALLET NO.	GROSS WEIGHT	SUBTRACTIONS	NETT WEIGHT
XXXX/Y	10					XXXX/d/X	100	3	97
XXXX/Z	10					XXXX/d/Y	100	4	96
XXXX/W	10					XXXX/d/Z	100	7	93
ACTIVITY SUMMARY									

ADMIN CONTROLLER	ADMIN CONTROLLER
DE-BOXING DATE	2011/01/01
START TIME	12:00:00 AM
END TIME	09:32:09 PM

**STEP ELEVEN**

When the job is done and the totals are displayed in the text boxes, click on the CONFIRM DE-BOXING button. The variance and percentage variance along with the amounts of each classification will be displayed as shown

TOTAL INCOMING	30	XXXX/d/X	100	3	NETT WEIGHT	97
		XXXX/d/Y	100	4		96
		XXXX/d/Z	100	7		93
<b>CONFIRM DE-BOXING</b>						
VARIANCE	14					
VARIANCE %	4.67%					
R.T.I	193					
U/R	93					
Dump	0					

**STEP TWELVE**

When a GRN must be sorted click on the next sheet named "1<sup>st</sup> Sorting".

1	ADMIN CONTROLLER					
2	DE-BOXING DATE					
3	START TIME					
4	END TIME					
5	<b>RECEIVED</b>			<b>SORTED</b>		
6	ADD INCOMING	TOTAL INCOMING	TOTAL OUTGOING	ADD OUTGOING		
7	BIN NO.	WEIGHT		PALLET NO.	WEIGHT	CLASSIFICATION
8						COMMENT
9						
10						
11						
12						
13						
14						
15						
16						
17						
18						
19						
20						
21						
22						
23						
24						
25						

**STEP THIRTEEN**

To start the process click on the START button

**STEP FOURTEEN**

The SORTING INFORMATION form will automatically open. The sorting date will already be there and you cannot edit that text box. Select your name from the drop down list and click "OK"

The screenshot displays a software interface with a 'START' button on the left. A 'SORTING INFO.' dialog box is open in the center, containing the following fields and controls:

- ADMIN CONTROLLER:** A dropdown menu currently showing 'ADMIN CONTRI...'.
- DE-BOXING DATE:** A text box containing the date '12-09-11'.
- OK** and **CANCEL** buttons at the bottom.

The background interface includes a 'RECEIVED' section with a table with columns 'BIN NO.' and 'WEIGHT'. At the top, there are sections for 'ADMIN CONTROL', 'DE-BOXING DATE', 'START TIME', and 'END TIME'. The bottom of the window shows a tabbed interface with tabs for 'De-Boxing', '1st Sorting', '2nd Sorting', '3rd Sorting', '4th Sorting', '5th Sorting', '6th Sorting', '7th Sorting', and 'Activity Summary'.

The rest of the interface is the same as the de-boxing sheet.

Repeat steps five to eleven for every sorting.

## Appendix G: EXCEL Interface User Manual-Issuing

### STEP ONE

Open the EXCEL document on the first sheet. This is the interface you will see.

**ISSUE SHEET** Dayshift

GRN

DEL. DATE

GROWER

PALLET NUMBER

FRUIT VARIETY

KG'S ON GRN STICKER

KG'S ON SCALE

COMMENT

CONTAINER WEIGHT

Add Issued Fruit Issued Fruit Sheet

**Issuing Details**

OPERATOR

SHIFT:

DAYSHIFT

NIGHTSHIFT

ENTER

**STEP TWO**

Select your name from the drop down list, click the shift that you are working and click on the ENTER button

**ISSUE SHEET** NAME AND SURNAME 2011/10/09 Dayshift

GRN

DEL. DATE

GROWER

PALLET NUMBER

FRUIT VARIETY

KG'S ON GRN STICKER

KG'S ON SCALE

COMMENT

PALLET WEIGHT

CONTAINER WEIGHT

Add Issued Fruit Issued Fruit Sheet

**STEP THREE**

Fill in all the empty black boxes and click on Add Issued Fruit

**STEP FOUR**

Click on Issued Fruit Sheet to capture transactions onto Sage

	C	D	E	F	G	H	I	L	N	O	P	Q
	GROWER	GRN	DEL. DATE	PALLET NUMBER	FRUIT VARIETY	KG'S ON GRN STICKER	KG'S ON SCALE	COMMENT	VARIANCE			
1												
2	ALLIANCE DIRECT	1234	2011/09/05	1234/01	MANGO TOMMY	800	1000	COMMENT	80	<input checked="" type="checkbox"/>		Update
3									0	<input type="checkbox"/>		Back
4									0	<input type="checkbox"/>		
5									0	<input type="checkbox"/>		
6									0	<input type="checkbox"/>		
7									0	<input type="checkbox"/>		
8									0	<input type="checkbox"/>		
9									0	<input type="checkbox"/>		
10									0	<input type="checkbox"/>		
11									0	<input type="checkbox"/>		
12									0	<input type="checkbox"/>		
13									0	<input type="checkbox"/>		
14									0	<input type="checkbox"/>		
15									0	<input type="checkbox"/>		
16									0	<input type="checkbox"/>		
17									0	<input type="checkbox"/>		
18									0	<input type="checkbox"/>		
19									0	<input type="checkbox"/>		
20									0	<input type="checkbox"/>		
21									0	<input type="checkbox"/>		
22									0	<input type="checkbox"/>		
23									0	<input type="checkbox"/>		
24									0	<input type="checkbox"/>		
25									0	<input type="checkbox"/>		
26									0	<input type="checkbox"/>		
27									0	<input type="checkbox"/>		

**STEP SIX**

Click the check box once you have captured the transaction on Sage

**STEP SIX**

Click the Back Button to return to the Input sheet and repeat steps three to five

**STEP FIVE**

Click the Update button to sort the issued fruit in alphabetical order