

Techno-economic and environmental optimization of a household photovoltaic-battery hybrid power system within demand side management

Fei Yang^{a,*}, Xiaohua Xia^b

^a*Department of Automation, School of Power and Mechanical Engineering, Wuhan University, Wuhan 430072, P.R.China*

^b*Centre of New Energy Systems, Department of Electrical, Electronic and Computer Engineering, University of Pretoria, Pretoria 0028, South Africa*

Abstract

This paper presents a power management system of a household photovoltaic-battery hybrid power system within demand side management under time of use electricity tariff. This system is easy to implement by employing cheap electrical switches, off-the-shelf chargers and inverters. Control system models combining both power dispatching level and home appliance scheduling level are proposed to minimize the residents' energy cost and energy consumption from the grid with the practical constraints strictly satisfied. In addition, the resident comfort inconvenience level is considered in the control system models. The trade-off among operating cost, energy consumption and inconvenience is considered and a multi-objective optimization problem is formulated. The optimal control strategies are derived by solving a mixed-integer nonlinear programming problem. Simulation results show that the energy cost and energy consumption from the grid can be largely reduced with the proposed strategies. These results are important for customers to dispel their major uncertainty in determining whether to newly install or update to such photovoltaic-battery hybrid power systems.

Keywords: Solar energy; Hybrid power system; Optimal control; Demand side management

1. Introduction

The global energy consumption continues to increase due to population growth, continued urbanization, and economic development with great threat to environment. Most of the energy consumed around the world comes from fossil fuels, and that would continue to provide most of the world's energy in future. It is reported that, liquid fuels, natural gas, and coal would still account for 78% of total world energy consumption in 2040 though renewable energy is the world's fastest-growing source of energy [1]. Therefore, much more coal, oil and natural gas will be burned to generate electrical energy and then supplied to residential, industrial and commercial consumers via the grid year after year. As a result, increasing amount of carbon dioxide (CO₂) and other air pollutants are emitted into the atmosphere, resulting in not only

*Corresponding author.

Email address: f.yang@whu.edu.cn (Fei Yang)

Nomenclature

PV	photovoltaic or photovoltaic system
BT	battery/batteries
PMU	power management unit
AC	alternating current
DC	direct current
Ah	ampere-hour
$P_{pv}(t)$	power generated by the PV at time t (kW)
$P_1(t)$	power flow into the BT from the solar charger at time t (kW)
$P_2(t)$	power flow into the inverter from the solar charger at time t (kW)
P_3	average power out of the grid to the AC charger (kW)
$P_4(t)$	discharging power from the BT at time t (kW)
$P_5(t)$	power from the grid to the appliances at time t (kW)
η_C	the efficiency coefficient of the AC charger
η_I	the efficiency coefficient of the inverter
η_B	the efficiency coefficient of the battery bank
η_S	the efficiency coefficient of the solar charger
N	Each day is divided into N sampling periods
Δt	the sampling interval, $\Delta t = 24 \text{hours} / N$
$g_1(t)$	status of the power flow from the PV to the BT at time t
$g_2(t)$	status of the power flow from the PV to the inverter at time t
$g_3(t)$	status of the power flow from the grid to the BT at time t
$g_4(t)$	status of the power flow from the BT to the inverter at time t
$g_5(t)$	status of the power flow from the grid to the appliances at time t
$\rho(t)$	the electricity price at time t
$u_i(t)$	the ON/OFF status of the i -th appliance at time t
$u_i^{bl}(t)$	the baseline ON/OFF status of the i -th appliance at time t
R	South African currency Rand, 1 Rand \approx 0.069 USD as at 31 Aug., 2016

remarkable global warming, but also serious environmental pollution [2]. To reduce emissions from fossil-fuel combustion is a pressing task for all countries, which could be contributed greatly by the decrease of energy consumption from the grid as well as the utilization of clean energy.

Rapid improvements in energy efficiency and shifts to renewable energy (RE) are essential for the dramatic decreases in fossil energy consumption. In fact, RE and energy efficiency improvement technologies may be the only ways that could achieve the target of emission reduction over the next decade. Nowadays, countries have to increasingly turn to RE to reduce the risks posed by climate change, air pollution and energy security concerns. Meanwhile, about 1.2 billion people still have no access to reliable electricity services despite efforts for bringing electrical power to remote regions are encouraged by national and international agencies and work programs [3]. In most developing countries, the main driver for RE is to access to electricity especially in remote and rural areas that are short of electricity [4]. Among available RE sources, solar energy is gaining more widespread exploitation, as it is freely available (nearly everywhere), and environmental friendly with several advantages [5]. However, solar photovoltaic (PV) systems, which are the main technology to convert solar energy to electrical power, still suffer from the instantaneous

and unstable nature of solar energy. Thus PV systems usually work with energy storage systems in order to provide continuous and stable power. Electrochemical batteries (BT) are one common type of energy storage system with low initial costs. The most widespread batteries in the family of electrochemical batteries are the lead-acid and lithium-ion ones, which are often attached to solar PV systems not only to store green energy but also to reduce the energy expenditure or energy consumption from the grid [6–10].

For such a hybrid power system with batteries, some analyses, designs and control strategies were given to help consumers dispel their uncertainty on both technology and economic performance [11–14]. On the other hand, as a kind of technology to foster better energy efficiency in electrical energy systems, demand side management (DSM) programs enable utility companies to manage the user-side electrical loads and also to motivate consumers to voluntarily lower their demand for electricity or to shift their loads from peak periods¹. Among them, residential demand response (DR) is widely used as an energy DSM strategy to boost consumers to play a significant role in the operation of the power system by reducing or shifting their electricity usage during peak times in response to time-of-use (TOU) tariff or other forms of financial incentives at household level². To minimize the electricity bill under TOU pricing programs, optimal control strategies were then proposed to schedule power flows of hybrid power systems [4, 15, 16]. However, these power flow control methods are impractical for residential hybrid power systems, one of the limitations is that their implementation asks for expensive power dispatching components and specifically customized controllers. Therefore, a simple switching model for the grid-tied PV-BT system was proposed in [2], which could be implemented even by manual operations with cheap switches instead of costly automatic controllers and actuators. Few works emphasize on this switching control structure of the hybrid power system, though it is more favorable in real-world applications. In the studies mentioned above and other power flow control studies (e.g., [17] and [18]), the focus is on the upper level of power management with a fixed energy consumption profile, offering ‘coarse’ control strategies with 1-hour control interval. Moreover, the capacity limitations of the power conversion and distribution components (mainly including chargers and inverters) are not taken into consideration at the power electronics level. Therefore, their control system models cannot ensure the strict satisfaction of some practical constraints. And these researches aim to minimize the electricity cost relying on the power flow control strategies without considering the user-side loads management, which is also an indispensable part in DSM programs. However, in a real-world power system, the former would be inevitably influenced by the latter. Electricity cost in a household is mostly dependent on the energy demand of the occupants as well as the scheduling of electric appliances under TOU pricing programs, only implementing suitable scheduling of home appliances can also make a realistic contribution to cutting down electricity bills [19]. Therefore, to enhance DSM and to minimize the residents’ electricity cost, both the power dispatching and load scheduling must be taken into account simultaneously, though that is rarely covered by the existing literature. On the other hand, existing literature about residential hybrid power systems focus on minimizing the residents’ electricity cost, which is a major incentive for most householders to turn to DSM. However, from the viewpoint of energy saving, minimizing the energy consumption from the grid is also important and

¹Sustainable energy regulation and policymaking for Africa, Module 14; Demand side management. <<http://africa-toolkit.reeep.org/modules/Module14.pdf>>.

²USA Department of energy <<http://energy.gov/oe/technology-development/smart-grid/demand-response>>.

should be taken into consideration as well.

If more effective DSM programs are deployed with the installation of hybrid PV-BT power systems, it would add extra values to the consumers and contribute a sizeable portion to both cost saving and energy saving. Therefore, the power management system for the household PV-BT system within DSM is further studied in this paper to help the residents to minimize the energy expenditure and energy consumption from the grid. This paper is also devoted to designing a more favorable power management system for real-world applications with consideration on both technical and economic levels. Firstly, an applicable power management system with a simple control structure is studied for the residential PV-BT system within DSM. To simplify the installation, operation as well as maintenance and to limit the initial cost to a lower level, this power management system is built with some off-the-shelf components (i.e., chargers and inverters). And a simple but practical switching control structure is implemented by electrical switches instead of costly power dispatching components and specifically customized controllers which will inevitably result in bigger budgets or even unacceptable prices for ordinary householders. Based on the designed power management system, control system models combining both power flow dispatching level and home appliance scheduling level are proposed to minimize residents' energy expenditure and energy consumption from the grid. And for ease of implementation, the power flow dispatching and home appliance scheduling are controlled in a synchronous manner. In fact, the optimal management strategy is a trade-off among a range of power related and non-power related factors, such as technical, economic, environmental and human factors. Therefore, the resident comfort inconvenience is also considered in the control system models, and a multi-objective optimization problem is formulated to cover all the factors.

The remainder of this paper is organized as follows. Section 2 presents the grid-tied PV-BT hybrid power system and its sub-systems. Section 3 focuses on the problem formulation and building of the optimization model. A typical household in South Africa is chosen as a case study and the simulation is given in Section 4, and simulation results and discussions are given in this section as well. At last a conclusion is drawn in Section 5.

2. Grid-tied PV-BT hybrid power system

A common household grid-tied PV-BT hybrid power system is shown in Fig. 1. This hybrid power system consists of PV system and BT bank which are connected with the power grid as well as some electric appliances. The BT bank brings more challenges to power management for more complicated scenarios must be considered, such as when to charge the BT bank using the electricity from the grid or the PV, and how to dispatch the power for driving the home appliances from the power sources, namely, the BT bank, the PV system and the grid. As a result, a power management unit (PMU) is required for PV-BT hybrid systems, such that the performance of solar energy usage can be significantly enhanced and the hybrid power regulation can be improved in terms of energy efficiency. The PMU is used to implement energy conversion (i.e., AC/DC, DC/DC, DC/AC) for voltage and current matching, as well as to dispatch energy. For example, the BT bank can charge electricity from the PV system in a DC/DC manner or from the grid in an AC/DC manner via the PMU; it can also discharge electricity to the electrical loads in a DC/AC manner via the PMU. And the home appliances are supplied by electricity from the grid or the BT or the PV via the PMU. In Fig. 1, it is clear that the PMU acts as the central equipment which is connected with all other equipment in the power system, so that it can carry out management of the power system at both the power dispatching level and the appliance scheduling level. In

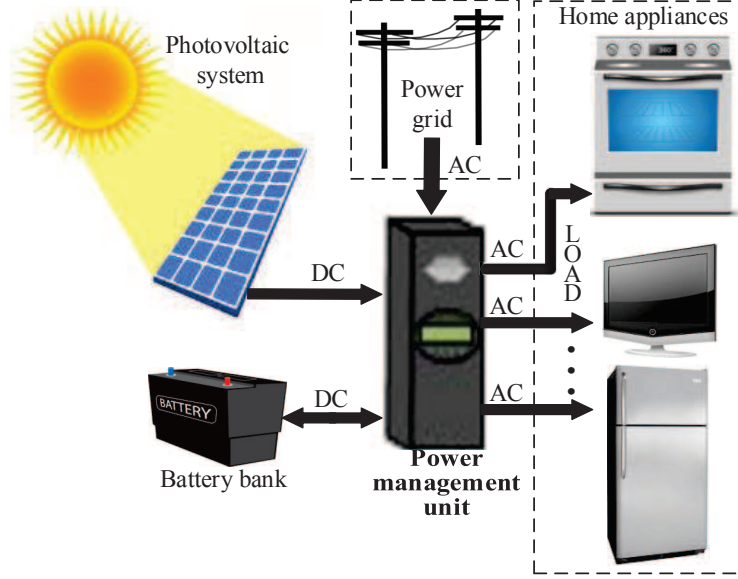

Fig. 1. General layout of the household PV-BT power system.

addition, this all-in-one design would simplify the structure of the residential power system and facilitate the installation and application of the power management system. With the development of the smart grid and the smart home technology, more and more appliances are equipped with open communication interfaces for external control, which makes it feasible for PMU to schedule the appliances via wired or wireless links. For other conventional appliances without the external control interface, some electrical switches are needed to connect/disconnect the appliances to the electric power supply. Because most households with small-capacity PV generation systems cannot guarantee that the energy they feed into the grid is always clean and without threatening the operation of the grid, selling electricity from the household PV-BT system to the grid has not been widely accepted by utility companies as yet. For this reason, it is not considered in this work.

A power management system is presented in Fig. 2. A PMU, as represented in the dash frame box, is composed of a solar charge controller, an AC charger, an inverter and five switches (i.e., g_1 , g_2 , g_3 , g_4 and g_5) to implement switching control strategies. All these components can be readily accessible at low costs. In order to maximally extract power from solar panels, an electric maximum power point tracking (MPPT) controller is generally integrated into the commercial charge controller with a DC/DC converter [20]. Thus the charge controller is not only a solar charger for BT but also a DC/DC power conditioning converter for DC loads. The inverter is used to convert the DC power from the BT or the charge controller to AC loads. The AC charger is used to charge the BT by means of an internal AC/DC power converting circuit. The energy converting efficiency coefficients of the charge controller, AC charger, and inverter are η_S , η_C and η_I , respectively. As shown in Fig. 2, each power line is equipped with a controllable switch, and the arrows indicate directions of power flows on the power lines. Let $g_1(t)$, $g_2(t)$, $g_3(t)$, $g_4(t)$, $g_5(t)$ denote the ON/OFF status of the switches at time t respectively, i.e., $g_i(t)=1$ means the switch g_i is ON at time t , $g_i(t)=0$ means the switch g_i is OFF at time t . However, for simplification of computation, the four binary variables g_1 , g_2 , g_4 and g_5 would not appear in the following modeling and computation process, because their states can be implied by the value of

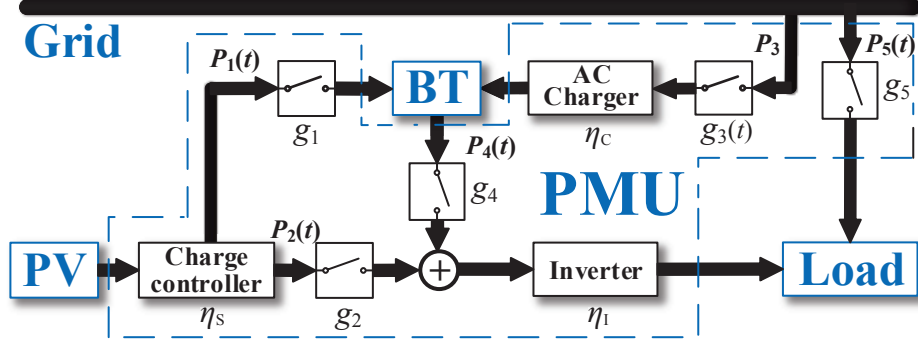

Fig. 2. Schematic of the presented power management system.

the variables $P_1(t)$, $P_2(t)$, $P_4(t)$ and $P_5(t)$, respectively. Moreover, commercial charge controllers, inverters and chargers products usually have built-in switches, which can realize power flow control as well. For example, $P_1(t)=0$ implies that g_1 is OFF at time t , and $P_1 \neq 0$ implies that g_1 is ON at time t . For simplicity, P_3 is assumed as a constant that represents the average power from the grid to the AC charger. And $g_3(t)$ is used to denote the ON/OFF status of the AC charger at time t .

In contrast to the conventional power system without PV and BT that only consumes power from the grid, putting up a grid-tied PV-BT system allows for a variety of operational strategies as well as potential benefits. This work looks at the operation of the power system from an energy efficiency viewpoint [21–23].

2.1. PV system

The PV system consists of several solar cells to convert solar irradiation into direct current power. The hourly power output of the PV system with a given panel size can be simply formulated as [4]:

$$P_{pv} = \eta_{pv} I_{pv} A_c, \quad (1)$$

where P_{pv} is the hourly power output from a PV system of a given solar array area; η_{pv} is the efficiency of solar generation; I_{pv} is the hourly solar irradiation incident on the PV panels (kW/m^2); A_c is the total size of the given solar panels. In this study, it is assumed that the day-ahead power output profile of the PV system can be forecasted.

2.2. Battery bank

The BT bank consists of one or more batteries, which can be charged from other power sources and discharge electricity to loads based on the electrochemical reaction process. All the batteries are usually required to work in the same states when they are used simultaneously in a power system. The state of charge (SOC) of BT changes dynamically owing to possible charge by the PV and the grid or possible discharge for electrical loads. Therefore, the operational conditions will mostly affect the SOC of BT.

One day is divided into N sampling periods. Let t denote the index of these time slots of a day, and $C(t)$ denote the available capacity of BT at the t -th time slot. In the hybrid power system studied in this paper, the BT's dynamic SOC can be expressed as follows

$$C(t) = C(0) + \sum_{\tau=1}^t \eta_B P_1(\tau) \Delta t + \sum_{\tau=1}^t \eta_B \eta_C g_3(\tau) P_3 \Delta t - \sum_{\tau=1}^t P_4(\tau) \Delta t, t = 1, 2, \dots, N, \quad (2)$$

where $C(0)$ is the initial capacity of BT in a day; Δt is the time span of a time slot (sampling interval), $\Delta t=24/N$ hour; $P_1(\tau)\Delta t$ is the PV energy charged into the BT over the τ -th time slot; $g_3(\tau)P_3\Delta t$ is the grid energy supplied for charging the BT over the τ -th time slot; $P_4(\tau)\Delta t$ is the energy discharged from the BT over the τ -th time slot. $\eta_C \leq 1$ is the coefficient of the AC/DC charging efficiency. η_B is the efficiency coefficient of the BT, which is the ratio of the energy that can be extracted from the BT during discharging compared to the energy that enter the BT during charging. Note that at a time when the BT is consuming power, it can be treated as an appliance, whereas during discharging it acts as a power source. There are several constraints on the SOC of BT, including the allowable minimum capacity and the depth of discharge (DOD).

$$C^{min} = (1 - DOD)C^{max}, \quad (3)$$

where DOD is the depth of discharge expressed as a percentage; C^{min} and C^{max} is the minimum and maximum capacity of the BT, respectively. The SOC must be bounded within the scale $[C^{min}, C^{max}]$:

$$C^{min} \leq C(t) \leq C^{max}. \quad (4)$$

Modeling of the lifetime characteristics of BT is a vital aspect that has not been fully considered in many existing studies on BT-based hybrid power management [15]. BT constitutes a sizeable part of the investment costs and are often the most expensive component in most PV-BT hybrid power systems when considering the lifetime costs, as their lifetime is considerably shorter than that of any of the other components [24]. Generally, in real-world scenarios, BT often experiences a wide range of operational conditions, which determine the BT lifetime directly. Thus BT's lifetime poses great financial uncertainty on BT-based applications owing to the replacement cost during the hybrid system's lifetime. There are various methods for calculating the lifetime consumption, including the Ah-throughput and cycle counting method [25]. In this paper, the Ah-throughput counting method is employed to evaluate the lifetime consumption of BT. This method assumes that a fixed amount of energy can be cycled through a BT before it requires replacement. The estimated total throughput, TH over a BT's lifetime can be obtained usually from the *DOD vs. cycles to failure* curve provided by the BT manufacture, which is expressed as follows:

$$TH = F_i DOD_i C^{max}, \quad (5)$$

where DOD_i is a depth of discharge being considered, F_i represents the corresponding number of cycles to failure, and i represents each *DOD vs. cycles to failure* curve as given by the manufacture. In the PV-BT hybrid power system presented in this work, the BT should be charged and discharged during each day to make full use of the solar energy to save conventional energy or save money. The total throughput of the BT, C_D over a given day can be counted as

$$C_D = \sum_{\tau=1}^N P_4(\tau) \Delta t. \quad (6)$$

In order to evaluate C_D , the cost of BT, transportation, installation and operation during its life-time should be taken into account in the life-cycle cost analysis. The sum of these costs B_C is divided by the total throughput and then the BT wear cost over a given day can be derived by

$$J_B = C_D B_C / TH, \quad (7)$$

where B_C/TH is the BT wear cost per kWh throughput energy. In fact, BT wear cost usually results from two kinds of degradation, one is cycle degradation, and the other is calendar degradation [26]. J_B actually represents the former which is caused by charging and discharging operations. The latter mainly results from the aging phenomena, which has a weak relationship with the operations provided that correct implementation and temperature is guaranteed. Therefore, the cost related to calendar degradation of BT can be considered as fixed and not taken into consideration in the optimization model in Section 3. Note that the wear cost of PV and other components in the residential power system are mainly caused by the calendar degradation and also not considered in the optimization model.

2.3. Power grid

The grid is modeled as an infinite bus-bar at alternative voltage levels of 230V. It is capable of supplying energy to a household for charging the BT and driving the loads directly, and these two parts of energy cost constitute the electricity bill paid to the utility. TOU pricing is considered as a typical DR program of DSM, which is adopted in the study. As the electricity prices are fixed in advance for the customer reference, day-ahead optimal control strategies can be applicable to minimize the electricity cost under the TOU pricing program. In South Africa, Eskom is the main power supply utility company which has TOU tariff programs: low price is paid for off-peak periods, medium price is paid for standard periods and high price is paid for peak periods. This study follows the TOU electricity tariff adopted in [17]:

$$\rho(h) = \begin{cases} 0.3656 \text{ R/kWh, if } h \in [00 : 00, 07 : 00) \cup [23 : 00, 24 : 00) \\ 0.6773 \text{ R/kWh, if } h \in [07 : 00, 08 : 00) \cup [11 : 00, 19 : 00) \cup [21 : 00, 23 : 00), \\ 2.2225 \text{ R/kWh, if } h \in [08 : 00, 11 : 00) \cup [19 : 00, 21 : 00) \end{cases} \quad (8)$$

where R is the South African Currency Rand and h is the time during a day. From the viewpoint of DSM, the BT can be charged using the grid power during the off-peak period, and then discharge electricity to home appliances during the peak period to reduce electricity cost. The introduction of PV could enhance the DSM in a way that the free and green energy from the PV is used to charge the BT and drive home appliances as a substitution for the energy from the grid. The grid can also provide electricity directly to home appliances when the power demand cannot be satisfied by the PV and BT. For a conventional household, the grid is the only power source, its electricity cost over a day is $\sum_{\tau=1}^N \rho(\tau) P_L(\tau) \Delta t$, where $P_L(\tau)$ is the total power consumed by the appliances working at the τ -th time slot.

2.4. Electric loads

The typical working class households are studied in this work. All the electric loads in the house can only use AC power, and most of their activities occur in the morning and after work in a day. For simplification of computation, the power factors of all home appliances are all assumed to be 1. All the home appliances can be divided into three categories according to their

working time: fixed loads, shiftable loads and flexible loads [8, 27]. The fixed loads' working time cannot be changed at all. The shiftable loads' working time can be shifted within a limited preferred period. And the flexible loads can be scheduled at any time. For example, TV sets and refrigerators are fixed loads, electric water heaters (EWHs), washing machines and stoves are shiftable loads, dishwashers and bread makers are flexible loads.

The total power consumed by the home appliances in a house working at the t -th time interval is

$$P_L(t) = \sum_{i=1}^A P'_i \Delta t u_i(t), \quad (9)$$

where A is the number of home appliances involved in the house; P'_i is the average power of the i -th appliance; Δt is the time span of the time interval; $u_i(t)$ is a binary variable, which represents ON/OFF status of the i -th appliance at the time interval t : when the i -th appliance is switched on, $u_i(t)=1$; otherwise $u_i(t)=0$.

The scheduling period is achieved by deciding whether to turn on the appliance at the beginning of each sampling period. The i -th appliance is assumed to start work at the time slot S_i , and continue to work until the time slot E_i , and the operation duration is D_i . This continuous operation requirement can be described by [23]:

$$\sum_{t=1}^{N-D_i+1} u_i(t)u_i(t+1)u_i(t+2)\dots u_i(t+D_i-1) = 1. \quad (10)$$

Some other operational constraints are also considered in this paper, such as operational coordination between washing machine and electric dryer, the dryer should work after the washing machine. Such an operational coordination constraint can be described by [28]:

$$S_r + D_r \leq S_q, \quad (11)$$

where S_r and D_r are the r -th appliance's scheduling period and operation duration respectively; S_q is the q -th appliance's scheduling period.

2.5. System constraints

Besides the constraints for the sub-system of the hybrid power system mentioned above, the PV-BT hybrid power system has to satisfy some other constraints at the power dispatching level: (a). Capacity constraints: Power flow from each source or into each component (e.g., the AC charger, charge controller and inverter) cannot exceed the corresponding maximum capacity, thus there must be some limitations:

$$0 \leq P_i(t) \leq P_i^{max}, \quad (12)$$

where $P_i(t)$ ($i=1, 2, 4, 5$) are the power flows marked in Fig. 2., and their values are nonnegative in this work. According to balance of power, the power output from the solar charge controller should satisfy:

$$0 \leq P_1(t) \leq \eta_S P_{pv}(t), \quad (13)$$

$$0 \leq P_2(t) \leq \eta_S P_{pv}(t), \quad (14)$$

where $P_{pv}(t)$ is the power output from the PV system at time t .

And the power flow into the inverter is not allowed to exceed the maximum input power of the inverter:

$$0 \leq P_2(t) \leq P_1(t)/\eta_I, \quad (15)$$

$$0 \leq P_4(t) \leq P_1(t)/\eta_I, \quad (16)$$

where P_1 is the rated maximum capacity of the inverter.

The power absorbed from the grid includes two parts: the first part is used to charge the BT, and the second part is used to afford the electric appliances directly. Thus the power consumed at time t from the grid $P_G(t)$ is:

$$P_G(t) = g_3(t)P_3 + P_5(t). \quad (17)$$

And there is also a limitation for $P_G(t)$. At any time, it cannot exceed the maximum power P_G^{\max} , which is determined by the utility and the capacity limitation of the installed electric wires and brakes in the house:

$$0 \leq P_G(t) \leq P_G^{\max}. \quad (18)$$

(b). Power balance constraint: The power demand of the loads at any time should be met by the power flow from the PV, the BT or the grid.

$$P_L(t) = \eta_I P_2(t) + \eta_I P_4(t) + P_5(t). \quad (19)$$

(c). Power flow constraints: Generally, BT's charging and discharging operations are mutually exclusive. Therefore the BT cannot charge and discharge at the same time. The constraints below are applied:

$$P_1(t)P_4(t) = 0, \quad (20)$$

$$g_3(t)P_4(t) = 0. \quad (21)$$

These constraints also allow the state of the BT to be idle while it is not charging or discharging.

Moreover, for safety and easier configuration, the BT must not be allowed to be charged by two heterogeneous power sources, i.e., PV power and the grid power; and the solar charge controller cannot charge the BT and supply power to home appliances synchronously. These constraints can be expressed as:

$$P_1(t)g_3(t) = 0, \quad (22)$$

$$P_1(t)P_2(t) = 0. \quad (23)$$

Because multiple power supplies are usually not supported in a simple power energy system, load demand of residents must be satisfied by the only one of the three power sources (i.e., the PV, the BT and the grid) at any time. These constraints can be expressed as:

$$P_2(t)P_4(t) = 0. \quad (24)$$

$$P_2(t)P_5(t) = 0, \quad (25)$$

$$P_4(t)P_5(t) = 0. \quad (26)$$

It is noted that the DC-coupling and AC-coupling can be realized for utilizing multiple power supplies at the same time by adopting some sophisticated equipment, and then the constraints (24)-(26) should be removed. However, these constraints are retained here for the consideration of building a simple power management system at low costs.

3. Optimal management model for the hybrid system

3.1. Optimization model

The prime motivation for most residents to participate in DR programs may be to minimize energy cost, especially for those who have already accessed to reliable electricity services. Therefore, this paper firstly presents the household energy cost minimization problem through appliance scheduling and power dispatching of the hybrid power system. In the present power system, the daily cost J_c is characterized by the electricity cost and the BT wear cost:

$$J_c = \sum_{t=1}^N \rho(t)[g_3(t)P_3 + P_5(t)]\Delta t + J_B, \quad (27)$$

where $[g_3(t)P_3 + P_5(t)]\Delta t$ is the total energy consumed by charging BT and driving home appliances from the grid at the t -th slot; $\rho(t)$ is the temporal electricity price at that time; J_B is the wear cost of the BT bank over a given day, which was neglected completely or regarded as a fixed average value in most of previous literature. However, the cycle life of current BT is short and its price is still high, it is easy to calculate that the wear cost per cycle is not low enough to be neglectable according to the Eqs. (5)-(7). Moreover, J_B is determined by the operation of the power system and thus it is not a fixed value.

Other than economic performance, some consumers may pay more attention to energy saving performance and environmental benefits. As is well known, most power of the grid is still generated from fossil-fuel combustion, and thus the less energy consumed from the grid, the less CO₂ emissions and the less negative impact on the environment. From the viewpoint of energy saving and environmental protection, minimizing the energy consumption from the grid is also important and should be taken into consideration as well. In the present power system, the daily energy consumption J_e can be calculated by the following expression:

$$J_e = \sum_{t=1}^N [g_3(t)P_3 + P_5(t)]\Delta t. \quad (28)$$

Moreover, the residents' decision to continue participating in the DR program may be influenced not only by the cost saving and energy saving benefits, but also by the inconvenience level that comes with the new schedule. The scheduling inconvenience level β seeks minimizing the disparity between the habitual schedule and the new schedule. Following the previous work [28], the scheduling inconvenience of the i -th appliance is defined by

$$\beta_i := \sum_{t=1}^N [u_i^{bl}(t) - u_i(t)]^2, \quad (29)$$

where $u_i^{bl}(t)$ is a binary variable, which represents the baseline switching status of the i -th appliance at time interval t : when $u_i^{bl}(t)=1$, the i -th appliance is switched on; otherwise $u_i^{bl}(t)=0$, the i -th appliance is switched off. The residents' habitual schedules are taken as the baseline schedules in this work. The general inconvenience level β is used to represent the total scheduling inconvenience of all appliances that are taken into consideration:

$$\beta := \sum_{i=1}^A \gamma_i \beta_i, \quad (30)$$

where γ_i is the weighting factor attached to the i -th appliance according to the residents' preference.

In real-world scenarios, consumers may expect the lowest operating cost, the least energy consumption from the grid as well as the lowest inconvenience level at the same time. However, the money-saving oriented operations may not always result in the reduction of energy consumption, and vice versa. Sometimes, it is necessary to change their habitual schedules if the residents want to reduce the energy cost or energy consumption from the grid. Therefore, the trade-off among operating cost, energy consumption and inconvenience is considered, and a weighted-objective function is formulated to minimize the daily cost J_c , the daily energy consumption J_e from the grid and the inconvenience level β as follows:

$$\text{Min } f = \delta J_c + \alpha J_e + \theta \beta, \quad (31)$$

where δ , α and θ are the weight factors attached to the operating cost, energy consumption and inconvenience level according to the residents' preference. This weighted-sum methodology is able to express all sub-objectives by the overall objective function (31) and then gets plausible results, however it is sometimes obscure for people to understand and choose the values of δ , α and θ . In addition, this method is one of the ways to solve multi-objective optimization problems, but sometimes it could not find all Pareto fronts for this NP-hard combinatorial problem. Another solution to the multi-objective optimization problem is developed by applying the constraint method, which treats other objective functions as constraint conditions while solving an optimization problem in a chosen objective function [29]. For example, if the residents expect least possible energy consumption from the grid while unwilling to spend more than an amount of money (e.g., J' Rand), and they also do not like to be subject to an inconvenience level higher than β' . In that case, the constraints $J_c \leq J'$ and $\beta \leq \beta'$ should be added to the objective function $\text{Min } f = J_e$, and then the sub-optimal operation strategy can be derived by solving this mathematical problem. This is the method we adopt in the sequel of the paper.

3.2. MINLP problem

The decision problem proposed in last subsection leads to a mixed-integer nonlinear programming (MINLP) problem that combines the combinatorial difficulty of optimizing over discrete variable sets with the challenges of handling nonlinear functions [30]. The MINLP problem has the following form:

$$\text{Min}_x f(x) \text{ subject to } \begin{cases} Ax \leq b \\ A_{eq}x = b_{eq} \\ l_b \leq x \leq u_b \\ c(x) \leq d \\ c_{eq}(x) = d_{eq} \\ x_k \in \{0, 1\} \\ x_j \in \mathbb{R} \end{cases}, \quad (32)$$

where $f(x)$ is a scalar function to be minimized, which is subject to the following constraints:

Linear inequalities: A is a $m \times n$ sparse matrix, b is a $m \times 1$ vector;

Linear equalities: A_{eq} is a $w \times n$ sparse matrix, b_{eq} is a $w \times 1$ vector;

Decision variable bounds: l_b and u_b indicating the lower and upper bound respectively;

Nonlinear inequalities: c is a $u \times 1$ vector of functions containing inequality constraints, d is a $u \times 1$ vector;

Nonlinear equalities: c_{eq} is a $v \times 1$ vector of functions containing inequality constraint, d_{eq} is a $v \times 1$ vector;

Discrete variables: x_k are decision variables which must be binary numbers;

Continuous variables: x_j are decision variables which must be real numbers, where $k \neq j$.

The optimization model presented in last subsection has n control variables: $u_i(t)$, $g_3(t)$, $P_1(t)$, $P_2(t)$, $P_4(t)$ and $P_5(t)$, where $n=(A+5)*N$, $i=1, 2, \dots, A$; $t=1, 2, \dots, N$. The n control variables are taken as the variables of the MINLP problem (32), which are composed of $(A+1)*N$ binary variables x_k and $4*N$ nonnegative real variables x_j :

$x_k = \{u_1(1), u_1(2), \dots, u_1(N), u_2(1), u_2(2), \dots, u_2(N), \dots, u_A(1), u_A(2), \dots, u_A(N), g_3(1), g_3(2), \dots, g_3(N)\}$, $k=1, 2, \dots, (A+1)*N$;

$x_j = \{P_1(1), P_1(2), \dots, P_1(N), P_2(1), P_2(2), \dots, P_2(N), P_4(1), P_4(2), \dots, P_4(N), P_5(1), P_5(2), \dots, P_5(N)\}$, $j=(A+1)*N+1, (A+1)*N+2, \dots, (A+5)*N$.

The constraints (4), (11)-(16) and (18) can be formed the linear inequalities $Ax \leq b$. The constraints (19) can be formed the linear equalities $A_{eq}x = b_{eq}$. The constraints (16) and (20)-(26) can be formed the nonlinear equalities $c_{eq}(x) = d_{eq}$. Therefore, the problem to derive the optimal operation strategy for the hybrid power system can be formulated as an MINLP problem. To solve the MINLP problem, an *OPTI toolbox in MATLAB*³ can be employed. Its solutions can be applicable to real-world scenarios directly for minimizing the operating cost or the energy consumption from the grid.

4. Simulation and discussion

A typical working class household in South Africa is chosen as a case study. The data of the main home appliances and usage profiles are considered. The maximum current supplied to the household by the utility is limited to 60A. As shown in Table 1, eight most commonly used home appliances are selected to be representatives of the three categories of home appliances and others are not taken into account for simplification and other reasons. For instance, with the

³<https://www.inverseproblem.co.nz/OPTI/index.php/DL/DownloadOPTI/>

development of light emitting diode (LED) technology, the lighting efficiency (lumens per watt) grows while the energy consumption of lighting decreases year by year, so the energy consumption of the lighting system is comparatively neglectable. Some occasionally used appliances such as electric iron and vacuum cleaner are not taken into account for they are not used regularly in every day. Some other appliances such as microwave oven, toaster and kettle which have a short working period are also not taken into account, considering their usage durations are even shorter than the sampling time Δt , which is set as 10 minutes in this study. So one day (24 hours) is decomposed into 144 time slots, and the first time slot starts at 0 o'clock.

In fact, owing to the simple switching control structure of the power management system, the control interval can be shorter than 10 minutes. However, frequent switching will be harmful to the electrical and electronic device as well as the power system for the switching surges and increased wear. In other words, if there is no difference in the performance of operation cost, energy consumption and inconvenience level, the longer control interval of the power dispatching level is preferable to the shorter one. On the other hand, according the common operational patterns of the home appliances, the control interval of 10 minutes can guarantee short waiting periods and ensure residents' real-life operational habits to be respected. Therefore, the control interval of 10 minutes is adopted as one of feasible parameters for both the power dispatching level (i.e., $g_3(t)$, $P_1(t)$, $P_2(t)$, $P_4(t)$ and $P_5(t)$) and the home appliance scheduling level (i.e., $u_i(t)$) to demonstrate the effectiveness of the proposed method in this section. In addition, within the proposed control framework, the control interval of the power dispatching level can also be set as 60 minutes or longer by adding continuous operation constraints of the equipment to the optimization problem, while setting the control interval of the home appliance scheduling level as 10 minutes or shorter. Relying on the proposed method, the customers can select multiple different control intervals and evaluate the respective optimal performance quantitatively, and then choose the comparatively better control strategy according to their own preference.

Table 1. Applications data and their baseline schedule.

Index(<i>i</i>)	Appliances A_i	$P'_i(i=1,\dots,8)$ Power (kW)	Duration D_i (Min)	Baseline slots	
				S_i	E_i
Shiftable					
1	EWH	3.0	120	31	42
			120	104	115
2	Stove	2.5	30	32	34
			50	113	117
3	Washing machine	0.5	60	109	114
4	Electric dryer	2.0	30	116	118
Fixed					
5	Refrigerator	0.1	1440	1	144
6	TV set	0.2	180	104	121
Flexible					
7	Dishwasher	1.8	150	116	130
8	Bread maker	1.5	150	118	132

In Table 1, average power of each appliance is measured and then calculated using the existing electric meter installed in the house. One month's weekday data on appliance usage in

the household under study were collected. The information on S_i and E_i as the starting and end of the time interval in which the appliance is to be scheduled are recorded in Table 1 based on the residents' preferred usual usage habit. These usual usage data listed in the last column of Table 1 are taken as the baseline schedule. For example, appliance A_1 is a rated power 3.0kW EWH, which is scheduled twice in a day to work for 120 minutes in the morning and for 120 minutes in the evening. According to the baseline schedule, it is to be turned on at the beginning of the 31-th time slot (05:00) and 104-th time slot (17:10), turned off at the end of 42-nd time slot (07:00) and 115-th time slot (19:10), respectively. From the prospective of DSM, EWH, as a kind of shiftable appliances which can change working time, could be turned on between 03:00 and 05:00 to guarantee hot water for the residents' consumption during the period 05:00-07:00 ahead of leaving for work in the morning. It is obviously uneconomical to turn on EWH before 03:00 as extra energy will be consumed to preserve heat. Moreover, EWH could be turned on again between 15:00 and 20:00 to guarantee hot water for the residents' consumption at home after work and before bed at 22:00. Refrigerator, as a fixed load, should be turned on over the whole day, and its rated power is approximately estimated by dividing total energy consumed during a day into 24 hours equally. For a conventional household without renewable energy sources and energy storage systems, i.e., the grid is the only power source, it is easy to calculate that these eight appliances' energy consumption from the grid and the corresponding electricity bill over a day with the baseline schedule is 28.08kWh and R30.47 (R represents South African currency Rand), respectively. And the baseline energy usage profile during a day is shown in Fig. 3.

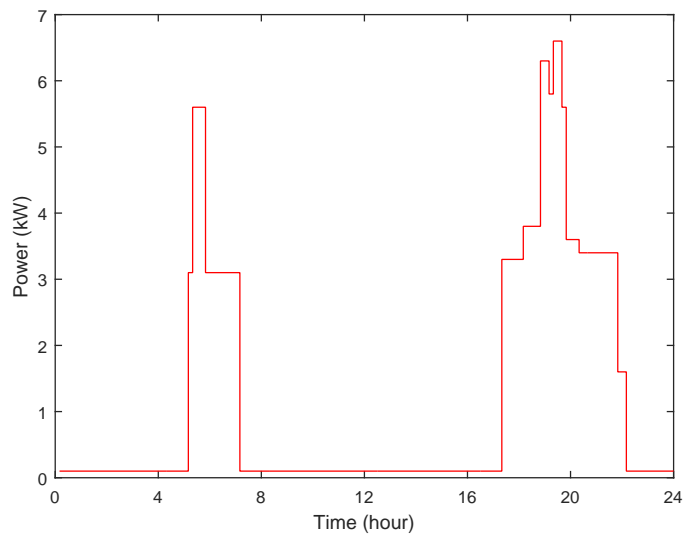

Fig. 3. The baseline energy usage profile.

As shown in Fig. 4, the power output data of solar arrays on the “average day” used in this study are obtained from [31]. This 1-hour step is used for many solar irradiation data sets and is considered adequate for modeling intermittent solar energy with acceptable accuracy, as the underlying principle used to model the power generated from the PV system is the same when using a 1- or 5-minutes and hourly data [15, 32]. Other PV power data can also be adopted in this study to demonstrate the effectiveness of the proposed power management system.

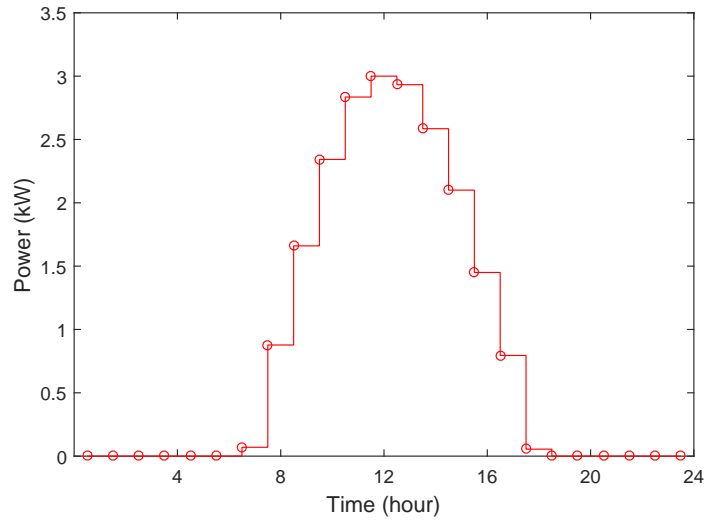

Fig. 4. Profile of hourly PV power output.

One applicable configuration of the hybrid power system is introduced here. The PV system is composed of 14 solar panels, each of them has the capacity 0.25kW_P . The BT bank consists of 4 serially connected lead-acid rechargeable batterie. Each BT's nominal voltage and capacity is 12V and 105Ah respectively, thus the total nominal capacity of the BT bank is 5.04 kWh. The minimum discharge capacity of 50% has been shown to sustain the lifespan of the BT [28, 33]. It is assumed that the initial state of energy stored in BT is 60% C^{max} , the BT's efficiency coefficient is 100%, and its lifespan is 1000 cycles at 50% DOD⁴. The BT's cost in Table 2 is adopted from [8], which includes capital cost as well as the cost of transportation, installation and operation. *Apert MKS Inverter*⁵ is a multi-function inverter/charger, combining functions of inverter, solar charger and AC charger to offer uninterruptible power support. This off-the-shelf product is not only integrated with the essential power conditioning, converting and switching functions, but also equipped with a remote control panel which facilitates controlling and monitoring from a distance, it is a good choice as the main component of the PMU. The parameters of *Apert MKS 5kVA Inverter* are adopted as the realistic parameters of the PMU, and thus the capacity parameters of the PMU are assumed as follows: the capacity of the inverter is 5kVA; the maximum charging current form the grid and the PV to the BT is 60A and 50A, respectively. The efficiency parameters of the PMU are given in Table 2. Note that the PMU can also be built by some other separate equipment (i.e., solar charger, inverter and AC charger) instead of this kind of all-in-one products.

For the installed PV-BT hybrid power system described above, one group of control variables (1296 binary variables and 576 nonnegative real variables) should be computed for the optimization problem. The binary variables represent the switching status of the 8 appliances and AC charger during 144 time slots over a day, and the real variables represent the values of power flows P_1 , P_2 , P_4 and P_5 during each time slot over a day. The parameters δ , α and θ are the

⁴<http://www.trojanbattery.com/markets/renewable-energy-re/>

⁵<http://www.voltronicpower.com>

Table 2. Parameters of the hybrid power system

PV's capacity	3.5 kW _P
BT's capacity (C^{max})	5.04 kWh
BT's cost	R5826
Initial state of energy	60% C^{max}
Depth of discharge	50%
η_C	85%
η_I	95%
η_S	90%

weight factors attached to the operating cost, energy consumption and inconvenience level according to the residents' preference only. They can be taken as variables of the objective function (31). In other words, actually the parameters can be assigned to any values if the customers like, and then the calculated results of the model should be completely accepted. However, it is sometimes obscure for people to understand and choose the values of δ , α and θ . Thus the simulation uses several groups of parameters not only to show how the model works, but also to show how to choose the reasonable values of δ , α and θ by means of some typical cases:

(i). If the resident only takes cost into consideration, the optimal operation strategy can be derived by solving the objective function $\text{Min } f = J_c$. In that case, the cost is computed as R10.92, and the cost saving is 64.2% comparing with the cost of the baseline schedule. The corresponding energy consumption is 18.83kWh. Fig. 5 demonstrates one optimal power dispatch profile in such a practical application.

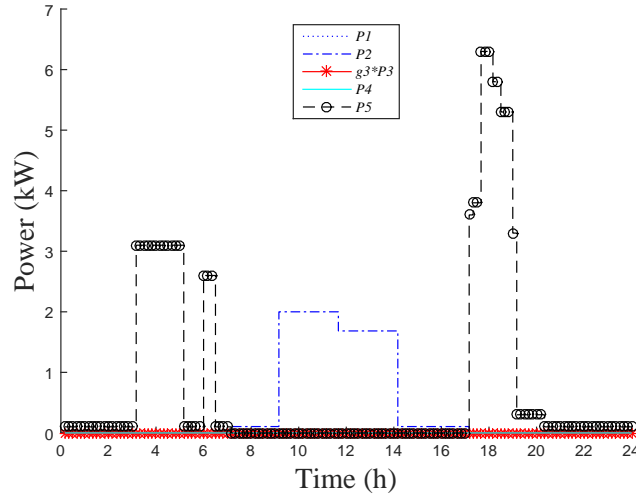

Fig. 5. Power dispatch for case (i).

(ii). If the resident only takes energy consumption into consideration, the optimal operation strategy can be derived by solving the objective function $\text{Min } f = J_e$. In that case, the energy consumption is computed as 15.73kWh, and the energy saving is 44.0% comparing with the energy consumption of the baseline schedule. The corresponding cost is R18.52. Fig. 6 demonstrates one optimal power dispatch profile in such a practical application.

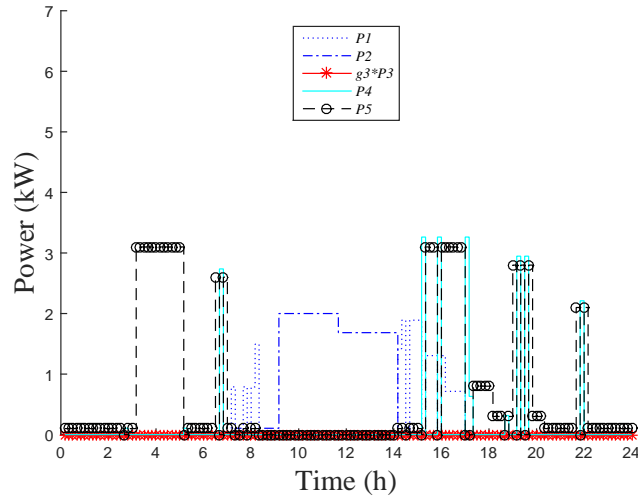

Fig. 6. Power dispatch for case (ii).

(iii). If the resident takes cost into consideration and he would not like to change the baseline schedule of home appliances at all, the optimal operation strategy can be derived by solving the objective function $\text{Min } f = J_c$ while $u_i(t)$ are pre-determined binary numbers according to the baseline schedule. In that case, the cost is computed as R29.33, and the cost saving is 3.7% comparing with the cost of the baseline schedule. The corresponding energy consumption is 27.08kWh. Fig. 7 demonstrates one optimal power dispatch profile in such a practical application.

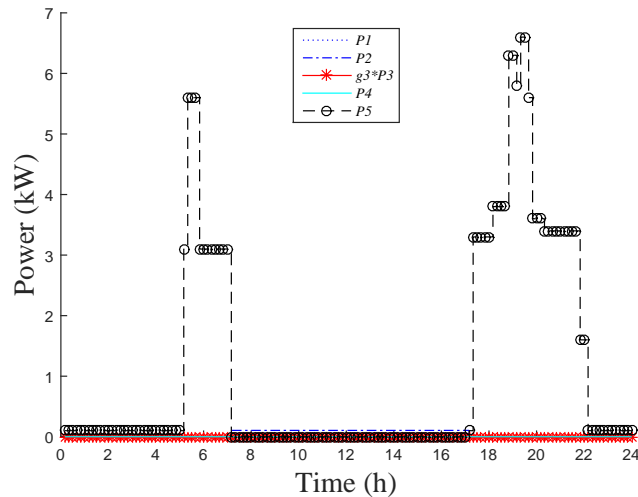

Fig. 7. Power dispatch for case (iii).

(iv). If the resident takes energy consumption into consideration and he would not like to change the baseline schedule of home appliances at all, the optimal operation strategy can be derived by solving the objective function $\text{Min } f = J_e$ while $u_i(t)$ are pre-determined binary numbers according to the baseline schedule. In that case, the energy consumption is computed as 24.35kWh,

and the energy saving is 13.3% comparing with the energy consumption of the baseline schedule. The corresponding energy consumption is R35.57. Fig. 8 demonstrates one optimal power dispatch profile in such a practical application.

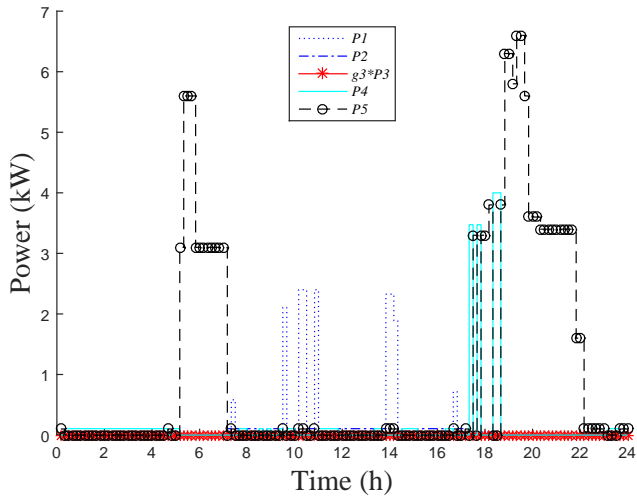

Fig. 8. Power dispatch for case (iv).

(v). If the resident expects lowest cost for the energy while hoping his energy consumption from the grid is less than 25.00kWh, but he is unwilling to be subjected to an inconvenience level higher than 50, the optimal operation strategy can be derived by solving the objective function $\text{Min } f = J_c$ with two additional constraints $J_e \leq 25.00$ and $\beta \leq 50$. In that case, the cost is computed as R16.16, and the cost saving is 47.0% comparing with the cost of the baseline schedule. The corresponding energy consumption is 22.58kWh. Fig. 9 demonstrates one optimal power dispatch profile in such a practical application.

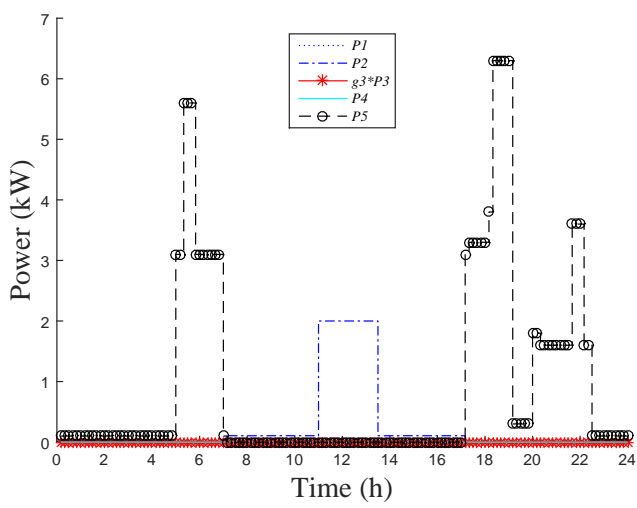

Fig. 9. Power dispatch for case (v).

(vi). If the resident expects least energy consumption from the grid while hoping to spend less

than R15.00 for the energy, but he is unwilling to be subjected to an inconvenience level higher than 50, the optimal operation strategy can be derived by solving the objective function $\text{Min } f = J_e$ with two additional constraints $J_c \leq 15.00$ and $\beta \leq 50$. In that case, feasible solutions cannot be got. The customer need to raise the budget or relax the convenience requirement.

It is noted that, for simplicity, the weighting factor attached to each appliance in the inconvenience function (30) is assumed to be the same (i.e., $\gamma_i = 1$) in the experiments. The results in case (i) and (ii) show that the energy expenditure and energy consumption can be largely reduced by the optimal control strategies, which also denote the exact maximum potential for cost saving and energy saving in such a hybrid power system. The results in case (iii) and (iv) indicate that the potential saving on energy expenditure and energy consumption would be attenuated remarkably if the scheduling of the home appliances is not taken into consideration. In case (iii), the resident would not like to reschedule the home appliances at all and is not concerned about environmental preserving, only the optimal power dispatching strategy is considered in order to satisfy the fixed energy demand profile as well as to save money, thus the multi-objective optimization problem is reduced to the power dispatching problem studied in [2] except that the BT's cycle degradation cost has been considered in our optimization model additionally. In order to evaluate the influence of BT wear cost on power management strategies, in case (iii), the BT's wear cost J_B was omitted and then the simulation was conducted again. The corresponding optimal power dispatch profile is demonstrated in Fig. 10. Compared with Fig. 7, $P_1(t)$ and $P_4(t)$ in Figs. 10 are not always equal to 0, it means that the BT will be utilized if its cycle life cost is negligible, and the corresponding lowest daily cost is R24.33. However, if the wear cost J_B in that case is taken into account, the realistic daily cost will increase to R30.96, which is higher than the lowest daily cost R29.33 in case (iii). These results validate BT's cycle degradation has a considerable influence on power management strategies as well as operating cost, that must be considered in the design and operation of such residential power systems.

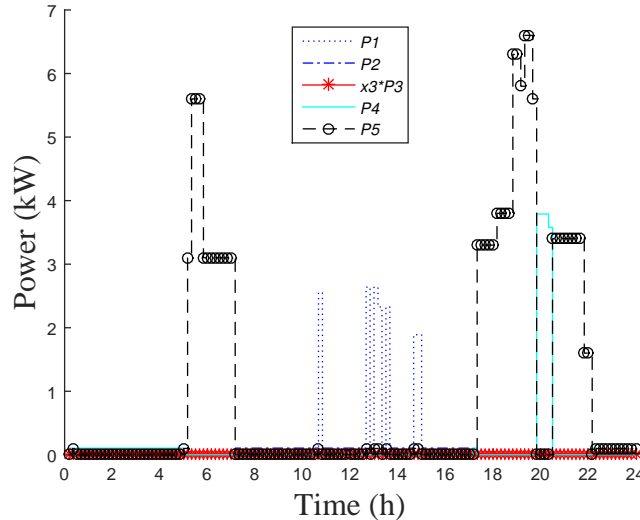

Fig. 10. Power dispatch for case (iii) without the consideration of BT wear cost.

It is easy to see that, in case (v) and (vi), the inconvenience factor, cost saving and energy saving are managed to be considered at the same time by the proposed method. The trade-off

among them could help residents in making an informed decision on how much they are willing to be inconvenienced, that may affect their energy consuming behavior. It is found that, $g_3(t)$ in the cases (i)-(v) are always equal to 0 (refer to Figs. 5-9). It means that the BT is never charged using the power from the grid, and thus the AC charger is redundant under these conditions. It is also found that, $g_3(t)$, $P_1(t)$ and $P_4(t)$ in the cases (i), (iii) and (v) are always equal to 0 (refer to Figs. 5, 7 and 9), and thus the BT would be redundant to the hybrid power system if the residents seek minimizing their operating cost. This is resulted from the high wear cost of the usage of BT. Therefore, the proposed method can help customers to simplify the hybrid power system as well as to decrease their initial capital by omitting some redundant components (e.g., an AC charger or BT) under certain conditions. Comparatively, $P_1(t)$ and $P_4(t)$ in Figs. 6 and 8 are not always equal to 0, it shows that the BT plays an important role by storing the energy from the PV and discharging to the home appliances when the residents seek minimizing the energy consumption from the grid so as to reduce emissions from fossil-fuel combustion.

It is noted that, the power output data of the PV system are the input data of the model and thus has no influence on the proposed model itself, though it could affect the maximum potential saving on energy expenditure and energy consumption for different configurations of PV-BT system. And, if the annual simulation is needed, the power output data of solar arrays on every day of the year should be used to calculate the optimal solution day by day, and the proposed management system will give each day's optimal operational strategy of the year separately. Note that the weight factors δ , α and θ could not be changed during one whole day but could be changed every day. That is the constraint of the system. However, this constraint has no influence on the application of the proposed system to other regions besides South Africa.

Finally, it is important to emphasize that since all kinds of home appliances can be covered by the three categories (i.e., fixed loads, shiftable loads and flexible loads), and their operational patterns are fully considered in this study, the proposed management method can be adjusted easily according to different households and still take effect. Moreover, the presented power management system and control system models are still available if the lead-acid batteries are replaced by lithium-ion ones for a dwelling. In that scenario, only the parameters of the BT should be updated accordingly in the computation process and then the optimal operation strategy could be derived in the same way. In the above experimental studies, the initial state, maximum capacity and efficiency of the BT are fixed over a day period. In the life cycle of BT, these parameters actually change year by year due to BT's deterioration. However, this paper mainly focuses on the control system framework combining both power dispatching level and home appliance scheduling level, for the method to analysis the effects of such varying parameters please refer to the Section 6 in the literature [2].

5. Conclusions

This paper presents an easily applicable power management system at comparably low cost for a household PV-BT hybrid power system. As a popular demand side management program, time of use tariff has been considered in this work. Not only is the power management system constructed technically, but also the optimal power management strategy is studied from the perspective of economic and environmental performance. The control system models framework combining both power dispatching level and home appliance scheduling level is proposed to minimize residents' energy cost and energy consumption from the grid. In addition, the resident comfort inconvenience level is also considered in the control system models. The optimal

management strategy is a trade-off among a range of power related and non-power related factors, such as technical, economic, environmental and human factors. Therefore, the trade-off of operating cost, energy consumption and consumer comfort convenience is also studied and a multi-objective optimization problem is formulated to cover all these real-world factors.

A typical household in South Africa is chosen as a case study to demonstrate the effectiveness of the proposed power management system. Both the economic and environmental performance are considered and calculated quantitatively to dispel consumers' uncertainty on these two aspects, which could aid the consumer to remove the major obstacle to determine whether to newly install or update to such PV-BT hybrid power systems. The results also indicate that the energy expenditure and energy consumption from the grid could be largely reduced by the optimal management strategies. In some cases, even without using optimisation or DSM techniques, only adopting PV and battery seems to be quite promising for cutting electricity bill or saving energy, especially in the house equipped with a large PV system [34]. However, these scenarios might result in unaffordable initial cost for working families. Moreover, in these scenarios, the proposed method could still aid the householder to assess the maximum potential benefit for different configurations of PV-BT system and then make a better investment plan.

References

- [1] U.S. Energy Information Administration. International Energy Outlook 2016; Available from: <http://www.eia.gov/forecasts/ieo/world.cfm> (accessed 25.8.2016)
- [2] Wu Z, Xia X. Optimal switching renewable energy system for demand side management. *Solar Energy* 2015; 114: 278-288.
- [3] International Energy Agency. World Energy Outlook 2015; Available from: <http://www.worldenergyoutlook.org/weo2015/> (accessed 25.8.2016)
- [4] Tazvinga H, Xia X, Zhang J. Minimum cost solution of photovoltaic-diesel-battery hybrid power systems for remote consumers. *Solar Energy* 2013; 96: 292-299.
- [5] Hong Y, Lian R. Optimal sizing of hybrid wind/PV/diesel generation in a stand-alone power system using Markov-based genetic algorithm. *IEEE Transactions on Power Delivery* 2012; 27(2): 640-647.
- [6] Khiareddine A, Ben Salah C, Mimouni MF. Power management of a photovoltaic/battery pumping system in agricultural experiment station. *Solar Energy* 2015; 112: 319-338.
- [7] Nicholls A, Sharma R, Saha TK. Financial and environmental analysis of rooftop photovoltaic installations with battery storage in Australia. *Applied Energy* 2015; 159: 252-264.
- [8] Setlhaolo D, Xia X. Combined residential demand side management strategies with coordination and economic analysis. *International Journal of Electrical Power & Energy Systems* 2016; 79: 150-160.
- [9] Salpakari J, Lund P. Optimal and rule-based control strategies for energy flexibility in buildings with PV. *Applied Energy* 2016; 161: 425-436.

- [10] Darcovich K, Kenney B, MacNeil D D, Armstrong M M. Control strategies and cycling demands for Li-ion storage batteries in residential micro-cogeneration systems. *Applied Energy* 2015; 141: 32-41.
- [11] Bortolini M, Gamberi M, Graziani A. Technical and economic design of photovoltaic and battery energy storage system. *Energy Conversion Management* 2014; 86: 81-92.
- [12] Hove T, Tazvinga H. A techno-economic model for optimising component sizing and energy dispatch strategy for PV-diesel-battery hybrid power systems. *Journal of Energy in Southern Africa* 2012; 23(4): 18-28.
- [13] Teleke S, Baran ME, Bhattacharya S, Huang A. Rule-based control of battery energy storage for dispatching intermittent renewable sources. *IEEE Transactions on Sustainable Energy* 2010; 1(3): 117-124.
- [14] Wang C, Nehrir MH. Power management of a stand-alone wind/photovoltaic/fuel cell energy system. *IEEE Transactions on Energy Conversion* 2008; 23(3): 957-967.
- [15] Tazvinga H, Zhu B, Xia X. Optimal power flow management for distributed energy resources with batteries. *Energy Conversion and Management* 2015; 102: 104-110.
- [16] Wu Z, Tazvinga H, Xia X. Demand side management of photovoltaic-battery hybrid system. *Applied Energy* 2015; 148: 294-304.
- [17] Sichilalu SM, Xia X. Optimal energy control of grid tied PV-diesel-battery hybrid system powering heat pump water heater. *Solar Energy* 2015; 115: 243-254.
- [18] Zhu B, Tazvinga H, Xia X. Switched model predictive control for energy dispatching of a photovoltaic-diesel-battery hybrid power system. *IEEE Transactions on Control Systems Technology* 2015; 23(3): 1229-1236.
- [19] Setlhaolo D, Xia X, Zhang J. Optimal scheduling of household appliances for demand response. *Electric Power Systems Research* 2014; 116: 24-28.
- [20] Karami N, Moubayed N, Outbib R. Analysis and implementation of an adaptative PV based battery floating charger. *Solar Energy* 2012; 86(9): 2383-2396.
- [21] Xia X, Zhang J. Energy efficiency and control systems-from a POET Perspective. *IFAC Proceedings Volumes* 2010; 43(1): 255-260.
- [22] Xia X, Zhang J, Cass W. Energy management of commercial buildings - a case study from a POET perspective of energy efficiency. *Journal of Energy in Southern Africa* 2012; 23(1): 23-31.
- [23] Xia X, Zhang J. Operation efficiency optimisation modelling and application of model predictive control. *IEEE/CAA Journal of Automatica Sinica* 2015; 2(2): 166-172.
- [24] Svoboda V, Wenzl H, Kaiser R, Jossenb A, Baring-Gouldd I, Manwelle J, et al. Operating conditions of batteries in off-grid renewable energy systems. *Solar Energy* 2007; 81(11): 1409-1425.

- [25] Bindner H W, Cronin T, Lundsager P, Manwell JF, Abdulwahid U, Baring-Gould I. Lifetime modelling of lead acid batteries. Denmark. Forskningscenter Risoe. R-1515(EN). 2005.
- [26] Jung J, Zhang L, Zhang J. Lead-Acid Battery Technologies: Fundamentals, Materials, and Applications. Taylor & Francis Inc., ISBN 9781466592223, Boca Roca, United States. 2015.
- [27] Yu T, Kim DS, Son SY. Optimization of scheduling for home appliances in conjunction with renewable and energy storage resources. *International Journal of Smart Home* 2013; 7(4): 261-272.
- [28] Setlhaolo D, Xia X. Optimal scheduling of household appliances with a battery storage system and coordination. *Energy and Buildings* 2015; 94: 61-70.
- [29] Carlos A, Gary B, David A. *Evolutionary Algorithms for Solving Multi-Objective Problems*. Springer. ISBN 9780387332543. 2007.
- [30] Belotti P, Kirches C, Leyffer S, Linderoth J, Luedtke J, Mahajan A. Mixed-integer non-linear optimization. *Acta Numerica* 2013; 22: 1-131.
- [31] Tazvinga H, Hove T. *Photovoltaic/diesel/battery hybrid power supply system*. VDM Publishers, ISBN 9783639284966. German. 2010.
- [32] Madaeni SH, Sioshansi R, Denholm P. Estimating the capacity value of concentrating solar power plants: a case study of the southwestern United States. *IEEE Transactions on Power Systems* 2012; 27(2): 1116-1124.
- [33] Dürr M, Cruden A, Gair S, McDonald JR. Dynamic model of a lead acid battery for use in a domestic fuel cell system. *Journal of Power Sources* 2006; 161(2): 1400-1411.
- [34] Reda F, Tuominen P, Hedman A, Ibrahim MGE. Low-energy residential buildings in New Borg El Arab: Simulation and survey based energy assessment. *Energy and Buildings* 2015; 93: 65-82.